

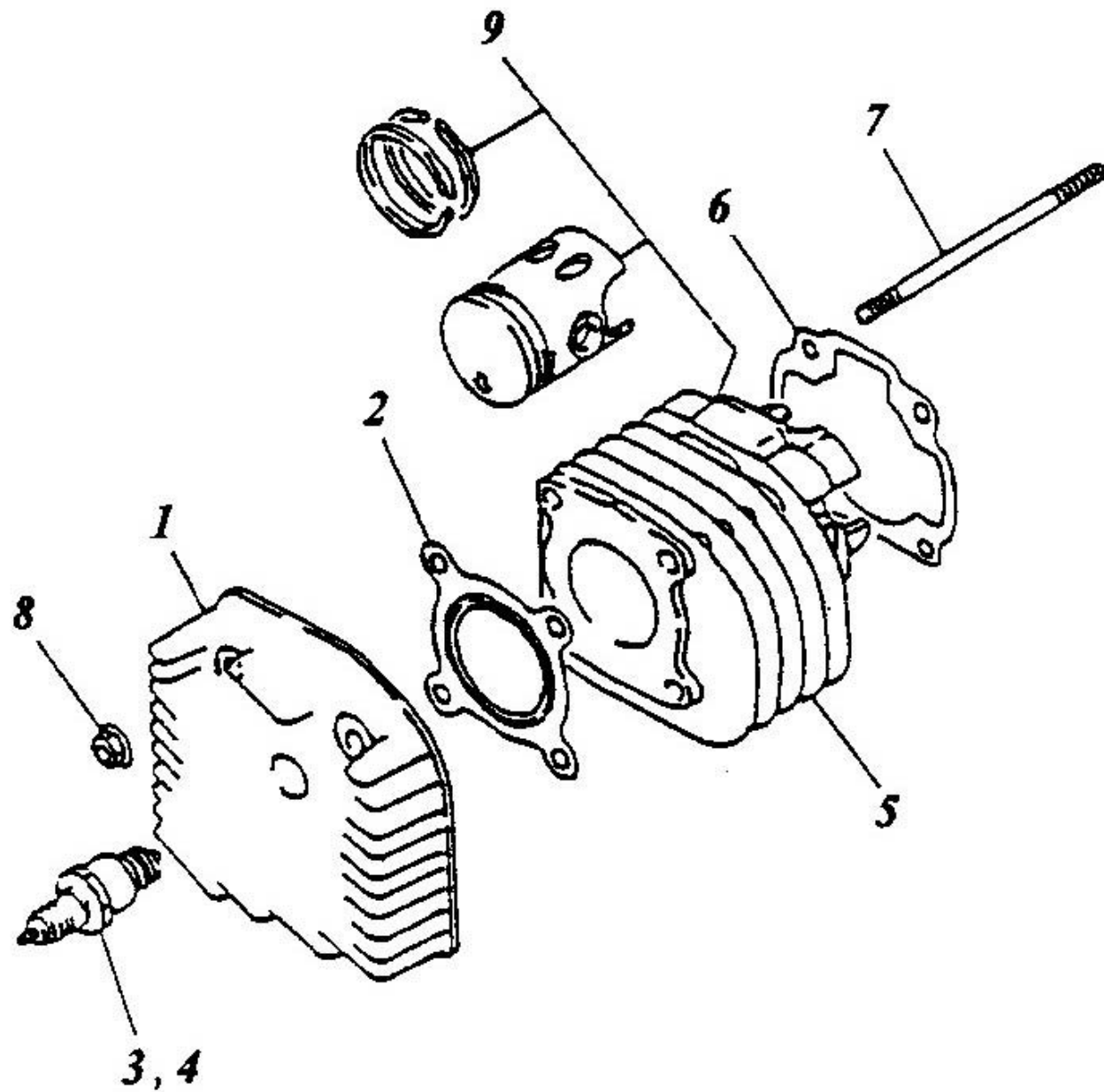

МУЛЫ®

CYLINDER, CYLINDER HEAD



Assembly No.:155-01		CYLINDER, CYLINDER HEAD		
No.	Parts No.	Q'ty	Parts Name	Specification
1	12201-116-000	1	CYLINDER HEAD	
2	12251-116-000	1	CYLINDER HEAD GASKET	
3	98076-101-00A	1	SPARK PLUG	NGK BPR7HS
5	12101-116-000	1	CYLINDER	
6	12191-116-000	1	CYLINDER GASKET	
7	91001-07110	4	STUD BOLT	7*110
8	94050-07000	4	HEX FLANGE NUT WITH SERRATION	7MM
9	12301-116-000	1	CYLINDER COMP	

CRANKSHAFT, PISTON

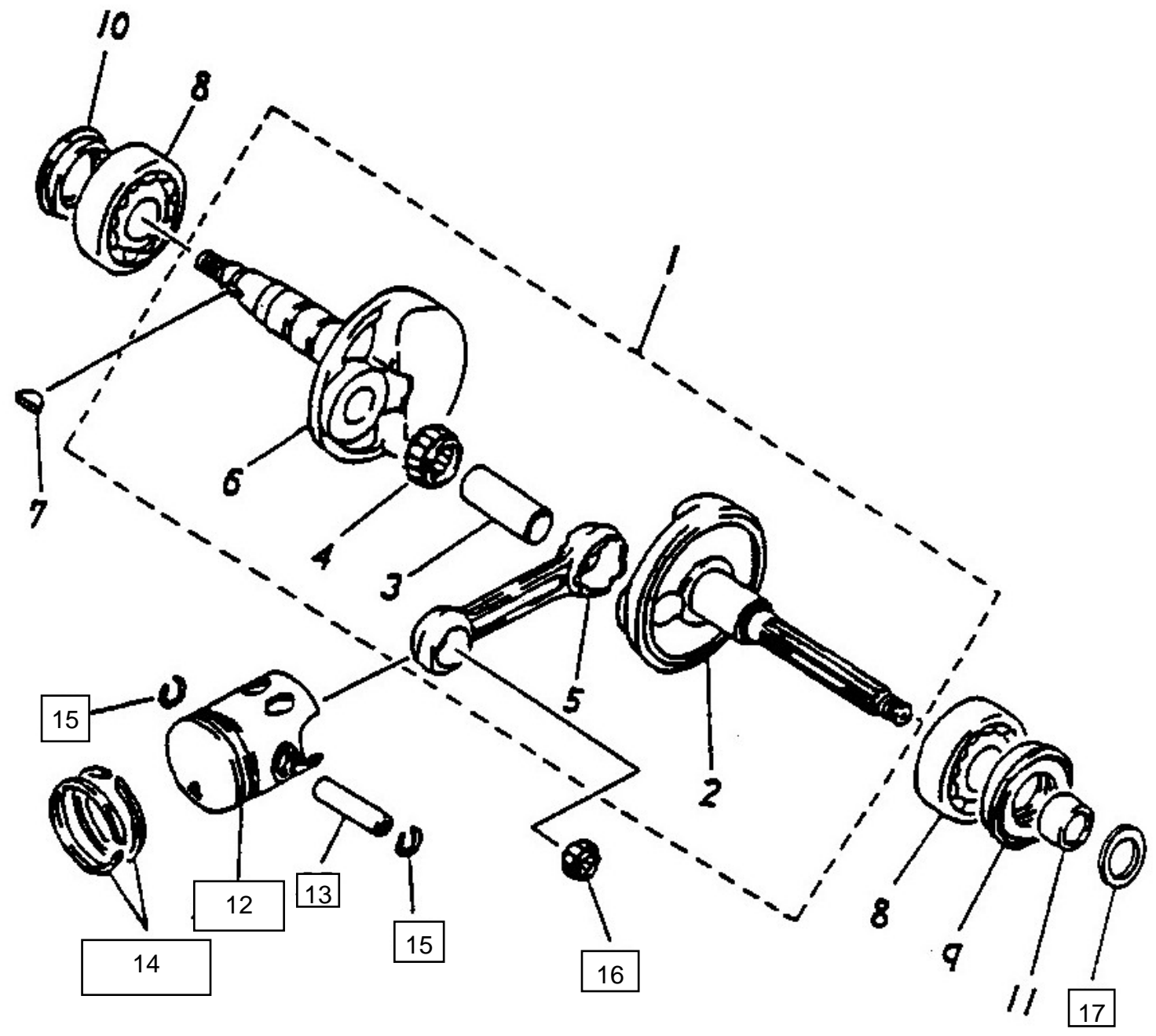

Assembly No.:155-02		CRANKSHAFT, PISTON		
No.	Parts No.	Qt'y	Parts Name	Specification
1	13000-116-000	1	CRANKSHAFT ASS'Y	
2	13321-116-000	1	LEFT CRANK	
3	13381-104-000	1	CRANK PIN	
4	96200-162212	1	NEEDLE BEARING	16*22*12
5	13201-104-000	1	CRANK CONNECTING ROD	
6	13311-116-000	1	RIGHT CRANK	
7	90471-104-000	1	SEMICYCLE KEY	3*13
8	96100-62040	2	RADIAL BALL BEARING	6204C3
9	96500-20428	1	OIL SEAL	20*42/43*8/9
10	96500-20306	1	OIL SEAL	20*30/33*6
11	13316-116-000	1	LEFT CRANK COLLAR	15*20*12
12	13100-116-000	1	PISTON	
13	13111-104-000	1	PISTON PIN	7*10*33
14	13011-116-000	1	PISTON RING SET	STD
15	13115-104-000	2	PISTON PING CLIP	1.0*12
16	96200-101412	1	NEEDLE BEARING	10*14*12.5
17	94101-1319005	1	PLAIN WASHER	13*19*0.5

FAN, AIR SHROUD

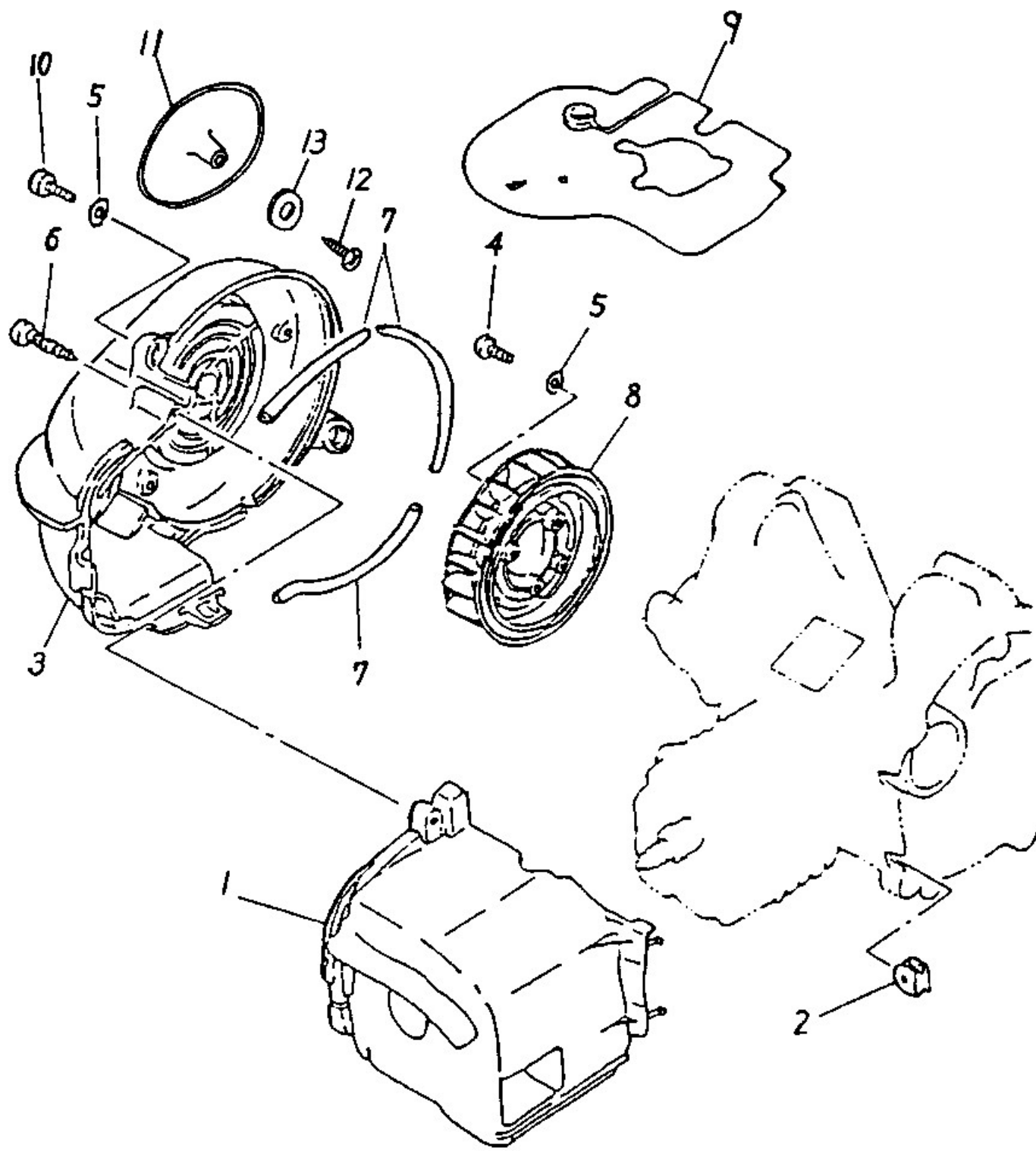

Assembly No.:155-03		FAN, AIR SHROUD		
No.	Parts No.	Qt'y	Parts Name	Specification
1	19620-116-000	1	CYLINDER AIR SHROUD	
2	83552-116-000	2	GROMMET	
3	19610-116-000	1	GENERATOR COVER	
4	91000-06015	4	HEX SOCKET BOLT	6*15
5	94101-0613010	6	PLAIN WASHER	6*13*1
6	93903-05040	1	TAPPING SCREW TRUSS HEAD PHILLIPS	5*40
7	17632-116-000	2	DAMPER	
8	19510-116-000	1	FAN	
9	55122-116-000	1	DEFLECTOR	
10	91000-06020	2	HEX SOCKET BOLT	6*20
11	19612-145-000	1	GENERATOR OUTER COVER	
12	93903-05016	1	TAPPING SCREW TRUSS HEAD PHILLIPS	5*16
13	94101-0618010	1	PLAIN WASHER	6*18*1

OIL PUMP

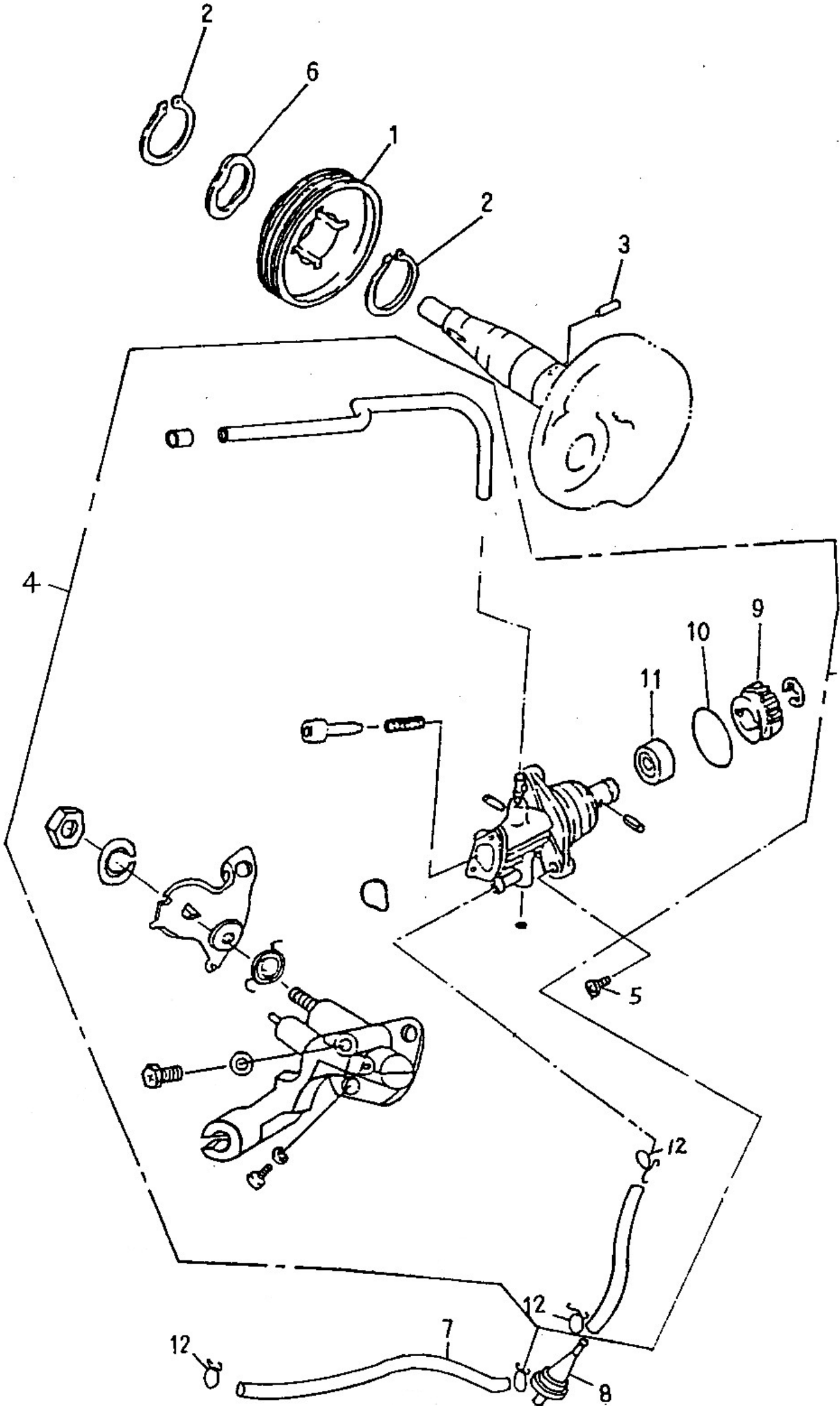

Assembly No.:155-04		OIL PUMP		
No.	Parts No.	Qt'y	Parts Name	Specification
1	15150-104-000	1	PUMP DRIVE GEAR	
2	94511-1900S	2	EXTERNAL CIR CLIP	STW-19
3	96300-030118	1	CRANK SHAFT PIN	3*11.8
4	15100-116-000	1	OIL PUMP	
5	93500-05015	2	PAN PHILLIPS BOLT	5*15
6	15151-104-000	1	WAVE WASHER	19.2*26*0.3
7	94400-0408490	1	TUBE	4.8*8*490
8	17502-101-000	1	OIL FILTER CUP	
9	15136-110-000	1	OIL PUMP WORM WHEEL	40T
10	91319-110-000	1	OIL RING	19.3*1.6
11	96500-09164	1	OIL SEAL	9.5*16*4
12	94510-08000	4	CLIP	8*0.8

REED VALVE, AIR CLEANER

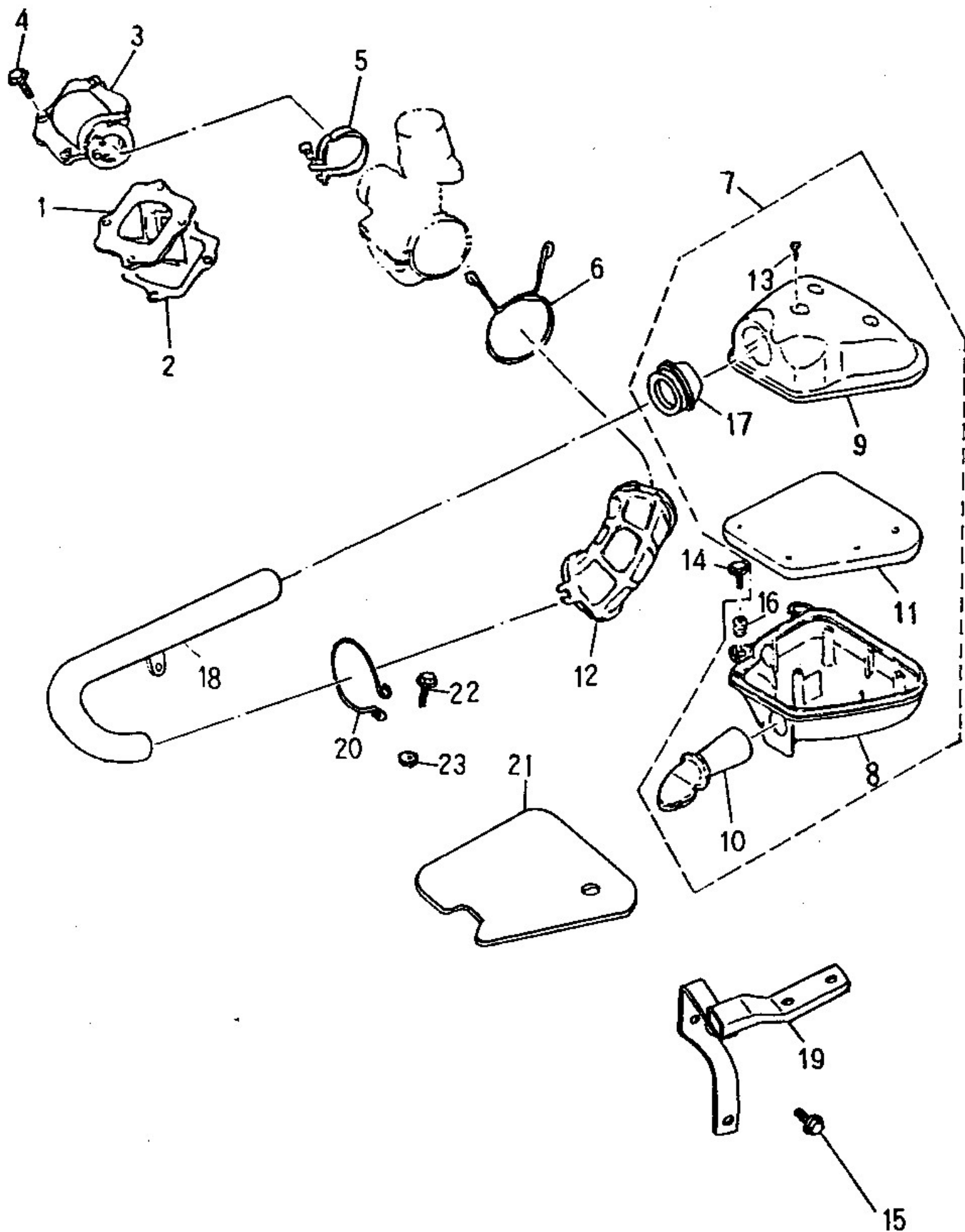

Assembly No.:155-05A		REED VALVE, AIR CLEANER		
No.	Parts No.	Qt'y	Parts Name	Specification
1	14100-116-000	1	REED VALVE ASS'Y	
2	17111-116-000	1	REED VALVE GASKET	
3	17100-116-000	1	INTAKE MANIFOLD(3XG)	
4	96000-06018-08	4	HEX WASHER FACE BOLT	6*18
5	14110-104-000	1	INTAKE MANIFOLD HOSE CLAMP	
6	94510-40000	1	CLIP	40*2.3
7	17200-145-001	1	AIR CLEANER ASS'Y	ECO
8	17206-116-00A	1	AIR CLEANER BASE	
9	17207-116-00A	1	AIR CLEANER COVER	
10	17219-116-000	1	GUIDE PIPE	
11	17205-116-000	1	AIR CLEANER ELEMENT	
12	17253-116-001	1	AIR CLEANER JOINT	ECO
13	93903-05025	3	TAPPING SCREW TRUSS HEAD PHILLIPS	5*25
14	92000-06020-10	2	HEX BOLT	6*20
15	96000-08020-12	1	HEX WASHER FACE BOLT	8*20
16	96485-116-000	2	GROMMET	
17	17254-145-000	1	AIR CLEANER CONNECTION	
18	17257-145-000	1	AIR DUCT	
19	17260-145-000	1	AIR CLEANER BRACKET	
20	94510-45000	1	CLIP	45*2
21	17220-145-00C	1	AIR CLEANER ISOLATION GASKET	0.1+5mm/200°C
22	96000-05024-08	1	HEX WASHER FACE BOLT	5*24
23	94050-05000	1	HEX FLANGE NUT WITH SERRATION	5mm

CARBURETOR

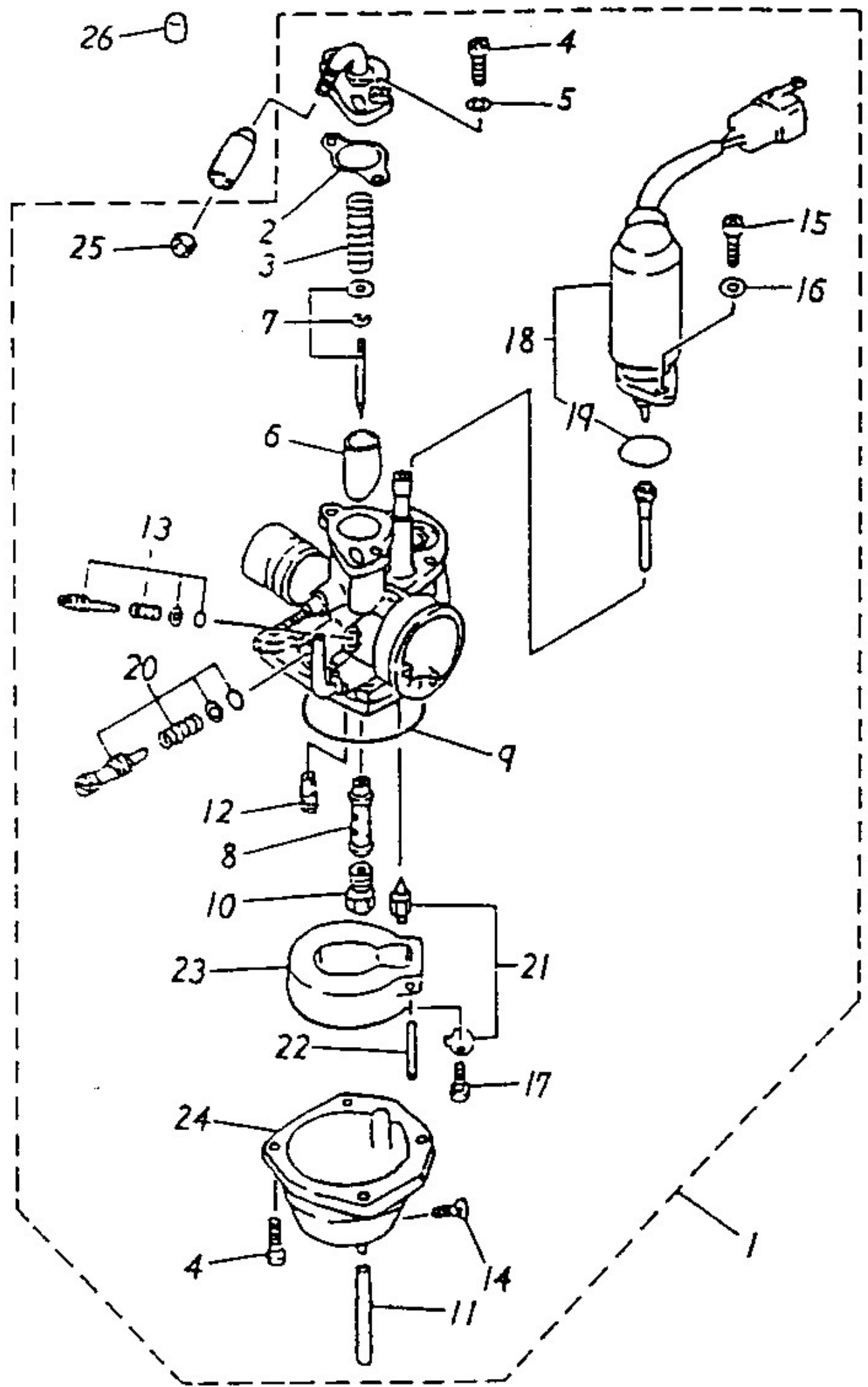

Assembly No.:155-06

CARBURETOR

No.	Parts No.	Qt'y	Parts Name	Specification
1	16100-116-00A	1	CARBURETOR ASS'Y	
2	16101-116-000	1	CARBURETOR GASKET	
3	16102-116-000	1	THROTTLE VALVE SPRING	
4	93500-04014	6	PAN PHILLIPS BOLT	4*14
5	94111-0407010	2	SPRING WASHER	4*7*1
6	16103-116-000	1	THROTTLE VALVE	
7	16104-116-000	1	NEEDLE SET	
8	16105-116-000	1	NEEDLE NOZZLE	
9	16106-116-000	1	FLOAT CHAMBER SEAL	
10	16108-116-000	1	MAIN NOZZLE	(#75)
11	16109-116-000	1	OVER FLOW TUBE	4*7
12	16110-116-000	1	PILOT JET	#17.5
13	16115-116-000	1	AIR ADJUST SCREW SET	
14	16111-116-000	1	DRAIN PLUG	
15	93500-04008	2	PAN PHILLIPS BOLT	4*8
16	94111-0406510	2	SPRING WASHER	4*6.5*1
17	93500-03008	1	PAN PHILLIPS BOLT	3*6
18	17215-116-000	1	PLUNGER STARTER	
19	91314-116-000	1	OIL RING	14*1.5
20	16114-116-000	1	THROTTLE SCREW SET	
21	16117-116-00A	1	NEEDLE VALVE ASS'Y	
22	16119-116-000	1	FLOAT PIN	
23	16118-116-000	1	FLOAT	
24	16107-116-000	1	FLOAT CHAMBER	
25	16113-116-000	1	CABLE ADJUST NUT	
26	42615-145-001	1	PURGE HOLE PLUG	

EXHAUST

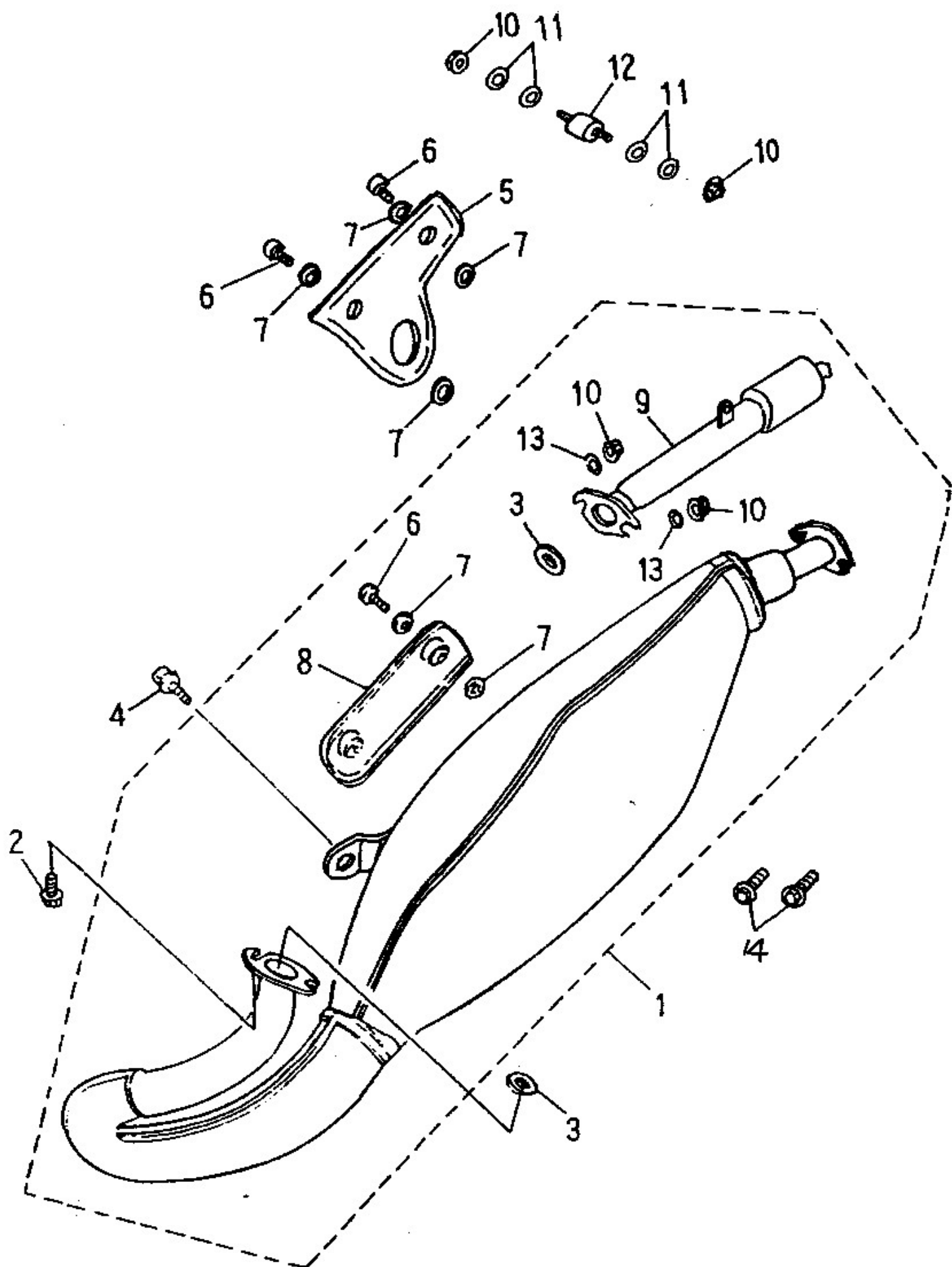

Assembly No.:155-07A		EXHAUST		
No.	Parts No.	Q'ty	Parts Name	Specification
1	18300-145-00A	1	EXHAUST PIPE ASS'Y	
2	92001-06018-10	2	HEX HEAD PHILLIPS BOLT	6*18
3	18291-104-000	2	EXHAUST PIPE GASKET	
4	96000-08020-12G	1	HEX WASHER FACE BOLT	8*20
5	18301-145-000	1	INSOLATOR	
6	96000-06012-08	4	HEX WASHER FACE BOLT	6*12
7	18292-104-000	8	MUFFLER SHROUD PACKING	6mm
8	18318-145-000	1	MUFFLER SHROUD	
9	18321-145-00A	1	SILENCER MUFFLER	
10	94050-06000	4	HEX FLANGE NUT WITH SERRATION	6mm
11	94101-0619010	4	PLAIN WASHER	6*19*1
12	18305-145-000	1	RUBBER DAMPER	
13	94101-0614020	2	PLAIN WASHER	6*14*2
14	96000-06025-10	2	HEX WASHER FACE BOLT	6*25

CRANKCASE

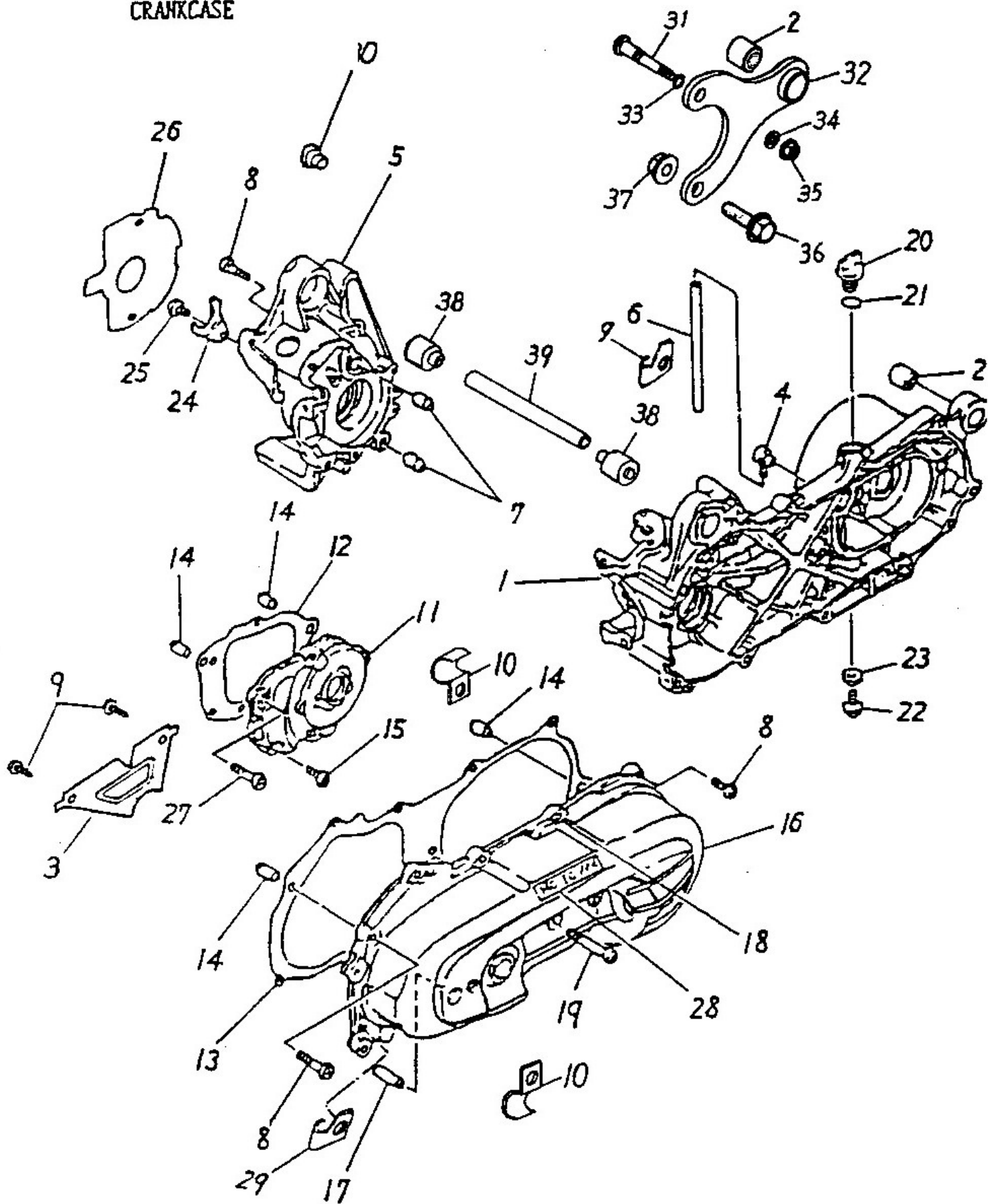

Assembly No.:155-08

CRANKCASE

No.	Parts No.	Q'ty	Parts Name	Specification
1	11201-116-000	1	LEFT CRANKCASE	
2	96400-082020	2	RUBBER BUSHING	8*20*20
3	11342-116-000	1	PLATE L COVER	
4	16610-104-00A	1	BREATHER HOSE HEAD	
5	11101-116-000	1	RIGHT CRANKCASE	
6	94400-0408A130	1	BREATHER HOSE	4.8*8*130
7	94301-12160	2	DOWEL PIN	8.5*12*16
8	91000-06035	8	HEX SOCKET BOLT	6*35
9	93903-04008	2	TAPPING SCREW TRUSS HEAD PHILLIPS	4*8
10	11351-120-00A	2	CLAMP	
11	21301-116-000	1	MISSION COVER	
12	21395-116-000	1	MISSION COVER GASKET	
13	11359-116-000	1	CRANKCASE COVER GASKET	
14	94301-10140	4	DOWEL PIN	8*10*14
15	91000-06020	3	HEX SOCKET BOLT	6*20
16	11341-116-000	1	LEFT CRANKCASE COVER	
17	96300-080320	1	SHAFT IDLER	8*32
18	91000-06025	9	HEX SOCKET BOLT	6*25
19	91000-06060	1	HEX SOCKET BOLT	6*60
20	15650-110-000	1	OIL PLUG	
21	91312-104-000	1	OIL RING	11.8*2.6
22	96000-08015-12	1	HEX WASHER FACE BOLT	8*15
23	94101-0813010	1	COPPER PLAIN WASHER	8*13*1
24	11111-104-000	1	OIL SEAL BRACKET	
25	91000-06010	1	HEX SOCKET BOLT	6*10
26	11121-116-000	1	GENERATOR GASKET	
27	91000-06030	2	HEX SOCKET BOLT	6*30
28	87733-116-000	1	"HER CHEE" STICKER	HER CHEE
29	11351-104-000	2	CARBURETOR TUBE BRACKET	
30	11102-116-000	1	PROTECT SHROUD	
31	45110-145-000	1	FIX SHAFT	
32	11202-145-000	1	CRANKCASE BRACKET	
33	91307-101-000	1	OIL RING	7.5*1.5
34	94101-0815015	1	PLAIN WASHER	8*15*1.5
35	94050-08000	1	HEX FLANGE NUT WITH SERRATION	8mm
36	96000-12040-17	1	HEX WASHER FACE BOLT	12*40
37	94050-12000	1	HEX FLANGE NUT WITH SERRATION	12mm
38	11203-145-000	2	BUSH	10.2*35*23/34
39	11150-145-000	1	CRANKCASE FIX SHAFT	114mm

STARTER

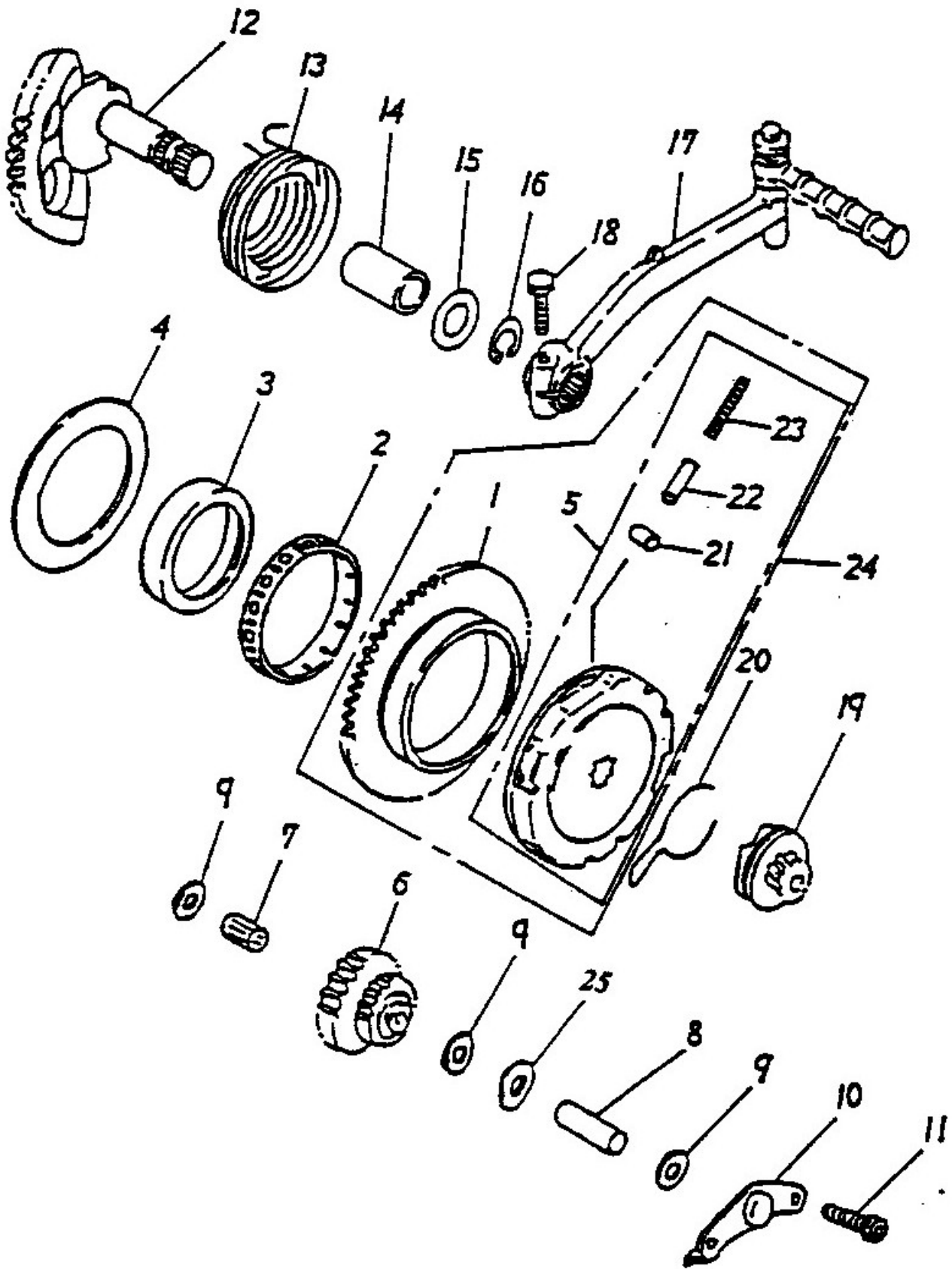

Assembly No.:155-09

STARTER

No.	Parts No.	Q'ty	Parts Name	Specification
1	28220-116-000	1	STARTER WHEEL	
2	96200-555912	1	NEEDLE BEARING	55*59*12.5
3	96202-116-000	1	BOSS	
4	94101-5676006	1	PLAIN WASHER	56*76*0.6
5	28410-116-000	1	ELECTRIC STARTER CLUTCH SET	
6	23422-116-000	1	IDLER GEAR	
7	96200-081210	1	NEEDLE BEARING	HK8*12*10
8	96300-080320	1	SHAFT IDLER	8*32
9	94101-0818008	3	PLAIN WASHER	8.2*18*0.8
10	11206-116-000	1	IDLER GEAR PLATE	
11	91000-06010	2	HEX SOCKET BOLT	6*10
12	28250-116-000	1	STARTING SHAFT ASS'Y	
13	28281-110-000	1	STARTING SHAFT RESET SPRING	
14	96401-152030	1	BUSHING	15*20*30
15	94101-1528010	1	PLAIN WASHER	15.2*28*1
16	94511-1500S	1	EXTERNAL CIR CLIP	STW-15
17	28300-145-000	1	KICK CRANK ASS'Y	
18	96000-06025-10	1	HEX WASHER FACE BOLT	6*25
19	28230-104-000	1	KICK PINION ASS'Y	
20	28223-104-000	1	KICK PINION SPRING CLIP	
21	28411-116-000	3	CLUTCH ROLLER	6*7
22	28412-116-000	3	CLUTCH GUIDER	
23	28413-116-000	3	CLUTCH SPRING	
24	28400-116-000	1	ELECTRIC STARTER CLUTCH ASS'Y	
25	92022-851618	1	WAVE WASHER	8.5*16*1.8

CLUTCH

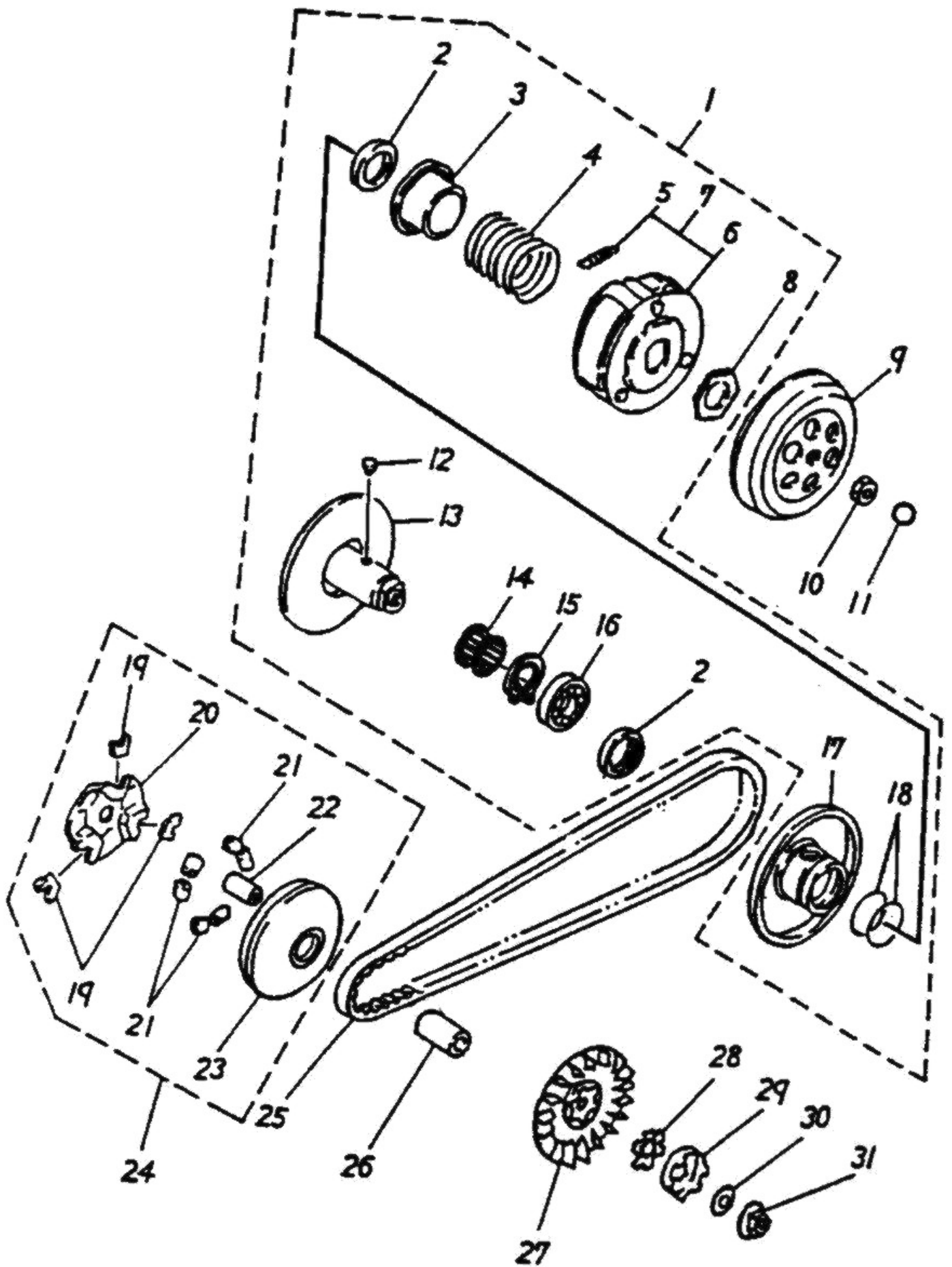

Assembly No.:155-10		CLUTCH		
No.	Parts No.	Q'ty	Parts Name	Specification
1	22000-116-00A	1	DRIVE FACE ASS'Y	B
2	96500-33394	2	OIL SEAL	33*39*4
3	23237-116-000	1	SECONDARY SPRING SEAT	
4	23233-116-00A	1	COMPRESSION SPRING	
5	22401-116-000	3	CLUTCH WEIGHT SPRING	
6	22350-116-000	1	CLUTCH CARRIER	
7	22535-116-000	1	CLUTCH WEIGHT SET	
8	90202-116-000	1	NUT	28*38*4
9	22100-116-000	1	CLUTCH COVER COMP	
10	94001-10000	1	HEX NUT	10MM
11	91313-104-000	1	OIL RING	12.5*3
12	23225-116-000	2	GUIDE PIN	
13	23200-116-000	1	SECONDARY FIX SLOT WHEEL	
14	96200-172518	1	NEEDLE BEARING	HKS-17*25*18
15	94512-240IR	1	INTERNAL CIR CLIP	IRTW-24
16	96100-6901U	1	RADIAL BALL BEARING	6901LU
17	23220-116-000	1	SECONDARY SLIDING SLOT WHEEL	
18	91336-104-000	2	OIL RING	36*2
19	22132-104-000	3	CAM PLATE SLIDER	
20	22131-116-000	1	CAM PLATE	
21	22121-116-000	6	WEIGHT ROLLER	
22	96401-182322	1	BUSHING	18*23*22.5
23	22110-116-000	1	PRIMARY SLIDING SLOT WHEEL	
24	22103-116-000	1	SLIDING DRIVE FACE ASS'Y	A
25	23100-117-000	1	V-BELT	
26	96401-131838	1	BUSHING	13*18*38
27	22102-116-000	1	PRIMARY FIX SHEAVE	
28	22150-110-000	1	LCAW WASHER	
29	22140-110-000	1	ONEWAY CLUTCH	
30	22145-104-000	1	CONE SPRING WASHER	10.2*24*2.6
31	94050-10000	1	HEX FLANGE NUT WITH SERRATION	10mm

TRANSMISSION

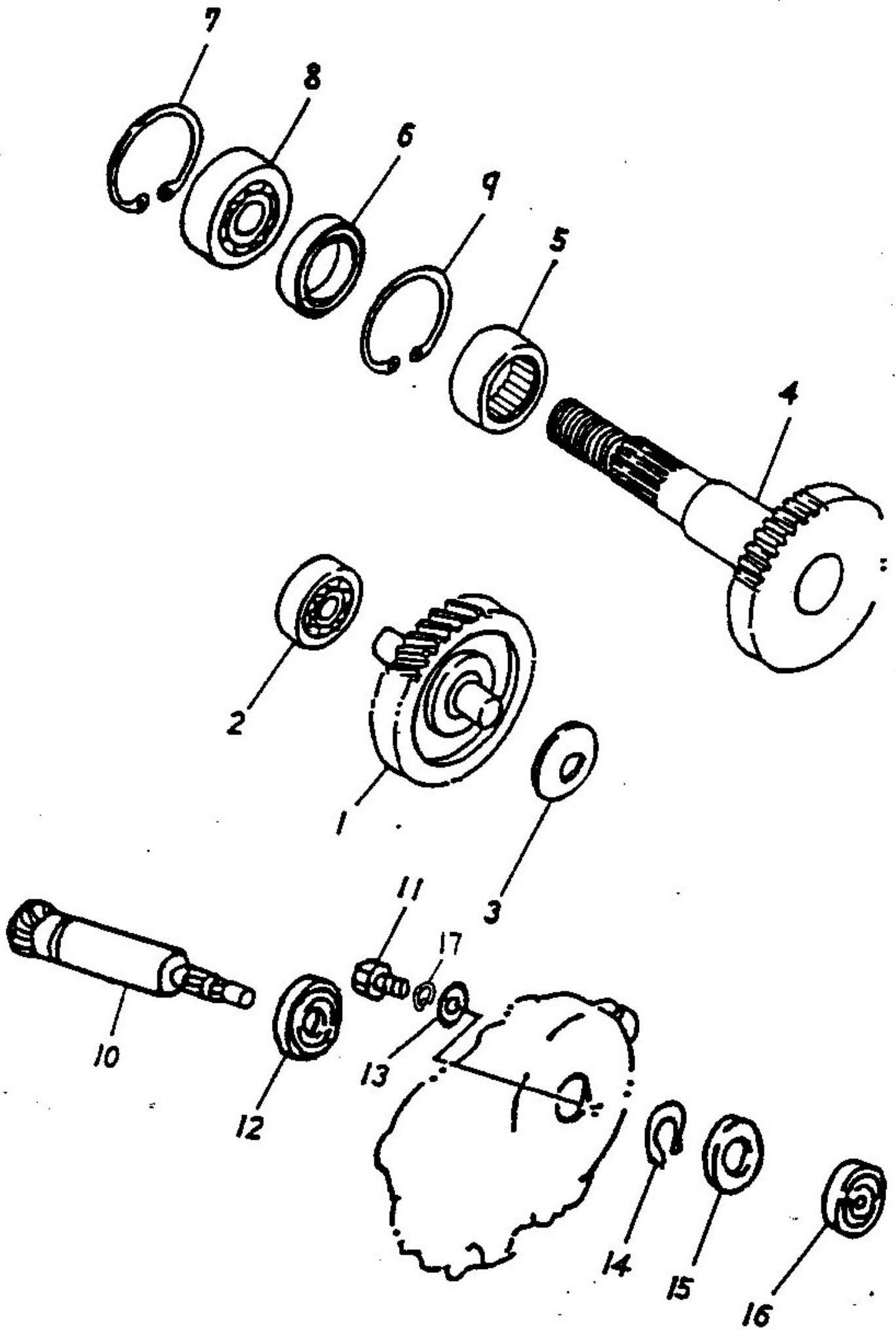

Assembly No.:155-11 TRANSMISSION

No.	Parts No.	Q'ty	Parts Name	Specification
=				
1	23420-116-000	1	MAIN AXLE COMP	48/12T
2	96100-62010	1	RADIAL BALL BEARING	6201
3	94101-1229016	1	PLAIN WASHER	12.2*29*1.6
4	23430-116-000	1	DRIVE AXLE	36T
5	96200-253315	1	NEEDLE BEARING	HMK2515
6	96500-25356	1	OIL SEAL	25*35*6
7	94512-4300R	2	INTERNAL CIR CLIP	RTW-43
8	96100-6004U	1	RADIAL BALL BEARING	6004 LU
9	94512-3400R	1	INTERNAL CIR CLIP	RTW-34
10	23411-116-000	1	PRIMARY DRIVE GEAR	13T
11	92000-06010-10	1	HEX BOLT	6*10
12	96100-60030	1	RADIAL BALL BEARING	6003
13	94101-0620005	1	PLAIN WASHER	6*20*0.5
14	94511-1700S	1	EXTERNAL CIRCLIP	STW-17
15	96500-17285	1	OIL SEAL	17*28*5.5
16	96100-638RD	1	RADIAL BALL BEARING	638RD
17	94111-0612015	1	SPRING WASHER	6*12*1.5

GENERATOR, STARTING MOTOR

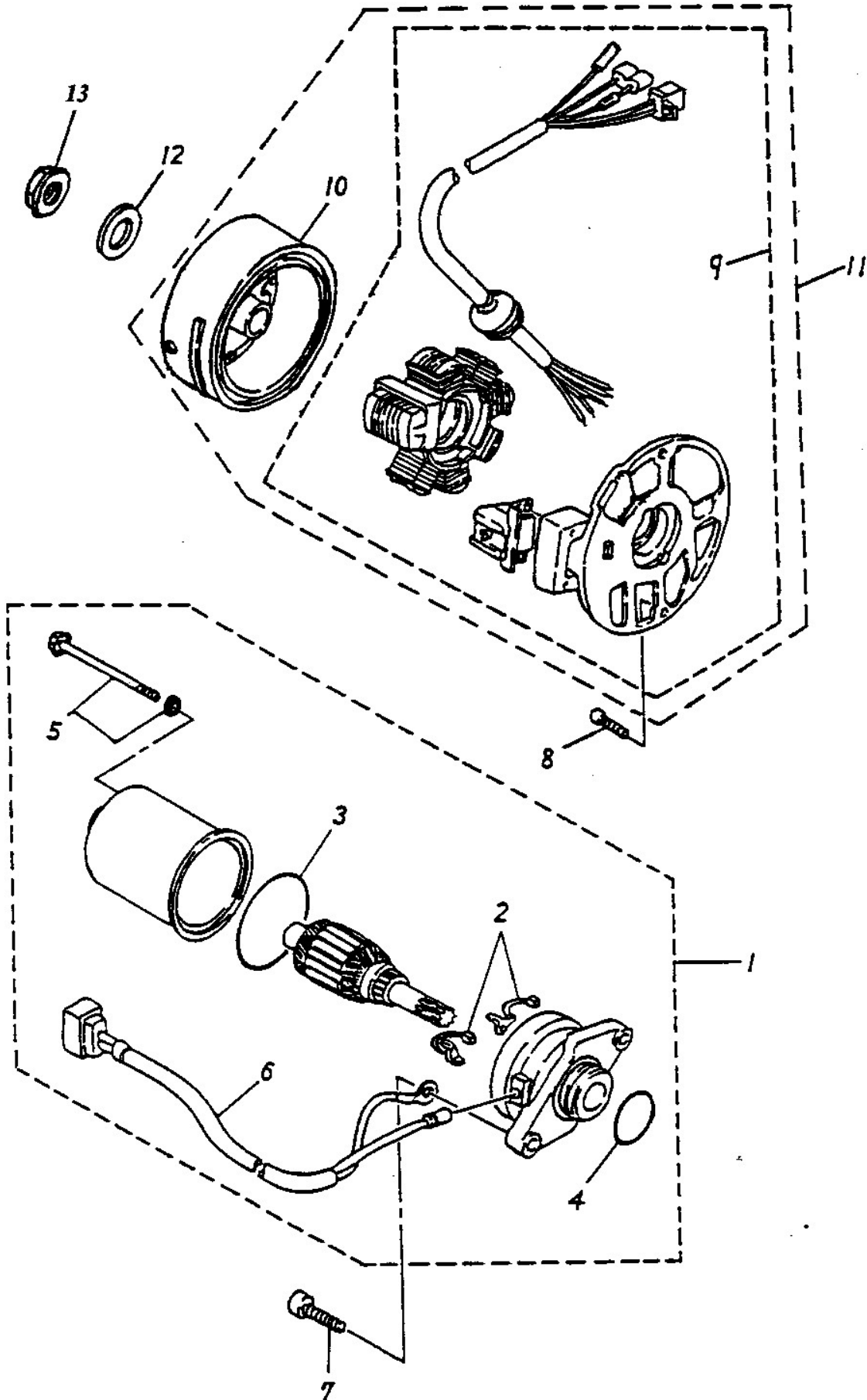

Assembly No.:155-12		GENERATOR, STARTING MOTOR		
No.	Parts No.	Q'ty	Parts Name	Specification
1	31200-116-000	1	STARTING MOTOR ASS'Y	
2	31201-104-000	1	BRUSH SET	
3	91342-104-000	1	OIL RING	42*1.5
4	91323-104-000	1	OIL RING	23*2
5	90115-104-000	2	BOLT SET	
6	31202-116-000	1	CORD COMP.	
7	91000-06020	2	HEX SOCKET BOLT	6*20
8	91000-06015	2	HEX SOCKET BOLT	6*15
9	31120-116-000	1	STATOR COMP.	
10	31110-116-000	1	GENERATOR FLYWHEEL	
11	31100-116-000	1	GENERATOR ASS'Y	
12	94101-1022020	1	PLAIN WASHER	10*22*2
13	94050-10000	1	HEX FLANGE NUT WITH SERRATION	10mm

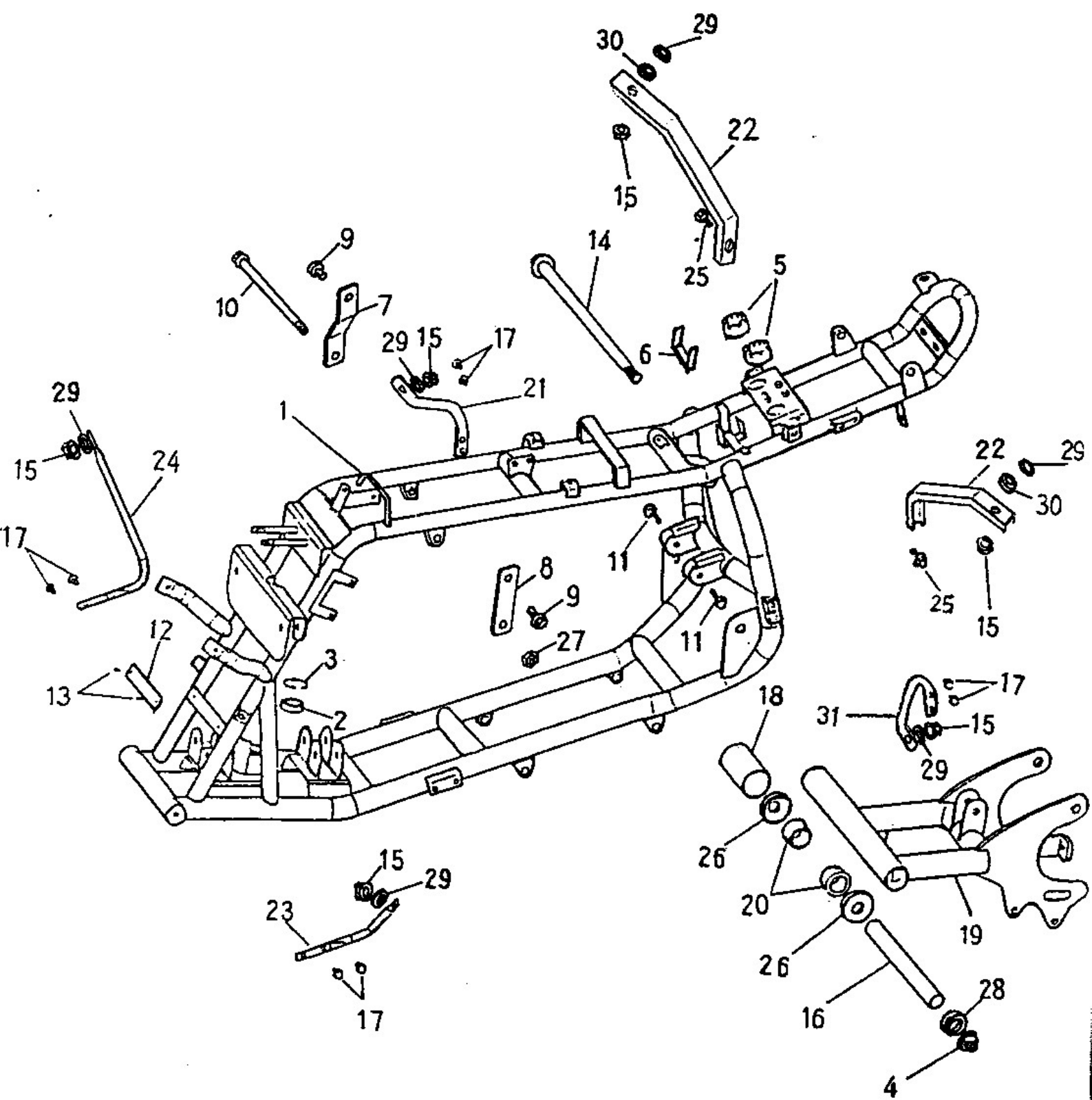

Assembly No.:155-13

RAME BODY

No.	Parts No.	Q'ty	Parts Name	Specification
1	50100-145-00C	1	FRAME COMP	
2	96100-6002ZZ	1	RADIAL BALL BEARING	6002ZZ
3	94512-3200R	1	INTERNAL CIR CLIP	RTW-32
4	90350-14000	1	NYLON NUT	14mm
5	77211-145-000	2	RUBBER	
6	17505-145-000	1	SPONGE PAD	15*100*4
7	50353-145-002	1	R. ENGINE FIXED PLATE(REV.1)	
8	50354-145-002	1	L. ENGINE FIXED PLATE(REV.2)	
9	96000-10020-14G	2	HEX WASHER FACE BOLT	10*20
10	96000-10208-14	1	HEX WASHER FACE BOLT	10*208
11	96000-08036-12G	2	HEX WASHER FACE BOLT	8*36
12	50110-145-00A	1	FRAME NO. PLATE	
13	90662-105-000	2	RIVET	#4-3
14	96000-14290-19	1	HEX WASHER FACE BOLT	14*290
15	90350-06000	6	NYLON NUT	6mm
16	52104-145-000	1	SWING ARM SPACER	14*20*253
17	92000-06014-10	8	HEX BOLT	6*14
18	52101-145-001	1	RUBBER SLEEVE	L=65mm ECO
19	52100-145-004	1	SWING ARM SUB ASSY	
20	52103-145-000	2	BUSH	
21	83401-155-000	1	REAR COVER LOWER RIGHT FIXED POLE(REV.3)	
22	83402-155-000	2	REAR COVER UP FIXED PLATE(REV.1)	
23	64307-155-000	1	FRONT COVER LEFT FIXED POLE(REV.2)	
24	64308-155-000	1	FRONT COVER RIGHT FIXED POLE(REV.2)	
25	96000-06012-10G	2	HEX WASHER FACE BOLT	6*12
26	52144-145-000	2	SWING ARM SEAL COVER	
27	90350-10000	1	NYLON NUT	10mm*1.25
28	94101-1426030	1	PLAIN WASHER	14*26*3
29	94101-0618020	6	PLAIN WASHER	6*18*2
30	94102-145-000	2	RUBBER WASHER	
31	83404-155-000	1	REAR COVER LOWER LEFT FIXED POLE(REV.3)	

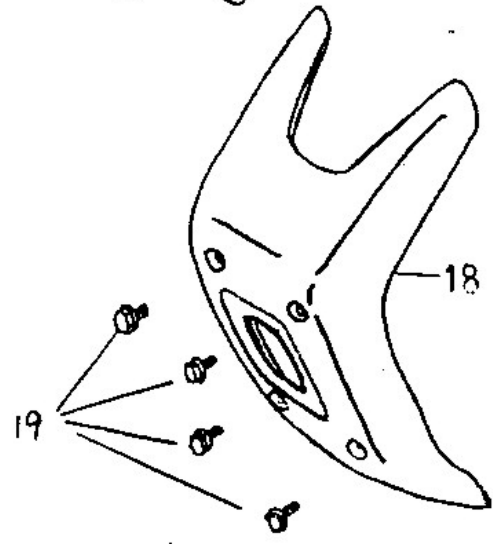
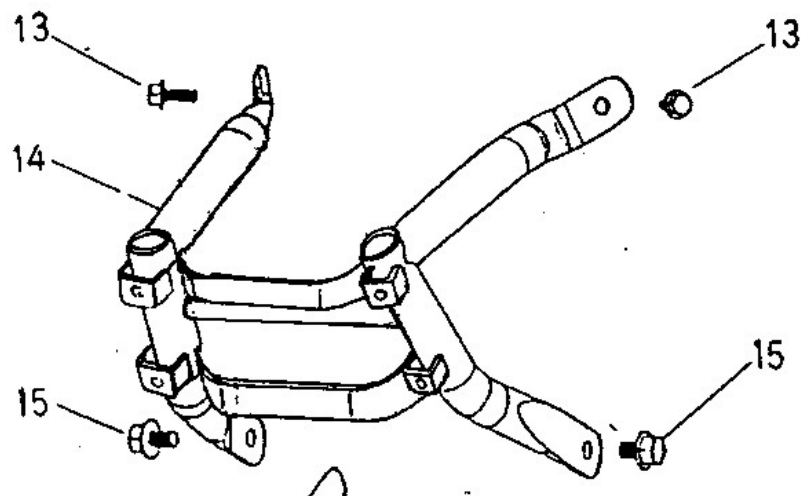
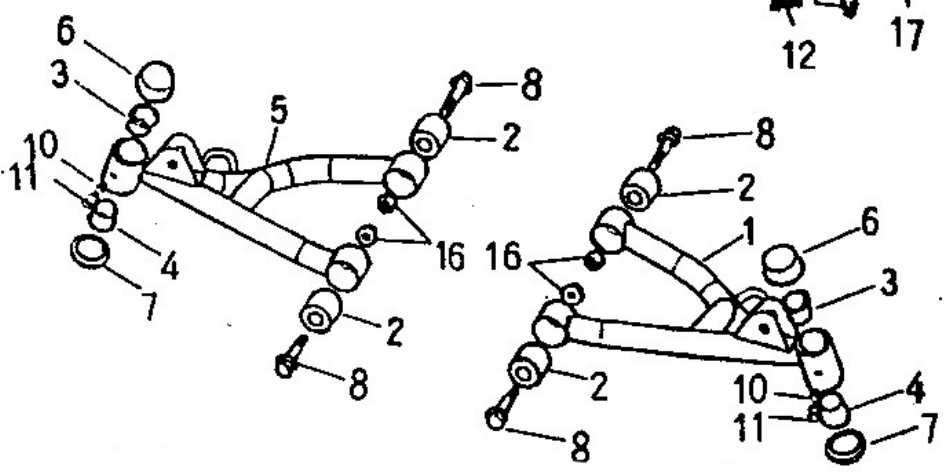
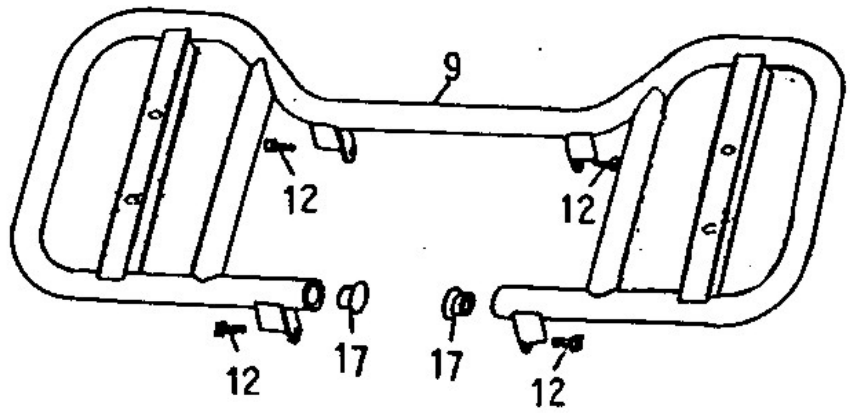

Assembly No.:155-14

ARM,FLOOR PANEL,BUMPER

No.	Parts No.	Q'ty	Parts Name	Specification
1	51300-145-001	1	LEFT SUSPENSION ARM(REV.1)	
2	96400-102829	4	RUBBER BUSHING	10*28*29
3	51201-145-000	2	BUSH	φ15.5
4	51202-145-000	2	BUSH	φ17
5	51200-145-001	1	RIGHT SUSPENSION ARM(REV.1)	
6	51203-145-000	2	WATERPROOF COVER	
7	51204-145-001	2	DUSTPROOF COVER	ECO
8	96000-10048-14G	4	HEX WASHER FACE BOLT	M10*48
9	64310-155-000	1	FLOOR PANEL(REV.2)	
10	96501-06000	2	GREASE VALEVE	6mm X 5牙
11	96502-06000	2	GREASE VALEVE CAP	6mm
12	96000-10020-14G	4	HEX WASHER FACE BOLT	10*20
13	96000-06016-10G	2	HEX WASHER FACE BOLT	6*16
14	50104-155-001	1	BUMPER(REV.1)	
15	96000-08015-12G	2	HEX WASHER FACE BOLT	M8*15
16	90350-10000G	4	NYLON NUT	M10*P1.25
17	64330-145-000	2	FLOOR PANEL RUBBER CAP	
18	50107-155-000	1	BUMPER COVER	
19	96000-06012-10G	4	HEX WASHER FACE BOLT	6*12

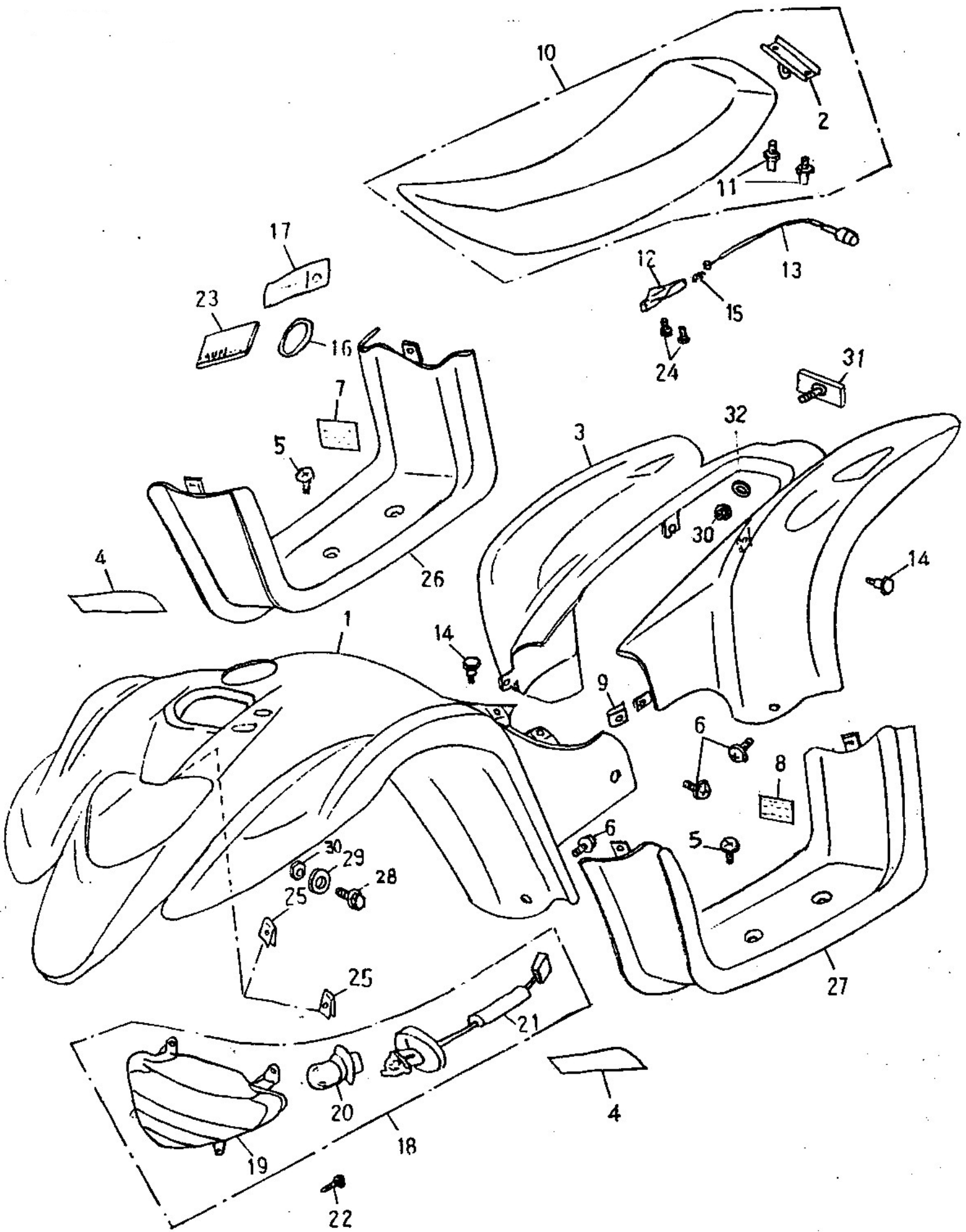

Assembly No.:155-15A

BODY COVER,SEAT
(HOMOLOGATION)

No.	Parts No.	Q'ty	Parts Name	Specification
1	64301-155-00A	1	FRONT COVER GRAY gris	
2	77201-145-000	1	SEAT BRACKET	
3	83400-155-00A	1	REAR COVER GRAY gris	
4	87700-181-00A	1	STICKER(SET)	ROCKY
5	93500-06012S	4	PAN PHILLIPS BOLT	6*12
6	93800-06020S	6	PAN PHILPS BOLT	6*20
7	87705-155-00D	1	STICKER, WARNING (Y-12)	Y-12
8	87704-155-00B	1	STICKER, WARNING(HOMOLOGATION)	
9	90344-0600A	6	U PLATE NUT	6mm
10	77200-145-000	1	SEAT ASS'Y	
11	77203-145-000	2	SEAT BOLT	
12	77230-145-000	1	SEAT LOCK ASS'Y	
13	77212-145-000	1	SEAT RELEASE CABLE(REV.1)	
14	90111-06014-18G	4	LADDER BOLT	6*14*2.5
15	77213-145-000	1	RESET SPRING	φ1*25
16	91350-145-000	1	RUBBER STRIP	50.1*5.3
17	50120-101-000	1	TOOL BAG	
18	33100-125-00A	1	HEAD LIGHT ASS'Y (E-MARK)	
19	33110-125-00A	1	HEAD LIGHT COVER (E-MARK)	
20	34901-110-00A	1	HEAD LIGHT BULB (E-MARK)	12V35W35W
21	34801-125-000	1	HEAD LIGHT WIRE	
22	93903-05016	4	TAPPING SCREW TRUSS HEAD PHILLIPS	5*16
23	50122-155-000	1	OWNER'S MANUAL	
24	96000-06012-10G	2	HEX WASHER FACE BOLT	6*12
25	90344-04000	2	U PLATE NUT	4mm
26	64312-155-000	1	R. FLOOR PANEL	
27	64313-155-000	1	L. FLOOR PANEL	
28	96000-06016-10	2	HEX WASHER FACE BOLT	6*16
29	94101-0618020	2	PLAIN WASHER	6*18*2
30	94050-06000	3	HEX FLANGE NUT WITH SERRATION	6mm
31	33741-133-000	1	REFLECTOR (E-MARK,SAE)	JUTE 9605
32	94101-0615010	1	PLAIN WASHER	6*15*1
33	11352-145-000	4	CABLE CLAMP	

1	64301-155-00A01	1	FRONT COVER RED	rouge
	64301-155-00A04	1	FRONT COVER BLUE	bleu
	64301-155-00A07	1	FRONT COVER BLACK	noir
3	83400-155-00A01	1	REAR COVER RED	rouge
	83400-155-00A04	1	REAR COVER BLUE	bleu
	83400-155-00A07	1	REAR COVER BLACK	noir
34	87700-181-00A	1	STICKERS SET	kit déco.

FUEL TANK, OIL TANK

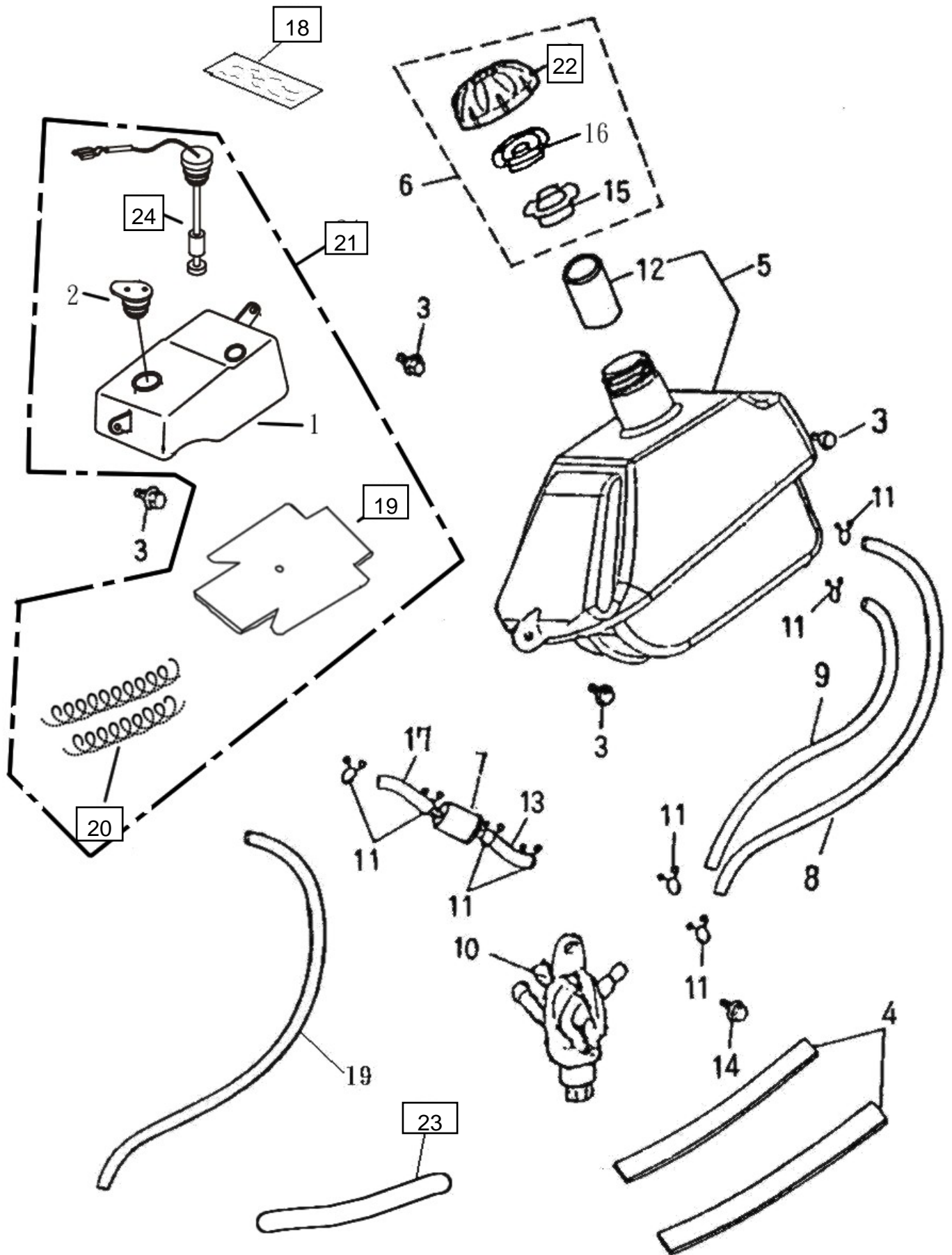

組件 編號：186-16A

油箱,機油箱(認證+機油計量器) FUEL TANK,OIL TANK(HOMOLCON)

Item No.	Parts No.	Unit	Q	'tyl	Parts Name	
項次	部品番號	用	量	零件名稱		
1	55100-145-00A		1	OIL TANK		機油箱(認證)
2	55105-145-000		1	OIL TANK CAP		機油箱蓋
3	92000-06014-10		4	HEX BOLT	6*14	六角螺栓附墊圈
4	17505-145-00A		2	SPONGE PAD	30*100*4	海綿條
5	17500-155-00A		1	FUEL TANK COMP		汽油箱(92/61)
6	17620-145-000		1	FUEL CAP ASS'Y		汽油箱蓋總成
7	16952-145-000		1	PETROL FILTER		汽油過濾杯
8	94400-0408300		1	TUBE	4.8*8*300	汽油管
9	94400-0408280		1	TUBE	4.8*8*280	汽油管
10	16950-145-000		1	FUEL CUP		汽油杯
11	94510-08000		8	CLIP	8*0.8	夾緊扣
12	17633-145-000		1	FUEL TANK TUBE		汽油箱套管
13	94400-0408160		1	TUBE	4.8*8*160	油管
14	96000-06012-10		1	HEX WASHER FACE BOLT	6*12	六角緣面螺栓
15	17631-145-000		1	FUEL TANK CAP GASKET		汽油箱蓋密合墊(黑)
16	17632-145-001		1	FUEL TANK CAP BUSHING		汽油箱蓋密合襯(白)
17	94400-0408075		1	TUBE	4.5*8.5*75	油管
18	87723-116-000		1	DECAL, WARNING BATTERY PROPOSITION		電池警告貼紙
19	55101-145-001		1	OIL TANK ISOLATION GASKET	0.1+5mm/200°C	機油箱隔熱墊
20	55106-145-000		2	CONSTRUCT SPRING	0.4*250mm	固定彈簧
21	55110-145-00A		1	OIL TANK COMP (W.ISOLATOR, SPRING, TUBE)		機油箱總成(含彈簧,隔熱墊,油管)
22	17621-145-001		1	FUEL TANK CAP BODY	NYLON66	汽油箱蓋本體NYLON66
23	94402-1617190		1	TUBE COVER		
24	35410-116-000		1	OIL LEVEL GAUGE		機油計量器

FRONT WHEEL, SUSPENSION

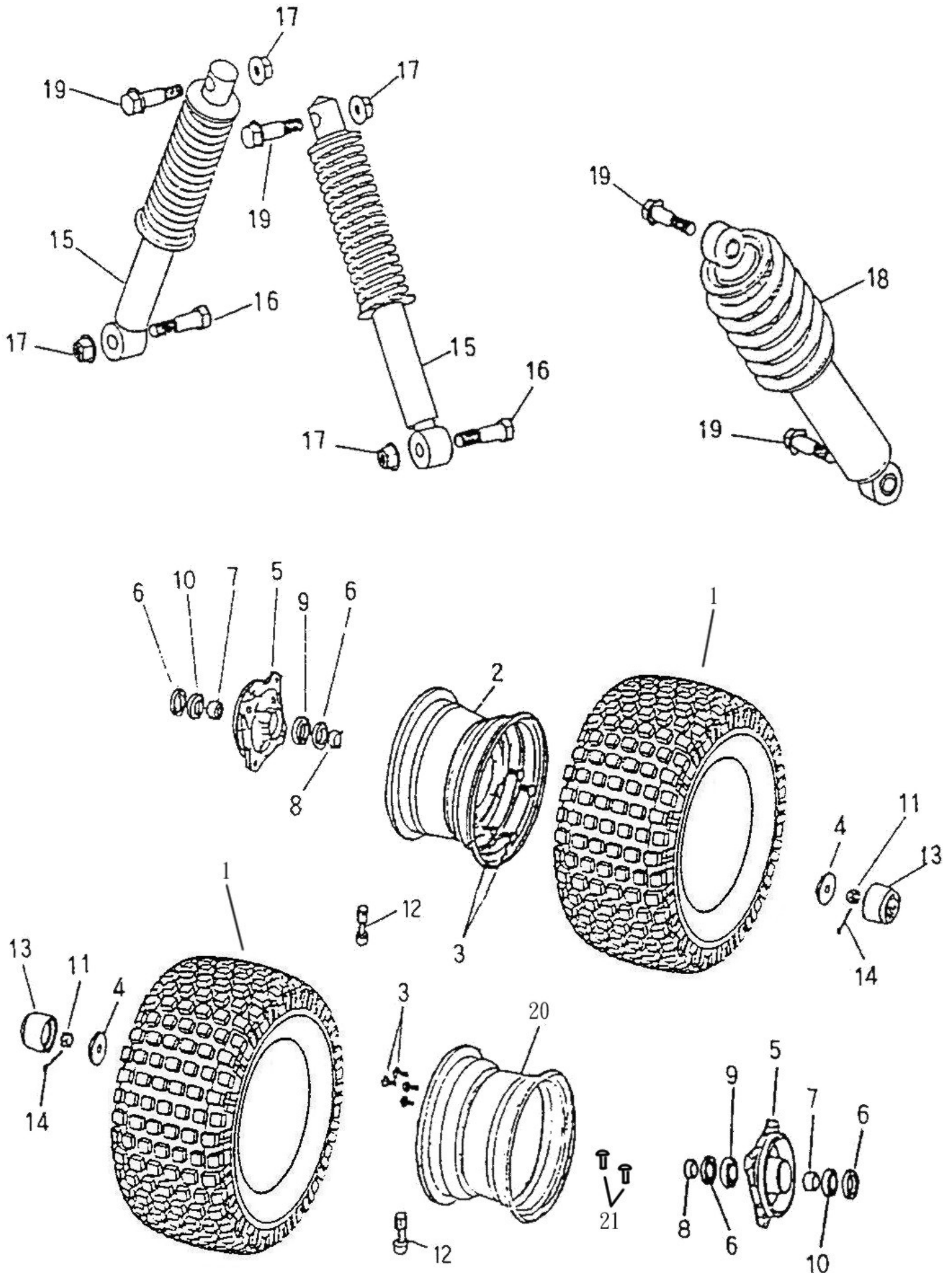

Assembly No.:155-17A

FRONT WHEEL,SUSPENSION(HOMOLOGATION)

No.	Parts No.	Q'ty	Parts Name	Specification
1	42711-146-000	2	TIRE(E-MARK)	19x7-8
2	42701-146-000	1	RIM ASS'Y(REV.2)	8x5.5
3	96000-10020-14	8	HEX WASHER FACE BOLT	10*20
4	94101-1240045	2	PLAIN WASHER	12*40*4.5
5	42710-145-000	2	FRONT BRAKE DRUM(REV.3)	
6	96500-22357	4	OIL SEAL	22*35*7
7	44620-145-000	2	SPACER TUBE	15*22*15
8	44311-145-000	2	FRONT COLLER(REV.1)	15*22*10
9	96100-6002Z	2	RADIAL BALL BEARING	6002Z
10	96100-6003Z	2	RADIAL BALL BEARING	6003Z
11	94051-12000-17	2	HEX,SLOTTED NUT	12mm
12	42616-145-000	2	AIR NOZZLE	
13	42814-145-000	2	RUBBER COVER	
14	94201-30320	2	COTTER PIN	3*32
15	51400-145-000	2	FRONT CUSHION(REV.1)	
16	92000-10040-14G	2	HEX BOLT	10*40
17	90350-10000G	4	NYLON NUT	M10*P1.25
18	52400-145-000	1	REAR CUSHION(REV.1)	
19	96000-10040-14G	4	HEX WASHER FACE BOLT	M10*40
20	42701-145-00B	1	RIM ASS'Y	7*5.2
21	93500-04008A	2	PAN PHILLIPS BOLT	3*8

REAR WHEEL

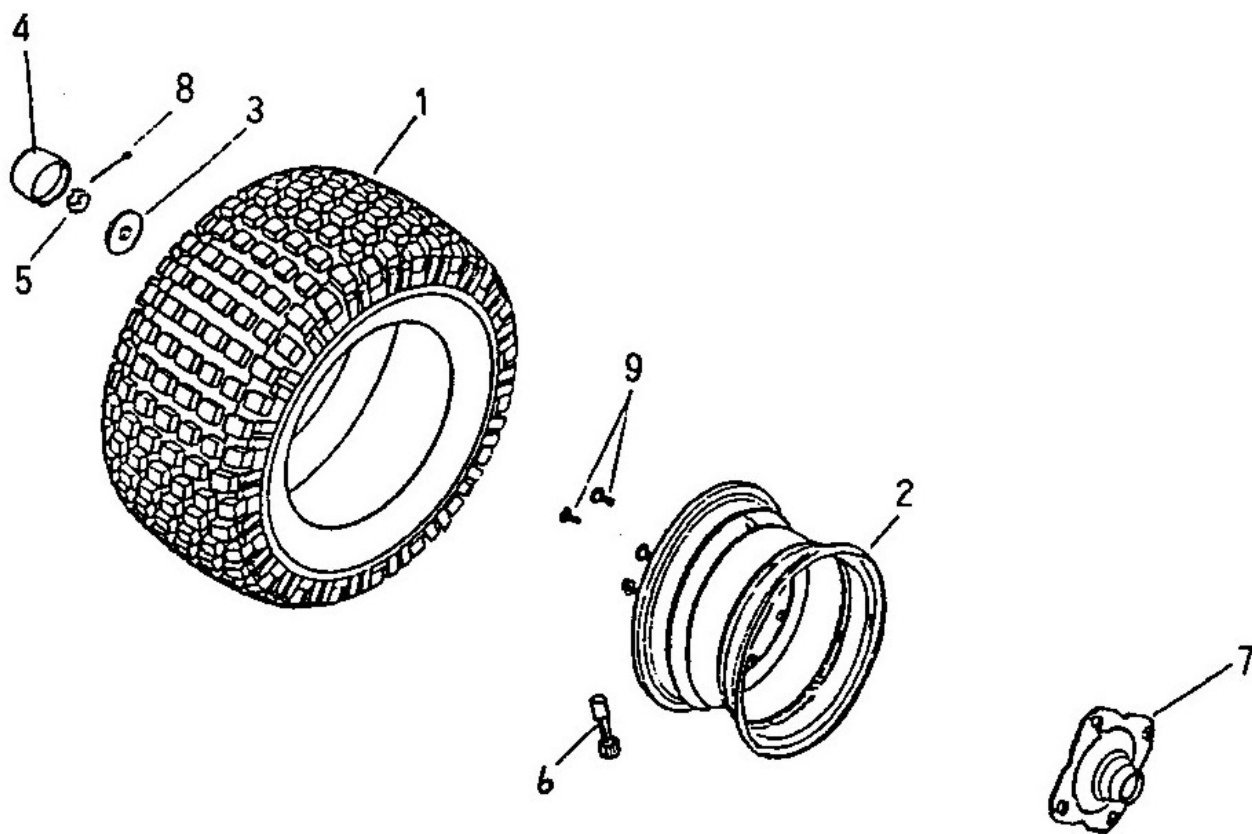
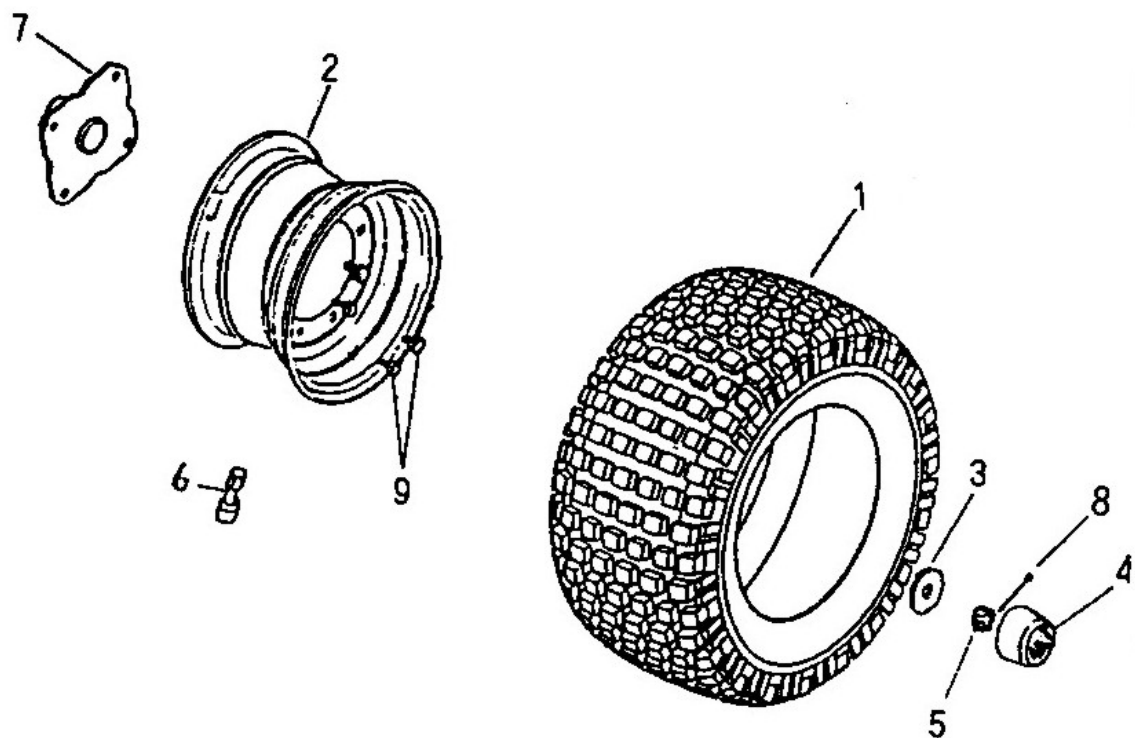

Assembly No.:155-18

REAR WHEEL

No.	Parts No.	Q'ty	Parts Name	Specification
1	42711-146-000	2	TIRE	19x7-8
2	42701-146-000	2	RIM ASS'Y	8x5.5
3	94101-1440045	2	PLAIN WASHERPPLAI	14*40*4.5
4	42814-145-000	2	RUBBER COVER	
5	94052-14000-21	2	SCOTCH FLANGE NUT	14mm
6	42616-145-000	2	AIR NOZZLE	
7	42036-145-001	2	SHAFT CONNECTOR	
8	94201-30320	2	COTTER PIN	3*32
9	96000-10020-14	8	HEX WASHER FACE BOLT	10*20

FRONT BRAKE

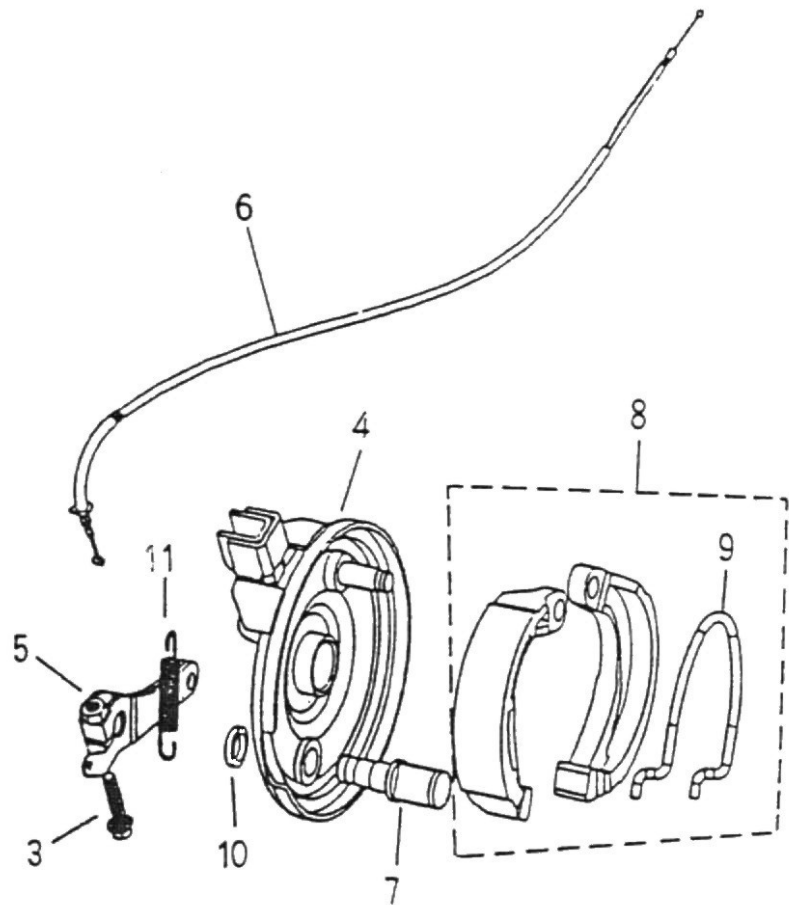
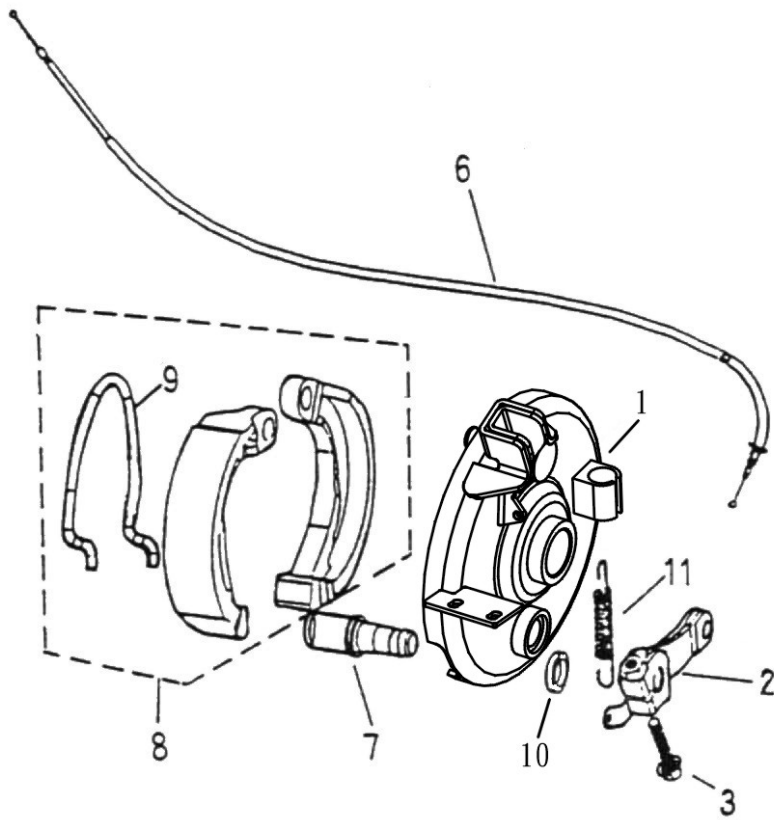

Assembly No.:155-19A

FRONT BRAKE

No.	Parts No.	Q'ty	Parts Name	Specification
1	45010-145-00A	1	FRONT LEFT BRAKE PANEL(REV.1)	
2	45410-145-000	1	FRONT LEFT BRAKE ARM	
3	96000-05024-08	2	HEX WASHER FACE BOLT	5*24
4	45020-145-000	1	FRONT RIGHT BRAKE PANEL(REV.4)	
5	45310-145-000	1	FRONT RIGHT BRAKE ARM	
6	45450-145-000	2	FRONT BRAKE CABLE	
7	45141-145-000	2	FRONT BRAKE CAM SHAFT(REV.3)	
8	45120-145-001	2	FRONT BRAKE SHOE COMP	
9	45133-145-000	2	STRAIN SPRING	
10	91313-104-000	2	OIL RING	12.5*3
11	45437-145-000	2	RESET SPRING	
12	93500-05008	1	PIN PHILLIPS BOLT	5*8
13	94101-0510008	1	PLAIN WASHER	5*10*0.8

REAR BRAKE

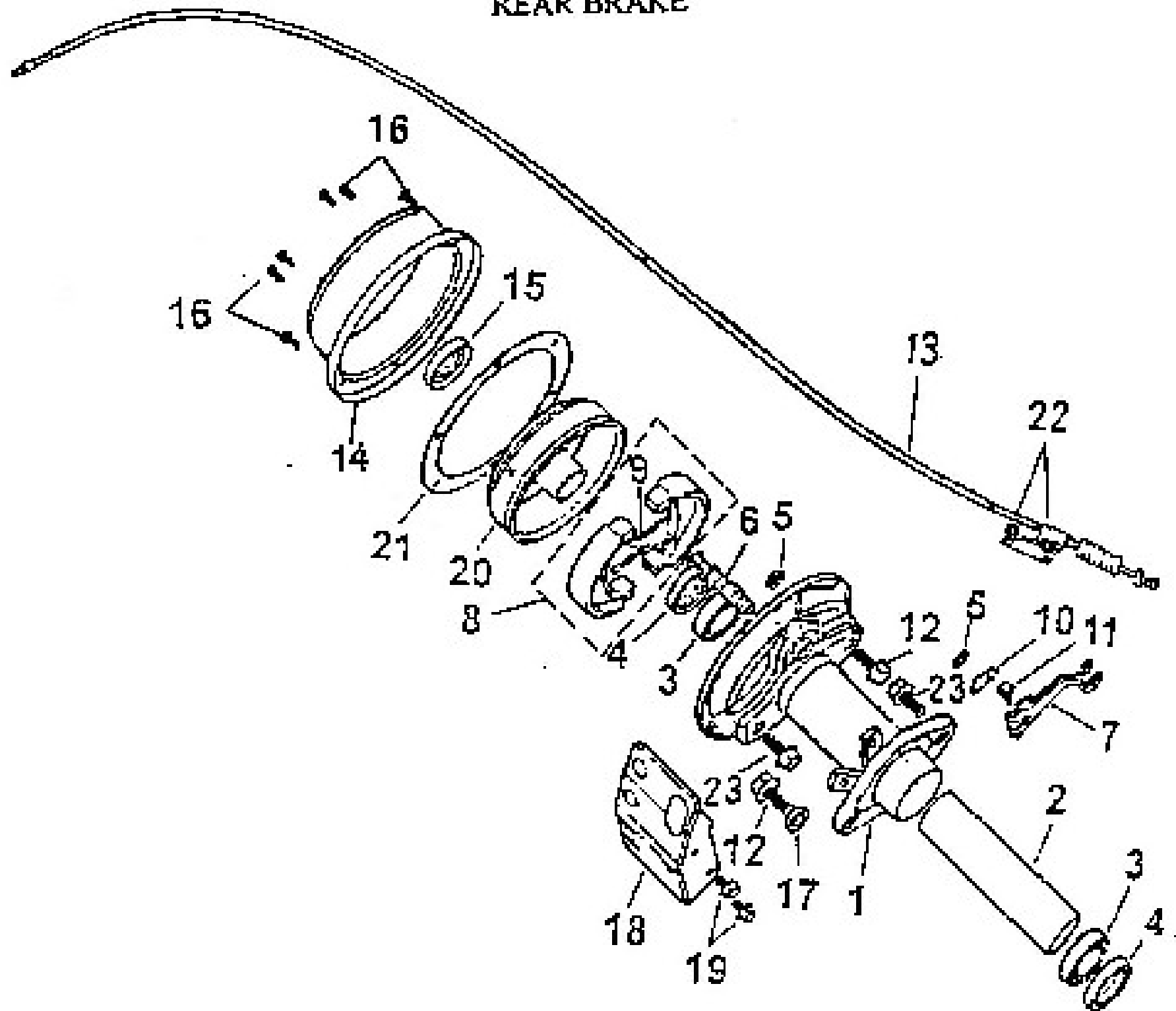

Assembly No.:155-20			REAR BRAKE	
No.	Parts No.	Q'ty	Parts Name	Specification
1	43101-145-001	1	REAR BRAKE PANEL	
2	42313-145-000	1	REAR BRAKE PANEL SPACER	
3	96100-6006ZZ	2	RADIAL BALL BEARING	6006ZZ
4	96500-355511	2	OIL SEAL	35*55*11
5	96500-14204	2	OIL SEAL	14*20*4
6	43141-145-000	1	REAR BRAKE CAM SHAFT	
7	43410-145-000	1	REAR BRAKE ARM	
8	43120-145-000	1	REAR BRAKE SHOE COMP.	
9	43151-145-000	2	SHOE STRAIN SPRING	1.6*36
10	42617-145-000	1	RETURN SPRING	
11	96000-06032-10	1	HEX WASHER FACE BOLT	6*32
12	96000-12027-17	2	HEX WASHER FACE BOLT	12*27
13	43450-145-000	1	REAR BRAKE CABLE	
14	42612-145-000	1	REAR DRUM COVER	
15	96500-325211	1	OIL SEAL	32*52*11
16	96000-06012-10	6	HEX WASHER FACE BOLT	6*12
17	94101-1225050	1	PLAIN WASHER	12*25*5
18	42613-145-000	1	REAR BRAKE COVER	
19	96000-08012-12G	2	HEX WASHER FACE BOLT	8*12
20	42601-145-000	1	REAR DRUM	
21	42614-145-000	1	REAR DRUM COVER GASKET	
22	94050-08000	2	HEX FLANGE NUT WITH SERRATION	8mm
23	96000-12022-17	2	HEX WASHER FACE BOLT	12*22

HANDLE BAR

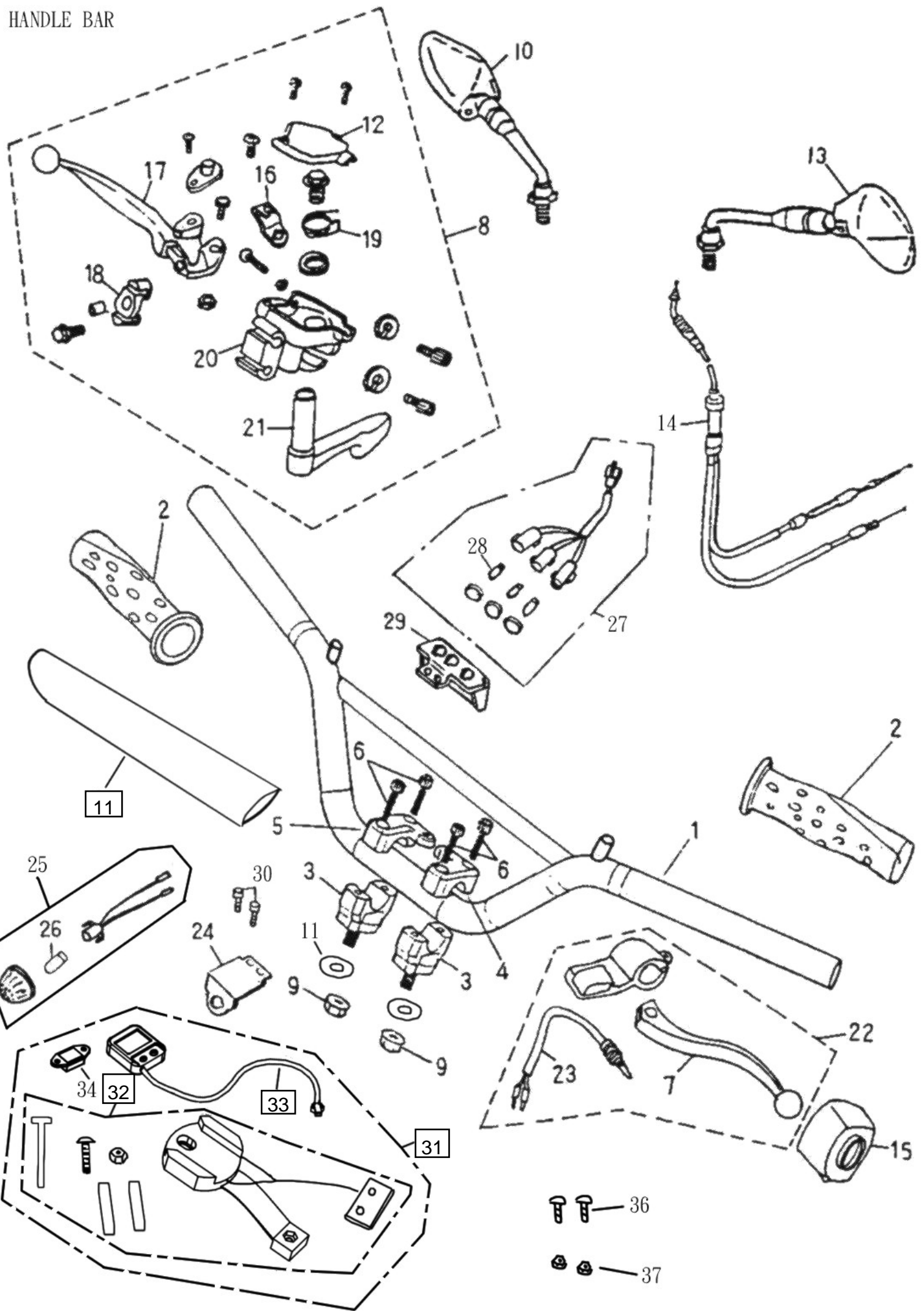

Assembly No.:155-21A

HANDLE BAR(HOMOLOGATION)

No.	Parts No.	Q'ty	Parts Name	Specification
1	53100-145-00B	1	HANDLE BAR(REV.3)	
2	53166-155-000	2	HANDLE GRIP	
3	53101-145-000	2	HANDLE BAR BOTTOM CLAMP	
4	53102-145-000	1	LEFT HANDLE BAR CLAMP	
5	53103-145-000	1	RIGHT HANDLE BAR CLAMP	
6	91000-06025	4	HEX SOCKET BOLT	6*25
7	53178-145-000	1	LEFT LEVER	
8	53170-155-002	1	RIGHT LEVER ASS'Y	螺絲 L=25mm
9	90350-10000G	2	NYLON NUT	M10*P1.25
10	88110-145-000	1	R.REAR VIEW MIRROR	
11	53132-145-000	1	SPONGE ASS'Y(ADLY MOTO) RED	rouge
12	53171-155-000	1	LEVER BODY COVER(ADLY)	
13	88120-145-000	1	L.REAR VIEW MIRROR	
14	17910-145-001	1	THROTTLE CABLE	ECO保護套
15	35200-145-00B	1	L.HANDLE SWITCH ASS'Y	
16	53174-155-000	1	THROTTLE CABLE BRACKET	
17	53175-155-000	1	RIGHT LEVER	
18	53173-145-000	1	CABLE BRACKET	
19	53184-155-000	1	THROTTE LEVER SPRING	
20	53172-155-000	1	LEVER BRACKET	
21	53180-155-000	1	THROTTLE LEVER	
22	53179-155-000	1	LEFT LEVER ASS'Y(REV.1)	
23	35345-145-000	1	L.BRAKE SWITCH WIRE	
24	37215-145-000	1	POSITION PLATE	
25	34900-145-000	1	POSITION LAMP(REV.1)	
26	34909-120-000	1	POSITION LIGHT BULB	12V5W
27	37250-145-00A	1	INDICATOR LIGHT	
28	34908-101-000	3	BULB	12V1.7W
29	37212-145-000	1	INDICATOR LIGHT PLATE(REV.1)	
30	91000-06012	2	HEX SOCKET BOLT	6*12
31	37200-145-0A0	1	SPEEDOMETER ASS'Y(Digital)	N+方形磁鐵
32	37216-145-000	1	SPEEDOMETER HOLDER	線長:110CM

11	53132-145-00003	1	SPONGE ASS'Y YELLOW	jaune.....
	53132-145-00004	1	SPONGE ASS'Y BLUE	bleu.....
	53132-145-00007	1	SPONGE ASS'Y BLACK	noir.....
33	37220-145-0A0	1	SPEEDOMETER BODY	non détaillé.....
34	37217-145-000	1	MAGNET

REAR WHEEL AXLE CHAIN

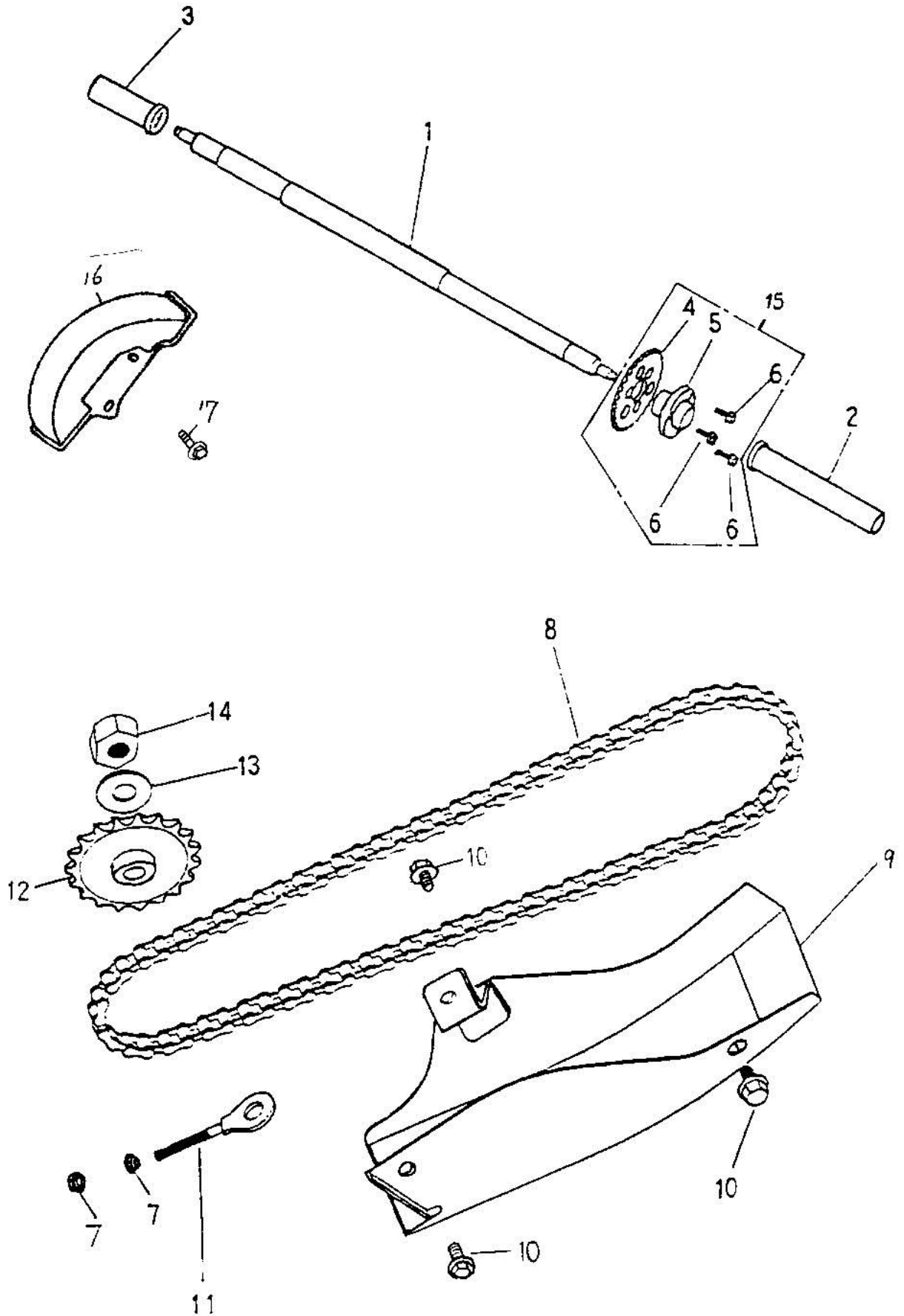

Assembly No.:155-22		REAR WHEEL AXLE, CHAIN		
No.	Parts No.	Q'ty	Parts Name	Specification
1	42301-145-000	1	REAR WHEEL AXLE	711mm
2	42620-145-001	1	RIGHT SPACER COLLAR	
3	42622-145-001	1	LEFT SPACER COLLAR	
4	41201-145-000	1	REAR SPROCKET	28T
5	42610-145-000	1	FINAL DRIVE FLANGE	
6	96000-08020-12G	3	HEX WASHER FACE BOLT	8*20
7	94050-06000	2	HEX FLANGE NUT WITH SERRATION	6mm
8	40530-145-000	1	DRIVE CHAIN	428*76
9	40510-145-001	1	CHAIN PROTECT COVER	
10	96000-08012-12G	3	HEX WASHER FACE BOLT	8*12
11	40543-145-001	1	DRIVE CHAIN ADJUSTER	
12	23801-145-000	1	DRIVE SPROCKET ASS'Y	19T
13	94101-1529030	1	PLAIN WASHER	15*29*3
14	90350-14000	1	NYLON NUT	14mm
15	42600-145-000	1	REAR SPROCKET ASS'Y	28T
16	40511-152-000	1	REAR CHAIN COVER	
17	96000-06012-10G	2	HEX WASHER FACE BOLT	6*12

STEERING

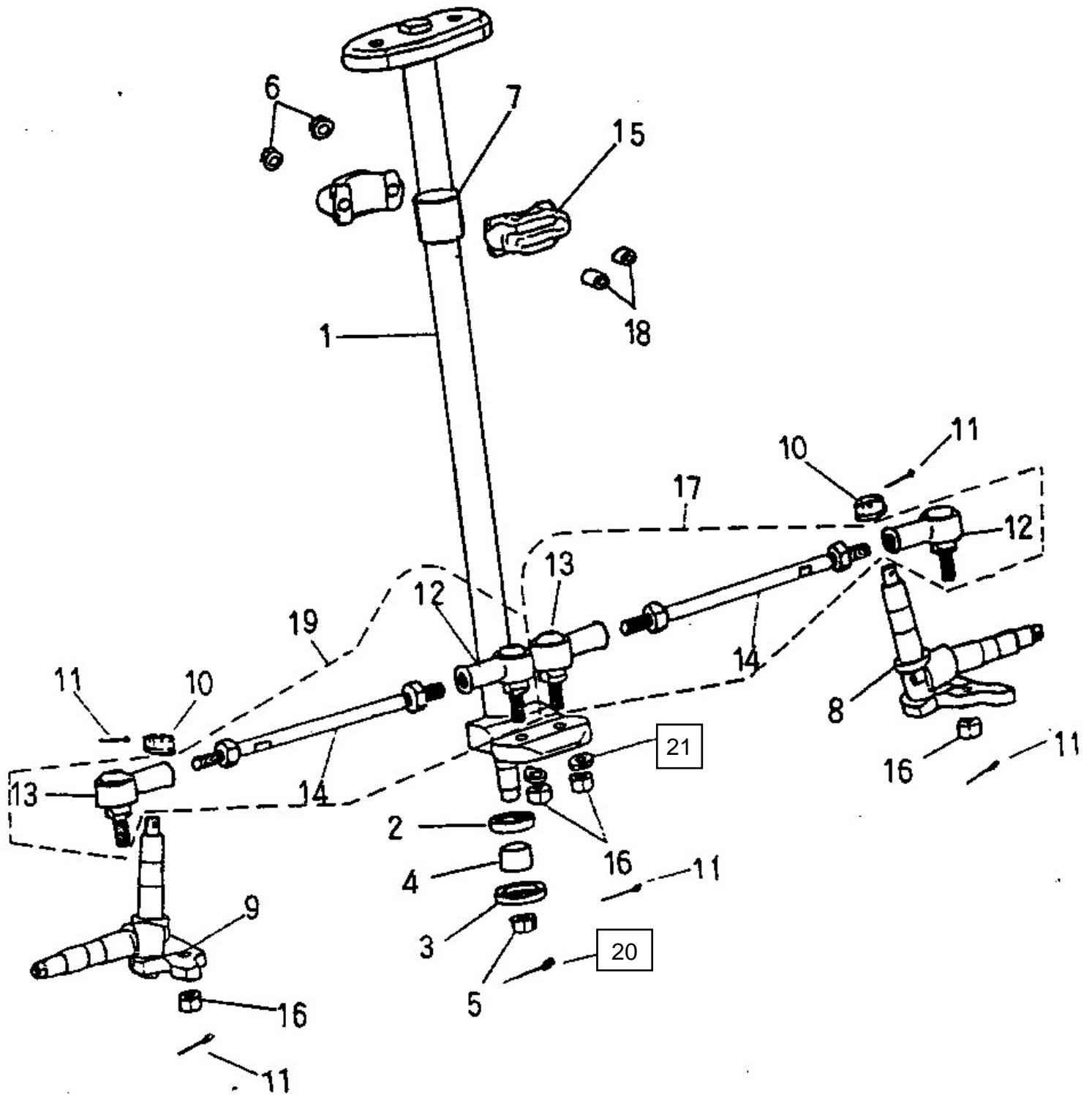

Assembly No.:155-23

STEERING

No.	Parts No.	Q'ty	Parts Name	
1	51109-155-00A	1	STEERING SHAFT ASS'Y	22.5*528
2	96500-18327	1	OIL SEAL	18*32*7
3	96500-22357	1	OIL SEAL	22*35*7
4	44620-145-000	1	SPACER TUBE	15*22*15
5	90350-14000	1	NYLON NUT	14mm
6	94050-08000	2	HEX FLANGE NUT WITH SERRATION	8mm
7	51114-145-000	1	PU BUSH	
8	44510-145-000	1	LEFT KNUCKLE	
9	44520-145-000	1	RIGHT KNUCKLE	
10	94052-10000-14	2	SCOTCH FLANGE NUT	10mm
11	94201-20190	6	COTTER PIN	2*19
12	44511-145-002	2	BALL JOINT,LEFT THREAD	
13	44521-145-002	2	BALL JOINT,RIGHT THREAD	
14	91001-10200	2	STUD BOLT	10*200
15	51113-145-000	2	STEERING SHAFT HOLDER	
16	90350-10000G	4	NYLON NUT	10mm*1.25
17	44500-145-002	1	RIGHT LINK ASS'Y	
18	51115-145-000	2	HOLDER SPACER COLLER	
19	44501-145-002	1	LEFT LINK ASS'Y	
20	94201-30320	1	COTTER PIN	3*32
21	94105-1022025G	2	PLAIN WASHER	10*22*2.5

ELETRICAL PARTS

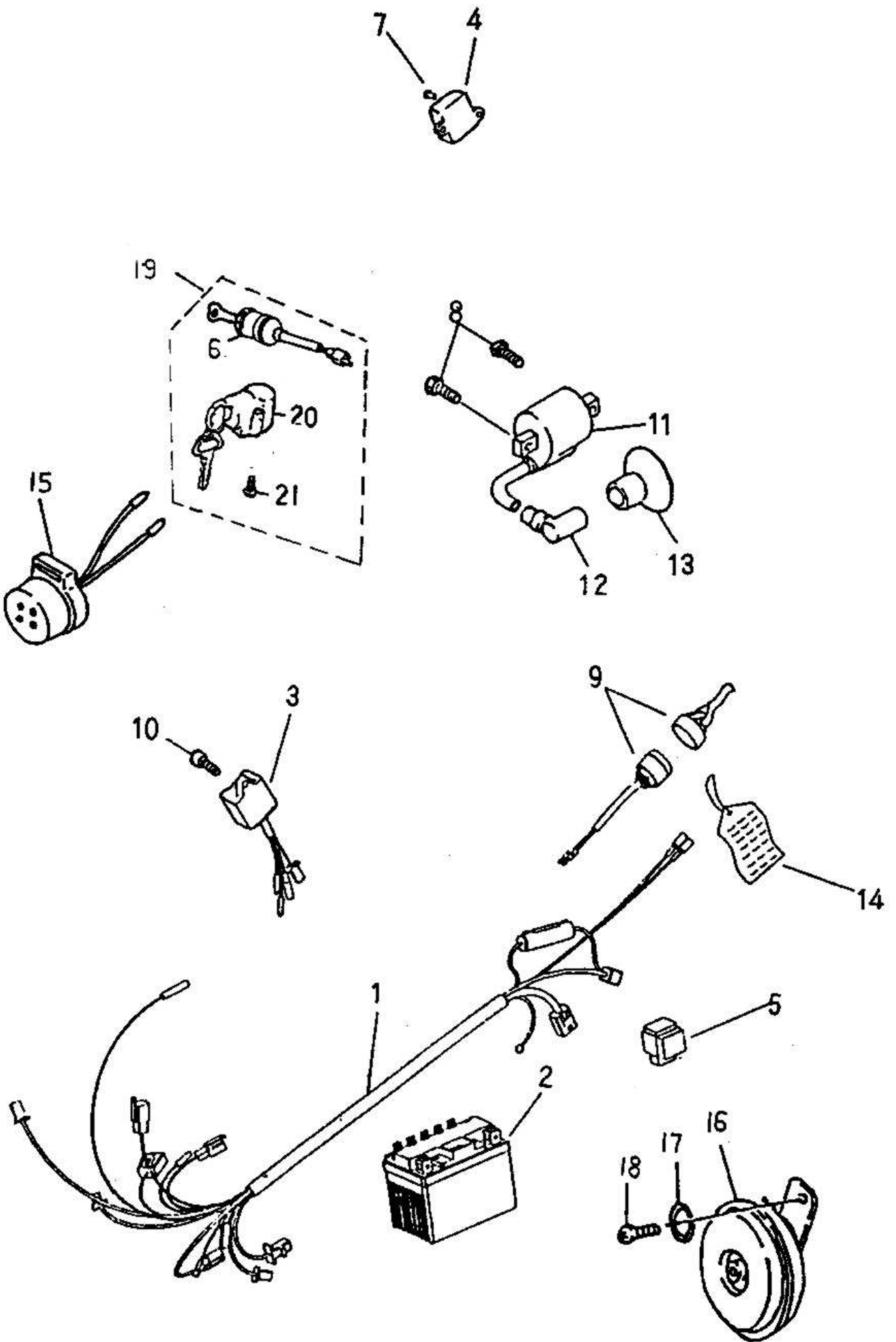

Assembly No.:155-24A

ELECTRICAL PARTS(HOMOLOGATION)

No.	Parts No.	Q'ty	Parts Name	Specification
1	32100-145-00E	1	MAIN WIRE HARNESS	加延長線
2	31500-116-000	1	BATTERY	12V
3	30410-116-000	1	C.D.I UNIT	
4	31600-110-000	1	REGULATOR RECTIFIER	
5	38501-105-001	1	STARTING RELAY	
6	35100-145-00B	1	MAIN SWITCH ASS'Y	
7	93500-05012	1	PAN PHILLIPS BOLT	5*12
8	96000-06020-10	2	HEX WASHER FACE BOLT	6*20
9	31800-145-000	1	SAFETY SWITCH(REV.1)	
10	93500-06015	1	PAN PHILLIPS BOLT	6*15
11	30510-116-000	1	HIGH TENSION COIL	
12	30700-101-001	1	SPARK PLUG CAP	10KΩ
13	30605-116-000	1	RUBBER CAP	
14	87707-145-000	1	SAFETY SWITCH WARNING TAG	
15	38301-107-000	1	FLASHER RELAY	標準 12V
16	38110-101-001	1	HORN (E-MARK)	12V
17	94111-0612015	1	SPRING WASHER	6*12*1.5
18	93500-06012	1	PAN PHILLIPS BOLT	6*12
19	35010-145-00A	1	KEY SET	
20	53600-128-000	1	STEERING HANDLE LOCK	
21	93500-05010	2	PAN PHILLIPS BOLT	5*10
22	35410-116-000	1	OIL LEVEL GAUGE	

SIGNAL LIGHT, TAIL LIGHT(HOMOLOGATION)

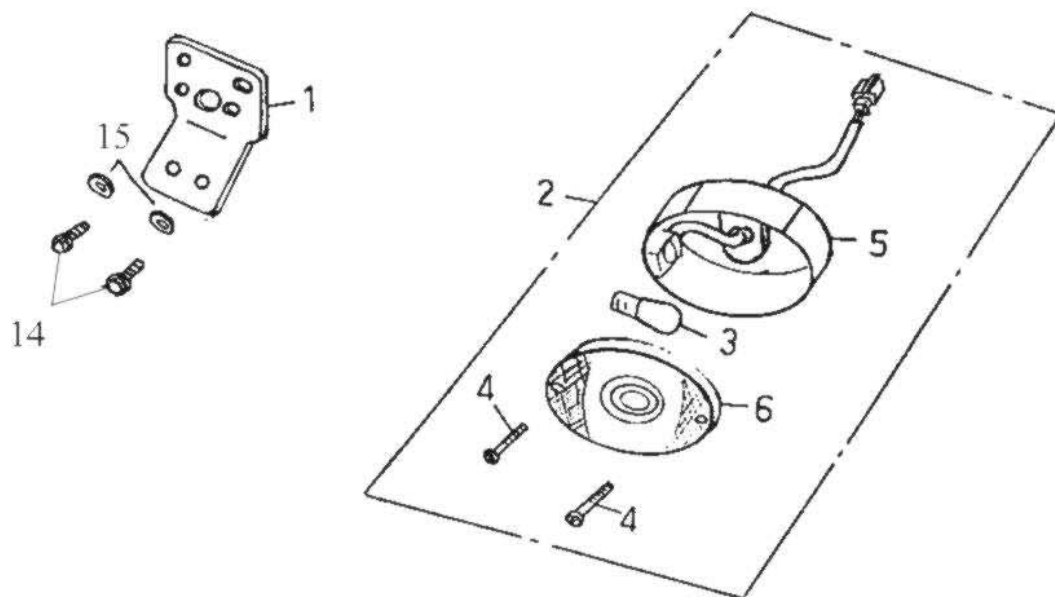
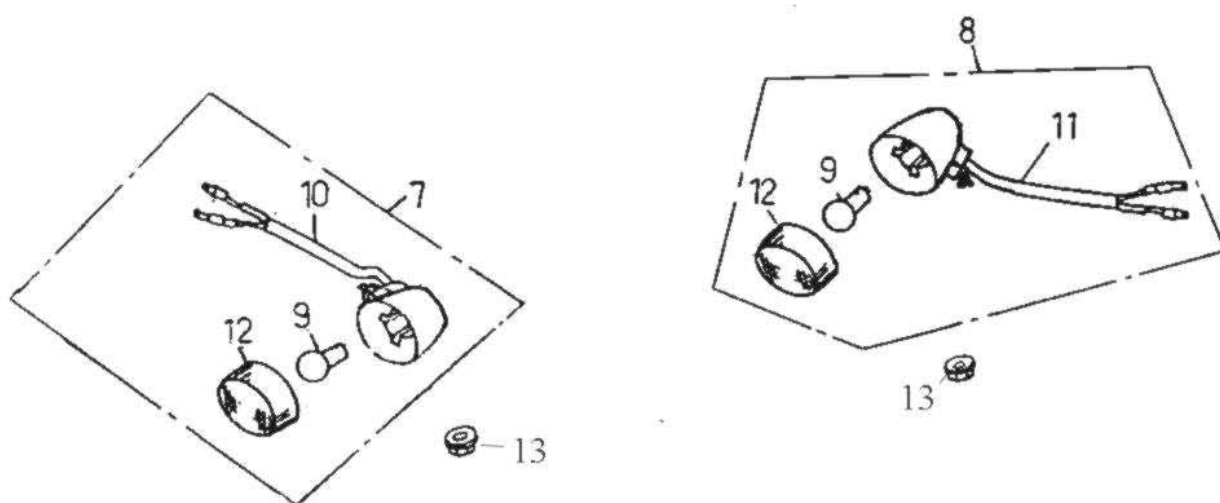

Assembly No.:155-25

SIGNAL LIGHT,TAIL LIGHT(HOMOLOGATION)

No.	Parts No.	Q'ty	Parts Name	Specification
1	50357-145-000	1	TAIL LIGHT FIX BRACKET(REV.1)	
2	33700-145-000	1	TAIL LIGHT ASS'Y (E-MARK,SAE)	
3	34906-105-00A	1	TAIL LIGHT BULB (E-MARK)	12V21/5W
4	93500-04010	2	PAN PHILLIPS BOLT	4*10
5	33711-145-000	1	REAR LIGHT BASE	
6	33702-145-000	1	TAIL LIGHT LENS	
7	33400-145-000	2	R.SIGNAL ASS'Y (E-MARK)	
8	33450-145-000	2	L.SIGNAL ASS'Y(E-MARK)	
9	34905-118-000	4	BULB (E-MARK)	12V/10W
10	33425-145-000	1	SIGNAL BULB SOCKET	
11	33435-145-000	1	L.SIGBAL BULB SOCKET	
12	33410-145-000	2	SIGNAL COVER	
13	94050-05000	2	HEX FLANGE NUT WITH SERRATION	5mm
14	96000-06012-10G	2	HEX WASHER FACE BOLT	6*12
15	94101-0614020	2	PLAIN WASHER	6*14*2