



PARTS CATALOGUE

YW100 (1S54) CHILE

YW100 (1S54) SOUTH KOREA

YW100
PARTS CATALOGUE
©2006 by Yamaha Motor Co., Ltd.
1st edition, September 2006
All rights reserved.
Any reprinting or unauthorized use
without the written permission of
Yamaha Motor Co., Ltd.
is expressly prohibited.

YW100
CATALOGO DE REPUESTOS
©2006 por Yamaha Motor Co., Ltd.
1ª edición, septiembre 2006
Todos los derechos reservados.
Toda reproducción o uso no autorizado
sin el consentimiento escrito de
Yamaha Motor Co., Ltd.
quedan expresamente prohibidos

FOREWORD

This Parts Catalogue is related to the parts for the model(s) on the cover page. When you are ordering replacement parts, please refer to this Parts Catalogue and quote both part numbers and part names correctly.

1. Modifications or additions which have been made after the issue of the Parts Catalogue will be announced in the Parts News.

It is advisable that you make the necessary corrections to the Parts Catalogue according to the Parts News.

2. Abbreviations

The following abbreviations are used in this Parts Catalogue.

“UR” Use specified parts number.

“UN” Use as many as needed.

“AP” Alternate Parts

“LM” Locally Made (Parts need to be ordered locally)

“F#” Frame No. (Applicable machine No.)

“O/S” Over Size

3. The number of components for assembly

- Parts, which are to be supplied in an assembly, are listed with a dot (.) in front of the part name as shown below.
- The numeral appearing to the right of each component part indicates the quantity of parts for each assembly unit.

PART NO.	DESCRIPTION	Q'TY	REMARKS
2F5-83310-60	FRONT FLASHER LIGHT ASSY	2	
115-83311-60	.BULB (6V-18W)	1	

4. Applicable colours of graphics are represented in the “REMARKS” as shown below.

PART NO.	DESCRIPTION	Q'TY	REMARKS
2N4-24110-00-X5	FUEL TANK COMP.	2	MXR
3J1-24240-10	.GRAPHIC, FUEL TANK	1	FOR MXR

5. Note that the illustrations for reference in finding parts numbers are not to be used for assembling. When assembling, please use the applicable service manual.

6. The asterisk (*) before a reference number indicates modified items after the first edition.

PROLOGO

Este catálogo de repuestos corresponde a las piezas para el o los modelos que figuran en la página de portada. Al formular el pedido de repuestos, se ruega citar este catálogo y especificar correctamente el número y el nombre de las piezas.

1. Las modificaciones y agregados que se hayan realizado después de la edición de este Catálogo de Repuestos, serán anunciados en las Informaciones de Recambios. Es recomendable que se hagan las correcciones necesarias en el Catálogo de Repuestos de acuerdo con las Informaciones de Recambios.

2. Abreviaciones

En este. Catálogo de Repuestos se emplean las siguientes abreviaciones.

“UR” Usar el número de partes especificado

“UN” Usar la cantidad necesaria

“AP” Piezas sustitutivas

“LM” Fabricación local (Hay que pedir los repuestos en las cercanías)

“F#” N° de bastidor (N° aplicable a la máquina)

“O/S” Sobredimensionado

3. La cantidad de componentes para el montaje

- Los componentes, suministrados como conjunto, se describen con un punto (.) que precede al nombre del parte como se indica a continuación.
- La numeración que aparece a la derecha de cada descripción indica la cantidad de partes por cada unidad de conjunto.

CODIGO N°	DESCRIPCION	CANT.	OBSERVACIONES
2F5-83310-60	ENSAMBLAJE DE LA LUZ	2	
115-83311-60	.BOMBILLA (6V-18W)	1	

4. Los colores de los componentes se indican como sigue en la columna de “OBSERVACIONES”.

CODIGO N°	DESCRIPCION	CANT.	OBSERVACIONES
2N4-24110-00-X5	COMP. DEL TANQUE	2	MXR
3J1-24240-10	.GRAFICO, DEL TANQUE	1	PARA MXR

5. Debe tenerse en cuenta que las ilustraciones sirven como guía para la búsqueda de los números de partes y no deben usarse para el montaje. Durante el montaje, se recomienda usar el manual de taller correspondiente.

6. EL asterisco (*) antes del número de referencia indica los elementos modificados después de la primera edición.

FOREWORD

7. Applicable Serial No.

Engine Serial No.

Frame Serial No.

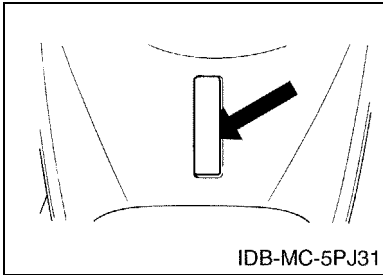
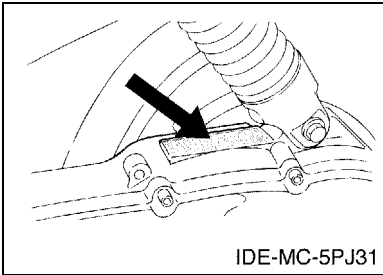

8. Applicable Colour Code (The (*) mark shows Model colour.)

Abbreviation	Colour Name	Colour Code
DPBMC(*)	DEEP PURPLISH BLUE METALLIC C	0564
FS	FAIRY SILVER	001V
LGB	LOW GLOSS BLACK	0098
SMX(*)	BLACK METALLIC X	0903
VRS5(*)	VIVID RED SOLID 5	0268
VYS2(*)	VIVID YELLOW SOLID 2	0657
YB	YAMAHA BLACK	0033

PROLOGO

7. Números de serie

Nº de Serie del motor

Nº de Serie del bastidor

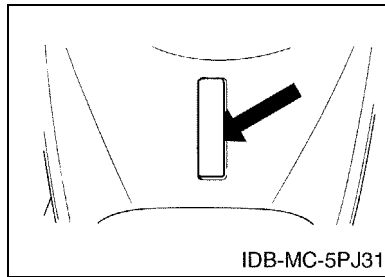
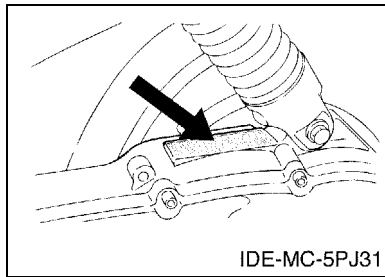

8. Códigos de color aplicables (El símbolo (*) muestra el color de modelo.)

Abreviatura	Nombre de color	Código de color
DPBMC(*)	DEEP PURPLISH BLUE METALLIC C	0564
FS	FAIRY SILVER	001V
LGB	LOW GLOSS BLACK	0098
SMX(*)	BLACK METALLIC X	0903
VRS5(*)	VIVID RED SOLID 5	0268
VYS2(*)	VIVID YELLOW SOLID 2	0657
YB	YAMAHA BLACK	0033

CONTENTS

ENGINE

CYLINDER	1
CRANKSHAFT & PISTON	2
AIR SHROUD & FAN	3
OIL PUMP	4
INTAKE	5
CARBURETOR	7
EXHAUST	8
CRANKCASE	9
STARTER	11
CLUTCH	12
TRANSMISSION	14

CHASSIS

FRAME	15
FRONT FENDER	16
SIDE COVER	17
OIL TANK	19
REAR SUSPENSION	20
FRONT FORK	21
FUEL TANK	23
SEAT & CARRIER	24
FRONT WHEEL	25
FRONT BRAKE CALIPER	26
REAR WHEEL	27
STEERING HANDLE & CABLE	28
FRONT MASTER CYLINDER	29
STAND & FOOTREST	30
LEG SHIELD	31
COWLING 1	33
GENERATOR	34
STARTING MOTOR	35
FLASHER LIGHT	36
METER	37
HEADLIGHT	38
TAILLIGHT	39
HANDLE SWITCH & LEVER	40
ELECTRICAL 1	41
ELECTRICAL 2	42

INDEX

NUMERICAL INDEX	43
-----------------------	----

CONTENIDO

MOTOR

CILINDRO	1
CIGUENAL & PISTON	2
CUBIERTA DE AIRE & VENTILADOR	3
BOMBA DE ACEITE	4
ADMISION	5
CARBURADOR	7
DESCARGA	8
CARTER	9
ARRANQUE	11
EMBRAGUE	12
TRANSMISION	14

SHASIS

CUADRO	15
GUARDABARRO DELANTERO	16
CUBIERTA LATERAL	17
DEPOSITO DE ACEITE	19
SUSPENSION TRASERO	20
HORQUILLA DELANTERA	21
DEPOSITO DE COMBUSTIBLE	23
ASIENTO & PORTAEQUIPAJE	24
RUEDA DELANTERA	25
CALIBRE FRENO DELANTERA	26
RUEDA TRASERA	27
MANILLAR & CABLE	28
CILINDRO MAESTRO DELANTERO	29
SOPORTE & APOYAPIE	30
PATA PROTEGIDA	31
BOVEDA 1	33
GENERADOR	34
MOTOR DE ARRANQUE	35
LUZ DE DESTELLADOR	36
MEDIDOR	37
FARO DELANTERO	38
LUZ DE COLA	39
INTERRUPTOR DE MANILLAR&PALANC	40
EQUIPO ELECTRICO 1	41
EQUIPO ELECTRICO 2	42

INDICE

INDICE NUMERICO	43
-----------------------	----

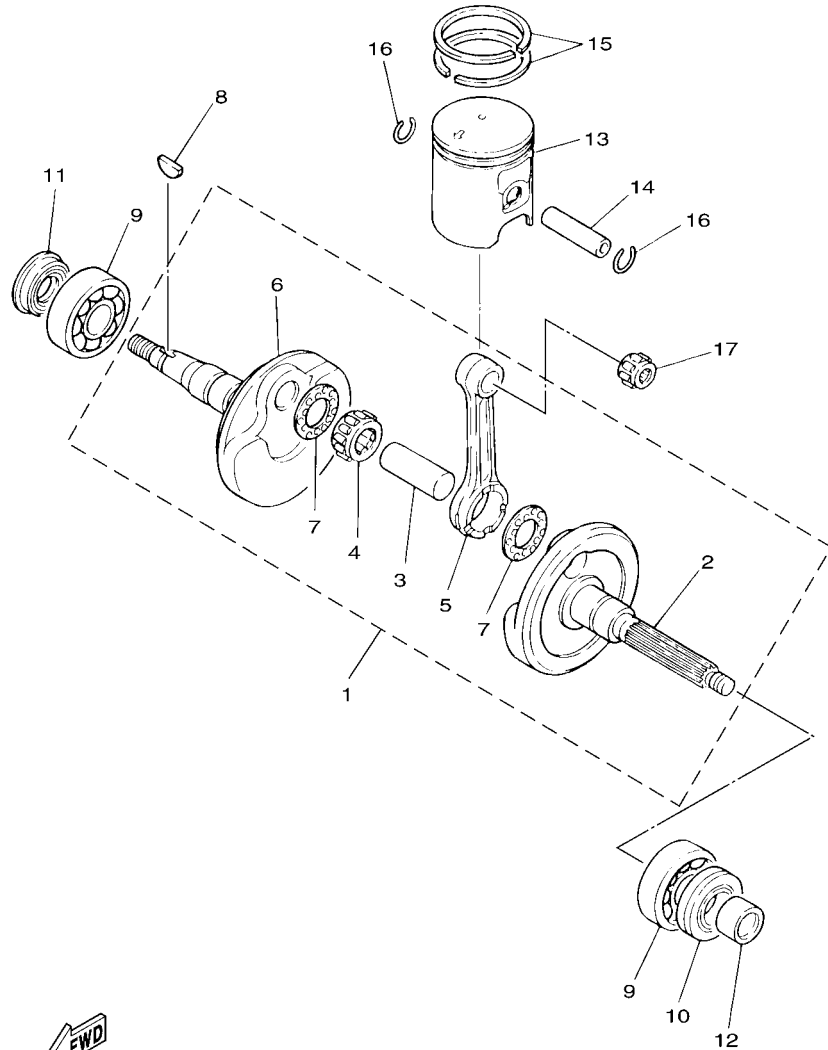

3NW1414-9020

FIG. 2 CRANKSHAFT & PISTON

CIGUENAL & PISTON

REF. NO.	PART NO. CODIGO Nº	DESCRIPTION DESCRIPCION	ISS4				REMARKS OBSERVACIONES
1	4VP-E1400-00	CRANKSHAFT ASSY CIGUENAL COMPLETO	1				
2	4VP-E1412-00	.CRANK 1 .MANIVELA 1	1				
3	4DM-E1681-00	.PIN, CRANK 1 .PASADOR MANIVELA 1	1				
4	93310-41810	.BEARING .COJINETE DE RODILLOS	1				
5	4VP-E1651-00	.ROD, CONNECTING .BIELA	1				
6	4VP-E1422-00	.CRANK 2 .MANIVELA 2	1				
7	90209-18112	.WASHER .ARANDELA DE SEPARACION	1				
8	90280-03017	KEY, WOODRUFF CUNA WOODRUFF	1				
9	93306-205Y6	BEARING COJINETE	2				
10	93102-22464	OIL SEAL SELLO ACEITE	1				
11	93101-20169	OIL SEAL SELLO ACEITE	1				
12	90387-178N6	COLLAR ESPACIADOR	1				
13	4VP-E1631-10-A0	PISTON (STD) PISTON (NORMA)	1				
	4VP-E1636-00	PISTON (0.50MM O/S) PISTON (0.50MM O/S)	1				AP AP
14	4VP-E1633-00	PIN, PISTON PASADOR, PISTON	1				
15	4VP-E1603-00	PISTON RING SET (STD) JUEGO DE ANILLOS (NORMA)	1				
	3YR-11605-00	PISTON RING SET (0.50MM O/S) JUEGO DE ANILLOS (0.50MM O/S)	1				AP AP
16	93450-16115	CIRCLIP SEGURO	2				
17	93310-21403	BEARING COJINETE DE RODILLOS	1				

FIG. 3 AIR SHROUD & FAN

CUBIERTA DE AIRE & VENTILADOR

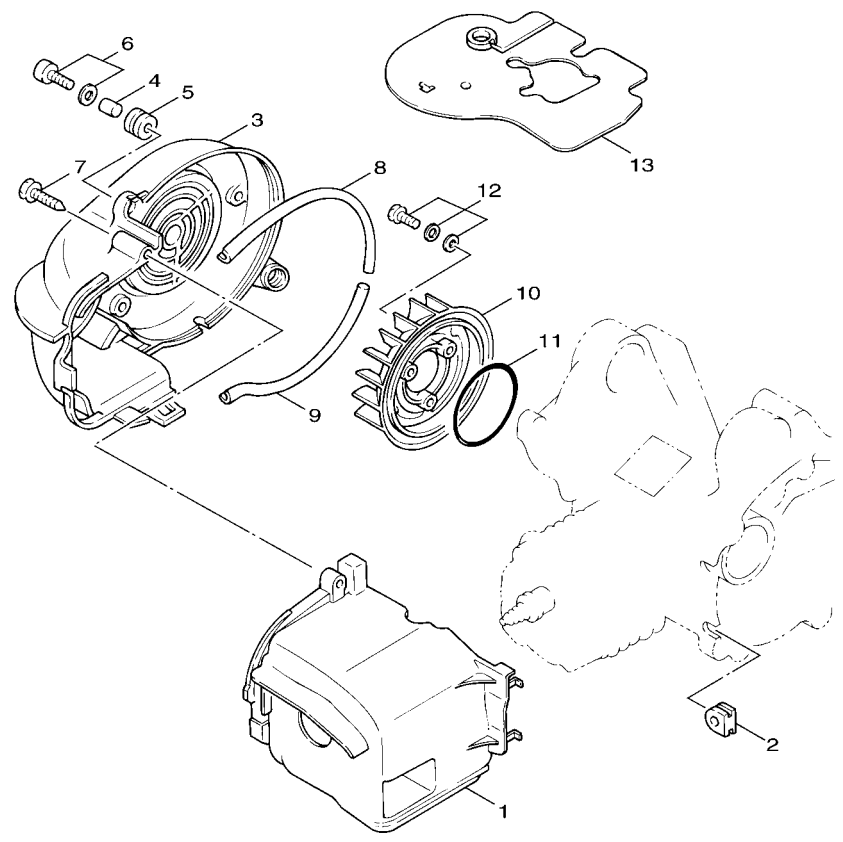

REF. NO.	PART NO. CODIGO Nº	DESCRIPTION DESCRIPCION	ISS4				REMARKS OBSERVACIONES
1	5FA-E2651-10	AIR SHROUD, CYLINDER 1 CUBIERTA DE PASO DE AIRE 1	1				
2	90480-11866	GROMMET TAPON	1				
3	5FA-E2653-02	AIR SHROUD, CYLINDER 3 CUBIERTA DE PASO DE AIRE 3	1				
4	90387-068J5	COLLAR ESPACIADOR	3				
5	90480-12497	GROMMET TAPON	3				
6	97607-06220	SCREW, WITH WASHER TORNILLO CAB CON PLANA C/ARAN	3				
7	97707-60540	SCREW, TAPPING TORNILLO ROSCA HEMBRA	1				
8	4VP-E2658-00	DAMPER, AIR SHROUD 1 AMORTIGUADOR DE CUBIERTA 1	1				
9	4VP-E2659-00	DAMPER, AIR SHROUD 2 AMORTIGUADOR DE CUBIERTA 2	1				
10	4VP-E2611-00	FAN VENTILADOR	1				
11	93210-64893	O-RING ANILLO O	1				
12	90119-06857	BOLT, WITH WASHER TORNILLO CON ARANDELA	3				
13	3XG-E2631-00	DEFLECTOR 1 DEFLECTOR 1	1				

4VPB300-9030

FIG. 4 OIL PUMP

BOMBA DE ACEITE

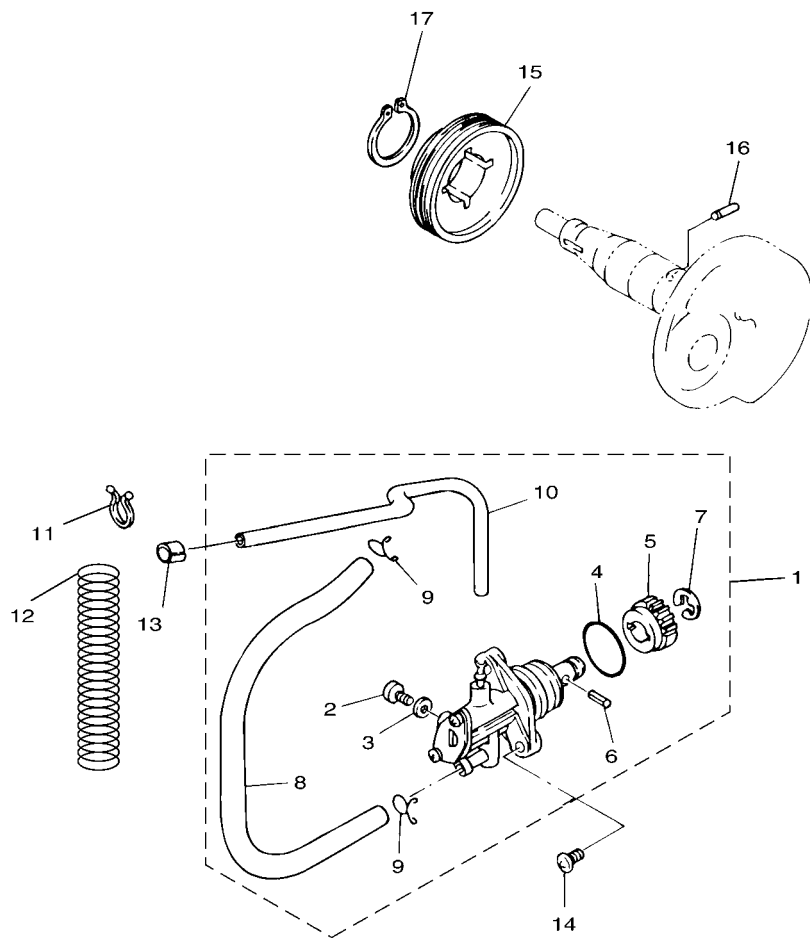

4VP1414-7042

REF. NO.	PART NO. CODIGO Nº	DESCRIPTION DESCRIPCION	ISS4				REMARKS OBSERVACIONES
1	5FA-E3100-11	OIL PUMP ASSY BOMBA DE ACEITE COMPLETA	1				
2	3WF-13185-00	.BOLT, BREATHER .PERNO DE RESPIRADERO	1				
3	1YU-13187-00	.GASKET, BREATHER BOLT .EMPAQUE TORNILLO P/RESPIRADER	1				
4	1YU-13473-00	.O-RING .ANILLO O	1				
5	3AA-13124-00	.GEAR WORM WHEEL (40T) .ENGREJE ROSCA SINFIN (40T)	1				
6	1YU-13516-00	.PIN, DOWEL .PASADOR, DE ESPIGA	1				
7	1YU-13577-00	.CLIP .PRESILLA	1				
8	4VP-E316F-00	.HOSE, OIL 1 .MANGUERA, DE ACEITE 1	1				
9	90467-08003	.CLIP .PRESILLA	2				
10	90445-05431	.HOSE (L240) .TUBO (L240)	1				
11	90464-16801	CLAMP BRIDA	1				
12	90501-08845	SPRING, COMPRESSION RESORTE DE COMPRESION	1				
13	90468-02033	CLIP PRESILLA	1				
14	98507-05014	SCREW, PAN HEAD TORNILLO DE CABEZA PLANA	2				
15	4VP-13178-00	GEAR, PUMP DRIVE ENGRANAJE TRACC.DE BOMBA	1				
16	93603-12827	PIN, DOWEL PASADOR DE CLAVIJA	1				
17	99009-19400	CIRCLIP PRESILLA REDONDA	1				

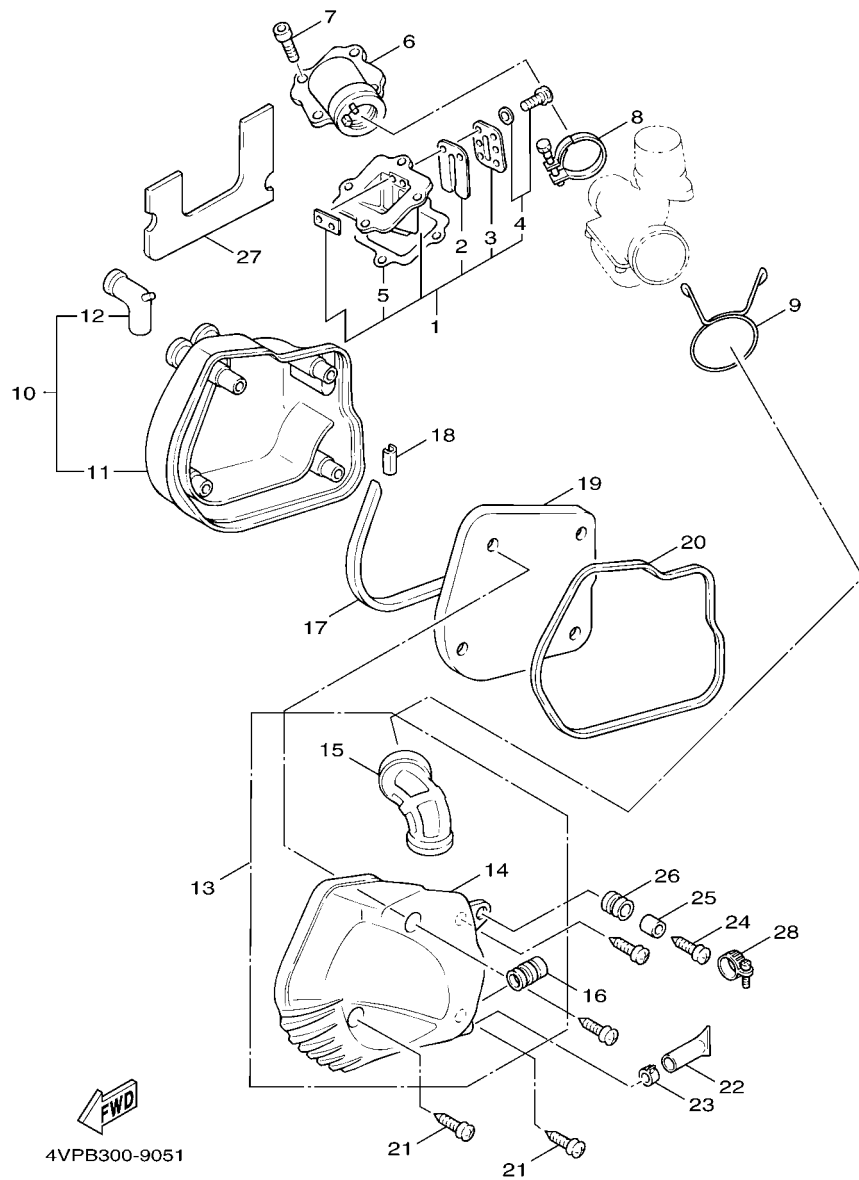
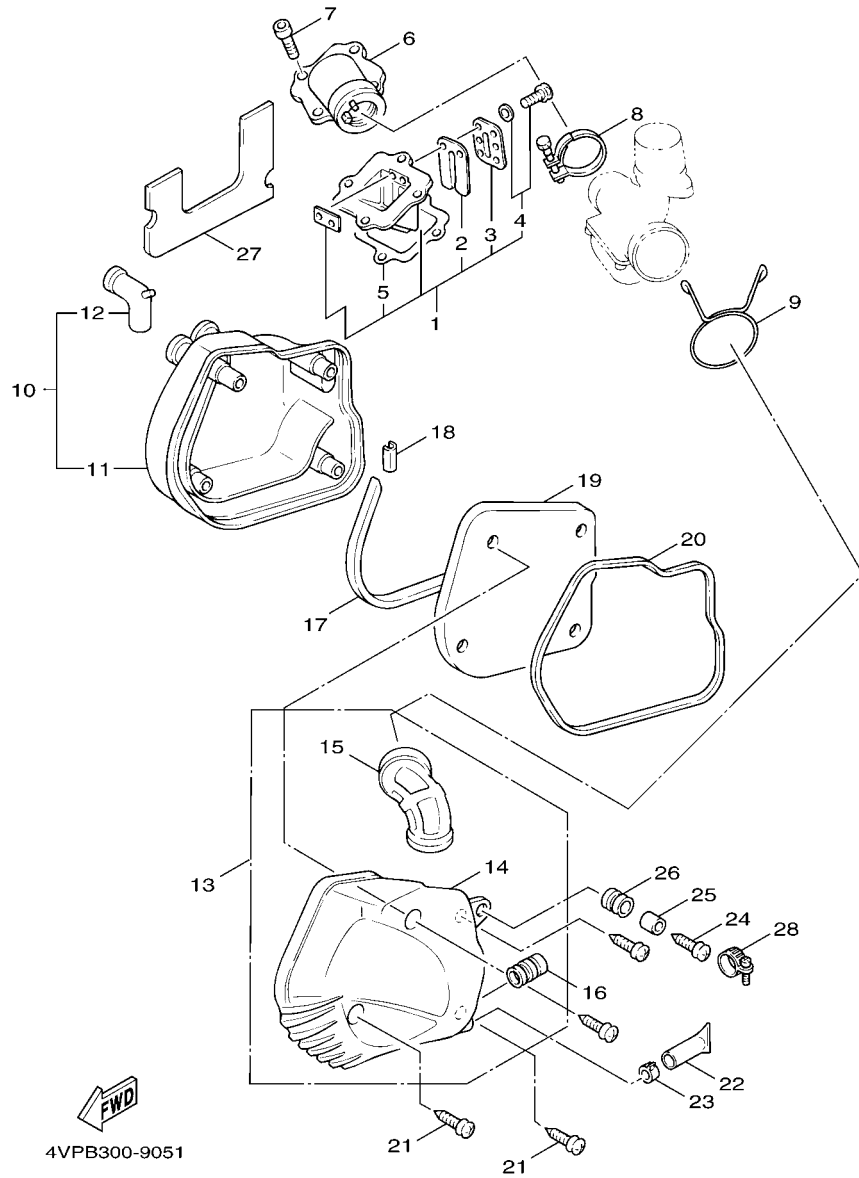

FIG. 5 INTAKE

ADMISION

REF. NO.	PART NO. CODIGO Nº	DESCRIPTION DESCRIPCION	ISS4				REMARKS OBSERVACIONES
1	4VP-E3610-00	REED VALVE ASSY VALVULA DE LAMINAS COMPLETA	1				
2	3XG-E3613-00	.REED, VALVE .VALVULA DE LAMINAS	2				
3	3XG-E3616-00	.STOPPER, REED VALVE .TOPE DE VALVULA DE LAMINAS	2				
4	98507-03006	.SCREW, PAN HEAD .TORNILLO DE CABEZA PLANA	4				
5	4SC-E3621-00	GASKET, VALVE SEAT JUNTA, DE VALV.DE EMPAQUE	1				
6	4WX-E3555-10	MANIFOLD, INTAKE CONECTOR	1				
7	90109-06801	BOLT PERNO	4				
8	4VP-E3575-00	BAND BANDA	1				
9	90467-01800	CLIP PRESILLA	1				
10	4VP-W1441-00	AIR CLEANER CASE COMP. CAJA COMPLETO FILTRO DE AIRE	1				
11	4VP-E4411-00	.CASE, AIR CLEANER 1 .CAJA FILTRO DEL AIRE 1	1				
12	4VP-E4437-00	.DUCT .CONDUCTO	1				
13	4VP-W1442-00	AIR CLEANER CASE COMP. ELEMENTO DE FILTRO DE AIRE	1				
14	4VP-E4412-00	.CAP, CLEANER CASE 1 .TAPA CAJA DEL FILTRO 1	1				
15	4VP-E4453-00	.JOINT, AIR CLEANER 1 .UNION DEL FILTRO DEL AIRE 1	1				
16	4VP-E4463-00	.JOINT, AIR CLEANER 2 .UNION DE FILTRO DE AIRE 2	1				
17	4VP-E4462-00	SEAL SELLO	1				
18	4VP-E4467-00	SEAL SELLO	1				
19	4VP-E4451-00	ELEMENT, AIR CLEANER ELEMENTO DEL FILTRO DEL AIRE	1				
20	4VP-E4452-00	SEAL SELLO	1				
21	97707-50125	SCREW, TAPPING TORNILLO ROSCA HEMBRA	4				
22	4VP-E443E-00	PIPE, DRAIN TUBO, DRENAJE	1				
23	90467-11823	CLIP PRESILLA	1				
24	97607-06220	SCREW, WITH WASHER TORNILLO CAB CON PLANA C/ARAN	1				
25	90387-068J5	COLLAR ESPACIADOR	1				
26	90480-12497	GROMMET TAPON	1				
27	5FA-E4425-00	DAMPER 1 AMORTIGUADOR 1	1				



4VPB300-9051

FIG. 5 INTAKE

ADMISION

REF. NO.	PART NO. CODIGO Nº	DESCRIPTION DESCRIPCION	ISS4				REMARKS OBSERVACIONES
28	90460-41191	CLAMP, HOSE BRIDA, DE UNION	1				

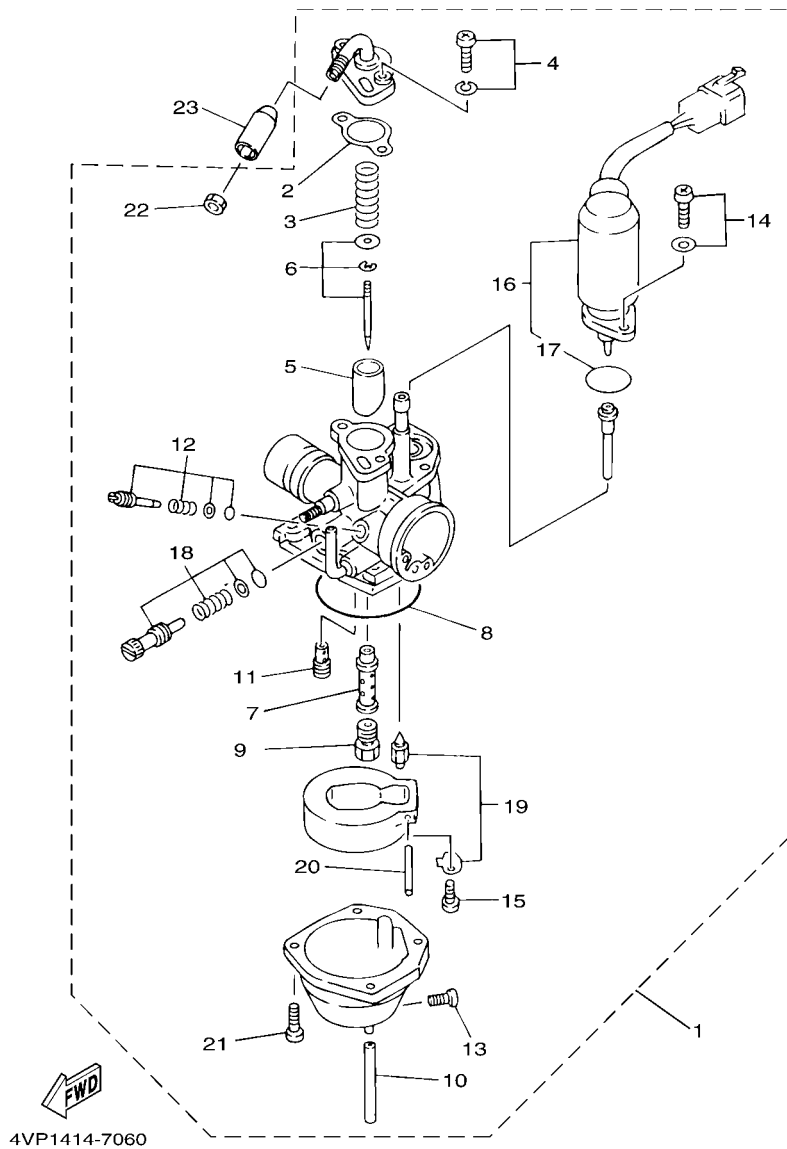

FIG. 6 CARBURETOR

CARBURADOR

REF. NO.	PART NO. CODIGO Nº	DESCRIPTION DESCRIPCION	ISS4				REMARKS OBSERVACIONES
1	4VP-E4101-30	CARBURETOR ASSY 1 CARBURADOR COMPLETO 1	1				
2	3XG-14198-00	.GASKET .EMPAQUE	1				
3	3XG-14133-00	.SPRING, THROTTLE STOP .RESORTE TOPE DE ACELERACION	1				
4	97607-04112	.SCREW, WITH WASHER .TORNILLO CAB CON PLANA C/ARAN	2				
5	4VP-1411F-35	.VALVE, THROTTLE 2 .VALVULA DE ACELERACION 2	1				
6	4VP-1490J-10	.NEEDLE SET .CJTO. AGUJA	1				
7	4VP-1414M-13	.NOZZLE, MAIN .BOQUILLA PRINCIPAL	1				
8	3XG-14997-00	.SEAL .SELLO	1				
9	18A-14143-15	.JET, MAIN (# 75) .SURTIDOR, PRINCIPAL (# 75)	1				
10	3XG-14196-00	.PIPE .TUBO DE DRENASE	1				
11	193-14142-32	.JET, PILOT (# 32.5) .SURTIDOR DE RALENTI (# 32.5)	1				
12	4VP-14104-00	.AIR SCREW SET .CJTO. TORNILLO DE AIRE	1				
13	4KP-14191-00	.PLUG, DRAIN .TORNILLO, DE DRENAJE	1				
14	97607-04108	.SCREW, WITH WASHER .TORNILLO CAB CON PLANA C/ARAN	2				
15	98507-03006	.SCREW, PAN HEAD .TORNILLO DE CABEZA PLANA	1				
16	4VP-14171-00	.PLUNGER, STARTER .EMBOLO DE ARRANQUE	1				
17	52W-14147-00	.O-RING .ANILLO O	1				
18	4UF-14103-00	.THROTTLE SCREW SET .CJTO. TORNILLO DEL RALENTI	1				
19	3XG-14107-00	.NEEDLE VALVE SET .VALVULA DE AGUJA	1				
20	53L-14186-00	.PIN, FLOAT .PASADOR DE LA BOYA	1				
21	98507-04012	.SCREW, PAN HEAD .TORNILLO DE CABEZA PLANA	4				
22	522-14161-00	.NUT, CABLE ADJUSTING .TUERCA AJUSTADOR DE CABLE	1				
23	1MH-F6329-00	CAP, RUBBER TAPA DE ANILLO PROTECTOR	1				

FIG. 7 EXHAUST

DESCARGA

REF. NO.	PART NO. CODIGO Nº	DESCRIPTION DESCRIPCION	ISS4				REMARKS OBSERVACIONES
1	4VP-E4610-40-98	EXHAUST PIPE ASSY 1 TUBO DE ESCAPE COMPLETO 1	1				LGB LGB
2	4VP-E4445-00	GROMMET TAPON PROTECTOR	1				
3	4VP-E4779-00	COLLAR COLLAR	1				
4	3NT-E4613-01	GASKET, EXHAUST PIPE JUNTA, TUBO DE ESCAPE	1				
5	90153-06800	SCREW, HEXAGON TORNILLO HEXAGONAL	2				
6	95817-08020	BOLT, FLANGE TORNILLO	1				
7	95817-08030	BOLT, FLANGE TORNILLO	1				
8	4VP-E4718-00	PROTECTOR, MUFFLER 1 PROTECTOR DE SILENCIADOR 1	1				
9	4VP-E4627-10	EXT.COVER ASSY PROTECTOR DE SILENCIADO	1				
10	97017-06010	BOLT PERNO	2				
11	4CW-E4766-00	WASHER, PROTECTOR ARANDELA DE PROTECTOR	4				
12	97517-06510	BOLT, WITH WASHER PERNO CON ARANDELA	3				
13	4VP-E4799-20	CAP TAPA	1				
14	4VP-E475M-00	PIPE TUBO	1				
15	92907-06200	WASHER ARANDELA	3				
16	90176-06065	NUT, CROWN TUERCA CORONA	3				
17	4CW-E4766-00	WASHER, PROTECTOR ARANDELA DE PROTECTOR	3				
18	98980-06010	SCREW, BIND TORNILLO DE LIGAR	3				
19	3XY-E4766-00	WASHER, PROTECTOR ARANDELA DE PROTECTOR	3				

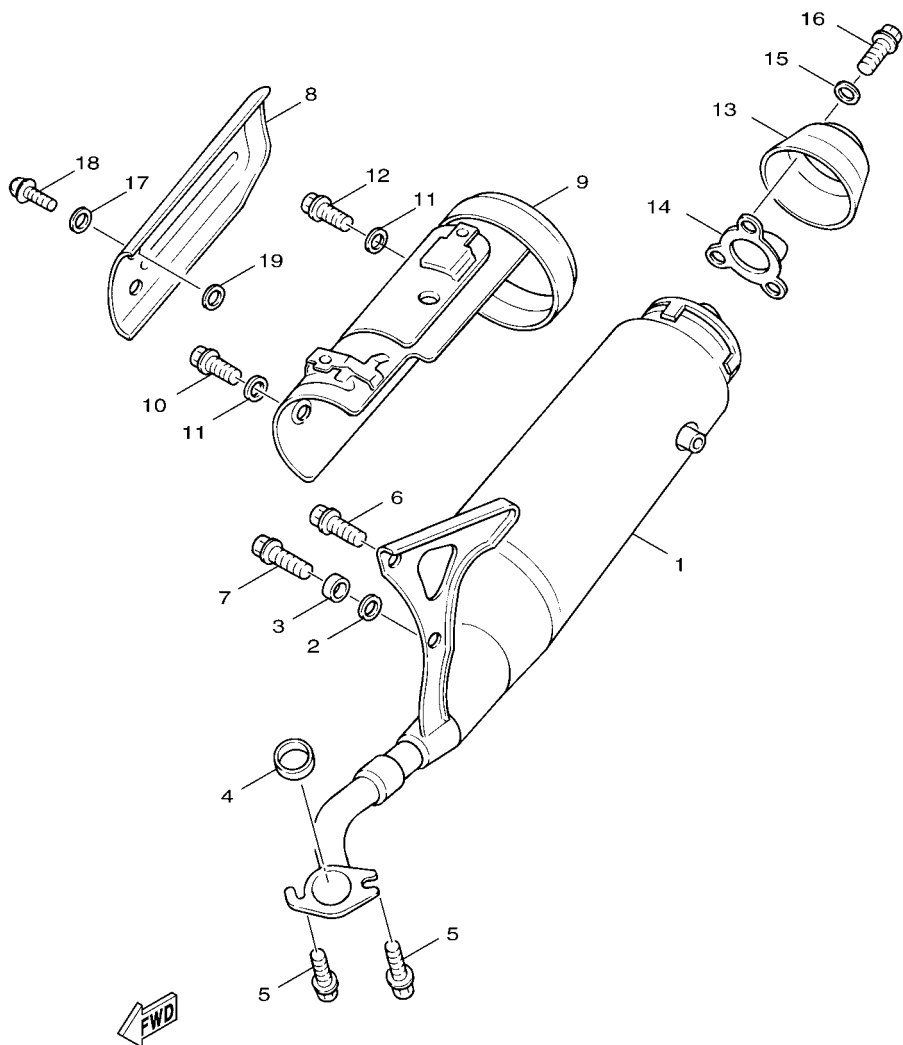

4VPB300-9070

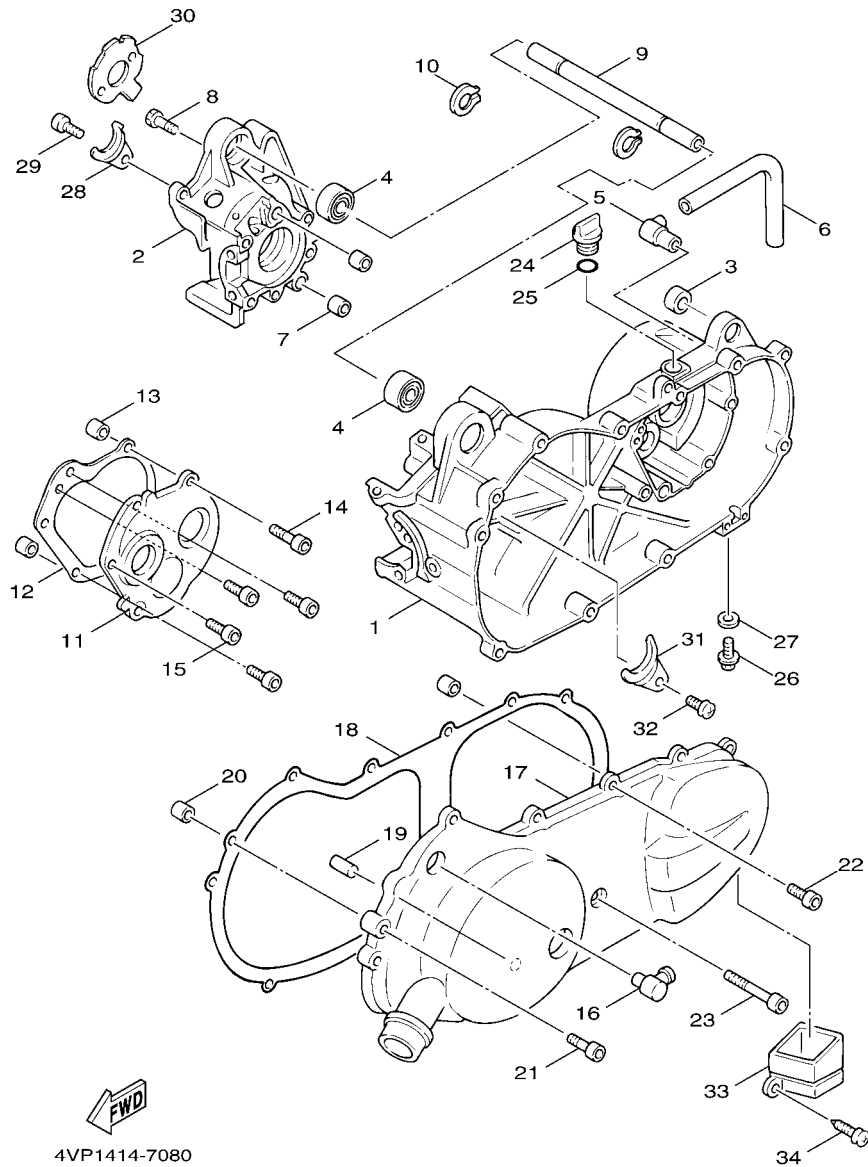

4VP1414-7080

FIG. 8 CRANKCASE

CARTER

REF. NO.	PART NO. CODIGO N°	DESCRIPTION DESCRIPCION	ISS4				REMARKS OBSERVACIONES
1	5FA-E5111-12	CRANKCASE 1 CARTER MANIVELA 1	1				
2	4VP-E5121-00	CRANKCASE 2 CARTER MANIVELA 2	1				
3	4X6-F2216-00	BUSH, REAR SHOCK ABSORBER BUJE DEL AMORTIGUADOR TRASERO	1				
4	93306-003Y4	BEARING COJINETE	2				
5	3XG-E5371-00	BREATHER RESPIRADERO	1				
6	4VP-E5373-00	PIPE, BREATHER MANGUELA DE RESPIRADERO	1				
7	91812-16805	PIN, DOWEL PASADOR DE CLAVIJA	2				
8	91318-06035	BOLT TORNILLO	6				
9	3XG-E5317-00	SPACER, ENGINE MOUNT SEPARADPR, MONTANTE DE MOTOR	1				
10	99009-17400	CIRCLIP PRESILLA REDONDA	2				
11	4VP-E5421-01	COVER, CRANKCASE 2 TAPA DE CARTER DERECHA	1				
12	5DA-E5461-00	GASKET, CRANKCASE COVER 2 JUNTA TAPA CARTER DERECHO 2	1				
13	91810-14807	PIN, DOWEL PASADOR DE CLAVIJA	2				
14	91318-06035	BOLT TORNILLO	2				
15	91318-06020	BOLT TORNILLO	4				
16	4VP-E5439-00	PLUG, BLIND TAPON CIEGO	1				
17	4VP-E5411-00-33	COVER, CRANKCASE 1 CUBIERTA DE CARTER 1	1				YB YB
18	5DA-E5451-00	GASKET, CRANKCASE COVER 1 EMPAQ DE CUBIERTA DE CARTER	1				
19	4VP-E5659-00	SHAFT EJE	1				
20	91810-14807	PIN, DOWEL PASADOR DE CLAVIJA	2				
21	91317-06025	BOLT PERNO	9				
22	91317-06035	BOLT PERNO	2				
23	91317-06045	BOLT PERNO	1				
24	4Y4-E5363-00	PLUG, OIL TAPON DE ACEITE	1				
25	93210-14805	O-RING ANILLO O	1				
26	95807-08016	BOLT, FLANGE TORNILLO	1				
27	90430-08119	GASKET JUNTA	1				

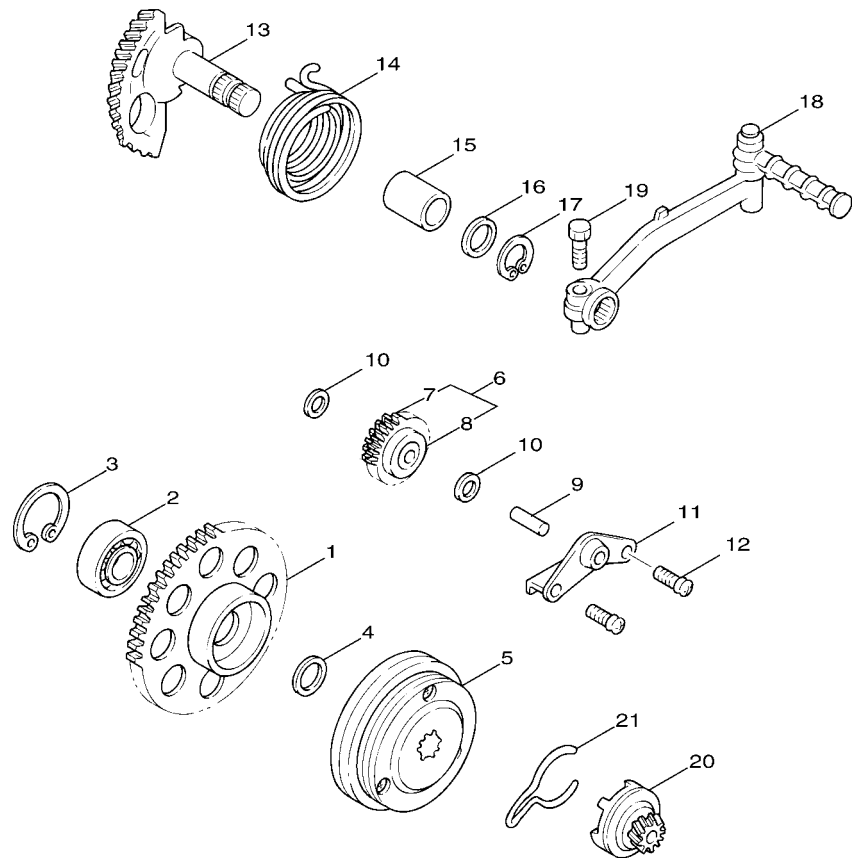

4VP1414-7090

FIG. 9 STARTER

ARRANQUE

REF. NO.	PART NO. CODIGO Nº	DESCRIPTION DESCRIPCION	ISS4				REMARKS OBSERVACIONES
1	4VP-E5524-00	WHEEL, STARTER RUEDA DE ARRANQUE	1				
2	93306-003Y4	BEARING COJINETE	1				
3	93450-35015	CIRCLIP SEGURO	1				
4	90201-163G6	WASHER, PLATE ARANDELA PLANA	1				
5	4CW-E5570-00	STARTER CLUTCH ASSY EMBRAGUE DEL ARRANQUE COMPLETA	1				
6	4VP-E5650-00	IDLE GEAR ASSY ENGRENAJE NEUTRO COMPLETO	1				
7	4VP-E5512-00	.GEAR, IDLER 1 .ENGRENAJE NEUTRO	1				
8	93315-108Y4	.BEARING .COJINETE DE RODILLOS	1				
9	3XG-E3342-00	SHAFT, IDLE GEAR EJE DE ENGRENAJE NEUTRO	1				
10	90201-08088	WASHER, PLATE ARANDELA PLANA	2				
11	3XG-E5532-00	PLATE, IDLE GEAR PLACA DE ENGRENAJE NEUTRO	1				
12	98507-06012	SCREW, PAN HEAD TORNILLO DE CABEZA PLANA	2				
13	4VP-E5601-00	KICK SHAFT ASSY EJE DE ARR. DE PIE COMPL	1				
14	90508-32768	SPRING, TORSION RESORTE DE TORSION	1				
15	90380-15817	BUSH, SOLID CASQUILLO SOLIDO	1				
16	90201-155G5	WASHER, PLATE ARANDELA PLANA	1				
17	99009-15400	CIRCLIP PRESILLA REDONDA	1				
18	5FA-E5620-00	KICK CRANK ASSY PEDAL DE ARRANQUE COMPLETO	1				
19	97017-06025	BOLT PERNO	1				
20	4VP-E5630-00	KICK PINION ASSY PINON DE PEDAL COMPLETA	1				
21	4VP-E5673-00	CLIP PRESILLA	1				

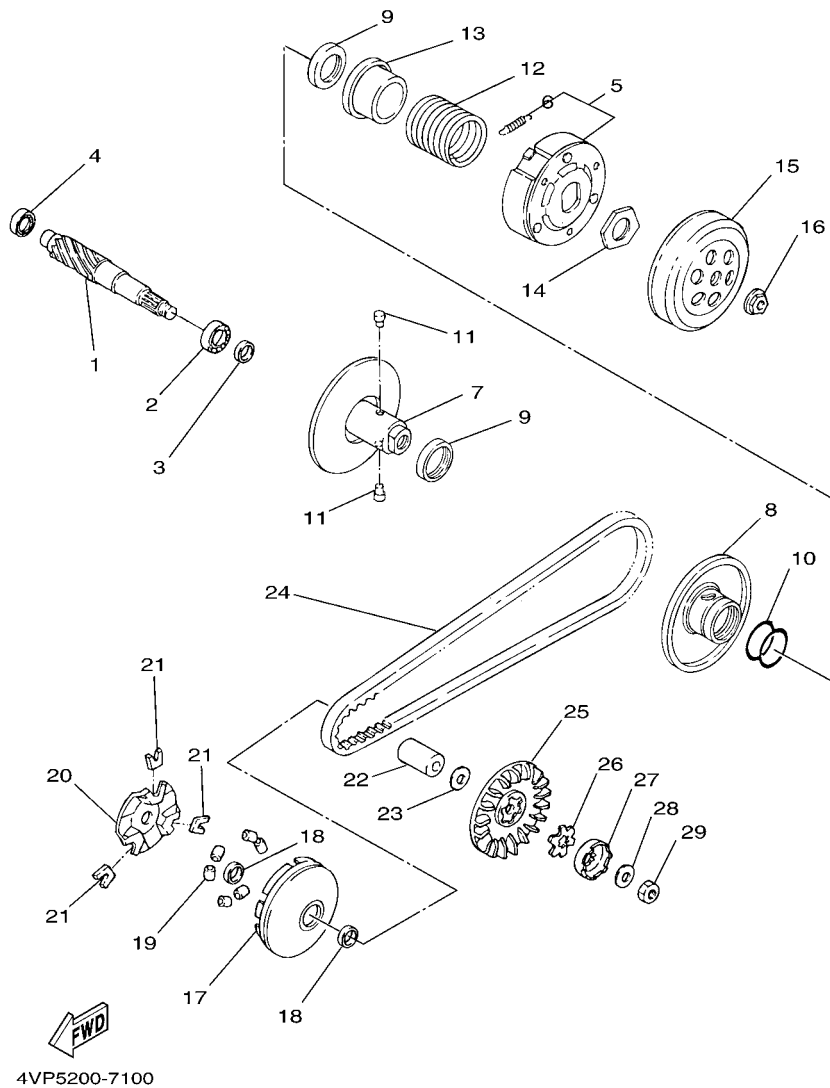
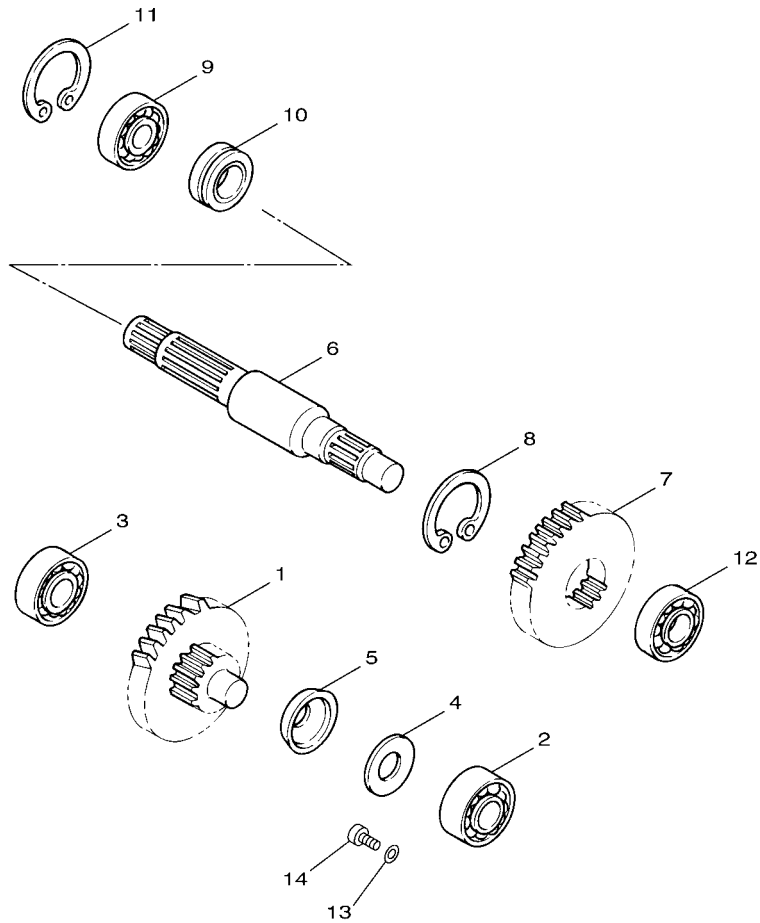

FIG. 10 CLUTCH

EMBRAGUE

REF. NO.	PART NO. CODIGO N°	DESCRIPTION DESCRIPCION	ISS4				REMARKS OBSERVACIONES
1	4VP-E6111-01	GEAR, PRIMARY DRIVE ENGRANAJE TRACC.PRIMARIA	1				
2	93306-203YE	BEARING COJINETE	1				
3	93102-17467	OIL SEAL SELLO ACEITE	1				
4	93306-200Y1	BEARING COJINETE	1				
5	3XY-E6620-01	CLUTCH CARRIER ASSY PORTADOR DE EMBRAGUE COMPLETO	1				
6	3UH-E6626-00	.SPRING, CLUTCH WEIGHT 1 .RESORTE CONTRAPESO EMBRAGUE	3				
7	4VP-E7660-01	SECONDARY FIXED SHEAVE COMP. ROLDANA SECUNDARIA FIJA COMPL.	1				
8	4VP-E7670-01	SECONDARY SLIDING SHEAVE ROLDANA SECUNDARIA CORREDIZA	1				
9	93104-33800	OIL SEAL SELLO ACEITE	2				
10	93210-368G9	O-RING ANILLO O	2				
11	4DM-E7664-00	PIN, GUIDE PASADOR DE GUIA	2				
12	90501-430K3	SPRING, COMPRESSION RESORTE DE COMPRESION	1				
13	4DM-E7684-00	SEAT, SECONDARY SPRING ASIENTO DE RESORTE SECUNDARIO	1				
14	90179-28415	NUT TUERCA	1				
15	4VP-E6611-00	CLUTCH HOUSING COMP. CAJA DE EMBRAGUE COMPLETO	1				
16	90179-10609	NUT TUERCA	1				
17	4VP-E7620-00	PRIMARY SLIDING SHEAVE COMP. ROLDANA PRIMARIA MOVIL	1				
18	93101-21801	OIL SEAL SELLO ACEITE	2				
19	4KX-17632-00	WEIGHT CONTRAPESO	6				
20	4VP-E7623-00	CAM LEVA	1				
21	4CW-E7653-00	SLIDER CORREDERA	3				
22	90387-168N7	COLLAR ESPACIADOR	1				
23	90201-16800	WASHER, PLATE ARANDELA PLANA	1				
24	4VP-17641-00	V-BELT CORREA EN V	1				
25	4VP-E7611-00	SHEAVE, PRIMARY FIXED PISCO FIXADOR DE POREA	1				
26	90209-14800	WASHER ARANDELA DE SEPARACION	1				
27	14T-15657-00	CLUTCH, ONEWAY EMBRAQUE SIN RETORNO	1				



5XB3200-E110

FIG. 11 TRANSMISSION

TRANSMISION

REF. NO.	PART NO. CODIGO Nº	DESCRIPTION DESCRIPCION	1554				REMARKS OBSERVACIONES
1	4VP-E7410-01	MAIN AXLE COMP. EJE PRINCIPAL COMPLETO	1				
2	93311-315Y2	BEARING COJINETE DE RODILLOS	1				
3	93306-200Y1	BEARING COJINETE	1				
4	90201-15819	WASHER, PLATE ARANDELA PLANA	1				
5	90208-21801	WASHER, CONICAL SPRING ARANDELA DE RESORTE CONICO	1				
6	4VP-E7421-01	AXLE, DRIVE EJE SECUNDARIO	1				
7	4VP-E7211-01	GEAR, 1ST WHEEL ENGRANAJE RUEDA DE 1 RA	1				
8	93410-20823	CIRCLIP SEGURO	1				
9	93306-004X7	BEARING COJINETE	1				
10	93102-25270	OIL SEAL SELLO ACEITE	1				
11	99009-42500	CIRCLIP PRESILLA REDONDA	1				
12	93306-203YE	BEARING COJINETE	1				
13	90201-06847	WASHER, PLATE ARANDELA PLANA	1				
14	95027-06010	BOLT, FLANGE PERNO, DE BRIDA	1				

FIG. 12 FRAME

CUADRO

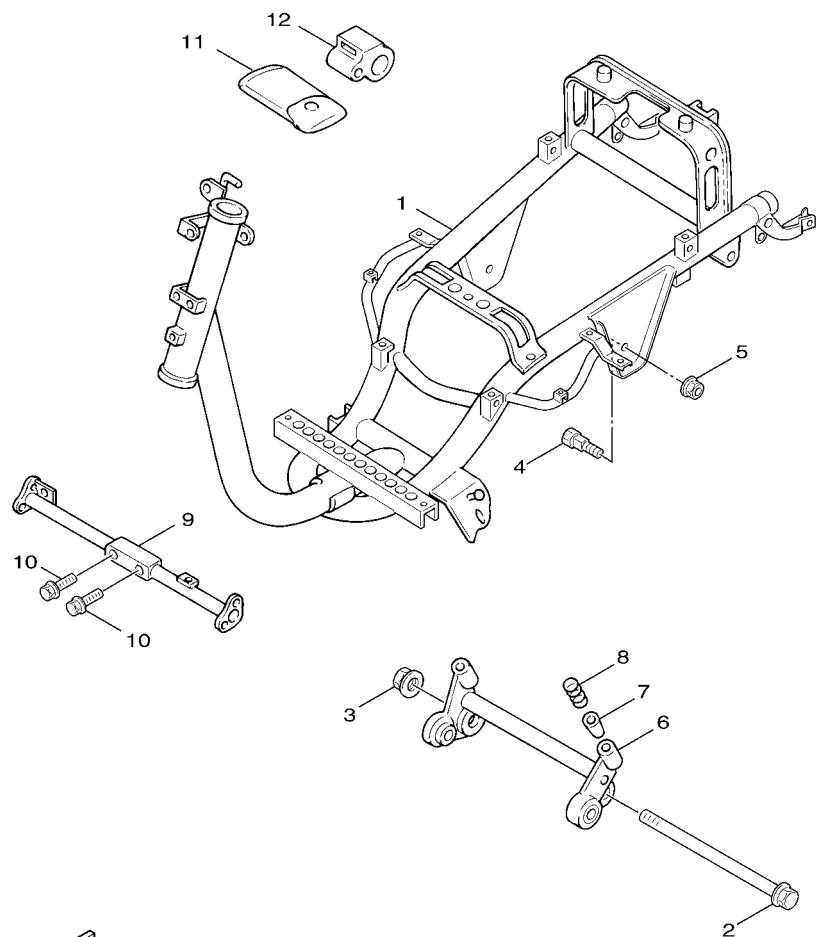

1S52200-D120

REF. NO.	PART NO. CODIGO Nº	DESCRIPTION DESCRIPCION	ISS4				REMARKS OBSERVACIONES
1	1S5-F1110-00-33	FRAME COMP. ARMAZON COMPLETO	1				YB YB
2	3XG-F1481-00	BOLT, ENGINE MOUNTING 1 PERNO DE MONTAJE DE MOTOR 1	1				
3	95607-12200	NUT, SELF-LOCKING TUERCA DE AUTO-CIERRE	1				
4	4Y4-F1481-00	BOLT, ENGINE MOUNTING 1 PERNO DE MONTAJE DE MOTOR 1	2				
5	90185-10801	NUT, SELF-LOCKING TUERCA AUTOBLOCANTE	2				
6	4VP-F1410-30	ENGINE BRACKET COMP. SOPORTE DE MOTOR COMPLETO	1				
7	4Y4-F139X-01	DAMPER AMORTIGUADOR	1				
8	90501-29517	SPRING, COMPRESSION RESORTE DE COMPRESION	1				
9	4VP-F1514-00	STAY, FENDER 2 SOPORTE DE GUARDABARRO 2	1				
10	95807-08035	BOLT, FLANGE TORNILLO	2				
11	45U-F8100-00	TOOL KIT JUEGO DE HERRAMIENTAS	1				
12	23Y-F8175-00	HOLDER, TOOL SOSTEN DE HERRAMIENTAS	1				

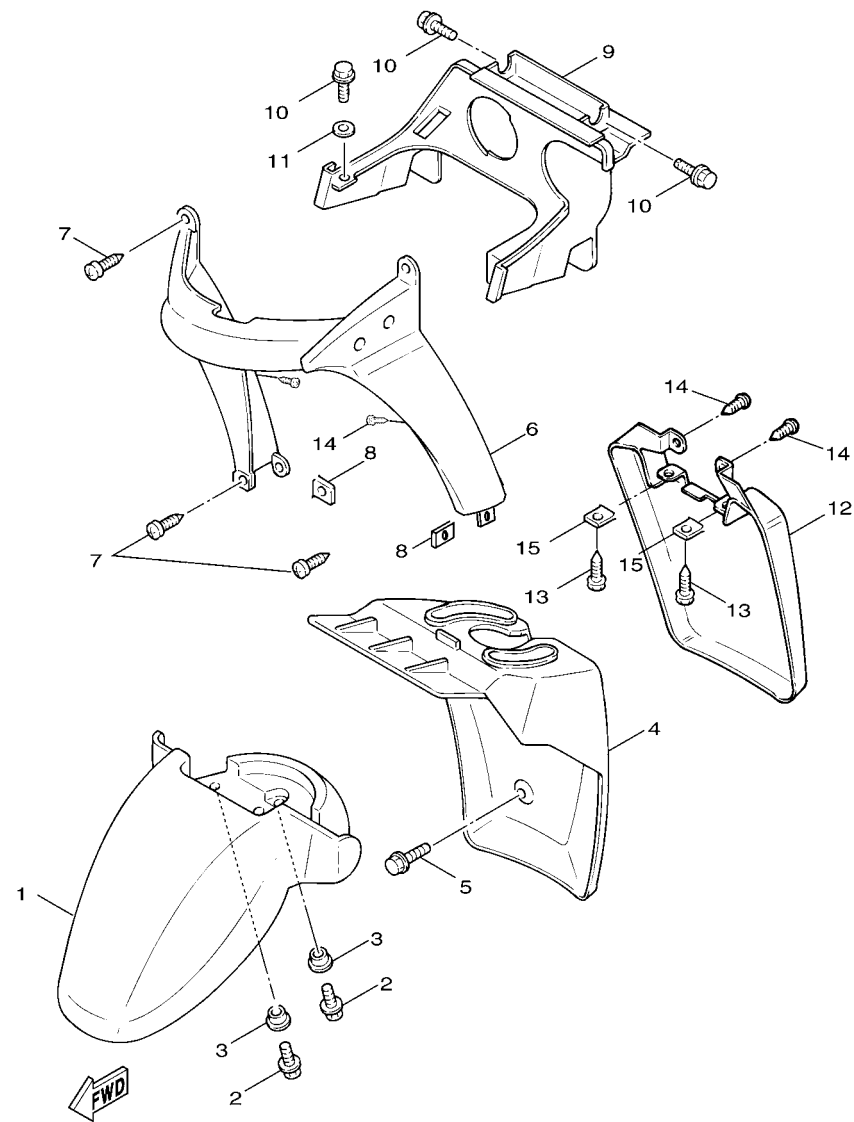

1S52200-D130

FIG. 13 FRONT FENDER

GUARDABARRO DELANTERO

REF. NO.	PART NO. CODIGO Nº	DESCRIPTION DESCRIPCION	1S54				REMARKS OBSERVACIONES
1	4VP-F1511-01	FENDER, FRONT GUARDABARRO DELANTERO	1				
2	90119-06821	BOLT, WITH WASHER TORNILLO CON ARANDELA	3				
3	90387-068F8	COLLAR ESPACIADOR	3				
4	4VP-F1552-00	FENDER, INNER GUARDABARRO	1				
5	95807-06012	BOLT, FLANGE TORNILLO	2				
6	4VP-F1519-01	MOLE, FENDER MUELLE DE GUARDABARRO	1				
7	97707-50016	SCREW, TRUSS HEAD TAPPING TORNILLO	4				
8	90183-05807	NUT, SPRING TUERCA DE RESORTE	2				
9	4VP-F1629-00	GUARD, MUD GUARDABARRO INFERIOR	1				
10	95807-06012	BOLT, FLANGE TORNILLO	4				
11	90201-06380	WASHER, PLATE ARANDELA PLANA	2				
12	4VP-F1691-01	FLAP CHARNELA	1				
13	97707-50012	SCREW, TRUSS HEAD TAPPING TORNILLO	2				
14	97707-50016	SCREW, TRUSS HEAD TAPPING TORNILLO	2				
15	90183-05807	NUT, SPRING TUERCA DE RESORTE	2				

FIG. 14 SIDE COVER

CUBIERTA LATERAL

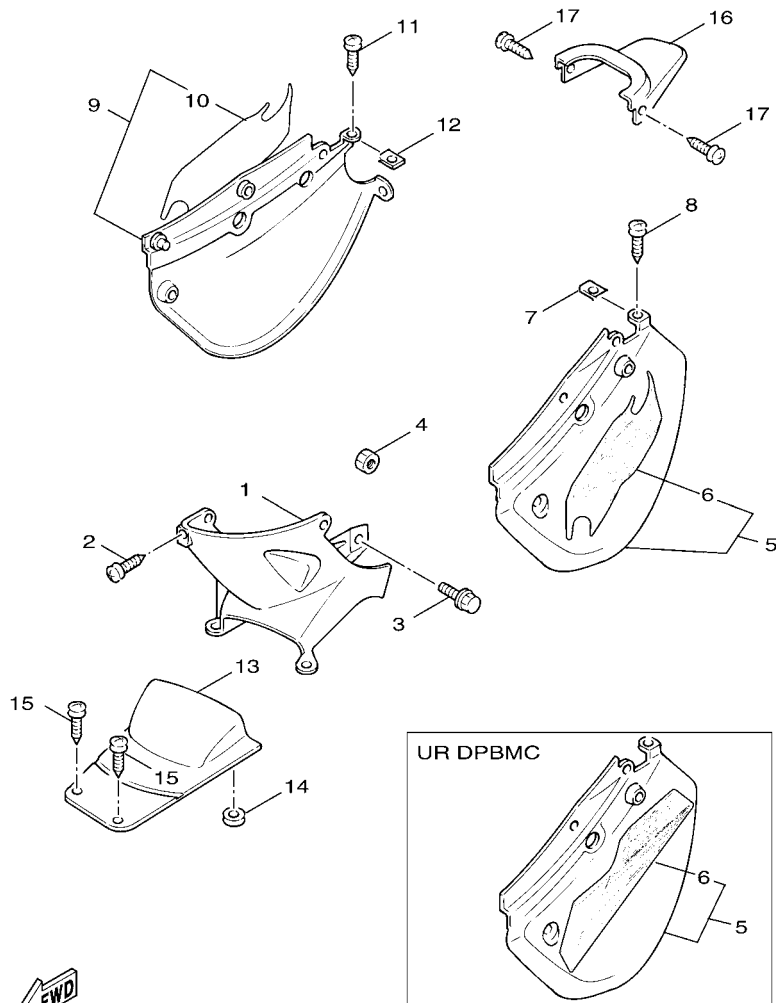

1S54200-F140

REF. NO.	PART NO. CODIGO Nº	DESCRIPTION DESCRIPCION	1S54				REMARKS OBSERVACIONES
1	4VP-F1711-00	COVER, SIDE 1 CUBIERTA LATERAL 1	1				
2	97707-50012	SCREW, TRUSS HEAD TAPPING TORNILLO	3				
3	90159-06822	SCREW, WITH WASHER TORNILLO CON VALONA	2				
4	2GF-F1535-00	NUT 1 TUERCA 1	2				
5	4VP-X2172-C0-P0	COVER, SIDE 2 TAPA LTERAL 2	1				UR DPBMC UR DPBMC
	4VP-X2172-20-P8	COVER, SIDE 2 TAPA LTERAL 2	1				UR SMX UR SMX
	4VP-X2172-20-PA	COVER, SIDE 2 TAPA LTERAL 2	1				UR VRS5 UR VRS5
	4VP-X2172-80-P3	COVER, SIDE 2 TAPA LTERAL 2	1				UR VYS2 UR VYS2
6	5XB-F1781-00	.EMBLEM 1 .EMBLEMA 1	1				UR DPBMC UR DPBMC
	5XB-F1783-00	.EMBLEM 3 .EMBLEMA 3	1				UR SMX VYS2 UR SMX VYS2
	5XB-F1783-10	.EMBLEM 3 .EMBLEMA 3	1				UR VRS5 UR VRS5
7	90183-05807	NUT, SPRING TUERCA DE RESORTE	1				
8	97707-50012	SCREW, TRUSS HEAD TAPPING TORNILLO	3				
9	4VP-X2173-C0-P0	COVER, SIDE 3 TAPA LATERAL 3	1				UR DPBMC UR DPBMC
	4VP-X2173-20-P8	COVER, SIDE 3 TAPA LATERAL 3	1				UR SMX UR SMX
	4VP-X2173-20-PA	COVER, SIDE 3 TAPA LATERAL 3	1				UR VRS5 UR VRS5
	4VP-X2173-80-P3	COVER, SIDE 3 TAPA LATERAL 3	1				UR VYS2 UR VYS2
10	5XB-F1782-00	.EMBLEM 2 .EMBLEMA 2	1				UR DPBMC UR DPBMC
	5XB-F1784-00	.EMBLEM 4 .EMBLEMA 4	1				UR SMX VYS2 UR SMX VYS2
	5XB-F1784-10	.EMBLEM 4 .EMBLEMA 4	1				UR VRS5 UR VRS5
11	97707-50012	SCREW, TRUSS HEAD TAPPING TORNILLO	3				
12	90183-05807	NUT, SPRING TUERCA DE RESORTE	1				
13	4VP-F1741-00	COVER, SIDE 4 CUBIERTA LATERAL 4	1				
14	90480-16278	GROMMET TAPON	1				
15	97707-50012	SCREW, TRUSS HEAD TAPPING TORNILLO	2				
16	4VP-F171E-00-P0	COVER, SIDE 5 CUBIERTA LATERAL 5	1				UR DPBMC UR DPBMC
	4VP-F171E-00-P3	COVER, SIDE 5 CUBIERTA LATERAL 5	1				UR VYS2 UR VYS2

FIG. 14 SIDE COVER

CUBIERTA LATERAL

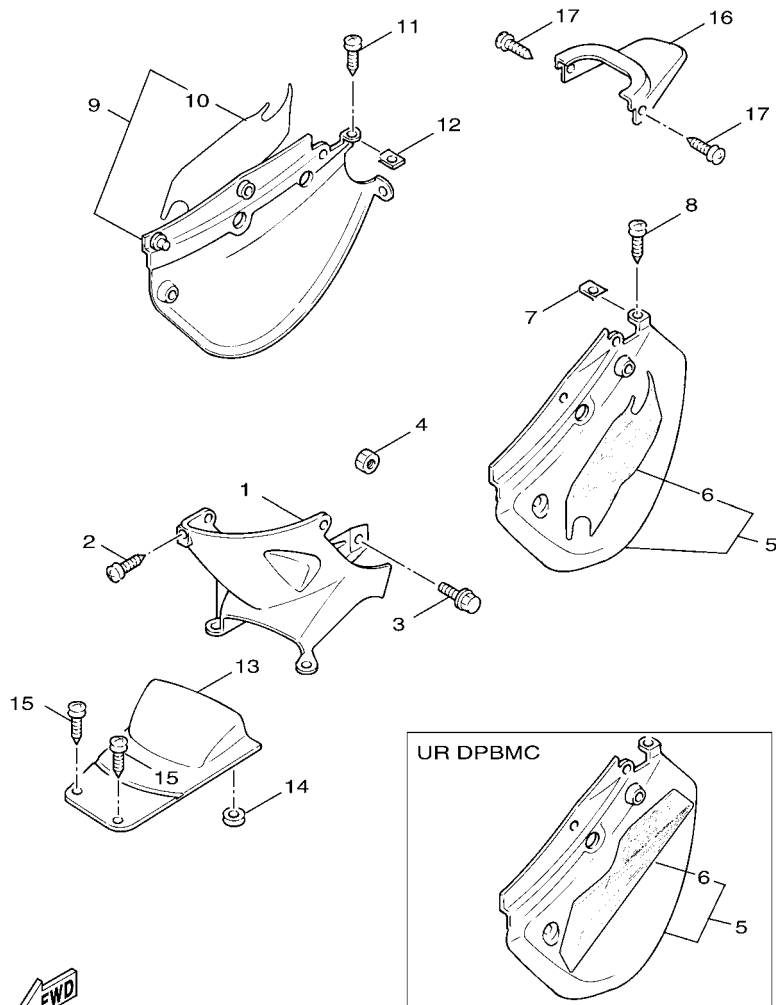

 1S54200-F140

REF. NO.	PART NO. CODIGO Nº	DESCRIPTION DESCRIPCION	1S54				REMARKS OBSERVACIONES
16	4VP-F171E-00-P8	COVER, SIDE 5 CUBIERTA LATERAL 5	1				UR SMX UR SMX
	4VP-F171E-00-PA	COVER, SIDE 5 CUBIERTA LATERAL 5	1				UR VRS5 UR VRS5
17	97707-50012	SCREW, TRUSS HEAD TAPPING TORNILLO	2				

FIG. 17 FRONT FORK

HORQUILLA DELANTERA

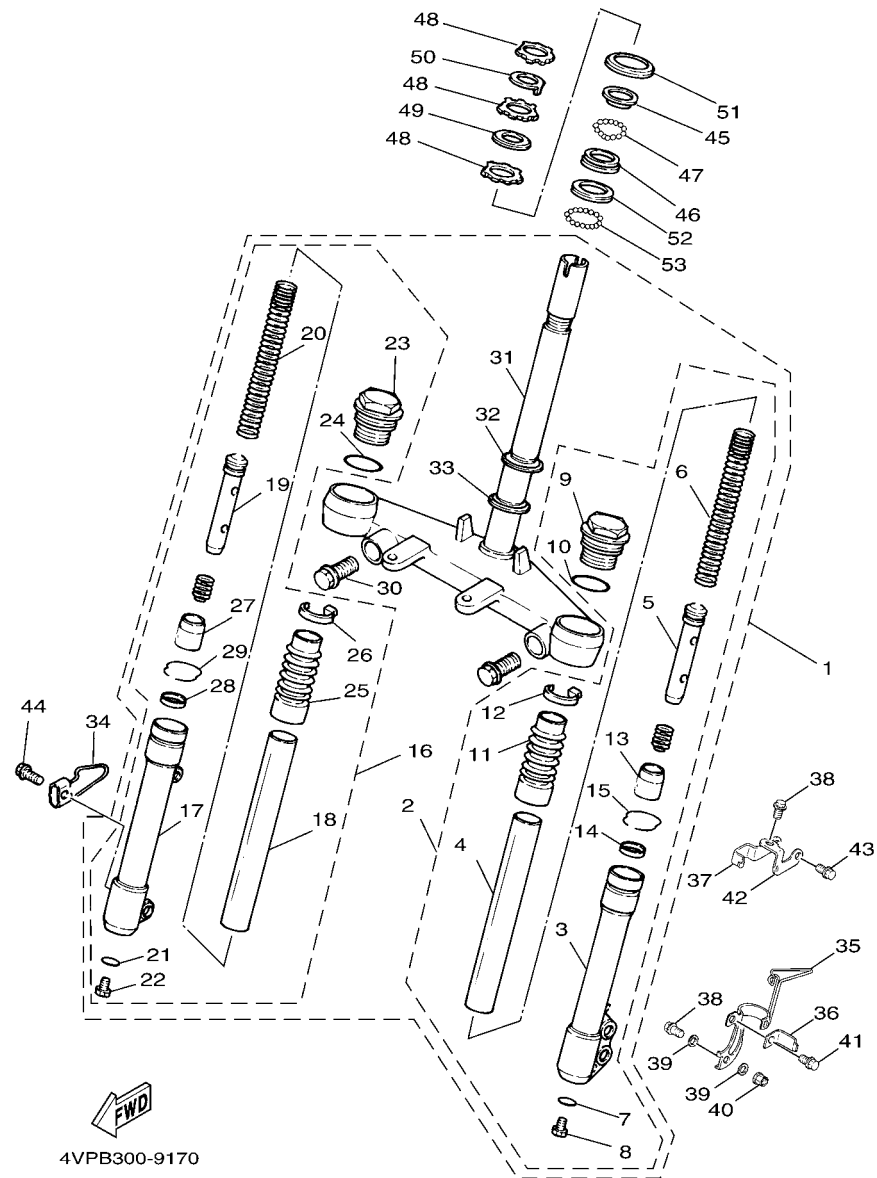

4VPB300-9170

REF. NO.	PART NO. CODIGO N°	DESCRIPTION DESCRIPCION	ISS4				REMARKS OBSERVACIONES
1	1S5-F3100-01	FRONT FORK ASSY HORQUILLA DELANTERA COMPLETA	1				
2	4VP-F3102-10	..FRONT FORK ASSY (L.H) ..HORQUILLA DELANTERA COMPL.(MI	1				
3	4VP-F3126-10	..TUBE, OUTER (LEFT) ..TUBO EXTERIOR (IZQUIERDO)	1				
4	4VP-F3110-00	..INNER TUBE COMP.1 ..TUBO INTERIOR COMPLETO 1	1				
5	4VP-F3170-10	..CYLINDER COMP., FRONT FORK ..CILINDRO COMPL DE HORQ DELA	1				
6	4VP-F3141-10	..SPRING, FRONT FORK ..RESORTE HORQUILLA DELANT.	1				
7	3GF-F3158-00	..GASKET ..EMPAQUE	1				
8	3GF-F3181-00	..BOLT, HEXAGON SOCKET HEAD ..TORNILLO CABEZAHEXAGONAL	1				
9	4VP-F3111-00	..BOLT, CAP ..TAPON	1				
10	4TE-F3147-00	..O-RING ..ARO	1				
11	4VP-F3191-00	..BOOT ..FUNDA	1				
12	4TE-F3192-00	..BAND ..BANDA	1				
13	4VP-F319U-00	..CAP ..TAPA	1				
14	4VP-F3145-00	..OIL SEAL ..RETEN DE ACEITE	1				
15	4VP-F3156-00	..CLIP, OIL SEAL ..PRESILLA DEL RETEN DE ACEITE	1				
16	4VP-F3103-10	..FRONT FORK ASSY (R.H) ..HORQUILLA DELANTERA COMPL.(MD	1				
17	4VP-F3136-10	..TUBE, OUTER (RIGHT) ..TUBO EXTERIOR	1				
18	4VP-F3110-00	..INNER TUBE COMP.1 ..TUBO INTERIOR COMPLETO 1	1				
19	4VP-F3170-10	..CYLINDER COMP., FRONT FORK ..CILINDRO COMPL DE HORQ DELA	1				
20	4VP-F3141-10	..SPRING, FRONT FORK ..RESORTE HORQUILLA DELANT.	1				
21	3GF-F3158-00	..GASKET ..EMPAQUE	1				
22	3GF-F3181-00	..BOLT, HEXAGON SOCKET HEAD ..TORNILLO CABEZAHEXAGONAL	1				
23	4VP-F3111-00	..BOLT, CAP ..TAPON	1				
24	4TE-F3147-00	..O-RING ..ARO	1				
25	4VP-F3191-00	..BOOT ..FUNDA	1				
26	4TE-F3192-00	..BAND ..BANDA	1				
27	4VP-F319U-00	..CAP ..TAPA	1				

FIG. 17 FRONT FORK

HORQUILLA DELANTERA

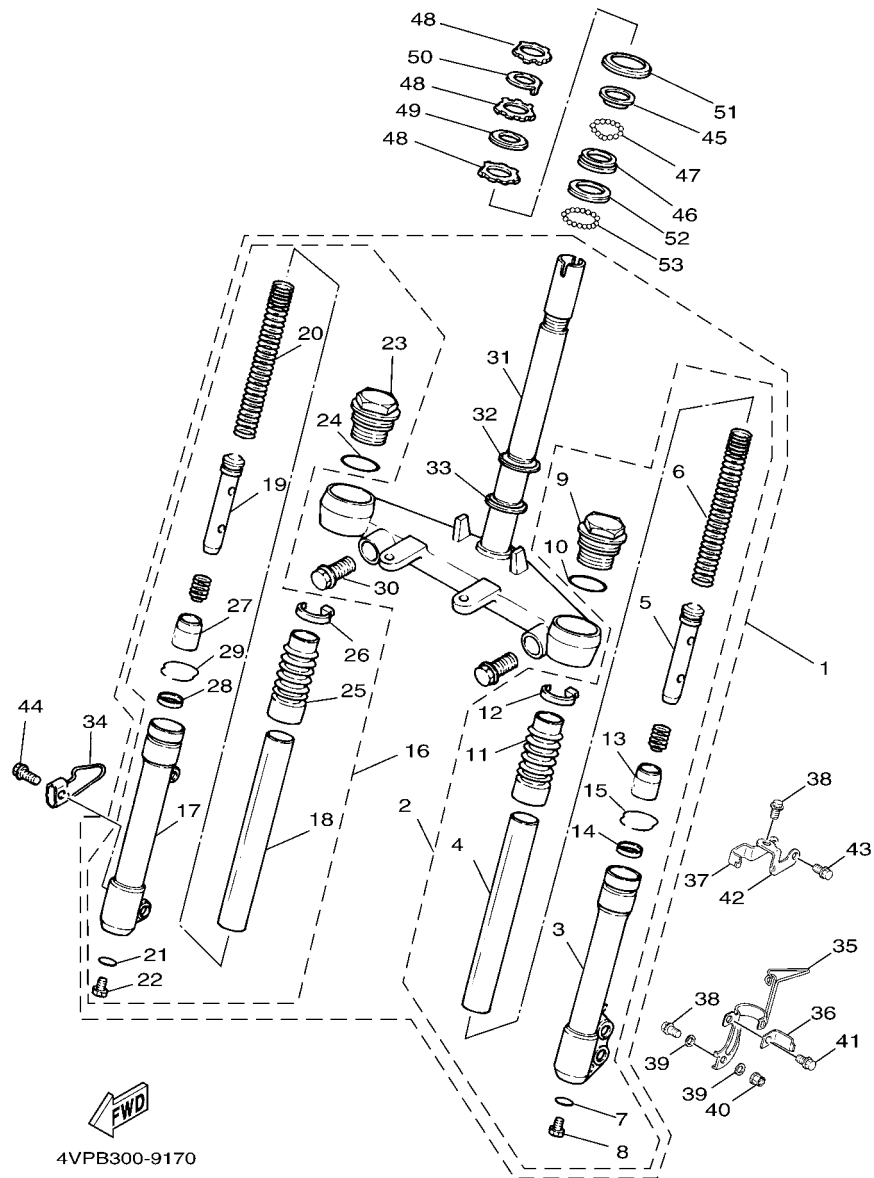

4VPB300-9170

REF. NO.	PART NO. CODIGO Nº	DESCRIPTION DESCRIPCION	ISS4				REMARKS OBSERVACIONES
28	4VP-F3145-00	..OIL SEAL ..RETEN DE ACEITE	1				
29	4VP-F3156-00	..CLIP, OIL SEAL ..PRESILLA DEL RETEN DE ACEITE	1				
30	4VP-F3346-10	.BOLT 1 .PERNO 1	2				
31	4VP-F3340-03	.UNDER BRACKET COMP. .PLATINA INFERIOR COMPLETA	1				
32	1MH-F3411-00	.RACE, BALL 1 .PISTA DE BOLAS 1	1				
33	3KW-F3462-00	.SEAL, STEERING .RETEN DE DIRECCION	1				
34	3GF-F3317-00	HOLDER, CABLE SOSTEN DE CABLE	1				
35	4VP-F5875-01	HOLDER, BRAKE HOSE 1 SOPORTE DE MANGUERA FRENO 1	1				
36	5FA-F5876-00	HOLDER, BRAKE HOSE 2 SOPORTE DE MANGUERA FRENO 2	1				
37	4VP-F5876-00	HOLDER, BRAKE HOSE 2 SOPORTE DE MANGUERA FRENO 2	1				
38	95817-06020	BOLT, FLANGE TORNILLO	2				
39	90201-064J1	WASHER, PLATE ARANDELA PLANA	2				
40	95607-06100	NUT, U TUERCA AUTOBLOCANTE	1				
41	90119-05062	BOLT, WITH WASHER TORNILLO CON ARANDELA	1				
42	5FJ-F5886-00	HOLDER, BRAKE HOSE SOPORTE DE MANGUERA FRENO	1				
43	9580L-06012	BOLT, FLANGE TORNILLO	1				
44	95807-06010	BOLT, FLANGE TORNILLO	2				
45	22F-23411-01	RACE, BALL 1 PISTA DE BOLAS 1	1				
46	22F-23412-01	RACE, BALL 2 PISTA DE BOLAS 2	1				
47	93503-16003	BALL ESFERA	22				
48	90179-25615	NUT TUERCA	3				
49	90202-26142	WASHER, PLATE ARANDELA DE PLANA	1				
50	4VP-F3418-00	WASHER, SPECIAL ARANDELA ESPECIAL	1				
51	4TE-F3416-00	COVER, BALL RACE 2 CUBIERTA DE BASE DE BOLA 2	1				
52	156-23412-00	RACE, BALL 2 PISTA DE BOLAS 2	1				
53	93501-04011	BALL BOLA	19				

FIG. 18 FUEL TANK

DEPOSITO DE COMBUSTIBLE

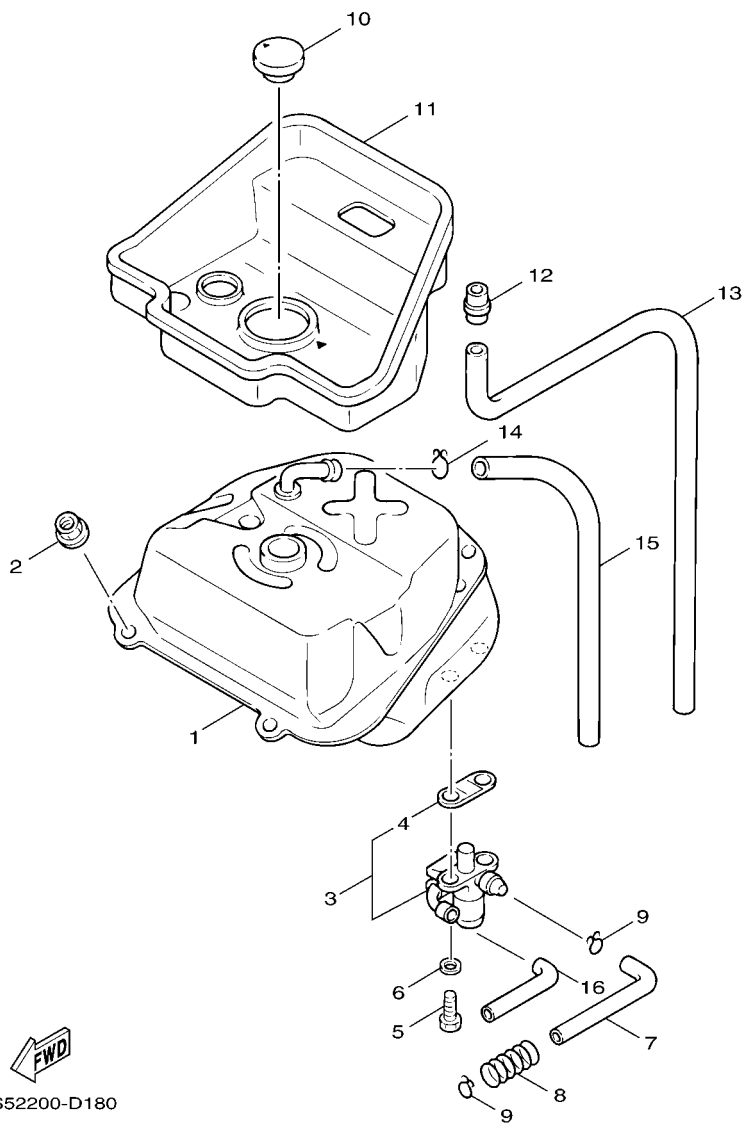

1S52200-D180

REF. NO.	PART NO. CODIGO Nº	DESCRIPTION DESCRIPCION	1S54				REMARKS OBSERVACIONES
1	4VP-F4110-00-33	FUEL TANK COMP. DEPOSITO DE COMBUSTIBLE COMP.	1				YB YB
2	95707-06500	NUT, FLANGE TUERCA DE BRIDA	2				
3	4CW-F4500-10	FUEL COCK ASSY 1 GRIFO DE COMBUSTIBLE 1	1				
4	4CW-F452K-10	.O-RING .ANILLO O	1				
5	90149-06011	SCREW TORNILLO DE REGLAJE	2				
6	90202-05193	WASHER, PLATE ARANDELA DE PLANA	2				
7	4VP-F4311-00	PIPE, FUEL 1 TUBO DE COMBUSTIBLE 1	1				
8	90501-08868	SPRING, COMPRESSION RESORTE DE COMPRESION	1				
9	90467-09006	CLIP PRESILLA	2				
10	4VP-F4610-01	CAP ASSY TAPA COMPLETA	1				
11	4VP-F414A-20	COVER, FILLER CUBIERTA DE LLENADOR	1				
12	4TE-F1753-00	BOSS, CONNECTOR COPA DE CONECTOR	1				
13	91A10-07056	TUBE, FLEXIBLE TUBO	1				
14	90467-09006	CLIP PRESILLA	1				
15	90445-078A3	HOSE (L460) TUBO (L460)	1				
16	90445-105H0	HOSE (L615) TUBO (L615)	1				

FIG. 19 SEAT & CARRIER

ASIENTO & PORTAEQUIPAJE

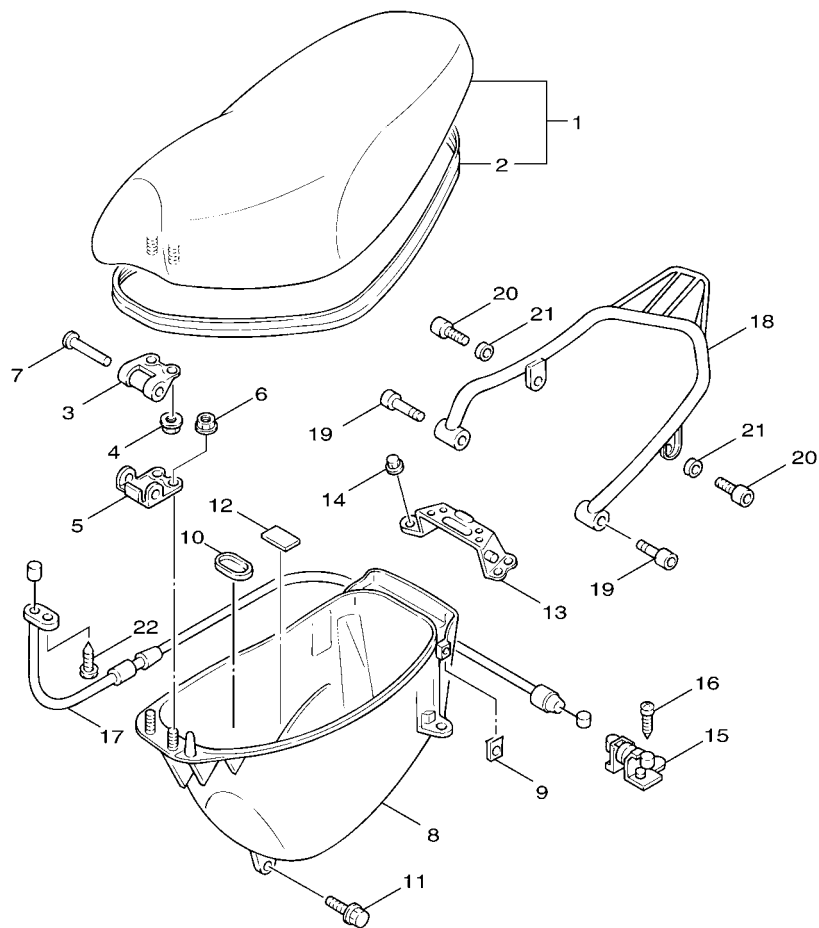

4VP1414-7231

REF. NO.	PART NO. CODIGO Nº	DESCRIPTION DESCRIPCION	ISS4				REMARKS OBSERVACIONES
1	5PJ-F4730-00	DOUBLE SEAT ASSY SILLIN DOBLE COMPLETO	1				
2	4VP-F475M-00	SEAL SELLO	1				
3	4CW-F4726-01	HINGE, SEAT HINGE SEAT	1				
4	95707-06500	NUT, FLANGE TUERCA DE BRIDA	2				
5	4VP-F4726-00	HINGE, SEAT HINGE SEAT	1				
6	95707-06500	NUT, FLANGE TUERCA DE BRIDA	2				
7	90241-10015	PIN PASADOR	1				
8	4VP-F473R-01	BOX 1 CAJA 1	1				
9	90183-05807	NUT, SPRING TUERCA DE RESORTE	2				
10	4VP-F4742-00	GROMMET ANILLO PROTECTOR	1				
11	90109-063F1	BOLT PERNO	4				
12	3KW-F139X-00	DAMPER AMORTIGUADOR	1				
13	4VP-F4738-10	BRACKET, SEAT SOPORTE DE ASIENTO	1				
14	95707-06500	NUT, FLANGE TUERCA DE BRIDA	4				
15	4UE-F4780-02	SEAT LOCK ASSY CERRADURA SILLIN COMPLETO	1				
16	97007-06016	BOLT PERNO	2				
17	4VP-F478E-00	CABLE, SEAT LOCK CABLE	1				
18	4VP-F4842-01-1V	CARRIER, REAR PARRILLA	1				FS FS
19	91317-06045	BOLT PERNO	2				
20	91317-06016	BOLT PERNO	2				
21	92907-06600	WASHER, PLATE ARANDELA	2				
22	98507-05010	SCREW, PAN HEAD TORNILLO DE CABEZA CON PLANA	1				

FIG. 20 FRONT WHEEL

RUEDA DELANTERA

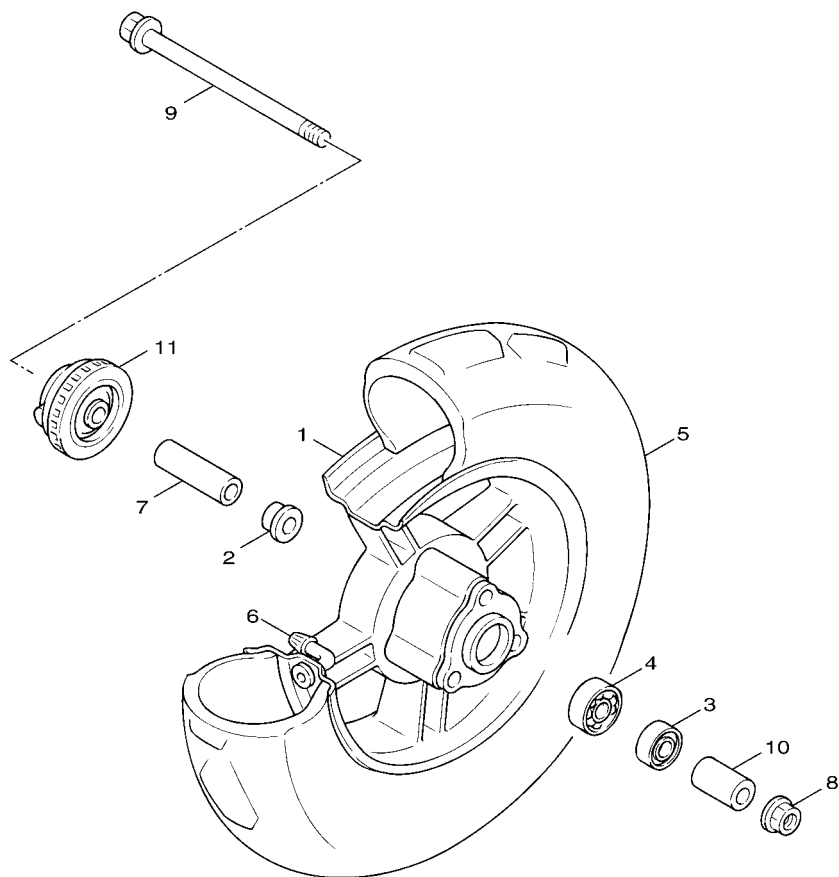



4VP1414-7240

REF. NO.	PART NO. CODIGO Nº	DESCRIPTION DESCRIPCION	ISS4				REMARKS OBSERVACIONES
1	4VP-F5168-00-33	CAST WHEEL, FRONT RUEDA FUNDIDA DELANTERA	1				YB YB
2	20A-F5115-00	FLANGE, SPACER 1 BRIDA DE ESPACIADOR 1	1				
3	93102-17838	OIL SEAL SELLO ACEITE	1				
4	93306-300Y4	BEARING COJINETE	2				
5	94112-108S3	TIRE (120/90-10 56J TL) NEUMATICO (120/90-10 56J TL)	1				
6	93900-00802	VALVE, RIM VALVULA	1				
7	4VP-F5183-00	COLLAR, WHEEL COLLAR DE RUEDA	1				
8	90185-10801	NUT, SELF-LOCKING TUERCA AUTOBLOCANTE	1				
9	4VP-F5181-00	AXLE, WHEEL EJE DE LA RUEDA	1				
10	90387-108S0	COLLAR ESPACIADOR	1				
11	5DA-F5190-10	GEAR UNIT ASSY UNIDAD DE ENGRANAJE COMPLETA	1				

FIG. 21 FRONT BRAKE CALIPER

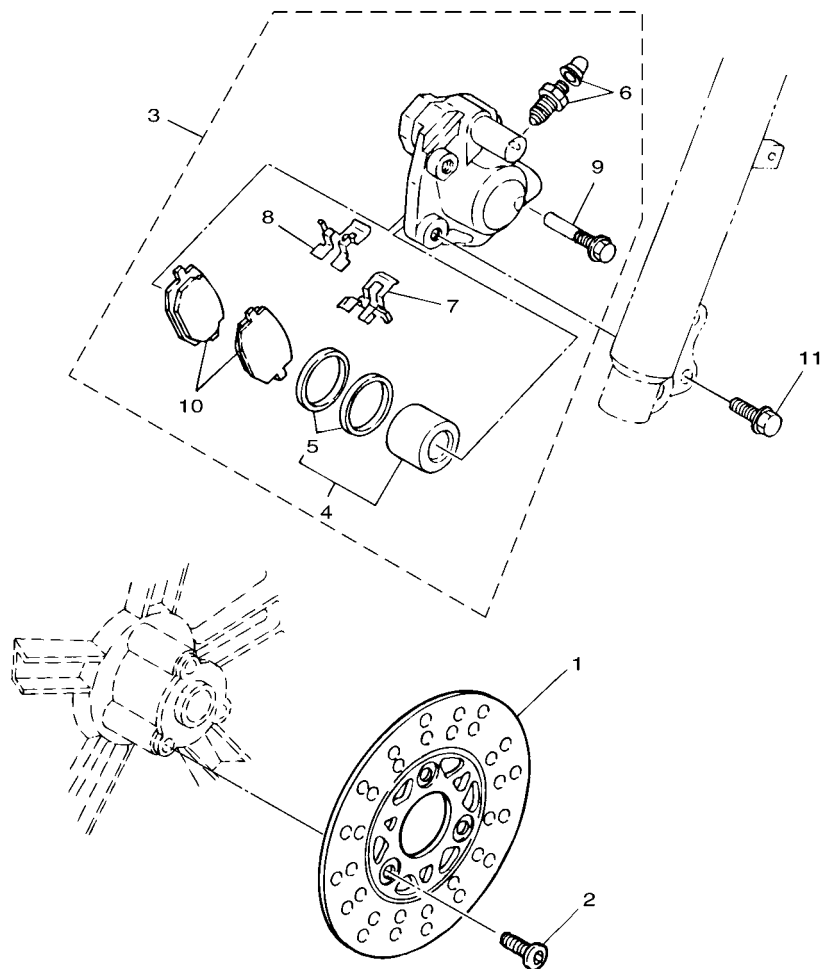
CALIBRE FRENO DELANTERA





4VP1414-7250

REF. NO.	PART NO. CODIGO Nº	DESCRIPTION DESCRIPCION	ISS4				REMARKS OBSERVACIONES
1	3UH-F582U-00	DISK, BRAKE (RIGHT) DISCO DE FRENO (DERECHO)	1				
2	90149-08814	SCREW TORNILLO DE REGLAJE	3				
3	3XG-F580T-01	CALIPER ASSY (LEFT) CALIBRE COMPLETO (IZQUIERDO)	1				
4	3XG-W0057-00	.PISTON ASSY, CALIPER .PISTON COMPLETO PINZA	1				
5	3XG-W0047-00	..CALIPER SEAL KIT ..JUEGO DE RETENES DE PINZA	1				
6	3XG-W0048-00	.BLEED SCREW KIT .CJTO TORNILLO DE PURGA	1				
7	3XG-F5919-01	.SUPPORT, PAD .SOPORTE DE PASTILLAS	1				
8	3XG-F5919-11	.SUPPORT, PAD .SOPORTE DE PASTILLAS	1				
9	3XG-F5926-01	.BOLT .PERNO	1				
10	3XG-W0045-01	.BRAKE PAD KIT ..JUEGO DE COJIN DE FRENO	1				
11	95827-08030	BOLT, FLANGE TORNILLO	2				

FIG. 22 REAR WHEEL

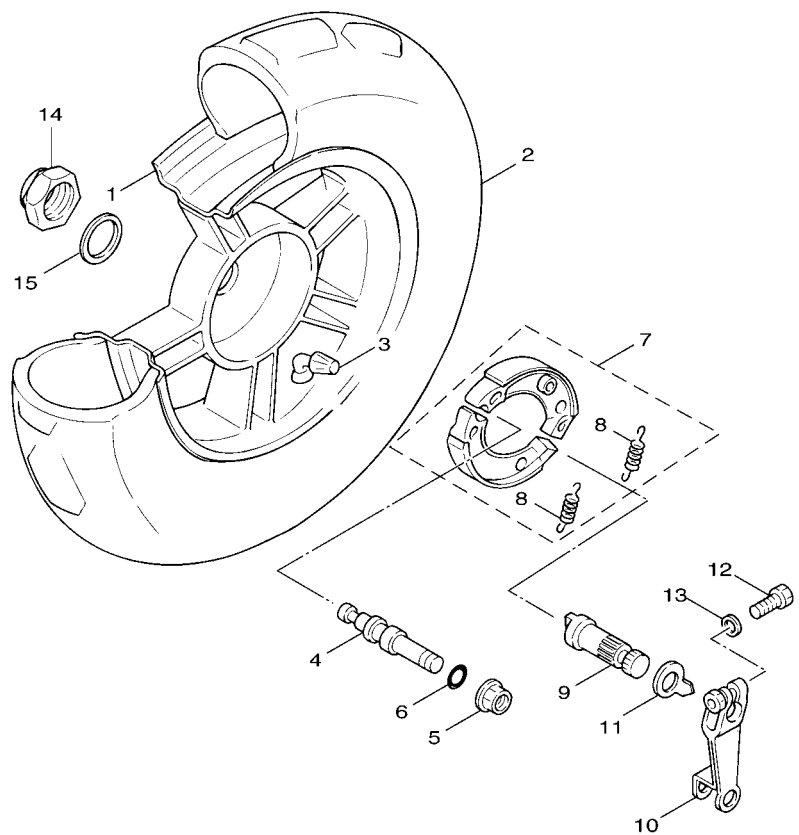
RUEDA TRASERA



4VP1414-7260

REF. NO.	PART NO. CODIGO Nº	DESCRIPTION DESCRIPCION	ISS4				REMARKS OBSERVACIONES
1	4VP-F5338-01-33	CAST WHEEL, REAR RUEDA FUNDIDA TRASERA	1				YB
2	94113-108S4	TIRE (130/90-10 59J TL) NEUMATICO (130/90-10 59J TL)	1				YB
3	93900-00802	VALVE, RIM VALVULA	1				
4	1P3-F5326-00	PIN, PIVOT PASADOR PIVOTE	1				
5	95707-10500	NUT, FLANGE TUERCA DE BRIDA	1				
6	93210-07890	O-RING ANILLO O	1				
7	3UH-X2533-00	BRAKE SHOE SET JUEGO DE ZAPATA DE FRENO	2				
8	90506-16447	.SPRING, TENSION .RESORTE DE TENSION	2				
9	3UH-F5351-00	CAMSHAFT ARBOL DE LEVAS	1				
10	4VP-F5355-00	LEVER, CAMSHAFT PALANCA DE ARBOL DE LEVAS	1				
11	4VP-F533A-00	PLATE, INDICATOR PLACA INDICADOR	1				
12	90101-06878	BOLT TORNILLO	1				
13	90201-142M6	WASHER, PLATE ARANDELA PLANA	1				
14	90185-14124	NUT, SELF-LOCKING TUERCA AUTOBLOCANTE	1				
15	90201-203E7	WASHER, PLATE ARANDELA PLANA	1				

FIG. 23 STEERING HANDLE & CABLE MANILLAR & CABLE

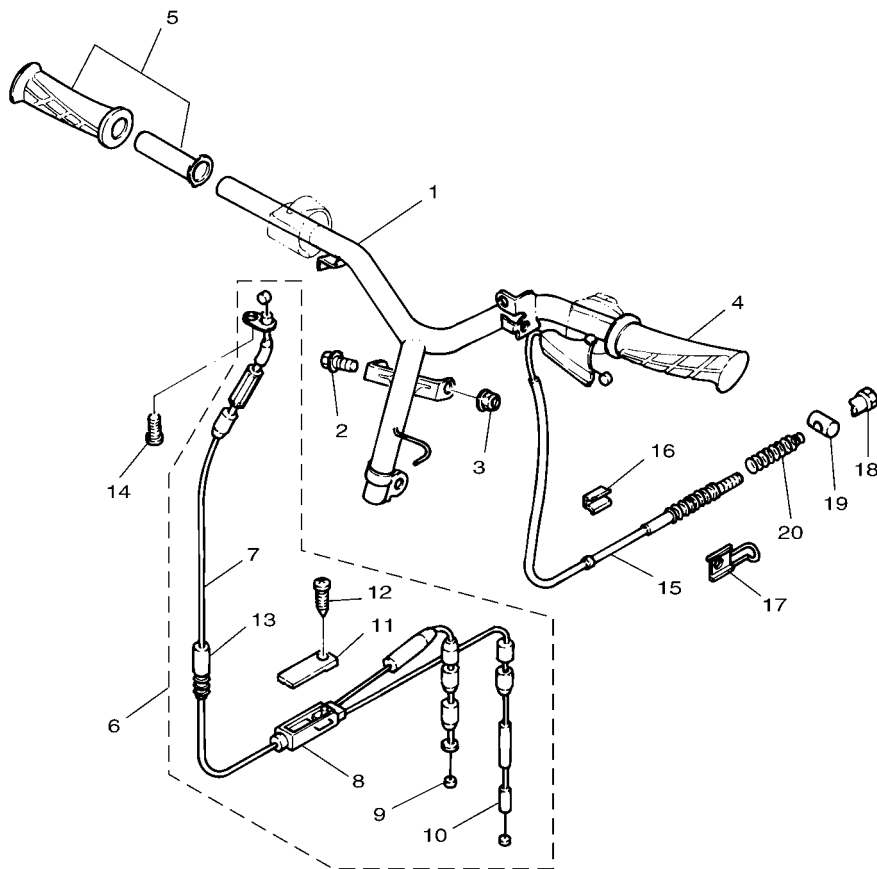

4VP1414-7270

REF. NO.	PART NO. CODIGO Nº	DESCRIPTION DESCRIPCION	ISS4				REMARKS OBSERVACIONES
1	4VP-F6110-01	HANDLE COMP. MANUBRIO COMPLETE	1				
2	90105-10036	BOLT, FLANGE TORNILLO	1				
3	90185-10801	NUT, SELF-LOCKING TUERCA AUTOBLOCANTE	1				
4	4VP-F6241-00	GRIP EMPUNADURA	1				
5	4VP-F6240-00	GRIP ASSY EMPUNADURA COMPLETA	1				
6	4VP-W2620-02	CABLE ASSY CABLE	1				
7	4VP-F6311-01	.CABLE, THROTTLE 1 .CABLE DE ACELERADOR 1	1				
8	4VP-F6260-02	.CABLE ASSY, THROTTLE & PUMP .CABLE OBTURADOR Y BOMBA	1				
9	4VP-F6321-02	.CABLE, PUMP .CABLE DE BOMBA	1				
10	4VP-F6312-00	.CABLE, THROTTLE 2 .CABLE DE ACELERADOR 2	1				
11	4VP-F6262-00	.CAP, CABLE CONNECTOR .TAPA DE CABLE CONECTOR	1				
12	90167-03800	.SCREW, TAPPING .TORNILLO DE ROSCA HEMBRA	1				
13	4VP-F6266-00	.BOOT, CYLINDER .FUNDA DE CILINDRO	1				
14	98507-05010	SCREW, PAN HEAD TORNILLO DE CABEZA CON PLANA	1				
15	4VP-F6351-01	CABLE, BRAKE CABLE DE FRENO	1				
16	4VP-F6393-00	HOLDER SOPORTE	1				
17	4VP-F637G-00	HOLDER, WIRE SOSTEN, DE CABLE	1				
18	90179-06411	NUT TUERCA	1				
19	90249-12008	PIN PASADOR	1				
20	90501-165J7	SPRING, COMPRESSION RESORTE DE COMPRESION	1				

FIG. 25 STAND & FOOTREST

SOPORTE & APOYAPIE

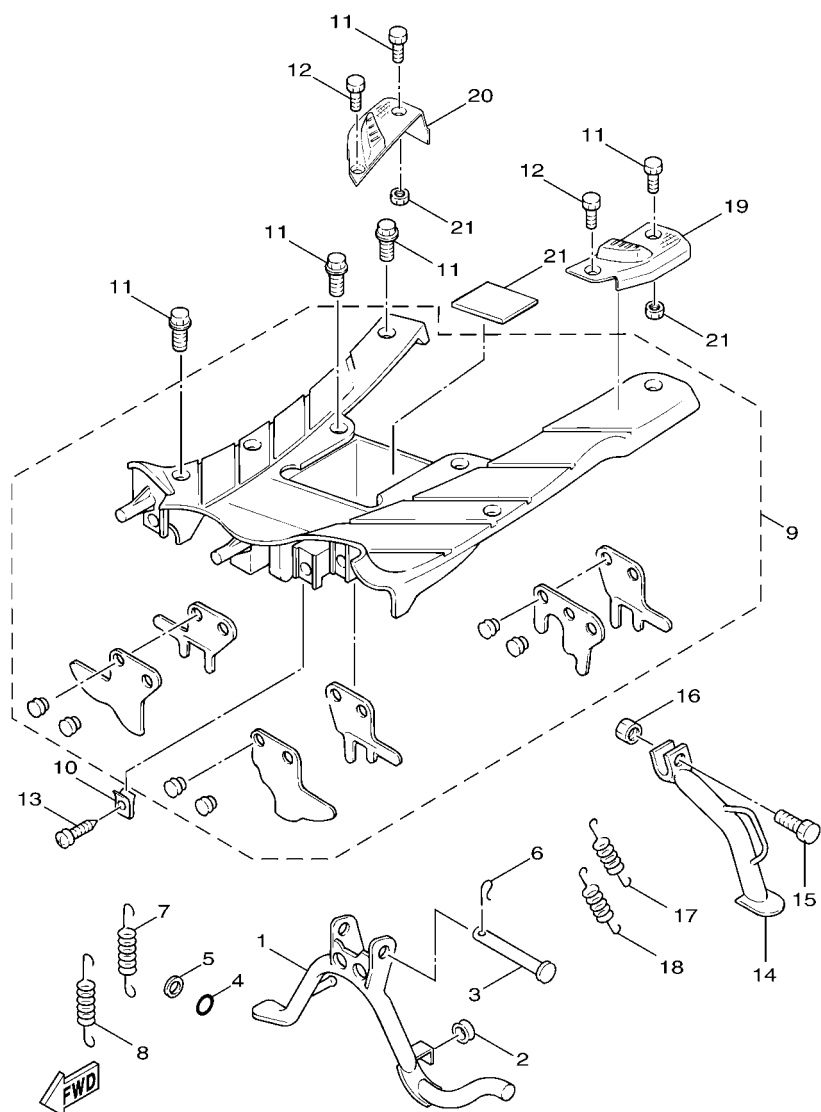

1S54200-F250

REF. NO.	PART NO. CODIGO Nº	DESCRIPTION DESCRIPCION	1S54				REMARKS OBSERVACIONES
1	4VP-F7111-01	STAND, MAIN PUNTAL PRINCIPAL	1				
2	4CW-F7114-00	STOPPER, MAIN STAND TOPE DE PUNTAL PRINCIPAL	1				
3	90240-10137	PIN, CLEVIS PASADOR CON HOYO	1				
4	93210-108B1	O-RING ANILLO O	1				
5	90202-10120	WASHER, PLATE ARANDELA DE PLANA	1				
6	90468-12006	CLIP PRESILLA	1				
7	90506-20800	SPRING, TENSION RESORTE DE TENSION	1				
8	90506-26801	SPRING, TENSION RESORTE DE TENSION	1				
9	5PJ-XF748-00	FOOTREST BOARD ASSY TABLERO DE APOYAPIE	1				
10	90183-05807	NUT, SPRING TUERCA DE RESORTE	8				
11	90119-06821	BOLT, WITH WASHER TORNILLO CON ARANDELA	6				
12	90119-06079	BOLT, WITH WASHER TORNILLO CON ARANDELA	2				
13	97707-50016	SCREW, TRUSS HEAD TAPPING TORNILLO	2				
14	5DA-F7311-00	STAND, SIDE PUNTAL LATERAL	1				
15	90109-10473	BOLT PERNO	1				
16	90185-10037	NUT, SELF-LOCKING TUERCA AUTOBLOCANTE	1				
17	90506-16800	SPRING, TENSION RESORTE DE TENSION	1				
18	90506-26800	SPRING, TENSION RESORTE DE TENSION	1				
19	5PJ-F7411-00	FOOTREST 1 APOYAPIE 1	1				
20	5PJ-F7421-00	FOOTREST 2 APOYAPIE 2	1				
21	5DA-H2176-00	DAMPÉR AMORTIGUADOR	1				

FIG. 26 LEG SHIELD

PATA PROTEGIDA

REF. NO.	PART NO. CODIGO Nº	DESCRIPTION DESCRIPCION	1S54				REMARKS OBSERVACIONES
1	4VP-X2831-B0-P0	LEG SHIELD 1 PROTECCION DE PATA 1	1				UR DPBMC UR DPBMC
	4VP-X2831-10-P7	LEG SHIELD 1 PROTECCION DE PATA 1	1				UR SMX UR SMX
	4VP-X2831-10-P8	LEG SHIELD 1 PROTECCION DE PATA 1	1				UR VRS5 UR VRS5
	4VP-X2831-80-P3	LEG SHIELD 1 PROTECCION DE PATA 1	1				UR VYS2 UR VYS2
2	5XB-F832B-00	.GRAPHIC15 .EMBLEMA 1	1				UR DPBMC UR DPBMC
	5XB-F832K-00	.GRAPHIC 12 .GRAFICO 12	1				UR SMX, VYS2 UR SMX, VYS2
	5XB-F832K-10	.GRAPHIC 12 .GRAFICO 12	1				UR VRS5 UR VRS5
3	5XB-F832C-00	.GRAPHIC 16 .GRAFICO	1				UR DPBMC UR DPBMC
	5XB-F832L-00	.GRAPHIC 13 .GRAFICO 13	1				UR SMX, VYS2 UR SMX, VYS2
	5XB-F832L-10	.GRAPHIC 13 .GRAFICO 13	1				UR VRS5 UR VRS5
4	4TH-F152A-E0	.EMBLEM 3 .EMBLEMA 3	1				UR DPBMC UR DPBMC
	5XB-F152A-00	.EMBLEM 3 .EMBLEMA 3	1				UR SMX UR SMX
	5XB-F152A-20	.EMBLEM 3 .EMBLEMA 3	1				UR VRS5 UR VRS5
	5XB-F152A-30	.EMBLEM 3 .EMBLEMA 3	1				UR VYS2 UR VYS2
5	4VP-F834V-00	PROTECTOR 1 PROTECTOR 1	1				
6	90159-06812	SCREW, WITH WASHER TORNILLO CON VALONA	1				
7	4VP-F8300-01	LEG SHIELD ASSY PROTECCION DE PATA COMPLETA	1				
8	5FM-F8349-00	CAP TAPA	1				
9	4JK-F1568-00	LABEL, WARNING ETIQUETA DE PRECAUCION	1				
10	97707-50016	SCREW, TRUSS HEAD TAPPING TORNILLO	4				
11	4VP-F8385-11	COVER, LOWER CUBIERTA INFERIOR	1				
12	97707-50016	SCREW, TRUSS HEAD TAPPING TORNILLO	6				
13	3GF-F6199-00	PLUG, BLIND TAPON	4				
14	4VP-F840K-00-1V	GUARD COMP. ACCESORIO	1				FS FS
15	95027-06020	BOLT, FLANGE PERNO, DE BRIDA	4				
16	4VP-F1535-00	NUT 1 TUERCA 1	4				
17	90338-16148	PLUG TAPON	2				

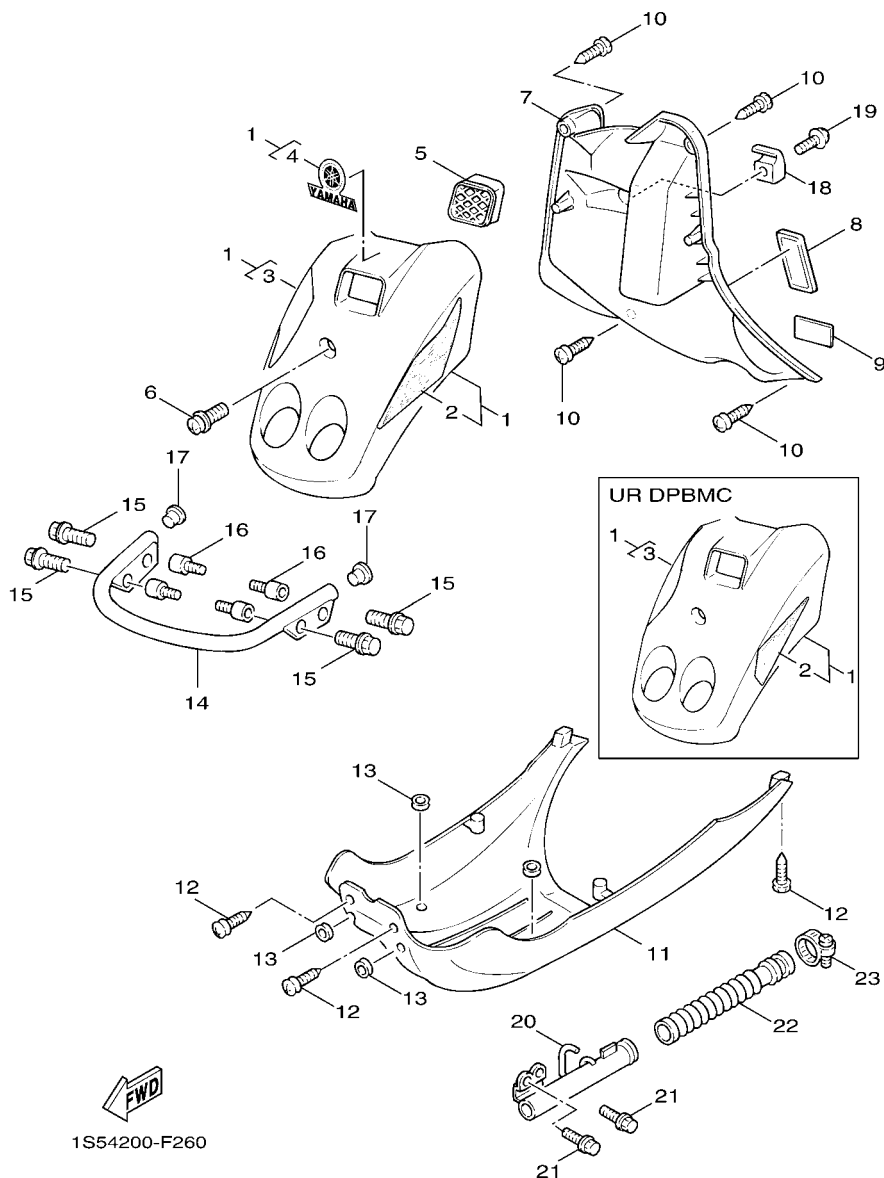
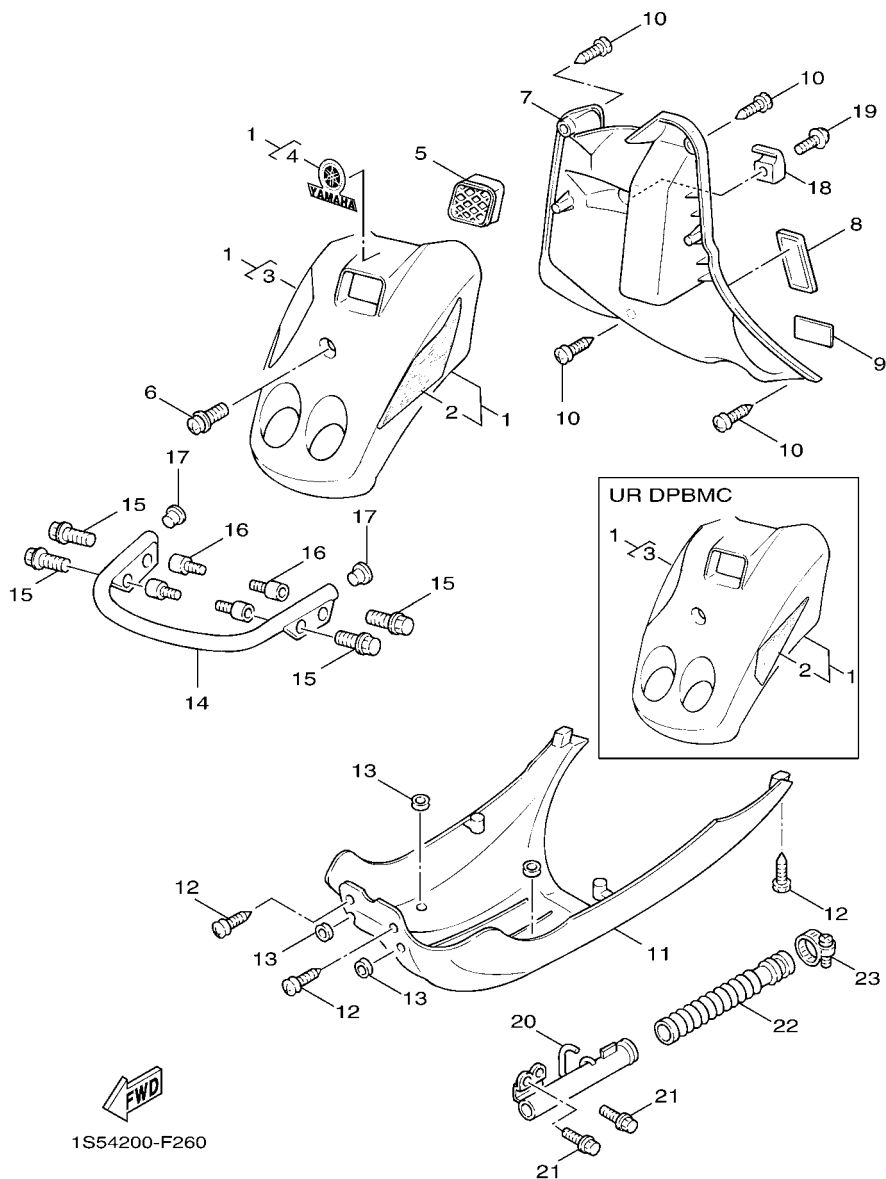

FIG. 26 LEG SHIELD

PATA PROTEGIDA

REF. NO.	PART NO. CODIGO Nº	DESCRIPTION DESCRIPCION	1S54				REMARKS OBSERVACIONES
18	4VP-F8257-01	HOOK 1 GANCHO 1	1				
19	90159-06811	SCREW, WITH WASHER TORNILLO CON VALONA	1				
20	4VP-F838K-00	BOX 1 CAJA 1	1				
21	95807-06014	BOLT, FLANGE TORNILLO	2				
22	4VP-F1851-00	DUCT, COOLER CONDUCTO DE ENFRIADOR	1				
23	90460-35260	CLAMP, HOSE BRIDA, DE UNION	2				



1S54200-F260

FIG. 27 COWLING 1

BOVEDA 1

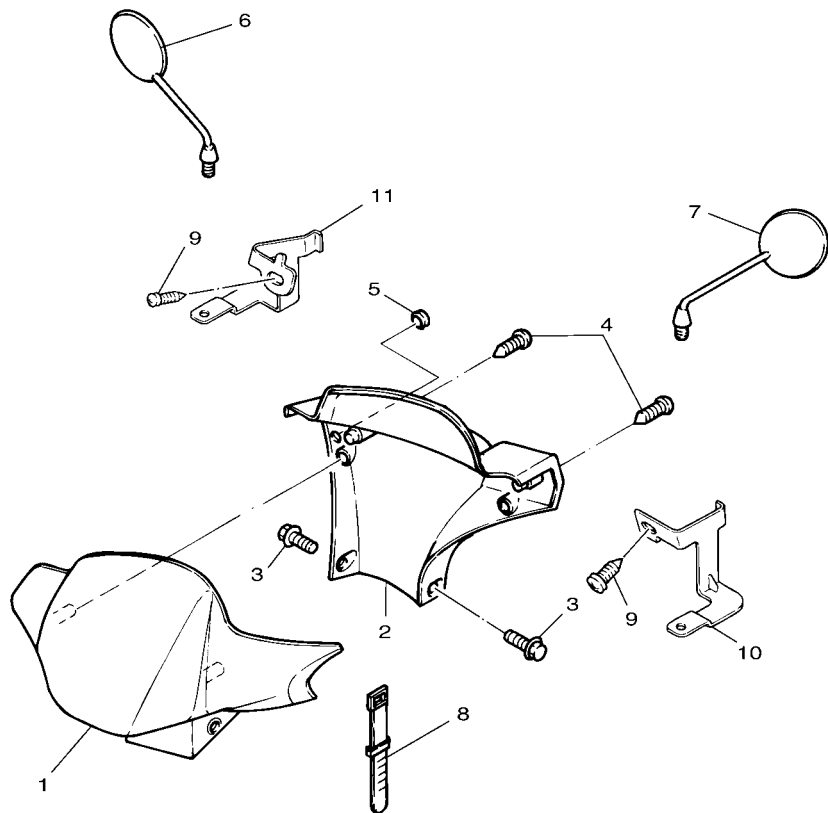



4VP1414-7341

REF. NO.	PART NO. CODIGO Nº	DESCRIPTION DESCRIPCION	ISS4				REMARKS OBSERVACIONES
1	4VP-F6143-00-P0	COVER, HANDLEBAR UPPER 1 CUBIERTA DE MANUBRIO SUPERIOR1	1				UR DPBMC UR DPBMC
	4VP-F6143-00-P3	COVER, HANDLEBAR UPPER 1 CUBIERTA DE MANUBRIO SUPERIOR1	1				UR VYS2 UR VYS2
	4VP-F6143-00-P8	COVER, HANDLEBAR UPPER 1 CUBIERTA DE MANUBRIO SUPERIOR1	1				UR SMX UR SMX
	4VP-F6143-00-PA	COVER, HANDLEBAR UPPER 1 CUBIERTA DE MANUBRIO SUPERIOR1	1				UR VRS5 UR VRS5
2	4VP-F6145-00	COVER, HANDLEBAR UPPER 2 CUBIERTA DE MANUBRIO SUPERIOR2	1				
3	90159-05831	SCREW, WITH WASHER TORNILLO CON VALONA	2				
4	90160-05803	SCREW, ROUND TAPPING TORNILLO REDONDO ROSCA HEMBRA	2				
5	3GF-F6199-00	PLUG, BLIND TAPON	1				
6	4VP-F6290-10	REAR VIEW MIRROR ASSY (RIGHT) ESPEJO COMPLETO (DERECHO)	1				
7	4VP-F6280-10	REAR VIEW MIRROR ASSY (LEFT) ESPEJO COMPLETO (IZQUIERDO)	1				
8	90465-13275	CLAMP BRIDA	1				
9	95807-06012	BOLT, FLANGE TORNILLO	2				
10	4WX-F612M-00	BRACKET 4 SUPOORTE 4	1				
11	4WX-F612N-00	BRACKET 5 SOPORTE 5	1				

FIG. 28 GENERATOR

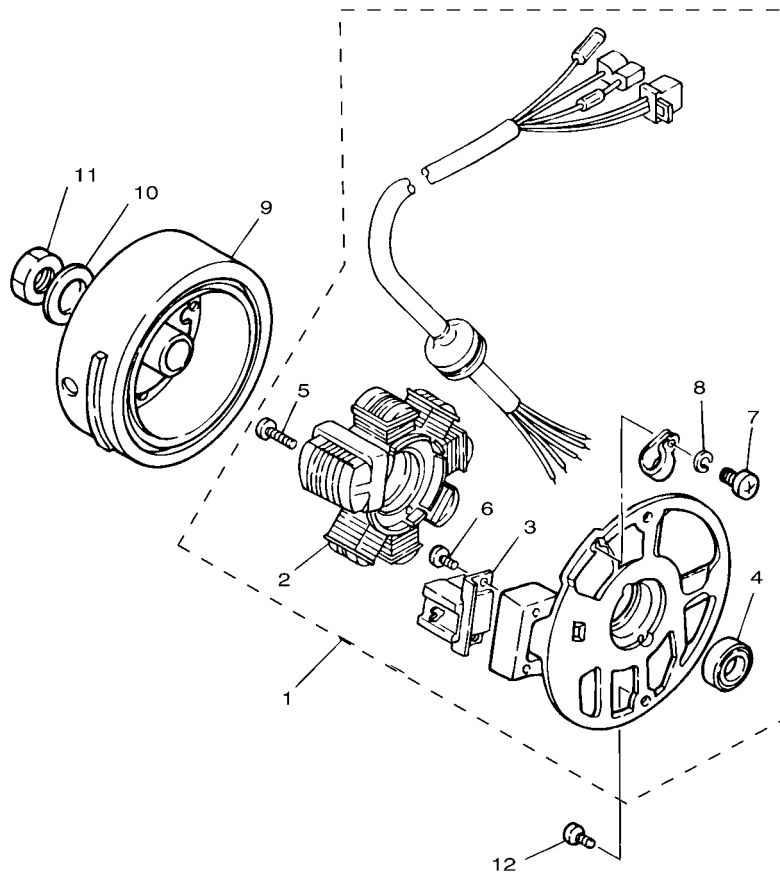
GENERADOR



REF. NO.	PART NO. CODIGO Nº	DESCRIPTION DESCRIPCION	ISS4				REMARKS OBSERVACIONES
1	3XG-H5560-00	BASE ASSY CONJUNTO BASE	1				
2	3GF-H1403-V0	.STATORCOMP. .ESTATOR COMPLETO	1				
3	3GF-H5580-V0	.COIL, PULSER .BOBINA DE PULSACION	1				
4	93104-19097	.OIL SEAL .SELLO ACEITE	1				
5	98501-05020	.SCREW, PAN HEAD .TORNILLO DE CABEZA CRUZADA	2				
6	98501-05010	.SCREW, PAN HEAD .TORNILLO DE CABEZA CRUZADA	2				
7	98501-04008	.SCREW, PAN HEAD .TORNILLO DE CABEZA CRUZADA	1				
8	92901-04100	.WASHER, SPRING .ARANDELA PLANA	1				
9	4KX-H5550-00	ROTOR ASSY ROTOR COMPLETO	1				
10	92907-12600	WASHER, PLATE ARANDELA	1				
11	95307-12600	NUT TUERCA	1				
12	98507-06016	SCREW, PAN HEAD TORNILLO DE CABEZA CON PLANA	2				

 3XG4414-4280

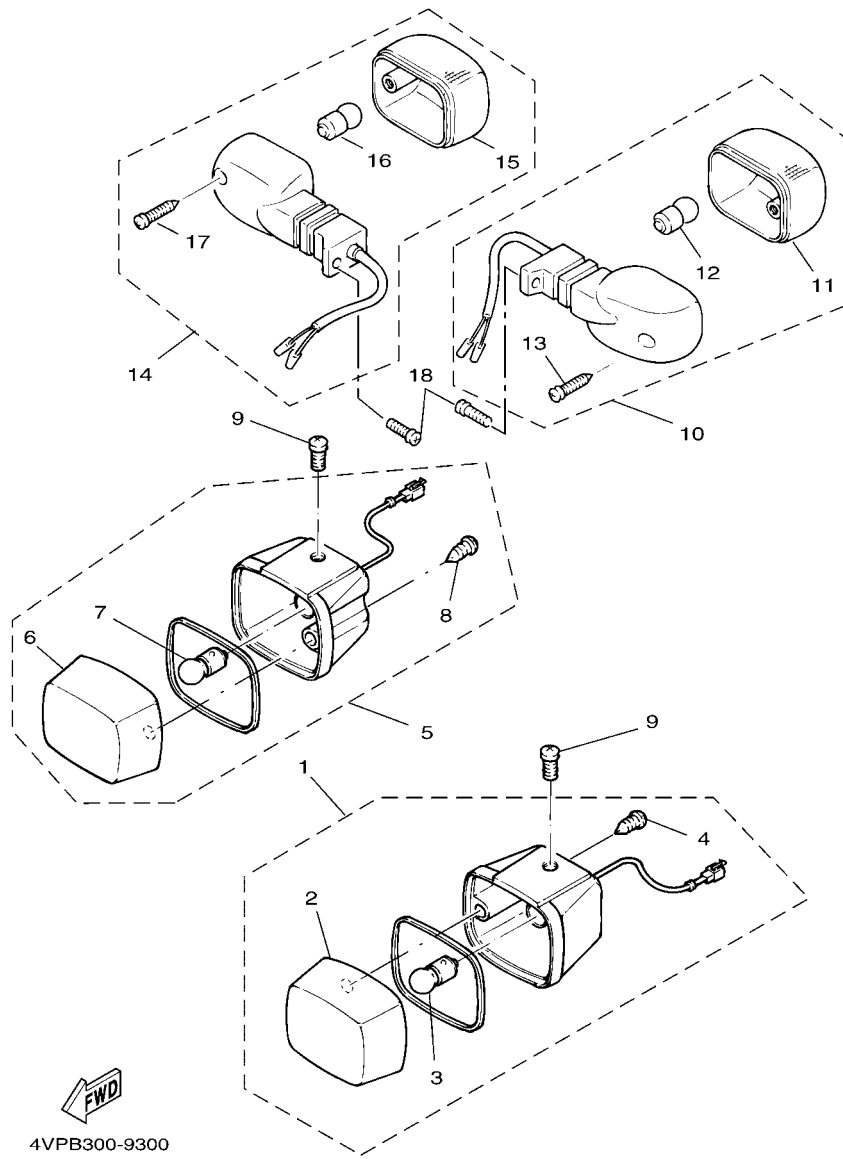
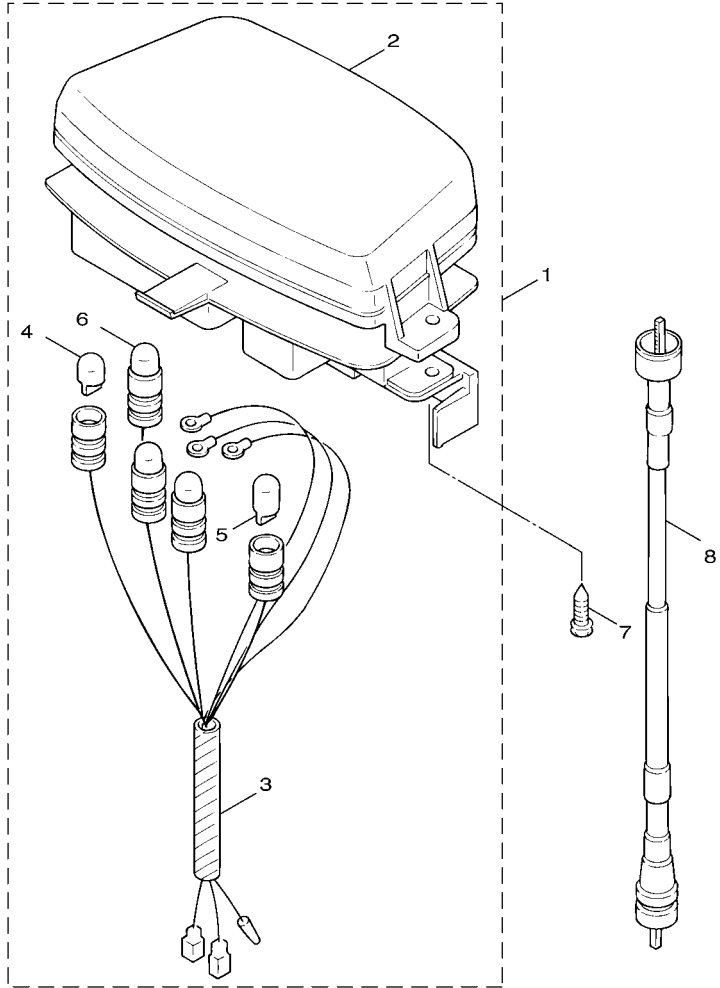

FIG. 30 FLASHER LIGHT

LUZ DE DESTELLADOR

REF. NO.	PART NO. CODIGO Nº	DESCRIPTION DESCRIPCION	ISS4				REMARKS OBSERVACIONES
1	4VP-H3310-10	FRONT FLASHER LIGHT ASSY 1 DESTELLADOR DE LUZ DELANT.	1				
2	4VP-H3312-10	.LENS, FLASHER .LENTE DE DESTELLADOR	1				
3	4VP-H3311-10	.BULB, FLASHER (12V-10W) .BOMBILLA (12V-10W)	1				
4	97707-30625	.SCREW, TAPPING .TORNILLO ROSCA HEMBRA	1				
5	4VP-H3320-10	FRONT FLASHER LIGHT ASSY 2 DESTELLADOR DE LUZ DELANT.	1				
6	4VP-H3312-10	.LENS, FLASHER .LENTE DE DESTELLADOR	1				
7	4VP-H3311-10	.BULB, FLASHER (12V-10W) .BOMBILLA (12V-10W)	1				
8	97707-30625	.SCREW, TAPPING .TORNILLO ROSCA HEMBRA	1				
9	98507-05010	SCREW, PAN HEAD TORNILLO DE CABEZA CON PLANA	2				
10	4VP-H3330-10	REAR FLASHER LIGHT ASSY 1 DESTELLADOR DE LUZ TRAS.COMPL.	1				
11	4VP-H3312-10	.LENS, FLASHER .LENTE DE DESTELLADOR	1				
12	4VP-H3311-10	.BULB, FLASHER (12V-10W) .BOMBILLA (12V-10W)	1				
13	97707-30625	.SCREW, TAPPING .TORNILLO ROSCA HEMBRA	1				
14	4VP-H3340-10	REAR FLASHER LIGHT ASSY 2 DESTELLADOR DE LUZ TRAS.COMPL.	1				
15	4VP-H3312-10	.LENS, FLASHER .LENTE DE DESTELLADOR	1				
16	4VP-H3311-10	.BULB, FLASHER (12V-10W) .BOMBILLA (12V-10W)	1				
17	97707-30625	.SCREW, TAPPING .TORNILLO ROSCA HEMBRA	1				
18	91317-06016	BOLT PERNO	2				



4VP1414-7391

FIG. 31 METER

MEDIDOR

REF. NO.	PART NO. CODIGO Nº	DESCRIPTION DESCRIPCION	ISS4				REMARKS OBSERVACIONES
1	4VP-H3510-10	SPEEDOMETER ASSY VELOCIMETRO COMPL.	1				
2	4TE-H353K-00	.GLASS PLATE .CUBIERTA DE MEDIDOR	1				
3	4VP-H3509-00	.SOCKET CORD ASSY .ENCASTRE DE CABLE COMPLETO	1				
4	3GF-H3517-00	.BULB (12V-1.7W) .AMPOLLETA	3				
5	4TE-H3517-00	.BULB (12V-3.4W) .AMPOLLETA (12V-3.4W)	1				
6	4TE-H3518-00	.BULB, METER (12V 1.7W) .AMPOLLETA DE MEDIDOR (1.7W)	1				
7	97707-50016	SCREW, TRUSS HEAD TAPPING TORNILLO	3				
8	4VP-H3550-03	SPEEDOMETER CABLE ASSY CABLE DE VELOCIMETRO COMPLETO	1				

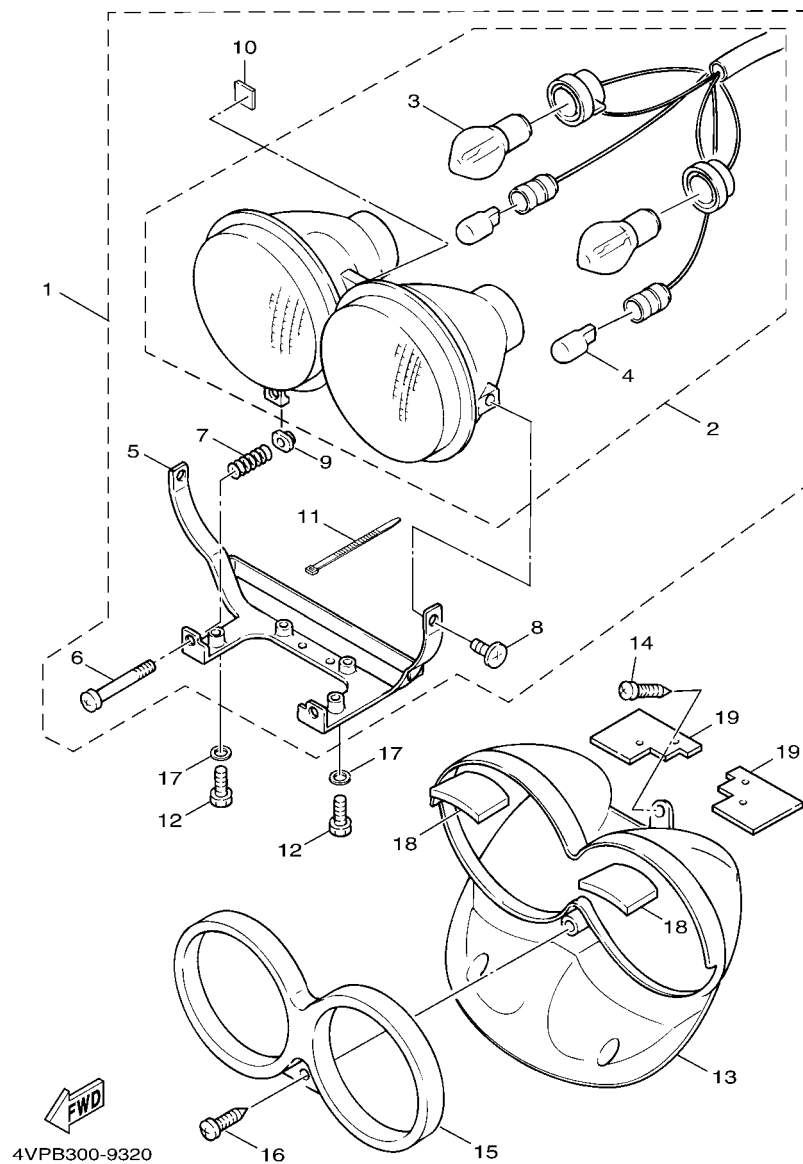

FIG. 32 HEADLIGHT

FARO DELANTERO

REF. NO.	PART NO. CODIGO Nº	DESCRIPTION DESCRIPCION	ISS4				REMARKS OBSERVACIONES
1	4VP-H430A-10	HEADLIGHT UNIT ASSY UNIDAD DE FARO DELANTERO COMPL	1				
2	4VP-H4310-00	.HEADLIGHT UNIT ASSY .UNIDAD DE FARO DELANTERO COMP	1				
3	4VP-H4314-10	..BULB, HEADLIGHT ..BOMBILLA DE FARO DELANTERO	2				
4	4VP-H4347-10	..BULB ..BOMBILLA	2				
5	4VP-H4318-10	.STAY, HEADLIGHT 1 .APOYO DE FARO DELANTERO 1	1				
6	4VP-H4331-00	.SCREW, RIM ADJUSTING .TORNILLO DE AJUSTE DE ARO	1				
7	4VP-H4332-00	.SPRING, SCREW .RESORTE DE TORNILLO	1				
8	4VP-H4337-00	.BOLT, SPECIAL .PERNO ESPECIAL	2				
9	4VP-H4317-00	.NUT .TUERCA	1				
10	4VP-H4367-00	.DAMPER, HEADLIGHT 2 .AMORTIGUADOR FARO DELANTERO	1				
11	90465-13152	.CLAMP .BRIDA	1				
12	90464-50802	CLAMP BRIDA	1				
13	95807-06016	BOLT, FLANGE TORNILLO	4				
14	4VP-H4144-00	COVER, HEADLIGHT CUBIERTA FARO DELANTERO	1				
15	97707-50012	SCREW, TRUSS HEAD TAPPING TORNILLO	1				
16	4VP-H4169-00	GUÁRD, HEADLIGHT PROTECCION DE FARO DELANTERO	1				
17	90163-05800	SCREW, TAPPING TORNILLO ROSCA HEMBRA	1				
18	90201-07081	WASHER, PLATE ARANDELA PLANA	4				
19	4VP-H4366-00	DAMPER, HEADLIGHT 1 AMORTIGUADOR FARO DELANTERO 1	2				
20	4VP-H4368-00	DAMPER 3 AMORTIGUADOR 3	2				

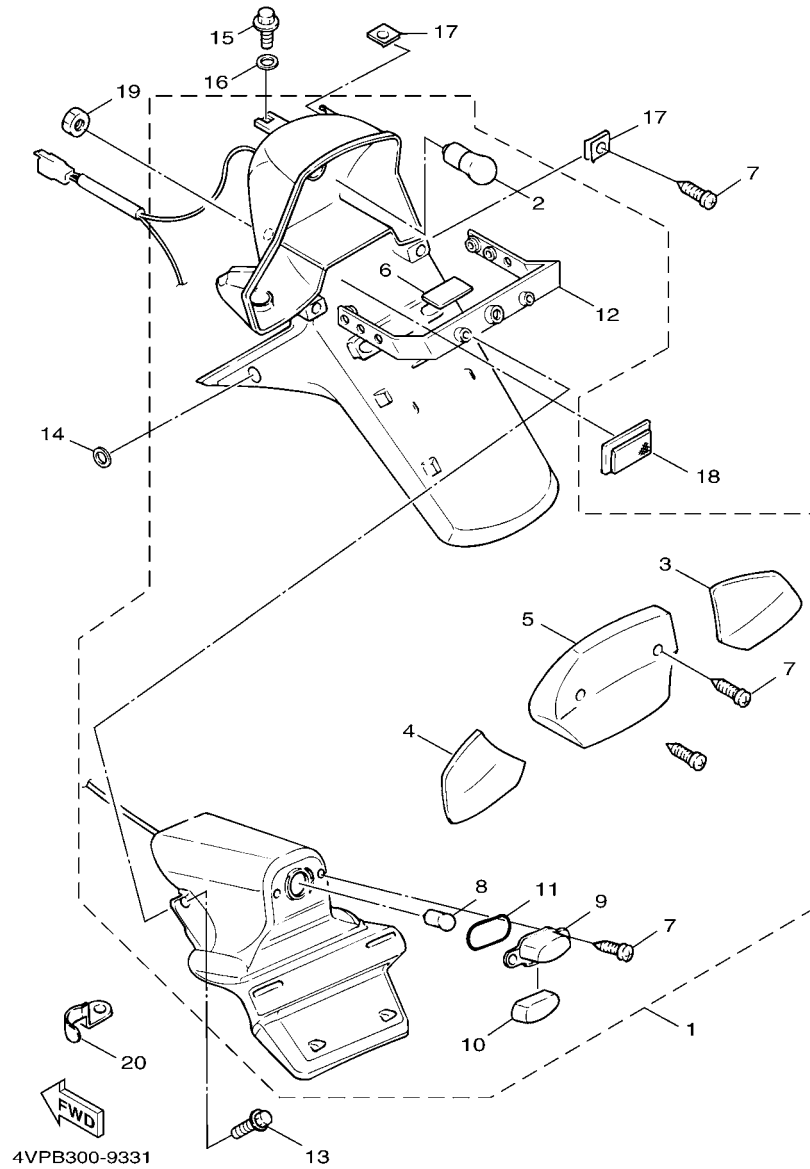

FIG. 33 TAILLIGHT

LUZ DE COLA

REF. NO.	PART NO. CODIGO Nº	DESCRIPTION DESCRIPCION	ISS4				REMARKS OBSERVACIONES
1	4VP-H4700-10	TAILLIGHT ASSY FARO TRASERO COMPLET.	1				
2	4VP-H4714-00	.BULB (12V-21/5W) .BOMBILLA (12V-21/5W)	1				
3	4VP-H3342-10	.LENS, FLASHER 2 .LENTE DE DESTELLADOR	1				
4	4VP-H3332-10	.LENS, FLASHER .LENTE DE DESTELLADOR	1				
5	4VP-H4721-00	.LENS, TAILLIGHT .LENTE DE FARO TRASERO	1				
6	4VP-H4743-10	.LENS, LICENCE LIGHT .LENTE DE LUZ DE LICENCIA	1				
7	97707-40616	.SCREW, TAPPING .TORNILLO ROSCA HEMBRA	4				
8	4VP-H4744-00	.BULB (12V-5W) .BOMBILLA (12V-5W)	1				
9	4MK-H4743-00	.LENS, LICENCE LIGHT .LENTE DE LUZ DE LICENCIA	1				
10	4VP-H4747-00	.COVER, LICENCE LIGHT .CUBIERTA DE LICENCIA	1				
11	4MK-H4545-00	.GASKET, LENS .EMPAQUE DE LENTE	1				
12	4VP-H4781-00	.BRACKET 1 .BRAZO DE CAJA DE ALTAVOZ 1	1				
13	91317-06035	BOLT PERNO	2				
14	90201-064J1	WASHER, PLATE ARANDELA PLANA	2				
15	90109-06877	BOLT PERNO	1				
16	92907-10600	WASHER, PLATE ARANDELA	1				
17	90183-05807	NUT, SPRING TUERCA DE RESORTE	4				
18	3KW-H5130-00	REAR REFLECTOR ASSY REFLECTOR TRASERO COMPLETO	1				
19	95707-05300	NUT, FLANGE TUERCA DE BRIDA	1				
20	4VP-H4519-00	BRACKET, TAILLIGHT SOPORTE DE FARO TRASERO	1				

FIG. 34 HANDLE SWITCH & LEVER

INTERRUPTOR DE MANILLAR&PALANC

REF. NO.	PART NO. CODIGO Nº	DESCRIPTION DESCRIPCION	ISS4				REMARKS OBSERVACIONES
1	4VP-H2910-10	LEVER HOLDER ASSY (LEFT) SOPORTE DE LEVA COMPLT 1	1				
2	4VP-H3912-10	.LEVER 1 .PALANCA 1	1				
3	3XG-H3915-00	.SCREW, LEVER FITTING .TORNILLO ACCESORIO DE PALANC	1				
4	95607-05100	.NUT, U .TUERCA AUTOBLOCANTE	1				
5	98507-05020	.SCREW, PAN HEAD .TORNILLO DE CABEZA PLANA	1				
6	98507-05030	.SCREW, PAN HEAD .TORNILLO DE CABEZA PLANA	1				
7	3XG-H3980-01	.FRONT STOP SWITCH ASSY .INTERRUP. DE PARADA DELANTERO	1				
8	4VP-H3975-00	SWITCH, HANDLE 2 INTERRUPTOR DE MANIJA 2	1				
9	98507-05020	.SCREW, PAN HEAD .TORNILLO DE CABEZA PLANA	1				
10	98507-05025	.SCREW, PAN HEAD .TORNILLO DE CABEZA PLANA	1				
11	3GF-H3980-00	FRONT STOP SWITCH ASSY INTERRUP. DE PARADA DELANTERO	1				
12	4VP-H3922-10	LEVER 2 PALANCA 2	1				
13	90109-06577	BOLT PERNO	1				
14	95607-06100	NUT, U TUERCA AUTOBLOCANTE	1				
15	90501-10312	SPRING, COMPRESSION RESORTE DE COMPRESION	1				

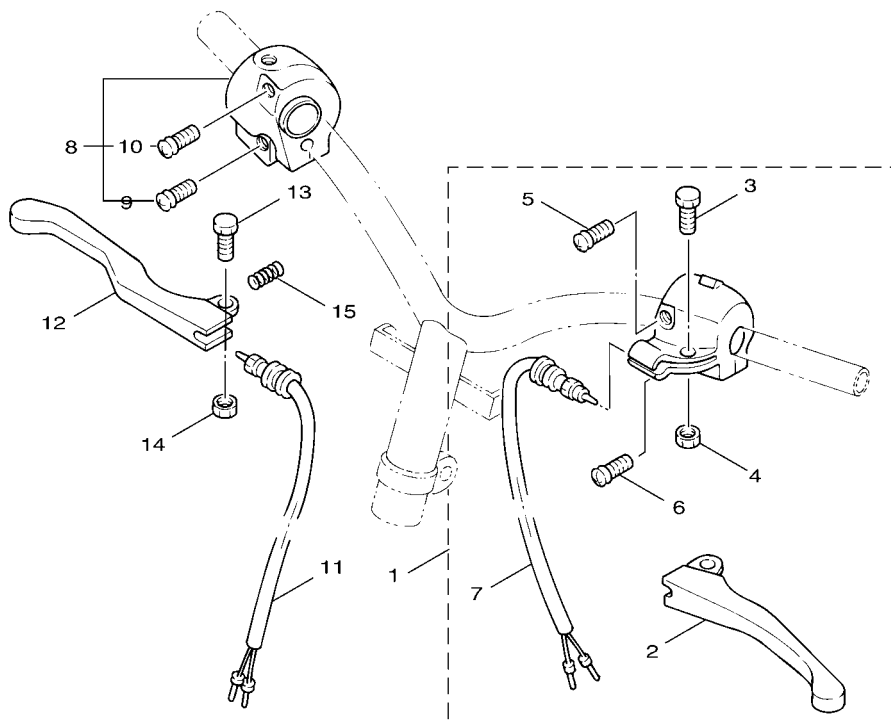

4VP1414-7420

FIG. 35 ELECTRICAL 1

EQUIPO ELECTRICO 1

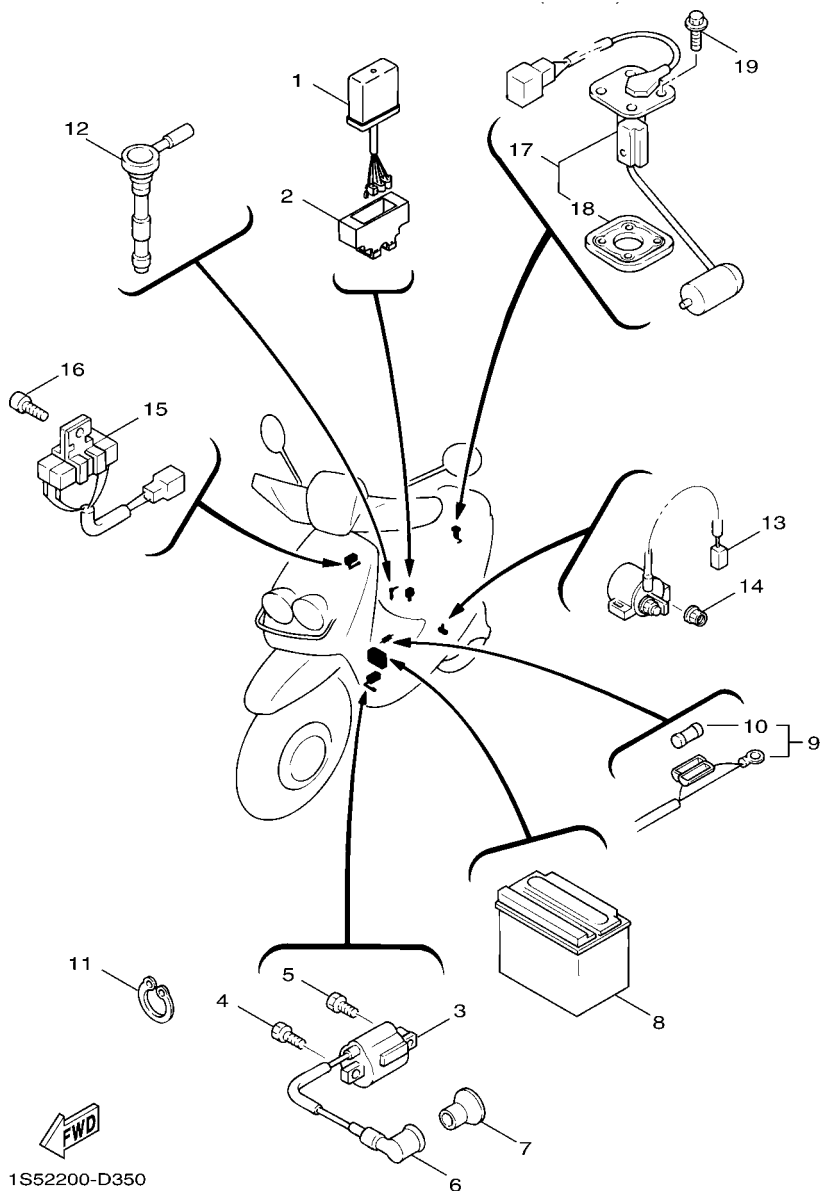

1S52200-D350

REF. NO.	PART NO. CODIGO Nº	DESCRIPTION DESCRIPCION	1S54				REMARKS OBSERVACIONES
1	4VP-H5540-20	C.D.I. UNIT ASSY UNIDAD C.D.I. COMPLETA	1				
2	3UH-H5546-00	BAND BANDA	1				
3	4VP-H2310-01	IGNITION COIL ASSY BOBINA DE ENCENDIDO COMPLETA	1				
4	97007-06016	BOLT PERNO	1				
5	90153-06839	SCREW, HEXAGON TORNILLO HEXAGONAL	1				
6	4VP-H2370-00	PLUG CAP ASSY TAPON DE BUJIA COMPLT	1				
7	4VP-H2372-00	SEAL, PLUG CAP SELLO DE TAPON	1				
8	4VP-H2100-00	BATTERY ASSY BATERIA COMPLETA	1				
9	4VP-H2590-20	WIRE HARNESS ASSY CONJUNTO DE CABLES	1				
10	1NT-H2151-00	.FUSE .FUSIBLE	1				
11	90465-13275	CLAMP BRIDA	2				
12	4VP-H5720-00	OIL LEVEL GAUGE ASSY MEDIDOR DE NIVEL DE ACEITE	1				
13	3KW-H1940-02	STARTER RELAY ASSY CONJUNTO ARRANCADOR RELEVO	1				
14	95307-06600	NUT TUERCA	2				
15	3GF-H5370-01	RESISTOR ASSY RESISTOR COMPLETO	1				
16	98507-06020	SCREW, PAN HEAD TORNILLO DE CABEZA CON PLANA	1				
17	4VP-X8575-00	SENDER UNIT ASSY MEDIDOR DE COMBUSTIBLE COMPL.	1				
18	53X-H5753-00	.GASKET, SENDER UNIT .EMPAQUE DE UNIDAD TRANSMISORA	1				
19	90119-05071	BOLT, WITH WASHER TORNILLO CON ARANDELA	4				

NUMERICAL INDEX
INDICE NUMERICO

PART NO. CODIGO N°	REF. NO.	PART NO. CODIGO N°	REF. NO.	PART NO. CODIGO N°	REF. NO.	PART NO. CODIGO N°	REF. NO.	PART NO. CODIGO N°	REF. NO.	PART NO. CODIGO N°	REF. NO.
3YR-11605-00	2 - 15	5FA-E2651-10	3 - 1	5DA-E5461-00	8 - 12	4VP-F171E-00-P0	14 - 16	4VP-F319U-00	17 - 27	4VP-F6110-01	23 - 1
3AA-13124-00	4 - 5	5FA-E2653-02	3 - 3	4SC-E5462-00	8 - 30	4VP-F171E-00-P3	14 - 16	3GF-F3317-00	17 - 34	4WX-F612M-00	27 - 10
4VP-13178-00	4 - 15	4VP-E2658-00	3 - 8	4VP-E5477-00	8 - 33	4VP-F171E-00-P8	14 - 16	4VP-F3340-03	17 - 31	4WX-F612N-00	27 - 11
3WF-13185-00	4 - 2	4VP-E2659-00	3 - 9	4VP-E5512-00	9 - 7	4VP-F171E-00-PA	14 - 16	4VP-F3346-10	17 - 30	4VP-F6143-00-P0	27 - 1
1YU-13187-00	4 - 3	5FA-E3100-11	4 - 1	4VP-E5524-00	9 - 1	4VP-F1733-00	15 - 3	1MH-F3411-00	17 - 32	4VP-F6143-00-P3	27 - 1
1YU-13473-00	4 - 4	4VP-E316F-00	4 - 8	3XG-E5532-00	9 - 11	4VP-F1734-00	15 - 4	4TE-F3416-00	17 - 51	4VP-F6143-00-P8	27 - 1
1YU-13516-00	4 - 6	3XG-E3342-00	9 - 9	4CW-E5570-00	9 - 5	4VP-F1741-00	14 - 13	4VP-F3418-00	17 - 50	4VP-F6143-00-PA	27 - 1
1YU-13577-00	4 - 7	4WX-E3555-10	5 - 6	4VP-E5601-00	9 - 13	4VP-F1745-00	15 - 7	3KW-F3462-00	17 - 33	4VP-F6145-00	27 - 2
4UF-14103-00	6 - 18	4VP-E3575-00	5 - 8	5FA-E5620-00	9 - 18	4VP-F1751-00	15 - 1	4VP-F4110-00-33	18 - 1	3GF-F6199-00	26 - 13
4VP-14104-00	6 - 12	4VP-E3610-00	5 - 1	4VP-E5630-00	9 - 20	4TE-F1753-00	18 - 12	4VP-F414A-20	18 - 11		27 - 5
3XG-14107-00	6 - 19	3XG-E3613-00	5 - 2	4VP-E5650-00	9 - 6	4VP-F1771-02	15 - 6	4VP-F4311-00	18 - 7	4VP-F6240-00	23 - 5
4VP-1411F-35	6 - 5	3XG-E3616-00	5 - 3	4VP-E5659-00	8 - 19	5XB-F1781-00	14 - 6	4CW-F4500-10	18 - 3	4VP-F6241-00	23 - 4
3XG-14133-00	6 - 3	4SC-E3621-00	5 - 5	4VP-E5673-00	9 - 21	5XB-F1782-00	14 - 10	4CW-F452K-10	18 - 4	4VP-F6260-02	23 - 8
193-14142-32	6 - 11	4VP-E4101-30	6 - 1	4VP-E6111-01	10 - 1	5XB-F1783-00	14 - 6	4VP-F4610-01	18 - 10	4VP-F6262-00	23 - 11
18A-14143-15	6 - 9	4VP-E4411-00	5 - 11	4VP-E6611-00	10 - 15	5XB-F1783-10	14 - 6	4VP-F4726-00	19 - 5	4VP-F6266-00	23 - 13
52W-14147-00	6 - 17	4VP-E4412-00	5 - 14	3XY-E6620-01	10 - 5	5XB-F1784-00	14 - 10	4CW-F4726-01	19 - 3	4VP-F6280-10	27 - 7
4VP-1414M-13	6 - 7	5FA-E4425-00	5 - 27	3UH-E6626-00	10 - 6	5XB-F1784-10	14 - 10	5PJ-F6290-10	19 - 1	4VP-F6290-10	27 - 6
522-14161-00	6 - 22	4VP-E4437-00	5 - 12	4VP-E7211-01	11 - 7	4VP-F1851-00	26 - 22	4VP-F4738-10	19 - 13	4VP-F6311-01	23 - 7
4VP-14171-00	6 - 16	4VP-E443E-00	5 - 22	4VP-E7410-01	11 - 1	4VP-F2210-10	16 - 1	4VP-F473R-01	19 - 8	4VP-F6312-00	23 - 10
53L-14186-00	6 - 20	4VP-E4445-00	7 - 2	4VP-E7421-01	11 - 6	4X6-F2216-00	8 - 3	4VP-F4742-00	19 - 10	4VP-F6321-02	23 - 9
4KP-14191-00	6 - 13	4VP-E4451-00	5 - 19	4VP-E7611-00	10 - 25	1S5-F3100-01	17 - 1	4VP-F475M-00	19 - 2	1MH-F6329-00	6 - 23
3XG-14196-00	6 - 10	4VP-E4452-00	5 - 20	4VP-E7620-00	10 - 17	4VP-F3102-10	17 - 2	4UE-F4780-02	19 - 15	4VP-F6351-01	23 - 15
3XG-14198-00	6 - 2	4VP-E4453-00	5 - 15	4VP-E7623-00	10 - 20	4VP-F3103-10	17 - 16	4VP-F478E-00	19 - 17	4VP-F637G-00	23 - 17
4VP-1490J-10	6 - 6	4VP-E4462-00	5 - 17	4CW-E7653-00	10 - 21	4VP-F3110-00	17 - 4	4VP-F4842-01-1V	19 - 18	4VP-F6393-00	23 - 16
3XG-14997-00	6 - 8	4VP-E4463-00	5 - 16	4VP-E7660-01	10 - 7		17 - 18	20A-F5115-00	20 - 2	4VP-F7111-01	25 - 1
14T-15657-00	10 - 27	4VP-E4467-00	5 - 18	4DM-E7664-00	10 - 11	4VP-F3111-00	17 - 9	4VP-F5168-00-33	20 - 1	4CW-F7114-00	25 - 2
4KX-17632-00	10 - 19	4VP-E4610-40-98	7 - 1	4VP-E7670-01	10 - 8		17 - 23	4VP-F5181-00	20 - 9	5DA-F7311-00	25 - 14
4VP-17641-00	10 - 24	3NT-E4613-01	7 - 4	4DM-E7684-00	10 - 13	4VP-F3126-10	17 - 3	4VP-F5183-00	20 - 7	5PJ-F7411-00	25 - 19
22F-23411-01	17 - 45	4VP-E4627-10	7 - 9	1S5-F1110-00-33	12 - 1	4VP-F3136-10	17 - 17	5DA-F5190-10	20 - 11	5PJ-F7421-00	25 - 20
156-23412-00	17 - 52	4VP-E4718-00	7 - 8	3KW-F139X-00	19 - 12	4VP-F3141-10	17 - 6	1P3-F5326-00	22 - 4	45U-F8100-00	12 - 11
22F-23412-01	17 - 46	4VP-E475M-00	7 - 14	4Y4-F139X-01	12 - 7		17 - 20	4VP-F5338-01-33	22 - 1	23Y-F8175-00	12 - 12
4DH-82566-00	36 - 11	3XY-E4766-00	7 - 19	4VP-F1410-30	12 - 6	4VP-F3145-00	17 - 14	4VP-F533A-00	22 - 11	4VP-F8257-01	26 - 18
4VP-E1111-00	1 - 1	4CW-E4766-00	7 - 11	3XG-F1481-00	12 - 2		17 - 28	3UH-F5351-00	22 - 9	4VP-F8300-01	26 - 7
4VP-E1162-00	1 - 4		7 - 17	4Y4-F1481-00	12 - 4	4TE-F3147-00	17 - 10	4VP-F5355-00	22 - 10	5XB-F832B-00	26 - 2
4VP-E1181-00	1 - 2	4VP-E4779-00	7 - 3	4VP-F1511-01	13 - 1		17 - 24	3XG-F580T-01	21 - 3	5XB-F832C-00	26 - 3
4VP-E1311-10	1 - 5	4VP-E4799-20	7 - 13	4VP-F1514-00	12 - 9	4VP-F3156-00	17 - 15	3UH-F582U-00	21 - 1	5XB-F832K-00	26 - 2
5FA-E1351-00	1 - 6	5FA-E5111-12	8 - 1	4VP-F1519-01	13 - 6		17 - 29	3GF-F5852-00	24 - 4	5XB-F832K-10	26 - 2
4VP-E1400-00	2 - 1	4VP-E5118-00	8 - 31	5XB-F152A-00	26 - 4	3GF-F3158-00	17 - 7	3GF-F5854-00	24 - 3	5XB-F832L-10	26 - 3
4VP-E1412-00	2 - 2	4VP-E5121-00	8 - 2	5XB-F152A-20	26 - 4		17 - 21	3GF-F5867-00	24 - 6	5XB-F832L-10	26 - 3
4VP-E1422-00	2 - 6	4VP-E5128-00	8 - 28	5XB-F152A-30	26 - 4	4VP-F3170-10	17 - 5	4JL-F5870-02	24 - 1	5FM-F8349-00	26 - 8
4VP-E1603-00	2 - 15	3XG-E5317-00	8 - 9	4TH-F152A-E0	26 - 4		17 - 19	4VP-F5872-13	24 - 8	4VP-F834V-00	26 - 5
4VP-E1631-10-A0	2 - 13	4Y4-E5363-00	8 - 24	2GF-F1535-00	14 - 4	3GF-F3181-00	17 - 8	4VP-F5875-01	17 - 35	4VP-F8385-11	26 - 11
4VP-E1633-00	2 - 14	3XG-E5371-00	8 - 5	4VP-F1535-00	26 - 16		17 - 22	4VP-F5876-00	17 - 37	4VP-F838K-00	26 - 20
4VP-E1636-00	2 - 13	4VP-E5373-00	8 - 6	4VP-F1552-00	13 - 4	4VP-F3191-00	17 - 11	5FA-F5876-00	17 - 36	4VP-F840K-00-1V	26 - 14
4VP-E1651-00	2 - 5	4VP-E5411-00-33	8 - 17	4JK-F1568-00	26 - 9		17 - 25	5FJ-F5886-00	17 - 42	3GF-H1403-V0	28 - 2
4DM-E1681-00	2 - 3	4VP-E5421-01	8 - 11	4VP-F1629-00	13 - 9	4TE-F3192-00	17 - 12	3XG-F5919-01	21 - 7	4VP-H1800-20	29 - 1
4VP-E2611-00	3 - 10	4VP-E5439-00	8 - 16	4VP-F1691-01	13 - 12		17 - 26	3XG-F5919-11	21 - 8	4DM-H1801-00	29 - 2
3XG-E2631-00	3 - 13	5DA-E5451-00	8 - 18	4VP-F1711-00	14 - 1	4VP-F319U-00	17 - 13	3XG-F5926-01	21 - 9	3NW-H1828-V0	29 - 5

NUMERICAL INDEX
INDICE NUMERICO

PART NO. CODIGO N°	REF. NO.	PART NO. CODIGO N°	REF. NO.	PART NO. CODIGO N°	REF. NO.	PART NO. CODIGO N°	REF. NO.	PART NO. CODIGO N°	REF. NO.	PART NO. CODIGO N°	REF. NO.
3KW-H1940-02	35 - 13	4VP-H4317-00	32 - 9	4VP-X2831-B0-P0	26 - 1	90185-10801	23 - 3	90465-13275	35 - 11	93102-17467	10 - 3
3GF-H1960-00	36 - 1	4VP-H4318-10	32 - 5	4VP-X8575-00	35 - 17	90185-14124	22 - 14	90467-01800	5 - 9	93102-17838	20 - 3
4VP-H2100-00	35 - 8	4VP-H4331-00	32 - 6	5PJ-XF748-00	25 - 9	90201-06380	13 - 11	90467-08003	4 - 9	93102-22464	2 - 10
1NT-H2151-00	35 - 10	4VP-H4332-00	32 - 7	90101-06878	22 - 12	90201-064J1	17 - 39	90467-09006	18 - 9	93102-25270	11 - 10
5DA-H2176-00	25 - 21	4VP-H4337-00	32 - 8	90102-10031	16 - 3		33 - 14		18 - 14	93104-19097	28 - 4
4VP-H2310-01	35 - 3	4VP-H4347-10	32 - 4	90105-08121	16 - 2	90201-06847	11 - 13	90467-11823	5 - 23	93104-33800	10 - 9
4VP-H2370-00	35 - 6	4VP-H4366-00	32 - 19	90105-10036	23 - 2	90201-07081	32 - 18	90468-02033	4 - 13	93210-07890	22 - 6
4VP-H2372-00	35 - 7	4VP-H4367-00	32 - 10	90109-063F1	19 - 11	90201-08088	9 - 10	90468-12006	16 - 5	93210-108B1	25 - 4
4VP-H2501-20	36 - 3	4VP-H4368-00	32 - 20	90109-06577	34 - 13	90201-10118	24 - 11		25 - 6	93210-14805	8 - 25
4VP-H2552-10	36 - 4	4VP-H4519-00	33 - 20	90109-06801	5 - 7	90201-142M6	22 - 13	90480-11866	3 - 2	93210-23614	29 - 4
4VP-H2590-20	35 - 9	4MK-H4545-00	33 - 11	90109-06877	33 - 15	90201-155G5	9 - 16	90480-12497	3 - 5	93210-368G9	10 - 10
4VP-H2910-10	34 - 1	4VP-H4700-10	33 - 1	90109-10473	25 - 15	90201-15819	11 - 4		5 - 26	93210-44678	29 - 3
4VP-H3310-10	30 - 1	4VP-H4714-00	33 - 2	90116-07834	1 - 7	90201-163G6	9 - 4	90480-16278	14 - 14	93210-64893	3 - 11
4VP-H3311-10	30 - 3	4VP-H4721-00	33 - 5	90119-05062	17 - 41	90201-16800	10 - 23	90501-08845	4 - 12	93306-003Y4	8 - 4
	30 - 7	4MK-H4743-00	33 - 9	90119-05071	35 - 19	90201-203E7	22 - 15	90501-08868	18 - 8		9 - 2
	30 - 12	4VP-H4743-10	33 - 6	90119-06079	25 - 12	90202-05193	18 - 6	90501-10312	34 - 15	93306-004X7	11 - 9
	30 - 16	4VP-H4744-00	33 - 8	90119-06802	15 - 2	90202-10120	25 - 5	90501-165J7	23 - 20	93306-200Y1	10 - 4
4VP-H3312-10	30 - 2	4VP-H4747-00	33 - 10	90119-06821	13 - 2	90202-26142	17 - 49	90501-29517	12 - 8		11 - 3
	30 - 6	4VP-H4781-00	33 - 12		25 - 11	90202-26166	29 - 6	90501-430K3	10 - 12	93306-203YE	10 - 2
	30 - 11	3KW-H5130-00	33 - 18	90119-06857	3 - 12	90208-12050	10 - 28	90506-16447	22 - 8		11 - 12
	30 - 15	3GF-H5370-01	35 - 15	90149-06011	18 - 5	90208-21801	11 - 5	90506-16800	25 - 17	93306-205Y6	2 - 9
4VP-H3320-10	30 - 5	4VP-H5540-20	35 - 1	90149-08814	21 - 2	90209-14800	10 - 26	90506-20800	25 - 7	93306-300Y4	20 - 4
4VP-H3330-10	30 - 10	3UH-H5546-00	35 - 2	90153-06800	7 - 5	90209-18112	2 - 7	90506-26800	25 - 18	93310-21403	2 - 17
4VP-H3332-10	33 - 4	4KX-H5550-00	28 - 9	90153-06839	35 - 5	90240-10137	25 - 3	90506-26801	25 - 8	93310-41810	2 - 4
4VP-H3340-10	30 - 14	3XG-H5560-00	28 - 1	90157-05079	36 - 12	90241-10015	19 - 7	90508-32768	9 - 14	93311-315Y2	11 - 2
4VP-H3342-10	33 - 3	3GF-H5580-V0	28 - 3	90159-05831	27 - 3	90249-12008	23 - 19	91317-06016	19 - 20	93315-108Y4	9 - 8
1MH-H3350-V0	36 - 7	4VP-H5720-00	35 - 12	90159-06811	26 - 19	90280-03017	2 - 8		30 - 18	93410-20823	11 - 8
4VP-H3371-10	36 - 8	53X-H5753-00	35 - 18	90159-06812	26 - 6	90338-16148	26 - 17	91317-06025	8 - 21	93450-16115	2 - 16
3XY-H3390-01	36 - 10	3GF-W0041-00	24 - 2	90159-06822	14 - 3	90380-15817	9 - 15		24 - 7	93450-35015	9 - 3
4VP-H3509-00	31 - 3	3XG-W0045-01	21 - 10	90160-05803	27 - 4	90387-068F8	13 - 3	91317-06035	8 - 22	93501-04011	17 - 53
4VP-H3510-10	31 - 1	3XG-W0047-00	21 - 5	90163-05800	32 - 17	90387-068J5	3 - 4		33 - 13	93503-16003	17 - 47
3GF-H3517-00	31 - 4	3XG-W0048-00	21 - 6	90167-03800	23 - 12		5 - 25	91317-06045	8 - 23	93603-12827	4 - 16
4TE-H3517-00	31 - 5	3XG-W0057-00	21 - 4	90176-06065	7 - 16	90387-108S0	20 - 10		19 - 19	93900-00802	20 - 6
4TE-H3518-00	31 - 6	4VP-W1441-00	5 - 10	90179-06411	23 - 18	90387-168N7	10 - 22	91318-06020	8 - 15		22 - 3
4TE-H353K-00	31 - 2	4VP-W1442-00	5 - 13	90179-07381	1 - 8	90387-178N6	2 - 12		29 - 7	94112-108S3	20 - 5
4VP-H3550-03	31 - 8	4VP-W2620-02	23 - 6	90179-10609	10 - 16	90401-10805	24 - 9	91318-06035	8 - 8	94113-108S4	22 - 2
4VP-H3912-10	34 - 2	4VP-X2172-20-P8	14 - 5	90179-25615	17 - 48		24 - 10		8 - 14	94700-00836	1 - 3
3XG-H3915-00	34 - 3	4VP-X2172-20-PA	14 - 5	90179-28415	10 - 14	90430-08119	8 - 27	91810-14807	8 - 13	95027-06010	11 - 14
4VP-H3922-10	34 - 12	4VP-X2172-80-P3	14 - 5	90183-05807	13 - 8	90445-05431	4 - 10		8 - 20	95027-06020	26 - 15
23Y-H3936-00	36 - 6	4VP-X2172-C0-P0	14 - 5		13 - 15	90445-078A3	18 - 15	91812-16805	8 - 7	95307-06600	35 - 14
4VP-H3975-00	34 - 8	4VP-X2173-20-P8	14 - 9		14 - 7	90445-105H0	18 - 16	91A10-07056	18 - 13	95307-12600	28 - 11
3GF-H3980-00	34 - 11	4VP-X2173-20-PA	14 - 9		14 - 12	90460-27815	15 - 8	92901-04100	28 - 8	95307-12700	10 - 29
3XG-H3980-01	34 - 7	4VP-X2173-80-P3	14 - 9		19 - 9	90460-35260	26 - 23	92907-06200	7 - 15	95607-05100	34 - 4
4VP-H4144-00	32 - 14	4VP-X2173-C0-P0	14 - 9		25 - 10	90460-41191	5 - 28	92907-06600	19 - 21	95607-06100	17 - 40
4VP-H4169-00	32 - 16	3UH-X2533-00	22 - 7		33 - 17	90464-16801	4 - 11	92907-10600	33 - 16		34 - 14
4VP-H430A-10	32 - 1	4VP-X2831-10-P7	26 - 1	90185-10037	25 - 16	90464-50802	32 - 12	92907-12600	28 - 10	95607-12200	12 - 3
4VP-H4310-00	32 - 2	4VP-X2831-10-P8	26 - 1	90185-10801	12 - 5	90465-13152	32 - 11	93101-20169	2 - 11	95707-05300	33 - 19
4VP-H4314-10	32 - 3	4VP-X2831-80-P3	26 - 1		20 - 8	90465-13275	27 - 8	93101-21801	10 - 18	95707-06500	18 - 2

NUMERICAL INDEX
INDICE NUMERICO

PART NO. CODIGO N°	REF. NO.	PART NO. CODIGO N°	REF. NO.	PART NO. CODIGO N°	REF. NO.	PART NO. CODIGO N°	REF. NO.	PART NO. CODIGO N°	REF. NO.	PART NO. CODIGO N°	REF. NO.
95707-06500	19 - 4	97707-60540	3 - 7								
	19 - 6	98501-04008	28 - 7								
	19 - 14	98501-05010	28 - 6								
95707-10500	16 - 4	98501-05020	28 - 5								
	22 - 5	98507-03006	5 - 4								
95807-06010	17 - 44		6 - 15								
95807-06012	13 - 5	98507-04012	6 - 21								
	13 - 10	98507-05010	19 - 22								
	27 - 9		23 - 14								
95807-06014	26 - 21		30 - 9								
95807-06016	32 - 13		36 - 2								
95807-08016	8 - 26	98507-05014	4 - 14								
95807-08035	12 - 10	98507-05020	34 - 5								
9580L-06012	17 - 43		34 - 9								
95817-06020	17 - 38	98507-05025	34 - 10								
95817-08020	7 - 6	98507-05030	34 - 6								
95817-08030	7 - 7	98507-06010	36 - 9								
95827-08030	21 - 11	98507-06012	8 - 29								
97007-06016	19 - 16		8 - 32								
	35 - 4		9 - 12								
97017-06010	7 - 10		36 - 5								
97017-06025	9 - 19	98507-06016	28 - 12								
97507-05510	15 - 5	98507-06020	35 - 16								
97517-06510	7 - 12	98706-04012	24 - 5								
97607-04108	6 - 14	98980-06010	7 - 18								
97607-04112	6 - 4	99009-15400	9 - 17								
97607-06220	3 - 6	99009-17400	8 - 10								
	5 - 24	99009-19400	4 - 17								
	8 - 34	99009-42500	11 - 11								
97707-30625	30 - 4										
	30 - 8										
	30 - 13										
	30 - 17										
97707-40616	33 - 7										
97707-50012	13 - 13										
	14 - 2										
	14 - 8										
	14 - 11										
	14 - 15										
	14 - 17										
	32 - 15										
97707-50016	13 - 7										
	13 - 14										
	25 - 13										
	26 - 10										
	26 - 12										
	31 - 7										
97707-50125	5 - 21										