

WORKSHOP MANUAL

Alfa 33 MANUAL SUPPLEMENT

models

33

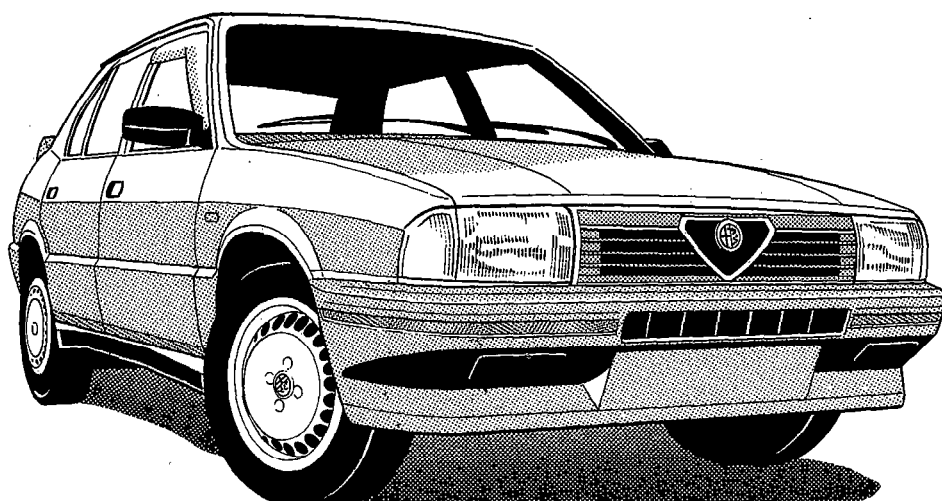

ASSISTENZA TECNICA *Alfa Romeo* 

Instructions for the insertion of the technical data in the binders



When inserting the updating pages in the **Alfa 33** VOLUME II binder, it is advisable to proceed as shown in the diagram below and to follow the order indicated.

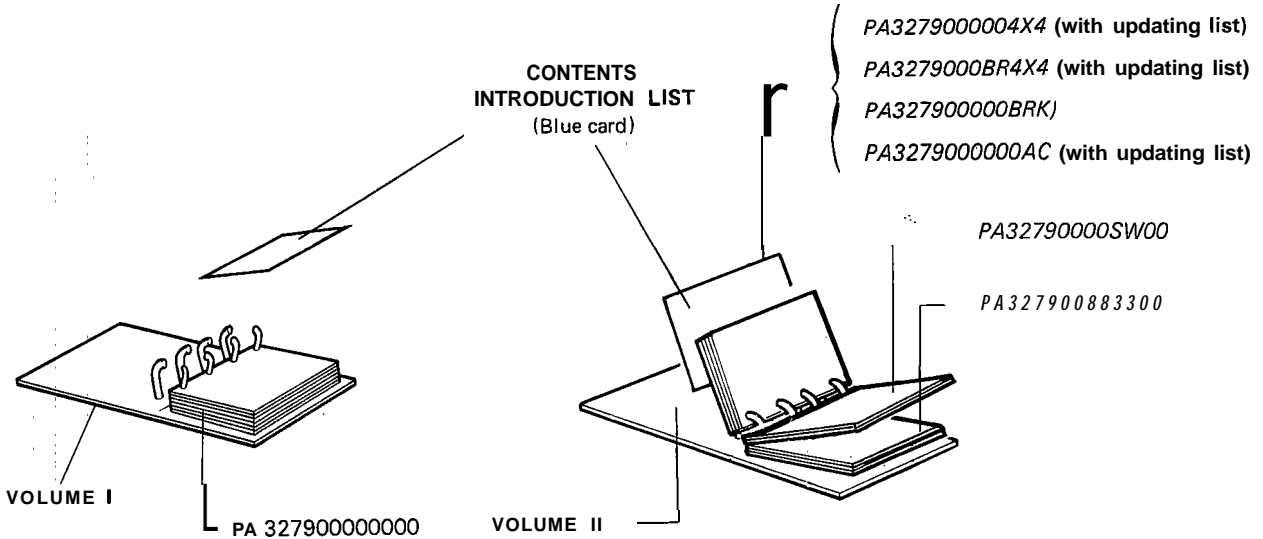

Detailed contents:

PA3279000004X4	"Workshop Manual Alfa 33 4x4"
PA3279000BR4X4	"Workshop Manual Alfa 33 4x4 giardinetta"
PA327900000BRK	"Workshop Manual Alfa 33 giardinetta"
PA3279000000AC	"*installation Instructions Alfa 33 r conditioner"
PA32790000TD00	"Workshop Manual 33 1.8 TD"
PA327900003300	"Workshop Manual- models 33 "
PA32790000SW00	"Workshop Manual models Sport Wagon "
PA327900883300	"Workshop Manual models 33 "

NOTE: For correct interpretation of the issue number, refer to the following code figures:

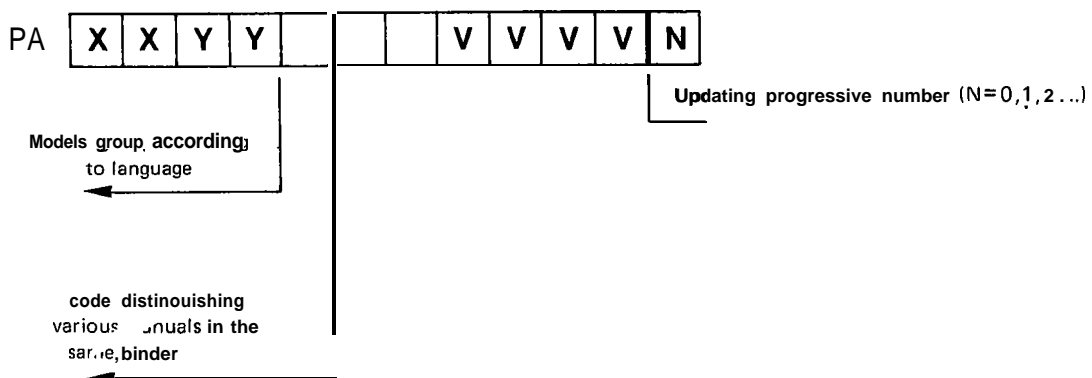

FOREWORD

This manual is intended for models **33 1.3** **33 1.3 s** **33 1.5 TI** **33 1.7 IE** **33 1.7 ***
33 1.8 TD **33 1.5 4x4** It complements the manuals referring to the corresponding (Alfa) models indicated here below:

PA32 790000000	"WORKSHOP MANUAL	Alfa 33	"
PA3279000004x4	"WORKSHOP MANUAL	Alfa 33 4x4	"
PA3279000B R4x4	"WORKSHOP MANUAL	Alfa 33 4x4	"giardinetta"
PA327900000B RK	"WORKSHOP MANUAL	Alfa 33	"giardinetta"
PA327900000TD00	"WORKSHOP MANUAL	33 1.8 TD	
PA32 7900003300	"WORKSHOP MANUAL - models	33	

Key to symbols:

Alfa 33 ← means that the corresponding Group in the basic manual **Alfa 33** should be referred to, for all details not dealt with specifically in this manual.

QUICK REFERENCE INDEX

	COMPLETE CAR	GR. 00
	ENGINE MAIN MECHANICAL UNIT	GR. 01
	FUEL SYSTEM	GR. 04
	IGNITION, STARTING, CHARGING SYSTEM	GR. 05
	ENGINE COOLING SYSTEM	GR. 07
← Alfa 33	CLUTCH	GR. 12
	GEARBOX	GR. 13
← Alfa 33	MOTION TRANSMISSION	GR. 15
	DIFFERENTIAL AND DRIVE SHAFT ASSEMBLY	GR. 17
	FRONT SUSPENSION	GR. 21
	FRONT AND REAR BRAKES	GR. 22
Alfa 33 ←	STEERING SYSTEM	GR. 23
	REAR SUSPENSION	GR. 25
	WHEELS AND TIRES	GR. 28
	ELECTRICAL SYSTEM	GR. 40
	BODY-SHEET METAL PANELS	GR. 49
	DOORS	GR. 55
	HOODS	GR. 56
Alfa 33 ←	INTERNAL TRIMMING	GR. 66
	EXTERNAL TRIMMING	GR. 75
	AIR VENTILATION	GR. 80

GROUP 00

CONTENTS

GENERAL VIEWS	00-2	TRUBLE DIAGNOSIS AND CORRECTION	
Dimensions and weights	00-3	ON IGNITION SYSTEM LE3.2 JETRONIC	
MODEL VARIATIONS	00-4	(1.7 IE with catalytic converter)	00-21
IDENTIFICATION DATA	(*)	ELECTRIC TROUBLESHOOTING	
Identification label	(*)	PROCEDURE	
Car identification codes	(*)	(1.7 IE with catalytic converter)	00-27
LIFTING AND TOWING POINT	(*)	INJECTION-IGNITION WIRING DIAGRAM	
SPECIAL SERVICE TOOLS	(*)	(1.7 IE with catalytic converter)	00-35
INSTRUCTIONS FOR PRE-DELIVERY		TRUBLE DIAGNOSIS AND CORRECTION	
EXECUTION AND PERIODICAL		ON INJECTION-IGNITION SYSTEM	
MAINTENANCE COUPONS..	(*)	(1.7 IE without catalytic converter)	00-35/1
MAINTENANCE SCHEDULE	00-6	TRUBLESHOOTING PROCEDURE	
NEW IDENTIFICATION LABEL..	00-10/3	ON INJECTION SYSTEM	
MODEL VARIATION		(1.7 IE without catalytic converter)	00-35/6
(according to new identification label)	00-10/4	TRUBLESHOOTING PROCEDURE	
FLUIDS AND LUBRICANTS CHARTS	(*)	ON IGNITION SYSTEM	
RECOMMENDED FUEL AND LUBRICANT .	00-11	(1.7 IE without catalytic converter)	00-35/13
Fuel	00-11	INJECTION-IGNITION WIRING DIAGRAM	
Fluids and lubricants	00-11	(1.7 IE with catalytic converter)	00-35/18
APPROXIMATE REFILL CAPACITIES	00-12	COMPONENTS AND BODY MAINTENANCE (*)	
ENGINE MAINTENANCE	00-13	SERVICES DATA AND SPECIFICATIONS . .	00-36
Basic mechanical system..	00-13	Engine maintenance	(*)
Fuel system	00-13	Components and body maintenance . .	00-36
Exhaust checking	00-15	SPECIAL SERVICE TOOLS	00-37

00

(*) See: "REPAIR MANUAL **Alfa 33**" VOLUMES I and II - Group 00

Alfa 33

GENERAL VIEW

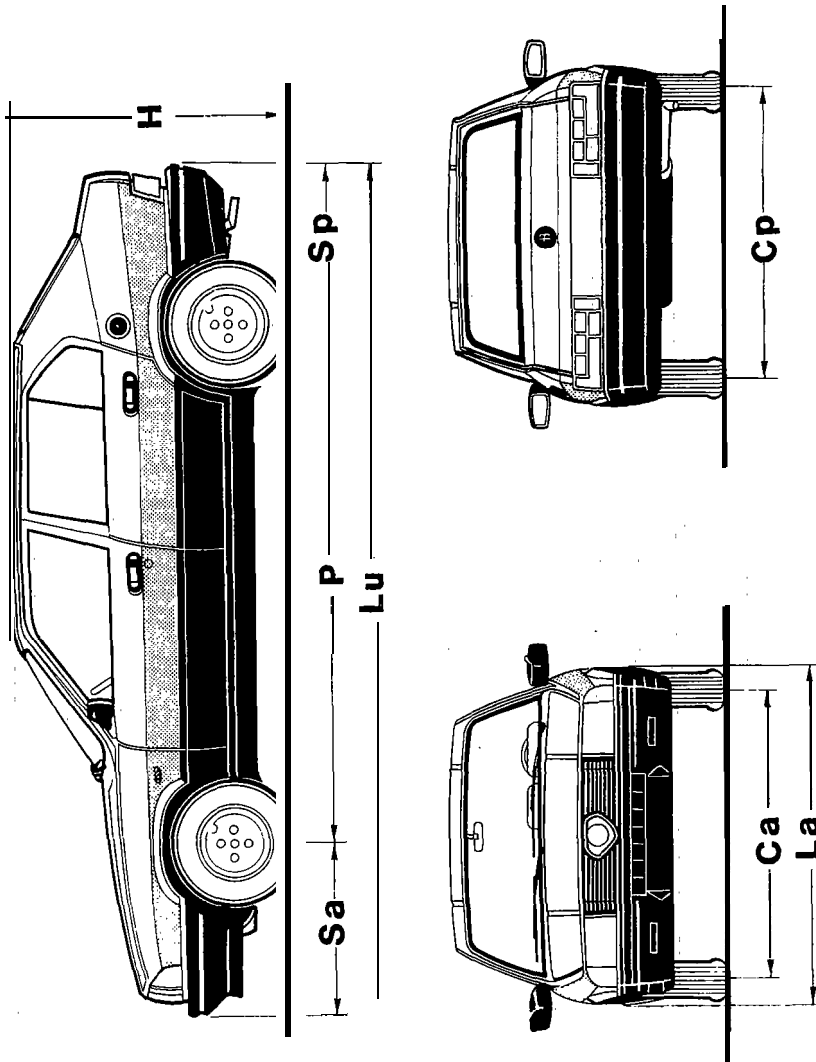

DIMENSIONS AND WEIGHTS

Model	ENGINES WITH ONE CARBURETOR		ENGINES WITH TWO CARBURETORS				ENGINES WITH ELECTRONIC FUEL INJECTION		ENGINES WITH TURBO COMPRESSOR
	33 *	33 1.3	33 1.3 s	33 1.5 TI	33 1.5 a x a	33 1.7 *	33 1.7 IE	33 1.7 *	33 1.5 TO
Identification number	908.260	908.060 908.061 A	908.080	908.100 908.110 908.101▲	908.220	908.160 908.170 908.161▲	908.140 908.200△ 908.150△	908.180△	908.120
Wheelbase	P (mm)	2470	2465						2455
Track	Front Ca (mm)	1366	1367	1362	1367	1364	1364	1397	
	Rear cp (mm)	1362	1364	1375	1364	1364	1364	1364	
Overall length	Lu (mm)	4015						4040	
Overhang	Front Sa (mm)	800	790				825		
	Rear SP (mm)	760	760				760		
Overall width	La (mm)	1612							
Height (unladen)	H (mm)	1340		1345	1370	1345			
Min. steering radius	(mm)	5500						5350	
Kerb weight	(kg)	910			970	930		1010	
Max. allowed gross weight	(kg)	1335			1395	1355		1435	
Payload	(kg)	3 5 5							
Max. allowed axle gross weight	Front (kg)	800			800				
	Rear (kg)	800			900				
Max. towing gross weight	(kg)	1000			1100	1000		1100	
Seating capacity	Front	2							
	Rear	3							

(A) With ecological materials for countries where antipollution regulations are in force

(*) With 1.2 engine not marketed in all countries

[A] With ecological materials.

MODEL VARIATION

		ENGINES WITH ONE CARBURETOR				ENGINES WITH TWO CARBURETORS						
Modal		33 *		33 1.3		33 1.3 S		33 1.5 TI		33 1.5 axa		
Body		5 door saloon										
Drive		L	R	L	R	L	R	L	R	L	R	
Identification NO.	Label type and location	- on certification label and - on identification label	908.260	-	908.060 908.061▲	-	908.080	-	908.100 908.101▲	908.110	908.220	-
		on identification label	905AB		905A1G		905A1H		905A2V		905A2T	
Chassis No.	Label type and location	- on intermediate bulkhead label	905A00		905A10				905A20			
		- on intermediate bulkhead label	-	-	▲	-	05410589	-	▲	05414309	05411133	05414275
Engine No.	Type and serial NO.	- on cylinder block label	30585 from 0000001		30586 from 0000001		30587 from 0000001		30588 from 0000001			
Tire dimensions		165/70 SR 13						175/70 RI 3 82T				
Rim dimensions		5½ J x 13"										

(A) With ecological materials
 (*) With 1.2 engine not marked in all countries

MODEL VARIATION

Model		Sport Wagon							
Versions		33 1.3 S				33 1.5 4x4			
Body		5 DOOR STATION WAGON							
Drive		L	R	L	R	L	R	L	R
Identification No.	- on certification label - on identification label	906.600	-	908.600	-	908.800	-	908.800	-
						908.801 ▲		908.801 ▲	
Chassis No.	- on identification label	905A1D		905A1F		905A2S		905A2U	
	- on intermediate bulkhead label	905A10		905A10		905A20		905A20	
	- on intermediate bulkhead label	05379411	-	-	-	05407366	-	-	-
Engine No.	- on cylinder block label	30168 from 0000001		30587 from 0000001		30508 from 0000001		30588 da 0000001	
Tyres dimensions		165/70XR13				175/70R1382T			
Rim dimensions		5½Jx13				5½Jx13			

(A) with ecological material

PA33350000SW01

00-3

MAY 1988

MODEL VARIATION

Model		Sport Wagon								
Versions		33 1.3 S		33 1.7 B Δ		33 1.7 4x4 Δ		33 1.8 TD		
Body		5 DOOR STATION WAGON								
Drive		L	R	L	R	L	R	L	R	
Identification No.	Label type and location	- on certification label	908.640	908.650	908.660	-	908.820	-	908.620	-
		- on identification label	908.641▲							
Chassis No.	Type approval No.	- on identification label	905A30		905A3F		905A3G		905A4A	
		- on intermediate bulkhead label	905A30		905A30		905A30		905A40	
Serial No.	Label type and location	- on intermediate bulkhead label	05381288	-	65407756	-	05408476	-	05381261	-
			▲							
Engine No.	Type and'serial No.	- on cylinder block label	30550 from 0000001		30558 from 0000001		30558 from 0000001		VM82A from 0000001	
Tyre dimensions		185/60R1482H						175/70R1382T		
Rim dimensions		5½Jx14						5½Jx13		

(A) With ecological material and electronic injection engine for countries where antipollution regulations are in force

(A) With ecological material

APPROXIMATE REFILL CAPACITIES

Model	Sport Wagon 33 1.3 S		Sport Wagon 33 1.7 B		Sport Wagon 33 1.6 4x4 33 1.7 4x4		Sport Wagon 33 1.8 TD			
	Measurement unit		Kg (lb)	l (imp. gal)	Kg (lb)	l (imp. gal)	Kg (lb)	l (imp. gal)	Kg (lb)	l (imp. gal)
Component										
FUEL TANK		-	50 (11)	-	50 (11)	-	53 (11.66)	-	50 (11)	
FUEL RESERVE			6.5 (1.43)	-	6.5 (1.43)	-	6.5 (1.43)	-	6.5 (1.43)	
ENGINE OIL SUMP	With filter (*)	3.6 (7.94)	4 (0.88)	3.6 (7.94)	4 (0.88)	3.6 (7.94)	4 (0.88)	4.57 (10.07)	5.25 (1.15)	
	Without filter (*)	3.15 (6.94)	3.5 (0.77)	3.15 (6.94)	3.5 (0.77)	3.15 (6.94)	3.5 (0.77)	4.35 (9.59)	5 (1.10)	
GEARBOX - DIFFERENTIAL OIL		2.4 (5.29)	2.6 (0.57)	2.4 (5.29)	2.6 (0.57)	2.4 (5.29)	2.6 (0.57)	2.4 (5.29)	2.6 (0.57)	
REAR DIFFERENTIAL OIL			-	-	-	0.9 (1.98)	1 (0.22)	-		
ENGINE COOLING SYSTEM		-	7.3 (1.61)	-	7.3 (1.61)	-	7.3 (1.61)	-	8	
CONCENTRATE ANTIFREEZE →	-15°C (+5°F)	-	2.2 (0.48)	-	2.2 (0.48)	-	2.2 (0.48)	-	2 (0.44)	
QUANTITY DEPENDING ON →	-20°C (-4°F)	-	2.6 (0.57)	-	2.6 (0.57)	-	2.6 (0.57)	-	2.64 (0.58)	
TEMPERATURE 3	-35°C (-31°F)	-	3.65 (0.80)	-	3.65 (0.80)	-	3.65 (0.80)	-	4 (0.88)	
ANTIFREEZE QUANTITY READY → FOR USE	-20°C (-4°F)	-	7.3 (1.61)	-	7.3 (1.61)	-	7.3 (1.61)	-	8 (1.76)	

(*) The indicated quantity refers to periodical changes.

COMPLETE CAR

CHASSIS AND BODY MAINTENANCE

TECHNICAL DATA - INSPECTION AND ADJUSTMENT

Axles and suspensions

Model	Sport Wagon	Sport Wagon	Sport Wagon	Sport Wagon
33 1.3 S	33 1.7 S	33 1.5 4x4 33 1.7 4x4	33 1.8 TD	33 1.8 TD
Features				
Vehicle static loading arrangement (1)	$2 + 3 = 490 + 245 = 735 \text{ N}$ $(50 + 25 = 75 \text{ kg})$ $C = 490 (50); (110)$			
Front wheel alignment	$A = -12_{-5}^{+10} (-0.47_{-0.20}^{+0.39})$ $B = 27_{-5}^{+10} (1.06_{-0.20}^{+0.39})$	$A = 3_{-5}^{+10} (-0.12_{-0.20}^{+0.39})$ $B = 53_{-5}^{+10} (2.09_{-0.20}^{+0.39})$	$A = -2_{-5}^{+10} (-0.47_{-0.20}^{+0.39})$ $B = 33_{-5}^{+10} (0.91_{-0.20}^{+0.39})$	
Rear wheel alignment	$M - H = 4 \pm 5 (0.57 \pm 0.079)$			
Front wheel toe-out (2) (3)	$M - H = 4 \pm 5 (0.57 \pm 0.079)$			
Front toe-out angle	$\alpha = 0'$			
Wheel rim diameter	$\alpha = 10'$			
Rear wheel toe-in	340 (13.38)	365 (14.37) (4)	340 (13.38) 365 (14.37) (4)	340 (13.38)
Front wheel camber (3)	$\alpha = 0 \pm 10'$			
Rear wheel camber (3)	$\beta = -1' \pm 30'$			
Front wheel caster (3)	$\beta = 0^\circ \pm 25'$			
Steering lock (3)	$\gamma = 2^\circ \pm 30'$			
Outer angle	$\delta_1 = 27^\circ 50'$			
Inner angle	$\delta_2 = 33^\circ 45'$			
Steering lock (3)	$\delta_1 = 29^\circ 00'$ $\delta_2 = 35^\circ 10'$			

(1) Load vehicle, move it up and down on suspensions a few times. Checking operations must be performed with vehicle fully set up for driving

(2) When turning a steering side rod joint 360°, M - H dimension changes by 2 mm (0.079 in).

(3) These values are referred to a vehicle in nominal driving condition, i.e. with static load.

(4) With rim 5½ Jx14".

MODEL VARIATION

		ENGINES WITH TWO CARBURETORS		ENGINES WITH ELECTRONIC FUEL INJECTION				ENGINE WITH TURBO COMPRESSOR	
Model		33 1.7 *		33 1.7 IE		33 1.7 *		33 1.8 T0	
Body		5 door saloon							
Drive		L	R	L	R	L	R	L	R
Identification NO.	- on certification label and - on identification label	908.160	908.170	908.140	908.150.	905.180.		908.120	-
		908.161▲		908.200▲					
Chassis No.	- on identification label	905A3		905A3D				905A4	
	- on intermediate bulkhead label	905A30						905A40	
	- on intermediate bulkhead label	05411704 A	-	05410692 A	-	-	-	05411250	-
Engine No.	Type and serial NO.	30550 from 0000001		305.58 from 0000001*		305.58 from A000001		VM82A from 00001	
Tire dimensions		185/60 R1482H		185/60 R1482H				175/70 RI 382T	
Ftirn dimensions		5½ J x 14"						5½ J x 13"	

(A) With ecological materials

(*) Not including numbers 908.200
908.150 that take the serial number A000001, as with number 908.180

MAINTENANCE SCHEDULE

The following schedule is valid for the Italian market only

N.	OPERATION	A (1)	Km/1000													Notes							
			10	20	30	40	50	60	70	80	90	100	110	120	130		140	150	160	170	180	190	200
			X	X	X	X	X	X	X	X	X	X	X	X	X		X	X	X	X	X	X	X
1	Replace engine oil and oil filter, check oil system for leaks	X	X	X	X	X	X	X	X	X	X	X	X	X	X	X	X	X	X	X	X	X	(2)
2	Replace gearbox, differential and rear differential (models 1.5 4X4) oil				X							X					X					X	
3	Check gearbox, differential and rear differential (model 1.5 4X4) oil level		X								X								X				
4	Check and top up (if necessary) the fluid level and verify correct operation of the windshield, headlights and rear window wash/wipe system	X	X	X	X	X	X	X	X	X	X	X	X	X	X	X	X	X	X	X	X	X	(4)
5	Check brake fluid and clutch fluid level	X	X	X	X	X	X	X	X	X	X	X	X	X	X	X	X	X	X	X	X	X	
6	Replace brake and clutch fluid				X												X					X	(6)
7	Check level of antifreeze mixture; test cooling circuit or leak	X	X	X	X	X	X	X	X	X	X	X	X	X	X	X	X	X	X	X	X	X	(4)
8	Replace antifreeze mixture and check cooling circuit for leaks				X							X					X					X	
9	Check front wheel toe-out and adjust, if necessary	X																					
10	Grease propeller shaft tunnel (models 1.5 4X4)	X	X		X							X					X					X	
11	Check condition of protective boots of constant velocity joints and steering joint caps	X	X	X	X	X	X	X	X	X	X	X	X	X	X	X	X	X	X	X	X	X	
12	Check tightness of brake system tubing	X	X	X	X	X	X	X	X	X	X	X	X	X	X	X	X	X	X	X	X	X	
13	Check front brake pads (possible pad replacement)		X	X	X	X	X	X	X	X	X	X	X	X	X	X	X	X	X	X	X	X	
14	Check rear brake drums and linings (possible lining replacement)		X	X	X	X	X	X	X	X	X	X	X	X	X	X	X	X	X	X	X	X	(5)
15	Check hand brake travel and adjust, if necessary	X	X	X	X	X	X	X	X	X	X	X	X	X	X	X	X	X	X	X	X	X	
16	Check tyre pressures		X	X	X	X	X	X	X	X	X	X	X	X	X	X	X	X	X	X	X	X	(4)
17	Check accelerator cable and adjust if necessary	X	X	X	X	X	X	X	X	X	X	X	X	X	X	X	X	X	X	X	X	X	
18	Check and adjust if necessary valve clearance	X	X	X	X	X	X	X	X	X	X	X	X	X	X	X	X	X	X	X	X	X	

N.	OPERATION	A (1)	Km/1000																		Notes	
			10	20	30	40	50	60	70	80	90	100	110	120	130	140	150	160	170	180		190
19	Check tension of and if necessary replace drive belts of: alternator, coolant pump and air conditioner compressor (if fitted)	X		X					X				X			X				X		
20	Replace drive belt of alternator and air conditioner compressor (if fitted)					X				X			X					X				X
21	Replace camshaft drive belts							X					X							X		
22	Check fuel system for leaks	X		X		X			X		X		X		X		X		X		X	
23	Clean and check air filter element		X		X		X		X		X		X		X		X		X		X	(3)
24	Check tightness of air intake system downstream from the air flow gauge (petrol Injection only)			X		X			X		X		X		X		X		X		X	
25	Replace fuel filter (where necessary)					X				X			X				X				X	
26	Replace air filter cartridge			X		X			X		X		X		X		X		X		X	
27	Clean carburetor jets and crankcase ventilation system backfires shield			X		X			X		X		X		X		X		X		X	
28	Check exhaust emissions	X		X		X			X		X		X		X		X		X		X	
29	Check and if necessary adjust ignition timing			X		X			X		X		X		X		X		X		X	
30	Inspect and clean spark plugs		X		X		X			X		X		X		X		X		X		
31	Replace spark plugs			X		X			X		X		X		X		X		X		X	
32	Check battery electrolyte level, top up, tighten and grease terminals			X		X			X		X		X		X		X		X		X	(4)
33	Lubricate door and hood/backdoor hinges. Adjust strikers, as necessary. Greasing of hood and backdoor catches			X		X			X		X		X		X		X		X		X	
34	Check underbody and body work			X		X			X		X		X		X		X		X		X	
35	Test vehicle	X		X		X			X		X		X		X		X		X		X	

(1) A = 1500 ÷ 2500 Km (621 ÷ 932 mi)

(2) To be performed in any case every 6 months. Check oil level frequently when refuelling

(3) Check more frequently if driving in very dust areas

(4) Check frequently when refuelling

(5) To be performed more frequently when driving under particular stress conditions (sport driving) or on hilly roads

(6) To be performed in any case every 12 months

MAINTENANCE SCHEDULE

The following schedule is not valid for the Italian market and for countries where antipollution regulations are in force

N.	A	Km/1000													Notes								
		10	20	30	40	50	60	70	80	90	100	110	120	130		140	150	160	170	180	190	200	
1	1)	X	X	X	X	X	X	X	X	X	X	X	X	X	X	X	X	X	X	X	X	X	(2)
2	X				X			X															
3			X			X																	
4	X	X	X	X	X	X	X	X	X	X	X	X	X	X	X	X	X	X	X	X	X	X	(4)
5	X	X	X		X	X	X	X	X	X	X	X	X	X	X	X	X	X	X	X	X	X	
6				X																			(6)
7	X	X	X		X	X	X	X	X	X	X	X	X	X	X	X	X	X	X	X	X	X	(4)
8				X																			
9	X																						
10	X	X	X	X	X	X	X	X	X	X	X	X	X	X	X	X	X	X	X	X	X	X	
11	X	X	X	X	X	X	X	X	X	X	X	X	X	X	X	X	X	X	X	X	X	X	
12	X																						
13					X	X	X	X	X	X	X	X	X	X	X	X	X	X	X	X	X	X	
14					X	X	X	X	X	X	X	X	X	X	X	X	X	X	X	X	X	X	(5)
15	X	X	X	X	X	X	X	X	X	X	X	X	X	X	X	X	X	X	X	X	X	X	
16	X	X	X	X	X	X	X	X	X	X	X	X	X	X	X	X	X	X	X	X	X	X	(4)
17	X																						
18	X	X	X	X	X	X	X	X	X	X	X	X	X	X	X	X	X	X	X	X	X	X	

N.	OPERATION	A (1)	Km/1000																		Notes		
			10	20	30	40	50	60	70	80	90	100	110	120	130	140	150	160	170	180		190	200
19	Check tension of and if necessary replace drive belts of; alternator. coolant pump and air conditioner compressor (if fitted)	X		X			X				X				X				X				
20	Replace drive belt of alternator and air conditioner compressor (if fitted)					X			X				X				X					X	
21	Replace camshaft drive belts						X						X							X			
22	Check fuel system for leaks	X		X		X		X		X		X		X		X		X		X		X	
23	Clean and check air filter element		X		X		X		X		X		X		X		X		X		X		(3)
24	Check tightness of air intake system downstream from the air flow gauge (petrol injection only)			X		X		X		X		X		X		X		X		X		X	
25	Replace fuel filter (where necessary)				X				X				X				X					X	
26	Replace air filter cartridge			X		X		X		X		X		X		X		X		X		X	
27	Clean carburetor jets and crankcase ventilation system backfire shield			X		X		X		X		X		X		X		X		X		X	
28	Check exhaust emissions	X		X		X		X		X		X		X		X		X		X		X	
29	Check and if necessary adjust ignition timing	X		X		X		X		X		X		X		X		X		X		X	
30	Inspect and clean spark plugs		X		X		X		X		X		X		X		X		X		X		
31	Replace spark plugs			X		X		X		X		X		X		X		X		X		X	
32	Check battery electrolyte level, top up, tighten and grease terminals	X		X		X		X		X		X		X		X		X		X		X	(4)
33	Lubricate door and hood/backdoor hinges. Adjust strikers, as necessary. Greasing of hood and backdoor catches	X		X		X		X		X		X		X		X		X		X		X	
34	Check underbody and body work			X		X		X		X		X		X		X		X		X		X	
35	Test vehicle	X		X		X		X		X		X		X		X		X		X		X	

(1) A = 1000 ÷ 1500 km (621 ÷ 932 mi)

(2) To be performed in any case every 6 months. Check oil level frequently when refuelling

(3) Check more frequently if driving in very dusty areas

(4) Check frequently when refuelling

(5) To be performed more frequently when driving under particular stress conditions (sport driving) or on hilly roads

(6) To be performed in any case every 12 months

MAINTENANCE SCHEDULE

The following schedule is valid only for those countries where antipollution regulations are in force

N.	OPERATION	A (1)	Km/1000																Notes					
			10	20	30	40	50	60	70	80	90	100	110	120	130	140	150	160		170	180	190	200	
1	Replace engine oil and oil filter; check oil system for leaks	X	X		X	X	X	X	X	X	X	X	X	X	X	X	X	X	X	X	X	X	X	(2) (7) E
2	Replace gearbox and differential oil	X			X																			
3	Check gearbox and differential oil level		X																					
4	Check and top up the fluid level of windscreen, and rear window wash. Check correct operation of the system	X	X	X	X	X	X	X	X	X	X	X	X	X	X	X	X	X	X	X	X	X	X	(4)
5	Check brake fluid and clutch fluid level	X	X	X	X	X	X	X	X	X	X	X	X	X	X	X	X	X	X	X	X	X	X	
6	Replace brake and clutch fluid				X				X															(7)
7	Check and top up the cooling system and verify system tightness	X	X	X	X	X	X	X	X	X	X	X	X	X	X	X	X	X	X	X	X	X	X	(4) E
8	Replace cooling fluid and check cooling circuit for leaks				X				X															(5) E
9	Check all bolts for tightness	X																						
10	Check front wheel toe-out and adjust, if necessary	X																						
11	Check condition of protective boots of constant velocity joints and steering box	X	X		X				X															
12	Inspect	X	X		X				X	X														
13	Check of pads wear degree and rear drums friction gaskets. Replace if necessary		X		X				X	X	X	X	X	X	X	X	X	X	X	X	X	X	X	(6)
14	Check and if necessary adjust handbrake travel	X	X		X				X															
15	Check tire pressure	X	X		X				X	X	X	X	X	X	X	X	X	X	X	X	X	X	X	(4)
16	Check accelerator cable adjust if necessary	X																						
17	Check integrity and if necessary adjust alternator control and conditioner compressor (if mounted belts).	X	X		X																			E

COMPLETE CAR

N.	OPERATION	A (1)	Km/1000																Notes				
			10	20	30	40	50	60	70	80	90	100	110	120	130	140	150	160		170	180	190	200
18	Check valve timing and timing belt tensions	X	X		X												X					X	E
19	Replace alternator control and conditioner compressor (if mounted) belts				X							X					X					X	E
20	Replace timing control belts						X												X				
21	Check tightness of fuel supply system. Check evaporation system	X	X		X						X				X							X	E
22	Check and clean air filter element		X		X					X					X							X	(3) E
23	Replace air filter element		X			X					X						X					X	E
24	Check tightness of air supply system downstream from the air flow gauge	X	X		X					X					X							X	E
25	Replace fuel filter	X			X												X					X	E
26	Check and, if necessary, adjust, idle speed, ignition timing and exhaust emissions	X	X		X					X					X							X	E
27	Clean and check spark plugs		X		X												X					X	E
28	Replace spark plugs		X		X					X					X							X	E
29	Check and if necessary tap up battery electrolyte level, tighten and grease terminals	X	X		X					X					X							X	(8) E
30	Check head lamps beam aiming and adjust it, if necessary	X																					
31	Lubricate door and hood hinges. Adjust strikers, as necessary. Grease the hood locking catches.	X	X		X					X					X							X	
32	Check underbody and body work		X		X					X					X							X	
33	Tune vehicle	X	X		X					X					X							X	

No.	OPERATION	A (1)	Km11000																		Notes		
			10	20	30	40	50	60	70	80	90	100	110	120	130	140	150	160	170	180		190	200
34	Check sensor of oxygen contents in exhaust gas										X											X	E
35	Replace catalyst of exhaust gas										X											X	(B) E

(1) A= 1000÷1500 K m

(2) Check **oil level** every 500 km and when refuelling

(3) Check more frequently if driving in **very dusty areas**

(4) Check frequently **when** refuelling

(5) To be performed in **any** case every **two** years

(6) To be **performed** more frequently when driving **under particular** stress conditions (sport driving) or on **hilly** roads

(7) To be performed in **any** case every 12 months

(8) To be performed in **any** case every 5 years

E) Operation relevant to **emission** control

COMPLETE CAR

MAINTENANCE SCHEDULE

The present periodical maintenance schedule, for all markets, is applicable to vehicles equipped with SERVICE BOOKLET having the new programmed maintenance.

N.	OPERATION	A (1)	Km/1000										Note	
			20	40	60	80	100	120	140	160	180	200		
1	Replace engine oil and oil filter; check tightness of lubricating circuit (every 10.000 km for diesel versions)	X	X	X	X	X	X	X	X	X	X	X	X	(2)
2	Replace oil in gearbox - differential (and rear differential in 4wd versions)			X		X		X		X		X		
3	Check oil level in gearbox - differential (and rear differential in 4wd versions)		X		X		X		X		X		X	
4	Check fluid level of windscreen, headlights and rear window wipers. Check correct operation of system	X												(4)
5	Check brake and clutch fluid levels	X	X	X	X	X	X	X	X	X	X	X	X	(6)
6	Check antifreeze mixture level and cooling system tightness	X												(4)
7	Replace antifreeze mixture				X			X				X		(7)
8	Check toe-out for front wheels	X												
9	Grease propeller shaft sleeve (4wd versions)		X	X	X	X	X	X	X	X	X	X	X	
10	Check conditions of semi-axle's protective boots and steering joint hoods	X	X	X	X	X	X	X	X	X	X	X	X	
11	Check tightness of braking system pipes	X	X	X	X	X	X	X	X	X	X	X	X	
12	Check wear of front brake pads		X	X	X	X	X	X	X	X	X	X	X	(5)
13	Check wear of friction gaskets for rear brake drums			X		X		X		X		X		(5)
14	Check hand brake travel	X	X	X	X	X	X	X	X	X	X	X	X	
15	Check adjustment of accelerator cable	X												
16	Check valve clearance (if required)		X	X	X	X	X	X	X	X	X	X	X	
17	Clean injectors (only in diesel engine vehicles)			X		X		X		X		X		
18	Check glow plugs (only in diesel engine vehicles)			X		X		X		X		X		
19	Check axial and radial play of supercharger rotor shaft and by-pass valve (only in diesel engine vehicles)							X					X	
20	Check idle r.p.m. (petrol versions)	X	X	X	X	X	X	X	X	X	X	X	X	
21	Check idle r.p.m. (diesel engine versions)	X												
22	Replace exhaust gas oxygen sensor (Lambda sensor) (only in vehicles with catalytic converters)							X					X	
23	Check integrity and tension of cooling liquid pump, alternator and conditioner compressor (if installed) drive belt	X	X	X	X	X	X	X		X		X	X	

COMPLETE CAR

N.	OPERATION	A (1)	Km/1000										Note	
			20	40	60	80	100	120	140	160	180	200		
24	Replace timing belts				X				X			X		
25	Check tightness of fuel supply circuit Check fuel vapour emission control circuit (if installed)	X												
26	Check air filter cartridge		X		X			X		X		X		(3)
27	Check tightness of air supply system downstream the air flow meter (only in fuel injection engines)	X												
26	Replace fuel filter (where foreseen)		X	X	X	X	X	X	X	X	X	X	X	
29	Replace air filter cartridge			X		X		X		X		X		
30	Clear flamedamper in exhaust gas recycling circuit (except in diesel or fuel injection cars)			X		X		X		X		X		
31	Check exhaust emission (only in vehicles with catalytic converter)	X	X	X	X	X	X	X	X	X	X	X	X	
32	Check spark advance (except diesel models)	X	X	X	X	X	X	X	X	X	X	X	X	
33	Replace spark plugs (except diesel engines)		X	X	X	X	X	X	X	X	X	X	X	
34	Check electric connections in engine compartment (condition and position of connectors and hoods)			X		X		X		X		X		
36	Grease door and hood hinges, grease hood locking catches.		X	X	X	X	X	X	X	X	X	X	X	
36	Test vehicle	X	X	X	X	X	X	X	X	X	X	X	X	

(1) A = 1500 - 2500 Km

(2) Check oil level every year and when refuelling

(3) Check more frequently if driving in very dusty areas

(4) Check frequently when refuelling

(5) To be performed more frequently when driving particular in stress conditions (sport driving) or on mountain roads

(6) To be replaced in any case every 12 months

(7) To be performed in any case every 2 years

NEW IDENTIFICATION LABEL

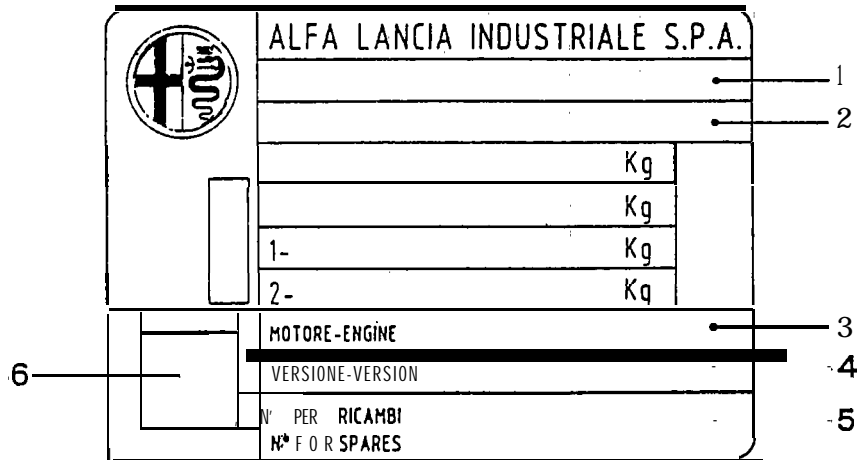

1 - Homologation code

2 - Body marking

3 - Engine type number

4 - Base type and vehicle version

5 - Serial number with relation to finished units: necessary when ordering spare parts, for identification of production or assembly plant and as reference for introduction of modifications.

6 Marking of correct value of smoke absorption coefficient (for diesel engines'only).

BODY MARKING

ZAR 905A00 + 05455.737
 (1) (2) (3)

(1) - Constructor identification code

(2) - Vehicle model

(3) - Chassis serial number

MODEL VARIATIONS

(According to E.E.C. markings adopted on new identification labels)

		ENGINES WITH ONE CARBURETOR		ENGINES WITH TWO CARBURETORS		
Model		33♦♦	3 3 1.3	3 3 1.3 s	3 3 1.9 TI	3 3 1.5 4x4
Body		5 DOOR SALOON				
Drive		LEFT	LEFT	LEFT	LEFT/RIGHT	LEFT
vehicle type No.	— on identification label	905AP	905A1G	905A1H	905A2V	905A2T
		905A00	905A10		905A20	
		05.455.737				
Chassis serial No:	— on service compartment front cross member, right side, horizontal plane					
Engine type and serial No.	— on special risid block on engine block, upper right part flywheel side	30565	30566	30567	30588	
		0000001	0000001	0000001	0000001	
Tyre dimensions		165/70 SR 13			175/70 R13 82T	
Rim dimensions		5½ J x 13"				

(*) With 1.2 engine **commercialised** only in certain countries.

October 1988

00-10/4

3279008833-1

COMPLETE CAR

MODEL VARIATIONS

(According to E.E.C. marking adopted on new identification labels)

		ENGINES WITH TWO CARBURETORS	ENGINES WITH ELECTRONIC FUEL INJECTION		ENGINES WITH TURBO COMPRESSOR
Model		33 9.7 ♣	33 1.7 IE	33 1.7 ♣	331.8TD
Body		5 DOOR SALOON			
Drive		left/right	leftright	leftright	left
vehicle type No.	— on identification label	905A3	905A3D		905A4
		— on service compartment front cross member, right side, horizontal plane.			905A40
	— on service compartment front cross member, right side, horizontal plane			05.455.737	
Chassis serial No.					
Engine type and serial No.	— on special raised block on engine block, upper right part flywheel side	30550 from 0000001	305.58 from 0000001*	305.58 from A000001	VM82A from 00001
Tyre dimensions		185/60 R1482H	185/60 R1482H		175/70 R1382T
Rim dimensions		5½ J x 14"			5½ J x 13"

(*) Excluding Nos. 908.2201908.150 which take serial No. A000001 as with No. 908.180.

PA327900883301

00-1015

October 1988

COMPLETE CAR

RECOMMENDED FUEL AND LUBRICANTS

00-I 1

FUEL

For correct engine functioning the specification is for premium grade or unleaded petrol: RON \geq 95.

For models **33 1.7** and **33 1.7 IE** with electronic injection and catalytic convertor only unleaded petrol to the following specifications must be used:

- Octane Number (Research method) R.O.N. \geq 95 (for Switzerland, Sweden versions)
- Octane Number (Research method) R.O.N. \geq 91 (for Australia version)

WARNING:

Never neither in an emergency nor in small quantities use conventional lead petrol. To do so will result in permanent damage to the exhaust gas catalyzer.

To prevent the tank from being accidentally filled with lead petrol, the inlet filler has been designed in such a way as to permit, the entry of only special filler spouts fitted exclusively on unleaded petrol pumps. Should the tank be filled with even a small quantity of lead petrol, do not start the engine, but proceed to the complete emptying of the tank and the fuel delivery system.

FLUIDS AND LUBRICANTS

As per **Alfa 33** except:

Type	Application	Classification	Name			Notes
			AGIP	IP	SHELL	
Oil	Engine - 01	API SF/CC MIL L46152B CCMC G2D1	Sint 2000 SAE 10W/40	Sintiax SAE 10W/40	Super Plus- Motor Oil SAE 15W/50	Environmental temperature — 18 ÷ + 40°C
	Gearbox - 13 Differential	SAE J 306a API GL-5	Rotra MP SAE 80W/90	Pontiax HD SAE 80W/90	Spirax HD SAE 80W/90	Environmental temperature — 30 ÷ + 40°C

APPROXIMATE REFILL CAPACITIES

Models		33♦* 3 3 1.3 3 3 1.3 S 33 1.5 TI 33 1.5 a x a 3 3 1.7♦ 3 3 1.7 IE	33 1.8 TD		
Measurement unit		Kg	Liters	Kg	Liters
FUEL TANK		—	50	—	50
FUEL RESERVE		—	6,5	—	6,5
ENGINE OIL SUMP	With filter (●)	3,6	4	4,57	5,25
	Without filter (●)	3,15	3,5	4,35	5
GEARBOX - DIFFERENTIAL OIL		2,4	2,6	2,4	2,6
REAR DIFFERENTIAL OIL (4x4 models)		0,9	1,0	—	—
ENGINE COOLING SYSTEM		—	7,3	—	7,5
CONCENTRATE ANTIFREEZE QUANTITY DEPENDING ON TEMPERATURE	→ - 15 °C	—	2,2	—	2
	→ - 20 °C	—	2,6	—	2,64
	→ - 35 °C	—	3,65	—	4
ANTIFREEZE QUANTITY READY FOR USE	→ - 2 0 %	—	7,3	—	7,5

(●) The indicated quantity refers to periodical changes

(*) Not marketed in all countries with 1.2 engine.

ENGINE MAINTENANCE

BASIC MECHANICAL SYSTEM

CHECK AND POSSIBLE ADJUSTMENT OF VALVE CLEARANCE

As for **Alfa 33** except for the 1.7 engine with hydraulic tappets which does not require any check or adjustment of valve clearance

CHECKING, REPLACING AND ADJUSTING DRIVE BELTS

Alternator and water pump control belt.

As for **Alfa 33** except for 1.3 - 1.5 - 1.7 engines with one carburetor where the tension value to be measured with the appropriate tool is:
 $78 \div 88$ N (8 ÷ 9 kg)

Replacing timing belts with engine on car

As for **Alfa 33**, only for 1.7 engines the procedure for the,  model is to be applied

CHANGING ENGINE OIL AND REPLACING OIL FILTER

As per **Alfa 33** except for the table referring to the refill capacities which has to be modified as follows:
 for 1.7 engines

ENGINE OIL QUANTITY

Capacity	l (Imp. Gal.)
Engine oil sump at max level	3.5 (0.77)
Oil filter and inner ducts	0.6 (0.13)
Periodical change (engine oil for sump and filter)	4.0 (0.88)

Before extracting the dipstick, disconnect the minimum oil level sensor wiring from the stick.

COOLING SYSTEM

Proceed as per **Alfa 33** except for the table referring to antifreeze fluid composition provided in "System Refill", which has to be changed as follows. for 1.7 engines

Minimum out-°C side temperature (°F)	-15 (+5)	-20 (-4)	-35 (-31)
Concentrated anti-freeze Std. No. 3681-69956	2.2 (0.48)	2.6 (0.57)	3.65 (0.80)
Diluting drinkable water	5.1 (1.12)	4.7 (1.03)	3.65 (0.80)
Ready-to-use anti-freeze Std. No. 3681-69956	—	7.3 (1.61)	—

1. Release clips which secure cover ① to container.
2. Lift cover enough to remove cartridge without damaging sleeve ②.
3. Clean the cartridge thoroughly, by blowing low pressure compressed air in the opposite direction with respect to the normal air flow.

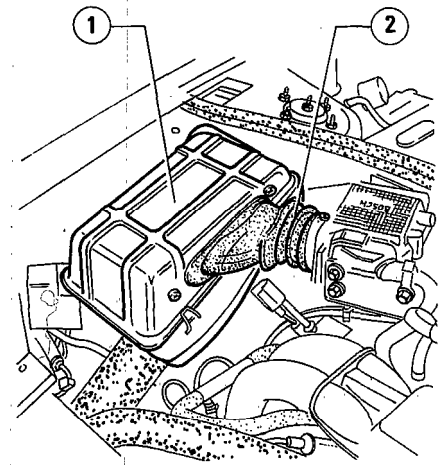

1 Air filter cover
2 Corrugated sleeve

CYLINDER COMPRESSION TEST

As per **Alfa 33**.

4. Clean the cartridge container.
5. Insert the cartridge into container positioning the protruding part downwards and hook the cover clips again.

Replace the element at the recommended intervals (see: Vehicle Maintenance Schedule).

FUEL SYSTEM

CHECK, CLEANING AND REPLACEMENT OF AIR FILTER CARTRIDGE

As per **Alfa 33** except for 1.7 electronic injection engines which require the following procedure.

FUEL FILTER REPLACEMENT

As per **Alfa 33** except for 1.7 electronic injection engines which require the following procedure.

1. Unscrew tubes ② and ③ fittings and recover the gaskets.

Properly plug fittings to prevent fuel outlet.

2. Loosen clamp ① and remove filter ④.
3. Remount the new filter in order that the arrow printed on filter body be positioned towards fuel delivery direction.
4. Complete the filter assembly operating in opposite order in respect to removal.

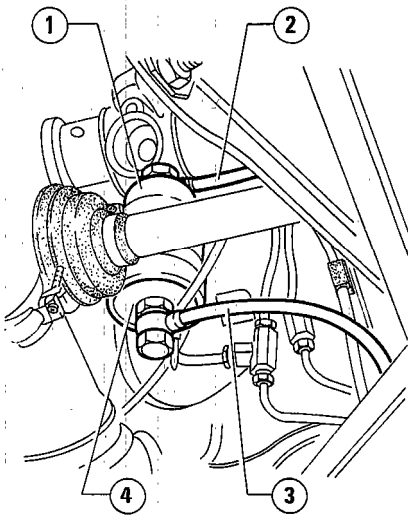

1 Filter support clamp
2 Fuel outlet tube
3 Fuel inlet tube
4 Fuel filter

CHECKING FUEL SUPPLY PRESSURE AND CIRCUIT TIGHTNESS

As for **Alfa 33** except for 1.7 electronic injection engines which require the following procedure

Effect checking as follows:

1. Circuit pressure checking

- a. Disconnect fuel delivery tube ④ downstream from the damper ③
- b. Connect a gauge by means of a T adaptor between damper ③ and tube ④ previously disconnected.
- c. Detach tube ① from pressure gauge ②.
This is in order to avoid that any possible anomalies on idle rotation speed could cause unusual readings.
- d. Start the engine; at idle speed check that fuel pressure value is:

280 ÷ 320 KPa
(2.8 ÷ 3.2 bars; 2.9 ÷ 3.3 Kg/cm²)

- e. Reconnect tube ① to pressure gauge; at idle, fuel pressure should drop of 0.5 bars approximatively and then rise again when throttle valve will open. Should this occur, please check any possible tube ① depression leaks.

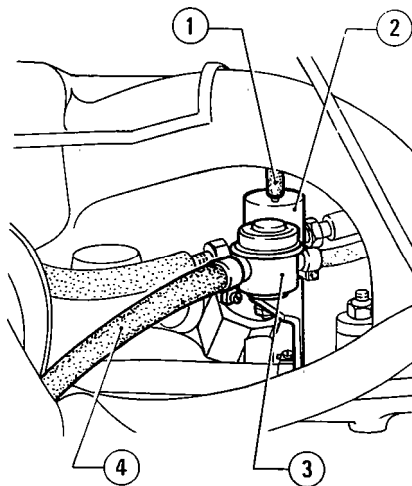

1 Depression tube
2 Fuel pressure gauge
3 Throb damper
4 Tube delivery to fuel distribution manifold

2. Checking on circuit tightness

- a. With pressure gauge plugged, and with engine on idle, throttle the delivery tube immediately downstream from pressure gauge, detecting a pressure increase up to

400 KPa
(4 bars; 4.1 Kg/cm²)

(do not let the pressure exceed this value)

- b. With pressure on 2.5 bars check that fuel delivery tubes and fittings do not show leaks.
- c. If fuel pressure does not reach this value and if no leaks are detected check the filter and/or the pump operation.

CHECKING AND POSSIBLE ACCELERATOR CONTROL ADJUSTMENT

As for **Alfa 33** except for 1.7 electronic injection engines which require the following procedure

1. Check cable sliding
Check that the accelerator control cable slides freely in its sheath

2. Check cable clearance

- a. With the accelerator pedal released, check that the accelerator pedal on control lever has an axial clearance of $G_1 = 1 \div 2 \text{ mm}$.

- b. If necessary, proceed to adjust the cable clearance extracting the adjustment clip ② in order to give the prescribed clearance to the cable, and reinsert the clip in the new position.

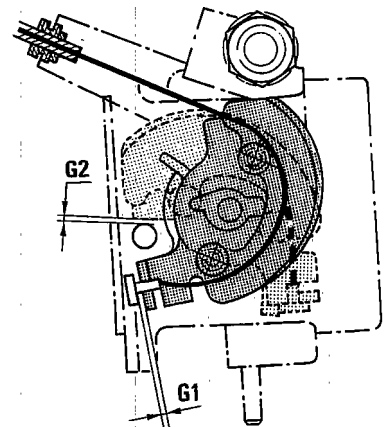

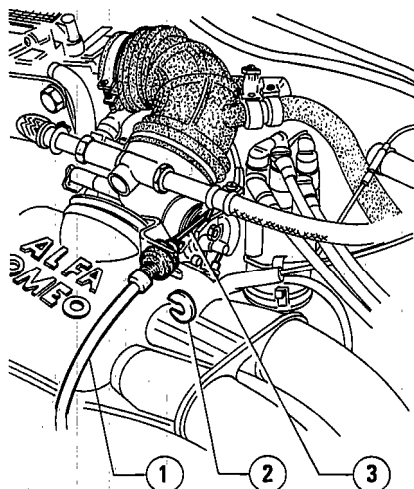

- 1 Accelerator cable
- 2 Adjustment clip
- 3 Accelerator cable sheath

3. Checking on maximum throttle valve opening

a. With accelerator pedal pressed as far as it will go, check that the accelerator control cam can still rotate by

$$. G_2 = 1 \div 2 \text{ mm}$$

If necessary, proceed to adjustment by acting on stop screw (2) below the accelerator pedal.

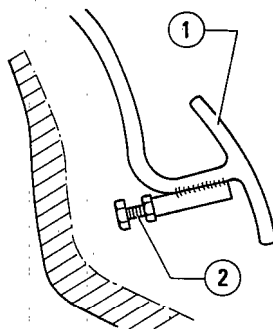

- 1 Accelerator pedal
- 2 Stop screw

CHECKING OF EMISSIONS

CHECK AND ADJUSTMENT OF IDLE R.P.M. AND EXHAUST EMISSIONS

Effect the following preliminary checks:

- a. Cleaning and replacement of air filter cartridge.
- b. Ignition system efficiency: spark plugs, cables, cap, rotary rotor (see Group 05 - transistorised ignition without contacts).
- c. Ignition timing.
- d. Checking of accelerator control adjustment (see Group 04 - Checking and accelerator control adjustment).

CAUTION

If during engine tuneup there is no extra cooling fan available, keep checking the thermometer and the water temperature warning light on dashboard and immediately suspend testing if temperature goes up, meaning that engine is overheating.

Single carburetor models

Check idle-rpm and overall CO% as follows:

1. Insert CO-tester probe (2) into the tail pipe (1).
2. Connect an electronic tachometer to the engine.
3. Start the workshop gas exhauster.
4. Start the engine and warm it up to normal running temperature.
5. Now check that engine rpm is within specified value.

Idle-rpm

$$900 \div 1000 \text{ r.p.m.}$$

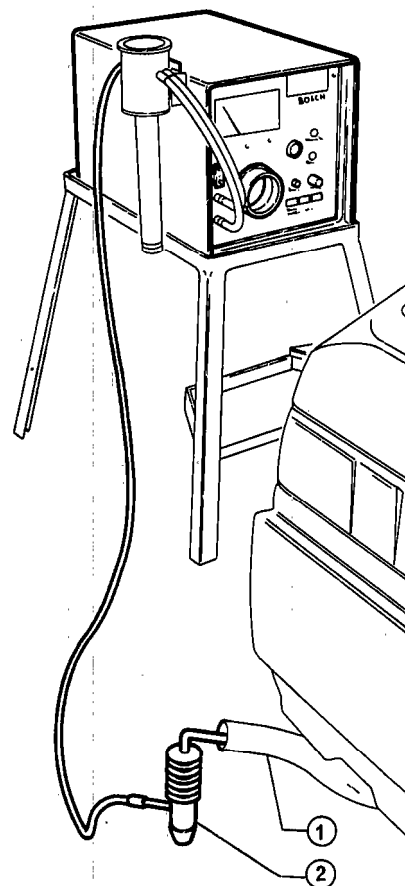

- 1 Tail pipe
- 2 CO-tester probe

6. If not within specified value, adjust idle-rpm just by turning relevant idle-adjusting screw (2) which makes it possible to change rpm without changing CO percentage (Carbon monoxide).

7. Verify that CO percentage picked up by tester corresponds to specified value and that engine runs smoothly.

Allowed CO%

$$1.5 \div 1.8$$

If notwithstanding specified value or in case of engine tune up after engine overhauling or after having cleaned or replaced the carburetor, an adjustment involving mixture metering screw ① and throttle valve screw ③ is required. In this instance, proceed as follows:

(1) Remove seals from mixture metering, screw ① and from throttle valve screw ③.

(2) Tighten idling screw ② all the way.

(3) Now act on throttle valve screw ③ and on mixture metering screw ① till following conditions are present:

Rpm
 $750 \div 800$
 C O %
 $0.5 \div 1\%$ total

(4) Loosen idling adjusting screw ② till a $900 \div 1000$ rpm idling speed is reached.

(5) Act on mixture metering screw ① till the smoothest possible engine running is obtained, while keeping CO% within the prescribed values.

% CO $0.5 \div 1$

(6) Fit back into place mixture metering and throttle valve screw seals.

(7) If further optimizing of idle-rpm is desired, just act on relevant idling adjusting screw ②.

Double carburetor models

Check idling-rpm, CO% on each cylinder and line-up of carburetor throttle valves as follows:

Before beginning this test check accelerator cable adjustment (Refer to: Group 04 - Accelerator Cable Adjustment)

misalignment (40 mm Hg) between cylinders of the same carburetor then it will be necessary to replace the carburetor.

4. Make sure that all cylinders are functioning correctly by grounding one spark plug at a time and checking that the increase in r.p.m. is identical for each cylinder.

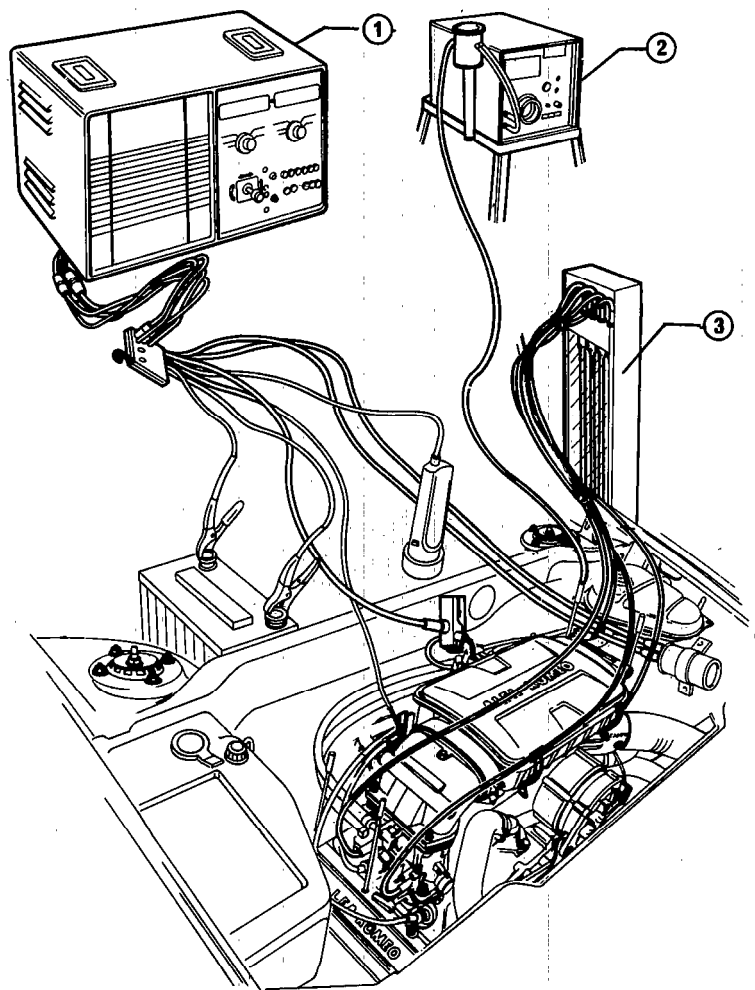

1 Electronic rev counter
 2 CO tester

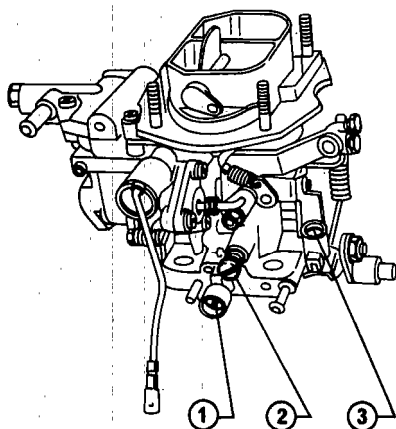

1 Idling mixture metering screw
 2 Idling adjusting screw
 3 Throttle valve adjusting screw

1. Insert the tube of the mercury vacuumometer in the appropriate fittings.
2. Start the engine and run it to normal running temperature so that the temperature is equal to or greater than 45°C.
3. With the gear shift in neutral, open the mercury vacuumometer valve and check that the Ap values of the manometers fall within 40mm Hg. Correct any differences between left and right carburetors by acting on the throttle valve screws. Should there be

If necessary act on the mixture metering screw of the out-of-tune cylinder until correct functioning is obtained.

5. Adjust the engine speed to 850 - 1000 r.p.m. by acting on the throttle valve screws, checking that the manometer readings fall within the specified values.
6. Using the CO% tester, check that the exhaust CO emissions are 1.5 - 2.5%.

COMPLETE CAR

To obtain better CO exhaust emission adjustment it is necessary to operate measuring the values cylinder by cylinder using special service tool C, 3.0054 connected as follows:

1 A. Raise car on lift and disconnect exhaust manifold from cylinder heads.

2 A. Now fit small flanges C.2.0054 with relevant gaskets and pipes for collection, of exhaust fumes - between each exhaust manifold flange and relevant fitting on cylinder heads.

3 A. Connect exhaust manifold back to cylinder heads.

The other ends of the four collection pipes emerge in the engine compartment and, being equipped with suitable plugs, are set up to test each cylinder CO%.

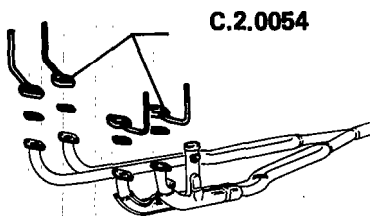

7. Check the idle r.p.m. and if necessary adjust it again repeating the operations described at step 5.

8. Re-set the play in the idle levers to 1 mm by tightening the stop screws and then check that the carburetors open simultaneously by acting on the point where the accelerator cable is attached, effecting short sharp spurts of acceleration (1200 - 1300 r.p.m.). Adjust the stop screws further to obtain Perfect synchronisation of the carburetors.~

9. Close the vacuum valves and remove the tubing from the fittings.

Check idle r.p.m.

The procedure is valid for 1.7 electronic injection engines with or without catalytic convertor.

1. Connect the engine to a rev counter.
2. Connect an exhaustor to the exhaust tail-pipe.
3. Start the engine and run it to normal running temperature (Engine oil temperature 75-80°C).
4. With the gears in neutral and the ancillary devices cut out check that the engine r.p.m. falls within the specified values.

For 1.7 electronic injection engines with catalytic convertor.

$$\text{idle r.p.m. } 950 \begin{matrix} +100 \\ -50 \end{matrix}$$

For 1.7 electronic injection engines

$$\text{idle r.p.m. } 800 - 900$$

5. If the idle r.p.m. does not fall within these values, adjust by operating as follows:

- (a) Loosen the locknut ① and turn the screw ② until the correct r.p.m. is obtained.
- (b) Lock the locknut ①

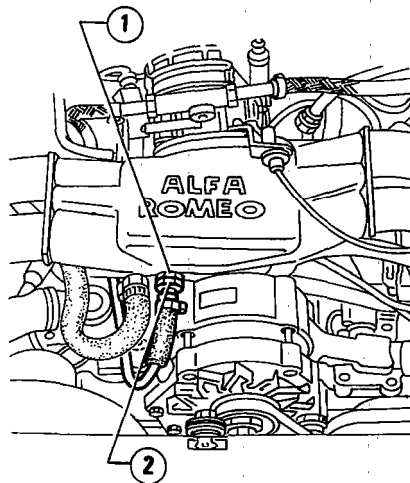

1 Locknut
2 Idle r.p.m. adjusting screw

Check exhaust emission

Procedure is applicable to 1.7 electronic injection engines without catalytic convertor only.

After adjustment of the idle r.p.m. following the above described procedure, proceed to the check and adjustment (if necessary) of the exhaust emissions by operating as follows.

1. Switch on the gas exhauster, start the engine and run it to normal running temperature.
2. With engine on idle and using a suitable exhaust gas tester, check that the percentage of CO and the quantity of hydrocarbons are less than the specified values.

Admissible CO% 0.8 - 1.7

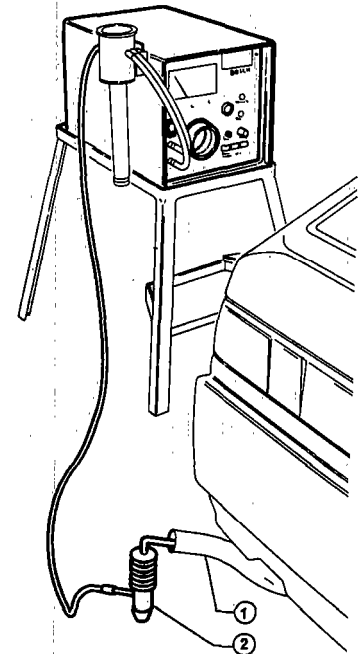

1 Exhaust tail-pipe
2 Probe of exhaust tester

3. Should the CO% be above the admissible limit it will be necessary to act on the appropriate screw positioned in the debimeter.

4. It will then be necessary to check that idle r.p.m. falls within the specified values 850 ± 50 r.p.m. and if it does not the "Idle r.p.m. Check" will have to be repeated.

Check of exhaust emissions

The procedure is valid for 1.7 electronic injection engines with catalytic convertor.

After adjustment of the idle r.p.m. following the above described procedure, proceed to the check and adjustment (if necessary) of the exhaust emissions by operating as follows.

This simplified procedure is for use with engines equipped with FIAT TESTER type wiring.

Use wiring instrument No. C. 90034 illustrated in the circuit diagram below:

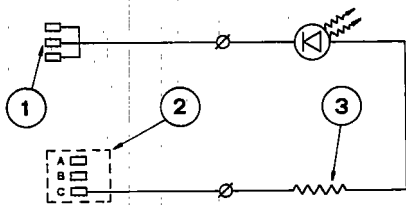

3 WAY CONNECTOR FOR 470 OHMS 1/2 W
MIN AND MAX SWITCH 3 WAY CONNECTOR FIAT TESTER
PIN C

1. Warm up engine
2. Remove min. and max switches wiring side connector and the 3 way connector Of the instrument.
4. Insert the connector of the instrument in the 3 way trouble diagnosis connector.
5. Check the state of the LED diode and proceed to adjust the screw of the potentiometer located in the plugged seating. The correct setting is obtained when the ~"ON" time of the flashing LED is equal to the "OFF" time. When this setting has been obtained replug the seating of the "CO" screw.

As an alternative to the above procedure, operate as follows.

1. Disconnect the wiring of the Lambda sensor.
2. Using the spanner A-5.021 2, unscrew the plug ① located at the inlet of the catalytic silencer box ②

4 Start the engine and check that with the engine running on idle the CO% and the quantity of unburned hydrocarbons are less than the specified values.

When the engine is in its normal running state and the lambda probe is disconnected, the value corresponding to the total emissions before the catalytic exhaust head shall be included in the range mentioned below.

volume % CO: 0.8 (min) to 1.5 (max)

5. Should the CO% not fall within the specified values, it will be necessary to act on the adjustment screw located in the debimeter in the plugged seating. It will then be necessary to check that the idle r.p.m. falls within the specified values of 900-1050 r.p.m. and if it does not to follow the procedure described at the previous step. Once the setting has been effected, re-plug the seating with the appropriate seal and reconnect the lambda sensor.

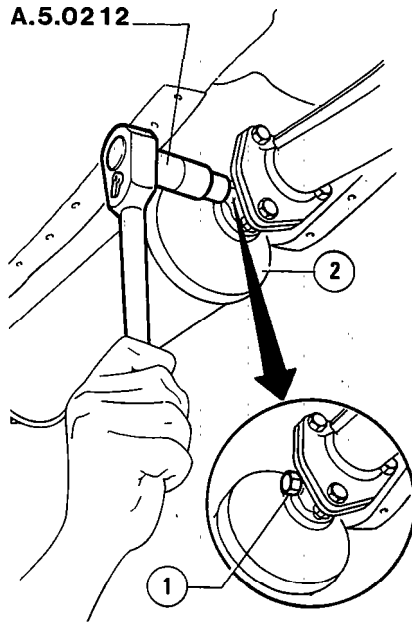

1. Plug for sampling exhaust gas
2. Catalytic silencer box

3. Fit the tool C.2.0051 on the fitting for sampling exhaust gases and connect it with tube ② to the exhaust gas tester

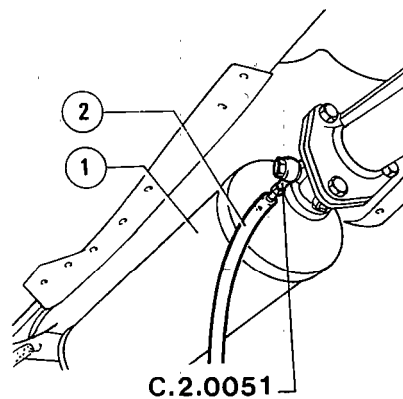

2 Catalytic silencer box
2 Tube connected to exhaust gas tester

CHECK AND ADJUSTMENT OF THE IDLE R.P.M.

For 331B TD only

Carry out the adjustment of the idle r.p.m. with the engine warmed up, the gears in neutral and all ancillary devices cut out, operating as follows. Unlock the locknut and turn the adjusting screw ① until the specified value

920 ÷ 960 r.p.m.

is encountered.

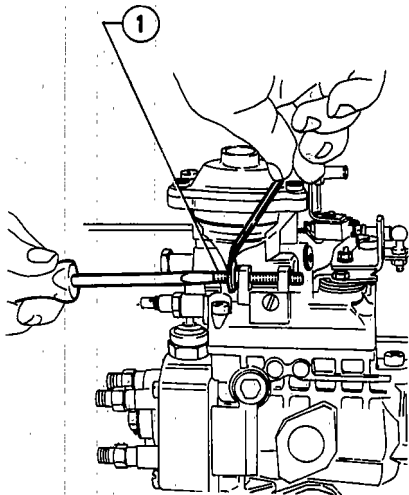

1 Adjusting screw

CATALYTIC MUFFLER REPLACEMENT

This procedure is for electronic injection 1.7 engines with catalytic muffler only.

When Km stated on "Chart of Vehicle Maintenance" Operations are covered, please proceed to replace catalytic muffler as follows:

1. Put the vehicle on auto lift.
2. Loosen clamp ③ bolt.
3. Unscrew the three bolts on flange ④ connecting catalytic muffler and exhaust manifolds.
4. Unscrew catalytic muffler ① from split rings ② and remove it disengaging it from rear track of exhaust pipe.~

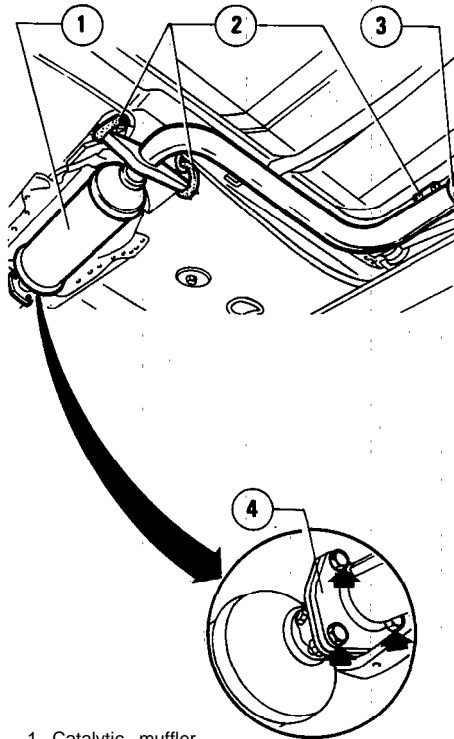

- 1 Catalytic muffler
- 2 Supporting split ring
3. Clamp
4. Flange connecting catalytic muffler - exhaust manifold
5. Install a new catalytic muffler working with opposite order in respect to removal, fitting a new gasket on flange connecting exhaust manifold.
6. Check that, with the engine running, there are no leaks from pipe connections and that the exhaust system is not unusually noisy

LAMBDA PROBE REPLACEMENT

This procedure is valid for electronic injection 1.7 engines with catalytic convertor only.

At km stated on "Chart of vehicle Maintenance Operations" replace lambda probe as follows:

1. Put the vehicle on auto lift.
2. Working from engine room, disconnect connectors ① and ② of lambda probe and disengage wiring from clips.

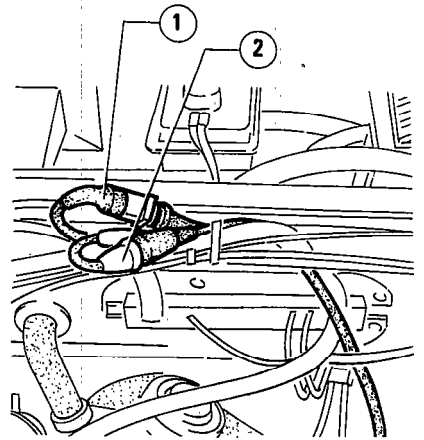

1 Lambda probe resistance connector
2 Lambda probe signal connector

- 3 Working from below the vehicle, unscrew Lambda probe ① and remove it.

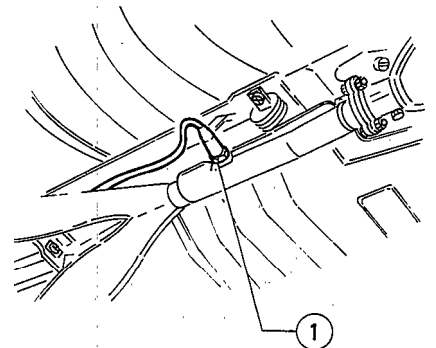

1 Lambda probe

4. On installation, spread the probe body thread with grease **R.GoriNever Seez** or Bosch 5.964.080.1005 and tighten it fully
5. Reconnect the wiring of the lambda probe.

CHECK ON AIR SUPPLY SYSTEM TIGHTNESS DOWNSTREAM FROM THE AIR FLOW SENSOR

This procedure is for electronic injection 1.7 engines with catalytic convertor only.

Make sure that all pipe fixing clamps are fully tightened

Start engine at idle r.p.m., then manually deform pipings and sleeve downstream from the air flow sensor

Should there be any faulty pipes with air inlets to engine undetected by sensor, some variations of idle r.p.m. will take place

To ease the location of any possible leaks in the air supply system, spread some suds on involved pipes.

TROUBLESHOOTING PROCEDURE TO CHECK FUEL SUPPLY SYSTEM TIGHTNESS

This procedure is valid for electronic injection 1.7 engines with catalytic convertor only.

This procedure is to be effected when reaching the km stated on "Chart of Vehicle Maintenance Operations", and if the following symptoms occur:

- Petrol smell.
- Visual signs of leaks from system fittings and connections.
- Effect the procedure stated in paragraph "Fuel Engine - Check on Fuel Supply Pressure and Circuit Tightness" - steps 1. and 2. completing it with what follows:

a. Make sure that fire-fighting appliances are available in order to be able to operate safely.

b. Warm engine up to normal running speed.

c. Disconnect ignition.

d. Effect a visual check. of fuel system components and fittings in order to locate leak origin.

e. Check the whole system (connecting pipes, fittings, components) using a gas detector.

f. Close to leak area, one will note a tester pointer reaction.

This test with tester must be effected slowly in order to compensate for the time delay of tester response.

g. Following leak location, follow procedure steps d. and/or e. then eliminate the leak replacing faulty components or properly tightening loosened clamps.

h. On completion of operation, start the engine letting it idle run for few minutes and then switch ignition off.

i. Repeat test as per steps c. and d. to check that diagnosis is correct and repair is efficient.

l. At end of whole procedure, road test for about 30 minutes and then make a final test to be sure of system integrity.

TROUBLESHOOTING PROCEDURE TO CHECK FUEL VAPOUR EMISSIONS CHECKING SYSTEM TIGHTNESS

Possible causes could be:

- Leaks of vapour from system components, accessories and connections.

a. Disconnect pipe 8 from dump valve 9. Connect a compressed air source to the end of pipe 8 with a gauge connected.

b. Pressurize the system with compressed air to reach a pressure of.

2.49 KPa (0.025 bars; 0.0255 Kg/cm²; 254 mm H₂O)

and then close the connection. If one can't (reach the specified value, open the compressed air supply system and check the system tightness (with gas detector).

c. Measure pressure drop in system (it must not exceed

0.125 KPa (0.00125 bars; 0.0127 Kg/cm²; 12.7 mm H₂O

in 10 minutes).

d. If within 10 minutes the pressure drop exceeds this value, locate leak spreading pipes with suds or using gas detector.

e. When there are leaks, some soap bubbles will appear.

f. Should the leak come from fuel cap filling union area, first replace the cap. If after replacing cap, tightness is restored, this means that cap was faulty, otherwise replace the union.

g. Replace faulty components or tighten loosened clamps.

h. Repeat procedure b. and c. to check diagnosis efficiency.

l. If after effecting the above mentioned process, leaks still exist, effect diagnostic procedure to check the supply system tightness of fuel injection system.

COMPLETE CAR

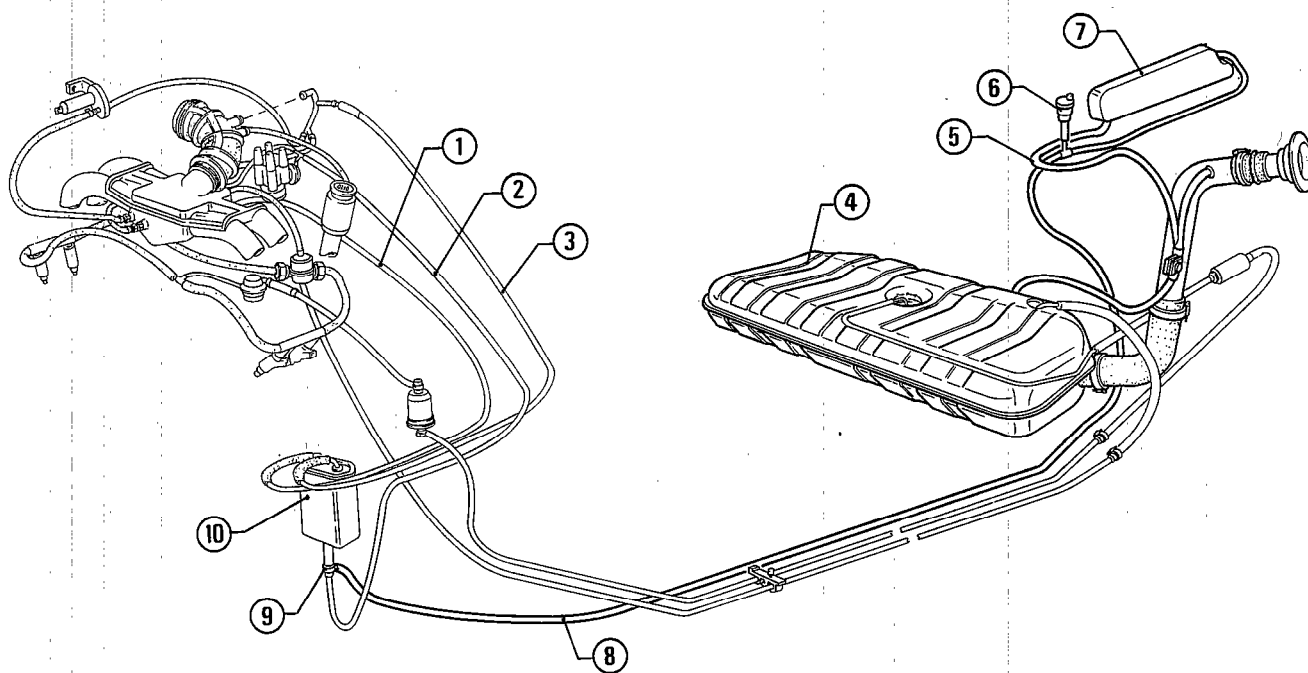

- | | | |
|---|----------------------------|-----------------------------|
| 1 Fuel vapour suction pipe | 5 Fuel vapour exhaust pipe | 8 Fuel vapour recovery pipe |
| 2 Decompression pipe for dump valve control | 6 Compensation valve | 9 Dump valve |
| 3 Air delivery pipe | 7 Fuel vapour separator | 10 Fuel vapour filter. |
| 4 Fuel tank | | |

DIAGNOSTIC AND CORRECTIVE INTERVENTIONS ON LE3.2 JETRONIC INJECTION SYSTEM

Procedures and diagrams
for electronic injection 1.7 engines with catalytic converter only.

WIRING DIAGRAM OF INJECTION SYSTEM

- 1 AIR FLOW SENSOR, INJECTION CONTROL UNIT AND SUCKED AIR TEMPERATURE SENSOR (S11)
- 2 EXTRA AIR VALVE (S9)
- 3 ENGINE COOLANT TEMPERATURE SENSOR (S7)
- 4 MAIN RELAY (S12b)
- 5 LAMBDA PROBE FUSE (7.5A) (G4)
- 6 FUEL PUMP RELAY (S12a)
- 7 FUEL PUMP FUSE (15A) (G4)
- 8 BODY CONNECTION
- 9 THROTTLE MINIMUM AND MAXIMUM OPENING SWITCH (S6)
- 10 IGNITION MODULE (N1)
- 11 IGNITION DISTRIBUTOR (A5)
- 12 IGNITION COIL (A9)
- 13 LAMBDA PROBE RESISTANCE CONNECTOR
- 14 LAMBDA PROBE CONNECTOR
- 15 LAMBDA PROBE CODING CONNECTOR (S3)
- 16 ELECTROINJECTORS (S3)
- 17 FUEL PUMP (P18a)
- 18 SPARK PLUGS(A12)
- 19 DETECTION OF ENGINE RPM
- 20 CENTRALISED GROUNDS (G60)

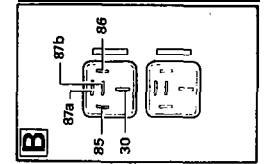
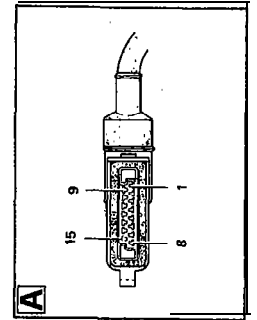
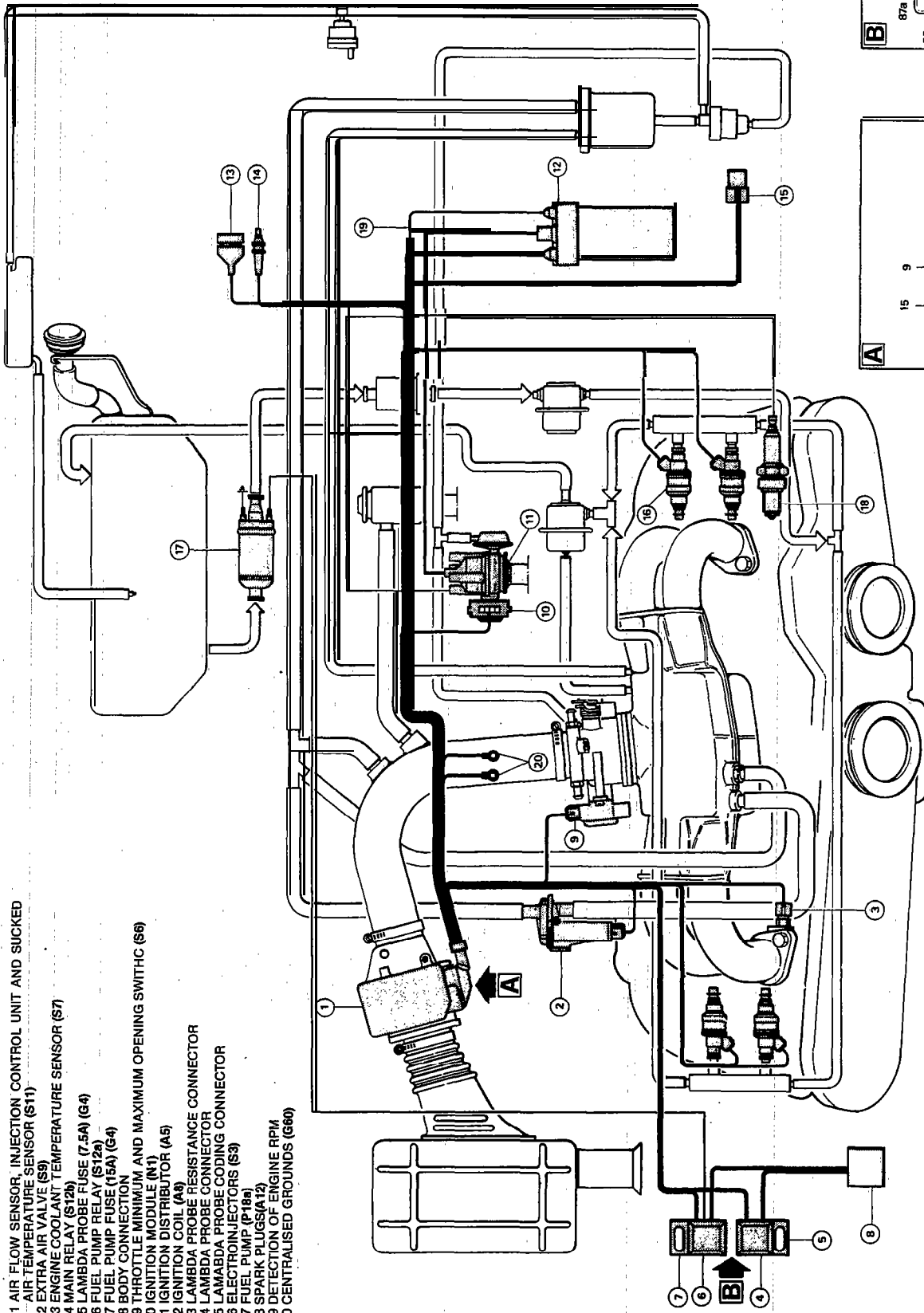

THE ENGINE DOES NOT START

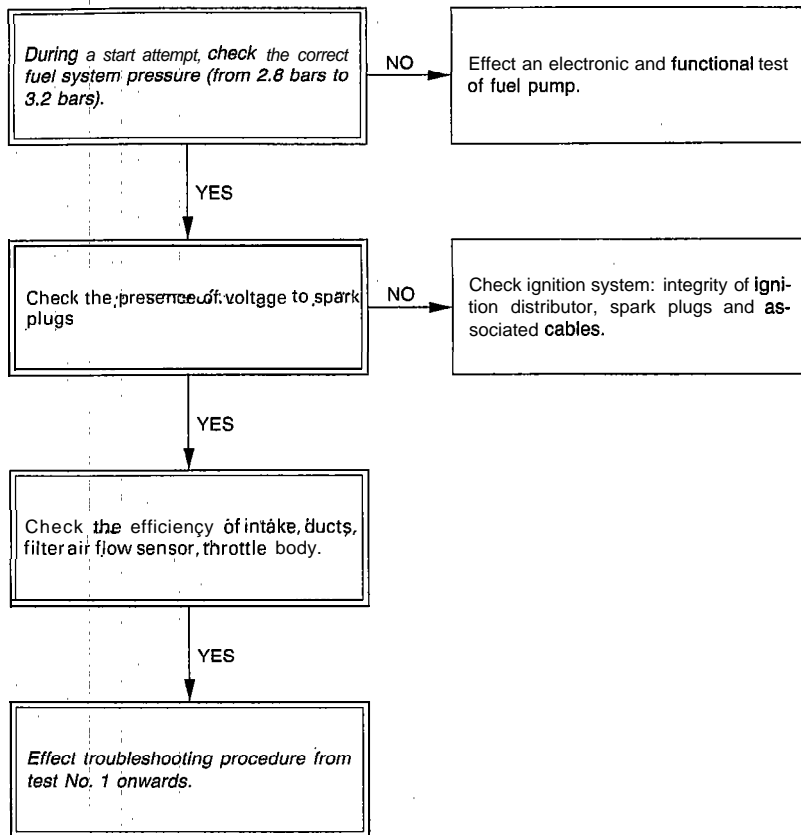

THE ENGINE STARTS WITH DIFFICULTY

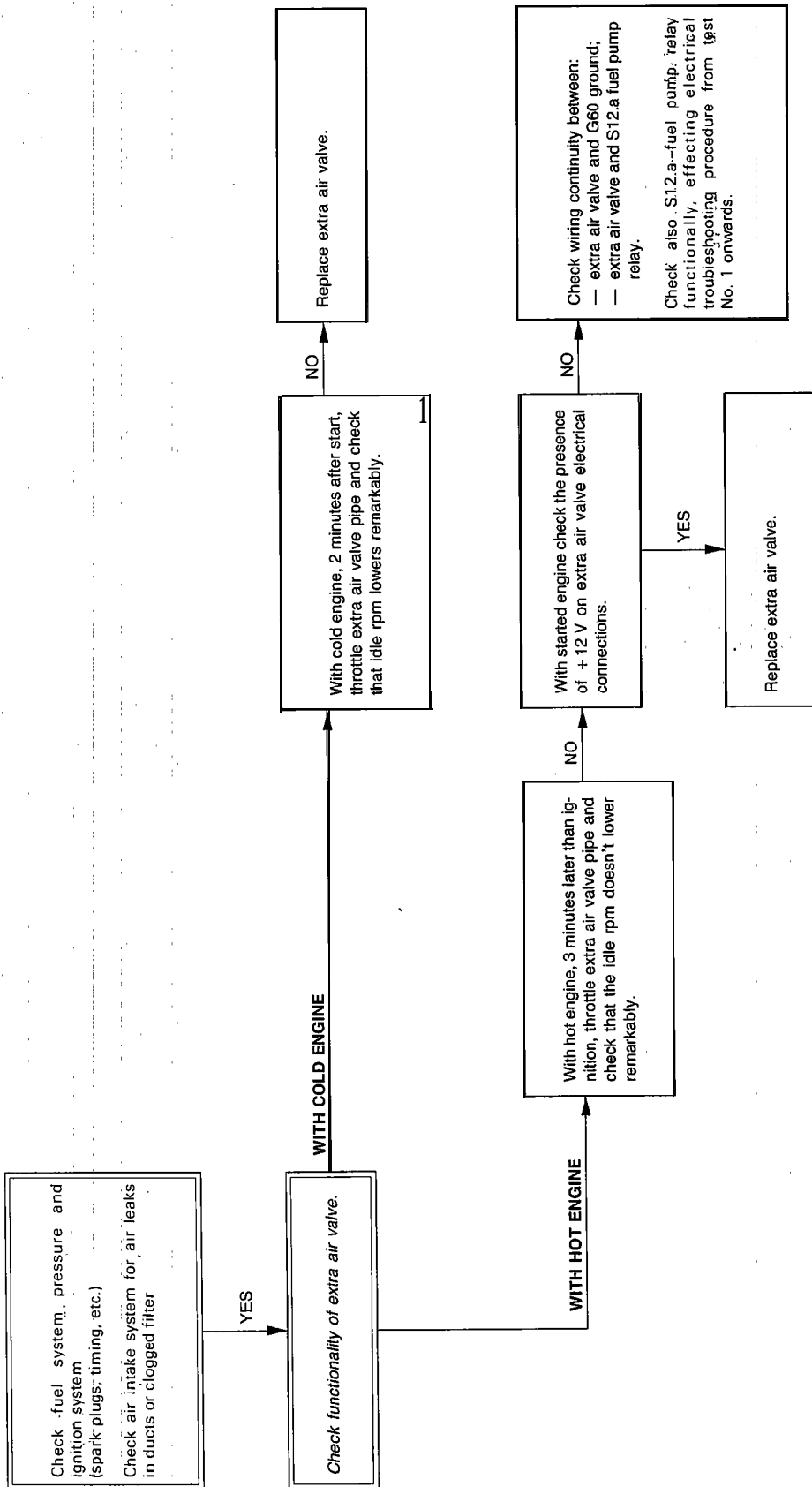

IRREGULAR IDLE RPM

Check for correct air flow through throttle body
Check that on a sucking ducts don't exist any leaks and that the air filter is not clogged

YES

Effect electrical troubleshooting from test No. 1 onwards.

ANOMALIES IN ACCELERATION AND BURSTS IN RELEASING

Check correct fuel system pressure and ignition system efficiency (spark plugs, timing, etc.).
Check that no leaks do exist in air intake ducts

YES

Check G60 ground efficiency.

YES

Check minimum & maximum opening throttle switch efficiency by effecting test No. 4 of electrical troubleshooting.

EXCESSIVE FUEL CONSUMPTION

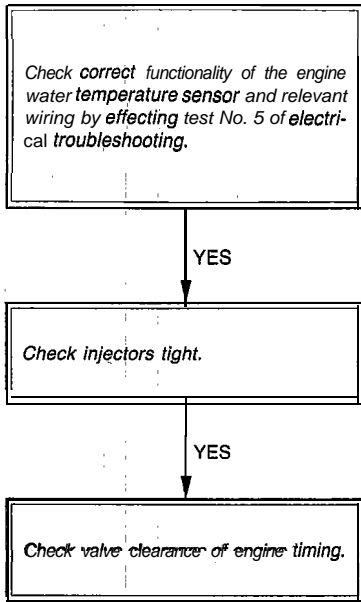

UNCORRECT DISCHARGE EMISSIONS

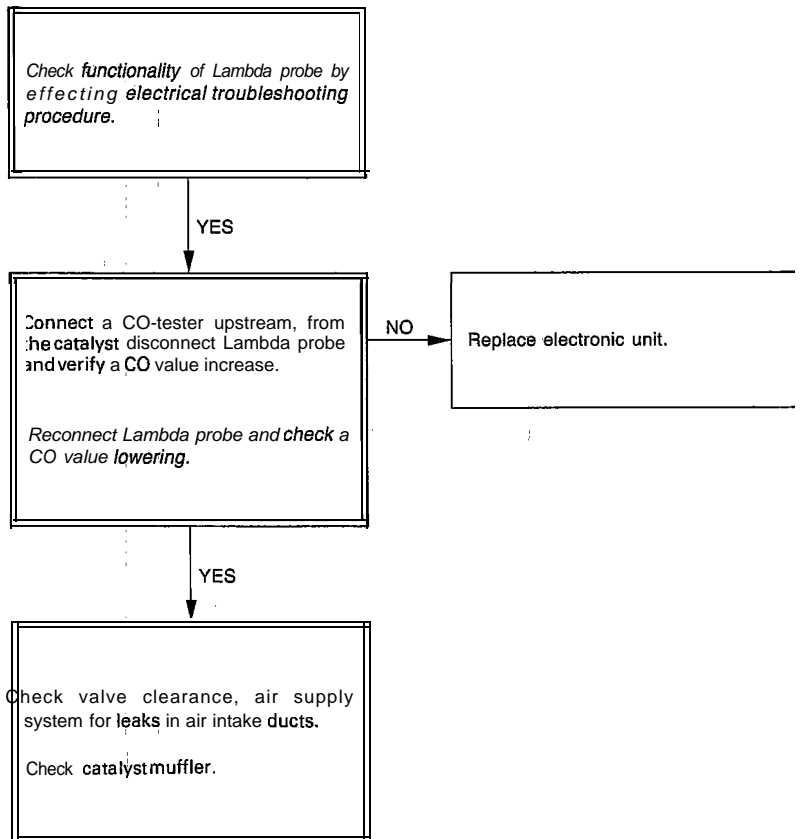

ELECTRICAL TROUBLESHOOTING PROCEDURE

for electronic injection 1.7 engines with catalytic convertor

NOTE:

THIS TROUBLESHOOTING MAINLY DEALS WITH THE ELECTRICAL/ELECTRONIC DIAGNOSIS OF SYSTEM AND SENSORS AND ACTUATORS ASSOCIATED TO IT.

IF AT THE END OF TEST THE ANOMALY SHOULD REMAIN, IT WILL BE NECESSARY TO CHECK MAIN MECHANICAL DEVICES SUCH AS. VALVES, CYLINDERS, COUPLINGS TIGHTNESS OF AIR INTAKE DUCTS, ETC.

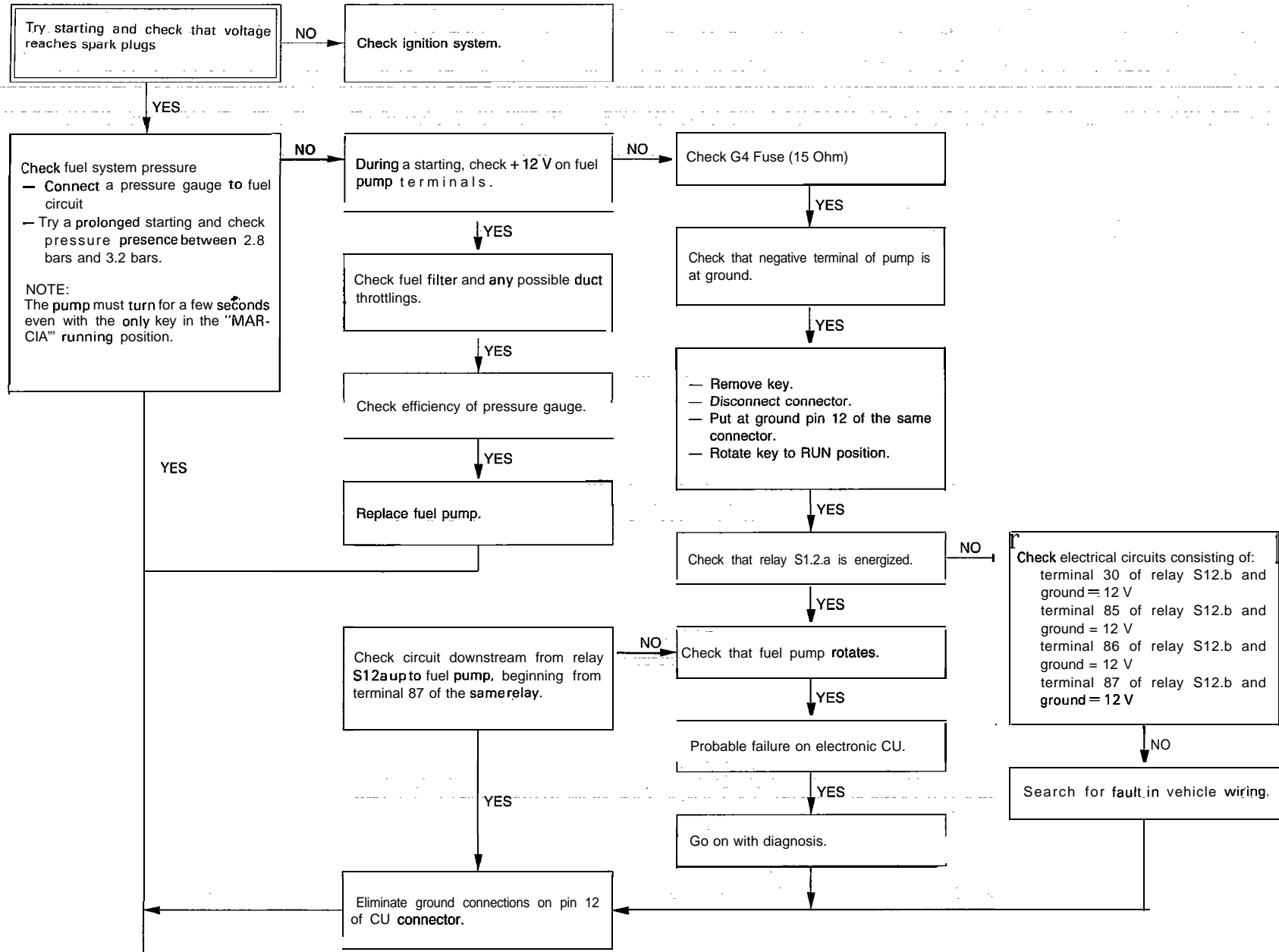

TEST No. 1

PA333500883300

00-28

May 1988

TEST No.2- CHECKINGS ON GROUNDS (PIN 4 AND 5 OF CU)

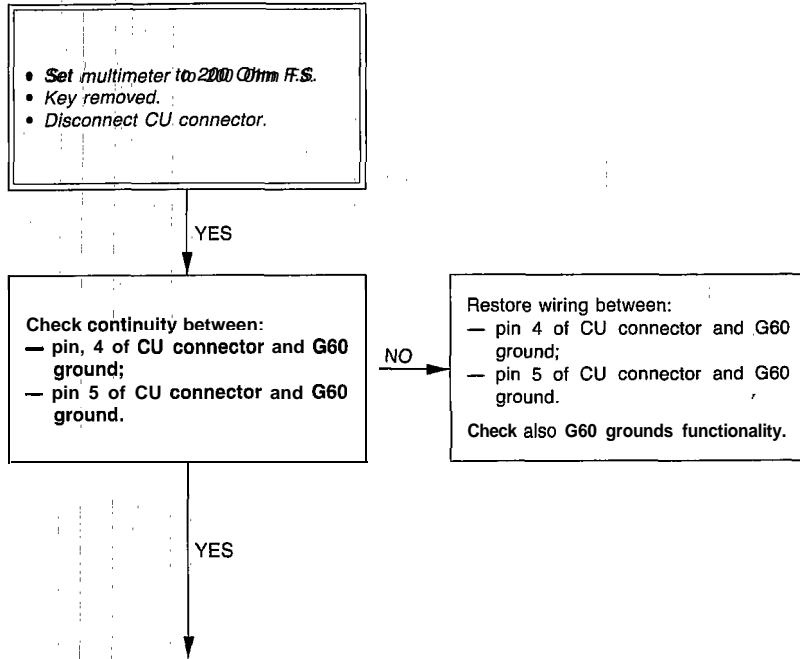

TEST No. 3 - CHECK CONNECTION TO RPM SIGNAL (CU PIN 1)

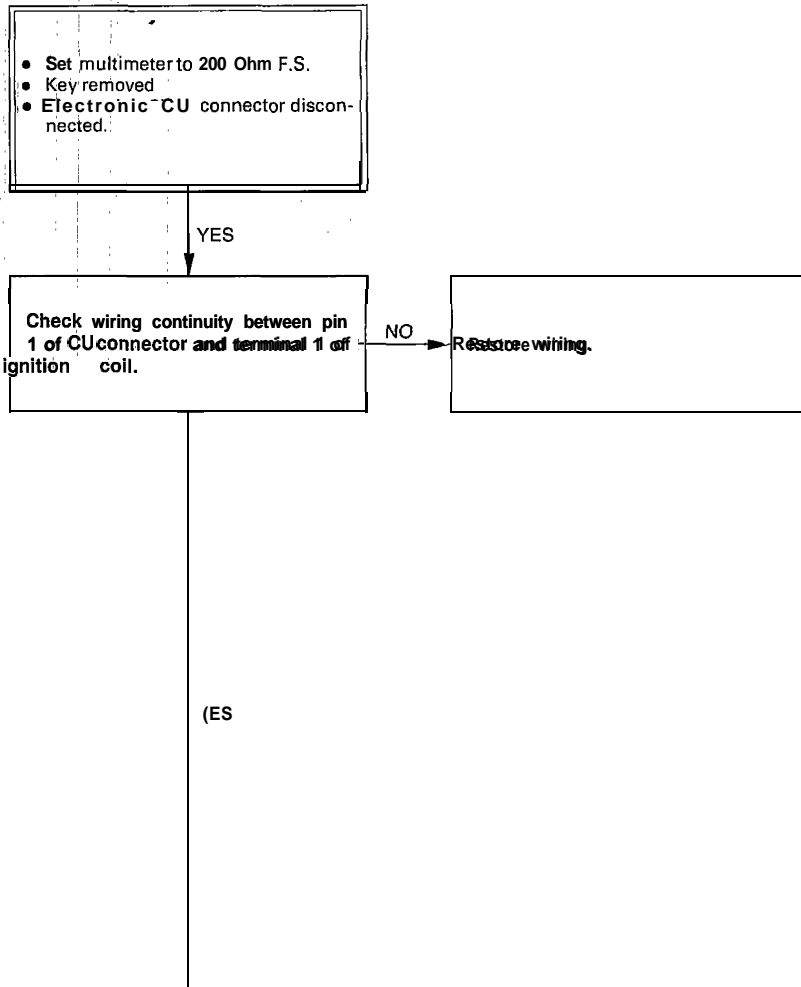

TEST No. 4

TEST No. 4 - CHECK ON MIN. & MAX. OPENING THROTTLE SWITCH (CU PIN 15 AND 14)

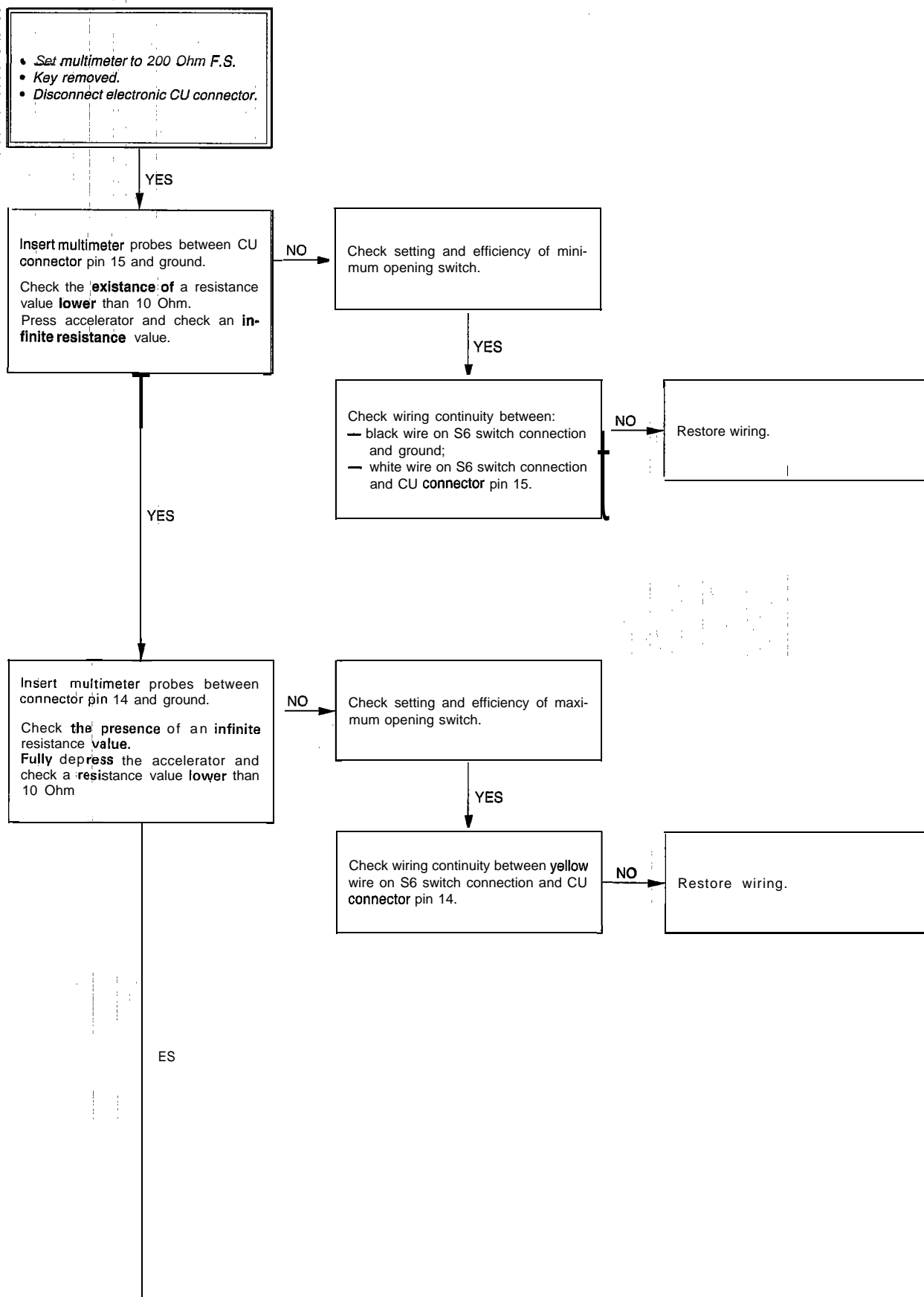

TEST No. 5

COMPLETE CAR

TEST No. 5 - CHECK ON ENGINE WATER TEMPERATURE SENSOR (CU PIN 8)

- Set multimeter to 20 KOhm F.S.
- Key removed.
- Disconnect electronic CU connector.

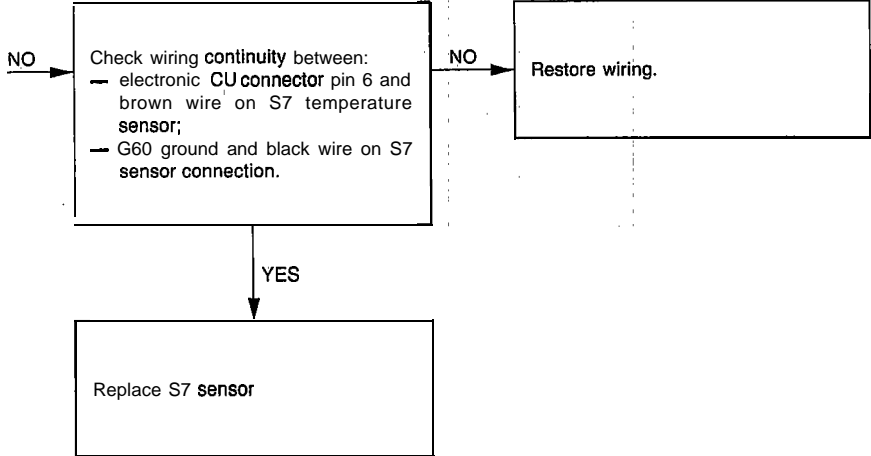
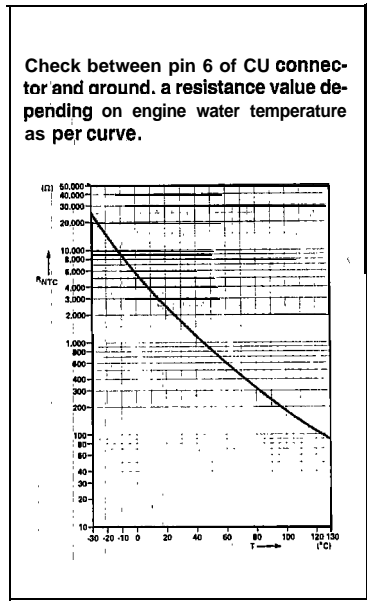

YES

TEST No. 6

TEST No! 6 - INJECTOR SYSTEM CHECKING

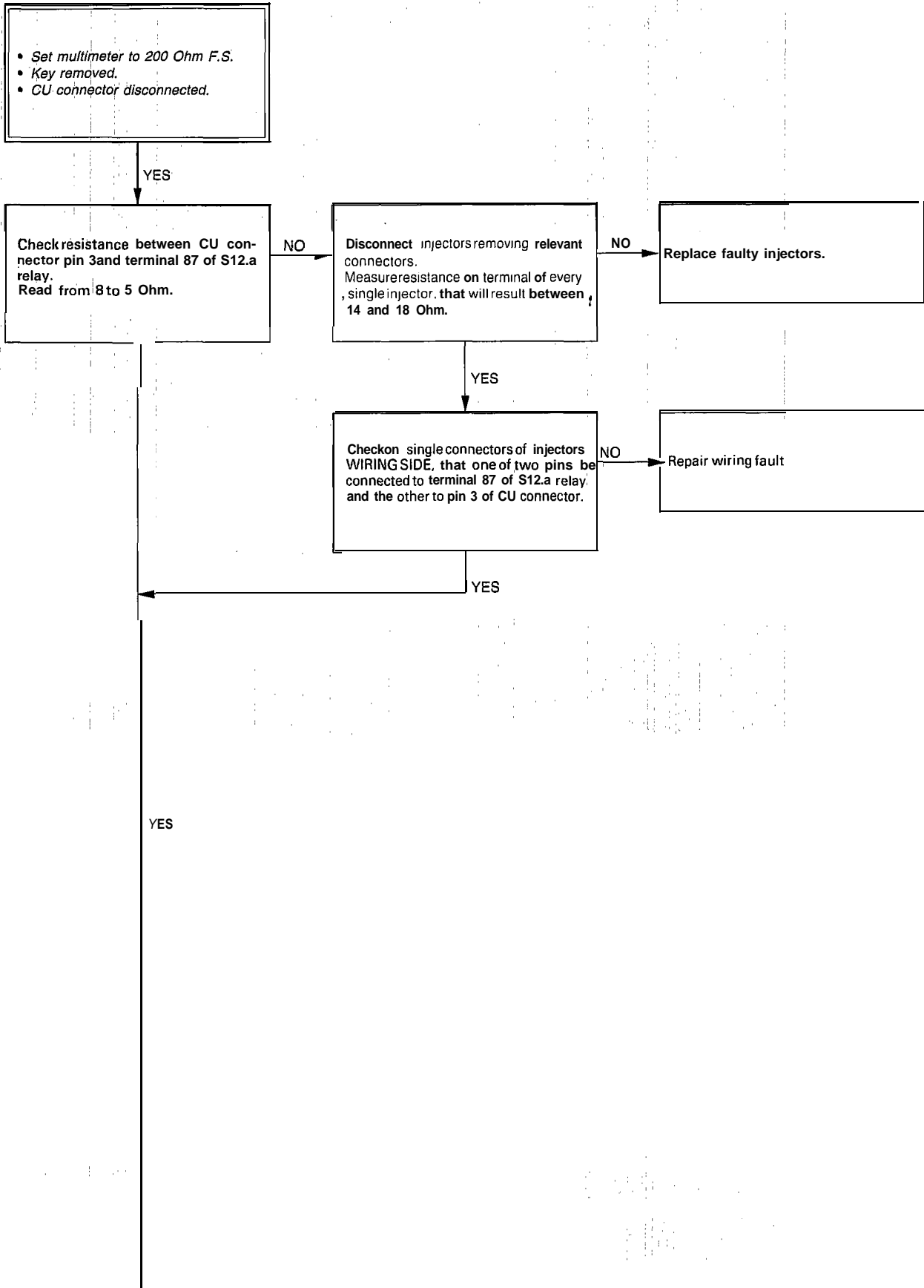

TEST No. 7

- - Set multimeter to 20 V F.S.
- Electronic CU connector disconnected.

With ignition key on RUN position, check presence of + 12 V between connector pin 2 and ground.

With ignition key in RUN position check presence of + 12 V between CU connector pin 7 and ground.

Check integrity of fuse No. 2.
With ignition key in RUN position check presence of + 12 V between S12.b main relay shoe terminal 30 and ground.

Restore wiring between S12.b relay shoe terminal 30 and CU connector pin 2.

Restore wiring between pins 2 and 7 of ECU connector.

Check presence of + 12 V between terminal 86 and S12.b relay shoe terminal 87.

Check presence of + 12 V between 512.6 relay shoe terminal 87 and ground.

Replace S12 relay.

Check wiring continuity between S12.b relay shoe terminal 85, and ground G60. iff necessary restore wiring.

With ignition key in RUN position, check presence of + 12 V on G67 connection pin 2. If necessary, restores wiring.

Check vehicle wiring (e.g. wiring between G67 connection and G99a connection, between G99a connection and G1 fuse holder box, integrity of fuse No. 7 and relevant supply from starting block.

Check presence of + 12 V between:
- G67 connection pin 3 and ground.
- G67 connection pin 4 and ground.
If necessary restore wiring.

Check vehicle wiring between positive battery and pin 3 and 4 on G67 connection

TEST No. 7 - CHECK ON + 12 V PIN 2 AND PIN 7 OF CU

COMPLETE CAR

TEST No. 8 - CHECK ON LAMBDA PROBE (CU PIN 13)

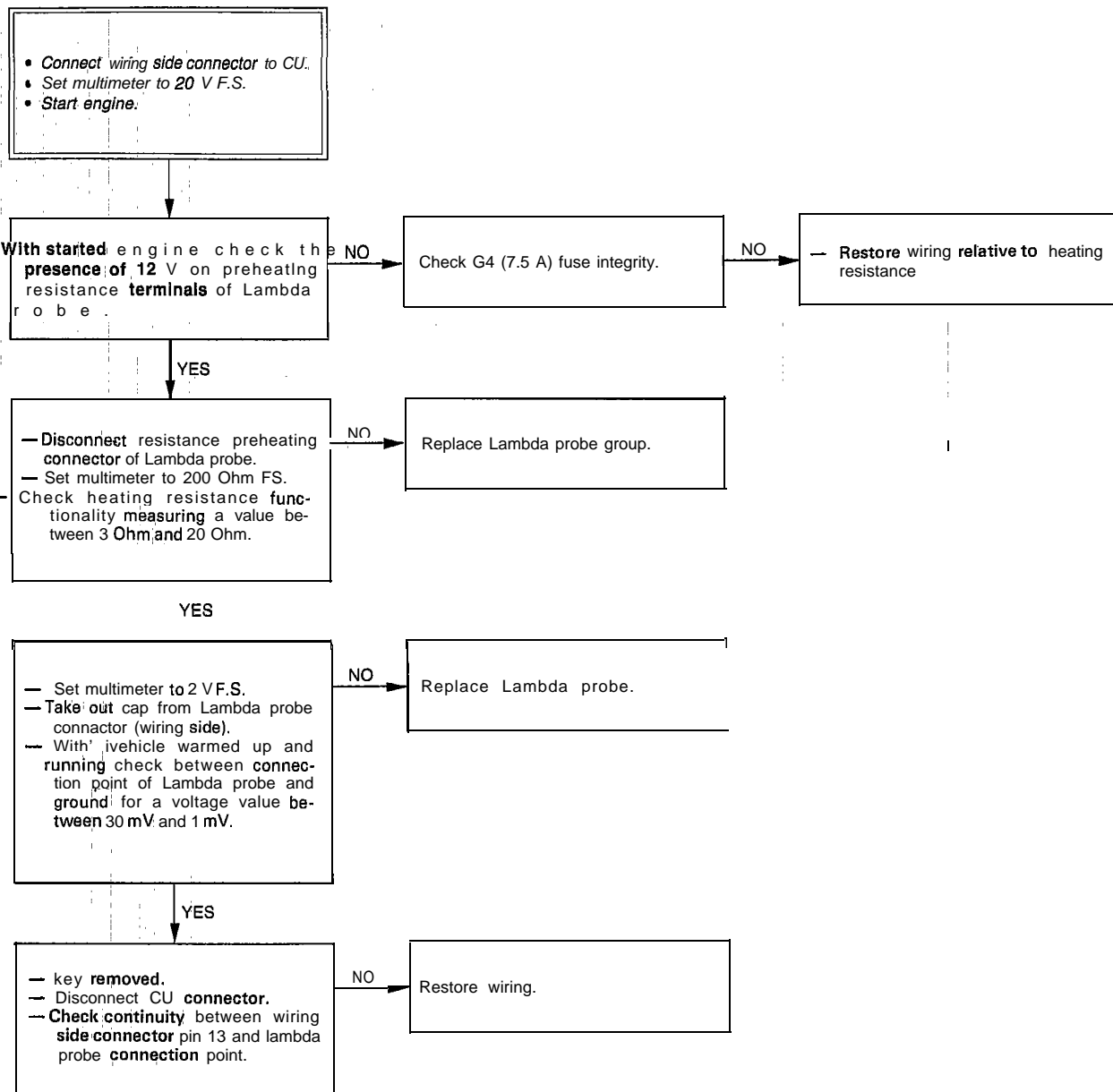

**END OF
ELECTRIC/ELECTRONIC
TROUBLESHOOTING**

If test results were positive, but fault still remains, try replacing in the order:

- CU.
- Air flow sensor.

INJECTION - IGNITION WIRING DIAGRAM

for electronic injection 1.7 engines with catalytic convertor only

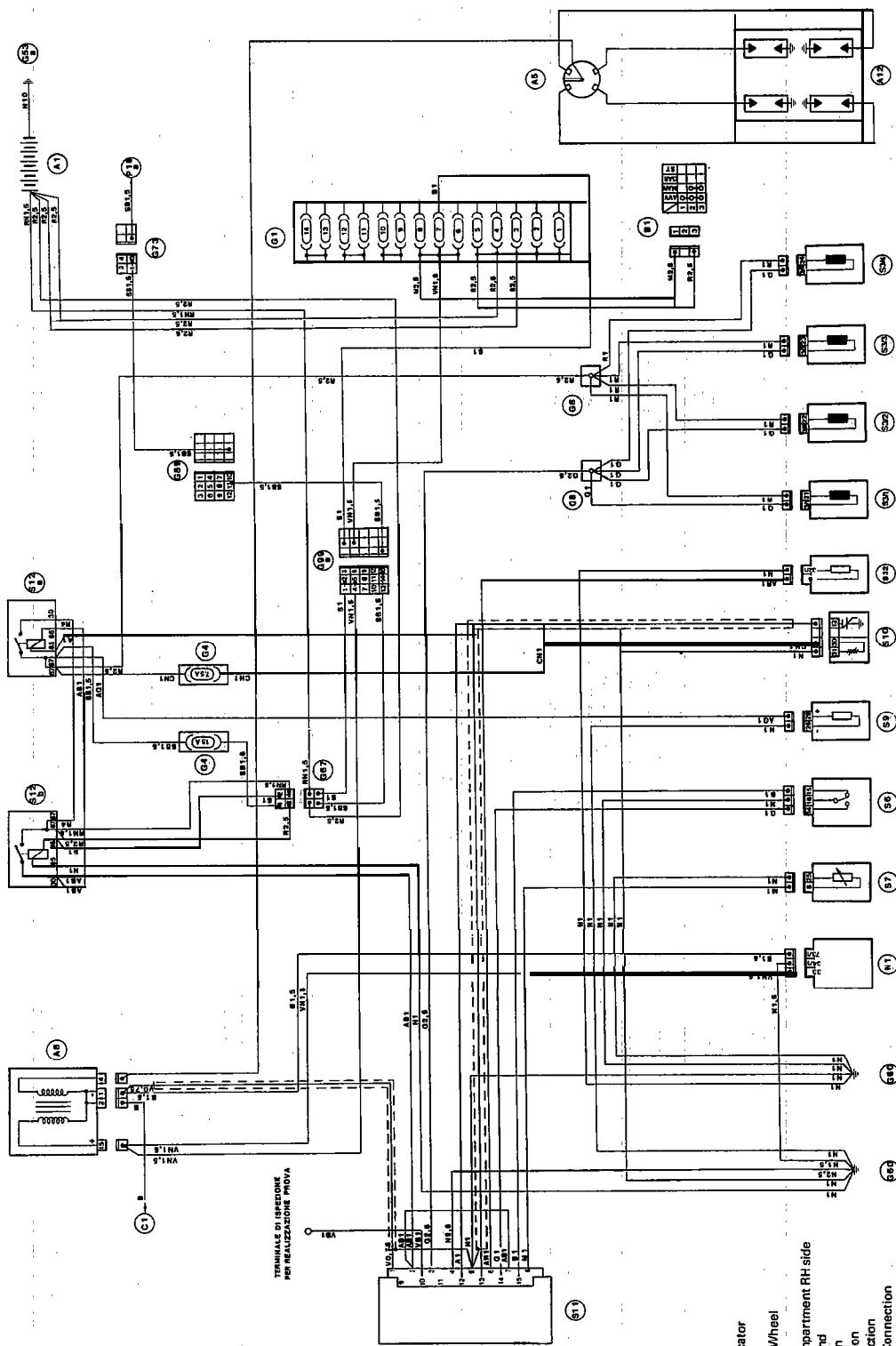

- A1 Battery
- A5 Ignition Distributor
- A8 Ignition Coil
- A12 Spark plugs
- B1 Ignition Switch
- C1 Electronic Speed Indicator
- G1 Fuse Holder Box
- G4 Fuse Holder Steering Wheel
- G8 Simple Connection
- G55a Ground of Engine Compartment RH side
- G60 Injection Wiring Ground
- G67 Motronic Connection
- G73 Rear Service Connection
- G89 Intermediate A Connection
- G99A Engine A Dashboard Connection
- N1 Electronic Ignition Module
- P18a Petrol Main Motor - Pump
- S3 Injectors
- S6 Accelerator Throttle Body Switch
- S7 Engine Cooling Fluid Temperature Sensor
- S9 Supplementary Air Valve
- S10 Lambda Probe
- S11 Motronic CU
- S12a Fuel Pump Motronic Solenoid Starter
- S12b Diode Equipped Motronic Solenoid Starter
- S32 Lambda Probe Code

**~DIAGNOSTIC AND CORRECTIVE INTERVENTIONS
ON LE3.2 JETRONIC
INJECTION/IGNITION SYSTEM**

Procedures and diagrams
for electronic injection 1.7 engines without catalytic converter only

WIRING DIAGRAM OF INJECTION SYSTEM

- 1 AIR FLOW SENSOR, INJECTION CONTROL UNIT AND SUCKED AIR TEMPERATURE SENSOR (S11)
- 2 EXTRA AIR VALVE (S9)
- 3 ENGINE COOLANT TEMPERATURE SENSOR (S7)
- 4 MAIN RELAY FUSE (7.5A) (G4)
- 5 LAMBDA PROBE FUSE (S12a)
- 6 FUEL PUMP RELAY (S12a)
- 7 FUEL PUMP FUSE (15A) (G4)
- 8 BODY CONNECTION
- 9 THROTTLE MINIMUM AND MAXIMUM OPENING SWITCH (S6)
- 10 IGNITION MODULE (N1)
- 11 IGNITION DISTRIBUTOR (A5)
- 12 IGNITION COIL (A8)
- 13 DIGITAL IGNITION ECU (N20)
- 14 ELECTROINJECTORS (S3)
- 15 FUEL PUMP (P18a)
- 16 SPARK PLUGS(A12)
- 17 DETECTION OF ENGINE RPM
- 18 CENTRALISED GROUNDS (G60)

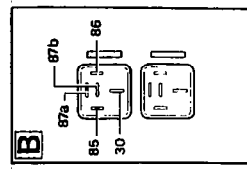
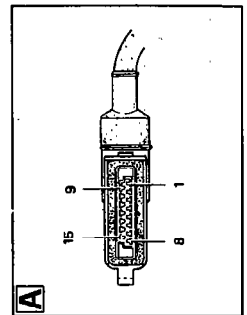
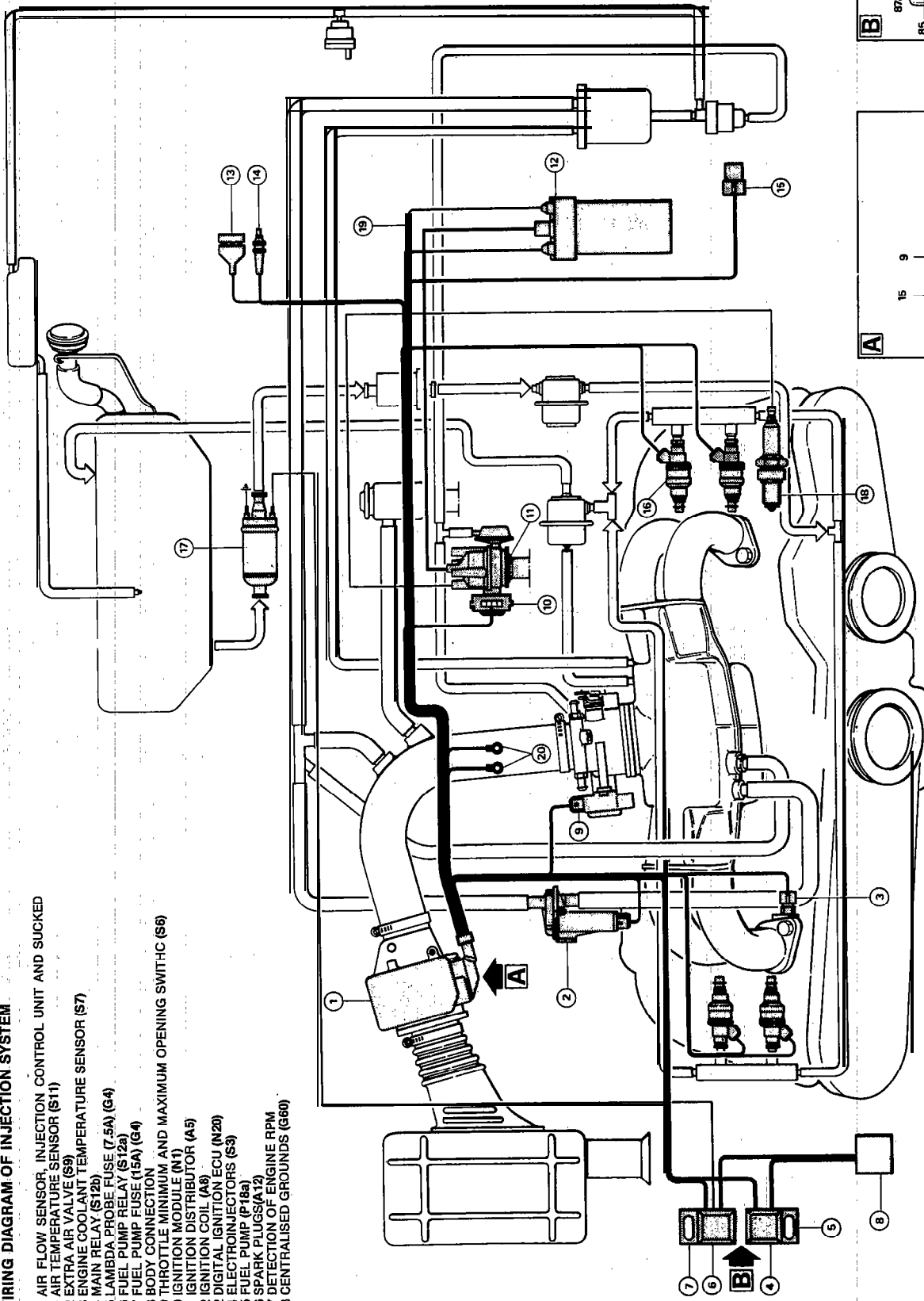

THE ENGINE DOES NOT START

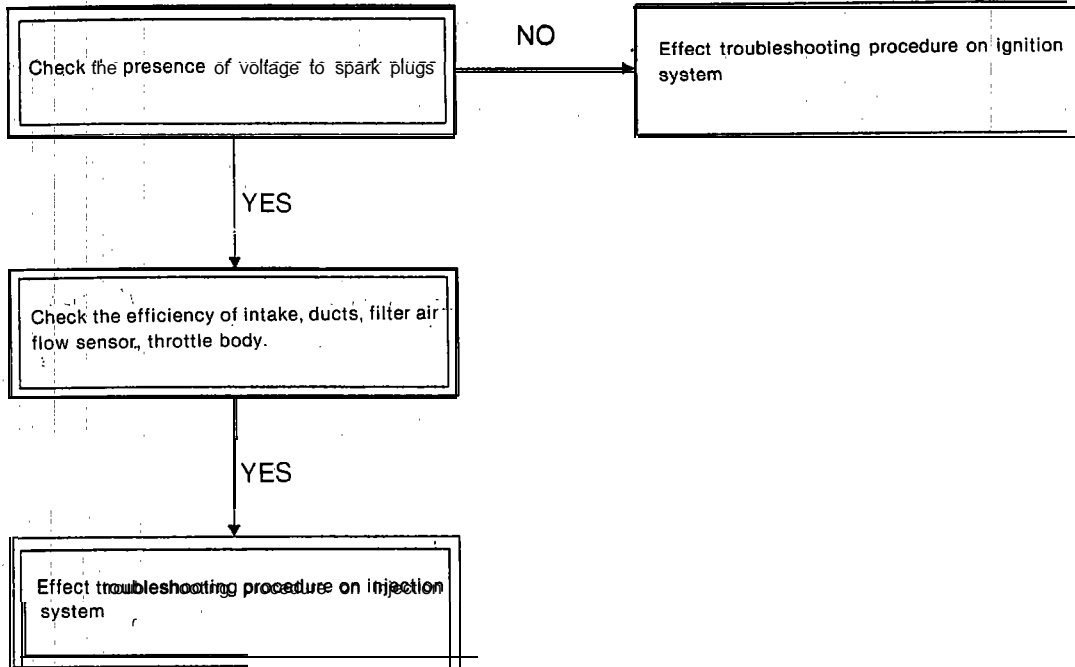

THE ENGINE START WITH DIFFICULTY

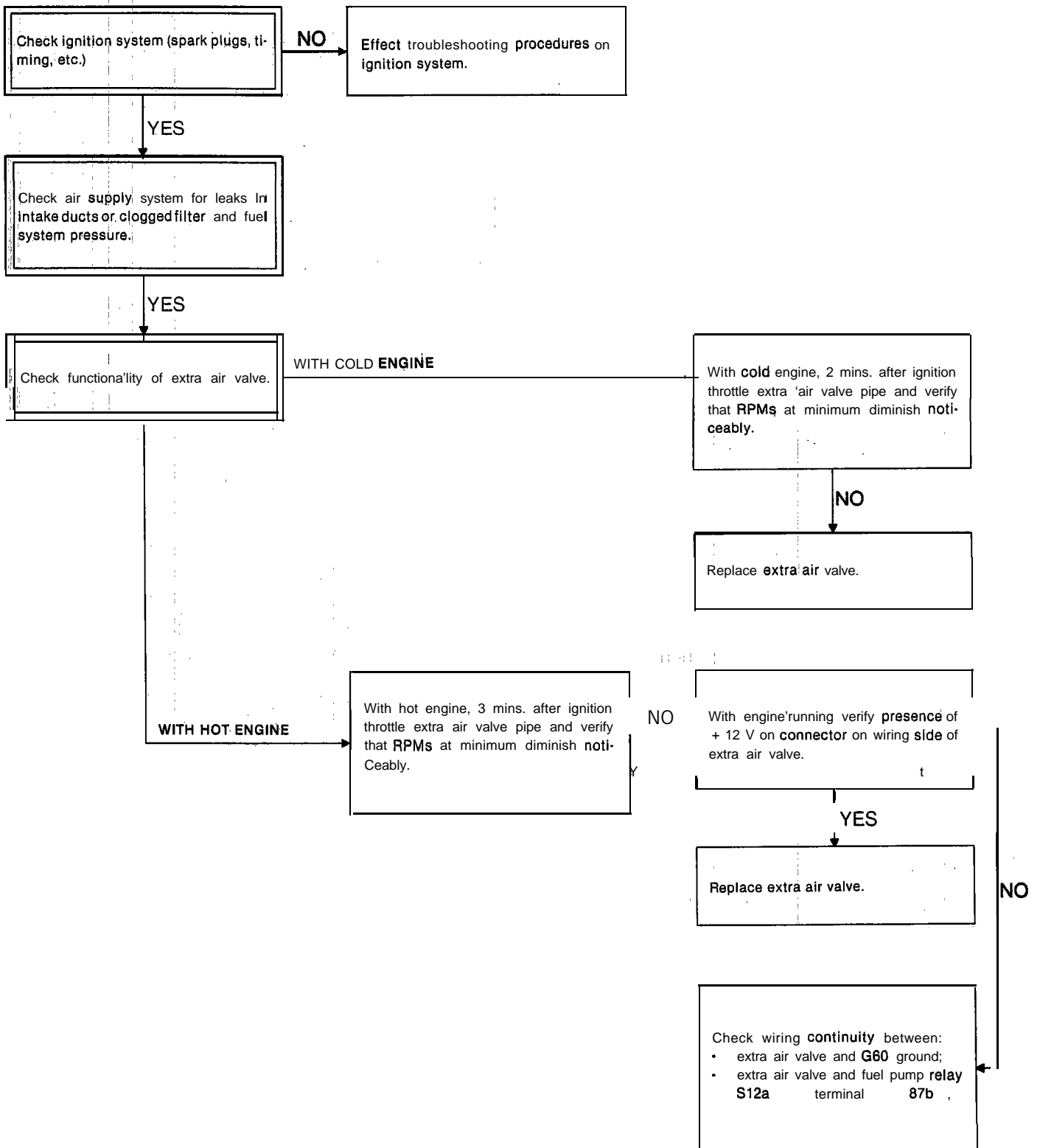

IRREGULAR IDLE RPM

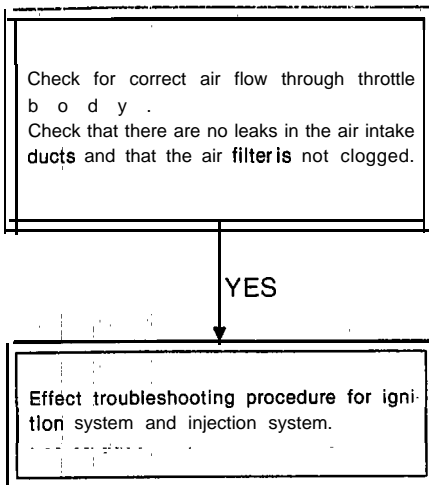

EXCESSIVE FUEL CONSUMPTION

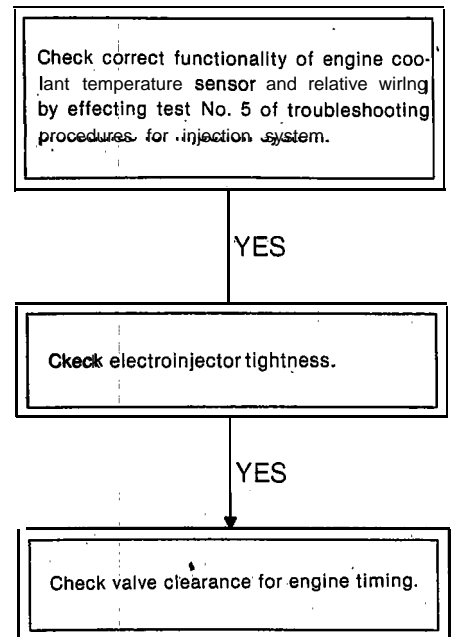

ANOMALIES IN ACCELERATION AND BURSTS IN RELEASING

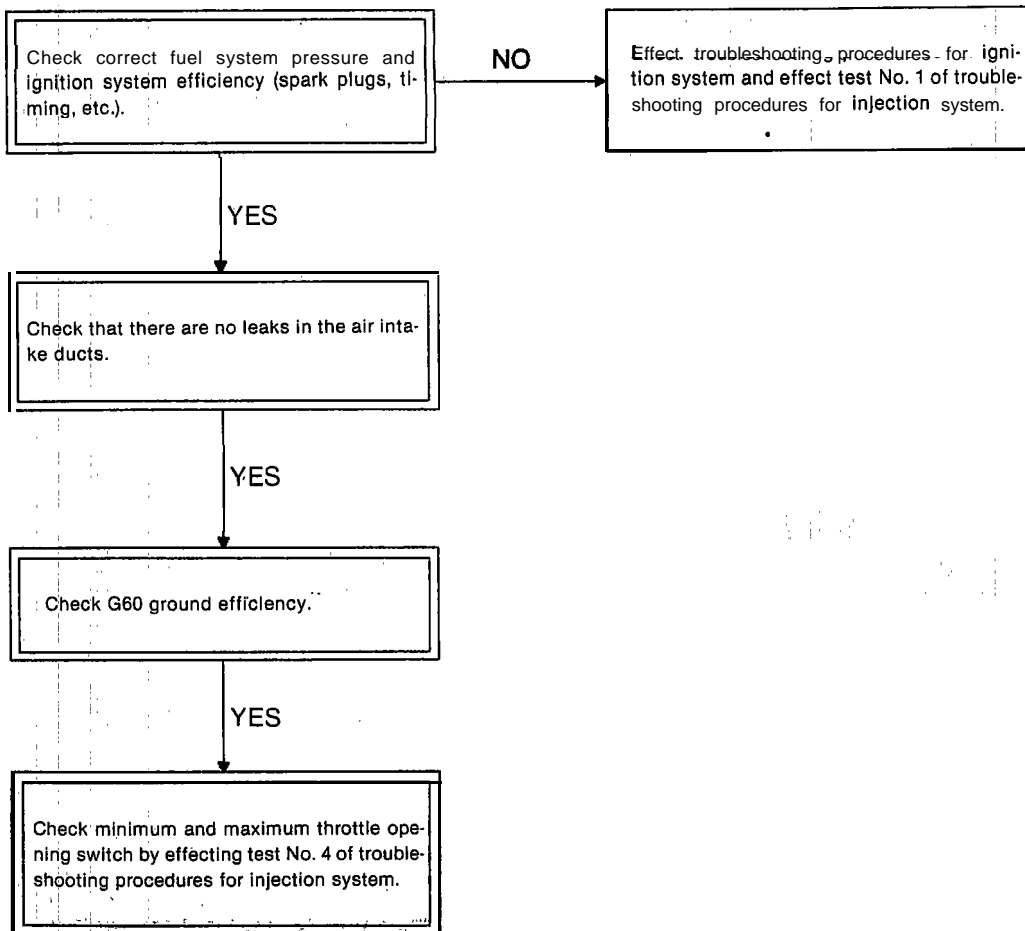

TROUBLESHOOTING PROCEDURE FOR INJECTION SYSTEM

for electronic injection 1.7 engines without catalytic converter

NOTE:

THIS TROUBLESHOOTING MAINLY DEALS WITH THE ELECTRICAL/ELECTRONIC DIAGNOSIS OF THE SYSTEM AND SENSORS AND ACTUATORS ASSOCIATED TO IT.

IF AT THE END OF TESTS THE ANOMALY SHOULD REMAIN, IT WILL BE NECESSARY TO CHECK MAIN MECHANICAL DEVICES SUCH AS VALVES, CYLINDERS, COUPLINGS, TIGHTNESS OF AIR INTAKE DUCTS, ETC.

TEST No.1 — CHECK OF FUEL PUMP CONTROL

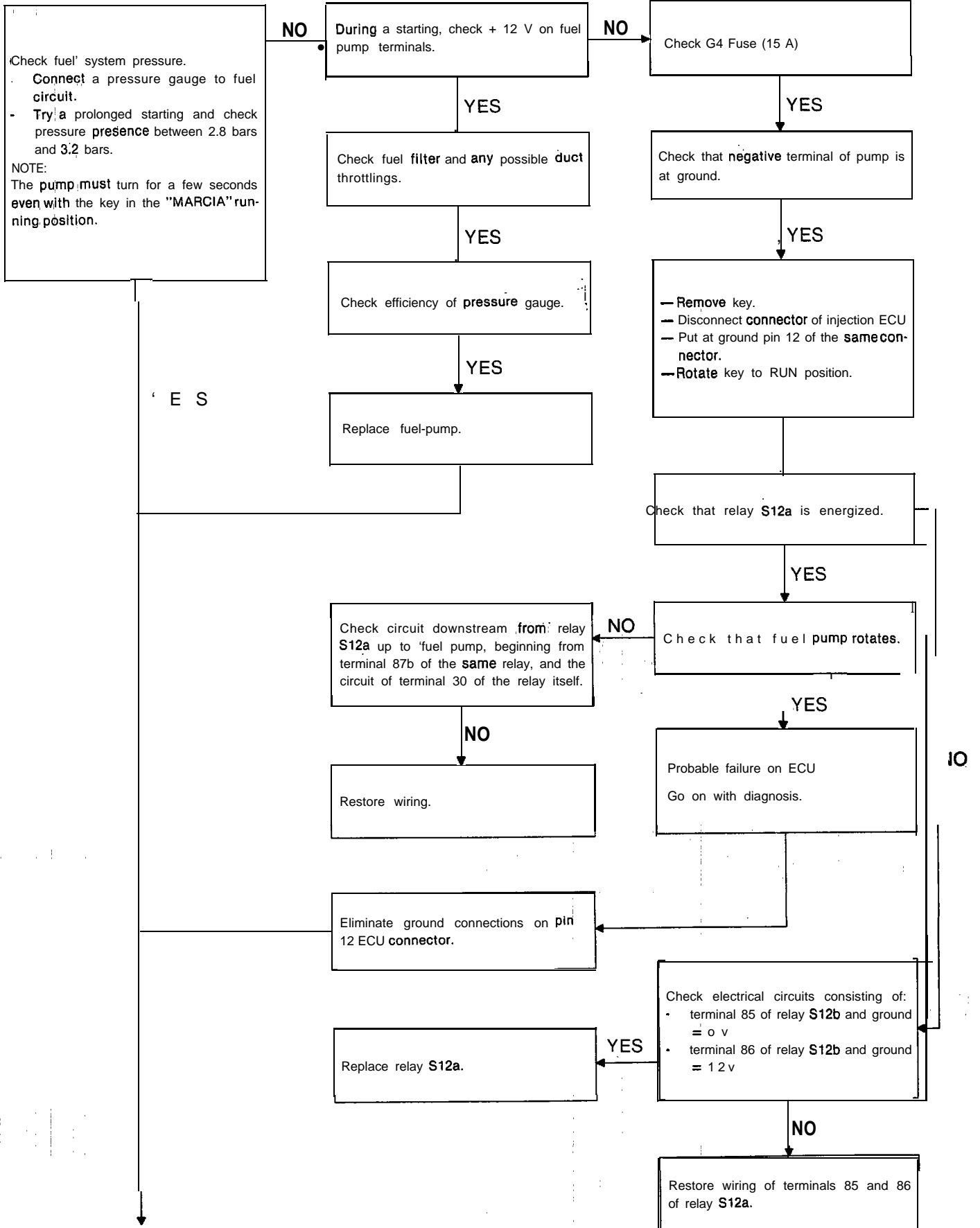

TEST Na. 2

TEST No. 2, — CHECKING OF GROUNDS (PIN 4 AND 5, OF CU)

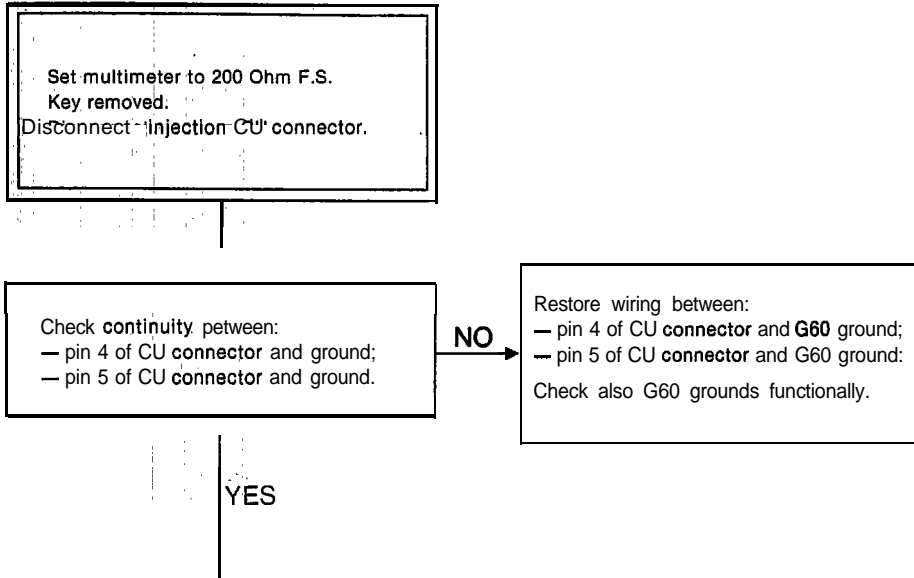

TEST No. 3 — CHECK CONNECTION TO RPM SIGNAL (CU PIN 1)

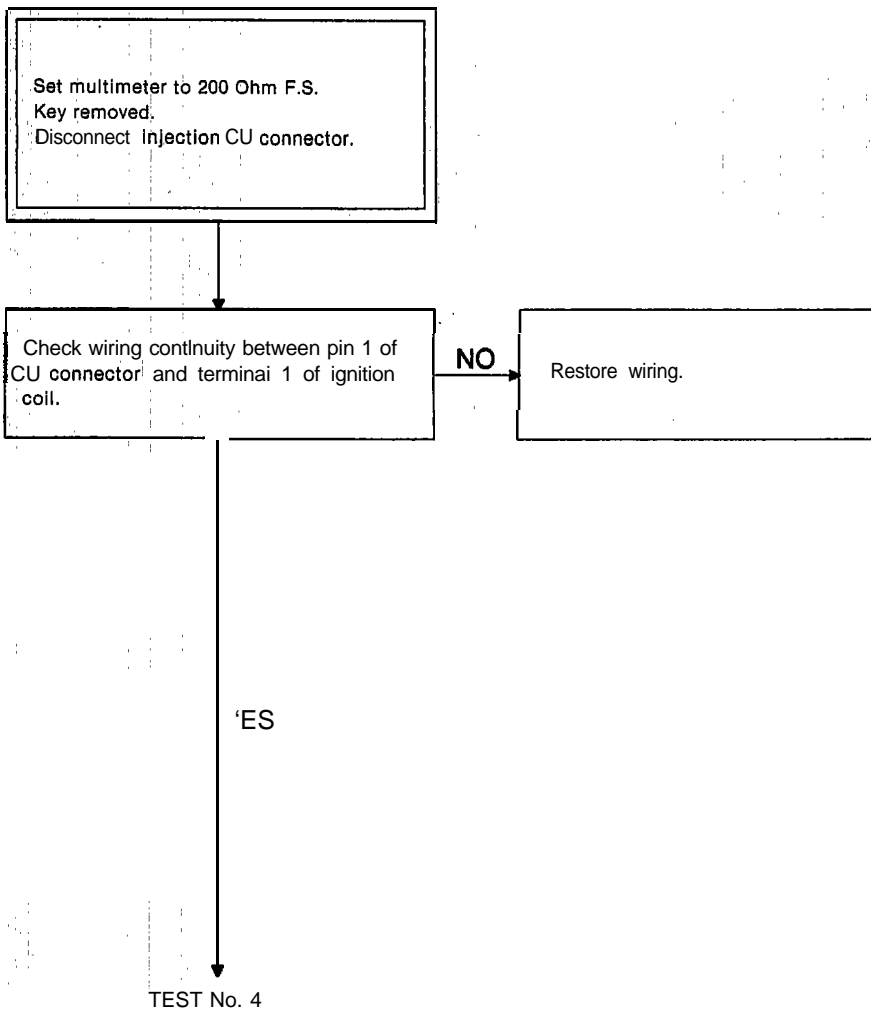

TEST No. 4 — CHECK ON MIN. & MAX. THROTTLE OPENING SWITCH (CU PIN 15 AND 14)

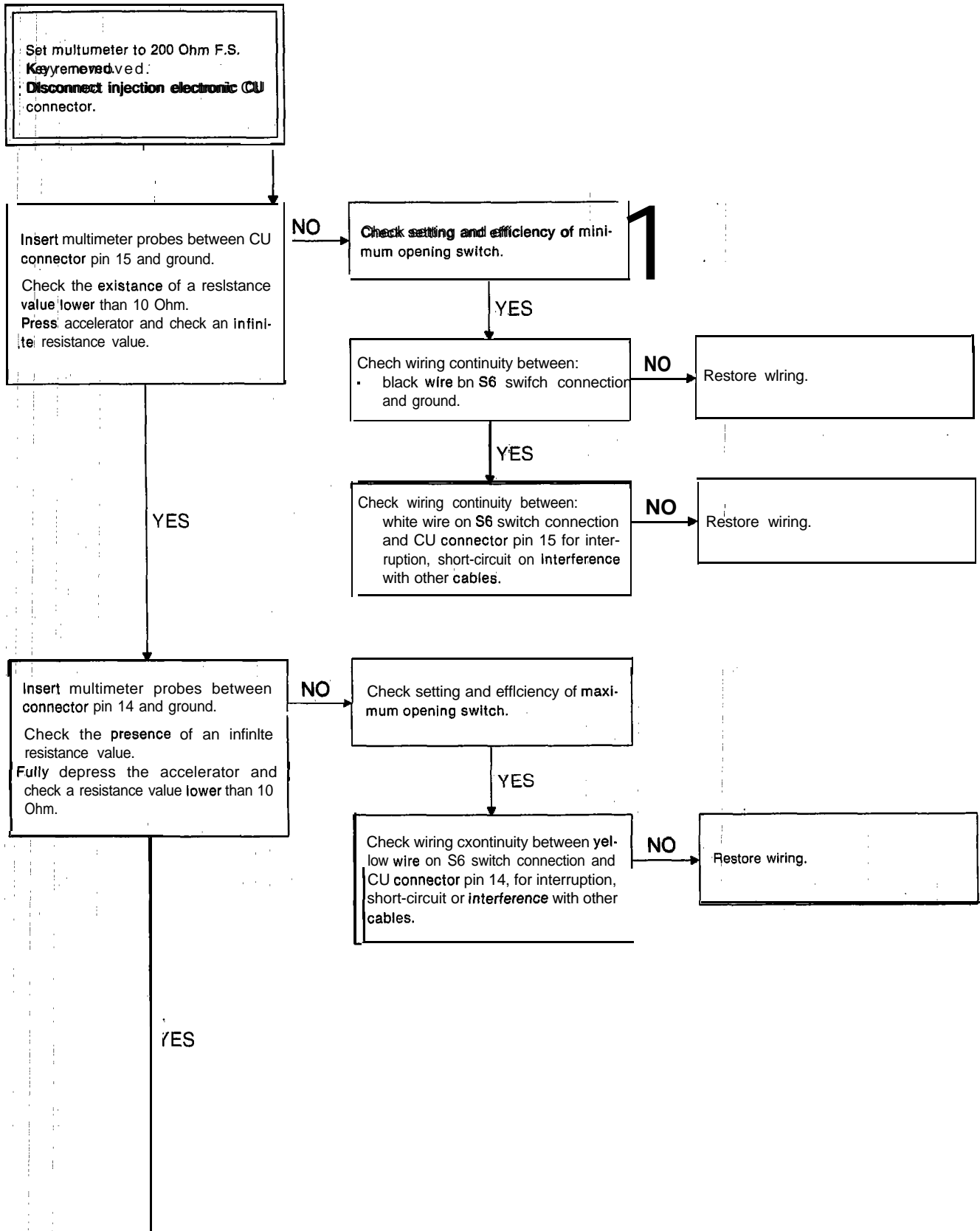

TEST No. 5

TEST No. 5 — CHECK OF ENGINE COOLANT TEMPERATURE SENSOR (CU PIN 8)

Set multimeter to 20 KOhm FS.
 Key removed: -
 Disconnect injection electronic CU connector.

Check between pin 8 of CU connector and ground, a resistance value depending on engine coolant temperature as per curve.

Temperature (T) in °C	Resistance (RNTC) in Ohms
-30	20,000
0	10,000
20	6,000
40	4,000
60	3,000
80	2,500
100	2,000
120	1,500
130	1,000

NO → Check wiring continuity between:
 - electronic CU connector pin 8 and brown wire on S7 temperature sensor;
 - G60 ground and black wire on S7 sensor connection 25.

NO → Restore wiring.

YES → Replace S7 sensor

YES

TEST No. 6

COMPLETE CAR

TEST No. 6 — CHECK OF ELECTROINJECTORS CIRCUIT

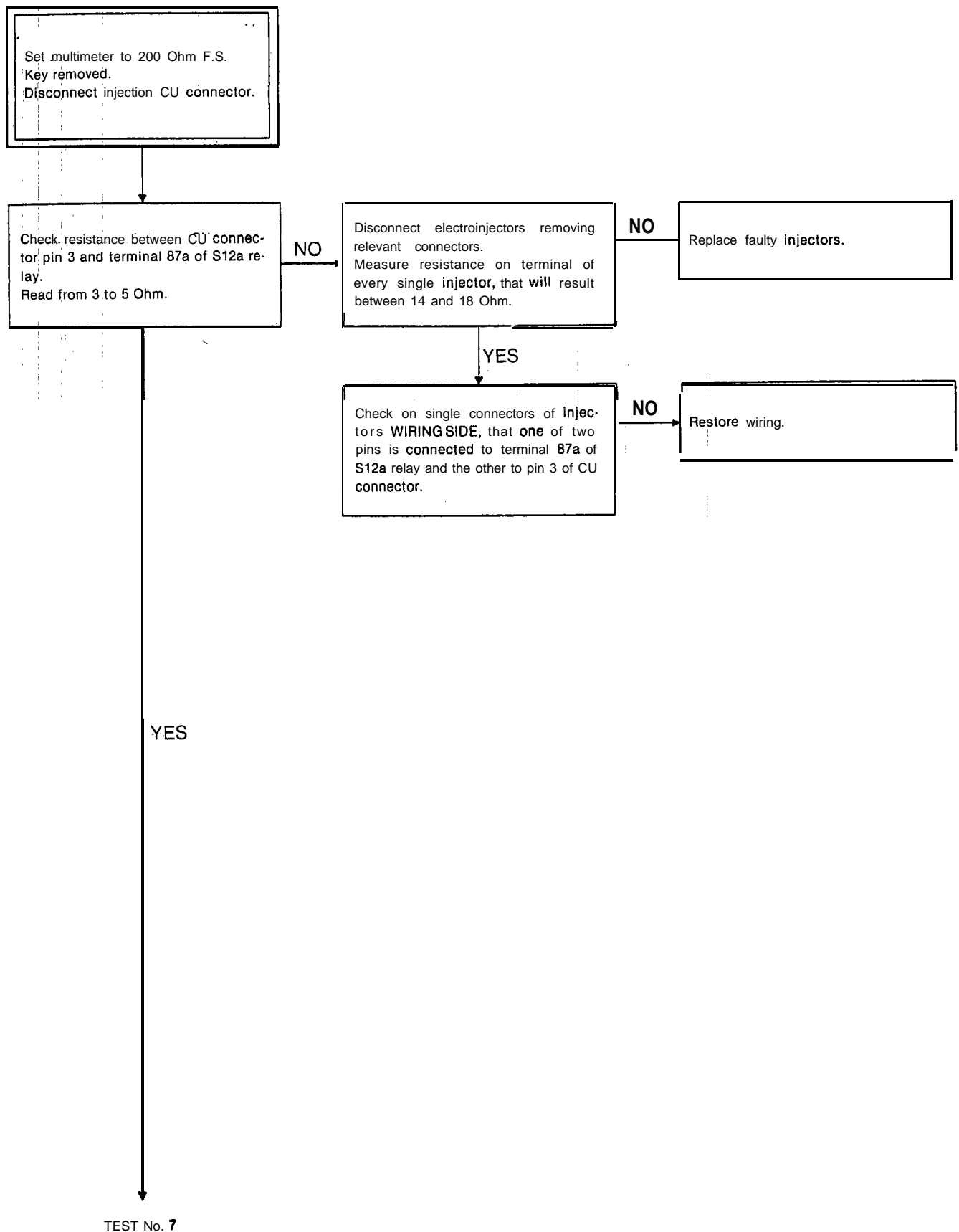

COMPLETE CAR

TEST No. 7 — CHECK OF + 12 V PIN 2 AND PIN 7 OF CU

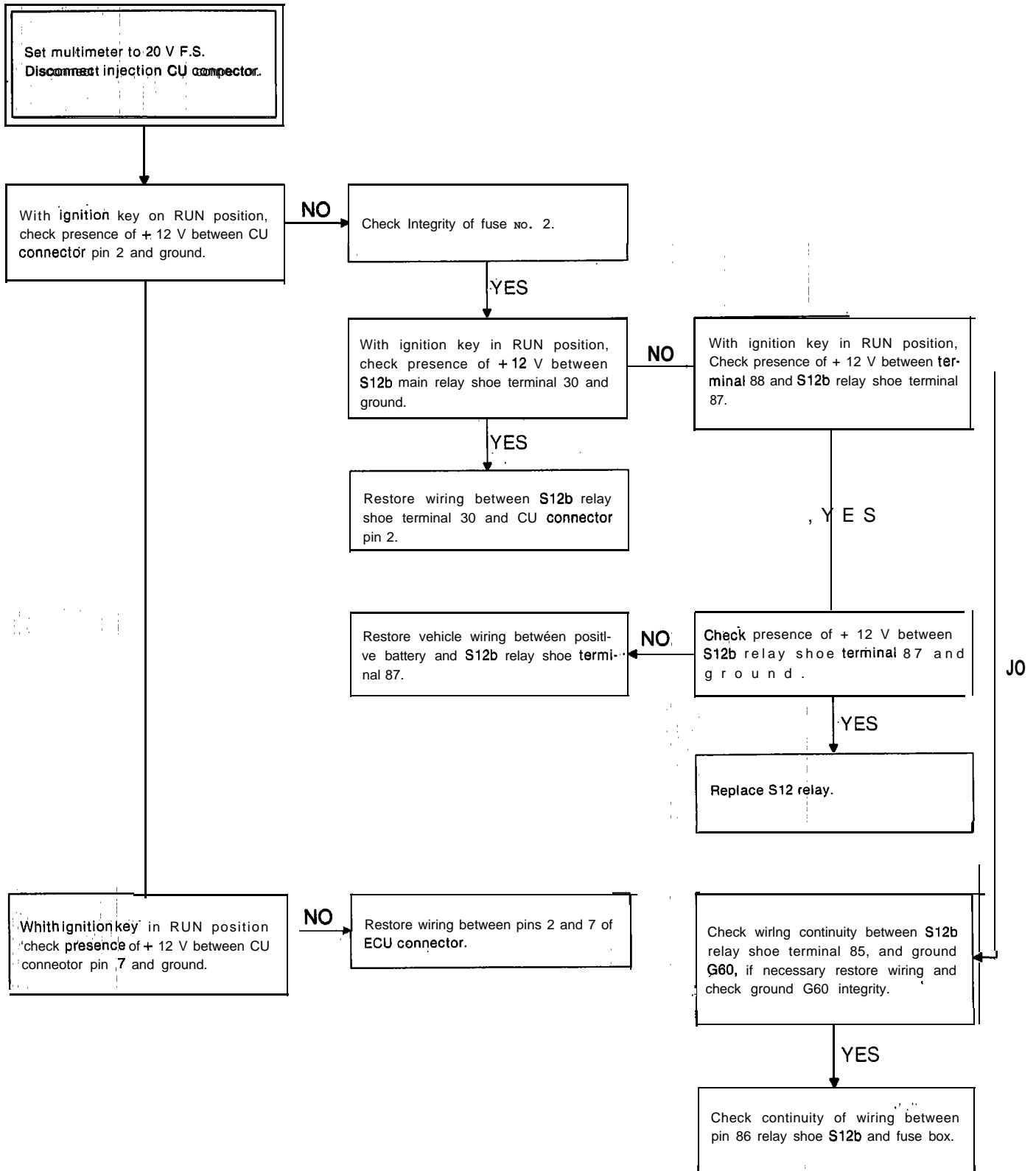

TROUBLESHOOTING PROCEDURE FOR IGNITION SYSTEM

for electronic injection 1.7 engines without catalytic converter

NOTE:

THIS TROUBLESHOOTING PROCEDURE MAINLY DEALS WITH THE ELECTRICAL/ELECTRONIC DIAGNOSIS OF THE SYSTEM AND SENSORS AND ACTUATORS ASSOCIATED TO IT. IF AT THE END OF TESTS THE ANOMALY SHOULD REMAIN, IT WILL BE NECESSARY TO CHECK MAIN MECHANICAL DEVICES SUCH AS VALVES, CYLINDERS, COUPLINGS, TIGHTNESS OF AIR INTAKE DUCTS, ETC.

THE ENGINE DOES NOT START

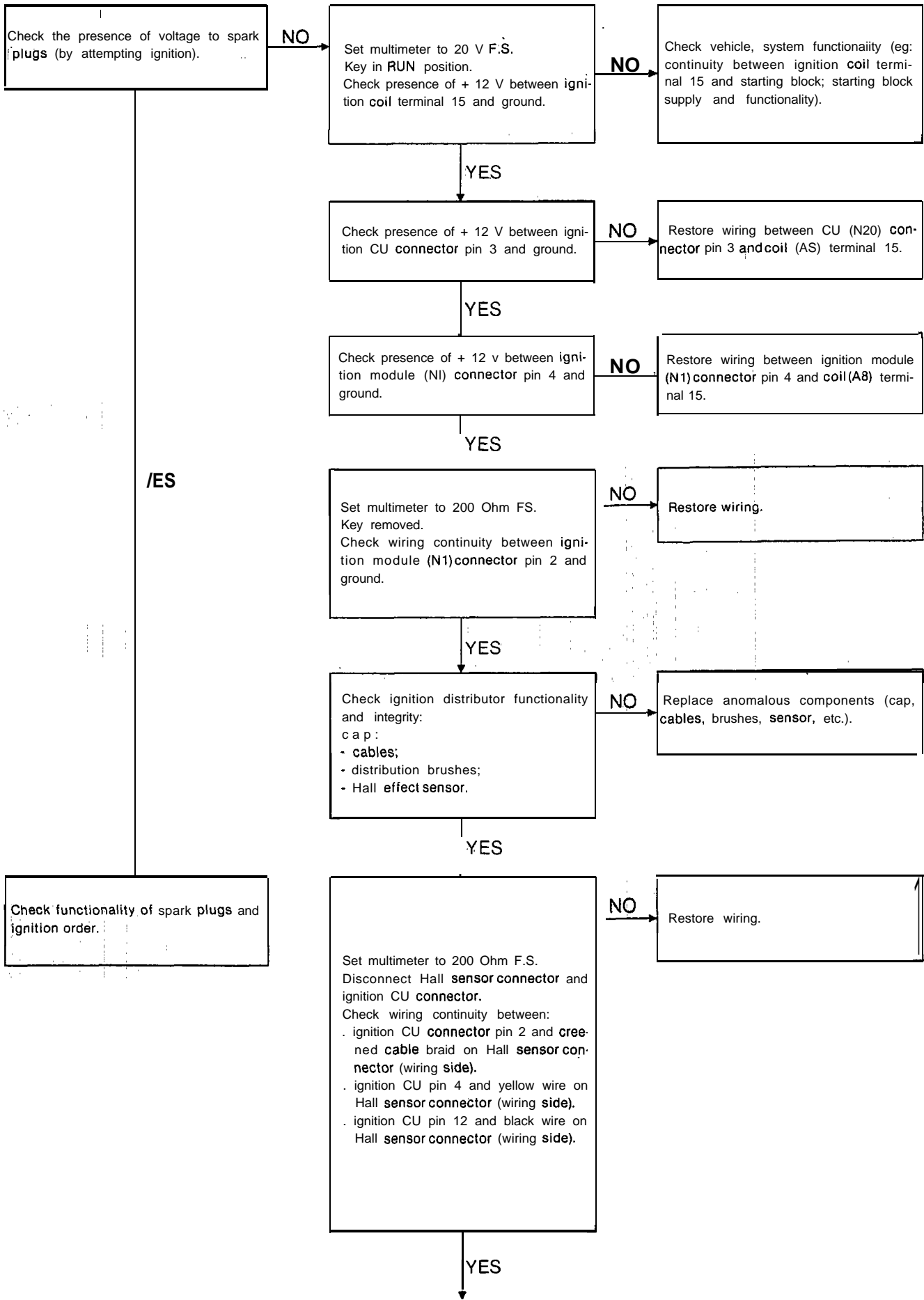

YES

Check wiring continuity (after having disconnected ignition CU (N20) connector and ignition CU (N1) connector between:

- ignition module connector pin 3 and ignition CU pin 1
- ignition CU connector pin 13 and ignition module connector pins 5 and 6
- ignition module connector pin 1 and white wire on ignition coil terminal 1.

NO

Restore wiring.

YES

Check ignition coil (A8) functionality verifying values listed hereunder:

- primary winding resistance: from 0.5 to 1.5 Ohm;
- secondary winding resistance: from 6 to 12 kOhm.

NO

Replace ignition coil.

YES

Disconnect white wire on coil terminal 1 (signal for speed indicator) and check that there is no short-circuit towards ground.

YES

Eventually replace ignition module (N1) and/or ignition CU (N20).

ADVANCE VARIATION CHECK

TEST No. 1

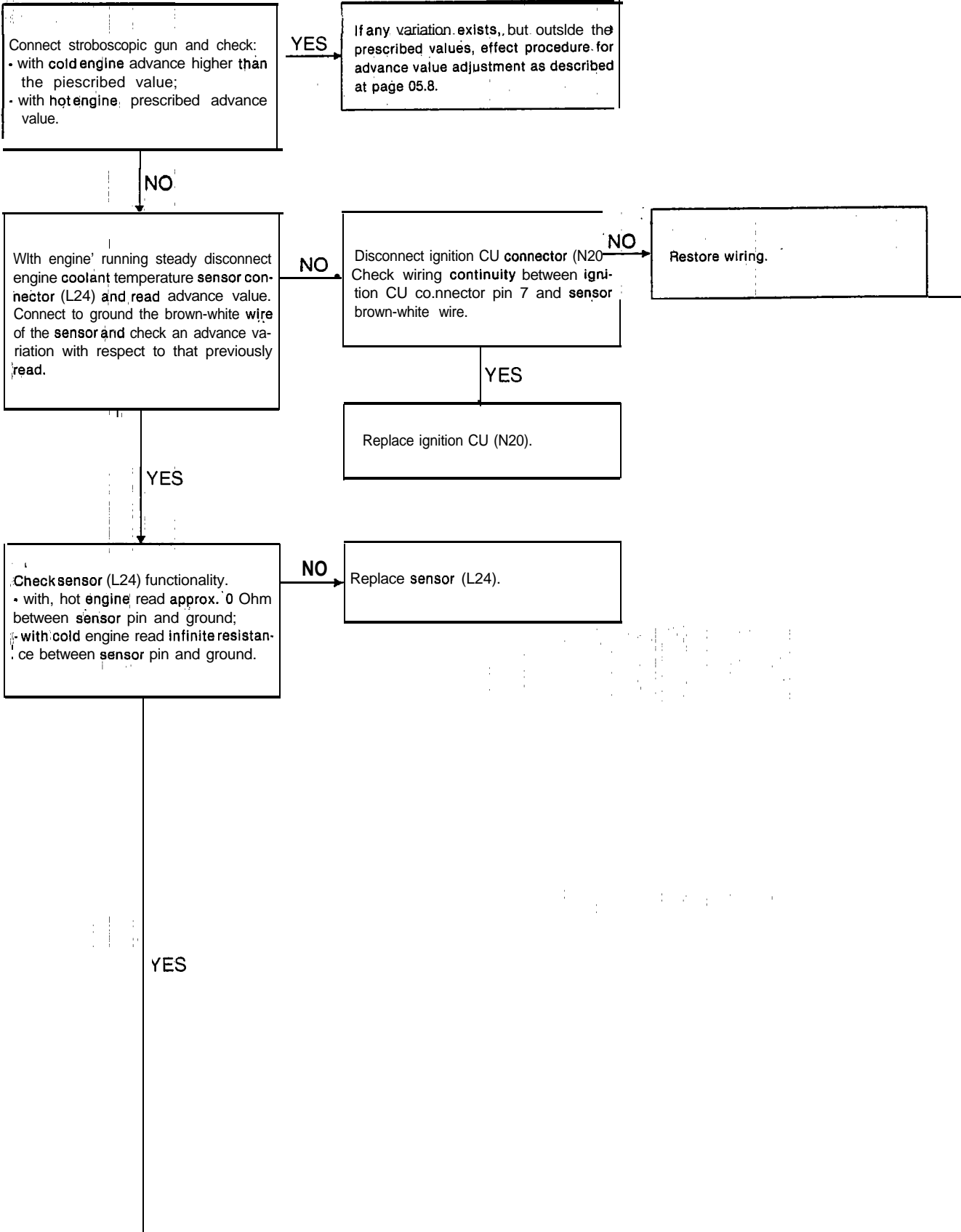

TEST No. 2

TEST No. 2

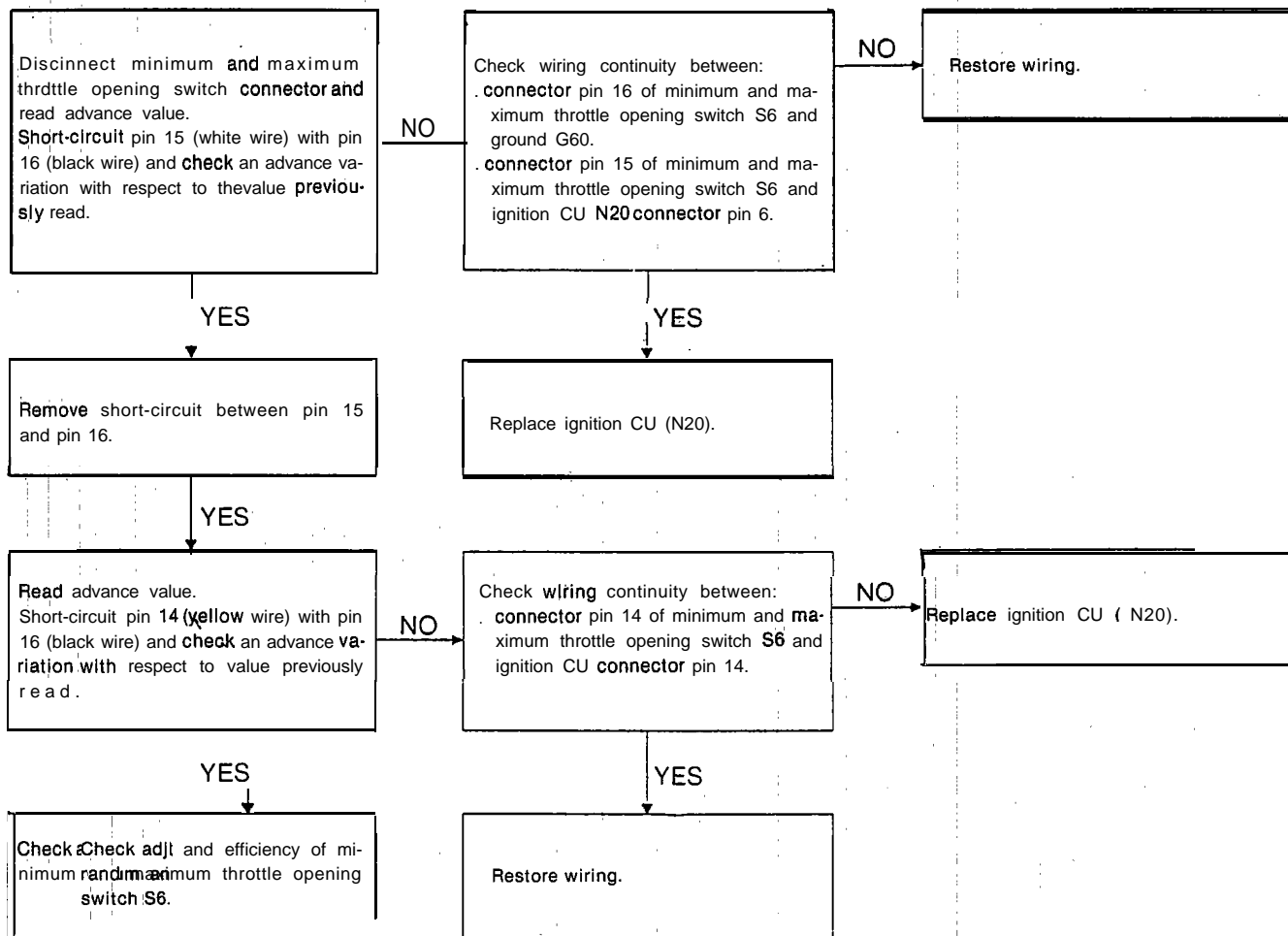

INJECTION - IGNITION WIRING DIAGRAM

for electronic injection 1.7 engines without catalytic converter only

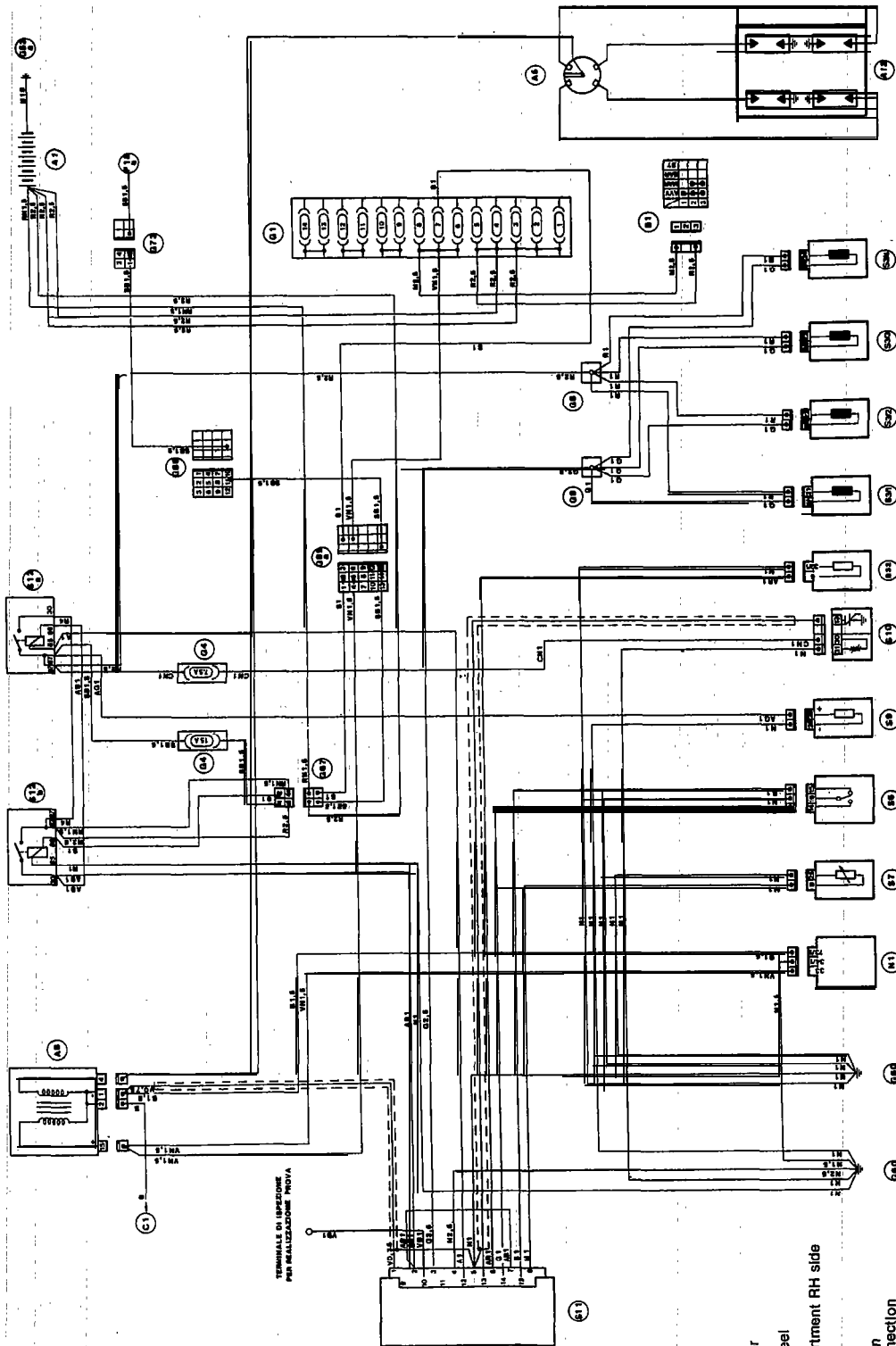

- A1 Battery
- A5 Ignition Distributor
- A6 Booster
- A8 Ignition Coil
- A12 Spark plugs
- B1 Electronic Speed Indicator
- C1 Fuse Holder Box
- G4 Fuse Holder Steering Wheel
- G8 Simple Connection
- G53a Ground of Engine Compartment RH side
- G60 Injection Wiring Ground
- G67 Connection
- G69 Rear Service Connection
- G99a Intermediate A Connection
- L25 Engine Coolant temperature thermal contact
- N1 Electronic Ignition module
- N20 Advance variation CU
- P18a Petrol Main Motor-Pump
- S3 Electroinjectors
- S6 Accelerator Throttle Body Switch
- S7 Engine Coolant Temperature Sensor
- S9 Supplementary Air Valve
- S11 Ignition CU
- S12a Fuel Pump Solenoid Starter
- S12b Diode Equipped Solenoid Starter

TECHNICAL DATA AND SPECIFICATIONS CHASSIS AND BODY MAINTENANCE

TECHNICAL DATA - INSPECTION AND ADJUSTMENT

Axles and suspensions

Model		33 *	33 1.7 *	33 1.5 axa	33 1.8 TD
		331.3 33 1.5 TI 33 1.7 IE			
Features					
Vehicle static loading arrangement (1)		$A + B = 490 + 245 = 735 \text{ N}$ (50 + 25 = 75 kg) $C = 490 \text{ N}$ (50 kg)			
Front wheel alignment	mm	$A = -12^{+10}_{-5}$	$A = -12^{+10}_{-5}$	$A = -2^{+10}_{-5}$	
Rear wheel alignment	mm	$B = 27^{+10}_{-5}$	$B = 41^{+10}_{-5}$	$B = +33^{+10}_{-5}$	
Front wheel toe-out(2)(3)	mm	M-H = 4 ± 2			M-H = 2 ± 2
Front toe-out angle		a = 10'			a = 10'
Wael rim diameter	mm	340	365 (4)	340	
Rear wheel toe-in		$\alpha = -20' \pm 10'$			$\alpha = 0' \pm 25'$
Front wheel camber (3)		$\beta = -1' \pm 30'$			$\beta = -1'55' \pm 30'$
Rear wheel camber (3)		$\beta = 0' \pm 25'$			
Front wheel caster(3)		y = 2" ± 30			y = 1" ± 30'
Steering lock(3)	Outer angle	$\delta_1 = 27^\circ 50'$			$\delta_1 = 29^\circ 38'$
	Inner angle	$\delta_2 = 33^\circ 45'$			$\delta_2 = 35^\circ 10'$

* Not marketed with 1.2 engine in all countries

- (1) Load vehicle, move it up and down on suspensions a few times. Checking operations must be performed with vehicle fully set up for driving.
- (2) When turning a steering side rod joint by 360°, M - H dimension changes by 2 mm (0.079 in)
- (3) These values are referred to a vehicle in nominal driving condition, i.e. with static load
- (4) With rim 5 1/2 J x 14"

SPECIAL SERVICE TOOLS

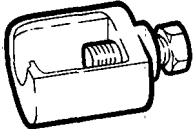
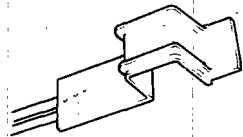
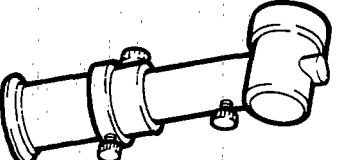
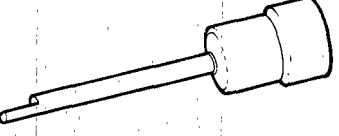
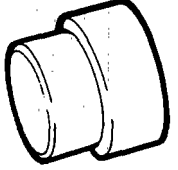
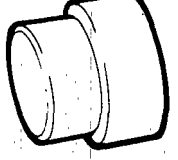
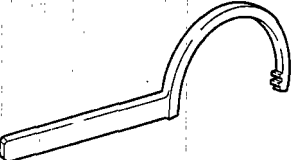
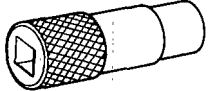
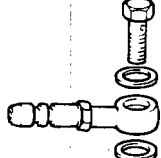
Tool number	Tool name	Refer to page
A.3.0156	Puller of pin from stub axle 	—
A.4.0146	Tool for suspension height check 	—
A.4.0149	Tool for suspension height check 	—
A.4.0150	Probe for suspension height check (to be used with A.4.0146 - A.4.0149) 	—
A.4.0153	Magnetic adapter for suspension height check (to be used with A.4.0146 - A.4.0149) 	—
A.4.0206	Magnetic adapter for suspension height check (to be used with A.4.0146 - A.4.0149) 	—
A.50195	Toothed wrench for locking camshaft pulley 	—
A.5.0212	Wrench for exhaust gas sampling plug 	00-14
C.2.0051	Fitting for exhaust gas sampling 	00-14

ENGINE MAIN MECHANICAL UNIT

GROUP 01

CONTENTS

DRIVE UNIT REMOVAL AND			
-INSTALLATION	01-2	Precautions	01-14
Removal (1.7 I.E. with catalytic converter);	01-2	Cylinder heads	01-14
Installation (1.7 with catalytic converter) 01-7		Pistons and connecting rods	(*)
Removal (1.7 I.E. without catalytic converter)	01-8	Crankshaft	(*)
Installation (1.7 without catalytic converter)	01-8/1	Engine unit	01-14
Supply and adjustment	01-8/1	ENGINE LUBRICATION SYSTEM	(*)
SEPARATION AND ASSEMBLY		Description	(*)
OF THE UNITS.....	(*)	Oil pump	(*)
ENGINE DISASSEMBLY	01-9	Oil filter	(*)
Preliminaries	01-12	HYDRAULIC TAPPETS	(*)
Engine unit	01-12	Operation description	(*)
Pistons and connecting rods	(*)	Differences from mechanical	
cylinder heads	(*)	tappets.	(*)
Crankshaft	(*)	General specifications	(*)
CHECKS AND INSPECTIONS	01-14	SERVICE DATA AND SPECIFICATIONS	
Cylinder heads and valves	01-14	(for petrol engines only)	01-18
Camshaft support	(*)	Technical data	01-18
Camshaft	(*)	Inspection and adjustment	01-19
Crankshaft	(*)	General, specifications	01-35
Main and connecting rod bearings ...	(*)	Tightening torques	01-35
Pistons and connecting rods	(*)	SERVICE DATA AND SPECIFICATIONS	
Flywheel	(*)	(for diesel engines only)	01-36
Cylinder block	(*)	Technical data	01-36
Piston - cylinder wall-fit	(*)	Inspection and adjustment	01-37
ENGINE ASSEMBLY	(*)	General specifications	(*)
		Tightening torques	(*)
		TRUBLE DIAGNOSIS AND	
		CORRECTIONS	(*)
		SPECIAL SERVICE TOOLS	(*)

(*) Refer to "VORKSHOP MANUAL

"VOLUME I and VOLUME II - Group 01

DRIVE UNIT REMOVAL AND INSTALLATION

These procedures are for electronic injection 1.7 engines

REMOVAL

1.7 I.E. with catalytic converter

During engine removal from car, it is necessary to remove engine and gearbox-differential as single unit. Put the vehicle on the auto lift and engage first gear.

WARNING:

Great care is required when dealing with a hot engine.

1. Preliminary operations

- Operating from passenger compartment, withdraw knob from gear lever, then remove the two protective rubber gaiters from gear lever.
- Remove the hood.
- Working from inside the engine compartment, disconnect the battery ground cable.

For following procedure steps, refer to figure at page 01-3.

2. Air filter, air flow sensor and sleeve removal.

- Unhook air filter cover (37) and remove filter element.
- Disconnect multiple connector (7) from air flow sensor (3).
- Disconnect pipe (16) from oil vapour separator (1).
- Disconnect metal fitting (14) from sleeve (9).
- Unscrew the three fixing screws of air flow sensor (3) to support (6).
- Loosen sleeve (9) fixing clamp to throttle body (10).
- Remove air filter cover (37) complete with air flow sensor (3) and sleeve (9).
- Unscrew the three support (6) fixing nuts and bolts and remove the support from body.

3. Removal of spark plugs supply cables

- Disconnect high voltage cables from spark plugs and coil.

- Disconnect the ignition distributor cap (12) and remove it complete with leads from engine.

4. Removal of air and fuel vapour pipes

Disengage the following pipes, disconnecting them from stated components:

- Pipes (28) and (29) from supply manifold (30).
- Pipe (15) from throttle body and pipe (11) from pneumatic gauge on ignition distributor (12).
- Pipe (13) from metal fitting (14).
- Pipe (33) from idle rpm setting fitting.
- Pipe (32) from supply manifold (30).
- Pipe (27) unscrewing fitting on supply manifold (30).

5. Removal of cooling system piping

- Unscrew and remove the coolant expansion tank plug.
- Raise the car from beneath, referring to Figure at page 01-6, remove the right hand drain plug and then the left hand drain plug (5) under the cylinder block and drain off the coolant; screw on the plugs again after draining and relower the car.

Put a suitable container under the car to collect the coolant.

- From the part stated, disconnect the following hoses and sleeves:
 - Sleeve (34) from thermostat and radiator and remove it.
 - Sleeve (32) from the union on the engine.
 - Hose (4) from throttle body (10).
 - Hose (1) from T fitting on engine rear side.

6. Removal of fuel hoses

- Disconnect hose (24) from damper (26).

- Disconnect hose (25) from pressure gauge (23).

7. Removal of accelerator control cable

- Rotate the accelerator lever (31) and withdraw the pawl on control cable end.
- Remove split ring and draw the accelerator cable sheath from the bracket.

6. Removal of ignition/injection wiring

- Disconnect the two Lambda probe connections (20) and disengage cable from clamps.
- Unscrew the two fixing screws and remove the solenoid starters (36) from body.
- Disconnect connection (35) between injection/ignition wiring and vehicle wiring.
- Disconnect connector (8) from the switch on throttle body (10).

9. Removal of supply manifold

Unscrew the three fixing nuts to the two supply manifold (30) ends and remove it with its relevant gaskets, complete with throttle body.

- The two central nuts also fix the engine lifting brackets (2); on right side the bracket supporting the oil dipstick is also fixed.
- Suitably plug the intake manifold on engine.

10. Removal of the clutch control hose

- Extract the fuseholder box (18).
- Unscrew the pipe fitting (19) of clutch pump and withdraw the hose from service tank sheet.

ENGINE MAIN MECHANICAL UNIT

LOCATION OF DRIVE UNIT ENGINE MOUNTINGS

As for

ENGINE COMPARTMENT - LOCATION COMPONENTS

Engine 1.7 Electronic Injection

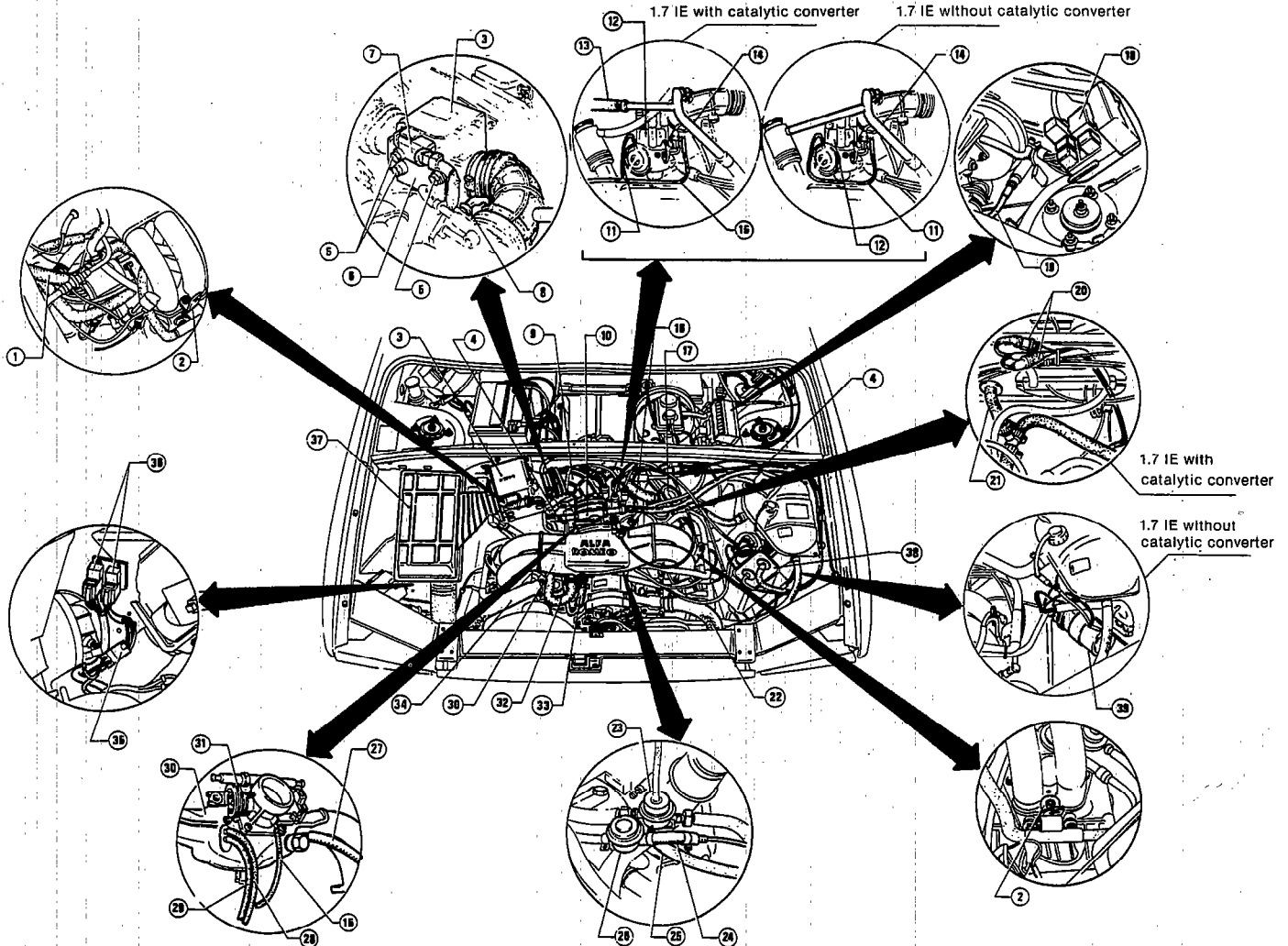

- 1 Coolant delivery hose . to radiant
- 2 Engine lifting brackets
- 3 Air flow/injection CU sensor
- 4 Cooling system breather pipes
- 5 Air flow sensor fixing screws
- 6 Air flow sensor support
- 7 Injection wiring multiple connector
- 8 Throttle body switch connector
- 9 Corrugated sleeve
- 10 Throttle body
- 11 Vacuum pipe to set pneumatic advance
- 12 Ignition distributor
- * 13 Air delivery tube to fuel vapour filter
- 14 Metal fitting
- * 15 Vacuum delivery tube for pneumatic advance control ignition distributor

- 16 Oil vapour recovery tube
- 17 Oil vapourator (oil filling union)
- 18 Fuseholder box
- 19 Pipe of clutch control hydraulic system
- * 20 Lambda probe connection
- 21 Return pipe of coolant from radiator
- 22 Sleeve of return coolant from radiator
- 23 Pressure gauge
- 24 Fuel delivery tube
- 25 Excess fuel return tube
- 26 Damper
- 27 Servobrake vacuum pipe
- 28 Vacuum pipe for fuel vapour filter
- * 29 Vacuum pipe for fuel pressure gauge

- 30 Air supply manifold (air intake box)
- 31 Accelerator throttle control lever
- 32 Supplementary air feed tube
- 33 Idle regulation by-pass tube
- 34 Collant delivery sleeve to radiator
- 35 Connection between injection wiring and vehicle wiring
- 36 Injection wiring solenoid starters
- 37 Air filter cover
- 38 Fuelvapour filter
- 39 Coil

(* For 1.7 IE with catalytic converter only.

ENGINE MAIN MECHANICAL UNIT

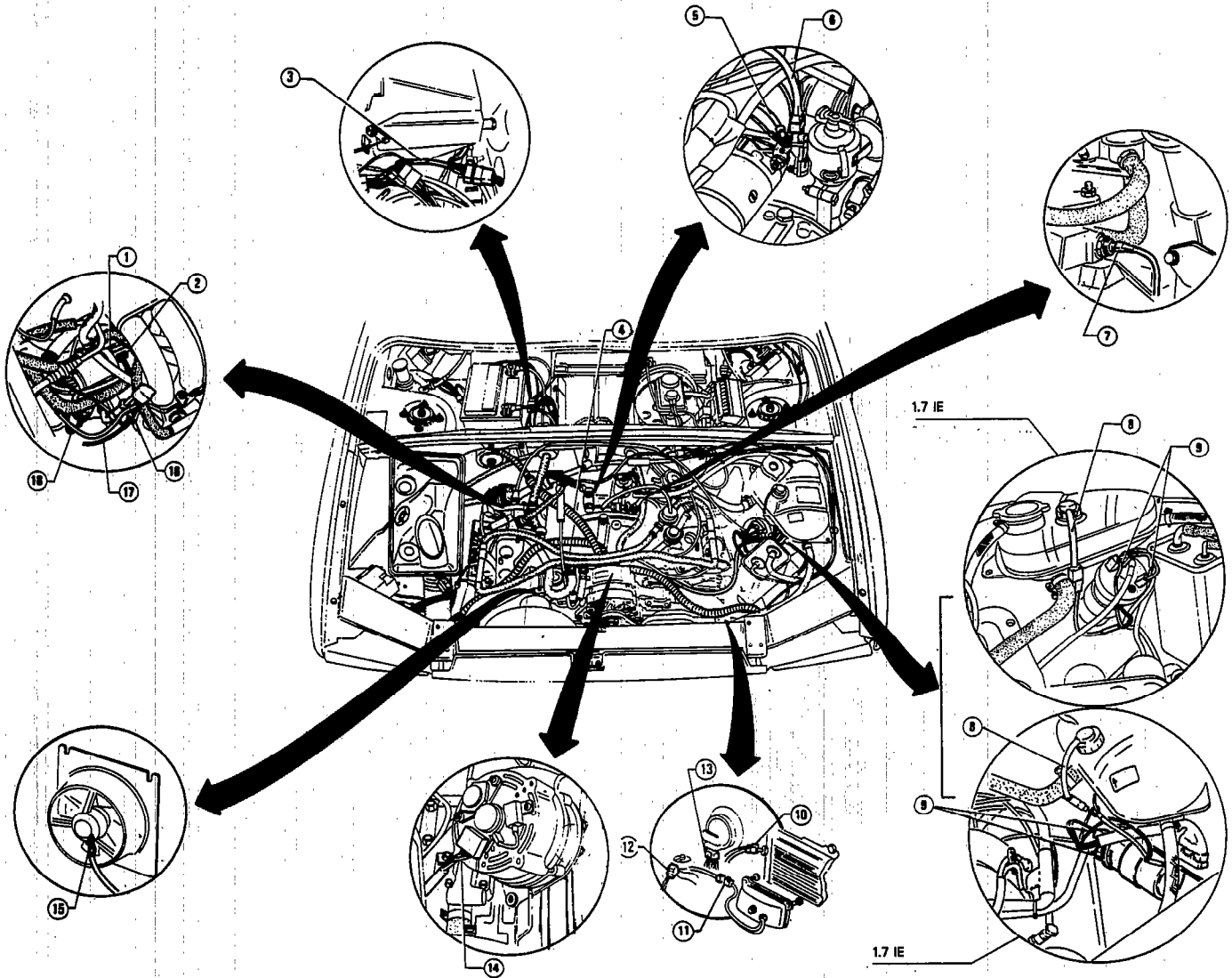

- 1 Starter energizing cable
- 2 Starter supply cables
- 3 Odometric sensor cable
- 4 Engine compartment wiring
- 5 Ground cable wiring
- 6 Power module on ignition distributor
- 7 Engine coolant temperature indicator cable
- 8 Engine coolant minimum level sensor cable
- 9 Coll low voltage cable
- 10 Electric fan cables for thermal contact consent
- 11 Foglamps cables
- 12 Horn cables
- 13 Front optical groups supply cables
- 14 Alternator and alternator warning light supply cable
- 15 Electrical fan supply cables
- 16 Min. level oil sensor cable
- 17 Engine max. oil pressure warning cable
- 19 Engine min. oil pressure warning cable

1.7 IE with catalytic converter

1.7 IE without catalytic converter

VIEW OF ENGINE COMPARTMENT LOCATION OF WIRING

11. Removal of electrical cables

For following removals, refer to figure at page 01-4.

a. Disconnect the following electrical cables, removing them from stated component:

- cables 13, from optical groups.
- cables 11, from foglamps connectors.
- cables 12, from horns.
- cable 6 from the movable connection of engine coolant minimum level sensor.
- low voltage cables 9 from coil.
- cables 10, from thermal contact of electric fan consent on radiator.
- cables 15, from electric fan connections
- cable 14, removing the pressure mounted connector on alternator.
- cable 7, from engine coolant temperature sensor.
- cable 1, energizing the starter from movable connection.
- cable 2, supplying the starter terminal.
- cable 18, from engine minimum oil pressure handcontact.
- cable 17, from engine maximum temperature thermal contact.
- cable 16, from oil level dipstick.
- Ground cable 5 unscrewing the engine cylinder block nuts, rear side.

- b. Release all wiring from wireblock and disengage them from the engine in order not to obstruct their removal.
- b. Disconnect odometer cable 3 connection, located in service tank.

12. Loosening nut of engine central support

With reference to the following figure loosen bolt 1 fixing central support 2 to the body without removing it.

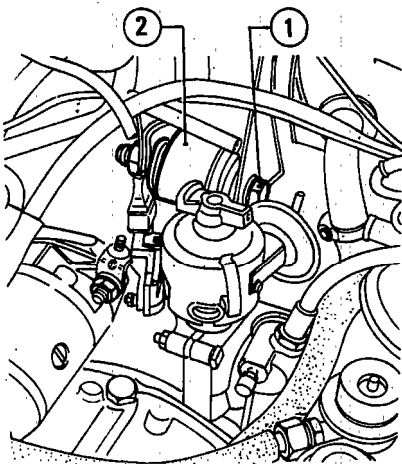

1 Bolt
2 Central support

For following procedure steps, refer to Figure at page 01-6.

13. Oil draining

(if required, as a function of intervention to be carried out)

- a. Raise the car on auto lift.
- b. Unscrew cap 10 and drain engine oil. Rescrew the cap, when this operation has been completed.
- c. Unscrew cap 15 and drain gear box-differential oil. Rescrew the cap when this operation has been completed.

14. Removal of exhaust pipe

- a. Disconnect mainfolds 9 from engine right and left heads, unscrewing the relevant fixing nuts.
- b. Unscrew the three bolts 13 connecting discharge mainfolds 9 to catalytic muffler 14 and disconnect them recovering the gasket.

c. Remove the discharge mainfolds 9 recovering the gaskets and withdrawing from bottom the wiring of lambda probe, previously disconnected.

15. Removal of reversing light cable

Disconnect reversing light cable 11 from gearbox switch.

16. Mechanical disconnection and removal of drive unit

a. Unscrew screws 16 fixing right and left semishfts to right and left shafts of the differential, and disengage the semishaft.

b. Unscrew to bracket attachment screw 17 on the engine antishock support bracket and position a column lifter under the drive unit. This column lifter will be fitted with a suitable supporting bracket R.4.0156 to take part of the drive unit weight.

c. Loosen and remove the two screws 4 fixing the engine front support to cross member.

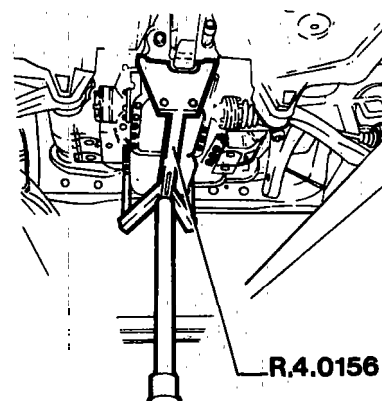

- d. Loosen and remove the remaining screws 1 and 7 fixing the front cross member to body.
- e. Loosen bolt 2 connecting front traverse to right strut.
- f. Unscrew and remove the bolt 6 connecting the front cross member to the left strut 8; then disengage the strut from the cross member.

ENGINE MAIN MECHANICAL UNIT

VIEW OF UNDERPART OF VEHICLE - LOCATION OF COMPONENTS

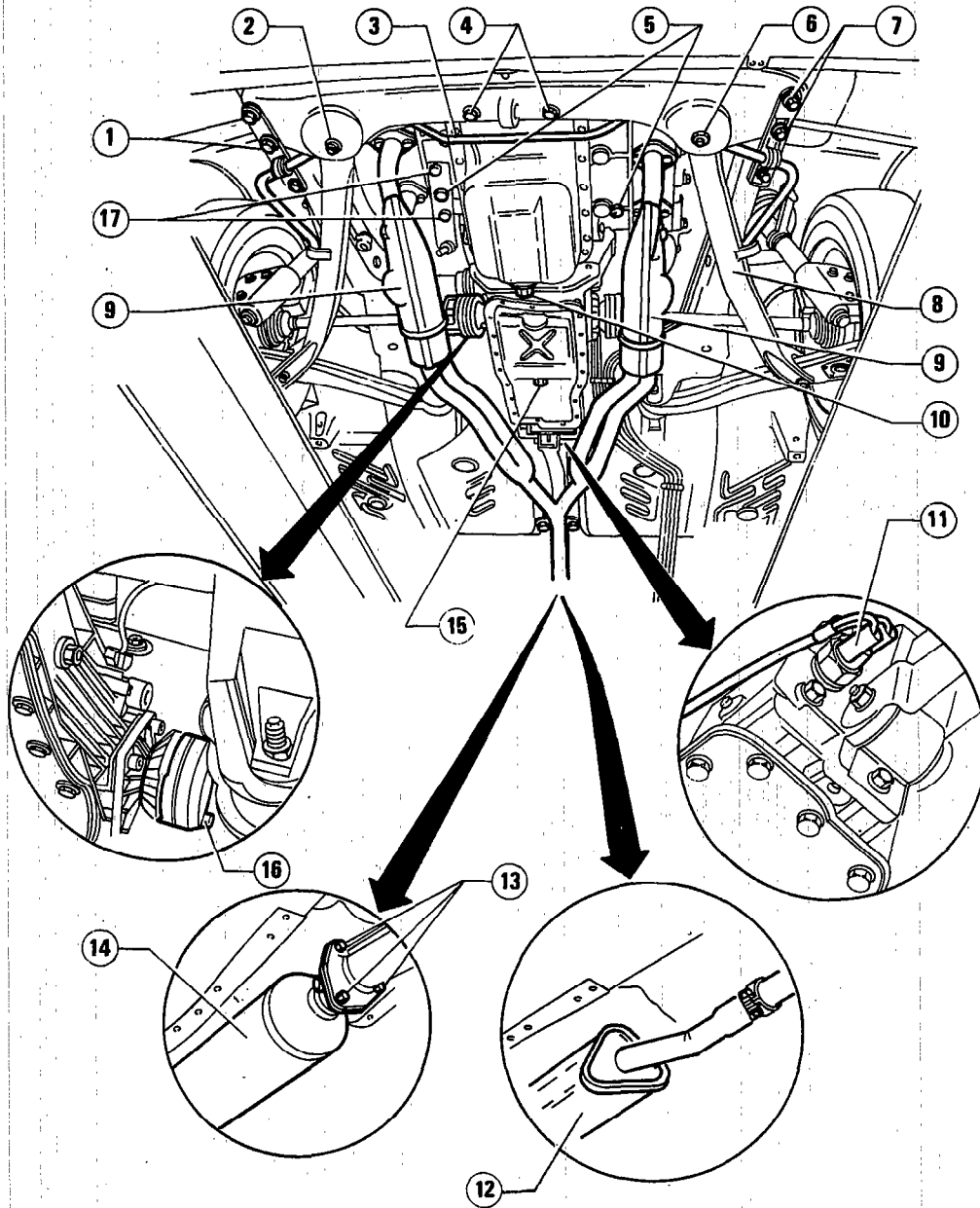

- | | |
|---|---|
| 1 Screws fixing cross member to body | 10 Engine oil drain plug |
| 2 Cross member to right strut connecting bolt | 11 Reverse light cable |
| 3 Stabilizing bar | 12 Muffler central silencer |
| 4 Screws fixing engine front support to crossmember | * 13 Exhaust manifold-catalytic muffer fixing bolts |
| 5 Coolant drain plugs | • 14 Catalytic muffer |
| 6 Cross member to left strut connecting bolt | 15 Gear box differential oil drain plug |
| 7 Cross member to body fixing screws | 16 Constant velocity joint screws |
| 8 Suspension left strut | 17 Bracket screws supporting engine anti-shock supporting bar |
| 9 Exhaust manifolds | 18 Exhaust manifold flange nuts |

(*) For models with catalytic converter only

g. Unscrew and remove the two bolts (3) connecting the front cross member to the left strut (8).
 h. Swing the front cross member round as shown in the illustration to allow the drive unit to be taken out downwards.

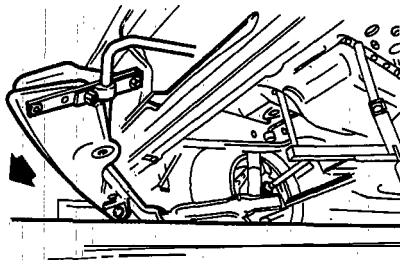

i. Unscrew and remove the two screws fixing the drive unit rear support (12) to the body.
 l. Remove bolt fixing engine central support to body, unloosened at step 1 2 .
 m. Lower column lift and take the drive unit out from the engine compartment.

INSTALLATION

1.7 IE with catalytic converter

1. Preliminary Operations

CAUTION:

Drive unit assembly must be performed in such a way that the gearbox rear support and the engine front support are not respectively upwards and longitudinally preloaded.

a. Raise the drive unit with the column lifter used for disassembly until the centre support axis (2) is at about the halfway point of the body slot and tighten the relevant bolt (1).

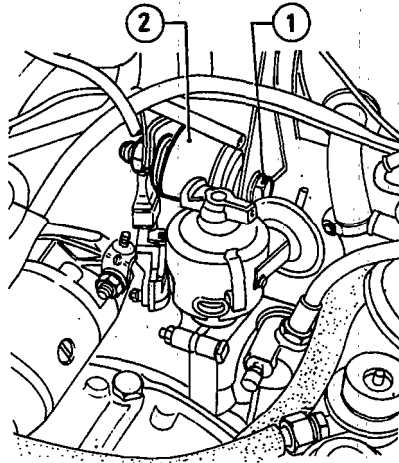

1 Bolt
 2 Central support

b. With reference to figure at page 01.6, rotate the front crossmember complete with stabilizing bar in mounting position and fix it with bolt (6) to strut (8) then fully tighten bolts (6) and (2).
 c. Tighten screws (4) fixing the engine front support.
 d. Tighten the following components to the specified torque.

- T** Tightening torques
- crossmember and stabilizing bar bracket to body
 $66,5 \div 83,3 \text{ N.m}$
 $(6,8 \div 8,5 \text{ kg.m})$
 - Screws fixing stabilizing bar to strut
 $14,7 \div 23,5 \text{ N.m}$
 $(1,5 \div 2,4 \text{ kg.m})$
 - Screws connecting semishaft differential shafts (in engine oil)
 $33 \div 36 \text{ N.m}$
 $(3,4 \div 3,7 \text{ kg.m})$

e. With reference to following figure remove lift and loosen lower bolt (4) fixing the rear support to gear box.
 f. Insert pin (2) into the elastic joint of rear support (1), position it on relevant point fixing it to body and tighten screws (3).
 g. Retighten lower nut (4)

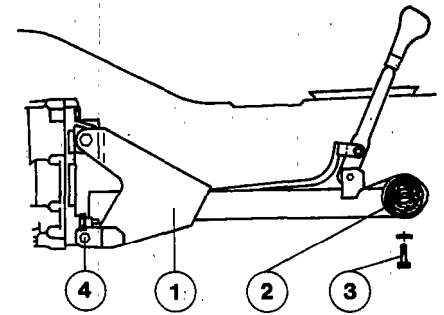

1 Rear support of gearbox
 2 Pin
 3 Rear support securing screw
 4 Bolt securing gearbox rear support

h. Insert the side rod (4) into support (3) on right side longitudinal member (2), then lock screw (6) first and then screw (5).

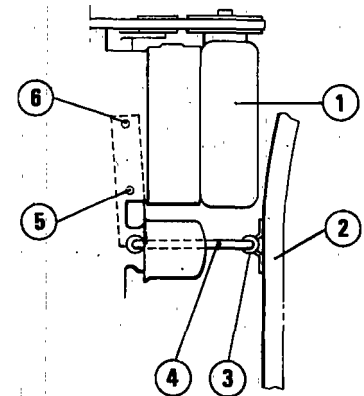

1 Right cylinder head
 2 Right side longitudinal member
 3 Support
 4 Side rod (engine antishock bar)
 5 Front screw
 6 Rear screw

2. Reinstallation of reverse light cable and of exhaust pipe

a. Reconnect the reverse light cable to gearbox switch.
 b. Remount exhaust manifolds in reverse order with respect to removal, new gaskets between manifolds and engine cylinder heads and between manifolds and catalytic muffler.

3. Reassembly of electrical cables

Lower the auto lift and, with reference to figure on page 01-4, reconnect electrical cables working in reverse order to that described under "Removal" step 11.

For following procedures steps, refer to Figure 01-3.

4. Reassembly of, clutch control hose

Refit hose (19) to clutch pump and fully tighten it.

5. Reassembly of air intake manifold

Refit inlet manifold (30) on intake manifolds, fitting new gaskets, then tighten securing nuts.

Mind that central nuts on two sides of the manifold- serve also to fix brackets (2).

6. Completion of reassembly

a. Reconnect injection/ignition wiring in reverse order to that described under "Removal" - Step 8.

b. Reconnect the accelerator cable to lever (31) on throttle body.

c. Reconnect hoses (24) and (25) respectively to damper (26) and pressure gauge (23).

d. Reconnect pipelines of engine cooling system in reverse order to that described under "Removal" - Step 5.

e. Reconnect fuel vapour and air in pipelines in reverse order to that described under "Removal" - Step 4.

f. Reconnect cables supplying spark plugs and reinstall the ignition distributor cap (12).

g. Reinstall air filter cover (37), air flow sensor (3) and corrugated sleeve (9) in reverse order to that described under "Removal" - Step 2.

h. Remount hood.

i. Remount the battery negative terminal.

l. Operating inside the passenger compartment refit the gear lever knob and rubber gaiters on the gear lever.

- Pipe (28) from supply manifold (30).
- Pipe (15), from throttle body and pipe (11) from pneumatic gauge on ignition distributor (12).

- Pipe (33), from idle RPM setting fitting.
- Pipe (32), from supply manifold (30).

- Pipe (27) unscrewing fitting on supply manifold (30).

5. Removal of cooling circuit pipes

Operate as described at Step 5 page 01-2.

6. Removal of fuel supply hose

Operate as described at Step 6 page 01-2.

7. Removal of accelerator control cable

Operate as described at Step 7 page 01-2.

8. Removal of ignition/injection cables

a. Unscrew two screws and remove solenoid starters (36) from body.

b. Disconnect connection (35) between ignition/injection wiring and vehicle wiring.

c. Disconnect connector (8) from throttle body switch (10).

9. Removal of supply manifold

Operate as described at Step 9 page 01-2.

10. Removal of clutch control hose

Operate as described at Step 10 page 01-2.

REMOVAL

1.7 IE without catalytic converter

During engine removal from the car, it is necessary to remove engine and gearbox-differential unit as a single unit. Put the vehicle on the auto lift and engage first gear.

WARNING:

Great care is required when operating on a hot engine.

1. Preliminary operations

Operate as described at Step 1 page 0-2

For the following procedure steps refer to Figure at page 01-9.

2. Air filter, air flow sensor and sleeve removal

Operate as described at Step 2 page 01-2.

3. Removal of spark plugs supply cables

Operate as described at Step 3 page 01-2.

4. Removal of air pipes

Disengage the following pipes, disconnecting them from stated components:

11. Removal of electrical cables

Operate as described at step 11 page 01-5 with reference to Fig. page 01-4.

12. Loosening nut of engine central support

Operate as described at step 12 page 01-5.
For following procedure steps refer to Figure at page 01-6.

13. Oil draining

(if required, as a function of intervention to be carried out, operate as described at step 13 page 01-5).

14. Removal of exhaust pipe.

- a. Disconnect exhaust gas manifolds from right and left engine heads, unscrewing the relevant fixing nuts 18.
- b. Disconnect exhaust pipe on vehicle rear side unscrewing screw of connecting clip to final trunk of exhaust pipe and remove it from elastic support.

Removal of reversing light cable

Disconnect reversing light cable 11 from gearbox switch.

16. Mechanical disconnection and removal of drive unit.

Operate as described at step 16 page 01-5.

INSTALLATION

1.7 IE without catalytic converter

1. Preliminary operations

Operate as described at step 1 page 01-7.

2. Reinstallation of reverse light cable and of exhaust pipe.

- a. Reconnect reverse light cable to gearbox switch.
- b. Remount exhaust manifold operating in reverse order to removal, with new gaskets between manifolds and engine heads.

3. Reassembly of electrical cables.

Lower the auto lift and, with reference to figure on page 01-4, reconnect electrical cables working in reverse order to that described T "Removal" step 11.

For following procedure steps, refer to Figure 01-3.

4. Reassembly of clutch control hose

Refit hose 19 to clutch pump and fully tighten it.

5. Reassembly of air intake manifold

Refit inlet manifold 30 on intake manifolds, fitting new gaskets, then tighten securing nuts.

Mind that the central nuts on two sides of manifold serve also fix brackets 2

6. Completion of reassembly

- a. Reconnect injection/ignition wiring in reverse order to that described under "Removal" step 8.
- b. Reconnect accelerator cable to lever 31 ON THROTTLE BODY.
- c. Reconnect hoses 24 and 25 respectively to damper 26 and pressure gauge 23.
- d. Reconnect pipelines of engine cooling system in reverse order to that described under "Removal" step 5.
- e. Reconnect cables supplying spark plugs and reinstall ignition distributor cap 12.
- f. Reinstall air filter cover 37, air flow sensor 3 and corrugated sleeve 9 in reverse order to that described under "Removal" step 2.
- g. Remount hood.
- h. Remount battery negative terminal.
- i. Operating inside the passenger compartment refit the gear lever knob and rubber gaiters in the gear lever.

REFILLING AND ADJUSTEMENTS

- a. Refill engine and gearbox-differential with type and quality of oil recommended.

WARNING:

Before refilling with oil, make sure that the engine pump drain plug and gearbox drain plug have been screwed back on.

ENGINE MAIN MECHANICAL UNIT

ENGINE OIL

Type:

AGIP Sint 2000 SAE 10W/40
IP Sintiax SAE 10W/40
SHELL Super Plus Motor Oil SAE
15W/50

Oil quantity for full refilling
(Pump, filter and ducts):
4,1 l

GEARBOX-DIFFERENTIAL OIL

Type:

AGIP Rotra MP SAE 80W/90
IP Pontiax HD SAE 80W/90
SHELL Spirax HD SAE 80W/90

Quantity:

2,4 kg

b. Effect cooling system refilling with special fluid (See: Group 00 - Engine Maintenance - Basic Mechanical System).

c. Effect the setting of the accelerator control cable (see: Group 00 - Engine Maintenance - Engine Supply).

d. **Bleed** the clutch hydraulic system and top up said circuit (as per Alfa 33 - Group 12).

e. Start the engine and, when at normal running temperature, check correct engine idle rpm running, the correct ignition timing and CO percentage at exhaust.

For engine tuning see Group 00 - Engine Maintenance.

ENGINE DISASSEMBLY

These procedures are for electronic injection 1.7 engines

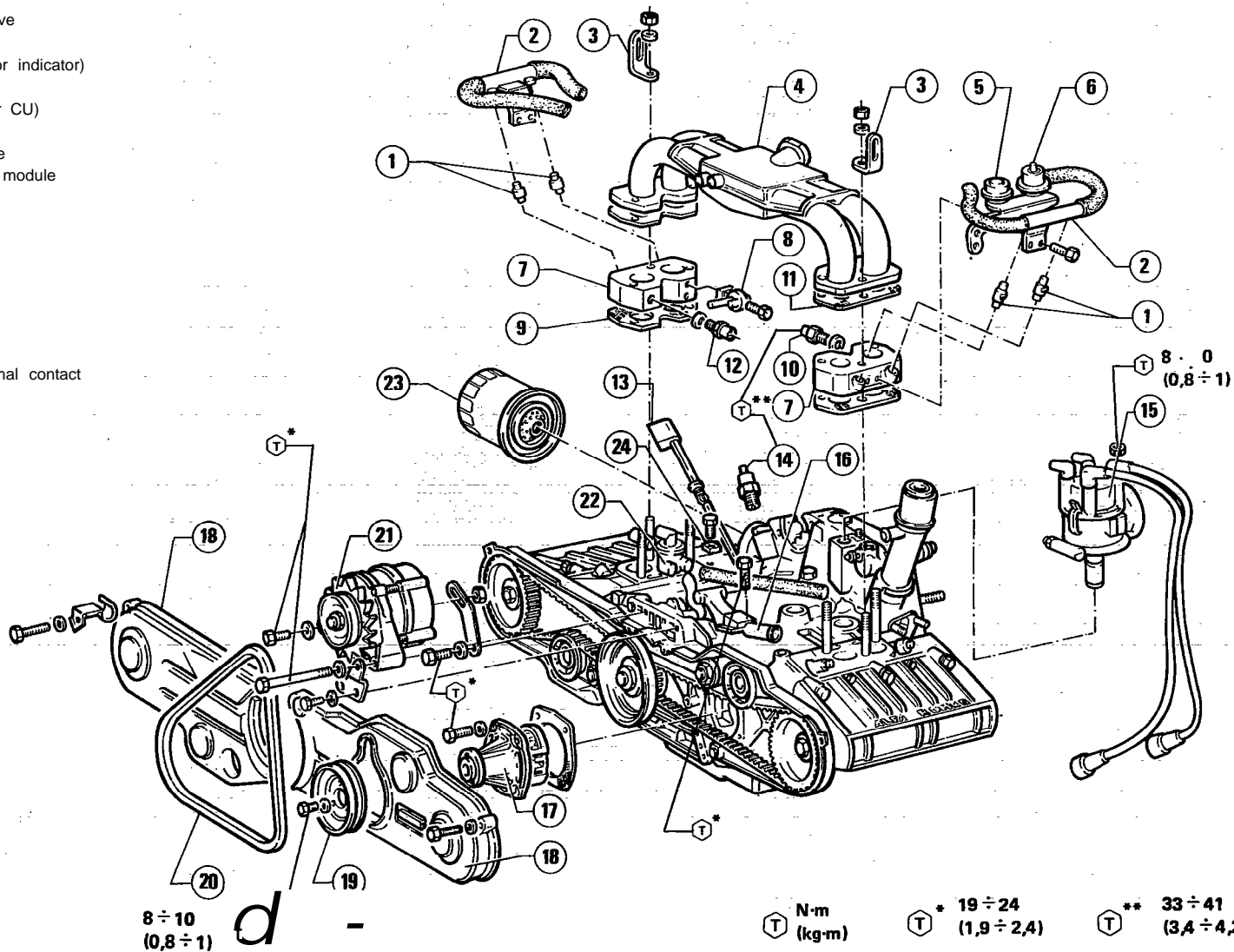

Outer parts

- 1 Electroinjectors
- 2 Fuel supply manifold
- 3 Lifting brackets
- 4 Supply manifold
- 5 Fuel pulse damper
- 6 Fuel pressure gauge
- 7 Intake manifolds
- 6 Supplementary air solenoid valve
- 9 Gasket
- 10 Coolant temperature sender (for indicator)
- 11 Gasket
- 12 Coolant temperature sender (for CU)
- 13 Dipstick
- 14 Single contact min. oil pressure
- 15 Ignition distributor with power module
- 16 Union
- 17 Coolant pump
- 16 Front protection of drive belts
- 19 Water pump pulley
- 20 Water pump/alternator belt
- 21 Alternator
- 22 Thermostat
- 23 Oil filter
- 24 Max. engine temperature thermal contact

8 ÷ 10
(0,8 ÷ 1)

d -

T N·m
(kg·m)

T* 19 ÷ 24
(1,9 ÷ 2,4)

T** 33 ÷ 41
(3,4 ÷ 4,2)

ENGINE MAIN MECHANICAL UNIT

Internal parts

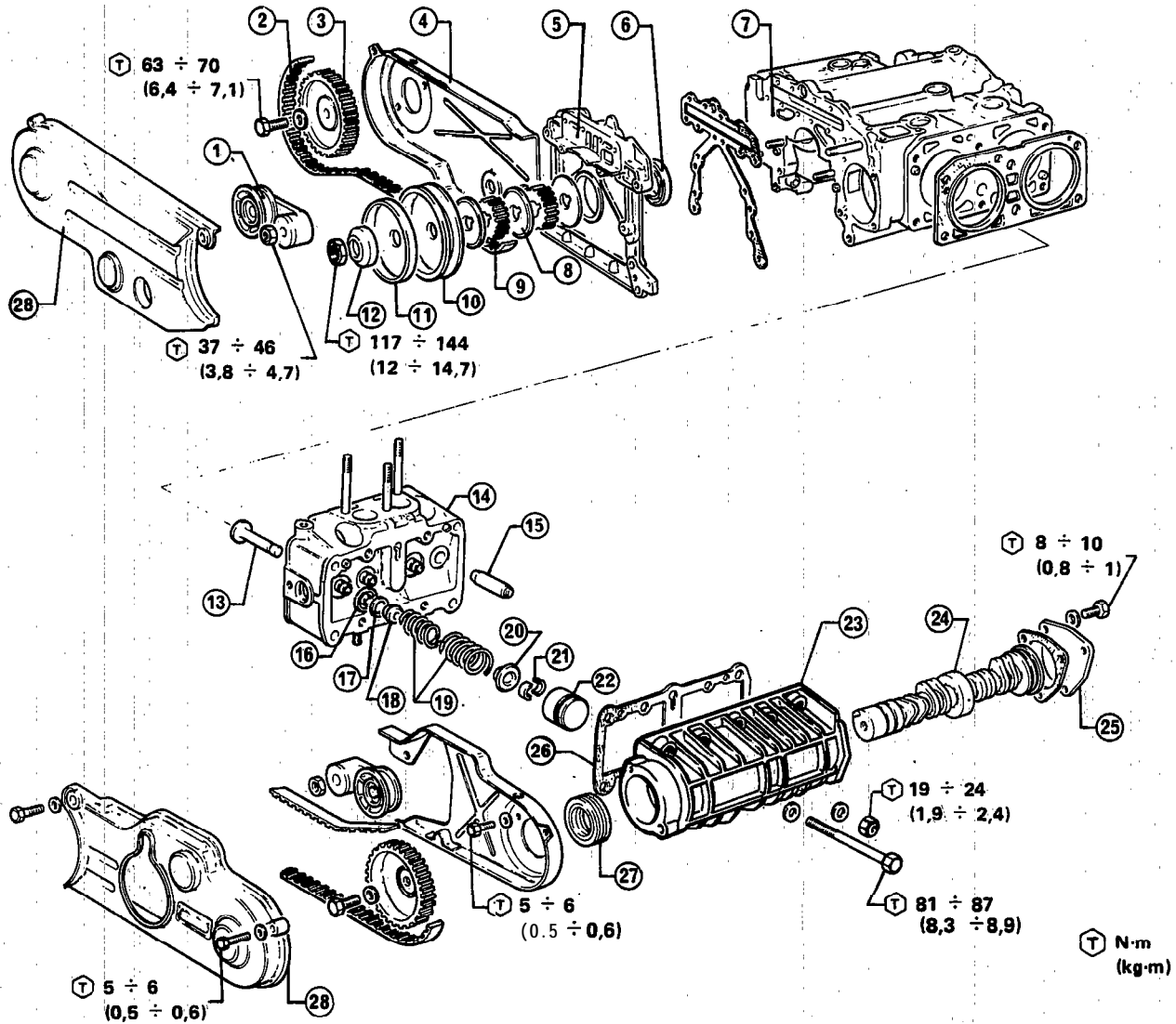

- 1 Jockey pulley
- 2 Timing belt
- 3 Right timing pulley
- 4 Timing belt rear cover
- 5 Engine front cover
- 6 Crankshaft seal ring
- 7 Engine block
- 8 Spacer
- 9 Timing Pulley
- 10 Water-pump-alternator pulley
- 11 Spacer
- 12 Washer
- 13 Valve
- 14 Cylinder head

- 15 Valve guide
- 16 Lower spring seat
- 17 Washer
- 18 Seal cap
- 19 Springs
- 20 Spring seat
- 21 Cotter
- 22 cup
- 23 Camshaft Support
- 24 Camshaft
- 25 Cover
- 26 Gasket
- 27 Seal ring
- 28 Timing belt front cover

ENGINE MAIN MECHANICAL UNIT

Internal parts

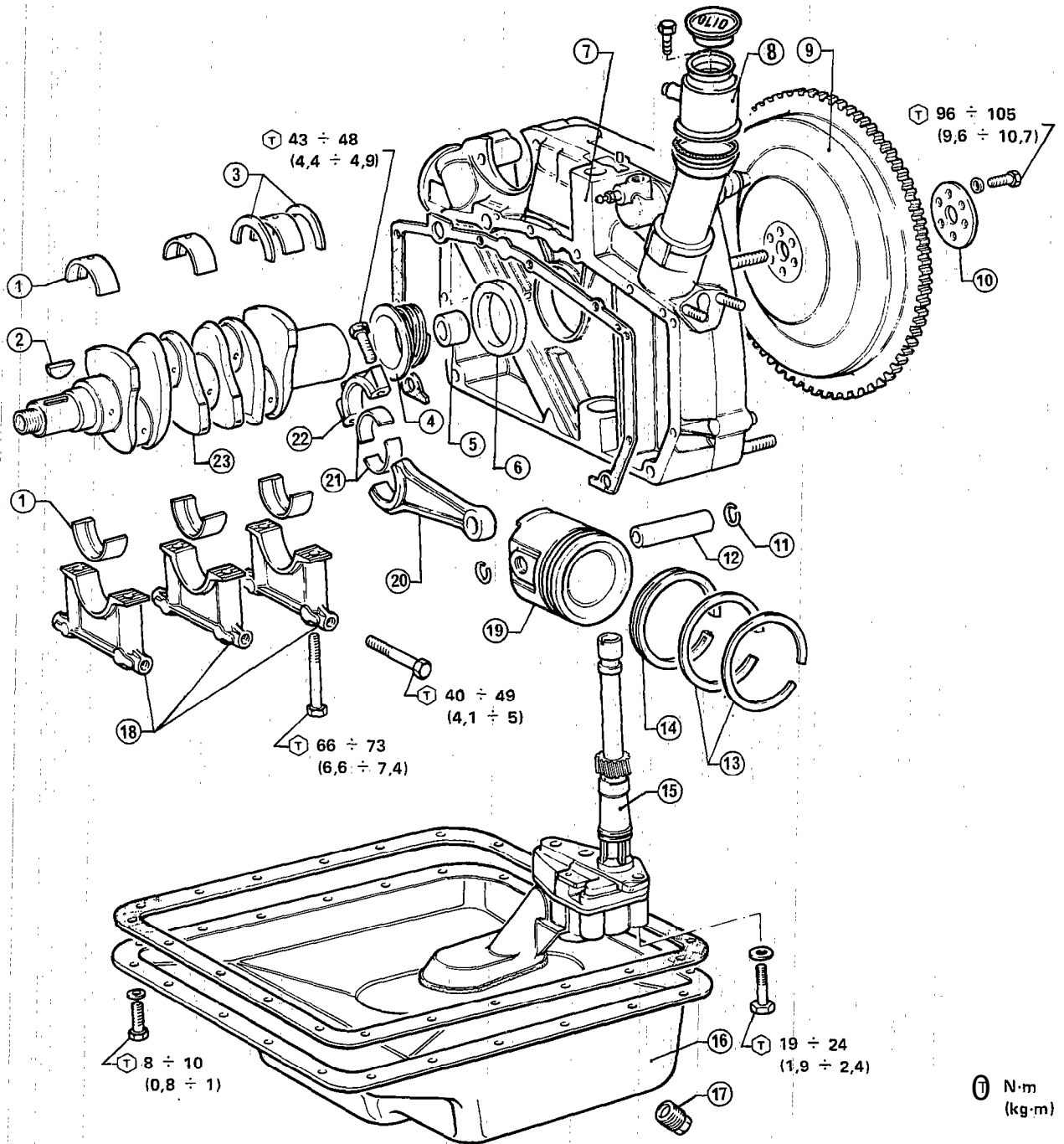

T N·m
(kg·m)

PRELIMINARY OPERATIONS

1. Remove drive unit from car according to procedures: Drive Unit Removal and Installation.

2. Remove gearbox - differential unit and clutch unit from engine according to procedures: Separation and Assembly of the Units (see: "WORKSHOP MANUAL Alfa 33" - Group O-I).

4. Remove spark plugs and ignition distributor.

(1) Unscrew and remove spark plugs from cylinder heads.

(2) Loosen distributor ① securing nut ② and withdraw distributor from rear cover.

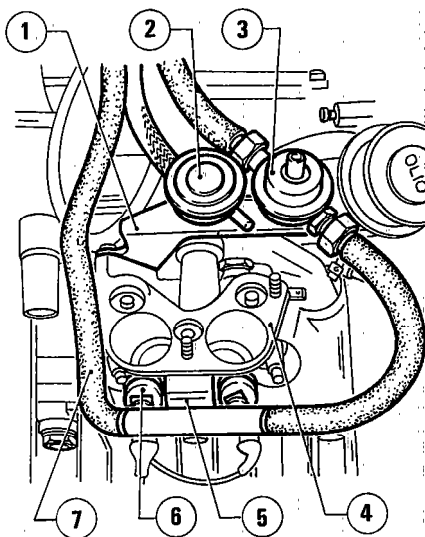

- 1 Bracket
- 2 Damper
- 3 Fuel pressure gauge
- 4 Intake manifold
- 5 Bracket
- 6 Injector
- 7 Fuel supply hose

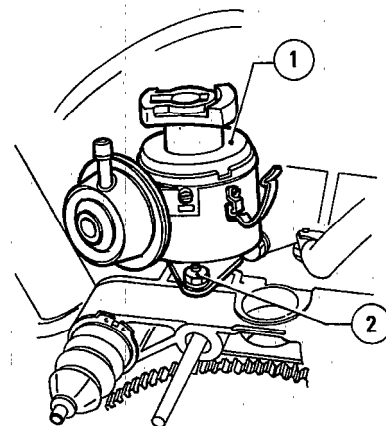

- 1 Ignition distributor
- 2 Distributor securing nut

ENGINE UNIT

The engine is on the stand without inlet manifold and with no spark plugs, cables, and distributor cap already removed on engine removal.

- 1 Ignition distributor
- 2 Distributor securing nut

5. Remove alternator.

(1) Loosen securing bolts ① fixing alternator ② and remove drive belt.

(2) Remove bolts and take out alternator (2).

(3) Unscrew screws ③ and remove bracket ④ and ⑤.

1. Removal of injection wiring

(1) Disconnect injection wiring connectors from following components:

- supplementary air valve
- power module on ignition temperature
- engine water temperature sensor
- Injectors:

Disengage wiring from wire clips and remove wiring from engine

3. Sequentially remove the following parts:

- Oil filter ① using suitable spanner.
- Dipstick ③ for minimum oil pressure check
- Thermal switch ④ from right cylinder head.

2. Remove fuel distribution manifold.

(1) Unscrew fixing screws from bracket ① supporting damper ② and pressure gauge ③

(2) Unscrew screws (two per side) fixing brackets ⑤ which support the fuel hose ⑦.

(3) Remove fuel hose disconnecting it from four injectors ⑥.

(4) Remove four injectors ⑥, extracting them from thermal switches ④.

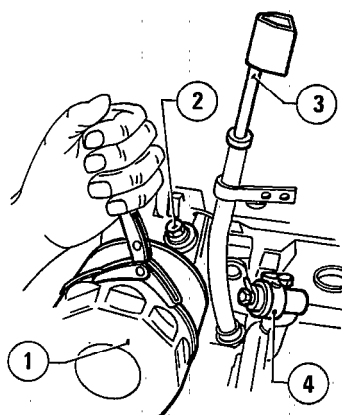

- 1 Oil filter
- 2 Pressure switch
- 3 Dipstick
- 4 Thermal switch

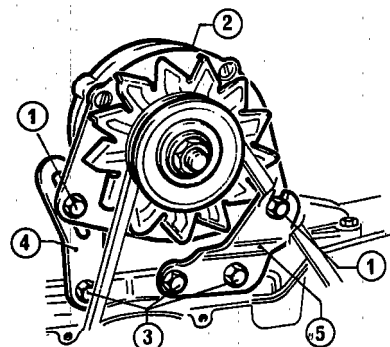

- 1 Bolt
- 2 Alternator
- 3 Screws
- 4 Bracket
- 5 Bracket

ENGINE MAIN MECHANICAL UNIT

6. Remove sleeve and cooling system union:

(1) Loosen clamps fixing following cooling system hoses:

- Hose ⑤ connecting between thermostat and union ②
- Hose ③ connecting between thermostat and union ②
- Hose ① connecting thermostat and right manifold.

(2) Remove hose ③ and ①.

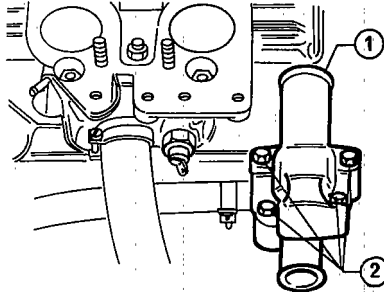

- 1 Union
2 Screws

7. Remove thermostat.

Remove screw ① fixing thermostat ② on cylinder block and remove it.

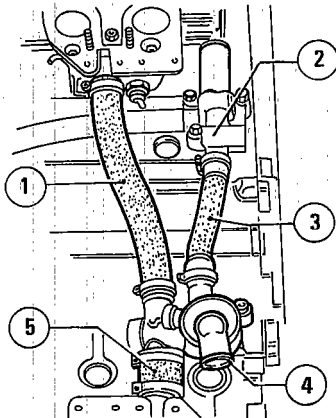

- 1 Hose connecting thermostat-union
2 Union
3 Hose connecting thermostat-union
4 Thermostat
5 Hose connecting thermostat - right manifold

(3) Unscrew and take out screws ② fixing union ① on cylinder block, then remove union.

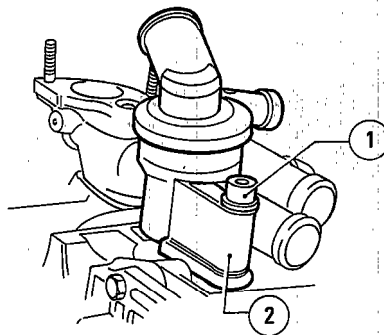

- 1 Screw
2 Thermostat

8. Remove intake manifolds

(1) Unscrew all three nuts securing each intake manifold and remove them from heads with relevant gaskets.

(2) If necessary, remove water temperature transmitters from intake manifolds.

(3) If necessary, working on bench, unscrew the two fixing screws and remove supplementary, air solenoid valve from right manifold.

9. Proceed as per **Alfa 33** from step 11 to end, but for step 21 "Remove Cylinder Heads", which should be modified as follows:

(1) Unscrew the six screws ① which secure cylinder heads to engine block.

(2) Remove heads along with camshaft Supports and the gaskets on engine block.

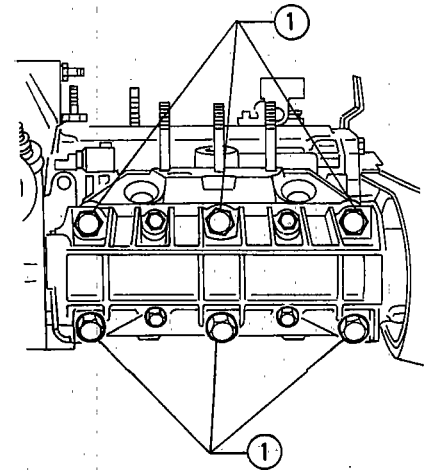

- 1 Screws securing heads and camshaft supports to engine block

CYLINDER HEADS

Procedure is as per **Alfa 33** taking into account that camshaft supports have no cover. Therefore, on head supports disassembly, recover the oil still present in the supports.

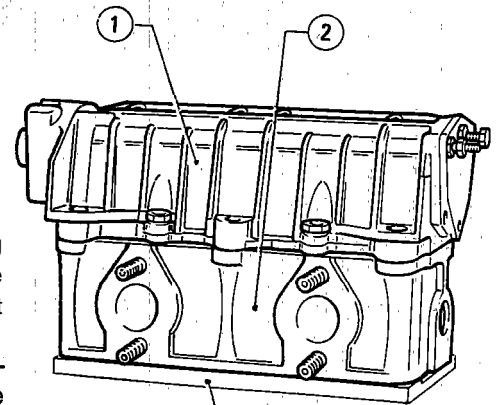

A.2.0226

- 1 Camshaft support
2 Cylinder head

CHECKS AND INSPECTIONS

These procedures are for electronic injection 1.7 engines with catalytic convertor only

WARNING

Procedures described for **Alfa 33** are still valid except for what follows.

For technical data of 1.7 injection engine, please refer to "Service Data and Specifications".

CYLINDER HEADS AND VALVES

As per **Alfa 33** except

CUPS

1. Check that outside surface of

cup is free of any trace of sizing, etching, or unusual wear.

2. Check that the cups upper plane on which cams work is free of unusual wear.

ENGINE ASSEMBLY

These procedures are for electronic injection 1.7 engines with catalytic convertor only

WARNING

Procedures described for **Alfa 33** are still valid but for what stated here below.

For technical data of 1.7 injection engine, please refer to "Service Data and Specifications".

WARNINGS

1. Lubricate, with engine oil bearings and slipping surfaces before assembly.

2. Use new gaskets, seal rings and lock rings!

3. Screw screws and nuts to specified tightening torque.

4. Apply specified sealant to components listed here below.

- Oil sump, block side
Mastics class: 3522-00040
DOW CORNING Silastick 732 R T V
- Water tubes, plugs, caps, cylinder heads and block.
Mastic class 3524-00011
Loctite 601 (green)

Before applying sealants eliminate any possible trace of old sealants by degreasing the surfaces.

CYLINDER HEAD

Operate as stated per **Alfa 33** taking into account the following:

- Lubricate thoroughly cups ② before inserting them into camshaft support ① seats.
- On reassembly of camshaft support on head, make sure the camshaft is in rest position (no cam engaged; valves closed).
- Secure camshaft support to head with gasket between tightening the four nuts in crosswise order to the temporary torque specified.

Ⓜ : Temporary tightening, torque
Nuts securing camshaft supports to cylinder head
 $10 \div 15 \text{ N}\cdot\text{m}$
($1 \div 1.5 \text{ Kg}\cdot\text{m}$)

- Before fitting rear cover onto support, insert $0.10 \div 0.15 \text{ l}$ engine oil into support itself.

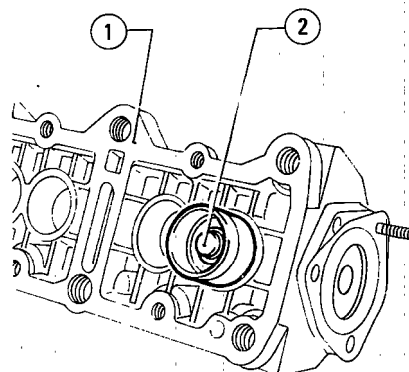

1 Camshaft
2 Hydraulic tappets cup

ENGINE, UNIT

As per **Alfa 33** but modifying the mentioned steps.

- Step 15.
Install cylinder heads

(1) Turn crankshaft till the piston in No. 1 cylinder is set at Top Dead Center in the explosion stroke; this correct positioning is further ensured by the "T" notch ① on the flywheel matching with the reference ② on the rear cover ③.

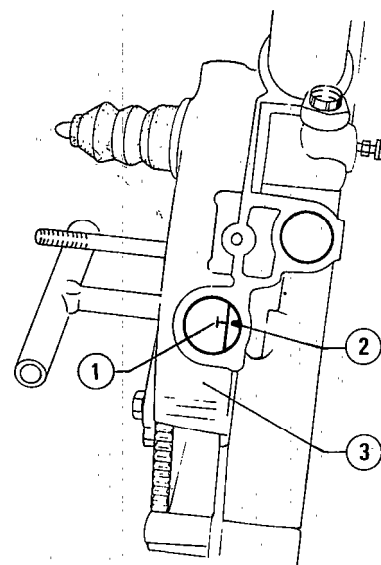

1 "T" notch
2 Reference
3 Cylinder block rear cover

(2) Set the camshaft in rest position (no cam engaged; valves closed).

(3) Fit the cylinder heads with crankshaft support on the cylinder block, and insert the appropriate gasket.

Proceed as per **Alfa 33** from Step (4).

- Step 18.
Install timing belts.

(1) Fit camshaft drive pulleys and tighten the retaining screw to specified torque being careful, at the same time, to stop pulley rotation by means of toothed spanner **A.5.0195**.

ⓘ : **Tightening torque**
Camshaft pulley retaining screw.
83 ÷ 70 N·m
(6.4 ÷ 7.1 Kg·m)

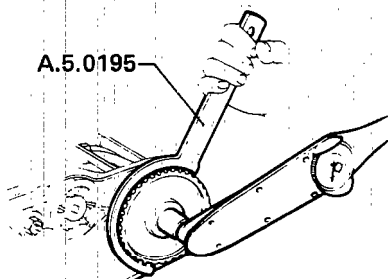

(2) Verify that the crankshaft's angular position corresponds to the Top Dead Center of cylinder No. 1, in the explosion stroke (alignment between notch "T" on flywheel and rear cover reference mark).

(3) Rotate crankshaft counterclockwise (seen from rear side) by 45° in order to move piston of cylinder No. 2 backwards so as to prevent valves striking against piston during camshaft rotation.

(4) Position the left camshaft so that the tooth and the two adjacent milled grooves of the left timing pulley are visible through the appropriate hole on rear guard ①.

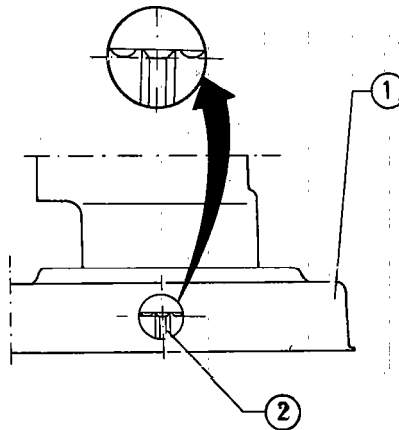

1 Timing belt rear cover
2 Left timing pulley

(5) Realign notch "T" on flywheel with the fixed reference mark (piston of cylinder No. 1 at T.D.C. in the explosion stroke) and, keeping shafts in this position, fit the left timing belt onto pulleys.

The belt shall be fitted with its dragging side, opposed to straighteners, under tension.

(6) Loosen the nut securing the belt straightener so that it can exert the spring load on the belt.

(7) Rotate the crankshaft 45° to move piston of cylinder No. 1 backwards so as to prevent valves striking against piston itself when positioning the camshaft.

(8) Position the right-hand camshaft so that the tooth and the two adjacent milled grooves of right-hand timing pulley are visible through the appropriate hole on rear guard ①; then bring the crankshaft back in the position, indicated in Step (2) and fit the timing belt onto pulleys.

CAUTION:
Pulley tends to rotate with respect to correct position since camshaft interacts with the intake valve of cylinder No. 3. For this reason, use appropriate wrench A.5.0195 in order to keep the pulley in the correct position for belt installation.

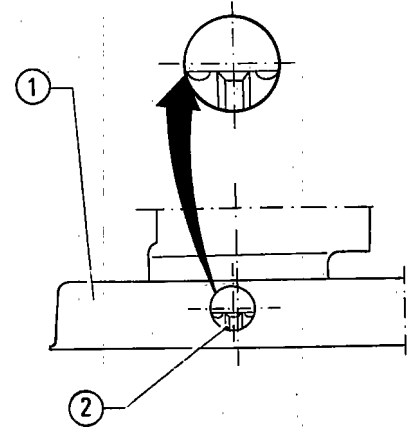

1 Timing belt rear guard
2 Right-hand timing pulley

(9) Verify that distance "S" between timing belt and contour of engine front support is not less than the minimum value prescribed.

Minimum distance "S" between timing belt and engine front support:
9 mm

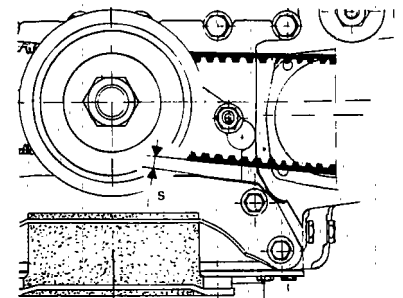

(11) Rotate crankshaft in the functioning direction so as to permit belts to assume their final position.

(12) Rotate crankshaft until piston of cylinder No. 1 is at its T.D.C. in the explosion stroke. (Notch "T" on flywheel aligned with reference mark). Then, further rotate the crankshaft counterclockwise (seen from rear side) until notch ∇ on flywheel is aligned with the reference mark (right-hand camshaft in rest position, no cam engaged).

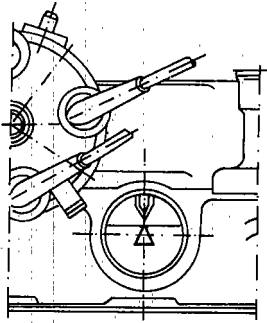

(13) Loosen the nut of right-hand belt straightener, then tighten it to the prescribed torque,

CAUTION:

During this operation, do not press the belt straightener to prevent altering the load envisaged for belt straightener itself.

Ⓜ : Tightening, torque
Nut securing belt straightener (on cold engine)
37 ÷ 46 N·m
(3.8 ÷ 4.7 Kg·m)

(14) Starting from the position corresponding to notch V on flywheel, rotate the crankshaft one complete revolution in the counterclockwise direction (seen from rear side) until notch V is realigned with the reference mark (left-hand camshaft in rest position; no cam engaged).

(15) Repeat Step (13) for the left-hand belt straightener.

(16) At the end of operations, recheck the correspondence of timing reference marks on pulleys with the appropriate holes on timing belts rear guards and with notch "T" on flywheel, aligned with the reference mark.

Proceed as per **Alfa 33** up to Step 20 included, then complete reassembly operating as stated below.

21. Fit front plastic covers of timing belts.

22. Mount pulley ① on pump hub and tighten it with screws ②.

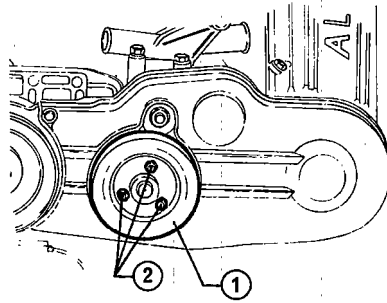

1 Cooling fluid pump pulley
 2 Screws

23. Screw onto block, pressure switch to signal minimum oil pressure, tightening it to specified torque.

Ⓜ : Tightening torque
Pressure switch
33 ÷ 41 N·m
(3.4 ÷ 4.2 Kg·m)

24. Fit intake manifold.
 (1) If you previously removed it, fit supplementary air solenoid valve on right intake manifold.
 (2) Insert intake manifolds complete with new gaskets on stud of two heads, then fix them with associated nuts.

Ⓜ : Tightening torque
Nuts securing intake manifolds
19 ÷ 24 N·m
(1.9 ÷ 2.4 Kg·m)

25. Fit the union, temperature senders, thermal switch and thermostat!
 (1) Fit union on block, tightening screws on intake manifolds.

Ⓜ : Tightening torque
Union securing screws
19 ÷ 24 N·m
(1.9 ÷ 2.4 Kg·m)

(2) Fit water temperature senders on intake manifolds.

Ⓜ : Tightening torque
 . Water temperature sender (for temperature gauge)
33 ÷ 41 N·m
(3.4 ÷ 4.2 Kg·m)
 . Water temperature sender (for injection CU). Max torque
15 N·m
(1.5 Kg·m)

(3) Fix thermal contact on right head, tightening screw to specified torque.

Ⓜ : Tightening torque
Thermal contact screw on right head
33 ÷ 41 N·m
(3.4 ÷ 4.2 Kg·m)

(4) Connect thermostat to right intake manifold through sleeve, then fix thermostat on engine block.

26. Refit hoses of cooling system.

Mount sleeve ④ connecting thermostat ⑤ to union ③ and sleeve ① which connects thermostat ⑤ to left intake manifold ②; tighten all screws of sleeve screwing clamps.

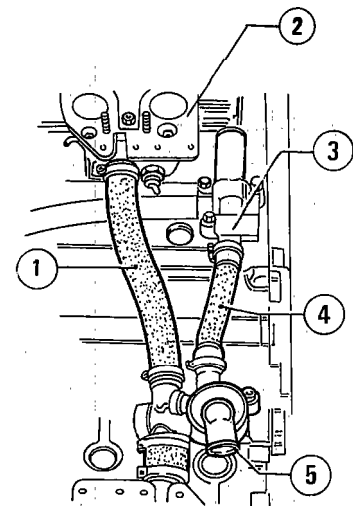

1 Hose
 2 Left intake manifold
 3 Union
 4 Hose
 5 Thermostat

27. Fit oil filter by manually tightening it and insert dipstick.

28. By means of a suitable box spanner fit spark plugs tightening them according to specified torque.

Ⓜ : Tightening torque
 Spark plugs:
 25 ÷ 34 N·m
 (2.5 ÷ 3.5 Kg·m)

29. Fit alternator and control belt.
 (1) Secure bracket (4) and (5) to engine front cover and tighten the two relevant screws (3).
 (2) Position alternator on engine supports and tighten bolts (1) without fully locking them.
 (3) Key alternator and water pump drive belt on relevant pulleys.

(4) Adjust belt tension according to specified value and then lock bolts (1).

Load: 8 Kg
 Arrow: 15 mm

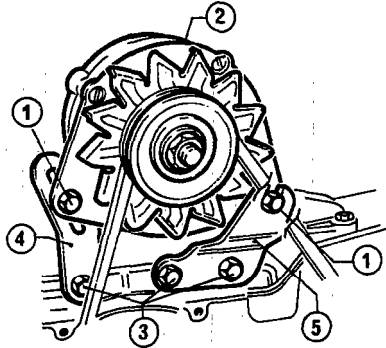

- 1 Bolts
- 2 Alternator
- 3 Screws
- 4 Bracket
- 5 Bracket

30. Remount injectors on intake manifolds, replacing relevant O-rings, and fix fuel manifold.

31. Position injection wiring on engine and reconnect it to stated components:

- supplementary air solenoid valve
- power module on distributor
- engine water temperature sensor
- injectors.

32. Fill the engine with specified engine oil and with specified quantity.
AGIP Sint 2000 SAE 10W/40
IP Sintiax SAE 10W/40
SHEEL Super Plus Motor Oil SAE 15W/50

Oil quantity required for complete refill (sump, filter and oil channels):
 4.1 litre

TECHNICAL DATA

ENGINES DATA

Models	Engines with one carburetor		Engines with two carburetors			Engines with electronic injection		
	1200 * 305.85	1350 305.86	1350 305.87	1500 305.88	1700 305.50	1700 305.58	1700 305.58 Δ	
Features								
Cycle	Otto 4 stroke							
Numbers of cylinders and arrangement	4 horizontally opposid							
Cylinder identification								
Bore • Stroke Displacement	m m cm ³	80x 59 1186	80 x 67,2 1351	80 x 67.2 1351	84 x 67,2 1490	87x72 1712	87x72 1712	
Combustion chamber volume	cm ³	37	42,2	39.7	44	49.5	49,5	
Compression ratio		9		9,5			9	
Power DIN Max Specific	kw (HP)	50 (68) 42 (57.3) at 6000 r.p.m.	58 (79) 43 (58,4) at 6000 r.p.m.	63 (86) 47 (64) at 6800 r.p.m.	77 (105) 51 (70) at 5600 r.p.m.	86,7 (118) 50,8 (69,8) at 6800 r.p.m.	79 (110) 46 (64) at 6800 r.p.m.	77 (105) 44,9 (61.3) at 6600 r.p.m.
Max Torque DIN	N • m (Kg • m)	90 at 3200 r.p.m.	111 (11,3) at 3600 r.p.m.	119 (12,1) at 4000 r.p.m.	133 (13.6) at 4000 r.p.m.	148 (15) at 3600 r.p.m.	148 (15,4) at 4600 r.p.m.	145 (15,2) at 4600 r.p.m.
Piston mean speed (1)	m/s	11,8	13,4	13		14,4		
Cylinder compression (2) Min. pressure Max difference in pression between cylinders	kPa (bar; Kg/cm ²)	1029.6 (10,3;10,5) 98 (0,98; 1)						
Oil pressura (3) kPa (bar); kg/cm ² — min on idle r.p.m. — min on max r.p.m. — max on idle r.p.m.		117.68 ÷ 274.60 (1,18 ÷ 2,75; 1,2 ÷ 2,8) 411.89 ÷ 568,81 (4.12 ÷ 5.69; 4,2 ÷ 5,8)				196 (1,96; 2) 441 (4,41; 4,5) 490 (4,90; 5.0)		

(1) At max power output rpm.

(2) Values to be read in these conditions:

— engine at operating temperature

— fully opened throttles

— engine cranked by starter motor, sparking plugs removed

(3) Values to be read at engine operating temperature (oil at 90°C=194°F)

(*) Not marketed in all countries

(Δ) For countries where antipollution regulations are in force.

INSPECTION AND ADJUSTMENT

CAMSHAFT SYSTEM

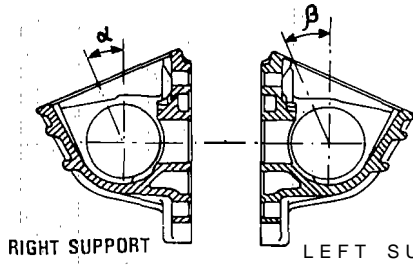

Unit: mm (in)

		Single carburetor engines		Double carburetor engines	
		1200 * 305.85	1350 305.86	1350 305.87	1500 305.88
Camshaft		545.766		546.232	
Tappet clearance	Intake	0.35 ÷ 0.40			
	Exhaust	0.45 ÷ 0.50 †			
Value of timing marks on camshaft supports	Right support	23°			
	Left support	23°			

* Not marketed in all countries
All values are with engine cold

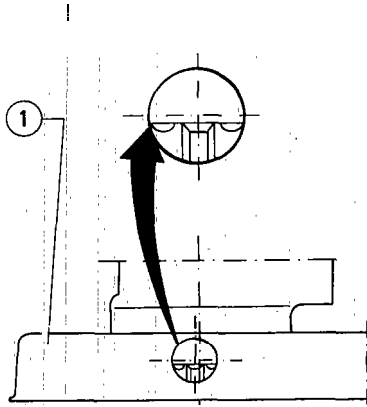

1 Rear guard for right - hand timing belt

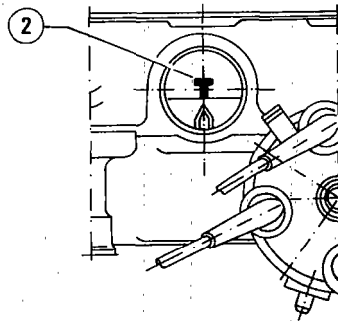

2 T-shaped notch on flywheel

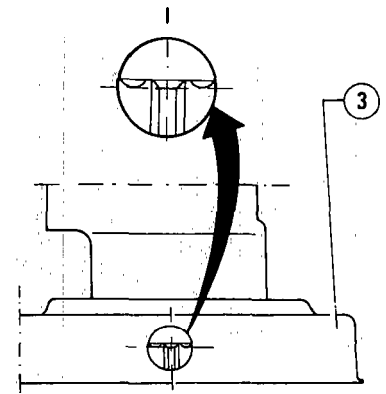

3 Rear guard for left - hand timing belt

Unit: mm (in)

		Double carburetors engines	Electronic injection engines	
		1 7 0 0 305.50	1700 305.58	1700 305.58 Δ
Camshaft		580.429	581.191	549.315
Tappet clearance	Intake	0 (*)		
	Exhaust	0 (*)		
Camshaft pulley alignment reference position (with T-shaped notch on flywheel aligned with the reference mark on engine rear cover, with the piston of cylinder No. 1 at T.D.C., in the explosion stroke).	right-hand pulley	(**)		
	left-hand pulley	(***)		

A † For countries where antipollution regulations are in force

(*) Engine with hydraulic tappets (with take-up of slack)

(**) Tooth with two milled grooves on right-hand camshaft pulley, in correspondence with the related hole on rear guard ① of timing pulley.

(***) Tooth with two milled grooves on the left-hand camshaft pulley in correspondence with the related hole on rear guard ③ of timing pulley.

CHECKING VALVE OPENING AND CLOSING ANGLES

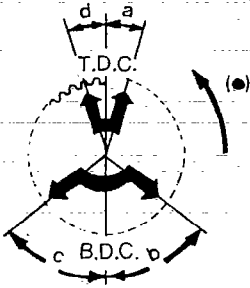

		mm (in)	Engines with one carburetor		Engines with two carburetors			Engines with electronic injection	
			1200 * 305.85	1350 305.86	1350 305.87	1500 305.88	1700 305.50	1700 305.58	1700 305.58 Δ
Intake	Valve clearance for checking		0,7			0			
	Opening BTDC	a	12°		19°		54°	30°	34°
	Closing ABDC	b	48°		53°		84°	84°	79°
Exhaust	Valve clearance for checking		0,7			0			
	Opening BBDC	c	45°			60° 30'	68°	64°	
	Closing ATDC	d	7°		11°		50°	34°	35°

Δ For countries where antipollution regulations are in force

(e) Crankshaft rotation ACW seen from flywheelside.

(*) Not marketed in all countries.

ENGINE MAIN MECHANICAL UNIT

CYLINDER BLOCK

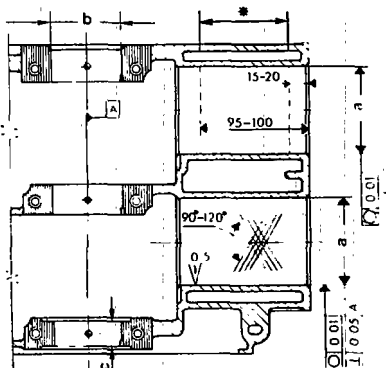

(●) Area for dimension check

Unit: mm

Inspection data			Engines		
			1200*-1350 305.85186187	1500 305.8%	1700 305.50-305.58
Cylinder bore "a"	Standard	Glass A	80,00 ÷ 80,01	84,00 ÷ 84,01	87,000 ÷ 87,010
		Class B	80,01 ÷ 80,02	84,01 ÷ 84,02	87,010 ÷ 87,020
		Class C	60,02 ÷ 80,03	84,02 ÷ 84,03	87,020 ÷ 87,030
		Class D	80,03 ÷ 80,04	84,03 ÷ 84,04	87,030 ÷ 87,040
		Class E	80,04 ÷ 80,05	84,04 ÷ 84,05	87,040 ÷ 87,050
	Oversize	1 s t	80,20 ÷ 80,21	84,20 ÷ 84,21	87,200 ÷ 87,210
		2nd	80,40 ÷ 80,41	84,40 ÷ 84,41	87,400 ÷ 87,410
		3rd	80,60 ÷ 80,61	84,60 ÷ 84,61	87,600 ÷ 87,610
Out-of-square between cylinder bore centreline and centreline of main bearings			0,05		
Taper and out-of-round limit		Standard	0.01		
		Max	0,02		
Cylinder bore surface roughness			(0,541) · 10 ⁻³		
Cylinder bore grinding angle			90° ÷ 120°		
Main bearing diameter "b"		Front Rear	63,663 ÷ 63,673		
		Central	63,673 ÷ 63,683		
Width of rear main bearing support "c"			23,68 ÷ 23,73		

(*) Not marketed in all countries.

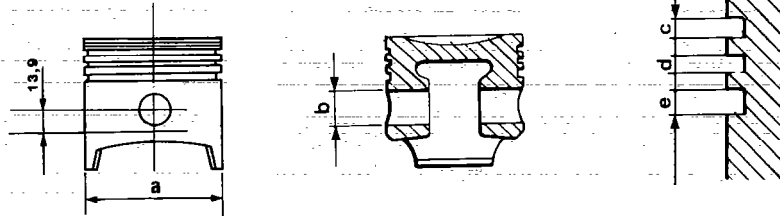

Unit: mm (in)

Inspection data			ENGINES				
			1200-1350 305.85 (1) 305.86 (2-3) 305.87 (2-3)	1500 305.88 (3-4)	1700 305.50 (5-6) 305.58 (5-6)	1700 A 305.58 (6)	
Piston diameter "a" (1) <small>(To be measured at right angles to the piston pin hole centre line and at height "H" from that centre line)</small>	Standard	Class A (Blue)	79,960 ÷ 79,970	83,960 ÷ 83,970	Pistone Borgo 86,960 ÷ 86,970	Pistone Mondial 86,950 ÷ 86,960	86,950 ÷ 86,960
		Class B (Pink)	79,970 ÷ 79,980	83,970 ÷ 83,980	86,970 ÷ 86,980	86,960 ÷ 86,970	86,960 ÷ 86,970
		Class C (Green)	79,980 ÷ 79,990	83,980 ÷ 83,990	86,980 ÷ 86,990	86,970 ÷ 86,980	86,970 ÷ 96,980
		Class D (Yellow)	79,990 ÷ 80,000	83,990 ÷ 84,000	86,990 ÷ 87,000	86,980 ÷ 86,990	86,980 ÷ 86,990
		Class E (White)	80,000 ÷ 80,010	84,000 ÷ 84,010	87,000 ÷ 87,010	86,990 ÷ 87,000	86,990 ÷ 87,000
	Oversize	1st	80,154 ÷ 80,170	84,154 ÷ 84,170	87,150 ÷ 87,170	87,144 ÷ 87,160	87,144 ÷ 87,160
	2nd	80,354 ÷ 80,370	84,354 ÷ 84,370	87,350 ÷ 87,370	87,344 ÷ 87,360	87,344 ÷ 87,360	
	3rd	80,554 ÷ 80,570	84,554 ÷ 84,570	87,550 ÷ 87,570	87,544 ÷ 87,560	87,544 ÷ 87,560	
First compression ring groove height "c"			1,525 ÷ 1,545		1,515 ÷ 1,535	1,535 ÷ 1,555	1,535 ÷ 1,555
Second compression ring groove height "d"			1,775 ÷ 1,795		1,775 ÷ 1,795		
Oil scraper ring groove height "e"			4,015 ÷ 4,035		3,015 ÷ 3,035		
Pin seat bore "b"			21,004 ÷ 21,008				

A For countries where antipollution regulations are in force

- (1) H = 7.6 mm MONDIAL Piston
- (2) H = 11.7 mm "
- (3) H = 16.5 mm BORGIO "
- (4) H = 15.5 mm "
- (5) H = 6.0 mm "
- (6) H = 13.9 mm MONDIAL "

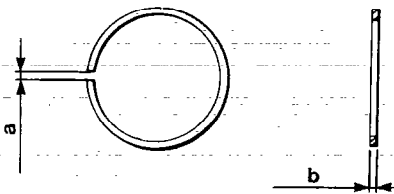

Unit: mm (in)

Inspection data		Engines			
		1200 * 305.85	1350 305.86 - 305.87	1500 305.88	1700 305.50-305-305.58
Ring thickness "b"	First compression ring	1,478 ÷ 1,490			1,478 ÷ 1,490
	Second compression ring	1,728 ÷ 1,740			1,728 ÷ 1,740
	Oil scraper ring	3,978 ÷ 3,990			2,978 ÷ 2,990
Ring gap "a" (1)	First compression ring	0,30 ÷ 0,45		0,30 ÷ 0,45 (2) 0,30 ÷ 0,50 (3)	0,30 ÷ 0,50
	Second compression ring,	0,30 ÷ 0,45		0,30 ÷ 0,45 (2) 0,30 ÷ 0,50 (3)	0,30 ÷ 0,50
	Oil scraper ring	0,25 ÷ 0,40		0,25 ÷ 0,40 (3) 0,25 ÷ 0,50 (3)	0,25 ÷ 0,50
	Limit gap for each ring	1			

(1) To be measured inside the cylinder bore or inside a ring gauge

(2) Borgo ring

(3) Gostze ring

(*) Not marketed in all countries

ENGINE MAIN MECHANICAL UNIT

Pin

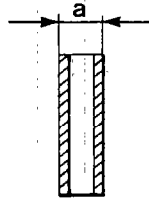

Unit: mm (in)

Inspection data	Engines			
	1200 * 305.85	1350 305.86 - 305.87	1500 305.88	1700 305.50 - 305.58
Pin diameter "a"	20,996 ÷ 21,000			
Pin-piston slack	0,004 ÷ 0,12			

(*) Not marketed in all countries

ENGINE MAIN MECHANICAL UNIT

CONNECTING ROD AND CONNECTING ROD BEARINGS

Connecting rod (1)

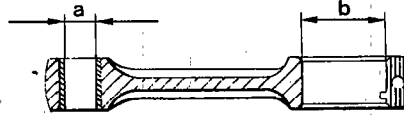

Unit: mm (in)

Inspection data	Engines			
	1200 * 305.85	1350 305.86/87	1500 305.88	1700 305.50/58
Small end bush bore diameter "a"	21,007 ÷ 21,015			
Big end bore diameter "b"	52,696 ÷ 53,708			

Connecting rod bearings

Unit: mm (in)

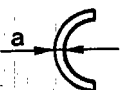
Inspection data		Engines			
		1200 * 305.85	1350 305.86/87	1500 305.88	1700 305.50/58
 Connecting rod bearing thickness "a"	Standard	Blue 1,831 ÷ 1,835 Red 1,827 ÷ 1,831	Blue 1,830 ÷ 1,836 Red 1,826 ÷ 1,832		
	Oversize	1st 2nd 3rd 4th	1,956 ÷ 1,962 2,083 ÷ 2,089 2,210 ÷ 2,216 2,337 ÷ 2,343		

- (1) If the connecting rods are completely removed, use post-modification ones (Std. No. 542.128)
 If the connecting rods are partially replaced it is still possible to mount pre-modification ones (Std. No. 535.022)

(*) Not marketed in all countries

FLYWHEEL

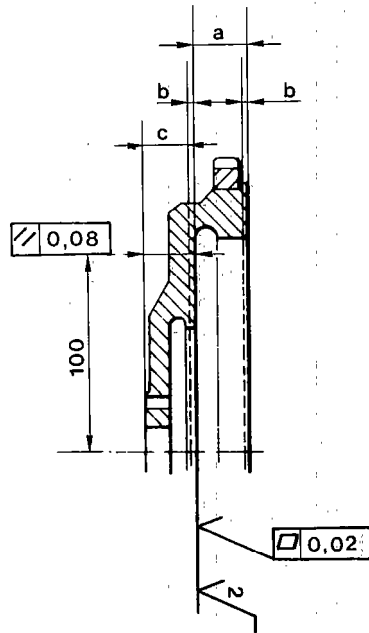

Unit: m (in)

Inspection data		Engine			
		1200 * 305.85	1350 305.86/87	a 500 305.88	1700 305.50/58
Regrinding dimensions (1)	a	24,0 ÷ 24.2			
	b	≤ 0.2			
	c	≥ 20.95			
Parallelism of the driven plate contact face compared with flywheel-to-crankshaft support face (as read at a 108 mm (3.94 in) radius)		0,08			
Maximum out-of-flat of driven plate contact face		0.02			
Surface roughness of driven plate contact face		2 · 10 ⁻³			

(1) The quantity of material removed by grinding dimension "b", must be the same both on clutch driven plate contact face and on the face of the register for the clutch cover, so that dimension "a" is kept constant., Dimension "c" must not be lower than the specified lit-oit.

(*) Not marketed in all countries

ENGINE MAIN MECHANICAL UNIT

CRANKSHAFT, THRUST RINGS AND MAIN BEARINGS

Crankshaft

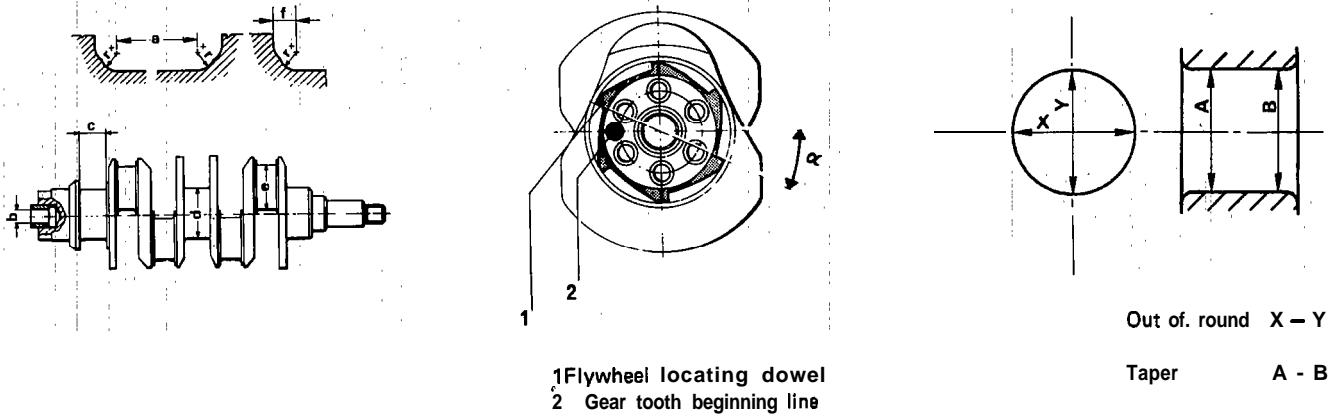

Unit: mm (in)

Inspection date		Engine			
		1200 * 305.85	1'350 305.86187	1500 305.88	1700 305.50/58
Main journal diameter "d"	Standard		59,944 ÷ 59,957		
	Undersize	1st	59,690 ÷ 59,703		
		2nd	59,436 ÷ 59,449		
		3rd	59,182 ÷ 59,195		
		4th	58,928 ÷ 58,941		
Crank pin diameter "e"	Standard	Blue	49,984 ÷ 49,992		
		Red	49,992 ÷ 50,000		
	Undersize	1st	49,733 ÷ 49,746		
		2nd	49,479 ÷ 49,492		
		3rd	49,225 ÷ 49,238		
4th	48,971 ÷ 48,984				
Rear main journal length "c"	Standard		28.51 ÷ 28.55		
	Oversize		28,764 ÷ 28,804 (1)		
Fillet radii "r"	Front and central main journals		1,8 ÷ 2		
	Rear main journal		1,5 ÷ 1,7		
	Crank pins		2,8 ÷ 3		
Length of fillet radii portions "f"	Front main journals		2,11 ÷ 2,81		
Length of parallel portion "a"	Central main journal		24.05 ÷ 24.15		
	Rear main journal		24.22 ÷ 24,32		
Surface roughness of main journals and crankpin			0,16 · 10 ⁻³		
X-Y Ovality and limit for taper A-B of main journals and crankpins	Standard		0,006		
	Maximum		0,020		
Max. error of parallelism between crankpins and main journals			0,015		
Max. misalignment among main journals			0.02		
			0.25		

(*) Not marketed in all countries

ENGINE MAIN MECHANICAL UNIT

Unit: mm (in)

Inspection data	Engine			
	1200 * 305.85	1350 305.86/87	1500 305.88	1700 305.50/58
Max. misalignment between the centrelines of the Mo pairs of crankpins and the journals centreline	0.03			
Rear crankshaft bush diameter "b"	16,065 ÷ 16,080			
Fitment of rear crankshaft gear "α" (distributor/oil pump drive)	22° ÷ 26°			

(1) Re-cutting equally spaced on both shoulders

Thrust rings

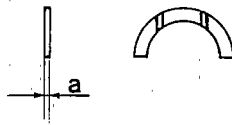

Unit: mm (in)

Inspection data		Engine			
		1200 * 305.85	1350 305.86/87	1500 305.88	1700 305.50/58
Thickness	"a"	Standard			
		Oversize			
		2,310 ÷ 2,362			
		2,437 ÷ 2,489			

Main bearings



Unit: mm (in)

Inspection data			Engine			
			1200 * 305.85	1350 305.86/87	1500 305.88	1700 305.50/58
Thickness "a"	Standard		1,832 ÷ 1,841			
	Oversize	1st	1,959 ÷ 1,968			
		2nd	2,086 ÷ 2,095			
3rd		2,273 ÷ 2,222				
	4th	2,340 ÷ 2,349				

(*) Not marketed in all countries

ENGINE MAIN MECHANICAL UNIT

CAMSHAFT SUPPORT, CAMSHAFT AND TAPPET BUCKET

Camshaft support and tappet bucket

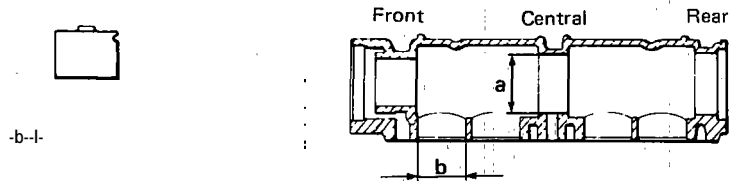

Unit: mm (in)

		E n g i n e			
		1200 * 305.85	1350 305.86/87	1500 305.88	1700 305.50/58
Bore of camshaft journal bearing diameter "a"	Front	35,015 ÷ 35,040			35,015 ÷ 35,040
	Central	46,500 ÷ 46,525			48,000 ÷ 48,025
	Rear	47,000 ÷ 47,025			49,200 ÷ 49,225
Seat tappet bucket diameter "b"		35,006 ÷ 35,027			35,000 ÷ 35,025
Tappet bucket diameter "c"		34,975 ÷ 34,995			34,975 ÷ 34,995

(*) Not marketed in all countries

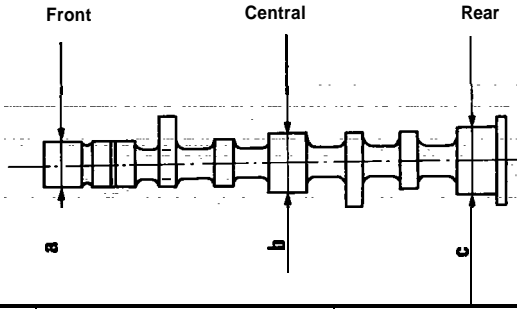

Unit: mm

Inspection data		Single carburetor engines		Double carburetor engines			Engine with electronic ignition		
		1200 * 305.85	1350 305.86	1350 305.87	1500 305.88	1700 305.50	1700 305.58	1700 305.58 A	
Cam height	Intake	8,50					10,2	9,80	9,50
	Exhaust	8,50					9,6	9,0	8,45
Camshaft journal diameter	Front "a"	34,940 ÷ 34,962							
	Central "b"	46,440 ÷ 46,456				47,940 ÷ 47,956			
	Rear "c"	46,940 ÷ 46,956				49,140 ÷ 49,156			

(*) Not marketed in all countries

(A) For countries where antipollution regulations are in force.

(*) Not marketed in all countries

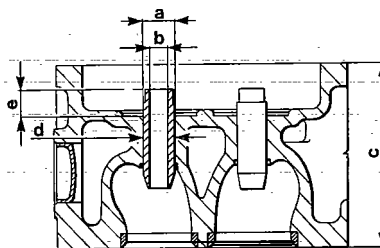

Cylinder head

Unit: mm (in)

Inspection data		Engine					
		1200 *	1350	1350	1500	1700	1700
		305.85	305.86	305.87	305.88	305.50	305.58
Valve guide seat diameter "d"		13,000 ÷ 13,018					
Valve guide O.D. "a"	Standard	13,050 ÷ 13,068					
	Spare	13,064 ÷ 13,082					
Diameter of valve guide bore "b"		8,013 ÷ 8,031					
Diameter of seating for valve stem sealing cap. "f"		10,85 ÷ 10,95					
Valve guide protrusion "e"		9,3 ÷ 9,5					
Min. cylinder head thickness after resurfacing "c" (1)		77,676 ÷ 77,750					
Max. error of parallelism between head surfaces ..		0,05					
Max. out of flat on head lower surface		0,03					
Head lower surface roughness		1.6 · 10 ⁻³					

(1) Resurfacing of cylinder head with hemispherical combustion chamber must be done on both heads of the same engine

(*) Not marketed in all countries

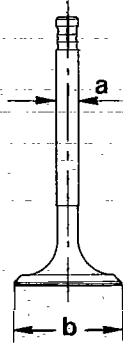

Unit: mm (in)

Inspection data		Engine				
		1200 * 305.85	1350 305.86	1350 305.87	1500 305.88	1700 305.50 - 305.58
Valve stem diameter "a"	Intake	7,985 ÷ 8,000				
	Exhaust	7,968 ÷ 7,983				
Valve head diameter "b"	Intake	38,00 ÷ 38,20		39,70 ÷ 39,90		
	Exhaust	33,00 ÷ 33,20				

(*) Not marketed in all countries

ENGINE' MAIN MECHANICAL UNIT

VALVE SEAT RECUTTING DIMENSIONS

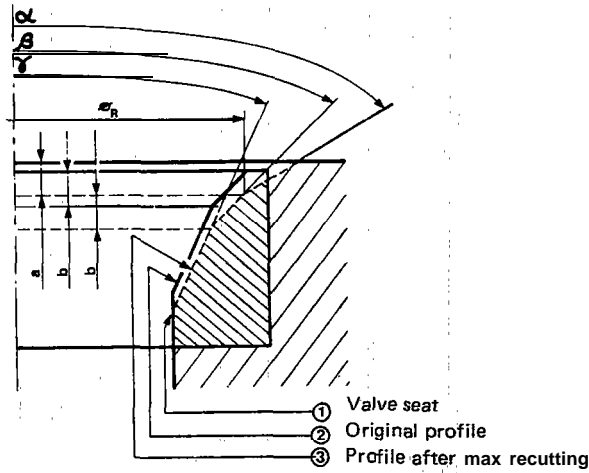

Unit: mm (in)

Inspection data		Engine				
		1200 * 305.85	1350 305.86	1350 305.87	1500 305.88	1700 305.50/85
Reference diameter " \varnothing_R "	Intake	37,3		39,0		
	Exhaust	31,9		31,9		
Cut limit of valve seat top surface "a"		2,9		2,9		
Cut limit of valve seat mating surface "b"	Intake	1,07 ÷ 1,37		1,07 ÷ 1,37		
	Exhaust	1,26 ÷ 1,56		1,26 ÷ 1,56		
Valve seat top surface limit angle "a"		120°		120°		
Valve seat mating surface limit angle "β"		90° ÷ 90° 30'		90° ÷ 90° 30'		
Valve seat inner face limit angle "γ"	Intake	50°		70°		
	Exhaust	30°		30°		

(*) Not marketed in all countries

FITMENT PLAYS OR INTERFERENCE FITS

Unit: mm (in)

inspection data		Engine		
		1200-1350-1500 305.85 - 305.86 - 306.88 305.87	1700 305.50	1700 305.58
Cylinder bore/piston play	Standard	0,03 ÷ 0,05	0,03 ÷ 0,05 (1) 0,04 ÷ 0,06 (2)	0,040 ÷ 0,060
	Oversize	0,03 ÷ 0,06	0,03 ÷ 0,06 (1) 0,04 ÷ 0,066 (2)	0,040 ÷ 0,066
Ring/groove end float	First compression ring	0,035 ÷ 0,067	0,035 ÷ 0,057 (1) 0,045 ÷ 0,077 (2)	0,045 ÷ 0,077
	Second compression ring		0,035 ÷ 0,067	
	Oil scraper ring		0,025 ÷ 0,057	
	Maximum for each ring		0,1	
Pin/small end bush bore play			0,007 ÷ 0,019	
Pin/piston bore play			0,004 ÷ 0,012	
Main bearing to journal play	Front and rear		0,024 ÷ 0,065	
	Central		0,034 ÷ 0,075	
	Maximum (with bearing in seat)		0,1	
Connecting rod bearing to crankpin play	Standard		Red/Blue 0,032 ÷ 0,064	
	Maximum (with bearing in seat)		0,090	
Crankshaft end float	Standard		0,056 ÷ 0,25	
	Max		0,35	
End float of big end	Standard		0,2 ÷ 0,392	
	Max		0,45	
Radial clearance between camshaft and bearing	Front	0,053 ÷ 0,100	0,020 ÷ 0,078	0,053 ÷ 0,100
	Central		0,044 ÷ 0,085	
	Rear			
Camshaft end float			0,10 ÷ 0,33	
Radial clearance between tappet bucket and seat in camshaft support	Standard	0,011 ÷ 0,052	0,005 ÷ 0,05	
	Max		0,1	
Valve stem-to guide play	Intake	Standard	0,013 ÷ 0,046	
		Max	0,07	
	Exhaust	Standard	0,030 ÷ 0,063	
		Max	0,09	
Valve guide-to-seat interference fit	Standard		0,032 ÷ 0,068	
	Spare		0,046 ÷ 0,082	

(1) Borgo Piston
(2) Mondial Piston

ENGINE MAIN MECHANICAL UNIT

HEATING TEMPERATURES

As per **Alfa 33**.

GENERAL SPECIFICATIONS

FLUIDS AND LUBRICANTS

Unit: l (Imp. Gal)

Application	Type	Denomination	Qty (litres)
Engine oil sump at max level	OIL	AGIP SINT 2000 10W40 Std. No. 3631 - 69352	3.5
Filter and internal piping		IP SINTIAX 10W40 Std. No. 3631 - 69353	0.6
Periodical change with filter replacement (*)		SHELL Super Plus Motor Oil 15W50	4 . 0

(*) Filter removal involves only the partial emptying of internal piping.

SEALING COMPOUNDS

As for **Alfa 33** together with the following torques for 1.7 engines

GRINDINGS

As per **Alfa 33**.

TIGHTENING TORQUES

As for **Alfa 33** except as follows for 1.7 engines

Item	Measurement unit	N·m	Kg·m
Screws securing engine front cross member and anti-roll bar bracket to body		66.5 ÷ 63.3	6.6 ÷ 6.5
Screws securing anti-roll bar to strut		14.7 ÷ 23.5	1.5 ÷ 2.4
Screws connecting constant velocity joints to differential shafts		33 ÷ 36	3.4 ÷ 3.7
Coolant temperature sender for fuel injection electronic control unit		15	1.5

SERVICE DATA AND SPECIFICATIONS

For diesel engines only

TECHNICAL DATA

As for **331.8TD** except for those features listed below:

ENGIN\$

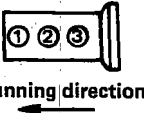
Features		Data
Engine type		VM 82 A
Cycle		4 - Stroka Diesel (Precombustion chamber COMET)
Number of cylinders and arrangement		3 in line
Cylinder identification		 Running direction
Bore - Stroke	mm (in)	92 x 89.2 (3.62 x 3.51)
Displacement	cm ³ (cu. in)	1779 (108.58)
Combustion chamber volume	cm ³ (cu. in)	23.2 to 24.3 (1.41 to 1.48)
Compression ratio		22 : 1
Power CEE (at 4000 r.p.m.)	Maximum Specific kW (CV) (HP)	5 5 (75) (73.97) (1) 30.55 (41.66) - (41.08) (1)
Max. torque DIN (at 2400 r.p.m.)	N·m (kg·m; ft·lb)	150 (15.3; 110.63) (1)
Piston, mean speed (2)	m/s (ft/s)	11.893 (39.02)
Cylinder compression (3)		
Specified value	kPa (kg/cm ² ; p.s.i.)	2156 (21.56) (306.65)
Max. difference in pressure between cylinders		9 8 (0.98) (13.94)
Engine oil pressure (4)		
At idle r.p.m.	kPa (kg/cm ² ; p.s.i.)	50 (0.5; 7.11)
At peak r.p.m.		400 (4; 56.89) (*) 550 (5.5; 78.23) (**)

- (1) Tolerance up to: - 4%
- (2) At maximum power output r.p.m.
- (3) Readings to be taken with engine at operating temperature driven by starter motor (140 to 160 r.p.m.)
- (4) Readings to be taken with engine at operating temperature (oil at 90°C; 194°F)
- (5) Min. allowable value
- (6) Max. allowable value

ENGINE MAIN MECHANICAL UNIT

CHECKS AND ADJUSTMENTS

TIMING DATA (1)

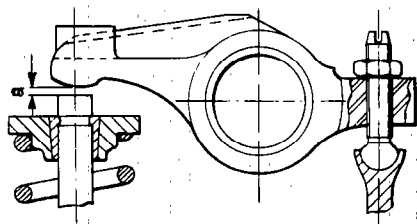

Unit: mm (in)

		Engine
		1800
		VM 82A
Camshaft	Alfa Romeo Part No.	129.958
Normal valve clearance "a"	Intake	0.30 (0.012)
	Exhaust	0.30 (0.012)
Normal cam lift	Intake	7.20 (0.283)
	Exhaust	7.64 (0.301)

(1) All values refer to cold engine

TIMING DIAGRAM (ANGULAR VALUES) (1)

(crankshaft clockwise rotation, viewed from front side)

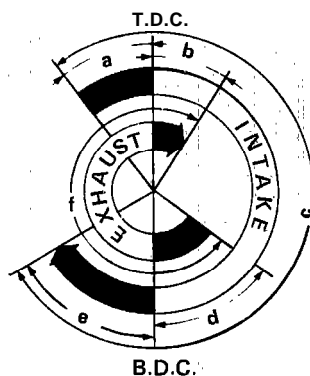

Unit: Grades

		Engine	
		1800	
		VM 82A	
Normal diagram	Intake	Opens (B.T.D.C.) " a "	$22^{\circ} \pm 5^{\circ}$
		Closes (A. 8. D. C.) "e"	$46^{\circ} \pm 5^{\circ}$
		Intake phase angle "c"	250°
	Exhaust	Opens (B.B.D.C.) " d "	$60^{\circ} \pm 5^{\circ}$
		Closes (A.T.D.C.) "b"	$24^{\circ} \pm 5^{\circ}$
		Exhaust phase angle " f "	264°
Diagram for timing check	Intake	Clearance for checking mm (in)	1.2 (0.047)
		Opens (A.T.D.C.)	$3^{\circ} \pm 2^{\circ}$
		Closes (A.B.D.C.)	$20^{\circ} \pm 3^{\circ}$
	Exhaust	Clearance for checking m m (in)	1 . 6 5 (0.065)
		Opens (B.B.D.C.)	$29^{\circ} \pm 3^{\circ}$
		Closes (B.T.D.C.)	$10^{\circ} \pm 2^{\circ}$

(1) All values refer to cold engine

ENGINE MAIN MECHANICAL UNIT

CYLINDER LINERS, COMPRESSION RINGS, GUDGEON PINS AND PISTONS

Cylinder liners

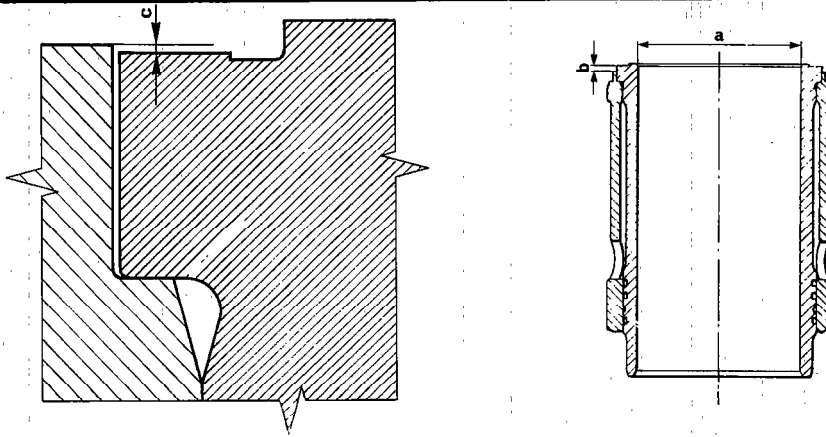

Unit: mm (in)

Inspection data		Engine
		1800
		VM 82A
Liner bore "a"	Grade A	92.000 to 92.010 (3.6220 to 3.6224)
Recess of cylinder liner outer rim from engine block (1) "c"		0.11 to 0.23 (0.0043 to 0.0091)
Liner stand-out "b" from engine block (1)		0.00 to 0.05 (0 to 0.0024)
Max liner ovality and taper (at wear limit)		0.010 (0.0004)
Liner inner surface roughness (new)	μm (in)	0.8 to 1.2 [(0.0315 to 0.0472) · 10 ⁻³]

(1) For this measurement, fit liner retaining tool A.7.0411 and tighten screws to 59 N·m (6 kg·m) (43.38 ft·lb)

Measurement of gasket thickness between liner and engine block

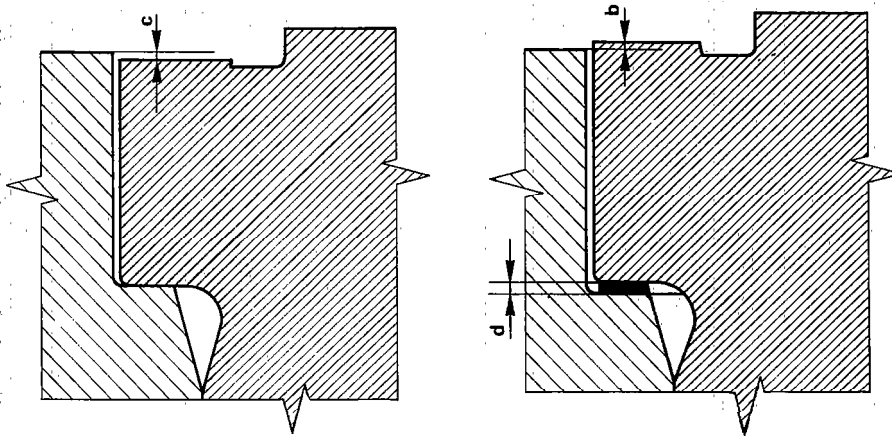

Unit: mm (in)

Recess of cylinder liner outer rim from engine block "c"		Engine
		1800
		VM 82A
Gasket "d" thickness		0.15 (0.0059)
0.11 to 0.14 (0.0043 to 0.0055)		0.20 (0.0079)
0.15 to 0.20 (0.0059 to 0.0079)		0.23 (0.0091)
0.21 to 0.23 (0.0083 to 0.0091)		

ENGINE MAIN MECHANICAL UNIT

Compression rings

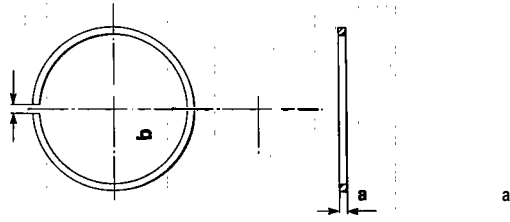

Unit: mm (in)

Inspection data		Engine
		1 8 0 0
		VM 82A
Ring thickness "a"	1 st compression ring	2.075 to 2.095 (0.0817 to 0.0825)
	2nd compression ring	1.978 to 1.990 (0.0779 to 0.0783)
	Oil scraper ring	3.978 to 3.990 (0.1566 to 0.1571)
Ring gap (1) "b"	1 st compression ring	0.40 to 0.65 (0.0157 to 0.0256)
	2nd compression ring	0.25 to 0.45 (0.0098 to 0.0177)
	Oil scraper ring	0.25 to 0.58 (0.0098 to 0.0228)

(1): To be measured by ring gauge or in cylinder liner

Gudgeon pins

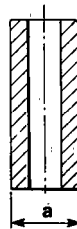

Unit: mm (in)

Inspection data		Engine
		1800
		VM 82A
Gudgeon pin diameter "a"		29.990 to 29.996 (1.1807 to 1.1809)

ENGINE MAIN MECHANICAL UNIT

Pistons~ (with insert)

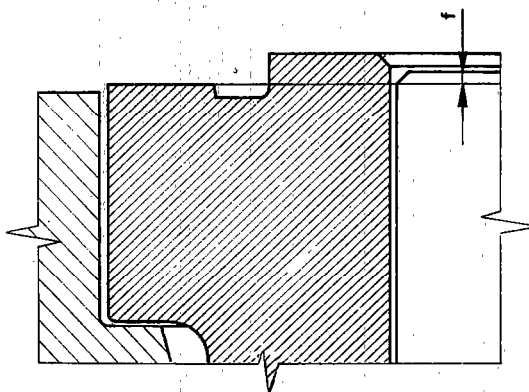
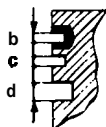
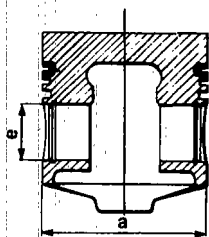

Unit: mm (in)

Inspection data		Engine
		1800
		VM 82A
Piston diameter (1) "a"	Grade A	91.965 to 91.975 (3.6206 to 3.6211)
1st compression ring groove height "b"		2.175 to 2.205 (0.0856 to 0.0868)
2nd compression ring groove height "c"		2.060 to 2.080 (0.0811 to 0.0819)
Oilscraper ring groove height "d"		4.020 to 4.040 (0.1583 to 0.1591)
Gudgeon pin bore dia. in piston "e"		30,002 ÷ 30,007
Max piston skirt wear limit		0.050 (0.002)
Max gudgeon pin bore ovality (at wear limit)		0.050 (0.002)

(1) To be measured perpendicularly to gudgeon pin, at 19.75 mm (0.7775 in) from lower edge of piston skirt

(2) For this measurement use special cylinder liner retaining tool A.7.0411 and tighten the screws to 59 N.m (6kg.m)

Measurement of cylinder head, gasket thickness

Unit: mm (in)

Cylinder head gasket thickness	Identification notches	Engine
		1800
		VM 82A
		Piston projection at T.D.C. with respect to liner outer rim "f" (1)
1.420 (0.0559)	0	0.480 to 0.570 (0.0189 to 0.0224)
1.520 (0.0598)	2	0.580 to 0.610 (0.0228 to 0.0264)
1.620 (0.0638)	1	0.880 to 0.770 (0.0268 to 0.0303)

ENGINE MAIN MECHANICAL UNIT

CRANKSHAFT, CYLINDER BLOCK AND MAIN BEARINGS, CONNECTING RODS, BIG END BEARING AND FLYWHEEL

Crankshaft

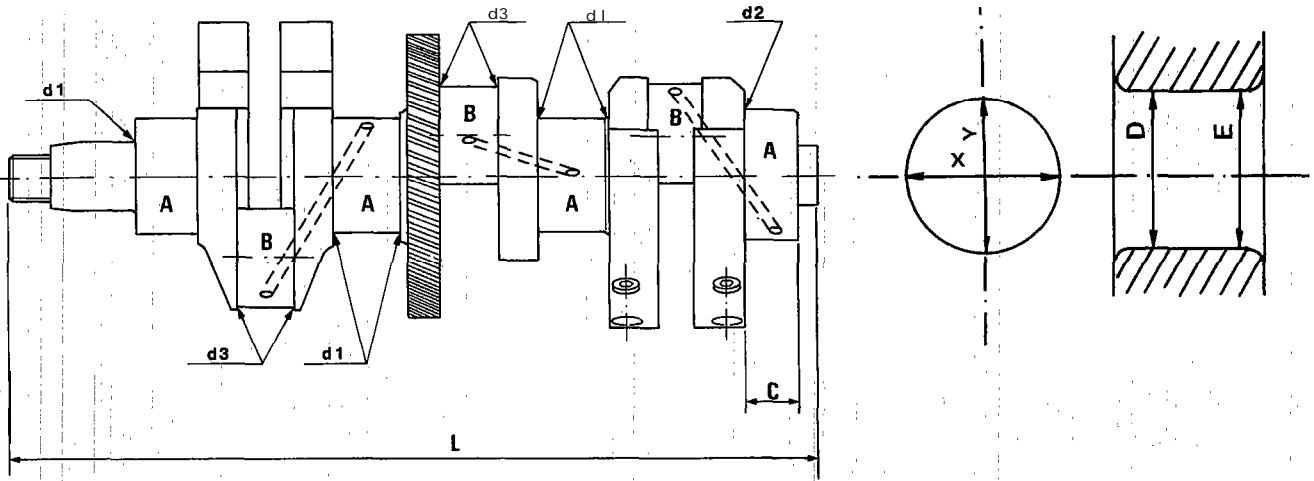

Ovality X-Y

Taper D-E

Unit: mm (in)

Inspection data			Engine	
			1800	
			VM 82 A	
Main journal diameter "A"	Front	62,995 ÷ 63,010		
	Intermediate	63,005 ÷ 63,020		
	Rear	69,985 ÷ 70,000		
Crankpin diameter "B"	Standard	53,940 953,955		
	Undersize	1st	53,670 ÷ 53,690	
		2nd	53,420 ÷ 53,440	
Rear main journal length "C"		27,975 G-28.025		
Filletts	Front and intermediate main journals	"d ₁ "	2.7 ÷ 3	
	Rear main journals	"d ₂ "	2.7 ÷ 3	
	Crankpins	"d ₃ "	2.7 ÷ 3	
Main, journal and crankpin surface roughness		μm (in)	0,12	
Max. main journal and crankpin ovality at wear limit		0 , 0 1 0		
Max. main journal and crankpin taper at wear limit		0.10		
Max. main journal eccentricity		0.03		
Final dimension "L"		430.5		

Note: Renitride crankshaft after grinding.

ENGINE MAIN MECHANICAL UNIT

Cylinder block and main bearings

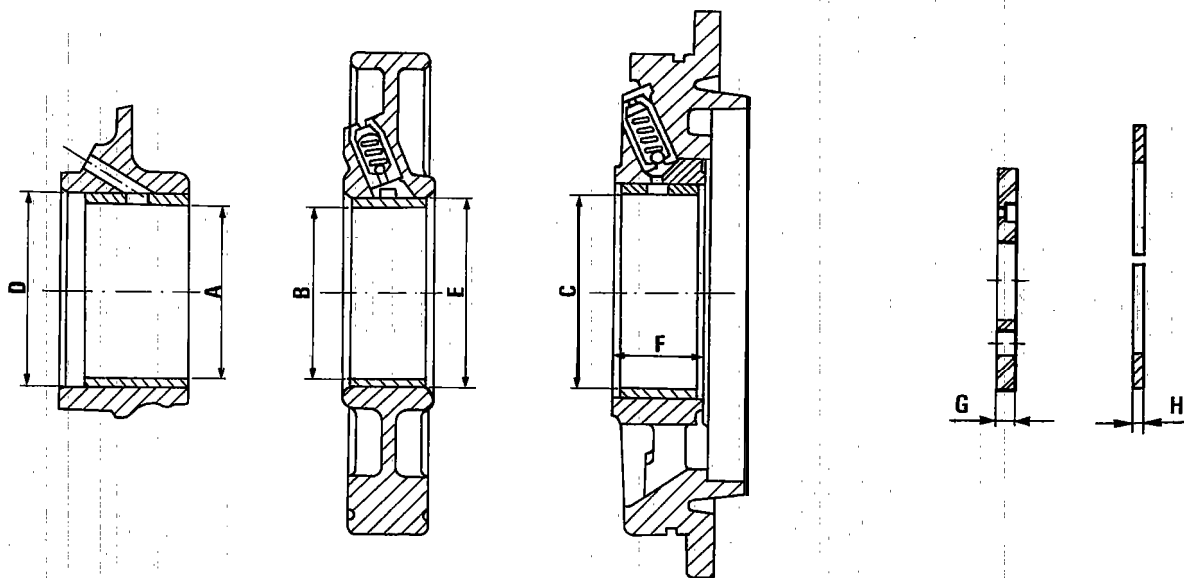

Unit: mm (in)

Inspection data			Engine	
			1800	
			VM 82A	
Front bearing housing bore dia. "A" in engine block			67.025 to 67.050 (2.6388 to 2.6398)	
Front bearing inner dia. "B" in engine block	Standard		63.060 to 63.110 (2.4826 to 2.4846)	
	Undersize	1st	62.810 to 62.860 (2.4728 to 2.4748)	
		2nd	62.560 to 62.610 (2.4630 to 2.4650)	
Intermediate bearing housing bore dia. "C" in bearing split rings (1)			66.670 to 66.687 (2.6248 to 2.6255)	
Intermediate bearing inner dia. "D" in bearing split rings (2)	Standard		63.050 to 63.093 (2.4823 to 2.4840)	
	Undersize	1st	62.800 to 62.843 (2.4724 to 2.4741)	
		2nd	62.550 to 62.593 (2.4626 to 2.4643)	
Rear bearing inner dia. "E" in bearing split ring	Standard		70,050 ± 70,065	
	Undersize	1st	69.800 to 69.825 (2.7480 to 2.7490)	
		2nd	69.550 to 69.575 (2.7382 to 2.7392)	
Rear bearing housing shoulder distance "F"			33.060 to 33.130 (1.3016 to 1.3043)	
Crankshaft abutment flange thickness "G"			7.90 to 8.10 (0.3110 to 0.3189)	
Shim rings thickness "H"	Standard		2.311 to 2.362 (0.0909 to 0.0930)	
	Oversize	1st	2.141 to 2.462 (0.0949 to 0.0969)	
		2nd	2.511 to 2.562 (0.0988 to 0.1008)	

(1) For this measurement, fit linear retaining tool A.7.0411 and tighten screws to 59 N·m (6 kg·m; 43.38 ft·lb)

(2) To be measured with bearing split ring screws tightened to 39 to 44 N·m (4 to 4.5 kg·m;)

E N G I N E MAIN MECHANICAL UNIT

Connecting rods and big end bearings

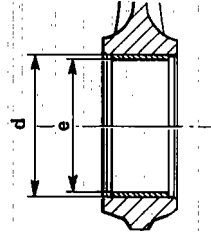
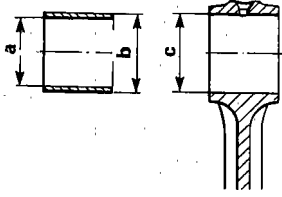

Unit: mm (in)

Inspection data		Engine	
		1800	
		V M 8 2 A	
Connecting rod small end bearing bore "a"		30.030 to 30.045 (1.1823 to 1.1829)	
Connecting rod small end bearing outside diameter "b"		34.089 to 34.129 (1.3421 to 1.3437)	
Bush housing inner dia. "c" in small end		34.000 to 34.025 (1.3386 to 1.3397)	
Big end inner dia. "d" (1)		57.563 to 57.582 (2.2663 to 2.2670)	
Connecting rod big end bearing bore (1) "e"		Standard	
		53.975 to 64.014 (2.1250 to 2.1265)	
		Undersize	1st
2nd	53.475 to 53.514 (2.1053 to 2.1068)		

(1) To be measured with connecting rod screws tightened to 79.4 to 84.3 N·m (8 to 8.6 kg·m; 57.84 to 62.18 ft·lb)

ENGINE MAIN- MECHANICAL UNIT

FITMENT PLAYS AND INTERFERENCE FITS

Unit: mm (in)

Inspection data		Engine
		1800
		VM 82A
Cylinder liner/piston clearance	New	0.625 to 0.045 [(0.984 to 1.772)·10 ⁻³]
	Wear limit	0.5 (19.68·10 ⁻³)
Ring/groove end float	1 st compression ring	0.080 to 0.130 [(3.149 to 5.118)·10 ⁻³]
	2nd compression ring	0.070 to 0.102 [(2.756 to 4.016)·10 ⁻³]
	Oil scraper ring	0.030 to 0.062 [(1.181 to 2.441)·10 ⁻³]
Pin/piston bore clearance		6,006 ÷ 0,017
Pin/small-end bush bore clearance	New	0.034 to 0.055 [(1.338 to 2.165)·10 ⁻³]
	Wear limit	0.100 (3.937·10 ⁻³)
Main journal/bearing running clearance (new)	Rear main journal	0,050 ÷ 0,080
	Front main journal	0,050 ÷ 0,115
	Intermediate main journal	0,030 ÷ 0,088
Big-end bearing/crankpin running clearance (new)		0,022 ÷ 0,076
Main journal and crankpin/bearing running clearance (at wear limit)		0.200 (7.874·10 ⁻³)
Crankshaft end float		0.121 to 0.323 [(4.764 to 12.716)·10 ⁻³]
Big-end end float		0.120 to 0.40 [(7.874 to 15.748)·10 ⁻³]
Camshaft journal/bearing running clearance	New	0.640 to 0.110 [(1.575 to 4.331)·10 ⁻³]
	Wear limit	0.200 (7.874·10 ⁻³)
Rocker bush/shaft running clearance	New	0.020 to 0.062 [(0.787 to 2.441)·10 ⁻³]
	Wear limit	0.200 (7.874·10 ⁻³)
Tappet/housing running clearance	New	0.025 to 0.070 [(0.984 to 2.756)·10 ⁻³]
	Wear limit	0.100 (3.937·10 ⁻³)
Valve stem/guide running clearance	Intake	0.640 to 0.075 [(1.575 to 2.953)·10 ⁻³]
	Exhaust	0.060 to 0.095 [(2.362 to 3.740)·10 ⁻³]
Valve seat/housing interference fit	Intake	0.085 to 0.124 [(3.346 to 4.882)·10 ⁻³]
	Exhaust	0.062 to 0.102 [(2.441 to 4.016)·10 ⁻³]
Valve guide/housing interference fit		0.020 to 0.047 [(0.787 to 1.850)·10 ⁻³]
Rotor stand-outs in oil pump		0.930 to 0.073 [(1.181 to 2.874)·10 ⁻³]
Oilpump inner/outer rotor max. clearance		0.070 to 0.20 [(2.756 to 7.874)·10 ⁻³]
Outer rotor/housing clearance in oil pump	New	0.130 to 0.185 [(5.118 to 7.283)·10 ⁻³]
	Wear limit	0.50 (19.68·10 ⁻³)
Gear end float in pump body		6.05 to 0.07 [(1.968 to 2.756)·10 ⁻³]

GROUP 04

CONTENTS

DESCRIPTION	04-2	Accelerator throttle switch calibration .	04-20
General description	04-2	Fuel pressure checking and fuel	
Injection system Jetronic LE 3.2	04-2	tightness	(•)
Ignition system	04-2	Adjustment for accelerator control cable (•)	
Air, fuel, fuel vapour system chart	04-3	Idle rpm adjustment	(•)
Wiring diagram for injection system	04-4	CO percentage adjustment at exhaust .	04-20
Main components	04-5	ELECTRICAL/ELECTRONIC	
important general data	04-8	COMPONENTS	04-21
AIR SUPPLY SYSTEM	04-9	Fuel level gauge	(*)
Air filter	04-10	Electronic CU	04-21
Air flow sensor	04-10	Accelerator throttle switch	04-21
Extra air solenoid valve	04-g 1	Collant temperature sensor	(••)
Throttle body	04-11	EXHAUST SYSTEM	04-23
Supply manifold	04-12	Precautions for catalytic muffler vehicles	04-23
FUEL SUPPLY SYSTEM	04-14	Checks and inspections	04-23
Fuel tank	(*)	Removal	04-23
Fuel pipes	(*)	Installation	04-24
Fuel pump	04-15	Replacement of catalytic muffler	(•)
Fuel filter	(•)	Lambda probe replacement	(•)
Damper	04-15	Troubleshooting for catalytic muffler ..	04-25
Electroinjectors	04-15	SERVICE DATA AND SPECIFICATIONS ..	04-26
Fuel pressure gauge	04-16	Technical data	04-26
FUEL VAPOUR EMISSION		Checks and adjustment	04-26
CONTROL SYSTEM	04-17	General specifications	04-27
Fuel vapour separator	04-18	SERVICE DATA AND SPECIFICATIONS ..	04-28
Compensation valve	04-18	Technical data	04-28
Dump valve	04-18	General specifications	04-28
Fuel vapour filter	04-18	Checks and adjustments	(*)
CALIBRATION AND ADJUSTMENTS	04-19	Tightening torques	(*)
Throttle body calibration (flow)	04-19	SPECIAL SERVICE TOOLS	04-30

(*) Refer to "WORKSHOP MANUAL" VOLUMES I and II - Group 04

(•) Refer to Group 00

(••) Refer to Group 07

(A) For electronic injection 1.7 engines with catalytic converter only

DESCRIPTION

For electronic injection 1.7 engines

GENERAL DESCRIPTION

The JETRONIC LE 3.2 electronic system consists an inductive discharge transistorized injection system equipped with a control unit (CU).

The ignition, however is ensured by an electronic ignition system equipped with an electronic power module.

The data necessary for controlling the system is collected by means of sensors that transform the data into electrical signals. This data concerns:

- battery voltage
- position of the accelerator throttle (completely closed or open)

- air intake temperature
- engine coolant temperature
- quantity of air taken in by the engine
- quantity of oxygen present in the exhaust gases
- engine r.p.m. (from the distributor)

The electronic CU calculates the opening time of the electroinjectors with relation to the instantaneous r.p.m. and load condition of the engine.

Having carried out the calculation, the CU sees to the opening of the electroinjectors for this time. Since the difference between fuel pressure and air pressure in the manifold is maintained constant by a regulator, the quantity of fuel injected is proportional to the delivery time.

Furthermore the injection CU is able to carry out from time to time certain operations considered necessary under certain engine conditions (e.g. electroinjector for cold start, interruption of fuel delivery when engine is decelerating).

The injection CU also controls the delivery of the fuel pump.

JETRONIC LE 3.2 INJECTION SYSTEM

The system, which consists of an air system and of a fuel system includes the following:

- A filter-equipped fuel pump
- a pulsation damper whose task is to eliminate pulsations due to pressure peaks
- a pressure gauge which keeps constant pressure difference between fuel system and intake manifold

- four electroinjectors which, owing to pressure gauge, supply a fuel quantity dependent on their opening time
- an air flow sensor, which measures air taken in by engine (adjusted in relation to air temperature)
- supplementary air solenoid valve supplying extra air when the engine is cold

a switch on accelerator, throttle recognizing the two cases of open or closed throttle

an engine Coolant temperature sensor for injection CU

- an rpm sensor
- pipes and electrical wiring, including remote control switches and CU (inserted in air flow sensor)
- a lambda probe determining oxygen differences, in exhaust gas, with respect to the air (only for models with catalytic converter).

IGNITION SYSTEM

This system consists of:

- an electronic power module
- a high voltage shock generating coil

- a high voltage distributor supplying power to spark plugs
- four ignition spark plugs

electrical wiring at low and high voltage

FUEL SYSTEM

AIR, FUEL, FUEL VAPOUR SYSTEM CHART

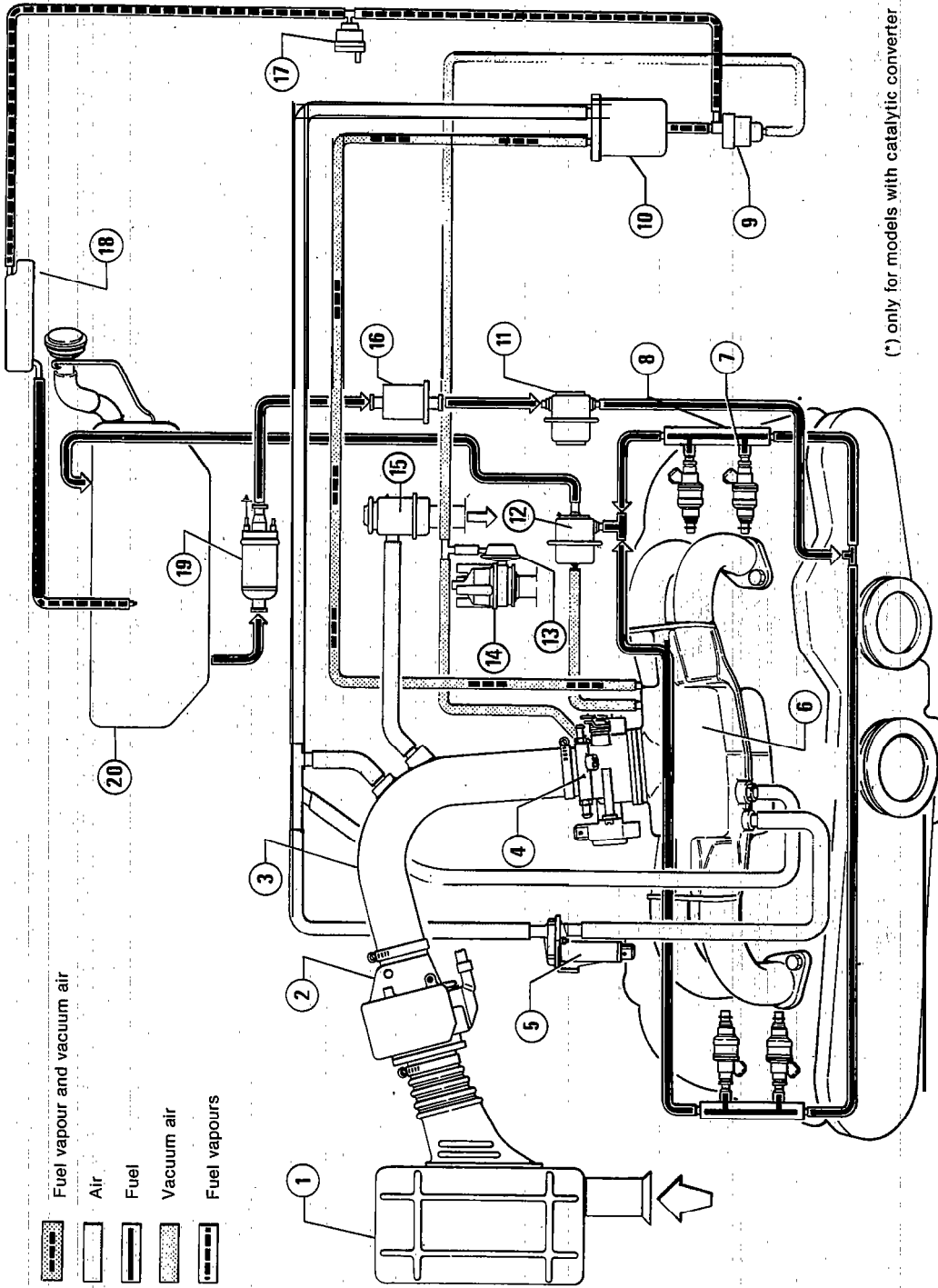

INJECTION SYSTEM WIRING DIAGRAM

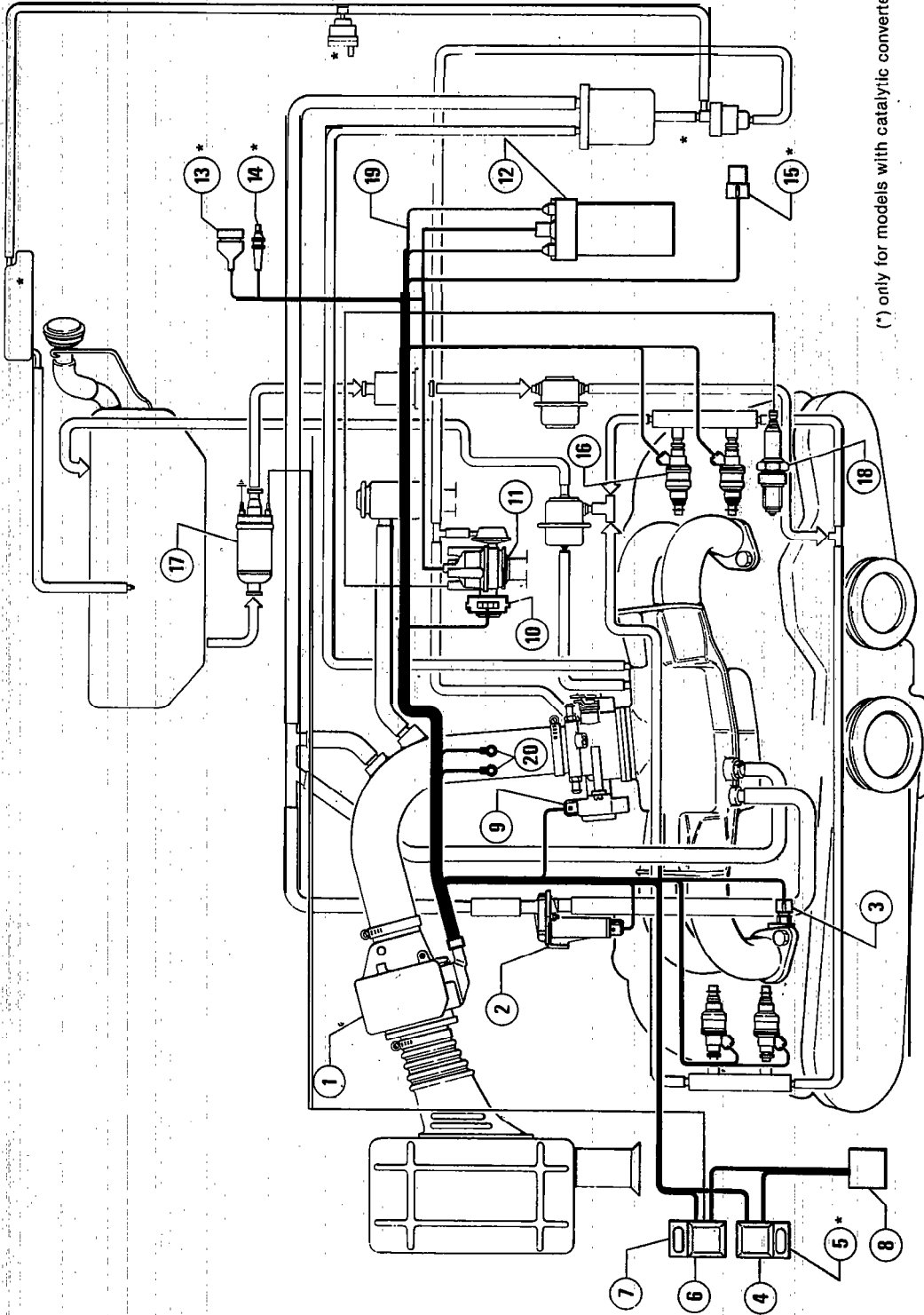

(*) only for models with catalytic converter

- 15 Lambda probe connector
- 16 Electroinjectors
- 17 Fuel pump
- 18 Spark plugs
- 19 Cable to detect engine rpm
- 20 Centralized ground
- 21 Ignition CU

- 8 Vehicle wiring connection
- 9 Min. & Max. throttle opening switch
- 10 Power module
- 11 Ignition distributor
- 12 Ignition coil
- 13 Lambda probe resistance connector
- 14 Lambda probe signal connector

- 1 Air flow sensor/injection CU
- 2 Supplementary air solenoid valve
- 3 Engine coolant temperature sensor
- 4 Main injection remote control switch
- 5 lambda probe resistance fuse
- 6 Fuel pump remote control switch
- 7 Fuel pump fuse

MAIN COMPONENTS

FUEL PUMP

The pump is of the rotating type with cells and rollers, driven by an electric motor which remains immersed in the fuel under pressure downstream the pumping unit. This arrangement results in a reduction in noise and furthermore the fuel under pressure acts as a hydraulic support between the spindle and relative supporting bushes. The pump delivers more fuel than the engine effectively requires, in order to maintain effective pressure in the supply system under all possible operating conditions. If the key is inserted in the ignition and turned to the "MARCIA" (running) position, the pump is not supplied with power; when the key is turned on the "AVVIAMENTO" (starting) position, the control unit measures the r.p.m. from ignition distributor and, when this exceeds a determined value, the control unit sees to supplying the fuel pump. With this electrical safety circuit, in the case of a faulty electroinjector with ignition inserted, one prevents the corresponding circuit from being filled with fuel.

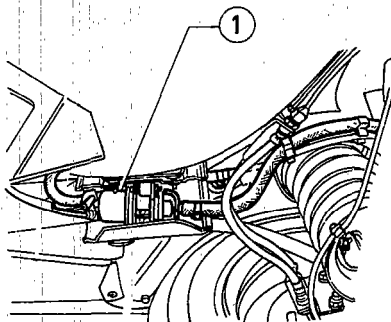

1 Fuel pump

DAMPER

The damper is connected upstream the fuel distribution tube. The function of the damper is to suppress hammering that can occur especially when the engine is running on low r.p.m.. The hammering is generated by jumps in fuel pressure that arise from the opening and closing of the electroinjectors or the pressure regulator.

FUEL PRESSURE REGULATOR

The fuel under pressure enters the lower chamber of the regulator and acts on a membrane which, overcoming the action of a spring, rises together with a small plate and opens the passage to tank return tube. In addition to the regulating function of the spring, which has a fixed setting, there is also that of the vacuum pressure of the supply manifold transmitted to the regulator upper chamber via a hose connected to the manifold.

When this pressure from the supply manifold increases the membrane rises, opening the fuel return passage and determining an equal decrease in the fuel pressure itself. The purpose of this additional adjustment is to maintain the jumps in pressure between the fuel upstream the electroinjectors and the air in the manifold constant. In this way the fuel delivered depends exclusively on the opening time of the electroinjector itself.

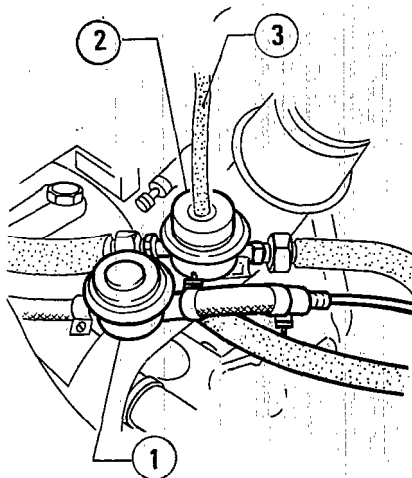

1 Hammering
2 Pressure regulator
3 Vacuum tube

ELECTROINJECTORS

There is one electromagnetically actuated injector for each cylinder; the electroinjectors are connected electrically in parallel and inject simultaneously once for each rotation of the crankshaft half of the necessary quantity of fuel.

An electroinjector consists essentially of a coil, a moving core, a guide for the needle and the needle. The core of the moving magnet is in one piece with the needle which is pressed against the sealed seating of the body of the electroinjector by a spring. The needle of the electroinjector is opened as a result of magnetic field created by the magnet and this is effected when the electronic CU sends an appropriate electric signal.

The stroke of the moving core, and therefore of the needle, is very limited (0.15 mm approx.) as a consequence of a stop disc which has the purpose of preventing the moving core from banging against the fixed internal part.

The opening time of the needle is 2-10 ms according to the signal arriving from the CU. The tip of the electroinjector is fitted with a thermal insulating bushing in teflon, the purpose of which is to prevent the evaporation of the fuel and the consequent crystallisation of the dry deposit on the needle. This bushing must not therefore be removed when fitting the electroinjector.

SUPPLEMENTARY AIR SOLENOID VALVE

The supplementary air solenoid valve determines, with the engine cold, the passage of supplementary air to the engine by means of the accelerator throttle by-pass.

A bi-metallic lamina inside the valve is affected by the temperature of the cylinder head in such a way as to obtain maximum closing of the by-pass when the engine is hot. In addition to this, a heater winding heats the lamina and closes the by-pass more quickly than would occur with the heating of the whole engine mass.

The purpose of the device is to give smoother engine running when the engine is cold, compensating for the greater resistances, due to friction, with an increased fuel supply.

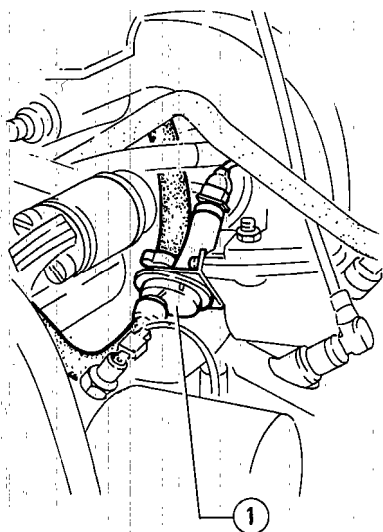

1 Supplementary air solenoid valve

**A I R F L O W
S E N S O R / C O N T R O L U N I T**

The air flow sensor has the task of furnishing the electronic CU with an electric signal, by means of a potentiometer, with relation to the air flow taken in by the engine. This signal is used by the CU to determine the duration of the injection time.

The sensitive element is a floating throttle which opens according to the amount of air taken in (a function of the engine r.p.m. and the opening of the accelerator throttle). The angular position of the floating throttle is measured by a potentiometer which is firmly fixed to the spindle of the floating throttle itself.

A compensating throttle coupled to the floating throttle compensates for any oscillations in the pressure of the flow due to backflow that may occur, so that these do not affect the measuring of the air flow.

A sensor for measuring the temperature of the air taken in is located at the entrance of the air flow sensor. The electronic CU for the control and monitoring of the whole injection system is located in the upper part (cover) of the air flow sensor.

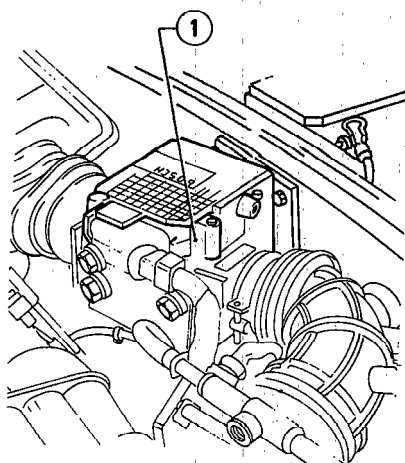

1 Air flow sensor

**C O O L A N T
T E M P E R A T U R E S E N S O R**

When starting the engine from cold, during the warming up of the engine, the engine requires a considerably enriched mixture. This enrichment must be reduced as the temperature of the engine increases and eliminated when the engine reaches normal running temperature.

These variations in temperature are transmitted to electronic CU by the coolant temperature sensor and the CU then control the quantity of fuel injected.

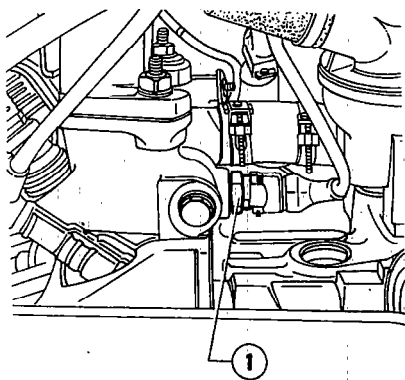

1 Engine coolant temperature sensor

**S W I T C H O N B O D Y
O F A C C E L E R A T O R T H R O T T L E**

The switch on the throttle body is firmly fixed to the spindle of the accelerator throttle valve. The switch contains

a full load contact. In this way a signal is sent to the electronic CU when the engine is running under conditions of full load and the CU is able to alter the air-petrol ratio according to the requirements of these engine conditions. When the accelerator is released the fuel supply is cut off by means of the minimum throttle opening switch. When the accelerator throttle valve closes and the engine r.p.m. is higher than 1600 r.p.m., the fuel supply is cut off until the engine r.p.m. comes down to 1100 rpm approx., where the fuel supply is restored. The main purpose of fuel cut-off when the accelerator is released is to reduce both fuel consumption and the emission of unburnt hydrocarbons which usually form during this phase.

I D L E A D J U S T M E N T B Y - P A S S

A tube connecting the corrugated air intake sleeve with the supply manifold acts as a by-pass to the accelerator throttle; the amount of air that can pass through, this tube can be varied by means of an adjusting screw. By acting on this adjusting screw the idle r.p.m. of the engine can be altered without affecting the exhaust CC%.

In fact, the variation in the amount of air taken in by the engine when this screw is adjusted is measured by the air flow sensor which in turn provides for the proportional correction of the quantity of fuel that is injected.

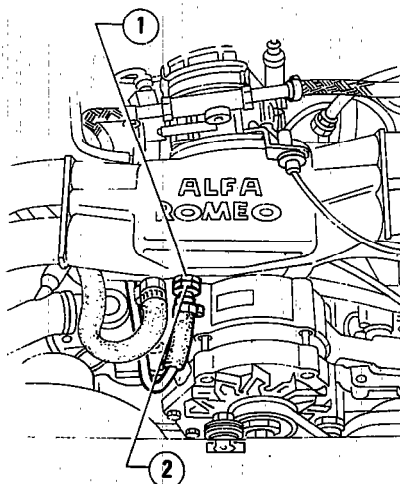

1 Lock nut
2 Idle r.p.m. adjusting screw

The following components are foreseen only on models with catalytic converter.

FILLER INLET FOR UNLEADED PETROL

The filler inlet of the fuel tank is fitted with a special device which prevents filling with petrols other than those which are unleaded.

Only the delivery nozzles of unleaded petrol pumps are able to pass through the neck of the filler inlet, thus opening the valve and filling the tank.

LAMBDA PROBE

The sensitive element of the lambda probe consists of a ceramic capsule coated with porous platinum on both sides; the external side comes into contact with the exhaust gases, whilst the internal side comes into contact with atmospheric air.

The difference in the oxygen content between the air of the atmosphere and the exhaust gases is transformed into an electrical potential difference across the two sides of the capsule. This electrical signal is sent to the electronic CU which carries out those corrections necessary for obtaining the stoichiometric air-petrol ratio required for the maximum operating efficiency of the catalyst, thus keeping harmful emissions contained in the exhaust gases to a minimum.

The probe is electrically preheated to obtain a faster response time.

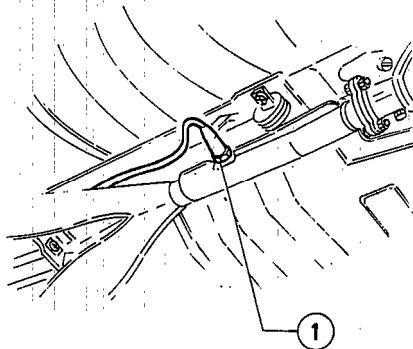

1 Lambda Probe

CATALYTIC MUFFLER

A catalytic converter is mounted in the exhaust system with the purpose of reducing exhaust emissions. The converter consists of an alumina monolith coated with an active material composed of noble metals and housed in a special steel container which is resistant to high temperatures. The system converts the HC and CO emissions contained in the exhaust gases into water and CO₂ (non-toxic substances).

The catalyst is efficient within a certain temperature range. At low temperatures no catalytic conversion occurs. High temperatures can cause deformation of the metallic container and deterioration of the alumina and a consequent loss in the efficiency of the operation of the catalyst itself. High temperatures can be caused by an excessive quantity of unburnt fuel passing through the alumina, following overloading of the engine or by the engine being badly tuned and out of adjustment.

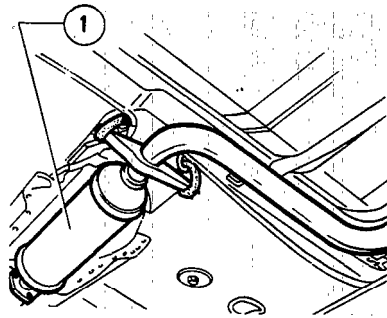

1 Catalytic muffler

FUEL VAPOUR EMISSION CONTROL SYSTEM

Fuel vapours emanating from the fuel tank (4) are collected, by means of a special tube (5) in a liquid vapour separator (7) which is arranged in such a way as to permit the return of condensed fuel to the tank.

The tank has a sealed filler cap to prevent fuel vapours from escaping into the atmosphere.

The fuel vapours coming from the separator (7) through the upper outlet, are conveyed to a fuel vapour filter (10).

The vapour flow is controlled by a valve (9) which opens or closes the passage to the fuel filter in relation to the vacuum pressure existing upstream the throttle body. When the vacuum pressure is lower than the specified value (e.g. with the engine switched off or on idle) the dump valve is closed and prevents vapours from flowing to the vapour filter. If this is not the case (engine running under normal conditions) the valve is open and the fuel vapours are able to flow to the filter where they are absorbed by activated carbon.

As a result of the difference in pressure existing inside the vapour filter, the activated carbon is "washed" by a current of air.

The vacuum pressure is taken upstream the throttle. In the "washing" action, the fuel vapours mixed with atmospheric air are conveyed to the supply manifold where they are added to the air taken in by the engine.

Should the pressure in the fuel vapour separator tend to a drop when the engine is stopped, due to a fall in temperature, a compensation valve (6) situated in the fuel vapour recovery tubing (8) between the separator (7) and the vapour filter (10), lets in atmospheric air thus maintaining the system at atmospheric pressure.

The dump valve (9) as an internal spring which is set in such a way as to open the passage should the vapour pressure in the tank be excessive. In this case the fuel vapours can be discharged into the vapour filter (10) and held in the activated carbon of the filter itself.

FUEL SYSTEM

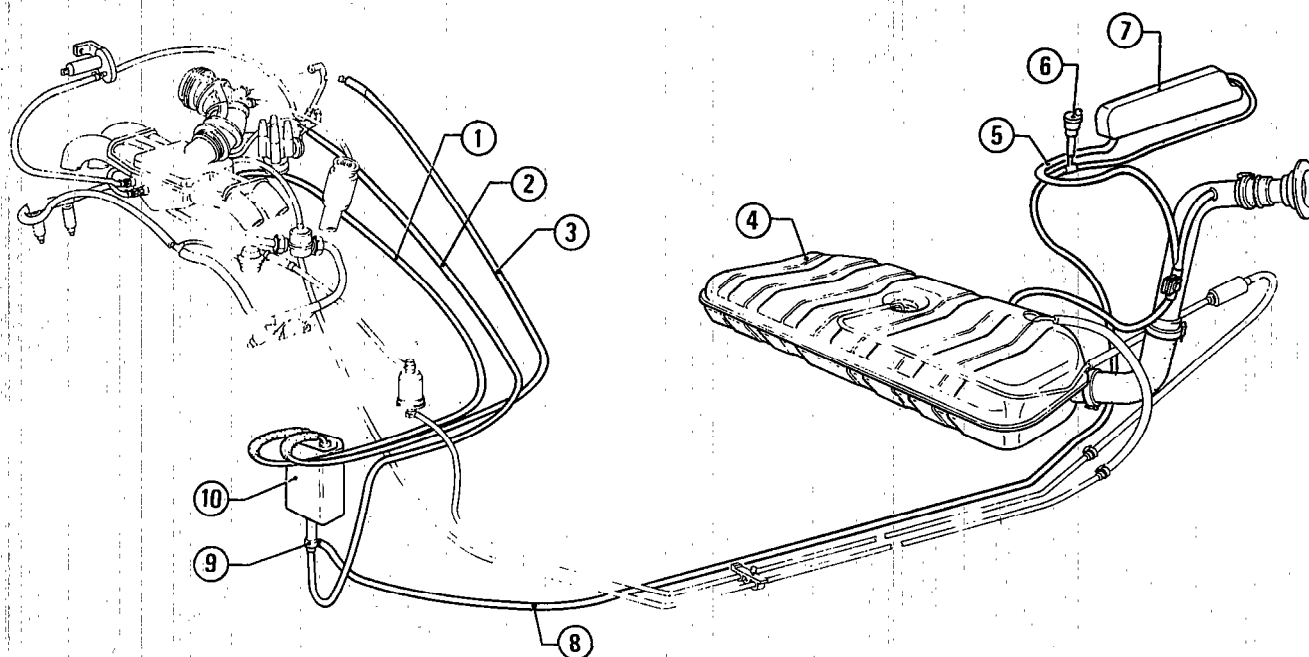

- 1 Fuel vapour intake tube
- 2 Vacuum pressure tube for dump valve control
- 3 External air delivery tube
- 4 Fuel tank
- 5 Fuel vapour breather hose

- 6 Compensation valve
- 7 Fuel vapour separator
- 8 Fuel vapour recovery tube
- 9 Dump valve
- 10 Fuel vapour filter

IMPORTANT GENERAL DATA

Never start the engine when the battery cables are not properly connected.

To start the engine, never use a rapid battery charger.

Never disconnect battery from vehicle electronic system when the engine is started.

In no case use a rapid battery charger.

- When painting in furnace at temperature over 80°C, remove the electronic control unit.
- Make sure that screened wire connections are properly connected.
- Never connect or disconnect electronic CU conductor plug when ignition is switched on.
- Never connect to ground high or

- low voltage cables, for testing.
- Should any accessories be mounted on vehicle, it is always advisable to disconnect electronic CU and to check the functioning accessories with the CU disconnected. It is very strongly advised never to connect any leads (other than those of the CU itself) to the wiring of the CU.

AIR SUPPLY CIRCUIT

For electronic injection 1.7 engine only

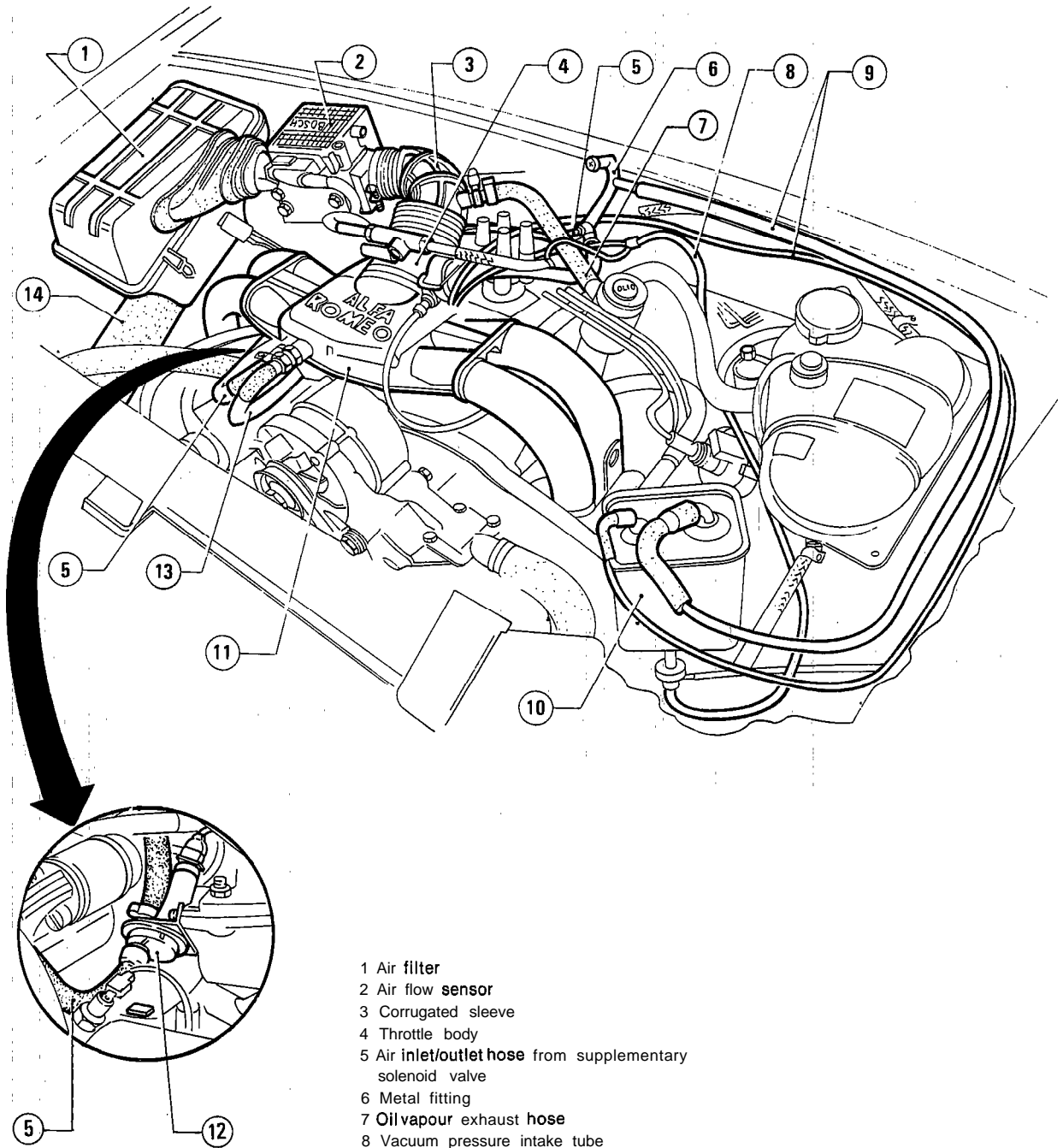

- 1 Air filter
- 2 Air flow sensor
- 3 Corrugated sleeve
- 4 Throttle body
- 5 Air inlet/outlet hose from supplementary solenoid valve
- 6 Metal fitting
- 7 Oil vapour exhaust hose
- 8 Vacuum pressure intake tube
- 9 Fuel vapour circulation pipe
- 10 Fuel vapour filter
- 11 Air manifold
- 12 Extra air solenoid valve
- 13 By-pass tube to set idle rpm
- 14 Air intake sleeve

(*) only for vehicles with catalytic converter

AIR FILTER

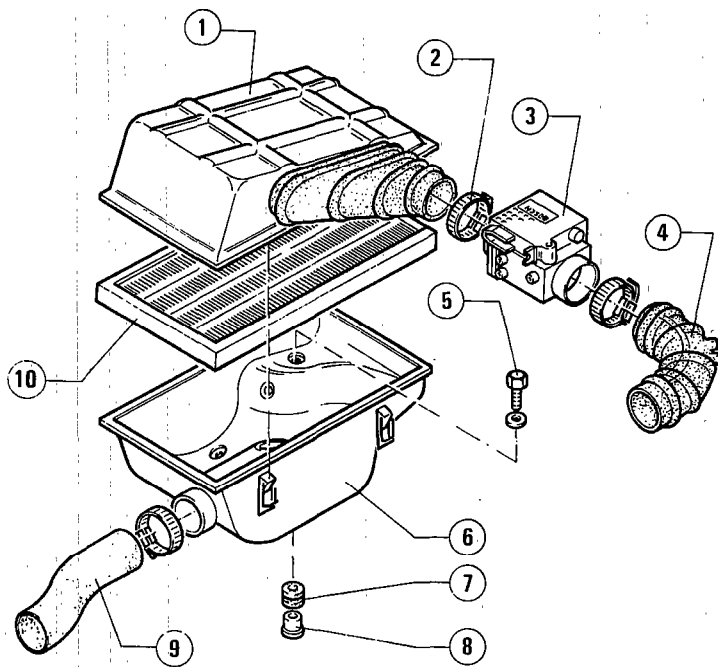

- | | |
|--|------------------------|
| 1 Air filter cover | 6 Air filter container |
| 2 Clamp | 7 Spring element |
| 3 CU flow meter | 8 Spacer |
| 4 Corrugated sleeve | 9 Air intake sleeve |
| 5 Adjustment screw to fix air filter container to body | 10 Filtering element |

REMOVAL

Disassemble air cleaner body as follows (see figure):

1. Unfasten the clamp (2) and disconnect air cleaner cover sleeve from air flow sensor (3).
2. Unfasten the four spring clips securing cover (1) and remove it; remove the filtering element (10).
3. Unscrew three screws (5) securing cartridge (6) to body; remove filter container (6) with spring element (7) and spacers (8) disconnecting sieve (9) from air intake.
4. If necessary, loosen clamp and disconnect sleeve (9) from container (6).

CHECK AND INSPECTIONS

Thoroughly clean filtering element by blowing low pressure compressed air through the filter in the opposite direction to that of the normal air flow. If necessary, replace filtering element.

ASSEMBLY

Assemble air flow sensor/CU following disassembly procedure in reverse sequence.

- Position the filtering element in the container so that the folded protruding part is facing downwards.

AIR FLOW SENSOR

The body of the air flow sensor incorporates the electronic control unit for the piloting of the fuel injection system.

REMOVAL

1. Disconnect the multipolar connector (4) from the body of the sensor (2).
2. Loosen the clips securing the ducts (1) and (2) and detach them from the air flow sensor.
3. Unscrew the three screws shown in the figure and remove the air flow sensor (2).
4. Only if necessary, unscrew the four screws (one of which lies beneath a sealed plug) and remove the cover of the air flow sensor. The electronic control unit is contained in the cover.

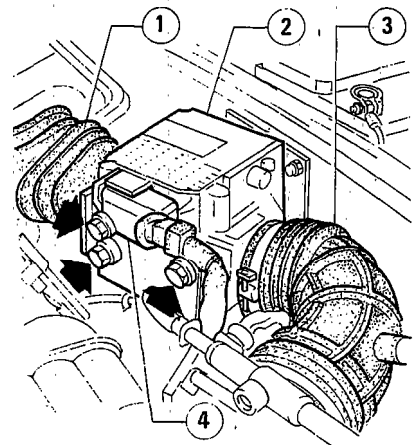

- | |
|------------------------------|
| 1 Air inlet duct |
| 2 Air flow sensor |
| 3 Corrugated air intake duct |
| 4 Multipolar connector |

CHECKS AND ADJUSTMENTS

Press gently on the floating throttle of the air flow sensor and check that it rotates freely and smoothly as far as the travel stop. If necessary, clean the internal surfaces of the air flow sensor with a cloth.

REFITTING

Refit the air flow sensor/electronic control unit by reversing the order of its removal.

If it is being replaced, proceed to the checking and adjustment (if necessary) of the exhaust CO% (see Setting and Adjustments).

SUPPLEMENTARY AIR SOLENOID VALVE

CHECK AND INSPECTIONS

1. Check solenoid valve opening

- Make sure that the engine is cold, then start and throttle several times outlet tube ① of solenoid valve ②
- Check that engine rpm falls and continues to fall with the passage of time (at room temperature of 20°C no fall in r.p.m. will be noticed after 3 minutes).

2. Check solenoid valve closing

With the engine at normal running temperature, throttle outlet tube ① of solenoid valve and make sure that engine rpm does not decrease.

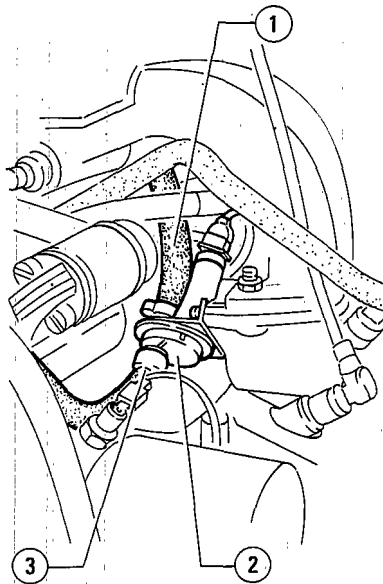

- Air outlet tube
- Supplementary air solenoid valve
- Air inlet tube

REPLACEMENT

- Disconnect battery negative terminal.
- Remove air filter cover, air flow sensor, and corrugated sleeve.
- Disconnect cables ④ and ⑤ from starter ③.

- Remove plastic cover ⑥.
- Unscrew the two figure-showing bolts fixing starter ③ and remove it.

One of the bolts fixes ground supports and battery negative terminal 8¹.

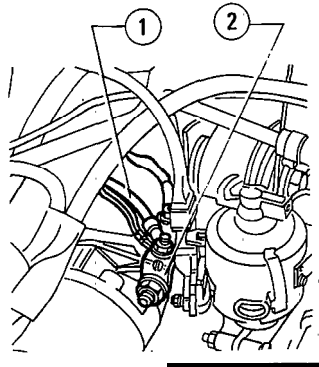

- Battery negative cable
- Ground support
- Starter
- Starter energization cable
- Starter supply cable
- Cover

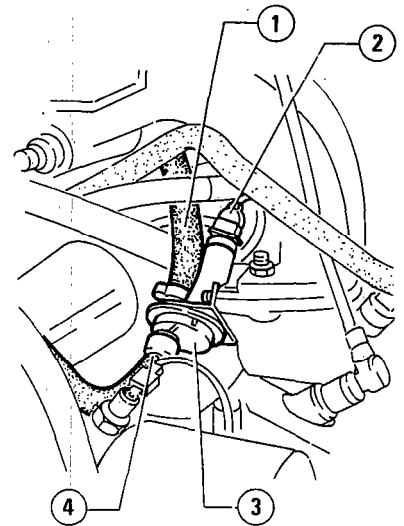

- Air outlet tube
- Solenoid valve control cable
- Supplementary air solenoid valve
- Air inlet tube

THROTTLE BODY REMOVAL

- Rotate accelerator control lever ④ and withdraw pawl on end of accelerator cable.
- Remove lock ring and withdraw sheath end from bracket ⑤
- Loosen clamp and disconnect tubes ① from throttle body ⑥
- Disconnect connector ② from switch.
- Loosen fixing clamp and disconnect sleeve ③ from throttle body.

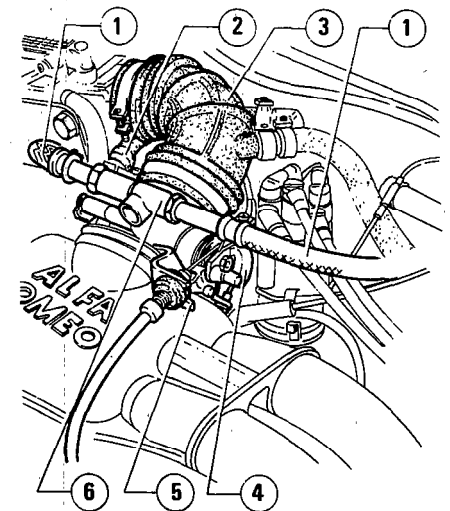

- Sheather tubes of engine cooling system
- Accelerator throttle switch connector
- Corrugated sleeve
- Accelerator control lever
- Bracket
- Throttle body

- Disconnect connector ②.
- Loosen clamps and disconnect tubes ① and ④ from solenoid valve.
- Unscrew fixing screws and remove solenoid valve ③.
- Proceed to assembly operating in reverse order in respect to removal.

6. Disconnect depression tube ③ .
7. Unscrew four fixing screws and remove throttle body ② and gasket from supply manifold ④ .

The two **upper screws** fix braket ① as well .

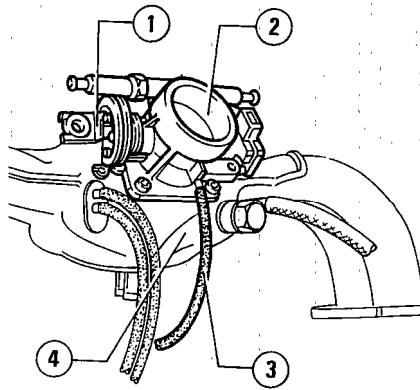

- 1 Cracket fixing accelerator cable sheath
- 2 Throttle body
- 3 Depression tube
- 4 Supply manifold

REMOVAL

Proceed to assembly operating in reverse order in respect to removal, following these instructions:

- Fit a new gasket between throttle body and intake manifold.
- Effect calibration and setting (see: Calibrations and Settings).

INTAKE MANIFOLD (AIR INTAKE BOX).

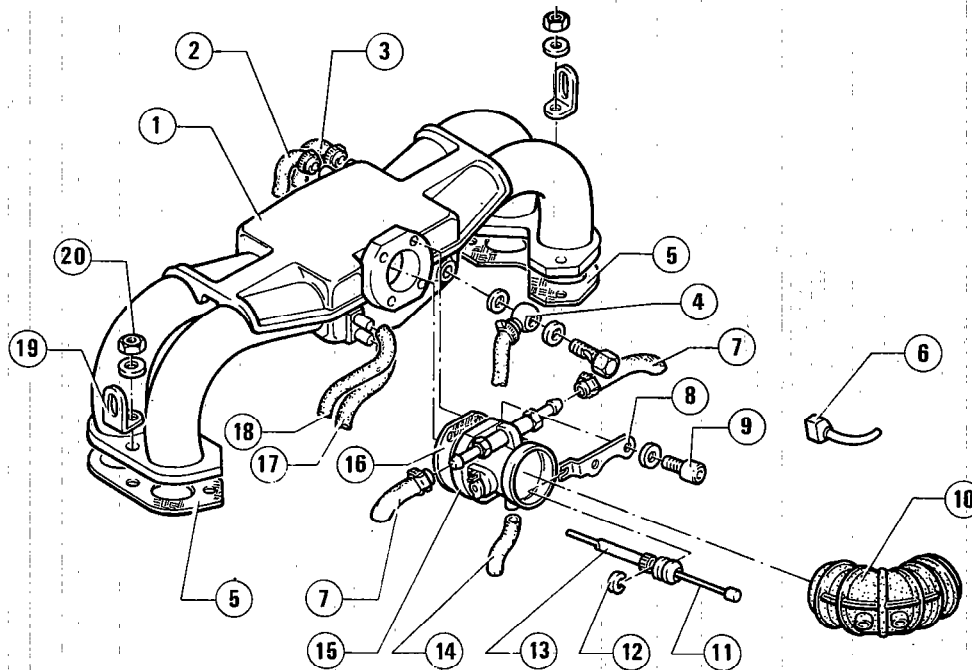

- 1 Intake manifold
- 2 By-pass tube to set idle rpm
- 3 Supplementary air feed tube
- 4 Servobrake depression tube fitting
- 5 Gaskets
- 6 Throttle body switch wiring
- 7 Cooling system breather pipes
- 8 Sheath fixing bracket of accelerator cable

- 9 Throttle body fixing screw to manifold
- 10 Corrugated sleeve
- 11 Accelerator control cable
- 12 Lock ring
- 13 Accelerator cable sheath
- 14 Depression tube for ignition advance pneumatic regulator

- 15 Throttle body
- 16 Gasket
- 17 Depression tube for fuel vapour cleaner (for models with catalytic converter only)
- 18 Depression tube for fuel pressure
- 19 Engine lifting bracket
- 20 Nut fixing supply manifold

REMOVAL

With reference to figure, operate as follows:

1. Remove air filter cover and air flow sensor.

2. Rotate accelerator control lever and unhook pawl at accelerator cable end ⑪ .

3. Remove lock ring ⑫ and disconnect sheath ⑬ from bracket ⑧.
4. Disconnect wiring ⑥.
5. Disconnect tube ⑦ from throttle body.
6. Loosen clamps and disconnect tubes ② and ③ from manifold ①.
7. Disconnect tubes ⑰ and ⑱ from manifold and tube ⑭ from throttle body; (only for models with catalytic converter).
6. Unscrew fixing ④ and separate servobrace depression tube from manifold.
9. Loosen clamp and disconnect sleeve ⑩ from throttle body ⑮.

10. Unscrew three nuts ⑳ on each manifold end and remove manifold with gasket ⑤.

Central nuts also secure the engine lifting brackets ⑲.

11. If necessary, remove four screws ⑨ and separate throttle body ⑮ with gasket ⑯ from manifold.

Two upper screws also secure brackets 6^B.

ASSEMBLY

Proceed to assembly operating in reverse order in respect to removal, following these instructions:

- Fit new gasket between:
 - Throttle body and manifold
 - Manifold and ducts on heads.
- Effect check and, if necessary, adjust accelerator control cable (see: Group 00)
- Effect check and, if necessary, adjust idle rpm (see: Group 00).

FUEL SUPPLY SYSTEM

For electronic injection 1.7 engines only

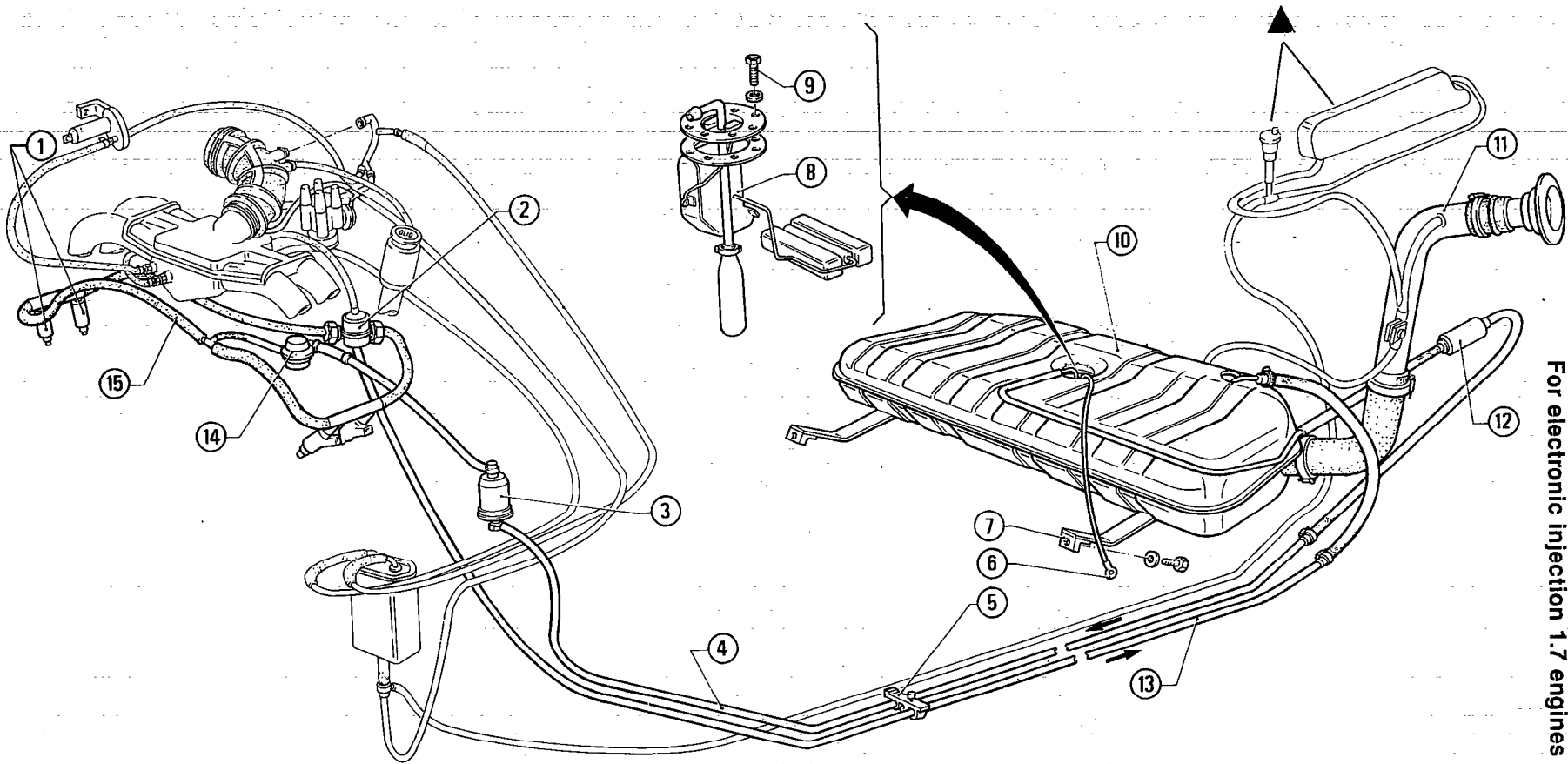

▲ (*) only for models with catalytic converter

- 2 Pressure gauges
- 3 Fuel filter
- 4 Fuel supply tube
- 5 Tube support spring

- 6 Ground cable
- 7 Fuel tank fixing strap
- 8 Fuel level gauge assy
- 9 Level gauge fixing screw
- 10 Tank

- 11 Filler pipe
- 12 Fuel pump
- 13 Excess fuel recovery pipe
- 14 Pulsation damper
- 15 Fuel supply hose

FUEL PUMP

REPLACEMENT

1. put the vehicle on auto lift and disconnect battery negative terminal.
2. Operating from below the vehicle, left rear side, disconnect cables (5) supplying the pump (2).
3. Pinch tubes (1) and (3), then loosen clamps and disconnect tubes from the pump.
4. Loosen clamp (4) and extract the pump (2).

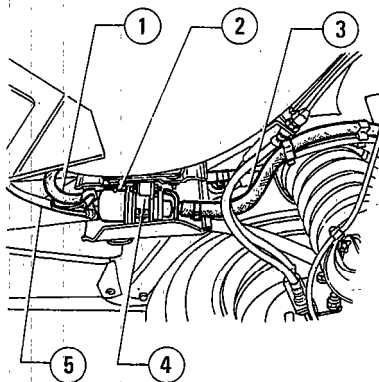

- 1 Fuel outlet tube from pump
- 2 Fuel pump
- 3 Fuel inlet tube into pump
- 4 Pump supporting clamp
- 5 Pump supply cable

5. Mount new fuel pump fixing it with relevant clamp, then reconnect tubes.
6. Reconnect pump supply cables, being careful to connect the correct lead to the correct terminal.
7. On completion of refitting, remove pliers on inlet and outlet tubes and reconnect battery.

DAMPER

REPLACEMENT

1. Loosen clamps and disconnect fuel inlet and outlet tube (2) and (4) from damper.

WARNING:

Be careful: fuel system could be pressurized

2. Unscrew figure-shown fixing nut and remove damper (1) from bracket (3).

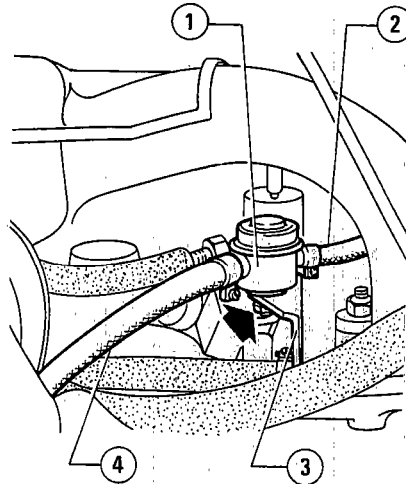

- 1 Damper
- 2 Fuel inlet tube into damper
- 3 Support bracket
- 4 Fuel outlet tube from damper

3. Refit a new damper working in reverse order respect to removal.

ELECTROINJECTORS

CHECKS AND INSPECTIONS

Check on correct electroinjectors opening

1. Detect CO percentage at exhaust (see: Group 00 - Engine Maintenance).

2. Disconnect electroinjectors connectors one by one; each time detect CO percentage at exhaust and check that value remains constant at all checks.

3. If this is not the case, locate the faulty electroinjector and replace it. (see Replacement).

4. In all cases, a visual index of electroinjectors functionality is provided by comparing spark plug electrodes.

- A too-rich mixture shows black colour.
- A too-poor mixture shows light colour.

REPLACEMENT

1. Disconnect battery negative terminal.
2. Disconnect supply wiring connectors (2) from electroinjectors.
3. Unscrew figure-shown fixing screw and lift the fuel supply hose (1) freeing it from electroinjectors.

WARNING:

Pay attention so that residual pressure in the tubing does not cause sprays of fuel.

FUEL SYSTEM

FUEL PRESSURE G A U G E

4. Effect assembly operating in reverse order in respect to removal.

REPLACEMENT

WARNING:

Operate carefully: fuel system could be pressurized.

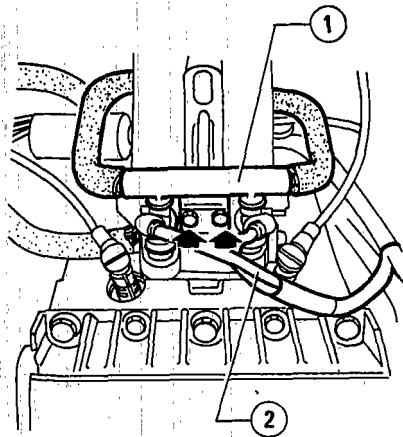

- 1 Fuel supply hose
- 2 Electroinjectors supply wiring

4. Remove electroinjectors (2) complete with b-ring (4) and gasket (3)

1. Unscrew the two connecting fittings of fuel supply hose (3) to regulator (1).
2. Disconnect tube (2) from regulator.
3. Connect tube (4), unscrew figure-shown nut, and remove regulator (1).

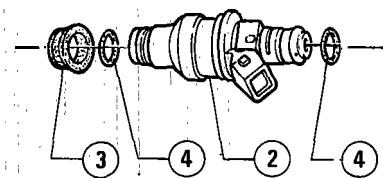
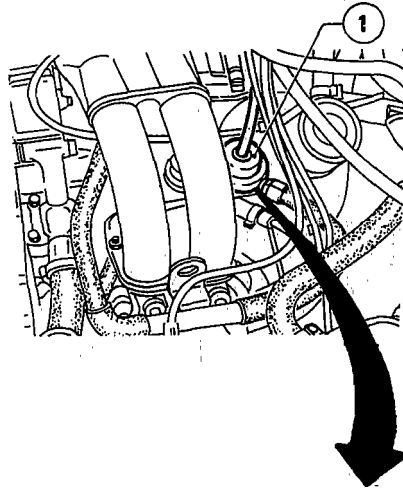
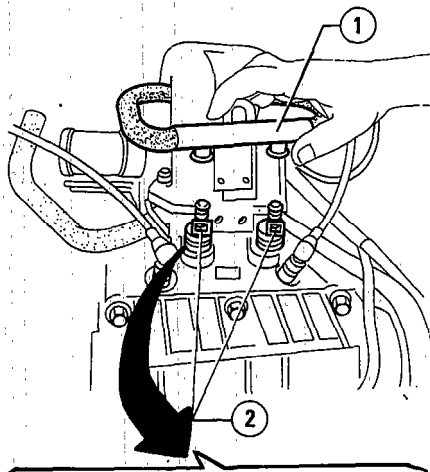

- 1 Fuel supply, hose
- 2 Electroinjectors
- 3 Gasket
- 4 O-rings

5. Proceed to assembly operating in reverse order in respect to removal, following these instructions:

- Replace all O-rings and gaskets.
- Position electroinjector and relevant connector outward.
- Reconnect all components removed at removal time.

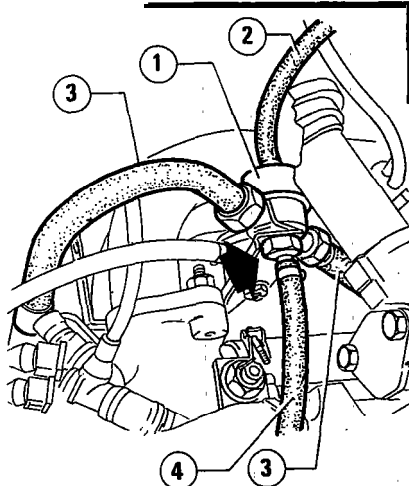

- 1 Pressure regulator
- 2 Depression tube for pressure regulator
- 3 Fuel supply hose
- 4 Excess fuel recovery tube

FUEL VAPOUR EMISSION CHECK SYSTEM

For electronic injection 1.7 engines with catalytic convertor

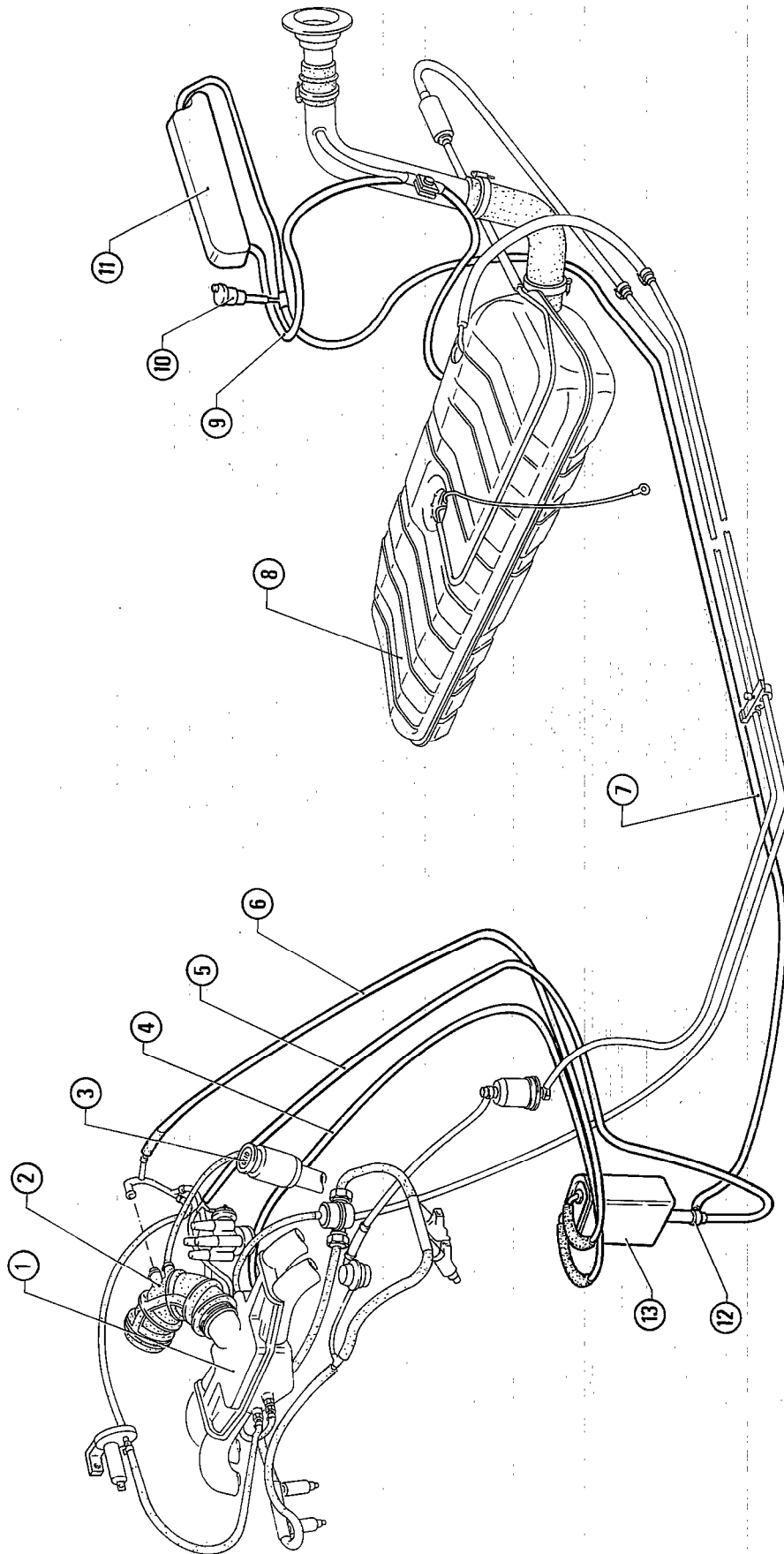

- | | | | | | |
|---|--|----|---------------------------|----|---------------------------------------|
| 1 | Fuel manifold | 6 | External air tube | 11 | Fuel vapour separator |
| 2 | Corrugated sleeve | 7 | Fuel vapour recovery tube | 12 | Air valve (check on fuel vapour flow) |
| 3 | Oil vapour separator | 8 | Fuel tank | 13 | Fuel vapour filter |
| 4 | Fuel vapour intake tube | 9 | Fuel vapour breather tube | | |
| 5 | Depression tube for dump valve control | 10 | Compensation valve | | |

FUEL VAPOUR SEPARATOR

REMOVAL AND ASSEMBLY

1. Move away left side covering of trunk.
2. Loosen clamps and disconnect tubes ① and ③ from separator.
3. Unscrew the two securing nuts indicated in the figure and remove the separator ②.

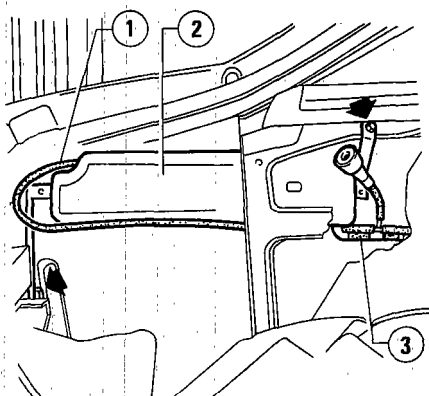

- 1 Fuel vapour recovery tube
- 2 Fuel vapour separator
- 3 Fuel vapour exhaust pipe

4. If necessary, blow compressed air inside the separator to clean it.
5. For assembly, operate in reverse order in respect to removal.

COMPENSATION VALVE

REMOVAL, CHECK AND INSPECTIONS, ASSEMBLY

1. Partially remove the trunk left side covering.

2. Disconnect valve ① from fuel recovery tube circuit.

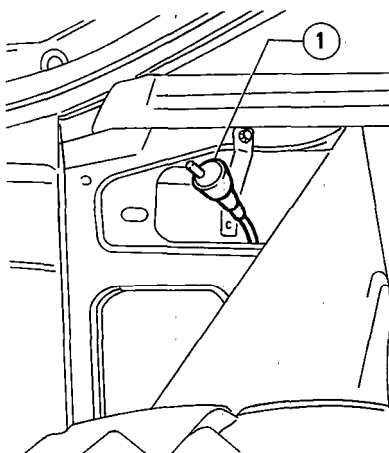

1 Retainer valve

3. Check that valve works properly that is, that otherwise, replace valve it allows the passage of air only in the direction shown by the arrow.

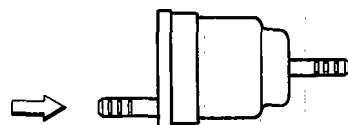

4. Proceed to assembly in reverse order in respect to removal, properly repositioning the valve as stated in the figure in step ②.

DUMP VALVE

REMOVAL AND ASSEMBLY

1. Operating in the engine compartment, front left area below fuel vapour filter, remove valve ② from tubes ①, ③, and ④.

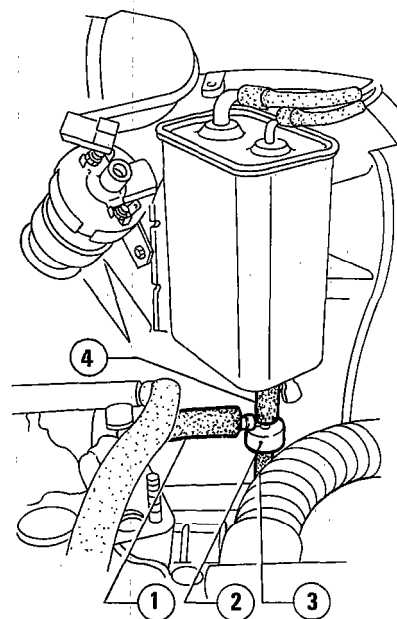

- 1 Fuel vapour recovery tube
- 2 Dump valve
- 3 Depression tube
- 4 Supply tube to fuel vapour filter

- 2 Proceed to assembly operating in reverse order in respect to removal, properly repositioning the valve as shown in previous figure.

FUEL VAPOUR FILTER

REMOVAL AND ASSEMBLY

1. Disconnect tubes ①, ②, and ③ from filter.
2. Unscrew fixing screw positioned under filter ④, lift it and remove it.

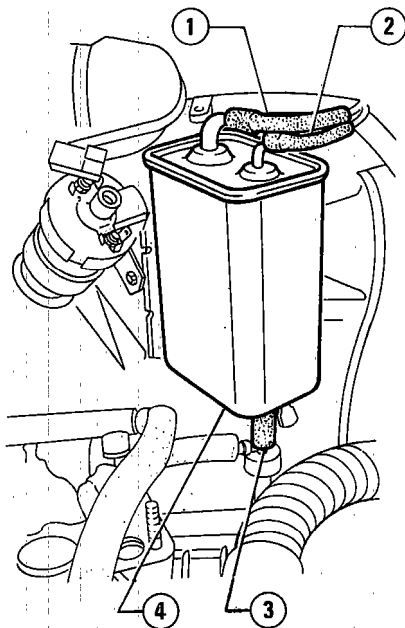

- 1 External air tube
- 2 Fuel vapour intake tube
- 3 Fuel vapour inlet tube
- 4 Fuel vapour filter

3. For assembly, operate in reverse order in respect to removal.

CALIBRATIONS AND ADJUSTMENTS

For electronic injection' 1.7 engines only

CALIBRATION THROTTLE BODY (Flow)

- 1. Loosen clamp and disconnect sleeve ② from throttle body ①.
- 2. Disconnect depression tube under throttle body ① and suitably plug the relevant fitting.
- 3. Loosen switch ④ fixing screws on throttle body.
- 4. Disconnect accelerator control cable.

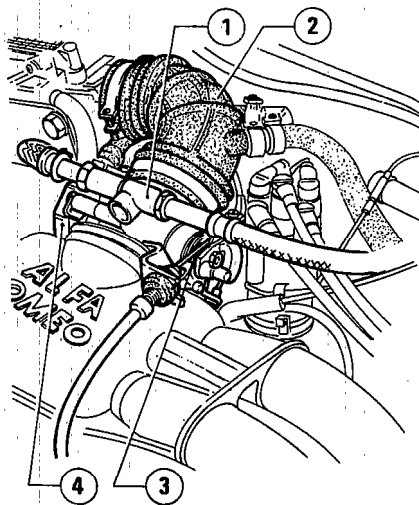

- 1 Throttle body
- 2 Corrugated sleeve
- 3 Accelerator control cable
- 4 Accelerator throttle switch

5. Verify throttle body calibration with a flowmeter, working as follows:

- a. Dismantle **C.2.0056** buffer, separating it from the relevant threaded stem.
- b. Screw **C.2.0057** fitting on buffer, and screw the threaded stem on fitting (as per figure).
- c. Connect flowmeter to **C.2.0056** buffer and rest buffer on throttle body.
- cl. Measure air flow through the throttle and check that this is within the specified values (plug the air intake fitting on the throttle body).

Blowby of air: accelerator throttle in the closed position (Solex flowmeter):

400 ± 10 on N scale

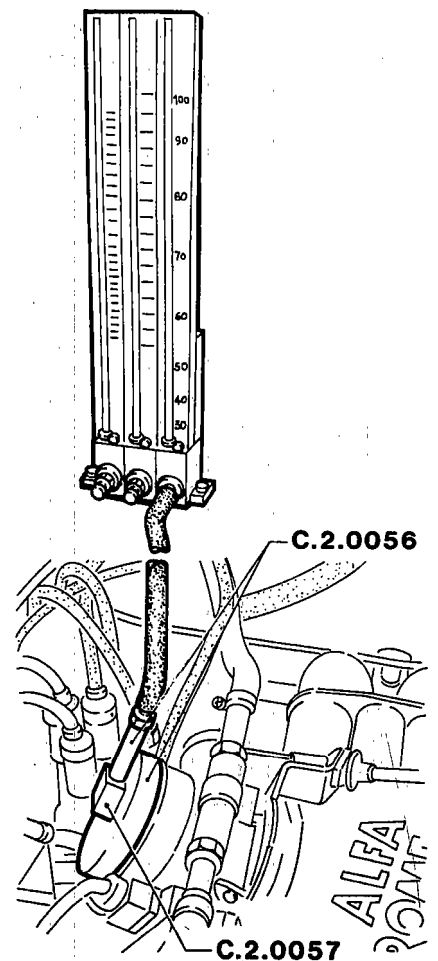

6. If you don't detect specified values, proceed to setting.

a. Break seal ① and act on adjusting screw ② until specified flow value is obtained.

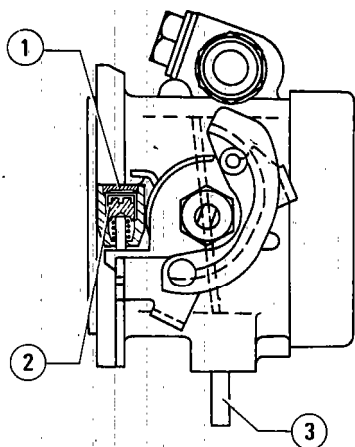

1 Seal
2 Adjusting screw
3 Air intake fitting

b. On completion of the setting reseal the seating of the adjusting screw with the relative cap.

7. Remount disconnected components operating in reverse order, then effect further setting.

3. Rotate throttle $60^\circ \pm 4^\circ$ and check full load contact closed, detecting following resistances on male connectors, with tester.

— With accelerator throttle open by an angle of α , $60^\circ \pm 4^\circ$ between terminals 3 and 13 one must detect a resistance of 0 approximately.

4. If these value are not detected, check accelerator control of replace switch.

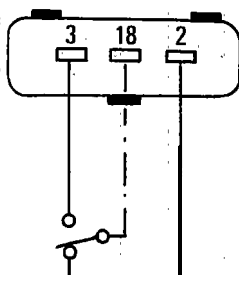
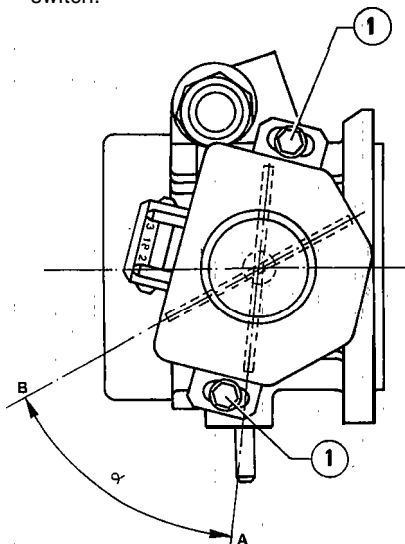

1 Screw fixing switch to throttle body
2 Idle rpm terminal (it corresponds to position A: closed throttle)
3 Max. rpm (it corresponds to position B: open throttle)

ACCELERATOR THROTTLE SWITCH CALIBRATION

1. Disconnect female connector from throttle switch. Check on male connector the following resistances with a tester.

a. With throttle entirely closed between terminals 2 and 18 one must detect a resistance of about 0

b. Slowly rotate throttle: with tester between terminals 2 and 18 one must detect an infinite resistance before throttle has rotated by 1° with respect to fully closed position.

2. If this Condition doesn't take place, loosen screw ① and rotate switch until the contact is obtained (resistance = 0) between terminals 2 and 18 with completely closed throttle; then tighten screws again.

CO PERCENTAGE TIMING AT EXHAUST

Detect CO percentage on exhaust gas following the procedure stated in Group 00 - Engine Maintenance - Exhaust Emission Control.

Whenever detected values are higher than maximum specified values, check power supply components and if they are faulty, replace them.

WARNING:
CO percentage setting and exhaust should be carried out, if necessary, only if an air flow sensor and electronic CU have been replaced.

Operate as stated below:

1. Remove seal cap ②.

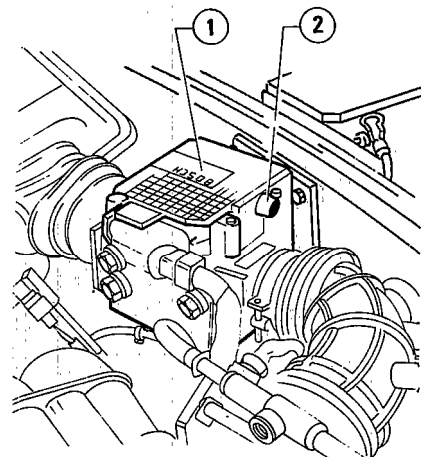

1 Air flow sensor/electronic C U
2 CO Setting screw seat sealing cap

2. Start engine and run it to normal running temperature.

3. Connect a suitable exhaust gas analyzer on exhaust pipe outlet.

4. Cautiously act on CO percentage adjustment screw until specified value is obtained.

5. When this operation is complete, put a new seal cap on CO adjustment screw seat.

ELECTRICAL/ELECTRONIC/ COMPONENTS

For electronic injection 1.7 engines only

ELECTRONIC CONTROL UNIT

CHECK OF FUNCTIONING

1. Make sure that lambda probe is efficient (see: Group 00 - Electrical Troubleshooting Procedure - Test No. 8).
2. Start the engine, run it to normal running temperature and keep it at idle r.p.m.
3. Connect a suitable exhaust gas analyzer at exhaust pipe outlet and detect CO percentage of gas (with lambda probe connected).
4. Disconnect depression pipe from pressure regulator and meanwhile look at exhaust gas analyzer gauge.

- If CO percentage rises momentarily and then goes down to normal values, this means that CU works properly (When it is informed that mixture is too rich it will reduce injection time).
- If CO percentage rises and stabilises at high values, this means that CU is not able to correct CO percentage. One can deduct that CU is faulty (since lambda probe is to be considered as efficient following check effected and Step 1).

REMOVAL AND ASSEMBLY

The electronic CU is built into the air flow sensor cover.

If necessary, remove CU from air flow sensor and operate as follow.

1. Disconnect multipolar connector ②.

2. Unscrew four fixing screws shown in figure (one of which is under seal cap).

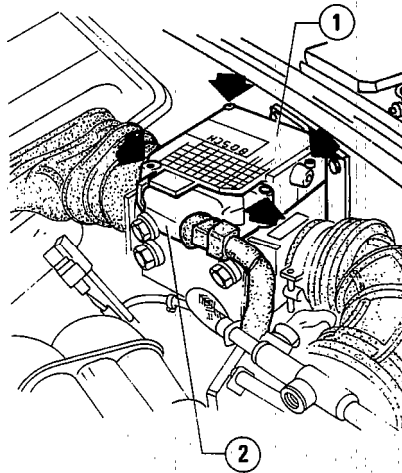

1 Electronic control unit
2 Multipolar connector

3. Remove CU ① with seal gasket ②.

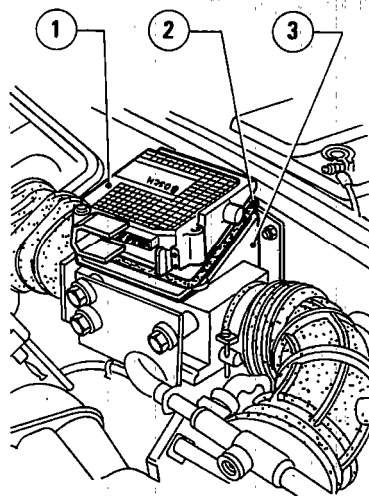

1 CU
2 Gasket
3 Air flow sensor

4. Remount CU operating in reverse order in respect to removal, then apply a new seal cap (in screw seat). If CU has been replaced, proceed to check and if necessary, to effect setting of CU percentage at exhaust (see: Calibration and Setting).

ACCELERATOR THROTTLE SWITCH

REMOVAL AND ASSEMBLY

1. Disconnect connector ①.
2. Unscrew two fixing screws and remove switch ③ from throttle body ②.

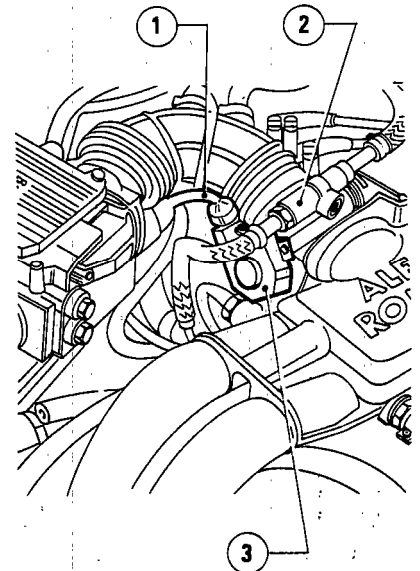

1 Connector
2 Throttle body
3 Accelerator Throttle switch

3. Remount switch operating in reverse order in respect to removal; then effect switch setting (see: Calibration and Setting).

EXHAUST SYSTEM

For electronic injection 1.7 engines with catalytic converter **Alfa 33**

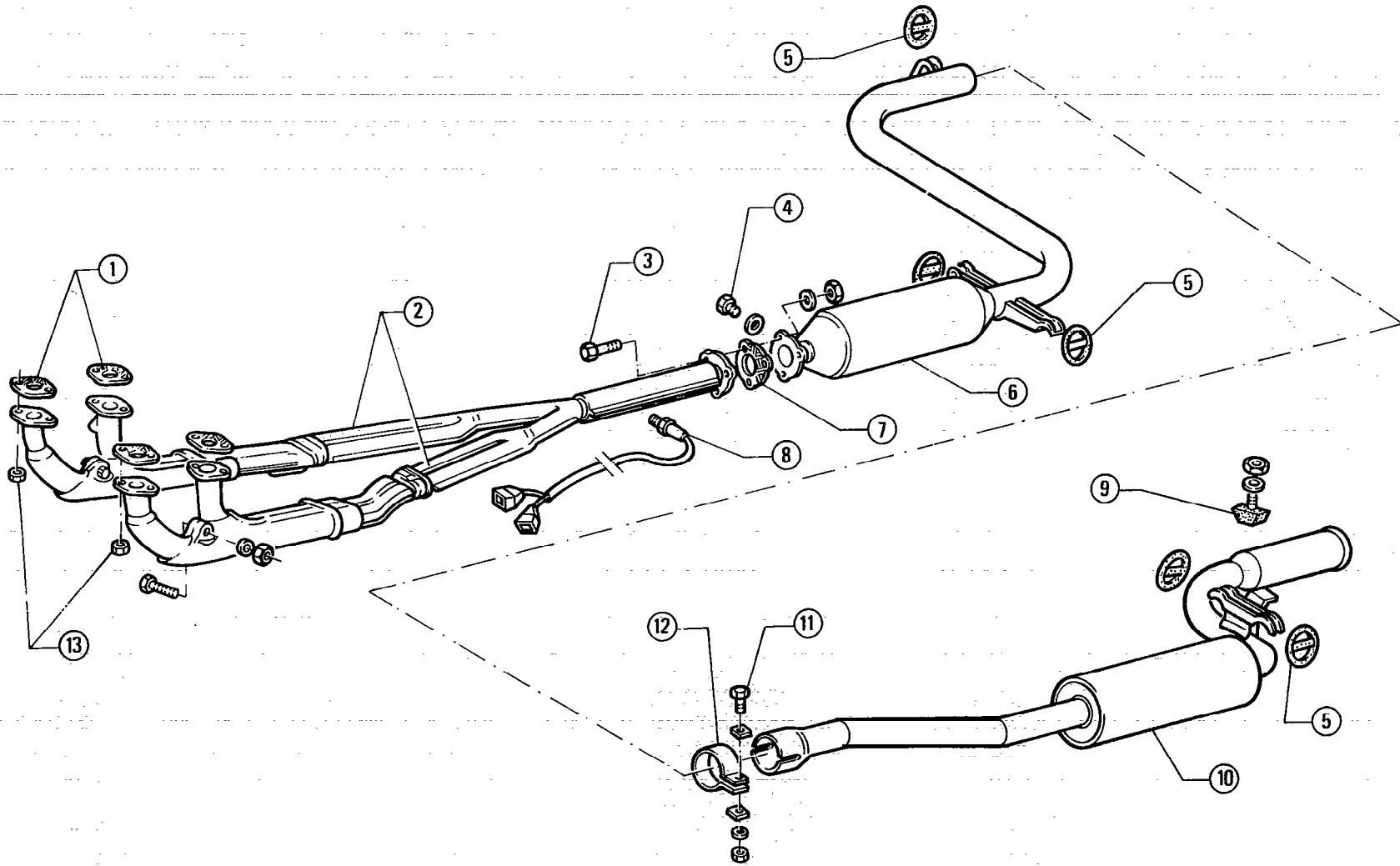

- 1 Gaskets
- 2 Front manifolds
- 3 Nut
- 4 Plug for CO% sampling upstream catalytic muffler
- 5 Support ring

- 6 Catalytic muffler
- 7 Gasket
- 8 Lambda probe
- 9 Buffer

- 10 Rear muffler
- 11 Clamp fixing bolt
- 12 Clamp
- 13 Nuts fixing manifold to heads

PRECAUTIONS TO ADOPT FOR CATALYTIC MUFFLER EQUIPPED VEHICLES

- Use only lead free petrol.
- Avoid petrol level in tank from becoming very low.
- Don't start engine with a disconnected spark plug.
- Don't overload excessively the engine for long periods of time. Be careful when towing uphill for long periods.
- Do not switch ignition off while vehicle is moving. Ignition is to be switched off with vehicle stopped.
- Do not stop or park car on or near inflammable materials (dry grass, fuel residuals, dry leaves, wastes, etc.).

CHECKS AND INSPECTIONS

1. Check mufflers and exhaust pipes making sure they are not in any way damaged or cracked and show no evidence of corrosion; contrarywise, replace them.

Catalytic muffler must be always replaced at Km interval stated in "Group 00 - Vehicle Maintenance Chart".

2. Thoroughly check support ring and do not hesitate to replace them if they are cracked, porous or worn.

3. Check buffer on exhaust pipe end.

MANIFOLDS AND MUFFLERS

Referring to the figure proceed, with removal as follows:

1. Raise car on lift.
2. Remove rear muffler as follows:
 - (1) Loosen clamp (12) connecting central element with rear one and release this one from support retaining rings.
 - (2) With a suitable hammer, lightly and repeatedly strike all around the muffler pipes connection area and then alternately turn muffler (10) clockwise and counterclockwise so as to make separation easier.

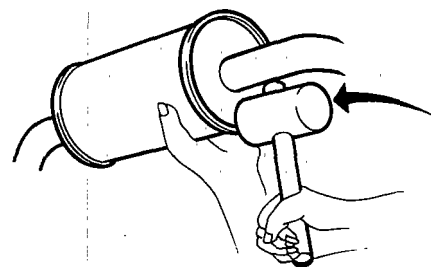

3. Remove central muffler (6) as follows:

- (1) Operating from below the engine room, disconnect connectors (1) shown on following picture and disengage plastic clamps wirings

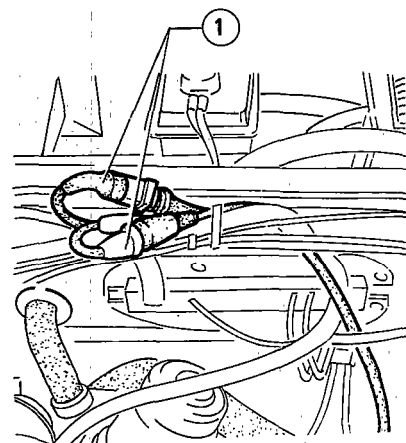

1 Lambda probe connector

REMOVAL

WARNINGS:

- Instructions hereafter described have been drawn up so as to allow separate removal of the exhaust system's single components.
- Consequently, removal procedure may be changed depending on the operation's purpose.
- When removing the entire exhaust system, it is advisable to get someone to help you with it.

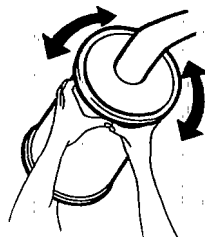

- (3) If necessary, use a plastic hammer and lightly strike the muffler in the direction of removal till rear muffler comes off the central muffler.

- (2) Remove muffler (refer to item 2. above).

FUEL SYSTEM

(3) Unscrew nuts (3) securing catalytic muffler (6) and exhaust manifold (2).

(4) Free catalytic muffler (6) support brackets from lock rings (5) and remove it.

4. Remove manifolds (2) as follows:

(1) Disconnect manifold (2) from catalytic muffler unscrewing nuts (3).

(2) Loosen nuts (13) securing manifold flanges to cylinder heads and then remove rear element (2) and gasket (1).

SUPPORT RINGS

Verify integrity of support rings and replace them if necessary.

INSTALLATION

Fit single parts back together following removal operations in reverse sequence and paying close attention to below instructions:

a. Always fit new gaskets between manifold flanges and cylinder heads, and on flange between muffler and exhaust manifold.

b. Having completed installation, check and make sure that support rings move freely and are free of undue stress; check brackets making sure they have been properly secured.

c. While engine is running check all pipe connections for gas leaks and the whole exhaust system for unusual noises.

TROUBLESHOOTING FOR CATALYTIC MUFFLER

WARNING:

High temperature of catalytic muffler could damage alumina monolith and consequently weaken the conversion efficiency. It could also damage the container and cause fire.

Integrate troubleshooting of basic manual as follows:

Troubles	Probables causes	Corrections
Overheating of catalytic muffler	<ul style="list-style-type: none"> • Scaling of one or more spark plugs • Clogged fuel filter • Very dirty air filter cartridge • Accelerator not set properly • Engine and relevant accessoires not set according to specifications • Imperfect exhaust manifold tightness • Battery voltage too-low (or faulty recharge system). <p>Catalytic muffler overheating could also be due to:</p> <ul style="list-style-type: none"> • Fuel level extremely low in tank. • Engine overloads for long periods of time, i.e.: maximum speed run, drawing of trailers, or run on long hilly roads. 	<p>Clean or replace spark plugs</p> <p>Clean or replace</p> <p>Replace</p> <p>Effect accelerator setting</p> <p>Effect accelerator timing</p> <p>Eliminate leaks</p> <p>Recharge battery (or review the system)</p> <p>Keep fuel at proper level</p> <p>Avoid engine overload</p>

SERVICE -DATA AND ~SPECIFICATIONS

For electronic injection 1.7 engines only.

TECHNICAL DATA

Fuel tank

Features	Measurement Unit,	Litres
Overall capacity		50
Reserve		6,5

CHECKS AND TIMINGS

Accelerator throttle switch calibration

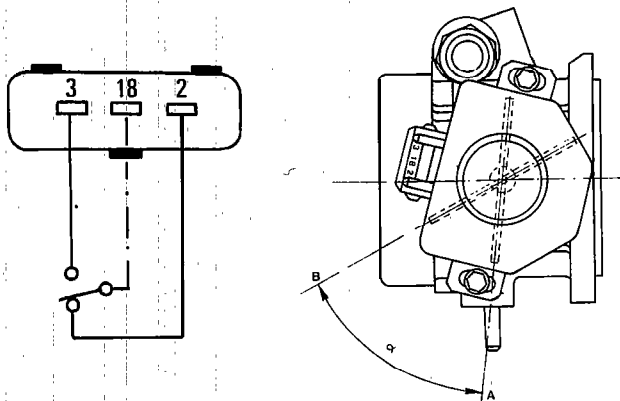

- 2 -Idle rpm terminal' (corresponding to position A: closed throttle)
- 3 - Maximum rpm terminal (corresponding to position B: open throttle)

Unit:

	Resistances	
	Terminals 2-18	Teimonials 3-18
Accelerator throttle completely closed	0	∞
Accelerator throttle open at an angle $\beta = 60^\circ \pm 4^\circ$	∞	0

Calibration accelerator throttle body (flow)

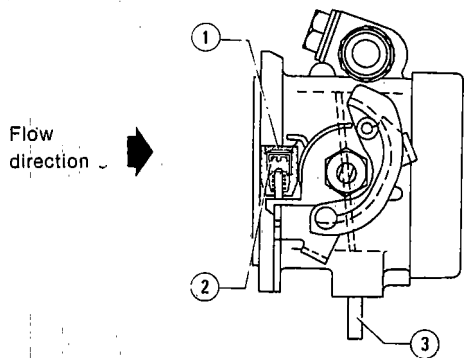

- 1 Seal
- 2 Adjustment screw
- 3 Depression intake fitting

	Reading
Air blowby with throttle disk in closed position (flowmeter Solex) (1) :	400 ± 10 N scale

(1) To detect plug depression intake fitting. Use C.2.0056 buffer with C.2.0057.

FUEL SYSTEM

Accelerator control

Clearance between throttle control and accelerator cable pawl
(with accelerator pedal at rest)

to

$$G_1 = 1 \pm 2 \text{ mm}$$

Clearance between throttle control and stroke end
(with accelerator pedal fully pressed)

to

$$G_2 = 1 \pm 2 \text{ mm}$$

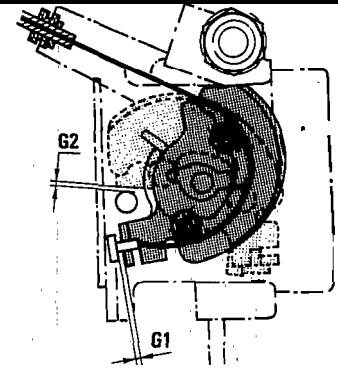

Idle rpm; emission at exhaust

Engine idle rpm (at hot engine, in neutral, clutch engaged)	rpm	950 ⁺¹⁰⁰ ₋₅₀ 850 ± 50
CC percentage at idle rpm	— total, upstream catalytic muffler with lambda probe disconnected	% in vol. ≤ 0,8 ± 0,2
	— total, at exhaust pipe outlet	% in vol. ≤ 0,2 0,8 ± 1,7
HC values at idle rpm	— total, upstream catalytic muffler	p.p.m. ≤ 500
	— total, at exhaust pipe outlet	p.p.m. ≤ 70

(*) For models without catalytic converter

Fuel supply system

Characteristics	Measurement unit	kPa (bar; kg/cm ²)
Working pressure (1)		280 ± 320 (2,8 ± 3,2; 2,9 ± 3,3)
Max. allowed pressure for system test		400 (4; 4.1)

(1) To be detected upstream the damper, with depression intake hose disconnected from pressure regulator.

GENERAL PRESCRIPTIONS

FLUIDS AND LUBRICANTS

Application	Type	Denomination	Q.ty
Accelerator pedal spindle (on support rubber)	GREASE	ISECOMolykote Longterm' n. 2 Categ. -3671-69831	—

CARBURETORS

ENGINE	Displacement	1200* - 1350		1350	
	Type	305.85 - 305.86		305.87	
CARBURETOR	ALFA ROMEO Part No.	580.981		580.852 - 580.853	580.850 - 580.851
	Model	Twin Weber 32 DIR 112/250		Twin Dellorto DRLA40FD - DRLA40FS	Twin Weber 40IDF79 - 40IDF78
	Position	1st Carb.	central	2nd Carb.	RH
Diffuser	0 mm	23	24	.28	28
Centering device	0 MM	3.5	4.5	12189.01	3,5
Main jet	0	122	130	118	125
Main air jet corrector	0	180	170	180	190
Diffuser		F 6 8	F67	9164.01	F67
Idling jet	0	50		46	48
Idling air corrector	0	175	115	220	195
Progression holes	0	120 - 100 100 - 100	120-120 120	100 - 140-140 140 - 140	100-120-130 140 - 150
Acceleration pump jet	0	50		35	33 (incl. 3°)
Needle valve	0	175		150	175
Float weight	9	11		10	11,8
Starting jet	0 mm	—		0,80	0.90
Starting diffuser		—		7482.03	F7
Acceleration pump capacity for 20 pumps		—		7 ÷ 9	6 ÷ 9
Level of float chamber	mm	7		5 ÷ 6	9 ÷ 9.5

(*) Dimensions in 10² mm
 (*) Not marketed in all countries.

TECHNICAL DATA AND SPECIFICATIONS
 FOR CARBURETOR ENGINES
 GENERAL SPECIFICATIONS

CARBURETORS

ENGINE	Displacement		1500		1700	
	Type		305.88		305.50	
CARBURETOR	ALFA ROMEO Part No.		580.778 - 580.777	580.776 - 580.775	546.860 - 546.861	546.858 - 546.859
	Model		Twin Dellorto - DRLA40FD - DRLA40FS	Twin Weber 40IDF81 - 40IDF80	Twin Dellorto DRLA40FD - DRLA40FS	Twin Weber 40IDF69 - 40IDF68
	Position		RH LH	RH LH	RH LH	RH LH
Venturi	0	mm	30	30	32	32
Centering device	0	mm	12189.01	3.5	—	—
Main jet	0	.	135	140	142	140
Main air jet corrector	0	.	205	200'	180	190
Diffuser			9164.01	F70	9164.4	
Idling jet	0	.	46	50	52	50
Idling air corrector	∅	•	220	195	220	195
Progression holes	0	.	100-140-140 140-140-140	100-120-130 140-150	100 - 140 - 140 140-140	106-120-130 140-150
Acceleration pump jet	0	.	35	33 (incl. 3°)	35	35
Needle valve	0	.	150	175	150	175
Float weight		g	10	11.8	10	11,8
Starting jet	0	mm	0,80	0,90	80	90
Starting diffuser			7482.03	F7	7482	F7
Acceleration pump capacity for 20 pumps			5 ÷ 7	6 ÷ 9	5,5 ÷ 6,5	5 ÷ 8
Level of float chamber		mm	5 ÷ 6	8.5 ÷ 9.5	20 ÷ 22	

(*) Dimensions in 10²

SPECIAL SERVICE TOOLS

[For electronic injection 1.7 engines only

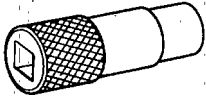
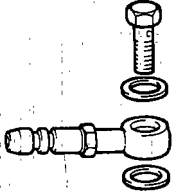
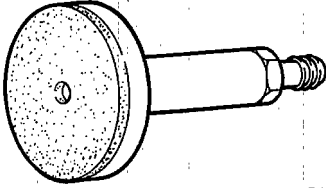
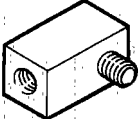
Identification Number	Denomination	Page Reference
A.5.0212	[Key for plug of exhaust gas sampling fitting of Lambda probe 	-
C.2.0051	[Fitting for exhaust gas sampling of Lambda probe 	
C.2.0056	Buffer for air flow checking to be used with C.2.0057 	04-19 04-26
C.2.0057	Fitting to be used with C.2.0056 	04-19 04-26

GROUP 05

C O N T E N T S

IGNITION	05-2	Checks and inspections	(*)
Fuel injection-ignition		Reassembly	(*)
wiring diagram	(*)	Test stand, inspection	(*)
Technical data and specifications ..	05-2	Service data and specifications	05-1 0
Distributor and ignition		Trouble diagnosis and corrections ..	(*)
advance diagrams	05-3	CHARGING	05-1 1
Check and adjustment of		Wiring diagram	(**)
ignition timing	05-8	Disassembly	(*)
Coil	05-9	Checks and inspections	(*)
Spark plugs	05-9	Reassembly	(*)
BATTERY	05-9	Test stand inspection	(*)
Service data and specifications .. ,	05-9	Service data and specifications	05-1 1
STARTER	05-1 0	Trouble diagnosis and corrections ..	(*)
Wiring diagram	(**)		
Disassembly	(*)		

05

(*) Refer to "WORKSHOP MANUAL **Alfa 33**" "VOLUME I AND VOLUME II - Group 05

(**) Refer to "WORKSHOP MANUAL **BB** models" - Group 0 5

(*) Refer to: Group 00

SERVICE DATA AND SPECIFICATIONS

TRANSISTORIZED IGNITION DISTRIBUTOR WITH NO CONTACTS AND WITH HIGH TENSION MODULE

Technical data and inspections

Engine	1200* - 1350 305.85 - 305.86	1350 1500 305.87 305.88	1700 305.50	1700 Electr. injection 305.58	1700 Electr. injection 305.58 Δ
Alfa Romeo	581.293	581.292	581.363	581.291	548.604
Type	Bosch 0.237.601	Bosch 0.237.601.021	Bosch 0.273.601 .017	Bosch B.237.540.173	Bosch 0.237.601.014
Firing order	1 - 3 - 2 - 4				
Pulse Generator Coil Resistance Ω	1100 \pm 10%				
Internal resistance of distributor rotor arm Ω	1 0 0 0				
Air gap mm (in)	-				

(A) For countries where antipollution regulations are in force.~

Not marketed in all countries.

IGNITION, STARTING, CHARGING SYSTEM

DISTRIBUTOR ADVANCE CURVES

ENGINES

1200 - 305.85

1350 - 305.86

Automatic advance curve

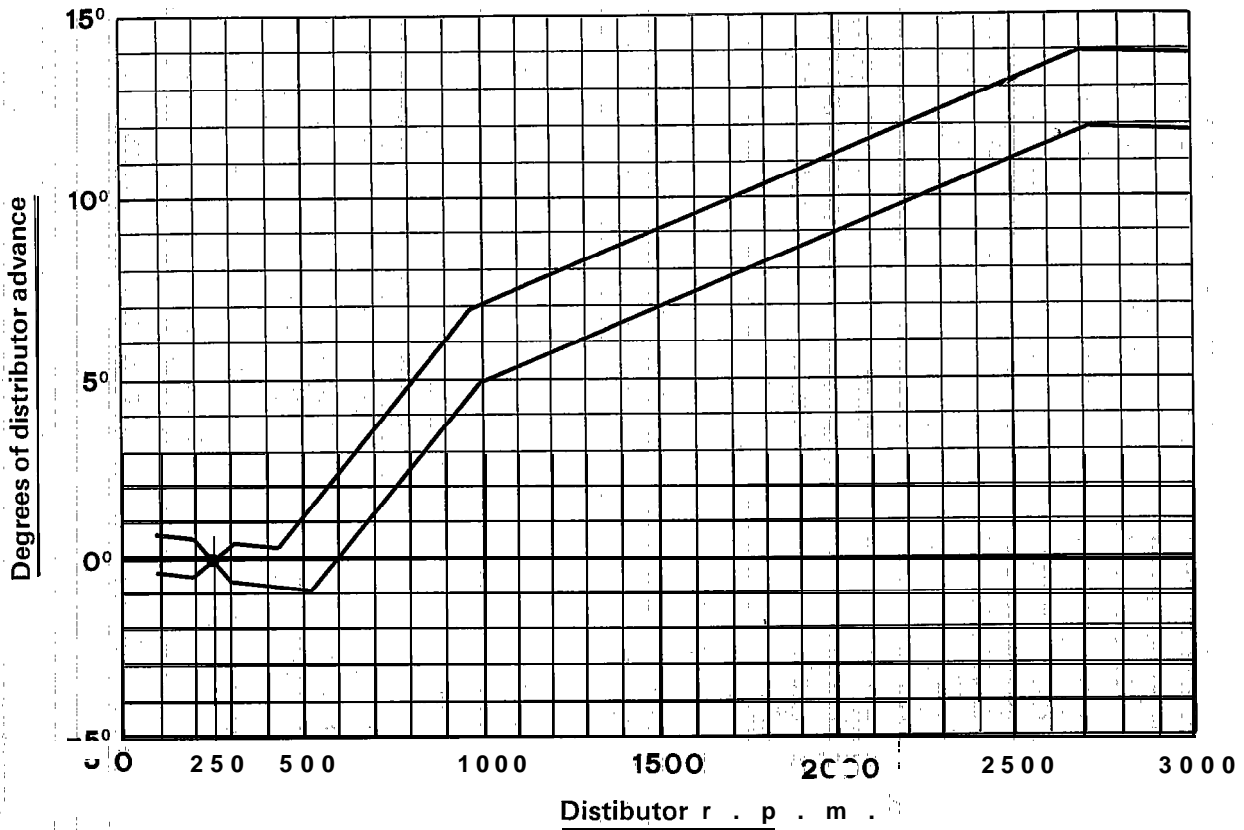

Vacuum pressure corrector curve

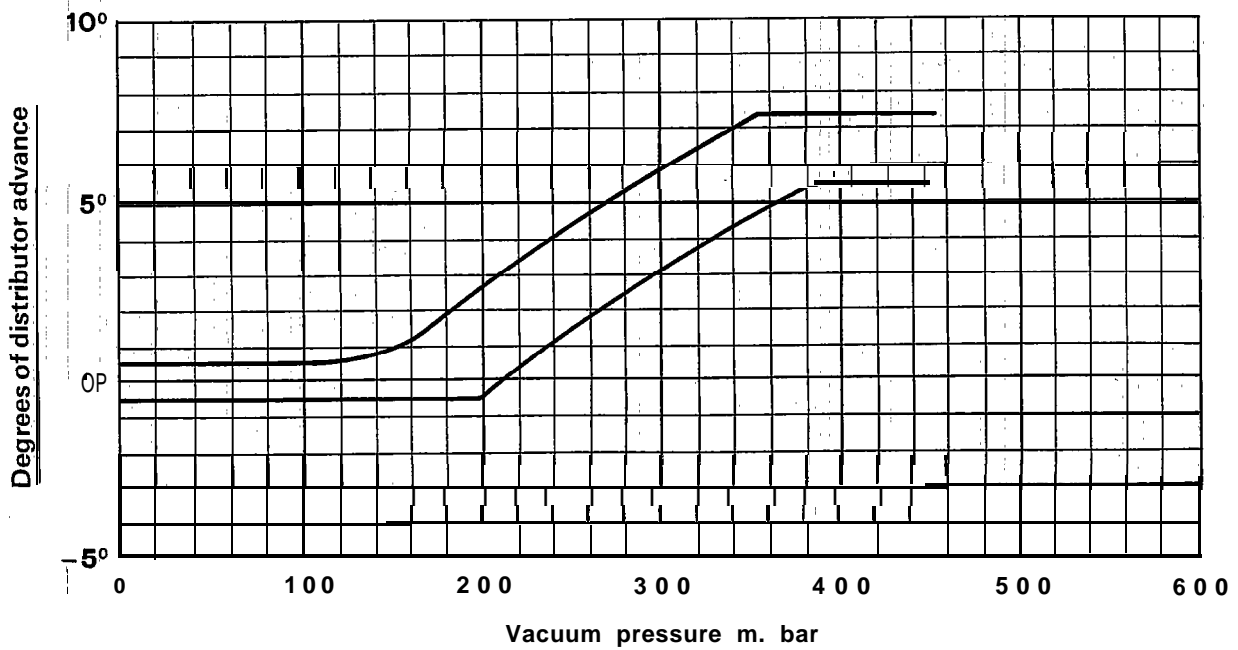

IGNITION, STARTING, CHARGING SYSTEM

DISTRIBUTOR ADVANCE CURVES

ENGINES
1350 - 305.87
1350 - 305.88

Automatic advance curve

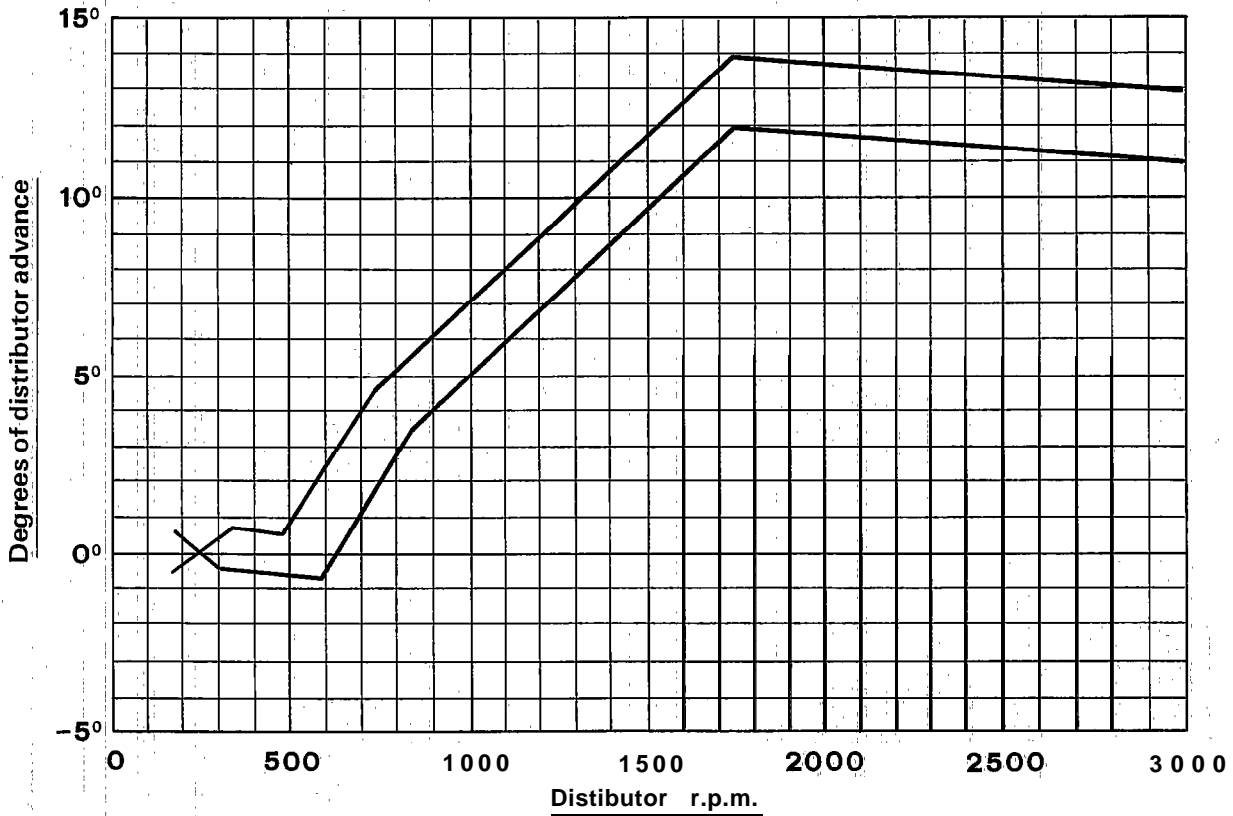

Vacuum pressure corrector curve

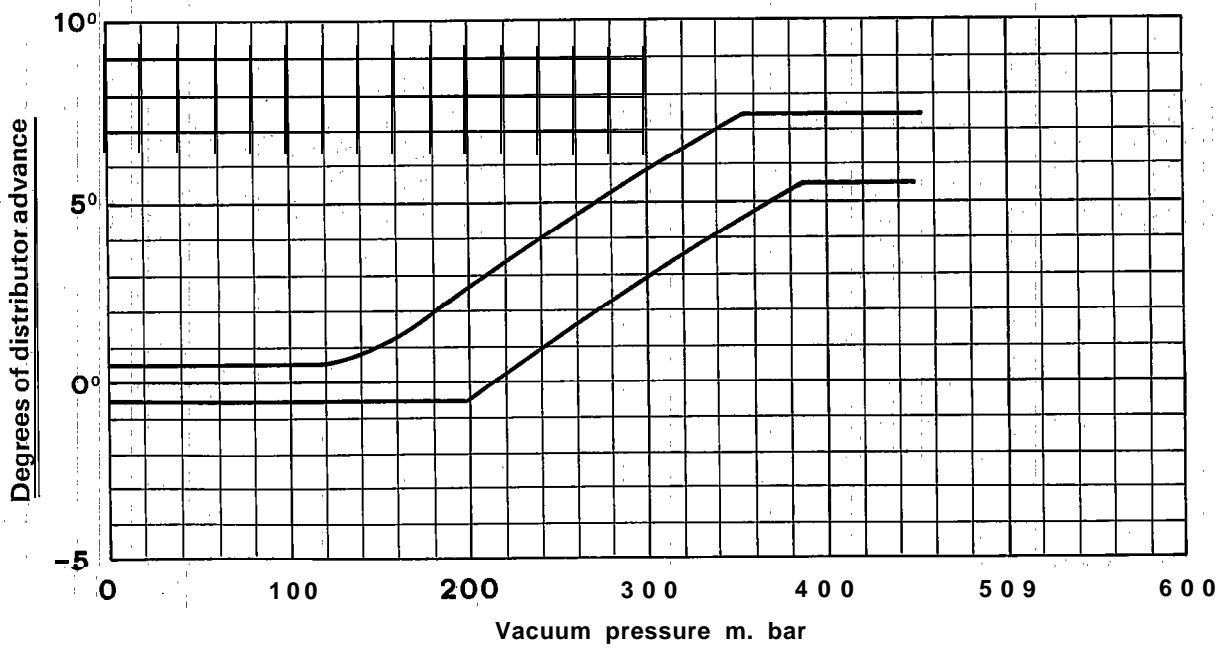

IGNITION, STARTING, CHARGING SYSTEM

DISTRIBUTOR ADVANCE CURVES

ENGINE
1700 - 305.50

Automatic advance curve

Distributor r.p.m.

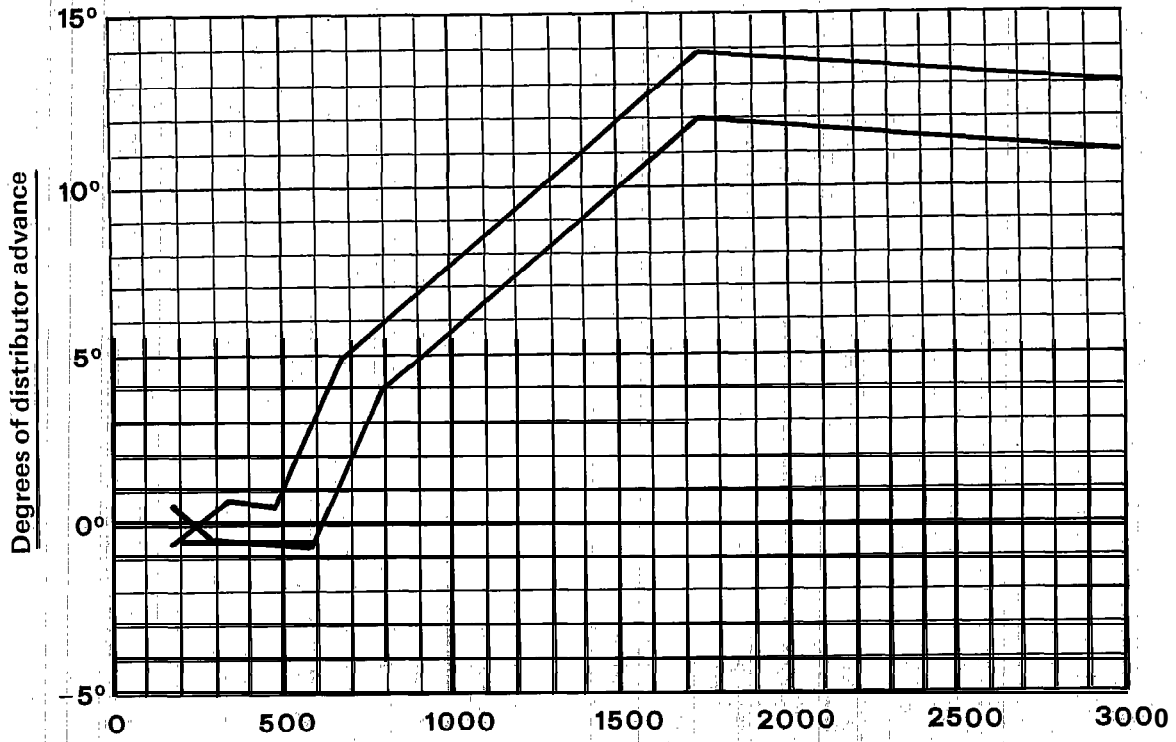

Vacuum pressure corrector curve

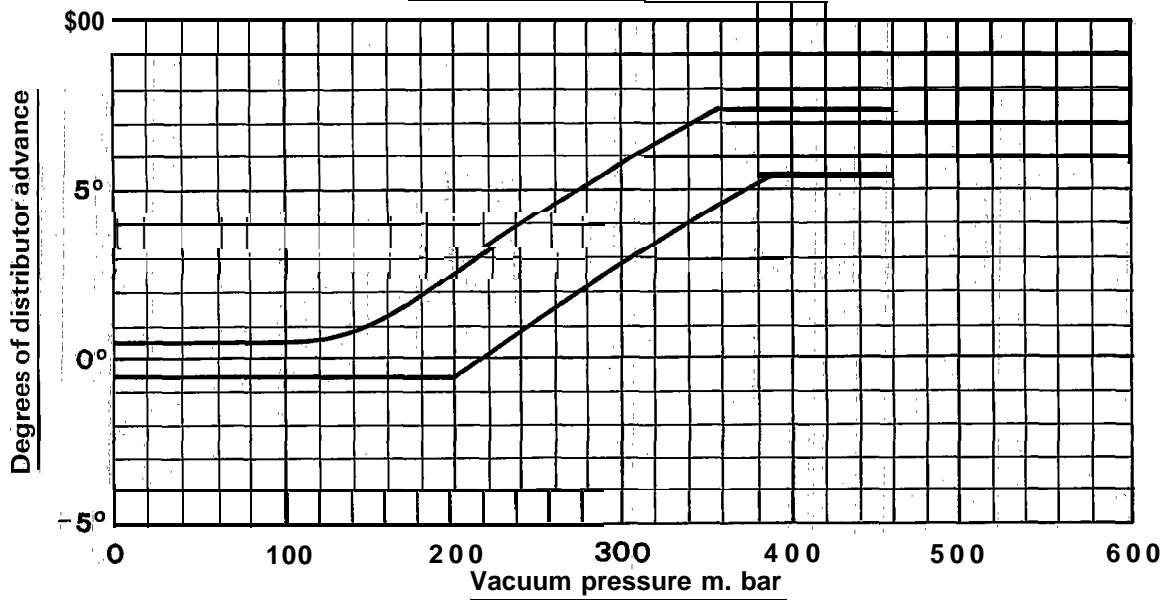

IGNITION, STARTING, CHARGING SYSTEM

DISTRIBUTOR ADVANCE CURVES

ENGINE
1700 - 305.58

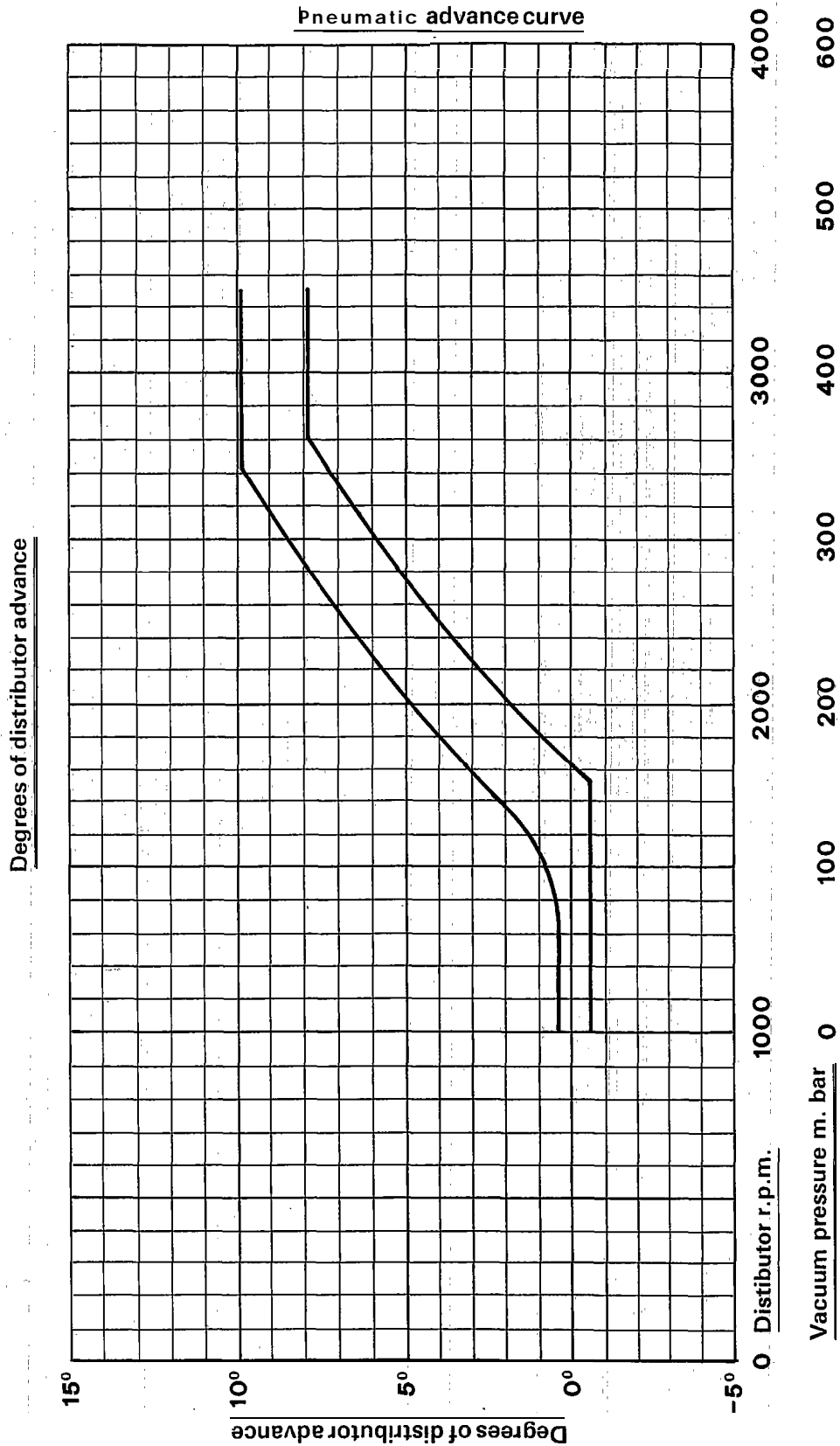

DISTRIBUTOR ADVANCE CURVES

ENGINE
1700 - 305.58

FOR COUNTRIES WHERE ANTIPOLLUTION REGULATION ARE IN FORCE

Automatic advance curve

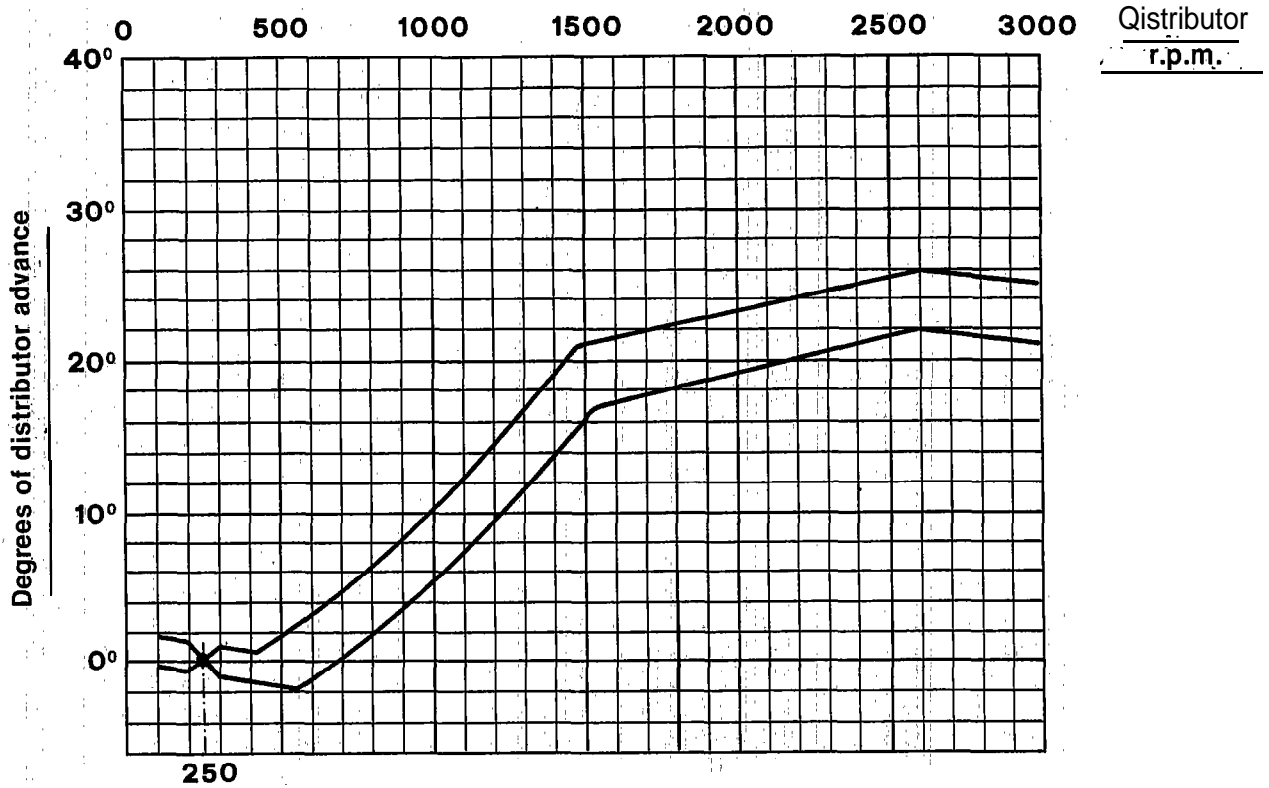

Vacuum pressure corrector curve

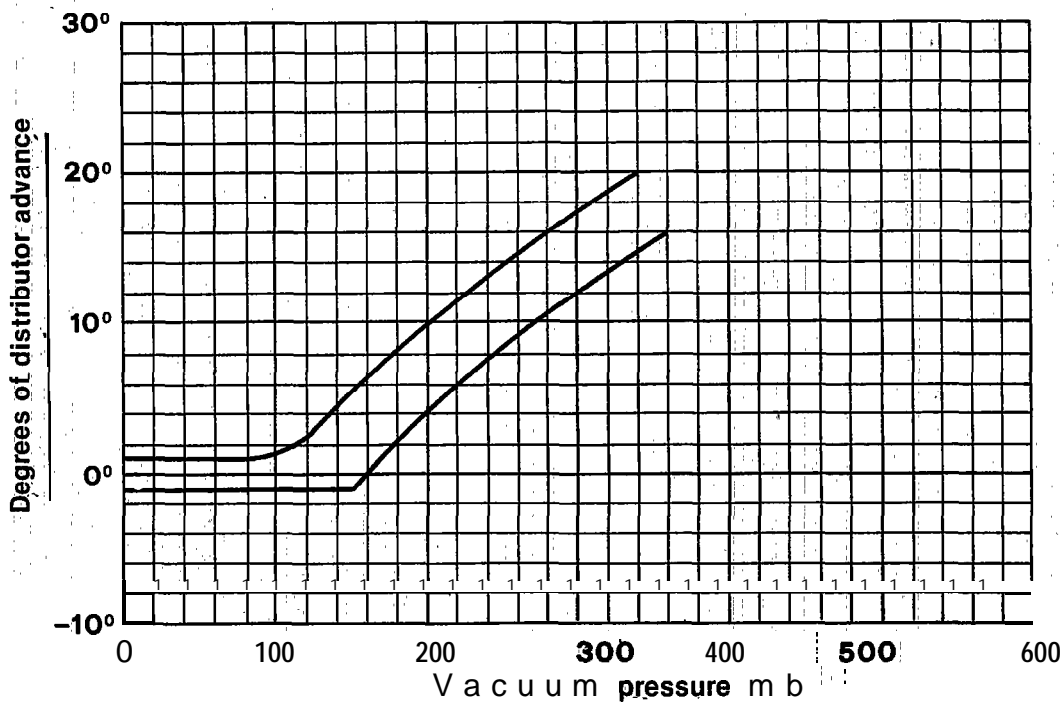

CHECKING AND ADJUSTING THE IGNITION TIMING

WARNING:

A very accurate check of the timing at idle speed has to be performed very carefully, since incorrect timing at idle greatly affects exhaust emission level which would not remain within the specified values.

For engines with carburetors, the procedure described in the paragraph "Check of Fixed and Maximum Advance" in the manual are to be followed taking into account the new technical data given in the table.

For the electronic injection 1.7 engine with catalytic convertor, the following procedure is to be followed:

1. Connect the supply terminal of stroboscopic gun to battery and the pickup to high voltage cable of cylinder No. 1.
2. Connect an electronic rev-counter to the engine inserting the terminals on the coil power supply and the pickup on the high tension lead of the coil.
3. Remove the plastic plug on engine rear cover.
4. Start the engine, warm it up to, operating temperature.

Oil Temperature:
75 thru 80°C

5. Disconnect the vacuum advance hose from distributor; with the stroboscopic gun check that at idling rpm:

950 + 100
- 50 r.p.m.

the marker on rear cover is aligned with notch I on flywheel of the engine.

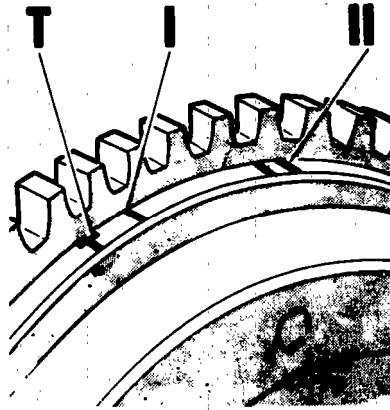

- T T.D.C. of cylinder No. 1.
- I Ignition advance at idle engine speed.
- II Advance at 5250 rpm.

Advance (With vacuum correcting hose disconnected)
8° ± before T.D.C.

8. If specified alignment does not occur, proceed to adjust timing operation as follows:
 - (1) Unscrew the securing nut on the distributor.
 - (2) Rotate the distributor body counterclockwise to advance, or clockwise to retard the ignition setting.
 - (3) Retighten the distributor securing nut.
 - (4) Check that timing is within specified values.

7. Reconnect the vacuum advance hose to the distributor.

8. Using the stroboscopic gun, check also that at engine rpm of

5250 r.p.m.

the marker of engine rear cover is aligned with notch II on engine flywheel.

9. Remount the plastic plug on engine rear cover.

For the electronic injection 1.7 engine without catalytic convertor, the following procedure is to be followed:

1. Disconnect the minimum and maximum accelerator throttle opening switch connector and short-circuit the three wiring side plus.
2. Disconnect vacuum pressure hose from ignition distributor.
3. Check with stroboscopic gun that the advance value is 8°. If this is not the case, rotate the distributor.

N O T E :

Connecting to ground those plus relative to the minimum and maximum accelerator throttle opening switch, the ou controls the coil power unit so as to obtain a fixed ignition advance value at 8° independently at engine r.p.m.

Engines	1200 - 305. 85 1350- 305. 86	1350-305. 87 1500 - 305. 88 1700 - 305.50	1700-305. 58 A	1700- 305. 58
Timing (1)				
Fixed advance	8° ± 1° at 900 rpm	8° ± 1° at 900 rpm	8° ± 1° at 900 thru 1050 rpm	8° (2)
Maximum advance	34° (3) at 5500 rpm	34° at 4500 rpm	32° at 5250 rpm	—

- (1) The timing values are to be measured with the vacuum advance hose disconnected
- (2) The value is measured independently of the engine speed
- (A) For countries where antipollution regulations are in force
- (3) For an additional check, check for 30° at 4500 r.p.m.

IGNITION, STARTING, CHARGING SYSTEM

IGNITION COIL (BREAKERLESS IGNITION) Electrical data and checks

ENGINE	1200-305.85 1350-305.86/87 1500-305.88	1700-305.50 1700-305.58 Δ	1700-305.58
Alfa Romeo Class	547.811		542.162
Type	B O S C H 0.221 .122.323		BOSCH 0.221.600.002
Primary winding voltage	V	12	
Primary winding resistance	R1 (20%)	Ω	0.7 thru 1
Primary winding resistance	R2 (20°C)	Ω	6700 thru 9600

(Δ) For countries where antipollution regulations are in force.

SPARK PLUGS

Alfa Romeo class	580.020
Type	LODGE 25 HL

BATTERY

SERVICE DATA AND SPECIFICATIONS

As per **Alfa 33** except for the data given below

Battery	Engine	1200-305.85 1700-305.50	1350-305.86/87 1700-305.58	1 1700-305.58 Δ	500-305.88	1800-VM82A
	Voltage	V 12				
Capacity	Ah	50 - 55 (1)				70
Discharge current	A	225 - 255 (1)				—

(Δ) For countries where antipollution regulations are in force.

(1) Only for engines mounted on 4x4 models and for models marketed in Sweden.

May 1988

SERVICE DATA AND SPECIFICATIONS

Starter Motor

ENGINE		1200-305.85 1500-305.88	1350-305.86/87 1700-305.50	1700-305.58Δ 1700-305.58	1800-VM82A	
Item	Alfa Romeo class	533.051	533.052	536.611	547.199	195.27.05.030.00
	Type	BOSCH EF 12 V - 0.8 kW 00012 11215	DUCELLIER 6246/C	MARELLI E95 - 0.9 kW 1 2 v	BOSCH EF(R) 12 V - 0.85 kW 0001208 266	BOSCH EV - 12 V - 2.2 kW
Voltage	V	12	-12	12	12	1 2
On load test (pinion meshed with crown wheel with torque dynamometer)	V	10	10	9.8	—	8
— Voltage	A	≲ 230	≲ 200	215	—	≲ 680
— Absorbed current	rpm	≳ 1450	≳ 1450	1800	—	≳ 1200
— Speed	N - m	5	5	5	—	19
— Torque	(kg.m)	(0.5)	(0.5)	(0.5)	—	(1.9)
Across-line test (pinion meshed with locked crown wheel)	V	8	8	8	—	4
— Voltage	A	≲ 400	≲ 380	400	—	≲ 1300
— Absorbed current	N . m	≳ 10.5	≳ 11	12	—	a 3 7
— Torque	(ft-lb) (kg.m)	(≳ 1)	(≳ 1.1)	(1.2)	—	(≳ 3.8)
Overrunning torque	N-cm (dl - ni) (kg.cm)	13 thru 22 1.3 thru 2.2	11 thru 17 1.1 thru 1.7	15 ± 3 (1.5 ± 0.3)	—	14 ± 22 1.4 thru 2.2
EM switch on starter motor						
— Max absorption current at rated voltage	A	a 40	≲ 40	55	—	—
— Min pick-up voltage	V	8	≲ 8	7	—	≲ 7.8
Pinion module		2.1167	2.116	2.116	—	2.1167

05-10

PA333500883300

IGNITION, STARTING, CHARGING SYSTEM

CHARGING

SERVICE DATA AND SPECIFICATIONS

ENGINE		1200-305.85 1350-305.86/7 1500-305.88 1700-305.50	1700-305.58Δ 1700-305.58	1800-VM82A
Alternator	Alfa Romeo Part No.	547.949	549.399	547.565
	Type	BOSCH 0.120.489.480	BOSCH K1 (R)14V-23/65A 0.120.488.118/119	K1-14V-23/65A
Nominal Voltage	V	—	14	—
Volt & range	V	—	—	—
Current output	Max current output	A	55	65
	Output starts	rpm	1000 (1)	—
	2/3 max output	rpm	1500 (1)	—
	Max output	rpm	6000 (1)	—
Brushwear limit	mm (in)	—	—	5
Rotor winding resistance	Ω	—	—	4 ± 0.1
Voltage regulator resistance	Ω	—	—	—
Diode resistance	Ω	—	—	0 thru 10

(1) Values read with engine at normal running temperature, at 25°C (77°F), at nominal voltage force.
For countries where antipollution regulations are in force.

FLUIDS AND LUBRICANTS }
TIGHTENING TORQUES }

As per **Alfa 33**

ENGINE COOLING SYSTEM

GROUP 07

CONTENTS

COOLING SYSTEM	(*)	HEADERTANK PRESSURIZED PLUG	0(*)
WATER PUMP	(*)	SERVICE DATA AND	
THERMOSTAT	07-2	SPECIFICATIONS	07-3
Removal and reassembly	07-2	Technical data	(*)
Checks and inspections	07-2	Inspections and adjustments	(*)
RADIATOR	(*)	General specification	07-3
COOLANT TEMPERATURE		Tightening torques	07-3
SENSOR (FOR IGNITION CU)	07-2	TROUBLE DIAGNOSIS AND	
Removal and installation	07-2	CORRECTIONS	(*)
ELECTRIC FAN CONTROL THERMAL			
CONTACT	(*)		

(*) See: "WORKSHOP MANUAL **Alfa 33**" VOLUME 1 - Group 07

THERMOSTAT

REMOVAL AND INSTALLATION

1. Drain coolant of cooling system into a suitable container.
2. Disconnect hose ① from thermostat ②.
3. Unscrew screw fixing thermostat to engine block.
4. Disconnect tubes ②, ③, ④, and ⑤ from thermostat, then remove it.
5. Proceed to installation by operating in reverse order of removal, then fill system with specified coolant.
6. Start engines for few minutes and check that no coolant leaks occur.

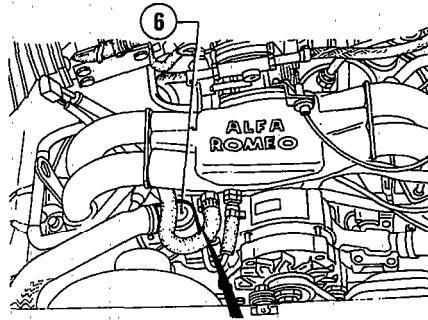

- 1 Coolant delivery hose to radiator
- 2 Tube connecting thermostat-RH. manifold
- 3 Tube supplying coolant to radiator
- 4 Tube connecting thermostat-L.H. manifold
- 5 Tube connecting thermostat to filler tube
- 6 Thermostat

CHECKS AND INSPECTIONS

Using suitable tools, check that initial thermostat opening occurs at a fluid temperature of:
64 thru 88°C
Otherwise replace thermostat.

COOLANT TEMPERATURE SENSOR (FOR INJECTION CU)

For electronic injection 1.7 engines only

REMOVAL AND INSTALLATION

1. Drain coolant of cooling system into a suitable container.
2. Disconnect sleeve ① from thermostat ②.
3. Disconnect connector ③.
4. unscrew sensor ④ and remove it from the R.H. feed manifold.

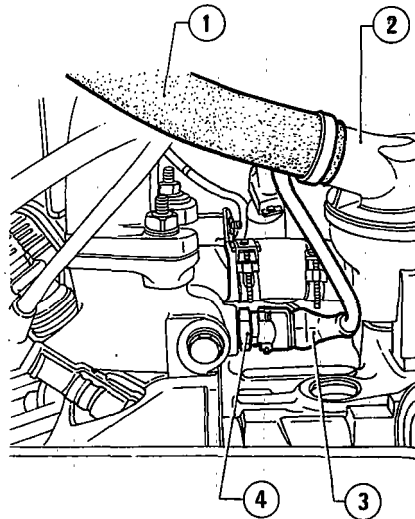

- 1 Coolant delivery hose to radiator
- 2 Thermostat
- 3 Connector
- 4 Coolant sensor (for injection CU)

5. Proceed to installation by operating in reverse order to removal, tightening sensor to a torque of not more than: 15 N.m (1.5 kg.m)
6. Refill system with specified coolant.

SERVICE DATA AND SPECIFICATIONS

GENERAL DATA

As per **Alfa 33** except for:

Min. external temperature	°C °F	-15 (+5)	-20 (-4)	-35 (-31)
Antifreeze cat. 3681-69956 (Imp. gall.)	l	2.2 (0.48)	2.6 (0.57)	3.65 (0.80)
F r e s h water (Imp. gall.)	l	5.1 (1.12)	4.7 (1.03)	3.65 (0.80)
Antifreeze ready for use cat. 3681-69958 (Imp. gall.)	l	—	7.3 (1.60)	—

CAUTION:
Product harmful to paint.
Avoid contact with painted parts.

TIGHTENING TORQUES

Item	Unit of measurement	N·m	Kg·m
Electric fan control thermal contact on radiator		29 thru 34	3 thru 3.5
Cooling temperature transmitter on feed manifold		33 thru 41	3.4 thru 4.2
Water pump securing screws		19 thru 24	1.9 thru 2.4
Coolant level sensor for injection CU (max. torque)		15	1.5

GROUP 13

C O N T E N T S

5 - SPEED MANUAL GEARBOX	(*)	General specifications	(*)
GEARBOX OUTER LINKAGE	13-2	Inspection and adjustment	(*)
SERVICE DATA AND SPECIFICATIONS	13-3	Tightening torques	(*)
Technical data	13-3	TRUBLE DIAGNOSIS AND CORRECTIONS	(*)
		SPECIAL SERVICE TOOLS	(*)

(*) Refer to "WORKSHOP MANUAL **Alfa 33**" VOLUME I and VOLUME II - Group 13.

GEARBOX OUTER LINKAGE

As per **Alfa 33** Volumes I and II except for the following procedures.

REAR WHEEL DRIVE SE LEGTOR

4 x 4 version

Disassembly

Place the gearbox - differential - propeller shaft group on a stand fitted with suitable support brackets, and proceed to dismantle the rear wheel drive selector in the following way.

1 Remove the retainer. split pin (2) of the stud (3) connecting the rear wheel drive selector bar (1) and the corresponding rod. Remove the stud.

The split pin must not be reused.

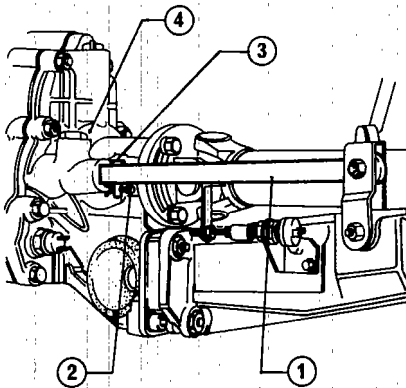

- 1 Rear wheel drive selector bar
- 2 Split pin
- 3 Stud
- 4 Rear cover

2. Unscrew bolt (2) connecting rear wheel drive selector lever (5) and lever support (1).

Remove lever and if necessary the silentblock (7) from lever support.

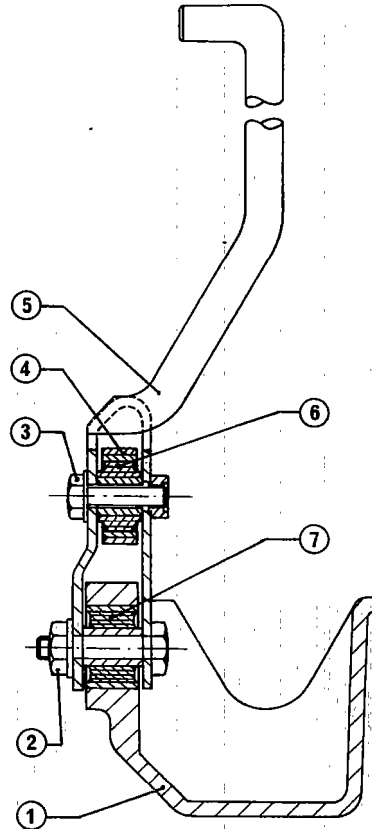

- 1 Lever support
- 2 Bolt
- 3 Screw
- 4 Rear wheel drive selector bar
- 5 Rear wheel drive selector lever
- 6 Silentblock
- 7 Silentblock

3. Loosen screw (3) connecting rear wheel drive selector lever (5) and corresponding bar (4).

If necessary remove the silentblock (6) from the bar.

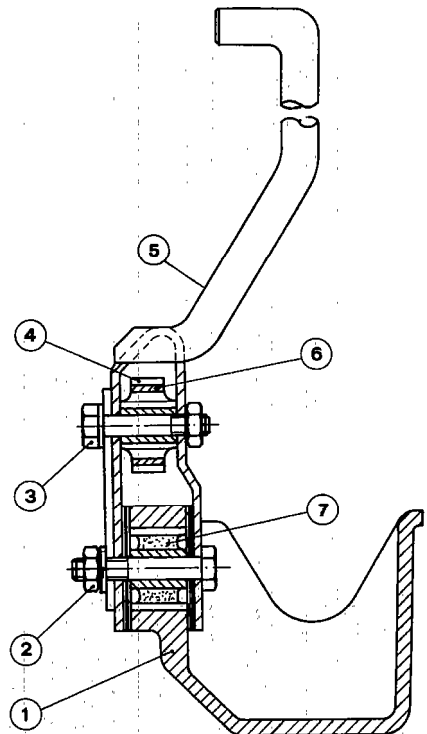

Inspections and checks

Check that the silentblocks situated on linkage articulated joints are in **good** condition; replace them if necessary.

Assembly

Go on assembling rear drive selector following disassembly procedure in reverse sequence.

SERVICE DATA AND SPECIFICATIONS

GEARBOX

TECHNICAL DATA

Characteristics:		Models		33 *		33 1.3		33 1.7 *		33 1.5 TI 33 1.5 4x4 33 1.7 IE 33 1.7 * Δ		33 1.8 TD	
		Crown gear and pinion ratio											
Speed selector lever positions	Gear	Gearbox ratio	9/35		9/37		10/37		9/35		11/35		
			Overall ratio	Speed at 1000 r.p.m	Overall ratio	Speed at 1000 r.p.m	Overall ratio	Speed at 1000 r.p.m	Overall ratio	Speed at 1000 r.p.m	Overall ratio	Speed at 1000 r.p.m	
			1st	1:3,143			1:12,921	8,010	1:11,629	9,081	1: 12,220	8,641	
2nd	1:1,864			1: 7,663	13,506	1:6,897	15,311	1: 7,247	14,571				
3rd	1:1,323			1: 5,439	19,029	1:4,895	21,573	1:5,144	20,529				
4th	1:1,027	-		1:4,222	24,514	1:3,800	27,790	1:3,993	26,446				
5th	1:0,854			1:3,511	29,479	1:3,160	33,418	1:3,320	31,807				
R.G.	1: 2,091			1: 12,707	8,145	1:11,437	9,233	1:12,018	8,787				
1st	1:3,750	1:14.58	7.099							1:11,932	8,850		
2nd	1:2,050	1:7.97	12.986							1:6,523	16,189		
3rd	1:1,387	1: 5.393	19.191							1:4,413	23,930		
4th	1:1,027	1:3.993	25.920							1:3,268	32,313		
5th	1:0,825	1:3.208	32.263							1:2,625	40,228		
R.G.	1:3,091	1:12.018	8.612							1:9,835	10,737		

(A) Electronic injection engine
 (*) Not marketed in all countries with 1.2 engine

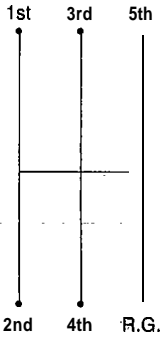

TECHNICAL DATA

Features		Model		Sport Wagon	Sport Wagon	Sport Wagon	Sport Wagon	Sport Wagon			
		33 1.3 S		33 1.7 B	33 1.5 4x4	33 1.7 B Δ	33 1.7 4x4 Δ	33 1.8 TD			
Speed selector lever position	Gear	Gearbox ratio	Crown gear and pinion ratio								
			9/37		10/37		[9/35 (1)]		11/35		
			Gearbox differential overall ratio	Speed at 1,000 r.p.m. Km/h	Gearbox differential overall ratio	Speed at 1,000 r.p.m. Km/h	Gearbox differential overall ratio	Speed at r.p.m. Km/h	Gearbox differential overall ratio	Speed at r.p.m. Km/h	
	1 st	1 : 3,143	1 : 12,921	6,010	1 : 11,629	9,081	1 : 12,220	8,641	1 : 12,220	8,641	
	2 nd	1 : 1,864	1 : 7,663	13,506	1 : 6,897	15,311	1 : 7,247	14,571	1 : 7,247	14,571	
	3 rd	1 : 1,323	1 : 5,439	19,029	1 : 4,895	21,573	1 : 5,144	20,529	1 : 5,144	20,529	
	4 th	1 : 1,027	1 : 4,222	24,514	1 : 3,800	27,790	1 : 3,993	26,446	1 : 3,993	26,446	
	5 th	1 : 0,854	1 : 3,551	29,479	1 : 3,160	33,418	1 : 3,320	31,807	1 : 3,320	31,807	
	R.G.	1 : 3,091	1 : 12,707	6,145	1 : 11,437	9,233	1 : 12,018	8,787	1 : 12,018	8,787	
							Crown gear and pinion ratio				
							9/37				
	1 st	1 : 3,750					1 : 15,416	6,850			1 : 11,932 8,850
	2 nd	1 : 2,050					1 : 8,427	12,531			1 : 6,523 16,189
	3 rd	1 : 1,387					1 : 5,702	18,520			1 : 4,413 23,930
	4 th	1 : 1,027					1 : 4,222	25,012			1 : 3,268 32,313
	5 th	1 : 0,825					1 : 3,391	31,141			1 : 2,625 40,228
	R.G.	1 : 3,091					1 : 12,707	8,310			1 : 9,835 10,737

(A) With electronic injection engine for countries where antipollution regulations are in force.

(1) Post modification, from chassis.

SERVICE DATA AND SPECIFICATIONS

GEARBOX

GEARBOX

GENERAL SPECIFICATIONS

FLUIDS AND LUBRICANTS

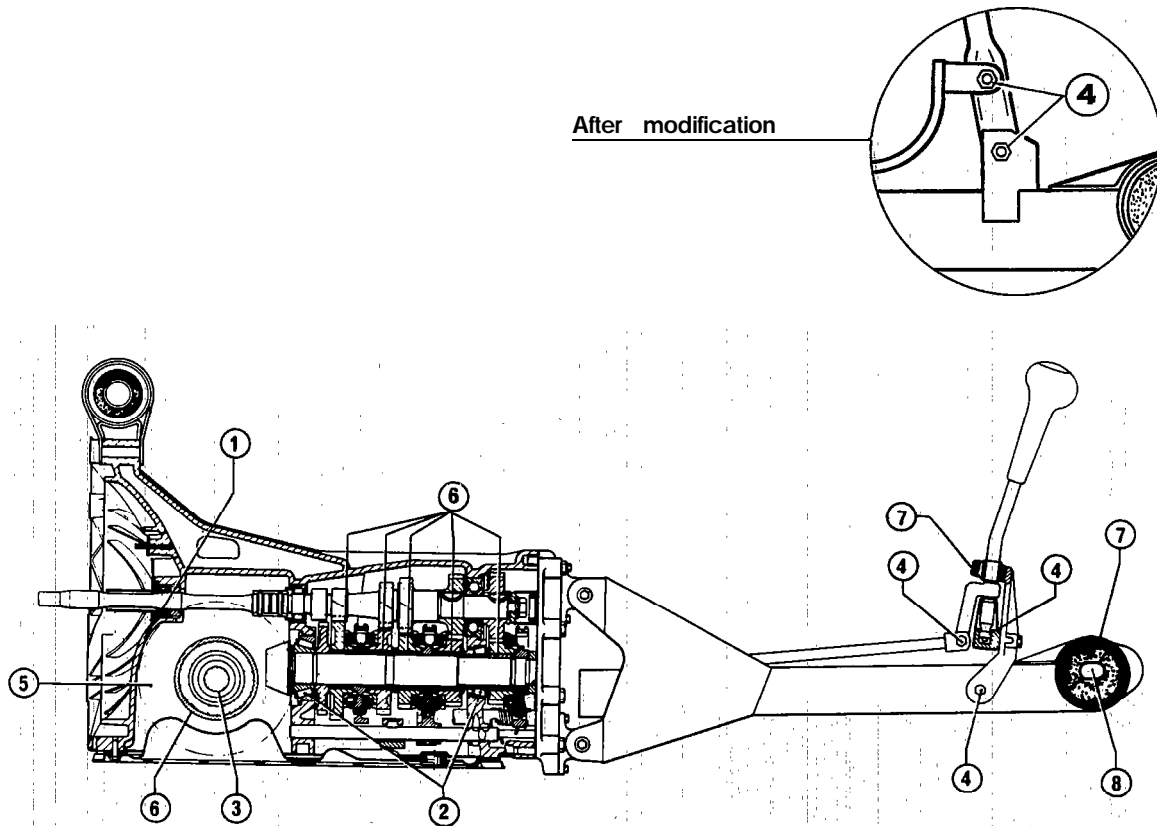

App. no.	Application	Type	Name	Q.ty
	Inner surface of: - Seal ring of main selector rod - Seal ring of primary shaft - Seal ring of differential shaft - Seal lip and work seat on shaft Outer surface of: - Seal rings	GREASE OIL	ISECO Molykote BR2 Std. No. 3671-69841 See item 5	-
	Outer races of differential casing and pinion taper roller bearings	GREASE	AGIP: F1 Grease 33 FD Std. No. 3671-69833	-
	Mating surfaces of: - Ring nut securing bearing to differential sha	OIL	See item 5	-

FRONT SUSPENSION

GROUP 21

CONTENTS

DESCRIPTION	(*)	General specifications	(*)
FRONT WHEEL HUB	(*)	Inspection and adjustment	21-2
FRONT SUSPENSION	(*)	Tightening torques	(*)
SERVICE DATA AND SPECIFICATIONS	21-2	TROUBLE DIAGNOSIS AND CORRECTIONS	(*)
! Technical data	21-2	SPECIAL SERVICE TOOLS	(*)

Refer to Group 00 - Chassis and Body Maintenance
for:

- Checking Suspension Height
- Wheel Alignment

(*) Refer to: "WORKSHOP MANUAL **Alfa 33**"
VOLUME I and VOLUME II - Group 21

FRONT SUSPENSION

SERVICE DATA AND SPECIFICATIONS

TECHNICAL DATA

COIL SPRING, SHOCK ABSORBER AND ANTI-ROLL BAR

Features	Model	Sport Wagon			
	Versions	33 1.3 S	33 1.7 Ⓟ 33 1.7 Ⓟ Δ	33 1.6 4x4 33 1.7 4x4 Δ	33 1.8 TD
Coil spring	Alfa Romeo Part No.	131883 Ⓢ			133018
	Wire diameter mm (in)	13.2 (0.520)			13.6 (0.53)
	Coil diameter mm (in)	160 (6.299)			
	Free length mm (in)	310 (12.205)			333 (13.11)
	Stiffness N/mm (kg/mm) (lb/in)	21.6 (2.2) (123.2)			24.5 (2.5)
Shock absorber	Type	SPICA			
		BOGE			
		HYDRAULIC			
	Piston rod diameter mm (in)	20 (0.787)			
Stroke mm (in)	196 (7.716) (1) 187 (7.36) (2)			185 (7.283)	
Anti-roll bar	Alfa Romeo Part No.	-		131835	
	Diameter mm (in)	18			

(1) For shock absorber SPICA only

(2) For shock absorber BOGE only

INSPECTION AND ADJUSTMENT

DATA OF SHOCK ABSORBER SETTING

Features	Model	Sport Wagon								
	Versions	33 1.3 S 33 1.7 Ⓟ 33 1.7 Ⓟ Δ				33 1.6 4x4 33 1.7 4x4 Δ				33 1.8 TD
SHOCK ABSORBER		LH	RH	LH	RH	LH	RH	LH	RH	
TYPE		SPICA		BOGE		SPICA		BOGE		
Alfa Romeo part number		548190	548191	549123	549122	549301	549300	581041	581047	
Low speed	Compression N (kg)	260±40 (26,5±4)		156,9±40 (1614)		255±40 (26,5±4)		260±50 (25,5±5)		
	Expansion N (kg)	510±40 (52±4)		392,3±40 (40±4)		510±40 (52±4)		490 ⁺¹⁰⁰ ₋₈₀ (49,9 ^{+10,2} _{-8,1})		
High speed	Compression N (kg)	490±40 (49,9±4)		529,5±40 (54±4)		491±40 (50±4)		490±50 (49,9±5)		
	Expansion N (kg)	1280±40 (130,5±4)		1421,9±40 (145±4)		1275±40 (130±4)		1650±150 (168,2±15,3)		

(A) With electronic injection engine for countries where antipollution regulations are in force.

NOTE: The shock absorbers are integrated in their strut tubes.

R E A R SUSPENSION

INSPECTION AND ADJUSTMENT

DATA OF SHOCK ABSORBER SETTING

Features		Versions	33 * *		33 1.5 TI		33 1.8 TD	
			33 1.3		33 1.5 a x a			
			33 1.3 S		33 1.7 *			
			33 1.7 IE		33 1.7 * A			
			33 1.7 IE Δ					
SHOCK ABSORBER			LH	RH	LH	RH	LH	RH
Type			BOGE		BOGE		BOGE	
Alfa Romeo part number			581045	581044	549123	549122	581046	581047
Low speed	Compression	N (kg)	150^{+40}_{-30} (15,3 ⁺⁴ ₋₃)		157 ± 40 (16 ± 4)		250 ± 50 (25,5 ± 5)	
	Expansion	N (kg)	330^{+80}_{-60} (33,6 ⁺⁸ ₋₆)		392 ± 40 (40 ± 4)		490^{+100}_{-80} (49,9 ⁺¹⁰ ₋₈)	
High speed	Compression	N (kg)	460 ± 60 (46,9 ± 6,1)		530 ± 40 (54 ± 4)		490 ± 50 (49,9 ± 5)	
	Expansion	N (kg)	1480 ± 130 (150,9 ± 13,2)		1422 ± 40 (145 ± 4)		1650 ± 150 (168,2 ± 15,3)	

Features		Versions	33 * *		33 1.5 TI		33 1.8 TD	
			33 1.3		33 1.5 a x a			
			33 1.3 5		33 1.7 *			
			33 1.7 IE		33 1.7 * Δ			
			33 1.7 IE Δ					
SHOCK ABSORBER			LH	RH	LH	RH	LH	RH
Type			SPICA		SPICA		SPICA	
Alfa Romeo part number			548615	548614	548190	549191	549300	549301
Low speed	Compression	N (kg)	186 ± 40 (19 ± 4)		260 ± 40 (26,5 ± 4)		255 ± 40 (26 ± 4)	
	Expansion	N (kg)	265 ± 40 (27 ± 4)		510 ± 40 (52 ± 4)		510 ± 40 (52 ± 4)	
High speed	Compression	N (kg)	461 ± 40 (47 ± 4)		490 ± 40 (49,9 ± 4)		491 ± 40 (49 ± 4)	
	Expansion	N (kg)	1216 ± 40 (124 ± 4)		1280 ± 40 (130,5 ± 4)		1275 ± 40 (130 ± 4)	

NOTE: The shock absorbers are integrated in their strut tubes

(*) Not marketed in all countries with 1.2 engine.

(Δ) With electronic injection engine for countries where antipollution regulations are in force.

GROUP 22

CONTENTS

DESC-RIPTION	(*)	Control lever	(*)
SERVICE BRAKES	(*)	Control cables	(*)
Brake system bleeding	(*)	SERVICE DATA AND	
Pedal assembly	(*)	SPECIFICATIONS	22-2
Brake master cylinder	(*)	Technical data	22-2
Hydraulic system piping	(*)	General specifications	(*)
Brake pressure proportioning valve	(*)	Inspection and adjustment	(*)
Servobrake	(*)	Tightening torques	(*)
Vacuum system	(*)	TROUBLE DIAGNOSIS AND	
Front disc brake	(*)	CORRECT;IONS	(*)
Rear drum brake	(*)	SPECIAL SERVICE TOOLS	(*)
PARKING BRAKE	(*)		

(*) Refer to "WORKSHOP MANUAL **Alfa 33**" VOLUME I and VOLUME II -
Group 22

SERVICE DATA AND SPECIFICATIONS

TECHNICAL DATA

FRONT BRAKES

Calipers, brake pads and discs

Features		Versions		33 * *	33 1.3	33 1.3 S	33 1.5 TI	33 1.7 IE	33 1.5 a x a	33 1.7 IE	33 1.BTD	Δ	33 1.7 *	33 1.7 * A
		ATE	DBA	Part No.	Part No.	Part No.	Part No.	Part No.	Part No.	Part No.	Part No.	Part No.	Part No.	Part No.
Calipers	Type	ATE	DBA	547168/9	54717819								547808/9	—
		ATE	DBA	7 9 5 3 5 7	7 9 5 3 5 6									720402
Brake pads	Type	ATE	DBA											
		ATE	DBA											
	Colours	LIGHT BLUE (FRENO) BLACK (EE RODO)												
	Pad nominal thickness "S"	mm (in)		15										16,5
Discs	External diameter	mm (in)												239
	Nominal thickness "C"	mm (in)		12,7 ^{-0,2}										22 ^{-0,2}

(*) Not marketed in all countries with 1.2 engine.

(Δ) With electronic injection engine for countries where antipollution regulations are in force.

FRONT AND REAR BRAKES

REAR BRAKES

Unit: mm (in)

Drum nominal diameter :	9"	8"
Part No.	130.695	131245
Drum nominal internal diameter	228,6 + 0,2	203,2 ^{-0,1} / _{+0,2}
Brake lining thickness	5	5

SERVOBRAKE

Type: BENDITALIA or ATE Diameter of working cylinder	7 in
---	------

BRAKE MASTER CYLINDER

Type: BENDITALIA	Part No. 546.657
Diameter	20.64 mm (0.812 in)
Stroke	32 mm (16+16) 1.26 in (0.63 + 0.63)
Type: ATE	Part No. 548.682
Diameter	20.64 mm (0.812 in)
Stroke	32 mm (17 + 15) 1.26 in (0.67 + 0.59)

BRAKE PRESSURE PROPORTIONING VALVE,

Type: BENDITALIA	Part No. 544.498
Ratio	0.36

Brake pad thickness

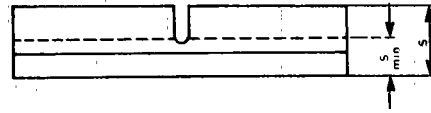

Unit: mm (in)

Brake pad	Single	Ventilated
Thickness:		
S	15.15 (0.596)	16.5 (0.650)
S_min (wear limit or min. serviceability thickness) (*)	7 (0.276)	7 (0.276)

(*) Serviceability limit is determined, anyway, by the lighting up of brake pad wear warning lamp

INSPECTION AND ADJUSTMENT

FRONT BRAKES

Dimensions for brake disc grinding (single or ventilated)

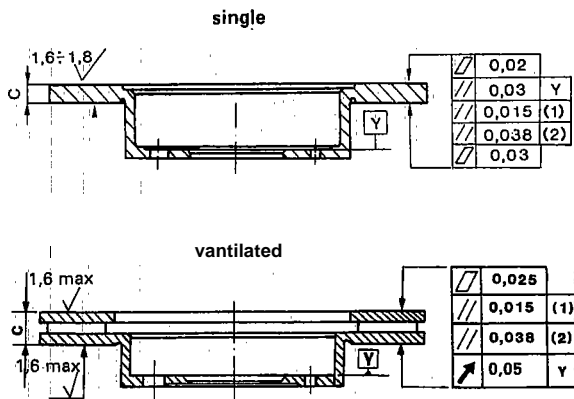

- (1) Circumferential
- (2) Radial

Brake disc thickness

Unit: mm (in)

Brake disc	Single	Ventilated
Thickness:		
C _{min} after machining	10 (0.394)	21 (0.827)
C _{min} serviceability thickness	9 (0.354)	20.2 (0.795)
Max disc banking	0.03 (0.00118)	0.03 (0.00118)

FRONT AND REAR BRAKES

Unit: mm (in)

REAR BRAKES

As per **Alfa 33** except:

Dimensions for brake drum turning

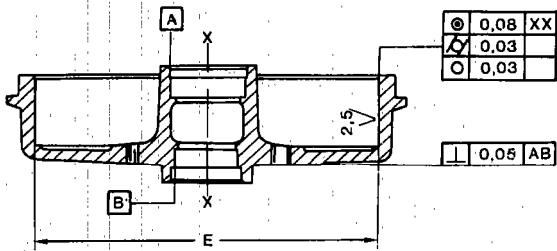

Drum nominal diameter	9"	8"
E _{max} after turning	229.1 (9.02)	204 (8.03)
E _{max} serviceability limit dimension,	229.6 (9.04)	204.5 (8.05)
Roundness error	< 0.03 (0.00118)	< 0.03 (0.00118)
Concentricity error	< 0.08 (0.00315)	< 0.08 (0.00315)
Brake shoe lining min. thickness (wear or serviceability limit)	0.5 (0.0197)	

BRAKE ~PRESSURE PROPORTIONING VALVE

Adjustment

HANDBRAKE LEVER ADJUSTMENT

Number of free notches on the sector gear before wheels locking

1 ÷ 3

Drum nominal diameter

9"

8"

- | | |
|---|--|
| <ul style="list-style-type: none"> - Vehicle at nominal height :one passenger and tank filled up - Valve piston at end of travel - Apply a load of 49 N (5 kg ;11.02lb) to the rocker hook | <ul style="list-style-type: none"> - Apply a load of 78.4 N (8 kg; 17.64 lb) to the rocker hook |
|---|--|

GENERAL SPECIFICATIONS

FLUIDS AND LUBRICANTS

Application	Type	Denomination
Refilling of brake Fluidsystem	Fluid	Std No. 3681-69906
		AGIP brake fluid DOT 4
		Std No. 3681-69906
		IP Auto Fluid FR DOT 4
		Std No. 3681-69906

FRONT AND REAR BRAKES

GROUP 22

CONTENTS

DESCRIPTION	(*)	Control lever	(*)
SERVICE BRAKES	(*)	Control cables	(*)
Brake system bleeding	(*)	SERVICE DATA AND SPECIFICATIONS	22-2
Pedal assembly	(*)	Technical data	22-2
Brake master cylinder	(*)	General specifications	(*)
Hydraulic system piping	(*)	Inspection and adjustment	22-3
Brake pressure proportioning valve ..	(*)	Tightening torques	(*)
Servobrake	(*)	TROUBLE DIAGNOSIS AND CORRECTIONS	(*)
Vacuum system	(*)	SPECIAL SERVICE TOOLS	(*)
Front disc brake	(*)		
Rear drum brake	(*)		
PARKING BRAKE	(*)		

(*) Refer to: "WORKSHOP MANUAL **Alfa 33**"
VOLUME I and VOLUME II - Group 22

FRONT BRAKES

Calipers, brake pads and discs

Features		Model		Sport Wagon		
		Versions		33 1.7 S	33 1.7 S 33 1.7 S Δ	33 1.5 4x4 33 1.7 4x4 Δ
Callipers	Type	ATE	part. No.	5471 68/9	54780819	54716819
		DBA	part. No.	54717819		54717819
Brake	Type	ATE	part. No.	795357	720402	795357
		DBA	part. No.	795356		795356
	Colours	LIGHT BLUE (FRENO) BLACK (FERODO)				
		Pad nominal thickness "S"	mm (in)	15	16,5	1,5
-Discs	External diameter	mm (in)	239			
	Nominal thickness "C"	mm (in)	12.7-O." (0.5 ^{-0.008})	22 ^{-0.2} (0.5 ^{-0.008})	12.7-O." (0.5 ^{-0.008})	

(A) With electronic injection engine for countries where antipollution regulations are in force.

FRONT AND REAR BRAKES

REAR BRAKES

Unit: mm (lb)

Drum nominal diameter:	9"*	8"
Part No.	130.895	131.245
Drum nominal internal diameter	228.6+0,2 (9+7.9 · 10 ⁻³)	203.2 ^{-0,1} _{+0,2} (8 ^{-3.9 · 10⁻³} _{+7.9 · 10⁻³})
Brake lining thickness	5 (0.197)	5 (0.197)

(*) Only for 4x4 versions

BRAKE MASTER CYLINDER

Type~ Diameter Stroke	BENDITALIA	Part. No. 548.857 20.64 mm (0.812 in) 32 mm (1.6+1.6) 1.28 in (0.63+0.63)
Type: Diameter Stroke	ATE	Part. No. 548.882 20.64 mm (0.812 in) 32 mm (1.7+1.5) 1.28 in (0.67+0.59)

INSPECTION AND ADJUSTMENT

FRONT BRAKES

Dimensions for brake disc grinding (single or ventilated)

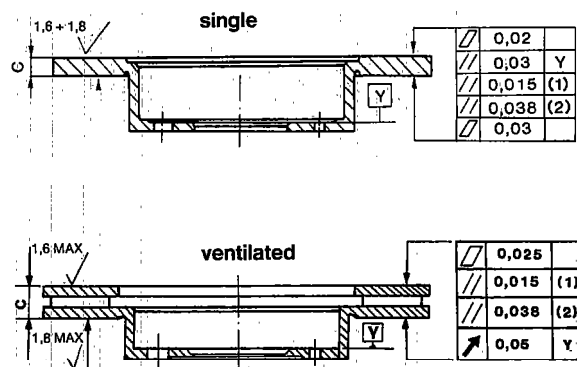

- (1) Circumferential
(2) Radial

Brake disc thickness

Unit: mm (in)

Brake disc	Single	Ventilated
Thickness:		
C _{min} after machining	10 (0.394)	21 (0.827)
C _{min} serviceability thickness	9 (0.354)	20.2 (.795)
Max disc banking	0.03 (0.00118)	0.03 (0.00118)

SERVOBRAKE

TYPE: ATE or BENDITALIA

Diameter of working cylinder

7 in

BRAKE PRESSURE PROPORTIONING VALVE

Type: BENDITALIA
R A T I O

Part No. 544.498
0.38

Brake pad thickness

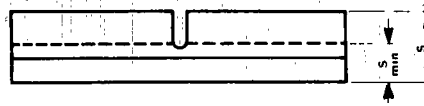

Unit: mm (in)

Brake disc	Single	Ventilated
Thickness:		
S	15.15 (0.596)	16.5 (0.850)
S min. (wear limit or min. serviceability thickness) (3)	7 (0.278)	7 (0.278)

(*) Serviceability limit is in any case determined by the lighting up of brake pad wear warning lamp.

REAR SUSPENSION

GROUP 25

CONTENTS

DESCRIPTION.....	(*)	General specifications.....	(*)
REAR HUB.....	(*)	Inspection and adjustment ,.....	25-2
REAR SUSPENSION.....	(*)	Tightening torques.....	(*)
SERVICE DATA AND		TRUBLE DIAGNOSIS AND	
SPECIFICATIONS.....	25-2	CORRECTIONS,.....	(*)
Technical data.....	25-2	SPECIAL SERVICE TOOLS.....	(*)

(*) Refer to "WORKSHOP MANUAL **Alfa 33** "VOLUME I and VOLUME II -
Group 25

SERVICE DATA AND' SPECIFICATION

TECHNICAL DATA

COIL SPRING AND SHOCK ABSORBER

Features		Versions	33 * *	3 3 1.7 *	33 1.8 TD	3 3 1.5 a x a
			33 1.3 3 3 1.3 s 33 1.5 TI 33 1.7 IE 33 1.7 IE A	3 3 1.7 * A		
Coil Springs	Alfa Romeo Part No.		130938	131805	131990	
	Wire diameter	mm	11,5 ± 0,1	11,2 ± 0,05	11,8 ± 0,1	
	Coil diameter	mm	111			
	Free length	mm	310	302	313	
	Stiffness	N/mm (kg/mm)	21,3 (2,17)	23,1 (2,35)	23,4 (2,39)	
	Static load	mm	204			
Shock absorbers	Type		Boge			
			Hydraulic			
	Piston rod diameter	mm	12 (1) 11 (2)			
	Stroke	mm	180 (1) 144 (2)			180 (1)

INSPECTION AND ADJUSTMENT

DATA OF SHOCK ABSORBER SETTING

Features		Versions	33 * *	3311.7 *	3 3 1.5 a x a	
			33 1.3 33 1.3 s 33 1.5 TI 33 1.7 IE 33 1.7 IE A	33 1.7 IE A 33 1.7 * A 33 1.7 IE 3 3 1.8 TD		
Shock absorber type			BOGE	SPICA	BOGE	SPICA
Alfa Romeo Part Number			581.052	549.141	549.134	549.142
Low speed	Compression	N (kg; lb)	100 ± 40 (10,2 ± 4)	220 ± 40 (22,4 ± 4)	117 ± 40 (12 ± 4)	180 ± 40 (18,4 ± 4)
	Extension	N (kg; lb)	90 ± 40 (9,2 ± 4)	200 ± 40 (20,4 ± 4)	157 ± 40 (16 ± 4)	200 ± 40 (20,4 ± 4)
High speed	Compression	N (kg; lb)	400 ± 50 (40,7 ± 5)	520 ± 40 (53 ± 4)	451 ± 50 (46 ± 5)	520 ± 40 (53 ± 4)
	Extension	N (kg; lb)	730 ± 75 (74,4 ± 7,6)	1160 ± 40 (118,3 ± 4)	211 ± 78 (21,5 ± 8)	1160 ± 40 (118,3 ± 4)

NOTE: Values to be measured with shock absorbers at 20 ± 2°C (68 ± 3.6°F) temperature.
 (*) Not marketed in all countries with 1.2 engine.
 (Δ) With electronic injection engine for countries where antipollution regulations are in force.

REAR SUSPENSION

GROUP 25

CONTENTS

DESCRIPTION	(*)	General specifications	(*)
REAR HUB	(*)	Inspection and adjustment	25-3]
REAR SUSPENSION	(*)	TRUBLE DIAGNOSIS AND CORRECTIONS	(*)
SERVICE DATA AND SPECIFICATIONS	25-2	SPECIAL SERVICE TOOLS	(*)
Technical data	25-2		

Refer to Group 00 - Chassis and Body Maintenance
for:

- Checking Rear Suspension Height

(*) Refer to: "WORKSHOP MANUAL **Alfa 33**"
VOLUME I and VOLUME II - Group 25

REAR SUSPENSION

SERVICE DATA AND SPECIFICATIONS

TECHNICAL DATA

COIL SPRING, SHOCK ABSORBER AND ANTI-ROLL BAR¹

Model		Sport Wagon			
		33 1.3 S	33 1.7 S	33 1.5 4x4 33 1.7 4x4	33 1.8 TD
Coil Spring	Alfa Romeo part No.	131990		131805	133007
	Wire diameter mm (in)	11.8 (0.464)		11.2 (0.440)	11.2 (0.440)
	Coil diameter mm (in)	111 (4.37)			
	Free length mm (in)	313 (12.32)		302 (11.89)	323 (12.72)
	Stiffness N/mm (kg/mm) (lb/in)	23,5 (2,4) (134.4)			
Shock absorber	Type	SPICA			
		B O G E			
		HYDRAULIC			
	Piston rod diameter mm (in)	12 (1) (0.472)	11' (2) (0.433)	12 (1) (0.472)	
Stroke mm (in)	180 (1) (7.086) 144 (2) (5.67)		180 (1) (7.086)		

(1) For SPICA shock absorbers only

(2) For BOGE shock absorbers only

INSPECTION AND ADJUSTMENT

DATA OF SHOCK ABSORBER SETTING

Features		Model	Sport Wagon				
		Versions	33 1.5 S	33 1.7 S	33 1.5 4x4	33 1.7 4x4	33 1.5 S 33 1.7 S 33 1.8 TD
TYPE		SPICA	BOGE	SPICA	BOGE	BOGE	SPICA
Alfa Romeo part No.		549137	5491230	549142	549134	581052	549141
Low speed	Compression N (kg)	216±40 (22±4)	117,6±40 (12 ±4)	180±40 (18,4±4)	117,6±40 (12±4)	100±40 (10,2±4)	220±40 (22,4±4)
	Extension N (kg)	196±40 (20±4)	117,6±40 (12±4)	200±40 (20,4±4)	157±40 (16±4)	90±40 (9,2±4)	200±40 (20,4±4)
High speed	Compression N (kg)	520±40 (53±4)	461 ±49(47±5)	520±40 (53-14)	451±50 (46±5)	400±50 (40,7±5)	520±40 (53±4)
	Extension N (kg)	760±40 (77,5±4)	853±83 (87±8,5)	1160±40 (118,3±40)	799±78 (81,5±8)	730±75 (74,4±7,6)	1160±40 (118,3±4)

NOTE: The **shock** absorbers are Integrated In the strut-tubes.

WHEELS AND TIRES

GROUP 28

C O N T E N T S

CHECKING TIRE CONDITIONS (*)	General specifications (*)
TIRE REPLACEMENT (*)	Inspection and adjustment (*)
CHECKING WHEEL CONDITIONS , . . . (*)	Tightening torques (*)
SERVICE 'DATA AND SPECIFICATIONS. 282	Technical data 282

(*) Refer to 'WORKSHOP MANUAL **Alfa 63** U M E I a n d VOLUME II -
Group 28

SERVICE DATA AND SPECIFICATIONS

TECHNICAL DATA

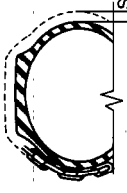
Dimension	Model								
	33** 33 13 33 13 S	33 1.5 T1	33 1.5 4x4	33 1.7*	33 1.7 IE 33 1.7* ELECTRONIC INJECTION	33 1.8 TD			
TIRE	RIM	INFLATING PRESSURES (1)							
Unit of measurement		P	a	P	a	P	a	P	a
165/70 R13 76S 165/70 R13 79T	5 1/2 J x 13"	1,8	1,6	-	-	-	-	-	-
175/70 R13 82T	5 1/2 J x 3"	-	-	1,8	1,8	1,8	1,8	-	1,8
185/60 R14 82H	5 1/2 J x 14"	-	-	-	-	1,8	1,6	1,8	1,8
Balance (max. allowed residual balance)		8 (0.28)							
Balance weights		10 ± 40 (at 10 g intervals) - 0.35 ± 1.40 (at 0.35 oz intervals)							
Snow chains Chain "s" max. dimensions (for tires 165/70 SR 13)		16 (0.63)							

A = Front
P = Rear

S rating = Up to 180 km/h (112 m.p.h.)
T rating = Up to 190 km/h (118 m.p.h.)
H rating = Up to 210 km/h (130 m.p.h.)

(1) Inflating pressure measured with cold tires.

In particularly heavy operating conditions (max. load, high temperatures, high speeds, etc...) it is advisable to increase inflating pressures by 0.2 kg/cm² (0.2 bar; 20 kPa; 2.84 p.s.i.).
In the event of rear axle overloading (trailer hauling, L.P.G. tank, etc...) it is advisable to increase rear tires inflating pressure by 0.6 kg/cm² (0.6 bar; 60 kPa; 8.53 p.s.i.)

Unit of measurement conversion:

2.2 kg/cm² = 2.16 bar = 216 kPa = 31.30 p.s.i.
1.8 kg/cm² = 1.76 bar = 176 kPa = 25.6 p.s.i.
1.6 kg/cm² = 1.57 bar = 157 kPa = 22.76 p.s.i.

GROUP 28

CONTENTS

CHECKING TIRE CONDITIONS	(*)	General specifications	(*)
TIRE REPLACEMENT	(*)	Inspection and adjustment	(*)
CHECKING WHEEL CONDITIONS	(*)	Tightening torques	(*)
SERVICE DATA AND SPECIFICATIONS	28-2	Technical data	28-2

(*) Refer to: "WORKSHOP MANUAL **Alfa 33**"
VOLUME I and VOLUME II - Group 28

Dimension		Model	Sport Wagon 33 1.3 S	Sport Wagon 33 1.7 S 33 1.7 S Δ 33 1.7 4x4 Δ	Sport Wagon 33 1.5 4x4	Sport Wagon 33 1.8 TD				
TYRES	RIM	Unit of measurement	INFLATING PRESSURE (1)							
			A	P	A	P	A	P	A	P
165/70 R1376S 165/70 R1379T	5 1/2 J x 13"	Kg/cm ²	1.8	1.8	-	-	-	-	-	-
175/70 R13 82T	5 1/2 J x 13"		-	-	-	-	1.8	1.8	2.2	1.8
185/60 R14 82H	5 1/2 J x 14"		-	-	2.0	2.0	-	-	-	-
Balance (max. allowed residual balance)		g	8							
Balance weights		g	10 ÷ 40 (at 10 g intervals)							
Snow chains Chain "S" max. dimensions (for tyres 165/70 R13)		mm	16							

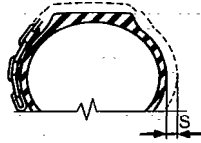

[(A) With electronic injection engine for countries where antipollution regulations are in-force.

A = Front
P = Rear

S rating = Up to 180 Km/h (112 m.p.h.)
T rating = Up to 190 Km/h (118 m.p.h.)
H rating = Up to 210 Km/h (130 m.p.h.)

(1) Inflating pressure measured with cold tyres.

In particularly heavy operating conditions (max. load, high temperatures, high speeds, etc...) it is advisable to increase inflating pressures by 0.2 kg/cm² (0.2 bar; 20 kPa; 2.84 p.s.i.).

In the event of rear axle overloading (trailer hauling, (L.P.G. tank, etc...)) it is advisable to increase rear tyre inflating pressure by 0.6 kg/cm² (0.6 bar; 60 kPa; 8.53 p.s.i.).

Unit of measurement conversion:

2.2 kg/cm² = 2.16 bar = 216 kPa = 31.30 p.s.i.

1.8 kg/cm² = 1.76 bar = 176 kPa = 25.6 p.s.i.

1.6 kg/cm² = 1.57 bar = 157 kPa = 22.76 p.s.i.

GROUP 40

All information contained in this group is applicable to
1.7 electronic injection engines with catalytic convertor only

CONTENTS

HOW TO READ THE WIRING DIAGRAM (*)	Cluster	40-9
FUEL DI-STRI-BUTION	Carburettor power supply and rpm pulser (wiring diagram)	40-2 40-1 2
Fuel wiring diagram	Engine, cooling, lubrication, brake pad wear sensor, minimum level, brake clutcher (wiring diagram)	40-2 40-13
Fuses		40-3
Ignition switch		(°)
ELECTROMECHANICAL AND ELECTRONIC DEVICES	WINDSCREEN WASH/WIPER HEADLIGHT WASH/WIPER AND REAR WINDOW WASH/WIPER	40-5 40-14
Relays, timer, and electronic devices and intermittences	Witidscreen wash/wiper, headlight wash/wiper and rear window wash/wiper (wiring diagram)	40-5 40-14
LIGHTING SYSTEM	Windscreen wiper	40-8 (*)
Lamps	Headlight washer	(*)
Combination switch assembly	Windscreen washer	(*)
Outside front lighting (wiring diagram)	Rear window wash/wiper	(°) 40-1 5
Rear combination lamps (wiring diagram)	Rear window wiper	40-8 (*)
Front optical groups	Rear window washer electric pump	(*)
Rear optical groups	ELECTRIC ACCESSORIES	(°) a.(°)
Foglights and rear foglights (wiring diagram)	KEY TO WIRING DIAGRAMS	(°) 40-17
Inside lightening (wiring diagram)		(°)
BOARD INSTRUMENTS AND SENSORS AND TRANSMITTERS		40-9

(*) Refer to "WORKSHOP MANUAL **Alfa 33**" VOLUME I AND VOLUME II - Group 40

(°) Refer to "WORKSHOP M A N U A L **BS** Models" - Group 40

POWER SUPPLY ROUTING

For 1.7 electronic injection engine. with catalytic donvertor only

POWER DISTRIBUTION WIRING DIAGRAM

(wiring diagram)

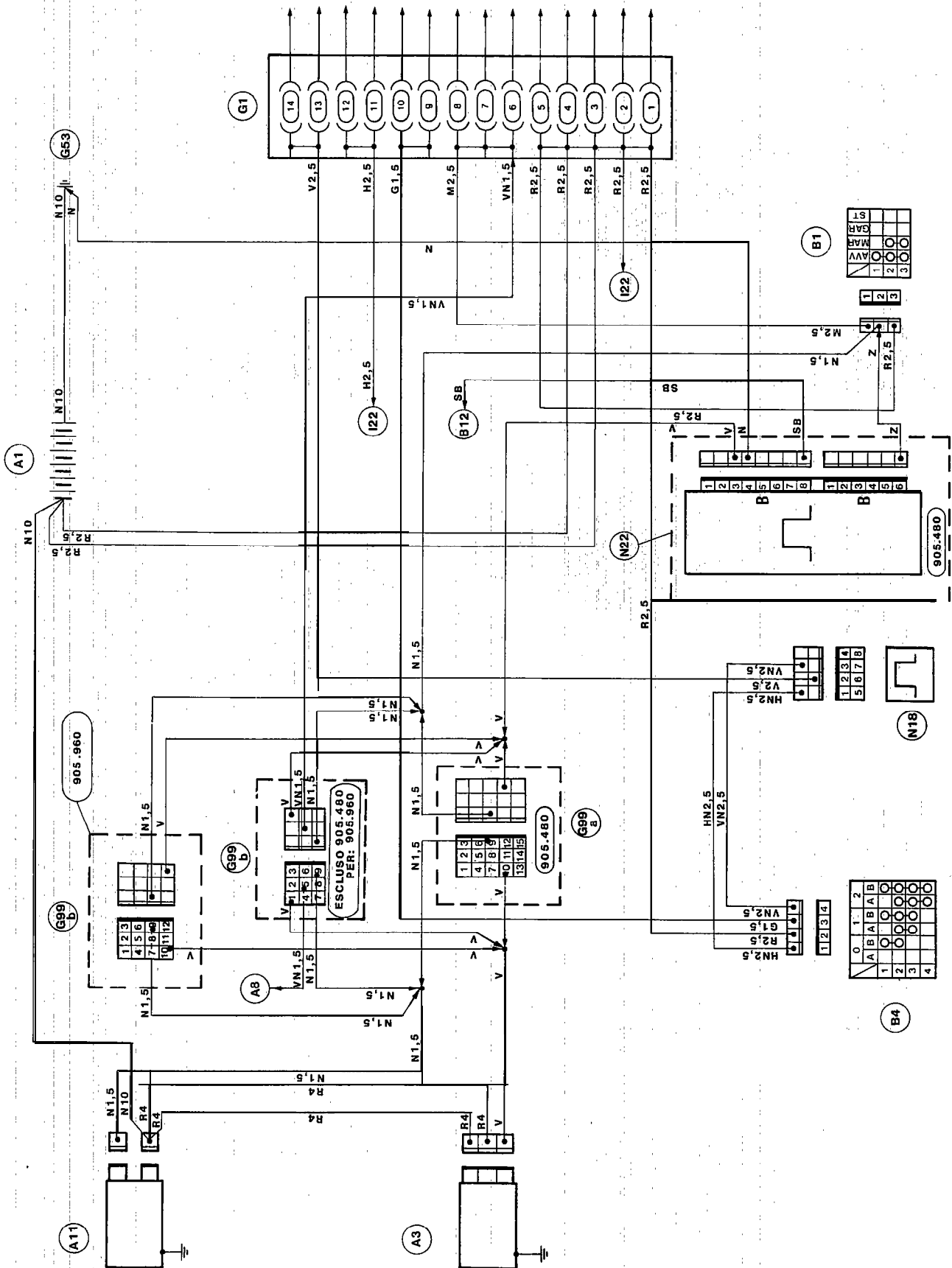

ELECTRICAL SYSTEM

FUSES

LOCATION

The fusebox is an integral part of the terminal board support and is located on left side of the intermediate bulkhead, in the engine compartment. Furthermore there are two fuses relating to Injection wiring in rightfront area of engine compartment close to relative lighting unit.

CHECK

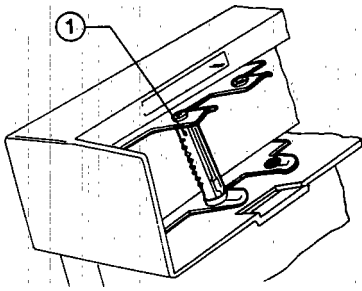

1 Fuse

CAUTION:

- a. Should a fuse blow, before replacing it, make sure that the cause of failure has been removed.
- b. Use fuses with the specified amperage only. Never use fuses with an amperage greater than that specified.
- c. Correctly insert fuse into fusebox, aligning it carefully in its seating.
- d. Should car remain stationary for a long time, remove fuse protecting supply circuit of clock.

SERVICES PROTECTED BY FUSES

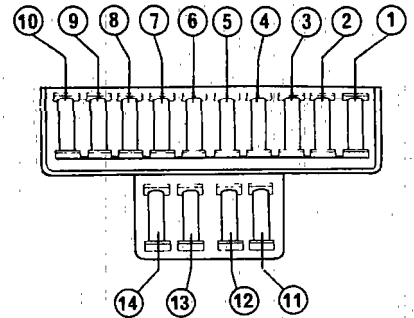

In the following table, for each model, it is specified which are the services protected by each fuse.

Fuse	Protected Service	Ampere	Models	
			33 1.7 IE	33 1.7 injection
1	Front power windows Headlight washer timer - Headlight washer electric pump(*)	16		X
2	Door lock control unit Front fog lights	16		X
3	Heated rear window	16		X
4	Car radio Cigar lighter - Horns	16		X
5	Passenger compartment roof lamp-Intermittence of direction and hazard lights - Stop switch	8		X
6	Windscreen wiper - Windscreen wiper electronic intermittence generator - Windscreen wiper control - Windscreen washer pump control - Cluster Windscreen washer electric pump	8		X
7	Heated rear window switch - Heater switch - Rear window relay Power window relay - electronic injection relay - clock Rear window wash/wiper	8	X X -	X X X

(*) Only for Sweden version

ELECTRICAL SYSTEM

Fuse	Protected Service	Ampere	Models	
			33 1.7 IE	33 1.7 Injection
8	Reverse switch - Hazard light switch lighting ALFA ROMEO Control	8	X -	X -
9	Side light left front and right rear - R.H. number plate light Drawer light ALFA ROMEO Control (Side light left front and right rear - R.H. number plate light) Cigar lighter	8	X X X X	X X - X
10	Side light: right front and left rear - L.H. number plate light ALFA ROMEO Control (Side light right front and left rear - L.H. number plate light) Heater control lighting lamp - Cluster lighting lamp Front fog light relay- front fog light switch lighting	8	X X X X	X - X X
11	Right low beam	8		X
12	Left low beam - Rear fog light, switch	8		X
13	Right full beam	8		X
14	Left full beam - Full beams warning lamp	8		X
(**)	Lambda sensor resistance	7.5		X
(**)	Fuel pump	1.5		X

(*) Only for Sweden version.

(**) These fuses are located on right front area of engine room close to optical groups.

ELECTROMECHANICAL AND ELECTRONIC DEVICES

Only for 1.7 electronic injection engine with catalytic convertor

RELAYS, ELECTRONIC AND INTERMITTENCE DEVICES

LOCATION

To locate components, see following figures and the two tables "remote control switches and electronic devices and intermittences".

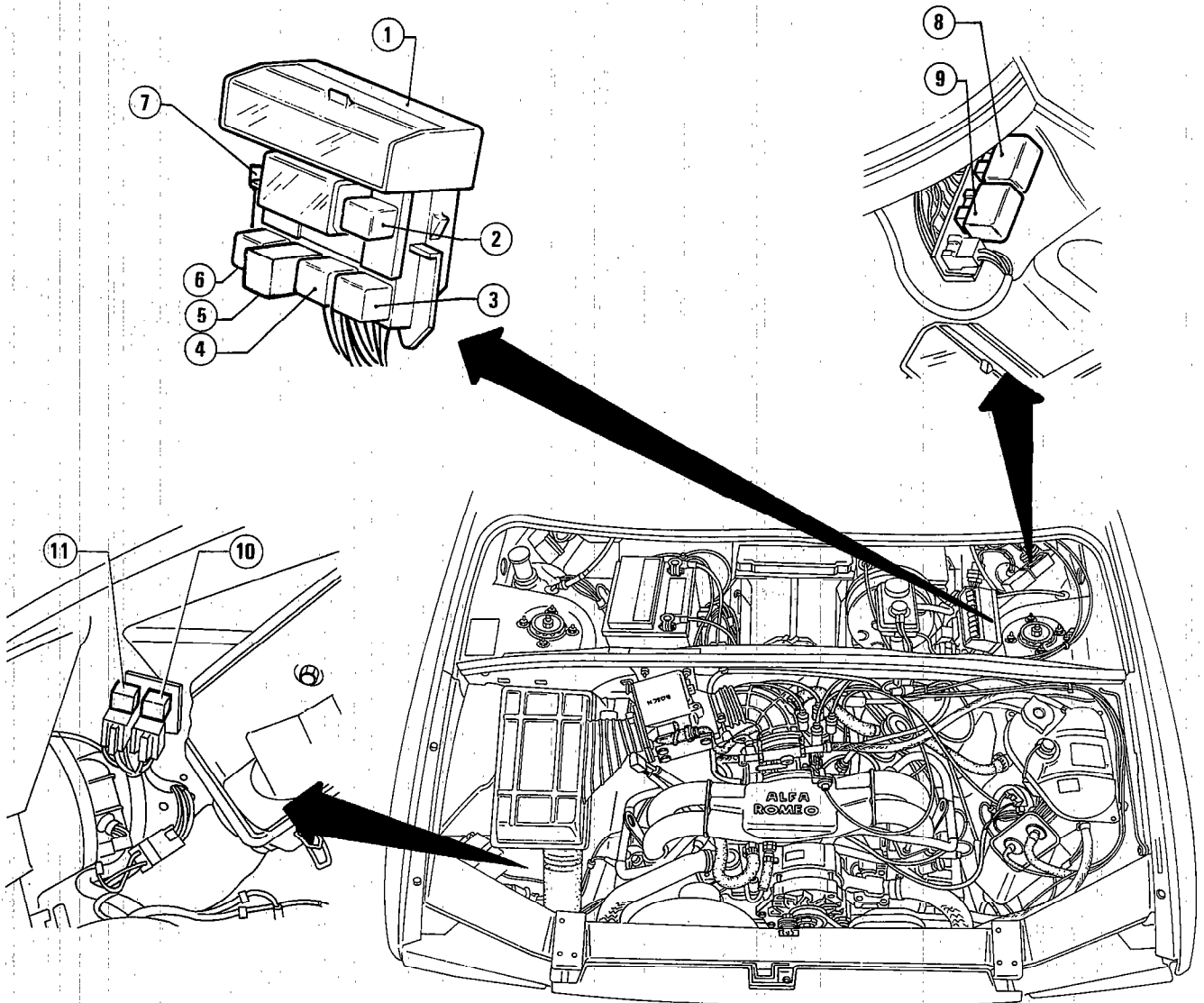

- 1 Fuseholder box
- 2 Beam excluding remote control switch
- 3 Horns remote control switch
- 4 Thermal window remote control switch

- 5 Lamp washing remote control switch
- 6 Front window lifting remote control switch
- 7 Fog lamps remote control switch
- 8 Electronic window intermittence

- 9 Lamps and beam switching device
- 10 Main injection remote control switch
- 11 Fuel pump remote control switch

CHECK

All components must be of the type stated on the specification table

ELECTRICAL SYSTEM

“Relays and Timer” Table

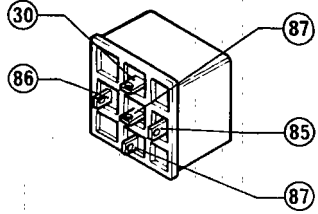
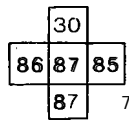
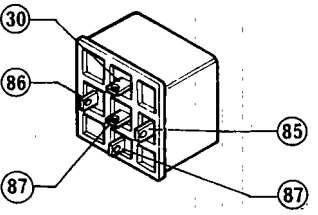
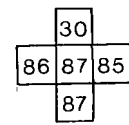
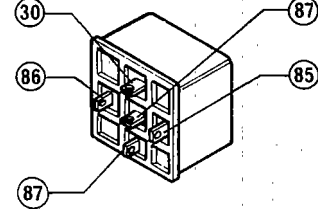
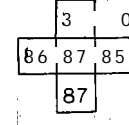
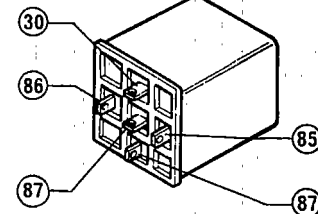
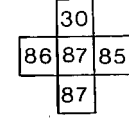
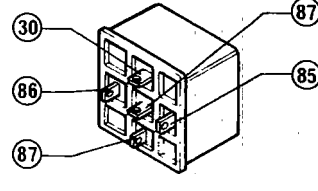
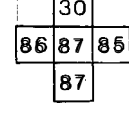
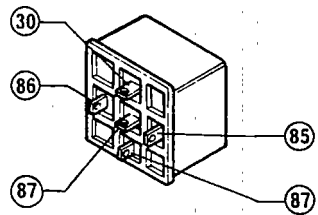
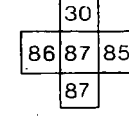
Component	External view	Symbols	Position (See fig. pag. 40-5)
Full beam cut-out relay I21			2
Horns relay I3			3
Heated rear window relay 1 2			4
Headlight washer relay I19			5
Power window relay I12			6
Front foglamp relay I17			7

ELECTRICAL SYSTEM

"Relays and Timer" (Table continued)

Component	External view	Symbols	Position (See fig. pag. 40-5)
Main injection relay S12b			10
Fuel pump relay S12a			11

"Intermittences and electronic devices" Table

Component	External view	Symbols	Position (See fig. pag. 40-5)
Windscreen wiper electronic intermittence N14			1
Electronic device for headlights and flashing changeover N18			2
Hazard and direction light intermittence N13			(*)

(*) Located in compartment, under the dashboard, at the right of steering column, as per **Alfa 33**.

LIGHTING SYSTEM

For 1.7 electronic injection engines with catalytic convertor only
EXTERNAL REAR LIGHTING (wiring diagram)

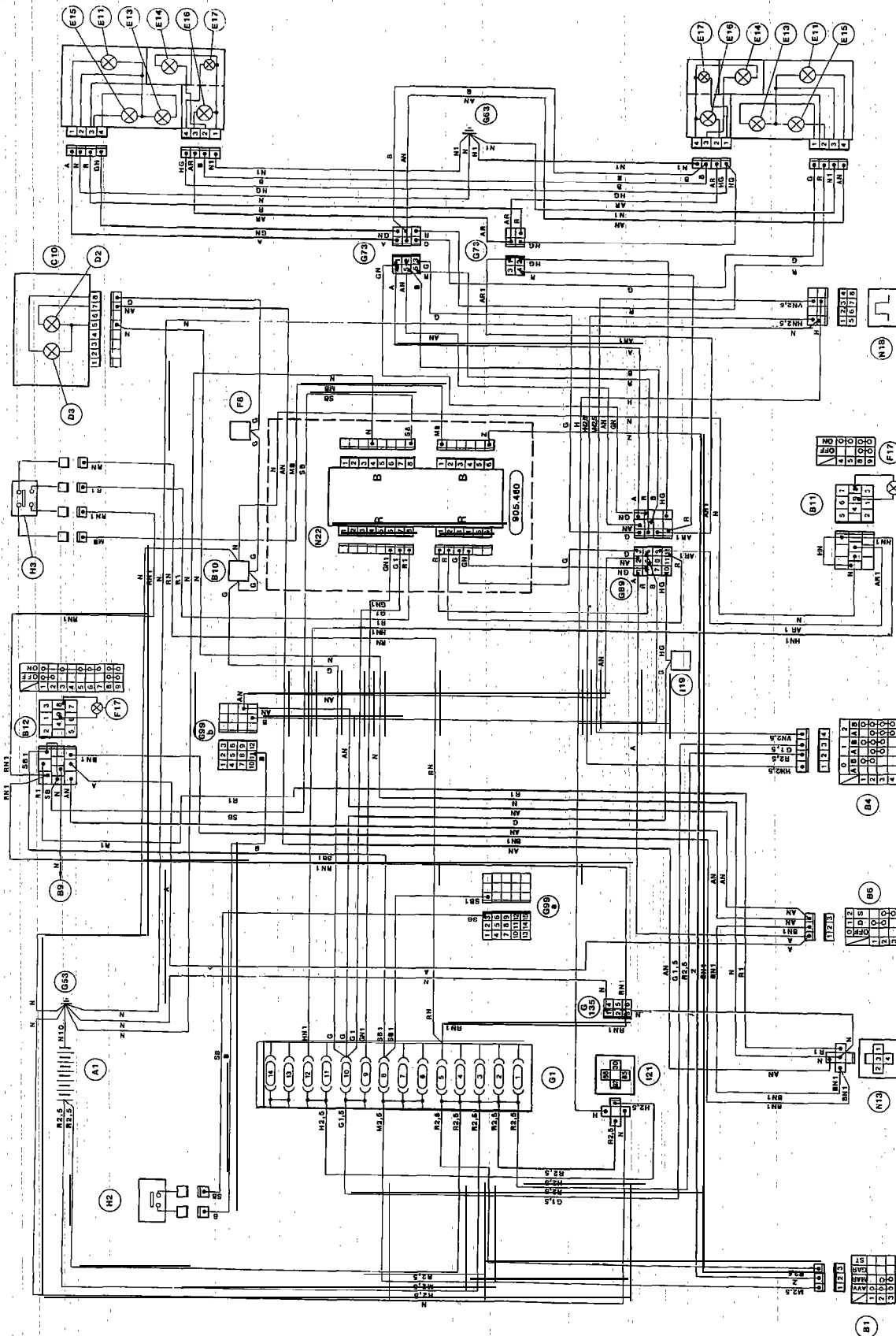

PANEL INSTRUMENTS, SENSORS AND SENDERS

For 1.7 electronic injection engine. with catalytic convertor only

CLUSTER

Front view

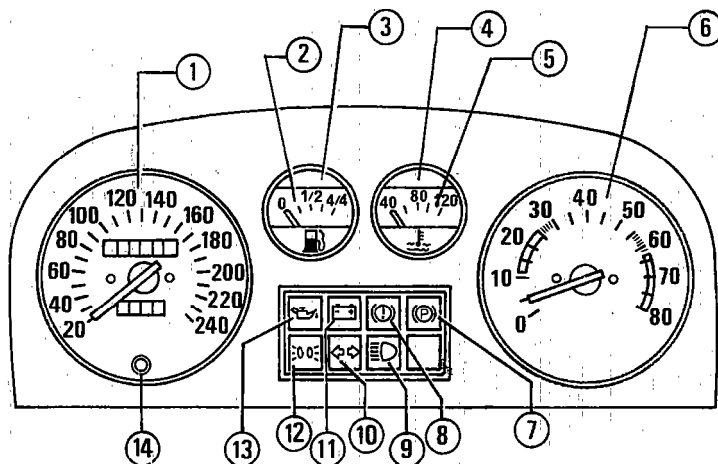

Rear view

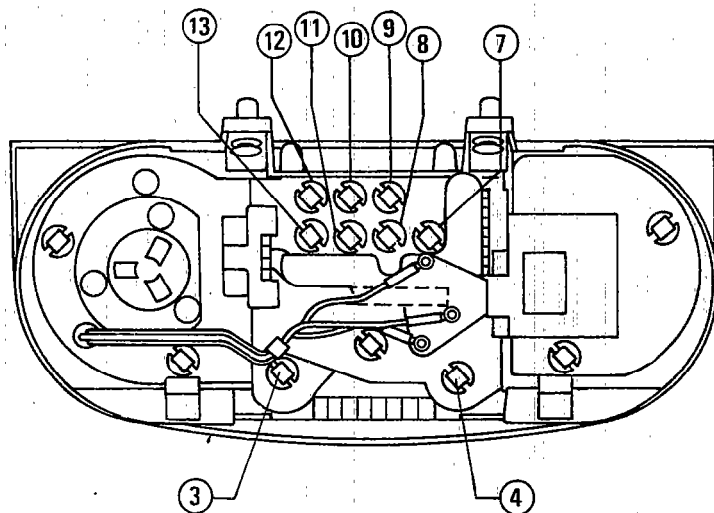

- | | |
|--|---|
| 1 Tachometer - odometer | 8 Brake fluid insufficient level warning lamp |
| 2 Fuel level gauge | 9 Headlight warning lamp |
| 3 Fuel reserve warning lamp | 10 Direction light warning lamp |
| 4 Max coolant temperature warning lamp | 11 Alternator charge warning lamp |
| 5 Coolant temperature gauge | 12 Lights warning lamp |
| 6 Rev. counter | 13 Insufficient oil pressure warning lamp |
| 7 Hand brake warning lamp | 14 Trip/odometer reset knob |

WIRING DIAGRAM

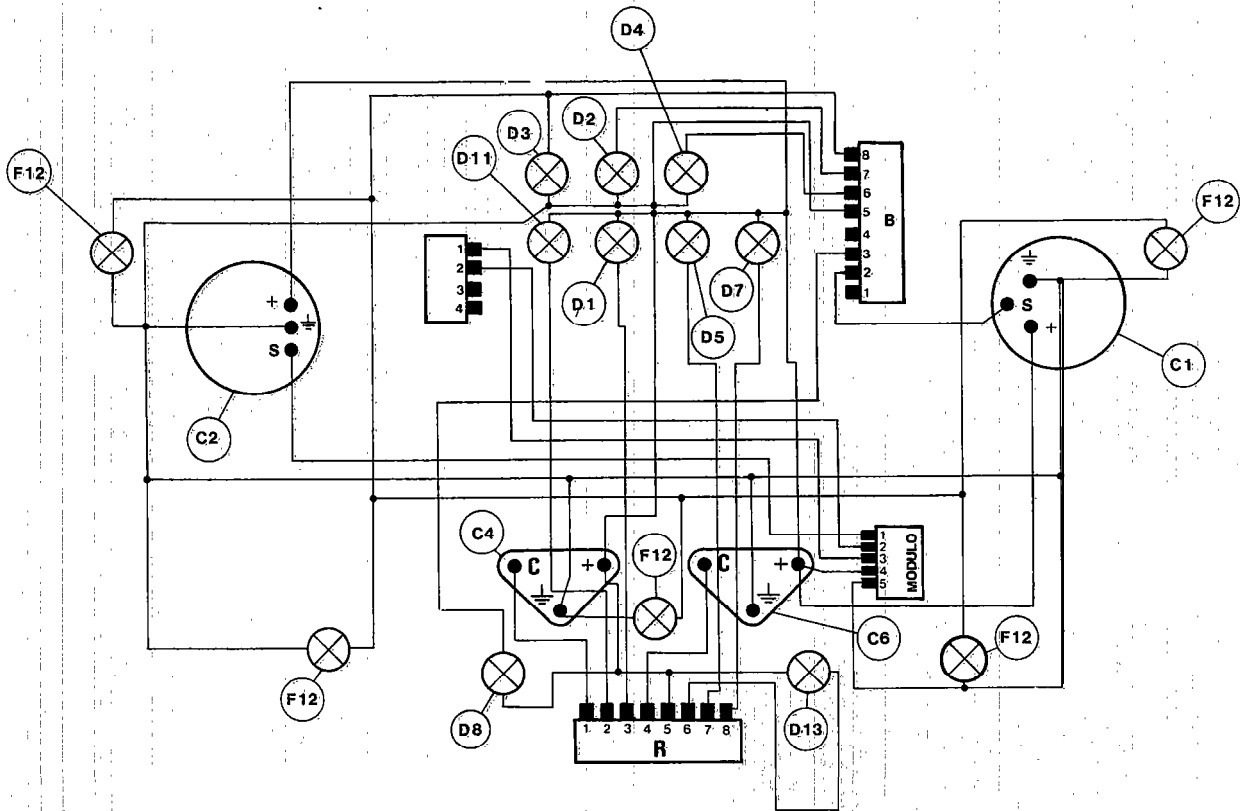

- C1 Electronic rev. counter
- C2 Electronic tachometer
- C4 Fuel level gauge
- C6 Coolant temperature gauge
- D1 Alternator charge warning lamp
- D2 Direction, light warning lamp
- D3 Side light warning lamp
- D4 Full beam warning lamp
- D5 Brake fluid level warning lamp

- D7 Hand brake warning lamp
- D8 Fuel reserve warning lamp
- D11 Engine oil min. pressure warning lamp
- D13 Engine coolant max. temperature warning lamp
- F12 Cluster lighting lamp
- G5 Connector
- G6 Cluster B connector
- G7 Cluster R connector

ELECTRICAL SYSTEM

PIN-OUT LOCATION

For location of pin-outs of connectors 1, 2 and 3, refer to the following figures and tables.

Cluster rear view

Borletti type

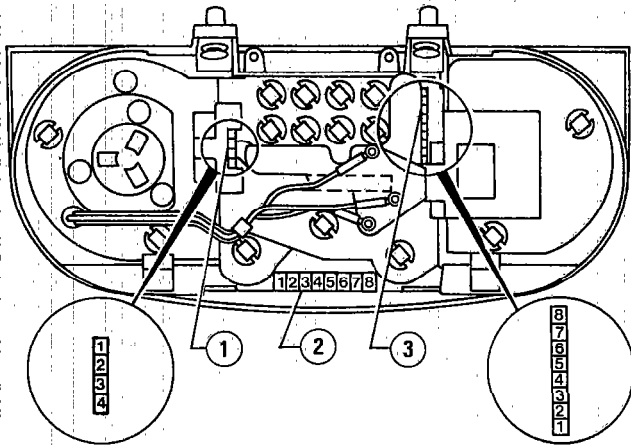

Jaeger type

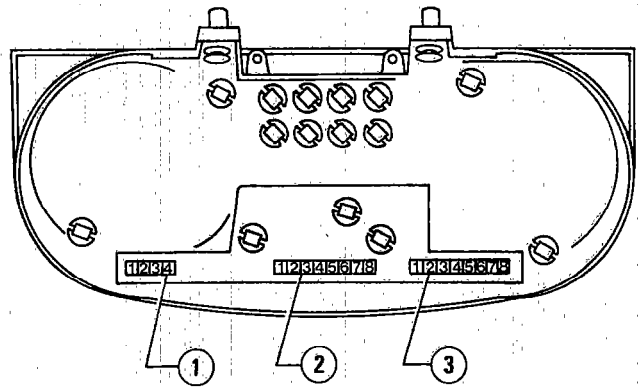

Connector 1 : white

Pin	Colour	Service
1	B + braid	Connector for tachimetric pulse generator
2	B	Connector for tachimetric pulse generator
3	—	Available
4	—	Available

Connector 3 : white

Pin	Colour	Service
1	—	Available
2	B	Engine wiring connector
3	ZN	Intermediate wiring connector
4	—	Available
5	N	Direction indicator intermittence
6	VN	Fuseholder box to fuse 14 (full beam warning lamp)
7	A N	Direction indicator intermittence
8	G	Illumination of heater fan switch

Connector 1 : white

Pin	Colour	Service
1	Z	Intermediate wiring connector
2	H	Engine wiring connector
3	V	Engine wiring connector
4	M	Engine wiring connector
5	SN	Combination switch unit, windscreen wash/wipe pump
6	C N	Engine wiring connector
7	C	Min. brake fluid level sensor and ALFA- ROMEO Control warning lamp
8	HN	Power window wiring connector

REMOVE AND INSTALLATION

As per models .

REMOVE AND INSTALLATION

As per models .

ELECTRICAL SYSTEM

FUEL SUPPLY AND REV. COUNTER PULSE GENERATOR

(wiring diagram)

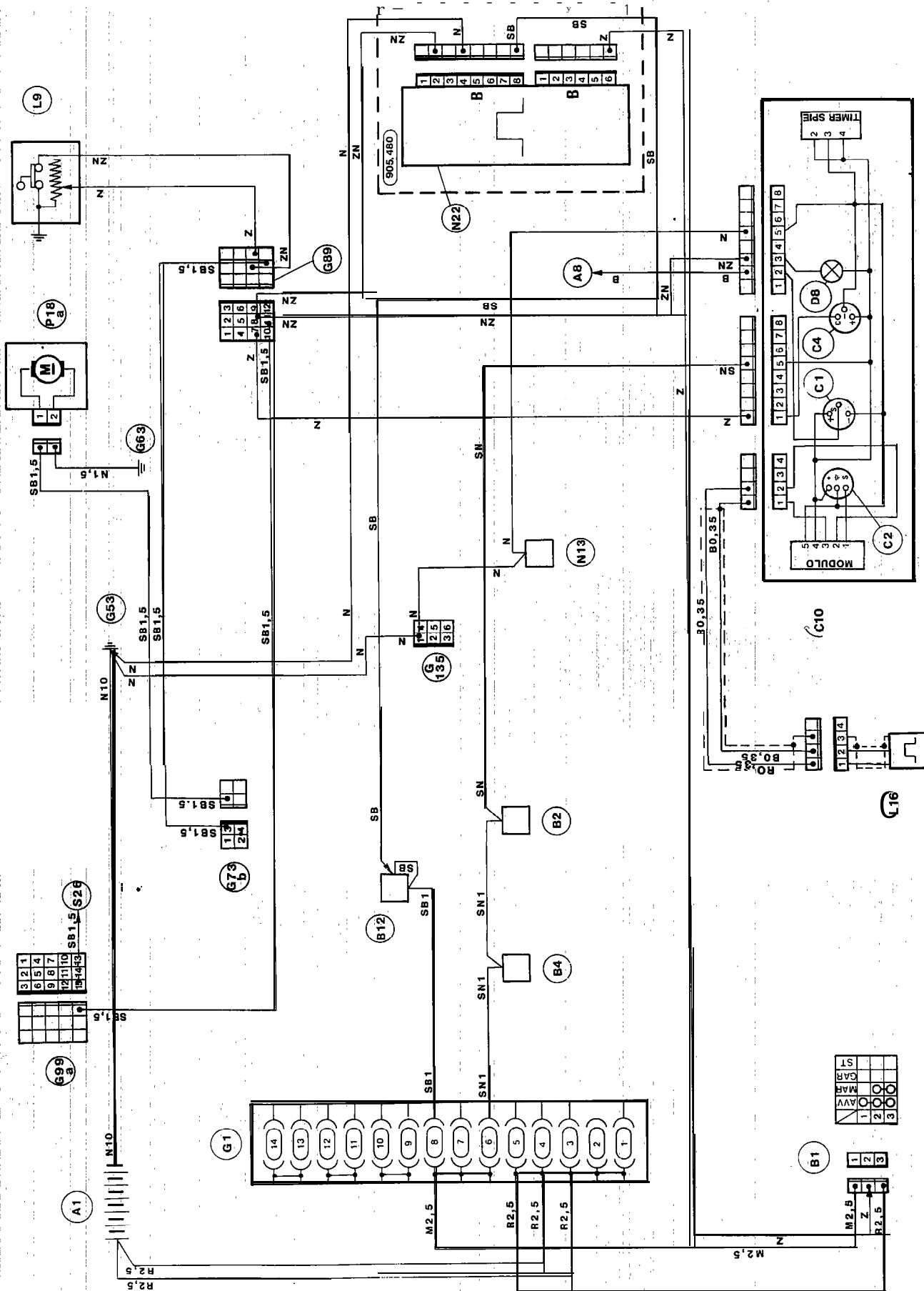

ELECTRICAL SYSTEM

ENGINE COOLING, LUBRICATION, BRAKE PAD WEAR SENSOR, BRAKE-CLUTCH FLUID MIN. LEVEL SENSOR (wiring diagram)

For 1.7 electronic injection engine with catalytic convertor only

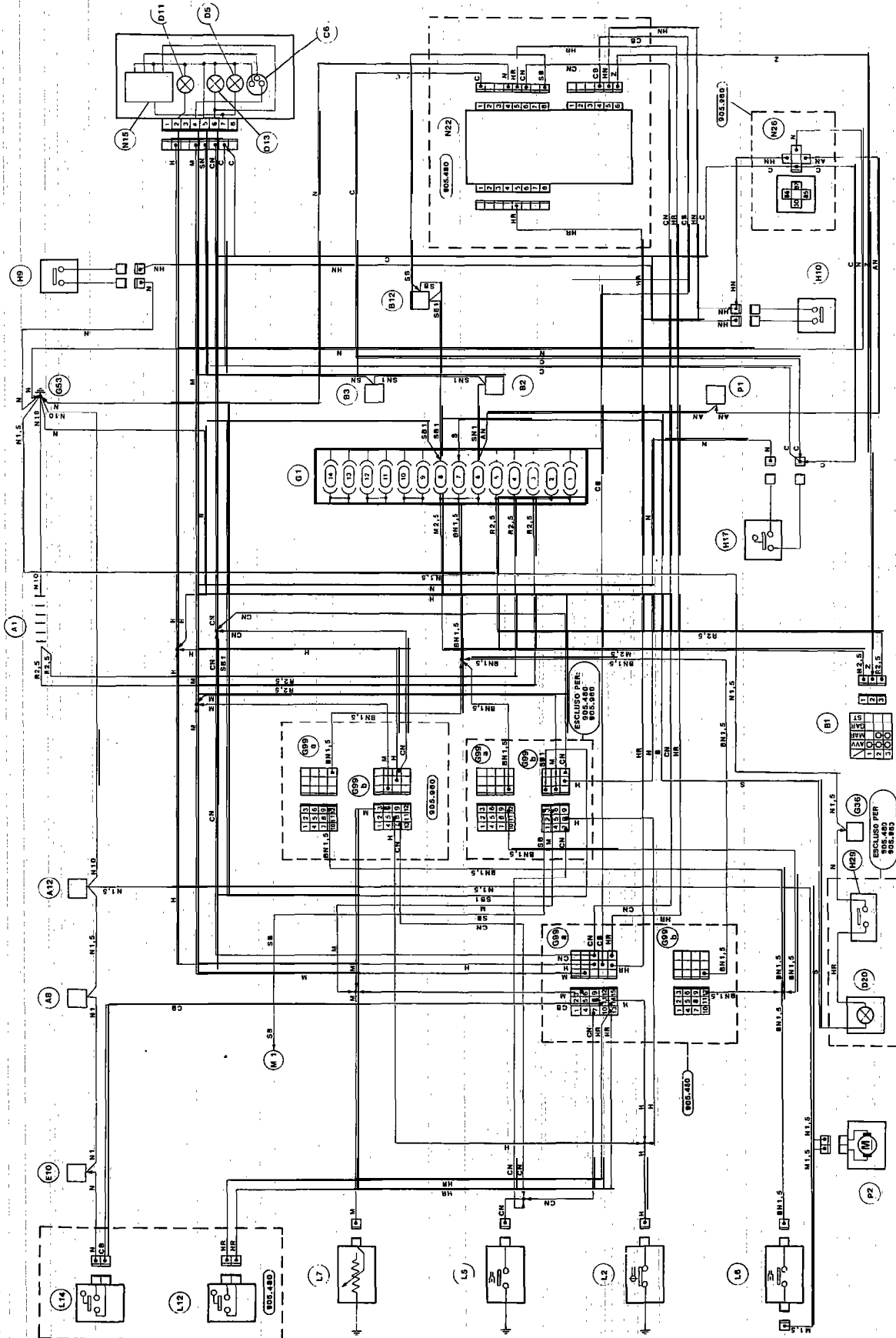

WINDSCREEN WASH/WIPER, HEADLIGHT WASHER AND REAR WINDOW WASH/WIPER

For 1.7 electronic injection engine with catalytic convertor only

(wiring diagram)

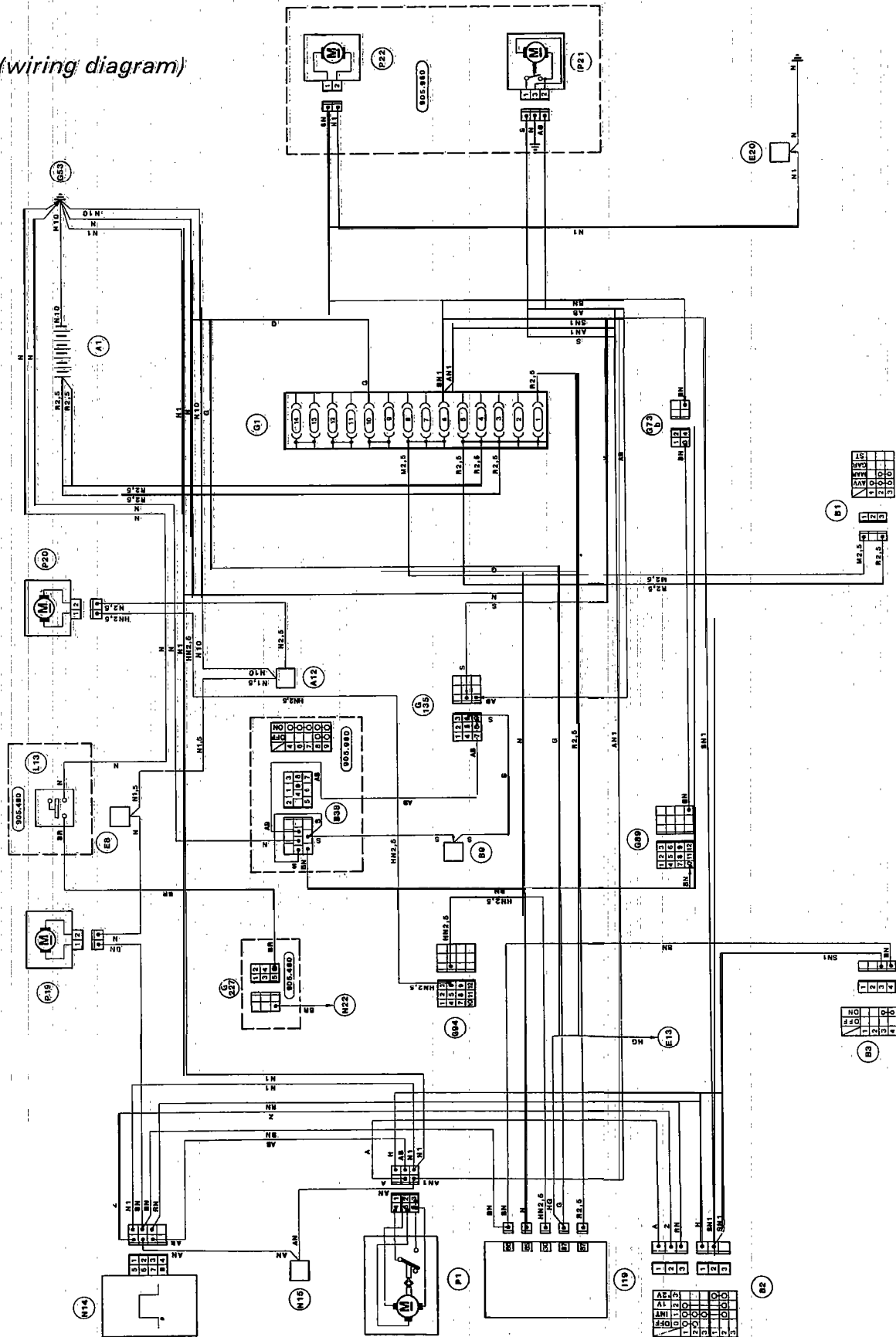

ELECTRICAL SYSTEM

WINSCREEN WASHER

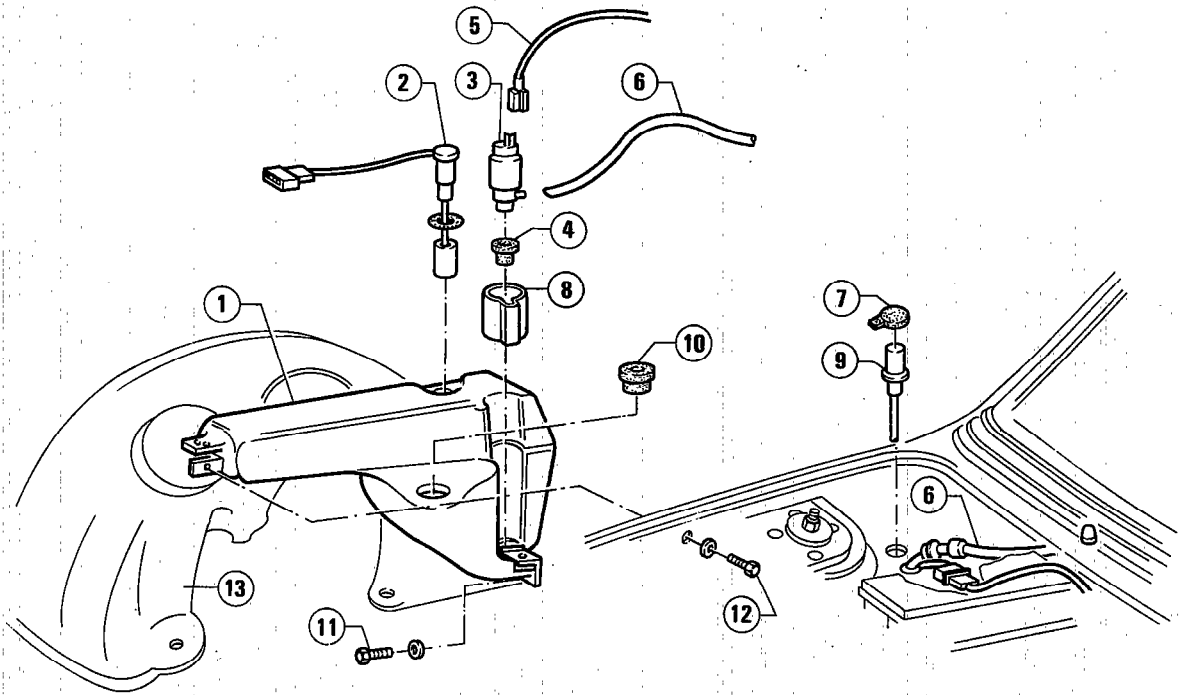

- 1 Tank
- 2 Liquid level sensor
- 3 Windscreen washer pump
- 4 Gasket
- 5 Pump wiring
- 6 Delivery tube to sprayers
- 7 Plug
- 8 Pump covering
- 9 Filler inlet
- 10 Gasket
- 11 Lower fixing screw
- 12 Upper fixing screw
- 13 Gravel guard of right front wheel

ELECTRICAL SYSTEM

TANK

REMOVAL AND INSTALLATION

With reference to the figure, operate as follows:

1. Remove front right wheel and its relevant gravel guard (13).
2. Disconnect right side direction indicator.
3. Operating from engine compartment, remove press-fit filler inlet fitting (9).
4. Unscrew upper fixing screw (12).
5. Operating from under wheel arch, unscrew screw (11) and lower tank (1).
6. Disconnect level sensor (2) wiring and wiring (5) from pump (3).
7. Disconnect tube (6) from pump, remove tank and drain liquid.
8. If necessary, remove pump (3) complete with gasket (4) and sensor (2) with associated gasket from tank (1).
9. For tank installation, reverse order of removal.

P U M P

REMOVAL AND INSTALLATION

1. Remove tank.
2. With reference to figure, remove covering (8) and pump (3) press fitted into its relative gasket (4).
3. For pump installation, reverse order of removal.

WINDSCREEN WASHER LIQUID LEVEL SENSOR

REMOVAL AND INSTALLATION

As per figure, operate as follows:

1. Disconnect tank (1) and lower it, as stated at "tank" up to step (5).
2. Disconnect sensor (2) wiring and remove it from tank.
3. Proceed to installation, operating in reverse order to removal.

CHECK

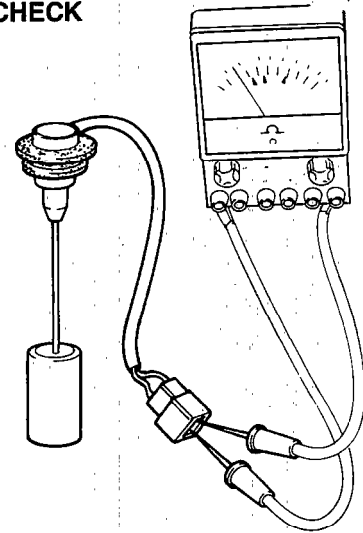

1. Connect the two ends of tester to sensor connector by operating as per figure.
2. Check sensor proper functioning by verifying the following.

Float lifted: ∞

Float lowered: 0 Ω

KEY TO WIRING DIAGRAM

- A : STARTING- CHARGING**
- A 1 Battery
 A2 Alternator
 A3 Alternator with integral electronic voltage regulator
 A4 Voltage regulator
 A5 Ignition distributor
 A5a Ignition distributor A
 A5b Ignition distributor B
 A6 Pulse generator
 A 7 Rotor
 A8 Ignition coil
 A8a Ignition coil A
 A8b Ignition coil B
 A9 Coil resistor
 A10 2-way connector for coil
 A11 Starter motor
 A12 Spark plugs
 A13 Pre-heating glow plugs
 A14 Alternator cable terminal board
- B: MANUAL ELECTRIC CONTROLS**
- B1 Ignition switch
 B2 Windscreen wiper control switch
 B3 Windshield washer and/or headlamp wash/wiper pump control switch
 B4 Control switch for side lights, flashing, low/full beam headlamps
 B5 Horn control switch
 B6 Direction indicator control switch
 B7 Low beam flashing control switch
 B8 Full beam flashing control switch
 B9 Heated rear window control switch
 B10 Fog lamp control switch
 B11 Rear fog lamp control switch
 B12 Road hazard lights control switch
 B13 Passenger compartment front roof lamp control switch
 B14 Passenger compartment rear roof lamp control switch
 B15 Passenger compartment roof lamp control switch
 B16 Cluster lighting dimmer rheostat
 B17 Gearbox oil level warning lamp switch
 B18 Door lock control switch on front right door
 B19 Door lock control switch on front left door
 B20 Interior door locking switch
 B21 Front right power window control switch
 B22 Front left power window control switch
 B23 Rear right power window control switch
 B24 Rear left power window control switch
 B25 Rear power window inhibitor switch
 B26 Rear power window and rear cigar lighter inhibitor switch
 B27 Front seat height control switch
 B28 Front left backrest control switch
 B29 Front right backrest control switch
 B30 Door mirror control switch
 B31 Antenna control switch
 B32 Windshield washer pump control
 B33 Front spot light switch
 B34 Rear left spot light switch
 B35 Rear right spot light switch
 B36 Door mirror double control switch
 B37 Parking light control switch
 B38 Rear window wiper control switch
 B39 Trip odometer recall microswitch
 B40 Trip odometer reset microswitch
 B41 VF electronic rheostat
- B42 Lamp dimmer rheostat
 B43 Internal control switch for door unlock
 B44 Rear spot light control switch
 B45 Identification light control switch
 B46 Two horn horns- normal horns control switch
 B47 Sun roof motor control switch
 B48 Intercom system control switch
 B49 Speak/listen changeover switch
 B50 Siren control switch
 B51 Driver's seat heater control switch
- c: INSTRUMENTS**
- C1 Electronic rev counter
 c2 Electronic speedometer
 c3 Voltmeter
 c4 Fuel level gauge
 c5 Oil pressure gauge
 C6 Coolant temperature gauge
 c7 Clock
 C8 Space free for instrument
 C9 Turbocharger air pressure gauge
 C10 Cluster (*)
 C11 ALFA ROMEO Control display
 C12 Performance gauge display
 C13 Optoelectronic cluster
 C14 Warning lamp panel
 (*) C10 AIBICIDIEIF Cluster connectors
- D: WARNING LAMPS**
- D1 Alternator charge warning lamp
 D2 Direction, indicator warning lamp
 D3 Side light warning lamp
 D4 Full beam warning lamp
 D5 Brake fluid level warning lamp
 D6 Heater/ventilation warning lamp
 D7 Handbrake warning lamp
 D8 Fuel reserve warning lamp
 D9 Choke warning lamp
 D10 Handbrake ON - brake fluid level warning lamp
 D11 Engine oil minimum pressure warning lamp
 D12 Pre-heating glow plug warning lamp
 D13 Engine coolant high temperature warning lamp
 D14 Maximum air pressure warning lamp
 D15 Minimum fuel pressure warning lamp
 D16 Free warning lamp
 D17 Gear position warning lamp
 D18 Manual injection advance warning lamp
 D19 Brake pad wear warning lamp
 D20 Rear drive engagement warning lamp
 D21 ALFA ROMEO Control warning lamp
 D22 Heated rear window warning lamp
 D23 Hazard light warning lamp
 D24 Rear fog light warning lamp
 D25 Fog light warning lamp
 D26 Injection diagnosis warning lamp
 D27 A.B.S. system warning lamp
 D28 Identification light warning lamp
 D29 Ignition diagnosis warning lamp (antiknocking)
- E: EXTERNAL LIGHTS**
- E 1 Front direction indicator

ELECTRICAL SYSTEM

- E: EXTERNAL LIGHTS (continued)**
- E2 Front side light
 - E 3 Front direction indicator and sidelight
 - E4 Frontside marker light
 - E5 Low beam light
 - E 6 Low beam light with incorporated side light
 - E7 Full beam light
 - E8 Low and full beam light
 - E9 Side repeater
 - E 1 0 Fog light
 - Ei1 Rear direction indicator
 - E12 Rearside marker light
 - E13 Rear parking light
 - E 1 4 Reversing light
 - E 1 5 Stop light
 - E16 Rear fbg lamp
 - E 1 7 Numberplate light
 - E18 Stop and rear side light
 - E19 Rear right light
 - E20 Rear left light
 - E21 Inspection light
 - E 2 2 Identification light
- F: INTERIOR LIGHTS**
- F1 Passenger compartment front roof lamp
 - F2 Passenger compartment rear roof lamp
 - F 3 Passenger compartment roof lamp
 - F 4 Engine compartment lamp
 - F5 Luggage compartment lamp
 - F 6 Door opening signalling light
 - F7 Fuse light
 - F8 Heater/ventilation control lighting lamp
 - F9 Glovebox light
 - F10 Ashtray light
 - F11 Map light
 - F12 Cluster light
 - F13 Front spot light
 - F14 Rear right spot light
 - F15 Rear left spot light
 - F16 Ignition switch light
 - F17 Switch illumination light
 - F18 Rear spot light
 - F19 Passenger compartment roof lamp - right side
 - F20 Passenger compartment roof lamp - left side
 - F21 Reading spot light with switch - right side
 - F22 Reading light with switch - left side
 - F23 Floor lighting lamp on right internal valance panel
 - F24 Floor lighting lamp on left internal valance panel
 - F25 Vanity mirror roof lighting on sun visor
 - F26 Gearbox lever panel lighting lamp
- G: FUSEBOX- CONNECTORS - GROUNDS**
- G1 Fusebox
 - G2 Auxiliary fusebox
 - G3 Fusebox terminal
 - G4 Frke fusebox
 - G5 Multiple connector
 - G6 Multiple connector 6 - cluster
 - G 7 Multiple connector R- cluster
 - G8 Single connector
 - G9 Coinnector between, front left door wiring and door mirror switch
 - G10 Connector between front right door wiring and door mirror Switch
 - G11 Connector between board wiring and rear wiring
 - G12 Connector between board wiring and courtesy mirror switch
 - G13 Connector between board wiring and console wiring
 - G14 3-way connector between board wiring and door wiring
 - G15 2-way connector between board wiring and door wiring
 - G16 6-way connector between board wiring and door wiring
 - G17 Connector between board wiring and front right door wiring
 - G18 Connector between board wiring and front left door wiring
 - G19 Connector between board wiring and pessenger compartment roof lamp
 - G20 Connector for front right door- locking motor
 - G21 Connector for front right door wiring
 - G22 Connector for front left door- locking motor
 - G23 Connector for front left door wiring
 - G24 Connector for rear right door- locking motor
 - G25 Connector for rear right door wiring
 - G26 Connector for rear left door - locking motor
 - G27 Connector for rear left door wiring
 - G28 Connector between front right door wiring and power window switch
 - G28a Connector between rear right door wiring and power window switch
 - G 2 9 Connector between doorlock wiring and rear power windows
 - G30 Connector for power windows and doorlock
 - G31 Connector between front left door wiring and power window switch
 - G31a Connector between rear left door wiring and power window switch
 - G 3 2 Connector between console wiring and rear right door wiring
 - G33 Connector between console wiring and rear left door wiring
 - G34 Connector for power window supply cable
 - G35 Connector between rear wiring and rear right tail light wiring,
 - G36 Connector for power window switch cables
 - G 3 7 Connector for combination switch on steering column
 - G 3 8 Connector for air conditioner wiring
 - G39 Connector for clock
 - G40 Connector for doorlock control unit
 - G41 Connector for tachymetric switch- rev counter pulse generator
 - G42 Connector between alternator and min engine oil pressure switch
 - G43 Connector for heater/ventilation control cables
 - G44 Connector for rear fog lamp
 - G45 Connector for headlight wash/wipe cables
 - G46 Connector for headlights
 - G 4 7 Connector for right side -repeater cables
 - G48 Connector between electric door mirror and left side . repeater cables
 - G49 Connector available
 - G50 Provision for loud speaker cables
 - G 5 1 Provision for car radio cables
 - G52 Fusebox ground
 - G53 Engine compartment ground
 - G53a Engine compartment ground - right side
 - G53b Engine compartment ground - left side
 - G54 Passenger compartment ground
 - G54a Passenger compartment ground - right side
 - G54b Passenger compartment ground - left side
 - G55 Valance panel ground
 - G56 Branch terminal board
 - G57 Provision for fuel tut-off solenoid valve
 - G58 Connector for cigar lighter
 - G 5 9 Connector for electric door mirror
 - G60 Injection wiring ground
 - G 6 1 Connector for ignition coil
 - G62 Clutch switch connector

ELECTRICAL SYSTEM

G: FUSEBOX - CONNECTORS - GROUNDS (continued)

- G63 Rear ground
 G63a Rear right ground
 G63b Rear left ground
 G64 Connector for Trip Computer - clock
 G65 Coaxial cable
 G66 Motronic wiring ground
 G67 Motronic connector
 G68 Connector A with board wiring
 G69 Connector B with board wiring
 G70 Connector C with board wiring
 G71 Connector for warning lamp on instruments
 G72 Connector for seatback adjustment wiring
 G73 Connector for rear services
 G73a Connector for right rear services
 G73b Connector for left rear services
 G74 Connectors between Televel rear wiring and ALFA ROMEO Control
 G75 Connector between right and left roof panel services
 G76 Connector for roof panel services - right side
 G77 Connector for roof panel services - left side
 G78 Connector for front door services wiring
 G79 Connector for rear door services wiring
 G80 Connector for board wiring
 G81 Connector for front left seatback adjustment
 G82 Connector for front right seatback adjustment
 G83 Rear connector for fast idle device
 G84 Console cable connector
 G84a Console cable connector (15 way)
 G84b Console cable connector (12-way)
 G85 Front service connector
 G86 Connector for passenger compartment roof lamp
 G87 Connector for rear door - locking motors
 G88 Connector for rear tail lights
 G89 Intermediate connector A
 G90 Intermediate connector B
 G91 Rear door sensor ground
 G92 Luggage compartment ground
 G93 Windshield frame upper cross member ground
 G94 Engine compartment connector
 G94a 10-way connector for engine compartment
 G94b 8-way connector for engine compartment
 G94c Engine compartment connector - right side
 G94d Engine compartment connector - left side
 G95 Central fusebox
 G95A Connector for switches
 G95B Connector for switches
 G95C Connector for cluster warning lamps
 G95D Connector for ALFA ROMEO Control
 G95E Connector for console
 G95F Connector for fog light - rear fog light
 G95G Connector for combination switch
 G95H Connector for LH interface
 G95I Connector for RH interface
 G95L Connector for clock - rheostats
 G95M Connector for sun - roof
 G95N Connector for battery
 G95O Connector for ignition switch
 G95P Connector for door services
 G95Q Connector for performance gauge
 G95R Connector for heated rear window
 G95S Connector for cluster
 G95V Fuses
 G96 Single connector for ALFA ROMEO Control - cluster
 G97 Connector for left doors services
 G98 Connector for right doors services
 G99a Connector for engine dashboard (A)
 G99b Connector for engine dashboard (B)
 G99c Connector for engine dashboard (C)
 G99d Connector for engine dashboard (D)
 G99e Connector for engine dashboard (E)
 G100 Connector for console - doors wiring
 G101 Trip Computer connector
 G102 Optoelectronic cluster connector
 G103 Connector for ground. and brake fluid tank
 G104 Connector for roof panel left pillar
 G105 Connector for ashtray lamp
 G106 Seat grounds
 G107 Connector for fuel pump
 G108 CEM wiring ground
 G109 Injection, wiring ground
 G110 Thermostat housing ground
 G111 Connector for dashboard instrument wiring
 G112a Connector A for roof wiring
 G112b Connector B for roof wiring
 G112c Connector C for roof wiring
 G112d Connector D for roof wiring
 G113 Connector for front left-hand fender
 G114 Connector for outside temperature sensor
 G115 Connector for tow bar vehicle socket
 G116 Connector for tow bar trailer plug
 G117 Connector for engine compartment lamp
 G118 Connector for luggage compartment lamp
 G119 Connector for vanity mirror roof lamp
 G120 Connector for map reading lamp
 G121 Connector for vehicle wiring
 G122 Connector for ignition wiring
 G123 Pedal assembly ground
 G124 Connector for A.B.S. system
 G125 A.B.S. system free fuse holder
 G126 Fuse protecting A.B.S. system relays
 G127 Free fuse holder for identification lights
 G128 Free fuse holder for transceiver
 G129 Connector for two-note horns - normal horns in engine compartment left side
 G130 Switches connector
 G131 Ground on upper cover
 G132 Ground on manifold
 G133a Electronic injection - ignition wiring connector A
 G133b Electronic injection - ignition wiring connector B
 G134 Left front pillar connector
 G135 Rear window shelf wiring connector
 G136 Front side marker intermediate connector
 G137 Injection supply wiring connector
 G138 Headlights - combination switch connector
 G139 Intercom system control unit connector
 G140 Petrol pump attachment to floor services intermediate connector
 G141 Intermediate connector for rear sidemarker
 G142 Engine services connector
 G143 Central bulkhead ground
 G144 Backdoor wiring connector
 G227 Mudguard under panel service connector
- H: SWITCHES
- H1 Handbrake switch
 H2 Reversing light switch
 H3 Stop light switch
 H4 Passenger compartment roof lamp switch on pillar
 H5 Left front door open indicator switch
 H6 Right front door open indicator switch
 H7 Left rear door open indicator switch
 H8 Right rear door open indicator switch
 H9 Right front brake pad switch
 H10 Left front brake pad switch
 H11 Right rear brake pad switch
 H12 Left rear brake pad switch
 H13 Choke switch
 H14 Injection advance switch
 H15 Gearbox oil low level switch (magnetic bulb)
 H16 Starting and back-up inhibitor switch

ELECTRICAL SYSTEM

H: SWITCHES (continued)

- Hi 7 Brake fluid minimum level check switch
- H18 Fast-idle switch in gearbox
- H19 Low fuel pressure switch
- H20 Inertia switch
- H21 Clutch pedal fast idle switch
- H22 Ignition microswitch
- H23 Engine compartment lamp switch
- H24 Luggage compartment lamp switch
- H25 Glovebox light switch
- H16 Contact switch on rear door for rear window wiper
- H27 Contact switch on rear door for heated rear window
- H28 Carburettor contact/switch
- H29 Switch for rear drive engagement warning lamp
- H30 R.p.m.-activated microswitch
- H31 Switch for idle r.p.m. adjusting screw on carburettor
- H32 Microswitch on carburettor for inserting timing variator
- H33 Numberplate lights contact switch
- H34 A.B.S. system brake fluid tank switch
- H35 Fuel pre-heating filter thermal switch
- H36 Diesel fuel post-heating microswitch

I: RELAYS

- I1 Engine cooling fan relay
- I2 Heated rear window relay
- I3 Horn relay
- I4 Headlamp wiper relay
- I5 Auxiliary relay for headlight wiper timer
- I6 Fast idle relay
- I7 Fuel pipe closing relay
- I8 Relay excluding retarded rotor arm
- I9 Glowplug relay
- I10 Starter inhibitor relay
- I11 Front power window and seat raising relay
- I12 Front power window relay
- I13 Rear power window relay
- I14 Brake fluid automatic warning lamp control relay
- I15 Low fuel pressure warning light relay
- I16 Headlight relay
- I17 Fog light relay
- I18 Double contact relay
- I19 Headlight washer pump relay
- I20 Beam changeover relay
- I21 Full beam exclusion relay
- I22 Low beam exclusion relay
- I23 Supplementary engine cooling fan relay
- I24 Direction and hazard lights relay
- I25 Rear fog light relay
- I26 Rooflamp relay
- I27 Seat height adjustment relay
- I28 Hazard light relay
- I29 Fuel pump relay
- I30 Relay with CEM diode
- I31 Front power windows/heater relay
- I32 Advance variation control unit relay
- I33 Carburetor microswitch relay
- I34 Rear fog light exclusion relay
- I35 Key operated supply relay
- I36 Relay for brake wear and liquid level
- I37 Relay for A.B.S. system control unit
- I38 Auxiliary A.B.S. system relay
- I39 Brake fluid level warning lamp relay
- I40 A.B.S. system brake fluid pump relay
- I41 Two note horns - normal horns relay
- I42 Two note horns relay
- I43 Inspection lamp relay
- I44 Fuel pre heating device relay
- I45 External rearview mirrors defrosting relay

- 146 Siren relay
- 147 Oil radiator electric fan relay

L: SENDERS

- L1 Low fuel pressure sender
- L2 Low oil pressure sender
- L3 Max air pressure sender
- L4 Thermal switch for engine cooling electromagnetic coupling
- L5 Thermal switch for engine coolant max temperature warning lamp
- L6 Thermal switch for engine cooling electric fan
- L7 Engine coolant temperature gauge sender
- L8 Oil pressure gauge sender
- L9 Fuel level gauge sender
- L10 Sender for engine coolant temperature gauge and max temperature warning lamp contact
- L11 Retarded rotor arm cut-out pressure switch
- L12 Engine oil level sensor
- L13 Windscreen washing liquid level sensor
- L14 Engine coolant level sensor
- L15 Fuel flow sensor
- L16 Rev counter pulse generator
- L17 Speedometer pulse generator
- L18 Load sender
- L19 External temperature sensor
- L20 Photoelectric cell
- L21 Pierburg valve (Solenoid valve regulating the supercharging pressure)
- L22 Knocking sensor
- L23 Potentiometer
- L24 Coolant temperature sensor for ignition advance adjustment
- L25 Thermal switch for engine coolant temperature
- L26 Vacuum sensor
- L27 Temperature sensor
- L28 Front right brake sensor
- L29 Front left (brake sensor)
- L30 Rear right brake sensor
- L31 Rear left brake sensor
- L32 Supercharging air pressure sender
- L33 Two-level thermal switch

M: SOLENOIDS - SOLENOID VALVES

- M1 Fuel cut-off solenoid valve
- M2 Injection pump solenoid valve
- M3 Solenoid with injection pump fuel cut-off microswitch
- M4 Fast idle solenoid
- M5 Engine stop solenoid
- M6 Fuel pipe closing solenoid
- M7 Door opening/closing solenoid
- M8 Auxiliary air device (for A/C equipped car)
- M9 Pierburg solenoid valve (for idle r.p.m.)
- M10 Brake fluid adjustment valves
- M11 Main A.B.S. valve

N: ELECTRONIC DEVICES - INTERMITTENCES - TIMERS

- N1 Electronic ignition module
- N1a Electronic ignition module A
- N1b Electronic ignition module B
- N2 Connector for Marelli module,
- N3 Capacitor for electronic ignition
- N4 Connector for Bosch module
- N5 Tachymetric switch device
- N6 Pre heating glowplug timer
- N7 Trip Computer
- N8 ALFA ROMEO Control

ELECTRICAL SYSTEM

R: SAFETY DEVICES

- R1 Seat belt device
- R2 Catalytic muffler temperature indicator
- R3 Thermocouple for catalytic muffler temperature detection
- R4 Buzzer signalling unfastened seatbelt
- R5 Buzzer signalling open door
- R6 Odometer
- R7 Seat belt warning lamp
- R8 30,000 mile warning lamp
- R9 Push-button switch on seat belts
- R10 Catalytic muffler maximum temperature warning lamp
- R11 Front left door switch for seat belt device

S: ELECTRONIC INJECTION

- S1 Injection control unit
- S2 Relay set
- S3 Electroinjectors
- S4 Cold start electroinjectors
- S5 Air flow sensor
- S6 Accelerator throttle switch
- S7 Engine coolant temperature sensor
- S8 Thermo-time switch
- S9 Supplementary air valve
- S10 Lambda probe
- S11 Motronic control unit
- S12 Motronic relay

- S12a Fuel pump Motronic relay
- S12b Motronic relay with diode
- S12c Timing variator device Motronic relay
- S12d Auxiliary Motronic relay
- s13 Timing sensor
- S14 Rev sensor
- S15 Timing variator device
- S16 Altitude compensation device
- S17 CEM control unit
- S17a CEM control unit white connector
- S17b CEM control unit black connector
- S18 Throttle angle sensor
- S19 Hall sensor
- S20 Deton sensor
- S21 Throttle actuator
- s22 Electroinjector terminal
- S23 Electroinjector resistor
- S24 Electroinjector terminal board
- S26 Injection system
- S27 Lambda probe resistance
- S28 Injection control relay
- S29 Minimum adjustment actuator
- S32 Lambda probe coder

T: DIAGNOSIS

- T1 ALFA TESTER connector
- T2 "Flashing Code" diagnosis connector

BODY-SHEET METAL PANELS

GROUP 49

CONTENTS

GENERAL INFORMATION	49-2	BODY CO-NSTRUCTION	(*)
Identification codes	(*)	BODY SEALING	(*)
Lifting points	(*)	BODY ALIGNMENT	(*)
Wheel alignment	49-2	CAUTIONS FOR THE OPERATORS ..	(*)
BODY COMPONENT PARTS	(*)	REPLACEMENT OPERATIONS	(*)

(*) Refer to "WORKSHOP MANUAL **Alfa 33**" VOLUME I
and VOLUME II - Group 49

GENERAL INFORMATION

WHEEL ALIGNMENT

CAUTION:

The technicians assigned to the repair and replacement operations of sheet panels, shall always take into account, content of the remaining part of the "Workshop Manual" in order always to maintain original quality and functioning conditions of car as a whole. As restoration of car correct alignment is of particular importance, in the following part are provided the data relevant to geometry of both front and rear suspensions. For any further information, refer to the specific Groups.

Wheel alignment is measured with car under nominal height (see: Group 00).

1. Front axle and suspension

Features	Model	33 **	33 1.7 *	33 1.8 TD
		33 1.3	33 1.7 IE	
		33 1.3 S	33 1.7 IE	
		33 1.5 TI	33 1.7 *	
		33 1.5 a x a	Electronic injection	
Toe-out Toe-out angle	mm (in)	M - H = 4 ± 2 $\alpha = 10'$		M - H = 2 ± 2 $\alpha = 10'$
Rim diameter	mm (in)	0 = 340	0 = 365	0 = 340
Camber angle		$\beta = -1^\circ \pm 30'$		$\beta = -1^\circ 55' \pm 30'$
Caster angle		$\gamma = 2^\circ \pm 30'$		$\gamma = 1^\circ \pm 30'$
Max steering angle	External angle	$\delta_1 = 27^\circ 50'$		$\delta_1 = 29^\circ 33'$
	Internal angle	$\delta_2 = 33^\circ 45'$		$\delta_2 = 35^\circ 10'$

2. Rear axle and suspension

Features	Model	33 **	33 1.3	33 1.3 S	33 1.8 TD
		33 1.5 TI	33 1.5 axa	33 1.7 *	
		33 1.7 * <td>33 1.7 IE <td>33 1.7 * <td>Electronic injection</td> </td></td>	33 1.7 IE <td>33 1.7 * <td>Electronic injection</td> </td>	33 1.7 * <td>Electronic injection</td>	Electronic injection
Toe-in angle		$\alpha = -20' \pm 10'$			$\alpha = 0^\circ \pm 25'$
Camber angle		$\beta = 0^\circ \pm 25'$			

(*) Not marketed in all countries with 1.2 engine.

GROUP 49

CONTENTS

GENERAL INFORMATION	49-2	BODY CONSTRUCTION	(*)
~Identification codes	(*)	BODY SEALING	(*)
Lifting points	(*)	BODY ALIGNMENT	(*)
Wheel alignment	49-2	CAUTIONS FOR THE OPERATORS	(*)
BODY COMPONENT PARTS	(*)	REPLACEMENT OPERATIONS	(*)

(*) Refer to: "WORKSHOP MANUAL **Alfa 33**"
-VOLUME I and VOLUME II - Group 49

GENERAL 'INFORMATION

WHEEL ALIGNMENT

CAUTION:

In order to maintain the original quality and functioning of the vehicle as a whole, technicians must always keep in mind and refer to the other parts of the Workshop Manual". However, as correct alignment of the vehicle is of particular importance, the data relating to the geometry of both front and rear suspensions is given below. For any further information refer to the specific groups.

Wheel alignment is measured with carat nominal height (see: Group 00).

1. Front axle and suspension.

Models		Sport Wagon		Sport Wagon		Sport Wagon		Sport Wagon	
		33 1.3 S		33 1.7 @ 33 1.7 @ Δ		33 1.5 4x4 33 1.7 4x4 A		33 1.8 TD	
Toe-out	mm	M - H = 4 ± 2						M - H = 2 1 2	
Toe-out angle		a = 10'						a = 10'	
Rim diameter	mm	340		365 (1)		340 365 (1)		340	
Camber angle		$\beta = -1^\circ \pm 30'$						$\beta = -1^\circ 55' \pm 30'$	
Caster angle		$\gamma = 2^\circ \pm 30'$						$\gamma = 1^\circ \pm 30'$	
Max steering angle	External angle	$\delta_1 = 27^\circ 50'$						$\delta_1 = 29^\circ 33'$	
	Internal angle	$\delta_2 = 33^\circ 45'$						$\delta_2 = 35^\circ 10'$	

(1) With 5½ J rim x 14 rim

2. Rear axle and suspension

Models		Sport Wagon		Sport Wagon		Sport Wagon		Sport Wagon	
		33 1.3 S		33 1.7 @ 33 1.7 @ Δ		33 1.5 4x4 33 1.7 4x4 Δ		33 1.8 TD	
Toe-in angle		a = -2 0' ± 10						a = 0° ± 25'	
Camber angle		$\beta = 0^\circ \pm 25'$							

(A) With electronic injection engine for countries where antipollution regulations are in force.