

CURSOR TIER 3 SERIES

Industrial application

C87

CURSOR 87 TE X

This publication provides unit and relevant component repair data, specifications, instructions and methodologies.

This publication has been drawn up for qualified and specialised personnel.

Before performing any operation check that the part relevant to the unit on which you must work is available along with all safety devices for accident-prevention, such as, goggles, helmet, gloves, shoes, etc. and hoisting and transporting equipment.

Operations are to be performed by following the indications included here, using the special equipment indicated and assuring proper repair, compliance with schedule and operator's safety requirements.

Each repair must aim to restore operating efficiency and safety in compliance with the FPT provisions.

FPT cannot be held liable for modifications, alterations or other interventions non authorised by FPT on the vehicle and if the unit is warranted the above mentioned interventions will cause its expiration.

FPT is not liable for repairing interventions.

FPT will provide further details required to carry out the interventions and all the instructions that are not included on this publication.

Data included in this publication may not be up-to-date therefore subject to Manufacturer's modifications that can be added at any time for technical or commercial purposes and also to meet new law regulations in other Countries.

If issues on this publication differ from what is actually noticed on the unit, please get in touch with the FPT network before starting any intervention".

It is forbidden to copy this text or any of its parts and all illustrations included.

Publication edited by
FIAT Powertrain Technologies
Mkt. Advertising & Promotion
Viale dell'Industria, 15/17
20010 Pregnana Milanese
Milano (Italy)
Print **P2D32C006 E** - 2nd Ed. 06.2007
CURSOR 87 TE X Series







Produced by:

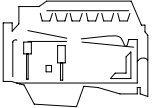

B.U. TECHNICAL PUBLISHING
Iveco Technical Publications
Lungo Stura Lazio, 15/19
10156 Turin - Italy

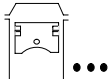

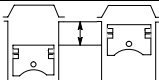
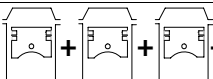

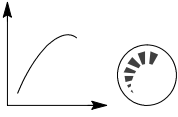
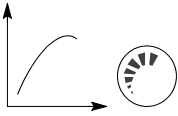
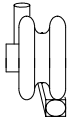
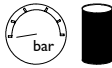
CORRESPONDENCE BETWEEN TECHNICAL CODE AND COMMERCIAL CODE

Technical Code	Commercial Code
F2CE9685A*E001	CURSOR 87 TE X
F2CE0685B*E002	

GENERAL CHARACTERISTICS		TECHNICAL CODE	
	Type	F2CE9685A*E001	
	Cycle	4-stroke Diesel engine	
	Fuel feed	Turbocharged	
	Injection	Direct	
	No. of cylinders	6 in line	
	Bore	mm	117
	Stroke	mm	135
	Total displacement	cm ³	8717
	Compression ratio	1: 15.9 ± 0.8	
	Europe market		
	Max output	kW (HP) rpm	263 (358) 1500
	Max. torque	Nm (kgm) rpm	1675 (170,7) 1500
	SUPERCHARGING		
	Turbocharger type	Intercooler Direct injection	
LUBRICATION			
	Oil pressure (warm engine)	Forced by gear pump, relief valve single action oil filter	
	- idling	bar	-
	- peak rpm	bar	-
COOLING			
	Water pump control	Liquid Through belt	
	Thermostat		
	- start of opening	°C	85 ± 1.5

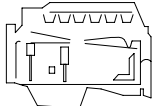
NOTE Data, features and performances are valid only if the setter fully complies with all the installation prescriptions provided by FPT.

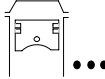
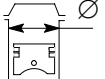
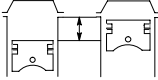
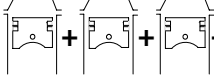
Furthermore, the users assembled by the setter shall always be in conformance to couple, power and number of turns based on which the engine has been designed.

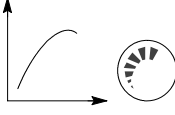
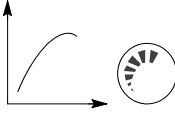
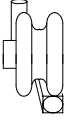
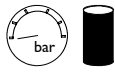



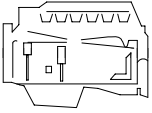
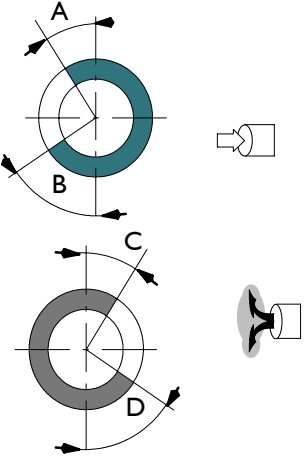
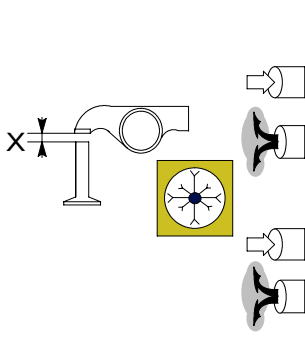
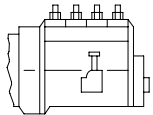
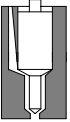
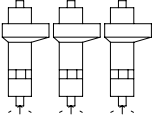
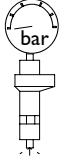

		TECHNICAL CODE	
	Type	F2CE0685B*E002	
	Cycle	4-stroke Diesel engine	
	Fuel feed	Turbocharged	
	Injection	Direct	
	No. of cylinders	6 in line	
	Bore	mm	117
	Stroke	mm	135
	Total displacement	cm ³	8717
	Compression ratio	1: 15.9 ± 0.8	
	USA market		
	Max output	kW (HP)	290 (401)
		rpm	1800
	Max. torque	Nm (kgm)	1539 (156,9)
		rpm	1800
	SUPERCHARGING		
	Turbocharger type	Intercooler Direct injection	
LUBRICATION			
	Oil pressure (warm engine)	Forced by gear pump, relief valve single action oil filter	
	- idling	bar	-
	- peak rpm	bar	-
COOLING			
	Water pump control	Liquid Through belt	
	Thermostat		
	- start of opening	°C	85 ± 1.5



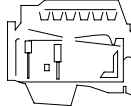
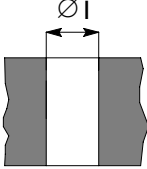
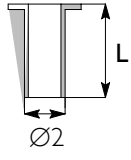

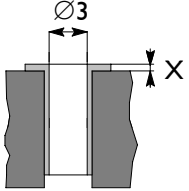
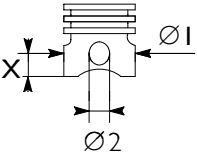

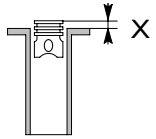
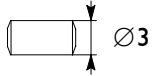
NOTE Data, features and performances are valid only if the setter fully complies with all the installation prescriptions provided by FPT.

Furthermore, the users assembled by the setter shall always be in conformance to couple, power and number of turns based on which the engine has been designed.

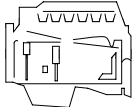
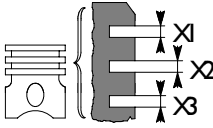
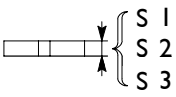

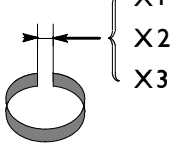
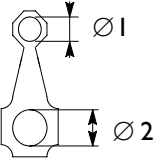
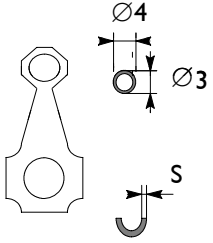

		TECHNICAL CODE	
	Type	F2CE9685A*E001	
		F2CE0685B*E002	
	<p>VALVE TIMING</p> <p>opens before T.D.C. A</p> <p>closes after B.D.C. B</p> <p>opens before B.D.C. D</p> <p>closes after T.D.C. C</p>		<p>17°</p> <p>31°</p> <p>48°</p> <p>9°</p>
	<p>For timing check</p> <p>Running</p>	<p>X { mm</p> <p>mm</p> <p>X { mm</p> <p>mm</p>	<p>-</p> <p>-</p> <p>0.35 to 0.45</p> <p>0.55 to 0.65</p>
	FEED	Bosch Common Rail with CRIN2 injectors and high pressure pump CP3.3	
	Nozzle type	DLLA 137	
	Injection order	1 - 4 - 2 - 6 - 3 - 5	
	<p>Injection pressure bar</p> <p>Injector calibration bar</p>	<p>bar</p> <p>bar</p>	<p>1800</p>

ASSEMBLY CLEARANCE DATA



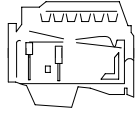
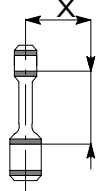
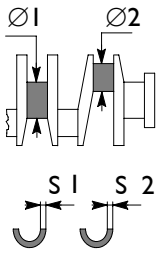
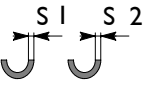
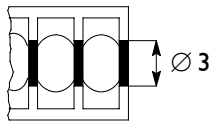

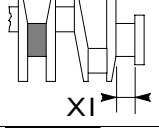
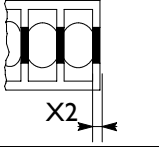
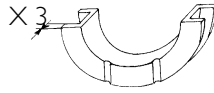

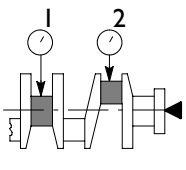



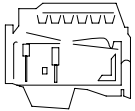
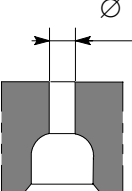
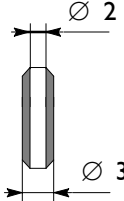



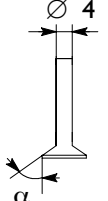

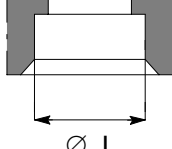

		Type	CURSOR 87 TE X
CYLINDER BLOCK AND CRANKMECHANISM COMPONENTS			mm
	Bores for cylinder liners:		
	upper		130.500 to 130.525
	lower		129.510 to 129.535
	Cylinder liners:		
	external diameter:		
	upper		130.461 to 130.486
	lower		129.475 to 129.500
	length	L	226,15 226.15
	Cylinder liners - crankcase bores		
	upper		0.014 to 0.064
	lower		0.010 to 0.060
	External diameter	Ø2	-
	Cylinder sleeve		
	inside diameter	Ø3A*	117.000 to 117.012
	inside diameter	Ø3B*	117.010 to 117.022
	Protrusion	X	0.035 to 0.065
* Selection class			
	Pistons:		
	measuring dimension	X	15
	external diameter	Ø1A	116.894 to 116.906
	external diameter	Ø1B	116.904 to 116.916
	pin bore	Ø2	52.010 to 52.016
	Piston - cylinder sleeve		
		A*	0.094 to 0.118
		B*	0.094 to 0.118
* Selection class			
	Piston diameter	Ø1	-
	Pistons protrusion	X	0.873 to 1.117
	Gudgeon pin	Ø3	51.994 to 52.000
	Gudgeon pin - pin housing		0.010 to 0.022

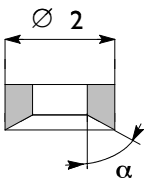

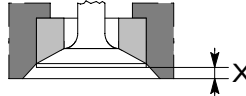

	Type	CURSOR 87 TE X	
		mm	
	Piston ring grooves	X1	3,120 ÷ 3,140
		X2	3.120 to 3.140
		X3	2.550 to 2.570
	Piston rings: trapezoidal seal	S1	3.000
	lune seal	S2	2.470 to 2.500
	milled scraper ring with slits and internal spring	S3	3.970 to 3.990
	Piston rings - grooves	1	-
		2	0.050 to 0.100
		3	0.030 to 0.070
	Piston rings		-
	Piston ring end gap in cylinder liners	X1	0.3 to 0.4
		X2	0.60 to 0.75
		X3	0.35 to 0.65
	Small end bush housing	∅1	55.700 to 55.730
	Big end bearing housing	∅2	85.987 to 86.013
	Selection classes	1	85.987 to 85.996
		2	85.997 to 86.005
	Small end bush diameter outside	∅4	55.780 to 55.820
	inside	∅3	52.015 to 52.030
	Big end bearing shell	S	
	Red		1.994 to 2.002
	Green		2.002 to 2.010
	Yellow ●		2.010 to 2.018
	Small end bush - housing		0.05 to 0.08
	Piston pin - bush		0.015 to 0.036
	Big end bearing		0.127 - 0.254 - 0.508
	Connecting rod weight	A	g
	Class	A	3450 to 3470
		B	3471 to 3490
		C	3491 to 3510





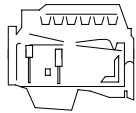
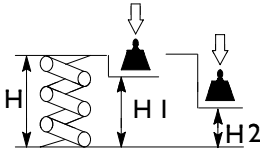
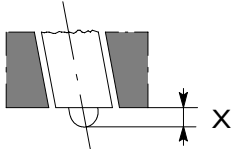
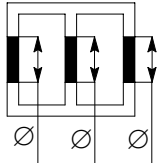
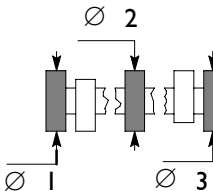
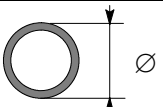
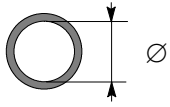

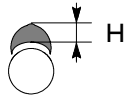
● Fitted in production only and not supplied as spares

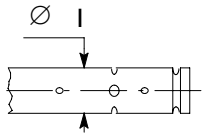
		CURSOR 87 TE X	
		mm	
	Measuring dimension	X	125
	Max. connecting rod axis misalignment tolerance	=	0.08
	Main journals	∅1	92.970 to 93.000
	- nominal		92.970 to 93.000
	- class	1	92.970 to 92.980
	- class	2	92.980 to 92.990
	- class	3	92.990 to 93.000
	Crankpins	∅2	81.915 to 81.945
	- nominal		81.915 to 81.945
	- class	1	81.915 to 81.925
	- class	2	81.925 to 81.935
	- class	3	81.935 to 81.945
	Main bearing shells	S1	
	Red		2.968 to 2.978
	Green		2.978 to 2.988
	Yellow*		2.988 to 2.998
	Big end bearing shells	S2	
	Red		1.994 to 2.002
Green		2.002 to 2.010	
Yellow*		2.010 to 2.018	
	Main bearing housings	∅3	99.000 to 99.030
	- nominal		99.000 to 99.030
	- class	1	99.000 to 99.009
	- class	2	99.010 to 99.019
- class	3	99.020 to 99.030	
	Bearing shells - main journals		0.050 to 0.090
	Bearing shells - big ends		0.040 to 0.080
	Main bearing shells	<	0.127 - 2.254 - 0.508
	Big end bearing shells		0.127 - 2.254 - 0.508
	Main journal, thrust bearing	X1	39.96 to 40.04
	Main bearing housing, thrust bearing	X2	38.94 to 38.99
	Thrust washer halves	X3	3.38 to 3.43
	Crankshaft end float		0.10 to 0.30
	Alignment	=	1 - 2
	Ovalization	○	1 - 2
	Taper	/	1 - 2
			0.04
			-

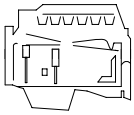
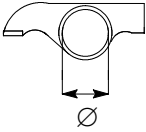
* Fitted in production only and not supplied as spares

 Type	CURSOR 87 TE X	
CYLINDER HEAD - VALVE TRAIN		
mm		
 Valve guide housings in cylinder head	Ø1	12.9800 to 12.997
 Valve guide	 Ø2 Ø3	8.023 to 8.038 13.012 to 13.025
 Valve guides - housings in the cylinder heads		0.015 to 0.045
 Valve guide		0.2 - 0.4
 Valves:	 Ø4 α  Ø4 α	7.970 to 7.985 60° 30' ± 7' 30" 7.970 to 7.985 45° $\begin{smallmatrix} +15 \\ -0 \end{smallmatrix}$
 Valve stem and its guide		0.040 to 0.070
 Valve seat in head	 Ø1  Ø1	41.985 to 42.020 40.985 to 41.020
 Outside diameter of valve seat; angle of valve seat in cylinder head:	 Ø2 α  Ø2 α	$\begin{smallmatrix} 0' \\ -0.5' \end{smallmatrix}$ 42.060 to 42.075 60° - 30' $\begin{smallmatrix} 0' \\ -0.5' \end{smallmatrix}$ 41.060 to 41.075 45° - 30'
 Recessing of valve	 X  X	0.5 to 0.8 1.6 to 1.9
 Between valve seat and head	 	0.040 to 0.090

 Type		CURSOR 87 TE X	
		mm	
 Valve spring height: free height H under a load of: N 460 ± 23 H1A } N 460 ± 22 H1B } N 740 ± 33 H2A } N 731,4 ± 42 H2B }	A	B	70.77
			51
 Injector protrusion X	X	1.2 to 1.5	
 Camshaft bushing housing in the cylinder head: I ⇒ 7	Ø	69.000 to 69.030	
 Camshaft bearing journals: I ⇒ 7	Ø	64.924 to 64.080	
 Outer diameter of camshaft bushings:	Ø	69.090 to 69.130	
 Inner diameter of camshaft bushings:	Ø	65.080 to 65.116	
 Bushings and housings in the cylinder head	0.060 to 0.130		
 Bushings and bearing journals	0.100 to 0.192		
 Cam lift:		7.4034 8.2108	
 Rocker shaft	Ø1	31.964 to 31.980	

 Type	CURSOR 87 TE X mm
 Bushing housing in rocker arms  	32.025 to 32.041 32.025 to 32.041
Between bushings and housings   	0.045 to 0.077 0.045 to 0.077
TURBOCHARGER Type End float Radial play	HX55 - -

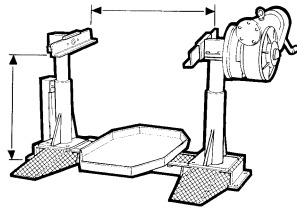
TOOLS**TOOL NO.****DESCRIPTION****99322230**

Rotary telescopic stand (range 2000 daN, torque 375 daNm)

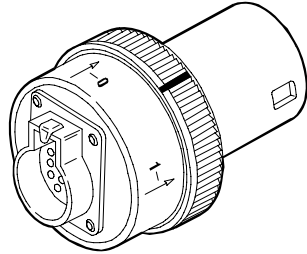
99331043

Tool to rotate engine flywheel (to be used with 99360325)

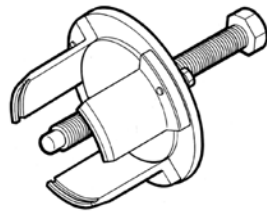
99340051

Extractor for crankshaft front gasket

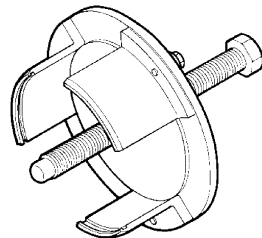
99340054

Extractor for crankshaft rear gasket

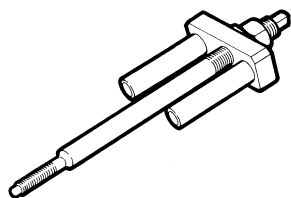

99342149

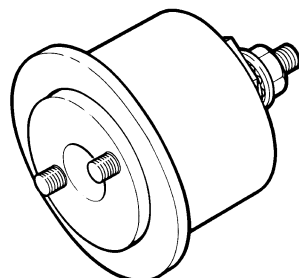
Extractor for injector-holder

99346245

Tool to install the crankshaft front gasket

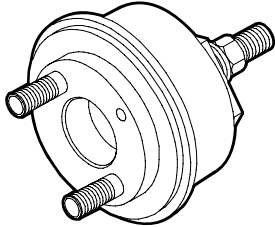
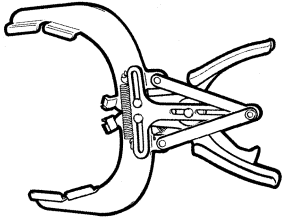
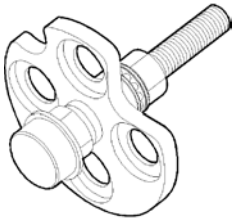
TOOLS

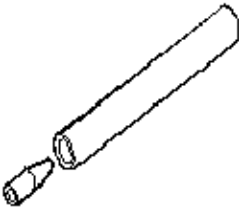
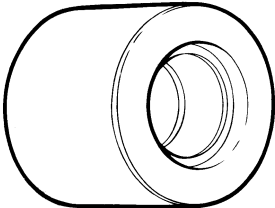
TOOL NO.		DESCRIPTION
99346260	 A cylindrical metal tool with a central hole and two threaded ports on the side.	Percussion extractor
99360184	 A pair of pliers with curved ends and a central mechanism for gripping split rings.	Pliers for assembling and disassembling piston split rings (105-106 mm)
99360264	 A tool with a central threaded shaft and a multi-lobed head for gripping internal components.	Universal extractor for 5 to 70 mm internal components
99360288	 A long, thin box wrench with a tapered handle.	Box wrench for block junction bolts to the underblock
99360292	 A long, thin box wrench with a tapered handle, similar to 99360288.	Box wrench for block junction bolts to the underblock
99360294	 A cylindrical tool with a flange on one end and a central hole.	Tool to fit back valve guide (to be used with 99360481)

TOOLS

TOOL NO.

DESCRIPTION

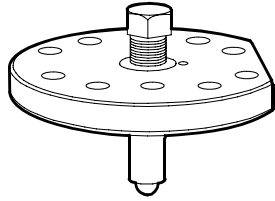
99360334

Compression tool for checking the protrusion of cylinder liners
(to be used with 99370415-99395603 and special plates)

99360335

Cylinder liner compression plate
(to be used with 99360334-99360336)

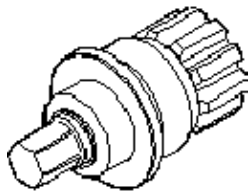
99360341

Cylinder liner compression plate
(to be used with 99360334-99360336)

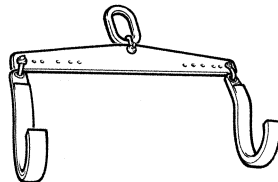
99360500

Tool to lift crankshaft

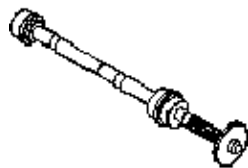
99360505

Tool to lift crankshaft

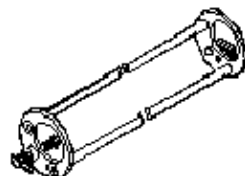
99360558

Percussion extractor

TOOLS

TOOL NO.	DESCRIPTION
99360585	Swing hoist for engine disassembly assembly
99360605	Belt to insert piston in cylinder liner (60 - 125 mm)
99360612	Tool for positioning engine P.M.S.
99360613	Tool for timing of phonic wheel on timing gear
99360703	Tool to stop cylinder liners
99360706	Tool to extract cylinder liners (to be used with specific rings)

TOOLS

TOOL NO.

DESCRIPTION

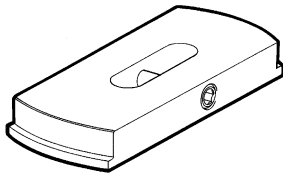
99360724

Ring (135 mm) (to be used with 99360706)

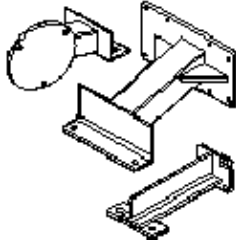
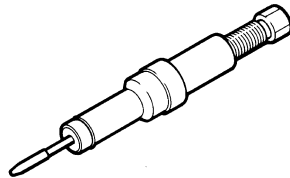
99361042Tool to take down-fit engine valves
(to be used with special plates)**99365054**

Tool for injector holder heading

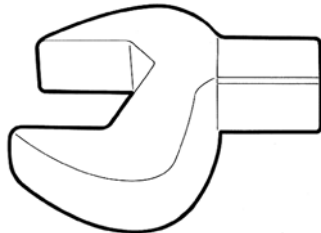
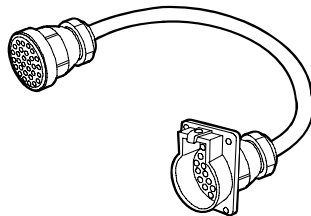
99368542Tool to take down-fit engine valves
(to be used with special plates)**99368554**Tool to take down-fit engine valves
(to be used with special plates)**99368555**Tool to take down-fit engine valves
(to be used with special plates)

TOOLS

TOOL NO.

DESCRIPTION

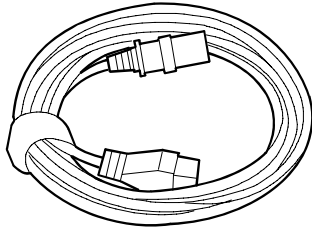
99368556

Tool to take down-fit engine valves
(to be used with special plates)

99368558

Tool to take down-fit engine valves
(to be used with special plates)

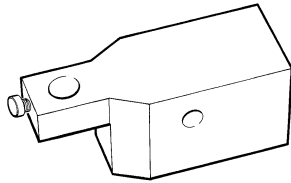
99370415

Base supporting the dial gauge for checking cylinder liner
protrusion (to be used with 99395603)

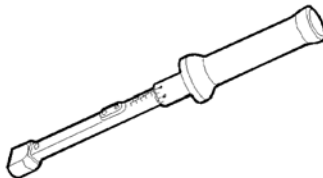
99389833

Base supporting the dial gauge for checking cylinder liner
protrusion (to be used with 99395603)

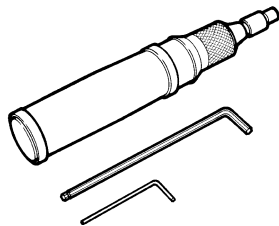
99389834

Torque screwdriver (1-6 Nm) for calibrating the injector solenoid
valve connector check nut

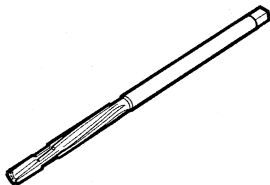
99390310

Valve guide sleeker

TOOLS

TOOL NO.

DESCRIPTION

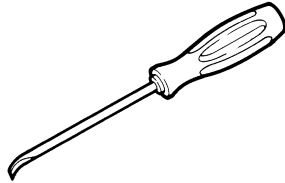
99390772

Tool for removing injector holding case deposits

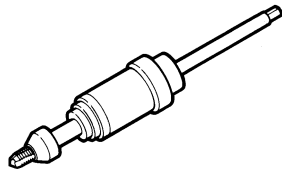
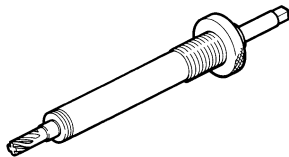
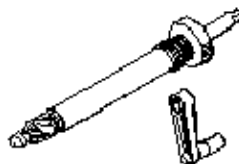
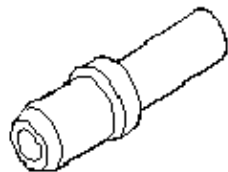
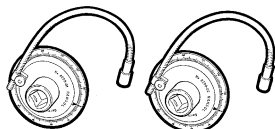
99390804Tool for threading injector holding cases to be extracted
(to be used with 99390805)**99394043**Reamer to rectify injector holder lower side
(to be used with 99394015)**99394044**Reamer to rectify injector holder lower side
(to be used with 99394015)**99394045**Reamer to rectify injector holder lower side
(to be used with 99394015)**99395216**Measuring pair for angular tightening with 1/2"
and 3/4" square couplings

TOOLS

TOOL NO.

DESCRIPTION

99395221

Tool to take down-fit engine valves
(to be used with special plates)

99395222

Plate for take down-fit engine valves
(to be used with 99360261)

99395223

Tool to remove oil filter (engine)

99395603

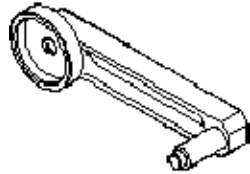
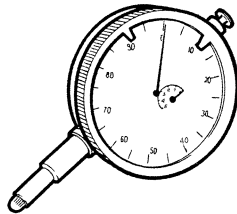
Dial gauge (0 - 5 mm)

EQUIPMENT MODIFIED FOR ADAPTATION TO CURSOR 9 ENGINE

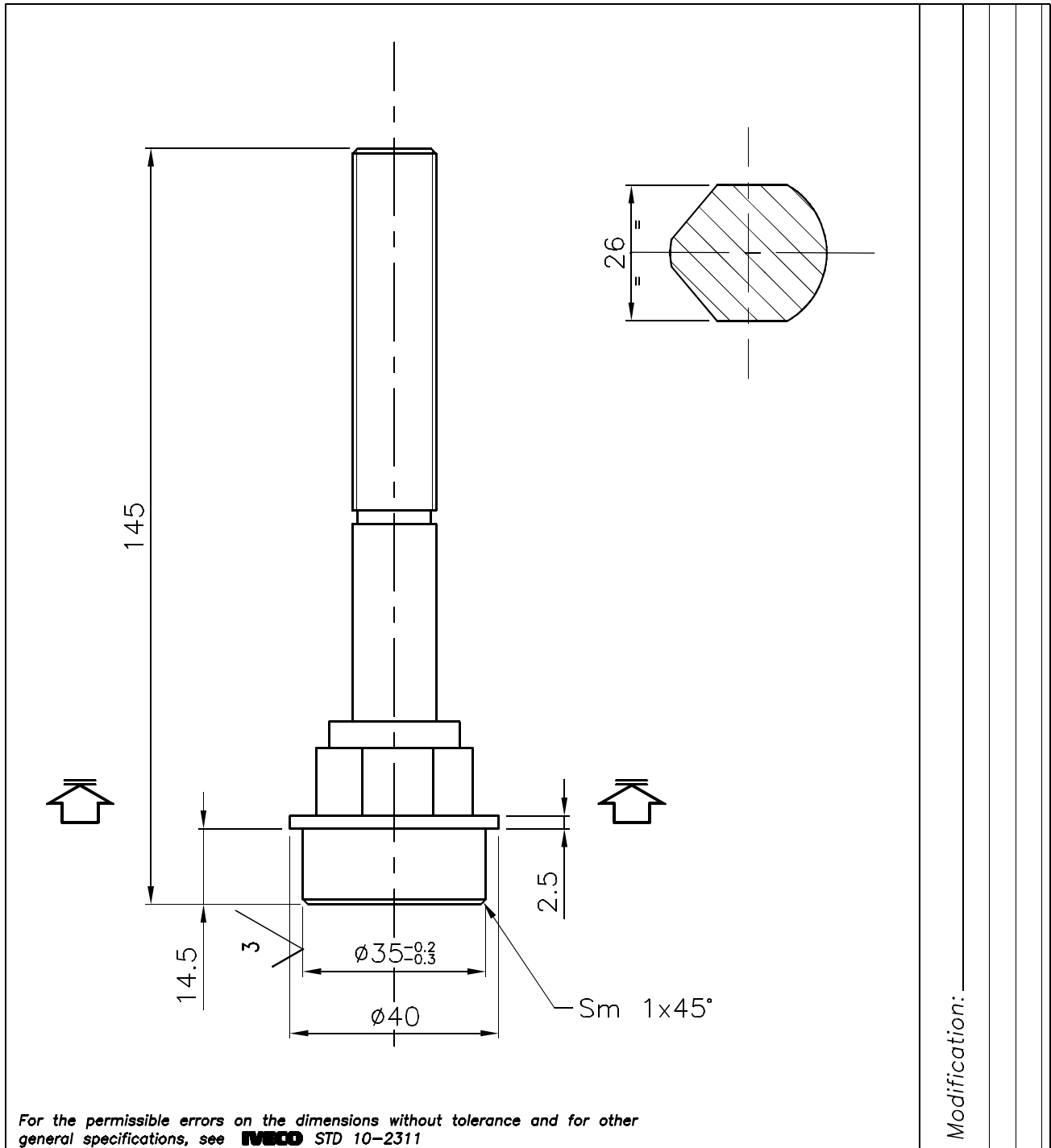

For the permissible errors on the dimensions without tolerance and for other general specifications, see **IVECO** STD 10-2311

Modification:

MAT.		COVER.	DRAWN UTS /	N°DRAWING 99360264		
All proprietary rights reserved by IVECO . This drawing shall not be reproduced or in any way utilised, for the manufacture or the component or unit herein illustrated and must not be released to other parties, without written consent. Any infringement will be legally pursued. C/=0 I.S. 18-0011	Modifica per adeguamento		APPROVED	EXPER.	SIZE A4	
	attrezzo a motore		DATE	SHEET		
	CURSOR 9		SUPERSEDES			
			SCALE 1:1			
			Q.TY 1			

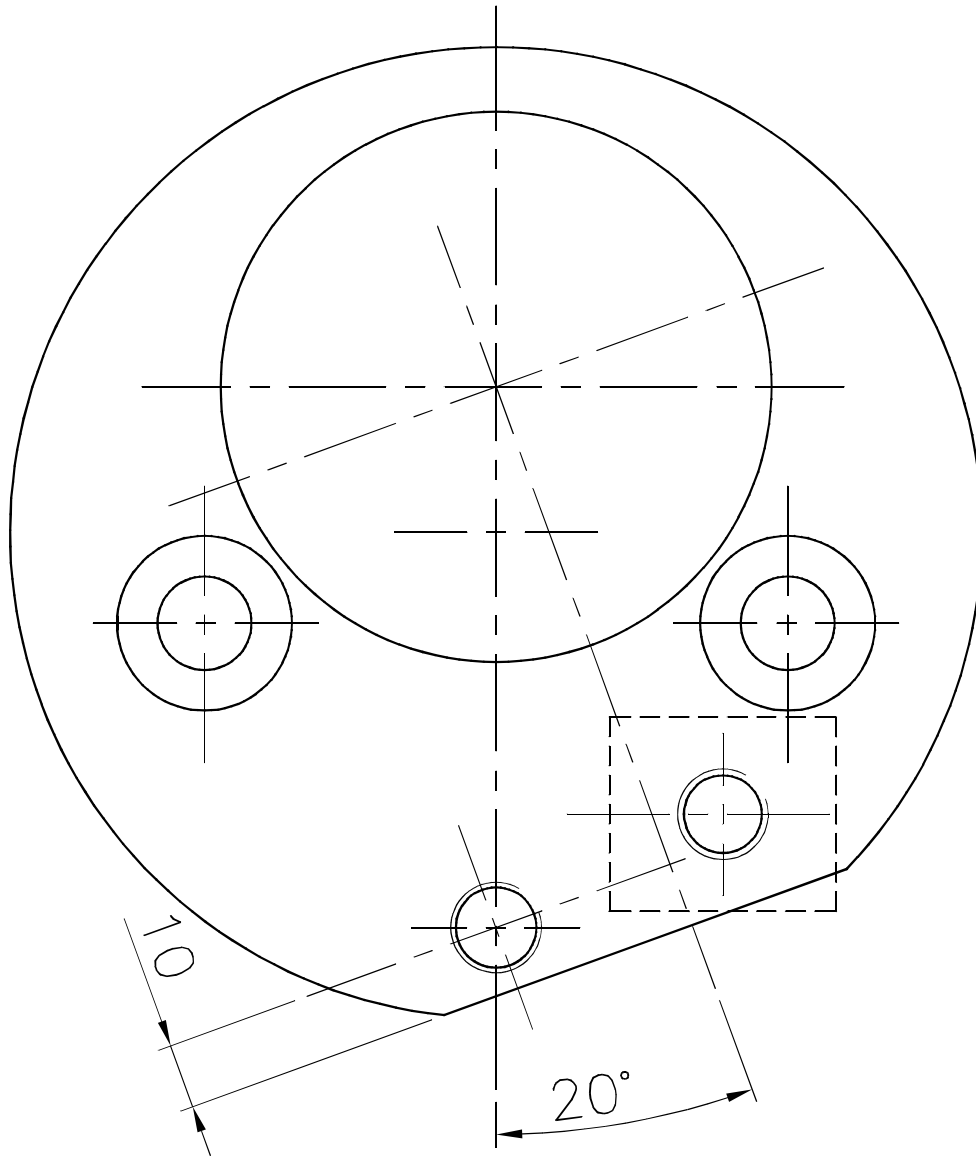

Modification:

For the permissible errors on the dimensions without tolerance and for other general specifications, see **IVECO** STD 10-2311

MAT.		COVER.	DRAWN UTS /	N°DRAWING 99360558		
All proprietary rights reserved by IVECO This drawing shall not be reproduced or in any way utilised, for the manufacture or the component or unit herein illustrated and must not be released to other parties, without written consent. Any infringement will be legally pursued.	C/=0 I.S. 18-0011	Modifica per adeguamento		APPROVED	EXPER. SIZE A4	
		attrezzo a motore		DATE	SHEET	
		CURSOR 9		SUPERSEDES		
				SCALE	1:1	
				Q.TY	1	
			IVECO			

02

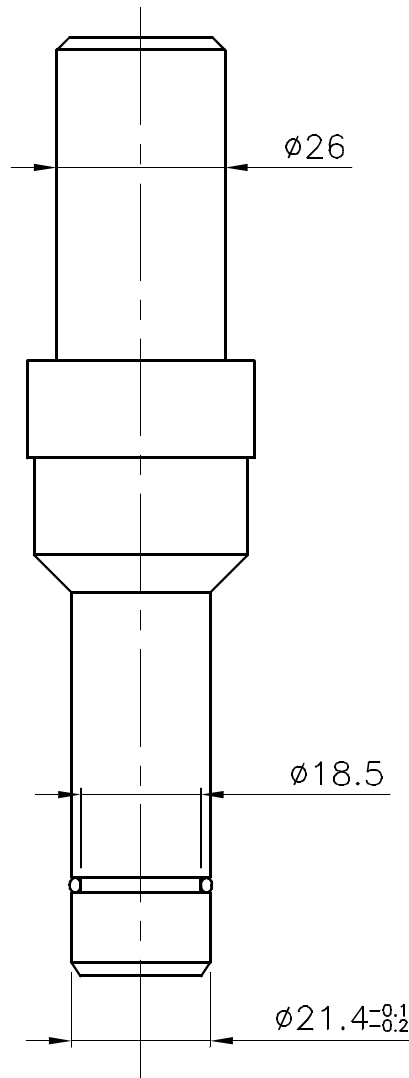

Modification:

For the permissible errors on the dimensions without tolerance and for other general specifications, see **IVECO** STD 10-2311

MAT.		COVER.	DRAWN UTS /	N°DRAWING 99365054	
All proprietary rights reserved by IVECO . This drawing shall not be reproduced or in any way utilised, for the manufacture or the component or unit herein illustrated and must not be released to other parties, without written consent. Any infringement will be legally pursued.		Modifica per adeguamento	APPROVED	EXPER.	SIZE A4
		attrezzo a motore	DATE	SHEET	
		CURSOR 9	SUPERSEDES		
	C/=0	SCALE	1:1	IVECO	
	I.S. 18-0011	Q.TY	1		

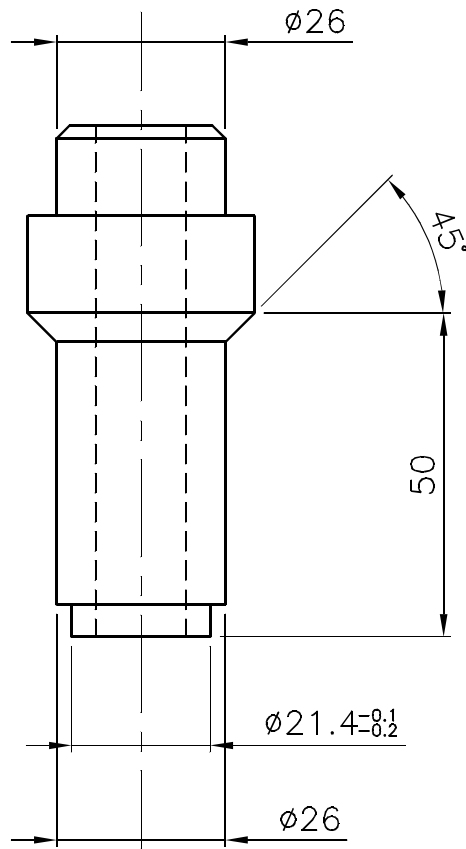

Modification:

For the permissible errors on the dimensions without tolerance and for other general specifications, see **IVECO** STD 10-2311

MAT.		COVER.	DRAWN UTS /	N°DRAWING 99390804	
All proprietary rights reserved by IVECO . This drawing shall not be reproduced or in any way utilised, for the manufacture or the component or unit herein illustrated and must not be released to other parties, without written consent. Any infringement will be legally pursued.	C/=0 I.S. 18-0011	Modifica per adeguamento	APPROVED	EXPER.	SIZE A4
		attrezzo a motore	DATE	SHEET	
		CURSOR 9	SUPERSEDES		
			SCALE 1:1		
	Q.TY 1				

02