

FI SERIES

Vehicle application

S23

S23 ENT C

This publication describes the characteristics, data and correct methods for repair operations on each component of the vehicle.

If the instructions provided are followed and the specified equipment is used, correct repair operations in the programmed time will be ensured, safeguarding against possible accidents.

Before starting to perform whatever type of repair, ensure that all accident prevention equipment is available and efficient.

All protections specified by safety regulations, i.e.: goggles, helmet, gloves, boot, etc. must be checked and worn.

All machining, lifting and conveying equipment should be inspected before use.

The data contained in this publication was correct at the time of going to press but due to possible modifications made by the Manufacturer for reasons of a technical or commercial nature or for adaptation to the legal requirements of the different countries, some changes may have occurred.

No part of this publication, including the pictures, may be reproduced in any form or by any means.

Publication edited by
Iveco Motors
Iveco SpA
PowerTrain
Mkt. Advertising & Promotion
Viale dell'Industria, 15/17
20010 Pregnana Milanese
Milano (Italy)
Print **P1D32S001GB/W** - 2nd Ed. 02.2005
S23 ENT C Series

Produced by:











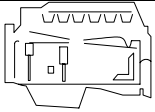
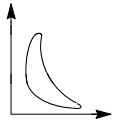
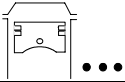
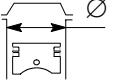
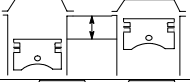
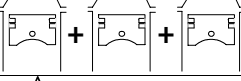
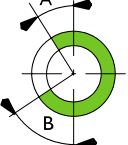

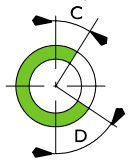

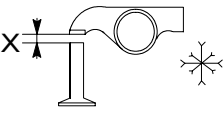
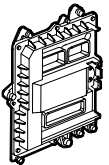
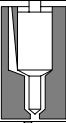
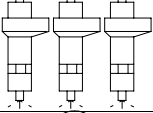
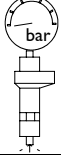

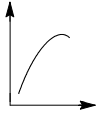

B.U. TECHNICAL PUBLISHING
Iveco Technical Publications
Lungo Stura Lazio, 15/19
10156 Turin - Italy

CORRESPONDENCE BETWEEN TECHNICAL CODE AND COMMERCIAL CODE

Technical Code	Commercial Code
FIAE048IB*A0..	S23 ENT C
FIAE048IB*B0..	S23 ENT C

SPECIFICATIONS

	Type	S23 ENT C SERIES	
	Cycle	Four-stroke diesel engine	
	Power	Supercharged with intercooler	
	Injection	Direct	
	Number of cylinders	4 in-line	
	Bore	mm	88
	Stroke	mm	94
	Total displacement	cm ³	2300
TIMING			
	 start before T.D.C. end after B.D.C.	A B	14° 27°
	 start before B.D.C. end after T.D.C.	D C	54° 10°
	Checking timing	mm	-
	X	mm	-
	Checking operation	mm	0.20 to 0.30
	X	mm	0.45 to 0.55
FUEL FEED			
	Injection Type:	Bosch	high pressure common rail EDC16
	Nozzle type	Injectors	
	Injection sequence	1 - 3 - 4 - 2	
	Injection pressure	bar	1600



S23 ENT C Series engines		TECHNICAL CODE	
	Type	FIAE048I*B...	
Q	Compression ratio	18	
	Maximum power	kW (HP)	85 (116)
		rpm	3000 ÷ 3900
	Maximum torque	kW (HP)	270 (27.5)
		rpm	1800 ÷ 2800
	Slow running of engine with no load	rpm	800
	Fast idling speed of engine with no load	rpm	4600
	Pressure at T.D.C.	*bar	20 ÷ 26
	Minimum permissible pressure at T.D.C.	*bar	16
	Bore x stroke	mm	88 x 94
	Displacement	cm ³	2300
	TURBOCHARGING	With intercooler	
	Turbocharger type	KKK K03-2072-EDC 5.68	
	Turbocharger shaft radial play	-	
	Turbocharger shaft end float	-	
	Maximum stroke of pressure relief valve opening	mm	3.5 ±0.5
	Pressure corresponding to maximum stroke:	bar	1.5 ±0.002
	LUBRICATION	forced by gear pump, pressure relief valve, oil filter with integral cartridge with total filtering	
	Oil pressure with engine hot (100°C ±5°C):		
	at idling speed	bar	≥0.6
	at top speed	bar	4
	COOLING	by centrifugal pump, thermostat for adjustment, coolant temperature, fan with electromagnetic coupling, radiator, heat exchanger	
	Water pump control:	by belt	
	Thermostat:	N. I.	
	start of opening:	82 ±2 °C	

(*) The pressure is measured by setting the engine turning with the aid of just the starter motor, with an oil temperature of 40 – 50°C.

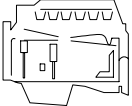

Data, features and performances are valid only if the setter fully complies with all the installation prescriptions provided by Iveco Motors.

Furthermore, the users assembled by the setter shall always be in conformance to couple, power and number of turns based on which the engine has been designed.







S23 ENT C Series engines		TECHNICAL CODE	
	Type	FIAE048I B	
 Urania Daily Urania LD 5	FLUIDS		
	Capacity:		
	engine sump at minimum level	liters kg	3 2.65
	engine sump at maximum level	litres kg	4.3 3.78
	quantity in circulation in cartridge filter and heat exchanger	litres kg	1.4 1.23
quantity of oil for first filling	liters kg	5.7 5.02	



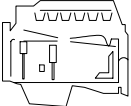
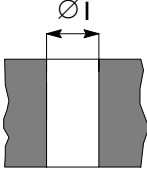
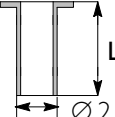

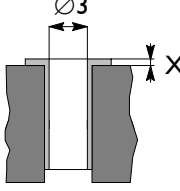
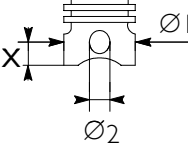

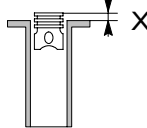
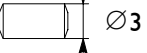



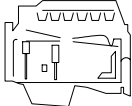
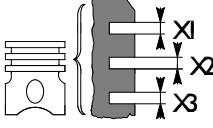
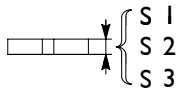

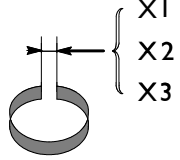
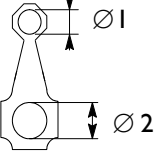
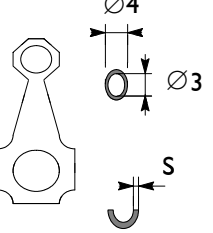

Data, features and performances are valid only if the setter fully complies with all the installation prescriptions provided by Iveco Motors.



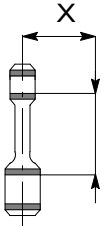
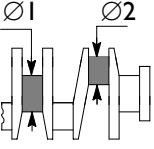
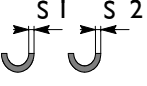
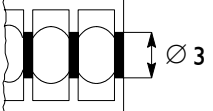



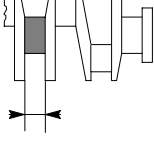
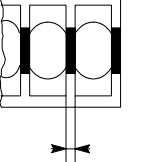
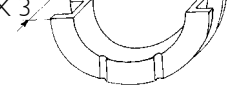



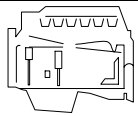
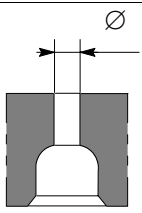
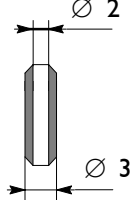



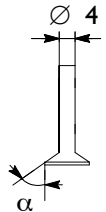



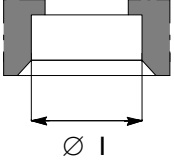

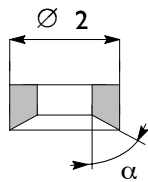
Furthermore, the users assembled by the setter shall always be in conformance to couple, power and number of turns based on which the engine has been designed.

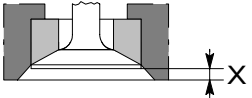





ASSEMBLY DATA – CLEARANCES

 Type	S23 ENT C SERIES	
CYLINDER ASSEMBLY AND CRANK MEMBERS		
	Cylinder liners: $\varnothing 1$	88.002 ÷ 88.022
	Cylinder liners: outside diameter \varnothing length L	- - -
	Cylinder liners – crankcase seats (interference)	-
	Outside diameter $\varnothing 2$	-
	Cylinder liners: (protrusion from bottom of crankcase) inside diameter $\varnothing 3$	- -
	Pistons: supplied as spares type measurement X outside diameter $\varnothing 1$ seat for pin $\varnothing 2$	MAHLE MONDIAL 45.5 87.832 ÷ 87.846 31.003 ÷ 31.009
	Piston – cylinder liners	0.156 ÷ 0.190
	Piston diameter $\varnothing 1$	0.4
	Piston protrusion from crankcase X	0.3 ÷ 0.6
	Piston gudgeon pin $\varnothing 3$	30.990 ÷ 30.996
	Piston gudgeon pin – pin seat	0.07 ÷ 0.019

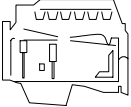
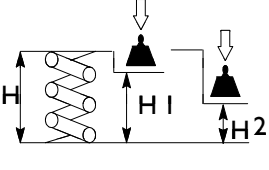
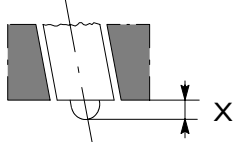
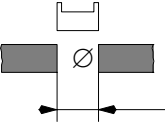
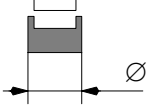
 Type	S23 ENT C SERIES	
CYLINDER ASSEMBLY AND CRANK MEMBERS		
		mm
 Type of piston Piston ring slots * measured on \varnothing of 85 mm	X1* X2 X3	MAHLE MONDIAL 2.200 ÷ 2.230 2.050 ÷ 2.070 2.540 ÷ 2.560
 Piston rings: * measured on \varnothing of 85 mm	S1* S2 S3	2.068 ÷ 2.097 1.970 ÷ 1.990 2.470 ÷ 2.490
 Piston rings – slots	1 2 3	0.103 ÷ 0.162 0.060 ÷ 0.100 0.050 ÷ 0.090
 Piston rings		0.4
 Piston ring end opening in cylinder liner:	X1 X2 X3	X1 0.20 ÷ 0.35 X2 0.60 ÷ 0.80 X3 0.25 ÷ 0.50
 Small end bushing seat Connecting rod bearing seat* * connecting rod supplied as spare part	Ø 1 Ø 2	34.460 ÷ 34.490 62.833 ÷ 62.841
 Small end bushing diameter outside inside Big end bearing shells supplied as spare part	Ø 4 Ø 3 S	34.560 ÷ 34.585 31.010 ÷ 31.020 -
 Small end bushing – seat (interference)		0.07 ÷ 0.125
 Piston gudgeon pin – bushing		0.014 ÷ 0.030
 Big end bearing shells		0.254 - 0.508

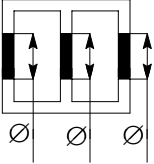
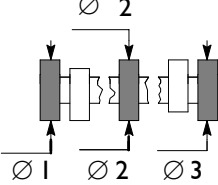
 Type	S23 ENT C SERIES	
CYLINDER ASSEMBLY AND CRANK MEMBERS		mm
	Measurement	X 125
	Maximum error on alignment of connecting rod axes	= 0.09
 	Main journals No. 1-2-3-4 No. 5 Crankpins Main bearing shells S1* Big end bearing shells S2* * supplied as spare parts	$\varnothing 1$ 71.182 + 71.208 76.182 + 76.208 $\varnothing 2$ 59.015 + 59.038 2.165 + 2.174 1.883 + 1.892
	Main bearing housings No. 1-2-3-4 No. 5	$\varnothing 3$ 75.588 + 75.614 80.588 + 80.614
	Bearing shells - main journals	0.032 + 0.102
	Bearing shells - crankpins	0.035 + 0.083
  	Main bearing shells Big end bearing shells	0.254 + 0.508 0.254 + 0.508
	Main journal for shoulder X 1	31.020 + 31.170
	Main bearing housing for shoulder X 2	25.790 + 25.840
	Half thrust washers X 3	30.810 + 30.960
	Crankshaft shoulder	0.060 + 0.260

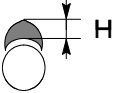
 Type		S23 ENT C SERIES	
CYLINDER HEAD – TIMING SYSTEM		mm	
	Guide valve seats on cylinder head	Ø 1	9.980 ± 10.000
	Valve guides	Ø 2  Ø 3	6.023 ± 6.038 10.028 ± 10.039
	Valve guides and seats on head (interference)		0.028 ± 0.059
	 > Valve guides		0.05 - 0.10 - 0.25
	Valves:	 Ø 4 α  Ø 4 α	5.975 ± 5.990 44°45' ± 7.5' 5.975 ± 5.990 44°45' ± 7.5'
	Valve stem and relevant guide		0.033 ± 0.063
	Seat on head for valve seat:	 Ø 1  Ø 1	31.390 ± 31.415 31.390 ± 31.415
	Outside diameter of valve seats; angle of valve seats on cylinder head:	 Ø 2 α  Ø 2 α	31.495 ± 31.510 44.5° ± 5' 31.495 ± 31.510 44.5° ± 5'
	Recessing	×  × 	0.5 ± 0.8 0.5 ± 0.8
	Between valve seat and head	 	0.08 - 0.12 0.08 - 0.12
	 > Valve seats		-

 Type	S23 ENT C SERIES	
CYLINDER HEAD – TIMING SYSTEM		
 Valve spring height: free spring H under a load of: N243 ± 12 H1 N533 ± 24 H2	mm	
 Injector protrusion X	2.77 ÷ 3.23	
 Seats for tappets on cylinder head normal Ø	12.016 ÷ 12.034	
 Normal diameter tappets	11.988 ÷ 12.000	
 Between tappets and seats	0.016 ÷ 0.046	
 Camshaft pin seats in cylinder overhead I ⇒ 7	Ø 1 Ø 2 Ø 3	48.987 ÷ 49.013 46.987 ÷ 47.013 35.987 ÷ 36.013
 Camshaft supporting pins: Ø 1 Ø 2 Ø 3	Ø 1 Ø 2 Ø 3	48.925 ÷ 48.950 46.925 ÷ 46.950 35.925 ÷ 35.950
 Supporting pins and seats	0.037 ÷ 0.088	
 Useful cam height	 H  H	3.77 4.203

TOOLS

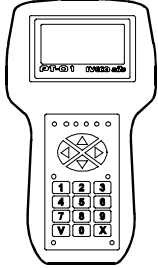
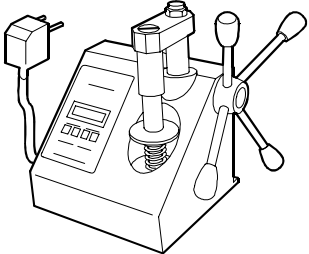
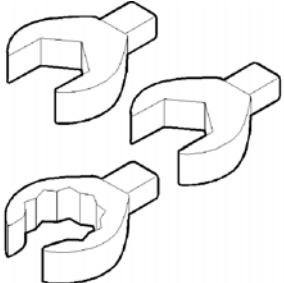
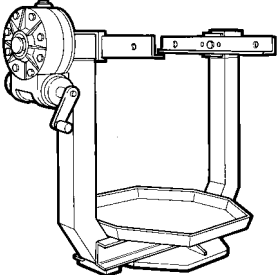
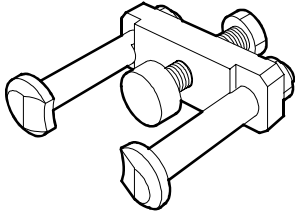
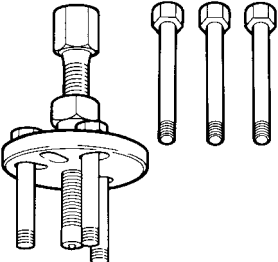
TOOL NO.	DESCRIPTION
8093731 	Tester PT01
99305047 	Appliance to check spring loads
99317915 	Set of six box-type wrenches (14-17-19 mm)
99322205 	Rotary telescopic stand for overhauling assemblies (capacity 700 daN, torque 120 daN/m)
99340028 	Extractor for camshaft pulley
99340035 	High-pressure pump toothed pulley extractor

TOOLS

TOOL NO.

DESCRIPTION

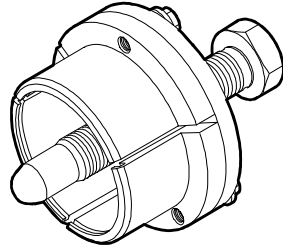
99340057

Tool to remove crankshaft front gasket

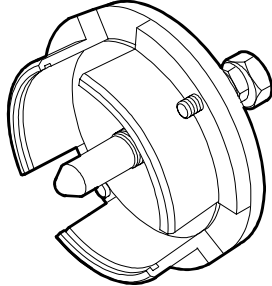
99340058

Tool to remove crankshaft rear gasket

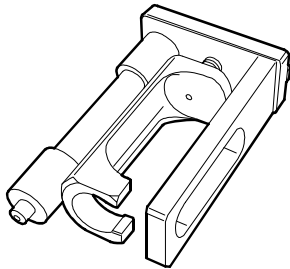
99342153

Tool to extract injectors

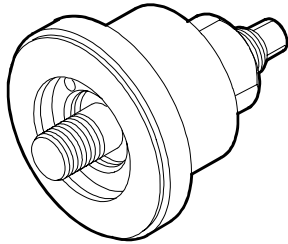
99346254

Keying device for mounting crankshaft front gasket

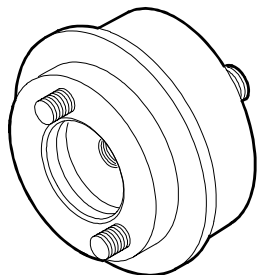
99346255

Keying device for mounting crankshaft rear gasket

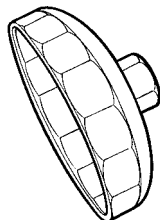
99360076

Tool to remove cartridge filters

TOOLS

TOOL NO.

DESCRIPTION

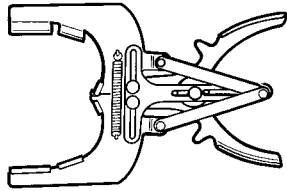
99360183

Pliers for mounting rings on engine pistons

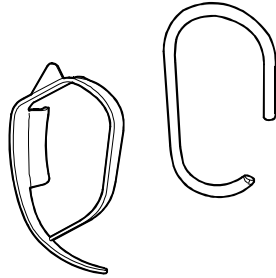
99360191

Guide for flexible belt

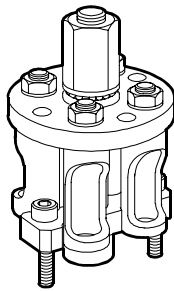
99360260

Tool for removing and refitting engine valves

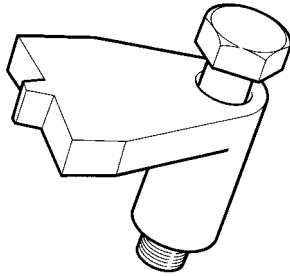
99360306

Tool to retain engine flywheel

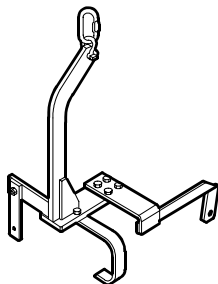
99360544

Arm for removing and refitting engine

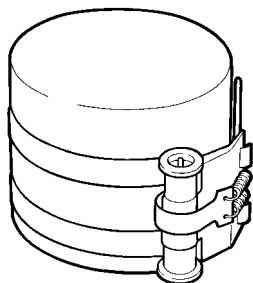
99360605

Band to insert standard and oversized pistons into the cylinders

TOOLS

TOOL NO.

DESCRIPTION

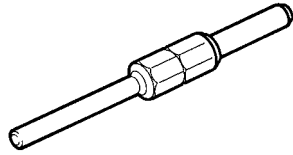
99360608

Tool for positioning timing gear

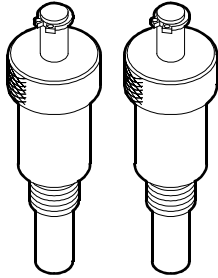
99360614

Tool (2) for camshaft timing

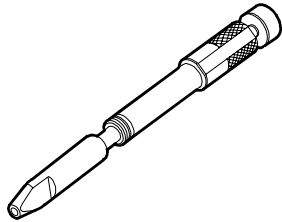
99360615

Tool for crankshaft timing

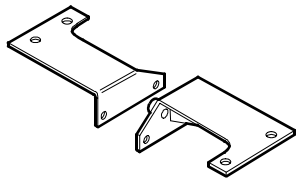
99361038

Brackets securing engine to rotary stand 99322205

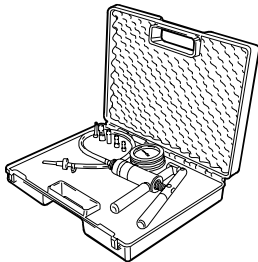
99367121

Manual pump to measure pressure and vacuum

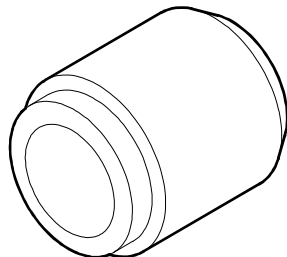
99374458

Keying device for mounting oil seal gasket on camshaft front cover

TOOLS

TOOL NO.	DESCRIPTION
99389819	Torque wrench (0-10 Nm) with square 1/4" connection
99389829	9x12 coupling torque wrench (5-60 Nm)
99394038	Milling cutter to regrind injector seat
99395216	Pair of meters for angular tightening with square 1/2" and 3/4" connection
99395363	Complete square to check for connecting rod distortion
99395687	Bore meter (50 – 178 mm)

TOOLS

TOOL NO.	DESCRIPTION
99395849	Device for checking belt tension (frequency from 10.0 to 600 Hz)
99396037	Centring ring for crankshaft front gasket cover

EXPERIMENTAL TOOLS

This section shows the working drawings for the experimental tools (S.P.) used in overhauling the engine described in this section, which may be made by the repair shops.

VARIA DA ART. COMMERCIALE USAG cod.235L 1/2" - Ch.19
SOLO PER QUANTO INDICATO

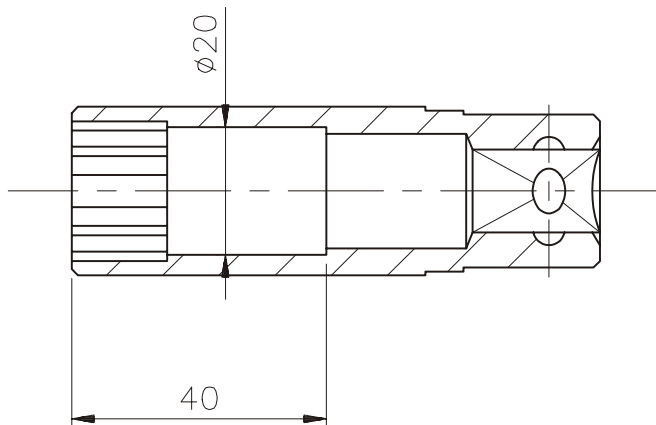

Modification:

For the permissible errors on the dimensions without tolerance and for other general specifications, see **IVECO** STD 10-2311

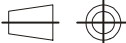
MAT. /		COVER. /	DRAWN UTS (B)	N°DRAWING SP. 2262		
All proprietary rights reserved by IVECO . This drawing shall not be reproduced or in any way utilised, for the manufacture or the component or unit herein illustrated and must not be released to other parties, without written consent. Any infringement will be legally pursued.	ISO \leq IT8 $\alpha \leq 30'$ Ra \leq 0.4	Chiave poligonale (19mm)	APPROVED	EXPER. 2262	SIZE A4	
		per sensore pompa acqua	DATE 19/06/2001	SHEET		
	C/		SUPERSEDES			
	I.S. 18-0011	MOTORE F1A	SCALE 1:1	IVECO		
			Q.TY 1			

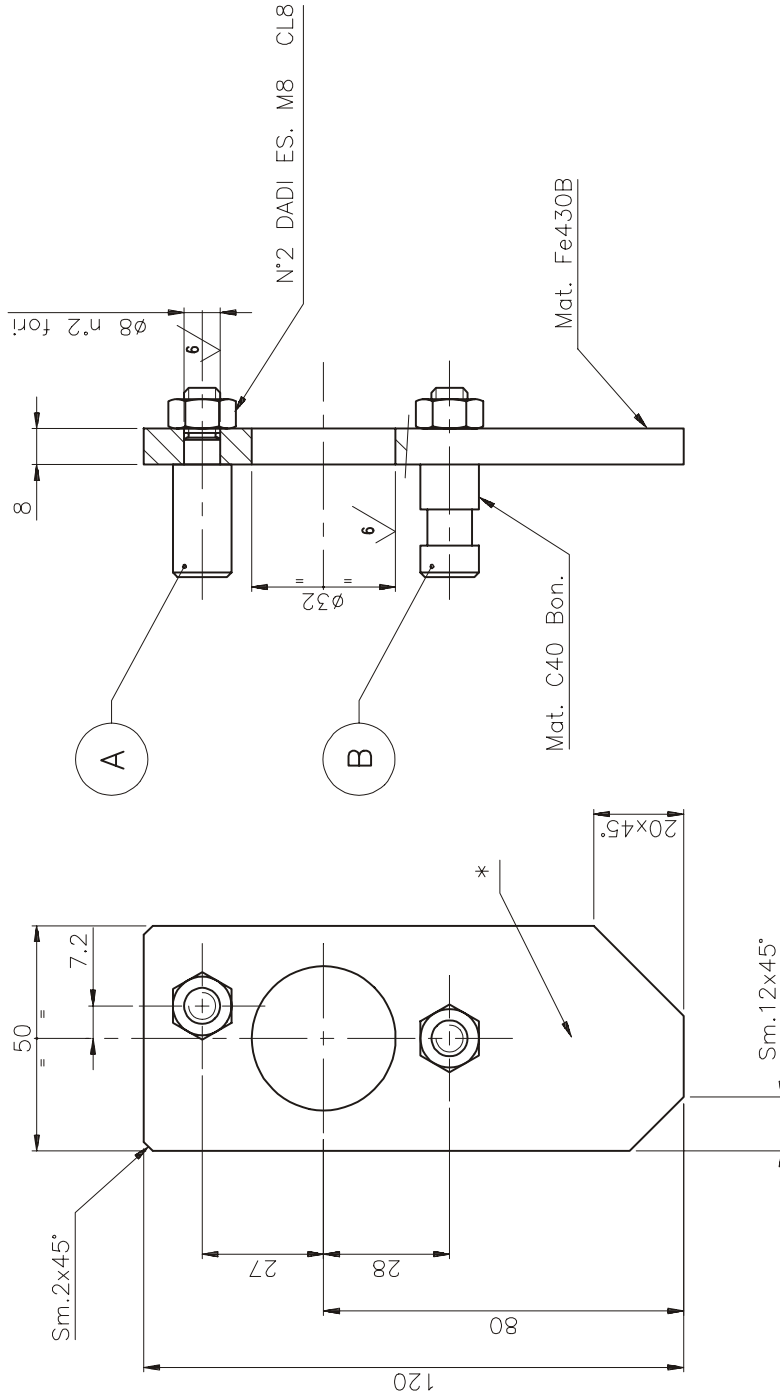

12 / (6) Sm. 0.5x45°

DETT. PERNO "A"
 DETT. PERNO "B"
 Varia dal dett. "A"

solo x quanto indicato

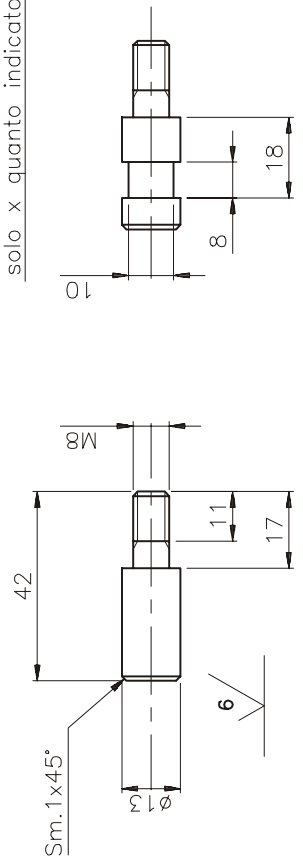

Modification:

For the permissible errors on the dimensions without tolerance and for other general specifications, see **IVECO** STD 10-2311

MAT. Vedl. dis.	COVER Fosfat.	DRAWN UTS (B)	N'DRAWING SP. 2263
		APPROVED	EXPER. 2263
ISO M TR ISO M 40 Rd M 0.4 +		DATE 09/01/2002	SHEET
ISO M TR 1.5. 10-0011 b		SUPERSEDES	SIZE A3
All proprietary rights reserved by IVECO . This drawing shall not be reproduced or in any way utilized, for the manufacture of the component or unit, herein illustrated and must not be released to other parties, without written consent. Any infringement will be legally pursued.		SCALE 1:1	
		Q.TY 1	
Attrezzo per ritegno puleggia dentata comando pompa alta pressione MOTORE FIA			

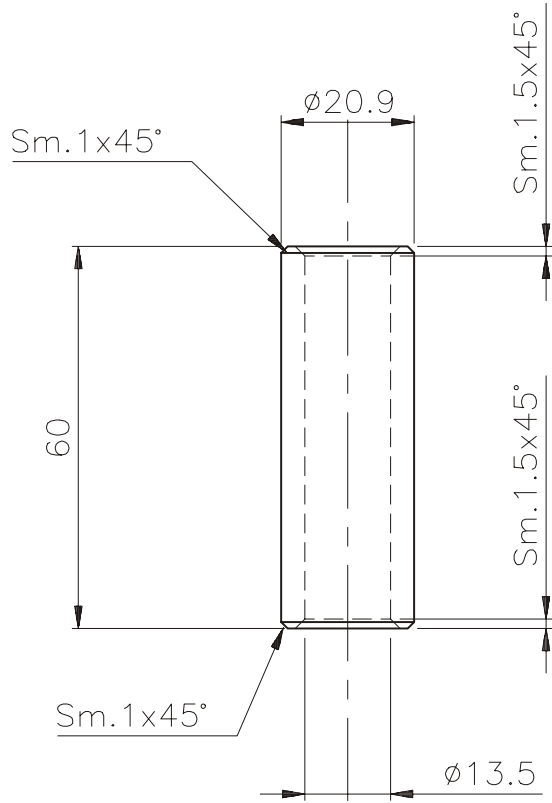

Modification:

For the permissible errors on the dimensions without tolerance and for other general specifications, see **IVECO** STD 10-2311

MAT. Pom / Nylon		COVER. /	DRAWN UTS (B)	N°DRAWING SP. 2264	
All proprietary rights reserved by IVECO . This drawing shall not be reproduced or in any way utilised, for the manufacture or the component or unit herein illustrated and must not be released to other parties, without written consent. Any infringement will be legally pursued.	ISO \leq IT8	Perni di centraggio sovratesta	APPROVED	EXPER. 2264	SIZE A4
	$\alpha \leq 30'$	e per piantaggio guarnizione	DATE 19/06/2001	SHEET	
	Ra \leq 0.4	guida valvole	SUPERSEDES		
	C/	MOTORE F1A	SCALE 1:1		
	I.S. 18-0011		Q.TY 2		

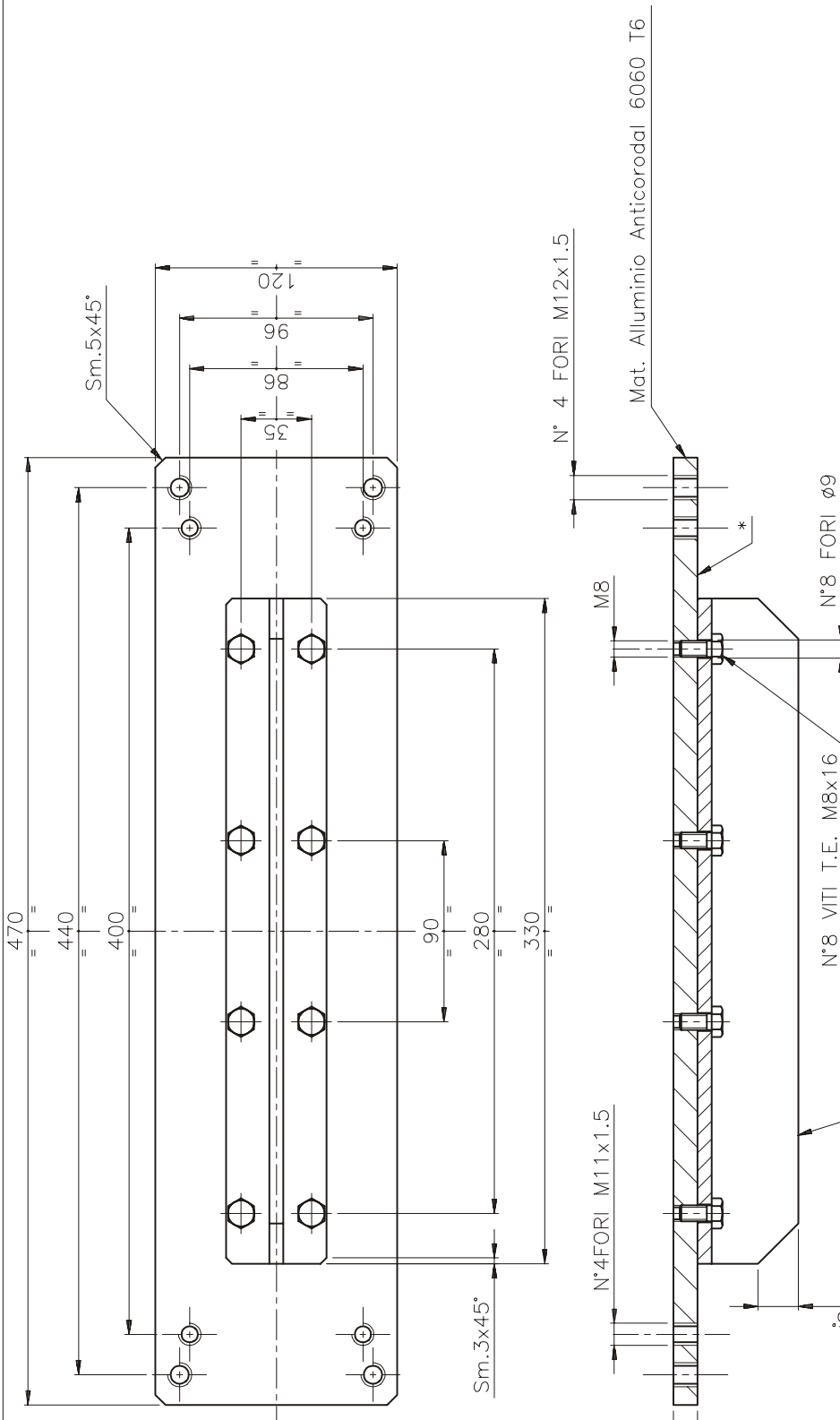

For the permissible errors on the dimensions without tolerance and for other general specifications, see **IVECO** STD 10-2311

MAT. Vedi dis. COVER Vedi dis.		DRAWING UTS (B) APPROVED	N°DRAWING SP. 2271 EXPER. 2271 SIZE A3
ISO 9001 Rd 4.0.4 +		DATE 22/11/2001 SUPERSEDES	SHEET
All proprietary rights reserved by IVECO . This drawing shall not be reproduced or in any way utilized, for the manufacture or the component or other parts, without written consent. Any infringement will be legally pursued.		SCALE 1:2	
0 (3) Sm. 0.5x45°		Q.TY 1	MOTORE FIA

Modification:

VARIA DA ART. COMMERCIALE USAG cod.235EL 1/4" - Ch.8
SOLO PER QUANTO INDICATO

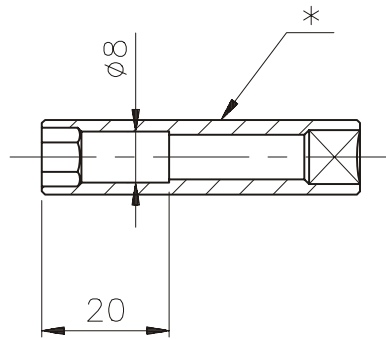

6
Sm. 0.5x45°

Modification:

For the permissible errors on the dimensions without tolerance and for other general specifications, see **IVECO** STD 10-2311

MAT. /		COVER. /	DRAWN UTS (B)	N°DRAWING SP. 2275	
All proprietary rights reserved by IVECO . This drawing shall not be reproduced or in any way utilised, for the manufacture or the component or unit herein illustrated and must not be released to other parties, without written consent. Any infringement will be legally pursued.	ISO \leq IT8	Bussola (8 mm) per montaggio/ smontaggio candele	APPROVED	EXPER. 2275	SIZE A4
	$\alpha \leq 30^\circ$ Ra \leq 0.4		DATE 25/07/2001	SHEET	
		SUPERSEDES			
	C/	SCALE 1:1			
	I.S. 18-0011	Q.TY 1			
MOTORE F1A					

PARTIC. DENTE - Scala 10:1

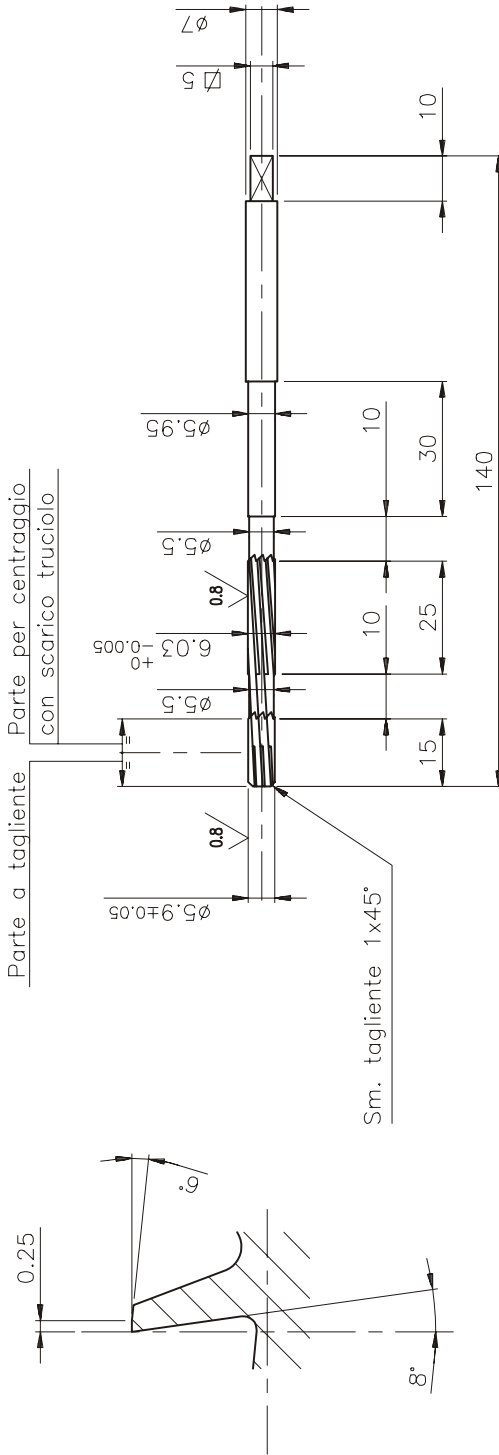

N° 6 DENTI - ELICA SINISTRA - INCLINAZIONE 6°

Modification:

For the permissible errors on the dimensions without tolerance and for other general specifications, see **IVECO** STD 10-2311

MATERIAL: UNI U100WC HRC 62-64		COVER: /		DRAWING: UTS (B)	N° DRAWING: SP. 2310
ISO M TR		ISO M TR		APPROVED	EXPER. SIZE: A3
R 4 0.4		R 4 0.4		DATE: 10/12/2001	SHEET
+		+		SUPERSEDES	
1:1		1:1		SCALE: 1:1	
b		b		Q.TY: 1	
1:10-011		1:10-011			
MOTORE FIA		MOTORE FIA			

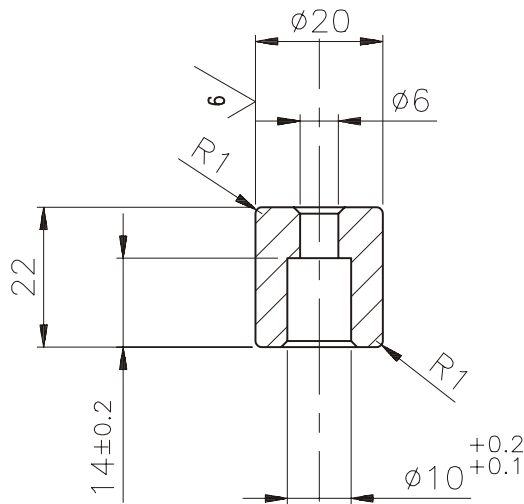

Modification:

For the permissible errors on the dimensions without tolerance and for other general specifications, see **IVECO** STD 10-2311

MAT. 39NiCrMo3 Bon.		COVER. Fosfat.	DRAWN UTS (B)	N°DRAWING SP. 2311		
All proprietary rights reserved by IVECO . This drawing shall not be reproduced or in any way utilised, for the manufacture or the component or unit herein illustrated and must not be released to other parties, without written consent. Any infringement will be legally pursued.	ISO \leq IT8 $\alpha \leq 30'$ Ra \leq 0.4	Battitoio per piantaggio	APPROVED	EXPER. 2311	SIZE A4	
	+	guida valvole	DATE 10/12/2001	SHEET		
	+	(usare con sp. 2312)	SUPERSEDES			
	C/	MOTORE F1A	SCALE 1:1			
	I.S. 19-0011		Q.TY 1			

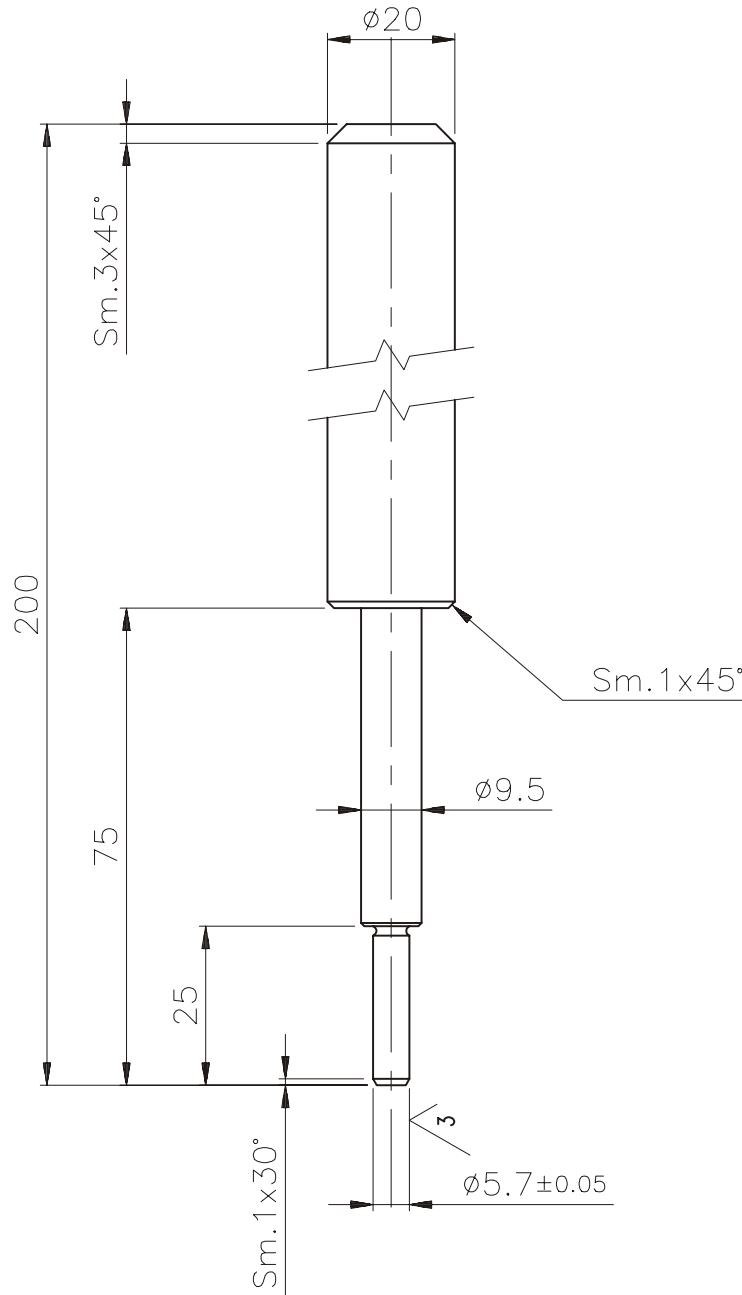

Modification: _____

For the permissible errors on the dimensions without tolerance and for other general specifications, see **IVECO** STD 10-2311

MAT. 39NiCrMo3 Bon.		COVER. Fosfat.	DRAWN UTS (B)	N°DRAWING SP. 2312	
All proprietary rights reserved by IVECO This drawing shall not be reproduced or in any way utilised, for the manufacture or the component or unit herein illustrated and must not be released to other parties, without written consent. Any infringement will be legally pursued. C/ I.S. 18-0011	ISO ≤ IT8 α ≤ 30° Ra ≤ 0.4	Battitoio per spiantaggio	APPROVED	EXPER. 2312	SIZE A4
		guida valvole	DATE 10/12/2001	SHEET	
			SUPERSEDES		
		MOTORE F1A	SCALE 1:1	IVECO	
			Q.TY 1		

N°4 viti autoperforanti a testa bombata

$\phi 4.8 \times 45$ - UNI 8118

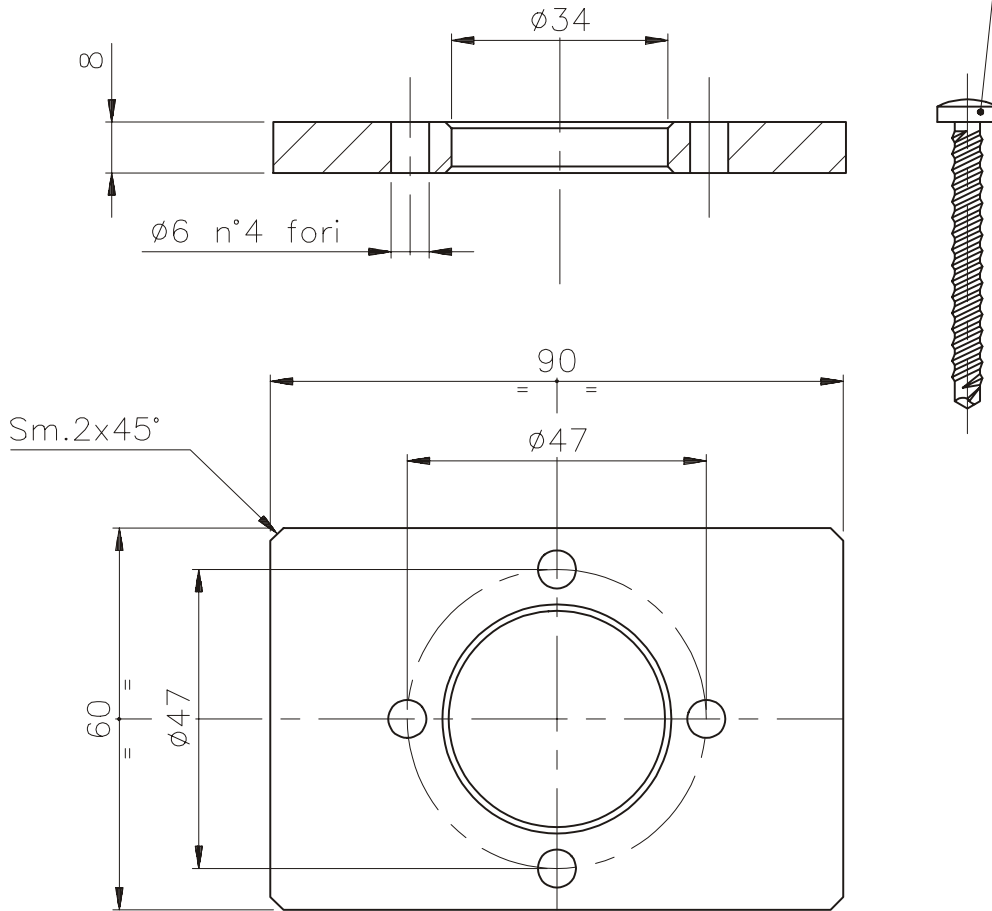

$\sqrt{6}$ Sm. 1x45°

Modification:

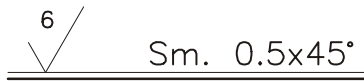
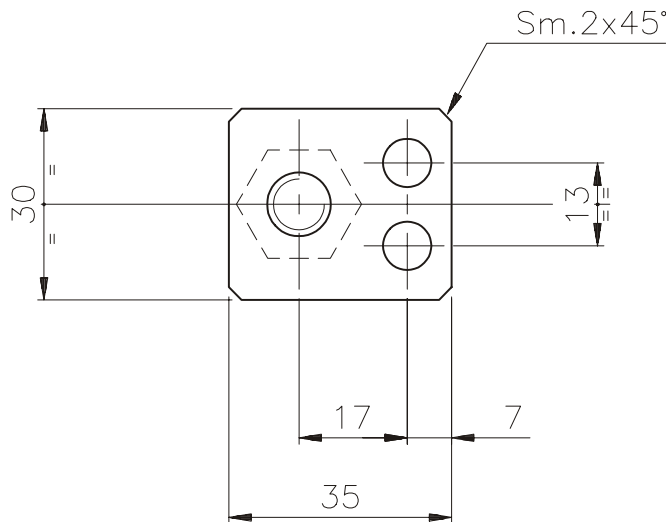
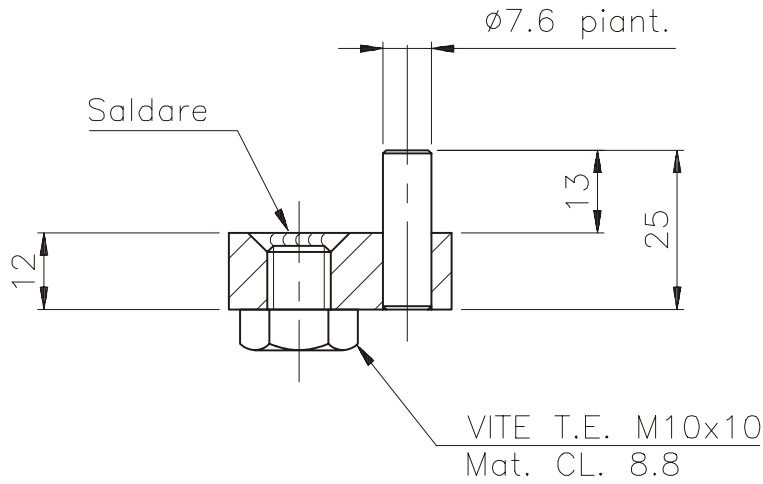

For the permissible errors on the dimensions without tolerance and for other general specifications, see **IVECO** STD 10-2311

MAT. Fe430B		COVER. Fosfat.	DRAWN UTS (B)	N°DRAWING SP. 2325	
All proprietary rights reserved by IVECO . This drawing shall not be reproduced or in any way utilised, for the manufacture or the component or unit herein illustrated and must not be released to other parties, without written consent. Any infringement will be legally pursued.	ISO \leq IT8 $\alpha \leq 30'$ Ra \leq 0.4	Attrezzo per estrazione	APPROVED	EXPER. 2325	SIZE A4
	C/	guarnizione albero distribuzione	DATE 01/02/2002	SHEET	
	I.S. 19-0011		SUPERSEDES		
		MOTORE F1A	SCALE 1:1		
			Q.TY 1		

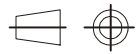

Modification:

For the permissible errors on the dimensions without tolerance and for other general specifications, see **IVECO** STD 10-2311

MAT. C40 Bon.		COVER. Fosfat.	DRAWN UTS (B)	N°DRAWING SP.2341		
All proprietary rights reserved by IVECO . This drawing shall not be reproduced or in any way utilised, for the manufacture or the component or unit herein illustrated and must not be released to other parties, without written consent. Any infringement will be legally pursued.  C/ I.S. 18-0011	ISO ≤ IT8 4 ≤ 30' Ra ≤ 0.4	Chiave per tensionamento tenditore	APPROVED	EXPER. 2341	SIZE A4	
		cinghia compressore condizionatore	DATE 05/03/2002	SHEET		
			SUPERSEDES			
			SCALE 1:1			
		MOTORE F1A	Q.TY 1			

