



---

## **Electrical Guide**

---

# **X-TYPE**

**Sedan and Estate (Wagon)**

**2.0 L, 2.5 L and 3.0 L Gasoline;**

**2.0 L and 2.2 L, Diesel**

**VIN: J40142 >**

---





BY APPOINTMENT TO  
HER MAJESTY QUEEN ELIZABETH II  
MANUFACTURERS OF DAIMLER AND JAGUAR CARS  
JAGUAR CARS LIMITED COVENTRY



BY APPOINTMENT TO  
HIS ROYAL HIGHNESS THE PRINCE OF WALES  
MANUFACTURERS OF DAIMLER AND JAGUAR CARS  
JAGUAR CARS LIMITED COVENTRY

PREVIOUS APPOINTMENT TO THE LATE QUEEN ELIZABETH THE QUEEN MOTHER 1964 - 2007

---

## Electrical Guide

---

# X-TYPE

## Sedan and Estate (Wagon)

2.0 L, 2.5 L and 3.0 L Gasoline;

2.0 L and 2.2 L, Diesel

VIN: J40142 >

---

Published by Technical Communications, **Jaguar Cars Limited**

Publication Part Number JLR 20 69 10\_1E, 08 2008

While every effort is made to ensure accuracy, design changes to the vehicle may be made in the period between the completion of this publication and the introduction of vehicles.

All rights reserved. No part of this publication may be reproduced, stored in a retrieval system or transmitted, in any form: electronic, mechanical, including photocopying, recording or other means without prior written permission from the Service Division of Jaguar Cars Limited.

Table of Contents: Figures ..... 2

Abbreviations and Acronyms ..... 5

Introduction ..... 7

User Instructions ..... 8

Symbols and Codes ..... 10

Network Configuration ..... 14

Relay and Fuse Location ..... 15

Fusebox Connectors ..... 17

Major Harnesses and Fusebox Location ..... 18

Harness In-Line Connector Location ..... 20

Ground Point Location ..... 23

Control Module Location ..... 24

Control Module Pin Identification ..... 26

Electrical Guide Figures and Data ..... follows after page 33  
(pages are numbered by Figure number)

Component Index ..... follows Electrical Guide Figures and Data

**FIGURES**

<b>Fig.</b>	<b>Description</b>	<b>Variant</b>
<b>01 Power Distribution</b>		
Fig. 01.1 . . . .	Main Power Distribution . . . . .	All Vehicles
Fig. 01.2 . . . .	Battery Power Distribution: Part 1 . . . . .	All Vehicles
Fig. 01.3 . . . .	Battery Power Distribution: Part 2 . . . . .	All Vehicles
Fig. 01.4 . . . .	Ignition Switched Power Distribution: I (Accessory) . . . . .	All Vehicles
Fig. 01.5 . . . .	Ignition Switched Power Distribution: II (Run) – Part 1 . . . . .	All Vehicles
Fig. 01.6 . . . .	Ignition Switched Power Distribution: II (Run) – Part 2 . . . . .	All Vehicles
Fig. 01.7 . . . .	Ignition Switched Power Distribution: Battery Saver . . . . .	All Vehicles
Fig. 01.8 . . . .	EMS Switched Power Distribution: Gasoline Engines . . . . .	Gasoline Engine Vehicles
Fig. 01.9 . . . .	EMS Switched Power Distribution: Diesel Engines . . . . .	Diesel Engine Vehicles
<b>02 Battery; Starter; Generator</b>		
Fig. 02.1 . . . .	Battery; Starter; Generator: 2.5 L & 3.0 L . . . . .	2.5 L & 3.0 L Vehicles
Fig. 02.2 . . . .	Battery; Starter; Generator: 2.0 L . . . . .	2.0 L Gasoline Engine Vehicles
Fig. 02.3 . . . .	Battery; Starter; Generator: Diesel . . . . .	Diesel Engine Vehicles
<b>03 Engine Management</b>		
Fig. 03.1 . . . .	Engine Management: 2.5 L & 3.0 L – Part 1 . . . . .	2.5 L & 3.0 L Vehicles
Fig. 03.2 . . . .	Engine Management: 2.5 L & 3.0 L – Part 2 . . . . .	2.5 L & 3.0 L Vehicles
Fig. 03.3 . . . .	Engine Management: 2.0 L – Part 1 . . . . .	2.0 L Gasoline Engine Vehicles
Fig. 03.4 . . . .	Engine Management: 2.0 L – Part 2 . . . . .	2.0 L Gasoline Engine Vehicles
Fig. 03.5 . . . .	Engine Management: Diesel – Part 1 . . . . .	Diesel Engine Vehicles
Fig. 03.6 . . . .	Engine Management: Diesel – Part 2 . . . . .	Diesel Engine Vehicles
Fig. 03.7 . . . .	Engine Management: Diesel – 2.2 L with DPF . . . . .	Diesel 2.2L with DPF Vehicles
<b>04 Transmission</b>		
Fig. 04.1 . . . .	Automatic Transmission: Gasoline . . . . .	Gasoline Vehicles
Fig. 04.2 . . . .	Automatic Transmission: Diesel . . . . .	Diesel Vehicles
<b>05 Chassis</b>		
Fig. 05.1 . . . .	Traction Control . . . . .	Traction Control Vehicles
Fig. 05.2 . . . .	Dynamic Stability Control . . . . .	DSC Vehicles
Fig. 05.3 . . . .	Tire Pressure Monitoring System . . . . .	TPMS Vehicles
<b>06 Climate Control</b>		
Fig. 06.1 . . . .	Automatic Climate Control . . . . .	Automatic Climate Control Vehicles
Fig. 06.2 . . . .	Glass Heaters . . . . .	Glass Heater Vehicles
<b>07 Instrumentation</b>		
Fig. 07.1 . . . .	Instrument Cluster . . . . .	All Vehicles
Fig. 07.2 . . . .	Audible Warnings . . . . .	All Vehicles

**FIGURES**

<b>Fig.</b>	<b>Description</b>	<b>Variant</b>
<b>08 Exterior Lighting</b>		
Fig. 08.1 . . . .	Exterior Lighting: Front – Auto Headlamps . . . . .	Auto Headlamp Vehicles
Fig. 08.2 . . . .	Exterior Lighting: Front – Non Autolamps; Daytime Running Lamps . . . . .	Non Autolamp Vehicles; Daytime Running Lamp Vehicles
Fig. 08.3 . . . .	Exterior Lighting: Rear – Sedan . . . . .	Sedan Vehicles
Fig. 08.4 . . . .	Exterior Lighting: Rear – Estate (Wagon) . . . . .	Estate (Wagon) Vehicles
Fig. 08.5 . . . .	Exterior Lighting: Rear – Sedan European Trailer Towing . . . . .	Euro. Sedan Trailer Towing Vehicles
Fig. 08.6 . . . .	Exterior Lighting: Rear – Sedan U.K. Trailer Towing . . . . .	U.K. Sedan Trailer Towing Vehicles
Fig. 08.7 . . . .	Exterior Lighting: Rear – Sedan NAS Trailer Towing . . . . .	NAS Sedan Trailer Towing Vehicles
Fig. 08.8 . . . .	Exterior Lighting: Rear – Estate (Wagon) European Trailer Towing . . . . .	Euro. Estate (Wagon) Trailer Towing Vehicles
Fig. 08.9 . . . .	Exterior Lighting: Rear – Estate (Wagon) U.K. Trailer Towing . . . . .	U.K. Estate (Wagon) Trailer Towing Vehicles
Fig. 08.10 . . . .	Headlamp Leveling (H/L) . . . . .	H/L & HID Headlamp Vehicles
<b>09 Interior Lighting</b>		
Fig. 09.1 . . . .	Interior Lighting . . . . .	All Vehicles
Fig. 09.2 . . . .	Dimmer-Controlled Lighting . . . . .	All Vehicles
<b>10 Door Mirrors</b>		
Fig. 10.1 . . . .	Door Mirrors: Movement; Fold-back – Non Memory . . . . .	Non Memory Vehicles
Fig. 10.2 . . . .	Door Mirrors: Movement; Fold-back – Memory . . . . .	Memory Vehicles
<b>11 Seat Systems</b>		
Fig. 11.1 . . . .	Powered Seat: Driver – Memory . . . . .	Memory Vehicles
Fig. 11.2 . . . .	Powered Seat: Passenger – Memory . . . . .	Memory Vehicles
Fig. 11.3 . . . .	Powered Seats: 4-way Movement . . . . .	4-way Powered Seat Vehicles
Fig. 11.4 . . . .	Seat Heaters: Memory . . . . .	Memory Vehicles
Fig. 11.5 . . . .	Seat Heaters: Non Memory . . . . .	Heated Seat Vehicles
<b>12 Door Locking; Security</b>		
Fig. 12.1 . . . .	Central Door Locking: Sedan – Double Locking . . . . .	Double Locking Sedan Vehicles
Fig. 12.2 . . . .	Central Door Locking: Sedan – Non Double Locking . . . . .	Non Double Locking Sedan Vehicles
Fig. 12.3 . . . .	Central Door Locking: Estate (Wagon) . . . . .	Estate (Wagon) Vehicles
Fig. 12.4 . . . .	Security: Sedan . . . . .	Sedan Vehicles
Fig. 12.5 . . . .	Security: Estate (Wagon) . . . . .	Estate (Wagon) Vehicles
<b>13 Wash / Wipe</b>		
Fig. 13.1 . . . .	Wash / Wipe: Front . . . . .	Non Rain Sensing Vehicles
Fig. 13.2 . . . .	Wash / Wipe: Front with Rain Sensing . . . . .	Rain Sensing Vehicles
Fig. 13.3 . . . .	Wash / Wipe: Rear . . . . .	Estate (Wagon) Vehicles
<b>14 Powered Windows; Sliding Roof</b>		
Fig. 14.1 . . . .	Powered Windows . . . . .	All Vehicles
Fig. 14.2 . . . .	Sliding Roof . . . . .	Sliding Roof Vehicles
<b>15 In-Car Entertainment</b>		
Fig. 15.1 . . . .	In-Car Entertainment: Standard . . . . .	Standard ICE Vehicles
Fig. 15.2 . . . .	In-Car Entertainment: Premium . . . . .	Premium ICE Vehicles
Fig. 15.3 . . . .	In-Car Entertainment: DAB . . . . .	DAB Vehicles

**FIGURES**

<b>Fig.</b>	<b>Description</b>	<b>Variant</b>
<b>16 Telematics</b>		
Fig. 16.1 . . . .	Telephone . . . . .	ROW Vehicles
Fig. 16.2 . . . .	Telephone with Voice Control . . . . .	ROW Voice Vehicles
Fig. 16.3 . . . .	Voice Control System . . . . .	Voice Control Vehicles
Fig. 16.4 . . . .	Navigation System. . . . .	NAV Vehicles (except Japan)
Fig. 16.5 . . . .	Navigation System: Japan. . . . .	Japan Vehicles
<b>17 Occupant Protection</b>		
Fig. 17.1 . . . .	Advanced Restraint System: Front Wheel Drive . . . . .	Front Wheel Drive Vehicles
Fig. 17.2 . . . .	Advanced Restraint System: All Wheel Drive . . . . .	All Wheel Drive Vehicles
<b>18 Driver Assist</b>		
Fig. 18.1 . . . .	Parking Aid . . . . .	Parking Aid Vehicles
<b>19 Ancillaries</b>		
Fig. 19.1 . . . .	Ancillaries . . . . .	All Vehicles
<b>20 Vehicle Multiplex Systems</b>		
Fig. 20.1 . . . .	Controller Area Network: LHD . . . . .	LHD Vehicles
Fig. 20.2 . . . .	Controller Area Network: RHD. . . . .	RHD Vehicles
Fig. 20.3 . . . .	Standard Corporate Protocol Network; Serial Data Link . . . . .	All Vehicles
Fig. 20.4 . . . .	D2B Network . . . . .	All Vehicles



The following abbreviations and acronyms are used throughout this Electrical Guide:

2.0 L	2.0 L V6 Vehicles
2.5 L, 3.0 L	2.5 L and 3.0 L V6 Vehicles
2.2 L DPF	2.2 L Diesel Vehicles with DPF
A/C	Air Conditioning
APP SENSOR	Accelerator Pedal Position Sensor
APP1	Accelerator Pedal Position Sensor Element 1
APP2	Accelerator Pedal Position Sensor Element 2
APP3	Accelerator Pedal Position Sensor Element 3
AWD	All Wheel Drive
BANK 1	RH Cylinder Bank (Cylinders 1, 3, 5)
BANK 2	LH Cylinder Bank (Cylinders 2, 4, 6)
CAN	Controller Area Network
CHT SENSOR	Cylinder Head Temperature Sensor
CKP SENSOR	Crankshaft Position Sensor
CMP SENSOR / 1	Camshaft Position Sensor / RH Bank
CMP SENSOR / 2	Camshaft Position Sensor / LH Bank
D2B	D2B Network
DAB	Digital Audio Broadcasting
DIESEL	2.0 L and 2.2 L Diesel Vehicles
DPF	Diesel Particulate Filter
DSC	Dynamic Stability Control
ECM	Engine Control Module
ECT SENSOR	Engine Coolant Temperature Sensor
EFT SENSOR	Engine Fuel Temperature Sensor
EGR VALVE	Exhaust Gas Recirculation Valve
EGT SENSOR	Exhaust Gas Temperature Sensor
EMS	Engine Management System
EOT SENSOR	Engine Oil Temperature Sensor
EST / WAG	Estate / Wagon Vehicles
EVAP CANISTER CLOSE VALVE	Evaporative Emission Canister Close Valve
EVAP CANISTER PURGE VALVE	Evaporative Emission Canister Purge Valve
FTP SENSOR	Fuel Tank Pressure Sensor
FWD	Front Wheel Drive
GPS	Global Positioning System
HID	High Intensity Discharge
HO2 SENSOR 1 / 1	Heated Oxygen Sensor – RH Bank / Upstream
HO2 SENSOR 1 / 2	Heated Oxygen Sensor – RH Bank / Downstream
HO2 SENSOR 2 / 1	Heated Oxygen Sensor – LH Bank / Upstream
HO2 SENSOR 2 / 2	Heated Oxygen Sensor – LH Bank / Downstream
IAT SENSOR	Intake Air Temperature Sensor
ICE	In-Car Entertainment System
IMT SOLENOID VALVE / 1	Intake Manifold Tuning Valve / Bottom
IMT SOLENOID VALVE / 2	Intake Manifold Tuning Valve / Top
IP SENSOR	Injection Pressure Sensor
KS	Knock Sensor
LH	Left-Hand
LHD	Left-Hand Drive
MAF SENSOR	Mass Air Flow Sensor
MAP SENSOR	Manifold Absolute Pressure Sensor
MOST	Media Orientated System Transport
N/A	Normally Aspirated
NAS	North American Specification
PATS	Passive Anti-Theft System
PWM	Pulse Width Modulated
RH	Right-Hand
RHD	Right-Hand Drive
ROW	Rest of World
SCP	Standard Corporate Protocol Network
TC	Traction Control
TCM	Transmission Control Module
T-MAP SENSOR	Temperature Manifold Absolute Pressure Sensor
TP SENSOR	Throttle Position Sensor
TP1	Throttle Position Sensor Element 1
TP2	Throttle Position Sensor Element 2
TPMS	Tire Pressure Monitoring System
TURN	Turn Signal
TV	Television
V6	V6 Engine

VICS	Vehicle Information Control System
VVT SOLENOID VALVE / 1	Variable Valve Timing Valve / Bank 1
VVT SOLENOID VALVE / 2	Variable Valve Timing Valve / Bank 2
+ve	Positive
-ve	Negative

## Electrical Guide Format

This Electrical Guide is made up of two major sections:

- the first section, at the front of the book, provides general information for and about the use of the book; model-specific information and illustrations to aid in the understanding of the Jaguar X-TYPE electrical / electronic systems, as well as the location and identification of components.
- the second section includes the Figures, which are the basis of the book. Each Figure is identified by a Figure Number (e.g. Fig. 01.1) and Title. The page adjacent to the Figure contains data information specific to that Figure.

**NOTE:** Data pages are not available for inclusion in Provisional versions of the Electrical Guide.

It is recommended that the user read through the front section of the book to develop a familiarity with the layout of the book and with the system of symbols and abbreviations used. The **Table of Contents** should help to guide the user.

## Vehicle Identification Numbers (VIN)

VIN ranges are presented throughout the book in the following manner:

> VIN 123456 indicates 'up to VIN 123456'; VIN 123456 > indicates 'from VIN 123456 on'.

## Electrical System Architecture

### Power Supplies

The electrical system is a supply-side switched system. The ignition switch directly carries much of the ignition switched power supply load.

Power supply is provided via three methods:

- Direct battery power supply;
- Ignition switched power supply;
- 'Battery Saver Power Supply'.

The 'Battery Saver Power Supply' circuit is controlled via the GEM (General Electronic Module). Refer to Fig. 01.7 for circuit activation details.

### Fuseboxes

The electrical harness incorporates two serviceable power distribution fuseboxes:

- the Power Distribution Fusebox located in the engine compartment;
- the Passenger Junction Fusebox located in the left-hand 'A' Post

All fuses and relays (except the trailer towing accessory kit and two Diesel vehicle relays) are located in the two fuseboxes.

### Vehicle Networks

The X-TYPE employs three different networks:

- CAN (Controller Area Network) for high-speed power train communications;
- SCP (Standard Corporate Protocol) network for slower speed body systems communications;
- D2B (Optical) Network for very high-speed 'real-time' audio data transfer.

**NOTE:** The D2B Network is a fiber optic network with a gateway to the remaining vehicle networks via the Audio Unit. Technician access to the three networks and the Serial Data Link is via the Data Link Connector.

### Ground Studs

Circuit ground connections are made at body studs located throughout the vehicle. There are no separate power and logic grounding systems; however, there are a certain number of components that use unique ground points.

## Figure and Data Page Layout

### Figure Pages

Each Figure represents a specific electrical system of the vehicle. The Figures are arranged numerically by system (**01 – Power Distribution, 02 – Battery; Starter; Generator**, etc.) with variations in the system identified by a numeral following a decimal point (**01.1, 01.2**, etc.). Refer to the **Table of Contents: Figures** for a complete list of the Figures.

The Figures **01 – Power Distribution** detail the distribution of power to each of the systems. Numbered reference symbols refer the user to a specific Figure and from a specific Figure back to the Power Distribution Figures. This method eliminates the need to include detailed Power Distribution information on each of the Figures. The reference symbols are defined on page 10.

Each Figure appears on a right-hand page with a corresponding Data page to the left. The Figure and Data pages are folding pages. The user must fold out both pages in order to access all the information provided.

### Data Pages

The Data page includes information to assist the user in identifying and locating components, connectors and grounds. This information is supplemented by the illustrations in this front section of the book.

Most circuits that incorporate a control module include pin-out information. The characteristics listed are approximately those that can be expected at the control module connector pins with all circuit connections made and all components connected and fitted. This information is provided to assist the user in understanding circuit operation and should be used FOR REFERENCE ONLY.

## CONTROL MODULE PIN OUT INFORMATION

## FIGURE NUMBER

## COMPONENT, CONNECTOR AND GROUND INFORMATION

Pin	Description and Characteristic
I	Pin-4
I	Pin-31
O	Pin-41
I	Pin-42
I	Pin-43
I	Pin-44
I	Pin-45
I	Pin-46
I	Pin-47
I	Pin-48
I	Pin-49
I	Pin-50
I	Pin-51
I	Pin-52
I	Pin-53
I	Pin-54
I	Pin-55
I	Pin-56
I	Pin-57
I	Pin-58
I	Pin-59
I	Pin-60
I	Pin-61
I	Pin-62
I	Pin-63
I	Pin-64
I	Pin-65
I	Pin-66
I	Pin-67
I	Pin-68
I	Pin-69
I	Pin-70
I	Pin-71
I	Pin-72
I	Pin-73
I	Pin-74
I	Pin-75
I	Pin-76
I	Pin-77
I	Pin-78
I	Pin-79
I	Pin-80
I	Pin-81
I	Pin-82
I	Pin-83
I	Pin-84
I	Pin-85
I	Pin-86
I	Pin-87
I	Pin-88
I	Pin-89
I	Pin-90
I	Pin-91
I	Pin-92
I	Pin-93
I	Pin-94
I	Pin-95
I	Pin-96
I	Pin-97
I	Pin-98
I	Pin-99
I	Pin-100

**Fig. 2.1**

Component	Connector(s)	Connector Description	Location
BATTERY	—	—	LOGGAGE COMPARTMENT
CLOCK/VEHICLE SAFETY SWITCH	CA306	2-WAY / BLACK	TOP OF CLUTCH PEDAL, BOTTOM SWITCH
ENGINE CONTROL MODULE	PH1	2-WAY / BLACK	FRONT BULKHEAD, PASSENGER SIDE
FRONT POWER DISTRIBUTION FUSE BOX	PH1	2-WAY / BLACK	ENGINE COMPARTMENT, RH SIDE
GENERATOR (A)	PH7	4-WAY / BLACK	ENGINE, RH SIDE, FRONT
IGNITION SWITCH	FCM	7-WAY / BLACK	STEERING COLUMN/CONSOLE
INSTRUMENT CLUSTER	FCM	20-WAY / GREY	INSTRUMENT PANEL
—	FC26	20-WAY / BLACK	—
—	FC27	20-WAY / BLACK	—
—	FC28	20-WAY / BLACK	—
—	FC29	20-WAY / BLACK	—
—	FC30	20-WAY / BLACK	—
—	FC31	20-WAY / BLACK	—
—	FC32	20-WAY / BLACK	—
—	FC33	20-WAY / BLACK	—
—	FC34	20-WAY / BLACK	—
—	FC35	20-WAY / BLACK	—
—	FC36	20-WAY / BLACK	—
—	FC37	20-WAY / BLACK	—
—	FC38	20-WAY / BLACK	—
—	FC39	20-WAY / BLACK	—
—	FC40	20-WAY / BLACK	—
—	FC41	20-WAY / BLACK	—
—	FC42	20-WAY / BLACK	—
—	FC43	20-WAY / BLACK	—
—	FC44	20-WAY / BLACK	—
—	FC45	20-WAY / BLACK	—
—	FC46	20-WAY / BLACK	—
—	FC47	20-WAY / BLACK	—
—	FC48	20-WAY / BLACK	—
—	FC49	20-WAY / BLACK	—
—	FC50	20-WAY / BLACK	—
—	FC51	20-WAY / BLACK	—
—	FC52	20-WAY / BLACK	—
—	FC53	20-WAY / BLACK	—
—	FC54	20-WAY / BLACK	—
—	FC55	20-WAY / BLACK	—
—	FC56	20-WAY / BLACK	—
—	FC57	20-WAY / BLACK	—
—	FC58	20-WAY / BLACK	—
—	FC59	20-WAY / BLACK	—
—	FC60	20-WAY / BLACK	—
—	FC61	20-WAY / BLACK	—
—	FC62	20-WAY / BLACK	—
—	FC63	20-WAY / BLACK	—
—	FC64	20-WAY / BLACK	—
—	FC65	20-WAY / BLACK	—
—	FC66	20-WAY / BLACK	—
—	FC67	20-WAY / BLACK	—
—	FC68	20-WAY / BLACK	—
—	FC69	20-WAY / BLACK	—
—	FC70	20-WAY / BLACK	—
—	FC71	20-WAY / BLACK	—
—	FC72	20-WAY / BLACK	—
—	FC73	20-WAY / BLACK	—
—	FC74	20-WAY / BLACK	—
—	FC75	20-WAY / BLACK	—
—	FC76	20-WAY / BLACK	—
—	FC77	20-WAY / BLACK	—
—	FC78	20-WAY / BLACK	—
—	FC79	20-WAY / BLACK	—
—	FC80	20-WAY / BLACK	—
—	FC81	20-WAY / BLACK	—
—	FC82	20-WAY / BLACK	—
—	FC83	20-WAY / BLACK	—
—	FC84	20-WAY / BLACK	—
—	FC85	20-WAY / BLACK	—
—	FC86	20-WAY / BLACK	—
—	FC87	20-WAY / BLACK	—
—	FC88	20-WAY / BLACK	—
—	FC89	20-WAY / BLACK	—
—	FC90	20-WAY / BLACK	—
—	FC91	20-WAY / BLACK	—
—	FC92	20-WAY / BLACK	—
—	FC93	20-WAY / BLACK	—
—	FC94	20-WAY / BLACK	—
—	FC95	20-WAY / BLACK	—
—	FC96	20-WAY / BLACK	—
—	FC97	20-WAY / BLACK	—
—	FC98	20-WAY / BLACK	—
—	FC99	20-WAY / BLACK	—
—	FC100	20-WAY / BLACK	—

DATA PAGE

The following abbreviations are used to represent values for Control Module Pin-Out data

I Input PG Power Ground C CAN Network D Serial and Encoded Data  
 O Output SS Sensor / Signal Supply V S SCP Network V Voltage (DC)  
 B+ Battery Voltage SG Sensor / Signal Ground D2 D2B Network PWM Pulse Width Modulated

CAUTION: The information on this data page is furnished to aid the user in understanding circuit operation. THIS INFORMATION SHOULD BE USED FOR REFERENCE ONLY.

NOTE: The values listed are approximately those that can be expected at the control module connector pins with all circuit connections made and all components connected and fitted.

Refer to the front of this book for detailed information and illustrations regarding the location and identification of harnesses, relays, fuses, grounds, control modules and control module pins.

DATE OF ISSUE: February 2004

DATE OF ISSUE

## FIGURE MODEL RANGE AND YEAR

## TITLE

## FIGURE NUMBER

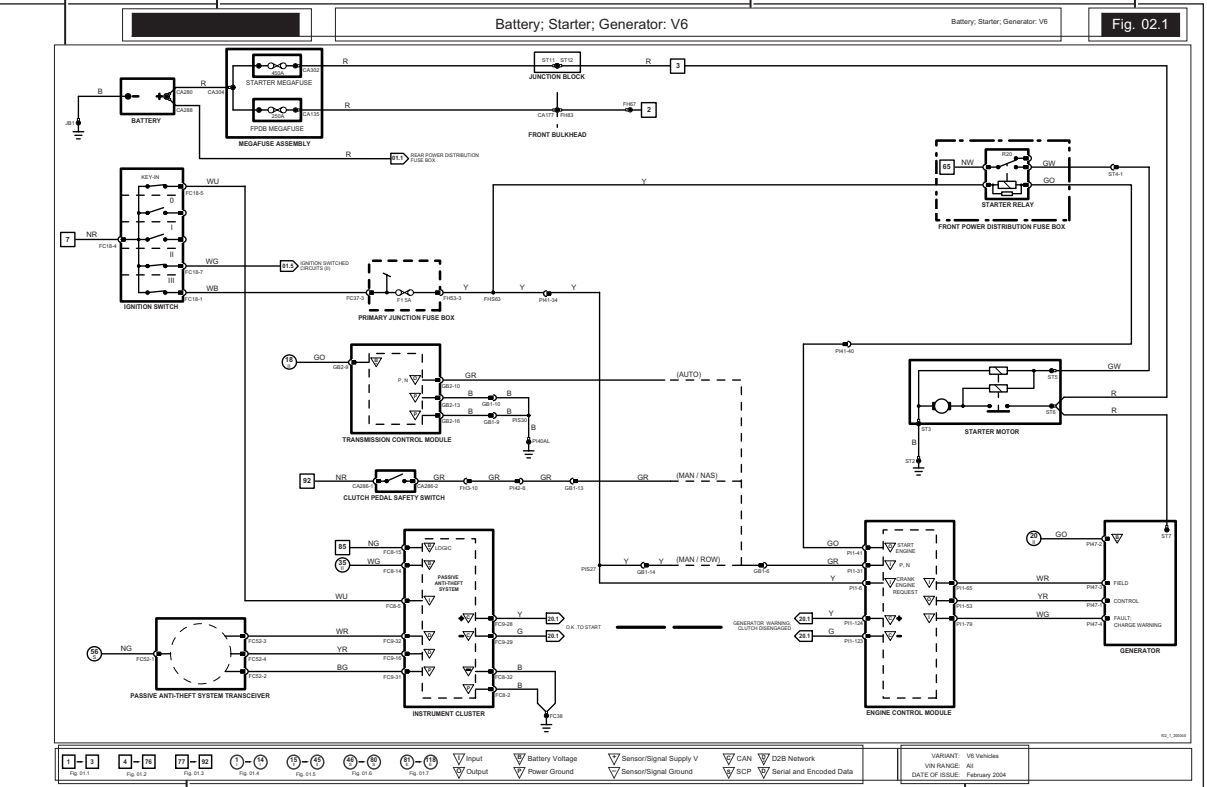

**Fig. 02.1**









FIGURE PAGE

KEY TO REFERENCE SYMBOLS











VARIANT, VIN RANGE AND DATE OF ISSUE

**NOTE:** In the examples on this page, an 'X' is used where a number would appear on an actual Figure.

**Reference Symbols**

-  Battery power supply
-  Ignition switched auxiliary power supply (key I)
-  Ignition switched power supply (key II, III)
-  Ignition switched Battery Saver power supply
-  Engine Management System power supply
-  Figure number reference
-  Controller Area Network
-  Standard Corporate Protocol network
-  D2B network













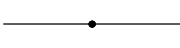

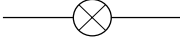
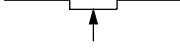
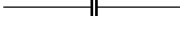

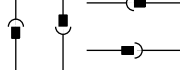
**Control Module Pin Symbols**

-  Input
-  Output
-  Battery voltage
-  Power ground
-  Sensor / signal supply V \*
-  Sensor / signal ground \*\*
-  CAN network
-  SCP network
-  D2B network
-  Serial and encoded data
-  MOST (Media orientated system transport)

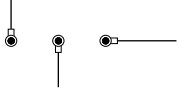
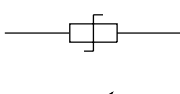
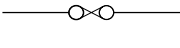
\* May also indicate Reference Voltage.

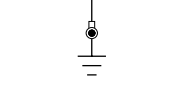
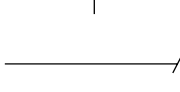
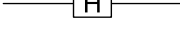
\*\* May also indicate Reference Ground or Logic Ground.  
Refer to Control Module Pin-out Information.

**Wiring Symbols**

- |                    |   |  |                            |
|--------------------|---|--|----------------------------|
| Splice             |    |    | Light emitting diode (LED) |
| Simplified splice  |  |  | Motor                      |
| Bulb               |  |  | Potentiometer              |
| Capacitor          |  |  | Pressure transducer        |
| Connector          |  |  | Resistor                   |
| Diode              |  |  | Solenoid                   |
| Eyelet and stud    |  |  | Suppression diode          |
| Fuse               |  |  | Suppression resistor       |
| Ground             |  |  | Thermistor                 |
| Hall effect sensor |  |  | Transistor                 |
|                    |   |  | Wire continued             |
|                    |   |  | Zener diode                |

## Harness Codes

AC	Climate Control
AS	Side Airbag
BH	Engine Block Heaters
BL	LH Rear Door
BR	RH Rear Door
CA	Cabin
DE	Diesel Engine
DL	Diesel Engine Link
EN	Engine
FB	Front Bumper
FL	LH Front Door
FR	RH Front Door
FT	Fuel Tank
GC	Cooling Pack
IJ	Injector Rail
IP	Instrument Panel
JB	Junction Box
LF	LH Front Wheel Speed Sensor
LR	LH Rear Wheel Speed Sensor
LS	LH Front Seat
NA	Navigation System
PA	Pedal Assembly
PH	Telephone
RB	Rear Bumper
RC	Roof Console
RF	RH Front Wheel Speed Sensor
RR	RH Rear Wheel Speed Sensor
RS	RH Front Seat
SL	Security Sounder Link
TL	Trunk Lid
TT	Trailer Towing
TV	Television
WG	Tailgate Glass (Estate / Wagon only)
WL	Tailgate Link (Estate / Wagon only)
WS	Weight Sensor
WT	Tailgate (Estate / Wagon only)

## Wiring Color Codes

N	Brown	S	Slate
B	Black	L	Light
W	White	U	Blue
K	Pink	P	Purple
G	Green	BRD	Braid
R	Red	BOF	Fiber optic (D2B Network)
Y	Yellow	SCR	Screen
O	Orange		

## Code Numbering

When numbering connectors, grounds and splices, Jaguar Engineering uses a three-position format: AC001, AC002, etc. Because space is limited in this Electrical Guide the codes have, in most cases, been shortened. Thus AC001-001 becomes AC1-1, AC002-001 becomes AC2-1, etc.

## Grounds

- There may be up to three eyelets on one ground stud.
- A, B and C are used to indicate the position of the eyelet on the stud: A – first (bottom), B – second (middle), C – third (top).
- Two eyelet variations are used: a single eyelet and an eyelet pair. The single eyelet has a single 'leg', which is identified by an S; the eyelet pair has two 'legs', identified as L (left) or R (right).

EXAMPLE:



On figures where LHD and RHD circuits are combined and the ground designation differs from LHD to RHD, the RHD ground is shown in parentheses. If the ground designation is the same for LHD and RHD, only one ground designation is used.

EXAMPLE:



## Relays

### Serviceable Relays:

- are located in both fuseboxes;
- do not have a separate relay connector (base);
- use the ISO pin numbering system – 1, 2, 3, 4, 5;
- are identified by an 'R' number unique only to the fusebox in which it is located.

EXAMPLE:



### Non-Serviceable Relays:

- are located in both fuseboxes;
- are a component part of the fusebox printed circuit board (PCB) and are arranged in singles or pairs;
- use the ISO pin numbering system – 1, 2, 3, 4, 5 (single relay or top pair relay) and 6, 7, 8, 9, 10 (bottom pair relay);
- are identified by an 'R' number unique only to the fusebox in which it is located;
- pair relays are normally depicted separately.

EXAMPLE:

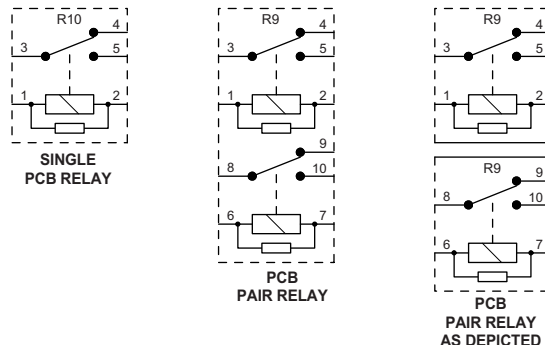

**NOTE:** Diesel vehicles have one serviceable relay located on the Junction Box harness and one serviceable relay attached to the Power Distribution Fusebox.



**Fuses**

All fuses are located in the fuseboxes. Each fuse is identified by an 'F' number unique only to the fusebox in which it is located.

EXAMPLE:

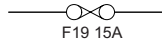

**Networks**

In most instances, networks are shown as a broken grey line to indicate that there is network communication between the depicted control modules. Refer to Figures 20.1, 20.2, 20.3 and 20.4 for circuit details.

EXAMPLE:

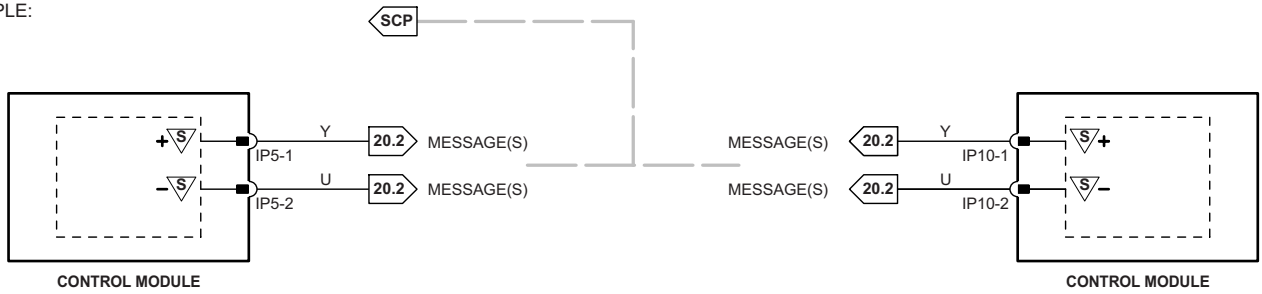

**Component Depictions**

EXAMPLE:

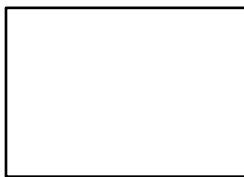

COMPLETE COMPONENTS AND CONTROL MODULES



INCOMPLETE COMPONENTS (EXCEPT CONTROL MODULES)



ASSEMBLIES AND POWER DISTRIBUTION FUSE BOXES

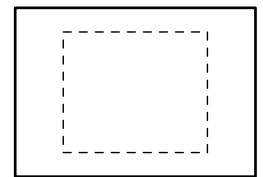

COMPONENTS WITH INTERNAL ELECTRONIC CIRCUIT

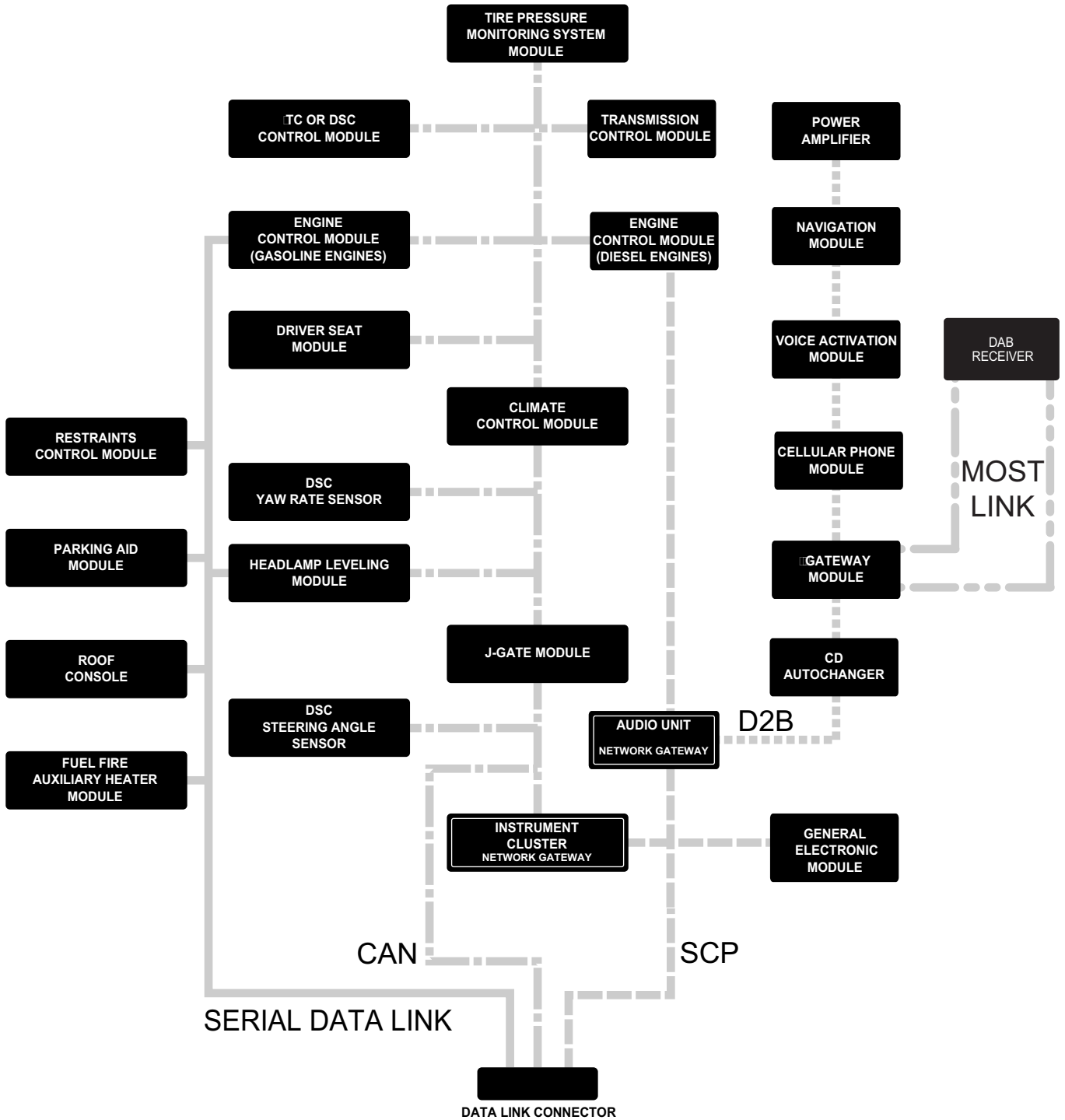

- CAN NETWORK
- . - . - . SCP NETWORK
- ..... D2B NETWORK
- SERIAL DATA LINK
- . - . - . MOST LINK

**NOTE:** TYPICAL NETWORK CONFIGURATION.  
REFER TO FIGURES 20.1, 20.2, 20.3 AND 20.4 FOR CIRCUIT DETAILS.

**POWER DISTRIBUTION FUSE BOX (TOP): GASOLINE ENGINE VEHICLES**

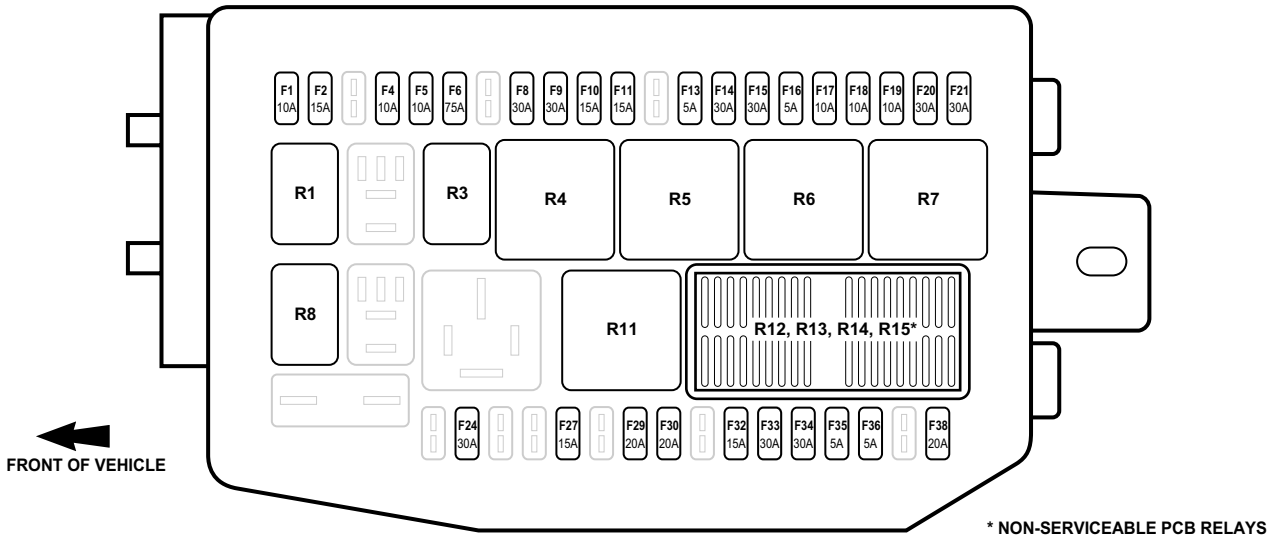

- |   |                          |
|---|--------------------------|
| R1 MAIN BEAM / FRONT FOG RELAY                | R9 NOT USED              |
| R2 NOT USED                                   | R10 NOT USED             |
| R3 A/C COMPRESSOR CLUTCH RELAY                | R11 DIP BEAM RELAY       |
| R4 WINDSHIELD WIPER MOTOR RELAY               | R12 STARTER RELAY        |
| R5 POWER DISTRIBUTION FUSE BOX IGNITION RELAY | R13 SLAVE IGNITION RELAY |
| R6 WINDSHIELD HEATER RELAY                    | R14 NOT USED             |
| R7 EMS CONTROL RELAY                          | R15 HORN RELAY           |
| R8 POWERWASH PUMP RELAY                       |                          |

**POWER DISTRIBUTION FUSE BOX (TOP): DIESEL ENGINE VEHICLES**

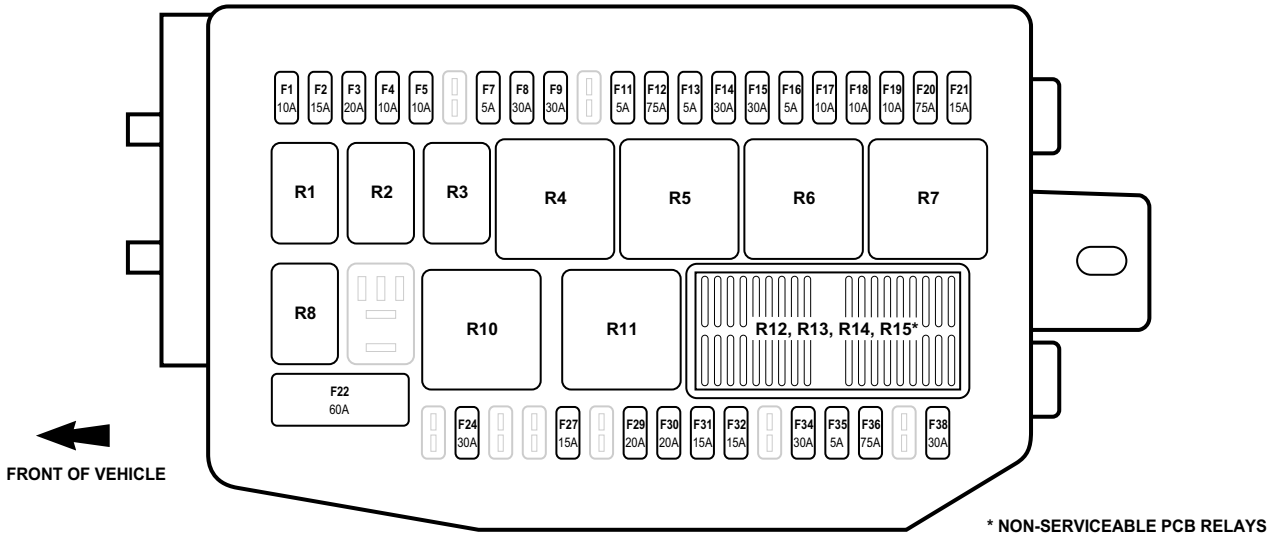

- |   |                              |
|---|------------------------------|
| R1 MAIN BEAM / FRONT FOG RELAY                | R9 NOT USED                  |
| R2 HORN RELAY                                 | R10 GLOW PLUG RELAY          |
| R3 A/C COMPRESSOR CLUTCH RELAY                | R11 DIP BEAM RELAY           |
| R4 WINDSHIELD WIPER MOTOR RELAY               | R12 STARTER RELAY            |
| R5 POWER DISTRIBUTION FUSE BOX IGNITION RELAY | R13 SLAVE IGNITION RELAY     |
| R6 WINDSHIELD HEATER RELAY                    | R14 NOT USED                 |
| R7 EMS CONTROL RELAY                          | R15 AUXILIARY HEATER RELAY 1 |
| R8 POWERWASH PUMP RELAY                       |                              |

pw\_dis\_fuse\_box\_40009

POWER DISTRIBUTION FUSE BOX (BOTTOM)

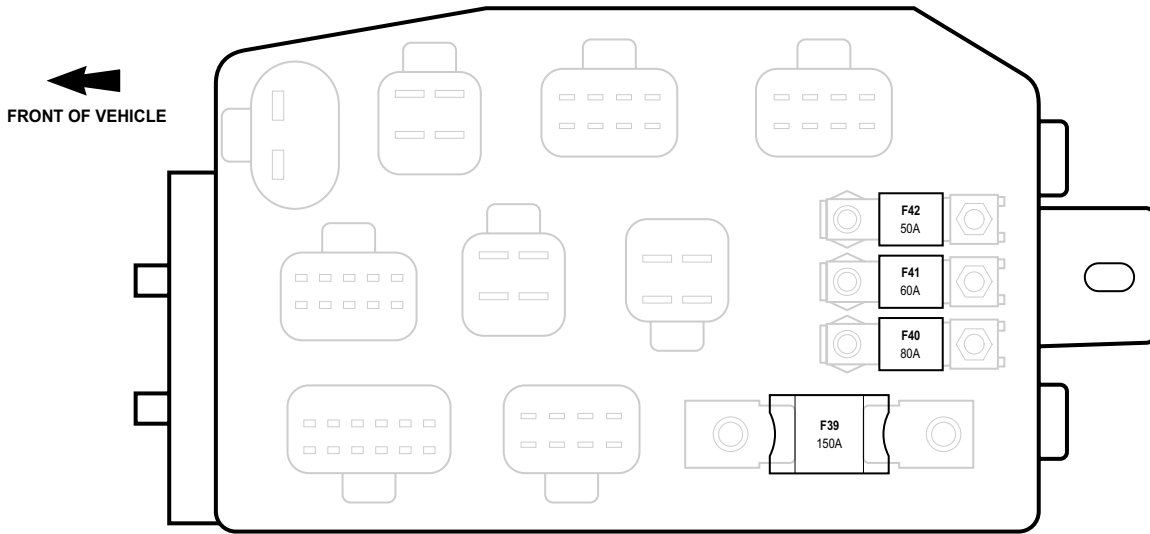

PASSENGER JUNCTION FUSE BOX (FRONT)

PASSENGER JUNCTION FUSE BOX (BACK)

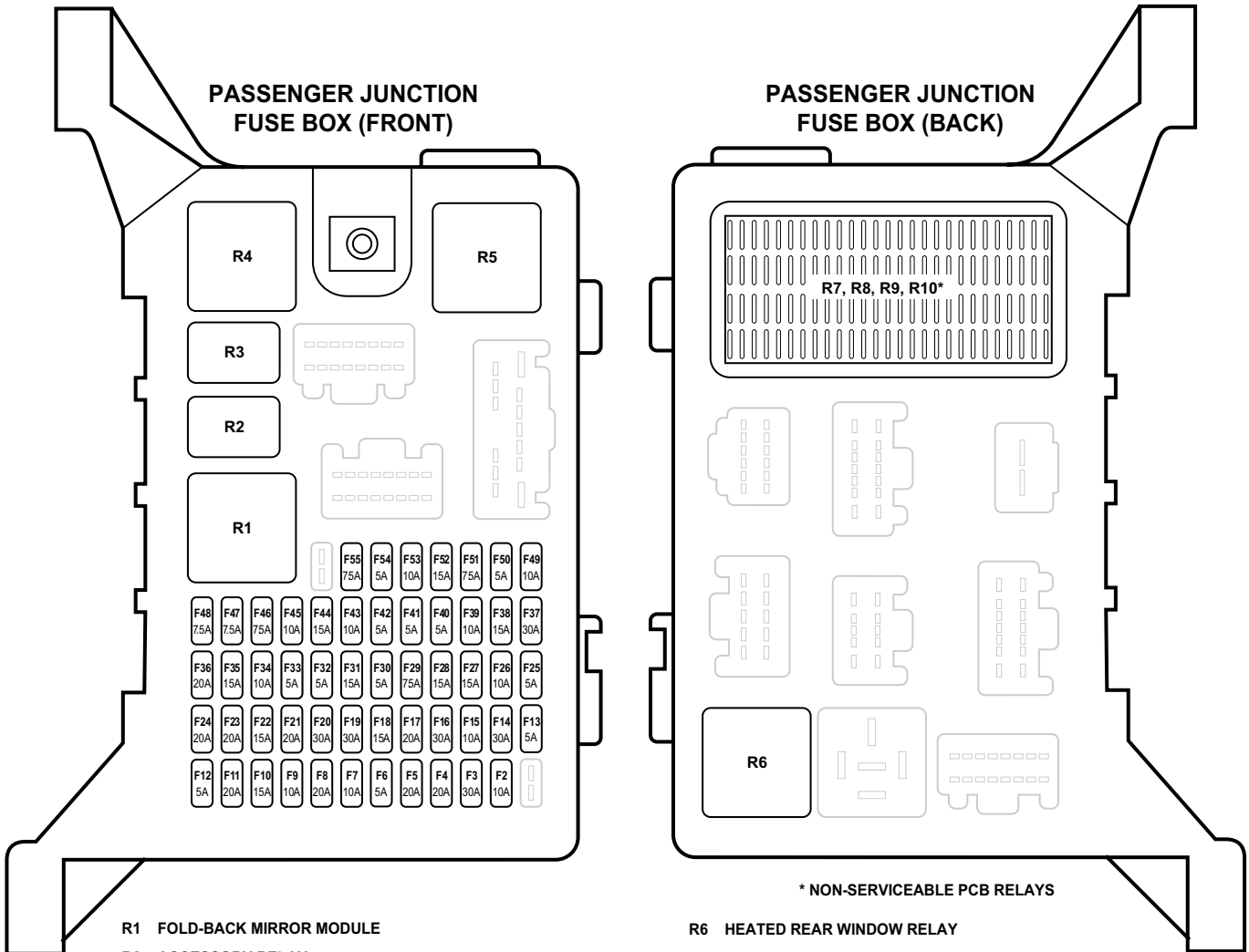

- R1 FOLD-BACK MIRROR MODULE
- R2 ACCESSORY RELAY
- R3 REAR WIPER MOTOR RELAY(ESTATE / WAGON ONLY)
- R4 BLOWER MOTOR RELAY
- R5 PASSENGER JUNCTION FUSE BOX IGNITION RELAY

- \* NON-SERVICEABLE PCB RELAYS
- R6 HEATED REAR WINDOW RELAY
  - R7 THROTTLE MOTOR RELAY (2.5 L, 3.0 L)  
FUEL PUMP RELAY (2.0 L)
  - R8 NOT USED
  - R9 REVERSE LAMPS RELAY
  - R10 BATTERY SAVER RELAY

pw\_dis\_fuse\_bot\_40009

POWER DISTRIBUTION FUSE BOX (BOTTOM)

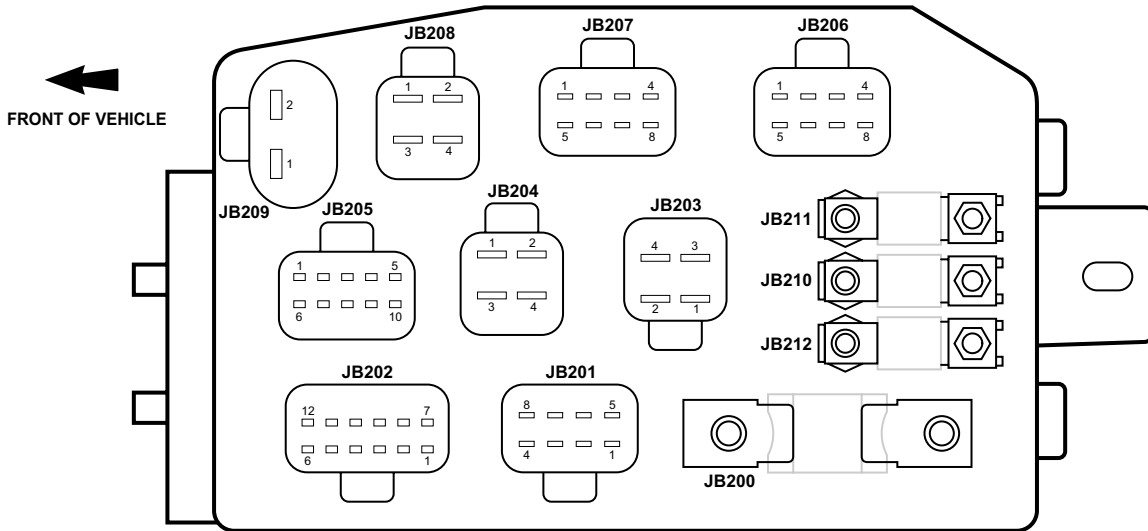

PASSENGER JUNCTION FUSE BOX (FRONT)

PASSENGER JUNCTION FUSE BOX (BACK)

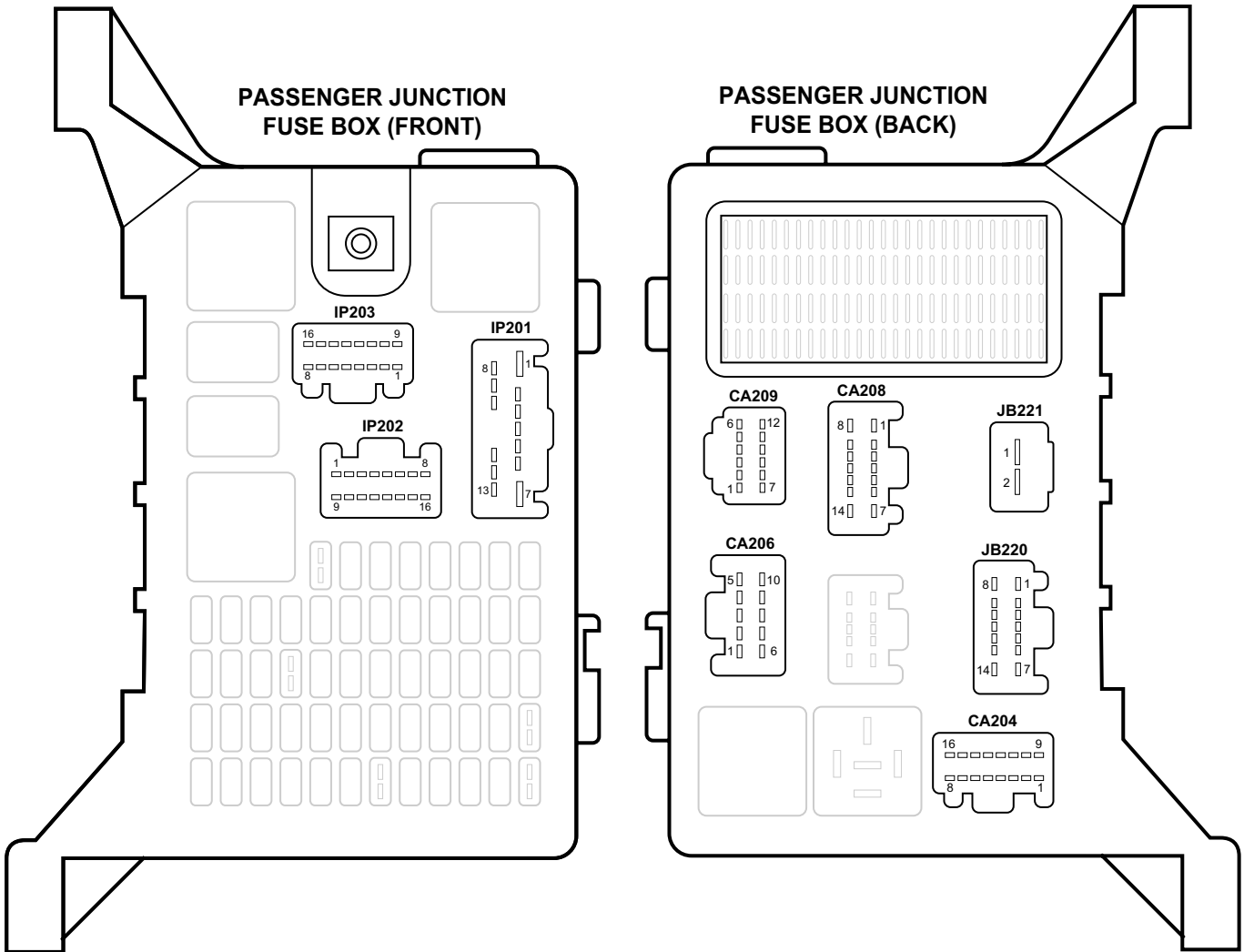

fuse\_box\_con\_4000625

SEDAN (GASOLINE ENGINE SHOWN)

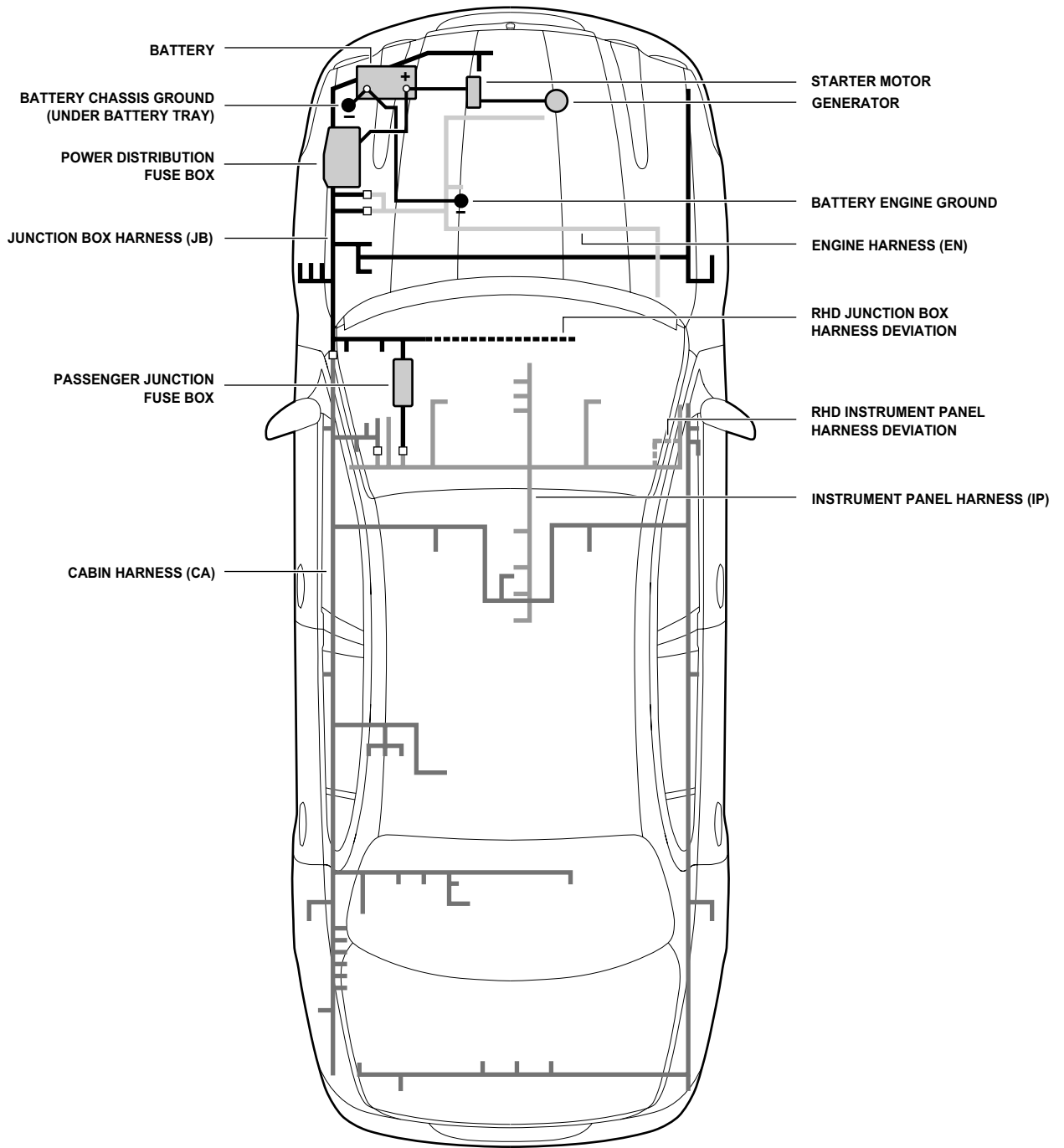

harn\_fuse\_box.loc\_4000625

ESTATE / WAGON (GASOLINE ENGINE SHOWN)

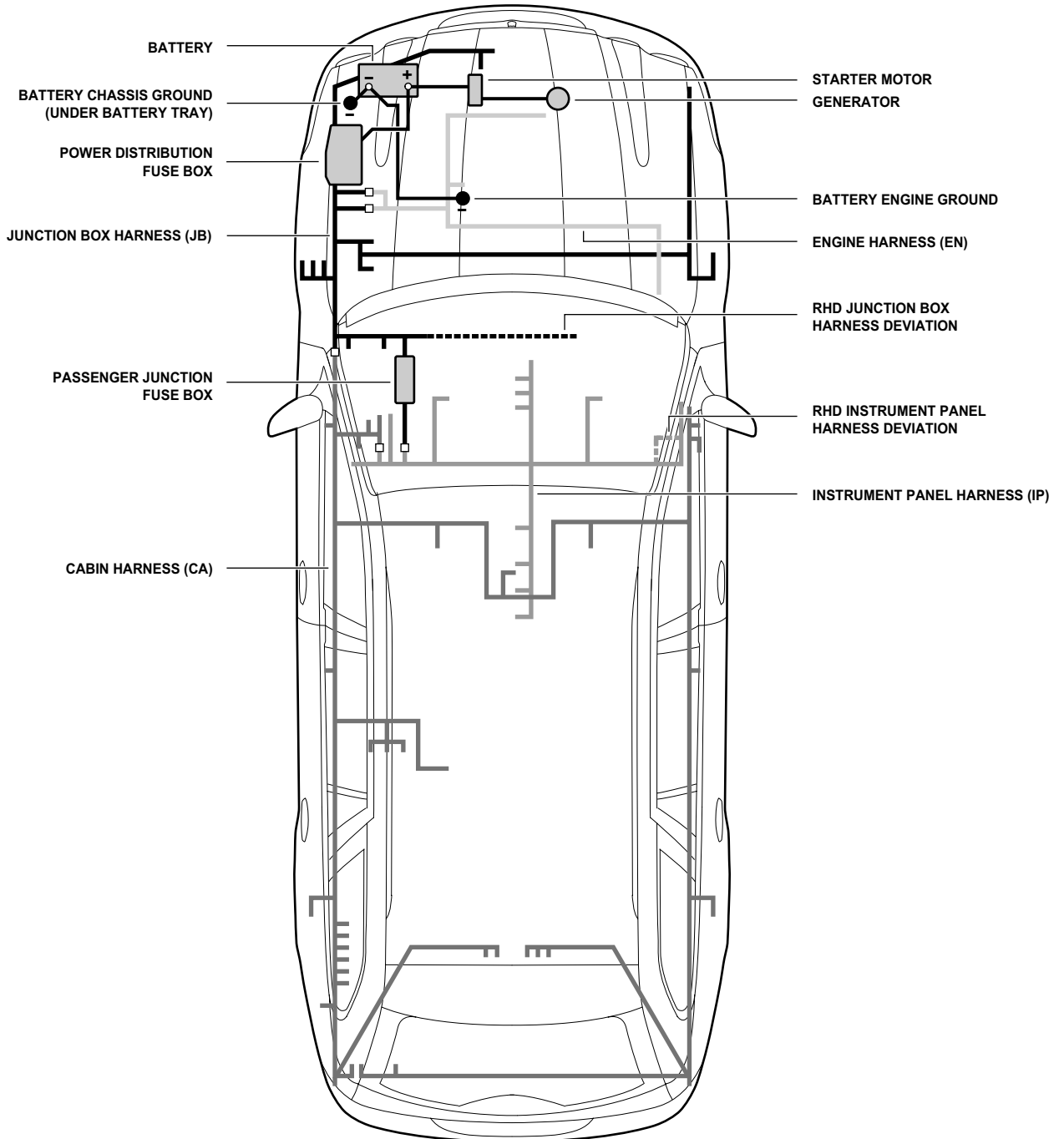

est\_fuse\_box\_loc\_4000625

SEDAN: GASOLINE ENGINE (LHD SHOWN)

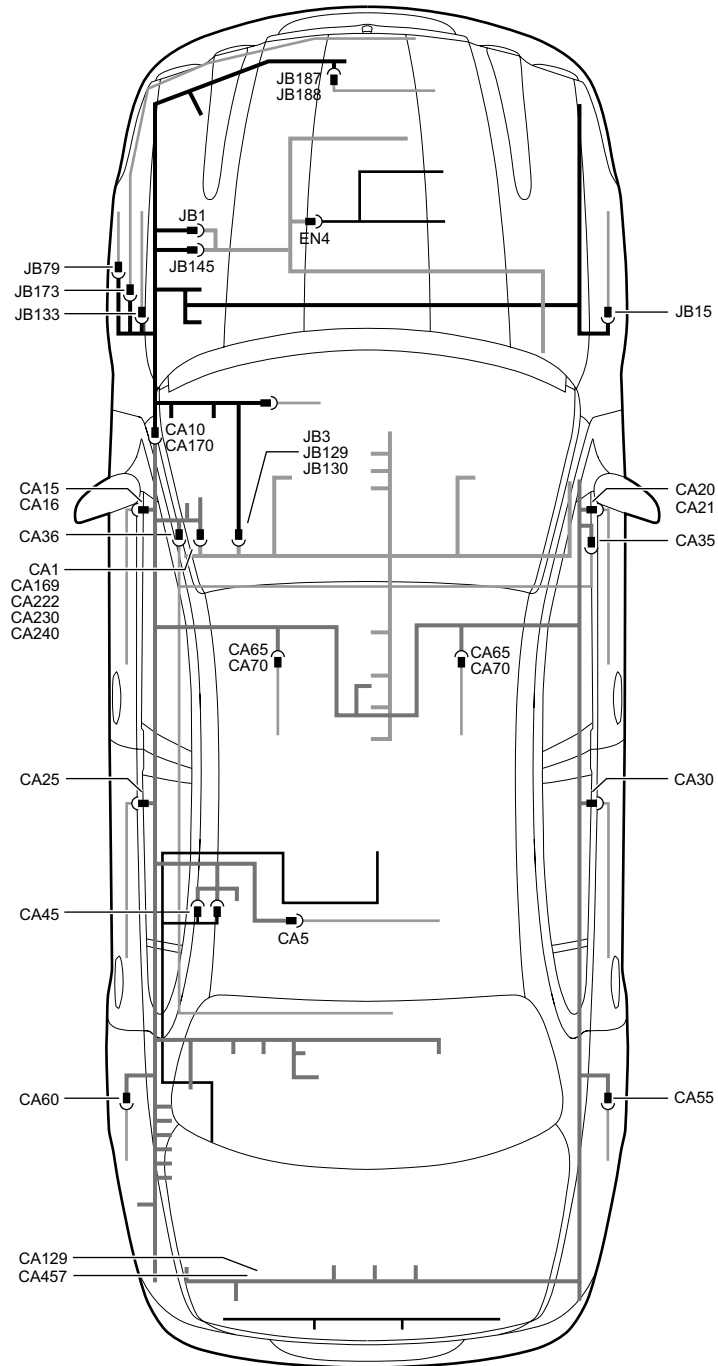

gas\_harn\_con\_loc\_40009



SEDAN: DIESEL ENGINE (RHD SHOWN)

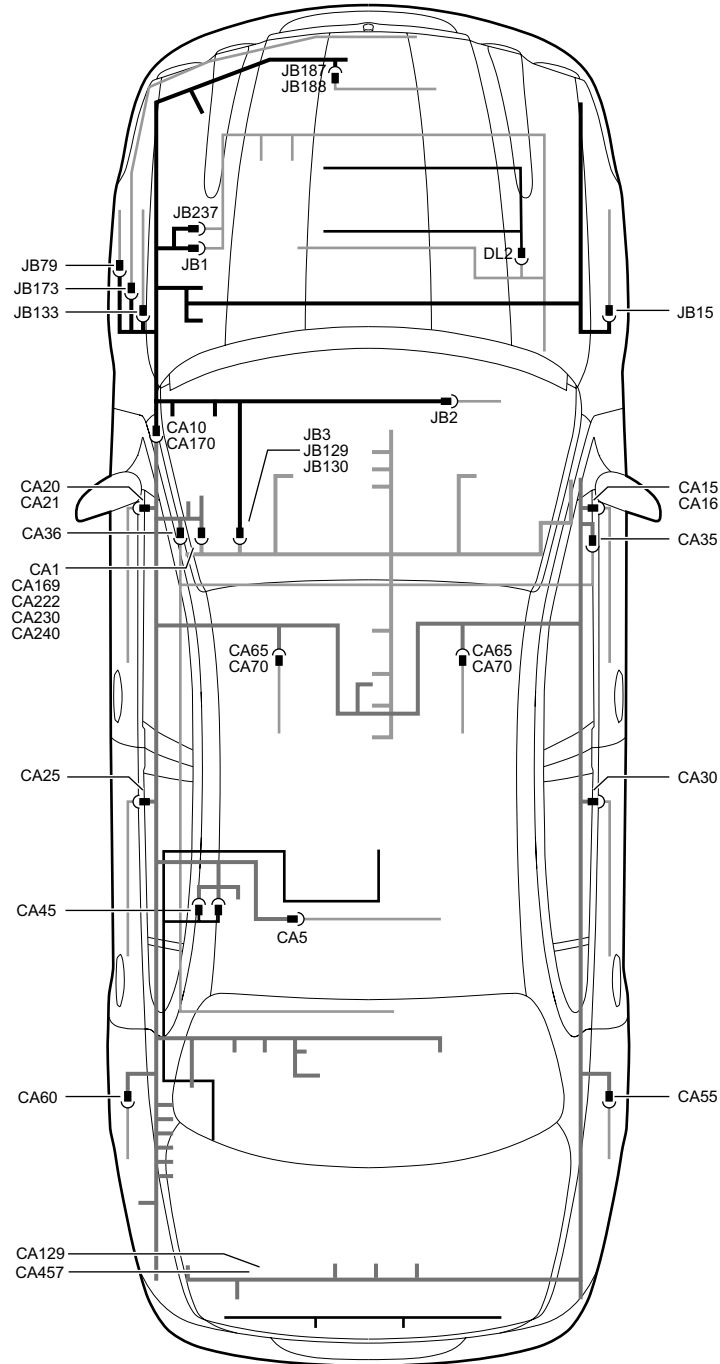

diesel\_harn\_con\_loc\_40009

ESTATE / WAGON (RHD SHOWN)

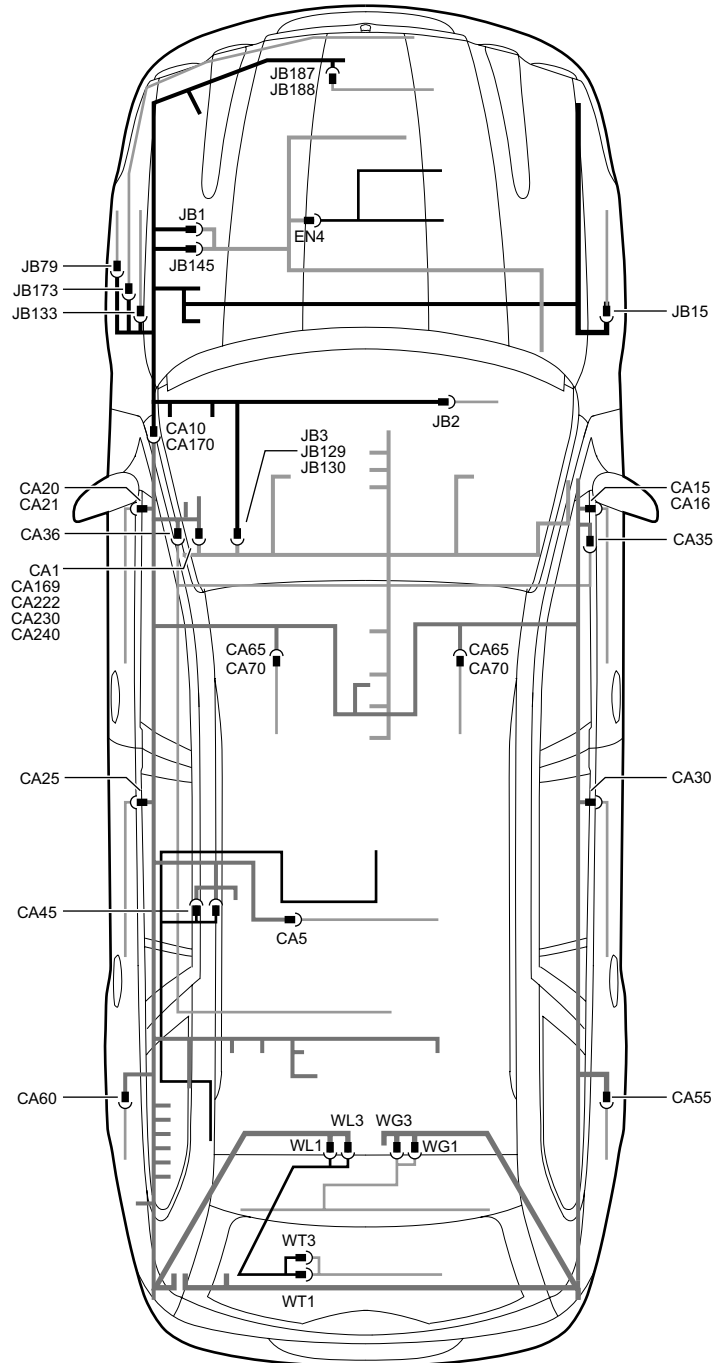

estate\_harn\_con\_loc\_40009

SEDAN SHOWN

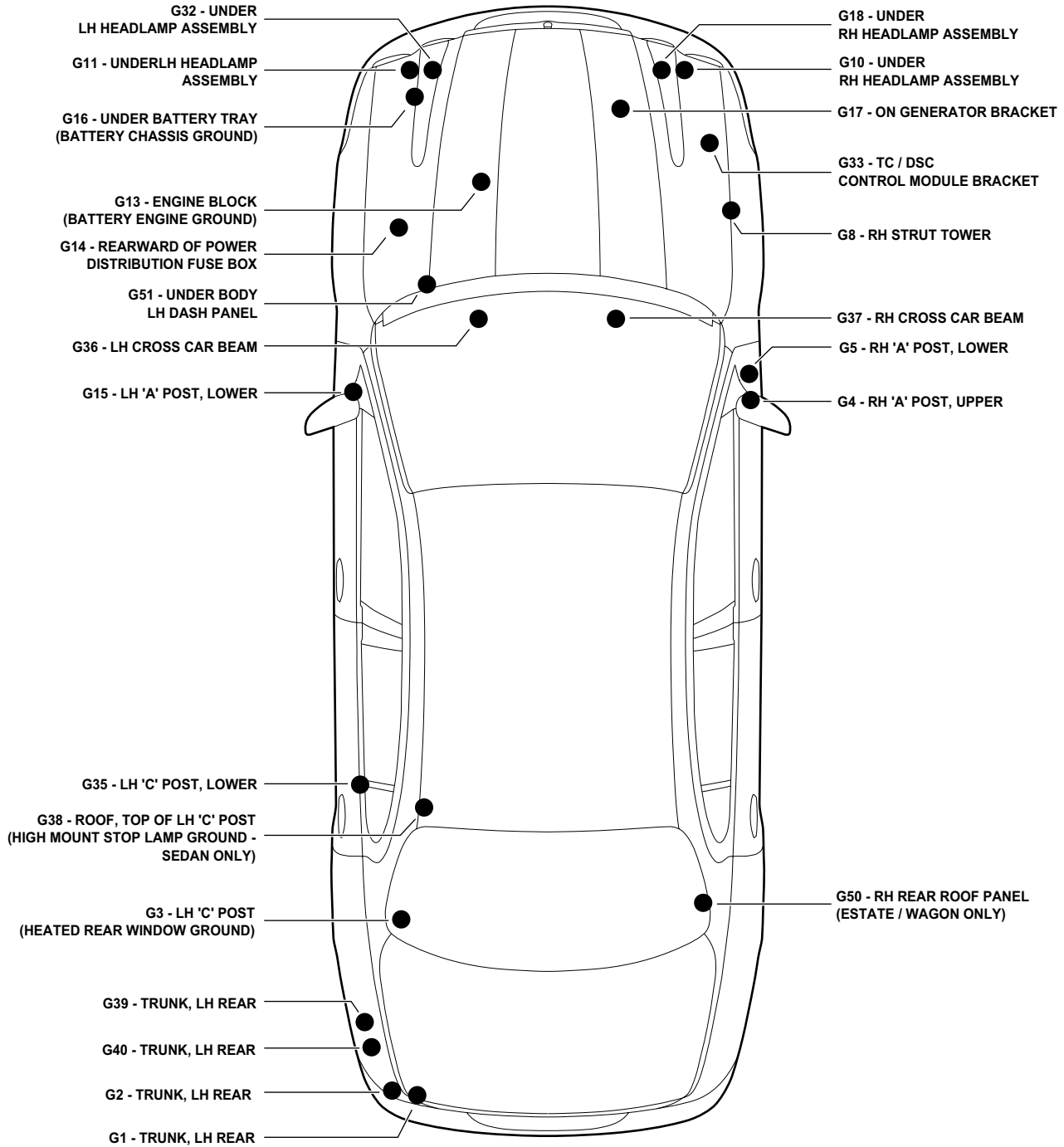

NOTE: UNIQUE GROUND STUDS ARE NOTED IN PARENTHESES.

grd\_pt\_loc\_40009

SEDAN

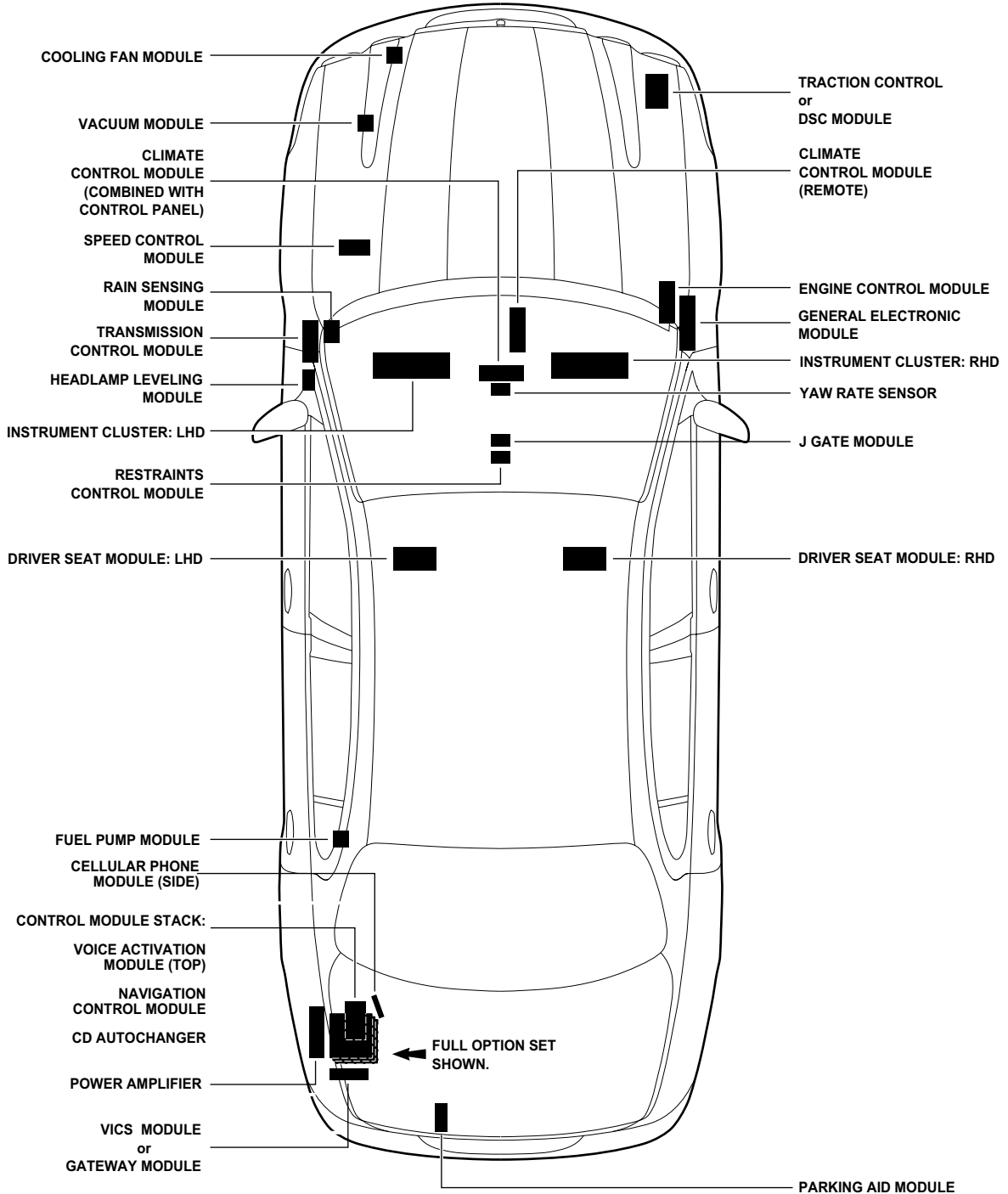

ESTATE / WAGON

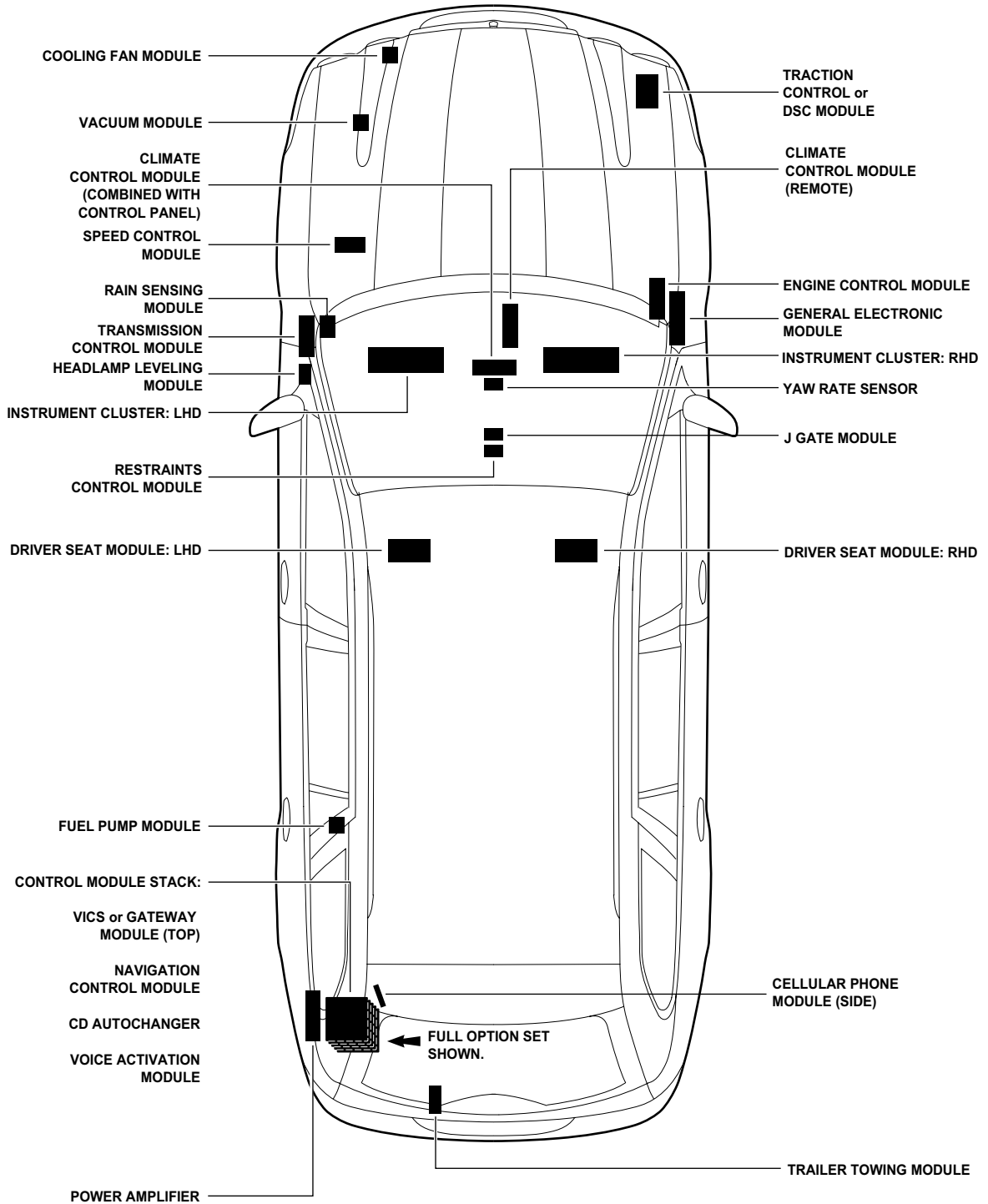

estate\_cnt\_mod\_loc\_40009

**ENGINE CONTROL MODULE - 2.5 L, 3.0 L**

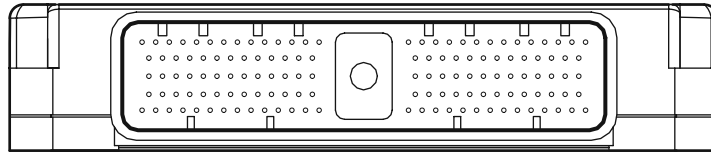

**EN16 / 134-WAY / BLACK**

107	108	109	110	111	112	113	114	115	116	117	118	119	120
Y	G	RW	G	B	-	BG	BO	BG	B	-	BO	BW	BW
81	82	83	84	85	86	87	88	89	90	91	92	93	
B	B	Y	G	-	-	GU	GW	GR	-	B	U	UY	
55	56	57	58	59	60	61	62	63	64	65	66	67	
GO	GO	-	-	-	-	GU	GW	GR	-	OG	UY	O	
29	30	31	32	33	34	35	36	37	38	39	40	41	
B	B	B	-	WG	BG	-	G	Y	OY	OY	B	GO	
1	2	3	4	5	6	7	8	9	10	11	12	13	14
RU	RU	-	B	B	Y	GO	GO	U	GU	-	OY	Y	-

121	122	123	124	125	126	127	128	129	130	131	132	133	134
WU	-	G	Y	-	-	BW	N	N	BR	YG	YG	BG	RW
94	95	96	97	98	99	100	101	102	103	104	105	106	
O	B	-	-	N	-	BG	-	R	Y	RG	W	R	
68	69	70	71	72	73	74	75	76	77	78	79	80	
G	N	UY	O	-	U	-	G	Y	-	Y	U	G	
42	43	44	45	46	47	48	49	50	51	52	53	54	
-	W	GW	BW	BW	YR	YG	-	U	WU	GR	RG	B	
15	16	17	18	19	20	21	22	23	24	25	26	27	28
-	-	B	B	BG	BG	-	NR	WG	WG	W	-	N	-

**ENGINE CONTROL MODULE - 2.0 L**

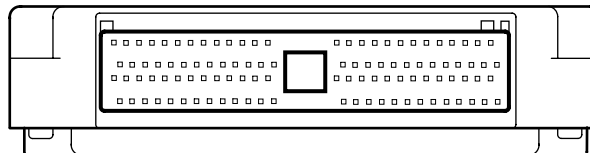

**EN65 / 104-WAY / BLACK**

79	80	81	82	83	84	85	86	87	88	89	90	91
Y	UY	O	-	-	WG	B	G	N	G	Y	-	B
53	54	55	56	57	58	59	60	61	62	63	64	65
N	N	BR	GW	GU	-	O	B	G	Y	GO	B	BG
27	28	29	30	31	32	33	34	35	36	37	38	39
N	-	BW	GW	BW	-	-	GO	U	GU	N	BG	W
1	2	3	4	5	6	7	8	9	10	11	12	13
BW	WU	BG	B	B	Y	U	OG	-	-	OY	YG	YG

92	93	94	95	96	97	98	99	100	101	102	103	104
BW	BW	BO	G	RW	G	R	GR	-	-	B	GO	RU
66	67	68	69	70	71	72	73	74	75	76	77	78
BO	BG	GO	B	-	OY	-	-	UY	B	GO	RU	B
40	41	42	43	44	45	46	47	48	49	50	51	52
GU	GW	GR	RG	WU	-	UY	U	B	-	G	Y	B
14	15	16	17	18	19	20	21	22	23	24	25	26
GU	GW	GR	G	B	B	BG	NR	WG	WG	-	G	Y



TRANSMISSION CONTROL MODULE - PETROL

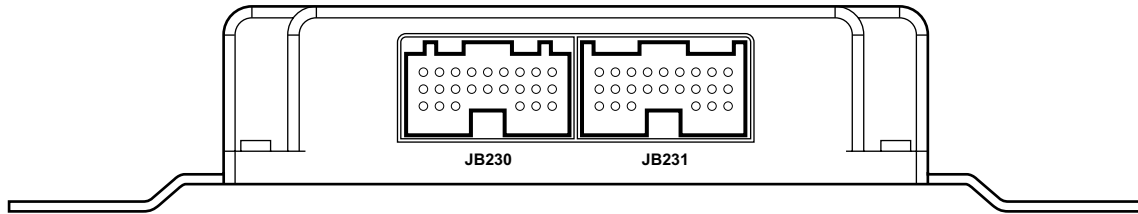

JB230 / 24-WAY / WHITE

1 R	2 G	3 O	4 B	5 Y	6 G	7 W	8 Y	9 -
10 WU	11 B	12 N	13 -	14 Y	15 G	16 -	17 -	18 U
19 WU	20 G	21 U				22 -	23 BRD	24 O

JB231 / 24-WAY / GREY

25 B	26 BRD	27 R	28 UY	29 O	30 -	31 -	32 -	33 -
34 Y	35 S	36 W	37 -	38 N	39 G	40 -	41 OY	42 R
43 BW	44 BRD	45 -				46 -	47 W	48 B



DYNAMIC STABILITY CONTROL MODULE  
OR  
TRACTION CONTROL MODULE

JB185 (JB197) / 46-WAY / BLACK

46	-	25	-
45	-	24	-
44	-	23	-
43	-	22	-
42	-	21	-
41	-	20	-
40	-	19	-
39	-	18	-
38	-	17	-
37	-	16	-
36	-	15	-
35	Y	14	G
34	-	13	-
33	-	12	-
32	-	11	-
31	B	10	WR
30	GO	9	NR
29	WG	8	NG
28	GW	7	-
27	WU	6	GB
26	N	5	W
4	B		
3	R		
2	R		
1	B		

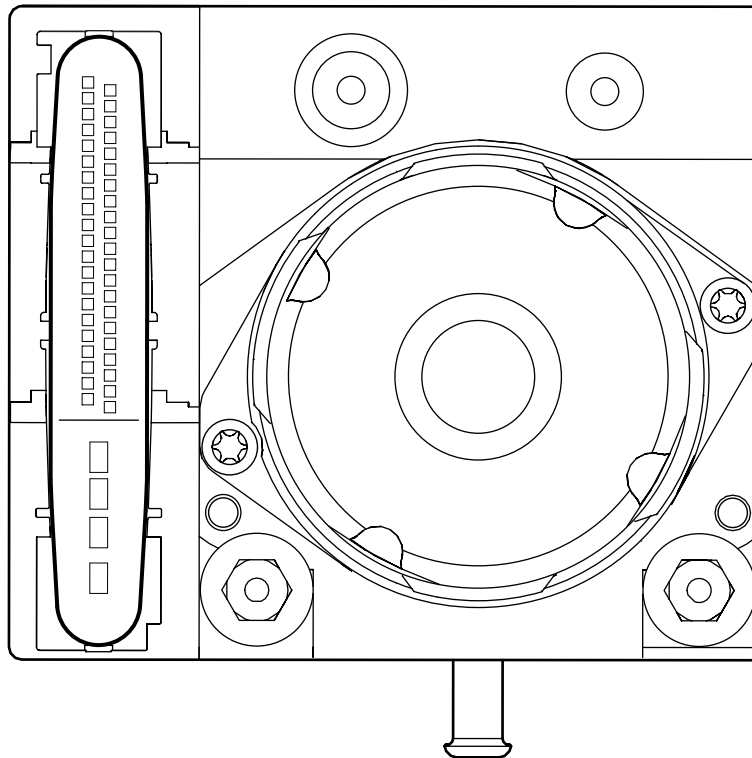

CLIMATE CONTROL MODULE - AUTOMATIC (REMOTE)

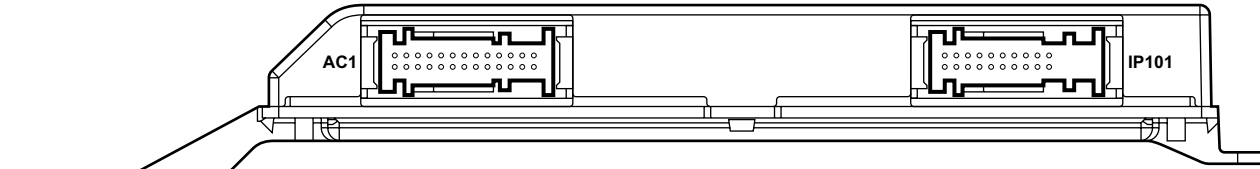

AC1 / 26-WAY / YELLOW

14	15	16	17	18	19	20	21	22	23	24	25	26
G	UY	B	-	-	-	GU	GB	OG	O	RW	RG	OY
1	2	3	4	5	6	7	8	9	10	11	12	13
-	-	-	GW	U	GR	GO	RU	R	WB	W	Y	R

IP101 / 26-WAY / WHITE

14	15	16	17	18	19	20	21	22	23
OG	B	W	B	-	B	G	W	Y	G
1	2	3	4	5	6	7	8	9	10
OY	WR	B	B	BW	B	BW	-	Y	G

CLIMATE CONTROL MODULE - AUTOMATIC (PANEL)

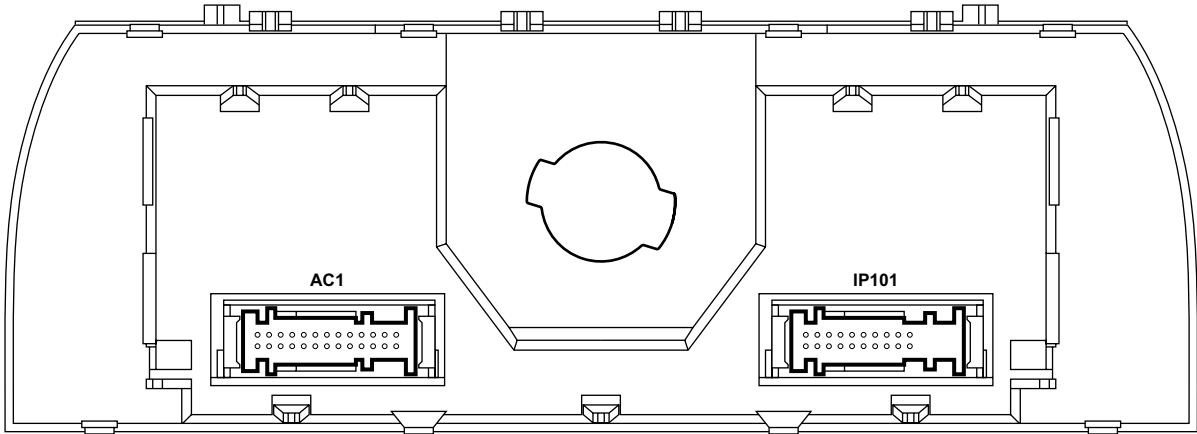

AC1 / 26-WAY / YELLOW

14	15	16	17	18	19	20	21	22	23	24	25	26
G	UY	B	-	-	-	GU	GB	OG	O	RW	RG	OY
1	2	3	4	5	6	7	8	9	10	11	12	13
-	-	-	GW	U	GR	GO	RU	R	WB	W	Y	R

IP101 / 26-WAY / WHITE

14	15	16	17	18	19	20	21	22	23
OG	B	W	B	-	B	G	W	Y	G
1	2	3	4	5	6	7	8	9	10
OY	WR	B	B	BW	B	BW	-	Y	G

cli\_cnt\_mod\_4000625

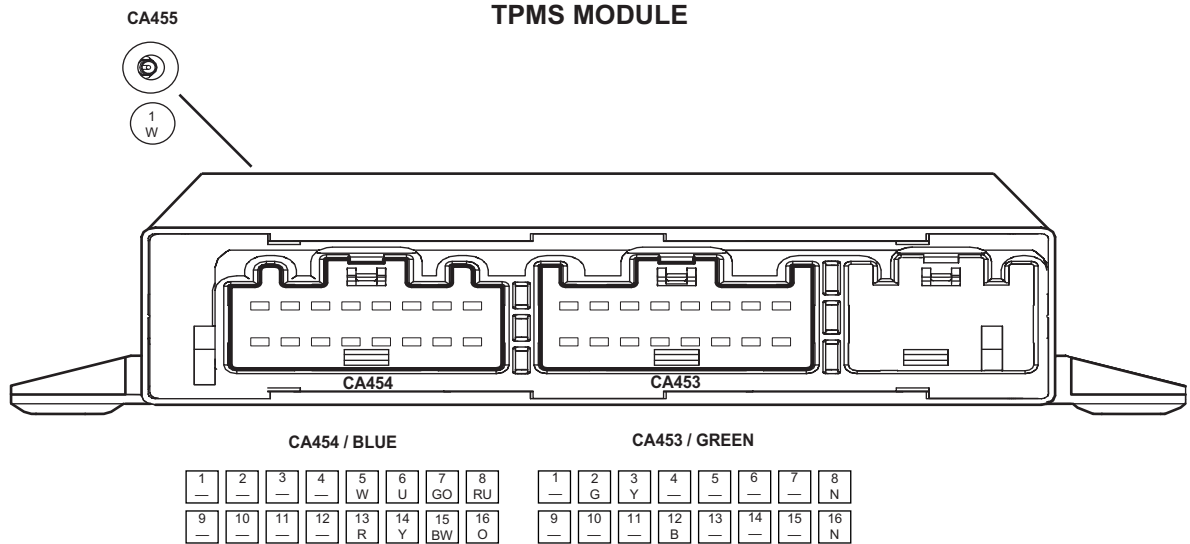

GENERAL ELECTRONIC MODULE

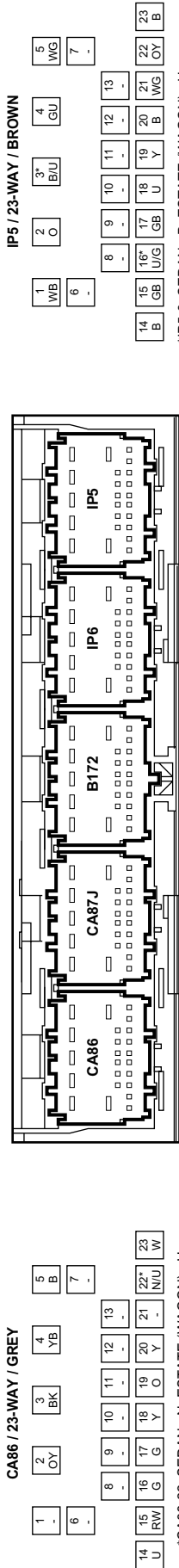

PARKING AID MODULE

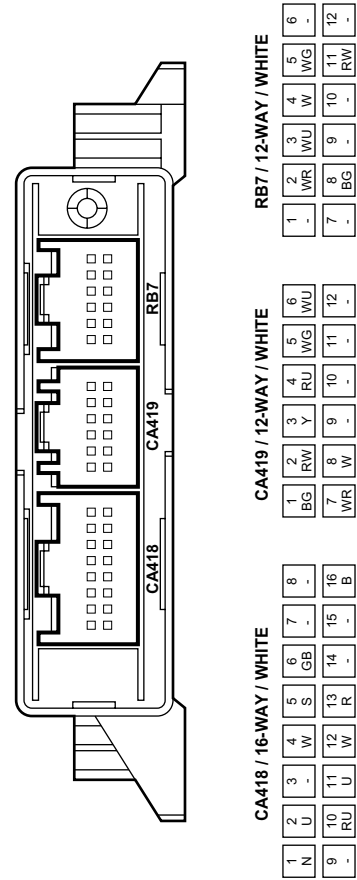

INSTRUMENT CLUSTER

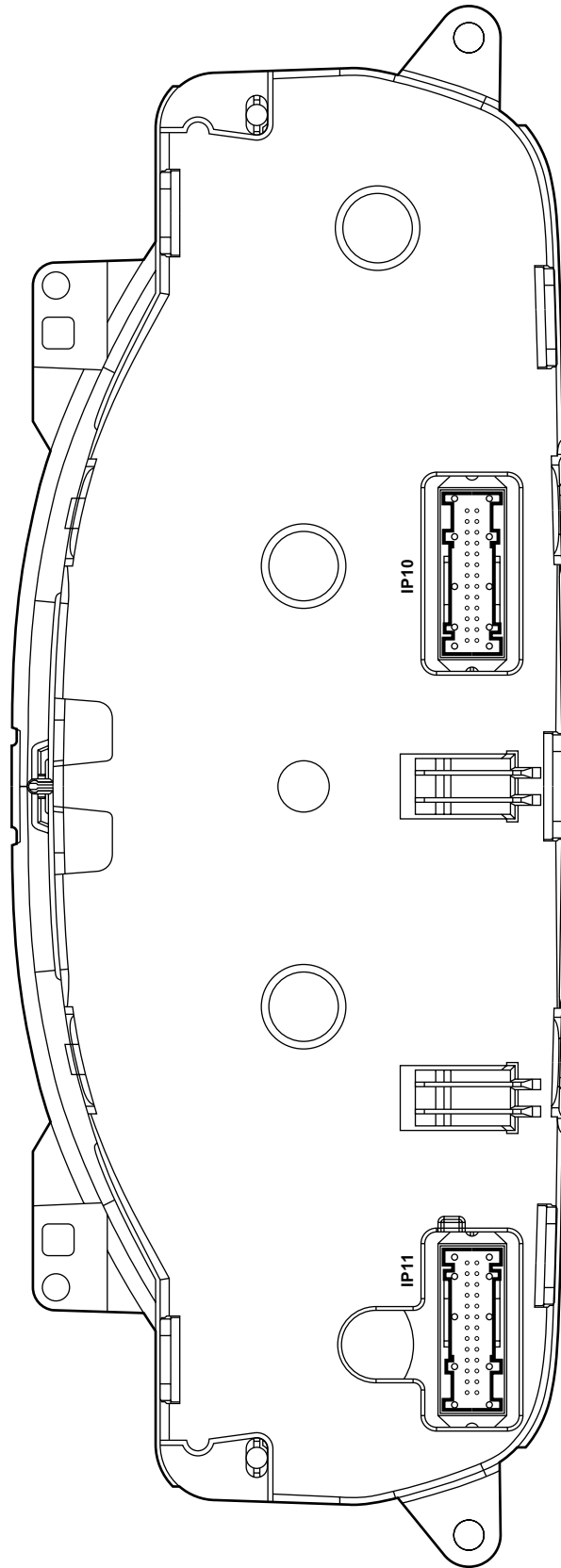

**IP10 / 26-WAY WHITE**

14	15	16	17	18	19	20	21	22	23	24	25	26
-	B	B	Y	G	U	WU	-	Y	U	Y	W	-
1	2	3	4	5	6	7	8	9	10	11	12	13
GB	OY	WG	O	B	G	WU	WB	B	U	B	B	GR

**IP11 / 26-WAY / WHITE**

13	12	11	10	9	8	7	6	5	4	3	2	1
YU	-	GR	-	B	OG	-	B	-	B	GB	-	-
26	25	24	23	22	21	20	19	18	17	16	15	14
-	R	GR	GR	U	O	-	U	-	OY	-	OG	-



Fuel Level Sensors		
2.0 L, Diesel	Fig. 07.1	
2.5 L, 3.0 L (NAS)	Fig. 07.1	
2.5 L, 3.0 L (ROW)	Fig. 07.1	
Fuel Metering Valve	Fig. 03.5	
Fuel Pump		
2.0 L	Fig. 03.4	
2.5 L, 3.0 L	Fig. 03.2	
Fuel Pump Module	Fig. 03.2	
Fuel Pump Relay	Fig. 03.4	
Fuel-Fired Auxiliary Heater Module	Fig. 03.6	
	Fig. 20.3	
<b>G</b>		
Gateway Module	Fig. 15.3	
	Fig. 20.4	
Gear Shift Module	Fig. 04.2	
General Electronic Module	Fig. 01.7	
	Fig. 02.1	
	Fig. 02.2	
	Fig. 02.3	
	Fig. 04.2	
	Fig. 07.1	
	Fig. 07.2	
	Fig. 08.1	
	Fig. 08.2	
	Fig. 08.3	
	Fig. 08.4	
	Fig. 09.1	
	Fig. 12.1	
	Fig. 12.2	
	Fig. 12.3	
	Fig. 12.4	
	Fig. 12.5	
	Fig. 13.1	
	Fig. 13.2	
	Fig. 13.3	
	Fig. 14.1	
	Fig. 14.2	
	Fig. 18.1	
	Fig. 19.1	
	Fig. 20.3	
Generator		
2.0 L	Fig. 02.2	
2.5 L, 3.0 L	Fig. 02.1	
Diesel	Fig. 02.3	
Glove Box Lamp	Fig. 08.1	
	Fig. 08.2	
	Fig. 09.1	
Glow Plug Power Eyelet	Fig. 03.5	
Glow Plug Relay	Fig. 03.5	
GPS Antenna	Fig. 15.3	
<b>H</b>		
Hazard and Seat Heater Switches	Fig. 09.2	
Hazard Switch	Fig. 08.1	
	Fig. 08.2	
	Fig. 08.3	
	Fig. 08.4	
Headlamp Leveling Module	Fig. 08.10	
	Fig. 20.1	
	Fig. 20.2	
	Fig. 20.3	
Headlamp Units	Fig. 08.1	
	Fig. 08.2	
	Fig. 08.10	
Heated Door Mirrors	Fig. 06.2	
Heated Rear Window		
Estate (Wagon)	Fig. 06.2	
Sedan	Fig. 06.2	
	Fig. 15.1	
	Fig. 15.2	
Heated Rear Window Relay	Fig. 06.2	
High-Mount Stop Lamp		
Estate (Wagon)	Fig. 08.4	
	Fig. 08.8	
	Fig. 08.9	
Sedan	Fig. 08.3	
	Fig. 08.5	
	Fig. 08.6	
	Fig. 08.7	
HO2 Sensors	Fig. 03.1	
	Fig. 03.3	
Hood Security Switch	Fig. 12.4	
	Fig. 12.5	
Horn - LH	Fig. 19.1	
Horn - RH	Fig. 19.1	
Horn Relay		
2.0 L, 2.5 L, 3.0 L	Fig. 19.1	
Diesel	Fig. 19.1	
Horn Switch	Fig. 19.1	
<b>I</b>		
Idle Speed Control Valve	Fig. 03.3	
Ignition Capacitor	Fig. 03.2	
	Fig. 03.4	
Ignition Modules and Coils	Fig. 03.2	
	Fig. 03.4	
Ignition Switch	Fig. 01.1	
	Fig. 01.4	
	Fig. 01.5	
	Fig. 02.1	
	Fig. 02.2	
	Fig. 02.3	
	Fig. 04.1	
	Fig. 07.2	
	Fig. 12.1	
	Fig. 12.2	
	Fig. 12.3	
	Fig. 12.4	
	Fig. 12.5	
Ignition Switch Keylock Solenoid	Fig. 04.2	
Impact Sensor – Front	Fig. 17.1	
	Fig. 17.2	
IMT Solenoid Valve	Fig. 03.1	
	Fig. 03.3	
In-Car Temperature Sensor	Fig. 06.1	
Inclination Sensor	Fig. 12.4	
	Fig. 12.5	
Inertia Switch	Fig. 01.1	
	Fig. 01.5	
	Fig. 12.1	
	Fig. 12.2	
	Fig. 12.3	

Instrument Cluster .....	Fig. 02.1
.....	Fig. 02.2
.....	Fig. 02.3
.....	Fig. 07.1
.....	Fig. 07.2
.....	Fig. 08.3
.....	Fig. 08.4
.....	Fig. 09.2
.....	Fig. 12.1
.....	Fig. 12.2
.....	Fig. 12.3
.....	Fig. 12.4
.....	Fig. 12.5
.....	Fig. 20.1
.....	Fig. 20.2
.....	Fig. 20.3
Interior Lamp – Rear .....	Fig. 09.1
IP Sensor	
2.5 L, 3.0 L .....	Fig. 03.1
Diesel .....	Fig. 03.5
<b>J</b>	
J-Gate Module .....	Fig. 04.1
.....	Fig. 07.2
.....	Fig. 09.2
.....	Fig. 20.1
.....	Fig. 20.2
<b>K</b>	
Knee Bolster Igniter – Driver .....	Fig. 17.2
Knock Sensor	
2.0 L .....	Fig. 03.3
2.5 L, 3.0 L .....	Fig. 03.1
Diesel .....	Fig. 03.5
<b>L</b>	
LH Turn Signal Repeater .....	Fig. 08.1
License Plate Lamps	
Estate (Wagon) .....	Fig. 08.4
.....	Fig. 08.8
.....	Fig. 08.9
Sedan .....	Fig. 08.3
.....	Fig. 08.5
.....	Fig. 08.6
.....	Fig. 08.7
Lumbar Switch Packs .....	Fig. 11.3
<b>M</b>	
MAF Sensor	
2.0 L .....	Fig. 03.3
2.5 L, 3.0 L .....	Fig. 03.1
Diesel .....	Fig. 03.5
Main Beam / Front Fog Relay .....	Fig. 08.1
.....	Fig. 08.2
MAP Sensor .....	Fig. 03.1
.....	Fig. 03.3
MAP Sensors – 2.2 L DPF .....	Fig. 03.7
Master Lighting Switch .....	Fig. 07.1
.....	Fig. 08.1
.....	Fig. 08.2
.....	Fig. 08.3
.....	Fig. 08.4
.....	Fig. 08.10
.....	Fig. 09.2

<b>N</b>	
Navigation Control Module .....	Fig. 15.3
.....	Fig. 16.1
.....	Fig. 16.2
.....	Fig. 16.4
.....	Fig. 16.5
.....	Fig. 20.3
.....	Fig. 20.4
Navigation GPS Antenna .....	Fig. 16.4
.....	Fig. 16.5
<b>O</b>	
Oil Pressure Switches	
2.0 L, 2.5 L, 3.0 L .....	Fig. 07.1
Diesel .....	Fig. 07.1
<b>P</b>	
Panel / Floor Actuator .....	Fig. 06.1
Parking Aid Module .....	Fig. 18.1
.....	Fig. 20.3
Parking Aid Sensors .....	Fig. 18.1
Parking Aid Sounders .....	Fig. 18.1
Parking Brake Switch .....	Fig. 07.1
Passenger Airbag Deactivated Indicator Lamp .....	Fig. 17.1
.....	Fig. 17.2
Passenger Junction Fusebox .....	Fig. 01.1
.....	Fig. 01.3
.....	Fig. 01.4
.....	Fig. 01.6
.....	Fig. 01.7
.....	Fig. 01.8
.....	Fig. 03.1
.....	Fig. 03.4
.....	Fig. 06.1
.....	Fig. 06.2
.....	Fig. 08.1
.....	Fig. 08.2
.....	Fig. 08.3
.....	Fig. 08.4
.....	Fig. 10.1
.....	Fig. 13.1
.....	Fig. 13.2
.....	Fig. 13.3
Passenger Junction Fusebox Ignition Relay .....	Fig. 01.6
Passenger Seat Belt Tension Sensor .....	Fig. 17.2
Passenger Seat Weight Pressure Sensor .....	Fig. 17.1
.....	Fig. 17.2
Passenger Seat Weight Sensing Module .....	Fig. 17.1
.....	Fig. 17.2
Passive Anti-Theft System Transceiver .....	Fig. 02.1
.....	Fig. 02.2
.....	Fig. 02.3
.....	Fig. 12.4
.....	Fig. 12.5
Power Amplifier .....	Fig. 15.2
.....	Fig. 20.4



Power Distribution Fusebox . . . . .	Fig. 01.1	Roof Console	
.....	Fig. 01.2	Printed Circuit Board . . . . .	Fig. 09.1
.....	Fig. 01.5	.....	Fig. 09.2
.....	Fig. 01.8	.....	Fig. 12.4
.....	Fig. 01.9	.....	Fig. 12.5
.....	Fig. 02.1	.....	Fig. 14.2
.....	Fig. 02.2	.....	Fig. 16.1
.....	Fig. 02.3	.....	Fig. 16.2
.....	Fig. 03.2	.....	Fig. 16.3
.....	Fig. 03.4	.....	Fig. 16.5
.....	Fig. 03.5	.....	Fig. 18.1
.....	Fig. 03.6	.....	Fig. 19.1
.....	Fig. 06.2	.....	Fig. 20.3
.....	Fig. 08.1	Without Printed Circuit Board . . . . .	Fig. 09.1
.....	Fig. 08.2	.....	Fig. 12.4
.....	Fig. 08.10	.....	Fig. 12.5
.....	Fig. 13.1	.....	Fig. 14.2
.....	Fig. 13.2	.....	Fig. 16.1
.....	Fig. 19.1	.....	Fig. 16.2
Power Distribution Fusebox Ignition Relay . . . . .	Fig. 01.5	.....	Fig. 16.3
Powerwash Pump . . . . .	Fig. 13.1	.....	Fig. 16.5
.....	Fig. 13.2	.....	Fig. 20.3
Powerwash Pump Relay . . . . .	Fig. 13.1		
.....	Fig. 13.2	<b>S</b>	
<b>R</b>		Seat Back Heaters . . . . .	Fig. 11.4
Rain Sensing Module . . . . .	Fig. 13.2	.....	Fig. 11.5
Rain Sensor . . . . .	Fig. 13.2	Seat Belt Buckle Pretensioner Igniters . . . . .	Fig. 17.1
Restraints Control Module		.....	Fig. 17.2
All Wheel Drive Vehicles . . . . .	Fig. 07.1	Seat Belt Reel Pretensioner Igniters . . . . .	Fig. 17.2
.....	Fig. 07.2	Seat Belt Switches . . . . .	Fig. 17.1
.....	Fig. 17.2	.....	Fig. 17.2
.....	Fig. 20.3	Seat Cushion Heaters . . . . .	Fig. 11.4
Front Wheel Drive Vehicles . . . . .	Fig. 07.1	.....	Fig. 11.5
.....	Fig. 07.2	Seat Heater Modules . . . . .	Fig. 11.5
.....	Fig. 17.1	Seat Heater Switches . . . . .	Fig. 09.2
.....	Fig. 20.3	.....	Fig. 11.4
Reverse Lamps Relay . . . . .	Fig. 08.3	.....	Fig. 11.5
.....	Fig. 08.4	Seat Lumbar Pump	
Reverse Lamps Switch		Driver . . . . .	Fig. 11.1
2.0 L, 2.5 L, 3.0 L . . . . .	Fig. 08.3	LH . . . . .	Fig. 11.3
.....	Fig. 08.4	Passenger . . . . .	Fig. 11.2
Diesel . . . . .	Fig. 08.3	RH . . . . .	Fig. 11.3
.....	Fig. 08.4	Seat Module	
RF Module . . . . .	Fig. 08.1	Driver . . . . .	Fig. 06.2
.....	Fig. 08.2	.....	Fig. 10.2
.....	Fig. 09.1	.....	Fig. 11.1
.....	Fig. 12.1	.....	Fig. 11.4
.....	Fig. 12.2	.....	Fig. 20.1
.....	Fig. 12.3	.....	Fig. 20.2
.....	Fig. 12.4	Passenger . . . . .	Fig. 11.2
.....	Fig. 12.5	.....	Fig. 11.4
.....	Fig. 14.1	Seat Motors and Position Sensors – Driver . . . . .	Fig. 11.1
.....	Fig. 14.2	Seat Motors – Passenger . . . . .	Fig. 11.2
RH Turn Signal Repeater . . . . .	Fig. 08.1	Seat Movement Motors	
		LH . . . . .	Fig. 11.3
		RH . . . . .	Fig. 11.3
		Seat Position Switch	
		Driver . . . . .	Fig. 17.1
		.....	Fig. 17.2
		Passenger . . . . .	Fig. 17.2
		Seat Switch Pack - LH . . . . .	Fig. 11.5
		Seat Switch Pack - RH . . . . .	Fig. 11.5
		Seat Switch Packs . . . . .	Fig. 11.3
		Security Indicator . . . . .	Fig. 12.4
		.....	Fig. 12.5
		Security Sounders . . . . .	Fig. 12.4
		.....	Fig. 12.5

Side Airbag Igniters .....	Fig. 17.1	T-MAP Sensor	
.....	Fig. 17.2	Diesel .....	Fig. 03.5
Side Impact Sensors .....	Fig. 17.1	TP Sensor	
.....	Fig. 17.2	2.0 L .....	Fig. 03.3
Side Marker Lamps		TPMS Antenna .....	Fig. 05.3
Front .....	Fig. 08.1	TPMS Initiators .....	Fig. 05.3
.....	Fig. 08.2	TPMS Module .....	Fig. 05.3
Rear .....	Fig. 08.3	.....	Fig. 20.1
.....	Fig. 08.7	Traction Control Module .....	Fig. 05.1
Slave Ignition Relay .....	Fig. 01.5	.....	Fig. 20.1
Sliding Roof Module .....	Fig. 14.2	.....	Fig. 20.2
Solid State Relay .....	Fig. 03.6	Traction Control Switch .....	Fig. 05.1
Speakers		.....	Fig. 09.2
Front .....	Fig. 15.1	Trailer Towing Connector .....	Fig. 08.5
.....	Fig. 15.2	.....	Fig. 08.6
Rear .....	Fig. 15.1	.....	Fig. 08.7
.....	Fig. 15.2	.....	Fig. 08.8
Speed Control Module .....	Fig. 03.4	.....	Fig. 08.9
Speed Control Switches .....	Fig. 03.2	Trailer Towing Module .....	Fig. 08.5
.....	Fig. 03.4	.....	Fig. 08.6
.....	Fig. 03.6	.....	Fig. 08.7
Starter Motor		.....	Fig. 08.8
2.0 L .....	Fig. 02.2	.....	Fig. 08.9
2.5 L, 3.0 L .....	Fig. 02.1	Transit Isolation Relay .....	Fig. 01.1
Diesel .....	Fig. 02.3	Transmission Control Module	
Starter Relay .....	Fig. 02.1	Diesel .....	Fig. 04.2
.....	Fig. 02.2	.....	Fig. 20.1
.....	Fig. 02.3	.....	Fig. 20.2
Steering Angle Sensor .....	Fig. 05.2	Petrol .....	Fig. 04.1
.....	Fig. 20.1	.....	Fig. 20.1
.....	Fig. 20.2	.....	Fig. 20.2
Steering Wheel .....	Fig. 09.2	Transmission Range Sensor .....	Fig. 02.1
.....	Fig. 16.2	.....	Fig. 02.2
.....	Fig. 16.3	.....	Fig. 04.1
.....	Fig. 19.1	Trunk Lamps .....	Fig. 09.1
Sub Woofer		Trunk Lock Motor .....	Fig. 09.1
Estate (Wagon) .....	Fig. 15.2	.....	Fig. 12.1
Sedan .....	Fig. 15.2	.....	Fig. 12.2
		.....	Fig. 12.4
<b>T</b>		Trunk Release Switch .....	Fig. 12.1
Tail Gate Latch .....	Fig. 09.1	.....	Fig. 12.2
.....	Fig. 12.3	Turbocharger Rotary Electronic Actuator .....	Fig. 03.6
.....	Fig. 12.5	.....	Fig. 20.1
Tail Gate Release Switch .....	Fig. 12.3	.....	Fig. 20.2
Tail Glass Latch .....	Fig. 09.1	Turn Signal Repeaters – Front .....	Fig. 08.2
.....	Fig. 12.3	Turn Signal Switch .....	Fig. 07.1
.....	Fig. 12.5	.....	Fig. 08.1
Tail Glass Release Switch .....	Fig. 12.3	.....	Fig. 08.2
Tail Lamp Units .....	Fig. 08.3	.....	Fig. 08.3
.....	Fig. 08.4	.....	Fig. 08.4
.....	Fig. 08.5	TV Antennas and Amplifiers .....	Fig. 16.4
.....	Fig. 08.6	.....	Fig. 16.5
.....	Fig. 08.7	Tweeters	
.....	Fig. 08.8	Front .....	Fig. 15.1
.....	Fig. 08.9	.....	Fig. 15.2
Telematics Display .....	Fig. 09.2	Rear .....	Fig. 15.2
.....	Fig. 16.1		
.....	Fig. 16.2	<b>V</b>	
.....	Fig. 16.4	Vacuum Module .....	Fig. 05.1
.....	Fig. 16.5	.....	Fig. 05.2
Throttle Body		Vacuum Pump .....	Fig. 05.1
2.5 L, 3.0 L .....	Fig. 03.1	.....	Fig. 05.2
Throttle Motor .....	Fig. 03.1	Vanity Mirror Lamps .....	Fig. 09.1
Throttle Motor Relay .....	Fig. 03.1		
Throttle Position Sensor – 2.2 L DPF .....	Fig. 03.7		
Tire Pressure Sensors .....	Fig. 05.3		

VICS Antenna	
Sedan .....	Fig. 16.5
Wagon .....	Fig. 16.5
VICS Module .....	Fig. 16.5
VICS Sensor .....	Fig. 16.5
Voice Activation Module .....	Fig. 16.2
.....	Fig. 16.3
.....	Fig. 20.4
VVT Solenoid Valves .....	Fig. 03.1
.....	Fig. 03.3

**W**

Washer Fluid Level Switch .....	Fig. 07.1
Wheel Speed Sensors .....	Fig. 05.1
.....	Fig. 05.2
Window Motors .....	Fig. 14.1
Windshield Heater Relay .....	Fig. 06.2
Windshield Heaters .....	Fig. 06.2
Windshield Washer Pump .....	Fig. 13.1
.....	Fig. 13.2
.....	Fig. 13.3
Windshield Wiper Motor Relay .....	Fig. 13.1
.....	Fig. 13.2
Wiper Motor	
Front .....	Fig. 13.1
.....	Fig. 13.2
Rear .....	Fig. 13.3
Wiper Motor Relay – Rear .....	Fig. 13.3
Wiper Switch Assembly .....	Fig. 13.1
.....	Fig. 13.2
.....	Fig. 13.3

**Y**

Yaw Rate Sensor .....	Fig. 05.2
.....	Fig. 20.1
.....	Fig. 20.2





## Fig. 01.1

### COMPONENTS

Component	Connector(s)	Connector Description	Location
BATTERY	—	—	ENGINE COMPARTMENT
IGNITION SWITCH	IP18	7-WAY / BLACK	STEERING COLUMN
INERTIA SWITCH	IP132	3-WAY / BLACK	LOWER RH 'A' POST
PASSENGER JUNCTION FUSEBOX	—	—	PASSENGER COMPARTMENT, FRONT BULKHEAD / LH SIDE
POWER DISTRIBUTION FUSEBOX	—	—	ENGINE COMPARTMENT
TRANSIT ISOLATION RELAY	JB186	2-WAY / BLACK	BATTERY

### HARNESS IN-LINE CONNECTORS

Connector	Connector Description / Location	Location
JB3	14-WAY / BLUE / JUNCTION BOX HARNESS TO INSTRUMENT PANEL HARNESS	BELOW INSTRUMENT PANEL / LH SIDE

### GROUNDS

Ground	Harness	Location
G13	B03	BATTERY ENGINE GROUND
G16	B03	ENGINE COMPARTMENT / UNDER BATTERY TRAY

Refer to the front of this book for detailed information and illustrations regarding the location and identification of harnesses, relays, fuses, grounds, control modules and control module pins.

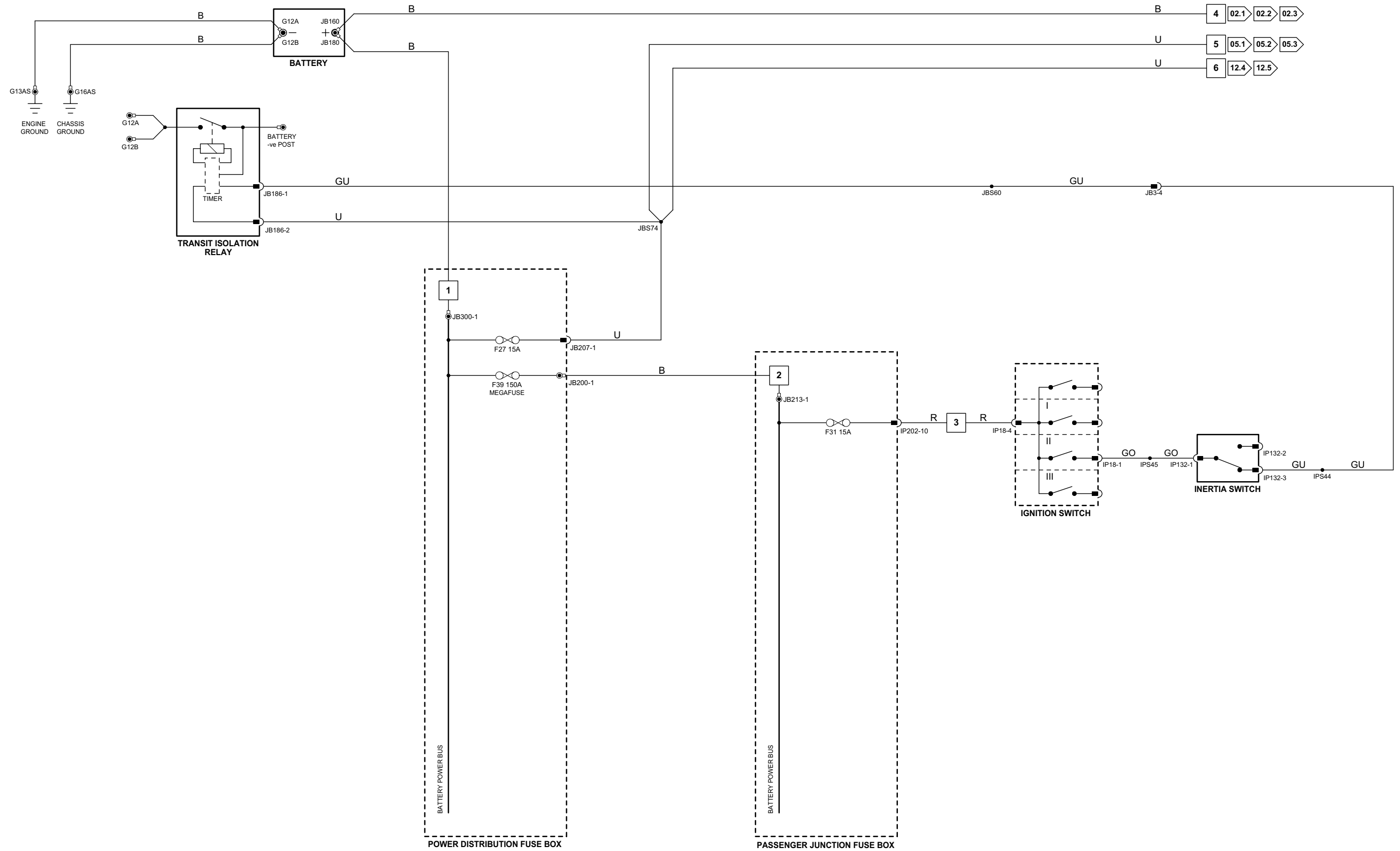

**Fig. 01.2**

**COMPONENTS**

<b>Component</b>	<b>Connector(s)</b>	<b>Connector Description</b>	<b>Location</b>
POWER DISTRIBUTION FUSEBOX	—	—	ENGINE COMPARTMENT

**HARNESS IN-LINE CONNECTORS**

<b>Connector</b>	<b>Connector Description / Location</b>	<b>Location</b>
JB1	42-WAY / BLACK / ENGINE MANAGEMENT HARNESS TO JUNCTION BOX HARNESS	ENGINE COMPARTMENT / LH SIDE
JB190	4-WAY / BLACK / JUNCTION BOX HARNESS TO COOLING FAN MODULE LINK LEAD	ENGINE COMPARTMENT / FRONT, LH SIDE

Refer to the front of this book for detailed information and illustrations regarding the location and identification of harnesses, relays, fuses, grounds, control modules and control module pins.



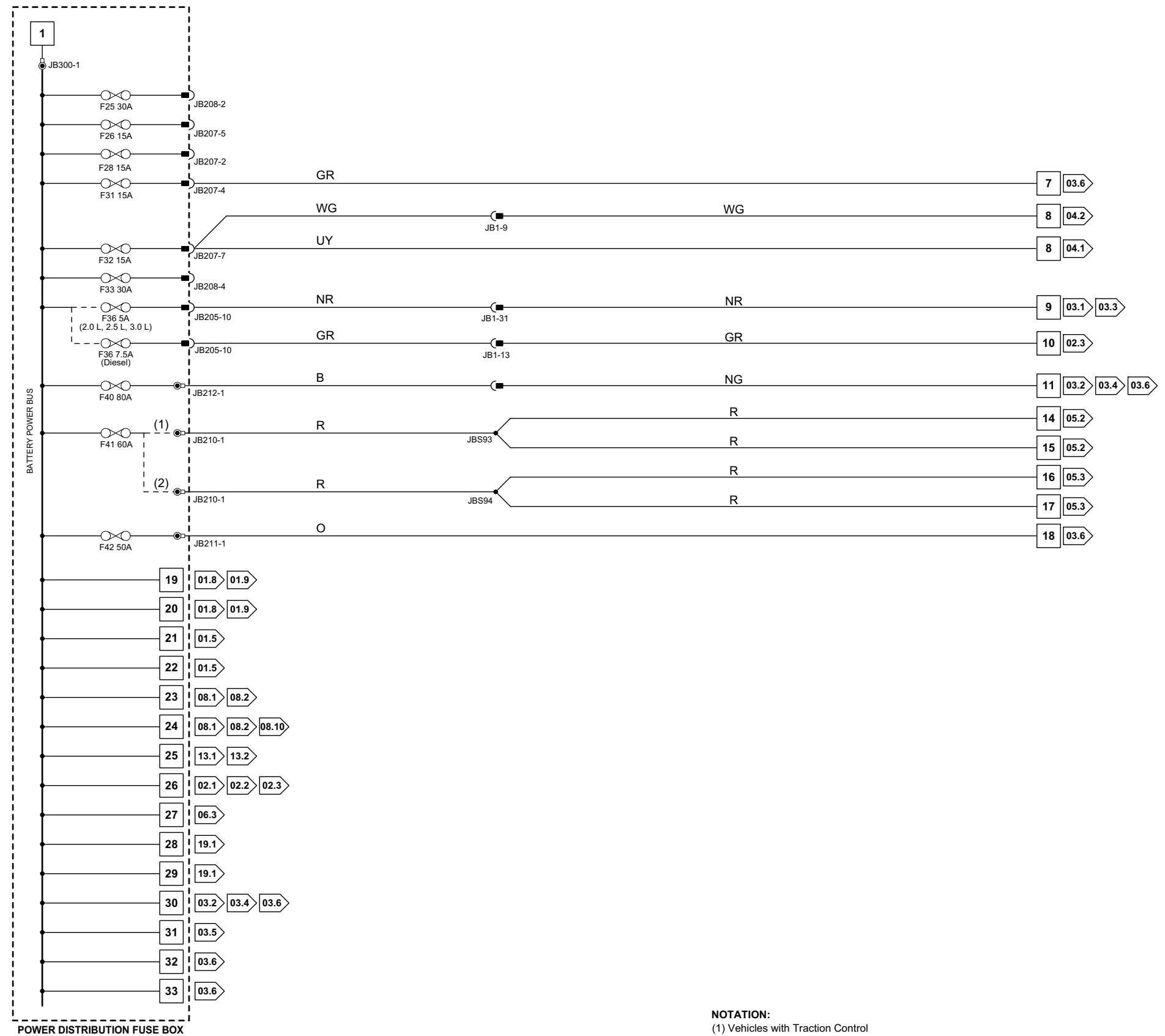

**NOTATION:**  
 (1) Vehicles with Traction Control  
 (2) Vehicles with Dynamic Stability Control

**Fig. 01.3****COMPONENTS**

Component	Connector(s)	Connector Description	Location
PASSENGER JUNCTION FUSEBOX	-	-	PASSENGER COMPARTMENT, FRONT BULKHEAD / LH SIDE

**HARNESS IN-LINE CONNECTORS**

Connector	Connector Description / Location	Location
CA15	20-WAY / BLACK / CABIN HARNESS TO DRIVER DOOR HARNESS	DRIVER DOOR / DOOR CASING
CA16	20-WAY / BLACK / CABIN HARNESS TO DRIVER DOOR HARNESS	DRIVER DOOR / DOOR CASING
CA20	20-WAY / BLACK / CABIN HARNESS TO PASSENGER DOOR HARNESS	PASSENGER DOOR / DOOR CASING
CA21	20-WAY / BLACK / CABIN HARNESS TO PASSENGER DOOR HARNESS	PASSENGER DOOR / DOOR CASING
CA25	14-WAY / NATURAL / CABIN HARNESS TO LH REAR DOOR HARNESS	LH 'B/C' POST / 'B/C' POST TRIM
CA30	14-WAY / NATURAL / CABIN HARNESS TO RH REAR DOOR HARNESS	RH 'B/C' POST / 'B/C' POST TRIM
CA36	16-WAY / GREEN / CABIN HARNESS TO ROOF HARNESS	LH 'A' POST / WINDSHIELD PILLAR
CA65	18-WAY / BLACK / CABIN HARNESS TO DRIVER SEAT HARNESS	UNDER DRIVER SEAT
CA70	18-WAY / BLACK / CABIN HARNESS TO DRIVER SEAT HARNESS	UNDER DRIVER SEAT
CA170	16-WAY / GREEN / JUNCTION BOX HARNESS TO CABIN HARNESS	LH 'A' POST / 'A' POST TRIM
CA407	16-WAY / GREY / CELLULAR PHONE HARNESS TO CABIN HARNESS	BELOW LH REAR SEAT CUSHION
CA414	16-WAY / BLUE / NAVIGATION HARNESS TO CABIN HARNESS	BELOW LH REAR SEAT CUSHION
CA431	16-WAY / GREY / CABIN HARNESS TO DRIVER SEAT HARNESS	UNDER DRIVER SEAT
JB3	14-WAY / BLUE / JUNCTION BOX HARNESS TO INSTRUMENT PANEL HARNESS	BELOW INSTRUMENT PANEL / LH SIDE

Refer to the front of this book for detailed information and illustrations regarding the location and identification of harnesses, relays, fuses, grounds, control modules and control module pins.

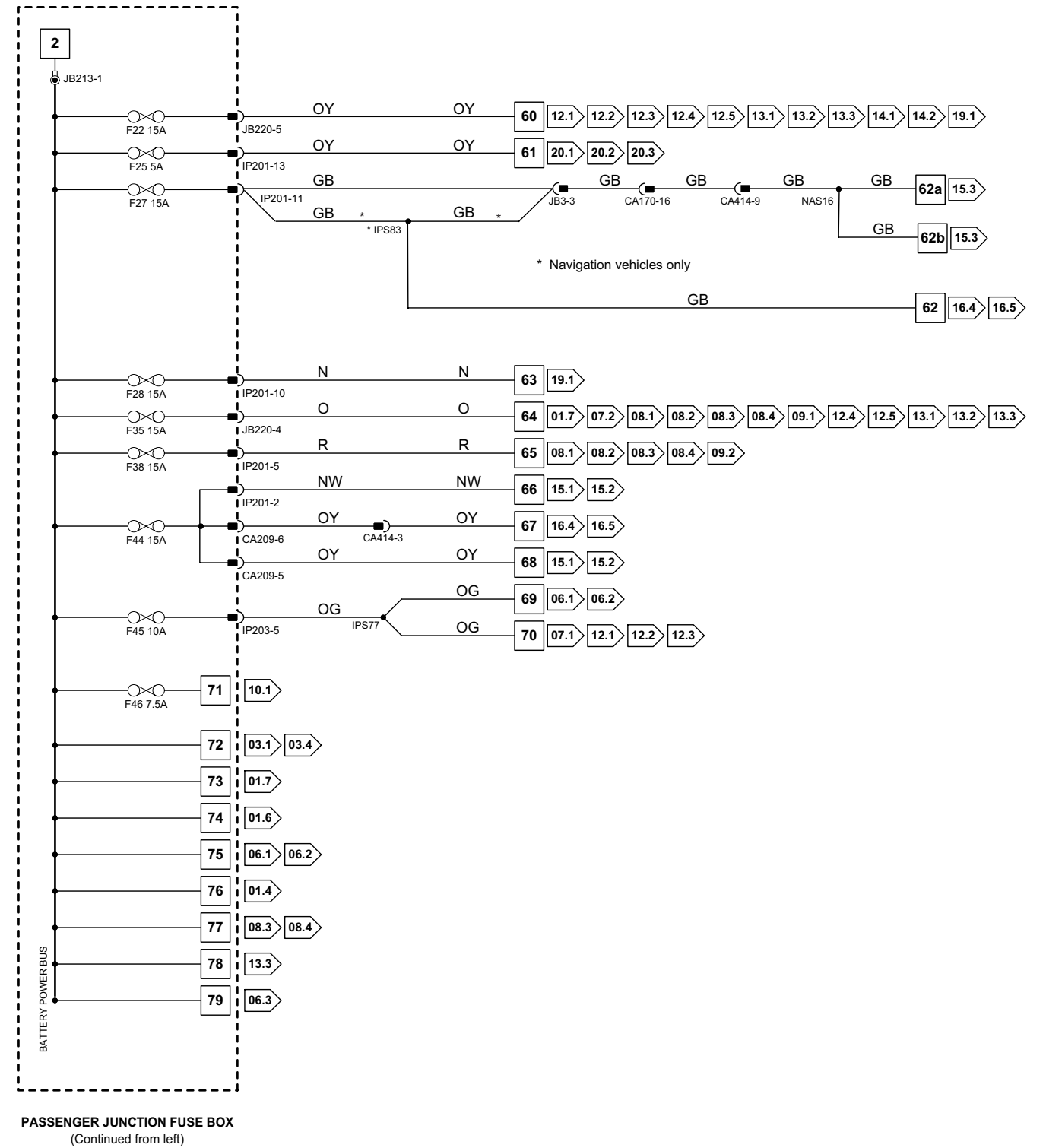
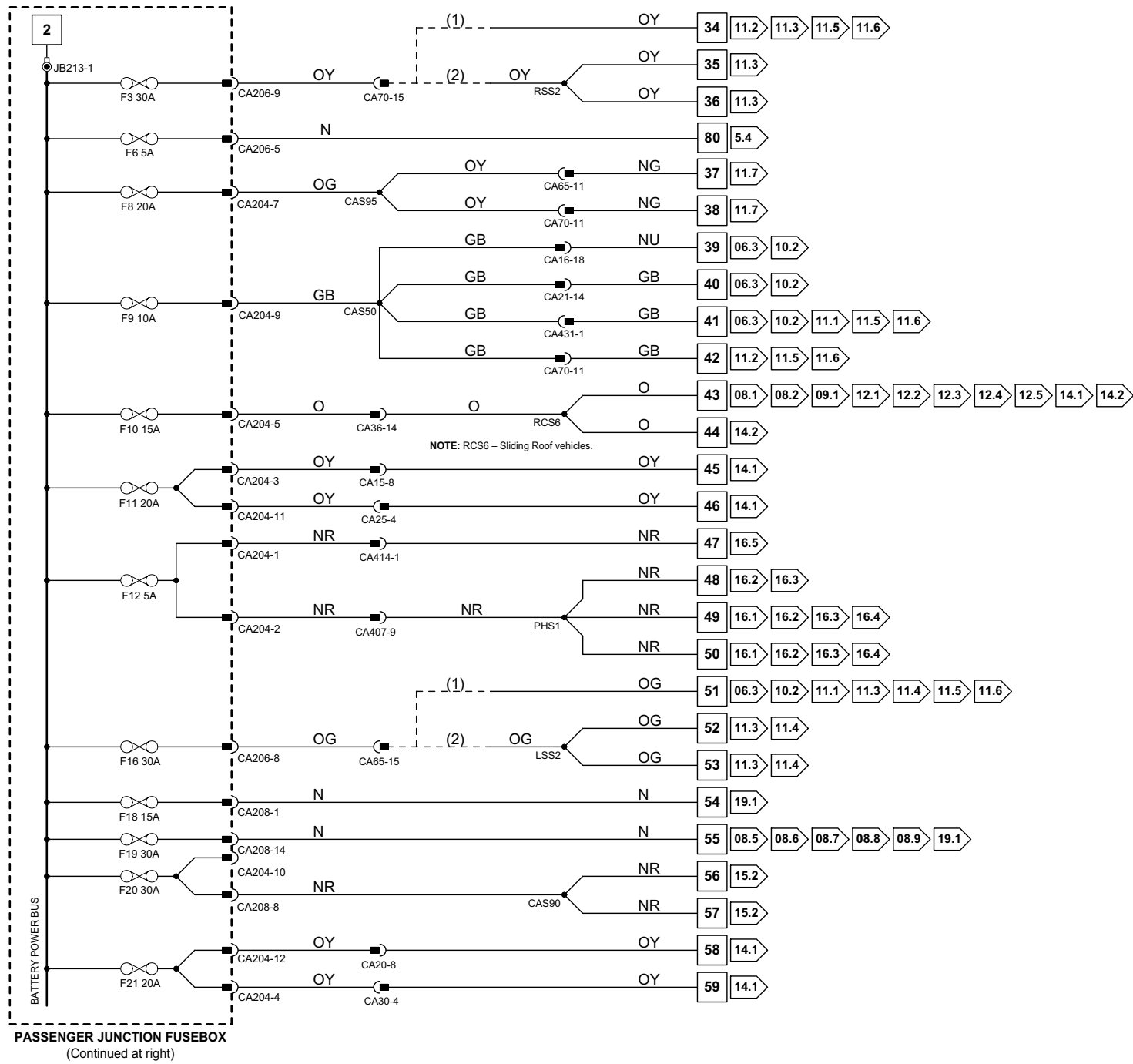

**NOTATION:**  
 (1) 4 Way without Lumbar  
 (2) 4 Way with Lumbar

**Fig. 01.4****COMPONENTS**

<b>Component</b>	<b>Connector(s)</b>	<b>Connector Description</b>	<b>Location</b>
ACCESSORY RELAY	-	-	PASSENGER JUNCTION FUSEBOX - R2
IGNITION SWITCH	IP18	7-WAY / BLACK	STEERING COLUMN
PASSENGER JUNCTION FUSEBOX	-	-	PASSENGER COMPARTMENT, FRONT BULKHEAD / LH SIDE

**HARNESS IN-LINE CONNECTORS**

<b>Connector</b>	<b>Connector Description / Location</b>	<b>Location</b>
CA230	16-WAY / BLUE / CABIN HARNESS TO INSTRUMENT PANEL HARNESS	LH LOWER 'A' POST / 'A' POST TRIM
CA240	12-WAY / GREY / CABIN HARNESS TO INSTRUMENT PANEL HARNESS	LH LOWER 'A' POST / 'A' POST TRIM
CA407	16-WAY / GREY / CELLULAR PHONE HARNESS TO CABIN HARNESS	BELOW LH REAR SEAT CUSHION
CA414	16-WAY / BLUE / NAVIGATION HARNESS TO CABIN HARNESS	BELOW LH REAR SEAT CUSHION

**GROUNDS**

<b>Ground</b>	<b>Harness</b>	<b>Location</b>
G15	CA	LOWER LH 'A' POST

Refer to the front of this book for detailed information and illustrations regarding the location and identification of harnesses, relays, fuses, grounds, control modules and control module pins.

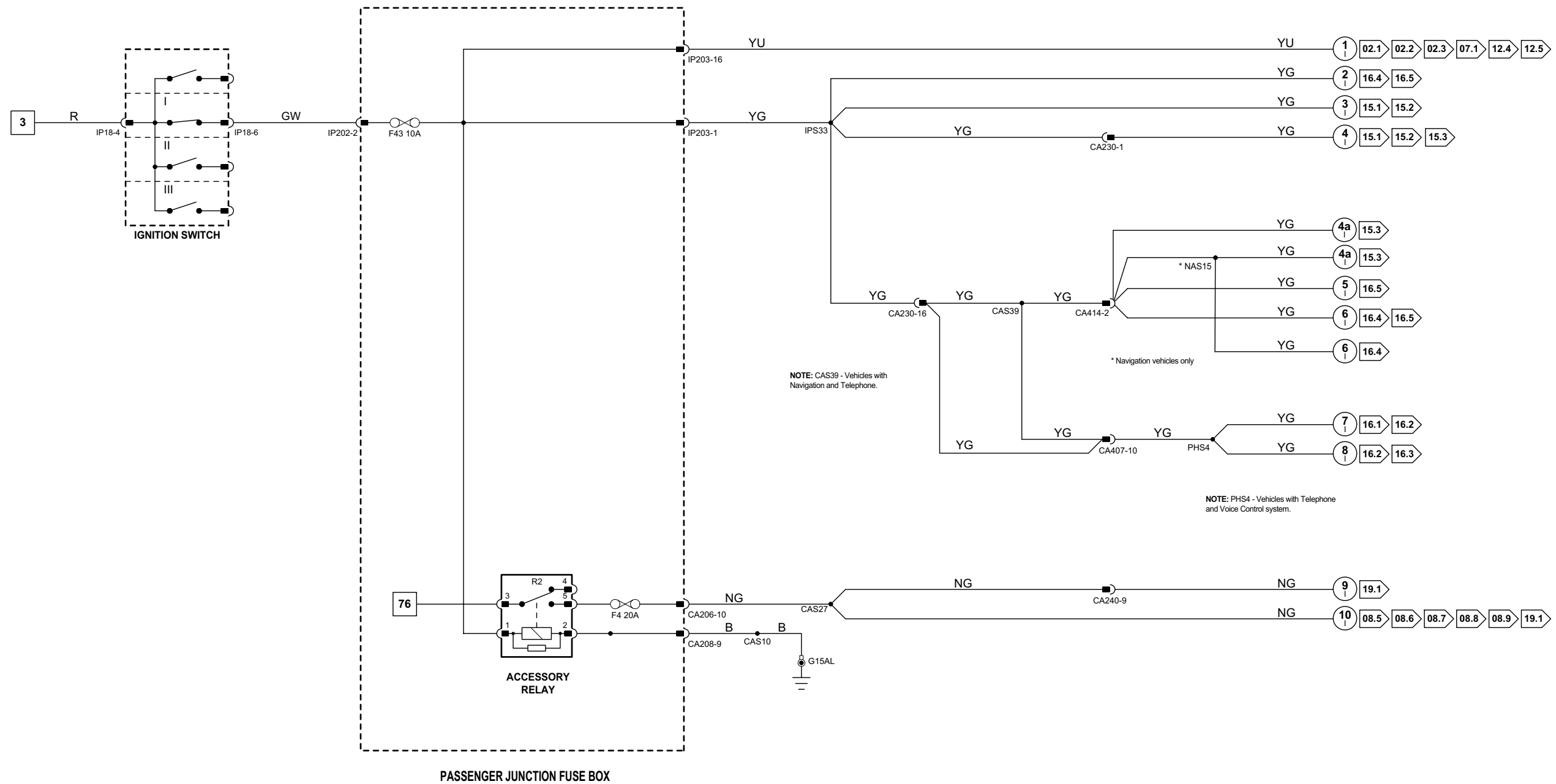

## Fig. 01.5

### COMPONENTS

Component	Connector(s)	Connector Description	Location
IGNITION SWITCH	IP18	7-WAY / BLACK	STEERING COLUMN
INERTIA SWITCH	IP132	3-WAY / BLACK	LOWER RH 'A' POST
POWER DISTRIBUTION FUSEBOX	-	-	ENGINE COMPARTMENT
POWER DISTRIBUTION FUSEBOX IGNITION RELAY	-	-	POWER DISTRIBUTION FUSEBOX - R5
SLAVE IGNITION RELAY	-	-	POWER DISTRIBUTION FUSEBOX - R13

### HARNESS IN-LINE CONNECTORS

Connector	Connector Description / Location	Location
JB1	42-WAY / BLACK / ENGINE MANAGEMENT HARNESS TO JUNCTION BOX HARNESS	ENGINE COMPARTMENT / LH SIDE
JB3	14-WAY / BLUE / JUNCTION BOX HARNESS TO INSTRUMENT PANEL HARNESS	BELOW INSTRUMENT PANEL / LH SIDE
JB129	22-WAY / GREY / JUNCTION BOX HARNESS TO INSTRUMENT PANEL HARNESS	BELOW INSTRUMENT PANEL / LH SIDE
JB130	22-WAY / GREEN / JUNCTION BOX HARNESS TO INSTRUMENT PANEL HARNESS	BELOW INSTRUMENT PANEL / LH SIDE

### GROUNDS

Ground	Harness	Location
G14	JB	ENGINE COMPARTMENT / BEHIND POWER DISTRIBUTION FUSEBOX

Refer to the front of this book for detailed information and illustrations regarding the location and identification of harnesses, relays, fuses, grounds, control modules and control module pins.

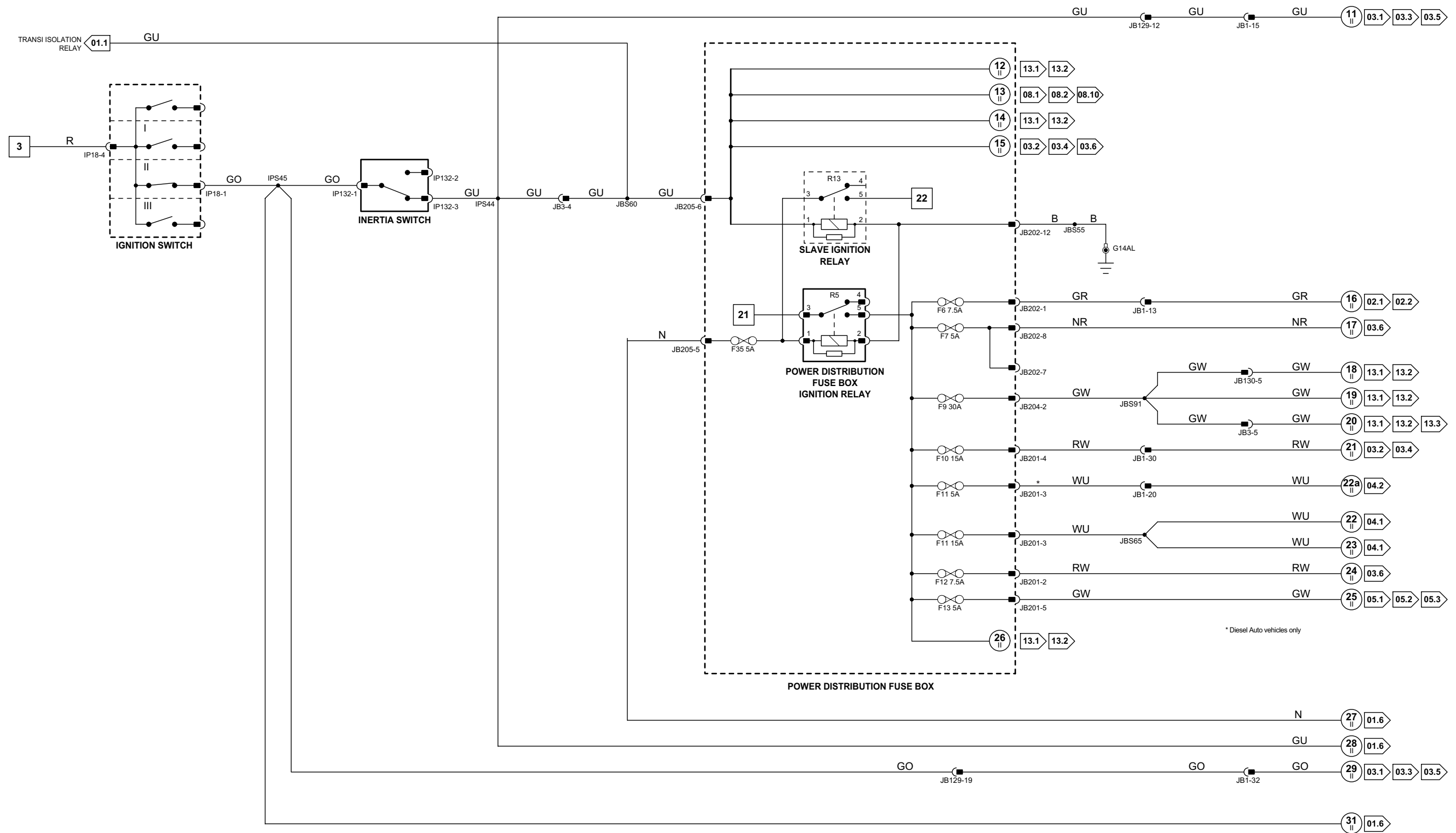

\* Diesel Auto vehicles only

**Fig. 01.6****COMPONENTS**

Component	Connector(s)	Connector Description	Location
PASSENGER JUNCTION FUSEBOX	-	-	PASSENGER COMPARTMENT, FRONT BULKHEAD / LH SIDE
PASSENGER JUNCTION FUSEBOX IGNITION RELAY	-	-	PASSENGER JUNCTION FUSEBOX - R5

**HARNESS IN-LINE CONNECTORS**

Connector	Connector Description / Location	Location
CA10	22-WAY / SLATE / CABIN HARNESS TO JUNCTION BOX HARNESS	LH 'A' POST / 'A' POST TRIM
CA15	20-WAY / BLACK / CABIN HARNESS TO DRIVER DOOR HARNESS	DRIVER DOOR / DOOR CASING
CA20	20-WAY / BLACK / CABIN HARNESS TO PASSENGER DOOR HARNESS	PASSENGER DOOR / DOOR CASING
CA25	14-WAY / NATURAL / CABIN HARNESS TO LH REAR DOOR HARNESS	LH 'B/C' POST / 'B/C' POST TRIM
CA30	14-WAY / NATURAL / CABIN HARNESS TO RH REAR DOOR HARNESS	RH 'B/C' POST / 'B/C' POST TRIM
CA36	16-WAY / GREEN / CABIN HARNESS TO ROOF HARNESS	LH 'A' POST / WINDSHIELD PILLAR
CA65	18-WAY / BLACK / CABIN HARNESS TO DRIVER SEAT HARNESS	UNDER DRIVER SEAT
CA70	18-WAY / BLACK / CABIN HARNESS TO DRIVER SEAT HARNESS	UNDER DRIVER SEAT
CA407	16-WAY / GREY / CELLULAR PHONE HARNESS TO CABIN HARNESS	BELOW LH REAR SEAT CUSHION
JB1	42-WAY / BLACK / ENGINE MANAGEMENT HARNESS TO JUNCTION BOX HARNESS	ENGINE COMPARTMENT / LH SIDE
JB2	16-WAY / GREEN / ENGINE MANAGEMENT HARNESS TO JUNCTION BOX HARNESS (PEDAL ASSEMBLY)	BELOW INSTRUMENT PANEL / DRIVER SIDE
JB196	10-WAY / GREY / ENGINE MANAGEMENT HARNESS TO JUNCTION BOX HARNESS (PEDAL ASSEMBLY)	BELOW INSTRUMENT PANEL / DRIVER SIDE

**GROUNDS**

Ground	Harness	Location
G15	CA	LOWER LH 'A' POST

Refer to the front of this book for detailed information and illustrations regarding the location and identification of harnesses, relays, fuses, grounds, control modules and control module pins.



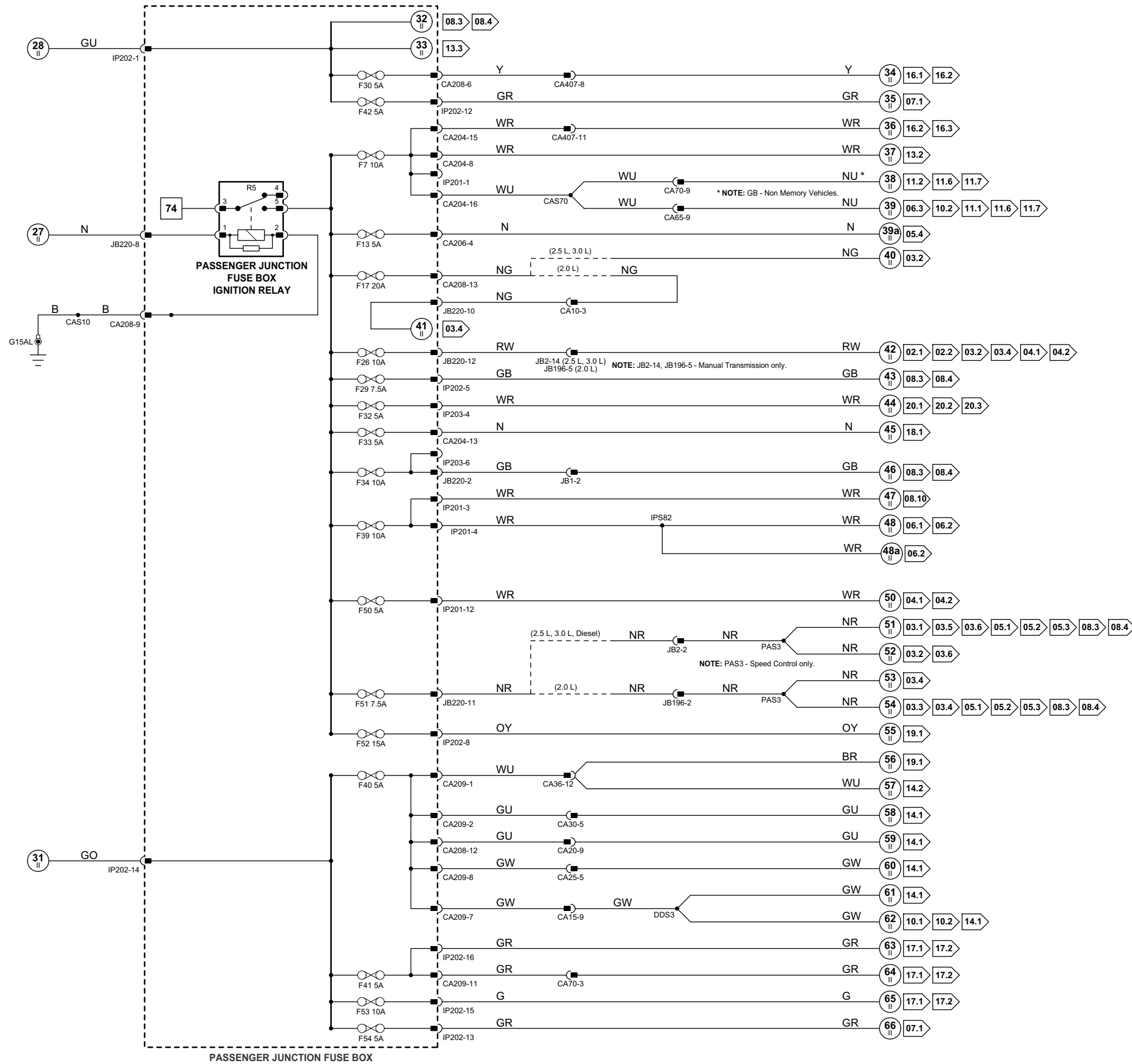

1 → 6 Fig. 01.1	34 → 80 Fig. 01.3	11 → 31 Fig. 01.5	67 → 76 Fig. 01.7	98 → 107 Fig. 01.9	Input	Battery Voltage	Sensor/Signal Supply V	CAN	D2B Network
7 → 33 Fig. 01.2	1 → 10 Fig. 01.4	32 → 66 Fig. 01.6	77 → 97 Fig. 01.8		Output	Power Ground	Sensor/Signal Ground	SCP	Serial and Encoded Data

VARIANT: All Vehicles  
VIN RANGE: All  
DATE OF ISSUE: February 2008

01\_6\_40007

**Fig. 01.7****COMPONENTS**

<b>Component</b>	<b>Connector(s)</b>	<b>Connector Description</b>	<b>Location</b>
BATTERY SAVER RELAY	-	-	PASSENGER JUNCTION FUSEBOX – R10
GENERAL ELECTRONIC MODULE	CA86	23-WAY / GREY	BEHIND INSTRUMENT PANEL / RH SIDE
	CA87	23-WAY / GREEN	
	IP5	23-WAY / BROWN	
	IP6	23-WAY / NATURAL	
	JB172	23-WAY / BLUE	
PASSENGER JUNCTION FUSEBOX	-	-	PASSENGER COMPARTMENT, FRONT BULKHEAD / LH SIDE

**HARNESS IN-LINE CONNECTORS**

<b>Connector</b>	<b>Connector Description / Location</b>	<b>Location</b>
CA36	16-WAY / GREEN / CABIN HARNESS TO ROOF HARNESS	LH 'A' POST / WINDSHIELD PILLAR

**GROUNDS**

<b>Ground</b>	<b>Harness</b>	<b>Location</b>
G4	CA	LOWER RH 'A' POST
G5	IP	UPPER RH 'A' POST

Refer to the front of this book for detailed information and illustrations regarding the location and identification of harnesses, relays, fuses, grounds, control modules and control module pins.

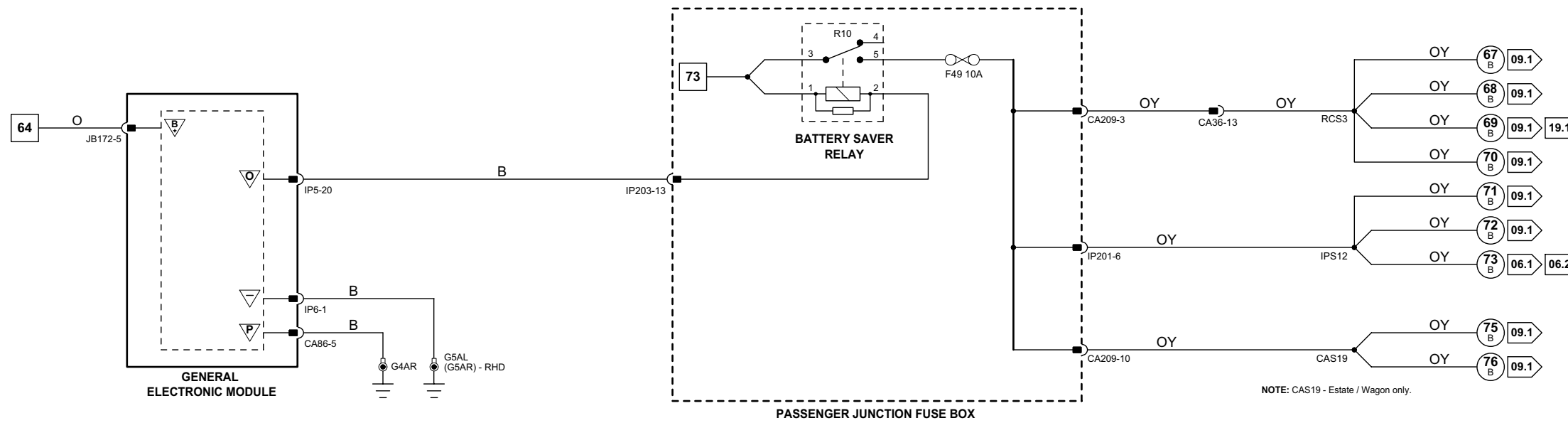

**NOTE:** 'Battery Saver' provides automatic switch-off of the Courtesy Lamps after 10 minutes and automatic switch-off of the Demand Lighting and Audible Warning after 30 minutes. Battery Saver is also active when GEM diagnostic mode is entered

GEM timers are started when the Ignition Key has been switched to the position I (Accessory) or 0 (Off) position. When the timers expire at 10 and 30 minutes, the feature(s) is/are switched off.

When one of the following actions is detected, all features are enabled, and the Battery Saver timer is reset:

- \* The Ignition is switched to position II (run) or position III (start).
- \* Any door or trunk lid becomes ajar or is opened.
- \* Any unlock is activated.

## Fig. 01.8

### Engine Control Module – 2.0 L

	Pin	Description and Characteristic
O	EN65-69	EMS CONTROL RELAY DRIVE: TO ACTIVATE, ECM SWITCHES CIRCUIT TO GROUND

### Engine Control Module – 2.5 L, 3.0 L

	Pin	Description and Characteristic
O	EN16-40	EMS CONTROL RELAY DRIVE: TO ACTIVATE, ECM SWITCHES CIRCUIT TO GROUND

### COMPONENTS

Component	Connector(s)	Connector Description	Location
EMS CONTROL RELAY	-	-	POWER DISTRIBUTION FUSEBOX – R5
ENGINE CONTROL MODULE – 2.0 L	EN65	104-WAY / BLACK	ENGINE COMPARTMENT, FRONT BULKHEAD / RH SIDE
ENGINE CONTROL MODULE – 2.5 L, 3.0 L	EN16	134-WAY / BLACK	ENGINE COMPARTMENT, FRONT BULKHEAD / RH SIDE
PASSENGER JUNCTION FUSEBOX	-	-	PASSENGER COMPARTMENT, FRONT BULKHEAD / LH SIDE
POWER DISTRIBUTION FUSEBOX	-	-	ENGINE COMPARTMENT

### HARNESS IN-LINE CONNECTORS

Connector	Connector Description / Location	Location
CA5	12-WAY / BLACK / FUEL TANK LINK HARNESS TO CABIN HARNESS	TOP OF FUEL TANK
CA210	2-WAY / BLACK / JUNCTION BOX HARNESS TO CABIN HARNESS	LH 'A' POST / 'A' POST TRIM
EN4	12-WAY / BLACK / ENGINE MANAGEMENT HARNESS TO FUEL INJECTION HARNESS	ENGINE COMPARTMENT / ENGINE TOP
JB1	42-WAY / BLACK / ENGINE MANAGEMENT HARNESS TO JUNCTION BOX HARNESS	ENGINE COMPARTMENT / LH SIDE
JB190	4-WAY / BLACK / JUNCTION BOX HARNESS TO COOLING FAN MODULE LINK LEAD	ENGINE COMPARTMENT / FRONT, LH SIDE

FOR CONTROL MODULE PIN-OUT INFORMATION, UNFOLD PAGE TO LEFT.

The following abbreviations are used to represent values for Control Module Pin-Out data

I	Input	PG	Power Ground	C	CAN Network	D	Serial and Encoded Data
O	Output	SS	Sensor / Signal Supply V	S	SCP Network	V	Voltage (DC)
B+	Battery Voltage	SG	Sensor / Signal Ground	D2	D2B Network	PWM	Pulse Width Modulated

**CAUTION:** The information on this data page is furnished to aid the user in understanding circuit operation. THIS INFORMATION SHOULD BE USED FOR REFERENCE ONLY.

**NOTE:** The values listed are approximately those that can be expected at the control module connector pins with all circuit connections made and all components connected and fitted.

Refer to the front of this book for detailed information and illustrations regarding the location and identification of harnesses, relays, fuses, grounds, control modules and control module pins.

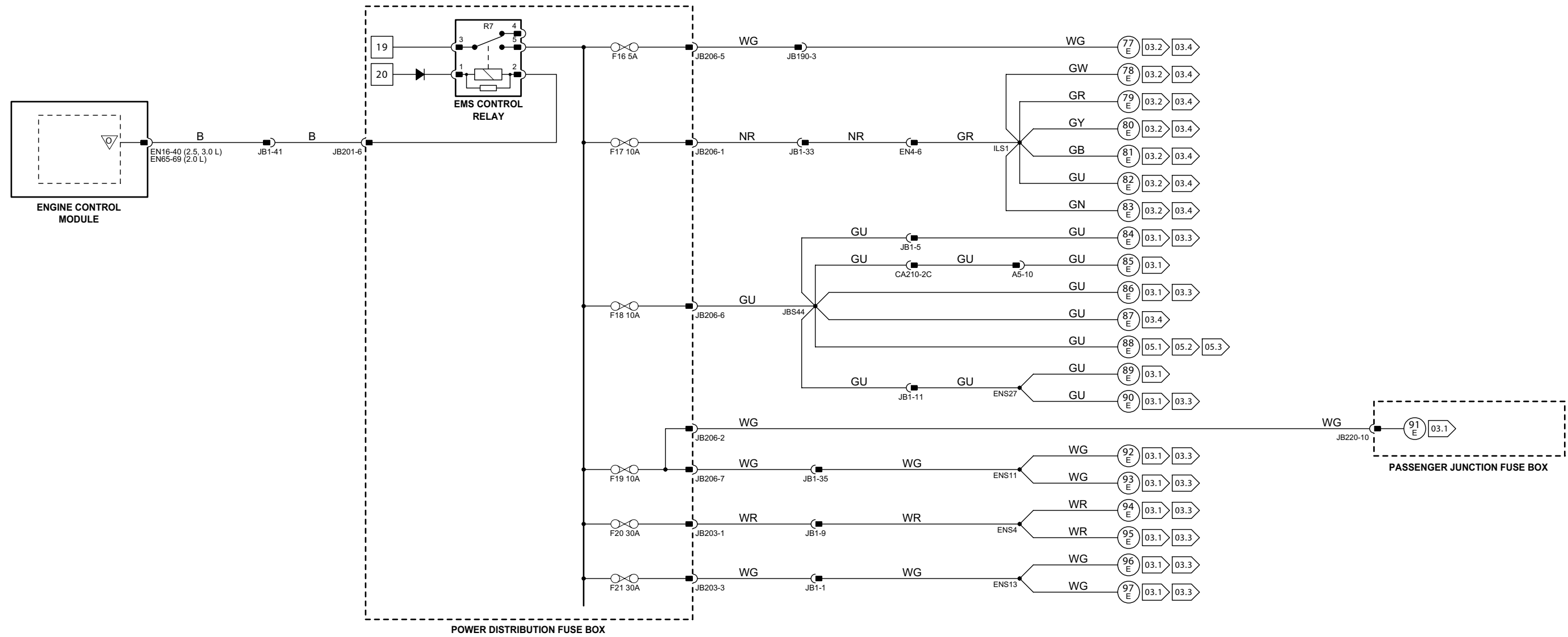

**Engine Control Module – Diesel**

Pin	Description and Characteristic
O DL1-9	EMS CONTROL RELAY ACTIVATE: TO ACTIVATE, ECM SWITCHES CIRCUIT TO GROUND

**Fig. 01.9**

**COMPONENTS**

Component	Connector(s)	Connector Description	Location
EMS CONTROL RELAY	-	-	POWER DISTRIBUTION FUSEBOX – R5
ENGINE CONTROL MODULE – DIESEL	DL1	121-WAY / BLACK	ENGINE COMPARTMENT, FRONT BULKHEAD / RH SIDE
POWER DISTRIBUTION FUSEBOX	-	-	ENGINE COMPARTMENT

**HARNESS IN-LINE CONNECTORS**

Connector	Connector Description / Location	Location
JB1	42-WAY / BLACK / ENGINE MANAGEMENT HARNESS TO JUNCTION BOX HARNESS	ENGINE COMPARTMENT / LH SIDE
JB190	4-WAY / BLACK / JUNCTION BOX HARNESS TO COOLING FAN MODULE LINK LEAD	ENGINE COMPARTMENT / FRONT, LH SIDE
DL2	42-WAY / BLACK / ENGINE HARNESS TO ENGINE MANAGEMENT HARNESS	ENGINE COMPARTMENT / RH SIDE

**FOR CONTROL MODULE PIN-OUT INFORMATION, UNFOLD PAGE TO LEFT.**

The following abbreviations are used to represent values for Control Module Pin-Out data

I	Input	PG	Power Ground	C	CAN Network	D	Serial and Encoded Data
O	Output	SS	Sensor / Signal Supply V	S	SCP Network	V	Voltage (DC)
B+	Battery Voltage	SG	Sensor / Signal Ground	D2	D2B Network	PWM	Pulse Width Modulated

**CAUTION:** The information on this data page is furnished to aid the user in understanding circuit operation. THIS INFORMATION SHOULD BE USED FOR REFERENCE ONLY.

**NOTE:** The values listed are approximately those that can be expected at the control module connector pins with all circuit connections made and all components connected and fitted.

Refer to the front of this book for detailed information and illustrations regarding the location and identification of harnesses, relays, fuses, grounds, control modules and control module pins.

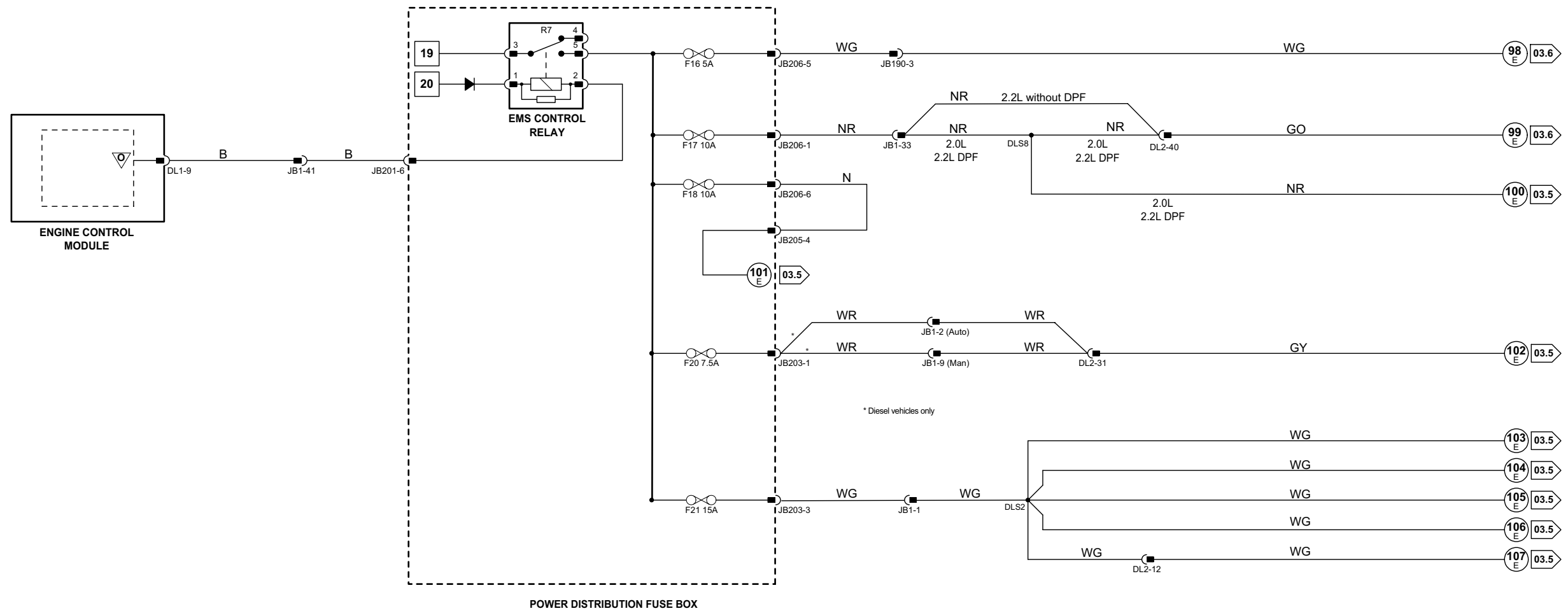

### Engine Control Module – 2.5 L, 3.0 L

	Pin	Description and Characteristic
I	EN16-006	ENGINE CRANK: B+
I	EN16-031	PARK / NEUTRAL SWITCH (AUTOMATIC TRANSMISSION); NORMALLY CLOSED / B+ IN P, N
O	EN16-041	STARTER RELAY DRIVE: TO ACTIVATE, ECM SWITCHES CIRCUIT TO GROUND
O	EN16-053	GENERATOR CONTROL: VARIABLE VOLTAGE
I	EN16-065	GENERATOR FIELD RETURN SIGNAL: VARIABLE VOLTAGE BY GENERATOR OPERATING CONDITION
I	EN16-079	GENERATOR CHARGE / FAULT: B+ = NORMAL, AFTER-START SWITCH-ON; GROUND = GENERATOR FAILURE, AFTER-START SWITCH-ON
C	EN16-123	CAN -
C	EN16-124	CAN +

### General Electronic Module

	Pin	Description and Characteristic
S	IP5-18	SCP -
S	IP5-19	SCP +

I	IP6-08	KEY-IN IGNITION SWITCH: B+ WHEN KEY IN
---	--------	--

### Instrument Cluster

	Pin	Description and Characteristic
D	IP10-03	PATS 1: ENCODED COMMUNICATION
D	IP10-04	PATS 2: ENCODED COMMUNICATION
I	IP10-05	PATS GROUND: GROUND
O	IP10-06	PATS TRANSCIEVER POWER: B+
C	IP10-17	CAN +
C	IP10-18	CAN -
S	IP10-22	SCP +
S	IP10-23	SCP -
I	IP11-08	POWER GROUND: GROUND
I	IP11-13	IGNITION SWITCHED POWER SUPPLY (I): B+

## Fig. 02.1

### COMPONENTS

Component	Connector(s)	Connector Description	Location
BATTERY	-	-	ENGINE COMPARTMENT
ENGINE CONTROL MODULE – 2.5 L, 3.0 L	EN16	134-WAY / BLACK	ENGINE COMPARTMENT, FRONT BULKHEAD / RH SIDE
GENERAL ELECTRONIC MODULE	CA86	23-WAY / GREY	BEHIND INSTRUMENT PANEL / RH SIDE
	CA87	23-WAY / GREEN	
	IP5	23-WAY / BROWN	
	IP6	23-WAY / NATURAL	
	JB172	23-WAY / BLUE	
GENERATOR – 2.5 L, 3.0 L	EN49	4-WAY / BLACK	ENGINE BANK 1 / FRONT
IGNITION SWITCH	IP18	7-WAY / BLACK	STEERING COLUMN
INSTRUMENT CLUSTER	IP10	26-WAY / WHITE	INSTRUMENT PANEL
	IP11	26-WAY / WHITE	
PASSIVE ANTI-THEFT SYSTEM TRANSCIEVER	IP15	4-WAY / BLACK	STEERING COLUMN, IGNITION SWITCH
POWER DISTRIBUTION FUSEBOX	-	-	ENGINE COMPARTMENT
STARTER MOTOR – 2.5 L, 3.0 L	EN700	EYELET	ENGINE BLOCK / RH SIDE
	ST2	EYELET	
STARTER RELAY	-	-	POWER DISTRIBUTION FUSEBOX – R12
TRANSMISSION RANGE SENSOR	JB156	10-WAY / BLACK	TOP OF TRANSMISSION

### HARNESS IN-LINE CONNECTORS

Connector	Connector Description / Location	Location
JB1	42-WAY / BLACK / ENGINE MANAGEMENT HARNESS TO JUNCTION BOX HARNESS	ENGINE COMPARTMENT / LH SIDE
JB2	16-WAY / GREEN / ENGINE MANAGEMENT HARNESS TO JUNCTION BOX HARNESS (PEDAL ASSEMBLY)	BELOW INSTRUMENT PANEL / DRIVER SIDE
JB129	22-WAY / GREY / JUNCTION BOX HARNESS TO INSTRUMENT PANEL HARNESS	BELOW INSTRUMENT PANEL / LH SIDE
JB145	8-WAY / BLACK / ENGINE MANAGEMENT HARNESS TO JUNCTION BOX HARNESS	ENGINE COMPARTMENT / LH SIDE

### GROUNDS

Ground	Harness	Location
G13	B03	BATTERY ENGINE GROUND
G16	B03	ENGINE COMPARTMENT / UNDER BATTERY TRAY
G36	IP	BEHIND INSTRUMENT PANEL / LH SIDE OF CROSS CAR BEAM
G37	IP	BEHIND INSTRUMENT PANEL / RH SIDE OF CROSS CAR BEAM

FOR CONTROL MODULE PIN-OUT INFORMATION, UNFOLD PAGE TO LEFT.

The following abbreviations are used to represent values for Control Module Pin-Out data

I	Input	PG	Power Ground	C	CAN Network	D	Serial and Encoded Data
O	Output	SS	Sensor / Signal Supply V	S	SCP Network	V	Voltage (DC)
B+	Battery Voltage	SG	Sensor / Signal Ground	D2	D2B Network	PWM	Pulse Width Modulated

**CAUTION:** The information on this data page is furnished to aid the user in understanding circuit operation. THIS INFORMATION SHOULD BE USED FOR REFERENCE ONLY.

**NOTE:** The values listed are approximately those that can be expected at the control module connector pins with all circuit connections made and all components connected and fitted.

Refer to the front of this book for detailed information and illustrations regarding the location and identification of harnesses, relays, fuses, grounds, control modules and control module pins.



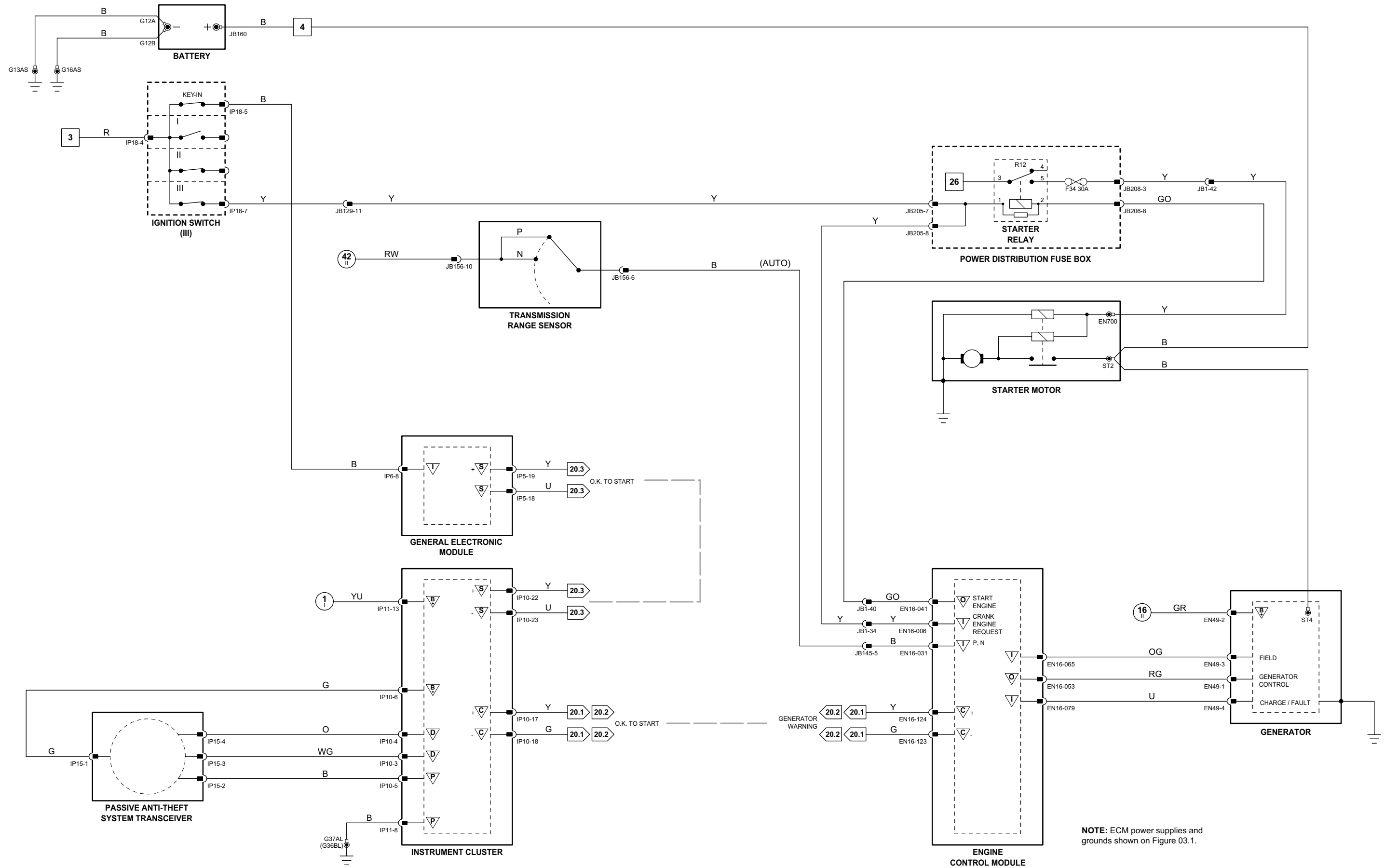

NOTE: ECM power supplies and grounds shown on Figure 03.1.

102\_1\_40009

1 → 6 Fig. 01.1	34 → 80 Fig. 01.3	11 → 31 Fig. 01.5	67 → 76 Fig. 01.7	98 → 107 Fig. 01.9	Input	Battery Voltage	Sensor/Signal Supply V	CAN	D2B Network
7 → 33 Fig. 01.2	1 → 10 Fig. 01.4	32 → 66 Fig. 01.6	77 → 97 Fig. 01.8		Output	Power Ground	Sensor/Signal Ground	SCP	Serial and Encoded Data

VARIANT: 2.5 L & 3.0 L Vehicles  
 VIN RANGE: All  
 DATE OF ISSUE: February 2008

**Fig. 02.2**

**Engine Control Module – 2.0 L**

	Pin	Description and Characteristic
I	EN65-006	ENGINE CRANK: B+
O	EN65-008	GENERATOR FIELD RETURN SIGNAL: VARIABLE VOLTAGE BY GENERATOR OPERATING CONDITION
I	EN65-035	GENERATOR CHARGE / FAULT: B+ = NORMAL, AFTER-START SWITCH-ON; GROUND = GENERATOR FAILURE, AFTER-START SWITCH-ON
I	EN65-043	GENERATOR CONTROL: VARIABLE VOLTAGE
O	EN65-068	STARTER RELAY DRIVE: TO ACTIVATE, ECM SWITCHES CIRCUIT TO GROUND
I	EN65-085	PARK / NEUTRAL SWITCH (AUTOMATIC TRANSMISSION); NORMALLY CLOSED / GROUND WHEN ACTIVATED
C	EN65-088	CAN -
C	EN65-089	CAN +

**General Electronic Module**

	Pin	Description and Characteristic
S	IP5-18	SCP -
S	IP5-19	SCP +

I	IP6-08	KEY-IN IGNITION SWITCH: B+ WHEN KEY IN
---	--------	--

**Instrument Cluster**

	Pin	Description and Characteristic
D	IP10-03	PATS 1: ENCODED COMMUNICATION
D	IP10-04	PATS 2: ENCODED COMMUNICATION
I	IP10-05	PATS GROUND: GROUND
O	IP10-06	PATS TRANSCIEVER POWER: B+
C	IP10-17	CAN +
C	IP10-18	CAN -
S	IP10-22	SCP +
S	IP10-23	SCP -
I	IP11-08	POWER GROUND: GROUND
I	IP11-13	IGNITION SWITCHED POWER SUPPLY (I): B+

**COMPONENTS**

Component	Connector(s)	Connector Description	Location
BATTERY	-	-	ENGINE COMPARTMENT
ENGINE CONTROL MODULE – 2.0 L	EN65	104-WAY / BLACK	ENGINE COMPARTMENT, FRONT BULKHEAD / RH SIDE
GENERAL ELECTRONIC MODULE	CA86	23-WAY / GREY	BEHIND INSTRUMENT PANEL / RH SIDE
	CA87	23-WAY / GREEN	
	IP5	23-WAY / BROWN	
	IP6	23-WAY / NATURAL	
	JB172	23-WAY / BLUE	
GENERATOR – 2.0 L	EN49	4-WAY / BLACK	ENGINE BANK 1 / FRONT
IGNITION SWITCH	IP18	7-WAY / BLACK	STEERING COLUMN
INSTRUMENT CLUSTER	IP10	26-WAY / WHITE	INSTRUMENT PANEL
	IP11	26-WAY / WHITE	
PASSIVE ANTI-THEFT SYSTEM TRANSCIEVER	IP15	4-WAY / BLACK	STEERING COLUMN, IGNITION SWITCH
POWER DISTRIBUTION FUSEBOX	-	-	ENGINE COMPARTMENT
STARTER MOTOR – 2.0 L	EN700	EYELET	ENGINE BLOCK / RH SIDE
	ST2	EYELET	
STARTER RELAY	-	-	POWER DISTRIBUTION FUSEBOX – R12
TRANSMISSION RANGE SENSOR	JB156	10-WAY / BLACK	TOP OF TRANSMISSION

**HARNESS IN-LINE CONNECTORS**

Connector	Connector Description / Location	Location
JB1	42-WAY / BLACK / ENGINE MANAGEMENT HARNESS TO JUNCTION BOX HARNESS	ENGINE COMPARTMENT / LH SIDE
JB129	22-WAY / GREY / JUNCTION BOX HARNESS TO INSTRUMENT PANEL HARNESS	BELOW INSTRUMENT PANEL / LH SIDE

**GROUNDS**

Ground	Harness	Location
G13	B03	BATTERY ENGINE GROUND
G16	B03	ENGINE COMPARTMENT / UNDER BATTERY TRAY
G36	IP	BEHIND INSTRUMENT PANEL / LH SIDE OF CROSS CAR BEAM
G37	IP	BEHIND INSTRUMENT PANEL / RH SIDE OF CROSS CAR BEAM

FOR CONTROL MODULE PIN-OUT INFORMATION, UNFOLD PAGE TO LEFT.

The following abbreviations are used to represent values for Control Module Pin-Out data

I	Input	PG	Power Ground	C	CAN Network	D	Serial and Encoded Data
O	Output	SS	Sensor / Signal Supply V	S	SCP Network	V	Voltage (DC)
B+	Battery Voltage	SG	Sensor / Signal Ground	D2	D2B Network	PWM	Pulse Width Modulated

**CAUTION:** The information on this data page is furnished to aid the user in understanding circuit operation. THIS INFORMATION SHOULD BE USED FOR REFERENCE ONLY.

**NOTE:** The values listed are approximately those that can be expected at the control module connector pins with all circuit connections made and all components connected and fitted.

Refer to the front of this book for detailed information and illustrations regarding the location and identification of harnesses, relays, fuses, grounds, control modules and control module pins.

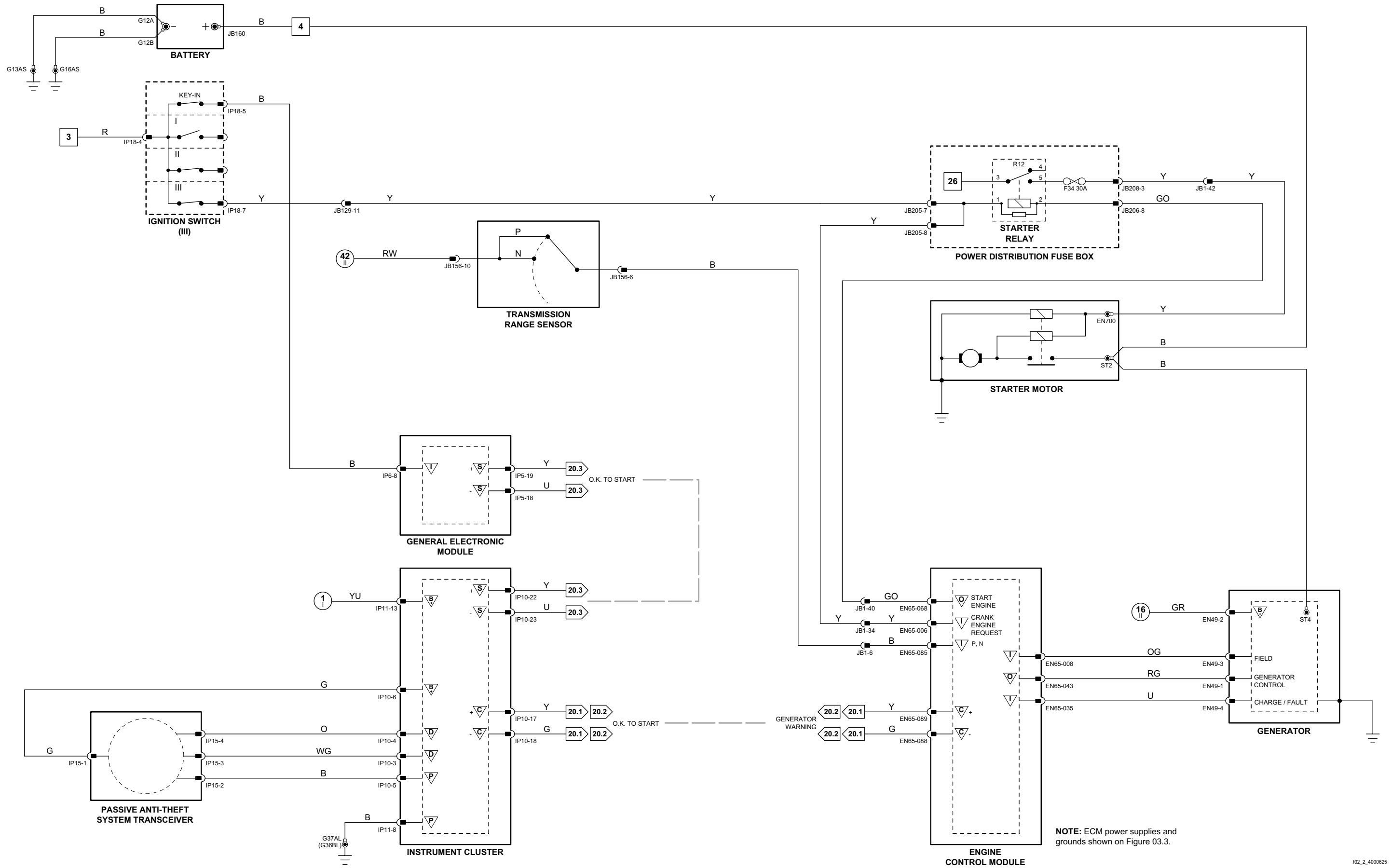

102\_2\_4000625

1 → 6 Fig. 01.1	34 → 80 Fig. 01.3	11 → 31 Fig. 01.5	67 → 76 Fig. 01.7	98 → 107 Fig. 01.9	Input	Battery Voltage	Sensor/Signal Supply V	CAN	D2B Network
7 → 33 Fig. 01.2	1 → 10 Fig. 01.4	32 → 66 Fig. 01.6	77 → 97 Fig. 01.8		Output	Power Ground	Sensor/Signal Ground	SCP	Serial and Encoded Data

**VARIANT:** 2.0 L Gasoline Engine Vehicles  
**VIN RANGE:** All  
**DATE OF ISSUE:** February 2008

**Engine Control Module –Diesel**

	Pin	Description and Characteristic
O	DL1-021	STARTER RELAY DRIVE: TO ACTIVATE, ECM SWITCHES CIRCUIT TO GROUND
O	DL1-047	GENERATOR MONITOR
C	DL1-054	CAN +
C	DL1-073	CAN -
O	DL1-112	GENERATOR COMMON

**General Electronic Module**

	Pin	Description and Characteristic
S	IP5-18	SCP -
S	IP5-19	SCP +
I	IP6-08	KEY-IN IGNITION SWITCH: B+ WHEN KEY IN

**Instrument Cluster**

	Pin	Description and Characteristic
D	IP10-03	PATS 1: ENCODED COMMUNICATION
D	IP10-04	PATS 2: ENCODED COMMUNICATION
I	IP10-05	PATS GROUND: GROUND
O	IP10-06	PATS TRANSCEIVER POWER: B+
C	IP10-17	CAN +
C	IP10-18	CAN -
S	IP10-22	SCP +
S	IP10-23	SCP -
I	IP11-08	POWER GROUND: GROUND
I	IP11-13	IGNITION SWITCHED POWER SUPPLY (I): B+

**Fig. 02.3**

**COMPONENTS**

Component	Connector(s)	Connector Description	Location
BATTERY	-	-	ENGINE COMPARTMENT
ENGINE CONTROL MODULE - Diesel	DL1	121-WAY / BLACK	ENGINE COMPARTMENT, FRONT BULKHEAD / RH SIDE
GENERAL ELECTRONIC MODULE	CA86	23-WAY / GREY	BEHIND INSTRUMENT PANEL / RH SIDE
	CA87	23-WAY / GREEN	
	IP5	23-WAY / BROWN	
	IP6	23-WAY / NATURAL	
	JB172	23-WAY / BLUE	
GENERATOR - Diesel	DB1	4-WAY / BLACK	ENGINE BLOCK / RH SIDE / FRONT
IGNITION SWITCH	IP18	7-WAY / BLACK	STEERING COLUMN
INSTRUMENT CLUSTER	IP10	26-WAY / WHITE	INSTRUMENT PANEL
	IP11	26-WAY / WHITE	
PASSIVE ANTI-THEFT SYSTEM TRANSCEIVER	IP15	4-WAY / BLACK	STEERING COLUMN, IGNITION SWITCH
POWER DISTRIBUTION FUSEBOX	-	-	ENGINE COMPARTMENT
STARTER MOTOR - Diesel	DL8	EYELET	ENGINE BLOCK / LH SIDE
	ST2	EYELET	
STARTER RELAY	-	-	POWER DISTRIBUTION FUSEBOX - R12

**HARNES IN-LINE CONNECTORS**

Connector	Connector Description / Location	Location
DE2	4-WAY / BLACK / GENERATOR LINK HARNESS	
DL2	42-WAY / BLACK / ENGINE HARNESS TO ENGINE MANAGEMENT HARNESS	ENGINE COMPARTMENT / RH SIDE
JB1	42-WAY / BLACK / ENGINE MANAGEMENT HARNESS TO JUNCTION BOX HARNESS	ENGINE COMPARTMENT / LH SIDE
JB129	22-WAY / GREY / JUNCTION BOX HARNESS TO INSTRUMENT PANEL HARNESS	BELOW INSTRUMENT PANEL / LH SIDE

**GROUNDS**

Ground	Harness	Location
G13	B03	BATTERY ENGINE GROUND
G16	B03	ENGINE COMPARTMENT / UNDER BATTERY TRAY
G36	IP	BEHIND INSTRUMENT PANEL / LH SIDE OF CROSS CAR BEAM
G37	IP	BEHIND INSTRUMENT PANEL / RH SIDE OF CROSS CAR BEAM

**FOR CONTROL MODULE PIN-OUT INFORMATION, UNFOLD PAGE TO LEFT.**

The following abbreviations are used to represent values for Control Module Pin-Out data

I	Input	PG	Power Ground	C	CAN Network	D	Serial and Encoded Data
O	Output	SS	Sensor / Signal Supply V	S	SCP Network	V	Voltage (DC)
B+	Battery Voltage	SG	Sensor / Signal Ground	D2	D2B Network	PWM	Pulse Width Modulated

**CAUTION:** The information on this data page is furnished to aid the user in understanding circuit operation. THIS INFORMATION SHOULD BE USED FOR REFERENCE ONLY.

**NOTE:** The values listed are approximately those that can be expected at the control module connector pins with all circuit connections made and all components connected and fitted.

Refer to the front of this book for detailed information and illustrations regarding the location and identification of harnesses, relays, fuses, grounds, control modules and control module pins.

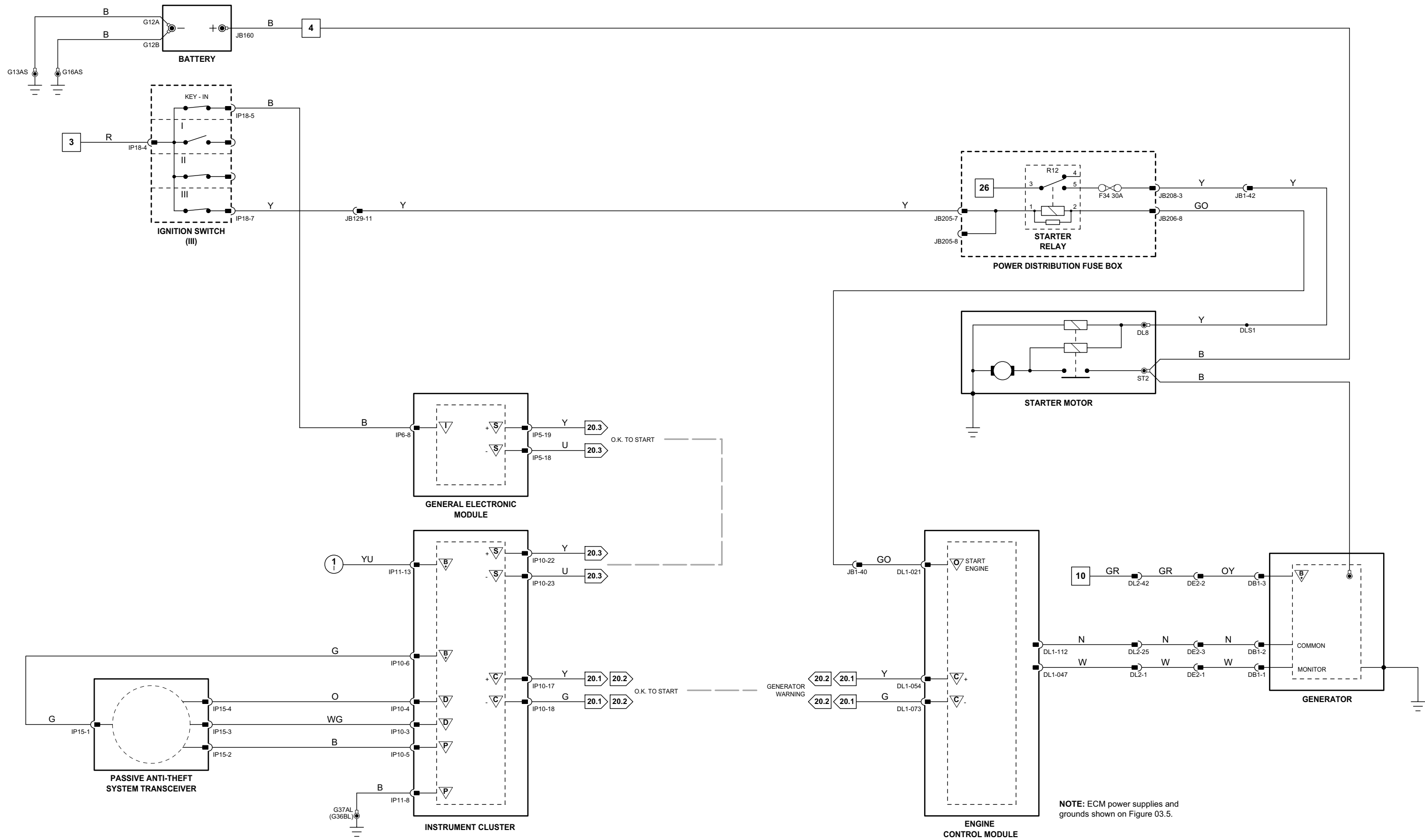

1 → 6 Fig. 01.1	34 → 80 Fig. 01.3	11 → 31 Fig. 01.5	67 → 76 Fig. 01.7	98 → 107 Fig. 01.9	Input	Battery Voltage	Sensor/Signal Supply V	CAN	D2B Network
7 → 33 Fig. 01.2	1 → 10 Fig. 01.4	32 → 66 Fig. 01.6	77 → 97 Fig. 01.8		Output	Power Ground	Sensor/Signal Ground	SCP	Serial and Encoded Data

VARIANT: Diesel Engine Vehicles  
 VIN RANGE: All  
 DATE OF ISSUE: February 2008

**Engine Control Module – 2.5 L, 3.0 L**

Pin	Description and Characteristic
O	EN16-001 HO2 SENSOR HEATER CONTROL – 1/1: PWM, 1 CYCLE PER 128 mS, VARIABLE DUTY CYCLE
O	EN16-002 HO2 SENSOR HEATER CONTROL – 1/1: PWM, 1 CYCLE PER 128 mS, VARIABLE DUTY CYCLE
PG	EN16-004 POWER GROUND 1: GROUND
PG	EN16-005 POWER GROUND 2: GROUND
I	EN16-006 ENGINE CRANK: B+
I	EN16-007 IGNITION ON: B+
I	EN16-008 BRAKE ON / OFF SWITCH: NORMALLY OPEN / B+ WHEN ACTIVATED
I	EN16-010 INERTIA SWITCH: NORMALLY CLOSED / OPEN CIRCUIT WHEN ACTIVATED
SS	EN16-012 SENSOR POWER SUPPLY 1: NOMINAL 5 V
SS	EN16-013 SENSOR POWER SUPPLY 2: NOMINAL 5 V
SG	EN16-017 SMALL SIGNAL GROUND 1: GROUND
SG	EN16-018 SMALL SIGNAL GROUND 2: GROUND
SG	EN16-019 SENSOR GROUND 1: GROUND
SG	EN16-020 SENSOR GROUND 2: GROUND
B+	EN16-022 BATTERY POWER SUPPLY: B+
B+	EN16-023 EMS SWITCHED POWER SUPPLY 1: B+
B+	EN16-024 EMS SWITCHED POWER SUPPLY 2: B+
SG	EN16-029 HO2 SENSOR HEATER GROUND – 1/1: GROUND
SG	EN16-030 HO2 SENSOR HEATER GROUND – 1/1: GROUND
I	EN16-031 (MANUAL TRANSMISSION) CLUTCH PEDAL SAFETY SWITCH: NORMALLY OPEN / B+ WHEN ACTIVATED
I	EN16-031 (AUTOMATIC TRANSMISSION) PARK / NEUTRAL SWITCH: NORMALLY CLOSED / B+ IN P, N
I	EN16-036 CRANKSHAFT SENSOR SIGNAL: PULSED SIGNAL, 70 PULSES PER ENGINE CYCLE
SG	EN16-037 CRANKSHAFT SENSOR SIGNAL GROUND: GROUND
O	EN16-038 INTAKE MANIFOLD TUNING VALVE SOLENOID DRIVE – 1 / BOTTOM: GROUND WHEN ACTIVATED
O	EN16-039 INTAKE MANIFOLD TUNING VALVE SOLENOID DRIVE – 2 / TOP: GROUND WHEN ACTIVATED
O	EN16-040 EMS CONTROL RELAY DRIVE: TO ACTIVATE, ECM SWITCHES CIRCUIT TO GROUND
O	EN16-041 STARTER RELAY DRIVE: TO ACTIVATE, ECM SWITCHES CIRCUIT TO GROUND
I	EN16-044 MASS AIR FLOW SENSOR SIGNAL: NOMINAL 0 – 5 V BY ENGINE OPERATING CONDITION
SG	EN16-045 MASS AIR FLOW SENSOR GROUND: GROUND
SG	EN16-046 MASS AIR FLOW SENSOR GROUND: GROUND
I	EN16-050 ENGINE FUEL TEMPERATURE SENSOR SIGNAL, NOMINAL 0 – 5 V: NTC SENSOR – VOLTAGE DECREASES AS TEMPERATURE INCREASES
O	EN16-052 THROTTLE MOTOR RELAY DRIVE: TO ACTIVATE, ECM SWITCHES CIRCUIT TO GROUND
O	EN16-053 GENERATOR CONTROL: VARIABLE VOLTAGE
SG	EN16-054 THROTTLE MOTOR GROUND: GROUND
O	EN16-055 HO2 SENSOR HEATER CONTROL – 2/1: PWM, 1 CYCLE PER 128 mS, VARIABLE DUTY CYCLE
O	EN16-056 HO2 SENSOR HEATER CONTROL – 2/1: PWM, 1 CYCLE PER 128 mS, VARIABLE DUTY CYCLE
I	EN16-065 GENERATOR FIELD RETURN SIGNAL: VARIABLE VOLTAGE BY GENERATOR OPERATING CONDITION
O	EN16-066 EVAP CANISTER PURGE VALVE DRIVE: PWM, 10 Hz, POSITIVE DUTY CYCLE RANGE 0.04% – 100%
O	EN16-067 EVAP CANISTER CLOSE VALVE DRIVE: TO CLOSE, ECM SWITCHES CIRCUIT TO GROUND
I	EN16-068 BANK 2 CAMSHAFT SENSOR SIGNAL: PULSED SIGNAL, 4 PULSES PER ENGINE CYCLE
SG	EN16-069 BANK 2 CAMSHAFT SENSOR GROUND: GROUND
I	EN16-070 ENGINE COOLANT TEMPERATURE SENSOR SIGNAL, NOMINAL 0 – 5 V: NTC SENSOR – VOLTAGE DECREASES AS TEMPERATURE INCREASES
I	EN16-071 INTAKE AIR TEMPERATURE SENSOR SIGNAL, NOMINAL 0 – 5 V: NTC SENSOR – VOLTAGE DECREASES AS TEMPERATURE INCREASES
I	EN16-073 INJECTION PRESSURE SENSOR SIGNAL, NOMINAL 0 – 5 V: POTENTIOMETER – VOLTAGE DECREASES AS PRESSURE INCREASES
I	EN16-075 THROTTLE POSITION SENSOR 1 SIGNAL: IDLE = 0.74 V; FULL THROTTLE = 3.97 V
I	EN16-076 THROTTLE POSITION SENSOR 2 SIGNAL: IDLE = 1.65 V; FULL THROTTLE = 4.20 V
I	EN16-078 ENGINE OIL TEMPERATURE SENSOR SIGNAL, NOMINAL 0 – 5 V: NTC SENSOR – VOLTAGE DECREASES AS TEMPERATURE INCREASES
I	EN16-079 GENERATOR CHARGE / FAULT: B+ = NORMAL, AFTER-START SWITCH-ON; GROUND = GENERATOR FAILURE, AFTER-START SWITCH-ON
O	EN16-080 THROTTLE MOTOR DRIVE: B+ TO ACTIVATE MOTOR
SG	EN16-081 HO2 SENSOR HEATER GROUND – 2/1: GROUND
SG	EN16-082 HO2 SENSOR HEATER GROUND – 2/1: GROUND
I	EN16-083 HO2 SENSOR 1/1 SIGNAL: VARIABLE CURRENT
I	EN16-084 HO2 SENSOR 1/1 SIGNAL: CONSTANT CURRENT
SG	EN16-091 HO2 SENSOR HEATERS 1/2, 2/2 GROUND: GROUND
O	EN16-092 HO2 SENSOR HEATER CONTROL – 1/2: PWM, 1 CYCLE PER 256 mS, POSITIVE DUTY CYCLE RANGE 0 mS = 0%, 77 mS = 30%, 256 mS = 100%
O	EN16-093 HO2 SENSOR HEATER CONTROL – 2/2: PWM, 1 CYCLE PER 256 mS, POSITIVE DUTY CYCLE RANGE 0 mS = 0%, 77 mS = 30%, 256 mS = 100%
I	EN16-094 BANK 1 CAMSHAFT SENSOR SIGNAL: PULSED SIGNAL, 4 PULSES PER ENGINE CYCLE
SG	EN16-095 BANK 1 CAMSHAFT SENSOR GROUND: GROUND
I	EN16-098 KNOCK SENSOR SIGNAL: PULSED SIGNAL
SG	EN16-100 SENSOR SHIELD: GROUND
I	EN16-102 ACCELERATOR PEDAL POSITION SENSOR 1 SIGNAL: FOOT OFF = 0.97 V; FULLY DEPRESSED = 3.33 V
I	EN16-103 ACCELERATOR PEDAL POSITION SENSOR 2 SIGNAL: FOOT OFF = 3.97 V; FULLY DEPRESSED = 0.84 V
I	EN16-104 FUEL TANK PRESSURE SENSOR SIGNAL, NOMINAL 0 – 5 V: VOLTAGE DECREASES AS PRESSURE INCREASES
D	EN16-105 SERIAL DATA LINK: SERIAL COMMUNICATION
O	EN16-106 THROTTLE MOTOR DRIVE: B+ TO ACTIVATE MOTOR
I	EN16-107 HO2 SENSOR 2/1 SIGNAL: VARIABLE CURRENT
I	EN16-108 HO2 SENSOR 2/1 SIGNAL: CONSTANT CURRENT
O	EN16-109 BANK 1 VVT SOLENOID VALVE: PWM, 300 Hz, POSITIVE DUTY CYCLE RANGE 0% – 100%
O	EN16-110 BANK 2 VVT SOLENOID VALVE: PWM, 300 Hz, POSITIVE DUTY CYCLE RANGE 0% – 100%
SG	EN16-111 BANK 1 FUEL INJECTORS (1, 3, 5) GROUND: GROUND
SG	EN16-116 BANK 2 FUEL INJECTORS (2, 4, 6) GROUND: GROUND
C	EN16-123 CAN –
C	EN16-124 CAN +
I	EN16-127 MAP SENSOR SIGNAL, NOMINAL 0 – 5 V: VOLTAGE INCREASES AS MANIFOLD ABSOLUTE PRESSURE INCREASES
I	EN16-128 HO2 SENSOR 1/2 SIGNAL, NOMINAL 1 V SWING: 0.1 – 0.9 V SWING
I	EN16-129 HO2 SENSOR 2/2 SIGNAL, NOMINAL 1 V SWING: 0.1 – 0.9 V SWING
SG	EN16-130 HO2 SENSORS GROUND: GROUND
B+	EN16-134 THROTTLE MOTOR POWER SUPPLY: B+ WHEN RELAY ACTIVATED

The following abbreviations are used to represent values for Control Module Pin-Out data

<b>I</b>	<b>Input</b>	<b>PG</b>	<b>Power Ground</b>	<b>C</b>	<b>CAN Network</b>	<b>D</b>	<b>Serial and Encoded Data</b>
<b>O</b>	<b>Output</b>	<b>SS</b>	<b>Sensor / Signal Supply V</b>	<b>S</b>	<b>SCP Network</b>	<b>V</b>	<b>Voltage (DC)</b>
<b>B+</b>	<b>Battery Voltage</b>	<b>SG</b>	<b>Sensor / Signal Ground</b>	<b>D2</b>	<b>D2B Network</b>	<b>PWM</b>	<b>Pulse Width Modulated</b>

**CAUTION:** The information on this data page is furnished to aid the user in understanding circuit operation. THIS INFORMATION SHOULD BE USED FOR REFERENCE ONLY.

**NOTE:** The values listed are approximately those that can be expected at the control module connector pins with all circuit connections made and all components connected and fitted.

**Fig. 03.1**

**COMPONENTS**

Component	Connector(s)	Connector Description	Location
APP SENSOR – 2.5 L, 3.0 L	PA1	6-WAY / BLACK	ABOVE ACCELERATOR PEDAL
BRAKE ON / OFF SWITCH	PA3	3-WAY / BLACK	TOP OF BRAKE PEDAL
CKP SENSOR – 2.5 L, 3.0 L	EN12	2-WAY / BLACK	ADJACENT TO ENGINE CRANKSHAFT PULLEY
CMP SENSOR 1 – 2.5 L, 3.0 L	EN43	2-WAY / BLACK	BANK 1 CYLINDER HEAD, FRONT
CMP SENSOR 2 – 2.5 L, 3.0 L	EN33	2-WAY / BLACK	BANK 2 CYLINDER HEAD, FRONT
ECT SENSOR	EN18	2-WAY / BLACK	ENGINE VEE, FRONT
EFT SENSOR – 2.5 L, 3.0 L	IL8	2-WAY / BLACK	FUEL RAIL, FRONT
ENGINE CONTROL MODULE – 2.5 L, 3.0 L	EN16	134-WAY / BLACK	ENGINE COMPARTMENT, FRONT BULKHEAD / RH SIDE
EOT SENSOR	EN25	2-WAY / GREY	ADJACENT TO ENGINE OIL FILTER
EVAP CANISTER CLOSE VALVE	FT5	2-WAY / BLACK	REARWARD OF FUEL TANK
EVAP CANISTER PURGE VALVE	JB170	2-WAY / BLACK	ENGINE COMPARTMENT BULKHEAD
FTP SENSOR	FT7	3-WAY / BLACK	TOP OF FUEL TANK
HO2 SENSOR DOWNSTREAM 1/2	EN14	4-WAY / BLACK	BANK 1 EXHAUST
HO2 SENSOR DOWNSTREAM 2/2	EN9	4-WAY / BLACK	BANK 2 EXHAUST
HO2 SENSOR UPSTREAM 1/1	EN37	4-WAY / GREY	BANK 1 EXHAUST
HO2 SENSOR UPSTREAM 2/1	EN32	4-WAY / GREY	BANK 2 EXHAUST
IMT SOLENOID VALVE 1	EN999	2-WAY / BLACK	INTAKE MANIFOLD BOTTOM
IMT SOLENOID VALVE 2	EN998	2-WAY / BLACK	INTAKE MANIFOLD TOP
IP SENSOR – 2.5 L, 3.0 L	IL7	2-WAY / BLACK	FUEL RAIL REAR
KNOCK SENSOR – 2.5 L, 3.0 L	EN23	2-WAY / BLACK	ENGINE VEE
MAF SENSOR – 2.5 L, 3.0 L	EN6	5-WAY / BLACK	ENGINE AIR INTAKE DUCT
MAP SENSOR	EN8	4-WAY / BLACK	INTAKE MANIFOLD, REAR
PASSENGER JUNCTION FUSEBOX	–	–	PASSENGER COMPARTMENT, FRONT BULKHEAD / LH SIDE
THROTTLE MOTOR RELAY	–	–	PASSENGER JUNCTION FUSEBOX – R7
THROTTLE BODY – 2.5 L, 3.0 L	EN95	6-WAY / BLACK	THROTTLE BODY
VVT SOLENOID VALVE 1	EN61	2-WAY / BLACK	BANK 1 CYLINDER HEAD
VVT SOLENOID VALVE 2	EN42	2-WAY / BLACK	BANK 2 CYLINDER HEAD

**HARNES IN-LINE CONNECTORS**

Connector	Connector Description / Location	Location
CA5	12-WAY / BLACK / FUEL TANK LINK HARNESS TO CABIN HARNESS	TOP OF FUEL TANK
CA170	16-WAY / GREEN / JUNCTION BOX HARNESS TO CABIN HARNESS	LH 'A' POST / 'A' POST TRIM
EN4	12-WAY / BLACK / ENGINE MANAGEMENT HARNESS TO FUEL INJECTION HARNESS	ENGINE COMPARTMENT / ENGINE TOP
JB1	42-WAY / BLACK / ENGINE MANAGEMENT HARNESS TO JUNCTION BOX HARNESS	ENGINE COMPARTMENT / LH SIDE
JB2	16-WAY / GREEN / ENGINE MANAGEMENT HARNESS TO JUNCTION BOX HARNESS (PEDAL ASSEMBLY)	BELOW INSTRUMENT PANEL / DRIVER SIDE

**GROUNDS**

Ground	Harness	Location
G8	EN	ENGINE COMPARTMENT / RH STRUT TOWER

**FOR CONTROL MODULE PIN-OUT INFORMATION, UNFOLD PAGE TO LEFT.**

Refer to the front of this book for detailed information and illustrations regarding the location and identification of harnesses, relays, fuses, grounds, control modules and control module pins.

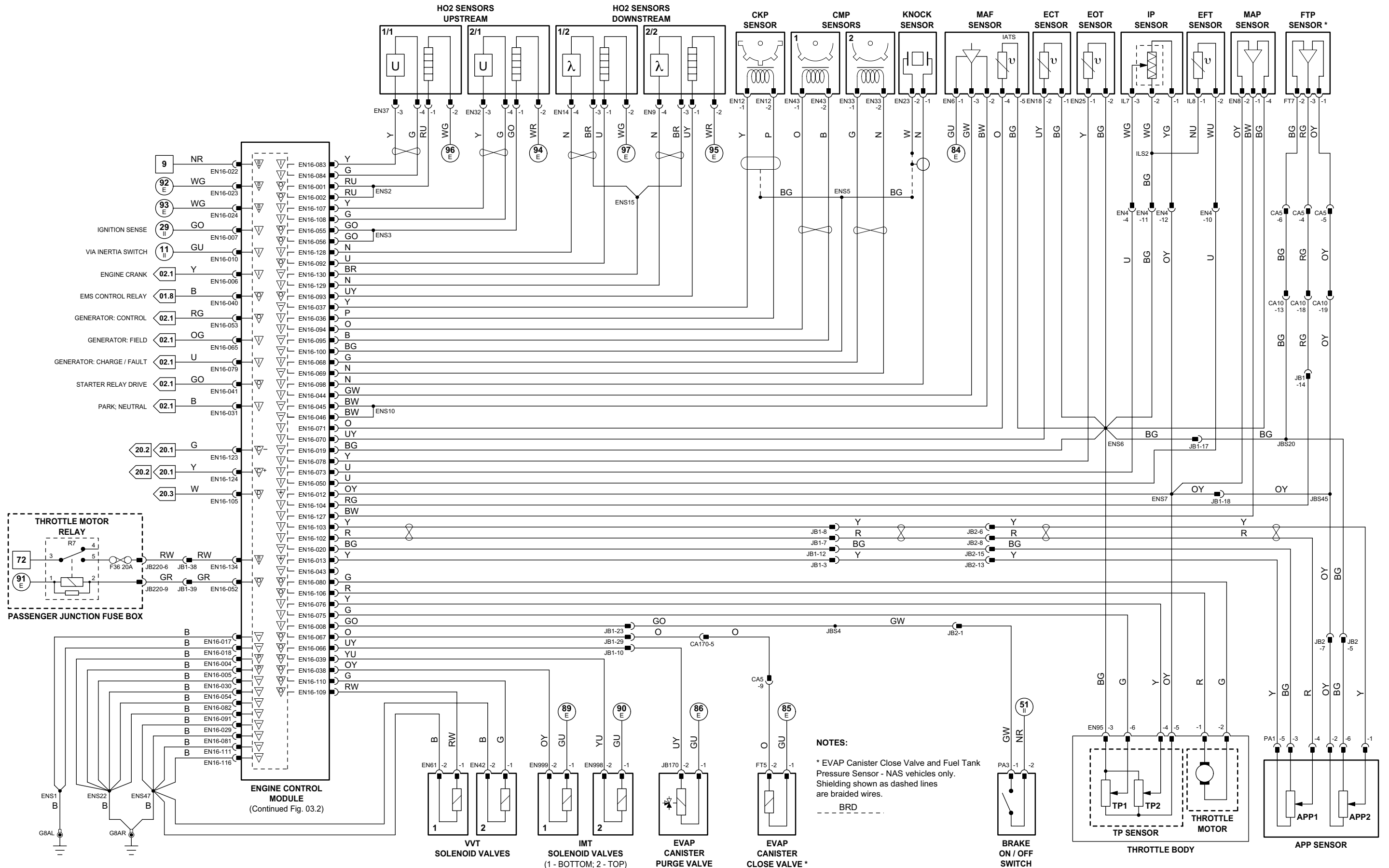

**Engine Control Module – 2.5 L, 3.0 L**

	Pin	Description and Characteristic
I	EN16-009	BRAKE CANCEL SWITCH: NORMALLY CLOSED / GROUND WHEN ACTIVATED
SS	EN16-012	SENSOR POWER SUPPLY 1: NOMINAL 5 V
SG	EN16-019	SENSOR GROUND 1: GROUND
I	EN16-025	FUEL PUMP MODULE MONITOR: PWM, 1 Hz, 50% POSITIVE DUTY CYCLE = NORMAL, 25% POSITIVE DUTY CYCLE = NO CONTROL SIGNAL, 75% POSITIVE DUTY CYCLE = FUEL PUMP INOPERATIVE
O	EN16-027	FUEL PUMP MODULE CONTROL: PWM, 150 Hz, NORMAL POSITIVE DUTY CYCLE RANGE = 4% – 51%
SG	EN16-029	HO2 SENSOR HEATER GROUND – 1/1: GROUND
I	EN16-033	CLUTCH CANCEL SWITCH: NORMALLY CLOSED / GROUND WHEN ACTIVATED
O	EN16-034	AIR CONDITIONING COMPRESSOR CLUTCH RELAY DRIVE: TO ACTIVATE, ECM SWITCHES CIRCUIT TO GROUND
SS	EN16-047	SPEED CONTROL SWITCH REQUEST: STEPPED RESISTANCE
I	EN16-048	SPEED CONTROL SWITCHES SIGNAL GROUND: GROUND
O	EN16-051	COOLING FAN MODULE CONTROL: PWM, 140 Hz, POSITIVE DUTY CYCLE RANGE 7% – 95%
O	EN16-061	IGNITION COIL ACTIVATE – CYLINDER 2: TO ACTIVATE, ECM SWITCHES CIRCUIT TO GROUND
O	EN16-062	IGNITION COIL ACTIVATE – CYLINDER 4: TO ACTIVATE, ECM SWITCHES CIRCUIT TO GROUND
O	EN16-063	IGNITION COIL ACTIVATE – CYLINDER 6: TO ACTIVATE, ECM SWITCHES CIRCUIT TO GROUND
O	EN16-087	IGNITION COIL ACTIVATE – CYLINDER 1: TO ACTIVATE, ECM SWITCHES CIRCUIT TO GROUND
O	EN16-088	IGNITION COIL ACTIVATE – CYLINDER 3: TO ACTIVATE, ECM SWITCHES CIRCUIT TO GROUND
O	EN16-089	IGNITION COIL ACTIVATE – CYLINDER 5: TO ACTIVATE, ECM SWITCHES CIRCUIT TO GROUND
O	EN16-113	FUEL INJECTOR DRIVE – CYLINDER 5: TO ACTIVATE, ECM SWITCHES CIRCUIT TO GROUND
O	EN16-114	FUEL INJECTOR DRIVE – CYLINDER 3: TO ACTIVATE, ECM SWITCHES CIRCUIT TO GROUND
O	EN16-115	FUEL INJECTOR DRIVE – CYLINDER 1: TO ACTIVATE, ECM SWITCHES CIRCUIT TO GROUND
O	EN16-118	FUEL INJECTOR DRIVE – CYLINDER 6: TO ACTIVATE, ECM SWITCHES CIRCUIT TO GROUND
O	EN16-119	FUEL INJECTOR DRIVE – CYLINDER 4: TO ACTIVATE, ECM SWITCHES CIRCUIT TO GROUND
O	EN16-120	FUEL INJECTOR DRIVE – CYLINDER 2: TO ACTIVATE, ECM SWITCHES CIRCUIT TO GROUND
I	EN16-121	AIR CONDITIONING PRESSURE SENSOR SIGNAL, NOMINAL 0 – 5 V; TRANSDUCER – VOLTAGE INCREASES AS PRESSURE INCREASES
I	EN16-131	IGNITION MONITOR BANK 1 (1, 3, 5): PULSED SIGNAL, 3 PULSES PER ENGINE CYCLE
I	EN16-132	IGNITION MONITOR BANK 2 (2, 4, 6): PULSED SIGNAL, 3 PULSES PER ENGINE CYCLE

**Fig. 03.2**

**COMPONENTS**

Component	Connector(s)	Connector Description	Location
AIR CONDITIONING COMPRESSOR CLUTCH	EN30	2-WAY / BLACK	2.0 L, 2.5 L, 3.0 L: ADJACENT TO ENGINE OIL FILTER
AIR CONDITIONING COMPRESSOR CLUTCH RELAY	–	–	POWER DISTRIBUTION FUSEBOX – R3
AIR CONDITIONING PRESSURE SENSOR	JB106	4-WAY / BLACK	BEHIND FRONT LH WHEEL ARCH LINER
BRAKE CANCEL SWITCH	PA2	2-WAY / BLACK	TOP OF BRAKE PEDAL
CLUTCH CANCEL SWITCH	PA4	5-WAY / BLACK	TOP OF CLUTCH PEDAL
COOLING FAN – LH	GC2	2-WAY / BLACK	COOLING PACK / LH SIDE
COOLING FAN – RH	GC1	2-WAY / BLACK	COOLING PACK / RH SIDE
COOLING FAN MODULE	JB190	4-WAY / BLACK	ADJACENT TO RADIATOR / LH SIDE
ENGINE CONTROL MODULE – 2.5 L, 3.0 L	EN16	134-WAY / BLACK	ENGINE COMPARTMENT, FRONT BULKHEAD / RH SIDE
FUEL INJECTOR 1 – 2.5 L, 3.0 L	IL1	2-WAY / BLACK	ENGINE FUEL RAIL
FUEL INJECTOR 2 – 2.5 L, 3.0 L	IL4	2-WAY / BLACK	ENGINE FUEL RAIL
FUEL INJECTOR 3 – 2.5 L, 3.0 L	IL2	2-WAY / BLACK	ENGINE FUEL RAIL
FUEL INJECTOR 4 – 2.5 L, 3.0 L	IL5	2-WAY / BLACK	ENGINE FUEL RAIL
FUEL INJECTOR 5 – 2.5 L, 3.0 L	IL3	2-WAY / BLACK	ENGINE FUEL RAIL
FUEL INJECTOR 6 – 2.5 L, 3.0 L	IL6	2-WAY / BLACK	ENGINE FUEL RAIL
FUEL PUMP – 2.5 L, 3.0 L (NAS)	FT6	6-WAY / BLACK	FUEL TANK
FUEL PUMP – 2.5 L, 3.0 L (ROW)	FT2	4-WAY / BLACK	FUEL TANK
FUEL PUMP MODULE	CA105	11-WAY / BLACK	UNDER REAR SEAT / LH SIDE
IGNITION CAPACITOR	EN94	2-WAY / BLACK	BELOW AIR INTAKE
IGNITION MODULE AND COIL 1	EN51	4-WAY / BLACK	BANK 1 CYLINDER HEAD
IGNITION MODULE AND COIL 2	EN54	4-WAY / BLACK	BANK 2 CYLINDER HEAD
IGNITION MODULE AND COIL 3	EN52	4-WAY / BLACK	BANK 1 CYLINDER HEAD
IGNITION MODULE AND COIL 4	EN55	4-WAY / BLACK	BANK 2 CYLINDER HEAD
IGNITION MODULE AND COIL 5	EN53	4-WAY / BLACK	BANK 1 CYLINDER HEAD
IGNITION MODULE AND COIL 6	EN56	4-WAY / BLACK	BANK 2 CYLINDER HEAD
POWER DISTRIBUTION FUSEBOX	–	–	ENGINE COMPARTMENT
SPEED CONTROL SWITCHES	SW4	4-WAY / BLACK	STEERING WHEEL

**HARNESS IN-LINE CONNECTORS**

Connector	Connector Description / Location	Location
CA5	12-WAY / BLACK / FUEL TANK LINK HARNESS TO CABIN HARNESS	TOP OF FUEL TANK
CA10	22-WAY / SLATE / CABIN HARNESS TO JUNCTION BOX HARNESS	LH 'A' POST / 'A' POST TRIM
CA170	16-WAY / GREEN / JUNCTION BOX HARNESS TO CABIN HARNESS	LH 'A' POST / 'A' POST TRIM
EN4	12-WAY / BLACK / ENGINE MANAGEMENT HARNESS TO FUEL INJECTION HARNESS	ENGINE COMPARTMENT / ENGINE TOP
IP34	10-WAY / NATURAL / INSTRUMENT PANEL HARNESS TO STEERING WHEEL HARNESS	STEERING WHEEL CASSETTE
JB1	42-WAY / BLACK / ENGINE MANAGEMENT HARNESS TO JUNCTION BOX HARNESS	ENGINE COMPARTMENT / LH SIDE
JB2	16-WAY / GREEN / ENGINE MANAGEMENT HARNESS TO JUNCTION BOX HARNESS (PEDAL ASSEMBLY)	BELOW INSTRUMENT PANEL / DRIVER SIDE
JB129	22-WAY / GREY / JUNCTION BOX HARNESS TO INSTRUMENT PANEL HARNESS	BELOW INSTRUMENT PANEL / LH SIDE
JB145	8-WAY / BLACK / ENGINE MANAGEMENT HARNESS TO JUNCTION BOX HARNESS	ENGINE COMPARTMENT / LH SIDE

**GROUNDS**

Ground	Harness	Location
G11	JB	ENGINE COMPARTMENT / BEHIND LH HEADLAMP
G17	EN	ENGINE COMPARTMENT / TOP OF GENERATOR BRACKET
G35	CA	LOWER LH 'E' POST

**FOR CONTROL MODULE PIN-OUT INFORMATION, UNFOLD PAGE TO LEFT.**

The following abbreviations are used to represent values for Control Module Pin-Out data

I	Input	PG	Power Ground	C	CAN Network	D	Serial and Encoded Data
O	Output	SS	Sensor / Signal Supply V	S	SCP Network	V	Voltage (DC)
B+	Battery Voltage	SG	Sensor / Signal Ground	D2	D2B Network	PWM	Pulse Width Modulated

**CAUTION:** The information on this data page is furnished to aid the user in understanding circuit operation. THIS INFORMATION SHOULD BE USED FOR REFERENCE ONLY.

**NOTE:** The values listed are approximately those that can be expected at the control module connector pins with all circuit connections made and all components connected and fitted.

Refer to the front of this book for detailed information and illustrations regarding the location and identification of harnesses, relays, fuses, grounds, control modules and control module pins.



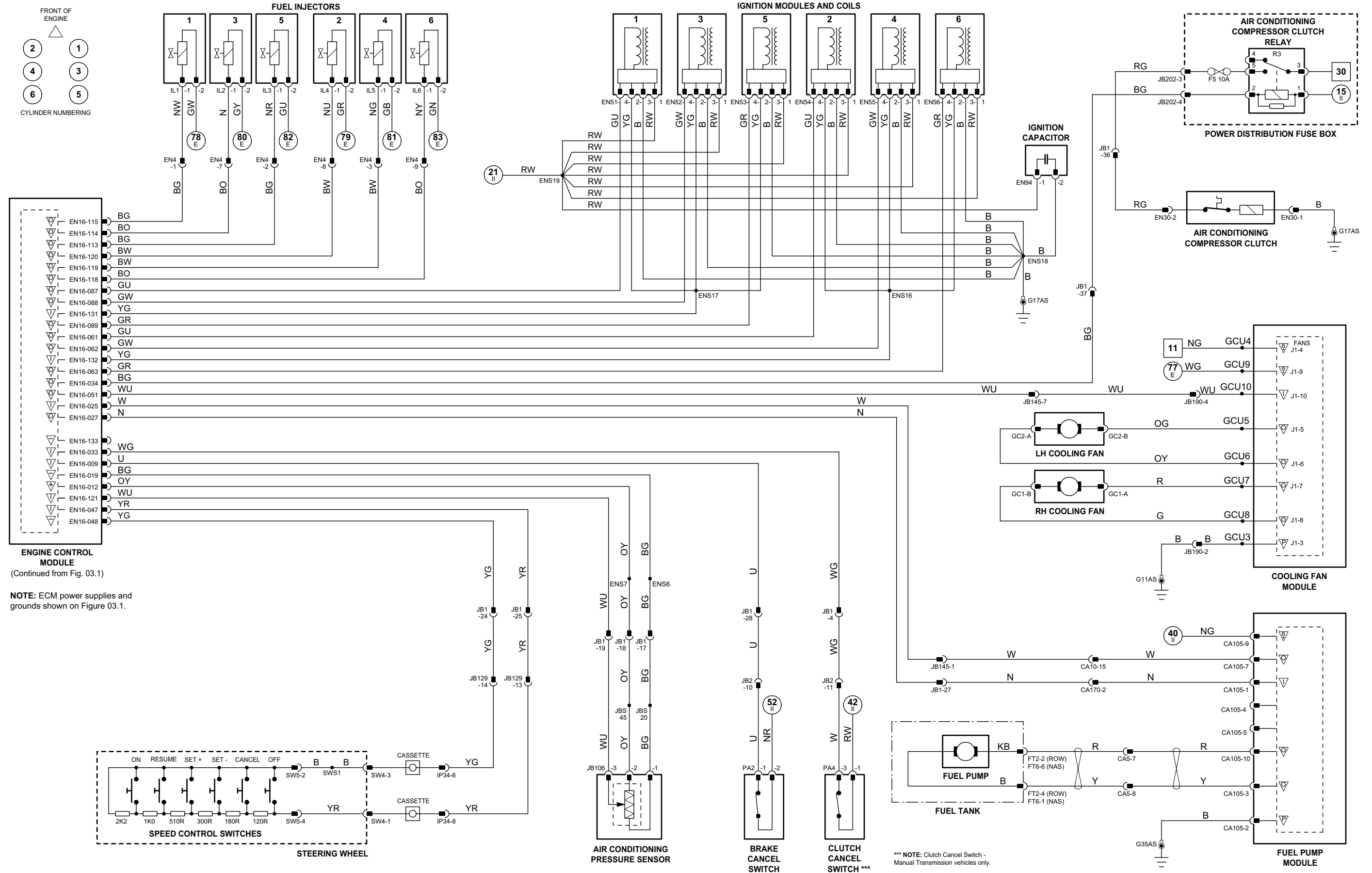

1 → 6 Fig. 01.1	34 → 80 Fig. 01.3	11 → 31 Fig. 01.5	67 → 76 Fig. 01.7	98 → 107 Fig. 01.9	Input	Battery Voltage	Sensor/Signal Supply V	CAN	D2B Network
7 → 33 Fig. 01.2	1 → 10 Fig. 01.4	32 → 66 Fig. 01.6	77 → 97 Fig. 01.8		Output	Power Ground	Sensor/Signal Ground	SCP	Serial and Encoded Data

**VARIANT:** 2.5 L & 3.0 L Vehicles  
**VIN RANGE:** All  
**DATE OF ISSUE:** February 2008

**Engine Control Module – 2.0 L**

Pin	Description and Characteristic
I	EN65-001 MAP SENSOR SIGNAL, NOMINAL 0 – 5 V; VOLTAGE INCREASES AS MANIFOLD ABSOLUTE PRESSURE INCREASES
SG	EN65-003 SENSOR GROUND: GROUND
SG	EN65-004 SMALL SIGNAL GROUND 1: GROUND
SG	EN65-005 SMALL SIGNAL GROUND 2: GROUND
I	EN65-006 ENGINE CRANK: B+
O	EN65-008 GENERATOR FIELD RETURN SIGNAL: VARIABLE VOLTAGE BY GENERATOR OPERATING CONDITION
SS	EN65-011 SENSOR POWER SUPPLY: NOMINAL 5 V
PG	EN65-018 POWER GROUND 2: GROUND
PG	EN65-019 POWER GROUND 1: GROUND
B+	EN65-021 BATTERY POWER SUPPLY: B+
B+	EN65-022 EMS SWITCHED POWER SUPPLY 1: B+
B+	EN65-023 EMS SWITCHED POWER SUPPLY 2: B+
I	EN65-025 HO2 SENSOR 2/1 SIGNAL: CONSTANT CURRENT
I	EN65-026 HO2 SENSOR 2/1 SIGNAL: VARIABLE CURRENT
I	EN65-027 THROTTLE POSITION SENSOR SIGNAL: CLOSED THROTTLE = 0.89 V; FULL THROTTLE = 4.50 V
SG	EN65-029 MASS AIR FLOW SENSOR GROUND: GROUND
I	EN65-030 MASS AIR FLOW SENSOR SIGNAL: NOMINAL 0 – 5 V BY ENGINE OPERATING CONDITION
SG	EN65-031 MASS AIR FLOW SENSOR GROUND: GROUND
I	EN65-034 BRAKE ON / OFF SWITCH: NORMALLY OPEN / B+ WHEN ACTIVATED
I	EN65-035 GENERATOR CHARGE / FAULT: B+ = NORMAL, AFTER-START SWITCH-ON; GROUND = GENERATOR FAILURE, AFTER-START SWITCH-ON
I	EN65-036 INERTIA SWITCH: NORMALLY CLOSED / GROUND WHEN ACTIVATED
I	EN65-037 KNOCK SENSOR SIGNAL: PULSED SIGNAL
SG	EN65-038 SENSOR SHIELD: GROUND
D	EN65-039 SERIAL DATA LINK: SERIAL COMMUNICATION
I	EN65-043 GENERATOR CONTROL: VARIABLE VOLTAGE
O	EN65-046 HO2 SENSOR HEATER CONTROL – 2/2: PWM, 1 CYCLE PER 256 mS, POSITIVE DUTY CYCLE RANGE 0 mS = 0%, 77 mS = 30%, 256 mS = 100%
O	EN65-047 HO2 SENSOR HEATER CONTROL – 1/2: PWM, 1 CYCLE PER 256 mS, POSITIVE DUTY CYCLE RANGE 0 mS = 0%, 77 mS = 30%, 256 mS = 100%
SG	EN65-048 HO2 SENSOR HEATER GROUND – 1/2 AND 2/2: GROUND
I	EN65-050 HO2 SENSOR 1/1 SIGNAL: CONSTANT CURRENT
I	EN65-051 HO2 SENSOR 1/1 SIGNAL: VARIABLE CURRENT
SG	EN65-052 HO2 SENSOR HEATER GROUND – 2/1: GROUND
I	EN65-053 HO2 SENSOR 1/2 SIGNAL, NOMINAL 1 V SWING: 0.1 – 0.9 V SWING
I	EN65-054 HO2 SENSOR 2/2 SIGNAL, NOMINAL 1 V SWING: 0.1 – 0.9 V SWING
SG	EN65-055 HO2 SENSORS GROUND: GROUND
I	EN65-059 BANK 1 CAMSHAFT SENSOR SIGNAL: PULSED SIGNAL, 4 PULSES PER ENGINE CYCLE
SG	EN65-060 BANK 1 CAMSHAFT SENSOR GROUND: GROUND
I	EN65-061 CRANKSHAFT SENSOR SIGNAL: PULSED SIGNAL, 70 PULSES PER ENGINE CYCLE
SG	EN65-062 CRANKSHAFT SENSOR SIGNAL GROUND: GROUND
I	EN65-063 IGNITION ON: B+
SG	EN65-064 BANK 2 FUEL INJECTORS (2, 4, 6) GROUND: GROUND
O	EN65-068 STARTER RELAY DRIVE: TO ACTIVATE, ECM SWITCHES CIRCUIT TO GROUND
O	EN65-069 EMS CONTROL RELAY DRIVE: TO ACTIVATE, ECM SWITCHES CIRCUIT TO GROUND
O	EN65-071 INTAKE MANIFOLD TUNING VALVE SOLENOID DRIVE: GROUND WHEN ACTIVATED
O	EN65-074 EVAP CANISTER PURGE VALVE DRIVE: PWM, 10 Hz, POSITIVE DUTY CYCLE RANGE 0.04% – 100%
SG	EN65-075 HO2 SENSOR HEATER GROUND – 1/1: GROUND
O	EN65-076 HO2 SENSOR HEATER CONTROL – 2/1: PWM, 1 CYCLE PER 128 mS, VARIABLE DUTY CYCLE
O	EN65-077 HO2 SENSOR HEATER CONTROL – 1/1: PWM, 1 CYCLE PER 128 mS, VARIABLE DUTY CYCLE
SG	EN65-078 HO2 SENSOR HEATER GROUND – 2/1: GROUND
I	EN65-079 ENGINE OIL TEMPERATURE SENSOR SIGNAL, NOMINAL 0 – 5 V: NTC SENSOR – VOLTAGE DECREASES AS TEMPERATURE INCREASES
I	EN65-080 ENGINE COOLANT TEMPERATURE SENSOR SIGNAL, NOMINAL 0 – 5 V: NTC SENSOR – VOLTAGE DECREASES AS TEMPERATURE INCREASES
I	EN65-081 INTAKE AIR TEMPERATURE SENSOR SIGNAL, NOMINAL 0 – 5 V: NTC SENSOR – VOLTAGE DECREASES AS TEMPERATURE INCREASES
I	EN65-085 PARK / NEUTRAL SWITCH (AUTOMATIC TRANSMISSION): NORMALLY CLOSED / GROUND WHEN ACTIVATED
I	EN65-086 BANK 2 CAMSHAFT SENSOR SIGNAL: PULSED SIGNAL, 4 PULSES PER ENGINE CYCLE
SG	EN65-087 BANK 2 CAMSHAFT SENSOR GROUND: GROUND
C	EN65-088 CAN –
C	EN65-089 CAN +
SG	EN65-091 BANK 1 FUEL INJECTORS (1, 3, 5) GROUND: GROUND
O	EN65-095 BANK 2 VVT SOLENOID VALVE: PWM, 300 Hz, POSITIVE DUTY CYCLE RANGE 0% – 100%
O	EN65-096 BANK 1 VVT SOLENOID VALVE: PWM, 300 Hz, POSITIVE DUTY CYCLE RANGE 0% – 100%
O	EN65-097 IDLE SPEED CONTROL VALVE MOTOR DRIVE (-): PWM
O	EN65-098 IDLE SPEED CONTROL VALVE MOTOR DRIVE (+): PWM
SG	EN65-102 HO2 SENSOR HEATER GROUND – 1/1: GROUND
O	EN65-103 HO2 SENSOR HEATER CONTROL – 2/1: PWM, 1 CYCLE PER 128 mS, VARIABLE DUTY CYCLE
O	EN65-104 HO2 SENSOR HEATER CONTROL – 1/1: PWM, 1 CYCLE PER 128 mS, VARIABLE DUTY CYCLE

The following abbreviations are used to represent values for Control Module Pin-Out data

<b>I</b>	<b>Input</b>	<b>PG</b>	<b>Power Ground</b>	<b>C</b>	<b>CAN Network</b>	<b>D</b>	<b>Serial and Encoded Data</b>
<b>O</b>	<b>Output</b>	<b>SS</b>	<b>Sensor / Signal Supply V</b>	<b>S</b>	<b>SCP Network</b>	<b>V</b>	<b>Voltage (DC)</b>
<b>B+</b>	<b>Battery Voltage</b>	<b>SG</b>	<b>Sensor / Signal Ground</b>	<b>D2</b>	<b>D2B Network</b>	<b>PWM</b>	<b>Pulse Width Modulated</b>

**CAUTION:** The information on this data page is furnished to aid the user in understanding circuit operation. THIS INFORMATION SHOULD BE USED FOR REFERENCE ONLY.

**NOTE:** The values listed are approximately those that can be expected at the control module connector pins with all circuit connections made and all components connected and fitted.

**Fig. 03.3**

**COMPONENTS**

Component	Connector(s)	Connector Description	Location
BRAKE ON / OFF SWITCH	PA3	3-WAY / BLACK	TOP OF BRAKE PEDAL
CKP SENSOR – 2.0 L	EN12	2-WAY / BLACK	ADJACENT TO ENGINE CRANKSHAFT PULLEY
CMP SENSOR 1 – 2.0 L	EN43	2-WAY / BLACK	BANK 1 CYLINDER HEAD, FRONT
CMP SENSOR 2 – 2.0 L	EN33	2-WAY / BLACK	BANK 2 CYLINDER HEAD, FRONT
ECT SENSOR	EN18	2-WAY / BLACK	ENGINE VEE, FRONT
ENGINE CONTROL MODULE – 2.0 L	EN65	104-WAY / BLACK	ENGINE COMPARTMENT, FRONT BULKHEAD / RH SIDE
EOT SENSOR	EN25	2-WAY / GREY	ADJACENT TO ENGINE OIL FILTER
EVAP CANISTER PURGE VALVE	JB170	2-WAY / BLACK	ENGINE COMPARTMENT BULKHEAD
HO2 SENSOR DOWNSTREAM 1/2	EN14	4-WAY / BLACK	BANK 1 EXHAUST
HO2 SENSOR DOWNSTREAM 2/2	EN9	4-WAY / BLACK	BANK 2 EXHAUST
HO2 SENSOR UPSTREAM 1/1	EN37	4-WAY / GREY	BANK 1 EXHAUST
HO2 SENSOR UPSTREAM 2/1	EN32	4-WAY / GREY	BANK 2 EXHAUST
IDLE SPEED CONTROL VALVE	EN87	2-WAY / BLACK	THROTTLE ASSEMBLY
IMT SOLENOID VALVE	EN990	2-WAY / BLACK	INTAKE MANIFOLD TOP
KNOCK SENSOR – 2.0 L	EN23	2-WAY / BLACK	ENGINE VEE
MAF SENSOR – 2.0 L	EN6	5-WAY / BLACK	ENGINE AIR INTAKE DUCT
MAP SENSOR	EN8	4-WAY / BLACK	INTAKE MANIFOLD, REAR
TP SENSOR – 2.0 L	EN88	3-WAY / BLACK	THROTTLE BODY
VVT SOLENOID VALVE 1	EN61	2-WAY / BLACK	BANK 1 CYLINDER HEAD
VVT SOLENOID VALVE 2	EN42	2-WAY / BLACK	BANK 2 CYLINDER HEAD

**HARNESS IN-LINE CONNECTORS**

Connector	Connector Description / Location	Location
CA170	16-WAY / GREEN / JUNCTION BOX HARNESS TO CABIN HARNESS	LH 'A' POST / 'A' POST TRIM
JB1	42-WAY / BLACK / ENGINE MANAGEMENT HARNESS TO JUNCTION BOX HARNESS	ENGINE COMPARTMENT / LH SIDE
JB196	10-WAY / GREY / ENGINE MANAGEMENT HARNESS TO JUNCTION BOX HARNESS (PEDAL ASSEMBLY)	BELOW INSTRUMENT PANEL / DRIVER SIDE

**GROUND**

Ground	Harness	Location
G8	EN	ENGINE COMPARTMENT / RH STRUT TOWER

**FOR CONTROL MODULE PIN-OUT INFORMATION, UNFOLD PAGE TO LEFT.**

Refer to the front of this book for detailed information and illustrations regarding the location and identification of harnesses, relays, fuses, grounds, control modules and control module pins.

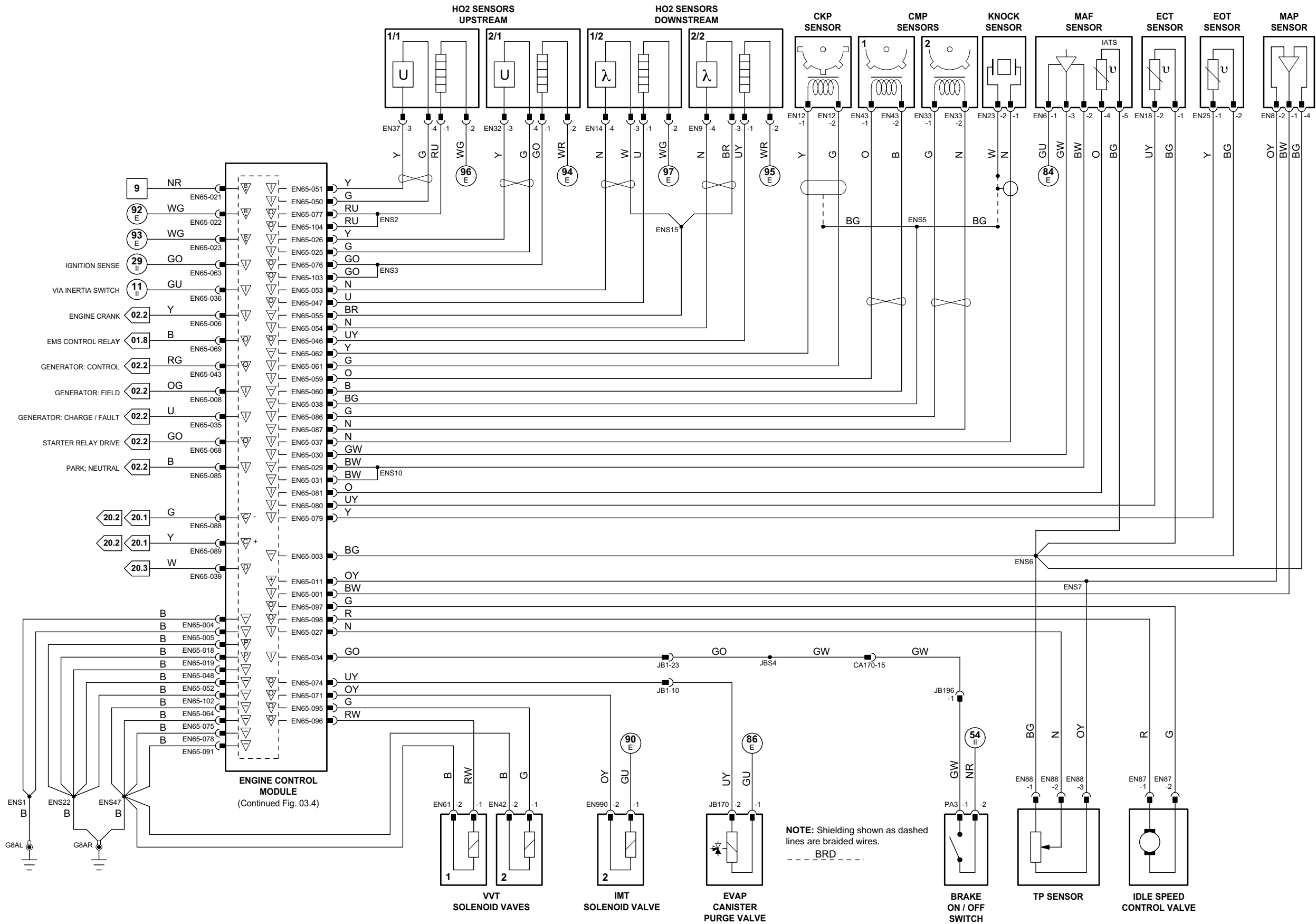

NOTE: Shielding shown as dashed lines are braided wires.  
 --- BRD ---

**Engine Control Module – 2.0 L**

	Pin	Description and Characteristic
I	EN65-002	AIR CONDITIONING PRESSURE SENSOR SIGNAL, NOMINAL 0 – 5 V; TRANSDUCER – VOLTAGE INCREASES AS PRESSURE INCREASES
SG	EN65-003	SENSOR GROUND: GROUND
I	EN65-007	BRAKE CANCEL SWITCH: NORMALLY CLOSED / GROUND WHEN ACTIVATED
SS	EN65-011	SENSOR POWER SUPPLY: NOMINAL 5 V
I	EN65-012	IGNITION MONITOR BANK 1 (1, 3, 5); PULSED SIGNAL, 3 PULSES PER ENGINE CYCLE
I	EN65-013	IGNITION MONITOR BANK 2 (2, 4, 6); PULSED SIGNAL, 3 PULSES PER ENGINE CYCLE
O	EN65-014	IGNITION COIL ACTIVATE – CYLINDER 1: TO ACTIVATE, ECM SWITCHES CIRCUIT TO GROUND
O	EN65-015	IGNITION COIL ACTIVATE – CYLINDER 3: TO ACTIVATE, ECM SWITCHES CIRCUIT TO GROUND
O	EN65-016	IGNITION COIL ACTIVATE – CYLINDER 5: TO ACTIVATE, ECM SWITCHES CIRCUIT TO GROUND
I	EN65-017	INTELLIGENT SPEED SIGNAL (VEHICLE SPEED) : PWM, DUTY CYCLE RANGE 30% – 70%
O	EN65-020	AIR CONDITIONING COMPRESSOR CLUTCH RELAY DRIVE: TO ACTIVATE, ECM SWITCHES CIRCUIT TO GROUND
I	EN65-034	BRAKE ON / OFF SWITCH: NORMALLY OPEN / B+ WHEN ACTIVATED
O	EN65-040	IGNITION COIL ACTIVATE – CYLINDER 2: TO ACTIVATE, ECM SWITCHES CIRCUIT TO GROUND
O	EN65-041	IGNITION COIL ACTIVATE – CYLINDER 4: TO ACTIVATE, ECM SWITCHES CIRCUIT TO GROUND
O	EN65-042	IGNITION COIL ACTIVATE – CYLINDER 6: TO ACTIVATE, ECM SWITCHES CIRCUIT TO GROUND
O	EN65-044	COOLING FAN MODULE CONTROL: PWM, 140 Hz, POSITIVE DUTY CYCLE RANGE 7% – 95%
I	EN65-056	SPEED CONTROL STATUS 1 ON / Off: GROUND = ON; 5 V = OFF
I	EN65-057	SPEED CONTROL STATUS 2 ACTIVE / INACTIVE: GROUND = ACTIVE; 5 V = INACTIVE
O	EN65-065	FUEL INJECTOR DRIVE – CYLINDER 1: TO ACTIVATE, ECM SWITCHES CIRCUIT TO GROUND
O	EN65-066	FUEL INJECTOR DRIVE – CYLINDER 3: TO ACTIVATE, ECM SWITCHES CIRCUIT TO GROUND
O	EN65-067	FUEL INJECTOR DRIVE – CYLINDER 5: TO ACTIVATE, ECM SWITCHES CIRCUIT TO GROUND
I	EN65-084	CLUTCH CANCEL SWITCH: NORMALLY CLOSED / GROUND WHEN ACTIVATED
O	EN65-092	FUEL INJECTOR DRIVE – CYLINDER 2: TO ACTIVATE, ECM SWITCHES CIRCUIT TO GROUND
O	EN65-093	FUEL INJECTOR DRIVE – CYLINDER 4: TO ACTIVATE, ECM SWITCHES CIRCUIT TO GROUND
O	EN65-094	FUEL INJECTOR DRIVE – CYLINDER 6: TO ACTIVATE, ECM SWITCHES CIRCUIT TO GROUND
O	EN65-099	FUEL PUMP RELAY DRIVE: TO ACTIVATE, ECM SWITCHES CIRCUIT TO GROUND

**Fig. 03.4**

**COMPONENTS**

Component	Connector(s)	Connector Description	Location
AIR CONDITIONING COMPRESSOR CLUTCH	EN30	2-WAY / BLACK	2.0 L, 2.5 L, 3.0 L: ADJACENT TO ENGINE OIL FILTER
AIR CONDITIONING COMPRESSOR CLUTCH RELAY	–	–	POWER DISTRIBUTION FUSEBOX – R3
AIR CONDITIONING PRESSURE SENSOR	JB106	4-WAY / BLACK	BEHIND FRONT LH WHEEL ARCH LINER
BRAKE CANCEL SWITCH	PA2	2-WAY / BLACK	TOP OF BRAKE PEDAL
BRAKE ON / OFF SWITCH	PA3	3-WAY / BLACK	TOP OF BRAKE PEDAL
CLUTCH CANCEL SWITCH	PA4	5-WAY / BLACK	TOP OF CLUTCH PEDAL
COOLING FAN – LH	GC2	2-WAY / BLACK	COOLING PACK / LH SIDE
COOLING FAN – RH	GC1	2-WAY / BLACK	COOLING PACK / RH SIDE
COOLING FAN MODULE	JB190	4-WAY / BLACK	ADJACENT TO RADIATOR / LH SIDE
ENGINE CONTROL MODULE – 2.0 L	EN65	104-WAY / BLACK	ENGINE COMPARTMENT, FRONT BULKHEAD / RH SIDE
FUEL INJECTOR 1 – 2.0 L	IL1	2-WAY / BLACK	ENGINE FUEL RAIL
FUEL INJECTOR 2 – 2.0 L	IL4	2-WAY / BLACK	ENGINE FUEL RAIL
FUEL INJECTOR 3 – 2.0 L	IL2	2-WAY / BLACK	ENGINE FUEL RAIL
FUEL INJECTOR 4 – 2.0 L	IL5	2-WAY / BLACK	ENGINE FUEL RAIL
FUEL INJECTOR 5 – 2.0 L	IL3	2-WAY / BLACK	ENGINE FUEL RAIL
FUEL INJECTOR 6 – 2.0 L	IL6	2-WAY / BLACK	ENGINE FUEL RAIL
FUEL PUMP – 2.0 L	CA415	6-WAY / BLACK	FUEL TANK
FUEL PUMP RELAY	–	–	PASSENGER JUNCTION FUSEBOX – R7
IGNITION CAPACITOR	EN94	2-WAY / BLACK	BELOW AIR INTAKE
IGNITION MODULE AND COIL 1	EN51	4-WAY / BLACK	BANK 1 CYLINDER HEAD
IGNITION MODULE AND COIL 2	EN54	4-WAY / BLACK	BANK 2 CYLINDER HEAD
IGNITION MODULE AND COIL 3	EN52	4-WAY / BLACK	BANK 1 CYLINDER HEAD
IGNITION MODULE AND COIL 4	EN55	4-WAY / BLACK	BANK 2 CYLINDER HEAD
IGNITION MODULE AND COIL 5	EN53	4-WAY / BLACK	BANK 1 CYLINDER HEAD
IGNITION MODULE AND COIL 6	EN56	4-WAY / BLACK	BANK 2 CYLINDER HEAD
PASSENGER JUNCTION FUSEBOX	–	–	PASSENGER COMPARTMENT, FRONT BULKHEAD / LH SIDE
POWER DISTRIBUTION FUSEBOX	–	–	ENGINE COMPARTMENT
SPEED CONTROL MODULE	JB161	10-WAY / BLACK	ENGINE COMPARTMENT BULKHEAD / LH SIDE
SPEED CONTROL SWITCHES	SW4	4-WAY / BLACK	STEERING WHEEL

**HARNESS IN-LINE CONNECTORS**

Connector	Connector Description / Location	Location
CA170	16-WAY / GREEN / JUNCTION BOX HARNESS TO CABIN HARNESS	LH 'A' POST / 'A' POST TRIM
EN4	12-WAY / BLACK / ENGINE MANAGEMENT HARNESS TO FUEL INJECTION HARNESS	ENGINE COMPARTMENT / ENGINE TOP
IP34	10-WAY / NATURAL / INSTRUMENT PANEL HARNESS TO STEERING WHEEL HARNESS	STEERING WHEEL CASSETTE
JB1	42-WAY / BLACK / ENGINE MANAGEMENT HARNESS TO JUNCTION BOX HARNESS	ENGINE COMPARTMENT / LH SIDE
JB129	22-WAY / GREY / JUNCTION BOX HARNESS TO INSTRUMENT PANEL HARNESS	BELOW INSTRUMENT PANEL / LH SIDE
JB196	10-WAY / GREY / ENGINE MANAGEMENT HARNESS TO JUNCTION BOX HARNESS (PEDAL ASSEMBLY)	BELOW INSTRUMENT PANEL / DRIVER SIDE

**GROUNDS**

Ground	Harness	Location
G11	JB	ENGINE COMPARTMENT / BEHIND LH HEADLAMP
G14	JB	ENGINE COMPARTMENT / BEHIND POWER DISTRIBUTION FUSEBOX
G17	EN	ENGINE COMPARTMENT / TOP OF GENERATOR BRACKET
G35	CA	LOWER LH 'E' POST

**FOR CONTROL MODULE PIN-OUT INFORMATION, UNFOLD PAGE TO LEFT.**

The following abbreviations are used to represent values for Control Module Pin-Out data

<b>I</b>	<b>Input</b>	<b>PG</b>	<b>Power Ground</b>	<b>C</b>	<b>CAN Network</b>	<b>D</b>	<b>Serial and Encoded Data</b>
<b>O</b>	<b>Output</b>	<b>SS</b>	<b>Sensor / Signal Supply V</b>	<b>S</b>	<b>SCP Network</b>	<b>V</b>	<b>Voltage (DC)</b>
<b>B+</b>	<b>Battery Voltage</b>	<b>SG</b>	<b>Sensor / Signal Ground</b>	<b>D2</b>	<b>D2B Network</b>	<b>PWM</b>	<b>Pulse Width Modulated</b>

**CAUTION:** The information on this data page is furnished to aid the user in understanding circuit operation. THIS INFORMATION SHOULD BE USED FOR REFERENCE ONLY.

**NOTE:** The values listed are approximately those that can be expected at the control module connector pins with all circuit connections made and all components connected and fitted.

Refer to the front of this book for detailed information and illustrations regarding the location and identification of harnesses, relays, fuses, grounds, control modules and control module pins.

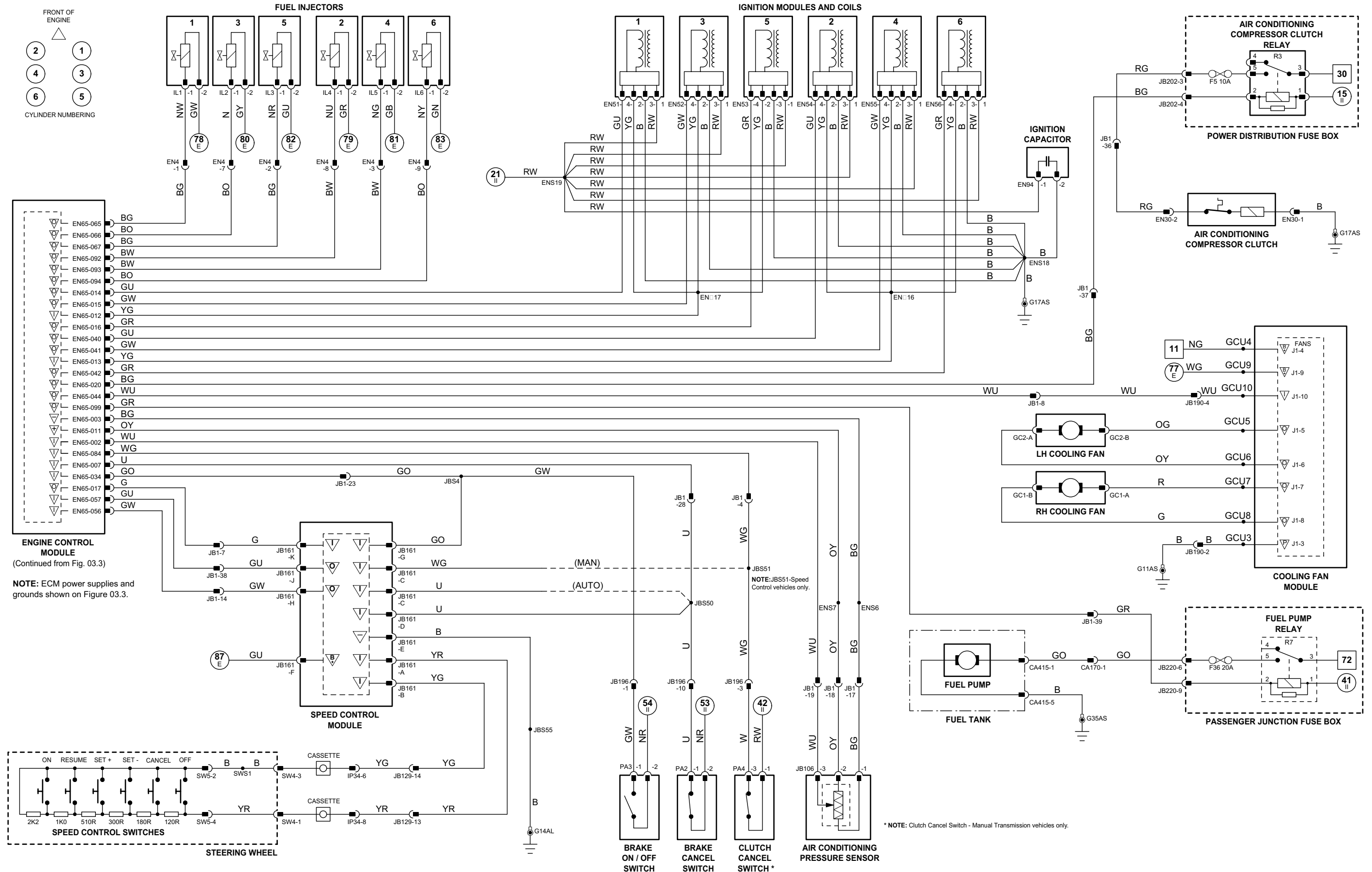

1 → 6 Fig. 01.1	34 → 80 Fig. 01.3	11 → 31 Fig. 01.5	67 → 76 Fig. 01.7	98 → 107 Fig. 01.9	Input	Battery Voltage	Sensor/Signal Supply V	CAN	D2B Network
7 → 33 Fig. 01.2	1 → 10 Fig. 01.4	32 → 66 Fig. 01.6	77 → 97 Fig. 01.8		Output	Power Ground	Sensor/Signal Ground	SCP	Serial and Encoded Data

**VARIANT:** 2.0 L Gasoline Engine Vehicles  
**VIN RANGE:** All  
**DATE OF ISSUE:** February 2008

**Engine Control Module – Diesel**

	Pin	Description and Characteristic
PG	DL1-001	POWER GROUND: GROUND
PG	DL1-002	POWER GROUND: GROUND
B+	DL1-003	EMS SWITCHED POWER SUPPLY: B+
B+	DL1-004	EMS SWITCHED POWER SUPPLY: B+
B+	DL1-005	EMS SWITCHED POWER SUPPLY: B+
SS	DL1-006	INJECTION PRESSURE SENSOR POWER SUPPLY V: NOMINAL 5 V
O	DL1-009	EMS CONTROL RELAY ACTIVATE: TO ACTIVATE, ECM SWITCHES CIRCUIT TO GROUND
SG	DL1-014	ACCELERATOR PEDAL POSITION SENSOR 2 GROUND: GROUND
I	DL1-018	INERTIA SWITCH: NORMALLY CLOSED / OPEN CIRCUIT WHEN ACTIVATED
O	DL1-020	GLOW PLUG RELAY DRIVE: TO ACTIVATE, ECM SWITCHES CIRCUIT TO GROUND
O	DL1-021	STARTER RELAY DRIVE: TO ACTIVATE, ECM SWITCHES CIRCUIT TO GROUND
I	DL1-025	INJECTION PRESSURE SENSOR SIGNAL, NOMINAL 0 – 5 V: 0.5 V – 4.5 V DEPENDANT ON FUEL RAIL PRESSURE
SG	DL1-026	INJECTION PRESSURE SENSOR GROUND: GROUND
PG	DL1-028	POWER GROUND: GROUND
I	DL1-032	ACCELERATOR PEDAL POSITION SENSOR 2 SIGNAL: VARIABLE VOLTAGE DEPENDANT ON PEDAL POSITION
SS	DL1-033	ACCELERATOR PEDAL POSITION SENSOR 2 POWER SUPPLY: NOMINAL 5 V
I	DL1-037	IGNITION SENSE: B+
I	DL1-038	CLUTCH SWITCH SIGNAL: NORMALLY OPEN / GROUND WHEN ACTIVATED
I	DL1-045	KNOCK SENSOR SIGNAL: VARIABLE VOLTAGE DEPENDENT ON ENGINE VIBRATION
SG	DL1-046	KNOCK SENSOR GROUND: GROUND
I	DL1-047	GENERATOR MONITOR
I	DL1-050	ACCELERATOR PEDAL POSITION SENSOR 3 SIGNAL: VARIABLE VOLTAGE DEPENDANT ON PEDAL POSITION
SS	DL1-051	ACCELERATOR PEDAL POSITION SENSOR 3 POWER SUPPLY: NOMINAL 5 V
SG	DL1-053	ACCELERATOR PEDAL POSITION SENSOR 1 GROUND: GROUND
S	DL1-055	SCP +
I	DL1-058	BRAKE ON / OFF SWITCH SIGNAL: NORMALLY OPEN / B+ WHEN ACTIVATED
I	DL1-064	AMBIENT TEMPERATURE SENSOR SIGNAL, NOMINAL 0 – 5 V: NTC SENSOR – VOLTAGE DECREASES AS TEMPERATURE INCREASES
SG	DL1-065	AMBIENT AIR TEMPERATURE SENSOR GROUND: GROUND
PG	DL1-066	POWER GROUND: GROUND
SG	DL1-070	ACCELERATOR PEDAL POSITION SENSOR 3 GROUND: GROUND
I	DL1-071	ACCELERATOR PEDAL POSITION SENSOR 1 SIGNAL: VARIABLE VOLTAGE DEPENDANT ON PEDAL POSITION
SS	DL1-072	ACCELERATOR PEDAL POSITION SENSOR 1 POWER SUPPLY: NOMINAL 5 V
S	DL1-074	SCP –
SG	DL1-082	CRANKSHAFT SENSOR SIGNAL GROUND: GROUND
I	DL1-083	MASS AIR FLOW SENSOR SIGNAL: NOMINAL 0 – 5 V BY ENGINE OPERATING CONDITION
SG	DL1-084	MASS AIR FLOW SENSOR GROUND: GROUND
O	DL1-087	FUEL METERING VALVE DRIVE: PWM
PG	DL1-088	POWER GROUND: GROUND
I	DL1-090	CRANKSHAFT SENSOR SIGNAL: PULSED SIGNAL
O	DL1-096	EXHAUST GAS RECIRCULATION SOLENOID VALVE DRIVE: PWM
I	DL1-099	T-MAP SENSOR PRESSURE SIGNAL, NOMINAL 0 – 5 V: VOLTAGE INCREASES AS MANIFOLD ABSOLUTE PRESSURE INCREASES
SG	DL1-100	T-MAP SENSOR GROUND: GROUND
I	DL1-101	CYLINDER HEAD TEMPERATURE SENSOR SIGNAL, NOMINAL 5 V: NTC SENSOR – VOLTAGE DECREASES AS TEMPERATURE INCREASES
SG	DL1-102	CYLINDER HEAD TEMPERATURE SENSOR GROUND: GROUND
I	DL1-103	CAMSHAFT POSITION SENSOR SIGNAL: PULSED SIGNAL
SG	DL1-104	CAMSHAFT POSITION SENSOR GROUND: GROUND
I	DL1-107	T-MAP SENSOR TEMPERATURE SIGNAL, NOMINAL 0 – 5 V: NTC SENSOR – VOLTAGE DECREASES AS TEMPERATURE INCREASES
SS	DL1-108	T-MAP SENSOR POWER SUPPLY: NOMINAL 5 V
I	DL1-109	ENGINE FUEL TEMPERATURE SENSOR SIGNAL, NOMINAL 0 – 5 V: NTC SENSOR – VOLTAGE DECREASES AS TEMPERATURE INCREASES
SG	DL1-110	ENGINE FUEL TEMPERATURE SENSOR GROUND: GROUND
O	DL1-112	GENERATOR COMMON
O	DL1-114	FUEL INJECTOR DRIVE – CYLINDER 1: TO ACTIVATE, ECM SWITCHES CIRCUIT TO GROUND
O	DL1-115	FUEL INJECTOR DRIVE – CYLINDER 4: TO ACTIVATE, ECM SWITCHES CIRCUIT TO GROUND
B+	DL1-117	FUEL INJECTORS 1, 4 POWER SUPPLY: B+
B+	DL1-118	FUEL INJECTORS 2, 3 POWER SUPPLY: B+
O	DL1-120	FUEL INJECTOR DRIVE – CYLINDER 2: TO ACTIVATE, ECM SWITCHES CIRCUIT TO GROUND
O	DL1-121	FUEL INJECTOR DRIVE – CYLINDER 3: TO ACTIVATE, ECM SWITCHES CIRCUIT TO GROUND

The following abbreviations are used to represent values for Control Module Pin-Out data

<b>I</b>	<b>Input</b>	<b>PG</b>	<b>Power Ground</b>	<b>C</b>	<b>CAN Network</b>	<b>D</b>	<b>Serial and Encoded Data</b>
<b>O</b>	<b>Output</b>	<b>SS</b>	<b>Sensor / Signal Supply V</b>	<b>S</b>	<b>SCP Network</b>	<b>V</b>	<b>Voltage (DC)</b>
<b>B+</b>	<b>Battery Voltage</b>	<b>SG</b>	<b>Sensor / Signal Ground</b>	<b>D2</b>	<b>D2B Network</b>	<b>PWM</b>	<b>Pulse Width Modulated</b>

**CAUTION:** The information on this data page is furnished to aid the user in understanding circuit operation. THIS INFORMATION SHOULD BE USED FOR REFERENCE ONLY.

**NOTE:** The values listed are approximately those that can be expected at the control module connector pins with all circuit connections made and all components connected and fitted.

**Fig. 03.5**

**COMPONENTS**

Component	Connector(s)	Connector Description	Location
AMBIENT TEMPERATURE SENSOR – Diesel	DL4	2-WAY / BLACK	ENGINE COMPARTMENT FRONT OF COOLING PACK
APP SENSOR – Diesel	PA6	10-WAY / GREY	ABOVE ACCELERATOR PEDAL
BRAKE ON / OFF SWITCH	PA3	3-WAY / BLACK	TOP OF BRAKE PEDAL
CHT SENSOR	DE13	2-WAY / GREY	ENGINE CYLINDER HEAD
CKP SENSOR – Diesel	DE6	2-WAY / GREY	ENGINE FLYWHEEL / RH SIDE
CLUTCH SWITCH – Diesel	PA4	5-WAY / BLACK	TOP OF CLUTCH PEDAL
CMP SENSOR – Diesel	DE7	3-WAY / GREY	CYLINDER HEAD INLET CAMSHAFT
EFT SENSOR – Diesel	DE1	2-WAY / BLUE	REAR OF HIGH PRESSURE FUEL PUMP
ENGINE CONTROL MODULE – Diesel	DL1	121-WAY / BLACK	ENGINE COMPARTMENT, FRONT BULKHEAD / RH SIDE
FUEL INJECTOR 1 – Diesel	DE9	2-WAY / GREY	ENGINE CYLINDER HEAD
FUEL INJECTOR 2 – Diesel	DE11	2-WAY / GREY	ENGINE CYLINDER HEAD
FUEL INJECTOR 3 – Diesel	DE12	2-WAY / GREY	ENGINE CYLINDER HEAD
FUEL INJECTOR 4 – Diesel	DE10	2-WAY / GREY	ENGINE CYLINDER HEAD
FUEL METERING VALVE	DE5	2-WAY / BROWN	REAR OF HIGH PRESSURE FUEL PUMP
GLOW PLUG POWER EYELET	DL10	EYELET	ENGINE CYLINDER HEAD
GLOW PLUG RELAY	–	–	POWER DISTRIBUTION FUSEBOX – R10
IP SENSOR – Diesel	DE3	3-WAY / PURPLE	FRONT OF FUEL RAIL
KNOCK SENSOR – Diesel	DE8	2-WAY / BLACK	CYLINDER BLOCK / LH SIDE
MAF SENSOR – Diesel	DL6	6-WAY / BLACK	ENGINE AIR INTAKE DUCT
POWER DISTRIBUTION FUSEBOX	–	–	ENGINE COMPARTMENT
T-MAP SENSOR	DL5	4-WAY / BLACK	ENGINE CHARGE AIR DUCT BETWEEN CHARGE AIR COOLER AND EGR VALVE

**HARNESS IN-LINE CONNECTORS**

Connector	Connector Description / Location	Location
DL2	42-WAY / BLACK / ENGINE HARNESS TO ENGINE MANAGEMENT HARNESS	ENGINE COMPARTMENT / RH SIDE
JB1	42-WAY / BLACK / ENGINE MANAGEMENT HARNESS TO JUNCTION BOX HARNESS	ENGINE COMPARTMENT / LH SIDE
JB2	16-WAY / GREEN / ENGINE MANAGEMENT HARNESS TO JUNCTION BOX HARNESS (PEDAL ASSEMBLY)	BELOW INSTRUMENT PANEL / DRIVER SIDE
JB237	2-WAY / BLACK / JUNCTION BOX HARNESS TO ENGINE MANAGEMENT HARNESS	ENGINE COMPARTMENT / LH SIDE

**GROUND S**

Ground	Harness	Location
G8	EN	ENGINE COMPARTMENT / RH STRUT TOWER
G14	JB	ENGINE COMPARTMENT / BEHIND POWER DISTRIBUTION FUSEBOX

**FOR CONTROL MODULE PIN-OUT INFORMATION, UNFOLD PAGE TO LEFT.**

Refer to the front of this book for detailed information and illustrations regarding the location and identification of harnesses, relays, fuses, grounds, control modules and control module pins.

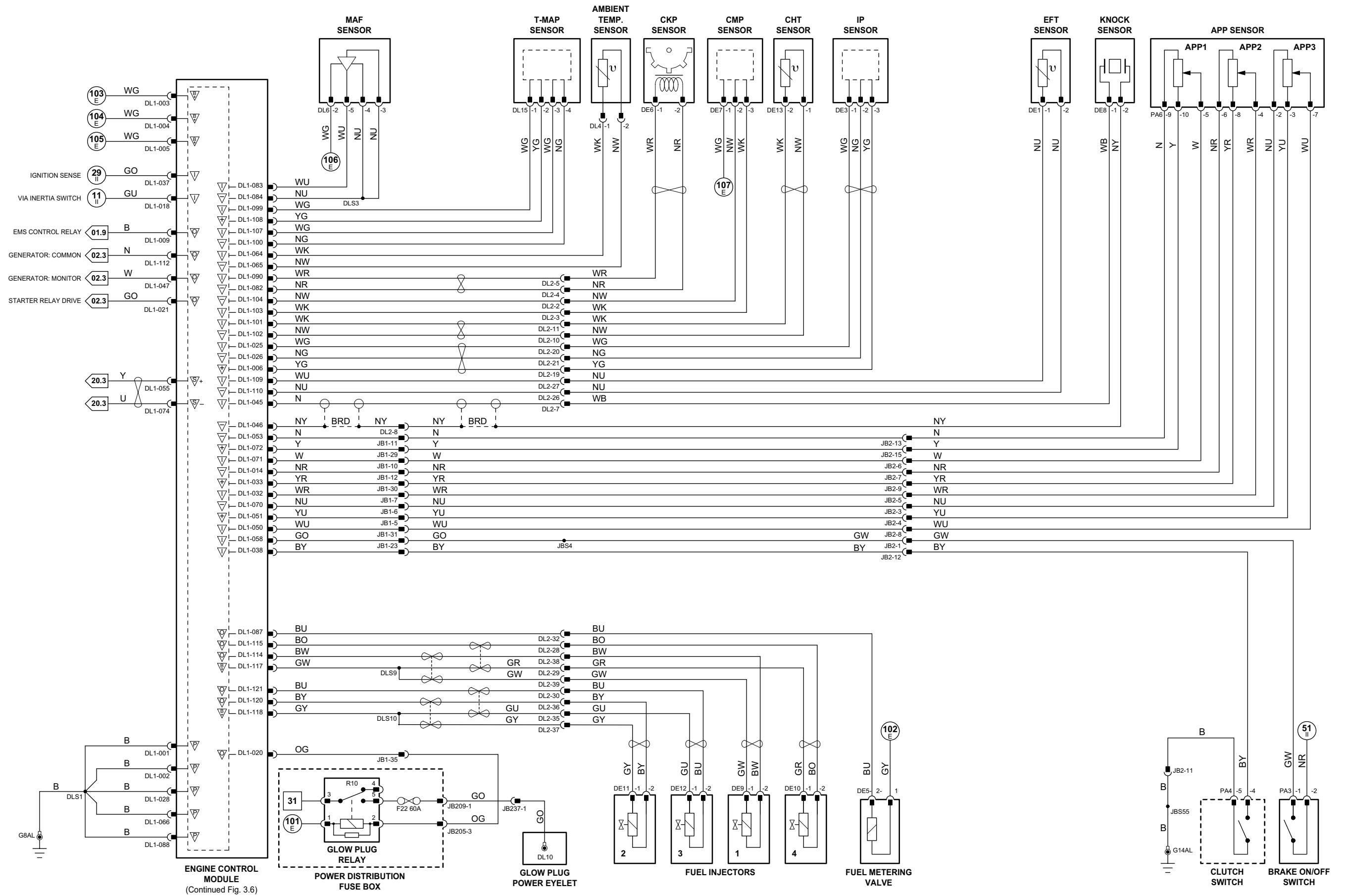

1 → 6 Fig. 01.1	34 → 80 Fig. 01.3	11 → 31 Fig. 01.5	67 → 76 Fig. 01.7	98 → 107 Fig. 01.9	Input	Battery Voltage	Sensor/Signal Supply V	CAN	D2B Network
7 → 33 Fig. 01.2	1 → 10 Fig. 01.4	32 → 66 Fig. 01.6	77 → 97 Fig. 01.8		Output	Power Ground	Sensor/Signal Ground	SCP	Serial and Encoded Data

VARIANT: Diesel Engine Vehicles  
 VIN RANGE: All  
 DATE OF ISSUE: February 2008

## Engine Control Module – Diesel

	Pin	Description and Characteristic
SS	DL1-007	EGR VALVE POSITION SENSOR POWER SUPPLY (2.0 L) OR ELECTRONIC EGR POWER SUPPLY (2.2 L)
I	DL1-008	EGR VALVE POSITION SENSOR SIGNAL (2.0 L) OR ELECTRONIC EGR SENSOR SIGNAL (2.2 L)
I	DL1-012	CLUTCH CANCEL SWITCH SIGNAL: NORMALLY CLOSED / OPEN CIRCUIT WHEN ACTIVATED
SG	DL1-013	SPEED CONTROL SWITCHES SIGNAL GROUND: GROUND
SG	DL1-027	EGR VALVE POSITION SENSOR GROUND (2.0 L) OR ELECTRONIC EGR GROUND (2.2 L)
C	DL1-054	CAN +
I	DL1-057	SPEED CONTROL SWITCH REQUEST: STEPPED RESISTANCE
I	DL1-058	BRAKE ON / OFF SWITCH SIGNAL: NORMALLY OPEN / B+ WHEN ACTIVATED
O	DL1-061	AUXILIARY HEATER RELAY 1 DRIVE: TO ACTIVATE, ECM SWITCHES CIRCUIT TO GROUND
O	DL1-062	AUXILIARY HEATER RELAY 2 DRIVE: TO ACTIVATE, ECM SWITCHES CIRCUIT TO GROUND
SG	DL1-068	AIR CONDITIONING PRESSURE SENSOR GROUND: GROUND
C	DL1-073	CAN -
I	DL1-077	BRAKE CANCEL SWITCH SIGNAL: NORMALLY CLOSED, B+ / OPEN CIRCUIT WHEN ACTIVATED
O	DL1-079	AIR CONDITIONING COMPRESSOR CLUTCH RELAY DRIVE: TO ACTIVATE, ECM SWITCHES CIRCUIT TO GROUND
O	DL1-080	SOLID STATE RELAY DRIVE: TO ACTIVATE, ECM SWITCHES CIRCUIT TO GROUND
SS	DL1-086	AIR CONDITIONING PRESSURE SENSOR POWER SUPPLY: NOMINAL 5 V
O	DL1-096	EGR SOLENOID VALVE DRIVE
O	DL1-105	COOLING FAN MODULE CONTROL: PWM, 140 Hz, POSITIVE DUTY CYCLE RANGE 7% – 95%
I	DL1-106	AIR CONDITIONING PRESSURE SENSOR SIGNAL, NOMINAL 0 – 5 V: TRANSDUCER – VOLTAGE INCREASES AS PRESSURE INCREASES
O	DL1-116	ELECTRONIC EGR DRIVE (2.2 L)
O	DL1-119	ELECTRONIC EGR DRIVE (2.2 L)

## Fig. 03.6

### COMPONENTS

Component	Connector(s)	Connector Description	Location
AIR CONDITIONING COMPRESSOR CLUTCH	DL9	2-WAY / BLACK	DIESEL: ENGINE BLOCK / LH FRONT
AIR CONDITIONING COMPRESSOR CLUTCH RELAY	-	-	POWER DISTRIBUTION FUSEBOX – R3
AIR CONDITIONING PRESSURE SENSOR	JB106	4-WAY / BLACK	BEHIND FRONT LH WHEEL ARCH LINER
AUXILIARY HEATER RELAY 1	-	-	POWER DISTRIBUTION FUSEBOX – R15
AUXILIARY HEATER RELAY 2	JB234	RELAY BASE	ENGINE COMPARTMENT / CENTER, FRONT
BRAKE CANCEL SWITCH	PA2	2-WAY / BLACK	TOP OF BRAKE PEDAL
BRAKE ON / OFF SWITCH	PA3	3-WAY / BLACK	TOP OF BRAKE PEDAL
CLUTCH SWITCH – Diesel	PA4	5-WAY / BLACK	TOP OF CLUTCH PEDAL
COOLING FAN – LH	GC2	2-WAY / BLACK	COOLING PACK / LH SIDE
COOLING FAN – RH	GC1	2-WAY / BLACK	COOLING PACK / RH SIDE
COOLING FAN MODULE	JB190	4-WAY / BLACK	ADJACENT TO RADIATOR / LH SIDE
ELECTRIC AUXILIARY HEATER	JB235	6-WAY / BLACK	VEHICLE UNDER-FLOOR REARWARD OF ENGINE
ELECTRONIC EGR – 2.2 L Diesel	DL16	6-WAY / GREY	
EGR SOLENOID VALVE – 2.0 L Diesel	DL14	2-WAY / BLACK	VACUUM RESERVOIR BRACKET
EGR VALVE POSITION SENSOR – 2.0 L Diesel	DL17	3-WAY / BLACK	
ENGINE CONTROL MODULE – Diesel	DL1	121-WAY / BLACK	ENGINE COMPARTMENT, FRONT BULKHEAD / RH SIDE
FUEL-FIRED AUXILIARY HEATER MODULE	JB232	6-WAY / BLACK	VEHICLE UNDER-FLOOR REARWARD OF ENGINE
POWER DISTRIBUTION FUSEBOX	-	-	ENGINE COMPARTMENT
SOLID STATE RELAY	JB238	7-WAY / BROWN	ATTACHED TO TOP OF PASSENGER JUNCTION FUSEBOX
SPEED CONTROL SWITCHES	SW4	4-WAY / BLACK	STEERING WHEEL
TURBOCHARGER ROTARY ELECTRONIC ACTUATOR	DE15	5-WAY / BLACK	ENGINE COMPARTMENT, FRONT / RH SIDE

### HARNESS IN-LINE CONNECTORS

Connector	Connector Description / Location	Location
JB1	42-WAY / BLACK / ENGINE MANAGEMENT HARNESS TO JUNCTION BOX HARNESS	ENGINE COMPARTMENT / LH SIDE
JB2	16-WAY / GREEN / ENGINE MANAGEMENT HARNESS TO JUNCTION BOX HARNESS (PEDAL ASSEMBLY)	BELOW INSTRUMENT PANEL / DRIVER SIDE
JB129	22-WAY / GREY / JUNCTION BOX HARNESS TO INSTRUMENT PANEL HARNESS	BELOW INSTRUMENT PANEL / LH SIDE
JB187	2-WAY / BLACK / JUNCTION BOX HARNESS TO COOLING FAN MODULE LINK LEAD	ENGINE COMPARTMENT / FRONT, LH SIDE

### GROUNDS

Ground	Harness	Location
G8	EN	ENGINE COMPARTMENT / RH STRUT TOWER
G11	JB	ENGINE COMPARTMENT / BEHIND LH HEADLAMP
G14	JB	ENGINE COMPARTMENT / BEHIND POWER DISTRIBUTION FUSEBOX
G51	JB	UNDER BODY / LH DASH PANEL

FOR CONTROL MODULE PIN-OUT INFORMATION, UNFOLD PAGE TO LEFT.

The following abbreviations are used to represent values for Control Module Pin-Out data

I	Input	PG	Power Ground	C	CAN Network	D	Serial and Encoded Data
O	Output	SS	Sensor / Signal Supply V	S	SCP Network	V	Voltage (DC)
B+	Battery Voltage	SG	Sensor / Signal Ground	D2	D2B Network	PWM	Pulse Width Modulated

**CAUTION:** The information on this data page is furnished to aid the user in understanding circuit operation. THIS INFORMATION SHOULD BE USED FOR REFERENCE ONLY.

**NOTE:** The values listed are approximately those that can be expected at the control module connector pins with all circuit connections made and all components connected and fitted.

Refer to the front of this book for detailed information and illustrations regarding the location and identification of harnesses, relays, fuses, grounds, control modules and control module pins.



\* NOTE: Either Fuel-Fired Auxiliary Heater or Electric Auxiliary Heater fitted.

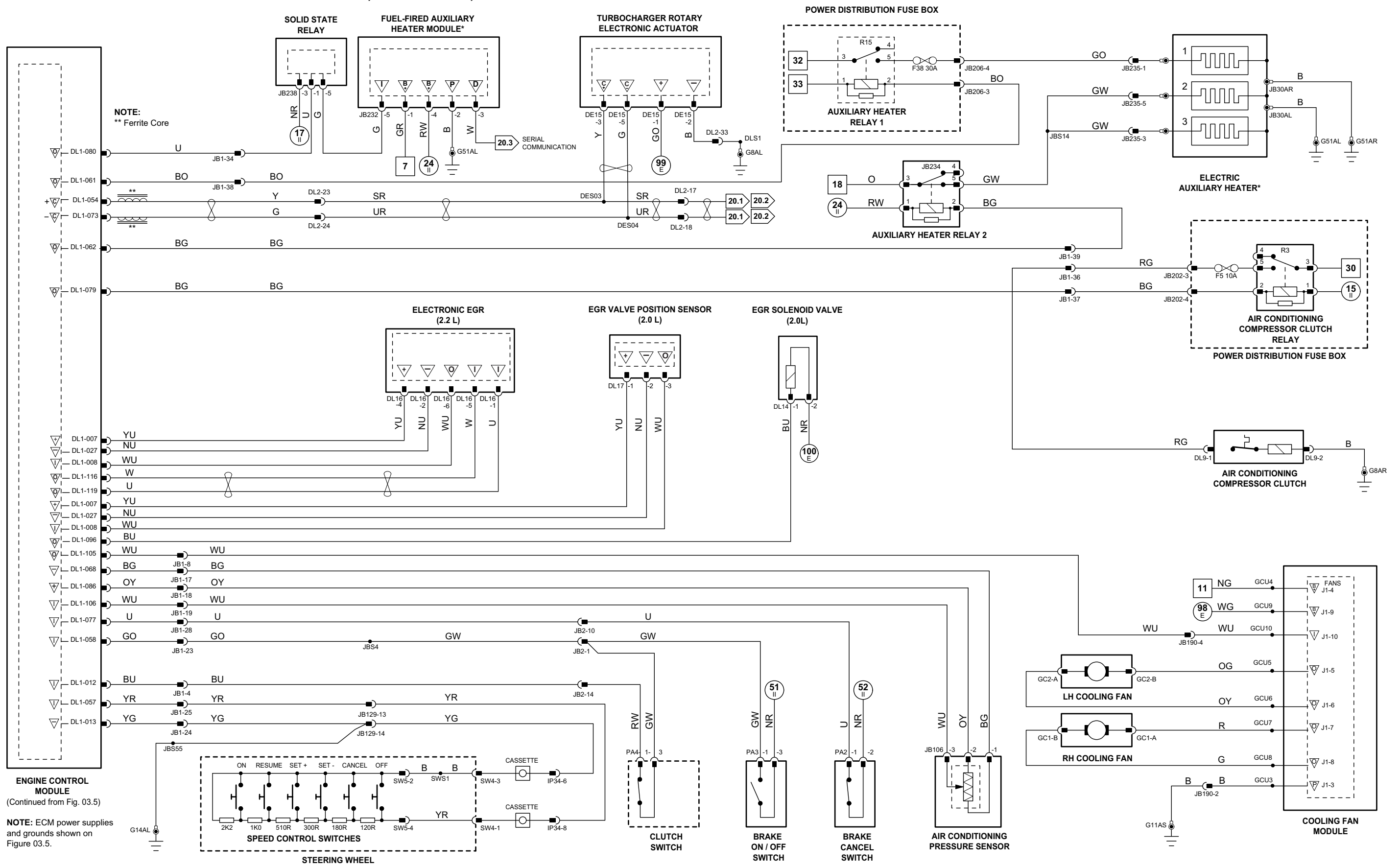

ENGINE CONTROL MODULE  
(Continued from Fig. 03.5)

NOTE: ECM power supplies and grounds shown on Figure 03.5.

1 → 6 Fig. 01.1	34 → 80 Fig. 01.3	11 → 31 Fig. 01.5	67 → 76 Fig. 01.7	98 → 107 Fig. 01.9	Input	Battery Voltage	Sensor/Signal Supply V	CAN	D2B Network
7 → 33 Fig. 01.2	1 → 10 Fig. 01.4	32 → 66 Fig. 01.6	77 → 97 Fig. 01.8		Output	Power Ground	Sensor/Signal Ground	SCP	Serial and Encoded Data

VARIANT: Diesel Engine Vehicles  
VIN RANGE: All  
DATE OF ISSUE: February 2008

**Engine Control Module – Diesel**

	Pin	Description and Characteristic
PG	DL1-001	POWER GROUND: GROUND
PG	DL1-002	POWER GROUND: GROUND
B+	DL1-003	EMS SWITCHED POWER SUPPLY: B+
B+	DL1-004	EMS SWITCHED POWER SUPPLY: B+
B+	DL1-005	EMS SWITCHED POWER SUPPLY: B+
O	DL1-009	EMS CONTROL RELAY ACTIVATE: TO ACTIVATE, ECM SWITCHES CIRCUIT TO GROUND
I	DL1-018	INERTIA SWITCH: NORMALLY CLOSED / OPEN CIRCUIT WHEN ACTIVATED
O	DL1-021	STARTER RELAY DRIVE: TO ACTIVATE, ECM SWITCHES CIRCUIT TO GROUND
PG	DL1-028	POWER GROUND: GROUND
I	DL1-031	PRE-DPF TEMPERATURE SENSOR SIGNAL
I	DL1-036	THROTTLE POSITION SENSOR SIGNAL
I	DL1-037	IGNITION SENSE: B+
S	DL1-055	SCP +
SG	DL1-063	DPF PRESSURE SENSOR GROUND
PG	DL1-066	POWER GROUND: GROUND
I	DL1-067	PRE-CATALYTIC CONVERTER TEMPERATURE SENSOR SIGNAL
S	DL1-074	SCP -
SG	DL1-075	THROTTLE POSITION SENSOR GROUND
I	DL1-085	DPF PRESSURE SENSOR
PG	DL1-088	POWER GROUND: GROUND
SS	DL1-092	THROTTLE POSITION SENSOR POWER SUPPLY
SS	DL1-093	DPF PRESSURE SENSOR POWER SUPPLY
SG	DL1-094	PRE-DPF TEMPERATURE SENSOR GROUND
SG	DL1-098	PRE-CATALYTIC CONVERTER TEMPERATURE SENSOR GROUND
I	DL1-099	MAP SENSOR PRESSURE SIGNAL, NOMINAL 0 – 5 V: VOLTAGE INCREASES AS MANIFOLD ABSOLUTE PRESSURE INCREASES
I	DL1-100	MAP SENSOR GROUND: GROUND
SG	DL1-107	MAP SENSOR TEMPERATURE SIGNAL, NOMINAL 0 – 5 V: NTC SENSOR – VOLTAGE DECREASES AS TEMPERATURE INCREASES
I	DL1-108	MAP SENSOR POWER SUPPLY: NOMINAL 5 V
SS	DL1-108	MAP SENSOR POWER SUPPLY: NOMINAL 5 V
O	DL1-112	GENERATOR COMMON

**Fig. 03.7**

**COMPONENTS**

Component	Connector(s)	Connector Description	Location
DPF PRESSURE SENSOR	LL1	3-WAY / DARK GREY	ENGINE COMPARTMENT, FRONT BULKHEAD / RH SIDE OF CENTER
ENGINE CONTROL MODULE	DL1	121-WAY / BLACK	ENGINE COMPARTMENT, FRONT BULKHEAD / RH SIDE
PRE-CATALYTIC CONVERTER TEMPERATURE SENSOR	DL21	2-WAY / BLACK	ABOVE GENERATOR
PRE-DPF TEMPERATURE SENSOR	DL22	2-WAY / BLACK	FRONT CROSS-MEMBER, RH SIDE
THROTTLE POSITION SENSOR	DL19	3-WAY / BLACK	
MAP SENSOR	DL15	4-WAY / BLACK	ENGINE CHARGE AIR DUCT, RH SIDE OF COOLING PACK
MAP SENSOR	DL23	3-WAY / BLACK	

**HARNES IN-LINE CONNECTORS**

Connector	Connector Description / Location	Location
DL20	3-WAY / BLACK /DPF PRESSURE SENSOR LINK HARNESS	

**GROUNDS**

Ground	Harness	Location
G8	EN	ENGINE COMPARTMENT / RH STRUT TOWER

FOR CONTROL MODULE PIN-OUT INFORMATION, UNFOLD PAGE TO LEFT.

The following abbreviations are used to represent values for Control Module Pin-Out data

I	Input	PG	Power Ground	C	CAN Network	D	Serial and Encoded Data
O	Output	SS	Sensor / Signal Supply V	S	SCP Network	V	Voltage (DC)
B+	Battery Voltage	SG	Sensor / Signal Ground	D2	D2B Network	PWM	Pulse Width Modulated

**CAUTION:** The information on this data page is furnished to aid the user in understanding circuit operation. THIS INFORMATION SHOULD BE USED FOR REFERENCE ONLY.

**NOTE:** The values listed are approximately those that can be expected at the control module connector pins with all circuit connections made and all components connected and fitted.

Refer to the front of this book for detailed information and illustrations regarding the location and identification of harnesses, relays, fuses, grounds, control modules and control module pins.

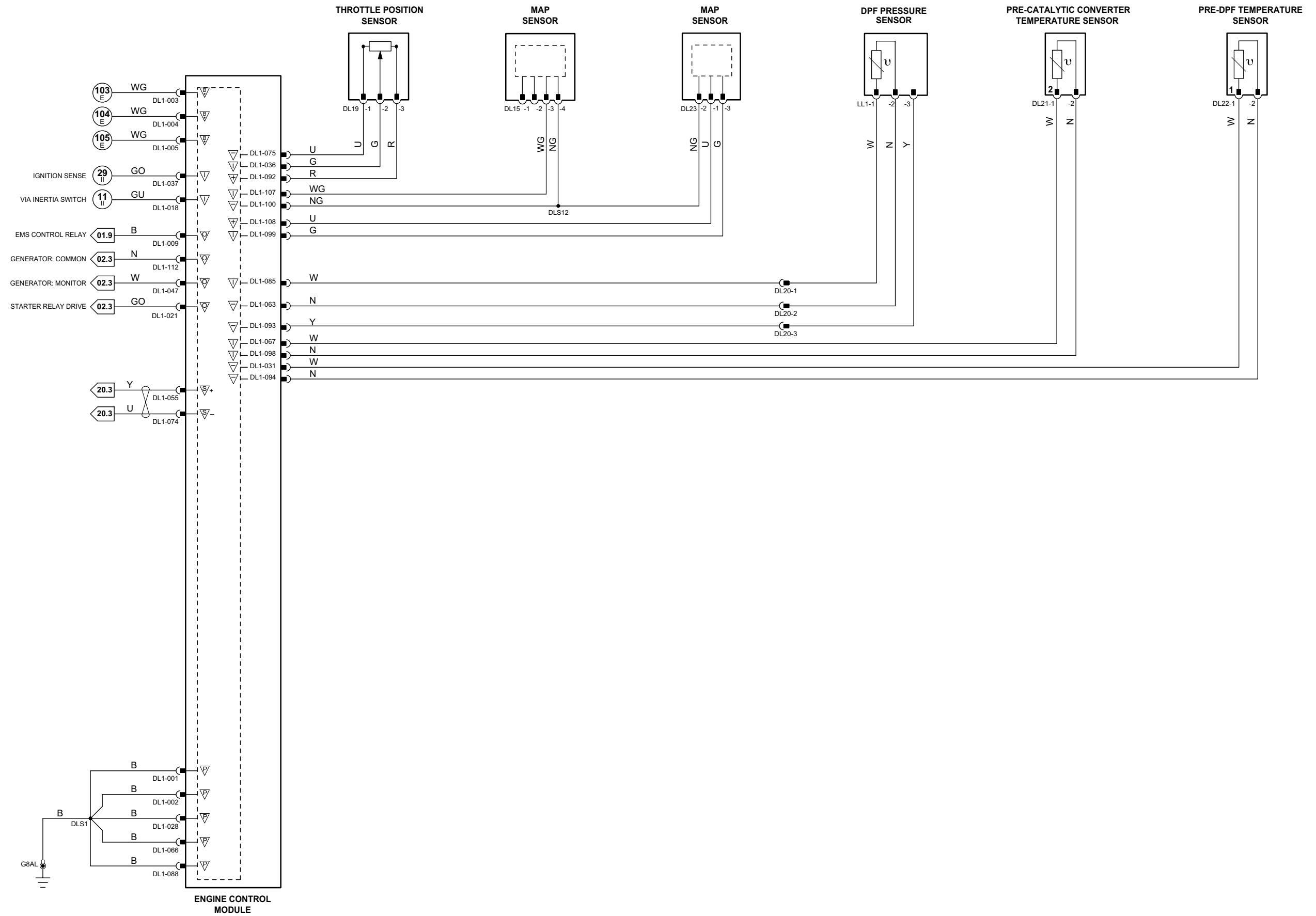

1 → 6 Fig. 01.1	34 → 80 Fig. 01.3	11 → 31 Fig. 01.5	67 → 76 Fig. 01.7	98 → 107 Fig. 01.9	Input	Battery Voltage	Sensor/Signal Supply V	CAN	D2B Network
7 → 33 Fig. 01.2	1 → 10 Fig. 01.4	32 → 66 Fig. 01.6	77 → 97 Fig. 01.8		Output	Power Ground	Sensor/Signal Ground	SCP	Serial and Encoded Data

VARIANT: Diesel 2.2L with DPF Vehicles  
 VIN RANGE: All  
 DATE OF ISSUE: February 2008

**Transmission Control Module**

Pin	Description and Characteristic
O	JB230-01 LINE PRESSURE CONTROL SOLENOID DRIVE: PWM, 1.25 kHz, POSITIVE DUTY CYCLE 5 – 95%
O	JB230-02 2 / 4 BRAKE PRESSURE CONTROL SOLENOID DRIVE: PWM, 1.25 kHz, POSITIVE DUTY CYCLE 5 – 95%
O	JB230-03 TCC PRESSURE CONTROL SOLENOID DRIVE: PWM, 1.25 kHz, POSITIVE DUTY CYCLE 5 – 95%
SG	JB230-04 SOLENOID GROUND RETURN: GROUND
C	JB230-05 CAN +
C	JB230-06 CAN –
O	JB230-07 REDUCTION TIMING SOLENOID DRIVE: B+ TO ACTIVATE
O	JB230-08 LOW CLUTCH TIMING SOLENOID DRIVE: B+ TO ACTIVATE
B+	JB230-10 IGNITION SWITCHED POWER SUPPLY: B+
O	JB230-11 SHIFT SOLENOID A DRIVE: B+ TO ACTIVATE
O	JB230-12 SHIFT SOLENOID B DRIVE: B+ TO ACTIVATE
C	JB230-14 CAN +
C	JB230-15 CAN –
I	JB230-18 RANGE SENSOR – P: P = GROUND; NOT IN P = OPEN CIRCUIT
B+	JB230-19 IGNITION SWITCHED POWER SUPPLY: B+
O	JB230-20 SHIFT SOLENOID C DRIVE: B+ TO ACTIVATE
O	JB230-21 2 / 4 BRAKE TIMING SOLENOID DRIVE: B+ TO ACTIVATE
SG	JB230-23 TURBINE SPEED SENSOR GROUND: GROUND
I	JB230-24 GEAR SELECTOR SIGNAL – 3: 3 = GROUND; NOT IN 3 = OPEN CIRCUIT
PG	JB231-25 POWER GROUND: GROUND
SG	JB231-26 SENSOR GROUND: GROUND
I	JB231-27 GEAR SELECTOR SIGNAL – 2: 2 = GROUND; NOT IN 2 = OPEN CIRCUIT
B+	JB231-28 BATTERY POWER SUPPLY: B+
I	JB231-29 OUTPUT SPEED SENSOR SIGNAL: 18 PULSES PER OUTPUT SHAFT REVOLUTION
I	JB231-34 RANGE SENSOR – D: D = GROUND; NOT IN D = OPEN CIRCUIT
I	JB231-35 RANGE SENSOR – R: R = GROUND; NOT IN R = OPEN CIRCUIT
I	JB231-36 RANGE SENSOR – N: N = GROUND; NOT IN N = OPEN CIRCUIT
I	JB231-38 TURBINE SPEED SENSOR SIGNAL: 36 PULSES PER ENGINE REVOLUTION
I	JB231-39 INTERMEDIATE SPEED SENSOR SIGNAL: 54 PULSES PER INTERMEDIATE SHAFT REVOLUTION*
I	JB231-41 MODE SWITCH: 'SPORT' SELECTED = GROUND
SG	JB231-42 SENSOR GROUND: GROUND
I	JB231-43 GEAR SELECTOR SIGNAL – 4: 4 = GROUND; NOT IN 4 = OPEN CIRCUIT
SG	JB231-44 SENSOR GROUND: GROUND
I	JB231-47 FLUID TEMPERATURE SENSOR SIGNAL, NOMINAL 0 – 5 V: NTC SENSOR – VOLTAGE DECREASES AS TEMPERATURE INCREASES
PG	JB231-48 POWER GROUND: GROUND

The following abbreviations are used to represent values for Control Module Pin-Out data

I	Input	PG	Power Ground	C	CAN Network	D	Serial and Encoded Data
O	Output	SS	Sensor / Signal Supply V	S	SCP Network	V	Voltage (DC)
B+	Battery Voltage	SG	Sensor / Signal Ground	D2	D2B Network	PWM	Pulse Width Modulated

**CAUTION:** The information on this data page is furnished to aid the user in understanding circuit operation. THIS INFORMATION SHOULD BE USED FOR REFERENCE ONLY.

**NOTE:** The values listed are approximately those that can be expected at the control module connector pins with all circuit connections made and all components connected and fitted.

**Fig. 04.1**

**COMPONENTS**

Component	Connector(s)	Connector Description	Location
AUTOMATIC TRANSMISSION	JB155	18-WAY / BLACK	ENGINE COMPARTMENT
IGNITION SWITCH	IP18	7-WAY / BLACK	STEERING COLUMN
J-GATE MODULE	IP14	16-WAY / GREY	CENTER CONSOLE
AUTOMATIC TRANSMISSION CONTROL MODULE - PETROL	auto	24-WAY / WHITE	LOWER LH 'A' POST
	JB231	24-WAY / GREY	
TRANSMISSION RANGE SENSOR	JB156	10-WAY / BLACK	TOP OF TRANSMISSION

**HARNESS IN-LINE CONNECTORS**

Connector	Connector Description / Location	Location
JB129	22-WAY / GREY / JUNCTION BOX HARNESS TO INSTRUMENT PANEL HARNESS	BELOW INSTRUMENT PANEL / LH SIDE

**GROUNDS**

Ground	Harness	Location
G14	JB	ENGINE COMPARTMENT / BEHIND POWER DISTRIBUTION FUSEBOX
G15	CA	LOWER LH 'A' POST
G37	IP	BEHIND INSTRUMENT PANEL / RH SIDE OF CROSS CAR BEAM

**FOR CONTROL MODULE PIN-OUT INFORMATION, UNFOLD PAGE TO LEFT.**

Refer to the front of this book for detailed information and illustrations regarding the location and identification of harnesses, relays, fuses, grounds, control modules and control module pins.

AUTOMATIC TRANSMISSION

TRANSMISSION RANGE SENSOR

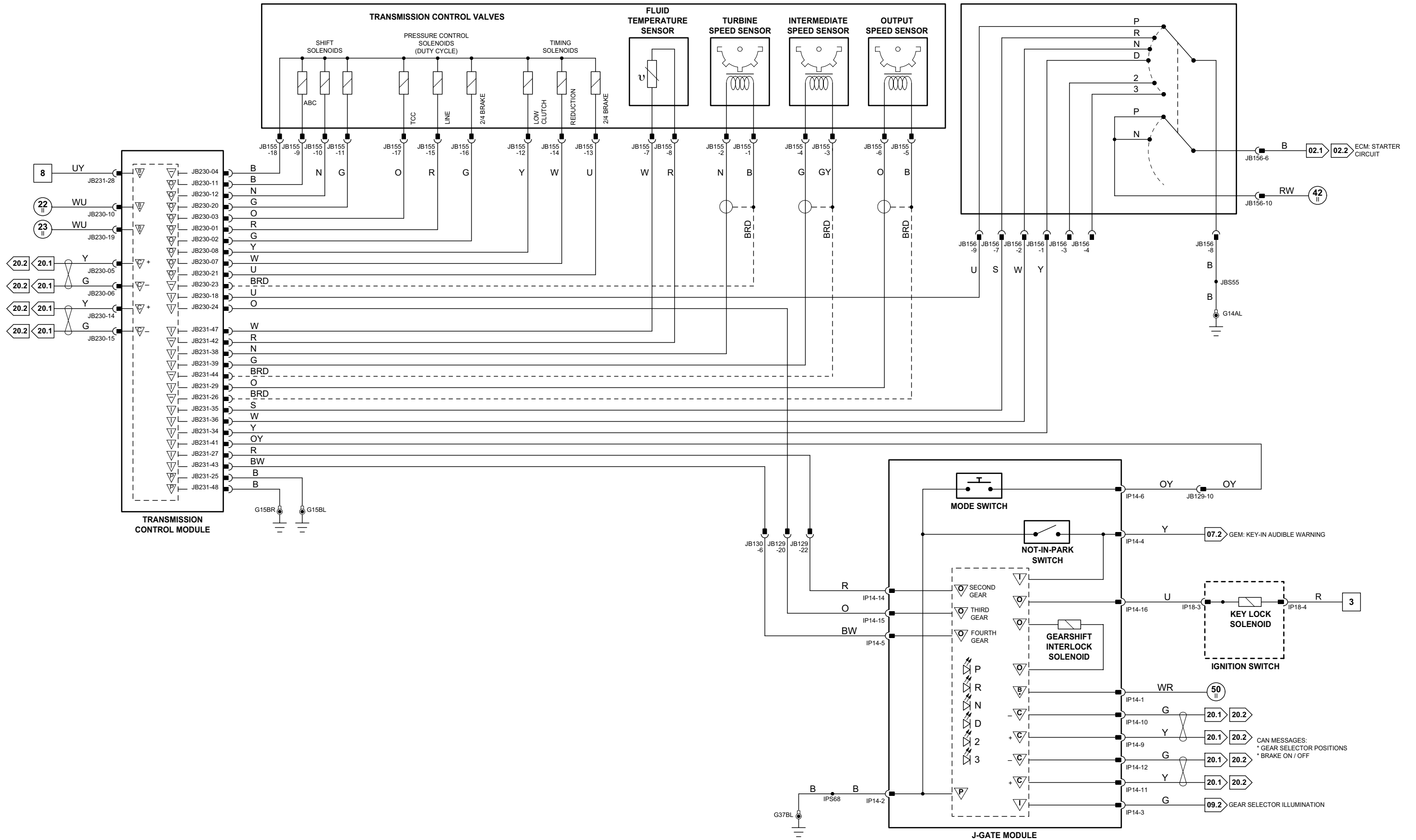

**Transmission Control Module - Diesel**

	Pin	Description and Characteristic
B+	DL24-01	BATTERY POWER SUPPLY: B+
O	DL24-05	START LOCK SIGNAL OUTPUT
C	DL24-06	CAN -
SG	DL24-07	LIN COMMUNICATION
PG	DL24-09	POWER GROUND: GROUND
B+	DL24-11	IGNITION SWITCHED POWER SUPPLY: B+
O	DL24-13	SHIFT LOCK SIGNAL OUTPUT
C	DL24-14	CAN +
O	DL24-16	GEAR SHIFT MODULE POWER SUPPLY

**Fig. 04.2**

**COMPONENTS**

Component	Connector(s)	Connector Description	Location
AUTOMATIC TRANSMISSION CONTROL MODULE - DIESEL	DL24	16-WAY / BLACK	ENGINE COMPARTMENT
GEAR SHIFT MODULE	IP204	6-WAY / DARK GREY	STEERING COLUMN
GENERAL ELECTRONIC MODULE	CA86	23-WAY / GREY	STEERING COLUMN
	CA87	23-WAY / GREEN	
	IP5	23-WAY / BROWN	
	IP6	23-WAY / NATURAL	
	JB172	23-WAY / BLUE	
IGNITION SWICH KEYLOCK SOLENOID	IP14	7-WAY / BLACK	STEERING COLUMN

**HARNESS IN-LINE CONNECTORS**

Connector	Connector Description / Location	Location
JB1	42-WAY / BLACK / ENGINE MANAGEMENT HARNESS TO JUNCTION BOX HARNESS	ENGINE COMPARTMENT / LH SIDE
JB130	22-WAY / GREEN / JUNCTION BOX HARNESS TO INSTRUMENT PANEL HARNESS	BELOW INSTRUMENT PANEL / LH SIDE

**GROUNDS**

Ground	Harness	Location
G8	EN	ENGINE COMPARTMENT / RH STRUT TOWER
G37	IP	BEHIND INSTRUMENT PANEL / RH SIDE OF CROSS CAR BEAM

**FOR CONTROL MODULE PIN-OUT INFORMATION, UNFOLD PAGE TO LEFT.**

The following abbreviations are used to represent values for Control Module Pin-Out data

I	Input	PG	Power Ground	C	CAN Network	D	Serial and Encoded Data
O	Output	SS	Sensor / Signal Supply V	S	SCP Network	V	Voltage (DC)
B+	Battery Voltage	SG	Sensor / Signal Ground	D2	D2B Network	PWM	Pulse Width Modulated

**CAUTION:** The information on this data page is furnished to aid the user in understanding circuit operation. THIS INFORMATION SHOULD BE USED FOR REFERENCE ONLY.

**NOTE:** The values listed are approximately those that can be expected at the control module connector pins with all circuit connections made and all components connected and fitted.

Refer to the front of this book for detailed information and illustrations regarding the location and identification of harnesses, relays, fuses, grounds, control modules and control module pins.

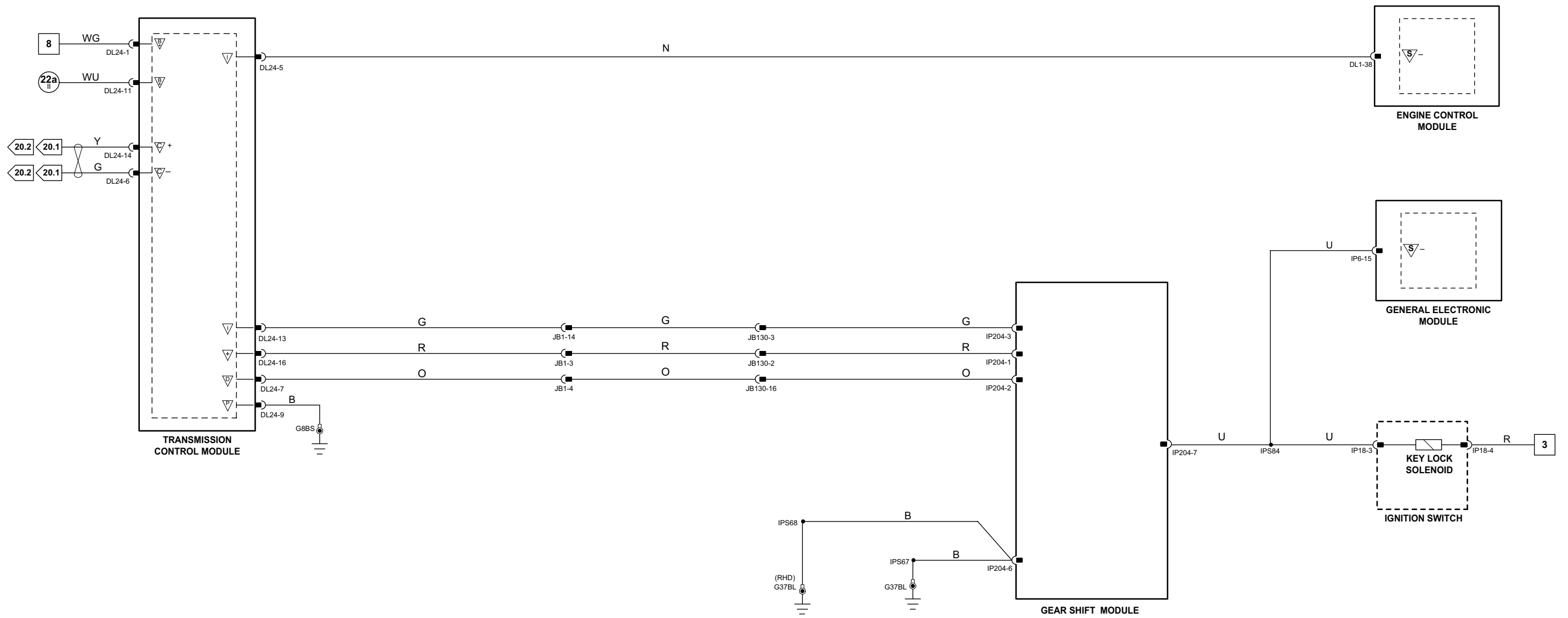

**Traction Control Module**

Pin	Description and Characteristic
PG	JB197-01 MOTOR GROUND: GROUND
B+	JB197-02 BATTERY POWER SUPPLY – MOTOR: B+
B+	JB197-03 BATTERY POWER SUPPLY: B+
PG	JB197-04 POWER GROUND: GROUND
I	JB197-05 LH FRONT WHEEL SPEED SENSOR SIGNAL: 32 PULSES PER WHEEL REVOLUTION
SS	JB197-06 LH REAR WHEEL SPEED SENSOR SUPPLY VOLTAGE: B+
O	JB197-08 RH REAR WHEEL SPEED SENSOR SUPPLY VOLTAGE: B+
SS	JB197-09 RH FRONT WHEEL SPEED SENSOR SUPPLY VOLTAGE: B+
I	JB197-10 RH FRONT WHEEL SPEED SENSOR SIGNAL: 32 PULSES PER WHEEL REVOLUTION
C	JB197-14 CAN –
O	JB197-26 LH FRONT WHEEL SPEED SENSOR SUPPLY VOLTAGE: B+
I	JB197-27 LH REAR WHEEL SPEED SENSOR SIGNAL: 32 PULSES PER WHEEL REVOLUTION
B+	JB197-28 IGNITION SWITCHED POWER SUPPLY: B+
I	JB197-29 RH REAR WHEEL SPEED SENSOR SIGNAL: 32 PULSES PER WHEEL REVOLUTION
I	JB197-30 BRAKE ON / OFF SWITCH: NORMALLY OPEN / B+ WHEN ACTIVATED
I	JB197-31 TRACTION CONTROL SWITCH SIGNAL: GROUND WHEN ACTIVATED
C	JB197-35 CAN +

**Fig. 05.1**

**COMPONENTS**

Component	Connector(s)	Connector Description	Location
TRACTION CONTROL MODULE	JB197	46-WAY / BLACK	ENGINE COMPARTMENT / RH SIDE
BRAKE ON / OFF SWITCH	PA3	3-WAY / BLACK	TOP OF BRAKE PEDAL
TRACTION CONTROL SWITCH	IP29	6-WAY / BLACK	INSTRUMENT PANEL
VACUUM MODULE	JB240	5-WAY / BLACK	UNDER BATTERY TRAY
	JB241	2-WAY / BLACK	
	JB242	2-WAY / GREY	
VACUUM PUMP	VP1	2-WAY / GREY	ADJACENT TO BRAKE SERVO
WHEEL SPEED SENSOR – LH FRONT	LF1	2-WAY / BLACK	LH FRONT WHEEL HUB
WHEEL SPEED SENSOR – LH REAR: 2.0 L	LR1	2-WAY / BLACK	LH REAR WHEEL HUB
WHEEL SPEED SENSOR – LH REAR: 2.5 L, 3.0 L, Diesel	CA55	2-WAY / BLACK	LH REAR WHEEL HUB
WHEEL SPEED SENSOR – RH FRONT	RF1	2-WAY / BLACK	RH FRONT WHEEL HUB
WHEEL SPEED SENSOR – RH REAR: 2.0 L	RR1	2-WAY / BLACK	RH REAR WHEEL HUB
WHEEL SPEED SENSOR – RH REAR: 2.5 L, 3.0 L, Diesel	CA60	2-WAY / BLACK	RH REAR WHEEL HUB

**HARNESS IN-LINE CONNECTORS**

Connector	Connector Description / Location	Location
CA10	22-WAY / SLATE / CABIN HARNESS TO JUNCTION BOX HARNESS	LH 'A' POST / 'A' POST TRIM
CA170	16-WAY / GREEN / JUNCTION BOX HARNESS TO CABIN HARNESS	LH 'A' POST / 'A' POST TRIM
JB2	16-WAY / GREEN / ENGINE MANAGEMENT HARNESS TO JUNCTION BOX HARNESS (PEDAL ASSEMBLY)	BELOW INSTRUMENT PANEL / DRIVER SIDE
JB15	2-WAY / BLACK / JUNCTION BOX HARNESS TO RH WHEEL SPEED SENSOR LINK LEAD	BEHIND RH FRONT WHEEL ARCH LINER
JB130	22-WAY / GREEN / JUNCTION BOX HARNESS TO INSTRUMENT PANEL HARNESS	BELOW INSTRUMENT PANEL / LH SIDE
JB133	2-WAY / BLACK / JUNCTION BOX HARNESS TO LH WHEEL SPEED SENSOR LINK LEAD	BEHIND LH FRONT WHEEL ARCH LINER
JB196	10-WAY / GREY / ENGINE MANAGEMENT HARNESS TO JUNCTION BOX HARNESS (PEDAL ASSEMBLY)	BELOW INSTRUMENT PANEL / DRIVER SIDE

**GROUNDS**

Ground	Harness	Location
G14	JB	ENGINE COMPARTMENT / BEHIND POWER DISTRIBUTION FUSEBOX
G18	JB	ENGINE COMPARTMENT / BEHIND RH HEADLAMP
G37	IP	BEHIND INSTRUMENT PANEL / RH SIDE OF CROSS CAR BEAM

**FOR CONTROL MODULE PIN-OUT INFORMATION, UNFOLD PAGE TO LEFT.**

The following abbreviations are used to represent values for Control Module Pin-Out data

I	Input	PG	Power Ground	C	CAN Network	D	Serial and Encoded Data
O	Output	SS	Sensor / Signal Supply V	S	SCP Network	V	Voltage (DC)
B+	Battery Voltage	SG	Sensor / Signal Ground	D2	D2B Network	PWM	Pulse Width Modulated

**CAUTION:** The information on this data page is furnished to aid the user in understanding circuit operation. THIS INFORMATION SHOULD BE USED FOR REFERENCE ONLY.

**NOTE:** The values listed are approximately those that can be expected at the control module connector pins with all circuit connections made and all components connected and fitted.

Refer to the front of this book for detailed information and illustrations regarding the location and identification of harnesses, relays, fuses, grounds, control modules and control module pins.



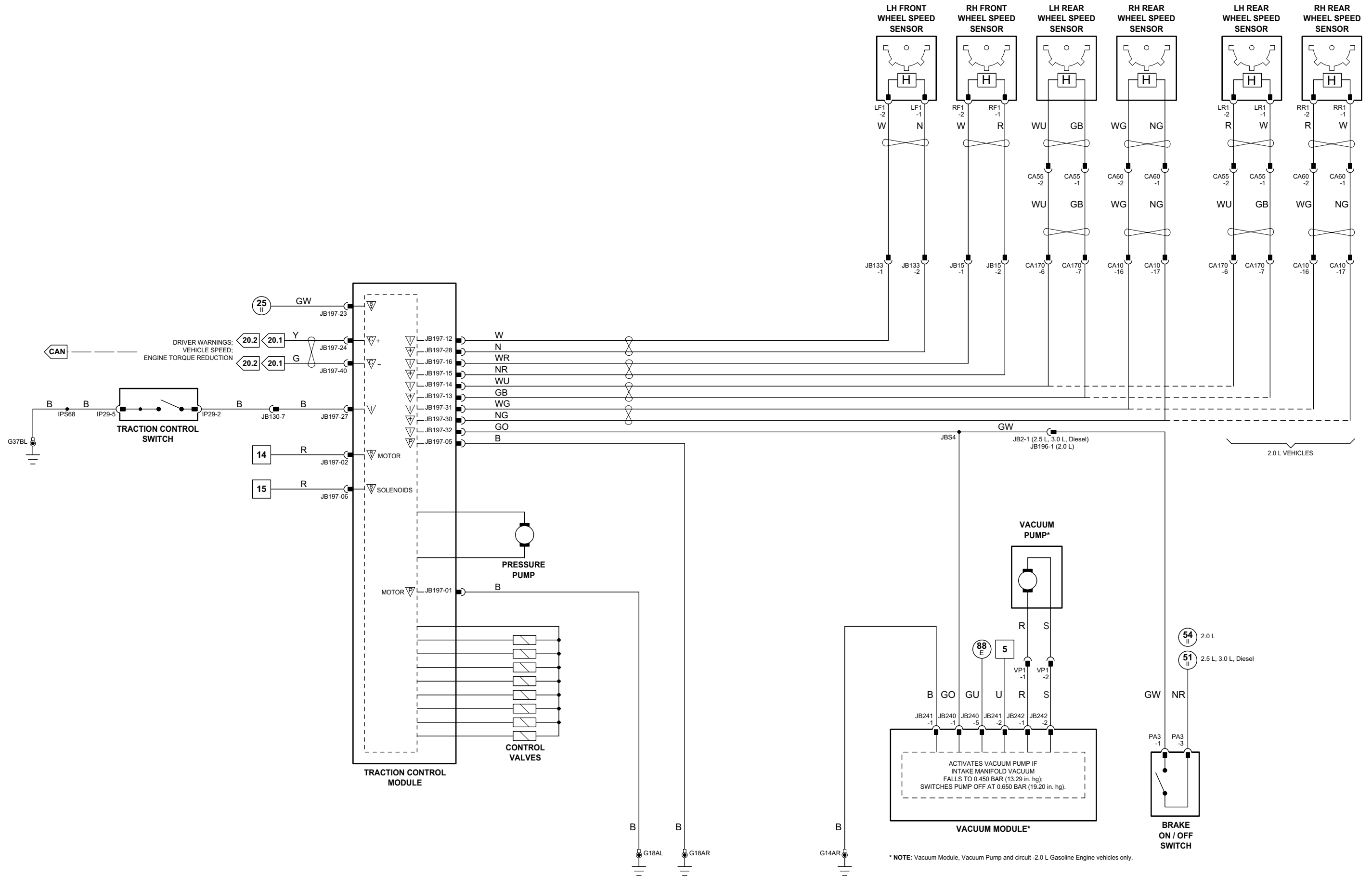

\* NOTE: Vacuum Module, Vacuum Pump and circuit -2.0 L Gasoline Engine vehicles only.

1 → 6 Fig. 01.1	34 → 80 Fig. 01.3	11 → 31 Fig. 01.5	67 → 76 Fig. 01.7	98 → 107 Fig. 01.9	Input	Battery Voltage	Sensor/Signal Supply V	CAN	D2B Network
7 → 33 Fig. 01.2	1 → 10 Fig. 01.4	32 → 66 Fig. 01.6	77 → 97 Fig. 01.8		Output	Power Ground	Sensor/Signal Ground	SCP	Serial and Encoded Data

VARIANT: Traction Control Vehicles  
 VIN RANGE: All  
 DATE OF ISSUE: February 2008

## Dynamic Stability Control Module

	Pin	Description and Characteristic
PG	JB185-01	MOTOR GROUND: GROUND
B+	JB185-02	BATTERY POWER SUPPLY – MOTOR: B+
B+	JB185-03	BATTERY POWER SUPPLY: B+
PG	JB185-04	POWER GROUND: GROUND
I	JB185-05	LH FRONT WHEEL SPEED SENSOR SIGNAL: 32 PULSES PER WHEEL REVOLUTION
SS	JB185-06	LH REAR WHEEL SPEED SENSOR SUPPLY VOLTAGE: B+
O	JB185-08	RH REAR WHEEL SPEED SENSOR SUPPLY VOLTAGE: B+
SS	JB185-09	RH FRONT WHEEL SPEED SENSOR SUPPLY VOLTAGE: B+
I	JB185-10	RH FRONT WHEEL SPEED SENSOR SIGNAL: 32 PULSES PER WHEEL REVOLUTION
C	JB185-14	CAN –
O	JB185-26	LH FRONT WHEEL SPEED SENSOR SUPPLY VOLTAGE: B+
I	JB185-27	LH REAR WHEEL SPEED SENSOR SIGNAL: 32 PULSES PER WHEEL REVOLUTION
B+	JB185-28	IGNITION SWITCHED POWER SUPPLY: B+
I	JB185-29	RH REAR WHEEL SPEED SENSOR SIGNAL: 32 PULSES PER WHEEL REVOLUTION
I	JB185-30	BRAKE ON / OFF SWITCH: NORMALLY OPEN / B+ WHEN ACTIVATED
I	JB185-31	DYNAMIC STABILITY CONTROL SWITCH: NORMALLY OPEN / GROUND WHEN ACTIVATED
C	JB185-35	CAN +

## Fig. 05.2

### COMPONENTS

Component	Connector(s)	Connector Description	Location
BRAKE ON / OFF SWITCH	PA3	3-WAY / BLACK	TOP OF BRAKE PEDAL
DYNAMIC STABILITY CONTROL MODULE	JB185	62-WAY / BLACK	ENGINE COMPARTMENT / RH SIDE
DYNAMIC STABILITY CONTROL SWITCH	IP29	6-WAY / BLACK	INSTRUMENT PANEL
STEERING ANGLE SENSOR	IP19	4-WAY / BLACK	STEERING COLUMN
VACUUM MODULE	JB240	5-WAY / BLACK	UNDER BATTERY TRAY
	JB241	2-WAY / BLACK	
	JB242	2-WAY / GREY	
VACUUM PUMP	VP1	2-WAY / GREY	ADJACENT TO BRAKE SERVO
WHEEL SPEED SENSOR – LH FRONT	LF1	2-WAY / BLACK	LH FRONT WHEEL HUB
WHEEL SPEED SENSOR – LH REAR: 2.0 L	LR1	2-WAY / BLACK	LH REAR WHEEL HUB
WHEEL SPEED SENSOR – LH REAR: 2.5 L, 3.0 L, Diesel	CA55	2-WAY / BLACK	LH REAR WHEEL HUB
WHEEL SPEED SENSOR – RH FRONT	RF1	2-WAY / BLACK	RH FRONT WHEEL HUB
WHEEL SPEED SENSOR – RH REAR: 2.0 L	RR1	2-WAY / BLACK	RH REAR WHEEL HUB
WHEEL SPEED SENSOR – RH REAR: 2.5 L, 3.0 L, Diesel	CA60	2-WAY / BLACK	RH REAR WHEEL HUB
YAW RATE SENSOR	IP20	4-WAY / BLACK	BEHIND CENTER CONSOLE

### HARNESS IN-LINE CONNECTORS

Connector	Connector Description / Location	Location
CA10	22-WAY / SLATE / CABIN HARNESS TO JUNCTION BOX HARNESS	LH 'A' POST / 'A' POST TRIM
CA170	16-WAY / GREEN / JUNCTION BOX HARNESS TO CABIN HARNESS	LH 'A' POST / 'A' POST TRIM
JB2	16-WAY / GREEN / ENGINE MANAGEMENT HARNESS TO JUNCTION BOX HARNESS (PEDAL ASSEMBLY)	BELOW INSTRUMENT PANEL / DRIVER SIDE
JB15	2-WAY / BLACK / JUNCTION BOX HARNESS TO RH WHEEL SPEED SENSOR LINK LEAD	BEHIND RH FRONT WHEEL ARCH LINER
JB129	22-WAY / GREY / JUNCTION BOX HARNESS TO INSTRUMENT PANEL HARNESS	BELOW INSTRUMENT PANEL / LH SIDE
JB130	22-WAY / GREEN / JUNCTION BOX HARNESS TO INSTRUMENT PANEL HARNESS	BELOW INSTRUMENT PANEL / LH SIDE
JB133	2-WAY / BLACK / JUNCTION BOX HARNESS TO LH WHEEL SPEED SENSOR LINK LEAD	BEHIND LH FRONT WHEEL ARCH LINER
JB196	10-WAY / GREY / ENGINE MANAGEMENT HARNESS TO JUNCTION BOX HARNESS (PEDAL ASSEMBLY)	BELOW INSTRUMENT PANEL / DRIVER SIDE

### GROUNDS

Ground	Harness	Location
G14	JB	ENGINE COMPARTMENT / BEHIND POWER DISTRIBUTION FUSEBOX
G18	JB	ENGINE COMPARTMENT / BEHIND RH HEADLAMP
G37	IP	BEHIND INSTRUMENT PANEL / RH SIDE OF CROSS CAR BEAM

FOR CONTROL MODULE PIN-OUT INFORMATION, UNFOLD PAGE TO LEFT.

The following abbreviations are used to represent values for Control Module Pin-Out data

I	Input	PG	Power Ground	C	CAN Network	D	Serial and Encoded Data
O	Output	SS	Sensor / Signal Supply V	S	SCP Network	V	Voltage (DC)
B+	Battery Voltage	SG	Sensor / Signal Ground	D2	D2B Network	PWM	Pulse Width Modulated

**CAUTION:** The information on this data page is furnished to aid the user in understanding circuit operation. THIS INFORMATION SHOULD BE USED FOR REFERENCE ONLY.

**NOTE:** The values listed are approximately those that can be expected at the control module connector pins with all circuit connections made and all components connected and fitted.

Refer to the front of this book for detailed information and illustrations regarding the location and identification of harnesses, relays, fuses, grounds, control modules and control module pins.

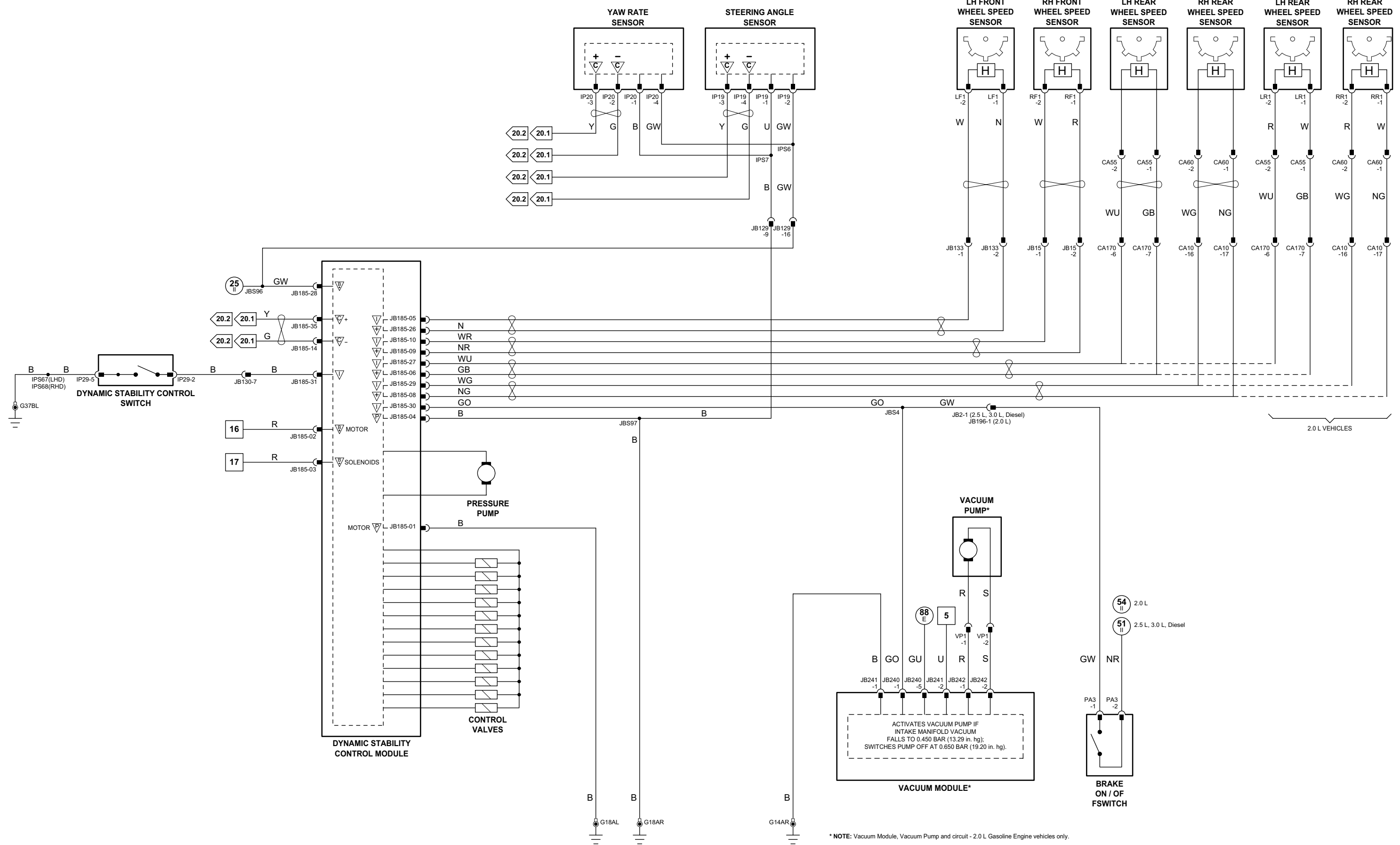

\* NOTE: Vacuum Module, Vacuum Pump and circuit - 2.0 L Gasoline Engine vehicles only.

1 → 6 Fig. 01.1	34 → 80 Fig. 01.3	11 → 31 Fig. 01.5	67 → 76 Fig. 01.7	98 → 107 Fig. 01.9	Input	Battery Voltage	Sensor/Signal Supply V	CAN	D2B Network
7 → 33 Fig. 01.2	1 → 10 Fig. 01.4	32 → 66 Fig. 01.6	77 → 97 Fig. 01.8		Output	Power Ground	Sensor/Signal Ground	SCP	Serial and Encoded Data

**VARIANT:** DSC Vehicles  
**VIN RANGE:** All  
**DATE OF ISSUE:** February 2008

## Tire Pressure Monitoring System Module

	Pin	Description and Characteristic
C	CA453-2	CAN -
C	CA453-3	CAN +
B+	CA453-8	IGNITION SWITCHED POWER SUPPLY (II): B+
PG	CA453-12	POWER GROUND: GROUND
B+	CA453-16	BATTERY POWER SUPPLY: B+
O	CA454-5	REAR LH TPMS INITIATOR: RF 125kHz +
O	CA454-6	REAR LH TPMS INITIATOR: RF 125kHz -
O	CA454-7	REAR RH TPMS INITIATOR: RF 125kHz +
O	CA454-8	REAR RH TPMS INITIATOR: RF 125kHz -
O	CA454-13	FRONT LH TPMS INITIATOR: RF 125kHz +
O	CA454-14	FRONT LH TPMS INITIATOR: RF 125kHz -
O	CA454-15	FRONT RH TPMS INITIATOR: RF 125kHz +
O	CA454-16	FRONT RH TPMS INITIATOR: RF 125kHz -
I	CA455-1	TPMS ANTENNA SIGNAL
I	CA455-2	TPMS ANTENNA GROUND SHIELD: GROUND

## Fig. 05.3

### COMPONENTS

Component	Connector(s)	Connector Description	Location
FRONT LH TIRE PRESSURE SENSOR			FRONT LH WHEEL
FRONT LH TPMS INITIATOR	JB250	2-WAY / GREY	FRONT LH WHEEL ARCH
FRONT RH TIRE PRESSURE SENSOR			FRONT RH WHEEL
FRONT RH TPMS INITIATOR	JB251	2-WAY / GREY	FRONT RH WHEEL ARCH
REAR LH TIRE PRESSURE SENSOR			REAR LH WHEEL
REAR LH TPMS INITIATOR	RB8	2-WAY / GREY	REAR LH WHEEL ARCH
REAR RH TIRE PRESSURE SENSOR			REAR RH WHEEL
REAR RH TPMS INITIATOR	RB9	2-WAY / GREY	REAR RH WHEEL ARCH
SPARE TIRE PRESSURE SENSOR			SPARE WHEEL
TPMS ANTENNA	RB10	1-WAY / GREY	BEHIND REAR BUMPER
TPMS MODULE	CA453	16-WAY / GREEN	REAR SEAT, RH SIDE
	CA454	16-WAY /BLUE	
	CA455	1-WAY /SCREENED	

### HARNESS IN-LINE CONNECTORS

Connector	Connector Description / Location	Location
CA10	22-WAY / SLATE / CABIN HARNESS TO JUNCTION BOX HARNESS	LH 'A' POST / 'A' POST TRIM
CA129	12-WAY / GREY / REAR BUMPER HARNESS TO CABIN HARNESS	SPARE WHEEL WELL
CA457	1-WAY / GREY / CABIN HARNESS TO REAR BUMPER HARNESS	SPARE WHEEL WELL

### GROUNDS

Ground	Harness	Location
G52	CA	LOWER RH 'E' POST

FOR CONTROL MODULE PIN-OUT INFORMATION, UNFOLD PAGE TO LEFT.

The following abbreviations are used to represent values for Control Module Pin-Out data

I	Input	PG	Power Ground	C	CAN Network	D	Serial and Encoded Data
O	Output	SS	Sensor / Signal Supply V	S	SCP Network	V	Voltage (DC)
B+	Battery Voltage	SG	Sensor / Signal Ground	D2	D2B Network	PWM	Pulse Width Modulated

**CAUTION:** The information on this data page is furnished to aid the user in understanding circuit operation. THIS INFORMATION SHOULD BE USED FOR REFERENCE ONLY.

**NOTE:** The values listed are approximately those that can be expected at the control module connector pins with all circuit connections made and all components connected and fitted.

Refer to the front of this book for detailed information and illustrations regarding the location and identification of harnesses, relays, fuses, grounds, control modules and control module pins.

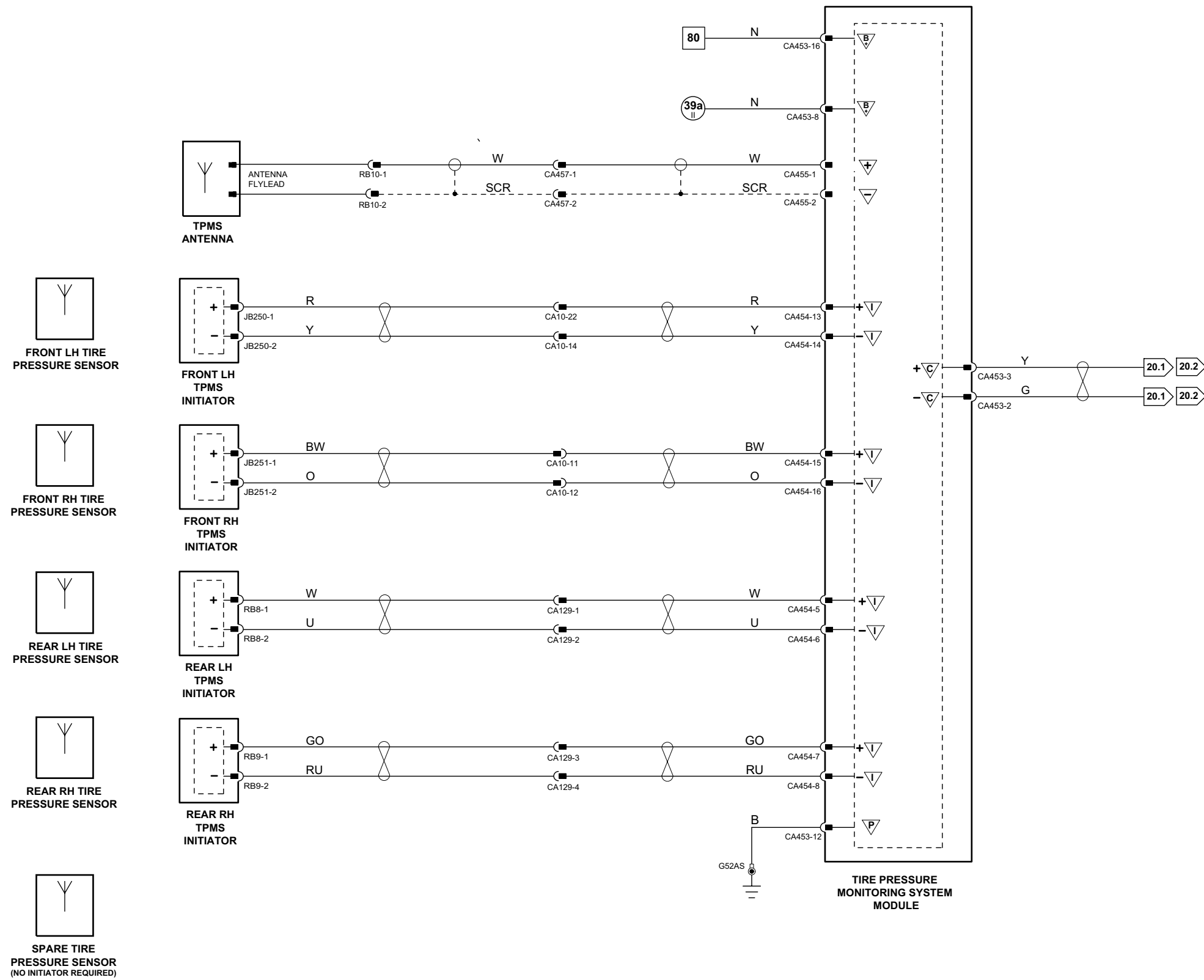

**Climate Control Module – Automatic**

Pin	Description and Characteristic
O	AC1-04 FRESH / RECIRCULATION FLAP ACTUATOR DRIVE: TO ACTIVATE, A/CCM SWITCHES CIRCUIT TO B+ OR TO GROUND
O	AC1-05 FRESH / RECIRCULATION FLAP ACTUATOR DRIVE: TO ACTIVATE, A/CCM SWITCHES CIRCUIT TO B+ OR TO GROUND
O	AC1-06 DEFROST DOOR ACTUATOR STEPPER COIL 1 DRIVE: TO ACTIVATE, A/CCM SWITCHES CIRCUIT TO GROUND
O	AC1-07 DEFROST DOOR ACTUATOR STEPPER COIL 2 DRIVE: TO ACTIVATE, A/CCM SWITCHES CIRCUIT TO GROUND
O	AC1-08 PANEL / FLOOR ACTUATOR STEPPER COIL 1 DRIVE: TO ACTIVATE, A/CCM SWITCHES CIRCUIT TO GROUND
O	AC1-09 PANEL / FLOOR ACTUATOR STEPPER COIL 2 DRIVE: TO ACTIVATE, A/CCM SWITCHES CIRCUIT TO GROUND
O	AC1-10 AIR TEMPERATURE BLEND ACTUATOR STEPPER COIL 1 DRIVE: TO ACTIVATE, A/CCM SWITCHES CIRCUIT TO GROUND
O	AC1-11 AIR TEMPERATURE BLEND ACTUATOR STEPPER COIL 2 DRIVE: TO ACTIVATE, A/CCM SWITCHES CIRCUIT TO GROUND
O	AC1-12 AIR TEMPERATURE BLEND ACTUATOR POWER SUPPLY: B+
O	AC1-13 DEFROST DOOR ACTUATOR POWER SUPPLY: B+
I	AC1-14 EVAPORATOR TEMPERATURE SENSOR SIGNAL, NOMINAL 0 – 5 V: NTC SENSOR – VOLTAGE DECREASES AS TEMPERATURE INCREASES
I	AC1-15 DISCHARGE TEMPERATURE SENSOR SIGNAL, NOMINAL 0 – 5 V: NTC SENSOR – VOLTAGE DECREASES AS TEMPERATURE INCREASES
I	AC1-16 SENSOR GROUND: GROUND
O	AC1-20 DEFROST DOOR ACTUATOR STEPPER COIL 3 DRIVE: TO ACTIVATE, A/CCM SWITCHES CIRCUIT TO GROUND
O	AC1-21 DEFROST DOOR ACTUATOR STEPPER COIL 4 DRIVE: TO ACTIVATE, A/CCM SWITCHES CIRCUIT TO GROUND
O	AC1-22 PANEL / FLOOR ACTUATOR STEPPER COIL 3 DRIVE: TO ACTIVATE, A/CCM SWITCHES CIRCUIT TO GROUND
O	AC1-23 PANEL / FLOOR ACTUATOR STEPPER COIL 4 DRIVE: TO ACTIVATE, A/CCM SWITCHES CIRCUIT TO GROUND
O	AC1-24 AIR TEMPERATURE BLEND ACTUATOR STEPPER COIL 3 DRIVE: TO ACTIVATE, A/CCM SWITCHES CIRCUIT TO GROUND
O	AC1-25 AIR TEMPERATURE BLEND ACTUATOR STEPPER COIL 4 DRIVE: TO ACTIVATE, A/CCM SWITCHES CIRCUIT TO GROUND
O	AC1-26 PANEL / FLOOR ACTUATOR POWER SUPPLY: B+
B+	IP101-01 BATTERY SAVER POWER SUPPLY: B+
B+	IP101-02 IGNITION SWITCHED POWER SUPPLY: B+
I	IP101-05 ASPIRATOR MOTOR DRIVE: PERMANENTLY CONNECTED TO GROUND; A/CCM MONITORS CIRCUIT FOR MOTOR RUNNING CONDITION
O	IP101-06 BLOWER MOTOR CONTROL: PWM, 400 Hz, APPROXIMATELY 8% – 90%; HIGHER DUTY CYCLE = HIGHER BLOWER SPEED
I	IP101-07 BLOWER MOTOR SPEED SENSE: FREQUENCY = RPM / 20; FREQUENCY PROPORTIONAL TO BLOWER SPEED
C	IP101-09 CAN +
C	IP101-10 CAN –
B+	IP101-14 BATTERY POWER SUPPLY: B+
PG	IP101-15 POWER GROUND: GROUND
I	IP101-16 IN-CAR TEMPERATURE SENSOR SIGNAL, NOMINAL 0 – 5 V: NTC SENSOR – VOLTAGE DECREASES AS TEMPERATURE INCREASES
SG	IP101-17 SENSOR GROUND: GROUND
I	IP101-19 AMBIENT TEMPERATURE SENSOR SIGNAL, NOMINAL 0 – 5 V: NTC SENSOR – VOLTAGE DECREASES AS TEMPERATURE INCREASES
I	IP101-20 DIMMER CONTROLLED ILLUMINATION: PWM, 80 Hz, GROUND = 0% DUTY CYCLE, B+ = 100% DUTY CYCLE
O	IP101-21 AIR CONDITIONING BLOWER RELAY DRIVE: TO ACTIVATE, A/CCM SWITCHES CIRCUIT TO B+
C	IP101-22 CAN +
C	IP101-23 CAN –

The following abbreviations are used to represent values for Control Module Pin-Out data

I	Input	PG	Power Ground	C	CAN Network	D	Serial and Encoded Data
O	Output	SS	Sensor / Signal Supply V	S	SCP Network	V	Voltage (DC)
B+	Battery Voltage	SG	Sensor / Signal Ground	D2	D2B Network	PWM	Pulse Width Modulated

**CAUTION:** The information on this data page is furnished to aid the user in understanding circuit operation. THIS INFORMATION SHOULD BE USED FOR REFERENCE ONLY.

**NOTE:** The values listed are approximately those that can be expected at the control module connector pins with all circuit connections made and all components connected and fitted.

**Fig. 06.1**

**COMPONENTS**

Component	Connector(s)	Connector Description	Location
AIR CONDITIONING BLOWER RELAY	–	–	PASSENGER JUNCTION FUSEBOX – R4
AIR TEMPERATURE BLEND ACTUATOR	AC2	6-WAY / BLACK	RH SIDE OF AIR DISTRIBUTION UNIT
AMBIENT TEMPERATURE SENSOR	JB105	2-WAY / BLACK	FRONT CROSS MEMBER, ADJACENT TO RADIATOR / LH SIDE
BLOWER – AUTOMATIC CLIMATE CONTROL	IP134	6-WAY / BLACK	BEHIND INSTRUMENT PANEL / RH SIDE
CLIMATE CONTROL MODULE – REMOTE	AC1	26-WAY / YELLOW	RH SIDE OF AIR DISTRIBUTION UNIT
	IP101	26-WAY / WHITE	
DEFROST DOOR ACTUATOR	AC4	6-WAY / BLACK	RH SIDE OF AIR DISTRIBUTION UNIT
DISCHARGE TEMPERATURE SENSOR	AC6	2-WAY / BLACK	RH SIDE OF AIR DISTRIBUTION UNIT
EVAPORATOR TEMPERATURE SENSOR	AC5	2-WAY / BLACK	RH SIDE OF AIR DISTRIBUTION UNIT
FRESH / RECIRCULATION FLAP ACTUATOR	AC7	4-WAY / BLACK	LHD: LH SIDE OF AIR DISTRIBUTION UNIT RHD: RH SIDE OF AIR DISTRIBUTION UNIT
IN-CAR TEMPERATURE SENSOR	IP66	4-WAY / BLACK	BELOW INSTRUMENT PANEL CENTER RIGHT
PANEL / FLOOR ACTUATOR	AC3	6-WAY / BLACK	RH SIDE OF AIR DISTRIBUTION UNIT
PASSENGER JUNCTION FUSEBOX	–	–	PASSENGER COMPARTMENT, FRONT BULKHEAD / LH SIDE

**HARNESS IN-LINE CONNECTORS**

Connector	Connector Description / Location	Location
JB3	14-WAY / BLUE / JUNCTION BOX HARNESS TO INSTRUMENT PANEL HARNESS	BELOW INSTRUMENT PANEL / LH SIDE

**GROUNDS**

Ground	Harness	Location
G15	CA	LOWER LH 'A' POST
G36	IP	BEHIND INSTRUMENT PANEL / LH SIDE OF CROSS CAR BEAM
G37	IP	BEHIND INSTRUMENT PANEL / RH SIDE OF CROSS CAR BEAM

**FOR CONTROL MODULE PIN-OUT INFORMATION, UNFOLD PAGE TO LEFT.**

Refer to the front of this book for detailed information and illustrations regarding the location and identification of harnesses, relays, fuses, grounds, control modules and control module pins.

**NOTE:** Vehicles without Navigation 'Touch Screen' - The CCM incorporates the control panel for the Climate Control System.

Vehicles with Navigation 'Touch Screen' - The CCM is remotely mounted on the Climate Control Unit. Driver control inputs are received via Network Communication.

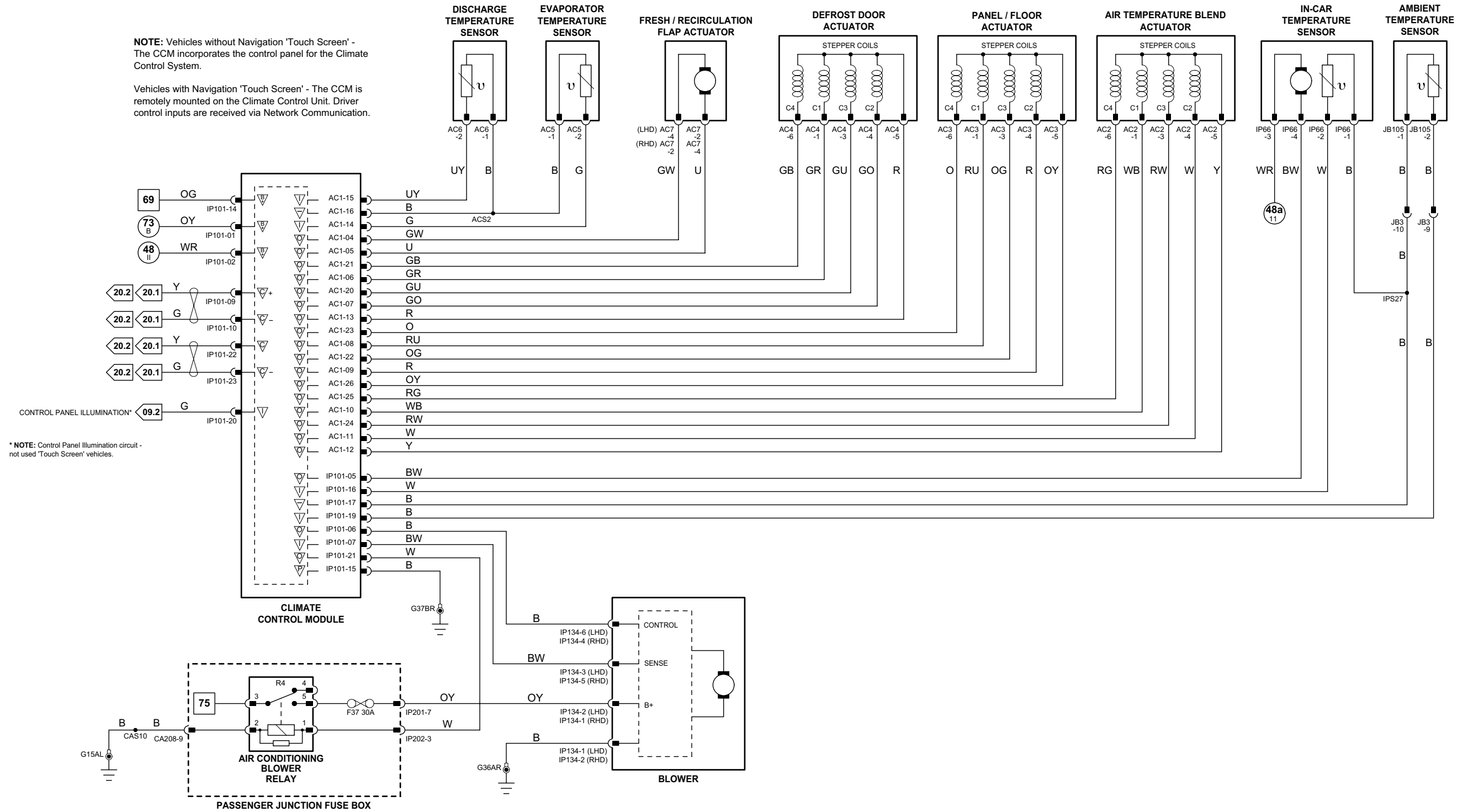

\* NOTE: Control Panel Illumination circuit - not used 'Touch Screen' vehicles.

**NOTE:** Refer to Figure 03.2, 03.4 or 03.6 for A/C Compressor Clutch and Cooling Fan circuits.

**Climate Control Module – Automatic**

	Pin	Description and Characteristic
O	IP101-03	WINDSHIELD HEATER RELAY DRIVE: TO ACTIVATE, A/CCM SWITCHES CIRCUIT TO GROUND
O	IP101-04	HEATED REAR WINDOW RELAY DRIVE: TO ACTIVATE, A/CCM SWITCHES CIRCUIT TO GROUND

**Driver Seat Module**

	Pin	Description and Characteristic
I	DM1-10	HEATED REAR WINDOW RELAY ACTIVATED SIGNAL
O	DM1-14	DOOR MIRROR MOVEMENT / HEATERS DRIVE
B+	DM2-01	BATTERY POWER SUPPLY: B+
SG	DM2-03	SIGNAL GROUND: GROUND
B+	DM2-04	IGNITION SWITCHED POWER SUPPLY II: B+
PG	DM2-05	POWER GROUND: GROUND
B+	DM2-06	BATTERY POWER SUPPLY: B+

**Fig. 06.2**

**COMPONENTS**

Component	Connector(s)	Connector Description	Location
CLIMATE CONTROL MODULE – PANEL	AC1	26-WAY / YELLOW	BEHIND CLIMATE CONTROL PANEL
	IP39	6-WAY / GREY	
	IP101	26-WAY / WHITE	
	IP135	2-WAY / GREY	
CLIMATE CONTROL MODULE – REMOTE	AC1	26-WAY / YELLOW	RH SIDE OF AIR DISTRIBUTION UNIT
	IP101	26-WAY / WHITE	
DOOR MIRROR – DRIVER	DD5	22-WAY / GREY	DRIVER DOOR
DOOR MIRROR – PASSENGER	PD4	22-WAY / GREY	PASSENGER DOOR
HEATED DOOR MIRROR – DRIVER	DD5	22-WAY / GREY	DRIVER DOOR
HEATED DOOR MIRROR – PASSENGER	PD4	22-WAY / GREY	PASSENGER DOOR
HEATED REAR WINDOW – ESTATE /WAGON	WG5	2-WAY / BLACK	REAR WINDOW
HEATED REAR WINDOW – SEDAN	ZA1	1-WAY / BLACK	REAR WINDOW
	ZA10	1-WAY / BLACK	
HEATED REAR WINDOW RELAY	-	-	PASSENGER JUNCTION FUSEBOX – R6
PASSENGER JUNCTION FUSEBOX	-	-	PASSENGER COMPARTMENT, FRONT BULKHEAD / LH SIDE
POWER DISTRIBUTION FUSEBOX	-	-	ENGINE COMPARTMENT
SEAT MODULE – DRIVER	DM2	10-WAY / GREY	DRIVER SEAT SWITCH PACK
	DM3	16-WAY / BLACK	
	DM4	8-WAY / BLUE	
	DM5	8-WAY / GREEN	
	DM5	8-WAY / GREEN	
WINDSHIELD HEATER – LH	JB95	2-WAY / BLACK	WINDSHIELD / LH SIDE
WINDSHIELD HEATER – RH	JB96	2-WAY / BLACK	WINDSHIELD / RH SIDE
WINDSHIELD HEATER RELAY	-	-	POWER DISTRIBUTION FUSEBOX – R6

**HARNESS IN-LINE CONNECTORS**

Connector	Connector Description / Location	Location
CA15	20-WAY / BLACK / CABIN HARNESS TO DRIVER DOOR HARNESS	DRIVER DOOR / DOOR CASING
CA16	20-WAY / BLACK / CABIN HARNESS TO DRIVER DOOR HARNESS	DRIVER DOOR / DOOR CASING
CA20	20-WAY / BLACK / CABIN HARNESS TO PASSENGER DOOR HARNESS	PASSENGER DOOR / DOOR CASING
CA21	20-WAY / BLACK / CABIN HARNESS TO PASSENGER DOOR HARNESS	PASSENGER DOOR / DOOR CASING
CA127	2-WAY / BLACK / CABIN HARNESS TO HEATER REAR WINDOW HARNESS	BEHIND LH 'E' POST TRIM
CA431	16-WAY / GREY / CABIN HARNESS TO DRIVER SEAT HARNESS	UNDER DRIVER SEAT
JB130	22-WAY / GREEN / JUNCTION BOX HARNESS TO INSTRUMENT PANEL HARNESS	BELOW INSTRUMENT PANEL / LH SIDE
WG3	3-WAY / BLACK / CABIN HARNESS TO TAIL GATE GLASS HARNESS	ROOF / CENTER REAR

**GROUNDS**

Ground	Harness	Location
G3	C03	LH 'E' POST
G4	CA	LOWER RH 'A' POST
G14	JB	ENGINE COMPARTMENT / BEHIND POWER DISTRIBUTION FUSEBOX
G15	CA	LOWER LH 'A' POST
G50	CA	HEADLINER / RH REAR ROOF PANEL

**NOTE: FOR CONTROL MODULE PIN-OUT INFORMATION, UNFOLD PAGE TO LEFT.**

The following abbreviations are used to represent values for Control Module Pin-Out data

I	Input	PG	Power Ground	C	CAN Network	D	Serial and Encoded Data
O	Output	SS	Sensor / Signal Supply V	S	SCP Network	V	Voltage (DC)
B+	Battery Voltage	SG	Sensor / Signal Ground	D2	D2B Network	PWM	Pulse Width Modulated

**CAUTION:** The information on this data page is furnished to aid the user in understanding circuit operation. THIS INFORMATION SHOULD BE USED FOR REFERENCE ONLY.

**NOTE:** The values listed are approximately those that can be expected at the control module connector pins with all circuit connections made and all components connected and fitted.

Refer to the front of this book for detailed information and illustrations regarding the location and identification of harnesses, relays, fuses, grounds, control modules and control module pins.



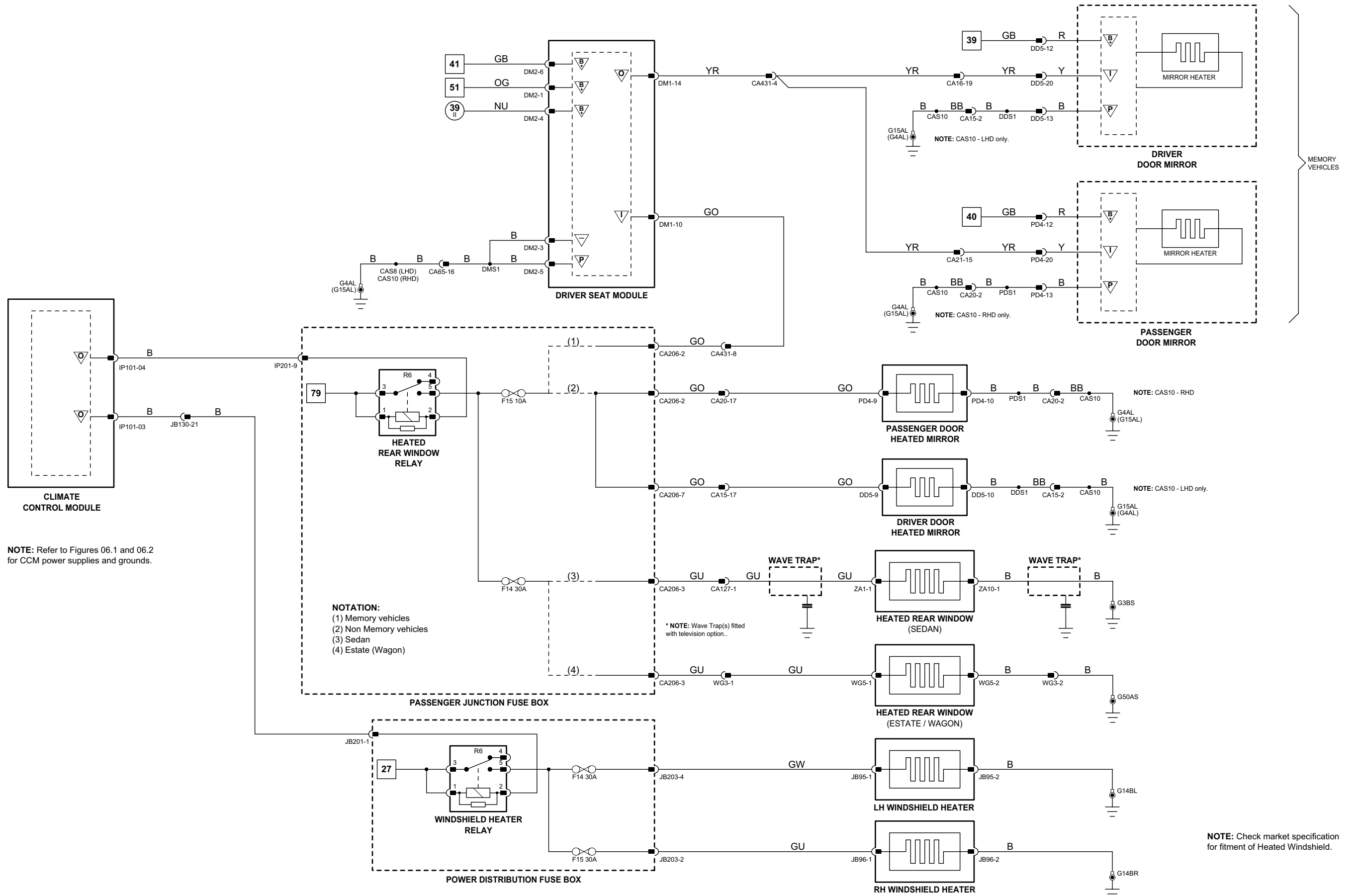

NOTE: Refer to Figures 06.1 and 06.2 for CCM power supplies and grounds.

NOTATION:  
 (1) Memory vehicles  
 (2) Non Memory vehicles  
 (3) Sedan  
 (4) Estate (Wagon)

\* NOTE: Wave Trap(s) fitted with television option..

NOTE: Check market specification for fitment of Heated Windshield.

1 → 6 Fig. 01.1	34 → 80 Fig. 01.3	11 → 31 Fig. 01.5	67 → 76 Fig. 01.7	98 → 107 Fig. 01.9	Input	Battery Voltage	Sensor/Signal Supply V	CAN	D2B Network
7 → 33 Fig. 01.2	1 → 10 Fig. 01.4	32 → 66 Fig. 01.6	77 → 97 Fig. 01.8		Output	Power Ground	Sensor/Signal Ground	SCP	Serial and Encoded Data

VARIANT: Glass Heater Vehicles  
 VIN RANGE: All  
 DATE OF ISSUE: February 2008

**General Electronic Module**

	Pin	Description and Characteristic
S	IP5-18	SCP -
S	IP5-19	SCP +
I	IP6-18	SEAT BELT AND AIRBAG AUDIBLE WARNING REQUEST: AUDIBLE WARNING REQUEST ACTIVE = GROUND

**Instrument Cluster**

	Pin	Description and Characteristic
I	IP10-01	REVERSE LAMP SWITCH: B+ WHEN ACTIVATED
I	IP10-07	FUEL LEVEL SENSOR 1 SIGNAL: VARIABLE RESISTANCE: 20 R = EMPTY; 160 R = FULL
I	IP10-08	FUEL LEVEL SENSOR 2 SIGNAL: VARIABLE RESISTANCE: 20 R = EMPTY; 160 R = FULL
SG	IP10-09	FUEL LEVEL SENSOR REFERENCE: GROUND
I	IP10-10	MAIN BEAM STATUS: B+ WHEN ACTIVATED
I	IP10-11	WASHER FLUID LEVEL LOW SIGNAL: FLUID LEVEL LOW = GROUND
I	IP10-12	BRAKE FLUID LEVEL WARNING SIGNAL: FLUID LEVEL LOW = GROUND
I	IP10-15	PARKING BRAKE SIGNAL: PARKING BRAKE ON = GROUND
I	IP10-16	TRIP COMPUTER CYCLE SWITCH: GROUND WHEN ACTIVATED
C	IP10-17	CAN +
C	IP10-18	CAN -
I	IP10-19	FRONT FOG STATUS (HARD WIRED TO INDICATOR): B+ WHEN ACTIVATED
I	IP10-20	REAR FOG STATUS (HARD WIRED TO INDICATOR): B+ WHEN ACTIVATED
S	IP10-22	SCP +
S	IP10-23	SCP -
I	IP10-24	TRIP COMPUTER MODE SIGNAL: STEPPED RESISTANCE
SG	IP10-25	TRIP COMPUTER SWITCH PACK REFERENCE: GROUND
I	IP11-05	ENGINE OIL PRESSURE SIGNAL: ENGINE OIL PRESSURE PRESENT = GROUND
I	IP11-07	BATTERY POWER SUPPLY: B+
I	IP11-08	POWER GROUND: GROUND
I	IP11-11	IGNITION SWITCHED POWER SUPPLY (II): B+
I	IP11-13	IGNITION SWITCHED POWER SUPPLY (I): B+
I	IP11-15	SIDE LAMPS STATUS: B+ WHEN ACTIVATED
I	IP11-17	DIP BEAM STATUS: B+ WHEN ACTIVATED
I	IP11-19	AIR BAG WARNING: HARD WIRED TO AIR BAG INDICATOR
I	IP11-21	DIMMER CONTROLLED ILLUMINATION: PWM, 80 Hz, GROUND = 0% DUTY CYCLE, B+ = 100% DUTY CYCLE; HARD WIRED TO BACK LIGHTING; MICRO SENSED FOR DISPLAY

**Fig. 07.1**

**COMPONENTS**

Component	Connector(s)	Connector Description	Location
BRAKE FLUID LEVEL SWITCH	JB70	3-WAY / BLACK	BRAKE MASTER CYLINDER
FUEL LEVEL SENSOR - 2.0 L, Diesel	CA415	6-WAY / BLACK	FUEL TANK
FUEL LEVEL SENSOR 1 - 2.5 L, 3.0 L (NAS)	FT6	6-WAY / BLACK	FUEL TANK
FUEL LEVEL SENSOR 1 - 2.5 L, 3.0 L (ROW)	FT2	4-WAY / BLACK	FUEL TANK
FUEL LEVEL SENSOR 2 - 2.5 L, 3.0 L (NAS)	FT6	6-WAY / BLACK	FUEL TANK
FUEL LEVEL SENSOR 2 - 2.5 L, 3.0 L (ROW)	FT3	4-WAY / BLACK	FUEL TANK
GENERAL ELECTRONIC MODULE	CA86	23-WAY / GREY	BEHIND INSTRUMENT PANEL / RH SIDE
	CA87	23-WAY / GREEN	
	IP5	23-WAY / BROWN	
	IP6	23-WAY / NATURAL	
	JB172	23-WAY / BLUE	
INSTRUMENT CLUSTER	IP10	26-WAY / WHITE	INSTRUMENT PANEL
	IP11	26-WAY / WHITE	
MASTER LIGHTING SWITCH	IP17	16-WAY / BLACK	INSTRUMENT PANEL
OIL PRESSURE SWITCH - Diesel	DE4	1-WAY / BLACK	ABOVE ENGINE OIL FILTER
OIL PRESSURE SWITCH - 2.0 L, 2.5 L, 3.0 L	EN19	1-WAY / BLACK	ADJACENT TO ENGINE OIL FILTER
PARKING BRAKE SWITCH	IP72	1-WAY / ORANGE	PARKING BRAKE
RESTRAINTS CONTROL MODULE - ALL WHEEL DRIVE VEHICLES	CA450	40-WAY / BLACK	UNDER CENTER CONSOLE
	IP74	24-WAY / BLACK	
RESTRAINTS CONTROL MODULE - FRONT WHEEL DRIVE VEHICLES	CA165	40-WAY / BLACK	UNDER CENTER CONSOLE
	IP74	24-WAY / BLACK	
TURN SIGNAL SWITCH	IP53	10-WAY / GREY	STEERING COLUMN
WASHER FLUID LEVEL SWITCH	JB103	2-WAY / BLACK	ENGINE COMPARTMENT / RH FRONT

**HARNESS IN-LINE CONNECTORS**

Connector	Connector Description / Location	Location
CA1	22-WAY / NATURAL / INSTRUMENT PANEL HARNESS TO CABIN HARNESS	LH 'A' POST / 'A' POST TRIM
CA5	12-WAY / BLACK / FUEL TANK LINK HARNESS TO CABIN HARNESS	TOP OF FUEL TANK
CA169	4-WAY / GREY / CABIN HARNESS TO INSTRUMENT PANEL HARNESS	LH LOWER A POST / A POST TRIM
CA240	12-WAY / GREY / CABIN HARNESS TO INSTRUMENT PANEL HARNESS	LH LOWER 'A' POST / 'A' POST TRIM
DL2	42-WAY / BLACK / ENGINE HARNESS TO ENGINE MANAGEMENT HARNESS	ENGINE COMPARTMENT / RH SIDE
JB1	42-WAY / BLACK / ENGINE MANAGEMENT HARNESS TO JUNCTION BOX HARNESS	ENGINE COMPARTMENT / LH SIDE
JB129	22-WAY / GREY / JUNCTION BOX HARNESS TO INSTRUMENT PANEL HARNESS	BELOW INSTRUMENT PANEL / LH SIDE

**GROUNDS**

Ground	Harness	Location
G10	JB	ENGINE COMPARTMENT / BEHIND RH HEADLAMP
G14	JB	ENGINE COMPARTMENT / BEHIND POWER DISTRIBUTION FUSEBOX
G36	IP	BEHIND INSTRUMENT PANEL / LH SIDE OF CROSS CAR BEAM
G37	IP	BEHIND INSTRUMENT PANEL / RH SIDE OF CROSS CAR BEAM

FOR CONTROL MODULE PIN-OUT INFORMATION, UNFOLD PAGE TO LEFT.

The following abbreviations are used to represent values for Control Module Pin-Out data

I	Input	PG	Power Ground	C	CAN Network	D	Serial and Encoded Data
O	Output	SS	Sensor / Signal Supply V	S	SCP Network	V	Voltage (DC)
B+	Battery Voltage	SG	Sensor / Signal Ground	D2	D2B Network	PWM	Pulse Width Modulated

CAUTION: The information on this data page is furnished to aid the user in understanding circuit operation. THIS INFORMATION SHOULD BE USED FOR REFERENCE ONLY.

NOTE: The values listed are approximately those that can be expected at the control module connector pins with all circuit connections made and all components connected and fitted.

Refer to the front of this book for detailed information and illustrations regarding the location and identification of harnesses, relays, fuses, grounds, control modules and control module pins.

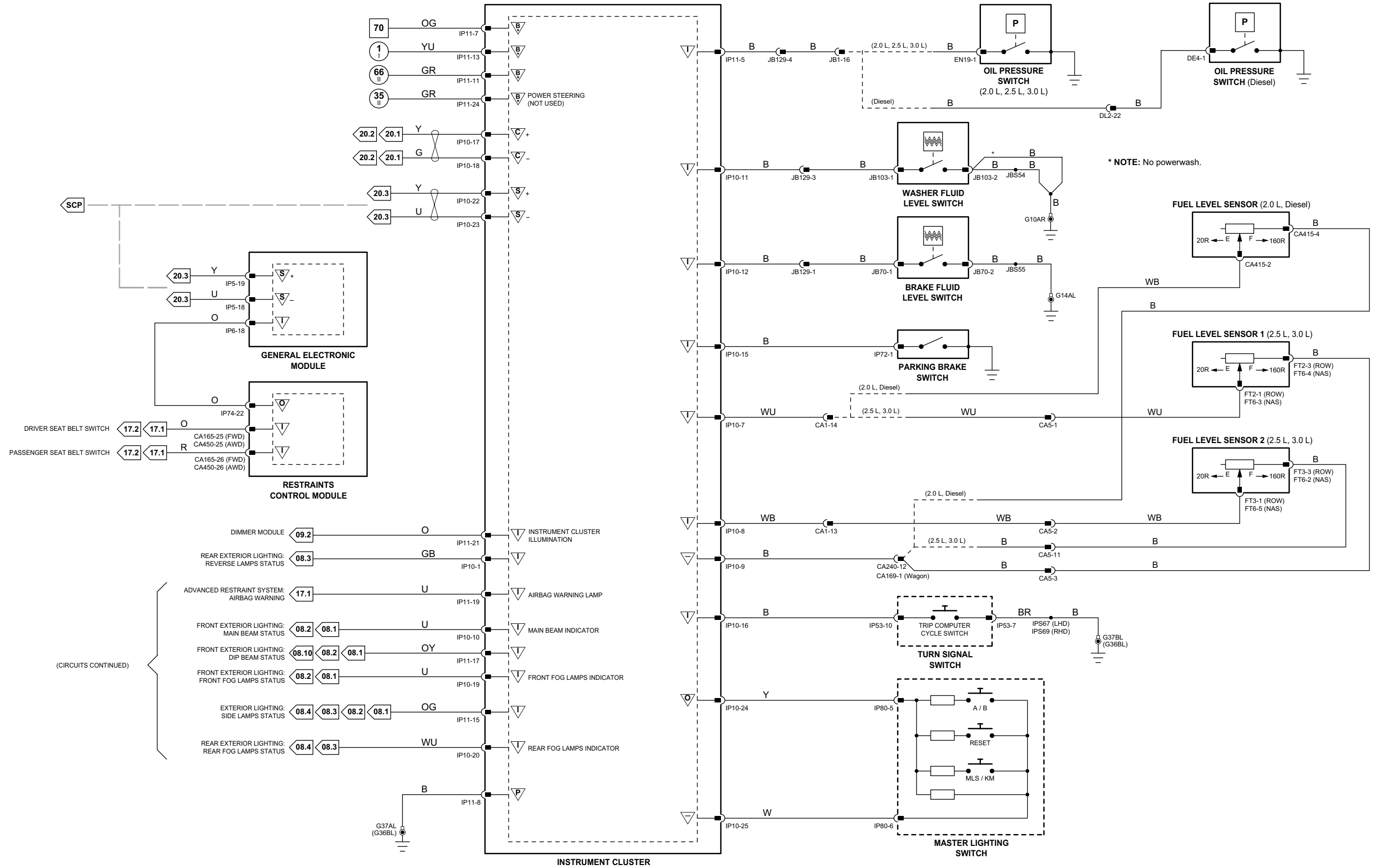

\* NOTE: No powerwash.

(CIRCUITS CONTINUED)

**Fig. 07.2**

**General Electronic Module**

	Pin	Description and Characteristic
PG	CA86-05	POWER GROUND
S	IP5-18	SCP -
S	IP5-19	SCP +
SG	IP6-01	LOGIC GROUND: GROUND
I	IP6-08	KEY-IN IGNITION SWITCH: B+ WHEN KEY IN
I	IP6-15	NOT-IN-PARK SWITCH: PARK = OPEN CIRCUIT; NOT-IN-PARK = GROUND
I	IP6-18	SEAT BELT AND AIRBAG AUDIBLE WARNING REQUEST: AUDIBLE WARNING REQUEST ACTIVE = GROUND
I	IP6-22	DRIVER DOOR AJAR: DOOR OPEN = OPEN CIRCUIT; DOOR CLOSED = GROUND
B+	JB172-05	BATTERY POWER SUPPLY (TURN SIGNALS): B+

**Instrument Cluster**

	Pin	Description and Characteristic
S	IP10-22	SCP +
S	IP10-23	SCP -

**COMPONENTS**

Component	Connector(s)	Connector Description	Location
DOOR LATCH - DRIVER	DD3	8-WAY / BLACK	DRIVER DOOR
	DD9	2-WAY / BLACK	
GENERAL ELECTRONIC MODULE	CA86	23-WAY / GREY	BEHIND INSTRUMENT PANEL / RH SIDE
	CA87	23-WAY / GREEN	
	IP5	23-WAY / BROWN	
	IP6	23-WAY / NATURAL	
	JB172	23-WAY / BLUE	
IGNITION SWITCH	IP18	7-WAY / BLACK	STEERING COLUMN
INSTRUMENT CLUSTER	IP10	26-WAY / WHITE	INSTRUMENT PANEL
	IP11	26-WAY / WHITE	
J-GATE MODULE	IP14	16-WAY / GREY	CENTER CONSOLE
RESTRAINTS CONTROL MODULE - ALL WHEEL DRIVE VEHICLES	CA450	40-WAY / BLACK	UNDER CENTER CONSOLE
	IP74	24-WAY / BLACK	
RESTRAINTS CONTROL MODULE - FRONT WHEEL DRIVE VEHICLES	CA165	40-WAY / BLACK	UNDER CENTER CONSOLE
	IP74	24-WAY / BLACK	

**HARNESS IN-LINE CONNECTORS**

Connector	Connector Description / Location	Location
CA1	22-WAY / NATURAL / INSTRUMENT PANEL HARNESS TO CABIN HARNESS	LH 'A' POST / 'A' POST TRIM
CA15	20-WAY / BLACK / CABIN HARNESS TO DRIVER DOOR HARNESS	DRIVER DOOR / DOOR CASING

**GROUNDS**

Ground	Harness	Location
G4	CA	LOWER RH 'A' POST
G5	IP	UPPER RH 'A' POST

FOR CONTROL MODULE PIN-OUT INFORMATION, UNFOLD PAGE TO LEFT.

The following abbreviations are used to represent values for Control Module Pin-Out data

I	Input	PG	Power Ground	C	CAN Network	D	Serial and Encoded Data
O	Output	SS	Sensor / Signal Supply V	S	SCP Network	V	Voltage (DC)
B+	Battery Voltage	SG	Sensor / Signal Ground	D2	D2B Network	PWM	Pulse Width Modulated

**CAUTION:** The information on this data page is furnished to aid the user in understanding circuit operation. THIS INFORMATION SHOULD BE USED FOR REFERENCE ONLY.

**NOTE:** The values listed are approximately those that can be expected at the control module connector pins with all circuit connections made and all components connected and fitted.

Refer to the front of this book for detailed information and illustrations regarding the location and identification of harnesses, relays, fuses, grounds, control modules and control module pins.

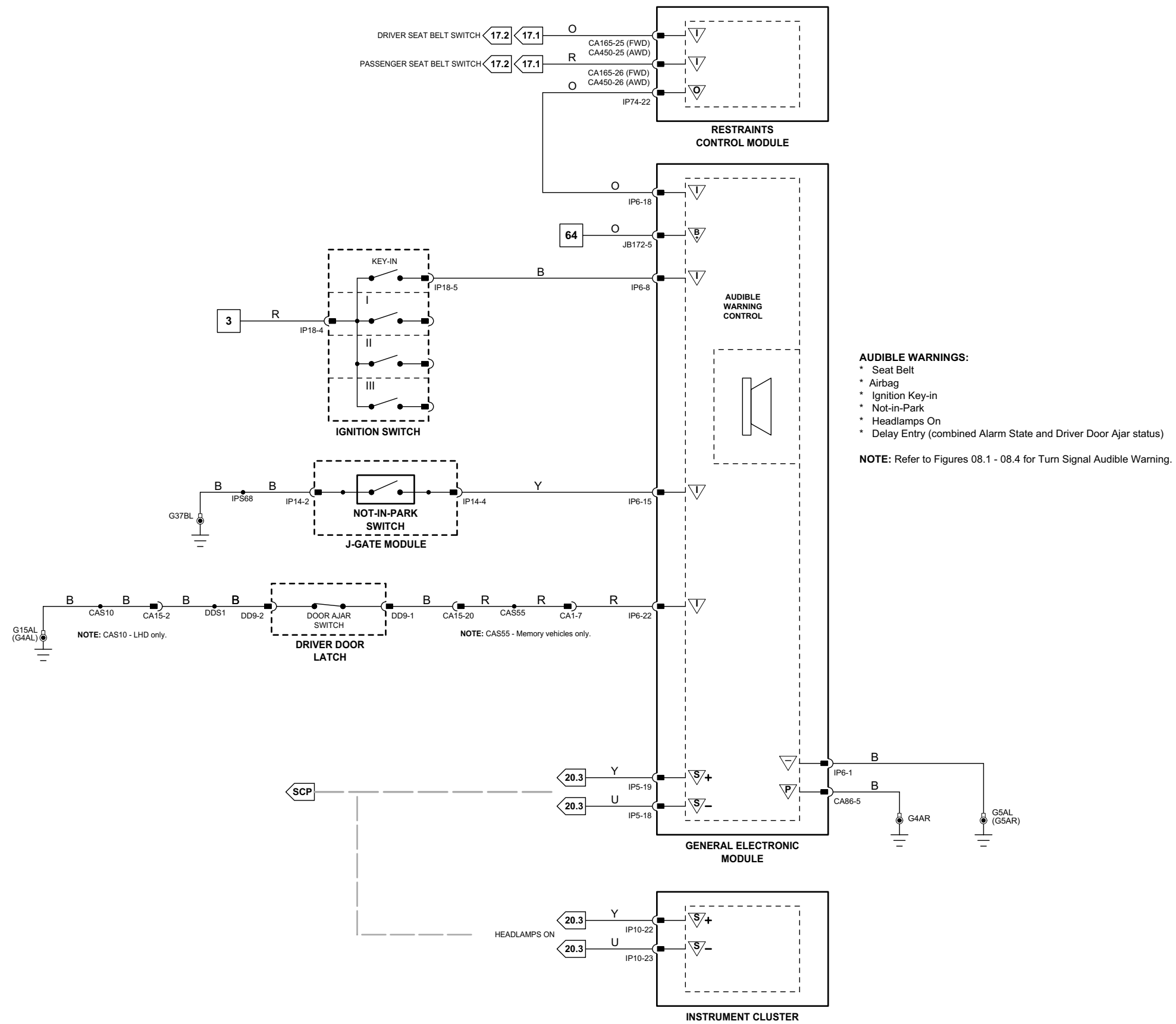

**General Electronic Module**

	Pin	Description and Characteristic
PG	CA86-05	POWER GROUND
I	IP5-03	SEDAN (EXCEPT JAPAN AND S. KOREA): EXTERNAL ANTENNA
S	IP5-18	SCP -
S	IP5-19	SCP +
O	IP5-22	TURN SIGNAL AUDIBLE WARNING: TO ACTIVATE, GEM SWITCHES CIRCUIT TO B+
I	IP5-23	REMOTE RF SIGNAL
SG	IP6-01	LOGIC GROUND: GROUND
I	IP6-09	HEADLAMP FLASH SWITCH: GROUND WHEN SELECTED
I	IP6-11	MAIN BEAM SWITCH: GROUND WHEN SELECTED
O	IP6-13	MAIN BEAM / FRONT FOG RELAY DRIVE: TO ACTIVATE, GEM SWITCHES CIRCUIT TO B+
I	IP6-17	LH TURN SIGNAL SWITCH: GROUND WHEN SELECTED
I	IP6-19	RH TURN SIGNAL SWITCH: GROUND WHEN SELECTED
I	IP6-23	HAZARD SWITCH: GROUND WHEN SELECTED
O	JB172-03	RH TURN SIGNAL: TO ACTIVATE, GEM SWITCHES CIRCUIT TO B+
O	JB172-04	LH TURN SIGNAL: TO ACTIVATE, GEM SWITCHES CIRCUIT TO B+
B+	JB172-05	BATTERY POWER SUPPLY (TURN SIGNALS): B+

**Fig. 08.1**

**COMPONENTS**

Component	Connector(s)	Connector Description	Location
AUTO HEADLAMPS SENSOR	RC36	8-WAY / GREY	BEHIND REAR VIEW MIRROR
DIP BEAM RELAY	-	-	POWER DISTRIBUTION FUSEBOX - R11
FOG LAMP - LH FRONT	FB1	2-WAY / BLACK	FRONT BUMPER / LH SIDE
FOG LAMP - RH FRONT	FB3	2-WAY / BLACK	FRONT BUMPER / RH SIDE
GENERAL ELECTRONIC MODULE	CA86	23-WAY / GREY	BEHIND INSTRUMENT PANEL / RH SIDE
	CA87	23-WAY / GREEN	
	IP5	23-WAY / BROWN	
	IP6	23-WAY / NATURAL	
	JB172	23-WAY / BLUE	
GLOVE BOX LAMP	IP25	2-WAY / BROWN	GLOVE BOX
HAZARD SWITCH	IP51	6-WAY / BLACK	CENTER CONSOLE
HEADLAMP UNIT - LH	JB84	10-WAY / BLACK	ENGINE COMPARTMENT / LH SIDE
HEADLAMP UNIT - RH	JB85	10-WAY / BLACK	ENGINE COMPARTMENT / RH SIDE
LH TURN SIGNAL REPEATER	PD4	22-WAY / GREY	PASSENGER DOOR
MAIN BEAM / FRONT FOG RELAY	-	-	POWER DISTRIBUTION FUSEBOX - R1
MASTER LIGHTING SWITCH	IP17	16-WAY / BLACK	INSTRUMENT PANEL
PASSENGER JUNCTION FUSEBOX	-	-	PASSENGER COMPARTMENT, FRONT BULKHEAD / LH SIDE
POWER DISTRIBUTION FUSEBOX	-	-	ENGINE COMPARTMENT
RF MODULE	RC35	3-WAY / BLACK	ROOF CONSOLE
RH TURN SIGNAL REPEATER	DD5	22-WAY / GREY	DRIVER DOOR
SIDE MARKER LAMP - LH FRONT	FB2	2-WAY / BLACK	FRONT BUMPER / LH SIDE
SIDE MARKER LAMP - RH FRONT	FB4	2-WAY / BLACK	FRONT BUMPER / RH SIDE
TURN SIGNAL SWITCH	IP53	10-WAY / GREY	STEERING COLUMN

**HARNESS IN-LINE CONNECTORS**

Connector	Connector Description / Location	Location
CA1	22-WAY / NATURAL / INSTRUMENT PANEL HARNESS TO CABIN HARNESS	LH 'A' POST / 'A' POST TRIM
CA15	20-WAY / BLACK / CABIN HARNESS TO DRIVER DOOR HARNESS	DRIVER DOOR / DOOR CASING
CA16	20-WAY / BLACK / CABIN HARNESS TO DRIVER DOOR HARNESS	DRIVER DOOR / DOOR CASING
CA20	20-WAY / BLACK / CABIN HARNESS TO PASSENGER DOOR HARNESS	PASSENGER DOOR / DOOR CASING
CA21	20-WAY / BLACK / CABIN HARNESS TO PASSENGER DOOR HARNESS	PASSENGER DOOR / DOOR CASING
CA36	16-WAY / GREEN / CABIN HARNESS TO ROOF HARNESS	LH 'A' POST / WINDSHIELD PILLAR
CA40	16-WAY / GREY / CABIN HARNESS TO ROOF HARNESS	RH 'A' POST / WINDSHIELD PILLAR
CA170	16-WAY / GREEN / JUNCTION BOX HARNESS TO CABIN HARNESS	LH 'A' POST / 'A' POST TRIM
CA240	12-WAY / GREY / CABIN HARNESS TO INSTRUMENT PANEL HARNESS	LH LOWER 'A' POST / 'A' POST TRIM
JB3	14-WAY / BLUE / JUNCTION BOX HARNESS TO INSTRUMENT PANEL HARNESS	BELOW INSTRUMENT PANEL / LH SIDE
JB129	22-WAY / GREY / JUNCTION BOX HARNESS TO INSTRUMENT PANEL HARNESS	BELOW INSTRUMENT PANEL / LH SIDE
JB173	10-WAY / BLACK / JUNCTION BOX HARNESS TO FRONT BUMPER HARNESS	BEHIND LH FRONT WHEEL ARCH LINER

**GROUNDS**

Ground	Harness	Location
G4	CA	LOWER RH 'A' POST
G5	IP	UPPER RH 'A' POST
G10	JB	ENGINE COMPARTMENT / BEHIND RH HEADLAMP
G11	JB	ENGINE COMPARTMENT / BEHIND LH HEADLAMP
G14	JB	ENGINE COMPARTMENT / BEHIND POWER DISTRIBUTION FUSEBOX
G15	CA	LOWER LH 'A' POST
G36	IP	BEHIND INSTRUMENT PANEL / LH SIDE OF CROSS CAR BEAM
G37	IP	BEHIND INSTRUMENT PANEL / RH SIDE OF CROSS CAR BEAM

FOR CONTROL MODULE PIN-OUT INFORMATION, UNFOLD PAGE TO LEFT.

The following abbreviations are used to represent values for Control Module Pin-Out data

I	Input	PG	Power Ground	C	CAN Network	D	Serial and Encoded Data
O	Output	SS	Sensor / Signal Supply V	S	SCP Network	V	Voltage (DC)
B+	Battery Voltage	SG	Sensor / Signal Ground	D2	D2B Network	PWM	Pulse Width Modulated

CAUTION: The information on this data page is furnished to aid the user in understanding circuit operation. THIS INFORMATION SHOULD BE USED FOR REFERENCE ONLY.

NOTE: The values listed are approximately those that can be expected at the control module connector pins with all circuit connections made and all components connected and fitted.

Refer to the front of this book for detailed information and illustrations regarding the location and identification of harnesses, relays, fuses, grounds, control modules and control module pins.

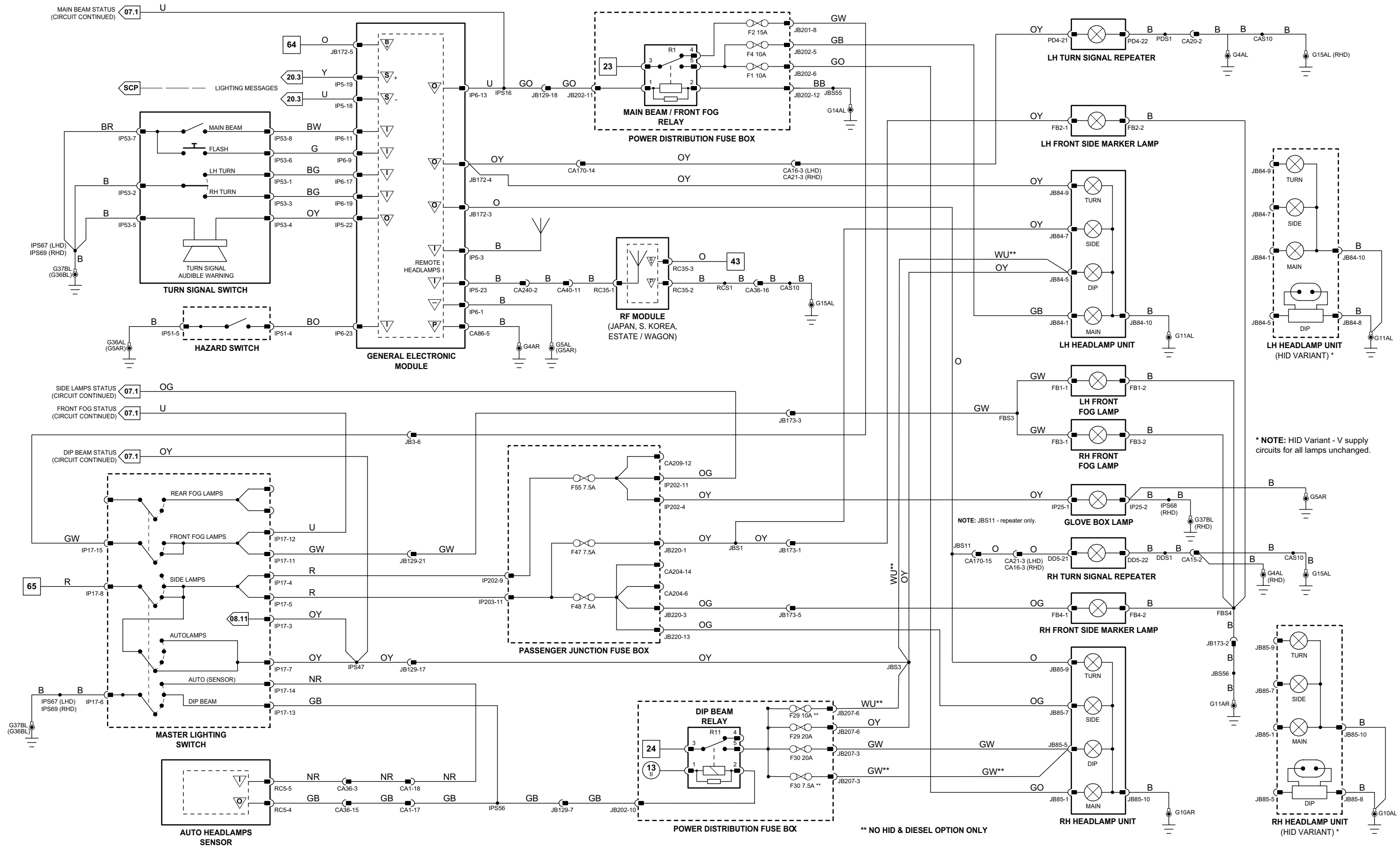

\* NOTE: HID Variant - V supply circuits for all lamps unchanged.

\*\* NO HID & DIESEL OPTION ONLY

1 → 6 Fig. 01.1	34 → 80 Fig. 01.3	11 → 31 Fig. 01.5	67 → 76 Fig. 01.7	98 → 107 Fig. 01.9	Input	Battery Voltage	Sensor/Signal Supply V	CAN	D2B Network
7 → 33 Fig. 01.2	1 → 10 Fig. 01.4	32 → 66 Fig. 01.6	77 → 97 Fig. 01.8		Output	Power Ground	Sensor/Signal Ground	SCP	Serial and Encoded Data

VARIANT: Auto Headlamp Vehicles  
 VIN RANGE: All  
 DATE OF ISSUE: February 2008

## General Electronic Module

	Pin	Description and Characteristic
PG	CA86-05	POWER GROUND
I	IP5-03	SEDAN (EXCEPT JAPAN AND S. KOREA): EXTERNAL ANTENNA
S	IP5-18	SCP -
S	IP5-19	SCP +
O	IP5-22	TURN SIGNAL AUDIBLE WARNING: TO ACTIVATE, GEM SWITCHES CIRCUIT TO B+
I	IP5-23	REMOTE RF SIGNAL
SG	IP6-01	LOGIC GROUND: GROUND
I	IP6-09	HEADLAMP FLASH SWITCH: GROUND WHEN SELECTED
I	IP6-11	MAIN BEAM SWITCH: GROUND WHEN SELECTED
O	IP6-13	MAIN BEAM / FRONT FOG RELAY DRIVE: TO ACTIVATE, GEM SWITCHES CIRCUIT TO B+
I	IP6-17	LH TURN SIGNAL SWITCH: GROUND WHEN SELECTED
I	IP6-19	RH TURN SIGNAL SWITCH: GROUND WHEN SELECTED
I	IP6-23	HAZARD SWITCH: GROUND WHEN SELECTED
O	JB172-03	RH TURN SIGNAL: TO ACTIVATE, GEM SWITCHES CIRCUIT TO B+
O	JB172-04	LH TURN SIGNAL: TO ACTIVATE, GEM SWITCHES CIRCUIT TO B+
B+	JB172-05	BATTERY POWER SUPPLY (TURN SIGNALS): B+

## Fig. 08.2

### COMPONENTS

Component	Connector(s)	Connector Description	Location
DIP BEAM RELAY	-	-	POWER DISTRIBUTION FUSEBOX - R11
FOG LAMP - LH FRONT	FB1	2-WAY / BLACK	FRONT BUMPER / LH SIDE
FOG LAMP - RH FRONT	FB3	2-WAY / BLACK	FRONT BUMPER / RH SIDE
GENERAL ELECTRONIC MODULE	CA86	23-WAY / GREY	BEHIND INSTRUMENT PANEL / RH SIDE
	CA87	23-WAY / GREEN	
	IP5	23-WAY / BROWN	
	IP6	23-WAY / NATURAL	
	JB172	23-WAY / BLUE	
GLOVE BOX LAMP	IP25	2-WAY / BROWN	GLOVE BOX
HAZARD SWITCH	IP51	6-WAY / BLACK	CENTER CONSOLE
HEADLAMP UNIT - LH	JB84	10-WAY / BLACK	ENGINE COMPARTMENT / LH SIDE
HEADLAMP UNIT - RH	JB85	10-WAY / BLACK	ENGINE COMPARTMENT / RH SIDE
LH TURN SIGNAL REPEATER	PD4	22-WAY / GREY	PASSENGER DOOR
MAIN BEAM / FRONT FOG RELAY	-	-	POWER DISTRIBUTION FUSEBOX - R1
MASTER LIGHTING SWITCH	IP17	16-WAY / BLACK	INSTRUMENT PANEL
PASSENGER JUNCTION FUSEBOX	-	-	PASSENGER COMPARTMENT, FRONT BULKHEAD / LH SIDE
POWER DISTRIBUTION FUSEBOX	-	-	ENGINE COMPARTMENT
RF MODULE	RC35	3-WAY / BLACK	ROOF CONSOLE
RH TURN SIGNAL REPEATER	DD5	22-WAY / GREY	DRIVER DOOR
SIDE MARKER LAMP - LH FRONT	FB2	2-WAY / BLACK	FRONT BUMPER / LH SIDE
SIDE MARKER LAMP - RH FRONT	FB4	2-WAY / BLACK	FRONT BUMPER / RH SIDE
TURN SIGNAL SWITCH	IP53	10-WAY / GREY	STEERING COLUMN

### HARNESS IN-LINE CONNECTORS

Connector	Connector Description / Location	Location
CA15	20-WAY / BLACK / CABIN HARNESS TO DRIVER DOOR HARNESS	DRIVER DOOR / DOOR CASING
CA16	20-WAY / BLACK / CABIN HARNESS TO DRIVER DOOR HARNESS	DRIVER DOOR / DOOR CASING
CA20	20-WAY / BLACK / CABIN HARNESS TO PASSENGER DOOR HARNESS	PASSENGER DOOR / DOOR CASING
CA21	20-WAY / BLACK / CABIN HARNESS TO PASSENGER DOOR HARNESS	PASSENGER DOOR / DOOR CASING
CA36	16-WAY / GREEN / CABIN HARNESS TO ROOF HARNESS	LH 'A' POST / WINDSHIELD PILLAR
CA40	16-WAY / GREY / CABIN HARNESS TO ROOF HARNESS	RH 'A' POST / WINDSHIELD PILLAR
CA170	16-WAY / GREEN / JUNCTION BOX HARNESS TO CABIN HARNESS	LH 'A' POST / 'A' POST TRIM
CA240	12-WAY / GREY / CABIN HARNESS TO INSTRUMENT PANEL HARNESS	LH LOWER 'A' POST / 'A' POST TRIM
JB3	14-WAY / BLUE / JUNCTION BOX HARNESS TO INSTRUMENT PANEL HARNESS	BELOW INSTRUMENT PANEL / LH SIDE
JB129	22-WAY / GREY / JUNCTION BOX HARNESS TO INSTRUMENT PANEL HARNESS	BELOW INSTRUMENT PANEL / LH SIDE
JB173	10-WAY / BLACK / JUNCTION BOX HARNESS TO FRONT BUMPER HARNESS	BEHIND LH FRONT WHEEL ARCH LINER

### GROUNDS

Ground	Harness	Location
G4	CA	LOWER RH 'A' POST
G5	IP	UPPER RH 'A' POST
G10	JB	ENGINE COMPARTMENT / BEHIND RH HEADLAMP
G11	JB	ENGINE COMPARTMENT / BEHIND LH HEADLAMP
G14	JB	ENGINE COMPARTMENT / BEHIND POWER DISTRIBUTION FUSEBOX
G15	CA	LOWER LH 'A' POST
G36	IP	BEHIND INSTRUMENT PANEL / LH SIDE OF CROSS CAR BEAM
G37	IP	BEHIND INSTRUMENT PANEL / RH SIDE OF CROSS CAR BEAM

FOR CONTROL MODULE PIN-OUT INFORMATION, UNFOLD PAGE TO LEFT.

The following abbreviations are used to represent values for Control Module Pin-Out data

I	Input	PG	Power Ground	C	CAN Network	D	Serial and Encoded Data
O	Output	SS	Sensor / Signal Supply V	S	SCP Network	V	Voltage (DC)
B+	Battery Voltage	SG	Sensor / Signal Ground	D2	D2B Network	PWM	Pulse Width Modulated

**CAUTION:** The information on this data page is furnished to aid the user in understanding circuit operation. THIS INFORMATION SHOULD BE USED FOR REFERENCE ONLY.

**NOTE:** The values listed are approximately those that can be expected at the control module connector pins with all circuit connections made and all components connected and fitted.

Refer to the front of this book for detailed information and illustrations regarding the location and identification of harnesses, relays, fuses, grounds, control modules and control module pins.



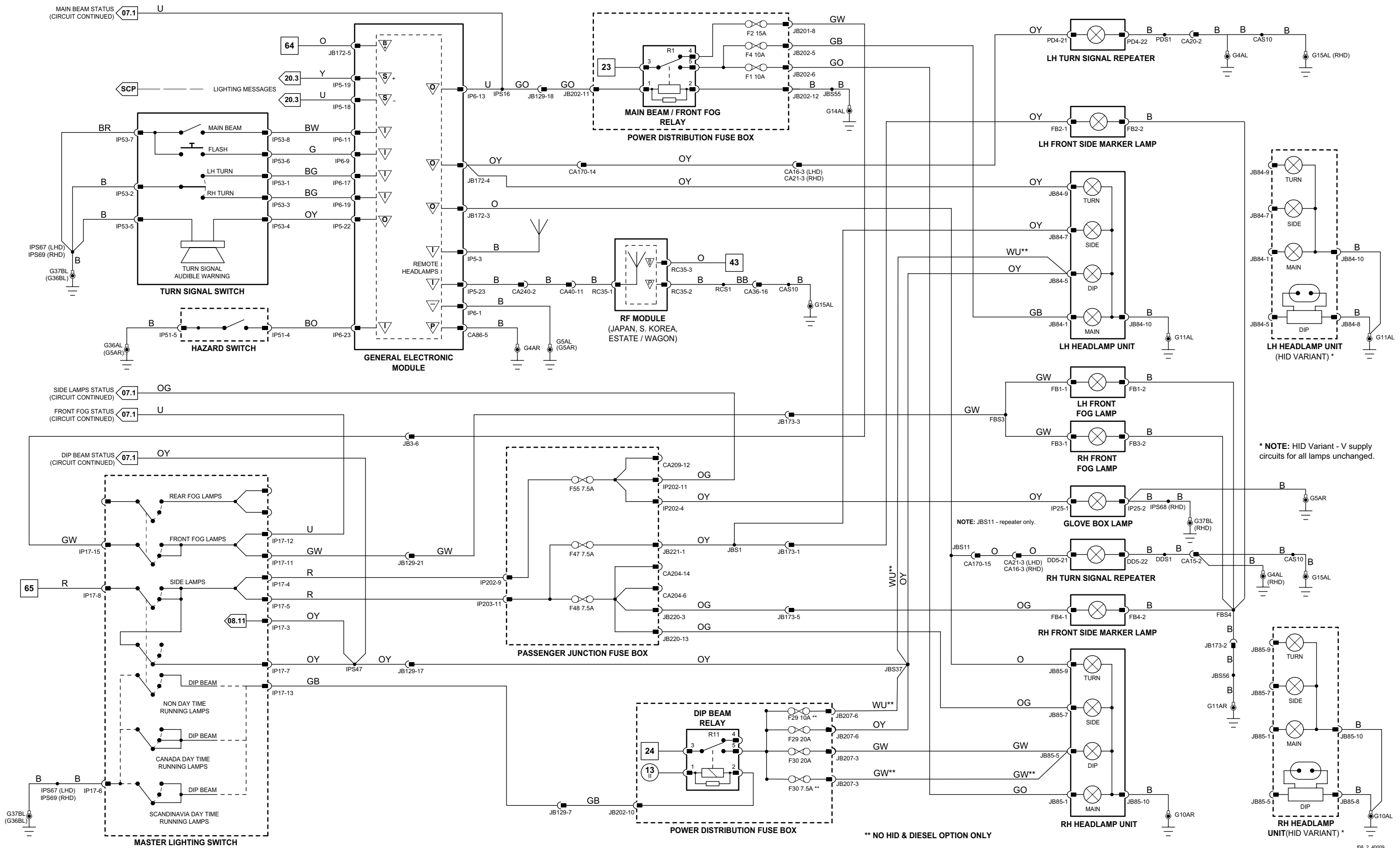

\* NOTE: HID Variant - V supply circuits for all lamps unchanged.

\*\* NO HID & DIESEL OPTION ONLY

1 → 6 Fig. 01.1	34 → 80 Fig. 01.3	11 → 31 Fig. 01.5	67 → 76 Fig. 01.7	98 → 107 Fig. 01.9	Input	Battery Voltage	Sensor/Signal Supply V	CAN	D2B Network
7 → 33 Fig. 01.2	1 → 10 Fig. 01.4	32 → 66 Fig. 01.6	77 → 97 Fig. 01.8		Output	Power Ground	Sensor/Signal Ground	SCP	Serial and Encoded Data

VARIANT: Non Autolamp Vehicles; Daytime Running Lamp Vehicles  
VIN RANGE: All  
DATE OF ISSUE: February 2008

**General Electronic Module**

	Pin	Description and Characteristic
O	CA86-02	LH REAR TURN SIGNAL: TO ACTIVATE, GEM SWITCHES CIRCUIT TO B+
PG	CA86-05	POWER GROUND
O	CA87-04	RH REAR TURN SIGNAL: TO ACTIVATE, GEM SWITCHES CIRCUIT TO B+
S	IP5-18	SCP -
S	IP5-19	SCP +
O	IP5-22	TURN SIGNAL AUDIBLE WARNING: TO ACTIVATE, GEM SWITCHES CIRCUIT TO B+
SG	IP6-01	LOGIC GROUND: GROUND
I	IP6-17	LH TURN SIGNAL SWITCH: GROUND WHEN SELECTED
I	IP6-19	RH TURN SIGNAL SWITCH: GROUND WHEN SELECTED
I	IP6-23	HAZARD SWITCH: GROUND WHEN SELECTED
B+	JB172-05	BATTERY POWER SUPPLY (TURN SIGNALS): B+

**Instrument Cluster**

	Pin	Description and Characteristic
I	IP10-01	REVERSE LAMP SWITCH: B+ WHEN ACTIVATED
C	IP10-17	CAN +
C	IP10-18	CAN -
O	IP11-03	REVERSE LAMPS RELAY DRIVE: TO ACTIVATE, IC SWITCHES CIRCUIT TO GROUND

**Fig. 08.3**

**COMPONENTS**

Component	Connector(s)	Connector Description	Location
BRAKE ON / OFF SWITCH	PA3	3-WAY / BLACK	TOP OF BRAKE PEDAL
GENERAL ELECTRONIC MODULE	CA86	23-WAY / GREY	BEHIND INSTRUMENT PANEL / RH SIDE
	CA87	23-WAY / GREEN	
	IP5	23-WAY / BROWN	
	IP6	23-WAY / NATURAL	
	JB172	23-WAY / BLUE	
HAZARD SWITCH	IP51	6-WAY / BLACK	CENTER CONSOLE
HIGH-MOUNT STOP LAMP - SEDAN	NA55	2-WAY / WHITE	REAR WINDOW
INSTRUMENT CLUSTER	IP10	26-WAY / WHITE	INSTRUMENT PANEL
	IP11	26-WAY / WHITE	
LICENSE PLATE LAMP - LH: SEDAN	TM5	2-WAY / BLACK	TRUNK LID
LICENSE PLATE LAMP - RH: SEDAN	TM5	2-WAY / BLACK	TRUNK LID
MASTER LIGHTING SWITCH	IP17	16-WAY / BLACK	INSTRUMENT PANEL
PASSENGER JUNCTION FUSEBOX	-	-	PASSENGER COMPARTMENT, FRONT BULKHEAD / LH SIDE
REVERSE LAMPS RELAY	-	-	PASSENGER JUNCTION FUSEBOX - R9
REVERSE LAMPS SWITCH - Diesel	DL7	2-WAY / BLACK	TOP OF TRANSMISSION
REVERSE LAMPS SWITCH - 2.0 L, 2.5 L, 3.0 L	EN85	2-WAY / BLACK	TOP OF TRANSMISSION
SIDE MARKER LAMP - LH REAR	RB5	2-WAY / BLACK	REAR BUMPER / LH SIDE
SIDE MARKER LAMP - RH REAR	RB6	2-WAY / BLACK	REAR BUMPER / RH SIDE
TAIL LAMP UNIT - LH	CA137	7-WAY / BLACK	TRUNK, LH REAR
TAIL LAMP UNIT - RH	CA138	7-WAY / BLACK	TRUNK, RH REAR
TURN SIGNAL SWITCH	IP53	10-WAY / GREY	STEERING COLUMN

**HARNESS IN-LINE CONNECTORS**

Connector	Connector Description / Location	Location
CA1	22-WAY / NATURAL / INSTRUMENT PANEL HARNESS TO CABIN HARNESS	LH 'A' POST / 'A' POST TRIM
CA10	22-WAY / SLATE / CABIN HARNESS TO JUNCTION BOX HARNESS	LH 'A' POST / 'A' POST TRIM
CA45	6-WAY / GREY / CABIN HARNESS TO TRUNK LID HARNESS	BEHIND LH 'E' POST TRIM
CA129	12-WAY / GREY / REAR BUMPER HARNESS TO CABIN HARNESS	SPARE WHEEL WELL
CA414	16-WAY / BLUE / NAVIGATION HARNESS TO CABIN HARNESS	BELOW LH REAR SEAT CUSHION
JB1	42-WAY / BLACK / ENGINE MANAGEMENT HARNESS TO JUNCTION BOX HARNESS	ENGINE COMPARTMENT / LH SIDE
JB2	16-WAY / GREEN / ENGINE MANAGEMENT HARNESS TO JUNCTION BOX HARNESS (PEDAL ASSEMBLY)	BELOW INSTRUMENT PANEL / DRIVER SIDE
JB145	8-WAY / BLACK / ENGINE MANAGEMENT HARNESS TO JUNCTION BOX HARNESS	ENGINE COMPARTMENT / LH SIDE
TL10	6-WAY / GREY / TRUNK LINK LEAD TO TRUNK LID HARNESS	BELOW PARCEL SHELF / LH SIDE

**GROUNDS**

Ground	Harness	Location
G1	CA	TRUNK / UNDER LH TAIL LAMP UNIT
G2	CA	TRUNK / UNDER LH TAIL LAMP UNIT
G4	CA	LOWER RH 'A' POST
G5	IP	UPPER RH 'A' POST
G36	IP	BEHIND INSTRUMENT PANEL / LH SIDE OF CROSS CAR BEAM
G37	IP	BEHIND INSTRUMENT PANEL / RH SIDE OF CROSS CAR BEAM
G38	CA	UPPER LH 'E' POST

**FOR CONTROL MODULE PIN-OUT INFORMATION, UNFOLD PAGE TO LEFT.**

The following abbreviations are used to represent values for Control Module Pin-Out data

I	Input	PG	Power Ground	C	CAN Network	D	Serial and Encoded Data
O	Output	SS	Sensor / Signal Supply V	S	SCP Network	V	Voltage (DC)
B+	Battery Voltage	SG	Sensor / Signal Ground	D2	D2B Network	PWM	Pulse Width Modulated

**CAUTION:** The information on this data page is furnished to aid the user in understanding circuit operation. THIS INFORMATION SHOULD BE USED FOR REFERENCE ONLY.

**NOTE:** The values listed are approximately those that can be expected at the control module connector pins with all circuit connections made and all components connected and fitted.

Refer to the front of this book for detailed information and illustrations regarding the location and identification of harnesses, relays, fuses, grounds, control modules and control module pins.

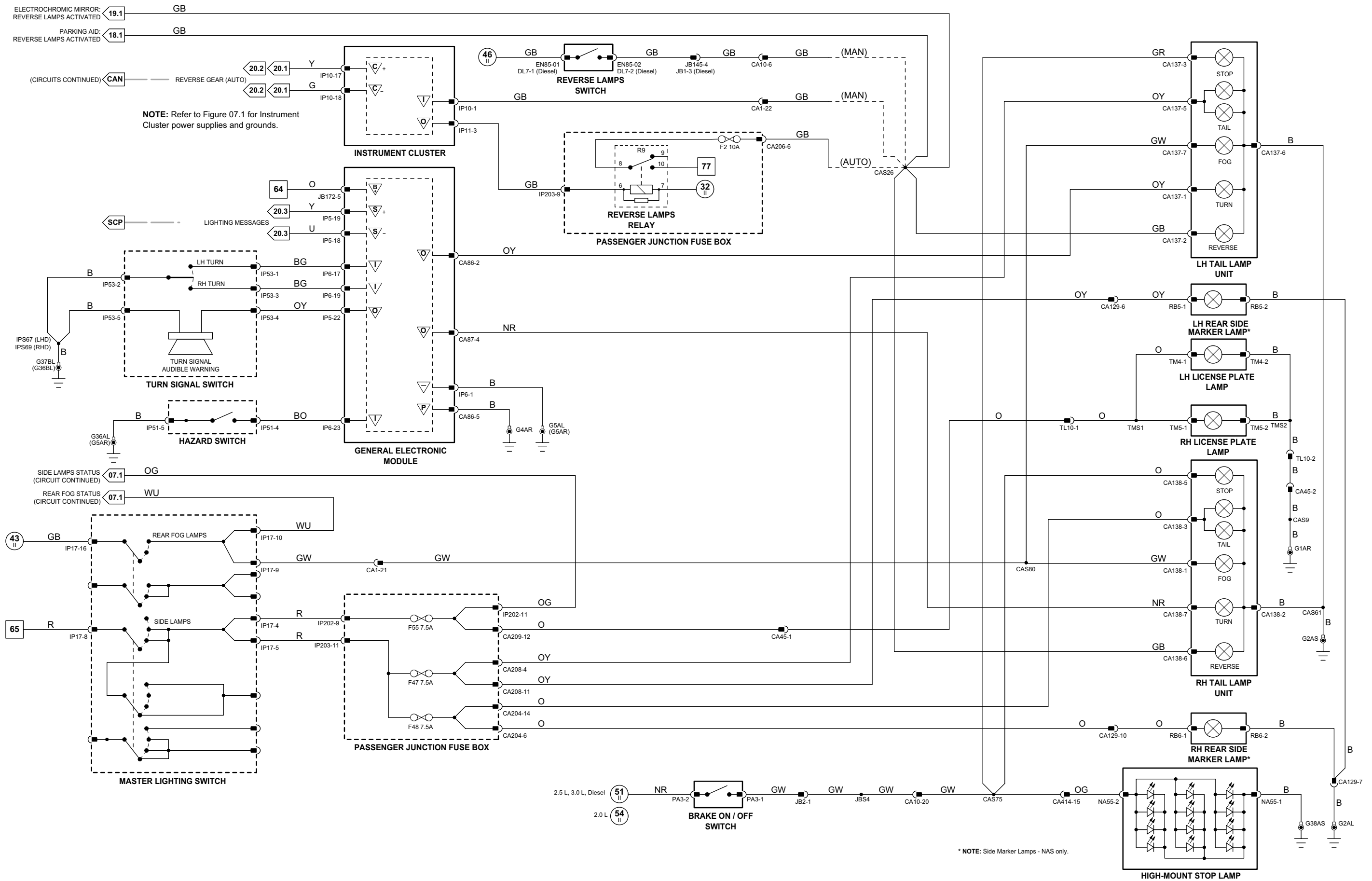

\* NOTE: Side Marker Lamps - NAS only.

1 → 6 Fig. 01.1	34 → 80 Fig. 01.3	11 → 31 Fig. 01.5	67 → 76 Fig. 01.7	98 → 107 Fig. 01.9	Input	Battery Voltage	Sensor/Signal Supply V	CAN	D2B Network
7 → 33 Fig. 01.2	1 → 10 Fig. 01.4	32 → 66 Fig. 01.6	77 → 97 Fig. 01.8		Output	Power Ground	Sensor/Signal Ground	SCP	Serial and Encoded Data

VARIANT: Sedan Vehicles  
 VIN RANGE: All  
 DATE OF ISSUE: February 2008

**General Electronic Module**

	Pin	Description and Characteristic
O	CA86-02	LH REAR TURN SIGNAL: TO ACTIVATE, GEM SWITCHES CIRCUIT TO B+
PG	CA86-05	POWER GROUND
O	CA87-04	RH REAR TURN SIGNAL: TO ACTIVATE, GEM SWITCHES CIRCUIT TO B+
S	IP5-18	SCP -
S	IP5-19	SCP +
O	IP5-22	TURN SIGNAL AUDIBLE WARNING: TO ACTIVATE, GEM SWITCHES CIRCUIT TO B+
SG	IP6-01	LOGIC GROUND: GROUND
I	IP6-17	LH TURN SIGNAL SWITCH: GROUND WHEN SELECTED
I	IP6-19	RH TURN SIGNAL SWITCH: GROUND WHEN SELECTED
I	IP6-23	HAZARD SWITCH: GROUND WHEN SELECTED
B+	JB172-05	BATTERY POWER SUPPLY (TURN SIGNALS): B+

**Instrument Cluster**

	Pin	Description and Characteristic
I	IP10-01	REVERSE LAMP SWITCH: B+ WHEN ACTIVATED
C	IP10-17	CAN +
C	IP10-18	CAN -
O	IP11-03	REVERSE LAMPS RELAY DRIVE: TO ACTIVATE, IC SWITCHES CIRCUIT TO GROUND

**Fig. 08.4**

**COMPONENTS**

Component	Connector(s)	Connector Description	Location
BRAKE ON / OFF SWITCH	PA3	3-WAY / BLACK	TOP OF BRAKE PEDAL
GENERAL ELECTRONIC MODULE	CA86	23-WAY / GREY	BEHIND INSTRUMENT PANEL / RH SIDE
	CA87	23-WAY / GREEN	
	IP5	23-WAY / BROWN	
	IP6	23-WAY / NATURAL	
	JB172	23-WAY / BLUE	
HAZARD SWITCH	IP51	6-WAY / BLACK	CENTER CONSOLE
HIGH-MOUNT STOP LAMP - ESTATE/WAGON	WG6	2-WAY / BLACK	REAR SPOILER
INSTRUMENT CLUSTER	IP10	26-WAY / WHITE	INSTRUMENT PANEL
	IP11	26-WAY / WHITE	
LICENSE PLATE LAMP - LH: ESTATE /WAGON	WT9	2-WAY / BLACK	TAIL GATE
LICENSE PLATE LAMP - RH: ESTATE /WAGON	WT10	2-WAY / BLACK	TAIL GATE
MASTER LIGHTING SWITCH	IP17	16-WAY / BLACK	INSTRUMENT PANEL
PASSENGER JUNCTION FUSEBOX	-	-	PASSENGER COMPARTMENT, FRONT BULKHEAD / LH SIDE
REVERSE LAMPS RELAY	-	-	PASSENGER JUNCTION FUSEBOX - R9
REVERSE LAMPS SWITCH - Diesel	DL7	2-WAY / BLACK	TOP OF TRANSMISSION
REVERSE LAMPS SWITCH - 2.0 L, 2.5 L, 3.0 L	EN85	2-WAY / BLACK	TOP OF TRANSMISSION
TAIL LAMP UNIT - LH	CA137	7-WAY / BLACK	TRUNK, LH REAR
TAIL LAMP UNIT - RH	CA138	7-WAY / BLACK	TRUNK, RH REAR
TURN SIGNAL SWITCH	IP53	10-WAY / GREY	STEERING COLUMN

**HARNESS IN-LINE CONNECTORS**

Connector	Connector Description / Location	Location
CA1	22-WAY / NATURAL / INSTRUMENT PANEL HARNESS TO CABIN HARNESS	LH 'A' POST / 'A' POST TRIM
CA10	22-WAY / SLATE / CABIN HARNESS TO JUNCTION BOX HARNESS	LH 'A' POST / 'A' POST TRIM
JB2	16-WAY / GREEN / ENGINE MANAGEMENT HARNESS TO JUNCTION BOX HARNESS (PEDAL ASSEMBLY)	BELOW INSTRUMENT PANEL / DRIVER SIDE
JB145	8-WAY / BLACK / ENGINE MANAGEMENT HARNESS TO JUNCTION BOX HARNESS	ENGINE COMPARTMENT / LH SIDE
WG1	4-WAY / BLACK / CABIN HARNESS TO TAIL GATE GLASS HARNESS	ROOF / CENTER REAR
WL1	8-WAY / BLACK / CABIN HARNESS TO TAIL GATE LINK LEAD	ROOF / CENTER REAR
WT1	8-WAY / BLACK / CABIN HARNESS TO TAIL GATE HARNESS	TAIL GATE

**GROUNDS**

Ground	Harness	Location
G1	CA	TRUNK / UNDER LH TAIL LAMP UNIT
G2	CA	TRUNK / UNDER LH TAIL LAMP UNIT
G4	CA	LOWER RH 'A' POST
G5	IP	UPPER RH 'A' POST
G36	IP	BEHIND INSTRUMENT PANEL / LH SIDE OF CROSS CAR BEAM
G37	IP	BEHIND INSTRUMENT PANEL / RH SIDE OF CROSS CAR BEAM
G50	CA	HEADLINER / RH REAR ROOF PANEL

FOR CONTROL MODULE PIN-OUT INFORMATION, UNFOLD PAGE TO LEFT.

The following abbreviations are used to represent values for Control Module Pin-Out data

I	Input	PG	Power Ground	C	CAN Network	D	Serial and Encoded Data
O	Output	SS	Sensor / Signal Supply V	S	SCP Network	V	Voltage (DC)
B+	Battery Voltage	SG	Sensor / Signal Ground	D2	D2B Network	PWM	Pulse Width Modulated

CAUTION: The information on this data page is furnished to aid the user in understanding circuit operation. THIS INFORMATION SHOULD BE USED FOR REFERENCE ONLY.

NOTE: The values listed are approximately those that can be expected at the control module connector pins with all circuit connections made and all components connected and fitted.

Refer to the front of this book for detailed information and illustrations regarding the location and identification of harnesses, relays, fuses, grounds, control modules and control module pins.

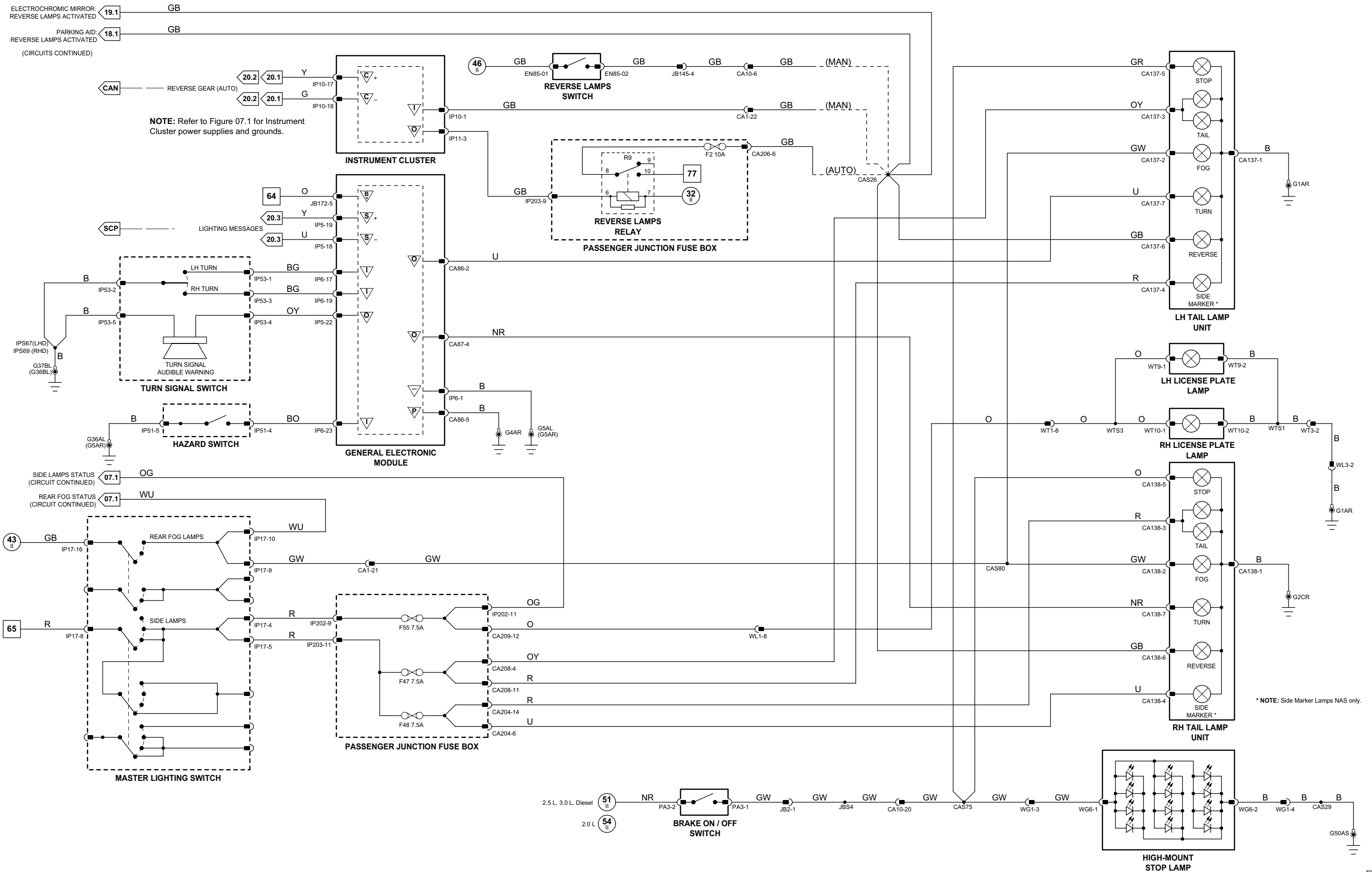

\* NOTE: Side Marker Lamps NAS only.

1 → 6 Fig. 01.1	34 → 80 Fig. 01.3	11 → 31 Fig. 01.5	67 → 76 Fig. 01.7	98 → 107 Fig. 01.9	Input	Battery Voltage	Sensor/Signal Supply V	CAN	D2B Network
7 → 33 Fig. 01.2	1 → 10 Fig. 01.4	32 → 66 Fig. 01.6	77 → 97 Fig. 01.8		Output	Power Ground	Sensor/Signal Ground	SCP	Serial and Encoded Data

VARIANT: Estate (Wagon) Vehicles  
 VIN RANGE: All  
 DATE OF ISSUE: February 2008

**Fig. 08.5****COMPONENTS**

<b>Component</b>	<b>Connector(s)</b>	<b>Connector Description</b>	<b>Location</b>
ACCESSORY CONNECTOR – REAR	CA146	3-WAY / BLACK	TRUNK, LH REAR
ACCESSORY CONNECTOR – TRAILER TOWING	T5001	DATA NOT AVAILABLE	
HIGH-MOUNT STOP LAMP – SEDAN	NA55	2-WAY / WHITE	REAR WINDOW
LICENSE PLATE LAMP – LH: SEDAN	TM5	2-WAY / BLACK	TRUNK LID
LICENSE PLATE LAMP – RH: SEDAN	TM5	2-WAY / BLACK	TRUNK LID
TAIL LAMP UNIT – LH	CA137	7-WAY / BLACK	TRUNK, LH REAR
TAIL LAMP UNIT – RH	CA138	7-WAY / BLACK	TRUNK, RH REAR
TRAILER TOWING CONNECTOR	T5011	DATA NOT AVAILABLE	
TRAILER TOWING MODULE	TT1	DATA NOT AVAILABLE	
	TT2	DATA NOT AVAILABLE	
	TT3	DATA NOT AVAILABLE	

**HARNES IN-LINE CONNECTORS**

<b>Connector</b>	<b>Connector Description / Location</b>	<b>Location</b>
CA45	6-WAY / GREY / CABIN HARNESS TO TRUNK LID HARNESS	BEHIND LH 'E' POST TRIM
CA302	2-WAY / BLACK / CABIN HARNESS TO TRAILER HARNESS	TRUNK / ADJACENT TO LH REAR TAIL LAMP
TL10	6-WAY / GREY / TRUNK LINK LEAD TO TRUNK LID HARNESS	BELOW PARCEL SHELF / LH SIDE
TT6	DATA NOT AVAILABLE	

**GROUNDS**

<b>Ground</b>	<b>Harness</b>	<b>Location</b>
G1	CA	TRUNK / UNDER LH TAIL LAMP UNIT
G2	CA	TRUNK / UNDER LH TAIL LAMP UNIT
G38	CA	UPPER LH 'E' POST

Refer to the front of this book for detailed information and illustrations regarding the location and identification of harnesses, relays, fuses, grounds, control modules and control module pins.

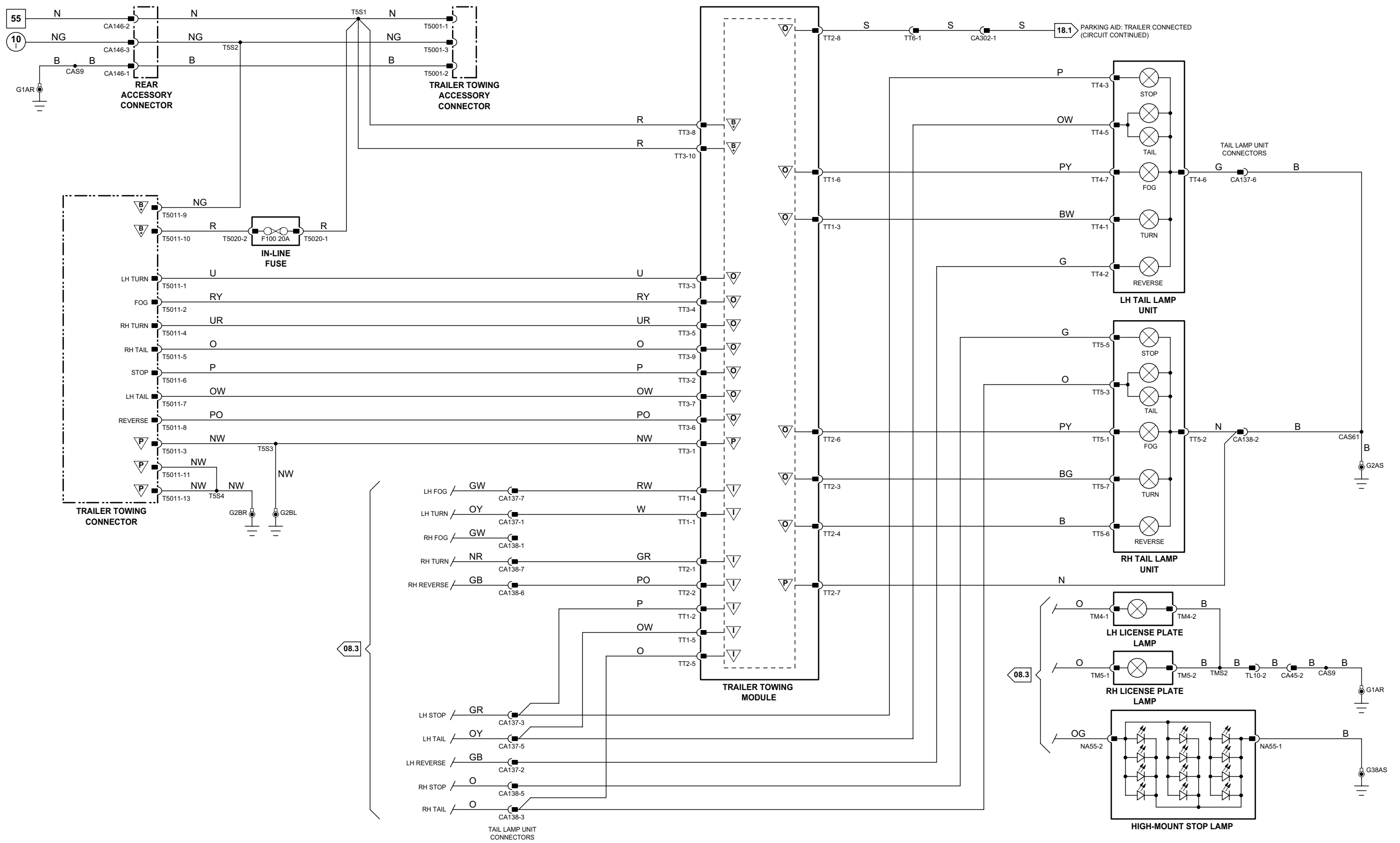

**Fig. 08.6****COMPONENTS**

Component	Connector(s)	Connector Description	Location
ACCESSORY CONNECTOR – REAR	CA146	3-WAY / BLACK	TRUNK, LH REAR
ACCESSORY CONNECTOR – TRAILER TOWING	T4001	DATA NOT AVAILABLE	
CARAVAN CONNECTOR	T412S	DATA NOT AVAILABLE	
HIGH-MOUNT STOP LAMP – SEDAN	NA55	2-WAY / WHITE	REAR WINDOW
LICENSE PLATE LAMP – LH: SEDAN	TM5	2-WAY / BLACK	TRUNK LID
LICENSE PLATE LAMP – RH: SEDAN	TM5	2-WAY / BLACK	TRUNK LID
TAIL LAMP UNIT – LH	CA137	7-WAY / BLACK	TRUNK, LH REAR
TAIL LAMP UNIT – RH	CA138	7-WAY / BLACK	TRUNK, RH REAR
TRAILER TOWING CONNECTOR	T312N	DATA NOT AVAILABLE	
TRAILER TOWING MODULE	TT1	DATA NOT AVAILABLE	
	TT2	DATA NOT AVAILABLE	
	TT3	DATA NOT AVAILABLE	

**HARNES IN-LINE CONNECTORS**

Connector	Connector Description / Location	Location
CA45	6-WAY / GREY / CABIN HARNESS TO TRUNK LID HARNESS	BEHIND LH 'E' POST TRIM
CA302	2-WAY / BLACK / CABIN HARNESS TO TRAILER HARNESS	TRUNK / ADJACENT TO LH REAR TAIL LAMP
TL10	6-WAY / GREY / TRUNK LINK LEAD TO TRUNK LID HARNESS	BELOW PARCEL SHELF / LH SIDE
TT6	DATA NOT AVAILABLE	
TT7	DATA NOT AVAILABLE	

**GROUNDS**

Ground	Harness	Location
G1		ENGINE COMPARTMENT / BEHIND LH HEADLAMP ASSEMBLY
G3		ENGINE COMPARTMENT / BELOW FRONT POWER DISTRIBUTION FUSEBOX
G17		CABIN / BELOW REAR SEAT / RH SIDE

Refer to the front of this book for detailed information and illustrations regarding the location and identification of harnesses, relays, fuses, grounds, control modules and control module pins.



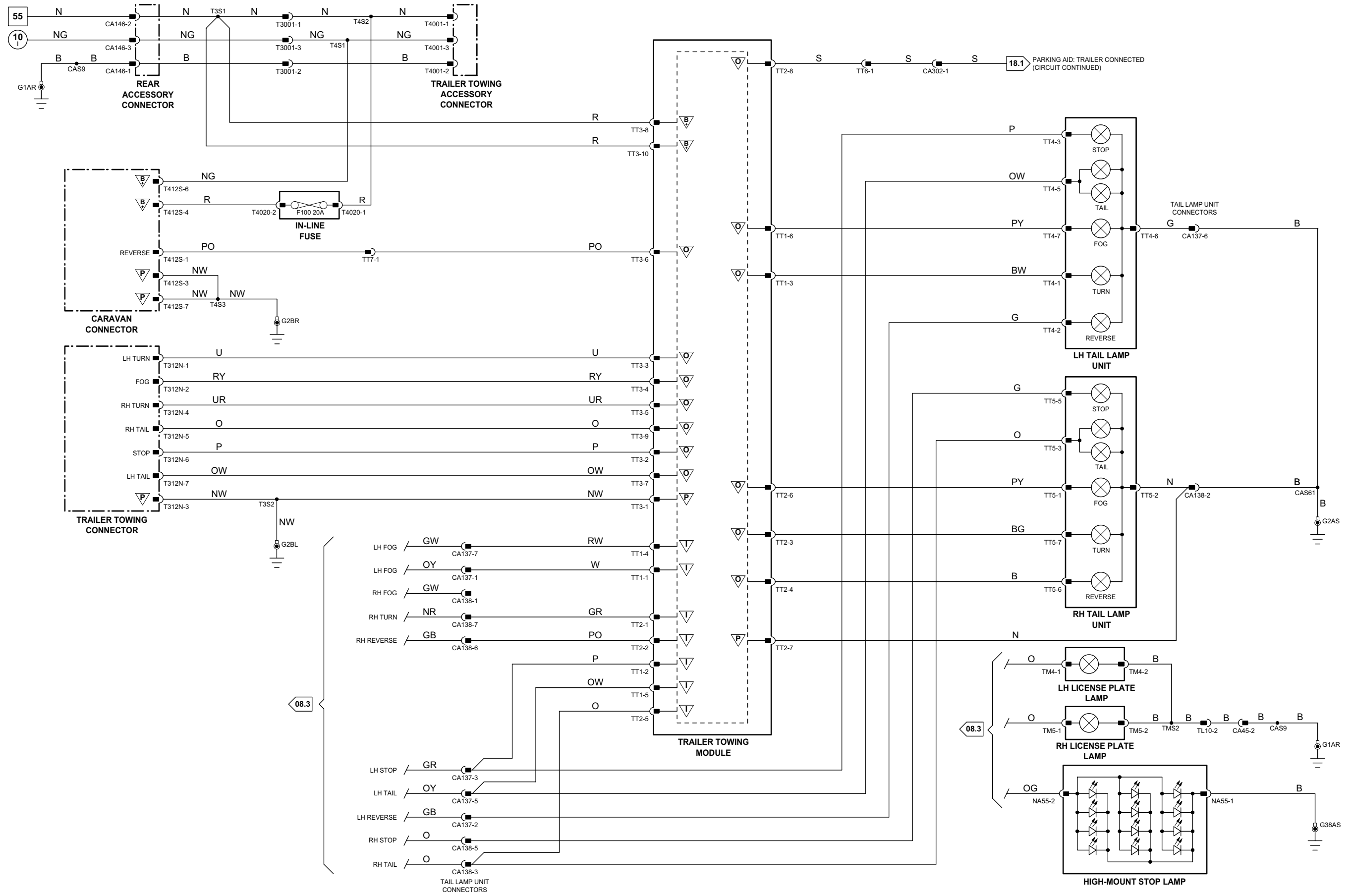

**Fig. 08.7****COMPONENTS**

Component	Connector(s)	Connector Description	Location
ACCESSORY CONNECTOR – REAR	CA146	3-WAY / BLACK	TRUNK, LH REAR
ACCESSORY CONNECTOR – TRAILER TOWING	T3001	DATA NOT AVAILABLE	
HIGH-MOUNT STOP LAMP – SEDAN	NA55	2-WAY / WHITE	REAR WINDOW
LICENSE PLATE LAMP – LH: SEDAN	TM5	2-WAY / BLACK	TRUNK LID
LICENSE PLATE LAMP – RH: SEDAN	TM5	2-WAY / BLACK	TRUNK LID
SIDE MARKER LAMP – LH REAR	RB5	2-WAY / BLACK	REAR BUMPER / LH SIDE
SIDE MARKER LAMP – RH REAR	RB6	2-WAY / BLACK	REAR BUMPER / RH SIDE
TAIL LAMP UNIT – LH	CA137	7-WAY / BLACK	TRUNK, LH REAR
TAIL LAMP UNIT – RH	CA138	7-WAY / BLACK	TRUNK, RH REAR
TRAILER TOWING CONNECTOR	T8US1	DATA NOT AVAILABLE	
TRAILER TOWING MODULE	TT1	DATA NOT AVAILABLE	
	TT2	DATA NOT AVAILABLE	
	TT3	DATA NOT AVAILABLE	

**HARNESS IN-LINE CONNECTORS**

Connector	Connector Description / Location	Location
CA45	6-WAY / GREY / CABIN HARNESS TO TRUNK LID HARNESS	BEHIND LH 'E' POST TRIM
CA129	12-WAY / GREY / REAR BUMPER HARNESS TO CABIN HARNESS	SPARE WHEEL WELL
CA302	2-WAY / BLACK / CABIN HARNESS TO TRAILER HARNESS	TRUNK / ADJACENT TO LH REAR TAIL LAMP
TL10	6-WAY / GREY / TRUNK LINK LEAD TO TRUNK LID HARNESS	BELOW PARCEL SHELF / LH SIDE
TT6	DATA NOT AVAILABLE	

**GROUNDS**

Ground	Harness	Location
G1	CA	TRUNK / UNDER LH TAIL LAMP UNIT
G2	CA	TRUNK / UNDER LH TAIL LAMP UNIT
G38	CA	UPPER LH 'E' POST

Refer to the front of this book for detailed information and illustrations regarding the location and identification of harnesses, relays, fuses, grounds, control modules and control module pins.

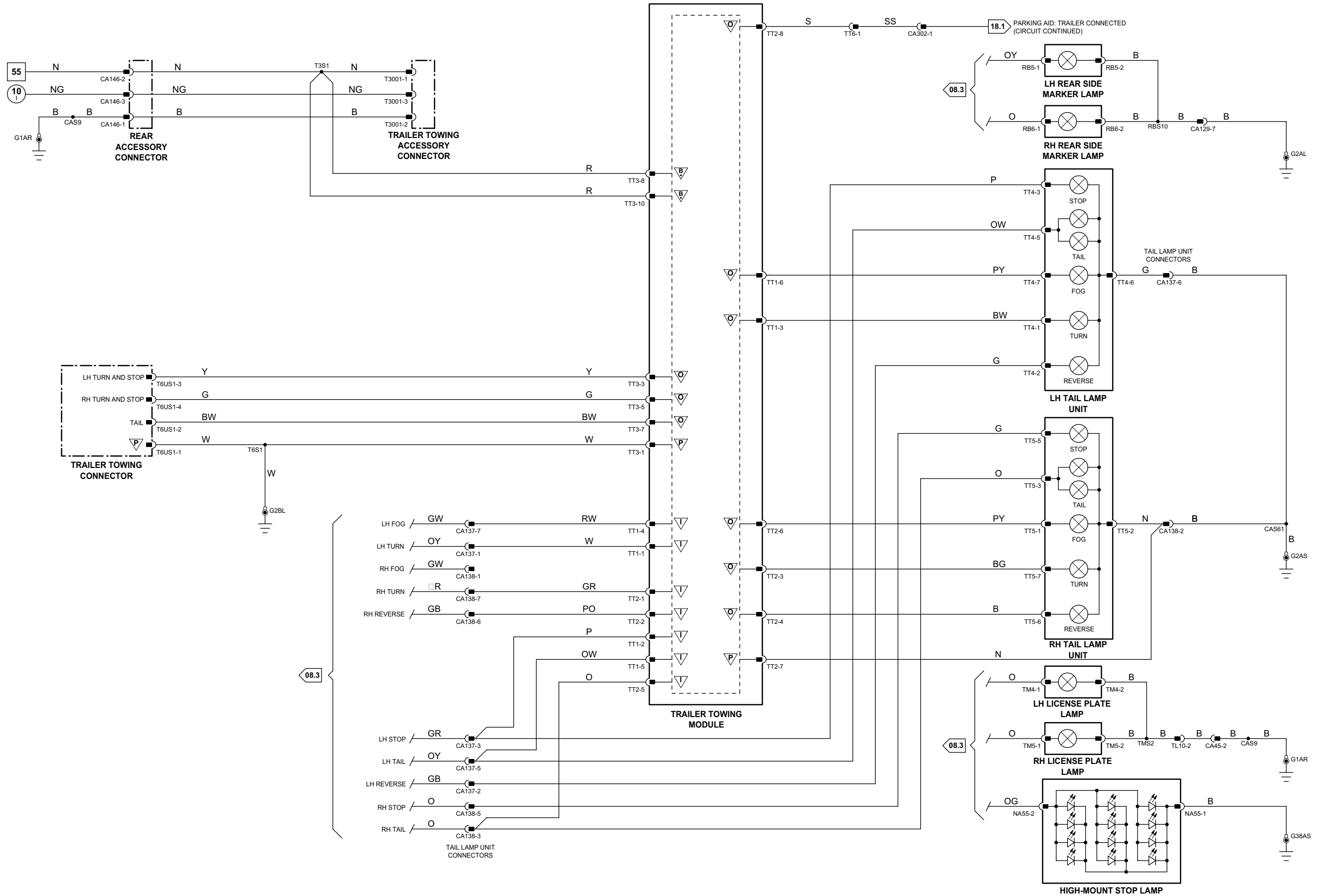

**Fig. 08.8****COMPONENTS**

Component	Connector(s)	Connector Description	Location
ACCESSORY CONNECTOR – REAR	CA146	3-WAY / BLACK	TRUNK, LH REAR
ACCESSORY CONNECTOR – TRAILER TOWING	T5001	DATA NOT AVAILABLE	
HIGH-MOUNT STOP LAMP – ESTATE (WAGON)	WG6	2-WAY / BLACK	REAR SPOILER
LICENSE PLATE LAMP – LH: ESTATE (WAGON)	WT9	2-WAY / BLACK	TAIL GATE
LICENSE PLATE LAMP – RH: ESTATE (WAGON)	WT10	2-WAY / BLACK	TAIL GATE
TAIL LAMP UNIT – LH	CA137	7-WAY / BLACK	TRUNK, LH REAR
TAIL LAMP UNIT – RH	CA138	7-WAY / BLACK	TRUNK, RH REAR
TRAILER TOWING CONNECTOR	T5011	DATA NOT AVAILABLE	
TRAILER TOWING MODULE	TT1	DATA NOT AVAILABLE	
	TT2	DATA NOT AVAILABLE	
	TT3	DATA NOT AVAILABLE	

**HARNES IN-LINE CONNECTORS**

Connector	Connector Description / Location	Location
CA302	2-WAY / BLACK / CABIN HARNESS TO TRAILER HARNESS	TRUNK / ADJACENT TO LH REAR TAIL LAMP
TT6	DATA NOT AVAILABLE	
WG1	4-WAY / BLACK / CABIN HARNESS TO TAIL GATE GLASS HARNESS	ROOF / CENTER REAR
WL3	3-WAY / BLACK / CABIN HARNESS TO TAIL GATE LINK LEAD	ROOF / CENTER REAR
WT3	3-WAY / BLACK / CABIN HARNESS TO TAIL GATE HARNESS	TAIL GATE

**GROUNDS**

Ground	Harness	Location
G1	CA	TRUNK / UNDER LH TAIL LAMP UNIT
G2	CA	TRUNK / UNDER LH TAIL LAMP UNIT
G50	CA	HEADLINER / RH REAR ROOF PANEL

Refer to the front of this book for detailed information and illustrations regarding the location and identification of harnesses, relays, fuses, grounds, control modules and control module pins.

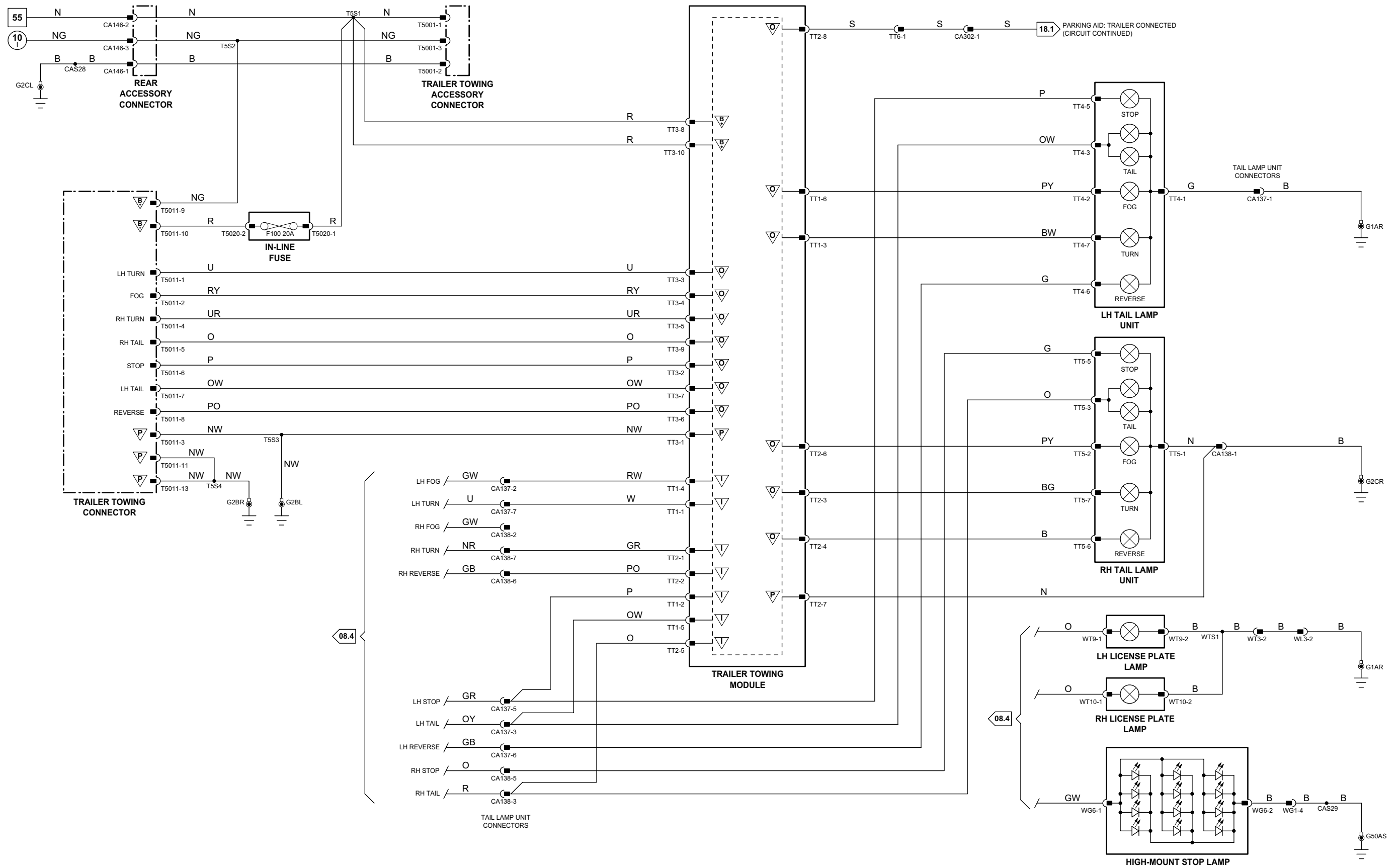

**Fig. 08.9****COMPONENTS**

Component	Connector(s)	Connector Description	Location
ACCESSORY CONNECTOR – REAR	CA146	3-WAY / BLACK	TRUNK, LH REAR
ACCESSORY CONNECTOR – TRAILER TOWING	T4001	DATA NOT AVAILABLE	
CARAVAN CONNECTOR	T412S	DATA NOT AVAILABLE	
HIGH-MOUNT STOP LAMP – ESTATE (WAGON)	WG6	2-WAY / BLACK	REAR SPOILER
LICENSE PLATE LAMP – LH: ESTATE (WAGON)	WT9	2-WAY / BLACK	TAIL GATE
LICENSE PLATE LAMP – RH: ESTATE (WAGON)	WT10	2-WAY / BLACK	TAIL GATE
TAIL LAMP UNIT – LH	CA137	7-WAY / BLACK	TRUNK, LH REAR
TAIL LAMP UNIT – RH	CA138	7-WAY / BLACK	TRUNK, RH REAR
TRAILER TOWING CONNECTOR	T312N	DATA NOT AVAILABLE	
TRAILER TOWING MODULE	TT1	DATA NOT AVAILABLE	
	TT2	DATA NOT AVAILABLE	
	TT3	DATA NOT AVAILABLE	

**HARNESS IN-LINE CONNECTORS**

Connector	Connector Description / Location	Location
CA302	2-WAY / BLACK / CABIN HARNESS TO TRAILER HARNESS	TRUNK / ADJACENT TO LH REAR TAIL LAMP
TT6	DATA NOT AVAILABLE	
TT7	DATA NOT AVAILABLE	
WG1	4-WAY / BLACK / CABIN HARNESS TO TAIL GATE GLASS HARNESS	ROOF / CENTER REAR
WL3	3-WAY / BLACK / CABIN HARNESS TO TAIL GATE LINK LEAD	ROOF / CENTER REAR
WT3	3-WAY / BLACK / CABIN HARNESS TO TAIL GATE HARNESS	TAIL GATE

**GROUNDS**

Ground	Harness	Location
G1	CA	TRUNK / UNDER LH TAIL LAMP UNIT
G2	CA	TRUNK / UNDER LH TAIL LAMP UNIT
G50	CA	HEADLINER / RH REAR ROOF PANEL

Refer to the front of this book for detailed information and illustrations regarding the location and identification of harnesses, relays, fuses, grounds, control modules and control module pins.

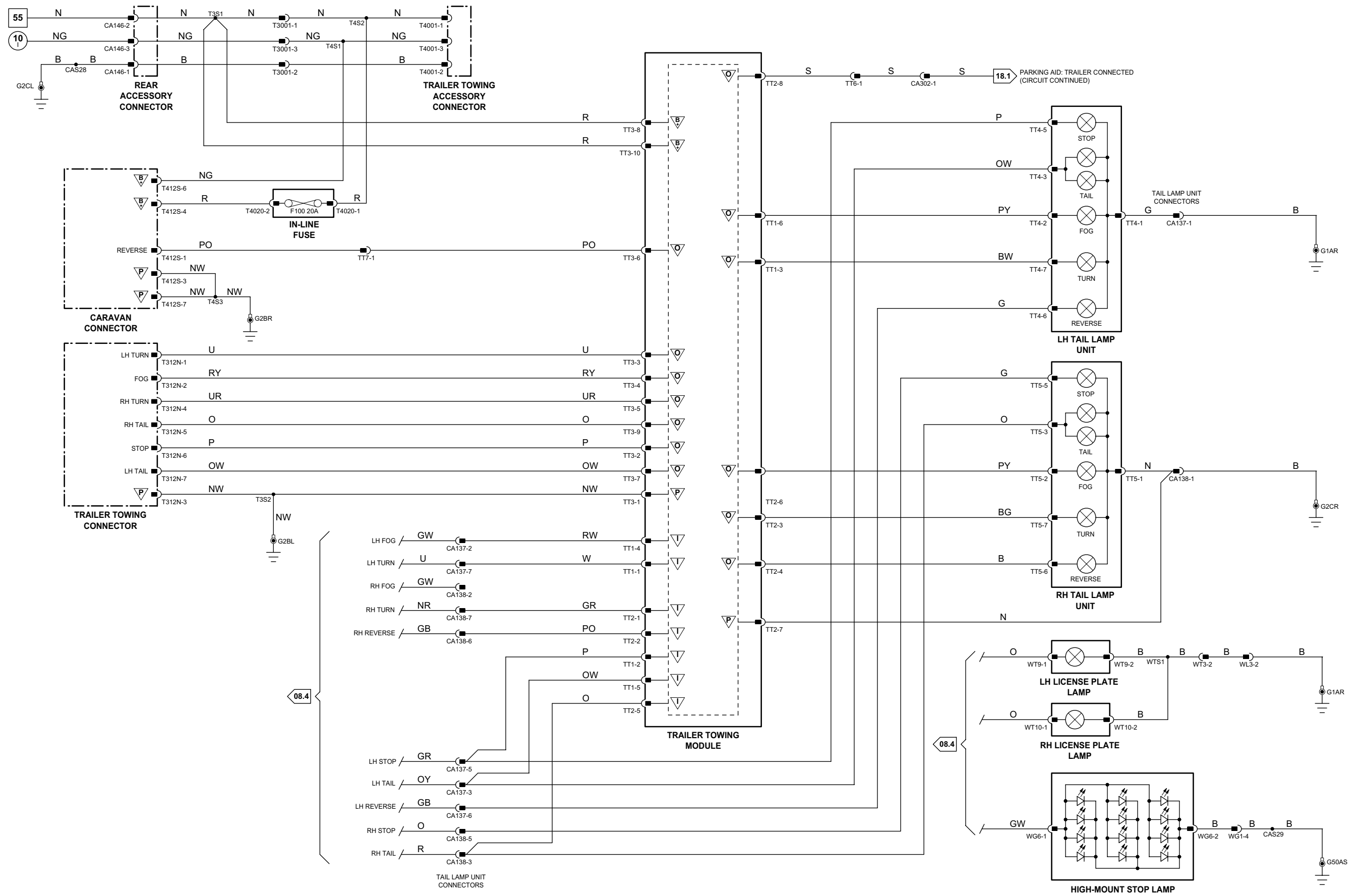

**Fig. 08.10****COMPONENTS**

Component	Connector(s)	Connector Description	Location
AXLE SENSOR – FRONT	JB140	6-WAY / BLACK	LH FRONT SUSPENSION
AXLE SENSOR – REAR	HI1	6-WAY / BLACK	LH REAR SUSPENSION
HEADLAMP LEVELING MODULE	IP130	26-WAY / WHITE	BEHIND INSTRUMENT PANEL / LH SIDE
HEADLAMP UNIT – LH	JB84	10-WAY / BLACK	ENGINE COMPARTMENT / LH SIDE
HEADLAMP UNIT – RH	JB85	10-WAY / BLACK	ENGINE COMPARTMENT / RH SIDE
MASTER LIGHTING SWITCH	IP17	16-WAY / BLACK	INSTRUMENT PANEL
POWER DISTRIBUTION FUSEBOX	–	–	ENGINE COMPARTMENT

**HARNESS IN-LINE CONNECTORS**

Connector	Connector Description / Location	Location
CA1	22-WAY / NATURAL / INSTRUMENT PANEL HARNESS TO CABIN HARNESS	LH 'A' POST / 'A' POST TRIM
CA10	22-WAY / SLATE / CABIN HARNESS TO JUNCTION BOX HARNESS	LH 'A' POST / 'A' POST TRIM
CA303	3-WAY GREY / CABIN HARNESS TO REAR AXLE HARNESS	BELOW LH REAR SEAT CUSHION
JB129	22-WAY / GREY / JUNCTION BOX HARNESS TO INSTRUMENT PANEL HARNESS	BELOW INSTRUMENT PANEL / LH SIDE
JB130	22-WAY / GREEN / JUNCTION BOX HARNESS TO INSTRUMENT PANEL HARNESS	BELOW INSTRUMENT PANEL / LH SIDE

**GROUNDS**

Ground	Harness	Location
G10	JB	ENGINE COMPARTMENT / BEHIND RH HEADLAMP
G11	JB	ENGINE COMPARTMENT / BEHIND LH HEADLAMP
G37	IP	BEHIND INSTRUMENT PANEL / RH SIDE OF CROSS CAR BEAM
G38	CA	UPPER LH 'E' POST

Refer to the front of this book for detailed information and illustrations regarding the location and identification of harnesses, relays, fuses, grounds, control modules and control module pins.



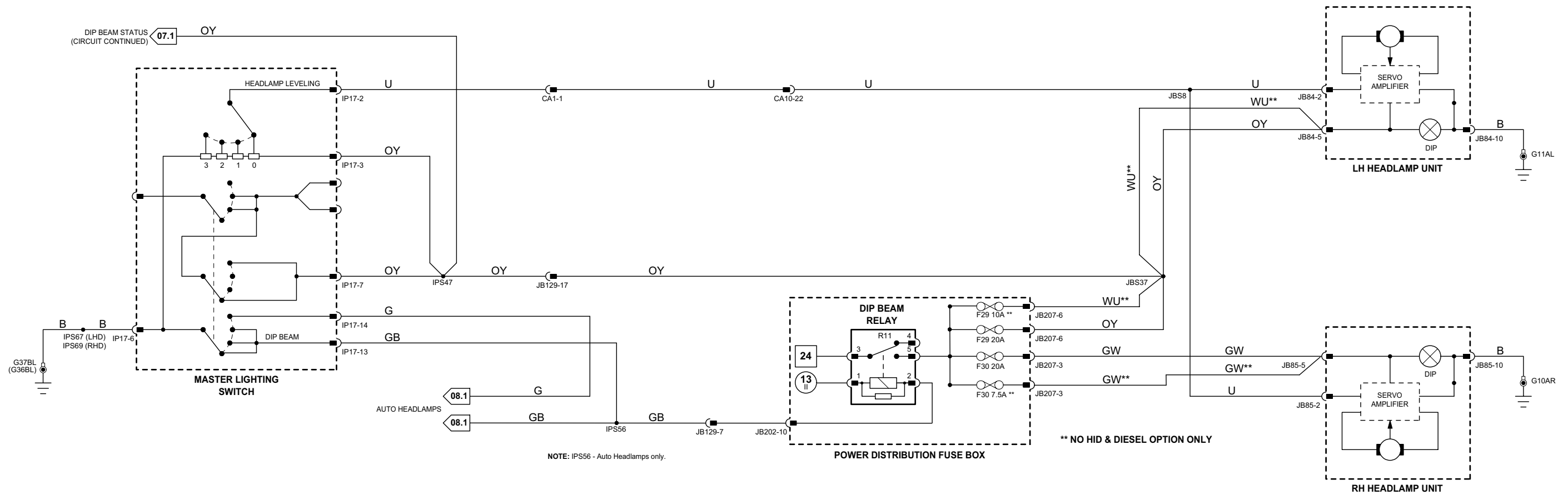

DRIVER-CONTROLLED HEADLAMP LEVELING

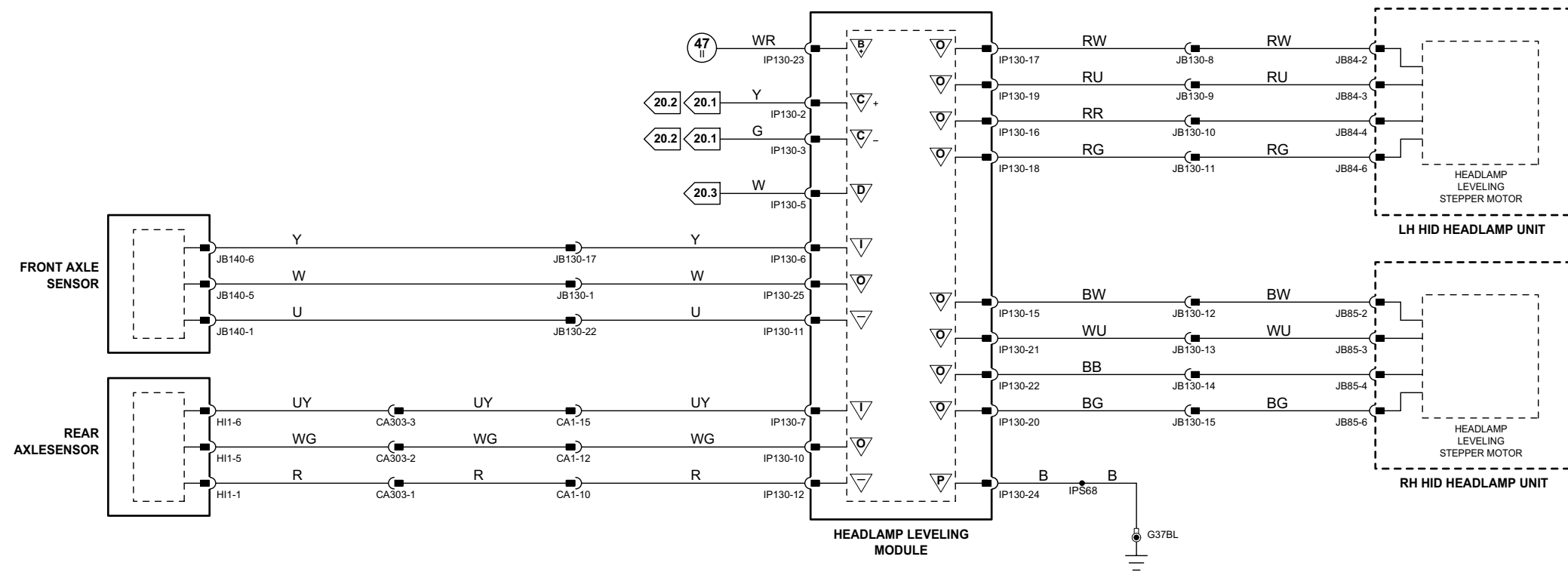

AUTOMATIC HEADLAMP LEVELING

1 → 6 Fig. 01.1	34 → 80 Fig. 01.3	11 → 31 Fig. 01.5	67 → 76 Fig. 01.7	98 → 107 Fig. 01.9	Input	Battery Voltage	Sensor/Signal Supply V	CAN	D2B Network
7 → 33 Fig. 01.2	1 → 10 Fig. 01.4	32 → 66 Fig. 01.6	77 → 97 Fig. 01.8		Output	Power Ground	Sensor/Signal Ground	SCP	Serial and Encoded Data

VARIANT: H/L & HID Headlamp Vehicles  
 VIN RANGE: All  
 DATE OF ISSUE: February 2008

**General Electronic Module**

	Pin	Description and Characteristic
O	CA86-03	INTERIOR LAMPS : TO ACTIVATE, GEM SWITCHES CIRCUIT TO GROUND
PG	CA86-05	POWER GROUND
I	CA86-14	RESET SWITCH: OPEN CIRCUIT / GROUND
I	CA86-15	TAIL GLASS RELEASE SWITCH: GROUND WHEN ACTIVATED
I	CA86-16	SET SWITCH: OPEN CIRCUIT / GROUND
I	CA87-15	LH REAR DOOR AJAR: DOOR OPEN = OPEN CIRCUIT; DOOR CLOSED = GROUND
I	IP5-03	SEDAN (EXCEPT JAPAN AND S. KOREA): EXTERNAL ANTENNA
S	IP5-18	SCP -
S	IP5-19	SCP +
SG	IP6-01	LOGIC GROUND: GROUND
I	IP6-21	PASSENGER DOOR AJAR: DOOR OPEN = OPEN CIRCUIT; DOOR CLOSED = GROUND
I	IP6-22	DRIVER DOOR AJAR: DOOR OPEN = OPEN CIRCUIT; DOOR CLOSED = GROUND
B+	JB172-05	BATTERY POWER SUPPLY (TURN SIGNALS): B+

**Fig. 09.1**

**COMPONENTS**

Component	Connector(s)	Connector Description	Location
DOOR LATCH – DRIVER	DD3	8-WAY / BLACK	DRIVER DOOR
	DD9	2-WAY / BLACK	
DOOR LATCH – LH REAR	BL3	8-WAY / BLACK	LH REAR DOOR
	BL6	2-WAY / BLACK	
DOOR LATCH – PASSENGER	PD3	8-WAY / BLACK	PASSENGER DOOR
	PD9	2-WAY / BLACK	
DOOR LATCH – RH REAR	BR3	8-WAY / BLACK	RH REAR DOOR
	BR6	2-WAY / BLACK	
FOOTWELL LAMP – LH	IP27	2-WAY / GREY	INSTRUMENT PANEL / LH SIDE
FOOTWELL LAMP – RH	IP26	2-WAY / GREY	INSTRUMENT PANEL / RH SIDE
GENERAL ELECTRONIC MODULE	CA86	23-WAY / GREY	BEHIND INSTRUMENT PANEL / RH SIDE
	CA87	23-WAY / GREEN	
	IP5	23-WAY / BROWN	
	IP6	23-WAY / NATURAL	
	JB172	23-WAY / BLUE	
GLOVE BOX LAMP	IP25	2-WAY / BROWN	GLOVE BOX
INTERIOR LAMP – REAR	RC11	2-WAY / BLACK	REAR HEAD LINER
	RC20	1-WAY / ORANGE	
RF MODULE	RC35	3-WAY / BLACK	ROOF CONSOLE
ROOF CONSOLE – PRINTED CIRCUIT BOARD	RC23	20-WAY / WHITE	ROOF CENTER FRONT
ROOF CONSOLE – WITHOUT PRINTED CIRCUIT BOARD	RC30	4-WAY / BLACK	ROOF CENTER FRONT
	RC31	2-WAY / BLACK	
	RC33	4-WAY / BLACK	
	RC34	6-WAY / BLACK	
TAIL GATE LATCH	WT6	6-WAY / BLACK	TAIL GATE
TAIL GLASS LATCH	WT7	4-WAY / BLACK	TAIL GATE
TRUNK LAMP – LH: ESTATE (WAGON)	CA434	2-WAY / BLACK	LH REAR INTERIOR TRIM
TRUNK LAMP – RH: ESTATE (WAGON)	CA433	2-WAY / BLACK	RH REAR INTERIOR TRIM
TRUNK LAMP – SEDAN	CA132	2-WAY / BLACK	TRUNK / RH SIDE
TRUNK LOCK MOTOR	TM6	5-WAY / NATURAL	TRUNK LID
VANITY MIRROR LAMP – LH	RC9	2-WAY / BLACK	LH SUN VISOR
VANITY MIRROR LAMP – RH	RC8	2-WAY / BLACK	RH SUN VISOR

**HARNES IN-LINE CONNECTORS**

Connector	Connector Description / Location	Location
CA1	22-WAY / NATURAL / INSTRUMENT PANEL HARNESS TO CABIN HARNESS	LH 'A' POST / 'A' POST TRIM
CA15	20-WAY / BLACK / CABIN HARNESS TO DRIVER DOOR HARNESS	DRIVER DOOR / DOOR CASING
CA16	20-WAY / BLACK / CABIN HARNESS TO DRIVER DOOR HARNESS	DRIVER DOOR / DOOR CASING
CA20	20-WAY / BLACK / CABIN HARNESS TO PASSENGER DOOR HARNESS	PASSENGER DOOR / DOOR CASING
CA25	14-WAY / NATURAL / CABIN HARNESS TO LH REAR DOOR HARNESS	LH 'B/C' POST / 'B/C' POST TRIM
CA30	14-WAY / NATURAL / CABIN HARNESS TO RH REAR DOOR HARNESS	RH 'B/C' POST / 'B/C' POST TRIM
CA36	16-WAY / GREEN / CABIN HARNESS TO ROOF HARNESS	LH 'A' POST / WINDSHIELD PILLAR
CA40	16-WAY / GREY / CABIN HARNESS TO ROOF HARNESS	RH 'A' POST / WINDSHIELD PILLAR
CA45	6-WAY / GREY / CABIN HARNESS TO TRUNK LID HARNESS	BEHIND LH 'E' POST TRIM
CA240	12-WAY / GREY / CABIN HARNESS TO INSTRUMENT PANEL HARNESS	LH LOWER 'A' POST / 'A' POST TRIM
TL10	6-WAY / GREY / TRUNK LINK LEAD TO TRUNK LID HARNESS	BELOW PARCEL SHELF / LH SIDE
WL1	8-WAY / BLACK / CABIN HARNESS TO TAIL GATE LINK LEAD	ROOF / CENTER REAR
WL3	3-WAY / BLACK / CABIN HARNESS TO TAIL GATE LINK LEAD	ROOF / CENTER REAR
WT1	8-WAY / BLACK / CABIN HARNESS TO TAIL GATE HARNESS	TAIL GATE
WT3	3-WAY / BLACK / CABIN HARNESS TO TAIL GATE HARNESS	TAIL GATE

**GROUNDS**

Ground	Harness	Location
G1	CA	TRUNK / UNDER LH TAIL LAMP UNIT
G2	CA	TRUNK / UNDER LH TAIL LAMP UNIT
G4	CA	LOWER RH 'A' POST
G5	IP	UPPER RH 'A' POST
G15	CA	LOWER LH 'A' POST
G37	IP	BEHIND INSTRUMENT PANEL / RH SIDE OF CROSS CAR BEAM

**FOR CONTROL MODULE PIN-OUT INFORMATION, UNFOLD PAGE TO LEFT.**

The following abbreviations are used to represent values for Control Module Pin-Out data

I	Input	PG	Power Ground	C	CAN Network	D	Serial and Encoded Data
O	Output	SS	Sensor / Signal Supply V	S	SCP Network	V	Voltage (DC)
B+	Battery Voltage	SG	Sensor / Signal Ground	D2	D2B Network	PWM	Pulse Width Modulated

**CAUTION:** The information on this data page is furnished to aid the user in understanding circuit operation. THIS INFORMATION SHOULD BE USED FOR REFERENCE ONLY.

**NOTE:** The values listed are approximately those that can be expected at the control module connector pins with all circuit connections made and all components connected and fitted.

Refer to the front of this book for detailed information and illustrations regarding the location and identification of harnesses, relays, fuses, grounds, control modules and control module pins.

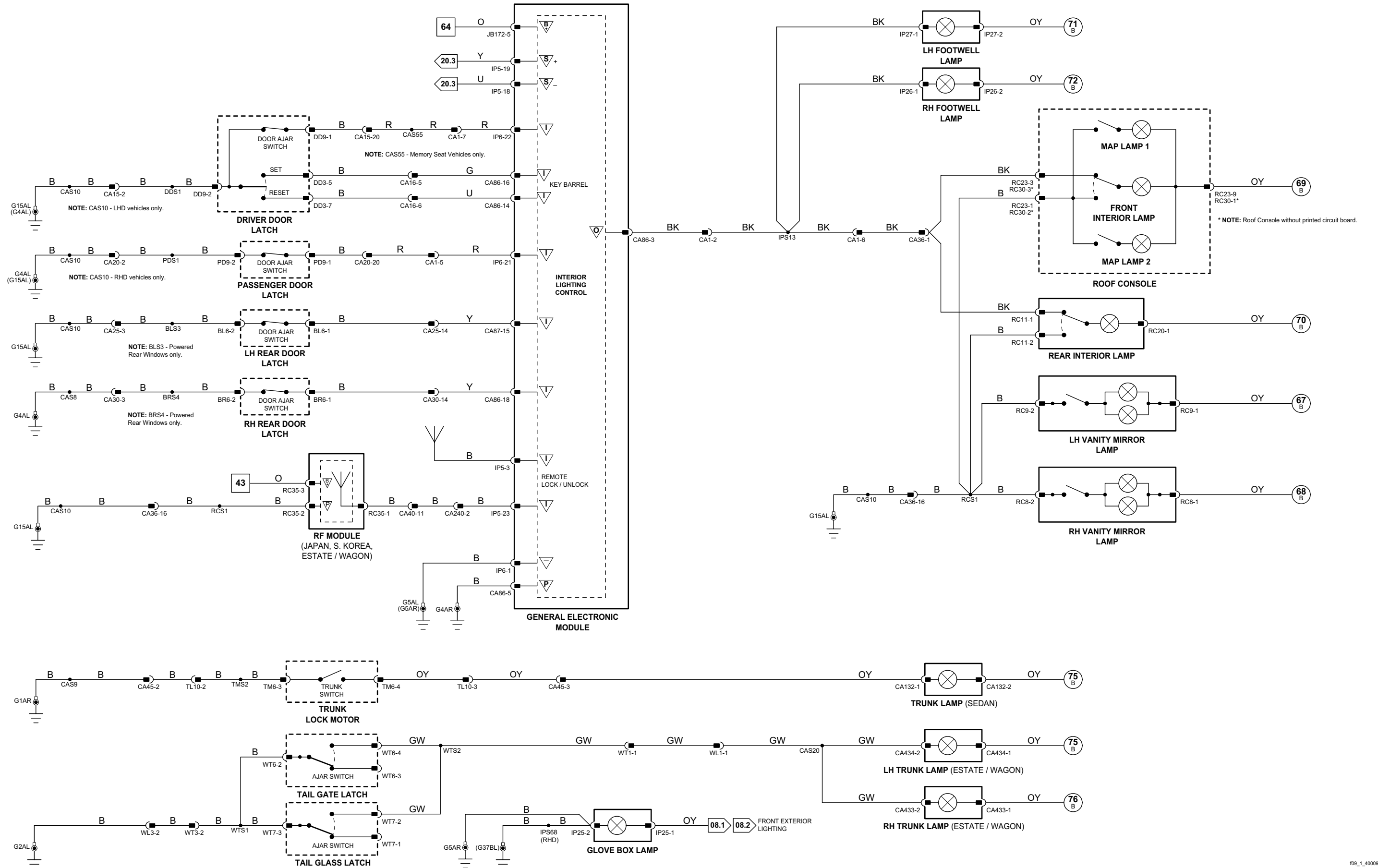

1 → 6 Fig. 01.1	34 → 80 Fig. 01.3	11 → 31 Fig. 01.5	67 → 76 Fig. 01.7	98 → 107 Fig. 01.9	Input	Battery Voltage	Sensor/Signal Supply V	CAN	D2B Network
7 → 33 Fig. 01.2	1 → 10 Fig. 01.4	32 → 66 Fig. 01.6	77 → 97 Fig. 01.8		Output	Power Ground	Sensor/Signal Ground	SCP	Serial and Encoded Data

VARIANT: All Vehicles  
 VIN RANGE: All  
 DATE OF ISSUE: February 2008

**Fig. 09.2****COMPONENTS**

Component	Connector(s)	Connector Description	Location
AUDIO UNIT	ID1	2-WAY / D2B	INSTRUMENT PANEL CENTER
	IP65	20-WAY / BLACK	
	IP106	2-WAY / METALLIC	
CIGAR LIGHTER	IP42	2-WAY / ORANGE	ASH TRAY
	AC1	26-WAY / YELLOW	BEHIND CLIMATE CONTROL PANEL
CLIMATE CONTROL MODULE – PANEL	IP39	4-WAY / GREY	
	IP101	26-WAY / WHITE	
	IP135	2-WAY / GREY	
	DD1	20-WAY / BLACK	DRIVER DOOR CASING
	BL1	8-WAY / BLACK	LH REAR DOOR CASING
DOOR SWITCH PACK – DRIVER	PD10	8-WAY / BLACK	PASSENGER DOOR CASING
DOOR SWITCH PACK – LH REAR	BR1	8-WAY / BLACK	RH REAR DOOR CASING
DOOR SWITCH PACK – PASSENGER	IP51	6-WAY / BLACK	CENTER CONSOLE
DOOR SWITCH PACK – RH REAR	IP10	26-WAY / WHITE	INSTRUMENT PANEL
HAZARD AND SEAT HEATER SWITCHES	IP11	26-WAY / WHITE	
INSTRUMENT CLUSTER	IP14	16-WAY / GREY	CENTER CONSOLE
J-GATE MODULE	IP17	16-WAY / BLACK	INSTRUMENT PANEL
MASTER LIGHTING SWITCH	RC23	20-WAY / WHITE	ROOF CENTER FRONT
ROOF CONSOLE – PRINTED CIRCUIT BOARD	SW4	6-WAY / BLACK	STEERING COLUMN
STEERING WHEEL	IP70	22-WAY / BLACK	CENTER CONSOLE
TELEMATICS DISPLAY	IP136	2-WAY / METALLIC	
	IP137	2-WAY / METALLIC	
	IP138	2-WAY / METALLIC	
	IP139	2-WAY / METALLIC	
	IP29	6-WAY / BLACK	INSTRUMENT PANEL
TRACTION CONTROL / DYNAMIC STABILITY CONTROL SWITCH			

**HARNES IN-LINE CONNECTORS**

Connector	Connector Description / Location	Location
CA1	22-WAY / NATURAL / INSTRUMENT PANEL HARNESS TO CABIN HARNESS	LH 'A' POST / 'A' POST TRIM
CA15	20-WAY / BLACK / CABIN HARNESS TO DRIVER DOOR HARNESS	DRIVER DOOR / DOOR CASING
CA20	20-WAY / BLACK / CABIN HARNESS TO PASSENGER DOOR HARNESS	PASSENGER DOOR / DOOR CASING
CA25	14-WAY / NATURAL / CABIN HARNESS TO LH REAR DOOR HARNESS	LH 'B/C' POST / 'B/C' POST TRIM
CA30	14-WAY / NATURAL / CABIN HARNESS TO RH REAR DOOR HARNESS	RH 'B/C' POST / 'B/C' POST TRIM
CA36	16-WAY / GREEN / CABIN HARNESS TO ROOF HARNESS	LH 'A' POST / WINDSHIELD PILLAR
IP34	10-WAY / NATURAL / INSTRUMENT PANEL HARNESS TO STEERING WHEEL HARNESS	STEERING WHEEL CASSETTE
JB1	42-WAY / BLACK / ENGINE MANAGEMENT HARNESS TO JUNCTION BOX HARNESS	ENGINE COMPARTMENT / LH SIDE
JB129	22-WAY / GREY / JUNCTION BOX HARNESS TO INSTRUMENT PANEL HARNESS	BELOW INSTRUMENT PANEL / LH SIDE

**GROUNDS**

Ground	Harness	Location
G4	CA	LOWER RH 'A' POST
G14	JB	ENGINE COMPARTMENT / BEHIND POWER DISTRIBUTION FUSEBOX
G15	CA	LOWER LH 'A' POST
G35	CA	LOWER LH 'E' POST
G36	IP	BEHIND INSTRUMENT PANEL / LH SIDE OF CROSS CAR BEAM
G37	IP	BEHIND INSTRUMENT PANEL / RH SIDE OF CROSS CAR BEAM
G38	CA	UPPER LH 'E' POST

Refer to the front of this book for detailed information and illustrations regarding the location and identification of harnesses, relays, fuses, grounds, control modules and control module pins.

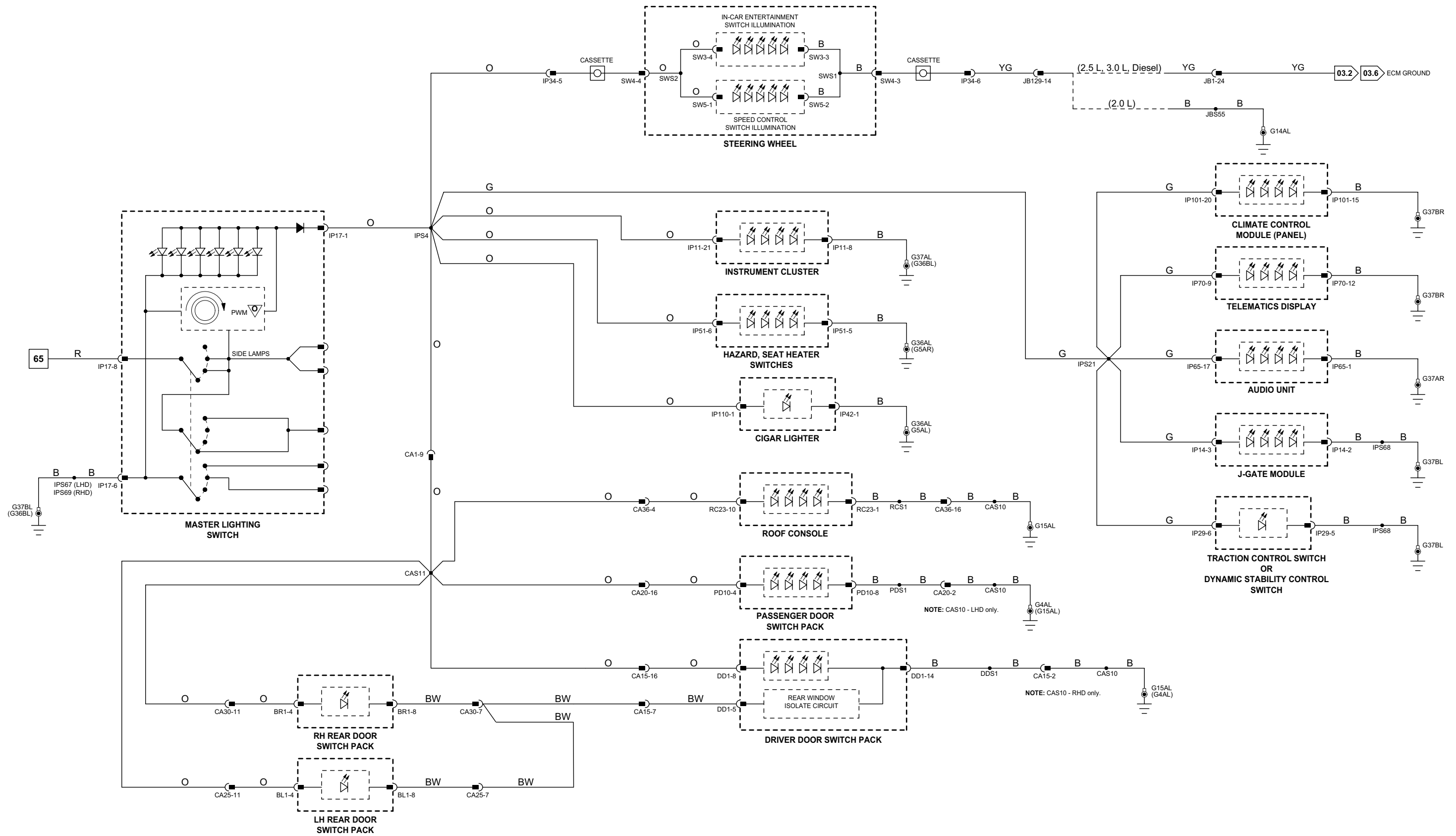

109\_2\_4000625

1 → 6 Fig. 01.1	34 → 80 Fig. 01.3	11 → 31 Fig. 01.5	67 → 76 Fig. 01.7	98 → 107 Fig. 01.9	Input	Battery Voltage	Sensor/Signal Supply V	CAN	D2B Network
7 → 33 Fig. 01.2	1 → 10 Fig. 01.4	32 → 66 Fig. 01.6	77 → 97 Fig. 01.8		Output	Power Ground	Sensor/Signal Ground	SCP	Serial and Encoded Data

**VARIANT:** All Vehicles  
**VIN RANGE:** All  
**DATE OF ISSUE:** February 2008

## Driver Seat Module

	Pin	Description and Characteristic
C	DM1-02	CAN -
C	DM1-12	CAN +
B+	DM2-01	BATTERY POWER SUPPLY: B+
SG	DM2-03	SIGNAL GROUND: GROUND
B+	DM2-04	IGNITION SWITCHED POWER SUPPLY II: B+
PG	DM2-05	POWER GROUND: GROUND
B+	DM2-06	BATTERY POWER SUPPLY: B+
I	DM2-07	DRIVER DOOR AJAR SWITCH SIGNAL: OPEN CIRCUIT WHEN ACTIVATED
PG	DM2-10	POWER GROUND: GROUND
I	DM3-01	DRIVER SEAT BACK RECLINE / INCLINE POSITION SIGNAL
SG	DM3-02	DRIVER SEAT BACK RECLINE / INCLINE POSITION SIGNAL GROUND
I	DM3-03	DRIVER SEAT CUSHION REAR UP / DOWN POSITION SIGNAL
SG	DM3-04	DRIVER SEAT CUSHION REAR UP / DOWN POSITION SIGNAL GROUND
I	DM3-05	DRIVER SEAT CUSHION FRONT UP / DOWN POSITION SIGNAL
SG	DM3-06	DRIVER SEAT CUSHION FRONT UP / DOWN POSITION SIGNAL GROUND
I	DM3-07	DRIVER SEAT FORE / AFT POSITION SIGNAL
SG	DM3-08	DRIVER SEAT FORE / AFT POSITION SIGNAL GROUND
O	DM4-01	DRIVER SEAT BACK RECLINE / INCLINE MOTOR DRIVE
O	DM4-02	DRIVER SEAT BACK RECLINE / INCLINE MOTOR DRIVE
O	DM4-03	DRIVER SEAT CUSHION REAR UP / DOWN MOTOR DRIVE
O	DM4-04	DRIVER SEAT CUSHION REAR UP / DOWN MOTOR DRIVE
O	DM4-05	DRIVER SEAT CUSHION FRONT UP / DOWN MOTOR DRIVE
O	DM4-06	DRIVER SEAT CUSHION FRONT UP / DOWN MOTOR DRIVE
O	DM4-07	DRIVER SEAT FORE / AFT MOTOR DRIVE
O	DM4-08	DRIVER SEAT FORE / AFT MOTOR DRIVE
O	DM5-01	DRIVER SEAT LUMBAR PUMP DRIVE
O	DM5-02	DRIVER SEAT LUMBAR PUMP DRIVE

## Fig. 11.1

### COMPONENTS

Component	Connector(s)	Connector Description	Location
DOOR LATCH - DRIVER	DD3	8-WAY / BLACK	DRIVER DOOR
	DD9	2-WAY / BLACK	
	DM10	3-WAY / WHITE	DRIVER SEAT
SEAT LUMBAR PUMP - DRIVER	DM2	10-WAY / GREY	DRIVER SEAT SWITCH PACK
SEAT MODULE - DRIVER	DM3	16-WAY / BLACK	
	DM4	8-WAY / BLUE	
	DM5	8-WAY / GREEN	
SEAT MOTORS AND POSITION SENSORS - DRIVER	DM7	4-WAY / GREY	DRIVER SEAT
	DM8	4-WAY / GREY	
	DM9	4-WAY / GREY	
	ML12	4-WAY / GREY	

### HARNESS IN-LINE CONNECTORS

Connector	Connector Description / Location	Location
CA15	20-WAY / BLACK / CABIN HARNESS TO DRIVER DOOR HARNESS	DRIVER DOOR / DOOR CASING
CA65	18-WAY / BLACK / CABIN HARNESS TO DRIVER SEAT HARNESS	UNDER DRIVER SEAT
CA431	12-WAY / BLACK / INSTRUMENT PANEL HARNESS TO CABIN HARNESS	INSTRUMENT PANEL
DM6	4-WAY / GREY / DRIVER SEAT HARNESS TO LINK LEAD HARNESS	UNDER DRIVER SEAT

### GROUNDS

Ground	Harness	Location
G4	CA	LOWER RH 'A' POST
G15	CA	LOWER LH 'A' POST

FOR CONTROL MODULE PIN-OUT INFORMATION, UNFOLD PAGE TO LEFT.

The following abbreviations are used to represent values for Control Module Pin-Out data

I	Input	PG	Power Ground	C	CAN Network	D	Serial and Encoded Data
O	Output	SS	Sensor / Signal Supply V	S	SCP Network	V	Voltage (DC)
B+	Battery Voltage	SG	Sensor / Signal Ground	D2	D2B Network	PWM	Pulse Width Modulated

**CAUTION:** The information on this data page is furnished to aid the user in understanding circuit operation. THIS INFORMATION SHOULD BE USED FOR REFERENCE ONLY.

**NOTE:** The values listed are approximately those that can be expected at the control module connector pins with all circuit connections made and all components connected and fitted.

Refer to the front of this book for detailed information and illustrations regarding the location and identification of harnesses, relays, fuses, grounds, control modules and control module pins.

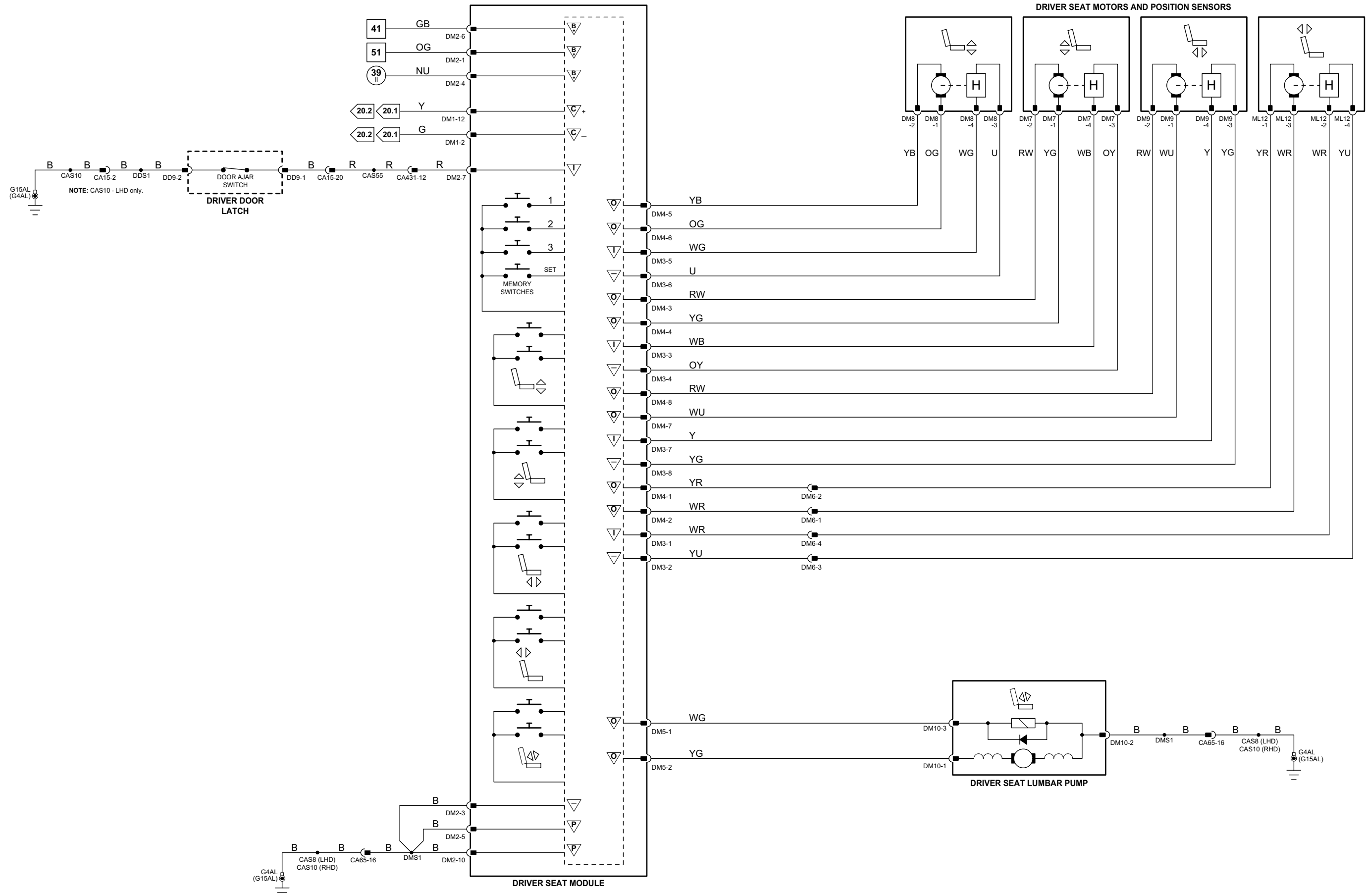

f11\_1\_4000625

1 → 6 Fig. 01.1	34 → 80 Fig. 01.3	11 → 31 Fig. 01.5	67 → 76 Fig. 01.7	98 → 107 Fig. 01.9	Input	Battery Voltage	Sensor/Signal Supply V	CAN	D2B Network
7 → 33 Fig. 01.2	1 → 10 Fig. 01.4	32 → 66 Fig. 01.6	77 → 97 Fig. 01.8		Output	Power Ground	Sensor/Signal Ground	SCP	Serial and Encoded Data

VARIANT: Memory Vehicles  
 VIN RANGE: All  
 DATE OF ISSUE: February 2008

**Passenger Seat Module**

	Pin	Description and Characteristic
B+	PM2-01	BATTERY POWER SUPPLY: B+
I	PM2-02	PASSENGER SEAT HEATER SWITCH SIGNAL
B+	PM2-04	IGNITION SWITCHED POWER SUPPLY II: B+
PG	PM2-05	POWER GROUND: GROUND
B+	PM2-06	BATTERY POWER SUPPLY: B+
PG	PM2-10	POWER GROUND: GROUND
O	PM4-01	PASSENGER SEAT BACK RECLINE / INCLINE MOTOR DRIVE
O	PM4-02	PASSENGER SEAT BACK RECLINE / INCLINE MOTOR DRIVE
O	PM4-03	PASSENGER SEAT CUSHION REAR UP / DOWN MOTOR DRIVE
O	PM4-04	PASSENGER SEAT CUSHION REAR UP / DOWN MOTOR DRIVE
O	PM4-05	PASSENGER SEAT CUSHION FRONT UP / DOWN MOTOR DRIVE
O	PM4-06	PASSENGER SEAT CUSHION FRONT UP / DOWN MOTOR DRIVE
O	PM4-07	PASSENGER SEAT FORE / AFT MOTOR DRIVE
O	PM4-08	PASSENGER SEAT FORE / AFT MOTOR DRIVE
O	PM5-01	PASSENGER SEAT LUMBAR PUMP DRIVE
O	PM5-02	PASSENGER SEAT LUMBAR PUMP DRIVE

**Fig. 11.2**

**COMPONENTS**

Component	Connector(s)	Connector Description	Location
SEAT LUMBAR PUMP – PASSENGER	PM19	3-WAY / WHITE	PASSENGER SEAT
SEAT MODULE – PASSENGER	PM2	10-WAY / GREY	PASSENGER SEAT SWITCH PACK
	PM4	8-WAY / BLUE	
	PM5	8-WAY / GREEN	
SEAT MOTORS – PASSENGER	PM6	2-WAY / RED	PASSENGER SEAT
	PM7	2-WAY / RED	
	PM8	2-WAY / BLACK	
	PM9	2-WAY / RED	

**HARNESS IN-LINE CONNECTORS**

Connector	Connector Description / Location	Location
CA70	18-WAY / BLACK / CABIN HARNESS TO DRIVER SEAT HARNESS	UNDER DRIVER SEAT

**GROUNDS**

Ground	Harness	Location
G4	CA	LOWER RH 'A' POST
G15	CA	LOWER LH 'A' POST

FOR CONTROL MODULE PIN-OUT INFORMATION, UNFOLD PAGE TO LEFT.

The following abbreviations are used to represent values for Control Module Pin-Out data

I	Input	PG	Power Ground	C	CAN Network	D	Serial and Encoded Data
O	Output	SS	Sensor / Signal Supply V	S	SCP Network	V	Voltage (DC)
B+	Battery Voltage	SG	Sensor / Signal Ground	D2	D2B Network	PWM	Pulse Width Modulated

**CAUTION:** The information on this data page is furnished to aid the user in understanding circuit operation. THIS INFORMATION SHOULD BE USED FOR REFERENCE ONLY.

**NOTE:** The values listed are approximately those that can be expected at the control module connector pins with all circuit connections made and all components connected and fitted.

Refer to the front of this book for detailed information and illustrations regarding the location and identification of harnesses, relays, fuses, grounds, control modules and control module pins.



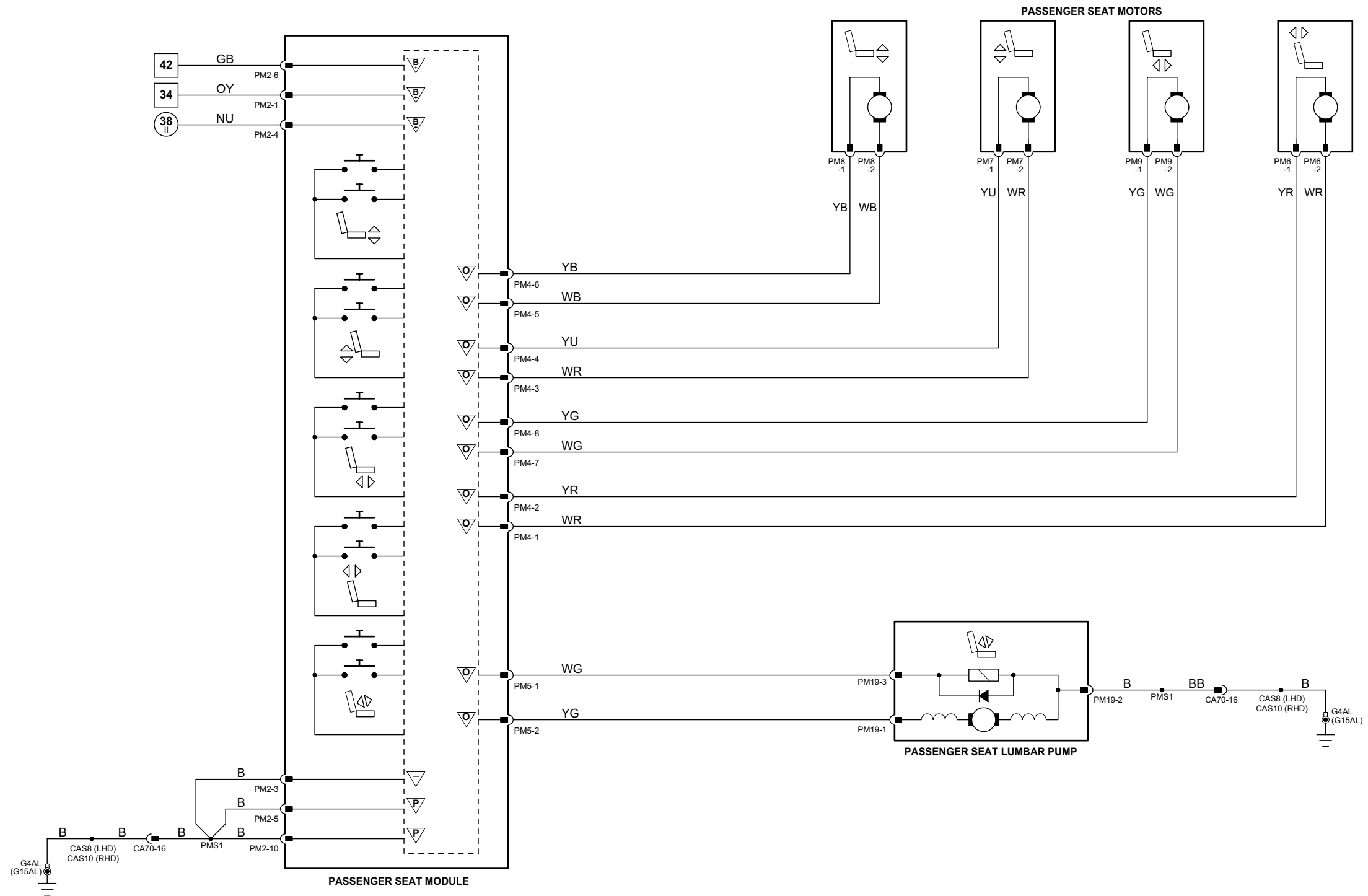

**Fig. 11.3****COMPONENTS**

<b>Component</b>	<b>Connector(s)</b>	<b>Connector Description</b>	<b>Location</b>
LUMBAR SWITCH PACK – LH	RS16	7-WAY / BLACK	LH FRONT SEAT
LUMBAR SWITCH PACK – RH	LS16	7-WAY / BLACK	RH FRONT SEAT
SEAT LUMBAR PUMP – LH	LS19	3-WAY / WHITE	LH FRONT SEAT
SEAT LUMBAR PUMP – RH	RS19	3-WAY / WHITE	RH FRONT SEAT
SEAT MOVEMENT MOTORS – LH	LS2	2-WAY / NATURAL	LH FRONT SEAT
	LS6	2-WAY / RED	
SEAT MOVEMENT MOTORS – RH	RS2	2-WAY / NATURAL	RH FRONT SEAT
	RS6	2-WAY / RED	
SEAT SWITCH PACK – LH	LS1	12-WAY / GREY	LH FRONT SEAT
SEAT SWITCH PACK – RH	RS1	12-WAY / GREY	RH FRONT SEAT

**HARNESS IN-LINE CONNECTORS**

<b>Connector</b>	<b>Connector Description / Location</b>	<b>Location</b>
CA65	18-WAY / BLACK / CABIN HARNESS TO DRIVER SEAT HARNESS	UNDER DRIVER SEAT
CA70	18-WAY / BLACK / CABIN HARNESS TO DRIVER SEAT HARNESS	UNDER DRIVER SEAT

**GROUNDS**

<b>Ground</b>	<b>Harness</b>	<b>Location</b>
G4	CA	LOWER RH 'A' POST
G15	CA	LOWER LH 'A' POST

Refer to the front of this book for detailed information and illustrations regarding the location and identification of harnesses, relays, fuses, grounds, control modules and control module pins.

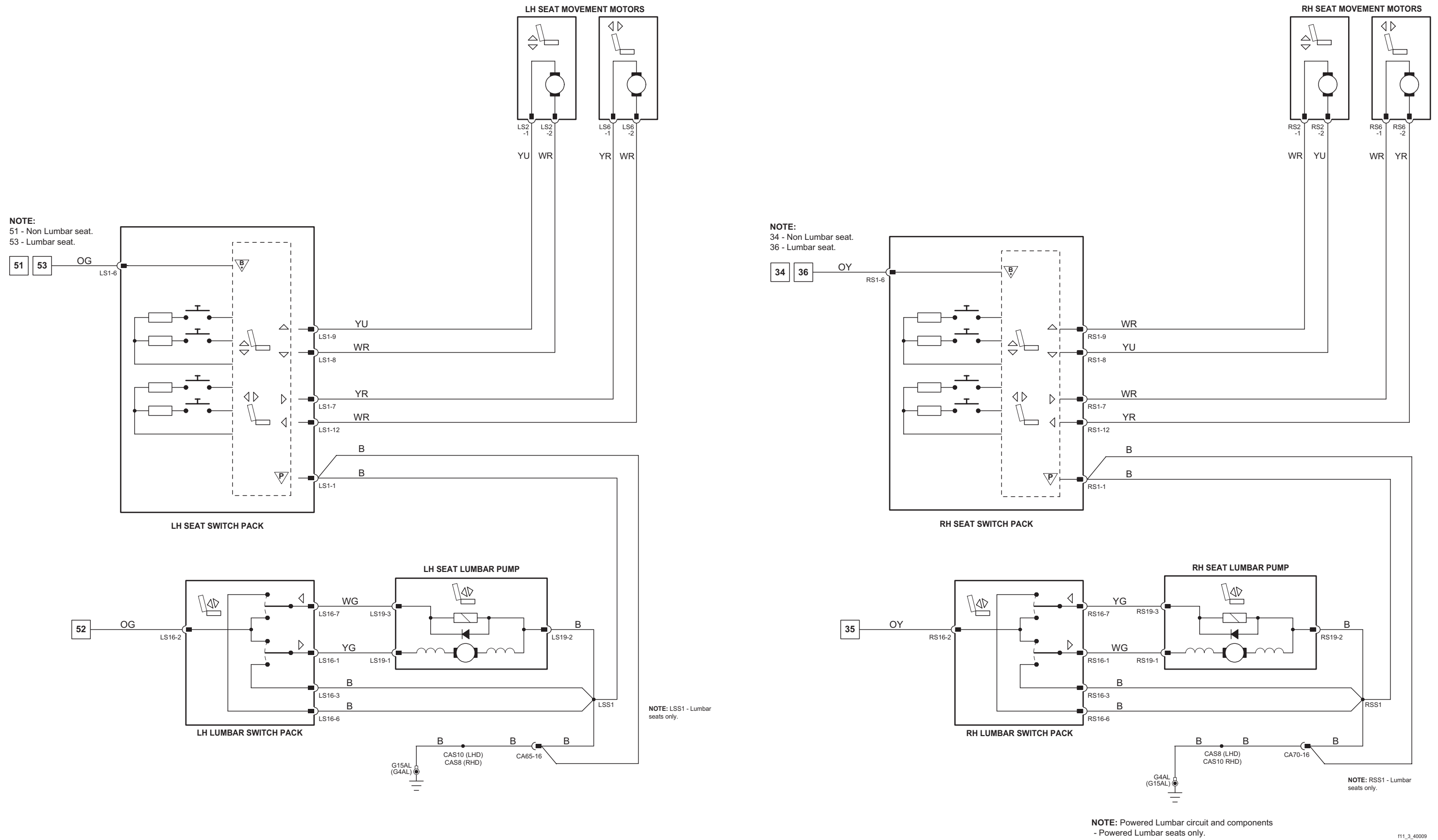

**Fig. 11.4**

**Driver Seat Module**

	Pin	Description and Characteristic
B+	DM2-01	BATTERY POWER SUPPLY: B+
I	DM2-02	DRIVER SEAT HEATER SWITCH SIGNAL
SG	DM2-03	SIGNAL GROUND: GROUND
B+	DM2-04	IGNITION SWITCHED POWER SUPPLY II: B+
PG	DM2-05	POWER GROUND: GROUND
B+	DM2-06	BATTERY POWER SUPPLY: B+
O	DM2-08	DRIVER SEAT HEATER STATE
O	DM2-09	DRIVER SEAT HEATER STATE
PG	DM2-10	POWER GROUND: GROUND
O	DM5-03	DRIVER SEAT HEATER DRIVE
I	DM5-04	DRIVER SEAT HEATER GROUND
I	DM5-07	DRIVER SEAT HEATER TEMPERATURE SENSOR SIGNAL
SG	DM5-08	DRIVER SEAT HEATER TEMPERATURE SENSOR SIGNAL GROUND

**Passenger Seat Module**

	Pin	Description and Characteristic
B+	PM2-01	BATTERY POWER SUPPLY: B+
I	PM2-02	PASSENGER SEAT HEATER SWITCH SIGNAL
SG	PM2-03	SIGNAL GROUND: GROUND
B+	PM2-04	IGNITION SWITCHED POWER SUPPLY II: B+
PG	PM2-05	POWER GROUND: GROUND
B+	PM2-06	BATTERY POWER SUPPLY: B+
O	PM2-08	PASSENGER SEAT HEATED STATE
O	PM2-09	PASSENGER SEAT HEATED STATE
PG	PM2-10	POWER GROUND: GROUND
O	PM5-03	PASSENGER SEAT HEATER DRIVE
I	PM5-04	PASSENGER SEAT HEATER GROUND
I	PM5-07	PASSENGER SEAT HEATER TEMPERATURE SENSOR SIGNAL
SG	PM5-08	PASSENGER SEAT HEATER TEMPERATURE SENSOR SIGNAL GROUND

**COMPONENTS**

Component	Connector(s)	Connector Description	Location
SEAT BACK HEATER – DRIVER	DM11	4-WAY / GREY	DRIVER SEAT
SEAT BACK HEATER – PASSENGER	PM10	4-WAY / GREY	PASSENGER SEAT
SEAT CUSHION HEATER – DRIVER	DM11	4-WAY / GREY	DRIVER SEAT
SEAT CUSHION HEATER – PASSENGER	PM10	4-WAY / GREY	PASSENGER SEAT
SEAT HEATER SWITCH – DRIVER: LHD	IP51	6-WAY / BLACK	CENTER CONSOLE
SEAT HEATER SWITCH – DRIVER: RHD	IP56	6-WAY / BLACK	CENTER CONSOLE
SEAT HEATER SWITCH – PASSENGER: LHD	IP56	6-WAY / BLACK	CENTER CONSOLE
SEAT HEATER SWITCH – PASSENGER: RHD	IP51	6-WAY / BLACK	CENTER CONSOLE
SEAT MODULE – DRIVER	DM2	10-WAY / GREY	DRIVER SEAT SWITCH PACK
	DM3	16-WAY / BLACK	
	DM4	8-WAY / BLUE	
	DM5	8-WAY / GREEN	
SEAT MODULE – PASSENGER	PM2	10-WAY / GREY	PASSENGER SEAT SWITCH PACK
	PM4	8-WAY / BLUE	
	PM5	8-WAY / GREEN	

**HARNESS IN-LINE CONNECTORS**

Connector	Connector Description / Location	Location
CA65	18-WAY / BLACK / CABIN HARNESS TO DRIVER SEAT HARNESS	UNDER DRIVER SEAT
CA70	18-WAY / BLACK / CABIN HARNESS TO DRIVER SEAT HARNESS	UNDER DRIVER SEAT
CA240	12-WAY / GREY / CABIN HARNESS TO INSTRUMENT PANEL HARNESS	LH LOWER 'A' POST / 'A' POST TRIM

**GROUNDS**

Ground	Harness	Location
G4	CA	LOWER RH 'A' POST
G5	IP	UPPER RH 'A' POST
G15	CA	LOWER LH 'A' POST
G36	IP	BEHIND INSTRUMENT PANEL / LH SIDE OF CROSS CAR BEAM

**FOR CONTROL MODULE PIN-OUT INFORMATION, UNFOLD PAGE TO LEFT.**

The following abbreviations are used to represent values for Control Module Pin-Out data

I	Input	PG	Power Ground	C	CAN Network	D	Serial and Encoded Data
O	Output	SS	Sensor / Signal Supply V	S	SCP Network	V	Voltage (DC)
B+	Battery Voltage	SG	Sensor / Signal Ground	D2	D2B Network	PWM	Pulse Width Modulated

**CAUTION:** The information on this data page is furnished to aid the user in understanding circuit operation. THIS INFORMATION SHOULD BE USED FOR REFERENCE ONLY.

**NOTE:** The values listed are approximately those that can be expected at the control module connector pins with all circuit connections made and all components connected and fitted.

Refer to the front of this book for detailed information and illustrations regarding the location and identification of harnesses, relays, fuses, grounds, control modules and control module pins.

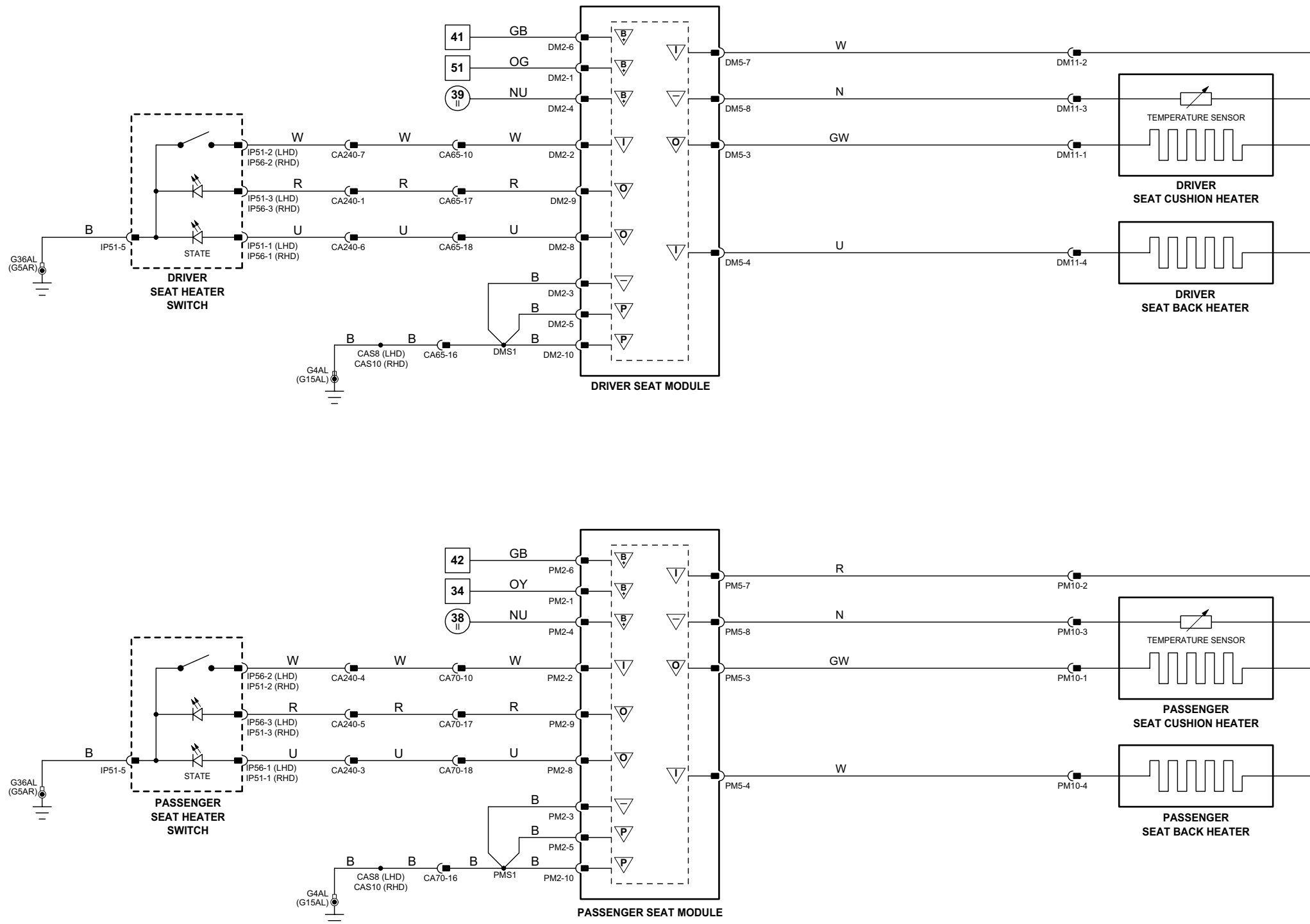

**Fig. 11.5****COMPONENTS**

Component	Connector(s)	Connector Description	Location
LH SEAT SWITCH PACK	LS1	12-WAY / GREY	LH FRONT SEAT
RH SEAT SWITCH PACK	RS1	12-WAY / GREY	RH FRONT SEAT
SEAT BACK HEATER – LH	LS7	4-WAY / GREY	LH FRONT SEAT
SEAT BACK HEATER – RH	RS7	4-WAY / GREY	RH FRONT SEAT
SEAT CUSHION HEATER – LH	LS7	4-WAY / GREY	LH FRONT SEAT
SEAT CUSHION HEATER – RH	RS7	4-WAY / GREY	RH FRONT SEAT
SEAT HEATER MODULE – LH	LS13	12-WAY / GREY	BELOW LH FRONT SEAT
SEAT HEATER MODULE – RH	RS13	12-WAY / GREY	BELOW RH FRONT SEAT
SEAT HEATER SWITCH – LH: LHD	IP51	6-WAY / BLACK	CENTER CONSOLE
SEAT HEATER SWITCH – LH: RHD	IP56	6-WAY / BLACK	CENTER CONSOLE
SEAT HEATER SWITCH – RH: LHD	IP56	6-WAY / BLACK	CENTER CONSOLE
SEAT HEATER SWITCH – RH: RHD	IP51	6-WAY / BLACK	CENTER CONSOLE

**HARNESS IN-LINE CONNECTORS**

Connector	Connector Description / Location	Location
CA65	18-WAY / BLACK / CABIN HARNESS TO DRIVER SEAT HARNESS	UNDER DRIVER SEAT
CA70	18-WAY / BLACK / CABIN HARNESS TO DRIVER SEAT HARNESS	UNDER DRIVER SEAT
CA240	12-WAY / GREY / CABIN HARNESS TO INSTRUMENT PANEL HARNESS	LH LOWER 'A' POST / 'A' POST TRIM

**GROUNDS**

Ground	Harness	Location
G4	CA	LOWER RH 'A' POST
G5	IP	UPPER RH 'A' POST
G15	CA	LOWER LH 'A' POST
G36	IP	BEHIND INSTRUMENT PANEL / LH SIDE OF CROSS CAR BEAM

Refer to the front of this book for detailed information and illustrations regarding the location and identification of harnesses, relays, fuses, grounds, control modules and control module pins.

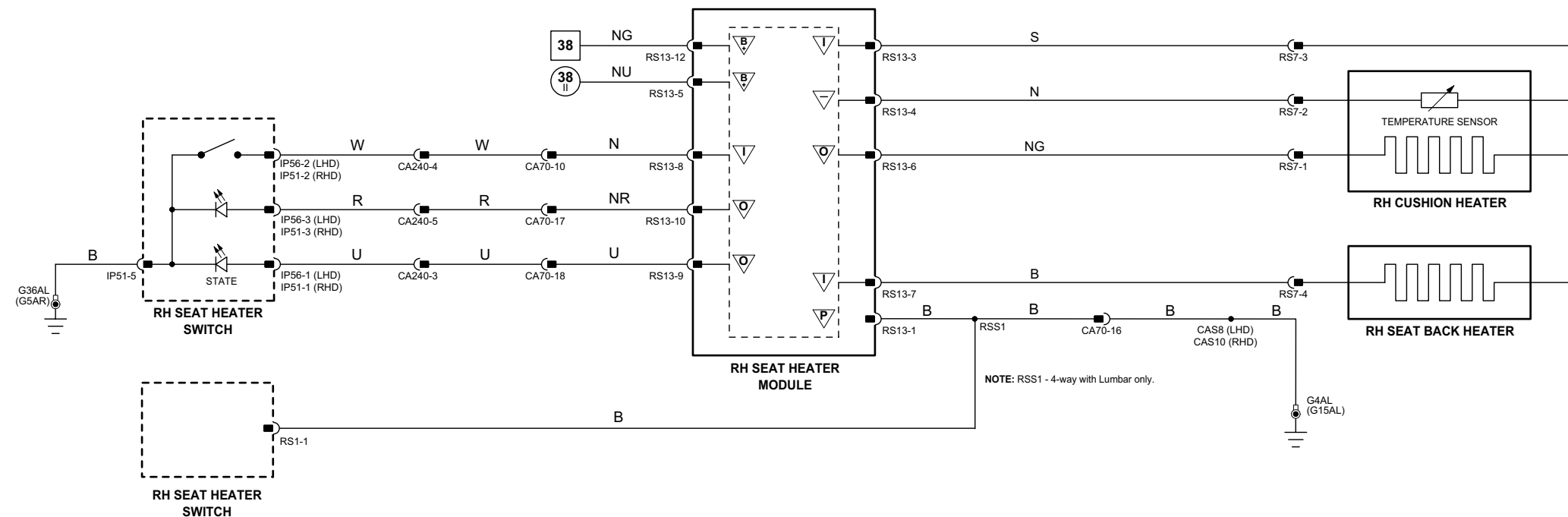
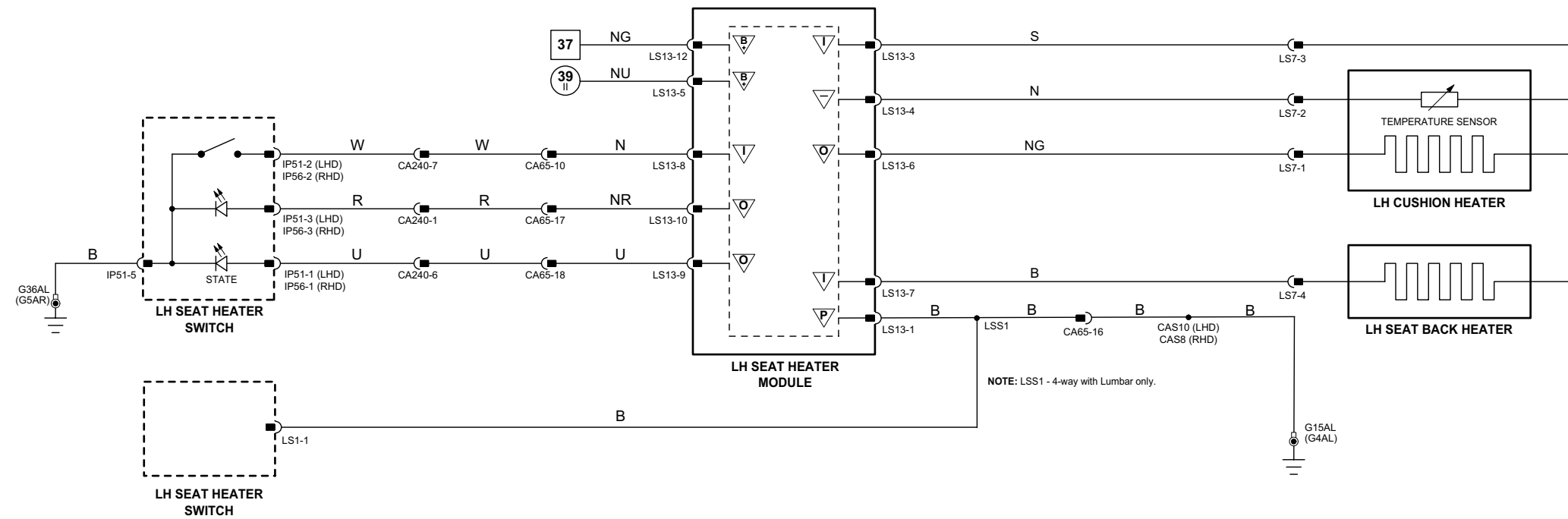

**General Electronic Module**

	Pin	Description and Characteristic
O	CA86-04	CENTRAL LOCKING MOTORS DRIVE – DOUBLE LOCKING: TO ACTIVATE, GEM SWITCHES CIRCUIT TO B+
PG	CA86-05	POWER GROUND
I	CA86-14	RESET SWITCH: OPEN CIRCUIT / GROUND
I	CA86-16	SET SWITCH: OPEN CIRCUIT / GROUND
I	CA86-18	RH REAR DOOR AJAR: DOOR OPEN = OPEN CIRCUIT; DOOR CLOSED = GROUND
I	CA86-19	LOCK SWITCH: OPEN CIRCUIT / GROUND
I	CA86-22	TRUNK LID AJAR / TAIL GATE AJAR: OPEN = OPEN CIRCUIT; CLOSED = GROUND
O	CA87-02	TRUNK / TAIL GATE LOCK MOTOR DRIVE: TO ACTIVATE, GEM SWITCHES CIRCUIT TO B+
O	CA87-03	CENTRAL LOCKING MOTORS DRIVE – LOCK: TO ACTIVATE, GEM SWITCHES CIRCUIT TO B+
O	CA87-05	CENTRAL LOCKING REAR MOTORS DRIVE – UNLOCK: TO ACTIVATE, GEM SWITCHES CIRCUIT TO B+
I	CA87-15	LH REAR DOOR AJAR: DOOR OPEN = OPEN CIRCUIT; DOOR CLOSED = GROUND
O	IP5-01	PASSENGER DOORS LOCK MOTOR DRIVE – UNLOCK: TO ACTIVATE, GEM SWITCHES CIRCUIT TO B+
I	IP5-03	SEDAN (EXCEPT JAPAN AND S. KOREA): EXTERNAL ANTENNA
O	IP5-05	DRIVER DOOR LOCK MOTOR DRIVE – UNLOCK: TO ACTIVATE, GEM SWITCHES CIRCUIT TO B+
I	IP5-16	TRUNK / TAIL GATE RELEASE SWITCH: GROUND WHEN SELECTED
S	IP5-18	SCP –
S	IP5-19	SCP +
I	IP5-23	REMOTE RF SIGNAL
SG	IP6-01	LOGIC GROUND: GROUND
I	IP6-08	KEY-IN IGNITION SWITCH: B+ WHEN KEY IN
I	IP6-21	PASSENGER DOOR AJAR: DOOR OPEN = OPEN CIRCUIT; DOOR CLOSED = GROUND
I	IP6-22	DRIVER DOOR AJAR: DOOR OPEN = OPEN CIRCUIT; DOOR CLOSED = GROUND
B+	JB172-01	BATTERY POWER SUPPLY (LOCKING): B+

**Instrument Cluster**

	Pin	Description and Characteristic
I	IP10-13	EMERGENCY UNLOCK: B+ WHEN ACTIVATED
S	IP10-22	SCP +
S	IP10-23	SCP –
I	IP11-07	BATTERY POWER SUPPLY: B+
I	IP11-08	POWER GROUND: GROUND

**Fig. 12.1**

**COMPONENTS**

Component	Connector(s)	Connector Description	Location
DOOR LATCH – DRIVER	DD3	8-WAY / BLACK	DRIVER DOOR
	DD9	2-WAY / BLACK	
DOOR LATCH – LH REAR	BL3	8-WAY / BLACK	LH REAR DOOR
	BL6	2-WAY / BLACK	
DOOR LATCH – PASSENGER	PD3	8-WAY / BLACK	PASSENGER DOOR
	PD9	2-WAY / BLACK	
DOOR LATCH – RH REAR	BR3	8-WAY / BLACK	RH REAR DOOR
	BR6	2-WAY / BLACK	
GENERAL ELECTRONIC MODULE	CA86	23-WAY / GREY	BEHIND INSTRUMENT PANEL / RH SIDE
	CA87	23-WAY / GREEN	
	IP5	23-WAY / BROWN	
	IP6	23-WAY / NATURAL	
	JB172	23-WAY / BLUE	
IGNITION SWITCH	IP18	7-WAY / BLACK	STEERING COLUMN
INERTIA SWITCH	IP132	3-WAY / BLACK	LOWER RH 'A' POST
INSTRUMENT CLUSTER	IP10	26-WAY / WHITE	INSTRUMENT PANEL
	IP11	26-WAY / WHITE	
RF MODULE	RC35	3-WAY / BLACK	ROOF CONSOLE
TRUNK LOCK MOTOR	TM6	5-WAY / NATURAL	TRUNK LID
TRUNK RELEASE SWITCH	TM8	2-WAY / WHITE	TRUNK LID

**HARNESS IN-LINE CONNECTORS**

Connector	Connector Description / Location	Location
CA1	22-WAY / NATURAL / INSTRUMENT PANEL HARNESS TO CABIN HARNESS	LH 'A' POST / 'A' POST TRIM
CA15	20-WAY / BLACK / CABIN HARNESS TO DRIVER DOOR HARNESS	DRIVER DOOR / DOOR CASING
CA16	20-WAY / BLACK / CABIN HARNESS TO DRIVER DOOR HARNESS	DRIVER DOOR / DOOR CASING
CA20	20-WAY / BLACK / CABIN HARNESS TO PASSENGER DOOR HARNESS	PASSENGER DOOR / DOOR CASING
CA21	20-WAY / BLACK / CABIN HARNESS TO PASSENGER DOOR HARNESS	PASSENGER DOOR / DOOR CASING
CA25	14-WAY / NATURAL / CABIN HARNESS TO LH REAR DOOR HARNESS	LH 'B/C' POST / 'B/C' POST TRIM
CA30	14-WAY / NATURAL / CABIN HARNESS TO RH REAR DOOR HARNESS	RH 'B/C' POST / 'B/C' POST TRIM
CA40	16-WAY / GREY / CABIN HARNESS TO ROOF HARNESS	RH 'A' POST / WINDSHIELD PILLAR
CA45	6-WAY / GREY / CABIN HARNESS TO TRUNK LID HARNESS	BEHIND LH 'E' POST TRIM
CA240	12-WAY / GREY / CABIN HARNESS TO INSTRUMENT PANEL HARNESS	LH LOWER 'A' POST / 'A' POST TRIM
TL10	6-WAY / GREY / TRUNK LINK LEAD TO TRUNK LID HARNESS	BELOW PARCEL SHELF / LH SIDE

**GROUNDS**

Ground	Harness	Location
G1	CA	TRUNK / UNDER LH TAIL LAMP UNIT
G4	CA	LOWER RH 'A' POST
G5	IP	UPPER RH 'A' POST
G15	CA	LOWER LH 'A' POST
G36	IP	BEHIND INSTRUMENT PANEL / LH SIDE OF CROSS CAR BEAM
G37	IP	BEHIND INSTRUMENT PANEL / RH SIDE OF CROSS CAR BEAM

**FOR CONTROL MODULE PIN-OUT INFORMATION, UNFOLD PAGE TO LEFT.**

The following abbreviations are used to represent values for Control Module Pin-Out data

I	Input	PG	Power Ground	C	CAN Network	D	Serial and Encoded Data
O	Output	SS	Sensor / Signal Supply V	S	SCP Network	V	Voltage (DC)
B+	Battery Voltage	SG	Sensor / Signal Ground	D2	D2B Network	PWM	Pulse Width Modulated

**CAUTION:** The information on this data page is furnished to aid the user in understanding circuit operation. THIS INFORMATION SHOULD BE USED FOR REFERENCE ONLY.

**NOTE:** The values listed are approximately those that can be expected at the control module connector pins with all circuit connections made and all components connected and fitted.

Refer to the front of this book for detailed information and illustrations regarding the location and identification of harnesses, relays, fuses, grounds, control modules and control module pins.



NOTE: Drive-Away Door Locking occurs when all doors are closed, the ignition is switched to II or III and the vehicle speed exceeds 7 k/ph (4 mph).

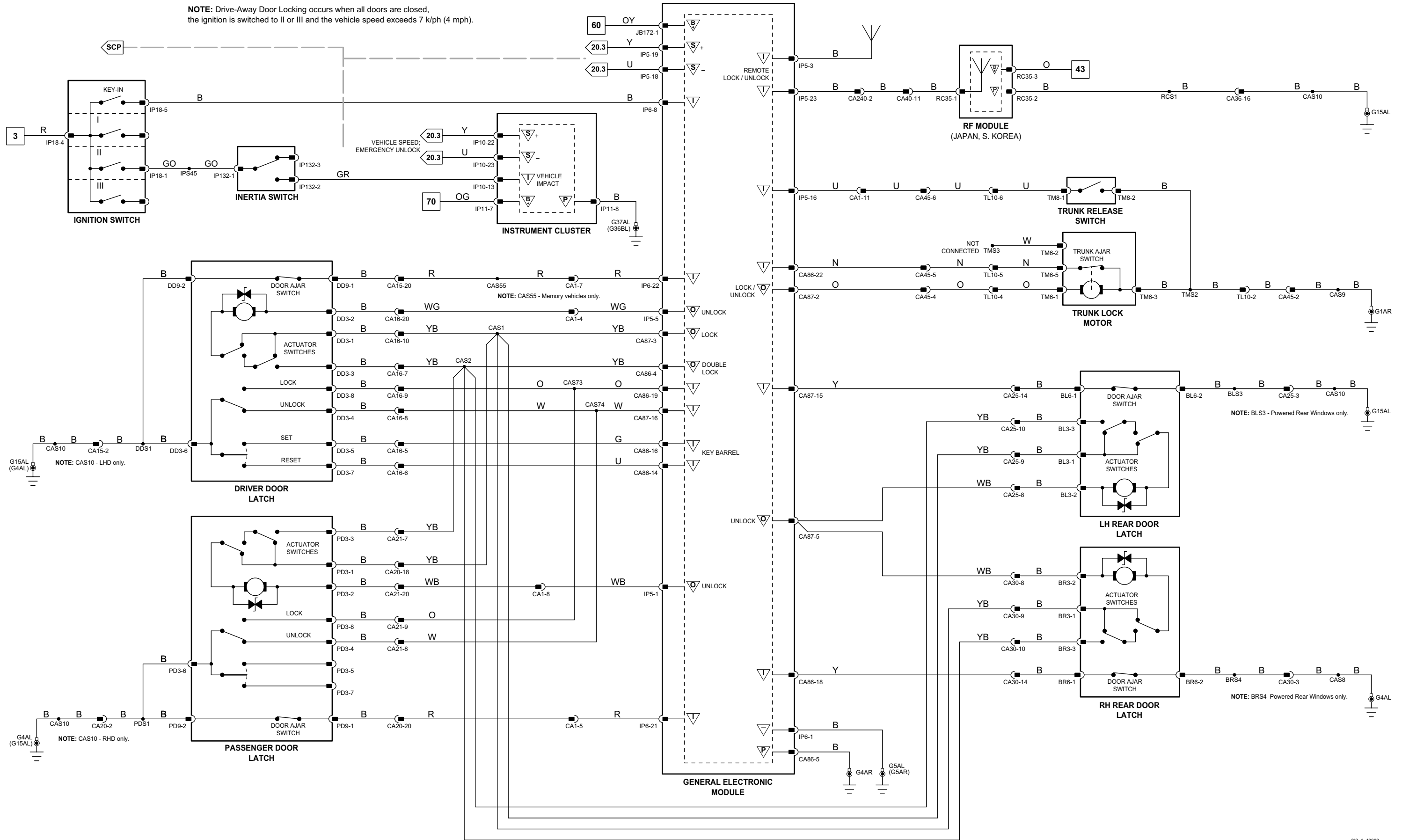

1 → 6 Fig. 01.1	34 → 80 Fig. 01.3	11 → 31 Fig. 01.5	67 → 76 Fig. 01.7	98 → 107 Fig. 01.9	Input	Battery Voltage	Sensor/Signal Supply V	CAN	D2B Network	VARIANT: Double Locking Sedan Vehicles
7 → 33 Fig. 01.2	1 → 10 Fig. 01.4	32 → 66 Fig. 01.6	77 → 97 Fig. 01.8		Output	Power Ground	Sensor/Signal Ground	SCP	Serial and Encoded Data	VIN RANGE: All
										DATE OF ISSUE: February 2008

**General Electronic Module**

	Pin	Description and Characteristic
PG	CA86-05	POWER GROUND
I	CA86-14	RESET SWITCH: OPEN CIRCUIT / GROUND
I	CA86-16	SET SWITCH: OPEN CIRCUIT / GROUND
I	CA86-18	RH REAR DOOR AJAR: DOOR OPEN = OPEN CIRCUIT; DOOR CLOSED = GROUND
I	CA86-19	LOCK SWITCH: OPEN CIRCUIT / GROUND
I	CA86-22	TRUNK LID AJAR / TAIL GATE AJAR: OPEN = OPEN CIRCUIT; CLOSED = GROUND
O	CA87-02	TRUNK / TAIL GATE LOCK MOTOR DRIVE: TO ACTIVATE, GEM SWITCHES CIRCUIT TO B+
O	CA87-03	CENTRAL LOCKING MOTORS DRIVE - LOCK: TO ACTIVATE, GEM SWITCHES CIRCUIT TO B+
O	CA87-05	CENTRAL LOCKING REAR MOTORS DRIVE - UNLOCK: TO ACTIVATE, GEM SWITCHES CIRCUIT TO B+
I	CA87-15	LH REAR DOOR AJAR: DOOR OPEN = OPEN CIRCUIT; DOOR CLOSED = GROUND
O	IP5-01	PASSENGER DOORS LOCK MOTOR DRIVE - UNLOCK: TO ACTIVATE, GEM SWITCHES CIRCUIT TO B+
I	IP5-03	SEDAN (EXCEPT JAPAN AND S. KOREA): EXTERNAL ANTENNA
O	IP5-05	DRIVER DOOR LOCK MOTOR DRIVE - UNLOCK: TO ACTIVATE, GEM SWITCHES CIRCUIT TO B+
I	IP5-16	TRUNK / TAIL GATE RELEASE SWITCH: GROUND WHEN SELECTED
S	IP5-18	SCP -
S	IP5-19	SCP +
I	IP5-23	REMOTE RF SIGNAL
SG	IP6-01	LOGIC GROUND: GROUND
I	IP6-08	KEY-IN IGNITION SWITCH: B+ WHEN KEY IN
I	IP6-21	PASSENGER DOOR AJAR: DOOR OPEN = OPEN CIRCUIT; DOOR CLOSED = GROUND
I	IP6-22	DRIVER DOOR AJAR: DOOR OPEN = OPEN CIRCUIT; DOOR CLOSED = GROUND
B+	JB172-01	BATTERY POWER SUPPLY (LOCKING): B+

**Instrument Cluster**

	Pin	Description and Characteristic
I	IP10-13	EMERGENCY UNLOCK: B+ WHEN ACTIVATED
S	IP10-22	SCP +
S	IP10-23	SCP -
I	IP11-07	BATTERY POWER SUPPLY: B+
I	IP11-08	POWER GROUND: GROUND

**Fig. 12.2**

**COMPONENTS**

Component	Connector(s)	Connector Description	Location
DOOR LATCH - DRIVER	DD3	8-WAY / BLACK	DRIVER DOOR
	DD9	2-WAY / BLACK	
DOOR LATCH - LH REAR	BL3	8-WAY / BLACK	LH REAR DOOR
	BL6	2-WAY / BLACK	
DOOR LATCH - PASSENGER	PD3	8-WAY / BLACK	PASSENGER DOOR
	PD9	2-WAY / BLACK	
DOOR LATCH - RH REAR	BR3	8-WAY / BLACK	RH REAR DOOR
	BR6	2-WAY / BLACK	
GENERAL ELECTRONIC MODULE	CA86	23-WAY / GREY	BEHIND INSTRUMENT PANEL / RH SIDE
	CA87	23-WAY / GREEN	
	IP5	23-WAY / BROWN	
	IP6	23-WAY / NATURAL	
	JB172	23-WAY / BLUE	
IGNITION SWITCH	IP18	7-WAY / BLACK	STEERING COLUMN
INERTIA SWITCH	IP132	3-WAY / BLACK	LOWER RH 'A' POST
INSTRUMENT CLUSTER	IP10	26-WAY / WHITE	INSTRUMENT PANEL
	IP11	26-WAY / WHITE	
RF MODULE	RC35	3-WAY / BLACK	ROOF CONSOLE
TRUNK LOCK MOTOR	TM6	5-WAY / NATURAL	TRUNK LID
TRUNK RELEASE SWITCH	TM8	2-WAY / WHITE	TRUNK LID

**HARNESS IN-LINE CONNECTORS**

Connector	Connector Description / Location	Location
CA1	22-WAY / NATURAL / INSTRUMENT PANEL HARNESS TO CABIN HARNESS	LH 'A' POST / 'A' POST TRIM
CA15	20-WAY / BLACK / CABIN HARNESS TO DRIVER DOOR HARNESS	DRIVER DOOR / DOOR CASING
CA16	20-WAY / BLACK / CABIN HARNESS TO DRIVER DOOR HARNESS	DRIVER DOOR / DOOR CASING
CA20	20-WAY / BLACK / CABIN HARNESS TO PASSENGER DOOR HARNESS	PASSENGER DOOR / DOOR CASING
CA21	20-WAY / BLACK / CABIN HARNESS TO PASSENGER DOOR HARNESS	PASSENGER DOOR / DOOR CASING
CA25	14-WAY / NATURAL / CABIN HARNESS TO LH REAR DOOR HARNESS	LH 'B/C' POST / 'B/C' POST TRIM
CA30	14-WAY / NATURAL / CABIN HARNESS TO RH REAR DOOR HARNESS	RH 'B/C' POST / 'B/C' POST TRIM
CA40	16-WAY / GREY / CABIN HARNESS TO ROOF HARNESS	RH 'A' POST / WINDSHIELD PILLAR
CA45	6-WAY / GREY / CABIN HARNESS TO TRUNK LID HARNESS	BEHIND LH 'E' POST TRIM
CA240	12-WAY / GREY / CABIN HARNESS TO INSTRUMENT PANEL HARNESS	LH LOWER 'A' POST / 'A' POST TRIM
TL10	6-WAY / GREY / TRUNK LINK LEAD TO TRUNK LID HARNESS	BELOW PARCEL SHELF / LH SIDE

**GROUNDS**

Ground	Harness	Location
G1	CA	TRUNK / UNDER LH TAIL LAMP UNIT
G4	CA	LOWER RH 'A' POST
G5	IP	UPPER RH 'A' POST
G15	CA	LOWER LH 'A' POST
G36	IP	BEHIND INSTRUMENT PANEL / LH SIDE OF CROSS CAR BEAM
G37	IP	BEHIND INSTRUMENT PANEL / RH SIDE OF CROSS CAR BEAM

FOR CONTROL MODULE PIN-OUT INFORMATION, UNFOLD PAGE TO LEFT.

The following abbreviations are used to represent values for Control Module Pin-Out data

I	Input	PG	Power Ground	C	CAN Network	D	Serial and Encoded Data
O	Output	SS	Sensor / Signal Supply V	S	SCP Network	V	Voltage (DC)
B+	Battery Voltage	SG	Sensor / Signal Ground	D2	D2B Network	PWM	Pulse Width Modulated

**CAUTION:** The information on this data page is furnished to aid the user in understanding circuit operation. THIS INFORMATION SHOULD BE USED FOR REFERENCE ONLY.

**NOTE:** The values listed are approximately those that can be expected at the control module connector pins with all circuit connections made and all components connected and fitted.

Refer to the front of this book for detailed information and illustrations regarding the location and identification of harnesses, relays, fuses, grounds, control modules and control module pins.

NOTE: Drive-Away Door Locking occurs when all doors are closed, the ignition is switched to II or III and the vehicle speed exceeds 7 k/ph (4 mph).

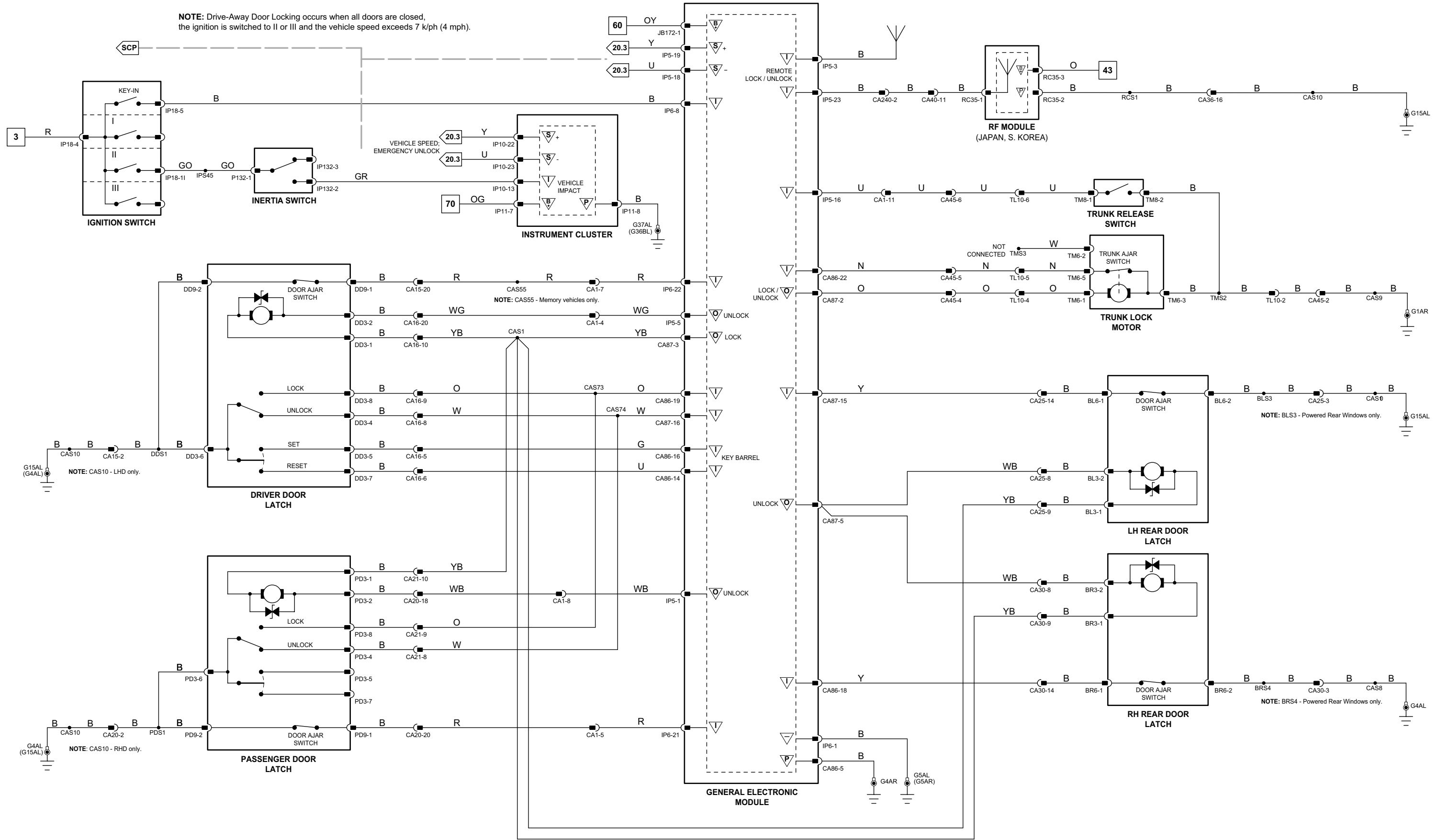

1 → 6 Fig. 01.1	34 → 80 Fig. 01.3	11 → 31 Fig. 01.5	67 → 76 Fig. 01.7	98 → 107 Fig. 01.9	Input	Battery Voltage	Sensor/Signal Supply V	CAN	D2B Network
7 → 33 Fig. 01.2	1 → 10 Fig. 01.4	32 → 66 Fig. 01.6	77 → 97 Fig. 01.8		Output	Power Ground	Sensor/Signal Ground	SCP	Serial and Encoded Data

VARIANT: Non Double Locking Sedan Vehicles  
 VIN RANGE: All  
 DATE OF ISSUE: February 2008

**General Electronic Module**

	Pin	Description and Characteristic
O	CA86-04	CENTRAL LOCKING MOTORS DRIVE – DOUBLE LOCKING: TO ACTIVATE, GEM SWITCHES CIRCUIT TO B+
PG	CA86-05	POWER GROUND
I	CA86-14	RESET SWITCH: OPEN CIRCUIT / GROUND
I	CA86-15	TAIL GLASS RELEASE SWITCH: GROUND WHEN ACTIVATED
I	CA86-16	SET SWITCH: OPEN CIRCUIT / GROUND
I	CA86-18	RH REAR DOOR AJAR: DOOR OPEN = OPEN CIRCUIT; DOOR CLOSED = GROUND
I	CA86-19	LOCK SWITCH: OPEN CIRCUIT / GROUND
I	CA86-22	TRUNK LID AJAR / TAIL GATE AJAR: OPEN = OPEN CIRCUIT; CLOSED = GROUND
O	CA87-02	TRUNK / TAIL GATE LOCK MOTOR DRIVE: TO ACTIVATE, GEM SWITCHES CIRCUIT TO B+
O	CA87-03	CENTRAL LOCKING MOTORS DRIVE – LOCK: TO ACTIVATE, GEM SWITCHES CIRCUIT TO B+
O	CA87-05	CENTRAL LOCKING REAR MOTORS DRIVE – UNLOCK: TO ACTIVATE, GEM SWITCHES CIRCUIT TO B+
I	CA87-15	LH REAR DOOR AJAR: DOOR OPEN = OPEN CIRCUIT; DOOR CLOSED = GROUND
O	IP5-01	PASSENGER DOORS LOCK MOTOR DRIVE – UNLOCK: TO ACTIVATE, GEM SWITCHES CIRCUIT TO B+
O	IP5-05	DRIVER DOOR LOCK MOTOR DRIVE – UNLOCK: TO ACTIVATE, GEM SWITCHES CIRCUIT TO B+
I	IP5-16	TRUNK / TAIL GATE RELEASE SWITCH: GROUND WHEN SELECTED
S	IP5-18	SCP –
S	IP5-19	SCP +
I	IP5-23	REMOTE RF SIGNAL
SG	IP6-01	LOGIC GROUND: GROUND
I	IP6-08	KEY-IN IGNITION SWITCH: B+ WHEN KEY IN
I	IP6-21	PASSENGER DOOR AJAR: DOOR OPEN = OPEN CIRCUIT; DOOR CLOSED = GROUND
I	IP6-22	DRIVER DOOR AJAR: DOOR OPEN = OPEN CIRCUIT; DOOR CLOSED = GROUND
B+	JB172-01	BATTERY POWER SUPPLY (LOCKING): B+

**Instrument Cluster**

	Pin	Description and Characteristic
I	IP10-13	EMERGENCY UNLOCK: B+ WHEN ACTIVATED
S	IP10-22	SCP +
S	IP10-23	SCP –
I	IP11-07	BATTERY POWER SUPPLY: B+
I	IP11-08	POWER GROUND: GROUND

**Fig. 12.3**

**COMPONENTS**

Component	Connector(s)	Connector Description	Location
DOOR LATCH – DRIVER	DD3	8-WAY / BLACK	DRIVER DOOR
	DD9	2-WAY / BLACK	
DOOR LATCH – LH REAR	BL3	8-WAY / BLACK	LH REAR DOOR
	BL6	2-WAY / BLACK	
DOOR LATCH – PASSENGER	PD3	8-WAY / BLACK	PASSENGER DOOR
	PD9	2-WAY / BLACK	
DOOR LATCH – RH REAR	BR3	8-WAY / BLACK	RH REAR DOOR
	BR6	2-WAY / BLACK	
GENERAL ELECTRONIC MODULE	CA86	23-WAY / GREY	BEHIND INSTRUMENT PANEL / RH SIDE
	CA87	23-WAY / GREEN	
	IP5	23-WAY / BROWN	
	IP6	23-WAY / NATURAL	
	JB172	23-WAY / BLUE	
IGNITION SWITCH	IP18	7-WAY / BLACK	STEERING COLUMN
INERTIA SWITCH	IP132	3-WAY / BLACK	LOWER RH 'A' POST
INSTRUMENT CLUSTER	IP10	26-WAY / WHITE	INSTRUMENT PANEL
	IP11	26-WAY / WHITE	
RF MODULE	RC35	3-WAY / BLACK	ROOF CONSOLE
TAIL GATE LATCH	WT6	6-WAY / BLACK	TAIL GATE
TAIL GATE RELEASE SWITCH	WT4	2-WAY / WHITE	TAIL GATE
TAIL GLASS LATCH	WT7	4-WAY / BLACK	TAIL GATE
TAIL GLASS RELEASE SWITCH	WG2	2-WAY / BLACK	TAIL GATE

**HARNESS IN-LINE CONNECTORS**

Connector	Connector Description / Location	Location
CA1	22-WAY / NATURAL / INSTRUMENT PANEL HARNESS TO CABIN HARNESS	LH 'A' POST / 'A' POST TRIM
CA15	20-WAY / BLACK / CABIN HARNESS TO DRIVER DOOR HARNESS	DRIVER DOOR / DOOR CASING
CA16	20-WAY / BLACK / CABIN HARNESS TO DRIVER DOOR HARNESS	DRIVER DOOR / DOOR CASING
CA20	20-WAY / BLACK / CABIN HARNESS TO PASSENGER DOOR HARNESS	PASSENGER DOOR / DOOR CASING
CA21	20-WAY / BLACK / CABIN HARNESS TO PASSENGER DOOR HARNESS	PASSENGER DOOR / DOOR CASING
CA25	14-WAY / NATURAL / CABIN HARNESS TO LH REAR DOOR HARNESS	LH 'B/C' POST / 'B/C' POST TRIM
CA30	14-WAY / NATURAL / CABIN HARNESS TO RH REAR DOOR HARNESS	RH 'B/C' POST / 'B/C' POST TRIM
CA40	16-WAY / GREY / CABIN HARNESS TO ROOF HARNESS	RH 'A' POST / WINDSHIELD PILLAR
CA169	4-WAY / GREY / CABIN HARNESS TO INSTRUMENT PANEL HARNESS	LH LOWER A POST / A POST TRIM
CA170	16-WAY / GREEN / JUNCTION BOX HARNESS TO CABIN HARNESS	LH 'A' POST / 'A' POST TRIM
CA240	12-WAY / GREY / CABIN HARNESS TO INSTRUMENT PANEL HARNESS	LH LOWER 'A' POST / 'A' POST TRIM
JB3	14-WAY / BLUE / JUNCTION BOX HARNESS TO INSTRUMENT PANEL HARNESS	BELOW INSTRUMENT PANEL / LH SIDE
WG1	4-WAY / BLACK / CABIN HARNESS TO TAIL GATE GLASS HARNESS	ROOF / CENTER REAR
WL1	8-WAY / BLACK / CABIN HARNESS TO TAIL GATE LINK LEAD	ROOF / CENTER REAR
WL3	3-WAY / BLACK / CABIN HARNESS TO TAIL GATE LINK LEAD	ROOF / CENTER REAR
WT1	8-WAY / BLACK / CABIN HARNESS TO TAIL GATE HARNESS	TAIL GATE
WT3	3-WAY / BLACK / CABIN HARNESS TO TAIL GATE HARNESS	TAIL GATE

**GROUNDINGS**

Ground	Harness	Location
G1	CA	TRUNK / UNDER LH TAIL LAMP UNIT
G4	CA	LOWER RH 'A' POST
G5	IP	UPPER RH 'A' POST
G15	CA	LOWER LH 'A' POST
G36	IP	BEHIND INSTRUMENT PANEL / LH SIDE OF CROSS CAR BEAM
G37	IP	BEHIND INSTRUMENT PANEL / RH SIDE OF CROSS CAR BEAM
G50	CA	HEADLINER / RH REAR ROOF PANEL

**FOR CONTROL MODULE PIN-OUT INFORMATION, UNFOLD PAGE TO LEFT.**

The following abbreviations are used to represent values for Control Module Pin-Out data

I	Input	PG	Power Ground	C	CAN Network	D	Serial and Encoded Data
O	Output	SS	Sensor / Signal Supply V	S	SCP Network	V	Voltage (DC)
B+	Battery Voltage	SG	Sensor / Signal Ground	D2	D2B Network	PWM	Pulse Width Modulated

**CAUTION:** The information on this data page is furnished to aid the user in understanding circuit operation. THIS INFORMATION SHOULD BE USED FOR REFERENCE ONLY.

**NOTE:** The values listed are approximately those that can be expected at the control module connector pins with all circuit connections made and all components connected and fitted.

Refer to the front of this book for detailed information and illustrations regarding the location and identification of harnesses, relays, fuses, grounds, control modules and control module pins.

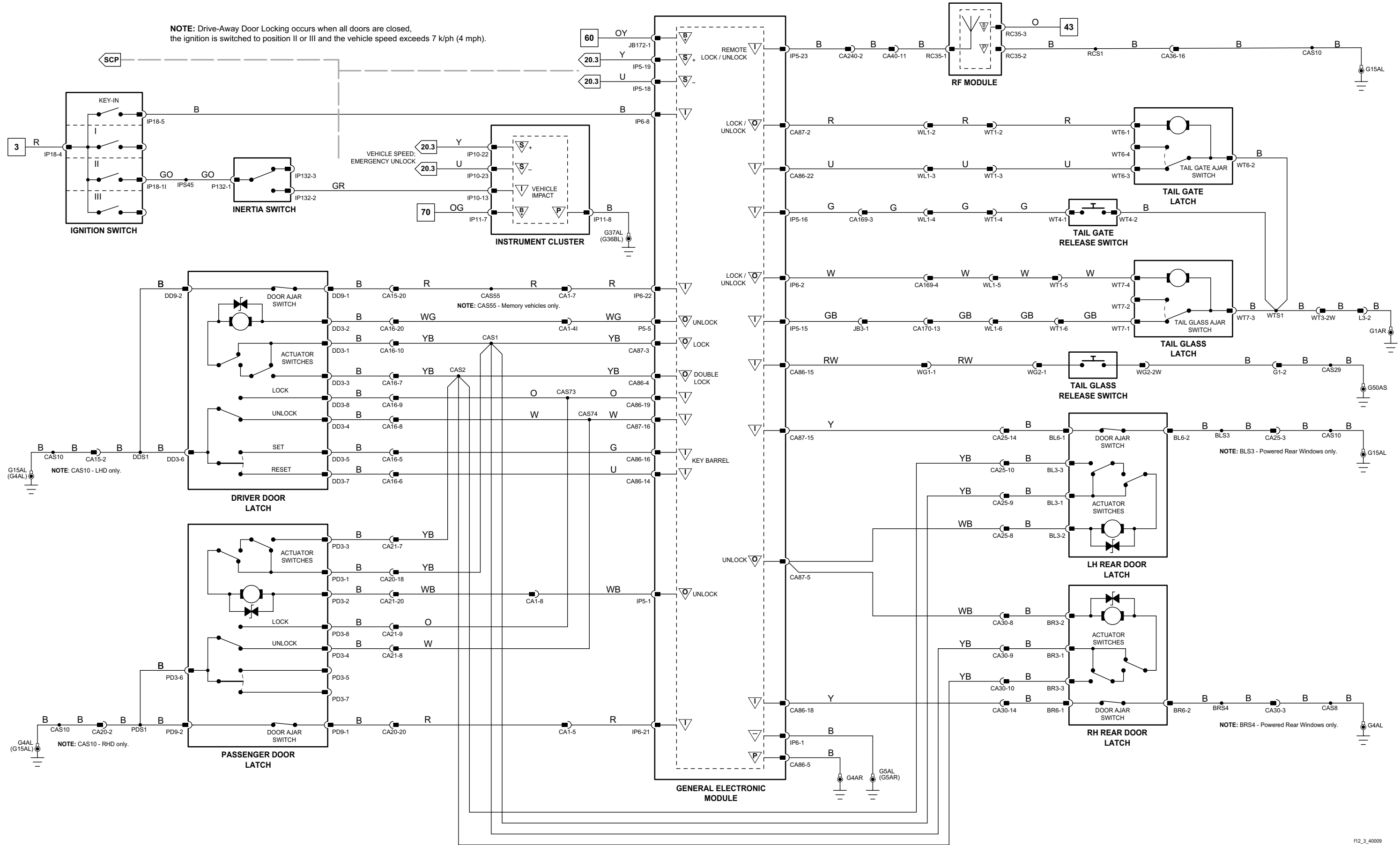

112\_3\_40009

1 → 6 Fig. 01.1	34 → 80 Fig. 01.3	11 → 31 Fig. 01.5	67 → 76 Fig. 01.7	98 → 107 Fig. 01.9	Input	Battery Voltage	Sensor/Signal Supply V	CAN	D2B Network
7 → 33 Fig. 01.2	1 → 10 Fig. 01.4	32 → 66 Fig. 01.6	77 → 97 Fig. 01.8		Output	Power Ground	Sensor/Signal Ground	SCP	Serial and Encoded Data

**VARIANT:** Estate (Wagon) Vehicles  
**VIN RANGE:** All  
**DATE OF ISSUE:** February 2008

### Engine Control Module – 2.0 L

	Pin	Description and Characteristic
C	EN65-088	CAN -
C	EN65-089	CAN +

### Engine Control Module – Diesel

	Pin	Description and Characteristic
C	DL1-054	CAN +
C	DL1-073	CAN -

### Engine Control Module – 2.5 L, 3.0 L

	Pin	Description and Characteristic
C	EN16-123	CAN -
C	EN16-124	CAN +

### General Electronic Module

	Pin	Description and Characteristic
PG	CA86-05	POWER GROUND
I	CA86-17	INCLINATION SENSOR SENSE; ALARM TRIGGERED = GROUND; ALARM NOT TRIGGERED = B+
I	CA86-18	RH REAR DOOR AJAR; DOOR OPEN = OPEN CIRCUIT; DOOR CLOSED = GROUND
O	CA86-20	INCLINATION AND INTRUSION SENSORS POWER SUPPLY: B+
I	CA86-22	TRUNK LID AJAR / TAIL GATE AJAR: OPEN = OPEN CIRCUIT; CLOSED = GROUND
I	CA86-23	INTRUSION SENSOR SENSE; ALARM TRIGGERED = GROUND; ALARM NOT TRIGGERED = B+
O	CA87-01	PASSIVE SECURITY SOUNDER DRIVE: TO ACTIVATE, GEM SWITCHES CIRCUIT TO B+
I	CA87-15	LH REAR DOOR AJAR: DOOR OPEN = OPEN CIRCUIT; DOOR CLOSED = GROUND
I	IP5-03	SEDAN (EXCEPT JAPAN AND S. KOREA); EXTERNAL ANTENNA
O	IP5-14	HORN RELAY DRIVE : TO ACTIVATE, GEM SWITCHES CIRCUIT TO GROUND
S	IP5-18	SCP -
S	IP5-19	SCP +
I	IP5-23	REMOTE RF SIGNAL
SG	IP6-01	LOGIC GROUND: GROUND
I	IP6-08	KEY-IN IGNITION SWITCH: B+ WHEN KEY IN
I	IP6-10	AUDIO UNIT PRESENCE SENSE: GROUND WHEN RADIO INSTALLED
I	IP6-21	PASSENGER DOOR AJAR: DOOR OPEN = OPEN CIRCUIT; DOOR CLOSED = GROUND
I	IP6-22	DRIVER DOOR AJAR: DOOR OPEN = OPEN CIRCUIT; DOOR CLOSED = GROUND
B+	JB172-01	BATTERY POWER SUPPLY (LOCKING): B+
O	JB172-03	RH FRONT TURN SIGNAL: TO ACTIVATE, GEM SWITCHES CIRCUIT TO B+
O	JB172-04	LH FRONT TURN SIGNAL: TO ACTIVATE, GEM SWITCHES CIRCUIT TO B+
B+	JB172-05	BATTERY POWER SUPPLY (TURN SIGNALS): B+
D	JB172-18	ACTIVE SECURITY SOUNDER DRIVE: ENCODED COMMUNICATIONS
I	JB172-21	HOOD AJAR: HOOD OPEN = OPEN CIRCUIT; HOOD CLOSED = GROUND

### Instrument Cluster

	Pin	Description and Characteristic
O	IP10-02	SECURITY INDICATOR DRIVE: TO ACTIVATE, IC SWITCHES CIRCUIT TO B+
D	IP10-03	PATS 1: ENCODED COMMUNICATION
D	IP10-04	PATS 2: ENCODED COMMUNICATION
I	IP10-05	PATS GROUND: GROUND
O	IP10-06	PATS TRANSCEIVER POWER: B+
C	IP10-17	CAN +
C	IP10-18	CAN -
S	IP10-22	SCP +
S	IP10-23	SCP -
I	IP11-08	POWER GROUND: GROUND
I	IP11-13	IGNITION SWITCHED POWER SUPPLY (I): B+

The following abbreviations are used to represent values for Control Module Pin-Out data

I	Input	PG	Power Ground	C	CAN Network	D	Serial and Encoded Data
O	Output	SS	Sensor / Signal Supply V	S	SCP Network	V	Voltage (DC)
B+	Battery Voltage	SG	Sensor / Signal Ground	D2	D2B Network	PWM	Pulse Width Modulated

**CAUTION:** The information on this data page is furnished to aid the user in understanding circuit operation. THIS INFORMATION SHOULD BE USED FOR REFERENCE ONLY.

**NOTE:** The values listed are approximately those that can be expected at the control module connector pins with all circuit connections made and all components connected and fitted.

## Fig. 12.4

### COMPONENTS

Component	Connector(s)	Connector Description	Location
AUDIO UNIT	ID1	2-WAY / D2B	INSTRUMENT PANEL CENTER
	IP65	20-WAY / BLACK	
	IP106	2-WAY / METALLIC	
DOOR LATCH – DRIVER	DD3	8-WAY / BLACK	DRIVER DOOR
	DD9	2-WAY / BLACK	
DOOR LATCH – LH REAR	BL3	8-WAY / BLACK	LH REAR DOOR
	BL6	2-WAY / BLACK	
DOOR LATCH – PASSENGER	PD3	8-WAY / BLACK	PASSENGER DOOR
	PD9	2-WAY / BLACK	
DOOR LATCH – RH REAR	BR3	8-WAY / BLACK	RH REAR DOOR
	BR6	2-WAY / BLACK	
ENGINE CONTROL MODULE – 2.0 L	EN65	104-WAY / BLACK	ENGINE COMPARTMENT, FRONT BULKHEAD / RH SIDE
ENGINE CONTROL MODULE – Diesel	DL1	121-WAY / BLACK	ENGINE COMPARTMENT, FRONT BULKHEAD / RH SIDE
ENGINE CONTROL MODULE – 2.5 L, 3.0 L	EN16	134-WAY / BLACK	ENGINE COMPARTMENT, FRONT BULKHEAD / RH SIDE
GENERAL ELECTRONIC MODULE	CA86	23-WAY / GREY	BEHIND INSTRUMENT PANEL / RH SIDE
	CA87	23-WAY / GREEN	
HOOD SECURITY SWITCH	IP5	23-WAY / BROWN	
	IP6	23-WAY / NATURAL	
	JB172	23-WAY / BLUE	
IGNITION SWITCH	JB81	2-WAY / BLACK	ADJACENT TO RH FRONT SUSPENSION TURRET
INCLINATION SENSOR	IP18	7-WAY / BLACK	STEERING COLUMN
INSTRUMENT CLUSTER	CA190	6-WAY / BLACK	TRUNK, LH REAR
	IP10	26-WAY / WHITE	INSTRUMENT PANEL
PASSIVE ANTI-THEFT SYSTEM TRANSCEIVER	IP11	26-WAY / WHITE	
	IP15	4-WAY / BLACK	STEERING COLUMN, IGNITION SWITCH
RF MODULE	RC35	3-WAY / BLACK	ROOF CONSOLE
ROOF CONSOLE – PRINTED CIRCUIT BOARD	RC23	20-WAY / WHITE	ROOF CENTER FRONT
ROOF CONSOLE – WITHOUT PRINTED CIRCUIT BOARD	RC30	4-WAY / BLACK	ROOF CENTER FRONT
	RC31	2-WAY / BLACK	
SECURITY INDICATOR	RC33	4-WAY / BLACK	
	RC34	6-WAY / BLACK	
	IP29	6-WAY / BLACK	CENTER CONSOLE
SECURITY SOUNDER – ACTIVE	SL3	3-WAY / BLACK	BEHIND FRONT LH WHEEL ARCH LINER
SECURITY SOUNDER – PASSIVE	SL1	1-WAY / ORANGE	LH FRONT OF VEHICLE
	SL2	1-WAY / ORANGE	
TRUNK LOCK MOTOR	TM6	5-WAY / NATURAL	TRUNK LID

### HARNES IN-LINE CONNECTORS

Connector	Connector Description / Location	Location
CA1	22-WAY / NATURAL / INSTRUMENT PANEL HARNESS TO CABIN HARNESS	LH 'A' POST / 'A' POST TRIM
CA15	20-WAY / BLACK / CABIN HARNESS TO DRIVER DOOR HARNESS	DRIVER DOOR / DOOR CASING
CA20	20-WAY / BLACK / CABIN HARNESS TO PASSENGER DOOR HARNESS	PASSENGER DOOR / DOOR CASING
CA25	14-WAY / NATURAL / CABIN HARNESS TO LH REAR DOOR HARNESS	LH 'B/C' POST / 'B/C' POST TRIM
CA30	14-WAY / NATURAL / CABIN HARNESS TO RH REAR DOOR HARNESS	RH 'B/C' POST / 'B/C' POST TRIM
CA36	16-WAY / GREEN / CABIN HARNESS TO ROOF HARNESS	LH 'A' POST / WINDSHIELD PILLAR
CA40	16-WAY / GREY / CABIN HARNESS TO ROOF HARNESS	RH 'A' POST / WINDSHIELD PILLAR
CA45	6-WAY / GREY / CABIN HARNESS TO TRUNK LID HARNESS	BEHIND LH 'E' POST TRIM
CA170	16-WAY / GREEN / JUNCTION BOX HARNESS TO CABIN HARNESS	LH 'A' POST / 'A' POST TRIM
CA240	12-WAY / GREY / CABIN HARNESS TO INSTRUMENT PANEL HARNESS	LH LOWER 'A' POST / 'A' POST TRIM
JB79	6-WAY / BLACK / JUNCTION BOX HARNESS TO SECURITY SOUNDER LINK LEAD	BEHIND LH FRONT WHEEL ARCH LINER
TL10	6-WAY / GREY / TRUNK LINK LEAD TO TRUNK LID HARNESS	BELOW PARCEL SHELF / LH SIDE

### GROUNDS

Ground	Harness	Location
G1	CA	TRUNK / UNDER LH TAIL LAMP UNIT
G4	CA	LOWER RH 'A' POST
G5	IP	UPPER RH 'A' POST
G14	JB	ENGINE COMPARTMENT / BEHIND POWER DISTRIBUTION FUSEBOX
G15	CA	LOWER LH 'A' POST
G36	IP	BEHIND INSTRUMENT PANEL / LH SIDE OF CROSS CAR BEAM
G37	IP	BEHIND INSTRUMENT PANEL / RH SIDE OF CROSS CAR BEAM

FOR CONTROL MODULE PIN-OUT INFORMATION, UNFOLD PAGE TO LEFT.

Refer to the front of this book for detailed information and illustrations regarding the location and identification of harnesses, relays, fuses, grounds, control modules and control module pins.

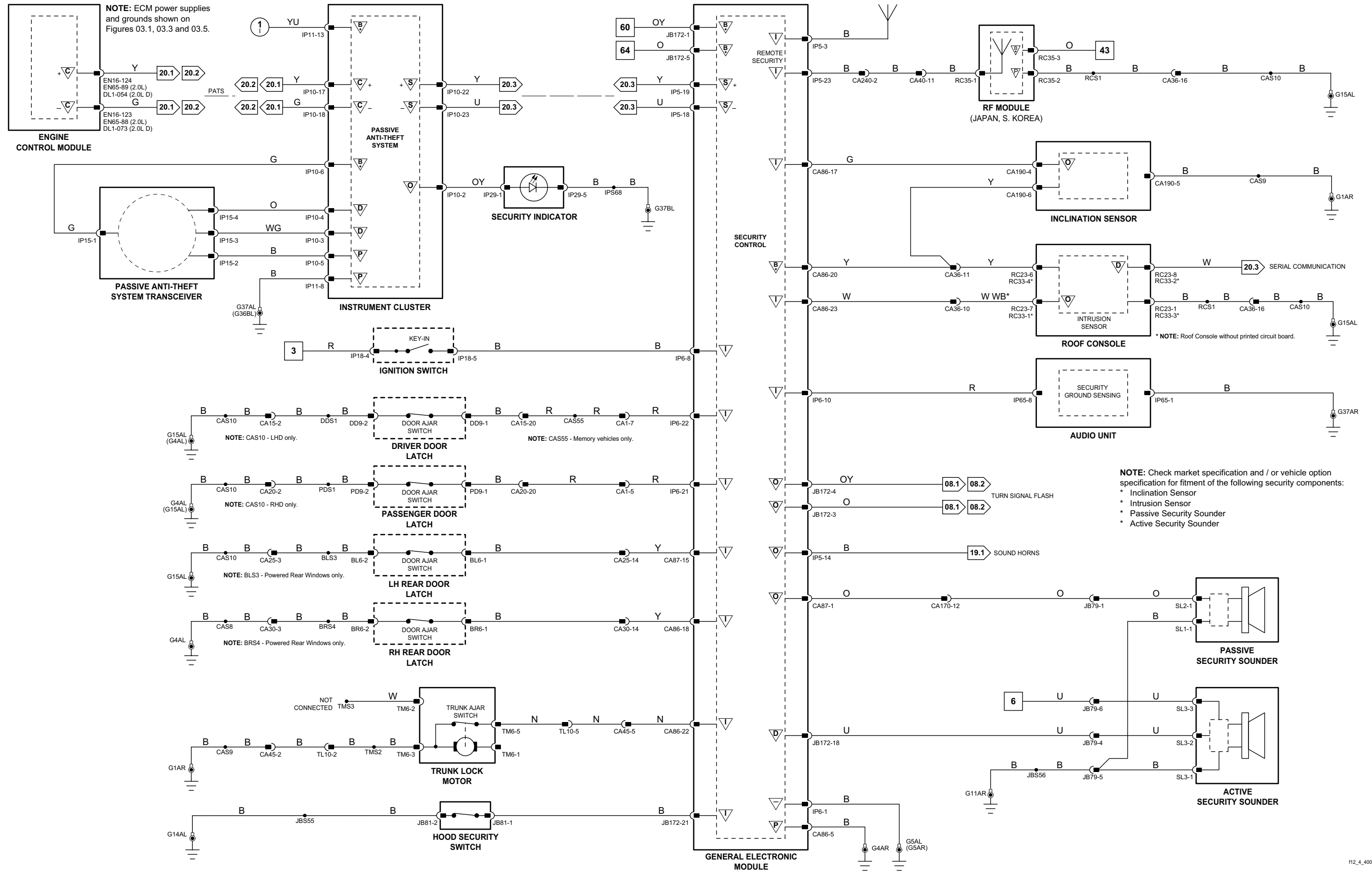

1 → 6 Fig. 01.1	34 → 80 Fig. 01.3	11 → 31 Fig. 01.5	67 → 76 Fig. 01.7	98 → 107 Fig. 01.9	Input	Battery Voltage	Sensor/Signal Supply V	CAN	D2B Network
7 → 33 Fig. 01.2	1 → 10 Fig. 01.4	32 → 66 Fig. 01.6	77 → 97 Fig. 01.8		Output	Power Ground	Sensor/Signal Ground	SCP	Serial and Encoded Data

**VARIANT:** Sedan Vehicles  
**VIN RANGE:** All  
**DATE OF ISSUE:** February 2008

**Engine Control Module – 2.0 L**

	Pin	Description and Characteristic
C	EN65-088	CAN -
C	EN65-089	CAN +

**Engine Control Module – Diesel**

	Pin	Description and Characteristic
C	DL1-054	CAN +
C	DL1-073	CAN -

**Engine Control Module – 2.5 L, 3.0 L**

	Pin	Description and Characteristic
C	EN16-123	CAN -
C	EN16-124	CAN +

**General Electronic Module**

	Pin	Description and Characteristic
PG	CA86-05	POWER GROUND
I	CA86-17	INCLINATION SENSOR SENSE: ALARM TRIGGERED = GROUND; ALARM NOT TRIGGERED = B+
I	CA86-18	RH REAR DOOR AJAR: DOOR OPEN = OPEN CIRCUIT; DOOR CLOSED = GROUND
O	CA86-20	INCLINATION AND INTRUSION SENSORS POWER SUPPLY: B+
I	CA86-22	TRUNK LID AJAR / TAIL GATE AJAR: OPEN = OPEN CIRCUIT; CLOSED = GROUND
I	CA86-23	INTRUSION SENSOR SENSE: ALARM TRIGGERED = GROUND; ALARM NOT TRIGGERED = B+
O	CA87-01	PASSIVE SECURITY SOUNDER DRIVE: TO ACTIVATE, GEM SWITCHES CIRCUIT TO B+
I	CA87-15	LH REAR DOOR AJAR: DOOR OPEN = OPEN CIRCUIT; DOOR CLOSED = GROUND
O	IP5-14	HORN RELAY DRIVE : TO ACTIVATE, GEM SWITCHES CIRCUIT TO GROUND
I	IP5-15	TAIL GLASS AJAR: GLASS OPEN = OPEN CIRCUIT; GLASS CLOSED = GROUND
S	IP5-18	SCP -
S	IP5-19	SCP +
I	IP5-23	REMOTE RF SIGNAL
SG	IP6-01	LOGIC GROUND: GROUND
I	IP6-08	KEY-IN IGNITION SWITCH: B+ WHEN KEY IN
I	IP6-10	AUDIO UNIT PRESENCE SENSE: GROUND WHEN RADIO INSTALLED
I	IP6-21	PASSENGER DOOR AJAR: DOOR OPEN = OPEN CIRCUIT; DOOR CLOSED = GROUND
I	IP6-22	DRIVER DOOR AJAR: DOOR OPEN = OPEN CIRCUIT; DOOR CLOSED = GROUND
B+	JB172-01	BATTERY POWER SUPPLY (LOCKING): B+
O	JB172-03	RH FRONT TURN SIGNAL: TO ACTIVATE, GEM SWITCHES CIRCUIT TO B+
O	JB172-04	LH FRONT TURN SIGNAL: TO ACTIVATE, GEM SWITCHES CIRCUIT TO B+
B+	JB172-05	BATTERY POWER SUPPLY (TURN SIGNALS): B+
D	JB172-18	ACTIVE SECURITY SOUNDER DRIVE: ENCODED COMMUNICATIONS
I	JB172-21	HOOD AJAR: HOOD OPEN = OPEN CIRCUIT; HOOD CLOSED = GROUND

**Instrument Cluster**

	Pin	Description and Characteristic
O	IP10-02	SECURITY INDICATOR DRIVE: TO ACTIVATE, IC SWITCHES CIRCUIT TO B+
D	IP10-03	PATS 1: ENCODED COMMUNICATION
D	IP10-04	PATS 2: ENCODED COMMUNICATION
I	IP10-05	PATS GROUND: GROUND
O	IP10-06	PATS TRANSCEIVER POWER: B+
C	IP10-17	CAN +
C	IP10-18	CAN -
S	IP10-22	SCP +
S	IP10-23	SCP -
I	IP11-08	POWER GROUND: GROUND
I	IP11-13	IGNITION SWITCHED POWER SUPPLY (I): B+

The following abbreviations are used to represent values for Control Module Pin-Out data

<b>I</b>	<b>Input</b>	<b>PG</b>	<b>Power Ground</b>	<b>C</b>	<b>CAN Network</b>	<b>D</b>	<b>Serial and Encoded Data</b>
<b>O</b>	<b>Output</b>	<b>SS</b>	<b>Sensor / Signal Supply V</b>	<b>S</b>	<b>SCP Network</b>	<b>V</b>	<b>Voltage (DC)</b>
<b>B+</b>	<b>Battery Voltage</b>	<b>SG</b>	<b>Sensor / Signal Ground</b>	<b>D2</b>	<b>D2B Network</b>	<b>PWM</b>	<b>Pulse Width Modulated</b>

**CAUTION:** The information on this data page is furnished to aid the user in understanding circuit operation. THIS INFORMATION SHOULD BE USED FOR REFERENCE ONLY.

**NOTE:** The values listed are approximately those that can be expected at the control module connector pins with all circuit connections made and all components connected and fitted.

**Fig. 12.5**

**COMPONENTS**

Component	Connector(s)	Connector Description	Location
AUDIO UNIT	ID1	2-WAY / D2B	INSTRUMENT PANEL CENTER
	IP65	20-WAY / BLACK	
	IP106	2-WAY / METALLIC	
DOOR LATCH – DRIVER	DD3	8-WAY / BLACK	DRIVER DOOR
	DD9	2-WAY / BLACK	
DOOR LATCH – LH REAR	BL3	8-WAY / BLACK	LH REAR DOOR
	BL6	2-WAY / BLACK	
DOOR LATCH – PASSENGER	PD3	8-WAY / BLACK	PASSENGER DOOR
	PD9	2-WAY / BLACK	
DOOR LATCH – RH REAR	BR3	8-WAY / BLACK	RH REAR DOOR
	BR6	2-WAY / BLACK	
ENGINE CONTROL MODULE – 2.0 L	EN65	104-WAY / BLACK	ENGINE COMPARTMENT, FRONT BULKHEAD / RH SIDE
ENGINE CONTROL MODULE – Diesel	DL1	121-WAY / BLACK	ENGINE COMPARTMENT, FRONT BULKHEAD / RH SIDE
ENGINE CONTROL MODULE – 2.5 L, 3.0 L	EN16	134-WAY / BLACK	ENGINE COMPARTMENT, FRONT BULKHEAD / RH SIDE
GENERAL ELECTRONIC MODULE	CA86	23-WAY / GREY	BEHIND INSTRUMENT PANEL / RH SIDE
	CA87	23-WAY / GREEN	
	IP5	23-WAY / BROWN	
	IP6	23-WAY / NATURAL	
	JB172	23-WAY / BLUE	
HOOD SECURITY SWITCH	JB81	2-WAY / BLACK	ADJACENT TO RH FRONT SUSPENSION TURRET
IGNITION SWITCH	IP18	7-WAY / BLACK	STEERING COLUMN
INCLINATION SENSOR	CA190	6-WAY / BLACK	TRUNK, LH REAR
INSTRUMENT CLUSTER	IP10	26-WAY / WHITE	INSTRUMENT PANEL
	IP11	26-WAY / WHITE	
PASSIVE ANTI-THEFT SYSTEM TRANSCEIVER	IP15	4-WAY / BLACK	STEERING COLUMN, IGNITION SWITCH
RF MODULE	RC35	3-WAY / BLACK	ROOF CONSOLE
ROOF CONSOLE – PRINTED CIRCUIT BOARD	RC23	20-WAY / WHITE	ROOF CENTER FRONT
ROOF CONSOLE – WITHOUT PRINTED CIRCUIT BOARD	RC30	4-WAY / BLACK	ROOF CENTER FRONT
	RC31	2-WAY / BLACK	
	RC33	4-WAY / BLACK	
	RC34	6-WAY / BLACK	
	IP29	6-WAY / BLACK	
SECURITY INDICATOR	IP29	6-WAY / BLACK	CENTER CONSOLE
SECURITY SOUNDER – ACTIVE	SL3	3-WAY / BLACK	BEHIND FRONT LH WHEEL ARCH LINER
SECURITY SOUNDER – PASSIVE	SL1	1-WAY / ORANGE	LH FRONT OF VEHICLE
	SL2	1-WAY / ORANGE	
TAIL GATE LATCH	WT6	6-WAY / BLACK	TAIL GATE
TAIL GLASS LATCH	WT7	4-WAY / BLACK	TAIL GATE

**HARNESS IN-LINE CONNECTORS**

Connector	Connector Description / Location	Location
CA1	22-WAY / NATURAL / INSTRUMENT PANEL HARNESS TO CABIN HARNESS	LH 'A' POST / 'A' POST TRIM
CA15	20-WAY / BLACK / CABIN HARNESS TO DRIVER DOOR HARNESS	DRIVER DOOR / DOOR CASING
CA20	20-WAY / BLACK / CABIN HARNESS TO PASSENGER DOOR HARNESS	PASSENGER DOOR / DOOR CASING
CA25	14-WAY / NATURAL / CABIN HARNESS TO LH REAR DOOR HARNESS	LH 'B/C' POST / 'B/C' POST TRIM
CA30	14-WAY / NATURAL / CABIN HARNESS TO RH REAR DOOR HARNESS	RH 'B/C' POST / 'B/C' POST TRIM
CA36	16-WAY / GREEN / CABIN HARNESS TO ROOF HARNESS	LH 'A' POST / WINDSHIELD PILLAR
CA40	16-WAY / GREY / CABIN HARNESS TO ROOF HARNESS	RH 'A' POST / WINDSHIELD PILLAR
CA170	16-WAY / GREEN / JUNCTION BOX HARNESS TO CABIN HARNESS	LH 'A' POST / 'A' POST TRIM
CA240	12-WAY / GREY / CABIN HARNESS TO INSTRUMENT PANEL HARNESS	LH LOWER 'A' POST / 'A' POST TRIM
JB3	14-WAY / BLUE / JUNCTION BOX HARNESS TO INSTRUMENT PANEL HARNESS	BELOW INSTRUMENT PANEL / LH SIDE
JB79	6-WAY / BLACK / JUNCTION BOX HARNESS TO SECURITY SOUNDER LINK LEAD	BEHIND LH FRONT WHEEL ARCH LINER
WL1	8-WAY / BLACK / CABIN HARNESS TO TAIL GATE LINK LEAD	ROOF / CENTER REAR
WL3	3-WAY / BLACK / CABIN HARNESS TO TAIL GATE LINK LEAD	ROOF / CENTER REAR
WT1	8-WAY / BLACK / CABIN HARNESS TO TAIL GATE HARNESS	TAIL GATE
WT3	3-WAY / BLACK / CABIN HARNESS TO TAIL GATE HARNESS	TAIL GATE

**GROUNDS**

Ground	Harness	Location
G1	CA	TRUNK / UNDER LH TAIL LAMP UNIT
G4	CA	LOWER RH 'A' POST
G5	IP	UPPER RH 'A' POST
G14	JB	ENGINE COMPARTMENT / BEHIND POWER DISTRIBUTION FUSEBOX
G15	CA	LOWER LH 'A' POST
G36	IP	BEHIND INSTRUMENT PANEL / LH SIDE OF CROSS CAR BEAM
G37	IP	BEHIND INSTRUMENT PANEL / RH SIDE OF CROSS CAR BEAM

**NOTE:** FOR CONTROL MODULE PIN-OUT INFORMATION, UNFOLD PAGE TO LEFT.

Refer to the front of this book for detailed information and illustrations regarding the location and identification of harnesses, relays, fuses, grounds, control modules and control module pins.



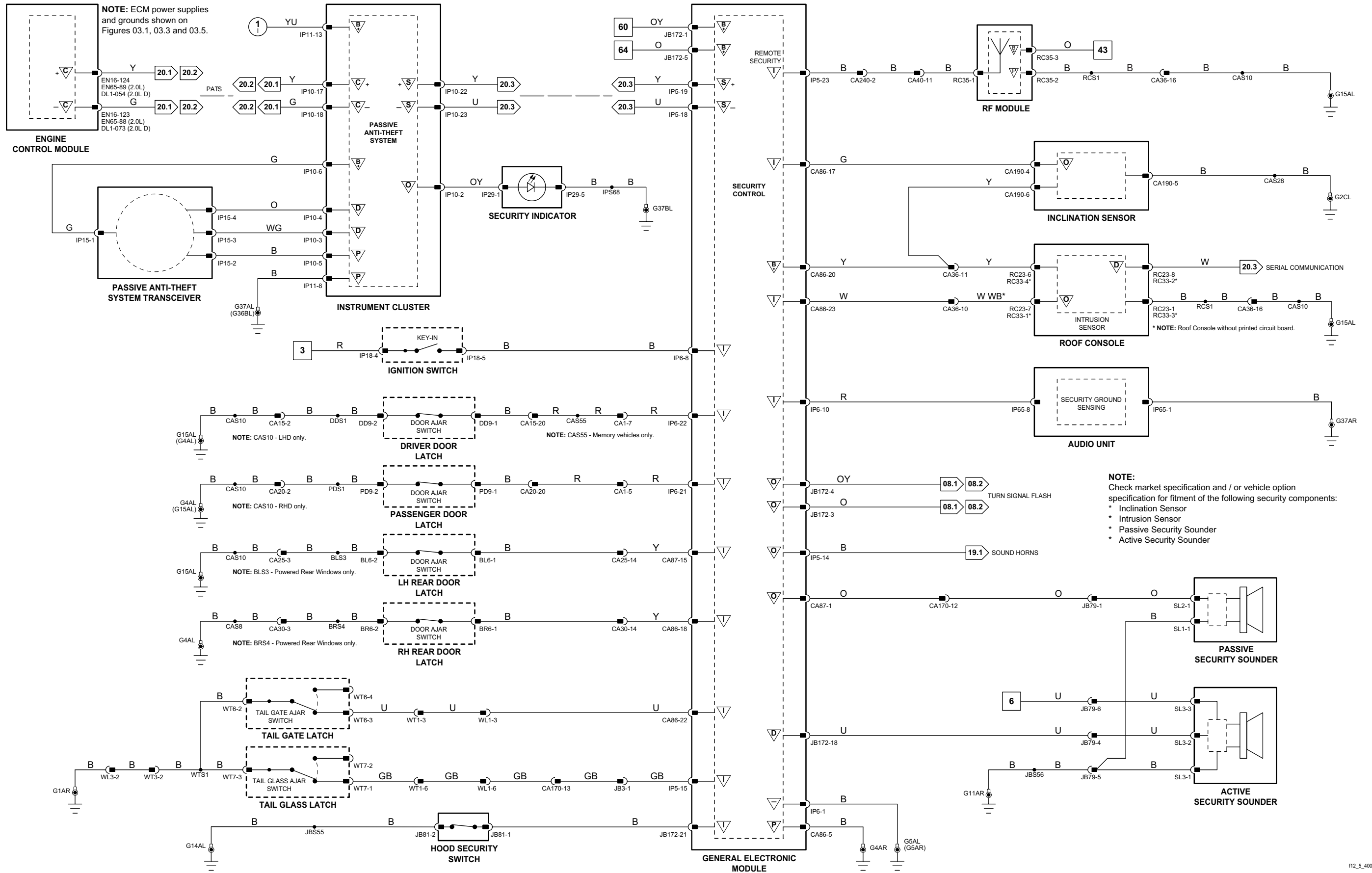

1 → 6 Fig. 01.1	34 → 80 Fig. 01.3	11 → 31 Fig. 01.5	67 → 76 Fig. 01.7	98 → 107 Fig. 01.9	Input	Battery Voltage	Sensor/Signal Supply V	CAN	D2B Network
7 → 33 Fig. 01.2	1 → 10 Fig. 01.4	32 → 66 Fig. 01.6	77 → 97 Fig. 01.8		Output	Power Ground	Sensor/Signal Ground	SCP	Serial and Encoded Data

**VARIANT:** Estate (Wagon) Vehicles  
**VIN RANGE:** All  
**DATE OF ISSUE:** February 2008

## General Electronic Module

	Pin	Description and Characteristic
PG	CA86-05	POWER GROUND
I	IP5-04	INTERMITTENT WIPE INTERVAL: 1 = 0.5†- 4 k; 2 = 4†- 14 k; 3 = 14†- 24 k; 4 = 24†- 34 k; 5 = 34†- 43 k; 6 = 43†- 57 k
S	IP5-18	SCP -
S	IP5-19	SCP +
O	IP5-21	WINDSHIELD WIPER RELAY DRIVE: TO ACTIVATE, CIRCUIT SWITCHED TO GROUND
SG	IP6-01	LOGIC GROUND: GROUND
I	IP6-04	INTERMITTENT WIPE: B+ WHEN SELECTED
I	IP6-05	FRONT WASHER SWITCH: WASHER ON = GROUND; WASHER OFF = B+
B+	JB172-01	BATTERY POWER SUPPLY (LOCKING): B+
I	JB172-02	WIPER MOTOR PARK SWITCH: PARKED = GROUND; NOT PARKED = B+
B+	JB172-05	BATTERY POWER SUPPLY (TURN SIGNALS): B+
O	JB172-23	POWER WASH PUMP RELAY DRIVE: TO ACTIVATE, GEM SWITCHES CIRCUIT TO GROUND

## Fig. 13.1

### COMPONENTS

Component	Connector(s)	Connector Description	Location
GENERAL ELECTRONIC MODULE	CA86	23-WAY / GREY	BEHIND INSTRUMENT PANEL / RH SIDE
	CA87	23-WAY / GREEN	
	IP5	23-WAY / BROWN	
	IP6	23-WAY / NATURAL	
	JB172	23-WAY / BLUE	
PASSENGER JUNCTION FUSEBOX	-	-	PASSENGER COMPARTMENT, FRONT BULKHEAD / LH SIDE
POWER DISTRIBUTION FUSEBOX	-	-	ENGINE COMPARTMENT
POWERWASH PUMP	JB65	2-WAY / GREY	BEHIND RH FRONT WHEEL ARCH LINER
POWERWASH PUMP RELAY	-	-	POWER DISTRIBUTION FUSEBOX - R8
WINDSHIELD WASHER PUMP	JB109	-	ENGINE COMPARTMENT / RH FRONT
WINDSHIELD WIPER MOTOR RELAY	-	-	POWER DISTRIBUTION FUSEBOX - R4
WIPER MOTOR - FRONT	JB63	-	BASE OF WINDSHIELD / LH SIDE
WIPER SWITCH ASSEMBLY	IP16	10-WAY / GREY	STEERING COLUMN

### HARNESS IN-LINE CONNECTORS

Connector	Connector Description / Location	Location
JB3	14-WAY / BLUE / JUNCTION BOX HARNESS TO INSTRUMENT PANEL HARNESS	BELOW INSTRUMENT PANEL / LH SIDE
JB129	22-WAY / GREY / JUNCTION BOX HARNESS TO INSTRUMENT PANEL HARNESS	BELOW INSTRUMENT PANEL / LH SIDE
JB130	22-WAY / GREEN / JUNCTION BOX HARNESS TO INSTRUMENT PANEL HARNESS	BELOW INSTRUMENT PANEL / LH SIDE

### GROUNDS

Ground	Harness	Location
G4	CA	LOWER RH 'A' POST
G5	IP	UPPER RH 'A' POST
G10	JB	ENGINE COMPARTMENT / BEHIND RH HEADLAMP
G14	JB	ENGINE COMPARTMENT / BEHIND POWER DISTRIBUTION FUSEBOX
G36	IP	BEHIND INSTRUMENT PANEL / LH SIDE OF CROSS CAR BEAM
G37	IP	BEHIND INSTRUMENT PANEL / RH SIDE OF CROSS CAR BEAM

FOR CONTROL MODULE PIN-OUT INFORMATION, UNFOLD PAGE TO LEFT.

The following abbreviations are used to represent values for Control Module Pin-Out data

I	Input	PG	Power Ground	C	CAN Network	D	Serial and Encoded Data
O	Output	SS	Sensor / Signal Supply V	S	SCP Network	V	Voltage (DC)
B+	Battery Voltage	SG	Sensor / Signal Ground	D2	D2B Network	PWM	Pulse Width Modulated

CAUTION: The information on this data page is furnished to aid the user in understanding circuit operation. THIS INFORMATION SHOULD BE USED FOR REFERENCE ONLY.

NOTE: The values listed are approximately those that can be expected at the control module connector pins with all circuit connections made and all components connected and fitted.

Refer to the front of this book for detailed information and illustrations regarding the location and identification of harnesses, relays, fuses, grounds, control modules and control module pins.

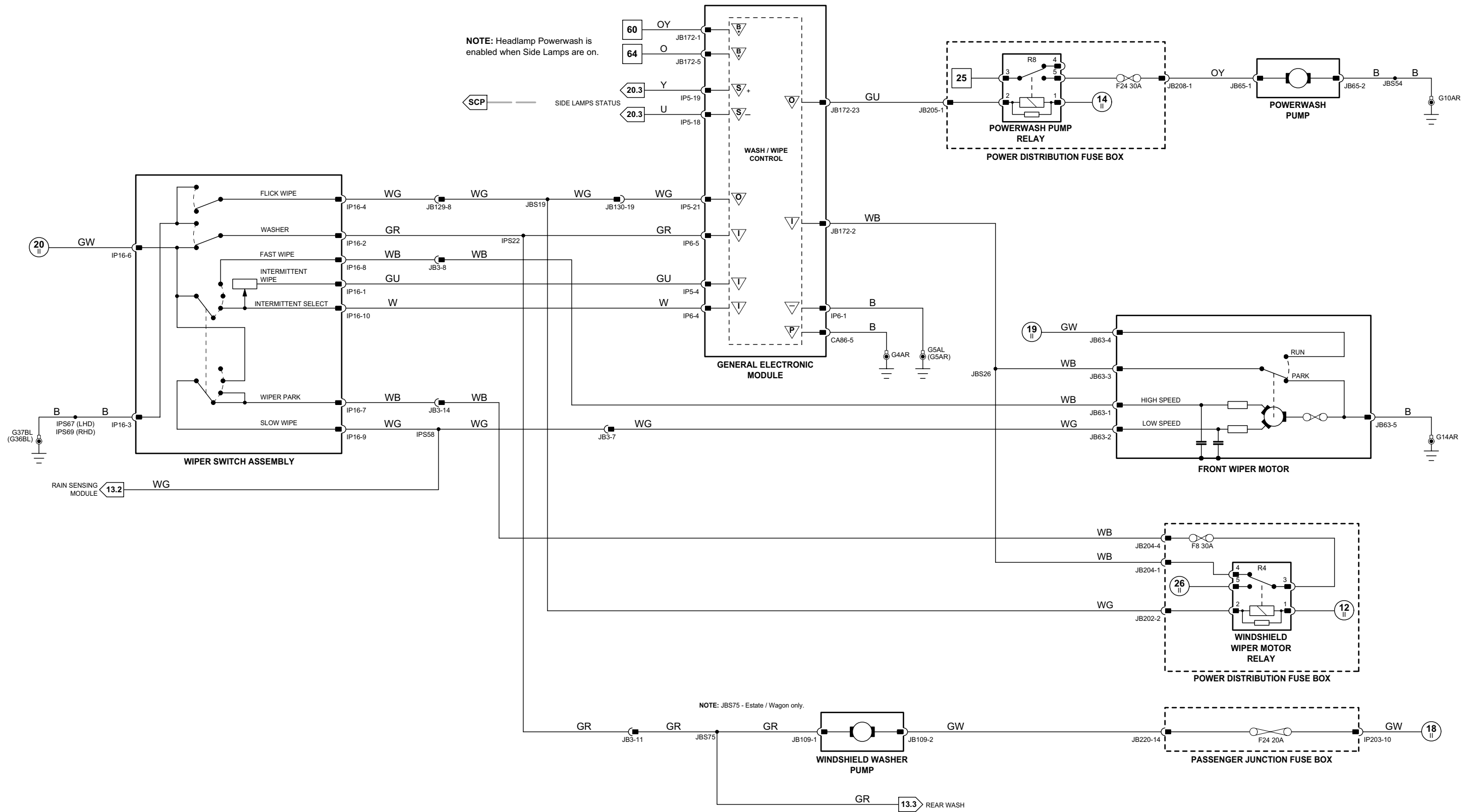

113\_1\_40009

1 → 6 Fig. 01.1	34 → 80 Fig. 01.3	11 → 31 Fig. 01.5	67 → 76 Fig. 01.7	98 → 107 Fig. 01.9	Input	Battery Voltage	Sensor/Signal Supply V	CAN	D2B Network
7 → 33 Fig. 01.2	1 → 10 Fig. 01.4	32 → 66 Fig. 01.6	77 → 97 Fig. 01.8		Output	Power Ground	Sensor/Signal Ground	SCP	Serial and Encoded Data

**VARIANT:** Non Rain Sensing Vehicles  
**VIN RANGE:** All  
**DATE OF ISSUE:** February 2008

## General Electronic Module

	Pin	Description and Characteristic
PG	CA86-05	POWER GROUND
I	IP5-04	INTERMITTENT WIPE INTERVAL: 1 = 0.5†- 4 k; 2 = 4†- 14 k; 3 = 14†- 24 k; 4 = 24†- 34 k; 5 = 34†- 43 k; 6 = 43†- 57 k
S	IP5-18	
S	IP5-19	
O	IP5-21	
SG	IP6-01	LOGIC GROUND: GROUND
I	IP6-04	INTERMITTENT WIPE: B+ WHEN SELECTED
I	IP6-05	FRONT WASHER SWITCH: WASHER ON = GROUND; WASHER OFF = B+
B+	JB172-01	BATTERY POWER SUPPLY (LOCKING): B+ WIPER MOTOR PARK SWITCH: PARKED = GROUND; NOT PARKED = B+ BATTERY POWER SUPPLY (TURN SIGNALS): B+ POWER WASH PUMP RELAY DRIVE: TO ACTIVATE, GEM SWITCHES CIRCUIT TO GROUND
I	JB172-02	
B+	JB172-05	
O	JB172-23	

## Fig. 13.2

### COMPONENTS

Component	Connector(s)	Connector Description	Location
GENERAL ELECTRONIC MODULE	CA86	23-WAY / GREY	BEHIND INSTRUMENT PANEL / RH SIDE
	CA87	23-WAY / GREEN	
	IP5	23-WAY / BROWN	
	IP6	23-WAY / NATURAL	
	JB172	23-WAY / BLUE	
PASSENGER JUNCTION FUSEBOX	-	-	PASSENGER COMPARTMENT, FRONT BULKHEAD / LH SIDE
POWER DISTRIBUTION FUSEBOX	-	-	ENGINE COMPARTMENT
POWERWASH PUMP	JB65	2-WAY / GREY	BEHIND RH FRONT WHEEL ARCH LINER
POWERWASH PUMP RELAY	-	-	POWER DISTRIBUTION FUSEBOX - R8
RAIN SENSING MODULE	CA6	12-WAY / BLACK	BEHIND INSTRUMENT PANEL / LH SIDE
RAIN SENSOR	RC15	3-WAY / BLACK	BEHIND REAR VIEW MIRROR
WINDSHIELD WASHER PUMP	JB109		ENGINE COMPARTMENT / RH FRONT
WINDSHIELD WIPER MOTOR RELAY	-	-	POWER DISTRIBUTION FUSEBOX - R4
WIPER MOTOR - FRONT	JB63		BASE OF WINDSHIELD / LH SIDE
WIPER SWITCH ASSEMBLY	IP16	10-WAY / GREY	STEERING COLUMN

### HARNESS IN-LINE CONNECTORS

Connector	Connector Description / Location	Location
CA1	22-WAY / NATURAL / INSTRUMENT PANEL HARNESS TO CABIN HARNESS	LH 'A' POST / 'A' POST TRIM
CA10	22-WAY / SLATE / CABIN HARNESS TO JUNCTION BOX HARNESS	LH 'A' POST / 'A' POST TRIM
CA40	16-WAY / GREY / CABIN HARNESS TO ROOF HARNESS	RH 'A' POST / WINDSHIELD PILLAR
CA230	16-WAY / BLUE / CABIN HARNESS TO INSTRUMENT PANEL HARNESS	LH LOWER 'A' POST / 'A' POST TRIM
JB3	14-WAY / BLUE / JUNCTION BOX HARNESS TO INSTRUMENT PANEL HARNESS	BELOW INSTRUMENT PANEL / LH SIDE
JB129	22-WAY / GREY / JUNCTION BOX HARNESS TO INSTRUMENT PANEL HARNESS	BELOW INSTRUMENT PANEL / LH SIDE
JB130	22-WAY / GREEN / JUNCTION BOX HARNESS TO INSTRUMENT PANEL HARNESS	BELOW INSTRUMENT PANEL / LH SIDE

### GROUNDS

Ground	Harness	Location
G4	CA	LOWER RH 'A' POST
G5	IP	UPPER RH 'A' POST
G10	JB	ENGINE COMPARTMENT / BEHIND RH HEADLAMP
G14	JB	ENGINE COMPARTMENT / BEHIND POWER DISTRIBUTION FUSEBOX
G15	CA	LOWER LH 'A' POST
G36	IP	BEHIND INSTRUMENT PANEL / LH SIDE OF CROSS CAR BEAM
G37	IP	BEHIND INSTRUMENT PANEL / RH SIDE OF CROSS CAR BEAM

FOR CONTROL MODULE PIN-OUT INFORMATION, UNFOLD PAGE TO LEFT.

The following abbreviations are used to represent values for Control Module Pin-Out data

I	Input	PG	Power Ground	C	CAN Network	D	Serial and Encoded Data
O	Output	SS	Sensor / Signal Supply V	S	SCP Network	V	Voltage (DC)
B+	Battery Voltage	SG	Sensor / Signal Ground	D2	D2B Network	PWM	Pulse Width Modulated

**CAUTION:** The information on this data page is furnished to aid the user in understanding circuit operation. THIS INFORMATION SHOULD BE USED FOR REFERENCE ONLY.

**NOTE:** The values listed are approximately those that can be expected at the control module connector pins with all circuit connections made and all components connected and fitted.

Refer to the front of this book for detailed information and illustrations regarding the location and identification of harnesses, relays, fuses, grounds, control modules and control module pins.

NOTE: Headlamp Powerwash enabled when Side Lamps on.

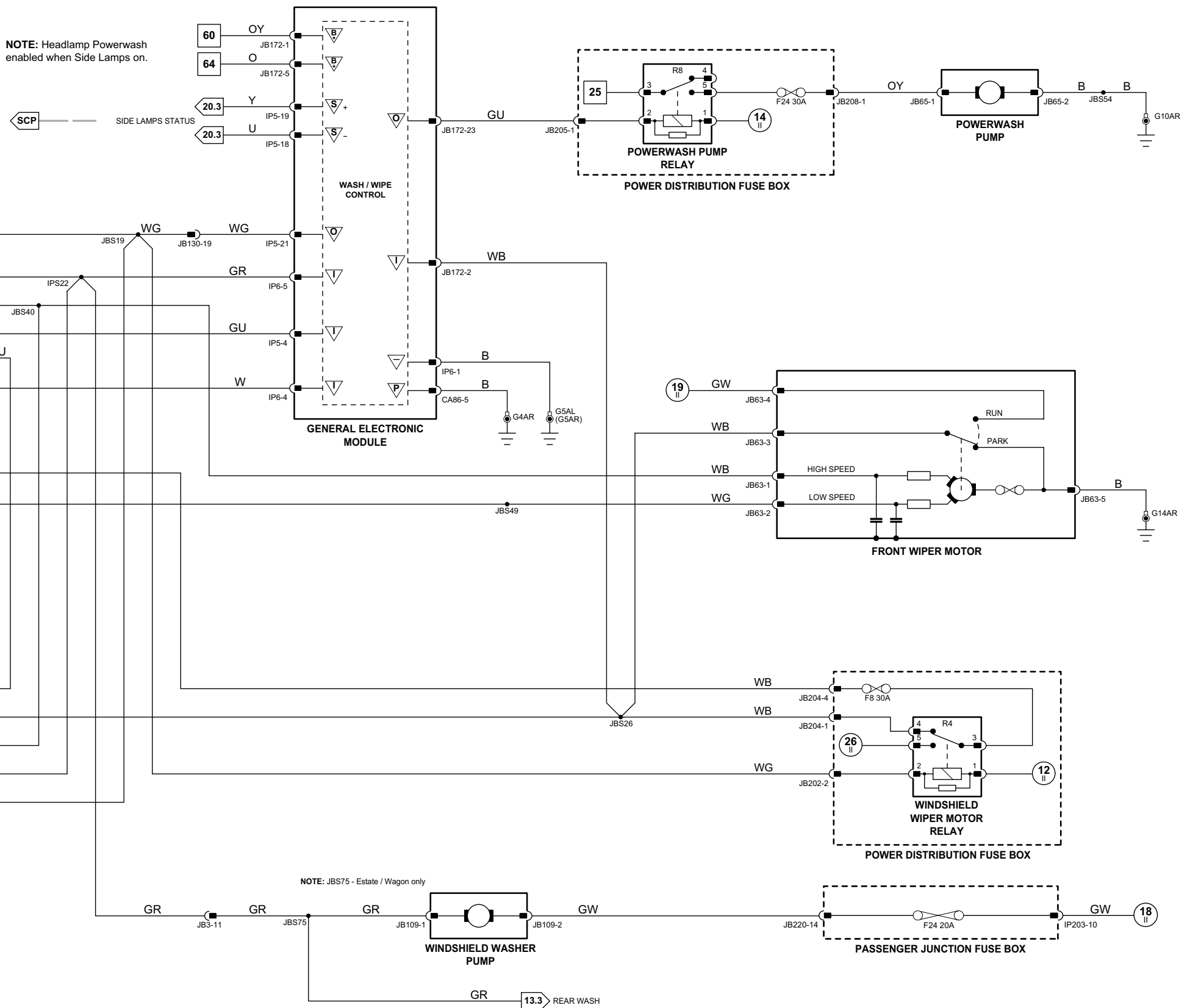

1 → 6 Fig. 01.1	34 → 80 Fig. 01.3	11 → 31 Fig. 01.5	67 → 76 Fig. 01.7	98 → 107 Fig. 01.9	Input	Battery Voltage	Sensor/Signal Supply V	CAN	D2B Network
7 → 33 Fig. 01.2	1 → 10 Fig. 01.4	32 → 66 Fig. 01.6	77 → 97 Fig. 01.8		Output	Power Ground	Sensor/Signal Ground	SCP	Serial and Encoded Data

VARIANT: Rain Sensing Vehicles  
 VIN RANGE: All  
 DATE OF ISSUE: February 2008

**General Electronic Module**

	Pin	Description and Characteristic
PG	CA86-05	POWER GROUND
I	IP5-02	REAR WASHER SWITCH: WASHER ON = GROUND; WASHER OFF = B+
I	IP5-03	ESTATE (WAGON); REAR WIPER SWITCH: B+ WHEN SELECTED
O	IP5-17	REAR WIPER MOTOR RELAY DRIVE: TO ACTIVATE, GEM SWITCH CIRCUIT TO GROUND
S	IP5-18	SCP -
S	IP5-19	SCP +
SG	IP6-01	LOGIC GROUND: GROUND
I	IP6-05	FRONT WASHER SWITCH: WASHER ON = GROUND; WASHER OFF = B+
I	IP6-12	REAR WIPER MOTOR PARK SWITCH: PARKED = GROUND; NOT PARKED = B+
B+	JB172-01	BATTERY POWER SUPPLY (LOCKING): B+
B+	JB172-05	BATTERY POWER SUPPLY (TURN SIGNALS): B+

**Fig. 13.3**

**COMPONENTS**

Component	Connector(s)	Connector Description	Location
GENERAL ELECTRONIC MODULE	CA86	23-WAY / GREY	BEHIND INSTRUMENT PANEL / RH SIDE
	CA87	23-WAY / GREEN	
	IP5	23-WAY / BROWN	
	IP6	23-WAY / NATURAL	
	JB172	23-WAY / BLUE	
	-	-	PASSENGER COMPARTMENT, FRONT BULKHEAD / LH SIDE
PASSENGER JUNCTION FUSEBOX	-	-	PASSENGER COMPARTMENT, FRONT BULKHEAD / LH SIDE
WINDSHIELD WASHER PUMP	JB109		ENGINE COMPARTMENT / RH FRONT
WIPER MOTOR - REAR	WT5		TAIL GATE
WIPER MOTOR RELAY - REAR	-	-	PASSENGER JUNCTION FUSEBOX - R3
WIPER SWITCH ASSEMBLY	IP16	10-WAY / GREY	STEERING COLUMN

**HARNESS IN-LINE CONNECTORS**

Connector	Connector Description / Location	Location
CA1	22-WAY / NATURAL / INSTRUMENT PANEL HARNESS TO CABIN HARNESS	LH 'A' POST / 'A' POST TRIM
CA169	4-WAY / GREY / CABIN HARNESS TO INSTRUMENT PANEL HARNESS	LH LOWER A POST / A POST TRIM
WL3	3-WAY / BLACK / CABIN HARNESS TO TAIL GATE LINK LEAD	ROOF / CENTER REAR
WT3	3-WAY / BLACK / CABIN HARNESS TO TAIL GATE HARNESS	TAIL GATE

**GROUNDS**

Ground	Harness	Location
G1	CA	TRUNK / UNDER LH TAIL LAMP UNIT
G4	CA	LOWER RH 'A' POST
G5	IP	UPPER RH 'A' POST
G36	IP	BEHIND INSTRUMENT PANEL / LH SIDE OF CROSS CAR BEAM
G37	IP	BEHIND INSTRUMENT PANEL / RH SIDE OF CROSS CAR BEAM

**FOR CONTROL MODULE PIN-OUT INFORMATION, UNFOLD PAGE TO LEFT.**

The following abbreviations are used to represent values for Control Module Pin-Out data

I	Input	PG	Power Ground	C	CAN Network	D	Serial and Encoded Data
O	Output	SS	Sensor / Signal Supply V	S	SCP Network	V	Voltage (DC)
B+	Battery Voltage	SG	Sensor / Signal Ground	D2	D2B Network	PWM	Pulse Width Modulated

**CAUTION:** The information on this data page is furnished to aid the user in understanding circuit operation. THIS INFORMATION SHOULD BE USED FOR REFERENCE ONLY.

**NOTE:** The values listed are approximately those that can be expected at the control module connector pins with all circuit connections made and all components connected and fitted.

Refer to the front of this book for detailed information and illustrations regarding the location and identification of harnesses, relays, fuses, grounds, control modules and control module pins.

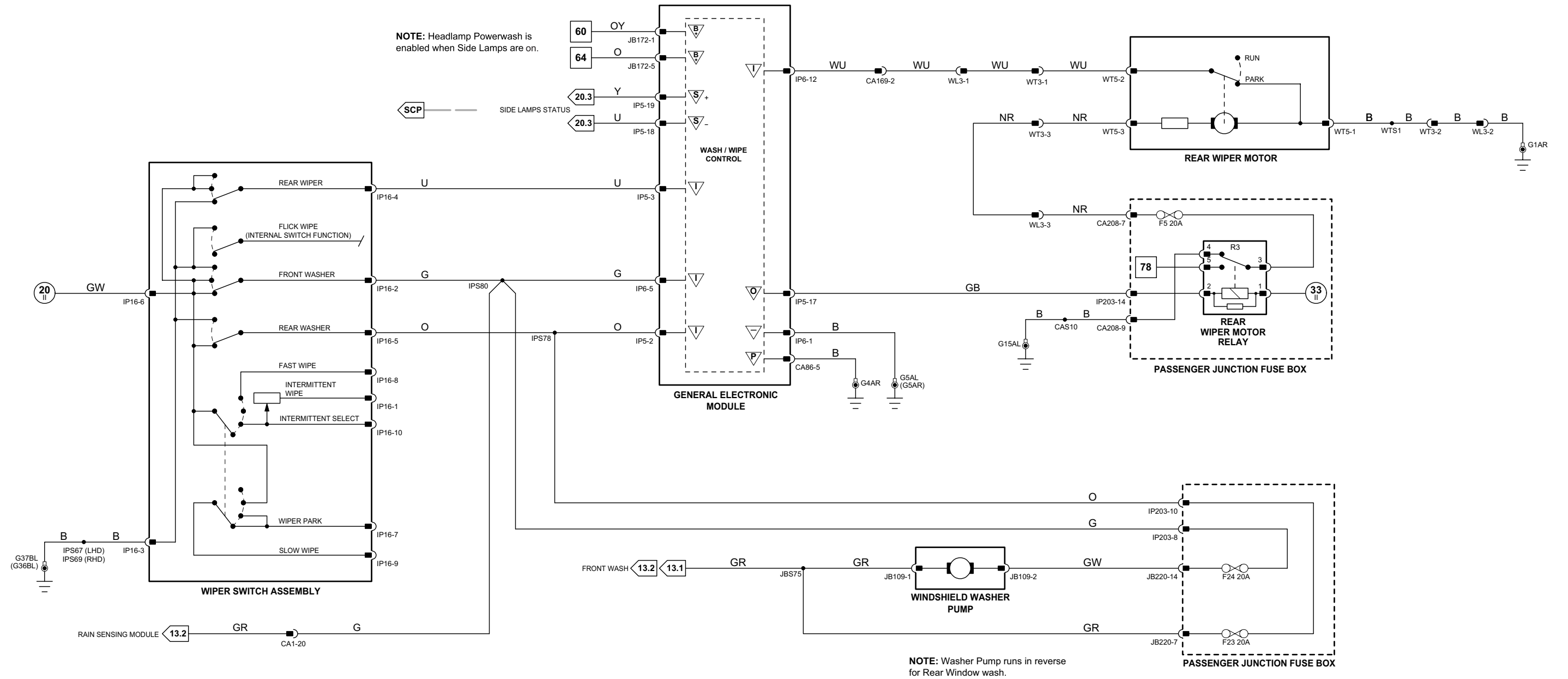

1 → 6 Fig. 01.1	34 → 80 Fig. 01.3	11 → 31 Fig. 01.5	67 → 76 Fig. 01.7	98 → 107 Fig. 01.9	Input	Battery Voltage	Sensor/Signal Supply V	CAN	D2B Network
7 → 33 Fig. 01.2	1 → 10 Fig. 01.4	32 → 66 Fig. 01.6	77 → 97 Fig. 01.8		Output	Power Ground	Sensor/Signal Ground	SCP	Serial and Encoded Data

**VARIANT:** Estate (Wagon) Vehicles  
**VIN RANGE:** All  
**DATE OF ISSUE:** February 2008

**General Electronic Module**

	Pin	Description and Characteristic
I	CA86-16	SET SWITCH: OPEN CIRCUIT / GROUND
O	CA87-17	GLOBAL CLOSE REQUEST: 20 mS PULSED SIGNAL
I	IP5-03	SEDAN (EXCEPT JAPAN AND S. KOREA): EXTERNAL ANTENNA
I	IP5-23	REMOTE RF SIGNAL
SG	IP6-01	LOGIC GROUND: GROUND
B+	JB172-01	BATTERY POWER SUPPLY (LOCKING): B+

**Fig. 14.1**

**COMPONENTS**

Component	Connector(s)	Connector Description	Location
DOOR LATCH – DRIVER	DD3	8-WAY / BLACK	DRIVER DOOR
	DD9	2-WAY / BLACK	
DOOR SWITCH PACK – DRIVER	DD1	20-WAY / BLACK	DRIVER DOOR CASING
DOOR SWITCH PACK – LH REAR	BL1	8-WAY / BLACK	LH REAR DOOR CASING
DOOR SWITCH PACK – PASSENGER	PD10	8-WAY / BLACK	PASSENGER DOOR CASING
DOOR SWITCH PACK – RH REAR	BR1	8-WAY / BLACK	RH REAR DOOR CASING
GENERAL ELECTRONIC MODULE	CA86	23-WAY / GREY	BEHIND INSTRUMENT PANEL / RH SIDE
	CA87	23-WAY / GREEN	
	IP5	23-WAY / BROWN	
	IP6	23-WAY / NATURAL	
	JB172	23-WAY / BLUE	
RF MODULE	RC35	3-WAY / BLACK	ROOF CONSOLE
WINDOW MOTOR – DRIVER	DD2	8-WAY / GREY	DRIVER DOOR
WINDOW MOTOR – LH REAR	BL2	8-WAY / GREY	LH REAR DOOR
WINDOW MOTOR – PASSENGER	PD2	8-WAY / GREY	PASSENGER DOOR
WINDOW MOTOR – RH REAR	BR2	8-WAY / GREY	RH REAR DOOR

**HARNESS IN-LINE CONNECTORS**

Connector	Connector Description / Location	Location
CA15	20-WAY / BLACK / CABIN HARNESS TO DRIVER DOOR HARNESS	DRIVER DOOR / DOOR CASING
CA16	20-WAY / BLACK / CABIN HARNESS TO DRIVER DOOR HARNESS	DRIVER DOOR / DOOR CASING
CA20	20-WAY / BLACK / CABIN HARNESS TO PASSENGER DOOR HARNESS	PASSENGER DOOR / DOOR CASING
CA25	14-WAY / NATURAL / CABIN HARNESS TO LH REAR DOOR HARNESS	LH 'B/C' POST / 'B/C' POST TRIM
CA30	14-WAY / NATURAL / CABIN HARNESS TO RH REAR DOOR HARNESS	RH 'B/C' POST / 'B/C' POST TRIM
CA36	16-WAY / GREEN / CABIN HARNESS TO ROOF HARNESS	LH 'A' POST / WINDSHIELD PILLAR
CA40	16-WAY / GREY / CABIN HARNESS TO ROOF HARNESS	RH 'A' POST / WINDSHIELD PILLAR
CA240	12-WAY / GREY / CABIN HARNESS TO INSTRUMENT PANEL HARNESS	LH LOWER 'A' POST / 'A' POST TRIM

**GROUNDS**

Ground	Harness	Location
G4	CA	LOWER RH 'A' POST
G5	IP	UPPER RH 'A' POST
G15	CA	LOWER LH 'A' POST

FOR CONTROL MODULE PIN-OUT INFORMATION, UNFOLD PAGE TO LEFT.

The following abbreviations are used to represent values for Control Module Pin-Out data

I	Input	PG	Power Ground	C	CAN Network	D	Serial and Encoded Data
O	Output	SS	Sensor / Signal Supply V	S	SCP Network	V	Voltage (DC)
B+	Battery Voltage	SG	Sensor / Signal Ground	D2	D2B Network	PWM	Pulse Width Modulated

**CAUTION:** The information on this data page is furnished to aid the user in understanding circuit operation. THIS INFORMATION SHOULD BE USED FOR REFERENCE ONLY.

**NOTE:** The values listed are approximately those that can be expected at the control module connector pins with all circuit connections made and all components connected and fitted.

Refer to the front of this book for detailed information and illustrations regarding the location and identification of harnesses, relays, fuses, grounds, control modules and control module pins.



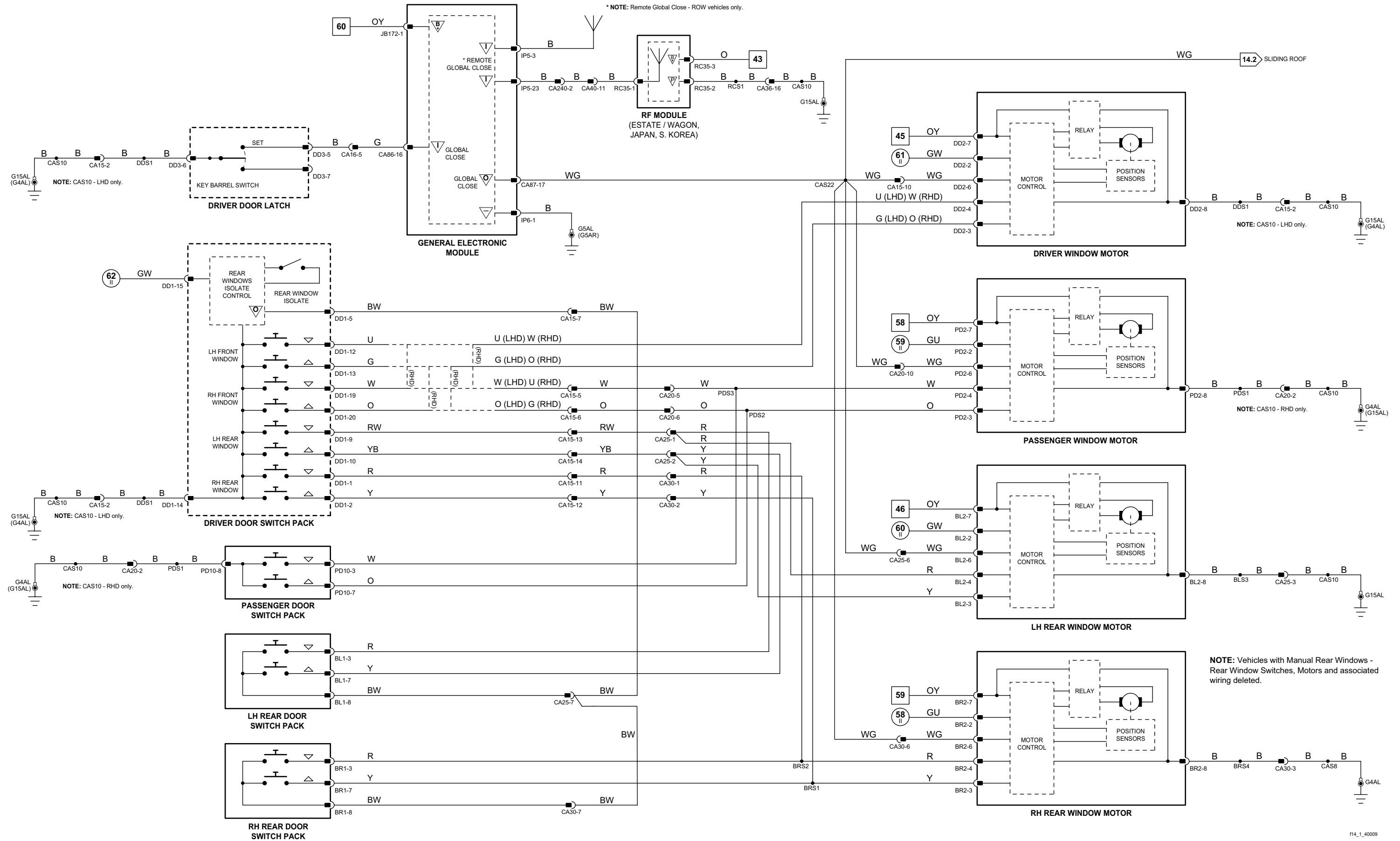

114\_1\_40009

1 → 6 Fig. 01.1	34 → 80 Fig. 01.3	11 → 31 Fig. 01.5	67 → 76 Fig. 01.7	98 → 107 Fig. 01.9	Input	Battery Voltage	Sensor/Signal Supply V	CAN	D2B Network
7 → 33 Fig. 01.2	1 → 10 Fig. 01.4	32 → 66 Fig. 01.6	77 → 97 Fig. 01.8		Output	Power Ground	Sensor/Signal Ground	SCP	Serial and Encoded Data

**VARIANT:** All Vehicles  
**VIN RANGE:** All  
**DATE OF ISSUE:** February 2008

**General Electronic Module**

	Pin	Description and Characteristic
I	CA86-16	SET SWITCH: OPEN CIRCUIT / GROUND
O	CA87-17	GLOBAL CLOSE REQUEST: 20 mS PULSED SIGNAL
O	CA87-20	VEHICLE SPEED SIGNAL: PULSED SIGNAL, 8000 PULSES PER MPH
I	IP5-03	SEDAN (EXCEPT JAPAN AND S. KOREA): EXTERNAL ANTENNA
S	IP5-18	SCP -
S	IP5-19	SCP +
I	IP5-23	REMOTE RF SIGNAL
SG	IP6-01	LOGIC GROUND: GROUND
B+	JB172-01	BATTERY POWER SUPPLY (LOCKING): B+

**Fig. 14.2**

**COMPONENTS**

Component	Connector(s)	Connector Description	Location
DOOR LATCH - DRIVER	DD3	8-WAY / BLACK	DRIVER DOOR
	DD9	2-WAY / BLACK	
GENERAL ELECTRONIC MODULE	CA86	23-WAY / GREY	BEHIND INSTRUMENT PANEL / RH SIDE
	CA87	23-WAY / GREEN	
	IP5	23-WAY / BROWN	
	IP6	23-WAY / NATURAL	
	JB172	23-WAY / BLUE	
RF MODULE	RC35	3-WAY / BLACK	ROOF CONSOLE
ROOF CONSOLE - PRINTED CIRCUIT BOARD	RC23	20-WAY / WHITE	ROOF CENTER FRONT
ROOF CONSOLE - WITHOUT PRINTED CIRCUIT BOARD	RC30	4-WAY / BLACK	ROOF CENTER FRONT
	RC31	2-WAY / BLACK	
	RC33	4-WAY / BLACK	
	RC34	6-WAY / BLACK	
SLIDING ROOF MODULE	RC14	10-WAY / GREY	ROOF CONSOLE

**HARNESS IN-LINE CONNECTORS**

Connector	Connector Description / Location	Location
CA15	20-WAY / BLACK / CABIN HARNESS TO DRIVER DOOR HARNESS	DRIVER DOOR / DOOR CASING
CA16	20-WAY / BLACK / CABIN HARNESS TO DRIVER DOOR HARNESS	DRIVER DOOR / DOOR CASING
CA36	16-WAY / GREEN / CABIN HARNESS TO ROOF HARNESS	LH 'A' POST / WINDSHIELD PILLAR
CA40	16-WAY / GREY / CABIN HARNESS TO ROOF HARNESS	RH 'A' POST / WINDSHIELD PILLAR
CA240	12-WAY / GREY / CABIN HARNESS TO INSTRUMENT PANEL HARNESS	LH LOWER 'A' POST / 'A' POST TRIM

**GROUNDS**

Ground	Harness	Location
G4	CA	LOWER RH 'A' POST
G5	IP	UPPER RH 'A' POST
G15	CA	LOWER LH 'A' POST

**FOR CONTROL MODULE PIN-OUT INFORMATION, UNFOLD PAGE TO LEFT.**

The following abbreviations are used to represent values for Control Module Pin-Out data

I	Input	PG	Power Ground	C	CAN Network	D	Serial and Encoded Data
O	Output	SS	Sensor / Signal Supply V	S	SCP Network	V	Voltage (DC)
B+	Battery Voltage	SG	Sensor / Signal Ground	D2	D2B Network	PWM	Pulse Width Modulated

**CAUTION:** The information on this data page is furnished to aid the user in understanding circuit operation. THIS INFORMATION SHOULD BE USED FOR REFERENCE ONLY.

**NOTE:** The values listed are approximately those that can be expected at the control module connector pins with all circuit connections made and all components connected and fitted.

Refer to the front of this book for detailed information and illustrations regarding the location and identification of harnesses, relays, fuses, grounds, control modules and control module pins.

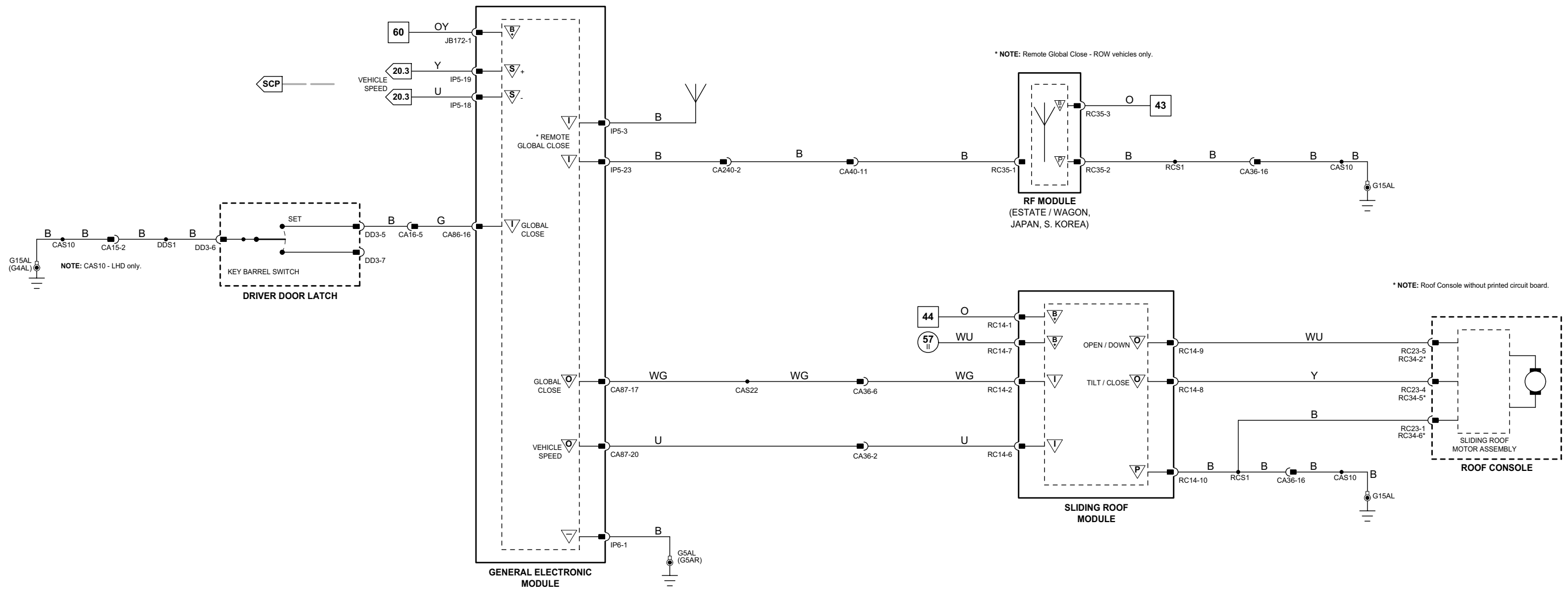

**General Electronic Module**

	Pin	Description and Characteristic
I	CA86-16	SET SWITCH: OPEN CIRCUIT / GROUND
O	CA87-17	GLOBAL CLOSE REQUEST: 20 mS PULSED SIGNAL
I	IP5-03	SEDAN (EXCEPT JAPAN AND S. KOREA): EXTERNAL ANTENNA
I	IP5-23	REMOTE RF SIGNAL
SG	IP6-01	LOGIC GROUND: GROUND
B+	JB172-01	BATTERY POWER SUPPLY (LOCKING): B+

**Fig. 14.1**

**COMPONENTS**

Component	Connector(s)	Connector Description	Location
DOOR LATCH – DRIVER	DD3	8-WAY / BLACK	DRIVER DOOR
	DD9	2-WAY / BLACK	
DOOR SWITCH PACK – DRIVER	DD1	20-WAY / BLACK	DRIVER DOOR CASING
DOOR SWITCH PACK – LH REAR	BL1	8-WAY / BLACK	LH REAR DOOR CASING
DOOR SWITCH PACK – PASSENGER	PD10	8-WAY / BLACK	PASSENGER DOOR CASING
DOOR SWITCH PACK – RH REAR	BR1	8-WAY / BLACK	RH REAR DOOR CASING
GENERAL ELECTRONIC MODULE	CA86	23-WAY / GREY	BEHIND INSTRUMENT PANEL / RH SIDE
	CA87	23-WAY / GREEN	
	IP5	23-WAY / BROWN	
	IP6	23-WAY / NATURAL	
	JB172	23-WAY / BLUE	
RF MODULE	RC35	3-WAY / BLACK	ROOF CONSOLE
WINDOW MOTOR – DRIVER	DD2	8-WAY / GREY	DRIVER DOOR
WINDOW MOTOR – LH REAR	BL2	8-WAY / GREY	LH REAR DOOR
WINDOW MOTOR – PASSENGER	PD2	8-WAY / GREY	PASSENGER DOOR
WINDOW MOTOR – RH REAR	BR2	8-WAY / GREY	RH REAR DOOR

**HARNESS IN-LINE CONNECTORS**

Connector	Connector Description / Location	Location
CA15	20-WAY / BLACK / CABIN HARNESS TO DRIVER DOOR HARNESS	DRIVER DOOR / DOOR CASING
CA16	20-WAY / BLACK / CABIN HARNESS TO DRIVER DOOR HARNESS	DRIVER DOOR / DOOR CASING
CA20	20-WAY / BLACK / CABIN HARNESS TO PASSENGER DOOR HARNESS	PASSENGER DOOR / DOOR CASING
CA25	14-WAY / NATURAL / CABIN HARNESS TO LH REAR DOOR HARNESS	LH 'B/C' POST / 'B/C' POST TRIM
CA30	14-WAY / NATURAL / CABIN HARNESS TO RH REAR DOOR HARNESS	RH 'B/C' POST / 'B/C' POST TRIM
CA36	16-WAY / GREEN / CABIN HARNESS TO ROOF HARNESS	LH 'A' POST / WINDSHIELD PILLAR
CA40	16-WAY / GREY / CABIN HARNESS TO ROOF HARNESS	RH 'A' POST / WINDSHIELD PILLAR
CA240	12-WAY / GREY / CABIN HARNESS TO INSTRUMENT PANEL HARNESS	LH LOWER 'A' POST / 'A' POST TRIM

**GROUNDS**

Ground	Harness	Location
G4	CA	LOWER RH 'A' POST
G5	IP	UPPER RH 'A' POST
G15	CA	LOWER LH 'A' POST

FOR CONTROL MODULE PIN-OUT INFORMATION, UNFOLD PAGE TO LEFT.

The following abbreviations are used to represent values for Control Module Pin-Out data

I	Input	PG	Power Ground	C	CAN Network	D	Serial and Encoded Data
O	Output	SS	Sensor / Signal Supply V	S	SCP Network	V	Voltage (DC)
B+	Battery Voltage	SG	Sensor / Signal Ground	D2	D2B Network	PWM	Pulse Width Modulated

**CAUTION:** The information on this data page is furnished to aid the user in understanding circuit operation. THIS INFORMATION SHOULD BE USED FOR REFERENCE ONLY.

**NOTE:** The values listed are approximately those that can be expected at the control module connector pins with all circuit connections made and all components connected and fitted.

Refer to the front of this book for detailed information and illustrations regarding the location and identification of harnesses, relays, fuses, grounds, control modules and control module pins.

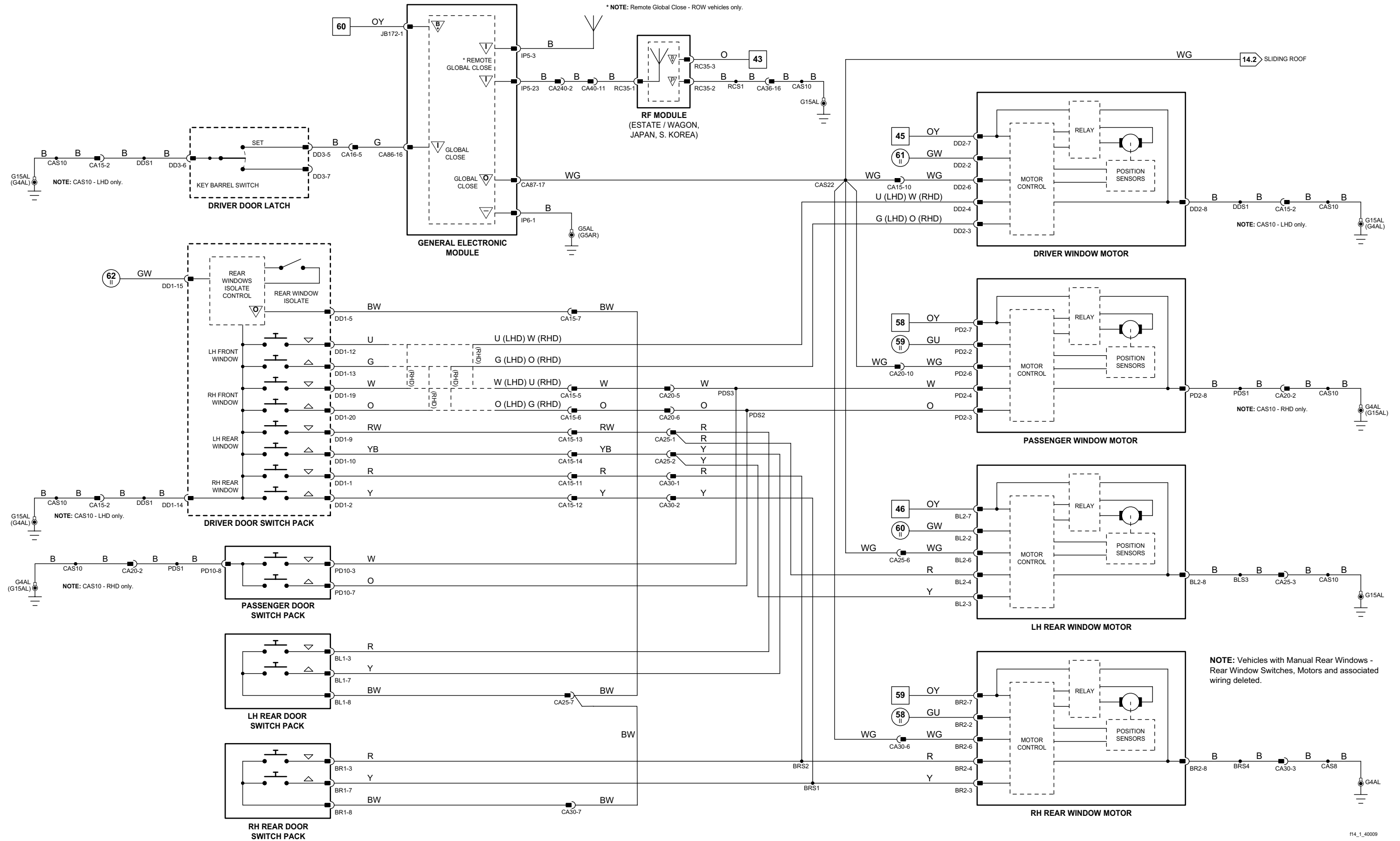

114\_1\_40009

1 → 6 Fig. 01.1	34 → 80 Fig. 01.3	11 → 31 Fig. 01.5	67 → 76 Fig. 01.7	98 → 107 Fig. 01.9	Input	Battery Voltage	Sensor/Signal Supply V	CAN	D2B Network
7 → 33 Fig. 01.2	1 → 10 Fig. 01.4	32 → 66 Fig. 01.6	77 → 97 Fig. 01.8		Output	Power Ground	Sensor/Signal Ground	SCP	Serial and Encoded Data

**VARIANT:** All Vehicles  
**VIN RANGE:** All  
**DATE OF ISSUE:** February 2008

**General Electronic Module**

	Pin	Description and Characteristic
I	CA86-16	SET SWITCH: OPEN CIRCUIT / GROUND
O	CA87-17	GLOBAL CLOSE REQUEST: 20 mS PULSED SIGNAL
O	CA87-20	VEHICLE SPEED SIGNAL: PULSED SIGNAL, 8000 PULSES PER MPH
I	IP5-03	SEDAN (EXCEPT JAPAN AND S. KOREA): EXTERNAL ANTENNA
S	IP5-18	SCP -
S	IP5-19	SCP +
I	IP5-23	REMOTE RF SIGNAL
SG	IP6-01	LOGIC GROUND: GROUND
B+	JB172-01	BATTERY POWER SUPPLY (LOCKING): B+

**Fig. 14.2**

**COMPONENTS**

Component	Connector(s)	Connector Description	Location
DOOR LATCH - DRIVER	DD3	8-WAY / BLACK	DRIVER DOOR
	DD9	2-WAY / BLACK	
GENERAL ELECTRONIC MODULE	CA86	23-WAY / GREY	BEHIND INSTRUMENT PANEL / RH SIDE
	CA87	23-WAY / GREEN	
	IP5	23-WAY / BROWN	
	IP6	23-WAY / NATURAL	
	JB172	23-WAY / BLUE	
RF MODULE	RC35	3-WAY / BLACK	ROOF CONSOLE
ROOF CONSOLE - PRINTED CIRCUIT BOARD	RC23	20-WAY / WHITE	ROOF CENTER FRONT
ROOF CONSOLE - WITHOUT PRINTED CIRCUIT BOARD	RC30	4-WAY / BLACK	ROOF CENTER FRONT
	RC31	2-WAY / BLACK	
	RC33	4-WAY / BLACK	
	RC34	6-WAY / BLACK	
SLIDING ROOF MODULE	RC14	10-WAY / GREY	ROOF CONSOLE

**HARNESS IN-LINE CONNECTORS**

Connector	Connector Description / Location	Location
CA15	20-WAY / BLACK / CABIN HARNESS TO DRIVER DOOR HARNESS	DRIVER DOOR / DOOR CASING
CA16	20-WAY / BLACK / CABIN HARNESS TO DRIVER DOOR HARNESS	DRIVER DOOR / DOOR CASING
CA36	16-WAY / GREEN / CABIN HARNESS TO ROOF HARNESS	LH 'A' POST / WINDSHIELD PILLAR
CA40	16-WAY / GREY / CABIN HARNESS TO ROOF HARNESS	RH 'A' POST / WINDSHIELD PILLAR
CA240	12-WAY / GREY / CABIN HARNESS TO INSTRUMENT PANEL HARNESS	LH LOWER 'A' POST / 'A' POST TRIM

**GROUNDS**

Ground	Harness	Location
G4	CA	LOWER RH 'A' POST
G5	IP	UPPER RH 'A' POST
G15	CA	LOWER LH 'A' POST

**FOR CONTROL MODULE PIN-OUT INFORMATION, UNFOLD PAGE TO LEFT.**

The following abbreviations are used to represent values for Control Module Pin-Out data

I	Input	PG	Power Ground	C	CAN Network	D	Serial and Encoded Data
O	Output	SS	Sensor / Signal Supply V	S	SCP Network	V	Voltage (DC)
B+	Battery Voltage	SG	Sensor / Signal Ground	D2	D2B Network	PWM	Pulse Width Modulated

**CAUTION:** The information on this data page is furnished to aid the user in understanding circuit operation. THIS INFORMATION SHOULD BE USED FOR REFERENCE ONLY.

**NOTE:** The values listed are approximately those that can be expected at the control module connector pins with all circuit connections made and all components connected and fitted.

Refer to the front of this book for detailed information and illustrations regarding the location and identification of harnesses, relays, fuses, grounds, control modules and control module pins.

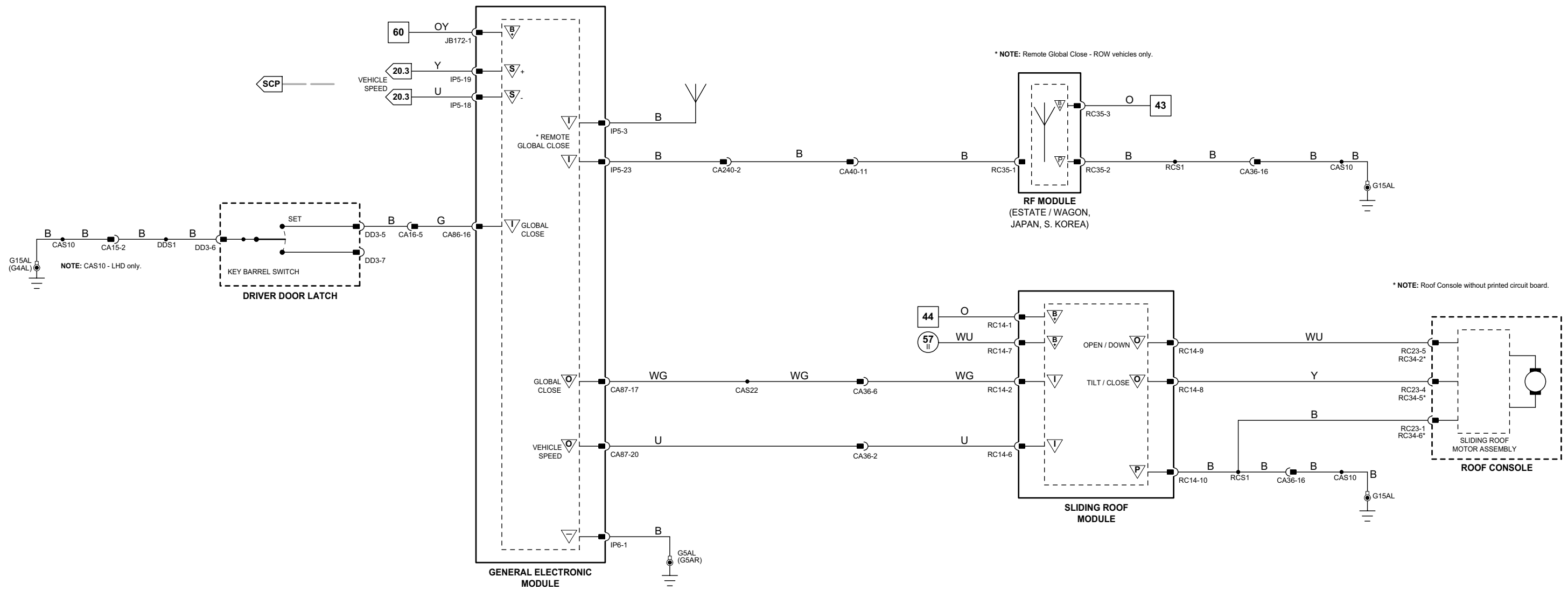

## Audio Unit

	Pin	Description and Characteristic
D2	ID1-1	D2B NETWORK TRANSMIT
D2	ID1-2	D2B NETWORK RECEIVE
PG	IP65-01	POWER GROUND: GROUND
B+	IP65-02	IGNITION SWITCHED POWER SUPPLY (I): B+
O	IP65-03	LH REAR AUDIO +
O	IP65-04	LH REAR AUDIO -
O	IP65-05	RH REAR AUDIO +
O	IP65-06	RH REAR AUDIO -
I	IP65-07	TELEPHONE MUTE SIGNAL
O	IP65-08	SECURITY SYSTEM GROUND SENSING: GROUND WHEN AUDIO UNIT INSTALLED
S	IP65-09	SCP +
S	IP65-10	SCP -
B+	IP65-11	BATTERY POWER SUPPLY: B+
O	IP65-13	LH FRONT AUDIO -
O	IP65-14	LH FRONT AUDIO +
O	IP65-15	RH FRONT AUDIO -
O	IP65-16	RH FRONT AUDIO +
I	IP65-17	DIMMER CONTROLLED ILLUMINATION: PWM, 80 Hz. GROUND = 0% DUTY CYCLE, B+ = 100% DUTY CYCLE
I	IP65-18	STEERING WHEEL SWITCHES: STEPPED RESISTANCE
O	IP65-19	D2B NETWORK WAKE-UP

## Fig. 15.1

### COMPONENTS

Component	Connector(s)	Connector Description	Location
AM / FM ANTENNA – ESTATE (WAGON)	NA56	1-WAY / CO-AX CONNECTOR	RH REAR SIDE GLASS - UPPER
	NA57	3-WAY / BLACK	
AM / FM ANTENNA MODULE – SEDAN	NA46	3-WAY / BLACK	BEHIND LH 'C' POST TRIM
	NA48	2-WAY / BLACK	
AUDIO CONTROL SWITCHES	SW3	4-WAY / BLACK	STEERING WHEEL
AUDIO UNIT	ID1	2-WAY / D2B	INSTRUMENT PANEL CENTER
	IP65	20-WAY / BLACK	
	IP106	2-WAY / METALLIC	
CD AUTOCHANGER	CA301	3-WAY / BLACK	TRUNK / LH SIDE
	CD2	2-WAY / D2B	
FULL RANGE SPEAKER – LH REAR	BL4	2-WAY / WHITE	LH REAR DOOR
FULL RANGE SPEAKER – RH REAR	BR4	2-WAY / WHITE	RH REAR DOOR
HEATED REAR WINDOW – SEDAN	ZA1	1-WAY / BLACK	REAR WINDOW
	ZA10	1-WAY / BLACK	
MID BASS SPEAKER – DRIVER DOOR	DD6	2-WAY / WHITE	DRIVER DOOR CASING
MID BASS SPEAKER – PASSENGER DOOR	PD5	2-WAY / WHITE	PASSENGER DOOR CASING
TWEETER SPEAKER – DRIVER DOOR	DD12	2-WAY / WHITE	DRIVER DOOR CASING
TWEETER SPEAKER – PASSENGER DOOR	PD11	2-WAY / WHITE	PASSENGER DOOR CASING

### HARNESS IN-LINE CONNECTORS

Connector	Connector Description / Location	Location
CA15	20-WAY / BLACK / CABIN HARNESS TO DRIVER DOOR HARNESS	DRIVER DOOR / DOOR CASING
CA16	20-WAY / BLACK / CABIN HARNESS TO DRIVER DOOR HARNESS	DRIVER DOOR / DOOR CASING
CA20	20-WAY / BLACK / CABIN HARNESS TO PASSENGER DOOR HARNESS	PASSENGER DOOR / DOOR CASING
CA21	20-WAY / BLACK / CABIN HARNESS TO PASSENGER DOOR HARNESS	PASSENGER DOOR / DOOR CASING
CA25	14-WAY / NATURAL / CABIN HARNESS TO LH REAR DOOR HARNESS	LH 'B/C' POST / 'B/C' POST TRIM
CA30	14-WAY / NATURAL / CABIN HARNESS TO RH REAR DOOR HARNESS	RH 'B/C' POST / 'B/C' POST TRIM
CA230	16-WAY / BLUE / CABIN HARNESS TO INSTRUMENT PANEL HARNESS	LH LOWER 'A' POST / 'A' POST TRIM
CA414	16-WAY / BLUE / NAVIGATION HARNESS TO CABIN HARNESS	BELOW LH REAR SEAT CUSHION
IP34	10-WAY / NATURAL / INSTRUMENT PANEL HARNESS TO STEERING WHEEL HARNESS	STEERING WHEEL CASSETTE
JB1	42-WAY / BLACK / ENGINE MANAGEMENT HARNESS TO JUNCTION BOX HARNESS	ENGINE COMPARTMENT / LH SIDE
JB129	22-WAY / GREY / JUNCTION BOX HARNESS TO INSTRUMENT PANEL HARNESS	BELOW INSTRUMENT PANEL / LH SIDE
NA50	2-WAY / GREY / NAVIGATION HARNESS TO INSTRUMENT PANEL HARNESS	TOP OF INSTRUMENT PANEL / LH SIDE

### GROUNDS

Ground	Harness	Location
G1	CA	TRUNK / UNDER LH TAIL LAMP UNIT
G14	JB	ENGINE COMPARTMENT / BEHIND POWER DISTRIBUTION FUSEBOX
G37	IP	BEHIND INSTRUMENT PANEL / RH SIDE OF CROSS CAR BEAM

FOR CONTROL MODULE PIN-OUT INFORMATION, UNFOLD PAGE TO LEFT.

The following abbreviations are used to represent values for Control Module Pin-Out data

I	Input	PG	Power Ground	C	CAN Network	D	Serial and Encoded Data
O	Output	SS	Sensor / Signal Supply V	S	SCP Network	V	Voltage (DC)
B+	Battery Voltage	SG	Sensor / Signal Ground	D2	D2B Network	PWM	Pulse Width Modulated

**CAUTION:** The information on this data page is furnished to aid the user in understanding circuit operation. THIS INFORMATION SHOULD BE USED FOR REFERENCE ONLY.

**NOTE:** The values listed are approximately those that can be expected at the control module connector pins with all circuit connections made and all components connected and fitted.

Refer to the front of this book for detailed information and illustrations regarding the location and identification of harnesses, relays, fuses, grounds, control modules and control module pins.



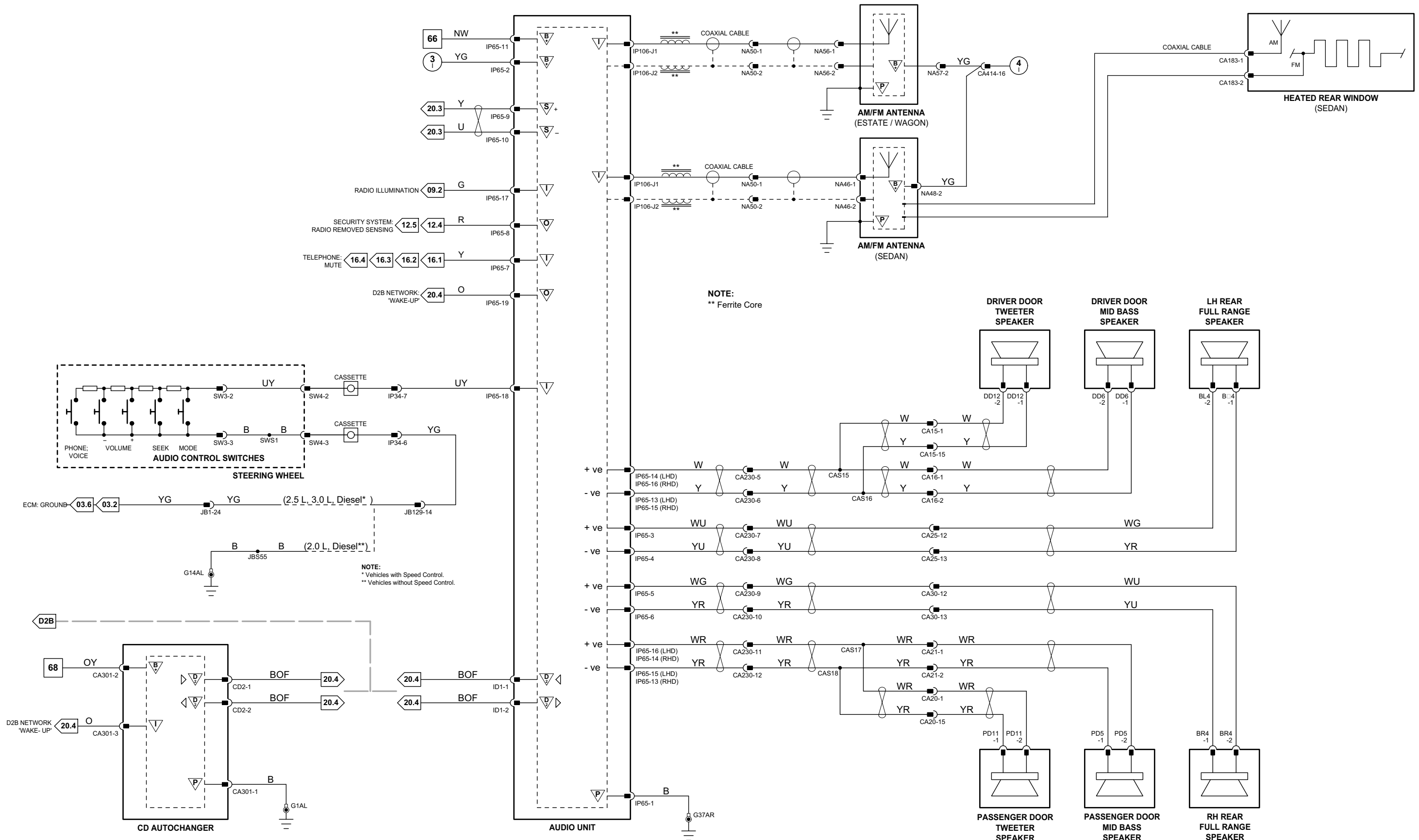

1 → 6 Fig. 01.1	34 → 80 Fig. 01.3	11 → 31 Fig. 01.5	67 → 76 Fig. 01.7	98 → 107 Fig. 01.9	Input	Battery Voltage	Sensor/Signal Supply V	CAN	D2B Network
7 → 33 Fig. 01.2	1 → 10 Fig. 01.4	32 → 66 Fig. 01.6	77 → 97 Fig. 01.8		Output	Power Ground	Sensor/Signal Ground	SCP	Serial and Encoded Data

**VARIANT:** Standard ICE Vehicles  
**VIN RANGE:** All  
**DATE OF ISSUE:** February 2008

## Audio Unit

	Pin	Description and Characteristic
D2	ID1-1	D2B NETWORK TRANSMIT
D2	ID1-2	D2B NETWORK RECEIVE
PG	IP65-01	POWER GROUND: GROUND
B+	IP65-02	IGNITION SWITCHED POWER SUPPLY (I): B+
I	IP65-07	TELEPHONE MUTE SIGNAL
O	IP65-08	SECURITY SYSTEM GROUND SENSING: GROUND WHEN AUDIO UNIT INSTALLED
S	IP65-09	SCP +
S	IP65-10	SCP -
B+	IP65-11	BATTERY POWER SUPPLY: B+
I	IP65-17	DIMMER CONTROLLED ILLUMINATION: PWM, 80 Hz. GROUND = 0% DUTY CYCLE, B+ = 100% DUTY CYCLE
I	IP65-18	STEERING WHEEL SWITCHES: STEPPED RESISTANCE
O	IP65-19	D2B NETWORK WAKE-UP

## Fig. 15.2

### COMPONENTS

Component	Connector(s)	Connector Description	Location
AM / FM ANTENNA MODULE-- ESTATE /WAGON	NA56	1-WAY / CO-AX CONNECTOR	RH REAR SIDE GLASS - UPPER
	NA57	3-WAY / BLACK	
AM / FM ANTENNA MODULE - SEDAN	NA46	3-WAY / BLACK	BEHIND LH 'C' POST TRIM
	NA48	2-WAY / BLACK	
AUDIO CONTROL SWITCHES	SW3	4-WAY / BLACK	STEERING WHEEL
AUDIO UNIT	ID1	2-WAY / D2B	INSTRUMENT PANEL CENTER
	IP65	20-WAY / BLACK	
	IP106	2-WAY / METALLIC	
CD AUTOCHANGER	CA301	3-WAY / BLACK	TRUNK / LH SIDE
	CD2	2-WAY / D2B	
HEATED REAR WINDOW - SEDAN	ZA1	1-WAY / BLACK	REAR WINDOW
	ZA10	1-WAY / BLACK	
MID BASS SPEAKER - DRIVER DOOR	DD6	2-WAY / WHITE	DRIVER DOOR CASING
MID BASS SPEAKER - LH REAR	BL4	2-WAY / WHITE	LH REAR DOR CASING
MID BASS SPEAKER - PASSENGER DOOR	PD5	2-WAY / WHITE	PASSENGER DOOR CASING
MID BASS SPEAKER - RH REAR	BR4	2-WAY / WHITE	RH REAR DOOR CASING
POWER AMPLIFIER	CA425	12-WAY / GREY	TRUNK, LH REAR
	CA426	18-WAY / BLACK	
	CD7	2-WAY / D2B	
SUB WOOFER - ESTATE /WAGON	CA428	4-WAY / BLACK	RH REAR INTERIOR TRIM
SUB WOOFER 1 - SEDAN	CA427	4-WAY / WHITE	PARCEL SHELF
SUB WOOFER 2 - SEDAN	CA427	4-WAY / WHITE	PARCEL SHELF
TWEETER SPEAKER - DRIVER DOOR	DD12	2-WAY / WHITE	DRIVER DOOR CASING
TWEETER SPEAKER - LH REAR	BL7	2-WAY / WHITE	LH REAR DOOR CASING
TWEETER SPEAKER - PASSENGER DOOR	PD11	2-WAY / WHITE	PASSENGER DOOR CASING
TWEETER SPEAKER - RH REAR	BR9	2-WAY / WHITE	RH REAR DOOR CASING

### HARNESS IN-LINE CONNECTORS

Connector	Connector Description / Location	Location
CA15	20-WAY / BLACK / CABIN HARNESS TO DRIVER DOOR HARNESS	DRIVER DOOR / DOOR CASING
CA16	20-WAY / BLACK / CABIN HARNESS TO DRIVER DOOR HARNESS	DRIVER DOOR / DOOR CASING
CA20	20-WAY / BLACK / CABIN HARNESS TO PASSENGER DOOR HARNESS	PASSENGER DOOR / DOOR CASING
CA21	20-WAY / BLACK / CABIN HARNESS TO PASSENGER DOOR HARNESS	PASSENGER DOOR / DOOR CASING
CA25	14-WAY / NATURAL / CABIN HARNESS TO LH REAR DOOR HARNESS	LH 'B/C' POST / 'B/C' POST TRIM
CA30	14-WAY / NATURAL / CABIN HARNESS TO RH REAR DOOR HARNESS	RH 'B/C' POST / 'B/C' POST TRIM
CA414	16-WAY / BLUE / NAVIGATION HARNESS TO CABIN HARNESS	BELOW LH REAR SEAT CUSHION
IP34	10-WAY / NATURAL / INSTRUMENT PANEL HARNESS TO STEERING WHEEL HARNESS	STEERING WHEEL CASSETTE
JB1	42-WAY / BLACK / ENGINE MANAGEMENT HARNESS TO JUNCTION BOX HARNESS	ENGINE COMPARTMENT / LH SIDE
JB129	22-WAY / GREY / JUNCTION BOX HARNESS TO INSTRUMENT PANEL HARNESS	BELOW INSTRUMENT PANEL / LH SIDE
NA50	2-WAY / GREY / NAVIGATION HARNESS TO INSTRUMENT PANEL HARNESS	TOP OF INSTRUMENT PANEL / LH SIDE

### GROUNDS

Ground	Harness	Location
G1	CA	TRUNK / UNDER LH TAIL LAMP UNIT
G14	JB	ENGINE COMPARTMENT / BEHIND POWER DISTRIBUTION FUSEBOX
G37	IP	BEHIND INSTRUMENT PANEL / RH SIDE OF CROSS CAR BEAM

FOR CONTROL MODULE PIN-OUT INFORMATION, UNFOLD PAGE TO LEFT.

The following abbreviations are used to represent values for Control Module Pin-Out data

I	Input	PG	Power Ground	C	CAN Network	D	Serial and Encoded Data
O	Output	SS	Sensor / Signal Supply V	S	SCP Network	V	Voltage (DC)
B+	Battery Voltage	SG	Sensor / Signal Ground	D2	D2B Network	PWM	Pulse Width Modulated

**CAUTION:** The information on this data page is furnished to aid the user in understanding circuit operation. THIS INFORMATION SHOULD BE USED FOR REFERENCE ONLY.

**NOTE:** The values listed are approximately those that can be expected at the control module connector pins with all circuit connections made and all components connected and fitted.

Refer to the front of this book for detailed information and illustrations regarding the location and identification of harnesses, relays, fuses, grounds, control modules and control module pins.

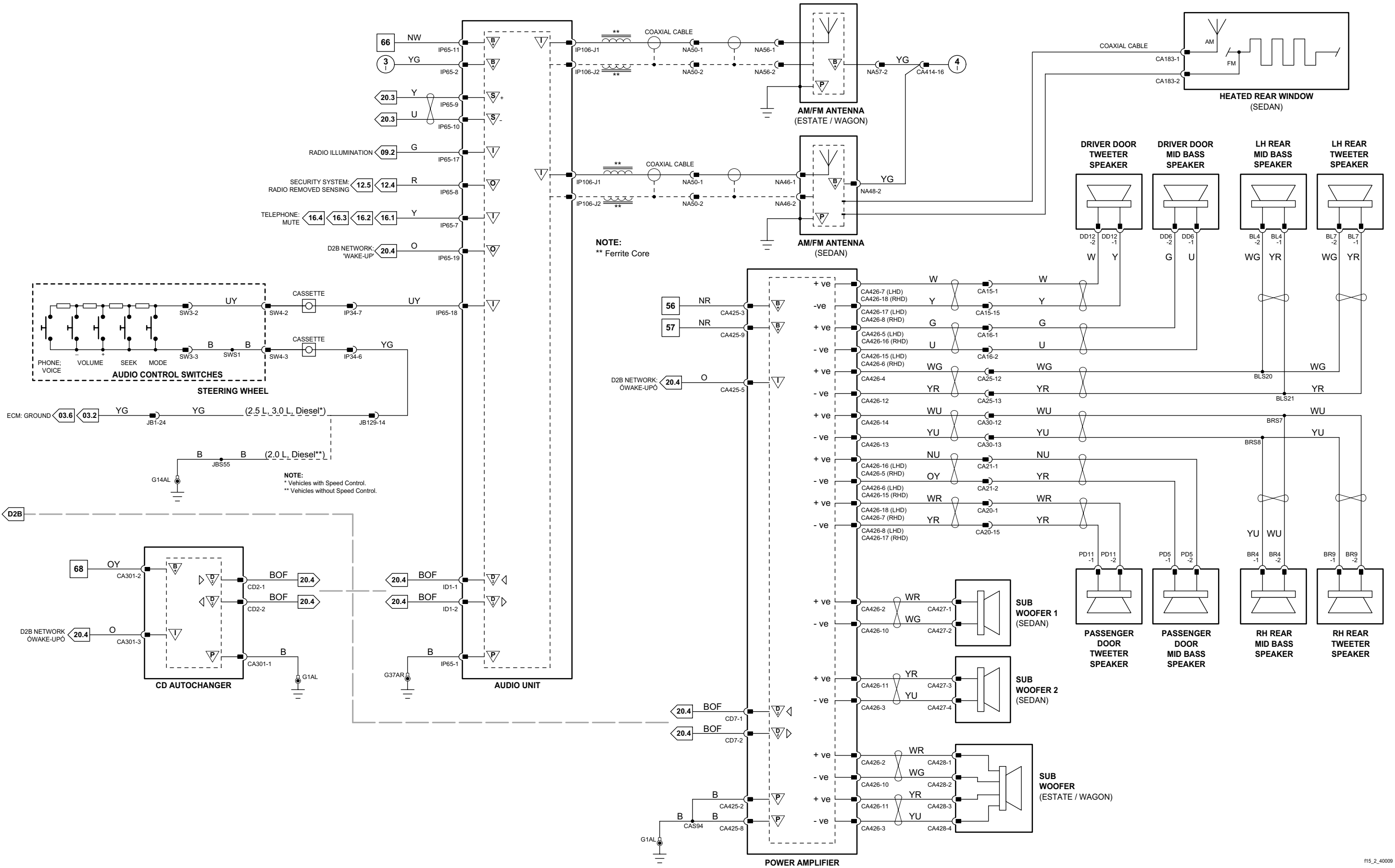

NOTE:  
\*\* Ferrite Core

NOTE:  
\* Vehicles with Speed Control.  
\*\* Vehicles without Speed Control.

**Fig. 15.3****COMPONENTS**

<b>Component</b>	<b>Connector(s)</b>	<b>Connector Description</b>	<b>Location</b>
BAND 3 AMPLIFIER - SEDAN	NA42	1-WAY / SCREENED	BEHIND RH 'C' POST TRIM - UPPER
BAND 3 AMPLIFIER - WAGON	NA43	1-WAY / SCREENED	ILH REAR SIDE GLASS - UPPER
DAB ANTENNA	NA41	1-WAY / SCREENED	
DAB RECEIVER MODULE	NA30	2-WAY / BLACK	CABIN / BEHIND REAR SEAT BACK
	NA36	2-WAY MOST / BLACK	TRUNK / LEFT SIDE / MODULE STACK
	NA40	4-WAY / WHITE	
GATEWAY MODULE	CD8	2- WAY FIBRE OPTICS	TRUNK / LEFT SIDE / MODULE STACK
	NA27	4-WAY / BLACK	
	NA35	2-WAY MOST / BLACK	
GPS ANTENNA	NA12	1-WAY / SCREENED / BLUE	BEHIND REAR CENTER ROOF HEADLINER
NAVIGATION CONTROL MODULE	NA6	1-WAY / SCREENED	TRUNK / LEFT SIDE / MODULE STACK / SECOND FROM TOP
	CD5	2-WAY / D2B	
	NA1	26-WAY / WHITE	
	NA2	12-WAY / BLACK	
	NA7	20-WAY / BLACK	

**GROUNDS**

<b>Ground</b>	<b>Harness</b>	<b>Location</b>
G40	NA	TRUNK / LH QUARTER PANEL

Refer to the front of this book for detailed information and illustrations regarding the location and identification of harnesses, relays, fuses, grounds, control modules and control module pins.

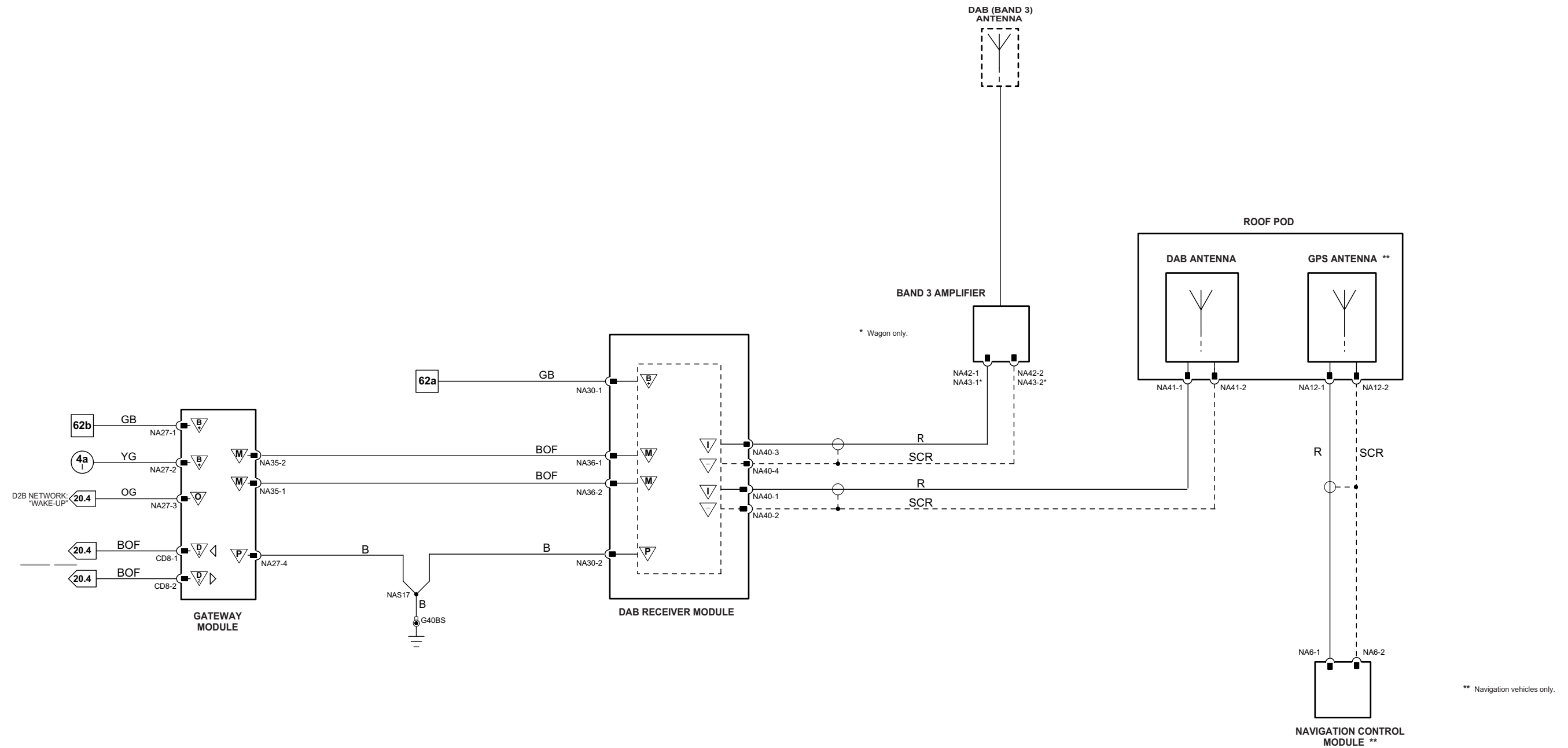

\*\* Navigation vehicles only.

1 → 6 Fig. 01.1	34 → 80 Fig. 01.3	11 → 31 Fig. 01.5	67 → 76 Fig. 01.7	98 → 107 Fig. 01.9	Input	Battery Voltage	Sensor/Signal Supply V	CAN	D2B Network	MOST
7 → 33 Fig. 01.2	1 → 10 Fig. 01.4	32 → 66 Fig. 01.6	77 → 97 Fig. 01.8		Output	Power Ground	Sensor/Signal Ground	SCP	Serial and Encoded Data	

VARIANT: DAB Vehicles  
 VIN RANGE: All  
 DATE OF ISSUE: February 2008

**Cellular Phone Module**

	Pin	Description and Characteristic
D2	CD3-1	D2B NETWORK TRANSMIT
D2	CD3-2	D2B NETWORK RECEIVE
O	PH3-04	MUTE COMMAND
PG	PH3-09	POWER GROUND: GROUND
SG	PH3-11	MICROPHONE SHIELD: GROUND
B+	PH3-12	BATTERY POWER SUPPLY: B+
B+	PH3-13	BATTERY POWER SUPPLY: B+
B+	PH3-14	IGNITION SWITCHED POWER SUPPLY (I): B+
I	PH3-17	MICROPHONE +
I	PH3-18	MICROPHONE -
I	PH3-23	D2B NETWORK WAKE-UP
PG	PH3-25	POWER GROUND: GROUND
B+	PH3-29	IGNITION SWITCHED POWER SUPPLY (II): B+
I	PH6-1	BLUETHOOT ANTENNA SIGNAL
SG	PH6-2	BLUETHOOT ANTENNA SHIELD: GROUND

**Fig. 16.1**

**COMPONENTS**

Component	Connector(s)	Connector Description	Location
AUDIO UNIT	ID1	2-WAY / D2B	INSTRUMENT PANEL CENTER
	IP65	20-WAY / BLACK	
CELLULAR PHONE MODULE	IP106	2-WAY / METALLIC	TRUNK / LH SIDE
	CD3	2-WAY / D2B	
	PH3	32-WAY / BLACK	
	PH6	2-WAY / BEIGE / SCREENED	
	PH4	1-WAY CO-AX CONNECTOR / BEIGE	
	PH5	1-WAY CO-AX CONNECTOR / BEIGE	
BLUETOOTH ANTENNA - ESTATE/WAGON	PH4	1-WAY CO-AX CONNECTOR / BEIGE	ROOF CENTER REAR
BLUETOOTH ANTENNA - SEDAN	PH5	1-WAY CO-AX CONNECTOR / BEIGE	ROOF CENTER REAR
NAVIGATION CONTROL MODULE	CD5	2-WAY / D2B	TRUNK, LH SIDE
	NA1	26-WAY / WHITE	
	NA2	12-WAY / BLACK	
	NA6	2-WAY / GREY	
	NA7	20-WAY / BLACK	
	RC23	20-WAY / WHITE	
	RC30	4-WAY / BLACK	
ROOF CONSOLE - PRINTED CIRCUIT BOARD	RC31	2-WAY / BLACK	ROOF CENTER FRONT
	RC33	4-WAY / BLACK	
	RC34	6-WAY / BLACK	
	RC34	6-WAY / BLACK	
ROOF CONSOLE - WITHOUT PRINTED CIRCUIT BOARD	RC30	4-WAY / BLACK	ROOF CENTER FRONT
TELEMATICS DISPLAY	IP70	22-WAY / BLACK	CENTER CONSOLE
	IP136	2-WAY / METALLIC	
	IP137	2-WAY / METALLIC	
	IP138	2-WAY / METALLIC	
	IP139	2-WAY / METALLIC	

**HARNES IN-LINE CONNECTORS**

Connector	Connector Description / Location	Location
CA1	22-WAY / NATURAL / INSTRUMENT PANEL HARNESS TO CABIN HARNESS	LH 'A' POST / 'A' POST TRIM
CA40	16-WAY / GREY / CABIN HARNESS TO ROOF HARNESS	RH 'A' POST / WINDSHIELD PILLAR
CA230	16-WAY / BLUE / CABIN HARNESS TO INSTRUMENT PANEL HARNESS	LH LOWER 'A' POST / 'A' POST TRIM
CA406	3-WAY / GREY / NAVIGATION HARNESS TO CABIN HARNESS	BELOW LH REAR SEAT CUSHION
CA407	16-WAY / GREY / CELLULAR PHONE HARNESS TO CABIN HARNESS	BELOW LH REAR SEAT CUSHION
CA414	16-WAY / BLUE / NAVIGATION HARNESS TO CABIN HARNESS	BELOW LH REAR SEAT CUSHION
PJ14	22-WAY / GREY / JUMPER LINK CONNECTOR	LUGGAGE COMPARTMENT

**GROUNDS**

Ground	Harness	Location
G39	PH	TRUNK / LH QUARTER PANEL

**FOR CONTROL MODULE PIN-OUT INFORMATION, UNFOLD PAGE TO LEFT.**

The following abbreviations are used to represent values for Control Module Pin-Out data

I	Input	PG	Power Ground	C	CAN Network	D	Serial and Encoded Data
O	Output	SS	Sensor / Signal Supply V	S	SCP Network	V	Voltage (DC)
B+	Battery Voltage	SG	Sensor / Signal Ground	D2	D2B Network	PWM	Pulse Width Modulated

**CAUTION:** The information on this data page is furnished to aid the user in understanding circuit operation. THIS INFORMATION SHOULD BE USED FOR REFERENCE ONLY.

**NOTE:** The values listed are approximately those that can be expected at the control module connector pins with all circuit connections made and all components connected and fitted.

Refer to the front of this book for detailed information and illustrations regarding the location and identification of harnesses, relays, fuses, grounds, control modules and control module pins.

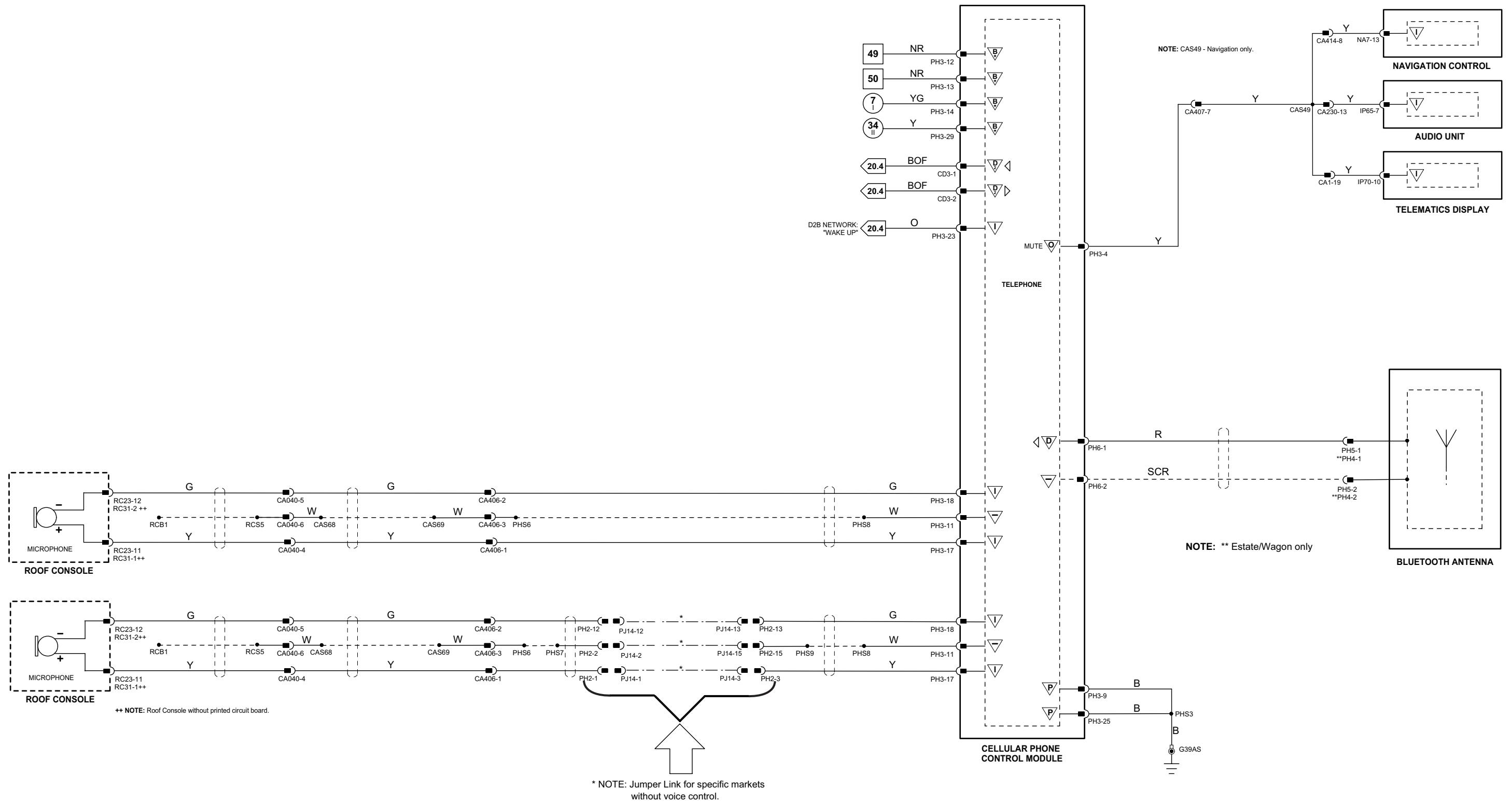

**Cellular Phone Module**

	Pin	Description and Characteristic
D2	CD3-1	D2B NETWORK TRANSMIT
D2	CD3-2	D2B NETWORK RECEIVE
O	PH3-04	MUTE COMMAND
PG	PH3-09	POWER GROUND: GROUND
SG	PH3-11	MICROPHONE SHIELD: GROUND
B+	PH3-12	BATTERY POWER SUPPLY: B+
B+	PH3-13	BATTERY POWER SUPPLY: B+
B+	PH3-14	IGNITION SWITCHED POWER SUPPLY (I): B+
I	PH3-17	MICROPHONE +
I	PH3-18	MICROPHONE -
I	PH3-23	D2B NETWORK WAKE-UP
PG	PH3-25	POWER GROUND: GROUND
B+	PH3-29	IGNITION SWITCHED POWER SUPPLY (II): B+
I	PH6-1	BLUETHOOT ANTENNA SIGNAL
SG	PH6-2	BLUETHOOT ANTENNA SHIELD: GROUND

**Voice Activation Module**

	Pin	Description and Characteristic
D2	CD4-1	D2B NETWORK TRANSMIT
D2	CD4-2	D2B NETWORK RECEIVE
I	PH2-01	MICROPHONE +
SG	PH2-02	MICROPHONE SHIELD
O	PH2-03	MICROPHONE +
B+	PH2-06	IGNITION SWITCHED POWER SUPPLY (II) (START / RUN STATUS)
B+	PH2-08	IGNITION SWITCHED POWER SUPPLY (I)
PG	PH2-11	POWER GROUND
I	PH2-12	MICROPHONE -
O	PH2-13	MICROPHONE -
O	PH2-14	D2B NETWORK WAKE UP
SG	PH2-15	MICROPHONE SHIELD
B+	PH2-22	BATTERY POWER SUPPLY: B+

**Fig. 16.2**

**COMPONENTS**

Component	Connector(s)	Connector Description	Location
AUDIO UNIT	ID1	2-WAY / D2B	INSTRUMENT PANEL CENTER
	IP65	20-WAY / BLACK	
	IP106	2-WAY / METALLIC	
	PH4	1-WAY CO-AX CONNECTOR	ROOF CENTER REAR
	PH5	1-WAY CO-AX CONNECTOR	ROOF CENTER REAR
	CD3	2-WAY / D2B	TRUNK / LH SIDE
	PH3	32-WAY / BLACK	
NAVIGATION CONTROL MODULE	PH6	2-WAY / BEIGE	
	CD5	2-WAY / D2B	TRUNK, LH REAR
	NA1	26-WAY / WHITE	
	NA2	12-WAY / BLACK	
	NA6	2-WAY / GREY	
	NA7	20-WAY / BLACK	
	RC23	20-WAY / WHITE	ROOF CENTER FRONT
ROOF CONSOLE - PRINTED CIRCUIT BOARD	RC30	4-WAY / BLACK	ROOF CENTER FRONT
	RC31	2-WAY / BLACK	
	RC33	4-WAY / BLACK	
	RC34	6-WAY / BLACK	
	SW4	6-WAY / BLACK	STEERING COLUMN
	IP70	22-WAY / BLACK	CENTER CONSOLE
	IP136	2-WAY / METALLIC	
ROOF CONSOLE - WITHOUT PRINTED CIRCUIT BOARD	IP137	2-WAY / METALLIC	
	IP138	2-WAY / METALLIC	
	IP139	2-WAY / METALLIC	
	CD4	2-WAY / D2B	TRUNK, LH REAR
	PH2	22-WAY / BLACK	
	STEERING WHEEL		
	TELEMATICS DISPLAY		
VOICE ACTIVATION MODULE			

**HARNESS IN-LINE CONNECTORS**

Connector	Connector Description / Location	Location
CA1	22-WAY / NATURAL / INSTRUMENT PANEL HARNESS TO CABIN HARNESS	LH 'A' POST / 'A' POST TRIM
CA40	16-WAY / GREY / CABIN HARNESS TO ROOF HARNESS	RH 'A' POST / WINDSHIELD PILLAR
CA230	16-WAY / BLUE / CABIN HARNESS TO INSTRUMENT PANEL HARNESS	LH LOWER 'A' POST / 'A' POST TRIM
CA406	3-WAY / GREY / NAVIGATION HARNESS TO CABIN HARNESS	BELOW LH REAR SEAT CUSHION
CA407	16-WAY / GREY / CELLULAR PHONE HARNESS TO CABIN HARNESS	BELOW LH REAR SEAT CUSHION
CA414	16-WAY / BLUE / NAVIGATION HARNESS TO CABIN HARNESS	BELOW LH REAR SEAT CUSHION
IP34	10-WAY / NATURAL / INSTRUMENT PANEL HARNESS TO STEERING WHEEL HARNESS	STEERING WHEEL CASSETTE
JB1	42-WAY / BLACK / ENGINE MANAGEMENT HARNESS TO JUNCTION BOX HARNESS	ENGINE COMPARTMENT / LH SIDE
JB129	22-WAY / GREY / JUNCTION BOX HARNESS TO INSTRUMENT PANEL HARNESS	BELOW INSTRUMENT PANEL / LH SIDE

**GROUNDS**

Ground	Harness	Location
G14	JB	ENGINE COMPARTMENT / BEHIND POWER DISTRIBUTION FUSEBOX
G39	PH	TRUNK / LH QUARTER PANEL

FOR CONTROL MODULE PIN-OUT INFORMATION, UNFOLD PAGE TO LEFT.

The following abbreviations are used to represent values for Control Module Pin-Out data

I	Input	PG	Power Ground	C	CAN Network	D	Serial and Encoded Data
O	Output	SS	Sensor / Signal Supply V	S	SCP Network	V	Voltage (DC)
B+	Battery Voltage	SG	Sensor / Signal Ground	D2	D2B Network	PWM	Pulse Width Modulated

**CAUTION:** The information on this data page is furnished to aid the user in understanding circuit operation. THIS INFORMATION SHOULD BE USED FOR REFERENCE ONLY.

**NOTE:** The values listed are approximately those that can be expected at the control module connector pins with all circuit connections made and all components connected and fitted.

Refer to the front of this book for detailed information and illustrations regarding the location and identification of harnesses, relays, fuses, grounds, control modules and control module pins.



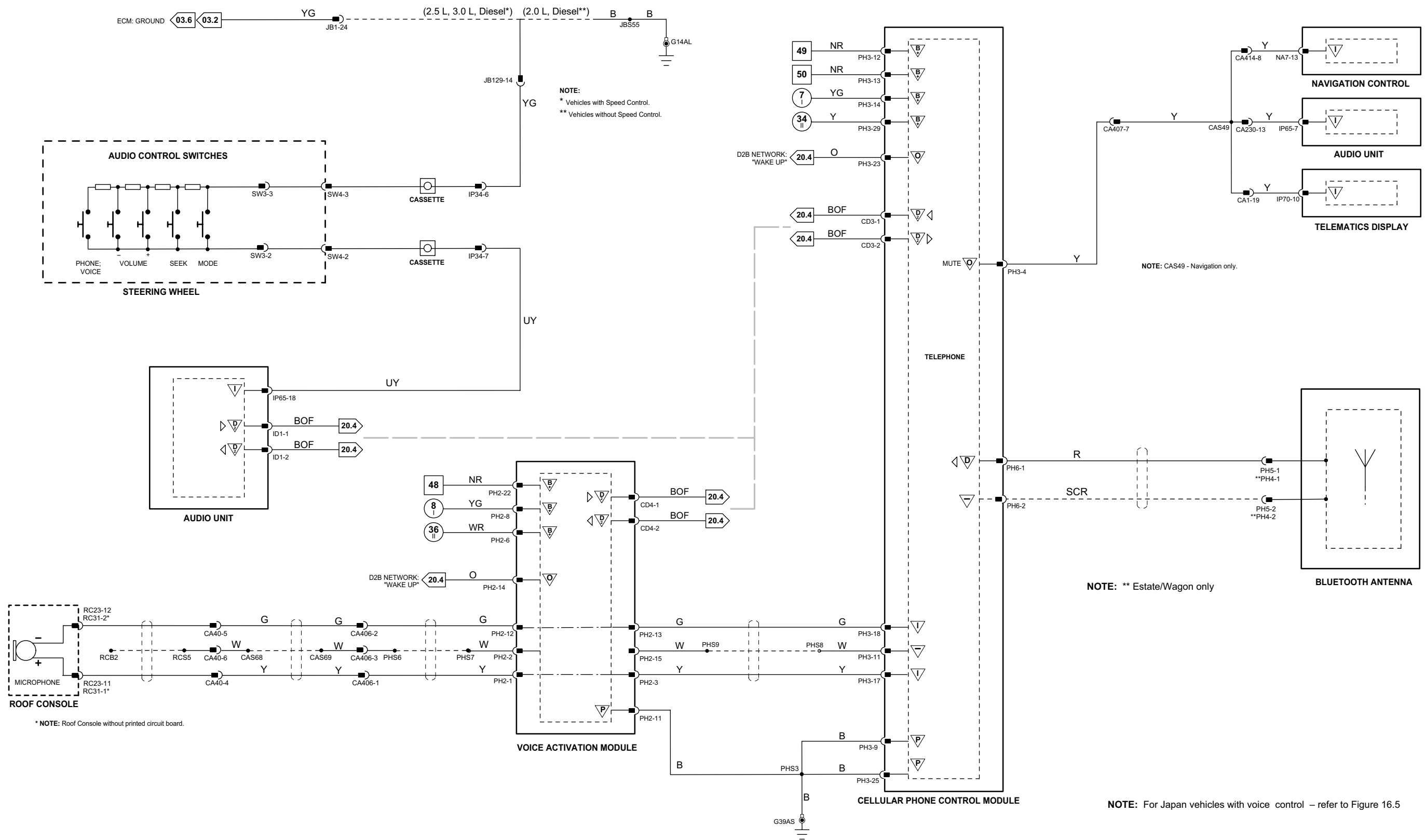

### Voice Activation Module

	Pin	Description and Characteristic
D2	CD4-1	D2B NETWORK TRANSMIT
D2	CD4-2	D2B NETWORK RECEIVE
I	PH2-01	MICROPHONE +
SG	PH2-02	MICROPHONE SHIELD
O	PH2-03	MICROPHONE +
B+	PH2-06	IGNITION SWITCHED POWER SUPPLY (II) (START / RUN STATUS)
B+	PH2-08	IGNITION SWITCHED POWER SUPPLY (I)
PG	PH2-11	POWER GROUND
I	PH2-12	MICROPHONE -
O	PH2-13	MICROPHONE -
O	PH2-14	D2B NETWORK WAKE UP
SG	PH2-15	MICROPHONE SHIELD
B+	PH2-22	BATTERY POWER SUPPLY: B+

## Fig. 16.3

### COMPONENTS

Component	Connector(s)	Connector Description	Location
AUDIO UNIT	ID1	2-WAY / D2B	INSTRUMENT PANEL CENTER
	IP65	20-WAY / BLACK	
	IP106	2-WAY / METALLIC	
ROOF CONSOLE - PRINTED CIRCUIT BOARD	RC23	20-WAY / WHITE	ROOF CENTER FRONT
ROOF CONSOLE - WITHOUT PRINTED CIRCUIT BOARD	RC30	4-WAY / BLACK	ROOF CENTER FRONT
	RC31	2-WAY / BLACK	
	RC33	4-WAY / BLACK	
	RC34	6-WAY / BLACK	
STEERING WHEEL	SW4	6-WAY / BLACK	STEERING COLUMN
VOICE ACTIVATION MODULE	CD4	2-WAY / D2B	TRUNK, LH REAR
	PH2	22-WAY / BLACK	

### HARNES IN-LINE CONNECTORS

Connector	Connector Description / Location	Location
CA40	16-WAY / GREY / CABIN HARNESS TO ROOF HARNESS	RH 'A' POST / WINDSHIELD PILLAR
CA406	3-WAY / GREY / NAVIGATION HARNESS TO CABIN HARNESS	BELOW LH REAR SEAT CUSHION
IP34	10-WAY / NATURAL / INSTRUMENT PANEL HARNESS TO STEERING WHEEL HARNESS	STEERING WHEEL CASSETTE
JB1	42-WAY / BLACK / ENGINE MANAGEMENT HARNESS TO JUNCTION BOX HARNESS	ENGINE COMPARTMENT / LH SIDE
JB129	22-WAY / GREY / JUNCTION BOX HARNESS TO INSTRUMENT PANEL HARNESS	BELOW INSTRUMENT PANEL / LH SIDE

### GROUNDS

Ground	Harness	Location
G39	PH	TRUNK / LH QUARTER PANEL

FOR CONTROL MODULE PIN-OUT INFORMATION, UNFOLD PAGE TO LEFT.

The following abbreviations are used to represent values for Control Module Pin-Out data

I	Input	PG	Power Ground	C	CAN Network	D	Serial and Encoded Data
O	Output	SS	Sensor / Signal Supply V	S	SCP Network	V	Voltage (DC)
B+	Battery Voltage	SG	Sensor / Signal Ground	D2	D2B Network	PWM	Pulse Width Modulated

CAUTION: The information on this data page is furnished to aid the user in understanding circuit operation. THIS INFORMATION SHOULD BE USED FOR REFERENCE ONLY.

NOTE: The values listed are approximately those that can be expected at the control module connector pins with all circuit connections made and all components connected and fitted.

Refer to the front of this book for detailed information and illustrations regarding the location and identification of harnesses, relays, fuses, grounds, control modules and control module pins.

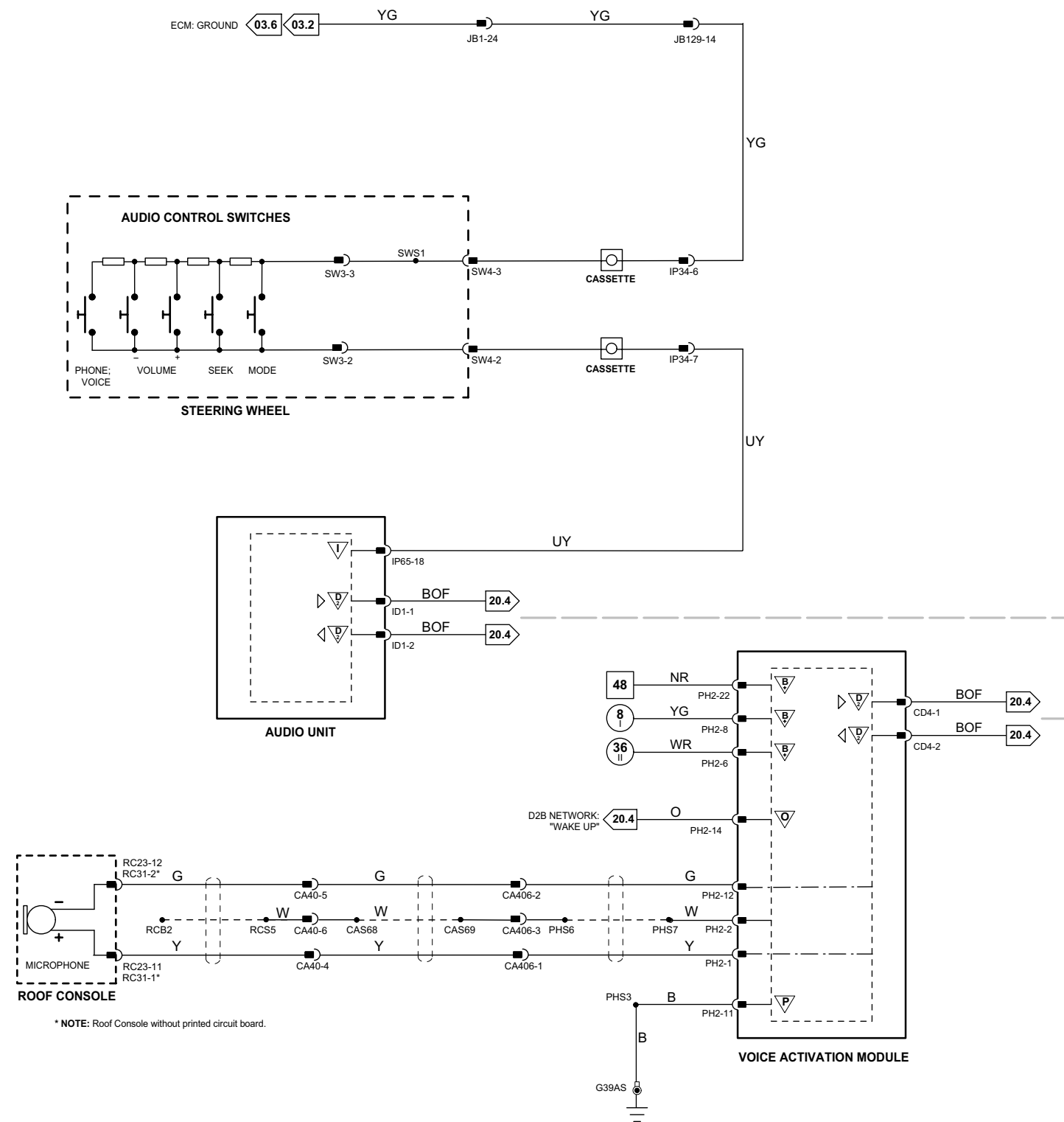

NOTE: For Japan vehicles with Voice Activation Control, refer to Figure 16.5.

**Fig. 16.4****COMPONENTS**

Component	Connector(s)	Connector Description	Location
NAVIGATION CONTROL MODULE	CD5	2-WAY / D2B	TRUNK, LH REAR
	NA1	26-WAY / WHITE	
	NA2	12-WAY / BLACK	
	NA6	2-WAY / GREY	
	NA7	20-WAY / BLACK	
	NA12	2-WAY / BLUE	
	IP70	22-WAY / BLACK	
NAVIGATION GPS ANTENNA TELEMATICS DISPLAY	IP136	2-WAY / METALLIC	BEHIND REAR CENTER ROOF HEADLINER CENTER CONSOLE
	IP137	2-WAY / METALLIC	
	IP138	2-WAY / METALLIC	
	IP139	2-WAY / METALLIC	
	TV1	2-WAY / METALLIC	
TV ANTENNA AND AMPLIFIER 1	TV1	2-WAY / METALLIC	REAR ROOF TRIM, ABOVE FIXED GLASS
TV ANTENNA AND AMPLIFIER 2	TV2	2-WAY / METALLIC	REAR ROOF TRIM, ABOVE FIXED GLASS
TV ANTENNA AND AMPLIFIER 3	TV3	2-WAY / METALLIC	REAR ROOF TRIM, ABOVE FIXED GLASS
TV ANTENNA AND AMPLIFIER 4	TV4	2-WAY / METALLIC	REAR ROOF TRIM, ABOVE FIXED GLASS

**HARNESS IN-LINE CONNECTORS**

Connector	Connector Description / Location	Location
NA24	16-WAY / GREEN / INSTRUMENT PANEL HARNESS TO NAVIGATION HARNESS	BELOW INSTRUMENT PANEL / LH SIDE
NA25	8-WAY / GREY / INSTRUMENT PANEL HARNESS TO NAVIGATION HARNESS	BELOW INSTRUMENT PANEL / LH SIDE

**GROUNDS**

Ground	Harness	Location
G37	IP	BEHIND INSTRUMENT PANEL / RH SIDE OF CROSS CAR BEAM
G40	NA	TRUNK / LH QUARTER PANEL

Refer to the front of this book for detailed information and illustrations regarding the location and identification of harnesses, relays, fuses, grounds, control modules and control module pins.

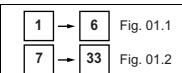
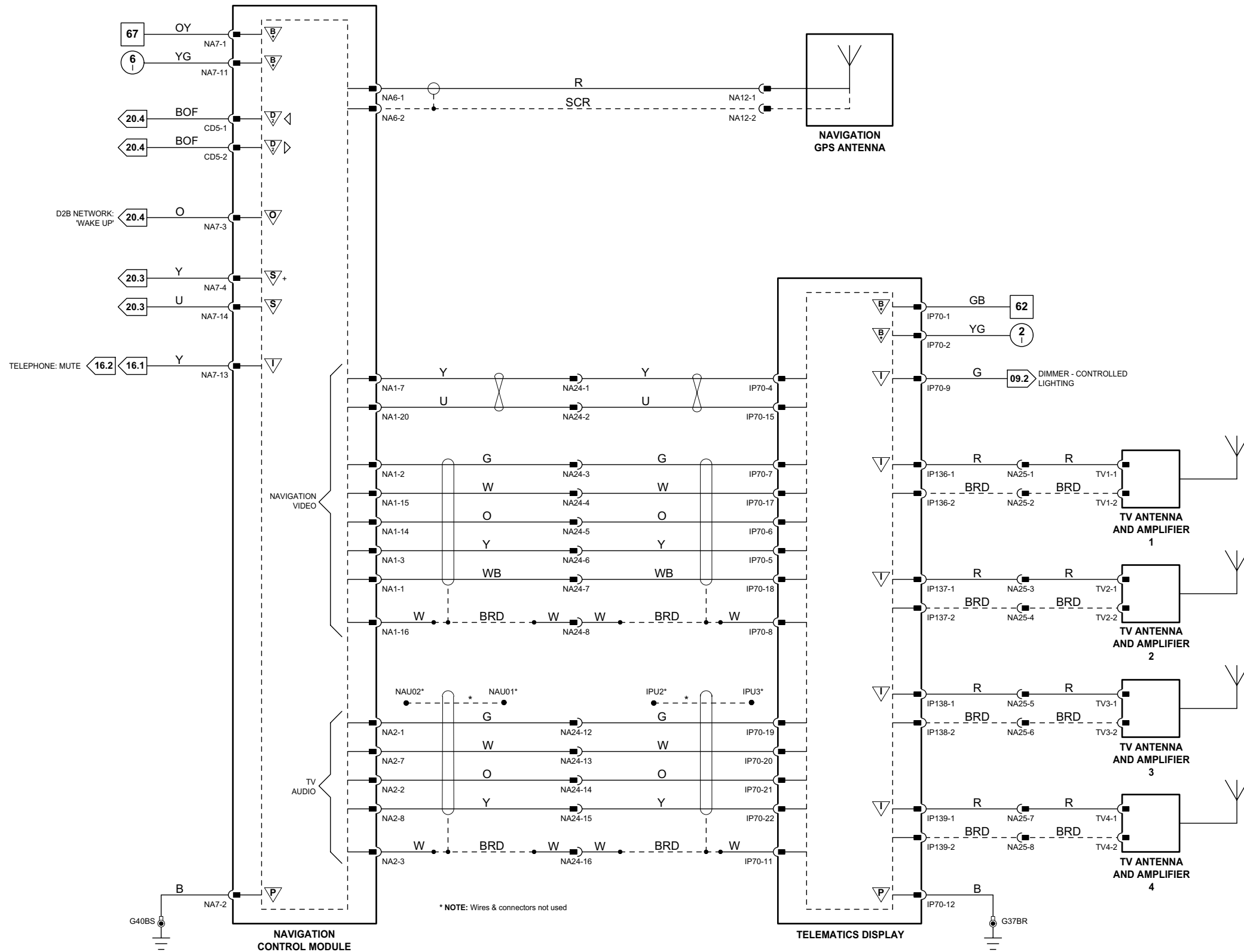

Fig. 01.1

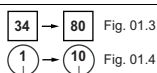

Fig. 01.3

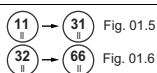

Fig. 01.5

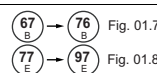

Fig. 01.7

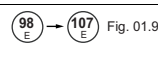
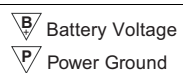

Fig. 01.9



Input  
Output



Battery Voltage  
Power Ground



Sensor/Signal Supply V  
Sensor/Signal Ground

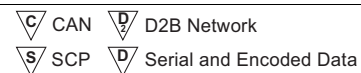

CAN  
D2B Network  
SCP  
Serial and Encoded Data

VARIANT: NAV Vehicles (except Japan)  
VIN RANGE: All  
DATE OF ISSUE: February 2008

**Fig. 16.5****COMPONENTS**

Component	Connector(s)	Connector Description	Location	
NAVIGATION CONTROL MODULE	CD5	2-WAY / D2B	TRUNK, LH REAR	
	NA1	26-WAY / WHITE		
	NA2	12-WAY / BLACK		
	NA6	2-WAY / GREY		
	NA7	20-WAY / BLACK		
	NAVIGATION GPS ANTENNA	NA12	2-WAY / BLUE	BEHIND REAR CENTER ROOF HEADLINER
	ROOF CONSOLE – PRINTED CIRCUIT BOARD	RC23	20-WAY / WHITE	ROOF CENTER FRONT
ROOF CONSOLE – WITHOUT PRINTED CIRCUIT BOARD	RC30	4-WAY / BLACK	ROOF CENTER FRONT	
	RC31	2-WAY / BLACK		
	RC33	4-WAY / BLACK		
	RC34	6-WAY / BLACK		
	TELEMATICS DISPLAY	IP70	22-WAY / BLACK	CENTER CONSOLE
	IP136	2-WAY / METALLIC		
	IP137	2-WAY / METALLIC		
	IP138	2-WAY / METALLIC		
	IP139	2-WAY / METALLIC		
TV ANTENNA AND AMPLIFIER 1	TV1	2-WAY / METALLIC	REAR ROOF TRIM, ABOVE FIXED GLASS	
TV ANTENNA AND AMPLIFIER 2	TV2	2-WAY / METALLIC	REAR ROOF TRIM, ABOVE FIXED GLASS	
TV ANTENNA AND AMPLIFIER 3	TV3	2-WAY / METALLIC	REAR ROOF TRIM, ABOVE FIXED GLASS	
TV ANTENNA AND AMPLIFIER 4	TV4	2-WAY / METALLIC	REAR ROOF TRIM, ABOVE FIXED GLASS	
VICS MODULE	NA8	2-WAY / METALLIC	TRUNK, LH REAR	
	NA9	10-WAY / NATURAL		
	NA10	2-WAY / METALLIC		
VICS ANTENNA - Sedan	NA11	2-WAY / SILVER	SEDAN: BEHIND RH 'C' POST	
VICS ANTENNA - Wagon	NA58	3-WAY / BLACK	ESTATE (WAGON): REAR ROOF TRIM ABOVE FIXED GLASS / LH SIDE	
	NA59	1-WAY / SILVER		
VICS SENSOR	CA222	2-WAY / METALLIC	TOP OF INSTRUMENT PANEL / LH SIDE	

**HARNES IN-LINE CONNECTORS**

Connector	Connector Description / Location	Location
CA40	16-WAY / GREY / CABIN HARNESS TO ROOF HARNESS	RH 'A' POST / WINDSHIELD PILLAR
CA406	3-WAY / GREY / NAVIGATION HARNESS TO CABIN HARNESS	BELOW LH REAR SEAT CUSHION
NA24	16-WAY / GREEN / INSTRUMENT PANEL HARNESS TO NAVIGATION HARNESS	BELOW INSTRUMENT PANEL / LH SIDE
NA25	8-WAY / GREY / INSTRUMENT PANEL HARNESS TO NAVIGATION HARNESS	BELOW INSTRUMENT PANEL / LH SIDE

**GROUNDS**

Ground	Harness	Location
G37	IP	BEHIND INSTRUMENT PANEL / RH SIDE OF CROSS CAR BEAM
G40	NA	TRUNK / LH QUARTER PANEL

Refer to the front of this book for detailed information and illustrations regarding the location and identification of harnesses, relays, fuses, grounds, control modules and control module pins.

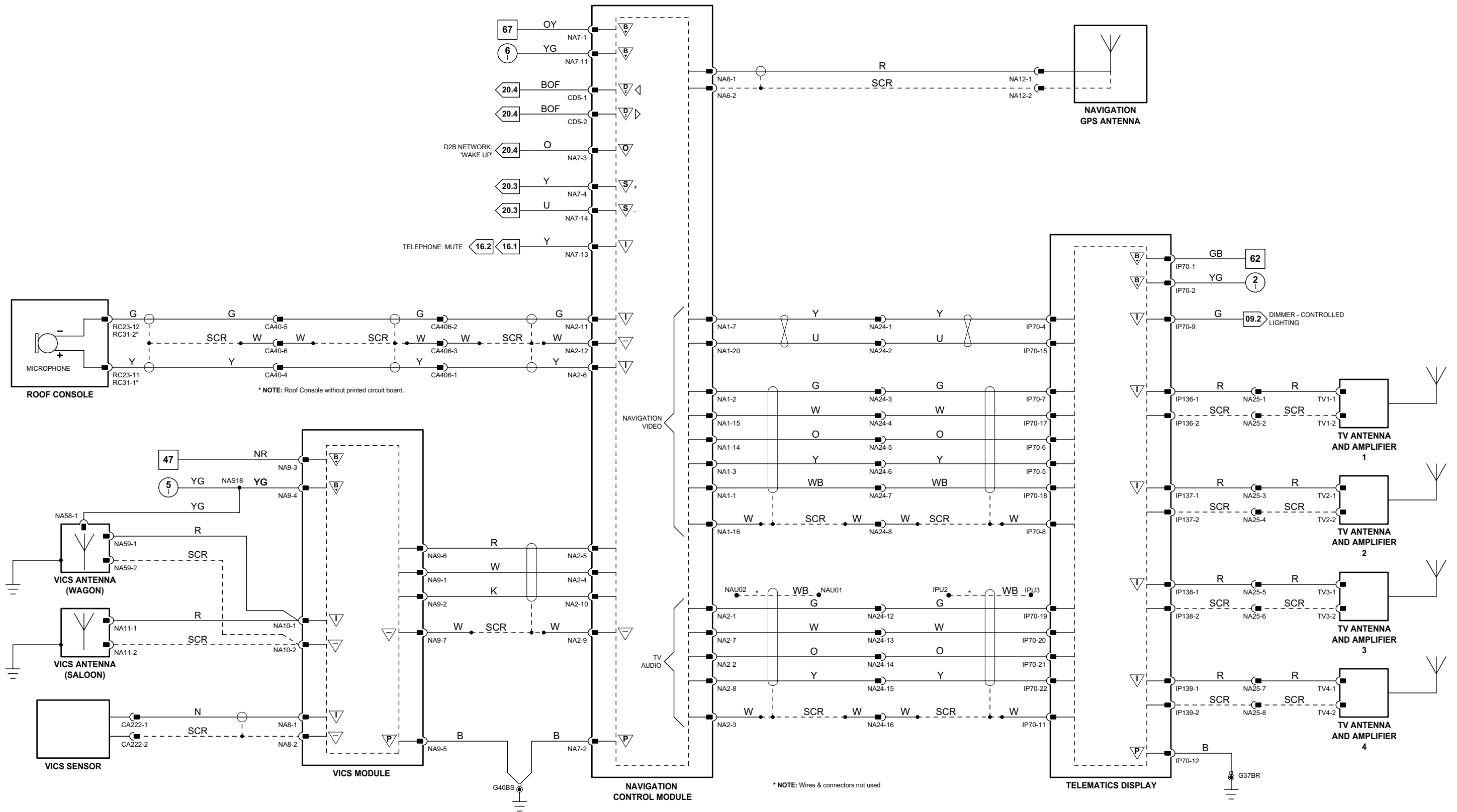

1 → 6 Fig. 01.1	34 → 80 Fig. 01.3	11 → 31 Fig. 01.5	67 → 76 Fig. 01.7	98 → 107 Fig. 01.9	Input	Battery Voltage	Sensor/Signal Supply V	CAN	D2B Network
7 → 33 Fig. 01.2	1 → 10 Fig. 01.4	32 → 66 Fig. 01.6	77 → 97 Fig. 01.8		Output	Power Ground	Sensor/Signal Ground	SCP	Serial and Encoded Data

VARIANT: Japan Vehicles  
 VIN RANGE: All  
 DATE OF ISSUE: February 2008

**Fig. 17.1****COMPONENTS**

Component	Connector(s)	Connector Description	Location
CURTAIN AIRBAG IGNITER – DRIVER	CA144	2-WAY / BLACK	DRIVER SIDE 'E' POST
CURTAIN AIRBAG IGNITER – PASSENGER	CA145	2-WAY / BLACK	PASSENGER SIDE 'E' POST
DUAL AIRBAG IGNITERS – DRIVER	SW1	2-WAY / BLACK	STEERING WHEEL
	SW2	2-WAY / BLACK	
DUAL AIRBAG IGNITERS – PASSENGER	IP36	2-WAY / BROWN	INSTRUMENT PANEL PASSENGER SIDE
	IP37	2-WAY / BROWN	
IMPACT SENSOR – FRONT	JB93	2-WAY / BLACK	ADJACENT TO HOOD CATCH
PASSENGER AIRBAG DEACTIVATED INDICATOR LAMP	IP140	4-WAY / BLACK	PASSENGER AIRBAG COVER
PASSENGER SEAT WEIGHT PRESSURE SENSOR	WS18	3-WAY / BLACK	PASSENGER SEAT CUSHION
PASSENGER SEAT WEIGHT SENSING MODULE	WS17	10-WAY / BLACK	UNDER PASSENGER SEAT
RESTRAINTS CONTROL MODULE – FRONT WHEEL DRIVE VEHICLES	CA165	40-WAY / BLACK	UNDER CENTER CONSOLE
	IP74	24-WAY / BLACK	
SEAT BELT BUCKLE PRETENSIONER IGNITER – DRIVER	CA65	18-WAY / BLACK	DRIVER SEAT BELT BUCKLE
SEAT BELT BUCKLE PRETENSIONER IGNITER – PASSENGER	CA70	18-WAY / BLACK	PASSENGER SEAT BELT BUCKLE
SEAT BELT SWITCH – DRIVER	CA65	18-WAY / BLACK	DRIVER SEAT BELT BUCKLE
SEAT BELT SWITCH – PASSENGER	CA70	18-WAY / BLACK	PASSENGER SEAT BELT BUCKLE
SEAT POSITION SWITCH – DRIVER	CA65	18-WAY / BLACK	DRIVER SEAT TRACK
SIDE AIRBAG IGNITER – DRIVER	AL1	2-WAY / BLACK	DRIVER SEAT BACK
SIDE AIRBAG IGNITER – PASSENGER	AD1	2-WAY / BLACK	PASSENGER SEAT BACK
SIDE IMPACT SENSOR – DRIVER	CA215	2-WAY / BLACK	DRIVER SIDE LOWER 'B/C' POST
SIDE IMPACT SENSOR – DRIVER REAR	CA140	2-WAY / BLACK	ADJACENT TO DRIVER SIDE REAR LOWER SAFETY BELT ANCHOR
SIDE IMPACT SENSOR – PASSENGER	CA216	2-WAY / BLACK	PASSENGER SIDE LOWER 'B/C' POST
SIDE IMPACT SENSOR – PASSENGER REAR	CA131	2-WAY / BLACK	ADJACENT TO PASSENGER SIDE REAR LOWER SAFETY BELT ANCHOR

**HARNES IN-LINE CONNECTORS**

Connector	Connector Description / Location	Location
CA10	22-WAY / SLATE / CABIN HARNESS TO JUNCTION BOX HARNESS	LH 'A' POST / 'A' POST TRIM
CA65	18-WAY / BLACK / CABIN HARNESS TO DRIVER SEAT HARNESS	UNDER DRIVER SEAT
CA70	18-WAY / BLACK / CABIN HARNESS TO DRIVER SEAT HARNESS	UNDER DRIVER SEAT
IP34	10-WAY / NATURAL / INSTRUMENT PANEL HARNESS TO STEERING WHEEL HARNESS	STEERING WHEEL CASSETTE

**GROUNDS**

Ground	Harness	Location
G4	CA	LOWER RH 'A' POST
G15	CA	LOWER LH 'A' POST
G37	IP	BEHIND INSTRUMENT PANEL / RH SIDE OF CROSS CAR BEAM

Refer to the front of this book for detailed information and illustrations regarding the location and identification of harnesses, relays, fuses, grounds, control modules and control module pins.



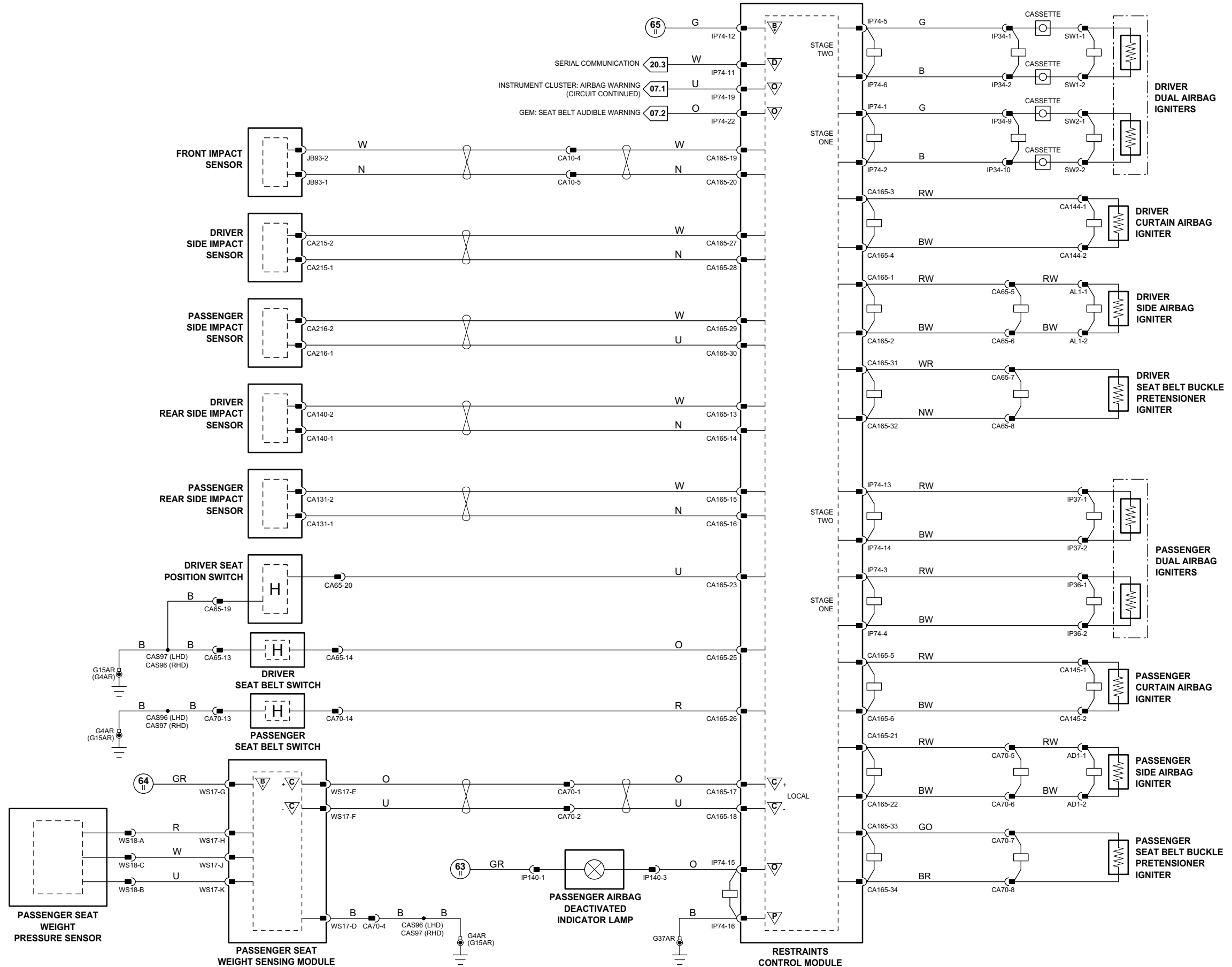

117\_1\_4000625

1 → 6 Fig. 01.1	34 → 80 Fig. 01.3	11 → 31 Fig. 01.5	67 → 76 Fig. 01.7	98 → 107 Fig. 01.9	Input	Battery Voltage	Sensor/Signal Supply V	CAN	D2B Network
7 → 33 Fig. 01.2	1 → 10 Fig. 01.4	32 → 66 Fig. 01.6	77 → 97 Fig. 01.8		Output	Power Ground	Sensor/Signal Ground	SCP	Serial and Encoded Data

VARIANT: Front Wheel Drive Vehicles  
 VIN RANGE: All  
 DATE OF ISSUE: February 2008

**Fig. 17.2****COMPONENTS**

Component	Connector(s)	Connector Description	Location
CURTAIN AIRBAG IGNITER – DRIVER	CA144	2-WAY / BLACK	DRIVER SIDE 'E' POST
CURTAIN AIRBAG IGNITER – PASSENGER	CA145	2-WAY / BLACK	PASSENGER SIDE 'E' POST
DUAL AIRBAG IGNITERS – DRIVER	SW1	2-WAY / BLACK	STEERING WHEEL
	SW2	2-WAY / BLACK	
DUAL AIRBAG IGNITERS – PASSENGER	IP36	2-WAY / BROWN	INSTRUMENT PANEL PASSENGER SIDE
	IP37	2-WAY / BROWN	
IMPACT SENSOR – FRONT	JB93	2-WAY / BLACK	ADJACENT TO HOOD CATCH
KNEE BOLSTER IGNITER – DRIVER	CA420	2-WAY / BROWN	BELOW STEERING COLUMN
PASSENGER AIRBAG DEACTIVATED INDICATOR LAMP	IP140	4-WAY / BLACK	PASSENGER AIRBAG COVER
PASSENGER SEAT BELT TENSION SENSOR	WS19	3-WAY / BLACK	PASSENGER SEAT BELT BUCKLE
PASSENGER SEAT WEIGHT PRESSURE SENSOR	WS18	3-WAY / BLACK	PASSENGER SEAT CUSHION
PASSENGER SEAT WEIGHT SENSING MODULE	WS17	10-WAY / BLACK	UNDER PASSENGER SEAT
RESTRAINTS CONTROL MODULE – ALL WHEEL DRIVE VEHICLES	CA450	40-WAY / BLACK	UNDER CENTER CONSOLE
	IP74	24-WAY / BLACK	
SEAT BELT BUCKLE PRETENSIONER IGNITER – DRIVER	CA65	18-WAY / BLACK	DRIVER SEAT BELT BUCKLE
SEAT BELT BUCKLE PRETENSIONER IGNITER – PASSENGER	CA70	18-WAY / BLACK	PASSENGER SEAT BELT BUCKLE
SEAT BELT REEL PRETENSIONER IGNITER – DRIVER	CA241	3-WAY / YELLOW	DRIVER SIDE 'B/C' POST
SEAT BELT REEL PRETENSIONER IGNITER – PASSENGER	CA422	3-WAY / YELLOW	PASSENGER SIDE 'B/C' POST
SEAT BELT SWITCH – DRIVER	CA65	18-WAY / BLACK	DRIVER SEAT BELT BUCKLE
SEAT BELT SWITCH – PASSENGER	CA70	18-WAY / BLACK	PASSENGER SEAT BELT BUCKLE
SEAT POSITION SWITCH – DRIVER	CA65	18-WAY / BLACK	DRIVER SEAT TRACK
SEAT POSITION SWITCH – PASSENGER	CA70	18-WAY / BLACK	PASSENGER SEAT TRACK
SIDE AIRBAG IGNITER – DRIVER	AL1	2-WAY / BLACK	DRIVER SEAT BACK
SIDE AIRBAG IGNITER – PASSENGER	AD1	2-WAY / BLACK	PASSENGER SEAT BACK
SIDE IMPACT SENSOR – DRIVER	CA215	2-WAY / BLACK	DRIVER SIDE LOWER 'B/C' POST
SIDE IMPACT SENSOR – DRIVER REAR	CA140	2-WAY / BLACK	ADJACENT TO DRIVER SIDE REAR LOWER SAFETY BELT ANCHOR
SIDE IMPACT SENSOR – PASSENGER	CA216	2-WAY / BLACK	PASSENGER SIDE LOWER 'B/C' POST
SIDE IMPACT SENSOR – PASSENGER REAR	CA131	2-WAY / BLACK	ADJACENT TO PASSENGER SIDE REAR LOWER SAFETY BELT ANCHOR

**HARNESS IN-LINE CONNECTORS**

Connector	Connector Description / Location	Location
CA10	22-WAY / SLATE / CABIN HARNESS TO JUNCTION BOX HARNESS	LH 'A' POST / 'A' POST TRIM
CA65	18-WAY / BLACK / CABIN HARNESS TO DRIVER SEAT HARNESS	UNDER DRIVER SEAT
CA70	18-WAY / BLACK / CABIN HARNESS TO DRIVER SEAT HARNESS	UNDER DRIVER SEAT
IP34	10-WAY / NATURAL / INSTRUMENT PANEL HARNESS TO STEERING WHEEL HARNESS	STEERING WHEEL CASSETTE

**GROUNDS**

Ground	Harness	Location
G4	CA	LOWER RH 'A' POST
G15	CA	LOWER LH 'A' POST
G37	IP	BEHIND INSTRUMENT PANEL / RH SIDE OF CROSS CAR BEAM

Refer to the front of this book for detailed information and illustrations regarding the location and identification of harnesses, relays, fuses, grounds, control modules and control module pins.

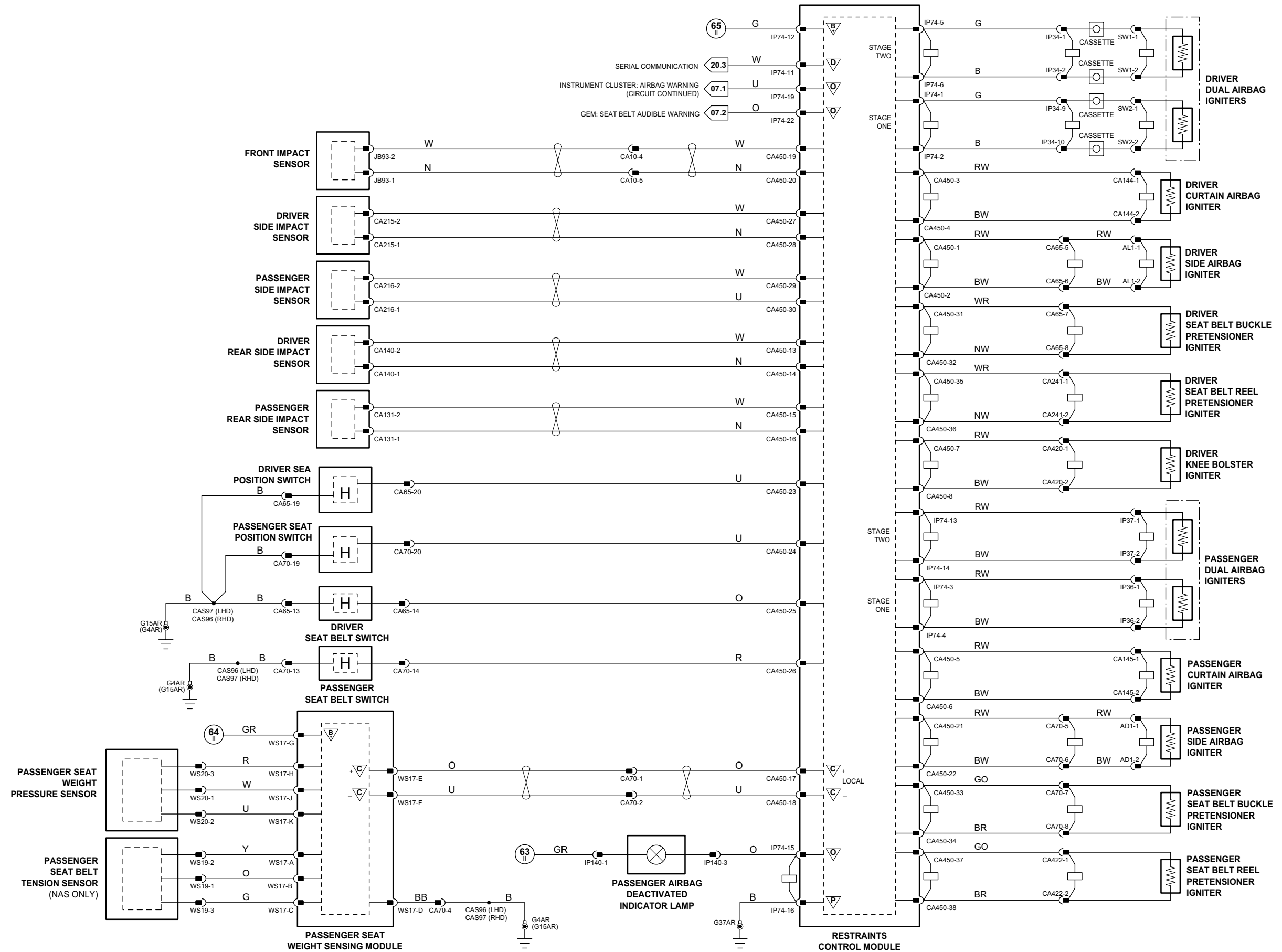

1 → 6 Fig. 01.1	34 → 80 Fig. 01.3	11 → 31 Fig. 01.5	67 → 76 Fig. 01.7	98 → 107 Fig. 01.9	Input	Battery Voltage	Sensor/Signal Supply V	CAN	D2B Network
7 → 33 Fig. 01.2	1 → 10 Fig. 01.4	32 → 66 Fig. 01.6	77 → 97 Fig. 01.8		Output	Power Ground	Sensor/Signal Ground	SCP	Serial and Encoded Data

VARIANT: All Wheel Drive Vehicles  
 VIN RANGE: All  
 DATE OF ISSUE: February 2008

**Parking Aid Module**

	Pin	Description and Characteristic
B+	CA418-01	IGNITION SWITCHED POWER SUPPLY: B+
O	CA418-02	REAR PARKING AID SOUNDER -
I	CA418-04	FRONT SENSORS SWITCH SIGNAL: GROUND WHEN ACTIVATED
I	CA418-05	TRAILER CONNECTED STATUS: GROUND = TRAILER CONNECTED
I	CA418-06	REVERSE LAMPS STATUS: B+ = REVERSE LAMPS ON
O	CA418-10	REAR PARKING AID SOUNDER +
I	CA418-11	CHIME INHIBIT SIGNAL
D	CA418-12	SERIAL DATA LINK
O	CA418-13	FRONT SENSORS STATUS LED ACTIVATE: TO ACTIVATE, PAM SWITCHES CIRCUIT TO B+
PG	CA418-16	POWER GROUND: GROUND
SG	CA419-01	FRONT SENSORS GROUND: GROUND
SS	CA419-02	FRONT SENSORS POWER SUPPLY: B+
O	CA419-03	FRONT PARKING AID SOUNDER -
O	CA419-04	FRONT PARKING AID SOUNDER +
D	CA419-05	FRONT LH SENSOR SIGNAL DATA
D	CA419-06	FRONT LH CENTER SENSOR SIGNAL DATA
D	CA419-07	FRONT RH CENTER SENSOR SIGNAL DATA
D	CA419-08	FRONT RH SENSOR SIGNAL DATA
D	RB7-02	REAR RH CENTER SENSOR SIGNAL DATA
D	RB7-03	REAR LH CENTER SENSOR SIGNAL DATA
D	RB7-04	REAR RH SENSOR SIGNAL DATA
D	RB7-05	REAR LH SENSOR SIGNAL DATA
SG	RB7-08	REAR SENSORS GROUND: GROUND
SS	RB7-11	REAR SENSORS POWER SUPPLY: B+

**Fig. 18.1**

**COMPONENTS**

Component	Connector(s)	Connector Description	Location	
GENERAL ELECTRONIC MODULE	CA86	23-WAY / GREY	BEHIND INSTRUMENT PANEL / RH SIDE	
	CA87	23-WAY / GREEN		
	IP5	23-WAY / BROWN		
	IP6	23-WAY / NATURAL		
	JB172	23-WAY / BLUE		
	PARKING AID MODULE	CA418	16-WAY / WHITE	SPARE WHEEL WELL
		CA419	12-WAY / WHITE	
		RB7	12-WAY / WHITE	
		FB7	3-WAY / BLACK	FRONT BUMPER
	PARKING AID SENSOR - LH CENTER: FRONT	RB2	3-WAY / BLACK	REAR BUMPER
PARKING AID SENSOR - LH CENTER: REAR	FB8	3-WAY / BLACK	FRONT BUMPER	
PARKING AID SENSOR - LH: FRONT	RB1	3-WAY / BLACK	REAR BUMPER	
PARKING AID SENSOR - LH: REAR	FB6	3-WAY / BLACK	FRONT BUMPER	
PARKING AID SENSOR - RH CENTER: FRONT	RB3	3-WAY / BLACK	REAR BUMPER	
PARKING AID SENSOR - RH CENTER: REAR	FB5	3-WAY / BLACK	FRONT BUMPER	
PARKING AID SENSOR - RH: FRONT	RB4	3-WAY / BLACK	REAR BUMPER	
PARKING AID SENSOR - RH: REAR	IP151	2-WAY / WHITE	INSTRUMENT PANEL CENTER	
PARKING AID SOUNDER - FRONT	CA136	2-WAY / WHITE	ESTATE (WAGON): LH REAR QUARTER PANEL INTERIOR TRIM SEDAN: PARCEL SHELF	
PARKING AID SOUNDER - REAR			ROOF CENTER FRONT	
ROOF CONSOLE - PRINTED CIRCUIT BOARD	RC23	20-WAY / WHITE		

**HARNESS IN-LINE CONNECTORS**

Connector	Connector Description / Location	Location
CA36	16-WAY / GREEN / CABIN HARNESS TO ROOF HARNESS	LH 'A' POST / WINDSHIELD PILLAR
CA170	16-WAY / GREEN / JUNCTION BOX HARNESS TO CABIN HARNESS	LH 'A' POST / 'A' POST TRIM
JB3	14-WAY / BLUE / JUNCTION BOX HARNESS TO INSTRUMENT PANEL HARNESS	BELOW INSTRUMENT PANEL / LH SIDE
JB129	22-WAY / GREY / JUNCTION BOX HARNESS TO INSTRUMENT PANEL HARNESS	BELOW INSTRUMENT PANEL / LH SIDE
JB173	10-WAY / BLACK / JUNCTION BOX HARNESS TO FRONT BUMPER HARNESS	BEHIND LH FRONT WHEEL ARCH LINER

**GROUNDS**

Ground	Harness	Location
G2	CA	TRUNK / UNDER LH TAIL LAMP UNIT
G15	CA	LOWER LH 'A' POST

FOR CONTROL MODULE PIN-OUT INFORMATION, UNFOLD PAGE TO LEFT.

The following abbreviations are used to represent values for Control Module Pin-Out data

I	Input	PG	Power Ground	C	CAN Network	D	Serial and Encoded Data
O	Output	SS	Sensor / Signal Supply V	S	SCP Network	V	Voltage (DC)
B+	Battery Voltage	SG	Sensor / Signal Ground	D2	D2B Network	PWM	Pulse Width Modulated

**CAUTION:** The information on this data page is furnished to aid the user in understanding circuit operation. THIS INFORMATION SHOULD BE USED FOR REFERENCE ONLY.

**NOTE:** The values listed are approximately those that can be expected at the control module connector pins with all circuit connections made and all components connected and fitted.

Refer to the front of this book for detailed information and illustrations regarding the location and identification of harnesses, relays, fuses, grounds, control modules and control module pins.

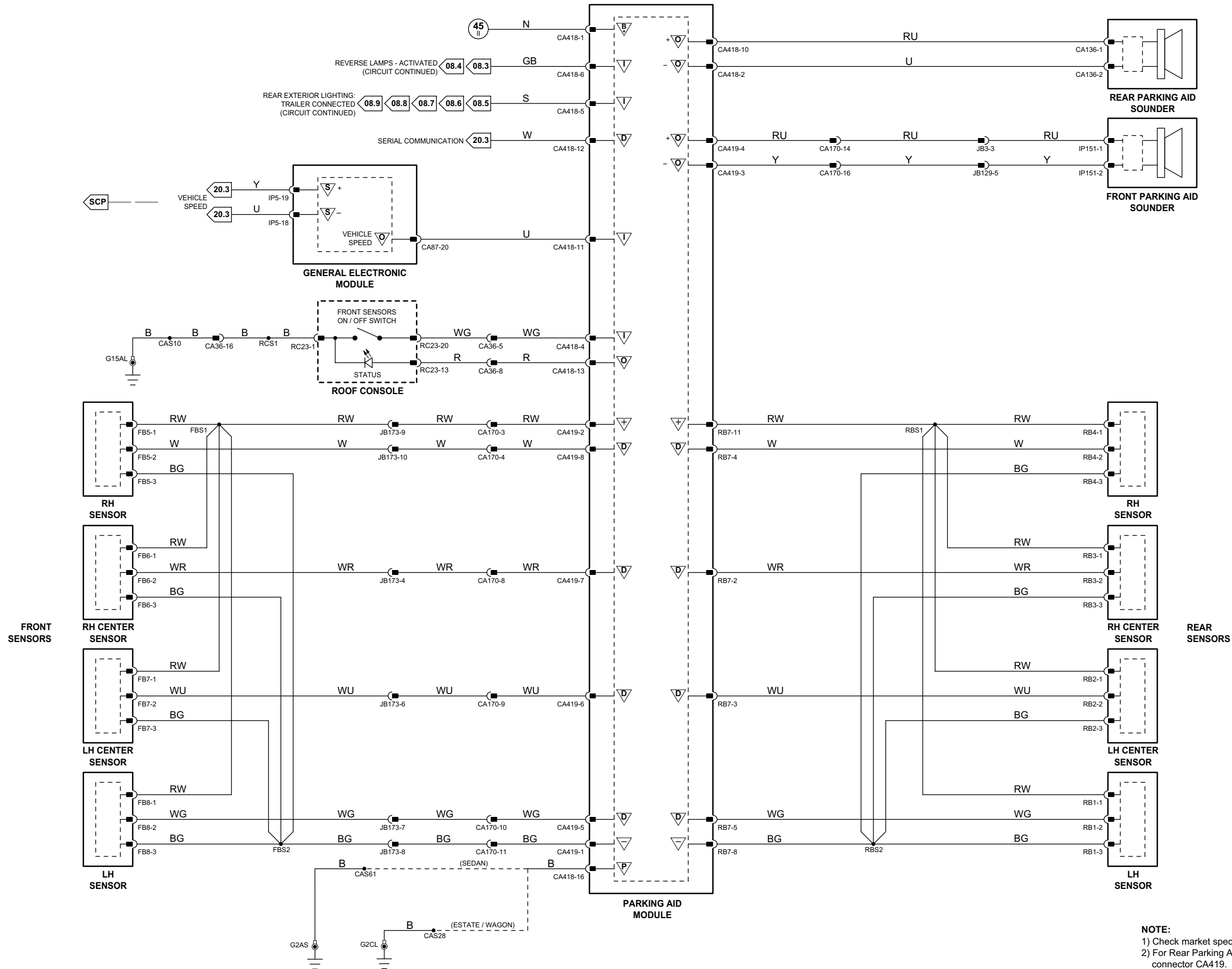

**NOTE:**  
 1) Check market specification for fitment of Front Parking Aid.  
 2) For Rear Parking Aid Only vehicles, disregard all connections to connector CA419.

**General Electronic Module**

	Pin	Description and Characteristic
PG	CA86-05	POWER GROUND
O	IP5-14	HORNS RELAY DRIVE : TO ACTIVATE, GEM SWITCHES CIRCUIT TO GROUND
I	IP6-20	STEERING WHEEL HORNS SWITCH: GROUND WHEN SELECTED
B+	JB172-01	BATTERY POWER SUPPLY (LOCKING): B+

**Fig. 19.1**

**COMPONENTS**

Component	Connector(s)	Connector Description	Location
ACCESSORY CONNECTOR – CABIN	IP24	3-WAY / BLACK	BEHIND GLOVE BOX
ACCESSORY CONNECTOR – REAR	CA146	3-WAY / BLACK	TRUNK, LH REAR
CIGAR LIGHTER	IP42	2-WAY / ORANGE	ASH TRAY
CUSTOMER POWER CONNECTOR	CA435	2-WAY / NATURAL	RH REAR INTERIOR TRIM
ELECTROCHROMIC REAR VIEW MIRROR	RC36	8-WAY / GREY	REAR VIEW MIRROR
GENERAL ELECTRONIC MODULE	CA86	23-WAY / GREY	BEHIND INSTRUMENT PANEL / RH SIDE
	CA87	23-WAY / GREEN	
	IP5	23-WAY / BROWN	
	IP6	23-WAY / NATURAL	
	JB172	23-WAY / BLUE	
HORN RELAY – DIESEL	–	–	POWER DISTRIBUTION FUSEBOX – R2
HORN RELAY – 2.0 L, 2.5 L, 3.0 L	–	–	POWER DISTRIBUTION FUSEBOX – R15
HORN SWITCH	SW6	2-WAY / BLACK	STEERING WHEEL
HORN - LH	JB302	2-WAY / BLACK	ADJACENT TO BATTERY
HORN - RH	JB301	2-WAY / BLACK	BEHIND FRONT BUMPER
POWER DISTRIBUTION FUSEBOX	–	–	ENGINE COMPARTMENT
ROOF CONSOLE – PRINTED CIRCUIT BOARD	RC23	20-WAY / WHITE	ROOF CENTER FRONT
STEERING WHEEL	SW4	6-WAY / BLACK	STEERING COLUMN

**HARNESS IN-LINE CONNECTORS**

Connector	Connector Description / Location	Location
CA36	16-WAY / GREEN / CABIN HARNESS TO ROOF HARNESS	LH 'A' POST / WINDSHIELD PILLAR
IP34	10-WAY / NATURAL / INSTRUMENT PANEL HARNESS TO STEERING WHEEL HARNESS	STEERING WHEEL CASSETTE
JB129	22-WAY / GREY / JUNCTION BOX HARNESS TO INSTRUMENT PANEL HARNESS	BELOW INSTRUMENT PANEL / LH SIDE

**GROUNDS**

Ground	Harness	Location
G1	CA	TRUNK / UNDER LH TAIL LAMP UNIT
G2	CA	TRUNK / UNDER LH TAIL LAMP UNIT
G4	CA	LOWER RH 'A' POST
G5	IP	UPPER RH 'A' POST
G11	JB	ENGINE COMPARTMENT / BEHIND LH HEADLAMP
G15	CA	LOWER LH 'A' POST
G36	IP	BEHIND INSTRUMENT PANEL / LH SIDE OF CROSS CAR BEAM
G37	IP	BEHIND INSTRUMENT PANEL / RH SIDE OF CROSS CAR BEAM

**FOR CONTROL MODULE PIN-OUT INFORMATION, UNFOLD PAGE TO LEFT.**

The following abbreviations are used to represent values for Control Module Pin-Out data

I	Input	PG	Power Ground	C	CAN Network	D	Serial and Encoded Data
O	Output	SS	Sensor / Signal Supply V	S	SCP Network	V	Voltage (DC)
B+	Battery Voltage	SG	Sensor / Signal Ground	D2	D2B Network	PWM	Pulse Width Modulated

**CAUTION:** The information on this data page is furnished to aid the user in understanding circuit operation. THIS INFORMATION SHOULD BE USED FOR REFERENCE ONLY.

**NOTE:** The values listed are approximately those that can be expected at the control module connector pins with all circuit connections made and all components connected and fitted.

Refer to the front of this book for detailed information and illustrations regarding the location and identification of harnesses, relays, fuses, grounds, control modules and control module pins.

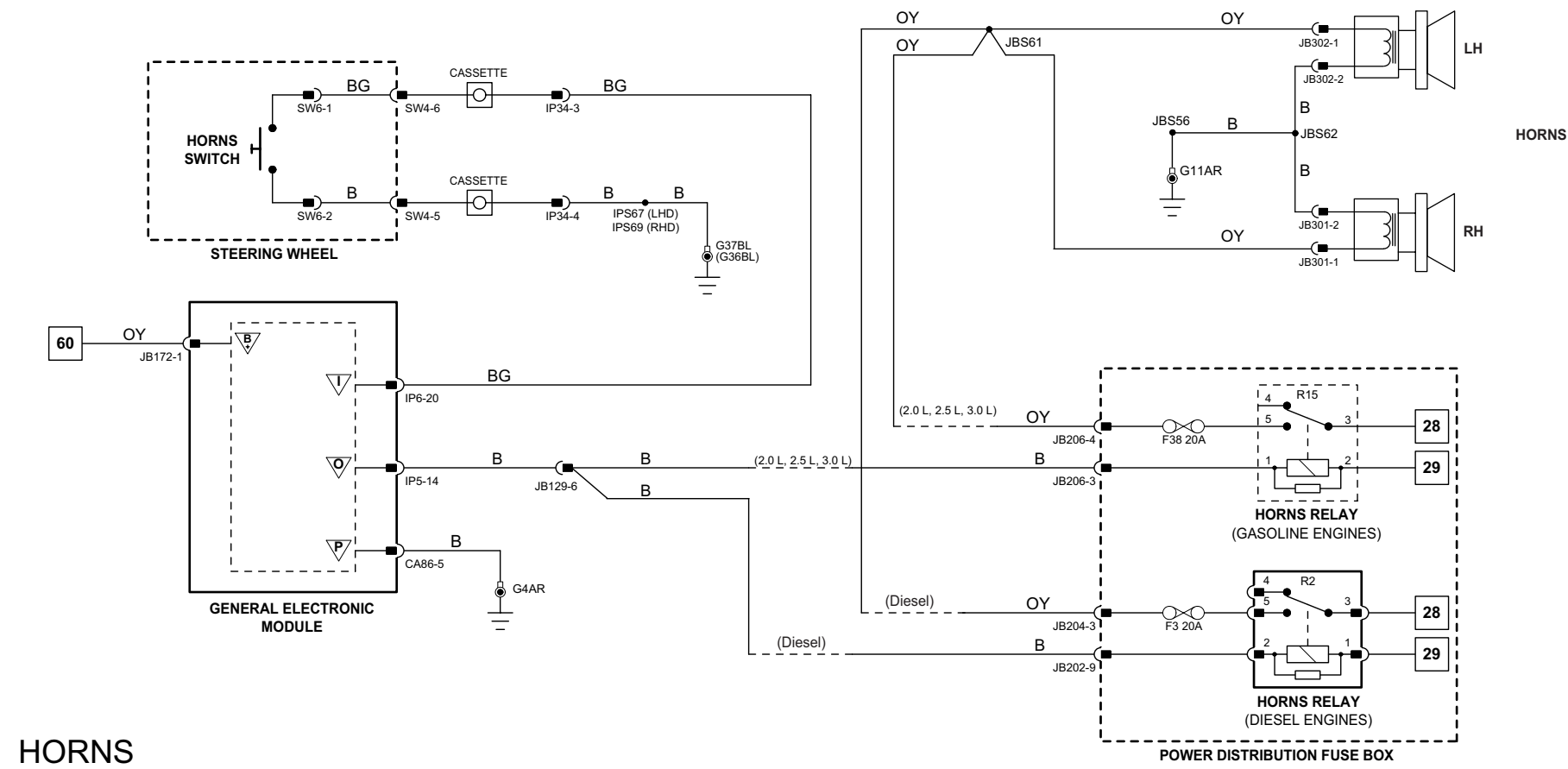

CIGAR LIGHTER

GARAGE DOOR OPENER

HORNS

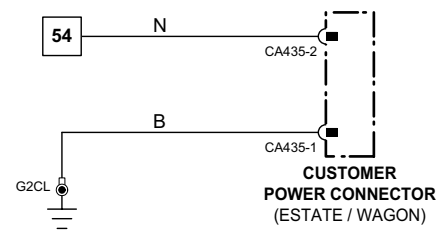
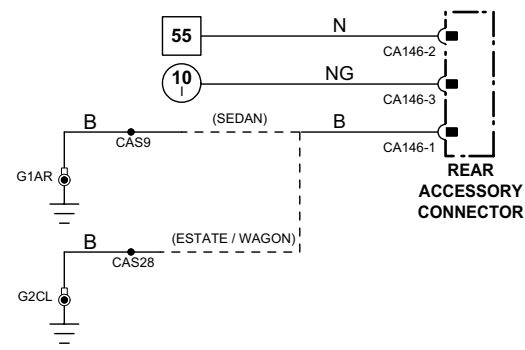
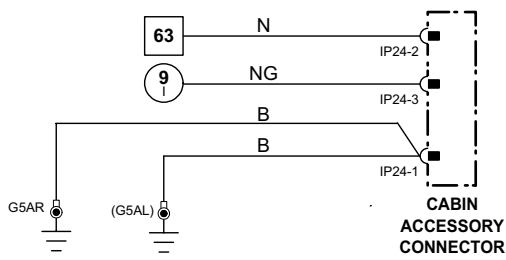

ACCESSORY CONNECTORS

ELECTROCHROMIC REAR VIEW MIRROR

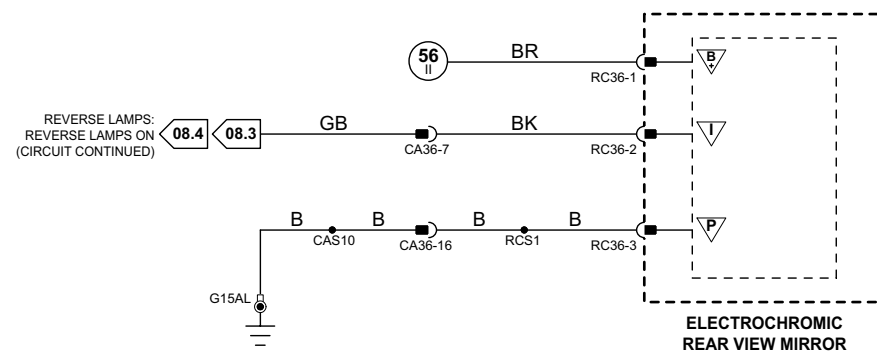

1 → 6 Fig. 01.1	34 → 80 Fig. 01.3	11 → 31 Fig. 01.5	67 → 76 Fig. 01.7	98 → 107 Fig. 01.9
7 → 33 Fig. 01.2	1 → 10 Fig. 01.4	32 → 66 Fig. 01.6	77 → 97 Fig. 01.8	

Input	Battery Voltage	Sensor/Signal Supply V	CAN	D2B Network
Output	Power Ground	Sensor/Signal Ground	SCP	Serial and Encoded Data

VARIANT: All Vehicles  
 VIN RANGE: All  
 DATE OF ISSUE: February 2008

**Fig. 20.1****COMPONENTS**

Component	Connector(s)	Connector Description	Location
CLIMATE CONTROL MODULE – PANEL	AC1	26-WAY / YELLOW	BEHIND CLIMATE CONTROL PANEL
	IP39	6-WAY / GREY	
	IP101	26-WAY / WHITE	
	IP135	2-WAY / GREY	
CLIMATE CONTROL MODULE – REMOTE	AC1	26-WAY / YELLOW	RH SIDE OF AIR DISTRIBUTION UNIT
	IP101	26-WAY / WHITE	
DATA LINK CONNECTOR	IP22	16-WAY / BLACK	BELOW STEERING COLUMN
DYNAMIC STABILITY CONTROL MODULE	JB185	42-WAY / BLUE	ENGINE COMPARTMENT / RH SIDE
ENGINE CONTROL MODULE – 2.0 L	EN65	104-WAY / BLACK	ENGINE COMPARTMENT, FRONT BULKHEAD / RH SIDE
ENGINE CONTROL MODULE – 2.5 L, 3.0 L	EN16	134-WAY / BLACK	ENGINE COMPARTMENT, FRONT BULKHEAD / RH SIDE
ENGINE CONTROL MODULE – DIESEL	DL1	121-WAY / BLACK	ENGINE COMPARTMENT, FRONT BULKHEAD / RH SIDE
HEADLAMP LEVELING MODULE	IP130	26-WAY / WHITE	BEHIND INSTRUMENT PANEL / LH SIDE
INSTRUMENT CLUSTER	IP10	26-WAY / WHITE	INSTRUMENT PANEL
	IP11	26-WAY / WHITE	
J-GATE MODULE - PETROL	IP14	16-WAY / GREY	CENTER CONSOLE
SEAT MODULE – DRIVER	DM2	10-WAY / GREY	DRIVER SEAT SWITCH PACK
	DM3	16-WAY / BLACK	
	DM4	8-WAY / BLUE	
	DM5	8-WAY / GREEN	
	IP19	4-WAY / BLACK	
STEERING ANGLE SENSOR	IP19	4-WAY / BLACK	STEERING COLUMN
TPMS MODULE	CA453	16-WAY / GREEN	REAR SEAT, RH SIDE
	CA454	16-WAY /BLUE	
	CA455	1-WAY /SCREENED	
TRANSMISSION CONTROL MODULE – DIESEL	DL24	37-WAY / BLUE	LOWER LH 'A' POST
TRANSMISSION CONTROL MODULE – PETROL	JB230	24-WAY / WHITE	LOWER LH 'A' POST
TRACTION CONTROL MODULE	JB197	42-WAY / BLUE	ENGINE COMPARTMENT / RH SIDE
TURBOCHARGER ROTARY ELECTRONIC ACTUATOR	DE15	5-WAY / BLACK	ENGINE COMPARTMENT / RH SIDE
YAW RATE SENSOR	IP20	4-WAY / BLACK	BEHIND CENTER CONSOLE

**HARNESS IN-LINE CONNECTORS**

Connector	Connector Description / Location	Location
CA10	22-WAY / SLATE / CABIN HARNESS TO JUNCTION BOX HARNESS	LH 'A' POST / 'A' POST TRIM
CA230	16-WAY / BLUE / CABIN HARNESS TO INSTRUMENT PANEL HARNESS	LH LOWER 'A' POST / 'A' POST TRIM
CA431	16-WAY / GREY / CABIN HARNESS TO DRIVER SEAT HARNESS	UNDER DRIVER SEAT
DL2	42-WAY / BLACK / ENGINE HARNESS TO ENGINE MANAGEMENT HARNESS	ENGINE COMPARTMENT / RH SIDE
JB1	42-WAY / BLACK / ENGINE MANAGEMENT HARNESS TO JUNCTION BOX HARNESS	ENGINE COMPARTMENT / LH SIDE

**GROUNDS**

Ground	Harness	Location
G37	IP	BEHIND INSTRUMENT PANEL / RH SIDE OF CROSS CAR BEAM

Refer to the front of this book for detailed information and illustrations regarding the location and identification of harnesses, relays, fuses, grounds, control modules and control module pins.



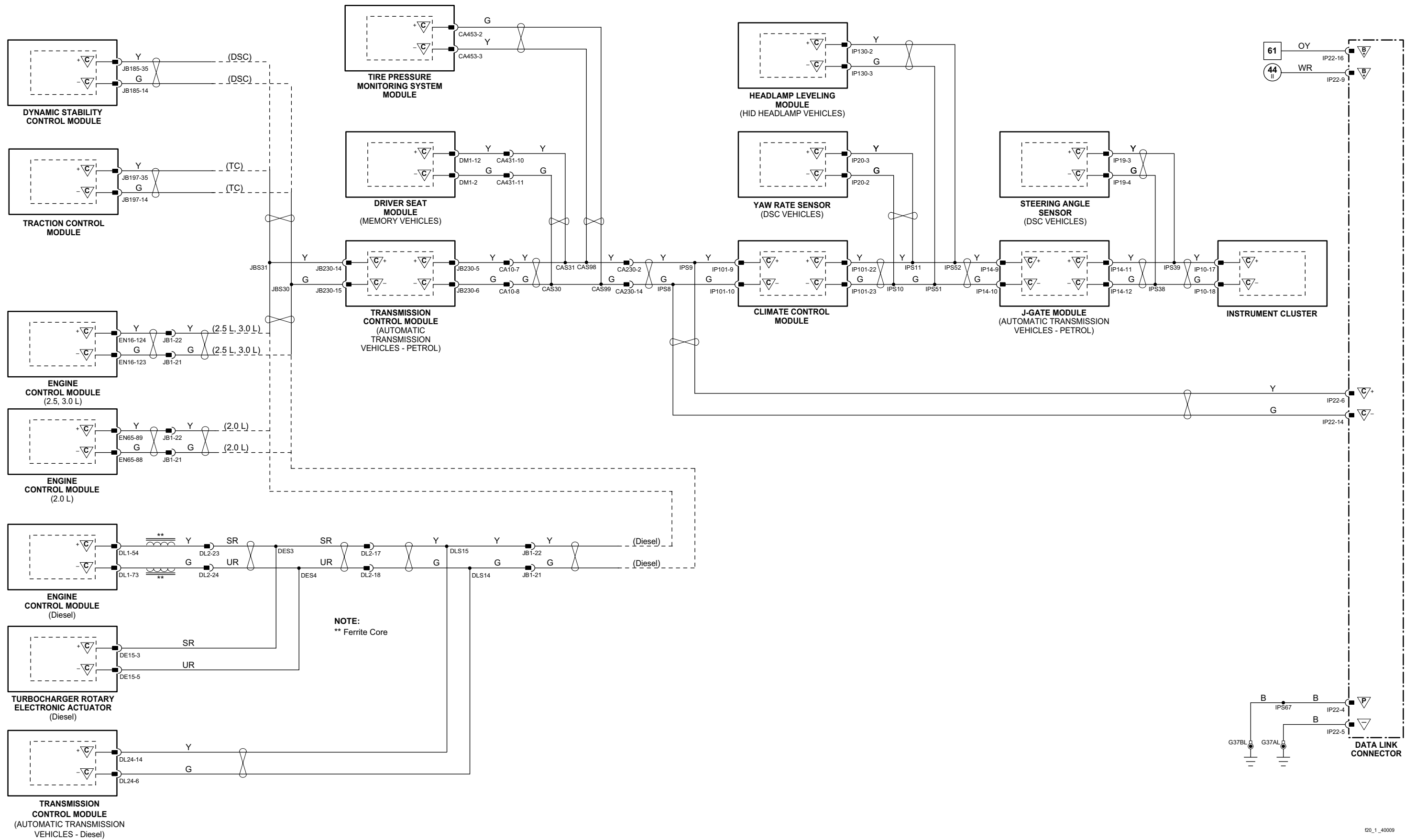

1 → 6 Fig. 01.1	34 → 80 Fig. 01.3	11 → 31 Fig. 01.5	67 → 76 Fig. 01.7	98 → 107 Fig. 01.9	Input	Battery Voltage	Sensor/Signal Supply V	CAN	D2B Network
7 → 33 Fig. 01.2	1 → 10 Fig. 01.4	32 → 66 Fig. 01.6	77 → 97 Fig. 01.8		Output	Power Ground	Sensor/Signal Ground	SCP	Serial and Encoded Data

VARIANT: LHD Vehicles  
VIN RANGE: All  
DATE OF ISSUE: February 2008

**Fig. 20.2****COMPONENTS**

Component	Connector(s)	Connector Description	Location
CLIMATE CONTROL MODULE – PANEL	AC1	26-WAY / YELLOW	BEHIND CLIMATE CONTROL PANEL
	IP39	6-WAY / GREY	
	IP101	26-WAY / WHITE	
	IP135	2-WAY / GREY	
CLIMATE CONTROL MODULE – REMOTE	AC1	26-WAY / YELLOW	RH SIDE OF AIR DISTRIBUTION UNIT
	IP101	26-WAY / WHITE	
DATA LINK CONNECTOR	IP22	16-WAY / BLACK	BELOW STEERING COLUMN
DYNAMIC STABILITY CONTROL MODULE	JB185	42-WAY / BLUE	ENGINE COMPARTMENT / RH SIDE
ENGINE CONTROL MODULE – 2.0 L	EN65	104-WAY / BLACK	ENGINE COMPARTMENT, FRONT BULKHEAD / RH SIDE
ENGINE CONTROL MODULE – 2.5 L, 3.0 L	EN16	134-WAY / BLACK	ENGINE COMPARTMENT, FRONT BULKHEAD / RH SIDE
ENGINE CONTROL MODULE – DIESEL	DL1	121-WAY / BLACK	ENGINE COMPARTMENT, FRONT BULKHEAD / RH SIDE
HEADLAMP LEVELING MODULE	IP130	26-WAY / WHITE	BEHIND INSTRUMENT PANEL / LH SIDE
INSTRUMENT CLUSTER	IP10	26-WAY / WHITE	INSTRUMENT PANEL
	IP11	26-WAY / WHITE	
J-GATE MODULE	IP14	16-WAY / GREY	CENTER CONSOLE
SEAT MODULE – DRIVER	DM2	10-WAY / GREY	DRIVER SEAT SWITCH PACK
	DM3	16-WAY / BLACK	
	DM4	8-WAY / BLUE	
	DM5	8-WAY / GREEN	
	IP19	4-WAY / BLACK	
STEERING ANGLE SENSOR	IP19	4-WAY / BLACK	STEERING COLUMN
TPMS MODULE	CA453	16-WAY / GREEN	REAR SEAT, RH SIDE
	CA454	16-WAY / BLUE	
	CA455	1-WAY / SCREENED	
	JB197	42-WAY / BLUE	
TRACTION CONTROL MODULE	JB197	42-WAY / BLUE	ENGINE COMPARTMENT / RH SIDE
TRANSMISSION CONTROL MODULE – DIESEL	DL24	16-WAY	LOWER LH 'A' POST
TRANSMISSION CONTROL MODULE – PETROL	JB230	24-WAY / WHITE	LOWER LH 'A' POST
	JB231	24-WAY / GREY	
	DE15	5-WAY / BLACK	
TURBOCHARGER ROTARY ELECTRONIC ACTUATOR	DE15	5-WAY / BLACK	ENGINE COMPARTMENT / RH SIDE
YAW RATE SENSOR	IP20	4-WAY / BLACK	BEHIND CENTER CONSOLE

**HARNES IN-LINE CONNECTORS**

Connector	Connector Description / Location	Location
CA10	22-WAY / SLATE / CABIN HARNESS TO JUNCTION BOX HARNESS	LH 'A' POST / 'A' POST TRIM
CA230	16-WAY / BLUE / CABIN HARNESS TO INSTRUMENT PANEL HARNESS	LH LOWER 'A' POST / 'A' POST TRIM
CA431	16-WAY / GREY / CABIN HARNESS TO DRIVER SEAT HARNESS	UNDER DRIVER SEAT
DL2	42-WAY / BLACK / ENGINE HARNESS TO ENGINE MANAGEMENT HARNESS	ENGINE COMPARTMENT / RH SIDE
JB1	42-WAY / BLACK / ENGINE MANAGEMENT HARNESS TO JUNCTION BOX HARNESS	ENGINE COMPARTMENT / LH SIDE

**GROUNDS**

Ground	Harness	Location
G37	IP	BEHIND INSTRUMENT PANEL / RH SIDE OF CROSS CAR BEAM

Refer to the front of this book for detailed information and illustrations regarding the location and identification of harnesses, relays, fuses, grounds, control modules and control module pins.

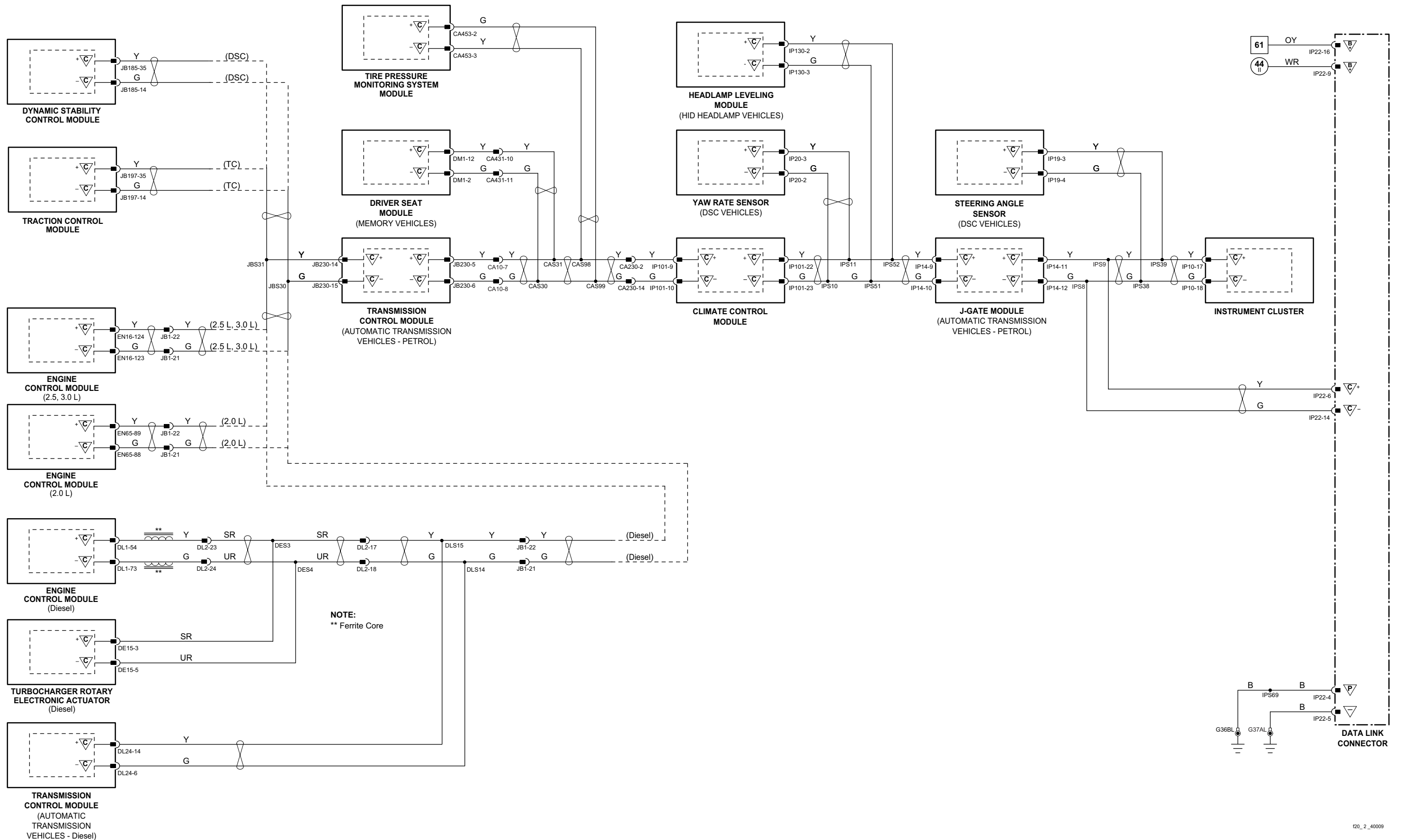

1 → 6 Fig. 01.1	34 → 80 Fig. 01.3	11 → 31 Fig. 01.5	67 → 76 Fig. 01.7	98 → 107 Fig. 01.9	Input	Battery Voltage	Sensor/Signal Supply V	CAN	D2B Network
7 → 33 Fig. 01.2	1 → 10 Fig. 01.4	32 → 66 Fig. 01.6	77 → 97 Fig. 01.8		Output	Power Ground	Sensor/Signal Ground	SCP	Serial and Encoded Data

VARIANT: RHD Vehicles  
 VIN RANGE: All  
 DATE OF ISSUE: February 2008

**Fig. 20.3****COMPONENTS**

Component	Connector(s)	Connector Description	Location
AUDIO UNIT	ID1	2-WAY / D2B	INSTRUMENT PANEL CENTER
	IP65	20-WAY / BLACK	
	IP106	2-WAY / METALLIC	
DATA LINK CONNECTOR	IP22	16-WAY / BLACK	BELOW STEERING COLUMN
ENGINE CONTROL MODULE – 2.0 L	EN65	104-WAY / BLACK	ENGINE COMPARTMENT, FRONT BULKHEAD / RH SIDE
ENGINE CONTROL MODULE – 2.5 L, 3.0 L	EN16	134-WAY / BLACK	ENGINE COMPARTMENT, FRONT BULKHEAD / RH SIDE
ENGINE CONTROL MODULE – DIESEL	DL1	121-WAY / BLACK	ENGINE COMPARTMENT, FRONT BULKHEAD / RH SIDE
FUEL-FIRED AUXILIARY HEATER MODULE	JB232	6-WAY / BLACK	VEHICLE UNDER-FLOOR REARWARD OF ENGINE
GENERAL ELECTRONIC MODULE	CA86	23-WAY / GREY	BEHIND INSTRUMENT PANEL / RH SIDE
	CA87	23-WAY / GREEN	
	IP5	23-WAY / BROWN	
	IP6	23-WAY / NATURAL	
	JB172	23-WAY / BLUE	
	IP130	26-WAY / WHITE	
	IP10	26-WAY / WHITE	
HEADLAMP LEVELING MODULE	IP11	26-WAY / WHITE	BEHIND INSTRUMENT PANEL / LH SIDE
INSTRUMENT CLUSTER	IP10	26-WAY / WHITE	INSTRUMENT PANEL
	IP11	26-WAY / WHITE	
NAVIGATION CONTROL MODULE	CD5	2-WAY / D2B	TRUNK, LH REAR
	NA1	26-WAY / WHITE	
	NA2	12-WAY / BLACK	
	NA6	2-WAY / GREY	
	NA7	20-WAY / BLACK	
	CA418	16-WAY / WHITE	
	CA419	12-WAY / WHITE	
RESTRAINTS CONTROL MODULE – ALL WHEEL DRIVE VEHICLES	RB7	12-WAY / WHITE	UNDER CENTER CONSOLE
	CA450	40-WAY / BLACK	
	IP74	24-WAY / BLACK	
RESTRAINTS CONTROL MODULE – FRONT WHEEL DRIVE VEHICLES	CA165	40-WAY / BLACK	UNDER CENTER CONSOLE
	IP74	24-WAY / BLACK	
	IP74	24-WAY / BLACK	
ROOF CONSOLE – PRINTED CIRCUIT BOARD	RC23	20-WAY / WHITE	ROOF CENTER FRONT
ROOF CONSOLE – WITHOUT PRINTED CIRCUIT BOARD	RC30	4-WAY / BLACK	ROOF CENTER FRONT
	RC31	2-WAY / BLACK	
	RC33	4-WAY / BLACK	
	RC34	6-WAY / BLACK	

**HARNESS IN-LINE CONNECTORS**

Connector	Connector Description / Location	Location
CA36	16-WAY / GREEN / CABIN HARNESS TO ROOF HARNESS	LH 'A' POST / WINDSHIELD PILLAR
CA230	16-WAY / BLUE / CABIN HARNESS TO INSTRUMENT PANEL HARNESS	LH LOWER 'A' POST / 'A' POST TRIM
CA240	12-WAY / GREY / CABIN HARNESS TO INSTRUMENT PANEL HARNESS	LH LOWER 'A' POST / 'A' POST TRIM
CA414	16-WAY / BLUE / NAVIGATION HARNESS TO CABIN HARNESS	BELOW LH REAR SEAT CUSHION
JB1	42-WAY / BLACK / ENGINE MANAGEMENT HARNESS TO JUNCTION BOX HARNESS	ENGINE COMPARTMENT / LH SIDE
JB3	14-WAY / BLUE / JUNCTION BOX HARNESS TO INSTRUMENT PANEL HARNESS	BELOW INSTRUMENT PANEL / LH SIDE

**GROUNDS**

Ground	Harness	Location
G36	IP	BEHIND INSTRUMENT PANEL / LH SIDE OF CROSS CAR BEAM
G37	IP	BEHIND INSTRUMENT PANEL / RH SIDE OF CROSS CAR BEAM

Refer to the front of this book for detailed information and illustrations regarding the location and identification of harnesses, relays, fuses, grounds, control modules and control module pins.

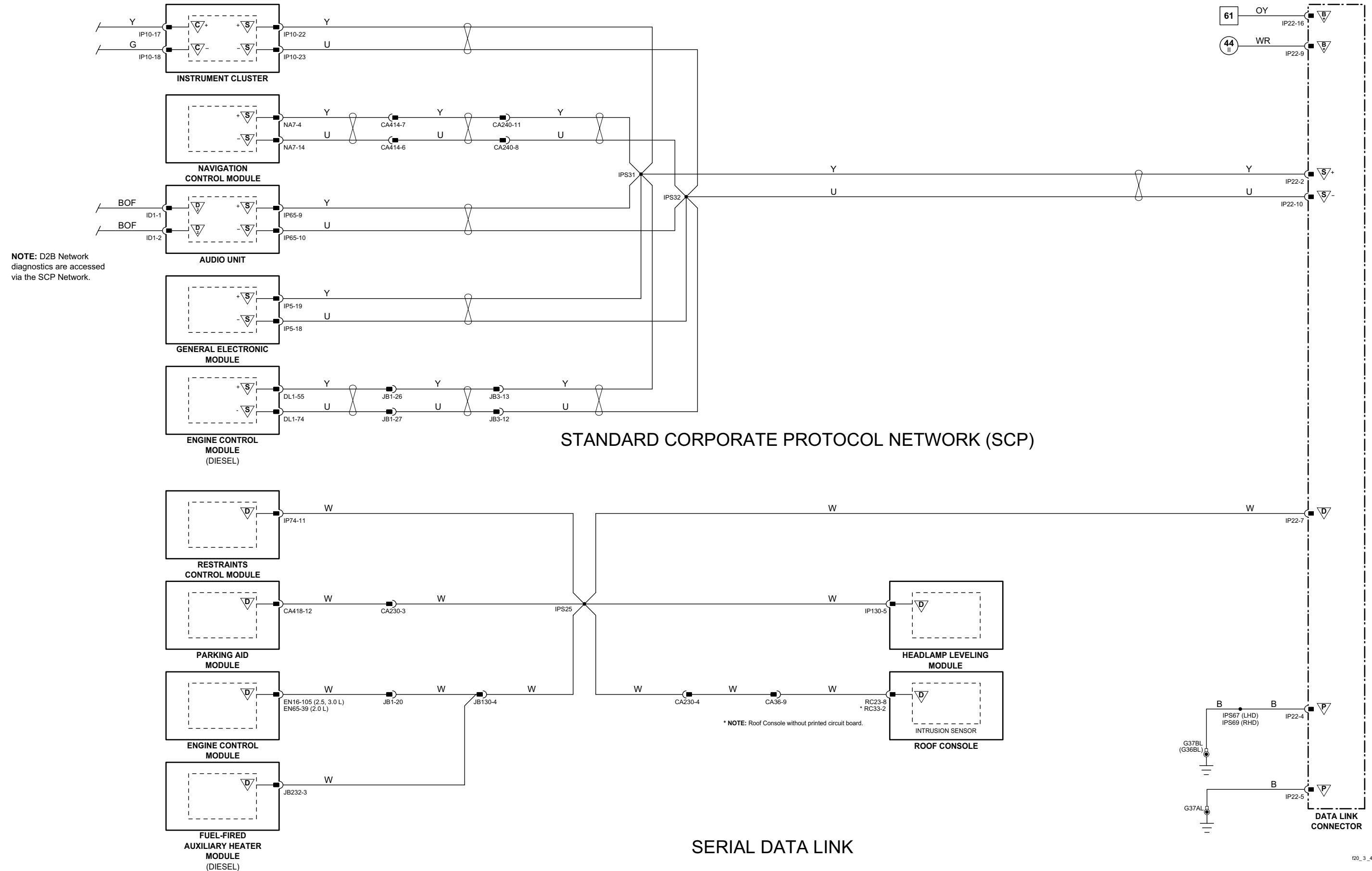

1 → 6 Fig. 01.1	34 → 80 Fig. 01.3	11 → 31 Fig. 01.5	67 → 76 Fig. 01.7	98 → 107 Fig. 01.9	Input	Battery Voltage	Sensor/Signal Supply V	CAN	D2B Network
7 → 33 Fig. 01.2	1 → 10 Fig. 01.4	32 → 66 Fig. 01.6	77 → 97 Fig. 01.8		Output	Power Ground	Sensor/Signal Ground	SCP	Serial and Encoded Data

**VARIANT:** All Vehicles  
**VIN RANGE:** All  
**DATE OF ISSUE:** February 2008

**Fig. 20.4****COMPONENTS**

Component	Connector(s)	Connector Description	Location
AUDIO UNIT	ID1	2-WAY / D2B	INSTRUMENT PANEL CENTER
	IP65	20-WAY / BLACK	
CD AUTOCHANGER	IP106	2-WAY / METALLIC	TRUNK / LH SIDE
	CA301	3-WAY / BLACK	
CELLULAR PHONE MODULE	CD2	2-WAY / D2B	TRUNK / LH SIDE
	CD3	2-WAY / D2B	
	PH1	32-WAY / BLACK	
	PH3	2-WAY / GREY	
GATEWAY MODULE	CD8	2- WAY FIBRE OPTICS	TRUNK / LEFT SIDE / MODULE STACK
	NA27	4-WAY / BLACK	
	NA35	2-WAY MOST / BLACK	
NAVIGATION CONTROL MODULE	CD5	2-WAY / D2B	TRUNK, LH REAR
	NA1	26-WAY / WHITE	
	NA2	12-WAY / BLACK	
	NA6	2-WAY / GREY	
	NA7	20-WAY / BLACK	
	CA425	12-WAY / GREY	
POWER AMPLIFIER	CA426	18-WAY / BLACK	TRUNK, LH REAR
	CD7	2-WAY / D2B	
VOICE ACTIVATION MODULE	CD4	2-WAY / D2B	TRUNK, LH REAR
	PH2	22-WAY / BLACK	

**HARNESS IN-LINE CONNECTORS**

Connector	Connector Description / Location	Location
CA240	12-WAY / GREY / CABIN HARNESS TO INSTRUMENT PANEL HARNESS	LH LOWER 'A' POST / 'A' POST TRIM
CA407	16-WAY / GREY / CELLULAR PHONE HARNESS TO CABIN HARNESS	BELOW LH REAR SEAT CUSHION
CA414	16-WAY / BLUE / NAVIGATION HARNESS TO CABIN HARNESS	BELOW LH REAR SEAT CUSHION
CD1	2-WAY / BLACK / FIBER OPTIC CONNECTOR	LH LOWER 'A' POST / 'A' POST TRIM
CD6	2-WAY / BLACK / FIBER OPTIC CONNECTOR	TRUNK, LH REAR

Refer to the front of this book for detailed information and illustrations regarding the location and identification of harnesses, relays, fuses, grounds, control modules and control module pins.

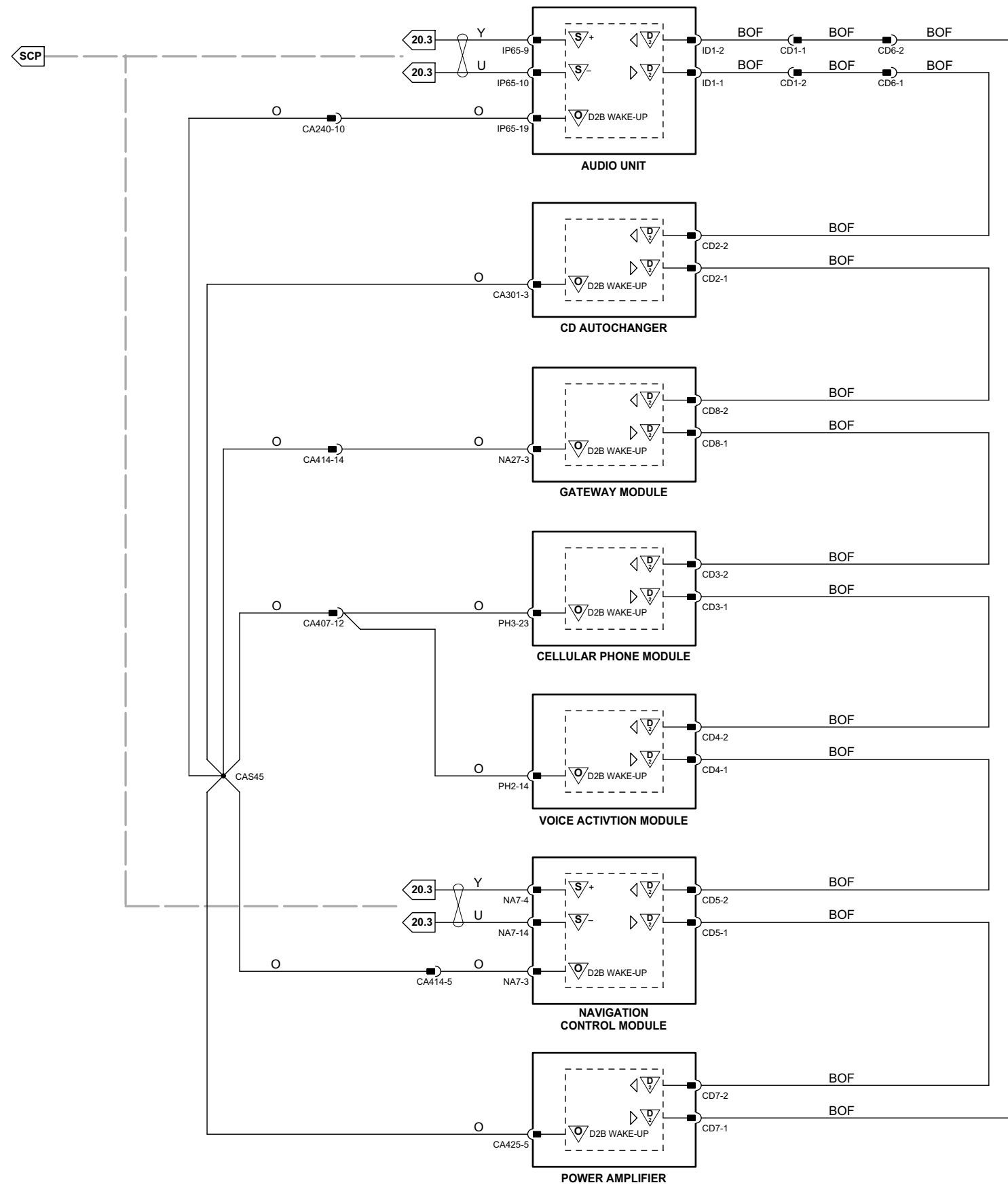

**NOTES:**

The 7-module D2B Network shown depicts the greatest number of modules available. D2B Networks containing less than 6 modules are always connected in the sequence shown from top to bottom.

- Audio Unit - Master Module  
 1 - CD Autochanger  
 2 - Gateway Module  
 3 - Cellular Phone Module  
 4 - Voice Activation Module  
 5 - Navigation Control Module  
 6 - Power Amplifier

When modules are not fitted to the vehicle, the fiber optic cables and the connectors are deleted. Therefore, each Network containing less than 6 modules has a unique fiber optic and 'wake up' circuit.

D2B Network diagnostics via SCP Network - refer to Figure 20.3.





<b>A</b>		Battery .....	Fig. 01.1
Accessory Connector		.....	Fig. 02.1
Cabin .....	Fig. 19.1	.....	Fig. 02.2
Rear .....	Fig. 08.5	.....	Fig. 02.3
.....	Fig. 08.6	Battery Saver Relay .....	Fig. 01.7
.....	Fig. 08.7	Blower	
.....	Fig. 08.8	Automatic Climate Control .....	Fig. 06.1
.....	Fig. 08.9	Bluetooth Antenna	
.....	Fig. 19.1	Sedan .....	Fig. 16.1
.....	Fig. 19.1	.....	Fig. 16.2
Trailer Towing .....	Fig. 08.5	Wagon .....	Fig. 16.1
.....	Fig. 08.6	.....	Fig. 16.2
.....	Fig. 08.7	Brake Cancel Switch .....	Fig. 03.2
.....	Fig. 08.8	.....	Fig. 03.4
.....	Fig. 08.9	.....	Fig. 03.6
Accessory Relay .....	Fig. 01.4	Brake Fluid Level Switch .....	Fig. 07.1
Air Conditioning		Brake On / Off Switch .....	Fig. 03.1
Blower Relay .....	Fig. 06.1	.....	Fig. 03.3
Compressor Clutch .....	Fig. 03.2	.....	Fig. 03.4
.....	Fig. 03.4	.....	Fig. 03.5
.....	Fig. 03.6	.....	Fig. 03.6
Compressor Clutch Relay .....	Fig. 03.2	.....	Fig. 05.1
.....	Fig. 03.4	.....	Fig. 05.2
.....	Fig. 03.6	.....	Fig. 08.3
Pressure Sensor .....	Fig. 03.2	.....	Fig. 08.4
.....	Fig. 03.4		
.....	Fig. 03.6	<b>C</b>	
Air Temperature Blend Actuator .....	Fig. 06.1	Caravan Connector .....	Fig. 08.6
AM/FM Antenna		.....	Fig. 08.9
Sedan .....	Fig. 15.1	CD Autochanger .....	Fig. 15.1
.....	Fig. 15.2	.....	Fig. 15.2
Wagon .....	Fig. 15.1	.....	Fig. 20.4
.....	Fig. 15.2	Cellular Phone Module .....	Fig. 16.1
Ambient Temperature Sensor .....	Fig. 06.1	.....	Fig. 16.2
Diesel .....	Fig. 03.5	.....	Fig. 20.4
APP Sensor		CHT Sensor .....	Fig. 03.5
2.5 L, 3.0 L .....	Fig. 03.1	Cigar Lighter .....	Fig. 09.2
Diesel .....	Fig. 03.5	.....	Fig. 19.1
Audio Control Switches .....	Fig. 15.1	CKP Sensor	
.....	Fig. 15.2	2.0 L .....	Fig. 03.3
Audio Unit .....	Fig. 09.2	2.5 L, 3.0 L .....	Fig. 03.1
.....	Fig. 12.4	Diesel .....	Fig. 03.5
.....	Fig. 12.5	Climate Control Module	
.....	Fig. 15.1	Panel .....	Fig. 06.2
.....	Fig. 15.2	.....	Fig. 09.2
.....	Fig. 16.1	.....	Fig. 20.1
.....	Fig. 16.2	.....	Fig. 20.2
.....	Fig. 16.3	Remote .....	Fig. 06.1
.....	Fig. 20.3	.....	Fig. 06.2
.....	Fig. 20.4	.....	Fig. 20.1
Auto Headlamps Sensor .....	Fig. 08.1	.....	Fig. 20.2
Automatic Transmission .....	Fig. 04.1	Clutch Cancel Switch .....	Fig. 03.2
Auxiliary Heater Relays .....	Fig. 03.6	.....	Fig. 03.4
Axle Sensors .....	Fig. 08.10	Clutch Switch – Diesel .....	Fig. 03.5
		.....	Fig. 03.6
<b>B</b>		CMP Sensors	
Band 3 (DAB) Amplifier		2.0 L .....	Fig. 03.3
Sedan .....	Fig. 15.3	2.5 L, 3.0 L .....	Fig. 03.1
Wagon .....	Fig. 15.3	Diesel .....	Fig. 03.5

Cooling Fan Module .....	Fig. 03.2	Dynamic Stability Control Module .....	Fig. 05.2
.....	Fig. 03.4	.....	Fig. 20.1
.....	Fig. 03.6	.....	Fig. 20.2
Cooling Fans .....	Fig. 03.2	Dynamic Stability Control Switch .....	Fig. 05.2
.....	Fig. 03.4	.....	Fig. 09.2
.....	Fig. 03.6		
Curtain Airbag Igniters .....	Fig. 17.1	<b>E</b>	
.....	Fig. 17.2	ECT Sensor .....	Fig. 03.1
Customer Power Connector .....	Fig. 19.1	.....	Fig. 03.3
		EFT Sensor	
<b>D</b>		2.5 L, 3.0 L .....	Fig. 03.1
DAB Antenna .....	Fig. 15.3	Diesel .....	Fig. 03.5
DAB Receiver Module .....	Fig. 15.3	EGR Solenoid Valve – 2.0 L Diesel .....	Fig. 03.6
Data Link Connector .....	Fig. 20.1	EGR Valve Position Sensor – 2.0 L Diesel .....	Fig. 03.6
.....	Fig. 20.2	Electric Auxiliary Heater .....	Fig. 03.6
.....	Fig. 20.3	Electrochromic Rear View Mirror .....	Fig. 19.1
Defrost Door Actuator .....	Fig. 06.1	Electronic EGR – 2.2 L Diesel .....	Fig. 03.6
Dip Beam Relay .....	Fig. 08.1	EMS Control Relay .....	Fig. 01.8
.....	Fig. 08.2	.....	Fig. 01.9
Discharge Temperature Sensor .....	Fig. 06.1	Engine Control Module	
Door Latch		2.0 L .....	Fig. 01.8
Driver .....	Fig. 07.2	.....	Fig. 02.2
.....	Fig. 09.1	.....	Fig. 03.3
.....	Fig. 11.1	.....	Fig. 03.4
.....	Fig. 12.1	.....	Fig. 12.4
.....	Fig. 12.2	.....	Fig. 12.5
.....	Fig. 12.3	.....	Fig. 20.1
.....	Fig. 12.4	.....	Fig. 20.2
.....	Fig. 12.5	.....	Fig. 20.3
.....	Fig. 14.1	2.5 L, 3.0 L .....	Fig. 01.8
.....	Fig. 14.2	.....	Fig. 02.1
LH Rear .....	Fig. 09.1	.....	Fig. 03.1
.....	Fig. 12.1	.....	Fig. 03.2
.....	Fig. 12.2	.....	Fig. 12.4
.....	Fig. 12.3	.....	Fig. 12.5
.....	Fig. 12.4	.....	Fig. 20.1
.....	Fig. 12.5	.....	Fig. 20.2
Passenger .....	Fig. 09.1	.....	Fig. 20.3
.....	Fig. 12.1	Diesel .....	Fig. 01.9
.....	Fig. 12.2	.....	Fig. 02.3
.....	Fig. 12.3	.....	Fig. 03.5
.....	Fig. 12.4	.....	Fig. 03.6
.....	Fig. 12.5	.....	Fig. 03.7
RH Rear .....	Fig. 09.1	.....	Fig. 12.4
.....	Fig. 12.1	.....	Fig. 12.5
.....	Fig. 12.2	.....	Fig. 20.1
.....	Fig. 12.3	.....	Fig. 20.2
.....	Fig. 12.4	.....	Fig. 20.3
.....	Fig. 12.5	EOT Sensor .....	Fig. 03.1
Door Mirrors .....	Fig. 06.2	.....	Fig. 03.3
.....	Fig. 10.1	EVAP Canister Close Valve .....	Fig. 03.1
.....	Fig. 10.2	EVAP Canister Purge Valve .....	Fig. 03.1
Door Switch Pack		.....	Fig. 03.3
Driver .....	Fig. 09.2	Evaporator Temperature Sensor .....	Fig. 06.1
.....	Fig. 10.1		
.....	Fig. 10.2	<b>F</b>	
.....	Fig. 14.1	Fog Lamps – Front .....	Fig. 08.1
LH Rear .....	Fig. 09.2	.....	Fig. 08.2
.....	Fig. 14.1	Fold Back Module .....	Fig. 10.1
Passenger .....	Fig. 09.2	Footwell Lamps .....	Fig. 09.1
.....	Fig. 14.1	Fresh / Recirculation Flap Actuator .....	Fig. 06.1
RH Rear .....	Fig. 09.2	FTP Sensor .....	Fig. 03.1
.....	Fig. 14.1	Fuel Injectors	
DPF Pressure Sensor .....	Fig. 03.7	2.0 L .....	Fig. 03.4
DPF Temperature Sensors .....	Fig. 03.7	2.5 L, 3.0 L .....	Fig. 03.2
Dual Airbag Igniters .....	Fig. 17.1	Diesel .....	Fig. 03.5
.....	Fig. 17.2		