

SORENTO

Body shop Manual

FOREWORD

This Body Shop Manual illustrates body structures and service procedures for the SORENTO.

This manual illustrates the replacement of major body panels, plastic parts, body dimensions, sealing treatment etc., in a systematic manner which is necessary for effective and lasting body repairs. You are encouraged to become familiar with this manual and understand each section in order to perform proper repair procedures. Keep this manual in a convenient location so that it is readily available.

All information in this manual including specifications, data and illustrations is made based on the vehicles built at the time the manual was printed.

Information regarding the removal/replacement of components not specifically covered in this manual can be found in the SORENTO Service Manual. Information regarding electrical harness routing/connections, etc. can be found in the SORENTO Electrical Troubleshooting Manual.

The descriptions and specifications contained in this manual were in effect at the time this manual was approved for printing. Kia Motors Corporation reserves the right to discontinue models at any time, or change specifications or design without notice and without incurring obligation.

Kia Motors Corporation
SEOUL, KOREA

CONTENTS

Title	Group
GENERAL INFORMATION	00
BODY STRUCTURE	11
REPLACING BODY PANELS	21
BODY DIMENSIONS	31
WATERPROOFING AND RUSTPROOFING	41
BODY MODIFICATION TOOLS	51
PLASTIC PARTS	61

Copyright © 2002, Kia Motors Corporation
Printed in Korea, October 2002
Pub. No.: A3EB-EG2OB(English)

All rights reserved. No part of this publication may be reproduced, stored in any retrieval system or transmitted in any form or by any means without the prior written permission of Kia Motors Corporation.

WARNING

Appropriate service methods and proper repair procedures are essential for the safe, reliable operation of all motor vehicles as well as the personal safety of the individual doing the repair. There are numerous variations in procedures, techniques, tools, and parts for servicing vehicles, as well as in the skill of the individual doing the work. This manual cannot possibly anticipate all such variations and provide advice or caution to each. Accordingly, anyone who departs from the instruction provided in this manual must first establish that he compromises neither his personal safety nor the vehicle integrity by his choice of methods, tools, or parts. The following list contains general warnings that should always be followed while working on a vehicle.

- Always wear safety glasses for eye protection.
- Use safety stands whenever a procedure requires underbody work.
- Be sure ignition switch is always off unless otherwise specified by a procedure.
- Set the parking brake when working on the vehicle.
- Operate the engine only in a well ventilated area.
- Keep clear of moving parts when engine is running.
- To prevent serious burns, avoid contact with hot metal parts such as the radiator, exhaust manifold, tail pipe, catalytic converter and muffler.
- Do not smoke while working on a vehicle.

General information

Fundamental procedures

Vehicle protection	00- 1
A word about safety	00- 1
Welding procedures	00- 1
Body frame straightener	00- 2
Electrical procedures	00- 2

For best results

Disassembly	00- 3
Preparation of assembly	00- 5
Assembly	00- 6
Rustproof treatment after assembly	00- 7

Vehicle lift (2-Support type) & and safety stand positions

Front end	00- 8
Rear end.....	00- 8

Towing	00- 8
--------------	-------

Body colors and major specifications

Kia color codes	00- 9
Paint manufacture codes	00- 9

Fundamental procedures

Vehicle protection

1. Cover the seats before performing any procedure to keep them from getting dirty.
2. Cover all glasses, seats and mats with a heat resistant cover when welding.

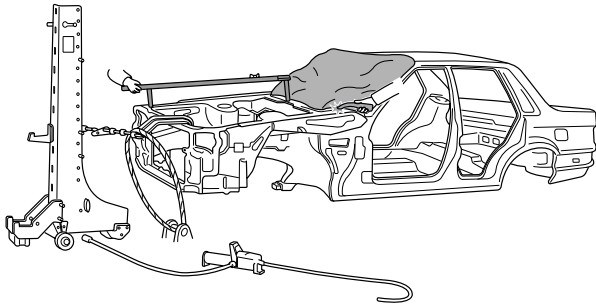

1SD1BM001

3. Protect moldings, garnishes and ornaments.

A word about safety

1. Wear the appropriate safety equipment that is necessary for the procedure being performed.

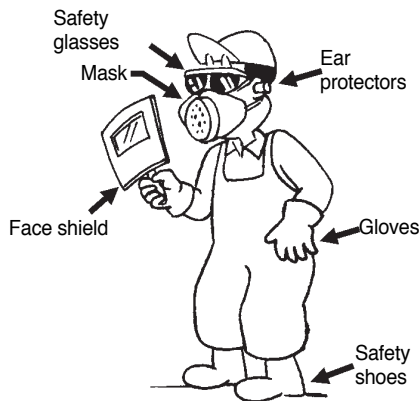

00003

2. When welding or performing other procedures that require the use of an open flame near the fuel tank, disconnect and remove the tank and fuel pipe, and cap the pipe to prevent fuel leakage.

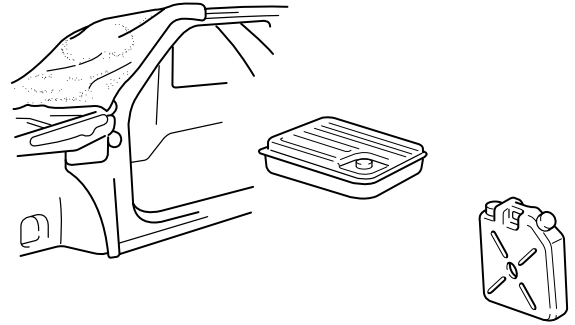

ASD1BM003

Welding procedures

Observe the following tips when welding.

1. Wear appropriate eye protection.
2. Carefully follow the manufacturers operating instructions for the welding machine you are using.
3. Do not weld, smoke or allow open flames around volatile chemicals, cleaners or solvents or in any area where they have just been used.

Body frame straightener

When using a frame straightener, do not enter the area where the body is being straightened by the chain.

Electrical procedures

1. Disconnect the negative battery terminal.
2. Do not pull on wires when disconnecting electrical connectors. Be careful to hold the connector itself when disconnecting it.
3. Insert the connector until it “clicks” when connecting the connector.
4. Handle all electrical components with care.

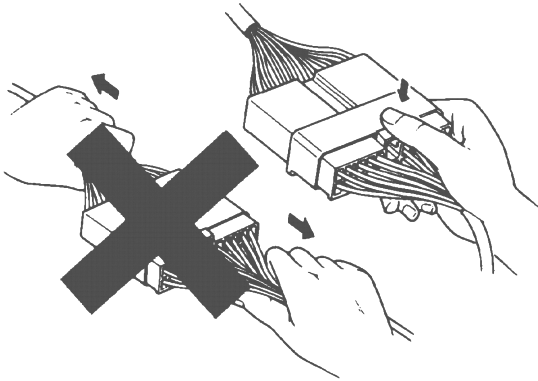

BSX061006

For best results

Disassembly

Measuring dimensions before beginning

Measure the dimensions of the damaged area according to the body dimension drawings before disassembling and repairing. Adjust dimensions with body frame adjuster if deformed.

Selecting cutting area

Select a cutting area that is easily accessible and that is prone to the least amount of distortion when welding. Select an area that would allow the new part to overlap repair area by 1.2~2.0 in (30~50 mm).

Protecting body from damage

Secure the body with clamps and jacks to prevent damage to the body when working on it.

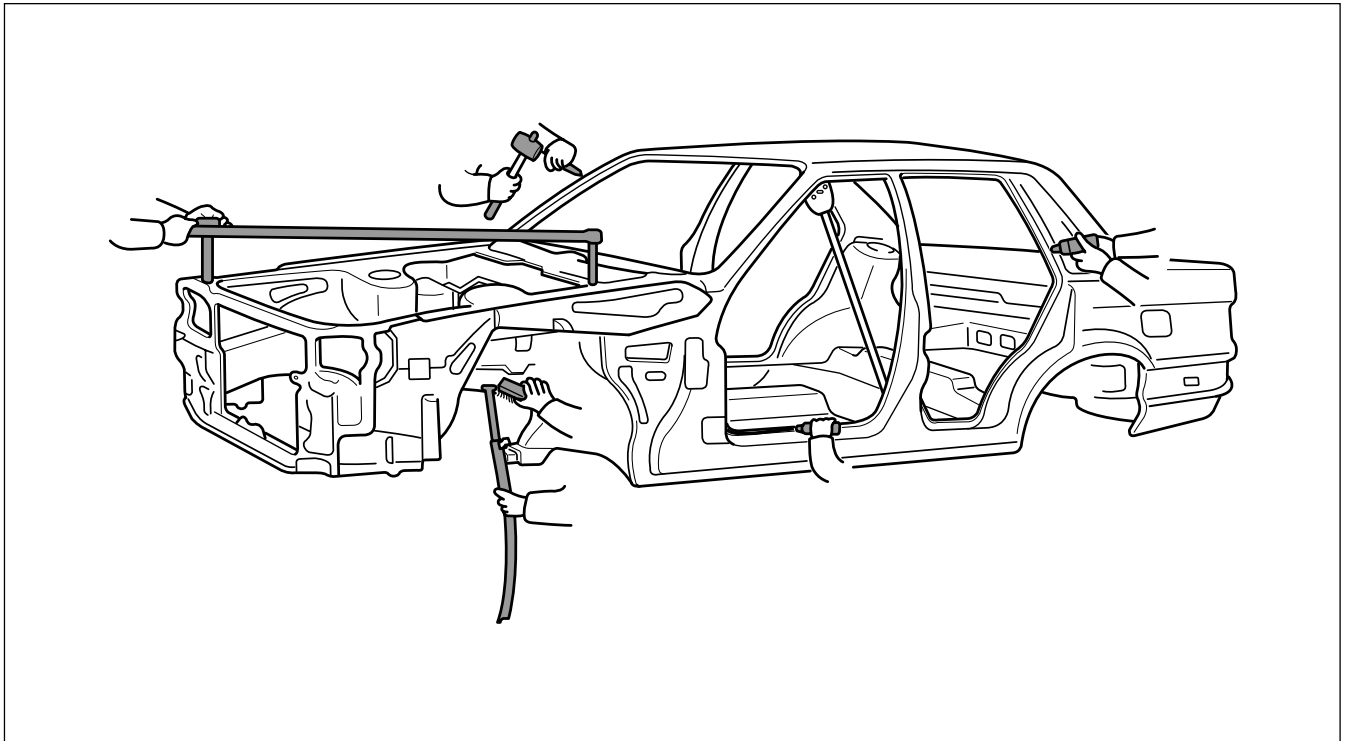

1SD1BM004

00-4 General information

Disassembling related parts

Use caution when removing body molding and trim from the area to be worked. Apply masking tape where needed to prevent damage to the part being removed or to the vehicle body. Before starting repairs, check if pipes, hoses or electrical components are present near damaged area.

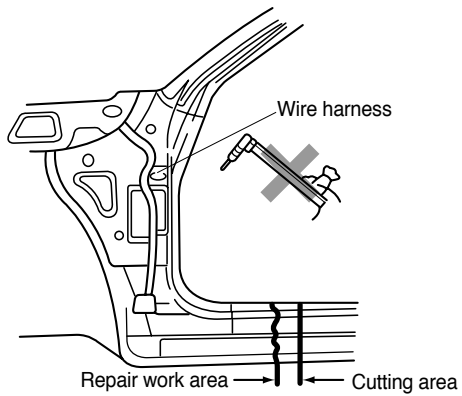

1SD1BM005

Preparation of assembly

Applying spot sealer

Remove paint from the surface of new parts and body to be spot welded, and apply spot sealer for rustproofing.

Selecting a welding method

If the thickness of the area to be welded with the panels overlapped is greater than 0.1 in (3 mm), do plug welding using a carbon arc welding machine.

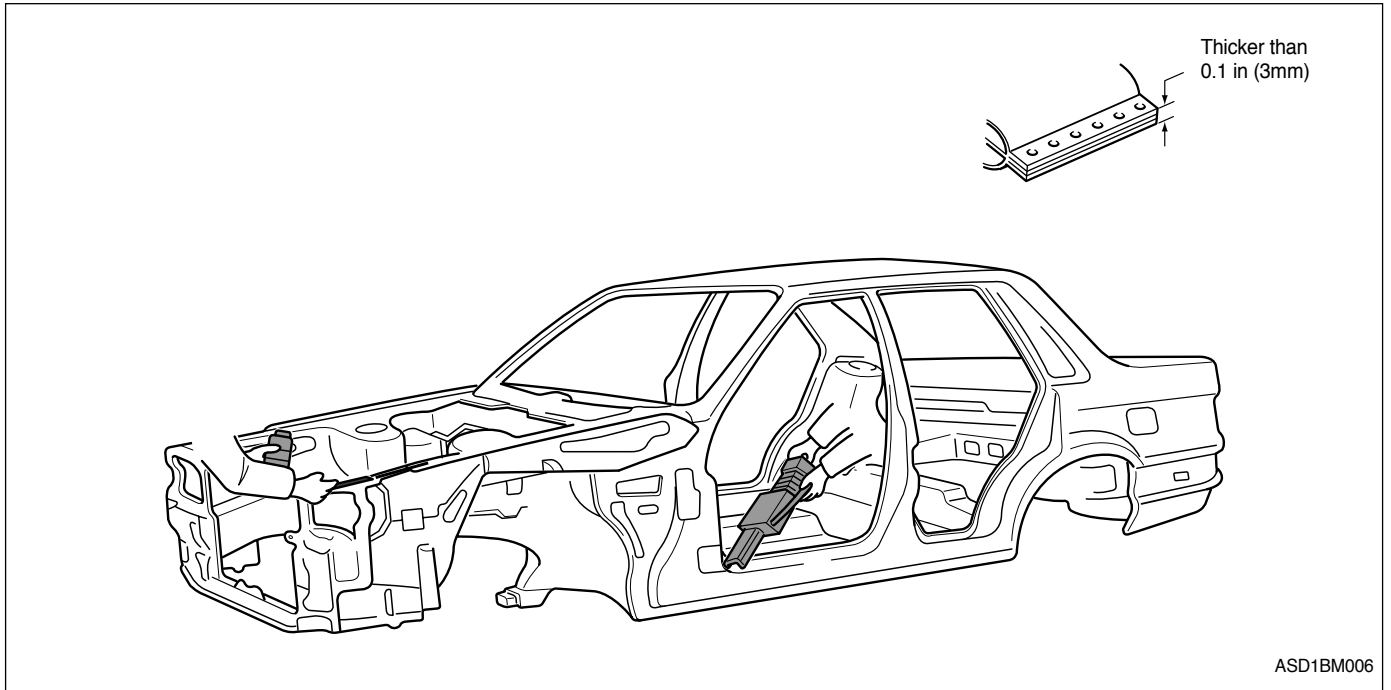

Machining holes for plug welding

Drill a hole of approximately 0.2~0.24 in (5~6 mm) in diameter in those areas which are not suitable for spot welding.

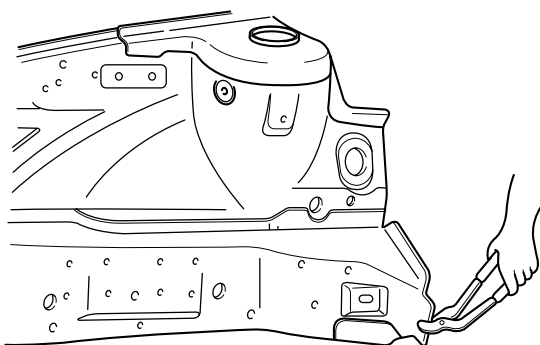

Adjusting a new part

The new part should be cut larger than the repair area, overlapping the repair area by 1.2~2.0 in (30~50 mm).

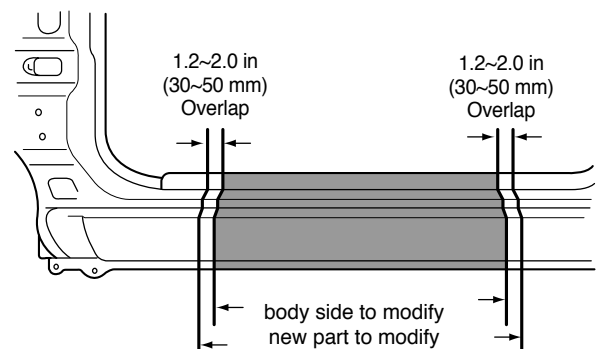

Assembly

Measuring dimensions before welding

When assembling a new part, assemble it according to the body dimensions given in Section 31, and start welding after checking the gaps with nearby parts.

Caution when welding

The number of welding points should be determined based on the criteria below:

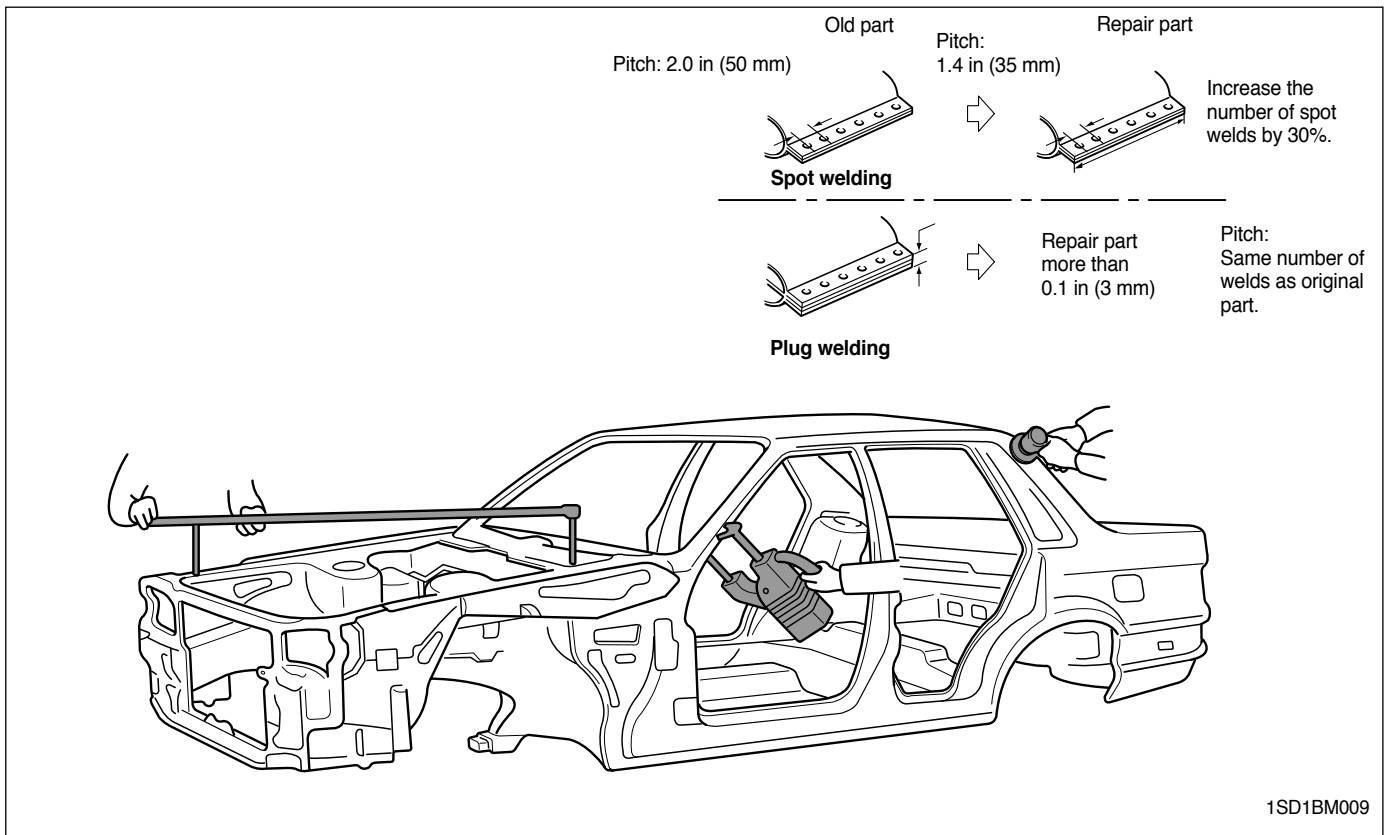

1SD1BM009

Caution when spot welding

- The tip of the spot welding machine should be maintained to a minimum of 0.1 in (3 mm) because it greatly affects welding strength. When possible, spot welding should be done between the existing spot welded points.
- Before and after spot welding, weld a test piece (test pin) of the same material as the body panel, and check the welding strength.

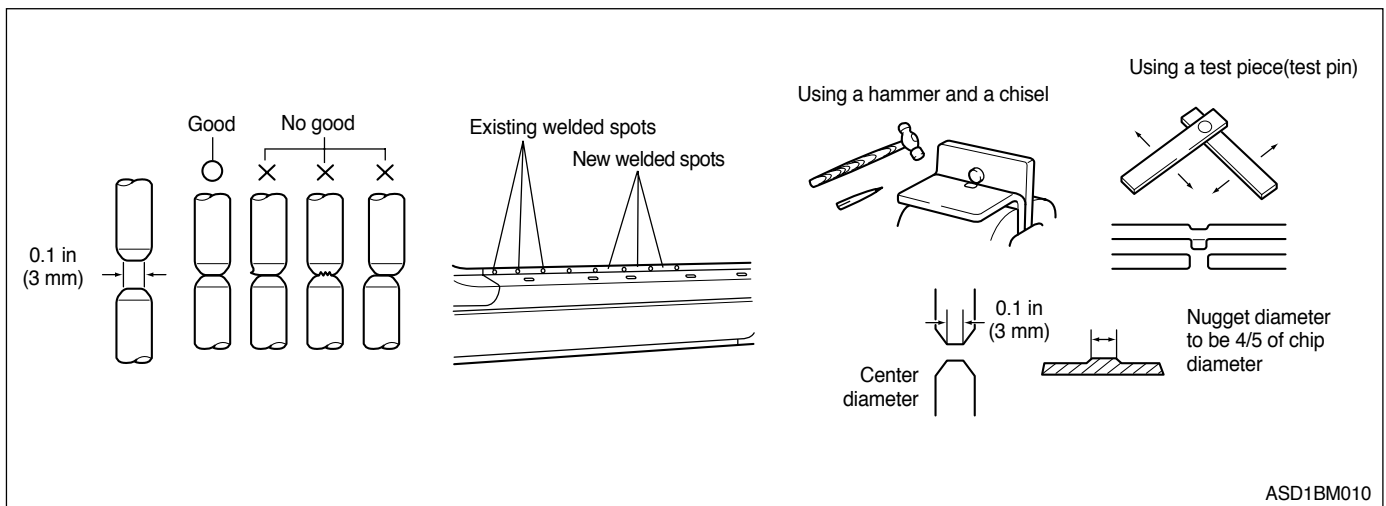

ASD1BM010

Rustproof treatment after assembly

Body sealing

Apply body sealer where necessary.

Applying rustproof material

Apply rustproofing material(wax, oil, etc.) behind welded area.

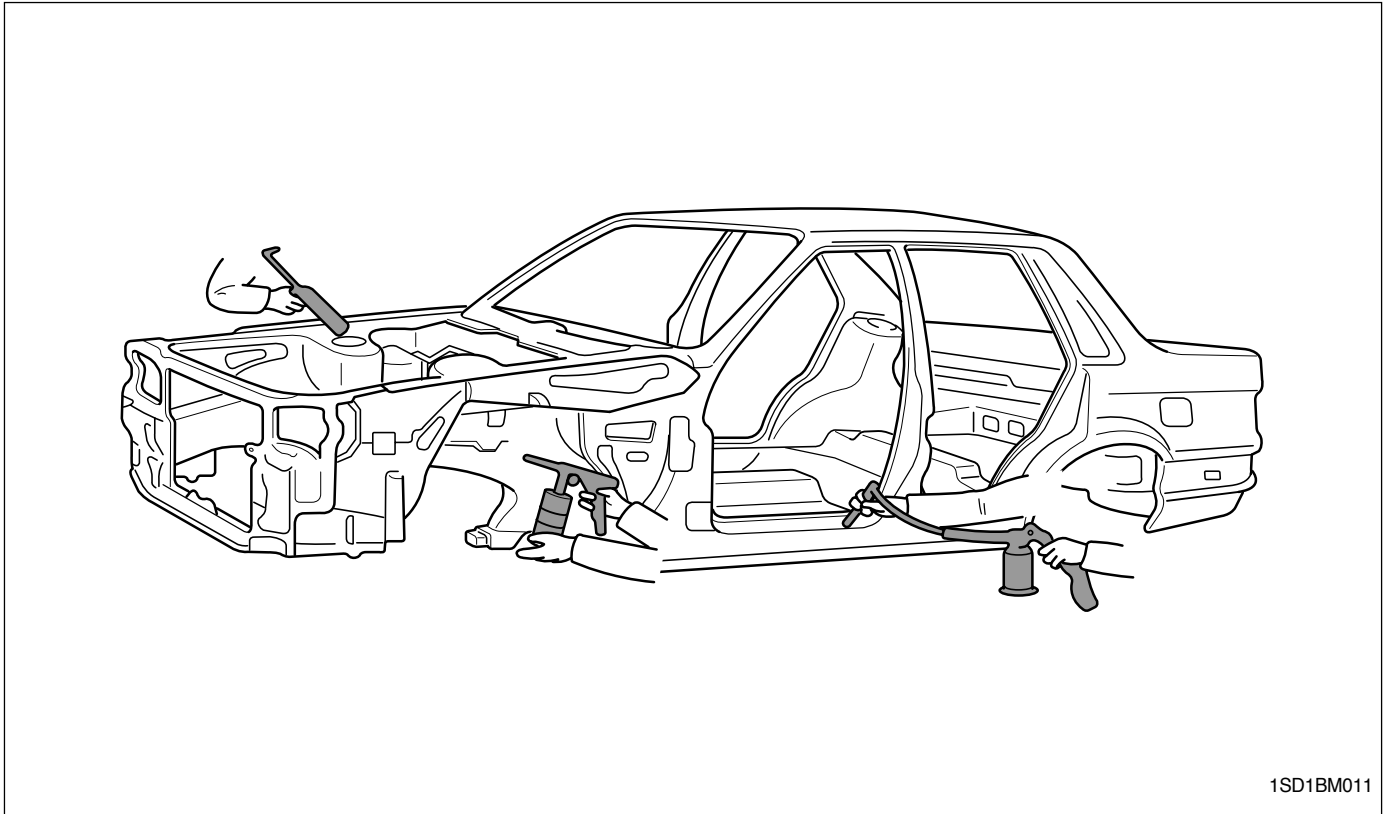

Applying undercoat

Apply undercoat on the body where necessary.

Vehicle Lift (2-Support Type) And Safety Stand Positions

Front end

At the front side member of the T/M cross member on the frame.

Rear end

At the front side member of the lower control arm bracket on the frame.

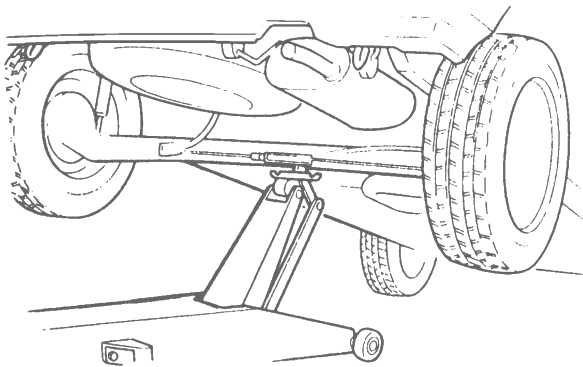

AV2A00002

Towing

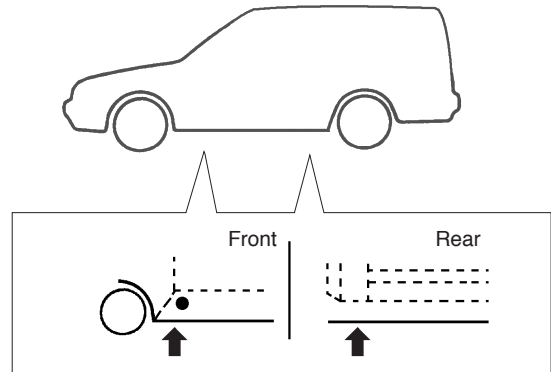

133-07009 / 133-07009-1

If emergency towing is necessary, we recommend having it done by an authorized KIA dealer or a commercial tow-truck service. Proper lifting and towing procedures are necessary to prevent damage to the vehicle.

It is recommended that your vehicle be towed with a wheel lift or flatbed equipment. Do not tow with a slingbelt. Our company has not approved a slingbelt towing procedure.

On 4x4 vehicles, it is recommended that your vehicle be towed with a wheel lift and dollies or flatbed equipment with all the wheels off the ground.

Body colors and major specifications

Kia color codes

Kia code	Paint color
UD	Clear White
C5	Diamond Silver
G7	Grayish Purple
7Y	Gold Beige
R9	Ruby Red
3N	Ivy Green
K2	Indigo Blue
L4	Aqua Blue
EB	Ebony Black

Paint manufacture codes

Kia code	Paint color	DUPONT	SPIES HECKER	AKZO NOVEL SIKKENS
UD	Clear white	F2756	15689	KIA4004
C5	Silver Metallic	M7633	24303	KIA9716
G7	Silky Beige	P6790	87867	KIA9727
7Y	Ruby Red	M7671	26972	KIA9801
R9	Dark Emerald Green	M7791	37661	KIA9313
3N	Blue Sapphire	P6787	87864	KIA9614
K2	Misty Blue	P6789	87866	KIA9528
L4	Midnight Black	P6788	87865	KIA9527
EB	Ebony Black	F0193	35992	KIA4002

Body structure

Body composition

- Body shell 11- 1
- Body service holes 11- 1

High tension steel sheet used area

- Radiator support panel 11- 2
- Fender & Wheel apron panel..... 11- 3
- Dash & Cowl panel 11- 4
- Side body panel..... 11- 5
- Roof panel 11- 6
- Floor panel 11- 7
- Hood & Tail gate..... 11- 8
- Front door & Rear door 11- 9

Body composition

Body shell

The body consists of the body shell, frame and cross members, etc, welded together. This provides safety, durability, noise protection, rustproofing and vibration proofing of the vehicle.

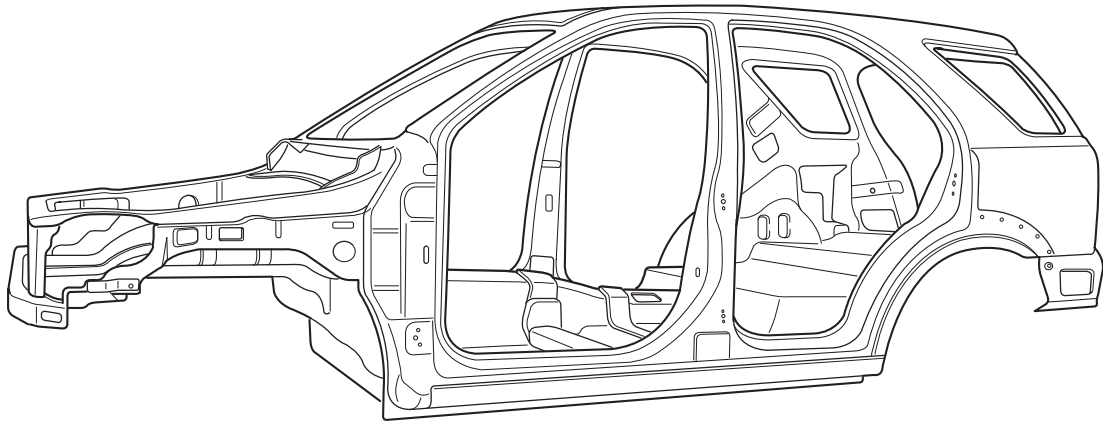

A3EB3304

Body service holes

Body service holes are provided in the inner panel to improve serviceability of the body.

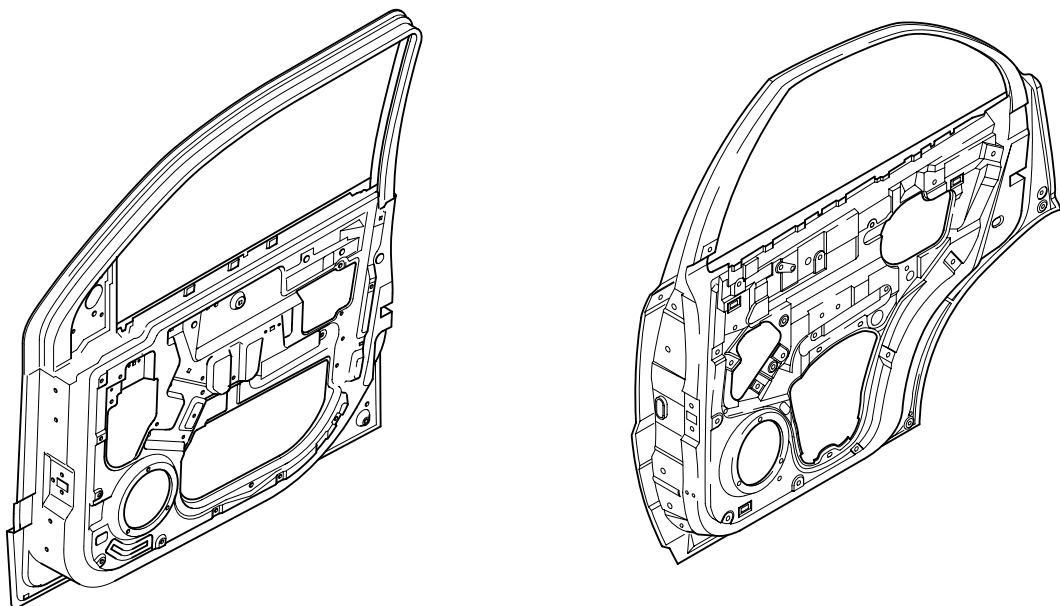

A3EB3102

High tension steel sheet used area

Radiator support panel

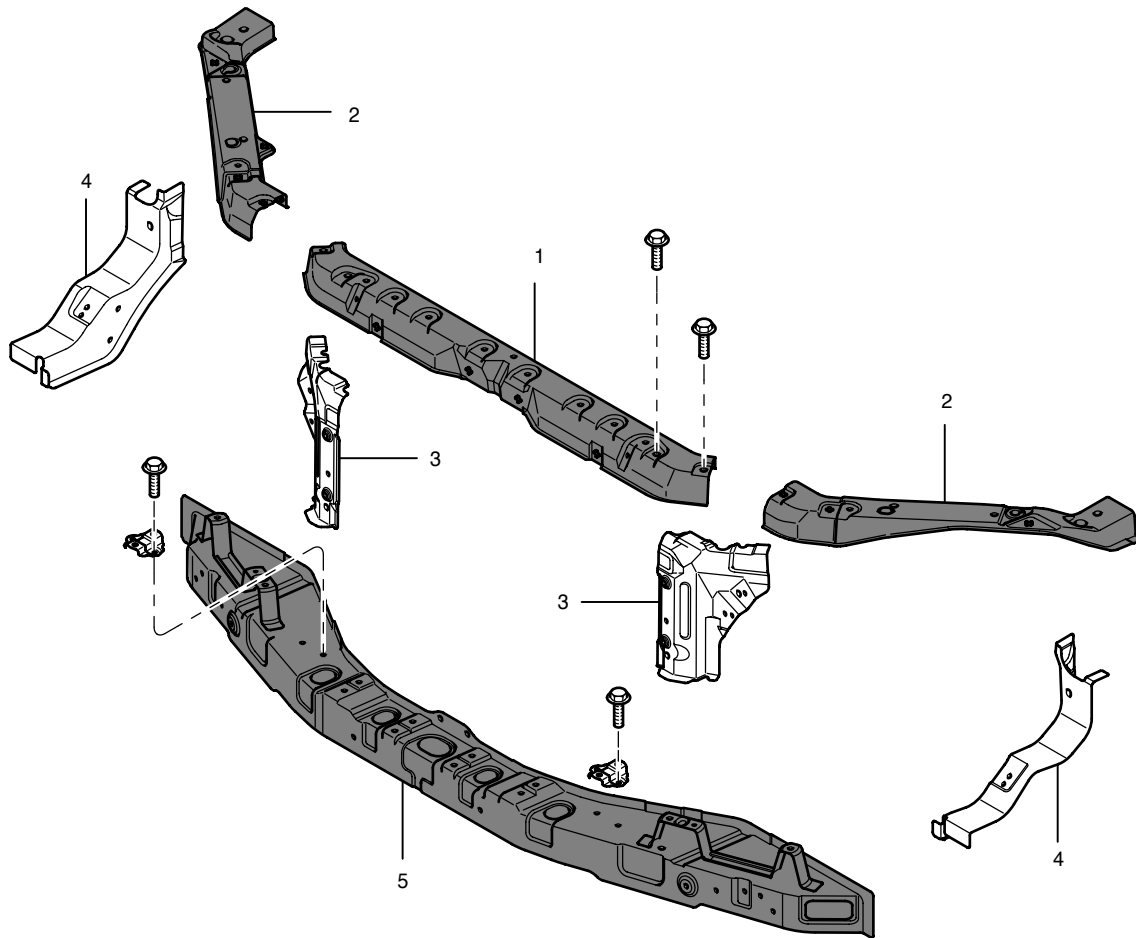

■ HIGH TENSION STEEL SHEET USED AREA

A3EB3103

- (1) Radiator support upper member A
- (2) Radiator support upper member B
- (3) Headlight support panel A

- (4) Headlight support panel B
- (5) Radiator support lower member

Fender & Wheel apron panel

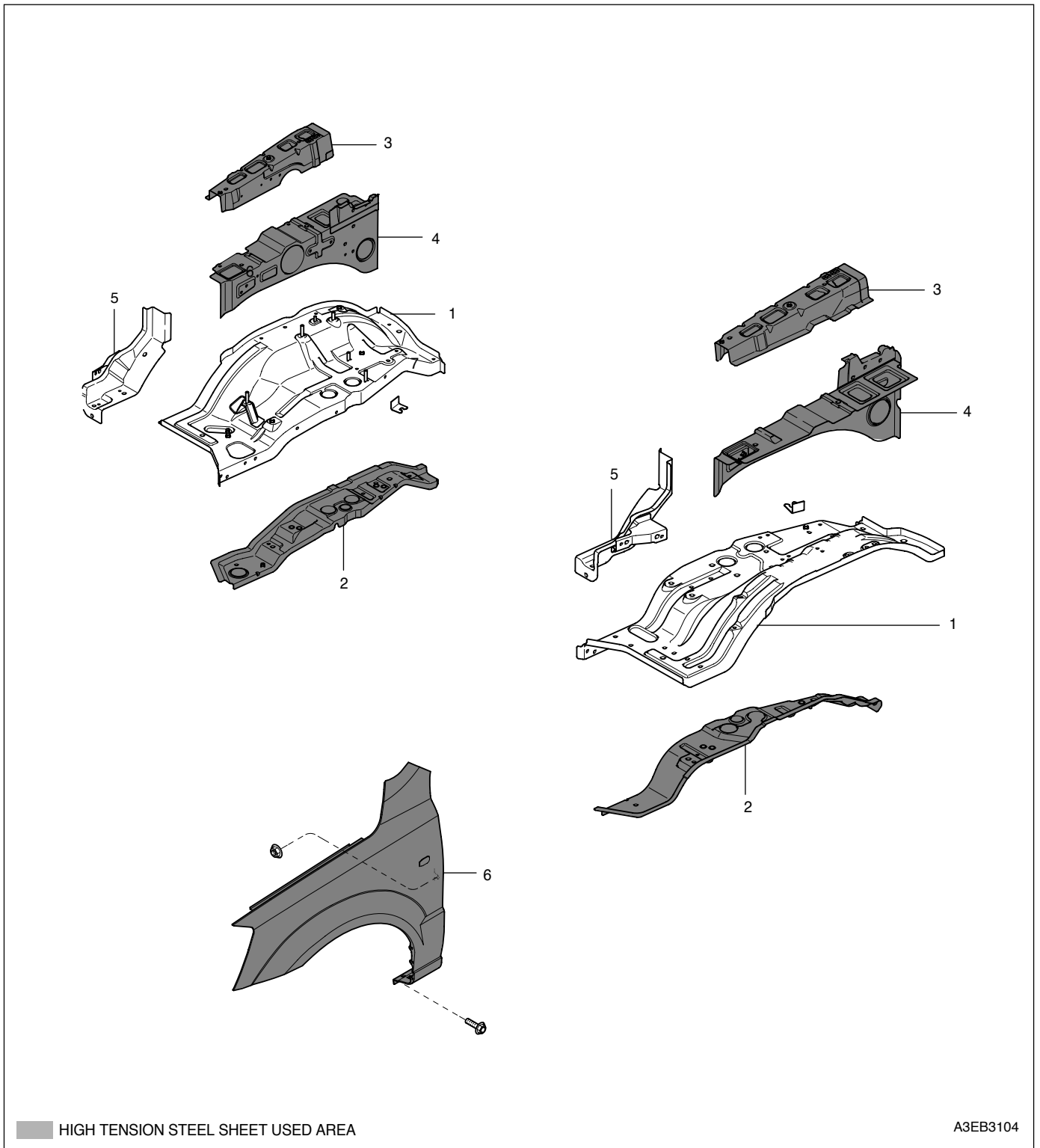

- (1) Front wheel apron panel
- (2) Front wheel apron member
- (3) Side rail upper panel

- (4) Side rail lower panel
- (5) Front wheel apron reinforcement No. 1
- (6) Fender panel

Dash & Cowl panel

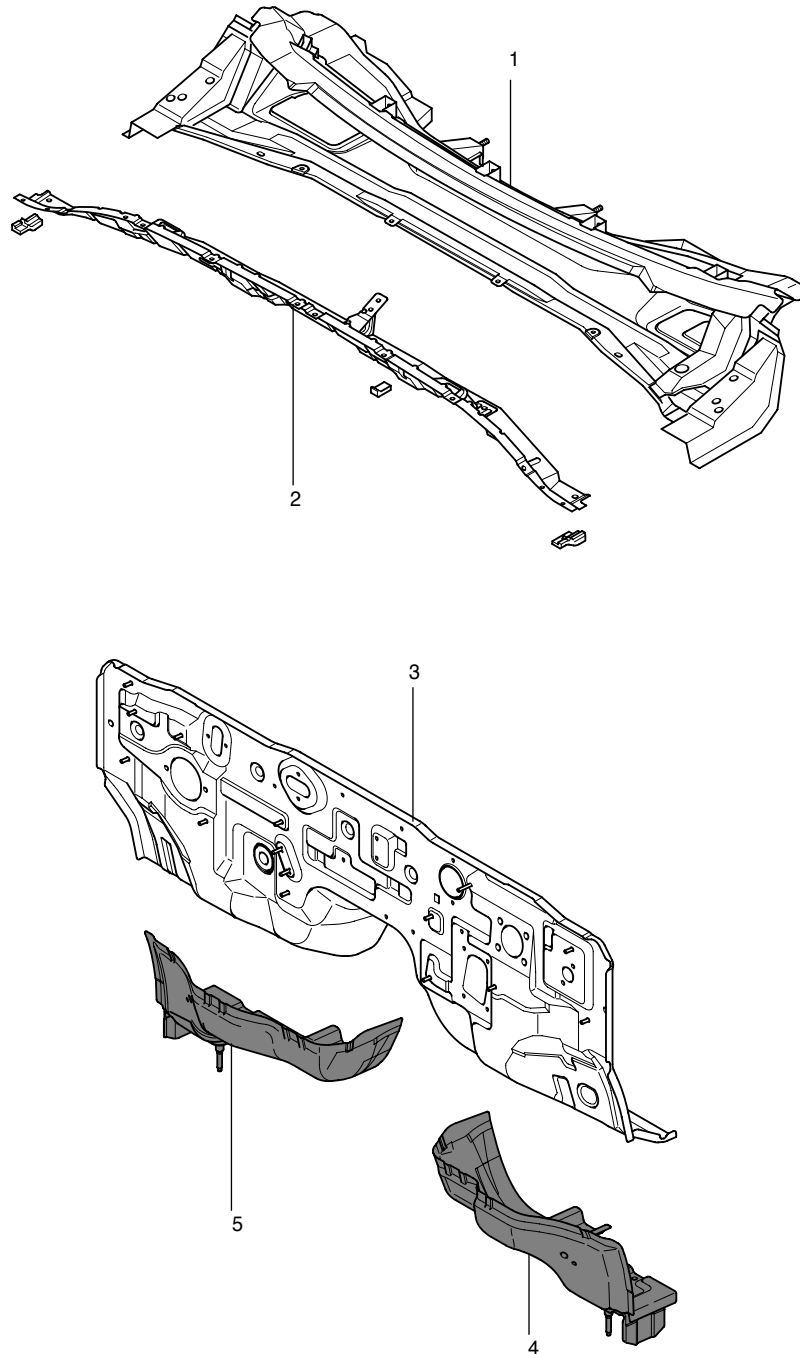

■ HIGH TENSION STEEL SHEET USED AREA

A3EB3105

- (1) Cowl panel
- (2) Front cowl panel
- (3) Dash lower panel

- (4) Dash lower member(LH)
- (5) Dash lower member(RH)

Side body panel

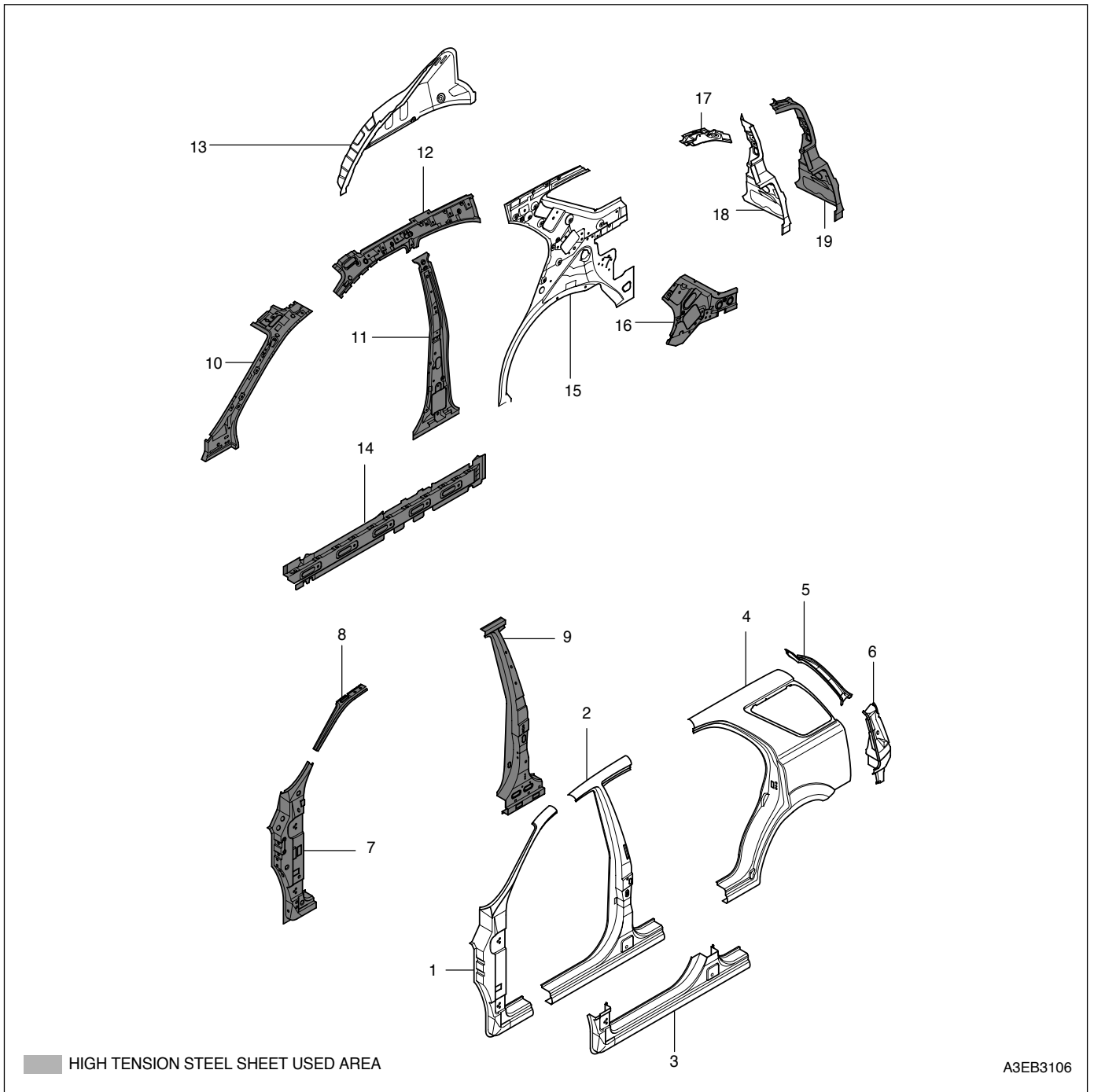

- | | |
|----------------------------------|------------------------------------|
| (1) Front pillar outer panel | (11) B pillar inner panel |
| (2) Center pillar outer panel | (12) Roof side inner rail |
| (3) Sill side outer panel | (13) Wheel house inner panel |
| (4) Quarter outer panel | (14) Sill side outer reinforcement |
| (5) Drain upper panel | (15) Quarter inner panel |
| (6) Drain lower panel | (16) C pillar reinforcement |
| (7) A pillar lower reinforcement | (17) D pillar inner up panel |
| (8) A pillar upper reinforcement | (18) D pillar inner lower panel |
| (9) B pillar reinforcement | (19) D pillar reinforcement |
| (10) A pillar inner up panel | |

Roof panel

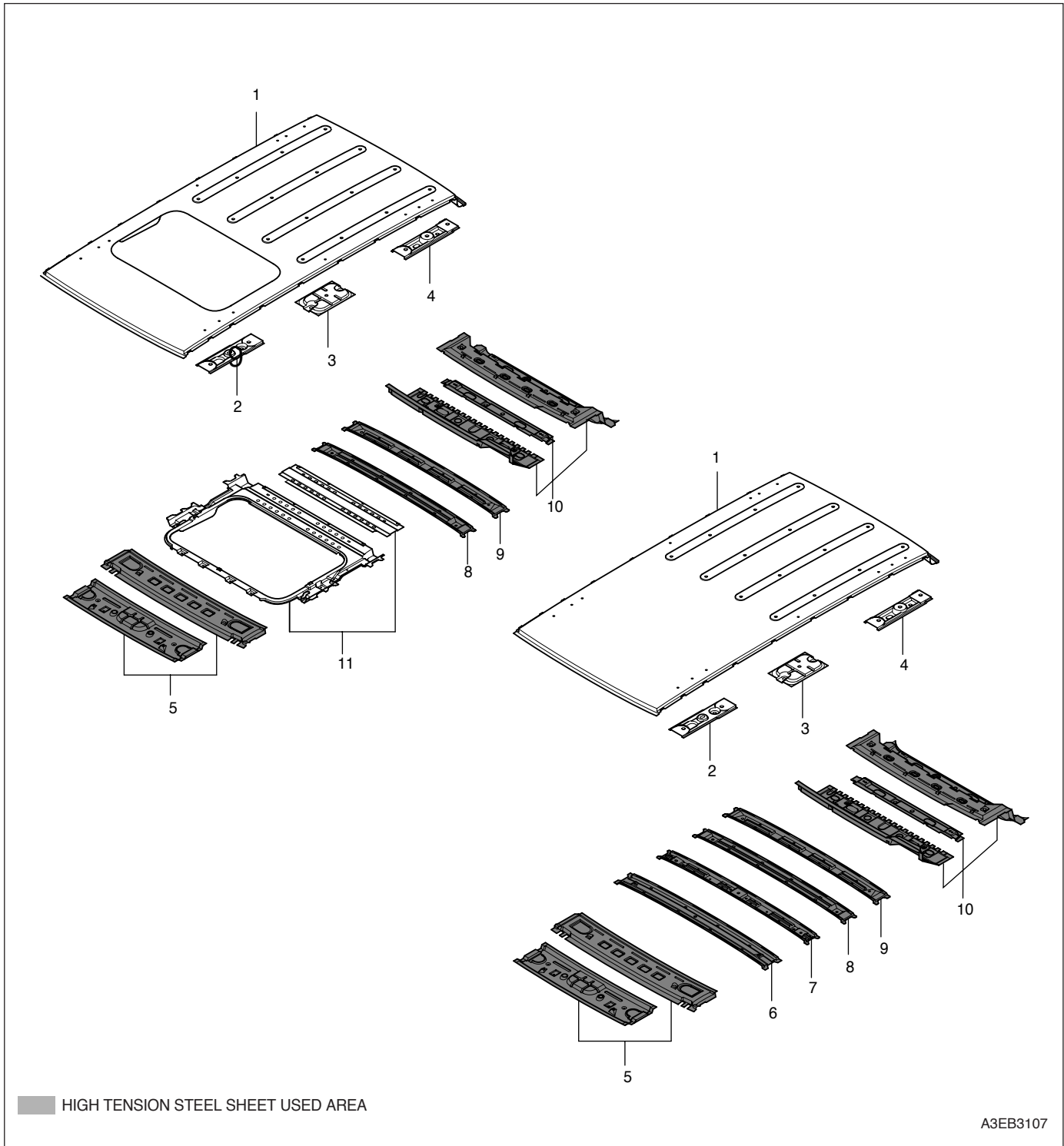

- | | |
|----------------------------------|---------------------------------|
| (1) Roof panel | (7) Roof center rail No. 2 |
| (2) Roof rack reinforcement A | (8) Roof center rail No. 3 |
| (3) Roof rack reinforcement B | (9) Roof center rail No. 4 |
| (4) Roof rack reinforcement C | (10) Roof rear rail |
| (5) Roof front rail | (11) Sunroof reinforcement ring |
| (6) Roof center lower rail No. 1 | |

Floor panel

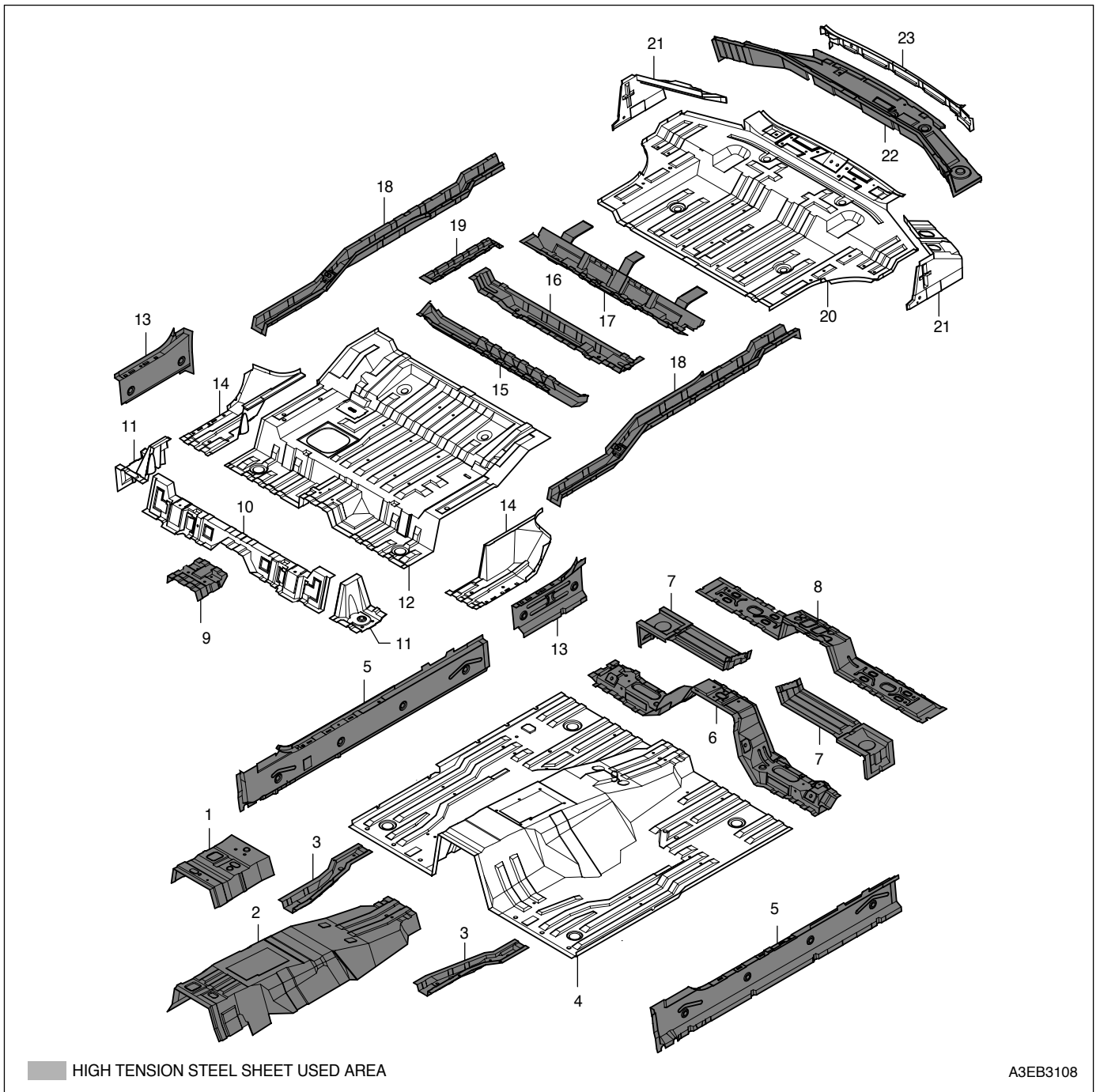

A3EB3108

- | | |
|--|-----------------------------------|
| (1) Tunnel upper reinforcement | (13) Sill side inner rear panel |
| (2) Tunnel lower reinforcement | (14) Side floor panel |
| (3) Center floor side member | (15) Rear floor crossmember No. 1 |
| (4) Center floor panel | (16) Rear floor crossmember No. 2 |
| (5) Sill side inner front panel | (17) Rear floor crossmember No. 3 |
| (6) Center floor crossmember No. 2 | (18) Rear floor side member |
| (7) Center floor lower crossmember No. 2 | (19) Rear floor center member |
| (8) Center floor crossmember No. 1 | (20) Rear floor panel |
| (9) Tunnel reinforcement | (21) Rear corner plate |
| (10) Seat support panel | (22) Rear end member |
| (11) Body mounting bracket No. 4 | (23) Rear end member |
| (12) Inter floor panel | |

Hood & Tail gate

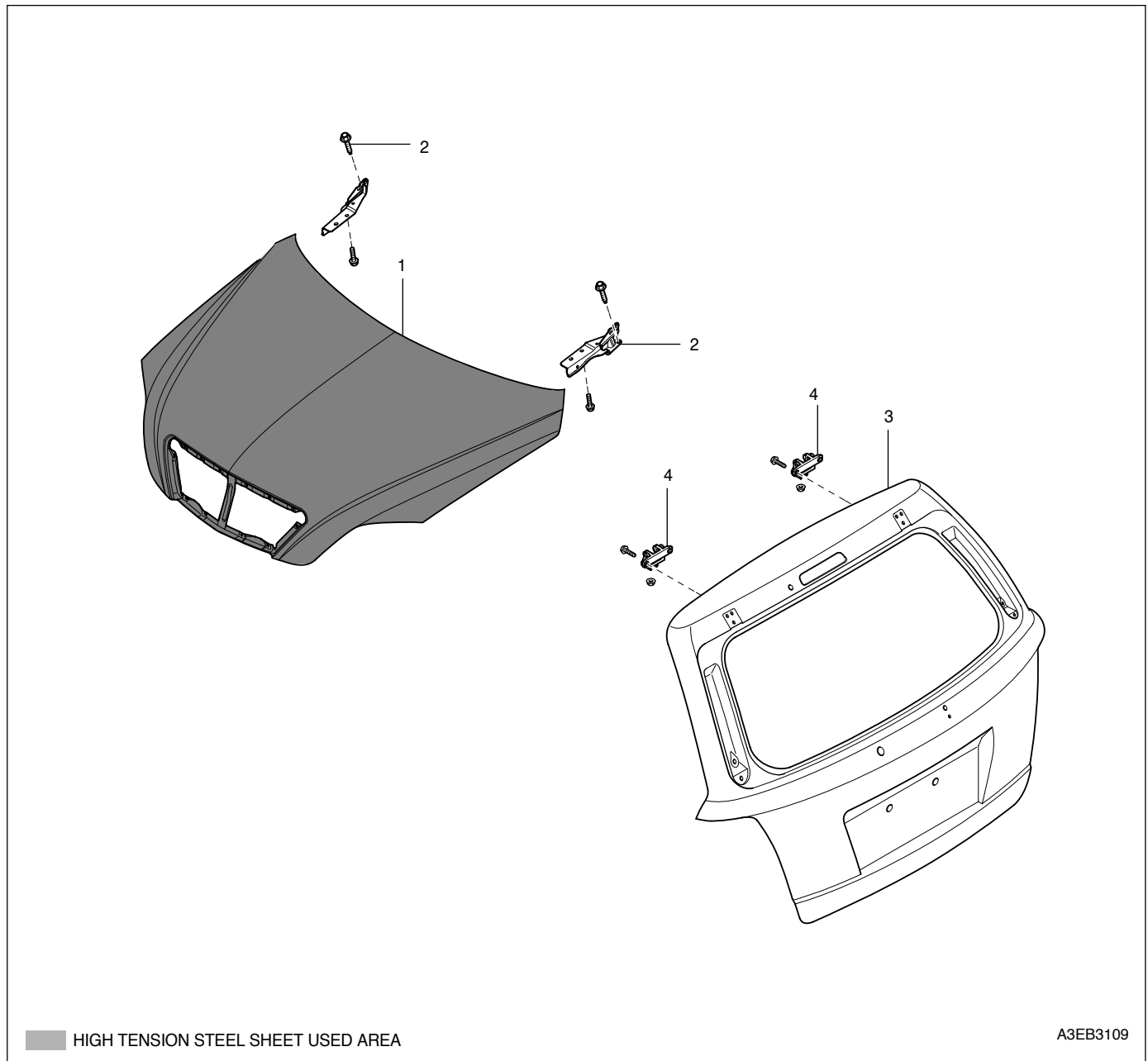

- (1) Hood panel
- (2) Hood hinge

- (3) Tail gate panel
- (4) Tail gate hinge

Front door & Rear door

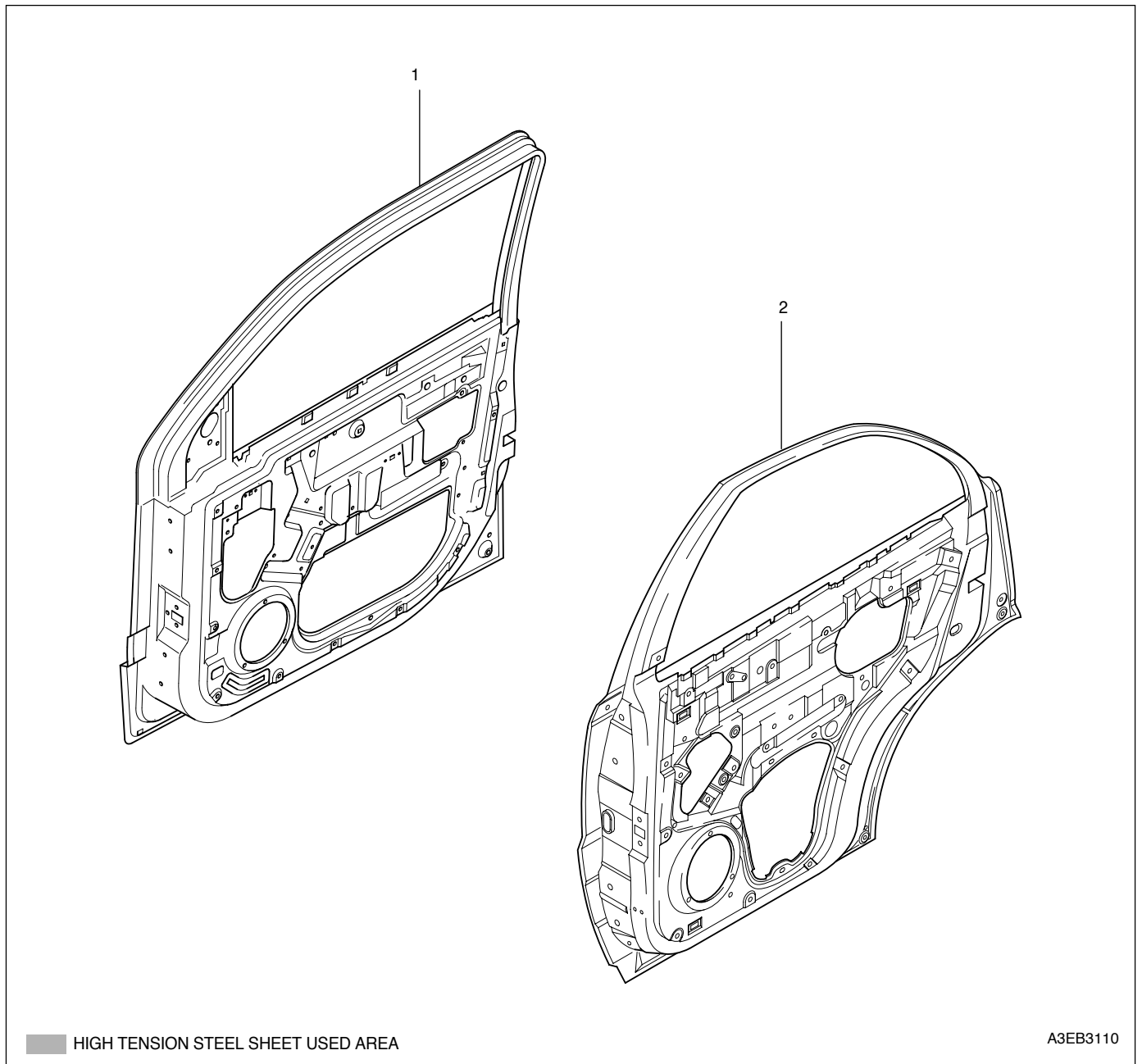

- (1) Front door panel
- (2) Slide door panel

Replacing body panels

Replacing body panels	
Codes for disassembling and assembling body panels	21- 1
Notes when welding body	21- 3
Disassembling spot welded area	21- 3
Assembling a new body frame	21- 5
Determining a welding method	21- 5
Spot welding	21- 5
Carbon arc welding	21- 6
Replacing body panel	21- 7
Radiator support panel assembly	21-12
Front wheel apron panel assembly (RH)	21-15
Front wheel apron panel assembly (LH)	21-18
Cowl panel assembly	21-21
Dash lower panel assembly	21-24
Side complete panel assembly (Upper)	21-27
Side complete panel assembly (Lower)	21-30
Side outer panel assembly	21-33
Front side inner panel assembly	21-36
Quarter inner & wheel house panel assembly	21-39
Front floor panel assembly	21-42
Rear floor panel assembly	21-45
Roof panel assembly	21-48

Body dimensions

Body dimensions	
Body dimension indications	31- 1
Projected dimensions	31 - 1
Straight-line dimensions	31- 1
Front body	31- 2
Side frame panel	31- 4
Interior A	31- 6
Interior B	31- 8
Interior C	31-10
Rear body	31-12
Under body	31-14

Body dimensions

Body dimension indication

Projected dimensions

The projected dimension indicates a dimension from a reference point on the body. (Height may be different in some cases)

Straight-line dimensions (Actual measured dimensions)

The straight-line dimension indicates a actual measured dimension between the measurement reference points.

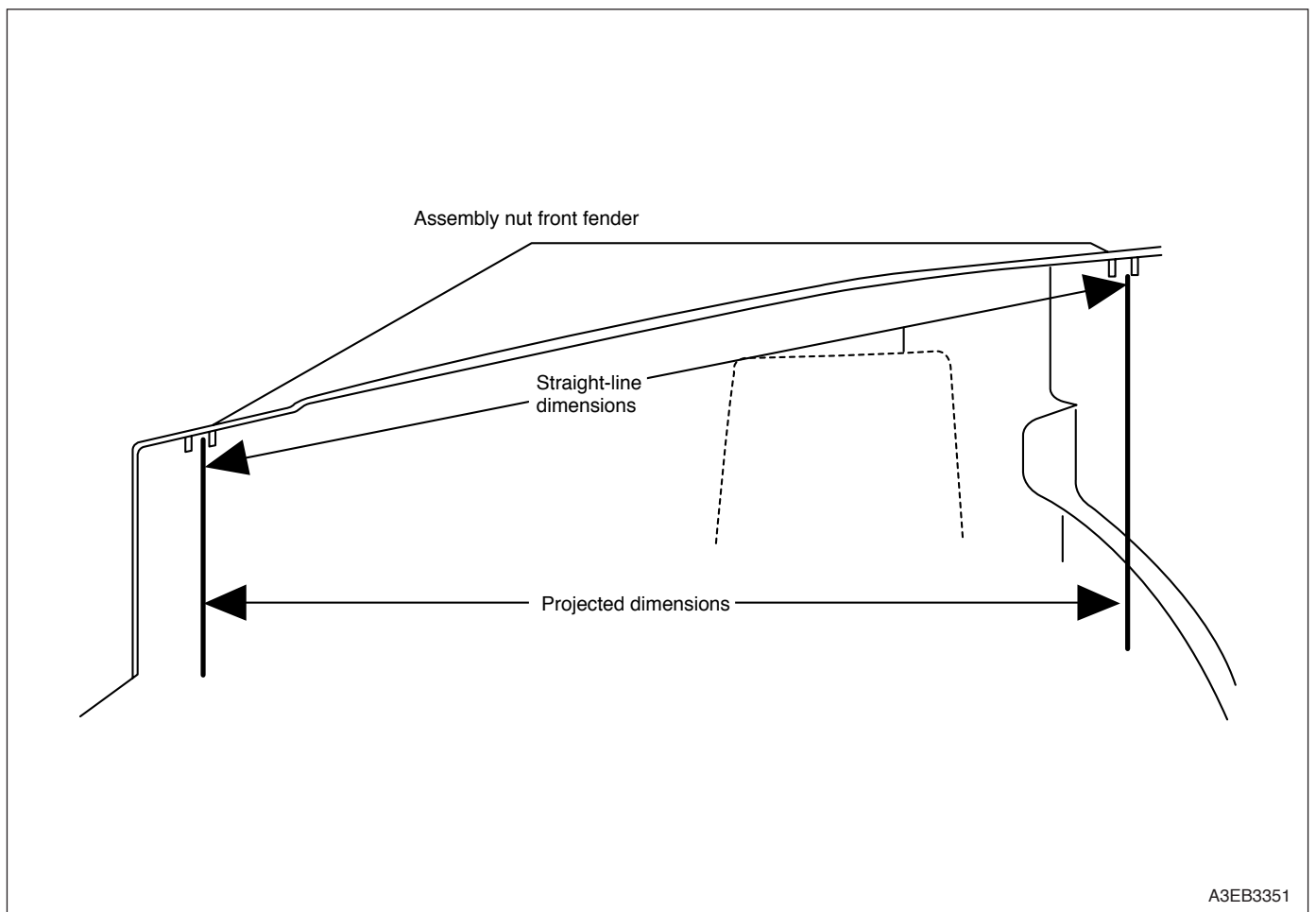

Front body straight - line dimensions

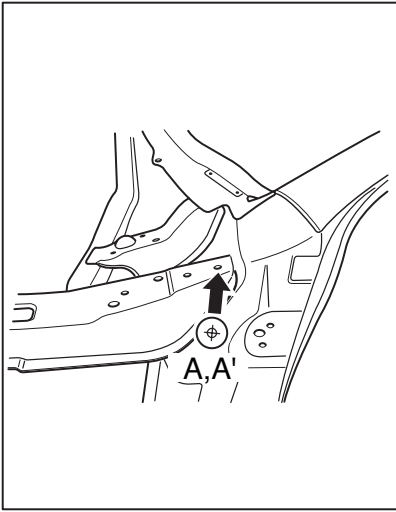

Hood hinge mounting hole

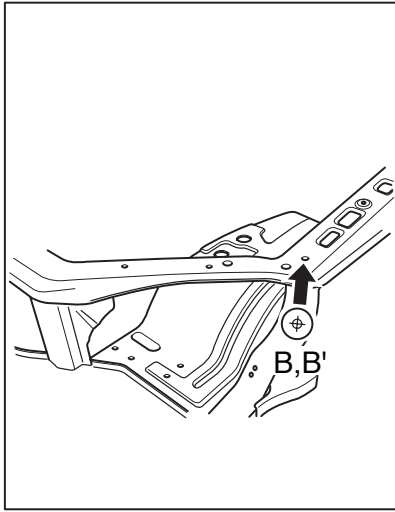

Front fender mounting hole

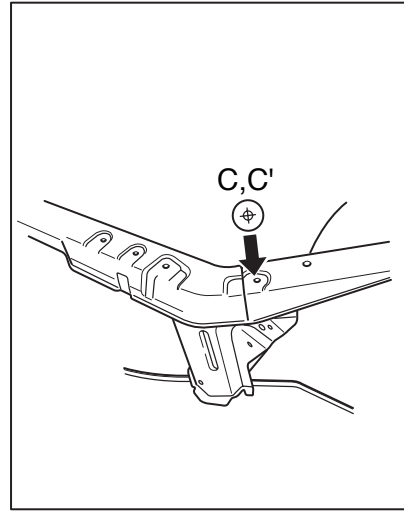

Head light mounting hole

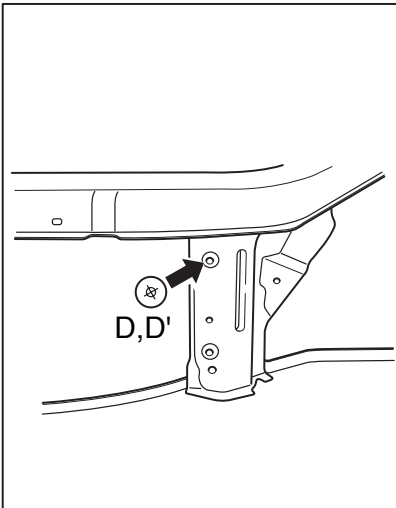

Seal board mounting hole

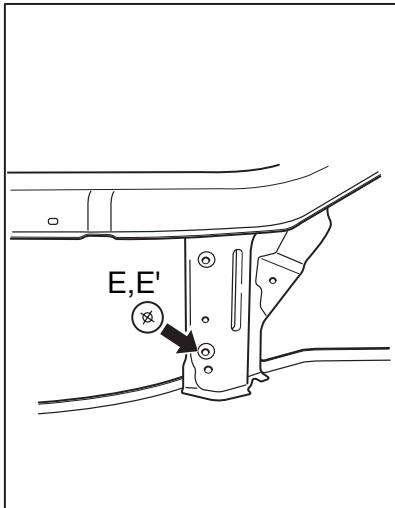

Seal board mounting hole

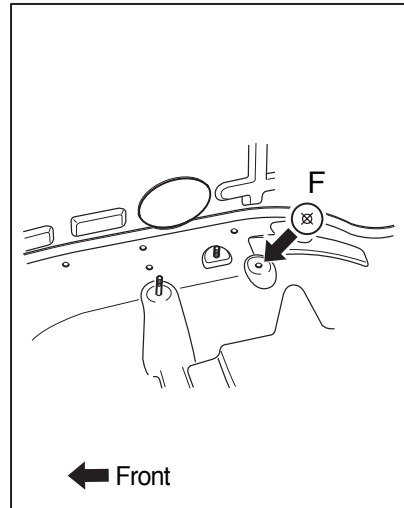

Front wheel apron hole

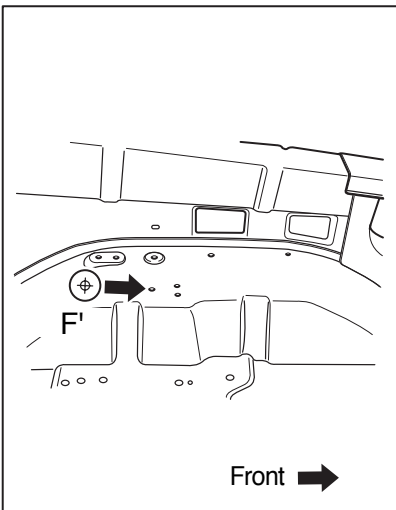

Front wheel apron hole

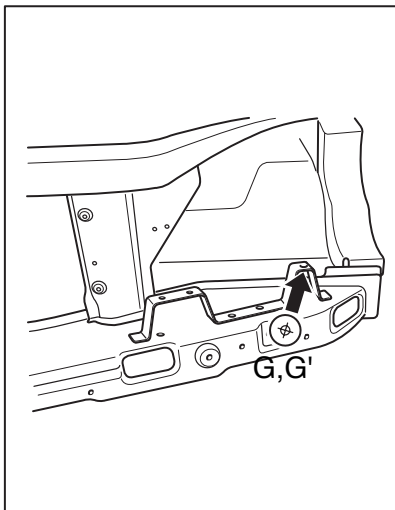

Bumper bracket hole

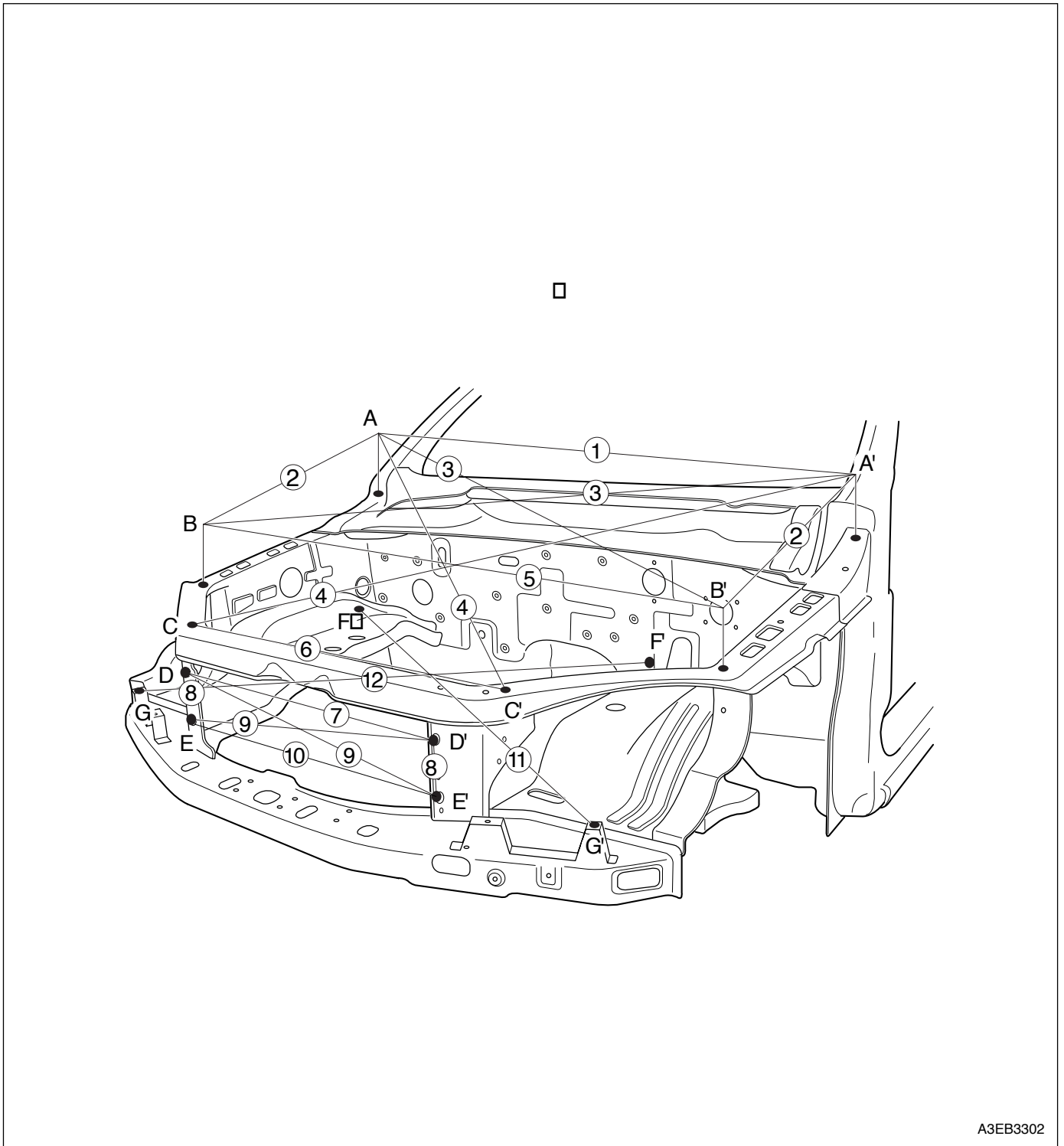

A3EB3302

Measurement point	①	②	③	④	⑤	⑥	⑦	⑧	⑨
Dimension (mm)	1556	680	1684	1566	1526	897	754	112	762
Measurement point	⑩	⑪	⑫						
Dimension (mm)	754	1496	1462						

Side frame panel straight - line dimensions

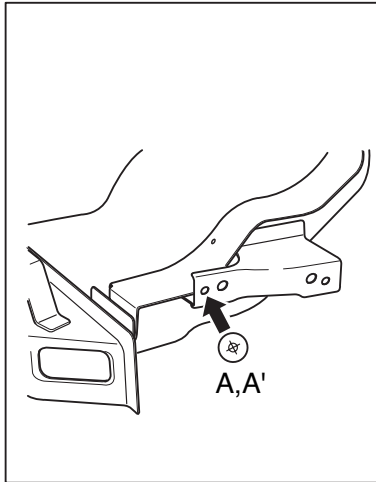

Front fender mounting hole

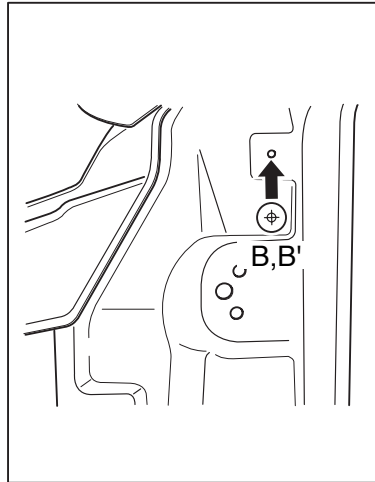

Front fender mounting hole

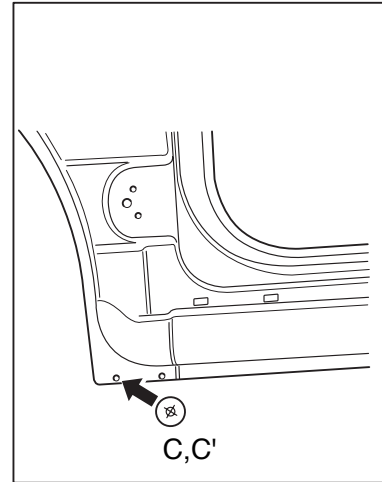

Front fender mounting hole

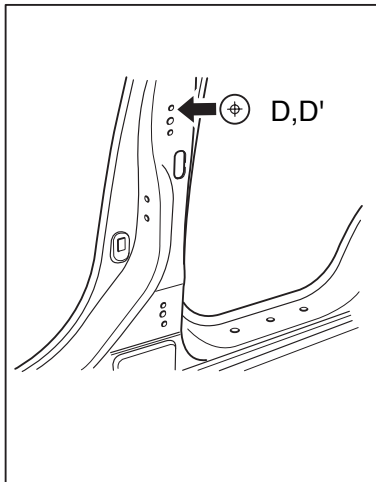

Door hinge mounting hole(upper)

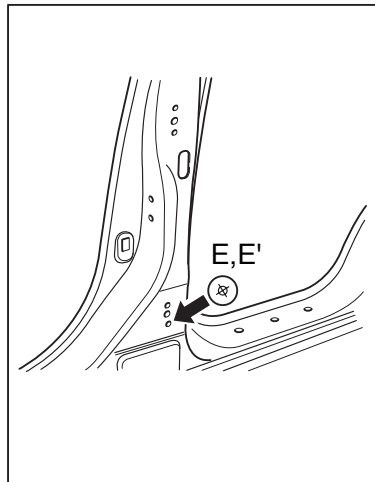

Door hinge mounting hole(lower)

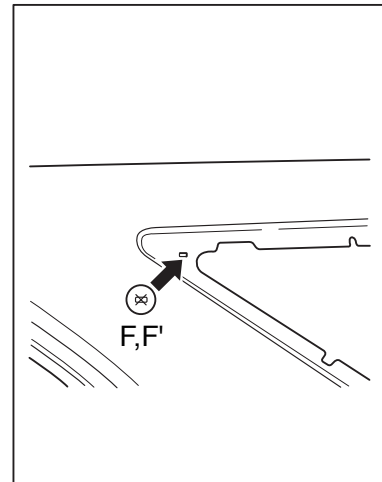

Quarter glass stopper hole

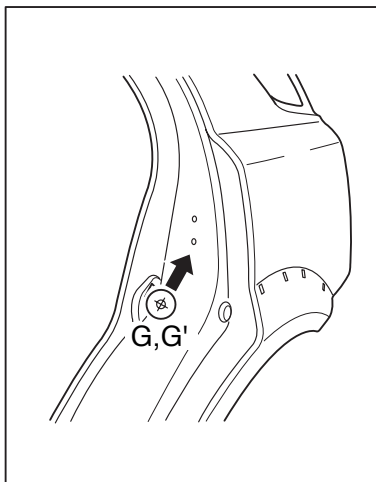

Rear door striker mounting hole

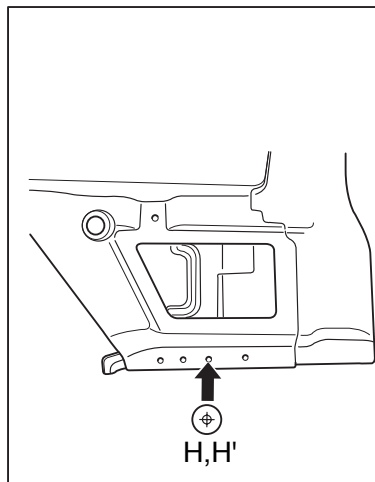

Rear bumper mounting hole

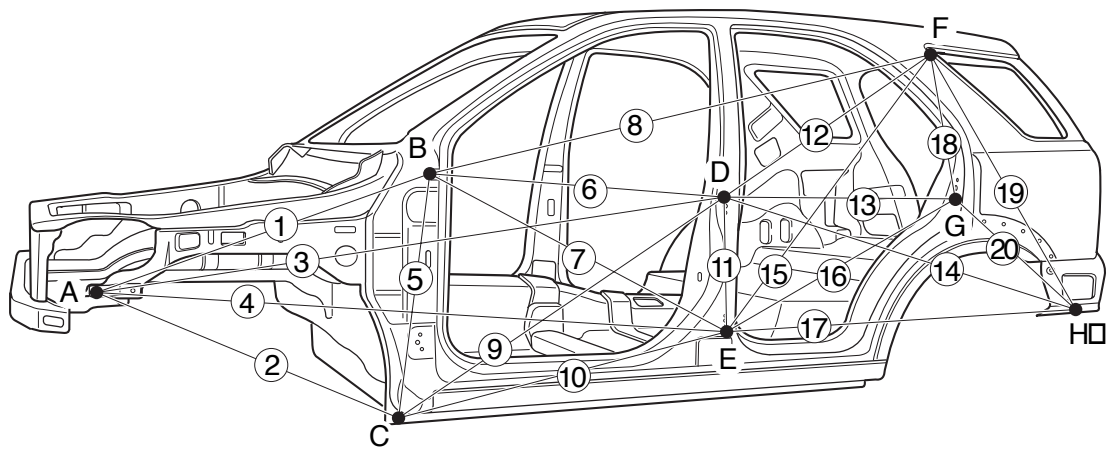

A3EB3304

Measurement point	①	②	③	④	⑤	⑥	⑦	⑧	⑨
Dimension (mm)	1053	1075	2054	2047	812	1058	1182	2101	1272
Measurement point	⑩	⑪	⑫	⑬	⑭	⑮	⑯	⑰	⑱
Dimension (mm)	1103	420	1158	1007	1717	1413	1098	1655	570
Measurement point	⑲	⑳							
Dimension (mm)	1221	804							

Interior A straight - line dimensions

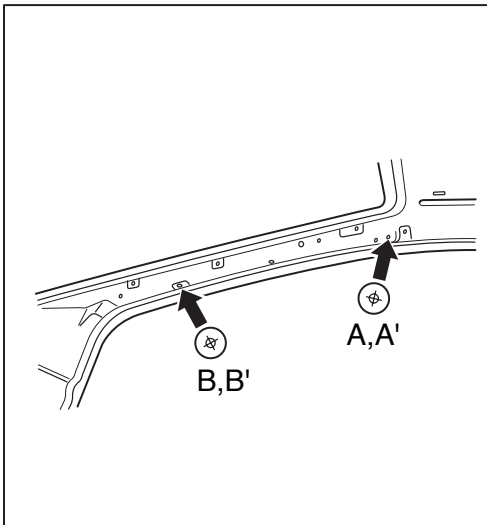

A pillar trim mounting hole

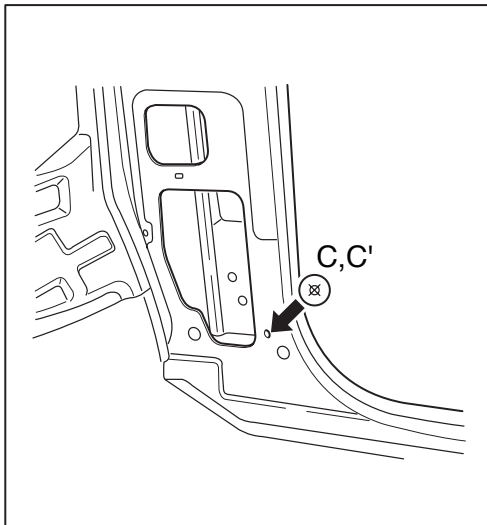

A pillar lower panel hole

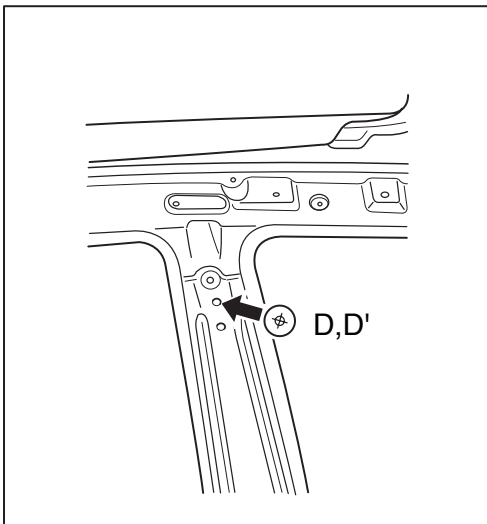

B pillar trim mounting hole

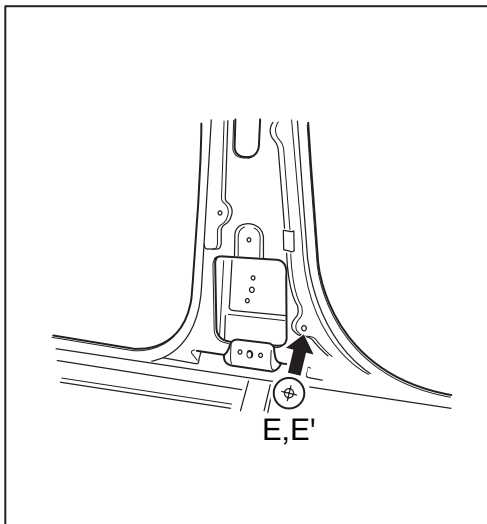

B pillar trim mounting hole

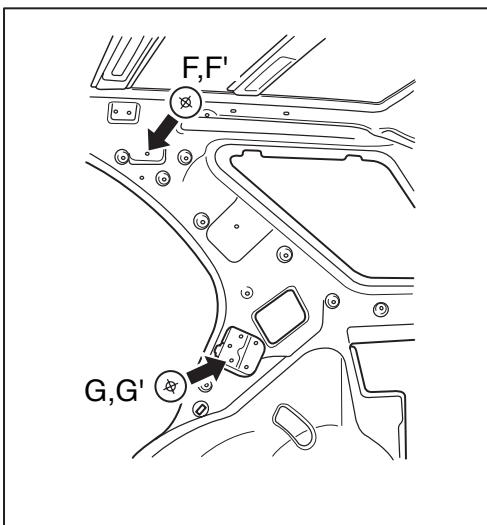

Quarter inner panel hole

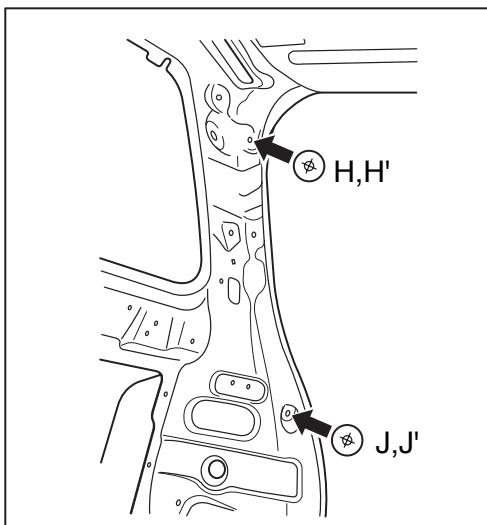

H : D pillar trim mounting hole
J : Quarter trim mounting hole

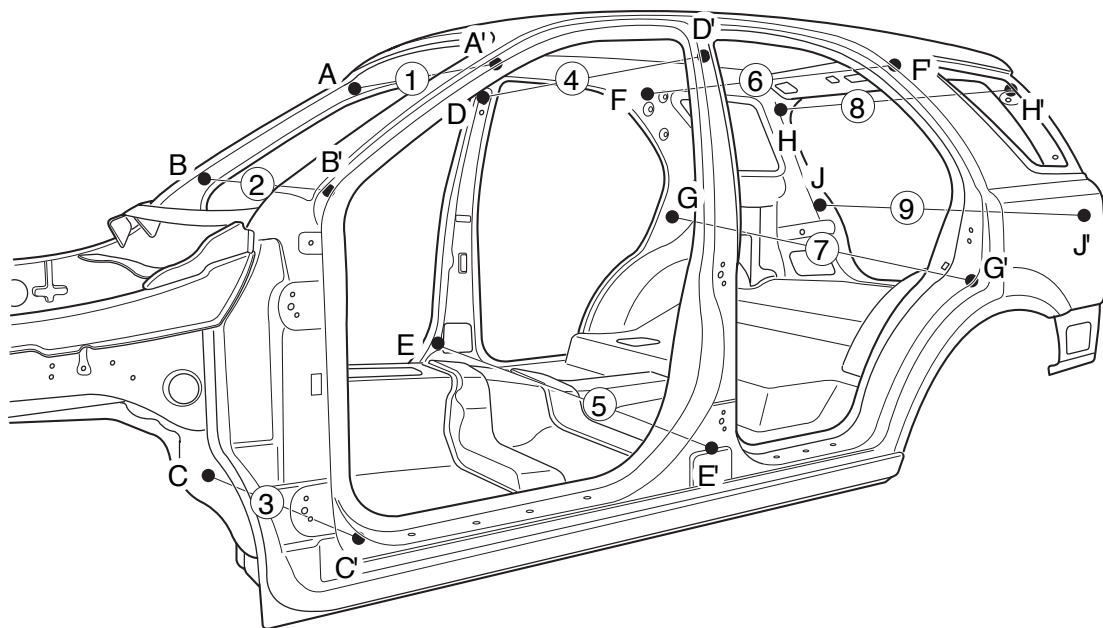

A3EB3306

Measurement point	①	②	③	④	⑤	⑥	⑦	⑧	⑨
Dimension (mm)	1260	1399	1454	1267	1452	1204	1448	1138	1174

Interior B straight - line dimensions

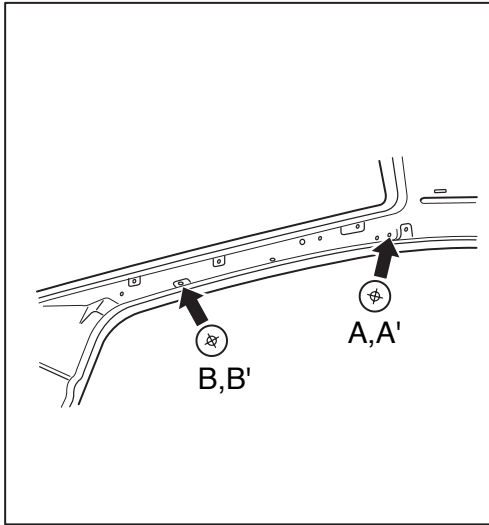

A pillar trim mounting hole

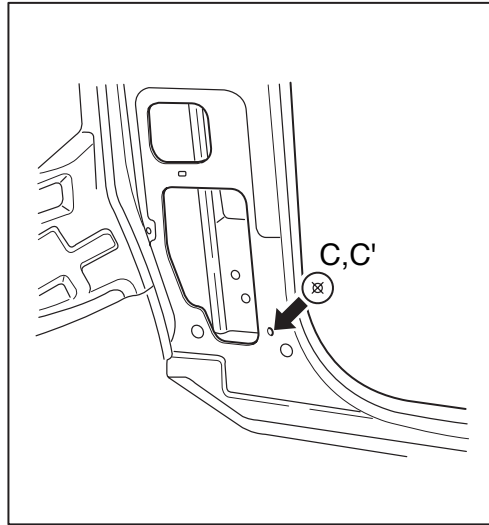

A pillar lower panel hole

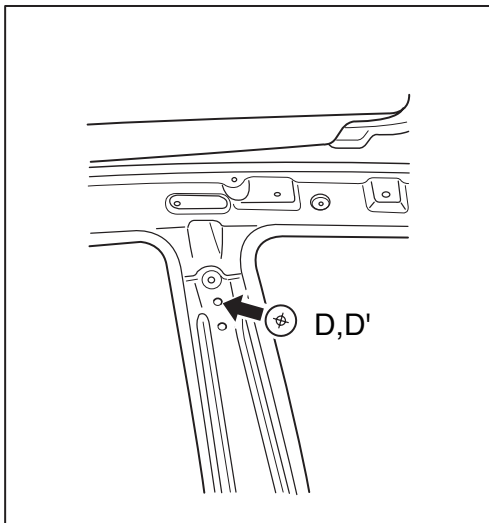

B pillar trim mounting hole

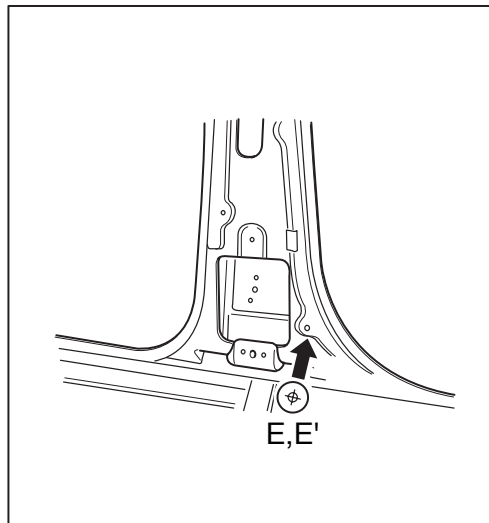

B pillar trim mounting hole

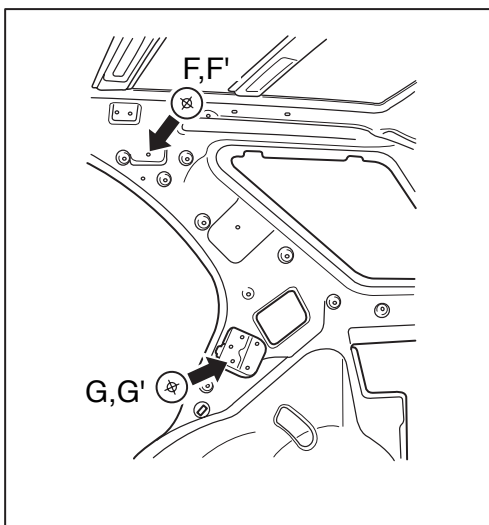

Quarter inner panel hole

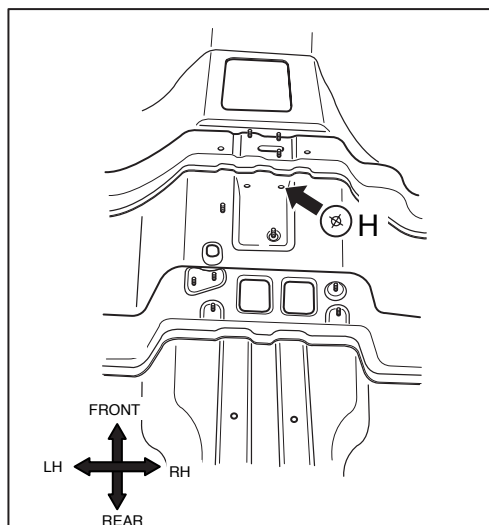

Tunnel reinforcement hole

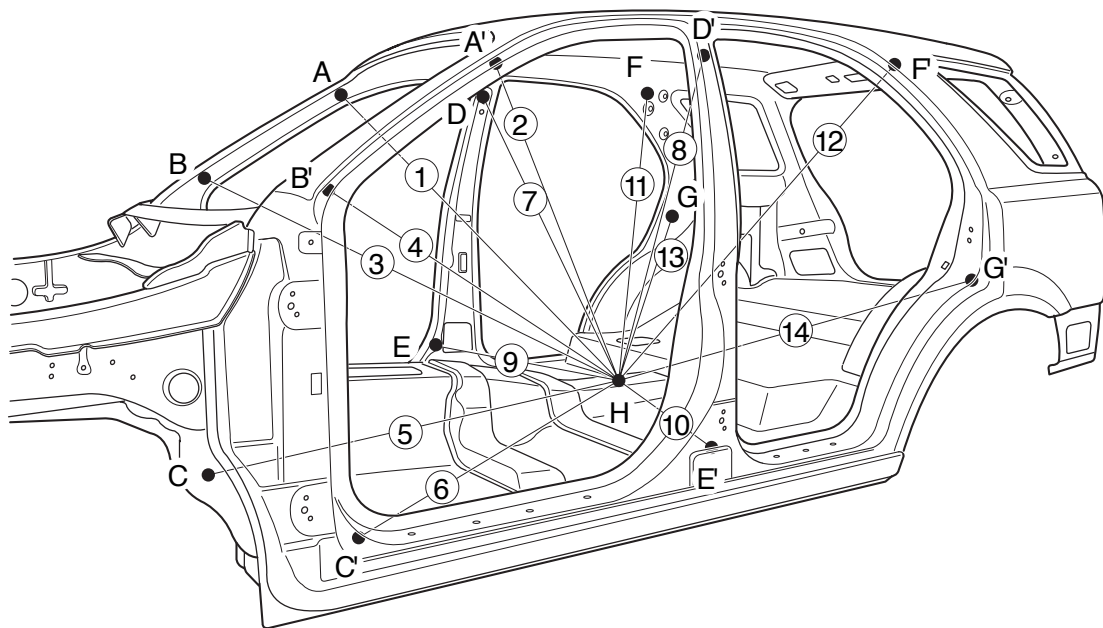

A3EB3308

Measurement point	①	②	③	④	⑤	⑥	⑦	⑧	⑨
Dimension (mm)	1085	1118	1108	1144	1011	1052	1152	1184	719
Measurement point	⑩	⑪	⑫	⑬	⑭				
Dimension (mm)	775	1534	1556	1530	1557				

Interior C straight - line dimensions

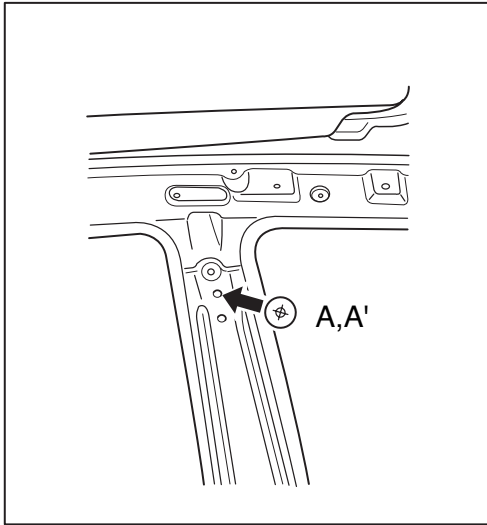

B pillar trim mounting hole

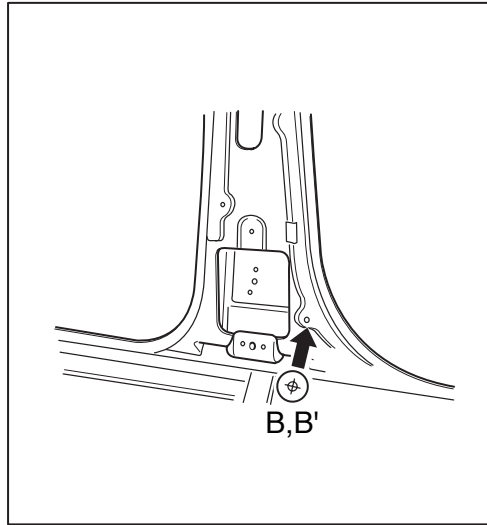

B pillar trim mounting hole

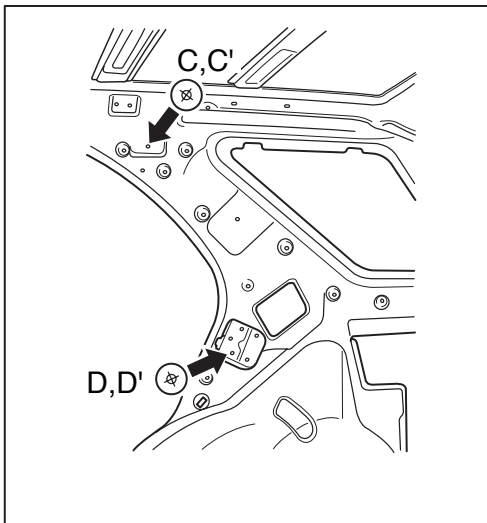

Quarter inner panel hole

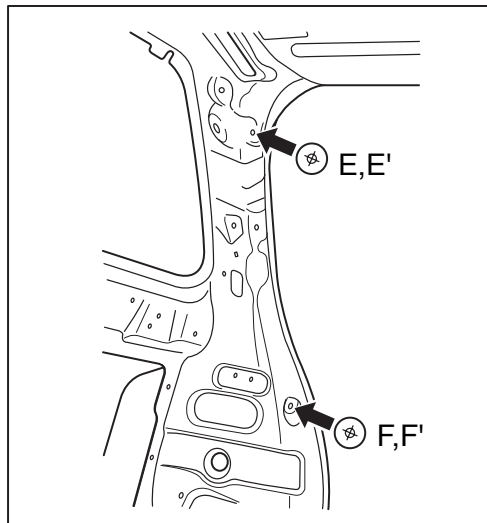

E : D pillar trim mounting hole
F : Quarter trim mounting hole

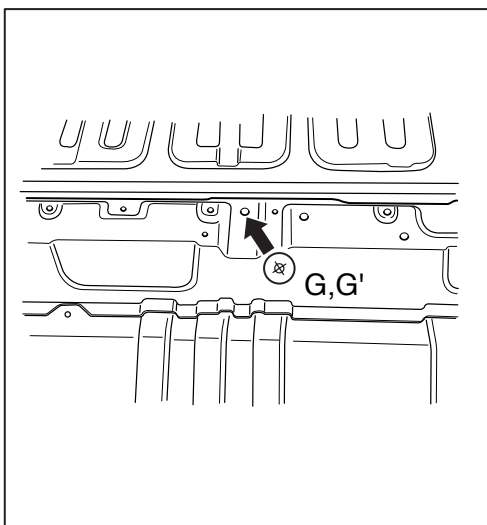

(5P) Rear seat support panel

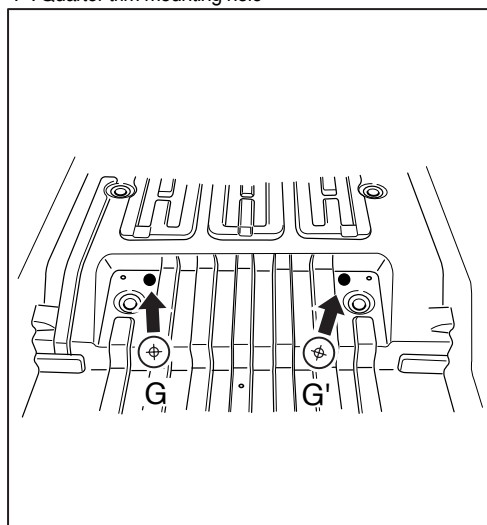

(7P) 3rd seat mounting hole

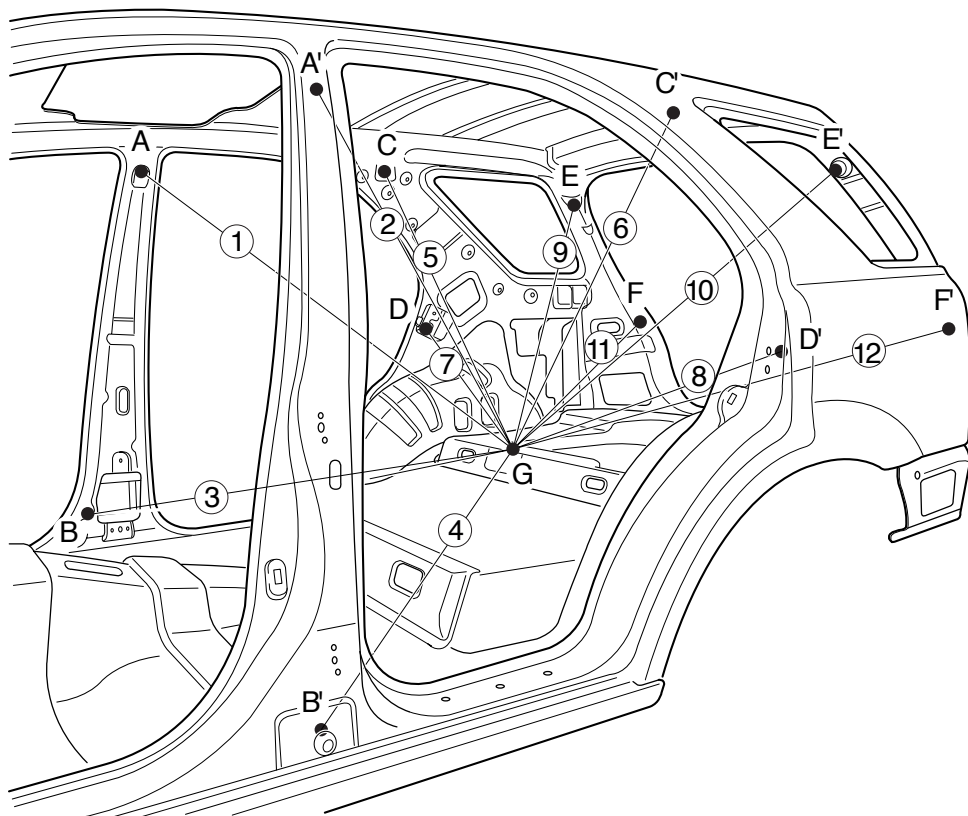

A3EB3310

Measurement point	①	②	③	④	⑤	⑥	⑦	⑧	⑨
Dimension (mm)	1319	1421	1250	1372	978	1105	696	896	1038
Measurement point	⑩	⑪	⑫						
Dimension (mm)	1153	1025	1144						

Rear body straight - line dimensions

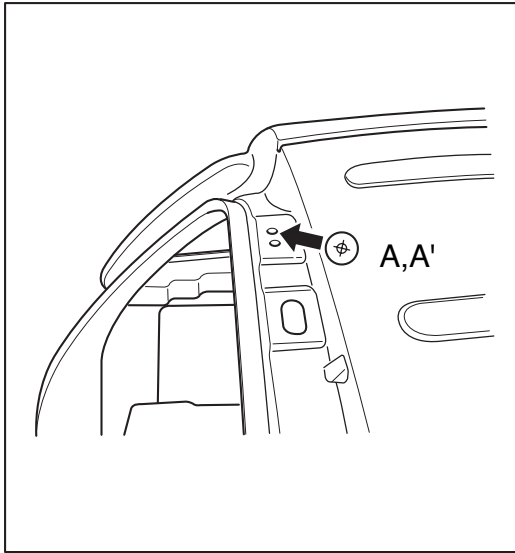

Tail gate hinge mounting hole

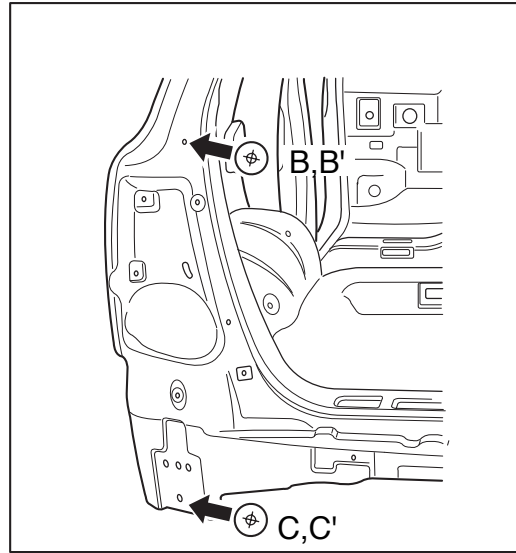

B : Damper mounting hole
C : Rear bumper mounting hole

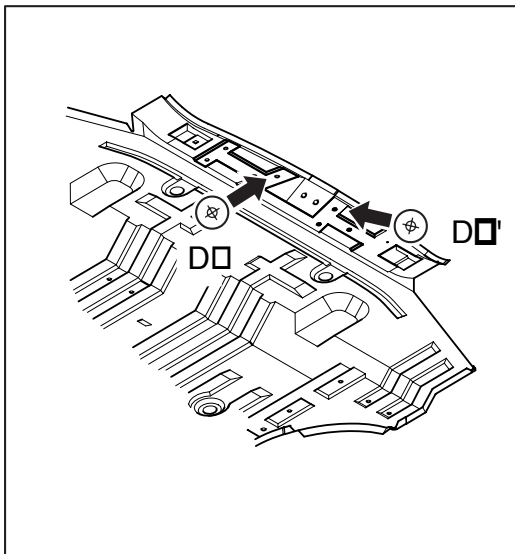

Rear end trim mounting hole

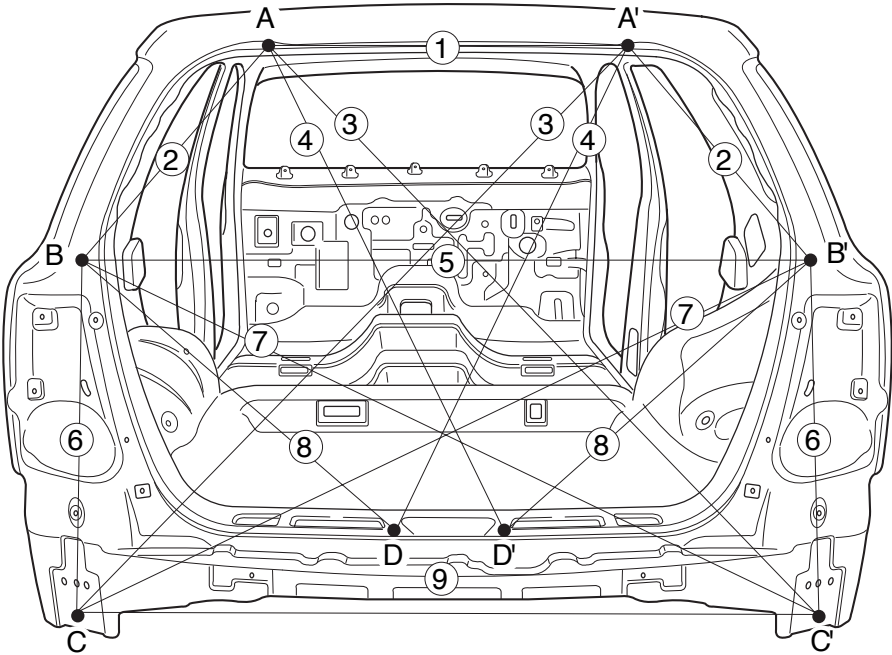

A3EB3312

Measurement point	①	②	③	④	⑤	⑥	⑦	⑧	⑨
Dimension (mm)	725	579	1535	1074	1341	660	1495	757	1343

31-14 Body dimensions

Under body dimensions

Projected dimensions

Measurement point	Description	Hole size
A	Body mounting bracket No.1	ø36 mm
B	Body mounting bracket No.2	LH : ø32 mm, RH : ø34 mm
C	Body mounting bracket No.3	ø30 mm
D	Body mounting bracket No.4	ø30 mm
E	Body mounting bracket No.5	LH : ø34 X 38 mm, RH : ø32 X 36 mm

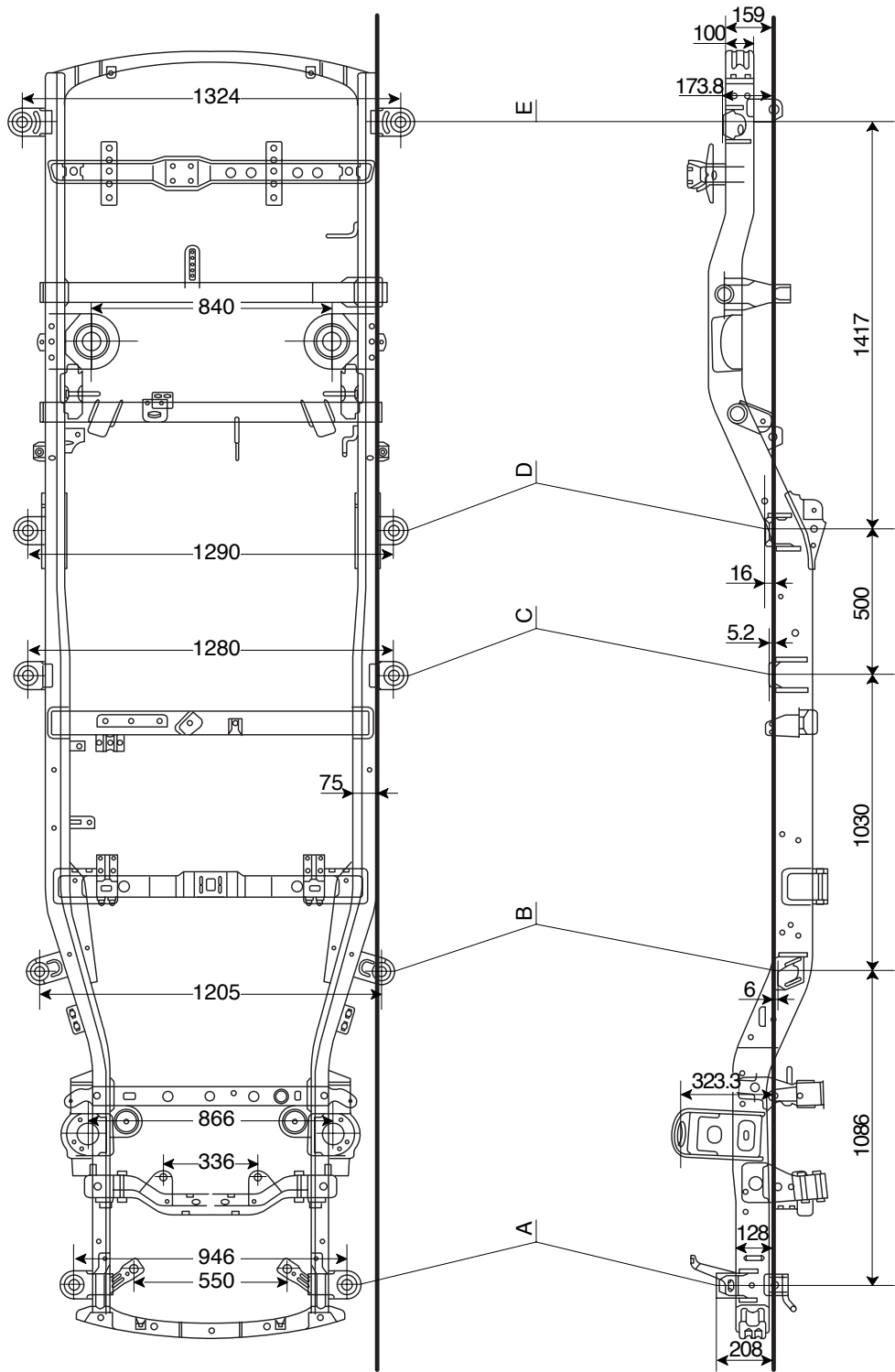

Unit : mm

31-16 Body dimensions

Straight - line dimensions

Measurement point	Description	Hole size
A	Body mounting bracket No.1	ø36 mm
B	Body mounting bracket No.2	LH : ø32 mm, RH : ø34 mm
C	Body mounting bracket No.3	ø30 mm
D	Body mounting bracket No.4	ø30 mm
E	Body mounting bracket No.5	LH : ø34 X 38 mm, RH : ø32 X 36 mm

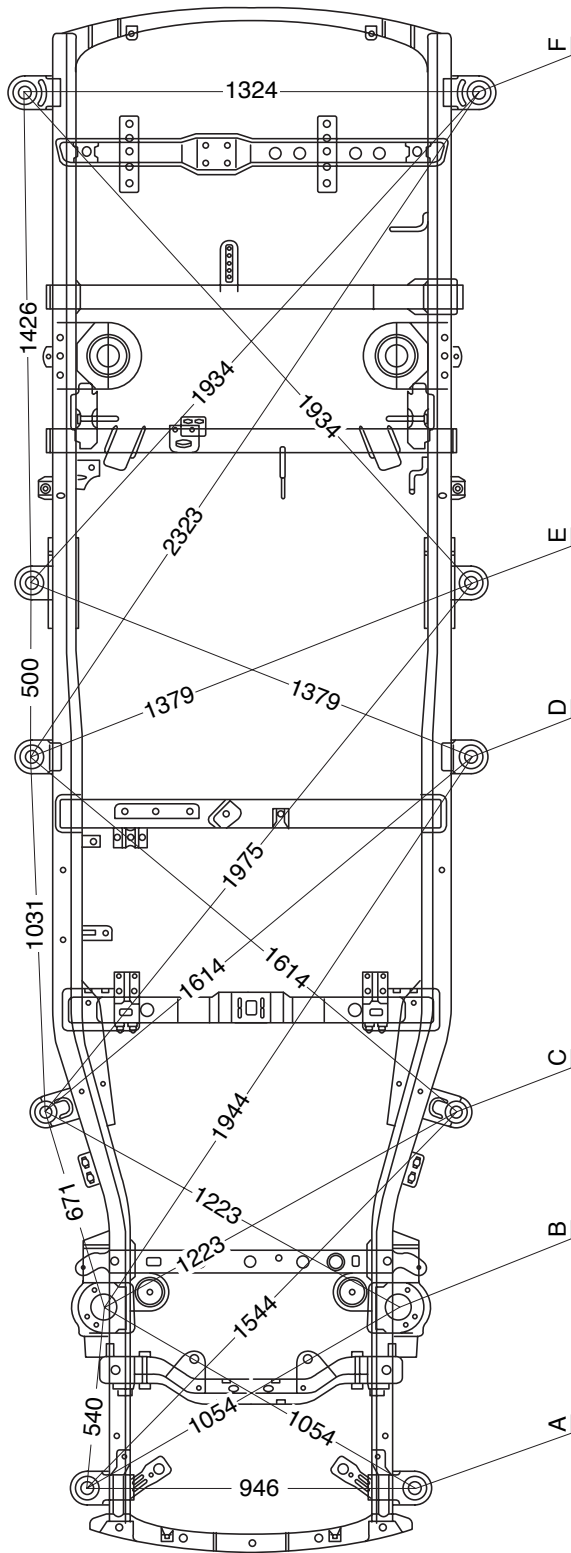

Unit : mm

Waterproof and rustproof

Body sealing

Hood.....	41- 1
Front & Rear door.....	41- 2
Tail gate	41- 4
Front body.....	41- 5
Side frame panel(Front).....	41- 6
Side frame panel(Rear)	41- 8
Floor panel	41-10
Rear body	41-11
Under body	41-12

Under coating.....	41-14
--------------------	-------

Applying urethane	41-16
-------------------------	-------

Applying rustproofing Material

Hood / tailgate.....	41-17
Front door / Rear door	41-18
Body parts.....	41-19

Body sealing

To waterproof and rustproof the vehicle, apply sealer on assembled area of the body panel and on any areas in contact with the body, such as doors(inner/outer), hood(inner/outer), and tail gate(inner/outer).

Hood

※ Trim each edge.

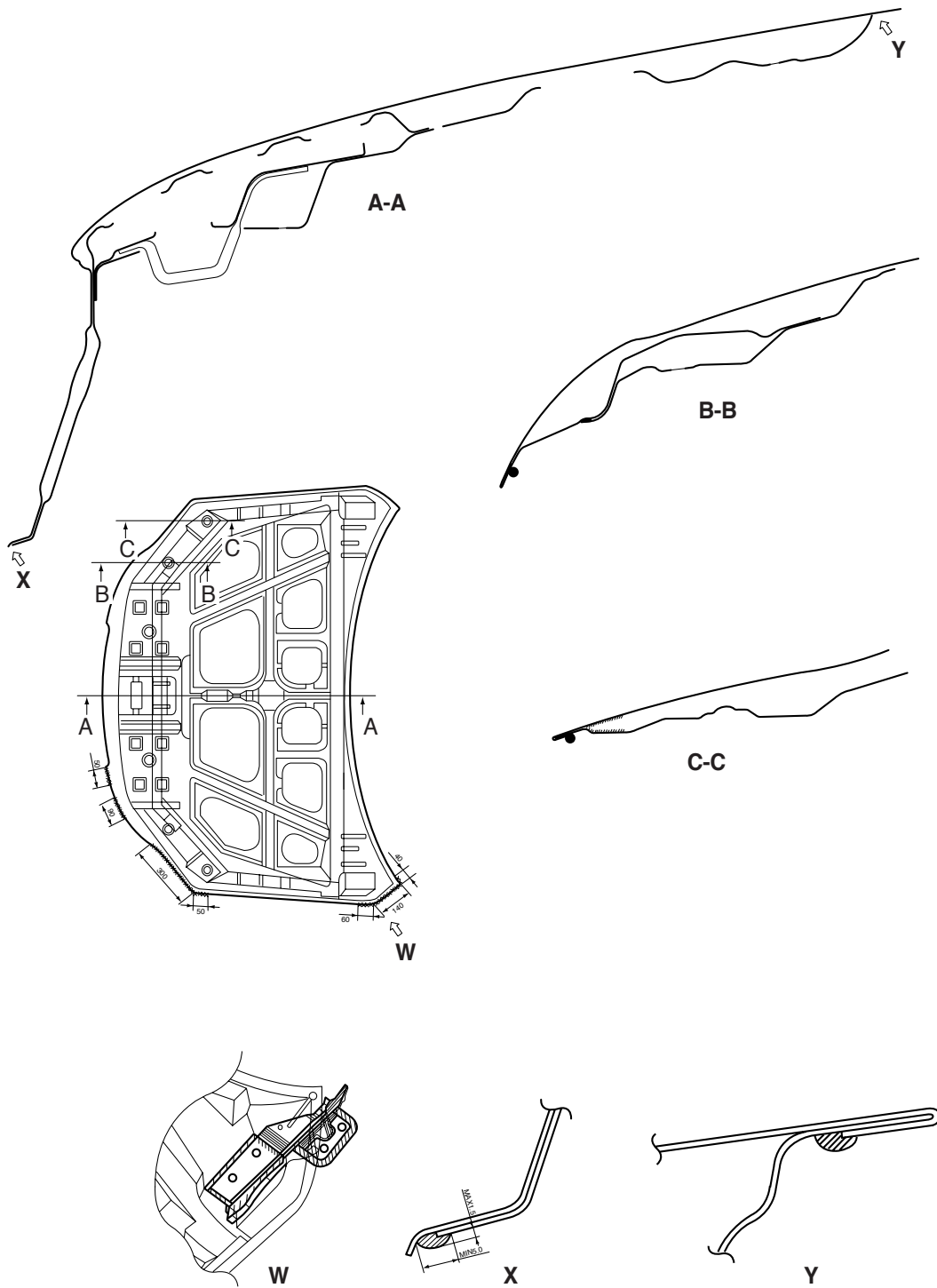

Front & Rear door

※ Trim each edge.

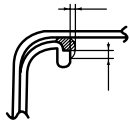

A

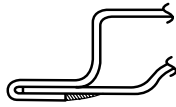

B



C

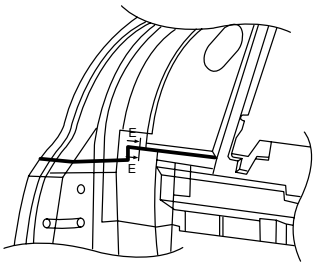

R

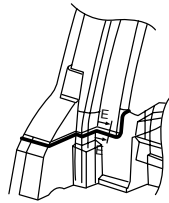

X

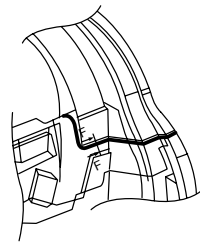

Y

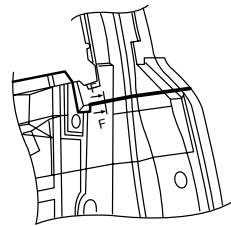

Z

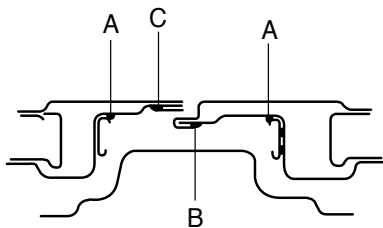

A-A

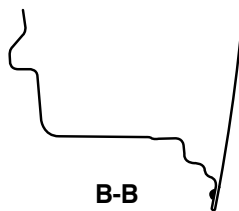

B-B

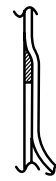

E-E



F-F

※ Trim each edge.

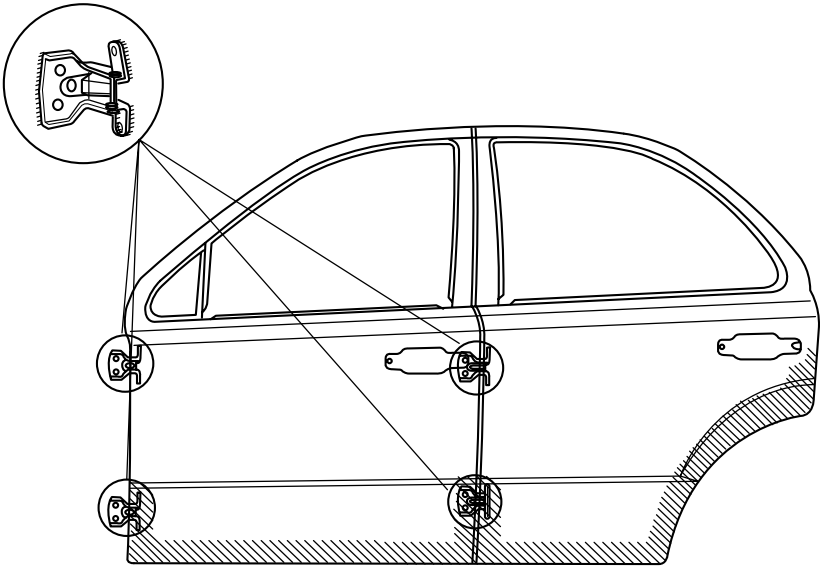
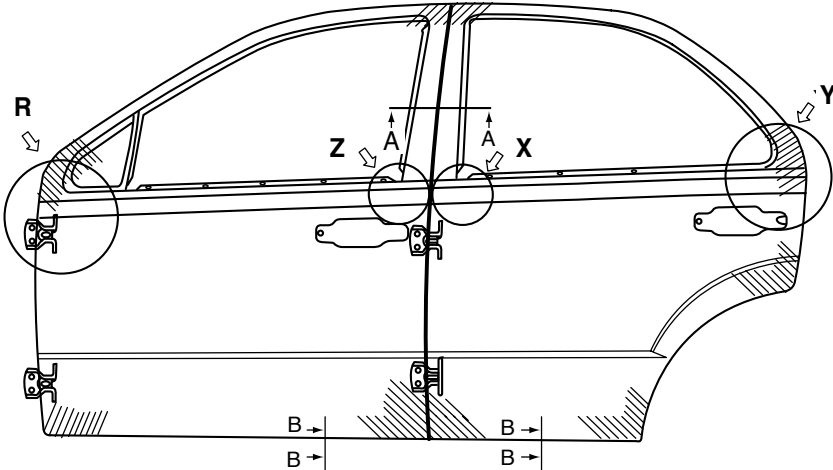

Tail gate

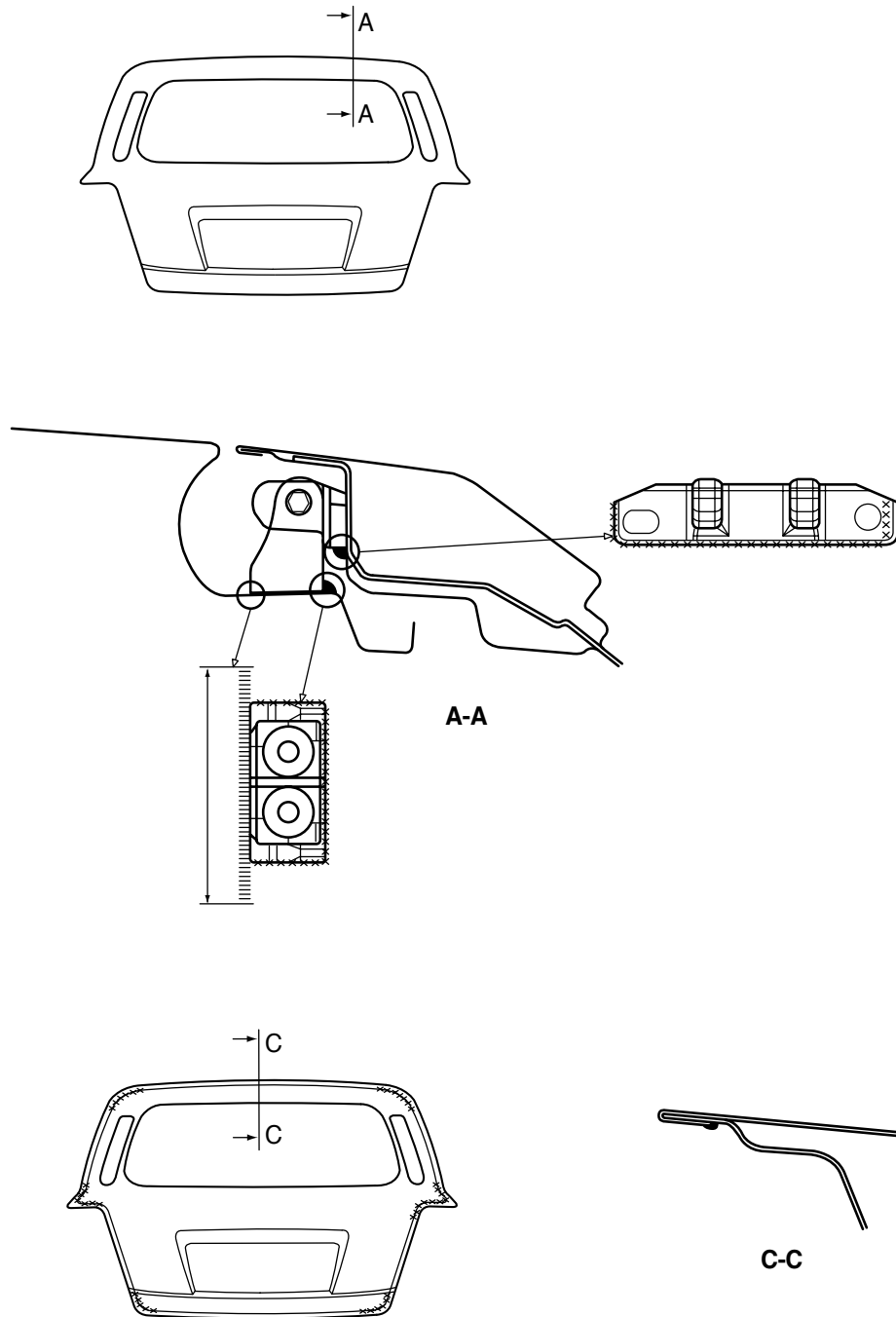

Front body

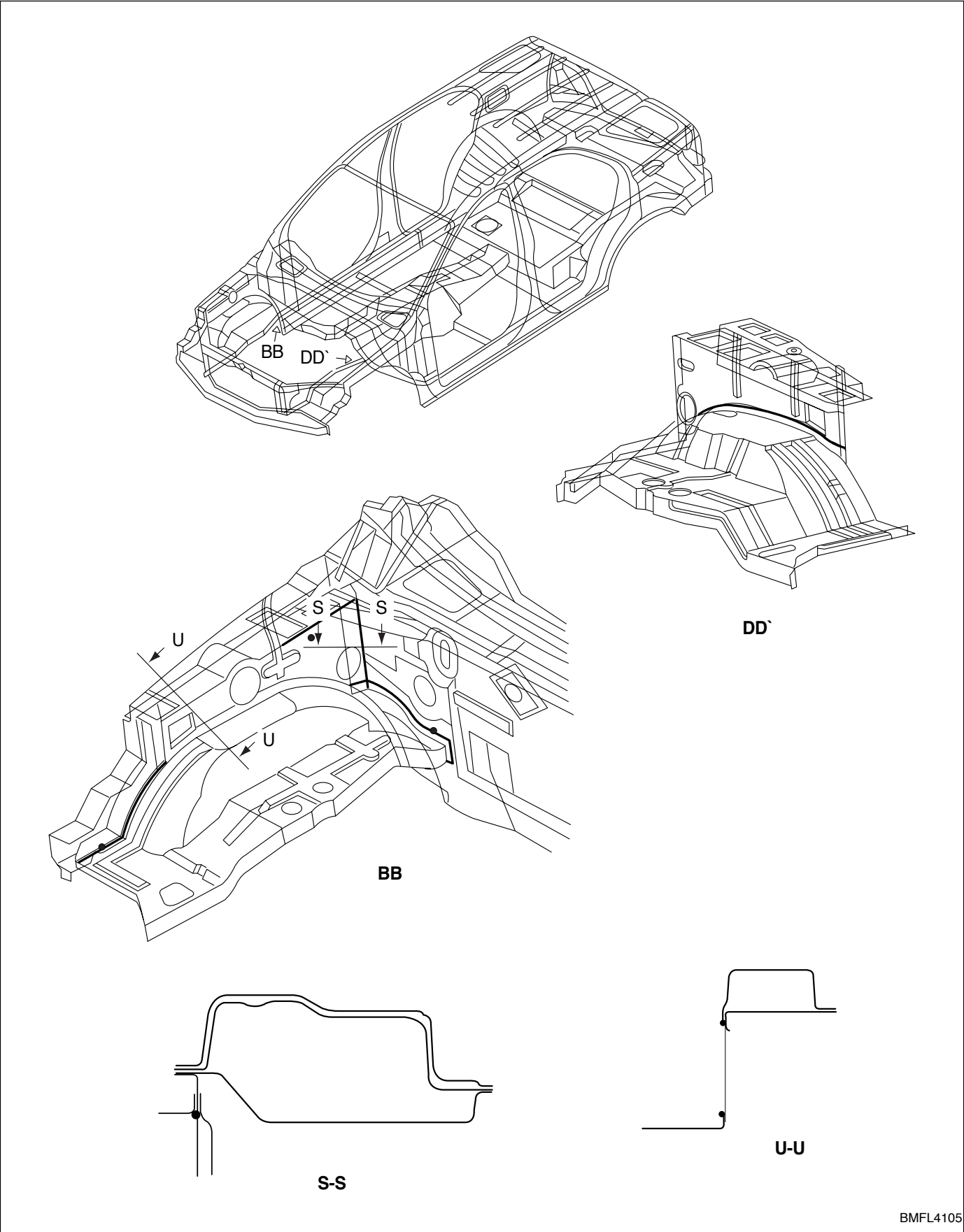

Side frame panel(Front)

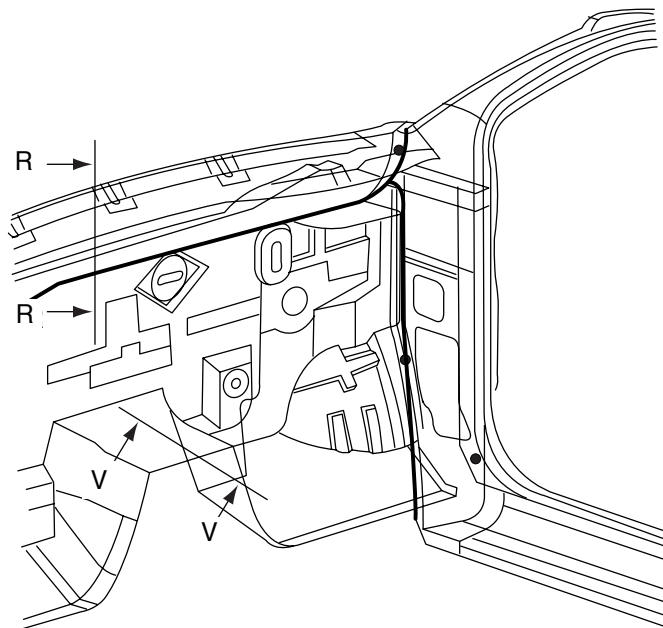
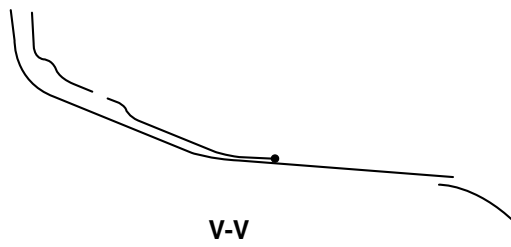
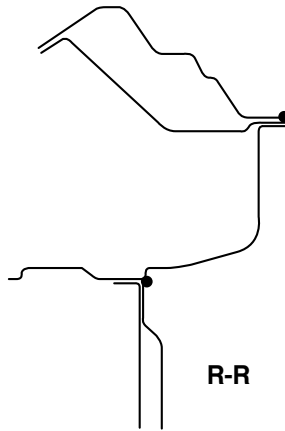

C-C

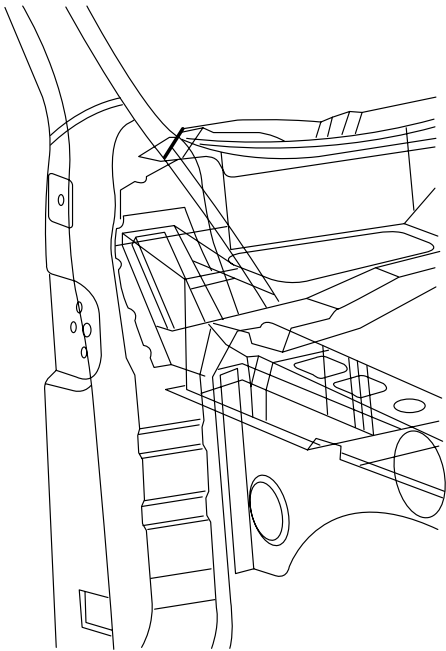
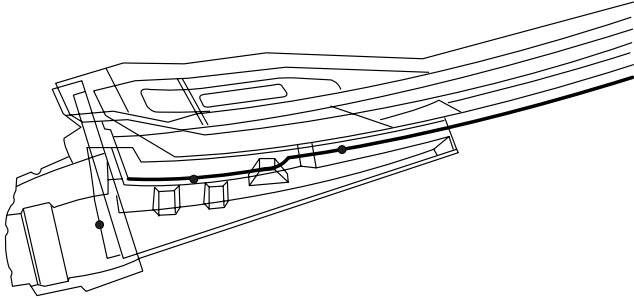
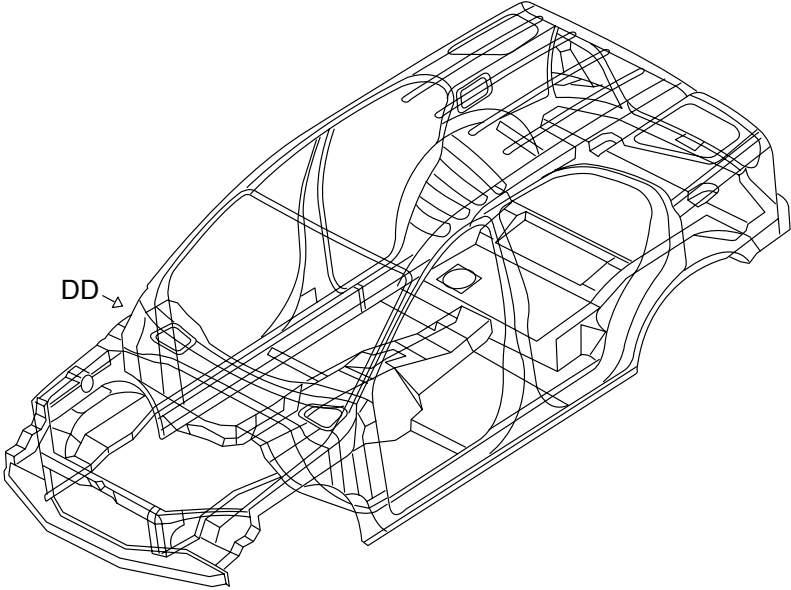

DD

Side frame panel(Rear)

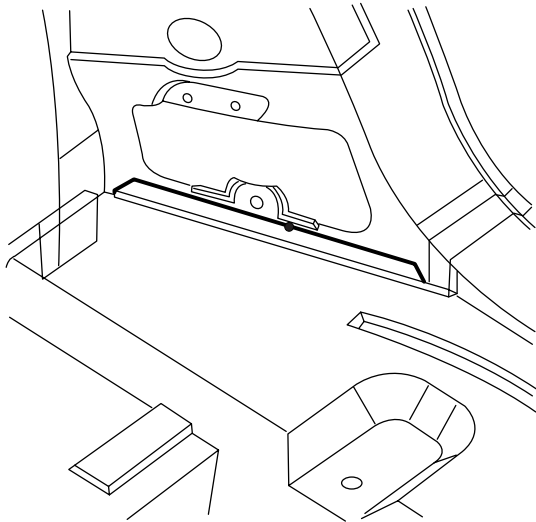

FF

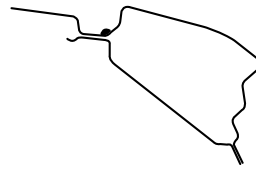

O-O

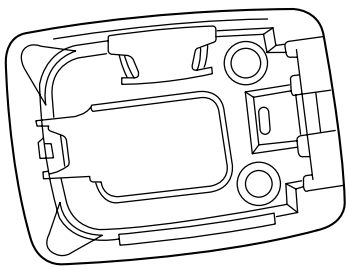

D-D

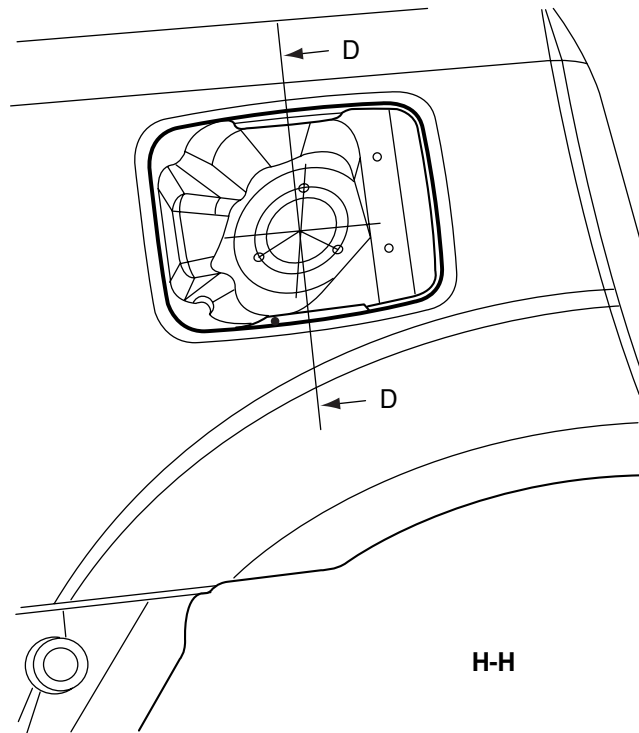

H-H

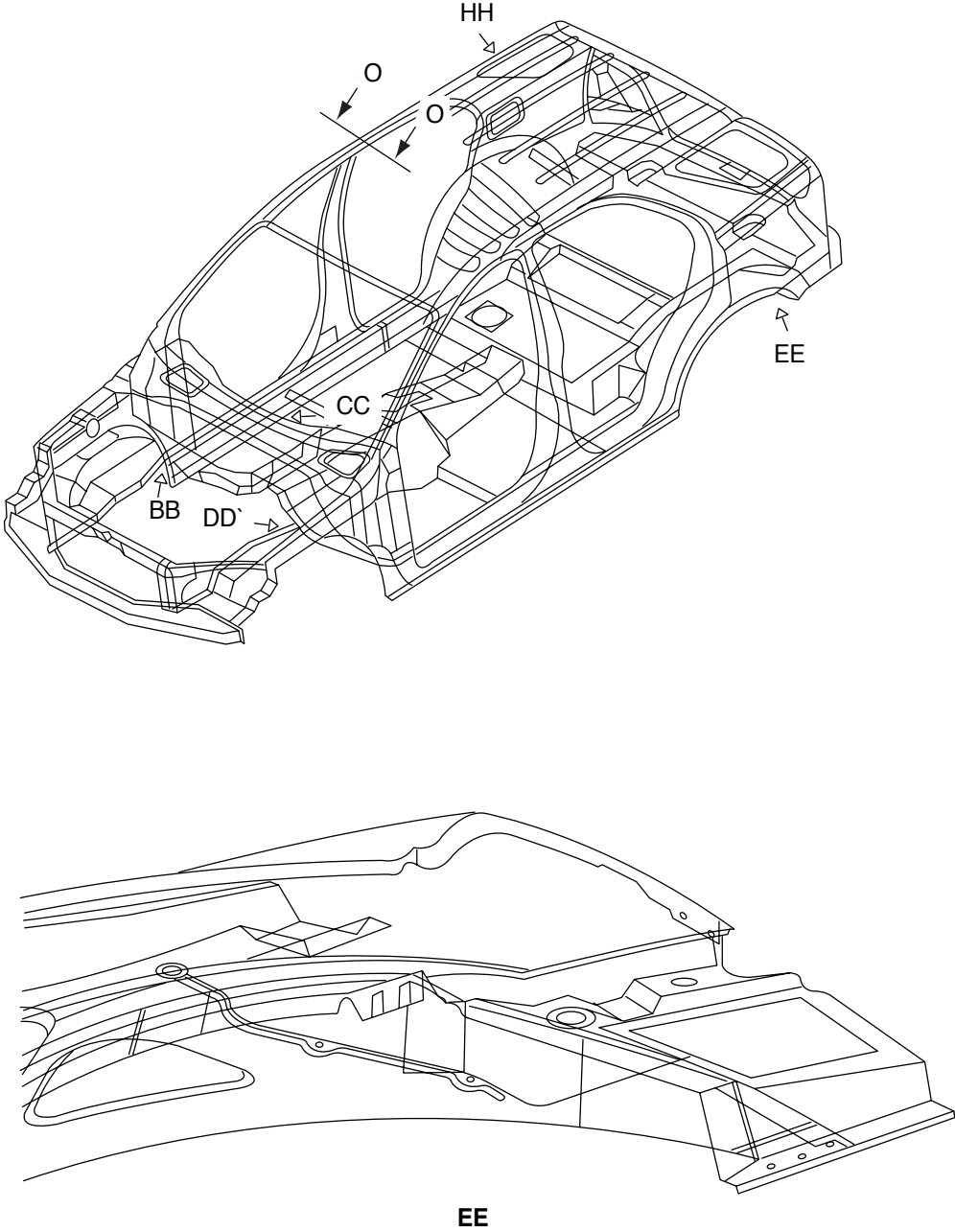

Floor panel

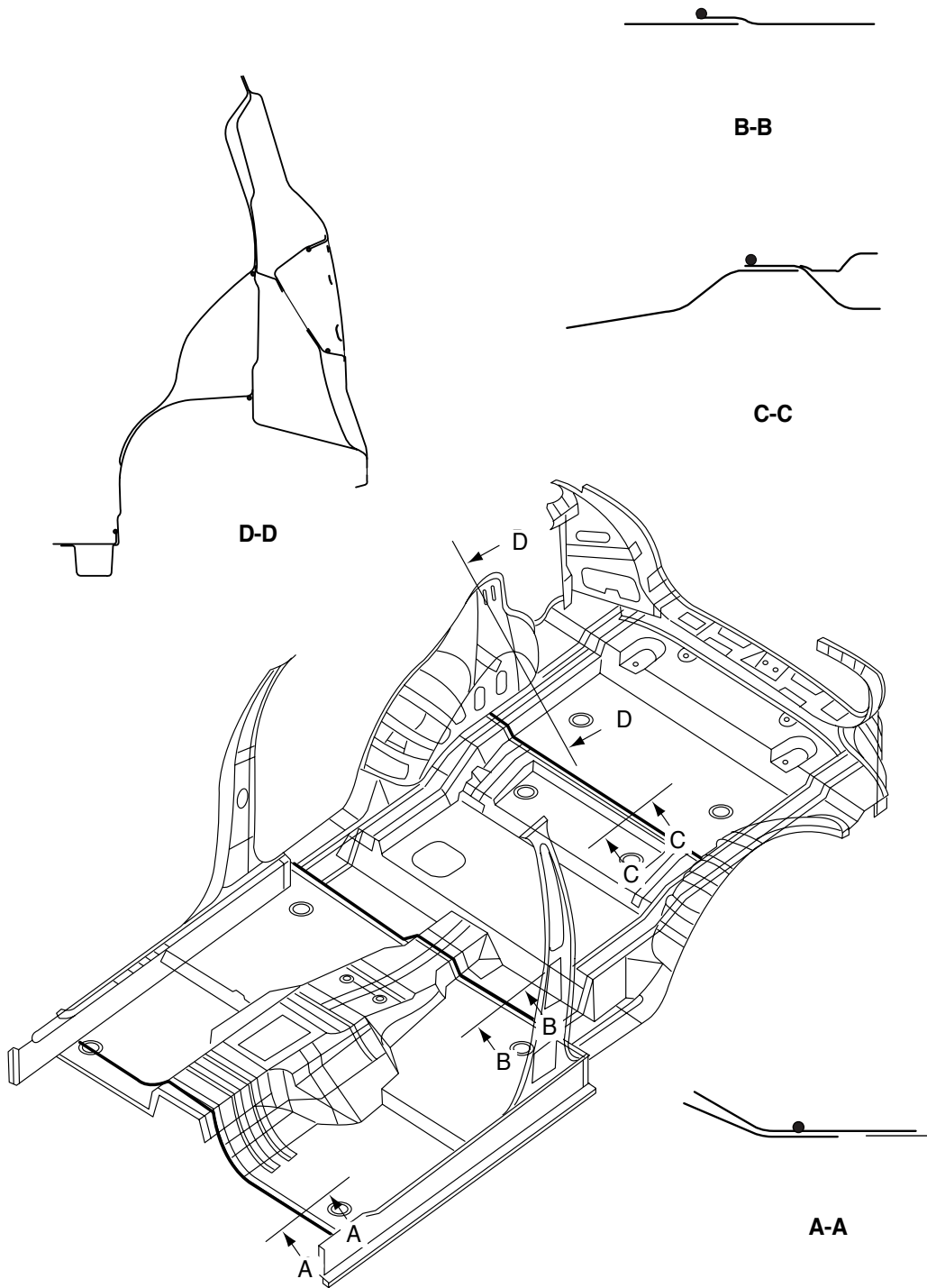

Rear body

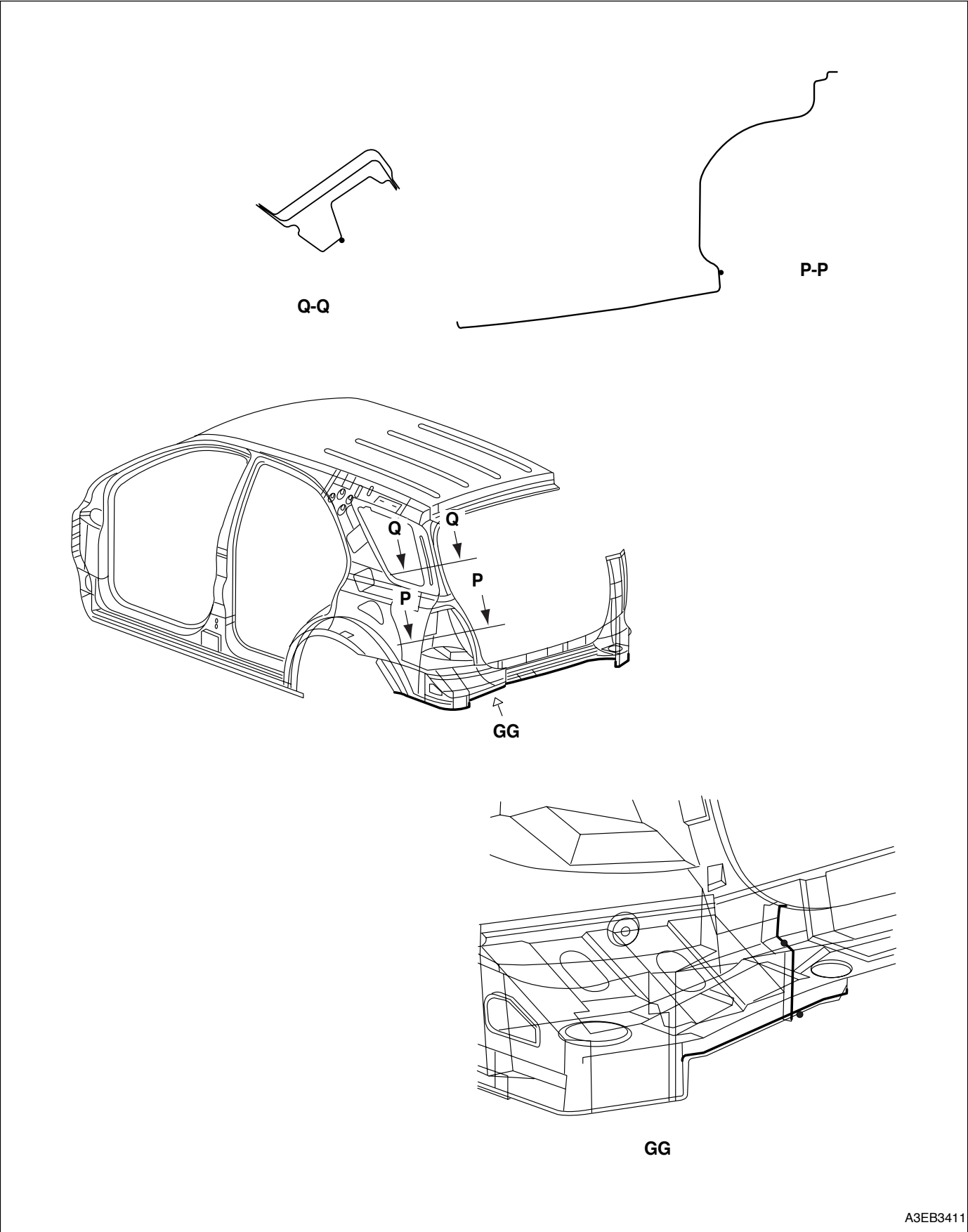

Under body

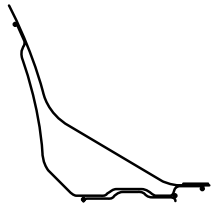

E-E

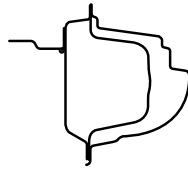

F-F



I-I

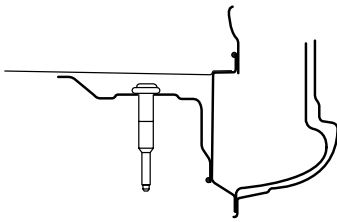

G-G

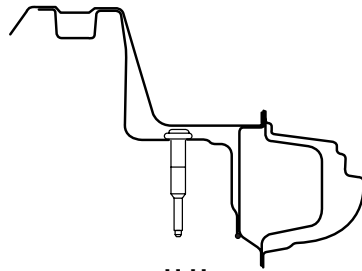

H-H



J-J

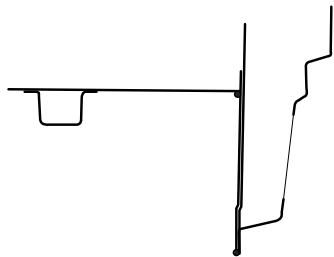

E-E

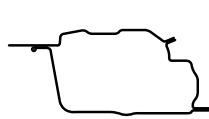

L-L

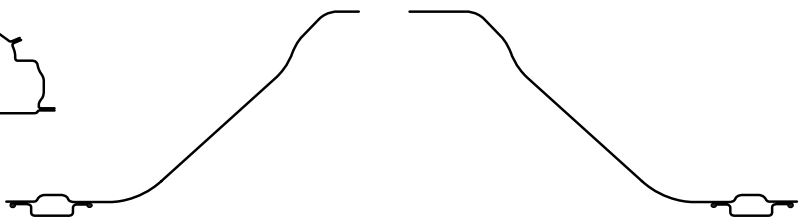

N-N

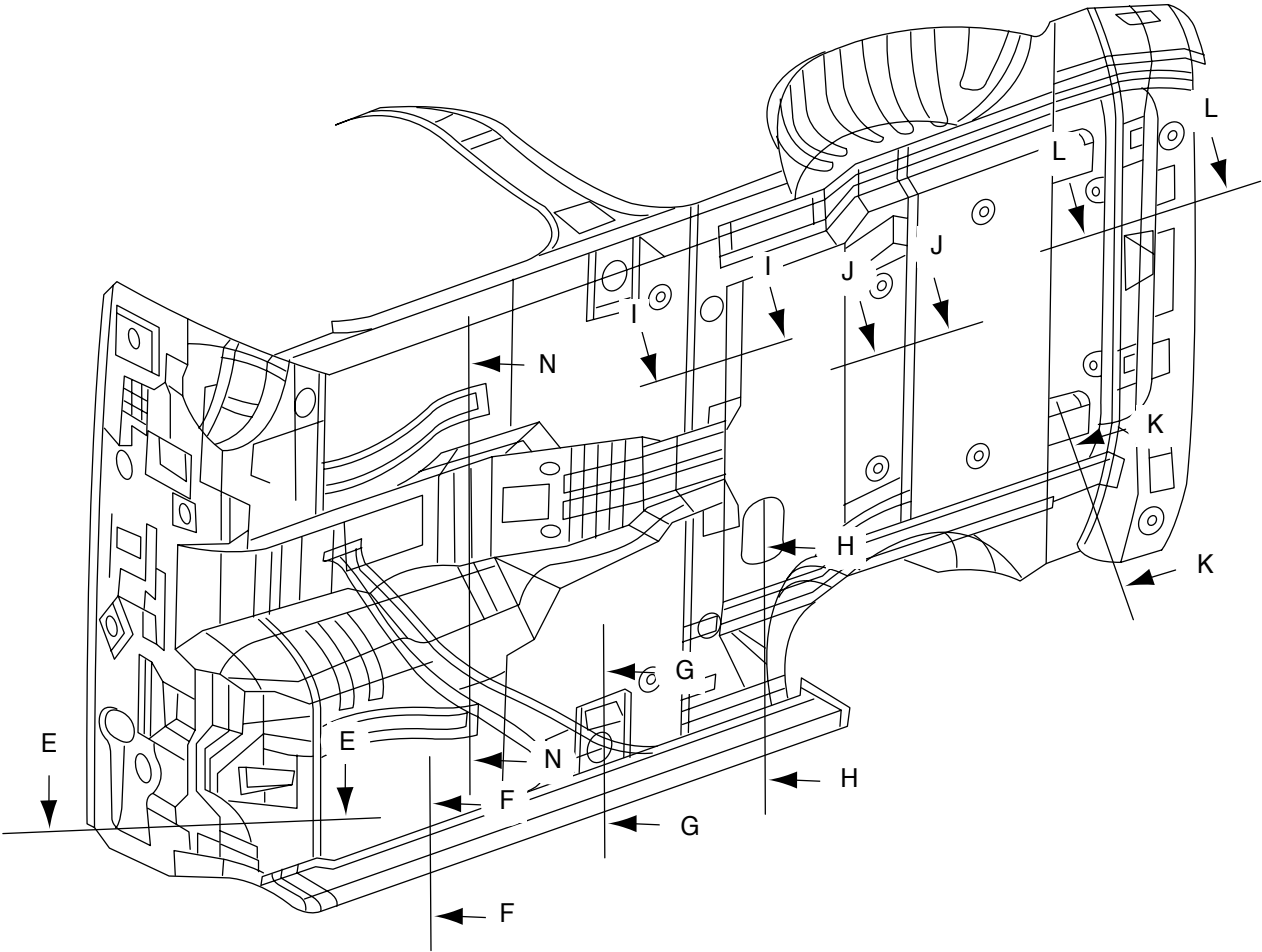

Under coating

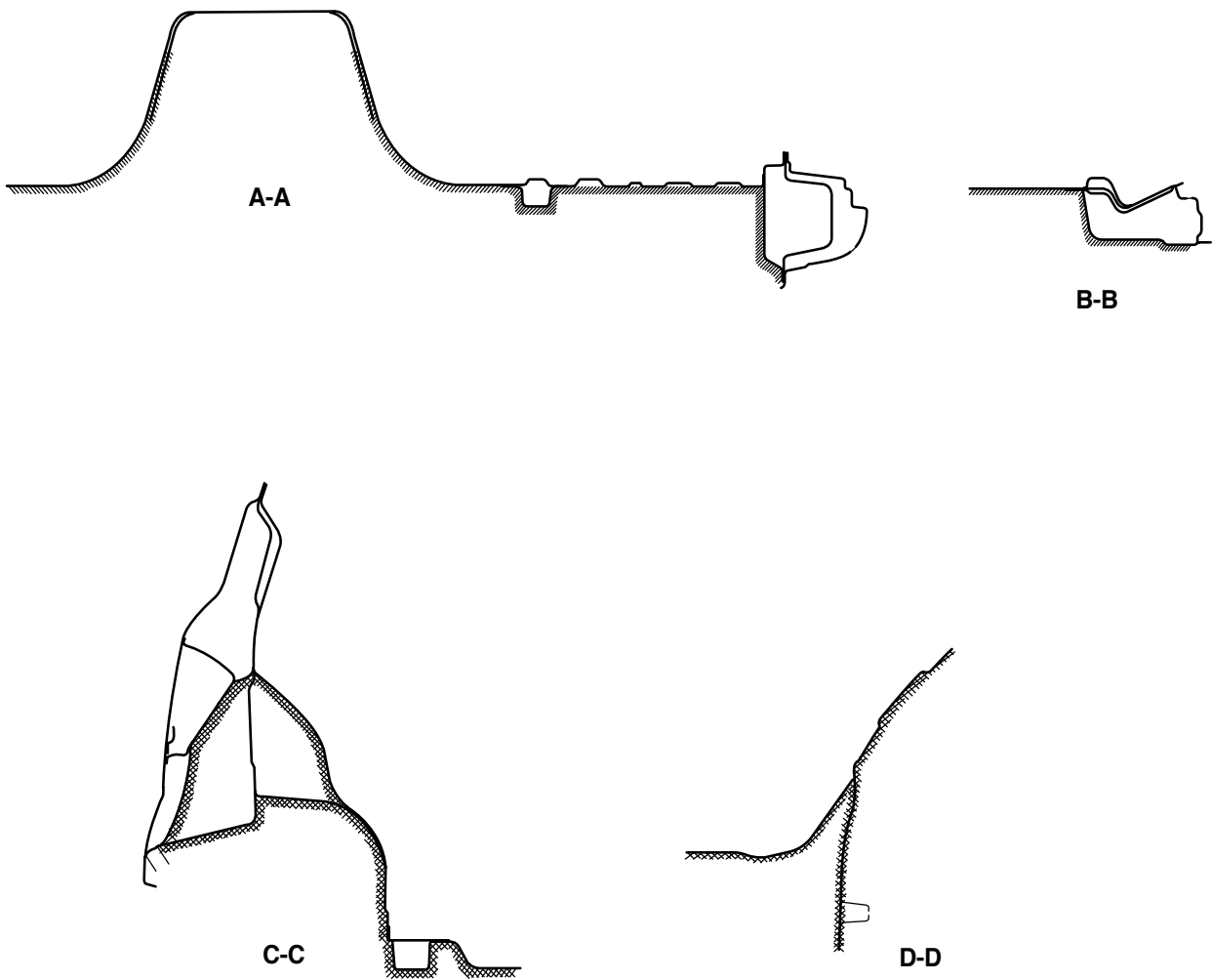

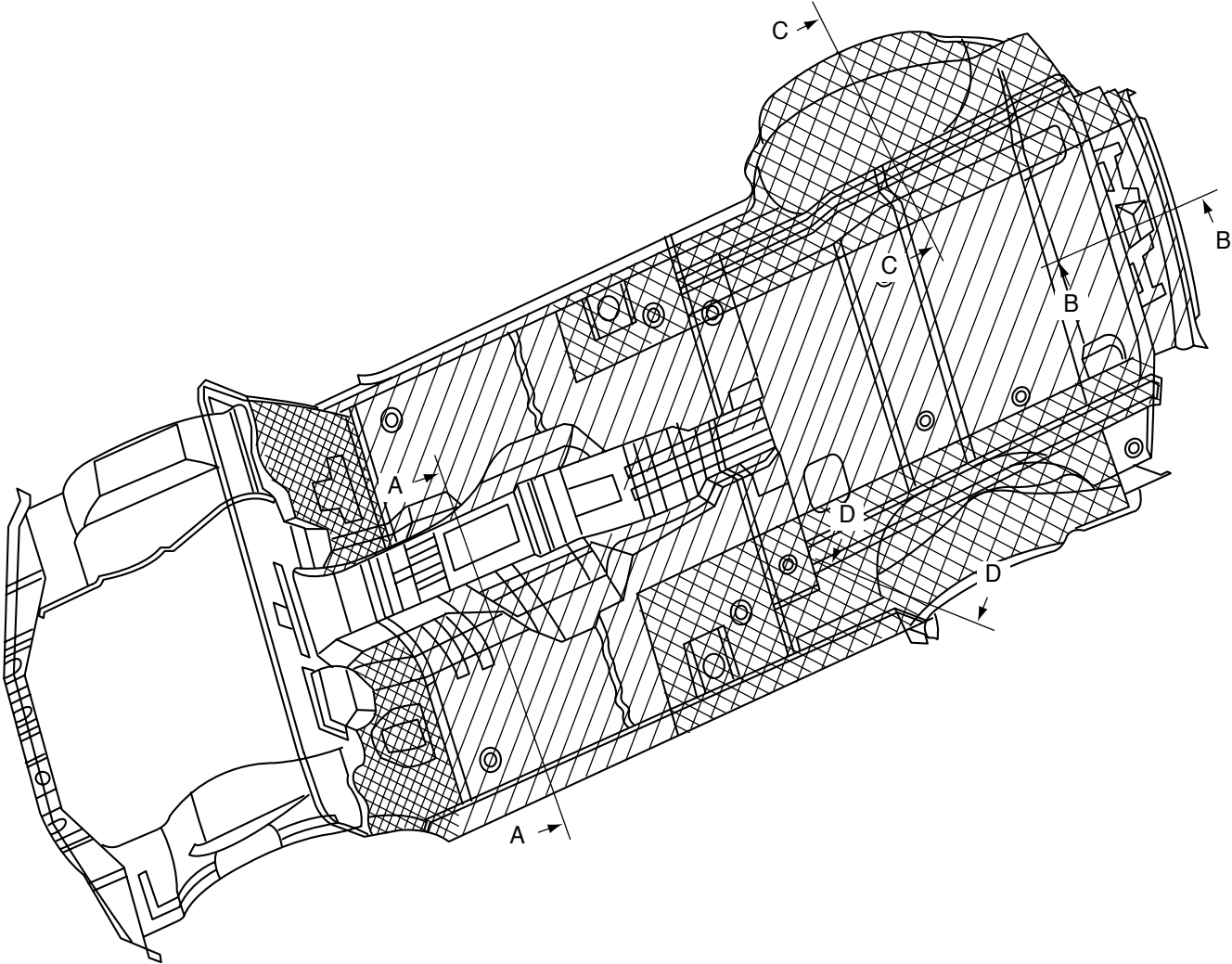

unit : mm

A3EB3415

Applying urethane

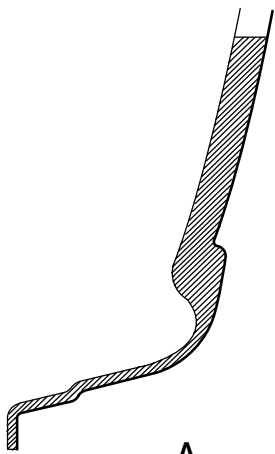
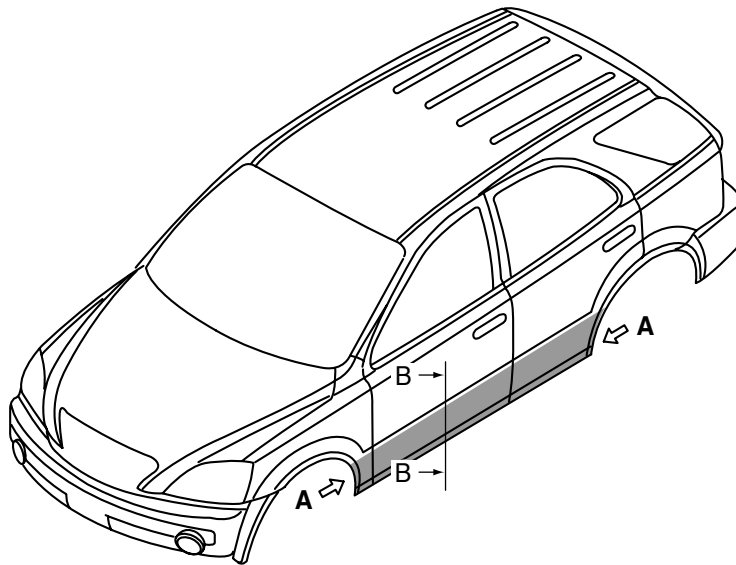

A

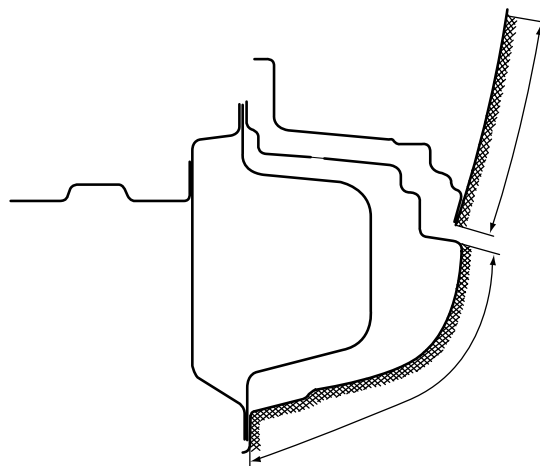

B-B

unit : mm

Applying rustproofing material Hood/Tail gate

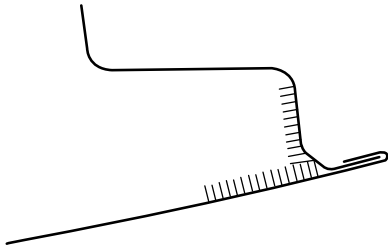
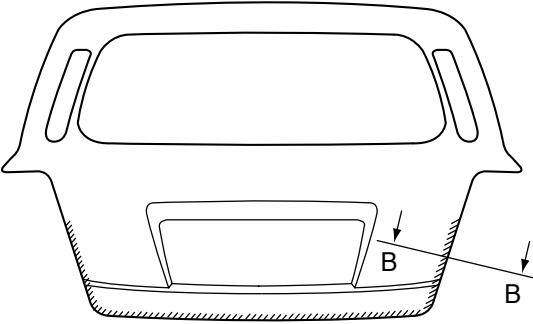
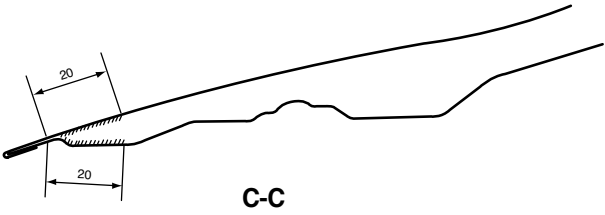
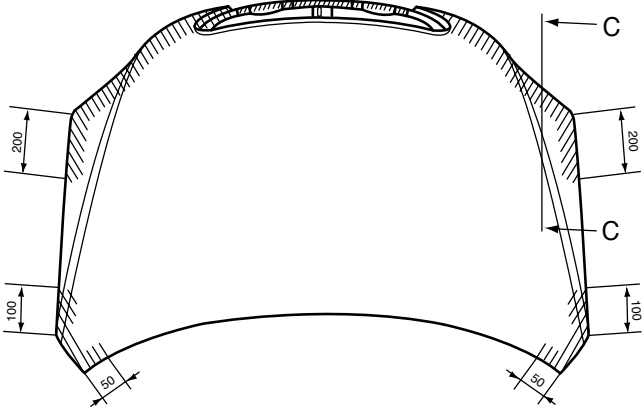

unit : mm

B-B

Front door / Rear door

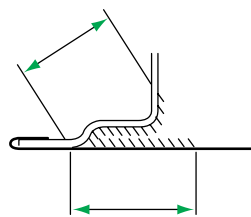
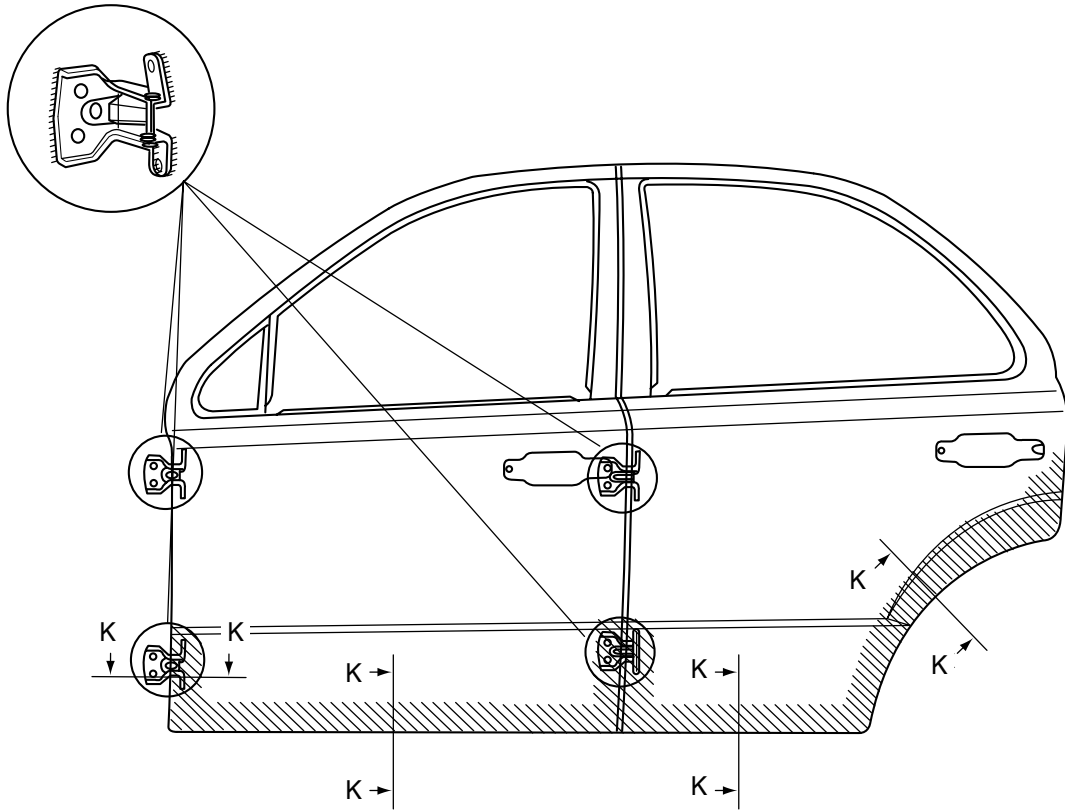

K-K

unit : mm

Body parts

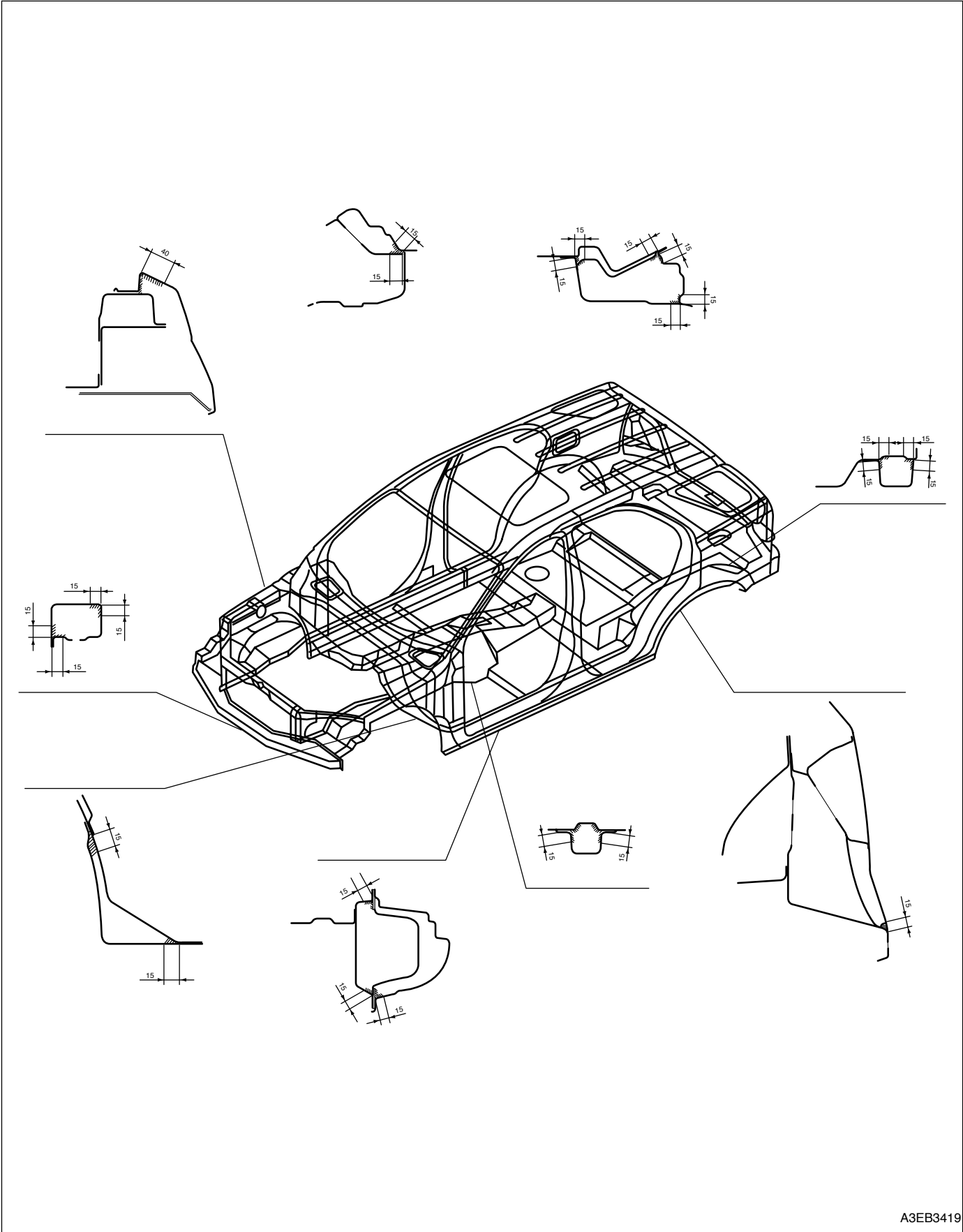

Body modification tools

Body modification tools	
Modification tools	51- 1
Cut and disassembly tools	51- 2
Assembly tools	51- 3
Measurement tools	51- 3
Welding machine	51- 4
Buffing and grinding tools	51- 5
Handheld tools	51- 7
Repair tools set	51- 8

Body modification tools

Modification tools

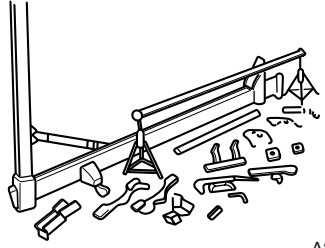
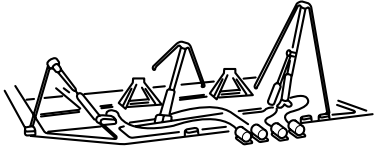
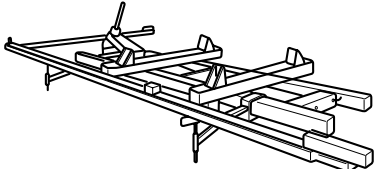
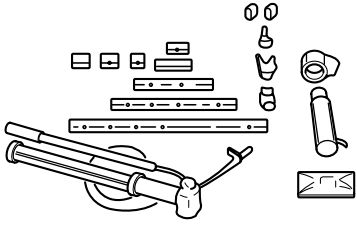
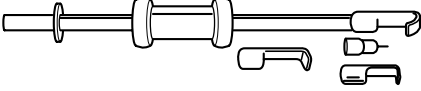
Name	Used for	Figure
<p>Frame straightener</p>	<p>Modify twisted or bent body</p>	 <p>A3EB3501</p>
		 <p>A3EB3502</p>
		 <p>A3EB3503</p>
<p>Port power</p>	<p>Push out, stretch, pull in damaged area</p>	 <p>A3EB3504</p>
<p>Body puller</p>	<p>Stretch damaged area</p>	 <p>A3EB3505</p>

Cut and disassembly tools

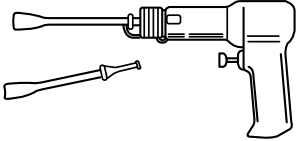
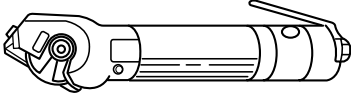
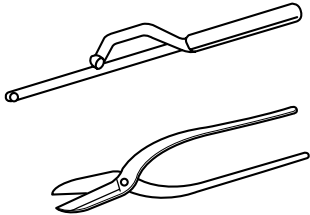
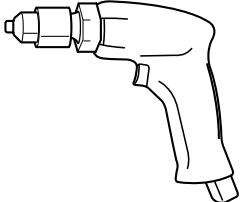
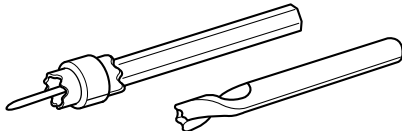
Name	Used for	Figure
Air saw	Cut a panel	 <p>A3EB3506</p>
Air diesel	Cut or bend a panel, cut and disassemble spot welded area	 <p>A3EB3507</p>
Rotary cutter	Cut a panel	 <p>A3EB3508</p>
Hand saw and metal scissors	Cut a panel	 <p>A3EB3509</p>
Air drill	Fix a spot cutter or drill to cut or disassemble spot welding area, to finish a hole.	 <p>A3EB3510</p>
Spot cutter	Cut and disassemble spot welded area	 <p>A3EB3511</p>

Assembly tools

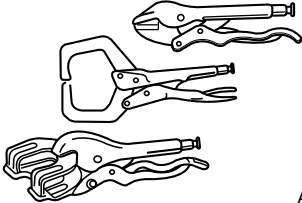
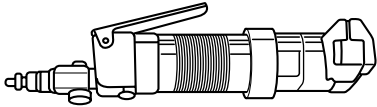
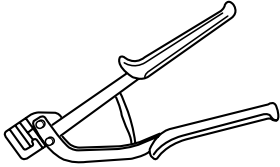
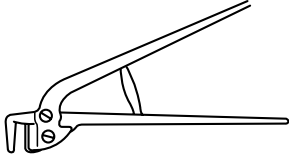

Name	Used for	Figure
Vice pliers	Fix a panel or area to weld	 <p>A3EB3512</p>
Air bench	Finish contact area of flange and finish a hole for plug welding	 <p>A3EB3513</p>
Quick bench	Finish a hole for plug welding	 <p>A3EB3514</p>
Flanging tool	Finish contact area of flange	 <p>A3EB3515</p>

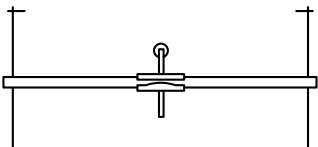
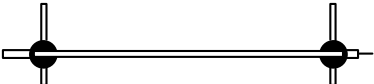
Measurement tools

Name	Used for	Figure
Centering gauge	Measure distortion of body and frame	 <p>A3EB3516</p>
Tracking gauge	Measure body and frame	 <p>A3EB3517</p>

51-4 Body modification tools

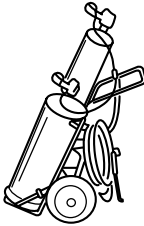
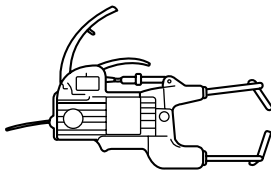
Welding machine

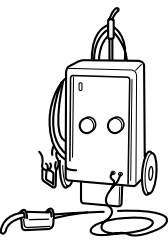
Name	Used for	Figure
Gas welding machine	Cut a panel	 <p>A3EB3518</p>
Spot welding machine	Weld a panel	 <p>A3EB3519</p>
Carbon arc welding machine	Weld a panel	 <p>A3EB3520</p>
Stud welding machine	Stretch a panel, weld a stud bolt to fix front window mold clip	 <p>A3EB3521</p>

Buffing and grinding tools

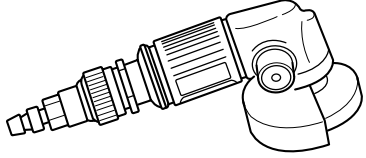
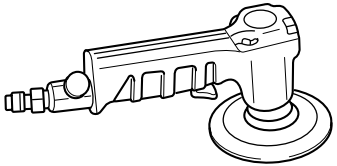
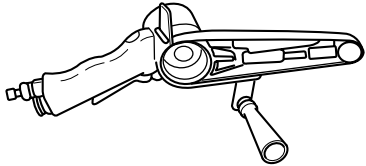
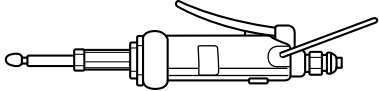
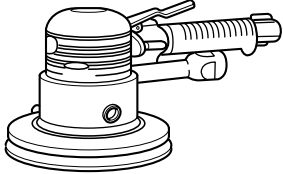
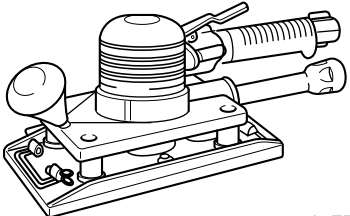
Name	Used for	Figure
Disk grinder	Buff	 <p>A3EB3522</p>
Disk sander	Buff	 <p>A3EB3523</p>
Belt sander	Buff paints	 <p>A3EB3524</p>
Small sized grinder	Buff paints or smooth finishing	 <p>A3EB3525</p>
Double action sander	Grind rough area of puttee assembled area	 <p>A3EB3526</p>
Orbital sander(short)	Grind rough area of puttee assembled area	 <p>A3EB3527</p>

51-6 Body modification tools

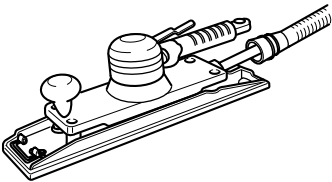
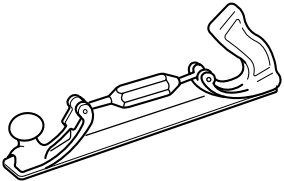
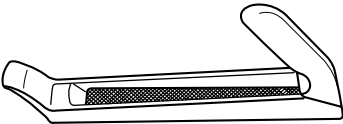
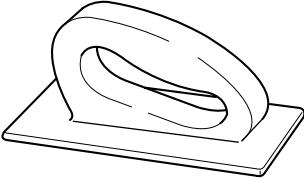
Name	Used for	Figure
Orbital sander(long)	Used for puttee grinding of wide area	 <p data-bbox="1334 548 1422 568">A3EB3528</p>
Flexible file	Grind touch up area, uneven area of a panel	 <p data-bbox="1334 835 1422 855">A3EB3529</p>
Surform tool	Buff rough area of puttee area	 <p data-bbox="1334 1120 1422 1140">A3EB3530</p>
Hand file	Grind body puttee, pulley, finish puttee	 <p data-bbox="1334 1411 1422 1431">A3EB3531</p>

Handheld tools

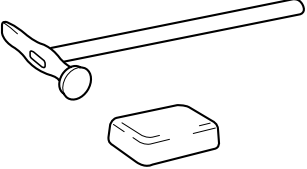
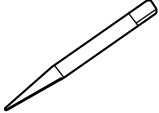
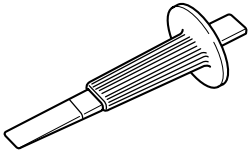
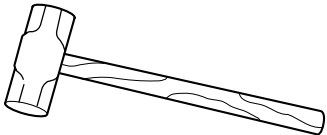
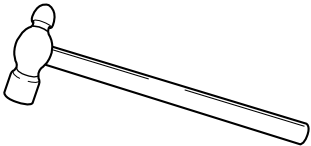
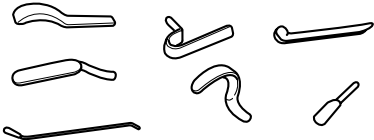
Name	Used for	Figure
Body hammer and dolly	—	 <p>A3EB3532</p>
Center punch	Punch a hole in the middle of a spot welding area	 <p>A3EB3533</p>
Plane chisel	Cut and disassemble a panel	 <p>A3EB3534</p>
Weight hammer	Used when greater force is required	 <p>A3EB3535</p>
Bowl pin hammer	Used when smaller force is required	 <p>A3EB3536</p>
Spoon	Used for an area where not reached by hand	 <p>A3EB3537</p>

51-8 Body modification tools

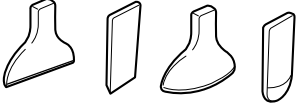
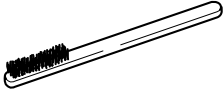
Name	Used for	Figure
<p>Body chisel</p>	<p>Bend rough body line damaged or sheet metal etc.</p>	 <p>A3EB3538</p>
<p>Wire brush</p>	<p>Remove paints, rust, slag on welded area which are hard to recognize</p>	 <p>A3EB3539</p>

Repair tools set

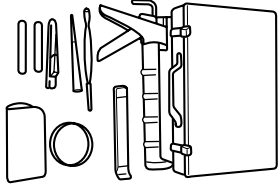
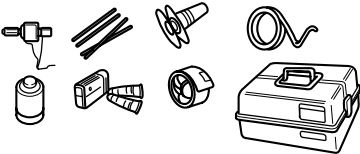
Name	Used for	Figure
<p>Window tool set</p>	<p>Repair window collar</p>	 <p>A3EB3540</p>
<p>Repair tool set for plastics</p>	<p>Repair plastic parts</p>	 <p>A3EB3541</p>

Plastic parts

Polypropylene (PP) bumper repairability	61- 1
Bumper repair procedure	61- 2
Repair method for PP bumper	61- 3

Polypropylene(PP) bumper repairability

The three types of damaged bumpers shown below can be repaired. Because of cost and quality considerations, bumpers with more damage may be repaired, but replacing the bumper is encouraged.

1. If a hole on a bumper is less than 2 in.(50 mm).

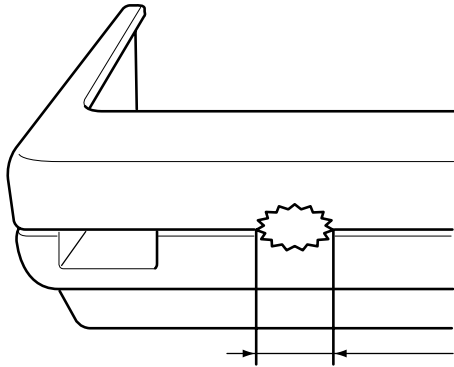

A3EB3601

2. If a crack on a bumper is less than 4 in.(100 mm).

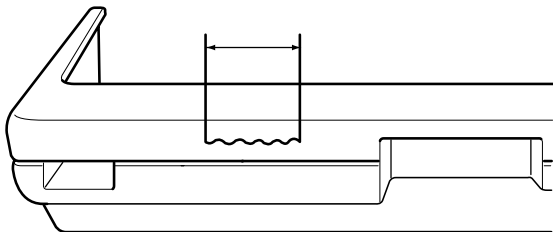

A3EB3602

3. If a crack on bumper section ① is less than 4 in.(100 mm) (less than half of the bumper height).

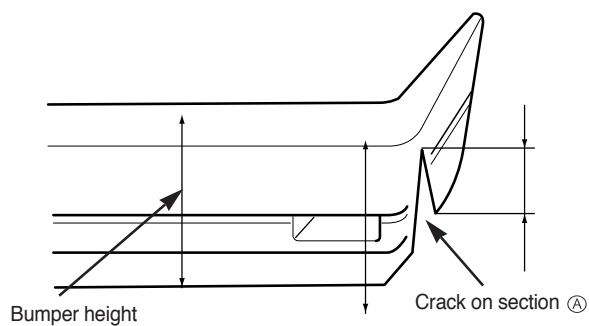

A3EB3603

Bumper repair procedure

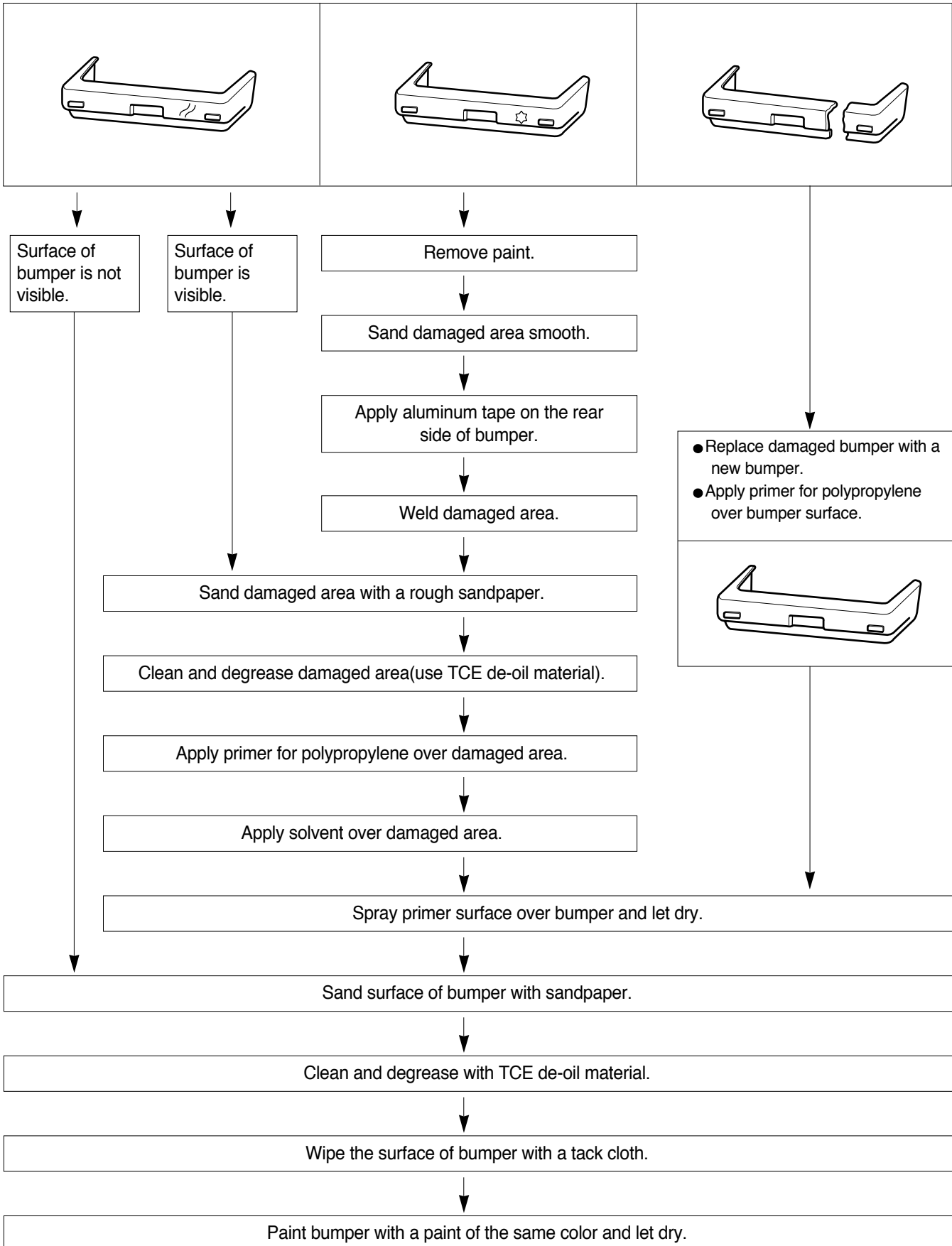

Repair method for PP bumper

Damage to the bumper that reaches the surface of the polypropylene cannot be fixed just by painting. Use the repair methods shown below to repair damage that reaches the surface of the polypropylene.

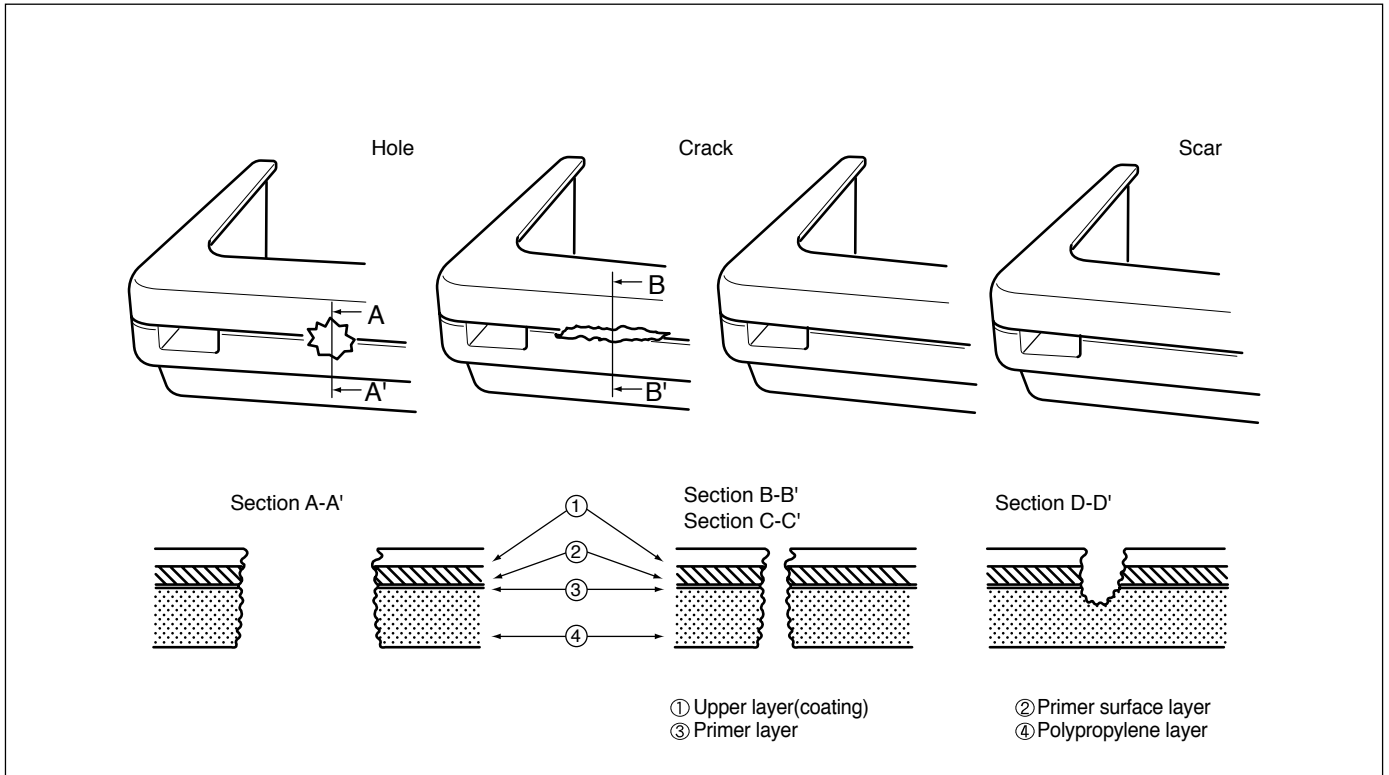

1. Rough cut the damaged area 45° using a knife and then sand the angle smooth.

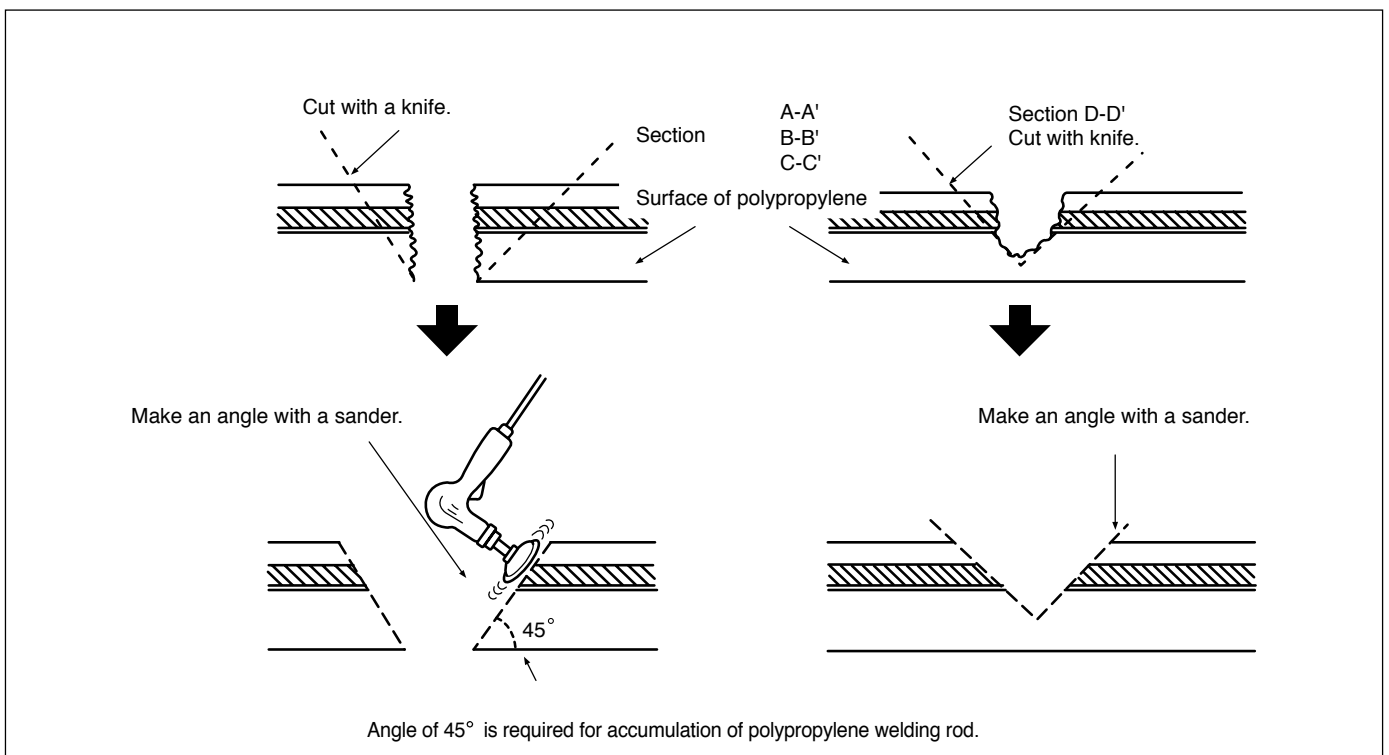

61-4 Plastic parts

2. Welding damaged area

a) To repair cracked area, melt the area using a heat gun and attachment.

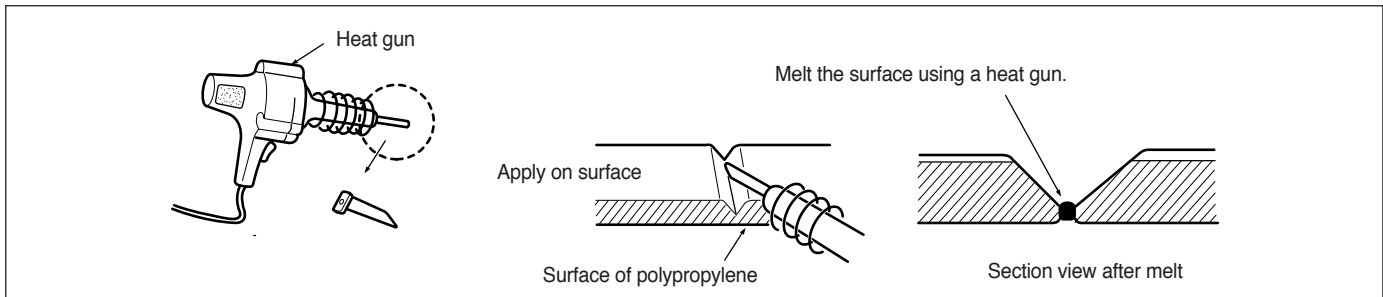

b) To repair a hole, remove oil from the damaged area and apply aluminum tape to the rear side of the damaged area.

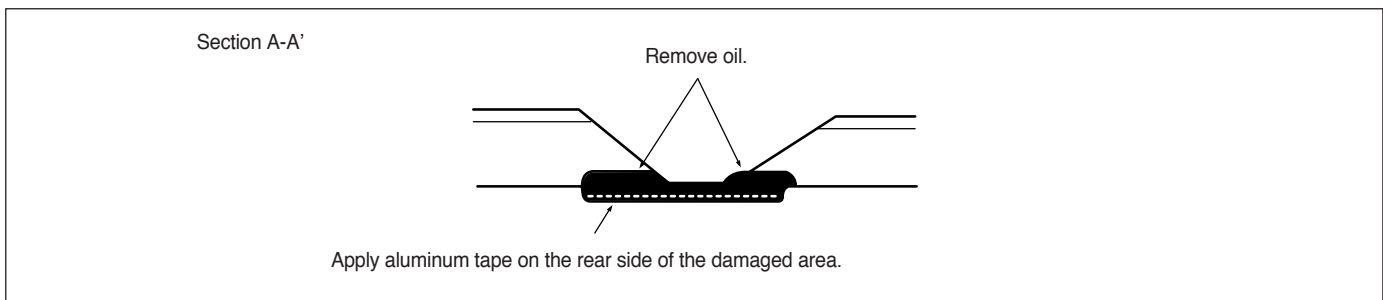

3. Melt polypropylene welding rod using a heat gun and fill in the cracked area.

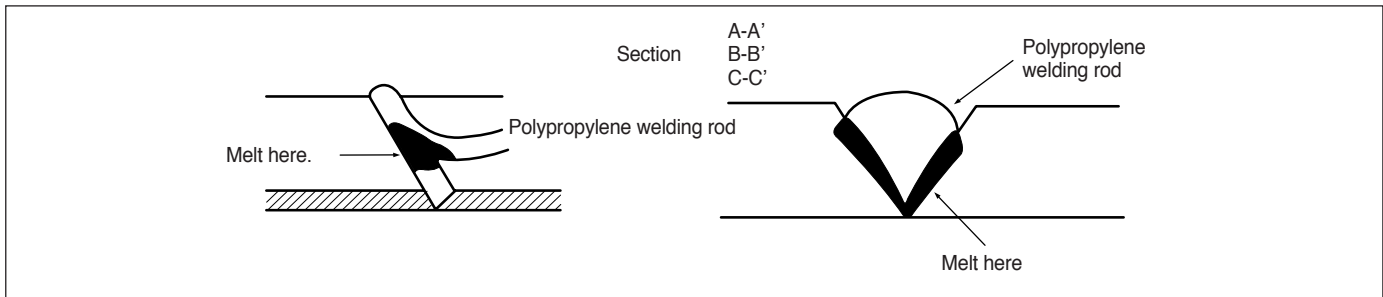

* Notice

- Heat and melt the area indicated.
- Melt the welding rod carefully so that it does not over-melt. If the welding rod over-melts like jelly, the welding strength will deteriorate.
- Use the heat gun 0.4–0.8 in. (10–20 mm) away from the repair area to be welded.
- Welding rod should not move until the welded area is cooled.

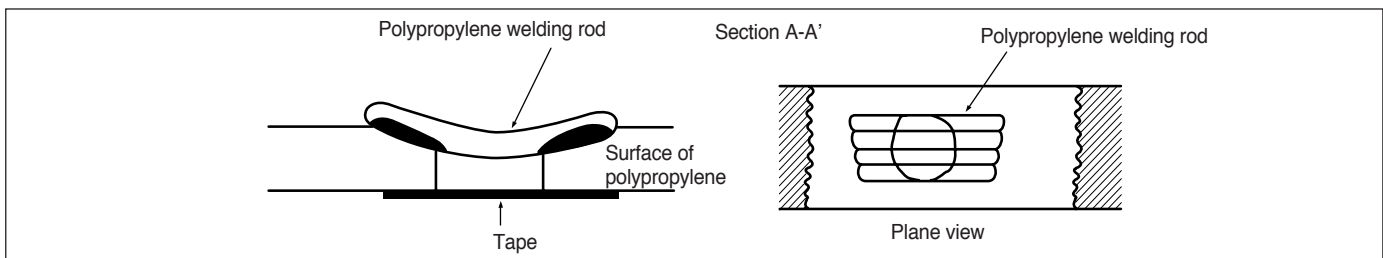

- Grind polypropylene surface carefully. It melts easily due to the heat generated by friction. If melted, remove that area. Also, grind the area where solvent is to be applied.

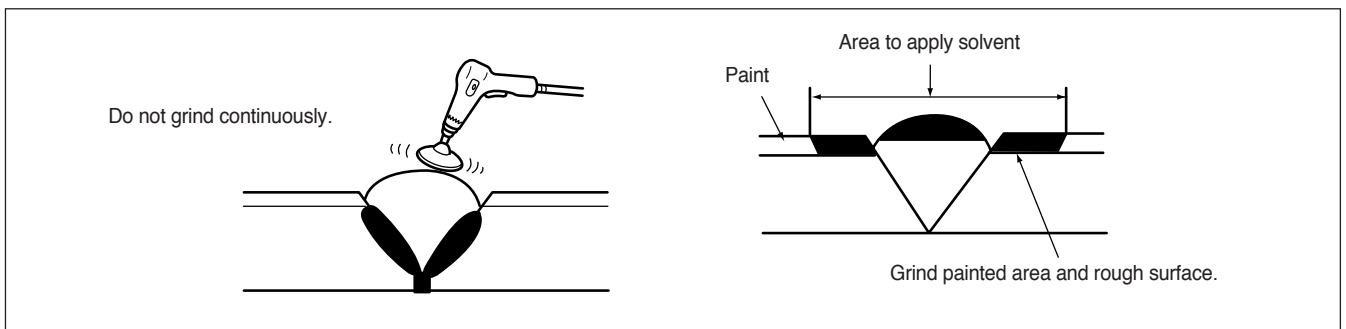

- Apply polypropylene primer evenly with a brush over an area wider than the area to be repaired. Dry it at 20°C(68°F) for more than 10 minutes.

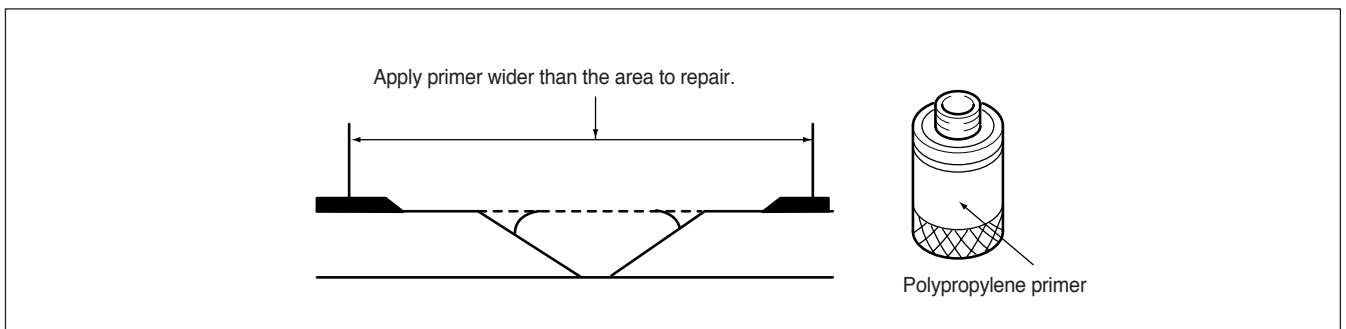

- Mix main filler material and hardener at a ratio depending on paint specifications. Mix filler material and apply over the damaged area.

*** Notice**

- Mix main filler material and hardener so that no bubbles are made.
- Work immediately after mixing filler material because the filler material hardens quickly(in about 5 minutes).
- Dry it at 20°C(68°F) for about 30 minutes before sanding.

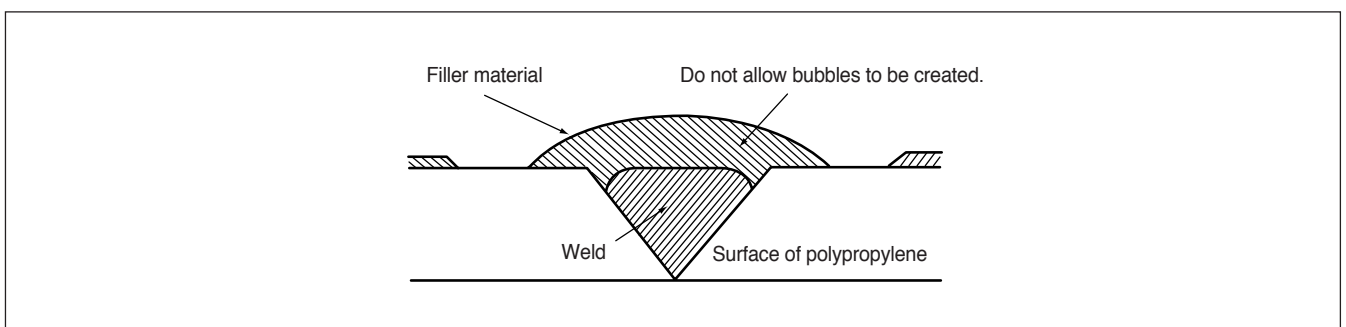

- Filler material consists of two types of epoxy. When the filler material hardens, you will have a desirable finish with flexibility like polypropylene.
- Use only filler material designed for use on polypropylene bumpers.

61-6 Plastic parts

7. Sand the damaged area with sandpaper using #180~#240 grit paper.

* Notice

- The surface will not be even if excessive force is applied during sanding.
- If there is fuzz in the damaged area, heat it a little bit with a heater gun and melt it.

8. Degrease the painted surface.

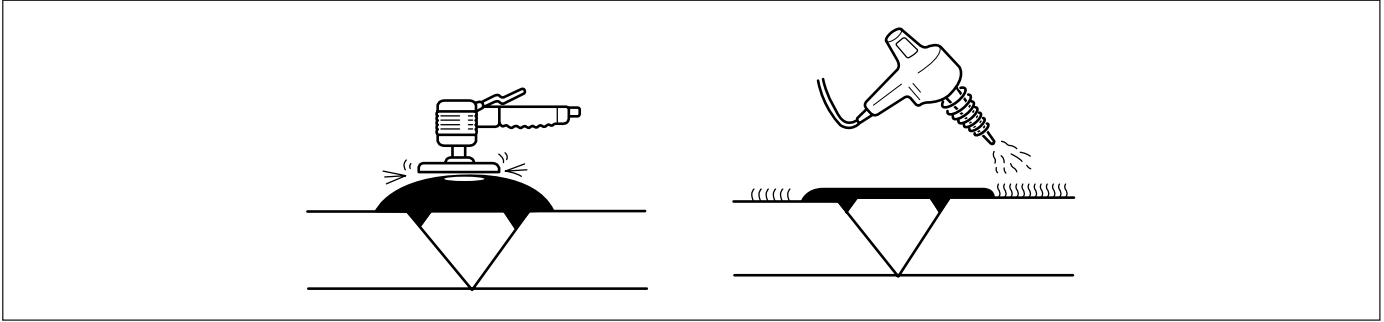

9. Mix polypropylene primer and hardener at a ratio depending on paint specifications. Spray polypropylene primer on the surface of the damaged area and the bumper.

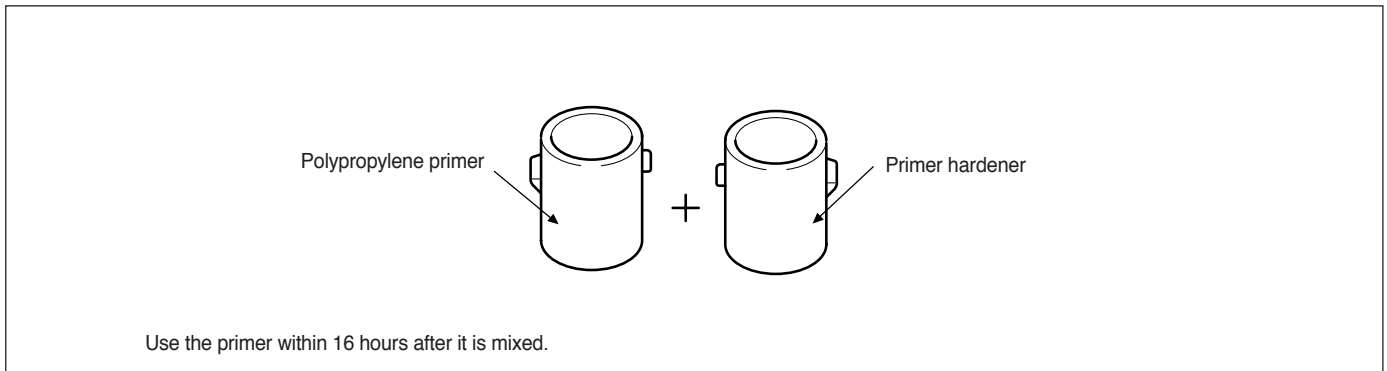

10. Apply polypropylene primer.

* Notice

- Use only water to clean after applying polypropylene primer. Solvent, if used, will melt the primer.

11. Lightly sand the sprayed area using a primer surfacer, and finish the surface of the bumper with a sandpaper(#400~#600).

The polypropylene surface should not be exposed.(Either wet sanding or dry sanding is all right.)

12. Use agent(TCE(Tir Chloro Ethane) degreasing material) to remove any grease or oil, and wipe the finished surface of the bumper quickly with a clean cloth.

* Notice

- *The painting method for the polypropylene bumper is the same used to paint the urethane bumper.*
- *Therefore, use urethane primer only on urethane bumpers and polypropylene primer on polypropylene bumpers.*

14. Air dry at 20°C(68°F) for about 8 hours, or dry in 60°C(140°F) for about 2 hours.

(Since drying time varies according to the type of paint used, follow paint manufacturers directions for drying times.)

* Notice

- *Air dry if possible. Forced drying may create air bubbles on the top layer.*