

This file is available for free download at <http://www.iluvmyrx7.com>

This file is fully text-searchable – select Edit and Find and type in what you’re looking for. This file is intended more for online viewing than printing out so some graphics may not print 100% legibly, you can zoom in on them if you need to.



www.iluvmyrx7.com

MAINTENANCE INFORMATION

Article Text

1984 Mazda RX7

For iluvmyrx7.com

Copyright © 1998 Mitchell Repair Information Company, LLC
Sunday, June 09, 2002 06:07AM

ARTICLE BEGINNING

1983-91 MAINTENANCE
Mazda Maintenance Information

RX7

* PLEASE READ THIS FIRST *

NOTE: For scheduled maintenance intervals and the related fluid capacities, fluid specifications and labor times for major service intervals, see SCHEDULED SERVICES article in this section. Warranty information and specifications for fluid capacities, lubrication specifications, wheel and tire size, and battery type are covered in this article.

MODEL IDENTIFICATION

VIN LOCATION

The Vehicle Identification Number (VIN) is located on the left side of the dash panel at the base of the windshield. The VIN chart explains the code characters.

VIN CODE ID EXPLANATION

Numbers preceding the explanations in the legend below refer to the sequence of characters as listed on VIN identification label. See VIN example below.

(VIN)	J	M	1	F	C	3	3	1	1	K	0	2	0	0	0	0	1
	1	2	3	4	5	6	7	8	9	10	11	12	13	14	15	16	17

1 - Manufacturing Country

J * Japan

2 - Make

M * Mazda Motors Corp., Japan

3 - Type

1 * Passenger Car

V * Passenger Car

4-5 - Model

FB * RX7 (1983-85)

FC * RX7 (1986-91)

6-7 - Body Style

33 * Hatchback

35 * Convertible

8 - Modification Code

1 * 13BE Rotary

2 * 13BT Rotary (Turbo)

9 - VIN Check Digit

1 * Constant For All Models

10 - Vehicle Model Year

D * 1983
E * 1984
F * 1985
G * 1986
H * 1987
J * 1988
K * 1989
L * 1990
M * 1991

11 - Assembly Plant

0 * Hiroshima, Japan

12-17 - Serial Number

* Sequential Production Number

MAINTENANCE SERVICE INFORMATION

SEVERE & NORMAL SERVICE DEFINITIONS

NOTE: Use the Severe Service schedule if the vehicle to be serviced is operated under ANY (one or more) of these conditions:

Service is recommended at mileage intervals based on vehicle operation. Service schedules are based on the following primary operating conditions:

Normal Service

- * Driven More Than 10 Miles Daily
- * No Operating Conditions From Severe Service Schedule

Severe Service (Unique Driving Conditions)

- * Repeated Short Distance Driving
- * Dusty Conditions
- * Extended Use Of Brakes
- * Salt Or Other Corrosive Materials On The Roads
- * Rough Or Muddy Roads
- * Extended Idling Or Low Speed Operation
- * Extended Operation In Extreme Temperatures

SERVICE POINT LOCATIONS

NON-TURBO MODELS

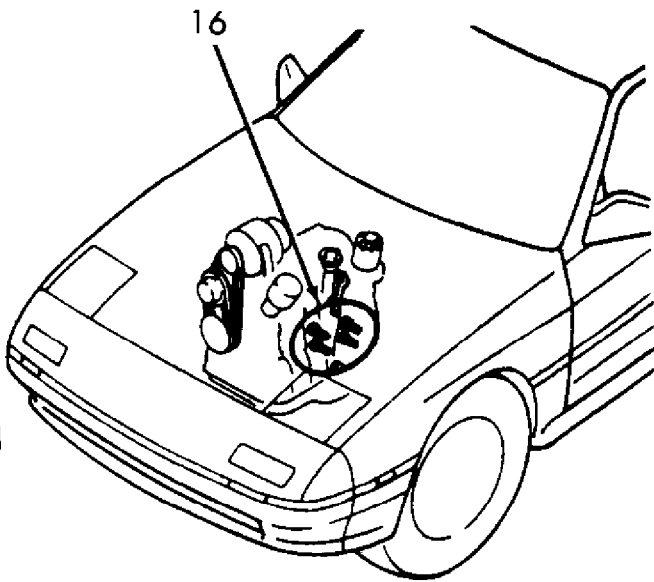
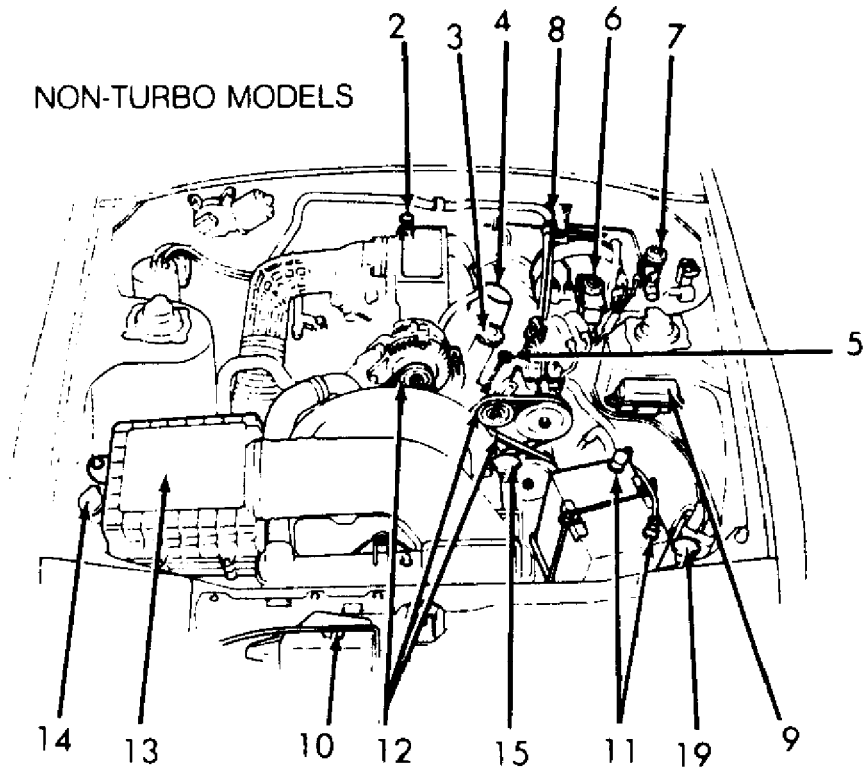

MAINTENAN

1. Sub-Zero Starting Assist Fluid Reservoir (If Equipped)
2. Automatic Transmission Fluid Level Gauge (If Equipped)
3. Engine Oil Filler Cap
4. Oil Filter
5. Engine Oil Dipstick
6. Brake Fluid Reservoir
7. Clutch Fluid Steering Reservoir
8. Power Steering Fluid Filler Cap (With Level Gauge)
9. Main Fuse Block
10. Coolant Reservoir
11. Battery Terminals
12. Drive Belts
13. Air Cleaner
14. Windshield Washer Reservoir
15. Radiator Cap
16. Spark Plugs
17. Intercooler (If Equipped)
18. Turbocharger (If Equipped)
19. Headlight Washer Fluid (If Equipped)

93F45703

Fig. 1: Service Point Locations (Typical Non-Turbo Engine)
 Courtesy of Mazda Motor of America, Inc.

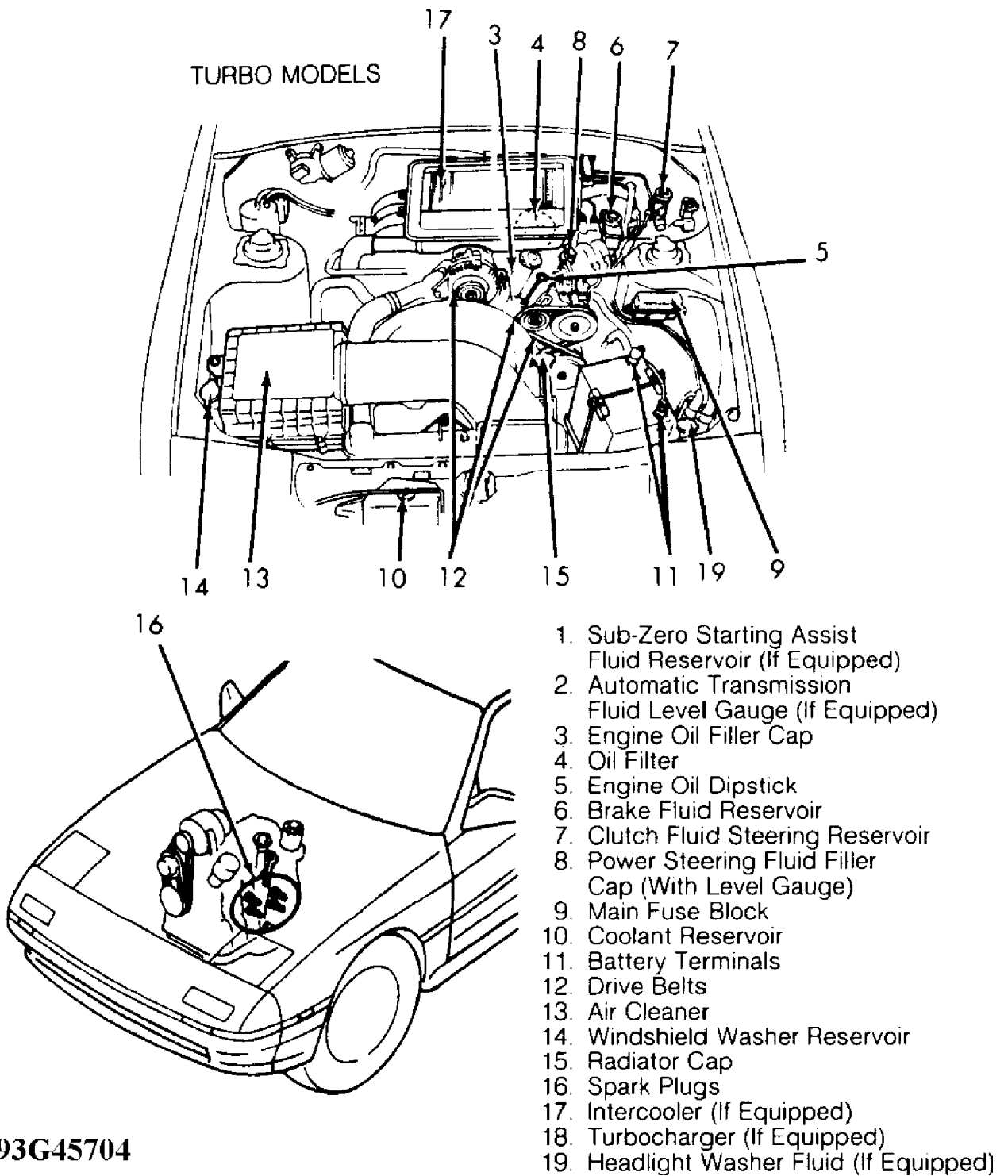

93G45704

Fig. 2: Service Point Locations (Typical Turbo Engine)
 Courtesy of Mazda Motor of America, Inc.

MODELS WITH SUB-ZERO STARTING ASSIST

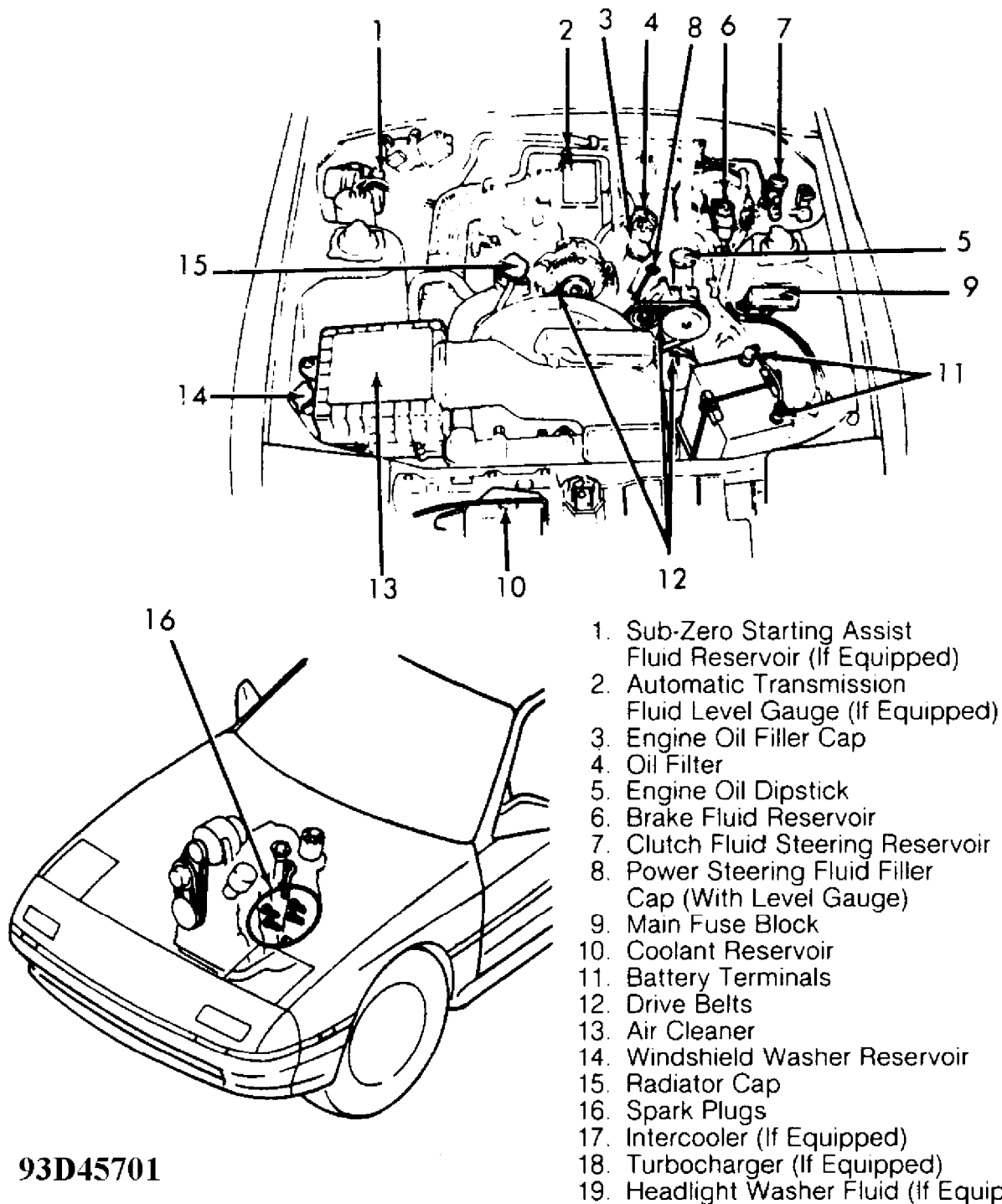

1. Sub-Zero Starting Assist Fluid Reservoir (If Equipped)
2. Automatic Transmission Fluid Level Gauge (If Equipped)
3. Engine Oil Filler Cap
4. Oil Filter
5. Engine Oil Dipstick
6. Brake Fluid Reservoir
7. Clutch Fluid Steering Reservoir
8. Power Steering Fluid Filler Cap (With Level Gauge)
9. Main Fuse Block
10. Coolant Reservoir
11. Battery Terminals
12. Drive Belts
13. Air Cleaner
14. Windshield Washer Reservoir
15. Radiator Cap
16. Spark Plugs
17. Intercooler (If Equipped)
18. Turbocharger (If Equipped)
19. Headlight Washer Fluid (If Equipped)

93D45701

Fig. 3: Service Point Locations (Non-Turbo W/Sub-Zero Start Assist)

TURBO MODELS WITH SUB-ZERO STARTING ASSIST

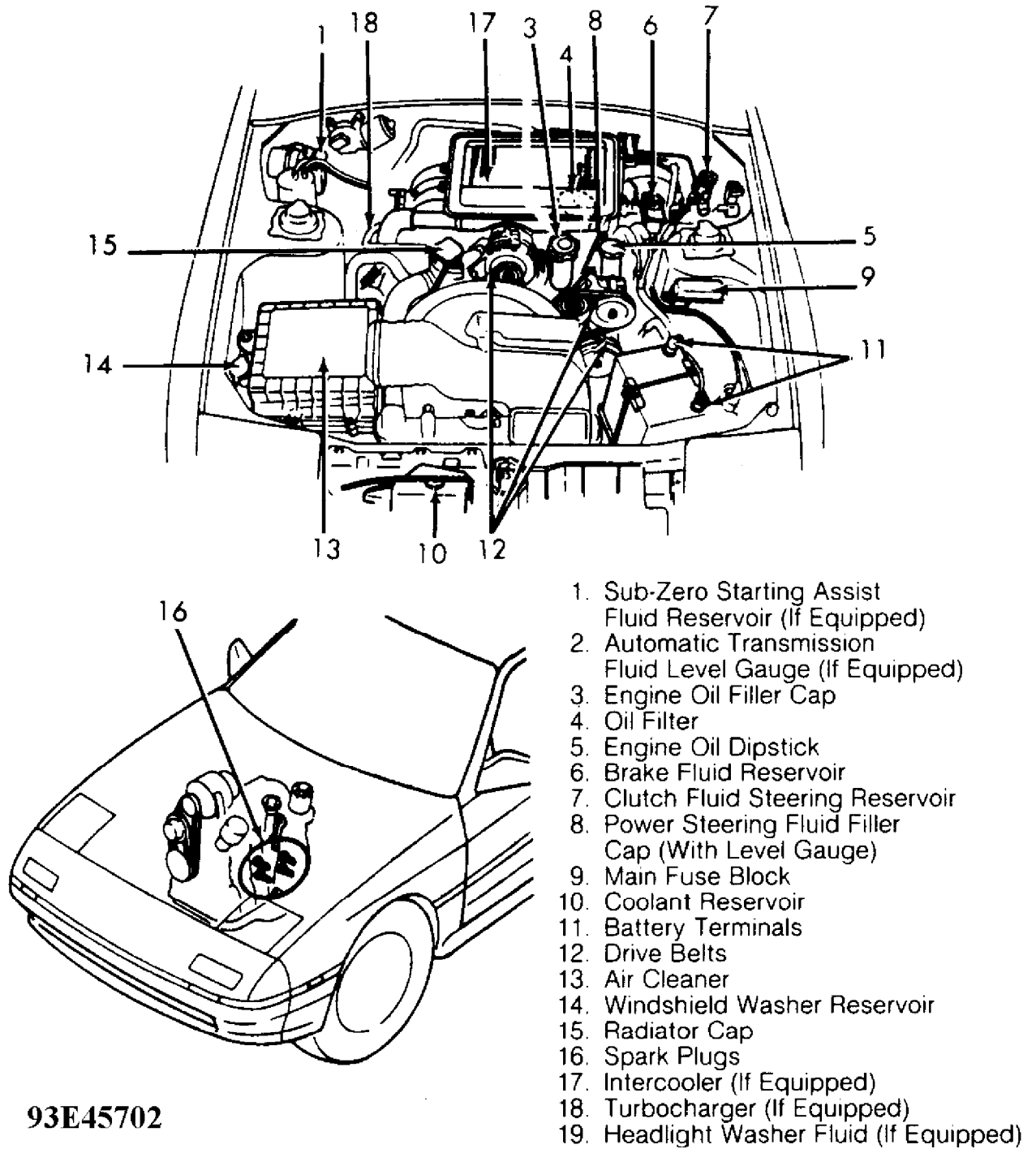

93E45702

Fig. 4: Service Point Locations (Turbo W/Sub-Zero Start Assist)
 Courtesy of Mazda Motor of America, Inc.

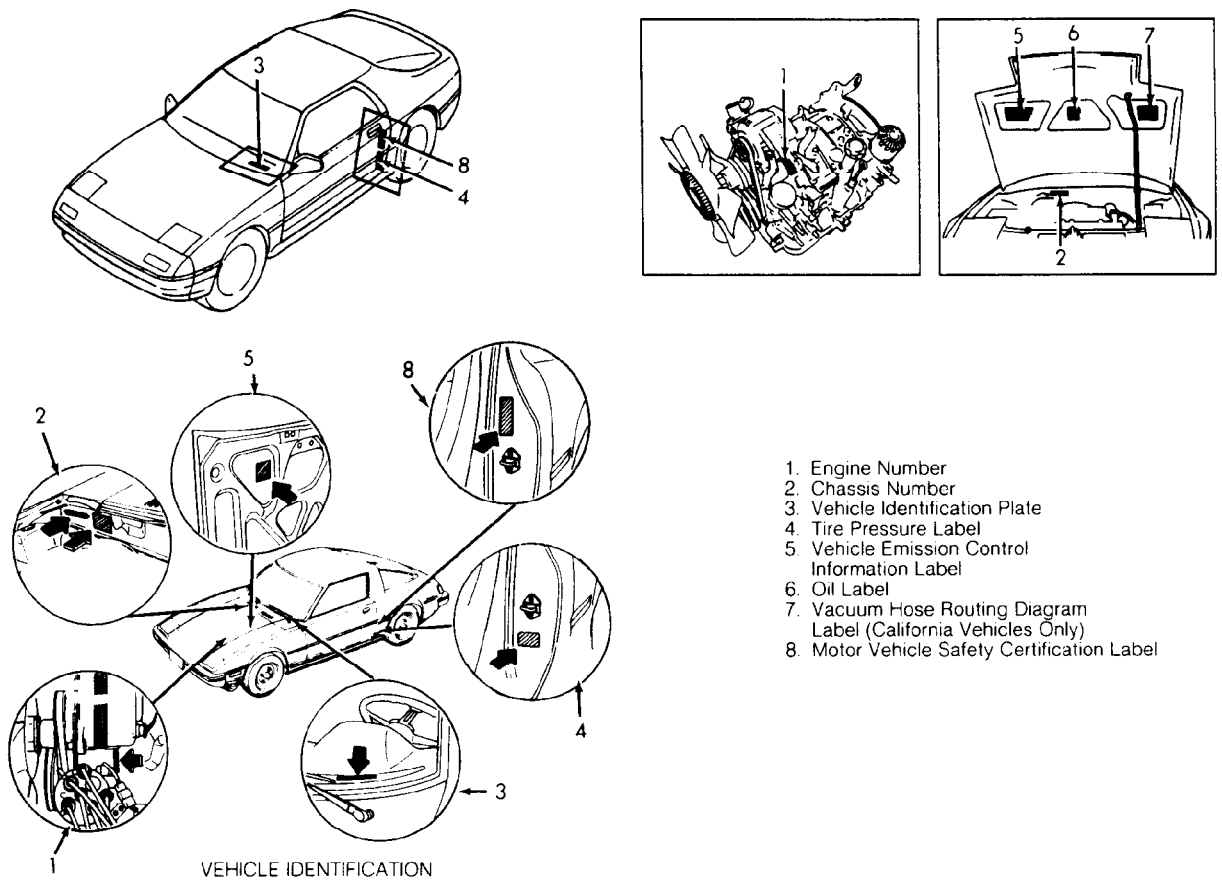

1. Engine Number
2. Chassis Number
3. Vehicle Identification Plate
4. Tire Pressure Label
5. Vehicle Emission Control Information Label
6. Oil Label
7. Vacuum Hose Routing Diagram Label (California Vehicles Only)
8. Motor Vehicle Safety Certification Label

90105054
 Fig. 5: Information Label Locations
 Courtesy of Mazda Motor of America, Inc.

SERVICE LABOR TIMES

SERVICE LABOR TIMES TABLE (HOURS)

Application	30,000 Mile Service	60,000 Mile Service
RX7		
Automatic Transmission	2.1	3.7
Manual Transmission	2.1	4.1

LUBRICATION SPECIFICATIONS

LUBRICATION SPECIFICATIONS TABLE

Application	Fluid Specifications
Brake Fluid	SAE J1703 or FMVSS116 DOT 3
Engine Oil	
Minimum Temperature	
Maximum Temperature	
Less Than 0°F (-18°C)	SAE 5W-30 API SG/CD
Automatic Transmission	ATF M-III or Dexron IIE

Manual Transmission	SAE 75W-90 GL-5
Power Steering Fluid	Dexron-II ATF
Rear Axle	SAE 80W-90 GL-5

FLUID CAPACITIES

FLUID CAPACITIES TABLE

Application	Quantity
A/C System R-12 Refrigerant Capacity	
1983-85	36 Ozs.
1986-89	
Nippondenso Compressor	22-25 Ozs.
Sanden Compressor	30 Ozs.
1990-91	26.5-28 Ozs.
Automatic Transaxle	7.7-7.9 Qts. (7.3-7.5L)
Cooling System	
1983-85	9.0-10.0 Qts. (8.5-9.5L)
1986-91	
Non-Turbo	7.7 Qts. (7.3L)
Turbo	9.2 Qts. (8.7L)
Engine Oil	4.4-4.7 Qts. (4.2-4.4L)
Fuel Tank	
1983-87	16.6 Gals. (63L)
1988-91	18.5 Gals. (70L)
Manual Transmission Oil	2.1-2.6 Qts. (2.0-2.5L)
Rear Axle Oil	
Turbo	1.3-1.5 Qts. (1.2-1.4L)
Non-Turbo	1.4-1.7 Qts. (1.3-1.6L)

WHEEL & TIRE SPECIFICATIONS

WHEEL & TIRE SPECIFICATIONS TABLE

Wheel Size	Tire Size
15 x 6 in. (Steel Non-Directional)	205/60 VR15
15 x 6.5" (Alloy, Directional)	205/60 VR15
16 x 7.0" (Alloy, Directional)	205/55 R16 88V
15 x 4T (Steel, Temporary)	T135/70 D15
15 x 4T (Alloy, Temporary)	T135/70 D16

TIRE INFLATION

TIRE INFLATION SPECIFICATIONS

Application (1)	Specification psi (kg/cm ²)
Normal Loads	32 (2.2)
Temporary Spare	60 (4.2)

(1) - Tire inflation label is located near top of driver's door.

Tighten wheel lug nuts to 65-87 ft. lbs. (88-118 N.m).

BATTERY SPECIFICATIONS

CAUTION: When battery is disconnected, vehicles equipped with computers may lose memory data. When battery power is restored, driveability problems may exist on some vehicles. These vehicles may require a relearn procedure. See COMPUTER RELEARN PROCEDURES article in the GENERAL INFORMATION Section.

If battery is replaced, new battery should be of the same group number as shown on the original battery's label. Use group 24 batteries with a cold crank rating of 600 amps.

CAUTIONS & WARNINGS

SUPPLEMENTAL RESTRAINT SYSTEM (AIR BAG)

NOTE: See the AIR BAGS article in the ACCESSORIES/SAFETY EQUIPMENT Section.

Modifications or improper maintenance, including incorrect removal and installation of the Supplemental Restraint System (SRS), can adversely affect system performance. DO NOT cover, obstruct or change the steering wheel horn pad in any way, as such action could cause improper function of the system. Use only plain water when cleaning the horn pad. Solvents or cleaners could adversely affect the air bag cover and cause improper deployment of the system.

WARNING: To avoid injury from accidental air bag deployment, read and carefully follow all warnings and service precautions. See appropriate AIR BAGS article in ACCESSORIES/SAFETY EQUIPMENT.

CAUTION: Disconnect negative battery cable before servicing any air bag system, steering column or passenger side dash component. After any repair, turn ignition key to the ON position from passenger's side of vehicle in case of accidental air bag inflation

ANTI-LOCK BRAKE SYSTEM

The anti-lock brake system contains electronic equipment that can be susceptible to interference caused by improperly installed or high output radio transmitting equipment. Since this interference could cause the possible loss of the anti-lock braking capability, such equipment should be installed by qualified professionals.

On models equipped with anti-lock brake systems, ALWAYS observe the following cautions:

- * DO NOT attempt to bleed hydraulic system without first referring to the appropriate ANTI-LOCK BRAKE SYSTEM article in the BRAKES Section.
- * DO NOT mix tire sizes. As long as tires remain close to the original diameter, increasing the width is acceptable. Rolling diameter must be identical for all 4 tires. Some manufacturers recommend tires of the same brand, style and type. Failure to follow this precaution may cause inaccurate wheel speed readings.

- * Use ONLY recommended brake fluids. DO NOT use silicone brake fluids in an ABS-equipped vehicle.

BATTERY WARNING

WARNING: When battery is disconnected, vehicles equipped with computers may lose memory data. When battery power is restored, driveability problems may exist on some vehicles. These vehicles may require a relearn procedure. See COMPUTER RELEARN PROCEDURES article in GENERAL INFORMATION section.

REPLACING BLOWN FUSES

Before replacing a blown fuse, remove ignition key, turn off all lights and accessories to avoid damaging the electrical system. Be sure to use fuse with the correct indicated amperage rating. The use of an incorrect amperage rating fuse may result in a dangerous electrical system overload.

BRAKE PAD WEAR INDICATOR

Indicator will cause a squealing or scraping noise, warning that brake pads need replacement.

CATALYTIC CONVERTER

Continued operation of vehicle with a severe malfunction could cause converter to overheat, resulting in possible damage to converter and vehicle.

Any modification to the exhaust system on turbo models, which reduces exhaust backpressure, will lead to lean fuel mixtures and excessive spark advance. This could cause serious engine damage.

COOLANT (PROPYLENE-GLYCOL FORMULATIONS)

CAUTION: To avoid possible damage to vehicle use only ethylene-glycol based coolants with a mixture ratio from 44-68% anti-freeze. DO NOT use 100% anti-freeze as it will cause the formation of cooling system deposits. This results in coolant temperatures of over 300° F (149°C) which can melt plastics. 100% anti-freeze has a freeze point of only -8° F (-22°C).

CAUTION: Propylene-Glycol Mixtures has a smaller temperature range than Ethylene-Glycol. The temperature range (freeze-boil) of a 50/50 Anti-Freeze/Water Mix is as follows:

Propylene-Glycol	-26° F (-32°C)	-	257° F (125°C)
Ethylene-Glycol	-35° F (-37°C)	-	263° F (128°C)

CAUTION: Propylene-Glycol/Ethylene-Glycol Mixtures can cause the destabilization of various corrosion inhibitors. Also Propylene-Glycol/Ethylene-Glycol has a different specific gravity than Ethylene-Glycol coolant, which will result in inaccurate freeze point calculations.

ELECTROSTATIC DISCHARGE SENSITIVE (ESD) PARTS

WARNING: Many solid state electrical components can be damaged by static electricity (ESD). Some will display a warning label, but many will not. Discharge personal static electricity by touching a metal ground point on the vehicle prior to servicing any ESD sensitive component.

ENGINE OIL

CAUTION: Never use non-detergent or straight mineral oil.

FUEL SYSTEM SERVICE

WARNING: Relieve fuel system pressure prior to servicing any fuel system component (fuel injection models).

HALOGEN BULBS

WARNING: Halogen bulbs contain pressurized gas which may explode if overheated. DO NOT touch glass portion of bulb with bare hands. Eye protection should be worn when handling or working around halogen bulbs.

HEADLIGHT RETRACTOR

CAUTION: Never operate headlight retractor when a person's hands, or other objects are on or near the headlights. When working on the headlights always remove the headlight retractor fuse.

RADIATOR CAP

CAUTION: Always disconnect the fan motor when working near the radiator fan. The fan is temperature controlled and could start at any time even when the ignition key is in the OFF position. DO NOT loosen or remove radiator cap when cooling system is hot.

RADIATOR FAN

WARNING: Keep hands away from radiator fan. Fan is controlled by a thermostatic switch which may come on or run for up to 15 minutes even after engine is turned off.

TURBOCHARGED MODELS

CAUTION: Do not race engine immediately after starting. When stopping engine, allow engine to idle for approximately 60 seconds before shutting it off. Failure to do so may cause turbocharger damage due to lack of oil flowing to the turbocharger bearings.

WARRANTY INFORMATION

CAUTION: Due to the different warranties offered in various regions and the variety of after-market extended warranties available, please refer to the warranty package that came with the vehicle to verify all warranty options.

BASIC NEW CAR LIMITED WARRANTY

Warrants basic components against defects in materials and workmanship for 36 months or 50,000 miles, whichever occurs first. Tires are covered by a separate warranty offered by the tire manufacturer.

AIR BAG WARRANTY

Covered by the basic warranty for a period of 3 years or 50,000 miles, whichever comes first. For 1991 model, the warranty lasts for a period of 5 years or 60,000 miles, whichever comes first.

ANTI-CORROSION WARRANTY

Covers holes caused by corrosion in body sheet metal panels for 60 months, without respect to mileage, so long as regular inspection and maintenance services are performed.

REPLACEMENT PARTS & ACCESSORIES

Manufacturer supplied parts and accessories are warranted against defects in material or workmanship for 12 months without regard to mileage. If installed by dealer, the part or accessory will be repaired or replaced without charge for parts or labor.

EMISSION CONTROL SYSTEM

Manufacturer warrants to the initial purchaser and each subsequent purchaser that this vehicle is designed, built, and equipped so as to conform at the time of sale with all U.S. and California Air Resources Board emission regulations applicable at the time of manufacture. Manufacturer also warrants that this vehicle is free from defects in materials and workmanship which cause it to fail to conform with applicable regulations within the first 5 years or 50,000 miles, which ever occurs first.

Emission Performance Warranty Parts List (60 Months Or 50,000 Miles)

- * Air/Fuel Metering System
- * Ignition Spark Advance/Retard System
- * Evaporative Emission Control
- * Positive Crankcase Ventilation System
- * Exhaust Gas Recirculation System
- * Air Injection System
- * Catalyst System
- * Electronic Controls Used In Above Systems
- * Miscellaneous Items Used In Above Systems

Additional Emission Warranty Parts List For California (7 Years Or 70,000 Miles)

- * Air Flow Meter
- * Throttle Body
- * E.G.I. Control Unit
- * Monolithic Catalytic Converter
- * Fuel Pump Assembly

FUSES & CIRCUIT BREAKERS

FUSE PANEL LOCATION

The main fuse block is located at the right rear side of the engine compartment and contains high amperage fuses which protect multiple circuits. Fuse box located above driver's left knee, accessible through a removable cover, contains fuses for individual circuits.

FUSE PANEL & FUSE BLOCK IDENTIFICATION (1983-85)

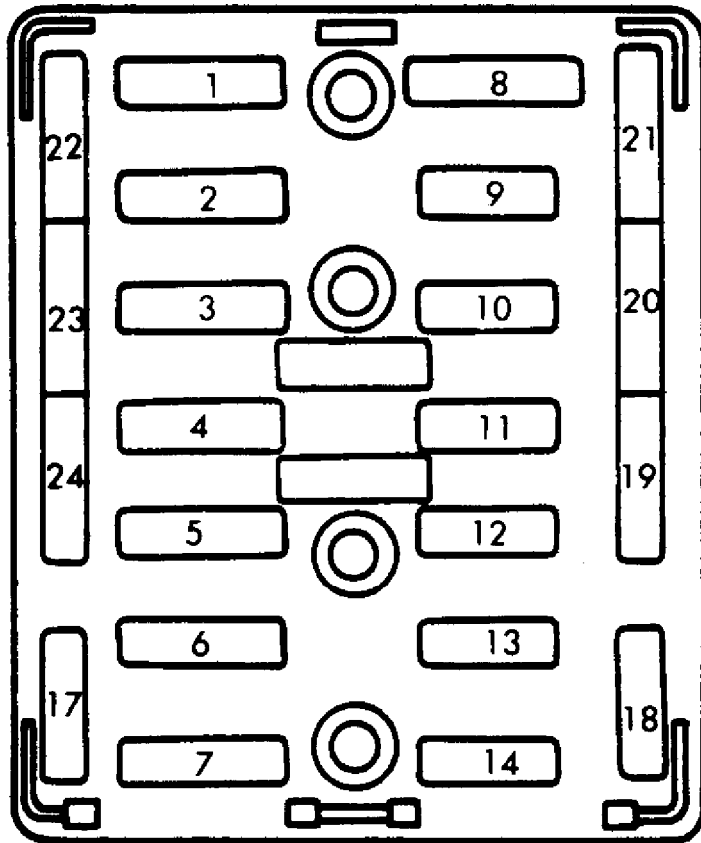

93C45387

Fig. 6: Fuse Panel Identification (1983-85)
 Courtesy of Mazda Motor of America Inc.

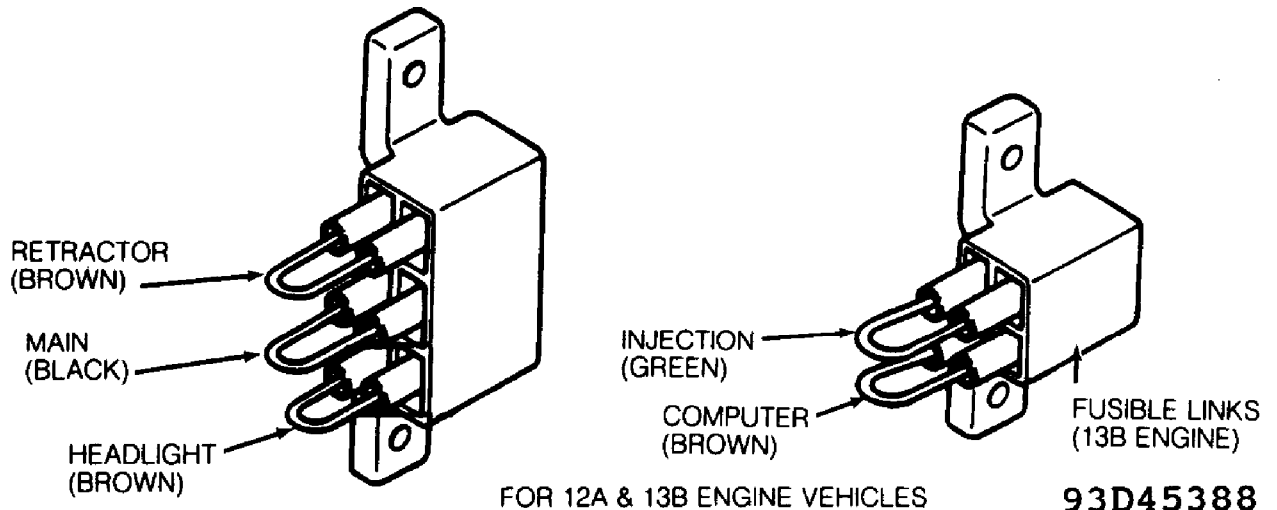

FOR 12A & 13B ENGINE VEHICLES

93D45388

Fig. 7: Fuse Block Identification (1983-85)
 Courtesy of Mazda Motor of America Inc.

- 1 - Empty
- 2 - 15 Amp

- 3 - 15 Amp
Hazard Warning Lights
- 4 - 10 Amp
Taillights
- 5 - 20 Amp
Roof Opener
- 6 - 10 Amp
Cigarette Lighter
- 7 - 20 Amp
Radio & Antenna
- 8 - 15 Amp
Gauges & Back-Up Lights
- 9 - 20 Amp
Engine
- 10 - 30 Amp
Power Windows
- 11 - 20 Amp
Heater Blower
- 12 - 15 Amp
Rear Defogger
- 13 - 15 Amp
Windshield Wipers
- 14 - 10 Amp
Rear Wiper
- 15 - Empty
- 16 - Empty
- 17 - Empty
- 18 - Empty
- 19 - 15 Amp
Air Conditioning
- 20 - Empty
- 21 - Empty
- 22 - Empty
- 23 - Empty
- 24 - Empty

FUSE PANEL & FUSE BLOCK IDENTIFICATION (1986-90)

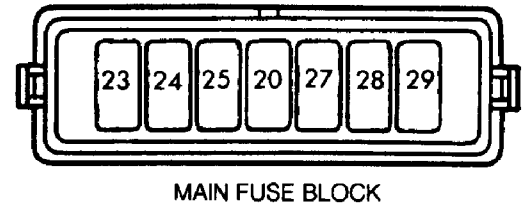
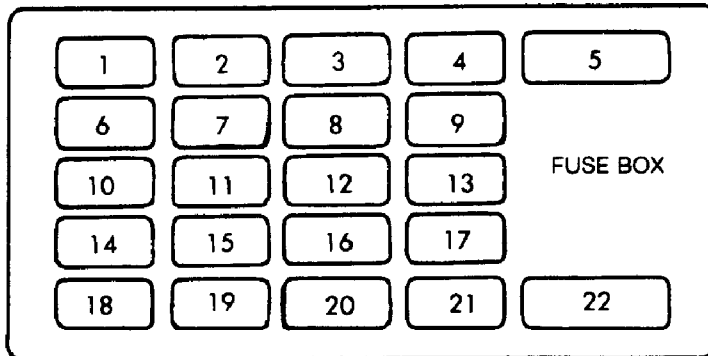

93E45389

FUSE PANEL CIRCUITS

Fig. 8: Fuse Panel & Fuse Block Identification (1986-90)
Courtesy of Mazda Motor of America, Inc.

Fuse & Circuit Breaker Identification

- 1 - 30 Amp
Rear Defogger
- 2 - 15 Amp
Headlights

- 3 - 30 Amp
Power Windows, AAS System
- 4 - 15 Amp
Cooling Fan System
- 5 - 15 Amp
Front Foglight
- 6 - 10 Amp
Power Door Lock, Power Antenna
- 7 - 15 Amp
Turn Lights, Hazard Lights, Rear Window Defogger, Passive
Shoulder Belt
- 8 - 15 Amp
Front Wiper & Washer, DRL System, Heater, A/C, Diagnostic
Module
- 9 - 30 Amp
Passive Shoulder Belt
- 10 - 7.5 Amp
Courtesy Lights, Cargo & Interior Lights, Stoplight, Warning
& Buzzer Or Chime, Door Lock Cylinder & Ignition Key Cylinder
Light, EGI, Emission Control System, Warning & Clock System,
Theft System, ECAT
- 11 - 10 Amp
Back-Up Light, Cruise Control, Shift Lock System, ECAT,
Gauges, Clock, Cooling Fan
- 12 - 10 Amp
Rear Wiper/Washer (Coupe)
- 13 - 15 Amp
Anti-Lock Brake System
- 14 - 10 Amp
Turn Lights, Hazard Lights
- 15 - 15 Amp
ECAT, Fuel System, EGI & Emission Control System
- 16 - 30 Amp
Convertible Top System
- 17 - 10 Amp
Cigarette Lighter, Warning & Clock, Remote Control Mirror,
Heater & A/C
- 18 - 30 Amp
Heater & A/C
- 19 - 20 Amp
Stoplight, Cruise Control
- 20 - 10 Amp
Rear Window Defogger, Starter, Charge System, Shift Lock,
ECAT, Power Antenna & Steering, Horn, Stoplight
- 21 - 15 Amp
Air Bag, Diagnostic Module, (Conv.) Sun Roof, Anti-Lock Brake
System, AAS System (Coupe)
- 22 - 20 Amp
Audio System
- 23 - 60 Amp
BTN, Light Switch, Heater, A/C
- 24 - 30 Amp
Headlights
- 25 - 30 Amp
Headlight Retractor
- 26 - 30 Amp
EGI & Emission System
- 27 - 100 Amp
Starter & Charge System
- 28 - 60 Amp
Anti-Lock Brake System
- 29 - 30 Amp
Back-Up Battery (Air Bag)

FUSE PANEL & FUSE BLOCK IDENTIFICATION (1991)

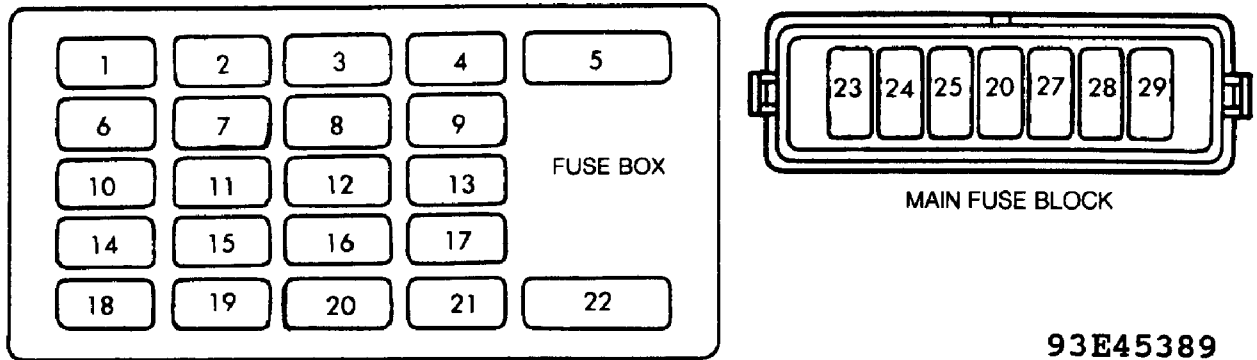

93E45389

FUSE PANEL CIRCUITS

Fig. 9: Fuse Panel & Fuse Block Identification (1991)
 Courtesy of Mazda Motor of America, Inc.

Fuse & Circuit Breaker Identification

- 1 - 20 Amp
Audio System
- 2 - 15 Amp
Sun Roof, Anti-Lock Brake System
- 2 - 15 Amp (Convertible)
Air Bag, Diagnostic Module
- 3 - 10 Amp
Rear Window Defogger, Starter, Charge System, Shift Lock System, ECAT, Power Antenna, Horn, Stoplight, Power Steering
- 4 - 20 Amp
Stoplight, Cruise Control System
- 5 - 30 Amp
Heater & A/C
- 6 - 10 Amp
Clock, Remote Control Mirror, Heater & A/C
- 7 - 30 Amp
Convertible Top System
- 8 - 15 Amp
ECAT, Fuel System, EGI & Emission Control System
- 9 - 10 Amp
Turn Lights, Hazard Lights
- 10 - 15 Amp (Except Convertible)
Anti-Lock Brake System
- 11 - 10 Amp (Except Convertible)
Rear Wiper & Washer
- 12 - 10 Amp
Back-Up Light, Cruise Control System, Shift Lock System, ECAT, Gauges, Clock, Cooling Fan
- 13 - 7.5 Amp
Cargo Light, Courtesy Lights, Interior Lights, Stoplights, Warning & Buzzer Or Chime, Door Lock Cylinder & Ignition Key Cylinder Light, EGI, Emission Control System, Warning Clock System, Theft System, ECAT
- 14 - 30 Amp (Except Convertible)
Passive Shoulder Belt
- 15 - 15 Amp
Front Wiper & Washer, DRL System Heater & A/C Diagnostic Module
- 16 - 15 Amp

- Turn Lights, Hazard Lights, Rear Window Defroster, Passive
Shoulder Belt
- 17 - 10 Amp
Power Door Lock System & Antenna
- 18 - 15 Amp
Front Foglight
- 19 - 15 Amp
Cooling Fan
- 20 - 30 Amp
Power Window
- 21 - 15 Amp
Headlight
- 22 - 30 Amp
Rear Window Defroster
- 23 - 30 Amp
EGI
- 24 - Blank
- 24 - 30 Amp (Convertible)
Air Bag
- 25 - 30 Amp
Head
- 26 - 100 Amp
Main
- 27 - 60 Amp (Except Convertible)
Anti-Lock Brake System
- 28 - 60 Amp
BTN
- 29 - 30 Amp
Retractor

END OF ARTICLE

SCHEDULED SERVICES

Article Text

1984 Mazda RX7

For iluvmyrx7.com

Copyright © 1998 Mitchell Repair Information Company, LLC

Sunday, June 09, 2002 06:10AM

ARTICLE BEGINNING

1983-91 MAINTENANCE
Mazda Maintenance & Service Intervals

RX7

* PLEASE READ THIS FIRST *

NOTE: All SERVICE SCHEDULES are listed for normal service vehicles. If vehicle is operated under severe service conditions, see SEVERE SERVICE REQUIREMENTS (PERFORM W/SERVICE SCHEDULES) for items requiring additional maintenance.

NOTE: This article contains scheduled maintenance service information. Fluid types and capacities listed with each service in this article are only those necessary to perform that scheduled service. For specifications pertaining to fluid capacities for the entire vehicle, fuse and circuit breaker identification, wheel and tire size, battery type, warranty information, or model identification refer to the MAINTENANCE INFORMATION article in this section.

CAUTIONS & WARNINGS

SUPPLEMENTAL RESTRAINT SYSTEM (AIR BAG)

NOTE: See the AIR BAGS article in the ACCESSORIES/SAFETY EQUIPMENT Section.

Modifications or improper maintenance, including incorrect removal and installation of the Supplemental Restraint System (SRS), can adversely affect system performance. DO NOT cover, obstruct or change the steering wheel horn pad in any way, as such action could cause improper function of the system. Use only plain water when cleaning the horn pad. Solvents or cleaners could adversely affect the air bag cover and cause improper deployment of the system.

WARNING: To avoid injury from accidental air bag deployment, read and carefully follow all warnings and service precautions. See appropriate AIR BAGS article in ACCESSORIES/SAFETY EQUIPMENT.

CAUTION: Disconnect negative battery cable before servicing any air bag system, steering column or passenger side dash component. After any repair, turn ignition key to the ON position from passenger's side of vehicle in case of accidental air bag inflation

ANTI-LOCK BRAKE SYSTEM

The anti-lock brake system contains electronic equipment that can be susceptible to interference caused by improperly installed or high output radio transmitting equipment. Since this interference could cause the possible loss of the anti-lock braking capability, such equipment should be installed by qualified professionals.

On models equipped with anti-lock brake systems, ALWAYS observe the following cautions:

- * DO NOT attempt to bleed hydraulic system without first referring to the appropriate ANTI-LOCK BRAKE SYSTEM article in the BRAKES Section.
- * DO NOT mix tire sizes. As long as tires remain close to the original diameter, increasing the width is acceptable. Rolling diameter must be identical for all 4 tires. Some manufacturers recommend tires of the same brand, style and type. Failure to follow this precaution may cause inaccurate wheel speed readings.
- * Use ONLY recommended brake fluids. DO NOT use silicone brake fluids in an ABS-equipped vehicle.

BATTERY WARNING

WARNING: When battery is disconnected, vehicles equipped with computers may lose memory data. When battery power is restored, driveability problems may exist on some vehicles. These vehicles may require a relearn procedure. See COMPUTER RELEARN PROCEDURES article in GENERAL INFORMATION section.

REPLACING BLOWN FUSES

Before replacing a blown fuse, remove ignition key, turn off all lights and accessories to avoid damaging the electrical system. Be sure to use fuse with the correct indicated amperage rating. The use of an incorrect amperage rating fuse may result in a dangerous electrical system overload.

BRAKE PAD WEAR INDICATOR

Indicator will cause a squealing or scraping noise, warning that brake pads need replacement.

CATALYTIC CONVERTER

Continued operation of vehicle with a severe malfunction could cause converter to overheat, resulting in possible damage to converter and vehicle.

Any modification to the exhaust system on turbo models, which reduces exhaust backpressure, will lead to lean fuel mixtures and excessive spark advance. This could cause serious engine damage.

COOLANT (PROPYLENE-GLYCOL FORMULATIONS)

CAUTION: To avoid possible damage to vehicle use only ethylene-glycol based coolants with a mixture ratio from 44-68% anti-freeze. DO NOT use 100% anti-freeze as it will cause the formation of cooling system deposits. This results in coolant temperatures of over 300° F (149°C) which can melt plastics. 100% anti-freeze has a freeze point of only -8° F (-22°C).

CAUTION: Propylene-Glycol Mixtures has a smaller temperature range than Ethylene-Glycol. The temperature range (freeze-boil) of a 50/50 Anti-Freeze/Water Mix is as follows:

Propylene-Glycol	-26° F (-32°C)	-	257° F (125°C)
Ethylene-Glycol	-35° F (-37°C)	-	263° F (128°C)

CAUTION: Propylene-Glycol/Ethylene-Glycol Mixtures can cause the destabilization of various corrosion inhibitors. Also Propylene-Glycol/Ethylene-Glycol has a different specific gravity than Ethylene-Glycol coolant, which will result in inaccurate freeze point calculations.

ELECTROSTATIC DISCHARGE SENSITIVE (ESD) PARTS

WARNING: Many solid state electrical components can be damaged by static electricity (ESD). Some will display a warning label, but many will not. Discharge personal static electricity by touching a metal ground point on the vehicle prior to servicing any ESD sensitive component.

ENGINE OIL

CAUTION: Never use non-detergent or straight mineral oil.

FUEL SYSTEM SERVICE

WARNING: Relieve fuel system pressure prior to servicing any fuel system component (fuel injection models).

HALOGEN BULBS

WARNING: Halogen bulbs contain pressurized gas which may explode if overheated. DO NOT touch glass portion of bulb with bare hands. Eye protection should be worn when handling or working around halogen bulbs.

HEADLIGHT RETRACTOR

CAUTION: Never operate headlight retractor when a person's hands, or other objects are on or near the headlights. When working on the headlights always remove the headlight retractor fuse.

RADIATOR CAP

CAUTION: Always disconnect the fan motor when working near the radiator fan. The fan is temperature controlled and could start at any time even when the ignition key is in the OFF position. DO NOT loosen or remove radiator cap when cooling system is hot.

RADIATOR FAN

WARNING: Keep hands away from radiator fan. Fan is controlled by a thermostatic switch which may come on or run for up to 15 minutes even after engine is turned off.

TURBOCHARGED MODELS

CAUTION: Do not race engine immediately after starting. When stopping engine, allow engine to idle for approximately 60 seconds before shutting it off. Failure to do so may cause turbocharger damage due to lack of oil flowing to the turbocharger bearings.

SERVICE POINT LOCATIONS

NON-TURBO MODELS

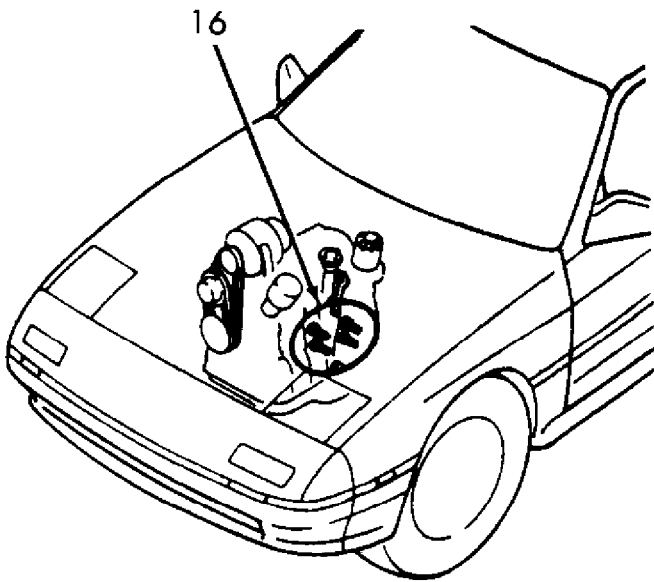
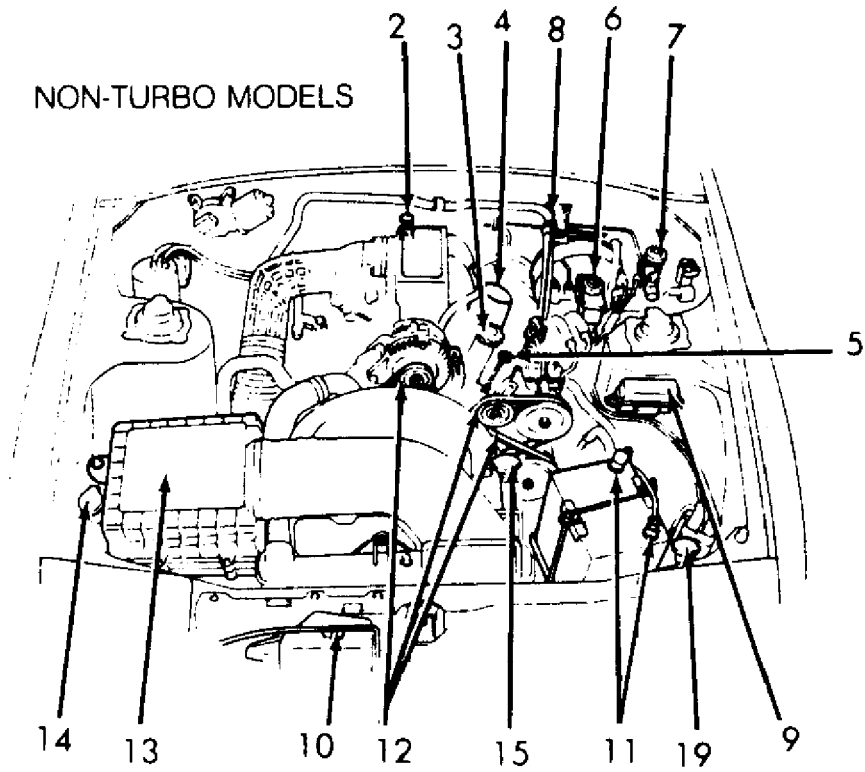

1. Sub-Zero Starting Assist Fluid Reservoir (If Equipped)
2. Automatic Transmission Fluid Level Gauge (If Equipped)
3. Engine Oil Filler Cap
4. Oil Filter
5. Engine Oil Dipstick
6. Brake Fluid Reservoir
7. Clutch Fluid Steering Reservoir
8. Power Steering Fluid Filler Cap (With Level Gauge)
9. Main Fuse Block
10. Coolant Reservoir
11. Battery Terminals
12. Drive Belts
13. Air Cleaner
14. Windshield Washer Reservoir
15. Radiator Cap
16. Spark Plugs
17. Intercooler (If Equipped)
18. Turbocharger (If Equipped)
19. Headlight Washer Fluid (If Equipped)

93F45703

Fig. 1: Service Point Locations (Typical Non-Turbo Engine)
SCHEDULED SERVICE Article Text (p. 4) 1984 Mazda RX7 For iluvmyrx7.com Copyright © 1998 Mitchell Repair

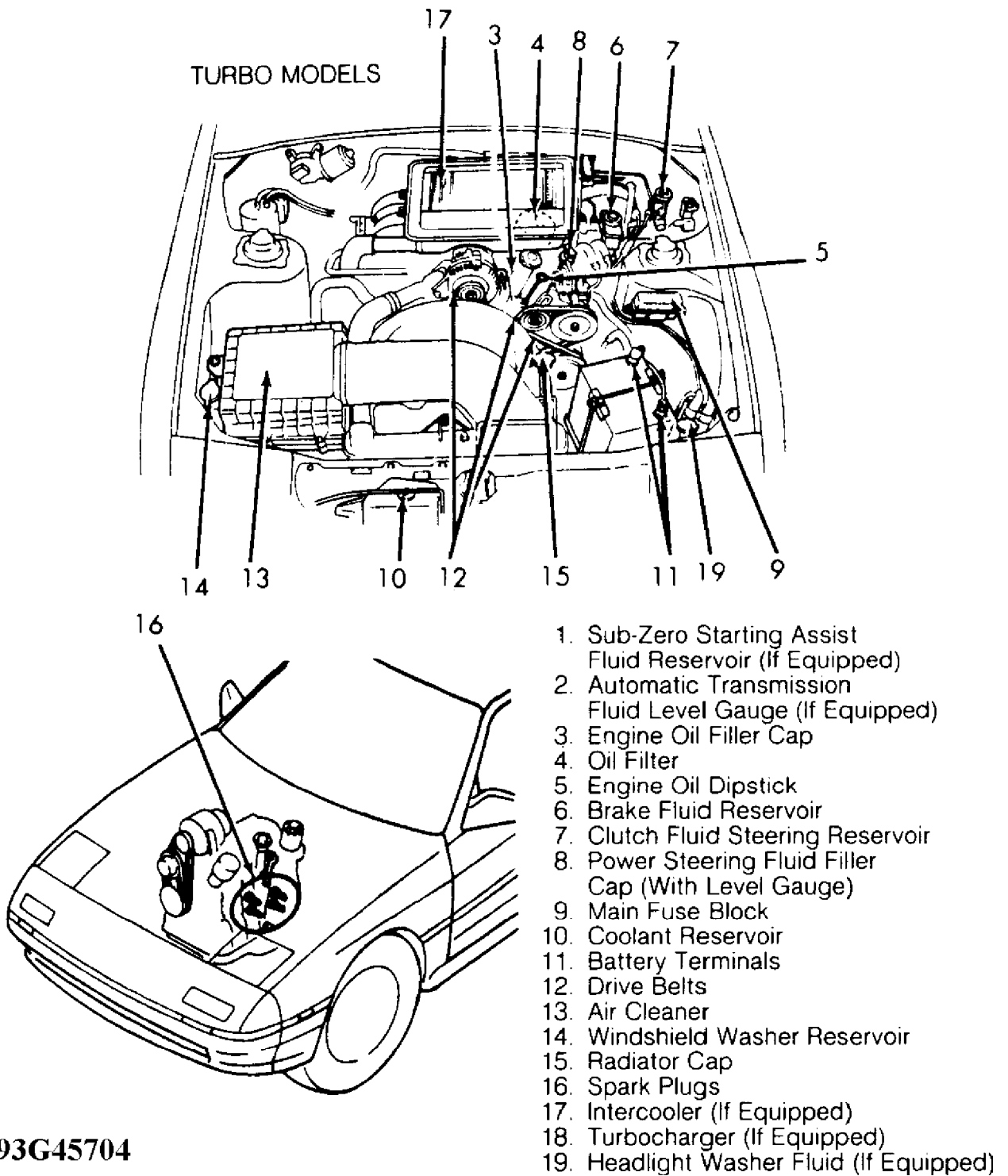

93G45704

Fig. 2: Service Point Locations (Typical Turbo Engine)
 Courtesy of Mazda Motor of America, Inc.

MODELS WITH SUB-ZERO STARTING ASSIST

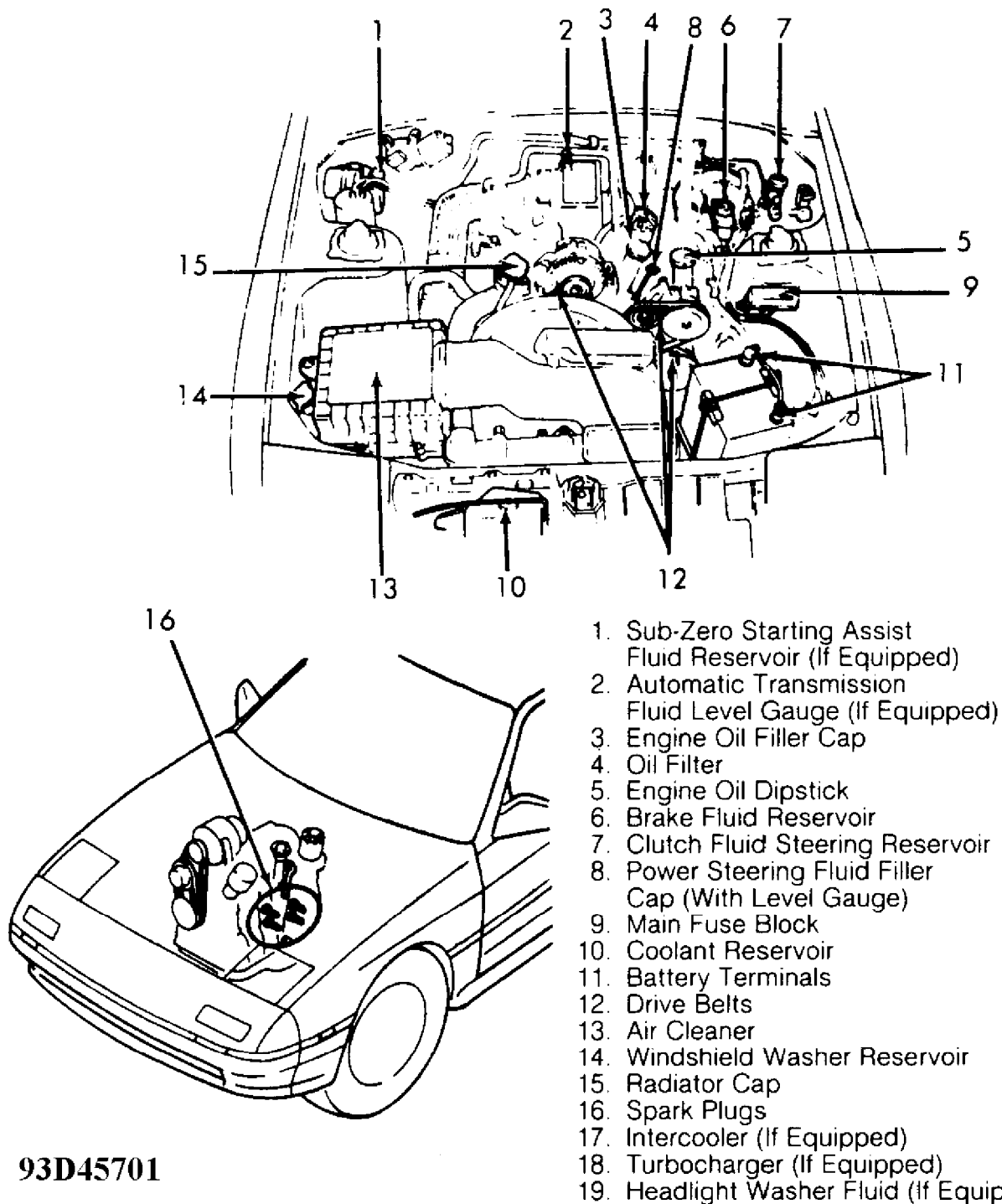

93D45701

Fig. 3: Service Point Locations (Non-Turbo W/Sub-Zero Start Assist)

TURBO MODELS WITH SUB-ZERO STARTING ASSIST

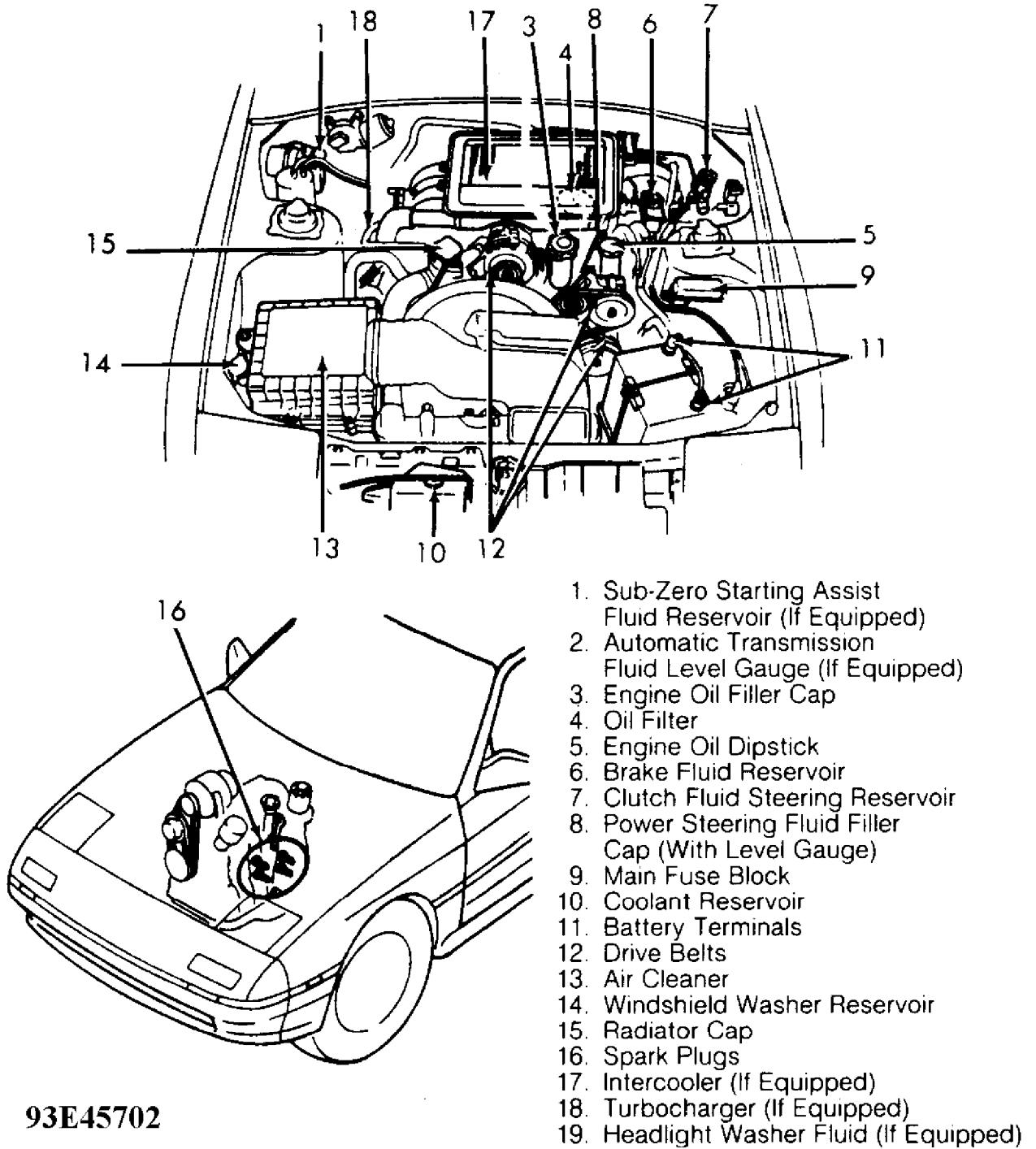

93E45702

Fig. 4: Service Point Locations (Turbo W/Sub-Zero Start Assist)
 Courtesy of Mazda Motor of America, Inc.

SCHEDULED SERVICE DEFINITIONS Mazda RX7 For iluvmyrx7.com Copyright © 1998 Mitchell Repair

NOTE: Use the Severe Service schedule if the vehicle to be serviced is operated under ANY (one or more) of these conditions:

Service is recommended at mileage intervals based on vehicle operation. Service schedules are based on the following primary operating conditions:

Normal Service

- * Driven More Than 10 Miles Daily
- * No Operating Conditions From Severe Service Schedule

Severe Service (Unique Driving Conditions)

- * Repeated Short Distance Driving
- * Dusty Conditions
- * Extended Use Of Brakes
- * Salt Or Other Corrosive Materials On The Roads
- * Rough Or Muddy Roads
- * Extended Idling Or Low Speed Operation
- * Extended Operation In Extreme Temperatures

SEVERE SERVICE REQUIREMENTS (PERFORM W/SERVICE SCHEDULES)

NOTE: The following services are to be performed on vehicles subjected to severe service. See SEVERE & NORMAL SERVICE DEFINITIONS. This service is to be performed in addition to the normal services listed in the NORMAL MAINTENANCE SERVICE SCHEDULES.

SEVERE SERVICE CONDITIONS/ACTIONS TABLE

Condition	Action	Item	Perform Every (1)
Repeated Short Distance Driving	Replace	Turbo: Oil & Filter	3,000 Miles or 3 Months
	Replace	Non-Turbo: Oil & Filter	5,000 Miles or 5 Months
	Replace	M/T Fluid	30,000 Miles
	Replace	Rear Axle Oil	30,000 Miles
Dusty Conditions	Replace	Turbo: Oil & Filter	3,000 Miles or 3 Months
	Replace	Non-Turbo: Oil & Filter	5,000 Miles or 5 Months
	Replace	M/T Fluid	30,000 Miles
	Replace	Rear Axle Oil	30,000 Miles
Extended Use Of Brakes	Replace	Turbo: Oil & Filter	3,000 Miles or 3 Months
	Replace	Non-Turbo: Oil & Filter	5,000 Miles or 5 Months
	Replace	M/T Fluid	30,000 Miles
	Replace	Rear Axle Oil	30,000 Miles

Corrosive Materials On The Roads		Filter	
	Replace	Non-Turbo: Oil & Filter	5,000 Miles or 5 Months
	Replace	M/T Fluid	30,000 Miles
Rough Or Muddy Roads	Replace	Rear Axle Oil	30,000 Miles
	Replace	Turbo: Oil & Filter	3,000 Miles or 3 Months
	Replace	Non-Turbo: Oil & Filter	5,000 Miles or 5 Months
	Replace	M/T Fluid	30,000 Miles
Extended Idling Or Low Speed Operation	Replace	Rear Axle Oil	30,000 Miles
	Replace	Turbo: Oil & Filter	3,000 Miles or 3 Months
	Replace	Non-Turbo: Oil & Filter	5,000 Miles or 5 Months
	Replace	M/T Fluid	30,000 Miles
Extended Operation In Extreme Temperatures	Replace	Rear Axle Oil	30,000 Miles
	Replace	Turbo: Oil & Filter	3,000 Miles or 3 Months
	Replace	Non-Turbo: Oil & Filter	5,000 Miles or 5 Months
	Replace	M/T Fluid	30,000 Miles
(1) - Perform these services at the mileage or number of months (since the last time), whichever comes first.			

NORMAL MAINTENANCE SERVICE SCHEDULES

CAUTION: The following service schedules refer to vehicles driven under normal operating conditions. For vehicles driven under severe conditions, additional services may be necessary. See SEVERE SERVICE REQUIREMENTS (PERFORM W/SERVICE SCHEDULES) above in this article for additional service requirements.

7,500 MILE (12,000 KM) SERVICE

7,500 MILE (12,000 KM) SERVICE

Service Or Inspect
Check Fluid Levels and Fluid Condition
Inspect Coolant Level, Hoses and Clamps

SCHEDULED SERVICE

Inspect Exhaust System	
Inspect C/V Joint Boots	
Inspect Brake Linings	
Lubricate Chassis	
Replace	
Engine Oil	
Oil Filter	
Lubrication Specifications	
Application	Specification
Engine Oil	
Minimum Temperature	
Greater Than 0°F (-18°C)	SAE 10W-30 API SG/CD
Maximum Temperature	
Less Than 0°F (-18°C)	SAE 5W-30 API SG/CD
Fluid Capacities	
Application	Quantity
Engine Oil	4.4-4.7 Qts. (4.2-4.4L)

15,000 MILE (24,000 KM) SERVICE

15,000 MILE (24,000 KM) SERVICE

Service Or Inspect
Verify Last Major Service Was Performed
Idle Speed
Check Fluid Levels and Fluid Condition
Inspect Coolant Level, Hoses and Clamps
Check Coolant Strength
Check Exhaust System & Heat Shielding
Check C/V Joint Boots
Clean Battery and Battery Terminals
Inspect/Adjust Accessory Drive Belts (Replace if Required)
Inspect Fuel/Tank/Cap/Lines
Check Operation of Horn, Wipers/Washers & All Exterior Lights
Inspect Condition of Wiper Blades

SCHEDULED SERVIC

Check Headlight Alignment	
Check Body Drain Holes	
Check Seat Belt Webbing and Release Mechanisms	
Check Parking Brake Operation	
Check Shift Interlock Operation	
Lubricate Weatherstripping with Silicone	
Lubricate Door Hinges	
Lubricate Door Locks	
Check Steering Rack Boots	
Inspect Steering Linkage/Front Suspension	
Lubricate Steering Linkage & Suspension	
Lubricate Chassis	
Inspect Brake System Hoses & Lines	
Inspect Front Brake Pads, Rotors and Calipers	
Lubricate Caliper Slide Rails	
Inspect Rear Brake Pads, Rotors and Calipers	
Inspect Shocks/Struts for Leakage	
Inspect Tire Wear Pattern	
Rotate Tires and Adjust Air Pressure (Including Spare)	
Replace	
Engine Oil	
Oil Filter	
Lubrication Specifications	
Application	Specification
Engine Oil	
Minimum Temperature	
Greater Than 0°F (-18°C)	SAE 10W-30 API SG/CD
Maximum Temperature	
Less Than 0°F (-18°C)	SAE 5W-30 API SG/CD
Fluid Capacities	
Application	Quantity
Cooling System	
1983-85	9.0-10.0 Qts. (8.5-9.5L)
1986-91	
Turbo	9.2 Qts. (8.7L)
Non-Turbo	7.7 Qts. (7.3L)

SCHEDULED SERVICE

Engine Oil	4.4-4.7 Qts. (4.2-4.4L)
------------------	-------------------------

22,500 MILE (36,000 KM) SERVICE

22,500 MILE (36,000 KM) SERVICE

Service Or Inspect	
Verify Last Major Service Was Performed	
Check Fluid Levels and Fluid Condition	
Inspect Coolant Level, Hoses and Clamps	
Inspect Exhaust System	
Inspect C/V Joint Boots	
Inspect Brake Linings	
Lubricate Chassis	
Replace	
Engine Oil	
Oil Filter	
Lubrication Specifications	
Application	Specification
Engine Oil	
Minimum Temperature Greater Than 0°F (-18°C)	SAE 10W-30 API SG/CD
Maximum Temperature Less Than 0°F (-18°C)	SAE 5W-30 API SG/CD
Fluid Capacities	
Application	Quantity
Engine Oil	4.4-4.7 Qts. (4.2-4.4L)

30,000 MILE (48,000 KM) SERVICE

30,000 MILE (48,000 KM) SERVICE

Service Or Inspect	
Verify Last Major Service Was Performed	
Check Fluid Levels and Fluid Condition	
Inspect Coolant Level, Hoses and Clamps	
Engine Coolant Level Warning System	
Check Exhaust System & Heat Shielding	

SCHEDULED SERVICE

Clean Battery and Battery Terminals
Inspect/Adjust Accessory Drive Belts (Replace if Required)
Inspect Underhood Wiring Harnesses and Connections
Inspect Emission Control Vacuum Hoses and Connections
Inspect Thermostatic Air Cleaner (If Equipped)
Inspect Distributor Cap & Rotor (If Equipped)
Inspect Spark Plug Wires
Inspect PCV Valve and Hoses
Inspect EGR Valve and Hoses
Check Ignition Timing
Idle Speed
Inspect Fuel/Tank/Cap/Lines
Check Operation of Horn, Wipers/Washers & All Exterior Lights
Inspect Condition of Wiper Blades
Check Headlight Alignment
Check Body Drain Holes
Check Seat Belt Webbing and Release Mechanisms
Check Parking Brake Operation
Check Shift Interlock Operation
Lubricate Weatherstripping with Silicone
Lubricate Door Hinges
Lubricate Door Locks
Check Steering Rack Boots
Check C/V Joint Boots
Inspect Steering Linkage/Front Suspension
Lubricate Steering Linkage & Suspension
Lubricate Chassis
Suspension Bushings, Springs, Arms & Rear Jounce Bumpers
Toe Control Hub & Control Link
Lubricate Front Wheel Bearings
Inspect Brake System Hoses & Lines

SCHEDULED SERVIC

Inspect Front Brake Pads, Rotors and Calipers	
Lubricate Caliper Slide Rails	
Inspect Rear Brake Pads, Rotors and Calipers	
Inspect/Repack Rear Wheel Bearings	
Inspect Shocks/Struts for Leakage	
Inspect Tire Wear Pattern	
Rotate Tires and Adjust Air Pressure (Including Spare)	
Replace	
Engine Oil	
Oil Filter	
Air Filter Element	
Spark Plugs	
PCV Filter	
Drain, Flush and Refill Engine Coolant	
Manual Transmission Oil	
Rear Axle Oil	
Lubrication Specifications	
Application	Specification
Engine Oil	
Minimum Temperature	
Greater Than 0°F (-18°C)	SAE 10W-30 API SG/CD
Maximum Temperature	
Less Than 0°F (-18°C)	SAE 5W-30 API SG/CD
Manual Transmission	SAE 75W-90 GL-5
Rear Axle	SAE 80W-90 GL-5
Fluid Capacities	
Application	Quantity
Automatic Transmission Fluid	7.7-7.9 Qts. (7.3-7.5L)
Cooling System	
1983-85	9.0-10.0 Qts. (8.5-9.5L)
1986-91	
Turbo	9.2 Qts. (8.7L)
Non-Turbo	7.7 Qts. (7.3L)
Engine Oil	4.4-4.7 Qts. (4.2-4.4L)
Manual Transmission Oil	2.1-2.6 Qts. (2.0-2.5L)
Rear Axle Oil	
Turbo	1.3-1.5 Qts. (1.2-1.4L)
Non-Turbo	1.4-1.7 Qts. (1.3-1.6L)
Service Labor Times	
Application	Hours

SCHEDULED SERVICE

Automatic Transmission	2.1
Manual Transmission	2.1

37,500 MILE (60,000 KM) SERVICE

37,500 MILE (60,000 KM) SERVICE

Service Or Inspect	
	Verify Last Major Service Was Performed
	Check Fluid Levels and Fluid Condition
	Inspect Coolant Level, Hoses and Clamps
	Inspect Exhaust System
	Inspect C/V Joint Boots
	Inspect Brake Linings
	Lubricate Chassis
Replace	
	Engine Oil
	Oil Filter
Lubrication Specifications	
Application	Specification
Engine Oil	
Minimum Temperature Greater Than 0°F (-18°C)	SAE 10W-30 API SG/CD
Maximum Temperature Less Than 0°F (-18°C)	SAE 5W-30 API SG/CD
Fluid Capacities	
Application	Quantity
Engine Oil	4.4-4.7 Qts. (4.2-4.4L)

45,000 MILE (72,000 KM) SERVICE

45,000 MILE (72,000 KM) SERVICE

Service Or Inspect	
	Verify Last Major Service Was Performed
	Idle Speed
	Check Fluid Levels and Fluid Condition
	Inspect Coolant Level, Hoses and Clamps

SCHEDULED SERVICE

Check Coolant Strength
Check Exhaust System & Heat Shielding
Check C/V Joint Boots
Clean Battery and Battery Terminals
Inspect/Adjust Accessory Drive Belts (Replace if Required)
Inspect Fuel/Tank/Cap/Lines
Check Operation of Horn, Wipers/Washers & All Exterior Lights
Inspect Condition of Wiper Blades
Check Headlight Alignment
Check Body Drain Holes
Check Seat Belt Webbing and Release Mechanisms
Check Parking Brake Operation
Check Shift Interlock Operation
Lubricate Weatherstripping with Silicone
Lubricate Door Hinges
Lubricate Door Locks
Check Steering Rack Boots
Inspect Steering Linkage/Front Suspension
Lubricate Steering Linkage & Suspension
Lubricate Chassis
Inspect Brake System Hoses & Lines
Inspect Front Brake Pads, Rotors and Calipers
Lubricate Caliper Slide Rails
Inspect Rear Brake Pads, Rotors and Calipers
Inspect Shocks/Struts for Leakage
Inspect Tire Wear Pattern
Rotate Tires and Adjust Air Pressure (Including Spare)
Replace
Engine Oil
Oil Filter
Lubrication Specifications

SCHEDULED SERVIC

Application	Specification
Engine Oil	
Minimum Temperature Greater Than 0°F (-18°C)	SAE 10W-30 API SG/CD
Maximum Temperature Less Than 0°F (-18°C)	SAE 5W-30 API SG/CD
Fluid Capacities	
Application	Quantity
Cooling System	
1983-85	9.0-10.0 Qts. (8.5-9.5L)
1986-91	
Turbo	9.2 Qts. (8.7L)
Non-Turbo	7.7 Qts. (7.3L)
Engine Oil	4.4-4.7 Qts. (4.2-4.4L)

52,500 MILE (84,000 KM) SERVICE

52,500 MILE (84,000 KM) SERVICE

Service Or Inspect	
Verify Last Major Service Was Performed	
Check Fluid Levels and Fluid Condition	
Inspect Coolant Level, Hoses and Clamps	
Inspect Exhaust System	
Inspect C/V Joint Boots	
Inspect Brake Linings	
Lubricate Chassis	
Replace	
Engine Oil	
Oil Filter	
Lubrication Specifications	
Application	Specification
Engine Oil	
Minimum Temperature Greater Than 0°F (-18°C)	SAE 10W-30 API SG/CD
Maximum Temperature Less Than 0°F (-18°C)	SAE 5W-30 API SG/CD
Fluid Capacities	
Application	Quantity
Engine Oil	4.4-4.7 Qts. (4.2-4.4L)

SCHEDULED SERVICE

60,000 MILE (96,000 KM) SERVICE

60,000 MILE (96,000 KM) SERVICE

Service Or Inspect
Verify Last Major Service Was Performed
Check Fluid Levels and Fluid Condition
Inspect Coolant Level, Hoses and Clamps
Engine Coolant Level Warning System
Check Exhaust System & Heat Shielding
Clean Battery and Battery Terminals
Inspect/Adjust Accessory Drive Belts (Replace if Required)
Inspect Underhood Wiring Harnesses and Connections
Inspect Emission Control Vacuum Hoses and Connections
Inspect Thermostatic Air Cleaner (If Equipped)
Inspect Distributor Cap & Rotor (If Equipped)
Inspect Spark Plug Wires
Inspect PCV Valve and Hoses
Inspect EGR Valve and Hoses
Check Ignition Timing
Idle Speed
Inspect Fuel/Tank/Cap/Lines
Check Operation of Horn, Wipers/Washers & All Exterior Lights
Inspect Condition of Wiper Blades
Check Headlight Alignment
Check Body Drain Holes
Check Seat Belt Webbing and Release Mechanisms
Check Parking Brake Operation
Check Shift Interlock Operation
Lubricate Weatherstripping with Silicone
Lubricate Door Hinges
Lubricate Door Locks
Check Steering Rack Boots

SCHEDULED SERVICE

Check C/V Joint Boots	
Inspect Steering Linkage/Front Suspension	
Lubricate Steering Linkage & Suspension	
Lubricate Chassis	
Suspension Bushings, Springs, Arms & Rear Jounce Bumpers	
Toe Control Hub & Control Link	
Lubricate Front Wheel Bearings	
Inspect Brake System Hoses & Lines	
Inspect Front Brake Pads, Rotors and Calipers	
Lubricate Caliper Slide Rails	
Inspect Rear Brake Pads, Rotors and Calipers	
Inspect/Repack Rear Wheel Bearings	
Inspect Shocks/Struts for Leakage	
Inspect Tire Wear Pattern	
Rotate Tires and Adjust Air Pressure (Including Spare)	
Replace	
Engine Oil	
Oil Filter	
Air Filter Element	
Spark Plugs	
PCV Filter	
Drain, Flush and Refill Engine Coolant	
Manual Transmission Oil	
Rear Axle Oil	
Lubrication Specifications	
Application	Specification
Engine Oil	
Minimum Temperature	
Greater Than 0°F (-18°C)	SAE 10W-30 API SG/CD
Maximum Temperature	
Less Than 0°F (-18°C)	SAE 5W-30 API SG/CD
Manual Transmission	SAE 75W-90 GL-5
Rear Axle	SAE 80W-90 GL-5
Fluid Capacities	

SCHEDULED SERVIC

Application	Quantity
Automatic Transmission Fluid	7.7-7.9 Qts. (7.3-7.5L)
Cooling System	
1983-85	9.0-10.0 Qts. (8.5-9.5L)
1986-91	
Turbo	9.2 Qts. (8.7L)
Non-Turbo	7.7 Qts. (7.3L)
Engine Oil	4.4-4.7 Qts. (4.2-4.4L)
Manual Transmission Oil	2.1-2.6 Qts. (2.0-2.5L)
Rear Axle Oil	
Turbo	1.3-1.5 Qts. (1.2-1.4L)
Non-Turbo	1.4-1.7 Qts. (1.3-1.6L)

Service Labor Times

Application	Hours
Automatic Transmission	3.7
Manual Transmission	4.1

67,500 MILE (108,000 KM) SERVICE

67,500 MILE (108,000 KM) SERVICE

Service Or Inspect	
Verify Last Major Service Was Performed	
Check Fluid Levels and Fluid Condition	
Inspect Coolant Level, Hoses and Clamps	
Inspect Exhaust System	
Inspect C/V Joint Boots	
Inspect Brake Linings	
Lubricate Chassis	
Replace	
Engine Oil	
Oil Filter	
Lubrication Specifications	
Application	Specification
Engine Oil	
Minimum Temperature	
Greater Than 0°F (-18°C)	SAE 10W-30 API SG/CD
Maximum Temperature	
Less Than 0°F (-18°C)	SAE 5W-30 API SG/CD
Fluid Capacities	
Application	Quantity

SCHEDULED SERVICE

Engine Oil 4.4-4.7 Qts. (4.2-4.4L)

75,000 MILE (120,000 KM) SERVICE

75,000 MILE (120,000 KM) SERVICE

Service Or Inspect
Verify Last Major Service Was Performed
Idle Speed
Check Fluid Levels and Fluid Condition
Inspect Coolant Level, Hoses and Clamps
Check Coolant Strength
Check Exhaust System & Heat Shielding
Check C/V Joint Boots
Clean Battery and Battery Terminals
Inspect/Adjust Accessory Drive Belts (Replace if Required)
Inspect Fuel/Tank/Cap/Lines
Check Operation of Horn, Wipers/Washers & All Exterior Lights
Inspect Condition of Wiper Blades
Check Headlight Alignment
Check Body Drain Holes
Check Seat Belt Webbing and Release Mechanisms
Check Parking Brake Operation
Check Shift Interlock Operation
Lubricate Weatherstripping with Silicone
Lubricate Door Hinges
Lubricate Door Locks
Check Steering Rack Boots
Inspect Steering Linkage/Front Suspension
Lubricate Steering Linkage & Suspension
Lubricate Chassis
Inspect Brake System Hoses & Lines
Inspect Front Brake Pads, Rotors and Calipers
Lubricate Caliper Slide Rails

SCHEDULED SERVICE

Inspect Rear Brake Pads, Rotors and Calipers	
Inspect Shocks/Struts for Leakage	
Inspect Tire Wear Pattern	
Rotate Tires and Adjust Air Pressure (Including Spare)	
Replace	
Engine Oil	
Oil Filter	
Lubrication Specifications	
Application	Specification
Engine Oil	
Minimum Temperature Greater Than 0°F (-18°C)	SAE 10W-30 API SG/CD
Maximum Temperature Less Than 0°F (-18°C)	SAE 5W-30 API SG/CD
Fluid Capacities	
Application	Quantity
Cooling System	
1983-85	9.0-10.0 Qts. (8.5-9.5L)
1986-91	
Turbo	9.2 Qts. (8.7L)
Non-Turbo	7.7 Qts. (7.3L)
Engine Oil	4.4-4.7 Qts. (4.2-4.4L)

82,500 MILE (132,000 KM) SERVICE

82,500 MILE (132,000 KM) SERVICE

Service Or Inspect
Verify Last Major Service Was Performed
Check Fluid Levels and Fluid Condition
Inspect Coolant Level, Hoses and Clamps
Inspect Exhaust System
Inspect C/V Joint Boots
Inspect Brake Linings
Lubricate Chassis
Replace
Engine Oil
Oil Filter

SCHEDULED SERVICE

Lubrication Specifications	
Application	Specification
Engine Oil	
Minimum Temperature Greater Than 0°F (-18°C)	SAE 10W-30 API SG/CD
Maximum Temperature Less Than 0°F (-18°C)	SAE 5W-30 API SG/CD
Fluid Capacities	
Application	Quantity
Engine Oil	4.4-4.7 Qts. (4.2-4.4L)

90,000 MILE (144,000 KM) SERVICE

90,000 MILE (144,000 KM) SERVICE

Service Or Inspect
Verify Last Major Service Was Performed
Check Fluid Levels and Fluid Condition
Inspect Coolant Level, Hoses and Clamps
Engine Coolant Level Warning System
Check Exhaust System & Heat Shielding
Clean Battery and Battery Terminals
Inspect/Adjust Accessory Drive Belts (Replace if Required)
Inspect Underhood Wiring Harnesses and Connections
Inspect Emission Control Vacuum Hoses and Connections
Inspect Thermostatic Air Cleaner (If Equipped)
Inspect Distributor Cap & Rotor (If Equipped)
Inspect Spark Plug Wires
Inspect PCV Valve and Hoses
Inspect EGR Valve and Hoses
Check Ignition Timing
Idle Speed
Inspect Fuel/Tank/Cap/Lines
Check Operation of Horn, Wipers/Washers & All Exterior Lights
Inspect Condition of Wiper Blades

SCHEDULED SERVICE

Check Headlight Alignment
Check Body Drain Holes
Check Seat Belt Webbing and Release Mechanisms
Check Parking Brake Operation
Check Shift Interlock Operation
Lubricate Weatherstripping with Silicone
Lubricate Door Hinges
Lubricate Door Locks
Check Steering Rack Boots
Check C/V Joint Boots
Inspect Steering Linkage/Front Suspension
Lubricate Steering Linkage & Suspension
Lubricate Chassis
Suspension Bushings, Springs, Arms & Rear Jounce Bumpers
Toe Control Hub & Control Link
Lubricate Front Wheel Bearings
Inspect Brake System Hoses & Lines
Inspect Front Brake Pads, Rotors and Calipers
Lubricate Caliper Slide Rails
Inspect Rear Brake Pads, Rotors and Calipers
Inspect/Repack Rear Wheel Bearings
Inspect Shocks/Struts for Leakage
Inspect Tire Wear Pattern
Rotate Tires and Adjust Air Pressure (Including Spare)
Replace
Engine Oil
Oil Filter
Air Filter Element
Spark Plugs
PCV Filter
Drain, Flush and Refill Engine Coolant
Manual Transmission Oil

SCHEDULED SERVIC

Rear Axle Oil	
Lubrication Specifications	
Application	Specification
Engine Oil	
Minimum Temperature Greater Than 0°F (-18°C)	SAE 10W-30 API SG/CD
Maximum Temperature Less Than 0°F (-18°C)	SAE 5W-30 API SG/CD
Manual Transmission	SAE 75W-90 GL-5
Rear Axle	SAE 80W-90 GL-5
Fluid Capacities	
Application	Quantity
Automatic Transmission Fluid	7.7-7.9 Qts. (7.3-7.5L)
Cooling System	
1983-85	9.0-10.0 Qts. (8.5-9.5L)
1986-91	
Turbo	9.2 Qts. (8.7L)
Non-Turbo	7.7 Qts. (7.3L)
Engine Oil	4.4-4.7 Qts. (4.2-4.4L)
Manual Transmission Oil	2.1-2.6 Qts. (2.0-2.5L)
Rear Axle Oil	
Turbo	1.3-1.5 Qts. (1.2-1.4L)
Non-Turbo	1.4-1.7 Qts. (1.3-1.6L)
Service Labor Times	
Application	Hours
Automatic Transmission	2.1
Manual Transmission	2.1

97,500 MILE (156,000 KM) SERVICE

97,500 MILE (156,000 KM) SERVICE

Service Or Inspect	
Verify Last Major Service Was Performed	
Check Fluid Levels and Fluid Condition	
Inspect Coolant Level, Hoses and Clamps	
Inspect Exhaust System	
Inspect C/V Joint Boots	
Inspect Brake Linings	
Lubricate Chassis	
Replace	
Engine Oil	

SCHEDULED SERVICE

Oil Filter	
Lubrication Specifications	
Application	Specification
Engine Oil	
Minimum Temperature Greater Than 0°F (-18°C)	SAE 10W-30 API SG/CD
Maximum Temperature Less Than 0°F (-18°C)	SAE 5W-30 API SG/CD
Fluid Capacities	
Application	Quantity
Engine Oil	4.4-4.7 Qts. (4.2-4.4L)

105,000 MILE (168,000 KM) SERVICE

105,000 MILE (168,000 KM) SERVICE

Service Or Inspect
Verify Last Major Service Was Performed
Idle Speed
Check Fluid Levels and Fluid Condition
Inspect Coolant Level, Hoses and Clamps
Check Coolant Strength
Check Exhaust System & Heat Shielding
Check C/V Joint Boots
Clean Battery and Battery Terminals
Inspect/Adjust Accessory Drive Belts (Replace if Required)
Inspect Fuel/Tank/Cap/Lines
Check Operation of Horn, Wipers/Washers & All Exterior Lights
Inspect Condition of Wiper Blades
Check Headlight Alignment
Check Body Drain Holes
Check Seat Belt Webbing and Release Mechanisms
Check Parking Brake Operation
Check Shift Interlock Operation
Lubricate Weatherstripping with Silicone

SCHEDULED SERVICE

Lubricate Door Hinges	
Lubricate Door Locks	
Check Steering Rack Boots	
Inspect Steering Linkage/Front Suspension	
Lubricate Steering Linkage & Suspension	
Lubricate Chassis	
Inspect Brake System Hoses & Lines	
Inspect Front Brake Pads, Rotors and Calipers	
Lubricate Caliper Slide Rails	
Inspect Rear Brake Pads, Rotors and Calipers	
Inspect Shocks/Struts for Leakage	
Inspect Tire Wear Pattern	
Rotate Tires and Adjust Air Pressure (Including Spare)	
Replace	
Engine Oil	
Oil Filter	
Lubrication Specifications	
Application	Specification
Engine Oil	
Minimum Temperature	
Greater Than 0°F (-18°C)	SAE 10W-30 API SG/CD
Maximum Temperature	
Less Than 0°F (-18°C)	SAE 5W-30 API SG/CD
Fluid Capacities	
Application	Quantity
Cooling System	
1983-85	9.0-10.0 Qts. (8.5-9.5L)
1986-91	
Turbo	9.2 Qts. (8.7L)
Non-Turbo	7.7 Qts. (7.3L)
Engine Oil	4.4-4.7 Qts. (4.2-4.4L)

112,500 MILE (180,000 KM) SERVICE

112,500 MILE (180,000 KM) SERVICE

Service Or Inspect
Verify Last Major Service Was Performed

SCHEDULED SERVICE

Check Fluid Levels and Fluid Condition	
Inspect Coolant Level, Hoses and Clamps	
Inspect Exhaust System	
Inspect C/V Joint Boots	
Inspect Brake Linings	
Lubricate Chassis	
Replace	
Engine Oil	
Oil Filter	
Lubrication Specifications	
Application	Specification
Engine Oil	
Minimum Temperature Greater Than 0°F (-18°C)	SAE 10W-30 API SG/CD
Maximum Temperature Less Than 0°F (-18°C)	SAE 5W-30 API SG/CD
Fluid Capacities	
Application	Quantity
Engine Oil	4.4-4.7 Qts. (4.2-4.4L)

120,000 MILE (192,000 KM) SERVICE

120,000 MILE (192,000 KM) SERVICE

Service Or Inspect
Verify Last Major Service Was Performed
Check Fluid Levels and Fluid Condition
Inspect Coolant Level, Hoses and Clamps
Engine Coolant Level Warning System
Check Exhaust System & Heat Shielding
Clean Battery and Battery Terminals
Inspect/Adjust Accessory Drive Belts (Replace if Required)
Inspect Underhood Wiring Harnesses and Connections
Inspect Emission Control Vacuum Hoses and Connections
Inspect Thermostatic Air Cleaner (If Equipped)
Inspect Distributor Cap & Rotor (If Equipped)

SCHEDULED SERVIC

Inspect Spark Plug Wires
Inspect PCV Valve and Hoses
Inspect EGR Valve and Hoses
Check Ignition Timing
Idle Speed
Inspect Fuel/Tank/Cap/Lines
Check Operation of Horn, Wipers/Washers & All Exterior Lights
Inspect Condition of Wiper Blades
Check Headlight Alignment
Check Body Drain Holes
Check Seat Belt Webbing and Release Mechanisms
Check Parking Brake Operation
Check Shift Interlock Operation
Lubricate Weatherstripping with Silicone
Lubricate Door Hinges
Lubricate Door Locks
Check Steering Rack Boots
Check C/V Joint Boots
Inspect Steering Linkage/Front Suspension
Lubricate Steering Linkage & Suspension
Lubricate Chassis
Suspension Bushings, Springs, Arms & Rear Jounce Bumpers
Toe Control Hub & Control Link
Lubricate Front Wheel Bearings
Inspect Brake System Hoses & Lines
Inspect Front Brake Pads, Rotors and Calipers
Lubricate Caliper Slide Rails
Inspect Rear Brake Pads, Rotors and Calipers
Inspect/Repack Rear Wheel Bearings
Inspect Shocks/Struts for Leakage
Inspect Tire Wear Pattern

SCHEDULED SERVICE

Rotate Tires and Adjust Air Pressure (Including Spare)	
Replace	
Engine Oil	
Oil Filter	
Air Filter Element	
Spark Plugs	
PCV Filter	
Fuel Filter	
Drain, Flush and Refill Engine Coolant	
Manual Transmission Oil	
Rear Axle Oil	
Lubrication Specifications	
Application	Specification
Engine Oil	
Minimum Temperature	
Greater Than 0°F (-18°C)	SAE 10W-30 API SG/CD
Maximum Temperature	
Less Than 0°F (-18°C)	SAE 5W-30 API SG/CD
Manual Transmission	SAE 75W-90 GL-5
Rear Axle	SAE 80W-90 GL-5
Fluid Capacities	
Application	Quantity
Automatic Transmission Fluid	7.7-7.9 Qts. (7.3-7.5L)
Cooling System	
1983-85	9.0-10.0 Qts. (8.5-9.5L)
1986-91	
Turbo	9.2 Qts. (8.7L)
Non-Turbo	7.7 Qts. (7.3L)
Engine Oil	4.4-4.7 Qts. (4.2-4.4L)
Manual Transmission Oil	2.1-2.6 Qts. (2.0-2.5L)
Rear Axle Oil	
Turbo	1.3-1.5 Qts. (1.2-1.4L)
Non-Turbo	1.4-1.7 Qts. (1.3-1.6L)
Service Labor Times	
Application	Hours
Automatic Transmission	3.7
Manual Transmission	4.1

LUBRICATION SPECIFICATIONS

Application	Fluid Specifications
Brake Fluid	SAE J1703 or FMVSS116 DOT 3
Engine Oil	
Minimum Temperature	
Greater Than 0°F (-18°C)	SAE 10W-30 API/SF/SG
Maximum Temperature	
Less Than 0°F (-18°C)	SAE 5W-30 API/SF/SG
Manual Transmission	SAE 75W-90 GL-4, GL-5
Power Steering Fluid	Dexron-II ATF Or Equivalent
Rear Axle	SAE 80W-90 GL-5

FLUID CAPACITIES

FLUID CAPACITIES TABLE

Application	Quantity
A/C System R-12 Refrigerant Capacity	
1983-85	36 Ozs.
1986-89	
Nippondenso Compressor	22-25 Ozs.
Sanden Compressor	30 Ozs.
1990-91	26.5-28 Ozs.
Automatic Transmission Fluid	7.7-7.9 Qts. (7.3-7.5L)
Cooling System	
1983-85	9.0-10.0 Qts. (8.5-9.5L)
1986-91	
Turbo	9.2 Qts. (8.7L)
Non-Turbo	7.7 Qts. (7.3L)
Engine Oil	4.4-4.7 Qts. (4.2-4.4L)
Fuel Tank	
1983-87	16.6 Gals. (63L)
1988-91	18.5 Gals. (70L)
Manual Transmission Oil	2.1-2.6 Qts. (2.0-2.5L)
Rear Axle Oil	
Turbo	1.3-1.5 Qts. (1.2-1.4L)
Non-Turbo	1.4-1.7 Qts. (1.3-1.6L)

END OF ARTICLE

SERVICE INDICATOR & WARNING LIGHTS

Article Text

1984 Mazda RX7

For iluvmyrx7.com

Copyright © 1998 Mitchell Repair Information Company, LLC

Sunday, June 09, 2002 06:10AM

ARTICLE BEGINNING

1983-91 MAINTENANCE

Mazda Service Indicator & Warning Lights

RX7

SERVICE INDICATOR & WARNING LIGHTS

The warning lights will come on with the ignition. Any warning light which does not come with the ignition must be checked and repaired.

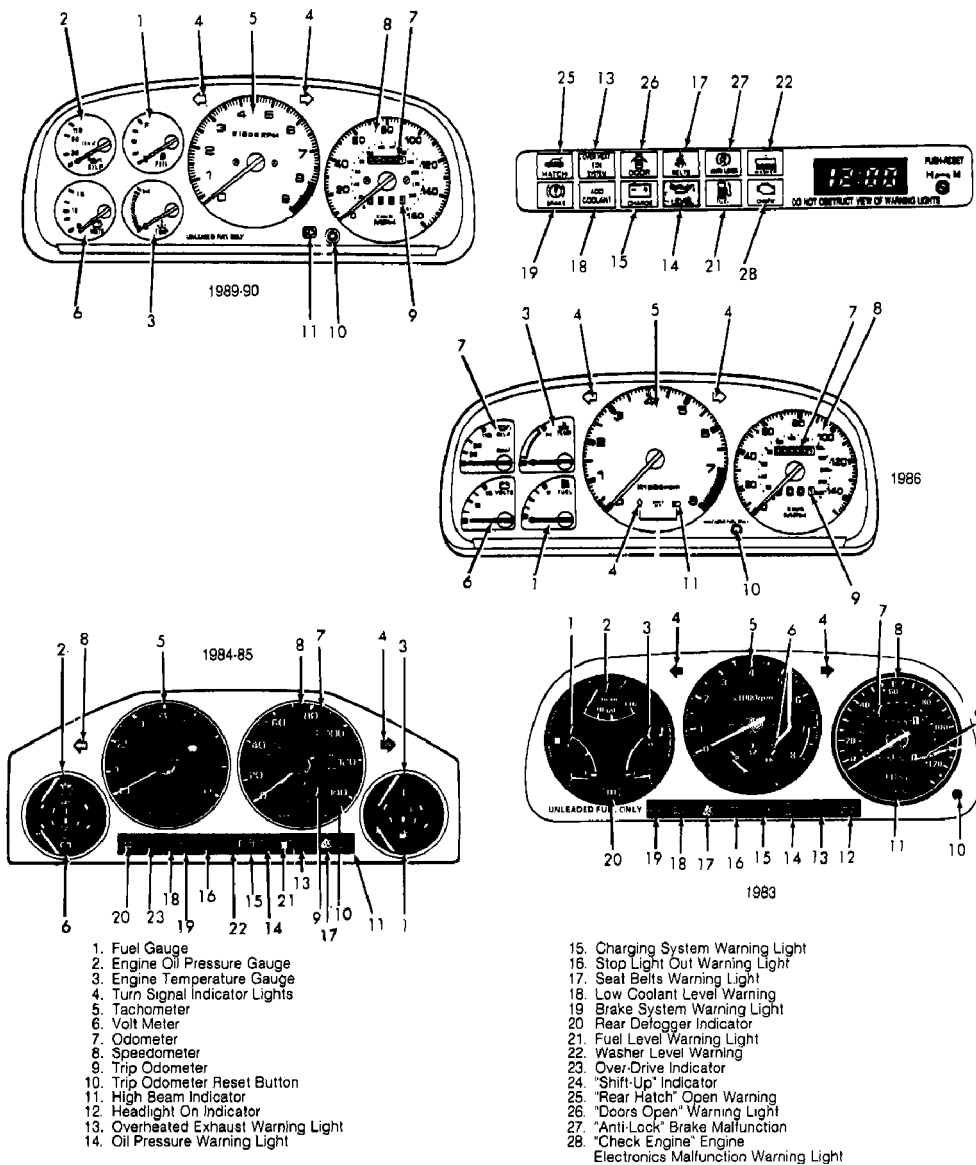

Fig. 1: Dash Gauges & Warning Lights
Courtesy of Mazda Motor of America Inc.

BRAKE SYSTEM WARNING LIGHT

Light comes on with parking brake. If light remains on, with parking brake off, fluid must be checked.

SEAT BELT WARNING

Light and beeper will go on for about 6 seconds, or until driver's belt is locked, when ignition is turned on.

CHARGE SYSTEM WARNING LIGHT

Warning indicates a malfunction of either the alternator or the electrical wiring system.

MALFUNCTION INDICATOR LIGHT

CHECK light indicates a fault in the electronic engine control system, sensors or emission components.

SUPPLEMENTAL DRIVER RESTRAINT SYSTEM WARNING LIGHT (IF EQUIPPED)

AIR BAG light indicates a system malfunction by flashing or continuous illumination.

HEADLIGHT HIGH BEAM INDICATOR

Indicates headlight high beam is on.

HEADLIGHT RETRACTOR INDICATOR

Comes on while headlights are retracting or extending. If indicator remains on check and repair headlight retractor.

HAZARD WARNING LIGHT

Flashes with hazard warning lights.

KEY REMINDER WARNING

A beep sounds if the key is left in the ignition and the door is opened.

END OF ARTICLE