

OWNER'S REPAIR GUIDE

MITSUBISHI

SPACE RUNNER AND SPACE WAGON

1.8 and 2.0 LITRE PETROL ENGINES

2.0 LITRE TURBO DIESEL ENGINE

FROM 1991

COVERING:

	Page No.
GENERAL INFORMATION, DIMENSIONS, WEIGHTS, CAPACITIES, GENERAL SERVICING NOTES	4
PETROL ENGINES	9
EXHAUST SYSTEM (Petrol and Diesel)	63
LUBRICATION SYSTEM (Petrol and Diesel)	66
COOLING SYSTEM (Petrol and Diesel)	74
FUEL INJECTION SYSTEM (Petrol)	82
IGNITION SYSTEM (Petrol)	84
CLUTCH	90
MANUAL TRANSMISSIONS	96
AUTOMATIC TRANSMISSION	104
FRONT DRIVE SHAFTS/WHEEL BEARINGS	109
FRONT SUSPENSION	117
REAR SUSPENSION	128
POWER-ASSISTED STEERING	137
BRAKES	143
ELECTRICAL EQUIPMENT	159
DIESEL ENGINE	163
FAULT FINDING SECTION	202
WIRING DIAGRAMS	End of Manual

BY PETER RUSSEK

**Published by
Peter Russek Publications Ltd.
Little Stone House, High Street,
Marlow, Bucks.
Tel.: High Wycombe (01494) 440829**

ISBN NO. 1 - 898780 - 36-6

**WITH FAULT FINDING SECTION
AT END OF MANUAL**

The publisher would like to thank the Colt Car Company Limited for their co-operation in producing this manual.

No part of this publication may be reproduced, stored in a retrieval system or transmitted in any form, electronic, mechanical, photocopying, recording, translating or other means without prior permission by the author.

No liability can be accepted for any inaccuracies or omissions in this workshop manual, or for personal injuries, arising from the use of this manual, although every possible care has been taken to make it as complete and accurate as possible. Every care has also been taken to prevent personal injury or damage to equipment when working on the vehicle. We have tried to cover all models produced to the day of publication, but are unable to refer to all modifications and changes for certain markets or up-dating of models.

PREFACE

Small though this Workshop Manual is in size, it lacks no detail in covering the whole of the servicing and repair of the Mitsubishi Space Wagon and Space Runner, introduced for model year 1991. Only the Space Wagon is available with petrol or diesel engine. 16 valve petrol engines are used throughout the vehicle range, an 1834 c.c. engine in the Space Runner and a 1997 c.c. in the Space Wagon. Both engines belong to the "G" series of engines. A turbo diesel engine can be fitted to the Space Wagon (2.0 litres), replacing the 1.8 litre engine used on earlier models. Brief, easy-to-follow instructions are given, free from all necessary complication and repetition, yet containing all the required technical detail and information, and many diagrams and illustrations.

Compiled and illustrated by experts, this manual provides a concise source of helpful information, all of which has been cross-checked for accuracy to the manufacturer's official service and repair procedures, but many instructions have derived from actual practice to facilitate your work. Where special tools are required, these are identified in the text if absolutely necessary and we do not hesitate to advise you if we feel that the operation cannot be properly undertaken without the use of such tools.

The readers own judgement must ultimately decide just what work he will feel able to undertake, but there is no doubt, that with this manual to assist him, there will be many more occasions where the delay, inconvenience and the cost of having the car off the road can be avoided or minimised.

The manual is called "Owner's Repair Guide" with the aim that it should be kept in the vehicle whilst you are travelling. Many garage mechanics themselves use these publications in their work and if you have the manual with you in the car you will have an invaluable source of reference which will quickly repay its modest initial cost.

A fault finding (trouble shooting) section is included at the end of the manual and all items listed are taken from actual experience, together with the necessary remedies to correct faults and malfunctioning of certain parts.

0. GENERAL INFORMATION

0.0. Introduction

The models covered in this publication is the Mitsubishi Space Wagon and the Space Runner, fitted with the engines specified on the previous page. A diesel engine with turbo charger is used in the other version.

The Space Runner/Wagon is a conventional front-wheel drive vehicle, with a transversely fitted engine.

All engine types are fitted with an overhead camshaft, driven by a toothed belt from the crankshaft. 16 valves are used in the petrol engines. The oil pump is fitted to the front housing and is driven from the engine timing belt. The cylinder head is made of aluminium alloy and has semi-spherical combustion chambers. Solid-skirt pistons of alloy material and a five-bearing crankshaft are fitted.

The transmission is fitted below the engine. Either a five-speed transmission or a three-speed automatic transmission can be fitted to both variants.

The front suspension consists of McPherson struts with integral hydraulic shock absorbers, coil springs, wishbone-type lower suspension arms and a stabiliser bar, also known as anti-roll bar. Coil springs and hydraulic shock absorbers are also used for the rear suspension. The semi-trailing rear suspension arms are attached at their inner ends to crossmember.

A power-assisted rack and pinion steering is fitted as standard fitment. Disc brakes at the front and self-adjusting drum brakes at the rear, together with a dual-line braking system and a brake servo make up the brake system. Disc brakes are also used on the rear wheels, if ABS is fitted.

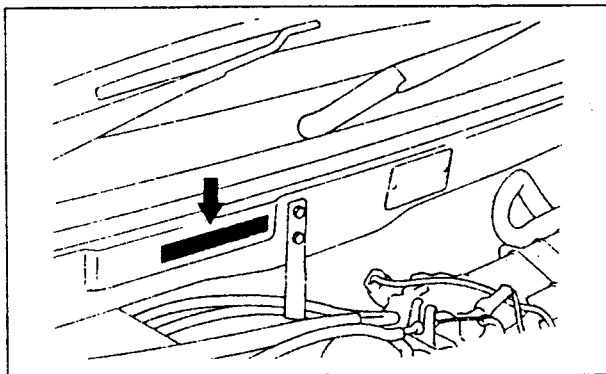

Fig. 0.1. — The location of the chassis number.

0.1 Vehicle Identification

A vehicle can be identified by the following type identification plates:

Chassis Number: The chassis number is stamped into the centre of the engine com-

partment bulk head, as shown in Fig. 0.1. Vehicle model, engine type, transmission type and model year are contained in this type identification plate. The letter "N" in the centre of the number refers to a space Runner or Space Wagon. "N11" is the identification for a Spacer runner with the 1.8 litre engine. "N33" (petrol) or "N38" (diesel) is used for the Space Wagon. The letter "W" (wagon) is next, followed by the code letter for the model year (for example "N" for 1992). The type of transmission fitted is shown after the letter "A" (Europe, R.H.D.). Either the letter "N" (five-speed transmission) or "R" (automatic transmission) can be found at this position. The following numbers are the actual chassis number.

Vehicle Information Code Plate: This plate can be found at the position shown in Fig. 0.2. The plate shows the model code, engine type, transmission type and the body colour code.

Engine Number: The engine number of a 1.8 litre petrol engine can be found near the water hose connection, as shown in Fig. 0.3 on the L.H. side. A similar location is used on the diesel engine, i.e. on the narrow side of the cylinder block, just below the cylinder head rocker cover. The number of the 2.0 litre petrol engine is located in the cylinder block face, facing the front of the vehicle, shown on the R.H. side of Fig. 0.3.

The serial number always commenced with the engine type.

Further identification numbers Fig. 0.2. The location of the vehicle information code plate.

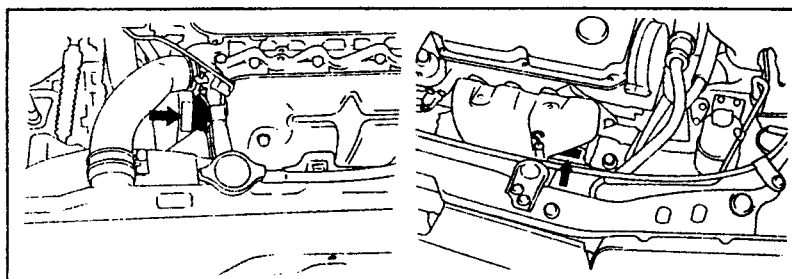
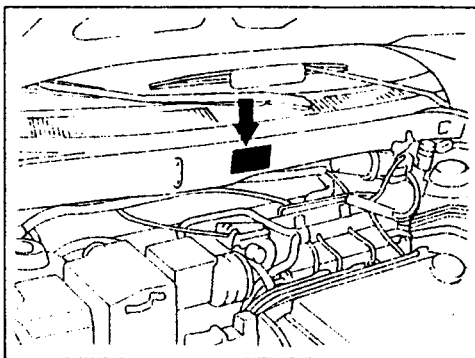

Fig. 0.3 — The location of the engine number on petrol engines. On the L.H. side in the case of the 1.8 litre engine, on the right in the case of a 2.0 litre engine.

are stamped into the upper part of the transmission. The transmission serial number returns from 99999 to 00101 and the letter changes in their alphabetical order.

These numbers and codes are important when ordering replacement parts and should always be quoted. Your Dealer will only be in a position to supply you with the correct part if he is able to identify your particular model.

NOTE: If parts are required, always supply the model code of the engine, the model year and the engine type and number. This will speed-up the processing of your parts order.

0.2. Dimensions and Weights

Overall Length:	
Space Runner:	4290 mm (170.75 in.)
Space Wagon:	4515 mm (179.3 in.)
Overall Width — All Models:	1695 mm (66.7 in.)

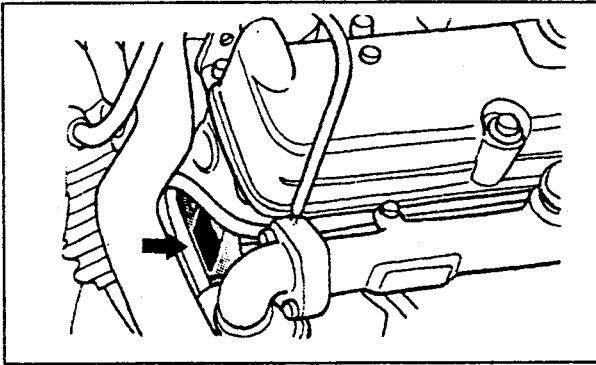

Fig. 0.4. — The location of the engine number of the diesel engine.

Overall Height — Space Runner:	
Without roof rail:	1625 mm (64.0 in.)
With roof rail:	1640 mm (64.6 in.)

Overall Height — Space Wagon:	
Without roof rail:	1580 mm (62.2 in.)
With roof rail:	1615 mm (63.6 in.)

Wheelbase:	
Space Runner:	2520 mm (99.2 in.)
Space Wagon:	2720 mm (107.1 in.)

Front Track:	1460 mm (57.5 in.)
Rear Track:	1460 mm (57.5 in.)
Ground clearance:	120 mm (4.7 in.) — 160 mm (6.3 in.) from May 1993

Weights (typical)

Kerb weight (weights have been changed during May 1993):

Space Runner, depending on version:	1279 to 1379 kg (2820 to 3040 lbs.) max.
Space Wagon — Petrol model, depending on version:	1353 to 1393 kg (2983 to 3071 lbs.)
Space Wagon — Diesel model:	1330 - 1431 kg (2932 - 3155 lbs.)

Max. gross vehicle weight:

Space Runner:	1720 kg (3792 lbs.)
Space Wagon — Petrol model:	1980 kg (4365 lbs.)
Space Wagon — Diesel model:	1960 kg (4321 lbs.)

0.3. Capacities

Fuel Tank:

Space Runner:	55 litres (12.1 imp. galls.)
Space Wagon:	60 litres (13.2 imp. galls.)

Cooling system:

Petrol engines:	6.0 litre (10.7 imp. pts.)
-----------------	----------------------------

Diesel engine:	7.5 litres (13.2 Imp. pts.)
Oil cooler for automatic transmission:	0.5 litre (approx. 1 pint)
Engine oil, incl. oil filter and oil cooler:	
1.8 litre petrol engine:	3.8 litres (6.6 Imp. pts.)
2.0 litre petrol engine:	4.3 litres (7.6 Imp. pts.)
Diesel engine:	5.1 litres (9.0 Imp. pts.)
Manual transmission:	
Petrol engine:	1.8 litres (3.2 Imp. pts.)
Diesel model:	2.3 litres (4.1 Imp. pts.)
Automatic transmission:	6.1 litres (10.8 Imp. pts.)
Power assisted steering:	950 c.c. (1.6 Imp. pts.)

0.4. General Servicing Notes

The servicing and overhaul instructions in this Workshop Manual are laid out in an easy-to-follow step-by-step fashion and no difficulty should be encountered if the text and diagrams are followed carefully and methodically. The "Technical Data" sections form an important part of the repair procedures and should always be referred to during work on the vehicle.

In order that we can include as much data as possible, you will find that we do not generally repeat in the text the values already given under the technical data headings. Again, to make the best use of the space available, we do not repeat at each operation the more obvious steps necessary — we feel it to be far more helpful to concentrate on the difficult or awkward procedures in greater detail. However, we summarise below a few of the more important procedures and draw your attention to various points of general interest that apply to all operations.

Always use the torque settings given in the end of most of the sections.

Bolts and nuts should be assembled in a clean and very lightly oiled condition and faces and threads should always be inspected to make sure that they are free from damage, burrs or scoring. DO NOT degrease bolts or nuts.

All joint washers, gaskets, tabs and lock washers, split pins and "O" rings must be replaced on assembly. Oil seals will, in all cases, also need to be replaced, if the shaft and seal have been separated. Always lubricate the lip of the seal before assembly and take care that the seal lip is facing the correct direction.

References to the left-hand and right-hand sides are always to be taken as if the observer is at the rear of the car, facing forwards, unless otherwise stated.

Always make sure that the vehicle is adequately supported, and on firm ground, before commencing any work on the underside of the car. A small jack or a make shift prop can be highly dangerous and proper axle stands are an essential requirement for your own safety.

Dirt, grease and mineral oil will rapidly destroy the seals of the hydraulic system and even the smallest amounts must be prevented from entering the system or coming into contact with the components. Use clean brake fluid or one of the proprietary cleaners to wash the hydraulic system parts. An acceptable alternative cleaner is methylated spirit, but if this is used, it should not be allowed to remain in contact with the rubber parts for longer than necessary. It is also important that all traces of the fluid should be removed from the system before final assembly.

Always use genuine manufacturer's spares and replacements for the best results.

Since the manufacturer uses metric units when building the cars it is recommended that these are used for all precise units. Inch conversions are given in most cases but these are not necessarily precise conversions, being rounded off for the unimportant values.

Removal and installation instructions, in this Workshop Manual, cover the steps to take away or put back the unit or part in question. Other instructions, usually headed "Ser-

ving", will cover the dismantling and repair of the unit once it has been stripped from the vehicle. It is pointed out that the major instructions cover a complete overhaul of all parts but, obviously, this will not always be either necessary and should not be carried out needlessly.

There are a number of variations in unit parts on the range of vehicles covered in this Workshop Manual. We strongly recommend that you take care to identify the precise model, and the year of manufacture, before obtaining any spares or replacement parts. The following abbreviations are sometimes used in the text and should be noted:

- Std.: To indicate sizes and limits of components as supplied by the manufacturer. Also to indicate the production tolerances of new unused parts.
- O/S: Parts supplied as Oversize or Undersize, or recommended limits for such parts to enable them to be used with worn or re-machined mating parts. O/S indicates a part that is larger than Std. size. U/S may indicate a bore of a bushing or female part that is smaller than Std.
- U/S: Parts supplied as Oversize or Undersize, or recommended limits for such parts to enable them to be used with worn or re-machined mating parts. O/S indicates a part that is larger than Std. size. U/S may indicate a bore of a bushing or female part that is smaller than Std.
- Max.: Where given against a clearance or dimension indicates the maximum allowable. If in excess of the value given it is recommended that the appropriate part is fitted.
- TIR: Indicates the Total Indicator Reading as shown by a dial indicator (dial gauge).
- HT: High Tension (ignition) wiring or terminals.
- TDC: Top Dead Centre (No. 1 piston on firing stroke).
- MP: Multi-Purpose grease.

0.5. Jacking up the Vehicle

Due to the construction of the vehicle, a jack and/or chassis stands should only be placed under the vehicle at certain position. These are shown in Fig. 0.5.

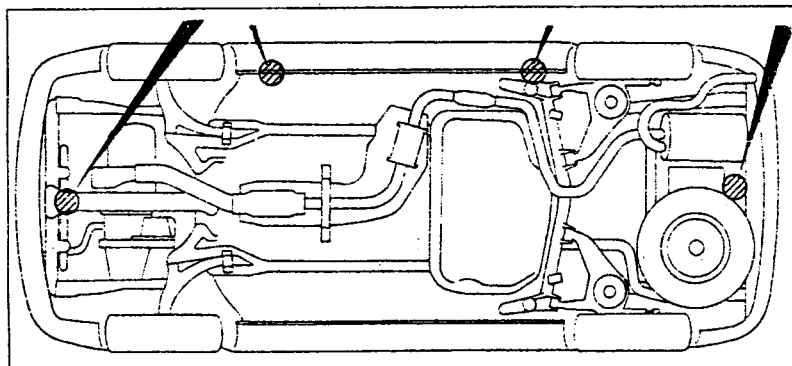

Fig. 0.5. — The jacking positions and locations where chassis stands can be placed. The large pointers show where a trolley jack can be applied. The small arrows show where chassis stands must be placed underneath the vehicle.

To jack up the front of the vehicle, place a mobile jack underneath the front suspension crossmember, as shown in the illustration. A piece of rubber or other soft material should be inserted between crossmember and jack head to prevent damage. Apply the handbrake or chock the rear wheels to add safety to the operation.

To jack up the rear end of the vehicle, place the jack underneath the position shown on the R.H. side in the illustration. Again use a piece of soft material between jack head and the jack location. The front wheels should be chocked (for example a brick) or a gear engaged to prevent the vehicle from rolling off the jack.

Always use secure chassis stands when working underneath the vehicle. Fig. 05 shows with the smaller pointers where chassis stands can be located. Any other location may lead to damage.

Before any jacking operation, check the condition of the ground to make sure the jack or the chassis stands cannot "sink" into the ground.

I. PETROL ENGINES

1.0. Main Features

NOTE: The Diesel Engine is covered separately at the end of the manual (Section 15).

Engine Identification:

Space Runner	4G93
Space Wagon:	4G63
Number and arrangement of cylinders:	4, in-line
Arrangement of camshaft/valves:	In cylinder head (OHC), 16 valves
Camshaft drive:	Toothed timing belt

Engine Capacity:

Space Runner:	1834 ccm
Space Wagon:	1997 ccm

Cylinder Bore:

Space Runner:	81.0 mm (3.19 in.)
Space Wagon:	85.0 mm (3.35 in.)

Piston stroke:

Space Runner:	89.0 mm (3.50 in.)
Space Wagon:	88.0 mm (3.46 in.)

Compression ratio:

Space Runner:	10.0 : 1 (9.5 : 1 without catalytic converter)
Space Wagon:	10.0 : 1

Max. Performance:

Space Runner:	120.6 B.H.P. at 6000 rpm
Space Wagon:	132 B.H.P. at 6000 rpm

Max. Torque:

Space Runner:	161 Nm (116 ft.lb.) at 4500 rpm
Space Wagon:	176 Nm (127 ft.lb.) at 4750 rpm

Compression Pressures at 250 rpm:

Space Runner:	14.5 kg/sq. cm. (206 psi.), 14.0/199 with catalytic converter
Space Wagon:	14.0 kg/sq.cm. (199 psi.)
Min. compression pressure at 250 rpm:	
Space Runner:	10.4 kg/sq.cm. (148 psi.), 10.0/142 without catalytic converter
Space Wagon:	10.6 kg/sq.cm (151 psi.)

Firing order: 1 — 3 — 4 — 2

Valve Clearances (engine warm) — Only 1.8 litre Engine:

Inlet valves:	0.20 mm (0.08 in.)
Exhaust valves:	0.30 mm (0.012 in.)

Ignition timing, all engines:	5° ± 2° before T.D.C. at idling speed
Oil pump type:	Gear-type pump
Oil sump capacity:	See Section 0.3
Fuel system:	Multi-point fuel injection system
Ignition system:	Combined with fuel injection system

1.1 Engine — Removal and Installation

The engine is removed without the transmission, but the transmission must be removed from the vehicle before the actual removal of the engine can take place. The relevant information are contained in Section 7, dealing with the manual transmission or Section 8, dealing with the automatic transmission. The instructions are based on the removal of the 1.8 litre engine. Any major differences for the 2.0 litre engine are given when applicable. Note that most hose connections use special hose clamps. A pair of special pliers may be needed to refit the clamps. Otherwise screw-clamps may be used.

Read Section 0.5 before jacking up the vehicle for operations to be carried out from underneath:

- Release the pressure in the fuel system before opening any of the fuel connections. Further information on this subject are given in Section 4.
- Open the bonnet. Mark the outline of the bonnet panel (using a pencil) and unscrew the bonnet from the hinges. This will give greater freedom of movement and will prevent damage to the bonnet paint work. Lift off the bonnet and store it in a safe place.
- Drain the cooling system. A drain plug is fitted to the bottom of the radiator. A further plug is fitted near the flywheel end of the cylinder block on a 1.8 litre engine. This engine also has a bleed screw at the top of the thermostat housing, which should be opened..
- Disconnect the battery and completely remove the battery, to have it out of the way.
- Remove the transmission as described in the relevant section.
- Remove the radiator as described in Section "Cooling System".
- Refer to Fig. 1.1 for the following removal operations:
- Disconnect the vacuum hoses (1). In the case of a 2.0 litre engine there is one hose at the front of the engine and three more near the hose location (1) in Fig. 1.1.
- Disconnect the heater hose (2) between thermostat housing and heater unit and the vacuum hose from the brake servo unit. On the 2.0 litre engine three hoses are connected in this area. All three can be disconnected; one of the hoses is the heater hose between heater unit and water inlet pipe, the other one is the brake servo unit hose.
- Disconnect the heater hose between heater unit and water inlet pipe (3).
- Unscrew the fuel pressure hose (4) and take off the "O" sealing ring (5). The arrangement is similar on the 2.0 litre engine. Remember that the system must be free of pressure.
- Disconnect the fuel return hose (6) after slackening the hose clip.
- Disconnect the throttle cable.
- The next operation concerns the removal of the various plugs and connectors. These are the connectors for the engine coolant temperature switch (9), the oxygen sensor (Lambda probe) (10), the oil pressure switch (11), the coolant thermometer (12), the engine coolant temperature sensor (13), if fitted, the engine coolant temperature switch for the condenser fan (14), if an automatic transmission is fitted, the two plugs from the distributor (15), the condenser (16), the idle speed regulator (17), the

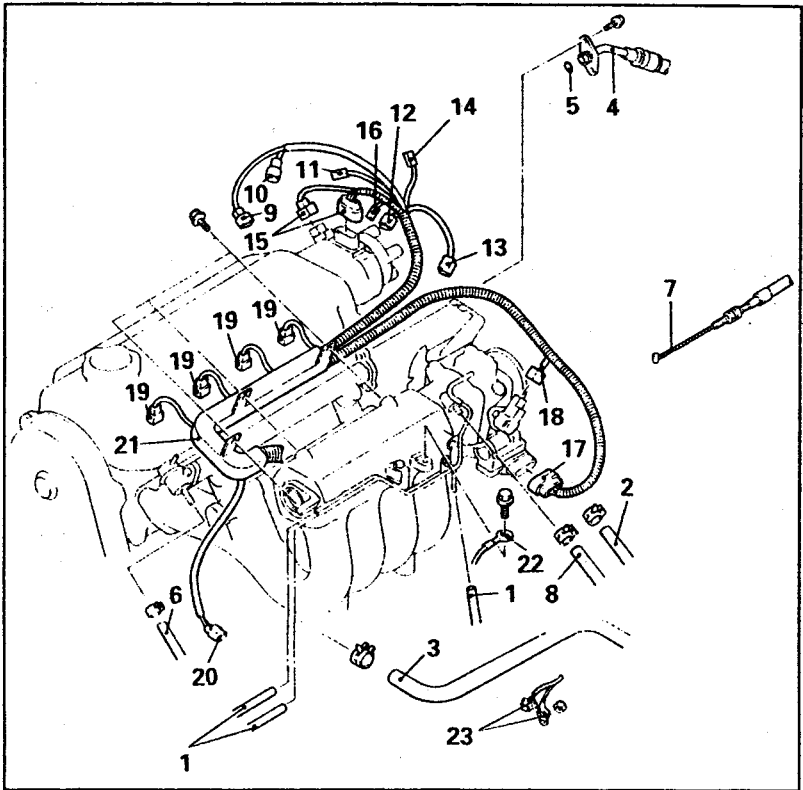

Fig. 1.1. — Order of removal of parts (engine removal, 1.8 litre, Space Runner).

throttle positioner (18), the fuel injectors (19) and the knock sensor (20). The connectors are located at similar locations on the 2.0 litre engine, but some are not used.

- Remove the engine main harness (21) and unscrew the earth cable (22).
- Disconnect the two plugs (23) from the rear of the alternator. On the 2.0 litre engine there is a third lead which leads to the oil pressure switch. Remove the single screw and withdraw the cable harness.
- Slacken the drive belt tension for the power steering drive, remove the belt and unscrew the steering pump without disconnecting the hose. On the 1.8 litre engine a connector plug for the steering pump oil pressure switch must be withdrawn. Place the pump assembly to one side where it will not be in the way when the engine is lifted out.
- Separate the front exhaust pipe from the bottom of the exhaust manifold and free the pipe from its bracket. Lower the exhaust pipe. If possible place a support underneath the pipe to prevent it from hanging down. Remove the gasket.
- If an air conditioning system is fitted, unscrew the compressor from the mounting bracket and tie it up with wire or string where it cannot interfere with the removal and installation of the engine.

- Remove the cooling system reservoir tank (1.8 litre).
- Suspend the engine and transmission on a chain or rope and slightly lift the unit until just under tension. Place a trolley jack underneath the engine oil sump (piece of wood between jack head and sump) and lift up the engine until there is no more tension on the engine mountings. Remove the engine mounting brackets. Section 1.1.1. gives further details of the mounting(s).
- Slowly lift the engine out of the engine compartment, continuously checking that it cannot interfere with other parts in the engine compartment. Wires, hoses, etc. must immediately be freed, if getting caught in the engine. Remember that the description of the removal is general for the two types of engines. There are some differences with cables being secured by additional cable clamps (for example the starter motor and alternator cable harness on the 2.0 litre) and other parts, which you will find as you go along.

To install the power unit, lift the assembly into the vehicle and attach all power unit mountings and fully lower the power unit and tighten all nuts and bolts to the corresponding tightening torques. Make sure that none of the wires, cables, hoses, etc. can get trapped between the engine and the mountings.

All other operations are carried out in reverse order to the removal procedure. Fill the transmission with the correct quantity and type of oil. Fill the cooling system with anti-freeze. Check the operation of the gearchange mechanism after connecting the gear-change rod and extension rod (manual transmission) or the gear selector cable (automatic transmission).

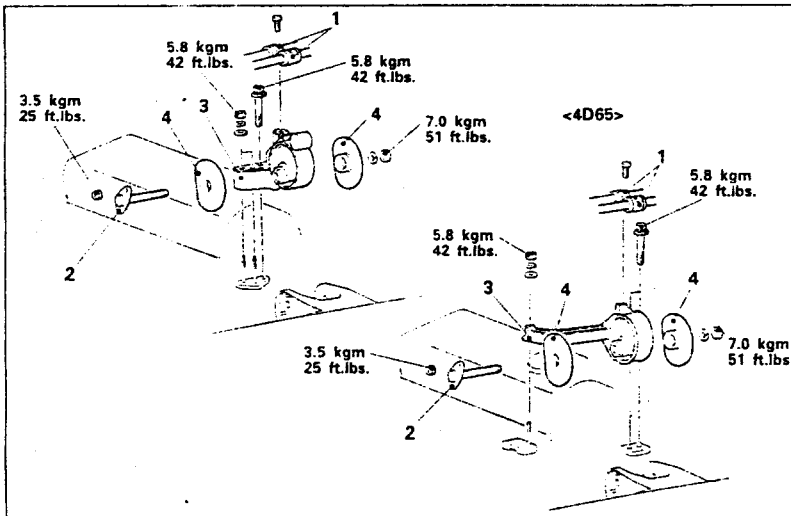

Fig. 1.2. — View of the engine mountings as seen from the engine compartment. The attachment of the engine from underneath is shown in Fig. 1.3 on the next page, where a central engine bearer and two further mountings (roll stoppers) are used to support the engine. The transmission mountings are referred to in the relevant section. Note the different tightening torque values. The same mountings are used on both engines.

- 1 Power steering and low pressure hose for A/C bolted to mounting
- 2 Mounting bolts

- 3 Engine mounting bracket
- 4 Stopper plates for engine mounting, one on each side

1.1.1 Removal and Installation of Engine Mountings

Fig. 1.2 shows a view of the front and rear engine mountings. The arrangement underneath the engine and transmission can be seen in Fig. 1.3.

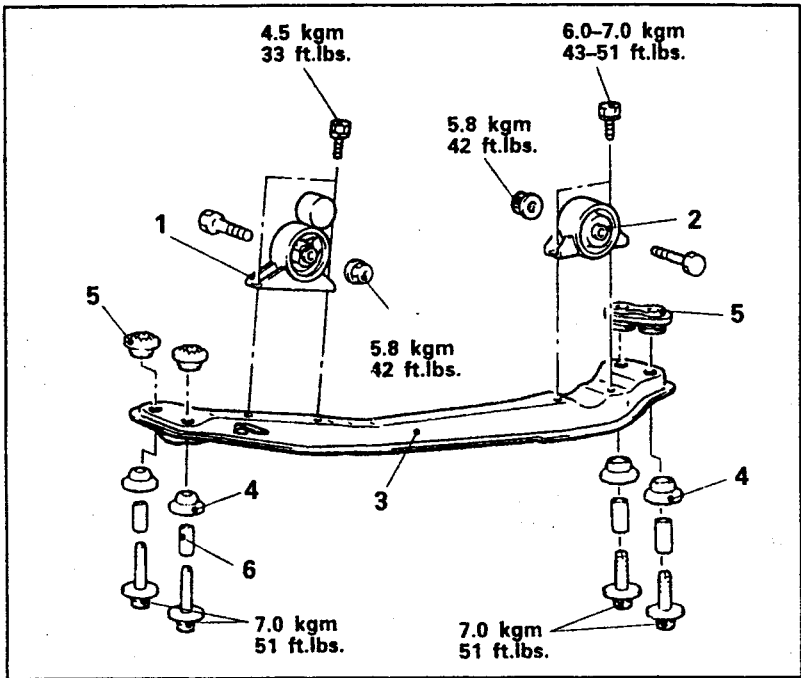

Fig. 1.3. — The arrangement of the engine mountings underneath the engine.

- | | |
|------------------------|----------------------------|
| 1 Front roll stopper | 4 Lower engine bearer bush |
| 2 Rear roll stopper | 5 Upper engine bearer bush |
| 3 Centre engine bearer | 6 Spacer bush |

The mountings can be replaced with the engine and transmission in position after the engine load has been taken off the mountings. Note the following points:

Mountings shown in Fig. 1.2

- Depending on the facilities, either suspend the power unit on a hoist or suitable hand crane with chains or ropes or simply place a trolley jack underneath the oil sump. Use a large wooden board to distribute the pressure of the jack between jack head and oil sump. Lift the engine until you feel that the mountings will be free of tension when you free them.
- Remove the mounting(s) as required. Rubber parts must be in good condition if re-used.
- Install the mounting(s) in reverse order to removal, following the tightening torques given in the illustration. Before fitting the stopper plates on each side of the mountings, find the arrow. Arrange each plate so that the arrow faces to the centre of the

engine. Then fit and washer and tighten the nut.

Mountings shown in Fig. 1.3

The undercover must be removed to gain access to the central engine bearer and the roll stopper. As in the case of the other mountings, the weight of the engine must be removed from the roll stoppers and/or the engine bearer before any of the bolts and nuts are removed. The bushes in the engine bearer can be replaced, if they are worn. The bushes are pushed from the top and bottom into the bearer. There is a spacer tube in the centre.

Note the tightening torques during installation. When installing the front roll stopper check the bracket to find a hole. As the bracket can be fitted either way round, make sure that the hole is nearer the front of the engine.

1.2. Dismantling the Engine

Before commencing dismantling of the engine, all exterior surfaces should be cleaned as far as possible, to remove dirt or grease. Plug the engine openings with clean cloth first to prevent any foreign matter entering the cavities and openings. Detailed information on engine dismantling and assembly is given in the section dealing with servicing and overhaul and these should be followed for each of the sub-assemblies or units to be dealt with.

Dismantling must be carried out in an orderly fashion to ensure that parts, such as valves, pistons, bearing caps, shells and so on, are replaced in the same position as they occupied originally. Mark them clearly, but take care not to scratch or stamp on any rotating or bearing surface. A good way to keep the valves in order is by piercing them through an upside-down cardboard box and writing the number against each valve.

It is of advantage if a dismantling stand can be used. Otherwise it will be useful to make up wooden support blocks to allow access to both the top and bottom faces of the engine. The cylinder head, once removed from the block, should be supported by a metal strap, screwed to the manifold face and secured by two nuts onto the manifold studs.

1.2.1. Basic Dismantling

The normal order of removal of parts for a complete engine strip-down is given below but this may, of course, be modified if only partial dismantling is required. Due to the different construction of the two engine types (the 2.0 litre engine has balance shafts, also referred to as silent shafts), separate instructions are given for the 1.8 and 2.0 litre engines, when dealing with the timing drive, balance shafts, etc.

- Remove all engine ancillary parts. If in doubt, refer to specific sections for removal details of a certain component.
- Remove the clutch. To do this, counterhold the flywheel ring gear by means of a strong screwdriver. Mark the relation of the clutch to the flywheel with a centre punch (punch at opposite points into clutch and flywheel) and evenly and slowly unscrew the clutch securing bolts.
- Slacken the alternator securing bolts and take off the drive belt. The alternator can now be removed completely. Also remove the tensioning link from the cylinder block.
- Unscrew the upper timing belt cover.

The next operation is the removal of the timing belt and the cylinder head.

1.8 Litre Engine

- Prevent the crankshaft from rotating (insert a strong screwdriver into the teeth of the flywheel ring gear and slacken the crankshaft pulley bolt.)
- Rotate the engine until the piston of the No. 1 cylinder is at T.D.C. position. *The crankshaft must only rotated clockwise*. Check that the timing marks on camshaft sprocket and crankshaft sprocket are aligned as shown in Fig. 1.4. This will set the piston of No. 1 cylinder to the top dead centre position. Using a felt pen or chalk, mark a line across the timing belt to identify its fitted position. If the timing belt is to be refitted (after inspection), mark an arrow into the outside of the belt to indicate the running direction.
- Slacken the bolt in the centre of the belt tensioner (see Fig. 1.4) and, using a screwdriver in the manner shown in Fig. 1.5, push the tensioner pulley in the direction of the arrow

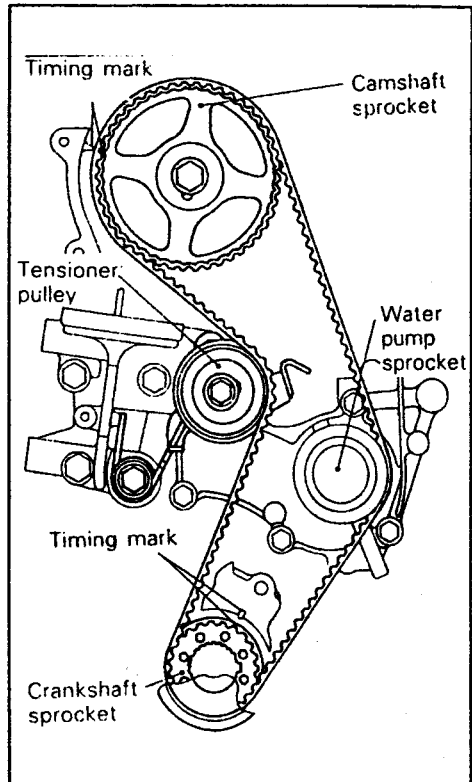

Fig. 1.4. — The timing marks of the 1.8 litre engine must be aligned as shown before the timing belt can be removed.

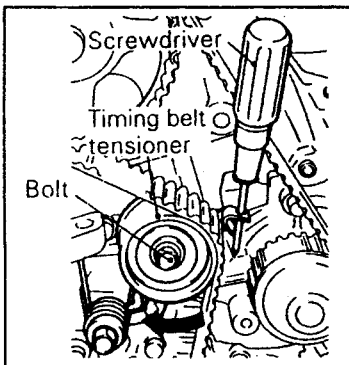

Fig. 1.5. — Turn the belt tensioner in the direction shown to slacken the tension.

until the timing belt is slack. The tensioner pulley can be pushed as close to the engine mounting as possible. Re-tighten the tensioner bolt provisionally to keep it in the tensioned position. The timing belt can now be lifted off.

- Remove the camshaft wheel securing bolt and withdraw the wheel. The gearwheel must be held against rotation when the bolt is slackened. A strong drift can be inserted into one of the sprocket holes and held against the cylinder head. Crankshaft and camshaft must not be rotated after the camshaft timing wheel has been removed.
- Unscrew the cylinder head cover and remove. Make a note where the various re-

taining clips are located to facilitate the installation. Remove the gasket.

- Unscrew the two rocker shaft assemblies, but note: **Rocker shafts and rocker arms must not be dismantled.**
- Remove the camshaft oil seal from its location.
- Slide out the camshaft without damaging the bearing journals or cams.

- Referring to Fig. 1.6 remove the cylinder head bolts in the numbered order shown, noting where intake (inlet) and exhaust side are located. Tighten the bolts in reverse order.

- If required, remove the crankshaft timing gearwheel. A timing wheel with a heavy fit can be removed with two tyre levers, inserted at opposite sides underneath the timing wheel or a two-arm/three-arm puller can be used. Also unscrew the timing belt tensioner.
- Remove the oil sump and unscrew the oil suction strainer.
- Remove the oil pump together with the front housing. A screwdriver can be inserted into the notch at the side of the housing to prise out the assembly. Take care not to damage the sealing faces.
- Turn the cylinder block so that the bottom end is at the top, or on a bench, rest the block on the cylinder head face. Proceed as described below.

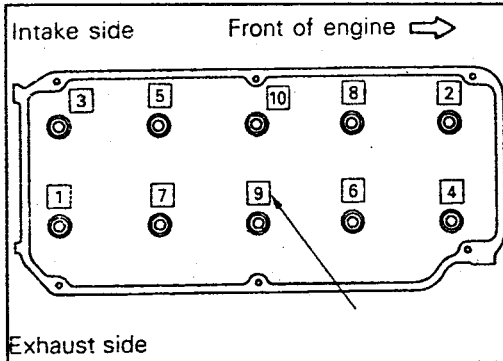

Fig. 1.6. — Slacken the cylinder head bolts in the numbered order shown, noting where intake (inlet) and exhaust side are located. Tighten the bolts in reverse order.

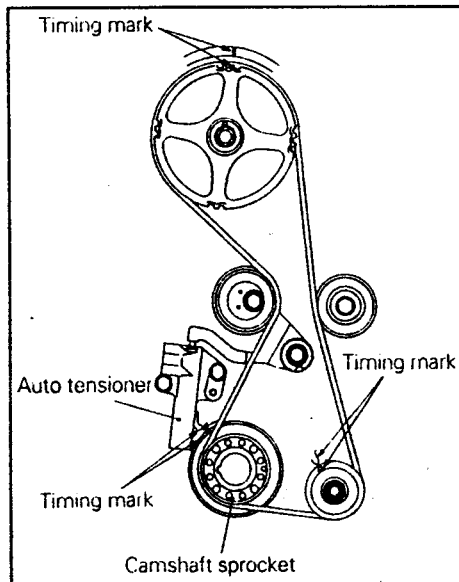

Fig. 1.7. — The alignment of the timing marks on camshaft, crankshaft and balance shaft gearwheel on a 2.0 litre engine.

2.0 Litre Engine

The more complex timing belt drive of the 2.0 litre engine is shown in Fig. 1.8. Also refer to Fig. 1.7 during the removal of the timing belt.

Fig. 1A. — The timing belt drive of a 2.0 litre engine. Note that items Nos. 1 to 10 are shown in an illustration referring to Section 1.4.4.

- 11 Auto tensioner
- 12 Timing belt
- 13 Tensioner pulley
- 14 Tensioner arm
- 15 Idler pulley
- 16 Camshaft sprocket
- 17 Oil pump sprocket
- 18 Crankshaft sprocket bolt
- 19 Special washer
- 20 Crankshaft sprocket
- 21 Flange
- 22 Timing belt tensioner, small belt
- 23 Small timing belt
- 24 R.H. balance shaft sprocket
- 25 Spacer
- 26 Balance shaft sprocket
- 27 Key
- 28 L.H. engine support bracket
- 29 Rear timing belt cover

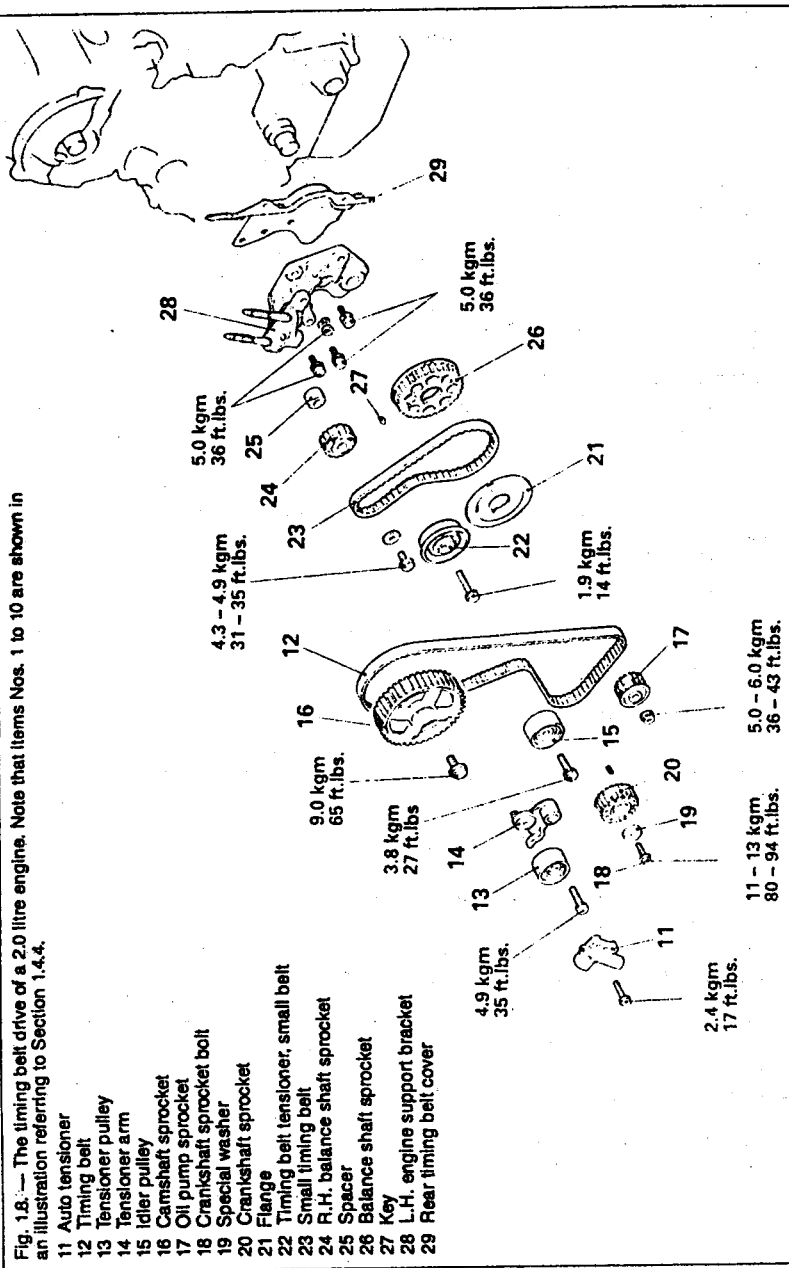

- It is assumed that the pulley belts, the upper timing belt cover and the tensioner for the pulley "V" belts have already been removed from the front of the engine. Prevent the crankshaft from rotating (insert a strong screwdriver into the teeth of the flywheel ring gear and unscrew the bolts securing the crankshaft pulley to the crankshaft timing gear. The lower timing belt cover can now be unscrewed).
- Rotate the engine until the piston of the No. 1 cylinder is at T.D.C. position. *The crankshaft must only rotated clockwise*. Check that the timing marks on camshaft sprocket and crankshaft sprocket are aligned as shown in Fig. 1.7. This will set the piston of No. 1 cylinder to the top dead centre position. To verify the setting, check that the mark in the camshaft gearwheel is level with the cylinder head joining face and the dowel pin in the crankshaft timing gearwheel is at the top. Otherwise turn the crankshaft accordingly (*only clockwise*). Using a felt pen or chalk, mark a line across the timing belt to identify its fitted position. If the timing belt is to be refitted (after inspection), mark an arrow into the outside of the belt to indicate the running direction.
- Remove the automatic belt tensioner (11) in Fig. 1.8.
- Slacken the bolt in the centre of the belt tensioner (15) in Fig. 1.8 and turn the belt towards the outside until the timing belt is slack. Re-tighten the tensioner bolt provisionally to keep it in the tensioned position. The timing belt can now be lifted off.
- Remove the camshaft wheel securing bolt and withdraw the wheel. The gearwheel must be held against rotation when the bolt is slackened. A strong drift can be inserted into one of the sprocket holes and held against the cylinder head. Crankshaft and camshaft must not be rotated after the camshaft timing wheel has been removed. See note below:

Important Note: If the timing belt is being removed as a routine operation, for example during the removal of the cylinder head, use a piece of string and tie the timing belt to the camshaft sprocket. This will facilitate the installation of the parts.

- Unscrew the cylinder head cover and remove. Make a note where the various retaining clips are located to facilitate the installation. Remove the gasket.
- Unscrew the two rocker shaft assemblies, but note: ***Rocker shafts and rocker arms must not be dismantled.*** It should be noted that special metal brackets are used to hold the hydraulic tappets, also referred to as lash adjusters, do not fall out of the rocker arms. This is more important when the timing belt is being removed with the engine fitted (see later section).
- Remove the camshaft oil seal from its location.
- Slide out the camshaft without damaging the bearing journals or cams.
- Referring to Fig. 1.6 remove the cylinder head bolts in the order of the numbered sequence shown (the sequence is the same for both engines). The cylinder head is located by two dowels and must be lifted straight up. Use a rubber or plastic mallet to free a sticking head. Never attempt to wedge the blade of a screwdriver between the sealing faces in order to separate the head. Take off the cylinder head gasket and immediately clean all gasket faces.
- If required, remove the crankshaft timing gearwheel (17) in Fig. 1.8. A timing wheel with a heavy fit can be removed with two tyre levers, inserted at opposite sides underneath the timing wheel or a two-arm/three-arm puller can be used. Also unscrew the timing belt tensioner and on the other side the belt idler pulley.
- Remove the oil pump drive gear. Before removing the nut, take out the plug at the bottom of the L.H. side of the cylinder block and insert a screwdriver as shown in Fig. 1.9 to retain the L.H. balance shaft in position. The screwdriver shaft should have a diameter of 8 mm (0.3 in.) and a length of 60 mm (2.5 in.).

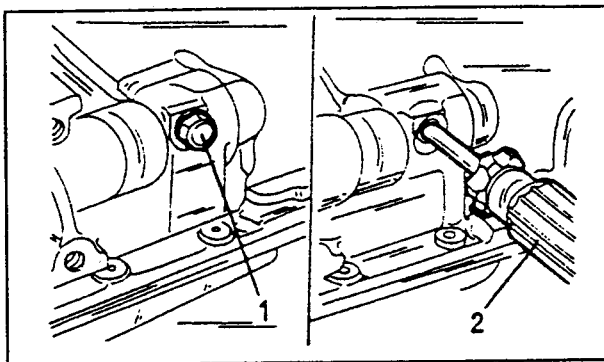

Fig. 1.9. — Details for the removal of the L.H. balance shaft. Remove the plug (1) and insert a screwdriver (2) into the bore.

- Slacken the bolt securing the balance shaft timing gearwheel until it can be removed by hand. Remove the belt tensioner and the second timing belt (Fig. 1.10). If there is a possibility to re-use the belt, mark the running direction of the belt into the outside (felt pen).

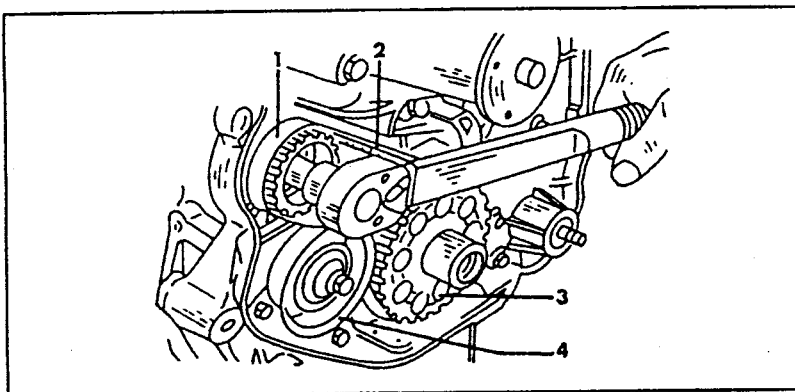

Fig. 1.10. — Removal of the lower timing belt together with the associated parts.

- | | |
|----------------|--|
| 1 Timing wheel | 3 Crankshaft timing gearwheel |
| 2 Timing belt | 4 Timing belt tensioner (22) in Fig. 1.8 |

- Remove the balance shaft timing gearwheel and also the second crankshaft timing sprocket. Use two tyre levers, if the wheel has a tight fit.
- Remove the oil sump and unscrew the oil suction strainer.
- Insert the screwdriver through the hole shown in Fig. 1.9 to counterhold the balance shaft (if not still in position) and remove the driven wheel of the oil pump.
- Remove the front housing together with the balance shaft. A screwdriver can be inserted into the notch shown by the arrow in Fig. 1.11 to prise off the assembly. Take care not to damage the sealing faces.
- Withdraw the oil pump gearwheel and the L.H. shaft from the housing and the R.H. shaft from the cylinder block.

- Turn the cylinder block so that the bottom end is at the top or, on a bench, rest the block on the cylinder head face and proceed as described below for both engine types.

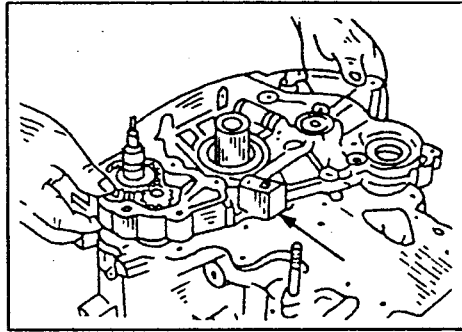

Fig. 1.11. — Removal of the front housing with the balance shaft. A screwdriver can be inserted at the arrow point to separate the housing.

All Engines

- Rotate the crankshaft until two of the connecting rods are at bottom dead centre. Unscrew the two big end bearing cap nuts and carefully tap the cap with a hammer until it can be removed. Take off the bearing shell and immediately insert it into the removed cap.
- Using a hammer handle push the connecting rod with the piston towards the top of the cylinder bore. If a carbon ring has formed at the top of the bore, preventing an easy removal, use a scraper and remove the carbon without damaging the bore. A number is stamped into the side of the connecting rod and this should always face towards the crankshaft pulley side. Mark the connecting rod and the piston with the cylinder No.

- Attach the removed bearing cap and the shell to the connecting rod and remove the other connecting rod and piston.
- Rotate the crankshaft until the other two big end bearing caps are at bottom dead centre and remove the two connecting rod and piston assemblies as described above. Make sure that each assembly is marked with the cylinder number.
- Block the flywheel by inserting a strong screwdriver into the teeth of the ring gear and remove the flywheel bolts. Remove the flywheel, using a rubber or plastic mallet if necessary. Take care not to drop the flywheel.
- Remove the rear engine intermediate plate.

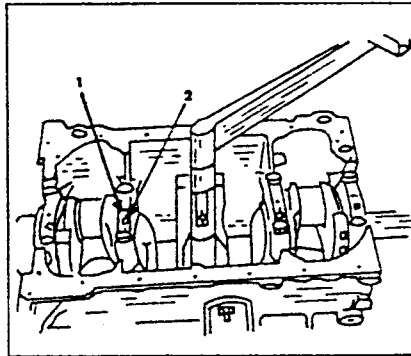

Fig. 1.12. — Removal of the crankshaft main bearing caps. The bearing number (1) and an arrow (2) are cast into each bearing cap.

- Remove the rear oil seal retainer from the cylinder block and unscrew the rear oil seal flange. Take off the gasket. Remove the oil seal from the flange with a suitable drift.
- Slacken the crankshaft main bearing cap bolts, commencing at the outsides and working towards the centre. Remove the caps one after the other, using a rubber mallet if they stick to the block. The caps are numbered and each cap has an arrow, facing towards the front of the engine (Fig. 1.12). The bearing shells must be kept with the caps.
- Carefully lift out the crankshaft. Remove the remaining main bearing shells from the

crankcase and keep them together with the other shell and bearing cap of each bearing.

1.2.2. Pistons and Connecting Rods — Dismantling

The piston pin has a floating fit in the piston and a press-fit in the connecting rod small end. For this reason it is essential that the piston pin is only removed under a press with a special extractor, available under Part No. MD 998300.

Remove the piston rings with a pair of piston ring pliers (Fig. 1.13). Take care not to break the rings if any other tool is used.

Support the piston from underneath when pressing out the pin. Fig. 1.14 shows how the pin is pressed out of the piston and connecting rod.

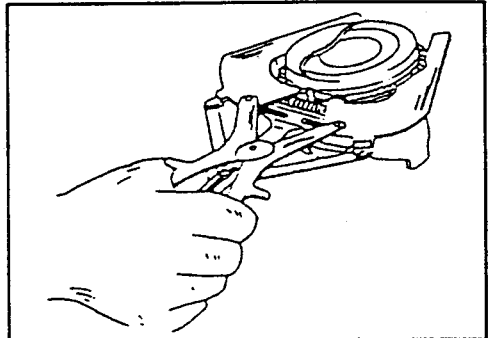

Fig. 1.13. — Removal or installation of the piston rings with a pair of piston ring pliers.

1.2.3. Valves — Removal

The removal of the valves requires the use of a valve spring

compressor. Compress the valve spring, as shown in Fig. 1.15, until the two valve cotter halves can be removed with a pair of pointed pliers from around the valve stem.

Remove the parts from each valve and keep each valve in its correct order of installation. Also keep the parts of each valve in a small cardboard box or plastic bag.

Fig. 1.16 shows the cylinder head in exploded condition. The heads of both engines use similar parts.

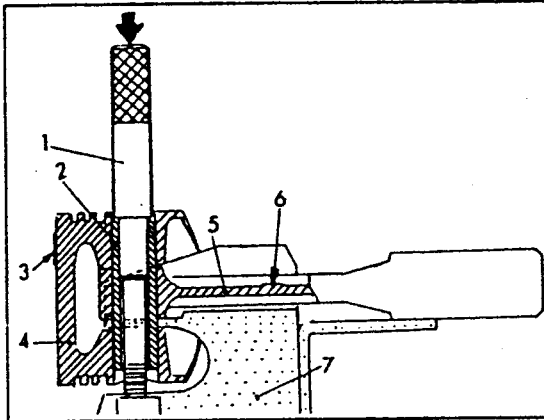

Fig. 1.14. — Removal of a piston pin.

- | | |
|-----------------|------------------|
| 1 Press mandrel | 5 Connecting rod |
| 2 Piston pin | 6 "Front" mark |
| 3 Arrow mark | 7 Tool support |
| 4 Piston | |

1.3. Assembling the Engine

Refer to the sections commencing at 1.4. for details of the assembly procedure for in-

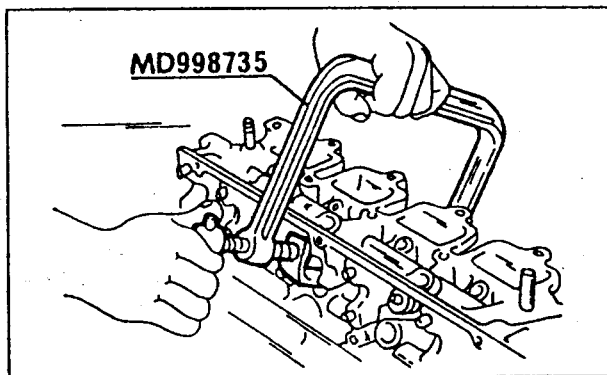

Fig. 1.15. — Removal of the valve springs, using a valve compressor.

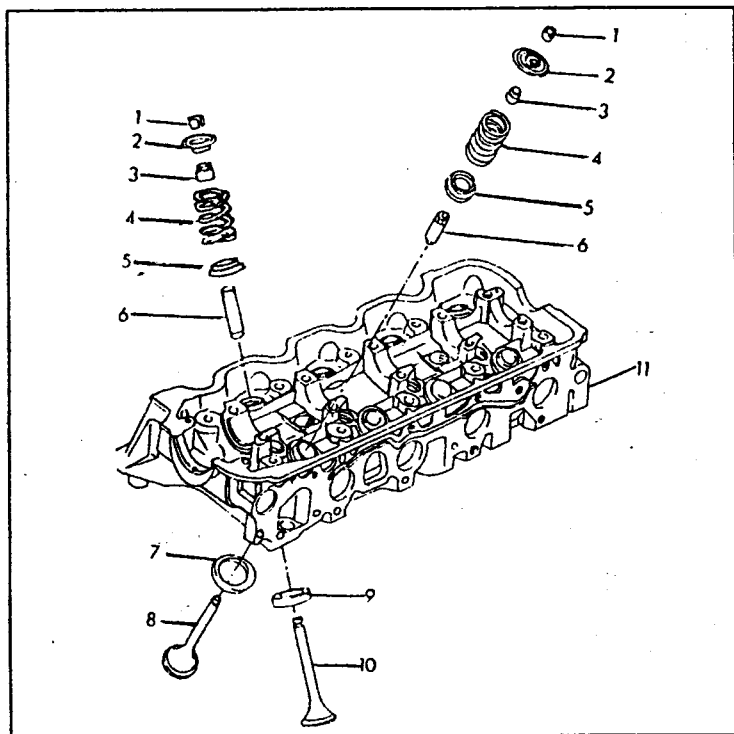

Fig. 1.16. — Exploded view of the cylinder head.

- | | |
|-----------------------|-----------------------------|
| 1 Valve cotter halves | 7 Inlet valve insert |
| 2 Valve spring cup | 8 Inlet valve |
| 3 Valve stem seal | 9 Exhaust valve seat insert |
| 4 Valve spring | 10 Exhaust valve |
| 5 Valve spring seat | 11 Cylinder head |
| 6 Valve guide | |

dividual parts and units. Follow the general instructions below at all times. In general proceed in reverse order to the dismantling procedure, but note the points given below:

- Take care that parts are only assembled in a clean condition.
- Keep tools, benches and hands free from dirt and swarf. Use only lint-free rags to wipe over the parts.
- Apply a film of clean engine oil to all parts that slide or rotate. Do this before the parts are assembled so that the lubricant is actually on the bearing surfaces. It will not do to apply the oil to the completed assembly.
- Make sure that all parts have been properly inspected for wear and damage before fitting. Renew any parts that are not up to standard.
- Obtain all spares and replacement parts from an authorised dealer, quoting the vehicle chassis number and the engine number. The manufacturers adopt a policy of continuous up-dating and improvements and only their official representatives are in a position to advise you of the latest component improvements and their application to your particular engine.
- Follow all tightening torques at the end of this manual.

1.4 Overhaul of the Engine

1.4.0. Cylinder Head

1.4.0.0. Technical Data

Cylinder head material: Light-alloy with pressed in valve guides and valve seat inserts
 Max. distortion of cylinder head surface: Less than 0.20 mm (0.008 in.)

Valves

Valve seat angle: 45°, all valves
 Correction angles: 30° and 65°, all valves

Valve Stem Diameters:

Inlet valves — 49G engine: 5.97 - 5.98 mm (0.2350 - 0.2354 in.)
 — 4G6 engine: 5.95 - 5.97 mm (0.2350 - 0.2354 in.)
 Exhaust valves — 4G9 engine: 5.95 - 5.98 mm (0.2343 - 0.2350 in.)
 — 4G6 engine: 5.95 - 5.97 mm (0.2343 - 0.2350 in.)

Valve Seat Width:

Inlet and exhaust valves: 0.9 - 1.3 mm (0.035 - 0.051 in.)

Valve Stem Running Clearance In Guides (in mm):

Inlet valves: 0.02 - 0.04 mm (4G9), 0.02 - 0.05 mm (4G6)
 Wear limit: 0.10 mm (0.004 in.)
 Exhaust valves: 0.03 - 0.06 mm (4G9), 0.03 - 0.07 mm (4G6)
 Wear limit: 0.15 mm (0.006 in.)

Thickness of Valve Head Edge (in mm):

Inlet valves: 1.0 mm (4G9), 1.0 mm (4G6)
 Exhaust valves: 1.3 mm (4G9), 1.2 mm (4G6)
 Wear limit — Inlet valves: 0.5 mm (4G9), 0.5 mm (4G6)
 — Exhaust valves: 0.8 mm (4G9), 0.7 mm (4G6)

Valve Guides

Length of Valve Guides (in mm):

Inlet valve guides: 45.5 mm (4G9), 45.5 mm (4G6)
 Exhaust valve guides: 50.5 mm (4G9), 50.5 mm (4G6)
 Valve Guide Outer Diameters: 11.055 - 11.065 mm (4G9), 11.06 - 11.07 mm (4G6)

Oversizes:	0.05, 0.25, 0.50 mm
Valve guide inner diameter:	6.00 - 6.01 mm (4G9), 6.00 - 6.02 mm (4G6)
Press-in temperature — all engines:	Room temperature

Valve Springs

Free length — 4G9 engine:	50.9 mm
Free length — 4G6 engine:	
Colour identification:	White
Length:	51.0 mm
Length under load - 4G9 engine:	44.2 mm at 22.0 kg
Length under load — 4G6 engine:	
White identification colour:	42.2 mm at 27.2 kg

Max. distortion of valve spring at upper end, spring placed vertical on surface plate:	Max. 4° (4G9), 4° (4G6)
Valve spring identification:	Both valves have identical valve springs
Valve identification colour spot:	None (4G9), white (4G6)
Arrangement during installation:	Colour code must be at the top

Valve Clearances (1.8 litre, 4G9 engine)

Engine Hot:	
Inlet valves:	0.20 mm (0.08 in.)
Exhaust valves:	0.30 mm (0.012 in.)

Camshaft

Camshaft end float:	0.05 - 0.15 mm (4G9), 0.1 - 0.2 mm (4G6)
Bearing journal diameter:	44.930 - 44.940 mm (4G9), 44.930 - 44.940 mm (4G6)
Bearing running clearance (both engines):	0.05 - 0.09 mm
Max. run-out of shaft:	0.10 mm (0.004 in.)
Camshaft identification in end face:	Always use camshaft with identical identification

Rocker Shafts

Rocker shaft diameter:	19.99 - 20.00 mm (4G9), 19.99 - 20.00 mm (4G6)
Running clearance of shaft:	0.02 - 0.05 mm (4G9), 0.02 - 0.05 mm (4G6)
Rocker Shaft Length — 4G6 Engine:	
Inlet valve shaft:	417.25 mm
Exhaust valve shaft:	417.25 mm

The cylinder head is made of light-alloy. Valve guides and valve seat inserts are pressed into the cylinder head. The arrangements of the inlet valves, exhaust valves and rocker levers are shown in Fig. 1.16, but note that the cylinder head shown in the illustration is of a different shape.

The individual components of the valve and timing mechanisms should be checked for wear or damage and parts must be repaired or overhauled as necessary. The engine has an overhead camshaft. The camshaft is inserted into the cylinder head, i.e. no bearing caps are used. The rocker shaft assembly of both engines is made-up of two rocker shafts with their respective rocker levers, springs, etc. The exhaust rocker shaft carries the four double exhaust valve rocker arms, the inlet rocker shaft carries eight individual inlet valve rocker arms. Fig. 1.17 shows the component parts on the example of a 1.8 litre engine. A very similar arrangement is used on the 2.0 litre engine.

1.4.0.1. Valve Springs

Check the valve springs for free length and load. Replace springs which do not conform to the values given in Section 1.4.0.0 (Technical Data).

Springs can only be properly checked if a spring tester is available. Otherwise compare the old springs with new springs. Slide the originally fitted spring and a new spring together over a long bolt (with large washers under bolt head and nut) and screw a nut on the end of the bolt. Clamp the bolt head into a vice and tighten the nut. If the coils

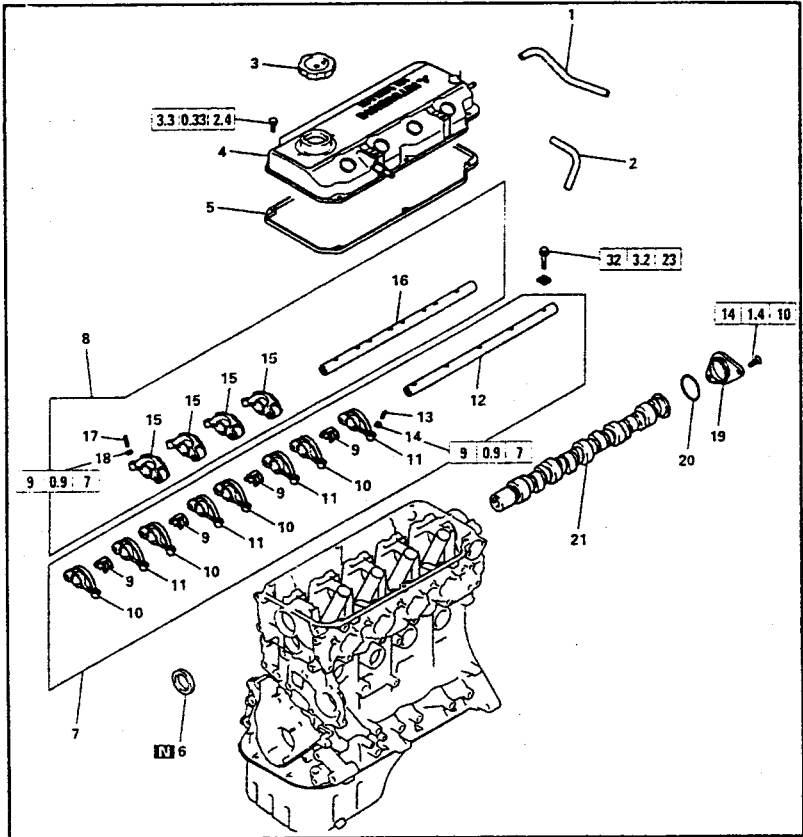

Fig. 1.17. — The arrangement of the rocker shaft assembly and the camshaft of a 1.8 litre engine.

- | | |
|--------------------------------|---------------------------|
| 1 Breather hose | 12 Rocker shaft (inlet) |
| 2 PCV. hose | 13 Adjusting screw |
| 3 Oil filler cap | 13 Adjusting screw |
| 4 Rocker cover | 14 Nut |
| 5 Rocker cover gasket | 15 Rocker arm |
| 6 Oil seal | 16 Rocker shaft (exhaust) |
| 7 Rocker arms and rocker shaft | 17 Adjusting screw |
| 8 Rocker arms and rocker shaft | 18 Nut |
| 9 Rocker shaft spring | 19 Thrust case |
| 10 Rocker arm | 20 "O" seal ring |
| 11 Rocker arm | 21 Camshaft |

of the original spring close before the coils of the new spring, replace the spring as a set, as the other springs will have similar defects.

Place the springs one after the other onto an even surface and place a steel square next to the spring. Check that the gap between the spring and the steel square at the top is not larger than or 4° (nominal 2°). A gap of less than 1.6 mm (0.06 in.) is acceptable for the purpose of this check. If this is exceeded, replace the spring.

Valve springs may be identified by a colour spot at one end and when fitting the

springs, this spot must always be at the top, with the close coiled end to the head. The colour spot on the valve springs has a special significance, as only springs with a white spot must be used, for example, on the 4G6 2.0 litre engine.

1.4.0.2. Valve Guides

Remove the valve stem seals, fitted over each valve guide, with a pair of pliers as shown in Fig. 1.18 and throw away the seals.

Valve guides and valve stems should first be inspected for visible wear. Clean the inside of the valve guides with a rag moistened in petrol, inserting the rag into the guides and move it to and fro to clean the inside bore. This may be rather difficult, due to the small diameter of the valve guide bores, but should be carried out. Valve stems are best cleaned by clamping them into an electric drill and using a wire brush to clean off the carbon deposits. A scraper can also be used carefully.

Valve guides can be checked for wear with a dial gauge, suitably clamped to the cylinder head. Check as follows:

- Lift the valve in question from its guide until the distance between the cylinder head face and the face of the valve head is approx. 30 mm (1 1/8 in.).
- Push the valve to one side and set the dial gauge to zero. Move the valve to the opposite side and read the indication on the dial gauge.
- The max. permissible reading is 0.20 mm (0.008 in.). If this value is exceeded, either the valves or the valve guides, or both, must be replaced.

To replace the valve guides, press out the old guides from the rocker shaft side, using a mandrel that will fit inside the guide bore. The cylinder head can be heated up to press out the guides, but this should not be necessary.

Before pressing out the guides measure the height of the guide above the cylinder head face with a depth gauge. Press the new guides into the cylinder head from the upper face, until the dimension previously measured has been obtained. This dimension is measured in a similar manner as shown in Fig. 1.19, but note that the illustration only serves as a guide.

Valve guides are available in three oversizes, i.e. 0.05, 0.25 and 0.50 mm (0.001, 0.01 and 0.02 in.) and are normally marked with "5", "25" and "50" to identify them. The lo-

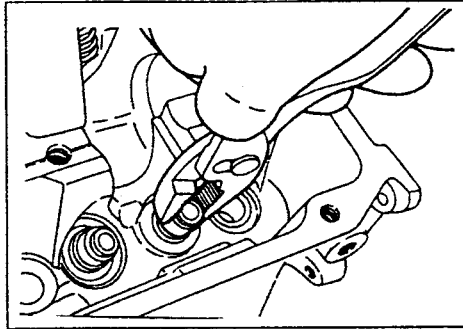

Fig. 1.18. — Removal of the valve stem oil seals with a pair of pliers. The seals are pushed over the valve guides.

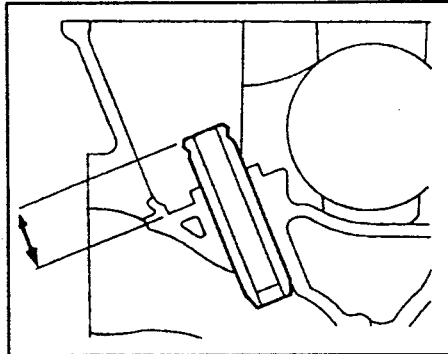
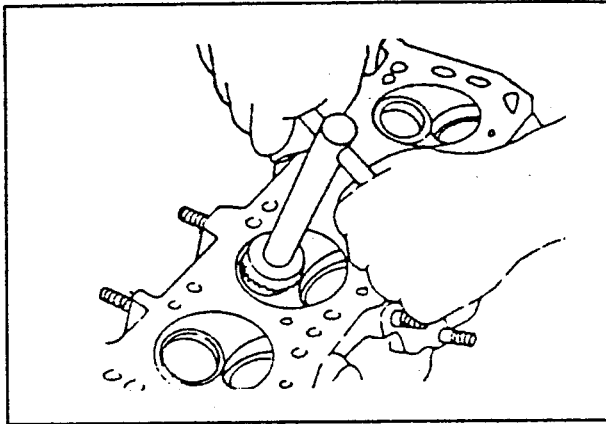

Fig. 1.19. — The protruding end of the valve guides must be measured between the arrow heads. New guides must be driven in slowly.

cating bores in the cylinder head must be reamed out to take the new guides. We would like to add that the bore diameter is approx. 6.0 mm on both engines. The majority of earlier Mitsubishi engines have a diameter of 8 mm.



1.20. — Re-cutting a valve seat.

Inlet valve guides and exhaust valve guides are of different length. Exhaust valve guides are longer and care must be taken to press the correct guides into the cylinder head. The guides of the 1.8 and 2.0 litre engines are of different length.

NOTE: Valve guides to be removed and replaced at room temperature. Valve seats must be re-ground, if new guides are fitted.

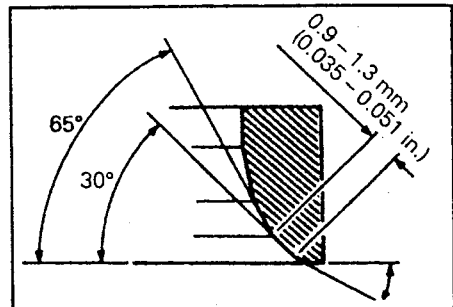

Fig. 1.21. — The valve seat width is to be measured between the arrows.

1.4.0.3. Valve Seats

Check the valve seats for signs of wear or pitting. Slight blemishes can be removed with a 45° cutter as shown in Fig. 1.20. Extended wear can only be rectified by fitting new valve seat inserts. In this case the cylinder head should be taken to a dealer to have the new seat inserts fitted. New valve seat inserts are available in oversizes of 0.3 or 0.6 mm (0.012 and 0.024 in.) and the cylinder head locating bores must be machined to the size in question to take the new inserts. Only precision machinery can carry out this operation.

A re-cut valve seat must be lapped. Use a suction tool to grind-in the new valve. Use fine lapping compound and work the seat until an uninterrupted ring is visible around the face of the valve.

After grinding-in the valve, clean the cylinder head, and even more important the inside of the valve guide bores thoroughly. Any lapping paste left inside the cylinder head will accelerate the wear of the new parts.

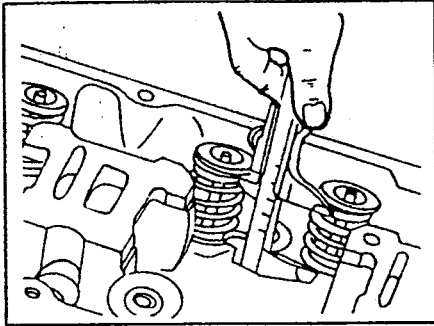

Fig. 1.22. — Measuring a valve spring height after installation.

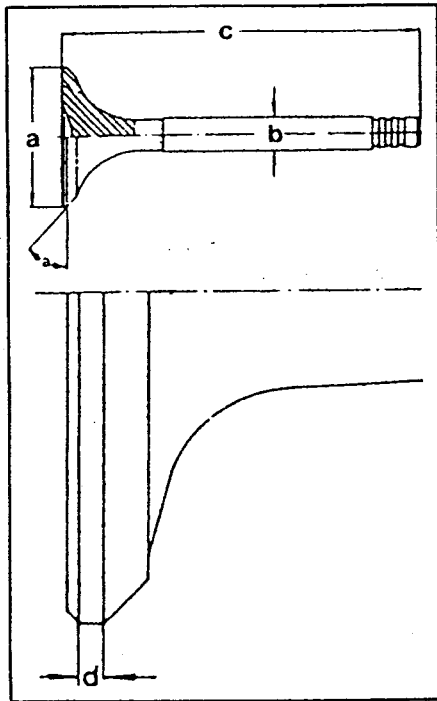

Fig. 1.23. — The principle valve dimensions are measured at the positions shown. The valve head thickness or edge "d" must have a min. thickness (Section 1.4.0.0) for the inlet and exhaust valves after a valve has been re-ground in a valve grinding machine.

- a. Valve head diameter
- b. Valve stem diameter
- c. Valve length
- d. Valve head thickness

Measure the width of the valve seats with a caliper. The width of inlet and exhaust valve seats is the same (0.9 - 1.3 mm/0.035 - 0.05 in.).

Fig. 1.21 shows the cutter angles used to re-cut the valve seats and also shows where the seat width is measured. The specified width applies to all valves and all engines.

After installation of the valve measure the height of the fitted valve spring as shown in Fig. 1.22. If the dimension is more than 49.30 mm (inlet valve) and 49.35 mm (exhaust valve), with a maximum tolerance of 0.5 mm in the case of a 1.8 litre engine or 49.30 mm in the case of the 2.0 litre engine (same tolerance), the valve seat inserts must be replaced, as the seat is cut too deep into the cylinder head.

1.4.0.4. Valves

Valves with bent or pitted stems should be replaced. Grinding or straightening of the valve stems is not permissible. A maximum of 0.5 mm (0.02 in.), however, can be taken off the ends of valve stems if the contacting area for the rocker levers needs attention. This should be carried out in a grinding machine with a proper chuck to ensure a straight face at the end of the stem. If stems ends are badly worn, check the rocker levers as described in the next section as these may also have suffered.

Slight blemishes on the valve head faces can be removed by grinding-in the valves as described in Section 1.4.0.3. Deeper grooves or other damage can be rectified in a valve grinding machine. The valve head thickness must not be smaller than specified for the inlet and exhaust valves (different on the two engine types), after grinding a valve to its original seat angle. Also measure the stem diameter and compare the results with the "Technical Data" in Section 1.4.0.0. Reject any valves which do not conform to the mini-

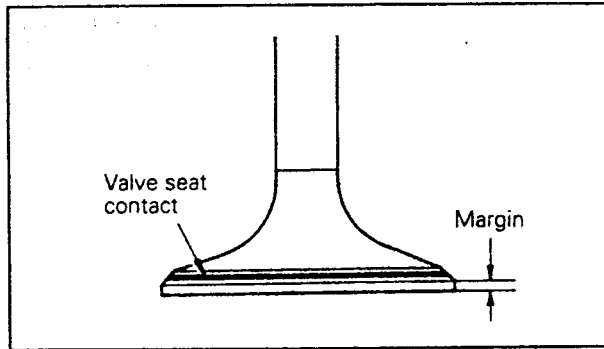

Fig. 1.24. — Before you decide to re-use a valve, check the valve head thickness (margin) at the position shown and compare with the technical data.

imum values. Check the running clearance of each valve stem in the valve guide bores as described in Section 1.4.0.2. and decide if it is necessary to replace the guides before any further inspection work is carried out on the valves.

1.4.0.5 Rocker Shafts and Rocker Levers

Check the rocker shafts and rocker levers for wear, pitting and other visible damage. Rocker arms have a roller. Check each roller for smooth operation. Rocker arms with a sticky roller must be replaced. The same applies if the roller(s) show signs of excessive wear. The ends of the valve adjusting screws (1.8 litre engine) must not be visibly worn. In this case the screw(s) can be replaced. Measure the outside diameter of each rocker shaft and the inside diameter of the rocker levers. The difference between the two dimensions should not exceed the value for the running clearance of the rocker arms, specified in Section 1.4.0.0.

If the running clearance is exceeded it is not always certain that shafts and rocker levers must be replaced. Check the shafts for grooves at the areas where the rocker levers are operating. Deep grooves at these areas indicate wear of the shaft. If on the other hand the shaft has no visible ridges it may only be the rocker lever that needs replacing.

The following points should be noted when dealing with the rocker shaft assembly. Both engines are dealt with in the same manner:

Refer to Fig. 1.17 and fit the parts over the two shafts in the order shown. Temporarily tighten the rocker shaft with the bolt so that all arms on the inlet valve side do not push the valves. Fit the rocker shaft springs (9) from above as shown in Fig. 1.25 and then rotate each spring in the direction of the arrow. Tighten the rocker

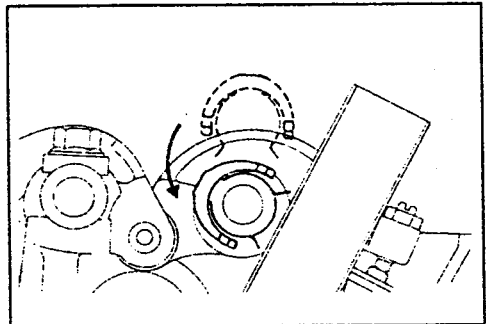

Fig. 1.25. — Insert the rocker shaft springs from above and then rotate them in the direction of the arrow (inlet side shaft only).

shaft bolt to 3.2 kgm (23 ft.lb.) to secure the assembly in position. *The rocker shaft springs must be inserted before the rocker shaft and rocker arms for the exhaust valves are fitted.* Fig. 1.26 shows an additional view of the rocker shaft spring installation.

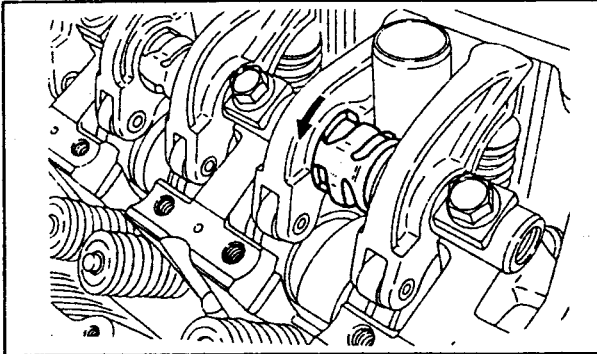

Fig. 1.26. — Installation of the rocker shaft springs. After inserting the springs as shown in Fig. 1.25, turn them in the direction of the arrow.

1.4.0.6. Hydraulic Valve Clearance Adjusters

The hydraulic valve clearance adjusters, also known as lash adjusters and fitted to the rocker arms of a 2.0 litre engine, tappets can be checked, among other things for leaks, but as special equipment is necessary, we recommend to have them checked at a dealer with facilities for engine overhaul, if it is suspected that there is a malfunction in the tappets. The alternative is the fitting of new tappets. The following precautions should always be taken:

- The hydraulic adjusters are precision-made and must be kept free of dust and other foreign matter.
- Never attempt to dismantle the adjusters.
- Use only diesel fuel to clean adjusters.

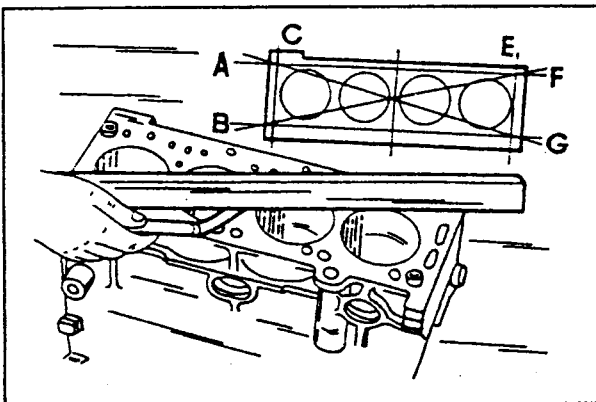

Fig. 1.27. — Checking the cylinder head gasket surface for distortion. Measure along the different directions shown.

1.4.0.7. Cylinder Head

Thoroughly clean the cylinder head face of old gasket material and check the surface for distortion. To do this, place a steel ruler over the cylinder head face in the directions shown in Fig. 1.27 and with a feeler gauge measure the gap between the ruler and the head surface. The cylinder head must be re-ground, or in severe cases replaced, if the gap is more than 0.10 mm (0.004 in.) at any of the points.

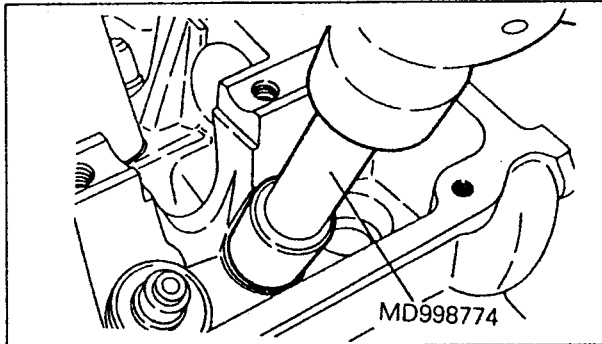

Fig. 1.28. — Driving a valve stem seal in position, using the special tool.

NOTE: The max. regrind value for the cylinder head is 0.20 mm (0.008 in.), but this dimension also includes any material that may have to be taken off the *cylinder block face*. If it is possible to re-use the cylinder head (i.e. there is no reason to suspect that the cylinder block is distorted), take it to an engine repair shop to have the face re-ground. Cylinder head gaskets are available in one thickness only.

1.4.0.8. Cylinder Head — Assembly and Installation

Refer to the exploded view (Fig. 1.16) when assembling the cylinder head. Both engines use similar parts:

- Place the valve spring seats over the valve guides.
- Fit the valve stem oil seals. To avoid oil leaks, a special tool, as shown in Fig. 1.28 should be used for this operation. Place the seals over each guide and carefully tap down with the hollow tool. Never attempt to use the old valve stem seals. The special tool shown can be substituted with a piece of tube of suitable diameter.
- Coat the valve stems with thin engine oil and insert into the correct valve guide. Take care not to damage the valve stem seal when the valve is inserted. Make absolutely sure that the valve is inserted into the guide where it has been lapped into the valve seat.

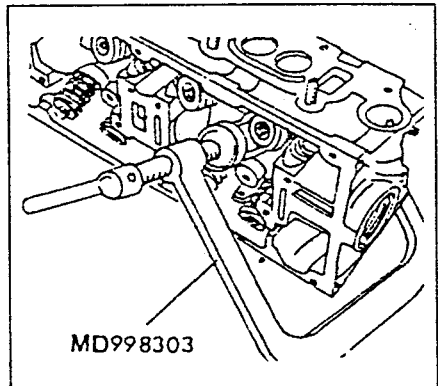

Fig. 1.29. — Compressing the valve springs with a typical, special valve spring compressor. Any other compressor with the same working principle can also be used.

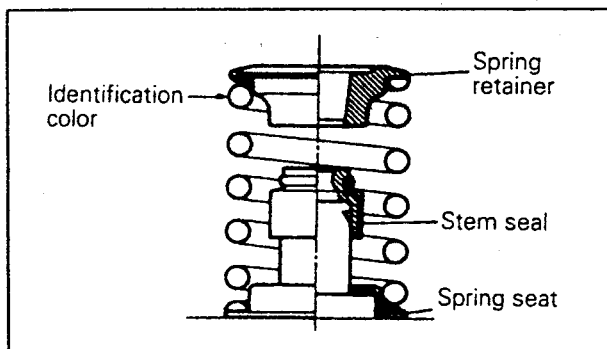

Fig. 1.29b. — Correct assembly of valves, valve springs, etc.

- Fit the valve springs (correct side up), place the upper spring retainer (cup) over the valve. Fig. 1.29b should be studied so that the fitted spring/valve assemblies can be compared. Using a valve compressor, as shown in Fig. 1.29 compress the valves springs until the two valve cotter halves can be inserted into the groove of the valve stem. Remove the valve compressor and check that the cotters have engaged in their groove by tapping the ends of the valve stems slightly with a hammer. Place a rag over each valve stem end to prevent the cotter halves from flying out.

The installation of the cylinder head is carried out as follows:

- Thoroughly clean the sealing faces of cylinder head and cylinder block and place a new cylinder head gasket in dry condition over the cylinder block. Under no circumstances use sealing compound. Gaskets for the 2.0 litre engine are marked with "4G63K"; gaskets for the 1.8 litre engine with "G9S". Fig. 1.30 shows where the identification number is located. Make sure to use the correct gasket (different location). Do not use sealing compound, thinking that you may improve the sealing of the gasket.

The cylinder head bolts are now tightened as follows, noting that a new method of

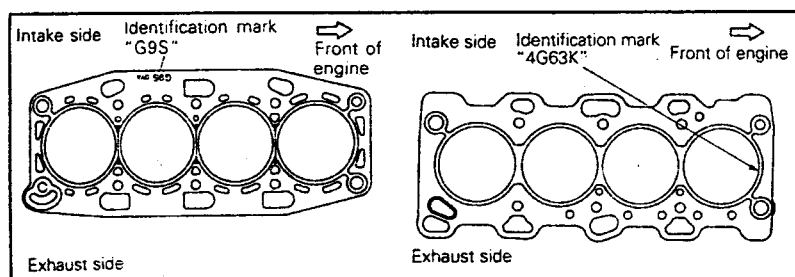

Fig. 1.30. — The identification of the cylinder head gasket can be found at the location shown. On the L.H. side for the 1.8 litre engine (Spacer Runner); on the R.H. side for the 2.0 litre engine (Space Wagon).

tightening for the cylinder head has been introduced. A new type of cylinder head bolt is used. These bolts can stretch and must be measured before they are re-used. A special cylinder head bolt wrench, suitable for the bolt heads, is required. This is a 12 mm, 12-point spline insert, which is now used by various engine ma-

nufacturers and can be obtained in accessory shops. Proceed as follows for the two engine types:

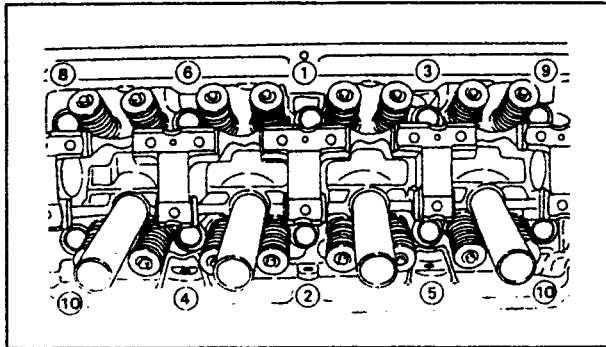

Fig. 1.31. — Tightening sequence for the cylinder head bolts. The bolts are slackened in reverse order.

2.0 Litre Engine

- Measure the length of each cylinder head bolt from end to end. Any bolt longer than 99.4 mm (measure with a "mm" caliper) must be replaced.
- Lubricate the threads and the underside of the washer with engine oil and insert the bolts. Tighten the bolts finger-tight.
- Tighten each cylinder head bolt in the order shown in Fig. 1.31 in several stages to 8.0 kgm (57 ft.lb.).
- In reverse order to Fig. 1.31 slacken all bolts (10 becomes 1, 9 becomes 2, etc.)
- Tighten the bolts in the order shown in Fig. 1.31 to 2.0 kgm (15 ft.lb.).
- The bolts must now be angle-tightened without the use of a torque wrench. Each bolt must be tightened **twice** by a further 90° (one quarter of a turn) in the tightening sequence. To obtain the angle, insert the wrench into the cylinder head bolt and arrange the tommy bar so that it is either in line with the cylinder head axis or at right angle to it. Tighten each bolt until the tommy bar has moved by a quarter of a turn.
- Repeat the above operation on each bolt in turn.
- The remaining operations are carried out in reverse order to the removal procedure.

1.8 Litre Engine

- Measure the length of each cylinder head bolt from end to end. Any bolt longer than 96.4 mm (measure with a "mm" caliper) must be replaced.
- Lubricate the threads and the underside of the washer with engine oil and insert the bolts. Tighten the bolts finger-tight.
- Tighten each cylinder head bolt in the order shown in Fig. 1.31 in several stages to 7.5 kgm (54 ft.lb.).
- In reverse order to Fig. 1.31 slacken all bolts (10 becomes 1, 9 becomes 2, etc.)
- Tighten the bolts in the order shown in Fig. 1.31 to 2.0 kgm (15 ft.lb.).
- The bolts must now be angle-tightened without the use of a torque wrench. Each bolt must be tightened **twice** by a further 90° (one quarter of a turn) in the tightening sequence, as described above for the 2.0 litre engine.

1.4.0.9. Adjusting the Valve Clearance (1.8 Litre)

Valve clearances can be adjusted with the engine hot or cold, but the final check, however, must be carried out on a hot engine. The cold values are only provisional values if the cylinder head has been dismantled. Although no factory values are given for the engine, it can be assumed that inlet valves should be set to 0.08 mm (0.0031 in.) and exhaust valves to 0.18 mm (0.007 in.). On a warm engine, adjust the inlet valves to 0.20 mm (0.008 in.) and the exhaust valves 0.30 mm (0.012 in.). The engine must have the coolant at its operating temperature, i.e. the temperature gauge must indicate "Normal".

We would like to repeat. The valves should only be adjusted on a cold engine after the cylinder head gasket has been replaced or the engine has been overhauled. Otherwise adjust the valves to the "hot" values when the engine has its operating temperature.

The clearances are adjusted as shown in Fig. 1.32, using a ring spanner and a screwdriver. Check each clearance in the order given below with a feeler gauge. Insert the gauge of correct thickness between the end of the valve stem and the adjusting screw. The other end of the rocker lever (i.e. the roller part of the rocker lever) must be resting against the heel of the cam, i.e. the valve must be fully closed. To check if the correct valve is being dealt with, grip the end of the lever with thumb and forefinger and check if a small clearance can be felt.

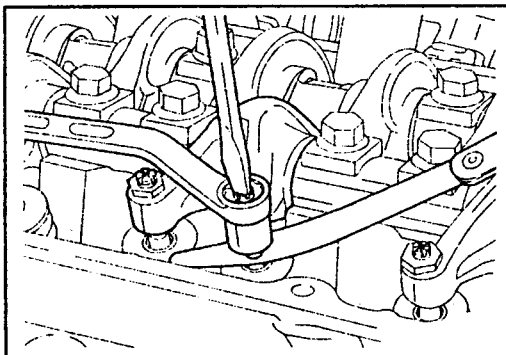

Fig. 1.32. — Adjusting the valve clearances with feeler gauge, screwdriver and ring spanner.

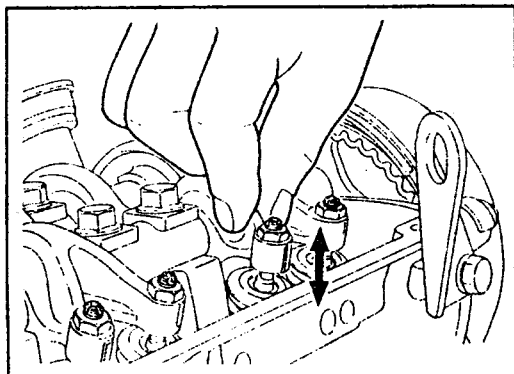

Fig. 1.33. — Grip each rocker lever between thumb and forefinger and move it up and down as shown. If there is a clearance on all levers of this cylinder, you have found the piston at top dead centre position.

rocker levers of this cylinder must have play, indicating that the correct cylinder is at the

Adjust the clearances as follows:

- If the engine is in cold condition (and fitted), start it up and let it run until the operating temperature is indicated (temperature gauge).
- Remove the spark plugs and the cylinder head cover.
- Rotate the engine until both valves of the No. 1 cylinder are closed, i.e. both rocker levers must have a slight play. To check, move the rocker lever up and down as shown in Fig. 1.33. All

top dead centre position. The notch in the crankshaft pulley must be in line with the "T" on the ignition timing scale (top dead centre). If this is not the case, rotate the engine one more turn.

- Adjust these valves and in the same engine position all other valves marked with the white arrows in Fig. 1.34.

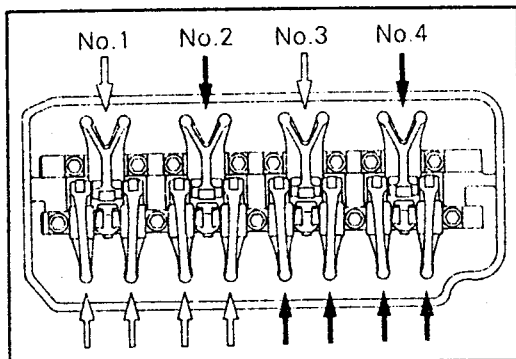

Fig. 1.34. — With the No. 1 cylinder at top dead centre position, adjust the valves shown by the white arrows. Adjust the valves shown by the black arrows when the piston of No. 4 cylinder is at top dead centre position.

check that all valves of No. 4 cylinder are closed. In this position adjust all valves marked with the black arrows in Fig. 1.34 as described above.

- Slacken the locknut for the valve adjusting screw with a ring spanner and turn the adjusting screw with a screwdriver. Turn the screw in a clockwise direction to reduce the valve clearance or in an anti-clockwise direction to increase the clearance.
- Tighten the locknut (1.0 kgm/7 ft.lb.) without rotating the adjusting screw. Re-check the clearance as before after the locknut is tight.
- Rotate the engine by one complete turn and

1.4.0.10. Checking the Cylinder Compression

Compression loss can be due to a valve not closing properly, a broken or worn piston ring, worn pistons or other faults in the cylinder. To check which of the cylinders is at fault, a compression check should be carried out. The engine must be at operating temperature to avoid incorrect readings.

- Unscrew the spark plugs.
- Fully depress the throttle pedal and make sure that the choke valve is fully open.
- Place the compression tester into the first spark plug hole and have the starter motor operated by a second person, with the throttle pedal fully to the floor.
- Crank the engine until the highest reading is indicated on the compression tester chart.
- Check the remaining cylinders in the same manner. At the end there will be four graphs showing the compression of each cylinder.

None of the cylinders must have a compression of less than 80% of the best cylinder. A low, irregular compression could be caused by worn piston rings, which is also shown by excessive oil consumption. Section 1.0 gives the standard values and the min. value for the compression.

Various fluids are available from accessory shops to "re-seal" the piston rings to the cylinder bore. This may be a temporary solution to overcome a slight loss of compression. In this case follow the manufacturers instruction and re-check the compression. Major loss of compression requires attention to the engine, normally involving a strip-down, re-bore, etc.

1.4.1. PISTONS AND CONNECTING RODS

1.4.1.1. Technical Data

Pistons

Material and construction:	Special alloy, solid skirt
Arrangement of Piston Pin:	
Fit in connecting rod:	Press-fit
Fit in piston:	Floating

Piston Diameter:

1.8 litre engine:	80.97 - 81.00 mm (3.1878 - 3.1890 in.)
2.0 litre engine:	84.97 - 85.00 mm (3.3453 - 3.3465 in.)
Max. ovality of bores:	Less than 0.02 mm (0.0008 in.)
Max. taper of bores:	0.02 mm (0.0008 in.)
Piston running clearance:	0.02 - 0.04 mm (4G9), 0.01 - 0.04 mm (4G6)
Oversize pistons available:	0.25, 0.50, 0.75 and 1.0 mm

Side Clearance of Rings in Grooves:

No. 1 ring:	0.03 - 0.07 mm (0.0012 - 0.0028 in.)
Wear limit:	0.10 mm (0.004 in.)
No. 2 ring:	0.02 - 0.06 mm (0.0008 - 0.0024 in.)
Wear limit:	0.10 mm (0.004 in.)

Piston Ring Gaps:

No. 1 rings:	0.25 - 0.40 mm (0.0098 - 0.0157 in.)
Wear limit:	0.8 mm (0.03 in.)
No. 2 rings:	
1.8 litre engine:	0.40 - 0.55 mm (0.0157 - 0.0217 in.)
2.0 litre engine:	0.45 - 0.60 mm (0.0177 - 0.0236 in.)
Wear limit:	0.8 mm (0.03 in.)
Oil control rings:	
1.8 litre engine:	0.20 - 0.60 mm (0.008 - 0.024 in.)
2.0 litre engine:	0.20 - 0.70 mm (0.008 - 0.028 in.)
Wear limit:	1.0 mm (0.04 in.)

Piston Pins:

Outer diameter:	
1.8 litre engine:	19.002 - 19.005 mm (0.7481 - 0.7482 in.)
2.0 litre engine:	21.000 - 21.001 mm (0.8268 - 0.8272 in.)
Press-in load — 1.8 litre:	500 - 1500 kg (1100 - 3300 lb.)
— 2.0 litre:	750 - 1750 kg (1653 - 3858 lbs.)
Press-in temperature:	Room temperature

Connecting Rods:

Length, centre to centre:	
1.8 litre:	133.4 - 133.5 mm (5.252 - 5.256 in.)
2.0 litre:	149.9 - 150.0 mm (5.902 - 5.906 in.)
Max. bend of connecting rods:	0.05 mm (0.002 in.) per 100 mm (3.94 in.) of length
Max. twist of connecting rods:	0.10 mm (0.004 in.) per 100 mm (3.94 in.) of length
Big end end float:	0.10 - 0.25 mm (0.004 - 0.001 in.)
Wear limit:	0.40 mm (0.016 in.)

1.4.1.0. General

The pistons and connecting rods are pushed out from the top of the block after removing the bearing caps and lower shells. Before carrying out these operations, note the following:

- Mark each of the pistons and connecting rods to the cylinder bore from which it is removed. This can be carried out by numbering the piston crowns with the numbers 1, 2, 3 and 4, as shown in Fig. 1.35 and with an arrow each, which should be facing

towards the crankshaft pulley. Remember that the arrow marked into the piston crown cannot be seen due to the carbon deposits.

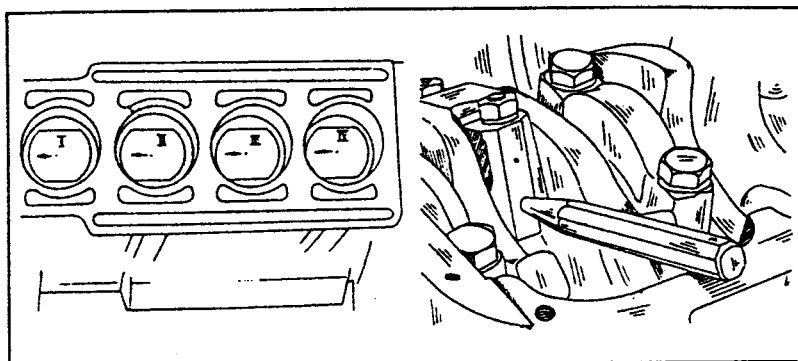

Fig. 1.35 — The L.H. view shows the piston identification. The top of the pistons should be marked with their cylinder number and arrows. The R.H. view shows how a connecting rod and bearing cap can be marked.

- Before removing the connecting rod bearing caps, mark each of the con rods and its cap with a centre punch to ensure assembly in the same position (Fig. 1.35).
- Mark the bearing shells and the rod to which they belong and mark the upper and the lower shells as soon as they have been removed.

Remove the bearing caps and shells to take out the piston assemblies, making sure that there is no ridge of carbon in the bore that might prevent removal.

- Push out the piston pin as described in Section 1.2.2. If the pin has a tight seat, heat the piston in hot water (to 60° C/140° F). Do not use a blow lamp.
- Using a pair of piston ring pliers, as shown in Fig. 1.13, remove the piston rings carefully from the pistons (over the crown) and keep them matched if they are to be re-used. If no piston ring pliers are available, insert some metal strips under the piston ring to be removed, on opposite sides of the piston and lift the ring this way over the piston crown. Clean all parts thoroughly, avoiding abrasive or sharp tools that might scratch the pistons.
- Piston ring grooves can be cleaned with a broken-off piston ring, which should be ground or filed flat at the broken end. Go around the circumference of the groove, being careful not to lift off any metal.

Carry out the inspections given below, all data being given in Section 1.4.1.0.

1.4.1.2. Measuring the Cylinder Bores

Measurement of the cylinder bores should be made in conjunction with the data given in Section 1.4.1.0. Bores should be measured in both transverse and longitudinal planes and at the three positions down the bore, as shown in Fig. 1.36. With other words, six measurements must be carried out and each value written down. The worst measurement must be taken into consideration when deciding on the size for re-machining. All bores must be re-machined, even if only one of the cylinders is outside the limits.

The final dimension of a cylinder bore is determined by measuring the outside diameter of the piston and adding the piston running clearance to this dimension.

The running clearance is given in Section 1.4.1.0. A dimension of 0.02 mm (0.0001 in.)

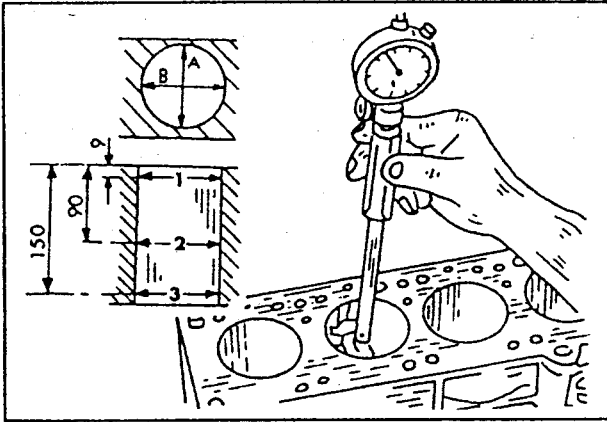

Fig. 1.36. — Measuring a cylinder bore.

must be added to the final value to allow for the honing of the cylinders. Cylinders must not be out-of-round or tapered by more than 0.02 mm (0.0001 in.)

1.4.1.3. Checking Pistons and Connecting Rods

- Check the clearance of the piston rings in their grooves as shown in Fig. 1.37. The grooves must be thoroughly cleaned before this check is carried out. If the values are not within the dimensions given, replace the piston ring in question or in severe cases replace the piston. Oversize piston rings are available in the same sizes as pistons.

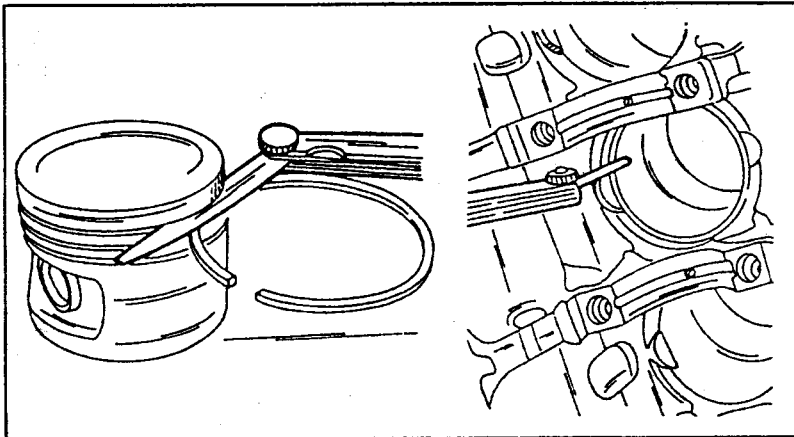

Fig. 1.37. — Checking the side clearance of the piston rings by means of a feeler gauge on the left. The R.H. view shows the checking the piston ring gap with a feeler gauge. The ring is inserted into the bottom of the cylinder bore.

- Check the ring gap by inserting the ring into the cylinder bore as shown in Fig. 1.37,

on the R.H. side. Make sure that the ring is inserted squarely — use the crown of a piston to press the ring down. Note that the gap is measured at the bottom end of the cylinder bore. Compare with the values given in Section 1.4.1.0.

- Check the piston pins and the bores of the connecting rods for wear. The piston fit must be so that the well oiled piston pin can be pushed with thumb pressure through the piston pin bore at room temperature. The pin has a press-fit in the connecting rod small end.
- The piston crown is marked with an arrow which points to the front of the engine. This installation direction is of importance as the piston pin is offset to one side. Oversize pistons have their size marked in the piston crown (for example "25", "50", etc.). Letters and numbers in the piston crown refer to the engine type.
- Check the connecting rods for damage. Never repair a damaged connecting rod but always replace. Re-useable connecting rods should be checked in an alignment fixture to make sure it is not bent by more than 0.05 mm (0.002 in.) or twisted by more than 0.10 mm (0.004 in.). Twisted or bent connecting rods should not be straightened and we recommend that a complete new set is fitted, if the values are exceeded.

1.4.1.4. Checking the Big End Bearing Running Clearance

Before bearing shells for the connecting rod bearings are ordered, it must be established to which size the crankpins have to be re-ground. Clean the crankshaft thoroughly and inspect the journals for signs of wear or damage. Measure the journals at two positions around the circumference and along its length. Out of round and taper of more than 0.03 mm (0.0012 in.) will mean that the crankshaft will have to be re-ground. All dimensions are given in the "Technical Data", Section 1.4.2.0. Several undersize bearing shells are available, but it should be noted that bearing shells are selective in accordance with the crankpin diameters. Your "re-bore" shop will fit the correct shells, ready for assembly.

The running clearance of the big end bearings must be between 0.02 - 0.05 mm (0.0008 - 0.0020 in.), with a wear limit of 0.10 mm (0.004 in.). The clearance can be checked with "Plastigage" plastic filament as follows:

- Rotate the crankshaft until two of the crankpins are at bottom dead centre if the shaft is still fitted to the engine.
- Remove all dirt and grease from the journals and the shells.
- Place a length of "Plastigage" wire along the complete length of the journal and fit the shell and bearing cap.

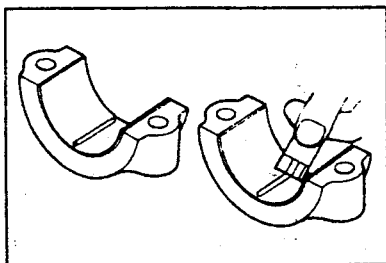

Fig. 1.38. — Checking the big end bearing running clearance. In the left-hand view the "Plastigage" wire is inserted into the bearing shell. In the right-hand view the flattened "Plastigage" wire is measured with the scale provided.

- Tighten the nuts to the correct tightening torque (refer to Section 1.4.1.6). Do not move the connecting rod after tightening the nuts. The pressure of the bearing shell will compress the "Plastigage" and flatten it.
- Now remove the bearing cap in question and take off the bearing shell. Compare the width of the compressed "Plastigage" wire with the scale provided, as shown in Fig. 1.38. The smallest width of the "Plastigage" indicates the largest running clearance.
- If the clearance is excessive, the crankshaft bearing journals must be re-ground and undersize bearing

shells fitted. Your dealer will advise you about availability.

1.4.1.5. Assembling Piston and Connecting Rods

The special tool shown in Fig. 1.14 must be used to assemble the pistons to the connecting rods. The piston pin must be pressed in with certain pressure (refer to Section 1.4.1.1., different for the two engines) and it may be better if the parts are assembled in a workshop with the proper tools.

- Lubricate the outside of the piston pin and the inside of the connecting rod small end with engine oil.

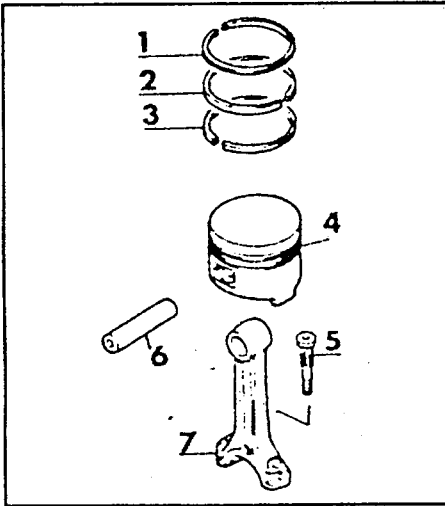

Fig. 1.39. — Exploded view of a piston with cond rod.

- | | |
|------------------------|-----------------------|
| 1 Top compression ring | 5 Connecting rod bolt |
| 2 2nd compression ring | 6 Piston pin |
| 3 Oil control ring | 7 Connecting rod |
| 4 Piston | |

- Align the connecting rod and the piston so that the "Front" mark of both components are facing towards the top. The piston has an arrow in the crown and the connecting rod is normally marked with a number in the shank.
- Press the piston pin in position with the special fixture. Connecting rod and/or piston pin must be replaced, if the pin slides into the connecting rod before the pressure given above is reached.
- After the piston pin has been pressed in position, check that the connecting rod can be moved to and fro without binding.

1.4.1.6. Fitting Pistons and Connecting Rods

Refer to Fig. 1.39 for the following operations. If parts are re-used, make sure to fit them into their original position. If cylinder bores have been re-bored, fit the new piston into the relevant cylinder bore.

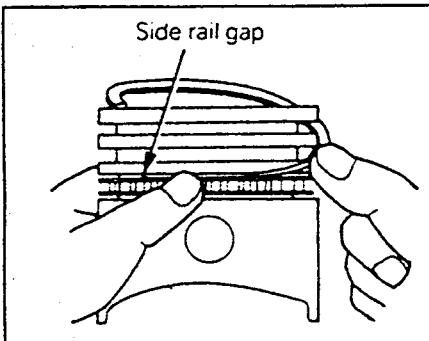

Fig. 1.40. — Fitting the two side rails of the three-part oil control ring. Fit the upper side rail first as shown.

- Arrange the connecting rods with the number in the shank facing towards the front of the engine.
- Fit the three-part oil control ring. Install the spacer expander with a pair of piston ring pliers. Fit the upper and lower side rails, but do not use the piston ring pliers as the rings may be broken if such a method is employed. To install the side rails, first insert one end

of the side rail between the piston ring groove and the spacer expander, hold it down firmly and then press down the portion which is to be inserted into the groove with a finger as shown in Fig. 1.40. In this manner the side rail can be easily fitted. The upper side rail is fitted first. After installation, check that both side rails can be turned smoothly. The size mark and the maker's mark in the side rails must be facing towards the piston crown after installation. Arrange the gaps so that the expander spacer gap is arranged 45° away from the two side rail gaps.

- Fit the centre piston ring (compression ring) and the upper compression ring with a pair of piston ring pliers, with the size mark and the maker's mark facing towards the piston crown. Note that the two compression rings are not identical, although of the same size. The chrome-plated piston ring is fitted to the upper groove. Fig. 1.41 shows a sectional view through piston and piston rings for reference.

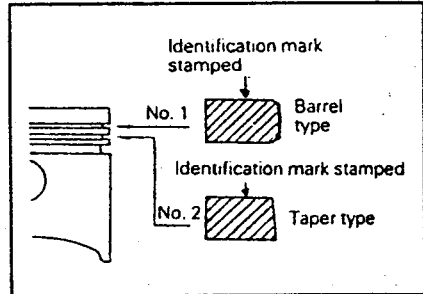

Fig. 1.41. — The correct arrangement of the piston ring gaps.

- Arrange the piston ring gaps in accordance with Fig. 1.42 on the circumference of the piston skirt. Make sure the "Front" mark points to the front of the engine.

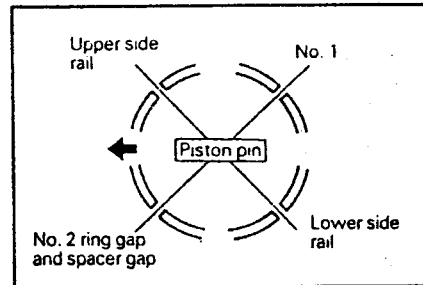

Fig. 1.42. — The correct arrangement of the piston ring gaps.

- A piston ring compressor is required to fit the pistons to the cylinder bores. Place the compressor around the piston rings (without disturbing their position) and push the piston rings into their grooves. A compressor can be hired out from most tool hire companies. Never try to fit pistons without compressing the piston rings.
- Insert the correct connecting rod into the cylinder bore, check that the arrow in the piston faces towards the front and guide the connecting rod, with the bearing shell inserted, into the cylinder bore. The lug in the bearing shell must be engaged into the cut-out of the connecting rod. The connecting rod bolts must be fitted. Small pieces of rubber or plastic sleeve can be fitted over the two bolts to prevent scratching of the cylinder bore.
- Insert the piston into the bore up to the piston ring area and carefully guide in the piston rings, at the same time pushing off the compressor and guiding the big end bearing over the crankpin. The cylinder block should be on its side to facilitate the installation.
- Insert the big end bearing shell into the cap, with the lug on the rear face into the cut-out of the cap and generously lubricate the bearing shell face with engine oil. Do not use a brush to oil the shells, as bristles could enter the bearing.
- Make sure that the connecting rod is in position on the crankpin and fit the bearing cap with the shell over the crankpin and against the connecting rod. Check that the two cut-outs in connecting rod and cap are on the same side. Tap the cap in position with a rubber or plastic mallet.

The connecting rod bearing cap nuts must now be tightened in the manner described

below. Again it should be noted that the nuts must be tightened to a certain angle without the use of a torque wrench. Follow the sequence given below:

- First check all bolts at the shafts. Bolts with obvious deformation at this area must be replaced.
- Coat the bolt threads and the contact faces for the nuts (on the bearing caps) with engine oil.
- Rotate the crankshaft until two of the crank throws are at the bottom of the crankcase and fit these two bearing caps. Carefully knock them in position with a plastic mallet.
- Screw the nuts finger-tight against the bearing caps.
- Alternatively tighten the two nuts of each connecting rod to 2.0 kgm (14.5 ft.lb.), to press the bearing cap in position.
- Each nut must now be tightened to 90 to 100°, i.e. approx. 1/4 of a turn and a little more. Apply the socket and the tommy bar and tighten each nut until the bar has been turned by one quarter of a turn. From this position tighten just a little more.

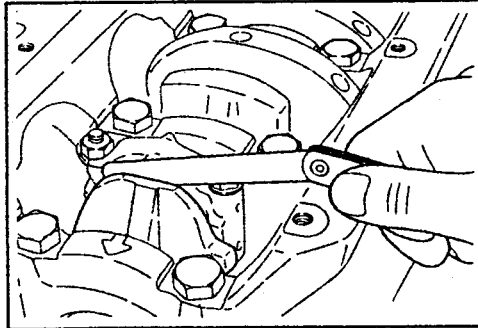

Fig. 1.43 — Measuring the end float of a connecting rod on the assembled big end bearing. Push the rod to one side and measure on the other side.

NOTE: Here is some help. Fit the socket over the nut and insert the socket extension and the tommy bar so that it is parallel to the crankshaft axis. Now tighten the nut until the tommy bar is at right angle to the crankshaft. You will have obtained the 90°. A little more will bring you within the allowed tolerance. All accessible nuts must be tightened in the same manner. Never over-tighten the bearing cap nuts. If this is done accidentally, start from scratch.

- After fitting the connecting rod, measure the end float of the big end bearing on the crankpin as shown in Fig. 1.43 by inserting a feeler gauge between the big end bearing and the thrust face of the crankpin. The nominal value is 0.10 - 0.25 mm (0.004 - 0.010 in.).
- Fit the remaining connecting rods and pistons to the crankpin at bottom dead centre position in the manner described above.
- Rotate the crankshaft by one turn and fit the two remaining assemblies in the manner described above.
- Rotate the crankshaft a few times and check for hard spots. To rotate the engine, fit two bolts to the crankshaft end flange and turn the crankshaft with a strong screwdriver.

1.4.2. CRANKSHAFT AND BEARINGS

1.4.2.0. Technical Data

Number of bearings: 5
 Main journal diameter:
 1.8 litre engine: 49.982 - 50.00 mm (1.9678 - 1.9685 in.)

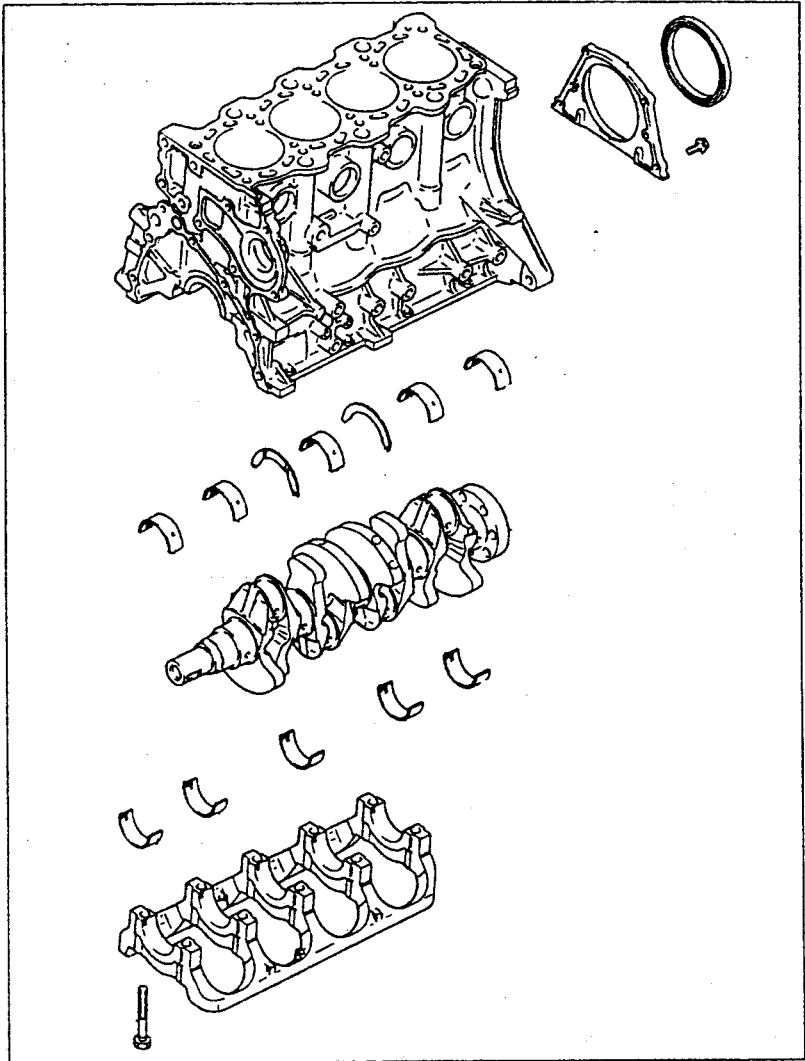

Fig. 1.44. — Exploded view of the crankshaft and the cylinder block of the 1.8 litre engine.

Main bearing journal diameter — 2.0 litre engine:	56.98 - 57.00 mm (2.2433 - 2.2441 in.)
Crankpin journal diameter:	
All engines:	44.980 - 45.00 mm (1.7709 - 1.9885 in.)
Max. permissible out-of-round:	0.03 mm (0.0001 in.)
Crankshaft end float:	
Nominal:	0.05 - 0.25 mm (0.002 - 0.0098 in.)
Wear limit:	0.40 mm (0.0098 in.)
Crankshaft thrust taken at:	Centre main bearing

Main bearing running clearance:	0.02 - 0.05 mm (0.0008 - 0.0020 in.)
Wear limit:	0.10 mm (0.004 in.)
Big end bearing running clearance:	0.02 - 0.05 mm (0.0008 - 0.0020 in.)
Wear limit:	0.10 mm (0.004 in.)

1.4.2.1. Inspection of the Crankshaft

The crankshaft is forged of steel and runs in five bearings. An oil seal is fitted to the flywheel end. The oil seal on the opposite end is inserted into the front housing into the front cover. A one-piece bearing cap, bolted to the underside of the cylinder block (crankcase) is used on both engines to secure the crankshaft/main bearings.

The end float of the crankshaft is controlled by the flanged bearing shells on the centre bearing, in the case of the 2.0 litre engine (one shell on each side of the crankshaft) or by two half thrust washers, one on each side of the upper, centre bearing shell.

Fig. 1.44 shows an exploded view of the crankshaft and the cylinder block for a 1.8 litre engine. The only major difference are the two flanges bearing shells of the 2.0 litre engine.

Thoroughly clean the crankshaft in paraffin or petrol and check that all oil drillings are free of obstructions. Clamp the crankshaft between the centres of a lathe or place the two end journals in "V" blocks and with a dial gauge, measure the run-out at the centre journal as shown in Fig. 1.45. The max. permissible indication is 0.05 mm (0.0020 in.). Note that the shaft should be rotated by two complete turns. Half of the indicator valve is the actual run-out.

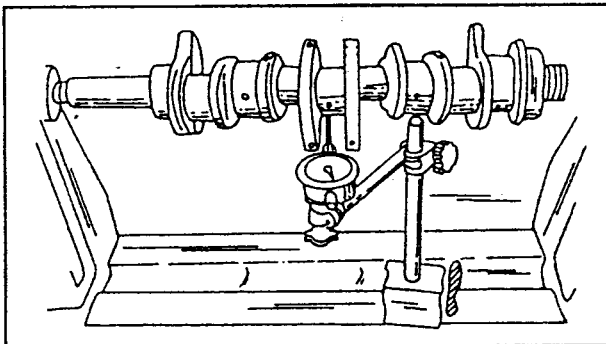

Fig. 1.45. — Checking the crankshaft for run-out. The shaft can be clamped between the centres of a lathe or the end journals are placed in "V" blocks.

Check the crankshaft main bearing journals and crankpin journals for grooves or other damage (seized bearings). If no obvious damage is seen, measure the diameters of all journals with a micrometer. Take care not to place the jaws of the micrometer against any of the oil drillings.

From the result decide if the crankshaft can be re-ground. Various undersize bearing shells are available and can be used as required. The diameters of main bearing journals and crankpin journals are different for the two engines. Section 1.4.2.0 gives the relevant information.

1.4.2.2. Crankpins

Apart from the nominal size big end bearing shells there are a number of undersize

shells available. The selection of the correct undersize shells depends on the condition of the individual crankpins as it is sometimes possible that the first undersize shell is not enough. Therefore, measure the crankpin diameters, compare with the nominal values and from the result decide to which undersize the journals must be ground. This also applies to the main bearings below.

1.4.2.3. Main Bearing Journals

Apart from the nominal size main bearing shells there are a number of undersize bearing shells available.

1.4.2.4. Main Bearing Running Clearance

The main bearing running clearance is between 0.02 - 0.05 mm (0.0001 - 0.0020 in.), with a wear limit of 0.10 mm (0.004 in.). All bearings have the same running clearance (also known as radial clearance) and can be measured as described in Section 1.4.1.4. for the big end bearings.

All bearings can be checked at the same time. The main bearing bolts must be tightened in the manner described in Section 1.4.2.5. Do not rotate the crankshaft after the bearing caps have been tightened with the "Plastigage" under the bearing shells.

1.4.2.5. Installation of Crankshaft

The one-piece bearing cover has an arrow at the position shown in Fig. 1.46. The following points should be noted during installation:

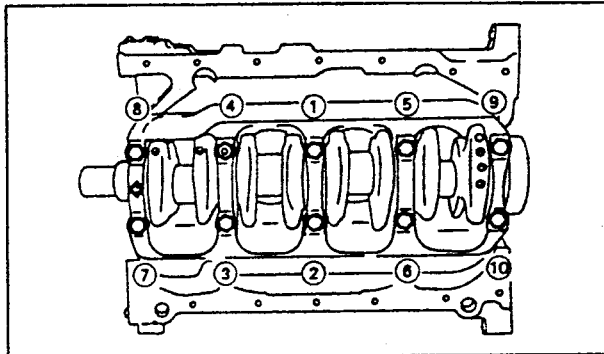

Fig. 1.46 — The arrow in the one-piece bearing cover must be located at the front end of the crankshaft.

- Bearing shells of No. 3 bearing of a 2.0 litre engine have a flange to control the crankshaft end float. The 1.8 litre engine has the two half thrust washers, fitted at the position shown in Fig. 1.44. The crankshaft end float must be measured after installation as shown in Fig. 1.47. To do this, push the crankshaft to one side, using a strong screwdriver and measure on the other side between bearing shell flange and crankshaft thrust face with a feeler gauge. The end float should be between 0.05 and 0.18 mm (0.002 and 0.007 in.), but a wear limit of 0.25 mm (0.010 in.) is acceptable.
- If the same bearing shells are re-used, make sure they are inserted into their

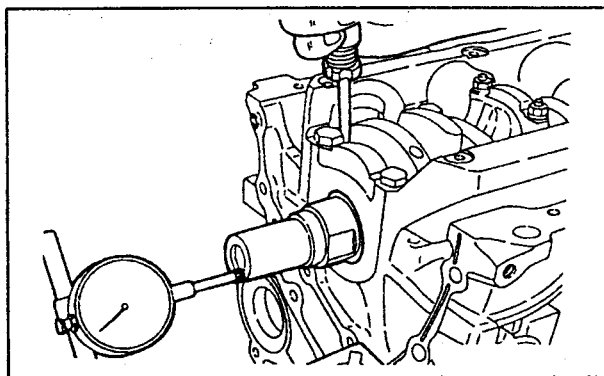

Fig. 1.47. — Checking the crankshaft end float.

original bearing bores. The bearing shells and the main bearing journals have formed a wear pattern which should not be disturbed.

The installation of the crankshaft is carried out as follows:

- Measure the length of all bearing cover bolts, but not from end to end, but as shown in Fig. 1.48. Bolts stretch in use and any bolt longer than 71.1 mm (use "mm" equipment to measure) must be replaced. Immediately coat the threads and the underside of the bolt head with engine oil. Note that the bolt heads have a special serration, i.e. a special socket may be required.
- Generously lubricate the bearing shell surfaces with engine oil.
- Insert the lugs at the back faces of each bearing shell into the cut-out of the locating bores of the crankcase. Make absolute sure that each bore receives the correct bearing shell and remember that No. 1 bearing is at the crankshaft pulley end.
- Carefully lift the crankshaft into the bearing shells and rotate it a few times to settle the bearings.
- Fit the lower bearing shells in the same manner into the main bearing cover and place the bearing cover with the shells in position over the crankshaft journals and the crankcase. Take care not to dislodge the shells. Fit the cap screws and tighten them finger-tight.
- Commencing at the centre of the bearing cover and in the numbered order shown in Fig. 1.46, tighten the bolts to 2.5 kgm (18 ft.lb.).
- Tighten all bolts in the sequence given in Fig. 1.46 by a further 90° (¼ of a turn). To this, fit the socket extension over the bolt and insert the tommy bar either at right angle to the crankcase or parallel with the crankcase. Then move the tommy bar by a quarter of a turn and a little more. *The following points must be observed when the main bearing bolts are tightened:*
 - If the bolts are tightened less than 90°, proper pre-tensioning of the bolts cannot take

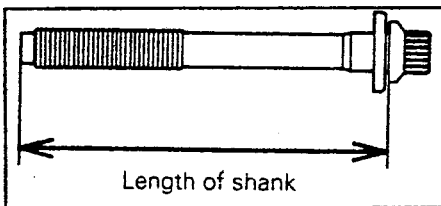

Fig. 1.48. — Main bearing cover bolts must be measured as shown. Reject bolts of less than 71.1 mm in length.

place. Therefore make absolutely sure that the quarter of a turn has been obtained for EACH bolt.

- If the bolts have accidentally tightened more than the limit (100°), slacken all bolts and re-start the tightening sequence from scratch.
- After all bearings caps have been tightened as described, rotate the crankshaft a few times to check for binding.
- Lubricate the sealing lip of a new rear oil seal with grease and drive the seal into the rear oil seal flange. The oil seal is driven in from the outside. Coat the oil seal retainer (flange) faces with sealing compound and fit it to the cylinder block.
- Clean the crankshaft flange with a clean rag and fit the flywheel. Tighten the flywheel bolts to 135 kgm (98 ft.lb.). On models with automatic transmission, fit the drive plate (Fig. 1.49). The bolts are tightened to the torque given above. Note that the plate (2) may not be fitted.

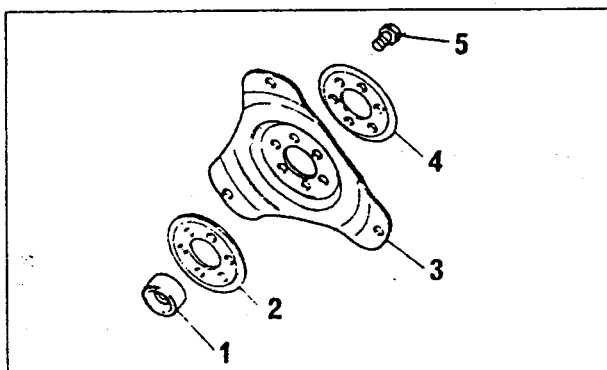

Fig. 1.49. — The component parts of the driven plate for an automatic transmission model.

- | | |
|-------------------------|---------------------|
| 1 Crankshaft pilot bush | 4 Adaptor plate |
| 2 Adaptor plate | 5 Driven plate bolt |
| 3 Driven plate | |

1.4.2.6. Checking the Cylinder Block

Thoroughly clean the top of the cylinder block and check the surface for distortion. Place a steel ruler on the top face of the block in the directions shown in Fig. 1.27, similar as for the cylinder head. Using a feeler gauge measure the gap between the ruler and the block. The cylinder block should be re-ground or, in severe cases, replaced, if the gap is more than 0.10 mm (0.004 in.), but remember that re-grinding must be considered together with the cylinder head (see "Note" on page 31 and note below).

Note: The maximum combined amount that can be removed from the block and cylinder head is 0.2 mm (0.008 in.).

1.4.2.7. Checking the Flywheel

The flywheel is designed for the particular engine. Check the face of the flywheel for ridges and check that the flywheel run-out is within 0.13 mm (0.005 in.).

Check the teeth on the flywheel ring gear for wear and damage. If it is in poor condition, also check the starter motor pinion. An excessively worn or damaged ring gear

requires the replacement of the complete flywheel.

The pilot bearing in the end of the crankshaft can be replaced. Remove the old bearing with a suitable puller and drive the new bearing into the crankshaft. Grease the bearing before installation.

Flywheel bolts are tightened to 135 kgm — 2.0 litre or 10.0 kgm — 1.8 litre. Counterhold the flywheel during the tightening operation. If the oil sump is removed, insert a block of wood between one of the crankshaft throws and the wall of the cylinder block.

1.4.2.8. Drive Plate (Automatic)

Fig. 1.49 shows the component parts of the drive plate. No pilot bearing is fitted into the end of the crankshaft if an automatic transmission is used with the engine, but a bush is fitted which can be removed with a threaded tab. Cut a thread of suitable size into the bush, screw in a bolt and withdraw the bush with a pair of pliers or similar.

When fitting the drive plate note the position of the washer plate (4). Plate (2) may not be used. Only use genuine Mitsubishi bolts. Tighten the bolts to the same torque as given for the flywheel above.

1.4.3. CAMSHAFT AND TIMING DRIVE

1.4.3.0. Technical Data

Drive:	Toothed belt
End float of camshaft:	0.05 - 0.20 mm (0.002 - 0.008 in.)
Bearing journal diameter:	See Section 1.4.0.0.
Bearing running clearance:	0.05 - 0.09 mm (0.002 - 0.0035 in.)
Camshaft identification number:	Stamped into rear end of shaft
Max. run-out of shaft:	0.10 mm (0.004 in.)

1.4.3.1. Short Description

The camshaft of both engines is fitted into the cylinder head and is driven by a toothed belt. The belt drive is different on the two engines.

On the 2.0 litre engine, the belt also drives one of the balance shafts and is kept under tension by an automatic tensioner. A second belt, having its own tensioner, drives the second balance shaft.

The belt of the 1.8 litre engine is fitted with an automatic tensioner and also drives the water pump.

Fig. 1.8 shows the component parts of timing drive of a 2.0 litre engine. A number identification in the rear face of the shaft indicates for which engine the shaft is suitable.

1.4.3.2. Removal of Timing Belt (and/or camshaft)

The timing belt must be replaced after a certain mileage. As these intervals are sometimes changed, we recommend to enquire at your dealer or study your vehicle documents (service booklet) when the replacement is necessary. The following text describes the removal of the belt. All operations concerning the installation are described in Section 1.4.4.

1.8 Litre Engine

- Remove the covering panel from underneath the engine compartment.

- Remove the cooling system expansion tank and place it to one side.
- Slacken and remove the drive belt for power steering and alternator.
- Prevent the crankshaft from rotating by engaging a gear and slacken the crankshaft pulley bolt. Remove the crankshaft pulley, if necessary with two tyre levers.
- Remove the upper and the lower timing belt cover.
- Rotate the engine until the piston of the No. 1 cylinder is at T.D.C. position. *The crankshaft must only rotated clockwise*). Check that the timing marks on camshaft sprocket and crankshaft sprocket are aligned as already shown in Fig. 1.4. This will set the piston of No. 1 cylinder to the top dead centre position. Using a felt pen or chalk, mark a line across the timing belt to identify its fitted position. If the timing belt is to be refitted (after inspection), mark an arrow into the outside of the belt to indicate the running direction.
- Slacken the bolt in the centre of the belt tensioner (see Fig. 1.4) and, using a screwdriver in the manner shown in Fig. 1.5, push the tensioner pulley in the direction of the arrow until the timing belt is slack. The tensioner pulley can be pushed as close to the engine mounting as possible. Re-tighten the tensioner bolt provisionally to keep it in the tensioned position. The timing belt can now be lifted off.
- Remove the camshaft wheel securing bolt and withdraw the wheel. The gearwheel must be held against rotation when the bolt is slackened. A strong drift can be inserted into one of the sprocket holes and held against the cylinder head. Crankshaft and camshaft must not be rotated after the camshaft timing wheel has been removed.
- Unscrew the cylinder head cover and remove. Make a note where the various retaining clips are located to facilitate the installation. Remove the gasket.
- Unscrew the two rocker shaft assemblies, but note: ***Rocker shafts and rocker arms must not be dismantled.***
- Remove the camshaft oil seal from its location.
- Slide out the camshaft without damaging the bearing journals or cams.

2.0 Litre Engine

The more complex timing belt drive of the 2.0 litre engine is shown in Fig. 1.8. Also refer to Fig. 1.7 during the removal of the timing belt.

- It is assumed that the pulley belts, the upper timing belt cover and the tensioner for the pulley "V" belts have already been removed from the front of the engine. Prevent the crankshaft from rotating by engaging a gear and unscrew the bolts securing the crankshaft pulley to the crankshaft timing gear. The lower timing belt cover can now be unscrewed.
- Rotate the engine until the piston of the No. 1 cylinder is at T.D.C. position. *The crankshaft must only rotated clockwise*). Check that the timing marks on camshaft sprocket and crankshaft sprocket are aligned as shown in Fig. 1.7. This will set the piston of No. 1 cylinder to the top dead centre position. To verify the setting, check that the mark in the camshaft gearwheel is level with the cylinder head joining face and the dowel pin in the crankshaft timing gearwheel is at the top. Otherwise turn the crankshaft accordingly (***only clockwise***). Using a felt pen or chalk, mark a line across the timing belt to identify its fitted position. If the timing belt is to be refitted (after inspection), mark an arrow into the outside of the belt to indicate the running direction.
- Remove the automatic belt tensioner (11) in Fig. 1.8.
- Slacken the bolt in the centre of the belt tensioner (15) in Fig. 1.8 and turn the belt towards the outside until the timing belt is slack. Re-tighten the tensioner bolt provisionally to keep it in the tensioned position. The timing belt can now be lifted off.

- Remove the camshaft wheel securing bolt and withdraw the wheel. The gearwheel must be held against rotation when the bolt is slackened. A strong drift can be inserted into one of the sprocket holes and held against the cylinder head. Crankshaft and camshaft must not be rotated after the camshaft timing wheel has been removed. See note below:

Important Note: If the timing belt is being removed as a routine operation, for example during the removal of the cylinder head, use a piece of string and tie the timing belt to the camshaft sprocket. This will facilitate the installation of the parts.

- Unscrew the cylinder head cover and remove. Make a note where the various retaining clips are located to facilitate the installation. Remove the gasket.
- Unscrew the two rocker shaft assemblies, but note: *Rocker shafts and rocker arms must not be dismantled.* It should be noted that special metal brackets are used to hold the hydraulic tappets, also referred to as lash adjusters, do not fall out of the rocker arms. This is more important when the timing belt is being removed with the engine fitted.
- Remove the camshaft oil seal from its location.
- Slide out the camshaft without damaging the bearing journals or cams.
- If required, remove the crankshaft timing gearwheel (17) in Fig. 1.8. A timing wheel with a heavy fit can be removed with two tyre levers, inserted at opposite sides underneath the timing wheel or a two-arm/three-arm puller can be used. Also unscrew the timing belt tensioner and on the other side the belt idler pulley.
- Remove the oil pump drive gear. Before removing the nut, take out the plug at the bottom of the L.H. side of the cylinder block and insert a screwdriver as shown in Fig. 1.9 to retain the L.H. balance shaft in position. The screwdriver shaft should have a diameter of 8 mm (0.3 in.) and a length of 60 mm (2.5 in.).
- Slacken the bolt securing the balance shaft timing gearwheel until it can be removed by hand. Remove the belt tensioner and the second timing belt (Fig. 1.10). If there is a possibility to re-used the belt, mark the running direction of the belt into the outside (felt pen).
- Remove the balance shaft timing gearwheel and also the second crankshaft timing sprocket. Use two tyre levers, if the wheel has a tight fit.
- Insert the screwdriver through the hole shown in Fig. 1.9 to counterhold the balance shaft (if not still in position) and remove the driven wheel of the oil pump.

1.4.3.3. Inspection of Parts

Clamp the camshaft between the centres of a lathe or place the end journals into "V" blocks (in a similar manner as shown in Fig. 1.45 for the crankshaft) and apply a dial gauge to the centre bearing journal. Rotate the camshaft by two revolutions and read off the indication. One half of the value is the run-out of the camshaft which should not exceed 0.05 mm (0.002 in.). Replace the shaft if the reading is outside the given value.

Check the cam surfaces on each side, top and bottom and if in good condition, measure the diameter of the camshaft journals. Also check the camshaft journals for wear. If the journals are worn, replace the camshaft without any further checks. In this case, also check the bearing bores in the cylinder head as these may also be damaged. Replace the cylinder head if necessary.

1.4.3.4 Fitting the Camshaft

The installation of the camshaft is a reversal of the removal procedure. Coat the

bearing journals with engine oil. Insert the camshaft without hitting the journal edges or cams against the edges of the camshaft bearing bores. A new oil seal must be fitted over the camshaft end and into the camshaft bearing bore. The semi-circular seal must be coated with sealing compound.

Fit the timing belt and adjust the timing setting as described below.

1.4.4. ADJUSTING THE VALVE TIMING

The component parts of the timing mechanism can be replaced when the engine is in the vehicle, as described during the dismantling of the engine or in Section 1.4.3.2 for the engine in question. Also refer to the illustrations in this section for particulars.

2.0 Litre Engine

The component parts of the timing mechanism are shown in Fig. 151 and all number references refer to this illustration, unless otherwise mentioned.

The following description assumes that the components of the timing mechanism are completely removed, as this is the case during an engine overhaul or during replacement of parts.

- Fit the balance (silent) shaft timing gear and provisionally fit the belt.
- Place the crankshaft timing wheel over the end of the crankshaft. Align the timing marks of all timing wheels as shown in Fig. 150.

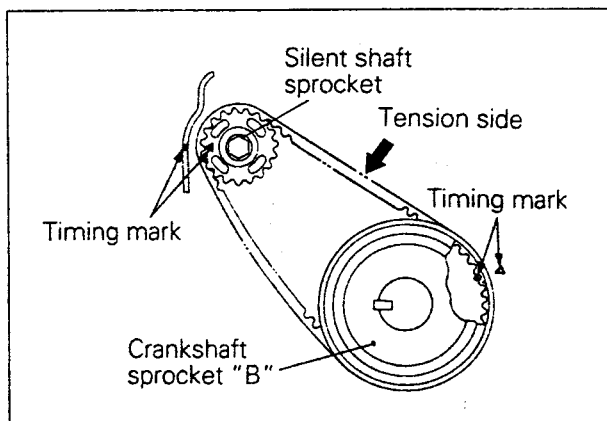

Fig. 150. — Details of fitting the timing wheels to crankshaft and balance (silent) shafts. Before fitting the small timing belt align the timing marks as shown. Note where the tensioned side of the belt is located.

- Place the timing belt over the two drive wheel so that the side opposite the belt tensioner is tight.
- Fit the belt tensioner. The centre point of the tensioner pulley must be located at the left-hand side of the mounting bolt. The pulley flange must be directed towards the front of the engine. Fig. 152 shows the tensioner pulley in fitted position.
- Fit the oil pump drive wheel and tighten the nut to 3.4 - 4.0 kgm (24.5 - 29 ft.lb.). Now rotate the shaft until the two timing marks, i.e. the one in the oil pump wheel and the other one in the front case, are opposite each other, as shown in Fig. 153.

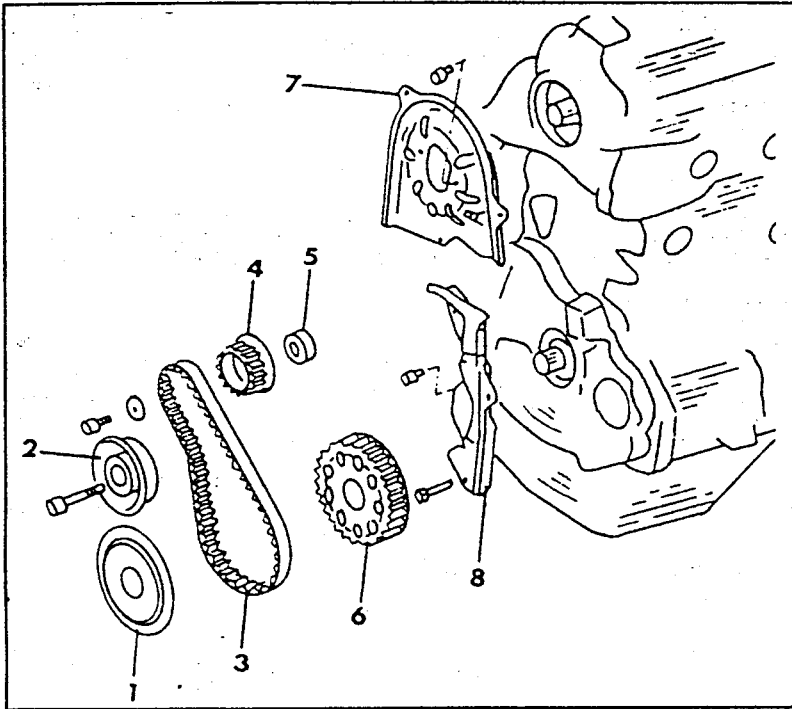

Fig. 151. — The component parts of the timing mechanism for the balance shafts (2.0 litre).

1 Guide flange	4 Balance shaft sprocket	7 Rear belt cover
2 Belt tensioner	5 Spacer bush	8 Rear belt cover
3 Small toothed belt	6 Crankshaft sprocket	

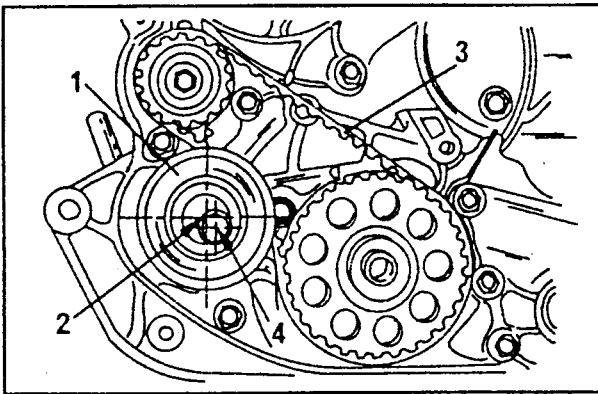

Fig. 152. — Fitting the tensioner pulley for the small timing belt.

1 Tensioner roller	3 Timing belt
2 Centre of tensioner roller	4 Centre of bolt

- After aligning the timing marks, insert a screwdriver into the opening on the left-hand side of the cylinder block as already shown in Fig. 1.9. If the screwdriver blade (approx. 8 mm /0.3 in. in diameter) can be inserted by approx. 60 mm (2.4 in.), the alignment is correct. If it can be inserted only by 25 mm (1 in.), rotate the oil pump drive wheel by one revolution and again align the timing marks. Keep the screwdriver in position until the timing belt has been fitted.

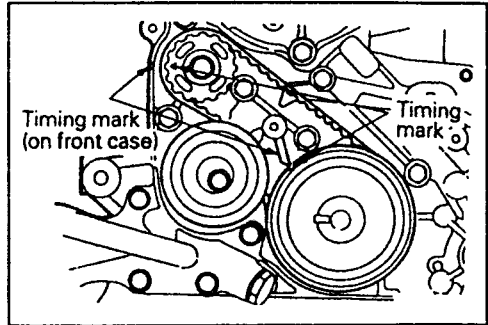

Fig. 1.53. — After fitting the oil pump drive wheel, turn the shaft until the two timing marks (arrows) are opposite each other.

- Push the flange located underneath the tensioner in the direction of the arrow in Fig. 1.54 until the belt is sufficiently tensioned. In this position tighten the tensioner bolt. Do not rotate the shafts after the bolt has been tightened.
- Check again if the timing marks are still in alignment on timing gearwheels and front case and press with the forefinger against the centre of the belt, at the point shown in Fig. 1.54. The belt must deflect by 5 to 7 mm (0.20 - 0.28 in.). If this is not the case, re-adjust the tensioner pulley accordingly.

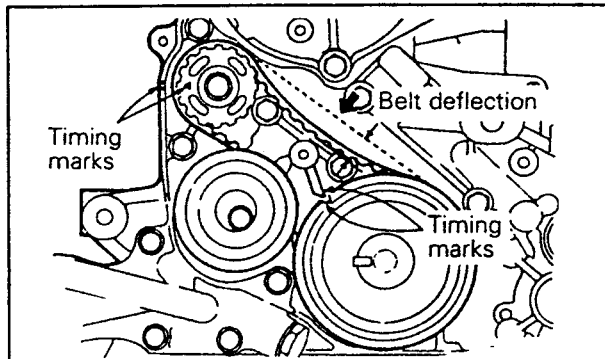

Fig. 1.54. — Checking the tension of the small timing belt. Press against the belt at the position shown to check the deflection.

The timing belt is fitted as follows, but first check the automatic tensioner as described below and replace the tensioner, if the following faults can be discovered:

- The tensioner shows oil leaks.
- The end of the push rod is worn or even damaged.
- The push rod does not protrude sufficiently above the tensioner body.

Check the automatic tensioner as follows:

- Clamp the tensioner in horizontal position into a vice and slowly close the vice. If no resistance can be felt, replace the tensioner. If the plug at the bottom of the automatic protrudes from the tensioner body, fit a washer against the tensioner body to

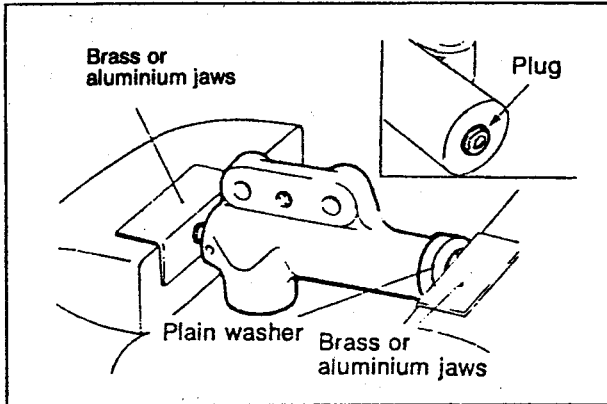

Fig. 155. — Clamp the automatic tensioner into the vice as shown to check it and to fit the locking wire during the pre-tensioning operation.

prevent the vice jaws from pressing against the plug. If a fair resistance can be felt, fit the automatic tensioner as follows:

- Clamp the tensioner once more into the vice so that the hole in the push rod is in line with the hole in the body. Again place a washer under the body to protect the plug.

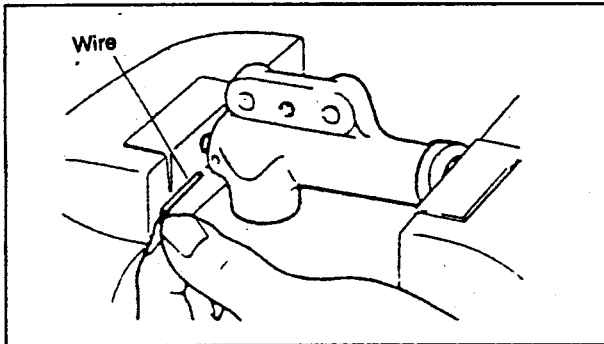

Fig. 156. — Pre-tension the automatic tensioner before installation.

- Insert a piece of wire of 1.4 mm (0.055 in.) into the two holes as shown in Fig. 156 to lock the push rod (plunger) inside the tensioner body. The wire should have a loop to be able to withdraw it later on. Remove the tensioner from the vice and fit it to the front of the engine, with the wire in position. Tighten the bolts to 2.0 - 2.7 kgm (14.5 - 19.5 ft.lb.).

The next operation is the fitting of the tensioner roller to the cylinder block:

- Fit the roller to the tensioner arm and rotate it until the two holes (1) in Fig. 157 are towards the L.H. side of the centre bolt, and tighten the bolt finger-tight. Do not remove the wire at this stage.

The timing belt can now be fitted. We would like to advise that the operations must be

carried out slowly and step by step to prevent mistakes and the consequent damage to the engine. A special tool is used in the workshop to tension the timing belt.

- The belt should be installed first under the tensioner pulley, then over the crankshaft timing wheel, then over the oil pump drive wheel and under the idler pulley and finally over the camshaft timing wheel. Before fitting the belt, check once more that all timing marks are still in line. Check with Fig. 158 to make absolutely sure. Take care that the belt is not slackened during installation.

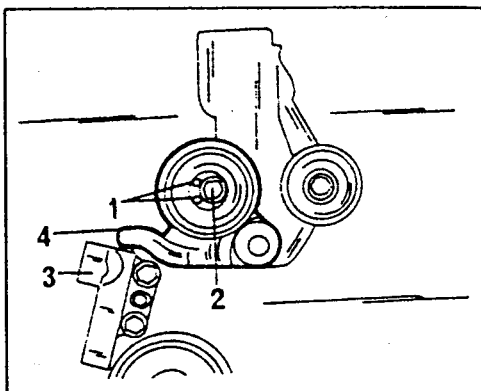

Fig. 157. — Rotate the tensioner roller until the two holes are in the position shown.

- 1 Holes
2 Centre bolt
3 Automatic tensioner
4 Tensioner arm

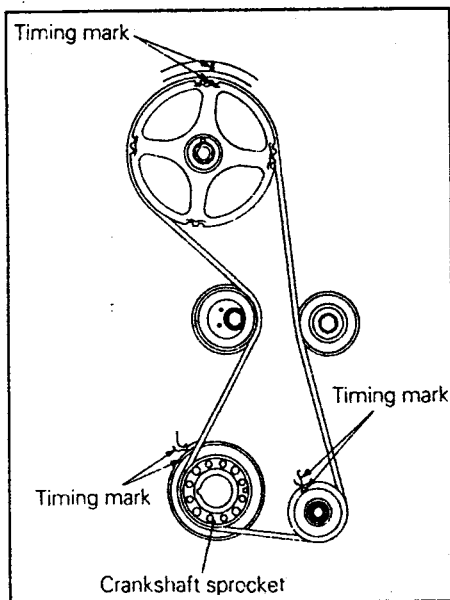

Fig. 158. — Align the timing marks as shown before the timing belt is fitted in the given order over the various gearwheels and rollers.

- Remove the screwdriver inserted into the cylinder block and temporarily fit the crankshaft pulley to prevent misalignment when the crankshaft is turned.
- Slacken the tensioner mounting bolt and slowly rotate the tensioner roller (L.H. side, Fig. 158) slowly in clockwise direction until all slack has been removed from the timing belt and temporarily tighten the roller securing bolt to keep roller and belt in position.
- Slowly rotate the crankshaft by a quarter of a turn towards the left (anti-clockwise) and then from this position towards the right (clockwise) until the piston of No. 1 cylinder is once more at the top dead centre position.
- The belt must now be tensioned, but you will need a tool that fits into the two holes in the belt tensioner roller. The workshop uses a special tool and a torque wrench, which is inserted as shown in Fig. 159.

The roller is rotated until the

torque reading is 0.36 kgm (2.6 ft.lb.). As you can see, the required torque is very small and it is perhaps possible to rotate the roller with a suitable peg spanner. If the engine is fitted, it will be rather difficult to reach the roller. This can be overcome by lifting the engine. The easiest method is the use of a trolley jack which can be

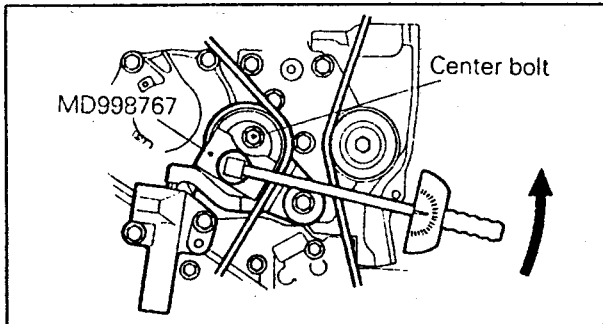

Fig. 1.59. — Use of the special tool and the torque wrench to tension the timing belt.

placed underneath the engine sump. A wooden block must be inserted between jack head and sump. The jack can now be operated to lift the engine to improve the access to the tensioner roller. The roller securing bolt must be tightened when the roller is held in the tensioned position.

- Screw the special tool into the L.H. engine support bracket, as shown in Fig. 1.60, until it makes contact with the tensioner arm. From this position screw the tool in a little further. This will push the tensioner arm against the push rod of the automatic tensioner which will be pushed inside the body, releasing the wire lock. Grip the wire loop and pull it out as soon as the wire is free of tension.

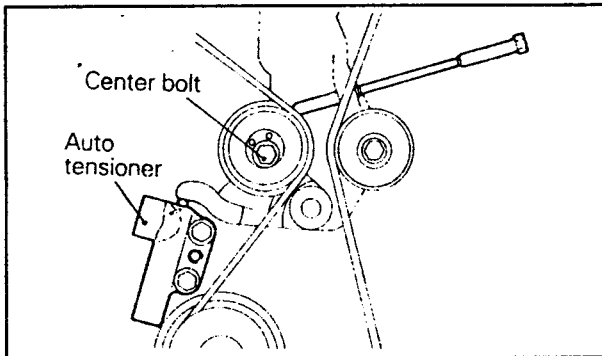

Fig. 1.60. — Releasing the automatic tensioner push rod with the special tool.

- Rotate the crankshaft by two complete revolutions and wait 15 minutes for the belt to settle. Then check the upper end of the tensioner push rod. There will be a gap between the upper face of the tensioner and the tensioning arm. This gap must be between 3.8 and 4.5 mm (0.15 - 0.18 in.). The easiest way to check it is by inserting the shaft of a drill bit of the given diameter into the gap. If the gap is not within the values given, repeat the adjustment from the beginning.
- Fit the rubber plug into the side of the engine (into the timing belt rear cover).
- Fit the lower and upper timing belt covers. Not all screws have the same length. If in doubt, screw them in position and find out by trial and error. Never tighten a screw which meets solid resistance. Fit the crankshaft pulley (2.5 kgm (18 ft.lb.).

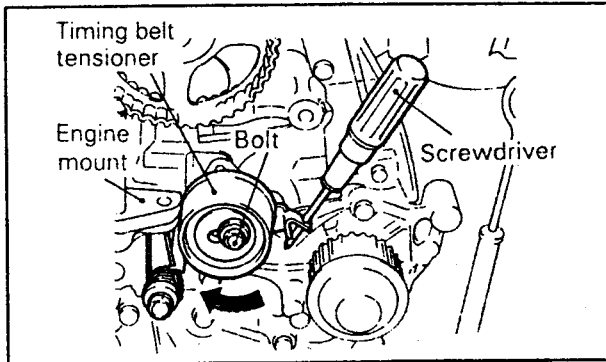

Fig. 1.61. — Rotate the tensioner roller in the direction shown and re-tighten the roller securing bolt. The roller will then be in the best position for the installation of the timing belt.

1.8 litre Engine

- First release the tensioning roller, ready for the installation of the timing belt. To do this, insert a screwdriver as shown in Fig. 1.61 and turn the roller as far as possible against the engine mounting. In this position tighten the roller securing bolt.
- Rotate the crankshaft and camshaft slowly until the timing marks of camshaft sprocket and crankshaft sprocket are aligned as shown in Fig. 1.62.
- Place the timing belt over the various sprockets and the tensioner roller. The belt must be placed over the crankshaft sprocket, then the water pump sprocket, the camshaft sprocket and finally under the tensioner roller. The belt must be tight on the side shown by the arrow in Fig. 1.62. If necessary, re-locate the belt by one tooth.
- Slacken the bolt securing the tensioner roller by approx. 1/2 of a turn and allow the tensioner spring to move the roller, thereby tensioning the belt. If the tensioner roller is seen not to move, slacken the bolt a little more.
- Rotate the crankshaft by complete turns in the direction of rotation (clockwise) and check that both sets of timing marks are aligned. The crankshaft must be turned clockwise. Check that all sprocket teeth are properly engaged with the belt teeth. The close-up views of Fig. 1.63 will help.

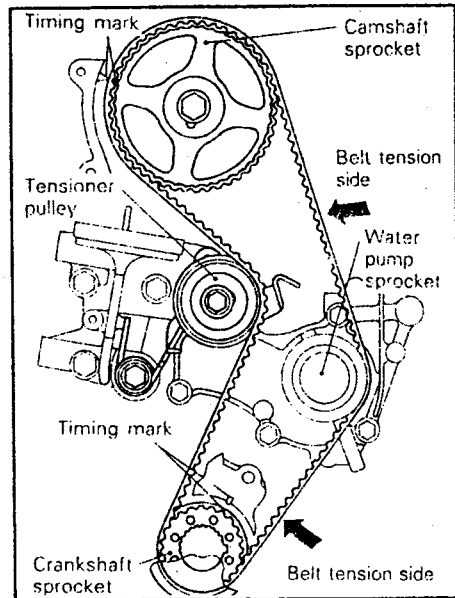

Fig. 1.62. — The timing belt of a 1.8 litre engine in position. Timing marks must be aligned as shown. The belt must be tight at the points shown by the arrows.

- Tighten the tensioner roller securing bolt to 2.4 kgm (18 ft.lb.) if you find the timing marks aligned as shown on the R.H. side.
- The timing belt tension now be checked. To do this, grip the belt on the side shown in Fig. 1.64 between forefinger and thumb and press the belt towards the outside. The gap shown between the arrows must be 30 mm (1.18 in.), when measured between the outside of the timing belt and the sealing line of the cover underneath the timing belt.
- If the gap cannot be obtained, re-start the adjustment, i.e. the tensioner roller must be reset.
- Prevent the rotation of the crankshaft and tighten the crankshaft sprocket bolt to 18.5 kgm (135 ft.lb.).
- The remaining operations are carried out in reverse order to the removal procedure. Tension all drive belts properly.

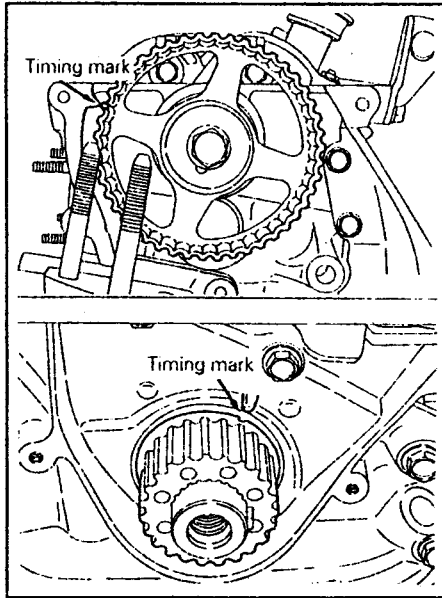

Fig. 1.63. — Close-up of the camshaft sprocket and crankshaft sprocket alignment.

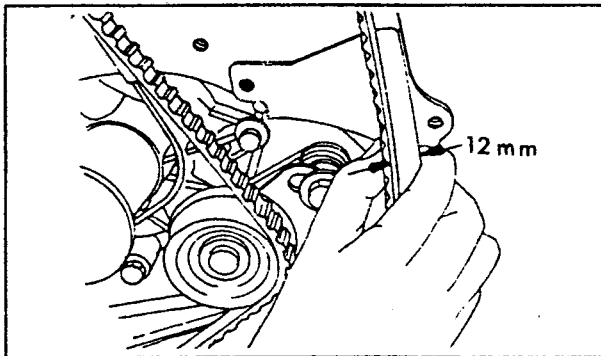

Fig. 1.64. — Checking the timing belt tension.

1.4.5. BALANCE SHAFTS (front housing 1.8 litre, see Section 2)

Two balance shafts are fitted to the 2.0 litre engine, one at the top of the R.H. side of the cylinder block and the other one at the bottom L.H. side of the block. The shafts are driven by means of two belt wheels, one by the large toothed belt and the other one by a smaller toothed belt. Fig. 1.65 shows the layout of the balance shafts.

The front housing, which must be removed to take out the shafts, contains the oil pump and the oil relief valve. An oil suction strainer is fitted to the bottom of the housing. The

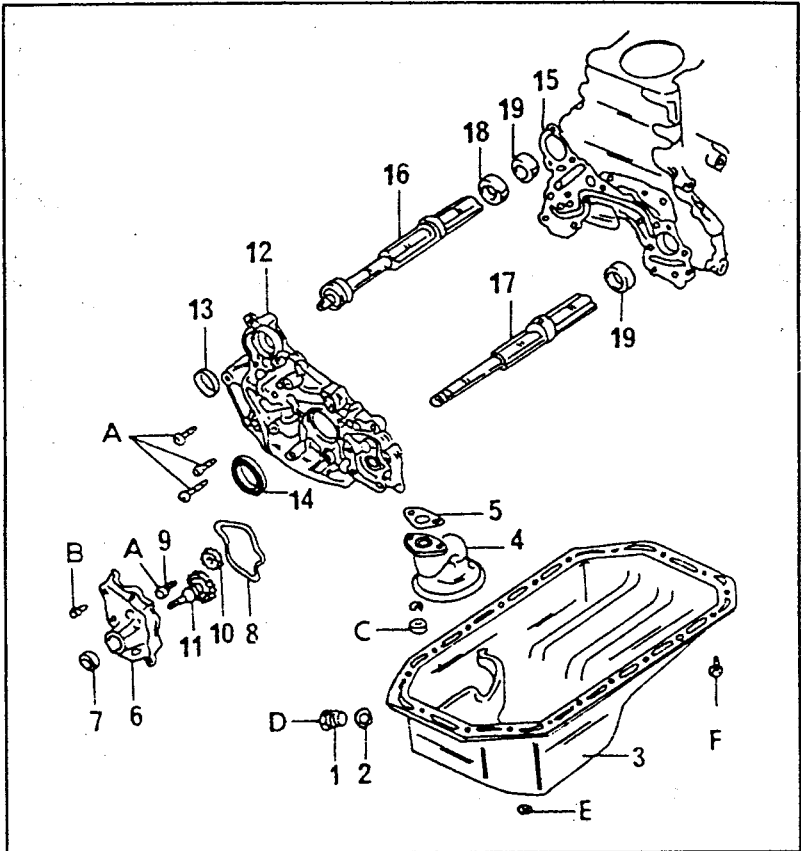

Fig. 1.65. — Exploded view of the balance shafts together with the front housing, oil pump and oil sump. The letters refer to the tightening torques. An oil level sensor is fitted into one end of the oil sump.

- | | | |
|------------------------------------|--------------------------------------|--------------------------|
| 1 Oil drain plug | 8 Gasket | 15 Front case gasket |
| 2 Drain plug gasket | 9 Flange bolt | 16 Balance shaft, right |
| 3 Oil sump | 10 Oil pump driven gear | 17 Balance shaft, left |
| 4 Oil suction screen | 11 Oil pump drive gear | 18 Balance shaft bearing |
| 5 Oil screen gasket | 12 Front case | 19 Rear bearing |
| 6 Oil pump cover | 13 Shaft oil seal | |
| 7 Oil pump oil seal | 14 Crankshaft front seal | |
| A = 1.5 - 1.8 kgm (11 - 13 ft.lb.) | D = 3.5 - 4.5 kgm (25 - 33 ft.lb.) | |
| B = 1.5 - 1.8 kgm (11 - 13 ft.lb.) | E = 0.5 - 0.7 kgm (3.6 - 5.1 ft.lb.) | |
| C = 1.8 - 2.5 kgm (13 - 18 ft.lb.) | F = 0.6 - 0.8 kgm (4.3 - 5.8 ft.lb.) | |

oil pump cover is fitted in front of the front housing.

The R.H. shaft rotates in the same direction as the crankshaft; the L.H. shaft rotates in opposite direction. Both shafts are rotating with twice the speed of the crankshaft.

The shafts are running in bearings at the front end rear. The front end of the L.H. shaft

is located in the front housing. The R.H. shaft is located at front and rear in a bearing bush, fitted to the cylinder block. The rear end of the L.H. shaft has a similar location. The removal of the shafts has already been described during the dismantling of the engine.

Before fitting the shafts check the front housing for cracks or other damage. Check the bearing bore for the L.H. shaft in the housing. If worn, replace the front housing.

If the engine has been overhauled, replace the oil seals for crankshaft, R.H. balance shaft and oil pump. Otherwise replace the oil seals if the sealing lips are no longer in good condition.

Measure the outside diameter of the bearing journals and the inside diameter of the bearing bores in the cylinder block. If the difference between the two dimensions is excessive the bushes in the block must be replaced. This is a job for a specialist shop.

Fit the balance shafts as follows:

- Insert the two oil pump gears from the front into the front housing, aligning the marks as shown in Fig. 1.66. The two alignment marks must be opposite each other.

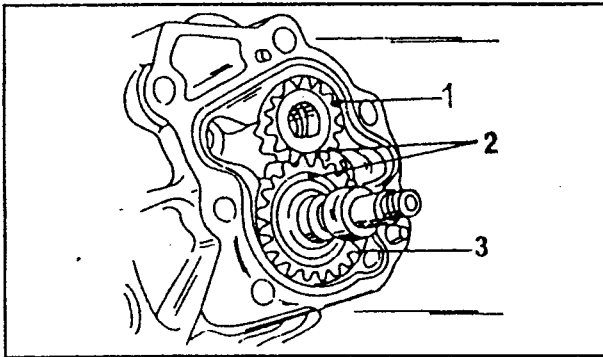

Fig. 1.66. — Aligning the timing marks when fitting the oil pump gears.
1 Driven gear 2 Timing mark 3 Drive gear

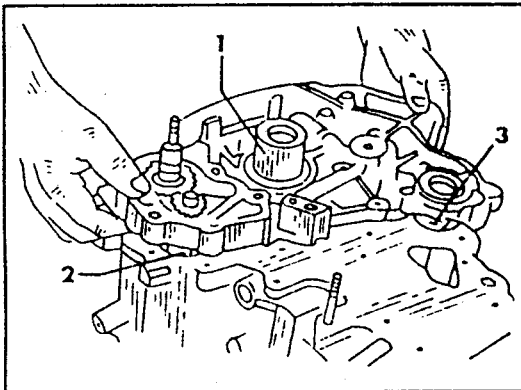

Fig. 1.67. — Fitting the front housing.
1 Guide for oil seal 2 L.H. balance shaft 3 R.H. balance shaft

- Lubricate the pump gears with engine oil and insert the L.H. balance shaft into the driven pump gear. Provisionally fit and tighten the screw.
- Lubricate the bearing journals of the R.H. shaft with engine oil and insert into the cylinder block. Wrap masking tape around the end of the crankshaft and place the front housing gasket in position.
- Insert the L.H. shaft

into the cylinder block at the same time place the housing over the cylinder block, as shown in Fig. 1.67. In order not to damage the oil seal, a guide bush should be placed over the shaft end.

- Insert a screwdriver into the block, as shown in Fig. 1.68 to lock the shaft in position and tighten the shaft bolt.
- Fit a new "O" seal ring into the groove of the oil pump cover and fit the cover. Tighten the cover bolts to 1.5 - 1.8 kgm (11 - 13 ft.lb.).
- Install a new "O" sealing ring into the groove of the front case and install the plug. A special tool (MD998162) is used to tighten the plug.
- Refit the oil sump. A special sealing compound must be used. Section "Lubrication System" gives details.

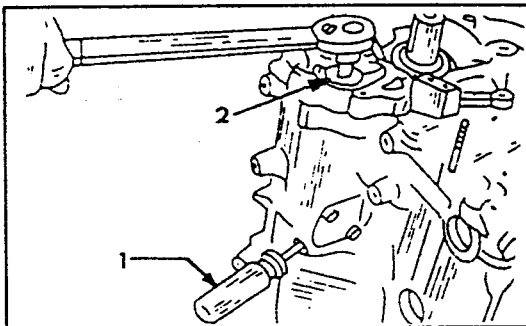
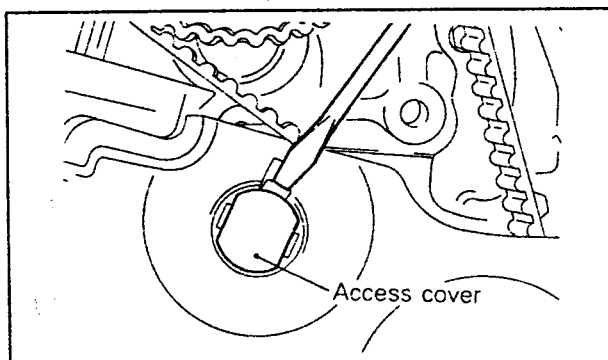

Fig. 1.68 — Tightening the balance shaft nut. A screwdriver must be inserted into the side of the block to prevent the shaft from rotating.

1.4.6. ADJUSTING THE TIMING BELT TENSION — ENGINE FITTED — 1.8 LITRE

The tension of the timing belt should be checked after a certain mileage (refer to your Maintenance Booklet), as this engine is not fitted with the automatic timing belt tensioner, used on the 2.0 litre engine.

The lower timing belt cover has an opening which enables the adjustment of the timing belt tension without removal of the lower timing cover. The opening is, however, closed off with an access cover which must first be removed with a screwdriver (see below).



The access cover is placed over the securing bolt for the timing belt tensioning roller. To adjust the belt tension, first remove the cover as shown. Underneath you will find the hexagon of the securing bolt.

Fig. 1.69. — The component parts of the exhaust system as fitted to the Space Runner. Similar parts are fitted to the Space Wagon. — Legend see opposite page.

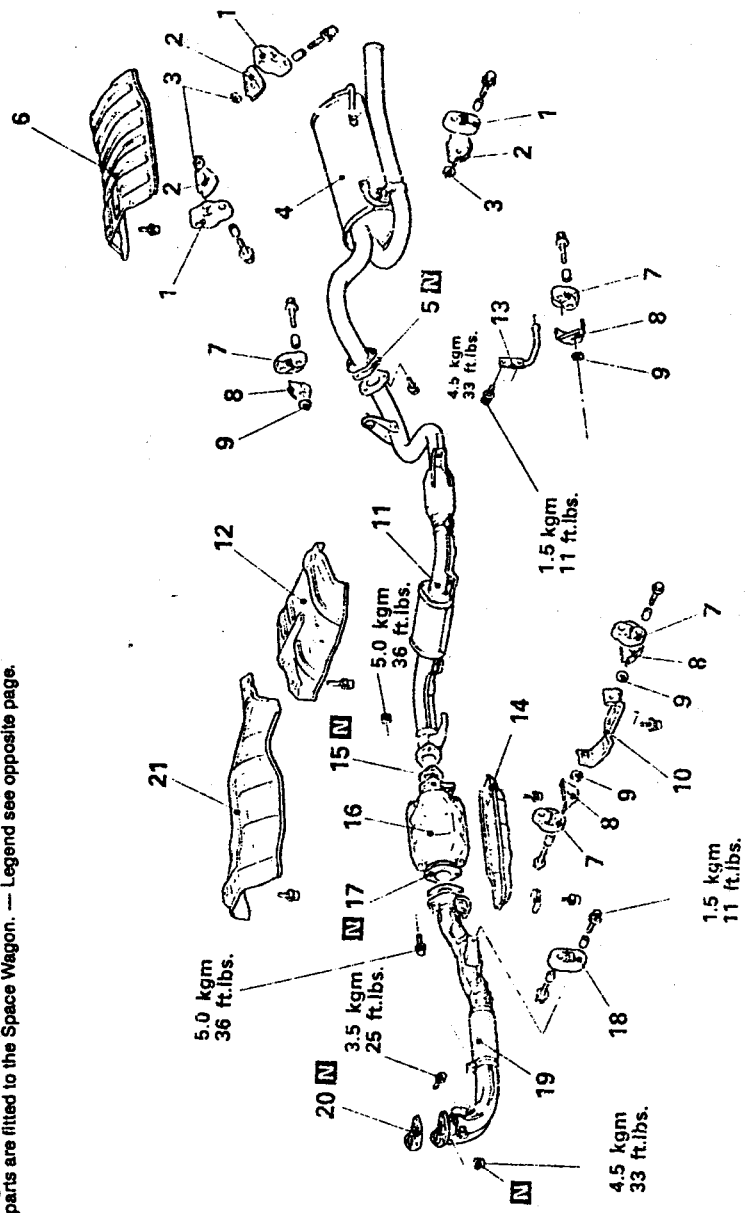

Legend for Fig. 1.68.

1 Mounting rubber	12 Centre heat protector
2 Heat protector	13 Mounting bracket
3 Seat	14 Converter heat protection panel
4 Main silencer	15 Gasket
5 Gasket	16 Catalytic converter
6 Rear floor heat protection pannel	17 Gasket
7 Mounting rubber	18 Mounting rubber
8 Heater protector	19 Front exhaust pipe
9 Seat	20 Gasket
10 Bracket	20 Gasket
11 Centre exhaust pipe	21 Front floor heat protection panel
12 Centre head protection panel	

Adjust the timing belt tension as follows:

- Remove the upper timing belt cover.
- Turn the crankshaft in the normal direction of rotation until the piston of No. 1 cylinder is at the top dead centre position in the firing stroke. This can be checked by various means, depending on the dismantled state of the engine. Check on the crankshaft pulley, if the cylinder head cover is fitted, check on the valves, if the cylinder head cover is removed. *Only turn the crankshaft in the normal direction of rotation when setting the piston to T.D.C.*
- Remove the closing cover for the inspection hole by applying a screwdriver at the position shown in Fig. 1.68.
- Insert a suitable socket with an extension through the opening, and slacken the nut securing the belt tensioner roller by no more than $\frac{1}{2}$ of a turn, perhaps a little more. Use a piece of sticky tape to attach the socket to the extension to prevent it from slipping off. The tension of the tensioner roller will move against the timing belt and take-up any slack that may have been present.
- Tighten the securing bolt for the tensioning roller to 2.5 kgm (18 ft.lb.).
- Fit the two closing cover.
- The tension of the belt can now be checked as shown in Fig. 1.64. The nominal value of 30 mm (1.18 in.) must be obtained between the arrows.
- Finally refit the upper timing belt cover.

Important Note: If the tensioning roller securing bolt is slackened by more than the quarter of a turn, there is a danger that it is unscrewed and can drop into the inside of the lower timing belt cover. This would require further dismantling of the engine.

1.5. EXHAUST SYSTEM

1.5.0. Removal

The exhaust system should only be removed completely if parts of it must be replaced. The system consists of three sections, i.e. the front section with the front exhaust pipe and the catalytic converter, the centre section consisting of centre pipe and a silencer and the rear section with the main silencer and the end pipe. Different exhaust systems are fitted for petrol and diesel models.

Replace the parts of the system as described below. The car should be jacked up and supported at a suitable height to gain access to the connections and mountings from underneath the vehicle.

- **Main Silencer and Pipe:** Support the end of the exhaust pipe from underneath with suitable wooden planks or blocks or by other means and unscrew the bolts connecting the rear pipe to the rear end of the centre pipe/silencer. Two or three bolts are used. Unhook the suspension rubbers, remove the suspension brackets and withdraw the end silencer together with the end pipe. A tight connection can be sprayed with rust-dissolving fluid. Wait a few minutes to allow the fluid to act.
- **Front Pipe/Converter:** Undo the connection between the catalytic converter and the front exhaust pipe. Unscrew the front pipe from the exhaust manifold connection. Spray the manifold bolts with rust-dissolving fluid if necessary. Unscrew the front exhaust pipe-to-transmission bracket and take out the assembly.
- To remove the catalytic converter separate the connections at both ends of the converter.

1.5.1 Installation

Loosely attach all sections of the exhaust system to their mountings in accordance with Fig. 1.69. All gaskets shown with "N" in the illustration must be replaced. Follow the tightening torques where given. Seal the joining faces of all pipes with heat-resistant sealing compound.

Check the correct layout of all pipes, to ensure that there is a gap of at least 20 - 30 mm (0.8 - 1.2 in.) between all pipes and other chassis or body parts. The rubber suspension rings must not be under tension.

1.6. Engine — Tightening Torque Values

1.8 Litre Engine

Cylinder head bolts:

First stage:	7.5 kgm (54 ft.lb.)
Second stage:	Slacken all bolts
Third stage:	2.0 kgm (15 ft.lb.)
Fourth stage:	Angle-tighten by 90°
Fifth stage:	Angle-tighten by 90°
Oil pressure switch:	1.0 kgm (7.2 ft.lb.)
Engine lifting hanger:	1.2 kgm (9 ft.lb.)
Water outlet elbow:	1.4 kgm (10 ft.lb.)
Connector for oil filter:	4.3 kgm (31 ft.lb.)
Front case bolts:	1.4 kgm (11 ft.lb.)
Oil suction strainer to crankcase:	1.9 kgm (14 ft.lb.)
Oil pump cover:	1.0 kgm (7.2 ft.lb.)
Oil sump to crankcase:	0.7 kgm (5 ft.lb.)
Oil drain plug:	4.0 kgm (30 ft.lb.)
Distributor to engine:	1.2 kgm (9 ft.lb.)
Oil dipstick tube to cylinder head:	1.1 kgm (8 ft.lb.)
Camshaft sprocket to camshaft:	9.0 kgm (65 ft.lb.)
Timing belt tensioning roller:	2.4 kgm (18 ft.lb.)
Crankshaft pulley/timing gear bolt:	18.5 kgm (134 ft.lb.)
Tensioner spring/spacer:	4.5 kgm (33 ft.lb.)
Alternator bracket, long bolt (upper):	5.0 kgm (36 ft.lb.)
Alternator bracket, short bolt (lower):	2.3 kgm (17 ft.lb.)
Cylinder head cover:	0.35 kgm (2.5 ft.lb.)
Front exhaust pipe to manifold:	4.0 - 5.0 kgm (30 - 36 ft.lb.)
Front exhaust pipe to bracket:	3.0 - 4.0 kgm (22 - 30 ft.lb.)
Timing belt covers:	1.0 kgm (7.2 ft.lb.)
Thermostat housing:	2.2 - 2.5 kgm (16 - 18 ft.lb.)

Engine mounting to engine:	5.8 kgm (42 ft.lb.)
Engine mounting to side mounting bracket (horizontal bolt):	7.0 kgm (51 ft.lb.)
Nuts for horizontal mounting shaft (2):	3.5 kgm (25 ft.lb.)
Engine mounting bracket (left) to engine:	5.0 kgm (36 ft.lb.)
Flywheel bolts:	10.0 kgm (72 ft.lb.)
Drive plate bolts (automatic):	10.0 kgm (72 ft.lb.)
Rear plate mounting bolts:	1.1 kgm (8 ft.lb.)
Rear oil seal flange bolts:	1.1 kgm (8 ft.lb.)
Flywheel housing undercover:	0.9 kgm (7 ft.lb.)
Crankshaft main bearing cover bolts:	2.5 kgm + 90°
Connecting rod bearing cap nuts:	2.0 kgm + 90°
Water pump to cylinder block:	2.4 kgm (18 ft.lb.)
Water pipe to cylinder block:	1.4 kgm (11 ft.lb.)
Engine coolant temperature sensor:	3.0 kgm (22 ft.lb.)
Engine coolant temperature gauge unit:	1.1 kgm (8 ft.lb.)
Inlet manifold assembly to cylinder head:	2.0 kgm (15 ft.lb.)
Rocker arm shaft mounting bolts:	3.2 kgm (23 ft.lb.)
Inlet manifold support stay:	3.1 kgm (22 ft.lb.)
Exhaust manifold to cylinder head (nuts):	1.8 kgm (13 ft.lb.)
Exhaust manifold bracket:	3.6 kgm (26 ft.lb.)
Cooling fan bracket to engine:	3.6 kgm (26 ft.lb.)
Fan clutch to fan pulley:	1.1 kgm (8 ft.lb.)
Fan to fan clutch:	0.9 kgm (7 ft.lb.)
Locknut, valve adjusting screws:	0.9 kgm (7 ft.lb.)

2.0 Litre Engine

Cylinder head bolts:

First stage:	8.0 kgm (58 ft.lb.)
Second stage:	Completely slacken all bolts
Third stage:	Tighten to 2.0 kgm (15 ft.lb.)
Fourth stage:	Angle-tighten by 90° (¼ of a turn)
Fifth stage:	Angle-tighten by 90° (¼ of a turn)
Oil pressure switch:	1.0 kgm (7.2 ft.lb.)

Timing Belt — Removal and Installation

Tensioner spring bolt:	5.0 kgm (36 ft.lb.)
Tensioner roller bolt:	5.0 kgm (36 ft.lb.)
Tensioner arm bolt:	2.2 kgm (16 ft.lb.)
Tensioner pulley bracket:	5.0 kgm (36 ft.lb.)
Idler pulley bolt:	3.5 kgm (26 ft.lb.)
Oil pump sprocket bolt:	5.5 kgm (40 ft.lb.)
Crankshaft sprocket bolt:	12.0 kgm (87 ft.lb.)
Bolt for tensioner (small belt):	1.9 kgm (14 ft.lb.)
Balance shaft sprocket bolts:	4.6 kgm (33 ft.lb.)
Camshaft sprocket bolt:	9.0 kgm (65 ft.lb.)
Timing belt rear cover:	1.4 kgm (10 ft.lb.)—M8, 3.1 kgm (22 ft.lb.)—M10
Crankshaft position sensor bolt:	0.9 kgm (6.5 ft.lb.)
Engine support bracket bolt:	5.0 kgm (36 ft.lb.)

Front case, balance shafts, oil sump

Oil drain plug:	4.0 kgm (29 ft.lb.)
Oil sump:	0.7 kgm (5 ft.lb.)
Oil suction filter, bolt and nut:	1.9 kgm (14 ft.lb.)
Check valve:	3.3 kgm (24 ft.lb.)
Oil cooler bolt:	4.3 kgm (31 ft.lb.)
Plug:	2.4 kgm (17 ft.lb.)
L.H. balance shaft flange bolt:	2.4 kgm (17 ft.lb.)
Front case bolts:	
M8 thread:	2.4 kgm (17 ft.lb.)
M10 thread:	3.1 kgm (22 ft.lb.)
Oil pressure switch:	1.0 kgm (7.2 ft.lb.)
Oil cooler by-pass valve:	5.5 kgm (40 ft.lb.)
Relief valve plug:	4.5 kgm (33 ft.lb.)

Oil pump cover bolts:	1.7 kgm (12 ft.lb.)
Oil level sensor bolts:	0.9 kgm (7 ft.lb.)
Baffle plate:	0.9 kgm (7 ft.lb.)

Crankshaft, flywheel, connecting rods, cylinder block

Flywheel bolts:	13.5 kgm (98 ft.lb.)
Rear oil seal flange bolts:	1.1 kgm (8 ft.lb.)
Main bearing cover bolts:	2.5 kgm + 90°
Oil jets:	3.3 kgm (24 ft.lb.)
L.H. and R.H. engine support bracket bolts:	4.5 kgm (33 ft.lb.)
Front roll stopper bracket:	6.5 kgm (47 ft.lb.)
Rear roll stopper bracket:	12 kgm (87 ft.lb.)
Front engine support bracket bolts:	6.0 kgm (43 ft.lb.)
L.H. engine support bracket bolts:	3.6 kgm (26 ft.lb.)

Rocker arms and camshaft

Rocker cover bolts:	0.3 kgm (2 ft.lb.)
Rocker shaft bolts:	3.2 kgm (23 ft.lb.)

Inlet and exhaust manifold, water pump

Inlet manifold bolts and nuts:	2.0 kgm (15 ft.lb.)
Inlet manifold stay:	3.1 kgm (22 ft.lb.)
Water inlet bolt:	1.3 kgm (9 ft.lb.)
Water outlet bolt:	1.3 kgm (9 ft.lb.)
Engine coolant temperature gauge unit:	1.1 kgm (8 ft.lb.)
Engine coolant temperature sensor:	3.0 kgm (22 ft.lb.)
Thermostat housing cover:	1.8 kgm (13 ft.lb.)
Thermostat housing:	2.4 kgm (17 ft.lb.)
Engine lifting hanger:	3.6 kgm (26 ft.lb.)
Exhaust manifold:	
M8 thread:	2.8 kgm (20 ft.lb.)
M10 thread:	3.0 kgm (22 ft.lb.)
Water inlet pipe:	1.4 kgm (10 ft.lb.)
Water pump:	1.4 kgm (10 ft.lb.)

Alternator, ignition system

Cooling fan:	1.1 kgm (8 ft.lb.)
Fan clutch, water pump pulley:	1.1 kgm (8 ft.lb.)
Alternator mounting bolt:	2.3 kgm (17 ft.lb.)
Alternator brace bolt:	2.4 kgm (17 ft.lb.)
Alternator pivot nut:	1.4 kgm (10 ft.lb.)
Crankshaft pulley to sprocket:	2.5 kgm (18 ft.lb.)
Spark plugs:	2.5 kgm (18 ft.lb.)
Distributor bracket:	2.4 kgm (18 ft.lb.)
Distributor installation:	1.2 kgm (9 ft.lb.)

2. THE LUBRICATION SYSTEM

2.0. Technical Data

Oil Pump:

Type — 2.0 litre:	Gear-type oil pump, fitted to front housing, driven through toothed belt. L.H. balance shaft driven from pump gearwheel
Type — 1.8 litre:	Trochoid rotor-type oil pump, driven from front of crankshaft, pump located in front cover

Oil sump capacity:

See Section 0.3, page 7

Oil Pump Clearances — 2.0 Litre Engine:

Side clearance of drive gear:	0.08 - 0.14 mm (0.0031 - 0.0055 in.)
Driven gear:	0.06 - 0.12 mm (0.0024 - 0.0047 in.)

1.8 Litre Engine:

Clearance between rotor tips:	0.03 - 0.08 mm (0.0012 - 0.0031 in.)
Side clearance of rotors:	0.04 - 0.10 mm (0.0016 - 0.004 in.)
Clearance between outer rotor and pump body bore:	0.10 - 0.18 mm (0.004 - 0.0071 in.)

2.1. The Oil Pump

A gear-type oil pump (2.0 litre) or rotor-type oil pump (1.8 litre) is used inside the engine.

The oil pump of the 2.0 litre engine is located in the front cover and consists of a drive gear and a driven gear. The pump is driven by a toothed belt from the crankshaft. One of the balance shafts is fitted to the driven pump gear and rotates against the normal direction of crankshaft rotation.

The oil pump of the 1.8 litre engine is also located inside the front case, but is driven from the front end of the crankshaft. The inner rotor is driven by flats on the crankshaft end and drives the outer rotor.

2.1.0. REMOVAL AND INSTALLATION

2.0 Litre Engine

The removal of the oil pump is carried out together with the balance shafts and these operations have already been described in Section 1.4.5 (see Fig. 2.2).

1.8 Litre Engine

Fig. 2.3 shows the front end of the engine together with the front case and the oil pump. Some of the parts shown are not fitted to this engine. The oil pump rotors are accessible after removal of the pump housing cover (20).

2.1.1. OIL PUMP OVERHAUL

- Remove the screws and take off the oil pump cover. Take out the gearwheels (2.0 litre) or rotors (1.8 litre). The pump rotors must be marked before removal. Use a centre punch and refer to Fig. 2.1.
- Unscrew the oil pressure relief valve plug from the bottom of the front case and take out the spring and the plunger in the case of a 1.8 litre engine. On the 2.0 litre engine this plug is inserted into the oil filter bracket.
- Thoroughly clean all parts and check for wear. Pay attention to grooves inside the pump housing and on the contact areas of the pump gearwheels. Check all openings and bores in the pump body for obstruction and

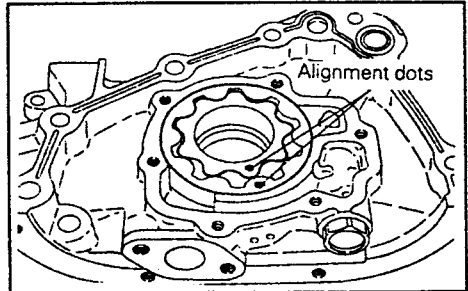

Fig. 2.1. — Before removal of the pump rotors of a 1.8 litre engine mark the two rotors as shown. If the same rotors are refitted, both marks must be visible from above after the rotors have been inserted.

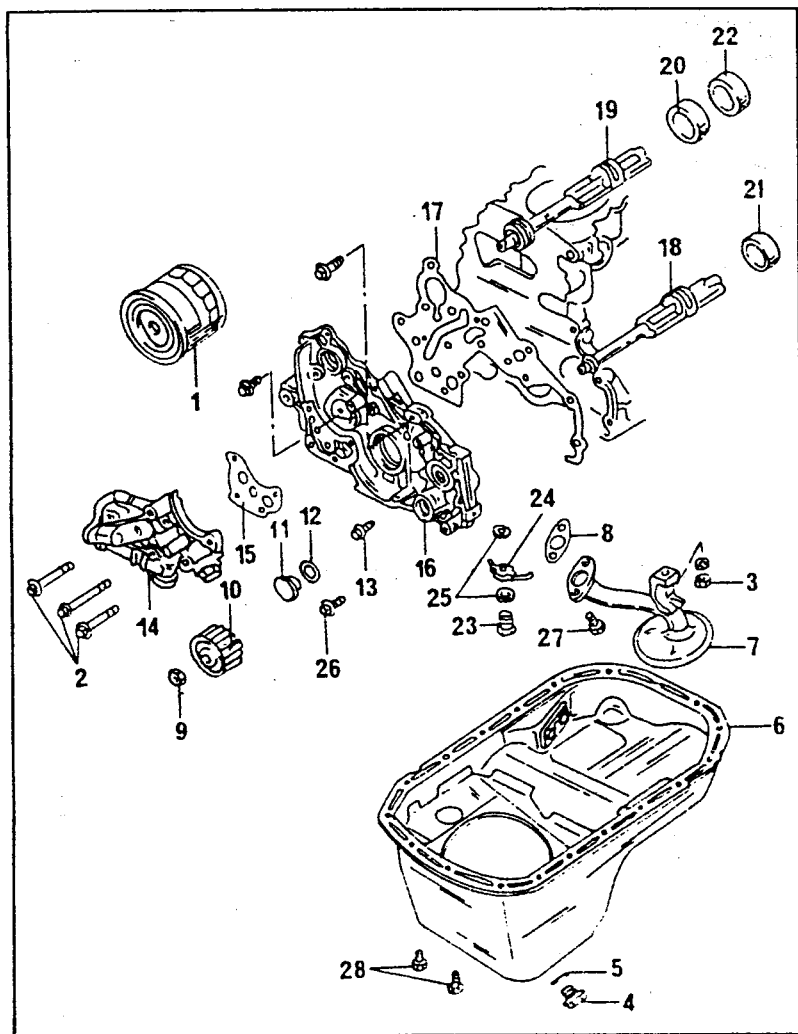

Fig. 2.2. — Exploded view of the balance shafts and the front housing ("G6" engine).

- | | | |
|---------------------------|-----------------------|---------------------------|
| 1 Oil filter | 10 Oil pump gear | 20 Front bearing bush |
| 2 Bolts, 1.9 kgm | 11 Plug, 2.4 kgm | 21 L.H. rear bearing bush |
| 3 Nut, 1.9 kgm | 12 "O" sealing ring | 22 R.H. rear bearing bush |
| 4 Oil drain plug, 4.0 kgm | 13 Flange bolt | 23 Check valve |
| 5 Sealing washer | 14 Oil filter bracket | 24 Oil jet |
| 6 Oil sump | 15 Gasket | 25 Sealing washer |
| 7 Oil suction strainer | 16 Front housing | 26 Bolt, 2.4 kgm |
| 8 Gasket | 17 Housing gasket | 27 Screw, 1.9 kgm |
| 9 Flange nut | 18 L.H. balance shaft | 28 Screw, 0.7 kgm |
| | 19 R.H. balance shaft | |

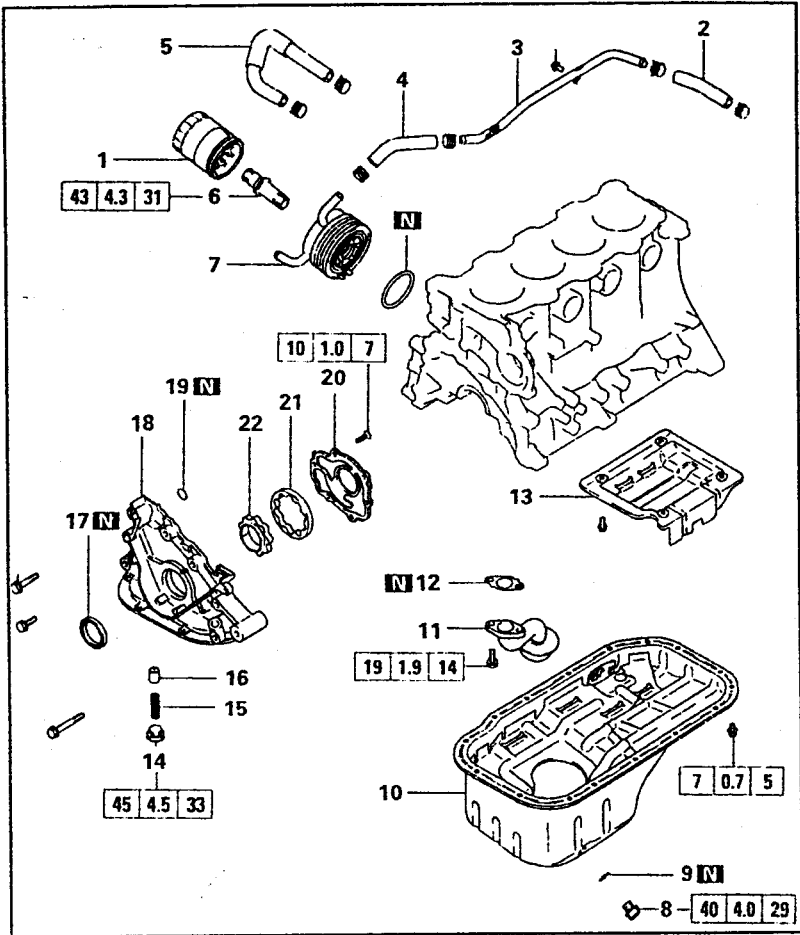

Fig. 2.3 — Front case and oil pump of a 1.8 litre engine.

- | | |
|---------------------------|----------------------------------|
| 1 Oil filter | 12 Oil suction filter gasket |
| 2 Water hose (not fitted) | 13 Oil baffle plate (not fitted) |
| 3 Water pipe | 14 Relief valve plug |
| 4 Water hose (not fitted) | 15 Relief valve spring |
| 5 Water hose | 16 Relief valve plunger |
| 6 Bolt | 17 Oil seal |
| 7 Oil cooler | 18 Oil pump case |
| 8 Drain plug | 19 "O" sealing ring |
| 9 Drain plug gasket | 20 Oil pump case cover |
| 10 Oil sump | 21 Outer pump rotor |
| 11 Oil suction filter | 22 Inner pump rotor |

clear, if necessary with compressed air. If the pump cover shows signs of wear replace it.

Check the clearances of the oil pump in accordance with Fig. 2.4 if a 2.0 litre engine is

dealt with. To do this, insert the gearwheels as shown and place a straight edge across the gearwheels and front case surface. With a feeler gauge measure the end float of the two gearwheels and compare the obtained values with the data given in "Technical Data" section (2.0).

Various checks are necessary to inspect the rotors of the oil pump of a 1.8 litre engine. Again the values are given in Section 2.0. Check as follows:

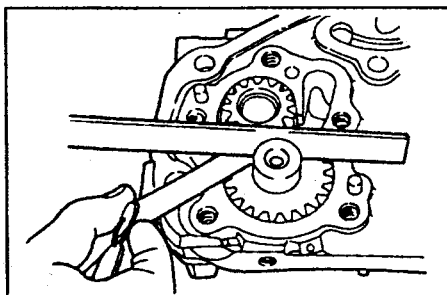

Fig. 2.4. — Checking the gearwheel side clearance (2.0 litre engine).

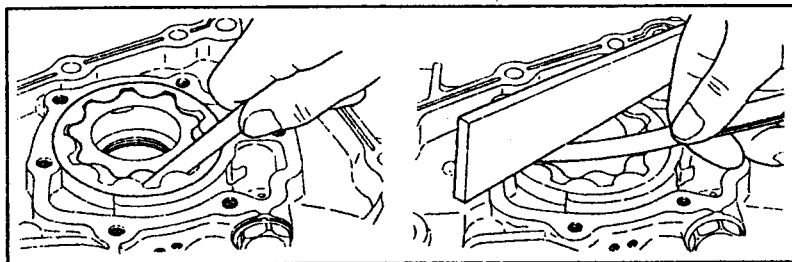

Fig. 2.5. — Checking the "tip clearance" on the L.H. side and the side clearance on the R.H. side (1.8 litre engine).

Tip Clearance

Tip clearance is the gap between the tips of the inner and outer rotors when the rotors are set into the position shown in Fig. 2.5. Use a feeler gauge to measure. Replace the rotor set, if outside the specified value.

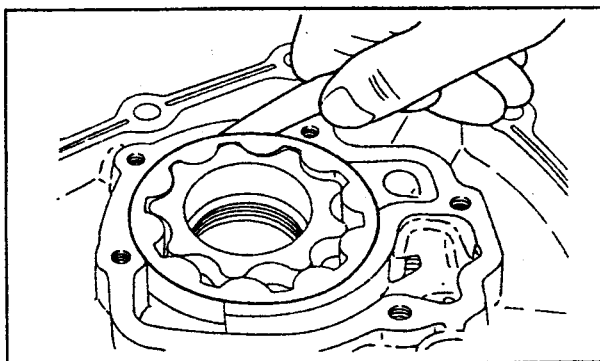

Fig. 2.6. — Checking the clearance between the outside of the outer rotor and the pump body bore.

Side Clearance

The side clearance is the end clearance (axial clearance) of the rotors. Place a steel ruler across the inserted rotors and the front case surface and measure the gap be-

tween the rotor faces and the surface with a feeler gauge as shown in Fig. 2.5 on the R.H. side. If the gap is outside the specified values, replace the rotor set or in extreme cases the front case.

Body Clearance

Body clearance denotes the gap between the outer diameter of the outer pump rotor and the pump body bore. The clearance is checked as shown in Fig. 2.6, but it should be noted that a fairly narrow feeler gauge is required. The wear limit is 0.35 mm (0.014 in.).

Insert the relief valve plunger into the bore (oil pump or filter bracket) and check for freedom of movement. Check the spring for distortion or fatigue.

The assembly of the oil pump is a reversal of the removal procedure. Lubricate the gearwheels or rotors and pump body with oil before assembly. When fitting the oil pump

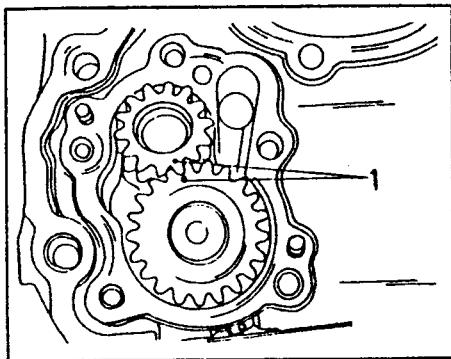

Fig. 2.7. — Aligning the timing marks when fitting the oil pump gears of a 2.0 litre engine. Arrange the marks (1) opposite each other.

gearwheels of a 2.0 litre, align the two mating marks as shown in Fig. 2.7. The final installation is carried out together with the front housing, described below for this engine. The two rotors of the 1.8 litre engine must have their marks facing towards the outside, as shown in Fig. 2.1 on page 67.

Rotate the gearwheels/rotors a few times after installation. 10 c.c. of engine oil can be filled into the pump to prime it for its first minutes of operation.

Fit the balance shafts and oil pump of a 2.0 litre engine as follows, if the whole front end of the engine has been dismantled:

- Check once more that the two pump gearwheels are aligned as shown in Fig. 2.7. The two alignment marks must be opposite each other.
- Lubricate the gearwheels with engine oil and fit the pump cover over the gearwheels. Tighten the screws to 1.7 kgm (12.5 ft.lb.).
- Lubricate the bearing journals of the R.H. shaft with engine oil and insert into the cylinder block. Wrap masking tape around the end of the crankshaft and place the front housing gasket in position.
- Insert the L.H. shaft into the cylinder block at the same time place the housing over the cylinder block, as shown in Fig. 2.8. Insert a screwdriver into the block (as shown in

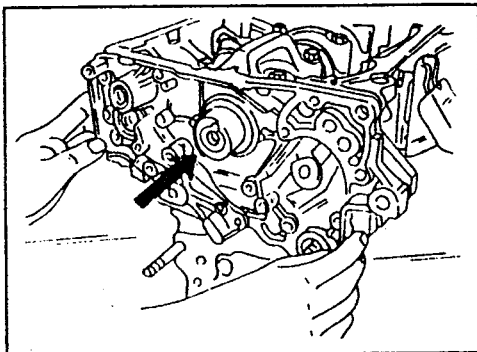

Fig. 2.8. — Fitting the front housing. Protect the oil seal by winding tape around the crankshaft end.

Insert a screwdriver into the block (as shown in

Fig. 1.68) to lock the shaft in position and tighten the shaft bolt to 3.7 kgm (27 ft.lb.). The bolt is inside the bore and must be tightened as shown in Fig. 2.9. Fit the plug (11) in Fig. 2.2 into the bore, using a new "O" sealing ring (12).

- Tighten the flange nut (9) for the oil pump drive gear with a torque of 5.5 kgm (39 ft.lb.).
- Fit the bracket for the oil filter with a new gasket and fit the front housing. The length of the bolts is different and must be taken from Fig. 2.10.
- Fit the oil suction pipe with a new gasket and tighten the nuts to 1.8 - 2.5 kgm (13 - 18 ft.lb.).
- Coat the oil sump with sealing compound at the points shown in Fig. 2.11 and fit a new gasket. Tighten the 20 bolts to 0.6 - 0.8 kgm (4.5 - 5.5 ft.lb.). Do not over-tighten these bolts.
- Refit the oil drain plug with a new sealing washer and tighten the plug to 4.0 kgm (30 ft.lb.).
- Refit all other parts in reverse sequence to the removal procedure.

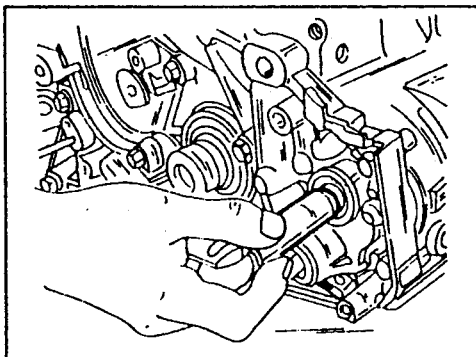

Fig. 2.9 — Tightening the bolt inside the housing bore on a 2.0 litre engine.

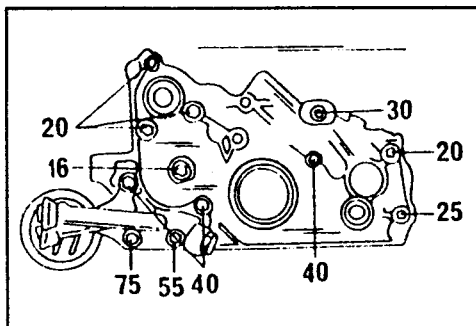

Fig. 2.10 — The length of the different bolts for the front housing. The numbers refer to the length in millimetres (2.0 litre).

NOTE: Before refitting the oil sump, clean the mating surfaces on the sump and cylinder block. Apply a 4 mm (0.16 in.) wide bead of 3M Part No. 8660 (or equivalent) sealer to the sump flange as illustrated in Fig. 2.11. Fit the sump within 15 minutes of applying the 3M sealer. Tighten the sump screws to 0.6 - 0.8 kgm (4.3 - 5.8 ft.lbs.).

2.2. Oil Filter

The oil filter of a "G9" engine is fitted to the cylinder block; the filter of a "G6" engine to the front housing. The oil filter is removed with a special filter wrench. This is one shown in Fig. 2.12 or a universal filter wrench is used, which can be purchased at most accessory shops. If no special appliance is available, drive the blade of a strong screw-driver through the side of the oil filter and use the handle as a lever to unscrew the filter. After removal thoroughly clean the filter seat on the front housing. Coat the gasket of the new oil filter with engine oil and screw the filter in position until the rubber seal touches the filter seat. From this position tighten the filter by a further 2/3 of a turn, using the hands only. No filter wrench should be used for this operation.

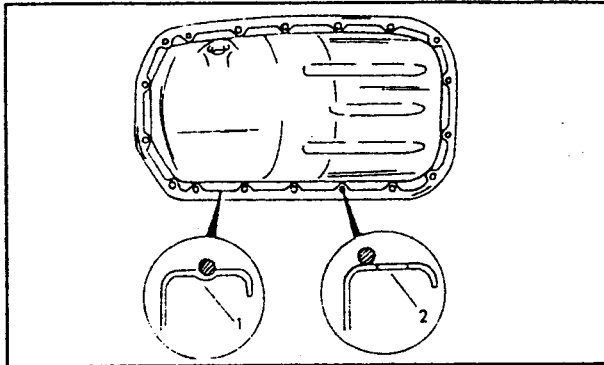

Fig. 2.11. — Coat the complete circumference of the oil sump with 3M sealer. Place the sealer bead (1) into the groove, taking care not to cover the screw holes (2).

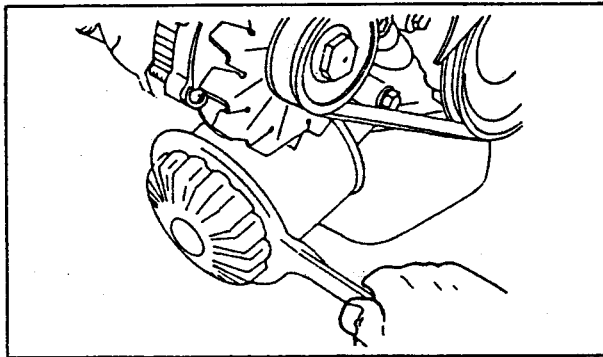

Fig. 2.12. — Removal of the oil filter. Shown is the special tool which engages into the ribs of the filter cartridge.

Check the engine oil level in the sump and start the engine. After the engine has been running for a while, check the filter connection for oil leaks.

2.3. Oil Sump — Removal and Installation

The removal of the oil sump of a 2.0 litre engine is straight forward. After draining the engine oil, unscrew the oil sump from the bottom of the engine. The sump may stick to the crankcase. Do not attempt to insert a sharp screwdriver or similar to force it off. "Rocking" it to and fro should free the sump.

The front exhaust pipe must be disconnected from the exhaust manifold and the under-cover must be unscrewed from the bottom of the flywheel housing to remove the oil sump of a 1.8 litre engine. The removal of the sump is then carried out in conventional manner.

Before refitting the oil sump, clean the mating surfaces on the sump and cylinder block. Apply a 4 mm (0.16 in.) wide bead of 3M Part No. 8660 (or equivalent) sealer to the sump flange as illustrated in Fig. 2.11. Fit the sump within 15 minutes of applying the

3M sealer. Tighten the sump screws to 0.6 - 0.8 kgm (4.3 - 5.8 ft.lbs.).

Allow the engine to stand for a while to allow the sealing compound to harden and then fill the engine with oil.

2.4 Checking the Oil Level

The oil level can only be checked properly if the vehicle is parked on a level ground. If the engine has been running, wait a few minutes. This gives the oil time to flow back into the oil sump.

Withdraw the oil level dipstick and wipe off with a clean cloth or tissue paper. Re-insert the dipstick and withdraw once more. The oil level mark will now appear on the dipstick.

If necessary, top-up with the recommended engine oil. Check the oil level once more. The oil should be up to the "H" mark on the dipstick. Never run the engine when the oil level is below the "L" mark. Overfilling of the oil sump will serve no useful purpose as the additional oil will be burnt very quickly and it may also cause damage to the catalytic converter.

2.5. Oil Pressure Switch

The oil pressure switch is connected by means of a lead with the oil pressure warning light in the dashboard. If a new switch is fitted, coat the threads with sealing compound. Tighten the switch to 1.5 - 2.2 kgm (11 - 15 ft.lb.).

To check the operation of the oil pressure switch, connect a 12 volt test lamp between the switch terminal and a good earthing point. Start the engine and check if the warning light comes on. If this is not the case, replace the switch.

2.6 Oil Level Sensor

An oil level sensor is fitted into the small side of the oil sump in the case of the 2.0 litre engine. Its function is to inform the driver of a low oil level in the oil sump. Removal is straight forward. After disconnecting the cable, unscrew the securing bolts and withdraw the sensor. Tighten the bolts with 0.7 kgm (5 ft.lb.) during installation.

3. COOLING SYSTEM

A thermo-syphon cooling system is used for the engine, consisting of a tube and fin radiator, an expansion tank, a centrifugal water pump and a wax thermostat. An oil cooler for the engine lubrication system is fitted to diesel-powered models; an oil cooler for the transmission is fitted to models with automatic transmission. Both coolers are cooled through the engine cooling system. Fig. 3.1 shows the layout of the cooling system. Some changes have taken place for later model years, but the illustration shown will serve its purpose for the following information.

The radiator functions together with an electrically operated cooling fans. The water pump is driven via a drive belt from the crankshaft in the case of the 2.0 litre engine or forms part of the timing belt drive in the case of the 1.8 litre engine, i.e. the drive wheel for the water pump has similar teeth as the sprockets for the camshaft and the crankshaft. The removal of the water pump will therefore require the removal of the timing belt. This also applies to the 2.0 litre engine, but in this case to gain access to the water pump attachment.

Fig. 3.1. — Layout of the principal parts of the cooling system. Some parts may be different on the latest models. Items marked with “...” must be removed to take out the fan motor.

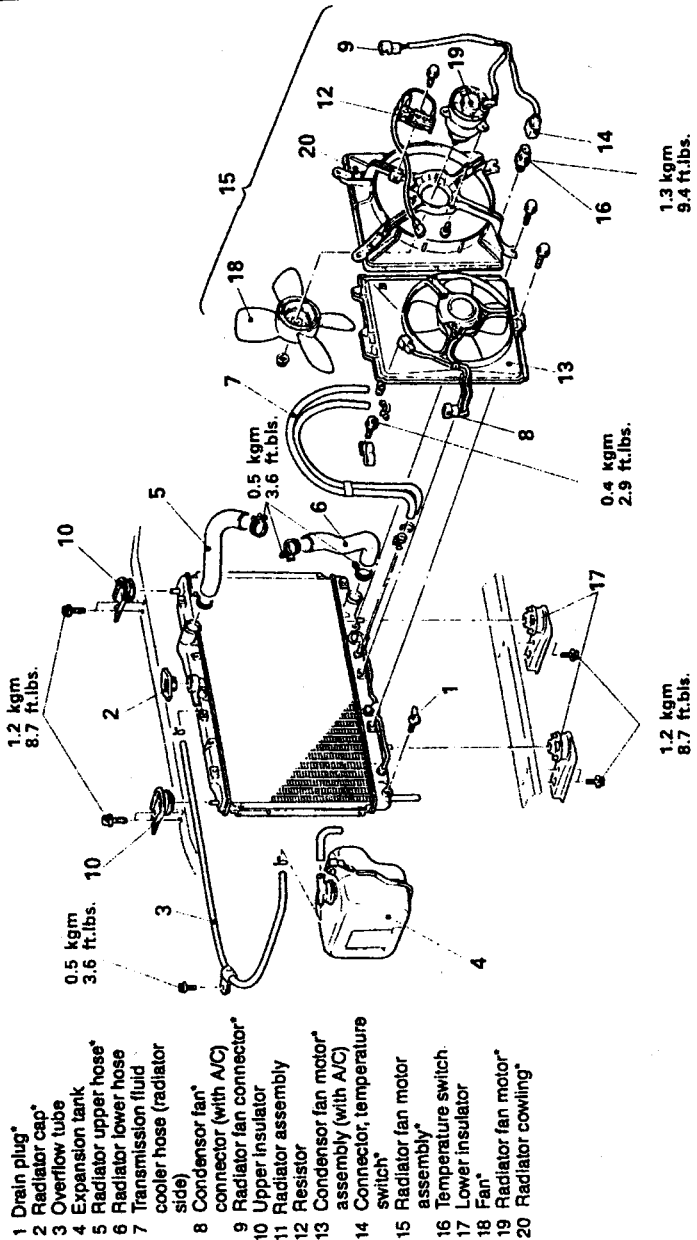

- 1 Drain plug*
- 2 Radiator cap*
- 3 Overflow tube
- 4 Expansion tank
- 5 Radiator upper hose*
- 6 Radiator lower hose
- 7 Transmission fluid cooler hose (radiator side)
- 8 Condensor fan* connector (with A/C)
- 9 Radiator fan connector*
- 10 Upper insulator
- 11 Radiator assembly
- 12 Resistor
- 13 Condensor fan motor* assembly (with A/C)
- 14 Connector, temperature switch*
- 15 Radiator fan motor assembly*
- 16 Temperature switch
- 17 Lower insulator
- 18 Fan*
- 19 Radiator fan motor*
- 20 Radiator cowl*

The thermostat is located in the water outlet elbow. The thermostat is closed when the coolant has a low temperature. This enables the coolant to by-pass the radiator, thereby ensuring a quick warming up of the engine.

3.0. Technical Data

Type: Thermo-syphon system with centrifugal water pump, thermostat, electro-magnetic cooling fan, controlled through switch in side of radiator

Radiator
Type: Fin and tube, oil cooler fitted to bottom in case of automatic transmission. Separate oil cooler for engine, depending on engine.

Cooling system capacity: See Section 0.3

Opening pressure of filler cap: 0.75 - 1.05 kg/sq. cm. (10.7 - 15 psi.)

Thermostat

Opening temperature:

1.8 litre engine: 76.5° C

2.0 litre engine: 82° C

Diesel engine: 76.5° C

Fully open at:

1.8 litre engine: 90° C

2.0 litre engine: 95° C

Diesel engine: 90° C

Water pump belt tension (if applicable): See Section 3.3.2

3.1. Draining and Filling the Cooling System

- Remove the filler caps from radiator and expansion chamber. The engine must be cold. On a hot engine, turn the radiator filler cap to the first detent and allow the vapour to blow off. Use a thick rag to protect the hands.
- The anti-freeze in the cooling system can be collected in a clean container if still in good condition. There is no need to drain the cooling system for certain operations. It is for example sufficient to drain the system to the level of the upper water hose or the thermostat if only these parts are to be replaced.
- Set the heater control lever in the dashboard to the "Warm" position and unscrew the "winged" drain plug at the bottom of the radiator (1, Fig. 3.1) and, if fitted on the side of the cylinder block (1.8 litre, flywheel end of engine).
- An air bleed screw must be opened when a 1.8 litre engine is drained. You will find the screw at the top of the thermostat housing.
- Remove the expansion tank and pour out the coolant. Refit the tank.
- After the cooling system has been completely drained, close the drain tap and refit the plug. Coat the plug threads with sealing compound and tighten to 4.0 kgm (30 ft.lb.).

If the cooling system has not been drained for a long time it should be flushed through with clean water. To do this, open the drain tap and insert a water mains connected hose into the radiator filler neck. Turn on the water and let it run until the water flowing from the drain tap opening is clean and free from contamination. Start the engine to assist the circulation.

To refill the system:

- Refit the drain plug. Check the sealing washer and replace if necessary.

- Prepare the anti-freeze solution in accordance with cold weather to be expected. A mixture of 50% anti-freeze and 50% water will cover normal temperatures below zero.
- Fill the radiator through the filler neck to the bottom of the neck and also fill the expansion chamber to the FULL line. Fit the two filler caps.
- Start the engine and let it run until the temperature gauge shows that the operating temperature of the engine has been obtained.
- Wait for the engine to cool down and re-check the coolant level in the radiator. If necessary fill in additional anti-freeze.
- Fill the expansion chamber to the "Full" mark (Fig. 3.2). When the engine is cold, the coolant level on the expansion tank must be between the "Full" and the "Low" mark.

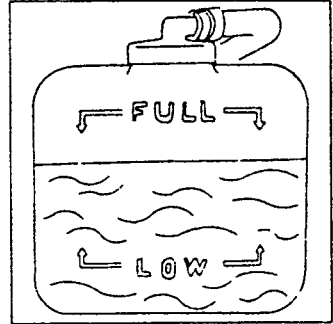

Fig. 3.2. — View of the cooling system expansion chamber. The coolant must be within the two marks when the engine is cold.

3.2. The Radiator

3.2.1. REMOVAL AND INSTALLATION

Carry out the following operations by referring to Fig. 3.1:

- Drain the cooling system as described in Section 3.1.
- Slacken the hose clips and remove the upper and lower radiator hoses from the radiator and also from the engine connections.
- Disconnect the battery.
- Disconnect the overflow hose from the expansion chamber.
- If an automatic transmission is fitted, disconnect the oil cooler hoses. Place a container underneath the connections to collect any transmission fluid running out. Fig. 3.1 shows where the pipes are connected.
- Disconnect the fan motor connector, free the clip from the cable harness and disconnect the wiring from the temperature switch for the fan operation.
- Remove the radiator securing screws on each side of the radiator and lift out the radiator. Take care not to damage the radiator core on any of the surrounding parts. The fan motor remains on the radiator during removal. If necessary unscrew the motor together with the fan cowling from the radiator.

Check the radiator hoses for cracks, porosity or other damage. Replace a doubtful hose as it may split whilst on the road with the consequent inconvenience. Check the radiator for rusty areas, indicating in most cases a leak. Leaking radiators can be repaired in a specialist shop.

Check the upper and lower mounting brackets for the radiator. All brackets can be replaced if necessary. The fan shroud (cowling) can be unscrewed from the radiator, if required. Cooling fan (1 nut) and cooling fan motor (3 bolts) can also be replaced.

If a radiator pressure testing pump is available, check the radiator cap. Attach the pump to the radiator cap and build-up pressure until the valve inside the cap opens. This should take place at a pressure of 0.8 - 1.0 kg/sq.cm. (11 - 14 psi.).

The same pump can also be used to test the fitted radiator and the connecting hoses for leaks. In this case, attach the pump to the radiator filler neck (Fig. 3.3) and operate the pump to build-up a pressure of 1.6 kg/sq.cm. (23 psi.). Observe the dial on the pump. There should be no visible drop-off of pressure for a considerable time. If a loss

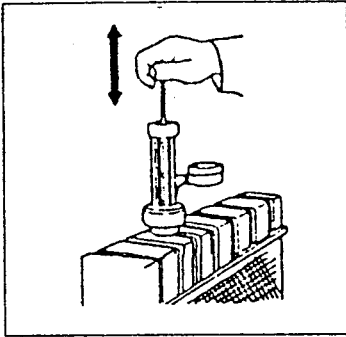

Fig. 3.3. — Checking the cooling system for leaks (loss of pressure) with the radiator test pump.

of pressure can be detected, drive the vehicle over a dry area to facilitate the tracing of the leak.

The installation of the radiator is a reversal of the removal procedure. Guide the pins at the bottom of the radiator into the rubber mounting bushes. When fitting the radiator hoses push them over their respective connections, ensuring that enough length of the hose is pushed over the radiator and engine elbows. The same applies to the small overflow hose. Tighten the hose clips without overtightening them. An overtightened hose clip will cut into the hose and may create water leaks.

Fill the cooling system as described in Section 3.1, start the engine and check all connections for leaks after the engine has reached its operating temperature.

3.3. Water Pump

There is no provision to overhaul the water pump. A new unit must be fitted if the original pump is damaged in any way. The only check on the water pump is for excessive clearance of the shaft bearing. If excessive side play can be noticed, the pump must be replaced.

3.3.1. REMOVAL AND INSTALLATION OF THE PUMP

Removal and installation follows a general pattern but there will obviously be some differences between the different engines, which will be seen during the actual work. We would like to point out that the replacement of the water pump is an extensive operation as the complete timing drive must be removed before the pump can be unscrewed.

- Drain the cooling system as described in Section 3.1.
- The engine mounting bracket must be removed. To do this, place a mobile jack underneath the oil sump (a piece of wood between jackhead and sump) and jack up the engine until the mounting bracket is free of tension. Completely remove the engine mounting. This may include the removal of the clamp for the pipe work for the power steering and air conditioning system, which are attached to the mounting bracket.
- Slacken the alternator mounting bolts at the mounting bracket and the tensioning device, push the unit towards the engine and take off the drive belt. Remove the remaining drive belts from the front of the engine.
- Unscrew the water pump pulley (4 screws), if the water pump is driven by the belt, and pull off the pulley by hand. A rubber mallet may be used.
- Remove the undercover from the front of the vehicle.
- Remove the crankshaft pulley, timing belt guard, timing belt, camshaft timing wheel and timing belt tensioner and the small toothed belt (2.0 litre and diesel) as described during the dismantling of the respective engine, with other words the whole of the front end of the engine must be stripped down before access to the water pump is possible. In the case of the 1.8 litre engine remove the timing belt rear cover.

- Remove the five bolts securing the water pump. Note that not all bolts are of the same length. Either mark the position of each bolt or refer to Figs. 3.4 to 3.6 for the correct length. Note that not all bolts have the same length.
- Remove the pump from the engine and take off the gasket. Immediately clean the gasket face on pump and cylinder block. Nu gasket is used on the 1.8 litre engine (sealed off with sealing compound).

Always use a new gasket when refitting the pump, with the exception of the 1.8 litre engine. The pump of this engine must be sealed with sealing compound. Apply a bead of sealing compound around the sealing face before fitting the pump against the cylinder block.

The installation of the pump is a reversal of the removal procedure. Refer to the various illustrations to check the length of the bolts before inserting them. On the 2.0 litre engine and the diesel engine replace the "O" sealing ring on the water pipe and push the pump over the pipe and against the engine.

Different tightening torques apply to the bolts. The belt driven pump of the 1.8 litre engine is tightened to 2.4 kgm (18 ft.lb.). The bolts of the other engines are tightened to 1.3 kgm (9 ft.lb.) in the case of the 2.0 litre engine or 1.4 kgm (10 ft.lb.) in the case of the diesel engine.

Refit the timing belts and adjust the valve timing as described in the relevant section for the engine in question. Adjust the drive belt tension as described in Section 3.3.2. Different tightening torques apply to the alternator adjusting brace:

- In the case of the 2.0 litre engine tighten both bolts to 2.4 kgm (17 ft.lb.).
- In the case of the diesel engine secure the adjuster brace with 2.4 kgm (17 ft.lb.) to the water pump and the long bolt in the adjusting slot of the brace to 1.4 kgm (10 ft.lb.).
- Finally refill the cooling system (Section 4.1.) and check the system for leaks.

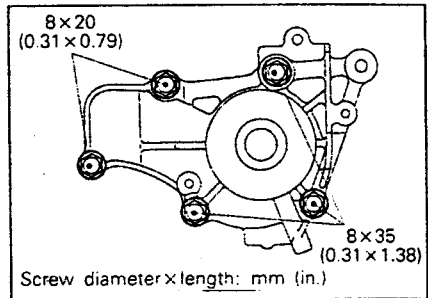

Fig. 3.4. — Front view of the water pump with the position of the different bolts and their length (1.8 litre).

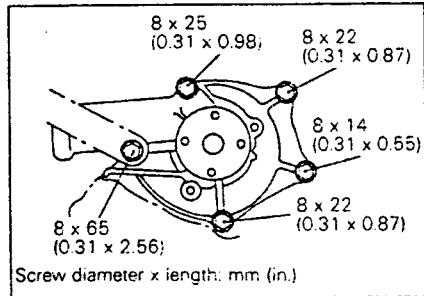

Fig. 3.5. — Front view of the water pump and the position of the different bolts and their length in the case of the 2.0 litre engine.

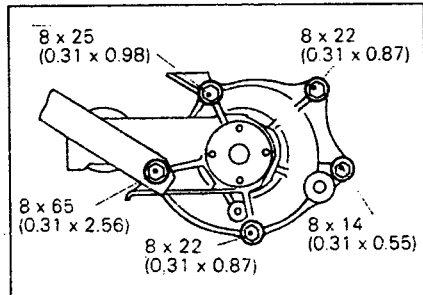

Fig. 3.6. — Front view of the water pump with the position of the different bolts and their length in the case of the diesel engine.

3.3.2. Adjusting the Drive Belt Tension

Always tension the drive belt whenever the alternator or water pump or the drive belt have been removed or slackened for any reason. The belt for the alternator is adjusted in the conventional manner or a tensioning device is fitted to adjust the belt. From the illustrations you will soon see which type of tensioner is used. The tension is measured by depressing the centre of its run with a good thumb pressure. If the alternator drive belt can be depressed the following amounts there is no need to adjust the tension:

1.8 litre:	8.5 - 12.0 mm (0.34 - 0.47 in.)
2.0 litre:	9.0 - 11.5 mm (0.35 - 0.45 in.)
Diesel engine ("V" belt):	7.0 - 10.0 mm (0.28 - 0.39 in.)
Diesel engine ("toothed" belt):	8.0 - 9.5 mm (0.34 - 0.38 in.)

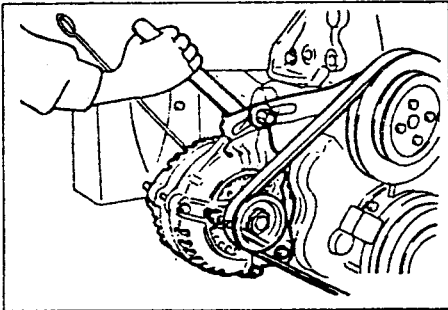

Fig. 3.7. — Adjusting the alternator belt tension when a conventional adjusting link is used (diesel engine).

Adjust the belt tension as follows, depending on the adjusting device:

With Adjusting Strut:

This type of tensioning device is used on the diesel engine. It should be noted that the belt in use can either be a conventional "V" belt or a ripped (cogged) belt (approx. from Jan. 1994). The checking and adjusting procedure is the same for both belts;

- Slacken the alternator mounting bolt at the bottom of the unit and the bolt and nut securing the strut to the alternator.

- Use a tyre lever or a strong screwdriver, as shown in Fig. 3.7 and force the alternator towards the outside until the belt is properly tensioned. If the original belt is used, tension the belt until it can be depressed by the amount given above for the diesel engine. If a new belt is fitted, tension it slightly more, as it will stretch during the first miles of operation. The tension is correct if the belt can be depressed by approx. 6.5 - 8.0 mm. Re-check the belt tension after the vehicle has been driven by approx. 500 miles. The deflection should then be between 7 and 10 mm ("V" belt) or 8.0 - 8.5 - 10 mm ("toothed" belt). Re-adjust as described above, if this is not the case. Signs of a slipping drive "V" belt are a squealing noise from the engine compartment when the engine is accelerated suddenly. The belt will slip in the pulleys, thereby producing a noise. This will not be the case with the "toothed" belt.

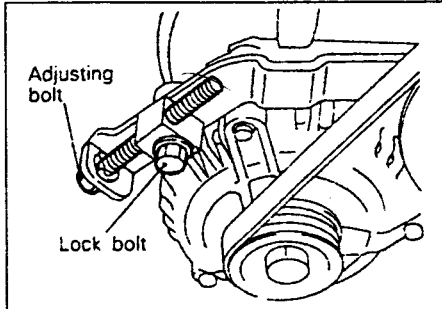

Fig. 3.8. — Adjusting the alternator belt tension when an adjusting device is used.

With Adjusting Device

The alternator has an adjuster for the belt tension. To adjust, refer to Fig. 3.8 and

slacken the alternator securing bolt at the bottom and the adjuster lock bolt. Turn the adjusting bolt to alter the belt tension and re-tighten the lock bolt and the alternator securing bolt. Check the drive belt deflection and re-adjust if required. If the original belt is used, adjust the tension as follows:

1.8 litre engine:	9.5 mm (0.37 in.)
2.0 litre engine:	10.0 mm (0.4 in.)

A new belt must be adjusted to have a deflection as follows:

1.8 litre engine:	7.0 - 8.5 mm (0.28 - 0.34 in.)
2.0 litre engine:	7.5 - 9.0 mm (0.30 - 0.35 in.)

Re-check the belt tension after a few hundred miles of driving. If outside the value given, re-adjust as described above to this value.

If a compressor for the air conditioning system is fitted, more than one belt will be used. Adjust the belt for the compressor to a deflection of 6 - 7 mm (0.24 - 0.28 in.). Again a tensioning device is used to tension the belt, with lock bolt at the side of the tensioner pulley and an adjusting bolt at the top. Refer to the "Steering" Section for the steering pump belt.

3.4. Thermostat

The thermostat is located beneath the water outlet elbow at different locations, depending on the engine. Follow the upper hose from the radiator to locate its position. To remove the thermostat, partially drain the cooling system, remove the two elbow securing screws and take off the upper radiator hose. Lift out the thermostat.

The average opening temperature is stamped into the thermostat. "82", for example, signifies an opening temperature of 82° C.

A thermostat can be tested by immersing it into a container of cool water and gradually raising the temperature to check that it opens properly.

Suspend the thermostat on a piece of wire so that it does not touch the sides or the bottom of the container. A thermometer must also be suspended in the same manner. Fig. 3.9 shows the arrangement. Observe the thermometer and check that the thermostat opens at around the temperature given in Section 3.0. and is fully open at 90° C or 95° C, depending on the engine. A thermostat failing this test must be replaced. It is possible to drive without thermostat for a short while if one is not handy for immediate installation.

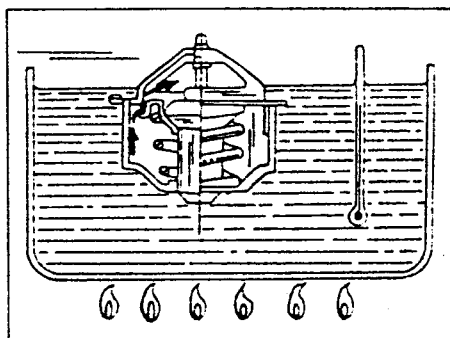

Fig. 3.9. — Checking a thermostat. Insert the thermostat and a thermometer as shown and slowly heat the water until the thermostat begins to open.

When fitting the thermostat take care not to damage the rubber sealing ring. The sealing ring must be free of oil or grease. Make sure that the flange of the thermostat is correctly seated in the opening of the thermostat housing. The thermostat must be inserted the correct way round. The thermostat has a small "jiggle" pin which must always be located at the upper side. Certain engines have an alignment mark on the thermostat housing to facilitate the alignment. Fill the cooling system after installation of the ther-

mostat. Start the engine and allow it to warm up in the normal manner. Check the proper operation of the thermostat.

4. FUEL INJECTION SYSTEM

4.0. Technical Data

Type:	MPI (multi-point injection system)
Fuel pump:	Electrically operated, situated in tank
Fuel Tank Capacity:	
Space Runner:	55 litres (12.1 Imp. gall.)
Space Wagon:	60 litres (13.2 Imp. gall.)
Throttle Housing Bore:	
1.8 litre engine:	50.0 mm (1.97 in.)
2.0 litre engine:	54.0 mm (2.15 in.)
Control servo for idle speed:	Electric motor
Idle position switch:	With contacts
Engine Control Unit:	
1.8 litre engine:	E2T37680 or E2T61585 (from May 1993)
2.0 litre engine:	
To April 1993:	E2T60575
From May 1993:	E2T61586
Idle Speed:	
1.8 litre engine:	800 ± 100 rpm
2.0 litre engine:	750 ± 50 rpm

4.1. Releasing the Fuel Pressure

The fuel pressure in the system must be released before a fuel line can be disconnected. If this is not carried out, fuel will splash out as soon as the union nut is slackened. The operation is not straight forward, as the connector must be separated from the fuel pump — and this is located underneath the floor panel (Space Runner) or the rear seat (Space Wagon). After separating the connector plug halves, at the positions shown in Figs. 4.1 and 4.2, start the engine and wait until it has run out of fuel.

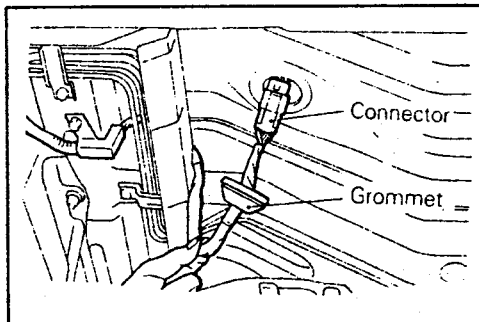

Fig. 4.1. — Disconnecting the fuel pump connector underneath the vehicle floor (Spacer Runner). Pull back the rubber grommet to expose the connector plug. Then separate the two plug halves.

Disconnect the battery and immediately re-connect the plug .

4.2. Idle Speed Adjustment

The idle speed is automatically controlled by the various sensors and switches and should not require adjustment. Special equipment list required to connect various connector plugs and a proper adjustment is outside the scope of this manual. If continuous problems with the idle speed are experienced, seek the advise of a

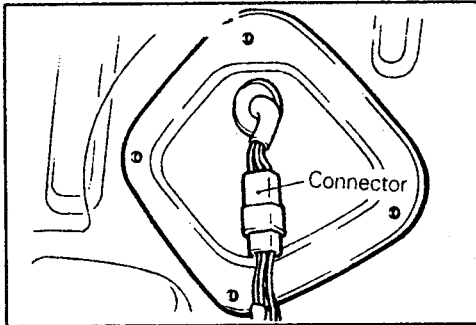

Fig. 4.2. — Disconnecting the fuel pump connector underneath the rear seat (Space Wagon). Remove the rear seat and then separate the two plug halves.

Mitsubishi dealer, as apart from the actual idle speed there may also be faults in the fuel/air mixture which requires electrical instruments for the adjustment.

4.3. Air Cleaner

The air cleaner contains a paper filter element. An electrical connector plug is fitted to the outside of the air cleaner cover, serving the sensors inside the housing. The element cannot be cleaned in liquid. Slightly soiled elements can be

blown out with an air line from the inside towards the outside.

Remember that the air flow sensor, together with two more sensors, are located inside the air cleaner and care must be taken not to damage these if the air cleaner is removed completely. The battery must be removed to gain access to various parts which must be removed.

4.4. Throttle Cable

The throttle cable operates in conjunction with the idle speed control motor and the idle position switch. There are two adjusting nuts where the cable is attached to the bracket.

There should be no need to adjust the idle speed, except when the throttle cable has been replaced. In this case check the adjustment as follows after the cable has been refitted:

- Check that there are no sharp kinks in the accelerator cable. There must be no slack in the cable.
- Check that the throttle lever is resting against the fixed idle speed stop screw (SAS) shown in Fig. 4.3.
- Check that the inner throttle cable has a free play of 1 to 2 mm (0.04 to 0.08 in.) if a manual transmission is fitted or 3 to 5 mm (0.12 to 0.20 in.) if an automatic transmission is fitted.
- If the play is outside the given values, slacken the two nuts shown in the illustration and move the cable accordingly until the cable free play has been obtained. Then tighten the two nuts against each other.
- Start the engine and check the general operation of the throttle cable, mainly making sure that the engine idles with the correct idle speed when the throttle pedal has been released.

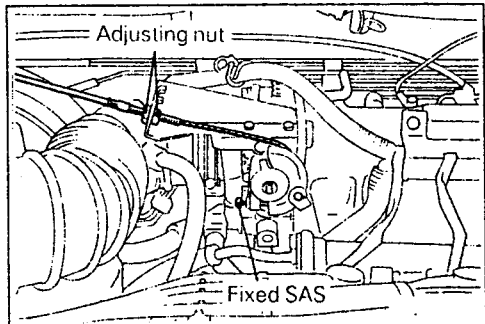

Fig. 4.3 — The attachment of the accelerator cable near its connection to the throttle lever. The two adjusting nuts are moved to adjust the cable.

4.5 Fuel Filter Replacement

The fuel filter is located in the engine compartment at the position shown in Fig. 4.4. The air cleaner and the air intake hose will have to be removed to gain access to the filter. The fuel will splash out as soon as the banjo bolt at the top of the filter is slackened. Use an open-ended spanner and counterhold the filter at flat below the banjo bolt and slacken the banjo bolt with a ring spanner. Place a thick rag over the connection and slacken the banjo bolt little by little until no more fuel is seen to come out. At the bottom of the filter unscrew the union nut. The filter body can again be held against

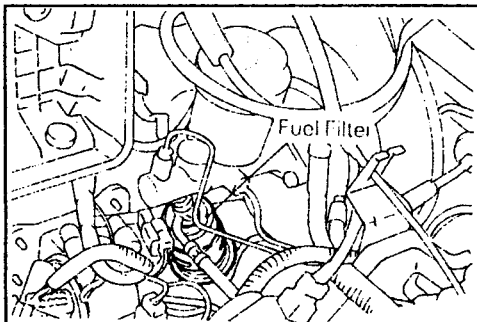

Fig. 4.4. — The location of the fuel filter in the engine compartment.

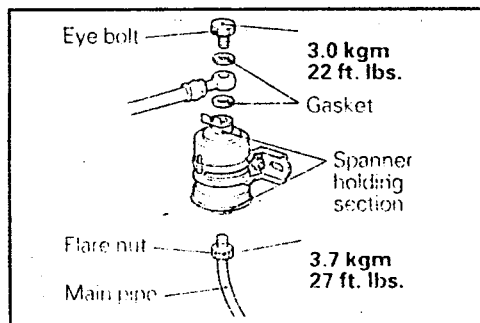

Fig. 4.5. — The attachment of the fuel filter.

rotation by applying an open-ended spanner. Fully unscrew the union nut and remove the fuel pipe. Unscrew the filter from the bracket and lift it out.

Use new sealing washers on both sides of the banjo bolt if possible. Tighten the union nut to 3.7 kgm (27 ft.lb.) and the banjo bolt to 3.0 kgm (22 ft.lb.). Again hold the filter on the flats when tightening the connections.

Start the engine and check the fuel filter connections for leaks.

5. IGNITION SYSTEM

All engines are fitted with an electronic ignition system. The ignition distributor is inserted into the end of the cylinder head, on the flywheel side of the engine and is driven by a slot in the camshaft end. Inside the distributor there are two sensors, one for the detection of the crank angle and the other one for the detection of the No. 1 cylinder top dead centre position.

5.0. Technical Data

Type: Electronic ignition, distributor without contact points. Timing point, centrifugal and vacuum ignition advance regulated by MPI (fuel injection system)

Ignition coil: Built into ignition distributor
 Primary resistance: 0.9 - 1.2 ohms
 Secondary resistance: 20 - 29 kilo ohms

Spark Plugs:

Type fitted:
 1.8 litre engine: NGK BKR6E-11 or Nippon Denso K20PR-U11
 2.0 litre engine: NGK BKR5E-11 or K16PR-U11
 Electrode gap: 1.0 - 1.1 mm (0.04 - 0.043 in.)

Firing order: 1—3—4—2

5.1. The Ignition Distributor

5.1.1. Distributor — Removal and Installation

The distributor is driven by the camshaft by means of a slot in the end of the camshaft. If the distributor is removed, mark all relevant parts that have influence on the distributor position. Do not rotate the engine. In this manner, the distributor can be inserted, with the drive dog in the same position.

To remove the distributor, proceed as follows:

- Disconnect the battery.
- Withdraw the spark plug cables from the distributor after marking their connections, if not sure where they have to be re-connected.
- Withdraw the connector plug from the distributor.
- Rotate the engine until the piston of the No. 1 cylinder is at top dead centre in the compression stroke (check on the timing marks at the crankshaft pulley) and suitably mark the distributor flange, where it is fitted to the cylinder head, with a scribe or small screwdriver.
- Unscrew the distributor securing nuts and withdraw the distributor as shown in Fig. 5.1, until it is free to be removed.

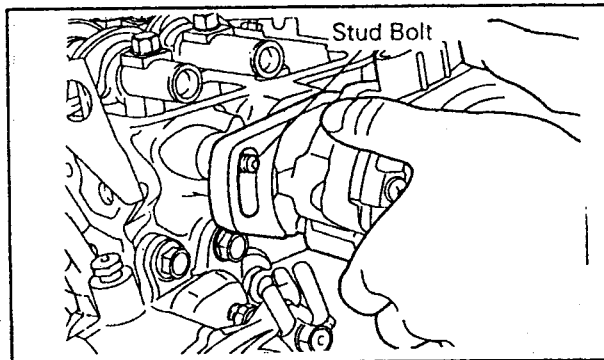

Fig. 5.1. — The distributor is secured with nuts to stud bolts screwed into the end of the cylinder head.

If the engine has not been rotated and no overhaul of the distributor has been carried out, fit the distributor in its original position, observing the marks made during removal. If the distributor is refitted after overhaul work, proceed as follows:

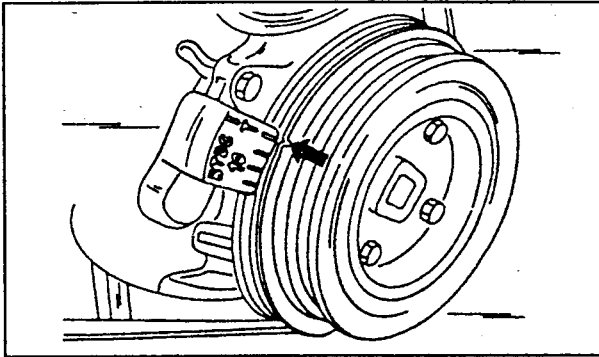

Fig. 5.2. — The engine is at the top dead centre position when the notch in the crankshaft pulley is opposite the "T" mark on the timing point indicator, but check which cylinder is at the firing point.

- Set the engine at T.D.C. position. To do this, turn the crankshaft by applying a socket to the crankshaft pulley bolt, until the notch in the crankshaft pulley (Fig. 5.3) is opposite the "T" mark on the timing scale. To make sure that the correct position has been obtained, remove the rocker cover and check that both valves of No. 1 cylinder have some clearance. The cylinder head cover must be removed to carry out the check. Otherwise unscrew the No. 1 spark plug and insert a finger into the plug hole. The compression can be felt if the correct cylinder is at T.D.C. position.
- Refer to Fig. 5.3 and turn the distributor drive dog until the two marks are opposite each other.

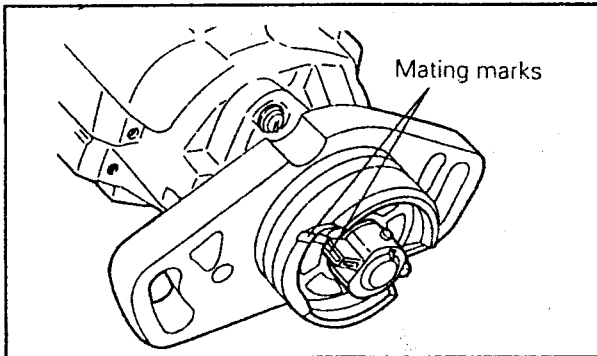

Fig. 5.3. — Turn the distributor shaft on the flange end until the two mating marks are aligned, before the distributor is fitted into the cylinder head.

- Insert the distributor in this position over the two studs shown in Fig. 5.1 and check that the mark made in the flange and cylinder head are in alignment. Tighten the nuts without moving the distributor.
- Re-connect all leads.
- Finally check and if necessary adjust the ignition timing point as described in Section 5.2. If the distributor has been properly marked and is correctly refitted, there should be no need to adjust the ignition timing point.

5.1.2. Ignition Distributor — Repairs

Apart from a regular maintenance we do not recommend to carry out any work on the distributor. The following information will help to cure a irregular running of the engine which you may attribute to the ignition system.

- Clean the outside and the inside of the distributor cap at regular intervals to remove carbon deposits, dust and moisture. Also clean the distributor rotor. Use a petrol-moistened cloth to clean the components. After cleaning check the cap check the cap and rotor for cracks or so-called "tracking". If present, you will see very thin black lines between the various metal segments inside the cap which lead to voltage jumping across, thereby shortening out some of the current.
- Keep the outside of all H.T. cables free of moisture to ensure proper electrical contact throughout the ignition system. Withdraw the all H.T. leads out of their connections and check and clean the connection ends. Badly corroded H.T. lead ends must not be shortened in order to rectify the fault. Always fit new leads.

5.2. Ignition Timing Point

It is essential that the ignition timing adjusted with a stroboscopic timing light with the engine running at 800 rpm (1.8 litre) or 750 rpm (2.0 litre) with a tolerance of 100 rpm to either side. Do not attempt this procedure unless a tachometer (revolution counter) is available. The checking and adjusting of the ignition timing cannot be described as straight forward, as an arrangement, consisting of a jumper lead and a paper clip, must be made up in order to obtain the correct value. It is therefore far better to have the timing point checked in a workshop. We will, however, include the adjustment of the timing point, if you are tempted to do it yourself. The following conditions must be obtained before the timing point can be checked/adjusted:

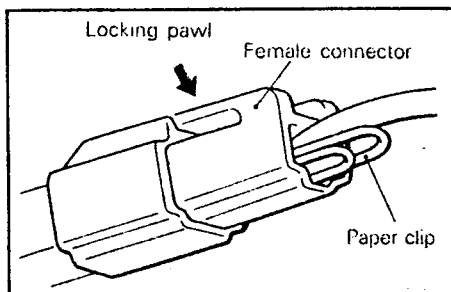

Fig. 5.4. — The paper clip must be inserted into the connector in the manner shown.

- The engine must be at operating temperature before the ignition timing can be adjusted. Check the idling speed of the engine.
- Switch off all electrical consumers. The cooling fan must not operate.
- The selector lever of an automatic transmission must be in the neutral position, the steering wheel must be in the straight-ahead position.
- Check at the crankshaft pulley that the notch in the outside edge of the pulley is visible. If necessary use chalk or a spot of white paint to highlight the notch.
- Connect a stroboscopic timing light in accordance with the instructions of the manufacturer.
- Insert a paper clip from the harness side into the 1 pin connector as shown in Fig. 5.4. The connector should not be separated. The paper clip is inserted into the terminal from the opposite side of the locking pawl on the female connector. The paper clip is necessary to connect the revolution counter. The arrangement will then have the appearance shown in Fig. 5.5.

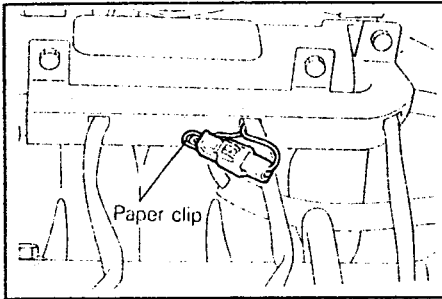

Fig. 5.5 — The connector plug with the inserted paper clip shown on the engine.

- Connect a revolution counter (tachometer) suitable for the ignition system in accordance with the instructions of the manufacturer with one of the terminals to the paper clip. The rev counter should be of the type to detect the primary voltage of the ignition system.
- With the timing light connected, start the engine and let it run at idle speed. Check the revolution counter to make sure that the idle speed given on the previous page has been obtained.

- Switch of the ignition and remove the waterproof connector from the ignition timing adjustment connector (brown colour). The location of the connector is shown in Figs. 5.6 and 5.7 for the two engines/models. Connect the jumper wire with one end to the brown connector and with the other end to a good earth point. By connecting this terminal to earth, the basic ignition timing will be indicated.

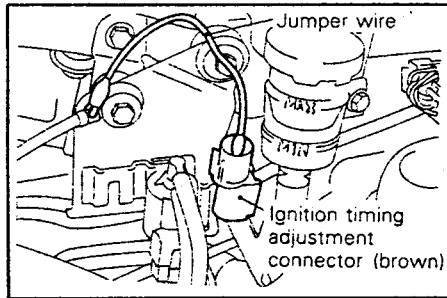

Fig. 5.6 — Connecting the jumper wire to the ignition timing adjustment connector on the Space Runner.

- Start the engine and run it at idle speed. Aim the flash of the timing light at the front of the crankshaft pulley and check that the timing mark in question is in line with the notch in the pulley. Both engines have an ignition timing point of 5° before top dead centre. There is, however, no need to adjust the timing point if the notch on the crankshaft pulley is between the 3° and 7° mark on the timing point indicator.

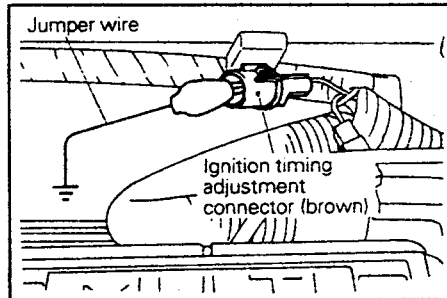

Fig. 5.7 — Connecting the jumper wire to the ignition timing adjusting connector on the Space Wagon.

- If the distributor must be adjusted, slacken the two securing nuts and rotate the the distributor to reset the timing point. Turning the distributor clockwise will advance the timing point, turning the distributor anti-clockwise will retard the ignition timing point.
- Without moving the distributor tighten the two securing nuts to 1.2 kgm (9 ft.lb.).
- Switch off the engine, remove the jumper wire from the ignition timing adjustment connector and return the connector to its original condition.
- Re-start the engine and re-check the ignition timing point on the pulley. The

notch in the crankshaft pulley should now be opposite the 10° mark on the ignition timing point indicator. The value applies again to both engines/models. Note the following points when adjusting the timing point:

- The ignition timing point is variable within about $\pm 7^\circ$, even under normal operation conditions.
- The ignition timing point adjustment on new vehicles is sealed off with sealing tape.

5.3. Spark Plugs

If spark plugs are removed, make sure that the surrounding area is clean to prevent foreign matter from falling into the plug holes as soon as the plugs are unscrewed. Clean the plug face with a wire brush and check the electrodes for wear or burns.

Use a feeler gauge to check the electrode gap (see Fig. 5.8). Close the gap if necessary, by tapping the outside electrode with the handle of a screwdriver. To open up a plug gap, insert the blade of a small screwdriver and bend up the side electrode. Never bend the centre electrode in order to correct plug gaps as this will damage the insulator. The spark plugs listed in Section 5.0 are fitted originally to the engine, depending on preference in a particular country.

Inspect the condition of the insulator tip and the electrodes. Following there are a few examples to interpret the condition of plugs removed from the engine.

Normal Plug Face: The colour of the of the insulator should appear greyish-brown or tan-coloured. The electrodes should be black or sooted. These are signs of a plug which has been used under normal conditions with alternative short and long driving periods. White or yellow deposits mean that the car has been used for long periods at high speeds and can be ignored.

Worn Plug Appearance: Insulator tip and electrodes are burnt off. All plugs which show this condition must be replaced. Always replace the whole set and make sure to fit the correct plug.

Oiled-up Appearance: Normally this condition is recognised by wet oil deposits which have been left by excessive ingress of oil into the combustion chamber (worn piston rings or pistons, inlet valves or valve guides, worn bearings, etc.). Hotter plugs are normally able to overcome the fault, but in serious cases an overhaul of the engine is necessary.

Burnt or Overheated Appearance: Burnt or overheated plugs can normally be recognised by their electrodes being coloured white or being burnt, or by the presence of blisters on the insulator or the electrodes. Electrodes may also be burnt off. Faults can be traced to the cooling system or improper ignition timing.

5.4 Ignition Coil

Any checks on the coil should be carried out by a Mitsubishi dealer.

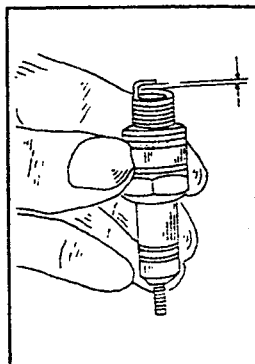

Fig. 5.8. — Electrode gaps of spark plugs are checked between the arrows. Set the gap to 1.0 - 1.1 mm.

6. CLUTCH

6.0. Technical Data

Type: Single disc with diaphragm spring
Operation: Hydraulic operation
Free play at clutch pedal: 6-13 mm (0.24-0.51 in.)
Clutch pedal height: 195-200 mm (7.68-7.87 in.)

Clutch Lining Dimensions:

Outer diameter—1800 c.c.: 200.0 mm (7.9 in.)
 —2000 c.c.: 215 mm (8.5 in.)
Inner diameter—1800 c.c.: 130 mm (5.1 in.)
 —2000 c.c.: 140 mm (5.5 in.)
Clutch release cylinder diameter: 20.64 mm
Clutch master cylinder diameter: 15.87 mm

The dry single plate clutch is of the diaphragm spring type for all engines covered in this Workshop Manual. The operation of the clutch is by means of a hydraulic system with clutch master and release cylinders.

The clutch is balanced as an assembly during manufacture and it is essential that all parts are refitted in their original positions to retain the balance. It should be noted that a clutch unit (and driven plate) of different diameter is used for the 1800 c.c. engine and the two 2000 c.c. engines covered in this manual.

6.1. Clutch — Removal

Refer to the section on the transmission and follow those instructions to remove the unit. If the engine or transmission is removed for any other reason, always unscrew the clutch to check it over. Remove the clutch as follows:

- Mark the clutch cover and the flywheel face to ensure correct re-assembly. This is carried out with a centre punch. Mark two punch dots at opposite points in flywheel and clutch cover.
- Remove the bolts carefully, a little at a time until the spring pressure is released and take off the clutch cover and the driven plate. Do not allow grease or oil to get on the lining faces or other parts. If necessary, the flywheel can also be removed from the engine.
- Immediately clean the inside face of the flywheel with a clean cloth and check the flywheel friction face. If the clutch linings are worn down to the rivet heads, there is the danger that the rivets have left grooves in the friction face.

6.2. Clutch — Installation

To install the clutch, the use of an alignment mandrel or a spare main drive shaft is necessary. Clutch alignment mandrel sets can be hired from tool hire companies and one of the mandrels will fit your clutch. Note that the long end of the clutch disc hub must face towards the rear, away from the flywheel.

If the flywheel has been removed, refit it to the crankshaft flange. Counterhold the flywheel by inserting a screwdriver into the teeth of the starter motor ring gear and evenly tighten the flywheel bolts to the torque setting given in Section 1.6. Before inserting the driven plate, have a last look to make sure that no foreign matter remains in the

flywheel. When refitting the original clutch align the punch mark in the flywheel and the clutch cover and install the six bolts. Tighten the clutch securing bolts in a diagonal pattern to a torque reading of 1.5 - 2.2 kgm (11 - 15 lb.).

6.3. Inspection of Parts

The parts must not be washed in solvent. Dirt should be removed with a stiff brush and an air line. Oily and greasy surfaces, except the friction surfaces, may be wiped down with a cloth moistened with fuel or suitable solvent.

The driven plate must be renewed if it is mechanically damaged, the linings excessively worn or if the linings are contaminated with oil or grease. Check that the damper springs are secure and that the splines on the hub are not worn so that they allow side clearance.

The driven plate should be mounted on a mandrel between a lathe and the run-out checked by applying a dial gauge at the outer edge as shown in Fig. 6.1. Rotate the disc slowly and read off the deflection of the dial gauge. The run-out should not exceed 0.5 mm (0.02 in.).

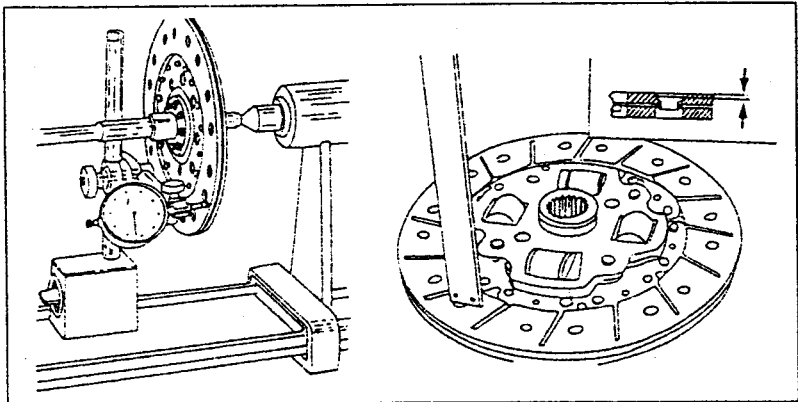

Fig. 6.1. — Checking the driven plate for run-out with a dial gauge between the centres of a lathe on the left. The R.H. view shows the measurement of the clutch lining thickness.

Replace if any of the faults are found. Check the fit of the splines to the gearbox input shaft. At the outer edge of the disc the backlash on the splines must not exceed 0.4 mm (0.016 in.).

Using a depth gauge, measure the distance from the clutch lining surface to the rivet heads on both sides of the driven plate. If this dimension is less than 0.3 mm (0.012 in.), replace the disc. The disc should also be replaced if this min. dimension is nearly reached.

Inspect the ends of the diaphragm spring for wear. If excessive, the complete cover assembly will have to be replaced. The height of the ends of the diaphragm spring must all be at the same level. If necessary, the ends can be bent (carefully) by using a strip of steel with a slit in the end to take the spring thickness.

6.4. Clutch Adjustments

The clutch pedal height can be adjusted. If the clutch pedal height is outside the dimen-

sions given in Section 6.0, adjust as described below.

6.4.1. Adjusting the Clutch Pedal Height and Clearance

If the pedal height is not within the dimensions given in Section 6.0, carry out the adjustments described below. The measurement is only necessary if a new clutch master cylinder has been fitted.

- Measure the clutch pedal height "A" in Fig. 6.2 between the pedal rubber and the floor board. If the dimension is outside the values given, slacken the stop bolt locknut at the upper end of the clutch pedal and turn the bolt until the correct height is obtained. If the pedal height is too low, slacken the locknut of the master cylinder push rod (2) in Fig. 6.3 and rotate the push rod (1) to raise the clutch pedal. Then use the stop bolt to adjust to the value given. The pedal free play must now be checked and if necessary adjusted.

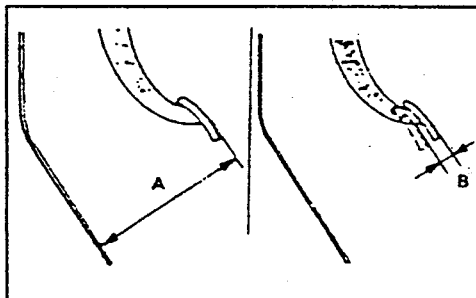

Fig. 6.2. — Measure the clutch pedal height (A) and the clutch pedal free play (B) at the positions shown.

- Grip the clutch pedal between thumb and forefinger and move it as shown by "B" in Fig. 6.2. This play represents the free clearance at the master cylinder push rod which should be between 1 and 3 mm (0.04 - 0.12 in.). If no clearance can be felt, tighten the clutch pedal stop bolt until it just contacts the pedal stop and tighten the locknut.

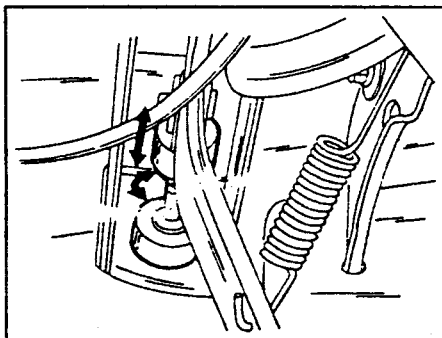

Fig. 6.3. — Adjusting the clutch pedal height and the clutch pedal free play on the master cylinder push rod.

- Rotate the push rod (Fig. 6.3) until the clearance of 1 to 3 mm is obtained when the push rod is moved in and out. Tighten the locknut. Care must be taken not to screw the push rod too far into the cylinder.
- After completing the adjustment, move the clutch pedal up and down as shown by "B" in Fig. 6.2. There should now be a free play of 6 - 13 mm (0.24 - 0.5 in.) before the push rod can be felt to push against the master cylinder piston.

6.5. Hydraulic Clutch Control

6.5.0. CLUTCH MASTER CYLINDER

Fig. 6.4 shows the arrangement of the clutch master cylinder together with the hydraulic pipe and hose. The illustration shows the layout of an earlier Space Wagon model, but

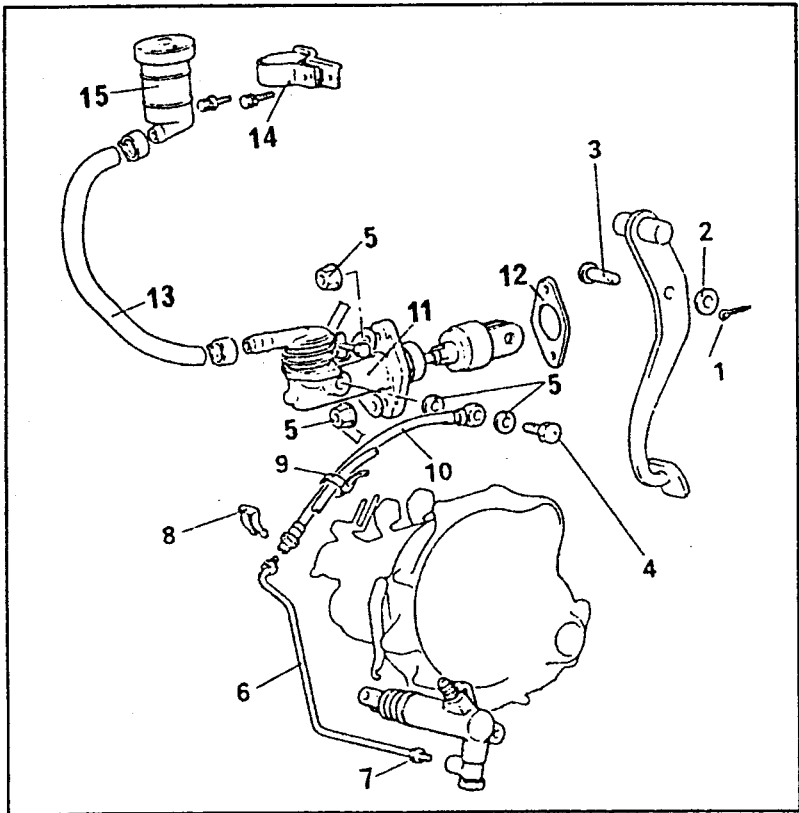

Fig. 64. — View of the component parts for the hydraulic clutch control.

- | | |
|-------------------------|---------------------------|
| 1 Split pin | 9 Hose clamp |
| 2 Washer | 10 Clutch hydraulic hose |
| 3 Clevis pin | 11 Clutch master cylinder |
| 4 Banjo bolt | 12 Gasket |
| 5 Securing nut | 13 Connecting hose |
| 6 Clutch hydraulic pipe | 14 Reservoir bracket |
| 7 Union nut | 15 Fluid reservoir |
| 8 Spring plate | |

apart from some changes in the shape of some of the pipes, hoses, etc., the general arrangement remains the same, apart from the differences for L.H. and R.H. drive models. A major difference is perhaps the connection of the fluid hose at the upper end which is now connected by means of a union nut to the pipe and secured in similar manner as the lower end. A further fluid pipe connects the upper end of the fluid hose directly with the master cylinder. Both ends are secured with union nuts; metal clamps secure the pipe in position. The following operations are carried out by referring to the illustration.

Removal and Installation:

- Jack up the front end of the vehicle and push a bleeder hose over the bleeder

screw of the clutch slave cylinder. Insert the other end of the hose into a jar. Open the bleeder screw and ask a helper to operate the clutch pedal until the clutch system is drained of fluid.

- Remove the splint pin (1) from the master cylinder push rod clevis pin (3), remove the washer (2) and withdraw the clevis pin.
- Remove the air cleaner element and the air cleaner housing.
- Unscrew the union nut connecting the metal pipe to the side of the master cylinder and carefully pull out the pipe.
- Unscrew the cylinder from its mounting. Remove the cylinder, taking care that no brake fluid is allowed to drip onto painted areas of the vehicle.

The installation is a reversal of the removal procedure. Lubricate the clutch pedal clevis pin with chassis grease. Tighten the master cylinder securing nuts to 1.0 - 1.5 kgm (7 - 11 ft.lb.). The union nuts are tightened to 1.3 - 1.7 kgm (9 - 12 ft.lb.). Finally fill the system with fresh brake fluid and bleed the system as described in Section 6.5.2.

Cylinder Overhaul: Clamp the cylinder into a vice, with the opening towards the top, and push the push rod towards the inside until the snap ring (1) in Fig. 6.5 can be removed from the cylinder bore. Remove the push rod and extract the piston out of the cylinder bore.

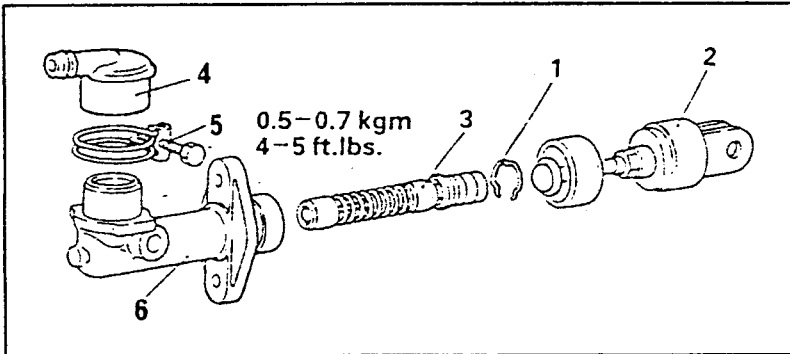

Fig. 6.5. — Exploded view of the clutch master cylinder.

- | | |
|-----------------------|------------------------|
| 1 Snap ring | 4 Fluid hose connector |
| 2 Damper and push rod | 5 Connector clamp |
| 3 Piston assembly | 6 Master cylinder |

Using the fingers only, remove the piston cup from the piston. Mark the hose connector for the fluid reservoir in suitable manner in relation to the cylinder body, slacken the clamp and withdraw the connector. If the reservoir is to be replaced, disconnect the hose.

Thoroughly clean all parts in brake fluid or white spirits and check for wear. If piston or cylinder bore show signs of seizure or other damage, fit a new cylinder.

Coat a new piston cup with brake fluid and, using the fingers only, fit the cup to the piston. The sealing lip must be facing towards the inside.

Push the piston carefully into the piston bore without damaging the edge of the sealing lip. Use the push rod to push the piston fully in and secure the piston with the retaining snap ring. Make sure the ring enters the groove fully.

Fit the rubber boot to the cylinder end. Fit the connector for the reservoir, align the marks made before removal and tighten the clamp.

6.5.1. CLUTCH SLAVE CYLINDER

Removal and Installation: Jack up the front end of the vehicle and place chassis stands in position. Push a bleeder hose over the slave cylinder bleeder screw and insert the other end of the hose into a jar.

Open the bleeder screw and ask a helper to operate the clutch pedal until all fluid contained in the system has been ejected.

Disconnect the fluid pipe from the slave cylinder, unscrew the two securing bolts and take the cylinder away from the transmission.

The installation of the cylinder is a reversal of the removal procedure. Fill the system with fresh brake fluid and bleed of air as described in the next section.

Pipes and Fluid Hose, Replacement

If any of the pipes or the hose between the lower pipe and the upper pipe must be replaced, unscrew the union nut at the ends and take out the pipe, releasing it from the metal clamps where necessary. The hose is held in position by a spring plate on both ends. Knock out the plates with a screwdriver and withdraw them with a pair of pliers, as soon as they are free.

When refitting the hose, make sure that the spring plate enters the groove of the hose connection. Tighten the union nuts (1.5 kgm/11 ft.lb.) without twisting the hose.

After the completed installation check the operation of the clutch with the engine running. Grating noises indicate a malfunction of the clutch assembly.

Cylinder Overhaul: No problems should be encountered to overhaul the slave cylinder. Shake out the piston after removal of the dust cap. Clean and check all parts as described for the master cylinder. Either replace the cylinder or assemble with new parts.

6.5.2. BLEEDING THE CLUTCH SYSTEM

The system must be bled of air if fluid lines have been disconnected or parts of the system have been removed. Proceed as follows:

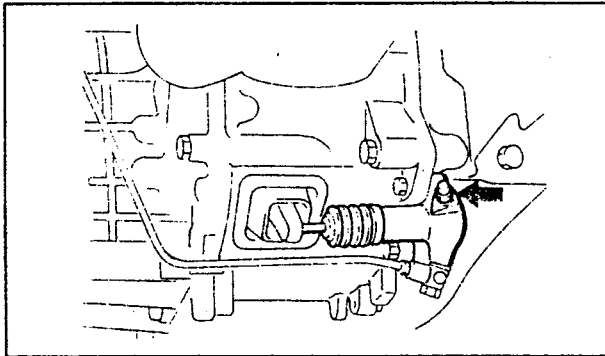

Fig. 6.6. — The location of the bleeder screw on the clutch slave cylinder.

- Fill the fluid reservoir to the correct level and jack up the front end of the vehicle (vehicle on chassis stands).

- Remove the dust cap from the slave cylinder bleed screw, push a bleeder hose over the screw and insert the other end of the hose into a glass jar, filled partially with brake fluid.
- Ask a helper to operate the clutch pedal with slow and even strokes and open the bleeder screw (Fig. 6.6) a little, when the pedal is being held on the floor. Close the bleeder screw.
- Repeat this pumping operation, until the fluid flowing into the glass jar is free of air bubbles.
- During the bleeding operation keep the fluid level in the reservoir to its max. mark by continuously adding fresh brake fluid. A reservoir allowed to run empty will require a re-start with the bleeding process.
- Finally top-up the reservoir once more and remove the bleeding hose. Fit the dust cap.

7. MANUAL TRANSMISSIONS

7.0. Technical Data

Type: — With petrol engine: 5-speed transmission F5M22 with cable gear-change mechanism.

Type — With diesel engine: 5-speed transmission F5M31 with cable gear-change mechanism

Gear Ratios:

	F5M22	F5M31
1st speed	3.454 : 1	3.250 : 1
2nd speed	1.947 : 1	1.833 : 1
3rd speed	1.285 : 1	1.271 : 1
4th speed	0.939 : 1	0.888 : 1
5th speed	0.756 : 1	0.651 : 1
Reverse:	3.083 : 1	3.166 : 1

Lubrication Oil:

Filling capacity:

F5M22 transmission:	1.8 litres (3.2 Imp. pts.)
F5M31 transmission:	2.3 litres (4.0 Imp. pts.)

Final Drive Ratios:

Petrol models:	4.591 : 1
Diesel model:	4.913 : 1

A five-speed transmission of the type given above is fitted. Models with petrol engine designate that the same transmission is fitted to the Space Runner and the Space Wagon. The gearchange mechanism is cable-operated on all models.

7.1. Transmission — Removal and Installation

Fig. 7.1 shows details of some of the parts that must be disconnected or removed to take out the five-speed transmission. Details for the removal of the front suspension parts which must be removed to take out the drive shafts are either shown in the "Drive Shaft" or "Front Suspension" sections and should be referred to when required. The

Fig. 7.1. — Details for the removal and transmission together with the important tightening torques (also see Fig. 7.2).

- 1 Gearchange cable connection
- 2 Connector plug for reversing light switch
- 3 Speedometer cable connection
- 4 Starter motor
- 5 Transmission-to-engine bolts
- 6 Transmission mounting bolt
- 7 Transmission mounting bracket

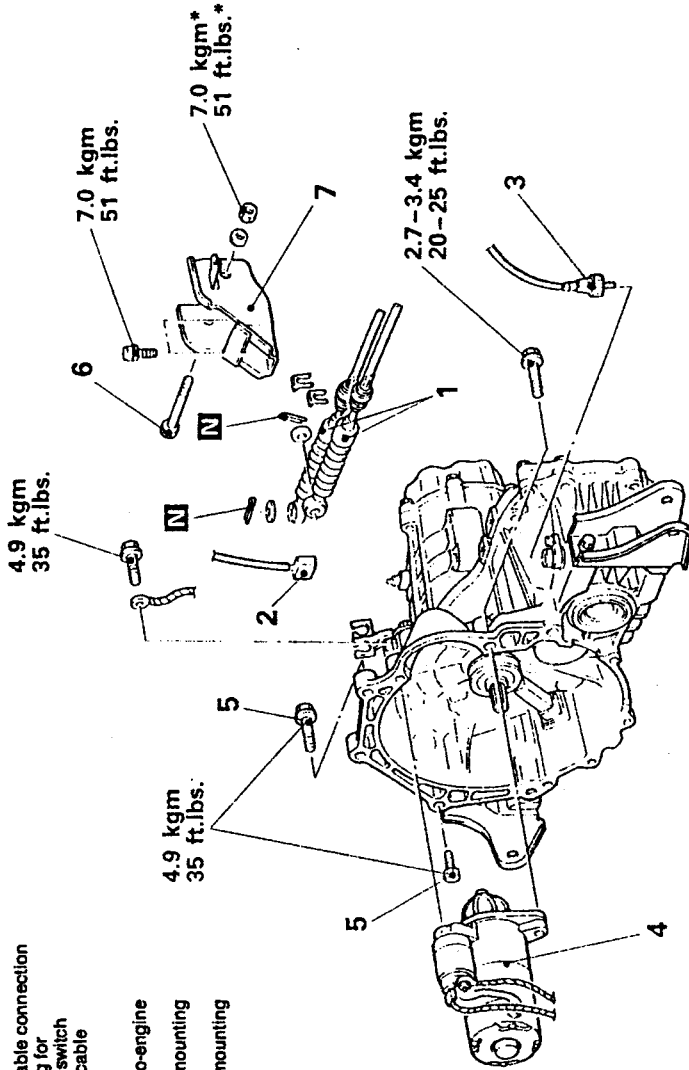
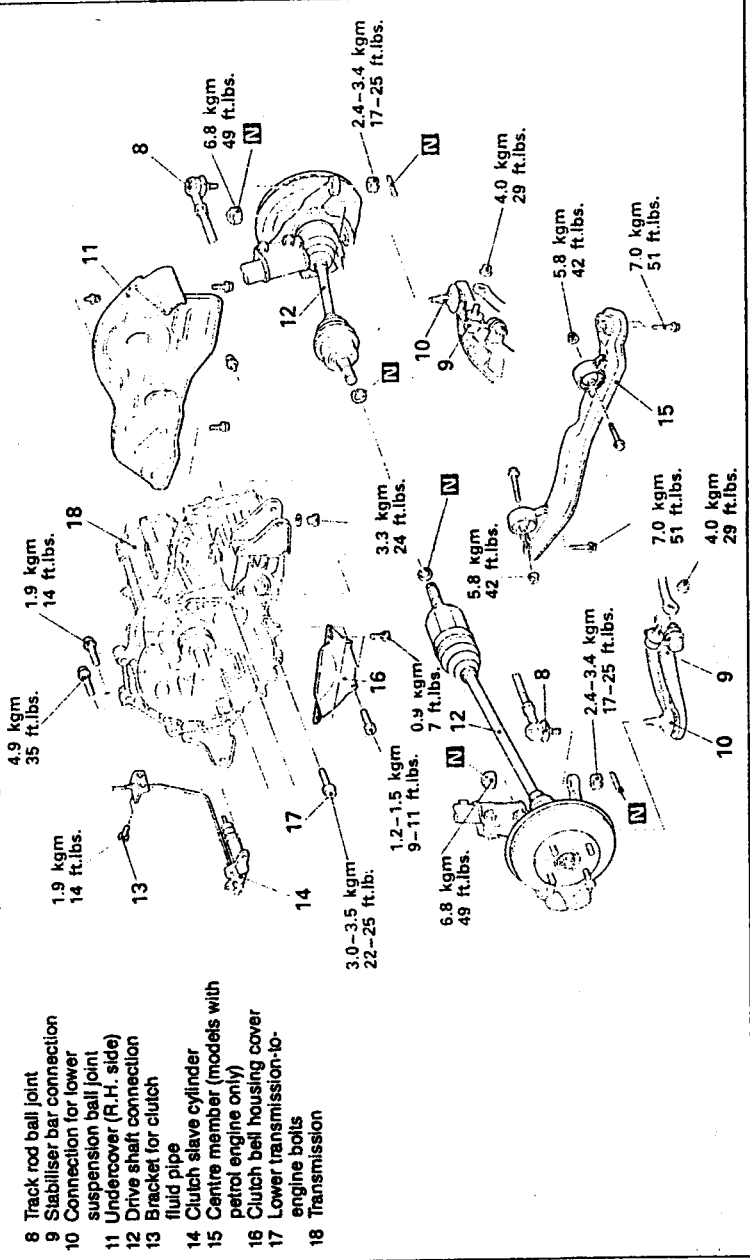

Fig. 7.2. — Details for the removal and installation of the transmission. Shown are the parts to be removed from underneath the vehicle (vehicle resting on chassis stands).



- 8 Track rod ball joint
- 9 Stabiliser bar connection
- 10 Connection for lower suspension ball joint
- 11 Undercover (R.H. side)
- 12 Drive shaft connection
- 13 Bracket for clutch fluid pipe
- 14 Clutch slave cylinder
- 15 Centre member (models with petrol engine only)
- 16 Clutch bell housing cover
- 17 Lower transmission bolts
- 18 Transmission

spring struts must be disconnected from the steering knuckles in order to withdraw the drive shafts from the inside of the transmission. The parts to be removed and details for the transmission mounting are shown in Fig. 7.2. The clutch system should be drained in order to avoid clutch fluid dripping on the working area.

Proceed as follows, noting that a trolley jack is required to lower the transmission to the ground. You will also need a piece of wire to tie the clutch slave cylinder to the chassis, a further wire sling to tie the drive shafts to the suspension struts, a puller to separate the track rod ball joints and the suspension arm ball joints, a hoist or hand crane to lift the engine out of the transmission mountings, if the transmission of a petrol-engined model is removed (the mobile jack will be enough to lift up the diesel engine) and a tyre lever or similar to pry the drive shafts out of the transmission.

First disconnect and/or remove the parts shown in Fig. 7.1:

- Disconnect the battery.
- Remove the air cleaner to facilitate access to some of the parts. By checking the layout you will quickly establish which parts must be removed.
- Disconnect the gearchange cable assembly (1) from the transmission (see Section 7.3).
- Withdraw the connector plug (2) from the reversing light switch.
- Unscrew the knurled nut securing the speedometer drive cable (3) to the transmission and withdraw the cable.
- Remove the starter motor (4) without disconnecting the leads. Place the starter motor somewhere in the engine compartment, from where it cannot fall down.
- Remove the upper bolts (5) between engine and transmission.

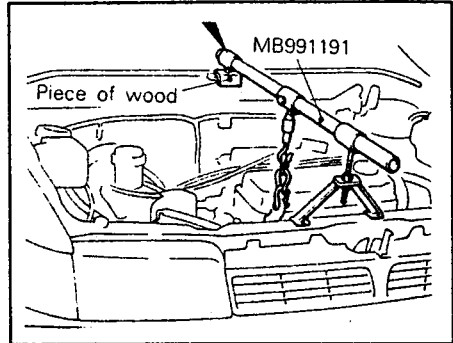

Fig. 7.3. — A petrol engine can be lifted out of the engine/transmission mountings in the manner shown. The device is the special bracket, but a similar arrangement can be used.

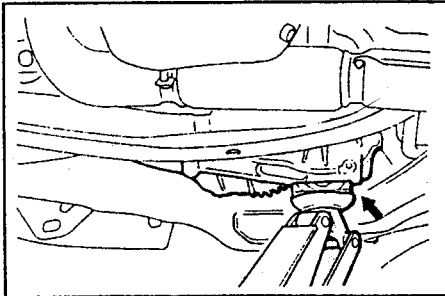

Fig. 7.4. — A diesel engine can be jacked up as shown. Place the jack head under the transmission as shown.

- Remove the transmission mounting bolt (6) after unscrewing the nut and removing the washer. Note the following points:

- If a transmission with petrol engine is being removed, lift the engine out of the mountings. Fig. 7.3 shows how this is carried out in a workshop. From the illustration you will see that a chain is attached to the lifting bracket. If a similar device cannot be made-up, lift the engine with a hoist

or hand crane, until the mountings are just under tension and then remove the transmission mounting bolt.

- If a transmission with a diesel engine is removed, place a mobile jack underneath the transmission, as shown in Fig. 7.4 (wooden board between jack head

and transmission) and jack up the transmission until the mounting is free of load and the bolt can be removed.

- Completely unscrew the transmission mounting bracket.

The next operations are carried out from underneath the vehicle, i.e. the front of the vehicle must be placed on chassis stands. Refer to Fig. 7.2. Refer to sections "Drive Shafts" and "Front Suspension" for details of the removal of the drive shafts and parts of the front suspension.

- Remove the nut securing the track rod ball joint to the steering knuckle lever (8) and separate the track rod ball joint with a suitable puller as shown in Fig. 7.5. *To prevent accidents, use a piece of cord and attach the puller to the front suspension.* This will prevent it from "flying off" when the ball joint stud "pops" out.
- Disconnect the stabiliser bar from the lower suspension arm (9).
- Disconnect the lower suspension arm ball joint (10) from the steering knuckle (section "Front Suspension").
- Remove the undercover (11) on the R.H. side.
- Drain the transmission oil (Section 7.4).
- Remove the drive shafts from the transmission (section "Drive Shafts"). Use a piece of wire and tie both shafts to the

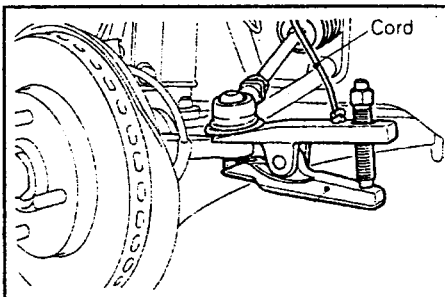

Fig. 7.5. — Separating a track rod ball joint. Note the cord which is used as a safety measure.

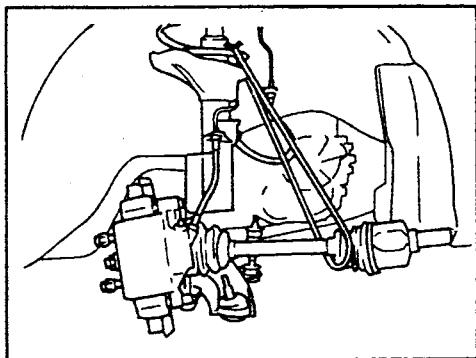

Fig. 7.6. — The removed drive shafts must be tied up to keep in a horizontal position after they have been removed from the transmission.

front spring struts to keep them in horizontal position and at the same time out of the way. Fig. 7.6 shows how this should be done.

- Unscrew the bolt securing the fluid pipe bracket and unscrew the clutch release cylinder from the transmission. There is no need to disconnect the fluid pipe, but a piece of wire should be used to tie up the cylinder to some part of the underbody. Do not allow the cylinder to hang down on the pipe.
- If a petrol engine is fitted, remove the centre engine carrier (15). Make sure that the engine/transmission assembly is still well supported by the hoist/hand crane or whatever has been used.
- Remove the metal cover (16) covering the bottom of the clutch housing (16).
- Place a jack underneath the transmission (if not already there) and lift up the jack until the transmission is well supported. Remove the bolts between engine and transmission at the bottom.
- Push the transmission away from the engine, still "balanced" on the jack until it

is clear of the engine. Take care not to allow the weight of the transmission to rest on the clutch drive shaft. This may either damage the clutch driven plate (or clutch) or could even bend the clutch drive shaft.

- Lower the transmission as far as possible and withdraw it from under the vehicle.

The installation of the transmission is a reversal of the removal procedure. Refer to Figs. 7.1 and 7.2 for the important tightening torques, to be observed during the installation. Refer to the "Front Suspension" and "Drive Shafts" section to refit the disconnected parts. Refill the transmission with oil after installation. Section 7.0 gives the filling capacity.

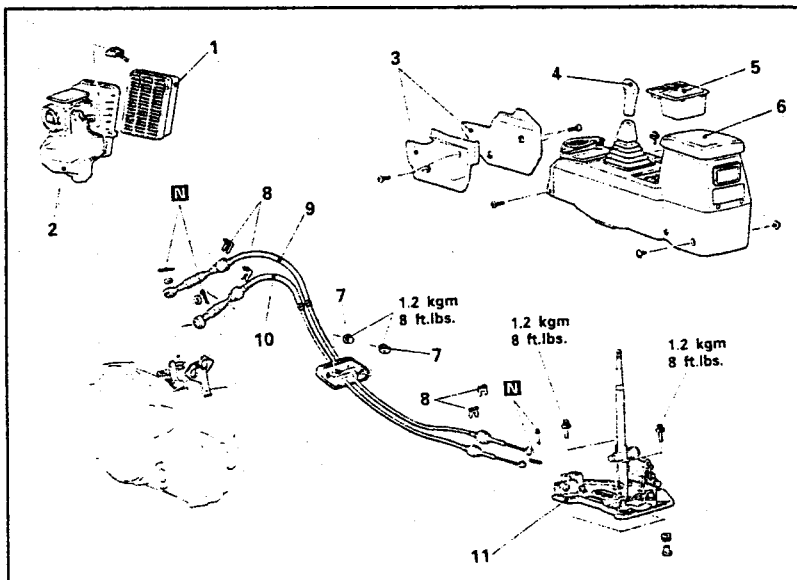

Fig. 7.7. — Exploded view of the gearchange mechanism. Remove the items in the numbered order.

- | | |
|------------------------------|------------------------------|
| 1 Air cleaner element | 7 Nut |
| 2 Air cleaner cover | 8 Clip |
| 3 Side cover | 9 Gearchange cable |
| 4 Gearchange lever knob | 10 Gear selector cable |
| 5 Floor console switch panel | 11 Gearchange lever assembly |
| 6 Floor console assembly | |

7.2. Transmission Overhaul

As special tools are necessary to overhaul the transmission, and also the differential, we do not intent to describe the dismantling and assembling of the unit. If faults are experienced with the transmission or the final drive we recommend to fit an exchange unit or have the original assembly overhauled at your dealer who may have the necessary special tools to assemble and adjust the transmission, but you may find that in most cases an exchange transmission will be recommended. Sometimes it may be possible to obtain a second-hand transmission, but make sure that a transmission with the type identification given in Section 7.0 is used to retain the final drive ratio. The same transmission is used in the Space Runner and the Space Wagon with petrol engine.

7.3. Gearchange Control

All models have a cable-operated gearchange system. The component parts of the cable selector mechanism are shown in Fig. 7.7. Removal and installation can be carried out by referring to this illustration, but it should be noted that the floor console side covers, the floor console and other parts shown in the illustration must be removed in order to gain access to the cable connections.

- Remove the air cleaner element (1) and the air cleaner cover (2).
- Unscrew the side covers (3).
- Unscrew the gearchange lever knob (4).
- Remove the switch panel (5). A blunt instrument, if possible plastic, should be used to prise the panel out of position.
- Remove the floor console box (6). Screws are situated at the front and the rear.
- Remove the nuts (7) securing the gearchange cable assembly to its support.
- Remove the split pins securing the cables at the gearlever bracket assembly and at the transmission. Take off the washers, where fitted.
- Remove the securing clips (8) at both cable ends.
- Slacken the cable adjusters and detach the cables from the gearlever assembly and the gear select lever and the gear lever at the transmission.

The refitting of the select cable and the gearchange cable is carried out in reverse order, but the cables must be adjusted, as you go along.

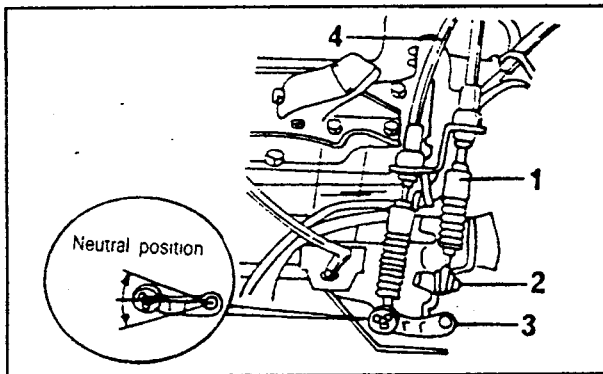

Fig. 7.8. — Connection of the gear select and gearchange cables on the transmission.

- | | |
|-----------------------|--------------------|
| 1 Gear selector cable | 3 Gearchange lever |
| 2 Gear selector lever | 4 Gearchange cable |

Gear Selector Cable: With the cable attached, move the gearchange lever (3) in Fig. 7.8 at the transmission end of the cable to the "neutral" position. This will set the gear select lever in the "neutral" position.

Inside the vehicle, place the gearchange lever "B" in Fig. 7.9 into the "neutral" position. Use the adjuster on the cable (11) and lengthen or shorten the cable until it can be engaged without tension over the spigot of the gear lever (B) in Fig. 7.9. Re-connect the cable with the split pin, but note that the flanged side of the resin bush must be facing towards the lever (B).

Gearchange Cable: Place the gear selector lever (2) in Fig. 7.8 into the neutral position and move the lever (3) downwards to bring it into the 4th speed position. If the lever is

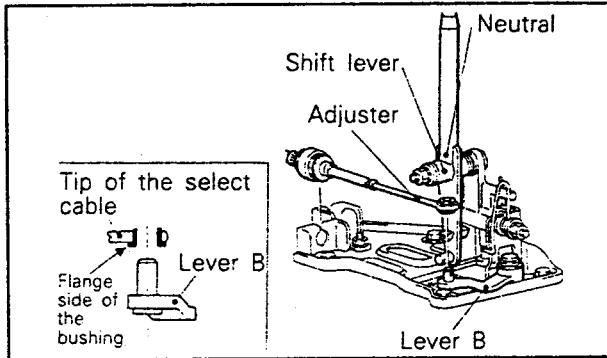

Fig. 7.9. — Move the lever "B" into the position shown before connecting the gear selector cable. Turn the adjuster to make the cable end fit over the spigot.

difficult to move, ask a helper to depress the clutch pedal.

In the passenger compartment move the gearchange lever towards the 4th gear position until the lever comes into contact with the stopper.

Use the adjuster to bring the end of the cable (10) in in Fig. 7.7 in line with the shift lever, until the cable end can be connected to the lever spigot without tension.

Adjust the length of the cable (10) so that the clearance between the change lever and the stopper is equal for the 3rd and 4th speed positions. Check that the lever can move easily in all directions.

Fit the cable end over the bottom end of the gearchange lever, with the flanged part of the resin bush on the outside. Secure the cable with the split pin.

Refit the remaining parts in reverse order to the removal procedure. Engage all gears during a road test to check for correct adjustment. Also check the reverse gear for proper engagement.

7.4. Transmission Oil Level and Oil Change

The oil level in the transmission must be checked from underneath the vehicle. The same applies when you want to change the transmission oil. Note that SAE 75W-85W hypoid gearoil is used in the transmission.

To check the oil level, place the front end of the vehicle on secure chassis stands and unscrew the plug (1) in Fig. 7.10 out of the side of the transmission. Insert the fore-finger into the plug hole and try to reach the oil. If oil is missing, use a gun filled with the specified oil and top-up until the oil just runs out of the plug hole. Refit the filler plug, first checking the condition of the sealing washer, and tighten to 3.0 - 3.5 kgm (22 - 25 ft.lb.).

To change the transmission oil, un-

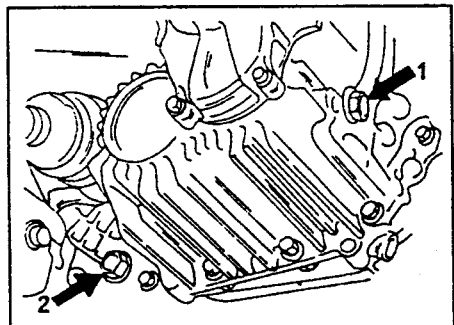

Fig. 7.10. The location of the oil filler/oil level check plug (1) and the oil drain plug (2).

screw the drain plug at the bottom of the transmission but note the following points:

- Drive the vehicle for a few miles to warm up the transmission oil. Be careful when the drain plug is removed, as the oil could be more hot than expected.
- Unscrew the oil filler/oil level check plug before the oil drain plug is removed. This will allow air into the transmission, thereby speeding-up the draining of the oil.

Clean the drain plug, check the sealing washer (replace if necessary) and refit the plug. Tighten to 3.0 - 3.5 kgm (21 - 25 ft.lb.). Refill the transmission through the filler hole with the correct oil. Refer to Section 7.0 for filling capacity of the transmission.

8. AUTOMATIC TRANSMISSION

8.0. Technical Data

Type:	F4A22
Gear Ratios:	
1st speed:	2.846 : 1
2nd speed:	1.581 : 1
3rd speed:	1.000 : 1
4th speed:	0.685 : 1
Reverse speed:	2.176 : 1
Oil capacity:	6.1 litres (10.8 Imp. pts.)
Recommended fluid:	Dexron II ATF
Final drive ratio:	4.350 : 1
Engine stall speed:	1800 - 2600 rpm

The automatic transmission is a complicated piece of equipment. Any dismantling or repairs should be entrusted to specialist who has the necessary knowledge and special tools required to overhaul the transmission. Only the operations described on the following pages should be carried out. Any major fault on the transmission can be rectified by fitting an exchange unit.

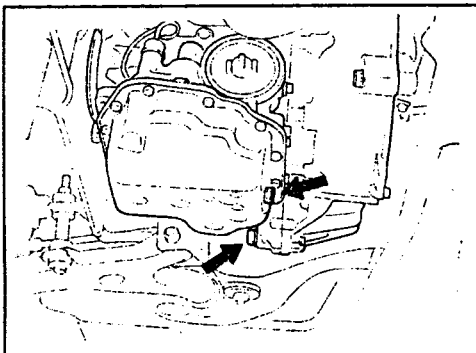

Fig. 8.1. — The drain plug at the lower part of the oil sump. A second plug is in the differential case.

8.1. Fluid Level Inspection and Fluid Change

- Drive the vehicle on a level surface and apply the handbrake and change the gear selector lever into position "P".
- Clean the area around the entry of the fluid dipstick and then start the engine. Allow the engine to run at idle speed until operating temperature is obtained. If the engine is already hot, ignore this step.

- Move the gear selector lever through all gear positions to fill the torque converter

and hydraulic circuit with fluid, finally placing the lever into the "N" (neutral) position.

- Remove the fluid level dipstick (Fig. 8.2) and check the indication. As the transmission fluid is hot, the fluid must be seen between the two lines where "HOT" is marked in the middle. If this is not the case, add Dexron or Dexron II fluid (both are suitable) through the filler tube. Never drive the vehicle with a low fluid level as air could enter the system, affecting the fluid pressure and causes all other sorts of trouble.

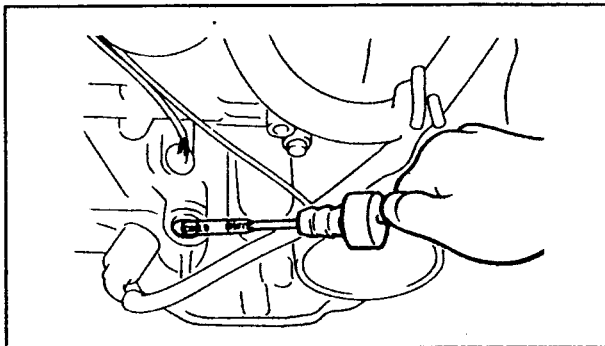

Fig. 8.2. — Checking the transmission fluid level.

As a quick check (for example before driving off on a fairly long journey) it is possible to check the fluid level on a cold transmission. In this case the fluid must be seen between the lines with the "COLD" in the middle.

The fluid should be hot before it is drained from the automatic transmission. If the transmission is cold, give the vehicle a short run to warm it up. It is a good practice to remove the transmission oil pan to clean it out and to replace the filter. Proceed as follows:

- Jack up the front end of the vehicle and place a suitable container underneath the transmission.
- Remove the two drain plugs from the automatic transmission. One is located at the lower part of the differential assembly and the other one in the oil sump. (Fig. 9.1). Drain the fluid into the container. Immediately clean the plugs and screw back in position. The tightening torque is 3.0 - 3.5 kgm (22 - 25 ft.lb.).
- Fill the transmission with Dexron or Dexron II automatic transmission fluid. The total capacity is 6.1 litres (10.8 Imp. pints), but it should be noted that some of the fluid remains inside the transmission and that a lot less may be needed (approx. 4.5 litres will drain).
- With the vehicle on a flat level surface, start the engine and allow to idle. Move the selector lever from "P" to "L" and then to "N" and stop the engine. Re-check the oil level. Depending on the temperature of the transmission fluid it should be between the "COLD" or the "HOT" range. Insert the fluid dipstick fully to prevent entry of dirt.

8.2. Gearchange Cable Adjustment

If the starter motor can be operated in positions "P" and "N" this is usually an indication that the cable is properly adjusted. Otherwise check the adjustment as follows and carry out corrections as required.

- Slacken the nut (3) in Fig. 8.3 and pull the cable in the direction of the arrow.
- Hold the cable under tension and tighten the nut to 1.0 - 1.4 kgm (7 - 10 ft.lb.).
- Check that the selector lever is in position "N". Change the selector lever through the gear range. The selector lever positions must correspond to the positions of the lever (1) on the transmission.

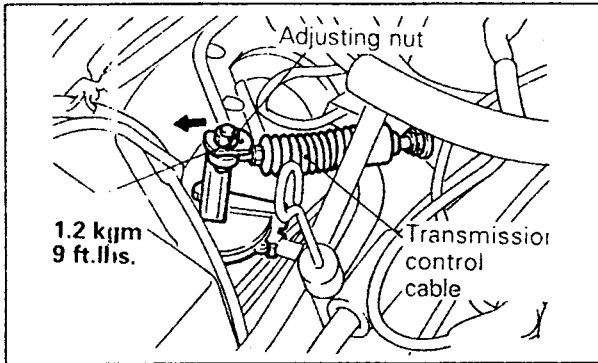

Fig. 8.3. — Details for the adjustment of the gearchange cable

8.3. Automatic Transmission — Removal and Installation

Fig. 8.5 shows a view of the automatic transmission, with some of the parts that must be removed or disconnected. Sections "Drive Shafts" and "Front Suspension" refer in detail to the removal of the two drive shafts from the transmission and the lower suspension arms which must be disconnected from the steering knuckles in order to remove the drive shafts. Fig. 7.2 shows the parts to be disconnected and/or removed from underneath the vehicle on manual transmission models. On a vehicle with automatic transmission you will find that, with the exception of the torque converter drive plate, identical parts are used. Proceed as follows with the removal:

- Disconnect the battery cable.
- Remove the air cleaner to gain access to the various parts.
- Disconnect the gearchange control cable (1) from the lever (also see Fig. 8.3), take out the cable retainer and push the cable away from the transmission.
- Disconnect the oil cooler hoses from the transmission. Plug the hoses and the transmission to prevent dirt, etc. from entering. Some fluid may run out and should be collected.
- Remove the screw (3) and then connect the various connector plugs. These are for the pulse generator (4), the oil temperature sensor (5), and the kick-down servo switch (6). Also in this vicinity disconnect the plugs from the inhibitor switch (7) and the solenoid valve (8).
- Disconnect the speedometer cable (knurled nut) and withdraw the cable out of the transmission. Protect the cable end against contamination.
- Disconnect the starter motor wiring and remove the bolts securing the upper portion of the transmission to the engine. One of the bolts secures an earth cable. Remember which one it is. The starter motor (10) can also be removed.
- Remove the bolt (11) securing the transmission mounting to the mounting bracket. The engine must be lifted up to take the load of the mounting. Refer to the removal of the manual transmission for some tips how this can be achieved. Remove the

Fig. 8.4. — Details for the removal and installation of the automatic transmission.

- 1 Control cable connection
- 2 Oil cooler hoses
- 3 Bolt
- 4 Connector, pulse generator
- 5 Connector, oil temperature sensor
- 6 Connector, kick-down servo switch
- 7 Connector, inhibitor switch
- 8 Connector, solenoid valve
- 9 Speedometer cable
- 10 Starter motor
- 11 Transmission mounting bolt
- 12 Bolt
- 13 Transmission mounting bracket
- 14 Transmission-to-engine bolts

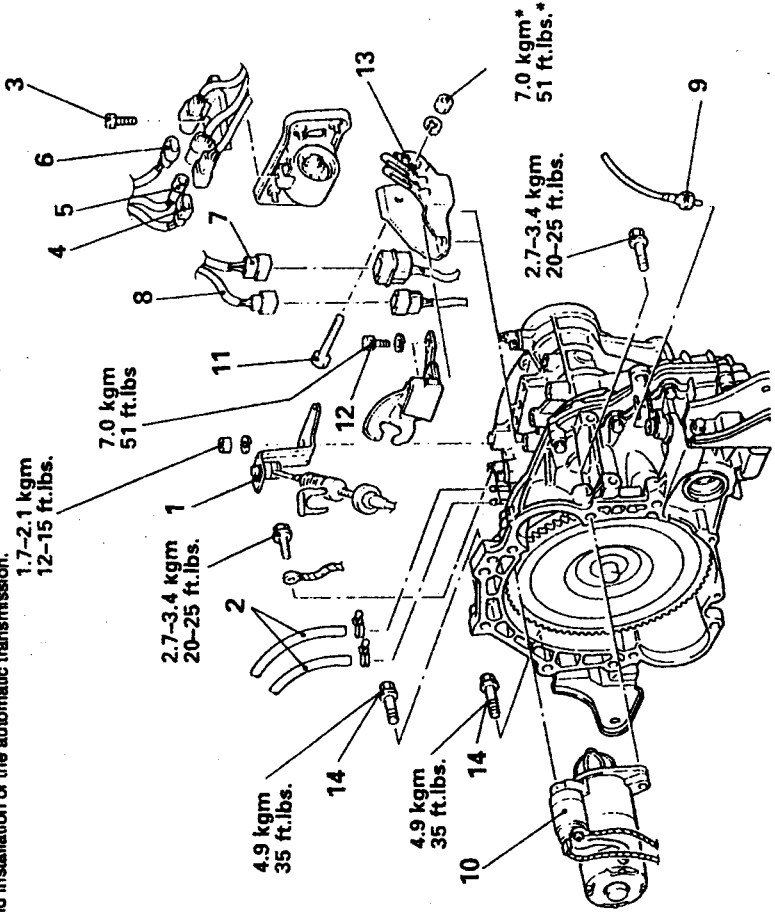

bolts (12) and then unscrew the mounting bracket (13).

- Remove the bolts between engine and transmission (14) from above.

The next operations are carried out from underneath the vehicle, i.e. the front of the vehicle must be placed on chassis stands. Refer to Fig. 7.2. Refer to sections "Drive Shafts" and "Front Suspension" for details of the removal of the drive shafts and parts of the front suspension.

- Remove the nut securing the track rod ball joint to the steering knuckle lever (8) and separate the track rod ball joint with a suitable puller as shown in Fig. 7.5. *To prevent accidents, use a piece of cord and attach the puller to the front suspension.* This will prevent it from "flying off" when the ball joint stud "pops" out.
- Disconnect the stabiliser bar from the lower suspension arm (9).
- Disconnect the lower suspension arm ball joint (10) from the steering knuckle (section "Front Suspension").
- Remove the undercover (11) on the R.H. side.
- Drain the transmission oil (Section 8.2).
- Remove the drive shafts from the transmission (section "Drive Shafts"). Use a piece of wire and tie both shafts to the front spring struts to keep them in horizontal position and at the same time out of the way. Fig. 7.6 shows how this should be done.
- Remove the centre engine carrier (15). Make sure that the engine/transmission assembly is still well supported by the hoist/hand crane or whatever has been used.
- Remove the metal cover (16) covering the bottom of the converter housing. This will expose the torque converter and the drive plate. Remove the three bolts securing the converter to the drive plate. Turn the crankshaft at the crankshaft pulley bolt with a socket until each bolt appears in the opening, as shown in Fig. 8.5 and remove the bolt. Push the torque converter away from the engine to prevent it from sticking to the engine.

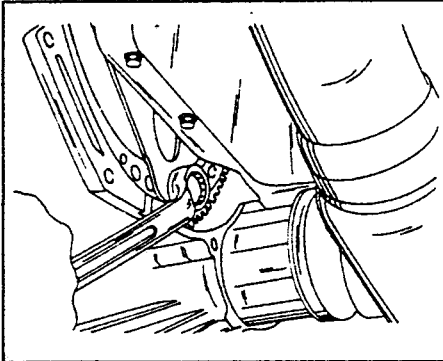

Fig. 8.5. — Removal of the torque converter from the drive plate.

- Support the lower part of the transmission and remove the remaining bolts securing the transmission to the engine. Use a piece of hardwood between jack head and transmission to prevent damage to the transmission oil sump.
- Slide the transmission assembly to the right and then lower it to remove from the vehicle.

The installation is the transmission is a reversal of the removal procedure. To prevent damaging the transmission oil seals, the torque converter must be connected to the transmission first and then to the engine.

Check the hose clips for the fluid hoses. Also make sure that the hose ends have not been cut by the old clips. Replace hoses if necessary.

Refill the transmission with the correct fluid as described below, noting that about 1.5 litres will have remained in the transmission.

Adjust the gearchange cable to take up any free play. Ensure that the inhibitor switch wiring is not in contact with the transmission mounting bracket.

Check that the engine will not start with the selector lever in any position other than

"N" or "P". Take the vehicle on a road test and check the up and down changing of all gears, kick-down operation, etc.

8.4. Automatic Transmission — Tightening Torques

Transmission to engine bolts:	See Fig. 8.4
Transmission Mounting Bolts:	See Fig. 8.4
Starter motor bolts:	2.2 - 3.2 kgm (16 - 23 ft.lb.)
Bell housing cover to transmission bolts:	1.0 - 1.2 kgm (7.7 - 9 ft.lb.)
Torque converter to drive plate:	4.6 - 5.3 kgm (34 - 38 ft.lb.)
Front suspension parts:	Refer to "Front Suspension"

9. FRONT DRIVE SHAFTS/WHEEL BEARINGS

9.0. Technical Data

Drive Shaft Length:	1800 c.c.	2000 c.c.
R.H. shaft:	368 mm (14.49 in.)	367 mm (14.45 in.)
L.H. shaft:	708 mm (27.87 in.)	707 mm (27.83 in.)

Drive Shaft Joints:

Outer joints:	Rzeppa or Birfield joints
Inner joints:	Tripod joints

Drive Shaft Boot Refit Length:

Distance between boot bands:	
All models, both shafts:82 ± 3 mm (3.23 ± 0.12 in.)

Wheel Bearings:

Type:	Taper roller bearings
Dimensions (O.D. x I.D.):	80 - 40 mm (3.15 - 1.57 in.)
Hub axial play:	0.2 mm (0.008 in.)

9.1. Drive Shafts — Removal and Installation

Note that different drive shafts are used in the various Mitsubishi Space Runner and Space Wagon models. Rzeppa or Birfield joints can be used on the outside; on the inner ends of all models tripod joints are used. Always ensure to fit the correct shaft, if replacements are necessary. Quote the engine size, model and Chassis No.

- Remove the centre cap from the wheel hub, remove the shaft nut split pin and slacken the shaft nut by a few turns before the vehicle is jacked up.
- Jack up the front end of the vehicle, remove the wheels and support the vehicle on stands. Remove the undercover.
- Fully unscrew the drive shaft nut and remove the washer.
- Unscrew the nut securing the suspension arm ball joint to the steering knuckle and separate the ball joint connection with a suitable puller, as shown in Fig. 9.1. Note that the puller is attached with a piece of cord to the front suspension to prevent it from "flying" away when the ball joint is free.
- Disconnect the track rod ball joint from the steering lever, using a suitable extractor (see Fig. 7.5), after removing the split pin and the nut.
- Drain the transmission oil.

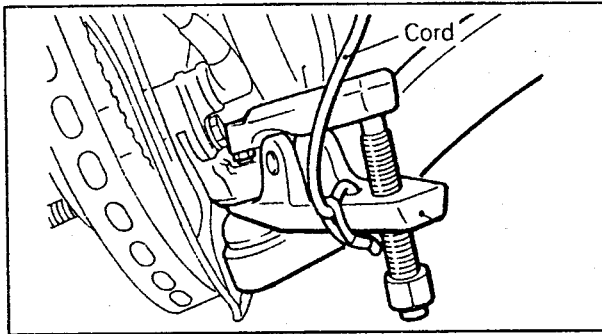

Fig. 9.1. — Separating the suspension ball joint from the bottom of the spring strut. Attach the puller with a piece of cord to prevent accidents.

- Insert the wheel nut wrench supplied with the vehicle or a similar lever between the transmission and the case of the inner CV. joint as shown in Fig. 9.2 (not more than 7 mm/0.28 in.) and with a short push against the lever, towards the transmission, disengage the drive shaft. Do not pull the hub assembly outwards to prevent possible deformation of the circlip in the joint. Take extra care with this type of drive shaft joint (easily damaged).

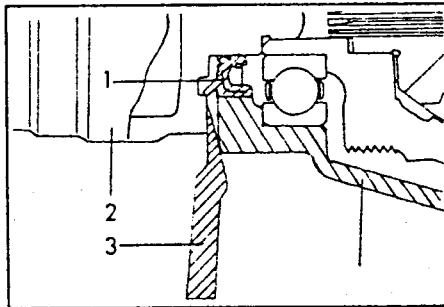

Fig. 9.2. — Removal of a drive shaft from the transmission. Take care not to damage the oil seal (1) by inserting the lever too far into the gap.

1 Oil seal 2 CV joint 3 Lever

- Attach the puller shown in Fig. 9.3. to two studs of the wheel

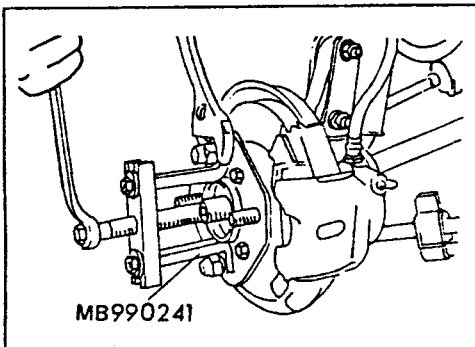

Fig. 9.3. — Removal of a wheel hub with the special puller.

hub and withdraw the wheel hub by tightening the centre spindle, i.e. push the drive shaft towards the inside. Take care that the inner end of the shaft cannot find anything solid as it is pushed out. The hub must be held against rotation during the removal operation.

- Withdraw the shaft towards the inside from the swivel joint and remove from the suspension.

NOTE: Do not remove the drive shaft with a hammer or a drift.

Check the drive shaft boots for damage or deterioration. Check the ball joint for excessive play and the splines for wear or damage.

The rubber boots can be replaced, if necessary, but we recommend to have this carried out at a Mitsubishi dealer, although the operation is fairly simple. If the boot of the inner joint has been replaced, set the length of the boot as specified in Section 9.0, measured as shown in Fig. 9.4, before securing the retaining clamps.

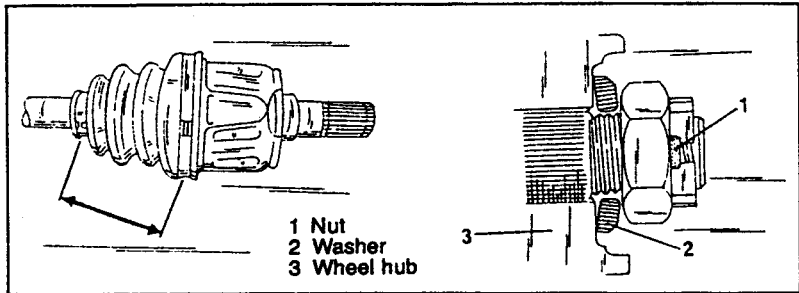

Fig. 9.4. — Measure the boot length as shown on the left. Refer to Section 9.0 for the length to be obtained. The R.H. view shows the correct fitting of the washer.

The installation of the drive shaft is a reversal of the removal procedure. Tighten the parts on the lower suspension arm, stabiliser, track rod ball joint, etc. to the correct torque settings.

The washer (2) in Fig. 9.4 behind the drive shaft nut must face with the curved part towards the outside, as shown in the illustration. Tighten the nut provisionally and finally tighten to 20 - 26 kgm (145 - 188 ft.lb.) when the wheels are back on the ground. Use a new split pin to secure the nut. As the torque of 26 kgm (188 ft.lb.) must not be exceeded, tighten the nut to the lower value and try to insert the split pin. If the holes are not in line, tighten to the next slot and insert the pin. Make sure that the joint operates properly.

9.2. Drive Shaft Rubber Boot and C.V. Joint Replacement

Different repair kits are available to repair drive shafts. Your dealer will be able to advise you regards availability and suitability for your particular model. As already mentioned, different shaft joints are fitted over the years, but note that Birfield joints and Rzeppa joints must not be dismantled.

9.2.1. Birfield Joint

As already mentioned above, this type of drive shaft joint, fitted to the outside of the drive shafts, must not be dismantled. Fig. 9.4a on the next page shows a drive shaft, indicating the parts which can be replaced. The shaft/joint assembly (10) must be replaced as a complete unit. A repair kit for the joint on the outside consists of the shaft with rubber boot and the parts of the dynamic damper.

9.2.2. Tripod Joint/Rubber Boot — Replacement

The individual parts of the joint are shown in Fig. 9.4a. Remove the retaining band for the rubber boot, using a screwdriver and remove the boot from the joint housing.

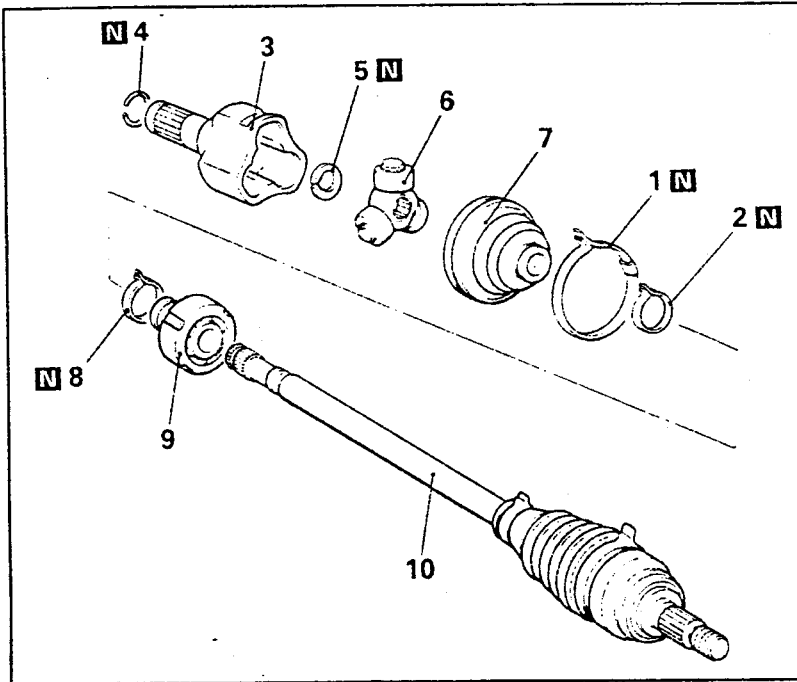

Fig. 9.4a. — Exploded view of a drive shaft.

- | | |
|----------------------------|--------------------------------------|
| 1 Rubber boot band (large) | 6 Spider assembly |
| 2 Rubber boot (small) | 7 Rubber boot |
| 3 Joint case | 8 Damper securing band |
| 4 Shaft circlip | 9 Dynamic damper |
| 5 Inner circlip | 10 Rzeppa or Birfield joint assembly |

Clean the grease from the joint, remove the circlip from the end of the shaft and remove the spider assembly. Fig. 9.5 shows where the circlip is located. Remove the retaining clamp securing the dynamic damper.

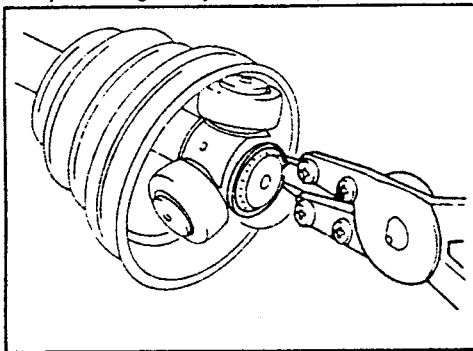

Fig. 9.5. — Removal of the circlip from the end of the spider.

To assemble the shaft, wrap tape around the spline part of the drive shaft and install the boot over the shaft.

Assemble the dynamic damper to the drive shaft. Slide the damper along the shaft until the specified dimension "A" shown in Fig. 9.6 is obtained. This dimension is different for petrol and diesel models and the L.H. and the R.H. shaft.

In the case of a petrol model set the dimension to 365 mm (14.37 in.) on the L.H. shaft and 200 mm (7.87 in.) on the right.

In the case of a diesel model, set the dimension to 375 mm (14.76 in.) on the L.H. shaft. A tolerance of 3 mm more or less is permissible. Measure between the front face of the joint face to the inner face of the damper. Secure the damper with the retaining clamp in this position.

Coat the spider assembly of the tripod joint and fit the spider over the end of the shaft. Fit a new circlip, making sure it enters the groove.

Fill the case of the tripod joint case with the grease supplied in the repair kit. 110 g are required. Fit the rubber boot bands and adjust the length of the rubber boot, measured as shown in Fig. 9.7, to the value given in Section 9.0.

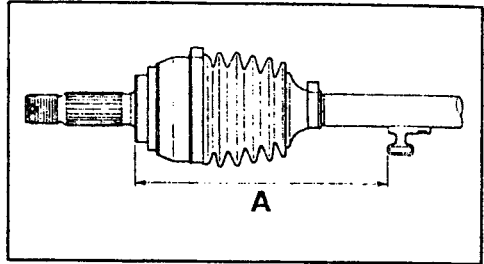

Fig. 9.6. — The fitting dimension of the dynamic damper "A" is measured between the arrow tips.

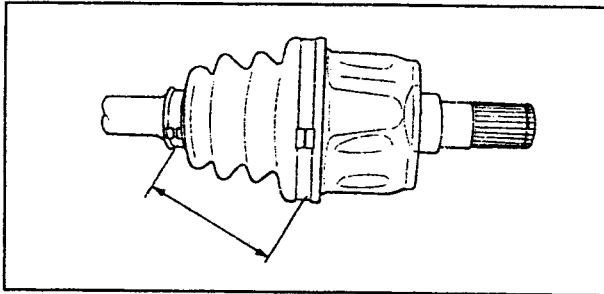

Fig. 9.7. — The length of the rubber boot is measured between the arrows.

9.3. Wheel Hub and Steering Knuckle Removal and Installation

Fig. 9.8 shows details of the parts which will have to be removed to take out the steering knuckle. The knuckle must be removed to replace the wheel bearing.

- Remove the drive shaft as described in Section 9.1. Remove the spacer ring from the end of the shaft and keep for re-assembly.
- Remove the two brake caliper mounting bolts and suspend the caliper with a piece of wire. Do not allow the caliper to hang on the flexible brake hose.
- If ABS is fitted, unscrew the speed sensor (1, Fig. 9.8) and withdraw it from the steering knuckle.
- Remove the split pin from the castellated nut on the track rod ball joint, unscrew the nut and separate the track rod ball joint with a ball joint extractor.
- Separate the ball joint connection at the bottom of the steering knuckle with a suitable puller (see Fig. 9.1).
- Remove the two bolts securing the spring strut to the steering knuckle joint and lift out the hub and steering knuckle as an assembly.

If the bearings are to be replaced, read under the next heading. Replace the oil seal in the rear of the steering knuckle if it shows signs of leakage. The installation of the com-

Fig. 9.8. — Details for the removal and installation of the steering knuckle, wheel hub, brake disc, etc.

- 1 Wheel speed sensor
- 2 Brake calliper
- 3 Brake disc
- 4 Split pin
- 5 Drive shaft nut
- 6 Lower suspension arm ball joint
- 7 Split pin
- 8 Track rod end
- 9 Drive shaft
- 10 Steering knuckle to spring strut bolt
- 11 Wheel hub and knuckle

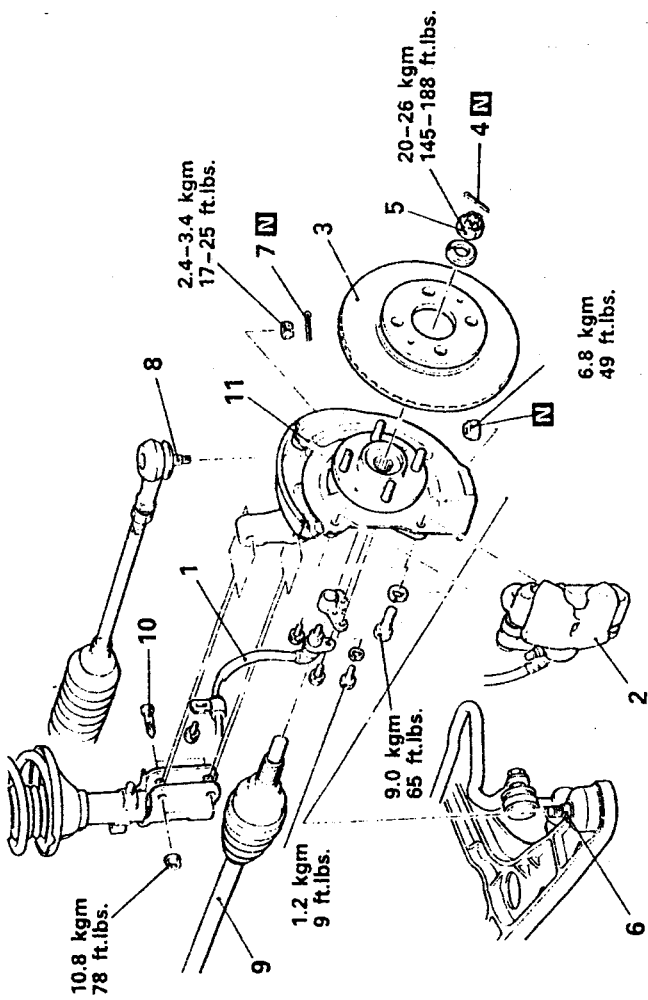

plete steering knuckle is a reversal of the removal procedure. Refer to the end of Section 10 and Fig. 9.8 for the relevant tightening torques. Section 9.1 describes the installation of the drive shaft. Special instructions must be noted if ABS is fitted:

- Temporarily fit the speed sensor into the steering knuckle. Take care not to make contact between the tip of the sensor and the teeth of the rotor on the wheel hub.
- Use feeler gauge of 0.3 - 0.9 mm in thickness and insert it between the tip of the sensor and the outside of the rotor teeth, as shown in Fig. 9.9. Push the sensor against the feeler gauge and tighten the screw.

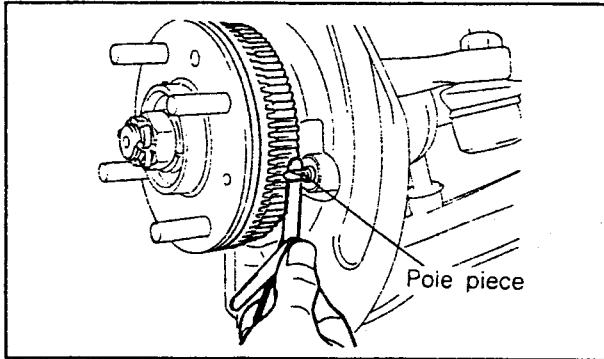

Fig. 9.9. — Measure the gap between the sensor end piece (pole piece) and the outside of the rotor teeth in the manner shown.

9.4. Replacement of Wheel Bearings

Normally a special puller is required to remove the wheel hub from the knuckle and to remove and refit the bearings. The bearing will have to be replaced any time the wheel

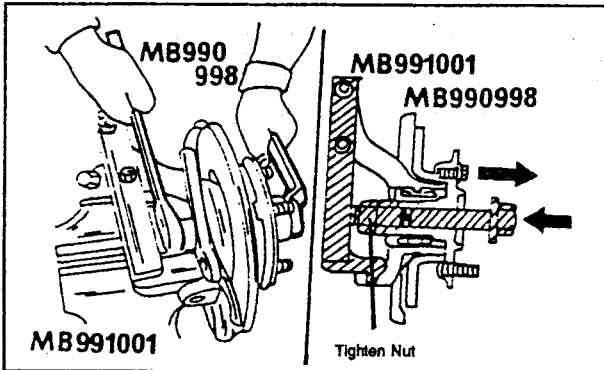

Fig. 9.10. — Use of the special tools to remove and refit the wheel bearings and wheel hub to the steering knuckle.

hub has been removed. A hammer and a drift can therefore be used to knock out the hub with the necessary care, but you will need a puller to withdraw the inner bearing

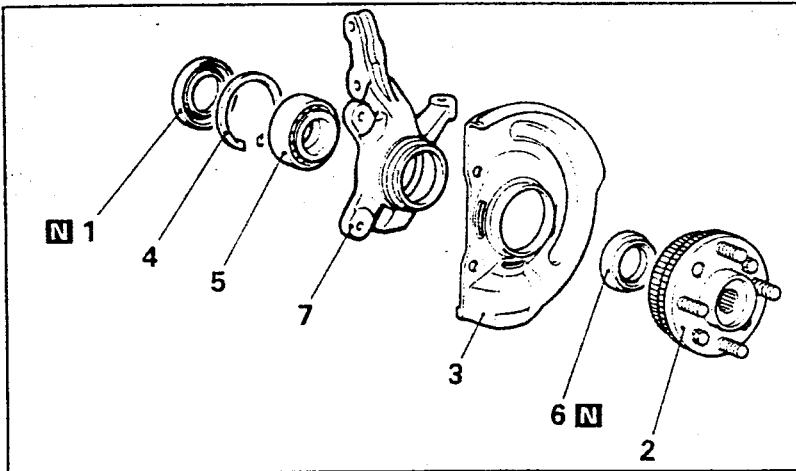

Fig. 9.11. — Wheel hub and wheel bearing. Only one bearing is used in each hub.

- | | |
|-------------------|--------------------|
| 1 Inner oil seal | 5 Wheel bearing |
| 2 Wheel hub | 6 Outer oil seal |
| 3 Dust cover | 7 Steering knuckle |
| 4 Bearing circlip | |

race which will remain on the wheel hub. Fig. 9.11 shows an exploded view of the bearings for reference. The following text assumed that the special tools shown in Fig. 9.11 are obtainable, as they will be required to refit the bearing.

- Remove the brake disc from the wheel hub and clamp the steering knuckle into a vice.
- Using a soft-metal drift, drive the wheel hub out of the wheel bearing from the rear of the steering knuckle, but only if the bearings need replacement. Otherwise use the extractor screw as shown in Fig. 9.10. The inner bearing race of the outer bearing will remain on the hub and must be removed with a suitable puller. As the oil seal will still be in position on the wheel hub you will have to cut it away in order to insert the claws of a two-arm puller underneath the bearing race. Take care not to damage the toothed rotor if the vehicle has ABS.
- Use a screwdriver to remove the inner oil seal, clean the exposed area and remove the large bearing circlip.
- Using a screwdriver, lever the oil seal out of the front of the steering knuckle.
- Thoroughly clean all parts.
- Coat the outside of the bearing and the inside of the steering knuckle with bearing grease and fit the bearing into the knuckle from the inside towards the outside. A handpress should be used if at all possible. Fill the bearing with multi-purpose grease and then fit the bearing circlip. Drive in the oil seal at the outside until the outer face is flush with the steering knuckle and wipe off surplus grease.

The wheel bearing torque must now be adjusted. The special tools shown in the illustrations are used in order to ensure the correct torque and end float. As there are, however, no adjustments possible, we take a chance and say that torque and end float will be in order, *provided that the wheel bearing has been fitted in accordance with the instructions above and the bearing was not damaged during installation*. If the tools can be obtained, proceed as follows:

- Use the extractor bolt, used for removal into the wheel hub and the bearings and tighten the nut to 20 to 26 kgm (145 - 188 ft.lb.), at the same time counterholding the bolt head (see Fig. 9.10). Rotate the wheel hub a few times during the tightening operation to settle the bearings.

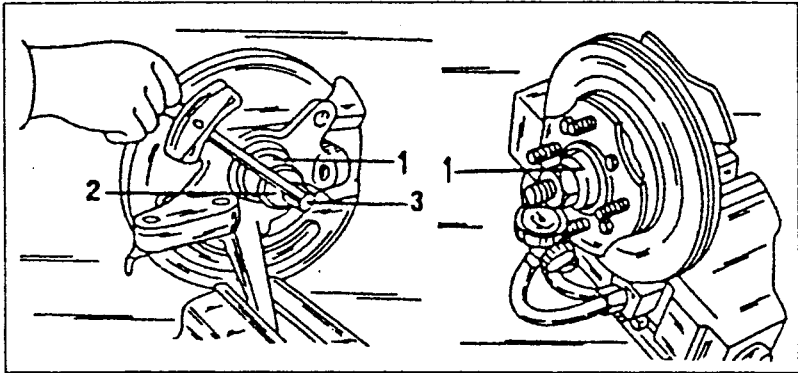

Fig. 9.12. — Checking the starting torque of the wheel hub (left) and the end play of the wheel bearings (right).

1 Special tool MB990998 2 Special tool MB990326 3 Special tool MB990685

- Measure the wheel hub starting torque with a torque wrench as shown in Fig. 9.12 (left) and write down the value. It should be around 18 kg.cm. (16 in.lbs.) or less. Next the end float of the wheel bearings must be measured with a dial gauge, as shown in Fig. 9.12 (right). Move the hub to and fro (the extractor bolt must be still in position) and read off the dial gauge. The play must not exceed 0.2 mm (0.008 in.).
- If either of these measurements are incorrect, and the nut has been tightened to the correct torque, remove the hub and bearing once more, and start again, as something has not been fitted correctly — but remember, the bearing will have to be replaced once more.
- Remove the special tool, grease the inside of the steering knuckle and the bearing and drive a new oil seal from the drive shaft side into the steering knuckle. Wipe off surplus grease. Make sure to coat the oil seal lip with grease.
- Refit the steering knuckle in reverse order to the removal procedure to the spring strut and the suspension arm and refit the drive shaft.

9.5. Drive Shafts and Hubs — Tightening Torques

Drive shaft nut:	20 - 26 kgm (145 - 188 ft.lb.)
Knuckle to strut assembly:	10.8 kgm (78 ft.lb.)
Other tightening torques:	See "Front Suspension"

10 FRONT SUSPENSION

10.0. Technical Data

Type: McPherson spring struts with integral shock ab-

sorbers and coil springs, lower suspension arms and front stabiliser bar.

Wheel Alignment

Camber:	20' ± 30'
Castor:	2° 10' ± 40'
Kingpin inclination:	13° 50'
Toe-in (measured at centre of tyre tread):	0 ± 3.0 mm (0.12 in.)
Toe-in (measured at rim edge):	0 ± 1.5 mm (0.06 in.)

Coil Springs

	Petrol Engine	Diesel Engine
Free Length:		
Models to May 1992:	313 mm (12.323 in.)	327.5 mm (12.894 in.)
Models from May 1992:	313 mm (12.323 in.)	327.5 mm (12.894 in.) SPACE RUNNER 335.0 mm (13.189 in.) SPACE WAGON
Coil Spring Colour Codes:		
Manual Transmission:	1 x light blue	1 x orange
Automatic transmission:	2 x light blue	To May 1992 1 x orange
From May 1992		SPACE RUNNER 2 x orange
Wire diameter:	13.8 mm (0.543 in.)	SPACE WAGON 14.2 mm (0.559 in.) 14.3 mm (0.563 in.) SPACE WAGON From May 1992
Outer diameter:	160.0 mm (6.299 in.)	160.0 mm (6.299 in.)

Shock Absorbers

Type:	Hydraulic, telescopic, double-acting
Max. length:	495 mm (19.5 in.)
Min. compressed length:	345 mm (13.6 in.)
Stroke:	150 mm (5.9 in.)

10.1. Front Spring Struts

10.1.1. Removal

A long socket, which fits the upper nut of the spring strut piston nut, is required to dismantle the spring strut (for example to replace the spring). Fig. 10.1 shows the parts which will have to be removed to take out a spring strut.

- Jack up the front of the vehicle and place support stands under the sides of the body. Remove the wheel on the side in question.
- Remove the daytime running lamp relay and the control unit from the top of the strut, where fitted.
- Disconnect the brake hose from the rigid brake pipe. Plug the open end of the pipe in a suitable manner to prevent entry of dirt. Knock out the retaining plate for the brake hose attachment and withdraw the hose from its bracket on the spring strut. Plug the end of the brake hose to prevent entry of dirt. This can be carried out by wrapping a piece of tape around the hose end. It is also possible to simply unscrew the bracket (2) for the brake pipe without disconnecting the brake hose connection.
- If ABS is fitted, unscrew a nut and remove the bracket (3) from the spring strut.
- From below the vehicle remove the two bolts securing the spring strut to the steering knuckle. Push the steering knuckle away from the spring strut. If the brake hose has not been disconnected, take care not to stretch it.

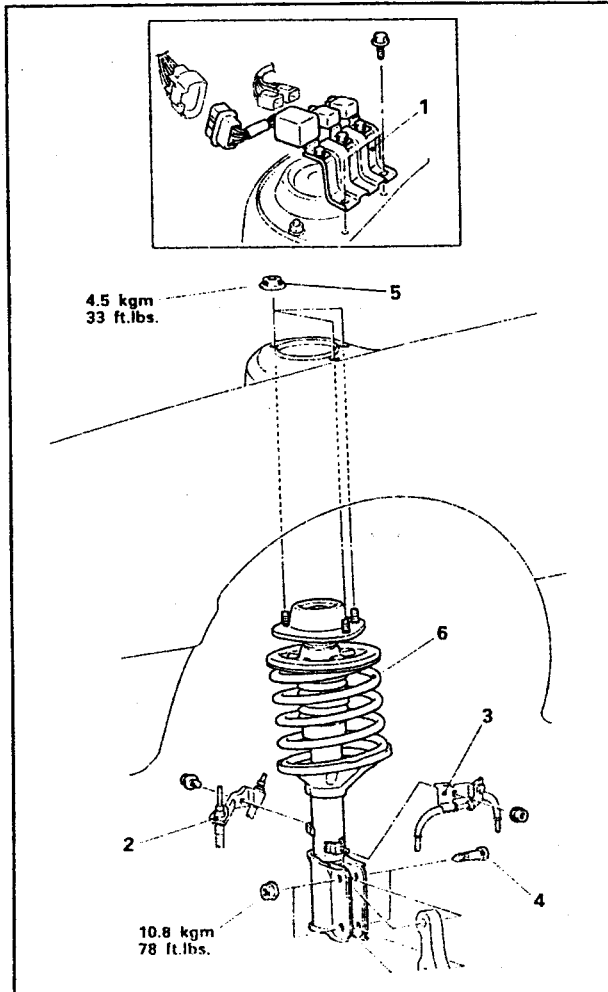

Fig. 10.1. — Details for the removal and installation of a front spring strut.

- | | |
|----------------------|------------------|
| 1 Relay assembly | 4 Bolts |
| 2 Pipe clamp bracket | 5 Flange nuts |
| 3 Front speed sensor | 6 Strut assembly |

- From the engine compartment remove the two flange nuts (5) from the upper spring strut mounting and remove the strut towards the bottom. The strut must be held from below before it is taken out through the wheel arch.
- If the spring strut is to be dismantled, for example to replace a coil spring, it may be of advantage to slacken the nut in the centre of the spring strut bearing. Remove the dust cover to expose the nut. Make sure the nut is slackened by no more than 2 or 3 turns.

10.1.2. Dismantling a Spring Strut

Before a spring strut is dismantled, note the following points before commencement of any work:

- The coil springs of the various models are not the same. Mainly models with diesel engine have been changed after May 1992. This must be noted when ordering new parts.
- The springs on the R.H. and L.H. sides are the same, but when both springs are removed at once, care should be taken to identify them accordingly.
- Never clamp the spring strut directly into a vice. Make up a plate and attach this to the spring strut. Clamp this plate in the vice.
- The shock absorbers cannot be replaced. A damaged shock absorber means a new spring strut.
- A spring compressor is required to replace parts of the spring strut.
- Referring to Fig. 10.2, compress the spring with the special tool shown or any other spring compressor that can be placed over 3 or 4 coils. Spring compressors can be hired from tool hire companies.
- Remove the plastic cap in the centre of the spring strut and remove the nut in the centre of the upper strut bearing. This normally requires the special tools shown in Fig. 10.3. Clamp the spring strut into a vice.
- Remove the parts of the upper bearing (3) and the coil spring (8) bearing from the spring strut. Remove the rebound rubber (6) from the strut. The numbers refer to the exploded view on the next page.
- Finally remove the protective gaiter (7), the upper spring rubber (5) and the upper spring seal (4).

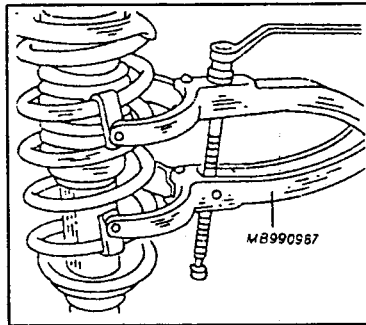

Fig. 10.2. — Compressing a coil spring with the special spring compressor.

Thoroughly clean all parts with petrol and dry, if possible, with compressed air. Other lint-free rags to wipe off remaining petrol

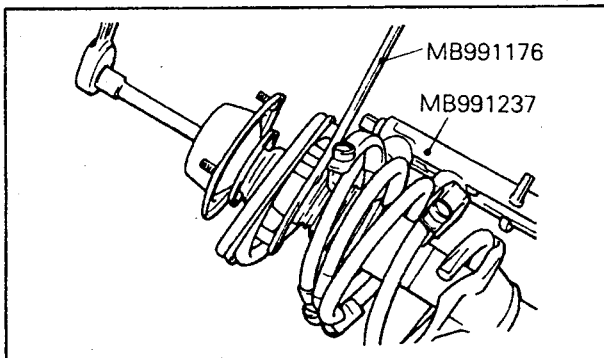

Fig. 10.3. — Removal of the piston rod nut. The piston rod is held on the inside to prevent it from rotating, when the nut is slackened. The spring must be compressed before the strut is dismantled.

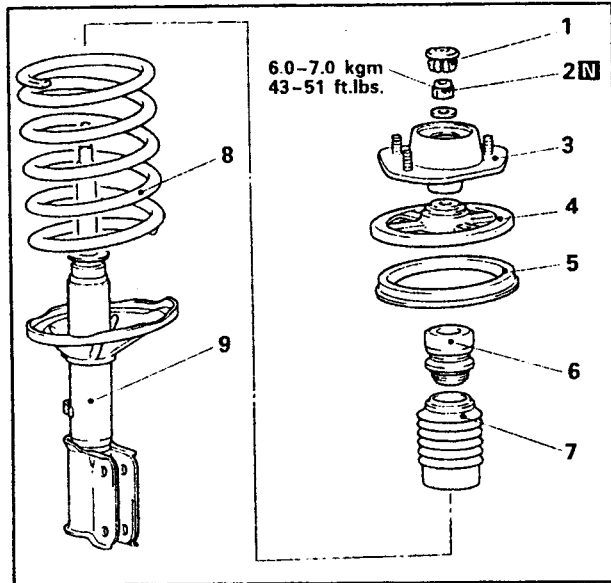

Fig. 10.4. — A dismantled spring strut.

- | | |
|---------------------|------------------|
| 1 Dust cover | 6 Rebound rubber |
| 2 Self-locking nut | 7 Dust cover |
| 3 Strut bearing | 8 Coil spring |
| 4 Upper spring seat | 9 Spring strut |
| 5 Upper spring pad | |

stains. Make sure that parts are free of dust and dirt. Worn or damaged parts must always be replaced, but ensure that the correct parts are fitted. Your Mitsubishi dealer will have the latest information.

10.1.3. Assembling a Spring Strut

Refer to Fig. 10.4 for the following operations, but note the following points:

- Before fitting a spring, check that the same colour mark as seen on the original spring is visible. The mark is approx. in the centre of the coil windings.
- Fit the rebound rubber in the direction shown in Fig. 10.4.
- Fit the compressed spring over the spring strut, taking care to position it correctly over the spring seat on the strut plate.
- Fit the parts over the spring strut in accordance with the exploded view (Fig. 10.4).
- Fit the spring seat (4) and the upper strut bearing (3). A hole in the upper spring seat (4) and the lower spring seat (the built-in plate on the spring strut) must be aligned when the upper spring seat is fitted. To make sure that the alignment is correct, insert a metal rod of 10 mm diameter through the two holes before the piston rod nut is tightened.
- Fit a self-locking nut to the piston rod and tighten to 6.0 - 7.0 kgm (43 - 51 ft.lb.). If possible, use the special tool shown in Fig. 10.3 for this operation.

- Check once more if the top and bottom of the spring is aligned with the respective spring seal grooves and release the spring compressor, ensuring that the spring seats do not become twisted.
- Smear some multi-purpose grease to the bearing part of the strut bearing, taking care not to allow the grease to get to the rubber part. Fit the plastic cap (1) into the centre of the spring strut. The spring strut is now ready for installation.

10.1.4. Installation of Spring Strut

The installation of the spring strut is a reversal of the removal procedure. Tighten the mounting bolts securing the steering knuckle to the spring strut to 10.8 kgm (78 ft.lb.). After installation turn the steering from one lock into the other to make sure the brake hose cannot touch other parts of the front suspension. Bleed the brake system.

10.2. Front Wheel Hubs

The front wheel hubs have already been covered in Section 10 together with the drive shafts. Refer to the relevant Section number if the wheel hubs or the wheel bearings are to be removed.

10.3. Lower Suspension Arm

10.3.1. Removal

The one-piece rubber bush in the mounting eye of the lower suspension arms cannot be replaced. The bush more likely to wear is the one on the other side (the one held by

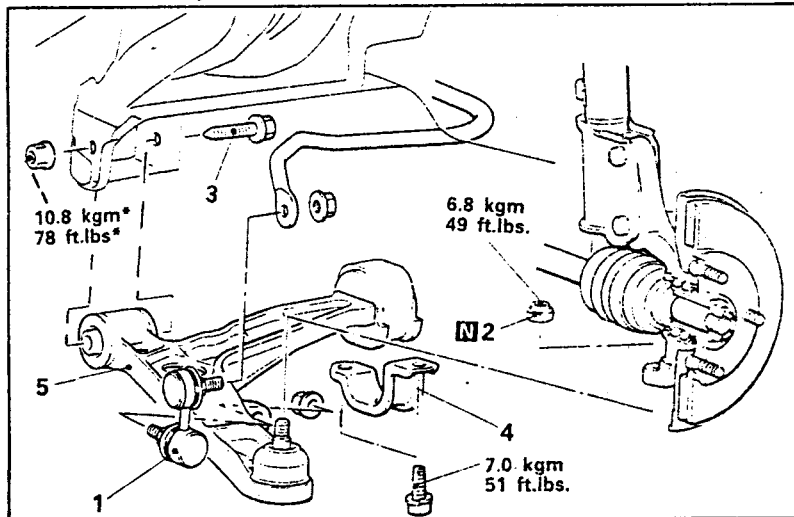

Fig. 105. — Details for the removal and installation of a lower suspension arm. Note that the nut of bolt (3) must be tightened when the weight of the vehicle is resting on the front wheels.

- | | |
|--------------------|------------------------|
| 1 Stabiliser link | 4 Mounting clamp |
| 2 Self-locking nut | 5 Lower suspension arm |
| 3 Mounting bolt | |

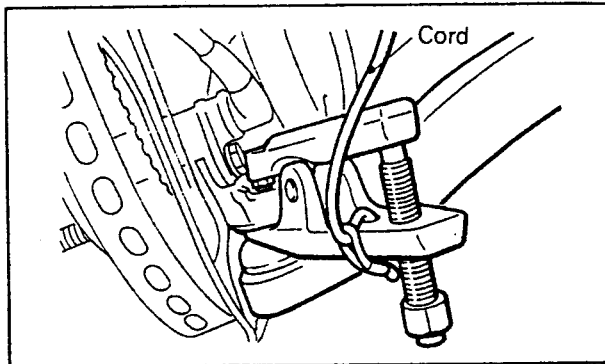

Fig. 10.6 — Separating the suspension ball joint from the steering knuckle with the special extractor. A similar tool can be used.

the clamp). This is fitted over a spigot on the suspension arm. The bush must, however, be fitted at a certain angle, i.e. if the old one is removed it is important to mark the position of the original, fitted bush. Fig. 10.5 shows an exploded view of the suspension arm together with its component parts. The suspension arm can easily be removed without dismantling other major parts of the front suspension.

- Support the front end of the vehicle on secure chassis stands. Remove the panel from underneath the front end.
- Remove stabiliser bar link from the suspension arm at one side and from the end of the stabiliser bar at the other side.
- Remove the suspension ball joint nut and separate the ball joint connection as shown in Fig. 10.6. Take care not to damage the rubber dust cap of the ball joint. To separate the ball joint, slacken the nut a few turns and then use the extractor as shown. An ordinary ball joint puller can also be used. Note the cord to secure the puller to the front suspension to prevent it from "flying off".
- Remove the suspension arm from its inner mounting. Note from which side the fulcrum bolt is fitted before driving out the bolt. Remove the two other bolts from below. Remove the suspension arm from the front suspension.

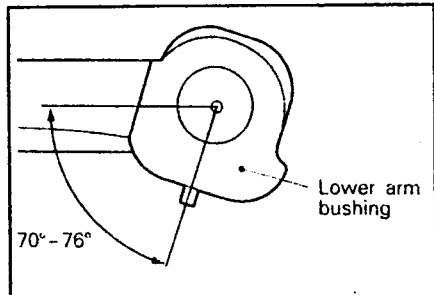

Fig. 10.7 — The angle position of the suspension arm rubber bush. Mark the old bush on the arm before removal.

10.3.2. Suspension Arm Repairs

The bush in the mounting eye end end of the suspension arm cannot be replaced. Excessive wear of this bush will mean a new suspension arm. The bush over the suspension arm spigot can be replaced in the following manner:

- Mark the fitted position of the bush on the suspension arm to obtain the angle shown in Fig. 10.7. Soak the old bush and the spigot with soapy water and then use a screwdriver to lever the bush off the spigot.

- Coat the new bush with soapy water and slide it over the spigot. You will now have to turn the bush until the marked position of the old bush is obtained. As there is a tolerance of 6° there should be no difficulties.
- The bush must now be pressed over the spigot. As you can see from Fig. 10.8 there must be a gap of 1 to 3 mm between the arm and the end face of the bush. To obtain this gap, use a feeler gauge of the given thickness. Press the bush over the arm as shown in the illustration. When the gap is nearly closed, insert the feeler gauge and press the bush fully in position until the feeler gauge can just be removed.

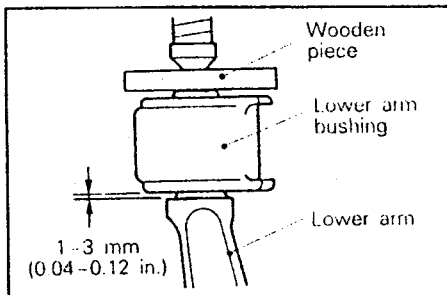

Fig. 10.8 — Fitting the bush over the suspension arm spigot.

Check the suspension arm for visible damage. If in doubt (for example after an accident), have the arm checked for distortion at your dealer.

Suspension ball joints cannot be dismantled. The end float of the ball joint should not exceed 0.10 mm (0.004 in.). The complete suspension arm must be replaced, if this is the case. The joint (arm) should also be replaced, if the rubber dust cap is torn, as dirt may have entered the joint. Otherwise replace the rubber dust boot. To replace the rubber dust boot, use a screwdriver and pry off the dust cap as shown in Fig. 10.9. Thoroughly clean the inside of the joint. Fill the joint with M.P. grease and fit a new dust cap in position, carefully using a piece of tube of suitable diameter.

To check the turning torque of a ball joint, a torque wrench with small divisions is required. Fit the nut to the ball joint stud and apply the torque wrench. Rotate the stud with the torque wrench and read off the indication when the ball joint stud starts to rotate. This should be at 20 to 90 kgcm (17 to 78 in.lb.). When the stud is continuously turned with a torque wrench, there should be a reading of 30 - 60 kgcm (26 - 52 in.lb.). Replace the suspension arm, if it fails the test.

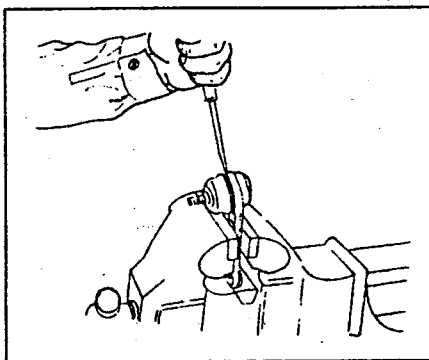

Fig. 10.9 — Removal of the suspension ball joint rubber dust cap.

10.33. Suspension Arm — Installation

Insert the suspension arm into the bracket on the front suspension member, drive in the bolt, with the head in its original position, as shown in Fig. 10.5, and tighten the nut finger-tight.

Place the mounting clamp over the rubber bush and fit the two bolts finger-tight. Reconnect the stabiliser bar link. Tighten the two nuts to 4.0 kgm (30 ft.lb.).

The remaining installation is a reversal of the removal procedure. Use a new nut for the ball joint, if the old one has lost its self-locking feature. Tighten the nut to 7.0 kgm.

The vehicle must now be lowered to the ground to tighten the remaining suspension arm mountings. As it will be difficult to get a torque wrench and socket to the nuts, due to the limited space underneath the vehicle, it may be of advantage to obtain two ramps to drive the front wheels onto the ramps. Tighten the two mounting clamp bolts to 7.0 kgm (51 ft.lb.) and the nut of the inner fulcrum bolt to 10.8 kgm (78 ft.lb.). This will ensure that the suspension arm bushes are pre-loaded for their proper operating position.

10.4. Stabiliser Bar

10.4.1. Removal and Installation

It should also be noted that the attachment of the stabiliser bar is different on models with petrol and diesel engine, but additionally the removal is far more complicated if a diesel engine is fitted. The engine carrier underneath the front of the vehicle must be removed to take out the stabiliser bar.

Models with Petrol Engine

- Remove the front exhaust pipe from the exhaust manifold. The exhaust pipe must be detached from its suspension bracket on the side and at the rear end. This will mean that the pipe can drop down. To prevent this, use a piece of wire and tie the pipe to a convenient point on the chassis. The gasket between manifold and pipe flange must always be replaced.
- Remove the nuts securing the stabiliser bar links at both ends and take out the links (on both sides of the vehicle).
- On each side of the vehicle remove the two bolts securing the stabiliser bar mounting clamp and take off the clamps.
- Remove the stabiliser bar from underneath the vehicle.

Stabiliser bar links with worn out ball joints must be replaced. Often overlooked are seized ball joints in the links. Joints can be checked in a similar manner as described for the suspension ball joints (refer to Page 124). The ball joints should start to rotate at 17 - 32 kgcm (15 - 28 in.lb.). Damaged rubber boots can be replaced. Remove the wire clip with a screwdriver. The inside of the joint should be filled with M.P. grease. Fit the new rubber boot over the joint and attach the wire clip. The open end of the clip should be away from the link.

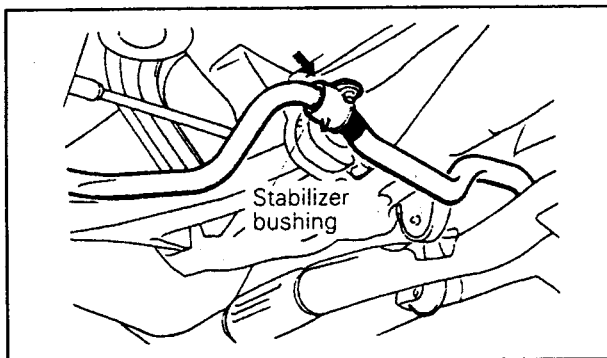

Fig. 10.10. — Fitting the stabiliser bar (refer to text).

The installation of the stabiliser bar is a reversal of the removal procedure, noting the following points:

- Position the stabiliser bar and loosely attach it with the rubber bushes and clamps.
- Push the stabiliser bar to one side so that the L.H. end of the stabiliser bar marking and the edge of the mounting bush clamp are aligned as shown in Fig. 10.10. In this position tighten the four mounting clamp bolts to 2.2 kgm (16 ft.lb.).
- Re-connect the stabiliser links and tighten the nuts to 4.0 kgm (30 ft.lb.).
- Refit the exhaust pipe to the manifold. New nuts must be used here. Tighten the nuts evenly to 4.5 kgm (33 ft.lb.). The suspension hanger bolts are tightened to 1.0 - 1.5 kgm (7 - 11 ft.lb.).

Models with Diesel Engine

- Jack up the front end of the vehicle, place chassis stands underneath the side of the body and remove the front wheels.
- Disconnect the track rod ball joints from the steering lever on each side of the vehicle.
- Place a mobile jack underneath the longitudinal engine member and operate the jack until the member is just under tension. Remove the two bolts nearest the steering from underneath and take off the spacer bushes and lower rubber mountings. Now remove the nut and bolt securing the roller stopper to the chassis. The jack must be operated to the best position to remove the bolt.

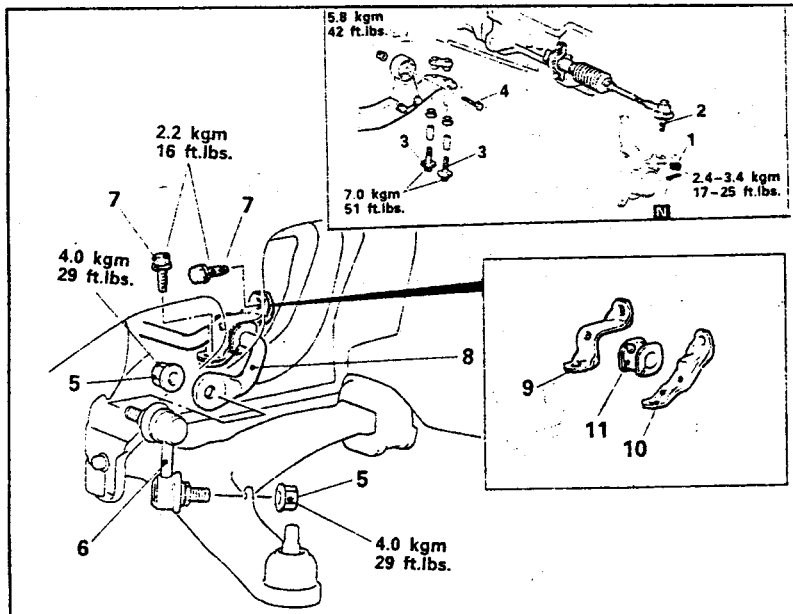

Fig. 10.11. — Details for the removal and installation of the stabiliser bar if a diesel engine is fitted.

- | | |
|-----------------------|------------------------|
| 1 Castle nut | 7 Mounting clamp bolts |
| 2 Track rod end | 8 Stabiliser bar |
| 3 Mounting bolts | 9 Upper clamp half |
| 4 Roller stopper bolt | 10 Lower clamp half |
| 5 Nut | 11 Stabiliser bar bush |
| 6 Stabiliser bar link | |

- On each side of the vehicle remove the stabiliser bar links, from the stabiliser bar at the upper end and the suspension arm at the lower end.
- Remove the two bolts securing the stabiliser clamp halves. Remove the upper half of the clamp and after lifting the bar, remove the lower half. The stabiliser bar can now be removed. Again move the engine member with the help of the jack to remove the bar.

Check the link ball joints in the manner described. The installation is a reversal of the removal procedure. Each stabiliser bar end has a mark for the installation of the bar. The mounting clamps must be arranged so that 7 mm of the marking is still visible. Fit the mounting clamps as shown in Fig. 10.11, noting their different shape. The bolts are tightened to 2.2 kgm (16 ft.lb.). The ball joint nuts to 4.0 kgm (30 ft.lb.). The remaining torque values are shown in Fig. 10.11.

10.5. Front Wheel Alignment

The vehicle must be standing on level ground and the tyres must have their correct pressure. Steering, front suspension and wheel bearings must be in proper working order. Excessive play in the wheel bearings or suspension and steering joints will give incorrect readings.

Camber, castor and king-pin inclination cannot be adjusted. If the values obtained are outside the figures given in Section 10.0 it can be assumed that parts of the front suspension are distorted. In this case check the front suspension and replace parts as necessary.

When checking the camber and castor values have the vehicle at its operating weight, i.e. in the condition it is used on the road. The fuel tank should be full.

10.5.1. Adjusting the Toe-in

The toe-in is adjusted by shortening or lengthening the track rods after slackening the locknuts. The track rod ball joint ends have threads and can rotate on the ball joint on

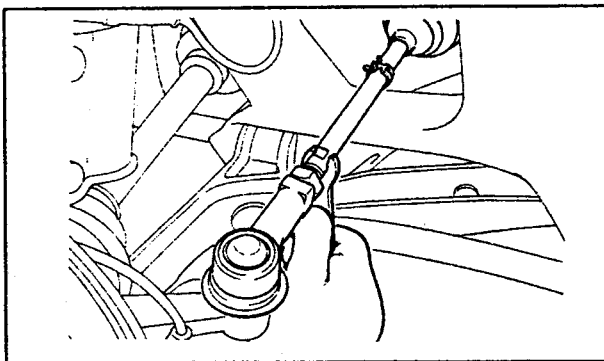

Fig. 10.12. — Adjusting the toe-in

the inside. This will allow the adjustment of the track rods without separating the ball joint connections from the steering levers. Measure the toe-in as follows:

- Place a tracking gauge in height of the front wheel hubs against the centre of the tyres in front of the vehicle. Set the pointers to "Zero" and mark the tyres with chalk

where the pointers are located. The pointers of the tracking gauge can also be placed against the outer edge of the wheel rims, depending what type of tracking gauge is used.

- Remove the tracking gauge and push the vehicle forward by half a turn of the wheels, until the chalk marks are once more at the height of the hubs, but this time at the rear of the tyres.
- Place the tracking gauge in position behind the front wheels and set the pointers against the centres of the tyres or the wheel rim edges. The difference between the first measurement at the front and the second measurement at the rear should be 0 mm, with a tolerance of plus or minus 3.0 mm (0.12 in.). This value applies when the measurement takes place at the centre of the tyres. If the wheels rims are used, the reading should also be "0", but only a tolerance of 1.5 mm (0.06 in.) is permissible. If the distance at the rear is smaller than at the front, the wheels are adjusted to toe-in; if the distance at the front is greater than at the rear, the wheels have toe-out.
- To correct the adjustment, slacken the locknut in Fig. 10.12 of both track rods and slacken the outer retaining clamp of both steering gaiters. Turn both track rods with an open-ended spanner. Half a turn of the track rod will alter the setting by approx.
- ~~Recheck the~~ setting as described above and if correct, tighten the locknuts to 5.0 - 5.5 kgm (36 - 39 ft.lb.). Also tighten the steering gaiter clamps.
- Check the position of the steering wheel and reset it to the centre position if necessary.

Excessive wear of the tyres on the outside or inside is normally an indication of in incorrect wheel alignment.

10.5.2 Castor and Camber

Measure the camber and castor with a conventional castor checking gauge. If the values are outside the figures given in Section 10.0, or the difference between the two wheels is more than 30', have the front suspension checked professionally, as some distortion will have taken place.

10.6. Front Suspension — Tightening Torques

Spring strut piston rod nut:	6.0 - 7.0 kgm (43 - 51 ft.lb.)
Upper spring strut bearing to body:	4.5 kgm (33 ft.lb.)
Steering knuckle to spring strut:	10.8 kgm (78 ft.lb.)
Stabiliser bar to connecting link, links to suspension arm:	4.0 kgm (30 ft.lb.)
Suspension arm, inner fulcrum bolt:	10.8 kgm (78.0 ft.lb.)
Suspension arm mounting clamp:	7.0 kgm (51 ft.lb.)
Steering knuckle to ball joint:	6.8 kgm (49 ft.lb.)
Stabiliser mounting clamps:	2.2 kgm (16 ft.lb.)
Steering track rod locknut:	5 - 5.5 kgm (36 - 39 ft.lb.)

11 REAR SUSPENSION

11.0. Technical Data

Type: Suspension arms with coil springs, hydraulic, telescopic shock absorbers and stabiliser bar

Coil Springs:	
Wire Diameter:	
Space Runner:	14.2 mm (0.559 in.)
Space Wagon:	15.2 mm (0.603 in.)
Spring Inner Diameter:	
Space Runner:	114.2 mm (4.496 in.)
Space Wagon:	115.2 mm (4.535 in.)
Spring Identification:	
Space Runner:	2 x red
Space Wagon:	2 x light blue
Shock Absorbers	
Max. extended length:	612.0 mm (24.1 in.)
Min. compressed length:	394.0 mm (15.5 in.)
Piston stroke:	218.0 mm (8.6 in.)

The rear suspension consists of a suspension crossmember with a semi-trailing suspension arm on either side, coil springs and hydraulic telescopic shock absorbers. A stabiliser bar is fitted to the rear suspension, connected to the bottom of the lower suspension arm.

Fig. 11.1 shows the component parts of the rear suspension without the stabiliser bar.

11.1. Rear Suspension

11.1.1. Removal and Installation of Shock Absorber

Fig. 11.1 shows how the shock absorber is fitted to the suspension arm and at the upper end, but as you will see on the R.H. side of the illustration, the unit will have to be dismantled in order to replace a shock absorber.

- Jack up the rear end of the vehicle and place chassis stands underneath the sides of the body. The wheel can be removed to improve the access.
- Place the mobile jack underneath the suspension arm and lift it up, until the shock absorber is compressed. Remove the nut (1) and take off the spring washer and the washer.
- In the inside of the cargo room remove the covering (2) to expose the cap (3). Remove the cap from the top of the shock absorber.
- Remove the two nuts (4) and lift out the shock absorber towards the bottom.

To replace the shock absorber, dismantle it by referring to the R.H. view of Fig. 11.1:

- Clamp the shock absorber with the lower end into a vice and remove the nut (6). The nut is self-locking and must be replaced, if removed.
- Remove the metal plate (7), the distance sleeve (8) and the upper rubber bush (9) from the upper end and remove the shock absorber mounting bracket (10).
- Remove the lower bush (11), the cup (12) and the rebound rubber (13). The smaller end of the rebound rubber is at the bottom.
- The shock absorber is now free and can be replaced.

The assembly of the new shock absorber is a reversal of the removal procedure. Arrange the parts as shown in the illustration. Tighten the new self-locking nut to 2.5 kgm. The shock absorber is now ready for installation.

The installation is carried out in reverse order. The lower end of the shock absorber can be fitted the wrong way round. Have a look at the shock absorber mounting eye and you will see that one side of the mounting bush is wider. This side must be arranged against the suspension arm. Tighten the mountings to the values given in Fig. 11.1. Refit the cap (3) and the cover (2) to complete the job.

Fig. 11.1. — Details for the removal and installation of a shock absorber.

- 1 Nut
- 2 Cover, inside vehicle
- 3 Cap over upper mounting
- 4 Securing nut
- 5 Shock absorber, assembled
- 6 Self-locking nut
- 7 Washer
- 8 Spacer sleeve
- 9 Upper bush
- 10 Mounting bracket
- 11 Lower bush
- 12 Cup assembly
- 13 Rebound rubber
- 14 Dust cover
- 15 Shock absorber

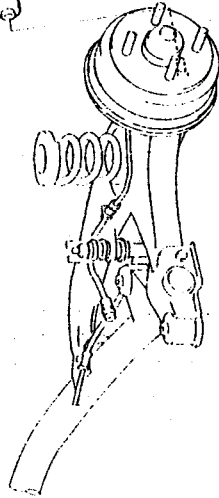
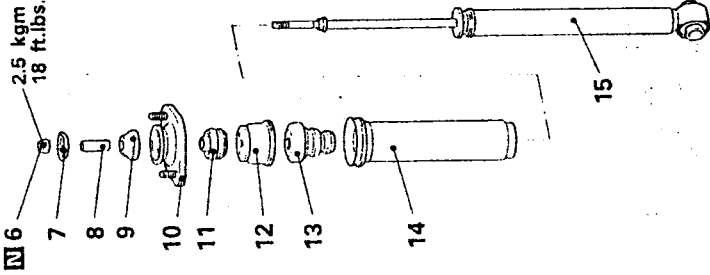
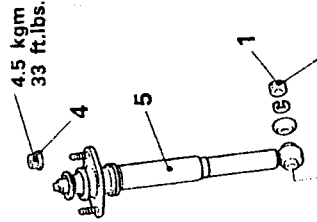
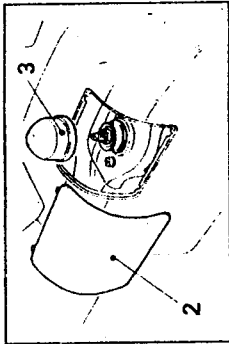

11.1.2 Removal and Installation of Rear Springs

Fig. 11.2 shows in detail how the coil spring is fitted between the underbody of the vehicle and the suspension arm. We refer immediately to the two mounting bolts for the suspension arm on the crossmember. These must be slackened in order to lower the suspension arm, but must be tightened when the vehicle is in the unladen condition and resting with the weight on the wheels.

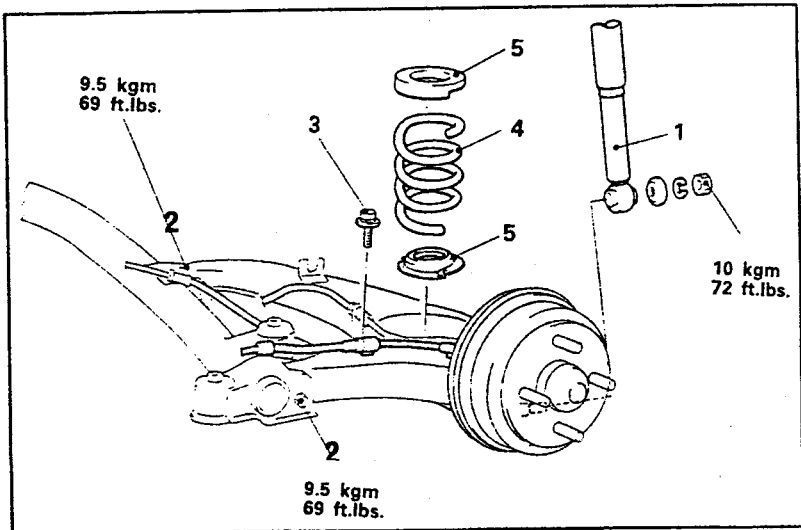

Fig. 11.2. — Details for the removal and installation of a rear coil spring.

- | | |
|---------------------------------|----------------|
| 1 Shock absorber | 4 Coil spring |
| 2 Suspension arm bolts | 5 Spring seats |
| 3 Speed sensor clamp bolt (ABS) | |

A rear coil spring is removed and refitted as follows:

- Remove the stabiliser bar as described alter on.
- Remove the shock absorber from the lower mounting as described in the last section. Leave the jack underneath the suspension arm.
- On the inner attachment of the suspension arm you will see an eccentric adjusting bolt, serving as fulcrum bolt for the suspension arm. The graduated disc on the bolt must be marked by painting a line across the disc and the crossmember or use a scribe and make a mark accordingly. Allow the paint to dry, if used.
- Slacken the nut on the other side of the bolt head and also slacken the nut and bolt securing the outer end of the suspension arm. There is no need to remove the nuts completely.
- Slowly lower the suspension arm. The spring will extend until it is free to be taken out. Remove the upper and lower spring seats.

Check the coil spring for cracks, damage or deterioration and the spring seats for cracks or wear. Replace parts as necessary. Rear springs for the Space Runner and the Space Wagon are not the same.

The installation is a reversal of the removal procedure, but a second person is required to operate the jack underneath the suspension arm to guide the rear spring in position:

Fig. 11.3. — Details for the removal and installation of a rear suspension arm. Refer to Page 133 for legend.

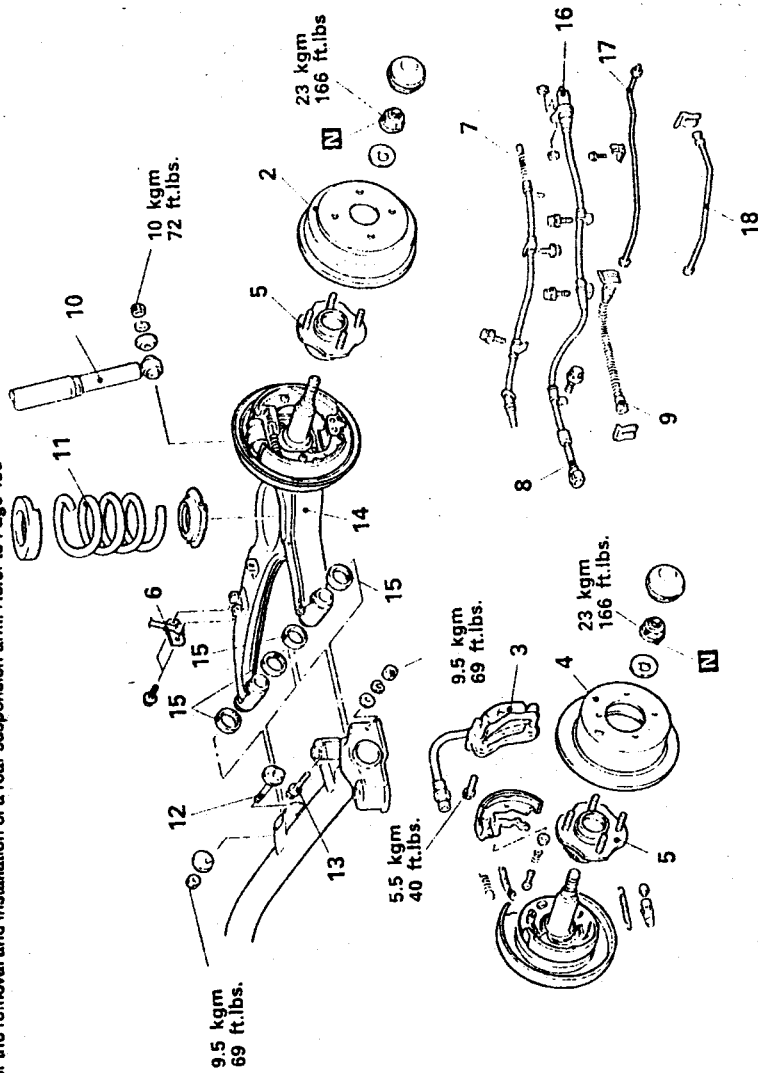

Legend to Fig. 11.3 (opposite page) for models with drum brakes and disc brakes (ABS)

2 Brake drum	10 Shock absorber
3 Brake caliper (with ABS)	11 Coil spring
4 Brake disc (with ABS)	12 Fulcrum shaft
5 Wheel hub assembly	13 Flange bolt
6 Link bracket, Space Wagon	14 Lower suspension arm
7 Handbrake cable connection	15 Stopper rings
8 Rear sensor connector (ABS)	16 Rear speed sensor
9 Brake hose	17 Brake pipe
	18 Brake pipe (with ABS)

-
- Place the two spring seats over the spring ends. The ends of the spring must be placed against the location stops on the spring seats.
 - Fit the spring onto the suspension arm, with both spring seats in position and ask for the jack to be raised. Guide the spring in position at the upper end. Raising the jack further will compress the spring enough for the shock absorber to be connected. Check once more that both spring seats are in their correct position.
 - Re-connect the shock absorber as described in Section 11.2.1.

11.1.3 Suspension Arms — Removal and Installation

Fig. 11.3 shows details for the removal and installation of a suspension arm. Note the differences between models without and with ABS. The rear wheel alignment should be checked after the suspension arm has been refitted. Proceed as follows to remove a suspension arm:

- Jack up the rear end of the vehicle, place chassis stands underneath the sides of the body and remove the rear wheel.
- Remove the stabiliser bar from the suspension arm as described later on.
- *On models with drum brakes* remove the brake drum and the wheel hub as described in Section 11.2.
- *On models with disc brakes* remove the brake caliper, the brake disc and the wheel hub as described in Section 11.2.
- On a Space Wagon remove the link bracket (6) from the suspension arm.
- Disconnect the handbrake cable (7). The brake shoes or the handbrake shoes must be removed to disconnect the handbrake cable on the inside. Further information can be found in section "Brakes".
- On vehicles with ABS disconnect and unscrew the connector for the rear wheel speed sensor (8).
- Disconnect the brake hose (9) from the brake pipe. Small spring plates are used to secure the brake hose to the metal brackets.
- Remove the shock absorber from its lower attachment to the suspension arm. Refer to Section 11.1.1.
- Remove the coil spring as described in Section 11.1.2. The instructions refer to the slackening and marking of the eccentric adjusting fulcrum bolt for the suspension arm. The graduated disc on the bolt must be marked by painting a line across the disc and the crossmember as before, but this time the nut must be fully removed. The same applies to the flange bolt (13) on the other side of the arm. Remove the two bolts carefully and take off the suspension arm. Remove the four stopper rings (15) from the inside and outside of the arm mountings.
- Remove the remaining parts not mentioned above in accordance with Fig. 11.3.

The following points should be noted during the removal:

- When removing the wheel hub on a vehicle with ABS, take care not to damage the teeth of the rotor for the wheel speed sensor.
- When removing the wheel speed sensor take care not to damage the end of the sensor tip.

The installation of the suspension arm is a reversal of the removal procedure. The following points should be noted in particular:

- Refer to Sections 11.1.1 and 11.1.2 when refitting the shock absorber and the coil spring.
- Turn the fulcrum bolt into the marked position and tighten the nut finger-tight. Also tighten the nut of bolt (13) finger-tight. The nuts are tightened to the specified torque settings when the vehicle is standing with its wheels on the floor. Remember that the rear wheel alignment should be checked after installation of the suspension arm, unless you are absolutely sure that the fulcrum shaft with the eccentric adjuster is in the correct position. Fig. 11.4 shows how the graduated disc is marked in relation to the crossmember mounting.

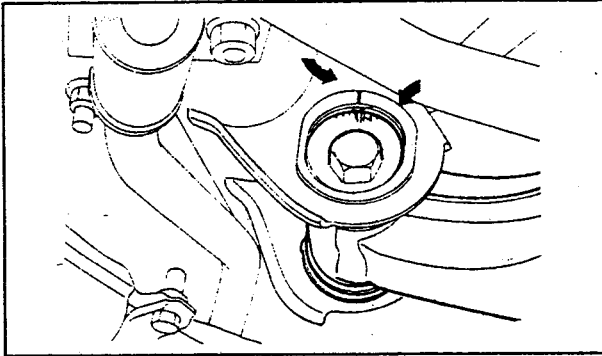

Fig. 11.4. — The disc of the eccentric adjuster and the crossmember must be marked as shown before removal and re-located during installation of the fulcrum bolt.

- Refit the rear wheel hub as described in Section 11.2.
- Bleed the brake system and adjust the handbrake as described in section "Brakes".

11.2. Rear Hubs and Rear Wheel Bearings

11.2.1. Wheel Hubs — Removal and Installation

The rear wheel hubs contain the wheel bearing and cannot be dismantled, i.e. a damaged wheel bearing requires the replacement of the complete with hub, together with the bearing. The hub and bearing can, however, be re-used if the assembly has been removed for other reasons than replacement. Fig. 11.5 shows the wheel hub when drum brakes are fitted. Note that the wheel hub nut (5) must always be replaced. The shoulder of the nut is peened into the slot of the wheel shaft and cannot be used a second time.

Models with disc brakes use a similar hub, but the brake caliper must be removed in order to remove the brake disc and the wheel hub.

The sensor for the wheel speed is inserted into the rear of the backplate and should be

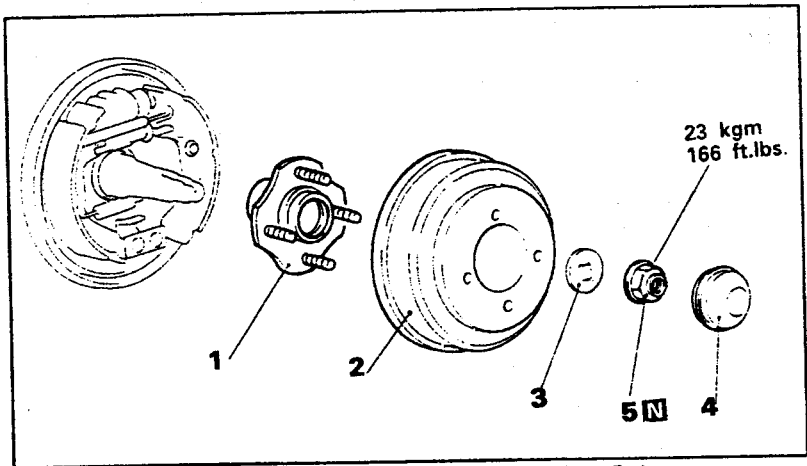

Fig. 11.5. — Rear wheel hub/bearing assembly — Drum Brakes

- | | |
|-----------------|-----------|
| 1 Wheel hub | 4 Hub cap |
| 2 Brake drum | 5 Hub nut |
| 3 Thrust washer | |

removed before the hub is removed. Take care not to damage the tip of the sensor after removal. Hubs of models with ABS have a toothed rotor on the inside. Take care not to drop such a hub, as the teeth of the rotor can be damaged.

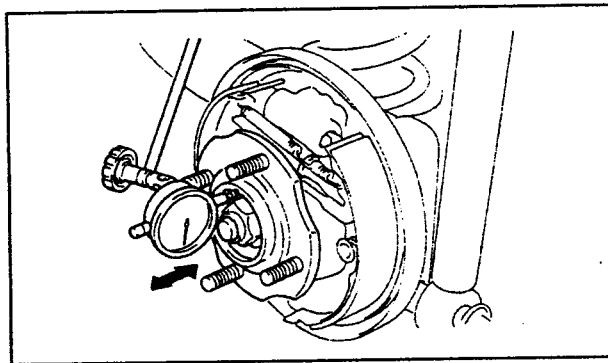

Fig. 11.6. — Checking a rear hub end float.

Before a wheel hub is removed for any reason, it is always of advantage to check the end float of the wheel bearing/hub assembly. This will show you, if the bearing requires replacement. Do this as follows:

- Remove the hub grease cap (screwdriver), release the handbrake and remove the brake drum. If disc brakes are fitted, remove the brake caliper (without disconnecting the brake line) and remove the brakew disc.
- Arrange a dial gauge as shown in Fig. 11.6, with the stylus placed against the outer face of the wheel hub. Push the hub fully towards the inside, set the dial gauge to "Zero" and then move the hub to and fro.

- If the indicated end float is greater than 0.05 mm (0.002 in.), re-tighten the hub nut to 23 kgm (166 ft.lb.) and re-check the end float. If you were able to increase the torque to the value given, it may be possible that the end float is now O.K. In this case remove the hub. Otherwise hub and bearing will have to be replaced. The nut must be re-secured as described below.

Note the following points during installation of the wheel hub:

- Tighten the hub nut to the torque given in Fig. 11.5 and check the wheel hub end float as described above. If satisfied, peen the metal of the nut into the cut-out of the wheel spindle to secure the nut in position, after reading the next paragraph.

If a new bearing/hub assembly has been fitted there will not be any detectable end float, but it is possible that the bearing is too tight. To check the correct rotating torque of the bearing, you can use a spring scale as shown in Fig. 11.7 and a piece of string. Wind the string around the wheel studs and pull the spring scale in the direction shown. The indication should be 1.8 kg (4 lbs.) or less. If this is the case, the hub has been installed correctly.

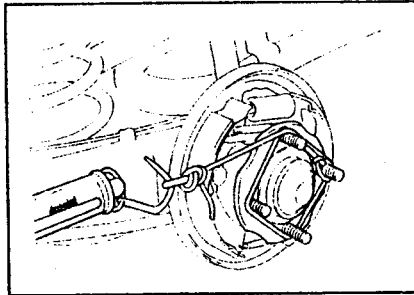

Fig. 11.7 — Checking the rotational torque of a rear wheel hub.

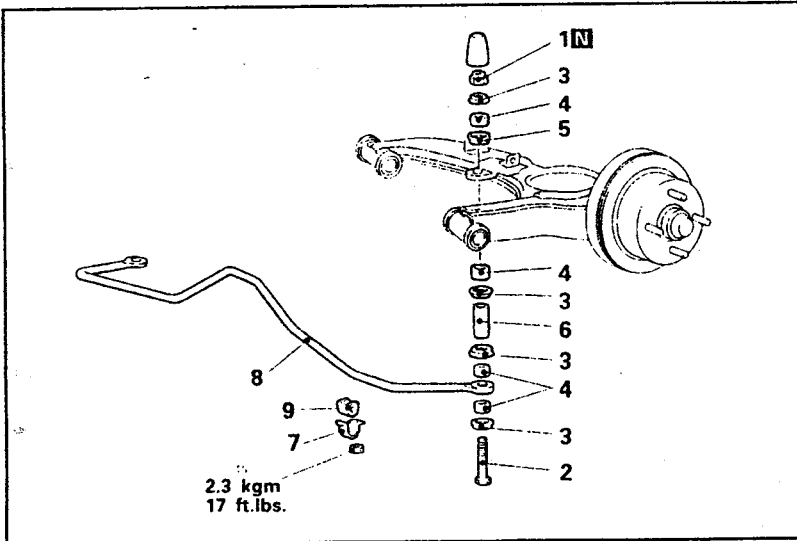

Fig. 11.8 — The attachment of the rear stabiliser bar.

- | | |
|-----------------------|-------------------|
| 1 Self-locking nut | 6 Spacer sleeve |
| 2 Connecting bolt | 7 Mounting clamp |
| 3 Lower dished washer | 8 Stabiliser bar |
| 4 Rubber bushes | 9 Stabiliser bush |
| 5 Upper dished washer | |

11.3. Stabiliser Bar

Fig. 11.8 shows the attachment of the stabiliser bar to the bottom of the trailing arm. Removal is straight-forward, but there are a few points which should be noted during installation:

- The rubber bushes for the bar-to-underbody mountings are split and can easily be replaced, if deteriorated.
- The stabiliser bar has a paint mark on each side. This mark determines the lateral position of the bar. When fitting the bar to the underbody, arrange the mounting clamp so that the outer edge of the clamp and the inner edge of the paint mark are aligned. In this position tighten the nuts to 2.3 kgm (17 ft.lb.).
- The nut (1) in Fig. 11.8 is self-locking und must be replaced. In order to compress the rubber bushes above and below the stabiliser bar it is important to tighten the nut correctly. With all parts fitted in accordance with the illustration, tighten the nut until the end of the connecting bolt protrudes by 25 - 27 mm (0.98 - 1.06 in.) as indicated by dimension "A" in Fig. 11.9. Measure from the upper metal plate to the end of the thread, using a depth gauge.

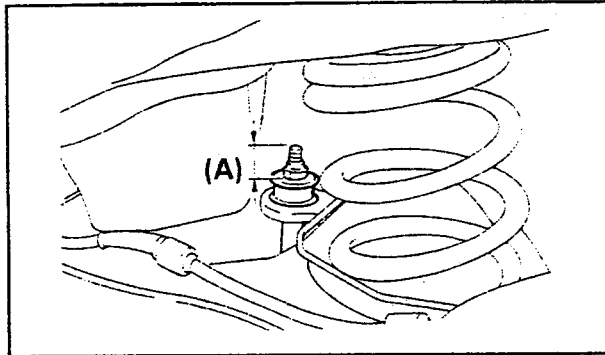

Fig. 11.9. — Tighten the nut at the upper end of the connecting bolt until dimension "A" is within the values given above. Fit the cap over the end of the bolt/nut after tightening.

11.4. Tightening Torque Values

All important tightening torques are given in the various exploded views.

12. STEERING

12.0. Technical Data

Type: Rack and pinion steering with safety steering column and tilt mechanism. All models with power-assisted steering

Max. free play at steering wheel:

With engine switched off: 15 mm (0.6 in.) or less
With engine running: 30.0 mm (1.2 in.)

Drive belt deflection:	
Petrol models without A/C, new belt:	7.5 - 9 mm (0.295 - 0.354 in.)
Petrol models without A/C, used belt:	9.5 - 11.5 mm (0.374 - 0.453 in.)
Petrol models with A/C, new belt:	5.5 - 6.0 mm (0.217 - 0.236 in.)
Petrol models with A/C, used belt:	6.8 - 7.6 mm (0.268 - 0.299 in.)
Diesel model, new belt:	4.5 - 6.5 mm (0.177 - 0.256 in.)
Diesel model, used belt:	6.5 - 9.0 mm (0.256 - 0.354 in.)
Recommended steering fluid:	Automatic transmission fluid Dexron or Dexron II
Capacity:	900 c.c. (1.6 lm. pts.)

Wheel alignment data:	See Section 10.0
Steering Lock Angles:	
Inner wheel:	36° 30' ± 2°
Outer wheel:	30° 30'

A rack and pinion steering with power assistance is fitted to Space Runner and Space Wagon models. The steering column is of the safety-type and will collapse in the case of a frontal collision.

12.1. Checks on the Steering System

In general it can be said that the steering will give no problems over a long period of operation. As vehicles get older, however, there are a few checks which can be carried out to keep the steering system at its best performance and a few maintenance operations which may have to be carried out from time to time.

Checking the Steering Wheel Free Play. Two checks should be carried out, one with the engine running and one with the engine stationary.

- Start the engine and set the front wheels into the straight-ahead position.
- Grip the steering wheel rim at the top and move it to and fro as shown in Fig. 12.1. If the movement is more than 30 mm before the front wheels are beginning to move, check the track rod ball joints for excessive play. There could also be excessive play in the steering shaft connection.

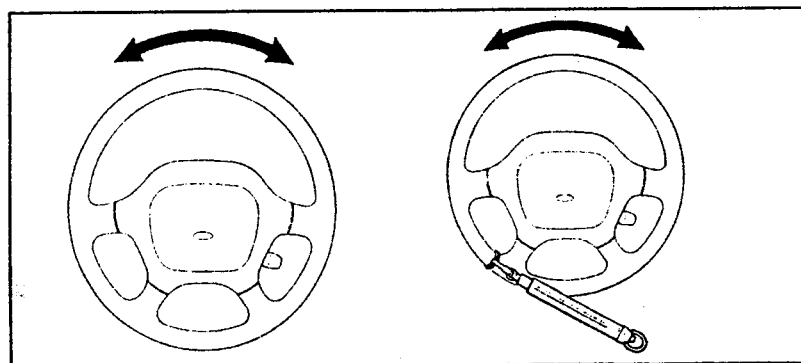

Fig. 12.1. — Checking the steering wheel play (see text).

- If no excessive play can be detected, there is one more check you can carry out, but you will need a spring scale. Switch off the engine and attach the spring scale to the steering wheel spoke as shown in Fig. 12.1. With the wheels still in the straight-ahead position, apply a load of 0.5 kg (1 lb.) and then move the steering wheel as in-

licated by the arrow. The steering wheel play should now be no more than 15 mm (0.6 in.). If the movement is exceeded, there is excessive play inside the steering.

Checking Track Rod Ball Joints: A workshop will check track rod ball joints for wear (up and down play) or seizure (articulation restricted). With simple means you can carry out a few checks, mainly before presentation of the vehicle to an MOT.

- Place the front end of the vehicle on chassis stands and remove the wheels.
- Insert a tyre lever between the steering lever on the steering knuckle and the track rod end and move the lever end up and down, at the same time placing the fingers of the other hand around the track rod ball joint. This is the check carried out during the MOT. If you can feel excessive up and down movement (you will have to judge for yourself), replace the track rod ball joint.
- If the steering feels "heavy", it is possible that track rod ball joints have seized up. If you have a torque wrench with "kgcm" or "in.lbs." divisions, you can check the rotating torque of the ball joint studs. To do this, disconnect the track rod from the steering lever and screw the nut onto the stud as far as it will go. Apply a socket and the torque wrench to the nut and rotate the stud. Note the indication when the stud begins to rotate. This should take place between 0.5 - 2.5 kgcm (4 - 22 in.lbs.). If the indication is higher, replace the track rod end. Lower values will show you excessive wear in the joint.

Checking the Drive Belt Tension. The deflection of the drive belt for the steering pump is different on petrol and diesel engines. Section 12.0 list the various options. We have quoted the official values given by Mitsubishi, despite the fact that some of them are very difficult to judge. The values for a used belt apply when the belt is re-adjusted.

Petrol Engine without Air Conditioning System

The belt is driven from the crankshaft pulley, the deflection is checked at the position shown in Fig. 12.2. The pressure on the belt should be approx. 10 kg (22 lbs.), but a firm pressure with the thumb will have to do.

If an adjustment is necessary the pump

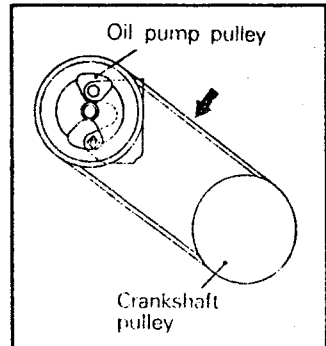

Fig. 12.2. — Checking the drive belt tension on a petrol engine without A/C system.

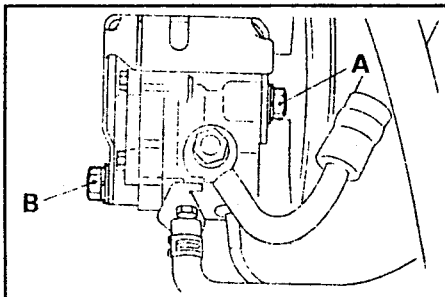

Fig. 12.3. — Bolts A and B secure the steering pump and must be slackened to adjust the drive belt tension on a 1.8 litre (4G93) engine.

mountings will have to be slackened. There are differences between the two engine capacities and you will have to refer to the illustration in question:

- In the case of the 1.8 litre engine refer to Fig. 12.3 and slacken the two bolts "A" and "B" and then move the steering pump as described on the next page.
- In the case of the 2.0 litre engine refer to Fig. 12.4 and slacken the bolts "A", "B" and "C" and then move the steering pump as described

below and shown in Fig. 12.5.

- Referring to Fig. 12.5, place a bar or a tyre lever against the steering pump housing and apply pressure to the lever until the deflection given in Section 12.0 has been obtained. Retighten the bolts in question and re-check the tension.
- If the belt has been replaced, carry out the same operations, with the difference that the values for a new belt apply.

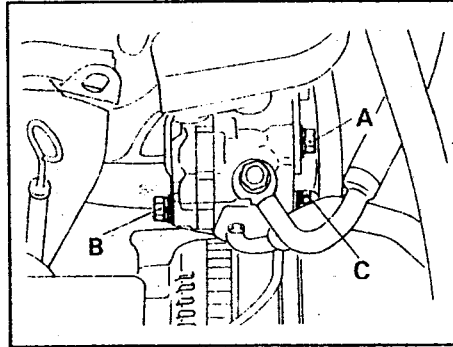

Fig. 12.4. — Bolts A, B and C secure the steering pump and must be slackened to adjust the drive belt tension on a 2.0 litre (4G63) engine.

Petrol Engine with Air Conditioning

The steering pump is driven by the same belt as the compressor for the A/C system. To adjust the belt tension there is no need to slacken the pump mounting bolts, as the belt has its own tensioning pulley with an adjusting bolt. The layout of the drive belt is shown in Fig. 12.6.

If the belt deflection is outside the values given in Section 12.0 for models with air conditioning system (A/C), slacken the nut in the centre of the tensioning pulley and turn the adjusting bolt at the top of the pulley until the correct tension is obtained. Tighten the nut after the adjustment.

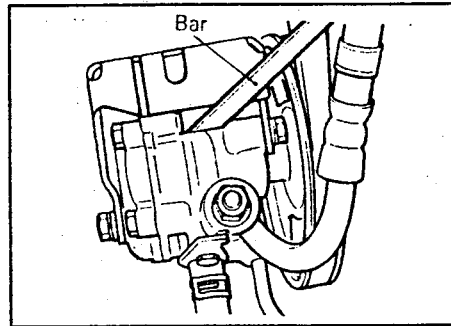

Fig. 12.5. — Insert a bar or tyre lever as shown to move the steering pump.

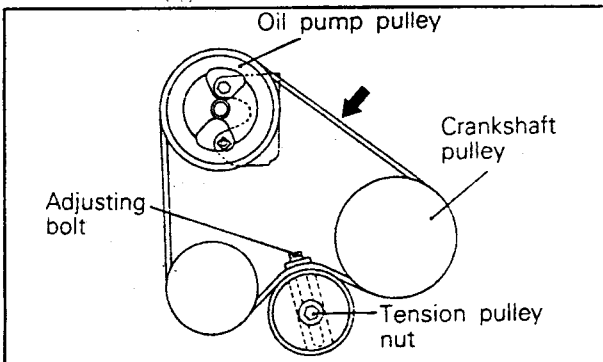

Fig. 12.6. — Layout of the drive belt and adjusting details for models with air conditioning system.

Diesel Engine: The belt deflection is adjusted in a similar manner as described for the

petrol engine without air conditioning system, but the steering pump belt is placed around the pump pulley and the water pump pulley. The belt tension is checked at the position shown in Fig. 12.2, but for crankshaft pulley read water pump pulley.

Refer to Fig. 12.4 when slackening the pump mounting bolts. To tension the belt, insert the bar or lever in the manner shown in Fig. 12.5. Again different values apply and Section 12.0 must be consulted.

Checking the Fluid Level

- Park the vehicle on a level surface and start the engine. Turn the steering wheel several times from one lock to the other. This will increase the fluid temperature to the operating value.
- Check the fluid level in the reservoir when the engine is running, make a mental note of the level and then switch off the engine. Check the fluid level once more. The level should now be higher, but only within 5 mm. If the difference in the fluid level is considerably more, bleed the steering system as described below.

Steering Fluid Replacement

- Place the front end of the vehicle on chassis stands.
- Have container ready, disconnect the return hose at the bottom of the fluid reservoir and quickly hold it into the container.
- Prevent the engine from starting. On a petrol engine, disconnect the high tension cable from the ignition distributor, on a diesel engine withdraw the connector plug from the fuel cut-out valve on the injection pump.
- Ask a second person to operate the starter motor, at the same time turning the steering wheel from lock to lock. Make sure that the fluid runs into the container.
- Refit the return hose to the bottom of the container and secure it with the clamp.
- Fill the container with the specified fluid (Section 12.0) to the lower position of the filter. The system must now be bled of air as described below.

Bleeding the Steering System

- With the front of the vehicle still on chassis stands turn the steering pump pulley a few times by hand. With the engine switched off, turn the steering wheel five or six times from one lock to the other.
- Prevent the engine from starting as described above. This, of course, will still be the case, if the bleeding takes place after the system has been filled.
- Operate the starter motor 15 to 20 seconds and at the same time turn the steering wheel five or six times from lock to lock. The fluid level in the reservoir must be maintained at all times. The help of a second person is required.
- Reconnect the high tension lead or the connector plug, as is the case and start the engine.
- Ask the helper to turn the steering wheel from one side to the other and check the fluid reservoir for evidence of air bubbles.
- Finally check the fluid level in accordance with the instructions given. If the fluid level rises after the engine has been switched off, there is still air in the system and the bleeding must be re-started. Air in the system will shorten the pump life.

12.2 Steering Unit — Removal and Installation

The removal and installation of the steering unit can be carried out by referring to Fig. 12.7. Follow the numbered order when removing the various parts. The steering fluid must be drained before removal. It will also be necessary to remove the centre engine

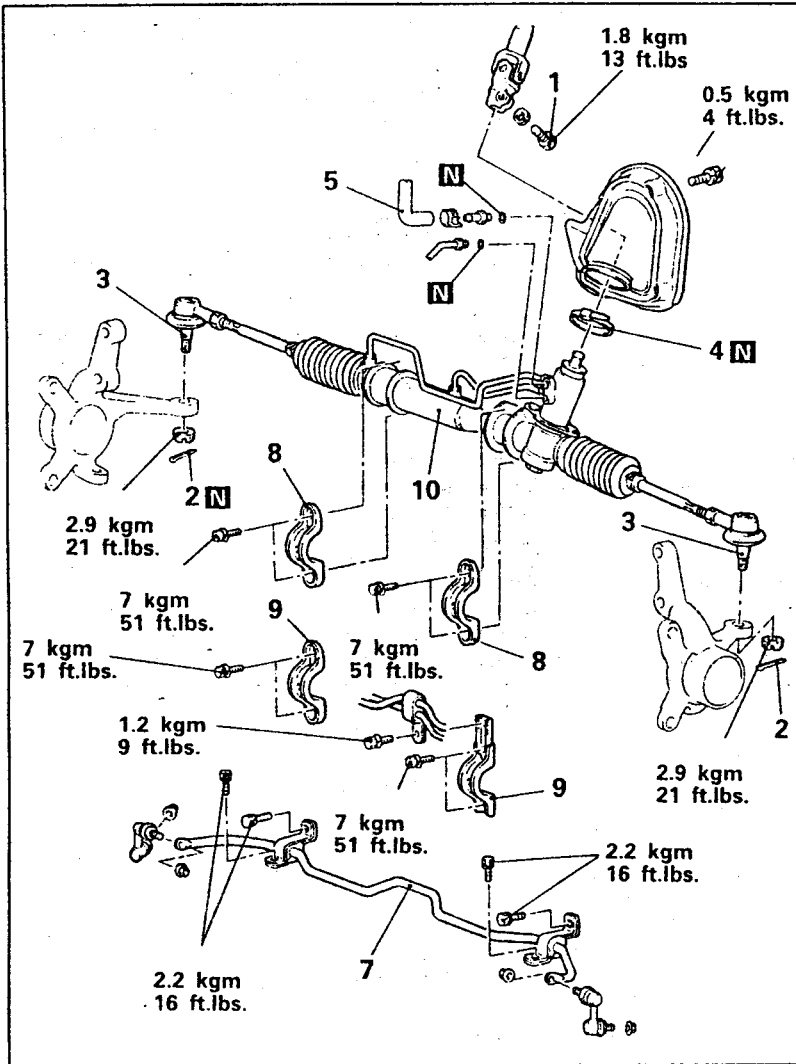

Fig. 12.7. — Removal and installation of the steering unit.

- | | |
|------------------------|----------------------------------|
| 1 Universal joint bolt | 7 Stabiliser bar (diesel engine) |
| 2 Split pin | 8 Clamp (L.H.D. vehicles) |
| 3 Track rod ball joint | 9 Clamp (R.H.D. vehicles) |
| 4 Clamp band | 10 Steering unit |

carrier below the engine, together with the roll stoppers to remove the steering from the crossmember. It will also be noticed that the stabiliser bar must be removed in order to take out the steering of a vehicle with diesel engine.

During installation replace the parts shown with "N" and follow the tightening torques. Also note the following instructions:

- Refer to Section 1.1.1 (page 13) and Fig. 1.13 to refit the centre engine carrier.
- Fill the steering system with fluid and bleed the system of air as already described.
- Check and if necessary adjust the toe-in setting as described in Section 10.5 (page 127).

13. BRAKES

13.0. Technical Data

Type: Disc brakes at the front and rear on models with ABS. Drum brakes at rear of other models. Identical brake calipers on all models. With brake servo unit, brake pressure regulator (Space Runner) or load-sensitive brake pressure proportioning valve (Space Wagon). Handbrake operating on rear wheels. Dual-line brake system.

Master Brake Cylinder Dia.:
 Vehicles without ABS: 23.8 mm (0.949 in.)
 Vehicles with ABS: 25.40 mm (1.0 in.)
 Handbrake adjustment:
 Vehicles with drum brakes: 5 - 7 notches of handbrake lever
 Vehicles with disc brakes: 4 - 6 notches of handbrake lever

Front Disc Brakes

Type: M-F44V
 Disc Brake Diameter: 256.0 mm (10.17 in.)
 Brake Disc Thickness: 24.0 mm (0.95 in.)
 Min. disc thickness: 22.4 mm (0.88 in.)
 Max. run-out of discs: 0.07 mm (0.0028 in.)
 Brake pad thickness: 10.0 mm (0.4 in.)
 Pad material wear limit: 2.0 mm (0.08 in.)
 Brake cylinder diameter: 53.90 mm (2.12 in.)
 Clearance adjustment: Automatic

Rear Brakes — Drum Brakes

Drum diameter: 203.0 mm (8.0 in.) or 228.6 mm (9.0 in.)
 Max. diameter: 205.0 mm (8.1 in.) or 230.6 mm (9.1 in.)
 Brake lining thickness: 4.5 mm (0.18 in.)
 Min. lining thickness: 1.0 mm (0.04 in.)

Brake Cylinder Diameter: 19.05mm (0.75 in.)
 Brake adjustment: Automatic

Rear Disc Brakes

Type: M-F45S
 Type of disc: Solid
 Disc diameter: 262.0 mm (10.3 in.)
 Disc thickness: 10.0 mm (0.4 in.)
 Min. disc thickness: 8.4 mm (0.34 in.)
 Brake pad thickness (with lining): 10.0 mm (0.4 in.)
 Min. lining thickness: 2.0 mm (0.08 in.)
 Brake cylinder diameter: 34.9 mm (1.38 in.)

All models are fitted with a dual-line brake system. Front and rear wheels of models with ABS are fitted with disc brakes; the remaining models have rear wheels with drum brakes. In the later life of the vehicle it may well be that a second-hand brake caliper is required. As a guide line you may note that the type fitted is the same as used on the Mitsubishi Galant after April 1990. All brake assemblies are self-adjusting. A brake pressure regulator, i.e. a brake pressure proportioning valve is fitted to the Space Runner to control the braking pressure to the wheels. A load-sensitive brake proportioning valve is fitted to the Space Wagon.

A mechanical handbrake system operates the rear brakes via cables. Models with disc brakes at the rear have their own brake shoes inside the brake discs. A brake servo unit is standard equipment, operated in the case of a diesel engine by means of a separate vacuum pump (exauster pump).

13.1. Front Disc Brakes

16.1.1. Replacing the Brake Pads

The brake pads are fitted with wear indicators. These indicators contact the brake disc face. As soon as the thickness of the remaining brake pad material is less than 2.0 mm, a squealing sound will be emitted to warn the driver. If, after inspection of the brake pads the thickness is near the 2.0 mm, replace the pads.

- Jack up the front end of the vehicle and support on chassis stands. Remove the front wheels.
- Before the caliper is removed, check the thickness of the brake pad material through the "window" in the caliper, shown by the arrow in Fig. 13.2. If a thickness of 2.0 mm (0.08 in.) remains, approx. the thickness of two matchsticks, there is no need to replace the pads.

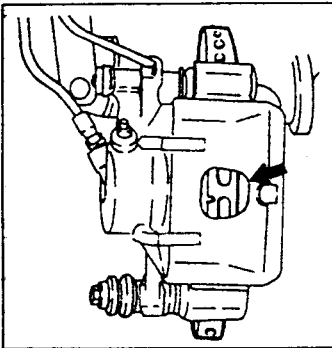

Fig. 13.2. — Check the thickness of the brake pad material through the opening in the caliper.

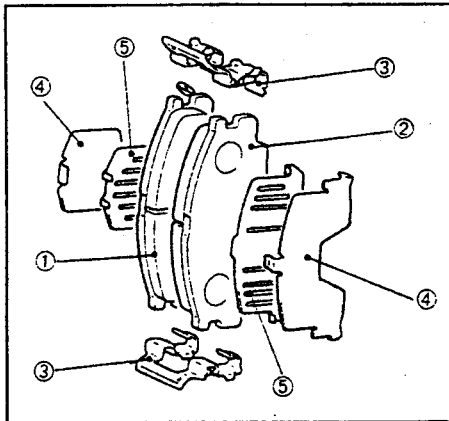

Fig. 13.1. — The component parts of the brake pads.

- | | |
|--------------------------|--------------|
| 1 Pad and wear indicator | 4 Outer shim |
| 2 Brake pad | 5 Inner shim |
| 3 Brake pad clips | |

- Remove the bolt at the bottom of the caliper (Fig. 13.3) and swing the caliper cylinder upwards. Tie the caliper in position with a piece of wire to keep it away from the brake pads.

NOTE: The bolt has a coating of special grease. Do not remove this grease and keep the bolt free from dirt and grit.

- Remove the inner shims, the outer shim and the two brake pads from the mounting frame. The parts are located on the sides of the brake pads, as shown in Figs. 16.1. Remove the two brake pad clips (3) from the top and bottom of the caliper. (illustration later on).

The brake pedal must not be operated, once the brake pads have been removed. Replace the brake pads as a set if the thickness of the pad material is less than 2.0 mm (0.08 in.). Never replace one brake pad only or attempt to

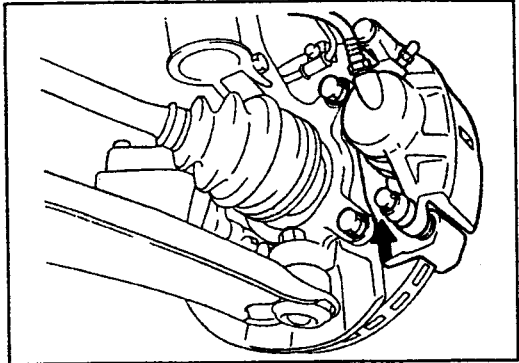

Fig. 13.3. — Remove the sleeve bolt (arrow) and lift up the caliper to expose the brake pads.

exchange brake pads from the inside to the outside or vice versa or from one side to the other. Clean the caliper with brake fluid or methylated spirits — never petrol.

Brake pad repair kits contain the two brake pads, anti-squeal shims and new pad clips. All parts must be used during assembly.

Check the brake disc for grooves, caused for example by worn brake pads. Measure the disc thickness. Replace the disc if the thickness is less than given in Section 16.0.

The installation of the brake pads is a reversal of the removal procedure, noting the following points:

- Fit brake pads, inner shims and outer shims in accordance with Fig. 13.1 and engage the clips.
- Before fitting the new brake pads, push the piston back into its bore. To do this, slacken the bleeder screw and use a non-metallic instrument or a clamp to push the piston or the two pistons into the bore. To avoid bleeding of the brake system, apply pressure to the piston and then open the bleed screw. Close the screw before releasing the pressure.
- Lower the caliper cylinder over the fitted brake pads and fit the lower bolt. Tighten the bolt to 75 kgm (54 ft.lb.). If you carried out work on the front brakes of a Mitsubishi vehicle in the past, you will notice the increased tightening torque for the guide bolts.

After completed installation, operate the brake pedal a few times and check if air has entered the system. In this case bleed the system as described later on in this section.

13.1.2. Brake Caliper — Removal and Overhaul

- Remove the brake hose from the brake pipe connection on the spring strut. To do this, undo the union nut, drive out the spring plate and withdraw the brake hose from the bracket. Plug the open end of the brake pipe to prevent entry of dirt.
- Remove the two bolts shown in Fig. 13.4 and lift off the brake caliper. Remove the brake pads as described in Section 13.1.1.
- To remove the piston apply an air line to the brake hose connecting bore, as shown in Fig. 13.5. Place a rag underneath the piston to prevent damage during ejection. Keep the hands away from the area below the piston. Do not use excessive air

pressure. — **Warning** — Make sure the piston cannot be damaged when it hits the other side of the caliper.

- Remove the piston dust seal carefully with a screwdriver, if it has come away with the piston. Use a blunt, pointed instrument and remove the piston seal from the inside of the cylinder bore. Take care not to scratch the surface.
- If the two rubber boots, shown in Fig. 13.5, are not

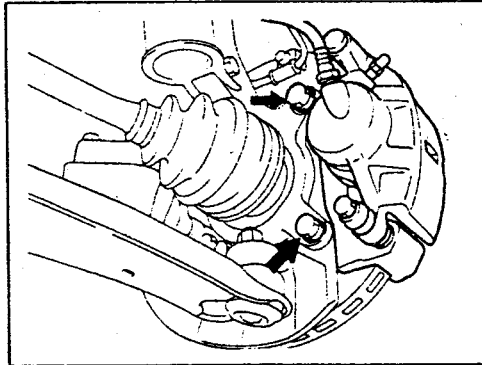

Fig. 13.4. — The arrows point to the brake caliper mounting bolts.

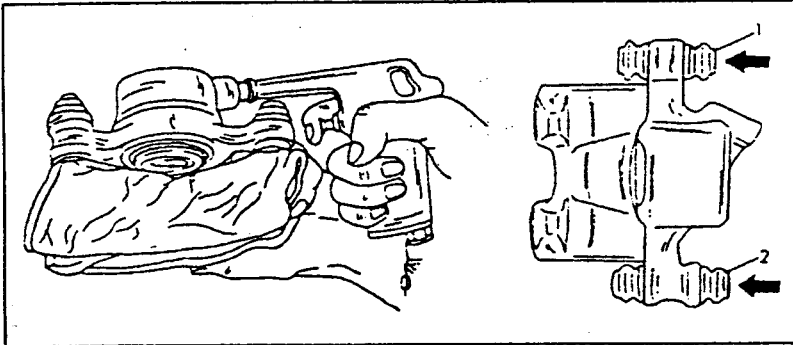

Fig. 13.5. — Removal of the piston with an air line (left) and the position of the rubber boot (1) and the rubber bush (2) in the caliper cylinder.

longer in good condition, remove them from the brake caliper cylinder.

Thoroughly clean all parts in methylated spirits or brake fluid. Check the inside of the caliper bore for grooves or other damage. Replace the cylinder assembly if wear is excessive. Slight blemishes can be removed with smooth sandpaper. The gliding face of the piston is specially treated and cannot be smoothed with sandpaper. Always replace the cylinder seal and the rubber dust seal.

Before assembly coat all internal parts of the cylinder with clean brake fluid or brake paste. Various repair kits are available to overhaul a caliper and all contain lubrication grease. Check with your dealer which repair kits are sold. They are available for caliper overhaul, seals and rubber boots and brake pads, but not all may be available in any one country.

Assemble the caliper as follows, referring to Fig. 13.6:

- Coat a new cylinder seal with rubber grease and install the seal into the cylinder groove without twisting it.
- Coat the inside of the cylinder bore with clean brake fluid.
- Push the piston carefully into its bore without tilting it. Coat the groove for the loca-

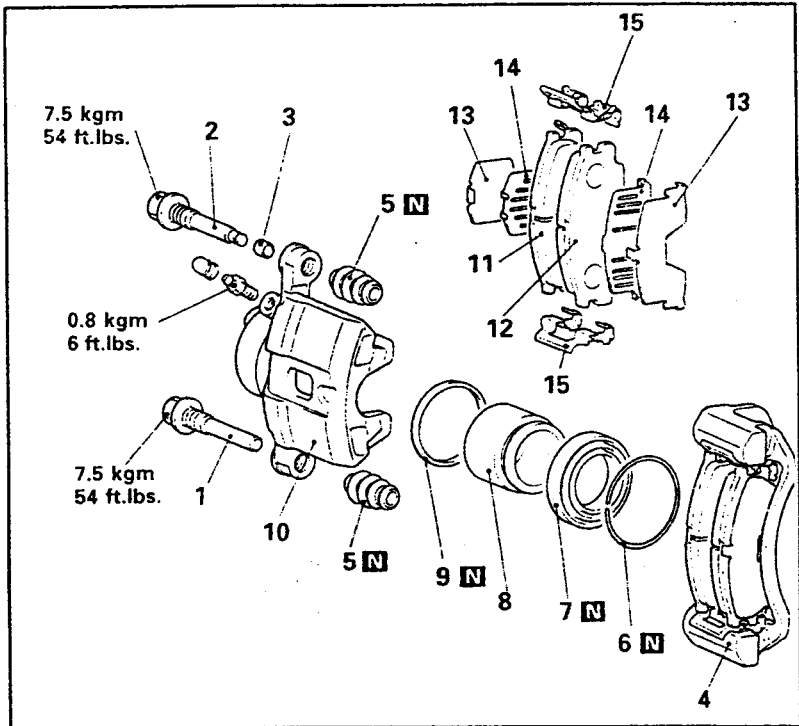

Fig. 13.8. — Exploded view of a brake caliper.

- | | |
|----------------------------|----------------------------------|
| 1 Lower bolt (guide pin) | 9 Piston seal |
| 2 Upper bolt (lock pin) | 10 Caliper body |
| 3 Bush | 11 Brake pad with wear indicator |
| 4 Caliper mounting bracket | 12 Brake pad |
| 5 Guide pin boot | 13 Outer shim |
| 6 Retaining ring | 14 Inner shim |
| 7 Dust seal | 15 Pad clip |
| 8 Piston | |

tion of the rubber dust seal with rubber grease and fit the seal into the piston and the caliper cylinder. Fit the retaining ring to the end of the piston dust seal.

- Fit the brake caliper to the mounting bracket. Coat the inside of the rubber bushes for glide sleeves and sleeve bolts with orange-coloured grease.

The installation of the brake caliper is a reversal of the removal procedure. Tighten the bolts to 7.5 kgm (54 ft.lb.) and bleed the brake system.

13.1.3. Brake Discs

The removal of a brake disc is straight forward after removal of the complete brake caliper. The disc is fitted over the outside of the wheel hub. Mark the position of the disc in relation to the hub. Check the brake disc as follows:

- Measure the thickness of the brake disc. Replace the disc if the thickness is less

then 22.4 mm (0.88 in.). The thickness tolerance must not exceed 0.07 mm (0.003 in.).

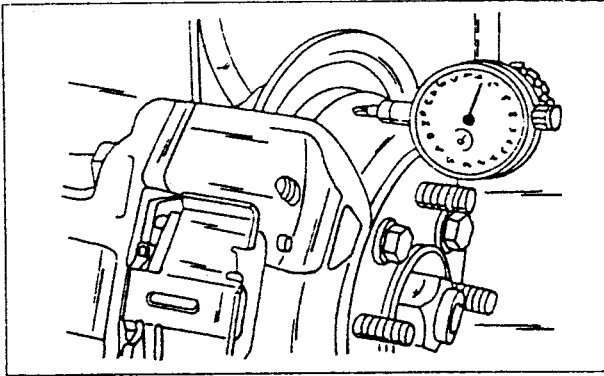

Fig. 13.7. — Checking a brake disc for run-out.

- To check a brake disc for distortion, refit it to the hub and use two of the wheel nuts to tighten the disc to the hub. Apply a dial gauge to the outer edge of the disc, as shown in Fig. 13.7 and slowly rotate the disc. Observe the needle deflection, indicating the run-out of the disc. This should not exceed 0.07 mm (0.0028 in.). Replace the disc if otherwise. If the disc has just been fitted to the hub, remove it once more and check that no foreign bodies are trapped between the surfaces of hub and disc. Then re-check.

13.4. Rear Drum Brakes

Although the diameter of the rear brakes is not the same on all models, their construction is. An exploded view of the rear brakes is shown in Fig. 13.8. Irrespective of the brake drum (shoe) diameter, the wheel brake cylinders are of the same diameter on all models. Quote the chassis number and the model when new parts are obtained.

The following operations should be carried out by referring to the illustration.

13.4.1. Replacing the Brake Shoes

Fig. 13.8 should be referred to in case of difficulties:

- Jack up the rear end of the vehicle and support on chassis stands.
- Remove the rear wheels.
- Remove the brake drums as described in Section 11.2.1 (page 135).
- Using a pair of pliers, unhook the lower return spring from the two brake shoes.
- Place the forefinger over one of the brake shoe hold-down pins (from the rear of the brake back plate) and grip the spring seat from the front with a pair of pliers. Turn the spring seat by 90° until the head of the pin can be guided through the elongated hole in the spring seat. Remove both spring seats and the springs. Remove the second hold-down pin in the same manner.
- Lift the brake shoes from the lower bracket and pull one of the brake shoes out of engagement with the wheel brake cylinder. This will release the tension of the upper brake shoe return springs, which can now be removed.

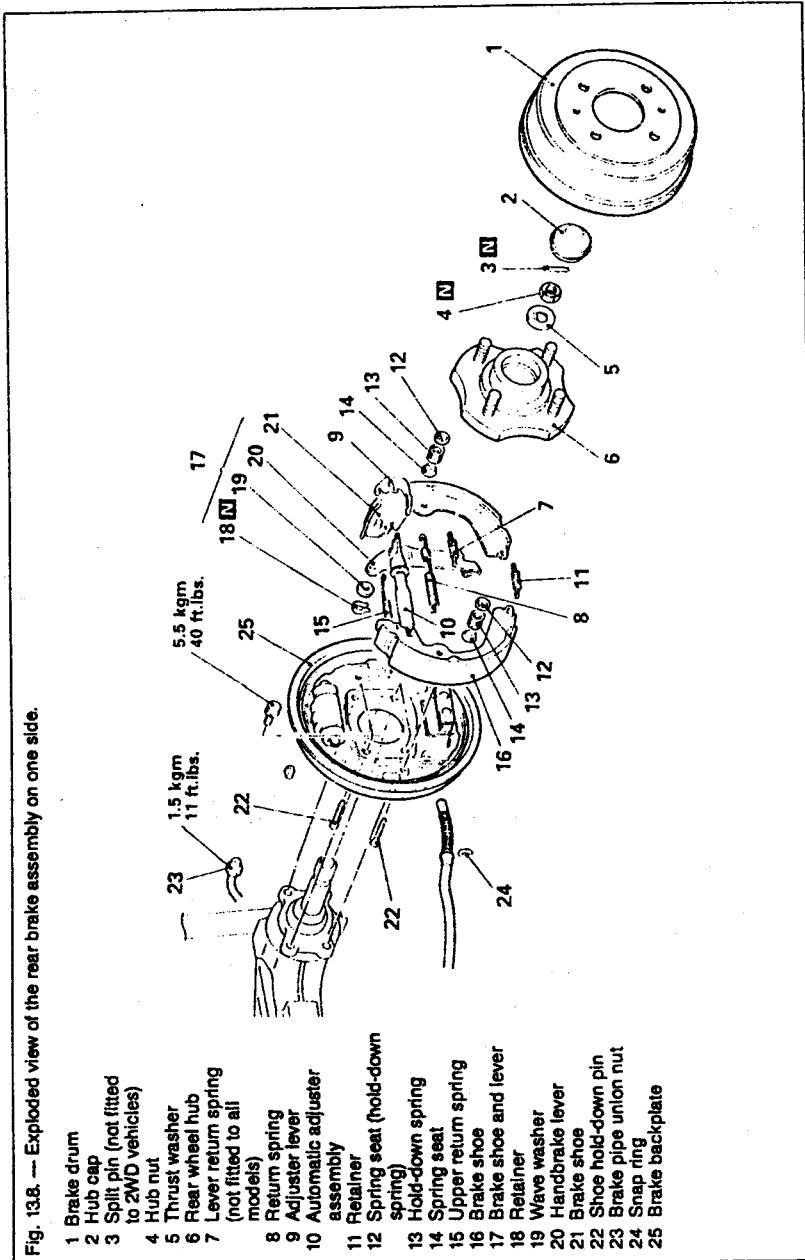

Fig. 13.8. — Exploded view of the rear brake assembly on one side.

- 1 Brake drum
- 2 Hub cap
- 3 Split pin (not fitted to 2WD vehicles)
- 4 Hub nut
- 5 Thrust washer
- 6 Rear wheel hub
- 7 Lever return spring (not fitted to all models)
- 8 Return spring
- 9 Adjuster lever
- 10 Automatic adjuster assembly
- 11 Retainer
- 12 Spring seat (hold-down spring)
- 13 Hold-down spring
- 14 Spring seat
- 15 Upper return spring
- 16 Brake shoe and lever
- 17 Brake shoe
- 18 Retainer
- 19 Wave washer
- 20 Handbrake lever
- 21 Brake shoe
- 22 Shoe hold-down pin
- 23 Brake pipe union nut
- 24 Snap ring
- 25 Brake backplate

- Tilt the brake shoes downwards and disconnect the handbrake cable from the operating lever after compressing the spring.

Thoroughly clean all parts. Brake shoes must be replaced if the material thickness is down to 1.0 mm (0.04 in.). Always replace brake shoes as a set and never interchange them from one side to the other to compensate for wear. Check that there are no signs of leaks on the rubber dust caps of the wheel brake cylinders. If this is the case, overhaul the cylinders as described in Section 13.4.2. or fit a new cylinder.

The handbrake lever is secured by means of a retaining clip, wave washer and pin to the brake shoe and must be removed if new brake shoes are fitted. To do this, insert a screwdriver into the gap of the retaining clip and open it up until it can be removed, as shown in Fig. 13.9 on the left. Fit the lever to the new shoe, insert the pin, place the wave washer in position and fit the clip into the groove. Use a pair of pliers and press the two ends of the clip together as much as possible (Fig. 13.9, right). Check the lever for free movement.

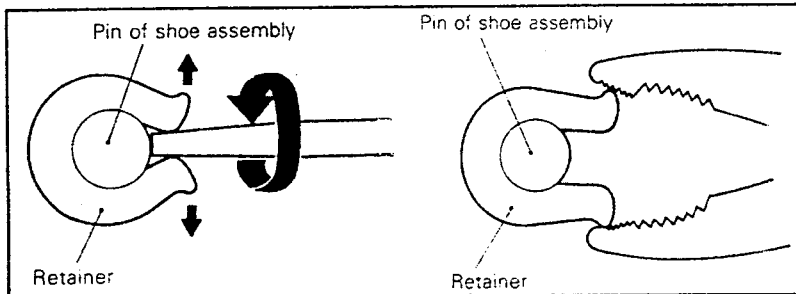

Fig. 13.9. — Removal (left) and installation (right) of the retaining clip for the handbrake operating lever.

Measure the inside diameter of each brake drum. The maximum permissible diameter is 205.0 mm (8.1 in.) or 230.6 mm (9.1 in.) and a drum must be replaced, if this dimension is reached.

The installation of the brake shoes is a reversal of the removal procedure. Coat the contacting areas for the brake shoes on the brake back plate with a little brake paste. The lower return spring must not be stretched during installation.

Turn the adjuster until the outer diameter of the has the approximate diameter of the brake shoes to set the shoes to the the basic setting for the operation of the self-adjusting mechanism. A caliper must be used to measure the diameter.

Refit the brake drum with the hub (if applicable) as described in Section 11.2.1 and tighten the wheel bearing nut. After installation of the drums depress the brake pedal a few times to bring the self-adjusting mechanism into operation. If necessary adjust the handbrake as described in Section 13.9.2.

13.4.2. Wheel Brake Cylinders — Overhaul

- Remove the brake shoes from the brake backplate as described in Section 13.4.1. Slacken the union nut at the rear of the brake backplate, withdraw the pipe and plug up the open end of the pipe to prevent entry of dirt. Unscrew the wheel brake cylinder from the plate.
- Remove the two rubber dust caps from the cylinder body and push the pistons through the bore. Using the fingers only, remove the piston cups from the pistons. Check the pistons and the inside of the cylinder bore for corrosion or seizure. A

cylinder should be replaced if such damage is visible.

- Coat the piston cups and pistons with clean brake fluid and fit the cups to the pistons, with the lips facing towards the inside. Only use the fingers and make sure that the cups are seated properly in the piston grooves.
- Wet the inside of the cylinder bore with clean brake fluid and insert the two pistons without turning over the sealing lips. Fit the rubber dust caps. Coat the face of the cylinder with sealing compound and refit to the brake back plate in reverse order to the removal procedure. Bleed the brake system after installation as described in Section 13.8.

13.5. Rear Disc Brakes

Fig. 13.11 shows an exploded view of the disc brakes (type M-R45S) as fitted to models with disc brakes on all four wheels (with ABS). The operation of the calipers is similar to the operation of the front brake calipers, i.e. one piston is used and the complete caliper slides on bolts against the disc. As soon as the first brake pad is in contact with the brake disc, the second brake pad is pushed against the disc. A toothed rotor is fitted to the inside of the wheel hub. Take care not to drop a removed wheel hub on the floor, as the rotor teeth can chip off easily. Note that the piston must be pushed into the caliper before new pads are fitted. Independent brake shoes are used to operate the handbrake. There is no special mechanism for operating the self-adjusting mechanism inside the brake calipers, as is the case with many rear calipers.

13.5.1. Brake Pads — Replacement

The rear caliper brake pads are also connected to the wear-indicator system and the squealing noise (this time at the rear) will point out to you that the brake pads have worn beyond their limit. As in the case of the front calipers, it is possible to check the thickness of the remaining material of the brake pads without removing the caliper. An inspection opening in the caliper, similar as shown in Fig. 13.2 enables the check after removal of the wheels. If it is estimated that the material thickness is less than 2.0 mm, replace the pads. Refer to Fig. 13.10 for details. You will find that rear brake pads last longer than anticipated.

- Jack up the rear end of the vehicle on place chassis stands underneath the body.

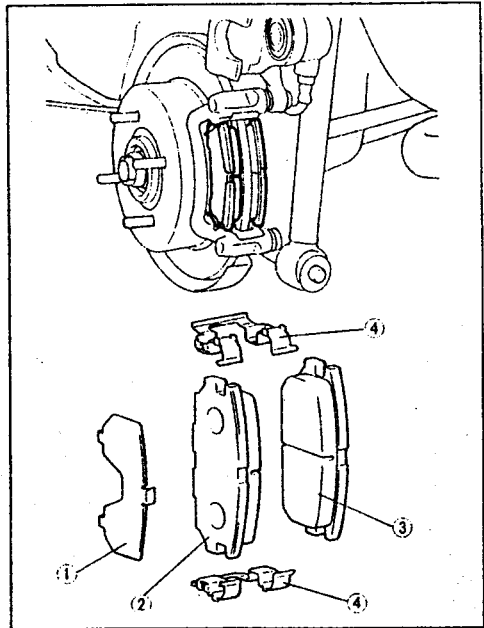

Fig. 13.10. — Details for the removal and installation of the rear brake pads. The wear indicator is fitted to brake pad (3).

- | | |
|--------------|-------------------|
| 1 Outer shim | 3 Brake pad |
| 2 Brake pads | 4 Brake pad clips |

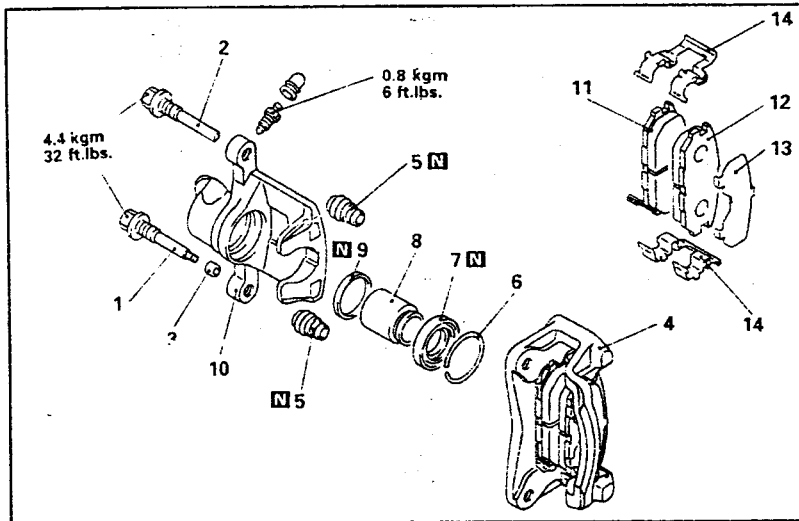

Fig. 13.11. — Details for the removal and installation of the rear brake pads and the overhaul of the rear brake caliper.

- | | |
|----------------------------|-------------------------------------|
| 1 Guide pin | 8 Caliper piston |
| 2 Lock pin | 9 Piston seal |
| 3 Bush | 10 Caliper body |
| 4 Caliper mounting bracket | 11 Pad with wear indicator |
| 5 Slide pin boot | 12 Brake pad without wear indicator |
| 6 Retaining ring | 13 Outer shim |
| 7 Dust excluder | 14 Pad clips |

- Remove the rear wheels.
- Remove the bolt at the bottom of the brake caliper and swing the caliper towards the top. Use a piece of wire to secure the caliper to the rear suspension to prevent stretching of the brake hose.
- Remove the outer shim (1) in Fig. 13.10 and the brake pad next to it. Remove the pad clips (4) and take out the second brake pad. One of the brake pads (3) has the wear indicator fitted. Make a note where it comes from. Brake pads must be removed on both sides of the vehicle. Make a note how the pads are installed to facilitate the refitting.

The brake pedal must not be operated, once the brake pads have been removed. Replace the brake pads as a set if the thickness of the pad material is less than 2.0 mm (0.08 in.).

Never replace one brake pad only or attempt to exchange brake pads from the inside to the outside or vice versa or from one side to the other. Clean the caliper with brake fluid or methylated spirits — never petrol. Check the cylinder seals for signs of leakage.

Brake pad repair kits contain the two brake pads, anti-squeal shims and new spring clips. All parts must be used during assembly.

Check the brake disc for grooves, caused for example by worn brake pads. Measure the disc thickness. Replace the disc if the thickness is less than given in Section 13.0.

The installation of the brake pads is a reversal of the removal procedure, noting the following points:

- Fit brake pads, the pad clips and the outer shim in accordance with Fig. 13.10, making sure that the brake pad with the wear indicator is fitted to the inside.
- Lower the caliper cylinder over the fitted brake pads and fit the lower bolt. Tighten the bolt to 4.4 kgm (32 ft.lb.).
- After completed installation, operate the brake pedal a few times and check if air has entered the system. In this case bleed the system as described later on in this section. Remember that new brake pads will take some time to adapt to the disc faces. Treat the brakes accordingly.

135.2. Brake Caliper — Removal and Overhaul

Removal, overhaul and installation follows the general pattern for the operations described for the front brake calipers. Fig. 13.11 shows an exploded view of the caliper. The only difference is the tightening torque for the guide bolt (lower bolt) and the lock bolt (upper bolt) which is lower for the rear calipers.

135.3. Brake Discs

The brake caliper must be removed as described (without disconnecting the brake hose). The disc is held by a screw to the outside of the wheel hub.

Check the brake disc as follows:

- Measure the thickness of the brake disc. Replace the disc if the thickness is less than 8.4 mm (0.33 in.). The thickness tolerance must not exceed 0.07 mm (0.003 in.).
- To check a brake disc for distortion, refit it to the hub and tighten the screw. Apply a dial gauge to the outer edge of the disc, similarly as shown in Fig. 13.7 and slowly rotate the disc. Observe the needle deflection, indicating the run-out of the disc. This should not exceed 0.08 mm (0.003 in.). Replace the disc if otherwise. If the disc has just been refitted there is the possibility that something has been tapped between disc and hub face. Remove the disc, wipe the faces clean and re-check as described.

13.6. Master Brake Cylinder

13.6.1. Removal and Installation

Fig. 13.12 shows a general view of the master cylinder installation on models without and with ABS system. The difference is the installation of a brake pressure proportioning valve which is not fitted to the cylinder used in models with ABS system. On models with ABS, a 6-way connector is fitted in its place. Remove the cylinder as follows:

- Remove the level sensor harness connector and unscrew the union nuts securing the brake pipes to the cylinder connections. Plug the open ends of the pipes to prevent entry of dirt.
- Remove the nuts securing the master brake cylinder to the front face of the brake servo unit and carefully lift out the cylinder without spilling brake fluid over painted areas of the vehicle.

The installation of the cylinder is a reversal of the removal procedure. Tighten the securing nuts to 0.8 - 1.2 kgm (6 - 9 ft.lb.). Take care when tightening the unit nuts in order to prevent damage to their fine threads. Fill the master cylinder reservoir. The brake system must be bled of air after installation (refer to Section 13.7).

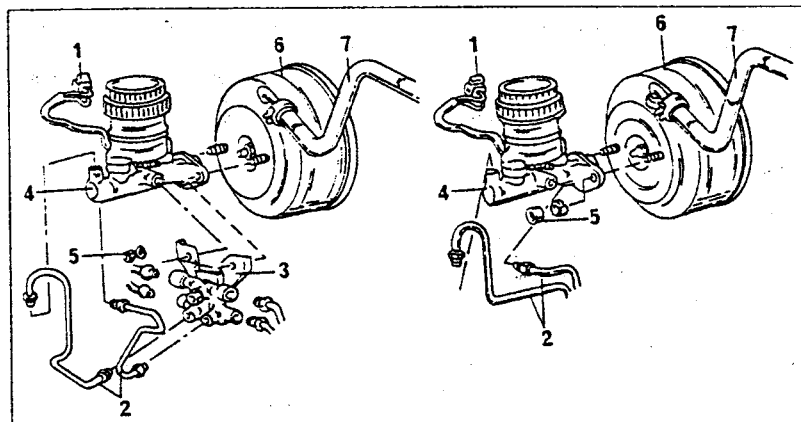

Fig. 13.12. — Details for the removal and installation of the master brake cylinder. On the L.H. side without ABS system; on the R.H. side with ABS system. The pipes may have a different shape, depending on the mode.

- | | |
|-----------------------------------|-------------------------------------|
| 1 Connector, brake fluid level | 5 Nut, 0.8 - 1.2 kgm (6 - 9 fl.lb.) |
| 2 Brake pipes | 6 Brake servo unit |
| 3 Bracket for proportioning valve | 7 Vacuum hose |
| 4 Master cylinder | |

13.6.2. Overhauling the Master Cylinder

The overhaul of the master cylinder is not recommended. Cylinders will work satisfactory for a long time. Although repair kits, containing complete pistons, sealing washers, etc. may be available, it is far better to fit a new unit, despite the fact that it will be more expensive. Your dealer may be able to overhaul the cylinder, but there is still the danger that the piston bore is worn or grooved, requiring a new cylinder after all.

13.7. Bleeding the Brake System

Bleeding of the brake system should be carried out at any time that any part of the system has been disconnected, for whatever reason. If only one brake circuit has been opened, it may be enough to bleed only this circuit. Otherwise commence the bleeding on the L.H. rear wheel and then follow in the sequence R.H. front, R.H. rear and L.H. front.

The procedure given below should be followed and it should be noted that an assistant will be required, unless a so-called "one-man" bleeding kit is available.

Always use clean fresh brake fluid of the recommended specification and never re-use fluid bled from the system. Be ready to top up the reservoir with fluid as the operations proceed. If the level is allowed to fall below the minimum the operations will have to be re-started.

Obtain a length of plastic tube, preferably clear, and a clean container. Put in an inch or two of brake fluid into the container and then go to the first bleed point. Take off the dust cap and attach the tube to the screw, immersing the other end of the tube into the fluid in the container.

Open the bleed screw about three quarters of a turn and have your assistant depress the brake pedal firmly to its full extent while you keep the end of the tube well below the fluid level in the container. Watch the bubbles emerging from the tube and repeat the

operation until no more are seen. Depress the brake pedal once more, hold it down and tighten the bleed screw firmly.

Check the fluid level, go to the next point and repeat the operations in the same way. Install all dust caps, depress the brake pedal several times and finally top up the reservoir.

13.8. Brake Pressure Regulating Valve

The brake pressure regulating valve is fitted below the brake servo unit. The valve cannot be repaired or dismantled and must be replaced in case of malfunction. When removing and refitting the valve note the pipe connections.

The operation of the valve can only be checked with the help of two pressure gauges and only a dealer should carry out this job.

To remove the valve, unscrew the union nut securing the brake pipes, withdraw the pipes and plug up the open ends to prevent entry of dirt. Unscrew the valve. Tighten the screws to 1.0 kgm (7 ft.lb.).

13.9. Adjusting the Brakes

13.9.1. Front and Rear Brakes

Front and rear brakes are self-adjusting and no regular adjustment is necessary. To bring the rear shoes or pads nearer to the disc or drum faces, operate the foot brake (without ABS) or the handbrake (with ABS) several times. The mechanism, depending on the version, is either operated by the handbrake or by the footbrake. This will actuate the adjusting mechanism.

13.9.2. Adjusting the Handbrake

If the handbrake lever can be pulled by more than 5 to 7 notches, when drum brakes are fitted or 4 to 6 notches, on vehicles with ABS, adjust the handbrake lever stroke as described below. It will be necessary to remove the rear wheels on vehicles with disc brakes to adjust the separate brake shoes inside the brake discs.

Models with Drum Brakes

- Release the handbrake lever and remove the switch panel on the floor console box. Using an open-ended spanner, slacken the handbrake cable adjusting nut, thereby freeing the handbrake cable (Fig. 13.13).
- Start the engine and operate the brake pedal five or six times until the pedal stroke remains constant. This indicates that the automatic take-up mechanism is working properly. Turn the adjusting nut against the handbrake lever until the

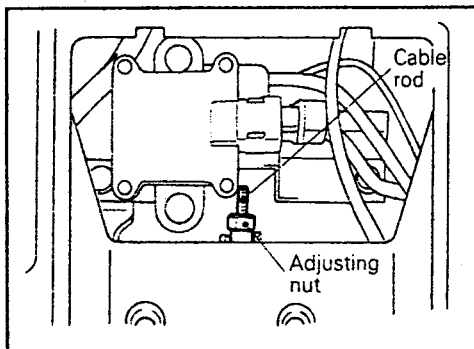

Fig. 13.13. — The adjusting nut for the handbrake cables.

lever can be pulled by the amount on notches (clicks) specified on the previous page. Refit the rear switch panel to the console box.

- Raise the rear end of the vehicle and with the handbrake lever released, check that the rear wheels rotate freely. Pull the handbrake lever by 5 to 7 notches and check that bolt wheels are locked.

Models with Disc Brakes

The adjustment of the handbrake is in general carried out as described above for models with drum brakes, i.e. the handbrake cable is adjusted as described above, but the brake shoes must be set to their correct position to take up future wear:

- Jack up the rear of the vehicle and place jacks underneath the sides of the body. Remove both rear wheels.

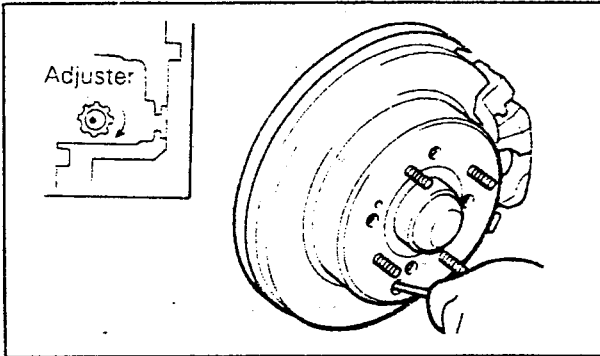

Fig. 13.14. — Adjusting the brake shoes inside the brake discs on models with disc brakes on the rear wheels.

- Rotate the rear wheel hubs to the position shown in Fig. 13.14 and remove the plug from the adjusting hole in the brake disc. Insert a screwdriver and operate the small adjuster wheel inside the disc in the direction of the arrow (inset, top left) until the brake shoes lock the brake disc. Carry out the operation on both sides of the vehicle.
- Return the adjuster wheels by five clicks.
- Check that there is no play on the handbrake cable end (Fig. 13.13). Otherwise tighten the nut until it is just touching its seat. The nut must be locked by the nut holder.
- Refit the wheels and release the handbrake. Turn the rear wheels and check that both wheels can be rotated freely without dragging or excessive "grinding" noises.

13.9.3 Replacing the Handbrake Brake Shoes inside the Discs

Fig. 13.15 shows the arrangement of the brake shoe assembly on the rear axle. There is no need to remove the rear wheel hubs to replace the brake shoes. The hold down springs for the brake shoes are removed in the manner described for the rear drum brakes.

Before installation of new brake shoes (always in sets), unscrew the adjuster (7) and clean the threads. Coat the threads of the adjuster pin and the glide spigot on the other side with M.P. grease. Screw the pin in and out to make sure it can rotate freely.

Replace the brake shoes if the thickness of the linings is less than 1.0 mm (0.04 in.). The standard thickness of the linings is 2.8 mm (0.11 in.), i.e. from the remaining thick-

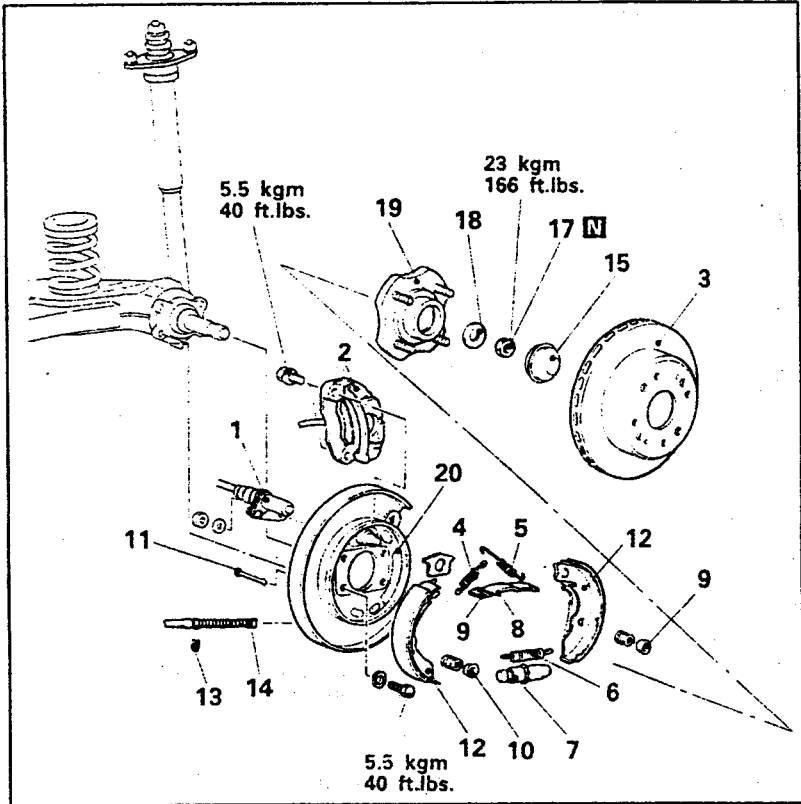

Fig. 13.15. — Exploded view of the handbrake brake shoes inside the brake discs on models with ABS. Follow the numbered order during removal.

- | | |
|-----------------------------|----------------------------------|
| 1 Rear speed sensor | 11 Shoe hold-down spring |
| 2 Rear brake caliper | 12 Brake shoes |
| 3 Rear brake disc | 13 Handbrake cable securing clip |
| 4 Shoe return spring, rear | 14 Handbrake cable |
| 5 Shoe return spring, front | 15 Hub cap |
| 6 Lower shoe return spring | 17 Wheel hub nut |
| 7 Brake shoe adjuster | 18 Tongued washer |
| 8 Thrust strut | 19 Wheel hub |
| 9 Rear hub assembly | 20 Brake backplate |
| 10 Spring retainer | |

ness you will be able to judge how much mileage is left in the brake shoes.

Check the inside face of the brake discs. Obvious wear (grooves, pitting, etc.) requires new brake discs. Disc in acceptable condition should be measured. A maximum inner diameter of 169.0 mm (6.7 in.) must not be exceeded. Use a caliper to measure.

The installation is a reversal of the removal procedure. Smear the contact faces for the brake shoes on the brake back plate and the fulcrum points for the brake shoes with a little M.P. grease.

Refit the shoe hold-down pins as described for the drum brakes.

13.9.4. Adjusting the Brake Pedal

As the free play at the tip of the brake pedal is governed by the brake servo unit push rod, there is no need to adjust the free clearance on the pedal. This play must only be checked and adjusted if the brake servo unit has been replaced.

To adjust the brake pedal height, slacken the brake light switch locknut and unscrew the switch until it no longer touches the pedal. Slacken the push rod locknut and with a pair of pliers, rotate the push rod into the required direction until the height is between 195 - 200 mm (7.7 - 7.9 in.). Tighten the locknut. Check that the free play at the pedal tip is between 3 and 8 mm (0.12 - 0.31 in.).

13.10. Brake Servo Unit

It is not recommended that the owner should attempt to repair the servo unit. This is best left to your dealer who has special tools to deal with renovating. Remember that a failure of the servo unit to act will not affect the efficiency of the braking system but, of course, additional effort will be required for the same braking distance to be maintained.

The brake pedal height must be checked and if necessary adjusted, if a new brake servo unit has been fitted. Slacken the locknut on the clevis fork and turn the operating rod with a pair of pliers. Turning the rod clockwise will lift the pedal up.

ATTENTION! If you coast downhill, for whatever reason, with a vehicle equipped with a brake servo unit, remember that the vacuum in the unit will be used up after a few applications of the brake pedal and the brake system will from then onwards operate without power-assistances. Be prepared for this.

The servo unit is removed by removing the master cylinder (Section 13.6.1.), taking off the vacuum hose and removing the servo unit attachment nuts from the mounting studs (from within the vehicle). Disconnect the brake servo push rod at the clevis fork.

13.11. Brakes — Tightening Torques

Master Brake Cylinder:

Piston stop screw:	0.15 - 0.3 kgm (1 - 2 ft.lb.)
Cylinder to brake servo:	0.8 - 1.2 kgm (6 - 9 ft.lb.)
Brake servo to pedal bracket:	0.8 - 1.2 kgm (6 - 9 ft.lb.)
Brake pipe union nuts:	1.3 - 1.7 kgm (9.5 - 12 ft.lb.)
Front brake caliper guide and lock pins:	7.5 kgm (54 ft.lb.)
Brake caliper mounting bracket to steering knuckle:	9 kgm (65 ft.lb.)
Brake pipe/hose bracket to steering knuckle:	1.5 kgm (11 ft.lb.)
Caliper bleeder screw:	0.8 kgm (6 ft.lb.)

Rear Drum Brake Assembly:

Bleeder screw:	0.7 - 0.9 kgm (5 - 7 ft.lb.)
Wheel cylinder to backplate:	0.8 kgm (6 ft.lb.)
Backplate to rear axle:	5.5 kgm (40 ft.lb.)
Brake pipe union nuts:	1.5 kgm (11 ft.lb.)
Rear wheel hub nuts:	2.3 kgm (166 ft.lb.)

Rear Disc Brake Assembly:

Brake caliper guide/lock bolts:	4.4 kgm (32 ft.lb.)
Brake caliper mounting bracket:	5.5 kgm (40 ft.lb.)
Wheel bearing nut:	23.0 kgm (166 ft.lb.)
Brake pipe union nut:	1.3 - 1.7 kgm (9.5 - 12 ft.lb.)
Bleeder screw:	0.7 - 0.9 kgm (5 - 7 ft.lb.)

14. ELECTRICAL EQUIPMENT

14.0. Technical Data

Battery

Capacity: Depending on engine and equipment
Spec. Gravity:	
Fully charged: 1.260
Half charged: 1.160 - 1.200
Fully discharged: 1.100
Charging Current: 10 % of battery capacity
Quick Charging: With battery capacity
Freezing Point:	
Fully charged: -60° C
Half charged: -22° C
Fully discharged: -8° C

Starter Motor

1800/2000 c.c.: Reduction drive with planetary gear, 0.9 kW at 12 volts
Diesel engine: Reduction drive, 2.0 kW at 12 volts

Alternator

Make: Mitsubishi
Voltage: 12 volts
Output: 60 amps (manual) or 65 (1800 c.c.) or 75 amps (2000 c.c.)
Regulating voltage: 13.9 - 14.9 volts at 20° C
Brush length: Given by wear line on brush

All models covered in this workshop manual operate with an electrical system of 12 volts with negative earth return. The battery is located in the engine compartment.

A pre-engaged starter motor with reduction drive is used on all models, but different starter motors are used for petrol and diesel models. The starter switch is part of the ignition switch and during operation energises a solenoid switch, mounted on the drive end bracket of the starter motor.

The alternator is driven via a "V" belt from the crankshaft pulley. An electronic regulator, built into the alternator controls the charging current.

14.1. Battery

The 12 volts battery consists of six cells, made-up of positive and negative plates, surrounded by a sulfuric acid solution. The battery provides the current to start the engine, for the ignition system, the lighting of the vehicle and other current consumers.

The following maintenance operations should be carried out at regular intervals to extend the life of the battery and to always keep it at its peak performance.

- Check the battery level once a week. If the battery case is translucent, the level can be seen through the case. Otherwise the filler plugs will have to be removed for inspection. If the electrolyte is below the separator plates, add distilled water. Do not over-fill the battery and wipe away any spilled water before replacing the filler plugs. Tap water must not be used to top-up the battery.
- If frequent topping-up is necessary, it may be that the battery is over-charged by the alternator and the latter should be checked accordingly. A cracked battery case can also be the cause.
- The battery cables should always be firmly clamped and the battery terminals must

be free of corrosion to ensure good electrical conduct. Corroded areas can be cleaned with a soda solution and a wire brush. A thin coating of petroleum jelly should be smeared on battery posts before cables are re-connected.

- Check the gravity of the electrolyte in each cell using a hydrometer. This is an indication of the charge condition of the battery. All cells should give the same reading (see Section 14.0) and if there is a great variation in one cell, then either the electrolyte in the cell is weak due to being topped-up with distilled water or that cell is defective. In this case, a new battery must be fitted.

17.2. The Alternator

14.2.1. Routine Precautions

The alternator contains polarity-sensitive components and the precautions below must be observed to avoid damage.

- Check the battery polarity **before** connecting the terminals. Immediate damage will result to the silicon diodes from a wrong connection — even if only momentarily.
- **Never** disconnect the battery or alternator terminals **whilst the engine is running**.
- **Never** allow the alternator to be rotated by the engine unless **ALL** connections are made.
- Disconnect the alternator multi-pin connector **before** using electric welding equipment anywhere on the vehicle.
- Disconnect the battery leads if a rapid battery charger is to be used.
- If an auxiliary battery is used to start the engine, take care that the polarity is correct. **Do not** disconnect the cables from the vehicle battery.

14.2.2. Checking a fitted Alternator

The charging warning light in the instrument panel must be extinguished during normal operation of the engine. If the light comes on whilst the engine is running check the alternator. The first check is on the drive belt as this may have snapped. Then check all electrical connections on the alternator. All further inspection work must be carried out on the removed alternator.

14.2.3. Removal and Installation

- Disconnect the battery earth cable. Disconnect the alternator cables by withdrawing the plug at the rear end of the alternator.
- Remove the adjuster bolt and the nut and slacken the other mounting point. Swing the adjuster upwards, press the alternator towards the inside and remove the "V" belt. Remove the adjusting mechanism.
- Remove the long bolt at the bottom of the alternator after removing the self-locking nut and lift out the alternator.

The installation of the alternator is a reversal of the removal procedure. Place the "V" belt into the pulley grooves and push the alternator towards the outside. Provisionally tighten all mounting bolts and adjust the belt tension as described in Section 4.3.2.

14.2.4. Dismantling the Alternator

Alternators should not be dismantled and/or overhauled. It is far better to obtain an ex-

change unit from your parts suppliers. These have in most cases the same warranty as new parts and will speed-up the repair time. Even the replacement of brushes is not the easiest of operation, as the new brushes must be soldered in position, with the risk of solder running into the cable network.

14.3. Starter Motor

14.3.1. Removal and Installation

Disconnect the battery cable. Disconnect the cables on the solenoid switch. One has a plug connector and is pushed on, the other one must be unscrewed from the stud. Push the cables to one side.

Remove the starter motor mounting bolts from the flywheel housing and remove the unit.

The installation of the starter motor is a reversal of the removal procedure.

14.3.2. Starter Motor Repairs

As in the case of the alternator, fit an exchange unit if the starter motor has burnt-out or suffered other damage. If you are familiar with starter motors, dismantle it in the conventional manner.

14.4. Fuses

The fuse box is located below the dashboard. The capacity of each fuse and the protected circuit is printed on the fuse box cover. Various other fuses, depending on the equipment, are located in the relay box. These include fuses for the L.H. and R.H. rear light circuits, the headlamp main beam circuit and the hazard warning light circuit.

Before replacing a fuse, check the fuse holder for corrosion. Never try to repair a burnt-out fuse by bridging the fuse holder with aluminium foil. Before inserting a new fuse make sure you have located the reason for the electrical fault.

Fusible links are fitted to the relay box, located near the battery.

These links are of different colour and must be replaced with a fusible link of the same colour. The fuse will melt if the designated current is exceeded. Never cover the fusible link with vinyl tape.

14.5. Wiring Diagram Cable Colours

The cables are covered with coloured insulating sleeves. The wiring diagram list these colours with abbreviations. In general the following colours denote the given circuits:

Starter/ignition system	BW = black/white
Charging circuit	W = white
Lighting system	R = red
Flasher indicators	G = green
Instruments	Y = yellow
Other consumers	L = blue
Earth connections	B = black

14.6. Headlamps

14.6.1. Removal and Installation

The component parts of a headlamp are shown in Fig. 14.1. The headlamp bulbs are replaced from the inside of the engine compartment. Remove a headlamp bulb as follows:

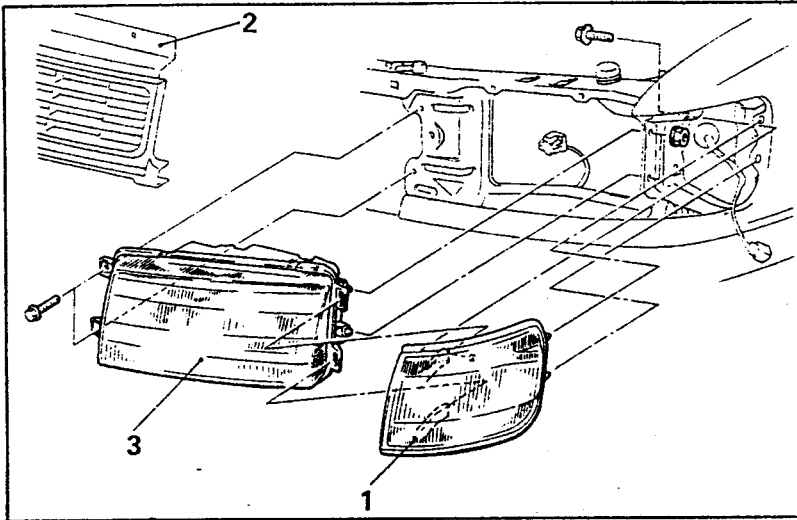

Fig. 14.1. — Details for the removal and installation of the headlamps.

1 Side lamp 2 Radiator grille 3 Headlamp

- Disconnect the battery negative cable and from the rear of the headlamp reflector withdraw the connector plug. Remove the bulb holder and replace the bulb. Never touch the glass of a new bulb with the fingers only, use a tissue to hold it whilst fitting it into the holder.

Replace aheadlamp as follows:

- Referring to Fig. 14.1, unscrew the position lamp from the side of the headlamp.
- Remove the radiator grille.
- From the rear of the headlamp reflector, disconnect the cable connector plug.
- Unscrew the headlamp securing nuts and bolts and lift out the headlamp.

The installation of the headlamp is a reversal of the removal procedure. Tighten the nuts and bolts evenly across.

14.6.2. Adjusting the Headlamps

The adjustment of the headlamps should only be carried out with an optical instrument. We strongly recommend to take the vehicle to a dealer or an auto-electric workshop and have the headlamp beam alignment checked and/or adjusted. The adjusting screws are located at the inside of the headlamp units. The long screw is used for the vertical adjustment (beams up or down). The other one is for the horizontal adjustment.

DIESEL ENGINE SUPPLEMENT

15. DIESELENGINE

15.0. Main Features

Engine Identification:	4D68
Number and arrangement of cylinders:	4, in-line
Arrangement of camshaft:	In cylinder head (OHC)
Camshaft drive:	Toothed timing belt
Engine Capacity:	1998 ccm
Cylinder Bore:	82.7 mm (3.26 in.)
Piston stroke:	93.0 mm (3.66 in.)
Compression ratio:	22.4:1
Max. Performance:	82 BHP at 4500 rpm
Max. Torque:	16.8 kgm (121 ft. lb.) at 2250 rpm
Compression Pressures at 250 rpm:	35.0 kg/sq.cm. (498 psi.)
Min. compression pressure:	25.6 kg/sq.cm. (364 psi.)
Firing order:	1—3—4—2
Valve Clearances (warm):	0.25 mm (0.010 in.), all valves
Injection timing:	9° after T.D.C. at idling speed
Idle speed:	750 rpm \pm 100 rpm
Oil pump type:	Gear-type pump
Oil sump capacity:	See Section 0.3

15.1 Engine—Removal and Installation

NOTE: The air conditioning system must be discharged if one is fitted. This is not a job for the unexperienced and advice should be sought before the removal and installation of the engine is attempted.

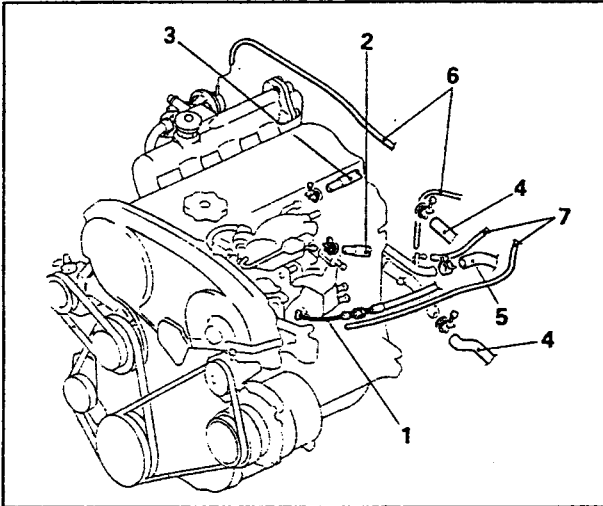

Fig. 15.1. — Initial steps during the removal of the engine. The numbers are referred to in the text.

The engine is removed together without the transmission, but the transmission must be removed from the vehicle before the engine can be removed and lifted out. First carry out the following preliminary operations:

- Open the bonnet and mark the outline of the bonnet hinges on the panel with a pencil. Ask a second person to hold the bonnet and unscrew the hinge securing screws. Free the bonnet of any attachments and carefully lift it off. Store the bonnet where it cannot be damaged.
- Refer to Section "Fuel System" and carry out the necessary operations to interrupt the fuel flow.
- Drain the cooling system and remove the radiator.
- Read section 0.5 before jacking up the front of the vehicle for operations to be carried out from underneath. The transmission can now be removed as described in Section 3.1.

The illustrations on the following pages show the location of the individual items referred to in the following text.

Referring to Fig. 15.1:

- Disconnect the battery and completely remove the battery.
- Disconnect the accelerator cable (1) from the fuel injection pump.
- Disconnect the fuel hoses. Each hose is secured with a wire clamp. Hose (2) is the fuel return hose, hose (3) is the fuel feed hose.
- Slacken the hose clamps and pull off the two heater hoses (4) on the engine side.
- Slacken the hose clamp and withdraw the vacuum hose for the brake servo unit (5).
- Remove the EGR hose (6) from the connections shown.
- On models with air conditioning system, disconnect the vacuum hose for the idle increase solenoid valve.

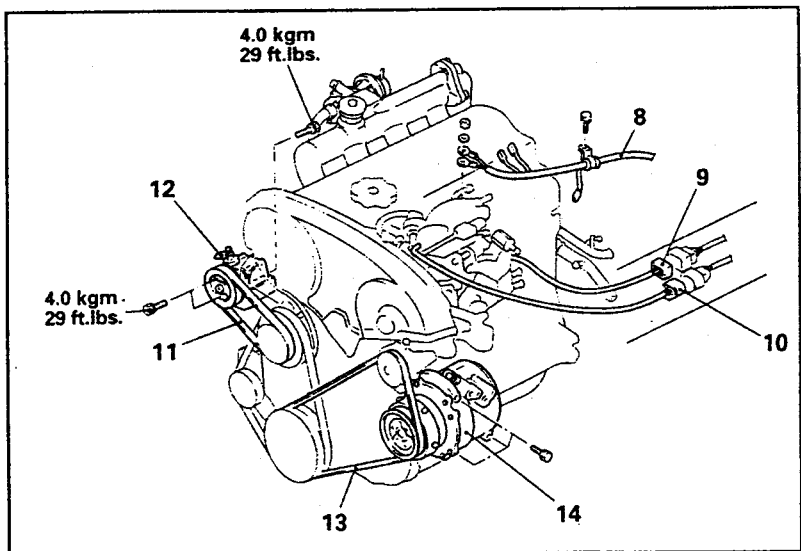

Fig. 15.2. — Second stage during the removal of the engine. The numbers are again referred to in the text.

The next operations are carried out by referring to Fig. 15.2:

- Disconnect the control harness (8), removing the nut and bolt. Push the cable harness to one side.
- Disconnect two connector plugs. Plug (9) is for the fuel injection pump harness, plug (10) is for the harness of the throttle lever position sensor.
- Slacken the tension of the power steering pump (11), take off the belt and unscrew the steering pump (12) as described in the relevant section.
- If an air conditioning system is fitted, slacken the tension of the compressor drive belt (13) and remove the compressor (14).

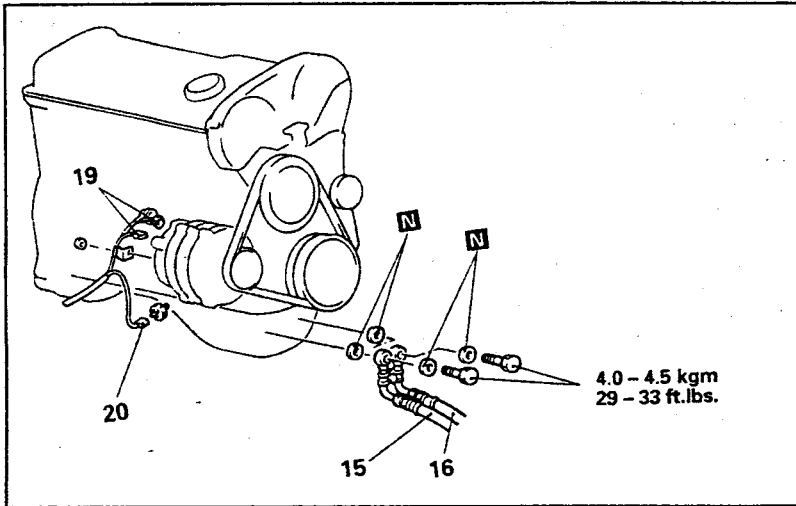

Fig. 15.3. — Third stage during the removal of the engine. All numbers are referred to in the text. Replace the items marked with the "N"

The next operations are carried out by referring to Figs. 15.3 and 15.4:

- Unscrew the two hollow bolts, remove the sealing washers and carefully take off the two hoses. Two further sealing washers are behind the hoses and must be collected (always replace washers). Hose (15) is the oil feed hose to the engine, hose (16) is the oil return from the engine. Take care not to interchange them.
- From below the engine unscrew the front exhaust pipe from the exhaust manifold and free the tube from the bracket. The self-locking nuts must be replaced. The latter items are shown in Fig. 15.4 by items (17). Remove and discard the exhaust pipe-to-manifold gasket (18). The gasket must always be replaced.
- Disconnect the cables from the alternator (19) and at the same time the connector plug for the oil pressure switch connector.
- Drain the fluid from the power steering system as described in the relevant section.
- Suspend the engine and transmission on a chain or rope and slightly lift the unit until just under tension. Place a trolley jack underneath the engine oil sump (piece of wood between jack head and sump) and lift up the engine until there is no more tension on the engine mountings. Remove the engine mounting brackets (21 in Fig. 15.4). Section 15.1.1. gives further details of the mountings).
- Slowly lift the engine out of the engine compartment, continuously checking that it cannot interfere with other parts in the engine compartment. Wires, hoses, etc. must

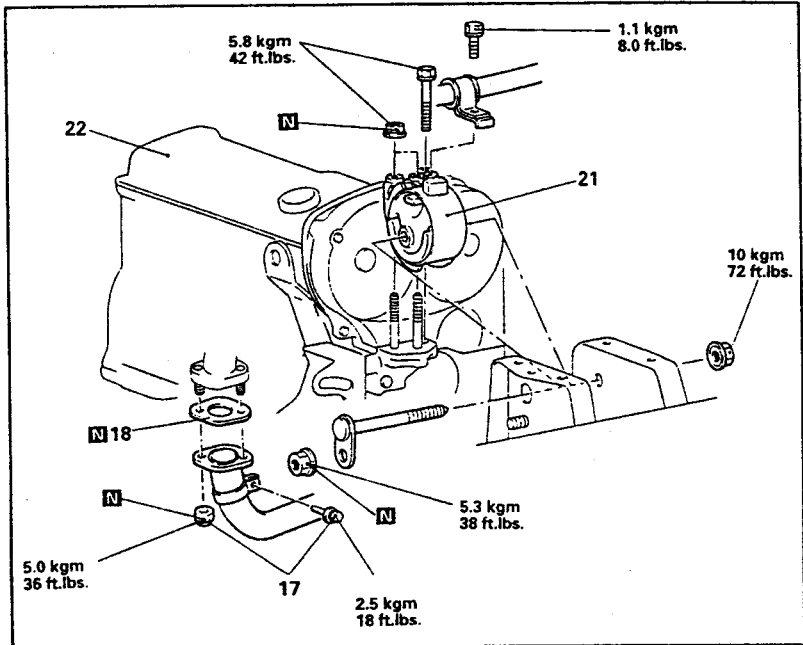

Fig. 15.4. — Remaining parts to be removed/disconnected during the removal of the engine.

immediately be freed, if getting caught in the engine. Continuously guide the engine from other parts in the engine compartment until it can be lifted out without interference.

To install the power unit, lift the assembly into the vehicle and attach all power unit mountings and fully lower the power unit and tighten all nuts and bolts to the corresponding tightening torques. Make sure that none of the wires, cables, hoses, etc. can get trapped between the engine and the mountings.

All other operations are carried out in reverse order to the removal procedure. Fill the transmission with the correct quantity and type of oil. Fill the cooling system with anti-freeze. Check the operation of the gearchange mechanism after connecting the gear-change rod and extension rod.

15.1.1 Removal and Installation of Engine Mountings

Fig. 1.2 shows a view of the front and rear engine mountings. The arrangement underneath the engine and transmission can be seen in Fig. 1.3. A similar arrangement is used on the diesel engine, with the exception that some of the parts are of different shape.

The mountings can be replaced with the engine and transmission in position after the engine load has been taken off the mountings. Refer to Pages 13 and 14 for further information.

The transmission has its own mounting points. Section 3.1 should be referred to when refitting the transmission to the vehicle.

15.2. Dismantling the Engine

The normal order of removal of parts for a complete engine strip-down is given below but this may, of course, be modified if only partial dismantling is required. Proceed as follows:

- Drain the engine oil.
- Remove all engine ancillary parts. If in doubt, refer to specific sections for removal details of a certain component.

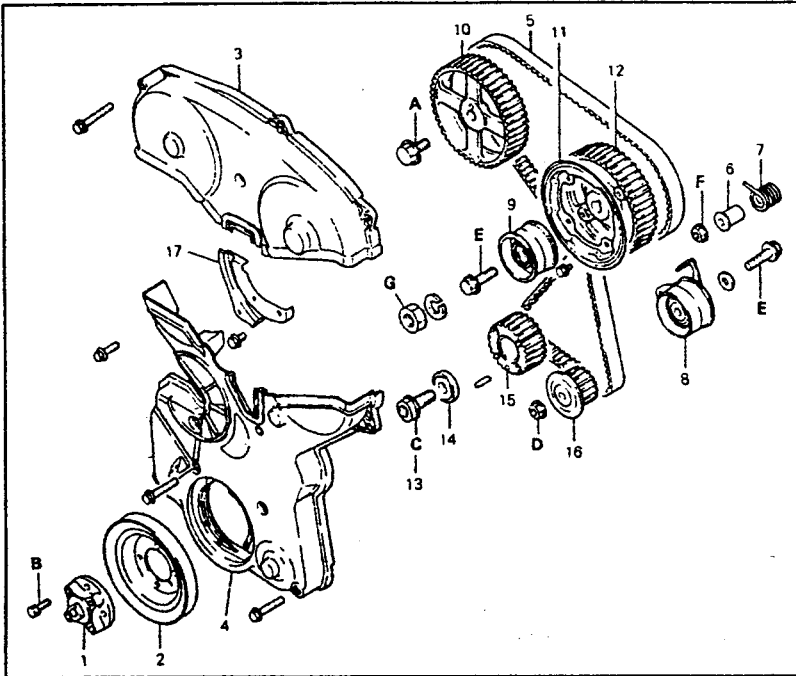

Fig. 15.5 — Sequence for the removal of the timing drive component parts. Follow the numerical sequence to remove. Installation is carried out in reverse order. The letters refer to the tightening torques.

- | | | |
|----------------------------------|------------------------------------|------------------------------------|
| 1 Cranking adaptor | 7 Tensioner spring | 13 Crankshaft sprocket bolt |
| 2 Crankshaft pulley | 8 Tensioner | 14 Special washer |
| 3 Upper timing belt cover | 9 Idler wheel | 15 Crankshaft sprocket |
| 4 Lower timing belt cover | 10 Camshaft sprocket | 16 Oil pump sprocket |
| 5 Timing belt | 11 Flange | A = 8 - 10 kgm (58 - 72 ft.lb.) |
| 7 Tensioner spring | 12 Injection pump sprocket | B = 2 - 3 kgm (15 - 21 ft.lb.) |
| C = 11 - 13 kgm (80 - 94 ft.lb.) | D = 3.4 - 4.0 kgm (25 - 28 ft.lb.) | E = 4.3 - 5.5 kgm (32 - 39 ft.lb.) |
| F = 2 - 2.7 kgm (15 - 19 ft.lb.) | G = 6 - 7 kgm (44 - 50 ft.lb.) | |

- Remove the clutch. To do this, counterhold the flywheel ring gear by means of a strong screwdriver. Mark the relation of the clutch to the flywheel with a centre punch (punch at opposite points into clutch and flywheel) and evenly and slowly unscrew the clutch securing bolts.
- Slacken the alternator securing bolts and take off the drive belt. The alternator can

- now be removed completely. Also remove the tensioning link from the cylinder block.
- Remove the V-belt for the power steering pump. To do this, refer to Section 12.4.4.
 - Remove the cooling fan and the fan clutch from the front of the engine and the water pump pulley.
 - Refer to Fig. 15.5 and remove the upper timing belt cover (3).
 - Remove two bolts and take off the cylinder head cover and remove the gasket.
 - Counterhold the crankshaft against rotation and slacken the four crankshaft pulley bolts. Remove the cranking adaptor (1) and the crankshaft pulley (2).
 - Unscrew the lower timing cover (4) and remove the gaskets.
 - Rotate the engine until the piston of the No. 1 cylinder is at T.D.C. position on the compression stroke. To do this, rotate the crankshaft until the timing marks on the camshaft sprocket and the mark on the injection pump bracket are aligned as shown in Fig. 15.6. To check the correct position move the two rocker arms of the first cylinder. Both should have slight play. If this is not the case, rotate the engine a further revolution.

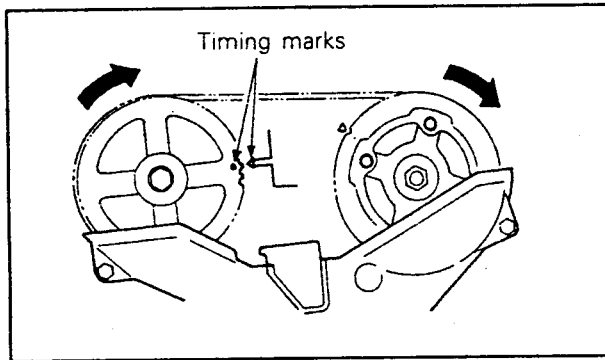

Fig. 15.6. — Align the two timing marks as shown to set the piston of No. 1 cylinder at top dead centre position.

- Using a felt pen or chalk, mark a line across the timing belt to identify its fitted position.
- Remove the camshaft wheel securing bolt and withdraw the wheel together with the timing belt from the camshaft. Crankshaft and camshaft should not be rotated when the belt has been removed and the the cylinder head is still in position.
- Remove the timing belt tensioner (8) from the cylinder block. Undo the nut, marked "F" in Fig. 15.5 (this particular engine has a bolt at this position) and take off the spacer (6) and the spring (7). Then unscrew the bolt marked "E" and take off the idler wheel (9) for the timing belt.
- From the front of the injection pump sprocket unscrew the flange (11) and then remove the pump gearwheel (12). Note that a puller is used to withdraw the gearwheel, as described in the section covering the fuel injection system. Do not attempt to hammer the wheel off the shaft, as this could damage the injection pump.
- Unscrew the rocker shaft from the cylinder head. Further details can be found in the section covering the cylinder head. Unscrew the camshaft bearing cap bolts and lift out the camshaft.
- Remove the camshaft oil seal from its location.
- Hold the flywheel ring gear with a strong screwdriver and remove the crankshaft timing gear bolt. Use two tyre levers, inserted under the pulley at opposite points, and

push the timing wheel off the crankshaft.

- Referring to Fig. 15.7 remove the cylinder head bolts in the order of the numbered sequence shown. A special Allen key (Part No. MD 998051) must be used to undo the bolts.

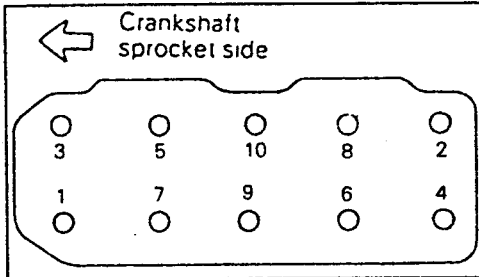

Fig. 15.7. — Sequence for the removal of the cylinder head bolts.

- The cylinder head is located by two dowels and must be lifted straight up. Use a rubber or plastic mallet to free a sticking head. Never attempt to wedge the blade of a screwdriver between the sealing faces in order to separate the head. Take off the cylinder head gasket and immediately clean all gasket faces.

the L.H. side of the cylinder block and insert a screwdriver into the exposed plug opening, as shown in Fig. 15.8 to retain the left-hand balance shaft in its position. The screwdriver shaft should have a diameter of 8 mm (0.31 in.) and a length of 60 mm (2.5 in.).

- Remove the oil pump drive gear. Before removing the nut, first remove the nut on

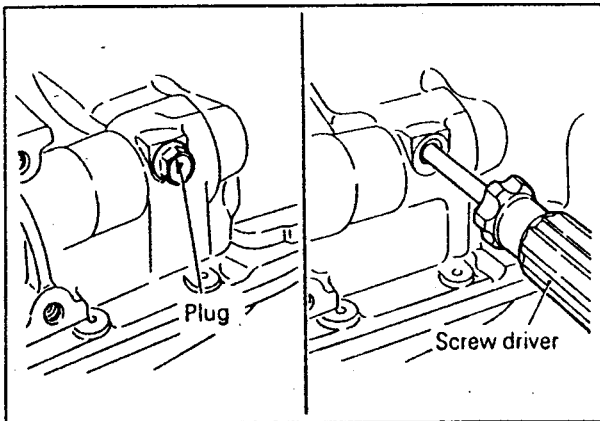

Fig. 15.8. — Preventing the rotation of the balance shaft (silent shaft).

- Slacken the bolt securing the balance shaft (also known as silent shaft) timing gear-wheel until it can be removed by hand. Remove the belt tensioner "B" and the second timing belt (Fig. 15.11).
- Remove the balance shaft timing wheel and also the second crankshaft timing wheel. Use two tyre levers if the wheels have a tight fit.
- Unscrew the oil sump and remove the oil suction strainer.
- Insert a screwdriver through the hole in Fig. 15.8 to counterhold the balance shaft and remove the bolt securing the driven wheel of the oil pump.
- Remove the front housing together with the balance shaft. A screwdriver can be in-

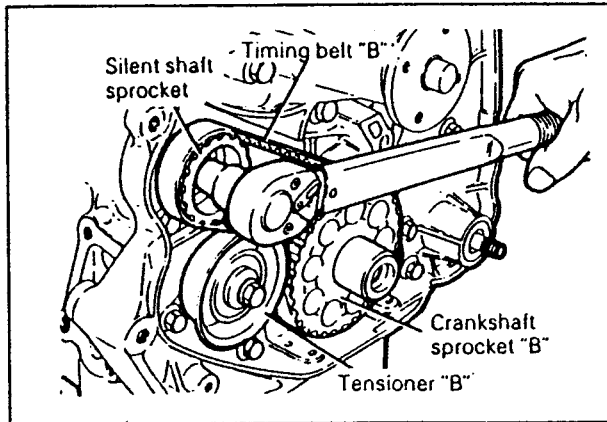

Fig. 15.9. — Removal of the second timing belt together with the associated parts.

serted into the notch at the side of the housing to prise it off. Take care not to damage the sealing faces.

- Withdraw the oil pump gearwheel and the L.H. shaft from the housing and the R.H. shaft from the cylinder block.
- Turn the cylinder block so that the bottom end is at the top or, on a bench, rest the block on the cylinder head face. Rotate the crankshaft until two of the connecting rods are at bottom dead centre. Unscrew the two big end bearing cap nuts and carefully tap the cap with a hammer until it can be removed. Take off the bearing shell and immediately insert it into the removed cap.
- Using a hammer handle push the connecting rod with the piston towards the top of the cylinder bore. If a carbon ring has formed at the top of the bore, preventing an easy removal, use a scraper and remove the carbon without damaging the bore. A number is stamped into the side of the connecting rod and this should always face towards the crankshaft pulley side. Mark the connecting rod and the piston with the cylinder No. Attach the removed bearing cap and the shell to the connecting rod and remove the other connecting rod and piston in the same manner.
- Rotate the crankshaft until the other two big end bearing caps are at bottom dead centre and remove the two connecting rod and piston assemblies as described above. Make sure that each assembly is marked with the cylinder number.
- Block the flywheel by inserting a strong screwdriver into the teeth of the ring gear and remove the flywheel bolts. Remove the flywheel, using a rubber or plastic mallet if necessary. Take care not to drop the flywheel. Remove the rear oil seal retainer from the cylinder block and unscrew the rear oil seal flange. Take off the gasket. Remove the oil seal from the flange with a suitable drift.
- Slacken the crankshaft main bearing cap bolts, commencing at the outsides and working towards the centre. A one-piece bearing capcover is used to retain all crankshaft bearings at once. Note that the front end of the bearing cap is marked with an arrow. Remove the cover, using a rubber mallet if it sticks to the block. The bearing shells must be kept with their location in the cap.
- Carefully lift out the crankshaft.
- Remove the remaining main bearing shells from the crankcase and keep them together with the other shell and bearing cap of each bearing. Use a piece of string or wire and tie the parts together.

15.2.1. PISTONS AND CONNECTING RODS — DISMANTLING

The piston pin has a floating fit in the piston and the connecting rod small end. Wire clips are used to retain the piston pins in position. No special tools are required to separate the pistons and connecting rods. Remove the wire clips from both sides of the piston and drive out the piston pin with a suitable mandrel.

Remove the piston rings with a pair of piston ring pliers (Fig. 1.13). Take care not to break the rings if any other tool is used.

15.2.2. VALVES AND ROCKER SHAFTS — DISMANTLING

The removal of the valves requires the use of a valve spring compressor. Compress the valve spring until the two valve cotter halves can be removed with a pair of pointed pliers from around the valve stem.

Remove the parts from each valve and keep each valve in its correct order of installation. Also keep the parts of each valve in a small cardboard box or plastic bag.

15.3. Assembling the Engine

Refer to the sections commencing at 15.4 for details of the assembly procedure for individual parts and units. Follow the general instructions already given for the petrol engines, commencing on page 23.

15.4. Overhaul of the Engine

15.4.0. CYLINDER HEAD AND VALVES

The cylinder head is made of light-alloy. Valve guides and valve seat inserts are pressed into the cylinder head. The arrangements of the inlet valves, exhaust valves for the diesel engine are shown in Fig. 15.10 in an exploded view.

The individual components of the valve and timing mechanisms should be checked for wear or damage and parts must be repaired or overhauled as necessary.

15.4.0.0. Technical Data

Cylinder head material: Light-alloy with pressed in valve guides and valve seat inserts

Max. distortion of cylinder head surface: Less than 0.20 mm (0.008 in.) Do not re-face

Valves

Valve seat angle: 45° all valves

Correction angles: 30° and 65° all valves

Valve Stem Diameters:

Inlet valves, without turbo charger: 7.96 - 7.975 mm (0.3134 - 0.3140 in.)

Inlet valves, with turbo charger: 7.930 - 7.950 mm (0.3122 - 0.3130 in.)

Exhaust valves (all engines): 7.930 - 7.950 mm (0.3122 - 0.3130 in.)

Valve Seat Width: 0.9 - 1.3 mm (0.035 - 0.051 in.)

Valve Stem Running Clearance in Guides:

Inlet valves — Without turbo charger: 0.03 - 0.06 mm (0.0012 - 0.0024 in.)

— With turbo charger: 0.05 - 0.09 mm (0.002 - 0.0035 in.)

Wear limit: 0.10 mm (0.004 in.)

Exhaust valves: 0.05 - 0.09 mm (0.002 - 0.0035 in.)

Wear limit: 0.15 mm (0.006 in.)

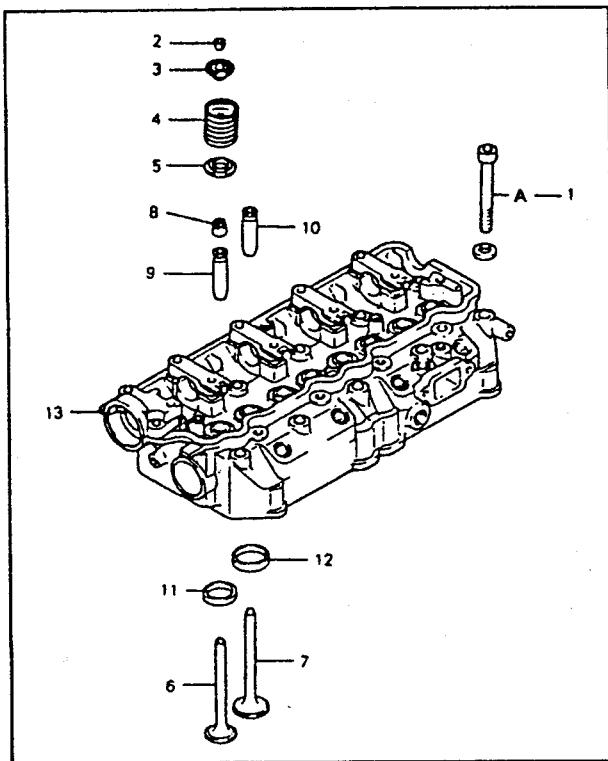

Fig. 15.10. — Exploded view of the cylinder head.

- | | |
|-----------------------|------------------------------|
| 1 Cylinder head bolt | 8 Valve stem seal |
| 2 Valve cotter halves | 9 Inlet valve guide |
| 3 Valve spring cup | 10 Exhaust valve guide |
| 4 Valve spring | 11 Inlet valve seat |
| 5 Spring seat | 12 Exhaust valve seat insert |
| 6 Inlet valve | 13 Cylinder head |
| 7 Exhaust valve | |

Thickness of Valve Head Edge: 1.5 mm (0.06 in.), all valves
 Wear limit — Inlet and exhaust valves: 0.7 mm (0.028 in.)

Valve Guides

Valve Guide Length:
 Inlet valve guides: 56.0 mm (2.20 in.)
 Exhaust valve guides: 58.0 mm (2.28 in.)

Valve Guide Outer Diameters:

Nominal diameter: 13.06 - 13.07 mm (0.5142 - 0.5146 in.)
 Oversizes: 0.05, 0.25 and 0.50 mm

Valve Guide Inner Diameter: 8.00 - 8.018 mm (0.3150 - 0.3157 in.)

Fitting temperature: Room temperature

Valve Springs

Free length: 49.1 mm (1.934 in.)
 Min. free height: 48.1 mm (1.895 in.)

Length under Load of 27.6 kg (6.6 lbs.): 40.4 mm (1.591 in.)
 Max. distortion of valve spring at upper end,
 spring placed vertical on surface plate: 1.5 mm (0.06 in.)
 Spring Arrangement during installation: Colour code must be at the top

Valve Clearances (engine cold):

Inlet valves: 0.15 mm (0.006 in.)
 Exhaust valves: 0.15 mm (0.006 in.)

Camshaft

Camshaft end float: 0.10 - 0.20 mm (0.004 - 0.008 in.)
 Cam Height:
 Inlet and exhaust cams: 41.84 mm (1.6472 in.)
 Wear limit: 41.34 mm (1.5551 in.)
 Bearing journal diameter: 29.935 - 29.950 mm (1.1785 - 1.1791 in.)
 Bearing running clearance: 0.05 - 0.09 mm (0.002 - 0.0035 in.)
 Max. run-out of shaft: 0.10 mm (0.004 in.)

Rocker Shafts

Rocker shaft diameter: 18.878 - 18.898 mm (0.7432 - 0.7440 in.)
 Rocker arm length: 410.0 mm (16.14 in.)
 Running clearance of shaft: 0.01 - 0.05 mm (0.0004 - 0.002 in.)

15.4.0.1. Inpection of Parts

Valve Springs: Check the valve springs for free length and load. Replace springs which do not conform to the values given in Section 15.4.0.0. All relevant operations are described in Section 1.4.0.1 and this section should be referred to.

As for the petrol engines, valve springs are identified by a colour spot at one end and when fitting the springs, this spot must always be at the top, with the close coiled end to the head.

Valve Guides: Remove the valve stem seals, fitted over each valve guide, with a pair of pliers as shown in Fig. 1.18 and throw away the seals. Never re-use them.

Valve guides and valve stems should first be inspected for visible wear as described in Section 1.4.0.2 on page 26.

To replace the valve guides, press out the old guides from the rocker shaft side, using a mandrel that will fit inside the guide bore. There is no need to heat the cylinder head as the guides are pressed in at room temperature. The special tool used in a workshop will automatically fit the new valve guide into the correct position. Without this tool, measure the distance from the end of the guide(s) to the cylinder head face with a depth gauge. Note down this value. Press the new guides into the cylinder head from the upper face, until the original dimension has been obtained.

As for the petrol engines, valve guides are available in three oversizes, i.e. 0.05, 0.25 and 0.50 mm (0.002, 0.01 and 0.02 in.) and are marked with "5", "25" and "50" to identify them. The locating bores in the cylinder head must be reamed out to take the new guides.

Inlet valve guides and exhaust valve guides are of different length. Exhaust valve guides are longer and care must be taken to press the correct guides into the cylinder head.

NOTE: Valve guides to be removed and replaced at room temperature of 20° C. Valve seats must be re-ground, irrespective of their condition, if the valve guides have been replaced.

Valve Seats: Check the valve seats as described on page 27 in Section 1.4.0.3. Extended wear can only be rectified by fitting new valve seat inserts. In this case the

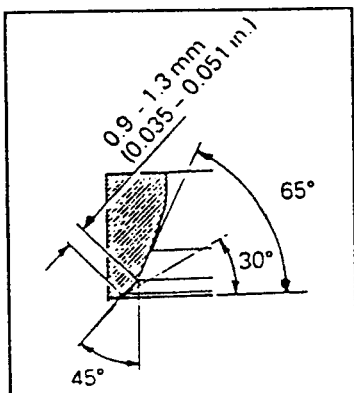

Fig. 15.11. — The valve seat angles of the diesel engine.

have a width of 0.9 - 1.3 mm (0.035 - 0.05 in.). Fig. 15.11 shows the cutter angles used to re-cut the valve seats and also shows where the seat width is measured.

Valves: Valves with bent or pitted stems should be replaced. Grinding or straightening of the valve stems is not permissible. A maximum of 0.5 mm (0.02 in.), however, can be taken off the ends of valve stems if the contacting area for the rocker levers needs attention. This should be carried out in a grinding machine with a proper chuck to ensure a straight face at the end of the stem. If stems ends are badly worn, check the rocker levers as described in the next section as these may also have suffered. Slight blemishes on the valve head faces can be removed by grinding-in the valves as described in Section 1.4.0.3. Deeper grooves or other damage can be rectified in a valve grinding machine. The valve head thickness must not be smaller than 0.7 mm (0.027 in.) after grinding the valves to their original seat angle. Also measure the stem diameter and compare the results with the "Technical Data" in Section 15.4.0.0. Reject any valves which do not conform to the minimum values.

Check the running clearance of each valve stem in the valve guide bores as described in Section 1.4.0.2 on page 26, and decide if it is necessary to replace the guides before any further inspection work is carried out on the valves.

15.4.0.2 Rocker Shafts and Rocker Levers

Fig. 15.12 shows the cylinder head together with the camshaft. To remove any of the parts, follow the numerical order of the illustration. Check the rocker shafts and rockers for wear, pitting and other visible damage. Measure the outside diameter of the rocker shaft and the inside diameter of the rockers. The difference between the two dimensions should not exceed 0.01 - 0.05 mm (0.004 - 0.002 in.) and is the running clearance for rocker levers.

If the running clearance is exceeded it is not always certain that shaft and rocker levers must be replaced. Check the shaft for grooves at the areas where the rocker levers are operating. Deep grooves at these areas indicate wear of the shaft. If on the other hand the shaft has no visible ridges it may only be the rocker lever that needs replacing.

A maximum of 0.5 mm (0.02 in.) can be ground of the rocker lever ends where they contact the valve stems. Badly pitted rocker lever ends make the adjustment of the valves difficult and only a smooth surface should be visible.

cylinder head should be taken to a dealer to have the new seat inserts fitted. New valve seat inserts are available in oversizes of 0.3 or 0.6 mm (0.012 and 0.024 in.) and the cylinder head locating bores must be machined to the size in question to take the new inserts. Only precision machinery can carry out this operation.

A re-cut valve seat must be lapped. Use a suction tool to grind-in the new valve. Use fine lapping compound and work the seat until an uninterrupted ring is visible around the valve face of the after grinding-in the valve, clean the cylinder head, and even more important the inside of the valve guide bores thoroughly. Any lapping paste left inside the cylinder head will accelerate the wear of the new parts.

Measure the width of the valve seats with a caliper. Inlet and exhaust valve seats should

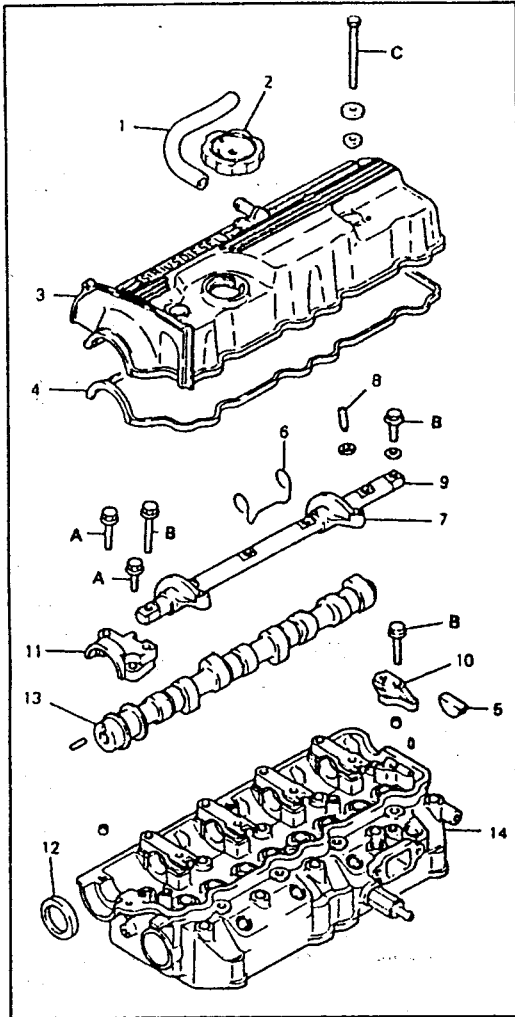

- 1 Breather hose
 - 2 Oil filler cap
 - 3 Rocker cover
 - 4 Rocker cover gasket
 - 5 Semi-circular seal
 - 6 Rocker arm spring
 - 7 Rocker arm
 - 8 Adjusting screw
 - 9 Rocker shaft
 - 10 Rocker shaft pedestal
 - 11 Camshaft bearing cap
 - 12 Camshaft oil seal
 - 13 Camshaft
 - 14 Cylinder head
- A = 1.9 - 2.1 kgm
 14 - 15 ft.l.b.)
- B = 2.8 - 3.2 kgm
 (21 - 23 ft.lb.)
- C = 0.5 - 0.7 kgm
 (3.7 - 5.0 ft.lb.)

Fig. 15.12. — The component parts fitted to the upper parts of the cylinder head.

If after grinding to the thickness given there is no improvement, replace the rocker lever in question.

The following points should be noted when dealing with the rocker shaft assembly, when the cylinder head is dismantled into the parts shown in Fig. 15.12. It should be noted that the breather hose (1) is connected at the R.H. corner of the cylinder head cover and not as shown.

- Fit the camshaft as described later on and tighten the six camshaft bearing cap

bolts finger-tight.

- Assemble the rocker arms and the rocker shaft springs to the rocker shaft.
- Fit the rocker shaft assembly over the bearing caps and fit the bolts.
- Tighten the camshaft bearing bolts and the rocker shaft bolts to the torque given in Fig. 15.12. After the installation hook the rocker shaft spring to the depression of the bearing cap. Make sure that all four rocker arm springs are properly in position.
- Fit a new camshaft oil seal into the front of the cylinder head until the outer face is flush with the head. Apply sealing compound to the centre groove of the semi-circular packing and fit the seal in position. The remaining operations are carried out in reverse order to the removal procedure. The installation of the timing gear is described in Section 15.4.4. The valve clearances must be adjusted as described in later on before the cylinder head cover is fitted in position. Note that the valve clearances must be adjusted on a cold engine.

Cylinder Head Thoroughly clean the cylinder head face of old gasket material and check the surface for distortion. To do this, place a steel ruler over the cylinder head face in the directions shown in Fig. 1.28 and with a feeler gauge measure the gap between the ruler and the head sur. Measure along the different directions shown. The cylinder head surface must not be re-ground. Distortion means the replacement of the cylinder head.

15.4.0.3. Cylinder Head — Assembly and Installation

Refer to Fig. 15.10 when assembling the cylinder head:

- Place the valve spring seats over the valve guides and fit the valve stem oil seals. To avoid oil leaks, a special tool, as shown in Fig. 15.13 should be used for this operation. Place the seals over each guide and carefully tap down with the hollow tool. Never attempt to use the old valve stem seals.

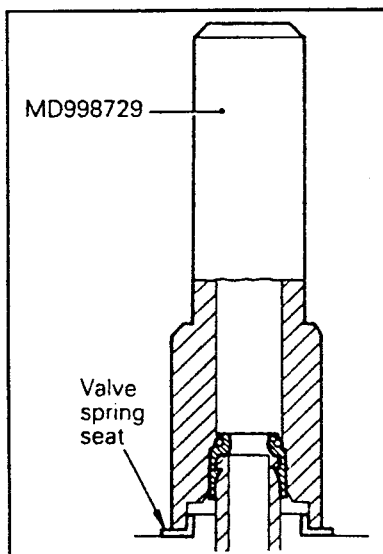

Fig. 15.13. — Fitting a valve stem oil seal.

- Coat the valve stems with thin engine oil and insert into the correct valve guide. Take care not to damage the valve stem seal when the valve is inserted. Make absolutely sure that the valve is inserted into the guide where it has been lapped into the valve seat.

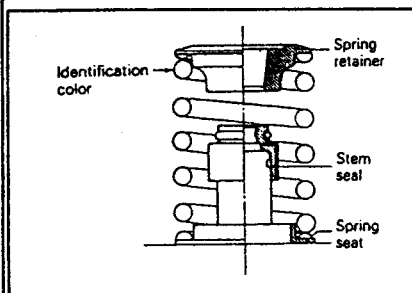

Fig. 15.14. — The correct installation of a valve spring

- Fit the valve springs (correct side up), place the upper spring retainer (cup)

over the valve and using a valve compressor, as shown in Fig. 1.29 compress the valves springs until the two valve cotter halves can be inserted into the groove of the valve stem. Remove the valve compressor and check that the cotters have engaged in their groove by tapping the ends of the valve stems slightly with a hammer. Place a rag over each valve stem end to prevent the cotter halves from flying out.

The installation of the cylinder head is carried out as follows:

- Thoroughly clean the sealing faces of cylinder head and cylinder block and place a new cylinder head gasket in dry condition over the cylinder block. Under no circumstances use sealing compound. The cylinder head gasket has an identification mark and identification holes at the positions shown in Fig. 15.15. The mark on the L.H. side must be visible after the gasket has been fitted. The identification holes also serve a certain purpose. If the cylinder block, pistons, connecting rods or the crankshaft have been replaced, it will be necessary to measure the protrusion of the pistons above the cylinder block face. From the values obtained, a different gasket may have to be selected. Further information are under the heading "Pistons and Connecting Rods" on the following pages.

- Tighten the cylinder head bolts in the reverse order to Fig. 15.7 in several stages in the following sequence:

- Measure the length of each cylinder head bolt from the end of the thread to the face of the bolt head. Any bolt longer than 119.7 mm must be replaced.
- Coat the bolt threads and the underside of the washer with engine oil.
- Tighten the bolts in several stages to a torque setting of 9.0 kgm (65 ft.lb.).

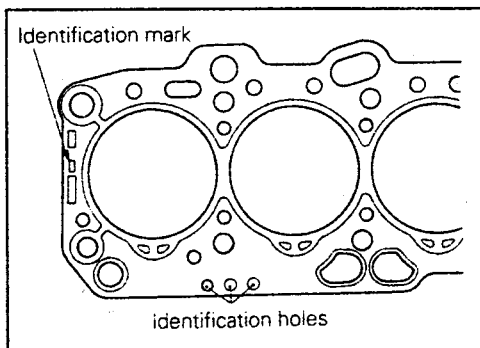

Fig. 15.15. — The identification mark and the identification holes must be visible after the gasket has been fitted.

Use the special cylinder head wrench available for this purpose.

- Completely slacken all cylinder head bolts in reverse order to Fig. 15.7.
- Tighten all cylinder head bolts in several stages in the order shown in Fig. 15.7 to a torque setting of 4.0 kgm (30 ft.lb.).
- The bolts must not be angle-tightened, twice by 90° (one quarter of a turn) without using the torque wrench. Apply the tommy bar of the socket extension either in line with the cylinder head or traverse to the cylinder head and tighten each bolt in the order shown in Fig. 15.7 until the ¼ of a turn has been obtained. After all bolts have been tightened, repeat the operation, again starting at bolt No. 1.

The remaining operations are carried out in reverse order to the dismantling operations. Install the camshaft and rocker shaft assembly as described later on (Section 15.4.3.). Other operations:

- Place a new inlet manifold gasket in position and fit the inlet manifold together with the carburetors and tighten the nuts to 1.5 - 2.0 kgm (11 - 15 ft.lb.).
- Fit a new exhaust manifold gasket, place the manifold in position and tighten the manifold nuts to 1.5 - 2.0 kgm (11 - 15 ft.lb.).

15.4.0.4. Adjusting the Valve Clearances

Valve clearances must be adjusted with the engine cold. The values are 0.15 mm (0.006 in.) for the inlet and exhaust valves.

The clearances are adjusted as shown in Fig. 1.32, using a ring spanner and a screwdriver. Check each clearance in the order given below with a feeler gauge. Insert the gauge of correct thickness between the end of the valve stem and the adjusting screw. The other end of the rocker lever must be resting against the heel of the cam, i.e. the valve must be fully closed. To check if the correct valve is being dealt with, grip the end of the lever with thumb and forefinger and check if a small clearance can be felt.

Adjust the clearances as follows:

- Rotate the engine until both valves of the No. 1 cylinder are closed, i.e. both rocker levers must have a slight play as described above. To check that the correct cylinder has been selected, grip the rocker levers in a similar manner as shown in Fig. 1.33. Both rocker levers must have a clearance. The timing mark in the camshaft sprocket must be opposite the timing mark on the injection pump bracket; the "T" mark on the timing indicator must be in line with the notch in the crankshaft pulley.
- Adjust these two valves and in the same engine position the other valves shown in Fig. 15.16a.

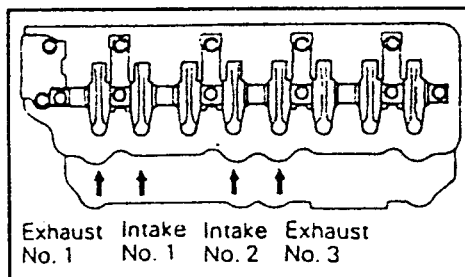

Fig. 15.16a. — Location of the valves to be adjusted when the piston of No. 1 cylinder is at top dead centre.

valves of No. 4 cylinder are closed. In this position adjust all valves marked with the arrows in Fig. 15.16b as described.

- After adjusting the valves fit the rocker cover with a new gasket. Check the oil level and if necessary correct. Check the idle speed and adjust if necessary.

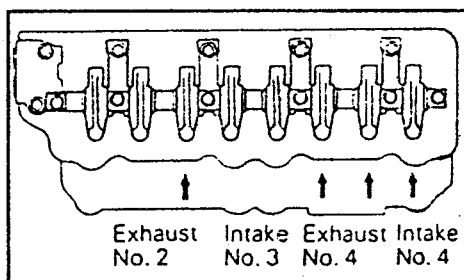

Fig. 15.16b. — Adjust the valves shown by the arrows when the piston of No. 4 cylinder is at top dead centre position. Always make sure that each valve is fully closed.

15.4.0.5. Checking Cylinder Compression

Refer to Section 1.4.0.10. on page 35, but note the compression pressures given in Section 15.0.

15.4.1. PISTONS AND CONNECTING RODS

15.4.1.0. Technical Data

Pistons

Material and construction: Special alloy, solid skirt
Piston pin fit: Fully floating

Piston Diameter: 82.66 - 82.69 mm (3.2543 - 3.2555 in.)
Max. ovality of bores: Less than 0.02 mm (0.0008 in.)
Max. taper of bores: 0.02 mm (0.0008 in.)
Piston running clearance: 0.03 - 0.05 mm (0.0012 - 0.0020 in.)
Oversize pistons available: 0.25, 0.50, 0.75 and 1.0 mm

Side Clearance of Rings in Grooves:

No. 1 ring: 0.05 - 0.07 mm (0.0020 - 0.0028 in.)
Wear limit: 0.10 mm (0.004 in.)
No. 2 ring:
Without turbo charger: 0.02 - 0.06 mm (0.0008 - 0.0024 in.)
With turbo charger: 0.05 - 0.07 mm (0.0020 - 0.0028 in.)
Wear limit: 0.10 mm (0.004 in.)
Oil control ring: 0.02 - 0.07 mm (0.0008 - 0.0028 in.)
Piston ring oversizes: As for pistons

Piston Ring Gaps:

No. 1 rings: 0.20 - 0.32 mm (0.008 - 0.126 in.)
No. 2 rings: 0.35 - 0.50 mm (0.014 - 0.020 in.)
Wear limit: 0.8 mm (0.03 in.)
Oil control rings: 0.10 - 0.30 mm (0.004 - 0.0118 in.)
Wear limit: 0.8 mm (0.031 in.)

Piston pin diameter: 24.994 - 25.000 mm (0.9840 - 0.9843 in.)

Connecting Rods:

Length between centres: 150.0 mm (5.91 in.)
Max. bend or twist of connecting rods: 0.05 mm (0.002 in.) per 100 mm (3.94 in.) of length
Big end end float: 0.10 - 0.25 mm (0.004 - 0.001 in.)
Wear limit: 0.40 mm (0.016 in.)

15.4.1.1. General

The general instructions given for the petrol engines also apply to the diesel engine, but remove the piston pins as described in Section 15.2.1 on page 168. Carry out all inspections described for the petrol engines, noting the standard and wear limit values in Section 15.4.1.0.

NOTE: If new pistons are fitted (also connecting rods, cylinder block or crankshaft), it will be necessary to measure the protrusion of the pistons above the cylinder block. From the values obtained, a cylinder head gasket of the correct thickness will have to be selected.

15.4.1.2. Measuring the Piston Protrusion

- Turn each piston to the top dead centre position and place a dial gauge (set to "Zero") on the cylinder block face, so that the stylus is resting on the edge of the piston, as shown in Fig. 15.17, and write down the indicated value.
- Measure on the opposite side of the piston in the same manner and again write down the value.
- Refer to Fig. 15.18 and carry out further six measurements in the manner described above. Note that the measurements are carried out on the centre line of the crankshaft.

- Add up the eight measurements and divide the total sum by 8. This will give you the average value for all pistons.
- The cylinder head gasket can now be selected. Fig. 15.15 shows a gasket with three identification holes. Other gaskets have either one or two holes. From the table below you will be able to select the correct gasket for the block/piston assembly, but it should be noted that the max. protrusion value at any of the eight measurement points must not exceed the protrusion tolerance given below. If this is the case, use the next gasket up.

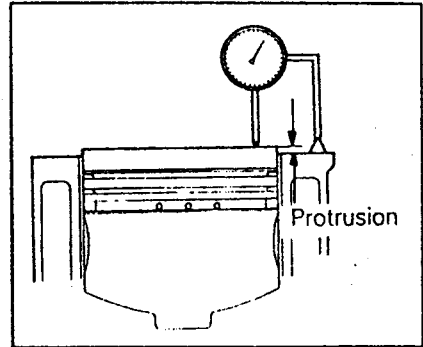

Fig. 15.17. — The stylus of the dial gauge must be placed against the edge of the piston. The other side of the piston must be measured in the same manner.

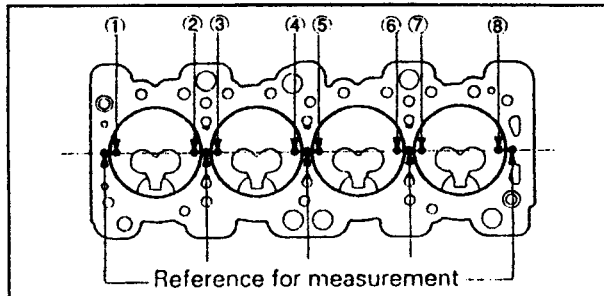

Fig. 15.18. — The eight numbers show where the piston protrusion must be measured when each piston is at the top dead centre position. The measurement must be carried out in each case in the centre of the cylinder block.

Measured average value	0.641 - 0.700 mm
Max. protrusion tolerance	0.750 mm
Select gasket class "A" (one hole)	1.40 ± 0.05 mm
Measured average value	0.700 - 0.760 mm
Max. protrusion tolerance	0.810 mm
Select gasket class "B" (2 holes)	1.45 ± 0.05 mm
Measured average value	0.760 - 0.823 mm
Max. protrusion tolerance	Not applicable
Select gasket class "C" (three holes)	1.50 ± 0.05 mm

15.4.13 Fitting Pistons and Connecting Rods

Refer to Fig. 1.39 for the following operations, but note that two wire clips are used to retain the piston pin. If parts are re-used, make sure to fit them into their original position. If cylinder bores have been re-bored, fit the new piston into the relevant cylinder bore.

- Arrange the connecting rods with the number in the shank facing towards the front.

- Fit the oil control ring to the piston, using a pair of piston pin pliers.
- Fit the centre piston ring (compression ring) and the upper compression ring with a pair of piston ring pliers, with the size mark and the maker's mark facing towards the piston crown. Note that the two compression rings are not identical, although of the same size.
- Arrange the piston ring gaps in accordance with Fig. 15.19 on the circumference of the piston skirt. Make sure the "Front" mark points to the front of the engine.
- A piston ring compressor is required to fit the pistons to the cylinder bores. Place the compressor around the piston rings (without disturbing their position) and push the piston rings into their grooves. If a compressor is not available, lay a piece of this metal around the pistons rings. Never try to fit pistons without compressing the piston rings.

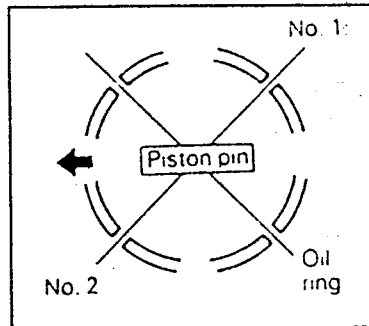

Fig. 15.19. — Correct arrangement of the piston ring gaps.

- Insert the correct connecting rod into the cylinder bore, check that the arrow in the piston faces towards the front and guide the connecting rod, with the bearing shell inserted, into the cylinder bore. The lug in the bearing shell must be engaged into the cut-out of the connecting rod. The remaining installation is carried out as described for the petrol engines (Section 1.4.1.6, Page 42), noting that the nuts must be tightened by a further 90° (¼ of a turn) after they have been tightened equally to 2.0 kgm (15 ft.lb.)

15.4.2. CRANKSHAFT AND BEARINGS

15.4.2.0. Technical Data

Number of bearings:	5
Main journal diameter:	56.98 - 57.00 mm (2.2433 - 2.440 in.)
Crankpin journal diameter:	44.98 - 45.00 mm (1.7709 - 1.7717 in.)
Max. permissible out-of-round:	0.005 mm (0.0002 in.)
Crankshaft end float:	
Nominal:	0.05 - 0.18 mm (0.002 - 0.0071 in.)
Wear limit:	0.25 mm (0.012 in.)
Crankshaft thrust taken at:	Centre main bearing
Main bearing running clearance:	0.02 - 0.04 mm (0.0008 - 0.0016 in.)
Wear limit:	0.10 mm (0.004 in.)
Big end bearing running clearance:	0.02 - 0.05 mm (0.0004 - 0.002 in.)
Wear limit:	0.10 mm (0.004 in.)

15.4.2.1. Crankshaft — Overhaul Instructions

The crankshaft fitted to the diesel engine is of the same construction as the one fitted to the petrol engines, with a one-piece main bearing cover, as shown in Fig. 1.44, securing the crankshaft to the cylinder block.

The main bearing shells are selected by a system of colour coding of main journals, crankpin journals and bearing shells and we consider it beyond the scope of the home mechanic to carry out the assessing and selection of new bearing shells. If a crankshaft needs re-grinding, the correct bearing shells will be supplied and the cylinder block and crankshaft will be returned, ready for assembly.

Refer to the sections covering the inspections, crankpins, main bearing journals, main bearing running clearance, installation of crankshaft, the checking of the cylinder block and the flywheel, commencing on page 43. All illustrations also apply to the diesel engine.

The following instructions must be followed when the crankshaft is fitted to the cylinder block:

- Lubricate the bearing shells with engine oil and insert them into their locations. If the old shells are used fit them in accordance with their marks made during dismantling. The bearing shells with the oil grooves are fitted to the cylinder block, the ones without grooves belong to the bearing cap. The centre shells have no oil grooves. Use an oil can and lubricate the shells. Spread the oil, using the fingers only.

NOTE: If the crankshaft has been re-ground, block and crankshaft will be supplied as a bolted-together assembly. In most cases it will be necessary to remove the crankshaft in order to clean the cylinder block. Make sure to mark each bearing shell in accordance with its location. As new shells have been selected by the colour-code method described above, it is quite possible that not all shells are the same.

- Fit the bearing shells into the bearing cover, with the notches engaging into the grooves of the bearing locations. Lubricate the shells with engine oil. Place the cover over the crankcase, taking care not to drop the shells. The one-piece bearing cover has one arrow at the position shown in Fig. 15.20, which must be facing towards the front end of the engine. Use a plastic mallet to tap the bearing cover in position.
- Measure the length of each bearing cap bolt from end to end. Any bolt that is longer than 71.1 mm must be replaced.
- Coat the threads and the underside of the bolt heads with engine oil and insert the bolts. Tighten them finger-tight, just enough to bring the bearing cover against the crankcase.
- Tighten all bearing cover bolts to 2.5 kgm (18 ft.lb.) from the centre towards the outside in several stages, in the order shown in Fig. 15.20. From the final position tighten each bolt in the same order by a further $\frac{1}{4}$ of a turn (90°).
- Rotate the crankshaft a few turns to check for binding. The crankshaft end float must now be checked as shown in Fig. 15.21. If the end float is more than 0.25 mm (0.010 in.), the centre bearing shells will need to be replaced. As the crankshaft end float

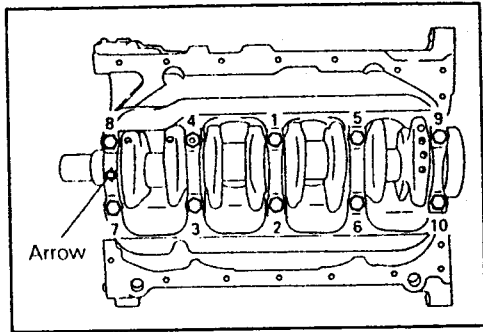

Fig. 15.20. — The arrow in the bearing cap must face towards the front of the engine. The numbers refer to the tightening sequence.

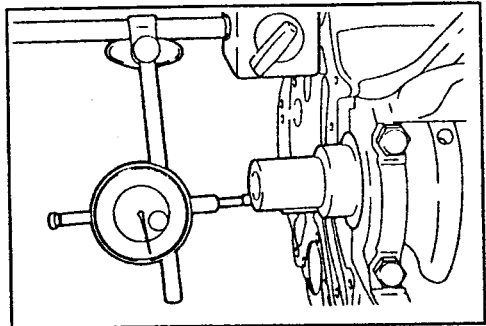

Fig. 15.21. — Checking the crankshaft end float.

should have been checked during removal of the crankshaft, you will have already corrected any discrepancies.

15.4.3 CAMSHAFT AND TIMING DRIVE

15.4.3.0 Technical Data

Camshaft drive:	Toothed belt
End float of camshaft: 0.10 - 0.20 mm (0.004 - 0.008 in.)	
Cam Heights:	See Section 15.4.0.0.
Bearing journal diameter:	See Section 15.4.0.0.
Bearing running clearance: 0.05 - 0.09 mm (0.002 - 0.0035 in.)	
Max. run-out of shaft: 0.10 mm (0.004 in.)	

Valve Timing		
Inlet valves open:	20° before T.D.C.
Inlet valves close:	48° after B.D.C.
Exhaust valves open:	54° before B.D.C.
Exhaust valves close:	22° after T.D.C.

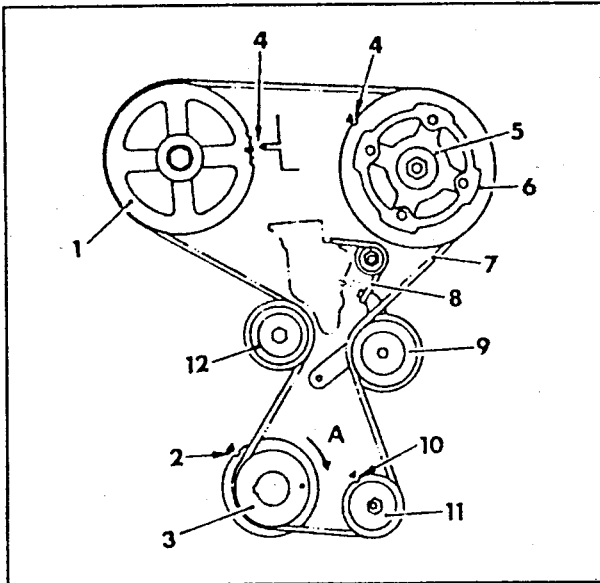

Fig. 15.22. — View of the camshaft and injection pump drive.

- | | |
|---------------------------|-----------------------------|
| 1 Camshaft sprocket | 7 Timing belt |
| 2 Timing mark | 8 Tensioner spring |
| 3 Crankshaft sprocket | 9 Belt tensioner |
| 4 Timing marks | 10 Timing mark (crankshaft) |
| 5 Injection pump sprocket | 11 Oil pump sprocket |
| 6 Flange | 12 Idler wheel |

15.4.3.1 Short Description

The camshaft and timing drive of the diesel engine are shown in Fig. 15.22. The cam-

shaft is mounted in five bearings and driven by a toothed belt. The belt also drives the injection pump gear and the oil pump (this in turn driving one of the balance shafts) and is kept under tension by a belt tensioner, fitted to the centre of its run. The opposite side of the belt is routed over an idler wheel. A second belt, having its own belt tensioner, drives the second balance shaft. Fig. 15.5 shows the component parts of the camshaft timing drive. Fig. 15.23 shows the drive for the second balance shaft.

The removal of the camshaft can be carried out by referring to Fig. 15.12. If the engine is fitted to the vehicle, slacken the camshaft sprocket bolt and then rotate the crankshaft until the two timing marks are aligned as shown in Fig. 15.8. Fully remove the camshaft sprocket bolt and remove the sprocket together with the timing belt. If no further work is to be carried out, rest the camshaft sprocket with the timing belt on the lower timing belt cover. Time. Take care not to drop the half-moon shaped sealing rubber in the cylinder head. The camshaft oil seal must be replaced.

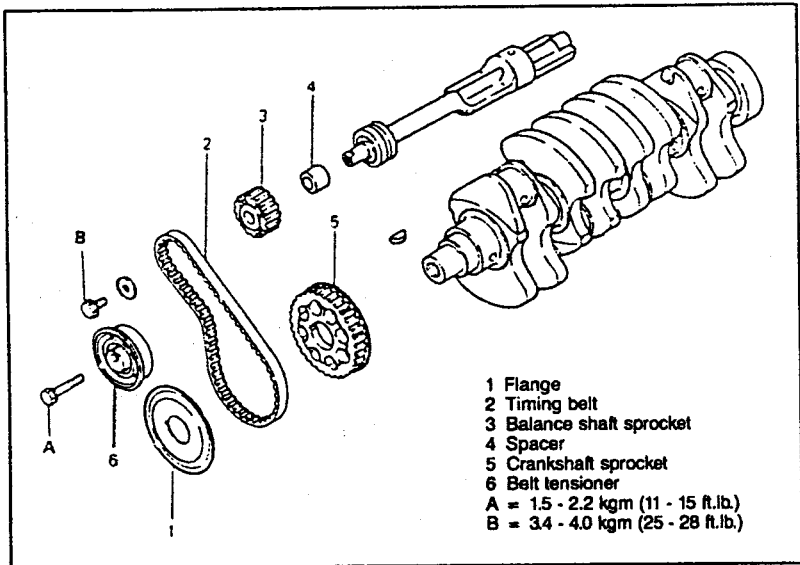

Fig. 15.23. — The drive parts for the balance shaft. The letters refer to the tightening torques.

15.4.4.2. Inspection of Parts

Refer to Section 1.4.4.3. The same instructions also apply to the diesel engine. The camshaft end float is checked in a different manner. Measure the width of the camshaft bearing and then deducted from the width of the camshaft bearing journal. The difference is the camshaft end float. If it, however, possible to check the camshaft end float with a dial gauge as described for the petrol engines.

15.4.3.3. Fitting the Camshaft

- Coat the camshaft bearing journals and the cams with engine oil and also the bearing faces in cylinder head and bearing caps.
- Place the camshaft into the cylinder head and rotate a few times to settle the shaft

into the bearings.

- Install the bearing caps in according with their number identification. No. 5 cap has no identification number. The other three have their number stamped into the position shown in Fig. 15.24.
- Fit the bearing cap bolts finger-tight and then fit the assembled rocker shaft in position over the bearing caps. Fit the bolts. Tighten the camshaft bearing cap bolts and the rocker shaft pedestal bolts to the torque values given in Fig. 15.12.
- Fit the camshaft oil seal, using a suitable piece of tube without damaging the seal. Drive the seal in position until the outer face is flush with the camshaft bearing cap.
- Fit the camshaft sprocket together with the timing belt over the dowel pin in the end of the camshaft and fit the bolt. Tighten the bolt to 8 - 10 kgm (58 - 72 ft.lb.). If the engine was completely dismantled, fit the remaining parts of the timing gear as described in the following section.

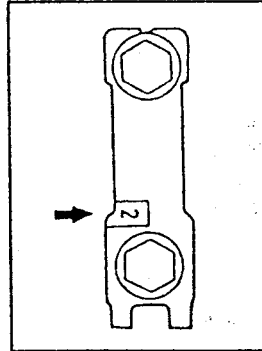

Fig. 15.24. — Bearing cap No.

15.4.4. ADJUSTING THE VALVE TIMING

The component parts of the timing mechanism can be replaced when the engine is in the vehicle, as described during the dismantling of the engine. Also refer to the illustrations in this section for particulars.

The component parts of the timing mechanism are shown in Figs. 15.5 and 15.23.

The following description assumes that the components of the timing mechanism are completely removed, as this is the case during an engine overhaul or during replacement of parts.

- Fit the balance shaft timing gear (3) in Fig. 15.23 and provisionally fit the bolt.
- Place the crankshaft timing wheel (5) over the end of the crankshaft. Align the timing marks of all timing wheels as shown in Fig. 15.25.

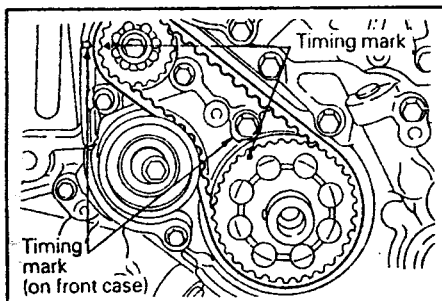

Fig. 15.25. — Details of fitting the timing gearwheel for the balance shaft.

- Place the timing belt over the two drive wheel so that the tensioner side is tight.
- Fit the belt tensioner. The centre point of the tensioner pulley must be located at the left-hand side of the mounting bolt. The pulley flange must be directed towards the front of the engine. Fig. 15.26 shows the tensioner pulley in fitted position.
- Refer to Fig. 15.27 and move the belt tensioner into the direction of the arrow, whilst lifting it with a finger, to give sufficient tension to

the tension side of the timing belt. In this position tighten the bolt to secure the tensioner. Prevent the shaft from turning when the bolt is tightened.

- Check that the timing marks on the sprocket and on the front housing are still aligned, as shown in Fig. 15.25 and push with the forefinger against the timing belt

at the point shown by the arrow in Fig. 15.26. With the tensioner tightened as described, it must be possible to deflect the belt by 5 to 7 mm.

- Fit the oil pump drive wheel and tighten the nut to 5.0 - 6.0 kgm (36 - 43 ft.lb.). Insert a screwdriver into the opening on the left-hand side of the cylinder block as shown in Fig. 15.8. If the screwdriver blade (approx. 8 mm /0.3 in diameter) can be inserted by approx. 60 mm (2.4 in.), the alignment is correct. If it can be inserted on-

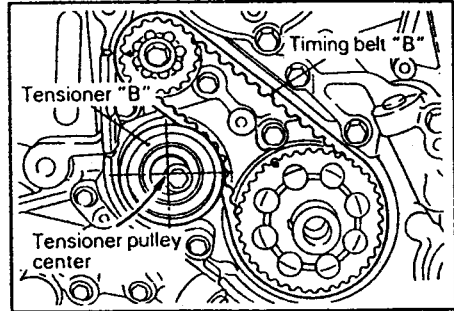

Fig. 15.26. — Fitting the tensioner for the small timing belt. Note where the tension side of the belt is located.

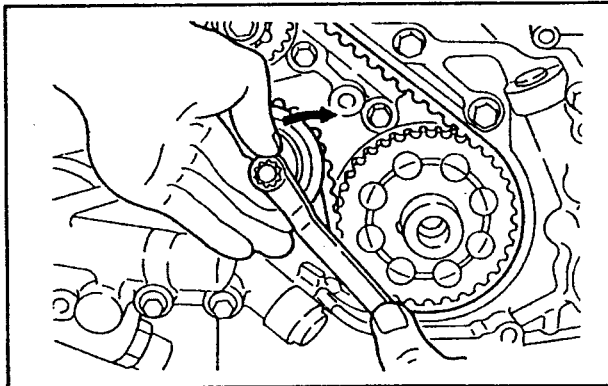

Fig. 15.27. — Tensioning the small toothed belt. Push the tensioner into the direction of the arrow whilst tightening the tensioner bolt.

ly by 25 mm (1 in.), rotate the oil pump drive wheel by one revolution and again align the timing marks. Keep the screwdriver in position until the timing belt has been fitted.

The timing belt can now be fitted as follows:

- Fit the tensioner pulley in the lowest position into the injection pump bracket slot.
- Remove the glow plugs.
- Slacken the locknuts of all valve clearance adjusting screws and unscrew each screw until its end projects by 0 - 2 mm (0 - 0.08 in.).
- Rotate the engine until the piston of No. 1 cylinder is at top dead centre in the firing stroke. Refer to Fig. 15.22 and align all timing marks in accordance.
- Place the timing belt in position, but each time the belt is fitted over one of the timing wheels, make sure there is no slack between the sprockets or between the sprocket and the pulley. The belt should be installed first over the crankshaft timing wheel, then over the idler wheel, then over the camshaft sprocket, over the injection pump sprocket and finally over the oil pump drive wheel. Rotate the crankshaft by half a tooth of the camshaft pulley in reverse direction. This will reduce any slackness in the belt. Finally place the belt over the tensioner pulley.

- Remove the screwdriver inserted into the cylinder block.
- Slacken the tensioner mounting bolt by $\frac{1}{4}$ to $\frac{1}{2}$ of a turn and allow the spring tension to move the tensioner against the belt.

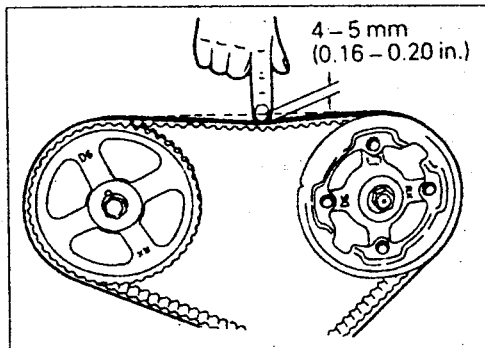

Fig. 15.28. — Checking the timing belt tension.

- Turn the crankshaft anti-clockwise by 3 teeth of the camshaft sprocket from the timing mark and hold the sprocket in this position. Check at all sprockets that the teeth of the belt have engaged properly. Turn the crankshaft once more in clockwise direction until the timing mark on the camshaft sprocket is aligned as shown in Fig. 15.6.
- Refer to Fig. 15.28 to check the timing belt tension. Use the thumb or index finger and press against the centre of the belt as shown in the illustration. The belt should deflect by the amount shown. If this is not the case, re-tension the belt.
- Re-check that all timing marks are in line, rotate the crankshaft by one revolution in normal direction of rotation and check the timing marks once more. Never turn the crankshaft against the normal direction of rotation.
- Carry out all other operations in reverse order to the removal procedures.

15.4.5. Balance Shafts

Two balance shafts are fitted to this engine, one at the top of the R.H. side of the cylinder block and the other one at the bottom L.H. side of the block. The shafts are driven by means of two belt wheels, one by the large toothed belt and the other one by a smaller toothed belt. Figs. 15.5 and 15.23 show the layout of the two timing belts.

The front housing, which must be removed to take out the shafts, contains the oil pump and the oil relief valve. An oil suction strainer is fitted to the bottom of the housing. The oil pump is fitted inside the front housing. Fig. 15.29 shows the component parts of the housing together with the drive shafts.

The R.H. shaft rotates in the same direction as the crankshaft; the L.H. shaft rotates in opposite direction. Both shafts are rotating with twice the speed of the crankshaft.

The shafts are running in bearings at the front end rear. The front end of the L.H. shaft is located in the front housing. The R.H. shaft is located at front and rear in a bearing bush, fitted to the cylinder block. The rear end of the L.H. shaft has a similar location. The removal of the shafts has already been described during the dismantling of the engine.

Before fitting the shafts check the front housing for cracks or other damage. Check the bearing bore for the L.H. shaft in the housing. If worn, replace the front housing.

If the engine has been overhauled, replace the oil seals for crankshaft, R.H. balance shaft and oil pump. Otherwise replace the oil seals if the sealing lips are no longer in good condition.

Measure the outside diameter of the bearing journals and the inside diameter of the bearing bores in the cylinder block. If the difference between the two dimensions is ex-

Fig. 15.29. — Front case, balance shafts and oil sump.

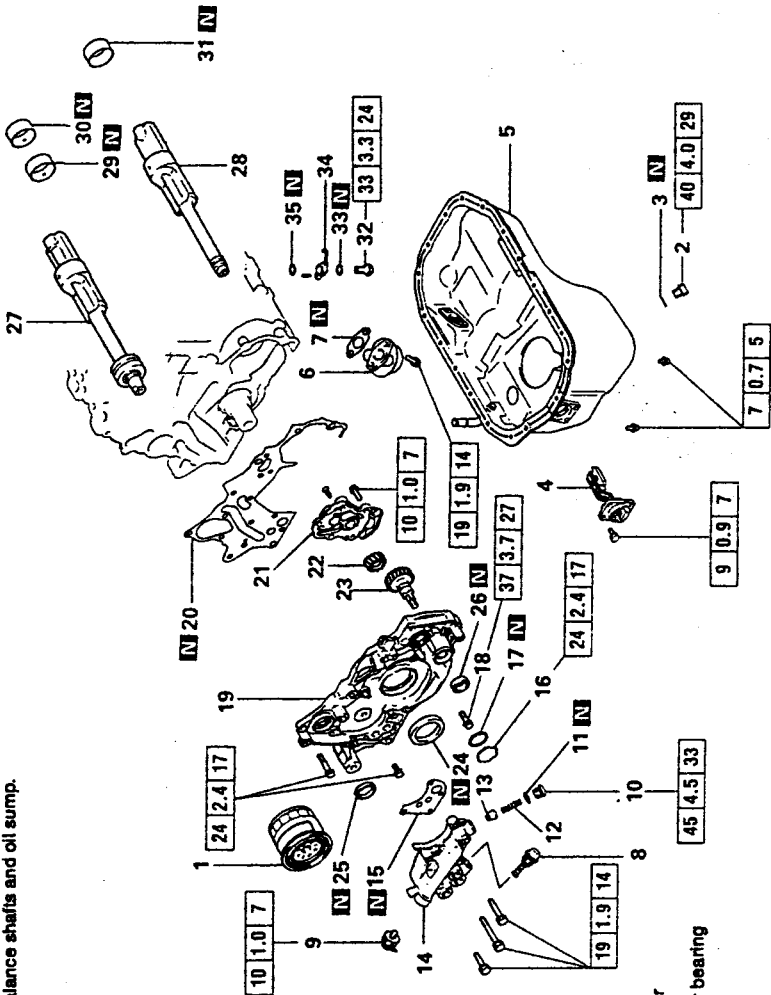

- 1 Oil filter
- 2 Oil drain plug
- 3 Sealing washer
- 4 Oil level sensor
- 5 Oil sump
- 6 Oil suction screen
- 7 Gasket
- 8 Oil cooler by-pass valve
- 9 Oil pressure switch
- 10 Plug
- 11 Gasket
- 12 Relief spring
- 13 Relief plunger
- 14 Oil filter bracket
- 15 Gasket
- 16 Plug
- 17 "O" sealing ring
- 18 Flange bolt
- 19 Front case
- 20 Front case gasket
- 21 Oil pump drive gear
- 22 Oil pump driven gear
- 23 Oil pump drive gear
- 24 Front oil seal
- 25 Balance shaft oil seal
- 28 Oil pump oil seal
- 27 R.H. balance shaft
- 28 L.H. balance shaft
- 29 Balance shaft front bearing
- 30 Balance shaft R.H. rear bearing
- 31 Balance shaft L.H. rear bearing
- 32 Check valve
- 33 Gasket
- 34 Oil jet
- 35 Gasket

cessive the bushes in the block must be replaced. This is a job for a specialist shop as the new bushes must be line-reamed.

Fit the balance shafts by referring to Fig. 15.28, but note some of the points to be observed:

- Insert the two oil pump gears from the front into the front housing, aligning the marks as shown in Fig. 15.30. The two alignment marks must be opposite each other. Fit the pump cover and tighten the screws.
- Insert the L.H. shaft into the driven pump gear. Provisionally fit and tighten the screw.
- Lubricate the bearing journals of the R.H. shaft with engine oil and insert into the cylinder block. Wrap masking tape around the end of the crankshaft and place the front housing gasket in position.
- Insert the L.H. shaft into the cylinder block at the same time place the housing over the cylinder block. Insert a screwdriver into the block, as shown in Fig. 15.8) to lock the shaft in position and tighten the shaft bolt. Fit the plug with a new "O" sealing ring and tighten the plug shown in Fig. 15.31 to to 2.4 kgm (17 ft.lb.).

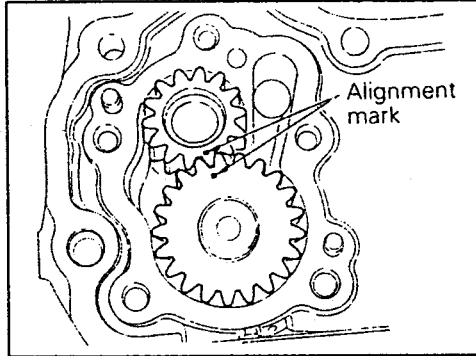

Fig. 15.30. — Aligning the timing marks when fitting the oil pump gears.

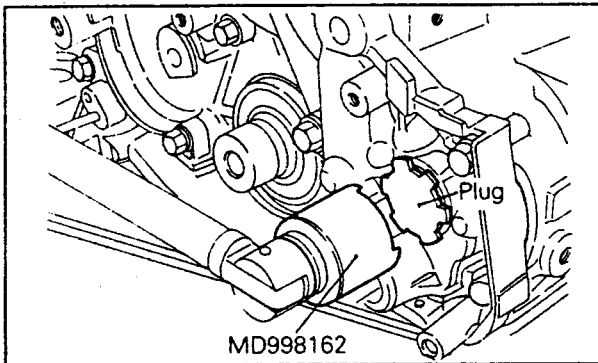

Fig. 15.31. — The plug in the front housing must be tightened as shown.

- Fit the oil suction pipe with a new gasket and tighten the nuts to 1.5 - 2.2 kgm (11 - 16 ft.lb.).
- Fit the oil sump in a similar manner as described for the petrol engines. Note that the two upper bolts have a different length. Tighten the 20 bolts to 0.6 - 0.8 kgm (4.5 - 5.5 ft.lb.). Do not over-tighten these bolts. If removed, fit the oil level sensor into one side of the oil sump (0.9 kgm/7 ft.lb.).
- Fit the rear timing belt guard and the lower guard panel. Tighten the lower screw to

1.5 -1.8 kgm (11 - 13 ft.lb.). This screw also secures the oil pump. The torque of the other screws is less.

15.5. Engine — Tightening Torque Values

Cylinder head bolts:	
First stage:	9.0 kgm (65 ft.lb.)
Second stage:	Slacken completely
Third stage:	Tighten to 4.0 kgm (30 ft.lb.)
Fourth stage:	Angle-tighten by 90° (in sequence)
Fifth stage:	Angle-tighten by 90° (in sequence)
Engine warm:	11.5 - 12.5 kgm (83 - 90 ft.lb.)
Camshaft bearing caps/rocker shaft:	
Bolts for caps and rocker shaft (5):	2.0 kgm (15 ft.lb.)
Rocker shaft:	3.0 (22 ft.lb.)
Camshaft timing gear bolt:	9.0 kgm (65 ft.lb.)
Injection pump sprocket nut:	8.5 kgm (61 ft.lb.)
Timing belt idler bolt:	5.0 kgm (36 ft.lb.)
Bolt/nut for L.H. engine support bracket:	5.0 kgm (36 ft.lb.)
Inlet and exhaust manifold:	1.8 kgm (13 ft.lb.)
Oil dipstick tube to block:	
M6 bolts:	1.0 kgm (7 ft.lb.)
M8 bolt:	1.4 kgm (10 ft.lb.)
Locknut for valve adjusting screws:	1.5 kgm (11 ft.lb.)
Main bearing cap bolts:	
First stage:	2.5 kgm (18 ft.lb.)
Second stage:	Angle-tighten by 90°
Big end bearing cap nuts:	
First stage:	2.0 kgm (15 ft.lb.)
Second stage:	Angle-tighten by 90°
Crankshaft pulley bolts:	2.5 kgm (18 ft.lb.)
Power steering pulley bolts:	0.9 kgm (7 ft.lb.)
Crankshaft timing gear bolt:	12 kgm (87 ft.lb.)
Oil pump drive gear nut:	5.5 kgm (40 ft.lb.)
Plug in front housing:	2.4 kgm (17 ft.lb.)
Belt tensioner bolt:	5.0 kgm (36 ft.lb.)
Balance shaft timing gear bolt:	4.6 kgm (33 ft.lb.)
Front housing bolts:	2.4 kgm (17 ft.lb.)
Bolt for housing and oil filter bracket:	1.9 kgm (14 ft.lb.)
Flywheel bolts:	135 kgm (98 ft.lb.)
Oil pump cover:	1.0 kgm (7 ft.lb.)
Oil pressure switch:	1.5 kgm (11 ft.lb.)
Oil sump bolts:	0.7 kgm (5 ft.lb.)
Sump oil drain plug:	4.0 kgm (29 ft.lb.)
Injection pump bracket bolts (3):	3.5 kgm (25 ft.lb.)
Injection pump mounting bracket nut:	2.5 kgm (18 ft.lb.)
Oil pump driven gear bolt (front of balance shaft):	3.7 kgm (27 ft.lb.)
Oil pressure relief valve:	4.5 kgm (33 ft.lb.)
Starter motor bolts:	2.5 kgm (18.0 ft.lb.)
Alternator mounting:	2.3 kgm (17.0 ft.lb.)
Alternator belt adjusting link:	2.4 kgm (17 ft.lb.)
Alternator adjuster bolt:	1.4 kgm (10 ft.lb.)
Exhaust tube to manifold:	1.5 - 2.5 kgm (11 - 18 ft.lb.)
Exhaust tube to silencer (clamp):	1.0 - 1.5 kgm (7 - 11 ft.lb.)
Rear silencer to front silencer:	2 - 3 kgm (14 - 21 ft.lb.)
Transmission mountings:	Refer to Text
Front engine mounting to engine:	Refer to Text
Clutch bolts:	1.5 - 2.2 kgm (11 - 18 ft.lb.)
Transmission case to engine:	4.3 - 5 kgm (31 - 36 ft.lb.)

15.6. Lubrication System

The lubrication system is constructed in similar manner as specified in Section 2.0 for the petrol engines., i.e. a gear-type oil pump, fitted to front housing, driven through toothed belt, with the L.H. balance shaft driven from pump gearwheel. Refer to Section 2. for details of removal and installation, pump overhaul, oil filter, oil level and oil pressure switch which are treated in similar manner for this engine.

15.7. Diesel Fuel Injection System

Absolute cleanliness is essential during any repairs or work on the diesel fuel injection system, irrespective of the nature of the work in question. Thoroughly clean union nuts before unscrewing any of the injection pipes.

The fuel injection pump cannot repaired or overhauled and an exchange pump or a new pump must be fitted in case of malfunction or damage.

The adjustment of the injection timing and also the removal and installation of the injection pump requires certain special tools and these operations should not be undertaken if these are not available. The following text describes these operations, in case that the listed special tools can be obtained or hired.

Diesel engines either operate with direct injection or indirect injection. The Mitsubishi diesel engine operates with indirect injection, i.e. the fuel is injected into a pre-chamber in the cylinder head which is in connection with the combustion chamber. The combustion is initiated in the pre-chamber and the resulting pressure increase directs the burning fuel particles into the main combustion chamber, where it is fully burnt.

15.7.0. PRECAUTIONS WHEN WORKING ON DIESEL INJECTION SYSTEMS

Whenever repairs are carried out on a diesel fuel injection system, whatever the extent, observe the greatest cleanliness, apart from the following points:

- Only carry out work on diesel injection systems under the cleanest of conditions. Work in the open air should only be carried out when there is no wind, to prevent dust entering open connections.
- Before removal of any union nut clean all around it with a clean cloth.
- Removed parts must only be deposited on a clean bench or table and must be covered with a sheet of plastic or paper. Never use fluffy shop rags to clean parts.
- All open or partially dismantled parts of the injection system must be fully covered or kept in a cardboard box, if the repair is not carried out immediately.
- Check the parts for cleanliness before installation.
- Never use an air line to clean the exterior of the engine when connections of the injection system are open. With the availability of air compressors which can be plugged into a cigar lighter socket, you may be tempted to use air for cleaning.
- Take care not to allow diesel fuel in contact with rubber hoses or other rubber parts. Immediately clean such a hose if it should happen accidentally.

15.7.1 FUEL FILTER

The fuel filter should be replaced in approx. every 20,000 miles, but must be drained of accumulated water, when the fuel filter warning light indicates that excess water is in the filter. To drain the filter, slacken the water drain plug at the bottom of the filter, as shown in Fig. 15.32 and operate the priming pump knob, as shown on the R.H. side of Fig. 15.32, until enough fuel has run out to clear the water.

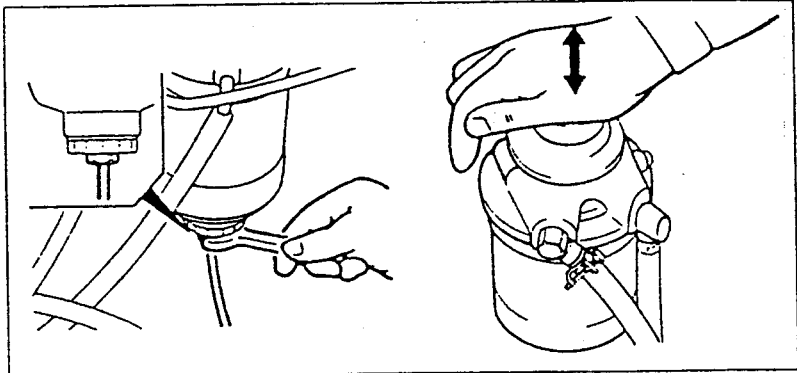

Fig. 15.32. — The L.H. view shows how the water is drained from the filter. Operate the priming pump plunger as shown in the R.H. view until fuel, free of water is running out of the drain plug opening.

To replace the filter insert, proceed as follows:

Remove the fuel filler cap to lower the pressure in the tank. Disconnect the electrical leads from the water level sensor connector and the wiring harness connector. Grip the fuel filter with both hand and unscrew the filter element from the filter head. A tight filter can be unscrewed with an oil filter wrench.

To remove the complete filter, disconnect the fuel hose and unscrew the two filter securing bolts, shown in Fig. 15.33 by the arrows.

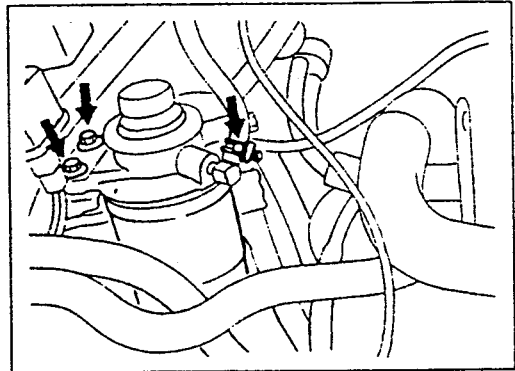

Fig. 15.33. — The arrows show the two securing screws for the fuel filter body and the electrical connector.

The installation is a reversal of the removal procedure. The fuel system must now be bled of air as follows:

- Slacken the bleeder plug on the side of the fuel filter. Operate the hand pump (priming pump), as shown in Fig. 15.32, until the fuel running out of the bleeder plug hole is free of air bubbles. Catch the draining diesel fuel with a thick rag.
- Tighten the bleeder plug, clean off all traces of diesel fuel and continue to operate the pump knob until it feels heavy, i.e. the fuel inside the system has built-up a certain pressure.
- Remember to refit the fuel tank filler cap after the fuel filter has been replaced.

NOTE The fuel system must be bled of air when the tank is empty, when the fuel filter has been replaced or the fuel lines have been disconnected. If air remains in the injection system it will be difficult to start the engine. Therefore, make sure that all has been removed in the manner described.

Fig. 15.34. — Details for the removal and installation of the fuel injection pump.

- 1 Accelerator cable connection
- 2 Vacuum hose connection
- 3 Fuel feed hose connection
- 4 Fuel return hose connection
- 5 Water hose connection
- 6 Timing belt upper cover
- 7 Fuel injection pipe
- 8 Fuel injection pump wiring harness
- 9 Lever position sensor connector
- 10 Lever position switch (with automatic transmission)
- 11 Fuel injection pump bracket
- 12 Fuel injection pump sprocket
- 13 Fuel injection pump
- 14 Key
- 15 Timing check plug bracket
- 16 Fuel injection pump under bracket

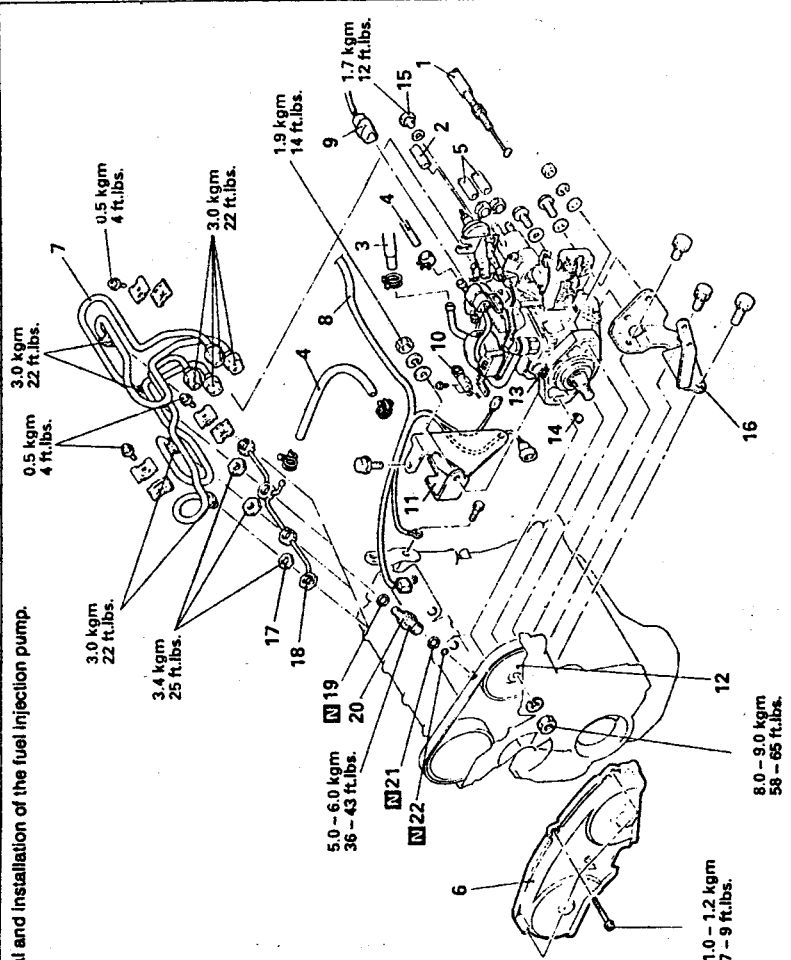

15.7.2. INJECTION PUMP — REMOVAL AND INSTALLATION

The timing adjustment of the injection pump requires the use of a special tool to remove the injection pump gearwheel. The injection pump should, therefore, only be removed on the understanding that a dealer should check the correct injection timing if the engine does not run as it should. If these can be obtained to carry out the job. It should also be remembered that the timing belt must be removed and refitted in order to remove the pump. Fig. 15.34 shows the parts that will have to be removed and/or disconnected to remove the injection pump. Follow the numbered order.

- Drain the cooling system.
- Disconnect the battery.
- Remove the glow plugs as described later on.
- Remove the front engine mounting bracket. This is required to gain access to the timing side of the engine. The engine must be suspended by means of a suitable hoist and sling assembly or a jack must be placed underneath the engine (wooden plank between engine and jack head).

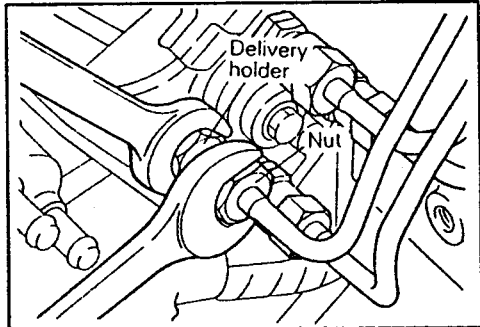

Fig. 15.35. — Slacken the injection pipes on the injection pump by means of two open-ended spanners.

- Referring to Fig. 15.34, disconnect in the following order: the accelerator cable (1), vacuum hose (2), the fuel feed pipe (3), but open the tank filler cap first to release the pressure, the fuel return hose (4), the water hoses. Unscrew the upper timing belt cover (6). Suitably close off the fuel lines to prevent entry of dirt. Fuel may squirt out as soon as the nuts are slack and the necessary precautions must be taken.

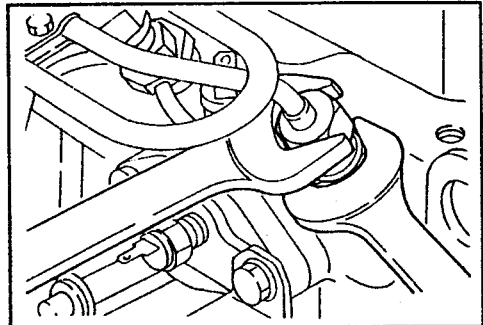

Fig. 15.36. — Slacken the injector pipe union nuts on the injector jets with two open-ended spanners as shown.

- Disconnect the union nuts connecting the injector pipes to the injectors and the injection pump. When slackening the pipes at the pump ends, counterhold the delivery valve holder on the injection pump head with an open-ended spanner to prevent the valve holders from rotating, as shown in Fig. 15.35. Fig. 15.36 shows how the other ends of the injection pipes are slackened. Mark the pipes before removing them.
- Disconnect the wiring harness for the injection pump (8), unscrew the cable harness (1 bolt) and push the harness to one side. From the rear withdraw the connector plug (9) and if fitted, the plug (10).
- Unscrew the pump support bracket (11).
- Remove the nut and spring washer securing the injection pump sprocket (12). Take

care not to drop the nut and washer into the lower timing belt cover during removal.

- Rotate the engine until the piston of the No. 1 cylinder is at top dead centre in the compression stroke.
- Use a puller, as shown in Fig. 15.37 and remove the pump drive gear from the shaft. Take care not to damage the sprocket or shock-load the pump shaft. Also take care not to place the timing belt under excessive stress, as the sprocket moves off the injection pump shaft. After removal do not rotate the crankshaft and make sure the timing belt cannot slip off the crankshaft or camshaft gearwheel.

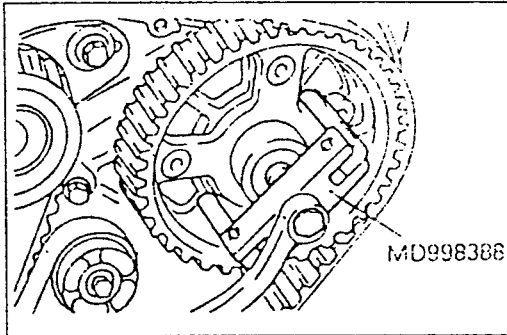

Fig. 15.37. — The injection pump sprocket must be removed with a two-arm puller.

- Using a scriber or small screwdriver and mark the precise fitted position of the pump. If the original pump is fitted as removed, there will be no need for any further adjustments. Remove the pump attachment bolts, nuts and washers and remove the pump. Make sure not to lift the pump on the accelerator lever.

The installation of the pump is a reversal of the removal procedure. Follow the tightening torques given in Fig. 15.34. Make sure that the marks on the injection pump and bracket are as marked before removal. Adjust the timing belt tension as described in the relevant section. When tightening the fuel injection pipes use two spanners, as shown in Figs. 15.35 or 15.36. The same applies when the fuel return pipe connection is tightened.

Bleed the fuel system of air after all connections have been re-made (Section 15.7.1).

15.7.2.0. Injection Timing Adjustment

As already mentioned above, have the timing of the fuel injection pump checked, if it doubt about its correct functioning.

The injection pump can also be adjusted as follows, but it must be noted that apart from special tools some knowledge is required to set the pump to the correct timing position. As we do not know the capabilities of the user of our manuals, we give you the description of the adjustment. Provided that the conditions mentioned above are met, proceed as follows:

- Warm up the engine until the operating temperature has been reached. At the injection pump check that the fast idle lever is separated from the accelerator lever.
- If the engine has been rotated in the meantime, reset it to the top dead centre position in the No. 1 cylinder, making sure that the compression stroke has been obtained. The notch in the crankshaft pulley must be opposite the "TDC" mark on the timing indicator, as shown in Fig. 15.38. Also check that the timing mark on the camshaft sprocket is opposite the arrow. Unscrew the glow plugs to facilitate the rotation of the crankshaft.
- Slacken, but do not remove the union nuts of the four injection pipes on the injection pump side, using two open-ended spanners, as shown in Fig. 15.34.

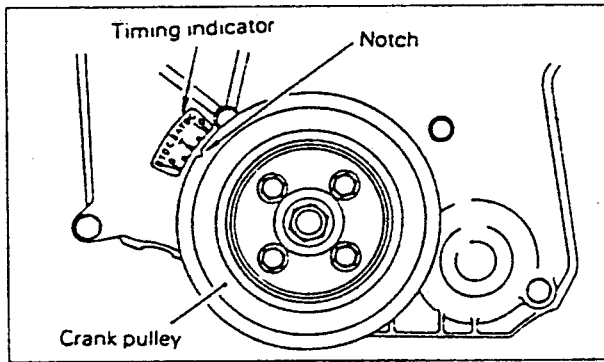

Fig. 15.38. — The top dead centre position of the No. 1 cylinder.

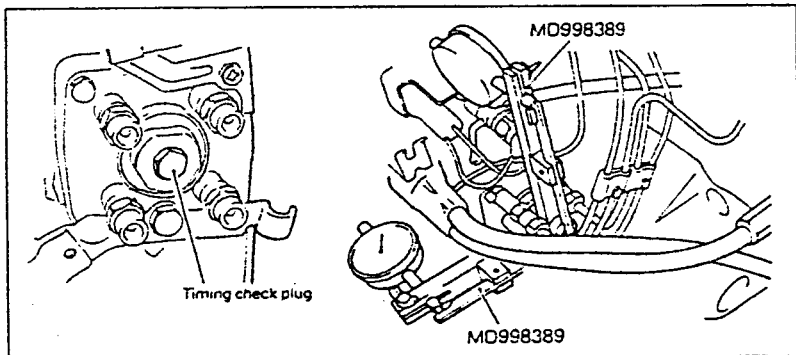

Fig. 15.39. — The location of the plug (left) and the fitted special tool with a dial gauge (right). The lower of the two tools is used for the Space Wagon engine.

- Slacken, but do not remove the two nuts and bolts securing the injection pump.
- Remove the plug in the centre of the four pipes (see location in Fig. 15.39) and fit the special tool MD998389 into the plug hole and screw into place. Fit the dial gauge as shown.
- Turn the crankshaft until the notch in the pulley is approx. 30° before the top dead centre in the compression stroke of No. 1 piston. In this position set the dial gauge to zero (Fig. 15.40). Slightly turn the crankshaft backwards and forwards to make sure that the dial gauge cannot deviate from the

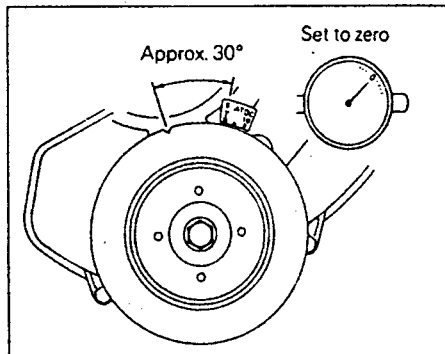

Fig. 15.40. — Adjusting the injection timing. The dial gauge is set to "Zero" when the the notch in the crankshaft is set to 30° before top dead centre of No. 1 piston.

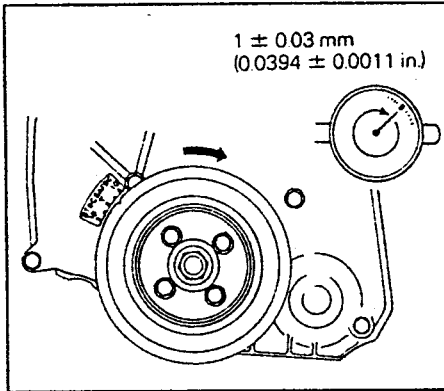

Fig. 15.41. — Rotate the crankshaft in its normal direction of rotation to the 9° mark on the timing scale and check the dial gauge reading.

“Zero” position.

- Turn the crankshaft in normal direction of rotation until the notch in the crankshaft pulley is opposite the 9° after top dead centre mark (Fig. 15.41). In this position read off the dial indicator reading. This should be between 0.97 - 1.03 mm (0.038 - 0.041 in.), with 1.0 mm (0.04 in.) the best value when adjustments are necessary.
- If the dial indicator reading is not within the values given, rotate the injection pump to the right or left, in accordance with Fig. 15.52, until the dial indicator shows the above value. Tighten the pump bolts and nuts to 2.0 - 2.7 kgm (15 -19 ft.lb.), taking care not to move

the injection pump when the bolts and nuts are tightened.

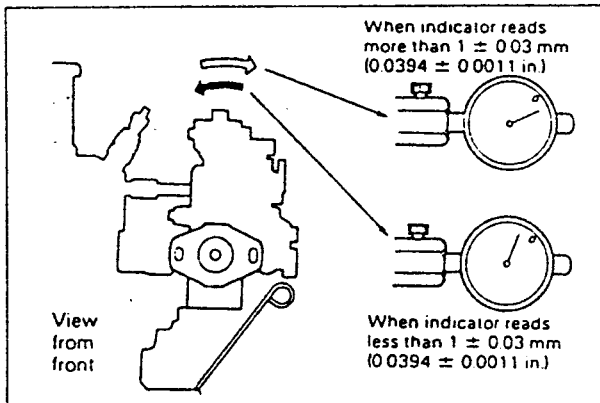

Fig. 15.42. — Rotate the injection pump in the direction shown to set the injection timing.

- Turn the crankshaft once more to the position shown in Fig. 15.40 and repeat the measurement. The correct dial gauge reading should now be obtained.
- Remove the special tool and the dial gauge, fit the plug with a new copper washer, even if the original washer appears to be in good condition.
- Fit the injection pipes with the union nuts and tighten the nuts with two open-ended spanners, as shown in Fig. 15.35. The torque must be estimated not to exceed 3.0 kgm (22 ft.lb.). Use well fitting spanners. An ordinary torque wrench cannot be used to tighten the union nuts.
- After fitting the injection pipes, bleed the fuel system as described in Section 15.7.1 to eject the air out of the pipes and connections.

15.7.3. INJECTOR HOLDERS AND INJECTORS

15.7.3.0. Removal and Installation

Refer to Fig. 15.43 for details of the parts to be removed. Disconnect the fuel return hose after opening the two clamps. Unscrew the fuel return pipe securing nut. Counterhold the hexagon of the return pipe connection with an open-ended spanner, similar as shown in Fig. 15.35, to prevent it from rotating with the nut.

Remove the fuel return pipe from all injector holders and remove the gaskets. The injectors must be removed with a long 22 mm socket, to reach the hexagon. Remove the gasket from the hole in the cylinder head.

The installation is a reversal of the removal procedure. Always replace the nozzle tip gasket. Tighten the injector holder to 5.0 - 6.0 kgm (36 - 43 ft.lb.).

Refit the fuel return pipe with new gaskets and fit the nuts. Counterhold the hexagon of the connectors and tighten the nuts to 3.0 - 4.0 kgm (22 - 29 ft.lb.). Refit the fuel return hose and bleed the fuel system as described in Section 15.7.1 to remove all air out of the fuel injection system (also see Fig. 15.32, right).

NOTE: The injection pressure of the injectors should only be tested in a specialist shop. Never attempt to carry out this operation yourself.

To find a faulty injector, unscrew the union nuts one after the other at the injector connection and start the engine. Run the engine at increased speed. If the engine noise does not change after a certain injection pipe has been disconnected, the faulty injector has been found.

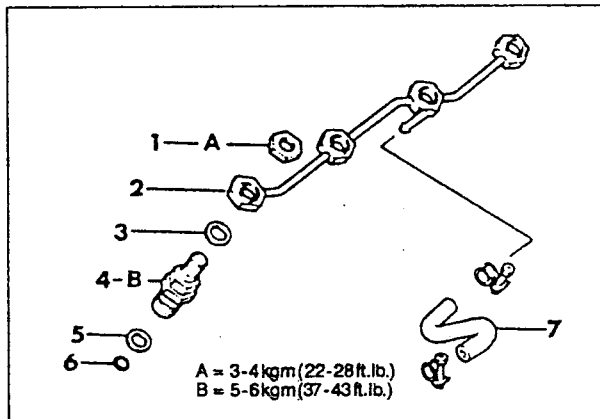

Fig. 15.43. — Removal and installation details for the injectors. The letters refer to the tightening torques.

- | | |
|----------------------|------------------------|
| 1 Nut | 5 Nozzle holder gasket |
| 2 Fuel return pipe | 6 Nozzle tip gasket |
| 3 Return pipe gasket | 7 Fuel return hose |
| 4 Injection nozzle | |

15.7.4. GLOW PLUGS

The glow plugs receive electrical current when the ignition switch is turned to the glow position. The plugs receive a voltage of at least 11.5 volts and are heated within seconds

to an approx. temperature of up to 1100° C. The glow time depends on the temperature of the engine and may be between 25 seconds during very cold temperatures and 2 seconds during the summer months. If the engine is not started immediately, the power supply is interrupted and will be operated once more when the key is turned into the glow position.

Because of the high temperatures it is quite possible that one of the glow plugs burns out. Glow plugs can also be damaged through faulty injectors, wrong injection times and low injection pressure.

The plugs are located in the cylinder head. Remove the nuts from the ends of the plugs and remove the bus bar. Unscrew the plug in question. A socket with extension and ratchet should be used to remove the plugs. Tighten the new plug to 1.5 - 2.0 kgm (11 - 15 ft.lb.).

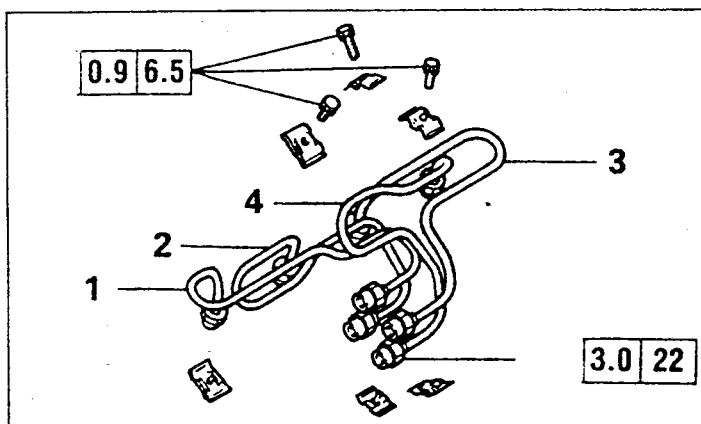

Fig. 15.44. — Removal and installation details for the injection pipes. The numbers refer to the injection pipe (cylinder) numbers.

15.7.5. INJECTION PIPES

Fig. 15.44 shows the set of injection pipes together with their attachment parts and tightening torques. Always hold the connector of the respective connection when a pipe is slackened or tightened. Use two open-ended spanners as shown in Figs. 15.35 and 15.36. The fuel system must be bled of air as described in Section 15.7.1 after a pipe has been disconnected.

15.7.6. IDLE SPEED ADJUSTMENT

Run the engine to operating temperature and switch off all lights and accessories. The transmission must be in neutral, if an automatic box is fitted.

A good idle speed can only be obtained if the valve clearances and the injection timing are correctly adjusted. A revolution counter must be connected in accordance with the instructions of the manufacturer, but note that an ordinary revolution counter, as used on a petrol engine, cannot be used on a diesel engine. You will need a rev counter suitable for a diesel engine.

- Start the engine and read off the idle speed.

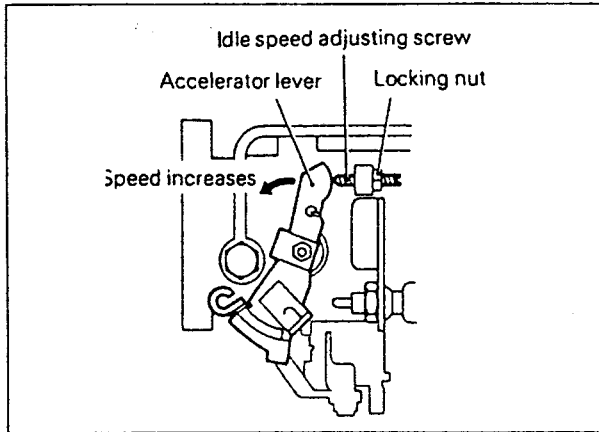

Fig. 15.45. — Idle speed adjusting details.

- If the speed is not within 750 ± 50 rpm, refer to Fig. 15.45 and slacken the locking nut. Use a screwdriver and turn the idle speed adjusting screw until the correct speed has been obtained. The screw is screwed further in to increase the idle speed, as shown by the arrow.
- Counterhold the adjusting screw against rotation and tighten the locking nut.

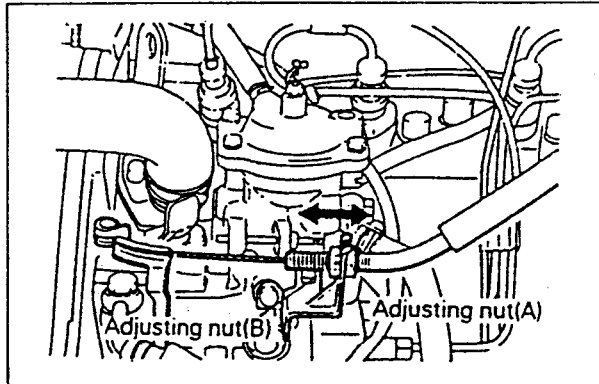

Fig. 15.46. — Throttle cable adjustment.

15.7.7. THROTTLE CABLE ADJUSTMENT

The engine must be at operating temperature, with the idle speed correctly adjusted, before the throttle cable can be adjusted. The adjusting point is shown in Fig. 15.46 from which can be seen that two nuts are used to move the cable in its bracket. First slacken the two nuts so that the throttle lever is free. Now turn the adjusting nut (A) until the throttle lever just starts to move. From this position turn the nut backwards by $\frac{1}{2}$ of a turn and tighten the nut (B). Operate the accelerator pedal and check that the throttle lever can travel between "fully closed" and "fully open."

FAULT FINDING SECTION

The following section lists some of the more common faults that can develop in a motor car. The section is divided into various categories and it should be possible to locate faults or damage by referring to the assembly group of the vehicle in question. Not covered are the complex fuel injection and ignition system.

The faults are listed in no particular order and their causes are given a number. By referring to this number it is possible to read off the possible cause and to carry out the necessary remedies, if this is within the scope of your facilities.

ENGINE FAULTS

Engine will not crank:	1, 2, 3, 4
Engine cranks, but will not start:	5, 6, 7, 8
Engine cranks very slowly:	1, 2, 3
Engine starts, but cuts out:	5, 6, 9, 10
Engine misfires in the lower speed ranges:	5, 6, 9, 11
Engine misfires in the higher speed ranges:	5, 6, 11, 12
Continuous misfiring:	5, 6, 7, 10 to 15, 21, 22
Max. revs not obtained:	5, 6, 12, 22
Faulty idling:	5, 6, 8 to 11, 13, 15, 16, 21 and 22
Lack of power:	3, 5 to 11, 13 to 15, 22
Lack of acceleration:	5 to 8, 12, 14 to 16
Lack of max. speed:	5 to 8, 10, 12, 13 to 15, 22
Excessive fuel consumption:	3, 5, 6, 15, 16
Excessive oil consumption:	16 to 19
Pinking and running-on (dieseling)	5, 6
Low compression:	7, 11 to 13, 16, 20 to 22

Causes and Remedies

NOTE: This is a general section and does not contain fuel/ignition faults.

1. Fault in the starter motor or its connection. Refer to "Electrical Faults".
2. Engine oil too thick. This can be caused by using the wrong oil, low temperatures or using oil not suitable for the prevailing climates. Depress the clutch whilst starting. Otherwise refill the engine with the correct oil grade.
3. Moveable parts of the engine not run-in. This fault may be noticed when the engine has been overhauled. It may be possible to free the engine by adding oil to the fuel for a while.
4. Mechanical fault. This may be due to seizure of the piston(s), broken crankshaft, connecting rods, clutch or other moveable parts of the engine. The engine must be stripped for inspection.
5. Faults in the ignition system. See a Mitsubishi Dealer.
6. Faults in the fuel system. See a Mitsubishi Dealer.
7. Incorrect valve timing. This will only be noticed after the engine has been re-assembled after overhaul. Re-dismantle the engine and check the timing marks on the timing gear wheels or the timing chain as may be the case.
8. Compression leak due to faulty closing of valves. Check valve clearances.

See also under (7) or leakage past worn piston rings or pistons. Cylinder head gasket blown.

9. Entry of air at inlet manifold, due to split manifold or damaged gasket. Correct as necessary.
10. Restriction in exhaust system, due to damaged exhaust pipes, dirt in end of exhaust pipe(s), kinked pipe(s), or collapsed silencer. Repair as necessary.
11. Worn valves or valve seats, no longer closing the valves properly. Top overhaul of engine is asked for.
12. Sticking valves due to excessive carbon deposits or weak valve springs. Top overhaul is asked for.
13. Cylinder head gasket blown. Replace gasket and check block and head surfaces for distortion.
14. Camshaft worn, not opening or closing one of the valves properly, preventing proper combustion. Check and if necessary fit new camshaft.
15. Incorrect valve (tappet) clearance. Re-adjust (if applicable).
16. Cylinder bores, pistons or piston rings worn. Overhaul is the only cure. Fault may be corrected for a while by adding "Piston Seal Liquid" into the cylinders, but will re-develop.
17. Worn valve guides and/or valve stems. Top overhaul is asked for.
18. Damaged valve stem seals (if fitted). Top overhaul is asked for.
19. Leaking crankshaft oil seal, worn piston rings or pistons, worn cylinders. Correct as necessary.
20. Loose spark plugs, gases escaping past threads, or plug sealing washer damaged. Correct.
21. Cracked cylinder or cylinder block. Dismantle, investigate and replace block as necessary and applicable.
22. Broken, weak or collapsed valve spring(s). Top overhaul is asked for.

IGNITION FAULTS (not all items applicable to models covered)

Engine does not start:	1 to 3, 5, 6, 8 to 14, 19
Engine misfires:	2 to 7, 9 to 12, 14, 19
One cylinder not working:	2 to 7, 9 to 14
Engine fails to rev, misfires on acceleration:	2 to 7, 9 to 12, 14, 19
Incorrect idling speed:	1 to 3, 5 to 15, 17, 19
Lack of power:	2 to 12, 14, 15, 17, 19
Poor acceleration:	As for "Lack of Power"
Lack of max. speed:	As for "Lack of Power"
Excessive fuel consumption:	As for "Lack of Power"
Pinking and running-on (dieseling)	2, 3, 5, 6, 8, 11, 12, 15, 16, 18

Causes and Remedies

1. Battery discharged or defective. Try charging the battery or replace. Use slave battery to start the engine.
2. Fault in electronic ignition distributor. Replace and/or check electronic ignition distributor.
3. Contact breakers connected to earth. This could happen after replacement of the points (not applicable to models covered).

4. Contact breaker arm spring too weak (conventional ignition — not applicable to models covered). Check with spring scale.
5. Spark plugs need attention. Check condition of plug faces, clean plugs and adjust electrode gaps to specifications. Check when plugs have been replaced last time.
6. Incorrect spark plug gaps. See also under 5.
7. Wrong type of spark plugs fitted. Check with the specifications and install correct plugs.
8. Ignition timing not correctly adjusted. Check and re-time ignition if necessary, using a stroboscopic timing lamp if possible or have timing checked.
9. Coil defective. No repairs possible, replace, making sure that correct coil is fitted (different for the various engines).
10. Loose connection in ignition circuit. Check and correct.
11. Open circuit, short circuit to ground (earth) or centre lead of coil not fitted properly. Check all cables and make sure centre lead makes contact.
12. The same as 11, but fault is in the spark plug leads. Check for broken cables and proper connections.
13. Plug leads incorrectly connected. Fault only evident after distributor or spark plugs have been removed and leads incorrectly connected. Follow the wiring order and connect properly.
14. "Tracking" present. This means that HT voltage is creeping to ground (earth) due to dirt or dampness. Various products (damp start) are available to overcome the problem, mainly if caused by dampness (water spray, heavy rain, etc.) — Only engine with distributor.
15. Centrifugal advance not working properly. Check by removing distributor cap, turn rotor against tension of flyweight springs and release. Rotor should return to original position (not sticking) — Not applicable to models covered.
16. Vacuum advance not operating. Pull off hose at distributor with engine running and then re-connect. Engine noise must change if engine speed is increased — not applicable to models covered.
17. Distributor cam or shaft worn. Fit replacement.
18. Fuel with incorrect octane rating used. Check with manufacturers recommendation. Pinking can also be caused by overheating of the engine or too much advanced ignition timing (have system checked).
19. Carbon brush in distributor cap worn or spring too weak. Check and replace if necessary.

LUBRICATION SYSTEM FAULTS

The only problem the lubrication system should give is excessive oil consumption or low oil pressure, or the oil warning light not going off.

Excessive oil consumption can be caused by worn cylinder bores, pistons and/or piston rings, worn valve guides, worn valve stem seals or a damaged crankshaft oil seal or leaking gasket on any of the engine parts. In most cases the engine must be dismantled to locate the fault.

Low oil pressure can be caused by a faulty oil pressure gauge, sender unit or wiring, a defective relief valve, low oil level, blocked oil pick-up pipe for the oil pump, worn oil pump or damaged main or big end bearings. In most cases it is logical to check the oil level first and then the operation of the oil pressure gauge (if fitted). All other causes require the dismantling and repair of the engine.

If the oil warning light stays on, switch off the engine immediately, as delay could cause complete seizure within minutes.

COOLING SYSTEM FAULTS

Common faults are: Overheating, loss of coolant and slow warming-up of the engine:

Overheating:

1. **Lack of coolant:** Open the radiator cap with care to avoid injuries. Never pour cold water into an overheated engine. Wait until engine cools down and pour in coolant whilst engine is running.
2. **Radiator core obstructed by leaves, insects, etc.:** Blow with air line from the back of the radiator or with a water hose to clean.
3. **Fan belt loose or slipping:** Re-adjust the fan belt tension or replace belt. In emergency use a nylon stocking to make up a make-shift fan belt by tying the stocking around all pulleys.
4. **Thermostat sticking:** If sticking in the closed position, coolant can only circulate within the cylinder head or block. Remove thermostat and check as described in section "Cooling".
5. **Water hose split:** Identified by rising steam from the engine compartment. Slight splits can be repaired with insulation tape. Drive without radiator cap to keep the pressure in the system down, to the nearest service station.
6. **Ignition incorrectly adjusted:** Have it seen to.
7. **Water pump inoperative:** Overhaul or replace water pump.
8. **Cylinder head gasket blown:** Replace the cylinder head gasket.

Loss of Coolant:

1. **Radiator leaks:** Slight leaks may be stopped by using radiator sealing compound (follow the instructions of the manufacturer). In emergency a raw egg can be cracked open and poured into the radiator filler neck. Sometimes it works.
2. **Hose leaks:** See under 5, "Overheating".
3. **Water pump leaks:** Check the gasket for proper sealing or overhaul (replace) the pump.

Long Warming-up Periods:

1. **Thermostat sticking in the open position:** Remove thermostat, check and if necessary replace.

FUEL SYSTEM FAULTS (not all items applicable to models covered)

Engine does not start:	1 to 8
Engine starts, but stops soon afterwards:	1, 3 to 6, 8 to 13, 18, 19
Engine misfires at low revs:	3, 4, 8, 9
Engine misfires at high revs:	1, 3, 4, 8, 9
Engine misfires continuously:	1 to 6, 8, 9, 12 to 14
Engine fails to rev:	1, 3, 4, 8, 9, 11 to 17, 21
Bad idling:	4, 8 to 14, 18, 19, 21
Lack of power:	4, 8, 11 to 14, 19, 21
Lack of max. speed:	4, 8, 11 to 15, 17, 19, 21
Excessive fuel consumption:	3, 4, 11, 12, 16, 17, 19, 21
Pinking:	15, 20, 21,
Backfiring:	4, 9, 11, 13, 14

Causes and Remedies

1. Fuel tank empty. Refuel.
2. Fuel line or pipe blocked. Remove pipes and blow through them with compressed air to remove obstructions.
3. Fuel pump not operating. Remove pump and check operation. Repair or replace.
4. Carburettor jets blocked (not applicable). Remove all jets and blow through them with compressed air or in emergency with the mouth.
5. Air lock in fuel pipe. Unscrew pipe and blow through it with compressed air.
6. Fuel filter blocked. Remove filter from its location and clean or replace.
7. Float chamber needle valve sticking. Unscrew float chamber cover, remove needle valve and free off or replace valve. Fit cover with new gasket (not applicable).
8. Not applicable.
9. Restricted fuel flow due to foreign body in fuel supply line. Clean out lines.
10. Slow-running speed too low. Have adjustment checked and/or adjusted at your dealer, if necessary.
11. Warming-up problems. See your dealer.
12. Float level out of adjustment. Adjust in accordance with the instructions in section "Fuel System". — Not applicable to models covered.
13. Carburettor icing up. Very rare fault on modern carburettors. Engine will start after the ice has been thawed up (not applicable).
14. Inlet manifold sucks in additional air. Check all gaskets on manifold and replace if necessary.
15. Fuel with incorrect octane rating used. Use proper fuel grade. Check with manufacturer.
16. Not applicable to models covered.

17. Throttle operating linkage wrongly adjusted. Check and adjust as necessary.
18. Slow-running mixture not adjusted properly. Have a dealer seen to the slow-idling system. See Section "Fuel System".
19. Air filter element obstructed. If necessary replace.
20. Ignition timing incorrectly adjusted. Have it checked.
21. (not applicable).

CLUTCH FAULTS

Clutch slipping:	1, 2, 3, 4, 5
Clutch will not disengage fully:	4, 6 to 12, 14
Whining from clutch when pedal is depressed:	13
Clutch judder:	1, 2, 7, 10 to 13
Clutch noise when idling:	2, 3
Clutch noise during engagement:	2

Causes and Remedies

1. Insufficient clutch free play at pedal. Adjust in accordance with instructions in section "Clutch".
2. Clutch disc linings worn, hardened, oiled-up, loose or broken. Disc distorted or hub loose. Clutch disc must be replaced.
3. Pressure plate faulty. Replace clutch.
4. Air in hydraulic system. Low fluid level in clutch cylinder reservoir.
5. Insufficient play at clutch pedal and clutch release linkage (the latter in the case of mechanical operation). Adjust as described.
6. Excessive free play in release linkage (only for cable and linkage operated clutch). Adjust or replace worn parts.
7. Misalignment of clutch housing. Very rare fault, but possible on transmissions with separate clutch housings. Re-align to correct.
8. Clutch disc hub binding on splines of main drive shaft (clutch shaft) due to dirt or burrs on splines. Remove clutch and clean and check splines.
9. Clutch disc linings loose or broken. Replace disc.
10. Pressure plate distorted. Replace clutch.
11. Clutch cover distorted. Replace clutch.
12. Fault in transmission or loose engine mountings.
13. Release bearing defective. Remove clutch and replace bearing.
14. Bend clutch release lever. Check lever and replace or straighten, if possible.
- The above faults and remedies are for hydraulic and mechanical clutch operation. Only fault for hydraulic operation apply to the models covered in this manual.

STEERING FAULTS

Steering very heavy:	1 to 6
Steering very loose:	5, 7 to 9, 11 to 13
Steering wheel wobbles:	4, 5, 7 to 9, 11 to 16
Vehicle pulls to one side:	1, 4, 8, 10, 14 to 18
Steering wheel does not return to centre position:	1 to 6, 18
Abnormal tyre wear:	1, 4, 7 to 9, 14 to 19
Knocking noise in column:	6, 7, 11, 12

Causes and Remedies

1. Tyre pressures not correct or uneven. Correct.
2. Low oil level in steering mechanism.
3. Stiff steering linkage ball joints. Replace ball joints in question.
4. Incorrect steering wheel alignment. Correct as necessary.
5. Steering needs adjustment. Have it seen to.
6. Steering column bearings too tight or seized or steering column bent. Have it seen to.
7. Steering linkage joints loose or worn. Check and replace joints as necessary.
8. Front wheel bearings worn, damaged or loose. Replace the bearings if no results can be obtained.
9. Front suspension parts loose. Check and correct.
10. Wheel bolts loose. Re-tighten.
11. Steering wheel loose (unlikely). Re-tighten nut.
12. Steering gear mounting loose. Check and tighten.
13. Steering gear worn. Although it may be possible to overhaul the steering, the fitting of a replacement steering could be the solution.
14. Steering damper defective or loose (not applicable to models covered).
15. Wheels not properly balanced or tyre pressures uneven. Correct pressures or balance wheels.
16. Suspension springs weak or broken. Replace spring in question or both.
17. Brakes are pulling to one side. See under "Brake Faults".
18. Suspension out of alignment. Have the complete suspension checked by a dealer.
19. Improper driving. We don't intend to tell you how to drive and are quite sure that this is not the cause of the fault.

BRAKE FAULTS

Brake Failure: Brake shoe linings or pads excessively worn, incorrect brake

fluid (after overhaul), insufficient brake fluid, fluid leak, master cylinder defective, wheel cylinder or caliper failure. Remedies are obvious in each instance.

Brakes ineffective: Shoe linings or pads worn, incorrect lining material or brake fluid, linings contaminated, fluid level low, air in brake system (bleed brakes), leak in pipes or cylinders, master cylinder defective. Remedies are obvious in each instance.

Brakes pull to one side: Shoes or linings worn, incorrect linings or pads, contaminated linings, drums or discs scored, fluid pipe blocked, unequal tyre pressures, brake back plate or caliper mounting loose, wheel bearings worn, wheel cylinder seized. Remedy as necessary.

Brake pedal spongy: Air in hydraulic system. System must be bled of air.

Pedal travel too far: Linings or pads worn, automatic brake adjustment not working, drums or discs scored, master cylinder or wheel cylinders defective, system needs bleeding. Rectify as necessary.

Loss of brake pressure: Fluid leak, air in system, leak in master or wheel cylinders, brake servo not operating (vacuum hose disconnected from inlet manifold or vacuum pump). Place vehicle on dry ground and depress brake pedal. Check where fluid runs out and rectify as necessary — With ABS — Have system checked.

Brakes binding: Incorrect brake fluid (boiling), weak shoe return springs, brakes adjusted improperly (if applicable), piston in caliper of wheel cylinder seized, push rod play on master cylinder insufficient (compensation port obstructed), handbrake adjusted too tightly. Rectify as necessary. Swelling of cylinder cups through use of incorrect brake fluid could be another reason.

Handbrake ineffective: Brake shoe linings worn, linings contaminated, operating lever on brake shoe seized, brake shoes or handbrake need adjustment. Rectify as necessary.

Excessive pedal pressure required: Brake shoe linings or pads worn, linings or pads contaminated, brake servo vacuum hose disconnected from manifold or vacuum pump, master or wheel cylinders seized. Rectify as necessary.

Brakes squealing: Brake shoe linings or pads worn so far that metal is grinding against drum or disc. Inside of drum is full of lining dust. Remove and replace, or clean out the drum(s).

ELECTRICAL FAULTS

Starter motor failure:	2 to 5, 8, 9
No starter motor drive:	1 to 3, 5 to 7
Slow cranking speed:	1 to 3
Charge warning light remains on:	3, 10, 12
Charge warning light does not come on:	2, 3, 9, 11, 13
Headlamp failure:	2, 3, 11, 13, 14

Battery needs frequent topping-up:	11
Direction indicators not working properly:	2, 3, 9, 13, 14
Battery frequently discharged:	3, 10, 11, 12

Causes and Remedies

1. Tight engine. Check and rectify.
2. Battery discharged or defective. Re-charge battery or replace if older than 2 years.
3. Interrupted connection in circuit. Trace and rectify.
4. Starter motor pinion jammed in flywheel. Release.
5. Also 6, 7 and 8. Starter motor defective, no engagement in flywheel, pinion or flywheel worn or solenoid switch defective. Correct as necessary.
9. Ignition/starter switch inoperative. Replace.
10. Drive belt loose or broken. Adjust or replace.
11. Regulator defective. Adjust or replace.
12. Generator inoperative. Overhaul or replace.
13. Bulb burnt out. Replace bulb.
14. Flasher unit defective. Replace unit.

CAUSES AND REMEDIES

1. Tight engine. Check and rectify.
2. Battery discharged or defective. Re-charge battery or replace if older than 2 years.
3. Interrupted connection in circuit. Trace and rectify.
4. Starter motor pinion jammed in flywheel. Release.
5. Also 6, 7 and 8. Starter motor defective, no engagement in flywheel, pinion or flywheel worn or solenoid switch defective. Correct as necessary.
9. Ignition/starter switch inoperative. Replace.
10. Drive belt loose or broken. Adjust or replace.
11. Regulator defective. Adjust or replace.
12. Generator inoperative. Overhaul or replace.
13. Bulb burnt out. Replace bulb.
14. Flasher unit defective. Replace unit.

DIESEL FUEL SYSTEM FAULTS

Engine is difficult to start or does not start	1 to 13
Engine starts, but stops soon afterwards:	14 to 20
Engine misfires continuously:	1 to 13
Bad idling:	14 to 20
Black, white or blue exhaust smoke	21 to 29
Lack of power:	30 to 39
Excessive fuel consumption:	40 to 47

CAUSES AND REMEDIES (general for diesel injection systems)

1. Fuel tank empty. Refuel.
2. Pre-glowing time too short. Operate until warning light goes "off".
3. Cold starting device not operated. Pull cable and push in after approx. 1 min.
4. Glow plug system inoperative. Refer to "Glow Plug Faults".
5. Cut-off device not operating.
6. Air in fuel system. Operate starter motor until fuel is delivered or bleed system.
7. Fuel supply faulty. Slacken the injection pipes at injectors, and check if fuel is running out. Other faults: kinked, blocked or leaking injection pipes, blocked fuel filter, tank breathing system blocked. Wrong fuel for cold temperatures.
8. Injection pipes refitted in wrong order after repair. Check correct fitting order.
9. Injection timing of pump out of phase: Have the adjustment checked and corrected.
10. One or more injectors faulty, dirty or incorrect injection pressure. Have injectors repaired or replace them.
11. Injection pump not operating properly. Fit an exchange pump.
12. Valve clearance incorrectly adjusted (after engine repairs). Adjust correctly.
13. Compression pressures too low. See "Engine Faults".
14. Idle speed not properly adjusted. Adjust.
15. Throttle cable not properly adjusted or sticking. Re-adjust or free-off.
16. Fuel hose between filter and pump not tightened properly. Tighten connections.
17. Rear mounting of injection pump loose or cracked. Tighten or replace.
18. See items 6, 7, 9, 11, 12 and 13
19. Engine mounting not tightened properly or worn. Tighten or replace.
20. Sticking accelerator pedal. Free-off pedal.
21. Engine not at operating temperature. Check exhaust smoke colour again when engine is warm.
22. Too much acceleration at low revs. Use individual gears in accordance with acceleration.
23. Air cleaner contaminated. Clean or replace.
24. Fuel filter contaminated. Replace.
25. Max. speed adjustment incorrect. Re-adjust.
26. Injectors are dripping. Have them checked or replace faulty ones.
27. Injector nozzles sticking or broken. Replace injector.
28. Injection pressure too low. Have injectors checked and adjusted.
29. See items 9, 11, 12 and 13
30. Throttle cable travel restricted. Re-adjust. Check that floor mats cannot obstruct pedal movement.
31. Throttle cable not correctly adjusted. Re-adjust.
32. Operating lever loose on pump. Re-tighten.
33. Max. speed not obtained. Re-adjust max. speed or have it adjusted.
34. Injector pipes restricted in diameter (near connections).
35. Heat protection sealing gaskets under injectors not sealing or damaged. Remove

injectors and check. Replace if necessary.

36. Injection pressure of injectors wrong. Have them re-adjusted.
37. See items 6, 7, 9, 11 and 13
38. See item 20.
39. See items 23, 24, 26 and 27.
40. Road wheels dragging. Brakes seized or wheel bearings not running freely.
41. Engine not running "free". Refers to new or overhauled engine.
42. Fuel system leaking. Check hoses, pipes, filter, injection pump, etc. for leaks.
43. Fuel return line blocked. Clean with compressed air if possible.
44. Idle speed too high. Have it seen to.
45. Max. speed too high. Have it seen to.
46. See items 10, 11, 12 and 13.
47. See items 24, 26, 27 and 28.

GLOW PLUG FAULTS

Check a suspect glow plug as follows:

- Remove the glow plug lead from the rear glow plug and from the remaining plug bus bars.
- Connect a 12 volts test lamp to the plus terminal of the battery and with the other lead of the lamp touch in turn the connecting threads of each glow plug. The faulty plug is detected when the test lamp does not light up.