

ROVER 214 & 414



214 Oct 1989 to Mar 1996 (G to N registration) Petrol
414 Mar 1990 to 1995 (G to N registration) Petrol

Haynes Service and Repair Manual



Includes **Roadside Repairs** and **MOT Test Checks**

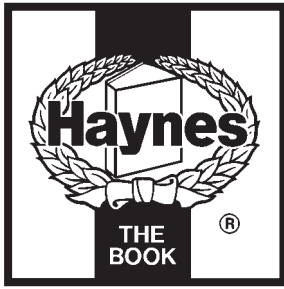

Rover 214 & 414 Service and Repair Manual

Mark Coombs and Christopher Rogers

Models covered

(1689-288-9AA3)

Rover 214 and 414 models fitted with eight or sixteen-valve 1397 cc 'K-series' engine

Covers major mechanical features of Cabriolet

Does not cover Diesel engine models

© Haynes Publishing 1997

ABCDE
FGHIJ
KLMNO
PQRST

A book in the Haynes Service and Repair Manual Series

All rights reserved. No part of this book may be reproduced or transmitted in any form or by any means, electronic or mechanical, including photocopying, recording or by any information storage or retrieval system, without permission in writing from the copyright holder.

ISBN 1 85960 458 7

British Library Cataloguing in Publication Data

A catalogue record for this book is available from the British Library.

Printed by J H Haynes & Co. Ltd, Sparkford, Nr Yeovil,
Somerset BA22 7JJ

Haynes Publishing
Sparkford, Nr Yeovil, Somerset BA22 7JJ, England

Haynes North America, Inc
861 Lawrence Drive, Newbury Park, California 91320, USA

Editions Haynes S.A.
147/149, rue Saint Honoré, 75001 PARIS, France

Haynes Publishing Nordiska AB
Fyrisborgsgatan 5, 754 50 Uppsala, Sverige

Contents

LIVING WITH YOUR ROVER 214 & 414

Introduction	Page	0•4
Safety First!	Page	0•5

Roadside Repairs

Introduction	Page	0•6
If your car won't start	Page	0•6
Jump starting	Page	0•7
Wheel changing	Page	0•8
Identifying leaks	Page	0•9
Towing	Page	0•9

Weekly Checks

Introduction	Page	0•10
Underbonnet check points	Page	0•10
Engine oil level	Page	0•11
Coolant level	Page	0•11
Brake fluid level	Page	0•12
Screen washer fluid level	Page	0•12
Power steering fluid level	Page	0•13
Wiper blades	Page	0•13
Tyre condition and pressure	Page	0•14
Electrical systems	Page	0•15
Battery	Page	0•15

Lubricants, Fluids, Capacities and Tyre Pressures	Page	0•16
---	------	------

MAINTENANCE

Routine Maintenance and Servicing	Page	1•1
Maintenance schedule	Page	1•3
Maintenance procedures	Page	1•6

Contents

REPAIRS AND OVERHAUL

Engine and Associated Systems

Engine in-car repair procedures	Page	2A•1
Engine removal and general overhaul procedures	Page	2B•1
Cooling, heating and ventilation systems	Page	3•1
Fuel and exhaust systems - carburettor engines	Page	4A•1
Fuel and exhaust systems - single-point fuel injected engines	Page	4B•1
Fuel and exhaust systems - multi-point fuel injected engines	Page	4C•1
Emission control systems	Page	4D•1
Ignition system - carburettor engines	Page	5A•1
Ignition system - fuel injected engines	Page	5B•1
Starting and charging systems	Page	5C•1

Transmission

Clutch	Page	6•1
Gearbox	Page	7•1
Driveshafts	Page	8•1

Brakes and Suspension

Braking system	Page	9•1
Suspension and steering	Page	10•1

Body Equipment

Bodywork and fittings	Page	11•1
Body electrical systems	Page	12•1

Wiring Diagrams

Page 12•20

REFERENCE

Dimensions and Weights	Page	REF•1
Conversion Factors	Page	REF•2
Buying Spare Parts and Vehicle Identification	Page	REF•3
General Repair Procedures	Page	REF•4
Jacking and Vehicle Support	Page	REF•5
Radio/cassette Anti-theft System - precaution	Page	REF•5
Tools and Working Facilities	Page	REF•6
MOT Test Checks	Page	REF•8
Fault Finding	Page	REF•12
Glossary of Technical Terms	Page	REF•19

Index

Page REF•24

The Rover 214 Hatchback and 414 Saloon models covered in this Manual are a much-developed version of the original 213 and 216 models first launched in 1984. The 214 five-door model was the first to be introduced in October 1989 and was closely followed by the 414 model introduced in March 1990. The 214 model range was further updated in September 1990 when a three-door variant was introduced.

All models are fitted with the new 1.4 litre 'K' series engine. The 214 S model (first introduced in September 1990) has an eight-valve single overhead camshaft version of the engine which is fed by an SU KIF carburettor.

All other 214 and 414 models are equipped with a sixteen-valve double overhead camshaft version of the engine which is controlled by a Rover/Motorola Modular Engine Management System (MEMS) with either single-point fuel injection (SPI) or multi-point fuel injection (MPI). All versions of the engine are able to accept a full range of emission control systems, up to and including a three-way regulated catalytic converter.

The five-speed transmission, which is a joint development by Rover and Peugeot engineers, is of Peugeot design and produced by Rover. The transmission is fitted to the left-

hand end of the engine. The complete engine/transmission unit is mounted transversely across the front of the car and drives the front wheels through unequal-length driveshafts.

The front suspension incorporates MacPherson struts and the rear is of the double wishbone type.

Braking is by discs at the front and drums at the rear, with a dual-circuit hydraulic system. On all models in the range, an Anti-lock Braking System (ABS) was offered as an optional extra. If ABS is fitted, then braking is by discs both at the front and rear.



Rover 114GTa



Rover Metro 1.1S

Your Rover 214 & 414 Manual

The aim of this manual is to help you get the best value from your vehicle. It can do so in several ways. It can help you decide what work must be done (even should you choose to get it done by a garage), provide information on routine maintenance and servicing, and give a logical course of action

and diagnosis when random faults occur. However, it is hoped that you will use the manual by tackling the work yourself. On simpler jobs it may even be quicker than booking the car into a garage and going there twice, to leave and collect it. Perhaps most important, a lot of money can be saved by

avoiding the costs a garage must charge to cover its labour and overheads.

The manual has drawings and descriptions to show the function of the various components so that their layout can be understood. Then the tasks are described and photographed in a clear step-by-step sequence.

Acknowledgements

Thanks are due to Champion Spark Plug who supplied the illustrations showing spark plug conditions, and to Duckhams Oils who provided lubrication data. Thanks are also due to Sykes-Pickavant Limited, who supplied some of the workshop tools, and to

all those people at Sparkford who helped in the production of this Manual.

We take great pride in the accuracy of information given in this manual, but vehicle manufacturers make alterations and design changes during the production

run of a particular vehicle of which they do not inform us. No liability can be accepted by the authors or publishers for loss, damage or injury caused by any errors in, or omissions from the information given.

Working on your car can be dangerous. This page shows just some of the potential risks and hazards, with the aim of creating a safety-conscious attitude.

General hazards

Scalding

- Don't remove the radiator or expansion tank cap while the engine is hot.
- Engine oil, automatic transmission fluid or power steering fluid may also be dangerously hot if the engine has recently been running.

Burning

- Beware of burns from the exhaust system and from any part of the engine. Brake discs and drums can also be extremely hot immediately after use.

Crushing

- When working under or near a raised vehicle, always supplement the jack with axle stands, or use drive-on ramps.

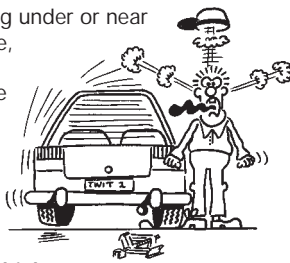

Never venture under a car which is only supported by a jack.

- Take care if loosening or tightening high-torque nuts when the vehicle is on stands. Initial loosening and final tightening should be done with the wheels on the ground.

Fire

- Fuel is highly flammable; fuel vapour is explosive.
- Don't let fuel spill onto a hot engine.
- Do not smoke or allow naked lights (including pilot lights) anywhere near a vehicle being worked on. Also beware of creating sparks (electrically or by use of tools).
- Fuel vapour is heavier than air, so don't work on the fuel system with the vehicle over an inspection pit.
- Another cause of fire is an electrical overload or short-circuit. Take care when repairing or modifying the vehicle wiring.
- Keep a fire extinguisher handy, of a type suitable for use on fuel and electrical fires.

Electric shock

- Ignition HT voltage can be dangerous, especially to people with heart problems or a pacemaker. Don't work on or near the ignition system with the engine running or the ignition switched on.

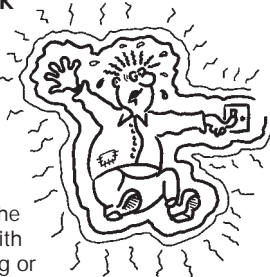

- Mains voltage is also dangerous. Make sure that any mains-operated equipment is correctly earthed. Mains power points should be protected by a residual current device (RCD) circuit breaker.

Fume or gas intoxication

- Exhaust fumes are poisonous; they often contain carbon monoxide, which is rapidly fatal if inhaled. Never run the engine in a confined space such as a garage with the doors shut.
- Fuel vapour is also poisonous, as are the vapours from some cleaning solvents and paint thinners.

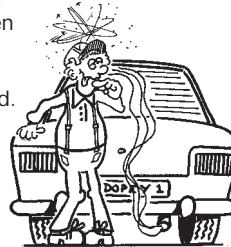

Poisonous or irritant substances

- Avoid skin contact with battery acid and with any fuel, fluid or lubricant, especially antifreeze, brake hydraulic fluid and Diesel fuel. Don't syphon them by mouth. If such a substance is swallowed or gets into the eyes, seek medical advice.
- Prolonged contact with used engine oil can cause skin cancer. Wear gloves or use a barrier cream if necessary. Change out of oil-soaked clothes and do not keep oily rags in your pocket.
- Air conditioning refrigerant forms a poisonous gas if exposed to a naked flame (including a cigarette). It can also cause skin burns on contact.

Asbestos

- Asbestos dust can cause cancer if inhaled or swallowed. Asbestos may be found in gaskets and in brake and clutch linings. When dealing with such components it is safest to assume that they contain asbestos.

Special hazards

Hydrofluoric acid

- This extremely corrosive acid is formed when certain types of synthetic rubber, found in some O-rings, oil seals, fuel hoses etc, are exposed to temperatures above 400°C. The rubber changes into a charred or sticky substance containing the acid. *Once formed, the acid remains dangerous for years. If it gets onto the skin, it may be necessary to amputate the limb concerned.*
- When dealing with a vehicle which has suffered a fire, or with components salvaged from such a vehicle, wear protective gloves and discard them after use.

The battery

- Batteries contain sulphuric acid, which attacks clothing, eyes and skin. Take care when topping-up or carrying the battery.
- The hydrogen gas given off by the battery is highly explosive. Never cause a spark or allow a naked light nearby. Be careful when connecting and disconnecting battery chargers or jump leads.

Air bags

- Air bags can cause injury if they go off accidentally. Take care when removing the steering wheel and/or facia. Special storage instructions may apply.

Diesel injection equipment

- Diesel injection pumps supply fuel at very high pressure. Take care when working on the fuel injectors and fuel pipes.



Warning: *Never expose the hands, face or any other part of the body to injector spray; the fuel can penetrate the skin with potentially fatal results.*

Remember...

DO

- Do use eye protection when using power tools, and when working under the vehicle.
- Do wear gloves or use barrier cream to protect your hands when necessary.
- Do get someone to check periodically that all is well when working alone on the vehicle.
- Do keep loose clothing and long hair well out of the way of moving mechanical parts.
- Do remove rings, wristwatch etc, before working on the vehicle – especially the electrical system.
- Do ensure that any lifting or jacking equipment has a safe working load rating adequate for the job.

DON'T

- Don't attempt to lift a heavy component which may be beyond your capability – get assistance.
- Don't rush to finish a job, or take unverified short cuts.
- Don't use ill-fitting tools which may slip and cause injury.
- Don't leave tools or parts lying around where someone can trip over them. Mop up oil and fuel spills at once.
- Don't allow children or pets to play in or near a vehicle being worked on.

The following pages are intended to help in dealing with common roadside emergencies and breakdowns. You will find more detailed fault finding information at the back of the manual, and repair information in the main chapters.

If your car won't start and the starter motor doesn't turn

- If it's a model with automatic transmission, make sure the selector is in 'P' or 'N'.
- Open the bonnet and make sure that the battery terminals are clean and tight.
- Switch on the headlights and try to start the engine. If the headlights go very dim when you're trying to start, the battery is probably flat. Get out of trouble by jump starting (see next page) using a friend's car.



A Check that the distributor HT lead connections are clean and secure



B Check that the spark plug HT lead connections are clean and secure - cover removed



C Check that the ignition coil HT and LT lead connections are clean and secure



Check that electrical connections are secure (with the ignition off) and spray them with a water-dispersing spray like WD40 if you suspect a problem due to damp



D Check the security and condition of the battery connections



E The ECU wiring plugs may cause problems if dirty or not properly connected

If your car won't start even though the starter motor turns as normal

- Is there fuel in the tank?
- Is there moisture on electrical components under the bonnet? Switch off the ignition, then wipe off any obvious dampness with a dry cloth. Spray a water-repellent aerosol product (WD-40 or equivalent) on ignition and fuel system electrical connectors like those shown in the photos. Pay special attention to the ignition coil wiring connector and HT leads. (Note that Diesel engines don't normally suffer from damp.)



Jump starting will get you out of trouble, but you must correct whatever made the battery go flat in the first place. There are three possibilities:

- 1) *The battery has been drained by repeated attempts to start, or by leaving the lights on.*
- 2) *The charging system is not working properly (alternator drivebelt slack or broken, alternator wiring fault or alternator itself faulty).*
- 3) *The battery itself is at fault (electrolyte low, or battery worn out).*

Jump starting

When jump-starting a car using a booster battery, observe the following precautions:

- ✓ Before connecting the booster battery, make sure that the ignition is switched off.
- ✓ Ensure that all electrical equipment (lights, heater, wipers, etc) is switched off.
- ✓ Take note of any special precautions printed on the battery case.

- ✓ Make sure that the booster battery is the same voltage as the discharged one in the vehicle.
- ✓ If the battery is being jump-started from the battery in another vehicle, the two vehicles **MUST NOT TOUCH** each other.
- ✓ Make sure that the transmission is in neutral (or PARK, in the case of automatic transmission).



1 Connect one end of the red jump lead to the positive (+) terminal of the flat battery



2 Connect the other end of the red lead to the positive (+) terminal of the booster battery



3 Connect one end of the black jump lead to the negative (-) terminal of the booster battery

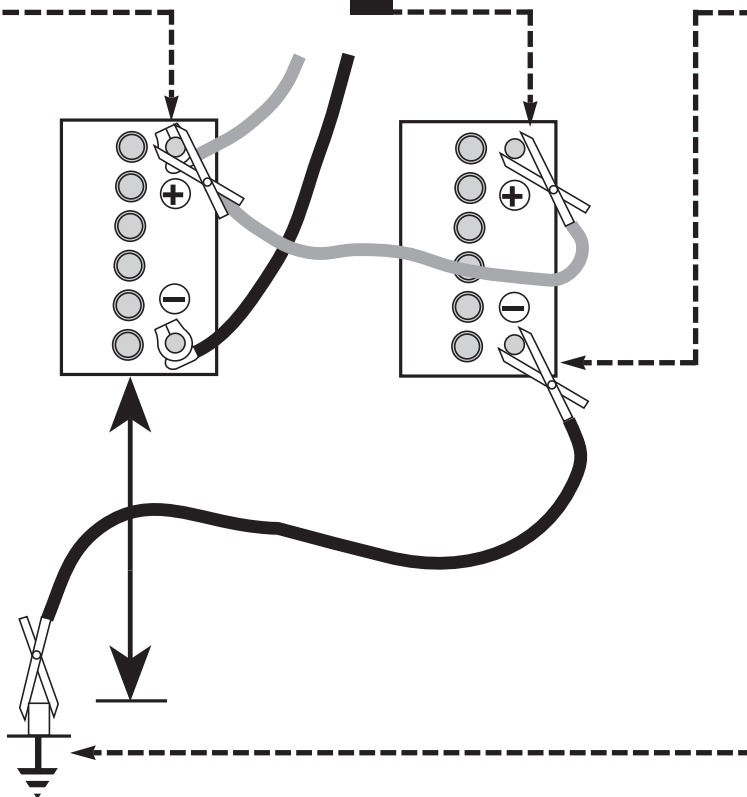

4 Connect the other end of the black jump lead to a bolt or bracket on the engine block, well away from the battery, on the vehicle to be started

5 Make sure that the jump leads will not come into contact with the fan, drivebelts or other moving parts of the engine

6 Start the engine using the booster battery, then with the engine running at idle speed, disconnect the jump leads in the reverse order of connection

Wheel changing

Some of the details shown here will vary according to model. For instance, the location of the spare wheel and jack is not the same on all cars. However, the basic principles apply to all vehicles.



Warning: Do not change a wheel in a situation where you risk being hit by other traffic. On busy roads, try to stop in a lay-by or a gateway. Be wary of passing traffic while changing the wheel – it is easy to become distracted by the job in hand.

Preparation

- When a puncture occurs, stop as soon as it is safe to do so.
- Park on firm level ground, if possible, and well out of the way of other traffic.
- Use hazard warning lights if necessary.
- If you have one, use a warning triangle to alert other drivers of your presence.
- Apply the handbrake and engage first or reverse gear (or Park on models with automatic transmission).
- Chock the wheel diagonally opposite the one being removed – a couple of large stones will do for this.
- If the ground is soft, use a flat piece of wood to spread the load under the jack.

Changing the wheel



1 Location of spare wheel and tools in boot



2 Unscrew the spare wheel retaining cap



3 Remove the trim to expose the wheelnuts



4 Use the wheel brace to slightly loosen the wheelnuts



5 Locate the jack head in the correct jacking point



6 Raise the jack until the wheel is clear of the ground



7 Remove the wheelnuts and lift off the wheel



8 Fit the replacement wheel and tighten the nuts

Finally...

- Remove the wheel chocks.
- Stow the jack and tools in the correct locations in the car.
- Check the tyre pressure on the wheel just fitted. If it is low, or if you don't have a pressure gauge with you, drive slowly to the nearest garage and inflate the tyre to the right pressure.
- Have the damaged tyre or wheel repaired as soon as possible.

Identifying leaks

Puddles on the garage floor or drive, or obvious wetness under the bonnet or underneath the car, suggest a leak that needs investigating. It can sometimes be difficult to decide where the leak is coming from, especially if the engine bay is very dirty already. Leaking oil or fluid can also be blown rearwards by the passage of air under the car, giving a false impression of where the problem lies.



Warning: Most automotive oils and fluids are poisonous. Wash them off skin, and change out of contaminated clothing, without delay.



The smell of a fluid leaking from the car may provide a clue to what's leaking. Some fluids are distinctively coloured. It may help to clean the car carefully and to park it over some clean paper overnight as an aid to locating the source of the leak. Remember that some leaks may only occur while the engine is running.

Sump oil



Engine oil may leak from the drain plug...

Oil from filter



...or from the base of the oil filter.

Gearbox oil

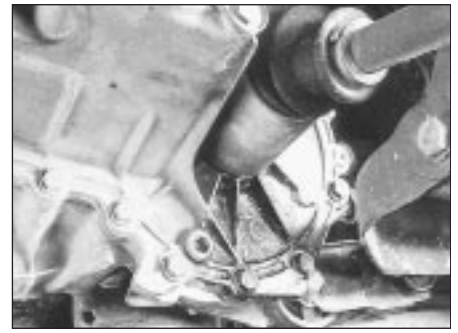

Gearbox oil can leak from the seals at the inboard ends of the driveshafts.

Antifreeze



Leaking antifreeze often leaves a crystalline deposit like this.

Brake fluid



A leak occurring at a wheel is almost certainly brake fluid.

Power steering fluid

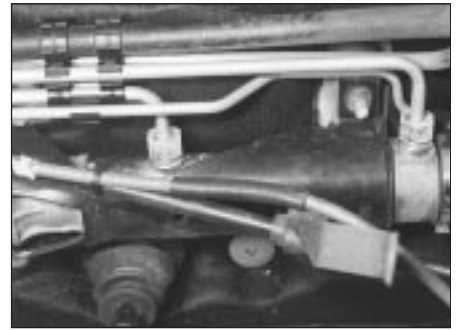

Power steering fluid may leak from the pipe connectors on the steering rack.

Towing

When all else fails, you may find yourself having to get a tow home – or of course you may be helping somebody else. Long-distance recovery should only be done by a garage or breakdown service. For shorter distances, DIY towing using another car is easy enough, but observe the following points:

- Use a proper tow-rope – they are not expensive. The vehicle being towed must display an 'ON TOW' sign in its rear window.
- Always turn the ignition key to the 'on' position when the vehicle is being towed, so

that the steering lock is released, and that the direction indicator and brake lights will work.

- Only attach the tow-rope to the towing eyes provided.
- Before being towed, release the handbrake and select neutral on the transmission.
- Note that greater-than-usual pedal pressure will be required to operate the brakes, since the vacuum servo unit is only operational with the engine running.
- On models with power steering, greater-than-usual steering effort will also be required.

The driver of the car being towed must keep the tow-rope taut at all times to avoid snatching.

- Make sure that both drivers know the route before setting off.
- Only drive at moderate speeds and keep the distance towed to a minimum. Drive smoothly and allow plenty of time for slowing down at junctions.
- On models with automatic transmission, special precautions apply. If in doubt, do not tow, or transmission damage may result.

Introduction

There are some very simple checks which need only take a few minutes to carry out, but which could save you a lot on inconvenience and expense.

These "Weekly Checks" require no great skill or special tools, and the small amount of time they take to perform could well prove to be very well spent, for example:

□ Keeping an eye on tyre condition and pressures, will not only help to stop them wearing out prematurely but could also save your life.

□ Many breakdowns are caused by electrical problems. Battery-related faults are particularly common and a quick check on a regular basis will often prevent the majority of these.

□ If your car develops a brake fluid leak, the first time you might know about it is when your brakes don't work properly. Checking the level regularly will give advance warning of this kind of problem.

□ If the oil or coolant levels run low, the cost of repairing any engine damage will be far greater than fixing the leak.

Underbonnet Check Points

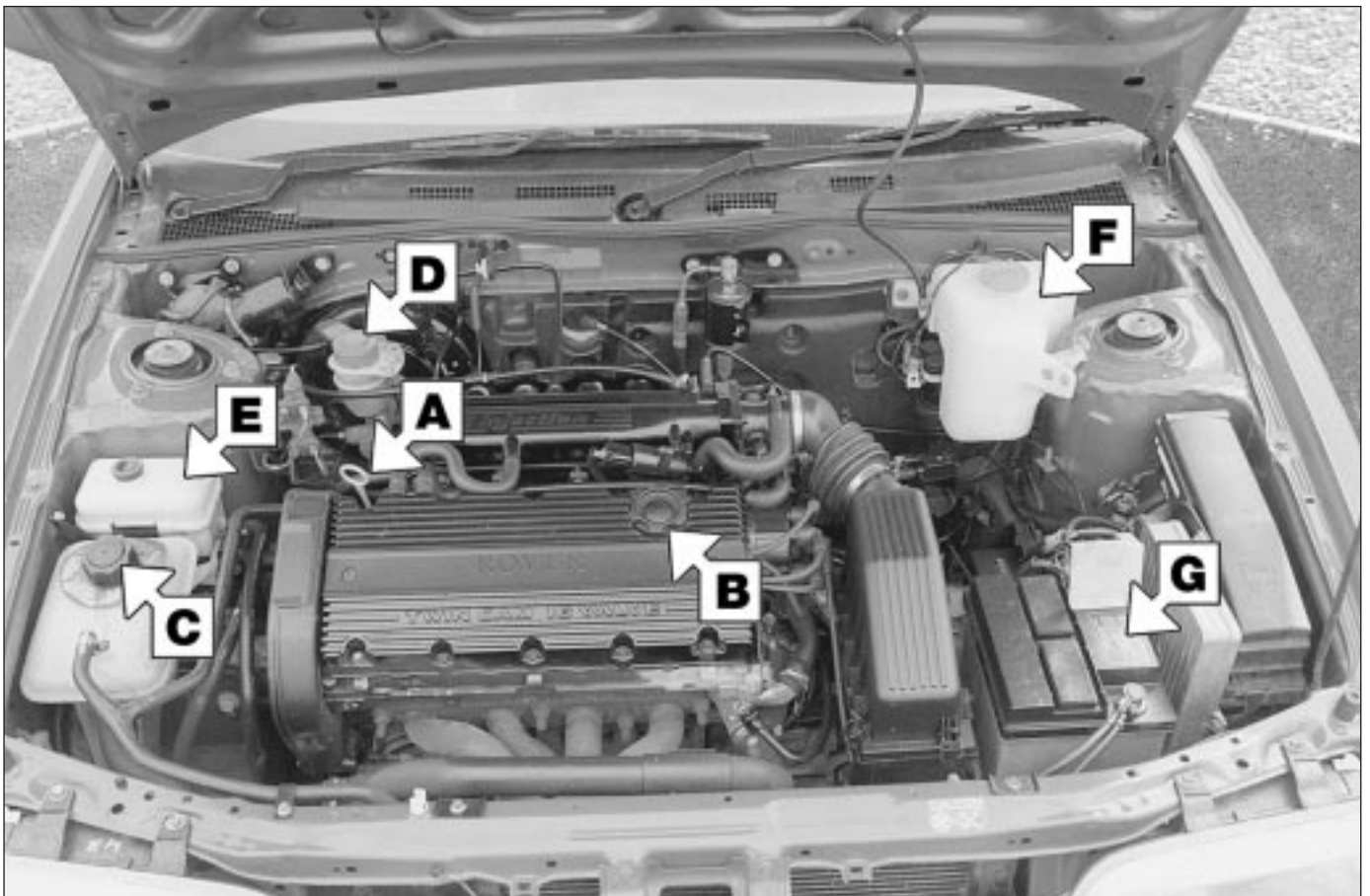

K16 MPI engine with plastic inlet manifold

A Engine oil level dipstick

B Engine oil filler cap

C Coolant expansion tank

D Brake fluid reservoir

E Power steering fluid reservoir

F Screen washer fluid reservoir

G Battery

Engine oil level

Before you start

- ✓ Make sure that your car is on level ground.
- ✓ Check the oil level before the car is driven, or at least 5 minutes after the engine has been switched off.

HAYNES
HiNT *If the oil is checked immediately after driving the vehicle, some of the oil will remain in the upper engine components, resulting in an inaccurate reading on the dipstick.*

The correct oil

Modern engines place great demands on their oil. It is very important that the correct oil for your car is used (see "Lubricants and Fluids" on page 0•16).

Car Care

- If you have to add oil frequently, you should check whether you have any oil leaks. Place some clean paper under the car overnight, and check for stains in the morning. If there are no leaks, then engine may be burning oil (see "Fault Finding").
- Always maintain the level between the upper and lower dipstick marks. If the level is too low, severe engine damage may occur. Oil seal failure may result if the engine is overfilled by adding too much oil.



1 The dipstick is located at the rear right-hand end of the engine (see "Underbonnet Check Points" on page 0•10 for exact location). Withdraw the dipstick.



2 Using a clean rag or paper towel, wipe all the oil from the dipstick. Insert the clean dipstick into the tube as far as it will go, then withdraw it again.



3 Note the oil level on the end of the dipstick, which should be between the upper HI mark and the lower LO mark. Approximately 1.0 litre of oil will raise the level from the lower mark to the upper mark.



4 Oil is added through the filler cap. Rotate the cap through a quarter-turn anti-clockwise and withdraw it. Top-up the level. A funnel may help to reduce spillage. Add the oil slowly, checking the level on the dipstick often. Do not overfill.

Coolant level



Warning: Do not attempt to remove the expansion tank pressure cap when the engine is hot, as there is a very great risk

of scalding. Do not leave open containers of coolant about, as it is poisonous.

Car Care

- With a sealed-type cooling system, adding coolant should not be necessary on a regular basis. If frequent topping-up is required, it is likely there is a leak. Check the radiator, all hoses and joint faces for signs of staining or wetness, and rectify as necessary.

- It is important that antifreeze is used in the cooling system all year round, not just during the winter months. Don't top up with water alone, as the antifreeze will become diluted.



1 When the engine is cold, the coolant level should be between the expansion tank ridge/seam and the level indicated above COOLANT LEVEL on the side of the expansion tank, which is located in the front right-hand corner of the engine compartment.



2 If topping-up, wait until the engine is cold, then cover the filler cap with a layer of rag and start unscrewing the cap. Wait until any hissing ceases, indicating that all pressure is released, then slowly unscrew the cap until it can be removed. At all times keep well away from the filler opening.



3 Add a mixture of water and antifreeze through the expansion tank filler neck, until the coolant is up to the upper level. Refit the cap, turning it clockwise as far as it will go until it is secure.

Brake fluid level



Warning: Brake fluid can harm your eyes and damage painted surfaces, so use extreme caution when handling and pouring it. Do not use fluid which has been standing open for some time, as it absorbs moisture from the air, which can cause a dangerous loss of braking effectiveness.

Before you start

- ✓ Make sure that the car is on level ground.
- ✓ Cleanliness is of great importance when dealing with the braking system, so take care to clean around the reservoir cap before topping-up. Use only clean brake fluid from a container which has stood for at least 24 hours (to allow air bubbles to separate out).

Safety first

- If the reservoir requires repeated topping-up, this is an indication of a fluid leak somewhere in the system, which should be investigated immediately.
- If a leak is suspected, the car should not be driven until the braking system has been checked. Never take any risks where brakes are concerned.



1 The brake master cylinder and fluid reservoir is mounted on the vacuum servo unit in the engine compartment. The MAX and MIN level marks are indicated on the side of the reservoir and the fluid level should be maintained between these marks at all times.



2 If topping-up is necessary, unplug the electrical connector and wipe the area around the filler cap with a clean rag before removing the cap. When adding fluid, pour it carefully into the reservoir to avoid spilling it on surrounding painted surfaces. Be sure to use only the specified brake hydraulic fluid since mixing different types of fluid can cause damage to the system.



3 Before adding fluid, it's a good idea to inspect the reservoir. The system should be drained and refilled if dirt is seen in the fluid (see Chapter 9 for details).



4 Carefully add fluid avoiding spilling it on surrounding paintwork. Use only the specified fluid; mixing different types can cause damage to the system. After filling to the correct level, refit the cap securely, to prevent leaks and the entry of foreign matter. Ensure that the fluid level switch plunger is free to move. Wipe off any spilt fluid.

Screen washer fluid level

Car care

- Screenwash additives not only keep the windscreen clean during bad weather, they also prevent the washer system freezing in cold weather - which is when you are likely to need it most. Don't top up using plain water, as the screenwash will become diluted and will freeze in cold weather.
- Check the operation of the windscreen and rear window washers. Adjust the nozzles using a pin if necessary, aiming the spray to a point slightly above the centre of the swept area.



Warning: On no account use engine coolant antifreeze in the screen washer system - this will damage the paintwork.



1 The reservoir for the windscreen and rear window (where fitted) washer systems is located on the left-hand side of the engine compartment.



2 When topping-up the reservoir(s) a screenwash additive should be added in the quantities recommended on the bottle.

Power steering fluid level

Before you start

- ✓ Make sure that the car is on level ground.
- ✓ Set the front roadwheels in the straight-ahead position.
- ✓ The engine should be stopped.
- ✓ Do not operate the steering once the engine is stopped.

Safety first

- If the reservoir requires repeated topping-up, there is a fluid leak somewhere in the system which should be investigated immediately.
- If a leak is suspected, the car should not be driven until the power steering system has been checked.



1 The power steering fluid reservoir is located on the right-hand side of the engine compartment, just behind the cooling system expansion tank. MAX and MIN level marks are indicated on the side of the reservoir and the fluid level should be maintained between these marks at all times.



2 If topping-up is necessary, first wipe the area around the filler cap with a clean rag before removing the cap. When adding fluid, pour it carefully into the reservoir to avoid spillage. Be sure to use only the specified fluid.



3 After filling the reservoir to the proper level, make sure that the cap is refitted securely to avoid leaks and the entry of foreign matter into the reservoir.

Wiper blades

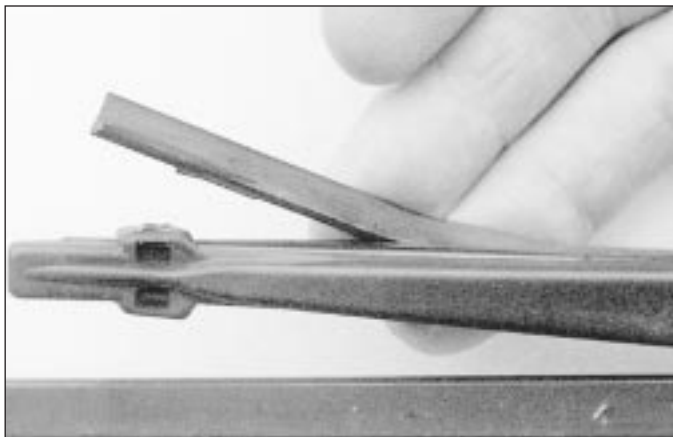

1 Check the condition of the wiper blades. If they are cracked or show any signs of deterioration, or if the glass swept area is smeared, renew them. For maximum clarity of vision, wiper blades should be renewed annually, as a matter of course.



2 To remove a wiper blade, pull the arm fully away from the glass until it locks. Swivel the blade through 90°, press the locking tab with a finger nail and slide the blade out of the arm's hooked end. On refitting, ensure that the blade locks securely into the arm.

Tyre condition and pressure

It is very important that tyres are in good condition, and at the correct pressure - having a tyre failure at any speed is highly dangerous. Tyre wear is influenced by driving style - harsh braking and acceleration, or fast cornering, will all produce more rapid tyre wear. As a general rule, the front tyres wear out faster than the rears. Interchanging the tyres from front to rear ("rotating" the tyres) may result in more even wear. However, if this is completely effective, you may have the expense of replacing all four tyres at once! Remove any nails or stones embedded in the tread before they penetrate the tyre to cause deflation. If removal of a nail does reveal that

the tyre has been punctured, refit the nail so that its point of penetration is marked. Then immediately change the wheel, and have the tyre repaired by a tyre dealer. Regularly check the tyres for damage in the form of cuts or bulges, especially in the sidewalls. Periodically remove the wheels, and clean any dirt or mud from the inside and outside surfaces. Examine the wheel rims for signs of rusting, corrosion or other damage. Light alloy wheels are easily damaged by "kerbing" whilst parking; steel wheels may also become dented or buckled. A new wheel is very often the only way to overcome severe damage.

New tyres should be balanced when they are fitted, but it may become necessary to re-balance them as they wear, or if the balance weights fitted to the wheel rim should fall off. Unbalanced tyres will wear more quickly, as will the steering and suspension components. Wheel imbalance is normally signified by vibration, particularly at a certain speed (typically around 50 mph). If this vibration is felt only through the steering, then it is likely that just the front wheels need balancing. If, however, the vibration is felt through the whole car, the rear wheels could be out of balance. Wheel balancing should be carried out by a tyre dealer or garage.

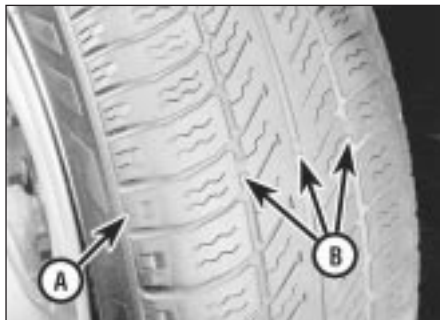

Tread Depth - visual check

1 The original tyres have tread wear safety bands (B), which will appear when the tread depth reaches approximately 1.6 mm. The band positions are indicated by a triangular mark on the tyre sidewall (A).



Tread Depth - manual check

2 Alternatively tread wear can be monitored with a simple, inexpensive device known as a tread depth indicator gauge.



Tyre Pressure Check

3 Check the tyre pressures regularly with the tyres cold. Do not adjust the tyre pressures immediately after the vehicle has been used, or an inaccurate setting will result. Tyre pressures are shown on page 0•16

4 Tyre tread wear patterns



Shoulder Wear

Underinflation (wear on both sides)

Under-inflation will cause overheating of the tyre, because the tyre will flex too much, and the tread will not sit correctly on the road surface. This will cause a loss of grip and excessive wear, not to mention the danger of sudden tyre failure due to heat build-up.

Check and adjust pressures

Incorrect wheel camber (wear on one side)

Repair or renew suspension parts

Hard cornering

Reduce speed!



Centre Wear

Overinflation

Over-inflation will cause rapid wear of the centre part of the tyre tread, coupled with reduced grip, harsher ride, and the danger of shock damage occurring in the tyre casing.

Check and adjust pressures

If you sometimes have to inflate your car's tyres to the higher pressures specified for maximum load or sustained high speed, don't forget to reduce the pressures to normal afterwards.



Uneven Wear

Front tyres may wear unevenly as a result of wheel misalignment. Most tyre dealers and garages can check and adjust the wheel alignment (or "tracking") for a modest charge.

Incorrect camber or castor

Repair or renew suspension parts

Malfunctioning suspension

Repair or renew suspension parts

Unbalanced wheel

Balance tyres

Incorrect toe setting

Adjust front wheel alignment

Note: *The feathered edge of the tread which typifies toe wear is best checked by feel.*

Electrical system

✓ Check all external lights and the horn. Refer to the appropriate Sections of Chapter 12 for details if any of the circuits are found to be inoperative, and replace the fuse if necessary. Most fuses are located behind the cover in the right-hand lower facia panel. Other fuses are located in the fusebox on the left-hand side of the engine compartment. To replace a blown fuse, pull it from position, using the plastic tool provided. Fit a new fuse of the same rating. If a second fuse blows, it is important that you find the reason - do not use a fuse with a higher rating.

✓ Visually check all accessible wiring connectors, harnesses and retaining clips for security, and for signs of chafing or damage.

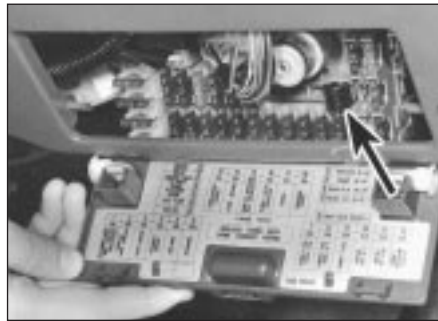

1 If a single indicator light, brake light or headlight has failed, it is likely that a bulb has blown and will need to be replaced. Refer to Chapter 12 for details. If both brake lights have failed, it is possible that the brake light switch operated by the brake pedal is faulty. Refer to Chapter 9 for details.

2 If more than one indicator light or headlight has failed, it is likely that either a fuse has blown or that there is a fault in the circuit (see Chapter 12).



If you need to check your brake lights and indicators unaided, back up to a wall or garage door and operate the lights. The reflected light should show if they are working properly.

Battery

Caution: Before carrying out any work on the vehicle battery, read the precautions given in "Safety first" at the start of this manual.

✓ Make sure that the battery tray is in good condition, and that the clamp is tight. Corrosion on the tray, retaining clamp and the battery itself can be removed with a solution of water and baking soda. Thoroughly rinse all cleaned areas with water. Any metal parts damaged by corrosion should be covered with a zinc-based primer, then painted.

✓ Periodically (approximately every three months), check the charge condition of the battery as described in Chapter 5A.

✓ If the battery is flat, and you need to jump start your vehicle, see "Jump starting".



1 The battery is located on the left-hand side of the engine compartment. The exterior of the battery should be inspected periodically for damage such as a cracked case or cover.

2 Check the tightness of battery clamps to ensure good electrical connections. You should not be able to move them. Also check each cable for cracks and frayed conductors.



Battery corrosion can be kept to a minimum by applying a layer of petroleum jelly to the clamps and terminals after they are reconnected.



3 If corrosion (white, fluffy deposits) is evident, remove the cables from the battery terminals, clean them with a small wire brush, then refit them. Accessory stores sell a useful tool for cleaning the battery post ...

4 ... as well as the battery cable clamps

Lubricants and fluids

Engine	Multigrade engine oil, viscosity SAE 10W/40 to spec. API-SG or SG/CD, CCMC G4, or RES.22.OL.G4 (<i>Duckhams QS, QXR, Hypergrade Plus, Hypergrade, or 10W/40 Motor Oil</i>)
Cooling system	Antifreeze to spec. BS 6580 and BS 5117. Ethylene-glycol based with non-phosphate corrosion inhibitors, containing no methanol. Mixture 50% by volume (<i>Duckhams Antifreeze and Summer Coolant</i>)
Gearbox	Special gearbox oil. Refer to your Rover dealer (<i>Duckhams Hypoid PT 75W/80 may be used for topping-up only</i>)
Braking system	Hydraulic fluid to spec. SAE J 1703 or DOT 4 (<i>Duckhams Universal Brake and Clutch Fluid</i>)
Power steering system	Automatic transmission fluid (ATF) to Dexron II D specification (<i>Duckhams Uni-Matic</i>)
General greasing	Multi-purpose lithium-based grease to NLGI consistency No. 2 (<i>Duckhams LB10</i>)

Capacities

Engine oil	4.5 litres - including filter
Cooling system	5.8 litres
Gearbox	2.0 litres
Power steering reservoir	1.2 litres
Fuel tank	55 litres
Washer system reservoir	3.1 litres

Tyre Pressures (tyres cold)

	Front	Rear
155 SR 13 tyres		
Normal driving conditions	2.1 bar (30 psi)	2.1 bar (30 psi)
Loads in excess of four persons	2.1 bar (30 psi)	2.3 bar (34 psi)
Speeds in excess of 100 mph - all loads	2.2 bar (32 psi)	2.2 bar (32 psi)
175/65 TR 14 tyres		
All loads - up to 100 mph	2.1 bar (30 psi)	2.1 bar (30 psi)
All loads - over 100 mph	2.2 bar (32 psi)	2.2 bar (32 psi)
185/60 HR 14 tyres		
All loads - up to 100 mph	2.1 bar (30 psi)	2.1 bar (30 psi)
All loads - over 100 mph	2.5 bar (36 psi)	2.5 bar (36 psi)
Note: Pressures apply only to original equipment tyres and may vary if any other make or type is fitted. Check with the tyre manufacturer or supplier for correct pressures if necessary		





Chapter 2 Part A

Engine in-car repair procedures

Contents

Camshaft oil seals - renewal	10	General information and precautions	1
Camshafts and hydraulic tappets - removal, inspection and refitting	11	Oil pump - dismantling, inspection and reassembly	16
Compression test - description and interpretation	3	Oil pump - removal and refitting	15
Crankshaft oil seals - renewal	17	Sump - removal and refitting	14
Crankshaft pulley - removal and refitting	6	Timing belt - removal, inspection, refitting and adjustment	8
Cylinder head - removal and refitting	13	Timing belt covers - removal and refitting	7
Cylinder head cover - removal and refitting	5	Timing belt tensioner and sprockets - removal, inspection and refitting	9
Engine oil and filter - renewal	2	Top Dead Centre (TDC) for number one piston - locating	4
Engine/gearbox mountings - inspection and renewal	19	Valve clearances - general information	12
Flywheel - removal, inspection and refitting	18		

Degrees of difficulty

Easy , suitable for novice with little experience 	Fairly easy , suitable for beginner with some experience 	Fairly difficult , suitable for competent DIY mechanic 	Difficult , suitable for experienced DIY mechanic 	Very difficult , suitable for expert DIY or professional 
---	--	--	---	--

Specifications

General

Type	Four-cylinder in-line, four-stroke, liquid-cooled
Designation:	
1.4 8-valve sohc	K8
1.4 16-valve dohc	K16
Bore	75.00 mm
Stroke	79.00 mm
Capacity	1396 cc
Firing order	1-3-4-2 (No 1 cylinder at timing belt end)
Direction of crankshaft rotation	Clockwise (seen from right-hand side of vehicle)
Compression ratio:	
K8	9.75 : 1
K16	9.50 : 1
Minimum compression pressure	10.3 bar
Maximum compression pressure difference between cylinders	1.4 bar
Maximum power (EEC):	
K8	76 ps (56 kW) @ 5700 rpm
K8 (with catalytic converter)	75 ps (55 kW) @ 5500 rpm
K16	95 ps (70 kW) @ 6250 rpm
K16 (with catalytic converter)	90 ps (66 kW) @ 6250 rpm
Maximum torque (EEC):	
K8	117 Nm (86 lbf ft) @ 3500 rpm
K16	124 Nm (91 lbf ft) @ 4000 rpm
K16 (with catalytic converter)	120 Nm (89 lbf ft) @ 4000 rpm

Cylinder block/crankcase

Note: Service liners are Grade B

Material	Aluminium alloy
Cylinder liner bore diameter - 60 mm from top of bore:	
Standard - grade A (Red)	74.975 to 74.985 mm
Standard - grade B (Blue)	74.986 to 74.995 mm
Service limit	75.045 mm

2A•2 Engine in-car repair procedures

Crankshaft

Number of main bearings	5
Main bearing journal diameter	47.979 to 48.000 mm
Main bearing journal size grades:	
Grade A	47.993 to 48.000 mm
Grade B	47.986 to 47.993 mm
Grade C	47.979 to 47.986 mm
Crankpin journal diameter	42.986 to 43.007 mm
Crankpin journal size grades:	
Grade A	43.000 to 43.007 mm
Grade B	42.993 to 43.000 mm
Grade C	42.986 to 42.993 mm
Main bearing and crankpin journal maximum ovality	0.010 mm
Main bearing and big-end bearing running clearance	0.021 to 0.049 mm
Crankshaft endfloat:	
Standard	0.10 to 0.30 mm
Service limit	0.50 mm
Thrustwasher thickness	2.61 to 2.65 mm

Gudgeon pins

Diameter	18.0 mm
Fit in connecting rod	Interference

Pistons and piston rings

Note: Service pistons are Grade B

Piston diameter:	Grade A	Grade B
K8	74.940 to 74.955 mm	74.956 to 74.970 mm
K16	74.945 to 74.960 mm	74.960 to 74.975 mm
Piston-to-bore clearance:		
K8 - standard	0.015 to 0.045 mm	
K16 - standard	0.010 to 0.040 mm	
Service limit - all	0.080 mm	
Piston ring end gaps (fitted 20 mm from top of bore):		
Top compression ring:		
K8	0.25 to 0.45 mm	
K16	0.30 to 0.50 mm	
Second compression ring - all models	0.30 to 0.50 mm	
Oil control ring:		
K8 - standard	0.25 to 1.00 mm	
K16:		
standard	0.25 to 0.50 mm	
service limit	0.60 mm	
Piston ring-to-groove clearance:		
Top compression ring:		
K8	0.04 to 0.09 mm	
K16	0.04 to 0.07 mm	
Second compression ring:		
K8	0.04 to 0.08 mm	
K16	0.04 to 0.07 mm	
Oil control ring - all models	0.02 to 0.06 mm	

Cylinder head

Material	Aluminium alloy
Height	118.95 to 119.05 mm
Reface limit	0.20 mm
Maximum acceptable gasket face distortion	0.05 mm
Valve seat angle	45°
Valve seat width	1.5 mm
Seat cutter correction angle:	
Upper	30°
Lower	60°
Valve stem installed height:	
K8:	
new	38.95 to 40.81 mm
service limit	41.06 mm
K16:	
new	38.93 to 39.84 mm
service limit	40.10 mm

Valves

Seat angle:	
Inlet	45°
Exhaust	44° 30'
Head diameter:	
Inlet:	
K8	34.0 mm
K16	28.0 mm
Exhaust:	
K8	31.0 mm
K16	24.0 mm
Stem outside diameter:	
Inlet:	
K8	6.967 to 6.975 mm
K16	5.952 to 5.967 mm
Exhaust:	
K8	6.952 to 6.967 mm
K16	5.947 to 5.962 mm
Guide inside diameter:	
K8	7.000 to 7.025 mm
K16	6.000 to 6.025 mm
Stem-to-guide clearance:	
Inlet:	
standard	0.03 to 0.04 mm
service limit	0.07 mm
Exhaust:	
standard	0.07 to 0.08 mm
service limit	0.11 mm
Valve timing:	
K8:	
Inlet opens	13° BTDC
Inlet closes	47° ABDC
Exhaust opens	53° BBDC
Exhaust closes	7° ATDC
K16:	
Inlet opens	15° BTDC
Inlet closes	45° ABDC
Exhaust opens	55° BBDC
Exhaust closes	5° ATDC
Valve spring free length:	
K8	46.2 mm
K16	50.0 mm
Valve guide fitted height	6.0 mm

Camshaft

Drive	Toothed belt
Number of bearings	6
Bearing journal running clearance:	
Standard	0.060 to 0.094 mm
Service limit	0.150 mm
Camshaft endfloat:	
Standard	0.060 to 0.190 mm
Service limit	0.500 mm
Valve lift:	
K8	9.0 mm
K16	8.2 mm
Hydraulic tappet outside diameter	32.959 to 32.975 mm

Lubrication system

System pressure	1.0 bar @ idle speed
Oil pump type	Trochoidal, eccentric-rotor
Oil pump clearances:	
Rotor endfloat	0.02 to 0.06 mm
Outer rotor-to-body clearance	0.28 to 0.36 mm
Rotor lobe clearance	0.05 to 0.13 mm
Pressure relief valve operating pressure	4.1 bar
Oil pressure warning lamp lights at	Below 0.3 to 0.5 bar

Torque wrench settings	Nm	lbf ft
Spark plug (HT) lead clip screws - K8	9	7
Air intake duct support bracket-to-cylinder head screws	4	3
Spark plug cover screws - K16	2	1.5
Cylinder head cover bolts	9	7
Camshaft bearing cap/carrier-to-cylinder head bolts	9	7
Cylinder head bolts:		
1st stage	20	15
2nd stage	Tighten through 180°	
3rd stage	Tighten through (a further) 180°	
Timing belt cover fasteners:		
Upper right-hand (outer) cover	4	3
Lower and upper left-hand (inner) covers	9	7
Timing belt tensioner backplate clamp bolt	25	19
Timing belt tensioner pulley Allen screw	45	33
Camshaft sprocket bolt	33	24
Crankshaft pulley bolt	160	118
Oil pump-to-cylinder block/crankcase bolt and screws	9	7
Alternator mounting bracket-to-cylinder block/crankcase bolts	45	33
Dipstick tube-to-cylinder block/crankcase bolts	9	7
Flywheel bolts	85	63
Transmission-to-engine bolts	85	63
Flywheel cover plate screws	9	7
Flywheel rear cover plate bolt and nut	38	28
Big-end bearing cap bolts:		
1st stage	20	15
2nd stage	Tighten through 45°	
Main bearing ladder-to-cylinder block/crankcase bolts	10	7
Oil rail-to-main bearing ladder nuts	9	7
Oil pump pick-up/strainer pipe bolts	9	7
Sump bolts	10	7
Engine oil drain plug	42	31
Engine/transmission right-hand mounting:		
Bracket-to-cylinder block/crankcase bolts	45	33
Mounting-to-bracket nuts	100	74
Mounting-to-body through-bolt and nut	85	63
Engine/transmission left-hand mounting:		
Mounting-to-body bolts	45	33
Mounting-to-transmission bracket bolts	60	44
Transmission bracket bolts	100	74
Engine/transmission rear mounting:		
Mounting bracket-to-transmission bolt	85	63
Connecting link-to- transmission bracket bolt	60	44
Connecting link-to-body bolt	85	63
Anti-beaming bracket-to-support bracket bolt	45	33

1 General information and precautions

How to use this Chapter

This Part of the Chapter describes those repair procedures that can reasonably be carried out on the engine whilst it remains in the vehicle. If the engine has been removed from the vehicle and is being dismantled as described in Part B of this Chapter, any preliminary dismantling procedures can be ignored.

Note that whilst it may be possible physically to overhaul items such as the piston/connecting rod assemblies with the engine in the vehicle, such tasks are not usually carried out as separate operations and usually require the execution of several

additional procedures (not to mention the cleaning of components and of oilways). For this reason, all such tasks are classed as major overhaul procedures and are described in Part B of this Chapter.

Engine information

The engine is of four-cylinder, in-line type, mounted transversely at the front of the vehicle with the clutch and transmission on its left-hand end. The engine is available in two forms - the K8 engine, which is the eight-valve single overhead camshaft engine fitted to the carburettor-equipped 214 S model, and the K16 engine, which is a sixteen-valve double overhead camshaft engine which is fitted to all fuel-injected models. Apart from the different cylinder head designs, both engines are of identical construction.

Apart from the pressed steel sump, the plastic timing belt covers and the aluminium

alloy cylinder head cover, the engine consists of three major castings which are the cylinder head, the cylinder block/crankcase and the crankshaft main bearing ladder. There is also an oil rail underneath the main bearing ladder and the camshaft carrier/bearing caps.

All major castings are of aluminium alloy and are clamped together by ten long through-bolts which perform the dual role of cylinder head bolts and crankshaft main bearing fasteners. Since these bolts pass through the cylinder block/crankcase and the main bearing ladder, the oil rail is secured also to the main bearing ladder (by two nuts) and the main bearing ladder is secured also to the cylinder block/crankcase (by ten smaller bolts) so that the cylinder head can be removed without disturbing the rest of the engine. The passages provided for the bolts in the major castings are used as breather passages or as returns for the oil to the sump.

The crankshaft runs in five main bearings. Thrustwashers are fitted to the centre main bearing (upper half) to control crankshaft endfloat.

The connecting rods rotate on horizontally-split bearing shells at their big-ends. The pistons are attached to the connecting rods by gudgeon pins which are an interference fit in the connecting rod small-end eyes. The aluminium alloy pistons are fitted with three piston rings, comprising two compression rings and an oil control ring.

The cylinder bores are formed by replaceable wet liners which are located from their top ends. Two sealing rings are fitted at the base of each liner to prevent the escape of coolant into the sump.

The inlet and exhaust valves are each closed by coil springs and operate in guides pressed into the cylinder head. The valve seat inserts are pressed into the cylinder head and can be renewed separately if worn.

On the K8 engine, the camshaft is driven by a toothed timing belt and operates the eight valves via self-adjusting hydraulic tappets, thus eliminating the need for routine checking and adjustment of the valve clearances. The camshaft rotates in six bearings that are line-bored direct in the cylinder head and the (bolted-on) bearing caps. This means that the bearing caps are not available separately from the cylinder head and must not be interchanged with others from another engine. The distributor is driven from the left-hand end of the camshaft and the mechanical fuel pump is operated by an eccentric on the camshaft.

Apart from the fact that it has two camshafts, one inlet and one exhaust, each controlling eight valves and both retained by a single camshaft carrier, the same applies to the K16 engine. On the K16 engine, the distributor is driven from the left-hand end of the inlet camshaft. The fuel pump is electrically-operated.

On both engine types, the coolant pump is driven by the timing belt.

Lubrication is by means of an eccentric-rotor trochoidal pump mounted on the crankshaft right-hand end. It draws oil through a strainer located in the sump and then forces it through an externally-mounted full-flow cartridge-type filter into galleries in the oil rail and cylinder block/crankcase, from where it is distributed to the crankshaft (main bearings) and camshaft(s). The big-end bearings are supplied with oil via internal drillings in the crankshaft, while the camshaft bearings and the hydraulic tappets receive a pressurised supply. The camshaft lobes and valves are lubricated by splash, as are all other engine components.

Repair operations possible with the engine in the car

The following work can be carried out with the engine in the vehicle:

- a) *Compression pressure - testing.*

- b) *Cylinder head cover - removal and refitting.*
- c) *Crankshaft pulley - removal and refitting.*
- d) *Timing belt covers - removal and refitting.*
- e) *Timing belt - removal, refitting and adjustment.*
- f) *Timing belt tensioner and sprockets - removal and refitting.*
- g) *Camshaft oil seal(s) - renewal.*
- h) *Camshaft(s) and hydraulic tappets - removal, inspection and refitting.*
- i) *Cylinder head - removal and refitting.*
- j) *Cylinder head and pistons - decarbonising.*
- k) *Sump - removal and refitting.*
- l) *Oil pump - removal, overhaul and refitting.*
- m) *Crankshaft oil seals - renewal.*
- n) *Engine/transmission mountings - inspection and renewal.*
- o) *Flywheel - removal, inspection and refitting.*

Precautions

Note that a side-effect of the above described engine design is that the crankshaft cannot be rotated once the cylinder head and block through-bolts have been slackened. During any servicing or overhaul work the crankshaft always must be rotated to the desired position before the bolts are disturbed.

2 Engine oil and filter - renewal

- 1 Details of checking the engine oil levels and renewing both the oil and filter are contained in "Weekly Checks" and Chapter 1.

3 Compression test - description and interpretation

- 1 When engine performance is down, or if misfiring occurs which cannot be attributed to the ignition or fuel systems, a compression test can provide diagnostic clues as to the engine's condition. If the test is performed regularly it can give warning of trouble before any other symptoms become apparent.
- 2 The engine must be fully warmed up to normal operating temperature, the battery must be fully charged and the spark plugs must be removed. The aid of an assistant will be required.
- 3 Disable the ignition system by disconnecting the ignition HT coil lead from the distributor cap and earthing it on the cylinder block. Use a jumper lead or similar wire to make a good connection.
- 4 Fit a compression tester to the No 1 cylinder spark plug hole. The type of tester which screws into the plug thread is preferred (see illustration).

5 Have the assistant hold the throttle wide open and crank the engine on the starter motor. After one or two revolutions, the compression pressure should build up to a maximum figure and then stabilise. Record the highest reading obtained.

6 Repeat the test on the remaining cylinders, recording the pressure in each.

7 All cylinders should produce very similar pressures. Any difference greater than that specified indicates the existence of a fault. Note that the compression should build up quickly in a healthy engine. Low compression on the first stroke, followed by gradually increasing pressure on successive strokes, indicates worn piston rings. A low compression reading on the first stroke, which does not build up during successive strokes, indicates leaking valves or a blown head gasket (a cracked head could also be the cause). Deposits on the undersides of the valve heads can also cause low compression.

8 If the pressure in any cylinder is reduced to the specified minimum or less, carry out the following test to isolate the cause. Introduce a teaspoonful of clean oil into that cylinder through its spark plug hole and repeat the test.

9 If the addition of oil temporarily improves the compression pressure, this indicates that bore or piston wear is responsible for the pressure loss. No improvement suggests that leaking or burnt valves, or a blown head gasket, may be to blame.

10 A low reading from two adjacent cylinders is almost certainly due to the head gasket having blown between them and the presence of coolant in the engine oil will confirm this.

11 If one cylinder is about 20 percent lower than the others and the engine has a slightly rough idle, a worn camshaft lobe could be the cause.

12 If the compression reading is unusually high, the combustion chambers are probably coated with carbon deposits. If this is the case, the cylinder head should be removed and decarbonised.

13 On completion of the test, refit the spark plugs and reconnect the ignition system.



3.4 Measuring compression pressure

4 Top Dead Centre (TDC) for number one piston - locating



General

1 The crankshaft pulley, crankshaft and camshaft sprockets are provided by the factory with clear marks which align only at 90° BTDC. This positions the pistons half-way up the bores so that there is no risk of damage as the engine is reassembled. These marks do not indicate TDC. Use only the ignition timing marks, as described in this Section, to find TDC.

2 Top dead centre (TDC) is the highest point in its travel up-and-down the cylinder bore that each piston reaches as the crankshaft rotates. While each piston reaches TDC both at the top of the compression stroke and again at the top of the exhaust stroke, for the purpose of timing the engine, TDC refers to the piston position (usually No 1) at the top of its compression stroke.

3 While all engine reassembly procedures use the factory timing marks (90° BTDC), it is useful for several other servicing procedures to be able to position the engine at TDC.

4 No 1 piston and cylinder is at the right-hand (timing belt) end of the engine. Note that the crankshaft rotates clockwise when viewed from the right-hand side of the vehicle.

Locating TDC

5 Disconnect the battery negative lead and remove all the spark plugs.

6 Trace No 1 spark plug (HT) lead from the plug back to the distributor cap and use chalk or similar to mark the distributor body or engine casting nearest to the cap's No 1 terminal. Undo the distributor cap retaining screws and remove the cap.

7 Apply the handbrake and ensure that the transmission is in neutral, then jack up the front of the vehicle and support it on axle stands. Remove the right-hand roadwheel.

8 From underneath the front of the vehicle, slacken and remove the three bolts securing the bumper flange to the body. Remove the seven bolts securing the front undercover panel to the body and remove the panel to gain access to the crankshaft pulley and ignition timing marks.

9 Using a spanner, or socket and extension bar, applied to the crankshaft pulley bolt, rotate the crankshaft clockwise until the notch on the crankshaft pulley's inboard (left-hand) rim is aligned with the TDC mark on the timing belt lower cover (see Chapter 1 for details of ignition timing marks).

10 With the crankshaft in this position, Nos 1 and 4 cylinders are now at TDC, one of them on the compression stroke. If the distributor rotor arm is pointing at (the previously-marked) No 1 terminal, then No 1 cylinder is correctly positioned. If the rotor arm is pointing at No 4 terminal, rotate the crankshaft one full turn (360°) clockwise until the arm points at the



5.3a Disconnecting breather hose from cylinder head cover - K8 engine

marked terminal. No 1 cylinder will then be at TDC on the compression stroke.

11 Once No 1 cylinder has been positioned at TDC on the compression stroke, TDC for any of the other cylinders can then be located by rotating the crankshaft clockwise 180° at a time and following the firing order.

5 Cylinder head cover - removal and refitting



Removal

1 Disconnect the battery negative lead.

2 Remove the air cleaner assembly and metal intake duct.

3 Using a suitable pair of pliers, release the retaining clip(s) and disconnect the breather hose(s) from the cylinder head cover (see illustrations).

K8 engines

4 Undo the bolts securing the HT lead mounting and air intake support brackets to the cylinder head cover, then remove the brackets and position the HT leads clear of the cover.

5 Remove the two uppermost retaining screws securing the timing belt upper right-hand/outer cover to the cylinder head cover, then slacken the remaining screws and bolts, as necessary, until the timing belt cover can be prised clear of the cylinder head cover without damaging it.

6 Working progressively and in the reverse of the tightening sequence (see illustration 5.14),



5.12a Ensure seal is correctly seated in cylinder head cover groove . . .



5.3b Disconnecting breather hoses from cylinder head cover - K16 engine

slacken and remove the cylinder head cover retaining bolts.

7 Remove the cover, peel off the rubber seal and check it for cuts, other damage or distortion. Renew the seal if necessary.

K16 engines

8 Undo the two spark plug cover retaining screws and lift off the cover. Disconnect the HT leads from the plugs and withdraw them from the cylinder head, along with the clip plate and the grommet which is fitted to the left-hand end of the cylinder head cover.

9 Working progressively and in the reverse of the tightening sequence (see illustration 5.22), slacken and remove the cylinder head cover retaining bolts, noting the correct fitted position of the air intake duct support bracket.

10 Carefully lift off the cylinder head cover, taking care not to damage the gasket. Check that the gasket sealing path is undamaged and is attached to the gasket all around its periphery. If the sealing path is undamaged, then the gasket is re-usable and should remain in place on the cover until reassembly, unless its removal is necessary for other servicing work.

Refitting

K8 engines

11 On reassembly, carefully clean the cylinder head mating surfaces and the cover seal's groove and remove all traces of oil.

12 Seat the seal in its groove in the cover and refit the bolts, pushing each through the seal, then apply a smear of silicone-RTV sealant to each corner of the seal (see illustrations).

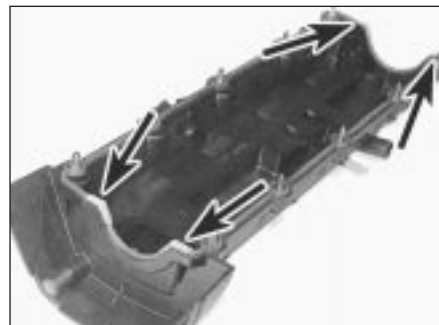

5.12b . . . then refit bolts and apply sealant at locations arrowed - K8 engine

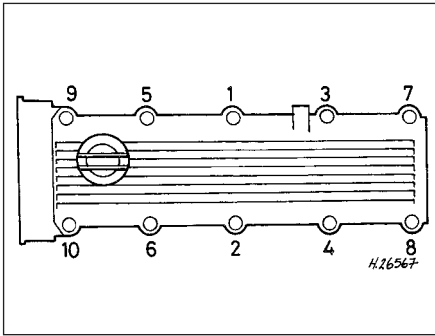

5.14 Cylinder head cover bolt tightening sequence - K8 engine

13 Refit the cover to the cylinder head, ensuring that the seal remains seated in its groove. Fit all bolts, finger-tight.

14 Tighten the cylinder head cover bolts in the sequence shown to the specified torque wrench setting (see illustration).

15 Refit the timing belt upper right-hand/outer cover to the cylinder head cover and tighten all the disturbed screws and bolts to the specified torque setting.

16 Refit the HT lead mounting clips and air cleaner intake support brackets to the cylinder head, then tighten the retaining bolts to the specified torque. Ensure the HT leads are correctly routed.

17 Connect the breather hose to the cylinder head cover and secure it in position with the retaining clip.

18 Refit the air cleaner housing and reconnect the battery negative lead.

K16 engines

19 On reassembly, carefully clean the mating surfaces, removing all traces of oil. If the gasket has been removed, the oil separator elements can be cleaned by removing them from the cover and washing them in solvent. Use compressed air to blow dry the elements before refitting them to the cover.

20 If a new gasket is to be fitted, press it onto the cover locating dowels so that if it were laid on the camshaft carrier its stamped markings would be legible. The TOP mark should be nearest the inlet manifold and the EXH MAN SIDE mark should have its arrows pointing to the exhaust manifold (see illustrations).

21 Lower the cover onto the cylinder head, ensuring that the gasket is not damaged or displaced. Install the cover retaining bolts, not forgetting to refit the air intake duct support bracket to its original position, and tighten them finger-tight.

22 Working in the sequence shown, tighten the cylinder head cover retaining bolts to the specified torque setting (see illustration).

23 Reconnect the HT leads to the spark plugs, then locate the clip plate and grommet in the left-hand end of the cylinder head cover. Ensure the HT leads are correctly routed then refit the spark plug cover and tighten its retaining screws to the specified

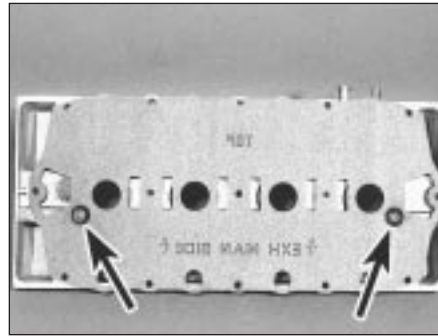

5.20a Fit gasket to cylinder head cover dowels (arrowed) so that . . .



5.20b . . . stamped markings would appear as shown if gasket were placed on camshaft carrier

torque. Tighten the air intake support bracket screws.

24 Connect both the breather hoses to the cylinder head cover and secure them in position with the retaining clips.

25 Refit the air cleaner housing and reconnect the battery negative lead.

6 Crankshaft pulley - removal and refitting

Removal

1 Apply the handbrake then jack up the front of the vehicle and support it on axle stands. Remove the right-hand roadwheel.

2 From underneath the front of the vehicle, slacken and remove the three bolts securing the bumper flange to the body. Remove the seven bolts securing the front undercover panel to the body and remove the panel.

3 If necessary, rotate the crankshaft until the relevant timing marks align.

4 Remove the power steering pump and/or alternator drivebelt(s) (as applicable).

5 To prevent crankshaft rotation while the pulley bolt is unscrewed, select top gear and have an assistant apply the brakes firmly. If the engine has been removed from the

vehicle, lock the flywheel using the arrangement shown (see illustration 18.2).

6 Unscrew the pulley bolt, noting the special washer behind it, then remove the pulley from the crankshaft.

Refitting

7 Align the crankshaft pulley centre notch with the locating lug on the crankshaft timing belt sprocket then refit the washer, ensuring that its flat surface is facing the pulley. Fit the retaining bolt (see illustration).

8 Lock the crankshaft by the method used on removal and tighten the pulley retaining bolt to the specified torque setting.

9 Refit the power steering pump and/or alternator drivebelt(s) (as applicable) and adjust them as described in Chapter 1.

10 Refit the undercover panel and roadwheel then lower the vehicle to the ground.

7 Timing belt covers - removal and refitting

Removal

Upper right-hand (outer) cover

1 Slacken the bolt situated at the cover's bottom corner, immediately behind the engine/gearbox unit right-hand mounting bracket.

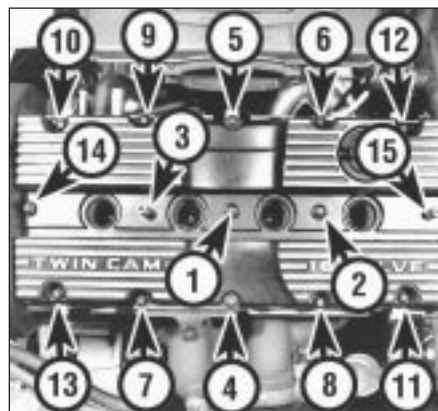

5.22 Cylinder head cover bolt tightening sequence - K16 engine



6.7 Ensure notch in crankshaft pulley centre fits over crankshaft timing belt sprocket locating lug (arrowed)

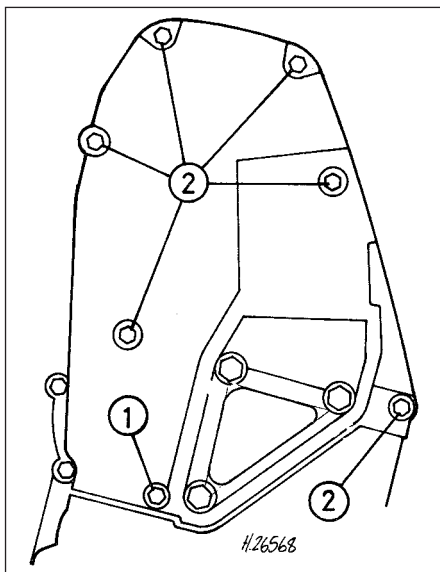

7.2a Timing belt upper right-hand (outer) cover fasteners - K8 engine

- 1 Slacken screw - cover should be slotted
- 2 Remove fasteners

2 Unscrew the remaining cover retaining bolts and withdraw the cover, noting the rubber seal fitted to the mounting bracket edge. Note that if the cover is not slotted at the bottom corner screw's location, the screw



7.9a Timing belt upper left-hand (inner) cover fasteners (arrowed) - K8 engine



7.9b Timing belt upper left-hand (inner) cover fasteners (arrowed) - K16 engine

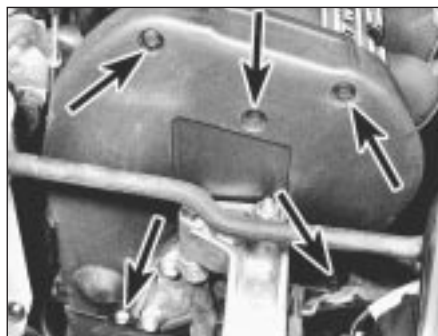

7.2b Timing belt upper right-hand (outer) cover fasteners (arrowed) - K16 engine, raised for clarity

will have to be removed fully. If this is the case, the cover can be slotted to ease future removal and refitting (see illustrations).

Lower cover

- 3 Remove the crankshaft pulley.
- 4 Remove the cover retaining screws, including the one which also secures the upper cover's bottom front corner. Remove the cover whilst noting the rubber seal fitted to its mounting bracket edge (see illustration).

Upper left-hand (inner) cover

- 5 Remove the timing belt.
- 6 Remove the camshaft sprocket(s) and the timing belt tensioner.
- 7 Unscrew the bolt securing the cover to the coolant pump.
- 8 On K16 engines, unbolt the engine/gearbox unit right-hand mounting bracket from the cylinder block/crankcase.
- 9 Remove the remaining cover retaining bolts and withdraw the cover (see illustrations).

Refitting

Upper right-hand (outer) cover

- 10 Refitting is the reverse of the removal procedure. Ensure that the seal fits correctly between the cover and the mounting bracket and that the cover edges mate correctly with those of the inner cover and (K8 engines only) cylinder head cover (see illustration).
- 11 Tighten the cover fasteners to the specified torque setting.



7.9c Removing timing belt upper left-hand (inner) cover - K16 engine

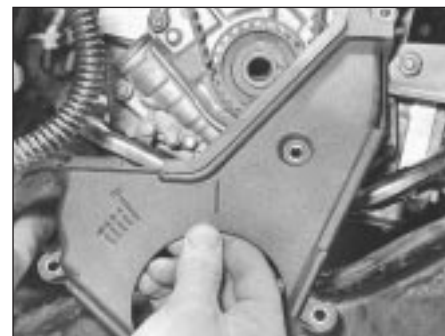

7.4 Removing timing belt lower cover

Lower cover

12 Refitting is the reverse of the removal procedure. Ensure that the seal fits correctly between the cover and the mounting bracket and tighten the cover fasteners to the specified torque setting.

Upper left-hand (inner) cover

13 Refitting is the reverse of the removal procedure. Tighten all disturbed fasteners to their specified torque wrench settings.

8 Timing belt - removal, inspection, refitting and adjustment



If the timing belt is to be re-used, use white paint or similar to mark the direction of rotation on the belt.

Removal

- 1 Disconnect the battery negative lead.
- 2 To improve access to the timing belt, remove the expansion tank mounting bolts then free the coolant hose from any relevant retaining clips and position the tank clear of the engine. On models equipped with power-assisted steering, undo all the power steering hose retaining clip bolts then slide the fluid reservoir out of its retaining clip and position it



7.10 Ensure timing belt upper right-hand (outer) cover engages correctly with cylinder head cover - K8 engine



8.6 Crankshaft pulley mark aligned with timing belt lower cover mark at 90° BTDC

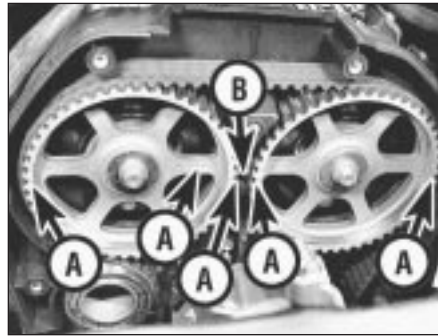

8.7 Camshaft sprocket marks (A) aligned with timing belt upper left-hand (inner) cover mark (B) - K16 engine



8.11 Removing engine/gearbox unit right-hand mounting bracket - K8 engine

clear of the timing belt covers. Take great care not to place any undue strain on hoses and mop up any spilled fluid immediately.

3 Remove the timing belt upper right-hand (outer) cover.

4 Firmly apply the handbrake then jack up the front of the vehicle and support it on axle stands. Remove the right-hand roadwheel

5 From underneath the front of the vehicle, slacken and remove the three bolts securing the bumper flange to the body. Remove the seven bolts securing the front undercover panel to the body and remove the panel to gain access to the crankshaft pulley bolt.

6 Using a suitable spanner or socket on the crankshaft pulley bolt, rotate the crankshaft in a clockwise direction until the long white-painted mark on the crankshaft pulley's outboard (right-hand) face is aligned with the single, separate mark on the timing belt lower cover so that the crankshaft is in the 90° BTDC position (see Chapter 1 for details of the pulley/cover marks) (see illustration).

7 Check that the camshaft sprocket mark(s) align as described in paragraph 15, showing that Nos 1 and 4 cylinders are at 90° BTDC so that there is no risk of the valves contacting the pistons during dismantling and reassembly. If the camshaft sprocket mark(s) are 180° out, rotate the crankshaft through one complete turn (360°) to align the marks as described (see illustration).

8 On K16 engines, use the tool described in Section 9 to lock up the camshaft sprockets

so that they cannot move under valve spring pressure when the timing belt is removed.

9 Remove the crankshaft sprocket and timing belt lower cover.

10 Position a trolley jack with a wooden spacer beneath the sump then gently jack it up to take the weight of the engine.

11 Slacken and remove the engine/gearbox unit right-hand mounting through-bolt and nut and the mounting-to-bracket nuts. Remove the mounting, along with the two rubber washers which are fitted on each side of the mounting. On K8 engines only, unscrew the retaining bolts securing the bracket to cylinder block/crankcase and remove it from the engine unit (see illustration).

12 Slacken both the timing belt tensioner pulley Allen screw and the tensioner backplate clamp bolt through half a turn each, then push the pulley assembly downwards to remove all the tension from the timing belt. Hold the tensioner pulley in this position and re-tighten the backplate clamp bolt securely (see illustration).

13 Slip the belt off the sprockets (see illustration). Do not rotate the crankshaft until the timing belt has been refitted.

Inspection

14 Check the timing belt carefully for any signs of uneven wear, splitting or oil contamination and renew it if there is the slightest doubt about its condition. If the engine is undergoing an overhaul and has

covered more than 48 000 miles (80 000 km) since the original belt was fitted, renew the belt as a matter of course, regardless of its apparent condition. If signs of oil contamination are found, trace the source of the oil leak and rectify it, then wash down the engine timing belt area and all related components to remove all traces of oil.

Refitting

15 On reassembly, thoroughly clean the timing belt sprockets and check that they are aligned as follows. It is most important that these marks are aligned exactly as this sets valve timing. Note that in this position, Nos 1 and 4 cylinders are at 90° BTDC so that there is no risk of the valves contacting the pistons during dismantling and reassembly.

- a) Camshaft sprocket on K8 engine - The EX line and the mark stamped on the sprocket rim must be at the front (looking at the sprocket from the right-hand side of the vehicle) and aligned exactly with the cylinder head top surface (see illustration).
- b) Camshaft sprockets on K16 engine - Both EXHAUST arrow marks must point to the rear (looking at the sprockets from the right-hand side of the vehicle) with the IN lines and the sprocket rim marks aligned exactly with the line on the timing belt upper left-hand/inner cover (representing the cylinder head top surface). See illustration 8.7.

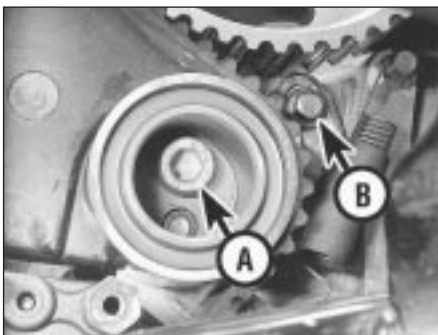

8.12 Timing belt tensioner pulley bolt (A) and tensioner backplate clamp bolt (B)



8.13 Mark direction of rotation of timing belt before removal

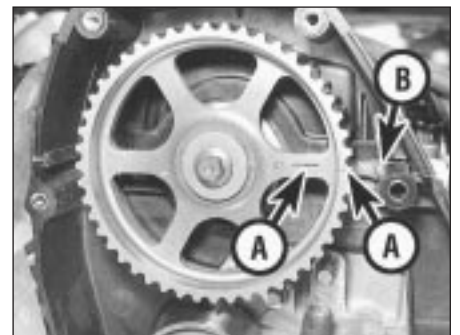

8.15a Camshaft sprocket marks (A) aligned with cylinder head top surface (B) - K8 engine

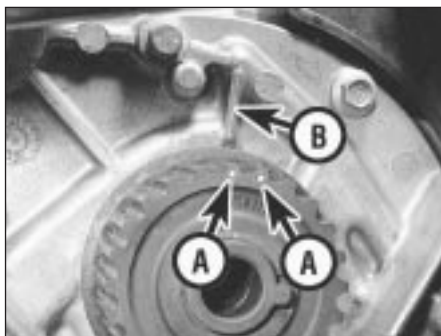

8.15b Crankshaft sprocket (A) aligned on each side of oil pump raised rib (B)

c) *Crankshaft sprocket* - The two dots must be positioned on each side of the raised rib on the oil pump body (see illustration).

16 If a used belt is being refitted, ensure that the arrow mark made on removal points in the normal direction of rotation. Fit the timing belt over the crankshaft and camshaft sprockets, ensuring that the belt front run (and, on K16 engines, the top run) is taut, ie: all slack is on the tensioner pulley side of the belt, then fit the belt over the coolant pump sprocket and tensioner pulley. Do not twist the belt sharply during refitting and ensure that the belt teeth are correctly seated centrally in the sprockets and that the timing marks remain in alignment (see illustration)..

17 Slacken the tensioner backplate clamp bolt and check that the tensioner pulley moves to tension the belt. If the tensioner assembly is not free to move under spring tension, rectify the fault or the timing belt will not be correctly tensioned.

18 On K16 engines, remove the camshaft sprocket locking tool.

19 On K8 engines, refit the engine/gearbox unit right-hand mounting bracket, tightening its bolts to the specified torque wrench setting.

20 On all engines, refit the timing belt lower cover and the crankshaft pulley.

21 Using a suitable spanner or socket, rotate the crankshaft two full turns clockwise to settle and tension the belt. Realign the crankshaft pulley (90° BTDC) mark and check that the sprocket timing mark(s) are still correctly aligned.

22 If all is well, first tighten the tensioner pulley backplate clamp bolt to the specified torque, then tighten the tensioner pulley Allen screw to the specified torque.

23 Reassemble the engine/gearbox unit right-hand mounting, ensuring that the rubber washers are correctly located, then tighten the mounting nuts and bolts to their specified torque settings. Remove the jack from underneath the engine unit.

24 Refit the front undercover panel and roadwheel, then lower the vehicle to the ground.

25 Refit the timing belt upper right-hand (outer) cover.



8.16 Refitting timing belt - K16 engine

26 Where necessary, refit the power steering fluid reservoir to the mounting bracket and secure the hydraulic hose clamps in position with the retaining bolts.

27 Refit the coolant expansion tank and tighten the mounting bolts securely. Secure the coolant hose in position with any necessary retaining clips and reconnect the battery negative lead.

Adjustment

28 As the timing belt is a 'fit-and-forget' type, the manufacturer states that tensioning need only be carried out when a belt is (re)fit. No

re-tensioning is recommended once a belt has been fitted and therefore this operation is not included in the manufacturer's maintenance schedule.

29 If the timing belt is thought to be incorrectly tensioned, then adjust the tension as described in paragraphs 1 to 7, 17, 21, 22 and 24 to 27 above.

30 If the timing belt has been disturbed, adjust its tension following the same procedure, omitting as appropriate the irrelevant preliminary dismantling/reassembly steps.

9 Timing belt tensioner and sprockets - removal, inspection and refitting



If both camshaft sprockets on K16 engines are to be removed, it is good practice to mark them (inlet or exhaust) so that they can be returned to their original locations on reassembly.

Note: This Section describes as individual operations the removal and refitting of the components concerned. If more than one

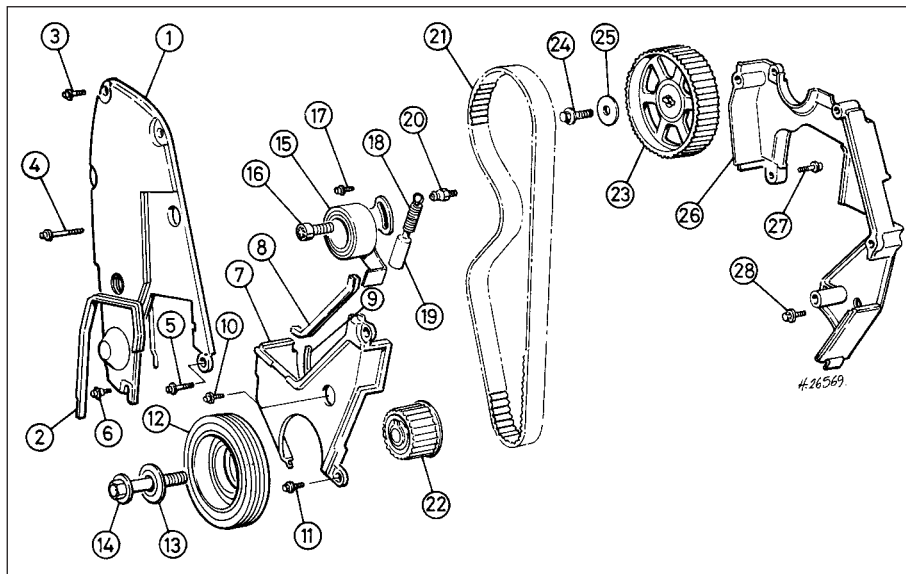

9.2a Timing belt, sprockets and covers - K8 engine

- | | | |
|--|--|--|
| 1 Timing belt upper right-hand (outer) cover | 12 Crankshaft pulley | 20 Pillar bolt |
| 2 Seal | 13 Washer | 21 Timing belt |
| 3 Bolt | 14 Crankshaft pulley bolt | 22 Crankshaft sprocket |
| 4 Bolt | 15 Timing belt tensioner pulley assembly | 23 Camshaft sprocket |
| 5 Bolt | 16 Tensioner pulley Allen screw | 24 Camshaft sprocket bolt |
| 6 Shouldered bolt | 17 Tensioner backplate clamp bolt | 25 Washer |
| 7 Timing belt lower cover | 18 Tensioner pulley spring | 26 Timing belt upper left-hand (inner) cover |
| 8 Seal | 19 Sleeve | 27 Bolt - cover to water pump |
| 9 Seal | | 28 Bolt |
| 10 Bolt | | |
| 11 Bolt | | |

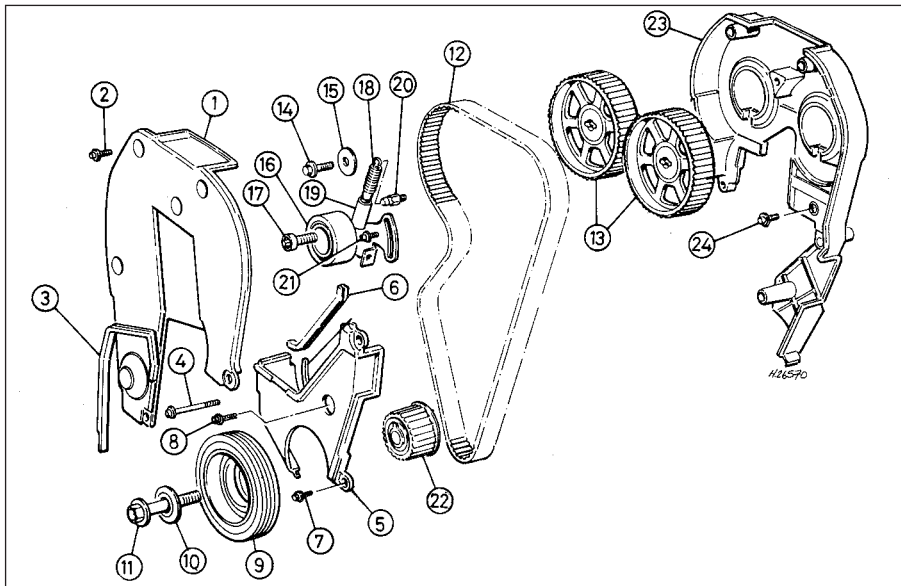

9.2b Timing belt, sprockets and covers - K16 engine

- | | | |
|--|--|--|
| 1 Timing belt upper right-hand (outer) cover | 10 Washer | 18 Tensioner pulley spring |
| 2 Bolt | 11 Crankshaft pulley bolt | 19 Sleeve |
| 3 Seal | 12 Timing belt | 20 Pillar bolt |
| 4 Bolt | 13 Camshaft sprockets | 21 Tensioner backplate clamp bolt |
| 5 Timing belt lower cover | 14 Bolt | 22 Crankshaft sprocket |
| 6 Seal | 15 Washer | 23 Timing belt upper left-hand (inner) cover |
| 7 Bolt | 16 Timing belt tensioner pulley assembly | 24 Bolt |
| 8 Bolt | 17 Tensioner pulley Allen screw | |
| 9 Crankshaft pulley | | |

component needs to be removed at the same time, start by removing the timing belt, then remove each component as described below whilst ignoring the preliminary dismantling steps.

Removal

- 1 Disconnect the battery negative lead.
- 2 To improve access to the timing belt components (see illustrations), remove the expansion tank mounting bolts then free the coolant hose from any relevant retaining clips and position the tank clear of the engine. On models equipped with power-assisted steering, undo all the power steering hose retaining clip bolts then slide the fluid

reservoir out of its retaining clip and position it clear of the timing belt covers. Take great care not to place any undue strain on hoses and mop up any spilled fluid immediately.

- 3 Remove the timing belt upper right-hand (outer) cover.
- 4 Apply the handbrake then jack up the front of the vehicle and support it on axle stands. Remove the right-hand roadwheel.
- 5 From underneath the front of the vehicle, slacken and remove the three bolts securing the bumper flange to the body. Remove the seven bolts securing the front undercover panel to the body and remove the panel.
- 6 Using a suitable spanner or socket on the crankshaft pulley bolt, rotate the crankshaft in

a clockwise direction until the long white-painted mark on the crankshaft pulley's outboard (right-hand) face is aligned with the single, separate mark on the timing belt lower cover so that the crankshaft is in the 90° BTDC position (see Chapter 1 for details of the pulley/cover marks).

7 Check that the camshaft sprocket mark(s) align as described in Section 8, paragraph 15 then proceed as described under the relevant sub-heading.

Camshaft sprocket(s)

8 Slacken through half a turn each, the timing belt tensioner pulley Allen screw and the tensioner backplate clamp bolt. Push the pulley assembly down to release all tension from the timing belt, then re-tighten the backplate clamp bolt securely.

9 Remove the belt from the camshaft sprocket(s), taking care not to twist it too sharply. Use fingers only to handle the belt. Do not rotate the crankshaft until the timing belt is refitted.

10 On K8 engines, slacken the camshaft sprocket retaining bolt and remove it, along with its washer. To prevent the camshaft from rotating, use Rover service tool 18G 1521 to retain the sprocket. If the tool is not available, then an acceptable substitute can be fabricated from two lengths of steel strip (one long, the other short) and three nuts and bolts. One nut and bolt should form the pivot of a forked tool with the remaining two nuts and bolts at the tips of the forks to engage with the sprocket spokes, as shown in illustration 9.23a.

11 On K16 engines, unscrew the appropriate camshaft sprocket retaining bolt and remove it, along with its washer. To prevent a camshaft from rotating, lock together both sprockets using Rover service tool 18G 1570. This tool is a metal sprag shaped on both sides to fit the sprocket teeth and is inserted between the sprockets. If the tool is not available, then an acceptable substitute can be cut from a length of square-section steel tube or similar to fit as closely as possible around the sprocket spokes (see illustrations).

12 On all engines, remove the sprocket(s) from the camshaft end(s), noting the locating roll pin(s) (see illustration). If a roll pin is a

2A



9.11a Camshaft locking tool cut from steel section . . .



9.11b . . . to fit sprocket spokes as closely as possible - K16 engine



9.12 Removing camshaft sprocket (roll pin arrowed) - K8 engine

2A•12 Engine in-car repair procedures

loose fit in the camshaft end, remove it and store it with the sprocket for safe-keeping.

Crankshaft sprocket

13 On K16 engines, use the tool described in paragraph 11 to lock together the camshaft sprockets so that they cannot move under valve spring pressure when the timing belt is removed.

14 Remove the crankshaft pulley and timing belt lower cover.

15 Slacken through half a turn each the timing belt tensioner pulley Allen screw and the tensioner backplate clamp bolt, push the pulley assembly down to release all the tension from the timing belt, then re-tighten the backplate clamp bolt securely.

16 Work the belt clear of the crankshaft sprocket, taking care not to twist it too sharply. Use fingers only to handle the belt. Do not rotate the crankshaft until the timing belt is refitted.

17 Remove the sprocket from the crankshaft.

Tensioner assembly

18 On K16 engines, use the tool described in paragraph 11 to lock together the camshaft sprockets so that they cannot move under valve spring pressure when the timing belt is removed.

19 Using a suitable pair of pliers, unhook the tensioner spring from the pillar bolt. Unscrew the tensioner pulley Allen screw and the tensioner backplate clamp bolt then withdraw the tensioner assembly from the engine unit. Do not rotate the crankshaft until the timing belt is re-tensioned.

Inspection

20 Clean thoroughly the camshaft/crankshaft sprockets and renew any that show signs of wear, damage or cracks.

21 Clean the tensioner assembly but do not use any strong solvent which may enter the pulley bearing. Check that the pulley rotates freely on the backplate, with no sign of stiffness or of free play. Renew the assembly if there is any doubt about its condition or if

there are any obvious signs of wear or damage. The same applies to the tensioner spring, which should be checked with great care as its condition is critical for the correct tensioning of the timing belt.

Refitting

Camshaft sprocket(s)

22 If removed, refit the roll pin to the camshaft end, ensuring that its split is facing the centre of the camshaft, then refit the sprocket so that the timing marks are facing outwards (to the right). On K16 engines, ensure that the appropriate sprocket keyway engages with the camshaft locating pin (ie: if refitting the inlet camshaft sprocket, engage its IN keyway with the roll pin and so on) then refit the sprocket retaining bolt and washer (**see illustration**). Where necessary, repeat the procedure for the second sprocket.

23 Prevent the sprocket(s) from rotating by using the method employed on removal, then tighten the sprocket retaining bolt(s) to the specified torque setting. Check that the sprocket timing marks align as described in Section 8, paragraph 15 (**see illustrations**).

24 Fit the timing belt over the camshaft sprockets, ensuring that the belt front run (and, on K16 engines, the top run) is taut, that is, all slack is on the tensioner pulley side of the belt. Do not twist the belt sharply while refitting it and ensure that the belt teeth are correctly seated centrally in the sprockets and that the timing marks remain in alignment.

25 Slacken the tensioner backplate clamp bolt and check that the tensioner pulley moves to tension the belt. If the tensioner assembly is not free to move under spring tension, rectify the fault or the timing belt will not be correctly tensioned.

26 On K16 engines, remove the camshaft sprocket locking tool.

27 Using a suitable spanner or socket, rotate the crankshaft two full turns clockwise to settle and tension the belt. Realign the crankshaft pulley (90° BTDC) mark and check that the sprocket timing mark(s) are still correctly aligned.

28 If all is well, first tighten the tensioner pulley backplate clamp bolt to the specified torque, then tighten the tensioner pulley Allen screw to the specified torque.

29 Refit the front undercover panel and roadwheel, then lower the vehicle to the ground.

30 Refit the timing belt upper right-hand (outer) cover.

31 Where necessary, refit the power steering fluid reservoir to the mounting bracket and secure the hydraulic hose clamps in position with the retaining bolts.

32 Refit the coolant expansion tank and tighten the mounting bolts securely. Secure the coolant hose in position with any necessary retaining clips and reconnect the battery negative lead.

Crankshaft sprocket

33 Refit the sprocket to the crankshaft so that it locates correctly on the crankshaft's flattened section, noting that the sprocket flange must be innermost so that the two timing marks are on the outside (right-hand side) of the sprocket. Check that the sprocket timing marks align as described in Section 8, paragraph 15.

34 Fit the timing belt over the crankshaft sprocket, ensuring that the belt front run (and, on K16 engines, the top run) is taut, that is, all slack is on the tensioner pulley side of the belt. Do not twist the belt sharply while refitting it and ensure that the belt teeth are correctly seated centrally in the sprockets and that the timing marks remain in alignment.

35 Slacken the tensioner backplate clamp bolt and check that the tensioner pulley moves to tension the belt. If the tensioner assembly is not free to move under spring tension, rectify the fault or the timing belt will not be correctly tensioned.

36 On K16 engines, remove the camshaft sprocket locking tool.

37 Refit the lower timing belt cover and the crankshaft pulley.

38 Carry out the operations described in paragraphs 27 to 32.



9.22 Camshaft sprockets have two keyways. Engage EX keyway with exhaust camshaft roll pin and IN keyway with inlet camshaft roll pin - K16 engine



9.23a Using fabricated tool to hold camshaft pulley in position - K8 engine



9.23b Locking camshafts in position with fabricated tool - K16 engine



9.39 Ensure timing belt tensioner spring is correctly hooked onto pillar bolt



10.4 Fitting a new camshaft right-hand oil seal - K16 engine

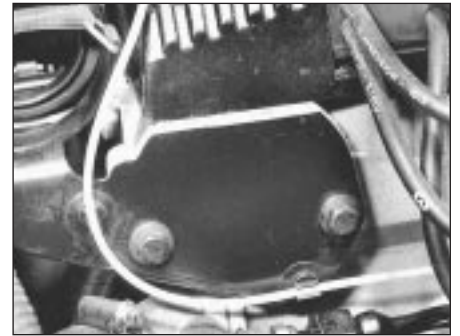

10.8 Remove air intake duct support bracket to reach exhaust camshaft left-hand oil seal - K16 engine

Tensioner pulley

39 Refit the tensioner pulley assembly and tighten the pulley Allen screw and the backplate clamp bolt lightly. Hook the tensioner spring over the pillar bolt and check that the tensioner is free to move under spring tension and that the pulley bears correctly against the timing belt (see illustration).

40 On K16 engines, remove the camshaft sprocket locking tool.

41 Carry out the operations described above in paragraphs 27 to 32.

10 Camshaft oil seals - renewal



Note: If a right-hand oil seal is to be renewed with the timing belt still in place, then check that the belt is free from oil contamination. Renew the belt if signs of oil contamination are found. Cover the belt to protect it from contamination while work is in progress and ensure that all traces of oil are removed from the area before the belt is refitted.

Right-hand seal(s)

1 Remove the camshaft sprocket(s).

2 Punch or drill two small holes opposite each other in the oil seal. Screw a self-tapping screw into each and pull on the screws with pliers to extract the seal.

3 Clean the seal housing and polish off any burrs or raised edges which may have caused the seal to fail in the first place.

4 Lubricate the lips of the new seal with clean engine oil and drive it into position until it seats on its locating shoulder. Use a suitable tubular drift, such as a socket, which bears only on the hard outer edge of the seal (see illustration). Take care not to damage the seal lips during fitting and note that the seal lips should face inwards.

5 Refit the camshaft sprocket(s).

Left-hand seals - K16 engines

6 Disconnect the battery negative lead.

7 To reach the inlet camshaft seal, remove the distributor.

8 To reach the exhaust camshaft seal,

unfasten the rubber strap securing the air intake duct to its support bracket, disconnect the vacuum pipe from the air temperature control valve and unclip the pipe from the support bracket. Undo the bracket's retaining bolts and remove the bracket from the cylinder head (see illustration).

9 Remove the old seal and install the new one as described above in paragraphs 2 to 4.

10 On the inlet camshaft, refit the distributor.

11 On the exhaust camshaft, refit the air intake duct support bracket, tightening its screws to the specified torque wrench setting. Reconnect and secure the air temperature control valve vacuum pipe and refit the rubber strap to secure the air intake duct.

12 Connect the battery negative lead.

11 Camshafts and hydraulic tappets - removal, inspection and refitting



If faulty tappets are diagnosed and the engine's service history is unknown, it is always worth trying the effect of renewing the engine oil and filter (using only good quality engine oil of the recommended viscosity and specification) before going to the expense of renewing any of the tappets.

Note: Prior to removing the camshaft(s), obtain Rover sealant kit LVV 10002 which also contains a plastic scraper. Read the instructions supplied with the kit and take care not to allow the sealant to contact the fingers, as it will bond the skin. If difficulty is experienced with the removal of hardened sealant from mating surfaces, it will be necessary to use a foam action gasket remover.

Removal

K8 engines

1 Remove the cylinder head cover (see illustration 11.0a overleaf).

2 Remove the distributor.

3 Remove the camshaft sprocket.

4 Carefully prise the oil feed tube away from the camshaft bearing caps and remove it from the head assembly. Remove the O-rings from the oil rail and discard them. The O-rings must be renewed whenever they are disturbed.

5 The camshaft right and left-hand end bearing caps are noticeably different and cannot be confused. The intermediate bearing caps (which are all similar) are marked by the manufacturer with a number (1, 2, 3, or 4) stamped in the boss next to the oil feed hole. Before unbolting any of the caps, make written notes to ensure that each can be easily identified and refitted in its original location.

6 Working in the reverse of the tightening sequence (see illustration 11.29), slacken the camshaft bearing cap bolts progressively, by one turn at a time. Work only as described to release the pressure of the valve springs on the bearing caps gradually and evenly.

7 Withdraw the bearing caps, noting the presence of the locating dowels on the end caps, then remove the camshaft and withdraw the oil seal.

8 Obtain eight small, clean plastic containers, number them 1 to 8, and then fill them with clean engine oil. Using a rubber sucker, withdraw each hydraulic tappet in turn (see illustration), and place it in its respective container, to prevent oil loss. Do not interchange the hydraulic tappets or the rate of wear will be much increased and do not allow them to lose oil or they will take a long



11.8 Use a valve-grinding sucker to extract hydraulic tappets

2A•14 Engine in-car repair procedures

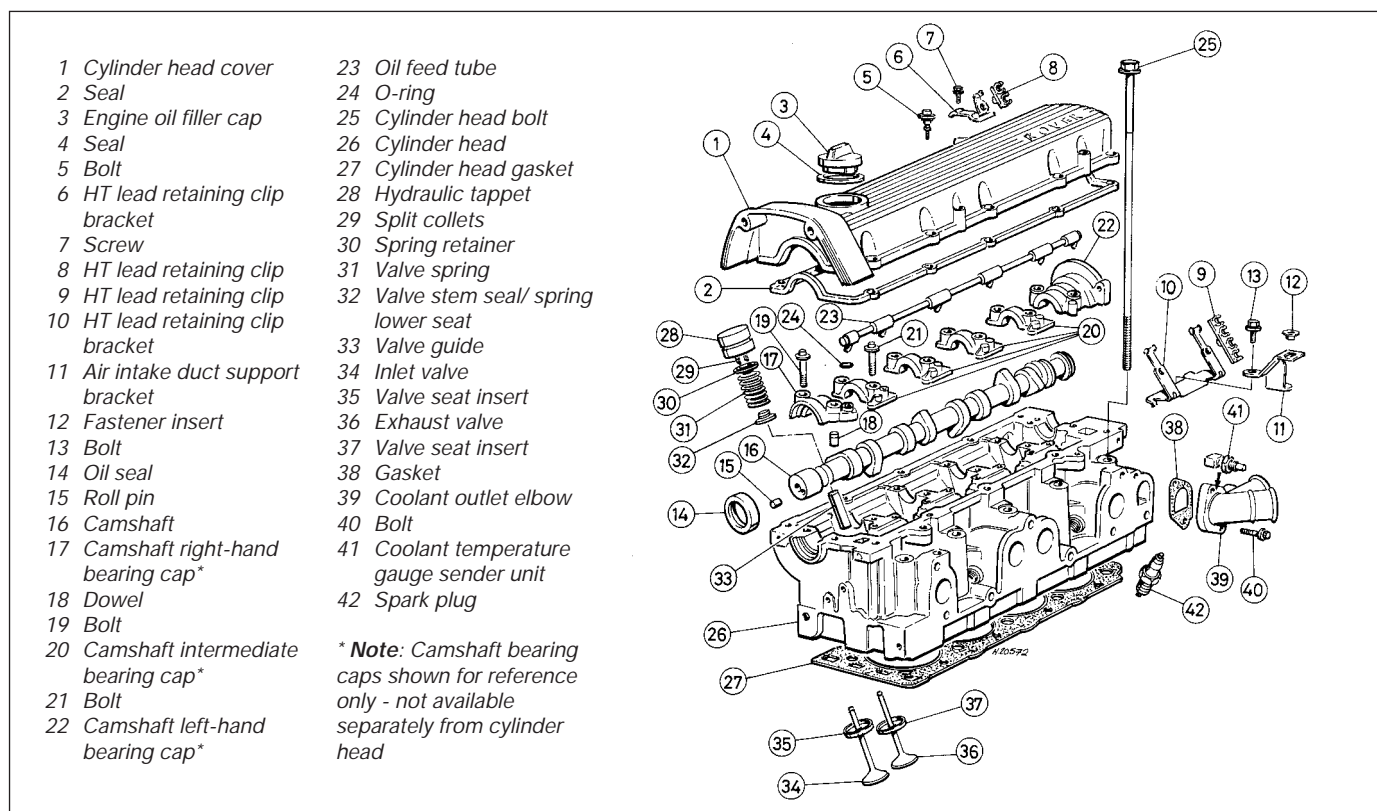

11.0a Top end components - K8 engine

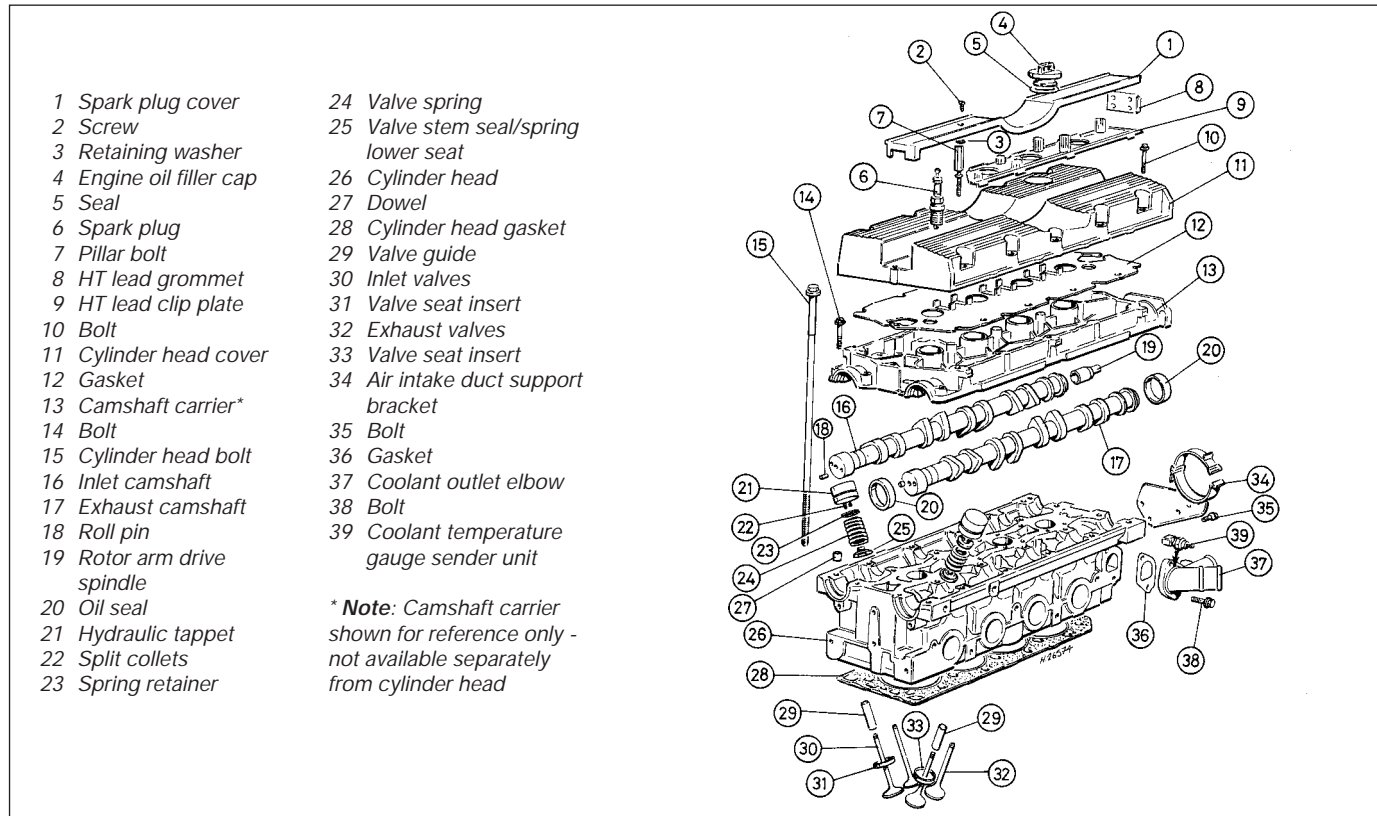

11.0b Top end components - K16 engine



11.9 Secure partly-removed timing belt upper left-hand (inner) cover clear of cylinder head - K16 engine

time to refill with oil on restarting the engine, resulting in incorrect valve clearances.

K16 engines

9 Remove both camshaft sprockets, then unscrew the inner cover's upper retaining bolts so that the cover can be pulled away from the cylinder head just far enough for adequate working clearance. Take care not to distort or damage the cover or the timing belt (see illustration).

10 Remove the cylinder head cover (see illustration 11.0b).

11 Remove the distributor.

12 Unclip the air temperature control valve vacuum pipe from the air intake duct support bracket, then unbolt the bracket from the cylinder head.

13 Working in the reverse of the tightening sequence (see illustration 11.36), evenly and progressively slacken the camshaft carrier bolts by one turn at a time. Once all valve spring pressure has been relieved, remove the bolts.

14 Withdraw the camshaft carrier, noting the presence of the locating dowels, then remove the camshafts and slide off the oil seals. The inlet camshaft can be identified by the distributor rotor arm drive spindle (or its location), therefore there is no need to mark the camshafts.

15 Obtain sixteen small, clean plastic containers, number them 1 to 16, and then fill them with clean engine oil. Using a rubber

sucker, withdraw each hydraulic tappet in turn (see illustration 11.8), and place it in its respective container, to prevent oil loss. Do not interchange the hydraulic tappets or the rate of wear will be much increased and do not allow them to lose oil or they will take a long time to refill with oil on restarting the engine, resulting in incorrect valve clearances.

Inspection

16 Check each hydraulic tappet for signs of obvious wear (scoring, pitting, etc) and for ovality. Renew if necessary.

17 If the engine's valve clearances have sounded noisy, particularly if the noise persists after initial start-up from cold, then there is reason to suspect a faulty hydraulic tappet. Only a good mechanic experienced in these engines can tell whether the noise level is typical, or if renewal is warranted of one or more of the tappets.

18 If any tappet's operation is faulty, then it must be renewed.

19 Carefully remove all traces of old sealant from the mating surfaces of the bearing caps or camshaft carrier and cylinder head by using a plastic scraper. Examine the camshaft bearing journals and the cylinder head bearing surfaces for signs of obvious wear or pitting. If any such signs are evident, renew the component concerned.

20 To check the bearing journal running clearance, remove the hydraulic tappets, carefully clean the bearing surfaces and refit the camshaft(s) and carrier/bearing caps with a strand of Plastigauge across each journal. Tighten the carrier/bearing cap bolts to the specified torque wrench setting whilst taking great care not to rotate the camshaft(s), then remove the carrier/bearing caps and use the scale provided with the Plastigauge kit to measure the width of each compressed strand.

21 If the running clearance of any bearing is found to be worn to the specified service limit or beyond, fit a new camshaft and repeat the check. If the clearance is still excessive, then the cylinder head must be renewed.

22 To check camshaft endfloat, remove the hydraulic tappets, carefully clean the bearing surfaces and refit the camshaft(s) and carrier/bearing caps. Tighten to the specified

torque wrench setting the carrier/bearing cap bolts, then measure the endfloat using a Dial Test Indicator (DTI) or dial gauge mounted on the cylinder head so that its tip bears on the camshaft right-hand end.

23 Tap the camshaft fully towards the gauge, zero the gauge, then tap the camshaft fully away from the gauge and note the gauge reading. If the endfloat measured is found to be worn to the specified service limit or beyond, fit a new camshaft and repeat the check. If the clearance is still excessive, then the cylinder head must be renewed.

24 The camshaft itself should show no signs of marks, pitting or scoring on the lobe surfaces. If such marks are evident, renew the camshaft.

25 If a camshaft is renewed, extract the roll pin from the old one and fit the pin to the new camshaft with its split towards the camshaft's centre.

Refitting

K8 engines

26 Liberally oil the cylinder head hydraulic tappet bores and the tappets (see illustration). Note that if new tappets are being fitted, they must be charged with clean engine oil before installation. Carefully refit the tappets to the cylinder head, ensuring that each tappet is refitted to its original bore and is the correct way up. Some care will be required to enter the tappets squarely into their bores.

27 Liberally oil the camshaft bearings and lobes then refit the camshaft. Position the shaft so that its No 1 cylinder lobes are pointing away from their valves and the roll pin in the camshaft's right-hand end is in the 4 o'clock position when viewed from the right-hand end of the engine (see illustration).

28 Ensure that the locating dowels are pressed firmly into their recesses. Check that the mating surfaces are completely clean, unmarked and free from oil, then apply a thin bead of special Rover sealant to the mating surfaces of the front and rear bearing caps as shown (see illustration 11.29). Carefully follow the instructions supplied with the sealant kit. Refit the bearing caps, using the notes made on removal, to ensure that each is installed correctly and in its original location (see illustration).



11.26 Lubricate hydraulic tappets thoroughly and refit correct way up - K8 engine

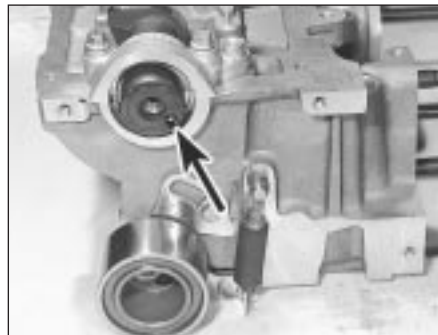

11.27 Camshaft roll pin location at TDC position (for refitting camshaft bearing caps) - K8 engine



11.28 Apply sealant (arrowed) and fit camshaft bearing caps - K8 engine

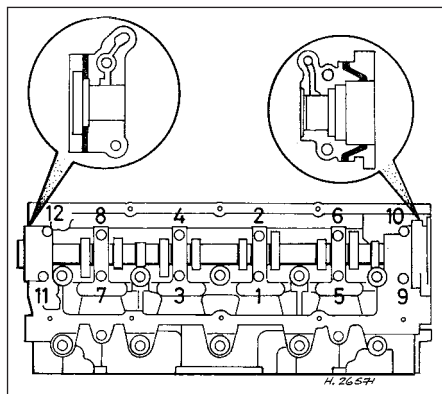

11.29 Camshaft bearing cap bolt tightening sequence - K8 engine

Note: Apply thin bead of sealant to end bearing cap mating surfaces along paths shown by heavy black lines

29 Working in the sequence shown (see illustration), progressively tighten the camshaft bearing cap bolts by one turn at a time until the caps touch the cylinder head evenly. Now go round again, working in the same sequence, and tighten all the bolts to the specified torque setting. Work only as described to impose the pressure of the valve springs gradually and evenly on the bearing caps. Wipe off all surplus sealant so



11.31 Fitting a new camshaft right-hand oil seal - K8 engine



11.34 Camshaft roll pin locations at TDC position for refitting camshaft carrier (arrowed) - K16 engine



11.30a Fill oil holes with clean engine oil - K8 engine

that none is left to find its way into any oilways.

30 Squirt clean engine oil into each camshaft bearing cap oil hole, then fit new O-rings to each of the oil feed tube stubs (see illustration). Refit the oil feed tube to the cylinder head and press it firmly into position in the camshaft bearing caps.

31 Fit a new camshaft oil seal (see illustration), then refit the cylinder head cover and camshaft sprocket.

32 Refit the distributor.

K16 engines

33 Liberally oil the cylinder head hydraulic tappet bores and the tappets. Note that if new tappets are being fitted, they must be charged with clean engine oil before installation. Carefully refit the tappets to the cylinder head, ensuring that each tappet is refitted to its original bore and is the correct way up. Some care will be required to enter the tappets squarely into their bores.

34 Liberally oil the camshaft bearings and lobes and refit them to the cylinder head. Position each shaft so that its No 1 cylinder lobes are pointing away from their valves. With the shafts in this position, the roll pin in the inlet camshaft's right-hand end will be in the 4 o'clock position when viewed from the right-hand end of the engine, while that of the

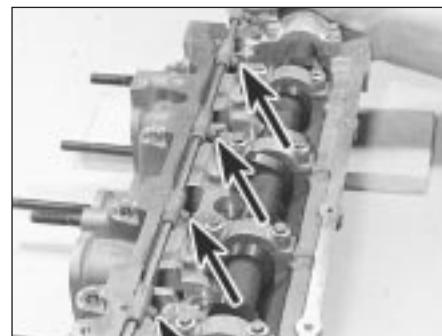

11.30b Renew O-rings (arrowed) before refitting oil feed tube - K8 engine

exhaust camshaft will be in the 8 o'clock position (see illustration).

35 Ensure that the locating dowels are pressed firmly into their recesses, check that the mating surfaces are completely clean, unmarked and free from oil, then apply a thin bead of special Rover sealant to the mating surfaces of the camshaft carrier as shown (see illustration). Carefully follow the instructions supplied with the sealant kit. Refit the carrier.

36 Working in the sequence shown (see illustration), progressively tighten the camshaft carrier bolts by one turn at a time until the carrier touches the cylinder head evenly. Now go round again, working in the same sequence, tightening all bolts to the specified torque setting. Work only as described to impose the pressure of the valve springs gradually and evenly on the carrier. Wipe off all surplus sealant so that none is left to find its way into any oilways.

37 Fit new camshaft oil seals, then refit the cylinder head cover, inner timing cover retaining bolts and camshaft sprockets.

38 Refit the distributor.

39 Refit the air intake duct support bracket, tightening its screws to their specified torque wrench setting, then reconnect and secure the air temperature control valve vacuum pipe and refit the rubber strap to secure the air intake duct.

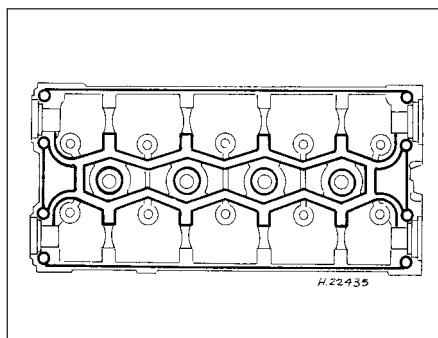

11.35 Apply thin bead of sealant to camshaft carrier mating surfaces along paths shown by heavy black lines - K16 engine

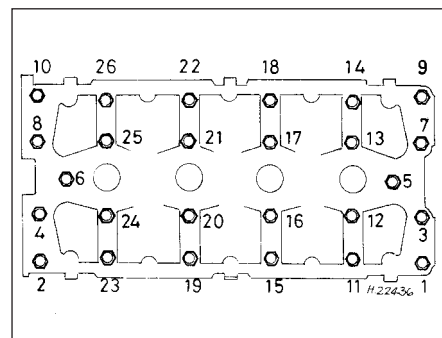

11.36 Camshaft carrier bolt tightening sequence - K16 engine

12 Valve clearances - general information

1 It is necessary for a clearance to exist between the tip of each valve stem and the valve operating mechanism. This allows for expansion of the various engine components as the engine reaches normal operating temperature.

2 On most older engine designs, this meant that the valve clearances (also known as 'tappet' clearances) had to be checked and adjusted regularly. If the clearances were too slack, the engine would be very noisy, its power output would suffer and its fuel consumption would increase. Conversely, if the clearances were too tight, the engine's power output would be reduced and the valves and their seats could be severely damaged.

3 The engines covered in this Manual employ hydraulic tappets which use engine oil pressure to automatically take up the clearance between each camshaft lobe and its respective valve stem. This means that there is no need for regular checking and inspection of the valve clearances, but it is essential that only good quality oil of the recommended viscosity and specification is used in the engine and that this oil is scrupulously changed at the recommended intervals. If this advice is not followed, the oilways and tappets may become clogged with particles of dirt or deposits of burnt engine oil, so that the system cannot work properly. Ultimately, one or more of the tappets may fail and expensive repairs may be required.

4 On starting the engine from cold, there will be a slight delay while full oil pressure builds up in all parts of the engine, especially in the tappets. The valve clearances, therefore, may well rattle for about 10 seconds or so and then quieten. This is a normal state of affairs and is nothing to worry about, provided that all tappets quieten quickly and stay quiet.

5 After the vehicle has been standing for several days, the valve clearances may rattle for longer than usual as nearly all the oil will have drained away from the engine's top end components and bearing surfaces. While this is only to be expected, care must be taken not to damage the engine by running it at high speed until all the tappets are refilled with oil and operating normally. With the vehicle stationary, hold the engine at no more than a fast idle speed (maximum 2000 to 2500 rpm) for 10 to 15 minutes or until the noise ceases. Do not run the engine at more than 3000 rpm until all tappets are fully recharged with oil and all noise has ceased.

6 If the valve clearances are thought to be noisy, or if a light rattle persists from the engine's top end after it has reached normal operating temperature, take the vehicle to a Rover dealer for expert advice. Depending on

the mileage covered and the usage to which each vehicle has been put, some vehicles may be noisier than others. Only a good mechanic experienced in these engines can tell if the noise level is typical for the vehicle's mileage or if a genuine fault exists. If any tappet's operation is faulty, then it must be renewed.

13 Cylinder head - removal and refitting



Note: Due to engine design, it will become very difficult, almost impossible, to turn the crankshaft once the cylinder head bolts have been slackened. The manufacturer states that the crankshaft will be 'tight' and should not be rotated more than absolutely necessary once the head has been removed. If the crankshaft cannot be rotated, then it must be removed for overhaul work to proceed. With this in mind, the crankshaft always must be rotated to the desired position before the bolts are disturbed.

Removal

- 1 Disconnect the battery negative lead.
- 2 Drain the cooling system.
- 3 Remove the camshaft sprocket(s).
- 4 Unscrew the bolts securing the timing belt upper left-hand (inner) cover to the cylinder head, so that the cover can be pulled away from the cylinder head just far enough for adequate working clearance. Take care not to distort or damage the cover or the timing belt.
- 5 Remove the cylinder head cover.
- 6 Disconnect the exhaust system front pipe from the manifold and, where fitted, disconnect or release the lambda sensor wiring so that it is not strained by the weight of the exhaust.
- 7 Note that the following text assumes that the cylinder head will be removed with both inlet and exhaust manifolds attached. This is easier but makes it a bulky and heavy assembly to handle. If it is wished first to remove the manifolds, proceed as described in the relevant Sections of Chapter 4.
- 8 On carburettor engines, disconnect the following from the carburettor and inlet manifold as described in the relevant Sections of Chapter 4A:
 - a) Fuel pump feed hose - plug both openings to prevent loss of fuel and entry of dirt into system.
 - b) Carburettor idle bypass solenoid wires.
 - c) Accelerator cable.
 - d) Choke cable.
 - e) Vacuum servo unit vacuum hose.
 - f) Inlet manifold PTC heater wire.
 - g) Inlet manifold heater temperature switch wiring.
- 9 On fuel-injected engines, refer to the relevant Sections of Chapter 4B or C, and disconnect or remove all throttle body/fuel rail components appertaining to cylinder head removal, noting the following:
 - a) The fuel system must be depressurised before any component is disconnected.
 - b) Plug the open ends of all disconnected pipes to prevent loss of fuel and entry of dirt into system.
 - c) Discard all sealing washers and O-rings, these must be renewed.

10 Working as described in Chapter 3, disconnect the connector plug from the coolant temperature sensor screwed into the coolant outlet elbow, then disconnect the coolant hoses from the (three) inlet manifold unions and from the coolant outlet elbow.

11 Unclip the engine wiring harness from the inlet manifold or its support stays. Slacken the bolts securing the stays to the manifold, then unbolt the support stays and the carburettor metal overflow pipes from the cylinder block/crankcase.

12 Remove the distributor cap, complete with the spark plug HT leads. Remove the spark plugs.

13 On K16 engines equipped with air conditioning, undo the nuts and bolts securing the heat shields to the rear of the alternator and air conditioning compressor and remove both heat shields. Slacken the two lower alternator mounting bolts then remove the upper mounting bolt and pivot the alternator away from the cylinder head.

14 Working in the reverse of the tightening sequence (see illustrations 13.29a or 13.29b), progressively slacken the ten cylinder head bolts by one turn at a time. A female Torx-type socket (No 12 size) will be required. Remove each bolt in turn and store it in its correct fitted order by pushing it through a clearly-marked cardboard template.

15 The joint between the cylinder head and gasket and the cylinder block/crankcase must now be broken without disturbing the wet liners. Although these liners are better located and sealed than some wet liner engines, there is still a risk of coolant and foreign matter leaking into the sump if the cylinder head is lifted carelessly. If care is not taken and the liners are moved, there is also a possibility of the bottom seals being disturbed, causing leakage after refitting the head.

16 To break the joint, obtain two L-shaped metal bars which fit into the cylinder head bolt holes and gently rock the cylinder head free towards the front of the vehicle (see illustration). Do not try to swivel the head on

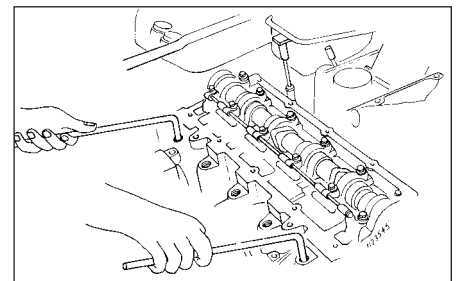

13.16 Using two cranked bars to break cylinder head joint



13.20 Checking condition of cylinder head bolt threads - cylinder head removed



13.26a Fit new cylinder head gasket on two locating dowels (arrowed) . . .



13.26b . . . so that TOP mark is upwards and FRONT arrow points to timing belt end

the cylinder block/crankcase as it is located by dowels as well as by the tops of the liners.

17 With the joint broken, lift the cylinder head away, using assistance if possible as it is a heavy assembly, especially if complete with the manifolds. Remove the gasket, noting the two locating dowels, and discard it.

18 Further to the warnings given in the note at the beginning of this Section, do not attempt to rotate the crankshaft with the cylinder head removed, otherwise the wet liners may be displaced. Operations that would normally require the rotation of the crankshaft (eg: cleaning the piston crowns) must be carried out with great care to ensure that no particles of dirt or foreign matter are left behind. If cylinder liner clamps are to be used, they must be clamped in place using

spacers fitted under the heads of the cylinder head bolts.

19 If the cylinder head is to be dismantled, remove the camshaft(s) then refer to the relevant Sections of Part B of this Chapter.

Refitting

20 Check the condition of the cylinder head bolts, particularly their threads. Keeping all bolts in their correct fitted order, wash them and wipe dry. Check each bolt for any sign of visible wear or damage, renewing as necessary. Lightly oil the threads of each bolt, carefully enter it into its original hole and screw it in, by hand only until finger-tight. Measure the distance from the cylinder block/crankcase gasket surface to under the bolt's head (see illustration).

21 If the distance measured is under 97 mm, the bolt may be re-used. If the distance measured is more than 97 mm, the bolt must be renewed. Considering the task these bolts perform and the pressures they must withstand, owners should consider renewing all the bolts as a matched set if more than one of the originals fail inspection or are close to the limit set.

22 The mating faces of the cylinder head and cylinder block/crankcase must be perfectly clean before refitting the head. Use a hard plastic or wood scraper to remove all traces of gasket and carbon.

23 Check the mating surfaces of the cylinder block/crankcase and the cylinder head for

nicks, deep scratches and other damage. If slight, they may be removed carefully with a file, but if excessive, machining may be the only alternative to renewal.

24 If warpage of the cylinder head gasket surface is suspected, use a straight-edge to check it for distortion. Refer to Part B of this Chapter if necessary.

25 Wipe clean the mating surfaces of the cylinder head and cylinder block/crankcase. Check that the two locating dowels are in position at each end of the cylinder block/crankcase surface.

26 Position a new gasket on the cylinder block/crankcase surface so that its TOP mark is uppermost and the FRONT arrow points to the timing belt end (see illustrations).

27 Refit the cylinder head, locating it on the dowels (see illustration).

28 Keeping all the cylinder head bolts in their correct fitted order, wash them and wipe dry. Lightly oil under the head and on the threads of each bolt, carefully enter it into its original hole and screw it in, by hand only, until finger-tight.

29 Working progressively and in the sequence shown (see illustrations), use first a torque wrench, then an ordinary socket extension bar to tighten the cylinder head bolts through the specified stages. To tighten the bolts through the specified angles, simply use a felt-tip pen or similar to mark the position on the cylinder head of each bolt head's radial mark. The second stage then



13.27 Refitting the cylinder head

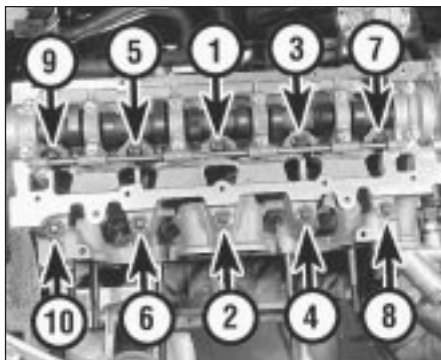

13.29a Cylinder head bolt tightening sequence - K8 engine

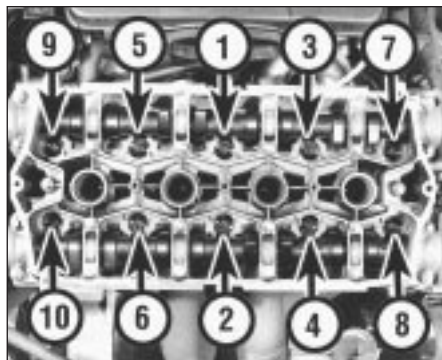

13.29b Cylinder head bolt tightening sequence - K16 engine

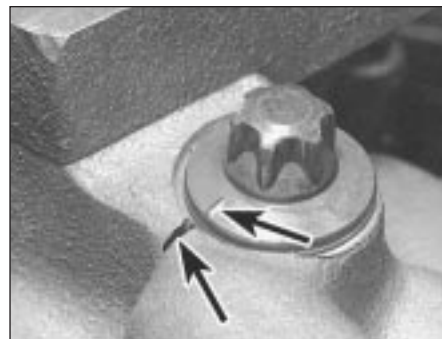

13.29c Alignment of bolt head radial marks with cylinder head to establish tightening angles (arrowed)

tightens each bolt through half a turn so that the marks face away from each other and the third stage tightens them through another half-turn so that all the bolt-head marks will then align again with their cylinder head counterparts. If any bolt is overtightened past its mark, slacken it through 90°, then re-tighten until the marks align (see illustration).

30 Refit and tighten the inlet manifold support stay bolts, then secure the engine wiring harness using the clips provided.

31 On K16 engines equipped with air conditioning, refit the alternator mounting bolts and tighten them to the specified torque setting. Refit the compressor and alternator heatshields, tightening their retaining bolts and nuts securely.

32 Connect all disturbed coolant hoses, securing them in position with their retaining clips. Reconnect the coolant temperature sensor wiring.

33 Working as described in Chapter 4, connect or refit all disturbed wiring, hoses and control cable(s) to the inlet manifold and fuel system components, then adjust the choke and/or accelerator cable(s).

34 Reconnect the exhaust system front pipe to the manifold and (if applicable) reconnect the lambda sensor wiring.

35 Refit the cylinder head cover, inner timing cover retaining bolts and camshaft sprocket(s).

36 Refit the spark plugs and distributor cap then reconnect the battery negative lead.

37 Refill the cooling system.



14.6 Remove flywheel lower cover plate to reach sump bolts



14.9 Removing the sump

wiring so that it is not strained by the weight of the exhaust.

6 Unscrew the three retaining bolts and remove the flywheel lower cover plate (see illustration).

7 Slacken and remove the bolts securing the anti-beaming bracket to the engine and transmission and remove the bracket.

8 Progressively slacken the sump retaining bolts then remove them along with the anti-beaming bracket support. Make a note of the correct fitted position of the support and of the longer bolts at positions 4, 8 and 12 (see illustration 14.14) to ensure correct refitment on reassembly.

9 Break the joint by striking the sump with the palm of the hand, then lower the sump and withdraw it (see illustration).

10 While the sump is removed, take the opportunity to unbolt the oil pump pick-up/strainer pipe and clean it using a suitable solvent. Inspect the strainer mesh for signs of clogging or splitting and renew if necessary.

Refitting

11 Clean all traces of gasket from the mating surfaces of the cylinder block/crankcase and sump, then use a clean rag to wipe out the sump and the engine's interior. If the oil pump pick-up/strainer pipe was removed, fit a new sealing O-ring to its end and refit the pipe, tightening its retaining bolts to the specified torque setting.

12 If the sump gasket is damaged or shows signs of deterioration, then it must be renewed. Fit the gasket to the sump mating

surface so that its 7 locating pegs fit into the sump holes (see illustration).

13 Offer up the sump to the cylinder block/crankcase then fit the new sump retaining bolts, not forgetting the anti-beaming bracket support. Tighten the bolts finger-tight only.

14 Working in the sequence shown (see illustration), tighten the sump bolts to the specified torque setting.

15 Refit the anti-beaming bracket and tighten the mounting bolts to the specified torque setting.

16 Install the flywheel lower cover plate and tighten the retaining bolts to the specified torque wrench setting.

17 Reconnect the exhaust system front pipe to the manifold and, where necessary, reconnect the lambda sensor wiring.

18 Refit the undercover panel and wheel, then lower the vehicle to the ground and reconnect the battery negative lead.

19 Replenish the engine oil.

14 Sump - removal and refitting



Note: It is essential that new bolts of the Patchlok type are used when refitting the sump.

Removal

1 Disconnect the battery negative lead.

2 Drain the engine oil then clean and refit the engine oil drain plug, tightening it to the specified torque wrench setting. If the engine is nearing its service interval when the oil and filter are due for renewal, it is recommended that the filter is also removed and a new one fitted. After reassembly, the engine can then be replenished with fresh engine oil.

3 Apply the handbrake, then jack up the front of the vehicle and support it on axle stands. Remove the right-hand roadwheel.

4 From underneath the front of the vehicle, slacken and remove the three bolts securing the bumper flange to the body. Remove the seven bolts securing the front undercover panel to the body and remove the panel.

5 Working as described in Chapter 4, disconnect the exhaust system front pipe from the manifold and, where fitted, disconnect or release the lambda sensor



14.12 Sump gasket pegs must engage with sump mating surface holes

15 Oil pump - removal and refitting



Note: The oil pressure relief valve can be dismantled without removing the oil pump from the vehicle. See Section 16 for details.

Removal

1 Remove the crankshaft sprocket and secure the timing belt clear of the working

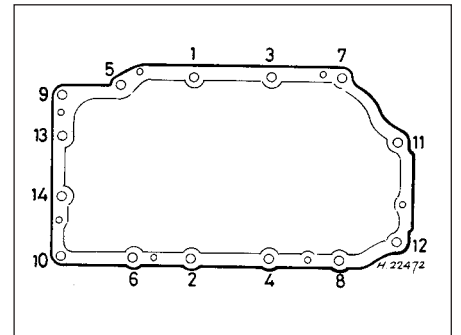

14.14 Sump bolt tightening sequence

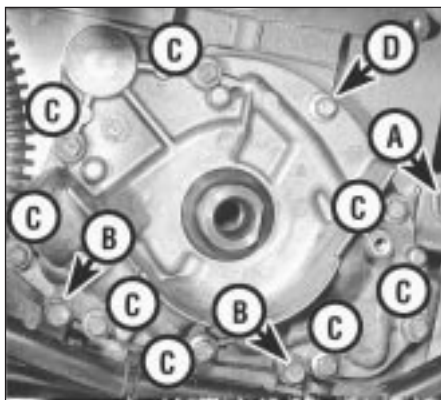

15.4 Alternator adjuster link nut (A) wiring guide screws (B) oil pump bolts (C) and special oil pump bolt (D)

area so that it cannot be contaminated with oil.

2 Drain the engine oil, then clean and refit the engine oil drain plug, tightening it to the specified torque wrench setting. If the engine is nearing its service interval when the oil and filter are due for renewal, it is recommended that the filter is also removed and a new one fitted. After reassembly, the engine can then be replenished with fresh engine oil.

3 Where necessary, unscrew the alternator adjuster link retaining nut and unbolt the engine wiring harness guide retaining screws, then move the link and guide clear of the oil pump.

4 Unscrew the oil pump retaining bolts, noting the fitted position of the special bolt, and withdraw the oil pump (see illustration). Recover the pump gasket and discard it, then carefully lever the crankshaft right-hand oil seal out of the oil pump. The oil seal should be renewed whenever it is disturbed.

Refitting

5 Thoroughly clean the mating faces of the oil pump and cylinder block/crankcase. Use grease to stick a new gasket in place.

6 Prime the pump before installation by injecting clean engine oil into it and turning it by hand.

7 Offer up the pump, ensuring that its inner



16.4 Unscrewing oil pressure relief valve threaded plug

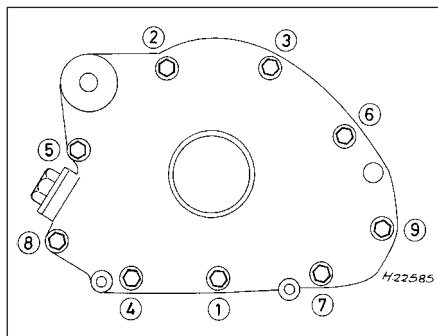

15.8 Oil pump bolt tightening sequence

gear engages fully on the crankshaft flats, then push the pump fully into position.

8 Refit the pump retaining bolts, ensuring that the special bolt is refitted to its original position. Tighten the retaining bolts to the specified torque setting in the order shown (see illustration).

9 If removed, refit the alternator adjuster link and the engine wiring harness guide, then tighten securely the retaining nut and screws.

10 Fit a new crankshaft right-hand oil seal.

11 Remove all traces of surplus oil then refit the crankshaft sprocket.

12 Replenish the engine oil.

16 Oil pump - dismantling, inspection and reassembly



Note: If oil pump wear is suspected, check the cost and availability of new parts (only available in the form of repair kit LQX 10001) against the cost of a new pump. Examine the pump as described in this Section and then decide whether renewal or repair is the best course of action.

Dismantling

1 Remove the oil pump.

2 Unscrew the Torx screws (size T25) and remove the pump cover plate. Discard the sealing ring.

3 Note the identification marks on the outer rotor then remove both the rotors from the body.

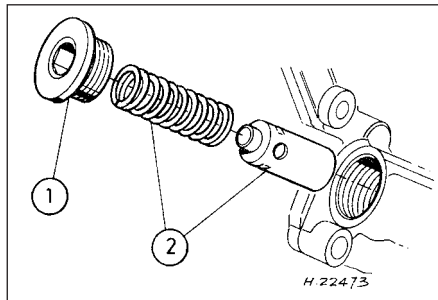

16.5 Oil pressure relief valve assembly

- 1 Threaded plug
- 2 Valve spring and plunger

4 The oil pressure relief valve can be dismantled, if required, without disturbing the pump. If this is to be done with the pump in position and the engine still installed in the vehicle, it will first be necessary to jack up the front of the vehicle and remove the right-hand roadwheel to gain access to the valve (see illustration).

5 To dismantle the valve, unscrew the threaded plug and recover the valve spring and plunger (see illustration). Discard the plug sealing washer.

Inspection

6 Inspect the rotors for obvious signs of wear or damage and renew if necessary. If the pump body or cover plate is scored or damaged, then the complete oil pump assembly must be renewed.

7 Using feeler gauge blades of the appropriate thickness, measure the clearance between the outer rotor and the pump body, then between the tips of the inner and outer rotor lobes (a and b respectively) (see illustration).

8 Using feeler gauge blades and a straight-edge placed across the top of the pump body and the rotors, measure the rotor endfloat (c).

9 If any measurement is outside the specified limits, the complete pump assembly must be renewed.

10 If the pressure relief valve plunger is scored, or if it does not slide freely in the pump body bore, then it must be renewed, using all the components from the repair kit.

11 To complete a thorough inspection of the oil pump components, the sump should be removed and the oil pump pick-up/strainer pipe removed and cleaned.

Reassembly

12 Lubricate the pump rotors with clean engine oil and refit them to the pump body,

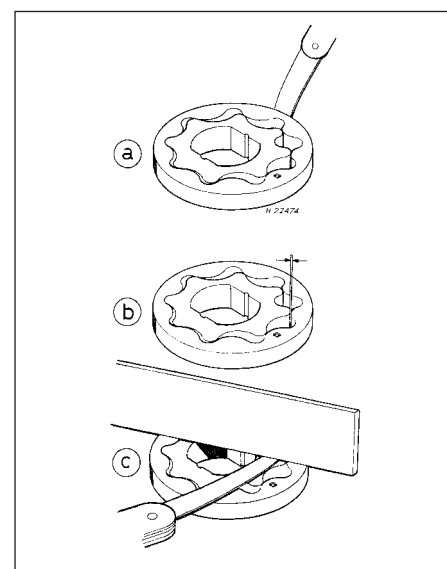

16.7 Checking oil pump rotors for wear - see text for details

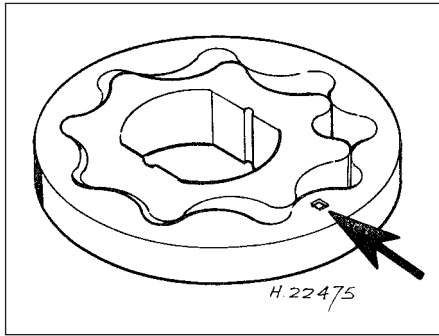

16.12 Oil pump outer rotor outside face identifying mark (arrowed)

ensuring that the outer rotor's identification mark faces outwards (see illustration).

13 Fit a new sealing ring to the pump body and refit the cover plate. Apply thread-locking compound to the threads of the cover plate Torx screws and tighten them securely.

14 Check that the pump rotates freely, then prime it by injecting oil into its passages and rotating it. If a long time elapses before the pump is refitted to the engine, prime it again before installation.

15 Refit the oil pressure relief valve plunger, ensuring that it is the correct way up, then install the spring. Fit a new sealing washer to the threaded plug and tighten the plug securely.

17 Crankshaft oil seals - renewal



Right-hand seal

1 Remove the crankshaft sprocket and secure the timing belt clear of the working area so that it cannot be contaminated with oil.

2 Punch or drill two small holes opposite each other in the seal. Screw a self-tapping screw into each and pull on the screws with pliers to extract the seal.

3 Clean the seal housing and polish off any burrs or raised edges which may have caused the seal to fail in the first place.

4 Lubricate the lips of the new seal with clean engine oil and drive it into position until it seats on its locating shoulder. Use a suitable tubular drift, such as a socket, which bears only on the hard outer edge of the seal. Take care not to damage the seal lips during fitting. Use either grease or a thin layer of insulating tape to protect the seal lips from the edges of the crankshaft flats but be careful to remove all traces of tape and to lubricate the seal lips if the second method is used. Note that the seal lips should face inwards.

5 Wash off any traces of oil, then refit the crankshaft sprocket.

Left-hand seal

6 Remove the flywheel.



18.2 Using fabricated tool to lock flywheel in position

7 Taking care not to mark either the crankshaft or any part of the cylinder block/crankcase, lever the seal evenly out of its housing.

8 Clean the seal housing and polish off any burrs or raised edges which may have caused the seal to fail in the first place.

9 Lubricate with grease the lips of the new seal and the crankshaft shoulder, then offer up the seal to the cylinder block/crankcase.

10 Ease the sealing lip of the seal over the crankshaft shoulder by hand only, then press the seal evenly into its housing until its outer flange seats evenly on the housing lip. If necessary, a soft-faced mallet can be used to tap the seal gently into place.

11 Wash off any traces of oil, then refit the flywheel.

18 Flywheel - removal, inspection and refitting



Removal

1 Remove the gearbox and the clutch assembly.

2 Prevent the flywheel from turning by locking the ring gear teeth (see illustration) or by bolting a strap between the flywheel and the cylinder block/crankcase.

3 Slacken and remove the flywheel retaining bolts and discard them. The bolts must be renewed whenever they are disturbed.

4 Remove the flywheel. Do not drop it, as it is very heavy.

Inspection

5 If the flywheel's clutch mating surface is deeply scored, cracked or otherwise damaged, then the flywheel must be renewed, unless it is possible to have it surface ground. Seek the advice of a Rover dealer or engine reconditioning specialist.

6 If the ring gear is badly worn or has missing teeth, then it must be renewed. This job is best left to a Rover dealer or engine reconditioning specialist. The temperature to which the new ring gear must be heated for installation (350°C - shown by an even light blue colour) is critical and, if not done

accurately, the hardness of the teeth will be destroyed.

7 Examine the reluctor ring (fitted to the rear of the flywheel) for signs of damage and check that it is securely fastened by the two retaining screws. If the reluctor ring is damaged, then it must be renewed.

Refitting

8 Clean the mating surfaces of the flywheel and crankshaft. Clean any remaining adhesive from the threads of the crankshaft threaded holes by making two saw cuts at opposite points along the (carefully-cleaned) threads of one of the original flywheel bolts and screwing it into each hole in turn. Do not use a tap to clean the threads in this way.

9 Position the flywheel over the crankshaft's locating dowel, press it into place and fit six new bolts.

10 Lock the flywheel using the method employed on dismantling, then tighten the retaining bolts to the specified torque wrench setting.

11 Refit the clutch, then remove the locking tool and refit the gearbox.

19 Engine/gearbox mountings - inspection and renewal



Inspection

1 If improved access is required, raise the front of the vehicle and support it securely on axle stands.

2 Check the mounting rubber to see if it is cracked, hardened or separated from the metal at any point. Renew the mounting if any such damage or deterioration is evident.

3 Check that all mounting fasteners are securely tightened. Use a torque wrench to check, if possible.

4 Using a large screwdriver or a pry bar, check for wear in the mounting by carefully levering against it to check for free play. Where this is not possible, enlist the aid of an assistant to move the engine/gearbox unit back and forth or from side to side while you watch the mounting. While some free play is to be expected even from new components, excessive wear should be obvious. If excessive free play is found, check first that the fasteners are correctly secured, then renew any worn components as described below.

Renewal

Right-hand mounting

5 Disconnect the battery negative lead.
6 To improve access to the mounting, remove the expansion tank mounting bolts then free the coolant hose from any relevant retaining clips and position the tank clear of the engine. On models equipped with power-assisted steering, undo all the power steering hose retaining clamp bolts then slide the fluid



19.7a Use trolley jack with wooden spacer to adjust height of engine/gearbox unit

reservoir out of its retaining clip and position it clear of the timing belt covers. Take great care not to place any undue strain on hoses and mop up any spilt fluid immediately.

7 Support the weight of the engine/gearbox unit by using a trolley jack, with a wooden spacer to prevent damage to the sump. Unscrew the mounting through-bolt and nut and the mounting to bracket nuts. Remove the mounting, noting the two rubber washers (see illustrations).

8 Where necessary, unscrew the retaining bolts and remove the bracket from the cylinder block/crankcase.

9 Check carefully for signs of wear or damage on all components and renew them where necessary.

10 On reassembly, refit the bracket to the

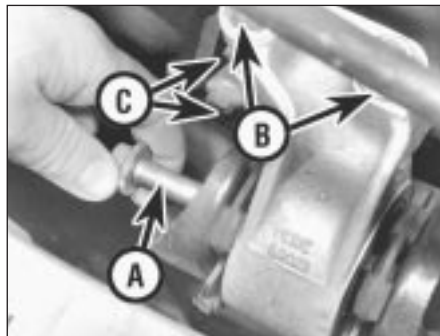

19.7b Right-hand mounting through-bolt (A), mounting-to-bracket nuts (B), bracket-to-cylinder block/crankcase bolts (two arrowed - C)

cylinder block/crankcase and tighten the retaining bolts to the specified torque setting.

11 Locate the rubber washers on the mounting, one on each side of its centre boss, then refit the mounting to the bracket and tighten the retaining nuts, finger-tight only.

12 Using the trolley jack to position the engine unit at the correct height, refit from rear to front the mounting-to-body through-bolt, ensuring that the rubber washers are correctly seated, then refit the nut (see illustration).

13 Tighten the mounting to bracket nuts and the through-bolt to the specified torque wrench settings, then lower and remove the jack.

14 Where necessary, refit the power steering fluid reservoir to its mounting bracket and secure the hydraulic hose clamps in position with the retaining bolts.

15 Refit the coolant expansion tank and tighten the mounting bolts securely. Secure the coolant hose in position with any necessary retaining clips and reconnect the battery negative lead.

Left-hand mounting

16 Disconnect the battery negative lead then disconnect the clutch cable.

17 To improve access to the mounting, unclip the engine wiring harness and position it clear of the mounting.

18 Support the weight of the engine/gearbox



19.18 Slacken and remove gearbox bracket-to-mounting bolts . . .

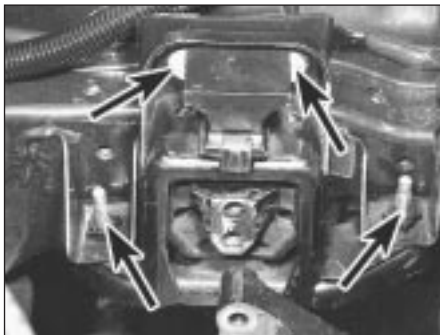

19.19a . . . then lower gearbox and remove four left-hand mounting-to-body bolts (arrowed) . . .

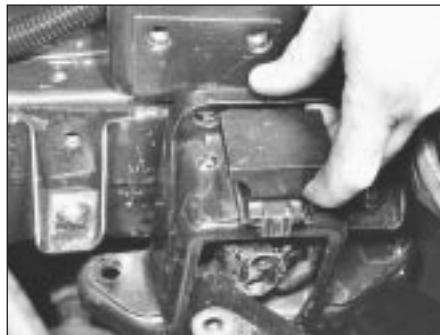

19.19b . . . and remove mounting



19.12 Check rubber washers are correctly installed before tightening through-bolt nut

unit by using a trolley jack, with a wooden spacer to prevent damage to the gearbox casing. Slacken and remove the two bolts securing the gearbox bracket to the mounting (see illustration).

19 Lower the engine/gearbox unit, then remove the four bolts securing the mounting to the body and manoeuvre the mounting out of position. If required, slacken and remove the two bolts which secure the bracket to the gearbox and remove the bracket (see illustrations).

20 Although the mounting rubber is secured by two nuts to a metal outer section, the two parts can be renewed only as a complete assembly. Check all components carefully for signs of wear or damage and renew where necessary.

21 On reassembly, refit the bracket to the gearbox and tighten the retaining bolts to the specified torque setting.

22 Manoeuvre the mounting into position then refit the retaining bolts and tighten them to the specified torque setting.

23 Use the trolley jack to raise the gearbox to the correct height, then refit the mounting bracket to mounting bolts and tighten them to the specified torque setting. Refit the wiring harness to its retaining clip.

24 Refit the clutch cable and reconnect the battery negative lead.

Rear mounting

25 Apply the handbrake then jack up the



19.19c Gearbox bracket is retained by two bolts (one arrowed)

front of the vehicle and support it securely on axle stands.

26 Support the weight of the engine/gearbox unit by using a trolley jack, with a wooden spacer to prevent damage to the transmission casing. Unbolt the mounting bracket from the gearbox and the connecting link from the underbody bracket, then remove the mounting (see illustrations).

27 Unscrew the through-bolt to separate the connecting link from the bracket. Check carefully for signs of wear or damage, paying particular attention to the connecting link rubber bushes. Renew as necessary.

28 Reassembly is the reverse of the removal procedure. Tighten all mounting bolts to the specified torque setting.

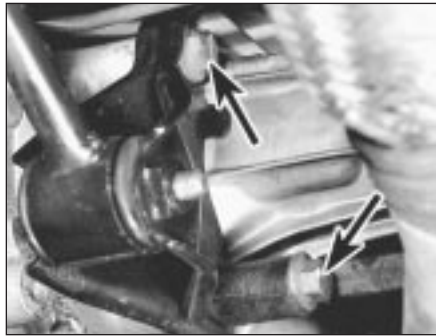

19.26a Unbolt rear mounting to gearbox bolts (arrowed) . . .

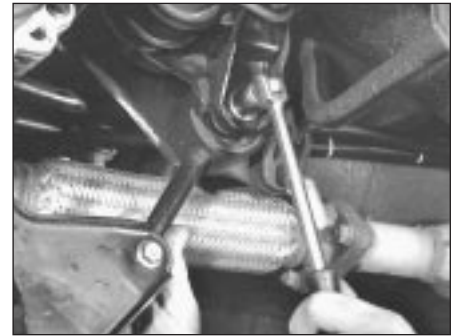





19.26b . . . then undo connecting link-to-underbody bracket bolt and remove mounting

Chapter 2 Part B Engine removal and general overhaul procedures

Contents

Crankshaft - inspection	14	Engine overhaul - general information	2
Crankshaft - refitting and main bearing running clearance check	18	Engine overhaul - reassembly sequence	16
Crankshaft - removal	10	Engine/gearbox - removal and refitting	4
Cylinder block/crankcase, bearing ladder and oil rail - cleaning and inspection	11	Engine/gearbox removal - methods and precautions	3
Cylinder head - dismantling	6	General information	1
Cylinder head - reassembly	8	Main and big-end bearings - inspection	15
Cylinder head and valves - cleaning and inspection	7	Piston rings - refitting	16
Cylinder liners - removal and refitting	12	Piston/connecting rod assembly - inspection	13
Engine - initial start-up after overhaul	19	Piston/connecting rod assembly - refitting and big-end bearing running clearance check	19
Engine overhaul - dismantling sequence	5	Piston/connecting rod assembly - removal	9

Degrees of difficulty

<p>Easy, suitable for novice with little experience</p> 	<p>Fairly easy, suitable for beginner with some experience</p> 	<p>Fairly difficult, suitable for competent DIY mechanic</p> 	<p>Difficult, suitable for experienced DIY mechanic</p> 	<p>Very difficult, suitable for expert DIY or professional</p> 
--	---	---	--	---

Specifications

Refer to Part A of this Chapter

1 General information

Included in this part of the Chapter are details of removing the engine/gearbox unit from the vehicle and general overhaul procedures for the cylinder head, cylinder block/crankcase and all other engine internal components.

The information given ranges from advice concerning preparation for an overhaul and the purchase of replacement parts to detailed step-by-step procedures covering removal, inspection, renovation and refitting of engine internal components.

After Section 5, all instructions are based on the assumption that the engine has been removed from the vehicle. For information concerning in-car engine repair, as well as the

removal and refitting of those external components necessary for full overhaul, refer to Part A of this Chapter and to Section 5. Ignore any preliminary dismantling operations described in Part A that are no longer relevant once the engine has been removed from the vehicle.

2 Engine overhaul - general information

It is not always easy to determine when, or if, an engine should be completely overhauled, as a number of factors must be considered.

High mileage is not necessarily an indication that an overhaul is needed, while low mileage does not preclude the need for an overhaul. Frequency of servicing is probably

the most important consideration. An engine which has had regular and frequent oil and filter changes, as well as other required maintenance, should give many thousands of miles of reliable service. Conversely, a neglected engine may require an overhaul very early in its life. If a complete service does not remedy any problems, major mechanical work is the only solution.

Excessive oil consumption is an indication that piston rings, valve seals and/or valve guides are in need of attention. Make sure that oil leaks are not responsible before deciding that the rings and/or guides are worn. Perform a compression test to determine the likely cause of the problem.

Check the oil pressure with a gauge fitted in place of the oil pressure switch and compare it with that specified. If it is extremely low, the main and big-end bearings and/or the oil pump are probably worn out.

2B•2 Engine removal and general overhaul procedures

Loss of power, rough running, knocking or metallic engine noises, excessive valve gear noise and high fuel consumption may also point to the need for an overhaul, especially if they are all present at the same time.

An engine overhaul involves restoring all internal parts to the specification of a new engine. During an overhaul, the cylinder liners, the pistons and the piston rings are renewed. New main and big-end bearings are generally fitted and, if necessary, the crankshaft may be renewed to restore the journals. The valves are serviced as well, since they are usually in less than perfect condition at this point. While the engine is being overhauled, other components, such as the distributor, starter and alternator, can be overhauled as well. The end result should be an as-new engine that will give many trouble-free miles.

Critical cooling system components such as the hoses, thermostat and coolant pump should be renewed when an engine is overhauled. The radiator should be checked carefully to ensure that it is not clogged or leaking. Also it is a good idea to renew the oil pump whenever the engine is overhauled.

Before beginning the engine overhaul, read through the entire procedure to familiarize yourself with the scope and requirements of the job. Overhauling an engine is not difficult if you follow carefully all of the instructions, have the necessary tools and equipment and pay close attention to all specifications. However, it can be time-consuming. Plan on the vehicle being off the road for a minimum of two weeks, especially if parts must be taken to an engineering works for repair or reconditioning. Check on the availability of parts and make sure that any necessary special tools and equipment are obtained in advance. Most work can be done with typical hand tools, although a number of precision measuring tools are required for inspecting parts to determine if they must be renewed. Often the engineering works will handle the inspection of parts and offer advice concerning reconditioning and renewal.

Always wait until the engine has been completely dismantled and all components, especially the cylinder block/crankcase, the cylinder liners and the crankshaft have been inspected before deciding what service and repair operations must be performed by an engineering works. Since the condition of these components will be the major factor to consider when determining whether to overhaul the original engine or buy a reconditioned unit, do not purchase parts or have overhaul work done on other components until they have been thoroughly inspected. As a general rule, time is the primary cost of an overhaul, so it does not pay to fit worn or substandard parts.

As a final note, to ensure maximum life and minimum trouble from a reconditioned engine, everything must be assembled with care in a spotlessly clean environment.

3 Engine/gearbox removal - methods and precautions

If you have decided that the engine must be removed for overhaul or major repair work, several preliminary steps should be taken.

Locating a suitable place to work is extremely important. Adequate work space, along with storage space for the vehicle, will be needed. If a shop or garage is not available, at the very least a flat, level, clean work surface is required.

Cleaning the engine compartment and engine/gearbox before beginning the removal procedure will help keep things clean and organised.

An engine hoist or A-frame will also be necessary. Make sure the equipment is rated in excess of the combined weight of the engine and gearbox (290 lb/130 kg approximately). Safety is of primary importance, considering the potential hazards involved in lifting the engine/gearbox unit out of the vehicle.

If the engine/gearbox unit is being removed by a novice, a helper should be available. Advice and aid from someone more experienced would also be helpful. There are many instances when one person cannot simultaneously perform all of the operations required when lifting the unit out of the vehicle.

Plan the operation ahead of time. Before starting work, arrange for the hire of or obtain all of the tools and equipment you will need. Some of the equipment necessary to perform engine/gearbox removal and installation safely and with relative ease are (in addition to an engine hoist) a heavy duty trolley jack, complete sets of spanners and sockets as described at the front of this Manual, wooden blocks and plenty of rags and cleaning solvent for mopping up spilled oil, coolant and fuel. If the hoist must be hired, make sure that you arrange for it in advance and perform all of the operations possible without it beforehand. This will save you money and time.

Plan for the vehicle to be out of use for quite a while. An engineering works will be required to perform some of the work which the do-it-yourselfer cannot accomplish without special equipment. These places often have a busy schedule, so it would be a good idea to consult them before removing the engine in order to accurately estimate the amount of time required to rebuild or repair components that may need work.

Always be extremely careful when removing and refitting the engine/gearbox unit. Serious injury can result from careless actions. Plan ahead, take your time and a job of this nature, although major, can be accomplished successfully.

4 Engine/gearbox - removal and refitting



Note: The engine can be removed from the vehicle only as a complete unit with the gearbox.

Removal

- 1 Park the vehicle on firm, level ground then remove the bonnet.
- 2 If the engine is to be dismantled, drain the oil and remove the oil filter, then clean and refit the drain plug, tightening it to its specified torque setting.
- 3 Firmly apply the handbrake then jack up the front of the vehicle and support it securely on axle stands. Remove both front roadwheels.
- 4 From underneath the front of the vehicle, slacken and remove the three bolts securing the bumper flange to the body. Remove the seven bolts securing the front undercover panel to the body and remove the panel.
- 5 Drain the gearbox oil, then clean and refit the drain plug, tightening it to its specified torque setting.
- 6 Drain the cooling system.
- 7 Remove the battery, followed by the battery tray and support bracket.
- 8 Remove the complete air cleaner assembly, including the intake duct and mounting bracket, intake hose and resonator.
- 9 Disconnect the ignition coil HT lead from the distributor cap.
- 10 Undo the nut and disconnect the battery positive lead from the main starter motor solenoid terminal, then carefully disconnect the spade connector from the solenoid.
- 11 Undo the two bolts securing the engine compartment fusebox to the body, then disconnect the two engine wiring harness block connectors from the underside of the fusebox. Undo the bolt securing the wiring harness earth lead to the bonnet platform, then disconnect the LT wiring connector from the ignition coil. On fuel-injected engines, also disconnect the wiring connector and vacuum pipe from the engine management ECU. Free the engine wiring harness from any relevant clips or ties so that it is free to be removed with the engine/gearbox unit (see illustrations).



4.11a Disconnecting engine harness wiring connectors from underside of fusebox . . .



4.11b . . . and ignition coil LT wiring connector

12 Trace the clutch cable back from the clutch release lever to the bulkhead and remove the C-clip which retains the outer cable spring in position. Unhook the inner cable from the release lever and free the outer cable from its mounting bracket and position it clear of the gearbox.

13 From underneath the vehicle, pull out the rubber retaining pin which secures the lower end of the speedometer cable to the gearbox housing. Withdraw the cable from the speedometer drive and remove the O-rings from the cable lower end. Renew the O-rings, regardless of their condition.

14 In the absence of the special gearchange linkage balljoint separator (Rover service tool number 18G 1592), use a suitable flat-bladed screwdriver to carefully lever the link rod balljoints off the gearbox upper and lower selector levers, taking care not to damage the balljoint gaiters.

15 Unscrew the reverse interlock cable nut from the top of the gearbox housing. In the absence of the special spanner (Rover service tool number 18G 1591), use a close-fitting spanner to unscrew the plastic nut, noting that it is easily damaged. Plug the gearbox orifice to prevent the entry of dirt.

16 Disconnect the coolant hose from the bottom of the expansion tank, the expansion tank hose from the inlet manifold union, both heater hoses from the heater matrix unions and the radiator top hose from the coolant outlet elbow. Either remove the radiator bottom hose or secure it so that it will not hinder engine/gearbox removal.

17 Slacken and remove the union bolt which secures the vacuum servo unit vacuum hose to the inlet manifold. Discard the sealing washers as they must be renewed whenever they are disturbed.

18 On carburettor engines, disconnect the feed hose from the fuel pump, then disconnect the accelerator and choke cables from the carburettor.

19 On fuel-injected engines, depressurise the fuel system and disconnect the fuel feed and return hoses from the throttle body/fuel rail. Disconnect the accelerator cable from the throttle housing.

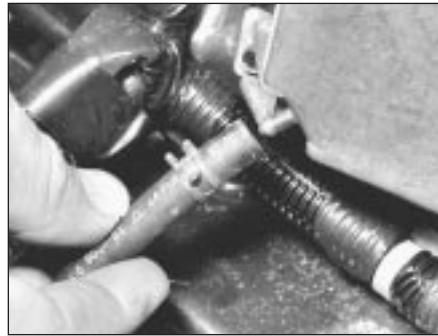

4.11c Disconnecting vacuum pipe from engine management ECU - fuel-injected engines

20 Remove the expansion tank mounting bolts and position the tank clear of the engine unit.

21 Remove the alternator.

22 On models equipped with power-assisted steering, remove the power steering pump.

23 On models equipped with air conditioning, slacken and remove the two compressor heatshield retaining bolts then remove the heatshield and disconnect the compressor wiring connector. Undo the four bolts securing the compressor to the mounting bracket and the single bolt securing the air conditioning pipe to the mounting bracket. Position the compressor clear of the engine unit. Secure it to the body to avoid placing any strain on the air conditioning pipes and hoses.

24 Disconnect the exhaust system front pipe from the manifold and, where necessary, disconnect the lambda sensor wiring connector.

25 Slacken and remove the bolt and washer securing the anti-roll bar connecting link to the left-hand lower suspension arm, then the two bolts securing the tie bar to the lower suspension arm.

26 Extract the split pins and undo the nuts securing the steering gear track rod end balljoint and the left-hand lower suspension arm balljoint to the swivel hub. Remove the nuts and release the balljoint tapered shanks using a universal balljoint separator.



4.29a Right-hand engine lifting bracket . . .

27 Insert a suitable flat bar in between the left-hand inner constant velocity joint and gearbox housing, then carefully lever the joint out of position, whilst taking great care not to damage the gearbox housing.

28 Withdraw the left-hand inner constant velocity joint from the gearbox and support the driveshaft to avoid damaging the constant velocity joints or gaiters. Repeat the operations described in paragraphs 25 to 28 for the right-hand driveshaft.

29 On K8 engines, the cylinder head has a tapped hole provided at the right-hand rear end (above the dipstick tube) and at the left-hand front end (behind the spark plug lead clips). On K16 engine cylinder heads, the right-hand end hole is in the same place but at the left-hand end, the air intake duct support bracket mounting points must be used. Attach lifting brackets to the engine at these points (see illustrations). Take the weight of the engine/gearbox unit on the engine hoist.

30 From underneath the vehicle, unscrew the two bolts securing the rear engine/gearbox mounting bracket to the gearbox, then slacken the connecting link-to-body through-bolt and pivot the mounting away from the gearbox.

31 Slacken and remove the two bolts securing the left-hand gearbox bracket to the mounting. Lower the gearbox slightly then undo the four bolts securing the mounting to the body and manoeuvre the mounting out of position.

32 Raise the gearbox again then slacken and remove the right-hand engine/gearbox mounting through-bolt and nut. Unscrew the two nuts securing the mounting to the engine bracket and remove it, noting the rubber washers which are fitted on each side of the bracket.

33 Make a final check that all components have been removed or disconnected that will prevent removal of the engine/gearbox unit from the vehicle and ensure that components such as the gearchange linkage link rods are secured so that they cannot be damaged on removal.

34 Lift the engine/gearbox unit out of the vehicle, ensuring that nothing is trapped or damaged. Once the unit is high enough, lift it



4.29b . . . and left-hand engine lifting bracket - K16 engine

2B•4 Engine removal and general overhaul procedures

out over the front of the body and lower the unit to the ground (see illustration).

35 To separate the engine and gearbox, first remove the starter motor.

36 Unbolt the flywheel front, lower and rear cover plates, then unscrew the four bolts securing the gearbox to the engine and gently prise the gearbox off the two locating dowels (at the front and rear of the main bearing ladder). Move the gearbox squarely away from the engine, ensuring that the clutch components are not damaged.

37 If the engine is to be overhauled, remove the clutch.

Refitting

38 Refitting is the reverse of removal, following where necessary the instructions given in the other Chapters of this Manual. Note the following additional points:

- Overhaul and lubricate the clutch components before refitting.
- When the gearbox, starter motor and flywheel cover plates have been refitted, lift the engine/gearbox unit and lower it into the engine compartment so that it is slightly tilted (gearbox down). Engage both driveshafts then return the unit to the horizontal and refit the engine/gearbox mountings.
- Remove the lifting brackets and refit any components removed to enable them to be fitted.
- Tighten all nuts and bolts to the specified torque wrench settings.
- Adjust the choke and/or accelerator cable(s).
- Refill the engine and gearbox with oil.
- Refill the cooling system.

5 Engine overhaul - dismantling sequence

Note: When removing external components from the engine, pay close attention to details that may be helpful or important during refitting. Note the fitted position of gaskets, seals, spacers, pins, washers, bolts and other small items.

1 It is much easier to work on the engine if it is mounted on a portable engine stand. These stands can often be hired from a tool hire shop. Before the engine is mounted on a stand, the flywheel should be removed so that the stand bolts can be tightened into the end of the cylinder block/crankcase (not the main bearing ladder).

2 If a stand is not available, it is possible to dismantle the engine with it blocked up on a sturdy workbench or on the floor. Be extra careful not to tip or drop the engine when working without a stand.

3 If you are going to obtain a reconditioned engine, all external components must be removed for transference to the replacement engine (just as if you are doing a complete



4.34 Lifting out engine/gearbox unit

engine overhaul yourself). These components include the following:

- Alternator mounting brackets.
- Power steering pump and air conditioning compressor brackets (where fitted).
- Distributor, HT leads and spark plugs.
- Thermostat and housing, coolant rail, coolant outlet elbow.
- Dipstick tube.
- Carburettor/fuel injection system components.
- All electrical switches and sensors.
- Inlet and exhaust manifolds.
- Oil filter.
- Fuel pump.
- Engine mountings.
- Flywheel.

4 If you are obtaining a short motor (which consists of the engine cylinder block/crankcase and main bearing ladder, crankshaft, pistons and connecting rods all assembled), then the cylinder head, sump, oil pump, and timing belt will have to be removed also.

5 If you are planning a complete overhaul, the engine can be dismantled in the following order:

- Inlet and exhaust manifolds.
- Timing belt, sprockets, tensioner and timing belt inner cover.
- Cylinder head.
- Flywheel.
- Sump.
- Oil pump.
- Piston/connecting rod assemblies.
- Crankshaft.



6.3a Using a valve spring compressor to release split collets

6 Before beginning the dismantling and overhaul procedures, make sure that you have all of the correct tools necessary. Refer to the introductory pages at the beginning of this Manual for further information.

6 Cylinder head - dismantling



Note: New and reconditioned cylinder heads are available from the manufacturer and from engine overhaul specialists. Due to the fact that some specialist tools are required for dismantling and inspection, and new components may not be readily available, it may be more practical and economical for the home mechanic to purchase a reconditioned head rather than dismantle, inspect and recondition the original.

1 Remove the camshaft(s) and hydraulic tappets.

2 Remove the cylinder head.

3 Using a valve spring compressor, compress each valve spring in turn until the split collets can be removed. Release the compressor and lift off the spring retainer and spring, then use a pair of pliers to extract the spring bottom seat/stem seal (see illustrations).



If, when the valve spring compressor is screwed down, the spring retainer refuses to free and expose the split collets, gently tap the top of the tool directly over the retainer with a light hammer. This will free the retainer.

4 Withdraw the valve through the combustion chamber.

5 It is essential that each valve is stored together with its collets, retainer and spring, and that all valves are kept in their correct sequence, unless they are so badly worn that they are to be renewed. If they are going to be kept and used again, place each valve assembly in a labelled polythene bag or



6.3b Extracting a valve spring bottom seat/stem seal



6.5 Use a labelled plastic bag to keep together and identify valve components

similar small container (see illustration). Note that No 1 valve is nearest to the timing belt end of the engine.

7 Cylinder head and valves - cleaning and inspection



Note: If the engine has been severely overheated, it is best to assume that the cylinder head is warped and to check carefully for signs of this.

Note: Be sure to perform all the following inspection procedures before concluding that the services of a machine shop or engine overhaul specialist are required. Make a list of all items that require attention.

1 Thorough cleaning of the cylinder head and valve components, followed by a detailed inspection, will enable you to decide how much valve service work must be carried out during the engine overhaul.

Cleaning

2 Scrape away all traces of old gasket material and sealing compound from the cylinder head.

3 Scrape away all carbon from the combustion chambers and ports, then wash the cylinder head thoroughly with paraffin or a suitable solvent.

4 Scrape off any heavy carbon deposits that may have formed on the valves, then use a power-operated wire brush to remove deposits from the valve heads and stems.

Inspection

Cylinder head

5 Inspect the head very carefully for cracks, evidence of coolant leakage and other damage. If cracks are found, a new cylinder head should be obtained.

6 Use a straight-edge and feeler gauge blade to check that the cylinder head surface is not distorted (see illustrations). If it is, it may be possible to resurface it, provided that the specified reface limit is not exceeded in so doing, or that the cylinder head is not reduced to less than the specified height.

7 Examine the valve seats in each of the combustion chambers. If they are severely



7.6a Checking a cylinder head gasket surface for warpage

pitted, cracked or burned, then they will need to be renewed or re-cut by an engine overhaul specialist. If they are only slightly pitted, this can be removed by grinding-in the valve heads and seats with fine valve-grinding compound as described below. To check for excessive wear, refit each valve and measure the installed height of the stem tip above the cylinder head upper surface (see illustration). If the measurement is above the specified limit, repeat the test using a new valve. If the measurement is still excessive, renew the seat insert.

8 If the valve guides are worn, indicated by a side to side motion of the valve, new guides must be fitted. Measure the diameter of the existing valve stems (see below) and the bore of the guides, then calculate the clearance and compare the result with the specified value. If the clearance is excessive, renew the valves or guides as necessary.

9 Valve guide renewal is best carried out by an engine overhaul specialist. If the work is to be carried out at home, then use a stepped, double-diameter drift to drive out the worn guide towards the combustion chamber. On fitting the new guide, place it first in a deep-freeze for one hour, then drive it into the cylinder head bore from the camshaft side until it projects the specified amount above the spring bottom seat/stem seal surface.

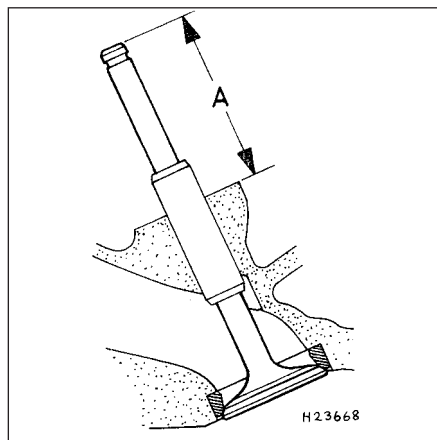

7.7 Check valve seat wear by measuring valve stem installed height (A)

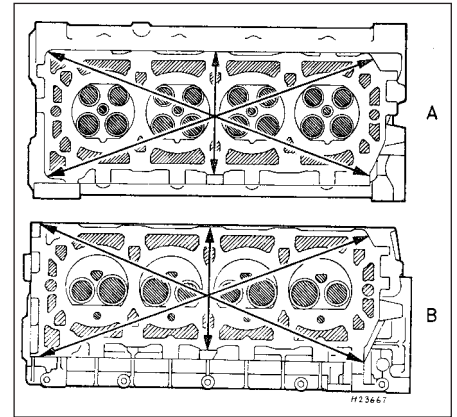

7.6b Check cylinder head gasket surface for warpage along paths shown

A K16 engine B K8 engine

10 If the valve seats are to be re-cut, this must be done only after the guides have been renewed.

Valves

11 Examine the head of each valve for pitting, burning, cracks and general wear, then check the valve stem for scoring and wear ridges. Rotate the valve and check for any obvious indication that it is bent. Look for pits and excessive wear on the tip of each valve stem. Renew any valve that shows any such signs of wear or damage.

12 If the valve appears satisfactory at this stage, measure the valve stem diameter at several points by using a micrometer (see illustration). Any significant difference in the readings obtained indicates wear of the valve stem. Should any of these conditions be apparent, the valve(s) must be renewed.

13 If the valves are in satisfactory condition they should be ground (lapped) into their respective seats to ensure a smooth gas-tight seal. If the seat is only lightly pitted, or if it has been re-cut, fine grinding compound only should be used to produce the required finish. Coarse valve-grinding compound should not be used unless a seat is badly burned or deeply pitted. If this is the case, the cylinder head and valves should be inspected by an expert to decide whether seat re-cutting or

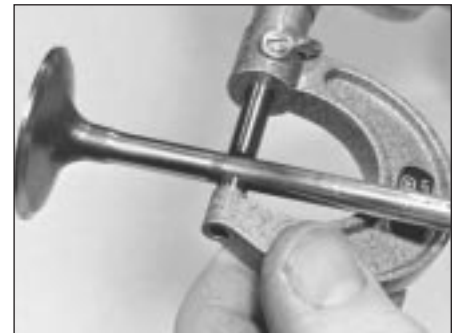

7.12 Measuring valve stem diameter

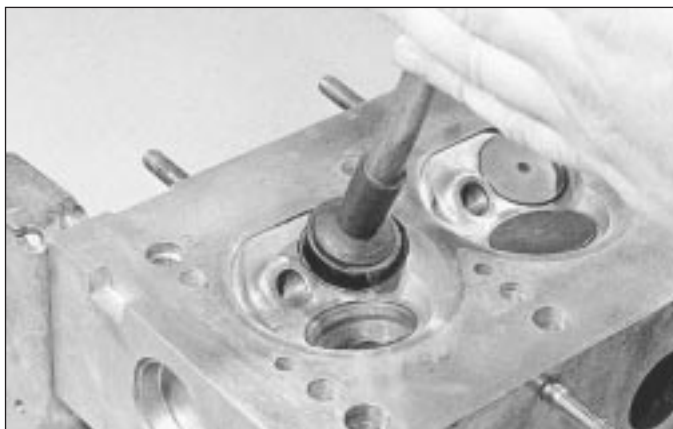

7.15 Grinding-in a valve seat



7.19 Measuring valve spring free length

even the renewal of the valve or seat insert is required.

14 Valve grinding is carried out as follows. Place the cylinder head upside down on a bench.

15 Smear a trace of (the appropriate grade of) valve-grinding compound on the seat face and press a suction grinding tool onto the valve head. With a semi-rotary action, grind the valve head to its seat, lifting the valve occasionally to redistribute the grinding compound (see illustration). A light spring placed under the valve head will greatly ease this operation.

16 If coarse grinding compound is being used, work only until a dull, matt even surface is produced on both the valve seat and the valve, then wipe off the used compound and repeat the process with fine compound. When a smooth unbroken ring of light grey matt finish is produced on both the valve and seat, the grinding operation is complete. Do not grind in the valves any further than absolutely necessary, or the seat will be prematurely sunk into the cylinder head.

17 To check that the seat has not been over-ground, measure the valve stem installed height, as described in paragraph 7.

18 When all the valves have been ground-in, carefully wash off all traces of grinding compound using paraffin or a suitable solvent.

Valve components

19 Examine the valve springs for signs of

damage and discoloration and also measure their free length using vernier calipers or by comparing each existing spring with a new component (see illustration).

20 Stand each spring on a flat surface and check it for squareness. If any of the springs are damaged, distorted or have lost their tension, then obtain a complete new set of springs.

21 Check the hydraulic tappets as described in Part A of this Chapter.

Use a little grease to hold the collets in place. Release the compressor, then repeat the procedure on the remaining valves.

5 With all the valves installed, place the cylinder head flat on the bench and, using a hammer and interposed block of wood, tap the end of each valve stem to settle the components.

6 Refit the hydraulic tappets and camshaft(s) as described in Part A of this Chapter.

8 Cylinder head - reassembly



1 Lubricate the valve stems with clean engine oil and insert each valve into its original location. If new valves are being fitted, insert them into the locations to which they have been ground.

2 Working on the first valve, dip the spring bottom seat/stem seal in clean engine oil then carefully locate it over the valve and onto the guide. Take care not to damage the seal as it is passed over the valve stem. Use a suitable socket or metal tube to press the seal firmly onto the guide (see illustration).

3 Locate the spring on the seat, followed by the spring retainer.

4 Compress the valve spring and locate the split collets in the recess in the valve stem.

9 Piston/connecting rod assembly - removal



Note: Due to the design of the engine, it will become very difficult, almost impossible, to turn the crankshaft once the cylinder head bolts have been slackened. The manufacturer accordingly states that the crankshaft will be 'tight' and should not be rotated more than absolutely necessary once the head has been removed. If the crankshaft cannot be rotated, then it must be removed for overhaul work to proceed. With this in mind, during any servicing or overhaul work the crankshaft must always be rotated to the desired position before the bolts are disturbed.

Removal - without removing crankshaft

1 Remove the timing belt, the camshaft sprocket(s) and tensioner, and the timing belt inner cover.

2 Remove the camshaft(s) and hydraulic tappets, being careful to store the hydraulic tappets correctly.

3 If the flywheel has been removed, temporarily refit the crankshaft pulley and apply a spanner to the bolt to rotate the crankshaft.

4 Rotate the crankshaft until Nos 1 and 4 cylinder pistons are at the top of their stroke.

5 Remove the cylinder head. The crankshaft cannot now be rotated.

6 Slacken and remove the two dipstick tube retaining bolts and remove the tube from the cylinder block/crankcase (see illustrations).



8.2 Using a socket to install valve stem seal

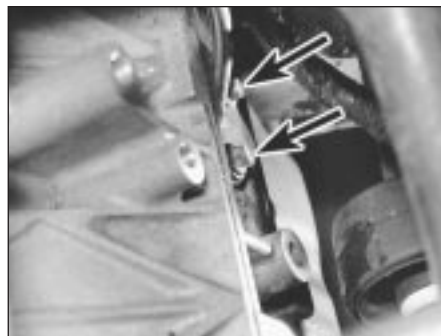

9.6a Dipstick tube mounting bolts (arrowed)

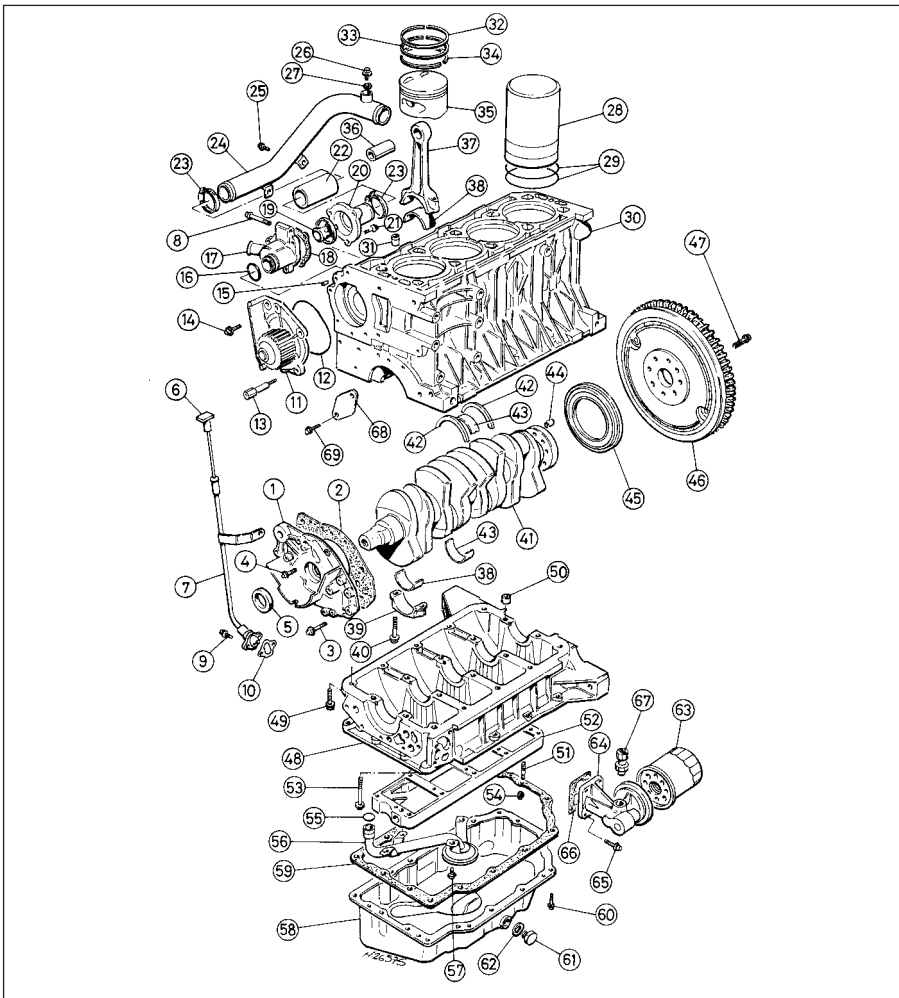

9.6b Engine bottom end components

- | | | |
|----------------------------------|-------------------------------------|--|
| 1 Oil pump | 27 Sealing washer | 51 Stud |
| 2 Gasket | 28 Liner | 52 Oil rail |
| 3 Bolt | 29 O-rings | 53 Bolt |
| 4 Bolt | 30 Cylinder block/crankcase | 54 Nut |
| 5 Oil seal | 31 Dowel | 55 O-ring |
| 6 Engine oil level dipstick | 32 Top compression ring | 56 Oil pump pick-up/
strainer pipe |
| 7 Dipstick tube | 33 Second compression
ring | 57 Bolt |
| 8 Bolt | 34 Oil control ring | 58 Sump |
| 9 Bolt | 35 Piston | 59 Gasket |
| 10 Gasket | 36 Gudgeon pin * | 60 Bolt |
| 11 Coolant pump | 37 Connecting rod | 61 Engine oil drain plug |
| 12 O-ring | 38 Big-end bearing shell | 62 Sealing washer |
| 13 Pillar bolt | 39 Big-end bearing cap | 63 Oil filter |
| 14 Bolt | 40 Big-end bearing cap bolt | 64 Oil filter adaptor |
| 15 Dowel pin | 41 Crankshaft | 65 Bolt |
| 16 O-ring | 42 Crankshaft thrustwasher | 66 Gasket |
| 17 Thermostat housing | 43 Crankshaft main bearing
shell | 67 Oil pressure switch |
| 18 Gasket | 44 Dowel | 68 Blanking plate -
carburettor engines |
| 19 Thermostat | 45 Oil seal | 69 Screw |
| 20 Thermostat housing | 46 Flywheel (with reluctor
ring) | |
| 21 Bolt | 47 Flywheel bolt | |
| 22 Coolant hose | 48 Main bearing ladder * | |
| 23 Hose clip | 49 Bolt | |
| 24 Coolant rail | 50 Dowel | |
| 25 Screw | | |
| 26 Cooling system bleed
screw | | |

* **Note:** Main bearing ladder is supplied only with cylinder block/crankcase assembly. Gudgeon pin is supplied only with piston assembly

7 Remove the sump and unbolt the oil pump pick-up/strainer pipe from the oil rail. Discard the sealing ring (see illustration).

8 Unscrew the two retaining nuts and remove the oil rail (see illustration).

9 Using a hammer and centre punch, paint or similar, mark each connecting rod big-end bearing cap with its respective cylinder number on the flat, machined surface provided. If the engine has been dismantled before, note carefully any identifying marks made previously (see illustration). Note that No 1 cylinder is at the timing belt end of the engine.

10 Unscrew and remove the big-end bearing cap bolts and withdraw the cap, complete with bearing shell, from the connecting rod. If only the bearing shells are being attended to,

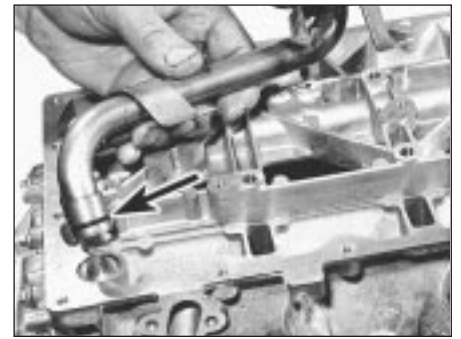

9.7 Removing oil pump pick-up/strainer pipe from oil rail - renew O-ring (arrowed)

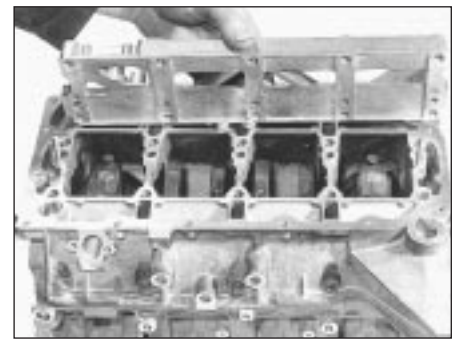

9.8 Removing oil rail to reach big-end bearings



9.9 Mark big-end bearing caps before removal - No 4 cylinder cap shown

push the connecting rod up and off the crankpin, ensuring that the connecting rod big-ends do not mark the cylinder bore walls, then remove the upper bearing shell. Keep the cap, bolts and (if they are to be refitted) the bearing shells together in their correct sequence.

11 With Nos 2 and 3 cylinder big-ends disconnected, repeat the procedure (exercising great care to prevent damage to any of the components) to remove Nos 1 and 4 cylinder bearing caps.

12 Remove the ridge of carbon from the top of each cylinder bore. Push each piston/connecting rod assembly up and remove it from the top of the bore, and ensure that the connecting rod big-ends do not mark the cylinder bore walls.

13 Note that the number stamped by you on each bearing cap should match the cylinder number stamped on the front (alternator bracket side) of each connecting rod. If any connecting rod number does not match its correct cylinder, mark or label it immediately so that each piston/connecting rod assembly can be refitted to its original bore.



Fit the bearing cap, shells and bolts to each removed piston/connecting rod assembly, so that they are all kept together as a matched set.

Removal - alternative methods

14 If the engine is being completely dismantled and the cylinder head has been removed, either unbolt the main bearing ladder so that the crankshaft can be rotated with care, or remove the crankshaft completely and then remove the connecting rods and pistons.

Cylinder head bolts - condition check

15 Check the condition of the cylinder head

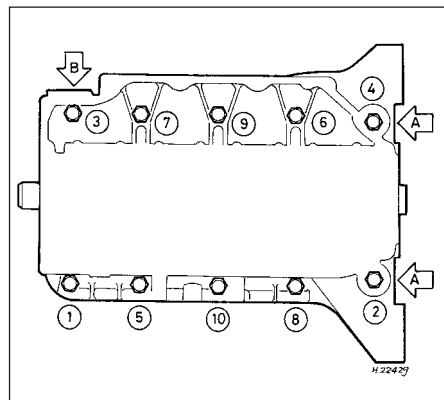

10.8a Crankshaft main bearing ladder bolt slackening sequence

- A Bolts hidden in ladder flanges
- B Location of single longer bolt



9.16 Checking length of cylinder head bolts

bolts and particularly their threads whenever they are removed. If the cylinder head only is removed, check the bolts as described in Part A of this Chapter. If the cylinder head and the oil rail are removed, check as follows.

16 Keeping all the bolts in their correct fitted order, wash them and wipe dry, then check each for any sign of visible wear or damage. Renew any bolt if necessary. Lightly oil the threads of each bolt, carefully enter it into the original hole and screw it in, by hand only until finger-tight. If the full length of thread is engaged, the bolt may be re-used. If the full length of thread is not engaged, measure the distance from the oil rail gasket surface to under the bolt head (see illustration).

17 If the distance measured is less than 378 mm, then the bolt may be re-used. If the distance measured is more than 378 mm, the bolt must be renewed. Considering the task these bolts perform and the pressures they must withstand, owners should consider renewing all the bolts as a matched set if more than one of the originals fail inspection or are close to the limit set.

18 Note that if any of the cylinder head bolt threads in the oil rail are found to be damaged, then the oil rail must be renewed. Thread inserts are not an acceptable repair in this instance.

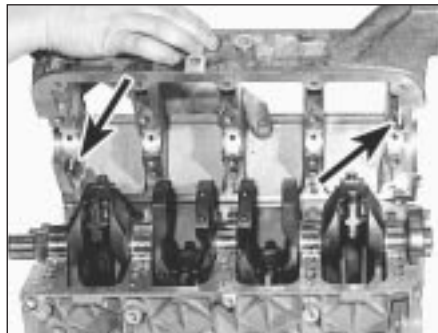

10.8b Removing main bearing ladder (two locating dowels arrowed)

10 Crankshaft - removal



Note: The following procedure assumes that the crankshaft alone is being removed and therefore uses a slightly different sequence of operations to that given in Section 9. Depending on the reason for dismantling, either sequence may be adapted as necessary. If the crankshaft endfloat is to be checked, this must be done when the crankshaft is free to move. If a dial gauge is to be used, check after paragraph 1, but if feeler gauges are to be used, check after paragraph 9.

- 1 Remove the timing belt, sprocket(s) and tensioner, and the timing belt inner cover.
- 2 Slacken and remove the two dipstick tube retaining bolts and remove it from the cylinder block/crankcase.
- 3 Remove the cylinder head. The crankshaft cannot now be rotated.
- 4 Remove the oil pump.
- 5 Remove the crankshaft left-hand oil seal.
- 6 Remove the sump and unbolt the oil pump pick-up/strainer pipe from the oil rail. Discard the sealing ring.
- 7 Unscrew the two retaining nuts and remove the oil rail.
- 8 Working in the sequence shown (see illustration), progressively unscrew the main bearing ladder retaining bolts by a turn at a time, then withdraw the ladder. Note the two locating dowels and the main bearing shells, which should be removed from the ladder and stored in their correct fitted order (see illustration).
- 9 Mark the big-end bearing caps, then unscrew and remove the big-end bearing cap bolts and withdraw the cap, complete with the lower bearing shell, from each of the four connecting rods (see illustration). Push the connecting rods up and off their crankpins, then remove the upper bearing shell. Keep the cap, bolts and (if they are to be refitted) the bearing shells together in their correct sequence.



10.9 Removing No 1 cylinder big-end bearing cap and lower bearing shell

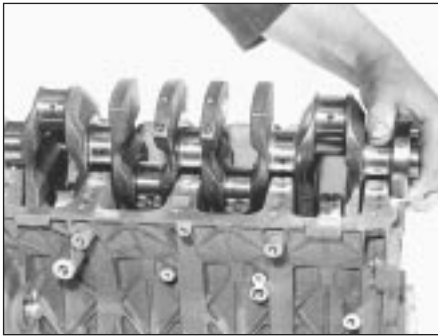

10.10 Removing the crankshaft

- 10 Remove the crankshaft (see illustration).
- 11 Withdraw the two thrustwashers from the No 3 main bearing upper location. Noting the position of the grooved shells, remove the upper main bearing shells, which must be kept with their correct respective partners from the main bearing ladder so that all shells can be identified and (if necessary) refitted in their original locations.
- 12 Check the condition of the cylinder head bolts, as described in Section 9.

11 Cylinder block/crankcase - cleaning and inspection



Warning: Wear eye protection when using compressed air!

Note: During any cleaning operations, take care not to score the mating surfaces of the cylinder block/crankcase, bearing ladder and oil rail. It may be necessary to use a foam action gasket remover.

Cleaning

- For complete cleaning, remove the cylinder liners, all external components and all electrical switches/sensors.
- Scrape all traces of gasket from the cylinder block/crankcase, bearing ladder and oil rail, taking care not to damage the gasket/sealing surfaces.
- Remove all oil gallery plugs (where fitted). The plugs are usually very tight and may have to be drilled out and the holes re-tapped. Use new plugs when the engine is reassembled.
- If any of the castings are extremely dirty, all should be steam cleaned.
- After the castings are returned, clean all oil holes and oil galleries one more time. Flush all internal passages with warm water until the water runs clear, then dry thoroughly and apply a light film of oil to all liner surfaces to prevent rusting. If you have access to compressed air, use it to speed up the drying process and to blow out all the oil holes and galleries.
- If the castings are not very dirty, you can do an adequate cleaning job with hot soapy water and a stiff brush. Take plenty of time

and do a thorough job. Regardless of the cleaning method used, be sure to clean all oil holes and galleries very thoroughly and to dry all components well. Protect the liners as described above to prevent rusting.

7 All threaded holes must be clean to ensure accurate torque readings during reassembly. To clean all threads **except** those of the flywheel retaining bolts, run the proper size tap into each of the holes to remove rust, corrosion, thread sealant or sludge and to restore damaged threads. If possible, use compressed air to clear the holes of debris produced by this operation. A good alternative is to inject aerosol-applied water-dispersant lubricant into each hole, using the long spout usually supplied. Always wear eye protection when cleaning out holes in this way. The flywheel retaining bolt threads must be cleaned by using the procedure described in Section 18, in Part A of this Chapter. Now is a good time to check the condition of the cylinder head bolts.

8 Apply suitable sealant to the new oil gallery plugs and insert them into the holes in the block. Tighten them securely.

9 If the engine is not going to be reassembled right away, cover it with a large plastic bag to keep it clean. Protect the liners as described above to prevent rusting.

Inspection

10 Inspect all castings for cracks and corrosion. Look for stripped threads. If there has been any history of internal coolant leakage, it may be worthwhile having an engine overhaul specialist check the cylinder block/crankcase with special equipment. If defects are found, have them repaired, if possible, or renew the assembly.

11 Check the bore of each cylinder liner for scuffing and scoring.

12 Measure the diameter of each cylinder liner bore 60 mm from the top of the bore, both parallel to the crankshaft axis and at right angles to it.

13 Compare the diameter with that specified. If any measurement exceeds the service limit then the liner must be renewed.

14 Measure the piston diameter at right angles to the gudgeon pin axis, 16 mm up from the bottom of the skirt. Compare the results with those specified.

15 To measure the piston-to-bore clearance, either measure the bore and piston skirt as described above and subtract the skirt diameter from the bore measurement, or insert each piston into the original bore, select a feeler gauge and slip it into the bore along with the piston. The piston must be aligned exactly in its normal attitude and the feeler gauge must be between the piston and bore on one of the thrust faces, 20 mm up from the bottom of the bore.

16 If the clearance is excessive, then a new piston will be required. If the piston binds at the lower end of the bore and is loose towards the top, then the bore is tapered. If

tight spots are encountered as the piston/feeler gauge is rotated in the bore, then the bore is out-of-round.

17 Repeat this procedure for the remaining pistons and cylinder liners.

18 If the cylinder liner walls are badly scuffed or scored, or if they are excessively worn, out-of-round or tapered, obtain new cylinder liners. New pistons will also be required.

19 If the bores are in reasonably good condition and not worn to the specified limits, and if the piston-to-bore clearances can be maintained properly, then it may only be necessary to renew the piston rings.

20 If this is the case, the bores should be honed to allow the new rings to bed in correctly and provide the best possible seal. The conventional type of hone has spring-loaded stones and is used with a power drill. You will also need some paraffin, or honing oil, and rags. The hone should be moved up and down the bore to produce a crosshatch pattern and plenty of honing oil should be used. Ideally the crosshatch lines should intersect at approximately a 60° angle. Do not take off more material than is necessary to produce the required finish. If new pistons are being fitted, the piston manufacturers may specify a finish with a different angle, so their instructions should be followed. Do not withdraw the hone from the bore while it is still being turned, but stop it first. After honing a bore, wipe out all traces of the honing oil. If equipment of this type is not available, or if you are not sure whether you are competent to undertake the task yourself, an engine overhaul specialist will carry out the work at moderate cost.

12 Cylinder liners - removal and refitting

Removal

1 Invert the cylinder block/crankcase and support it on blocks of wood, then use a hard wood drift to tap out each liner from the crankshaft side. When all the liners are released, tip the cylinder block/crankcase on its side and remove each liner from the cylinder head side. Discard the two sealing rings from the base of each. If the liners are to be re-used, mark each one by sticking masking tape on its right-hand (timing belt) face and writing the cylinder number on the tape.

Refitting

2 To install the liners, thoroughly clean the liner mating surfaces in the cylinder block/crankcase and use fine abrasive paper to polish away any burrs or sharp edges which might damage the liner sealing rings. Clean the liners and wipe dry, then fit new sealing rings to the two grooves at the base of each liner and apply a thin film of oil to the



12.2 Renew liner O-rings



12.3 Tap liner onto locating shoulder - ensuring O-rings are not displaced



13.1 Measuring piston diameter

rings and to the liner surface on each side of the rings (see illustration).

3 If the original liners are being refitted, use the marks made on removal to ensure that each is refitted the same way round into its original bore. Insert each liner into the cylinder block/crankcase, taking great care not to displace or damage the sealing rings, and press it home as far as possible by hand. Using a hammer and a block of wood, tap each liner lightly but fully onto its locating shoulder (see illustration). Wipe clean, then lightly oil all exposed liner surfaces to prevent rusting.

13 Piston/connecting rod assembly - inspection



1 Examine all pistons for ovality, scoring and scratches, and for wear of the piston ring grooves. Use a micrometer to measure the pistons (see illustration).

2 If the pistons or connecting rods are to be renewed, it is necessary to have this work carried out by a Rover dealer or suitable engine overhaul specialist who will have the necessary tooling to remove and install the gudgeon pins.

3 If new rings are to be fitted to the original pistons, expand the old rings over the top of the pistons. The use of two or three old feeler gauge blades will be helpful in preventing the

rings dropping into empty grooves (see illustration).

4 When the original piston rings have been removed, ensure that the ring grooves in the piston are free of carbon by cleaning them with a ring cleaning tool or an old ring. Break a ring in half to do this.

5 When measuring new rings, lay out each piston set with a piston/connecting rod assembly and keep them together as a matched set from now on.

6 Check the ring-to-groove clearance by inserting each ring from the outside together with a feeler gauge blade between the ring's top surface and the piston land. Check the ring end gaps by inserting each ring into the cylinder bore and pushing it in with the piston crown to ensure that it is square in the bore, 20 mm from the top. Use feeler gauges to measure the gap (see illustrations).

7 If the end gap of a new ring is found to be too large or too small, double-check to ensure that you have the correct rings. If the end gap is still too small, it must be opened up by careful filing of the ring ends using a fine file. If it is too large, this is not as serious unless the specified service limit is exceeded, in which case very careful checking is required of the dimensions of all components as well as of the new parts.

8 Note that each piston should be considered as being matched to its respective liner and they must not be interchanged.

14 Crankshaft - inspection



Warning: Wear eye protection when using compressed air! Be sure to clean oil holes with a pipe cleaner or similar probe.

Checking endfloat

1 If crankshaft endfloat is to be checked, this must be done when the crankshaft is still installed in the cylinder block/crankcase but is free to move.

2 Check endfloat by using a dial gauge in contact with the end of the crankshaft. Push the crankshaft fully one way and then zero the gauge. Push the crankshaft fully the other way and check the endfloat. The result can be compared with the specified amount and will give an indication as to whether new thrustwashers are required.

3 If a dial gauge is not available, feeler gauges can be used. First push the crankshaft fully towards the flywheel end of the engine, then use feeler gauges to measure the gap between the web of No 3 crankpin and the thrustwasher.

Inspection

4 Clean the crankshaft and dry it with compressed air, if available.

5 Check the main and crankpin (big-end)



13.3 Removing piston rings with feeler blades



13.5a Measuring piston ring-to-groove clearance



13.5b Measuring piston ring end gap



14.6 Using a penny to check crankshaft journal condition



14.8 Measuring crankshaft journal diameter

bearing journals for uneven wear, scoring, pitting and cracking.

6 Rub a penny across each journal several times. If a journal picks up copper from the penny, it is too rough (see illustration).

7 Remove any burrs from the crankshaft oil holes with a stone, file or scraper.

8 Using a micrometer, measure the diameter of the main bearing and crankpin (big-end) journals and compare the results with those specified (see illustration). Check carefully that each journal's diameter is within the tolerances of the size grade corresponding to the code number on the crankshaft right-hand web (main bearing) or indicated by the code letter on the left-hand web (crankpin/big-end bearing). If any diameter measured is incorrect for the grade indicated, re-check the measurement carefully. If the journal is fit for further service, the correct grade code should be substituted when selecting new bearing shells.

9 By measuring the diameter at a number of points around each journal's circumference,

you will be able to determine whether or not the journal is out-of-round. Take the measurement at each end of the journal (near the webs) to determine if the journal is tapered.

10 If the crankshaft journals are damaged, tapered, out-of-round or worn beyond the limits specified, the crankshaft must be renewed unless an engine overhaul specialist can be found who will regrind it and supply the necessary undersize bearing shells.

11 Check the oil seal journals at each end of the crankshaft for wear and damage. If either seal has worn an excessive groove in its journal, consult an engine overhaul specialist who will be able to advise whether a repair is possible or whether a new crankshaft is necessary.

bearing surface with your fingers while checking it, or the delicate surface may be scratched.

4 Dirt and other foreign particles get into the engine in a variety of ways. It may be left in the engine during assembly, or it may pass through filters or the crankcase ventilation system. It may get into the oil and from there into the bearings. Metal chips from machining operations and normal engine wear are often present. Abrasives are sometimes left in engine components after reconditioning, especially when parts are not thoroughly cleaned by using the proper cleaning methods. Whatever the source, these foreign objects often end up embedded in the soft bearing material and are easily recognized. Large particles will not embed in the bearing but will score or gouge the bearing and journal. The best prevention for this cause of bearing failure is to clean all parts thoroughly and keep everything spotlessly clean during engine assembly. Frequent and regular engine oil and filter changes are also recommended.

5 Lack of lubrication (or lubrication breakdown) has a number of interrelated causes. Excessive heat (which thins the oil), overloading (which squeezes the oil from the bearing face) and oil leakage (from excessive bearing clearances, worn oil pump or high engine speeds) all contribute to lubrication breakdown. Blocked oil passages, which usually are the result of misaligned oil holes in a bearing shell, will also oil starve a bearing and destroy it. When lack of lubrication is the cause of bearing failure, the bearing material is wiped or extruded from the steel backing of the bearing. Temperatures may increase to the point where the steel backing turns blue from overheating.

6 Driving habits can have a definite effect on bearing life. Full throttle, low speed operation (labouring the engine) puts very high loads on bearings, which tends to squeeze out the oil film. These loads cause the bearings to flex, which produces fine cracks in the bearing face (fatigue failure). Eventually, the bearing material will loosen in pieces and tear away from the steel backing. Short-distance driving leads to corrosion of bearings because insufficient engine heat is produced to drive off the condensed water and corrosive gases. These products collect in the engine oil, forming acid and sludge. As the oil is carried to the engine bearings, the acid attacks and corrodes the bearing material.

7 Incorrect bearing installation during engine assembly will lead to bearing failure as well. Tight fitting bearings leave insufficient bearing running clearance and will result in oil starvation. Dirt or foreign particles trapped behind a bearing shell result in high spots on the bearing which lead to failure. Do not touch any shell's bearing surface with your fingers during reassembly as there is a risk of scratching the delicate surface or of depositing particles of dirt on it.

15 Main and big-end bearings - inspection

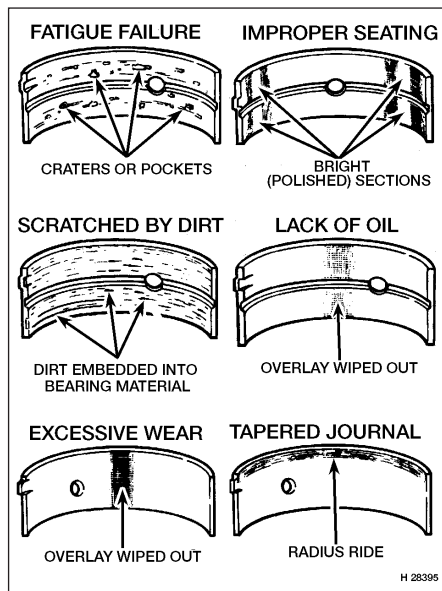

15.2 Typical bearing shell failures

1 Even though the main and big-end bearings should be renewed during the engine overhaul, the old bearings should be retained for close examination, as they may reveal valuable information about the condition of the engine. The bearing shells are graded by thickness, the grade of each shell being indicated by the colour code marked on it.

2 Bearing failure occurs because of lack of lubrication, the presence of dirt or other foreign particles, overloading the engine and corrosion. Regardless of the cause of bearing failure, it must be corrected before the engine is reassembled to prevent it from happening again (see illustration).

3 When examining the bearing shells, remove them from the cylinder block/crankcase, the main bearing ladder, the connecting rods and the connecting rod big-end bearing caps, then lay them out on a clean surface in the same general position as their location in the engine. This will enable you to match any bearing problems with the corresponding crankshaft journal. Do not touch any shell's

16 Engine overhaul - reassembly sequence

1 Before reassembly begins, ensure that all new parts have been obtained and that all necessary tools are available. Read through the entire procedure to familiarise yourself with the work involved and to ensure that all items necessary for reassembly of the engine are at hand. In addition to all normal tools and materials, it will be necessary to obtain the Rover sealant kit LVV 10002. Carefully read the instructions supplied with the sealant kit and take care not to allow the sealant to contact the fingers, as it will bond skin.

2 In order to save time and avoid problems, engine reassembly can be carried out in the following order:

- a) Crankshaft.
- b) Piston/connecting rod assemblies.
- c) Oil pump.
- d) Sump.
- e) Flywheel.
- f) Cylinder head.
- g) Timing belt inner cover, tensioner and sprockets, and timing belt.
- h) Engine external components.

3 At this stage, all engine components should be absolutely clean and dry, with all faults

repaired, and should be laid out (or in individual containers) on a completely clean work surface.

17 Piston rings - refitting



- 1 Refer to Section 13 for inspection details.
- 2 Once all rings have been checked, they can be installed. Ensure that each ring is refitted only to its matched piston and bore.
- 3 Install the new rings by fitting them over the top of the piston, starting with the oil control ring spring. Note that all rings must be fitted with the word TOP uppermost (see illustration).
- 4 With all the rings in position, space the ring gaps as shown (see illustration), noting that the FRONT marking shown is usually in fact an arrow mark on the piston crown and indicates the timing belt end of the engine.

18 Crankshaft - refitting and main bearing running clearance check



Selection of bearing shells

1 The main bearing running clearance is controlled in production by selecting one of three grades of bearing shell. The grades are indicated by a colour-coding marked on the edge of each shell which governs the shell's thickness, as follows:

- a) Green - Thin.
- b) Blue - Intermediate.
- c) Red - Thick.

2 If shells of differing grades are to be fitted to the same journal, the thicker shell must always be fitted to the main bearing ladder location. Bear this carefully in mind when ordering replacement shells for Nos 2, 3 and 4 bearings.

3 If the bearing shells are to be renewed, first check and record the main bearing ladder letters stamped on the right-hand front face of the main bearing ladder (see illustration). The letters are read with the ladder inverted, No 1 bearing's code letter then being at the top and the remainder following in order from the engine's timing belt end.

4 Secondly, check and record the crankshaft journal code numbers stamped on the crankshaft's right-hand web, No 1 journal's code number being the first. If the original crankshaft is to be re-used, the size grade can be checked by direct measurement, as described in Section 14.

5 Note that if the crankshaft is found to be excessively worn, then it must be renewed and the code numbers of the new component must be used instead to select a new set of bearing shells.

6 Matching the codes noted to the following table, select a new set of bearing shells.

Ladder code letter	Crankshaft code number	Shells
A	1	Blue, Blue
A	2	Red, Blue
A	3	Red, Red
B	1	Blue, Green
B	2	Blue, Blue
B	3	Red, Blue
C	1	Green, Green
C	2	Blue, Green
C	3	Blue, Blue

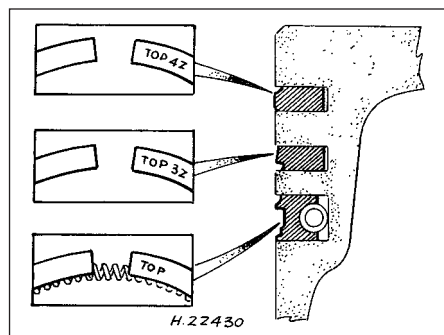

17.3 Piston ring fitting details and top surface markings

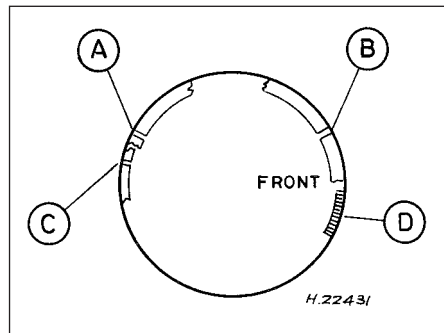

17.4 Piston ring end gap locations

- A Top compression ring
- B Second compression ring
- C Oil control ring
- D Oil control ring spring

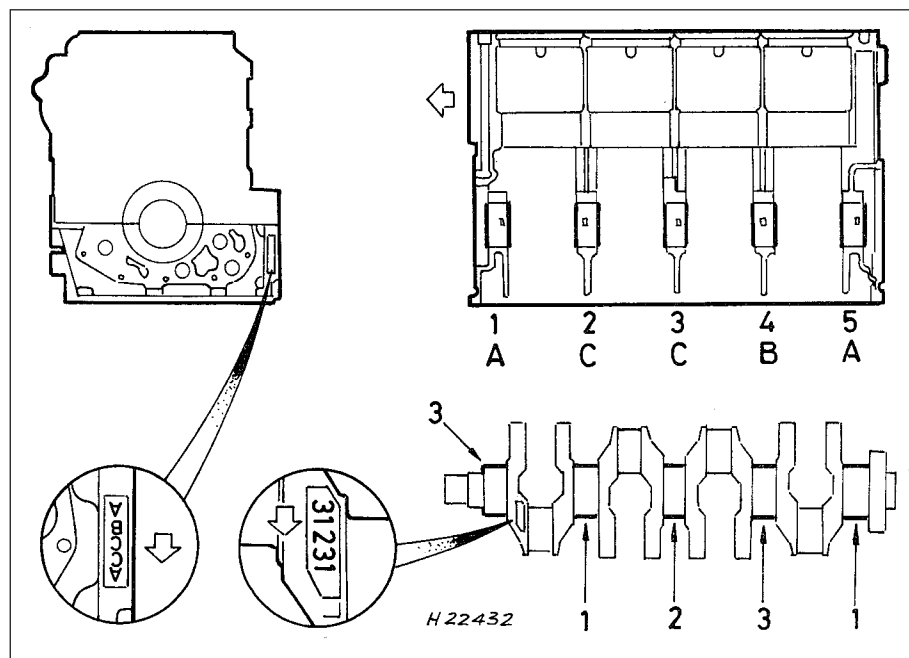

18.3 Crankshaft main bearing size code locations

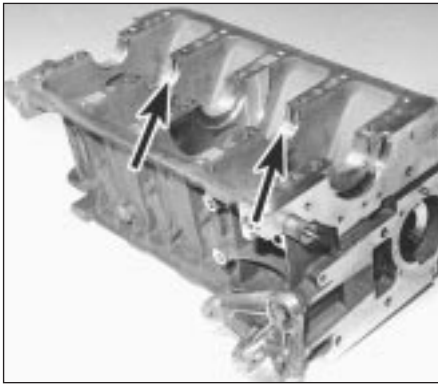

18.9 Ensure grooved bearing shells (arrowed) are installed exactly as described in text - early engine shown

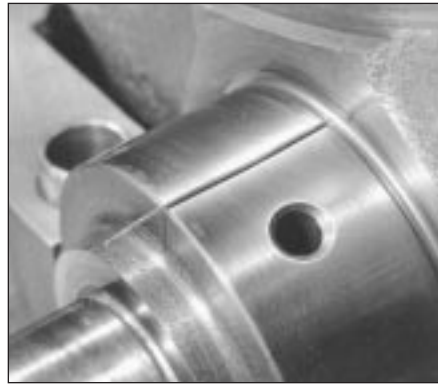

18.14 Lay length of Plastigauge on journal to be measured, parallel to crankshaft centre-line



18.18 Using scale on Plastigauge envelope to check (at widest point) width of crushed Plastigauge

Main bearing running clearance check

7 Clean the backs of the bearing shells and the bearing locations in both the cylinder block/crankcase and the main bearing ladder.

8 Press the bearing shells into their locations, ensuring that the tab on each shell engages in the notch in the cylinder block/crankcase or main bearing ladder location. Take care not to touch any shell bearing surface with your fingers.

9 Press the bearing shells with the oil grooves into the upper locations (in the cylinder block/crankcase). Note the following points (see illustration):

- a) On all engines, grooved bearing shells are fitted to Nos 2, 3 and 4 upper bearing locations. Note the central locating tabs of the grooved shells.
- b) On early engines, grooved bearing shells were fitted only to Nos 2 and 4 upper bearing locations at the factory. On reassembly of one of these units, a grooved shell must be fitted at No 3 upper bearing location as well, instead of the plain item originally used. Note, however, that this will require a grooved shell with an offset locating tab instead of the central tab that is used on all other grooved shells. See your Rover dealer for details.
- c) If bearing shells of differing grades are to be fitted to the same journal, the thicker shell must always be fitted to the main bearing ladder location (see paragraph 1).
- d) On all engines, if the original main bearing shells are being re-used, these must be refitted to their original locations in the cylinder block/crankcase and main bearing ladder.

10 The main bearing running clearance should be checked if there is any doubt about the amount of crankshaft wear that has taken place, if the crankshaft has been reground and is to be refitted with non-Rover undersized bearing shells, or if non-genuine

bearing shells are to be fitted. If the original crankshaft or a Rover replacement part is to be installed, the shell selection procedure given above will produce the correct clearances and a further check will not be necessary. If the clearance is to be checked, it can be done in either of two ways.

11 The first method (which will be difficult to achieve without a range of internal micrometers or internal/external expanding calipers) is to refit the main bearing ladder to the cylinder block/crankcase, with bearing shells in place. With the ladder retaining bolts tightened to the specified torque, refit the oil rail and the cylinder head, then measure the internal diameter of each assembled pair of bearing shells. If the diameter of each corresponding crankshaft journal is measured and then subtracted from the bearing internal diameter, the result will be the main bearing running clearance.

12 The second (and more accurate) method is to use product known as Plastigauge. This consists of a fine thread of perfectly round plastic which is compressed between the bearing shell and the journal. When the shell is removed, the plastic is deformed and can be measured with a special card gauge supplied with the kit. The running clearance is determined from this gauge. Plastigauge is sometimes difficult to obtain but enquiries at one of the larger specialist quality motor factors should produce the name of a stockist in your area. The procedure for using Plastigauge is as follows.

13 With the main bearing upper shells in place, carefully lay the crankshaft in position. Do not use any lubricant. The crankshaft journals and bearing shells must be perfectly clean and dry.

14 Cut several lengths of the appropriate size Plastigauge (they should be slightly shorter than the width of the main bearings) and place one length on each crankshaft journal axis (see illustration).

15 With the main bearing lower shells in position, refit the main bearing ladder (see below) and the oil rail, tightening the fasteners

to the specified torque wrench settings. Take care not to disturb the Plastigauge.

16 Refit the cylinder head (using the original gasket, to save over-compressing the new one). Tighten the bolts to the specified torque in the approved sequence. **Do not** rotate the crankshaft at any time during this operation.

17 Remove the cylinder head, the oil rail and the main bearing ladder. Do not disturb the Plastigauge or rotate the crankshaft.

18 Compare the width of the crushed Plastigauge on each journal to the scale printed on the Plastigauge envelope to obtain the main bearing running clearance (see illustration).

19 If the clearance is not as specified, the bearing shells may be the wrong grade (or excessively worn if the original shells are being re-used). Before deciding that different grade shells are needed, make sure that no dirt or oil was trapped between the bearing shells and the ladder or cylinder block/crankcase when the clearance was measured. If the Plastigauge was wider at one end than at the other, the journal may be tapered.

20 Carefully scrape away all traces of the Plastigauge material from the crankshaft and bearing shells using a fingernail or other object which is unlikely to score the shells.

Final crankshaft refitting

21 Carefully lift the crankshaft out of the cylinder block once more.

22 Using a little grease, stick the thrustwashers to each side of the No 3 main bearing upper location. Ensure that the oilway grooves on each thrustwasher face outwards.

23 Place the bearing shells in their locations, as described in paragraphs 7 to 9. If new shells are being fitted, ensure that all traces of the protective grease are cleaned off using paraffin. Wipe dry the shells and connecting rods with a lint-free cloth. Liberally lubricate each bearing shell in the cylinder block/crankcase, then lower the crankshaft into position so that Nos 2 and 3 cylinder crankpins are at TDC.

24 Refit the piston/connecting rod

2B•14 Engine removal and general overhaul procedures

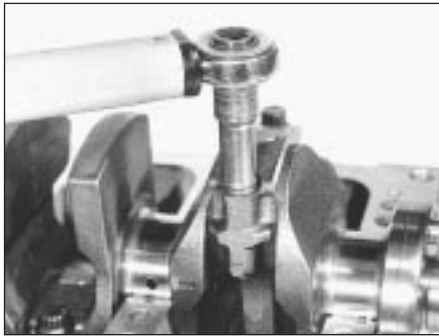

18.24a If piston/connecting rod assemblies are refitted before main bearing ladder . . .

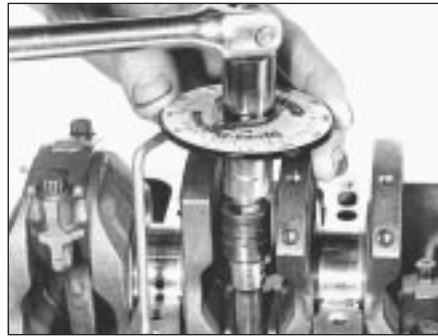

18.24b . . . care is required to hold crankshaft steady while connecting rod big-end cap bolts are tightened

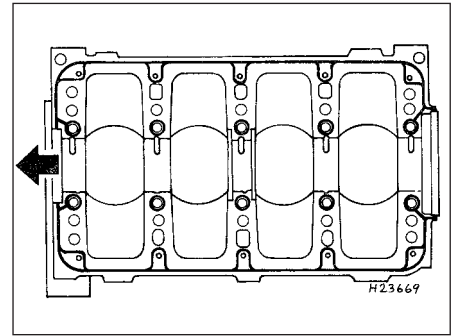

18.25 Apply thin bead of sealant to cylinder block/crankcase mating surface along paths shown by heavy black lines, then spread to an even film

assemblies (see illustrations). Leave No 1 and 4 cylinders at the TDC position

25 Thoroughly degrease the mating surfaces of the cylinder block/crankcase and the main bearing ladder. Apply the special Rover sealant to the mating surface of the cylinder block/crankcase as shown (see illustration). Carefully follow the instructions supplied with the sealant kit. If the Rover sealant is being used, assembly must be completed as soon as possible after the sealant has been applied (maximum of 20 minutes). If another sealant is being used, follow the manufacturer's instructions.

26 Lubricate the bearing shells, then refit the main bearing ladder, ensuring that the shells are not displaced and that the locating dowels engage correctly. Working progressively, by a turn at a time and in the sequence shown (see illustration), tighten the ladder bolts to the specified torque wrench setting. The crankshaft cannot now be rotated.

27 Thoroughly degrease the mating surfaces of the oil rail and the main bearing ladder. Apply the special Rover sealant to the oil rail mating surface as shown (see illustration). Carefully follow the instructions supplied with the sealant kit.

28 Refit the oil rail, tightening the nuts to the specified torque wrench setting.

29 Using a new sealing ring, refit the oil pump pick-up/strainer pipe to the oil rail, then refit the sump. Tighten all nuts and bolts to the specified torque wrench settings.

30 Fit a new crankshaft left-hand oil seal, then refit the flywheel (see illustrations).

31 Refit the oil pump and install a new crankshaft right-hand oil seal (see illustrations).

32 Refit the cylinder head. Rotate the crankshaft to the 90° BTDC position so that the crankshaft sprocket timing marks align.

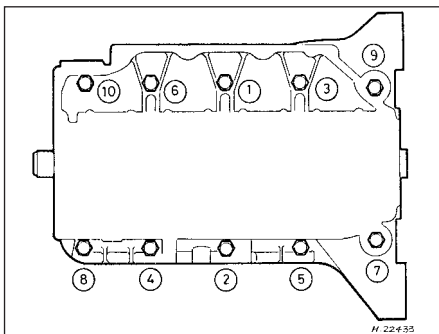

18.26 Crankshaft main bearing ladder bolt tightening sequence

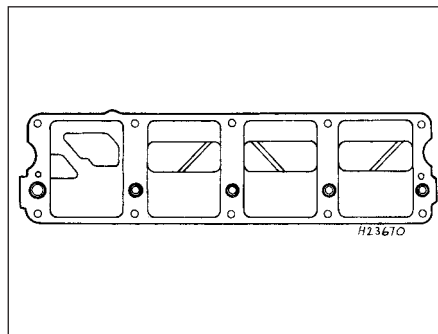

18.27 Apply thin bead of sealant to oil rail mating surface as shown by heavy black lines, then spread to an even film



18.30a Fitting a new crankshaft left-hand oil seal



18.30b Always use new bolts when refitting flywheel



18.30c Use fabricated tool to lock flywheel while slackening or tightening flywheel bolts



18.31a Use grease to stick new gasket in place when refitting oil pump



18.31b Fitting a new crankshaft right-hand oil seal

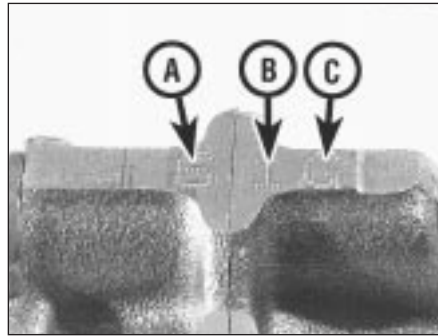

19.3 Big-end bearing size code number (A - on cap) piston/connecting rod assembly cylinder number (B) and connecting rod weight code letter (C)

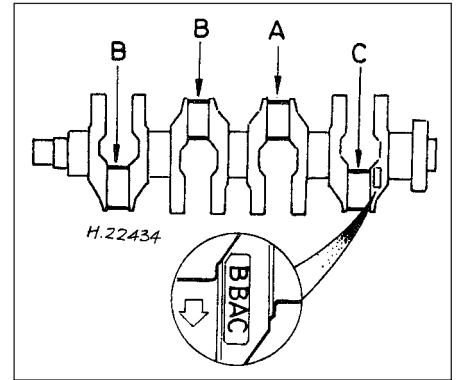

19.4 Crankpin (big-end) journal size code location

33 Refit the dipstick tube to the cylinder block/crankcase, tightening the bolts to the specified torque wrench setting.

34 Refit the timing belt inner cover, the sprocket(s) and tensioner, and the belt itself.

35 Using a torque wrench, check that the amount of force required to rotate the crankshaft does not exceed 31 Nm. If the effort required is greater than this, the engine must be dismantled again to trace and rectify the cause. This value takes into account the increased friction of a new engine and is much higher than the actual pressure required to rotate a run-in engine, so do not make allowances for tight components.

19 Piston/connecting rod assembly - refitting and big-end bearing running clearance check



Selection of bearing shells

1 The big-end bearing running clearance is controlled in production by selecting one of three grades of bearing shell. The grades are indicated by a colour-coding marked on the edge of each shell which governs the shell's thickness, as follows:

- a) *Yellow - Thin.*
- b) *Blue - Intermediate.*
- c) *Red - Thick.*

2 If shells of differing grades are to be fitted to the same journal, the thicker shell must always be fitted to the big-end bearing cap location.

3 If the bearing shells are to be renewed, first check and record the codes stamped on the front face of each big-end bearing cap and connecting rod. The number stamped on the big-end bearing cap is the bearing size code, the number stamped on the connecting rod is the piston/rod assembly's cylinder number and the letter stamped on the connecting rod is the weight code (see illustration).

4 Secondly, check and record the crankpin/big-end journal code letters stamped on the crankshaft's left-hand web (see illustration), No 1 journal's code letter

being the first. If the original crankshaft is to be re-used, the code letter can be checked by direct measurement.

5 If the crankshaft is found to be excessively worn, then it must be renewed and the code letters of the new component must be used instead to select a new set of bearing shells.

6 Matching the codes noted to the following table, select a new set of bearing shells:

Cap code number	Crankshaft code letter	Shells
5	A	Blue, Blue
5	B	Red, Blue
5	C	Red, Red
6	A	Blue, Yellow
6	B	Blue, Blue
6	C	Red, Blue
7	A	Yellow, Yellow
7	B	Blue, Yellow
7	C	Blue, Blue

Big-end bearing running clearance check

7 The big-end bearing running clearance should be checked if there is any doubt about the amount of crankshaft wear that has taken place, if the crankshaft has been reground and is to be refitted with non-Rover undersized bearing shells, or if non-genuine bearing shells are to be fitted. If the original crankshaft or a Rover replacement part is to be installed, the shell selection procedure given above will produce the correct clearances and a further check will not be necessary. If the clearance is to be checked, it can be done in either of two ways.

8 The first method is to refit the big-end bearing cap to the connecting rod, with bearing shells in place. With the cap retaining bolts tightened to the specified torque, use an internal micrometer or vernier caliper to measure the internal diameter of each assembled pair of bearing shells. If the diameter of each corresponding crankshaft journal is measured and then subtracted from the bearing internal diameter, the result will be the big-end bearing running clearance.

9 The second method is to use Plastigauge. Place a strand of Plastigauge on each

(cleaned) crankpin journal and refit the (clean) piston/connecting rod assemblies, shells and big-end bearing caps, tightening the bolts to the specified torque wrench settings. Take care not to disturb the Plastigauge. Dismantle the assemblies without rotating the crankshaft and use the scale printed on the Plastigauge envelope to obtain the big-end bearing running clearance. On completion of the measurement, carefully scrape off all traces of Plastigauge from the journal and shells using a fingernail or other object which will not score the components.

Final piston/connecting rod assembly refitting

10 Note that the following procedure assumes that the cylinder liners have been refitted to the cylinder block/crankcase and that the crankshaft and main bearing ladder are in place. It is of course possible to refit the piston/connecting rod assemblies to the cylinder bores, to refit the crankshaft and to reassemble the piston/connecting rods on the crankshaft before refitting the main bearing ladder (see Section 18).

11 Clean the backs of the bearing shells and the bearing recesses in both the connecting rod and the big-end bearing cap. If new shells are being fitted, ensure that all traces of the protective grease are cleaned off using paraffin. Wipe dry the shells and connecting rods with a lint-free cloth.

12 Press the bearing shells into their locations, ensuring that the tab on each shell engages in the notch in the connecting rod or big-end bearing cap and taking care not to touch any shell's bearing surface with your fingers. Note the following points:

- a) *If bearing shells of differing grades are to be fitted to the same journal, the thicker shell must always be fitted to the big-end bearing cap location (see paragraph 1).*
- b) *On all engines, if the original big-end bearing shells are being re-used, these must be refitted to their original locations in the connecting rod and big-end bearing cap.*

2B•16 Engine removal and general overhaul procedures



19.15a Arrow or FRONT marking (arrowed) on piston crown must point to timing belt end of engine



18.15b Using piston ring compressor to clamp piston rings

13 Lubricate the cylinder bores, the pistons and piston rings, then lay out each piston/connecting rod assembly in its respective position.

14 Starting with assembly No 1, make sure that the piston rings are still correctly spaced, then clamp them in position with a piston ring compressor.

15 Insert the piston/connecting rod assembly into the top of liner No 1, ensuring that the arrow (or FRONT marking) on the piston crown faces the timing belt end of the engine. Note that the stamped marks on the connecting rod and big-end bearing cap should face the front (alternator bracket side) of the engine. Using a block of wood or hammer handle against the piston crown, tap the assembly into the liner until the piston crown is flush with the top of the liner (see illustrations).

16 Ensure that the bearing shell is still correctly installed. Taking care not to mark the liner bores, liberally lubricate the crankpin and

both bearing shells, then pull the piston/connecting rod assembly down the bore and onto the crankpin. Noting that the faces with the stamped marks must match (which means that the bearing shell locating tabs about each other), refit the big-end bearing cap, tightening the bolts finger-tight at first.

17 Use a torque wrench to tighten the bolts evenly to the (first stage) torque wrench setting specified, then use an angular torque gauge to tighten the bolts evenly through the (second stage) angle specified (see illustrations).

18 Repeat the procedure for the remaining three piston/connecting rod assemblies, but do not attempt to rotate the crankshaft.

19 Thoroughly degrease the mating surfaces of the oil rail and the main bearing ladder. Apply the special Rover sealant to the oil rail mating surface (see illustration 18.27). Carefully follow the instructions supplied with the sealant kit.

20 Refit the oil rail, tightening the nuts to the specified torque wrench setting.

21 Refit the oil pump pick-up/strainer pipe and sump.

22 Refit the cylinder head. Rotate the crankshaft to the 90° BTDC position so that the crankshaft sprocket timing marks align.

23 Refit the dipstick tube to the cylinder block/crankcase, tightening the bolts to the specified torque wrench setting.

24 Refit the hydraulic tappets and camshaft(s).

25 Refit the timing belt inner cover, sprocket(s) and tensioner, and the belt itself.

26 Using a torque wrench, check that the amount of force required to rotate the crankshaft does not exceed 31 Nm. If the effort required is greater than this, the engine must be dismantled again to trace and rectify the cause. This value takes into account the increased friction of a new engine and is much higher than the actual pressure required to rotate a run-in engine, so do not make allowances for tight components.



19.17a Tighten connecting rod big-end bearing cap bolts to specified torque wrench setting (first stage) . . .



19.17b . . . then use angular torque gauge to tighten bolts through angle specified (second stage)

20 Engine - initial start-up after overhaul



- 1 With the engine refitted in the vehicle, double-check the engine oil and coolant levels. Make a final check that everything has been reconnected and that there are no tools or rags left in the engine compartment.
- 2 With the spark plugs removed and the ignition system disabled by earthing the ignition HT coil distributor spark plug (HT) lead with a jumper lead, turn the engine over on the starter until the oil pressure warning lamp goes out.
- 3 Refit the spark plugs and connect all the spark plug (HT) leads.
- 4 Start the engine, noting that this may take a little longer than usual due to the fuel system components being empty.
- 5 While the engine is idling, check for fuel, coolant and oil leaks. Do not be alarmed if there are some odd smells and smoke from parts getting hot and burning off oil deposits. If the hydraulic tappets have been disturbed, some valve gear noise may be heard at first; this should disappear as the oil circulates fully around the engine and normal pressure is restored in the tappets.
- 6 Keep the engine idling until hot coolant is felt circulating through the top hose, check the ignition timing and idle speed and mixture (as appropriate), then switch it off.
- 7 After a few minutes, recheck the oil and coolant levels and top up as necessary.
- 8 If they were tightened as described, there is no need to re-tighten the cylinder head bolts once the engine has first run after reassembly.
- 9 If new pistons, rings or crankshaft bearings have been fitted, the engine must be run-in for the first 500 miles (800 km). Do not operate the engine at full throttle or allow it to labour in any gear during this period. It is recommended that the oil and filter be changed at the end of this period.





Chapter 3

Cooling, heating and ventilation systems

Contents

Air conditioning compressor drivebelt - inspection, adjustment and renewal	13	Cooling system hoses - renewal	4
Air conditioning refrigerant - level check	14	Electric cooling fan - testing, removal and refitting	8
Air conditioning system components - removal and refitting	15	General information and precautions	1
Coolant pump - removal and refitting	7	Heater components - removal and refitting	10
Cooling system - draining, flushing and filling	2	Heater controls - removal, refitting and adjustment	12
Cooling system - general inspection	3	Heater ducts and vents - removal and refitting	11
Cooling system electrical switches - testing, removal and refitting	9	Radiator and expansion tank - removal, inspection and refitting	5
		Thermostat - removal, testing and refitting	6

Degrees of difficulty

Easy , suitable for novice with little experience 	Fairly easy , suitable for beginner with some experience 	Fairly difficult , suitable for competent DIY mechanic 	Difficult , suitable for experienced DIY mechanic 	Very difficult , suitable for expert DIY or professional 
---	--	--	---	--

Specifications

System

Type Pressurised, pump-assisted thermo-syphon with front mounted radiator and thermostatically-controlled electric cooling fan

Thermostat

Type Wax
 Start to open temperature 76 to 80°C
 Fully open temperature 82 or 88°C (actual value stamped in unit end)
 Full lift height 9.0 mm

Expansion tank

Cap pressure 0.9 to 1.0 bar

Cooling fan

Operating temperature 88 to 92°C

Torque wrench settings

	Nm	lbf ft
Cooling system		
Fan motor nuts	5	4
Temperature gauge sender unit	15	11
Thermostat housing cover bolts	9	7
Thermostat housing/dipstick tube-to-cylinder block/crankcase bolt	9	7
Coolant rail-to-cylinder block/crankcase bolts	9	7
Coolant pump-to-timing belt upper left-hand (inner) cover bolt	9	7
Coolant pump-to-cylinder block/crankcase bolts	10	7
Heating system		
Heater lower mounting nut	21	15
Heater blower motor mounting bolts	10	7
Air conditioning system		
Compressor mounting bolts	45	33
Condenser unions	17	13
Evaporator inlet union (from receiver drier)	17	13
Evaporator outlet union	33	24
Receiver drier union	17	13
Trinary switch	12	9

1 General information and precautions

General information

The cooling system is of the pressurised, pump-assisted thermo-syphon type. It consists of the front-mounted radiator, a translucent expansion tank mounted on the right-hand inner wing, a thermostatically-controlled electric cooling fan mounted on the rear of the radiator, a thermostat and a centrifugal coolant pump, as well as the connecting hoses (see illustration). The coolant pump is driven by the engine timing belt.

The system is of the by-pass type, allowing coolant to circulate around the engine while the thermostat is closed. With the engine cold, the thermostat closes off the coolant feed from the bottom radiator hose. Coolant is then drawn into the engine via the heater matrix, inlet manifold and from the top of the cylinder block. This allows some heat transfer, by convection, to the radiator through the top

hose whilst retaining the majority of heat within the cylinder block.

The siting of the thermostat in the intake rather than the outlet side of the system ensures that the engine warms up quickly by circulating a small amount of coolant around a shorter tract. This also prevents temperature build-up in the cylinder head prior to the thermostat opening.

When the coolant reaches a predetermined temperature, the thermostat opens and the coolant is allowed to flow freely through the top hose to the radiator. As the coolant circulates through the radiator, it is cooled by the inrush of air when the vehicle is in forward motion. Airflow is supplemented by the action of the electric cooling fan when necessary. Upon reaching the bottom of the radiator, the coolant is now cooled and the cycle is repeated.

With the engine at normal operating temperature, the coolant expands and some of it is displaced into the expansion tank. This coolant collects in the tank and is returned to the radiator when the system cools.

The electric cooling fan mounted behind the radiator is controlled by a thermostatic

switch located in the radiator side tank. At a predetermined coolant temperature the switch contacts close, thus actuating the fan.

Precautions

Cooling system

Do not attempt to remove the expansion tank filler cap or to disturb any part of the cooling system whilst it or the engine is hot, as there is a very great risk of scalding. If the expansion tank filler cap must be removed before the engine and radiator have fully cooled down (even though this is not recommended) the pressure in the cooling system must first be released. Cover the cap with a thick layer of cloth, to avoid scalding, and slowly unscrew the filler cap until a hissing sound can be heard. When the hissing has stopped, showing that pressure is released, slowly unscrew the filler cap until it can be removed. If more hissing sounds are heard, wait until they have stopped before unscrewing the cap completely. At all times keep well away from the filler opening.

Do not allow antifreeze to come in contact with your skin or painted surfaces of the vehicle. Rinse off spills immediately with plenty of water. Never leave antifreeze lying around, it is fatal if ingested.

If the engine is hot, the electric cooling fan may start rotating even if the engine is not running, so be careful to keep hands, hair and loose clothing well clear when working in the engine compartment.

Air conditioning system

On models equipped with an air conditioning system, it is necessary to observe special precautions whenever dealing with any part of the system, its associated components and any items which necessitate disconnection of the system. If for any reason the system must be disconnected, entrust this task to your Rover dealer or a refrigeration engineer.

Refrigerant must not be allowed to come in contact with a naked flame, otherwise a poisonous gas will be created. Do not allow the fluid to come in contact with the skin or eyes.

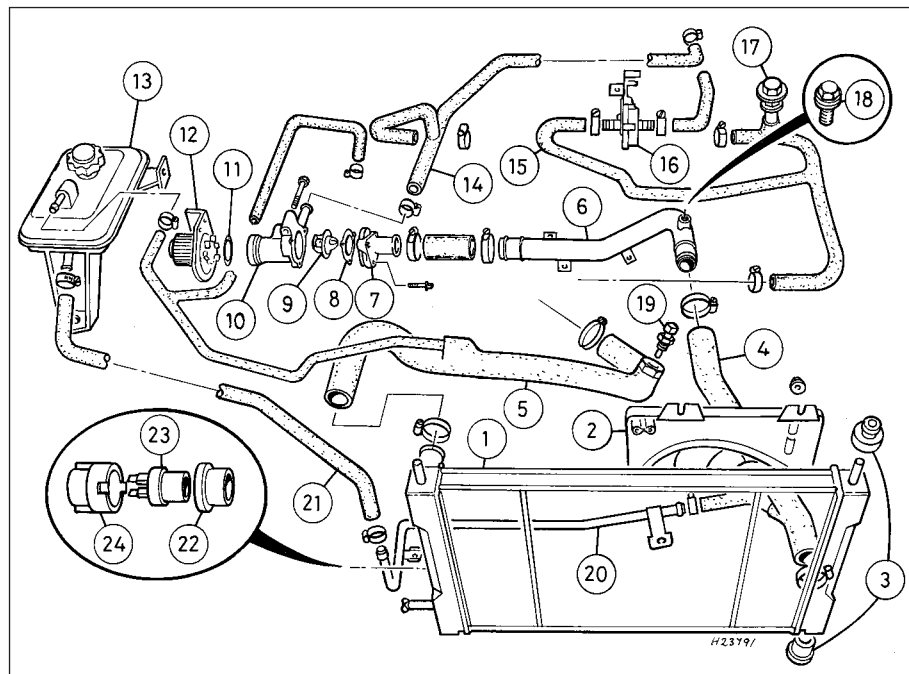

1.0 Cooling system components

- | | | |
|--|---|---|
| 1 Radiator | 9 Thermostat | 18 Cooling system bleed screw |
| 2 Cooling fan and cowling | 10 Thermostat housing | 19 Engine overheat switch - where fitted |
| 3 Radiator mounting rubbers | 11 O-ring | 20 Coolant pipe - expansion tank to bottom hose |
| 4 Bottom hose | 12 Coolant pump | 21 Hose - expansion tank return |
| 5 Top hose | 13 Expansion tank | 22 Sealing ring |
| 6 Coolant pipe - bottom hose to thermostat housing | 14 Hose - heater matrix and manifold return | 23 Cooling fan thermostatic switch |
| 7 Thermostat housing cover | 15 Hose - heater matrix and manifold feed | 24 Locking ring |
| 8 Gasket | 16 Heater temperature control valve | |
| | 17 Coolant filler stem | |

2 Cooling system - draining, flushing and refilling

Refer to Chapter 1.

3 Cooling system - general inspection

Refer to "Weekly Checks" and Chapter 1.

4 Cooling system hoses - renewal



Never work on the cooling system when it is hot. Release any pressure from the system by loosening the expansion tank cap, having first covered it with a cloth to avoid any possibility of scalding.

1 If inspection of the cooling system reveals a faulty hose, then it must be renewed as follows.

2 First drain the cooling system. If the coolant is not due for renewal, it may be re-used if collected in a clean container.

3 To disconnect any hose, use a screwdriver to slacken the clips then move them along the hose clear of the outlet. Carefully work the hose off its outlets. Do not attempt to disconnect any part of the system when still hot.

4 Note that the radiator hose outlets are fragile. Do not use excessive force when attempting to remove the hoses. If a hose proves stubborn, try to release it by rotating it on its outlets before attempting to work it off. If all else fails, cut the hose with a sharp knife then slit it so that it can be peeled off in two pieces. While expensive, this is preferable to buying a new radiator.

5 When refitting a hose, first slide the clips onto the hose then work the hose onto its outlets. If the hose is stiff, use soap as a lubricant or soften it by first soaking it in boiling water whilst taking care to prevent scalding.

6 Work each hose end fully onto its outlet, check that the hose is settled correctly and is properly routed, then slide each clip along the hose until it is behind the outlet flared end before tightening it securely.

7 Refill the system with coolant.

8 Check carefully for leaks as soon as possible after disturbing any part of the cooling system.

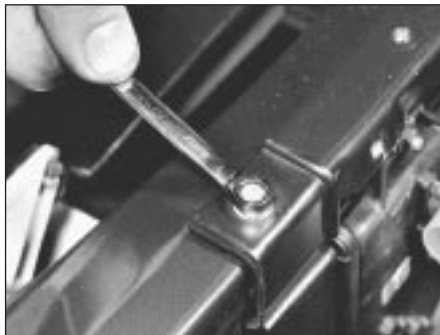

5.7a Undo radiator mounting bolts . . .

5 Radiator and expansion tank - removal, inspection and refitting



Removal

Radiator

1 Drain the cooling system.

2 On models equipped with air conditioning, remove the condenser fan, then undo the two bolts securing the air conditioning pipes to the bonnet platform.

3 Remove the air cleaner metal intake duct and intake hose.

4 Disconnect the radiator cooling fan wiring connector, then slacken and remove the bolt

securing the earth leads to the bonnet platform. Disconnect the wiring from the thermostatic switch(es) which are fitted to the right-hand side of the radiator (see illustrations).

5 Slacken the bottom hose retaining clip and disconnect the hose from the radiator.

6 Slacken the retaining clips and disconnect the top hose from both the radiator and engine coolant elbow (see illustrations). Position the hose clear of the radiator so that it does not hinder removal.

7 Undo the two bolts securing the upper mounting brackets to the bonnet platform and remove the brackets from the radiator. Disengage the radiator from its lower mounting points and carefully manoeuvre it out of the engine compartment (see illustrations).



5.4a Disconnect cooling fan wiring connector then remove earth lead retaining bolt (arrowed)



5.4b Disconnecting wiring connector from radiator switch



5.6a Slacken clips and disconnect top hose from radiator . . .



5.6b . . . and engine coolant elbow



5.7b . . . remove mounting brackets . . .



5.7c . . . and manoeuvre radiator out of engine compartment

3•4 Cooling, heating and ventilation systems

Expansion tank

8 Slacken and remove the three bolts securing the expansion tank to the body. Unscrew the expansion tank cap and tip out its contents into a suitable container.

9 Slacken the retaining clips then disconnect both the hoses from the expansion tank and remove the tank from the vehicle.

Inspection

Radiator

10 If the radiator was removed because of clogging (causing overheating) then try reverse flushing or, in severe cases, use a radiator cleanser strictly in accordance with the manufacturer's instructions. Ensure that the cleanser is suitable for use in a copper/brass radiator. Refer to Chapter 1 for further information

11 Use a soft brush and an air line or garden hose to clear the radiator matrix of leaves, insects etc.



Minor leaks from the radiator can be cured using a suitable sealant with the radiator in situ.

12 Major leaks or extensive damage should be repaired by a specialist, or the radiator should be renewed or exchanged for a reconditioned unit.

13 Examine the mounting rubbers for signs of damage or deterioration and renew if necessary.

Expansion tank

14 Empty any remaining coolant from the tank and flush it with fresh water to clean it. If the tank is leaking it must be renewed but it is worth first attempting a repair using a proprietary sealant or suitable adhesive.

15 The expansion tank cap should be cleaned and checked whenever it is removed. Check that its sealing surfaces and threads are clean and undamaged and that they mate correctly with those of the expansion tank.

16 The cap's performance can only be checked by using a cap pressure-tester (cooling system tester) with a suitable

adaptor. On applying pressure, the cap's pressure relief valve should hold until the specified pressure is reached, at which point the valve should open.

17 If there is any doubt about the cap's performance, then it must be renewed. Ensure that the replacement is of the correct type and rating.

Refitting

Radiator

18 Refitting is the reverse of the removal procedure whilst noting the following:

- Ensure that the radiator is seated correctly and without strain on its mountings.
- Ensure that the radiator hoses are securely held by the retaining clips.
- Ensure that all wiring connectors are correctly routed so that they are clear of the cooling fan and are retained by any necessary clips or ties.
- Refill the cooling system as described in Chapter 1.

Expansion tank

19 Refitting is the reverse of the removal procedure whilst noting the following:

- Ensure that all hoses are correctly routed with no kinks or sharp bends and are securely held by the retaining clips.
- Top up the expansion tank as described in Chapter 1.

6 Thermostat - removal, testing and refitting



Removal

1 Note that access to the thermostat is very limited. Depending on the tools available, it may be easier to raise the front of the vehicle and to work from underneath, ensuring that the vehicle is securely supported on axle stands. In most cases, access is better if the air cleaner and carburettor (or throttle body on SPi engines) are removed and is best if the complete inlet manifold is removed. If the inlet manifold is removed, the thermostat housing



6.1 Thermostat can be removed without disturbing housing if inlet manifold is first removed

cover can be unbolted to remove the thermostat without disturbing the housing itself (see illustration). Whichever method is used, first drain the cooling system.

2 On carburettor models equipped with a catalytic converter, either remove the thermostatically-operated vacuum switch or disconnect the vacuum pipes from the switch so that it can be removed with the thermostat housing.

3 Unbolt the coolant rail from the rear of the cylinder block/crankcase, then slacken the clips and disconnect the coolant rail hose and heater/inlet manifold return hose from the thermostat housing (see illustration).

4 Undo the thermostat housing/dipstick tube-to-cylinder block/crankcase bolt and remove the thermostat housing from the cylinder block/crankcase. Remove the housing O-ring which must be renewed whenever it is disturbed (see illustrations).

5 Slacken and remove the three thermostat housing cover bolts and lift off the housing cover. Discard the gasket and remove the thermostat.

Testing

6 If the thermostat remains in the open position at room temperature, then it is faulty and must be renewed.

7 To test it fully, suspend the (closed) thermostat on a length of string in a container of cold water, with a thermometer beside it.

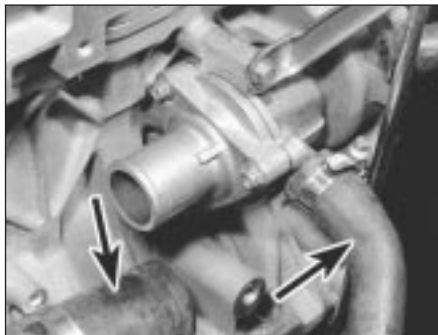

6.3 Disconnect coolant rail and heater/inlet manifold hoses (arrowed) . . .



6.4a . . . unscrew dipstick tube retaining bolt . . .



6.4b . . . and withdraw thermostat housing (O-ring arrowed) - inlet manifold removed for clarity

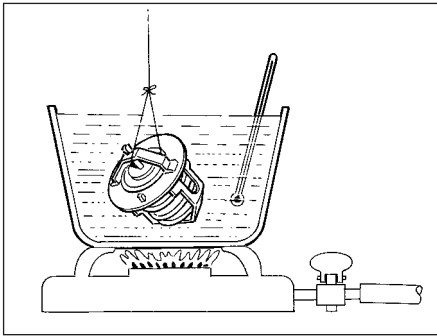

6.7 Testing the thermostat



6.8 Note temperature specification stamped on thermostat end



6.10 Thermostat housing and coolant hoses refitted

Ensure that neither touches the side of the container (see illustration).

8 Heat the water and check the temperature at which the thermostat begins to open. Compare this value with that specified. Continue to heat the water until the thermostat is fully open. The temperature at which this should happen is stamped in the unit's end (see illustration). Remove the thermostat and measure the height of the fully opened valve, then allow the thermostat to cool down and check that it closes fully.

9 If the thermostat does not open and close as described, if it sticks in either position, or if it does not open at the specified temperature, then it must be renewed.

Refitting

10 Refitting is the reverse of the removal procedure, noting the following (see illustration):

- Clean the thermostat housing, housing cover and cylinder block/crankcase mating surfaces thoroughly.
- Always fit a new housing cover gasket and O-ring. Smear the O-ring with grease to aid refitting.
- Tighten all bolts to their specified torque wrench settings (where given).
- Ensure the coolant hose clips are positioned so that they do not foul any other component, then tighten them securely.
- Refit any components removed for improved access.
- Refill the cooling system as described in Chapter 1.



7.5 Removing the coolant pump

7 Coolant pump - removal and refitting

Removal

1 Coolant pump failure is usually indicated by coolant leaking from the gland behind the pump bearing, or by rough and noisy operation, usually accompanied by excessive pump spindle play. If the pump shows any of these symptoms then it must be renewed as follows.

2 Drain the cooling system.

3 Remove the timing belt.

4 Noting the location of the pillar bolt(s), unscrew the five bolts securing the coolant pump to the cylinder block/crankcase, then unscrew the single bolt securing the pump to the timing belt upper left-hand (inner) cover.

5 Withdraw the coolant pump and discard its sealing ring which should be renewed whenever it is disturbed. Carefully clean the cylinder block/crankcase mating surface and the pump socket (see illustration).

Refitting

6 On refitting, install the pump using a new sealing ring and tighten all bolts to the specified torque wrench settings.

7 The remainder of the refitting procedure is the reverse of removal.

8 Electric cooling fan - testing, removal and refitting

Note: On models equipped with air conditioning, there are two switches fitted to the right-hand side of the radiator, the lower of these is the cooling fan switch.

Testing

1 The cooling fan motor is supplied with current via the ignition switch, fuse 4 and the cooling fan relay. The relay is energised by the radiator-mounted thermostatic switch which is fed via fuse number 15.

2 If the fan does not appear to work, first check that both fuses are in good condition and have not blown. Run the engine until normal operating temperature is reached, then allow it to idle. If the fan does not cut in within a few minutes, switch off the ignition and disconnect the two wires from the thermostatic switch. Bridge these two wires with a length of spare wire and switch on the ignition. If the fan now operates, the thermostatic switch is probably faulty and must be tested further as described in Section 9.

3 If the fan still fails to operate, check that full battery voltage is available at the switch's light green and grey wire terminal. If not, check the feed for a blown fuse or other fault such as a broken wire. If the feed is good, check the cooling fan relay, see Chapter 12. If the relay operates correctly, check for continuity between the fan motor black wire terminal and a good earth point on the body. If not, then the earth connection is faulty and must be remade. The circuit earth connection is one of those at earth header 1, attached to the left-hand inner wing panel next to the battery.

4 If the switch and wiring are in good condition, the fault must be in the motor itself. This can be checked by disconnecting it from the wiring loom and connecting a 12 volt supply directly to it. If the motor does not work then it must be renewed.

Removal

5 Drain the cooling system, then jack up the front of the vehicle and support it securely on axle stands.

6 From underneath the front of the vehicle, slacken and remove the three bolts securing the bumper flange to the body. Remove the seven bolts securing the front undercover panel to the body and remove the panel.

7 Remove the air cleaner metal intake duct and intake hose.

8 Slacken the retaining clips and disconnect the top hose from both the radiator and engine. Position the hose clear of the radiator so that it does not hinder removal.

9 Disconnect the radiator cooling fan wiring connector.

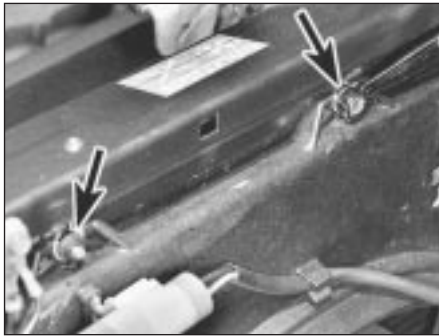

8.10a Undo cooling fan cowl retaining nuts (2 arrowed) . . .



8.10b . . . and remove fan assembly



8.11 Cooling fan motor retaining nuts (arrowed)

10 Undo the four nuts securing the cooling fan cowl to the rear of the radiator and manoeuvre the fan assembly out of the engine compartment (see illustrations).

11 To dismantle the assembly, first prise off the fan retaining circlip, then lift the fan off the motor spindle. Undo the three nuts which secure the motor assembly to the cowl then release the motor wiring and connector and separate the motor and cowl (see illustration).

Refitting

12 Refitting is a reverse of the removal procedure, noting the following:

- a) If necessary, reassemble the fan motor, cowl and fan, then tighten the motor retaining nuts to the specified torque. Ensure that the motor wiring is securely retained by the cowl clips.
- b) Ensure that the radiator hose is securely held by its retaining clips.
- c) On completion, refill the cooling system as described in Chapter 1.

9 Cooling system electrical switches - testing, removal and refitting



Note: On models equipped with air conditioning, there are two switches fitted to the right-hand side of the radiator, the lower of these is the cooling fan switch.

Testing

Cooling fan thermostatic switch

1 Refer to Section 8 for details of a quick test which should eliminate most faulty switches. If the switch is to be renewed, or to be tested thoroughly, it must be removed.

2 To carry out a thorough test of the switch, use two spare wires to connect to it either a multimeter (set to the resistance function) or a battery and bulb test circuit. Suspend the switch in a pan of water which is being heated. Measure the temperature of the water with a thermometer. Do not let either the switch or the thermometer touch the pan itself (see illustration).

3 The switch contacts should close to the ON position (ie: continuity should exist) when the water reaches the temperature specified. Stop heating the water and allow it to cool down. The switch contacts should open.

4 If the switch's performance is significantly different from that specified, or if it does not work at all, then it must be renewed.

Coolant temperature gauge sender unit

5 The coolant temperature gauge mounted in the instrument panel is fed with a stabilised 10 volt supply from the instrument panel feed (via the ignition switch and fuse 1), its earth being controlled by the sender unit.

6 The sender unit is screwed into the coolant outlet elbow mounted on the left-hand end of the cylinder head, underneath the distributor (see illustration). It contains a thermistor, which is an element whose electrical resistance decreases at a predetermined rate as its temperature rises. Thus, when the coolant is cold, the sender's resistance is high, current flow through the gauge is reduced and the gauge needle points to the C (cold) end of the scale. If the unit is faulty it must be renewed.

7 If the gauge develops a fault, check first the other instruments. If they do not work at all, check the instrument panel feed. If the readings are erratic, there may be a fault in the voltage stabiliser which will necessitate the renewal of the gauge unit or printed circuit. If the fault is in the temperature gauge alone, check it as follows.

8 If the gauge needle remains at the C end of the scale, disconnect the sender unit wire and earth it to the cylinder head. If the needle then deflects when the ignition is switched on, then the sender unit is proven faulty and must be renewed. If the needle still does not move, remove the instrument panel and check the continuity of the green/blue wire between the gauge and the sender unit and the feed to the gauge unit. If continuity is shown and the fault still exists, then the gauge is faulty and the gauge unit must be renewed.

9 If the gauge needle remains at the H end of the scale, disconnect the sender unit wire. If the needle then returns to the C end of the scale when the ignition is switched on, then the sender unit is proven faulty and must be renewed. If the needle still does not move, check the remainder of the circuit as described above.

Inlet manifold pre-heater temperature switch - carburettor engines

10 The switch screwed into the underside of the inlet manifold on carburettor engines

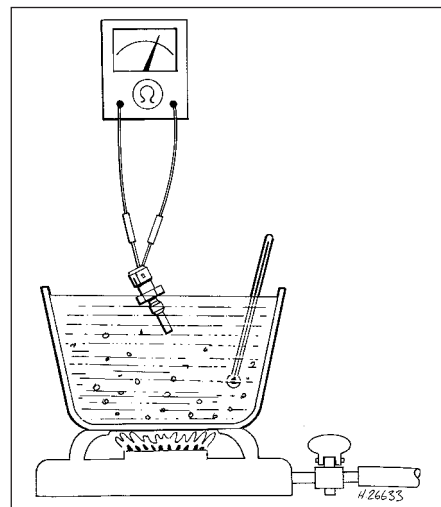

9.2 Testing cooling system electrical switch



9.6 Coolant temperature gauge sender unit

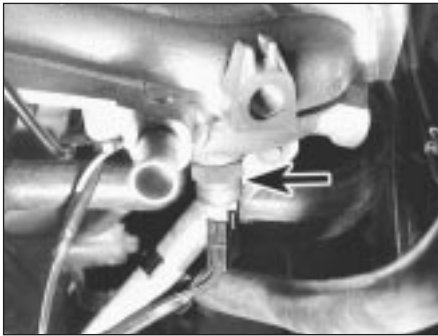

9.10 Inlet manifold pre-heater temperature switch (carburettor engines)

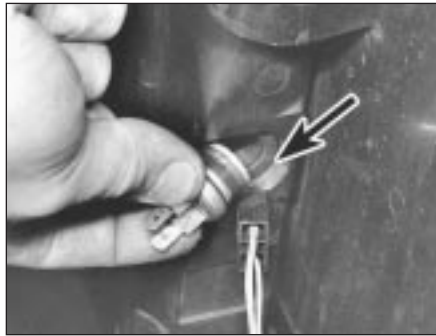

9.20 Remove cooling fan thermostatic switch and withdraw sealing ring (arrowed)

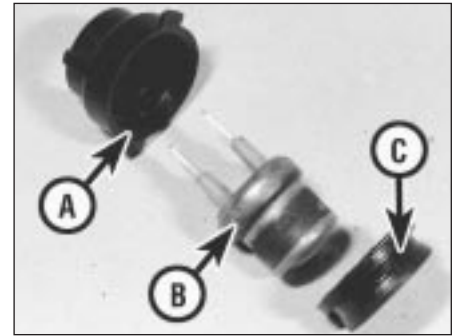

9.27 Cooling fan switch locking ring (A) thermostatic switch (B) and sealing ring (C)

controls the inlet manifold heater circuit (see illustration).

11 The switch contacts should be closed to the ON position (ie: continuity should exist) only at temperatures below 50°C. Remove the switch and test it as described in paragraphs 2 to 4.

Thermostatically-operated vacuum switch - carburettor engines equipped with catalytic converters

12 This switch is screwed into the thermostat housing.

13 To test the switch, fit two suitable lengths of hose to the switch and suspend the switch in a pan of water which is being heated. Measure the temperature of the water with a thermometer. Do not let either the switch or the thermometer touch the pan itself.

14 Blow down one of the hoses attached to the switch. The switch should be closed (ie: passes no air) when the water temperature is below 70°C. Above 70°C, the switch should open and air should flow freely through the hoses. Stop heating the water then allow the water to cool down and check that the switch closes at 70°C or just below.

15 If the switch performance is significantly different from that specified, or if it does not work at all, then it must be renewed.

Coolant temperature sensor - fuel injected engines

16 This sensor, which is screwed into the underside of the inlet manifold (SPi engines), or located in the coolant pipe adjacent to the forward top edge of the timing belt cover (MPI engines), is a thermistor (see paragraph 6) which is supplied with approximately 5 volts by the engine management system ECU. The ECU also controls the sensor's earth path and, by measuring the amount of current in the sensor circuit, determines the engine's temperature. This information is used, in conjunction with other inputs, to control idle speed, injector opening time duration and ignition timing.

17 If the sensor circuit should fail to provide adequate information, the ECU's back-up

facility assumes a value corresponding to 60°C. The sensor itself can be tested only by having a Rover dealer check the complete system using the correct diagnostic equipment. Do not attempt to test the circuit using any other equipment, or the ECU will be damaged.

Removal

Cooling fan thermostatic switch

18 With the engine and radiator cold, either drain the cooling system down to the level of the sender unit, or unscrew the expansion tank filler cap to release any remaining pressure and have a suitable plug ready that can be used to stop the escape of coolant while the switch is removed.

19 Disconnect the battery negative lead.

20 Disconnect the wiring connector from the switch then rotate the locking ring to release it. Withdraw the switch and sealing ring from the radiator (see illustration).

Coolant temperature gauge sender unit

21 With the engine and radiator cold, either drain the cooling system down to the level of the switch, or unscrew the expansion tank filler cap to release any remaining pressure and have a suitable plug ready that can be used to stop the escape of coolant while the unit is removed.

22 Disconnect the battery negative lead.

23 Disconnect the unit's wiring connector and unscrew the unit from the coolant outlet elbow.

Inlet manifold pre-heater temperature switch - carburettor engines

24 Refer to Chapter 4.

Thermostatically-operated vacuum switch - carburettor engines equipped with catalytic converters

25 Refer to Chapter 5.

Coolant temperature sensor - fuel injected engines

26 Refer to Chapter 4.

Refitting

Cooling fan thermostatic switch

27 On refitting, renew the sealing ring if it is worn or compressed and carefully clean the radiator seat before pressing in the sealing ring and switch (see illustration). Refit the locking ring and rotate it to tighten it securely. Reconnect the switch and battery, then replenish the cooling system.

Coolant temperature gauge sender unit

28 On refitting, apply a suitable sealant to the unit threads and tighten it to its specified torque wrench setting. Reconnect the unit and battery, then replenish the cooling system.

Inlet manifold pre-heater temperature switch - carburettor engines

29 Refer to Chapter 4.

Thermostatically-operated vacuum switch - carburettor engines equipped with catalytic converters

30 Refer to Chapter 5.

Coolant temperature sensor - fuel injected engines

31 Refer to Chapter 4.

10 Heater components - removal and refitting



Removal

Heater unit

1 Drain the cooling system.

2 Working in the engine compartment, slacken the hose clips and disconnect the heater feed and return hoses from the matrix outlets on the bulkhead. Disconnect the cable inner from the heater valve and free the cable outer from its retaining clip. Slacken and

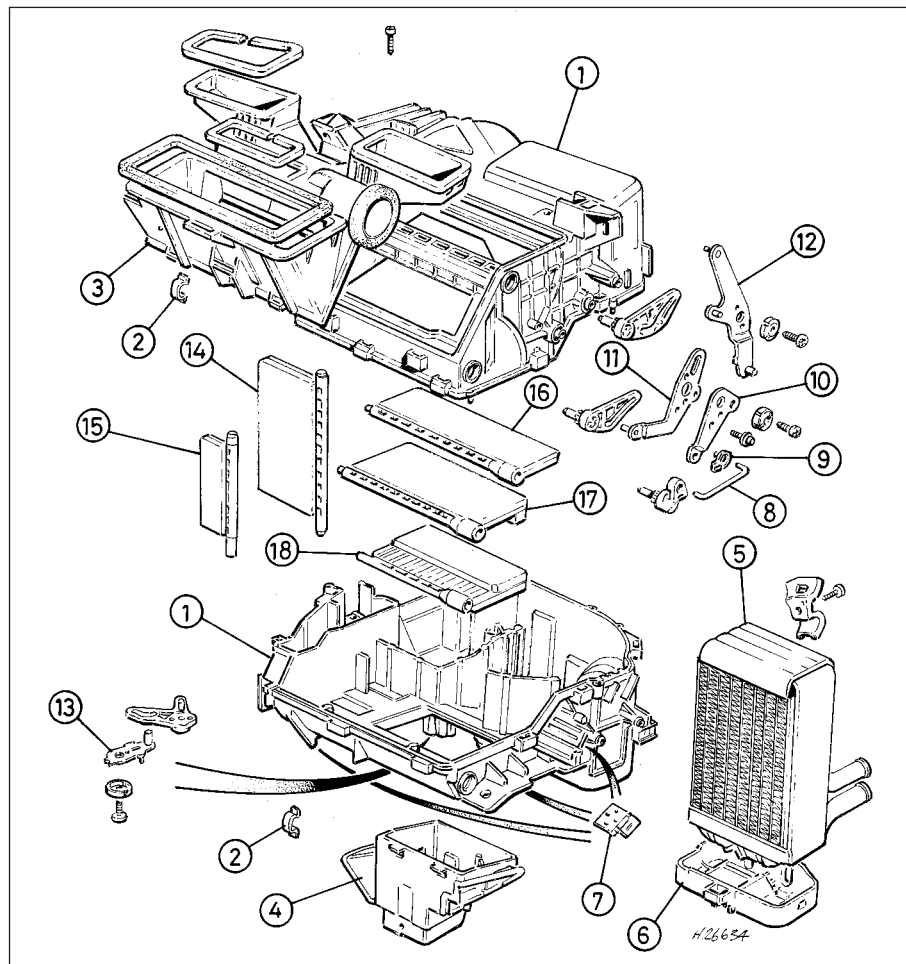

10.2a Heater unit components

- | | | |
|------------------------------|------------------------------------|--|
| 1 Heater case | 8 Floor level flap operating lever | 15 Ambient air flap - centre console vents |
| 2 Heater case clip | 9 Clip | 16 Distribution flap - windscreen |
| 3 Face level/windscreen duct | 10 Floor level flap idler lever | 17 Distribution flap - face level vents |
| 4 Floor level duct | 11 Face level flap idler lever | 18 Distribution flap - floor level vents |
| 5 Heater matrix | 12 Flap operating lever | |
| 6 Heater matrix cover | 13 Air mix flap operating lever | |
| 7 Cable retaining clip | 14 Air mix flap | |

remove the heater lower mounting nut which is situated just to the left of the matrix outlets (see illustrations).

3 Working inside the vehicle, remove the fascia.

4 Slacken and remove the two retaining screws and remove the blower motor-to-heater unit duct (see illustration). On models equipped with air conditioning, the evaporator unit is fitted in place of the duct. It may be possible to gain the necessary clearance required to disengage the evaporator from the heater unit by removing the mounting brackets and nuts. If not, the evaporator must be removed.

5 Undo the screw securing the right-hand heater duct to the mounting bracket, then move the duct to the right to disengage it from the heater unit (see illustrations).

6 Undo the inertia switch retaining nut and disengage the switch from the steering column support bracket.



10.4 Remove blower motor-to-heater unit duct



10.2b Disconnect heater feed and return hoses . . .



10.2c . . . and free heater valve cable from retaining clip



10.2d Slacken and remove heater unit lower mounting nut

7 Release the wiring block connector from the right-hand end of the steering column support bracket and undo the fusebox



10.5a Undo right-hand duct retaining screw (arrowed) . . .



10.5b ... and disengage duct from heater unit



10.7a Release wiring connector from steering column support bracket and remove fusebox nut (arrowed)



10.7b Remove mounting bolts and manoeuvre steering column mounting bracket out of position

retaining nut. Slacken and remove the five support bracket retaining bolts and remove the bracket from the vehicle (see illustrations).

8 Disconnect the air recirculation cable inner from the flap and free the cable outer from the blower motor.

9 Prise out the stud securing the rear heater duct sleeve to the bottom of the heater unit, then slide the sleeve down to disengage it from the unit (see illustration).

10 Disconnect the wiring connectors from the heater control panel, then remove the two upper heater unit retaining nuts and carefully manoeuvre the heater unit out of the vehicle (see illustrations).

Heater matrix

11 Remove the heater unit.

12 Undo the screw securing the matrix outlet pipe bracket to the heater unit and remove the bracket (see illustration).

13 Slacken and remove the two matrix cover retaining screws, then remove the cover and withdraw the matrix from the heater unit (see illustrations).

14 If the matrix is leaking, it is best to obtain a new or reconditioned unit as home repairs are seldom successful. If it is blocked, it can sometimes be cleared by reverse flushing using a garden hose. Use a proprietary radiator cleaning product if absolutely necessary.



10.9 Remove retaining stud and disengage rear heater duct sleeve from heater unit

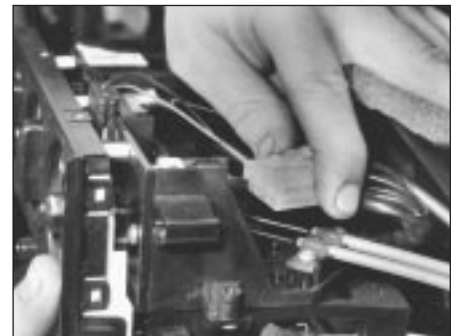

10.10a Disconnect wiring from heater control panel ...



10.10b ... and remove heater retaining nuts



10.12 Undo retaining screw and remove matrix outlet pipe bracket



10.13a Undo two matrix cover retaining screws ...



10.13b ... then remove cover ...



10.13c ... and withdraw matrix from heater unit



10.15 Glovebox damper retaining screw (arrowed)



10.16 Remove glovebox support rail . . .



10.17 . . . then remove blower motor-to-heater unit duct

Heater blower motor

15 Undo the two glovebox retaining screws then partially withdraw the glovebox until access can be gained to the glovebox damper to fascia screw. Undo the damper screw and remove the glovebox and damper (see illustration).

16 Slacken and remove the four glovebox support rail mounting bolts and remove the rail (see illustration).

17 Slacken and remove the two retaining screws and remove the blower motor-to-heater unit duct (see illustration). On models equipped with air conditioning, the evaporator unit is fitted in place of the duct. It may be possible to gain the necessary clearance

required to disengage the evaporator and remove the blower motor by removing the mounting brackets and nuts. If not, the evaporator must be removed.

18 Disconnect the air recirculation cable inner from the flap and free the cable outer from the blower motor. Disconnect the two blower motor wiring connectors (see illustration).

19 Slacken and remove the three blower motor mounting bolts and manoeuvre the blower unit out from underneath the fascia (see illustrations).

20 To remove the motor from the unit, undo the four motor cover retaining screws, then disconnect the breather hose and lift off the

cover. Slacken and remove the three motor retaining bolts and withdraw the motor assembly from the blower unit. Undo the fan retaining nut and separate the fan and motor, noting the seal fitted between the two components (see illustrations).

Heater blower motor resistor

21 Remove the glovebox as described in paragraphs 15 and 16.

22 Disconnect the wiring connector, then undo the two retaining screws and remove the resistor from the front of the motor assembly.

Heater valve

23 Working in the engine compartment, disconnect the cable inner from the heater

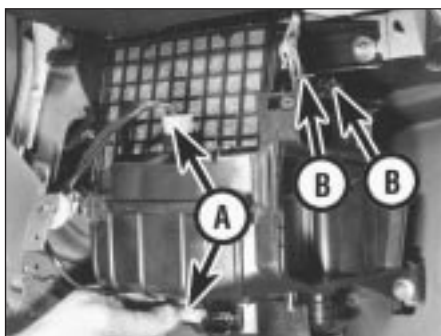

10.18 Disconnect motor wiring connectors (A) and air recirculation cable (B)



10.19a Undo three blower motor mounting bolts (arrowed) . . .



10.19b . . . and remove unit from behind fascia



10.20a Remove motor cover retaining screws (arrowed) . . .



10.20b . . . and disconnect breather hose



10.20c Undo motor retaining bolts and withdraw motor from unit



10.20d Remove fan retaining nut . . .



10.20e . . . and lift off fan (seal arrowed)

valve and free the cable outer from the retaining clip.

24 Slacken and remove the bolt securing the heater valve mounting bracket to the engine compartment bulkhead.

25 Either drain the cooling system or clamp the coolant hoses on each side of the coolant valve to minimise the loss of coolant.

26 Slacken the hose retaining clips, then disconnect both hoses from the coolant valve and remove the valve from the engine compartment. Mop up any spilt coolant immediately.

Refitting

Heater unit

27 Refitting is a reverse of the removal procedure, noting the following:

- Ensure that the heater ducts are securely connected to the unit so that there are no air leaks or gaps.
- Check the operation of all heater cables before refitting the facia, ensuring that the relevant component moves smoothly from the fully open to the fully closed position. If necessary, adjustments can be made by releasing the relevant retaining clip and repositioning the cable outer.
- Ensure that the heater hoses are correctly reconnected and are securely held by the retaining clips.
- Tighten the heater lower mounting nut to the specified torque setting.
- Refill the cooling system as described in Chapter 1.



12.2a Disconnect control cables from heater unit . . .



12.2b . . . and remove heater control panel with cables

Heater matrix

28 Refitting is a reverse of the removal procedure.

Heater blower motor

29 Refitting is a reversal of the removal sequence, noting the following:

- Ensure that the foam rubber seal is refitted correctly so that the blower motor-to-bulkhead aperture is closed off.
- Tighten the blower motor mounting bolts to the specified torque setting.
- Ensure that the air recirculation cable and flap functions correctly before refitting the glovebox. If necessary, adjust by releasing the cable retaining clip and repositioning the cable outer.

Heater blower motor resistor

30 Refitting is a reverse of the removal procedure.

Heater valve

31 Refitting is a reversal of the removal procedure. On completion, check the heater cable operates smoothly and replenish the cooling system.

11 Heater ducts and vents - removal and refitting



Removal

Facia ducts

- Remove the facia.

2 The ducts are mounted on the facia assembly and can be removed individually, once the retaining screws have been removed.

Heater unit ducts

3 The left-hand heater unit to blower motor duct is removed as described in paragraphs 15 to 17 of Section 10.

4 To remove the right-hand duct, first remove the facia. Slacken and remove the retaining screw which secures the right-hand end of the duct to the mounting bracket and release the radio aerial from the retaining clips on the underside of the duct. The duct can then be manoeuvred out of position.

5 Removal of the lower ducts which supply air to the rear passenger footwells is a complex job, requiring the removal of the front seats, centre console and the various trim panels so that the floor carpet can be peeled back, and is therefore not recommended.

Centre console vents

6 Remove the centre console.

7 The vents can then be unclipped from the rear of the front console section and removed.

Facia vents

8 The adjustable face-level vents can be removed by prising them gently out of the facia until the clips are released, taking care not to mark the facia.

9 The door window demister vents, fitted to the sides of the facia, can also be prised out of position once the relevant door has been opened.

Refitting

10 Refitting is a reverse of the removal procedure.

12 Heater controls - removal, refitting and adjustment



Removal

- Remove the heater unit.
- Disconnect the heater control cables from the heater unit and unclip the control panel. Remove the panel assembly complete with cables (see illustrations).

Refitting and adjustment

- Refit the heater control panel to the heater unit and reconnect the necessary control cables to their original positions.
- Check the operation of the control cables, ensuring that they operate smoothly and move the necessary component from the fully open to the fully closed position. Adjustments can be made by releasing the cable retaining clip and repositioning the cable outer.
- Once the necessary control cables are functioning correctly, refit the heater unit.

13 Air conditioning compressor drivebelt - inspection, adjustment and renewal

Refer to Chapter 1 (alternator drivebelt check).

14 Air conditioning refrigerant - level check

Refer to Chapter 1.

15 Air conditioning system components - removal and refitting



Warning: The air conditioning system must be professionally discharged before carrying out any of the following work. Cap or plug the pipe lines as soon as they are disconnected to prevent the entry of moisture.

or plug the pipe lines as soon as they are disconnected to prevent the entry of moisture.

Compressor

Removal

1 Remove the alternator/air conditioning compressor drivebelt as described in Chapter 1.

2 Disconnect the air conditioning pipes from the compressor (see illustration).

3 Slacken and remove the four bolts securing the compressor to the mounting bracket and manoeuvre it downwards and away from the engine.

Refitting

4 Refitting is a reverse of the removal sequence, tightening the compressor mounting bolts to the specified torque setting. Ensure that the compressor pipe unions are securely tightened then refit and adjust the drivebelt as described in Chapter 1. On completion, have the air conditioning system recharged by a refrigeration specialist or suitably-equipped Rover dealer.

Condenser

Removal

5 Remove the front bumper.

6 Slacken and remove the bolts securing the power steering oil cooler to the body, then undo the bonnet lock mounting bracket bolts and position the lock assembly clear of the condenser unit.

7 Unscrew the air conditioning pipe union nuts from the condenser unit then disconnect the pipes. Discard the union pipe O-rings as these must be renewed whenever they are disturbed.

8 Slacken and remove the four retaining bolts and withdraw both the condenser upper mounting brackets. Release the condenser from its lower mounting points and manoeuvre it away from the vehicle.

Refitting

9 Prior to refitting, check the condenser lower mounting rubbers for signs of damage or deterioration and renew as necessary. Renew the pipe union O-rings.

10 Refitting is a direct reversal of the removal procedure, tightening the pipe union nuts to the specified torque setting. On completion, have the air conditioning system recharged by a refrigeration specialist or a suitably equipped Rover dealer.

Condenser cooling fan

Removal

11 Drain the cooling system.

12 Disconnect the wiring connector from the engine overheat switch, located in the top coolant hose, then slacken the clips securing the hose to the radiator and engine. Disconnect the hose from the radiator and engine and position it clear of the condenser so that it does not hinder removal.

13 Disconnect the condenser fan electrical wiring connector then undo the four fan cowling retaining nuts and manoeuvre the assembly out of the engine compartment.

14 To dismantle the assembly, first undo the fan retaining nut then lift the fan off the motor spindle. Undo the two screws which secure the motor assembly to the cowling then release the motor wiring and connector and separate the motor and cowling.

Refitting

15 Refitting is a reverse of the removal procedure, noting the following points:

- a) Ensure that the motor wiring is securely retained by the cowling clips and is clear of the condenser fan.
- b) Ensure that the radiator hose is securely held by its retaining clips.
- c) On completion, refill the cooling system.

Evaporator

Removal

16 Undo the three bolts which secure the washer system reservoir to the engine compartment bulkhead and move the reservoir to gain access to the two evaporator union nuts. Slacken both the union nuts and disconnect the pipes from the evaporator. Remove the O-rings from the union nuts and discard them.

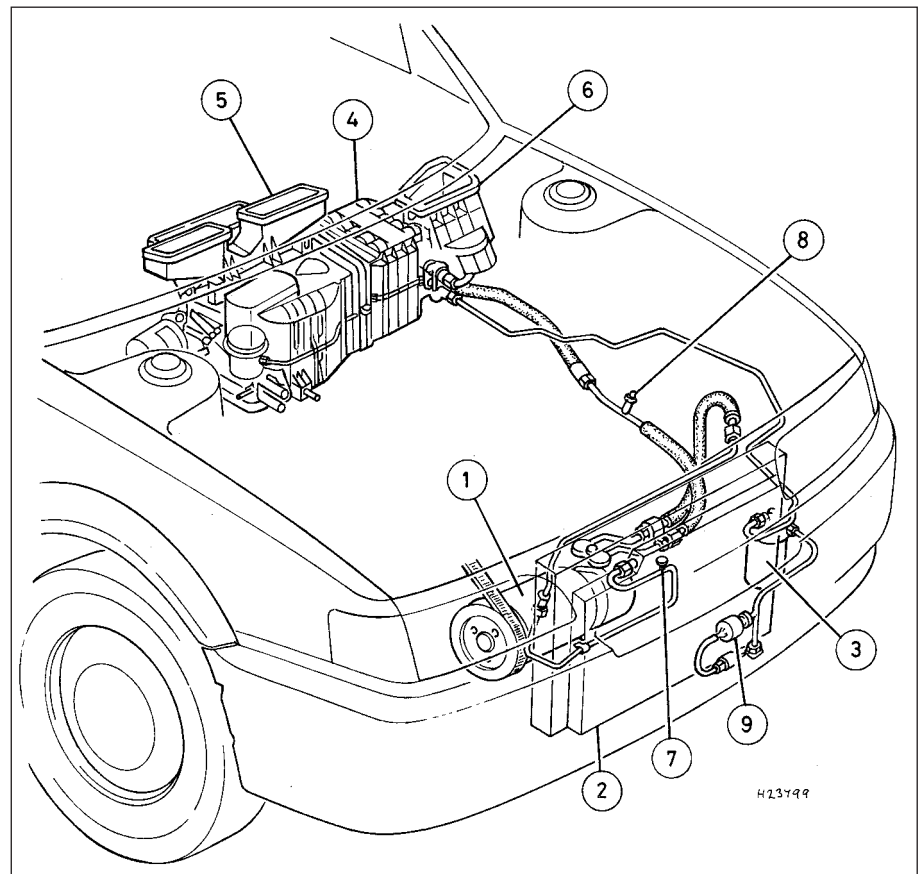

15.2 Air conditioning system layout

- | | | |
|------------------|--------------------------------------|-------------------------------------|
| 1 Compressor | 5 Heater unit | 8 Low pressure servicing connection |
| 2 Condenser | 6 Blower unit | 9 Trinary switch |
| 3 Receiver drier | 7 High pressure servicing connection | |
| 4 Evaporator | | |

17 Working from inside the vehicle, undo the two glovebox retaining screws, then partially withdraw the glovebox until access can be gained to the glovebox damper-to-facia screw. Undo the damper screw and remove the glovebox and damper.

18 Slacken and remove the four glovebox support rail mounting bolts and remove the rail.

19 Undo the two evaporator bracket retaining bolts and remove both the brackets.

20 Disconnect the wiring connector from the right-hand side of the evaporator.

21 Slacken and remove the two evaporator mounting nuts and manoeuvre the unit out of position.

Refitting

22 Refitting is a reverse of the removal procedure noting the following:

- a) *Ensure that the evaporator is correctly joined to the heater unit and blower motor, so that there are no air leaks or gaps, then tighten the retaining nuts and bracket bolts securely.*
- b) *Fit new O-rings to the pipe unions and*

tighten the union nuts to the specified torque setting.

- c) *On completion, have the system recharged by a refrigeration specialist or a suitably-equipped Rover dealer.*

Receiver drier

Removal

23 Remove the left-hand headlamp and the battery and battery tray.

24 Undo the two screws securing the air intake grille to the body. Disengage the grille from the resonator and remove it from the vehicle. Move the resonator to one side to gain access to the receiver drier.

25 Slacken the union nuts and disconnect the pipes from the receiver drier noting the O-rings which are fitted to the pipe unions. Discard the O-rings as they must be renewed whenever they are disturbed. The receiver drier unit unions must be capped immediately after they are disconnected and must remain capped until they are to be reconnected. If the receiver drier unit is left uncapped for any period of time it must be renewed.

26 Slacken the receiver drier clamp bolt then slide the unit out of the retaining clamp and remove it from the engine compartment.

Refitting

27 Refitting is a direct reversal of the removal sequence, tightening the pipe union nuts to the specified torque setting. On completion, have the system recharged by a refrigeration specialist or suitably-equipped Rover dealer.

Trinary switch

Removal

28 Remove the front bumper.

29 Disconnect the wiring connector and unscrew the switch from the air conditioning pipe. Remove the O-ring from the switch and discard it.

Refitting

30 Refitting is a reverse of the removal procedure. Fit a new O-ring to the switch and tighten it to the specified torque setting. On completion, have the system recharged by a refrigeration specialist or suitably-equipped Rover dealer.





Chapter 3

Cooling, heating and ventilation systems

Contents

Air conditioning compressor drivebelt - inspection, adjustment and renewal	13	Cooling system hoses - renewal	4
Air conditioning refrigerant - level check	14	Electric cooling fan - testing, removal and refitting	8
Air conditioning system components - removal and refitting	15	General information and precautions	1
Coolant pump - removal and refitting	7	Heater components - removal and refitting	10
Cooling system - draining, flushing and filling	2	Heater controls - removal, refitting and adjustment	12
Cooling system - general inspection	3	Heater ducts and vents - removal and refitting	11
Cooling system electrical switches - testing, removal and refitting	9	Radiator and expansion tank - removal, inspection and refitting	5
		Thermostat - removal, testing and refitting	6

Degrees of difficulty

Easy , suitable for novice with little experience 	Fairly easy , suitable for beginner with some experience 	Fairly difficult , suitable for competent DIY mechanic 	Difficult , suitable for experienced DIY mechanic 	Very difficult , suitable for expert DIY or professional 
---	--	--	---	--

Specifications

System

Type Pressurised, pump-assisted thermo-syphon with front mounted radiator and thermostatically-controlled electric cooling fan

Thermostat

Type Wax
 Start to open temperature 76 to 80°C
 Fully open temperature 82 or 88°C (actual value stamped in unit end)
 Full lift height 9.0 mm

Expansion tank

Cap pressure 0.9 to 1.0 bar

Cooling fan

Operating temperature 88 to 92°C

Torque wrench settings

	Nm	lbf ft
Cooling system		
Fan motor nuts	5	4
Temperature gauge sender unit	15	11
Thermostat housing cover bolts	9	7
Thermostat housing/dipstick tube-to-cylinder block/crankcase bolt	9	7
Coolant rail-to-cylinder block/crankcase bolts	9	7
Coolant pump-to-timing belt upper left-hand (inner) cover bolt	9	7
Coolant pump-to-cylinder block/crankcase bolts	10	7
Heating system		
Heater lower mounting nut	21	15
Heater blower motor mounting bolts	10	7
Air conditioning system		
Compressor mounting bolts	45	33
Condenser unions	17	13
Evaporator inlet union (from receiver drier)	17	13
Evaporator outlet union	33	24
Receiver drier union	17	13
Trinary switch	12	9

1 General information and precautions

General information

The cooling system is of the pressurised, pump-assisted thermo-syphon type. It consists of the front-mounted radiator, a translucent expansion tank mounted on the right-hand inner wing, a thermostatically-controlled electric cooling fan mounted on the rear of the radiator, a thermostat and a centrifugal coolant pump, as well as the connecting hoses (see illustration). The coolant pump is driven by the engine timing belt.

The system is of the by-pass type, allowing coolant to circulate around the engine while the thermostat is closed. With the engine cold, the thermostat closes off the coolant feed from the bottom radiator hose. Coolant is then drawn into the engine via the heater matrix, inlet manifold and from the top of the cylinder block. This allows some heat transfer, by convection, to the radiator through the top

hose whilst retaining the majority of heat within the cylinder block.

The siting of the thermostat in the intake rather than the outlet side of the system ensures that the engine warms up quickly by circulating a small amount of coolant around a shorter tract. This also prevents temperature build-up in the cylinder head prior to the thermostat opening.

When the coolant reaches a predetermined temperature, the thermostat opens and the coolant is allowed to flow freely through the top hose to the radiator. As the coolant circulates through the radiator, it is cooled by the inrush of air when the vehicle is in forward motion. Airflow is supplemented by the action of the electric cooling fan when necessary. Upon reaching the bottom of the radiator, the coolant is now cooled and the cycle is repeated.

With the engine at normal operating temperature, the coolant expands and some of it is displaced into the expansion tank. This coolant collects in the tank and is returned to the radiator when the system cools.

The electric cooling fan mounted behind the radiator is controlled by a thermostatic

switch located in the radiator side tank. At a predetermined coolant temperature the switch contacts close, thus actuating the fan.

Precautions

Cooling system

Do not attempt to remove the expansion tank filler cap or to disturb any part of the cooling system whilst it or the engine is hot, as there is a very great risk of scalding. If the expansion tank filler cap must be removed before the engine and radiator have fully cooled down (even though this is not recommended) the pressure in the cooling system must first be released. Cover the cap with a thick layer of cloth, to avoid scalding, and slowly unscrew the filler cap until a hissing sound can be heard. When the hissing has stopped, showing that pressure is released, slowly unscrew the filler cap until it can be removed. If more hissing sounds are heard, wait until they have stopped before unscrewing the cap completely. At all times keep well away from the filler opening.

Do not allow antifreeze to come in contact with your skin or painted surfaces of the vehicle. Rinse off spills immediately with plenty of water. Never leave antifreeze lying around, it is fatal if ingested.

If the engine is hot, the electric cooling fan may start rotating even if the engine is not running, so be careful to keep hands, hair and loose clothing well clear when working in the engine compartment.

Air conditioning system

On models equipped with an air conditioning system, it is necessary to observe special precautions whenever dealing with any part of the system, its associated components and any items which necessitate disconnection of the system. If for any reason the system must be disconnected, entrust this task to your Rover dealer or a refrigeration engineer.

Refrigerant must not be allowed to come in contact with a naked flame, otherwise a poisonous gas will be created. Do not allow the fluid to come in contact with the skin or eyes.

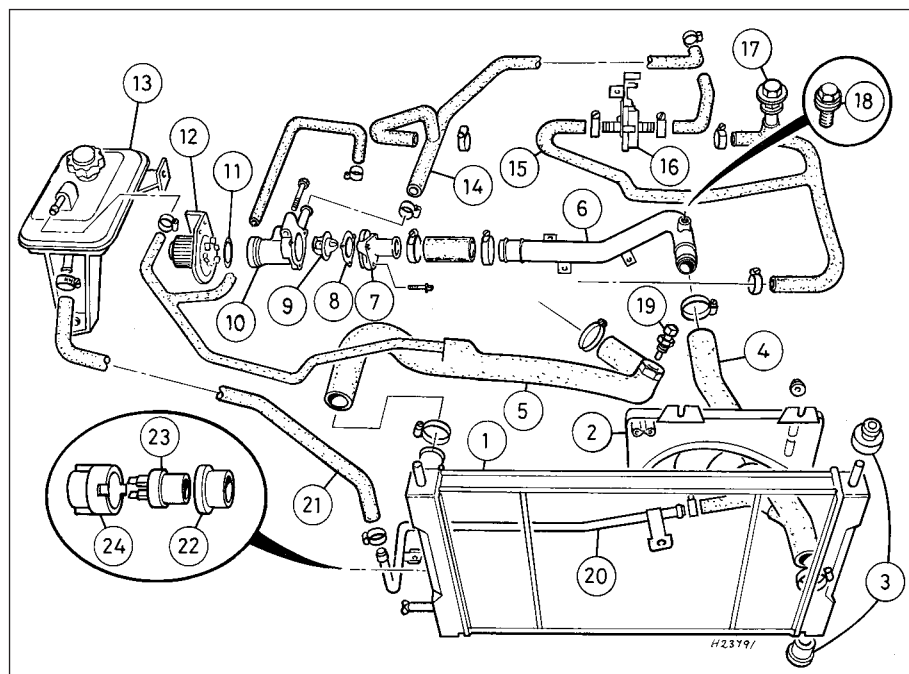

1.0 Cooling system components

- | | | |
|--|---|---|
| 1 Radiator | 9 Thermostat | 18 Cooling system bleed screw |
| 2 Cooling fan and cowling | 10 Thermostat housing | 19 Engine overheat switch - where fitted |
| 3 Radiator mounting rubbers | 11 O-ring | 20 Coolant pipe - expansion tank to bottom hose |
| 4 Bottom hose | 12 Coolant pump | 21 Hose - expansion tank return |
| 5 Top hose | 13 Expansion tank | 22 Sealing ring |
| 6 Coolant pipe - bottom hose to thermostat housing | 14 Hose - heater matrix and manifold return | 23 Cooling fan thermostatic switch |
| 7 Thermostat housing cover | 15 Hose - heater matrix and manifold feed | 24 Locking ring |
| 8 Gasket | 16 Heater temperature control valve | |
| | 17 Coolant filler stem | |

2 Cooling system - draining, flushing and refilling

Refer to Chapter 1.

3 Cooling system - general inspection

Refer to "Weekly Checks" and Chapter 1.

4 Cooling system hoses - renewal



Never work on the cooling system when it is hot. Release any pressure from the system by loosening the expansion tank cap, having first covered it with a cloth to avoid any possibility of scalding.

1 If inspection of the cooling system reveals a faulty hose, then it must be renewed as follows.

2 First drain the cooling system. If the coolant is not due for renewal, it may be re-used if collected in a clean container.

3 To disconnect any hose, use a screwdriver to slacken the clips then move them along the hose clear of the outlet. Carefully work the hose off its outlets. Do not attempt to disconnect any part of the system when still hot.

4 Note that the radiator hose outlets are fragile. Do not use excessive force when attempting to remove the hoses. If a hose proves stubborn, try to release it by rotating it on its outlets before attempting to work it off. If all else fails, cut the hose with a sharp knife then slit it so that it can be peeled off in two pieces. While expensive, this is preferable to buying a new radiator.

5 When refitting a hose, first slide the clips onto the hose then work the hose onto its outlets. If the hose is stiff, use soap as a lubricant or soften it by first soaking it in boiling water whilst taking care to prevent scalding.

6 Work each hose end fully onto its outlet, check that the hose is settled correctly and is properly routed, then slide each clip along the hose until it is behind the outlet flared end before tightening it securely.

7 Refill the system with coolant.

8 Check carefully for leaks as soon as possible after disturbing any part of the cooling system.

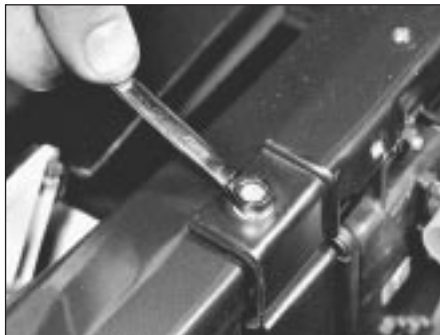

5.7a Undo radiator mounting bolts . . .

5 Radiator and expansion tank - removal, inspection and refitting



Removal

Radiator

1 Drain the cooling system.

2 On models equipped with air conditioning, remove the condenser fan, then undo the two bolts securing the air conditioning pipes to the bonnet platform.

3 Remove the air cleaner metal intake duct and intake hose.

4 Disconnect the radiator cooling fan wiring connector, then slacken and remove the bolt

securing the earth leads to the bonnet platform. Disconnect the wiring from the thermostatic switch(es) which are fitted to the right-hand side of the radiator (see illustrations).

5 Slacken the bottom hose retaining clip and disconnect the hose from the radiator.

6 Slacken the retaining clips and disconnect the top hose from both the radiator and engine coolant elbow (see illustrations). Position the hose clear of the radiator so that it does not hinder removal.

7 Undo the two bolts securing the upper mounting brackets to the bonnet platform and remove the brackets from the radiator. Disengage the radiator from its lower mounting points and carefully manoeuvre it out of the engine compartment (see illustrations).



5.4a Disconnect cooling fan wiring connector then remove earth lead retaining bolt (arrowed)



5.4b Disconnecting wiring connector from radiator switch



5.6a Slacken clips and disconnect top hose from radiator . . .



5.6b . . . and engine coolant elbow



5.7b . . . remove mounting brackets . . .



5.7c . . . and manoeuvre radiator out of engine compartment

3•4 Cooling, heating and ventilation systems

Expansion tank

8 Slacken and remove the three bolts securing the expansion tank to the body. Unscrew the expansion tank cap and tip out its contents into a suitable container.

9 Slacken the retaining clips then disconnect both the hoses from the expansion tank and remove the tank from the vehicle.

Inspection

Radiator

10 If the radiator was removed because of clogging (causing overheating) then try reverse flushing or, in severe cases, use a radiator cleanser strictly in accordance with the manufacturer's instructions. Ensure that the cleanser is suitable for use in a copper/brass radiator. Refer to Chapter 1 for further information

11 Use a soft brush and an air line or garden hose to clear the radiator matrix of leaves, insects etc.



Minor leaks from the radiator can be cured using a suitable sealant with the radiator in situ.

12 Major leaks or extensive damage should be repaired by a specialist, or the radiator should be renewed or exchanged for a reconditioned unit.

13 Examine the mounting rubbers for signs of damage or deterioration and renew if necessary.

Expansion tank

14 Empty any remaining coolant from the tank and flush it with fresh water to clean it. If the tank is leaking it must be renewed but it is worth first attempting a repair using a proprietary sealant or suitable adhesive.

15 The expansion tank cap should be cleaned and checked whenever it is removed. Check that its sealing surfaces and threads are clean and undamaged and that they mate correctly with those of the expansion tank.

16 The cap's performance can only be checked by using a cap pressure-tester (cooling system tester) with a suitable

adaptor. On applying pressure, the cap's pressure relief valve should hold until the specified pressure is reached, at which point the valve should open.

17 If there is any doubt about the cap's performance, then it must be renewed. Ensure that the replacement is of the correct type and rating.

Refitting

Radiator

18 Refitting is the reverse of the removal procedure whilst noting the following:

- Ensure that the radiator is seated correctly and without strain on its mountings.
- Ensure that the radiator hoses are securely held by the retaining clips.
- Ensure that all wiring connectors are correctly routed so that they are clear of the cooling fan and are retained by any necessary clips or ties.
- Refill the cooling system as described in Chapter 1.

Expansion tank

19 Refitting is the reverse of the removal procedure whilst noting the following:

- Ensure that all hoses are correctly routed with no kinks or sharp bends and are securely held by the retaining clips.
- Top up the expansion tank as described in Chapter 1.

6 Thermostat - removal, testing and refitting



Removal

1 Note that access to the thermostat is very limited. Depending on the tools available, it may be easier to raise the front of the vehicle and to work from underneath, ensuring that the vehicle is securely supported on axle stands. In most cases, access is better if the air cleaner and carburettor (or throttle body on SPi engines) are removed and is best if the complete inlet manifold is removed. If the inlet manifold is removed, the thermostat housing



6.1 Thermostat can be removed without disturbing housing if inlet manifold is first removed

cover can be unbolted to remove the thermostat without disturbing the housing itself (see illustration). Whichever method is used, first drain the cooling system.

2 On carburettor models equipped with a catalytic converter, either remove the thermostatically-operated vacuum switch or disconnect the vacuum pipes from the switch so that it can be removed with the thermostat housing.

3 Unbolt the coolant rail from the rear of the cylinder block/crankcase, then slacken the clips and disconnect the coolant rail hose and heater/inlet manifold return hose from the thermostat housing (see illustration).

4 Undo the thermostat housing/dipstick tube-to-cylinder block/crankcase bolt and remove the thermostat housing from the cylinder block/crankcase. Remove the housing O-ring which must be renewed whenever it is disturbed (see illustrations).

5 Slacken and remove the three thermostat housing cover bolts and lift off the housing cover. Discard the gasket and remove the thermostat.

Testing

6 If the thermostat remains in the open position at room temperature, then it is faulty and must be renewed.

7 To test it fully, suspend the (closed) thermostat on a length of string in a container of cold water, with a thermometer beside it.

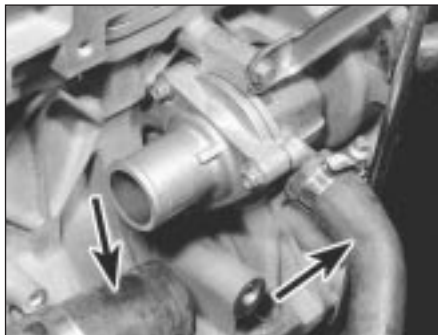

6.3 Disconnect coolant rail and heater/inlet manifold hoses (arrowed) . . .



6.4a . . . unscrew dipstick tube retaining bolt . . .



6.4b . . . and withdraw thermostat housing (O-ring arrowed) - inlet manifold removed for clarity

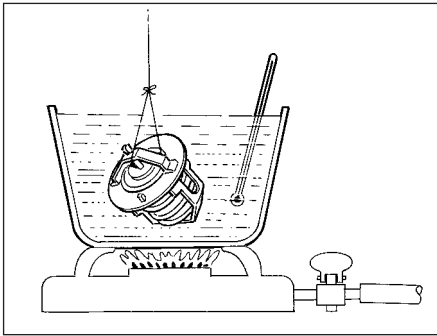

6.7 Testing the thermostat



6.8 Note temperature specification stamped on thermostat end



6.10 Thermostat housing and coolant hoses refitted

Ensure that neither touches the side of the container (see illustration).

8 Heat the water and check the temperature at which the thermostat begins to open. Compare this value with that specified. Continue to heat the water until the thermostat is fully open. The temperature at which this should happen is stamped in the unit's end (see illustration). Remove the thermostat and measure the height of the fully opened valve, then allow the thermostat to cool down and check that it closes fully.

9 If the thermostat does not open and close as described, if it sticks in either position, or if it does not open at the specified temperature, then it must be renewed.

Refitting

10 Refitting is the reverse of the removal procedure, noting the following (see illustration):

- Clean the thermostat housing, housing cover and cylinder block/crankcase mating surfaces thoroughly.
- Always fit a new housing cover gasket and O-ring. Smear the O-ring with grease to aid refitting.
- Tighten all bolts to their specified torque wrench settings (where given).
- Ensure the coolant hose clips are positioned so that they do not foul any other component, then tighten them securely.
- Refit any components removed for improved access.
- Refill the cooling system as described in Chapter 1.



7.5 Removing the coolant pump

7 Coolant pump - removal and refitting

Removal

1 Coolant pump failure is usually indicated by coolant leaking from the gland behind the pump bearing, or by rough and noisy operation, usually accompanied by excessive pump spindle play. If the pump shows any of these symptoms then it must be renewed as follows.

2 Drain the cooling system.

3 Remove the timing belt.

4 Noting the location of the pillar bolt(s), unscrew the five bolts securing the coolant pump to the cylinder block/crankcase, then unscrew the single bolt securing the pump to the timing belt upper left-hand (inner) cover.

5 Withdraw the coolant pump and discard its sealing ring which should be renewed whenever it is disturbed. Carefully clean the cylinder block/crankcase mating surface and the pump socket (see illustration).

Refitting

6 On refitting, install the pump using a new sealing ring and tighten all bolts to the specified torque wrench settings.

7 The remainder of the refitting procedure is the reverse of removal.

8 Electric cooling fan - testing, removal and refitting

Note: On models equipped with air conditioning, there are two switches fitted to the right-hand side of the radiator, the lower of these is the cooling fan switch.

Testing

1 The cooling fan motor is supplied with current via the ignition switch, fuse 4 and the cooling fan relay. The relay is energised by the radiator-mounted thermostatic switch which is fed via fuse number 15.

2 If the fan does not appear to work, first check that both fuses are in good condition and have not blown. Run the engine until normal operating temperature is reached, then allow it to idle. If the fan does not cut in within a few minutes, switch off the ignition and disconnect the two wires from the thermostatic switch. Bridge these two wires with a length of spare wire and switch on the ignition. If the fan now operates, the thermostatic switch is probably faulty and must be tested further as described in Section 9.

3 If the fan still fails to operate, check that full battery voltage is available at the switch's light green and grey wire terminal. If not, check the feed for a blown fuse or other fault such as a broken wire. If the feed is good, check the cooling fan relay, see Chapter 12. If the relay operates correctly, check for continuity between the fan motor black wire terminal and a good earth point on the body. If not, then the earth connection is faulty and must be remade. The circuit earth connection is one of those at earth header 1, attached to the left-hand inner wing panel next to the battery.

4 If the switch and wiring are in good condition, the fault must be in the motor itself. This can be checked by disconnecting it from the wiring loom and connecting a 12 volt supply directly to it. If the motor does not work then it must be renewed.

Removal

5 Drain the cooling system, then jack up the front of the vehicle and support it securely on axle stands.

6 From underneath the front of the vehicle, slacken and remove the three bolts securing the bumper flange to the body. Remove the seven bolts securing the front undercover panel to the body and remove the panel.

7 Remove the air cleaner metal intake duct and intake hose.

8 Slacken the retaining clips and disconnect the top hose from both the radiator and engine. Position the hose clear of the radiator so that it does not hinder removal.

9 Disconnect the radiator cooling fan wiring connector.

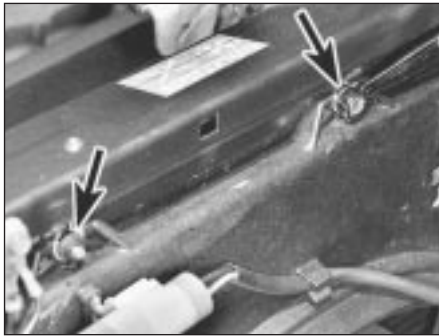

8.10a Undo cooling fan cowl retaining nuts (2 arrowed) . . .



8.10b . . . and remove fan assembly



8.11 Cooling fan motor retaining nuts (arrowed)

10 Undo the four nuts securing the cooling fan cowl to the rear of the radiator and manoeuvre the fan assembly out of the engine compartment (see illustrations).

11 To dismantle the assembly, first prise off the fan retaining circlip, then lift the fan off the motor spindle. Undo the three nuts which secure the motor assembly to the cowl then release the motor wiring and connector and separate the motor and cowl (see illustration).

Refitting

12 Refitting is a reverse of the removal procedure, noting the following:

- a) If necessary, reassemble the fan motor, cowl and fan, then tighten the motor retaining nuts to the specified torque. Ensure that the motor wiring is securely retained by the cowl clips.
- b) Ensure that the radiator hose is securely held by its retaining clips.
- c) On completion, refill the cooling system as described in Chapter 1.

9 Cooling system electrical switches - testing, removal and refitting



Note: On models equipped with air conditioning, there are two switches fitted to the right-hand side of the radiator, the lower of these is the cooling fan switch.

Testing

Cooling fan thermostatic switch

1 Refer to Section 8 for details of a quick test which should eliminate most faulty switches. If the switch is to be renewed, or to be tested thoroughly, it must be removed.

2 To carry out a thorough test of the switch, use two spare wires to connect to it either a multimeter (set to the resistance function) or a battery and bulb test circuit. Suspend the switch in a pan of water which is being heated. Measure the temperature of the water with a thermometer. Do not let either the switch or the thermometer touch the pan itself (see illustration).

3 The switch contacts should close to the ON position (ie: continuity should exist) when the water reaches the temperature specified. Stop heating the water and allow it to cool down. The switch contacts should open.

4 If the switch's performance is significantly different from that specified, or if it does not work at all, then it must be renewed.

Coolant temperature gauge sender unit

5 The coolant temperature gauge mounted in the instrument panel is fed with a stabilised 10 volt supply from the instrument panel feed (via the ignition switch and fuse 1), its earth being controlled by the sender unit.

6 The sender unit is screwed into the coolant outlet elbow mounted on the left-hand end of the cylinder head, underneath the distributor (see illustration). It contains a thermistor, which is an element whose electrical resistance decreases at a predetermined rate as its temperature rises. Thus, when the coolant is cold, the sender's resistance is high, current flow through the gauge is reduced and the gauge needle points to the C (cold) end of the scale. If the unit is faulty it must be renewed.

7 If the gauge develops a fault, check first the other instruments. If they do not work at all, check the instrument panel feed. If the readings are erratic, there may be a fault in the voltage stabiliser which will necessitate the renewal of the gauge unit or printed circuit. If the fault is in the temperature gauge alone, check it as follows.

8 If the gauge needle remains at the C end of the scale, disconnect the sender unit wire and earth it to the cylinder head. If the needle then deflects when the ignition is switched on, then the sender unit is proven faulty and must be renewed. If the needle still does not move, remove the instrument panel and check the continuity of the green/blue wire between the gauge and the sender unit and the feed to the gauge unit. If continuity is shown and the fault still exists, then the gauge is faulty and the gauge unit must be renewed.

9 If the gauge needle remains at the H end of the scale, disconnect the sender unit wire. If the needle then returns to the C end of the scale when the ignition is switched on, then the sender unit is proven faulty and must be renewed. If the needle still does not move, check the remainder of the circuit as described above.

Inlet manifold pre-heater temperature switch - carburettor engines

10 The switch screwed into the underside of the inlet manifold on carburettor engines

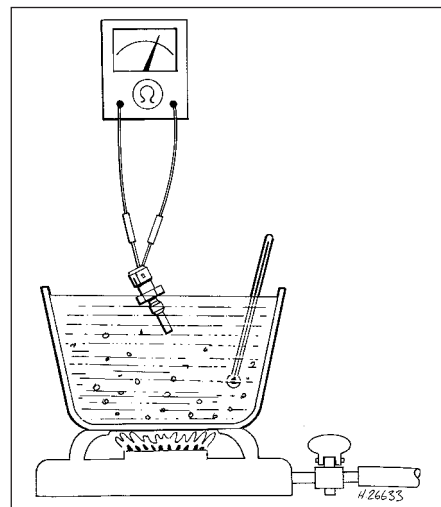

9.2 Testing cooling system electrical switch



9.6 Coolant temperature gauge sender unit

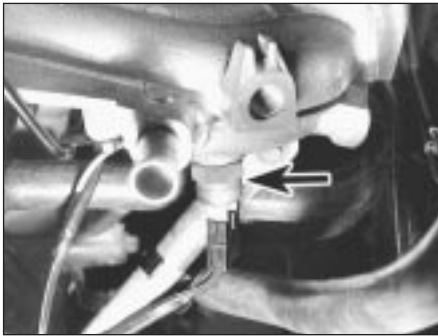

9.10 Inlet manifold pre-heater temperature switch (carburettor engines)

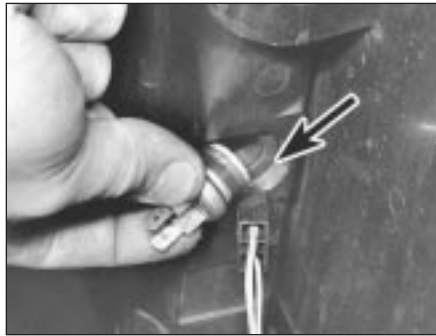

9.20 Remove cooling fan thermostatic switch and withdraw sealing ring (arrowed)

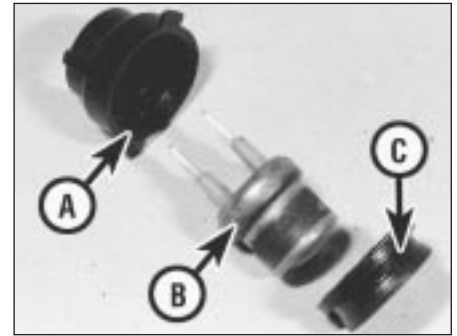

9.27 Cooling fan switch locking ring (A) thermostatic switch (B) and sealing ring (C)

controls the inlet manifold heater circuit (see illustration).

11 The switch contacts should be closed to the ON position (ie: continuity should exist) only at temperatures below 50°C. Remove the switch and test it as described in paragraphs 2 to 4.

Thermostatically-operated vacuum switch - carburettor engines equipped with catalytic converters

12 This switch is screwed into the thermostat housing.

13 To test the switch, fit two suitable lengths of hose to the switch and suspend the switch in a pan of water which is being heated. Measure the temperature of the water with a thermometer. Do not let either the switch or the thermometer touch the pan itself.

14 Blow down one of the hoses attached to the switch. The switch should be closed (ie: passes no air) when the water temperature is below 70°C. Above 70°C, the switch should open and air should flow freely through the hoses. Stop heating the water then allow the water to cool down and check that the switch closes at 70°C or just below.

15 If the switch performance is significantly different from that specified, or if it does not work at all, then it must be renewed.

Coolant temperature sensor - fuel injected engines

16 This sensor, which is screwed into the underside of the inlet manifold (SPi engines), or located in the coolant pipe adjacent to the forward top edge of the timing belt cover (MPI engines), is a thermistor (see paragraph 6) which is supplied with approximately 5 volts by the engine management system ECU. The ECU also controls the sensor's earth path and, by measuring the amount of current in the sensor circuit, determines the engine's temperature. This information is used, in conjunction with other inputs, to control idle speed, injector opening time duration and ignition timing.

17 If the sensor circuit should fail to provide adequate information, the ECU's back-up

facility assumes a value corresponding to 60°C. The sensor itself can be tested only by having a Rover dealer check the complete system using the correct diagnostic equipment. Do not attempt to test the circuit using any other equipment, or the ECU will be damaged.

Removal

Cooling fan thermostatic switch

18 With the engine and radiator cold, either drain the cooling system down to the level of the sender unit, or unscrew the expansion tank filler cap to release any remaining pressure and have a suitable plug ready that can be used to stop the escape of coolant while the switch is removed.

19 Disconnect the battery negative lead.

20 Disconnect the wiring connector from the switch then rotate the locking ring to release it. Withdraw the switch and sealing ring from the radiator (see illustration).

Coolant temperature gauge sender unit

21 With the engine and radiator cold, either drain the cooling system down to the level of the switch, or unscrew the expansion tank filler cap to release any remaining pressure and have a suitable plug ready that can be used to stop the escape of coolant while the unit is removed.

22 Disconnect the battery negative lead.

23 Disconnect the unit's wiring connector and unscrew the unit from the coolant outlet elbow.

Inlet manifold pre-heater temperature switch - carburettor engines

24 Refer to Chapter 4.

Thermostatically-operated vacuum switch - carburettor engines equipped with catalytic converters

25 Refer to Chapter 5.

Coolant temperature sensor - fuel injected engines

26 Refer to Chapter 4.

Refitting

Cooling fan thermostatic switch

27 On refitting, renew the sealing ring if it is worn or compressed and carefully clean the radiator seat before pressing in the sealing ring and switch (see illustration). Refit the locking ring and rotate it to tighten it securely. Reconnect the switch and battery, then replenish the cooling system.

Coolant temperature gauge sender unit

28 On refitting, apply a suitable sealant to the unit threads and tighten it to its specified torque wrench setting. Reconnect the unit and battery, then replenish the cooling system.

Inlet manifold pre-heater temperature switch - carburettor engines

29 Refer to Chapter 4.

Thermostatically-operated vacuum switch - carburettor engines equipped with catalytic converters

30 Refer to Chapter 5.

Coolant temperature sensor - fuel injected engines

31 Refer to Chapter 4.

10 Heater components - removal and refitting



Removal

Heater unit

1 Drain the cooling system.

2 Working in the engine compartment, slacken the hose clips and disconnect the heater feed and return hoses from the matrix outlets on the bulkhead. Disconnect the cable inner from the heater valve and free the cable outer from its retaining clip. Slacken and

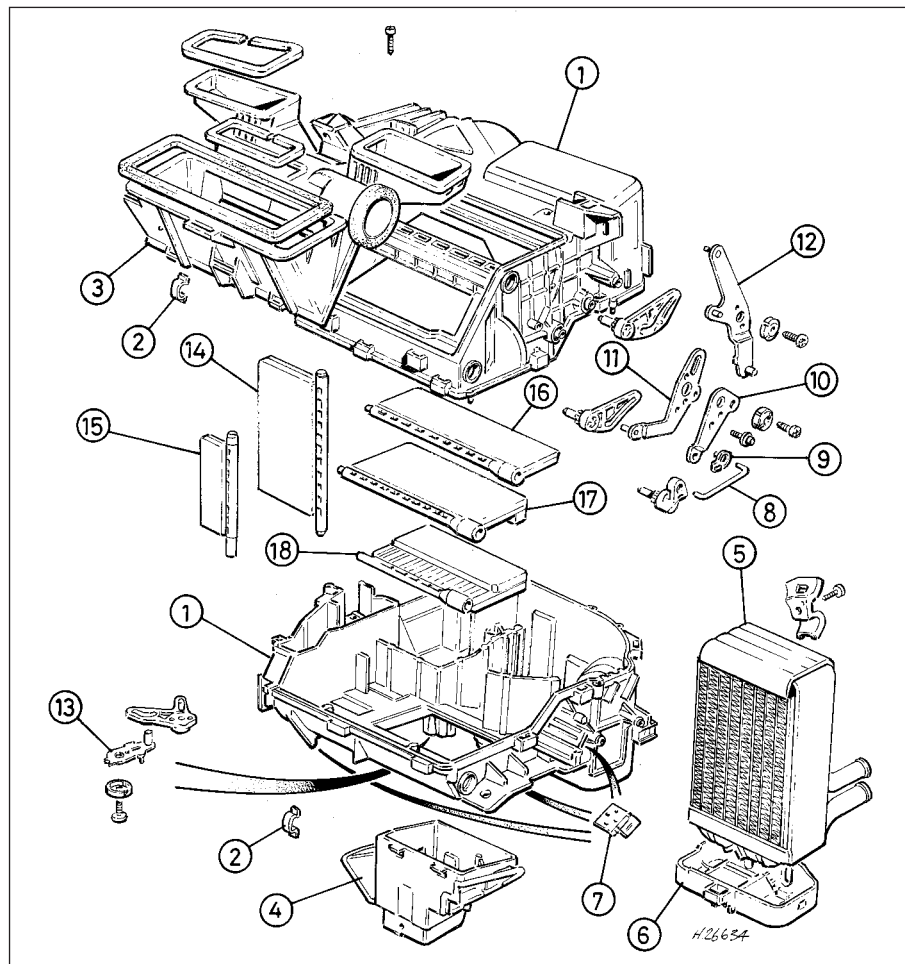

10.2a Heater unit components

- | | | |
|------------------------------|------------------------------------|--|
| 1 Heater case | 8 Floor level flap operating lever | 15 Ambient air flap - centre console vents |
| 2 Heater case clip | 9 Clip | 16 Distribution flap - windscreen |
| 3 Face level/windscreen duct | 10 Floor level flap idler lever | 17 Distribution flap - face level vents |
| 4 Floor level duct | 11 Face level flap idler lever | 18 Distribution flap - floor level vents |
| 5 Heater matrix | 12 Flap operating lever | |
| 6 Heater matrix cover | 13 Air mix flap operating lever | |
| 7 Cable retaining clip | 14 Air mix flap | |

remove the heater lower mounting nut which is situated just to the left of the matrix outlets (see illustrations).

3 Working inside the vehicle, remove the fascia.

4 Slacken and remove the two retaining screws and the blower motor-to-heater unit duct (see illustration). On models equipped with air conditioning, the evaporator unit is fitted in place of the duct. It may be possible to gain the necessary clearance required to disengage the evaporator from the heater unit by removing the mounting brackets and nuts. If not, the evaporator must be removed.

5 Undo the screw securing the right-hand heater duct to the mounting bracket, then move the duct to the right to disengage it from the heater unit (see illustrations).

6 Undo the inertia switch retaining nut and disengage the switch from the steering column support bracket.



10.4 Remove blower motor-to-heater unit duct



10.2b Disconnect heater feed and return hoses . . .



10.2c . . . and free heater valve cable from retaining clip



10.2d Slacken and remove heater unit lower mounting nut

7 Release the wiring block connector from the right-hand end of the steering column support bracket and undo the fusebox



10.5a Undo right-hand duct retaining screw (arrowed) . . .



10.5b ... and disengage duct from heater unit



10.7a Release wiring connector from steering column support bracket and remove fusebox nut (arrowed)



10.7b Remove mounting bolts and manoeuvre steering column mounting bracket out of position

retaining nut. Slacken and remove the five support bracket retaining bolts and remove the bracket from the vehicle (see illustrations).

8 Disconnect the air recirculation cable inner from the flap and free the cable outer from the blower motor.

9 Prise out the stud securing the rear heater duct sleeve to the bottom of the heater unit, then slide the sleeve down to disengage it from the unit (see illustration).

10 Disconnect the wiring connectors from the heater control panel, then remove the two upper heater unit retaining nuts and carefully manoeuvre the heater unit out of the vehicle (see illustrations).

Heater matrix

11 Remove the heater unit.

12 Undo the screw securing the matrix outlet pipe bracket to the heater unit and remove the bracket (see illustration).

13 Slacken and remove the two matrix cover retaining screws, then remove the cover and withdraw the matrix from the heater unit (see illustrations).

14 If the matrix is leaking, it is best to obtain a new or reconditioned unit as home repairs are seldom successful. If it is blocked, it can sometimes be cleared by reverse flushing using a garden hose. Use a proprietary radiator cleaning product if absolutely necessary.



10.9 Remove retaining stud and disengage rear heater duct sleeve from heater unit

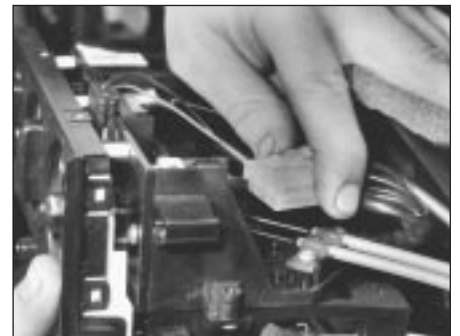

10.10a Disconnect wiring from heater control panel ...



10.10b ... and remove heater retaining nuts



10.12 Undo retaining screw and remove matrix outlet pipe bracket



10.13a Undo two matrix cover retaining screws ...



10.13b ... then remove cover ...



10.13c ... and withdraw matrix from heater unit



10.15 Glovebox damper retaining screw (arrowed)



10.16 Remove glovebox support rail . . .



10.17 . . . then remove blower motor-to-heater unit duct

Heater blower motor

15 Undo the two glovebox retaining screws then partially withdraw the glovebox until access can be gained to the glovebox damper to fascia screw. Undo the damper screw and remove the glovebox and damper (see illustration).

16 Slacken and remove the four glovebox support rail mounting bolts and remove the rail (see illustration).

17 Slacken and remove the two retaining screws and remove the blower motor-to-heater unit duct (see illustration). On models equipped with air conditioning, the evaporator unit is fitted in place of the duct. It may be possible to gain the necessary clearance

required to disengage the evaporator and remove the blower motor by removing the mounting brackets and nuts. If not, the evaporator must be removed.

18 Disconnect the air recirculation cable inner from the flap and free the cable outer from the blower motor. Disconnect the two blower motor wiring connectors (see illustration).

19 Slacken and remove the three blower motor mounting bolts and manoeuvre the blower unit out from underneath the fascia (see illustrations).

20 To remove the motor from the unit, undo the four motor cover retaining screws, then disconnect the breather hose and lift off the

cover. Slacken and remove the three motor retaining bolts and withdraw the motor assembly from the blower unit. Undo the fan retaining nut and separate the fan and motor, noting the seal fitted between the two components (see illustrations).

Heater blower motor resistor

21 Remove the glovebox as described in paragraphs 15 and 16.

22 Disconnect the wiring connector, then undo the two retaining screws and remove the resistor from the front of the motor assembly.

Heater valve

23 Working in the engine compartment, disconnect the cable inner from the heater

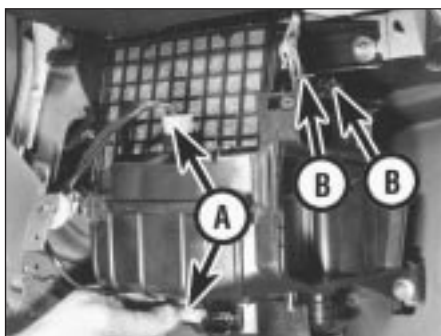

10.18 Disconnect motor wiring connectors (A) and air recirculation cable (B)



10.19a Undo three blower motor mounting bolts (arrowed) . . .



10.19b . . . and remove unit from behind fascia



10.20a Remove motor cover retaining screws (arrowed) . . .



10.20b . . . and disconnect breather hose



10.20c Undo motor retaining bolts and withdraw motor from unit



10.20d Remove fan retaining nut . . .



10.20e . . . and lift off fan (seal arrowed)

valve and free the cable outer from the retaining clip.

24 Slacken and remove the bolt securing the heater valve mounting bracket to the engine compartment bulkhead.

25 Either drain the cooling system or clamp the coolant hoses on each side of the coolant valve to minimise the loss of coolant.

26 Slacken the hose retaining clips, then disconnect both hoses from the coolant valve and remove the valve from the engine compartment. Mop up any spilt coolant immediately.

Refitting

Heater unit

27 Refitting is a reverse of the removal procedure, noting the following:

- Ensure that the heater ducts are securely connected to the unit so that there are no air leaks or gaps.
- Check the operation of all heater cables before refitting the facia, ensuring that the relevant component moves smoothly from the fully open to the fully closed position. If necessary, adjustments can be made by releasing the relevant retaining clip and repositioning the cable outer.
- Ensure that the heater hoses are correctly reconnected and are securely held by the retaining clips.
- Tighten the heater lower mounting nut to the specified torque setting.
- Refill the cooling system as described in Chapter 1.



12.2a Disconnect control cables from heater unit . . .



12.2b . . . and remove heater control panel with cables

Heater matrix

28 Refitting is a reverse of the removal procedure.

Heater blower motor

29 Refitting is a reversal of the removal sequence, noting the following:

- Ensure that the foam rubber seal is refitted correctly so that the blower motor-to-bulkhead aperture is closed off.
- Tighten the blower motor mounting bolts to the specified torque setting.
- Ensure that the air recirculation cable and flap functions correctly before refitting the glovebox. If necessary, adjust by releasing the cable retaining clip and repositioning the cable outer.

Heater blower motor resistor

30 Refitting is a reverse of the removal procedure.

Heater valve

31 Refitting is a reversal of the removal procedure. On completion, check the heater cable operates smoothly and replenish the cooling system.

11 Heater ducts and vents - removal and refitting



Removal

Facia ducts

- Remove the facia.

2 The ducts are mounted on the facia assembly and can be removed individually, once the retaining screws have been removed.

Heater unit ducts

3 The left-hand heater unit to blower motor duct is removed as described in paragraphs 15 to 17 of Section 10.

4 To remove the right-hand duct, first remove the facia. Slacken and remove the retaining screw which secures the right-hand end of the duct to the mounting bracket and release the radio aerial from the retaining clips on the underside of the duct. The duct can then be manoeuvred out of position.

5 Removal of the lower ducts which supply air to the rear passenger footwells is a complex job, requiring the removal of the front seats, centre console and the various trim panels so that the floor carpet can be peeled back, and is therefore not recommended.

Centre console vents

6 Remove the centre console.

7 The vents can then be unclipped from the rear of the front console section and removed.

Facia vents

8 The adjustable face-level vents can be removed by prising them gently out of the facia until the clips are released, taking care not to mark the facia.

9 The door window demister vents, fitted to the sides of the facia, can also be prised out of position once the relevant door has been opened.

Refitting

10 Refitting is a reverse of the removal procedure.

12 Heater controls - removal, refitting and adjustment



Removal

- Remove the heater unit.
- Disconnect the heater control cables from the heater unit and unclip the control panel. Remove the panel assembly complete with cables (see illustrations).

Refitting and adjustment

- Refit the heater control panel to the heater unit and reconnect the necessary control cables to their original positions.
- Check the operation of the control cables, ensuring that they operate smoothly and move the necessary component from the fully open to the fully closed position. Adjustments can be made by releasing the cable retaining clip and repositioning the cable outer.
- Once the necessary control cables are functioning correctly, refit the heater unit.

13 Air conditioning compressor drivebelt - inspection, adjustment and renewal

Refer to Chapter 1 (alternator drivebelt check).

14 Air conditioning refrigerant - level check

Refer to Chapter 1.

15 Air conditioning system components - removal and refitting



Warning: The air conditioning system must be professionally discharged before carrying out any of the following work. Cap or plug the pipe lines as soon as they are disconnected to prevent the entry of moisture.

Compressor

Removal

- 1 Remove the alternator/air conditioning compressor drivebelt as described in Chapter 1.
- 2 Disconnect the air conditioning pipes from the compressor (see illustration).
- 3 Slacken and remove the four bolts securing the compressor to the mounting bracket and manoeuvre it downwards and away from the engine.

Refitting

4 Refitting is a reverse of the removal sequence, tightening the compressor mounting bolts to the specified torque setting. Ensure that the compressor pipe unions are securely tightened then refit and adjust the drivebelt as described in Chapter 1. On completion, have the air conditioning system recharged by a refrigeration specialist or suitably-equipped Rover dealer.

Condenser

Removal

- 5 Remove the front bumper.
- 6 Slacken and remove the bolts securing the power steering oil cooler to the body, then undo the bonnet lock mounting bracket bolts and position the lock assembly clear of the condenser unit.
- 7 Unscrew the air conditioning pipe union nuts from the condenser unit then disconnect the pipes. Discard the union pipe O-rings as these must be renewed whenever they are disturbed.
- 8 Slacken and remove the four retaining bolts and withdraw both the condenser upper mounting brackets. Release the condenser from its lower mounting points and manoeuvre it away from the vehicle.

Refitting

- 9 Prior to refitting, check the condenser lower mounting rubbers for signs of damage or deterioration and renew as necessary. Renew the pipe union O-rings.
- 10 Refitting is a direct reversal of the removal procedure, tightening the pipe union nuts to the specified torque setting. On completion, have the air conditioning system recharged by a refrigeration specialist or a suitably equipped Rover dealer.

Condenser cooling fan

Removal

- 11 Drain the cooling system.
- 12 Disconnect the wiring connector from the engine overheat switch, located in the top coolant hose, then slacken the clips securing the hose to the radiator and engine. Disconnect the hose from the radiator and engine and position it clear of the condenser so that it does not hinder removal.
- 13 Disconnect the condenser fan electrical wiring connector then undo the four fan cowling retaining nuts and manoeuvre the assembly out of the engine compartment.

14 To dismantle the assembly, first undo the fan retaining nut then lift the fan off the motor spindle. Undo the two screws which secure the motor assembly to the cowling then release the motor wiring and connector and separate the motor and cowling.

Refitting

- 15 Refitting is a reverse of the removal procedure, noting the following points:
 - a) Ensure that the motor wiring is securely retained by the cowling clips and is clear of the condenser fan.
 - b) Ensure that the radiator hose is securely held by its retaining clips.
 - c) On completion, refill the cooling system.

Evaporator

Removal

16 Undo the three bolts which secure the washer system reservoir to the engine compartment bulkhead and move the reservoir to gain access to the two evaporator union nuts. Slacken both the union nuts and disconnect the pipes from the evaporator. Remove the O-rings from the union nuts and discard them.

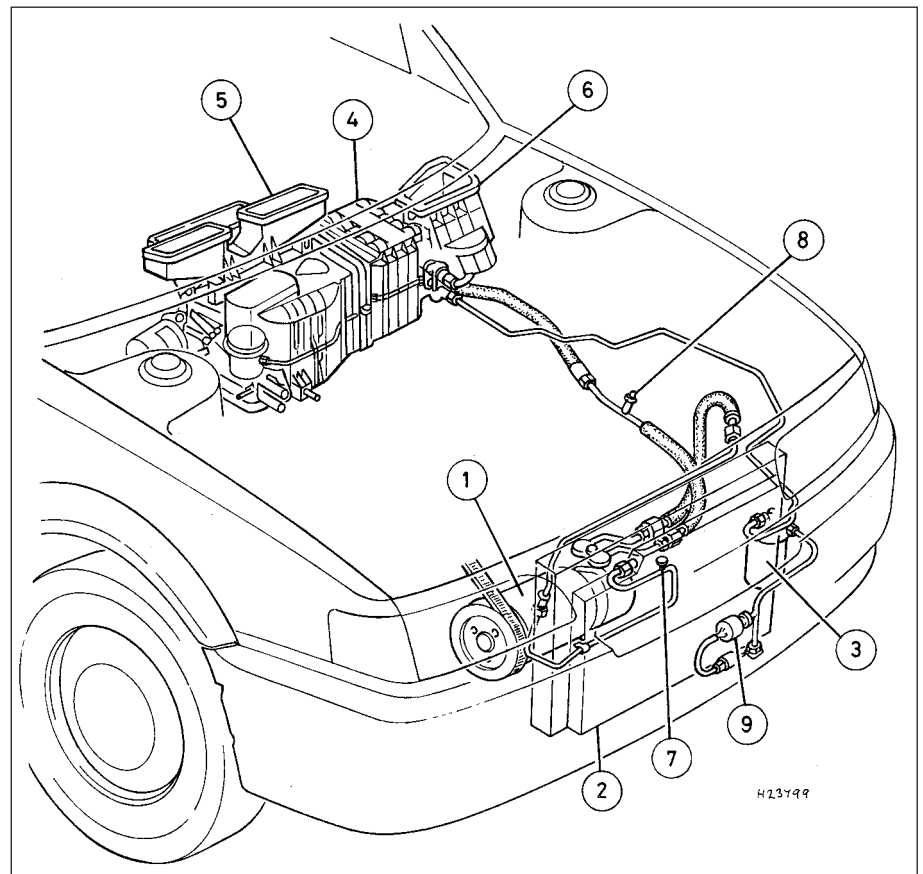

15.2 Air conditioning system layout

- | | | |
|------------------|--------------------------------------|-------------------------------------|
| 1 Compressor | 5 Heater unit | 8 Low pressure servicing connection |
| 2 Condenser | 6 Blower unit | 9 Trinary switch |
| 3 Receiver drier | 7 High pressure servicing connection | |
| 4 Evaporator | | |

17 Working from inside the vehicle, undo the two glovebox retaining screws, then partially withdraw the glovebox until access can be gained to the glovebox damper-to-facia screw. Undo the damper screw and remove the glovebox and damper.

18 Slacken and remove the four glovebox support rail mounting bolts and remove the rail.

19 Undo the two evaporator bracket retaining bolts and remove both the brackets.

20 Disconnect the wiring connector from the right-hand side of the evaporator.

21 Slacken and remove the two evaporator mounting nuts and manoeuvre the unit out of position.

Refitting

22 Refitting is a reverse of the removal procedure noting the following:

- a) *Ensure that the evaporator is correctly joined to the heater unit and blower motor, so that there are no air leaks or gaps, then tighten the retaining nuts and bracket bolts securely.*
- b) *Fit new O-rings to the pipe unions and*

tighten the union nuts to the specified torque setting.

- c) *On completion, have the system recharged by a refrigeration specialist or a suitably-equipped Rover dealer.*

Receiver drier

Removal

23 Remove the left-hand headlamp and the battery and battery tray.

24 Undo the two screws securing the air intake grille to the body. Disengage the grille from the resonator and remove it from the vehicle. Move the resonator to one side to gain access to the receiver drier.

25 Slacken the union nuts and disconnect the pipes from the receiver drier noting the O-rings which are fitted to the pipe unions. Discard the O-rings as they must be renewed whenever they are disturbed. The receiver drier unit unions must be capped immediately after they are disconnected and must remain capped until they are to be reconnected. If the receiver drier unit is left uncapped for any period of time it must be renewed.

26 Slacken the receiver drier clamp bolt then slide the unit out of the retaining clamp and remove it from the engine compartment.

Refitting

27 Refitting is a direct reversal of the removal sequence, tightening the pipe union nuts to the specified torque setting. On completion, have the system recharged by a refrigeration specialist or suitably-equipped Rover dealer.

Trinary switch

Removal

28 Remove the front bumper.

29 Disconnect the wiring connector and unscrew the switch from the air conditioning pipe. Remove the O-ring from the switch and discard it.

Refitting

30 Refitting is a reverse of the removal procedure. Fit a new O-ring to the switch and tighten it to the specified torque setting. On completion, have the system recharged by a refrigeration specialist or suitably-equipped Rover dealer.





Chapter 4 Part A

Fuel and exhaust systems - carburettor engines

Contents

Accelerator cable - removal, refitting and adjustment	9	Exhaust manifold - removal and refitting	17
Accelerator pedal - removal and refitting	10	Exhaust system - inspection, removal and refitting	18
Accelerator pedal switch - removal and refitting	11	Fuel gauge sender unit - removal and refitting	7
Air cleaner air temperature control system - inspection and component renewal	4	Fuel pump - testing, removal and refitting	6
Air cleaner assembly - removal and refitting	3	Fuel system - inspection	5
Air cleaner filter element - renewal	2	Fuel tank - removal and refitting	8
Carburettor - diagnosis, overhaul and adjustments	14	General information and precautions	1
Carburettor - removal and refitting	13	Inlet manifold - removal and refitting	16
Choke cable - removal, refitting and adjustment	12	Inlet manifold pre-heater - operation, removal and refitting	15

Degrees of difficulty

Easy , suitable for novice with little experience 	Fairly easy , suitable for beginner with some experience 	Fairly difficult , suitable for competent DIY mechanic 	Difficult , suitable for experienced DIY mechanic 	Very difficult , suitable for expert DIY or professional 
--	---	---	--	---

Specifications

Fuel pump

Type Mechanical, driven by eccentric on camshaft

Carburettor

Type Hobourn-SU constant-depression/variable choke
 Designation KIF 44
 Carburettor number:
 Without catalytic converter MAC 10004 or 10025
 With catalytic converter MAC 10011 or 10027
 Throttle bore diameter 44.0 mm
 Piston spring colour code Red
 Damper LZX 2337
 Jet size ZX 2237 (0.100 in)
 Needle identification BGZ
 Needle valve seat LZX 1756
 Fast idle speed - at choke control first detent 1200 rpm
 Idle speed 850 ± 50 rpm
 CO level at idle speed - engine at normal operating temperature:
 Without catalytic converter 2.0 to 3.0 %
 With catalytic converter - at gas sampling pipe 1.0 to 3.0 %
 Choke type Manual

Recommended fuel

Minimum octane rating:
 Without catalytic converter 95 RON unleaded (ie: unleaded Premium) or 97 RON leaded (ie: 4-star)
 With catalytic converter 95 RON unleaded (ie: unleaded Premium)

4A•2 Fuel and exhaust systems - carburettor engines

Torque wrench settings	Nm	lbf ft
Fuel system		
Carburettor retaining screws	10	7
Carburettor vent and air bleed pipe mounting nuts and bolts	9	7
Needle retaining (grub) screw	1.7 to 2.3	1.3 to 1.7
Throttle disc retaining screws	0.80 to 1.14	0.59 to 0.84
Fuel pump mounting nuts	10	7
Fuel tank hose retaining clip and union nuts	9	7
Manifold temperature sensor	15	11
Inlet manifold nuts and bolts	25	18
Inlet manifold support stay bolts	25	18
Exhaust system		
Manifold retaining nuts	45	33
Manifold shroud screws	6	4
System flange nuts:		
Manifold-to-front pipe joint	50	37
All other joints	45	33
Front pipe mounting bolts	15	11

1 General information and precautions

General information

The fuel system consists of a fuel tank mounted under the rear of the vehicle, a mechanical fuel pump and a carburettor. The fuel pump is operated by an eccentric on the camshaft and is mounted on the rear of the cylinder head. The air cleaner contains a disposable paper filter element and incorporates a flap valve air temperature control system which allows cold air from the outside of the vehicle and warm air from around the exhaust manifold to enter the air cleaner in the correct proportions.

The carburettor is the Hobourn SU-manufactured KIF type, a development by Rover of the previous HIF instrument. To reduce emissions and to improve driveability when the engine is cold, the inlet manifold is heated by the cooling system coolant and by an electric pre-heater system. Mixture enrichment for cold starting is by a manually-operated choke control.

The exhaust system consists of three sections which are the front pipe and front silencer box, the intermediate pipe and middle silencer box, and the tailpipe and main silencer box. The system is suspended throughout its entire length by rubber mountings. If a catalytic converter is fitted, the exhaust system consists of four sections, the catalytic converter being situated between the front pipe and the (much shorter) intermediate pipe.

Precautions

Fuel warning

Many of the procedures in this Chapter require the removal of fuel lines and

connections which may result in some fuel spillage. Before carrying out any operation on the fuel system, refer to the precautions given in *Safety first!* at the beginning of this Manual and follow them implicitly. Petrol is a highly dangerous and volatile liquid and the precautions necessary when handling it cannot be overstressed.

Unleaded petrol - usage

The information given in this Chapter is correct at the time of writing and applies only to petrol currently available in the UK. If updated information is required, check with a Rover dealer. If travelling abroad, consult one of the motoring organisations (or a similar authority) for advice on petrol types available and their suitability for your vehicle.

The fuel recommended by Rover for the 214 and 414 models is given in Specifications, followed by the equivalent petrol currently on sale in the UK. RON and MON are different testing standards. RON stands for Research Octane Number (also written as RM); MON stands for Motor Octane Number (also written as MM, which is a different name for the same octane scale).

All Rover 214 and 414 models are designed

to run on 95 (RON) octane petrol. Super/Super Plus (unleaded) petrols can be used without modification. If nothing else is available, 4-star (leaded) petrol can only be used if the vehicle is **not** fitted with a catalytic converter. The only vehicles which **must** use unleaded petrol at all times are those with catalytic converters.

Catalytic converters

Before attempting work on these items, carefully read the precautions listed in Part D of this Chapter.

2 Air cleaner filter element - renewal

Refer to Chapter 1.

3 Air cleaner assembly - removal and refitting



Removal

1 Release the two clips securing the air intake duct to the assembly, then undo the four screws securing the assembly to its mounting bracket.

2 Release the assembly from the intake duct and withdraw it until the thermac switch vacuum pipes can be reached. Make a note of the correct fitted positions of the pipes to ensure that they are correctly connected on refitting (yellow to the temperature control valve, red to the inlet manifold) then disconnect them and withdraw the air cleaner assembly (see illustration).

3 Check the condition of the O-ring around the carburettor inlet and renew it if worn or damaged.



3.2 Note colour-coding of thermac switch vacuum pipes before disconnecting



3.4 Slacken clamp to disconnect intake hose from air cleaner assembly metal intake duct

4 To remove the metal intake duct, disconnect the vacuum pipe from the air temperature control valve and slacken the intake hose retaining clamp (see illustration). Undo the fastener securing the duct to its mounting bracket and remove the metal duct, taking care not to lose the hot air intake connector hose which connects the duct to the exhaust manifold shroud.

5 To remove the air intake hose, it will first be necessary to remove the left-hand headlamp assembly so as to gain access to the two retaining screws. Remove the retaining screws securing the front of the hose to the body front panel then release the clip securing the ignition HT lead to the hose. If the metal intake duct is still in position, slacken the hose clamp then remove the hose from the engine compartment.

6 A resonator chamber is fitted to the intake hose to reduce the amount of induction noise. To remove the chamber, first remove the battery and battery tray. Disconnect the intake hose and release any relevant retaining clips from the resonator then remove the resonator from the engine compartment.

Refitting

7 Refitting is the reverse of the removal procedure. Ensure that the vacuum pipes are correctly reconnected and are not trapped as the assembly is refitted, then check that the assembly sits properly on the carburettor inlet before tightening the screws securely.

4 Air cleaner air temperature control system - inspection and component renewal



Inspection

1 The system is controlled by a thermac switch mounted in the air cleaner assembly. When the engine is started from cold, the switch is closed to allow inlet manifold depression to act on the air temperature control valve in the intake duct. This raises a vacuum servo in the valve assembly and draws a flap valve across the cold air intake,



4.4 Disconnect vacuum pipe from control valve to check operation of system components

thus allowing only (warmed) air from around the exhaust manifold to enter the air cleaner.

2 As the temperature of the exhaust-warmed air in the air cleaner rises, a bi-metallic strip in the thermac switch deforms and opens the switch to shut off the depression in the air temperature control valve assembly. The flap is lowered gradually across the hot air intake until, when the engine is fully warmed-up to normal operating temperature, only cold air from the front of the vehicle is entering the air cleaner.

3 To check the system, allow the engine to cool down completely, then slacken the intake hose retaining clamp and disconnect the hose from the metal intake duct. The flap valve in the duct should be securely seated across the hot air intake. Start the engine. The flap should immediately rise to close off the cold air intake and should then lower steadily as the engine warms up, until it is eventually seated across the hot air intake again.

4 To check the thermac switch, disconnect the vacuum pipe from the control valve when the engine is running and place a finger over the pipe end (see illustration). When the engine is cold, full inlet manifold vacuum should be present in the pipe. When the engine is at normal operating temperature, there should be no vacuum in the pipe.

5 To check the air temperature control valve, slacken the intake hose retaining clamp and disconnect the hose from the metal intake duct. The flap valve should be securely seated



4.11 Disconnecting vacuum pipe from air temperature control valve - intake hose-to-metal intake duct securing clamp (arrowed)



4.9 Thermac switch is clipped into air cleaner assembly

across the hot air intake. Disconnect the vacuum pipe and suck hard at the control valve stub. The flap should rise to shut off the cold air intake.

6 If any component is faulty then it must be renewed.

Thermac switch - renewal

7 Remove the air cleaner assembly.

8 Release the lid retaining clips then remove the lid and withdraw the air cleaner filter element.

9 Bend up the tags on the switch clip and remove the clip, then withdraw the switch and its seal (see illustration).

10 Refitting is the reverse of the removal procedure. Ensure that the switch mating surfaces are clean and that the switch and seal are correctly located before fastening the clip.

Air temperature control valve - renewal

11 Disconnect the vacuum pipe from the air temperature control valve, then slacken the intake hose retaining clamp and disconnect the hose from the metal intake duct (see illustration).

12 Release the two clips securing the air intake duct to the air cleaner assembly and undo the fastener securing the duct to its mounting bracket. Withdraw the duct, taking care not to lose the hot air intake connector hose which connects the duct to the manifold shroud (see illustration).



4.12 Do not lose hot air intake connector hose when removing air cleaner metal intake duct



6.3 Plug fuel hoses after disconnection - pump inlet hose disconnected, outlet hose arrowed

13 The air temperature control valve can be renewed only with the complete intake duct assembly. If a new intake duct assembly is being fitted, undo the four screws securing the hot air intake adaptor plate to the bottom of the duct and transfer the adaptor plate to the new duct.

14 Refitting is the reverse of the removal procedure.

5 Fuel system - inspection

Refer to Chapter 1.

6 Fuel pump - testing, removal and refitting



Testing

1 To test the fuel pump on the engine, temporarily disconnect the outlet pipe which leads to the carburettor and hold a wad of rag over the pump outlet while an assistant spins the engine on the starter. Keep your hands away from the electric cooling fan. Regular spurts of fuel should be ejected as the engine turns.

2 The pump can also be tested by removing it. With the pump outlet pipe disconnected but the inlet pipe still connected, hold a wad



7.4 Undo three screws to remove fuel gauge sender unit access cover



6.5 Removing fuel pump and insulating block

of rag by the outlet. Operate the pump lever by hand, moving it in and out. If the pump is in a satisfactory condition, a strong jet of fuel should be ejected.

Removal

3 Identify the pump inlet and outlet hoses then, using a pair of pliers, release the retaining clips and disconnect them from the pump. Place wads of rag beneath the hose unions to catch any spilled fuel and plug the hose ends to minimise fuel loss (see illustration).

4 Slacken and remove the nuts and washers securing the pump to the cylinder head.

5 Withdraw the fuel pump from the engine and remove the insulating block (see illustration).

Refitting

6 Refitting is the reverse of the removal procedure. Clean the mating surfaces and renew the insulating block if its sealing surfaces are marked or damaged. Tighten the pump mounting nuts to the specified torque wrench setting.

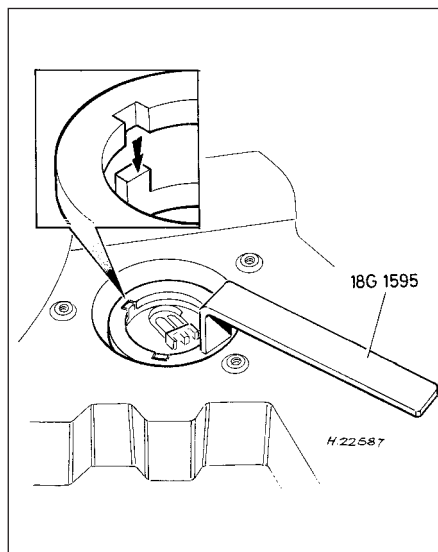

7.6 Using Rover special tool to remove fuel gauge sender unit

7 Fuel gauge sender unit - removal and refitting



Removal

1 Disconnect the battery negative lead.
2 On 214 models, open the tailgate and remove the parcel tray shelf. Fold the rear seats fully forwards then raise the luggage compartment carpet to gain access to the fuel sender unit access cover.

3 On 414 models, open the boot lid and lift up the luggage compartment carpet to gain access to the fuel sender unit access cover.

4 On all models, undo the three screws and remove the access cover from the floor (see illustration).

5 Remove the sender unit wiring connector rubber cover and disconnect the connector from the sender.

6 Unscrew the sender unit retaining ring by turning it in an anti-clockwise direction and remove it from the fuel tank. In the absence of the special Rover ring spanner, Service tool number 18G 1595 (see illustration), a pair of slip-jointed pliers will serve as an adequate substitute to slacken the ring.

7 Carefully lift the sender unit, taking great care not to bend or damage the sender float, and remove the sealing ring. Examine the sealing ring and renew it if it is worn or damaged.

Refitting

8 Refitting is the reverse of the removal procedure. Ensure that the tab on the sender unit is correctly engaged with the cutout in the fuel tank.

8 Fuel tank - removal and refitting



Warning: Do not under any circumstances attempt to solder or weld a fuel tank.

Removal

1 Before removing the fuel tank, all fuel must be drained from the tank. Since a fuel tank drain plug is not provided, it is therefore preferable to carry out the removal operation when the tank is nearly empty. Before proceeding, disconnect the battery negative lead and syphon or hand pump the remaining fuel from the tank.

2 Chock the front wheels, then jack up the rear of the vehicle and support it on axle stands. Remove the left-hand rear roadwheel.

3 Undo the bolt then slacken and remove the two screws securing the cover fitted to the left-hand side of the fuel tank. Prise out the screw retaining plugs and remove the cover to



8.3 Removing cover retaining bolt (arrowed) and screw retaining plugs

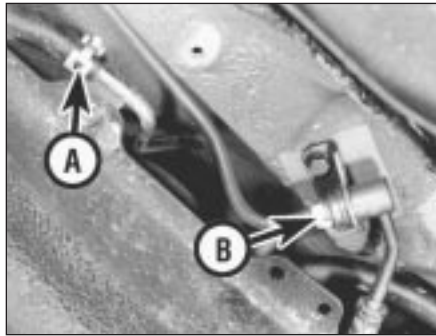

8.4 Fuel tank return pipe retaining clip (A) and feed pipe union nut (B)

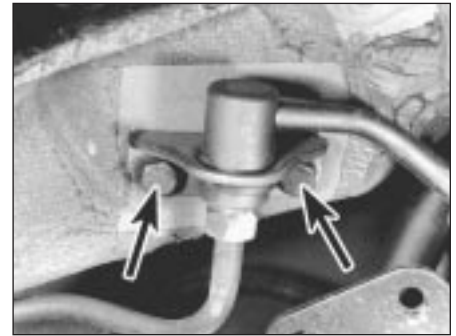

8.5 Feed pipe union mounting bolts (arrowed)

gain access to the fuel tank feed and return pipes (see illustration).

4 Using a suitable pair of pliers, release the retaining clip and disconnect the small section of return pipe hose from the fuel tank (see illustration).

5 Slacken the fuel feed pipe union nut and disconnect the pipe from the union. Undo the two union mounting bolts and free the union from the body (see illustration).

6 Disconnect the fuel tank wiring block connector from the main wiring harness. If the block connector cannot yet be reached, it may be disconnected as the tank is lowered out of position.

7 Slacken the clamp securing the filler neck hose to the tank and use a pair of pliers to release the filler neck breather pipe retaining clip (see illustration). Disconnect both the filler neck hose and breather pipe from the fuel tank.

8 Release the fuel tank breather, situated directly above the filler neck hose, from the vehicle body.

9 Slacken the tank retaining strap locknuts, then unscrew the lower locknuts and remove the straps whilst supporting the tank (see illustration).

10 Lower the fuel tank out of position and remove it from under the vehicle.

11 If the tank is contaminated with sediment or water, remove the sender unit and swirl the tank out with clean fuel. If the tank is damaged or leaks, it should be repaired by a

specialist or alternatively renewed. Do not under any circumstances attempt to solder or weld a fuel tank.

Refitting

12 Refitting is the reverse of the removal procedure. Tighten all nuts and bolts to their specified torque wrench settings and ensure that all hoses are correctly routed and securely fastened so that there can be no risk of fuel leakage.

9 Accelerator cable - removal, refitting and adjustment



Removal

1 Unscrew the four windscreen wiper motor mounting bolts to free the motor from the engine compartment bulkhead.

2 Slacken the accelerator cable locknuts and free the cable outer from its mounting bracket on the carburettor. Release the cable inner from the accelerator cam (see illustration).

3 Work back along the cable outer and release it from any retaining clamps and ties.

4 Working from inside the vehicle, undo the five right-hand lower fascia panel retaining screws and remove the panel.

5 Release the cable from the upper end of the accelerator pedal and withdraw the cable from the engine compartment.

Refitting

6 Refitting is the reverse of the removal procedure. Tighten the windscreen wiper motor retaining bolts to the specified torque (Chapter 12). Prior to tightening the cable locknuts, adjust the cable as follows.

Adjustment

7 Slacken both locknuts then gently pull up on the cable outer until all free play is removed from the cable and the accelerator cam just starts to move.

8 Holding the cable in position, screw the upper locknut down until there is a gap of approximately 5.0 mm between the lower edge of the nut and the cable mounting bracket. Release the cable then have an assistant depress the accelerator pedal fully and check that the throttle opens fully and returns to the at-rest position when the pedal is released. If the throttle operation is correct, hold the upper locknut stationary and tighten the lower locknut securely.

10 Accelerator pedal - removal and refitting



4A

Removal

1 Working from inside the vehicle, undo the five right-hand lower fascia panel retaining screws and remove the panel.

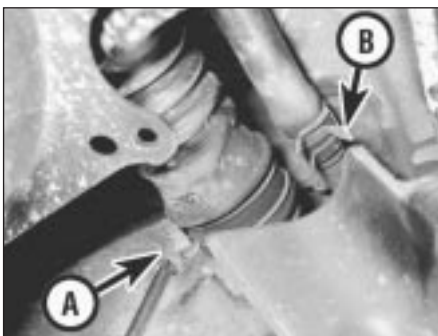

8.7 Slacken filler neck hose retaining clamp (A) and disconnect breather pipe (B)



8.9 Fuel tank mounting strap retaining locknut



9.2 Disconnecting accelerator cable from carburettor

4A•6 Fuel and exhaust systems - carburettor engines

2 Release the accelerator cable from the upper end of the pedal and, using a pair of pliers, unhook the accelerator pedal return spring.

3 Prise off the circlip from the pedal pivot and withdraw the accelerator pedal from the mounting bracket.

Refitting

4 Refitting is a reverse of the removal procedure. Apply a smear of multi-purpose grease to the pedal pivot. On completion, adjust the accelerator cable.

11 Accelerator pedal switch - removal and refitting



Removal

1 Working from inside the vehicle, undo the five right-hand lower facia panel retaining screws and remove the panel.

2 Using a suitable pair of pliers, unhook the accelerator pedal return spring from the pedal then disconnect the accelerator cable from the pedal.

3 Disconnect the wiring connectors from the accelerator pedal switch then prise off the C-clip and remove the switch from the mounting bracket. Note the wave washer fitted between the switch and bracket.

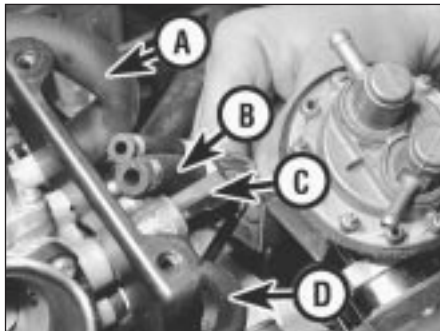

13.4 Breather hose (A), float chamber vent and full load air bleed hoses (B), idle bypass solenoid wiring (C) and fuel pump outlet hose (D)



13.7 Note connections before disconnecting idle bypass solenoid wiring



12.2 Releasing clip to disconnect choke cable from carburettor - fast idle adjusting screw arrowed

Refitting

4 Refitting is a reversal of the removal procedure.

12 Choke cable - removal, refitting and adjustment



Removal

1 Remove the air cleaner assembly.

2 Free the choke cable outer from its retaining clip on the carburettor and disconnect the cable inner from the choke cam (see illustration).

3 Work back along the cable outer and release it from any retaining clamps and ties. Prise the cable grommet out of the engine compartment bulkhead.

4 Working inside the vehicle, undo the five right-hand lower facia panel retaining screws and remove the panel.

5 Using a suitable small screwdriver, slacken and remove the choke knob grub screw then pull the knob off the cable.

6 Unscrew the choke cable retaining nut then release the cable from the facia and disconnect the choke switch wiring connectors. The cable can then be withdrawn from the engine compartment and removed from the vehicle.

Refitting

7 Refitting is a reverse of the removal procedure. On completion adjust as follows.



13.8a Unscrew upper-to-lower inlet manifold Torx screws . . .

Adjustment

8 Have an assistant pull the choke control knob fully out and check that the choke cam opens fully. Push the choke knob fully in and check that the choke cam returns to the fully-off position so that there is clearance between the cam and the fast idle adjusting screw. Providing that the choke cam returns fully, there should be no free play present in the cable.

9 The cable is adjusted by releasing the carburettor clip and repositioning the cable outer.

13 Carburettor - removal and refitting



Removal

1 Remove the air cleaner assembly.

2 Slacken the accelerator cable locknuts and free the cable outer from its mounting bracket on the carburettor. Release the cable inner from the accelerator cam.

3 Free the choke cable outer from its retaining clip on the carburettor and disconnect the cable inner from the choke cam.

4 Make a note of the correct fitted positions of the two small bore vacuum pipes, to ensure they are correctly positioned on refitting, then disconnect them from the carburettor (see illustration).

5 Using pliers, release the retaining clip and disconnect the fuel feed hose from the carburettor. Place wads of rag around the union to catch any spilled fuel and plug the hose as soon as it is disconnected to minimise fuel loss.

6 Make a note of the correct fitted positions of the breather hoses then, where necessary, release the retaining clips and disconnect the three breather hoses from the carburettor.

7 Disconnect the wiring connector from the carburettor idle bypass solenoid (see illustration).

8 Unscrew the four Torx screws securing the carburettor manifold adaptor to the inlet manifold and remove the carburettor assembly from the vehicle (see illustrations). Remove the gasket and discard it, as a new one must be used on refitting. Plug the inlet



13.8b . . . and remove carburettor assembly

port with a wad of clean cloth to prevent the possible entry of foreign matter.

Refitting

9 Refitting is the reverse of the removal procedure, noting the following:

- a) Ensure the carburettor and inlet manifold sealing faces are clean and flat. Fit a new gasket and tighten the carburettor retaining screws to the specified torque.
- b) Use the notes made on dismantling to ensure all hoses are refitted to their original positions and, where necessary, are securely held by their retaining clips.
- c) Adjust the choke cable and accelerator cables.
- d) Adjust the idle speed and mixture settings.

14 Carburettor - diagnosis, overhaul and adjustments



Diagnosis

1 The SU carburettor does not usually suffer from jet blockages and wear is usually only found between the needle and jet, although it is worth checking the fit of the piston in the suction chamber whenever the carburettor is dismantled. If the idle speed is too high and cannot be reduced by normal adjustment, it is worth checking the throttle disc overrun valve spring (if fitted). If this spring has weakened, the throttle disc must be renewed.

2 If a carburettor fault is suspected, always check first the following:

- a) That the ignition timing is accurate.
- b) That the spark plugs are in good condition and correctly gapped.
- c) That the accelerator and choke cables are correctly adjusted.
- d) That the carburettor piston damper is topped-up.
- e) That the float chamber vent hose and (especially if the mixture is very rich) the full load air bleed hose are clear.
- f) That the air cleaner filter element is clean.

3 If the engine is running very roughly, check the compression pressures, bearing in mind the possibility that one of the hydraulic tappets might be faulty, thereby producing an incorrect valve clearance.

4 If careful checking of all of the above produces no improvement, the carburettor must be removed for cleaning and overhaul.

Overhaul

5 A complete strip-down of a carburettor is unlikely to cure a fault which is not immediately obvious without introducing new problems. If persistent carburation problems are encountered, it is recommended that the advice of a Rover dealer or carburettor specialist is sought. Most dealers will be able to provide carburettor re-jetting and servicing facilities and if necessary, it should be

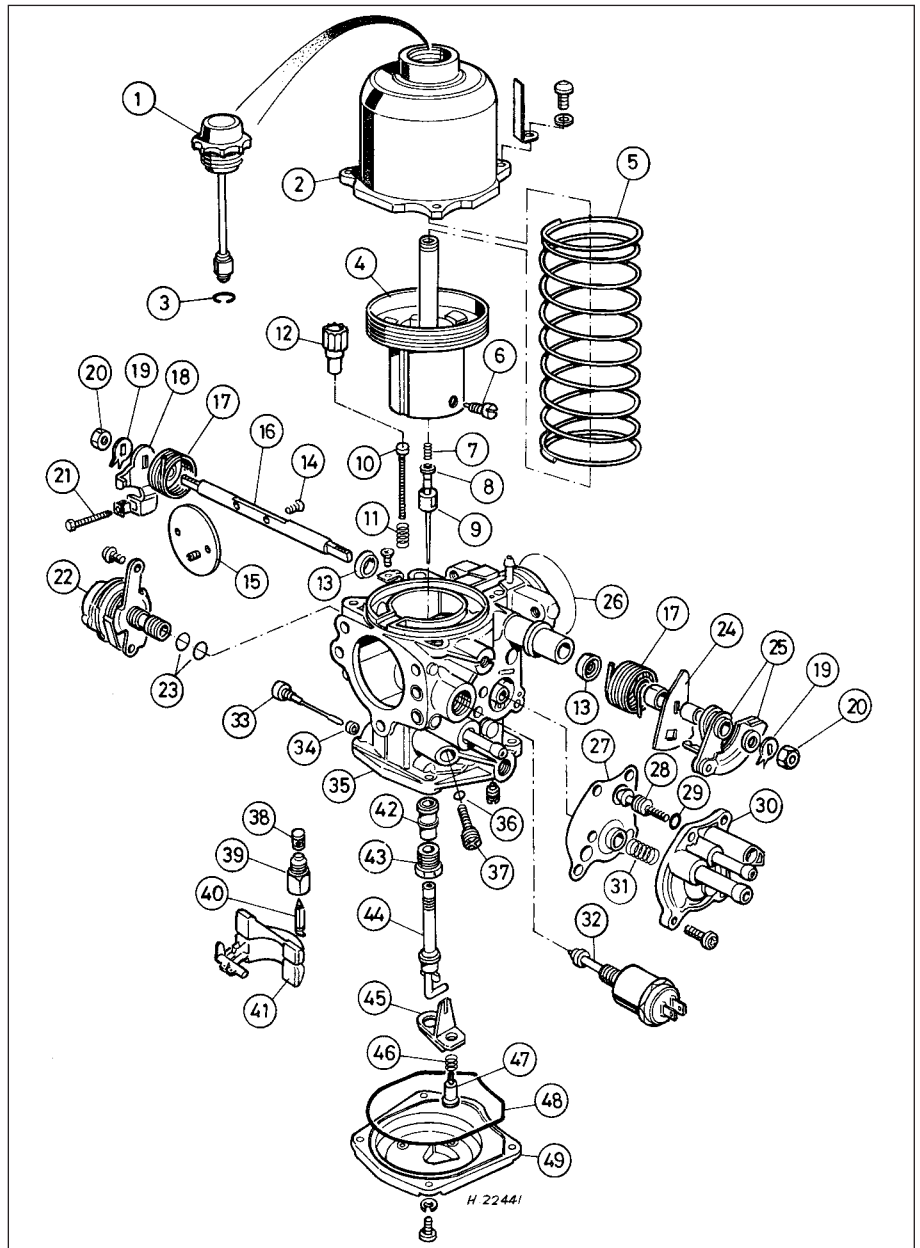

14.8 SU KIF carburettor assembly

- | | | |
|---------------------------------------|---------------------------------|----------------------------|
| 1 Piston damper | 16 Throttle spindle | 33 Float pivot |
| 2 Suction chamber | 17 Return spring | 34 Pivot seal |
| 3 C-clip | 18 Fast idle lever | 35 Carburettor body |
| 4 Piston | 19 Lockwasher | 36 O-ring |
| 5 Piston spring | 20 Nut | 37 Jet adjusting screw |
| 6 Needle retaining (grub) screw | 21 Fast idle adjusting screw | 38 Fuel strainer |
| 7 Needle spring | 22 Choke assembly | 39 Float needle seat |
| 8 Needle | 23 O-ring | 40 Float needle |
| 9 Needle guide | 24 Throttle return spring lever | 41 Float |
| 10 Idle speed screw | 25 Throttle lever | 42 Jet bearing |
| 11 Spring | 26 O-ring | 43 Jet bearing nut |
| 12 Idle speed adjusting knob | 27 Diaphragm | 44 Jet |
| 13 Throttle spindle seal | 28 Idle air bypass screw | 45 Bi-metal lever assembly |
| 14 Screw | 29 O-ring | 46 Spring |
| 15 Throttle disc - with overrun valve | 30 Full load enrichment device | 47 Jet retaining screw |
| | 31 Spring | 48 O-ring |
| | 32 Idle bypass solenoid | 49 Float chamber cover |

4A•8 Fuel and exhaust systems - carburettor engines

possible to purchase a reconditioned carburettor of the relevant type.

6 If it is decided to go ahead and service a carburettor, check the cost and availability of spare parts before commencement. Obtain a carburettor repair kit, which will contain the necessary gaskets, diaphragms and other renewable items.

7 When working on carburettors, scrupulous cleanliness must be observed and care must be taken not to introduce any foreign matter into components. Carburettors are delicate instruments and care should be taken not to disturb any components unnecessarily.

8 Referring to the relevant exploded view of the carburettor (**see illustration on previous page**), remove each component part whilst making a note of its fitted position. Make alignment marks on linkages, etc.

9 Reassemble the carburettor in the reverse order to dismantling, using new gaskets, O-rings, etc. Be careful not to kink any diaphragms.

Adjustments

Idle speed and mixture

10 Refer to Chapter 1.

Fast idle speed

11 Check the accelerator and choke cables are correctly adjusted.

12 Warm the engine up to normal operating temperature and check that the idle speed and mixture are correctly set.

13 Pull out the choke control to the first detent position and check that the engine speed increases to the specified amount.

14 If adjustment is required, screw the fast idle adjusting screw in or out until the engine speed is correct.

Fuel level

15 The carburettor fuel level is adjusted by bending the float arm to alter the float height, usually measured with the carburettor inverted. However, since the necessary information is not provided by the manufacturer, the vehicle should be taken to a Rover dealer or SU carburettor specialist if the fuel level is thought to be incorrect.

Jet adjustment

16 Accurate jet adjustment is not easy for the inexperienced and can only be carried out using an exhaust gas analyser. If the jet adjustment is thought to be incorrect or is to be checked, owners without the required equipment and the skill to use it are advised to have the work carried out by a Rover dealer or SU carburettor specialist, otherwise proceed as follows.

17 Warm the engine up to normal operating temperature and check that the ignition timing, idle speed and mixture are correctly set and that the carburettor piston damper is topped-up, see Chapter 1.

18 Remove the tamperproof cap from the jet adjusting screw recess at the front left-hand corner of the carburettor body.

19 Counting the exact number of turns required to do so, screw the idle air bypass screw clockwise until it seats lightly, then start the engine, switch on the headlamps, heated rear window and heater blower motor (first speed only) and adjust the idle speed to 700 to 750 rpm.

20 Connect the exhaust gas analyser following its manufacturer's instructions.

21 Turning the jet adjusting screw either way (clockwise to richen the mixture) by half a turn at a time and waiting for the analyser reading to respond and stabilise before making a further alteration, set the mixture to a base CO level of 5.5 % \pm 0.5 %. When the analyser reading is steady at the correct level, switch off all electrical loads.

22 Screw the idle air bypass screw anti-clockwise by the number of turns previously noted to return it to its original setting, then set the true idle mixture to the specified value.

23 Stop the engine when the adjustment is correct, disconnect the test equipment and fit a new tamperproof cap to the jet adjusting screw recess.

Idle bypass system

24 As well as the carburettor idle air bypass passage and screw, the system incorporates the solenoid and the accelerator pedal switch.

25 When the accelerator is closed and the ignition is switched on the solenoid is energised, its plunger being retracted to open the bypass passage. This allows air to bypass the carburettor piston and thus makes the idle mixture independent of the needle metering. Screwing in (clockwise) the idle air bypass screw reduces the amount of air bypassing the piston and richens the idle mixture.

26 As soon as the accelerator pedal is depressed, the accelerator pedal switch opens, the solenoid is de-energised and the bypass passage is shut off.

27 To check the system, listen closely by the carburettor while an assistant switches on the ignition and depresses and releases the accelerator pedal several times. The solenoid should be heard to be clicking in and out.

28 If no clicking is heard, remove the air cleaner assembly and use a meter or similar to check the solenoid earth and feed, see Chapter 12.

Use a meter to check that the accelerator pedal switch contacts open and close. If the solenoid or switch is faulty, then it must be renewed. Note that if trouble is encountered with an ignition system fuse blowing repeatedly, and the fault cannot otherwise be traced, the solenoid may be at fault.

15 Inlet manifold pre-heater - operation, removal and refitting



Operation

1 The system incorporates the manifold PTC (Positive Temperature Coefficient) heater, the relay and the manifold temperature switch.

2 When the ignition is switched on and the engine is cold (coolant below 50°C), the relay-energising current flows through the closed manifold temperature switch contacts, which then closes the relay contacts and allows current to flow from the battery to the heater. This ensures that the inlet manifold is warm enough, even before the effect of the coolant heating becomes apparent, to prevent fuel droplets condensing in the manifold, thus improving driveability and reducing exhaust emissions when the engine is cold.

3 As soon as the engine warms up to temperatures above 50°C, the switch contacts open and the relay cuts off the power supply to the manifold heater.

4 If the engine suddenly develops flat spots when cold, the system may be faulty.

PTC heater

Removal

5 Drain the cooling system.

6 Apply the handbrake then jack up the front of the vehicle and support it on axle stands. Access to the PTC heater can then be gained from underneath the vehicle, via the gap between the engine and engine compartment bulkhead.

7 Disconnect the wiring connector from the heater terminal then extract the heater retaining circlip. Withdraw the heater from the underside of the manifold (**see illustrations**).

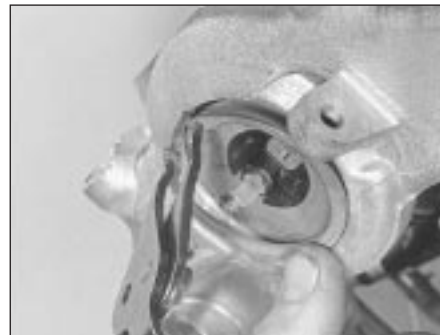

15.7a Extract circlip . . .



15.7b . . . and remove PTC heater from inlet manifold - manifold removed for clarity

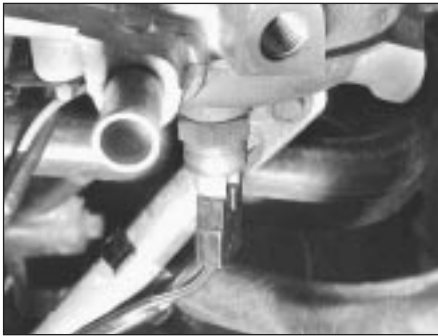

15.9 Inlet manifold pre-heater temperature switch location

Inspect the heater rubber seal for signs of damage or deterioration and renew if necessary.

Refitting

8 Refitting is the reverse of the removal procedure. Ensure that the heater locating projection is correctly engaged in the manifold recess. On completion, lower the vehicle to the ground and refill the cooling system.

Pre-heater temperature switch

Removal

9 The pre-heater temperature switch is fitted to the underside of the inlet manifold (see illustration). Either drain the cooling system or be prepared for some loss of coolant as the switch is unscrewed.

10 Release the wire retaining clip and disconnect the wiring connector from the switch.

11 Unscrew the switch from the manifold and withdraw it, then plug the opening to prevent the entry of dirt. If the cooling system has not been drained, work quickly to minimise coolant loss.

Refitting

12 Wipe clean the threads of the switch and of the thermostat housing. If a sealing washer is fitted, renew it whenever it is disturbed to prevent leaks. If no sealing washer is fitted, apply a smear of sealant to the switch threads.

13 Refit the switch, working quickly if the



16.13a Fit a new manifold gasket . . .



16.11a Inlet manifold support stay upper end bolt (arrowed)

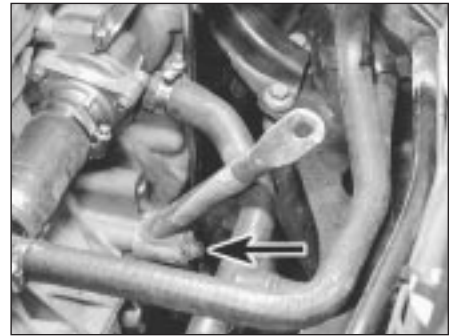

16.11b Inlet manifold support stay lower end bolt (arrowed)

cooling system was not drained, and tighten it. Reconnect the wiring connector.

14 Replenish the cooling system.

Manifold heater relay

15 Refer to Chapter 12.

16 Inlet manifold - removal and refitting



Note: The following procedure describes removal of the manifold with the carburettor. Access to some of the components concerned is much improved if the carburettor is first removed separately and if this is done, the following procedure should be amended as required.

Removal

- 1 Disconnect the battery negative terminal.
- 2 Remove the air cleaner assembly.
- 3 Drain the cooling system.
- 4 Disconnect the accelerator and choke cables.
- 5 Slacken the retaining clamps and disconnect the coolant hoses from the inlet manifold.
- 6 Trace the float chamber vent hose and the full load air bleed hose from the carburettor down to their metal pipes then unscrew the nut and bolts securing the pipes to the cylinder block/crankcase.
- 7 Using pliers, release the retaining clip and



16.13b . . . and fit inlet manifold - less carburettor

disconnect the fuel feed hose from the carburettor. Place wads of rag around the union to catch any spilled fuel and plug the hose as soon as it is disconnected to minimise fuel loss.

8 Disconnect the vacuum pipe from the distributor vacuum diaphragm unit and disconnect the breather hose from the cylinder head cover.

9 Slacken and remove the brake vacuum servo unit hose union bolt and disconnect the hose. Discard the hose union sealing washers which must be renewed whenever they are disturbed.

10 Disconnect the idle bypass solenoid wiring, making notes of the connections so that they can be correctly reconnected, then disconnect the wiring from the manifold pre-heater switch and heater which are situated on the underside of the manifold.

11 Undo the single bolt which secures each manifold support stay to the cylinder block/crankcase and slacken the bolts which secure the stays to the inlet manifold (see illustrations).

12 Make a final check that all the necessary fuel/breather hoses have been disconnected from the carburettor/manifold then unscrew the nuts and bolts securing the manifold to the cylinder head. Manoeuvre the manifold out of the engine compartment and discard its gasket.

Refitting

13 Refitting is the reverse of the removal procedure, noting the following (see illustrations):

a) Ensure that the manifold and cylinder

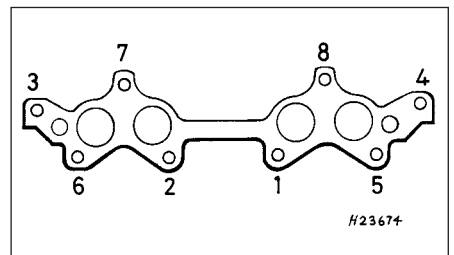

16.13c Inlet manifold tightening sequence - K8 engine

4A•10 Fuel and exhaust systems - carburettor engines

head mating surfaces are clean and dry, then fit a new manifold gasket.

- b) Working in the sequence shown, tighten the manifold retaining nuts and bolts evenly to the specified torque wrench setting.
- c) Ensure all relevant hoses are reconnected to their original positions and are securely held (where necessary) by their retaining clips.
- d) Renew the vacuum servo unit vacuum hose banjo union sealing washers and tighten the union bolt.
- e) Adjust the accelerator and choke cables.
- f) On completion, refill the cooling system.



17.8a Refitting exhaust manifold with new gasket

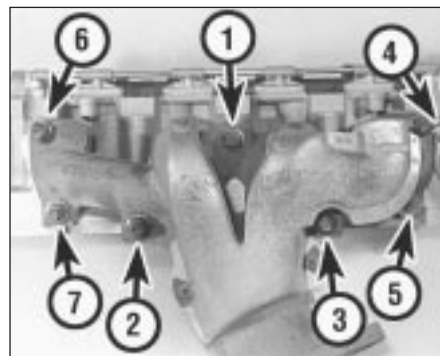

17.8b Exhaust manifold tightening sequence - K8 engine

17 Exhaust manifold - removal and refitting



Removal

- 1 Disconnect the battery negative terminal.
- 2 Remove the air cleaner metal intake duct assembly.
- 3 Firmly apply the handbrake then jack up the front of the vehicle and support it on axle stands.
- 4 Unscrew the nuts securing the exhaust front pipe to the manifold, then disconnect the pipe and collect the gasket.
- 5 Remove the four exhaust manifold shroud retaining screws and remove the shroud.
- 6 Unscrew the nuts securing the manifold to the cylinder head, then manoeuvre it out of the engine compartment. Remove the manifold gasket and discard it.
- 7 Examine all the exhaust manifold studs for signs of damage and corrosion. Remove all traces of corrosion and repair or renew any damaged studs.

Refitting

8 Refitting is the reverse of the removal procedure, noting the following (see illustrations):

- a) Ensure that the manifold and cylinder head sealing faces are clean and flat, then fit a new manifold gasket.
- b) Working in the sequence shown, tighten the manifold retaining nuts evenly to the specified torque wrench setting.
- c) Tighten all other disturbed nuts and bolts to their specified torque wrench settings (where given).

1 On models not equipped with a catalytic converter the exhaust system is in three sections. All exhaust sections are joined by a flanged joint. If a catalytic converter is fitted, it is situated between the front pipe and the

intermediate pipe, with a flanged joint at each end. The front pipe then has a gas-sampling take off point which is fitted to permit mixture checks using an exhaust gas analyser (see illustrations).

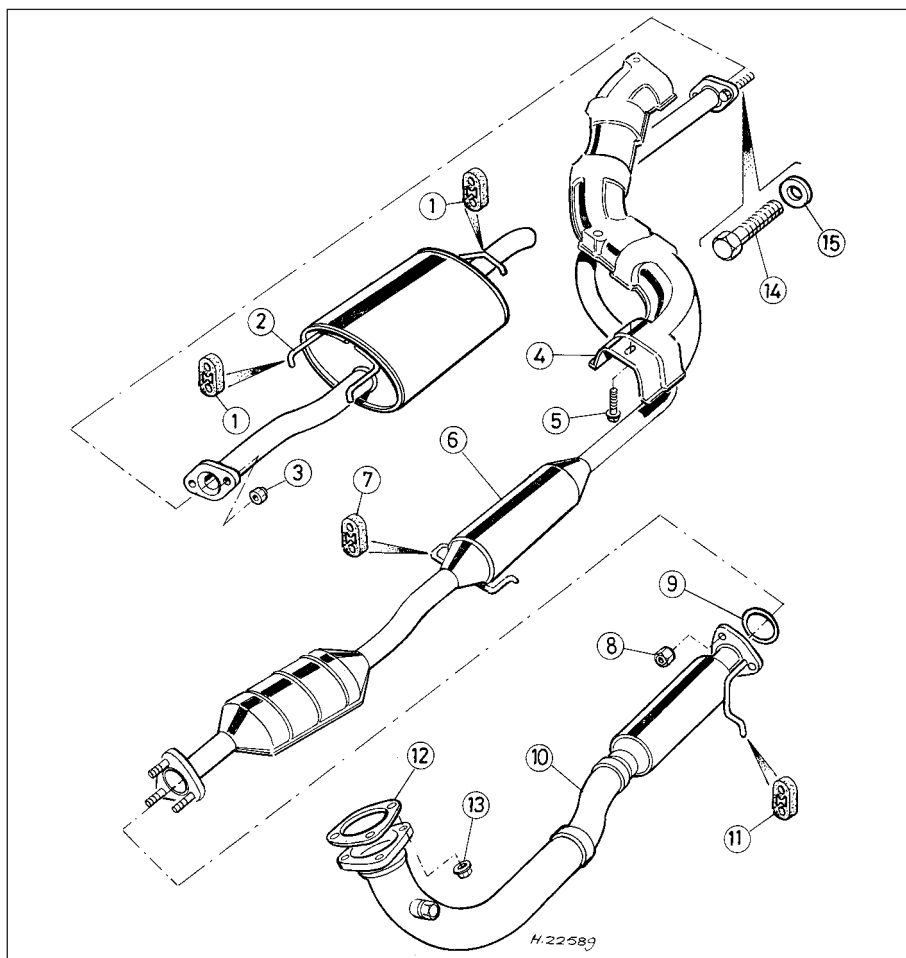

18.1a Exhaust system components - without catalytic converter

18 Exhaust system - inspection, removal and refitting



Note: If a catalytic converter is fitted to the exhaust system, remember that it is FRAGILE. Do not use hammers, mallets, etc. to strike any part of the system and take care not to drop it or strike the converter against anything while handling it.

- | | | |
|---------------------|--|--|
| 1 Mounting rubber | 7 Mounting rubber | 12 Gasket - front pipe to exhaust manifold |
| 2 Tailpipe | 8 Nut | 13 Nut |
| 3 Nut | 9 Gasket - front pipe to intermediate pipe | 14 Bolt (stud replacement) |
| 4 Heatshield | 10 Front pipe | 15 Plain washer |
| 5 Bolt | 11 Mounting rubber | |
| 6 Intermediate pipe | | |

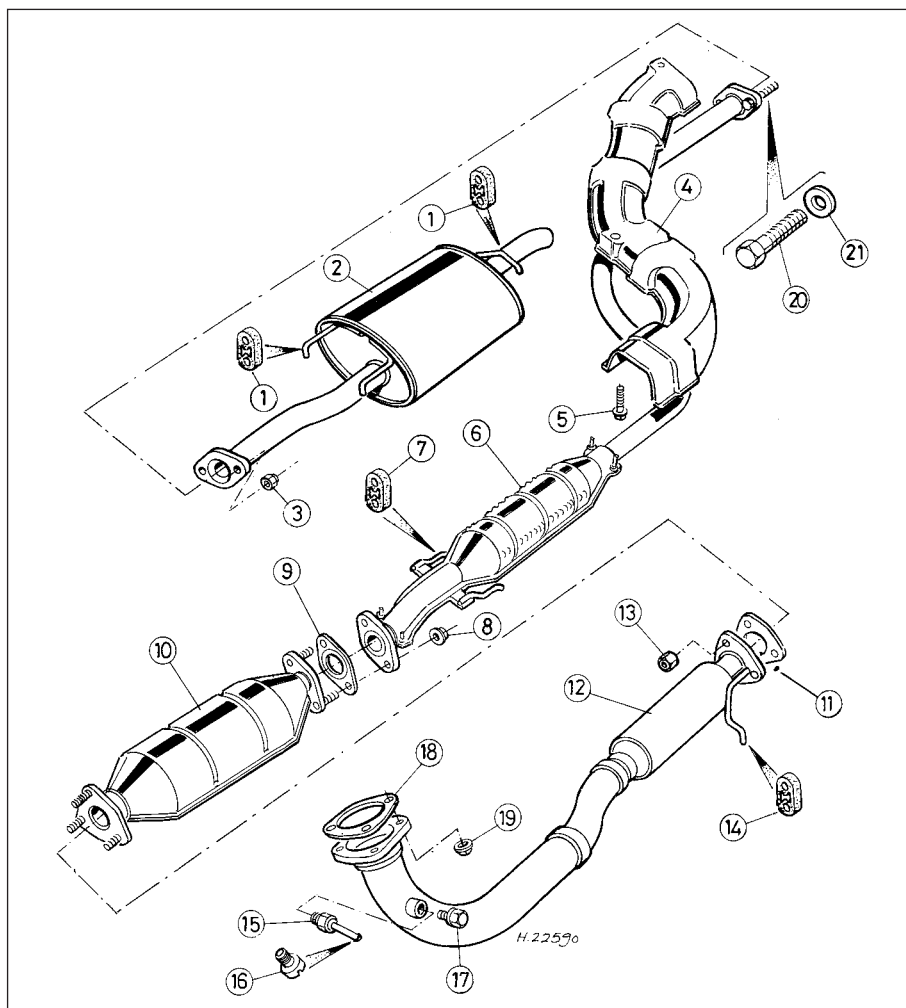

18.1b Exhaust system components - with catalytic converter

- | | | |
|---|---|---|
| 1 Mounting rubber | 10 Catalytic converter | 16 Gas sampling pipe sealing screw - open loop system |
| 2 Tailpipe | 11 Gasket - front pipe to catalytic converter | 17 Blanking plug - closed loop system |
| 3 Nut | 12 Front pipe | 18 Gasket - front pipe to exhaust manifold |
| 4 Heatshield | 13 Nut | 19 Nut |
| 5 Bolt | 14 Mounting rubber | 20 Bolt (stud replacement) |
| 6 Intermediate pipe | 15 Gas sampling pipe - open loop system | 21 Plain washer |
| 7 Mounting rubber | | |
| 8 Nut | | |
| 9 Gasket - catalytic converter to intermediate pipe | | |

2 The exhaust system is suspended throughout its entire length by rubber mountings (see illustration).

Inspection

3 Refer to Chapter 1.

Removal

4 Each exhaust section can be removed individually or, alternatively, the complete system can be removed as a unit once the front pipe has been unbolted from the manifold and the system has been freed from all its mounting rubbers.

5 To remove the system or any part of the system, first jack up the front or rear of the vehicle and support it on axle stands. Alternatively position the vehicle over an inspection pit or on car ramps.

Front pipe

6 Remove the three nuts securing the front pipe flange joint to the manifold and, where necessary, the two bolts securing the front pipe to its mounting bracket. Separate the flange joint and collect the gasket (see illustration).

7 Free the pipe from its mounting rubber then undo the three nuts securing the front pipe to the intermediate pipe/catalytic converter (as applicable) and manoeuvre the front pipe out from under the vehicle (see illustration).

Catalytic converter

8 Slacken and remove the two nuts securing the catalytic converter to the intermediate pipe, then separate the flange joint and recover the gasket.

9 Undo the three nuts securing the converter to the front pipe then remove it from the vehicle.

Intermediate pipe

10 Slacken the two nuts securing the tailpipe flange joint to the intermediate pipe and separate the flange joint.

11 Undo the three nuts securing the intermediate pipe to the front pipe, or the two nuts securing the pipe to the catalytic converter (as applicable).

12 Free the intermediate pipe from all its mounting rubbers and manoeuvre it out from under the vehicle.



18.2 Exhaust system rubber mounting



18.6 Front pipe-to-manifold flange joint



18.7 Front pipe-to-intermediate pipe flange joint and mounting rubber

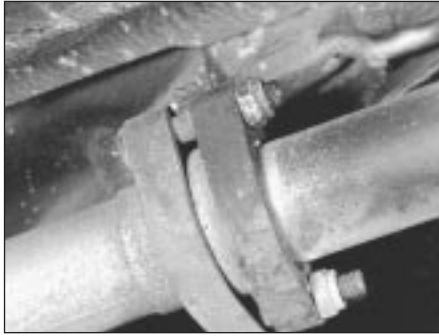

18.13 Tailpipe-to-intermediate flange joint

Tailpipe

13 Remove the two nuts securing the tailpipe flange joint to the intermediate pipe and separate the joint (**see illustration**).

14 Unhook the tailpipe from its three mounting rubbers and remove it from the vehicle.

15 If the threads of the intermediate pipe to tailpipe studs are damaged, or the studs snap when the nuts are being undone, the studs can be knocked out of position and replaced with bolts.

Refitting

16 Each section is refitted by a reverse of the removal sequence, noting the following:





- a) *Ensure that all traces of corrosion have been removed from the flanges.*
- b) *Renew all necessary gaskets.*
- c) *Inspect all rubber mountings for signs of damage or deterioration and renew as necessary.*
- d) *Tighten all flange nuts by hand only to locate the disturbed section in position, then ensure all exhaust system rubber mountings are correctly seated.*
- e) *Check that there is adequate clearance between the exhaust system and vehicle underbody before tightening all flange nuts to the specified torque.*

Chapter 4 Part B Fuel and exhaust systems - single-point fuel injection engines

Contents

Accelerator cable - removal, refitting and adjustment	11	Fuel injection system components - testing	14
Accelerator pedal - removal and refitting	12	Fuel pump - removal and refitting	8
Air cleaner assembly - removal and refitting	3	Fuel system - depressurisation	6
Air cleaner air temperature control system - inspection and component renewal	4	Fuel system - inspection	5
Air cleaner filter element - renewal	2	Fuel system - pressure check	7
Exhaust manifold - removal and refitting	18	Fuel tank - removal and refitting	10
Exhaust system - inspection, removal and refitting	19	General information and precautions	1
Fuel gauge sender unit - removal and refitting	9	Inlet manifold pre-heater - operation, removal and refitting	16
Fuel injection system components - removal and refitting	15	Inlet manifold - removal and refitting	17
		Throttle housing - removal and refitting	13

Degrees of difficulty

Easy , suitable for novice with little experience 	Fairly easy , suitable for beginner with some experience 	Fairly difficult , suitable for competent DIY mechanic 	Difficult , suitable for experienced DIY mechanic 	Very difficult , suitable for expert DIY or professional 
---	--	--	---	--

Specifications

4B

System

Type	Rover/Motorola Modular Engine Management System, using ECU-controlled single-point injection (MEMS-SPi) and speed/density method of airflow measurement
------	---

MEMS-SPi system data

Fuel pump type	Electric, immersed in fuel tank
Fuel pump pressure:	
Maximum - at 16 volts	2.7 bar
Regulated constant pressure	1.0 to 1.2 bar
Injector/pressure regulator assembly	JZX 3028
Throttle potentiometer voltage:	
Throttle closed	0 to 1 volt
Throttle open	4 to 5 volts
Idle speed - nominal value given for reference purposes only	850 ± 50 rpm
CO level at idle speed - engine at normal operating temperature:	
Without catalytic converter - at tailpipe	0.5 to 2.0 %
With catalytic converter - at gas-sampling pipe	0.5 to 2.0 %

Recommended fuel

Minimum octane rating:	
Without catalytic converter	95 RON unleaded (ie: unleaded Premium) or 97 RON leaded (ie: 4-star)
With catalytic converter	95 RON unleaded (ie: unleaded Premium)

Torque wrench settings

Fuel system

	Nm	lbf ft
Injector housing fuel pipe union nuts	24	18
Injector housing fuel pipe adaptors	24	18
Injector housing screws	5	4
Throttle housing retaining nuts	18	13
Fuel system pressure release bolt - models without catalytic converter	12	9
Fuel pump retaining nuts	9	7
Vent valve and hose retaining nuts	9	7
ECU retaining nuts	9	7
Intake air temperature sensor	7	5
Coolant temperature sensor	15	11
Inlet manifold nuts and bolts	25	18
Inlet manifold support stay bolts	25	18

Exhaust system

Oxygen (lambda) sensor	55	41
Exhaust manifold retaining nuts	45	33
Exhaust manifold shroud screws	6	4
Exhaust system flange nuts:		
Manifold-to-front pipe joint	50	37
All other joints	45	33
Exhaust front pipe mounting bolts	15	11

1 General information and precautions

General information

The fuel system consists of a fuel tank mounted under the rear of the vehicle with an electric fuel pump immersed in it, a fuel filter, fuel feed and return lines and the throttle body assembly (which incorporates the single fuel injector and the fuel pressure regulator), as well as the Engine Management Electronic Control Unit (ECU) and the various sensors, electrical components and related wiring. The ECU fully controls both the ignition system and the fuel injection system, integrating the two in a complete engine management system (see illustration). Refer to Chapter 5 for information on the ignition side of the system.

The Rover/Motorola Modular Engine Management System uses ECU-controlled single-point injection (MEMS-SPI) and the speed/density method of airflow measurement. The whole system is best explained if considered as three sub-systems which are, the fuel delivery, air metering and electrical control systems.

The fuel delivery system incorporates the fuel tank with an electric fuel pump, which is immersed in a swirl pot to prevent aeration of the fuel, inside it. When the ignition is switched on, the pump is supplied with current via the fuel pump relay, under the control of the ECU. The pump feeds petrol via a non-return valve (to prevent fuel draining out of the system components and back to the tank when the pump is not working) to the fuel filter and from the filter to the injector. Fuel pressure is controlled by the pressure regulator, which lifts to allow excess fuel to

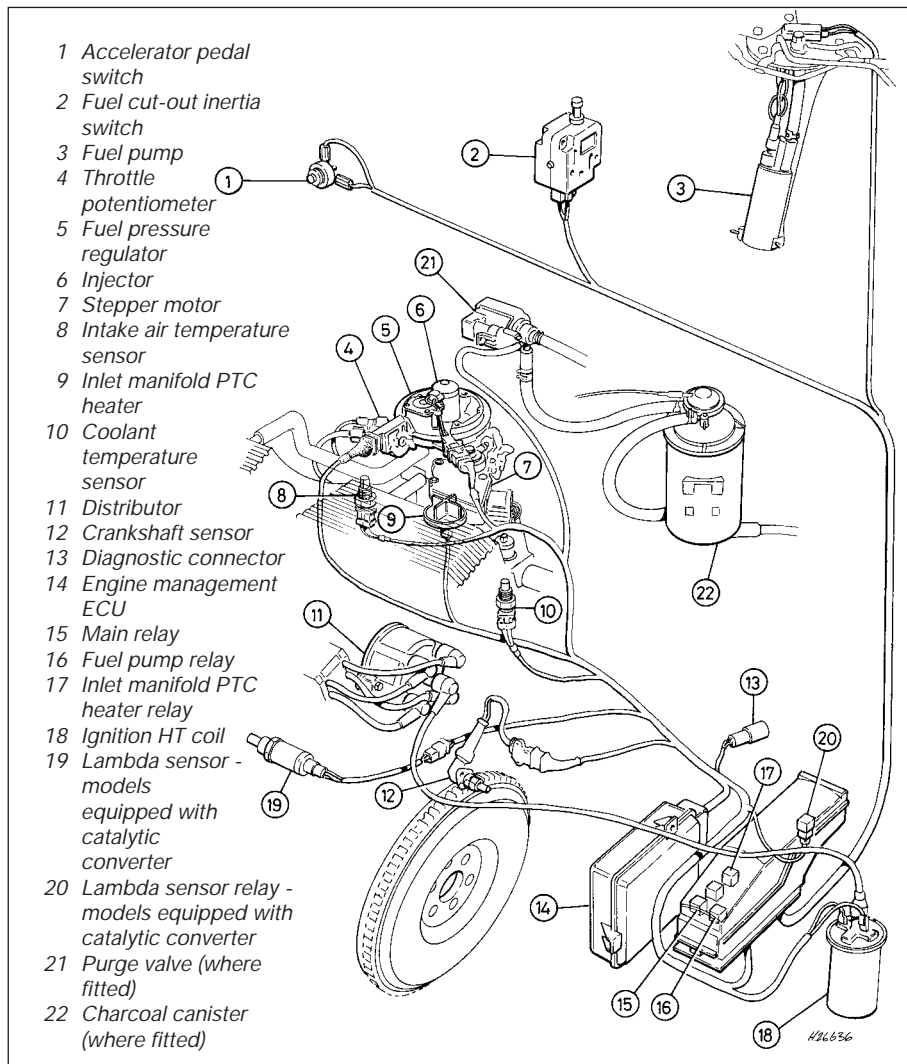

1.0 Fuel and ignition system components - MEMS-SPI

return to the tank swirl pot, where a venturi causes the returning fuel to draw cool fuel from the tank into the swirl pot. In the event of sudden deceleration (ie: an accident) an inertia switch cuts off the power to the pump so that the risk of fire is minimised from fuel spraying out of broken fuel lines under pressure.

The air metering system includes the intake air temperature control system and the air cleaner, but the main components are in the throttle body assembly. This incorporates the injector, which sprays fuel onto the back of the throttle disc, the throttle potentiometer, which is linked to the throttle disc spindle and sends the ECU information on the rate of throttle opening by transmitting a varying voltage, and the stepper motor, which is controlled by the ECU and operates the throttle disc spindle lever via a cam and pushrod to provide idle speed control. Note that there is no provision for adjustment of the idle speed except by reprogramming the ECU using Rover diagnostic equipment. If checking idle speed, remember that it will vary constantly under ECU control.

The electrical control system consists of the ECU, with all the sensors that provide it with information, and the actuators by which it controls the whole system's operation. The ECU's manifold absolute pressure sensor is connected, by hoses and a fuel (vapour) trap mounted in the air cleaner assembly, to the inlet manifold. Variations in manifold pressure are converted into graduated electrical signals which are used by the ECU to determine the load on the engine. The intake air temperature sensor is self-explanatory, the crankshaft sensor gives it the engine speed and crankshaft position, the coolant temperature sensor gives it the engine temperature and the accelerator pedal switch tells it when the accelerator is closed. The throttle potentiometer is explained above and the lambda sensor (where fitted) in Part D of this Chapter. In addition, the ECU senses battery voltage (adjusting the injector pulse width to suit and using the stepper motor to increase the idle speed and, therefore, the alternator output if it is too low), incorporates short-circuit protection and diagnostic capabilities and can both receive and transmit information



3.1 Releasing clips to separate intake duct from air cleaner

via the diagnostic connector, thus permitting engine diagnosis and tuning by Rover diagnostic equipment. If either the coolant temperature sensor, the intake air temperature sensor or the manifold absolute pressure sensor circuits should fail to provide adequate information, the ECU has a back-up facility which assumes a value corresponding to a coolant temperature of 60°C, an intake air temperature of 35°C and an engine load based on the engine speed and throttle position. These are used to implement a back-up air/fuel mixture ratio.

All these signals are compared by the ECU, using digital techniques, with set values pre-programmed (mapped) into its memory. Based on this information, the ECU selects the response appropriate to those values and controls the ignition HT coil (varying the ignition timing as required), the fuel injector (varying its pulse width - the length of time the injector is held open - to provide a richer or weaker mixture, as appropriate), the stepper motor (controlling the idle and fast idle speeds), the fuel pump relay (controlling the fuel delivery), the manifold heater relay (controlling the inlet manifold pre-heater system) and the main relay, the purge control valve (where fitted) and the lambda sensor and relay (where fitted) accordingly. The mixture, idle speed and ignition timing are constantly varied by the ECU to provide the best settings for cranking, starting and engine warm-up (with either a hot or cold engine), idle, cruising and acceleration. A rev-limiter circuit is built into the ECU which switches off the injector earth (ie: the fuel supply) if engine speed exceeds 6860 rpm, switching it back on at 6820 rpm. The injector earth is also switched off on the overrun (coolant temperature above 80°C, throttle pedal switch contacts closed, engine speed above 1500 rpm) to improve fuel economy and reduce exhaust emissions.

The ECU idle control is an adaptive system which learns the engine load and wear characteristics over a period of time and adjusts the idle speed to suit. If the ECU is renewed, or one from another vehicle is fitted, it will take a short period of normal driving for

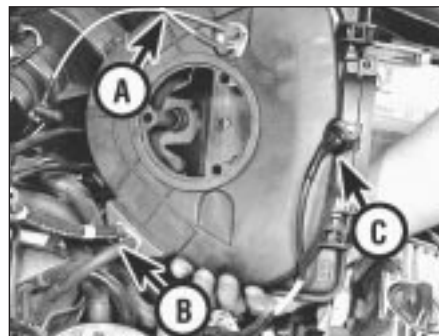

3.2 Thermac switch vacuum pipes (A), fuel trap vacuum hoses (B), intake air temperature sensor wiring (C) and throttle housing seal (D)

the new ECU to learn the engine's characteristics and restore full idle control.

To reduce emissions and to improve driveability when the engine is cold, the inlet manifold is heated by the cooling system coolant and by an electric pre-heater system. Mixture enrichment for cold starting is a pre-programmed function of the system.

The air cleaner contains a disposable paper filter element and incorporates a flap valve air temperature control system which allows cold air from the outside of the vehicle and warm air from the exhaust manifold to enter the air cleaner in the correct proportions.

The exhaust system is as described in Part A of this Chapter.

Precautions

Fuel injection system

Residual pressure will remain in the fuel lines long after the vehicle was last used, therefore extra care must be taken when disconnecting a fuel line hose. Loosen any fuel hose slowly to avoid a sudden release of pressure which may cause fuel spray. As an added precaution, place a rag over each union as it is disconnected to catch any fuel which is forcibly expelled.

Fuel usage

Refer to Part A of this Chapter.

Catalytic converters

Before attempting work on these items, carefully read the precautions listed in Part D of this Chapter.

2 Air cleaner filter element - renewal

Refer to Chapter 1.

3 Air cleaner assembly - removal and refitting



Removal

1 Release the two clips securing the air intake duct to the assembly, then undo the three screws securing the assembly to the throttle body (see illustration).

2 Release the assembly from the intake duct and withdraw it, collecting the throttle housing seal and the intake duct sealing ring (where fitted), then disconnect the following (see illustration):

- The thermac switch vacuum pipes. These are colour-coded (yellow to the temperature control valve, red to the inlet manifold).
- The ECU manifold absolute pressure sensor fuel trap vacuum hoses. These are colour-coded (green to the ECU, white to the inlet manifold).
- The intake air temperature sensor wiring.



3.6a Remove T-piece . . .



3.6b . . . then remove resonator

3 Check the condition of the throttle housing seal and the intake duct O-ring (where fitted). Renew either if worn or damaged.

4 To remove the metal intake duct, refer to Section 4, paragraphs 3 and 4.

5 To remove the air intake hose it will first be necessary to remove the left-hand headlamp assembly, to gain access to the two retaining screws. Remove the two retaining screws and disconnect the duct from the body front panel, release the clip securing the ignition HT lead, then slacken the retaining clamp and unfasten the rubber strap to separate the cold air duct from the intake duct. Release the intake hose from the resonator T-piece and remove it from the engine compartment.

6 A resonator chamber is fitted to the intake hose to reduce the amount of induction noise. To remove the chamber, first remove the battery and battery tray. Disconnect the intake hose from the T-piece then remove the resonator T-piece. Release any relevant retaining clips from the resonator, then remove the resonator from the engine compartment (see illustrations).

Refitting

7 Refitting is the reverse of the removal procedure. Ensure that the vacuum pipes and hoses are correctly reconnected and are not trapped as the assembly is refitted, then check that the assembly sits properly on the throttle body before tightening the screws securely.

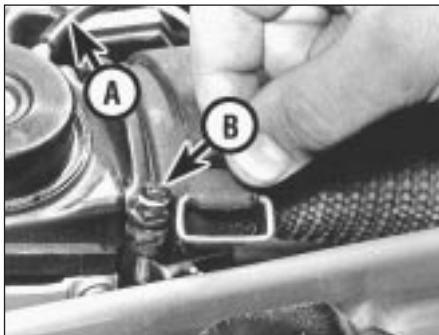

4.3 Unfastening cold air intake duct rubber strap - vacuum pipe (A) and clamp screw (B)



4.4 Unfastening intake duct-to-support bracket retaining bolt

4 Air cleaner air temperature control system - inspection and component renewal



Inspection

1 Refer to Section 4 in Part A of this Chapter.

Thermac switch - renewal

2 Refer to Section 4 in Part A of this Chapter, removing the air cleaner assembly as described in the previous Section.

Air temperature control valve - renewal

3 Disconnect the vacuum pipe from the air temperature control valve, then slacken the intake hose retaining clamp. Release the intake hose rubber retaining strap and disconnect the hose from the metal intake duct (see illustration).

4 Release the two clips securing the air intake duct to the air cleaner assembly and undo the bolt securing the duct to its mounting bracket (see illustration). Withdraw the duct, taking care not to lose the hot air intake connector hose which connects the duct to the exhaust manifold shroud.

5 The air temperature control valve can be renewed only with the complete intake duct assembly. If a new intake duct assembly is being fitted, undo the three screws securing

the hot air intake adaptor plate to the bottom of the duct and transfer the adaptor plate to the new duct.

6 Refitting is the reverse of the removal procedure.

5 Fuel system - inspection

Refer to Chapter 1.

6 Fuel system - depressurisation



Warning: The following procedure will merely relieve the pressure in the fuel system.

Remember that fuel will still be present in the system components and take precautions accordingly before disconnecting any of them.

1 The fuel system referred to in this Section is defined as the tank-mounted fuel pump, the fuel filter, the fuel injector and the pressure regulator in the injector housing, and the metal pipes and flexible hoses of the fuel lines between these components. All these contain fuel which will be under pressure while the engine is running and/or while the ignition is switched on. The pressure will remain for some time after the ignition has been switched off and must be relieved before any of these components are disturbed for servicing work.

Models with a catalytic converter

2 On models equipped with a catalytic converter, the system is depressurised via the small bolt fitted to the fuel filter inlet (feed) union nut.

3 Position wads of rag around the union to catch the spilled fuel and slowly slacken the bolt.

4 Once all pressure has been released, remove the bolt. Inspect the sealing washer for signs of wear or damage and renew if necessary.

5 Refit the bolt and sealing washer to the union nut and tighten it securely.

Models without a catalytic converter

6 On models not fitted with a catalytic converter, the system is depressurised via the bolt in the metal fuel filter outlet pipe.

7 Position wads of rag around the pipe to catch the spilled fuel as the bolt is removed. Carefully slacken the bolt whilst holding the fuel pipe boss with an open-ended spanner to

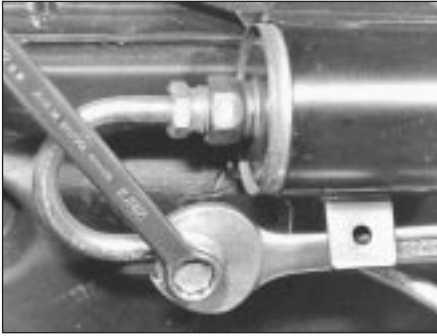

6.7 Slackening pressure release bolt to depressurise fuel system - non-catalyst system

prevent any undue strain being placed on the fuel pipe (see illustration).

8 Once all pressure has been relieved, remove the bolt and inspect the sealing washer for signs of wear or damage and renew if necessary.

9 Refit the bolt and washer to the fuel pipe and tighten it to the specified torque wrench setting whilst using a spanner to counter-hold the pipe boss, to prevent the pipe or filter being damaged.

7 Fuel system - pressure check

1 The following procedure is based on the use of the Rover pressure gauge and adaptor (Service tool numbers 18G 1500 and 18G 1500/3).

2 Depressurise the fuel system.

3 Unscrew the pressure release bolt and screw in the adaptor, then connect the pressure gauge.

4 Turn the engine over on the starter motor. The pressure should reach the specified

value. Stop cranking the engine and watch the gauge. The pressure drop in the first minute should not exceed 0.7 bar.

5 If the pressure first recorded was too high, renew the pressure regulator, which means renewing the complete injector housing assembly.

6 If the pressure first recorded was too low or if it falls too quickly, check the system carefully for leaks. If no leaks are found, check the pump by substituting a new one, then recheck the pressure. If the pressure does not improve, the fault is in the pressure regulator and the complete injector housing assembly must be renewed. If this is the case, it is worth dismantling the regulator to check that the fault is not due to its being jammed open with dirt.

8 Fuel pump - removal and refitting



Removal

1 Remove the fuel tank.

2 Release the clips securing the tank vent hose to the fuel tank breather and fuel cut-off valve, then disconnect the hose. Undo the vent hose and valve retaining nuts, then disconnect the vent valve hose from the fuel pump and remove the vent hose and valve assembly from the tank (see illustration).

3 Disconnect the wiring connector from the fuel pump.

4 Slacken and remove the six fuel pump retaining nuts. Carefully withdraw the fuel pump assembly from the tank and remove the pump seal.

Refitting

5 Refitting is a reversal of the removal sequence, noting the following:

- Renew the pump seal if there is any doubt as to its condition.
- Tighten all retaining nuts to the specified torque setting.
- Ensure that the vent hoses are correctly connected and are securely held by any necessary retaining clips.

9 Fuel gauge sender unit - removal and refitting

Refer to Section 7 in Part A of this Chapter.

10 Fuel tank - removal and refitting

1 Refer to Section 8 in Part A of this Chapter. Note that the fuel system must be depressurised before any fuel hose is disconnected.

11 Accelerator cable - removal, refitting and adjustment



Removal

1 Remove the four windscreen wiper motor mounting bolts to free the motor from the engine compartment bulkhead.

2 Slacken the accelerator cable locknuts and free the cable outer from its mounting bracket. Release the cable inner from the throttle cam (see illustration).

3 Work back along the cable outer and release it from any retaining clamps.

4 Working inside the vehicle, undo the five right-hand lower fascia panel retaining screws and remove the panel.

5 Release the cable from the upper end of the accelerator pedal and withdraw the cable from the engine compartment.

Refitting

6 Refitting is the reverse of the removal procedure. Tighten the windscreen wiper motor retaining bolts to the specified torque

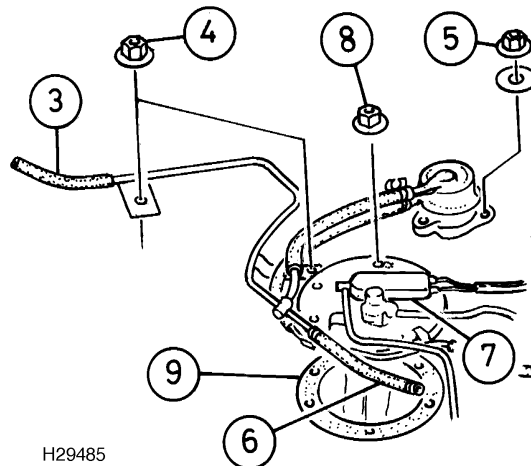

- Tank vent hose
- Vent pipe nuts
- Vent valve nut
- Cut-off valve hose
- Pump multiplug
- Pump housing nuts
- Pump housing seal

H29485

8.2 Fuel pump connections



11.2 Disconnecting accelerator cable from throttle cam pulley

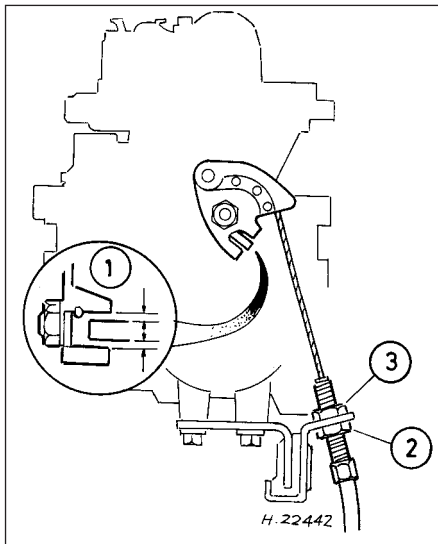

11.7 Accelerator cable adjustment

- 1 Throttle lever to lost motion link clearance should be equal on each side
- 2 Adjuster nut
- 3 Adjuster locknut

(Chapter 12) and prior to tightening the cable locknuts, adjust the cable as follows.

Adjustment

7 With the pedal fully released, check that there is equal clearance on each side of the throttle lever at the lost motion link (see illustration) and no slack in the cable. Have an assistant fully depress the pedal and check that the throttle cam opens fully, then check that it returns to the at-rest position when released.

8 To adjust the cable, switch on the ignition and position the stepper motor by moving the cam only to open, and fully close the throttle. Note that it is essential for accurate positioning of the stepper motor that the accelerator pedal switch contacts remain closed, so that the ECU recognises the throttle movement as a command and indexes the stepper motor to 25 steps.

9 Slacken the adjuster locknut (upper nut), then tighten the adjuster (lower) nut until the clearance is equal on each side of the throttle

lever at the lost motion link. Tighten the locknut without disturbing this setting. Recheck the adjustment and switch off the ignition.

12 Accelerator pedal - removal and refitting

Refer to Section 10 in Part A of this Chapter.

13 Throttle housing - removal and refitting

Removal

- 1 Depressurise the fuel system.
- 2 Disconnect the battery negative terminal and remove the air cleaner assembly.
- 3 Examine the injector housing fuel pipe feed and return unions for signs of leakage, then wipe them clean.
- 4 Using a spanner to hold each adaptor, unscrew the pipe union nuts and release the fuel feed and return pipes from the adaptors. Plug each pipe and adaptor to minimise the loss of fuel and prevent the entry of dirt into the system.
- 5 Release the wire retaining clips then disconnect the wiring connectors from the injector housing, the throttle potentiometer and the stepper motor.
- 6 Slacken the accelerator cable locknuts and free the cable outer from its mounting bracket. Release the cable inner from the throttle cam.
- 7 Using a suitable pair of pliers, release the retaining clips and disconnect the breather hoses from the throttle housing (see illustration).
- 8 Slacken and remove the four nuts securing the throttle housing to the inlet manifold, then remove the throttle housing from the vehicle. Remove the throttle housing insulating spacer and examine it for signs of wear or damage, renewing it if necessary (see illustrations).
- 9 If leakage was detected from the feed and return pipes or their union nuts, check the sealing surfaces of the nuts and adaptors and

renew the adaptor or the pipe assembly, as necessary.

10 If leakage is detected from the adaptors, unscrew each through one turn with a spanner, then through two turns by hand. If the adaptor is still a tight fit in the housing, the threads are damaged and the housing and adaptors must be renewed as a set. If the threads are sound, fit new sealing washers to the adaptors and refit them, tightening them to their specified torque wrench setting.

Refitting

11 Refitting is a reverse of the removal sequence, noting the following:

- a) Ensure that the mating surfaces of the throttle housing and inlet manifold are clean then fit the insulating spacer.
- b) Tighten the throttle housing and fuel pipe union nuts to their specified torque settings.
- c) On completion, reconnect and adjust the accelerator cable.

14 Fuel injection system components - testing

1 If a fault appears in the engine management (ignition/fuel injection) system, first ensure that the fault is not due to poor maintenance. That is, check that the air cleaner filter element is clean, the spark plugs are in good condition and correctly gapped, and that the engine breather hoses are clear and undamaged. Also check that the throttle cable is correctly adjusted. If the engine is running very roughly, check its compression pressures, bearing in mind that possibly one of the hydraulic tappets might be faulty, producing an incorrect valve clearance.

2 If these checks fail to reveal the cause of the problem, the vehicle should be taken to a suitably-equipped Rover dealer for testing. A wiring block connector is incorporated in the engine management circuit into which a special electronic diagnostic tester can be plugged. The tester will locate the fault quickly and simply, thereby alleviating the need to test all the system components individually



13.7 Disconnecting breather hoses from throttle housing



13.8a Lift throttle body assembly away from inlet manifold . . .



13.8b . . . and remove throttle body gasket spacer



15.1 Disconnecting fuel feed and return pipes from injector housing



15.2 Disconnecting wiring connector from injector housing

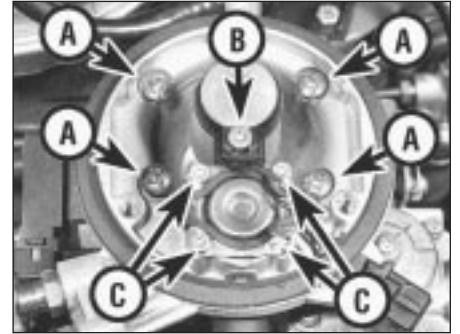

15.3a Injector housing-to-throttle body screws (A), connector cap screw (B) and pressure regulator screws (C)

which is a time consuming operation that carries a high risk of damaging the ECU.
3 If necessary, the system wiring and wiring connectors can be checked as described in Chapter 12. Ensure that the ECU wiring connectors have first been disconnected.

15 Fuel injection system components - removal and refitting



- a) Ensure the injector and throttle housing mating surfaces are clean, then fit a new gasket.
- b) Apply thread locking compound (Rover recommend Loctite Screwlock or Nutlock) to the threads of the injector housing screws, then tighten them to the specified torque.
- c) Tighten the fuel pipe union nuts to the specified torque setting.



15.3b Remove injector housing from throttle body - noting gasket

only as part of the injector housing assembly. Refer to paragraphs 1 to 5 for details on removal and refitting.

Injector housing

Removal

- 1** Carry out the operations described in paragraphs 1 to 4 of Section 13 (see illustration).
- 2** Release the wire retaining clip and disconnect the wiring connector from the injector housing (see illustration).
- 3** Remove the four screws securing the injector housing to the throttle body, then lift off the injector housing and remove the gasket (see illustrations).
- 4** If leakage was detected from the fuel feed and/or return pipes, perform the checks described in paragraph 9 of Section 13.

Refitting

5 Refitting is a reversal of the removal procedure, noting the following:

Fuel injector

Removal

- 6** Note that as a Rover replacement part, the injector is available only as part of the injector housing. Commence removal by depressurising the fuel system.
- 7** Disconnect the battery negative terminal then remove the air cleaner assembly.
- 8** Slacken and remove the injector connector cap retaining screw and lift off the connector cap. The injector can then be lifted out of the housing (see illustrations).

Refitting

9 Refitting is the reverse of the removal procedure. Ensure that the connector cap makes good contact with the injector pins.

Fuel pressure regulator

10 The fuel pressure regulator is available

Stepper motor

Removal

- 11** Remove the injector housing as described in paragraphs 1 to 4.
- 12** Release the retaining clip and disconnect the stepper motor wiring connector (see illustration).
- 13** Remove the four stepper motor retaining screws and remove the stepper motor assembly from the throttle housing (see



15.8a Remove screw then lift off injector connector cap . . .



15.8b . . . and withdraw injector



15.12 Disconnecting stepper motor wiring connector



15.13a Undo stepper motor retaining screws (arrowed) . . .



15.13b . . . and remove stepper motor assembly



15.17 Disconnecting throttle potentiometer wiring connector (mounting screws arrowed)

illustrations). Do not attempt to dismantle the assembly.

Refitting

14 Refitting is the reverse of the removal procedure. Ensure that the throttle housing and motor mating surfaces are clean and on completion, adjust the throttle cable to ensure that the stepper motor is correctly indexed.

Throttle potentiometer

Removal

15 Although not strictly necessary, access is greatly improved if the air cleaner assembly is first removed.



15.19 Ensure potentiometer tongue engages correctly with throttle lever (spacer arrowed)

16 Disconnect the battery negative lead.

17 Release the wire retaining clip and disconnect the potentiometer wiring connector (see illustration).

18 Remove the two screws and remove the potentiometer from the throttle housing, noting how its tongue engages with the throttle disc spindle lever. Withdraw the spacer if required.

Refitting

19 Refitting is the reverse of the removal procedure, noting the following (see illustration):

- a) Carefully clean the mating surfaces of the throttle body, the spacer and the potentiometer, then refit the spacer.
- b) Refit the potentiometer so that its tongue engages FORWARD of (ie: inside) the throttle disc spindle lever, then rotate the throttle cam to check the action of the lever and tongue.
- c) Securely tighten the potentiometer screws then recheck the potentiometer operation before reconnecting the wiring connector.

Engine management (ignition/fuel injection) ECU

Removal

20 Disconnect the battery negative terminal and unplug the wiring connector(s) from the ECU (see illustration).

21 Disconnect the absolute pressure sensor vacuum hose from the unit, then undo the three retaining nuts and remove the ECU from the engine compartment (see illustrations).

Refitting

22 Refitting is a reverse of the removal sequence. Tighten the ECU retaining nuts to the specified torque. Due to the nature of the ECU, if a new or different ECU has been fitted, it may take a short while for full idle control to be restored.

Manifold absolute pressure sensor

23 This is part of the ECU and is removed and refitted as described above.

24 The sensor's vacuum hose runs from the inlet manifold to the ECU via a fuel (vapour) trap mounted in the air cleaner assembly.

25 To remove the fuel trap, remove the air cleaner assembly cover, release the clips and disconnect the hoses, then remove the single retaining screw and withdraw the trap.

26 On refitting, note that the hoses are colour-coded (green to the ECU, white to the inlet manifold) to ensure correct reconnection (see illustration).

Intake air temperature sensor

Removal

27 Disconnect the battery negative lead.



15.20 Disconnect wiring connector . . .

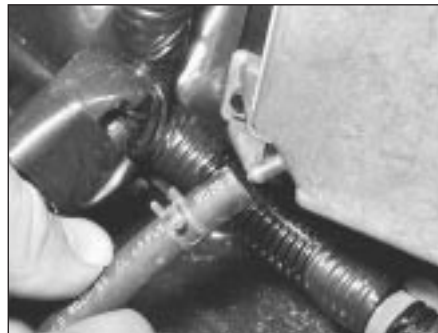

15.21a . . . and absolute pressure sensor vacuum hose from ECU . . .



15.21b . . . then undo ECU mounting nuts (arrowed) and remove unit

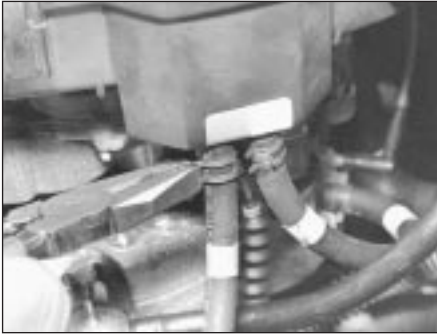

15.26 Absolute pressure sensor fuel trap hoses are colour-coded to ensure correct refitting



15.28 Remove air cleaner metal intake duct to gain access to intake air temperature sensor

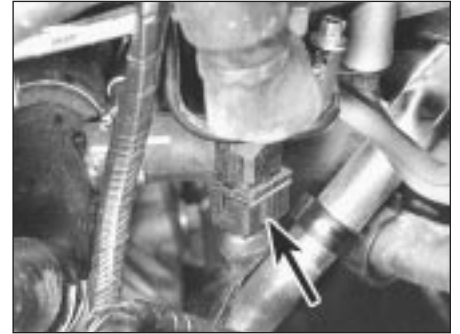

15.32 Coolant temperature sensor (arrowed)

28 Remove the air cleaner metal intake duct (see illustration).

29 Release the wire clip and disconnect the sensor wiring.

30 Unscrew the sensor and remove it from the air cleaner housing.

Refitting

31 Refitting is the reverse of the removal procedure. Tighten the sensor to its specified torque wrench setting.

Coolant temperature sensor

Removal

32 The coolant temperature sensor is fitted to the underside of the inlet manifold (see illustration). Either drain the cooling system or be prepared for some loss of coolant as the sensor is unscrewed.

33 Release the wire retaining clip and disconnect the wiring connector from the sensor.

34 Unscrew the sensor from the manifold and withdraw it, then plug the opening to prevent the entry of dirt. If the cooling system has not been drained, work quickly to minimise coolant loss.

Refitting

35 Wipe clean the threads of the sensor and of the thermostat housing. If a sealing washer is fitted, renew it whenever it is disturbed to

prevent leaks. If no sealing washer is fitted, apply a smear of sealant to the sensor threads.

36 Refit the sensor, working quickly if the cooling system was not drained, and tighten it to the specified torque. Reconnect the wiring connector.

37 Replenish the cooling system.

Accelerator pedal switch

38 Refer to Section 11 in Part A of this Chapter.

Fuel cut-off inertia switch

39 The fuel cut-off inertia switch is located behind the centre console where it is mounted on the steering column support bracket. If the switch has tripped, it can be reset by pressing in the plunger situated at the top of the switch (see illustration).

Removal

40 Remove the centre console.

41 Disconnect the wiring connector, then undo the switch mounting bracket retaining nut and remove the switch (see illustrations).

Refitting

42 Refitting is a reverse of the removal sequence. Before installing the centre console, reset the inertia switch by pressing in the plunger.



15.39 Reset fuel cut-off inertia switch by depressing plunger

Relays

43 Refer to Chapter 12 for further information.

16 Inlet manifold pre-heater - operation, removal and refitting

1 Refer to Section 15 in Part A of this Chapter. Note that there is no separate manifold pre-heater temperature switch. The ECU uses the information sent from the coolant temperature sensor (see illustration).



15.41a Undo inertia switch retaining nut . . .



15.41b . . . and remove switch



16.1 Inlet manifold partially removed to show manifold PTC heater and coolant temperature sensor (arrowed)

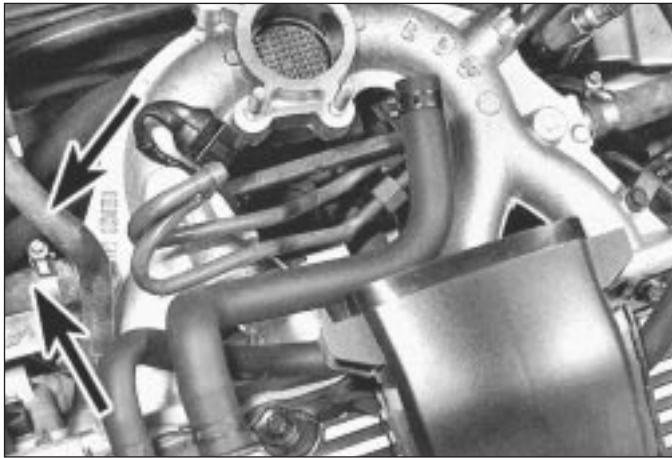

17.3 Disconnect coolant hoses (arrowed) . . .

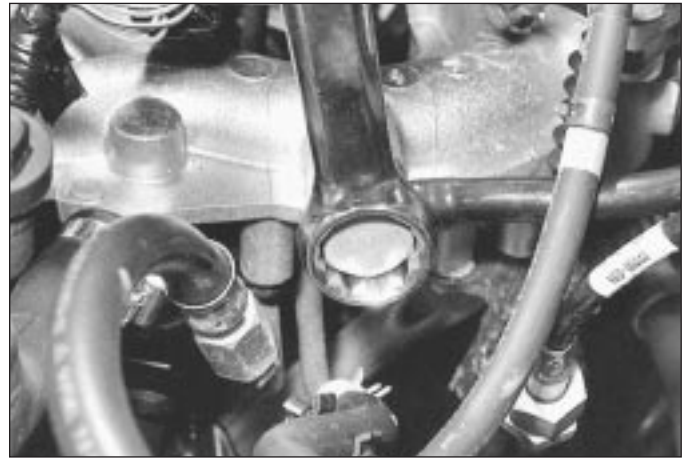

17.4 . . . and brake servo vacuum hose from inlet manifold



17.6a Ensure all vacuum pipes and hoses are disconnected



17.6b Remove inlet manifold and withdraw gasket

17 Inlet manifold - removal and refitting



Removal

- 1 Remove the throttle housing.
- 2 Drain the cooling system.
- 3 Slacken the retaining clamps and disconnect the coolant hoses from the inlet manifold (see illustration).
- 4 Slacken and remove the brake vacuum servo unit hose union bolt and disconnect the hose (see illustration). Discard the hose union sealing washers which must be renewed whenever they are disturbed.
- 5 Undo the single bolt securing each manifold support stay to the cylinder block/crankcase and slacken the bolts which secure the stays to the inlet manifold.
- 6 Make a final check that all the necessary vacuum hoses have been disconnected from the manifold then unscrew the nuts and bolts securing the manifold to the cylinder head.

Manoeuvre the manifold out of the engine compartment and discard the manifold gasket (see illustration).

Refitting

7 Refitting is the reverse of the removal procedure, noting the following (see illustration):

- a) Ensure that the manifold and cylinder head mating surfaces are clean and dry, then fit a new manifold gasket.
- b) Working in the sequence shown, tighten the manifold retaining nuts and bolts evenly, to the specified torque wrench setting.
- c) Ensure all relevant hoses are reconnected to their original positions and are securely held (where necessary) by the retaining clips.
- d) Renew the vacuum servo unit vacuum hose banjo union sealing washers and tighten the union bolt securely.
- e) On completion, refill the cooling system.

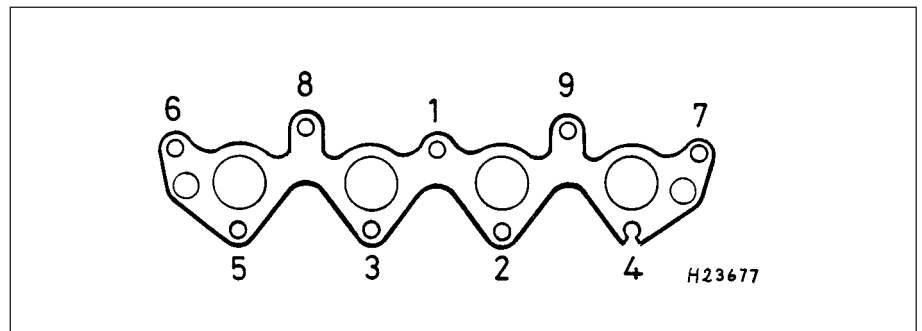

17.7 Inlet manifold tightening sequence - K16 engine

18 Exhaust manifold - removal and refitting



Removal

- 1 Disconnect the battery negative lead. Firmly apply the handbrake then jack up the front of the vehicle and support it on axle stands.
- 2 Remove the air cleaner metal intake duct. Undo the two bolts securing the duct mounting bracket to the cylinder head cover and remove the bracket.
- 3 Undo the two bolts securing the upper radiator mountings to the bonnet platform, then remove the mountings and tilt the radiator forward to gain the clearance necessary to remove the manifold.
- 4 Unscrew the nuts securing the exhaust front pipe to the manifold, then disconnect the pipe and collect the gasket.
- 5 Undo the five nuts securing the exhaust manifold to the cylinder head, then carefully manoeuvre the manifold out of the engine compartment. Remove the manifold gasket and discard it.
- 6 Examine all the exhaust manifold studs for signs of damage and corrosion. Remove all traces of corrosion and repair or renew any damaged studs.

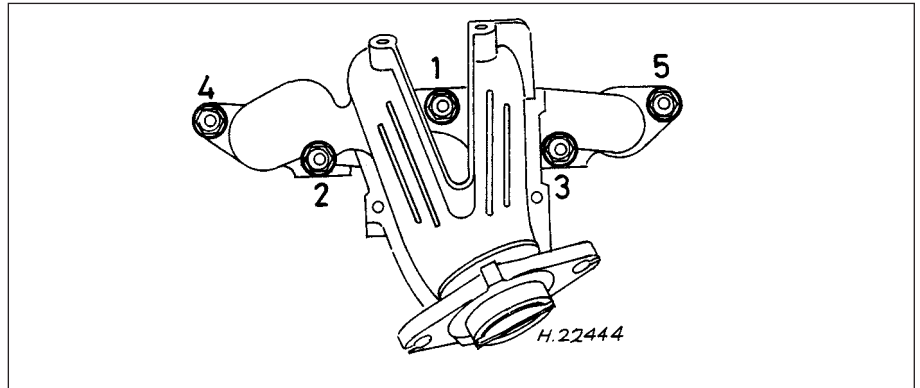

18.7 Exhaust manifold tightening sequence - K16 engine

Refitting

- 7 Refitting is the reverse of the removal procedure, noting the following (see illustration):
 - a) *Ensure that the manifold and cylinder head sealing faces are clean and flat, then fit a new manifold gasket.*
 - b) *Working in the sequence shown, tighten the manifold retaining nuts evenly to the specified torque wrench setting.*
 - c) *Tighten all other disturbed nuts and bolts to their specified torque wrench settings (where given).*

19 Exhaust system - inspection, removal and refitting

- 1 Refer to Section 18 in Part A of this Chapter. Note that on models fitted with a closed-loop catalytic converter, the lambda sensor must be removed or its wiring disconnected whenever the exhaust system front pipe is disconnected from the manifold.

Chapter 4 Part C

Fuel and exhaust systems - multi-point fuel injection engines

Contents

Air cleaner assembly - removal and refitting	3	Fuel pump - removal and refitting	7
Air cleaner filter element - renewal	2	Fuel system - depressurisation	5
Accelerator cable - removal, refitting and adjustment	10	Fuel system - inspection	4
Accelerator pedal - removal and refitting	11	Fuel system - pressure check	6
Exhaust manifold - removal and refitting	17	Fuel tank - removal and refitting	9
Exhaust system - inspection, removal and refitting	18	General information and precautions	1
Fuel gauge sender unit - removal and refitting	8	Inlet manifold pre-heater - operation, removal and refitting	15
Fuel injection system components - removal and refitting	14	Inlet manifold - removal and refitting	16
Fuel injection system components - testing	13	Throttle housing - removal and refitting	12

Degrees of difficulty

Easy , suitable for novice with little experience 	Fairly easy , suitable for beginner with some experience 	Fairly difficult , suitable for competent DIY mechanic 	Difficult , suitable for experienced DIY mechanic 	Very difficult , suitable for expert DIY or professional 
---	--	--	---	--

Specifications

System

Type	Rover/Motorola Modular Engine Management System, using ECU-controlled multi-point injection (MEMS-MPI) and speed/density method of airflow measurement
------	--

MEMS-MPi system data

Fuel pump type	Electric, immersed in fuel tank
Fuel pressure	3.0 ± 0.2 bar constant
MEMS - ECU assembly:	
Alloy inlet manifold	MNE 101470
Plastic inlet manifold	MKC 101730
Injectors	MJY 10015
Throttle potentiometer voltage:	
Throttle closed	0 to 1 volt
Throttle open	4 to 5 volt
Idle speed - nominal value given for reference purposes only	850 ± 50 rpm
CO level at idle speed — engine at normal operating temperature	0.5 %

Recommended fuel

Minimum octane rating	95 RON unleaded (ie: unleaded Premium) only
-----------------------	---

Torque wrench settings

	Nm	lbf ft
Fuel system		
ECU mounting bracket nuts	9	7
Vent valve-to-fuel tank nut	9	7
Vent pipe-to-fuel tank nuts	9	7
Fuel pump-to-fuel tank nuts	9	7
Fuel filter pressure release union	38	28
Fuel feed hose union-to-body bolts	9	7
Fuel feed hose bolts	10	7
Fuel rail bolts	10	7
Fuel rail support bracket bolts - alloy manifold	10	7
Intake air temperature sensor	7	5
Coolant temperature sensor	15	11
Crankshaft sensor bolts	6	4

Torque wrench settings

Fuel system (continued)

	Nm	lbf ft
Throttle housing-to-alloy manifold nuts	8	6
Throttle housing-to-plastic manifold bolts	4	3
Throttle potentiometer screws - plastic manifold	1.5	1.1
Stepper motor screws - plastic manifold	1.5	1.1
Pressure regulator-to-fuel rail bolts - alloy manifold	10	8
Pressure release bolt	12	9
Inlet manifold mounting nuts and bolts	25	18

Exhaust system

Oxygen (lambda) sensor	55	40
Exhaust manifold retaining nuts	45	33
Exhaust manifold shroud screws	6	4
Exhaust system flange nuts:		
Manifold-to-front pipe joint	50	37
All other joints	45	33
Exhaust front pipe mounting bolts	15	11

1 General information and precautions

General information

The fuel system comprises a fuel tank which is mounted under the rear of the vehicle with an electric fuel pump immersed in it, a fuel filter, fuel feed and return lines which service four fuel injectors interlinked by a rail, as well as the Electronic Control Unit (ECU) and the various sensors, electrical components and related wiring which make up the system as a whole (see illustration). Inlet manifolds of either alloy or plastic construction are fitted.

The air cleaner assembly contains a disposable paper filter element and is mounted on the side of the battery tray.

To reduce emissions and to improve driveability when the engine is cold, the inlet manifold is heated by the coolant. Mixture enrichment for cold starting is a pre-programmed function of the system.

The ECU fully controls both the ignition system and the fuel injection system, integrating the two in a complete engine management system (MEMS-MPi). System operation is similar to that described for the single-point fuel injection system (MEMS-SPi) in Part B of this Chapter, any differences being made clear in the following Sections. Refer to Chapter 5 for information on the ignition side of the system and to Chapter 12 for details of the system relays.

The exhaust system consists of four main components which are the front downpipe, the catalytic converter, the intermediate pipe and middle silencer box, and the tailpipe and main silencer box. The system is suspended throughout its entire length by rubber mountings.

Precautions

Fuel injection system

Residual pressure will remain in the fuel lines long after the vehicle was last used,

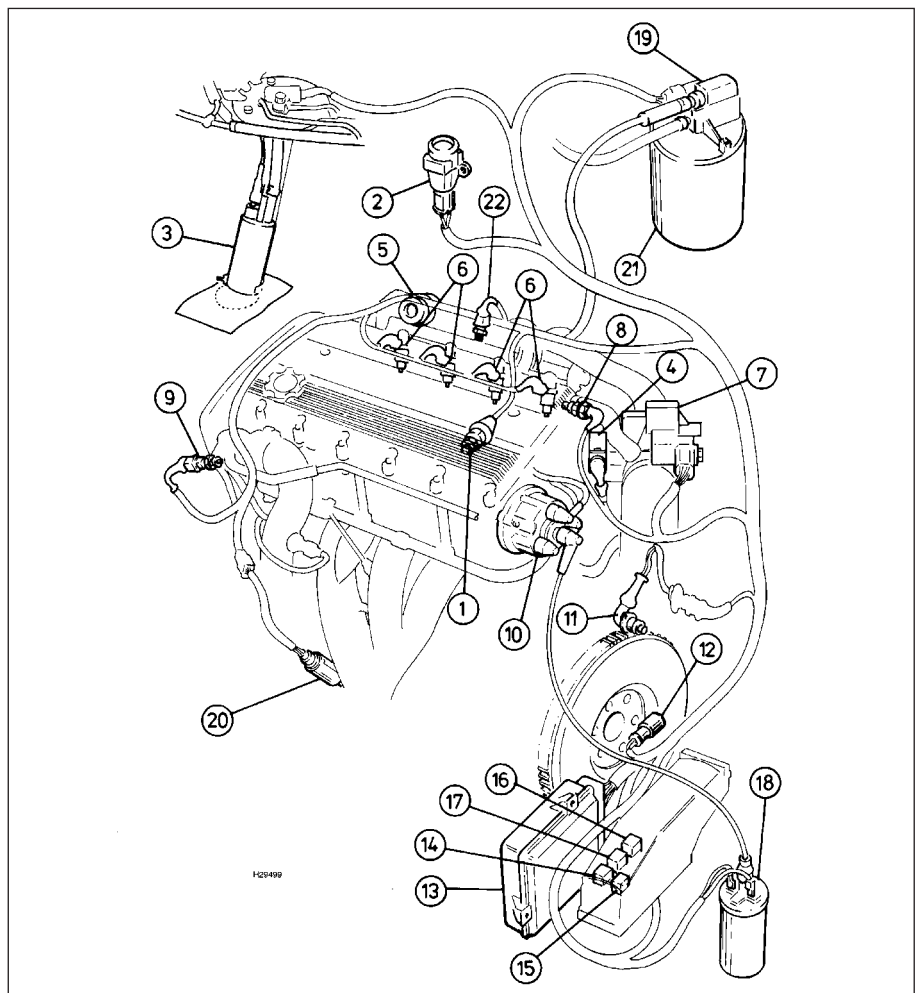

1.0 Fuel and ignition system components - MEMS-MPi

- | | | |
|---------------------------------|------------------------------|----------------------------|
| 2 Fuel cut-out inertia switch | 9 Coolant temperature sensor | 15 Fuel pump relay |
| 3 Fuel pump | 10 Distributor | 16 Lambda sensor relay |
| 4 Throttle potentiometer | 11 Crankshaft sensor | 17 Starter relay |
| 5 Fuel pressure regulator | 12 Diagnostic connector | 18 Ignition HT coil |
| 6 Injectors | 13 Engine management ECU | 19 Purge valve |
| 7 Stepper motor | 14 Main relay | 20 Lambda sensor |
| 8 Intake air temperature sensor | | 21 Charcoal canister |
| | | 22 Fuel temperature sensor |



3.2 Releasing throttle housing-to-air cleaner securing clips

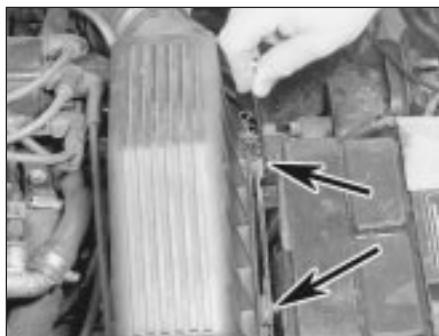

3.3 Removing battery tray-to-air cleaner securing bolts (arrowed)



3.4 Releasing HT coil-to-distributor cap lead from air cleaner

therefore extra care must be taken when disconnecting a fuel line hose. Loosen any fuel hose slowly to avoid a sudden release of pressure which may cause fuel spray. As an added precaution, place a rag over each union as it is disconnected to catch any fuel which is forcibly expelled.

Fuel usage

Refer to Part A of this Chapter.

Catalytic converters

Before attempting work on these items, carefully read the precautions listed in Part D of this Chapter.

2 Air cleaner filter element - renewal

Refer to Chapter 1.

3 Air cleaner assembly - removal and refitting



Removal

- 1 For improved access, remove the battery.
- 2 Release the two securing clips and detach the connecting hose from between the throttle housing and air cleaner (**see illustration**). Note that on engines fitted with a plastic inlet manifold, the hose is secured to the throttle housing with a spring clip.
- 3 Remove the two battery tray-to-air cleaner securing bolts (**see illustration**).
- 4 Disconnect the HT coil-to-distributor cap lead at the cap and from its retaining clip on the air cleaner (**see illustration**).
- 5 Pull the air cleaner assembly free of its mounting bracket, release it from its inlet hose, then remove it from the vehicle.

Refitting

- 6 Refitting is the reverse of the removal procedure. Ensure that all rubber mounting grommets and hoses are free of splits or perishing and that all hose clips are securely tightened.

4 Fuel system - inspection

Refer to Chapter 1.

5 Fuel system - depressurisation



Note: *The following procedure will merely relieve pressure in the fuel system. Remember that fuel will still be present in the system components and take precautions accordingly before disconnecting any of them.*

1 The fuel system is defined as the tank-mounted fuel pump, the fuel filter, the fuel injectors and the metal pipes and flexible hoses of the fuel lines between these components. All these contain fuel which will be under pressure while the engine is running and/or while the ignition is switched on. The pressure will remain for some time after the ignition has been switched off and must be relieved before any of these components are disturbed for servicing work.

2 The fuel system is depressurised by loosening the fuel filter pipe union.

3 Position wads of rag around the union to catch spilled fuel. Carefully loosen the union whilst holding the fuel pipe with an open-ended spanner to prevent any undue strain being placed upon it (**see illustration**).

4 Once all pressure has been released, retighten the union to the specified torque setting whilst using a spanner to counter-hold the pipe.

6 Fuel system - pressure check

1 Fuel system testing will involve the use of specialist Rover tools. Consult your Rover dealer as to the availability of these tools and refer to Section 7 in Part B of this Chapter and to the figures given in the Specifications Section before proceeding.

7 Fuel pump - removal and refitting

Refer to Section 8 in Part B of this Chapter.

8 Fuel gauge sender unit - removal and refitting

Refer to Section 9 in Part A of this Chapter.

9 Fuel tank - removal and refitting

1 Refer to Section 10 in Part A of this Chapter but depressurise the fuel system before disconnecting any of the fuel lines.

10 Accelerator cable - removal, refitting and adjustment



Note: *Before proceeding with any adjustment of the accelerator cable, ensure that it is correctly routed. Do not attempt to adjust the cable by means of the throttle stop screw.*

Removal

1 Detach the cable adjuster nut from its abutment bracket and disengage the cable



5.3 Loosening fuel filter pipe union

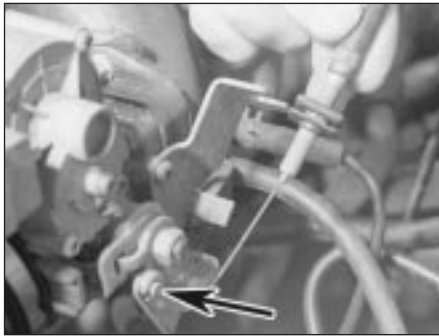

10.1 Remove accelerator cable adjuster nut from abutment bracket and disengage cable end nipple from throttle cam (arrowed)



10.2 Releasing accelerator cable from retaining clip on engine compartment bulkhead



10.5 Release accelerator cable from bulkhead by turning retaining clip (arrowed)

end nipple from the throttle cam (see illustration).

2 On vehicles with an alloy inlet manifold, release the cable from its retaining clip on the engine compartment bulkhead (see illustration).

3 On vehicles with a plastic inlet manifold, release the cable from its retaining clip on the manifold.

4 It may be necessary to remove the windscreen wiper motor to gain access to where the cable passes through the bulkhead.

5 Release the cable outer from the bulkhead by turning its retaining clip (see illustration).

6 Remove the cable inner-to-throttle pedal securing clip and detach the cable from the pedal.

7 Withdraw the cable from the vehicle.

Refitting

8 Refitting is the reverse of the removal procedure. Adjust the cable as follows:

Adjustment

Alloy inlet manifold only

9 Ensure that the throttle potentiometer and stepper motor are synchronised.

10 Turn the ignition on and wait for 10 seconds before turning the ignition off to

ensure that the stepper motor is in the setting position.

Alloy and plastic inlet manifolds

11 Detach the cable adjuster nut from its abutment bracket and reposition the cable outer in the bracket.

12 Turn the cable adjuster nut until it just makes contact with the top of the abutment bracket.

Alloy inlet manifold only

13 Hold the cam in the "throttle closed" position and ensure that the screw is in contact with the stepper motor pin. Turn the cable adjuster nut until all slack is removed from the cable inner. Any linkage gap must be removed without opening the throttle (see illustration).

Plastic inlet manifold only

14 Hold the throttle cam in contact with the throttle stop screw and turn the cable adjuster nut until all slack is removed from the cable inner. This must be achieved without opening the throttle.

Alloy and plastic inlet manifolds

15 Check that there is no free play in the cable outer and refit the cable adjuster nut into its abutment bracket.

16 Operate the throttle pedal, checking that the throttle opens to its stop.

11 Accelerator pedal - removal and refitting

Refer to Section 10 in Part A of this Chapter.

12 Throttle housing - removal and refitting



Alloy inlet manifold

- 1** Disconnect the battery earth lead.
- 2** Release the two securing clips and detach the connecting hose from between the throttle housing and air cleaner (see illustration).
- 3** Disconnect the stepper motor and throttle potentiometer multiplugs.
- 4** Disconnect the breather hose from the throttle housing.
- 5** Pull the accelerator cable adjuster nut from its abutment bracket and release the cable inner from the throttle cam.
- 6** Remove the four nuts securing the throttle housing to its mounting and remove the housing from the vehicle.
- 7** Refitting is the reverse of the removal procedure, noting the following:

- a) Thoroughly clean all component parts, paying particular attention to the mating surfaces.
- b) Examine the throttle housing mounting for splits or damage and renew if necessary.
- c) Tighten the housing securing nuts to the specified torque wrench settings.
- d) Check all hose connections are secure.
- e) Check accelerator cable adjustment.

Plastic inlet manifold

- 8** Disconnect the battery earth lead.
- 9** Release the two securing clips and

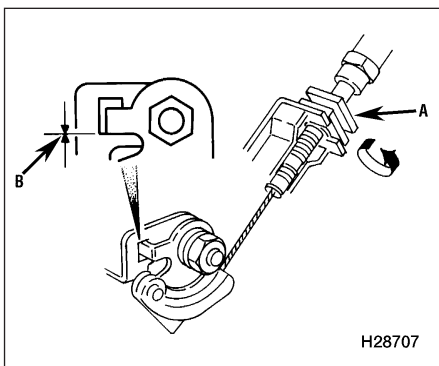

10.13 Turn accelerator cable adjuster nut (A) until all slack is removed from cable inner. Any linkage gap (B) must be removed without opening throttle

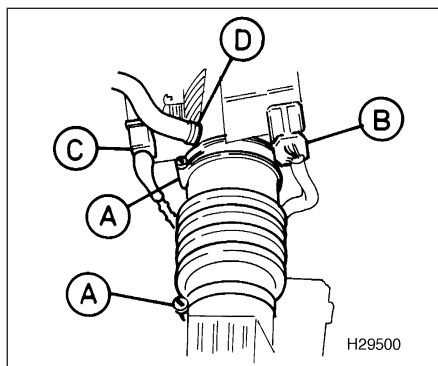

12.2 Release hose securing clips (A), disconnect stepper motor multiplug (B), throttle potentiometer multiplug (C) and breather hose (D)

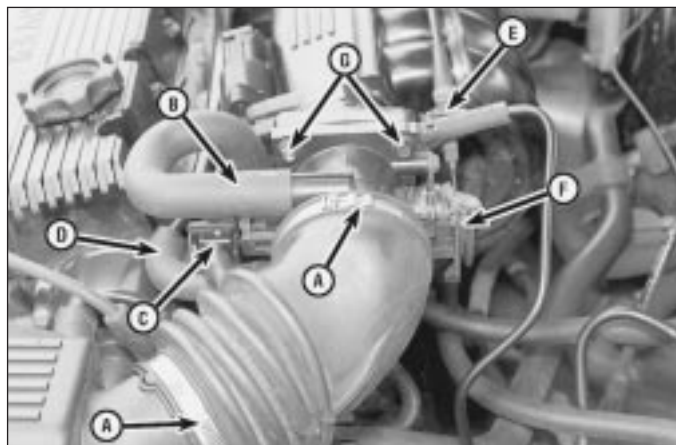

12.9 Throttle housing assembly - plastic inlet manifold

- | | |
|------------------------------------|---|
| A Hose securing clips | E Throttle cable adjuster |
| B Stepper motor hose | F Throttle cam |
| C Throttle potentiometer multiplug | G Throttle housing securing bolts (two shown) |
| D Throttle housing breather hose | |

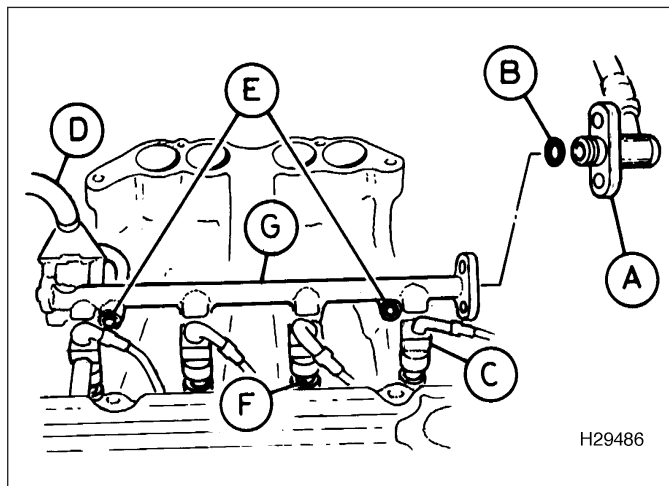

14.4 Fuel rail/injector assembly - alloy inlet manifold

- | | |
|-------------------------------|----------------------------|
| A Fuel feed hose connection | E Fuel rail securing bolts |
| B O-ring | F Fuel injector (1 of 4) |
| C Injector multiplug (1 of 4) | G Fuel rail |
| D Fuel pressure regulator | |

detach the connecting hose from between the throttle housing and air cleaner (see illustration).

10 Loosen the stepper motor hose-to-throttle housing retaining clip and detach the hose from the housing.

11 Disconnect the multiplug from the throttle potentiometer.

12 Disconnect the breather hose from the throttle housing after loosening its retaining clip.

13 Pull the accelerator cable adjuster nut from its abutment bracket and release the cable inner from the throttle cam.

14 Remove the four bolts securing the throttle housing to the inlet manifold, detach the throttle housing from the manifold and discard the sealing ring.

15 Refitting is the reverse of the removal procedure, noting the following.

- Thoroughly clean all component parts, paying particular attention to the mating surfaces.
- Fit a new throttle housing sealing ring, lubricating it with silicone grease.

c) Tighten the housing securing bolts to the specified torque wrench settings.

d) Check all hose connections are secure.

e) Check accelerator cable adjustment.

13 Fuel injection system components - testing

Refer to Section 14 in Part B of this Chapter.

14 Fuel injection system components - removal and refitting

Fuel rail/injectors

Alloy inlet manifold

- Disconnect the battery earth lead.
- Depressurise the fuel system.
- Detach the inlet manifold chamber and discard the gasket.

4 Remove the two bolts securing the fuel feed hose to the fuel rail and release the hose from the rail, discarding the O-ring (see illustration).

5 Disconnect the four injector multiplugs.

6 Release the retaining clip and disconnect the hose from the fuel pressure regulator.

7 Remove the two bolts securing the fuel rail to the inlet manifold.

8 Pull each injector from its location in the inlet manifold and remove the fuel rail, complete with injectors and pressure regulator, from the vehicle, placing it on a clean surface.

9 Remove and discard the O-ring fitted to the base of each injector, then cover the exposed end of each injector to prevent the ingress of dirt or moisture (see illustration).

10 To remove the injectors from the fuel rail, first remove the spring clip which secures each injector to the rail (see illustration). Pull each injector from the rail and discard the O-ring fitted to its upper end. Again, cover the exposed end of each injector to prevent the ingress of dirt or moisture.

11 Refitting of the injectors and rail is the reverse of the removal procedure, noting the following:

- Thoroughly clean all component parts, paying particular attention to the mating surfaces.
- Fit new O-rings, lubricating them with clean fuel.
- Where applicable, tighten all securing bolts to the specified torque wrench settings.

Plastic inlet manifold

12 Disconnect the battery earth lead.

13 Depressurise the fuel system.

14 Loosen the throttle housing breather

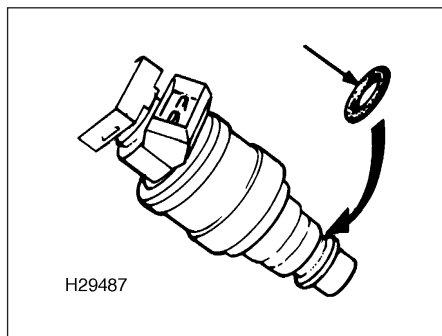

14.9 Discard O-ring (arrowed) fitted to injector base

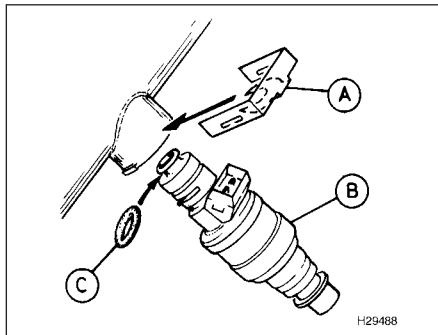

14.10 Remove spring clip (A), pull injector (B) from rail and discard O-ring (C)

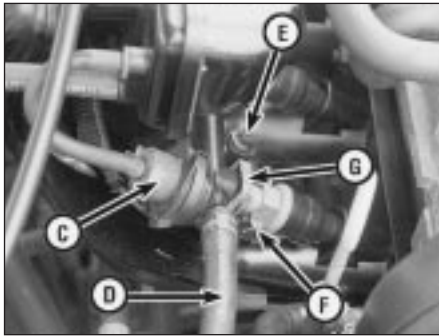

14.14 Fuel rail/injector components - plastic inlet manifold

- A Throttle housing breather hose
- B Inlet manifold breather hose
- C Fuel pressure regulator
- D Fuel return hose
- E Fuel rail securing bolt (1 of 2)
- F Fuel injector multiplug (1 of 4)
- G Fuel injector securing clip (1 of 4)

hose-to-camshaft cover retaining clip and detach the hose (see illustration).

15 Disconnect the multiplug from the stepper motor.

16 Disconnect the inlet manifold breather hose from the camshaft cover.

17 Disconnect the vacuum pipe from the fuel pressure regulator.

18 Loosen the retaining clip and disconnect the fuel return hose from the fuel rail.

19 Remove the two bolts which secure the fuel feed pipe to the fuel rail and release the pipe from the rail, discarding the O-ring (see illustration 14.4).

20 Disconnect each injector multiplug and securing clip.

21 Remove the two bolts securing the fuel rail to the inlet manifold and detach the rail from the manifold, together with the fuel pressure regulator.

22 Note that the rail and regulator are serviced as an assembly and should not be separated. If unions are to be left disconnected for any length of time, then plug them with clean cloth to prevent the ingress of dirt or moisture into the system.

23 To remove the injectors, pull each one from its location in the inlet manifold and discard both of its O-rings. If leaving the injectors for any length of time, cover their exposed ends to prevent the ingress of dirt or moisture.

24 Refitting of the injectors and rail is the reverse of the removal procedure, noting the following:

- a) Thoroughly clean all component parts, paying particular attention to the mating surfaces.
- b) Fit new O-rings, lubricating them with silicone grease.
- c) Where applicable, tighten all securing bolts to the specified torque wrench settings.



14.25 Fuel pressure regulator location - alloy inlet manifold

Fuel pressure regulator

Alloy inlet manifold

25 The fuel pressure regulator is secured to the end of the fuel rail by two bolts (see illustration).

26 With fuel system pressure released and the fuel hose disconnected from the regulator (see fuel rail removal above), remove the securing bolts and detach the regulator from the rail.

27 Remove the spacer and O-ring, discarding the O-ring.

28 Refitting the regulator is the reverse of the removal procedure. Thoroughly clean the mating surfaces and fit a new O-ring, lubricating it with clean fuel.

Plastic inlet manifold

29 The fuel pressure regulator is available only as part of the fuel rail and should not be separated from the same.

Stepper motor

Alloy inlet manifold

30 The stepper motor fitted to this type of manifold is an integral part of the throttle housing and as a consequence, cannot be removed.

Plastic inlet manifold

31 Disconnect the multiplug from the stepper motor (see illustration).

32 Remove the two Torx screws which



14.35 Disconnecting potentiometer multiplug - alloy inlet manifold

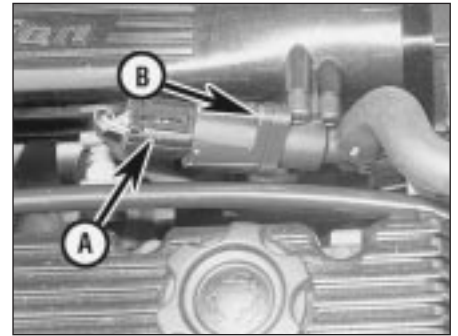

14.31 Disconnect stepper motor multiplug (A) and remove Torx screws (B - one hidden)

secure the motor to the inlet manifold and remove the motor, discarding its O-ring.

33 Refitting is the reverse of the removal procedure, noting the following:

- a) Thoroughly clean the mating surfaces.
- b) Fit a new O-ring to the motor, lubricating it with silicone grease.
- c) Tighten the motor securing bolts to the specified torque wrench setting.

Throttle potentiometer

Alloy inlet manifold

34 Disconnect the battery earth lead.

35 Disconnect the multiplug from the potentiometer (see illustration).

36 Remove the two securing screws and detach the potentiometer from the throttle housing.

37 Refitting is the reverse of the removal procedure, noting the following:

- a) Thoroughly clean the mating surfaces.
- b) Ensure correct engagement of the potentiometer before fitting the securing screws.

Plastic inlet manifold

38 Disconnect the potentiometer multiplug (see illustration).

39 Remove and discard the two securing screws and washers and remove the clamping plate.

40 Pull the potentiometer off the throttle spindle being careful not to apply leverage or twist the potentiometer.

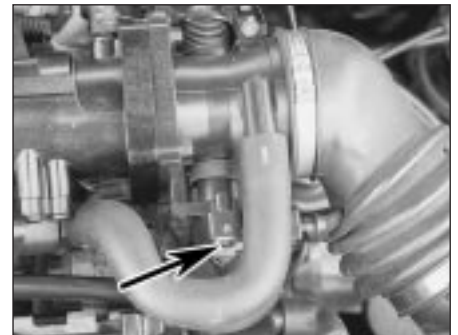

14.38 Potentiometer multiplug (arrowed) - plastic inlet manifold

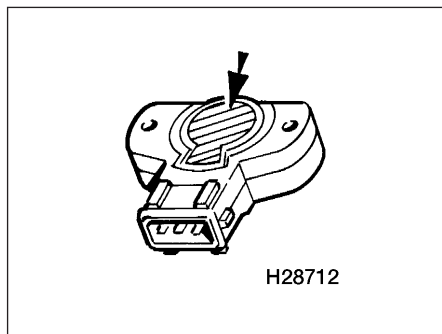

14.41 When pressing potentiometer onto spindle, apply finger pressure only to shaded area

- 41 Refitting is the reverse of the removal procedure, noting the following:
- Carefully clean the mating surfaces of the throttle housing and potentiometer.
 - Refit the potentiometer so that the flat on the spindle is aligned with the mating portion of the potentiometer.
 - When pressing the potentiometer onto the spindle, apply finger pressure only to the shaded area shown (see illustration).
 - Rotate the potentiometer anti-clockwise only to align the fixing holes.
 - Tighten the potentiometer screws to their specified torque wrench setting.
 - Operate the throttle cam 2 or 3 times and ensure that full travel exists between the throttle open and closed positions.

Engine management (ignition/fuel injection) ECU

- Remove the battery.
- Undo the three nuts securing the ECU to its mounting bracket (see illustration).
- Unplug the two multiplug connectors from the ECU.
- Release the securing clip and pull the vacuum hose from the ECU.
- Remove the ECU from the vehicle.
- Refitting the ECU is the reverse of the removal procedure. If a new or different ECU has been fitted, it may take a short while for full idle control to be restored.



14.53 Coolant temperature sensor multiplug (arrowed)

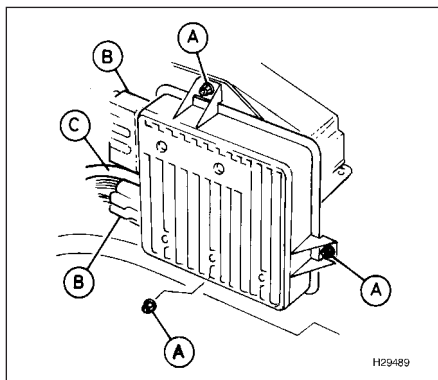

14.43 ECU connection points

- A Mounting nuts
B Multiplug connectors
C Vacuum hose

Intake air temperature sensor

- Disconnect the battery earth lead.
- Disconnect the sensor multiplug and unscrew the sensor from the inlet manifold (see illustration).
- Refitting is the reverse of the removal procedure, noting the following:
 - Thoroughly clean the sensor threads and mating surfaces.
 - Tighten the sensor to the specified torque wrench setting.

Coolant temperature sensor

- Disconnect the battery earth lead.
- Either drain the cooling system or be prepared for some loss of coolant as the sensor is unscrewed.
- Disconnect the sensor multiplug (see illustration).
- Unscrew the sensor and withdraw it, then plug the opening to prevent any entry of dirt. If the cooling system has not been drained, work quickly to minimise coolant loss.
- Refitting is the reverse of the removal procedure, noting the following:
 - Thoroughly clean the sensor threads and mating surfaces.
 - If a sealing washer is fitted, renew it. If no sealing washer is fitted, apply a smear of sealant to the sensor threads.



16.6 Disconnecting stepper motor multiplug



14.49 Intake air temperature sensor multiplug (arrowed)

- Tighten the sensor to the specified torque wrench setting.
- On completion, replenish the cooling system.

Accelerator pedal switch

- Refer to Section 11 in Part A of this Chapter.

Fuel cut-off inertia switch

- Refer to Section 15 in Part B of this Chapter.

Relays

- Refer to Chapter 12 for further information.

15 Inlet manifold pre-heater - operation, removal and refitting

- Refer to Section 15 in Part A of this Chapter. Note that there is no separate manifold pre-heater temperature switch. The ECU uses the information sent from the coolant temperature sensor.

16 Inlet manifold - removal and refitting



Alloy inlet manifold

Removal

- Disconnect the battery earth lead.
- Depressurise the fuel system.
- Disconnect the hose from the fuel filter, covering the open connections to prevent any ingress of dirt.
- Refer to Chapter 1 and drain the cooling system.
- Release the securing clip and detach the throttle housing-to-air cleaner hose from the throttle housing.
- Disconnect the stepper motor and throttle potentiometer multiplugs (see illustration).
- Disconnect the breather hose from the throttle housing.

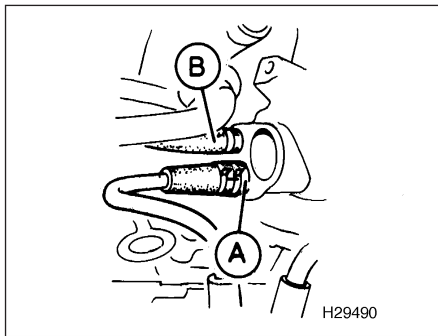

16.8 Disconnect breather pipe (A) from manifold chamber
B Manifold chamber breather hose (1 of 3)

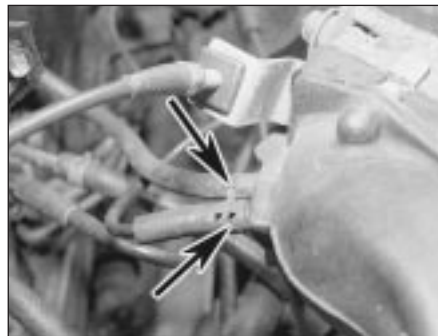

16.9 Disconnect breather hoses (arrowed) from manifold chamber

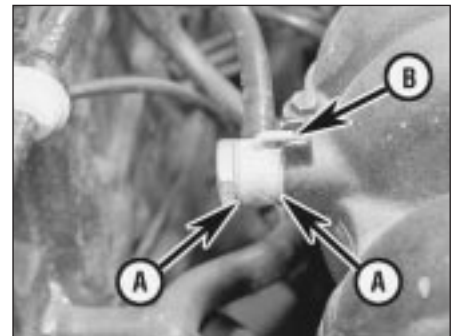

16.10 Brake servo line banjo union
A Sealing washers
B Union alignment tang in manifold chamber slot

8 Release the retaining clip and disconnect the breather pipe from the manifold chamber (see illustration).

9 Release the retaining clips and disconnect the three breather hoses from the manifold chamber (see illustration, also illustration 16.8).

10 Unscrew the brake servo line banjo bolt from the manifold chamber, discarding both sealing washers (see illustration).

11 Remove the five bolts securing the manifold chamber to the inlet manifold.

12 Remove the support stay to manifold chamber securing bolt.

13 Detach the manifold chamber from the inlet manifold and discard its gasket.

14 Remove the engine oil dipstick, covering the open pipe to prevent any ingress of dirt.

15 Disconnect the four fuel injector multiplugs and the intake air temperature sensor multiplug.

16 Release the coolant hose from the inlet manifold (see illustration).

17 Remove the two nuts and three bolts securing the upper face of the inlet manifold to the cylinder head, loosening each one a little at a time.

18 Remove the two bolts securing the engine wiring harness brackets to the inlet manifold.

19 Release the two clips which secure the fuel return hose.

20 Remove the bolt securing the support stay to the inlet manifold.

21 Remove the four bolts securing the lower face of the inlet manifold to the cylinder head, loosening each one a little at a time.

22 Remove the inlet manifold, discarding the gasket.

Refitting

23 Refitting is the reverse of the removal procedure, noting the following:

- a) *Thoroughly clean all component parts, paying particular attention to the mating surfaces.*
- b) *Always fit a new manifold gasket.*
- c) *Working in the sequence shown (see illustration), tighten the manifold retaining nuts and bolts evenly to the specified torque wrench setting.*
- d) *Tighten all disturbed fasteners to their specified torque wrench settings (where given).*
- e) *Renew all sealing washers and O-rings.*
- f) *Remove all masking materials.*
- g) *Ensure all hose connections are securely remade.*
- h) *Ensure the brake servo line banjo union alignment tang is located in the manifold chamber slot.*
- i) *Refill the cooling system and check the coolant level, then wash off any spilt coolant.*

25 Depressurise the fuel system.

26 Refer to Chapter 1 and drain the cooling system.

27 Release the securing clip and detach the throttle housing-to-air cleaner hose from the air cleaner.

28 Release the retaining clip and detach the purge hose from the inlet manifold (see illustration).

29 Disconnect the breather hose from the throttle housing after loosening its retaining clip.

30 Disconnect the multiplug from the throttle potentiometer.

31 Loosen the stepper motor hose-to-abutment retaining clip and detach the hose, moving it to one side.

32 Release the accelerator cable from its retaining clip on the right-hand side of the manifold.

33 Remove the four bolts securing the throttle housing to the inlet manifold.

34 Detach the throttle housing from the manifold and discard its sealing ring.

35 Disconnect the multiplug from the stepper motor.

36 Release the breather hose from the inlet manifold and depress the plastic collar of the brake servo hose quick-fit connector to



16.16 Releasing coolant hose from inlet manifold

Plastic inlet manifold

Removal

24 Disconnect the battery earth lead.

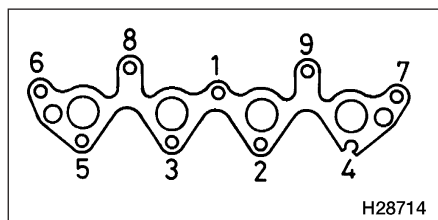

16.23 Alloy inlet manifold tightening sequence

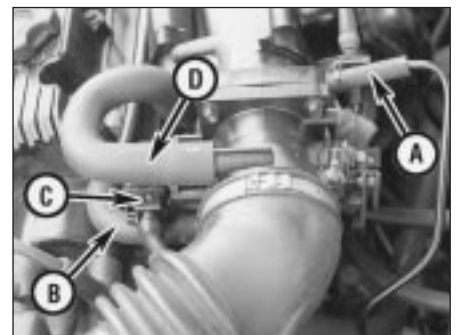

16.28 Throttle housing connections - plastic inlet manifold

- A Purge hose*
- B Breather hose*
- C Throttle potentiometer*
- D Stepper motor hose*

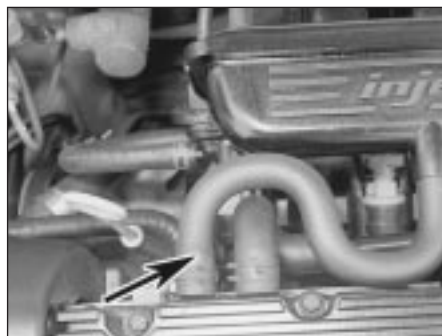

16.36a Release breather hose (arrowed) . . .

release it from the manifold (see illustrations).

37 Disconnect the ECU vacuum pipe from the manifold.

38 Loosen the retaining clip and disconnect the fuel return hose from the fuel rail, covering the open connections to prevent any ingress of dirt (see illustration).

39 Disconnect the coolant system expansion tank hose from the inlet manifold.

40 Release the fuel return hose from its retaining clips.

41 Disconnect the injector harness and air temperature sensor multiplugs.

42 Remove the two bolts which secure the fuel feed pipe to the fuel rail and release the pipe from the rail. Discard the O-ring and cover the open connections to prevent any ingress of dirt.

43 Working from the centre of the manifold outwards, progressively loosen the manifold securing nuts and bolts. Remove the manifold, discarding the gasket.

Refitting

44 Refitting is the reverse of the removal procedure, noting the following:

- a) Thoroughly clean all component parts, paying particular attention to the mating surfaces.
- b) Ensure that a metal insert is located in each manifold stud or bolt hole.
- c) Always fit a new manifold gasket (see illustration).
- d) Working in the sequence shown (see illustration), tighten the manifold

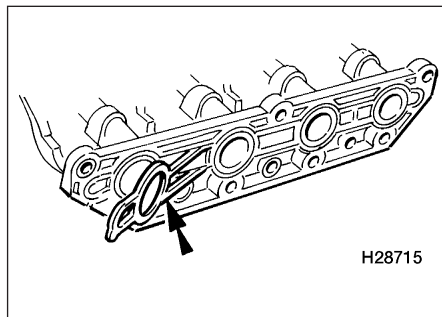

16.44a Fit a new inlet manifold gasket (arrowed)

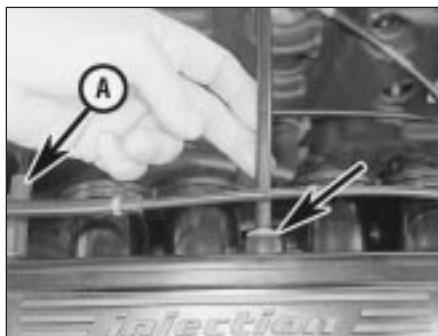

16.36b . . . and depress plastic collar (arrowed) of brake servo hose quick-fit connector to release from manifold

A ECU vacuum pipe

retaining nuts and bolts evenly to the specified torque wrench setting.

- e) Tighten all disturbed fasteners to their specified torque wrench settings (where given).
- f) Fit new O-rings, lubricating them with silicone grease.
- g) Remove all masking materials.
- h) Ensure all hose connections are securely remade.
- i) Refill the cooling system and check the coolant level, then wash off any spilt coolant.

17 Exhaust manifold - removal and refitting



Removal

- 1 Disconnect the battery negative lead.
- 2 Remove the air cleaner assembly.
- 3 Remove the alternator.
- 4 Referring to Part D of this Chapter, release the lambda sensor multiplug from the gearbox bracket and disconnect the plug from the sensor.
- 5 Firmly apply the handbrake then jack up the front of the vehicle and support it on axle stands.
- 6 Unscrew the nuts securing the exhaust front pipe to the manifold, then disconnect the pipe and collect the gasket.

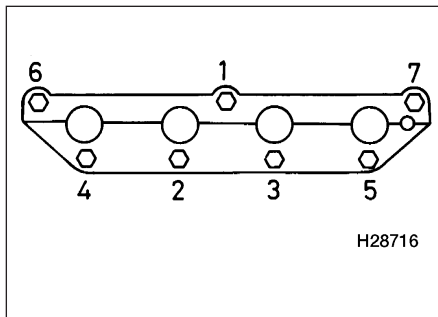

16.44b Plastic inlet manifold tightening sequence

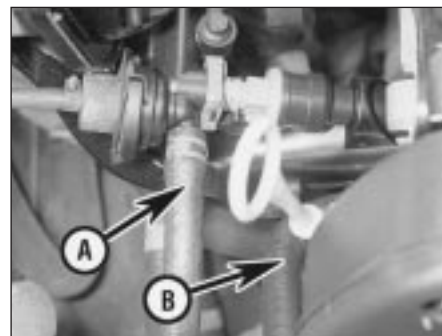

16.38 Disconnect fuel return hose (A) and expansion tank hose (B)

7 Undo the five nuts securing the exhaust manifold to the cylinder head, then carefully manoeuvre the manifold out of the engine compartment. Remove the manifold gasket and discard it.

8 Examine all the exhaust manifold studs for signs of damage and corrosion. Remove all traces of corrosion and repair or renew any damaged studs.

Refitting

9 Refitting is the reverse of the removal procedure, noting the following:

- a) Ensure that the manifold and cylinder head sealing faces are clean and flat, then fit a new manifold gasket.
- b) Working in the sequence shown (see illustration), tighten the manifold retaining nuts evenly to the specified torque wrench setting.
- c) Tighten all other disturbed nuts and bolts to their specified torque wrench settings (where given).

18 Exhaust system - inspection, removal and refitting

1 Refer to Section 18 in Part A of this Chapter. Note that on models fitted with a closed-loop catalytic converter, the lambda sensor must be removed or its wiring disconnected whenever the exhaust system front pipe is disconnected from the manifold.

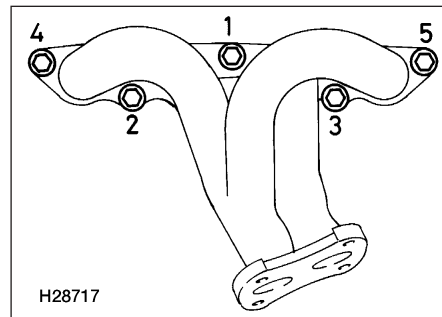

17.9 Exhaust manifold tightening sequence

Chapter 4 Part D

Emission control systems

Contents

Catalytic converters - general information and precautions	2	General information	1
Emission control system components - testing and renewal	3		

Degrees of difficulty

Easy , suitable for novice with little experience 	Fairly easy , suitable for beginner with some experience 	Fairly difficult , suitable for competent DIY mechanic 	Difficult , suitable for experienced DIY mechanic 	Very difficult , suitable for expert DIY or professional 
---	--	--	---	--

Specifications

Torque wrench settings	Nm	lbf ft
Lambda sensor	55	41

1 General information

Apart from their ability to use unleaded petrol and the various features which help to minimise emissions and are built into the fuel system, all models have at least the crankcase emission-control system described below. Models equipped with a catalytic converter are also fitted with the exhaust and evaporative emission control system.

Crankcase emission control

To reduce the emission of unburned hydrocarbons from the crankcase into the atmosphere, the engine is sealed and the blow-by gases and oil vapour are drawn from

the crankcase, through a wire mesh oil separator in the cylinder head cover, into the inlet tract to be burned by the engine during normal combustion. On carburettor engines, a single breather hose connects the cylinder head cover to the carburettor continuous-depression area. On fuel-injected engines, a small-bore breather hose connects the cylinder head cover to the throttle body downstream of the throttle disc, while a larger-bore hose is connected above the throttle disc so that the same effect is obtained at all states of manifold depression.

Under conditions of high manifold depression (idling, deceleration), the gases will be sucked positively out of the crankcase. Under conditions of low manifold depression (acceleration, full-throttle running), the gases are forced out of the crankcase by the (relatively) higher crankcase pressure. If the

engine is worn, the raised crankcase pressure (due to increased blow-by) will cause some of the flow to return under all manifold conditions.

Evaporative emission control

To minimise the escape into the atmosphere of unburned hydrocarbons, an evaporative emissions control system is fitted to models equipped with a catalytic converter. The fuel tank filler cap is sealed and a charcoal canister is mounted in the engine compartment to collect the petrol vapours generated in the tank when the vehicle is parked. It stores them until they can be cleared from the canister (under the control of the fuel-injection/ignition system ECU via the purge control valve) into the inlet tract to be burned by the engine during normal combustion.

4D•2 Emission control systems

To ensure that the engine runs correctly when it is cold and/or idling and to protect the catalytic converter from the effects of an over-rich mixture, the purge control valve is not opened by the ECU until the engine has warmed up to above 70°C, the engine speed exceeds 1500 rpm and manifold absolute pressure is below 30 kPa. The valve solenoid is then modulated on and off to allow the stored vapour to pass into the inlet tract.

Exhaust emission control

To minimise the amount of pollutants which escape into the atmosphere, some models are fitted with a catalytic converter in the exhaust system. Either an open-loop control system, which has no feedback from the converter to the fuel system, or a closed-loop control system, in which the lambda sensor in the exhaust system provides the fuel-injection/ignition system ECU with constant feedback (which enables it to adjust the mixture to provide the best possible conditions for the converter to operate) may be fitted.

If a lambda sensor is fitted, it has a heating element built-in that is controlled by the ECU through the lambda sensor relay to quickly bring the sensor's tip to an efficient operating temperature. The sensor's tip is sensitive to oxygen and sends the ECU a varying voltage depending on the amount of oxygen in the exhaust gases. If the intake air/fuel mixture is too rich, the exhaust gases are low in oxygen so the sensor sends a low-voltage signal, the voltage rises as the mixture weakens and the amount of oxygen rises in the exhaust gases. Peak conversion efficiency of all major pollutants occurs if the intake air/fuel mixture is maintained at the chemically-correct ratio for the complete combustion of petrol of 14.7 parts (by weight) of air to 1 part of fuel (the stoichiometric ratio). The sensor output voltage alters in a large step at this point, the ECU using the signal change as a reference point and correcting the intake air/fuel mixture accordingly by altering the fuel injector pulse width.

2 Catalytic converters - general information and precautions

The catalytic converter is a reliable and simple device which needs no maintenance in itself but there are some facts of which an owner should be aware if the converter is to function properly for its full service life.

- DO NOT use leaded petrol in a vehicle equipped with a catalytic converter.*
- Always keep the ignition and fuel systems well-maintained in accordance with the manufacturer's schedule.*
- If the engine develops a misfire, do not drive the vehicle at all (or at least as little as possible) until the fault is cured.*

- DO NOT push-start or tow-start the vehicle.*
- DO NOT switch off the ignition at high engine speeds.*
- DO NOT use fuel or engine oil additives.*
- DO NOT continue to use the vehicle if the engine burns oil to the extent of leaving a visible trail of blue smoke.*
- Remember that the catalytic converter operates at very high temperatures, hence the heat shields on the vehicle's underbody, and the casing will become hot enough to ignite combustible materials which brush against it. DO NOT, therefore, park the vehicle in dry undergrowth, over long grass or piles of dead leaves.*
- Remember that the catalytic converter is FRAGILE. DO NOT strike it with tools during servicing work, take great care when working on the exhaust system, ensure that the converter is well clear of any jacks or other lifting gear used to raise the vehicle and do not drive the vehicle over rough ground, road humps, etc. in such a way as to ground the exhaust system.*
- In some cases, particularly when the vehicle is new and/or is used for stop/start driving, a sulphurous smell (like that of rotten eggs) may be noticed from the exhaust. Once the vehicle has covered a few thousand miles the problem should disappear. In the meantime, a change of driving style or of the brand of petrol used may effect a solution.*
- The catalytic converter, used on a well-maintained and well-driven vehicle, should last for between 50 000 and 100 000 miles.*

3 Emission control system components - testing and renewal

Crankcase emission control

1 The components of this system require no attention other than to check that all hoses

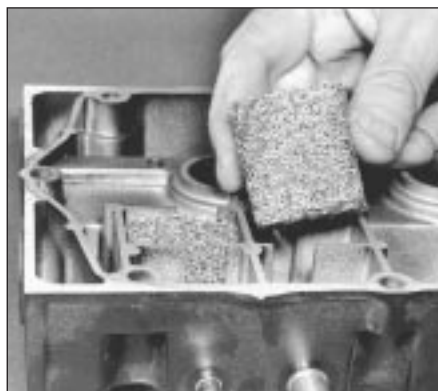

3.1 Clean oil separators whenever cylinder head cover is removed

are clear and that the wire mesh oil separators are flushed clean with a suitable solvent whenever the cylinder head cover is removed (see illustration).

Evaporative emission control

Testing

2 If the system is thought to be faulty, disconnect the hoses from the charcoal canister and purge control valve and check that they are clear by blowing through them. If the purge control valve or charcoal canister are thought to be faulty, they must be renewed. Note that the purge control valve may either be separate from, or mounted on top of, the charcoal canister.

Charcoal canister (purge valve separate) - renewal

3 Disconnect the battery negative lead.

4 Note the fitted positions of the canister hoses, then use a suitable pair of pliers to release the retaining clips (where fitted) and disconnect all the hoses from the canister (see illustration).

5 Lift the canister up to free it from its mounting bracket then remove it from the engine compartment.

6 Refitting is the reverse of the removal procedure. Ensure that all hoses are correctly refitted and, where necessary, securely held by their retaining clips.

Charcoal canister/purge valve assembly - renewal

7 Disconnect the battery negative lead.

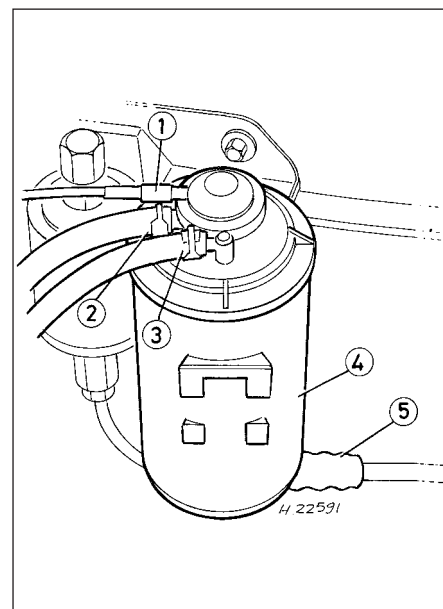

3.4 Charcoal canister hose connections

- Vacuum hose
- Outlet hose - canister to purge valve
- Inlet hose - fuel tank to canister
- Charcoal canister
- Drain hose

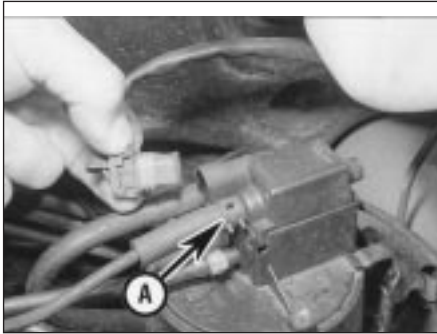

3.8 Disconnecting multiplug from purge valve

A Hose securing clip

8 Disconnect the multiplug from the purge valve (see illustration).

9 Release the securing clip and disconnect the hose from the purge valve.

10 Note the fitted positions of the canister fuel and vent hoses, then use a suitable pair of pliers to release the retaining clips (where fitted) and disconnect both hoses from the canister.

11 Release the securing strap and remove the canister/purge valve assembly.

12 Refitting is the reverse of the removal procedure. Ensure that all hoses are correctly refitted and, where necessary, securely held by their retaining clips.

Purge valve (charcoal canister separate) - renewal

13 Disconnect the battery negative terminal then disconnect the wiring connector from the purge valve (see illustration).

14 Release the retaining clips and disconnect the inlet and outlet hoses from the valve.

15 Prise out the C-clip which secures the inlet hose adaptor to the mounting bracket, then withdraw the adaptor, noting the O-ring which is fitted between the adaptor and purge valve. Discard the O-ring which must be renewed.

16 Undo the bolt securing the purge valve to its mounting bracket and remove the valve from the vehicle.

17 Refitting is a reverse of the removal procedure. Use a new inlet hose adaptor O-ring.

Purge valve (on charcoal canister) - renewal

18 Disconnect the battery negative lead.

19 Disconnect the multiplug from the purge valve.

20 Release the securing clip and disconnect the hose from the purge valve.

21 Pull the valve from its location on the canister and discard its O-ring (see illustration).

22 Refitting the valve is the reverse of the removal procedure, noting the following:

- Thoroughly clean the mating surfaces.
- Fit a new O-ring to the valve.
- Ensure all connections are secure.

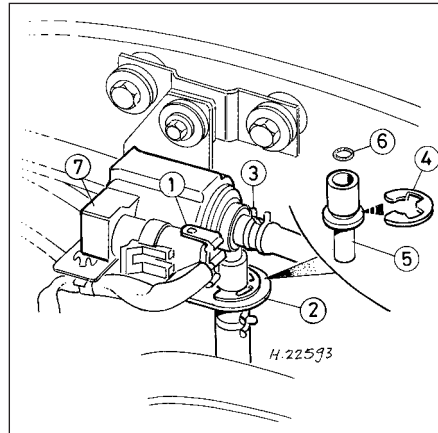

3.13 Purge valve assembly

- | | |
|---|------------------------|
| 1 Wiring connector | 4 C-clip |
| 2 Inlet hose - charcoal canister to purge valve | 5 Inlet hose connector |
| 3 Outlet hose - purge valve to throttle housing | 6 O-ring |
| | 7 Purge valve |

Exhaust emission control

23 If the CO level reading is too high (or if any other symptom is encountered which causes you to suspect a fault in the exhaust emission control system), always check first that the air cleaner filter element is clean, the spark plugs are in good condition and correctly gapped, that the engine breather and vacuum hoses are clear and undamaged, and that the accelerator cable is correctly adjusted. If the engine is running very roughly, check its compression pressures, bearing in mind the possibility that one of the hydraulic tappets might be faulty, producing an incorrect valve clearance. Check also that all wiring is in good condition, with securely-fastened connectors, that the fuel filter (fuel-injected engines only) has been renewed at the recommended intervals and that the exhaust system is entirely free of air leaks which might upset the operation of the catalytic converter. Only when all these have been checked and found to be in serviceable condition should the converter be suspected.

Testing - open-loop system

24 The performance of the catalytic converter can be checked only by using a good-quality, carefully-calibrated exhaust gas analyser.

25 Check that the CO level is as specified at the gas-sampling pipe when the engine is fully warmed-up to normal operating temperature. If not, check the fuel and ignition systems until the fault is found and the level is restored to its correct value.

26 Once the CO level is known to be correct upstream of the catalytic converter, take the vehicle on a brisk 4-mile road test and check the CO level at the tailpipe immediately on return. It should be significantly lower than the

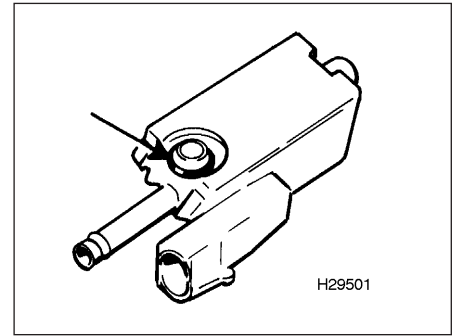

3.21 Renew purge valve O-ring (arrowed)

level at the gas-sampling pipe (below 0.5 % approximately on fuel-injected engines, slightly higher on carburettor engines).

27 If the tailpipe CO level is little different from that at the gas-sampling pipe, repeat the check ensuring that it is made immediately on return from road test or the converter may not be at normal operating temperature and will not have reached its peak conversion efficiency. If the results are the same, the catalytic converter is proven faulty and must be renewed.

Testing - closed-loop system

28 The performance of the catalytic converter can be checked only by using a good-quality, carefully-calibrated exhaust gas analyser.

29 Where a gas-sampling pipe is fitted, the test described above can be carried out. If the CO level at the tailpipe is little different from that at the gas-sampling pipe, the catalytic converter is probably faulty and must be renewed, once the fuel-injection and ignition systems have been checked thoroughly using Rover diagnostic equipment and are known to be free from faults.

30 If a gas-sampling pipe is not fitted and the CO level at the tailpipe is too high, the complete fuel-injection and ignition systems must be checked thoroughly by using Rover diagnostic equipment. Once these have been checked and are known to be free from faults, the fault must be in the catalytic converter, which must be renewed.

Catalytic converter - renewal

31 Refer to Section 18 in Part A of this Chapter.

Lambda (oxygen) sensor - operational check

32 The manufacturer's maintenance schedule calls for regular checks of the lambda sensor's operation. This can be done only by attaching Rover diagnostic equipment to the sensor wiring and checking that the voltage varies from low to high values when the engine is running. Do not attempt to test any part of the system with anything other than the correct test equipment.



3.35 Lambda sensor viewed from above

Lambda sensor - renewal

33 Note that the lambda sensor is delicate and will not work if it is dropped or knocked, if its power supply is disrupted, or if any cleaning materials are used on it.

34 Disconnect the battery earth lead.

35 Release the sensor's wiring connector from the bracket on the gearbox and unplug it to disconnect the sensor (**see illustration**).

36 Raising and supporting the front of the vehicle, if required, to remove the sensor from

underneath, unscrew the sensor from the exhaust system front pipe. Retain its sealing washer.

37 On refitting, clean the sealing washer and renew it if it is damaged or worn, then refit the sensor, tightening it to its specified torque wrench setting. Reconnect the wiring and refit the connector plug.

Lambda sensor relay - general

38 Refer to Chapter 12.





Chapter 3

Cooling, heating and ventilation systems

Contents

Air conditioning compressor drivebelt - inspection, adjustment and renewal	13	Cooling system hoses - renewal	4
Air conditioning refrigerant - level check	14	Electric cooling fan - testing, removal and refitting	8
Air conditioning system components - removal and refitting	15	General information and precautions	1
Coolant pump - removal and refitting	7	Heater components - removal and refitting	10
Cooling system - draining, flushing and filling	2	Heater controls - removal, refitting and adjustment	12
Cooling system - general inspection	3	Heater ducts and vents - removal and refitting	11
Cooling system electrical switches - testing, removal and refitting	9	Radiator and expansion tank - removal, inspection and refitting	5
		Thermostat - removal, testing and refitting	6

Degrees of difficulty

Easy , suitable for novice with little experience 	Fairly easy , suitable for beginner with some experience 	Fairly difficult , suitable for competent DIY mechanic 	Difficult , suitable for experienced DIY mechanic 	Very difficult , suitable for expert DIY or professional 
---	--	--	---	--

Specifications

System

Type Pressurised, pump-assisted thermo-syphon with front mounted radiator and thermostatically-controlled electric cooling fan

Thermostat

Type Wax
 Start to open temperature 76 to 80°C
 Fully open temperature 82 or 88°C (actual value stamped in unit end)
 Full lift height 9.0 mm

Expansion tank

Cap pressure 0.9 to 1.0 bar

Cooling fan

Operating temperature 88 to 92°C

Torque wrench settings

	Nm	lbf ft
Cooling system		
Fan motor nuts	5	4
Temperature gauge sender unit	15	11
Thermostat housing cover bolts	9	7
Thermostat housing/dipstick tube-to-cylinder block/crankcase bolt	9	7
Coolant rail-to-cylinder block/crankcase bolts	9	7
Coolant pump-to-timing belt upper left-hand (inner) cover bolt	9	7
Coolant pump-to-cylinder block/crankcase bolts	10	7
Heating system		
Heater lower mounting nut	21	15
Heater blower motor mounting bolts	10	7
Air conditioning system		
Compressor mounting bolts	45	33
Condenser unions	17	13
Evaporator inlet union (from receiver drier)	17	13
Evaporator outlet union	33	24
Receiver drier union	17	13
Trinary switch	12	9

1 General information and precautions

General information

The cooling system is of the pressurised, pump-assisted thermo-syphon type. It consists of the front-mounted radiator, a translucent expansion tank mounted on the right-hand inner wing, a thermostatically-controlled electric cooling fan mounted on the rear of the radiator, a thermostat and a centrifugal coolant pump, as well as the connecting hoses (see illustration). The coolant pump is driven by the engine timing belt.

The system is of the by-pass type, allowing coolant to circulate around the engine while the thermostat is closed. With the engine cold, the thermostat closes off the coolant feed from the bottom radiator hose. Coolant is then drawn into the engine via the heater matrix, inlet manifold and from the top of the cylinder block. This allows some heat transfer, by convection, to the radiator through the top

hose whilst retaining the majority of heat within the cylinder block.

The siting of the thermostat in the intake rather than the outlet side of the system ensures that the engine warms up quickly by circulating a small amount of coolant around a shorter tract. This also prevents temperature build-up in the cylinder head prior to the thermostat opening.

When the coolant reaches a predetermined temperature, the thermostat opens and the coolant is allowed to flow freely through the top hose to the radiator. As the coolant circulates through the radiator, it is cooled by the inrush of air when the vehicle is in forward motion. Airflow is supplemented by the action of the electric cooling fan when necessary. Upon reaching the bottom of the radiator, the coolant is now cooled and the cycle is repeated.

With the engine at normal operating temperature, the coolant expands and some of it is displaced into the expansion tank. This coolant collects in the tank and is returned to the radiator when the system cools.

The electric cooling fan mounted behind the radiator is controlled by a thermostatic

switch located in the radiator side tank. At a predetermined coolant temperature the switch contacts close, thus actuating the fan.

Precautions

Cooling system

Do not attempt to remove the expansion tank filler cap or to disturb any part of the cooling system whilst it or the engine is hot, as there is a very great risk of scalding. If the expansion tank filler cap must be removed before the engine and radiator have fully cooled down (even though this is not recommended) the pressure in the cooling system must first be released. Cover the cap with a thick layer of cloth, to avoid scalding, and slowly unscrew the filler cap until a hissing sound can be heard. When the hissing has stopped, showing that pressure is released, slowly unscrew the filler cap until it can be removed. If more hissing sounds are heard, wait until they have stopped before unscrewing the cap completely. At all times keep well away from the filler opening.

Do not allow antifreeze to come in contact with your skin or painted surfaces of the vehicle. Rinse off spills immediately with plenty of water. Never leave antifreeze lying around, it is fatal if ingested.

If the engine is hot, the electric cooling fan may start rotating even if the engine is not running, so be careful to keep hands, hair and loose clothing well clear when working in the engine compartment.

Air conditioning system

On models equipped with an air conditioning system, it is necessary to observe special precautions whenever dealing with any part of the system, its associated components and any items which necessitate disconnection of the system. If for any reason the system must be disconnected, entrust this task to your Rover dealer or a refrigeration engineer.

Refrigerant must not be allowed to come in contact with a naked flame, otherwise a poisonous gas will be created. Do not allow the fluid to come in contact with the skin or eyes.

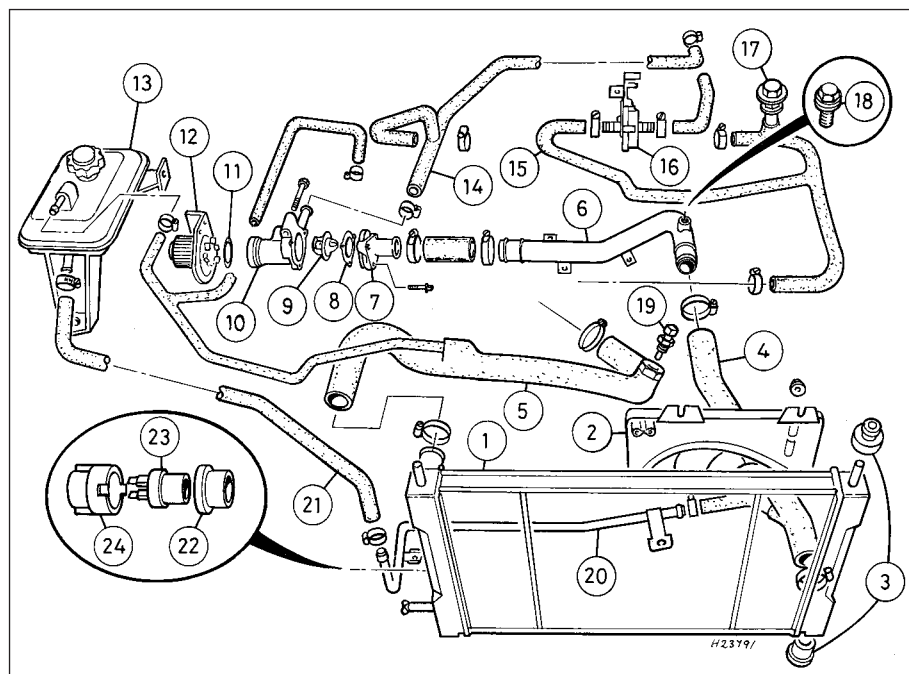

1.0 Cooling system components

- | | | |
|--|---|---|
| 1 Radiator | 9 Thermostat | 18 Cooling system bleed screw |
| 2 Cooling fan and cowling | 10 Thermostat housing | 19 Engine overheat switch - where fitted |
| 3 Radiator mounting rubbers | 11 O-ring | 20 Coolant pipe - expansion tank to bottom hose |
| 4 Bottom hose | 12 Coolant pump | 21 Hose - expansion tank return |
| 5 Top hose | 13 Expansion tank | 22 Sealing ring |
| 6 Coolant pipe - bottom hose to thermostat housing | 14 Hose - heater matrix and manifold return | 23 Cooling fan thermostatic switch |
| 7 Thermostat housing cover | 15 Hose - heater matrix and manifold feed | 24 Locking ring |
| 8 Gasket | 16 Heater temperature control valve | |
| | 17 Coolant filler stem | |

2 Cooling system - draining, flushing and refilling

Refer to Chapter 1.

3 Cooling system - general inspection

Refer to "Weekly Checks" and Chapter 1.

4 Cooling system hoses - renewal



Never work on the cooling system when it is hot. Release any pressure from the system by loosening the expansion tank cap, having first covered it with a cloth to avoid any possibility of scalding.

- 1 If inspection of the cooling system reveals a faulty hose, then it must be renewed as follows.
- 2 First drain the cooling system. If the coolant is not due for renewal, it may be re-used if collected in a clean container.
- 3 To disconnect any hose, use a screwdriver to slacken the clips then move them along the hose clear of the outlet. Carefully work the hose off its outlets. Do not attempt to disconnect any part of the system when still hot.
- 4 Note that the radiator hose outlets are fragile. Do not use excessive force when attempting to remove the hoses. If a hose proves stubborn, try to release it by rotating it on its outlets before attempting to work it off. If all else fails, cut the hose with a sharp knife then slit it so that it can be peeled off in two pieces. While expensive, this is preferable to buying a new radiator.
- 5 When refitting a hose, first slide the clips onto the hose then work the hose onto its outlets. If the hose is stiff, use soap as a lubricant or soften it by first soaking it in boiling water whilst taking care to prevent scalding.
- 6 Work each hose end fully onto its outlet, check that the hose is settled correctly and is properly routed, then slide each clip along the hose until it is behind the outlet flared end before tightening it securely.
- 7 Refill the system with coolant.
- 8 Check carefully for leaks as soon as possible after disturbing any part of the cooling system.

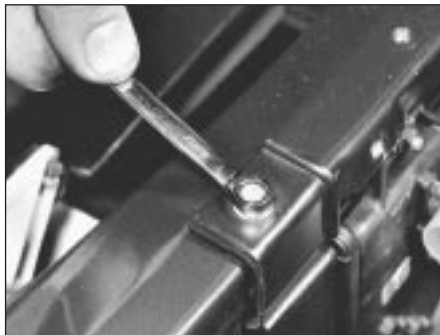

5.7a Undo radiator mounting bolts . . .

5 Radiator and expansion tank - removal, inspection and refitting



Removal

Radiator

- 1 Drain the cooling system.
- 2 On models equipped with air conditioning, remove the condenser fan, then undo the two bolts securing the air conditioning pipes to the bonnet platform.
- 3 Remove the air cleaner metal intake duct and intake hose.
- 4 Disconnect the radiator cooling fan wiring connector, then slacken and remove the bolt

securing the earth leads to the bonnet platform. Disconnect the wiring from the thermostatic switch(es) which are fitted to the right-hand side of the radiator (see illustrations).

5 Slacken the bottom hose retaining clip and disconnect the hose from the radiator.

6 Slacken the retaining clips and disconnect the top hose from both the radiator and engine coolant elbow (see illustrations). Position the hose clear of the radiator so that it does not hinder removal.

7 Undo the two bolts securing the upper mounting brackets to the bonnet platform and remove the brackets from the radiator. Disengage the radiator from its lower mounting points and carefully manoeuvre it out of the engine compartment (see illustrations).



5.4a Disconnect cooling fan wiring connector then remove earth lead retaining bolt (arrowed)



5.4b Disconnecting wiring connector from radiator switch



5.6a Slacken clips and disconnect top hose from radiator . . .



5.6b . . . and engine coolant elbow



5.7b . . . remove mounting brackets . . .



5.7c . . . and manoeuvre radiator out of engine compartment

3•4 Cooling, heating and ventilation systems

Expansion tank

8 Slacken and remove the three bolts securing the expansion tank to the body. Unscrew the expansion tank cap and tip out its contents into a suitable container.

9 Slacken the retaining clips then disconnect both the hoses from the expansion tank and remove the tank from the vehicle.

Inspection

Radiator

10 If the radiator was removed because of clogging (causing overheating) then try reverse flushing or, in severe cases, use a radiator cleanser strictly in accordance with the manufacturer's instructions. Ensure that the cleanser is suitable for use in a copper/brass radiator. Refer to Chapter 1 for further information

11 Use a soft brush and an air line or garden hose to clear the radiator matrix of leaves, insects etc.



Minor leaks from the radiator can be cured using a suitable sealant with the radiator in situ.

12 Major leaks or extensive damage should be repaired by a specialist, or the radiator should be renewed or exchanged for a reconditioned unit.

13 Examine the mounting rubbers for signs of damage or deterioration and renew if necessary.

Expansion tank

14 Empty any remaining coolant from the tank and flush it with fresh water to clean it. If the tank is leaking it must be renewed but it is worth first attempting a repair using a proprietary sealant or suitable adhesive.

15 The expansion tank cap should be cleaned and checked whenever it is removed. Check that its sealing surfaces and threads are clean and undamaged and that they mate correctly with those of the expansion tank.

16 The cap's performance can only be checked by using a cap pressure-tester (cooling system tester) with a suitable

adaptor. On applying pressure, the cap's pressure relief valve should hold until the specified pressure is reached, at which point the valve should open.

17 If there is any doubt about the cap's performance, then it must be renewed. Ensure that the replacement is of the correct type and rating.

Refitting

Radiator

18 Refitting is the reverse of the removal procedure whilst noting the following:

- Ensure that the radiator is seated correctly and without strain on its mountings.
- Ensure that the radiator hoses are securely held by the retaining clips.
- Ensure that all wiring connectors are correctly routed so that they are clear of the cooling fan and are retained by any necessary clips or ties.
- Refill the cooling system as described in Chapter 1.

Expansion tank

19 Refitting is the reverse of the removal procedure whilst noting the following:

- Ensure that all hoses are correctly routed with no kinks or sharp bends and are securely held by the retaining clips.
- Top up the expansion tank as described in Chapter 1.

6 Thermostat - removal, testing and refitting



Removal

1 Note that access to the thermostat is very limited. Depending on the tools available, it may be easier to raise the front of the vehicle and to work from underneath, ensuring that the vehicle is securely supported on axle stands. In most cases, access is better if the air cleaner and carburettor (or throttle body on SPi engines) are removed and is best if the complete inlet manifold is removed. If the inlet manifold is removed, the thermostat housing



6.1 Thermostat can be removed without disturbing housing if inlet manifold is first removed

cover can be unbolted to remove the thermostat without disturbing the housing itself (see illustration). Whichever method is used, first drain the cooling system.

2 On carburettor models equipped with a catalytic converter, either remove the thermostatically-operated vacuum switch or disconnect the vacuum pipes from the switch so that it can be removed with the thermostat housing.

3 Unbolt the coolant rail from the rear of the cylinder block/crankcase, then slacken the clips and disconnect the coolant rail hose and heater/inlet manifold return hose from the thermostat housing (see illustration).

4 Undo the thermostat housing/dipstick tube-to-cylinder block/crankcase bolt and remove the thermostat housing from the cylinder block/crankcase. Remove the housing O-ring which must be renewed whenever it is disturbed (see illustrations).

5 Slacken and remove the three thermostat housing cover bolts and lift off the housing cover. Discard the gasket and remove the thermostat.

Testing

6 If the thermostat remains in the open position at room temperature, then it is faulty and must be renewed.

7 To test it fully, suspend the (closed) thermostat on a length of string in a container of cold water, with a thermometer beside it.

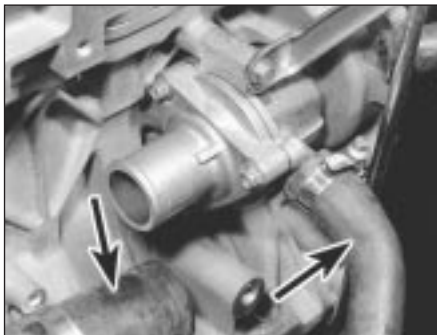

6.3 Disconnect coolant rail and heater/inlet manifold hoses (arrowed) . . .



6.4a . . . unscrew dipstick tube retaining bolt . . .



6.4b . . . and withdraw thermostat housing (O-ring arrowed) - inlet manifold removed for clarity

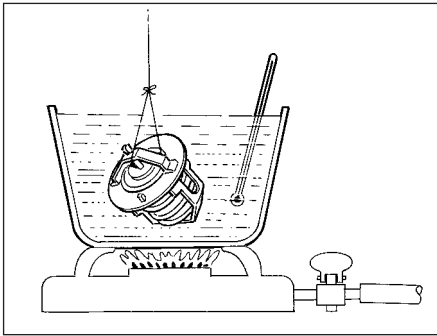

6.7 Testing the thermostat



6.8 Note temperature specification stamped on thermostat end



6.10 Thermostat housing and coolant hoses refitted

Ensure that neither touches the side of the container (see illustration).

8 Heat the water and check the temperature at which the thermostat begins to open. Compare this value with that specified. Continue to heat the water until the thermostat is fully open. The temperature at which this should happen is stamped in the unit's end (see illustration). Remove the thermostat and measure the height of the fully opened valve, then allow the thermostat to cool down and check that it closes fully.

9 If the thermostat does not open and close as described, if it sticks in either position, or if it does not open at the specified temperature, then it must be renewed.

Refitting

10 Refitting is the reverse of the removal procedure, noting the following (see illustration):

- Clean the thermostat housing, housing cover and cylinder block/crankcase mating surfaces thoroughly.
- Always fit a new housing cover gasket and O-ring. Smear the O-ring with grease to aid refitting.
- Tighten all bolts to their specified torque wrench settings (where given).
- Ensure the coolant hose clips are positioned so that they do not foul any other component, then tighten them securely.
- Refit any components removed for improved access.
- Refill the cooling system as described in Chapter 1.



7.5 Removing the coolant pump

7 Coolant pump - removal and refitting

Removal

1 Coolant pump failure is usually indicated by coolant leaking from the gland behind the pump bearing, or by rough and noisy operation, usually accompanied by excessive pump spindle play. If the pump shows any of these symptoms then it must be renewed as follows.

2 Drain the cooling system.

3 Remove the timing belt.

4 Noting the location of the pillar bolt(s), unscrew the five bolts securing the coolant pump to the cylinder block/crankcase, then unscrew the single bolt securing the pump to the timing belt upper left-hand (inner) cover.

5 Withdraw the coolant pump and discard its sealing ring which should be renewed whenever it is disturbed. Carefully clean the cylinder block/crankcase mating surface and the pump socket (see illustration).

Refitting

6 On refitting, install the pump using a new sealing ring and tighten all bolts to the specified torque wrench settings.

7 The remainder of the refitting procedure is the reverse of removal.

8 Electric cooling fan - testing, removal and refitting

Note: On models equipped with air conditioning, there are two switches fitted to the right-hand side of the radiator, the lower of these is the cooling fan switch.

Testing

1 The cooling fan motor is supplied with current via the ignition switch, fuse 4 and the cooling fan relay. The relay is energised by the radiator-mounted thermostatic switch which is fed via fuse number 15.

2 If the fan does not appear to work, first check that both fuses are in good condition and have not blown. Run the engine until normal operating temperature is reached, then allow it to idle. If the fan does not cut in within a few minutes, switch off the ignition and disconnect the two wires from the thermostatic switch. Bridge these two wires with a length of spare wire and switch on the ignition. If the fan now operates, the thermostatic switch is probably faulty and must be tested further as described in Section 9.

3 If the fan still fails to operate, check that full battery voltage is available at the switch's light green and grey wire terminal. If not, check the feed for a blown fuse or other fault such as a broken wire. If the feed is good, check the cooling fan relay, see Chapter 12. If the relay operates correctly, check for continuity between the fan motor black wire terminal and a good earth point on the body. If not, then the earth connection is faulty and must be remade. The circuit earth connection is one of those at earth header 1, attached to the left-hand inner wing panel next to the battery.

4 If the switch and wiring are in good condition, the fault must be in the motor itself. This can be checked by disconnecting it from the wiring loom and connecting a 12 volt supply directly to it. If the motor does not work then it must be renewed.

Removal

5 Drain the cooling system, then jack up the front of the vehicle and support it securely on axle stands.

6 From underneath the front of the vehicle, slacken and remove the three bolts securing the bumper flange to the body. Remove the seven bolts securing the front undercover panel to the body and remove the panel.

7 Remove the air cleaner metal intake duct and intake hose.

8 Slacken the retaining clips and disconnect the top hose from both the radiator and engine. Position the hose clear of the radiator so that it does not hinder removal.

9 Disconnect the radiator cooling fan wiring connector.

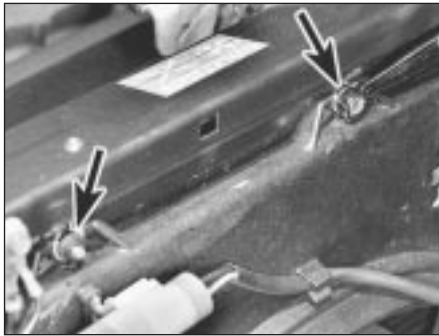

8.10a Undo cooling fan cowl retaining nuts (2 arrowed) . . .

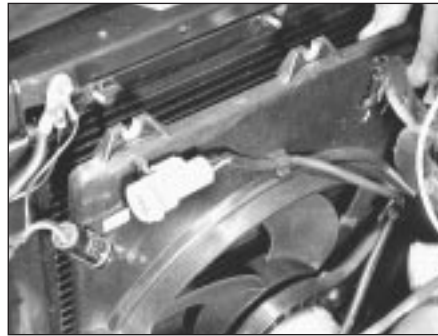

8.10b . . . and remove fan assembly



8.11 Cooling fan motor retaining nuts (arrowed)

10 Undo the four nuts securing the cooling fan cowl to the rear of the radiator and manoeuvre the fan assembly out of the engine compartment (see illustrations).

11 To dismantle the assembly, first prise off the fan retaining circlip, then lift the fan off the motor spindle. Undo the three nuts which secure the motor assembly to the cowl then release the motor wiring and connector and separate the motor and cowl (see illustration).

Refitting

12 Refitting is a reverse of the removal procedure, noting the following:

- a) If necessary, reassemble the fan motor, cowl and fan, then tighten the motor retaining nuts to the specified torque. Ensure that the motor wiring is securely retained by the cowl clips.
- b) Ensure that the radiator hose is securely held by its retaining clips.
- c) On completion, refill the cooling system as described in Chapter 1.

9 Cooling system electrical switches - testing, removal and refitting



Note: On models equipped with air conditioning, there are two switches fitted to the right-hand side of the radiator, the lower of these is the cooling fan switch.

Testing

Cooling fan thermostatic switch

1 Refer to Section 8 for details of a quick test which should eliminate most faulty switches. If the switch is to be renewed, or to be tested thoroughly, it must be removed.

2 To carry out a thorough test of the switch, use two spare wires to connect to it either a multimeter (set to the resistance function) or a battery and bulb test circuit. Suspend the switch in a pan of water which is being heated. Measure the temperature of the water with a thermometer. Do not let either the switch or the thermometer touch the pan itself (see illustration).

3 The switch contacts should close to the ON position (ie: continuity should exist) when the water reaches the temperature specified. Stop heating the water and allow it to cool down. The switch contacts should open.

4 If the switch's performance is significantly different from that specified, or if it does not work at all, then it must be renewed.

Coolant temperature gauge sender unit

5 The coolant temperature gauge mounted in the instrument panel is fed with a stabilised 10 volt supply from the instrument panel feed (via the ignition switch and fuse 1), its earth being controlled by the sender unit.

6 The sender unit is screwed into the coolant outlet elbow mounted on the left-hand end of the cylinder head, underneath the distributor (see illustration). It contains a thermistor, which is an element whose electrical resistance decreases at a predetermined rate as its temperature rises. Thus, when the coolant is cold, the sender's resistance is high, current flow through the gauge is reduced and the gauge needle points to the C (cold) end of the scale. If the unit is faulty it must be renewed.

7 If the gauge develops a fault, check first the other instruments. If they do not work at all, check the instrument panel feed. If the readings are erratic, there may be a fault in the voltage stabiliser which will necessitate the renewal of the gauge unit or printed circuit. If the fault is in the temperature gauge alone, check it as follows.

8 If the gauge needle remains at the C end of the scale, disconnect the sender unit wire and earth it to the cylinder head. If the needle then deflects when the ignition is switched on, then the sender unit is proven faulty and must be renewed. If the needle still does not move, remove the instrument panel and check the continuity of the green/blue wire between the gauge and the sender unit and the feed to the gauge unit. If continuity is shown and the fault still exists, then the gauge is faulty and the gauge unit must be renewed.

9 If the gauge needle remains at the H end of the scale, disconnect the sender unit wire. If the needle then returns to the C end of the scale when the ignition is switched on, then the sender unit is proven faulty and must be renewed. If the needle still does not move, check the remainder of the circuit as described above.

Inlet manifold pre-heater temperature switch - carburettor engines

10 The switch screwed into the underside of the inlet manifold on carburettor engines

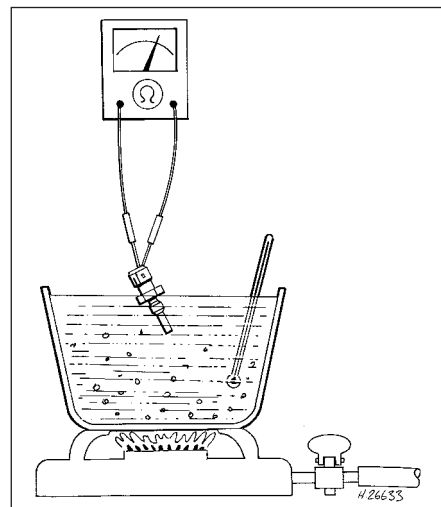

9.2 Testing cooling system electrical switch



9.6 Coolant temperature gauge sender unit

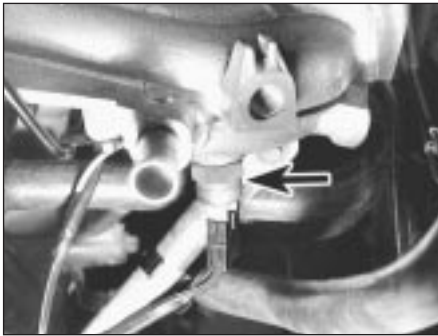

9.10 Inlet manifold pre-heater temperature switch (carburettor engines)



9.20 Remove cooling fan thermostatic switch and withdraw sealing ring (arrowed)

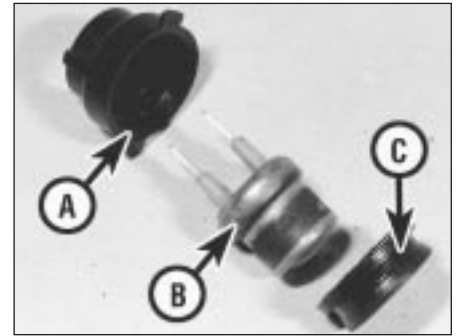

9.27 Cooling fan switch locking ring (A) thermostatic switch (B) and sealing ring (C)

controls the inlet manifold heater circuit (see illustration).

11 The switch contacts should be closed to the ON position (ie: continuity should exist) only at temperatures below 50°C. Remove the switch and test it as described in paragraphs 2 to 4.

Thermostatically-operated vacuum switch - carburettor engines equipped with catalytic converters

12 This switch is screwed into the thermostat housing.

13 To test the switch, fit two suitable lengths of hose to the switch and suspend the switch in a pan of water which is being heated. Measure the temperature of the water with a thermometer. Do not let either the switch or the thermometer touch the pan itself.

14 Blow down one of the hoses attached to the switch. The switch should be closed (ie: passes no air) when the water temperature is below 70°C. Above 70°C, the switch should open and air should flow freely through the hoses. Stop heating the water then allow the water to cool down and check that the switch closes at 70°C or just below.

15 If the switch performance is significantly different from that specified, or if it does not work at all, then it must be renewed.

Coolant temperature sensor - fuel injected engines

16 This sensor, which is screwed into the underside of the inlet manifold (SPi engines), or located in the coolant pipe adjacent to the forward top edge of the timing belt cover (MPI engines), is a thermistor (see paragraph 6) which is supplied with approximately 5 volts by the engine management system ECU. The ECU also controls the sensor's earth path and, by measuring the amount of current in the sensor circuit, determines the engine's temperature. This information is used, in conjunction with other inputs, to control idle speed, injector opening time duration and ignition timing.

17 If the sensor circuit should fail to provide adequate information, the ECU's back-up

facility assumes a value corresponding to 60°C. The sensor itself can be tested only by having a Rover dealer check the complete system using the correct diagnostic equipment. Do not attempt to test the circuit using any other equipment, or the ECU will be damaged.

Removal

Cooling fan thermostatic switch

18 With the engine and radiator cold, either drain the cooling system down to the level of the sender unit, or unscrew the expansion tank filler cap to release any remaining pressure and have a suitable plug ready that can be used to stop the escape of coolant while the switch is removed.

19 Disconnect the battery negative lead.

20 Disconnect the wiring connector from the switch then rotate the locking ring to release it. Withdraw the switch and sealing ring from the radiator (see illustration).

Coolant temperature gauge sender unit

21 With the engine and radiator cold, either drain the cooling system down to the level of the switch, or unscrew the expansion tank filler cap to release any remaining pressure and have a suitable plug ready that can be used to stop the escape of coolant while the unit is removed.

22 Disconnect the battery negative lead.

23 Disconnect the unit's wiring connector and unscrew the unit from the coolant outlet elbow.

Inlet manifold pre-heater temperature switch - carburettor engines

24 Refer to Chapter 4.

Thermostatically-operated vacuum switch - carburettor engines equipped with catalytic converters

25 Refer to Chapter 5.

Coolant temperature sensor - fuel injected engines

26 Refer to Chapter 4.

Refitting

Cooling fan thermostatic switch

27 On refitting, renew the sealing ring if it is worn or compressed and carefully clean the radiator seat before pressing in the sealing ring and switch (see illustration). Refit the locking ring and rotate it to tighten it securely. Reconnect the switch and battery, then replenish the cooling system.

Coolant temperature gauge sender unit

28 On refitting, apply a suitable sealant to the unit threads and tighten it to its specified torque wrench setting. Reconnect the unit and battery, then replenish the cooling system.

Inlet manifold pre-heater temperature switch - carburettor engines

29 Refer to Chapter 4.

Thermostatically-operated vacuum switch - carburettor engines equipped with catalytic converters

30 Refer to Chapter 5.

Coolant temperature sensor - fuel injected engines

31 Refer to Chapter 4.

10 Heater components - removal and refitting



Removal

Heater unit

1 Drain the cooling system.

2 Working in the engine compartment, slacken the hose clips and disconnect the heater feed and return hoses from the matrix outlets on the bulkhead. Disconnect the cable inner from the heater valve and free the cable outer from its retaining clip. Slacken and

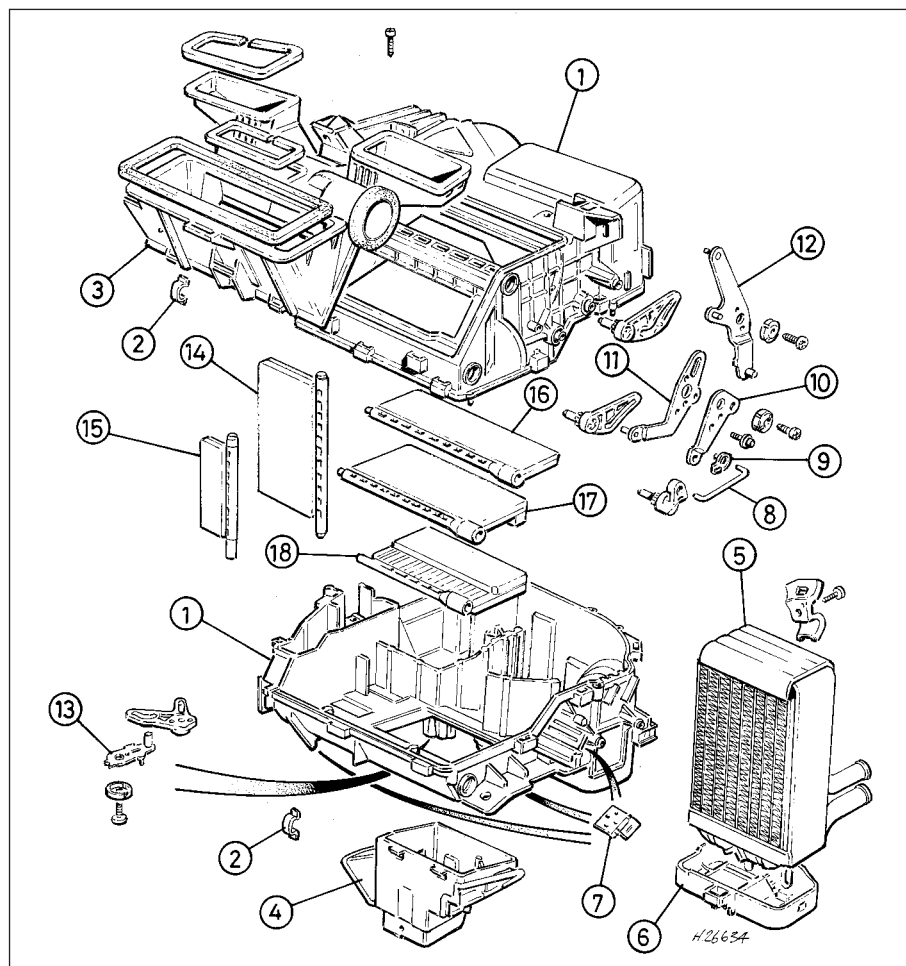

10.2a Heater unit components

- | | | |
|------------------------------|------------------------------------|--|
| 1 Heater case | 8 Floor level flap operating lever | 15 Ambient air flap - centre console vents |
| 2 Heater case clip | 9 Clip | 16 Distribution flap - windscreen |
| 3 Face level/windscreen duct | 10 Floor level flap idler lever | 17 Distribution flap - face level vents |
| 4 Floor level duct | 11 Face level flap idler lever | 18 Distribution flap - floor level vents |
| 5 Heater matrix | 12 Flap operating lever | |
| 6 Heater matrix cover | 13 Air mix flap operating lever | |
| 7 Cable retaining clip | 14 Air mix flap | |

remove the heater lower mounting nut which is situated just to the left of the matrix outlets (see illustrations).

3 Working inside the vehicle, remove the fascia.

4 Slacken and remove the two retaining screws and the blower motor-to-heater unit duct (see illustration). On models equipped with air conditioning, the evaporator unit is fitted in place of the duct. It may be possible to gain the necessary clearance required to disengage the evaporator from the heater unit by removing the mounting brackets and nuts. If not, the evaporator must be removed.

5 Undo the screw securing the right-hand heater duct to the mounting bracket, then move the duct to the right to disengage it from the heater unit (see illustrations).

6 Undo the inertia switch retaining nut and disengage the switch from the steering column support bracket.

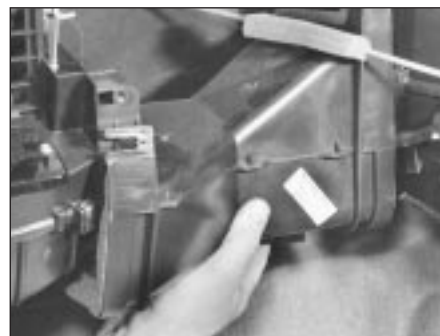

10.4 Remove blower motor-to-heater unit duct



10.2b Disconnect heater feed and return hoses . . .



10.2c . . . and free heater valve cable from retaining clip



10.2d Slacken and remove heater unit lower mounting nut

7 Release the wiring block connector from the right-hand end of the steering column support bracket and undo the fusebox



10.5a Undo right-hand duct retaining screw (arrowed) . . .



10.5b ... and disengage duct from heater unit



10.7a Release wiring connector from steering column support bracket and remove fusebox nut (arrowed)



10.7b Remove mounting bolts and manoeuvre steering column mounting bracket out of position

retaining nut. Slacken and remove the five support bracket retaining bolts and remove the bracket from the vehicle (see illustrations).

8 Disconnect the air recirculation cable inner from the flap and free the cable outer from the blower motor.

9 Prise out the stud securing the rear heater duct sleeve to the bottom of the heater unit, then slide the sleeve down to disengage it from the unit (see illustration).

10 Disconnect the wiring connectors from the heater control panel, then remove the two upper heater unit retaining nuts and carefully manoeuvre the heater unit out of the vehicle (see illustrations).

Heater matrix

11 Remove the heater unit.

12 Undo the screw securing the matrix outlet pipe bracket to the heater unit and remove the bracket (see illustration).

13 Slacken and remove the two matrix cover retaining screws, then remove the cover and withdraw the matrix from the heater unit (see illustrations).

14 If the matrix is leaking, it is best to obtain a new or reconditioned unit as home repairs are seldom successful. If it is blocked, it can sometimes be cleared by reverse flushing using a garden hose. Use a proprietary radiator cleaning product if absolutely necessary.



10.9 Remove retaining stud and disengage rear heater duct sleeve from heater unit

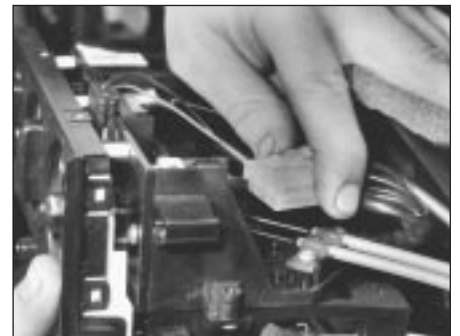

10.10a Disconnect wiring from heater control panel ...



10.10b ... and remove heater retaining nuts



10.12 Undo retaining screw and remove matrix outlet pipe bracket



10.13a Undo two matrix cover retaining screws ...



10.13b ... then remove cover ...



10.13c ... and withdraw matrix from heater unit



10.15 Glovebox damper retaining screw (arrowed)



10.16 Remove glovebox support rail . . .



10.17 . . . then remove blower motor-to-heater unit duct

Heater blower motor

15 Undo the two glovebox retaining screws then partially withdraw the glovebox until access can be gained to the glovebox damper to fascia screw. Undo the damper screw and remove the glovebox and damper (see illustration).

16 Slacken and remove the four glovebox support rail mounting bolts and remove the rail (see illustration).

17 Slacken and remove the two retaining screws and remove the blower motor-to-heater unit duct (see illustration). On models equipped with air conditioning, the evaporator unit is fitted in place of the duct. It may be possible to gain the necessary clearance

required to disengage the evaporator and remove the blower motor by removing the mounting brackets and nuts. If not, the evaporator must be removed.

18 Disconnect the air recirculation cable inner from the flap and free the cable outer from the blower motor. Disconnect the two blower motor wiring connectors (see illustration).

19 Slacken and remove the three blower motor mounting bolts and manoeuvre the blower unit out from underneath the fascia (see illustrations).

20 To remove the motor from the unit, undo the four motor cover retaining screws, then disconnect the breather hose and lift off the

cover. Slacken and remove the three motor retaining bolts and withdraw the motor assembly from the blower unit. Undo the fan retaining nut and separate the fan and motor, noting the seal fitted between the two components (see illustrations).

Heater blower motor resistor

21 Remove the glovebox as described in paragraphs 15 and 16.

22 Disconnect the wiring connector, then undo the two retaining screws and remove the resistor from the front of the motor assembly.

Heater valve

23 Working in the engine compartment, disconnect the cable inner from the heater

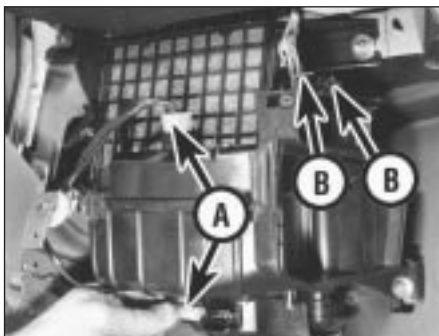

10.18 Disconnect motor wiring connectors (A) and air recirculation cable (B)



10.19a Undo three blower motor mounting bolts (arrowed) . . .



10.19b . . . and remove unit from behind fascia



10.20a Remove motor cover retaining screws (arrowed) . . .



10.20b . . . and disconnect breather hose



10.20c Undo motor retaining bolts and withdraw motor from unit



10.20d Remove fan retaining nut . . .



10.20e . . . and lift off fan (seal arrowed)

valve and free the cable outer from the retaining clip.

24 Slacken and remove the bolt securing the heater valve mounting bracket to the engine compartment bulkhead.

25 Either drain the cooling system or clamp the coolant hoses on each side of the coolant valve to minimise the loss of coolant.

26 Slacken the hose retaining clips, then disconnect both hoses from the coolant valve and remove the valve from the engine compartment. Mop up any spilt coolant immediately.

Refitting

Heater unit

27 Refitting is a reverse of the removal procedure, noting the following:

- Ensure that the heater ducts are securely connected to the unit so that there are no air leaks or gaps.
- Check the operation of all heater cables before refitting the facia, ensuring that the relevant component moves smoothly from the fully open to the fully closed position. If necessary, adjustments can be made by releasing the relevant retaining clip and repositioning the cable outer.
- Ensure that the heater hoses are correctly reconnected and are securely held by the retaining clips.
- Tighten the heater lower mounting nut to the specified torque setting.
- Refill the cooling system as described in Chapter 1.



12.2a Disconnect control cables from heater unit . . .



12.2b . . . and remove heater control panel with cables

Heater matrix

28 Refitting is a reverse of the removal procedure.

Heater blower motor

29 Refitting is a reversal of the removal sequence, noting the following:

- Ensure that the foam rubber seal is refitted correctly so that the blower motor-to-bulkhead aperture is closed off.
- Tighten the blower motor mounting bolts to the specified torque setting.
- Ensure that the air recirculation cable and flap functions correctly before refitting the glovebox. If necessary, adjust by releasing the cable retaining clip and repositioning the cable outer.

Heater blower motor resistor

30 Refitting is a reverse of the removal procedure.

Heater valve

31 Refitting is a reversal of the removal procedure. On completion, check the heater cable operates smoothly and replenish the cooling system.

11 Heater ducts and vents - removal and refitting



Removal

Facia ducts

- Remove the facia.

2 The ducts are mounted on the facia assembly and can be removed individually, once the retaining screws have been removed.

Heater unit ducts

3 The left-hand heater unit to blower motor duct is removed as described in paragraphs 15 to 17 of Section 10.

4 To remove the right-hand duct, first remove the facia. Slacken and remove the retaining screw which secures the right-hand end of the duct to the mounting bracket and release the radio aerial from the retaining clips on the underside of the duct. The duct can then be manoeuvred out of position.

5 Removal of the lower ducts which supply air to the rear passenger footwells is a complex job, requiring the removal of the front seats, centre console and the various trim panels so that the floor carpet can be peeled back, and is therefore not recommended.

Centre console vents

6 Remove the centre console.

7 The vents can then be unclipped from the rear of the front console section and removed.

Facia vents

8 The adjustable face-level vents can be removed by prising them gently out of the facia until the clips are released, taking care not to mark the facia.

9 The door window demister vents, fitted to the sides of the facia, can also be prised out of position once the relevant door has been opened.

Refitting

10 Refitting is a reverse of the removal procedure.

12 Heater controls - removal, refitting and adjustment



Removal

- Remove the heater unit.
- Disconnect the heater control cables from the heater unit and unclip the control panel. Remove the panel assembly complete with cables (see illustrations).

Refitting and adjustment

- Refit the heater control panel to the heater unit and reconnect the necessary control cables to their original positions.
- Check the operation of the control cables, ensuring that they operate smoothly and move the necessary component from the fully open to the fully closed position. Adjustments can be made by releasing the cable retaining clip and repositioning the cable outer.
- Once the necessary control cables are functioning correctly, refit the heater unit.

13 Air conditioning compressor drivebelt - inspection, adjustment and renewal

Refer to Chapter 1 (alternator drivebelt check).

14 Air conditioning refrigerant - level check

Refer to Chapter 1.

15 Air conditioning system components - removal and refitting



Warning: The air conditioning system must be professionally discharged before carrying out any of the following work. Cap or plug the pipe lines as soon as they are disconnected to prevent the entry of moisture.

Compressor

Removal

- 1 Remove the alternator/air conditioning compressor drivebelt as described in Chapter 1.
- 2 Disconnect the air conditioning pipes from the compressor (see illustration).
- 3 Slacken and remove the four bolts securing the compressor to the mounting bracket and manoeuvre it downwards and away from the engine.

Refitting

4 Refitting is a reverse of the removal sequence, tightening the compressor mounting bolts to the specified torque setting. Ensure that the compressor pipe unions are securely tightened then refit and adjust the drivebelt as described in Chapter 1. On completion, have the air conditioning system recharged by a refrigeration specialist or suitably-equipped Rover dealer.

Condenser

Removal

- 5 Remove the front bumper.
- 6 Slacken and remove the bolts securing the power steering oil cooler to the body, then undo the bonnet lock mounting bracket bolts and position the lock assembly clear of the condenser unit.
- 7 Unscrew the air conditioning pipe union nuts from the condenser unit then disconnect the pipes. Discard the union pipe O-rings as these must be renewed whenever they are disturbed.
- 8 Slacken and remove the four retaining bolts and withdraw both the condenser upper mounting brackets. Release the condenser from its lower mounting points and manoeuvre it away from the vehicle.

Refitting

- 9 Prior to refitting, check the condenser lower mounting rubbers for signs of damage or deterioration and renew as necessary. Renew the pipe union O-rings.
- 10 Refitting is a direct reversal of the removal procedure, tightening the pipe union nuts to the specified torque setting. On completion, have the air conditioning system recharged by a refrigeration specialist or a suitably equipped Rover dealer.

Condenser cooling fan

Removal

- 11 Drain the cooling system.
- 12 Disconnect the wiring connector from the engine overheat switch, located in the top coolant hose, then slacken the clips securing the hose to the radiator and engine. Disconnect the hose from the radiator and engine and position it clear of the condenser so that it does not hinder removal.
- 13 Disconnect the condenser fan electrical wiring connector then undo the four fan cowling retaining nuts and manoeuvre the assembly out of the engine compartment.

14 To dismantle the assembly, first undo the fan retaining nut then lift the fan off the motor spindle. Undo the two screws which secure the motor assembly to the cowling then release the motor wiring and connector and separate the motor and cowling.

Refitting

- 15 Refitting is a reverse of the removal procedure, noting the following points:
 - a) Ensure that the motor wiring is securely retained by the cowling clips and is clear of the condenser fan.
 - b) Ensure that the radiator hose is securely held by its retaining clips.
 - c) On completion, refill the cooling system.

Evaporator

Removal

16 Undo the three bolts which secure the washer system reservoir to the engine compartment bulkhead and move the reservoir to gain access to the two evaporator union nuts. Slacken both the union nuts and disconnect the pipes from the evaporator. Remove the O-rings from the union nuts and discard them.

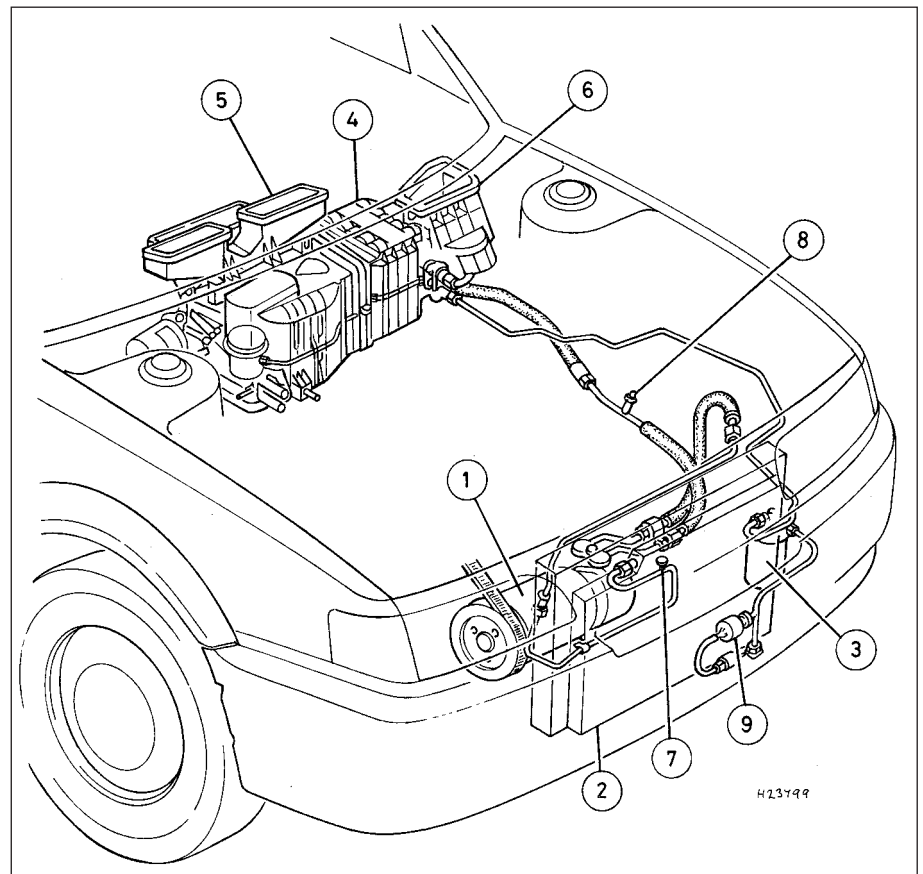

15.2 Air conditioning system layout

- | | | |
|------------------|--------------------------------------|-------------------------------------|
| 1 Compressor | 5 Heater unit | 8 Low pressure servicing connection |
| 2 Condenser | 6 Blower unit | 9 Trinary switch |
| 3 Receiver drier | 7 High pressure servicing connection | |
| 4 Evaporator | | |

17 Working from inside the vehicle, undo the two glovebox retaining screws, then partially withdraw the glovebox until access can be gained to the glovebox damper-to-facia screw. Undo the damper screw and remove the glovebox and damper.

18 Slacken and remove the four glovebox support rail mounting bolts and remove the rail.

19 Undo the two evaporator bracket retaining bolts and remove both the brackets.

20 Disconnect the wiring connector from the right-hand side of the evaporator.

21 Slacken and remove the two evaporator mounting nuts and manoeuvre the unit out of position.

Refitting

22 Refitting is a reverse of the removal procedure noting the following:

- a) *Ensure that the evaporator is correctly joined to the heater unit and blower motor, so that there are no air leaks or gaps, then tighten the retaining nuts and bracket bolts securely.*
- b) *Fit new O-rings to the pipe unions and*

tighten the union nuts to the specified torque setting.

- c) *On completion, have the system recharged by a refrigeration specialist or a suitably-equipped Rover dealer.*

Receiver drier

Removal

23 Remove the left-hand headlamp and the battery and battery tray.

24 Undo the two screws securing the air intake grille to the body. Disengage the grille from the resonator and remove it from the vehicle. Move the resonator to one side to gain access to the receiver drier.

25 Slacken the union nuts and disconnect the pipes from the receiver drier noting the O-rings which are fitted to the pipe unions. Discard the O-rings as they must be renewed whenever they are disturbed. The receiver drier unit unions must be capped immediately after they are disconnected and must remain capped until they are to be reconnected. If the receiver drier unit is left uncapped for any period of time it must be renewed.

26 Slacken the receiver drier clamp bolt then slide the unit out of the retaining clamp and remove it from the engine compartment.

Refitting

27 Refitting is a direct reversal of the removal sequence, tightening the pipe union nuts to the specified torque setting. On completion, have the system recharged by a refrigeration specialist or suitably-equipped Rover dealer.

Trinary switch

Removal

28 Remove the front bumper.

29 Disconnect the wiring connector and unscrew the switch from the air conditioning pipe. Remove the O-ring from the switch and discard it.

Refitting

30 Refitting is a reverse of the removal procedure. Fit a new O-ring to the switch and tighten it to the specified torque setting. On completion, have the system recharged by a refrigeration specialist or suitably-equipped Rover dealer.





Chapter 5 Part A

Ignition system - carburettor engines

Contents

Distributor - removal, overhaul and refitting	5	Ignition system - testing	9
General information and precautions	1	Ignition timing - checking and adjustment	8
HT coil - removal, testing and refitting	4	Spark plugs - renewal	2
HT leads, distributor cap and rotor arm - inspection and renewal	3	Thermostatically-operated vacuum switch - removal and refitting	7
Ignition amplifier module - removal and refitting	6		

Degrees of difficulty

Easy , suitable for novice with little experience 	Fairly easy , suitable for beginner with some experience 	Fairly difficult , suitable for competent DIY mechanic 	Difficult , suitable for experienced DIY mechanic 	Very difficult , suitable for expert DIY or professional 
---	--	--	---	--

Specifications

General

System type	Lucas constant energy inductive
Firing order	1-3-4-2 (No 1 cylinder at timing belt end)
Direction of crankshaft rotation	Clockwise (viewed from right-hand side of vehicle)

Distributor

Type	Lucas 67 DM4, incorporating centrifugal and vacuum advance mechanisms and externally-mounted amplifier module
------	---

Identification:

With catalytic converter	NJC 10026
Without catalytic converter	NJC 10033
Direction of rotor arm rotation	Anti-clockwise (viewed from left-hand side of vehicle)
Pick-up coil resistance	950 to 1150 ohms

Vacuum diaphragm unit identification:

With catalytic converter	80-200-8
Without catalytic converter	80-200-6
Vacuum advance commences	107 mbar (80 mm Hg)

Maximum vacuum advance:

With catalytic converter	16° @ 267 mbar (200 mm Hg)
Without catalytic converter	12° @ 267 mbar (200 mm Hg)
Deceleration check - vacuum disconnected	4° to 8° @ 2500 rpm

Note: Degree and speed values to be measured at crankshaft

HT coil

Type	AUU 1326 or ADU 8779
Manufacturer	Bosch, Ducellier or Rudi Cajavec
Current consumption - average	0.25 to 0.75 amps @ idle speed
Winding resistances:	
Primary	0.3 to 0.5 ohms @ 20°C
Secondary	5 to 15 K ohms @ 20°C

Ignition timing

At 1500 rpm (vacuum pipe disconnected)	9° ± 1° BTDC
--	--------------

Torque wrench settings

	Nm	lbf ft
Spark plugs	25	18
Distributor cap screws	2	21
Amplifier module-to-distributor body (hex-head) screws	5	4
Distributor mounting bolts	25	18
Ignition HT coil mounting bolts	7	5

1 General information and precautions

General information

The ignition system is fully-electronic in operation and of the inductive type, incorporating a contact-less distributor (driven off the camshaft left-hand end) and an amplifier module, as well as the spark plugs, HT leads, ignition HT coil and associated wiring.

The system is divided into two circuits, which are the primary (low tension/LT) and secondary (high tension/HT). The primary circuit consists of the battery, ignition switch, ignition HT coil primary windings, amplifier module and distributor pick-up coil and wiring. The secondary circuit consists of the ignition HT coil secondary windings, the distributor cap and rotor arm, the spark plugs and HT leads.

The distributor incorporates features which advance the ignition timing both mechanically and by vacuum operation. Its shaft, driven by the camshaft, incorporates a reluctor which has four shaped poles and is mounted on the centre of a centrifugal advance assembly, whose two weights move outwards under centrifugal force as engine speed rises, thus rotating the reluctor on the shaft and advancing or retarding the spark, the amount of movement being controlled by light springs. A pick-up coil generates a weak magnetic field whenever the ignition is switched on. As the engine rotates the reluctor poles pass the coil, disturbing the field each time and sending a signal current to the amplifier module. Whenever this signal exceeds a threshold level determined by engine speed, a high-voltage transistor in the amplifier is switched on, thus allowing HT coil current to flow. When this current has reached the required level, it is held constant until the transistor is switched off, thus triggering the spark. The pick-up coil is clamped to a stator pack that is able to rotate under the control of the vacuum diaphragm unit mounted on the side of the distributor. The unit consists of a diaphragm, one side of which is connected via a small-bore pipe to the carburettor and the other side to the stator pack. Inlet manifold depression, which varies with engine speed and throttle position, causes the diaphragm to move, thus rotating the stator pack and advancing or retarding the spark.

Models fitted with catalytic converters have a thermostatically-operated vacuum switch

screwed into the cooling system thermostat housing. The switch is connected into the vacuum hose linking the carburettor to the distributor vacuum diaphragm unit. At coolant temperatures below 70°C, the switch cuts off the vacuum supply to the diaphragm and prevents the unit from advancing the ignition timing. This causes the exhaust gas temperatures to rise, due to the retarded ignition timing, and brings the catalytic converter swiftly up to its efficient operating temperature. Once coolant temperature rises above 70°C, the switch opens and allows the vacuum to reach the diaphragm unit, thus restoring normal advance and retard of the ignition timing.

Precautions

General

It is necessary to take extra care when working on the electrical system to avoid damage to semi-conductor devices (diodes and transistors), and to avoid the risk of personal injury. In addition to the precautions given in the "Safety first!" Section at the beginning of this manual, take note of the following points when working on the system.

Always remove rings, watches, etc. before working on the electrical system. Even with the battery disconnected, capacitive discharge could occur if a component live terminal is earthed through a metal object. This could cause a shock or nasty burn.

Do not reverse the battery connections. Components such as the alternator or any other having semi-conductor circuitry could be irreparably damaged.

If the engine is being started using jump leads and a slave battery, connect the batteries *positive to positive* and *negative to negative*. This also applies when connecting a battery charger.

Never disconnect the battery terminals, or alternator multi-plug connector, when the engine is running.

The battery leads and alternator multi-plug must be disconnected before carrying out any electric welding on the car.

Never use an ohmmeter of the type incorporating a hand cranked generator for circuit or continuity testing.

Ignition and engine management systems

The HT voltage generated by an electronic ignition system is extremely high, and in certain circumstances could prove fatal. Take care to avoid receiving electric shocks from the HT side of the ignition system. *Persons*

with surgically-implanted cardiac pacemaker devices should keep well clear of the ignition circuits, components and test equipment.

Do not handle HT leads, or touch the distributor or coil when the engine is running. If tracing faults in the HT circuit, use well insulated tools to manipulate live leads.

Engine management modules are very sensitive components. Certain precautions must be taken to avoid damage to the module when working on a vehicle equipped with an engine management system, as follows.

When carrying out welding operations on the vehicle using electric welding equipment, the battery and alternator should be disconnected.

Although underbonnet-mounted modules will tolerate normal underbonnet conditions, they can be adversely affected by excess heat or moisture. If using welding equipment or pressure washing equipment in the vicinity of the module, take care not to direct heat, or jets of water or steam at the module. If this cannot be avoided, remove the module from the vehicle, and protect its wiring plug with a plastic bag.

Before disconnecting any wiring, or removing components, always ensure that the ignition is switched off.

On models with underbonnet-mounted modules, do not run the engine with the module detached from the body panel, as the body acts as an effective heat sink and the module may be damaged due to internal overheating.

Do not attempt to improvise fault diagnosis procedures using a test lamp or multimeter, as irreparable damage could be caused to the module.

After working on ignition/engine management system components, ensure that all wiring is correctly reconnected before reconnecting the battery or switching on the ignition.

2 Spark plugs - renewal

Refer to Chapter 1.

3 HT leads, distributor cap and rotor arm - inspection and renewal

Refer to Chapter 1.

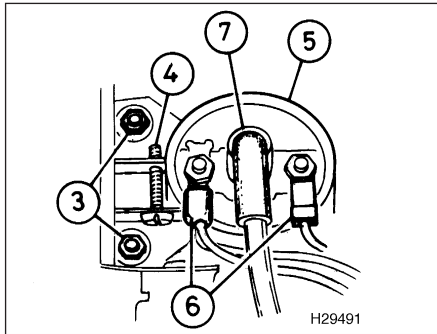

4.4 HT coil connections

- 3 Mounting bolts
- 4 Clamp screw
- 5 HT coil
- 6 LT connections
- 7 HT connection

4 HT coil - removal, testing and refitting



Removal

- 1 The coil is mounted on the left-hand side of the engine compartment, between the battery and the left-hand headlamp unit.
- 2 Disconnect the battery negative terminal.
- 3 To improve access to the coil, remove the headlamp bulb cover.
- 4 Peel back the end cover, then disconnect the HT lead from the coil. Note which terminals they are connected to and disconnect the two pairs of LT wires from the coil (see illustration).
- 5 Remove the two coil mounting bolts and withdraw the coil from the engine compartment. If necessary, slacken the clamp screw and separate the coil from its mounting bracket.

Testing

- 6 Test the coil by using a multimeter, set to its resistance function, to check the primary (LT + to - terminals) and secondary (LT + to HT



5.2 Disconnecting wiring connector from ignition amplifier module

lead terminal) windings for continuity. The resistance of either winding can be checked and compared with the specified value. Note that the resistance of the coil windings will vary slightly according to the coil temperature.

7 Using an ohmmeter or continuity tester, check that there is no continuity between the HT lead terminal and the coil body.

8 If the coil is faulty it must be renewed.

Refitting

- 9 Refitting is the reverse of the removal procedure.

5 Distributor - removal, overhaul and refitting



Removal

- 1 Disconnect the battery negative terminal.
- 2 Release the wire retaining clip and unplug the wiring connector from the ignition amplifier module (see illustration).
- 3 Disconnect the vacuum pipe from the vacuum diaphragm unit (see illustration).
- 4 Position the engine so that No 1 cylinder is at TDC on the compression stroke.
- 5 Mark the relationship of the distributor body



5.3 Disconnecting vacuum pipe from distributor vacuum diaphragm unit



5.5 Making alignment marks on distributor body and cylinder head

to the cylinder head, as a guide for refitting (see illustration).

- 6 Unscrew the distributor mounting bolts and withdraw the distributor (see illustration). Do not disturb the crankshaft setting while the distributor is removed.
- 7 Remove the distributor body sealing ring which must be renewed whenever it is disturbed (see illustration).

Overhaul

- 8 Remove the distributor cap and withdraw the rotor arm, if not already removed (see illustration).



5.6 Unscrew distributor mounting bolts (remaining bolt arrowed) . . .

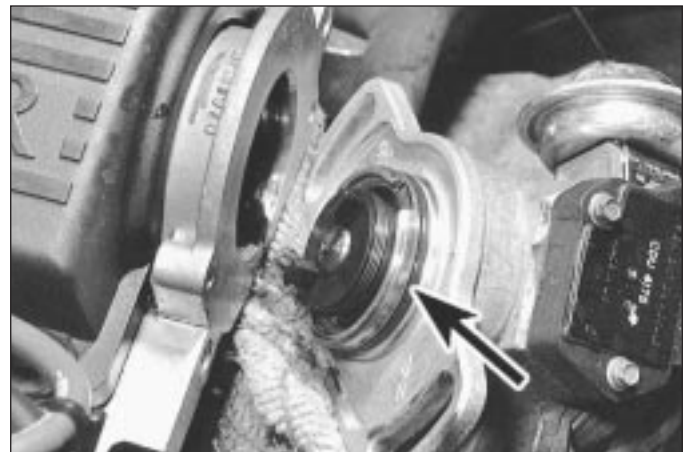

5.7 . . . then remove distributor (O-ring arrowed)

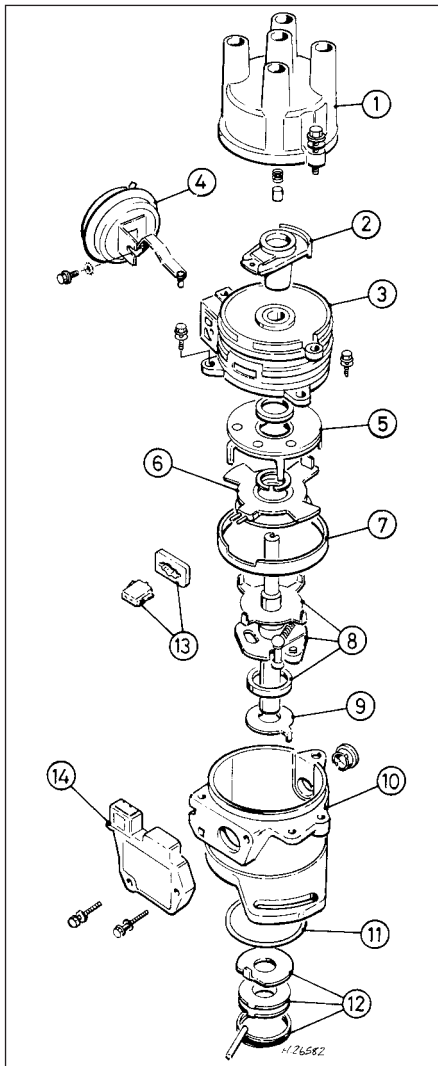

5.8 Lucas 67 DM4 distributor

- 1 Distributor cap
- 2 Rotor arm
- 3 Upper housing
- 4 Vacuum diaphragm unit
- 5 Stator pack including thrustwasher(s) and circlip
- 6 Pick-up coil
- 7 Clamp ring
- 8 Distributor shaft, including reluctor and advance assembly
- 9 Thrustwasher
- 10 Lower housing
- 11 O-ring
- 12 Drive coupling, including thrustwasher, spring and roll pin
- 13 Connector and gasket
- 14 Amplifier module

9 Undo the two bolts securing the amplifier module to the body, then carefully remove the gasket and withdraw the connector.

10 Remove the screws and separate the upper housing from the lower.

11 Remove the clamp ring and pick-up coil from the upper housing.

12 Remove the circlip (and first thrustwasher, if fitted) from the underside of the upper housing, disengage the stator pack from the vacuum diaphragm unit arm and withdraw the stator pack, followed by the (second) thrustwasher.

13 Remove the retaining screw and withdraw the vacuum diaphragm unit from the distributor.

14 Check the distributor shaft endfloat and if it seems excessive, seek expert advice.

15 Remove the spring from the distributor drive coupling, then use a scribe or similar to mark the relationship of the coupling to the shaft. It is essential that the coupling is refitted correctly in relationship to the rotor arm on refitting. Release the distributor shaft by driving out the retaining roll pin and removing the coupling, noting the toothed thrustwasher which is fitted behind it.

16 Withdraw the shaft, noting the toothed thrustwasher underneath the centrifugal advance assembly. Be very careful not to bend any of the reluctor poles and do not attempt to remove it from the shaft.

17 The advance assembly and shaft can be lubricated but if any part of the assembly is found to be worn or damaged, then the complete distributor must be renewed. Individual replacement parts are not available.

18 Clean and examine all components. If any are found to be worn or damaged, seek expert advice. A repair kit of sundry parts is available separately, also the coupling assembly, the pick-up coil and vacuum diaphragm unit, as well as the rotor arm and the distributor cap. If any other parts are worn or damaged, the complete distributor must be renewed.

19 In addition to the checks in Chapter 1, use an ohmmeter or continuity tester to check that there is no continuity between any of the cap's terminal segments. Similarly, check that there is no continuity between the rotor arm body and its brass segment. Note that the arm has a built-in resistance.

20 Reassembly is the reverse of the dismantling procedure, noting the following:

- a) Apply a few drops of suitable oil to the advance assembly pivots and springs, also to the shaft, upper housing and stator pack bearing surfaces.
- b) Using the marks made on dismantling, be very careful to ensure that the coupling is located correctly on the shaft end (in relationship to the rotor arm) before driving in the roll pin to secure it, then ensure that the spring is fitted over the roll pin ends.
- c) Grease the vacuum diaphragm unit arm before refitting it and use grease to stick the thrustwasher to the underside of the upper housing. Refit the stator pack, ensuring it engages correctly with the vacuum diaphragm unit arm peg, followed by the (remaining thrustwasher, if fitted, and) circlip. Tighten the unit retaining screw securely.

d) Refit the pick-up coil to the upper housing and centre its terminals in the aperture before fitting the clamp ring so that its cut-out is over the aperture.

e) Refit the upper housing to the lower, tighten the screws lightly and check that the shaft is free to rotate. There must be no sign of the reluctor poles touching the stator pack arms, as either can easily be bent. Tighten the screws securely.

f) Refit the connector and its gasket.

g) Refit the amplifier module and the rotor arm.

h) Fit a new sealing ring to the distributor body.

Refitting

Original distributor

21 Ensure that No 1 cylinder is at TDC, then rotate the rotor arm to align with the distributor cap's No 1 terminal. Fit a new sealing ring to the distributor body and lubricate it with a smear of engine oil.

22 Align the marks made on removal and refit the distributor to the cylinder head. If necessary, rotate the rotor arm very slightly to help the distributor drive dogs locate in the camshaft slots; they are offset and so will fit only one way. Refit the distributor mounting bolts and tighten them to the specified torque.

23 Refit the spark plugs.

24 Refit the distributor cap, ensuring it is correctly located, and tighten its retaining screws to the specified torque. Reconnect the HT leads to the relevant spark plugs.

25 Reconnect the vacuum pipe to the vacuum diaphragm unit and the wiring connector to the ignition amplifier module.

26 Check and, if necessary, adjust the ignition timing.

New distributor

27 If a new distributor is to be fitted (or no marks were made on removal), the following procedure will produce a basic setting which will enable the engine to start and run while the ignition timing is accurately set.

28 Position the engine so that No 1 cylinder is at TDC on the compression stroke.

29 Rotate the crankshaft slightly anti-clockwise until the pulley notch is positioned in the 9° BTDC position (between the 8 and 12 marks on the timing scale).

30 Rotate the distributor rotor arm to align with the distributor cap's No 1 terminal. This terminal is marked with a K which is cast on the outside of the distributor cap. Fit a new sealing ring to the distributor body and lubricate it with a smear of engine oil.

31 Fit the distributor to the cylinder head and refit its mounting bolts. Positioning the distributor body so that the mounting bolts are in the middle of their respective slots then tighten the bolts finger-tight only.

32 Perform the operations given in paragraphs 23 to 25.

33 Check and adjust the ignition timing.

6 Ignition amplifier module - removal and refitting



Warning: Do not attempt to open or repair the ignition amplifier module. If faulty, it must be renewed.

Removal

- 1 Disconnect the battery negative terminal.
- 2 Releasing its wire clip, unplug the wiring connector from the amplifier module.
- 3 Remove the two bolts and withdraw the module, taking care not to damage the terminal pins.
- 4 Check carefully that the mating surfaces of the module and distributor are completely clean and unmarked and that the pick-up coil terminal pins are clean and a secure fit in the module. If in doubt, it is permissible to remove the connector and its gasket and to gently squeeze together the female terminals to improve the fit.
- 5 The pick-up coil-to-connector and connector-to-module connections must be checked with particular care if the module is thought to be faulty. Similarly, check, clean and tighten (if necessary) the distributor wiring connector-to-module terminals. It is essential that there is good electrical contact between the module and the distributor and at all four LT wiring connections mentioned above.

Refitting

- 6 On refitting, apply a smear of heat-conducting silicone grease to the mating surfaces of the module and distributor. The correct grease can be obtained from Rover dealers under Part Number BAU 5812 but if this is not available, either a heat-sink compound or an anti-seize compound (such as Holt's Copaslip), will serve as an adequate substitute.
- 7 Check that the terminal pins are not bent or damaged and that they engage correctly with the module's connections.
- 8 Tighten the module retaining bolts to the specified torque wrench setting, then reconnect the distributor wiring and battery.

7 Thermostatically-operated vacuum switch - removal and refitting



- 1 On models fitted with a catalytic converter, a thermostatically-operated vacuum switch is screwed into the cooling system thermostat housing.

Removal

- 2 Either drain the cooling system or be prepared for some loss of coolant as the switch is unscrewed.
- 3 Access to the thermostat housing is

possible with the inlet manifold and carburettor in place, but is made much easier if these are first removed.

- 4 Disconnect and plug the switch vacuum pipes.
- 5 Unscrew the switch and withdraw it, then plug the opening to prevent the entry of dirt. If the cooling system has not been drained, work quickly to minimise coolant loss.
- 6 If required, the switch can be tested as described in Chapter 3.

Refitting

- 7 Refitting is the reverse of the removal procedure, noting the following:
 - a) Wipe clean the threads of the switch and thermostat housing.
 - b) If a sealing washer is fitted, renew it whenever it is disturbed so as to prevent leaks. If no sealing washer is fitted, apply a smear of sealant to the switch threads.
 - c) Tighten the switch securely and reconnect the vacuum pipes.
 - d) Refit any components removed to improve access.
 - e) Replenish the cooling system.

8 Ignition timing - checking and adjustment

Refer to Chapter 1.

9 Ignition system - testing



Note: Always switch off the ignition before disconnecting or connecting any system component and when using a multi-meter to check resistances. Any voltmeter or multi-meter used to test ignition system components must have an impedance of 10 Mohms or greater.

General

- 1 The components of electronic ignition systems are normally very reliable. Most faults are likely to be due to loose or dirty connections or to 'tracking' of HT voltage due to dirt, dampness or damaged insulation, than to the failure of any of the system's components. Always check all wiring thoroughly before condemning an electrical component and work methodically to eliminate all other possibilities before deciding that a particular component is faulty.
- 2 The old practice of checking for a spark by holding the live end of an HT lead a short distance away from the engine is not recommended. Not only is there a high risk of a powerful electric shock but the HT coil or amplifier module will be damaged. Never try to diagnose misfires by pulling off one HT lead at a time.

Engine will not start

- 3 If the engine will not turn over at all or only turns very slowly, check the battery and starter motor. Connect a voltmeter across the battery terminals (meter positive probe to battery positive terminal), disconnect the ignition coil HT lead from the distributor cap and earth it, then note the voltage reading obtained while turning over the engine on the starter for (no more than) ten seconds. If the reading obtained is less than approximately 9.5 volts, check the battery, starter motor and charging system.
- 4 If the engine turns over at normal speed but will not start, check the HT circuit by connecting a timing light (following the manufacturer's instructions) and turning the engine over on the starter motor. If the light flashes then voltage is reaching the spark plugs, so these should be checked first. If the light does not flash, check the HT leads themselves followed by the distributor cap, carbon brush and rotor arm.
- 5 If there is a spark, check the fuel system for faults.
- 6 If there is still no spark, check the voltage at the ignition HT coil + terminal. It should be the same as the battery voltage (ie: at least 11.7 volts). If the voltage at the coil is more than 1 volt less than that at the battery, check the feed back through the fusebox and ignition switch to the battery and its earth until the fault is found.
- 7 If the feed to the HT coil is sound, check the coil's primary and secondary winding resistance. Renew the coil if faulty but be careful to carefully check the condition of the LT connections themselves before doing so, to ensure that the fault is not due to dirty or poorly-fastened connectors.
- 8 If the HT coil is in good condition, the fault is probably within the amplifier module or distributor pick-up coil. So that the operation of these two can be checked quickly, Rover dealers have a neon indicator, which when connected across the HT coil's LT terminals, flashes every time the amplifier triggers an HT pulse in the coil if the ignition is switched on and the engine is turned over on the starter. Owners can substitute a low-wattage bulb. If the bulb flickers or flashes when the engine is turned over, the amplifier and distributor are sound.
- 9 If the amplifier and distributor are sound, and the entire LT circuit is in good condition, the fault, if it lies in the ignition system, must be in the HT circuit components. These should be checked carefully, as outlined above.
- 10 If the indicator or bulb does not flash, the fault is in either the distributor pick-up coil or the amplifier module. Owners should note that by far the commonest cause of failure of either of these is a poor connection, either between the amplifier module and the distributor body or in the LT circuit wiring connections themselves. If a voltmeter or

5A•6 Ignition system - carburettor engines

multi-meter is available, check the feed to the amplifier (the voltage reading obtained should be the same as that measured at the HT coil LT + terminal), then check that there is no measurable resistance between the amplifier module fixing screws and engine earth and that there is no continuity between either module terminal and earth. If any doubt exists as to the condition of the connections, remove the module, clean and check carefully the module earth and the connections and, if necessary, improve their fit. If these checks fail to correct the fault, measure the resistance of the pick-up coil, comparing it with the specified value. Renew the coil if the reading obtained differs significantly from that given. If

the fault still exists, the only solution is to try the effect of renewing the amplifier module.

Engine misfires

11 An irregular misfire suggests either a loose connection or intermittent fault on the primary circuit, or an HT fault on the coil side of the rotor arm.

12 With the ignition switched off, check carefully through the system ensuring that all connections are clean and securely fastened. If the equipment is available, check the LT circuit as described in paragraphs 6 to 10 above.

13 Check that the HT coil, the distributor cap and the HT leads are clean and dry. Check the leads themselves and the spark

plugs (by substitution, if necessary), then check the distributor cap, carbon brush and rotor arm.

14 Regular misfiring is almost certainly due to a fault in the distributor cap, HT leads or spark plugs. Use a timing light to check whether HT voltage is present at all leads.

15 If HT voltage is not present on any particular lead, the fault will be in that lead or in the distributor cap. If HT is present on all leads, the fault will be in the spark plugs. Check and renew them if there is any doubt about their condition.

16 If no HT is present, check the HT coil as its secondary windings may be breaking down under load.





Chapter 5 Part B

Ignition system - fuel injection engines

Contents

Crankshaft sensor and reluctor ring - removal and refitting	6	HT coil - removal, testing and refitting	4
Distributor - removal and refitting	5	HT leads, distributor cap and rotor arm - inspection and renewal . . .	3
Engine management electronic control unit (ECU) - removal and refitting	7	Ignition system - testing	9
General information and precautions	1	Ignition timing - checking and adjustment	8
		Spark plugs - renewal	2

Degrees of difficulty

Easy , suitable for novice with little experience 	Fairly easy , suitable for beginner with some experience 	Fairly difficult , suitable for competent DIY mechanic 	Difficult , suitable for experienced DIY mechanic 	Very difficult , suitable for expert DIY or professional 
---	--	--	---	--

Specifications

General

System types	Rover/Motorola Modular Engine Management System (MEMS), fully electronic, controlled by ECU. Either single-point (SPi) or multi-point (MPi) fuel injection.
Firing order	1-3-4-2 (No 1 cylinder at timing belt end)
Direction of crankshaft rotation	Clockwise (viewed from right-hand side of vehicle)

Distributor

Type	Spark distribution only (ignition timing controlled by ECU)
Direction of rotor arm rotation	Anti-clockwise (viewed from left-hand side of vehicle)
Distributor cap:	
SPi	AUU 1186
MPi	NJD 10010
Rotor arm	AUU 1641 (resistive type)

Engine management Electronic Control Unit (ECU)

SPi:	
With catalytic converter	MNE 10008, MNE 10023 or MNE 10042
Without catalytic converter	MNE 10011, MNE 10013 or MNE 10051
MPi:	
Alloy inlet manifold	MNE 101470
Plastic inlet manifold	MKC 101730

Ignition timing @ idle speed (ECU-controlled)

SPi with catalytic converter - by ECU number (vacuum pipe connected) :	
MNE 10008	13° ± 2° BTDC
MNE 10023, MNE 10042	14° ± 2° BTDC
SPi without catalytic converter - by ECU number (vacuum pipe connected) :	
MNE 10011	13 ± 2° BTDC
MNE 10013, MNE 10051	14 ± 2° BTDC
MPi - by ECU number (vacuum pipe connected) :	
MNE 101470, MKC 101730	10 ± 5° BTDC

Note: Nominal value given for checking purposes only - not adjustable and may vary under ECU control

Crankshaft sensor

Type ADU 7340

HT coil

Type:

 Spi NEC 10002 or NEC 10003
 Mpi NEC 10002, NEC 10003 or NEC 10004
 Manufacturer Bosch, Ducellier or Rudi Cajavec
 Current consumption - average 0.25 to 0.75 amps @ idle speed
 Winding resistances:
 Primary:
 Spi 0.3 to 0.5 ohms @ 20°C
 Mpi 0.7 to 0.8 ohms @ 20°C
 Secondary 5 to 15 K ohms @ 20°C

Torque wrench settings

	Nm	lbf ft
Spark plugs	25	18
Distributor cap screws	2	1
Distributor rotor arm grub screw	10	7
Reluctor ring to flywheel setscrews	3	2
Ignition HT coil mounting screws	7	5
Crankshaft sensor mounting screws	6	4
Crankshaft sensor lead-to-flywheel cover plate screw	6	4

1 General information and precautions

General information

The ignition system is fully electronic in operation, incorporating an Electronic Control Unit (mounted on the engine compartment bulkhead), a distributor (driven off the inlet camshaft left-hand end) and a crankshaft sensor (mounted in the left-hand rear end of the engine cylinder block/crankcase) which registers with the reluctor ring fixed to the flywheel. The system also incorporates spark plugs, HT leads, an ignition HT coil and associated wiring.

The system is divided into two circuits, which are the primary (low tension/LT) and secondary (high tension/HT) circuits. The primary circuit consists of the battery, ignition switch, ignition HT coil primary windings, ECU and wiring. The secondary circuit consists of the ignition HT coil secondary windings, the distributor cap and rotor arm, the spark plugs and the interconnecting HT leads.

The ECU controls both the ignition system and the fuel injection system, integrating the two in a complete engine management system. Refer to Chapter 4 for information on any part of the system not given in this Chapter.

As far as the ignition system is concerned, the ECU receives information in the form of electrical impulses or signals from the crankshaft sensor (which gives it the engine speed and crankshaft position), from the coolant temperature sensor (which gives it the engine temperature), from the throttle pedal switch (which tells it when the throttle is

closed) and from the manifold absolute pressure sensor (which gives it the load on the engine). All these signals are compared by the ECU, using digital techniques, with set values pre-programmed (mapped) into its memory. Based on this information, the ECU selects the ignition timing appropriate to those values and controls the ignition HT coil accordingly.

This means that the distributor is just that, a distributor of the HT pulse to the appropriate spark plug. It has no effect whatsoever on the ignition timing. Also, the system is so sensitive that, at idle speed, the ignition timing may be constantly changing. This should be remembered if trying to check the ignition timing.

Precautions

Refer to Part A of this Chapter.

2 Spark plugs - renewal

Refer to Chapter 1.

3 HT leads, distributor cap and rotor arm - inspection and renewal

1 Refer to Chapter 1. Note the anti-flash shield fitted beneath the rotor arm.

4 HT coil - removal, testing and refitting

1 Refer to Section 4 in Part A of this Chapter.

5 Distributor - removal and refitting



Removal

- 1 Disconnect the battery negative terminal.
- 2 Disconnect the HT leads from the spark plugs.
- 3 Undo the two distributor cap retaining screws and remove the cap and leads as an assembly.
- 4 Slacken and remove the grub screw securing the rotor arm to the camshaft end then pull off the rotor arm (see illustration).
- 5 Remove the distributor cap insulating plate from the cylinder head.
- 6 Examine each components for signs of wear or damage and renew as necessary.

Refitting

7 Refitting is a reverse of the removal procedure. Tighten the rotor arm grub screw and distributor cap screws to the specified torque settings.

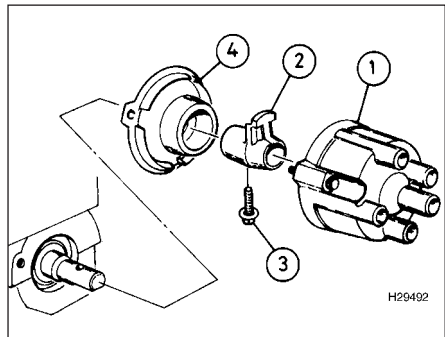

5.4 Distributor assembly

- | | |
|-------------------|--------------------|
| 1 Distributor cap | 3 Grub screw |
| 2 Rotor arm | 4 Insulating plate |



6.3 Removing crankshaft sensor (wiring lead screw arrowed)



6.6 Reluctor ring-to-flywheel screws (arrowed)

6 Crankshaft sensor and reluctor ring - removal and refitting



Removal

Crankshaft sensor

- 1 Disconnect the battery negative terminal.
- 2 Disconnect the sensor wiring at its connector plug on the flywheel rear cover plate, then undo the retaining screw to release the wiring lead.
- 3 Remove the two retaining screws and withdraw the sensor from the cylinder block/crankcase (see illustration).
- 4 Inspect the sensor for obvious signs of wear or damage and renew it if necessary. No data is available to enable the sensor to be tested. If thought to be faulty, it can be checked only by substitution with a new component.

Reluctor ring

- 5 Remove the flywheel.
- 6 Undo the two screws securing the reluctor ring to the rear of the flywheel and withdraw it (see illustration).

- 7 Check the ring for obvious signs of wear or damage and renew it if necessary.

Refitting

Crankshaft sensor

- 8 Ensure that the sensor and cylinder block/crankcase mating surfaces are clean then refit the sensor and tighten its retaining screws to the specified torque.
- 9 Connect the sensor wiring connector and tighten the connector mounting screw to the specified torque.
- 10 Reconnect the battery negative terminal.

Reluctor ring

- 11 Refitting is a reversal of the removal procedure. Tighten the reluctor retaining screws to the specified torque.

7 Engine management electronic control unit (ECU) - removal and refitting

Refer to Chapter 4.

8 Ignition timing - checking and adjustment

Refer to Chapter 1.

9 Ignition system - testing



- 1 If a fault appears in the engine management (ignition/fuel) system, first ensure that the fault is not due to poor maintenance. Check that the air cleaner filter element is clean, the spark plugs are in good condition and correctly gapped, and that the engine breather hoses are clear and undamaged. Also check that the accelerator cable is correctly adjusted. If the engine is running very roughly, check the compression pressures, bearing in mind that possibly one of the hydraulic tappets might be faulty, producing an incorrect valve clearance.
- 2 If these checks fail to reveal the cause of the problem, the vehicle should be taken to a suitably-equipped Rover dealer for testing. A wiring block connector is incorporated in the engine management circuit into which a special electronic diagnostic tester can be plugged. The tester will locate the fault quickly and simply, alleviating the need to test all the system components individually, which is a time-consuming operation that carries a high risk of damaging the ECU.
- 3 The only ignition system checks which can be carried out by the home mechanic are those described for the spark plugs, HT leads, rotor arm and distributor cap (Chapter 1), and the ignition HT coil (this Chapter). If necessary, the system wiring and wiring connectors can be checked as described in Chapter 12, ensuring that the ECU wiring connectors have first been disconnected.





Chapter 5 Part C

Starting and charging systems

Contents

Alternator - removal and refitting	8	Charging system - testing	5
Alternator brush holder and voltage regulator - renewal	7	General information and precautions	1
Alternator drivebelt - inspection, adjustment and renewal	6	Starter motor - brush and solenoid renewal	11
Battery - maintenance	2	Starter motor - removal and refitting	10
Battery - removal and refitting	4	Starting system - testing	9
Battery - testing and charging	3		

Degrees of difficulty

Easy , suitable for novice with little experience 	Fairly easy , suitable for beginner with some experience 	Fairly difficult , suitable for competent DIY mechanic 	Difficult , suitable for experienced DIY mechanic 	Very difficult , suitable for expert DIY or professional 
---	--	--	---	--

Specifications

System

Type 12 volt, negative earth

Battery

Type Maintenance-free (sealed for life) lead-acid

Lucas code:

Standard equipment 063

Cold climates 063S

Performance:

	Cold cranking	Reserve capacity
063	360 amps	60 amps
063S	405 amps	70 amps

Alternator

Type Lucas/Magneti Marelli A127-65

Output - @ 14 volts and 6000 rpm 65 amps

Regulated voltage 14 volts maximum

Brush minimum protrusion 5.0 mm approx.

Voltage regulator Lucas 21TR

Starter motor

Type Lucas M79

Rating 0.8 kW

Brush minimum length 3.5 mm approx.

Torque wrench settings

	Nm	lbf ft
Alternator		
Pulley retaining nut	25	18
Mounting/pivot/adjusting arm bolts	25	18
Starter motor		
Motor-to-gearbox bolts	45	33
Motor support bracket fasteners:		
Bracket front half-to-motor nuts	25	18
Bracket front half-to-rear half bolt	45	33
Bracket rear half-to-gearbox bolts	25	18

1 General information and precautions

General information

The electrical system is of the 12 volt negative earth type and comprises a 12 volt battery, alternator with integral voltage regulator, starter motor and related electrical accessories, components and wiring. The battery is charged by an alternator which is belt-driven.

The starter motor is of the pre-engaged type incorporating an integral solenoid. On starting, the solenoid moves the drive pinion into engagement with the flywheel ring gear before the starter motor is energised. Once the engine has started, a one-way clutch prevents the motor armature being driven by the engine until the pinion disengages from the flywheel.

Precautions

It is necessary to take extra care when working on the electrical system to avoid damage to semi-conductor devices (diodes and transistors), and to avoid the risk of personal injury. In addition to the precautions given in the "Safety first!" Section at the beginning of this manual, take note of the following points when working on the system.

Always remove rings, watches, etc before working on the electrical system. Even with the battery disconnected, capacitive discharge could occur if a component live terminal is earthed through a metal object. This could cause a shock or nasty burn.

Do not reverse the battery connections. Components such as the alternator or any other having semi-conductor circuitry could be irreparably damaged.

If the engine is being started using jump leads and a slave battery, connect the batteries *positive to positive* and *negative to negative*. This also applies when connecting a battery charger.

Always ensure that the battery negative lead is disconnected when working on the electrical system.

Do not allow the engine to turn the alternator when the alternator is not connected.

Never test for alternator output by 'flashing' the output lead to earth.

Never disconnect the battery terminals, or alternator multi-plug connector, when the engine is running.

The battery leads and alternator multi-plug must be disconnected before carrying out any electric welding on the vehicle.

Never use an ohmmeter of the type incorporating a hand cranked generator for circuit or continuity testing.

2 Battery - maintenance

Refer to Chapter 1 and "Weekly Checks".

3 Battery - testing and charging



Warning: Specially rapid 'boost' charges which are claimed to restore the power of a battery in 1 to 2 hours are not recommended as they can cause serious damage to the battery plates through overheating.



Warning: During battery electrolyte replenishment, never add water to sulphuric acid otherwise it will explode. Always pour the acid slowly onto the water.



Warning: The battery will be emitting significant quantities of highly inflammable hydrogen gas during charging and for approximately 15 minutes afterwards. Do not allow sparks or naked flames near the battery or it may explode.

Testing

1 In normal use, the battery should not require charging from an external source unless very heavy use is made of electrical equipment over a series of journeys that are too short to allow the charging system to keep pace with demand. Otherwise, a need for regular recharging points to a fault either in the battery or in the charging system.

2 If the vehicle is laid up for long periods (in excess of thirty days at a time) the battery will lose approximately 1% of its charge per week. This figure is for a disconnected battery. If the battery is left connected, circuits such as the clock (where fitted) will drain it at a faster rate. To prevent this happening, always disconnect the battery negative lead whenever the vehicle is to be laid up for a long period. To keep the battery fully charged, it should be given regular 'refresher' charges every six weeks or so. This is particularly important on 'maintenance-free' batteries, which will suffer permanent reduction of charge capacity if allowed to become fully discharged.

3 If a discharged battery is suspected, the simplest test for most owners is as follows. Leave the battery disconnected for at least two hours, then measure the (open circuit, or no-load) voltage using a sensitive voltmeter connected across the battery terminals. Compare the reading obtained with the following:

Voltmeter reading	Charge condition
0.50 volts	Fully discharged - battery scrap
12.30 volts	50% charged
12.48 volts	75% charged
12.66 volts or more	Fully charged

4 If frequent topping-up is required and the battery case is not fractured, then the battery is being over-charged and the voltage regulator will have to be checked.

5 If the vehicle covers a very small annual mileage, it is worthwhile checking the specific gravity of the electrolyte every three months to determine the state of charge of the battery. Use a hydrometer to make the check and compare the results with the following table:

	Normal climates	Tropics
Discharged	1.120	1.080
Half charged	1.200	1.160
Fully charged	1.280	1.230

6 If the battery condition is suspect, first check the specific gravity of electrolyte in each cell. A variation of 0.040 or more between any cells indicates loss of electrolyte or deterioration of the internal plates.

7 A further test can be made only by a battery specialist using a battery heavy discharge meter. Alternatively, connect a voltmeter across the battery terminals and operate the starter motor with the ignition coil HT lead disconnected from the distributor and earthed, and with the headlamps, heated rear window and heater blower switched on. If the voltmeter reading remains above approximately 9.5 volts, the battery condition is satisfactory. If the voltmeter reading drops below 9.5 volts and the battery has already been charged, it is proven faulty.

Charging

8 In winter when heavy demand is placed on the battery (starting from cold and using more electrical equipment), it is a good idea occasionally to have the battery fully charged from an external source. The battery's bench charge rate depends on its code (see a Rover dealer or Lucas agent for details). For most owners, the best method will be to use a trickle-charger overnight, charging at a rate of 1.5 amps. Rapid 'boost' charges which are claimed to restore the power of the battery in 1 to 2 hours are not recommended, as they can cause serious damage to the battery plates through overheating and may cause a sealed battery to explode.

9 Ideally, the battery should be removed from the vehicle before charging and moved to a well-ventilated area. As a minimum precaution, both battery terminal leads must be disconnected (negative lead first) before connecting the charger leads.

10 Continue to charge the battery until all cells are gassing vigorously and no further rise in specific gravity or increase in no-load voltage is noted over a four-hour period. When charging is complete, turn the charger off before disconnecting the leads from the battery.



4.4 Battery clamp bolt

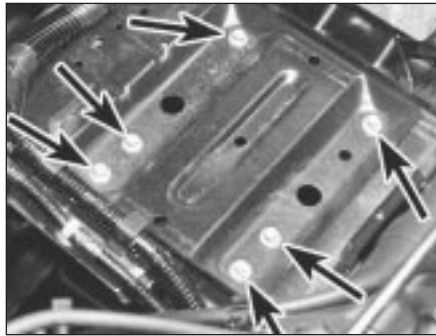

4.6a Battery tray retaining bolts (arrowed)



4.6b Battery tray mounting bracket retaining bolts (viewed from underneath)

4 Battery - removal and refitting



Removal

1 First check that all electrical components are switched off to avoid a spark occurring as the negative lead is disconnected. If the radio/cassette unit has a security code, deactivate the code temporarily and re-activate it when the battery is re-connected. Refer to the instructions and code supplied with the unit.

2 Slacken the terminal clamp nut then lift the clamp and negative (-) lead from the terminal. This is the terminal to disconnect before working on any electrical component on the vehicle. If the terminal is tight, carefully ease it off by moving it from side to side.

3 Raise the plastic cover from the positive (+) terminal clamp and slacken the clamp nut, then lift the clamp and lead from the terminal.

4 Unscrew the clamp bolt and remove the clamp from the battery tray (see illustration).

5 Lift the battery from the tray, keeping it upright and taking care not to allow it to contact your clothing.

6 If the battery tray is to be removed, first release any relevant wiring harness clips from the tray. Unscrew the six bolts securing the battery tray in position and remove the tray. If necessary, undo the two bolts securing the battery tray mounting bracket to the body and remove the bracket (see illustrations).

7 Clean the battery terminal posts, clamps, tray and battery casing. If the bodywork is rusted as a result of battery acid spilling onto it, clean it thoroughly and re-paint.

8 Whenever the battery is removed, check it for cracks and leakage.

Refitting

9 Refitting is the reverse of the removal procedure. Ensure that the terminal posts and leads are cleaned before re-connection. Smear petroleum jelly on the terminals after reconnecting the leads. Always connect the positive terminal clamp first and the negative terminal clamp last.

5 Charging system - testing



1 If the ignition warning lamp fails to light when the ignition is switched on, first check the alternator wiring connections for security. If satisfactory, check that the warning lamp bulb has not blown and is secure in its holder. If the lamp still fails to light, check the continuity of the warning lamp feed wire from the alternator to the bulbholder. If all is satisfactory, the alternator is at fault and should be renewed or taken to an auto-electrician for testing and repair.

2 If the ignition warning lamp lights when the engine is running, stop the engine and check that the drivebelt is correctly tensioned and that the alternator connections are secure. If all is satisfactory, check the alternator brushes and commutator. If the fault persists, the alternator should be renewed or taken to an auto-electrician for testing and repair.

3 If the alternator output is suspect, even though the warning lamp functions correctly, the regulated voltage may be checked as follows.

4 Connect a voltmeter across the battery terminals and start the engine.

5 Increase engine speed until the voltmeter reading remains steady. This should be approximately 12 to 13 volts and no more than 14 volts.

6 Switch on as many electrical accessories (eg: the headlamps, heated rear window and heater blower) as possible and check that the alternator maintains the regulated voltage at around 13 to 14 volts.

7 If the regulated voltage is not as stated, the fault may be due to worn brushes, weak brush springs, a faulty voltage regulator, a faulty diode, a severed phase winding or a worn or damaged commutator. The brushes and commutator may be checked but if the fault persists, the alternator should be renewed or taken to an auto-electrician for testing and repair.

6 Alternator drivebelt - inspection, adjustment and renewal

Refer to Chapter 1.

7 Alternator brush holder and voltage regulator - renewal



Note: The vast majority of actual alternator faults are due to the voltage regulator or brushes being defective. If the renewal of either assembly does not cure the fault, then the advice of an expert should be sought. For most owners, the best course of action will be to renew the alternator as a complete unit. In many cases, overhaul will not be viable on economic grounds alone.

Removal

1 While it is physically possible to remove the voltage regulator and brush holder assembly with the alternator in place on the vehicle, owners are advised to remove the alternator so that it can be serviced in clean working conditions.

2 Unscrew the screws securing the voltage regulator and brush holder assembly to the alternator. Lift off the regulator/brush holder, disconnect the electrical lead and remove the regulator/brush holder from the alternator (see illustration).



7.2 Remove voltage regulator/brush holder from alternator and disconnect wiring lead

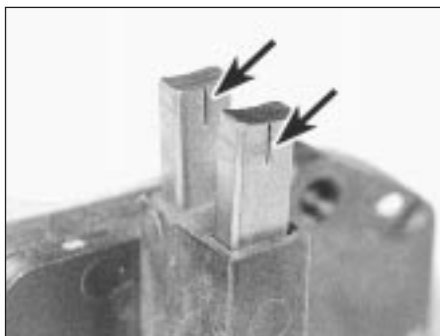

7.3 Alternator brush wear limit marks (arrowed)

Inspection

3 In most cases, the brushes will have wear limit marks in the form of a groove etched along one face of each brush. When these marks are erased by wear, the brushes are worn out (see illustration). If no marks are provided, measure the protrusion of each brush from the brush holder end to the tip of the brush. No dimension is given by Rover but as a rough guide, 5.0 mm should be regarded as a minimum. If either brush is worn to or below this amount, renew the voltage regulator and brush holder assembly. If the brushes are still serviceable, clean them with a solvent-moistened cloth. Check that the brush spring pressure is equal for both brushes and holds the brushes securely against the slip rings. If in doubt about the condition of the brushes and springs, compare them with new components.

4 Clean the slip rings with a solvent-moistened cloth, then check for signs of scoring, burning or severe pitting. If worn or damaged, the slip rings should be attended to by an auto-electrician.

Refitting

5 Refitting is the reverse of the removal procedure.

8 Alternator - removal and refitting



Removal

1 Disconnect the battery negative lead.
2 Firmly apply the handbrake then jack up the front of the vehicle and remove the right-hand front roadwheel.
3 From underneath the front of the vehicle, slacken and remove the three bolts securing the bumper flange to the body. Remove the seven bolts securing the front undercover panel to the body and remove the panel.

Models with air conditioning

4 Undo the two bolts and washers securing the heat shield to the rear of the alternator,



8.8a Remove cover from rear of alternator . . .



8.8b . . . and disconnect wiring connector

then remove the nut securing the heat shield to the engine and lift the shield out of the engine compartment.

5 Disconnect the wiring connector from the rear of the alternator.

6 Slacken the adjuster pulley retaining nut, then turn the pulley adjusting bolt until sufficient drivebelt free play is obtained to be able to disengage the drivebelt from the alternator pulley.

7 Slacken and remove the three bolts securing the alternator to its mounting bracket then manoeuvre the alternator out of the engine compartment.

Models without air conditioning

8 Unscrew the three nuts and washers securing the rear cover to the alternator and remove the cover. Release the wire retaining clip and disconnect the alternator wiring connector (see illustrations).

9 Slacken the lower alternator-to-adjusting arm bolt and the two upper alternator pivot bolts, then slacken the drivebelt adjusting bolt until sufficient free play is obtained to disengage the drivebelt from the alternator pulley (see illustrations).

10 Remove the alternator adjusting arm and upper pivot bolts and manoeuvre the alternator out of the engine compartment.

Refitting

11 If a new alternator is being fitted, it will be necessary to remove the pulley and cooling fan from the old unit. To do this, slacken the

pulley retaining nut whilst preventing it from rotating by using a suitable Allen key to retain the alternator shaft, or by clamping the pulley firmly in a vice equipped with soft jaws. Remove the pulley, cooling fan and fan washer from the old alternator and, ensuring that the pulley and shaft mating surfaces are clean, fit them to the new unit. Tighten the pulley retaining nut to the specified torque whilst using the method employed on removal to retain the pulley.

Models with air conditioning

12 Manoeuvre the alternator into position then refit its mounting bolts and tighten them to the specified torque.

13 Locate the drivebelt on the alternator pulley then adjust drivebelt tension as described in Chapter 1.

14 Reconnect the wiring connector to the rear of the alternator then refit the heat shield, tightening its retaining nut and bolts securely. Reconnect the battery.

Models without air conditioning

15 Manoeuvre the alternator into position then refit the adjusting arm and pivot bolts and tighten them lightly.

16 Locate the drivebelt on the alternator pulley and adjust drivebelt tension as described in Chapter 1.

17 Reconnect the wiring connector to the rear of the alternator then refit the rear cover, tightening its retaining nuts securely. Reconnect the battery.

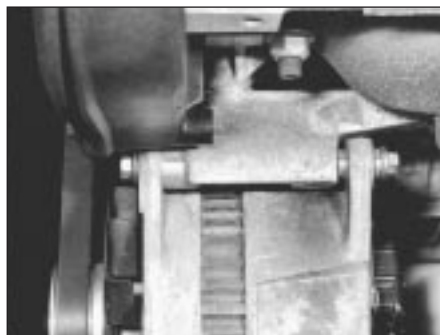

8.9a Slacken upper pivot mounting bolts . . .



8.9b . . . and lower adjusting arm bolt (A) then rotate adjuster bolt (B) to slacken drivebelt tension

9 Starting system - testing



1 If the starter motor fails to operate when the switch is operated, the following may be the cause:

- a) *The battery is faulty.*
- b) *The electrical connections between the ignition switch, solenoid, battery and starter motor are somewhere failing to pass the necessary current from the battery through the starter to earth.*
- c) *The solenoid is faulty.*
- d) *The starter relay is faulty.*
- e) *The starter motor is mechanically or electrically defective.*

2 To check the battery, switch on the headlamps. If they dim after a few seconds then the battery is discharged. Recharge or renew the battery. If the lamps glow brightly, operate the ignition switch and see what happens to the lamps. If they dim, then you know that power is reaching the starter motor, therefore the motor must be removed and renewed or overhauled to cure the fault. If the lamps stay bright (and no clicking sound can be heard from the solenoid), there is a fault in the circuit or solenoid. If the starter turns slowly when switched on, but the battery is in good condition, then either the starter must be faulty or there is considerable resistance in the circuit.

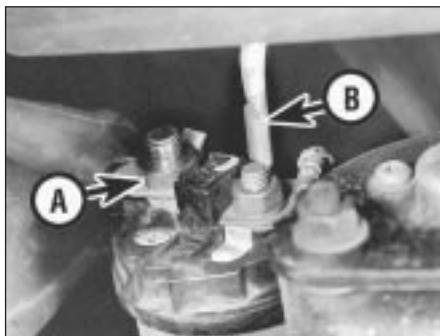

10.4 Starter solenoid main terminal nut (A) and spade connector (B)

3 If the circuit is suspected, disconnect the battery terminals (including the earth connection to the body), the starter/solenoid wiring and the engine/gearbox unit earth lead, thoroughly clean their connections and refit them, then use a meter or test lamp to check that full battery voltage is available at the solenoid terminal of the battery positive lead and that the earth is sound. Smear petroleum jelly around the battery terminals to prevent corrosion. Corroded connections are the most frequent cause of electrical system malfunctions.

4 If the battery and all connections are in good condition, check the circuit first by disconnecting the wire from the solenoid blade terminal. Connect a meter or test lamp between the wire end and the terminal and check that the wire is live when the ignition switch is operated. If it is, then the circuit is sound. If not, proceed to paragraph 7.

5 The solenoid contacts can be checked by putting a voltmeter or test lamp across the main cable connection on the starter side of the solenoid and earth. When the switch is operated, there should be a reading or lighted bulb. If there is no reading or lighted bulb, the solenoid is faulty and should be renewed.

6 If the circuit and solenoid are proved sound, the fault must be in the starter motor. Remove the motor and check its brushes. If the fault does not lie in the brushes, the motor windings must be faulty. In this event, the



10.5 Starter motor support bracket-to-gearbox bolts

motor must be renewed, unless an auto-electrical specialist can be found who will overhaul the unit at a cost significantly less than that of a new or exchange starter motor.

7 If the circuit is thought to be faulty, first check the starter relay which is situated in the engine compartment fusebox. A simple test is to temporarily replace it with one of the other relays from the fusebox, such as the cooling fan relay, which is known to be in a good condition. If this resolves the fault, then the starter relay is faulty and must be renewed. If not, check the ignition switch and wiring.

10 Starter motor - removal and refitting



Removal

- 1 Disconnect the battery negative lead.
- 2 Firmly apply the handbrake then jack up the front of the vehicle and support it on axle stands. Remove the right-hand front roadwheel.
- 3 From underneath the front of the vehicle, slacken and remove the three bolts securing the bumper flange to the body. Remove the seven bolts securing the front undercover panel to the body and remove the panel.
- 4 Undo the nut and disconnect the battery cable from the main solenoid terminal. Carefully disconnect the spade connector from the solenoid (**see illustration**).
- 5 Unscrew the two bolts securing the starter motor support bracket to the gearbox (**see illustration**).
- 6 Slacken and remove the three starter motor mounting bolts, noting the earth strap which is fitted to the upper bolt, and manoeuvre the starter motor out from underneath the vehicle (**see illustrations**).

Refitting

7 Refitting is a reverse of the removal sequence, tightening all nuts and bolts to their specified torque settings.



10.6a Starter motor lower mounting bolts viewed from underneath



10.6b Starter motor upper mounting bolt and earth strap (arrowed) - viewed from above



10.6c Removing the starter motor



11.2 Undo retaining nuts and remove support bracket from starter motor



11.3 Remove cover to gain access to armature C-clip

11 Starter motor - brush and solenoid renewal



1 Remove the starter motor.

Brushes

Removal

2 Undo the two nuts securing the support bracket to the rear of the starter motor and remove the bracket (see illustration).

3 Undo the two screws and remove the small cover and gasket from the centre of the starter motor end cover (see illustration). Prise out the C-clip and withdraw any thrustwashers fitted to the armature end.

4 Noting the alignment marks between the

end cover or grommet and the yoke, unscrew the two through-bolts and withdraw the end cover (see illustrations).

5 Carefully prise off the negative (field coil) brush retaining caps from the brush holder assembly then remove the springs and slide the brushes out of the holder.

6 Remove the nut and spring washer securing the positive brush lead to the solenoid terminal and slide the brush holder assembly off the end of the commutator. Withdraw the plastic insulating plate then remove the positive brush retaining caps and springs and remove the positive brushes from the holder (see illustrations).

Inspection

7 In most cases, the brushes will have wear limit marks in the form of a groove etched

along one face of each brush. When the brushes are worn down to these marks, they are worn out and must be renewed. If no marks are provided, measure the length of each brush (see illustration). No dimension is given by Rover but as a rough guide 3.5 mm should be regarded as a minimum. If any brush is worn below this amount, renew the brushes as a set. If the brushes are still serviceable, clean them with a solvent-moistened cloth. Check that the brush spring pressure is equal for all brushes and holds the brushes securely against the commutator. If in doubt about the condition of the brushes and springs, compare them with new components.

8 Clean the commutator with a solvent-moistened cloth, then check for signs of scoring, burning, excessive wear or severe pitting. If worn or damaged, the commutator should be attended to by an auto-electrician.

Refitting

9 On refitting, slot the positive brushes into position in the brush holder then refit the insulating plate, ensuring that the small threaded brackets are correctly positioned on the brush holder and locate with the pins on the insulating plate.

10 Fit the brush holder assembly to the commutator and slot the negative (field coil) brushes into position in the brush holder. With all the brushes in position, fit the brush springs and secure them in position with the retaining caps. Check that the brushes are



11.4a Note alignment marks between yoke and grommet . . .



11.4b . . . then remove through-bolts and withdraw end cover

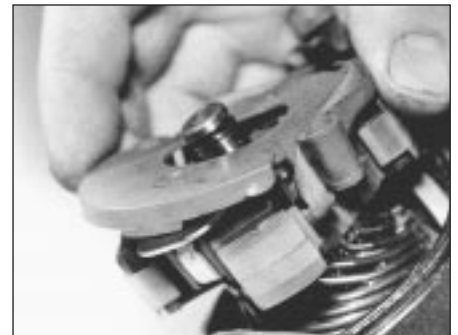

11.6a Remove plastic insulating plate . . .



11.6b . . . remove brush spring caps and springs . . .



11.6c . . . and remove positive brush assembly from motor



11.7 Measuring starter motor brush length



11.14 Unscrew nut and disconnect starter motor lead from solenoid terminal

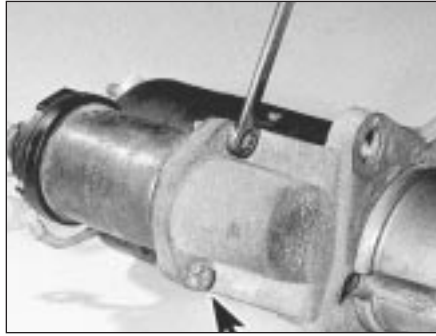

11.15 Remove solenoid retaining bolts (one arrowed) . . .



11.16 . . . then release solenoid plunger from lever and remove assembly from motor

free to move in their holders against spring pressure.

11 Refit the starter motor end cover, engaging it with the grommet, and aligning the marks noted on removal. Tighten the cover through-bolts securely.

12 Refit any necessary thrustwashers to the end of the armature and secure them in position with the C-clip. Refit the gasket and small cover to the end cover and tighten its retaining screws securely. Connect the positive brush lead to the solenoid terminal and tighten the nut securely.

13 Refit the support bracket to the motor and tighten its retaining nuts to the specified torque.

Solenoid

Removal

14 Slacken and remove the nut and spring washer securing the starter motor (positive brush) lead to the solenoid and disconnect the lead from the solenoid terminal (**see illustration**).

15 Unscrew the two bolts and spring washers securing the solenoid to the starter

motor drive end bracket (**see illustration**).

16 Release the solenoid plunger from the starter engaging lever, then withdraw the solenoid, noting the spring which is fitted to the plunger (**see illustration**).

Refitting

17 Refitting is the reverse of the removal procedure. Ensure that the solenoid, its plunger and the motor/solenoid mating surfaces are clean and lubricate the plunger/starter engaging lever surfaces with a smear of grease (Rover recommend Shell Alvania).





Chapter 9

Braking system

Contents

Anti-lock Braking System (ABS) - component removal and refitting . . .	26	Master cylinder - removal, overhaul and refitting	9
Brake pedal - removal and refitting	2	Pressure regulating valve - testing, removal and refitting	14
Front brake caliper - removal, overhaul and refitting	12	Rear brake caliper - removal, overhaul and refitting	21
Front brake disc - inspection, removal and refitting	13	Rear brake disc - inspection, removal and refitting	22
Front brake pads - inspection	10	Rear brake drum - removal, inspection and refitting	17
Front brake pads - renewal	11	Rear brake pads - inspection	19
General information and precautions	1	Rear brake pads - renewal	20
Handbrake cables - removal and refitting	24	Rear brake shoes - inspection	15
Handbrake lever - removal and refitting	23	Rear brake shoes - renewal	16
Hydraulic fluid - level check and renewal	5	Rear wheel cylinder - removal, overhaul and refitting	18
Hydraulic pipes and hoses - inspection	7	Stop lamp switch - removal, refitting and adjustment	25
Hydraulic pipes and hoses - renewal	8	Vacuum servo unit - testing, removal and refitting	3
Hydraulic system - bleeding	6	Vacuum servo unit check valve - removal, testing and refitting	4

Degrees of difficulty

Easy , suitable for novice with little experience 	Fairly easy , suitable for beginner with some experience 	Fairly difficult , suitable for competent DIY mechanic 	Difficult , suitable for experienced DIY mechanic 	Very difficult , suitable for expert DIY or professional 
---	--	--	---	--

Specifications

Brake system

Type	Dual hydraulic circuit, split diagonally on models without ABS and front to rear on models with ABS. Disc front brakes. Drum rear brakes except on models with ABS which have rear disc brakes. Vacuum servo-assistance on all models. Cable-operated handbrake on rear brakes
----------------	--

Front brakes

Type	Disc, with single piston sliding caliper
Disc diameter:	
Non-ABS	238 mm
ABS	262 mm
Disc thickness:	
New:	
Non-ABS	12.80 mm
ABS	21.60 mm
Minimum thickness after machining:	
Non-ABS	10.70 mm
ABS	19.00 mm
Maximum disc run-out	0.02 mm
Brake pad friction material minimum thickness	3.0 mm

9•2 Braking system

Rear brakes

Non-ABS

Type	Single leading shoe drum
Drum diameter:	
New	200 mm
Maximum diameter after machining	204 mm
Maximum drum ovality	0.012 mm
Brake shoe friction material minimum thickness	2.0 mm

ABS

Type	Disc, with single piston sliding caliper
Disc diameter	239 mm
Disc thickness:	
New	10 mm
Minimum thickness after machining	8 mm
Maximum disc run-out	0.06 mm
Brake pad friction material minimum thickness	3.0 mm

Torque wrench settings

	Nm	lbf ft
Servo vacuum hose-to-inlet manifold union bolt	50	37
Brake hose union bolt	38	28
Master cylinder-to-servo unit nuts	17	13
Master cylinder brake pipe union nuts	24	18
Brake caliper guide pin bolt	32	24
Brake disc retaining screws	12	9
Front brake caliper bracket-to-hub bolts	81	60
Pressure regulating valve union nuts	14	10
Rear brake drum retaining screws	10	7
Rear wheel cylinder-to-backplate bolts	10	7
Rear brake caliper bracket-to-trailing arm bolts	40	30
Handbrake cable-to-underbody retaining bolts	22	16
ABS modulator mounting nuts	7	5
ABS modulator brake pipe union nuts:		
Upper union nuts	15	11
Lower union nuts	24	18
ABS front wheel sensor retaining bolts	25	18
ABS rear wheel sensor retaining bolts	10	7
ABS wheel sensor wiring bracket bolts	10	7
ABS rear wheel sensor cover and cover strap bolts	10	7
Roadwheel nuts	100	74

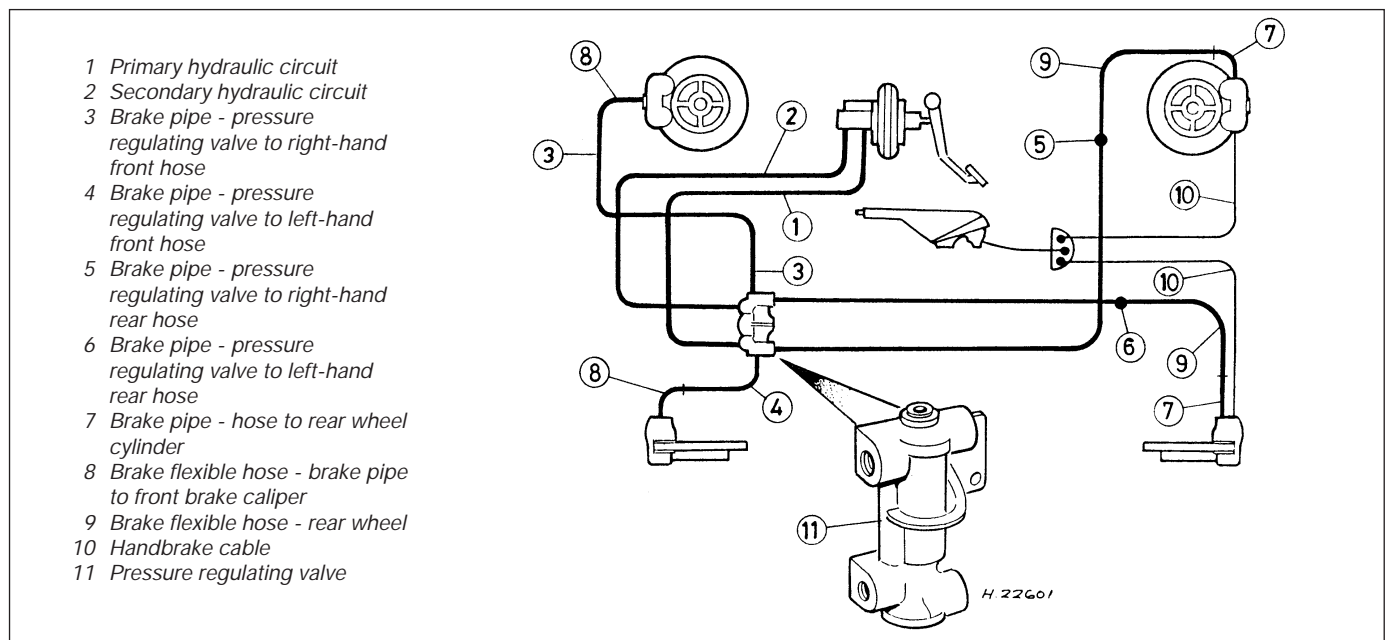

1.0a Non-ABS braking system component layout

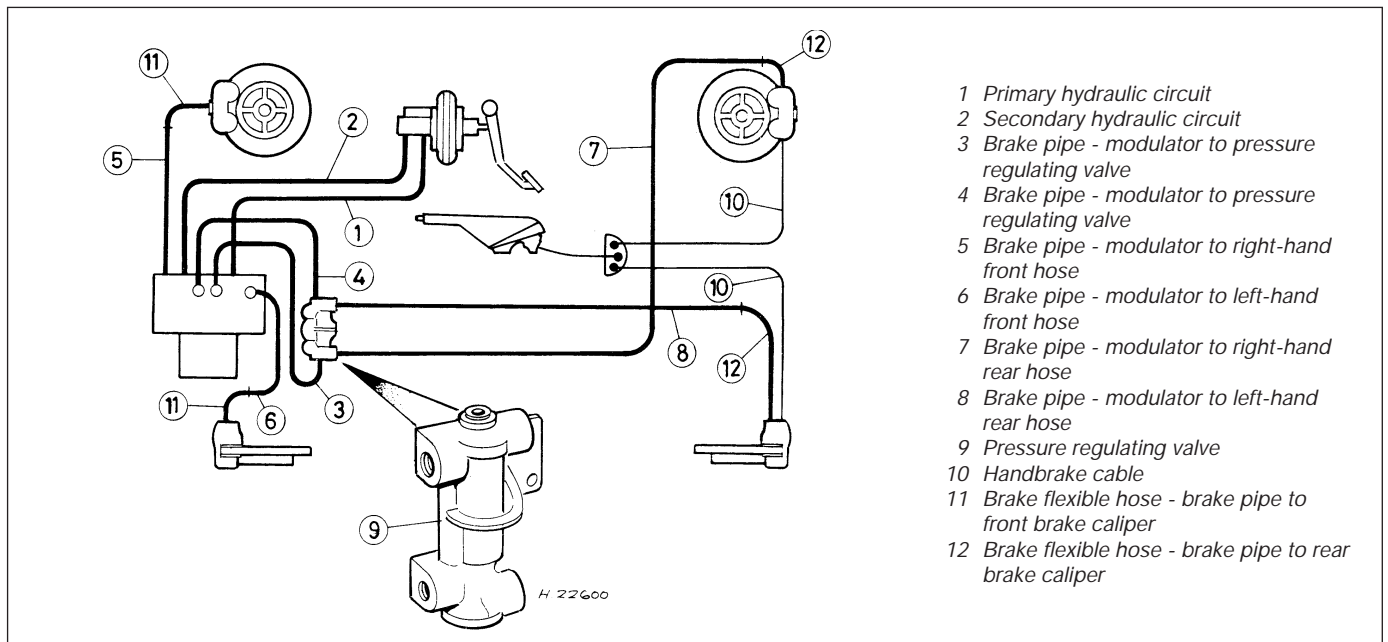

- 1 Primary hydraulic circuit
- 2 Secondary hydraulic circuit
- 3 Brake pipe - modulator to pressure regulating valve
- 4 Brake pipe - modulator to pressure regulating valve
- 5 Brake pipe - modulator to right-hand front hose
- 6 Brake pipe - modulator to left-hand front hose
- 7 Brake pipe - modulator to right-hand rear hose
- 8 Brake pipe - modulator to left-hand rear hose
- 9 Pressure regulating valve
- 10 Handbrake cable
- 11 Brake flexible hose - brake pipe to front brake caliper
- 12 Brake flexible hose - brake pipe to rear brake caliper

1.0b ABS braking system component layout

1 General information and precautions

General information

The braking system is of the servo-assisted, dual circuit hydraulic type. The arrangement of the hydraulic system is such that each circuit operates one front and one rear brake from a tandem master cylinder. Under normal circumstances both circuits operate in unison. However, in the event of hydraulic failure in one circuit, full braking force will still be available at two wheels (see illustrations).

On models not equipped with an Anti-lock Braking System (ABS), a pressure regulating valve is also incorporated in the hydraulic circuit to regulate the pressure applied to the rear brakes and reduce the possibility of the rear wheels locking under heavy braking. On models equipped with ABS, the pressure regulating valve is fitted but it is non-operational.

All models are fitted with front disc brakes. Models equipped with ABS are fitted with ventilated discs, whereas non-ABS models are fitted with solid discs. The disc brakes are actuated by single piston sliding type calipers which ensure that equal pressure is applied to each disc pad.

Non-ABS models are fitted with rear drum brakes, incorporating leading and trailing shoes which are actuated by twin piston wheel cylinders. A self-adjust mechanism is incorporated to automatically compensate for brake shoe wear. As the brake shoe linings

wear, the footbrake operation automatically operates the adjuster mechanism quadrant which effectively lengthens the shoe strut and repositions the brake shoes to remove the lining-to-drum clearance.

ABS models are equipped with rear disc brakes. The disc brakes are actuated by a single piston sliding caliper which incorporates a mechanical handbrake mechanism.

On all models, the handbrake provides an independent mechanical means of rear brake application. Full details of ABS system operation are as follows.

Anti-lock Braking System (ABS) - operation

ABS is available as an option on all models covered in this Manual. The system comprises a modulator block which contains an ABS Electronic Control Unit (ECU), hydraulic solenoid valves and accumulators, and an electrically-driven return pump. One sensor is fitted to each roadwheel. The purpose of this system is to prevent wheel locking during heavy braking. This is achieved by automatic release of the brake on the relevant wheel, followed by reapplication of the brake.

The solenoids are controlled by the ECU which receives signals from the four roadwheel sensors, which in turn monitor the speed of rotation of each wheel. By comparing these speed signals from the four wheels, the ECU can determine the speed at which the vehicle is travelling. It can then use this speed to determine when a wheel is decelerating at an abnormal rate compared to the speed of the vehicle and therefore predict when a wheel is about to lock. During normal

operation, the system functions in the same way as a non-ABS braking system.

If the ECU senses that a wheel is about to lock, the ABS system enters the 'pressure maintain' phase. The ECU operates the relevant solenoid valve in the modulator block which then isolates the brake caliper on the wheel which is about to lock from the master cylinder, effectively sealing in the hydraulic pressure.

If the speed of rotation of the wheel continues to decrease at an abnormal rate, the ABS system then enters the 'pressure decrease' phase, where the electrically-driven return pump operates and pumps the hydraulic fluid back into the master cylinder, releasing pressure on the brake caliper so that the brake is released. Once the speed of rotation of the wheel returns to an acceptable rate, the pump stops and the solenoid valve opens thereby allowing the hydraulic master cylinder pressure to return to the caliper which then reapplies the brake. This cycle can be carried out at up to 10 times a second.

The action of the solenoid valves and return pump creates pulses in the hydraulic circuit. When the ABS system is functioning, these pulses can be felt through the brake pedal.

The solenoid valves connected to the front calipers operate independently, but the valve connected to the rear calipers, together with the pressure regulating valve, operates both calipers simultaneously.

Operation of the ABS system is entirely dependent on electrical signals. To prevent the system responding to any inaccurate signals, a built-in safety circuit monitors all signals received by the ECU. If an inaccurate signal or low battery voltage is detected, the ABS system is automatically

9•4 Braking system

shut down and the warning lamp on the instrument panel is illuminated to inform the driver that the ABS system is not operational.

If a fault does develop in the ABS system the vehicle must be taken to a Rover dealer for fault diagnosis and repair.

Precautions

Hydraulic fluid is poisonous. Wash off immediately and thoroughly in the case of skin contact and seek immediate medical advice if any fluid is swallowed or gets into the eyes. Certain types of hydraulic fluid are inflammable and may ignite when allowed into contact with hot components.

When servicing any hydraulic system, it is safest to assume that the fluid is inflammable and to take precautions against the risk of fire as though it is petrol that is being handled. Hydraulic fluid is also an effective paint stripper and will attack plastics. If any is spilt, it should be washed off immediately using copious quantities of fresh water.

Hydraulic fluid is hygroscopic, that is, it absorbs moisture from the air, so old fluid may be contaminated and unfit for further use. When topping-up or renewing fluid, always use the recommended type and ensure that it comes from a freshly-opened sealed container.

When working on brake components, take care not to disperse brake dust into the air, or to inhale it, since it may contain asbestos which is injurious to health.

When servicing any part of the system, work carefully and methodically. Also observe scrupulous cleanliness when overhauling any part of the hydraulic system. Always renew components (in axle sets, where applicable) if in doubt about their condition and use only genuine Rover replacement parts, or at least those of known good quality.

2 Brake pedal - removal and refitting

Removal

- 1 Working inside the vehicle, undo the five screws and remove the right-hand lower fascia panel.
- 2 Extract the R-clip and clevis pin securing the servo unit pushrod to the brake pedal.
- 3 Using pliers, carefully unhook the brake pedal return spring from the pedal to release all the spring tension.
- 4 Slacken and remove the nut and washers (as applicable) from the brake pedal pivot bolt then withdraw the pivot bolt and remove the brake pedal and return spring.
- 5 Examine all brake pedal components for signs of wear, paying particular attention to the pedal bushes, pivot bolt and return spring, renewing as necessary.

Refitting

- 6 Refitting is a reverse of the removal procedure. Lubricate the bushes, pivot bolt and clevis pin with multi-purpose grease.
- 7 On completion, check the operation of the pedal and ensure that it returns smoothly to its at rest position under the pressure of the return spring.

3 Vacuum servo unit - testing, removal and refitting

Testing

1 To test operation of the servo unit, depress the footbrake several times to exhaust the vacuum, then start the engine whilst keeping the pedal firmly depressed. As the engine starts, there should be a noticeable 'give' in the brake pedal as the vacuum builds up. Allow the engine to run for at least two minutes then switch it off. If the brake pedal is now depressed it should feel normal, but further applications should result in the pedal falling firmer, with the pedal stroke decreasing with each application.

2 If the servo does not operate as described, inspect the servo unit check valve, see Section 4.

3 If the servo unit still fails to operate satisfactorily, the fault lies within the unit itself. Repairs to the unit are possible but special tools are required and the work should be entrusted to a suitably equipped Rover dealer.

Removal

- 4 Remove the air cleaner assembly.
- 5 Remove the master cylinder.
- 6 Disconnect the vacuum hose connection from the grommet on the servo unit, taking great care not to damage or displace the sealing grommet (see illustration).
- 7 Working inside the vehicle, undo the five retaining screws and remove the right-hand lower fascia panel.
- 8 Extract the R-clip and clevis pin securing the servo unit pushrod to the brake pedal (see illustration).

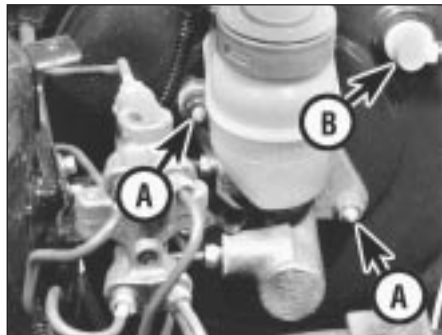

3.6 Master cylinder mounting nuts (A) and servo vacuum hose connection (B)

9 Slacken and remove the four nuts securing the servo unit to the engine compartment bulkhead then remove the unit, noting the gasket which is fitted to the rear of the unit.

Refitting

- 10 Prior to refitting, check the servo unit to vacuum hose sealing grommet for signs of damage or deterioration and renew if necessary.
- 11 Fit a new gasket to the rear of the servo unit and reposition the unit in the engine compartment.
- 12 From inside the vehicle, ensure the servo unit pushrod is correctly engaged with the brake pedal then refit the servo unit mounting nuts and tighten them securely.
- 13 Refit the servo unit pushrod to brake pedal clevis pin and secure it in position with the R-clip.
- 14 Refit the right-hand lower fascia panel, tightening its retaining screws securely.
- 15 From inside the engine compartment, carefully ease the vacuum hose connection back into position in the servo unit, taking care not to displace the sealing grommet.
- 16 Refit the air cleaner assembly and master cylinder.
- 17 On completion, start the engine and check for air leaks at the vacuum hose to servo unit connection and the operation of the braking system.

4 Vacuum servo unit check valve - removal, testing and refitting

Note: The vacuum servo unit check valve is only available as part of the vacuum hose assembly. Do not try to remove the valve, the servo unit connection, or the inlet manifold union from the hose or air leaks may ensue, necessitating renewal of the hose assembly.

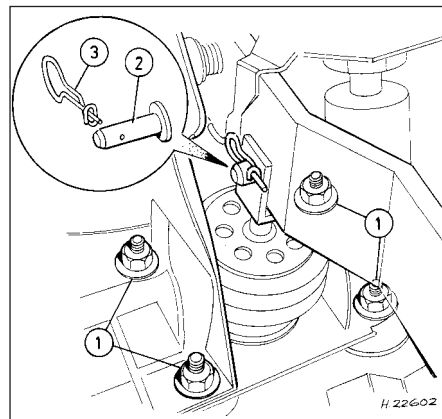

3.8 Vacuum servo unit and pushrod attachments

- 1 Servo unit mounting nuts
- 2 Pushrod clevis pin
- 3 R-clip

Removal

1 Carefully unplug the hose connection from the vacuum servo unit taking care not to damage the sealing grommet.

2 Unscrew the union bolt securing the vacuum hose assembly to the inlet manifold and withdraw the hose assembly from the engine compartment. Remove the union bolt from the hose end and discard the sealing washers.

Testing

3 Examine the hose for damage, splits, cracks or general deterioration. Make sure that the check valve inside the hose is working correctly by blowing through the hose from the servo unit connection end. Air should flow in this direction but not when blown through from the inlet manifold union. Renew the hose and check valve assembly if at all suspect.

4 Examine the servo unit sealing grommet for signs of damage or deterioration and renew if necessary.

Refitting

5 Position a new sealing washer on each side of the hose union and refit the hose-to-inlet manifold union bolt. Ensure that the hose union locating pin is correctly situated between the lugs on the manifold then tighten the union bolt to the specified torque setting (see illustration).

6 Carefully ease the hose connection into the servo unit sealing grommet, taking care not to displace or damage the grommet.

7 On completion, start the engine and check the vacuum hose-to-servo unit connection for signs of air leaks.

5 Hydraulic fluid - level check and renewal

Refer to "Weekly Checks" and Chapter 1.

6 Hydraulic system - bleeding



Hydraulic fluid is an effective paint stripper and will attack plastics. If any is spilled, it should be washed off immediately using copious quantities of fresh water.

General

1 The correct operation of any hydraulic system is only possible after removal of all air from the components and circuit. This is achieved by bleeding the system.

2 During the bleeding procedure, add only clean, unused hydraulic fluid of the



4.5 Ensure hose union locating pin is correctly located between lugs on inlet manifold

recommended type. Never re-use fluid that has already been bled from the system. Ensure that sufficient fluid is available before starting work.

3 If there is any possibility of incorrect fluid being already in the system, the brake components and circuit must be flushed completely with uncontaminated, correct fluid and new seals should be fitted to the various components.

4 If hydraulic fluid has been lost from the system, or air has entered because of a leak, then ensure that the fault is cured before proceeding further.

5 Park the vehicle on level ground, switch off the engine and select first or reverse gear, then chock the wheels and release the handbrake.

6 Check that all pipes and hoses are secure, unions tight and bleed screws closed. Clean any dirt from around the bleed screws.

7 Unscrew the master cylinder reservoir cap and top the master cylinder reservoir up to the MAX level line. Refit the cap loosely and remember to maintain the fluid level at least above the MIN level line throughout the procedure or there is a risk of further air entering the system.

8 There are a number of one-man, do-it-yourself brake bleeding kits currently available from motor accessory shops. It is recommended that one of these kits is used whenever possible as they greatly simplify the bleeding operation and also reduce the risk of expelled air and fluid being drawn back into the system. If such a kit is not available, then the basic (two-man) method must be used which is described in detail below.

9 If a kit is to be used, prepare the vehicle as described previously and follow the kit manufacturer's instructions as the procedure may vary slightly according to the type being used. Generally, they are as outlined below in the relevant sub-section.

10 Whichever method is used, the same sequence must be followed (paragraphs 11 and 12) to ensure the removal of all air from the system.

Bleeding sequence

11 If the system has been only partially disconnected and suitable precautions were

taken to minimise fluid loss, it should be necessary only to bleed that part of the system (ie: the primary or secondary circuit).

12 If the complete system is to be bled, then it should be done working in the following sequence:

Non-ABS models

Left-hand front brake.

Right-hand rear brake.

Right-hand front brake.

Left-hand rear brake.

ABS models

Left-hand front brake.

Right-hand front brake.

Left-hand rear brake.

Right-hand rear brake.

Bleeding - basic (two-man) method

13 Collect a clean glass jar, a suitable length of plastic or rubber tubing which is a tight fit over the bleed screw and a ring spanner to fit the screw. The help of an assistant will also be required.

14 Remove the dust cap from the first screw in the sequence. Fit the spanner and tube to the screw, place the other end of the tube in the jar and pour in sufficient fluid to cover the end of the tube.

15 Ensure that the master cylinder reservoir fluid level is maintained at least above the MIN level line throughout the procedure.

16 Have the assistant fully depress the brake pedal several times to build up pressure, then maintain it on the final stroke.

17 While pedal pressure is maintained, unscrew the bleed screw (approximately one turn) and allow the fluid and air to flow into the jar. The assistant should maintain pedal pressure, following it down to the floor if necessary and should not release it until instructed to do so. When the flow stops, tighten the bleed screw again, release the pedal slowly and recheck the reservoir fluid level.

18 Repeat the steps given in paragraphs 16 and 17 until the fluid emerging from the bleed screw is free from air bubbles. If the master cylinder has been drained and refilled and air is being bled from the first screw in the sequence, allow approximately five seconds between cycles for the master cylinder passages to refill.

19 When no more air bubbles appear, tighten the bleed screw securely, remove the tube and spanner and refit the dust cap. Do not overtighten the bleed screw.

20 Repeat the procedure on the remaining screws in the sequence until all air is removed from the system and the brake pedal feels firm again.

Bleeding - using a one-way valve kit

21 As their name implies, these kits consist of a length of tubing with a one-way valve

9•6 Braking system



6.21 Using a one-way valve kit to bleed braking system

fitted to prevent expelled air and fluid being drawn back into the system. Some kits include a translucent container which can be positioned so that the air bubbles can be more easily seen flowing from the end of the tube (see illustration).

22 The kit is connected to the bleed screw, which is then opened. The user returns to the driver's seat and depresses the brake pedal with a smooth, steady stroke and slowly releases it. This sequence is repeated until the expelled fluid is clear of air bubbles.

23 Note that these kits simplify work so much that it is easy to forget the master cylinder reservoir fluid level. Ensure that this is maintained at least above the MIN level line at all times.

Bleeding - using a pressure bleeding kit

24 These kits are usually operated by the reservoir of pressurised air contained in the spare tyre, although note that it will probably be necessary to reduce the pressure to a lower limit than normal. Refer to the instructions supplied with the kit.

25 By connecting a pressurised, fluid-filled container to the master cylinder reservoir, bleeding can be carried out simply by opening each screw in turn (in the specified sequence) and allowing the fluid to flow out until no more air bubbles can be seen in the expelled fluid.

26 This method has the advantage that the large reservoir of fluid provides an additional safeguard against air being drawn into the system during bleeding.

27 Pressure bleeding is particularly effective when bleeding 'difficult' systems or when bleeding the complete system at the time of routine fluid renewal.

All methods

28 When bleeding is complete and firm pedal feel is restored, wash off any spilt fluid, tighten the bleed screws securely and refit their dust caps.

29 Check the hydraulic fluid level and top up if necessary.

30 Discard any hydraulic fluid that has been bled from the system as it will not be fit for re-use.

31 Check the feel of the brake pedal. If it

feels at all spongy, air must still be present in the system and further bleeding is required. Failure to bleed satisfactorily after a reasonable repetition of the bleeding procedure may be due to worn master cylinder seals.

7 Hydraulic pipes and hoses - inspection

Refer to Chapter 1, Section 6.

8 Hydraulic pipes and hoses - renewal



1 If any pipe or hose is to be renewed, minimise fluid loss by removing the master cylinder reservoir cap and then tightening it down onto a piece of polythene (taking care not to damage the sender unit) to obtain an airtight seal. Alternatively, flexible hoses can be sealed by using a proprietary brake hose clamp, while metal brake pipe unions can be plugged (if care is taken not to allow dirt into the system) or capped immediately they are disconnected (see illustration). Place a wad of rag under any union that is to be disconnected to catch any spilt fluid.

2 If a flexible hose is to be disconnected, unscrew the brake pipe union nut before removing the spring clip which secures the hose to its mounting bracket.

3 To unscrew the union nuts it is preferable to obtain a brake pipe spanner of the correct size. These spanners are available from most large motor accessory shops (see illustration). Failing this, a close-fitting open-ended spanner will be required, though if the nuts are tight or corroded, their flats may be rounded-off if the spanner slips. In such a case, a self-locking wrench is often the only way to unscrew a stubborn union but it follows that the pipe and the damaged nuts must be renewed on reassembly. Always clean a union and surrounding area before disconnecting it. If disconnecting a component with more than one union, make a careful note of the connections before disturbing any of them.



8.1 Using a brake hose clamp to minimise fluid loss

4 If a brake pipe is to be renewed, then it can be obtained from Rover dealers, cut to length and with the union nuts and end flares in place. All that is then necessary is to bend it to shape, following the line of the original, before fitting it to the vehicle. Alternatively, most motor accessory shops can make up brake pipes from kits but this requires very careful measurement of the original to ensure that the replacement is of the correct length. The safest answer is usually to take the original to the shop as a pattern.

5 On refitting, do not overtighten the union nuts. The specified torque wrench settings, where given, are not high and it is not necessary to exercise brute force to obtain a sound joint. When refitting flexible hoses, always renew any sealing washers used.

6 Ensure that the pipes and hoses are correctly routed with no kinks and that they are secured in the clips or brackets provided. After fitting, remove the polythene from the reservoir and bleed the hydraulic system. Wash off any spilt fluid and check carefully for fluid leaks.

9 Master cylinder - removal, overhaul and refitting



Warning: Do not syphon brake fluid by mouth as it is poisonous.

Note: Before attempting to overhaul the master cylinder, check the price and availability of individual components and compare this with the price of a new or reconditioned unit, as overhaul may not be viable on economic grounds alone.

Removal

1 Remove the master cylinder reservoir cap, having disconnected the sender unit wiring connector, and syphon all hydraulic fluid from the reservoir. Do not syphon the fluid by mouth as it is poisonous but use a syringe or an old poultry baster. Alternatively, open any convenient bleed screw in the system and gently pump the brake pedal to expel the fluid through a plastic tube connected to the screw.

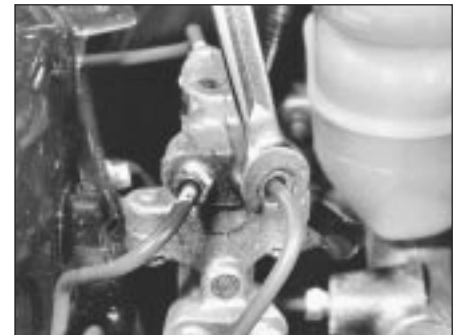

8.3 Using a brake pipe spanner to unscrew a union nut

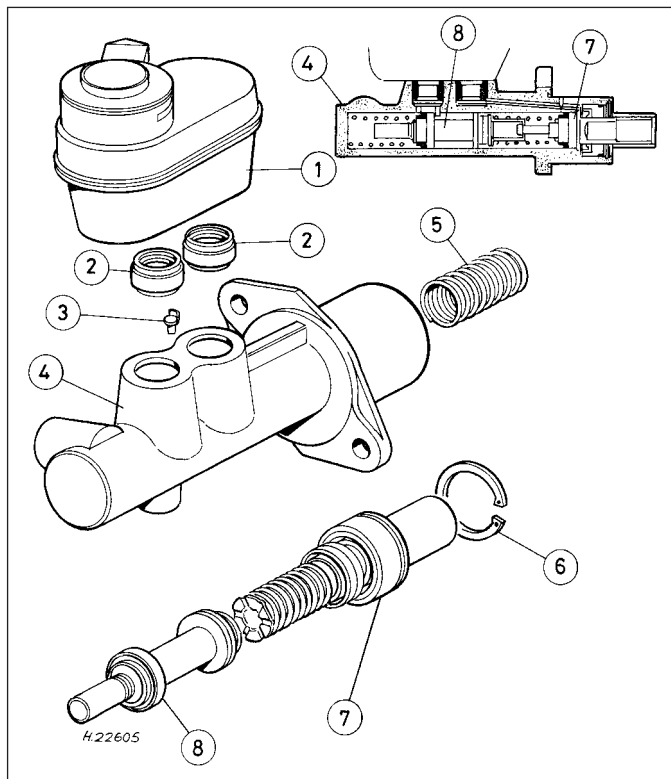

9.5a Non-ABS master cylinder components

- | | |
|-----------------------------|--------------------|
| 1 Master cylinder reservoir | 5 Spring |
| 2 Mounting seals | 6 Circlip |
| 3 Secondary piston stop pin | 7 Primary piston |
| 4 Master cylinder body | 8 Secondary piston |

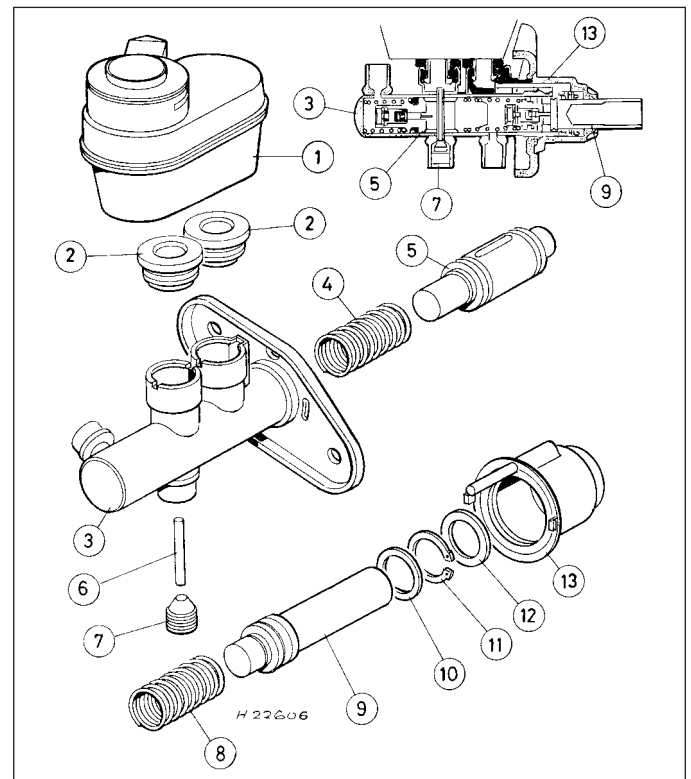

9.5b ABS master cylinder components

- | | | |
|-----------------------------|--------------------|------------------|
| 1 Master cylinder reservoir | 4 Spring | 9 Primary piston |
| 2 Mounting seals | 5 Secondary piston | 10 Washer |
| 3 Master cylinder body | 6 Retaining pin | 11 Circlip |
| | 7 Grub screw | 12 Flat washer |
| | 8 Spring | 13 Dust cap |

2 Wipe clean the area around the brake pipe unions on the side of the master cylinder and place absorbent rags beneath the pipe unions to catch any surplus fluid. Unscrew the two union nuts and carefully withdraw the pipes. Plug or tape over the pipe ends and master cylinder orifices to minimise loss of brake fluid and to prevent the entry of dirt into the system. Wash off any spilt fluid immediately with cold water.

3 Slacken and remove the two nuts and washers securing the master cylinder to the vacuum servo unit then withdraw the unit from the engine compartment. Remove the O-ring from the rear of the master cylinder and discard it.

Overhaul

4 Remove the master cylinder from the vehicle as described above and clean it thoroughly.

5 Carefully prise the reservoir from the master cylinder body and remove the two mounting seals (see illustrations).

6 Prepare a clean working surface and proceed as follows.

Non-ABS system

7 Using a wooden dowel, press the primary piston in as far as possible and extract the

secondary piston stop pin from the reservoir inlet port, then remove the retaining circlip.

8 Noting the order of removal and the direction of fitting of each component, withdraw the piston assemblies with their springs and seals, tapping the body on to a clean wooden surface to dislodge them. If necessary, clamp the master cylinder body in a vice (fitted with soft jaw covers) and use compressed air of low pressure (applied through the secondary circuit fluid port) to assist the removal of the secondary piston assembly.

9 Thoroughly clean all components using only methylated spirit, isopropyl alcohol or clean hydraulic fluid as a cleaning medium. Never use mineral-based solvents such as petrol or paraffin which will attack the hydraulic system's rubber components. Dry the components immediately using compressed air or a clean, lint-free cloth.

10 Check all components and renew any that are worn or damaged. Check particularly the cylinder bores and pistons. The complete assembly should be renewed if these are scratched, worn or corroded. If there is any doubt about the condition of the assembly or of any of its components, renew it. Check that the body's inlet and bypass ports are clear.

11 If the assembly is fit for further use, obtain a repair kit. Renew all seals and O-rings disturbed on dismantling, never re-use them. Renew also any other items included in the repair kit.

12 On reassembly, soak the pistons and new seals in clean hydraulic fluid. Smear clean fluid into the cylinder bore.

13 Fit the new seals to their pistons, using only the fingers to manipulate them into the grooves.

14 Insert the pistons into the bore by using a twisting motion to avoid trapping the seal lips. Ensure that all components are refitted in the correct order and the right way round.

15 Press the secondary piston assembly fully up into the bore using a clean wooden dowel, then refit the stop pin.

16 Refit the primary piston assembly, then secure it in position with a new circlip.

17 Press the new mounting seals into the master cylinder body and carefully refit the reservoir ensuring that it is pressed fully into position.

ABS system

18 Carefully prise out the dust cap from the rear of the master cylinder body and remove the flat washer.

19 Using a wooden dowel, press the primary

9•8 Braking system

piston in as far as possible and extract the circlip and washer. Withdraw the primary piston assembly and spring.

20 Undo the grub screw from the underside of the master cylinder body then use the wooden dowel to press the secondary piston into the body and withdraw the secondary piston retaining pin. Extract the secondary piston assembly and spring. If necessary, the piston can be dislodged by tapping the master cylinder body on a wooden block.

21 Examine and overhaul the master cylinder components as described above in paragraphs 9 to 14.

22 Fit the spring to the secondary piston assembly and use a clean wooden dowel to press the assembly fully into the master cylinder bore. Align the slot in the piston with the retaining pin hole then insert the secondary piston retaining pin. Refit the grub screw and tighten it securely.

23 Fit the spring to the primary piston assembly and press the assembly into position using the wooden dowel. Refit the washer and secure the piston assembly in position with the circlip, ensuring that it is correctly located in its groove in the master cylinder bore.

24 Fit the flat washer and refit the dust cap to the rear of the master cylinder body.

25 Align the lugs on the new mounting seals with the slots in the master cylinder body and press them into position. Carefully refit the reservoir, ensuring that it is pressed fully into the master cylinder body.



11.2a Remove lower caliper guide pin bolt . . .

Refitting

26 Remove all traces of dirt from the master cylinder and servo unit mating surfaces, then fit a new O-ring to the groove on the master cylinder body.

27 Fit the master cylinder to the servo unit, ensuring that the servo unit pushrod enters the master cylinder bore centrally. Refit the master cylinder washers and mounting nuts and tighten them to the specified torque.

28 Wipe clean the brake pipe unions then refit them to the master cylinder ports and tighten them to the specified torque setting.

29 Refill the master cylinder reservoir with new fluid and bleed the hydraulic system.

10 Front brake pads - inspection

Refer to Chapter 1.

11 Front brake pads - renewal



Warning: Renew both sets of front brake pads at the same time. Never renew the pads on only one wheel as uneven braking may result. The dust created by pad wear may contain asbestos, which is a health hazard.



11.2b . . . and pivot caliper away from disc



11.3 Removing circular shim from caliper piston



11.4 Removing pads with springs and shims



11.5 Measuring thickness of brake pad friction material

Never blow it with compressed air or inhale it. An approved filtering mask should be worn when working on the brakes. DO NOT use petroleum-based solvents to clean brake parts. Use brake cleaner or methylated spirit only.

Removal

1 Chock the rear wheels, firmly apply the handbrake then jack up the front of the vehicle and support it on axle stands. Remove both front roadwheels.

2 Remove the lower caliper guide pin bolt whilst, if necessary, using a slim open-ended spanner to prevent the guide pin itself from rotating. Pivot the caliper away from the disc to gain access to the brake pads and tie it to the suspension strut using a piece of wire (see illustrations).

3 Remove the circular shim which is fitted to the caliper piston (see illustration).

4 Remove the brake pads from the caliper mounting bracket whilst noting the correct position of the pad retainer springs and pad shims (see illustration).

5 Measure the thickness of friction material remaining on each brake pad (see illustration). If either pad is worn at any point to the specified minimum thickness or less, all four pads must be renewed. Also, the pads should be renewed if any are fouled with oil or grease as there is no satisfactory way of degreasing friction material once contaminated. If any of the brake pads are worn unevenly or fouled with oil or grease, trace and rectify the cause before reassembly. New brake pad kits are available from Rover dealers and include new shims and pad retainer springs.

6 If the brake pads are still serviceable, carefully clean them using a clean, fine wire brush or similar, paying particular attention to the sides and back of the metal backing. Clean out the grooves in the friction material (where applicable) and pick out any large embedded particles of dirt or debris. Carefully clean the pad retainer springs and the pad locations in the caliper body and mounting bracket.

Fitting

7 Prior to fitting the pads, check that the guide pins are free to slide easily in the caliper



11.7 Check condition of guide pins and gaiters before refitting pads

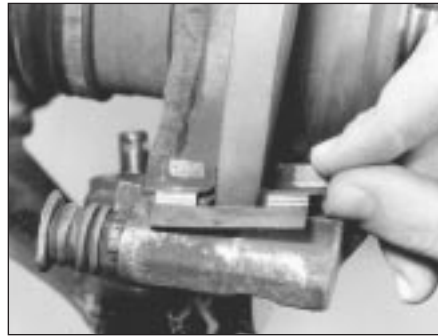

11.8 Fit pad retainer springs to caliper bracket . . .



11.9 . . . and fit shims on pads

bracket and check that the rubber guide pin gaiters are undamaged (see illustration). Brush the dust and dirt from the caliper and piston but **do not** inhale it as it is injurious to health. Inspect the dust seal around the piston for damage and the piston for evidence of fluid leaks, corrosion or damage. Renew as necessary.

8 On refitting, first fit the pad retainer springs to the caliper mounting bracket (see illustration).

9 Apply a thin smear of high-temperature brake grease (silicone- or PBC/Poly Butyl Cuprysil-based) or anti-seize compound (eg Holts Copaslip) to the sides and back of each pad's metal backing and to those surfaces of the caliper body and mounting bracket which bear on the pads. Fit the shims to the back of both pads and apply a thin smear of lubricant to the back of each shim. Do not allow the lubricant to foul the friction material (see illustration).

10 Install the brake pads in the caliper mounting bracket, ensuring that the friction material is against the disc.

11 If new brake pads have been fitted, the caliper piston must be pushed back into the cylinder to make room for them. Either use a G-clamp or similar tool, or use suitable pieces of wood as levers. Provided that the master cylinder reservoir has not been overfilled with hydraulic fluid there should be no spillage but keep a careful watch on the fluid level while retracting the piston. If the fluid level rises above the MAX level line at any time, the surplus should be syphoned off or ejected via a plastic tube connected to the bleed screw.

12 Apply a thin smear of the recommended lubricant (see above) to the circular shim and fit the shim to the caliper piston. Pivot the caliper body down over the brake pads then refit the bottom guide pin bolt and tighten it to the specified torque wrench setting.

13 Check that the caliper body slides smoothly in the mounting bracket, then depress the brake pedal repeatedly until the pads are pressed into firm contact with the brake disc and normal (non-assisted) pedal pressure is restored.

14 Repeat the above procedure on the remaining front brake caliper.

15 Refit the roadwheels, then lower the vehicle to the ground and tighten the roadwheel nuts to the specified torque setting.

16 On completion, check the hydraulic fluid level.

12 Front brake caliper - removal, overhaul and refitting



Warning: Brake hydraulic fluid may be under considerable pressure in a pipeline, take care not to allow hydraulic fluid to spray into the face or eyes when loosening a connection.

Removal

1 Chock the rear wheels, firmly apply the handbrake, jack up the front of the vehicle

and support on axle stands. Remove the appropriate front roadwheel.

2 Minimise fluid loss either by removing the master cylinder reservoir cap and then tightening it down onto a piece of polythene to obtain an airtight seal (taking care not to damage the sender unit), or by using a brake hose clamp, a G-clamp or a similar tool to clamp the flexible hose.

3 Clean the area around the union, then undo the brake hose union bolt and disconnect the hose from the caliper. Plug the end of the hose and the caliper orifice to prevent dirt entering the hydraulic system. Discard the sealing washers as they must be renewed whenever disturbed.

4 Unscrew the two caliper guide pin bolts whilst, if necessary, using a slim open-ended spanner to prevent the guide pins themselves from rotating (see illustration).

5 Carefully lift the caliper assembly off the brake pads and remove the circular shim from

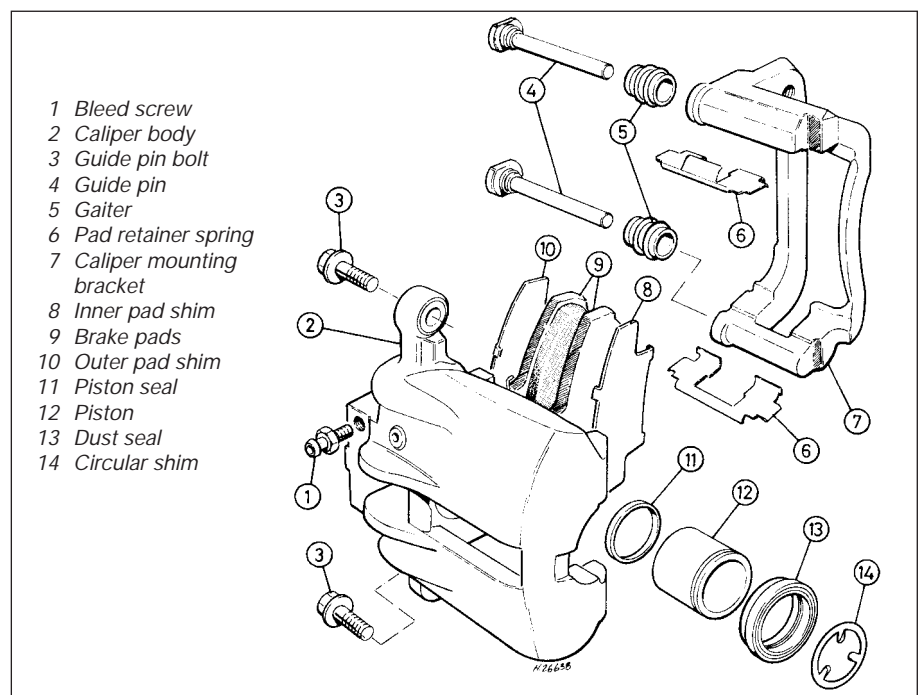

- 1 Bleed screw
- 2 Caliper body
- 3 Guide pin bolt
- 4 Guide pin
- 5 Gaiter
- 6 Pad retainer spring
- 7 Caliper mounting bracket
- 8 Inner pad shim
- 9 Brake pads
- 10 Outer pad shim
- 11 Piston seal
- 12 Piston
- 13 Dust seal
- 14 Circular shim

12.4 Front brake caliper components

9•10 Braking system

the caliper piston. Note that the brake pads need not be disturbed and can be left in position in the caliper mounting bracket.

Overhaul

6 With the caliper on the bench, wipe away all traces of dust and dirt. Avoid inhaling the dust as it is injurious to health.

7 Withdraw the piston from the caliper body and remove the dust seal. The piston can be withdrawn by hand or if necessary, pushed out by applying compressed air to the union bolt hole. Only low pressure should be required such as is generated by a foot pump.

8 Using a small screwdriver, extract the piston hydraulic seal whilst taking great care not to damage the caliper bore.

9 Withdraw the guide pins from the caliper mounting bracket and remove the guide pin gaiters.

10 Thoroughly clean all components using only methylated spirit, isopropyl alcohol or clean hydraulic fluid as a cleaning medium. Never use mineral-based solvents such as petrol or paraffin which will attack the hydraulic system's rubber components. Dry the components immediately using compressed air or a clean, lint-free cloth. Use compressed air to blow clear the fluid passages.

11 Check all components and renew any that are worn or damaged. Check particularly the cylinder bore and piston. These should be renewed (note that this means the renewal of the complete body assembly) if they are scratched, worn or corroded in any way. Similarly, check the condition of the guide pins and their bores in the mounting bracket. Both guide pins should be undamaged and (when cleaned) a reasonably tight sliding fit in the mounting bracket bores. If there is any doubt about the condition of any component, renew it.

12 If the assembly is fit for further use, obtain the appropriate repair kit. Components are available from Rover dealers in various combinations.

13 Renew all rubber seals, dust covers and caps. Also the sealing washers disturbed on dismantling.

14 On reassembly, ensure that all components are absolutely clean and dry.

15 Soak the piston and the new piston (fluid) seal in clean hydraulic fluid. Smear clean fluid on the cylinder bore surface.

16 Fit the new piston (fluid) seal using only the fingers to manipulate it into the cylinder bore groove. Fit the new dust seal to the piston and refit it to the cylinder bore using a twisting motion, ensuring that the piston enters squarely into the bore. Press the piston fully into the bore, then secure the dust seal to the caliper body.

17 Apply the grease supplied in the repair kit, or a good quality high-temperature brake grease (silicone- or PBC/Poly Butyl Cuprysil-based) or anti-seize compound (eg Holts Copaslip), to the guide pins and fit the new gaiters. Fit the guide pins to the caliper mounting bracket, ensuring that the gaiters are correctly located in the grooves on both the guide pin and mounting bracket.

Refitting

18 Refit the circular shim to the piston and carefully slide the caliper into position over the brake pads. Refit the caliper guide pin bolts and tighten them to the specified torque setting.

19 Position a new sealing washer on each side of the hose union and refit the brake hose union bolt. Ensure that the brake hose union is correctly positioned between the lugs on the caliper then tighten the union bolt to the specified torque setting.

20 Remove the brake hose clamp, where fitted, and bleed the hydraulic system. Providing the precautions described were taken to minimise brake fluid loss, it should only be necessary to bleed the relevant front brake.

21 Refit the roadwheel then lower the vehicle to the ground and tighten the roadwheel nuts to the specified torque.

13 Front brake disc - inspection, removal and refitting



Note: If either brake disc requires renewal, both should be renewed at the same time to ensure even and consistent braking.

Inspection

1 Chock the rear wheels, firmly apply the handbrake, jack up the front of the vehicle and support on axle stands. Remove the appropriate front roadwheel.

2 Slowly rotate the brake disc so that the full area of both sides can be checked. Remove the brake pads if better access is required to the inboard surface. Light scoring is normal in the area swept by the brake pads but if heavy scoring is found, then the disc must be renewed. The only alternative to this is to have the disc surface-ground until it is flat again, but this must not reduce the disc to less than the minimum thickness specified.

3 It is normal to find a lip of rust and brake dust around the disc's perimeter. This can be scraped off if required. If, however, a lip has formed due to excessive wear of the brake pad swept area, then the disc's thickness must be measured by using a micrometer (see illustration). Take measurements at four places around the disc at the inside and outside of the pad swept area. If the disc has worn at any point to the specified minimum thickness or less, then it must be renewed.

4 If the disc is thought to be warped, it can be checked for run-out (at a point 6.0 mm in from the disc's outer edge) by either using a dial gauge mounted on any convenient fixed point, while the disc is slowly rotated, or by using feeler gauges to measure (at several points all around the disc) the clearance between the disc and a fixed point, such as the caliper mounting bracket (see illustration). If the measurements obtained are at the specified maximum or beyond, the disc is excessively warped and must be renewed. However, it is worth checking first that the hub bearing is in good condition. Also, try the effect of removing the disc and turning it through 180° to reposition it on the hub. If run-out is still excessive the disc must be renewed.

5 Check the disc for cracks, especially around the stud holes, and any other wear or damage. Renew it if any of these are found.

Removal

6 Unscrew the two bolts securing the caliper mounting bracket to the swivel hub and slide the caliper assembly off the disc (see illustration).



13.3 Using a micrometer to measure brake disc thickness



13.4 Using a dial gauge to check brake disc run-out



13.6 Removing caliper assembly

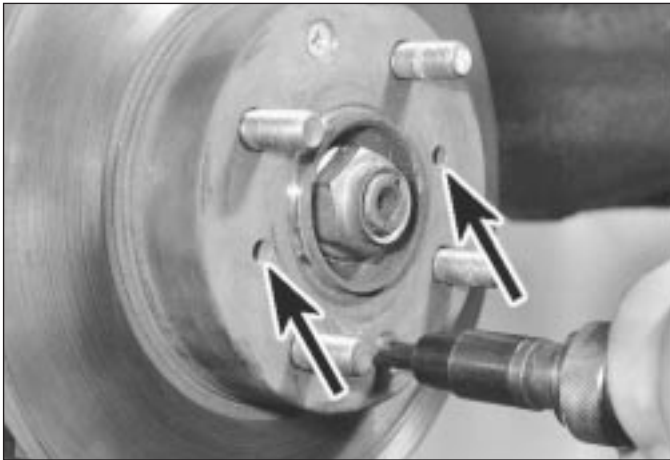

13.7a Removing disc retaining screws (jacking holes arrowed)



13.7b Drawing off a disc using two 8 mm bolts

Using a piece of wire or string, tie the caliper to the front suspension coil spring to avoid placing any strain on the hydraulic brake hose.

7 Use chalk or paint to mark the relationship of the disc to the hub, then remove the two screws securing the brake disc to the hub and remove the disc. If the disc is a tight fit on the hub it can be drawn off by screwing two bolts into the jacking holes provided (see illustrations).

Refitting

8 Refitting is the reverse of the removal procedure, noting the following:

- Ensure that the mating surfaces of the disc and hub are clean and flat.
- Align (if applicable) the marks made on removal.
- If a new disc has been fitted, use a suitable solvent to wipe any preservative coating from the disc before refitting the caliper.
- Tighten the disc retaining screws, caliper bracket bolts and roadwheel nuts to their specified torque wrench settings.

14 Pressure regulating valve - testing, removal and refitting



Testing

1 The pressure regulating valve is mounted on the right-hand side of the engine compartment bulkhead.

2 Specialist equipment is required to check valve performance. If the valve is thought to be faulty, the vehicle should be taken to a suitably equipped Rover dealer for testing. However, in the event of an internal failure, brake fluid will seep from the plug on the front face of the valve which is situated directly above the lower two hose unions (see illustration). Repairs are not possible and, if faulty, the valve must be renewed.

Removal

3 Disconnect the sender unit wiring connector and unscrew the master cylinder reservoir filler cap. Place a piece of polythene over the filler neck and securely refit the cap (taking care not to damage the sender unit). This will minimise brake fluid loss during subsequent operations. As an added precaution, place absorbent rags beneath the pressure regulating valve brake pipe unions.

4 Wipe clean the area around the brake pipe unions on the pressure regulating valve, then make a note of how the pipes are arranged for reference on refitting. Unscrew the union nuts and carefully withdraw the pipes. Plug or tape over the pipe ends and valve orifices to minimise the loss of brake fluid and to prevent the entry of dirt into the system. Wash off any spill fluid immediately with cold water.

5 Slacken the two bolts which secure the valve to the bulkhead and remove it from the engine compartment.

Refitting

6 Refit the pressure regulating valve to the bulkhead and tighten its mounting bolts securely.

7 Wipe the brake pipe unions clean and refit them to the valve, using the notes made on

dismantling to ensure they are correctly positioned. Tighten the union nuts to the specified torque.

8 Remove the polythene from the master cylinder reservoir filler neck and bleed the complete hydraulic system.

15 Rear brake shoes - inspection

Refer to Chapter 1.

16 Rear brake shoes - renewal



Warning: Brake shoes must be renewed on both rear wheels at the same time. Never renew the shoes on only one wheel as uneven braking may result.

Removal

1 Remove the brake drum.
2 Working carefully and noting all precautions, remove all traces of brake dust from the brake drum, backplate and shoes.
3 Measure the thickness of friction material remaining on each brake shoe at several points. If either shoe is worn at any point to the specified minimum thickness or less, all four shoes must be renewed as a set. Also, the shoes should be renewed if any are fouled with oil or grease as there is no satisfactory way of degreasing friction material once contaminated.

4 If any of the brake shoes are worn unevenly or fouled with oil or grease, trace and rectify the cause before reassembly.

5 To remove the brake shoes, first remove the shoe retainer springs and pins, using a pair of pliers to press in each retainer clip until it can be rotated through 90° and released. Ease the shoes out one at a time from the



14.2 In the event of failure, fluid will seep from pressure regulating valve plug (arrowed)

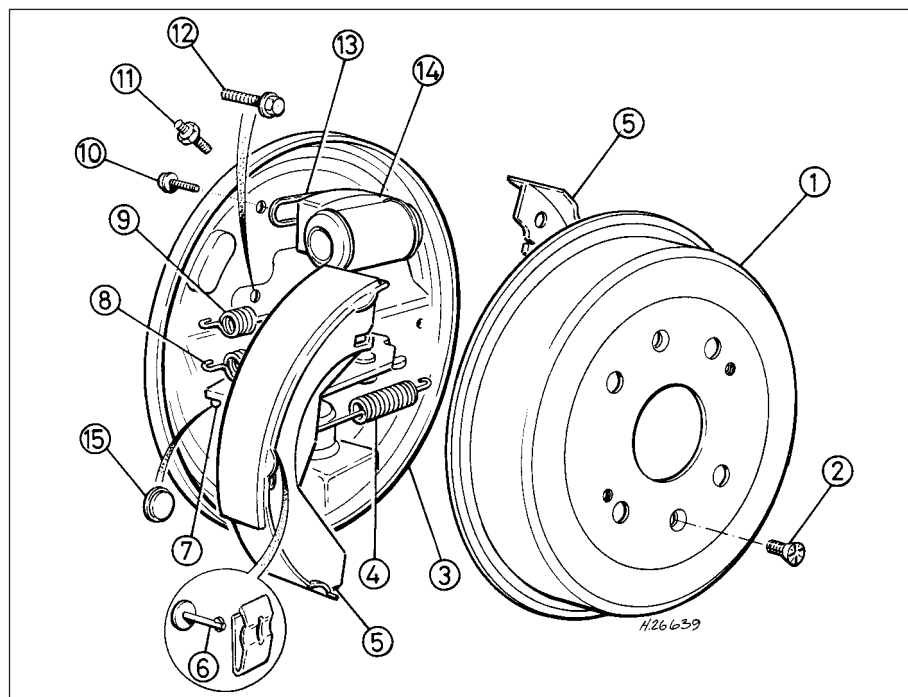

16.5a Rear drum brake assembly

- | | | |
|---------------------------|----------------------------------|----------------------------|
| 1 Brake drum | 7 Adjuster strut | 11 Bleed screw |
| 2 Drum retaining screw | 8 Strut spring | 12 Backplate mounting bolt |
| 3 Backplate | 9 Upper return spring | 13 Seal |
| 4 Lower return spring | 10 Wheel cylinder retaining bolt | 14 Wheel cylinder |
| 5 Brake shoe | 15 Grommet | |
| 6 Retainer pin and spring | | |

lower pivot point to release the tension of the return spring, then disconnect the lower return spring from both shoes. Ease the upper end of both shoes out from their wheel cylinder locations, taking great care not to damage the wheel cylinder seals, and disconnect the handbrake cable from the trailing shoe. The brake shoe and adjuster strut assembly can now be manoeuvred out of position and away from the backplate (see illustrations). Do not depress the brake pedal until the brakes are reassembled. Wrap a strong elastic band around the wheel cylinder pistons to retain them.

6 With the brake shoe assembly on the worksurface, make a note of the fitted positions of the adjuster strut and springs to use as guide on reassembly (see illustration). Carefully ease the adjuster strut from its slot in the trailing shoe and remove the short spring which secures the two components together. Detach the upper return spring and separate the shoes and strut.

7 Examine the adjuster strut assembly for signs of wear or damage, paying particular attention to the adjuster quadrant and knurled wheel. If damaged, the strut assembly must be renewed. Renew all the brake shoe return springs regardless of their apparent condition.

8 Peel back the rubber protective caps and check the wheel cylinder for fluid leaks or other damage. Check that both cylinder pistons are free to move easily.

Fitting

9 Prior to fitting, clean the backplate and apply a thin smear of high-temperature brake grease (silicone- or PBC/Poly Butyl Cuprysil-based) or anti-seize compound (eg Holts Copaslip) to all those surfaces of the backplate which bear on the shoes, particularly the adjuster and the wheel cylinder pistons. Do not allow lubricant to foul the friction material.

10 Ensure the handbrake lever stop on the trailing shoe is correctly engaged with the lever and is pressed tight against the brake shoe (see illustration).

11 Fully extend the adjuster strut quadrant and fit the leading brake shoe into the adjuster strut slot, ensuring that the strut spring and



16.5b Remove brake shoe retainer springs . . .



16.5c . . . unhook lower return spring . . .



16.5d . . . and manoeuvre shoe and adjuster strut assembly away from backplate



16.6 Correct fitted positions of adjuster strut and springs



16.10 Ensure handbrake stop lever is correctly located



16.14 Reset adjuster strut prior to refitting drum

knurled wheel are situated on the underside of the strut assembly. Using a screwdriver, move the quadrant away from the knurled wheel and set it in the minimum adjustment position.

12 Fit the upper return spring to its respective location on the leading shoe. Fit the trailing shoe to the upper return spring and carefully ease the shoe into position in the adjuster strut slot. Once in position, fit the small spring which secures the trailing shoe to the strut assembly.

13 Remove the elastic band fitted to the wheel cylinder and manoeuvre the shoe and strut assembly into position on the backplate. Locate the upper end of both shoes with the wheel cylinder pistons and fit the handbrake cable to the trailing shoe operating lever. Fit the lower return spring to both shoes and ease the shoes into position on the lower pivot point.

14 Tap the shoes to centralise them with the backplate, then refit the shoe retainer pins and springs and secure them in position with the retainer clips. Check that the adjuster quadrant is still in the minimum adjuster position and if necessary, reset as follows. Place a block of wood between the trailing shoe and hub, to prevent the shoe moving forwards, then lever the leading shoe away from the hub to release the brake shoe return spring pressure on the adjuster quadrant. With the shoe held in this position, reset the quadrant to the minimum adjustment setting (see illustration). Once the adjuster strut is correctly set, ease the leading shoe back into position then remove the block of wood and check that the shoes are still central.



17.3 Removing brake drum retaining screws (jacking holes arrowed)

15 Refit the brake drum and repeat the above operation on the remaining rear brake assembly.

16 On completion, apply the footbrake repeatedly to set the shoe-to-drum clearance, until normal (non-assisted) brake pedal operation returns.

17 Check handbrake cable operation and, if necessary, adjust as described in Chapter 1.

18 Refit the roadwheels then lower the vehicle to the ground and tighten the roadwheel nuts to the specified torque.

19 Check the hydraulic fluid level.

17 Rear brake drum - removal, inspection and refitting



Note: If either brake drum requires renewal, both should be renewed at the same time to ensure even and consistent braking.

Removal

1 Chock the front wheels then jack up the rear of the vehicle and support it on axle stands. Remove the appropriate rear wheel.

2 Use chalk or paint to mark the relationship of the drum to the hub.

3 With the handbrake firmly applied to prevent drum rotation, unscrew the drum retaining screws (see illustration). Fully release the handbrake cable and withdraw the drum.

4 If the drum will not pull away, first check that the handbrake is fully released. If the drum will still not come away, remove the grommet from the rear of the backplate and, using a small screwdriver, disengage the handbrake lever stop from behind the lever to increase the shoe to drum clearance. If removal still proves troublesome, the brake drum can be drawn off by screwing two bolts into the jacking holes provided (see illustrations).

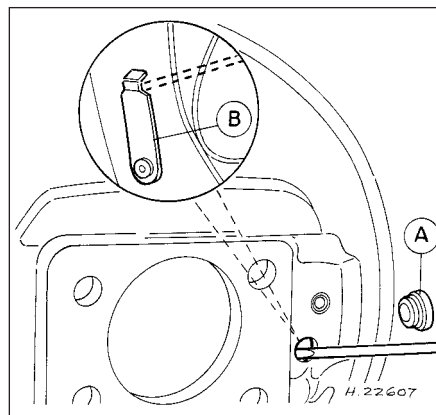

17.4a Releasing handbrake mechanism stop lever

Remove rubber grommet (A) and use small screwdriver to depress handbrake lever stop (B)

Inspection

5 Working carefully, remove all traces of brake dust from the drum. Avoid inhaling the dust as it is injurious to health.

6 Scrub clean the outside of the drum and check it for obvious signs of wear or damage such as cracks around the roadwheel stud holes. Renew the drum if necessary.

7 Examine carefully the inside of the drum. Light scoring of the friction surface is normal but if heavy scoring is found, the drum must be renewed. It is usual to find a lip on the drum's inboard edge which consists of a mixture of rust and brake dust. This should be scraped away to leave a smooth surface which can be polished with fine (120 to 150 grade) emery paper. If, however, the lip is due to the friction surface being recessed by excessive wear, then the drum must be renewed.

8 If the drum is thought to be excessively worn or oval, its internal diameter must be measured at several points by using an internal micrometer. Take measurements in pairs, the second at right angles to the first, and compare the two to check for signs of ovality. Provided that it does not enlarge the drum to beyond the specified maximum diameter, it may be possible to have the drum refinished by skimming or grinding but if this is not possible, the drums on both sides must be renewed.

Refitting

9 Refitting is the reverse of the removal procedure, noting the following:

- On fitting a new brake drum, use a suitable solvent to remove any preservative coating that may have been applied to its interior.
- Use a clean wire brush to remove all traces of dirt, brake dust and corrosion from the mating surfaces of the drum and the hub flange.
- Align (if applicable) the marks made on removal.
- Tighten the drum retaining screws and the roadwheel nuts to their specified torque wrench settings.



17.4b Brake drum can be drawn off hub by using two 8 mm bolts

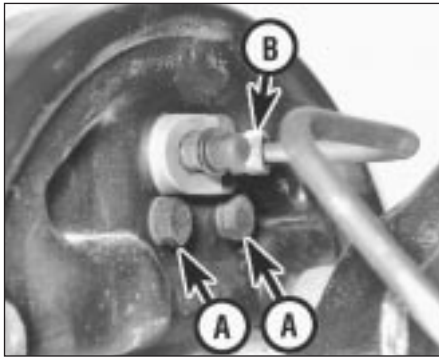

18.3 Wheel cylinder retaining bolts (A) and brake pipe union nut (B)

18 Rear wheel cylinder - removal, overhaul and refitting



Note: Before attempting to overhaul a rear wheel cylinder, check the price and availability of individual components and the price of a new or reconditioned unit, as overhaul may not be viable on economic grounds alone.

Removal

- 1 Remove the brake shoes.
- 2 Minimise fluid loss by removing the master cylinder reservoir cap and then tightening it down onto a piece of polythene to obtain an airtight seal (taking care not to damage the sender unit), or by using a brake hose clamp, a G-clamp or a similar tool to clamp the flexible hose.
- 3 Wipe away all traces of dirt around the brake pipe union at the rear of the wheel cylinder and unscrew the union nut. Carefully ease the pipe out of the wheel cylinder and plug or tape over its end to prevent dirt entry (see illustration).
- 4 Unscrew the two wheel cylinder retaining bolts from the rear of the backplate and remove the cylinder, noting the rubber sealing ring which is fitted between the cylinder and backplate.

Overhaul

- 5 Remove the wheel cylinder from the vehicle and clean it thoroughly.
- 6 Mount the wheel cylinder in a soft-jawed vice and remove the rubber protective caps. Extract the piston assemblies.
- 7 Thoroughly clean all components using only methylated spirit, isopropyl alcohol or clean hydraulic fluid as a cleaning medium. Never use mineral-based solvents such as petrol or paraffin which will attack the hydraulic system's rubber components. Dry the components immediately using compressed air or a clean, lint-free cloth.
- 8 Check all components and renew any that are worn or damaged. Check particularly the cylinder bore and pistons. The complete assembly must be renewed if these are

scratched, worn or corroded. If there is any doubt about the condition of the assembly or of any of its components, renew it. Remove the bleed screw and check that the fluid entry port and bleed screw passages are clear.

- 9 If the assembly is fit for further use, obtain a repair kit. Renew the rubber protective caps, dust caps and seals disturbed on dismantling, these should never be re-used. Renew also any other items included in the repair kit.
- 10 On reassembly, soak the pistons and the new seals in clean hydraulic fluid. Smear clean fluid on the cylinder bore surface.
- 11 Fit the new seals to their pistons using only the fingers to manipulate them into the grooves. Ensure that all components are refitted in the correct order and the right way round.
- 12 Insert the pistons into the bore using a twisting motion to avoid trapping the seal lips. Apply a smear of rubber lubricant to each piston before fitting the new rubber protective caps.

Refitting

- 13 Fit a new sealing ring to the rear of the wheel cylinder and place the cylinder in position on the backplate.
- 14 Refit the wheel cylinder retaining bolts and tighten them to the specified torque.
- 15 Tighten the brake pipe union nut and, if necessary, remove the clamp from the brake hose.
- 16 Refit the brake shoes.
- 17 Bleed the hydraulic braking system. If precautions were taken to minimise fluid loss, it should only be necessary to bleed the relevant rear brake. On completion, check that both footbrake and handbrake function correctly before taking the vehicle on the road.

19 Rear brake pads - inspection

Refer to Chapter 1.

20 Rear brake pads - renewal



Warning: Renew both sets of rear brake pads at the same time. Never renew the pads on only one wheel as uneven braking may result.

Removal

- 1 Chock the front wheels then jack up the rear of the vehicle and support on axle stands. Remove the rear roadwheels.
- 2 Undo the two bolts securing the caliper shield in position and remove the shield from the rear of the caliper.
- 3 Remove both caliper guide pin bolts whilst,

if necessary, using a slim open-ended spanner to prevent the guide pins from rotating. Lift the caliper away from the disc, noting the upper pad spring which is fitted to the roof of the caliper. Tie the caliper to the suspension strut using a piece of wire to avoid straining the hydraulic hose (see illustration).

- 4 Remove the brake pads from the caliper mounting bracket whilst noting the correct fitted positions of the brake pads, pad retainer springs and pad shims.
- 5 Inspect the pads as described for the front brake pads and, if necessary, renew as a complete axle set.

Fitting

- 6 Fit the pad retainer springs to the caliper mounting bracket.
- 7 Apply a thin smear of Molykote M77 compound to the sides and back of each pad's metal backing and to those surfaces of the caliper body and mounting bracket which bear on the pads. In the absence of the specified lubricant, a good quality high-temperature brake grease (silicone- or PBC/Poly Butyl Cuprysil-based) or anti-seize compound (eg Holts Copaslip) may be used. Fit the shims to the back of both pads, noting that the smaller shim must be fitted to the piston side pad, and apply a thin smear of lubricant to the back of each shim. Do not allow lubricant to foul the friction material.
- 8 Install the brake pads in the caliper mounting bracket, ensuring that the friction material is against the disc and the pad with the smaller shim attached is fitted on the inside.
- 9 If new pads have been fitted, it will be necessary to retract the piston fully into the caliper bore by rotating it in a clockwise direction. This can be achieved by using a suitable pair of circlip pliers as a peg spanner or by fabricating a peg spanner for the task. Provided that the master cylinder reservoir has not been overfilled with hydraulic fluid, there should be no spillage, but keep a careful watch on the fluid level while retracting the piston. If the fluid level rises above the MAX level line at any time, the surplus should be syphoned off or ejected via a plastic tube connected to the bleed screw.
- 10 Ensure the upper pad spring is still in position in the caliper then slide the caliper into position in its mounting bracket. When fitting the caliper, ensure that the lug on the rear of the piston side pad is located in one of the piston slots. Refit the caliper guide pin bolts and tighten them to the specified torque setting.
- 11 Depress the footbrake to bring the piston into contact with the pads then check that the lug on the piston side pad is located in one of the piston slots. If necessary, remove the caliper and adjust the piston position as described above. Refit the shield to the rear of the caliper.
- 12 Repeat the above procedure on the remaining rear brake caliper.

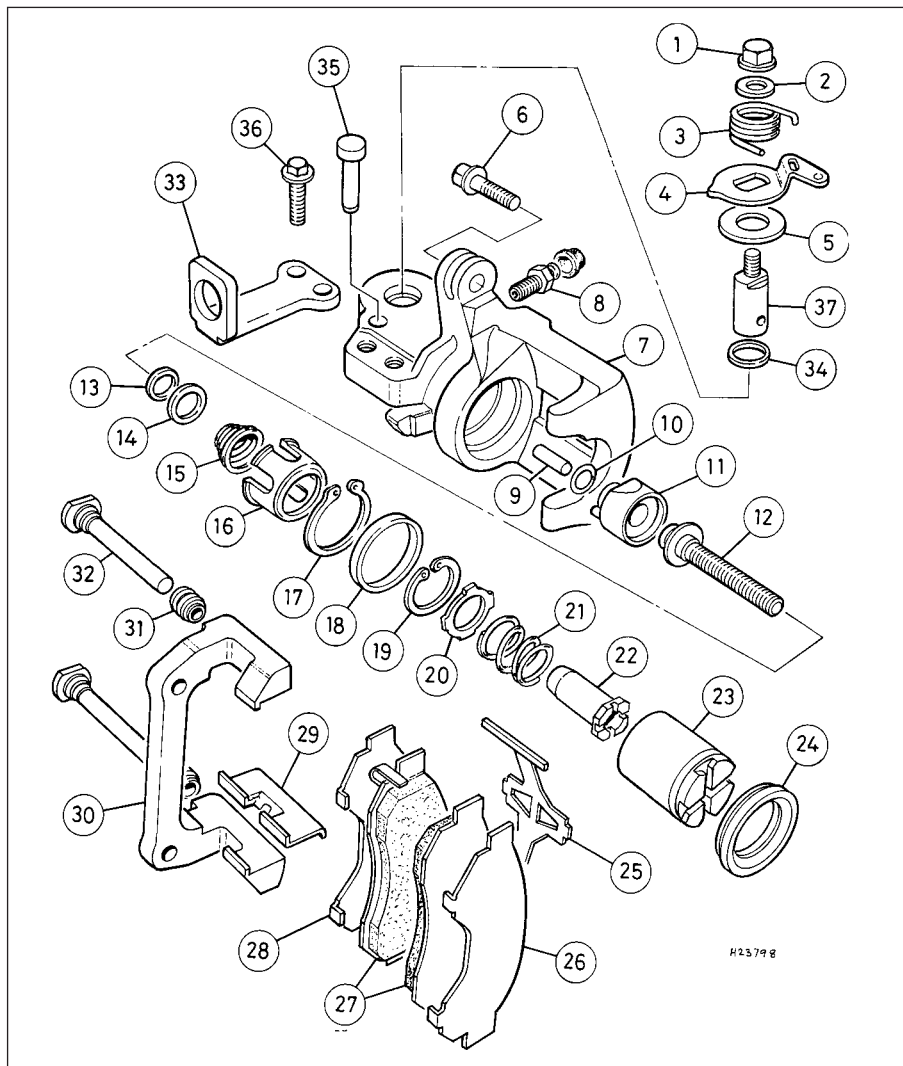

20.3 Rear brake caliper components

1 Handbrake lever retaining nut	13 Bearing	26 Inner pad shim
2 Washer	14 Spring seat	27 Brake pads
3 Return spring	15 Spring	28 Outer pad shim
4 Handbrake operating lever	16 Spring cover	29 Pad spring
5 Dust seal	17 Circlip	30 Caliper mounting bracket
6 Guide pin bolt	18 Piston seal	31 Gaiter
7 Caliper body	19 Circlip	32 Guide pin
8 Bleed screw	20 Thrustwasher	33 Handbrake cable mounting bracket
9 Pushrod	21 Spring	34 Cam washer
10 O-ring	22 Adjuster nut	35 Pin
11 Adjusting bolt piston	23 Piston	36 Bolt
12 Adjusting bolt	24 Dust seal	37 Handbrake mechanism cam
	25 Pad spring	

13 Once both calipers have been done, repeatedly depress the brake pedal until normal (non-assisted) pedal operation returns, then repeatedly apply the handbrake to set handbrake adjustment. Check the operation of the handbrake and, if necessary, adjust the cable as described in Chapter 1.

14 Refit the roadwheels, then lower the vehicle to the ground and tighten the roadwheel nuts to the specified torque.

15 Check the hydraulic fluid level.

21 Rear brake caliper - removal, overhaul and refitting

Removal

1 Chock the front wheels, then jack up the rear of the vehicle and support on axle stands. Remove the rear wheel.

2 Undo the two bolts securing the caliper

shield in position and remove the shield from the rear of the caliper.

3 Extract the spring clip and clevis pin securing the handbrake cable to the caliper handbrake lever, then remove the clip securing the outer cable to its mounting bracket and detach the handbrake cable from the caliper.

4 Minimise fluid loss by removing the master cylinder reservoir cap and then tightening it down onto a piece of polythene to obtain an airtight seal (taking care not to damage the sender unit), or by using a brake hose clamp, a G-clamp or a similar tool to clamp the flexible hose.

5 Clean the area around the hose union, then undo the brake hose union bolt and disconnect the hose from the caliper. Plug the end of the hose and the caliper orifice to prevent dirt entering the hydraulic system. Discard the sealing washers as they must be renewed whenever disturbed.

6 Remove both the caliper guide pin bolts whilst, if necessary, using a slim open-ended spanner to prevent the guide pins from rotating, then lift the caliper away from the disc, noting the upper pad spring which is fitted to the roof of the caliper. Note that the brake pads need not be disturbed and can be left in position in the caliper mounting bracket.

Overhaul

7 With the caliper on the bench, wipe away all traces of dust and dirt. Avoid inhaling the dust as it is injurious to health.

8 Using a small screwdriver, carefully prise out the dust seal from the caliper bore.

9 Remove the piston from the caliper bore by rotating it in an anti-clockwise direction. This can be achieved using a suitable pair of circlip pliers as a peg spanner or by fabricating a peg spanner for the task. Once the piston turns freely but does not come out any further, then it can be withdrawn by hand, or if necessary, pushed out by applying compressed air to the union bolt hole. Only low pressure should be required such as is generated by a foot pump.

10 With the piston removed, extract the circlip from inside the piston and withdraw the thrustwasher, spring and adjuster nut.

11 Remove the piston (fluid) seal whilst taking great care not to scratch the caliper bore.

12 Extract the circlip from the caliper bore and withdraw the spring cover, spring, spring seat, bearing and adjusting bolt. Then remove the adjusting bolt piston, noting the O-ring fitted to the rear of the piston, and withdraw the small pushrod.

13 Slacken and remove the handbrake lever retaining nut and washer and remove the return spring, lever and dust seal. Withdraw the handbrake mechanism cam from the caliper and remove the cam washer.

14 Withdraw the guide pins from the caliper mounting bracket and remove the guide pin gaiters.

9•16 Braking system

15 Inspect all the caliper components as described for the front brake caliper and renew as necessary.

16 On reassembly ensure that all components are absolutely clean and dry.

17 Apply a good quality high-temperature brake grease (silicone- or PBC/Poly Butyl Cuprysil-based) or anti-seize compound (eg Holts Copaslip) to the handbrake mechanism cam and refit the cam washer and cam to the caliper. Fit the dust seal, lever, return spring and washer and tighten the handbrake lever retaining nut securely.

18 Fit a new O-ring to the adjusting bolt piston then insert the small pushrod into the rear of the piston and install the adjusting bolt piston assembly in the caliper bore. Operate the handbrake lever and check that the piston is free to move smoothly then refit the adjusting bolt, followed by the bearing and spring seat. Fit the spring, so that its tapered end is innermost, then install the spring cover. Secure all the above components in position with the circlip, ensuring that it is correctly seated in the groove in the caliper bore.

19 Locate the adjusting nut with the cutout on the inside of the caliper piston and refit the spring, thrustwasher and circlip. Ensure the circlip is correctly located in its groove.

20 Soak the piston and the new piston (fluid) seal in clean hydraulic fluid. Smear clean fluid on the cylinder bore surface.

21 Fit the new piston (fluid) seal using only the fingers to manipulate it into the cylinder bore groove and refit the piston assembly. Turn the piston in a clockwise direction, using the method employed on dismantling, until it is fully retracted into the caliper bore.

22 Fit the dust seal to the caliper ensuring that it is correctly located in the caliper and also the groove on the piston.

23 Apply the grease supplied in the repair kit, or a good quality high-temperature brake grease (silicone- or PBC/Poly Butyl Cuprysil-based) or anti-seize compound (eg Holts Copaslip), to the guide pins and fit the new gaiters. Fit the guide pins to the caliper mounting bracket, ensuring that the gaiters are correctly located in the grooves on both the guide pin and mounting bracket.

Refitting

24 Ensure the upper pad spring is still in position in the caliper then slide the caliper into position in its mounting bracket. When fitting the caliper, ensure that the lug on the rear of the piston side pad is located in the centre of the caliper piston at the point where the two piston slots cross. Refit the caliper guide pin bolts and tighten them to the specified torque setting.

25 Position a new sealing washer on each side of the hose union and refit the brake hose union bolt. Ensure that the brake hose union is correctly positioned between the lugs on the caliper then tighten the union bolt to the specified torque setting.

26 Remove the brake hose clamp, where

fitted, and bleed the hydraulic system. Providing the precautions described were taken to minimise brake fluid loss, it should only be necessary to bleed the relevant rear brake.

27 Refit the handbrake cable outer to its mounting bracket and secure it in position with the retaining clip. Ensure the return spring is located in the groove in the operating lever then refit the handbrake cable to lever clevis pin and secure it in position with the spring clip.

28 Depress the brake pedal several times until normal (non-assisted) operation returns then check and, if necessary, adjust the handbrake cable as described in Chapter 1.

29 Refit the shield to the rear of the caliper and tighten its retaining bolts securely.

30 Refit the roadwheel, then lower the vehicle to the ground and tighten the roadwheel nuts to the specified torque.

31 Check the hydraulic fluid level.

22 Rear brake disc - inspection, removal and refitting



Note: If either rear brake disc requires renewal, both should be renewed at the same time to ensure even and consistent braking.

Inspection

1 Chock the front wheels, then jack up the rear of the vehicle and support on axle stands. Remove the appropriate rear roadwheel.

2 Inspect the disc as described for the front brake disc.

Removal

3 Undo the two caliper shield retaining bolts and remove the shield from the rear of the caliper.

4 Undo the two bolts securing the caliper mounting bracket to the trailing arm assembly and slide the caliper assembly off the disc. Using a piece of wire or string, tie the caliper to the rear suspension coil spring to avoid placing any strain on the hydraulic brake hose.

5 Use chalk or paint to mark the relationship of the disc to the hub, then remove the two screws securing the brake disc to the hub and remove the disc. If the disc is a tight fit on the hub, it can be drawn off by screwing two bolts into the jacking holes provided.

Refitting

6 Refitting is the reverse of the removal procedure, noting the following:

- Ensure that the mating surfaces of the disc and hub are clean and flat.
- Align (if applicable) the marks made on removal.
- If a new disc has been fitted, use a suitable solvent to wipe any preservative coating from the disc before refitting the caliper.

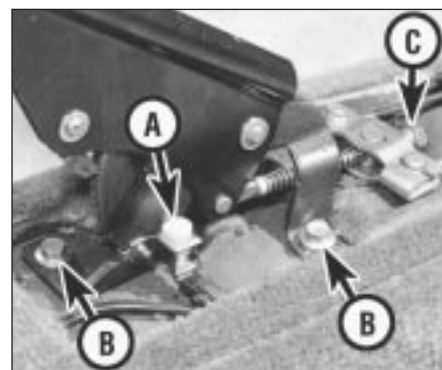

23.3 Handbrake lever switch (A), mounting bolts (B) and adjusting nut (C)

- Tighten the disc retaining screws, caliper bracket bolts and roadwheel nuts to their specified torque wrench settings.

23 Handbrake lever - removal and refitting



Removal

1 With the vehicle parked on level ground, chock the roadwheels so that the vehicle cannot move.

2 From inside the vehicle, prise out the cover from the top of the rear centre console section to gain access to the two retaining screws. Undo the two screws and remove the rear console section.

3 Remove the handbrake lever rubber gaiter and disconnect the wiring connector from the lever warning lamp switch (see illustration).

4 Slacken and remove the handbrake cable adjusting nut from the rear of the lever and undo the bolts securing the handbrake lever assembly to the floorpan (see illustration opposite).

5 Lift the handbrake assembly out of position, noting the spring which is fitted to the lever adjusting rod.

Refitting

6 Refitting is a reverse of the removal procedure. Prior to refitting the handbrake lever rubber gaiter, adjust the handbrake cable as described in Chapter 1.

24 Handbrake cables - removal and refitting



Removal

1 Firmly chock the front wheels then jack up the rear of the vehicle and support it on axle stands. The handbrake cable consists of two sections (right and left-hand), which are linked to the lever assembly by an equalizer plate. Each section can be removed individually.

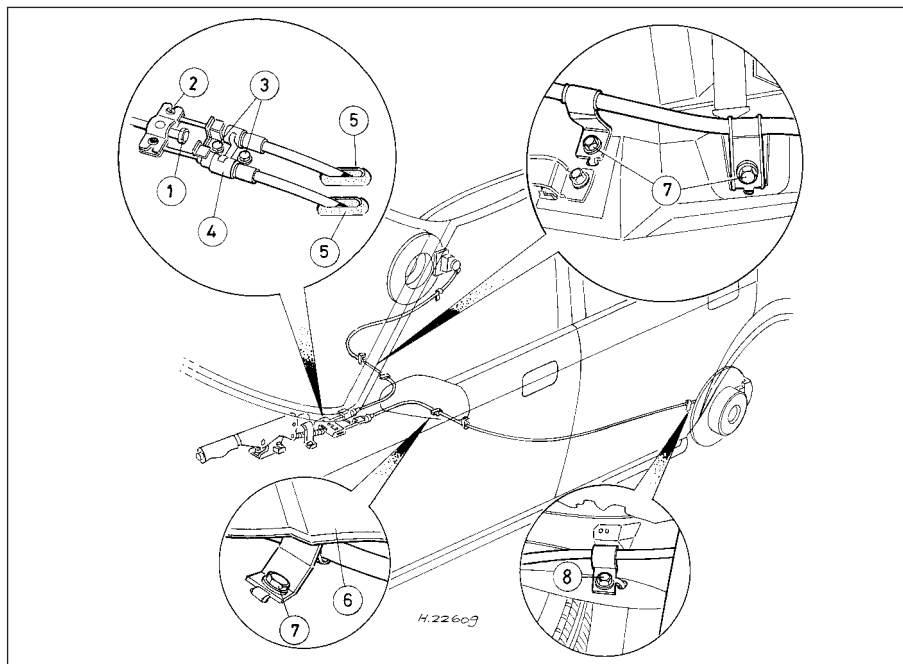

23.4 Handbrake mechanism layout

- | | | |
|--------------------------------|-------------------------|---------------------------------|
| 1 Handbrake cable adjuster nut | 3 Bolts | 6 Exhaust heatshield |
| 2 Equalizer plate | 4 Cable retaining plate | 7 Bolts - cable to body |
| | 5 Grommet | 8 Bolts - cable to trailing arm |

2 From inside the vehicle, prise out the cover from the top of the rear centre console section to gain access to the two retaining screws. Undo the two screws and remove the rear console section.

3 Slacken and remove the handbrake cable adjusting nut from the rear of the lever and disconnect the equalizer plate, noting the spring which is fitted to the lever adjusting rod.

4 Undo the two bolts securing the cable outer retaining plate to the floor pan (see illustration). Remove the retaining plate then detach the relevant cable inner from the equalizer plate and release the cable grommet from the floorpan.

5 On models equipped with ABS, working from underneath the vehicle, remove the two brake caliper shield retaining bolts and remove the shield from the caliper. Extract the

spring clip and clevis pin securing the handbrake cable to the caliper handbrake lever then remove the clip securing the cable outer to its mounting bracket and detach the handbrake cable from the caliper.

6 On non-ABS models, remove the relevant rear brake drum. Remove the trailing shoe retainer spring and pin, using a pair of pliers to press in the retainer clip until it can be rotated through 90° and released. Ease the trailing shoe out of the lower pivot point to release the tension of the return spring, then disconnect the lower return spring from both shoes. Disconnect the handbrake cable from the trailing shoe then use a 12 mm spanner to compress the handbrake cable retaining tangs and withdraw the cable from the rear of the backplate (see illustration).

7 On all models, release the main silencer from its three rubber mountings and carefully

lower the tailpipe section to gain access to the heat shield. Undo the three heat shield retaining bolts and remove the shield from the vehicle underbody.

8 Work along the length of the cable section and remove all bolts securing the cable outer to the vehicle underbody and trailing arm. Once free, withdraw the cable from underneath the vehicle and, if necessary, repeat the procedure for the remaining cable section.

Refitting

9 Refitting is a reversal of the removal sequence noting the following:

- Lubricate all exposed linkages and cable pivots with a good quality multi-purpose grease.
- Ensure the cable outer grommet is correctly located in the floorpan and that all retaining bolts are tightened to the specified torque.
- On non-ABS models, relocate the trailing shoe and refit the brake drum.
- Prior to refitting the rear centre console section, adjust the handbrake cable as described in Chapter 1.

25 Stop lamp switch - removal, refitting and adjustment



Removal

1 Working inside the vehicle, undo the five screws and remove the right-hand lower facia panel.

2 Disconnect the wiring connector from the stop lamp switch (see illustration).

3 Slacken the stop lamp switch locknut and unscrew the switch from its mounting bracket.

Refitting and adjustment

4 Screw the switch back into position in the mounting bracket.

5 Connect an ohmmeter across the stop lamp switch terminals and screw the switch in until an open circuit is present between the switch terminals. Gently depress the pedal and check that continuity exists between the

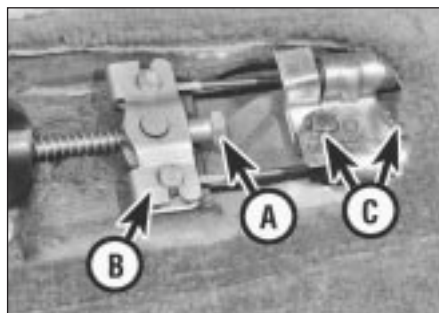

24.4 Handbrake cable adjusting nut (A), equalizer plate (B) and cable outer retaining plate bolts (C)



24.6 Using a 12 mm spanner to compress cable outer retaining tangs

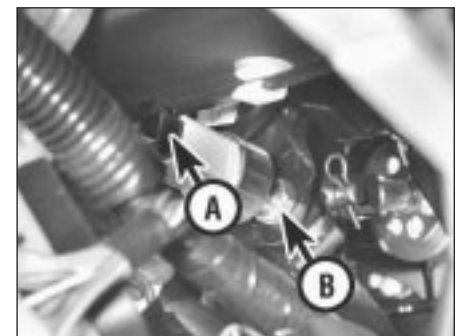

25.2 Stop lamp switch wiring connector (A) and locknut (B)

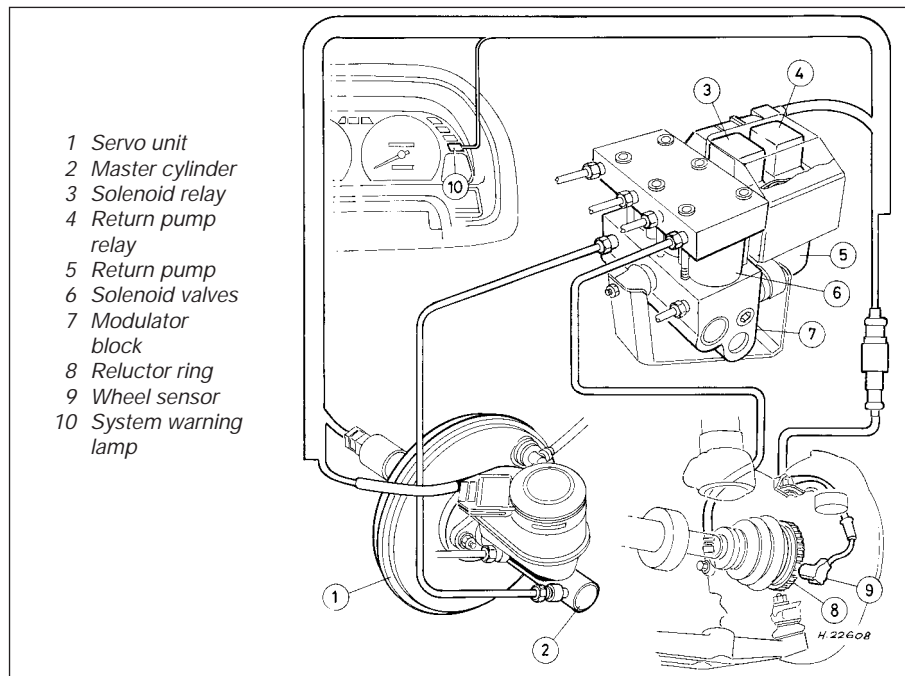

26.1 ABS system components

switch terminals as soon as the pedal is depressed. If necessary, reposition the switch until it operates as specified.

6 Once the stop lamp switch is correctly adjusted, hold the switch stationary and tighten the locknut securely.

7 Connect the wiring connector to the switch and refit the lower fascia panel.

26 Anti-lock Braking system (ABS) - component removal and refitting



Modulator block

Removal

1 Disconnect the battery negative terminal then undo the screw and remove the modulator relay cover (see illustration).

2 Disconnect the wiring connectors from the modulator and free the wiring from its retaining clip on the unit.

3 Disconnect the sender unit wiring connector and unscrew the master cylinder reservoir filler cap. Place a piece of polythene over the filler neck and securely refit the cap (taking care not to damage the sender unit). This will minimise brake fluid loss during subsequent operations. As an added precaution, place absorbent rags beneath the modulator brake pipe unions.

4 Wipe clean the area around the brake pipe unions then make a note of how the pipes are arranged for reference when refitting. Unscrew the union nuts and carefully withdraw the pipes. Plug or tape over the pipe ends and valve orifices to minimise the loss of

brake fluid and to prevent the entry of dirt into the system. Wash off any spilt fluid immediately with cold water.

5 Undo the earth lead retaining nut and slacken the modulator block mounting nuts. Disconnect the earth lead and remove the modulator assembly from the engine compartment. Do not attempt to dismantle the modulator block assembly. Overhaul of the unit is a complex job and should be entrusted to a Rover dealer.

Refitting

6 Refitting is the reverse of the removal procedure, noting the following:

- Tighten the modulator block mounting nuts to the specified torque.
- Refit the brake pipes to their respective unions and tighten the union nuts to the specified torque.
- On completion, bleed the braking system.

Front wheel sensor

Removal

7 Chock the rear wheels, firmly apply the handbrake, jack up the front of the vehicle and support on axle stands. Remove the appropriate front roadwheel.

8 From inside the engine compartment, disconnect the relevant sensor wiring connector and displace the sensor wiring grommet.

9 From underneath the vehicle, pull the sensor wiring lead through the wing valance then undo the sensor lead bracket retaining bolts and remove the brackets.

10 Slacken and remove the two bolts securing the sensor unit to the wheel hub then remove the sensor and lead assembly.

Refitting

11 Refitting is the reverse of the removal procedure, noting the following:

- Ensure that the sensor and hub sealing faces are clean then refit the sensor and tighten its retaining bolts to the specified torque.
- Ensure the sensor wiring is correctly routed and all bracket retaining bolts are tightened to the specified torque.

Rear wheel sensor

Removal

12 Chock the front wheels then jack up the rear of the vehicle and support it on axle stands. Remove the appropriate roadwheel.

13 Trace the wiring back from the sensor to the wiring connector then free the connector from its retaining clips and disconnect it.

14 Undo the sensor lead bracket retaining bolts and remove the brackets.

15 Slacken and remove the bolt securing the strap to the sensor cover then undo the sensor cover retaining bolts and remove the cover.

16 Undo the two bolts securing the sensor to the rear hub assembly and remove it from the vehicle, along with the shim which is fitted behind it.

Refitting

17 Refitting is the reverse of the removal procedure, noting the following:

- Ensure the sensor and hub sealing faces are clean, then install the sensor and shim and tighten the sensor retaining bolts to the specified torque.
- Refit the sensor cover, cover strap retaining bolt and sensor lead brackets, then tighten all retaining bolts to the specified torque.
- Reconnect the sensor lead wiring connector and refit the connector to its retaining clip.

Reluctor rings

18 The reluctor rings are not available as separate items. The front rings are available only as an integral part of the outer constant velocity joint assembly and the rear rings are available only as an integral part of the rear hub.

19 The front reluctor rings are situated on the outer constant velocity joint and the rear reluctor rings are part of the stub axle assembly. Examine the rings for signs of damage such as chipped or missing teeth and renew as necessary.

Relays

20 Both the solenoid relay and return pump relay are located in the modulator block assembly. To gain access to them, undo the relay cover retaining screw and lift off the cover. Either relay can then be simply pulled out of position. Refer to Chapter 12 for further information on relays.





Chapter 10

Suspension and steering

Contents

Front hub bearings - removal and refitting	3	Rear suspension lateral links - removal, inspection and refitting	15
Front anti-roll bar - removal and refitting	7	Rear suspension strut - dismantling, inspection and reassembly	14
Front anti-roll bar connecting link - removal and refitting	8	Rear suspension strut - removal and refitting	13
Front suspension lower arm - removal, overhaul and refitting	10	Rear suspension trailing arm - removal and refitting	16
Front suspension strut - dismantling, inspection and reassembly	6	Steering - inspection	17
Front suspension strut - removal and refitting	5	Steering column - overhaul	20
Front suspension tie bar - removal and refitting	9	Steering column - removal and refitting	19
Front swivel hub assembly - removal and refitting	2	Steering gear - removal, overhaul and refitting	23
General information and precautions	1	Steering gear rubber gaiters - renewal	22
Power steering oil cooler - removal and refitting	26	Steering lock/ignition switch - removal and refitting	21
Power steering pump - removal and refitting	25	Steering wheel - removal and refitting	18
Power steering pump drivebelt - inspection and adjustment	24	Suspension - inspection	4
Power steering system - bleeding	27	Track rod balljoint - removal and refitting	28
Rear hub and bearings - removal and refitting	11	Wheel alignment and steering angles	29
Rear stub axle - removal and refitting	12		

Degrees of difficulty

Easy , suitable for novice with little experience 	Fairly easy , suitable for beginner with some experience 	Fairly difficult , suitable for competent DIY mechanic 	Difficult , suitable for experienced DIY mechanic 	Very difficult , suitable for expert DIY or professional 
---	--	--	---	--

Specifications

Front suspension

Type	Fully independent, by MacPherson struts with coil springs and integral shock absorbers. Anti-roll bar mounted onto both lower suspension arms
------	---

Rear suspension

Type	Fully independent double wishbone type, by trailing arms with transverse lateral links, suspension struts with coil springs and integral shock absorbers
------	--

Steering

Type	Rack and pinion, power-assisted steering available as an option
Turns lock-to-lock:	
Manual	4.0
Power-assisted	3.4

10•2 Suspension and steering

Wheel alignment and steering angles

All measurements are with vehicle at kerb weight

Toe-out in turns	Inside roadwheel 17° 17'
	Outside roadwheel 16° 21' ± 2'
Camber angle:	
Front	0° 20' negative ± 0° 10'
Rear	0° 50' negative to 0° 50' positive
Castor angle:	
Front	1° 59' positive ± 0° 30'
Rear	N/A
Steering axis inclination (SAI) or kingpin inclination (KPI)	12°
Toe setting:	
Front	0° 10' ± 0° 15' toe-out
Rear	0° 11' ± 0° 7.5' toe-in

Roadwheels

Type:	
214 GSi	Steel (alloy optional)
All other models	Steel
Size:	
214 S without ABS	4.5 x 13
214 S with ABS, 214, 414 Si and SLi	5 x 14
214 GSi:	
Standard (steel wheels)	5 x 14
Optional (alloy wheels)	5.5 x 14

Tyres

Type	Tubeless, steel-braced radial	
Size:		
214 S without ABS	155 SR 13	
214 S with ABS, 214, 414 Si and SLi	175/65 TR 14	
214 GSi:		
Standard (steel wheels)	175/65 TR 14	
Optional (alloy wheels)	185/60 HR 14	
Pressures (cold) - 155 SR 13 tyres:	Front	Rear
Normal driving conditions	2.1 bar (30 psi)	2.1 bar (30 psi)
Loads in excess of four persons	2.1 bar (30 psi)	2.3 bar (34 psi)
Speeds in excess of 100 mph - all loads	2.2 bar (32 psi)	2.2 bar (32 psi)
Pressures (cold) - 175/65 TR 14 tyres:	Front	Rear
All loads - up to 100 mph	2.1 bar (30 psi)	2.1 bar (30 psi)
All loads - over 100 mph	2.2 bar (32 psi)	2.2 bar (32 psi)
Pressures (cold) - 185/60 HR 14 tyres:	Front	Rear
All loads - up to 100 mph	2.1 bar (30 psi)	2.1 bar (30 psi)
All loads - over 100 mph	2.5 bar (36 psi)	2.5 bar (36 psi)

Note: Pressures apply only to original equipment tyres and may vary if any other make or type is fitted. Check with the tyre manufacturer or supplier for correct pressures if necessary

Torque wrench settings

	Nm	lbf ft
Front suspension		
Driveshaft retaining nut	185	137
Front suspension strut:		
Upper mounting nuts	32	24
Swivel hub pinch-bolt	100	74
Brake hose clamp bolt	25	18
Upper mounting plate retaining nut	40	30
Anti-roll bar:		
Mounting clamp bolts	15	11
Connecting link bolts	45	33
Tie bar:		
Lower suspension arm bolts	80	59
Retaining nut	55	41
Lower arm:		
Balljoint retaining nut	60	44
Body pivot bolt	45	33

Torque wrench settings (continued)	Nm	lbf ft
Rear suspension		
Rear hub nut	185	137
Drum brake backplate-to-trailing arm bolts	65	48
Disc brake shield-to-trailing arm bolts	15	11
Brake hose bracket-to-trailing arm bolts	15	11
Handbrake cable-to-trailing arm bolts	22	16
Stub axle:		
Retaining nut	170	125
Trailing arm bolts	55	41
Rear suspension strut:		
Upper mounting nuts	32	24
Lower mounting bolt	45	33
Upper mounting plate retaining nut	40	30
Lateral link pivot bolts	45	33
Trailing arm mounting bolts	83	61
Steering		
Steering wheel nut:		
Without airbag	52	39
With airbag	45	32
Steering column:		
Lower mounting bolt and nut	20	15
Upper mounting bolts	20	15
Upper mounting nuts	13	10
Universal joint pinch-bolts	30	22
Steering gear mounting bolts	42	31
Steering gear mounting nuts	25	18
Power-assisted steering gear:		
Feed pipe union nut	39	29
Return pipe union nut	31	23
Track rod balljoint:		
Retaining nut	44	32
Locknut	55	41
Power steering pump:		
Mounting bolts	48	35
Outlet pipe union nut	55	41
Pulley retaining bolts	9	7
Power steering oil cooler mounting bolts	9	7
Roadwheels		
Roadwheel nuts	100	74

1 General information and precautions

General information

The independent front suspension is of the MacPherson strut type, incorporating coil springs and integral telescopic shock absorbers. The MacPherson struts are located by transverse lower suspension arms, which utilize rubber inner mounting bushes and incorporate a balljoint at the outer ends, and forward facing longitudinal tie bars. Both lower suspension arms are connected to an anti-roll bar via a small connecting link. The front swivel hubs, which carry the wheel bearings, brake calipers and the hub/disc assemblies, are bolted to the MacPherson struts and connected to the lower arms via the balljoints.

The fully independent rear suspension is of double wishbone type, utilising pressed steel trailing arms which have the roadwheel stub axles bolted into their rear ends. These are located longitudinally on the vehicle underbody via a large rubber bush which is situated towards the centre of each arm. Each trailing arm assembly is located transversely by three lateral links, which utilize rubber mounting bushes at both their inner and outer ends. The rear suspension struts incorporate coil springs and integral telescopic shock absorbers and are mounted onto the rear lower lateral link via a rubber mounting bush.

The steering wheel is of the energy-absorbing type (to protect the driver in the event of an accident) and is attached by a deeply-recessed nut to the steering column which is also collapsible. In the event of an impact, such as in an accident, the lower steering column clamp and the upper column mounting, fitted with energy absorbing

bending plates, is designed to allow the column to slide downwards. The downwards movement of the column bends the mounting plates which absorb some of the energy, so lessening the force transmitted to the driver via the steering wheel.

An airbag is available as an option and, when fitted, is mounted in the centre of the steering wheel. See Chapter 12 for full details.

The steering column has a universal joint fitted towards the lower end of its length and its bottom end is clamped to a second universal joint, which is in turn clamped to the steering gear pinion.

The steering gear is mounted onto the engine compartment bulkhead and is connected by two track rods, with balljoints at their outer ends, to the steering arms projecting rearwards from the hub carriers. The track rod ends are threaded to facilitate adjustment.

Power-assisted steering is available as an

10•4 Suspension and steering

option on all models. The main components being a rack and pinion steering gear unit, a hydraulic pump which is belt-driven off the crankshaft and the hydraulic feed and return lines between the pump and steering gear.

Precautions

The driveshaft hub and stub axle nuts are

very tight – ensure the car is securely supported when loosening and tightening them.

A number of precautions must be observed when working on the steering components of vehicles equipped with airbags, these are listed in Chapter 12.

2 Front swivel hub assembly - removal and refitting



Removal

1 Chock the rear wheels, firmly apply the handbrake then jack up the front of the vehicle and support it on axle stands. Remove the appropriate front roadwheel.

2 Using a hammer and suitable chisel nosed tool, tap up the staking securing the driveshaft retaining nut to the groove in the outer constant velocity joint (see illustration).

3 Have an assistant firmly depress the footbrake, then using a socket and extension bar, slacken and remove the driveshaft retaining nut. Discard the nut. A new nut must be obtained for reassembly.

4 If the hub bearings are to be disturbed, remove the brake disc. If not, undo the two bolts securing the caliper mounting bracket to the hub and slide the caliper off the disc. Tie the caliper to the suspension strut to avoid placing any strain on the brake hose.

5 On models equipped with ABS, remove the front wheel sensor.

6 Slacken and remove the bolt and washer securing the anti-roll bar connecting link to the lower suspension arm and undo the two bolts securing the tie bar to the lower suspension arm.

7 Extract the split pins and undo the nuts securing the steering gear track rod and lower suspension arm balljoints to the swivel hub. Release both the balljoints from the swivel hub by using a suitable balljoint separator, taking great care not to damage the balljoint gaiters.

8 Slacken the swivel hub-to-suspension strut clamp bolt then carefully ease the hub off the strut. Once free, pull the hub outwards to free it from the constant velocity joint splines, then remove it from the vehicle (see illustration). Whilst the hub is removed, support the driveshaft by tying it to the suspension strut to avoid damaging the inner constant velocity joint or gaiter.

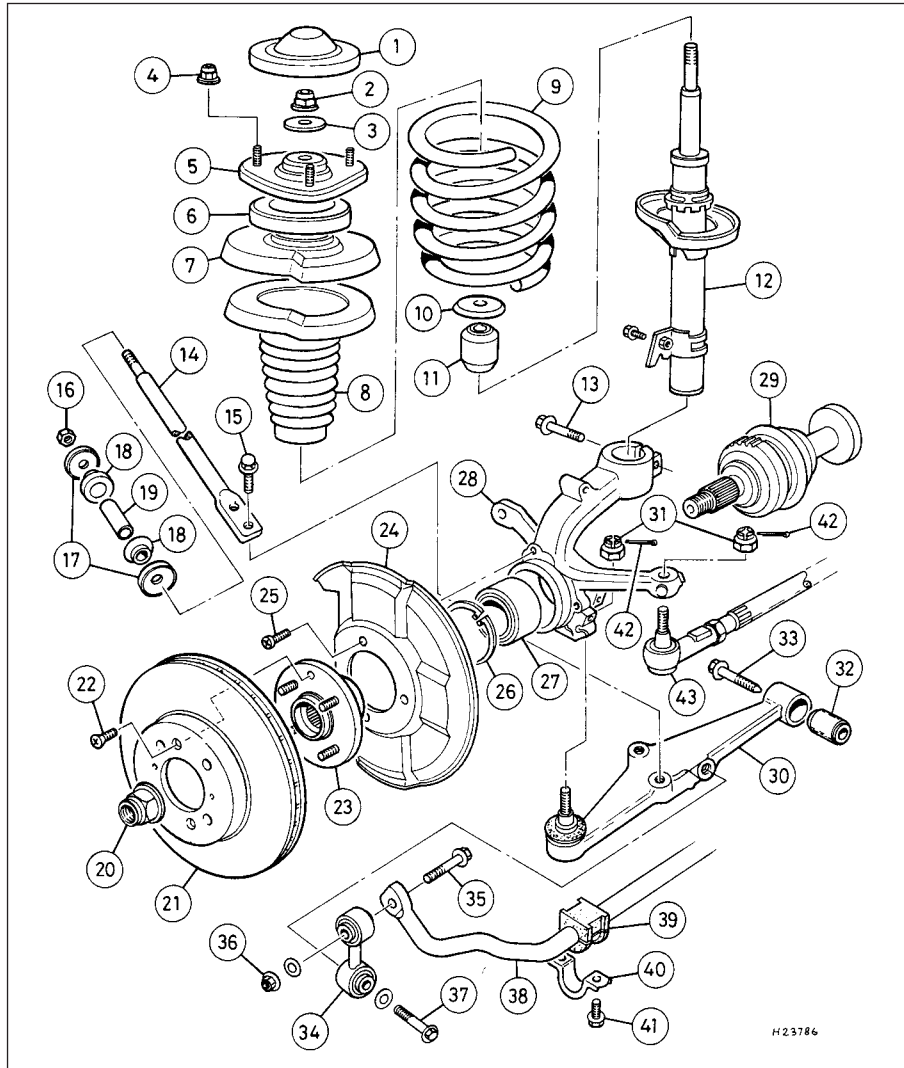

2.2 Front suspension components

- | | | |
|--------------------------------|-----------------------------|--|
| 1 Rubber cover | 17 Flanged washer | 32 Lower arm pivot bush |
| 2 Self-locking nut | 18 Mounting bush | 33 Lower arm pivot bolt |
| 3 Washer | 19 Spacer | 34 Anti-roll bar connecting link |
| 4 Strut upper mounting nut | 20 Driveshaft retaining nut | 35 Bolt |
| 5 Upper mounting plate | 21 Brake disc | 36 Nut |
| 6 Bearing | 22 Disc retaining screw | 37 Bolt - anti-roll bar connecting link to lower arm |
| 7 Upper spring seat | 23 Hub | 38 Anti-roll bar |
| 8 Dust cover | 24 Disc shield | 39 Mounting rubber |
| 9 Coil spring | 25 Bolt | 40 Mounting clamp |
| 10 Washer | 26 Circlip | 41 Bolt |
| 11 Rubber damper stop | 27 Hub bearing | 42 Split pin |
| 12 Strut | 28 Swivel hub | 43 Track rod balljoint |
| 13 Strut lower clamp bolt | 29 Driveshaft | |
| 14 Tie bar | 30 Lower suspension arm | |
| 15 Bolt - tie bar to lower arm | 31 Balljoint retaining nut | |
| 16 Nut - tie bar to subframe | | |



2.8 Removing swivel hub assembly

Refitting

9 Refitting is reversal of the removal procedure noting the following:

- Ensure that the lug on the base of the suspension strut correctly engages with the slot in the swivel hub assembly clamp.
- Tighten all nuts and bolts to the specified torque.
- Where necessary, refit the brake disc and/or ABS wheel sensor as described in Chapter 9.
- Use new split pins to secure the track rod and lower suspension arm balljoint retaining nuts in position.
- When fitting the new driveshaft retaining nut, tighten it to the specified torque then stake it firmly into the groove in the constant velocity joint by using a suitable punch.

3 Front hub bearings - removal and refitting



Note: The front hub bearing is a sealed, pre-adjusted and pre-lubricated, double-row roller type, and is intended to last the vehicle's entire service life without maintenance or attention. Do not attempt to remove the bearing unless absolutely necessary, as it will probably be damaged during the removal operation. Never overtighten the driveshaft nut beyond the specified torque wrench setting in an attempt to 'adjust' the bearing.

Note: A press will be required to dismantle and rebuild the hub assembly. If such a tool is not available, a large bench vice and suitable spacers (such as large sockets) will serve as an adequate substitute. The service tool numbers for the special Rover mandrels are given in the accompanying illustrations. The bearing's inner races are an interference fit on the hub. If the outboard inner race remains on the hub when it is pressed out of the hub carrier, a proprietary knife-edged bearing puller will be required to remove it.

Removal

- Remove the swivel hub assembly, then undo the brake disc shield retaining screws and remove the shield from the hub.
- Press the hub out of the swivel hub using a tubular spacer (see illustration). If the bearing's outboard inner race remains on the hub, remove it using a suitable bearing puller.
- Extract both circlips from the swivel hub and discard them as they should be renewed whenever disturbed.
- Press the bearing out of the swivel hub by using a suitable tubular spacer (see illustration).
- Thoroughly clean the hub and swivel hub, removing all traces of dirt and grease. Polish away any burrs or raised edges which might hinder reassembly. Check both for cracks or any other signs of wear or damage and renew

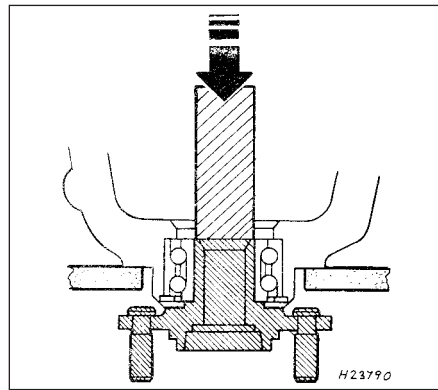

3.2 Pressing out hub from swivel hub

the hub if necessary. The bearing and its circlips must be renewed whenever they are disturbed. A replacement bearing kit is available from Rover dealers which consists of the bearing and both circlips.

6 Check the condition of the roadwheel studs in the hub flange. If any are sheared off, stretched or have damaged threads, they can be pressed out of the hub providing that its flange is fully supported. On refitting, support the hub flange and press in the new stud until it seats fully.

Refitting

- On reassembly, check (if possible) that the new bearing is packed with grease and fit the new circlip to the swivel hub outboard groove. Apply a light film of oil to the bearing inner and outer races and to the matching surfaces in the hub and swivel hub to aid fitting of the bearing.
- Support the swivel hub outboard face and, using a suitable tubular spacer which bears only on the bearing's outer race, press in the new bearing until it seats against the circlip (see illustration). Secure the bearing in position by fitting the second new circlip to the swivel hub's inboard groove.
- Fully supporting the bearing inner race, press the hub into the bearing and swivel hub until the hub shoulder seats against the bearing's inner race (see illustration). Wipe off any surplus oil or grease.

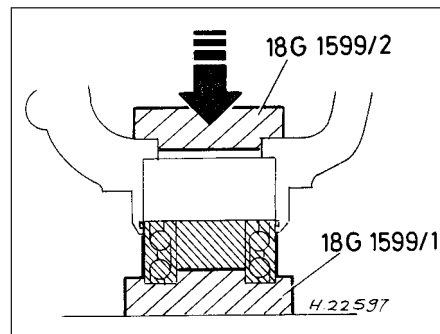

3.8 Pressing new hub bearing into swivel hub

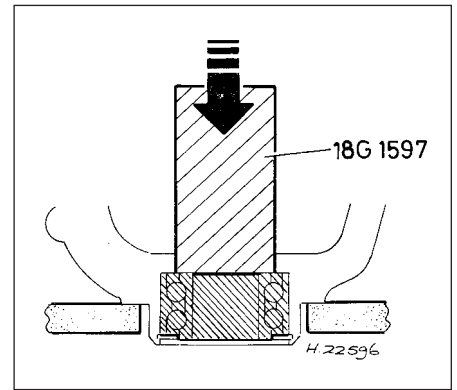

3.4 Pressing hub bearing out of swivel hub

- Refit the brake disc shield to the swivel hub and tighten its retaining screws securely.
- Refit the swivel hub assembly.

4 Suspension - inspection

Refer to Chapter 1.

5 Front suspension strut - removal and refitting



Removal

- Chock the rear wheels, firmly apply the handbrake, then jack up the front of the vehicle and support on axle stands. Remove the appropriate roadwheel.
- Extract the split pin and undo the nut securing the steering gear track rod balljoint to the swivel hub. Release the balljoint shank, using a suitable balljoint separator tool whilst taking care not to damage the balljoint gaiter.
- Slacken and remove the bolt and washer securing the anti-roll bar connecting link to the lower suspension arm, then undo the two

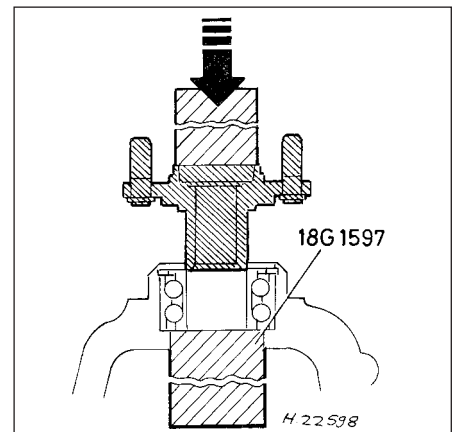

3.9 Pressing hub into swivel hub - note support for bearing inner race



5.4 Removing bolt securing brake hose to suspension strut



5.6a Remove rubber cover and strut upper mounting nuts (arrowed)



5.6b Removing a front suspension strut

bolts securing the tie bar to the lower suspension arm.

4 Undo the bolt securing the brake hose retaining clamp to the strut, then remove the clamp and free the flexible hose (see illustration).

5 Slacken the swivel hub-to-suspension strut clamp bolt, then carefully ease the swivel hub assembly off the end of the strut.

6 Working in the engine compartment, remove the rubber suspension strut cover. Use chalk or a dab of paint to mark the relative positions of the suspension strut upper mounting and body. Undo the three strut upper mounting nuts and manoeuvre the strut out from under the wheelarch whilst noting the seal which is fitted between the upper mounting plate and vehicle body (see illustrations).

Refitting

7 Refitting is a reversal of the removal procedure, noting the following (see illustration):

- a) Ensure that the marks made on removal are aligned when fitting the strut.
- b) Ensure that the lug on the base of the suspension strut correctly engages with the slot in the swivel hub assembly.
- c) Tighten all nuts and bolts to the specified torque.
- d) Use a new split pin to secure the track rod balljoint retaining nut in position.

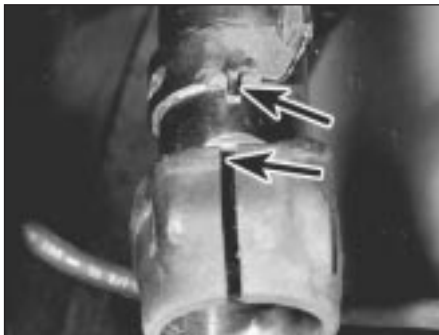

5.7 Align suspension strut lug with slot in swivel hub (arrowed)

6 Front suspension strut - dismantling, inspection and reassembly

Note: Before attempting to dismantle the front suspension strut, a suitable tool to hold the coil spring in compression must be obtained. Adjustable coil spring compressors are readily available and are recommended for this operation. Any attempt to dismantle the strut without such a tool is likely to result in damage or personal injury.

Dismantling

1 With the strut removed from the vehicle, clean away all external dirt then mount it upright in a vice.

2 Fit the spring compressor and compress the coil spring until all tension is relieved from the upper mounting plate (see illustration).

3 Slacken the upper mounting retaining nut whilst retaining the strut piston with an Allen key (see illustration).

4 Remove the nut and washer followed by the mounting plate, bearing and upper spring seat. Lift off the coil spring and damper piston dust cover and separate the two components. Slide the washer and rubber damper stop off the strut piston.

Inspection

5 With the strut assembly completely dismantled, examine all components for wear,

damage or deformation and check the bearing for smoothness of operation. Renew any of the components, as necessary.

6 Examine the strut for signs of fluid leakage. Check the strut piston for signs of pitting along its entire length and check the strut body for signs of damage. Test the operation of the strut, while holding it in an upright position, by moving the piston through a full stroke and then through short strokes of 50 to 100 mm. In both cases the resistance felt should be smooth and continuous. If the resistance is jerky, or uneven, or if there is any visible sign of wear or damage to the strut, renewal is necessary.

7 If any doubt exists about the condition of the coil spring, carefully remove the spring compressors and check the spring for distortion and signs of cracking. Since no minimum free length is specified by Rover, the only way to check the tension of the spring is to compare it to a new component. Renew the spring if it is damaged or distorted or there is any doubt as to its condition.

8 Inspect all other components for signs of damage or deterioration and renew any that are suspect.

Reassembly

9 Reassembly is a reversal of dismantling. Ensure that the spring ends are correctly located in the upper and lower seats and that the upper mounting plate retaining nut is tightened to the specified torque.



6.2 Compress coil spring with suitable pair of spring compressors . . .



6.3 . . . and remove upper mounting nut whilst retaining piston with Allen key



7.4 Slacken and remove anti-roll bar-to-connecting link bolts



7.5 Correct position of anti-roll bar mounting bush split (arrowed)

7 Front anti-roll bar - removal and refitting



Removal

1 Chock the rear wheels, firmly apply the handbrake then jack up the front of the vehicle and support it on axle stands. Remove both front roadwheels.

2 From underneath the vehicle, undo the bolts securing the gearchange control rod rear rubber mounting to the vehicle underbody. Remove the rubber mounting assembly and bolts, noting the correct fitted positions of the mounting rubber spacers and mounting plate.

3 Release the exhaust system from its front rubber mountings, then undo the three gearchange linkage bellcrank assembly retaining bolts and lower the gearchange linkage assembly down onto the exhaust system.

4 Slacken and remove the nuts and washers securing each end of the anti-roll bar to the connecting links and remove the bolts (see illustration).

5 Mark the location of the clamp bushes on the bar, then undo the mounting clamp retaining bolts and remove the clamps. Make a note of the fitted position of the rubber bush splits to ensure that they are positioned correctly on refitting (see illustration). Manoeuvre the anti-roll bar out over the gearchange linkage and exhaust system and remove it from the right-hand side of the vehicle.

6 Carefully examine the anti-roll bar components for signs of wear, damage or deterioration, paying particular attention to the mounting rubbers. Inspect the gearchange mechanism control rod mounting rubber and bush for signs of wear or deterioration. Renew worn components as necessary.

Refitting

7 Manoeuvre the anti-roll bar into position from the right-hand side of the vehicle and refit the connecting link bolts. Refit the

washers and tighten the nuts, finger tight only.

8 Lubricate the mounting clamp bushes with a solution of soapy water then lever the bar down and slide them into position on the anti-roll bar. Ensure that the splits are on the right side of the bushes then align them with the marks made on dismantling.

9 Refit the anti-roll bar mounting clamps and tighten the retaining bolts to the specified torque setting, then tighten the anti-roll bar-to-connecting link bolts to the specified torque.

10 Refit the front gearchange mechanism linkage mounting plate assembly retaining bolts and tighten them securely.

11 Apply a smear of grease to the gearchange control rod bush and refit the rear mounting rubber assembly. Tighten the mounting bolts to the specified torque setting and check that the gearchange mechanism operates smoothly. Refit the exhaust system to the front mounting rubbers.

12 Refit the roadwheels then lower the vehicle to the ground and tighten the roadwheel nuts to the specified torque.

8 Front anti-roll bar connecting link - removal and refitting



Removal

1 Chock the rear wheels, firmly apply the handbrake, jack up the front of the vehicle



8.2 Anti-roll bar connecting link

and support on axle stands. Remove the appropriate front roadwheel.

2 From underneath the vehicle, slacken and remove the bolt and washer securing the connecting link to the lower suspension arm (see illustration).

3 Remove the nut and washer securing the connecting link to the anti-roll bar, then withdraw the bolt and remove the connecting link from under the vehicle.

4 Inspect the connecting link rubber mounting bushes for signs of damage and renew them if they are cracked, worn, split or perished. The bushes are a press fit in the connecting link and can be pressed out and in using a vice and two suitable sized tubular drifts, such as sockets (one bearing on the hard outer edge of the bush and another bearing against the edge of the connecting link).

Refitting

5 Refitting is the reverse of the removal sequence. Tighten both the connecting link bolts to the specified torque setting.

9 Front suspension tie bar - removal and refitting



Removal

1 Chock the rear wheels, firmly apply the handbrake, jack up the front of the vehicle and support on axle stands. Remove the appropriate front roadwheel.

2 From underneath the front of the vehicle, slacken and remove the three bolts securing the bumper flange to the body. Remove the seven bolts securing the front undercover panel to the body and remove the panel.

3 Undo the nut securing the front of the tie bar to the front subframe then remove the flanged washer and mounting bush, noting which direction the flange is facing (see illustration).

4 Undo the two bolts securing the tie bar to the lower suspension arm, then remove the rod from the vehicle and slide the spacer,



9.3 Tie bar retaining nut is accessed from front of subframe



9.4 Tie bar-to-lower suspension arm bolts



9.5 Renew tie bar mounting bushes if damaged (arrowed)



9.6 Fit flange washer, spacer and mounting bush onto tie bar . . .

mounting bush and flanged washer off the tie bar (see illustration).

5 Examine all the components for signs of wear or damage, paying particular attention to the mounting bushes and tie bar threads. Renew components as necessary (see illustration).

Refitting

6 Slide the flange washer, mounting bush and spacer onto the tie bar threads. Ensure that the flange of the washer is facing away from the mounting bush and that the rounded surface of the bush is facing the washer (see illustration).

7 Refit the tie bar to the front subframe and fit the second mounting bush and flanged washer. Ensure the flat surface of the mounting bush is facing the subframe and that the flange of the washer is facing away from the mounting bush, then refit the tie bar nut, tightening it finger tight (see illustration).

8 Refit the tie bar-to-lower suspension arm bolts and tighten them to the specified torque, then tighten the tie bar retaining nut to the specified torque setting.

9 Refit the front undercover panel and tighten all the panel and bumper flange bolts securely.

10 Refit the roadwheel then lower the vehicle to the ground and tighten the roadwheel nuts to the specified torque.

10 Front suspension lower arm - removal, overhaul and refitting



Note: The lower arm balljoint is an integral part of the lower arm assembly and is not available separately. If renewal of the balljoint is necessary, then the complete lower arm assembly must be renewed.

Removal

1 Chock the rear wheels, firmly apply the handbrake, jack up the front of the vehicle and support on axle stands. Remove the appropriate front roadwheel.

2 Slacken and remove the bolt and washer securing the anti-roll bar connecting link to the lower suspension arm and undo the two bolts securing the tie bar to the lower suspension arm.

3 Extract the split pin and undo the nut securing the lower arm balljoint to the swivel hub. Release the balljoint shank by using a



9.7 . . . then refit tie bar to subframe and install second mounting bush and flange washer

suitable balljoint separator tool whilst taking care not to damage the balljoint gaiter.

4 Undo the lower suspension arm-to-body pivot bolt and withdraw the lower arm from the vehicle (see illustrations).

Overhaul

5 Thoroughly clean the lower arm and the area around the arm mountings, removing all traces of dirt and underseal if necessary, then check carefully for cracks, distortion or any other signs of wear or damage. Check that the



10.4a Release balljoint from swivel hub assembly . . .

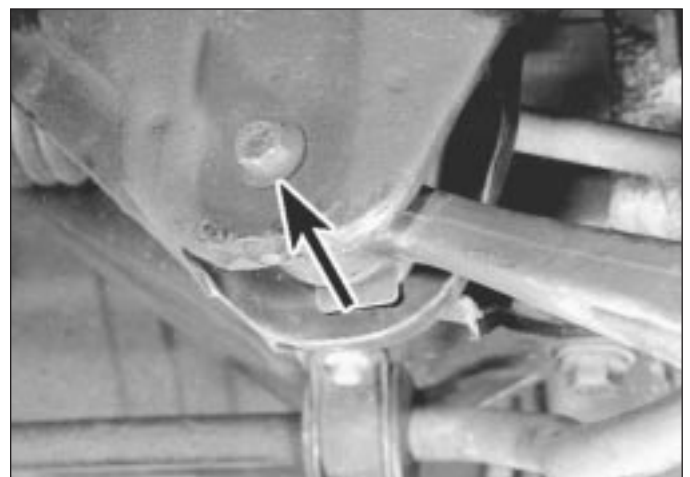

10.4b . . . then remove pivot bolt (arrowed) and withdraw lower suspension arm

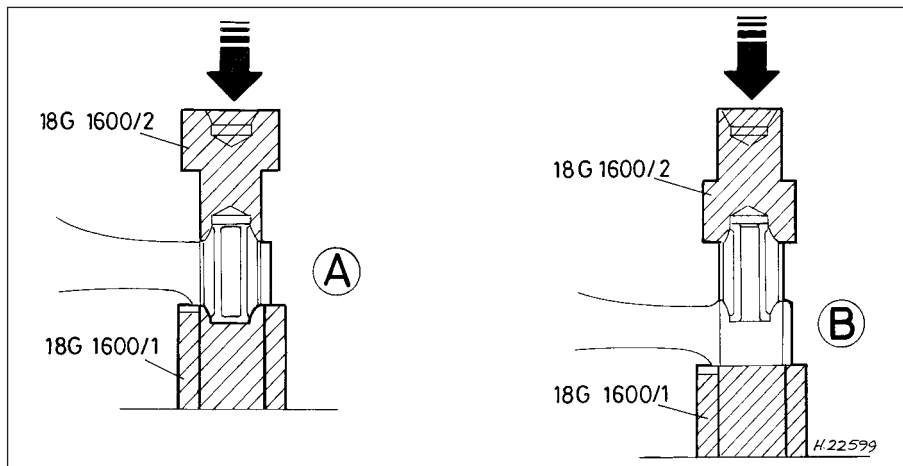

10.6 Using special Rover mandrels to renew lower suspension arm bush

A Removing old bush B Fitting new bush

lower arm balljoint moves freely without any sign of roughness and that the balljoint gaiter shows no sign of deterioration and is free from cracks and splits. Examine the shank of the pivot bolt for signs of wear or scoring. Renew worn components, as necessary.

6 Check the lower arm inner pivot bush and renew it if worn, cracked, split or perished. Bush renewal is best left to a Rover dealer as a press, a special bush removal/refitting mandrel and a support are required (Rover Service Tool Numbers 18G 1600/2 and 18G 1600/1 respectively). While the old bush can be extracted using a strong bench vice and suitable sockets, it is unlikely that new bushes can be installed successfully without the shaped mandrel (see illustration).

Refitting

7 Offer up the lower arm and fit the arm to body pivot bolt. Tighten the bolt by hand only at this stage.

8 Insert the lower arm balljoint shank into the swivel hub and tighten its retaining bolt to the specified torque. Secure the balljoint nut in position with a new split pin.

9 Refit the tie bar and anti-roll bar connecting link to lower arm bolts and tighten them to the specified torque.

10 Refit the roadwheel, then lower the vehicle to the ground and tighten the roadwheel nuts to the specified torque.

11 With the vehicle standing on its wheels, rock the suspension to settle the lower arm bush in position then tighten the lower arm-to-body pivot bolt to the specified torque setting.

12 Check and, if necessary, adjust front wheel alignment.

11 Rear hub and bearings - removal and refitting



Note: The bearing is a sealed, pre-adjusted and pre-lubricated, double-row tapered-roller type and is intended to last the vehicle's entire service life without maintenance or attention. Never overtighten the hub nut beyond the specified torque wrench setting in an attempt to 'adjust' the bearings.

Note: The bearing is an integral part of the hub and can not be purchased separately. If renewal of the bearing is necessary, the complete hub assembly must be renewed as a unit. The only component which is available separately are roadwheel studs.

Removal

1 Chock the front wheels, then jack up the rear of the vehicle and support it on axle stands. Remove the appropriate rear roadwheel.

2 Prise out the cap from the centre of the hub assembly and, using a hammer and suitable chisel nosed tool, tap up the staking securing the hub retaining nut to the groove in the stub axle (see illustration).

3 Have an assistant firmly depress the footbrake then, using a socket and extension bar, slacken but do not remove the hub retaining nut.

4 Remove the brake drum or disc, as applicable.

5 Once the brake drum/disc has been removed, remove the hub nut and toothed washer and pull the hub assembly off the stub axle. If necessary, the hub can be drawn off the stub axle using a three-legged puller. Discard the nut, noting that a new hub retaining nut must be obtained for reassembly.

6 Check that there is no sign of free play in the hub bearing and that the bearing inner race rotates smoothly and easily without any sign of roughness. If there is any sign of wear or damage to the hub assembly or bearing, the complete hub assembly must be renewed as a unit.

7 Check the condition of the roadwheel studs in the hub flange. If any are sheared off, stretched or have damaged threads, they can be pressed out of the hub providing that its flange is fully supported. On refitting, support the hub flange and press in the new stud until it seats fully.

Refitting

8 Prior to refitting the hub, inspect the stub axle for signs of wear or scoring and, if necessary, renew it.

9 Apply a thin smear of grease to the hub bearing seal and refit the hub assembly. Refit the toothed washer, ensuring that its tooth locates with the groove in the stub axle. Install the new hub nut, tightening it by hand only (see illustrations).

10 Refit the brake drum or disc (as applicable) but do not refit the roadwheel.



11.2 Prise off centre cap to gain access to rear hub nut



11.9a Refit the hub . . .



11.9b . . . and washer, ensuring its tooth engages with stub axle groove

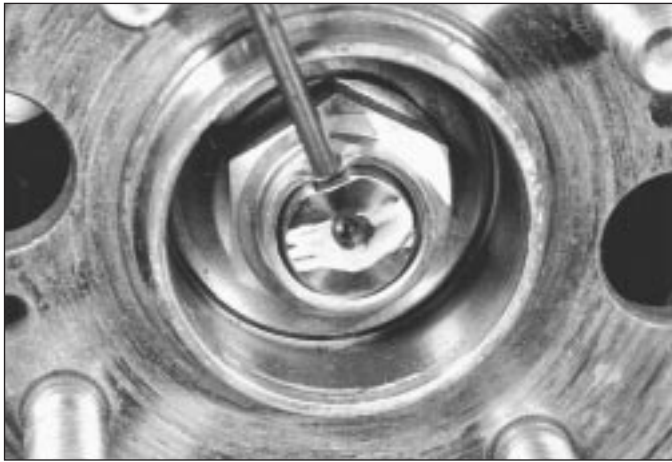

11.11 Stake hub retaining nut firmly into stub axle groove



12.2a Using 12 mm spanner to compress handbrake cable retaining tangs

11 Have an assistant firmly apply the footbrake, then tighten the hub retaining nut to the specified torque. Release the brake and check that the hub rotates smoothly then stake the hub retaining nut fully into the stub axle groove (see illustration). Refit the hub centre cap.

12 Refit the roadwheel, then lower the vehicle to the ground and tighten the roadwheel nuts to the specified torque.

13 Check and, if necessary, adjust rear wheel alignment.

trailing shoe. Undo the bolts securing the handbrake cable and brake hose brackets to the trailing arm, then use a 12 mm ring spanner to compress the handbrake cable retaining clip and withdraw the cable from the backplate. Remove the four bolts securing the backplate to the trailing arm and carefully ease the backplate assembly outwards and off the end of the stub axle (see illustrations). Position the backplate assembly out of the way of the stub axle and tie it to the rear suspension unit coil spring using a piece of wire.

3 On models fitted with rear disc brakes, undo the four disc shield retaining bolts and remove the shield from the trailing arm.

4 On all models, using a socket and extension bar, undo the large stub axle retaining nut from the rear of the trailing arm assembly (see illustration).

5 Slacken and remove the four Torx bolts securing the stub axle mounting plate to the trailing arm assembly, then withdraw the stub axle and remove it from the vehicle.

6 Examine the stub axle spindle and mounting plate for signs of wear or damage such as scoring or cracking. If damaged, the stub axle must be renewed.

Refitting

7 Refitting is a reverse of the removal procedure, tightening all nuts and bolts to the specified torque settings.

12 Rear stub axle - removal and refitting



13 Rear suspension strut - removal and refitting



Removal

- 1 Remove the rear hub assembly.
- 2 On models fitted with rear drum brakes, remove the lower brake shoe return spring, then disconnect the handbrake cable from the

Removal

- 1 Chock the front wheels, then jack up the rear of the vehicle and support it on axle stands. Remove the appropriate rear roadwheel.
- 2 Slacken and remove both pivot bolts securing the rear lower lateral link to the body

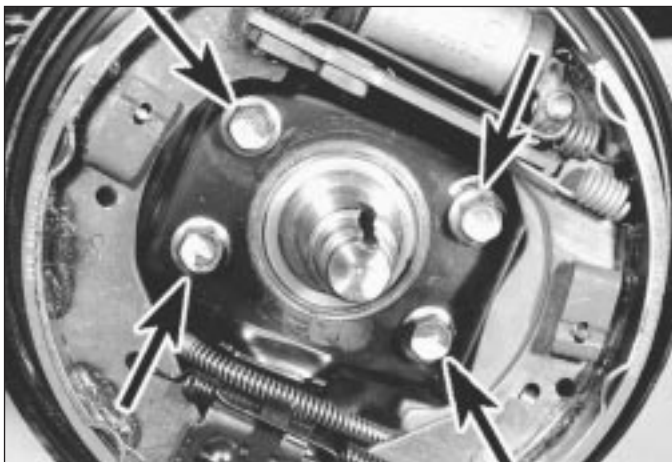

12.2b Backplate retaining bolts (arrowed)

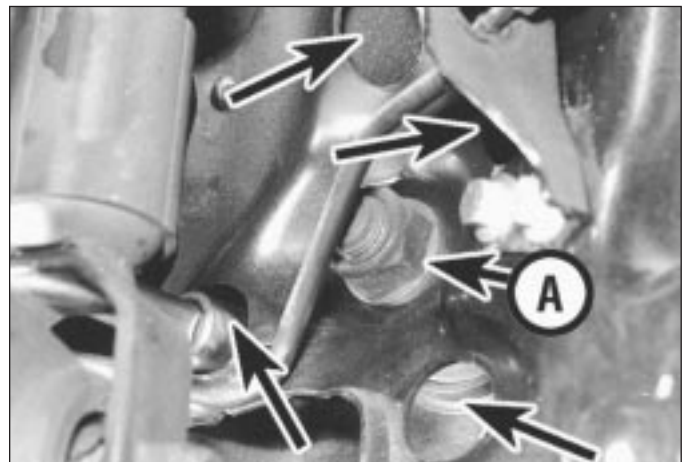

12.4 Stub axle retaining nut (A) - Torx bolts are accessed via four holes (arrowed)

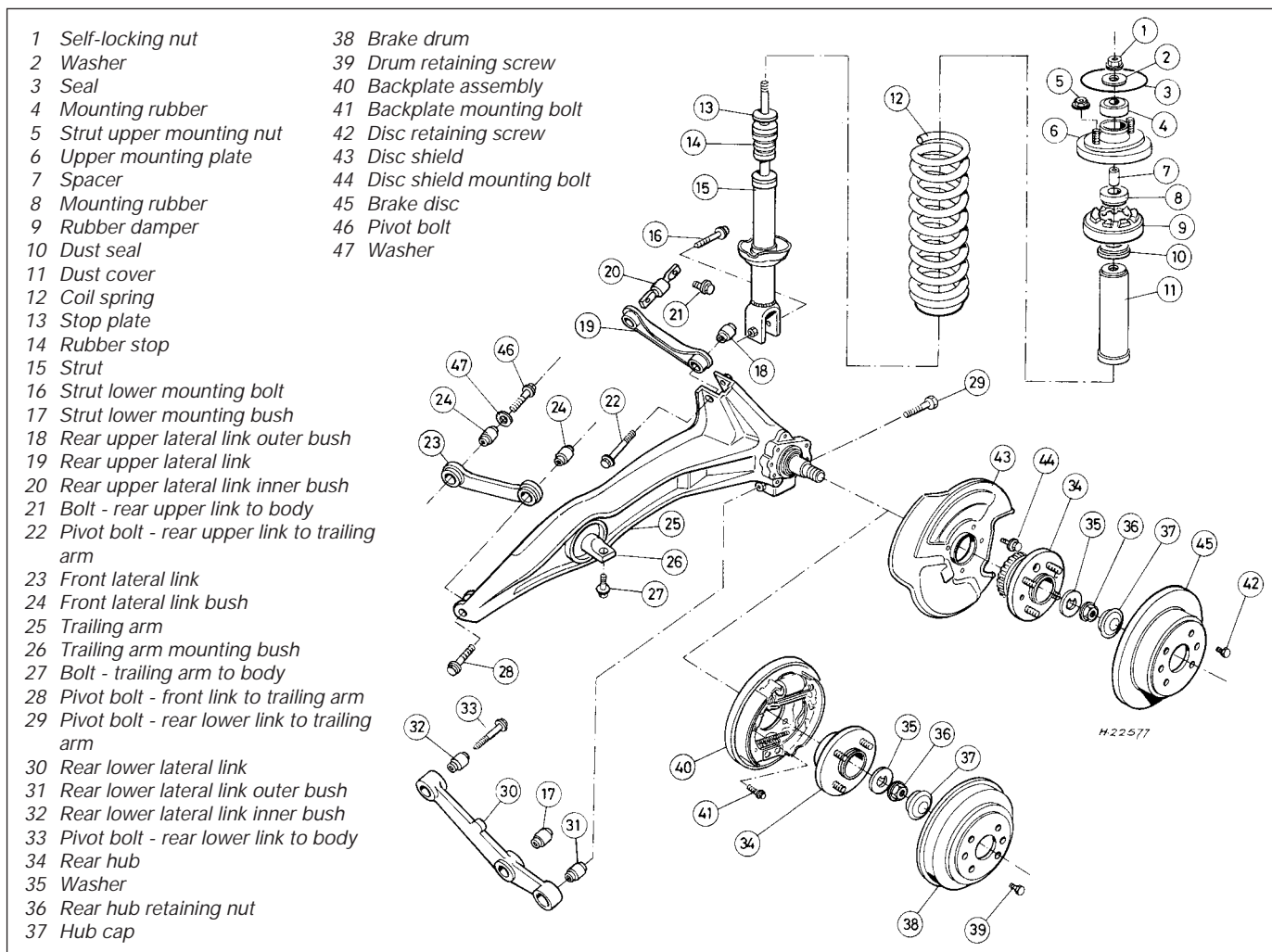

13.2 Rear suspension components

and trailing arm (see illustration). On models equipped with ABS, undo the bolts securing the wheel sensor wiring lead bracket to the lower arm and release the wiring. On all models, undo the lower suspension strut mounting bolt and remove the rear lower lateral link.

3 On 214 models, from inside the luggage compartment, prise off the trim cap to gain access to the rear suspension strut upper mounting nuts. On 414 models, remove the relevant luggage compartment side trim panel to gain access (see illustration).

4 Remove the rubber cover and use chalk or a dab of paint to mark the relative positions of the suspension strut upper mounting and body. Undo the two suspension strut upper mounting nuts and manoeuvre the strut out from under the wheelarch, noting the seal fitted between the upper mounting plate and vehicle body (see illustration).

Refitting

5 Prior to refitting, examine the rear lower lateral link mounting bushes and renew any which are worn or damaged.

6 Ensure the rubber seal is in position on the upper mounting plate then refit the suspension strut, aligning the marks made on removal (where necessary). Refit the upper mounting nuts. Tighten the nuts to the specified torque setting and refit the rubber cover and trim cap/panel.

7 Offer up the lower lateral link and refit the lower suspension strut mounting bolt followed by both the lower lateral link pivot bolts. Tighten the bolts loosely. On models equipped with ABS, refit the wheel sensor wiring bracket retaining bolts and tighten them securely.



13.3 Remove luggage compartment side trim to gain access to strut upper mounting nuts - 414 models



13.4 Removing rear suspension strut

8 Refit the roadwheel, then lower the vehicle to the ground and tighten the roadwheel nuts to the specified torque.

9 With the vehicle standing on its wheels, rock the vehicle to settle the disturbed components in position then tighten the lower lateral link pivot bolts and the lower suspension strut mounting bolt to the specified torque.

14 Rear suspension strut - dismantling, inspection and reassembly



Note: Before attempting to dismantle the rear suspension strut, a suitable tool to hold the coil spring in compression must be obtained. Adjustable coil spring compressors are readily available and are recommended for this operation. Any attempt to dismantle the strut without such a tool is likely to result in damage or personal injury.

Dismantling

1 With the strut removed from the vehicle, clean away all external dirt then mount it upright in a vice.

2 Fit the spring compressor and compress the coil spring until all tension is relieved from the upper mounting plate.

3 Slacken the upper mounting retaining nut whilst retaining the strut piston with an Allen key.

4 Remove the nut and washer followed by the mounting plate assembly, noting the correct fitted positions of the mounting rubbers and spacer, and the upper spring rubber damper. Remove the coil spring then lift the dust seal and cover off the damper and slide the damper stop plate and rubber stop off the strut piston.

Inspection

5 Examine all the rear suspension strut components, using the information given for the front suspension strut.

Reassembly

6 Reassembly is a reversal of the removal procedure. Ensure that the spring ends are correctly located in the upper and lower seats and that the upper mounting plate retaining nut is tightened to the specified torque setting.

15 Rear suspension lateral links - removal, inspection and refitting



Removal

1 Chock the front wheels, then jack up the rear of the vehicle and support it on axle stands. Remove the appropriate rear roadwheel.

Front link

2 Mark the position of the lateral link body pivot bolt in relation to the body. This mark can then be used as a guide on refitting.

3 Slacken and remove both the pivot bolts securing the front lateral link to the body and trailing arm and remove the link from the vehicle (see illustration).

Rear upper link

4 Slacken and remove the pivot bolt securing the rear upper lateral link to the trailing arm assembly (see illustration).

5 Undo the two bolts securing the inner mounting to the vehicle body and remove the link assembly from the vehicle.

Rear lower link

6 Slacken and remove both the pivot bolts securing the lower rear lateral link to the body and trailing arm. On models equipped with ABS, undo the bolts securing the wheel sensor wiring lead bracket to the lower arm and release the wiring. On all models, undo the lower suspension mounting bolt and remove the rear lower lateral link (see illustration).

Inspection

7 Examine the lateral link for signs of cracking and check the mounting bushes for signs of wear or deterioration, renewing as necessary (see illustration).

8 The bushes are a press fit in the link and can be pressed out and in using a vice and

two suitable-sized tubular drifts, such as sockets (one bearing on the hard outer edge of the bush and another bearing against the edge of the lateral link).

9 When renewing the inner bush on the rear upper lateral link, mark the position of the bush mounting plate in relation to the lateral link before removing the worn bush. Fit the new bush so that the mounting plate is in the same position in relation to the lateral link. This avoids placing any undue strain on the rubber bush when the link is refitted to the vehicle.

10 Examine the pivot bolt shanks for signs of wear or damage such as scoring and renew as necessary.

Refitting

11 Refitting is the reverse of removal, noting the following:

- Refit the pivot bolts and tighten them loosely.
- When refitting the front lateral link, align the inner pivot bolt using the marks made on dismantling.
- With the vehicle standing on its wheels, rock the suspension to settle all disturbed components in position then tighten all the disturbed pivot bolts to the specified torque.
- On completion, check and, if necessary, adjust rear wheel alignment.



15.3 Front lateral link to body mounting bolt (arrowed) is slotted to permit rear wheel alignment

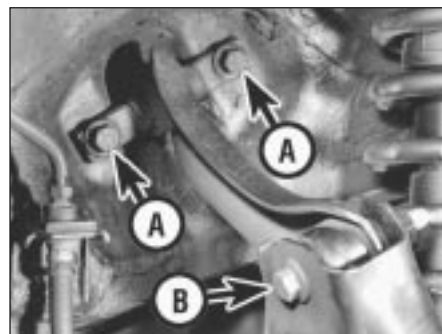

15.4 Rear upper lateral link to body bolts (A) and trailing arm pivot bolt (B)



15.6 Removing rear lower lateral link



15.7 Examine lateral link bushes for signs of wear and renew if necessary



16.3 Remove retaining clip and free brake hose from trailing arm

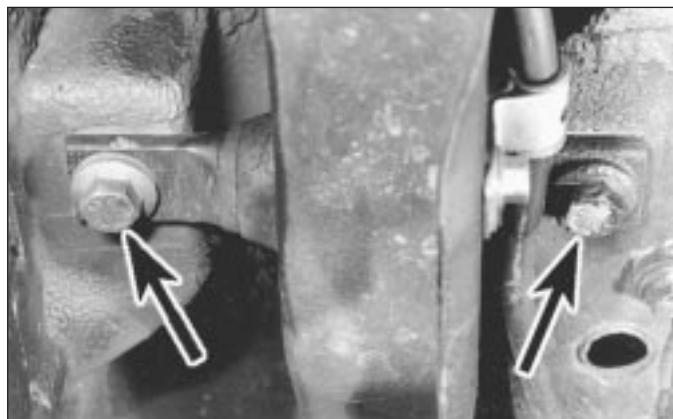

16.8 Trailing arm mounting bolts (arrowed)

16 Rear suspension trailing arm - removal and refitting



Removal

1 Chock the front wheels then jack up the rear of the vehicle and support it on axle stands. Remove the appropriate rear roadwheel, then follow the procedure under the relevant sub heading.

Non-ABS models

2 Remove the rear hub assembly.

3 Undo the bolts and remove the clips securing the handbrake cable and brake hose brackets to the trailing arm (see illustration). Remove the four bolts securing the backplate to the trailing arm and carefully ease the backplate assembly outwards and off the end of the stub axle. Position the backplate out of the way of the stub axle and tie it to the rear suspension unit coil spring using a piece of wire.

ABS models

4 Remove the two brake caliper shield retaining screws and remove the shield from the caliper.

5 Slacken and remove the bolts securing the handbrake cable and brake hose retaining clamps to the trailing arm. Undo the two bolts securing the caliper mounting bracket to the trailing arm and slide the caliper off the disc. Tie the caliper to the rear suspension strut coil spring to avoid placing any strain on the hydraulic hose or handbrake cable.

6 Remove the ABS rear wheel sensor.

All models

7 Slacken and remove the three pivot bolts securing the front lateral link, rear lower lateral link and rear upper lateral link to the trailing arm.

8 Remove the two bolts securing the trailing arm mounting bracket to the vehicle body, then manoeuvre the trailing arm assembly out of position and away from the vehicle (see illustration).

9 Inspect the trailing arm for signs of damage such as cracks, paying particular to the areas around the mounting bolt holes, and examine the mounting bush for signs of damage and deterioration. If either the arm or bush show signs of wear or damage, the trailing arm and bush assembly must be renewed as a unit since neither component is available separately.

Refitting

10 Refitting is the reverse of removal, noting the following:

- Manoeuvre the trailing arm into position and tighten its mounting bolts to the specified torque.
- Refit all the pivot bolts and tighten them only loosely.
- On non-ABS models, tighten the backplate retaining bolts to the specified torque then refit the hub.
- On ABS models, tighten the brake caliper mounting bracket bolts to the specified torque and refit the wheel sensor.
- With the vehicle standing on its wheels, rock the suspension to settle all the suspension components in position then tighten all the disturbed pivot bolts to their specified torque setting.
- On completion, check and, if necessary, adjust rear wheel alignment.



18.2a Remove horn button from steering wheel . . .

17 Steering - inspection

Refer to Chapter 1.

18 Steering wheel - removal and refitting



Models without airbag (SRS)

Removal

1 Set the front wheels in the straight-ahead position. The steering wheel spokes should be horizontal.

2 Carefully prise out the horn button from the centre of the steering wheel. Disconnect the wires from the button terminals and remove the button (see illustrations).

3 Using a socket, unscrew and remove the steering wheel retaining nut.

4 Mark the steering wheel and steering column shaft in relation to each other then lift the steering wheel off the column splines. If it is tight, tap it up near the centre, using the palm of your hand, or twist it from side to side whilst pulling upwards to release it from the shaft splines.



18.2b . . . and disconnect wiring from button terminals



18.6a Ensure steering wheel cut-outs are correctly engaged with indicator cancelling cam tabs (arrowed) . . .



18.6b . . . then refit wheel retaining nut

- 12 Mark the steering wheel and steering column shaft in relation to each other then lift the steering wheel off the column splines. If it is tight, tap it up near the centre, using the palm of your hand, to release it from the shaft splines.
- 13 Remove and discard the steering wheel retaining nut. A new self-locking nut must be obtained for reassembly.
- 14 Remove the steering wheel from the column.

Refitting

- 15 Refit the steering wheel by reversing the removal procedure, noting the following:
- Before refitting, check that the steering column splines are clean.
 - Enter the cut-outs on the lower surface of the wheel with the direction indicator cancelling cam tabs and align the marks made on dismantling. This should leave the wheel in the same position as before removal.
 - Take care to ensure that wiring is not trapped between mating surfaces.
 - Fit a new wheel retaining nut and tighten it to the specified torque wrench setting
 - Refit the airbag unit, carrying out the system check given in Chapter 12.
 - When reconnecting the battery leads, fit the negative lead last

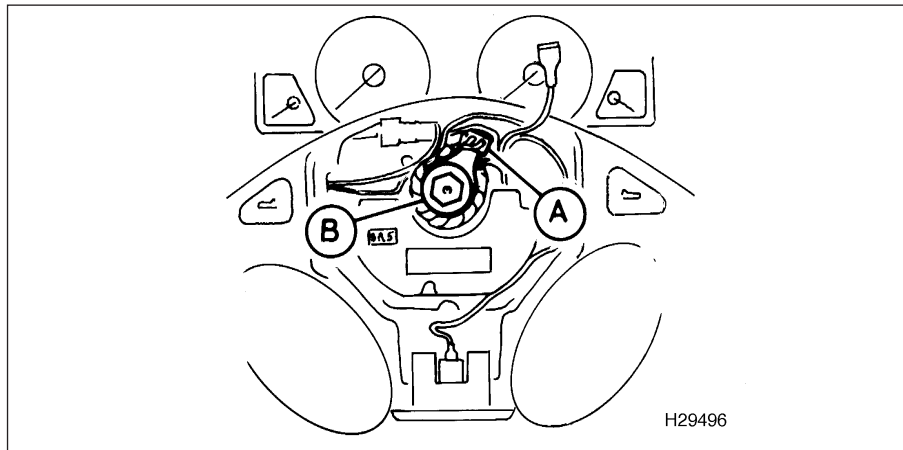

18.10 Detach SRS harness multiplug (A) from slip ring and unscrew steering wheel retaining nut (B)

19 Steering column - removal and refitting



Models without airbag

Removal

- Insert the key to ensure the steering column is unlocked, then release the column tilt lever and position the steering wheel at the lowest possible position. Remove the steering wheel.
- Disconnect the battery negative terminal then undo the five right-hand lower fascia panel retaining screws and remove the panel from the fascia.
- Prise off the large snap-ring which secures the two halves of the steering column shroud together from the top of the shrouds and remove the ignition key. Undo the three screws securing the lower shroud to the steering column and remove both the upper and lower steering column shrouds (see illustrations).

Refitting

- Before refitting, check that the steering column splines are clean.
- Refit the wheel, entering the cut-outs on its lower surface with the direction indicator cancelling cam tabs and aligning the marks made on dismantling. This should leave the wheel positioned as described in paragraph 1 (see illustrations).
- Tighten the steering wheel nut to the specified torque wrench setting, then reconnect the horn wiring to the horn terminals and press the horn into position in the centre of the wheel.

Models with airbag (SRS)

Removal

- Remove the ignition key and wait at least ten minutes to allow the SRS system backup circuit to fully discharge. Disconnect both battery leads, earth lead first, to avoid accidental detonation of the airbag.
- Remove the airbag unit, see Chapter 12.
- Detach the SRS harness multiplug from the slip ring (see illustration).
- Set the steering in the straight-ahead position and, using a socket, unscrew the steering wheel retaining nut until its top is flush with the end of the column shaft.



19.3a Prise off snap-ring . . .



19.3b . . . undo lower shroud retaining screws (arrowed) . . .



19.3c . . . and remove lower and upper shrouds



19.5 Combination switch assembly is retained by two screws (arrowed)



19.7a Remove retaining clips . . .



19.7b . . . and withdraw lower steering column cover

4 Lift the indicator cancelling cam off the steering column and disconnect the wiring connectors from the rear of the steering column combination switch assembly.

5 Undo the two combination switch retaining screws and slide the assembly off the end of the steering column (see illustration).

6 Trace the ignition switch wiring back to its wiring connectors and disconnect them from the main wiring loom.

7 Pull back the driver's footwell carpet and remove the two studs securing the lower steering column cover to the floor. Remove the two retaining clips from the upper end of the cover and withdraw the cover (see illustrations).

8 Using a hammer and punch, white paint or similar, mark the exact relationship between the steering column shaft and shaft-to-steering gear universal joint, then slacken and remove the pinch-bolt securing the joint to the column shaft.

9 Undo the nut and bolt securing the lower steering column mounting clamp in position and remove the clamp (see illustration). Slacken and remove the two nuts and bolts securing the upper mounting assembly to the vehicle then disengage the column from its mounting studs and universal joint then remove it from the vehicle.

Refitting

10 Before refitting the steering column, closely examine the upper mounting assembly for damage or misalignment.



19.9 Steering column lower mounting clamp components

11 Align the marks made on dismantling and engage the steering column shaft splines with those of the universal joint.

12 Locate the upper mounting bracket assembly over its mounting studs and refit the upper mounting nuts and bolts. Refit the lower mounting clamp and tighten its retaining nut and bolt to the specified torque setting, then tighten the upper mounting nuts and bolts to their specified torque settings.

13 Refit the universal joint to steering column pinch-bolt and tighten it to the specified torque. Refit the lower cover over the steering column and secure it in position with the retaining clips and studs.

14 Refit the combination switch to the column and tighten its screws securely. Refit the indicator cancelling cam to the steering column, ensuring that it is correctly located with the switch assembly, and reconnect the combination and ignition switch wiring connectors (see illustration). Ensure that the wiring is correctly routed and secured by any relevant clips.

15 Offer up the two halves of the steering column shroud and refit the three retaining screws to the lower shroud. Ensure the shroud halves are clipped firmly together, then refit the snap ring to its groove.

16 Refit the lower fascia panel, tightening its retaining screws securely, then refit the steering wheel.



19.14 Ensure that indicator cancelling cam is correctly engaged with combination switch assembly

Models with airbag (SRS) Removal

17 Remove the ignition key and wait at least ten minutes to allow the SRS system backup circuit to fully discharge. Disconnect both battery leads, earth lead first, to avoid accidental detonation of the airbag.

18 Set the steering in the straight-ahead position then lock the steering column in its lowest position.

19 Remove the airbag unit, see Chapter 12.

20 Remove the steering wheel.

21 Remove the steering column combination switch, see Chapter 12.

22 Disconnect the combination switch and ignition switch multiplugs, then release the cable tie securing the wiring harness to the steering column (see illustration).

23 Carry out the sequence given in paragraphs 7 to 9 inclusive.

Refitting

24 Carry out the sequence given in paragraphs 10 to 13 inclusive.

25 Reconnect the combination switch and ignition switch multiplugs, then secure the wiring harness to the steering column.

26 Refit the steering column combination switch, see Chapter 12.

27 Refit the steering wheel, then refit the airbag unit, see Chapter 12.

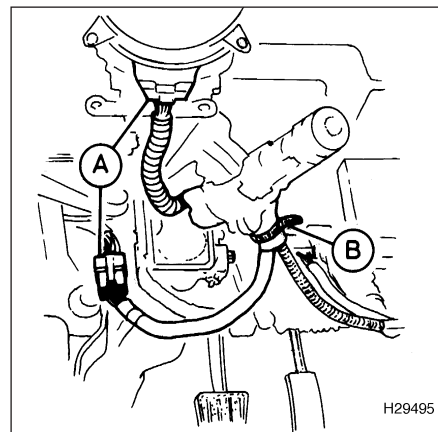

19.22 Disconnect switch multiplugs (A) then release cable tie (B)

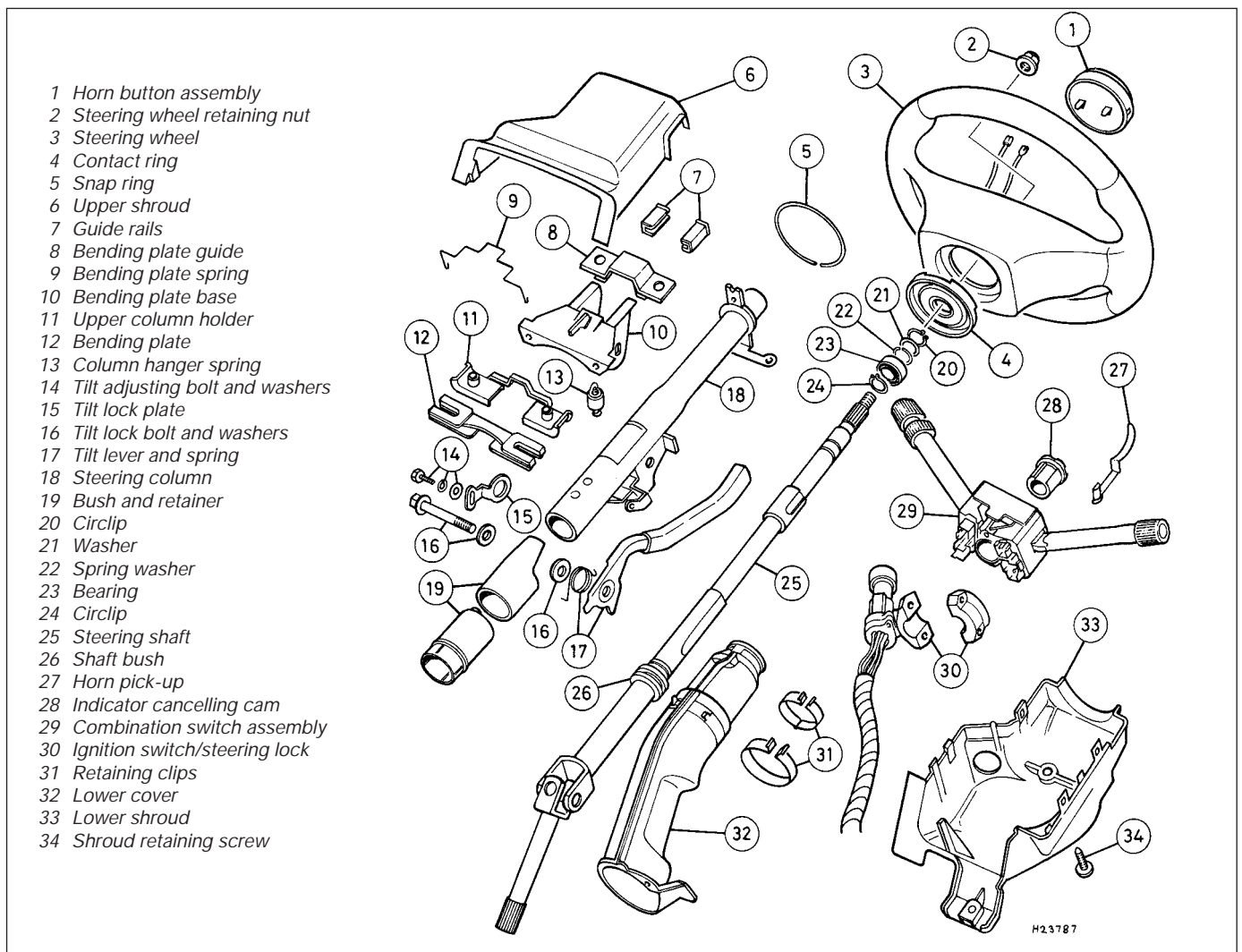

20.1 Steering column components

20 Steering column - overhaul



1 With the steering column removed from the vehicle, fit the ignition key and check that the steering lock is off. Remove the circlip from the upper end of the column shaft and lift off the washer and spring washer (see illustration).

2 Carefully withdraw the steering shaft from the lower end of the steering column. Note the inner circlip fitted to the shaft upper end.

3 Inspect the steering shaft for straightness and for signs of impact and damage to the collapsible portion. Check for signs of wear, such as scoring, on the shaft bush and check the steering shaft universal joint for signs of damage or roughness in the joint bearings. If any damage or wear is found on the steering shaft, shaft bush or universal joint, the shaft must be renewed as an assembly.

4 Inspect the steering column for signs of damage and renew if necessary. Closely examine the column upper mounting and tilt assembly for signs of damage or distortion, paying particular attention to the upper mounting bending plate and its spring retainer. The bending plate is designed to distort in the event of an impact hitting the steering wheel and must be renewed, along with its spring retainer, if it is not completely straight. Renew other components as necessary.

5 If renewal of any of the upper mounting or steering column tilt assembly components is necessary, make a note of the correct fitted positions of all components before dismantling the assembly. Use this as a guide when reassembling all the components to ensure they are correctly fitted. Ensure that the ends of the bending plate spring retainer are correctly located in the holes in the mounting bracket and the retainer is hooked over the claw situated in the centre of the bracket (see illustration).

6 Apply a smear of grease to the steering shaft and column bearing surfaces and to the shaft bush. If a new steering shaft is being installed, transfer the inner circlip from the old shaft onto the second groove in the upper end of the new shaft.



20.5 Fitted positions of upper mounting assembly components

7 Insert the steering shaft into position in the steering column and refit the spring washer and flat washer to the upper end of the steering shaft, securing them in position with the circlip. Ensure that the circlip is correctly located in its groove and check that the shaft rotates freely in the column. Remove the ignition key and check that the steering lock functions correctly.

8 Before installing the column assembly, check the steering shaft-to-steering gear universal joint for signs of wear or damage and smoothness of operation. If there is any sign of roughness in the joint bearing, it must be renewed before refitting the steering column.

21 Steering lock/ignition switch - removal and refitting



Warning: Before attempting removal of the ignition switch, read carefully the precautions listed in Chapter 12,

appertaining to vehicles equipped with airbags (SRS).

Note: The steering lock/ignition switch is secured by two shear-head bolts. Although new bolts are supplied with replacement steering lock assemblies, always ensure that the bolts themselves are available before beginning work.

Removal

- 1 Remove the steering column.
- 2 Securely clamp the column assembly in a vice equipped with soft jaws, taking great care not to overtighten the vice and distort the steering column.
- 3 Centre-punch the two steering lock shear bolts then drill off the heads of the bolts. Note that new shear bolts must be obtained for refitting.
- 4 Withdraw the steering lock/ignition switch, then unscrew the remains of the shear bolts by using a self-locking wrench or similar on the exposed ends.

Refitting

- 5 On refitting, carefully align the assembly on the steering column, lightly tighten the bolts and check that the steering lock works smoothly.
- 6 Tighten the shear bolts evenly until their heads shear off.
- 7 Refit the steering column.

22 Steering gear rubber gaiters - renewal



1 Remove the track rod balljoint and unscrew the locknut from the track rod end (see illustration).

2 Using a pair of pliers, release the outer steering gear gaiter retaining clip and slide it off the track rod end. Remove the inner gaiter retaining clip by cutting it, then slide the gaiter off the end of the track rod.

3 Thoroughly clean the track rod and the steering gear housing, using fine abrasive paper to polish off any corrosion, burrs or sharp edges which might damage the new gaiter's sealing lips on fitting. Repair kits which consist of new gaiters and retaining clips are available from Rover dealers.

4 Fit the new rubber gaiter, ensuring that it is correctly seated in the grooves in the steering gear housing and track rod.

5 Check that the gaiter is not twisted or dented then secure it in position using new retaining clips.

6 Refit the locknut and balljoint onto the track rod end.

23 Steering gear - removal, overhaul and refitting



Removal

1 Chock the rear wheels, firmly apply the handbrake, jack up the front of the vehicle and support on axle stands. Remove the appropriate front roadwheel.

2 Working inside the vehicle, peel back the driver's footwell carpet and remove the studs securing the lower steering column cover to the floor. Remove the two retaining clips from the upper end of the cover and withdraw the cover.

3 Mark the relative positions of the steering gear pinion and joint to use as a guide when refitting, then slacken and remove the two universal joint pinch-bolts (see illustration). Slide the universal joint up the steering

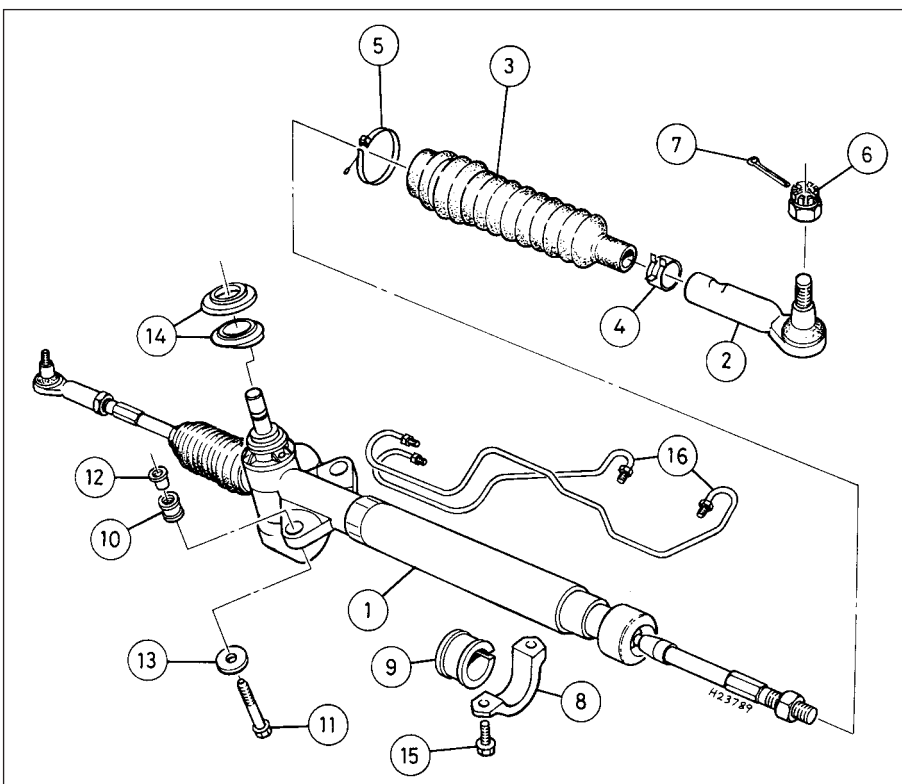

22.1 Steering gear components

- | | | |
|-------------------------------|--------------------------------|--|
| 1 Steering rack | 8 Mounting clamp | 13 Washer |
| 2 Track rod balljoint | 9 Mounting bush | 14 Washers |
| 3 Steering rack gaiter | 10 Mounting bush | 15 Steering rack mounting clamp bolt |
| 4 Gaiter outer retaining clip | 11 Steering rack mounting bolt | 16 Power steering fluid pipes (where fitted) |
| 5 Gaiter inner retaining clip | 12 Spacer | |
| 6 Balljoint retaining nut | | |
| 7 Split pin | | |

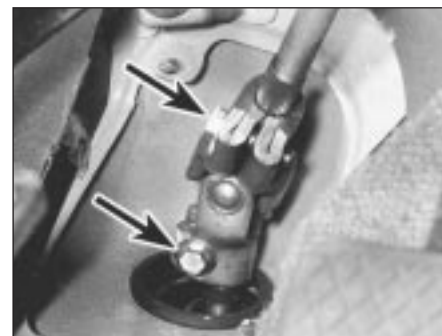

23.3 Steering column universal joint pinch-bolts (arrowed)

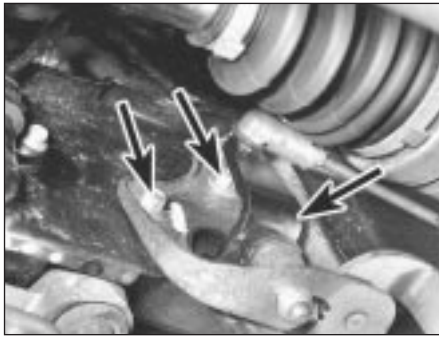

23.7 Gearchange linkage bellcrank mounting bolts (arrowed)

column shaft splines until it is free from the steering gear pinion.

4 Extract the split pins and undo the nuts securing the steering gear track rod balljoints to the swivel hubs. Release the balljoint shanks by using a suitable balljoint separator tool whilst taking care not to damage the balljoint gaiters.

5 From underneath the vehicle, slacken and remove the bolt securing the rear engine/gearbox unit mounting connecting link to the subframe bracket, then remove the three subframe bracket retaining bolts and remove the bracket, releasing it from the exhaust mounting rubber. Undo the two bolts securing the connecting link and bracket assembly to the gearbox housing and remove the assembly from the vehicle.

6 Undo the three front exhaust pipe to manifold retaining nuts and, where necessary, the two bolts securing the front pipe mounting bracket to the vehicle. Release the intermediate exhaust section from its mountings and lower the front of the exhaust system.

7 In the absence of the special gearchange linkage balljoint separator (Rover service tool Number 18G 1592), use a suitable flat-bladed screwdriver to carefully lever the lower gearchange rod balljoint off the gearchange linkage bellcrank assembly. Remove the three bolts securing the assembly to the subframe (see illustration).

8 Using a suitable stout bar, lever down on the rear of the engine/gearbox unit and insert a block of wood between the gearbox and subframe to hold it in position. This is necessary to gain the required clearance to remove the steering gear.

9 On models equipped with power-assisted steering, remove the bolt securing the feed and return pipe mounting bracket to the subframe. Mark the pipe union bolts to ensure they are correctly positioned on reassembly, then unscrew the pipe to steering gear union nuts (see illustration). Be prepared for fluid spillage and position a suitable container beneath the pipes whilst unscrewing the union nuts. This fluid must be disposed of and new fluid of the specified type used when refilling. Plug the pipe ends and steering gear orifices to prevent excessive fluid

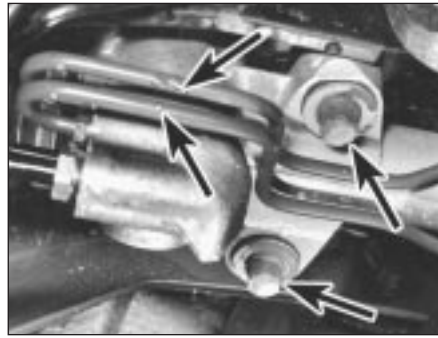

23.9 Power steering pipes and steering gear right-hand mounting bolts (arrowed)

leakage and entry of dirt into the hydraulic system.

10 On all models, fully extend the left-hand track rod then undo the two left-hand steering gear mounting bolts and remove the mounting bracket. Undo the two right-hand mounting bolts, noting the mounting bushes and spacers, and free the steering gear pinion from its cutout.

11 Initially move the steering gear to the left, to free the right-hand track rod from the subframe, then manoeuvre the assembly out from the right-hand side of the vehicle. Remove the washers from the steering gear pinion.

Overhaul

12 Examine the steering gear assembly for signs of wear or damage and check that the rack moves freely throughout the full length of its travel with no signs of roughness or excessive free play between the steering gear pinion and rack. The steering gear is available only as a complete assembly with no individual components, the exception being the track rod balljoints and rubber gaiters. Therefore, if worn, the complete assembly must be renewed.

13 Inspect the steering gear mounting bushes for signs of damage or deterioration and renew as necessary.

Refitting

14 Refit the washers to the pinion and, with the left-hand track rod fully extended, manoeuvre the steering gear into position from the right-hand side of the vehicle. Once both the track rods are located in the subframe cutouts, refit the mounting clamp and bolts, ensuring that the mounting bushes and spacers are correctly positioned. Tighten the mounting bolts to the specified torque.

15 Centralise the steering gear rack so that both track rods are protruding by an equal distance.

16 On models equipped with power-assisted steering, wipe clean the feed and return pipe unions then refit them to their respective positions on the steering gear and tighten the union nuts to the specified torque. Refit the bolt securing the pipe retaining bracket to the subframe and tighten securely.

17 The remainder of the refitting procedure is direct reversal of removal, noting the following:

- Tighten all nuts and bolts to the specified torque settings.
- Secure the track rod balljoint retaining nuts in position with new split pins.
- When refitting the universal joint to the steering gear pinion splines, ensure that the front wheels are pointing in the straight-ahead direction then, if necessary, align the marks made on dismantling and check that the steering wheel spokes are horizontal.
- On completion, check and, if necessary, adjust front wheel alignment.
- On models equipped with power-assisted steering, bleed the hydraulic system.

24 Power steering pump drivebelt - inspection and adjustment

Refer to Chapter 1.

25 Power steering pump - removal and refitting



Removal

1 Slacken, but do not remove, the three power steering pump pulley retaining bolts, then remove the power steering pump drivebelt.

2 Position a suitable container beneath the power steering pump to catch any spilt fluid, then slacken the inlet hose retaining clip and disconnect the hose from the top of the steering pump. Undo the bolt securing the outlet pipe retaining bracket to the pump, then unscrew the outlet pipe union nut and disconnect the pipe from the pump, noting the O-ring which is fitted to the union (see illustrations). Plug the hose ends and pump unions to prevent excessive fluid loss and the possible entry of dirt into the system.

3 Remove the reservoir from its mounting



25.2a Slacken retaining clamp and disconnect inlet hose from pump



25.2b Remove outlet pipe bracket retaining bolt . . .



25.2c . . . and unscrew outlet pipe union nut from pump



25.3 Removing power steering fluid reservoir from retaining clamp

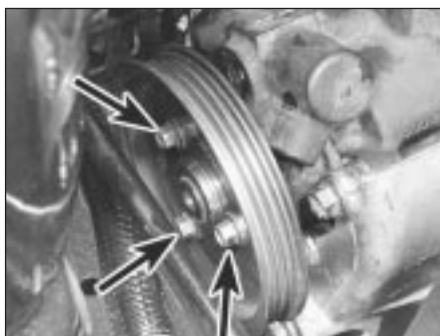

25.4a Remove pulley retaining bolts (arrowed) . . .



25.4b . . . and withdraw pulley. Note FRONT mark on pulley face (arrowed)



25.5a Unscrew power steering pump mounting bolts (three arrowed) . . .

bracket and position it clear of the pump assembly (see illustration).

4 Unscrew the pump pulley retaining bolts and remove the pulley. Check that the front face of the pulley is marked FRONT and if not, mark it by using a dab of white paint. This mark can then be used to ensure that the pulley is correctly refitted (see illustrations).

5 Undo the five bolts (three on the right-hand side of the pump, and two on the left) securing the power steering pump to the mounting bracket and remove the pump from the engine (see illustrations).

6 The power steering pump is a sealed unit and cannot be repaired. If faulty the pump assembly must be renewed.

Refitting

7 Refitting is a reverse of the removal procedure, noting the following (see illustration):

- a) Tighten the pump mounting bolts to the specified torque.
- b) Fit a new O-ring to the pump outlet pipe union and tighten the union nut to the specified torque.
- c) Ensure the pulley is correctly installed and lightly tighten its mounting bolts.
- d) Refit and adjust the drivebelt, then tighten the pulley mounting bolts to the specified torque.
- e) On completion, bleed the hydraulic system.

26 Power steering oil cooler - removal and refitting



Removal

- 1 Remove the right-hand headlamp assembly.
- 2 Remove the bonnet lock.
- 3 Position a suitable container beneath the power steering oil cooler hose connections to catch any spilt fluid, then slacken the hose retaining clips and disconnect both hoses (see illustration). Plug the hose and oil cooler ends to prevent excessive fluid loss and possible entry of dirt into the system.



25.5b . . . and remove pump



25.7 Always renew outlet pipe O-ring (arrowed)



26.3 Slacken clamps and disconnect hoses from power steering oil cooler



26.4a Power steering oil cooler upper mounting bolts (arrowed)

4 Undo the three oil cooler mounting bracket retaining bolts, then manoeuvre the oil cooler assembly out from between the front bumper and body (see illustrations).

Refitting

5 Refitting is the reverse of the removal procedure. On completion, bleed the system.

27 Power steering system - bleeding



Warning: Avoid holding the steering at full lock for long periods of time. Failure to do so could lead to overheating, and possible damage, of the power steering pump and steering gear.

1 Remove the cap from the power steering fluid reservoir and fill the reservoir with the specified fluid.

2 Disconnect the distributor wiring to prevent the engine from starting, then turn the engine over for approximately 5 seconds to prime the power steering pump.

3 Reconnect the distributor wiring, then check the reservoir fluid level is between the MAX and MIN level markings on the side of the reservoir, topping up if necessary.

4 Start the engine and allow it to idle for approximately 30 seconds with the front wheels

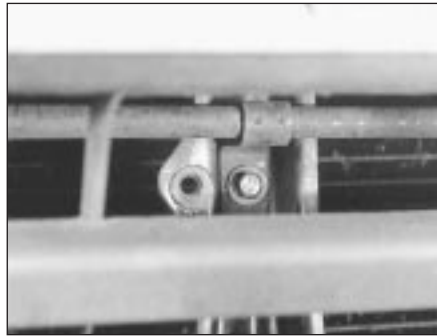

26.4b Oil cooler lower mounting bolt can be accessed via bumper grille

pointing in the straight-ahead position. After 30 seconds, turn the steering onto full lock in one direction, hold it there for a few seconds, then turn it onto full lock in the opposite direction and hold it there for a few seconds. Return the front wheels to the straight-ahead position. Repeat this procedure until air bubbles cease to appear in the fluid reservoir.

5 If, when turning the steering, an abnormal noise is heard from the fluid lines, it indicates that there is still air in the system. Check this by turning the wheels to the straight-ahead position and switching off the engine. If the fluid level in the reservoir rises, then air is present in the system and further bleeding is necessary.

6 Once all traces of air have been removed from the power steering hydraulic system, turn the engine off and allow the system to cool. Once cool, check that fluid level is up to the MAX mark on the power steering fluid reservoir. Top up if necessary.

28 Track rod balljoint - removal and refitting



Removal

1 Apply the handbrake, then jack up the front of the vehicle and support it on axle stands. Remove the appropriate front roadwheel.

2 If the balljoint is to be re-used, use a straight-edge and a scribe, or similar, to mark its relationship to the track rod.

3 Holding the balljoint, unscrew its locknut by one quarter of a turn.

4 Extract the split pin and undo the nut securing the steering gear track rod balljoint to the swivel hub. Release the balljoint shank by using a suitable balljoint separator tool whilst taking care not to damage the balljoint gaiter (see illustration).

5 Unscrew the balljoint from the track rod, counting the exact number of turns necessary to do so. If the locknut is to be removed, mark its position on the track rod and count the number of turns required to remove it so that it can be returned exactly to its original position on reassembly.

6 Carefully clean the balljoint and the threads. Renew the balljoint if its movement is sloppy or too stiff, if it is excessively worn, or if it is damaged in any way. Carefully check the stud taper and threads. No grease leakage should be visible.

Refitting

7 If necessary, screw the locknut onto the track rod by the number of turns noted on removal. This should align the locknut with the mark made on dismantling.

8 Screw the balljoint onto the track rod by the number of turns noted on removal. This should bring the balljoint to within a quarter of a turn from the locknut, with the alignment marks that were made (if applicable) on removal lined up.

9 Refit the balljoint shank to the swivel hub and tighten its retaining nut to the specified torque setting. Use a new split pin to secure the retaining nut in position (see illustration).

10 Refit the roadwheel, then lower the vehicle to the ground and tighten the roadwheel nuts to the specified torque setting.

11 Check and, if necessary, adjust front wheel alignment.



28.4 Using a universal balljoint separator to free track rod balljoint from swivel hub



28.9 Secure balljoint retaining nut in position with new split pin

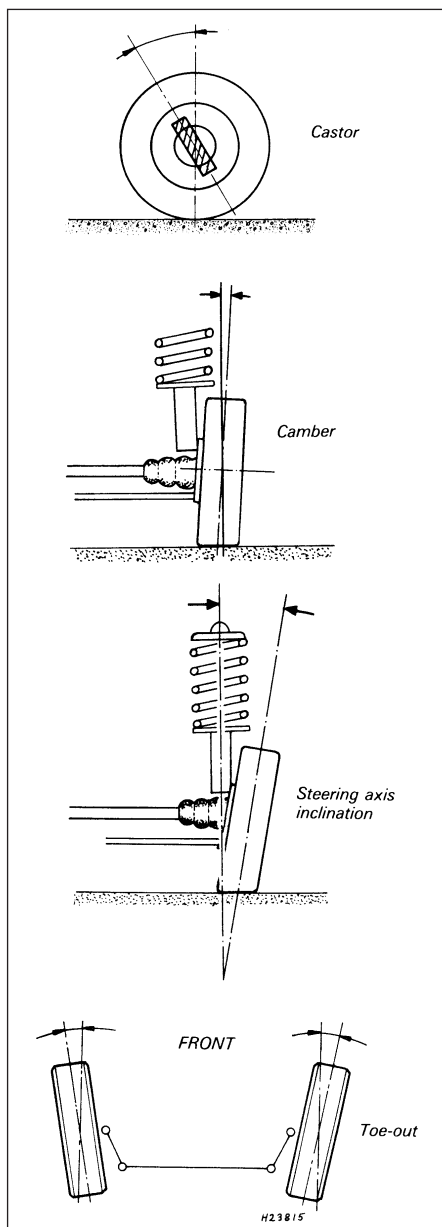

29.1 Wheel alignment and steering angles

29 Wheel alignment and steering angles



1 A vehicle's steering and suspension geometry is defined in five basic settings. All angles are expressed in degrees and the steering axis is defined as an imaginary line drawn through the centres of the front suspension upper and lower balljoints, extended where necessary to contact the ground (see illustration).

Camber

2 Camber is the angle between each roadwheel and a vertical line drawn through its centre and tyre contact patch when viewed from the front or rear of the vehicle. Positive camber is when the roadwheels are tilted outwards from the vertical at the top. Negative camber is when they are tilted inwards.

3 Camber is not adjustable and given for reference only. While it can be checked using a camber checking gauge, if the figure obtained is significantly different from that specified, then the vehicle must be taken for careful checking by a professional, as the fault can only be caused by wear or damage to the body or suspension components.

Castor

4 Castor is the angle between the steering axis and a vertical line drawn through each roadwheel's centre and tyre contact patch when viewed from the side of the vehicle. Positive castor is when the steering axis is tilted so that it contacts the ground ahead of the vertical. Negative castor is when it contacts the ground behind the vertical.

5 Castor is not adjustable and is given for reference only. While it can be checked using a castor checking gauge, if the figure obtained is significantly different from that specified, then the vehicle must be taken for careful checking by a professional, as the fault can only be caused by wear or damage to the body or suspension components.

Steering axis inclination/SAI

6 Also known as kingpin inclination/KPI, this is the angle between the steering axis and a vertical line drawn through each roadwheel's centre and tyre contact patch when viewed from the front or rear of the vehicle.

7 SAI/KPI is not adjustable and is given for reference only.

Toe

8 Toe is the difference, viewed from above, between lines drawn through the roadwheel centres and the vehicle's centre-line. Toe-in is when the roadwheels point inwards, towards each other at the front. Toe-out is when they splay outwards from each other at the front.

9 At the front, toe setting is adjusted by screwing the track rods in or out of their balljoints to alter the effective length of the track rod assemblies.

10 At the rear, toe setting is adjusted by slackening the front lateral link-to-body pivot bolt and repositioning the bolt in its mounting slot, thereby altering the position of the trailing arm assembly.

Toe-out on turns

11 Also known as turning angles or Ackermann angles, this is the difference, viewed from above, between the angles of rotation of the inside and outside front roadwheels when they have been turned through a given angle.

12 Toe-out on turns is set in production and is not adjustable as such, but can be upset by altering the length of the track rods unequally. It is essential, therefore, to ensure that the track rod lengths are exactly the same and that they are turned by the same amount whenever the toe setting is altered.

Checking and adjustment

13 Due to the special measuring equipment necessary to check wheel alignment and the skill required to use it properly, checking and adjustment of the aforementioned settings is best left to a Rover dealer or similar expert. Note that most tyre-fitting shops now possess sophisticated checking equipment.





Chapter 12

Body electrical systems

Contents

Bulbs (exterior lamps) - renewal	5	Radio/cassette player - removal and refitting	24
Bulbs (interior lamps) - renewal	6	Speedometer drive cable - removal and refitting	17
Cigar lighter - removal and refitting	12	Speakers - removal and refitting	25
Clock - removal and refitting	13	Switches - removal and refitting	4
Dim-dip headlamp system - operation	9	Supplementary Restraint System (SRS) - component removal and refitting	16
Electrical fault finding - general information	2	Supplementary Restraint System (SRS) - operation	15
Exterior lamp units - removal and refitting	7	Tailgate wiper motor - removal and refitting	23
Fuses, fusible links and relays - location and renewal	3	Windscreen/headlamp washer system - inspection and adjustment	20
General information and precautions	1	Windscreen/tailgate wiper blades and arms - inspection and renewal	19
Headlamp beams - alignment	8	Windscreen/tailgate washer system components - removal and refitting	21
Horn - removal and refitting	18	Windscreen wiper motor and linkage - removal and refitting	22
Instrument panel components - removal and refitting	11		
Instrument panel - removal and refitting	10		
Multi-function unit - operation, removal and refitting	14		
Radio aerial - removal and refitting	26		

Degrees of difficulty

Easy , suitable for novice with little experience 	Fairly easy , suitable for beginner with some experience 	Fairly difficult , suitable for competent DIY mechanic 	Difficult , suitable for experienced DIY mechanic 	Very difficult , suitable for expert DIY or professional 
---	--	--	---	--

Specifications

System

Type 12 volt, negative earth

Relays and control units

Component

Starter relay
Intake manifold heater relay
Main relay
Fuel pump relay
Cooling fan relay
Direction indicator relay
Heated rear window relay
Cigar lighter relay, fog lamp relay, horn relay and main beam relay
Electric window relay
Electric window control unit
Central locking control unit
Air conditioning relay
Dim-dip relay
Windscreen wiper relay
Sunroof relay
Lambda sensor relay - catalytic converter models only
Tailgate wiper relay

Location

Engine compartment fusebox, centre relay of right-hand three
Engine compartment fusebox, rear relay of right-hand three
Engine compartment fusebox, front relay of right-hand three
Engine compartment fusebox, front relay of left-hand two
Engine compartment fusebox, rear relay of left-hand two
Behind right-hand lower facia panel (square relay)
Behind right-hand lower facia panel (circular relay)
Part of relay module, mounted on transmission tunnel behind lower central facia panel
Behind lower central facia panel
Behind right-hand front door inner trim panel
Behind left-hand front door inner trim panel
Mounted on left-hand side of engine compartment bulkhead
Behind right-hand lower facia panel
Behind right-hand lower facia panel
Behind right-hand lower facia panel
Engine compartment fusebox, next to fusible links
Behind right-hand luggage compartment trim

12•2 Body electrical systems

Fuses

Fuse	Rating (amps)	Circuit(s) protected
1	10	Clock, instruments, direction indicators and dim-dip unit
2	10	Starter signal
3	15	Central locking
4	10	Cigar lighter
5	10	Dim-dip resistor
6	30	Sunroof
7	10	Right-hand sidelamps, tail lamp and number plate lamps
8	10	Left-hand sidelamps, tail lamp and interior lamps
9	10	Fog lamps
10	10	Left-hand headlamp dipped beam
11	10	Right-hand headlamp dipped beam
12	15	Radio/cassette memory, clock and interior lamps
13	15	Front windscreen washers and wipers
14	10	Engine management system
15	15	Cooling fan, tailgate washer and wiper
16	15	Reversing lamps, stop lamps and electric windows
17	10	Cigar lighter, Multi-function unit and radio/cassette player
18	10	Electric door mirrors
19	15	Headlamp dim-dip
20	15	Fuel pump
21	15	Right-hand headlamp main beam
22	15	Left-hand headlamp main beam
23	25	Heated rear window and heated door mirrors
24	20	Heater blower motor
25	15	ABS system
26	15	Left-hand rear electric window
27	15	Right-hand rear electric window
28	15	Left-hand front electric window
29	15	Right-hand front electric window
Additional		Airbag (SRS). Do not remove

Note: Fuse locations are typical and may vary slightly according to model type. Refer to vehicle handbook.

Fusible links

Link	Rating (amps)	Circuit(s) protected
1	40	ABS pump
2	40	Lighting and cigar lighter
3	40	Ignition switch
4	40	Electric window relay, sunroof, central locking and heated rear window
5	40	Ignition switch
6	60	Main relay, fuel pump relay and lambda sensor relay

Bulbs

Headlamps:

	Fitting	Wattage
Dip/main beam bulb	H4	60/55
Individual main beam bulb	H1	55
Front sidelamps	Capless	5
Direction indicator lamps	Bayonet	21
Direction indicator side repeater lamps	Capless	5
Interior lamp	Festoon	5
Instrument panel warning and illumination	Integral with holder*	14V 1.4 or 3W
Glovebox lamp	Festoon	5
Luggage compartment lamp	Bayonet	10
Reversing lamps	Bayonet	21
Tail lamps	Capless	5
Stop lamps	Bayonet	21
Rear foglamps	Bayonet	21
Number plate lamps	Capless	5

* With exception of rear illumination panel bulb which is capless

Torque wrench settings

	Nm	lbf ft
Wiper arm spindle nut	14	10
Wiper motor mounting bolts	9	6
Windscreen wiper linkage spindle assembly bolts	9	6
Airbag-to-steering wheel (Torx) screws	8	6
Airbag control unit-to-steering wheel (Torx) screws	3	2

1 General information and precautions

General information

The electrical system is of the 12-volt negative earth type and comprises a 12-volt battery, an alternator with integral voltage regulator, a starter motor and related electrical accessories, components and wiring. The battery is of the maintenance-free (sealed for life) type and is charged by the alternator, which is belt-driven from a crankshaft-mounted pulley.

While some repair procedures are given, the usual course of action is to renew a defective component. The owner whose interest extends beyond mere component renewal should obtain a copy of the *Automobile Electrical & Electronic Systems Manual*, available from the publishers of this Manual.

Precautions

It is necessary to take extra care when working on the electrical system to avoid damage to semi-conductor devices (diodes and transistors) and to avoid the risk of personal injury. In addition to the precautions given in "Safety first!" at the beginning of this Manual, observe the following when working on the system:

- a) Always remove rings, watches, etc. before working on the electrical system. Even with the battery disconnected, capacitive discharge could occur if a component's live terminal is earthed through a metal object. This could cause a shock or nasty burn.
 - b) Do not reverse the battery connections. Components such as the alternator, fuel injection/ignition system ECU, or any other having semi-conductor circuitry could be irreparably damaged.
 - c) If the engine is being started using jump leads and a slave battery, connect the batteries positive-to-positive and negative-to-negative. This also applies when connecting a battery charger.
 - d) Never disconnect the battery terminals, the alternator, any electrical wiring or any test instruments when the engine is running.
 - e) Do not allow the engine to turn the alternator when the alternator is not connected.
 - f) Never test for alternator output by 'flashing' the output lead to earth.
 - g) Never use an ohmmeter of the type incorporating a hand-cranked generator for circuit or continuity testing.
 - h) Always ensure that the battery negative lead is disconnected when working on the electrical system.
 - i) Before using electric-arc welding equipment on the vehicle, disconnect the battery, alternator and components such as the fuel injection/ignition system ECU to protect them.
- A number of additional precautions must be observed when working on vehicles equipped with airbags (SRS), they are as follows:
- a) When cleaning the interior of the vehicle, do not allow the airbag unit to become flooded with detergents or water and do not clean with petrol or furniture cream and polishes. Clean the unit sparingly with a damp cloth and upholstery cleaner.
 - b) Before working on any part of the system, remove the ignition key and wait at least ten minutes to allow the system backup circuit to fully discharge. Disconnect both battery leads, earth lead first, to avoid accidental detonation of the airbag.
 - c) Make no attempt to splice into any of the electric cables in the SRS wiring harness as this may affect the operation of the SRS. Never fit electronic equipment such as mobile telephones, radios, etc. into the harness and ensure that the harness is routed so that it cannot be trapped.
 - d) Avoid hammering or causing any harsh vibration at the front of the vehicle, particularly in the engine bay, as this may trigger the crash sensors and activate the SRS.
 - e) Do not use ohmmeters or any other device capable of supplying current on any of the SRS components, as this may cause accidental detonation. Use only a digital circuit tester.
 - f) Always use new replacement parts. Never fit parts that are from another vehicle or show signs of damage through being dropped or improperly handled
 - g) Airbags are classed as pyrotechnical devices and must be stored and handled according to the relevant laws in the country concerned. In general, do not leave these components disconnected from their electrical cabling any longer than is absolutely necessary as in this state they are unstable and the risk of accidental detonation is introduced. Rest a disconnected airbag unit with the pad surface facing upwards and never rest anything on the pad. Store it on a secure flat surface, away from flammable materials, high heat sources, oils, grease, detergents or water, and never leave it unattended.
 - h) The SRS indicator light should extinguish 3 seconds after the ignition switch is turned to position "II". If this is not the case, check the electrical system connections as soon as possible.
 - i) The airbag control unit and slip ring are non-serviceable components and no attempt should be made to carry out repairs or modifications to them.
 - j) Only use the recommended special bolts when fitting the airbag assembly. Do not use any other type of bolt.
 - k) Never invert the airbag unit.
 - l) Renew the airbag unit and slip ring every ten years, regardless of condition.
 - m) Return an unwanted airbag unit to your Rover dealer for safe disposal. Do not endanger others by careless disposal of a unit.

2 Electrical fault finding - general information

1 A typical electrical circuit consists of an electrical component, any switches, relays, motors, fuses, fusible links or circuit breakers related to that component and the wiring and connectors that link the component to both the battery and the chassis. To help you pinpoint an electrical circuit problem, wiring diagrams are included at the end of this Chapter.

2 Before tackling any troublesome electrical circuit, first study the appropriate wiring diagrams to get a complete understanding of what components are included in that individual circuit. Trouble spots, for instance, can be narrowed down by noting if other components related to the circuit are operating properly. If several components or circuits fail at one time, then the problem is probably in a fuse or earth connection, because several circuits are often routed through the same fuse and earth connections.

3 Electrical problems usually stem from simple causes, such as loose or corroded connections, a blown fuse, a melted fusible link or a faulty relay. Inspect the condition of all fuses, wires and connections in a problem circuit before testing the components. Use the diagrams to note which terminal connections will need to be checked in order to pinpoint the trouble spot.

4 The basic tools needed for electrical fault finding include a circuit tester or voltmeter (a 12-volt bulb with a set of test leads can also be used), a continuity tester, a battery and set of test leads, and a jumper wire, preferably with a circuit breaker incorporated, which can be used to bypass electrical components. Before attempting to locate a problem with test instruments, use the wiring diagram to decide where to make the connections.

Voltage checks

5 Voltage checks should be performed if a circuit is not functioning properly. Connect one lead of a circuit tester to either the negative battery terminal or a known good earth. Connect the other lead to a connector in the circuit being tested, preferably nearest to the battery or fuse. If the bulb of the tester lights then voltage is present, which means that the part of the circuit between the connector and the battery is problem free. Continue checking the rest of the circuit in the same fashion. When you reach a point at which no voltage is present, the problem lies between that point and the last test point with

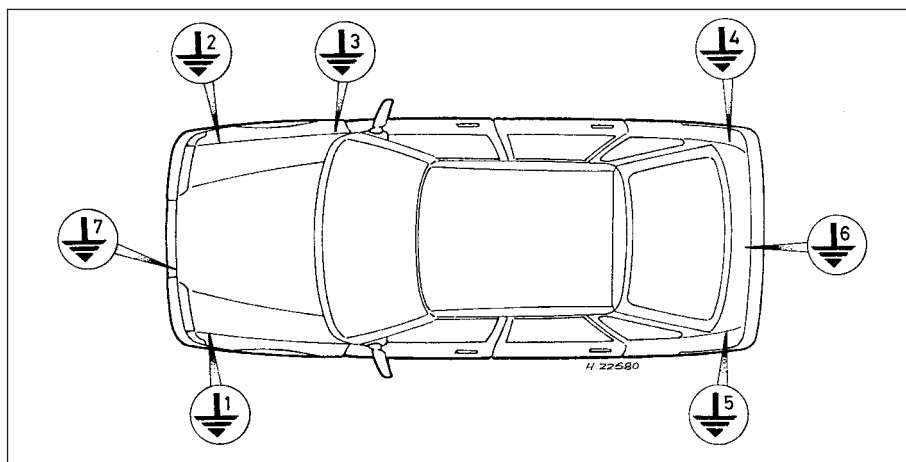

2.9 Electrical system earth points

- | | |
|---|--|
| 1 Behind left-hand headlamp - E1 | 5 Beneath left-hand rear lamp cluster - E5 |
| 2 Behind right-hand headlamp - E2 | 6 Centre of tailgate/boot lid - E6 |
| 3 Base of right-hand front door pillar - E3 | 7 Bonnet lock platform - E7 |
| 4 Beneath right-hand rear lamp cluster - E4 | |

voltage. Most problems can be traced to a loose connection. Bear in mind that some circuits are only live when the ignition switch is switched to a particular position.

Finding a short circuit

6 One method of finding a short circuit is to remove the fuse and connect a test light or voltmeter to the fuse terminals with all the relevant electrical components switched off. There should be no voltage present in the circuit. Move the wiring from side to side while watching the test light. If the bulb lights up, there is a short to earth somewhere in that area, probably where the insulation has rubbed through. The same test can be performed on each component in the circuit, even a switch.

Earth check

7 Perform an earth test to check whether a component is properly earthed. Disconnect the battery and connect one lead of a self-powered test light, known as a continuity tester, to a known good earth point. Connect the other lead to the wire or earth connection being tested. If the bulb lights up, the earth is good. If not, the earth is faulty.

8 If an earth connection is thought to be faulty, dismantle the connection and clean back to bare metal both the bodyshell and the wire terminal or the component's earth connection mating surface. Be careful to remove all traces of dirt and corrosion, then use a knife to trim away any paint, so that a clean metal-to-metal joint is made. On reassembly, tighten the joint fasteners securely; if a wire terminal is being refitted, use serrated washers between the terminal and the bodyshell to ensure a clean and secure connection. When the connection is remade, prevent the onset of corrosion in the future by applying a coat of petroleum jelly or silicone-based grease or by spraying on a

proprietary ignition sealer or a water dispersant lubricant at regular intervals.

9 The vehicle's wiring harness has seven multiple-earth connections, each one being identified in the wiring diagrams by a reference number (E1 to E7). Each of these earth connections serves several circuits and are located as follows (see illustration):

- E1 Behind left-hand headlamp.
- E2 Behind right-hand headlamp.
- E3 Base of right-hand front door pillar.
- E4 Beneath right-hand rear lamp cluster.
- E5 Beneath left-hand rear lamp cluster.
- E6 Centre of tailgate/boot lid.
- E7 Bonnet lock platform.

Continuity check

10 A continuity check is necessary to determine if there are any breaks in a circuit. With the circuit off (ie: no power in the circuit), a self-powered continuity tester can be used to check the circuit. Connect the test leads to both ends of the circuit, or to the positive end and a good earth. If the test light comes on, the circuit is passing current properly. If the light does not come on, there is a break somewhere in the circuit. The same



3.2 Remove fuses with plastic tweezers supplied (arrowed)

procedure can be used to test a switch, by connecting the continuity tester to the switch terminals. With the switch turned on, the test light should come on.

Finding an open circuit

11 When checking for possible open circuits, it is often difficult to locate them by sight because oxidation or terminal misalignment are hidden by the connectors. Merely moving a connector on a sensor or in the wiring harness may correct the open circuit condition. Remember this when an open circuit is indicated when fault finding in a circuit. Intermittent problems may also be caused by oxidized or loose connections.

General

12 Electrical fault finding is simple if you keep in mind that all electrical circuits are basically electricity flowing from the battery, through the wires, switches, relays, fuses and fusible links to each electrical component (light bulb, motor, etc.) and to earth, from which it is passed back to the battery. Any electrical problem is an interruption in the flow of electricity from the battery.

3 Fuses, fusible links and relays - location and renewal



Fuses

1 Most of the fuses are located behind the panel in the right-hand lower facia panel, with a few odd fuses being located in the fusebox on the left-hand side of the engine compartment.

2 Access to the fuses is gained by removing the fusebox lid/cover. Symbols on the reverse of the lid/cover indicate the circuits protected by the fuses and five spare fuses are supplied, together with plastic tweezers to remove and fit them (see illustration). Further details on fuse ratings and circuits protected are given in the Specifications.

3 On vehicles equipped with airbags, the fuse protecting the airbag circuit is located on the side of the main fuse box (see illustration).

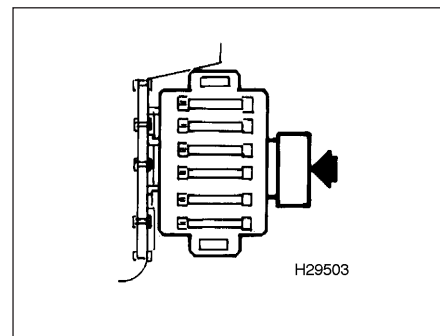

3.3 Airbag circuit fuse (arrowed) is located on side of main fusebox

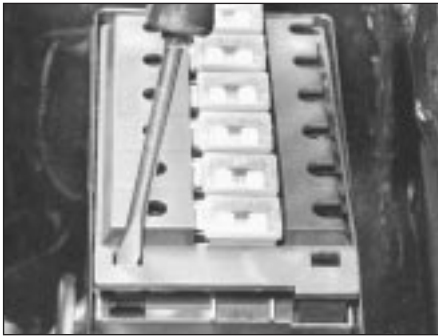

3.10a Unclip plastic cover . . .



3.10b . . . then undo retaining screws and remove fusible link



3.15a Use a screwdriver to release relay module retaining clip . . .

Under no circumstances should this fuse be removed as this may cause inflation of the airbag. Refer to your Rover dealer if you think fuse renewal is necessary.

4 To remove a fuse, first switch off the circuit concerned (or the ignition), then fit the tweezers and pull the fuse out of its terminals. Slide the fuse sideways from the tweezers. The wire within the fuse is clearly visible. If the fuse is blown, the wire will be broken or melted.

5 Always renew a fuse with one of an identical rating. Never use a fuse with a different rating from the original or substitute anything else. The fuse rating is stamped on top of the fuse. Fuses are also colour-coded for easy recognition.

6 If a new fuse blows immediately, find the cause before renewing it again. A short to earth as a result of faulty insulation is the most likely cause. Where a fuse protects more than one circuit, try to isolate the defect by switching on each circuit in turn (if possible) until the fuse blows again.

7 If any of the spare fuses are used, always replace them so that a spare of each rating is available.

Fusible links

8 The fusible links are located in the rear of the fusebox, situated on the left-hand side of the engine compartment. Unclip the lid to gain access to them.

9 Details of link ratings and circuits protected are given in the Specifications. All links are numbered on the rear of the fusebox lid.

10 To remove a fusible link, first ensure that the circuit concerned is switched off then prise off the plastic cover. Slacken the two link retaining screws then lift the fusible link out of the fusebox (see illustrations). The wire within the fusible link is clearly visible. If the fuse is blown, it will be broken or melted. A blown fusible link indicates a serious wiring or system fault which must be diagnosed before the link is renewed.

11 Always renew a fusible link with one of an identical rating. Never use a link with a different rating from the original or substitute anything else. On refitting, tighten the link

retaining screws securely and refit the link cover.

Relays

12 The Specifications Section gives full information on the location and function of the various relays fitted. Refer to the relevant wiring diagram for details of wiring connections.

13 If a circuit or system controlled by a relay develops a fault and the relay is suspect, operate the system. If the relay is functioning, it should be possible to hear it click as it is energized. If this is the case, the fault lies with the components or wiring of the system. If the relay is not being energized, then either [the relay is not receiving a main supply or a switching voltage, or the relay itself is faulty. Testing is by the substitution of a known good unit but be careful as some relays are identical in appearance, but perform different functions.

14 To renew a relay, ensure that the ignition switch is off, then simply pull direct from the socket and press in the new relay.

15 Certain relays are contained in the relay module which is situated behind the lower central fascia panel. To remove this, first remove the lower central panel from the fascia. Disconnect its two wiring block connectors then release its retaining clip and slide to the left to withdraw it from the mounting bracket (see illustrations). The complete module must be renewed, even if only one of the relays is faulty.

4 Switches - removal and refitting



Note: Disconnect the battery negative lead before removing any, switch and after refitting the switch, reconnect the lead.

Ignition switch

1 Refer to Chapter 10 for details of switch removal and refitting. A Rover dealer will be able to tell you whether the switch can be obtained separately from the steering lock.



3.15b . . . then slide module out of position and disconnect its wiring connectors

Steering column combination switch

Models without airbag (SRS)

2 Remove the steering wheel and steering column shrouds, then disconnect the switch wiring, as described in Chapter 10.

3 Each individual switch can be removed by unscrewing its two retaining screws and sliding the switch out of the housing (see illustrations).

4 To remove the complete switch assembly, slacken and remove the two retaining screws and slide the assembly off the steering column.



4.3a Individual combination switches can be removed by slackening retaining screws . . .



4.3b ... and sliding switch out of main assembly

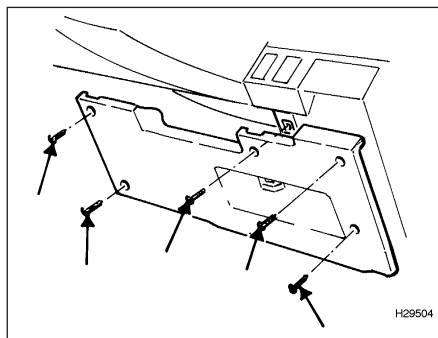

4.10 Remove fusebox cover securing screws (arrowed)

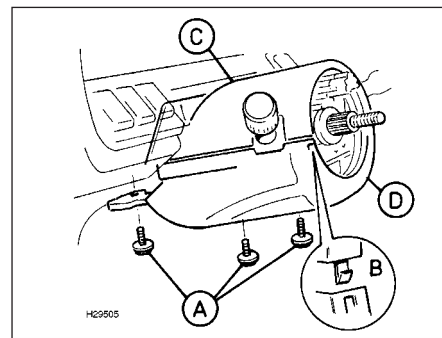

4.11 Remove screws (A), release clips (B) and separate two halves of shroud (C and D)

5 Refitting is the reverse of the removal procedure.

Models with airbag (SRS)

6 Remove the ignition key and wait at least ten minutes to allow the SRS system backup circuit to fully discharge. Disconnect both battery leads, earth lead first, to avoid accidental detonation of the airbag.

7 Set the steering in the dead-ahead position then lock the steering column in its lowest position.

8 Remove the airbag unit.

9 Remove the steering wheel, see Chapter 10.

10 Remove the five fusebox cover securing screws and release the cover from the fascia (see illustration).

11 Remove the three screws securing the lower half of the steering column shroud, release the two clips securing the front of the shroud, then separate the two halves of the shroud, manoeuvring each one clear of the column (see illustration).

12 Disconnect the four multiplugs from the combination switch (see illustration).

13 Remove the four screws securing the slip ring to the combination switch, remove the ring from the column and place it to one side whilst taking care not to allow it to hang from its wiring.

14 Remove the indicator cancelling cam (see illustration).

15 Each individual switch can be removed by unscrewing its two retaining screws and sliding the switch out of the housing.

16 To remove the complete combination switch, slacken and remove the two retaining screws and slide the switch off the steering column.

17 Refitting is the reverse of the removal procedure.

18 Upon completion of refitting the airbag unit, reconnect both battery leads, negative lead last, and turn the ignition switch to the

"II" position. Check the condition of the system by observing the SRS warning light located in the steering wheel centre pad. The light should stay illuminated for 3 seconds whilst the system performs a self-diagnosis test. If the test is satisfactory, the light will extinguish. If the test is unsatisfactory, the light will remain on or fail to illuminate at all, denoting that the system must be serviced as soon as possible.

Instrument panel and fascia switches

19 Check that the switch is in the off position, then taking great care not to scratch or damage the switch or its surround, prise it out using a suitable flat-bladed screwdriver. Withdraw the switch until the connector plug appears then disconnect the wiring connector and remove the switch (see illustrations). Tie a piece of string to the wiring connector to prevent it from falling behind the fascia panel.

20 On refitting, connect the wiring connector to the switch and press the switch into position until the retaining clips click into place.

Electrically-operated window switches

21 Remove the door inner trim panel.

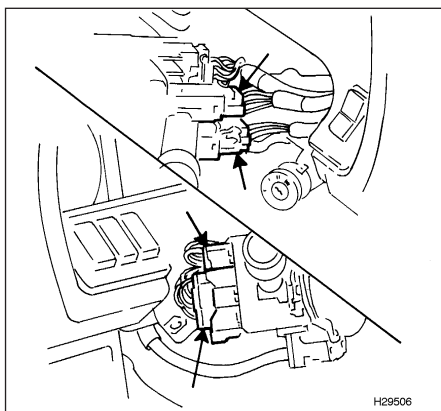

4.12 Disconnect four multiplugs (arrowed) from combination switch

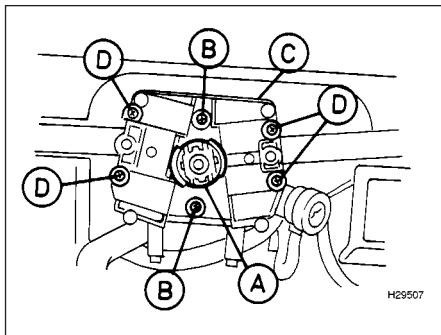

4.14 Steering column switch assembly

- A Indicator cancelling cam
- B Column switch screws
- C Column switch assembly
- D Combination switch screws



4.19a Carefully prise fascia switches out of position ...



4.19b ... and disconnect wiring connectors

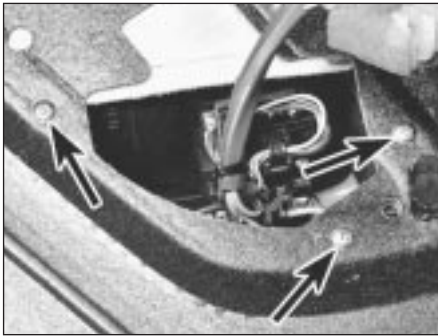

4.22 Driver's side window switch retaining screws (arrowed)

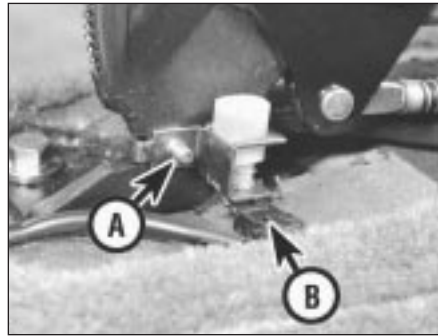

4.28 Handbrake warning lamp switch retaining screw (A) and wiring connector (B)



4.30 Prise horn button from steering wheel . . .

22 Undo the retaining screws and remove the switch from the trim panel (see illustration).

23 On refitting tighten the switch screws securely.

Courtesy lamp switches

24 With the door open, undo the two screws securing the switch to the body. Pull out the switch and tie a piece of string to the wiring to prevent it dropping into the body.

25 Disconnect the switch and remove it from the vehicle.

26 Refitting is a reverse of removal.

Handbrake warning lamp switch

27 From inside the vehicle, carefully prise out the cover from the top of the centre console rear section to gain access to the two retaining screws. Undo the two screws and remove the rear centre console section.

28 Disconnect the wiring connector from the switch, then slacken and remove the retaining screw and remove the switch from the handbrake lever quadrant (see illustration).

29 Refitting is a reverse of the removal procedure.

Horn push switch

Models without airbag (SRS)

30 Using the flat of a screwdriver, carefully prise the horn button out of the centre of the steering wheel (see illustration).

31 Disconnect the wire from each button terminal and remove the button (see illustration).

32 Refitting is a reverse of the removal procedure. Test the horn on completion.

Models with airbag (SRS)

33 Remove the airbag unit, noting all precautions.

34 Detach the earth wire from the steering wheel (see illustration).

35 Disconnect the Lucar connector from the steering wheel connection.

36 Remove each horn button by carefully using the flat blade of a small screwdriver to lever it from position.



4.31 . . . and disconnect wire from each button terminal

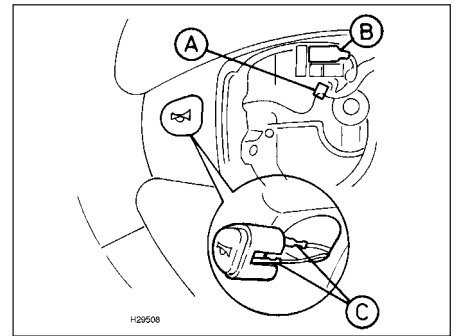

4.34 Disconnect earth wire (A) and Lucar connector (B), then lever button from position and detach electrical connectors (C)

37 Detach the two electrical connectors from the button and remove it.

38 Refitting is the reversal of removal, noting the following:

- a) Take care to ensure that wiring is not trapped between mating surfaces.
- b) Refit the airbag unit, carrying out the system check.
- c) Test the horn after refitting each button.

5 Bulbs (exterior lamps) - renewal



General

1 Whenever a bulb is renewed, note the following:

- a) Disconnect the battery negative lead before starting work.
- b) Remember that if the lamp has just been in use, the bulb may be extremely hot.
- c) Always check the bulb contacts and holder, ensuring that there is clean metal-to-metal contact between the bulb and its live contacts and earth. Clean off any corrosion or dirt before fitting a new bulb.
- d) Wherever bayonet-type bulbs are fitted, ensure that the live contacts bear firmly against the bulb contact.
- e) Always ensure that the new bulb is of the

correct rating and that it is completely clean before fitting. This applies particularly to headlamp bulbs.

Headlamp

2 Working in the engine compartment, twist off the relevant circular plastic cover and remove it from the rear of the headlamp unit (see illustration).

3 Unplug the wiring connector, then press together the ears of the bulb retaining clip and



5.2 Remove large circular cover to access dip/main beam bulb and sidelamp bulbs and smaller cover (arrowed) to access individual main beam bulb

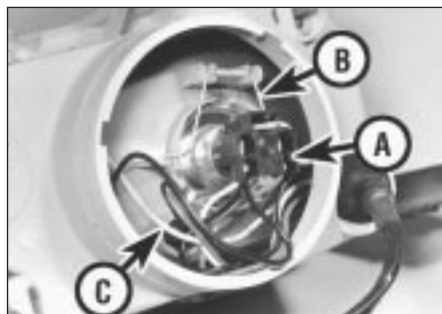

5.3 Headlamp dip/main beam bulb wiring connector (A), retaining clip (B) and sidelamp bulbholder (C)

release it from the rear of the lamp (see illustration).

4 Withdraw the bulb.

5 When handling a new bulb, use a tissue or clean cloth to avoid touching the glass with the fingers. Moisture and grease from the skin can cause blackening and rapid failure of this type of bulb.



If the glass of a headlamp bulb is accidentally touched, wipe it clean using methylated spirit.

6 Refitting is the reverse of the removal procedure. Ensure that the new bulbs locating tabs are correctly located in the lamp cutouts.

Front sidelamp

7 Working in the engine compartment, twist



5.13 Indicator bulbs are of bayonet type



5.16 ... then withdraw lamp and pull out bulbholder



5.11 Remove retaining screw ...

off the large circular plastic cover and remove it from the rear of the headlamp unit (see illustration 5.2).

8 Pull the bulbholder from the headlamp reflector.

9 Pull the capless (push fit) bulb out of its socket.

10 Refitting is the reverse of the removal procedure.

Front direction indicator

11 Working in the engine compartment, undo the indicator lamp upper retaining screw and withdraw the lamp (see illustration).

12 Twist the bulbholder in an anti-clockwise direction to free it from the lamp and remove it from the lamp unit (see illustration).

13 The bulb is a bayonet fit in the holder and can be removed by pressing it and twisting in an anti-clockwise direction (see illustration).



5.15 Push indicator side repeater lamp to right ...

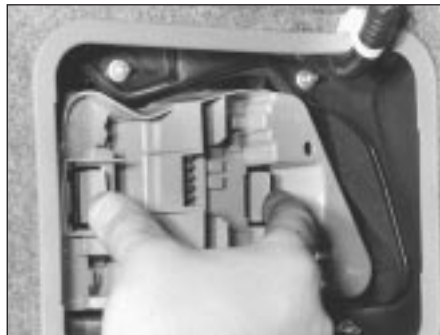

5.19 Depress catches and withdraw rear lamp bulb panel



5.12 ... then withdraw indicator lamp and twist bulbholder free

14 Refitting is a reverse of the removal procedure.

Front direction indicator side repeater

15 Push the lamp unit towards the right to free its retaining clips then withdraw it from the wing (see illustration).

16 Pull the bulbholder out of the lamp unit then pull the capless (push fit) bulb out of its holder (see illustration).

17 Refitting is a reverse of the removal procedure.

Rear lamp cluster

18 From inside the luggage compartment, remove the relevant rear cover from the lamp.

19 Depress the catches and withdraw the bulb panel from the lens unit (see illustration).

20 The relevant bulb can then be removed from the panel. The tail lamp bulb is of the capless (push fit) type, whereas all other bulbs have a bayonet fitting (see illustrations).

21 Refitting is the reverse of the removal sequence. Note that the rubber seal must be renewed if damaged.

Number plate lamps

22 Undo the two mounting screws and remove the number plate lamp lens and seal.

23 Withdraw the lamp and remove the clip

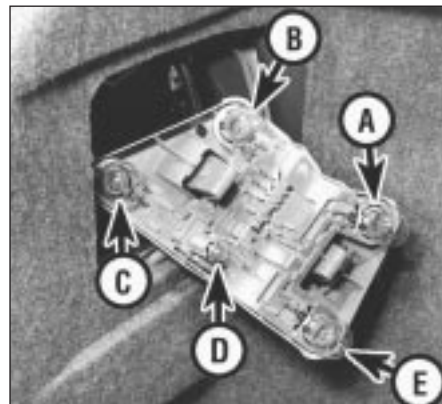

5.20a Rear lamp cluster

A Direction indicator D Tail lamp
B Reversing lamp E Stop lamp
C Foglamp



5.20b Rear cluster tail lamp bulb is of capless type . . .



5.20c . . . whereas all other bulbs have bayonet type fitting



6.9 Luggage compartment lamp bulb is of bayonet type

from the top of the lamp body to gain access to the bulb.

24 The bulb is of the capless (push fit) type and can be pulled out of the lamp unit.

25 Refitting is a reverse of the removal procedure.

6 Bulbs (interior lamps) - renewal



General

1 Refer to Section 5.

Courtesy lamps

2 Carefully prise the lens off the lamp unit then remove the festoon bulb from its end contacts.

3 Fit the new bulb using a reversal of the removal procedure. Check the tension of the spring contacts and if necessary, bend them so that they firmly contact the bulb end caps.

Glovebox lamp

4 Open up the glovebox and undo the two switch/lamp assembly retaining screws. Disconnect the wiring connector and remove the switch/lamp unit from the glovebox.

5 Depress the lens retaining lug and remove the lens assembly from the unit.

6 Release the festoon bulb from its contacts and remove it from the lens.

7 Fit the new bulb using a reversal of the removal procedure. Check the tension of the spring contacts and if necessary, bend them so that they firmly contact the bulb end caps.

Luggage compartment lamp

8 Carefully prise the lamp out of the trim panel using a suitable flat-bladed screwdriver.

9 The bulb is a bayonet fit and can be removed by pressing it in and twisting anti-clockwise (see illustration).

10 Refitting is a reverse of the removal procedure.

Instrument panel illumination and warning lamps

11 Remove the instrument panel.

12 Twist the relevant bulbholder (see illustration) anti-clockwise and withdraw it from the rear of the panel.

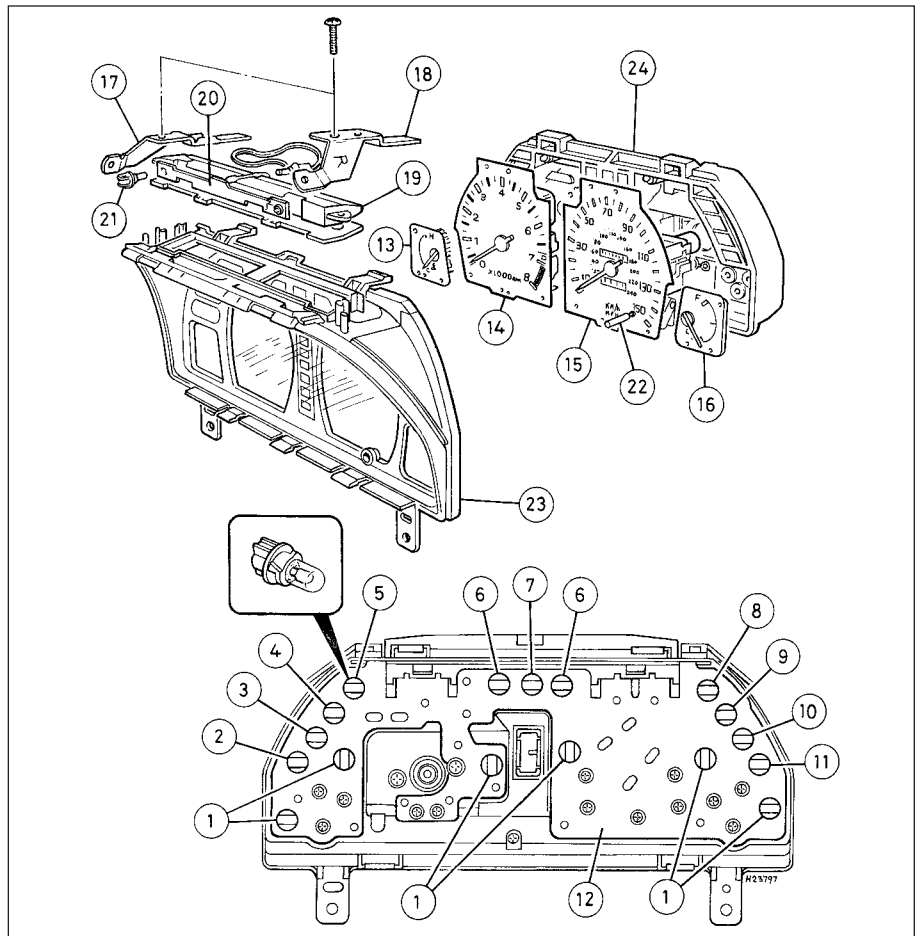

6.12 Instrument panel assembly

- | | | |
|--|---|---------------------------------------|
| 1 Panel rear illumination bulbs | 8 Oil pressure warning lamp bulb | 16 Fuel gauge |
| 2 ABS warning lamp bulb (where fitted) | 9 Ignition/charging lamp warning bulb | 17 Left-hand support bracket |
| 3 Boot open warning lamp bulb | 10 Choke warning lamp bulb - carburettor models | 18 Right-hand support bracket |
| 4 Hazard warning lamp bulb | 11 Caravan/trailer indicator warning lamp bulb | 19 Illumination panel cover |
| 5 Brake fail/handbrake warning lamp bulb | 12 Printed circuit | 20 Illumination panel printed circuit |
| 6 Direction indicator warning lamp bulb | 13 Coolant temperature gauge | 21 Panel front illumination bulb |
| 7 Main beam warning lamp bulb | 14 Tachometer | 22 Tripmeter reset knob |
| | 15 Speedometer | 23 Instrument panel cover |
| | | 24 Instrument panel case |



6.13a Instrument panel illumination bulbholder is a twist fit in panel . . .

13 All bulbs, with the exception of the main panel illumination bulb, are integral with their holders. The main panel illumination bulb is of the capless type and is a push fit in its holder (see illustrations). Be very careful to ensure that the new bulbs are of the same rating as those removed as this is especially important in the case of the ignition/battery charging warning lamp.

14 Refitting is the reverse of the removal procedure.

Facia illumination bulbs

15 To renew the various facia illumination bulbs, it will first be necessary to remove the relevant facia panel to gain access to the bulb.

Switch illumination bulbs

16 All of the facia panel switches are fitted



6.13b . . . bulb being of capless type

with illuminating bulbs. Some are also fitted with a bulb to show when the circuit concerned is operating. These bulbs are an integral part of the switch assembly and cannot be obtained separately. Bulb replacement will therefore require renewal of the complete switch assembly.

7 Exterior lamp units - removal and refitting



Note: Disconnect the battery negative lead before removing any lamp unit, and reconnect the lead after refitting the lamp.

Headlamp

1 Open up the bonnet, then undo the four screws securing the radiator grille to the

headlamps and remove the grille from the vehicle.

2 Remove the screw securing the indicator lamp assembly to the wing and position the lamp unit clear of the headlamp assembly.

3 Undo the two headlamp retaining screws situated behind the indicator lamp and undo the two upper headlamp retaining bolts (see illustrations).

4 Disconnect the headlamp wiring connector (see illustration).

5 Gently pull the headlamp upwards to release it from its lower retainer, then remove the headlamp and lower finisher trim panel assembly from the vehicle.

6 If necessary, the lower finisher can be removed from the headlamp by removing the retaining screw and releasing the two retaining clips.

7 Refitting is a reversal of the removal procedure. On completion adjust the headlamp beam.

Front direction indicator

8 Open up the bonnet and remove the indicator lamp upper retaining screw.

9 Withdraw the lamp unit from the wing, then twist the bulbholder in an anti-clockwise direction to free it from the lamp and remove the lamp unit from the vehicle.

10 Refitting is the reverse of the removal procedure.

Front direction indicator side repeater

11 Push the lamp unit towards the right to free its retaining clips then withdraw it from the wing.

12 Pull the bulbholder out and remove the lamp from the vehicle.

13 Refitting is a reverse of the removal procedure.

Rear lamp cluster

14 Working from within the luggage compartment, remove the relevant rear lamp cover and disconnect the lamp wiring connector (see illustration).

15 Undo the four nuts securing the lamp unit to the body and remove the unit from the vehicle. Note the rubber seal which is fitted between the lamp unit and body (see illustration).



7.3a Remove headlamp retaining screws (remaining one arrowed) . . .



7.3b . . . and two headlamp retaining bolts



7.4 Disconnecting headlamp wiring connector

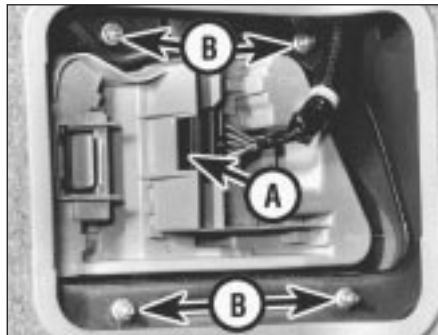

7.14 Disconnect wiring connector (A) and remove rear lamp unit retaining nuts (B)



7.15 Withdraw rear lamp unit noting rubber seal

16 Refitting is a reversal of the removal procedure. The rubber seal must be renewed if damaged.

Number plate lamps

17 Undo the two mounting screws and remove the number plate lamp lens and seal.

18 Withdraw the lamp unit until the wiring connector appears then disconnect the connector and remove the unit from the vehicle.

19 Refitting is the reverse of the removal procedure. The rubber seal must be renewed if damaged.

8 Headlamp beams - alignment

Refer to Chapter 1.

9 Dim-dip headlamp system - operation

1 This system comprises the dim-dip unit (mounted behind the right-hand lower facia panel) and a resistor (situated behind the left-hand headlamp assembly).

2 The dim-dip unit is supplied with current from the sidelamp circuit and energised by a feed from the ignition switch. When energised, the unit allows battery voltage to pass through the resistor to the headlamp



10.4 On models without electric sunroof, remove cover from right-hand side of instrument panel shroud



10.5c ... then withdraw instrument panel shroud



10.2a Carefully prise left-hand switch assembly out of instrument panel shroud ...

dipped-beam circuits. This lights the headlamps with approximately one-sixth of their normal power so that the vehicle cannot be driven using sidelamps alone.

10 Instrument panel - removal and refitting

Removal

1 Working in the engine compartment, disconnect the battery negative lead, then unscrew the union nut which secures the upper and lower sections of the speedometer cable together.

2 Position the steering column in its lowest possible height setting then, using a suitable flat-bladed screwdriver, carefully prise out the switch assembly from the left-hand side of the



10.5a Instrument panel shroud lower retaining screws are accessed through switch apertures



10.6a Remove instrument panel upper (arrowed) and lower retaining screws ...



10.2b ... then withdraw assembly and disconnect wiring connectors

instrument panel shroud. Disconnect the switch wiring connector and remove the switch assembly (see illustrations).

3 On models equipped with an electrically-operated sunroof, repeat the above operation for the sunroof switch.

4 On models without an electrically-operated sunroof, carefully prise out the cover from the right-hand lower corner of the instrument shroud (see illustration).

5 Remove the four instrument panel shroud retaining screws and remove the shroud from the facia (see illustrations).

6 Undo the four screws securing the instrument panel to the facia and carefully withdraw the panel until access can be gained to the rear of the panel. Release the speedometer cable retaining clip then disconnect the cable and three wiring block connectors from the panel (see illustrations).



10.5b Remove upper retaining screws ...



10.6b ... then disconnect speedometer cable ...



10.6c ... and wiring connectors ...



10.7 ... and withdraw instrument panel from fascia

7 Remove the instrument panel from the fascia (see illustration).

Refitting

8 Refitting is a reverse of the removal procedure. On completion, check the operation of all panel warning lamps and instrument shroud switches to ensure that they are functioning correctly.

11 Instrument panel components - removal and refitting

1 Remove the instrument panel then proceed as described under the relevant sub heading.

Instrument illumination panel

Removal

2 Remove the screws securing the right and left-hand upper mounting brackets to the panel assembly and remove both brackets (see illustrations).

3 Release the rear illumination panel bulbholder by twisting it in an anti-clockwise direction, then remove the illumination panel from the top of the instruments (see illustration).

Refitting

4 Refitting is a reversal of the removal procedure.

Instruments

Removal

5 Remove the instrument illumination panel.
6 Release the instrument panel cover retaining clips and lift the cover off the instrument panel case (see illustration).

7 Individual instruments can now be removed separately by unscrewing their retaining screws (see illustrations). When removing the speedometer, note the foam washer which is fitted around the base of the instrument stalk.

Refitting

8 Refitting is a reversal of the removal procedure.

Printed circuit

Removal

9 Remove the speedometer, tachometer, fuel gauge and temperature gauge from the meter case as described in paragraphs 5 to 7.

10 Remove all bulbholders from the rear of the case by twisting them in an anti-clockwise direction, then release the printed circuit from its retaining pins and remove it from the case.

Refitting

11 Refitting is a reverse of the removal sequence.



11.2a Unscrew retaining screws ...



11.2b ... and remove upper mounting brackets from instrument panel



11.3 Removing instrument illumination panel



11.6 Release retaining clips and separate instrument panel case and cover

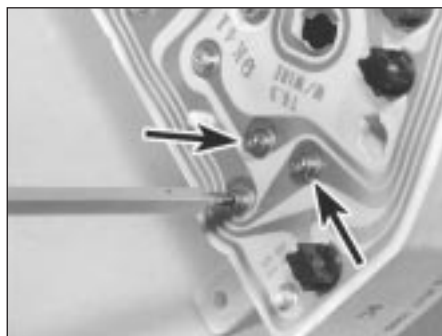

11.7a Remove retaining screws (remaining two arrowed) ...

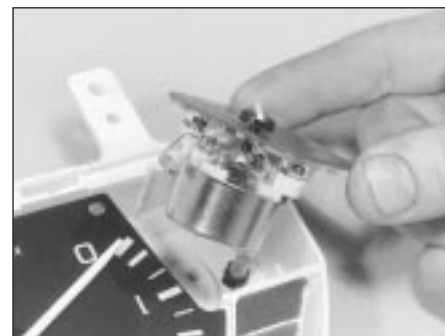

11.7b ... and remove relevant instrument from panel case (temperature gauge shown)



13.2a Carefully prise out clock mounting trim strip . . .



13.2b . . . and disconnect clock wiring connector

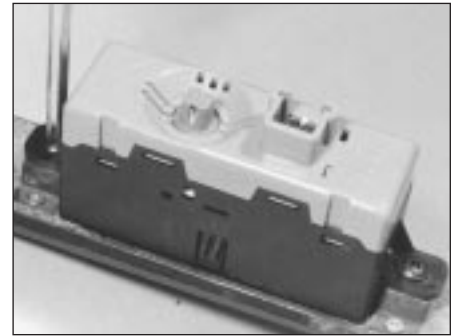

13.3 Removing clock retaining screws (remaining one arrowed)

12 Cigar lighter - removal and refitting

Removal

- 1 Disconnect the battery negative lead.
- 2 Remove the lighter element, then carefully prise out the metal surround, followed by the plastic body. Note the wiring connections before disconnecting them and tie a piece of string around the connector to prevent the wire from falling back inside the fascia.

Refitting

- 3 Refitting is the reverse of the removal procedure.

13 Clock - removal and refitting

Removal

- 1 Disconnect the battery negative lead.
- 2 Using a suitable flat-bladed instrument, carefully prise out the clock mounting trim strip from the fascia. Withdraw the trim and disconnect the wiring connector from the rear of the clock. Tie a piece of string around the connector to prevent it from falling back inside the fascia (see illustrations).
- 3 Undo the two clock retaining screws and

remove the clock from the trim strip (see illustration).

Refitting

- 4 Refitting is a reversal of the removal procedure.

14 Multi-function unit - operation, removal and refitting

Operation

- 1 The multi-function unit (MFU) is mounted onto the rear of the fusebox, which is located behind the right-hand lower fascia panel. The unit controls the following functions:
 - a) Front and rear wiper system delay intervals.
 - b) Heated rear window timer.
 - c) Courtesy lamp delay.
 - d) Lamps-on warning bleeper.
- 2 The MFU also has a self diagnostic mode where it checks out all the relevant circuits it controls.
- 3 To start the diagnostic sequence, press the heated rear window switch and turn on the ignition switch on simultaneously. Release the heated rear window switch as soon as the ignition switch is turned on, the MFU should then bleep to indicate it has entered its diagnostic mode, then press the heated rear window switch for a second time. Subsequent

operations of the interior lamp switches, wiper switches and headlamp switch will result in a bleep from the MFU as it receives a signal. If the unit does not bleep, a fault is indicated in the relevant circuit. A third press on the heated rear window switch will enter the MFU into the second stage of its diagnostic sequence. The MFU will now operate each of its functions in turn starting with the heated rear window, followed by the front and rear wipers and finally the courtesy lamp will operate for approximately two seconds if there are no faults. When all checks are complete, turn the ignition switch off to take the MFU out of its diagnostic sequence.

- 4 If a fault appears in one of the circuits controlled by the MFU, then check the relevant relay (where fitted) and wiring. If this fails to locate the fault, it is likely that the MFU is at fault. The MFU is a sealed unit and must be renewed even if only one of its control functions is faulty.

Removal

- 5 Disconnect the battery negative terminal.
- 6 Undo the five retaining screws and remove the right-hand lower fascia panel (see illustration).
- 7 Release the left-hand fuse panel from the side of the main fusebox and disconnect the two wiring block connectors from the front of the fusebox (see illustrations).
- 8 Remove the two fusebox retaining nuts then partially withdraw the fusebox until the



14.6 Remove retaining screws (arrowed) and withdraw right-hand lower fascia panel



14.7a Release left-hand fuse panel . . .



14.7b . . . and disconnect wiring connectors from front of fusebox

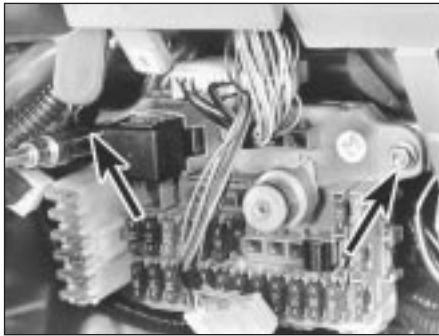

14.8 Fusebox retaining nuts (arrowed)

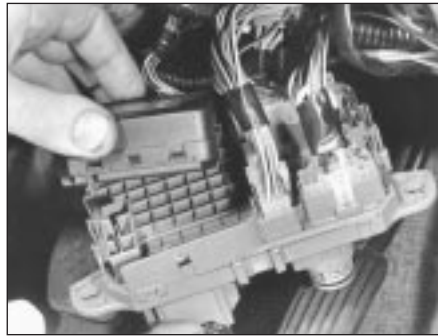

14.9a Release Multi-Function Unit from rear of fusebox . . .



14.9b . . . and disconnect wiring connector

upper wiring block connector(s) can be disconnected (see illustration).

9 Carefully turn the fusebox assembly around and disconnect the block connector from the MFU. Release the MFU from the rear of the fusebox and remove it from the vehicle (see illustrations).

Refitting

10 Refitting is a reversal of the removal procedure. Ensure that all wiring connectors are correctly refitted. On completion, reconnect the battery terminal and check that all electrical circuits function correctly.

15 Supplementary Restraint System (SRS) - operation

1 At vehicle start-up, a warning light located in the steering wheel centre pad will illuminate when the system electrical circuits are activated by turning the ignition switch to position "II" and will stay illuminated for 3 seconds whilst the system performs a self-diagnosis test. If this test is satisfactory, the light will extinguish. If the test is unsatisfactory, the light will remain on or fail to illuminate at all, denoting that the system must be serviced as soon as possible. System operation is as follows:

2 Upon the vehicle suffering a frontal impact over a specified force, a sensor inside the airbag control unit, which is located in the steering wheel centre, activates the system. A sensor (fitted to discriminate between actual impact and driving on rough road surfaces, etc.) is also activated and power is supplied to the airbag ignitor from the battery or a backup circuit, causing the airbag to inflate within 30 milliseconds.

3 As the driver of the vehicle is thrown forward into the inflated airbag it immediately discharges its contents through a vent, thereby providing a progressive deceleration and reducing the risk of injury from contact with the steering wheel, fascia or windscreen. The total time taken from the start of airbag inflation to its complete deflation is approximately 0.1 seconds.

16 Supplementary Restraint System (SRS) - component removal and refitting



Warning: Under no circumstances, attempt to diagnose problems with SRS components using standard workshop equipment.

Note: For safety reasons, owners are strongly advised against attempting to diagnose problems with the SRS using standard workshop equipment. The information in this Section is therefore limited to those components in the SRS which must be removed to gain access to other components on the vehicle. Read carefully the precautions given in Section 1 of this Chapter before commencing work on any part of the system.

Note: All SRS system wiring can be identified by its yellow protective covering.

Airbag unit

Removal

1 Remove the ignition key and wait at least ten minutes to allow the system backup circuit to fully discharge. Disconnect both battery leads, earth lead first, to avoid accidental detonation of the airbag.

2 Remove the two airbag unit retaining screws which are accessed from behind the steering wheel (see illustration).

3 Carefully prise the airbag unit away from the steering wheel to gain access to its wiring behind. Do not allow the unit to hang from its wiring.

4 Unplug the wiring connector from the rear of the airbag unit and carefully remove the unit from the vehicle, placing it in safe storage.

Refitting

5 Refit the airbag unit by reversing the removal procedure, noting the following:

- a) The cable connector must face uppermost when refitted to the airbag unit.

- b) Observe the specified torque wrench setting when tightening the airbag retaining screws (TX30 Torx type) and take care not to cross-thread them.

- c) With the airbag unit in position, press either side of the steering wheel to allow the ridge on the wheel to engage in the groove of the airbag unit.

- d) Reconnect both battery leads, negative lead last, and turn the ignition switch to the "II" position. Check the condition of the system by observing the SRS warning light located in the steering wheel centre pad. The light should stay illuminated for 3 seconds whilst the system performs a self-diagnosis test. If the test is satisfactory, the light will extinguish. If the test is unsatisfactory, the light will remain on or fail to illuminate at all, denoting that the system must be serviced as soon as possible.

Airbag control unit

Removal

6 Remove the airbag unit.

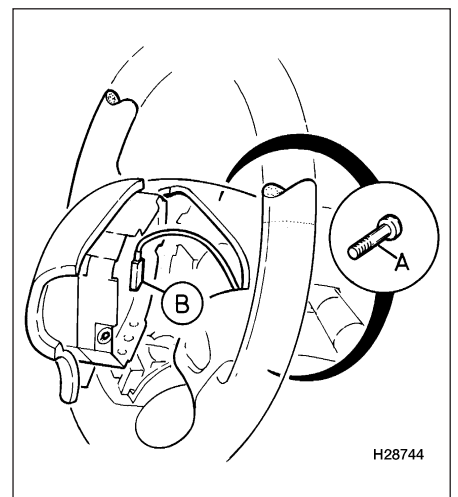

16.2 Remove retaining screws (A) to release airbag unit (B)

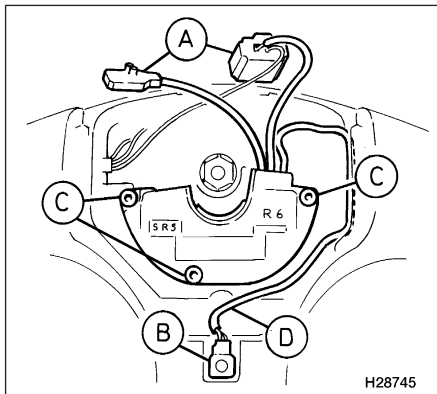

16.7 Disconnect Lucar connection and multiplug (A), SRS warning light (B), remove control unit securing screws (C) and release SRS warning light wiring harness (D)

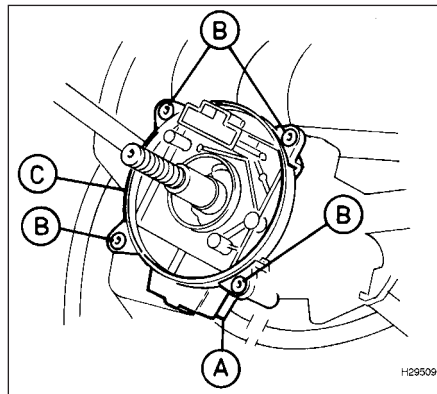

16.15 Disconnect SRS wiring harness multiplug (A), remove slip ring securing screws (B) and remove slip ring (C)

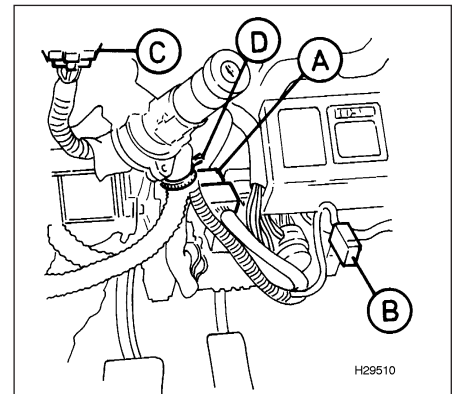

16.23 Disconnect SRS multiplug from main harness (A), SRS fuse (B), SRS multiplug from slip ring (C) and cable tie (D)

7 Disconnect the control unit multiplug and Lucar connection (see illustration).

8 Detach the SRS warning light from the steering wheel.

9 Remove the three screws securing the control unit to the steering wheel.

10 Release the SRS warning light wiring harness and remove the control unit.

Refitting

11 Refit the control unit by reversing the removal procedure, noting the following:

- If the control unit is to be renewed, then the bar code on the new item must be recorded by your Rover dealer.
- Take care to ensure that wiring is not trapped between mating surfaces.
- Observe the specified torque wrench setting when tightening the control unit retaining screws (TX20 Torx type) and take care not to cross-thread them.
- Refit the airbag unit, carrying out the system check.

Slip ring

Removal

12 Set the steering in the straight-ahead position.

13 Remove the airbag unit.

14 Refer to Chapter 10 and remove the steering wheel, followed by the steering column nacelle.

15 Disconnect the airbag wiring harness multiplug from the underside of the slip ring (see illustration).

16 Remove the four screws securing the ring to the column switch assembly and remove the ring from the vehicle.

Refitting

17 Refit the slip ring by reversing the removal procedure, noting the following:

- If the slip ring is to be renewed, then the bar code on the new item must be recorded by your Rover dealer.

b) Take care to ensure that wiring is not trapped between mating surfaces.

c) Refit the airbag unit, carrying out the system check.

Airbag link harness

Removal

18 Remove the ignition key and wait at least ten minutes to allow the SRS system backup circuit to fully discharge. Disconnect **both** battery leads, earth lead first, to avoid accidental detonation of the airbag.

19 Remove the airbag unit.

20 Set the steering in the straight-ahead position then lock the steering column in its lowest position.

21 Remove the five fusebox cover securing screws and release the cover from the fascia.

22 Remove the three screws securing the lower half of the steering column shroud and manoeuvre the lower half of the shroud clear of the column.

23 Disconnect the SRS multiplug from the main wiring harness (see illustration).

24 Release the SRS fuse from the side of the main fusebox.

25 Detach the SRS harness multiplug from the slip ring.

26 Release the cable tie securing the wiring harness to the steering column and remove the harness from the vehicle.

Refitting

27 Refit the harness by reversing the removal procedure, noting the following:

- Take care to ensure that the harness is correctly routed and not trapped between mating surfaces.
- Check all wiring connectors are firmly fastened
- Refit the airbag unit, carrying out the system check.

17 Speedometer drive cable - removal and refitting



1 The speedometer drive cable is in two parts. The lower cable runs from the gearbox to a point just below the fuel filter, while the upper cable runs from that point to the rear of the instrument panel.

Upper cable

Removal

2 Remove the instrument panel and make a note of the correct routing of the speedometer cable.

3 Working in the engine compartment, release the cable sealing grommet from the engine compartment bulkhead and withdraw the cable section from the bulkhead.

Refitting

4 If a new cable is being fitted, transfer the grommet from the old cable to the new item.

5 Have an assistant feed the cable in through the engine compartment bulkhead whilst checking from inside the vehicle that the cable is following the correct route behind the demister duct, over the pedal mounting bracket and through the steering column support bracket.

6 With the cable correctly routed, refit the sealing grommet to the bulkhead then draw the cable through until the coloured tape on the outer cable abuts the sealing grommet.

7 Refit the instrument panel then reconnect the speedometer cable sections and tighten the union nut securely.

Lower cable

Removal

8 Apply the handbrake then jack up the front of the vehicle and support it on axle stands to improve access to the lower end of the cable.



17.10 Slacken union nut and disconnect two speedometer cable sections

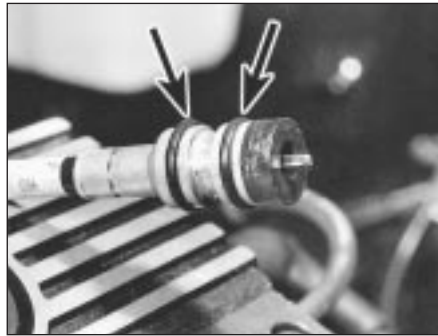

17.11 Lower speedometer cable O-rings (arrowed) must be renewed

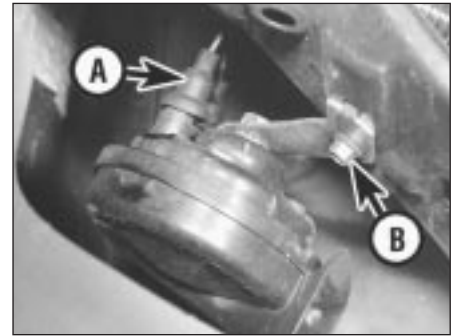

18.3 Horn wiring connectors (A) and retaining bolt (B)

9 Pull out the rubber retaining pin which secures the lower end of the cable in position then withdraw the cable from the gearbox.

10 Slacken the union nut securing the upper and lower cable sections together, then disconnect the two cable sections (see illustration).

11 Release the lower cable from any relevant retaining clips or ties and remove it from the vehicle. Remove the O-rings from the lower end of the cable and discard them as these should be renewed whenever disturbed (see illustration).

Refitting

12 Lubricate the cable lower end fitting O-rings with engine oil and insert the end fitting into the gearbox. Refit the rubber retaining pin to secure the cable in position.

13 Ensure the cable section is correctly routed and is retained by any necessary clamps or ties.

14 Connect the upper cable to the lower cable and tighten the union nut securely. Lower the vehicle to the ground.

18 Horn - removal and refitting



Removal

- 1 Disconnect the battery negative terminal.
- 2 Remove the front bumper.
- 3 Disconnect the horn wiring connectors and unbolt the horn(s) from the body (see illustration).

Refitting

4 Refitting is a reversal of the removal procedure.

19 Windscreen/tailgate wiper blades and arms - inspection and renewal

Refer to "Weekly Checks".

20 Windscreen/headlamp washer system - inspection and adjustment

Refer to "Weekly Checks".

21 Windscreen/tailgate washer system components - removal and refitting



1 The windscreen washer reservoir is situated in the rear left-hand corner of the engine

compartment, with the washer system pump being mounted on the side of the reservoir. On 214 models, the reservoir is also used to supply the tailgate washer system via a second pump (see illustration).

Removal

2 To remove the washer reservoir and pump(s), unscrew the mounting nut and bolts and lift the reservoir from the left-hand corner of the engine compartment.

3 Disconnect the wiring connector(s) from the pump(s) then disconnect the plastic tubing from the reservoir and remove the assembly from the vehicle.

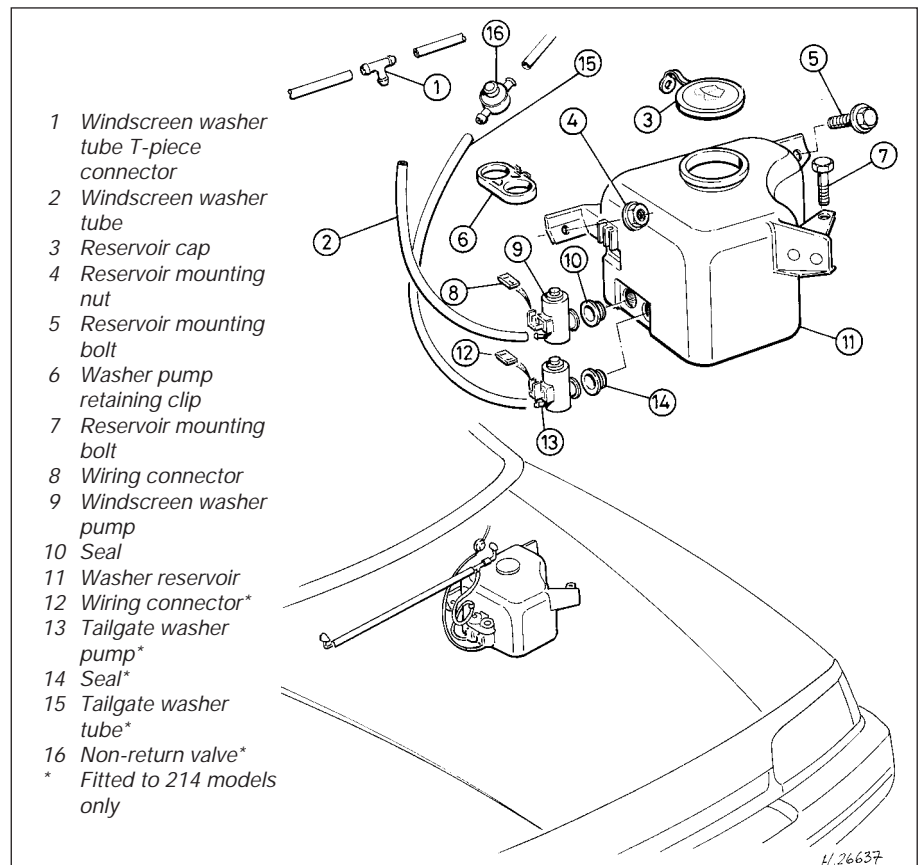

- 1 Windscreen washer tube T-piece connector
 - 2 Windscreen washer tube
 - 3 Reservoir cap
 - 4 Reservoir mounting nut
 - 5 Reservoir mounting bolt
 - 6 Washer pump retaining clip
 - 7 Reservoir mounting bolt
 - 8 Wiring connector
 - 9 Windscreen washer pump
 - 10 Seal
 - 11 Washer reservoir
 - 12 Wiring connector*
 - 13 Tailgate washer pump*
 - 14 Seal*
 - 15 Tailgate washer tube*
 - 16 Non-return valve*
- * Fitted to 214 models only

21.1 Windscreen/tailgate washer system components



21.5 Removing tailgate washer jet - 214 models



22.3a Slacken spindle nuts . . .



22.3b . . . and remove wiper arms from spindles

4 Empty the reservoir of any remaining fluid then undo the retaining screws and separate the pump(s) and reservoir.

5 If necessary, the windscreen washer nozzles can carefully be prised out of the ventilation grille and disconnected from the tubing. On 214 models, prise the washer jet out and remove it from the tailgate (see illustration).

6 If trouble is experienced at any time with the flow to the tailgate washer, check that the non-return valve is not blocked. The valve is fitted in the tube next to the reservoir and should allow fluid to pass only outwards to the jet.

Refitting

7 Refitting is a reversal of removal. Ensure that the washer tubes are not trapped when refitting the reservoir and note that the connectors for the pumps are colour-coded to aid correct reconnection on reassembly.

22 Windscreen wiper motor and linkage - removal and refitting

Removal

1 Operate the wiper motor then switch it off so that the wiper blades return to the rest position.

2 Stick a piece of masking tape on the windscreen alongside the edge of each wiper blade to use as an alignment aid on refitting, then open the bonnet.

3 Slacken and remove the wiper arm spindle nuts and pull the arms off their spindles (see illustrations). If necessary, the arms can be levered off their spindles by using a large flat-bladed screwdriver.

4 Carefully prise out the seven trim caps from the ventilation grille to gain access to the grille retaining screws. Slacken and remove all the retaining screws then release the eight retaining clips situated along the front edge of the grille and remove the grille from the vehicle (see illustration).

5 Using a large flat-bladed screwdriver,

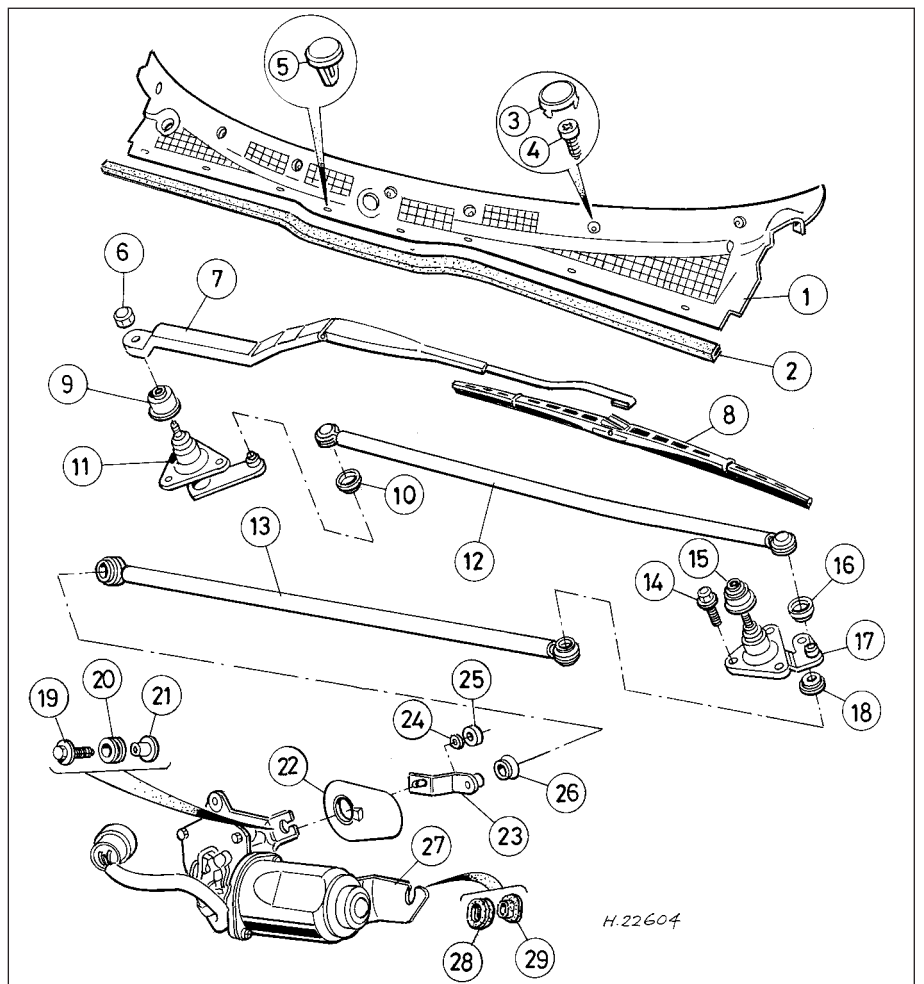

22.4 Windscreen wiper motor and linkage assembly

- | | | |
|-------------------------|-------------------------|--------------------------|
| 1 Ventilation grille | assembly | 20 Mounting rubber |
| 2 Sealing strip | 12 Connecting rod | 21 Spacer |
| 3 Trim cap | 13 Operating rod | 22 Water shield |
| 4 Screw | 14 Bolt | 23 Wiper motor crank arm |
| 5 Retaining clip | 15 Spindle cap | 24 Spring washer |
| 6 Wiper arm spindle nut | 16 Dust seal | 25 Nut |
| 7 Wiper arm | 17 Left-hand spindle | 26 Dust seal |
| 8 Wiper blade | assembly | 27 Wiper motor |
| 9 Spindle cap | 18 Dust seal | 28 Mounting rubber |
| 10 Dust seal | 19 Wiper motor mounting | 29 Spacer |
| 11 Right-hand spindle | bolt | |

H.22604

carefully lever the wiper linkage arm off the wiper motor crank arm balljoint.

6 Disconnect the wiring connector from the wiper motor and remove the four bolts securing the motor to the bulkhead, then remove the motor from the engine compartment taking care not to lose its mounting rubbers (see illustration).

7 Remove the three bolts securing the right-hand wiper arm spindle in position then, using a large flat-bladed screwdriver, disconnect the linkage rod from the spindle balljoint and remove the spindle assembly.

8 Disconnect the two linkage rods from the left-hand wiper arm spindle assembly balljoints and remove the rods.

9 Undo the three left-hand wiper arm spindle retaining bolts and remove the spindle assembly.

Refitting

Refitting is a reversal of the removal procedure, noting the following:

- a) Examine the wiper motor mounting rubbers for signs of damage or deterioration and renew if necessary.
- b) Tighten the wiper arm spindle assembly and wiper motor mounting bolts to the specified torque and ensure all linkage balljoints are pressed firmly together.
- c) Ensure the wiper arm spindles are clean then align the wiper blades with the tape fitted on removal and press the arms firmly onto the spindles. Tighten the wiper arm spindle nuts to the specified torque.

23 Tailgate wiper motor - removal and refitting



Removal

1 Operate the wiper motor, then switch it off so that the wiper blade returns to the rest position.

2 Stick a piece of masking tape alongside the edge of the wiper blade to use as an alignment aid on refitting.



23.4a Unscrew wiper spindle retaining nut . . .



23.4b . . . and withdraw toothed washer and rubber seal



23.7 Tailgate wiper motor mounting bolts (arrowed)



22.6 Windscreen wiper motor mounting bolts (arrowed - lower bolt hidden)



23.3 Removing cover to reveal tailgate wiper arm spindle nut

3 Prise off the wiper arm spindle nut cover then slacken and remove the wiper arm spindle nut and pull the arm off its spindle (see illustration). If necessary, the arm can be levered off using a large flat-bladed screwdriver.

4 Undo the spindle retaining nut then remove the toothed washer and rubber seal (see illustrations).

5 Open up the tailgate and undo the two screws securing the tailgate inner trim panel to the tailgate. Carefully prise out the screw retaining plugs.

6 Using a large flat-bladed screwdriver, work around the outside of the trim panel and carefully prise it away from the tailgate to free all its retaining clips. Once all retaining clips have been freed, remove the trim panel.

7 Disconnect the wiring connector and undo the bolts securing the wiper motor to the tailgate (see illustration). Remove the motor from the tailgate, noting the motor mounting rubbers and the washer and rubber seal fitted to the wiper spindle.

Refitting

8 Refitting is a reverse of the removal procedure, noting the following:

- a) Examine the wiper motor mounting rubbers and spindle seals for signs of damage and deterioration and renew if necessary.
- b) Tighten the wiper motor mounting bolts to the specified torque.

- c) Ensure the wiper arm spindle is clean, then align the wiper blade with the tape fitted on removal and press the arm firmly onto the spindle. Tighten the wiper arm spindle nut to the specified torque and refit the nut cover.

24 Radio/cassette player - removal and refitting



Note: The following removal and refitting procedure is for the range of radio/cassette units which Rover fit as standard equipment. Removal and refitting procedures of non-standard units may differ slightly.

Removal

1 Referring to the instructions supplied with the radio/cassette unit, temporarily deactivate the security code.

2 Disconnect the battery negative lead.

3 To remove the unit, two standard DIN extraction tools are required. These are two U-shaped rods which are inserted into the four small holes in the front of the unit to release the unit retaining clips. The tools may possibly be obtained from a Rover dealer or any audio accessory outlet, or can be made out of 3.0 mm wire rod, such as welding rod. Using the tools, push back the clamps on the left and right-hand sides, withdraw the unit



24.3a Use DIN tools to release retaining clips . . .

and disconnect the wiring plugs and aerial (see illustrations).

Refitting

4 Refitting is the reverse of the removal procedure. On completion, connect the battery negative terminal and reactivate the security code.

25 Speakers - removal and refitting



Removal

Front speaker

- 1 Remove the front door inner trim panel.
- 2 Undo the three speaker retaining screws



25.2a Slacken three retaining screws . . .



24.3b . . . then withdraw radio/cassette unit and disconnect aerial and wiring connectors

then withdraw the speaker. Disconnect the speaker wiring connectors and remove the speaker from the door (see illustrations).

Rear speaker - 214 models

- 3 Prise off the trim cap from the rear seat belt upper mounting point, then slacken and remove the two seat belt guide retaining bolts.
- 4 Open up the tailgate, then remove the four screws securing the speaker grille panel and position the panel clear of the speaker (see illustration).
- 5 Undo the four speaker retaining screws then lift out the speaker. Disconnect the wiring connectors and remove the speaker from the vehicle (see illustration).

Rear speaker - 414 models

- 6 Working from inside the luggage compartment, disconnect the speaker wiring



25.2b . . . withdraw speaker from door and disconnect wiring connectors

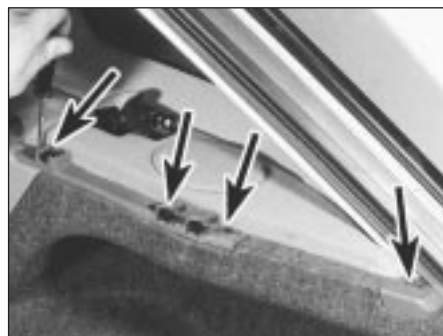

25.4 Rear speaker grille panel retaining screws (arrowed) - 214 models



25.5 Rear speakers are retained by four screws - 214 models

connections and undo the three nuts securing the speaker to the parcel shelf (see illustration).

7 The speaker can then be lifted away from the parcel shelf from inside the vehicle.

Refitting

8 Refitting is a reverse of the removal procedure.

26 Radio aerial - removal and refitting



Removal

- 1 Remove the radio/cassette player.
- 2 Undo the five screws securing the right-hand lower fascia panel and remove the panel to gain access to the relay mounting bracket. Remove the relay mounting bracket retaining bolt.
- 3 Trace the aerial lead back along its length and free it from any retaining clips or ties. Tie a long piece of string around the aerial end plug.
- 4 Undo the two screws securing the aerial to the roof and remove the aerial and sealing rubber. Carefully withdraw the aerial lead until the plug comes out of the aerial aperture then untie the string and leave it in position in the vehicle.

Refitting

- 5 Securely tie the string around the aerial lead plug and fit the rubber seal to the aerial.
- 6 From inside the vehicle, gently pull the string through the radio aperture whilst feeding the aerial lead in through the roof. When the aerial lead plug emerges on the inside of the vehicle, untie the string.
- 7 Ensure the rubber seal is correctly located on the base of the aerial then tighten the aerial retaining screws securely.
- 8 Refit the aerial lead to the necessary retaining clips and ties then refit the relay mounting bracket and right-hand lower fascia panel. Tighten all retaining screws and bolts securely.
- 9 Refit the radio/cassette unit.

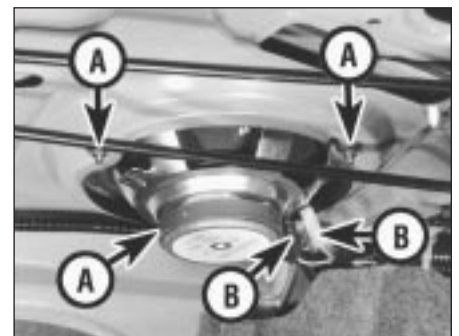

25.6 Rear speaker retaining nuts (A) and wiring connectors (B) - 414 models

NOTES:

1. All diagrams are divided into numbered circuits depending on function e.g. Diagram 2: Exterior Lighting.
2. Items are arranged in relation to a plan view of the vehicle.
3. Items may appear on more than one diagram so are found using a grid reference e.g. 2/A1 denotes an item on diagram 2 grid location A1.
4. Complex items appear on the diagrams as blocks and are expanded on the internal connections page.
5. Feed wire colour varies dependant on the circuit supplied but all earth wires are coloured black or have a black tracer.
6. Not all items are fitted to all models.

ENGINE COMPARTMENT FUSEBOX

FUSE	RATING	CIRCUIT
3	10A	Hazard Warning Lamps
4	25A	Cooling Fan Relay
7	15A	Horn

ENGINE COMPARTMENT FUSEBOX

FUSE -LINK	RATING	CIRCUIT	ITEM	DESCRIPTION	DIAGRAM/ GRID REF.
FL1	40A	ABS Pump	1	ABS Electronic Control Unit	4/F5
FL2	40A	Lighting, Cigar Lighter	2	ABS Pump	4/F7
FL3	40A	Ignition Switch	3	ABS Pump Relay	4/F7
FL4	40A	Electric Window Relay, Sunroof, Central Door Locking, Heated Rear Window	4	ABS Solenoid Relay	4/E7
			5	ABS Solenoid Valve LH Front	4/F5
			6	ABS Solenoid Valve Rear	4/F6
FL5	40A	Ignition Switch	7	ABS Solenoid Valve RH Front	4/F5
FL6	60A	Main Relay, Fuel Pump Relay, Lambda Sensor Relay	8	Alternator	1/A2
			9	Ashtray Illumination	2b/F5
			10	Battery	1/B6, 1a/B6, 2/B6, 2a/B6, 2b/B6, 2b/A7, 3/B7, 3a/B7, 4/B7, 5/B6

PASSENGER COMPARTMENT FUSEBOX

FUSE	RATING	CIRCUIT	ITEM	DESCRIPTION	DIAGRAM/ GRID REF.
1	10A	Clock, Instruments, Direction Indicators, Dim/Dip Unit			1a/B3
2	10A	Starter Signal			3a/H1
3	15A	Central Locking	11	Canister Purge Solenoid (Cat. Only)	1a/B3
4	10A	Cigar Lighter	12	Central Locking Control Unit	3a/H1
5	10A	Dim/Dip Resistor	13	Central Locking Motor LH Front	3a/J8
6	30A	Sunroof	14	Central Locking Motor LH Rear	3a/M8
7	10A	RH Side, Tail, Number Plate Lamps	15	Central Locking Motor RH Rear	3a/M1
8	10A	LH Side, Tail, Interior Illumination	16	Central Locking Switch	3a/J1
9	10A	Fog Lamps	17	Choke Switch	1/K4
10	10A	LH Headlamp Dipped Beam	18	Cigar Lighter	2b/F6
11	10A	RH Headlamp Dipped Beam	19	Cigar Lighter Relay	2b/E4
12	15A	Clock, Interior Lamps, Radio Memory	20	Clock	2b/D5
13	15A	Front Wash/Wipe	21	Coolant Temp. Gauge Sender Unit	1/C1
14	10A	Engine Management System	22	Coolant Temp. Sensor	1a/D4
15	15A	Cooling Fan, Rear Wash/Wipe	23	Cooling Fan Motor	1/R4
16	15A	Reversing Lamps, Stop Lamps, Electric Windows	24	Cooling Fan Switch	1/R3
			25	Cooling Fan Relay	1/E8
17	10A	Cigar Lighter, Multi-Function Unit, Radio Cassette Unit	26	Crank Position Sensor	1a/B5
			27	Dim/Dip Resistor	2/R5
18	10A	Electric Door Mirrors	28	Dim/Dip Unit	2/J2
19	15A	Headlamp Dim/Dip	29	Dimmer Unit	2b/J1
20	15A	Fuel Pump	30	Direction Indicator Flasher Relay	2a/F2
21	15A	RH Headlamp Main Beam	31	Direction Indicator LH Front	2a/B8
22	15A	LH Headlamp Main Beam	32	Direction Indicator RH Front	2a/A1
23	25A	Heated Rear Window, Heated Door Mirrors	33	Direction Indicator Side Repeater LH	2a/C8
			34	Direction Indicator Side Repeater RH	2a/C1
24	20A	Heater Blower Motor	35	Direction Indicator Switch	2a/J3
25	15A	Anti-lock Braking System	36	Distributor	1/C4, 1a/B3
26	15A	LH Rear Electric Window			
27	15A	RH Rear Electric Window	37	Electric Door Mirror LH	3a/E8
28	15A	LH Front Electric Window			
29	15A	RH Front Electric Window			

Notes, fuses and key to wiring diagrams

H24200
T.M.MARKE

ITEM	DESCRIPTION	DIAGRAM/ GRID REF.	ITEM	DESCRIPTION	DIAGRAM/ GRID REF.
38	Electric Door Mirror RH	3a/E1	86	Lamp Cluster LH Rear	2/M8, 2a/M8
39	Electric Door Mirror Switch	3a/F2	87	Lamp Cluster RH Rear	2/M1, 2a/M1
40	Electric Window Control Unit	3a/H8	88	Light Switch	2/J3, 2a/J4, 2b/J3, 5/J4
41	Electric Window Motor LH Front	3a/G8	89	Low Brake Fluid Sender Unit	1/E2
42	Electric Window Motor LH Rear	3a/L8	90	Luggage Comp. Lamp	2b/L5
43	Electric Window Motor RH Front	3a/H1	91	Luggage Comp. Lamp Switch	2b/M4
44	Electric Window Motor RH Rear	3a/L1	92	Main Beam Relay	2/E5
45	Electric Window Relay	3a/E5	93	Main Relay	1a/F6
46	Electric Window Switch LH Front	3a/G7	94	Manifold Heater	1/F4, 1a/F3
47	Electric Window Switch LH Rear	3a/L7	95	Manifold Heater Relay	1/F7, 1a/H6
48	Electric Window Switch RH Front	3a/J4	96	Manifold Temp. Switch	1/E4
49	Electric Window Switch RH Rear	3a/L2	97	MEMS Unit	1a/C7
50	Foglamp Relay	2a/G6	98	Multi-Function Unit	2b/D2, 3/E2
51	Foglamp Switch	2a/J5, 2b/J4	99	Number Plate Lamp	2/M4, 2/M5
52	Fuel Gauge Sender Unit	1/M4	100	Oil Pressure Switch	1/C2
53	Fuel Injector	1a/F3	101	Radio/Cassette Unit	5/F5
54	Fuel Pump	1a/M4	102	Reversing Lamp Switch	2a/C5
55	Fuel Pump Relay	1a/F8	103	Spark Plugs	1/C3, 1a/B3
56	Glove Box Lamp	2b/E7	104	Speaker LH Front	5/F8
57	Glove Box Lamp Switch	2b/E7	105	Speaker LH Rear	5/M8
58	Handbrake Warning Switch	1/L5	106	Speaker RH Front	5/F1
59	Hazard Warning Lamp Switch	2a/J5, 2b/J5	107	Speaker RH Rear	5/M1
60	Headlamp Unit LH	2/R7	108	Starter Motor	1/A5
61	Headlamp Unit RH	2/R2	109	Starter Relay	1/D7, 1a/G6
62	Heated Rear Window	3/L4	110	Stepper Motor	1a/E3
63	Heated Rear Window Relay	3/F1	111	Stop-Lamp Switch	2a/E4, 4/D3
64	Heated Rear Window Switch	2b/J5, 3/J5	112	Sunroof Control Switch	5/J2
65	Heater Blower Motor	3/G7	113	Sunroof Control Unit	5/H5
66	Heater Blower Resistor Pack	3/G7	114	Sunroof Microswitch	5/K5
67	Heater Blower Switch	3/J7	115	Sunroof Motor	5/K4
68	Heater Blower Switch Illumination	2b/E6	116	Sunroof Relay	5/H6
69	Horn	3/R1, 3/R8	117	Throttle Pedal Switch	1/G3, 1a/H3
70	Horn Relay	3/G5	118	Throttle Potentiometer	1a/E2
71	Horn Switch	3/K3	119	Washer Pump Front	3/E6
72	Idle Solenoid	1/F4	120	Washer Pump Rear	3/E6
73	Ignition Amplifier Module	1/C4	121	Wheel Sensor LH Front	4/D8
74	Ignition Coil	1/R7, 1a/R7	122	Wheel Sensor LH Rear	4/L8
75	Ignition Switch	1/K1, 1a/L1, 2/J1, 2a/J1, 2b/K1, 3/J1, 3a/F2, 4/J1, 5/J1	123	Wheel Sensor RH Front	4/D1
76	Inertia Switch	1a/L4	124	Wheel Sensor RH Rear	4/L1
77	Instrument Cluster	1/J3, 1a/K3, 2/G4, 2a/G3, 2b/G3, 4/J3	125	Wiper Motor Front	3/C3
78	Intake Air Temp. Sensor	1a/E3	126	Wiper Motor Rear	3/M4
79	Interior Lamp	2b/J4	127	Wiper Relay Front	3/D1
80	Interior Lamp Door Switch LH Front	2b/H8	128	Wiper Relay Rear	3/M1
81	Interior Lamp Door Switch LH Rear	2b/L8	129	Wiper Switch Front	3/J3
82	Interior Lamp Door Switch RH Front	2b/H1	130	Wiper Switch Rear	3/K3
83	Interior Lamp Door Switch RH Rear	2b/L1			
84	Lambda Sensor (Cat. Only)	1a/R4			
85	Lambda Sensor Relay (Cat. Only)	1a/H8			

Key to wiring diagrams (continued)

H24201
T.M.MARKE

INTERNAL CONNECTION
DETAILS

INTERNAL CONNECTIONS FOR ITEM 39

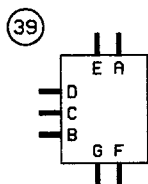

LH	B	C	A	F	G
UP	○	○	○	○	○
DOWN	○	○	○	○	○
LEFT	○	○	○	○	○
RIGHT	○	○	○	○	○

RH	B	C	A	F	G
UP	○	○	○	○	○
DOWN	○	○	○	○	○
LEFT	○	○	○	○	○
RIGHT	○	○	○	○	○

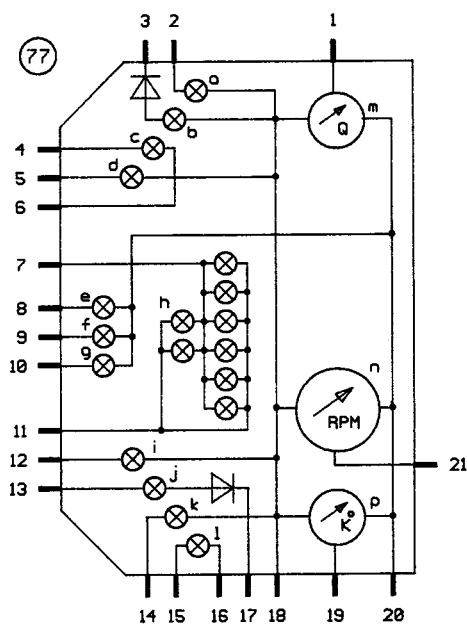

KEY TO INSTRUMENT CLUSTER (ITEM 77)

- a = ABS Warning Lamp
- b = Tailgate Open Warning Lamp
- c = Hazard Warning Lamp
- d = Handbrake/Low Brake Fluid Warning Lamp
- e = RH Direction Indicator Lamp
- f = Main Beam Warning Lamp
- g = LH Direction Indicator Lamp
- h = Instrument Illumination
- i = Oil Pressure Warning Lamp
- j = Ignition Warning Lamp
- k = Choke Warning Lamp
- l = Trailer Warning Lamp
- m = Fuel Gauge
- n = Tachometer
- p = Coolant Temperature Gauge

WIRE COLOURS

- | | |
|-----------------|----------|
| B Blue | A Red |
| Bk Black | Rs Pink |
| Bn Brown | S Grey |
| LGn Light Green | V Violet |
| Gn Green | W White |
| O Orange | Y Yellow |
| P Purple | |

KEY TO SYMBOLS

- PLUG-IN CONNECTOR
- EARTH
- BULB
- LINE CONNECTOR
- DIODE
- FUSE/
FUSIBLE LINK
- EARTH POINT

Internal connection details, wire colours and key to symbols

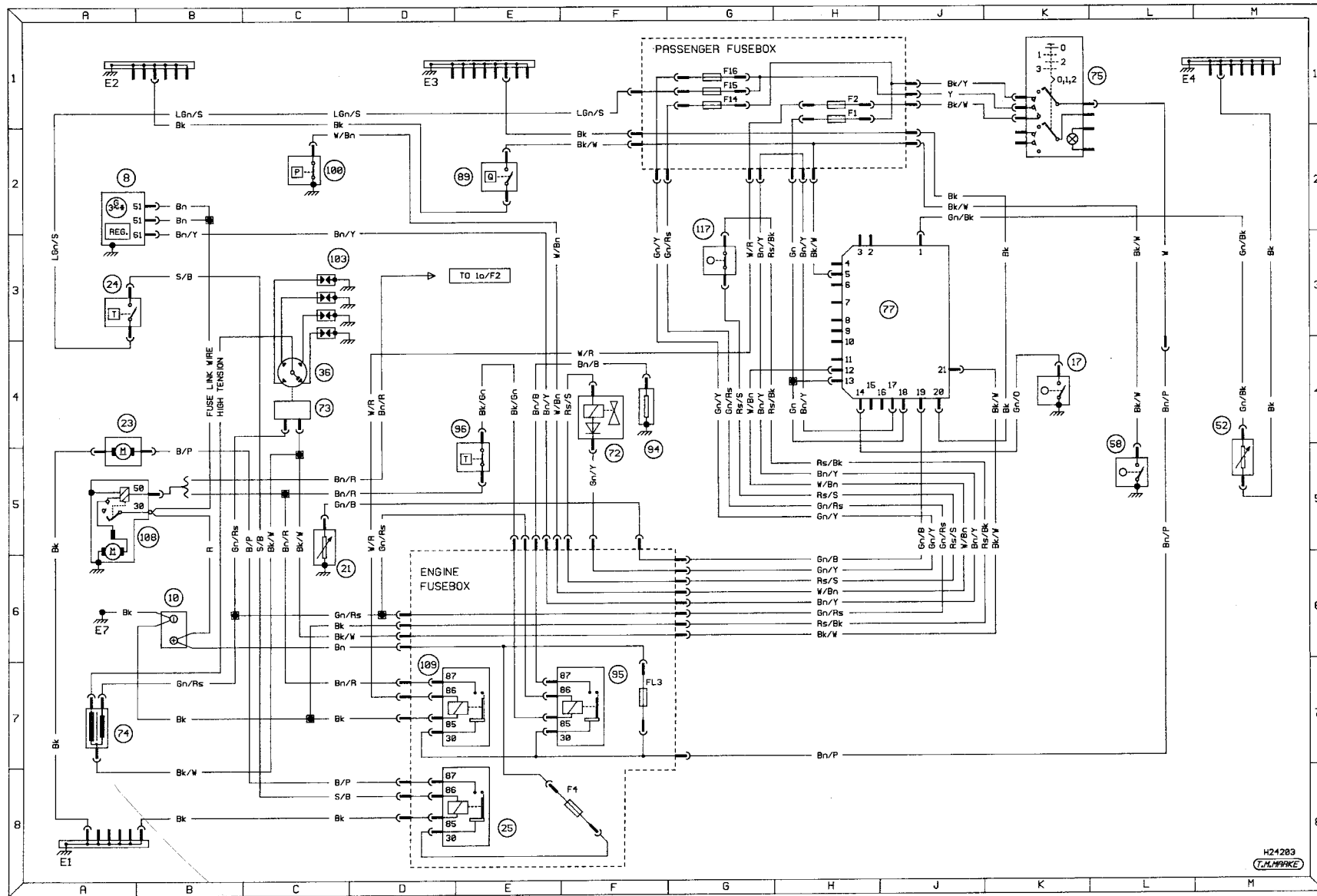

Diagram 1: Starting, charging, ignition (carburettor models), cooling fan, warning lamps and gauges. All models

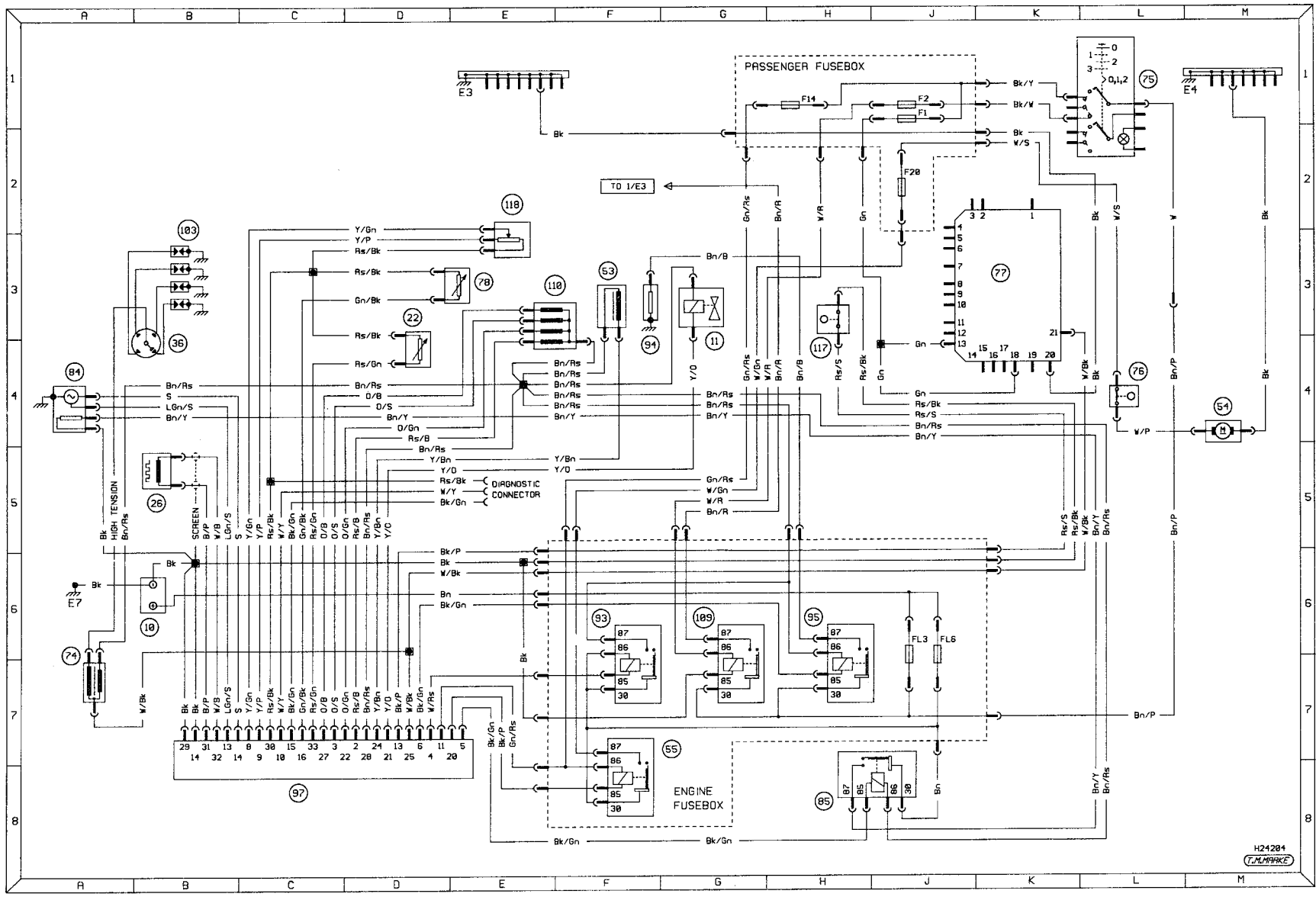

Diagram 1a: Modular engine management - single point injection

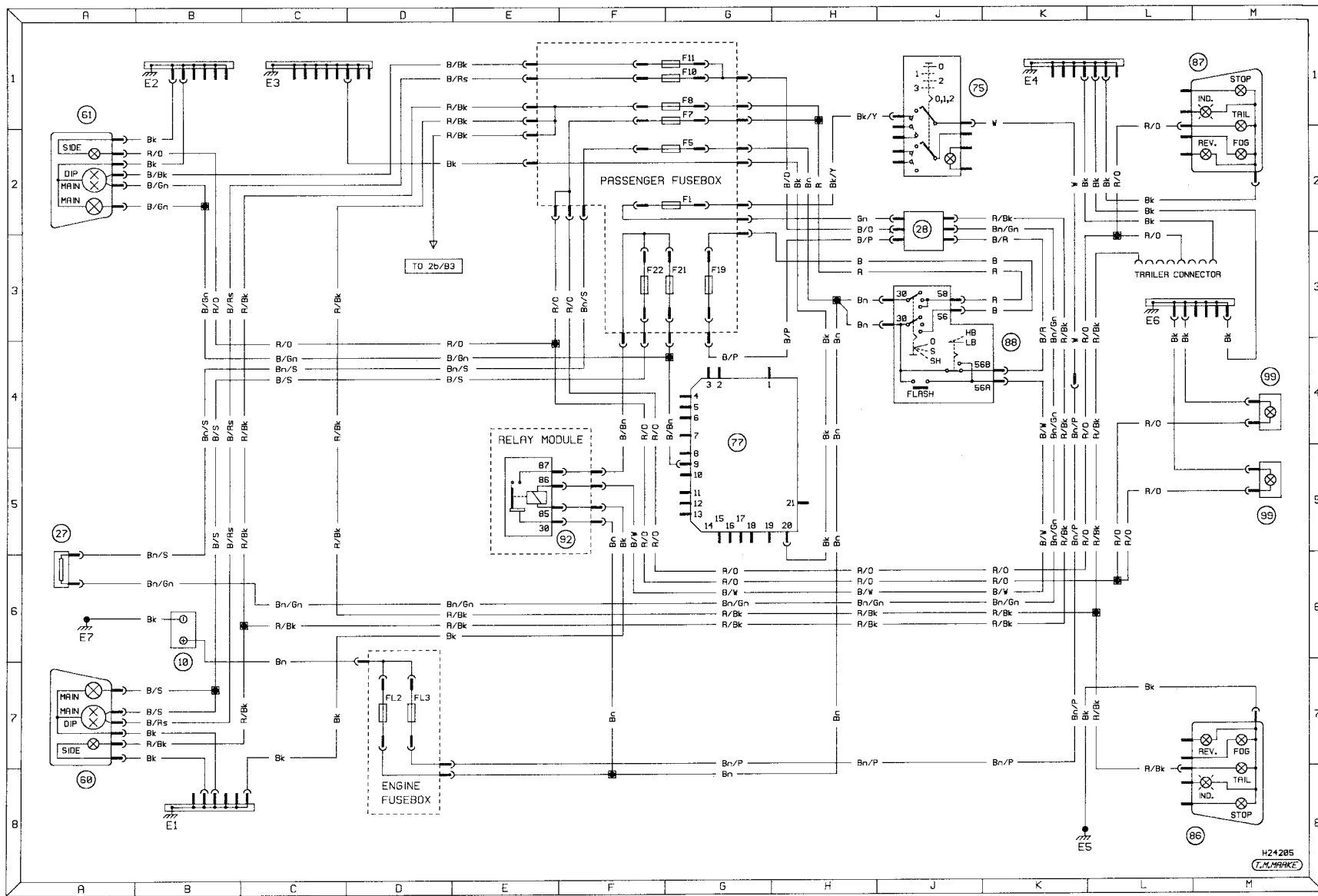

Diagram 2: Exterior lighting - sidelamps and headlamps. All models

H24285
T.M.HARKE

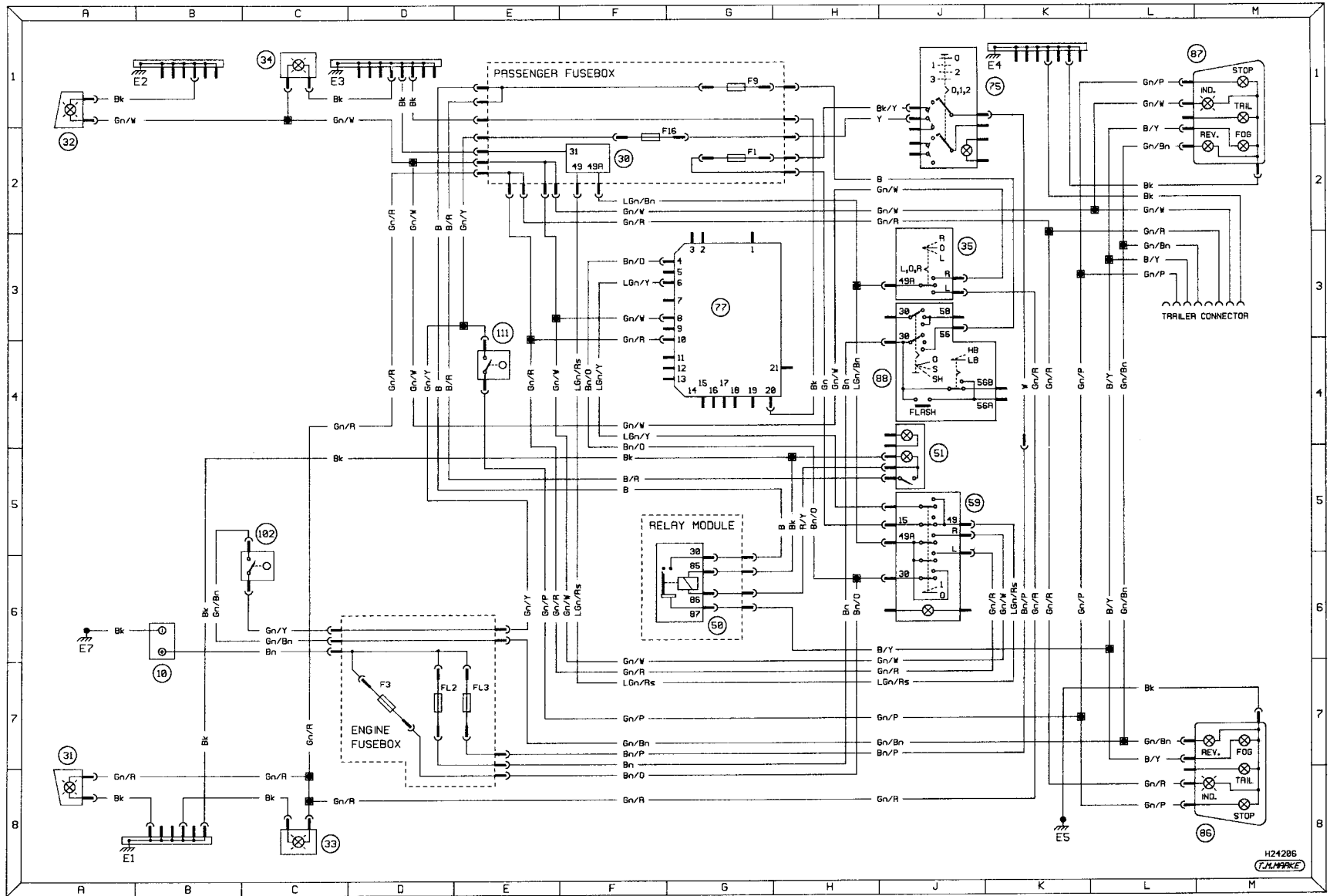

Diagram 2a: Exterior lighting - signal/warning lamps. All models

H24286
TUMPAKE

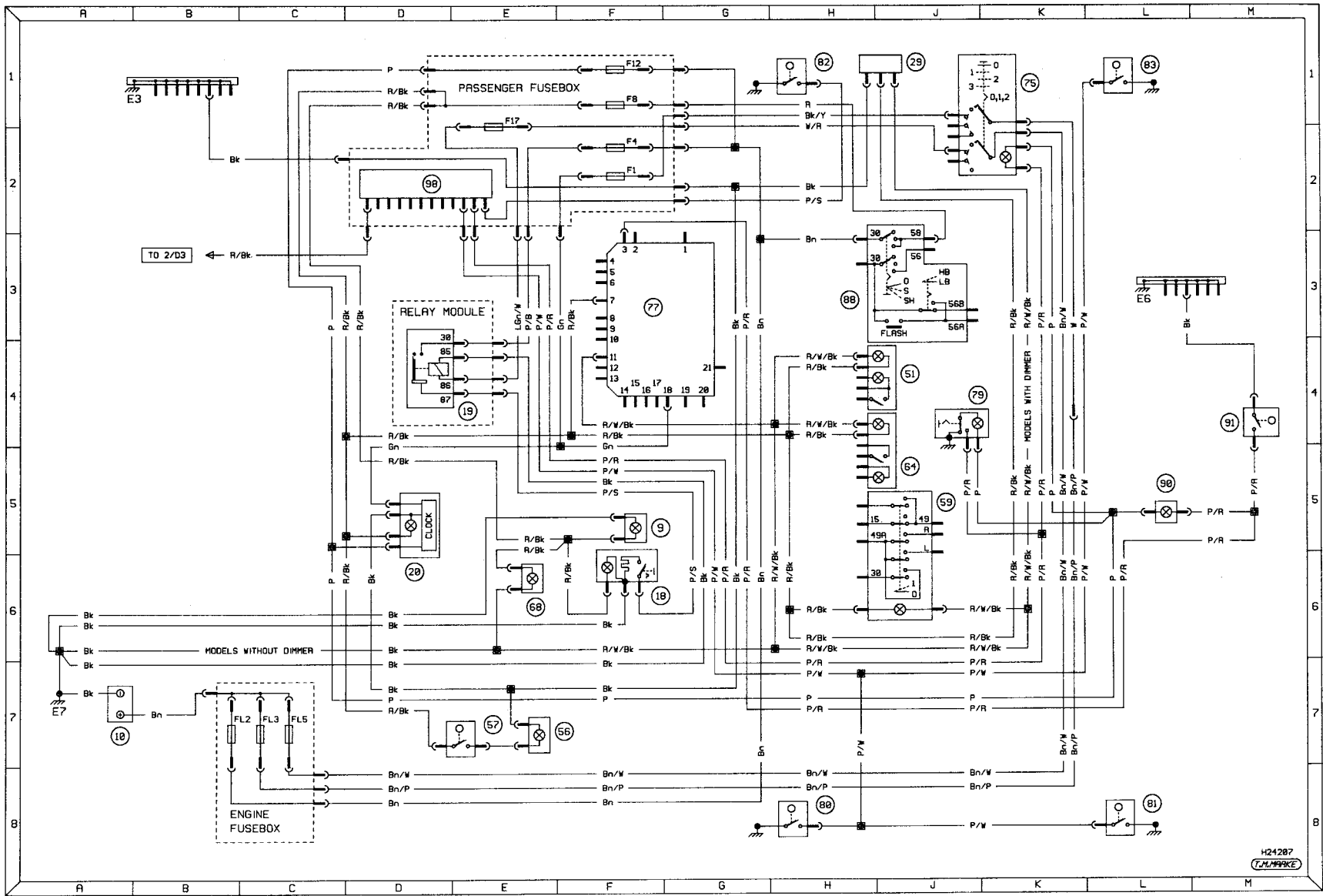

Diagram 2b: Interior lighting and associated circuits. All models

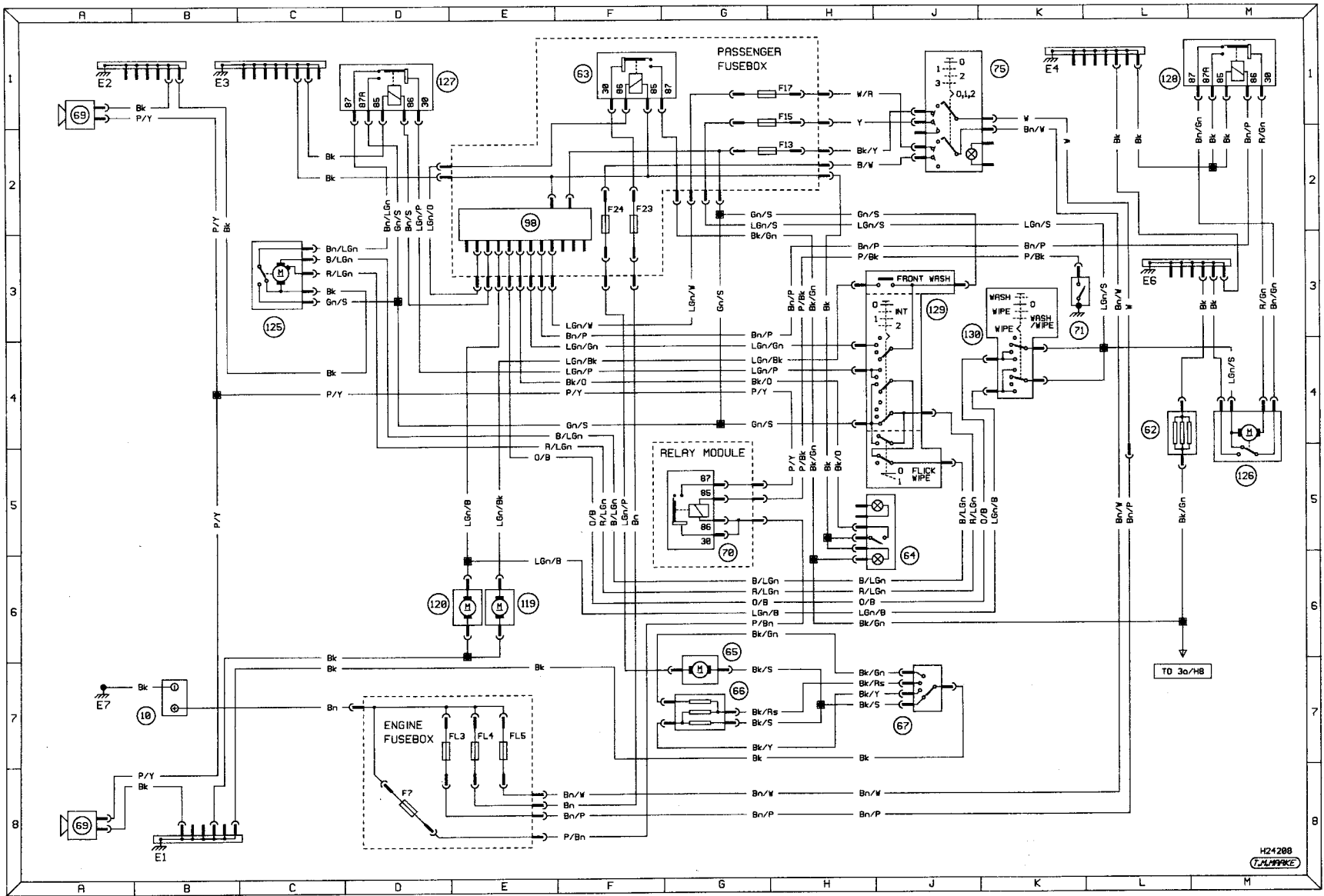

Diagram 3: Ancillary circuits - wash/wipe, heater blower and heated rear window. All models

H24288
TRW

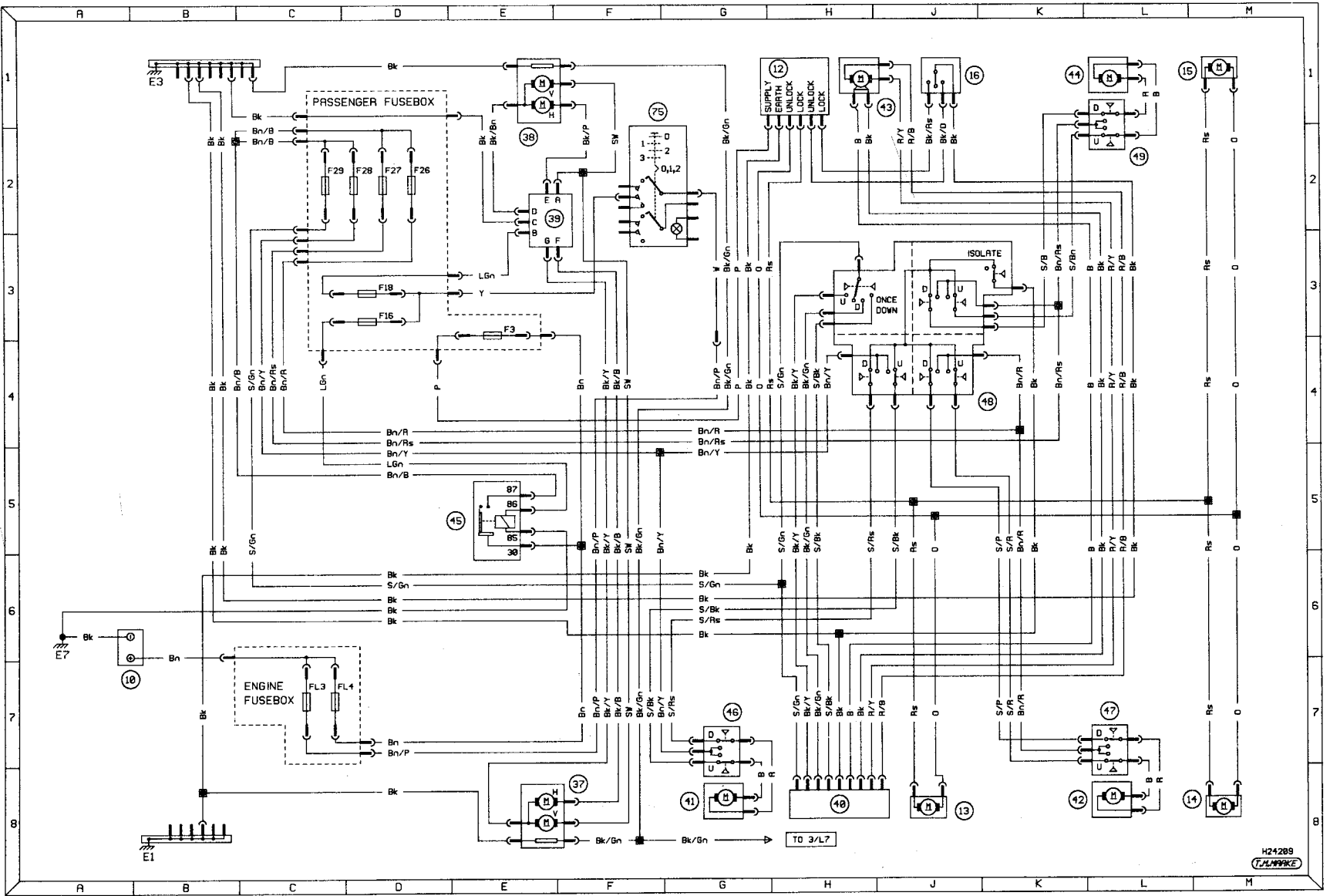

Diagram 3a: Ancillary circuits - electric windows, mirrors and central locking

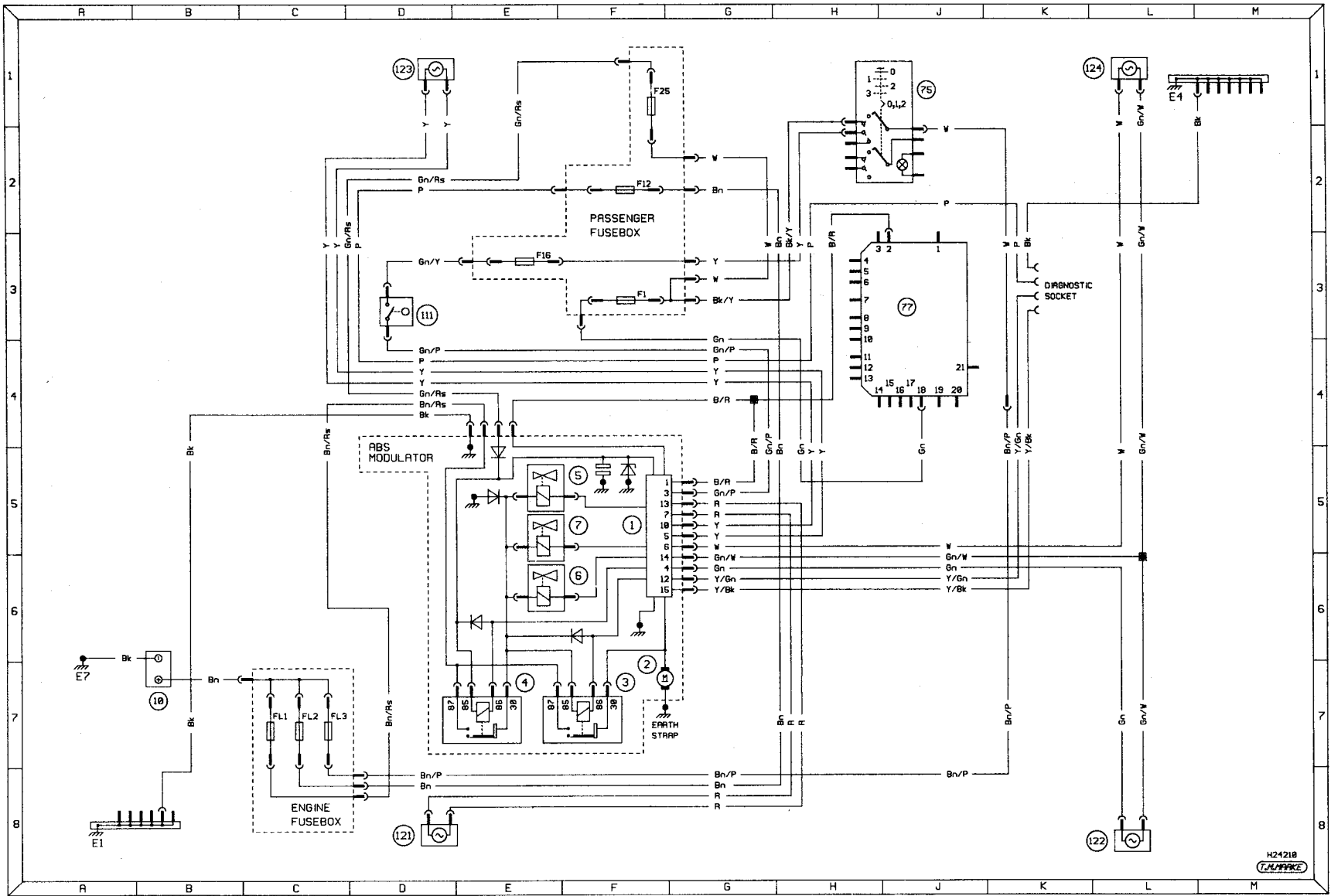

Diagram 4: Anti-lock braking system

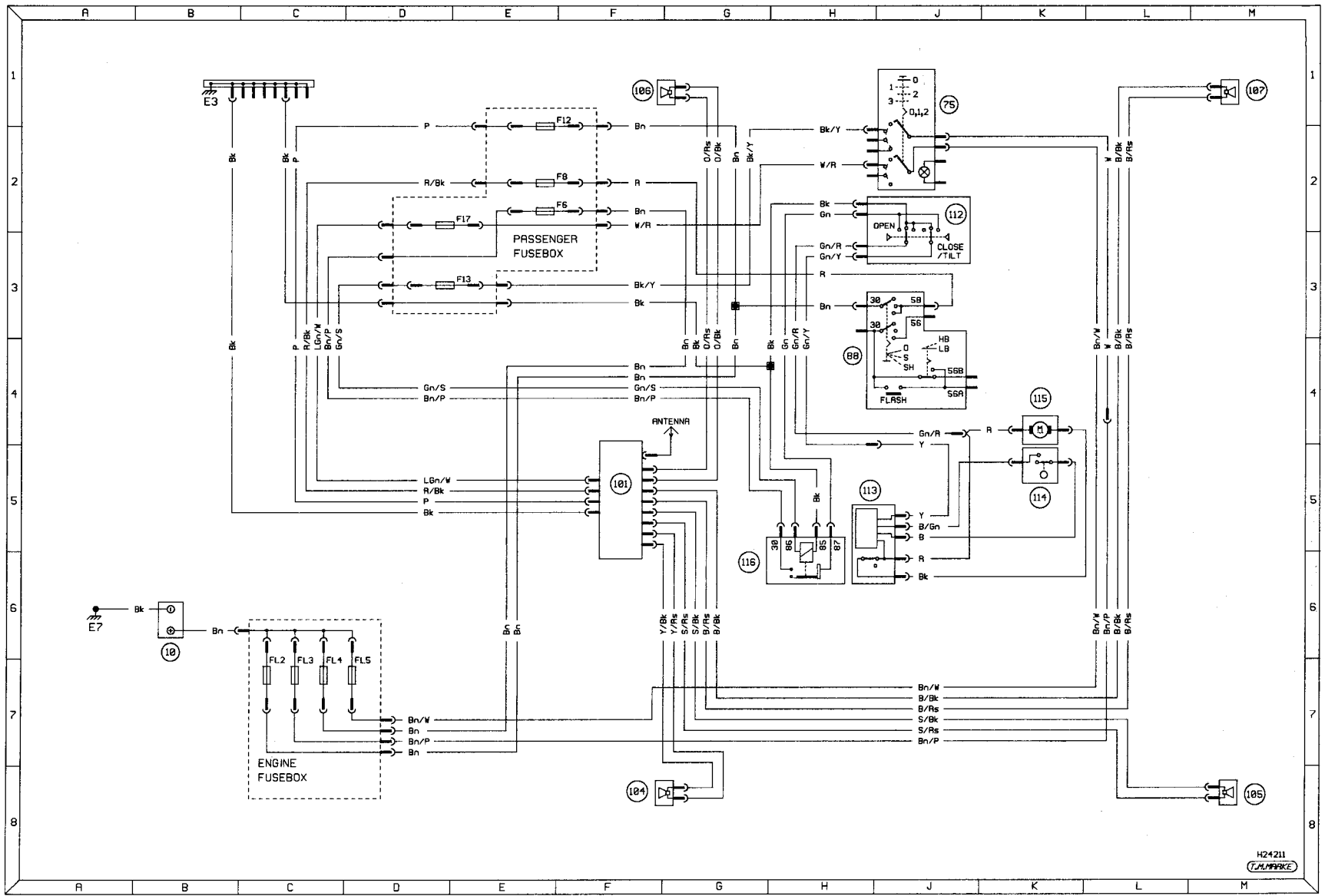

Diagram 5: In-car entertainment and electric sunroof