

EVINRUDE

TRAILBLAZER



OWNER MANUAL / models E2020 - E2025



MODEL AND SERIAL NUMBER IDENTIFICATION

EVINRUDE MOTORS MILWAUKEE, WIS., U. S. A.	
MODEL NO.	<input type="text"/>
SERIAL NO.	<input type="text"/>
OUTBOARD MARINE CORPORATION OF CANADA LTD PETERBOROUGH CANADA MADE IN CANADA	

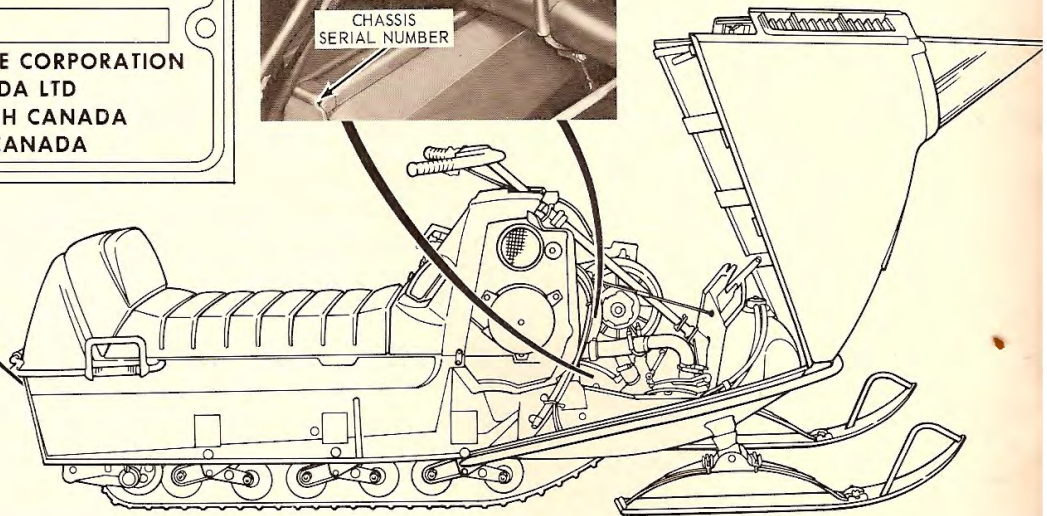
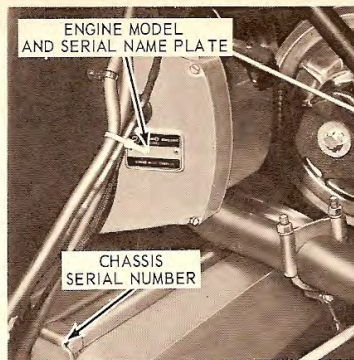

SEE YOUR EVINRUDE DEALER FOR SNOWMOBILE ACCESSORIES.

PARTS AND REPAIR SERVICE

Be sure that only factory approved parts are used in your vehicle. Dealers usually have a complete stock of genuine OMC parts and can provide expert service. Replacement

parts not of our manufacture have not been approved for your Snowmobile. If failure occurs in parts not made or approved by OMC, your warranty is void. Your dealer can be found in the yellow pages of your phone directory under "Snow Vehicles."

FOREWORD

This Owner's Manual has been prepared to assist you in the operation and maintenance of your new Evinrude Trail-Blazer. It contains information that you should know in order to realize peak performance and pleasure of operation. Please read the entire book carefully and keep it handy for future reference.

Many Evinrude Dealers or OMC Servicentres in snow areas will stock service parts and will have service information for the complete unit.

For service, always contact your Evinrude dealer. Specify the model number of the complete unit and the engine specification number.

TABLE OF CONTENTS

PARTS AND REPAIR SERVICE	Inside Front Cover
MODEL AND SERIAL NUMBER	Inside Front Cover
SPECIFICATIONS AND FEATURES	2-3
FUEL RECOMMENDATIONS	4-5
OMC 2+4 Fuel Conditioner	5
BREAK-IN PERIOD	5
CONTROLS	6
-Hand Brake and Parking Lock	6
-Neutral Control	6
-Choke	6
-Primer	6
-Compression Relief	6
-Throttle	6
-Ignition/Lights Switch	6
-Manual Starter Handle	6
-Reverse Control	7
-Headlight Retracting Lever	7
-Hood Lock Lever	7
-Lighter	7
-Fuel Level Gauge	7
-Tachometer	7
-Speedometer/Odometer	7
-Instrument Panel Door	7
HOW TO GET STARTED	8-9
-Emergency Starting	9
SAFETY PRECAUTIONS	10

TUNE-UP	11
-Raising Hood	11
-Carburetor High Speed Needle Valve	11
-Low Speed Needle and Idle Adjustment Screw	12
-Spark Plug Recommendation and Replacement	12
DRIVE TRAIN	13
-Transmission Belt Inspection and Replacement	13
-Procedure for Installing Transmission Belt	14
-Brake Adjustment	15
-Drive Chain Adjustment	15
-Drive Chain Lubrication	16
-Reversing Mechanism Lubrication	16
-Track Tension	17
-Track Alignment	17
-Ski Alignment	18
BATTERY MAINTENANCE AND SPECIFICATIONS	18
BATTERY WARRANTY	19
OFF SEASON STORAGE	20
-After Storing Before Using	20
SERVICE MANUAL	20
PREVENTIVE MAINTENANCE	21
-Carburetor - Air Filter	21
-Chain and Track	21
-Fuel Filter	21
LUBRICATION RECOMMENDATIONS	22
SERVICE DIAGNOSIS	23-24
OWNER'S WARRANTY CERTIFICATE	Inside Back Cover
WARRANTY SERVICE	Inside Back Cover
WARRANTY	Back Cover

© OUTBOARD MARINE CORPORATION ALL RIGHTS RESERVED 1971

MODELS: E2020 E2025 (ELECTRIC START)

FEATURES...

- Capacitor Discharge (C.D.) Ignition
- Dash Mounted Fuel Gauge
- One Piece Polycarbonate Hood
- Safety Padded Steering Bar
- Retractable Sealed Beam Headlights
- Cigarette Lighter On Electric Start Model
- Steel Skis With Replaceable Runners
- Chrome Wrap-Around Front & Rear Bumpers
- Compression Relief
- Power Tuned Muffler
- Super-Range Automatic Torque-Sensing Transmission
- Under Seat Storage Compartment
- Neutral Lockout
- Polyurethane Track
- Reverse Gear
- Low Center Of Gravity
- Wide Track Stability
- Reaction Balanced (Opposed Firing) Two Cylinder Engine



SPECIFICATIONS AND FEATURES

CAUTION: Snow Vehicles are not manufactured for highway use and the manufacturer does not represent that they are equipped with all the devices legally required for such use.

DIMENSIONS IN INCHES

LENGTH	103"
WIDTH	37"
HEIGHT - With windshield	41.4"
Without windshield	37"
TRACK WIDTH	20.5"
ENGINE	OMC 2-cycle opposed twin
BORE	2.750
STROKE	2.250
DISPLACEMENT	26.7 cu in (437 C.C.)
COOLING	Air
CARB	Tillotson HD-11A
IGNITION	Capacitor discharge (C.D.)
RATING	Maximum 30 HP at 5800 rpm
VARIABLE SPEED DRIVE	Centrifugal operated sheave engages V-belt Overall ratio 5 to 1
FINAL DRIVE	ASA 35 double chain Sprocket ratio 16 to 42
REVERSE TRANSMISSION	Dog clutch and bevel gears

COMPRESSION RELIEF

This control is used to ease starting by reducing the initial compression. Pull it out before starting. After machine is started be sure to push it in.

MUFFLER	Tuned for maximum performance
BRAKE	Disc type, hand operated
TRACK	One piece molded polyurethane track, fully adjustable
SKIS	Formed steel, equipped with shock-absorbing leaf springs and replaceable wear runners
SEATING CAPACITY	Two adults. Vinyl coated cover, molded urethane foam cushion.
HOOD	Molded polycarbonate
FUEL TANK CAPACITY	6 U.S. gallons or 5 Imperial gallons
ENGINE FUEL MIXTURE	Gas/oil ratio 24:1
GASOLINE	Premium leaded
LUBRICANT	Evinrude Snowmobile Lubricant, (in Canada) OMC 2-cycle motor oil
SPARK PLUG AND GAP	Champion UJ2J - .028" to .033" gap
HEADLIGHTS	Retractable sealed beam - GE-4415-1
TAILLIGHTS	GE #194

OUTBOARD MARINE CORPORATION reserves the right to change weight, construction, materials, specifications or prices without notice and without obligation.

FUEL RECOMMENDATIONS

The correct fuel mixture ratio is 50 parts of a good grade, regular leaded gasoline to one part Evinrude 50:1 Snowmobile Lubricant, or in Canada OMC 2-cycle motor oil.

In some gasolines the amount of lead has been replaced with phosphorus. Since phosphorus is detrimental when used in 2-cycle engines, the use of these gasolines is not recommended.

If recommended lubricant is not available, use an ashless outboard or ashless snowmobile oil mixed at 24:1 ratio. Automotive oils and 24:1 premix fuels should not be used except in emergencies when the recommended oil is not available. It should be recognized that automotive oils are formulated to fit the needs of 4-cycle automotive engines and Evinrude 50:1 Snowmobile Lubricant and OMC 2-cycle motor oils are formulated for the 2-cycle engine installed in your snowmobile.

Use the following table to determine the 50:1 fuel and oil mixture for U.S. and Imperial measures:

50 TO 1 MIXTURE RATIO CHART FOR EVINRUDE SNOWMOBILE LUBRICANT AND OMC 2 CYCLE MOTOR OIL		
U.S. MEASURE - 1 PINT - 16 OZ. IMPERIAL MEASURE - 1 PINT - 20 OZ.		
LUBRICANT	GASOLINE	
	U.S. MEASURE	IMP. MEASURE
1/2 U.S. pint . . Mix with	3 U.S. gal.	2.4 Imp. gal.
1/2 Imp. pint . . Mix with	3.7 U.S. gal.	3 Imp. gal.
1 U.S. pint . . . Mix with	6 U.S. gal.	4.8 Imp. gal.
1 Imp. pint . . . Mix with	7.5 U.S. gal.	6 Imp. gal.
1 U.S. quart . . Mix with	12 U.S. gal.	9.6 Imp. gal.
1 Imp. quart . . Mix with	15 U.S. gal.	12 Imp. gal.

4

SAFETY PRECAUTIONS

Gasoline is extremely flammable and highly explosive under certain conditions. Always stop engine, and do not smoke or allow open flames or spark near the snowmobile when refueling or servicing the fuel system.

1. Always use a separate clean container for mixing fuel (See Figure 4.)
2. Do not pour lubricant or gasoline separately into vehicle tank.
3. To prepare the snowmobile fuel properly, pour into SEPARATE, clean container half the amount of gasoline required and add all the required lubricant.

Thoroughly shake this partial mixture. Next, add the balance of gasoline necessary to bring the mixture to the required ratio of 24:1. Again, thoroughly agitate the mixture. A clean funnel equipped with a fine screen should be used when pouring the fuel mixture into the vehicle tank.

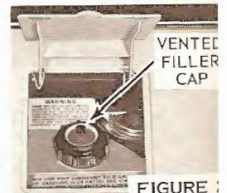

FIGURE 4

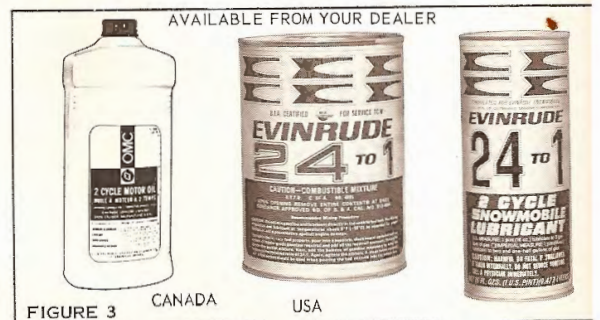

FIGURE 3 CANADA

USA

FUEL RECOMMENDATIONS..continued

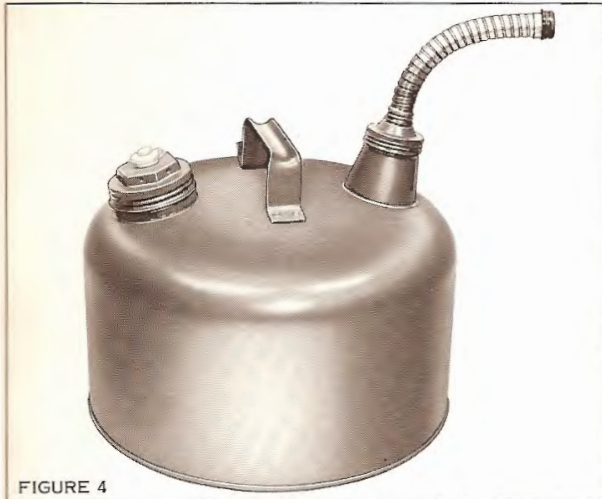

FIGURE 4

DO NOT POUR GASOLINE OR LUBRICANT DIRECTLY INTO VEHICLE FUEL TANK. USE AN APPROPRIATE CONTAINER FOR MIXING AND STORING THE FUEL.

Whenever it is necessary to mix fuel and lubricant at temperature below 32° F (0° C), the lubricant should be prediluted with gasoline to improve its mixability. The lubricant should be prediluted with approximately one part gasoline to one part lubricant. Predilution of the lubricant should take place with the lubricant temperature above 32° F.

Do not use kerosene or fuel oils for pre-mixing. When pouring fuel into vehicle tank, use a clean funnel equipped with a fine screen.

OMC 2+4 FUEL CONDITIONER

For added protection to your snowmobile engine, the use of OMC 2 + 4 Fuel Conditioner is recommended. Available from your dealer.

- Fuel Stabilizer - prevents formation of gum and varnish deposits in fuel system for one year of storage. Eliminates need for draining fuel for storage.
- Carburetor Cleaner - dissolves gum and varnish deposits in carburetor and fuel system.
- Corrosion Resistance - protects carburetor, fuel system and internal engine parts from corrosion.
- De-Icer - prevents carburetor icing and gas line freeze-up.
- Absorbs moisture and water in fuel system.
- Extends spark plug life by reducing fouling and misfire.

BREAK-IN PERIOD

For the first tank full of fuel, we suggest that you operate your vehicle at reduced speeds. This will allow the internal moving parts to seat themselves, thus greatly prolonging engine life. Treat this vehicle as you would any other piece of precision machinery. Always allow the engine to warm up before putting vehicle in gear, start out slowly and avoid sudden starts. Do not overspeed for load and operating conditions. Give it reasonable and periodic care and it will give you many hours of enjoyment.

IMPORTANT

Adjust drive chain tension after the first ten hours of operation. Refer to page 15 for drive chain adjustment instructions.

Adjust track tension after the first 10 hours of operation. Refer to page 17 for track tension and track alignment adjustment instructions.

5

CONTROLS

1 HAND BRAKE AND PARKING LOCK

To apply brake, squeeze brake lever. **CAUTION:** Do not race engine with brake applied.

To apply parking lock, engage brake and push lock into position as illustrated in Figure 5. To release, squeeze brake lever.

2 NEUTRAL LOCKOUT

The neutral lockout locks the transmission in neutral when pulled out. When starting engine, neutral lockout lever must be pulled out. To engage transmission, reduce engine speed to idle and push neutral lockout lever in.

SAFETY PRECAUTION

Engine RPM must be under 2000 RPM before transmission can be locked in neutral. After neutral lockout lever has been pulled out, accelerate engine slowly to be sure transmission is in neutral.

3 CHOKE

The choke is pulled outward during starting and engine warm-up to richen the fuel-air mixture to the engine.

4 PRIMER

Pushing the primer knob manually pumps fuel into the intake manifold. A cold engine should be primed prior to starting.

5 COMPRESSION RELIEF

Pull compression relief knob out before starting engine. This eases starting by reducing the cylinder compression.

6 Push knob in after engine is started.

6 THROTTLE

The thumb operated throttle lever is located on the right hand steering arm. Squeezing the throttle increases engine speed and power is transmitted to the track. When lever is released, engine returns to idle.

7 IGNITION/LIGHTS SWITCH

The key operated ignition switch has OFF, LIGHTS/RUN and START positions. The manual starting motor does not have START position.

8 MANUAL STARTER HANDLE

Non-electric model snowmobiles are started by pulling the manual starter handle.

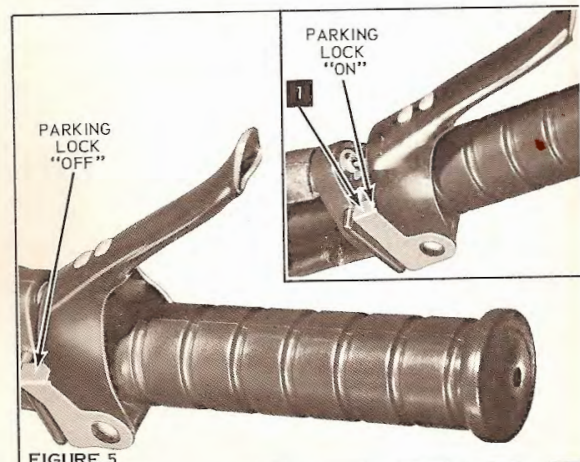
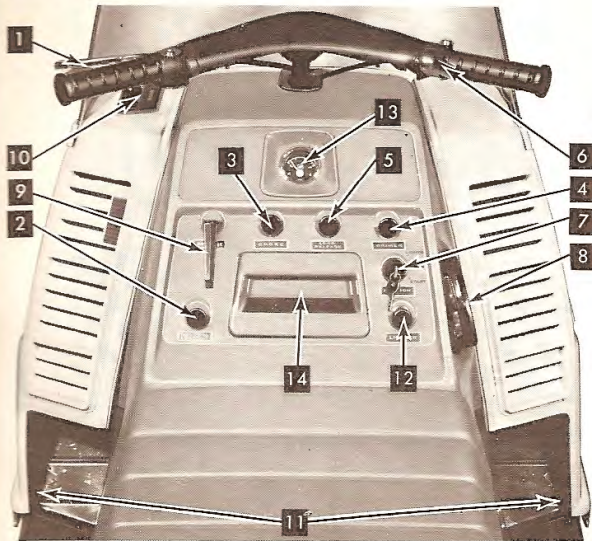

FIGURE 5

CONTROLS ...continued



9 REVERSE CONTROL

Reverse control simplifies backing the snowmobile from a trailer or out of a parking area.

CAUTION

Vehicle must be at a complete stop before engaging reverse control. Make sure lever is pulled out all the way before operating throttle.

10 HEADLIGHT RETRACTING LEVER

Headlights are retracted under the hood with lever in up position. With hood raised, the headlights in the retracted position can be used to light the engine compartment at night.

11 HOOD LOCK LEVERS

Pulling the hood lock levers upward unlatches the hood. To open hood, grasp the TOP louver on both sides and pull up and forward.

12 LIGHTER

The cigarette lighter is on the electric start model only.

13 FUEL LEVEL GAUGE

The fuel gauge is mechanically operated, giving a fuel level reading at all times.

14 INSTRUMENT PANEL DOOR

The instrument panel door provides access to the rear spark plug.

15 SPEEDOMETER/ODOMETER (ACCESSORY-NOT SHOWN)

The speedometer/odometer, which indicates MPH and miles traveled, is an accessory available from your Evinrude Dealer.

16 TACHOMETER (ACCESSORY-NOT SHOWN)

The tachometer, which indicates engine RPM, is an accessory available from your Evinrude dealer

7

HOW TO GET STARTED

- 1 Put Brake Lever in "PARKING LOCK" position. See Figure 7.
- 2 Pull out Neutral Lockout knob.
- 3 Pull out Choke knob.
- 4 Pull Compression Relief knob out.
- 5 Press Primer three or four times.
- 6 Partially depress Throttle lever.
- 7 Turn Ignition Key to "RUN" position.
- 8 (ELECTRIC START) - Turn ignition key to "START" position. Release key when engine starts. **DO NOT** hold key in "START" position for more than 10 seconds.
- 9 (MANUAL START) - Grasp starter handle firmly, pull slowly until starter engages, and then pull to start.

FIGURE 7

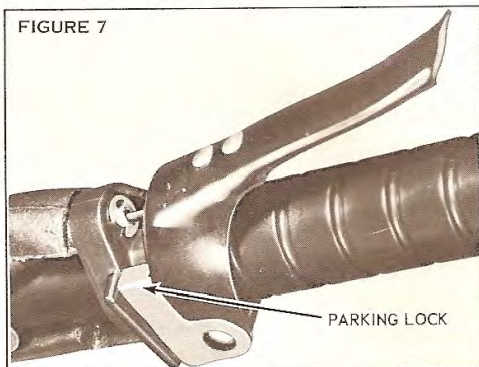

8

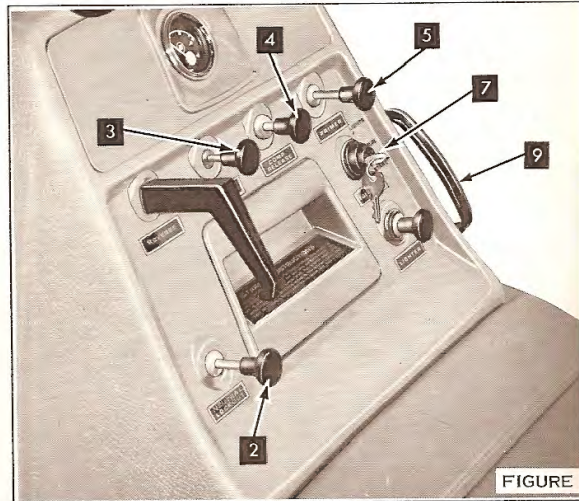

FIGURE

CAUTION

Do not operate engine at high speeds when vehicle is stationary and neutral lockout knob is pulled out.

If engine does not start immediately, prime once more repeat from Step 6. The number of times the primer is pressed will depend upon the operator becoming familiar with starting a cold or warm engine. Do not over prime.

After engine starts, push compression relief and choke in. Partial choke may be required while the engine is cold.

Allow engine to warm-up, reduce speed to idle and push neutral lockout knob in.

HOW TO GET STARTED...continued

To move forward, **RELEASE BRAKE** and apply throttle as desired. To stop, release throttle and depress hand brake. For reverse operation, **STOP VEHICLE**, release throttle and pull out the reverse control lever.

CAUTION

DO NOT SHIFT AT HIGH ENGINE SPEEDS OR WHEN UNDERWAY. Be careful to avoid catching rear end of skis when operating vehicle in reverse.

To stop engine, turn ignition switch key to "OFF." When vehicle is not in use, engage **PARKING LOCK** and pull out neutral lockout knob.

EXTREME COLD WEATHER

Operation in extreme cold weather can cause a slow down in the drive and track mechanism. When this occurs, block up rear of snowmobile so that track is off ground, place front edge of skis against stationary object and run for short time at low speed to free drive mechanism. **DO NOT** overspeed.

EMERGENCY STARTING

If the Rewind Starter should not function, proceed as follows.

1. Raise hood. See Figure 6.
2. Follow Steps 1 through 7, page 8. Then wind starter rope, provided in tool kit, or a similar rope, around sheave in a counterclockwise direction. Refer to Figure 9 for sheave location. Grasp starter rope handle securely and pull.
3. After engine is started, close hood and continue with "HOW TO GET STARTED" on page 8.

CAUTION

Never disconnect battery and run snowmobile. Operating the snowmobile without a battery can damage the electrical system of electric start snowmobiles.



FIGURE 9

SAFETY PRECAUTION

- All operators must be properly instructed in the operation of the vehicle. Many dangerous situations are created by negligence. **READ THE OWNER MANUAL.** Be sure there is adult supervision whenever the vehicle is in operation.
 - When operating a snowmobile, wear protective clothing and head-gear such as a brightly colored helmet as well as padded clothes. **DO NOT WEAR LOOSE CLOTHING** such as scarves, tassel caps, etc. Such clothing could get entangled with the machinery, branches or other objects and cause personal bodily injury.
 - Do not overload vehicle with passengers. Two adults or one adult and two children makes a safe load. Keep feet on running boards at all times.
 - Use headlight for early morning, evening and night operation. Use headlight in heavily wooded areas during the day.
 - Do not operate vehicle on or around sled, ski, and toboggan hills.
 - Do not operate vehicle at maximum speeds in other than a supervised, charted area. Be certain no one is behind unit when making a fast start, as ice, stones, etc., may be thrown into the air by lugs on the track.
 - Do not operate vehicle on public roads, streets or highways unless it is legal to do so.
 - Extra caution should be exercised when using vehicle on ice. Steering control is greatly reduced on ice. Beware of thin ice. Always use two hands for steering.
 - When crossing plowed roads, approach with caution. Do not jump snow banks as you might find yourself in the path of oncoming traffic.
 - Do not operate vehicle on stone or gravel.
 - Do not execute "blind jumps." Snow drifts can hide tree stumps, logs and excessive drop offs.
 - Do not smoke while operating vehicle. Ashes can be dangerous to passengers as well as operator.
 - Do not operate on private property without owner's permission.
 - Do not operate vehicle while under the influence of alcohol or stimulants.
 - Never leave the machine unattended while engine is running.
 - Remove key from vehicle whenever it is not in use.
 - Wear goggles to protect the eyes from lashing tree or shrub branches, and from wind and sun glare.
- ### WHEN MAKING ADJUSTMENTS
- Do not attempt to perform repairs on your vehicle while engine is running.
 - Always disconnect spark plug wires before servicing any part of the engine or drive unit.

TUNE-UP

RAISING HOOD

1. Pull hood lock levers up to release hood latches. See Figure 6.
2. Grasp top louver on both sides and pull up and forward. A retainer bar will prevent hood from being damaged against the front bumper.
3. When closing hood, end of retainer bar must be held up so that it does not catch on latch.

CARBURETOR HIGH SPEED NEEDLE VALVE

For average use, the engine will operate satisfactorily with the carburetor adjusted as it left the factory. If it becomes necessary to readjust see your dealer.

CAUTION

"LEANING OUT" OF THE HIGH SPEED NEEDLE VALVE WILL RESULT IN SERIOUS DAMAGE TO THE ENGINE. NEVER SET THE HIGH SPEED NEEDLE LESS THAN ONE TURN OPEN.

The correct high speed needle valve setting is obtained as follows:

1. Pre-set high speed needle approximately 1-1/8 turn open. (See Figures 10 and 11.)
2. Start and warm up engine with drive in neutral for 3 or 4 minutes. Do not over speed engine when warming up in neutral. Push choke knob in to "off" position.
3. Drive snowmobile at moderate to high speed and observe engine performance. Observe all safety precautions while driving. If further adjustment is necessary, proceed as follows:

- A. If engine misses, dies out or otherwise runs rough, stop engine and open needle slightly (approximately 1/8 turn) by turning counterclockwise. Test drive snowmobile to check results.
- B. If engine loads up or four cycles (fires on every other cycle) then it is running too rich. Stop engine and adjust needle slightly in clockwise direction. Test drive snowmobile again to check results.

TO MAINTAIN ADEQUATE CYLINDER LUBRICATION THE HIGH SPEED NEEDLE VALVE SHOULD NEVER BE LESS THAN ONE TURN OPEN.

ADJUSTING HIGH SPEED NEEDLE VALVE ON REAR OF CARBURETOR

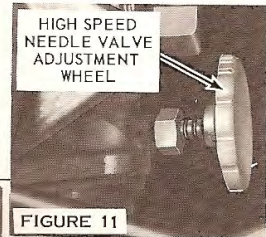
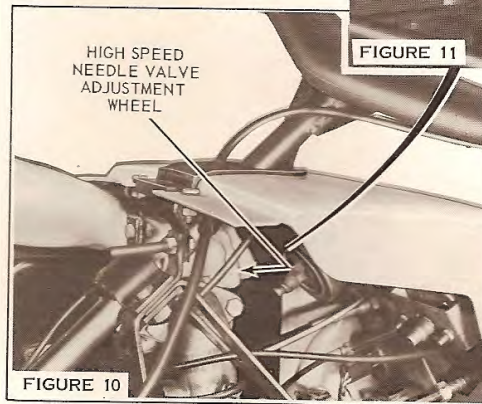

11

TUNE-UP..continued

LOW SPEED NEEDLE AND IDLE ADJUSTMENT SCREW (See Figure 12)

1. Pre-set "low speed needle valve" one turn open.
2. Turn "idle adjustment screw" to the left (counterclockwise) until throttle plate is completely closed and screw is not in contact with throttle lever.
3. Start engine and allow warm up time of 3 or 4 minutes. If engine will not idle, turn "idle adjustment screw" to right to keep engine running. Push choke knob in all the way.

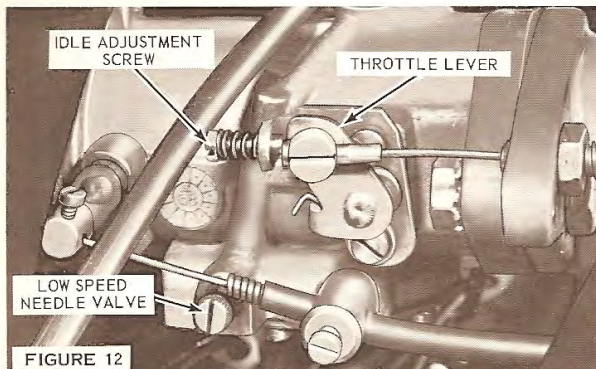

4. Turn "idle adjustment screw" to attain the recommended idle speed of 1300-1600 rpm.
5. Accelerate engine, if a flat spot (hesitation to accelerate) is noted readjustment of low speed needle is necessary. Turn "low speed needle" counterclockwise 1/8 turn at a time. Reset "idle adjustment screw" to attain 1300-1600 rpm each time low speed needle is adjusted.
6. Accelerate engine then release throttle, engine should return to idle speed. If engine does not idle immedi-

ately, adjustment of the low speed needle may be necessary. Turn low speed needle clockwise to reduce amount of fuel to the engine. Reset "idle adjustment screw" to attain 1300-1600 rpm each time low speed needle is adjusted.

SPARK PLUG RECOMMENDATION AND REPLACEMENT

Recommended spark plug for your engine is Champion UJ2J. The proper spark plug gap is .028" to .033". Carry a spare set of spark plugs.

To remove spark plugs for inspection, pull off rubber covered spark plug terminal with a slight counterclockwise twist. Don't clean badly carboned plugs. Replace them.

Before reinstalling plugs, clean the seats in cylinder heads. Install plugs and gaskets finger-tight plus 1/4 turn. Recommended torque is 20 to 25 ft. lbs. DO NOT EXCEED 25 FT. LBS. Spring inside rubber covered spark plug terminal must fit securely over spark plug terminal as illustrated.

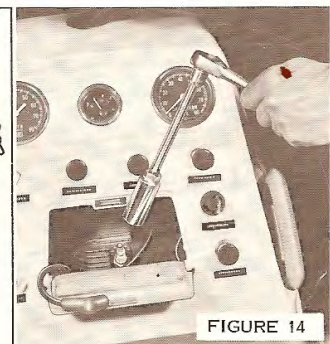
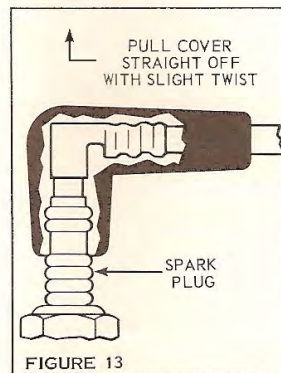

ACCESS TO REAR SPARK PLUG

12

DRIVE TRAIN

The drive train transmits power from the engine, through a variable speed drive, forward or reverse transmission, drive chain and track which propels the snowmobile.

The "Primary Sheave Assembly" attaches directly to the power take off end of the crankshaft.

The "Secondary Sheave Assembly" is larger in diameter than the Primary Assembly. The two are connected by the transmission belt.

The Primary Sheave is centrifugally operated and engages when the engine speed reaches approximately 2700 rpm.

As the engine speed is increased, the Primary Sheave halves close forcing the belt to ride on the outer diameter of the primary drive which increases the belt speed.

At this point the Secondary Sheave halves spread apart, allowing the belt to ride on the small diameter.

Basically, the vehicle speed increases due to the power being transmitted from the primary pulley to the secondary drive mechanism.

The secondary drive mechanism incorporates a torque sensing device that allows automatic shifting to a lower gear for steep inclines or deep snow.

The primary assembly is equipped with an emergency starting sheave and a neutral shift mechanism, both of which are covered in other parts of this Manual.

Do not attempt to disassembly the variable speed drive or reverse transmission. Contact your dealer. The reverse

transmission is gear operated. Operation of reverse control is covered on page 7 and 8 and lubrication on page 22.

TRANSMISSION BELT INSPECTION AND REPLACEMENT

A belt measuring less than 1-9/16" across the width or outer surface must be replaced with a new one. Worn belt may be retained and used as a spare. A spare belt should be carried at all times.

NOTE: DO NOT RUN ENGINE WITHOUT BELT.

Procedure for Removing Transmission Belt:

1. Open hood, see Figure 6.
2. Refer to Figure 15. Remove two quarter turn wing fasteners and belt guard.

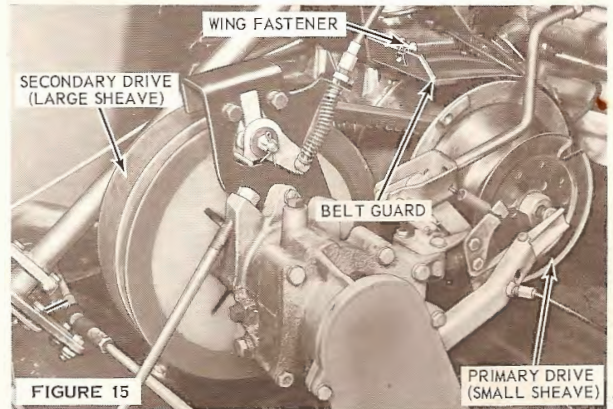

DRIVE TRAIN ..continued

3. Spread the secondary sheaves by pulling movable half of the sheave toward the steering column, at the same time pull belt up until the belt holds the sheave apart. (Fig. 16)

SAFETY PRECAUTION

Keep fingers from between halves of secondary sheave when performing next step.

4. Work belt over top of movable half of secondary sheave (Fig. 16-A).

5. Work belt between primary and secondary sheaves. See Fig. 17.

6. Disconnect neutral control cable from actuator arm & move belt between actuator arm and primary sheave. See Figure 18.

PROCEDURE FOR INSTALLING TRANSMISSION BELT

1. Pass belt between actuator arm and primary sheave. Reconnect neutral lockout cable to actuator arm.
2. Loop one end of the replacement belt around the primary sheave.
3. Spread halves of secondary sheave and work other end of belt around bottom of movable half and roll sheave forward.
4. Belt will ride the sheave up and fall in place between the two halves.

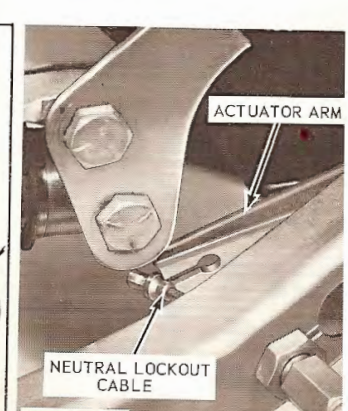
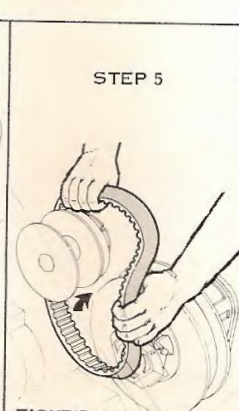
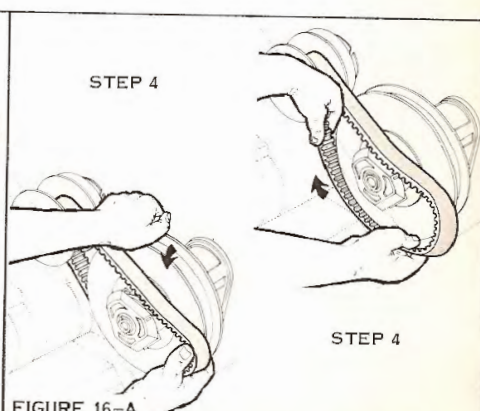
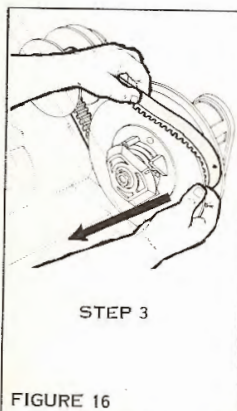

DRIVE TRAIN ..continued

BRAKE ADJUSTMENT

Brake is positive acting disc type with long lasting fibre pads and requires little maintenance, only an occasional adjustment. See Figure 19.

Brake adjustments can be made by removing the cotter pin and turning the castellated nut Ref. 1 to the right to tighten brake. Turn the nut until there is a light drag on the brake disc, Ref. 2, then back the nut off one notch and reinstall the cotter pin. If hand brake lever does not have proper amount of travel or cable needs adjustment, see your dealer.

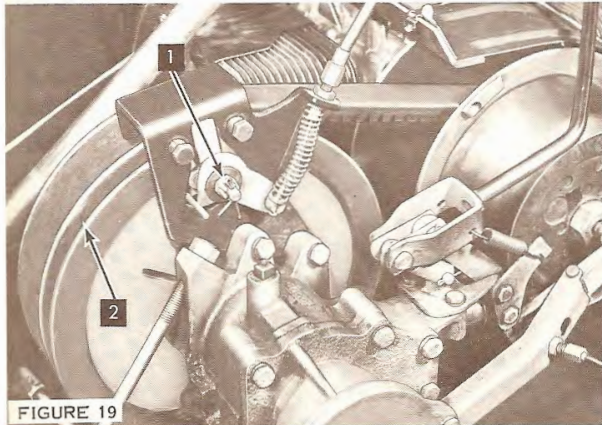

FIGURE 19

IMPORTANT

Before completing the adjustment, be certain there is sufficient movement of the lever to permit use of the Parking Lock.

DRIVE CHAIN ADJUSTMENT

Check drive chain adjustment after the first ten hours of operation and thereafter every 50 hours of operation or as required. Total slack must be $1/4'' \pm 1/16''$ as shown in Figure 20. To measure this distance, first remove the

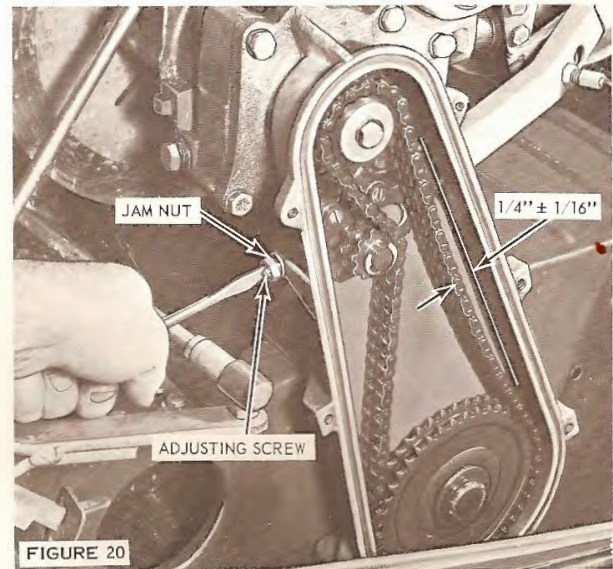

FIGURE 20

15

DRIVE TRAIN ..continued

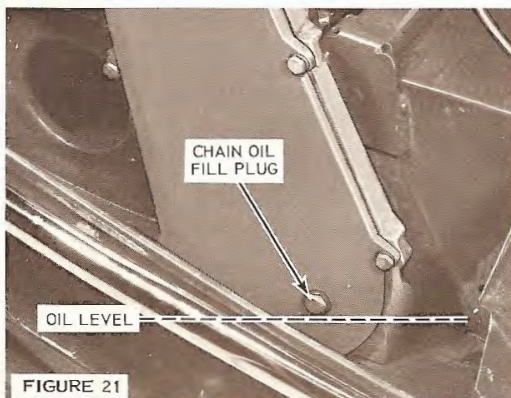

FIGURE 21

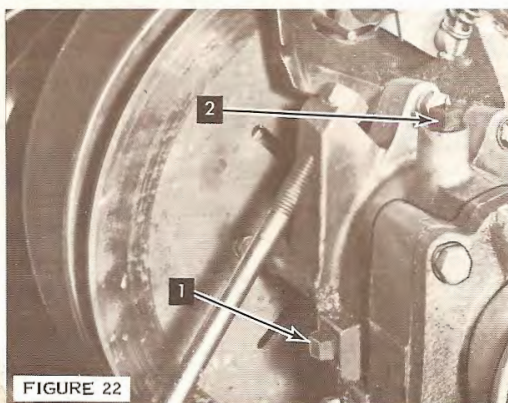

FIGURE 22

16

chain case cover. (NOTE: Oil will drain when cover removed unless machine is tilted on side.) Place straightedge over the chain at the sprockets, press it in the center of the chain and measure the amount of slack at this point.

If the chain requires adjustment, use the following steps:

1. Loosen jam nut, see Figure 20.
2. To tighten chain, turn adjusting screw clockwise.
3. To loosen chain, turn adjusting screw counterclockwise.
4. Retighten jam nut.
5. Replace chain case cover, snugging the 6 bolts tightly.
6. Replace oil in chain case. See Drive Chain Lubrication below.

Consult your dealer when chain replacement is necessary or when chain can no longer be tightened to specifications.

DRIVE CHAIN LUBRICATION

The drive chain is lubricated by running through an oil hole in the bottom of the chain case. Check level of oil in chain case periodically. Oil level should come up to the bottom of oil fill hole. Fill with OMC Type "C" Oil. See Figure 21.

REVERSING MECHANISM LUBRICATION

Use the following procedure to check the oil level in reversing mechanism. See Figure 22.

1. Remove the square plug, Ref. 1. If oil runs out, or oil level is up to the threads in the hole, the level is satisfactory.
2. If oil level is low, remove the square plug, Ref. 2, and slowly pour OMC Type "C" oil in this hole until it runs out the lower hole, Ref. 1.
3. Replace plugs.

DRIVE TRAIN ..continued

TRACK TENSION

Proper track tension is essential to keep sprocket and track wear at a minimum. Track tension can be checked by first blocking up the snowmobile, so that the track hangs free, and placing the front edge of the skis against a stationary object. Next, measure the distance from the bottom of the pivot arm bearing bore to underside of running board as shown in Figure 23. Track tension is correct in this distance is $2-7/8" \pm 1/32"$. If track tension must be adjusted, proceed as follows:

1. Loosen track tension nuts. See Figure 23.
2. Loosen nut on pivot arm adjusting screw.
3. Turn pivot arm adjusting screw clockwise to tighten, counterclockwise to loosen to attain proper dimension.
4. Now measure distance from bracket to rear of frame on both sides. If measurements are not equal, move

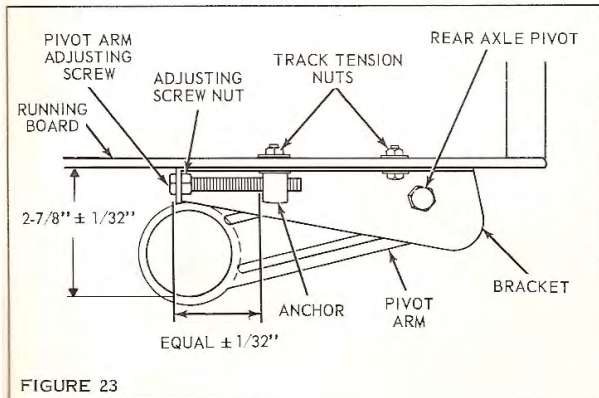

FIGURE 23

bracket closest to rear of frame forward until both sides are equal. This is done by turning the pivot arm adjusting screw counterclockwise.

5. Tighten all retaining nuts.

TRACK ALIGNMENT

To check for proper track alignment, with snowmobile blocked up as described earlier, start engine and run track at slow speed. There must be an equal clearance on each side of the track edge between the track edge and pivot arm as shown in Figure 24. If this clearance cannot be obtained, consult your dealer.

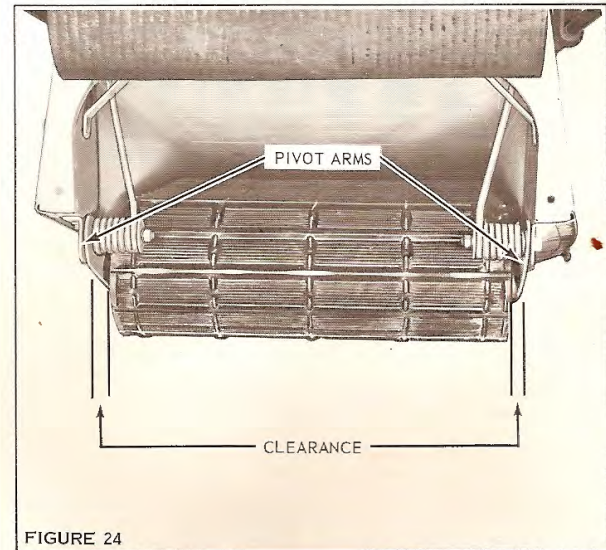

FIGURE 24

17

DRIVE TRAIN ..continued

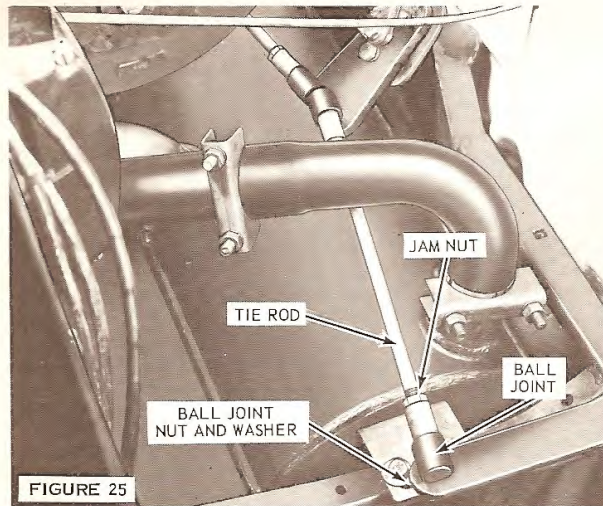

FIGURE 25

SKI ALIGNMENT

The skis require alignment if the skis are not parallel with each other and the vehicle body when the steering bar is in the normal straight-driving position.

To align skis, proceed as follows:

1. Open hood.
2. Place steering bar in the normal straight-driving position.
3. Loosen jam nut, as illustrated in Figure 25.
4. Remove nut and washer from ball joint.
5. Turn ball joint clockwise to toe skis out or counterclockwise to toe skis in.
6. Tighten jam nuts when skis are parallel with each other and snowmobile body. Reassemble ball joint nut and washer.

BATTERY MAINTENANCE AND SPECIFICATIONS

SAFETY PRECAUTION

Battery Electrolyte is a caustic fluid and should be handled with care. If Electrolyte is spilled or splashed on any part of the body, IMMEDIATELY flush the exposed area with liberal amounts of water and obtain medical aid as soon as possible.

Use of a battery having the correct rating is very important, due to the extreme temperature conditions under which the snowmobile must operate. Use a 12 volt battery having a 32 ampere hour rating or better. The dimensions are $7-3/4"$ long x $5-1/8"$ wide x $7-1/4"$ high (top of terminals).

The Prestolite brand battery, which is included with electric start vehicles, is recommended and is manufactured for snow vehicle use. Anchored elements reduce the possibility of vibration damage. The battery is shipped dry. It is activated with dry charge electrolyte available locally. Replacement battery type in U.S. is 9948X and in Canada is type 27-20 or 28-20.

NOTE

In order to provide maximum protection from battery acid damage in the event of accidental upset, the battery is equipped with SPILL-PROOF CAPS. Be sure these caps only, are on your battery at all times. See Figure 27. Transfer caps to new battery if battery is replaced. CAUTION: Do not over fill. Spilled acid may damage surrounding parts.

Battery is kept charged by alternator coils located beneath flywheel. It may be necessary to use a separate 12 volt battery charger occasionally to keep battery fully charged during long storage periods, or in extreme cold weather if engine is started repeatedly. Battery is fully charged when hydrometer scale shows a corrected reading of 1.260 and does not change after three hourly readings.

CAUTION

NEVER operate ELECTRIC START model without battery. Operation without battery can damage electrical system.

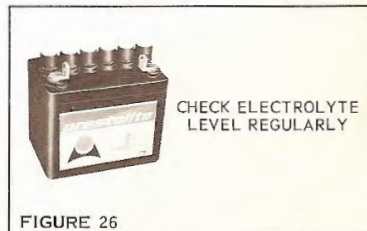

FIGURE 26

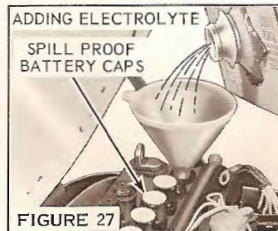

FIGURE 27

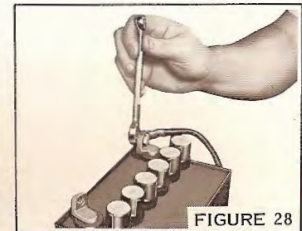

FIGURE 28

19

CAUTION

Before disconnecting any electrical components, disconnect the battery cables, see Figure 28, thus removing the battery from the electrical circuit. When reconnecting battery cables, observe polarity, red cable to positive (+) battery terminal and black cable to negative (-) battery terminal. Reverse polarity will damage the electrical system.

BATTERY WARRANTY

Warranty on Prestolite batteries used in your snowmobile is covered directly by Prestolite, through their authorized battery service stations, for a period of 18 months in the United States and 9 months in Canada. Should a battery fail, due to inherent defects, during the first three (3) months of service, it will be replaced on a no-charge basis. Batteries that fail during the balance of the warranty period (15 months) in the U.S. and (6 months) in Canada will be replaced on a prorata basis.

In Canada Prestolite warranty should be handled through the dealer from whom the snowmobile was purchased or through a Prestolite battery depot.

The warranty period starts on the date the snowmobile is delivered to the original owner.

OFF SEASON STORAGE

1. Block vehicle off ground to take weight off track.
2. If fuel is to be left in tank for extended periods, the addition of OMC 2-4 Fuel Conditioner is recommended, available from your Evinrude Dealer.
3. Remove fuel pump filter and clean or replace. See Page 21.
4. Run engine with air filter removed and neutral lockout knob pulled out. Inject OMC Rust Preventative Oil (with oil can) rapidly into carburetor until engine stops. This oil is available at your Evinrude Dealer.
5. Turn off ignition and clean (or replace) air filter. See Page 21.
6. Rub bottom of skis, and other unprotected surfaces of vehicle with oily cloth.
7. Store in dry, well-ventilated area.
8. Disconnect battery in electric start models. (Keep battery charged during off season.) See Page 19.

20

AFTER STORING - BEFORE USING

1. Check track for proper alignment and tension. See Page 17.
2. Lubricate all points as specified under "Lubrication."
3. Tighten all screws and nuts.
4. Thoroughly clean any surfaces that need refinishing, and touch-up. Obtain paint from your Dealer.

SERVICE MANUAL

A Service Manual is written primarily for the service technician with prior snowmobile training and who is equipped with the proper special tools. Although limited in use to the average individual, this publication is available for purchase.

To obtain a Service Manual, contact your local Evinrude Dealer or send check or money order for \$6.00 direct to Evinrude Motors. Sorry, no C.O.D. shipments will be made. To assure receiving the correct manual, state full model and serial number.

In Canada, contact your nearest authorized Evinrude snowmobile Dealer.



FIGURE 29

PREVENTIVE MAINTENANCE

FUEL FILTER

CARBURETOR – air filter

The carburetor is equipped with an air filter that should be cleaned during the operating season and at the end of the season for storage. To clean filter, wash with solvent and shake dry. See Figure 30.

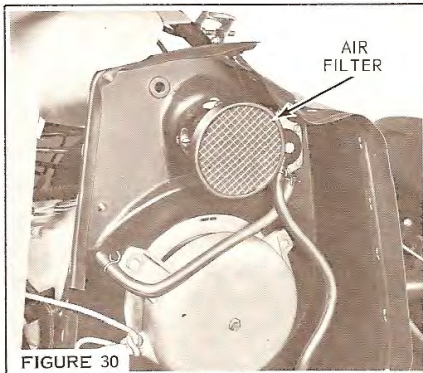

FIGURE 30

SAFETY PRECAUTION

Exercise care to prevent fuel spillage when removing fuel filter when engine is hot.

The fuel filter is attached to the fuel pump. See Figure 31. To inspect for sediment or water accumulation, back off the mounting screw approximately three turns (counterclockwise) and remove the cover together with the screen, gasket and mounting screw. Remove and wash filter screen with clean solvent and brush. Assemble filter as shown in Figure 32, being careful to assemble gasket and filter screen on fuel filter cover. Tighten mounting screw securely with screwdriver (do not over-tighten).

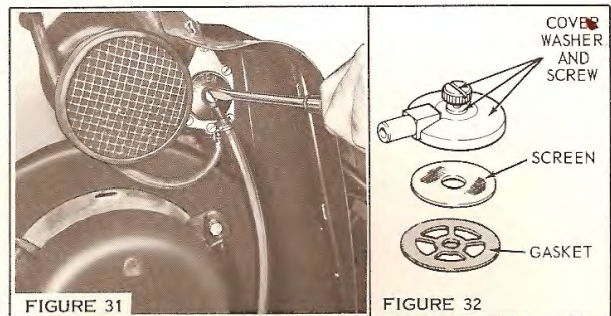

FIGURE 31

FIGURE 32

CHAIN AND TRACK

TIME	MAINTENANCE
After first 10 hours, then every 50 hrs. or as required	Adjust Chain Tension
After first 10 hours., then every 25 hrs. or as required	Adjust Track Tension Check Track Alignment

LUBRICATION RECOMMENDATIONS

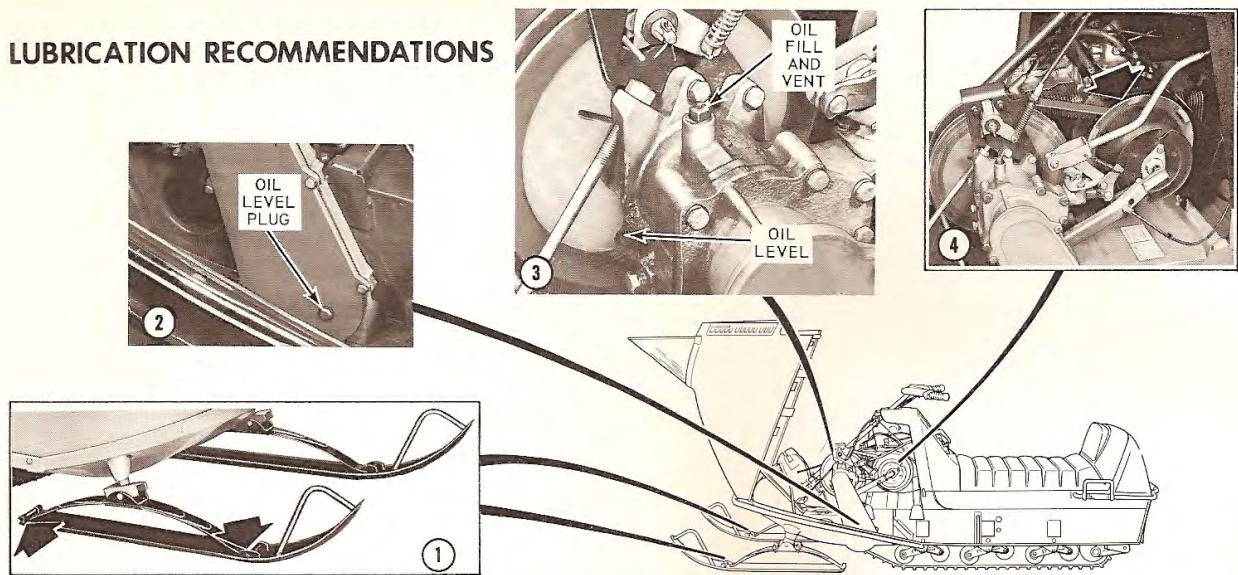

TIME	MAINTENANCE	LUBRICANT
Every 25 hrs.	① Ski Pivots (leaf spring connections to skis)	SAE #10 oil
After 10 hrs. then every 25 hrs. of operation	② Drive Chain - oil bath	OMC Type "C"
	③ Reversing transmission	OMC Type "C"
Once a season (normal use) Twice a season (extended use)	④ Primary Drive (disassembly required, see your dealer)	Standard Oil Rykon EP#2

Specified lubricants available from your dealer.

SERVICE DIAGNOSIS

TROUBLE	PROBABLE CAUSE	REMEDY
Engine fails to start.	Fuel tank empty. Ignition switch off. Engine starving for fuel. Plugged fuel line or filter. Engine floods. Improper or no ignition.	Fill with correct fuel mixture. Turn on or check for short. Prime and check carburetor adjustment. Check for position of choke. Check the fuel pump. Clean fuel lines and filter screen in fuel pump and carburetor. Check carburetor adjustment, and position of choke. Check spark plug leads to be sure they are securely in place. Check for correct spark plug in good condition. Replace if necessary. If engine fails to start after spark plug check has been made, consult your dealer.
Rewind starter fails to engage.	Broken or worn parts internally.	Consult your dealer. Follow procedure outlined for emergency starting until starter can be serviced.
Engine runs rough.	Carburetor out of adjustment. Poor ignition.	Adjust carburetor. Follow same check procedure as for "improper or no ignition" under "engine fails to start."
Engine won't idle.	Idle speed set too low. Carburetor out of adjustment.	Increase idle speed setting to approximately 1300-1600 RPM. Adjust carburetor.
Poor acceleration.	Carburetor out of adjustment.	See item 5, Page 12.
Engine run-away.	Carburetor out of adjustment.	See item 6, Page 12.

23

SERVICE DIAGNOSIS...continued

TROUBLE	PROBABLE CAUSE	REMEDY
Low RPM.	Poor ignition. Carburetor air filter dirty. Carburetor out of adjustment. Excessive engine wear.	Follow same check procedure as for "improper or no ignition" under "engine fails to start." Remove and wash in solvent. See page 21. Adjust carburetor. Consult your dealer.
Vehicle fails to move when throttle is depressed.	Neutral lockout in neutral position. Transmission belt worn or broken. Drive chain out of adjustment or broken.	Push neutral lockout knob into drive position. (Neutral lockout will not engage unless engine speed is below 2000 RPM.) Replace transmission belt. Adjust or replace drive chain.
Low vehicle speed.	Transmission belt worn. Skis out of alignment.	Replace transmission belt. Align skis.
Lights won't light.	Operating on only one spark plug. Chain and/or track too tight. Loose connections. Corroded connections. Bad switch. Bulb burned out. No output from alternator.	Follow same check procedure as for "improper or no ignition" under "engine fails to start." Readjust. Check and tighten. Clean. Repair or replace. Replace bulb Consult your dealer.

24

OWNER'S WARRANTY CERTIFICATE

OWNER IDENTIFICATION CARD. Your dealer will supply to you, at the time you purchase your Snowmobile an "Owner Identification Card." THIS CARD MUST BE FILLED OUT COMPLETELY BY YOU AND THE DEALER

AT THE TIME SALE IS COMPLETED. It is presented, by you, to any Evinrude Snowmobile dealer when making a claim for warranty.

Warranty Service

1. Proof of purchase will be required by the dealer to substantiate a warranty claim. You must use your Evinrude Owner I.D. Card to establish proof of purchase which is required by the dealer to substantiate a warranty claim.
2. All warranty work must be performed by an Authorized Evinrude Snowmobile Dealer.
3. Warranty Service: while service under the new snow vehicle warranty may be furnished by any authorized Evinrude Snowmobile Dealer, it is recommended that such warranty service be performed by the Evinrude Snowmobile Dealer from whom you purchased your vehicle, because of his personal interest in you.

ITEMS NOT COVERED BY WARRANTY

- Provisions of the warranty will not apply to:
1. Vehicles subject to misuse, accident, neglect, alterations or used for racing purposes including abnormal use of vehicle such as jumping, etc.
 2. Pick-up and delivery of vehicle, mechanics travel time, telephone or telegram charges, taxi or towing charges, or rental of another snow vehicle during period warranty repairs are being performed.
 3. Used or second hand vehicles are not covered under the provisions of warranty. This warranty applies only to the original retail purchaser.
 4. Damage to skis, track, or suspension system due to using Snowmobile on bare ground or running over sharp objects.
 5. Damage due to impact, upset or trailering at high speed.

OWNER'S OBLIGATION AND RESPONSIBILITY

Normal maintenance service and replacement of service items are the responsibility of the owner and such are not considered defects in material and workmanship within the terms of the warranty. Individual operating habits and usage contribute to the need for maintenance service. To assist you in obtaining maximum service and satisfaction from your new Evinrude Snowmobile the principle service and replacement items are described as follows:

PROPER MAINTENANCE AND CARE. Will assist in keeping your over-all operating cost at a minimum. Your Evinrude Snowmobile Dealer will help you to avoid conditions due to neglect.

10 HOUR CHECK AT CUSTOMER'S EXPENSE. Any precision piece of mechanical equipment such as your snow vehicle should have an inspection after initial break in period. This inspection will be performed at local dealer rates and paid for by the owner. This is an opportune time to discuss with your dealer any questions on your snow vehicle which have arisen in the first 10 hours of operation, and establish a routine preventative maintenance schedule. After the 10 hour check your snow vehicle should be taken to an authorized dealer every 3 months or 50 hours for:

Ski and track suspension alignment and lubrication - Carbon removal - Tune-up

WARRANTY IDENTIFICATION. The Owner Identification Card is your only valid identification should warranty service be needed. This card should be presented to any Evinrude Snowmobile Dealer when making a claim for warranty. It will insure prompt, courteous service.

LUBRICATION. Grease ski linkage and primary drive.

ENGINE TUNE UP AND ELECTRICAL CHECK. Fuel and electrical systems are subject to wear and contamination and require periodic cleaning and adjustment to maintain top performance.

INDIVIDUAL OPERATING HABITS. Vehicles not operated or maintained in accordance with instructions in Owner's Manual may contribute to the need for maintenance service.

CARBON DEPOSITS. A degree of carbon build up is normal in the combustion chamber of any gasoline engine, depending on fuel quality and operating conditions, and should be periodically removed. For best results, follow the gasoline and oil recommendations.

SPARK PLUGS AND IGNITION POINTS. These items are subject to wear and/or contamination. Check and replace, if necessary, for maximum engine performance and economy. In most cases, these items are part of normal tune up and are not subject to warranty.

FILTERS. Should be replaced when necessary to perform their function of cleaning the fuel mixture. This is a normal service replacement item.

CARBURETOR ADJUSTMENTS. After dealer check-out are normal maintenance service and an owner expense. Should be done periodically to obtain a smooth idle and maintain peak performance.

WARRANTY

"We warrant, to the original purchaser, each new snowmobile of our manufacture to be free from defects material and workmanship under normal use and service, our obligation under this warranty being limited repairing or replacing at the factory, any part or parts thereof which shall, within 90 days from date of first use be returned to an authorized Evinrude Snowmobile Dealer with transportation charges prepaid, and which examination shall disclose to our satisfaction to have been thus defective. All warranty work must be performed by an authorized Evinrude Snowmobile Dealer. This warranty is expressly in lieu of all other warranties representations expressed or implied and of all other liabilities in connection with the sale or use of a snowmobile. The Manufacturer reserves the right to change or improve the design of any snowmobiles without assuming any obligations to modify any snowmobile previously manufactured.

Due to their expendable nature the warranty period of the Drive Belt is limited to thirty (30) days and the following items are excluded from this warranty: Head Light, Lens, Light Bulbs, Spark Plugs, Windshield.

Warranty is 45 days from date of first use on snowmobiles used for commercial purposes such as rental or other income producing activities.

This warranty shall not apply to any snowmobile which shall have been repaired or altered outside the factory any way so as to affect its stability, nor which has been subject to misuse, negligence or accident, or operated for racing purposes, or operated in any other way than in accordance with our operating and maintenance instructions. Nor does the warranty extend to repairs made necessary by normal wear, by the use of inferior parts or accessories, or by the use of types of accessories not recommended by Evinrude Motors.

We make no warranty in respect to trade accessories not of our manufacture, inasmuch as they are usually warranted separately by their respective manufacturers.

To make a claim under this warranty, contact the authorized Evinrude Snowmobile Dealer from whom the snowmobile was originally purchased or the nearest authorized Evinrude Snowmobile Dealer. Snowmobiles or parts thereof shipped to the factory for our inspection must show model and serial number, and must be shipped with transportation charges prepaid.

This warranty applies to all snowmobiles sold in the United States and Canada.

Snowmobiles sold elsewhere are warranted either by Outboard Marine Belgium S.A., Bruges, Belgium; Outboard Marine International, Inc., Miami, Florida; Outboard Marine International S.A., Hong Kong; or Outboard Marine Australia Pty. Limited, Bankstown, N.S.W., Australia."

EVINRUDE MOTORS

A Division of OUTBOARD MARINE CORPORATION MILWAUKEE, WISCONSIN
OUTBOARD MARINE CORPORATION OF CANADA LTD., PETERBOROUGH, CANADA

