



Photocopy manuals and illustrated spare parts lists are reproduced with the consent of the copyright holders. The new page arrangement is also itself copyright and that of Bruce Main-Smith & Co. Ltd. Further reproduction, in whole or part, is expressly forbidden. In some cases we have deleted passages which are irrelevant today, due to factory closures, e.g. spares ordering procedures, warranty claim systems and telephone numbers of factories now closed down.

The page numbering may be changed as a result but the sequence of the original is preserved. Nothing is ever deleted. In this way the cost of photocopying may be kept down. Whilst every effort is made to produce photocopies of the highest quality, the final reproduction is dependant on the state of preservation of the original manual or parts list.

© 1991 BRUCE MAIN-SMITH & CO. LTD.

To avoid confusion with similar manuals or parts list, please quote make, model and year when ordering.

Please also quote the B.M.S. Code as shown in our "LIST"

The



code for this item : - RUSSELL/1126

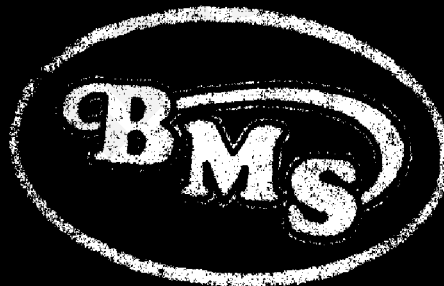

BRUCE MAIN-SMITH & COMPANY LTD.

132 SAFFRON ROAD,

WIGSTON

LEICESTERSHIRE

LE18 4UP, ENGLAND.

TELEPHONE : 0116 277 7669

FAX : 0116 277 7669

HANDBOOK
OF
Motor **A.J.S.** Cycles

INSTRUCTIONS FOR OWNERS
ON THE CARE AND MAINTENANCE
OF A.J.S. MACHINES.

SERIES M.

2.48 h.p., 3.49 h.p., 4.98 h.p., and 9.96 h.p. Models.

1929.

MANUFACTURED THROUGHOUT BY
A. J. STEVENS & CO. (1914) LTD.,
GRAISELEY HOUSE, WOLVERHAMPTON, ENGLAND.

TELEPHONE 1731
(Five Lines).

Copies :
A.B.C. 5th Edition.
A.B.C. 6th Edition.
Bentley's, Marconi International.

TELEGRAMS :
"HOPPT, Wolverhampton."

FOREWORD.

THE information given in this booklet has been very carefully compiled in the hope that it will prove of assistance to the rider in keeping his machine in the best possible condition, and aid him in elucidating any little difficulties which may arise from time to time.

The reader's attention is especially drawn to the pages devoted to Driving Instructions and General Care of the Machine, these apply with equal significance to all types of 1929 A.J.S. Models. Particular attention should be given to those parts of the instructions which are emphasised by being printed either in italics or heavy type.

This booklet covers the whole range of the 1929 A.J.S. Models and as there is much in their constructional details that is common to all types, these will be found grouped under such headings as "Driving Instructions," "Care of the Machine," "Change Speed Gear," "Detachable Wheel," etc. Where, however, differences in design occur they are dealt with in separate sections.

It has always been our aim to construct A.J.S. Motor Cycles on such simple and straightforward lines that their management, running and upkeep, shall present no difficulties, even to the motor cyclist with little or no previous experience.

Re Supply of this Publication.

A copy of this booklet is supplied free with every new A.J.S. Motor Cycle. Applications for extra copies must be accompanied in every case by a remittance for 1/- to cover cost and postage.

A. J. STEVENS & CO. (1914) Ltd.

1929.

CONTENTS.

	PAGE
Foreword	2
Driving Instructions	8-11
Engine Lubrication	12
Engine Adjustments, Cleaning, and Removal of Cylinder	13-16
Overhead Camshaft Engine	17-18
Magneto	19
„ Contact Breaker Point Adjustment	19
„ Timing	19
„ Ignition Trouble	20
Engine Timing	21
Gear Box	22
Gear Box Dismantling	23
Clutch Adjustment	24-26
Dismantling Clutch	24-26
Adjustment of Chains	27
Care of Chains	28
Chain Repairs	28
Chain Rivet Extractor	29
Steering Head, Steering Damper and Handlebar Adjustment	30
Spring Fork Adjustment	31
Rear Wheel Adjustment Gauge	31
Removal of Wheels	31-33
Brake Adjustment	34
General Instructions	34
Sidecar Hints	35-36
Hints and Tips for Hill Climbs and Speed Events	36

INDEX TO ILLUSTRATIONS.

	PAGE
Plan Views	5-6-7
Change Speed Gear Lever	8
A.J.S. Overhead Valve Engine	9
A.J.S. Single Cylinder Side Valve Engine	10
Dry Sump Lubrication	11
A.J.S. Twin Cylinder Engine	12
Removing Cylinder Heads	13
Removing Cylinder Head and Barrel	14
Push Rod Extractor	15
Valve Extractor	16
A.J.S. Camshaft Engine	18
Magneto	19
Magneto Timing	21
Arrangement of Timing Gear	21
Gear Box in Section	22-23
Clutch Parts	24-25
Chain Case	25-26-27
Chain Repair Parts	28
Chain Rivet Extractor	29
Front Forks and Adjustable Handlebars	30
Rear Wheel Adjustment	31
Quick Detachable Rear Wheel	32
Front Wheel removed... ..	33
Internal Expanding Brake	34

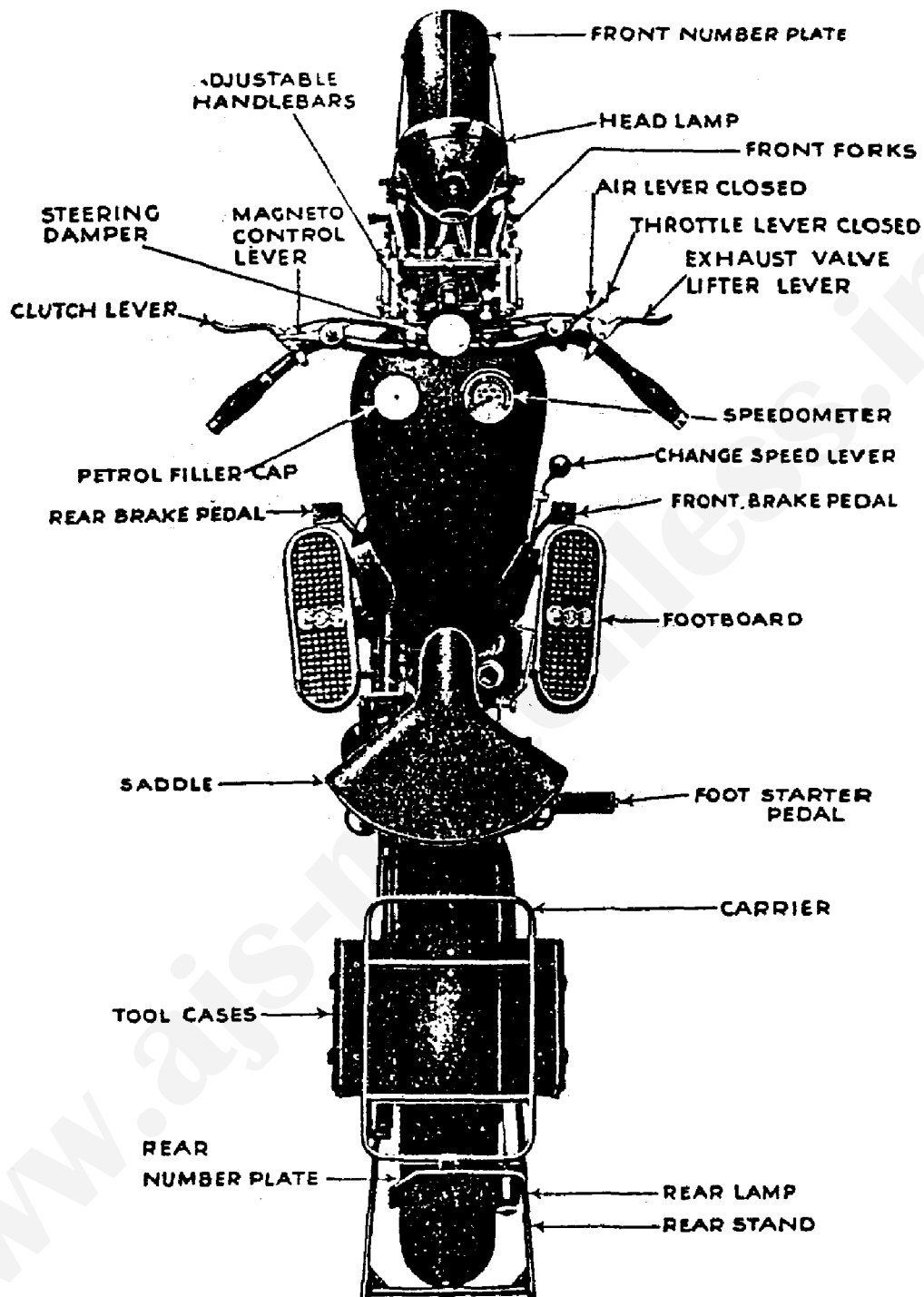

Illustration 1.

PLAN VIEW 9.96 h.p. MODEL M1.

Applicable also to Model M2.

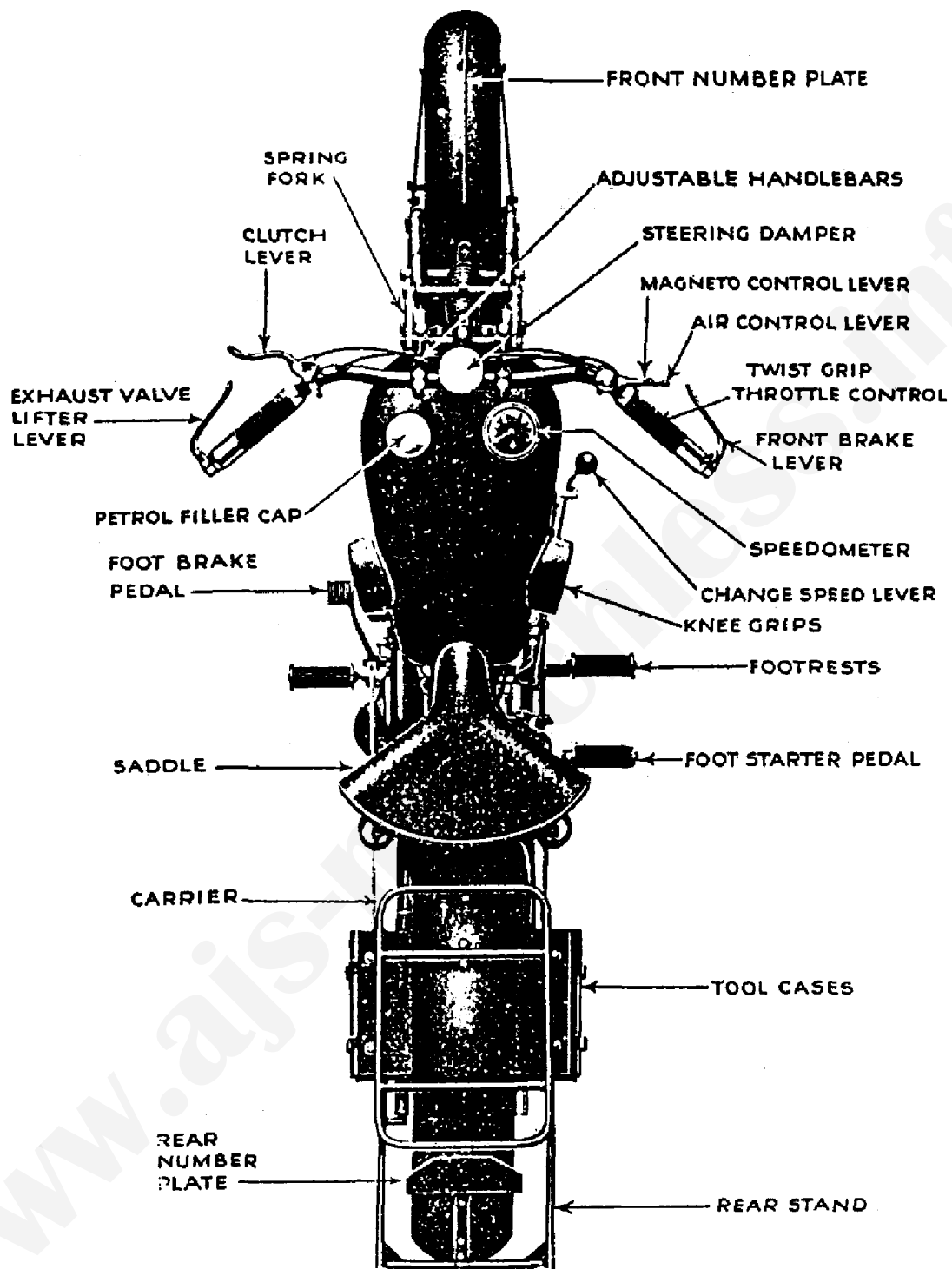

Illustration 2.
PLAN VIEW.

Applicable to Models M 6, M 7, M 8, M 9 and M 10.

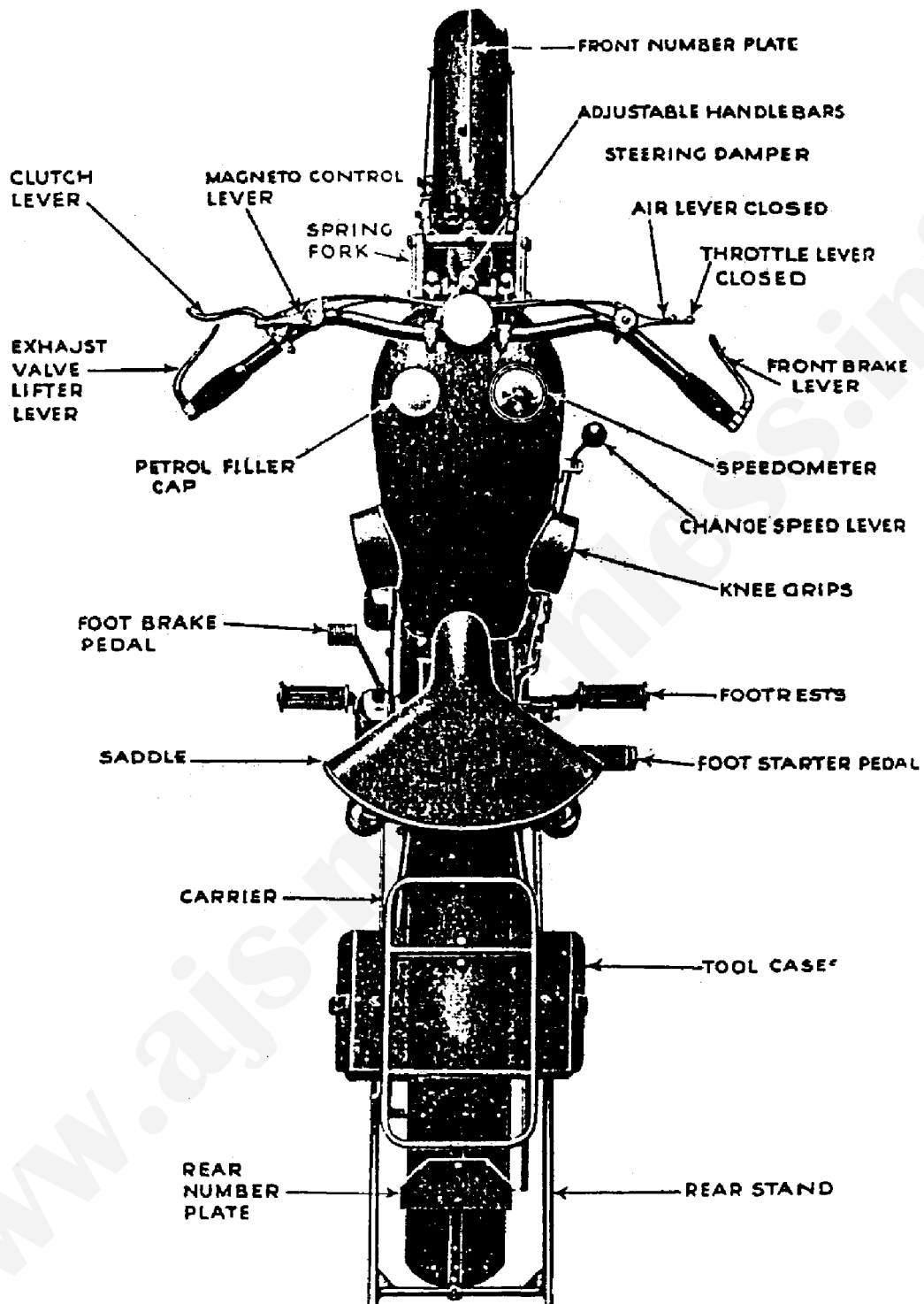

Illustration 3.

PLAN VIEW.

Applicable to Models M 3, M 4, M 5 and M 12.

DRIVING INSTRUCTIONS, ETC.

For 2.48 h.p., 3.49 h.p., 4.98 h.p., and 9.96 h.p. Motor Cycles.

AFTER receiving the machine, thoroughly examine it and get conversant with its details. Fill up with petrol and oil.

The oil tank will be found situated behind the rear down tube. For further instructions respecting lubrication see "Care of Machine—Engine," page 12.

To Start the Machine.

See that the gate change lever is in the neutral position marked on the gate change quadrant.

Retard the ignition lever about $\frac{1}{4}$ or $\frac{1}{2}$ its travel. This is to prevent back-firing.

Move the lever to the left to retard the ignition and vice versa.

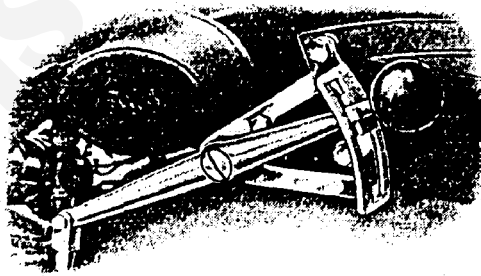

Illustration 4.

THE A.J.S. CHANGE SPEED.

The Lever is shown in the neutral position.

On machines fitted with twist grip control, the ignition lever is mounted on the right handlebar above the air lever, and to advance the ignition this lever is moved to the left, and to the right to retard. Machines fitted with the lever control to the carburettor have the gas and air levers on the right handlebar, the throttle lever being the bottom or lower one. These open inwards, that is to the left when seated on the machine. The magneto lever is on the left handlebar.

If the cables are properly adjusted, the least movement should begin to operate against the springs in the carburettor. If there is any slackness in the cable, the adjusting screw in the top of the carburettor should be raised to remove the back lash.

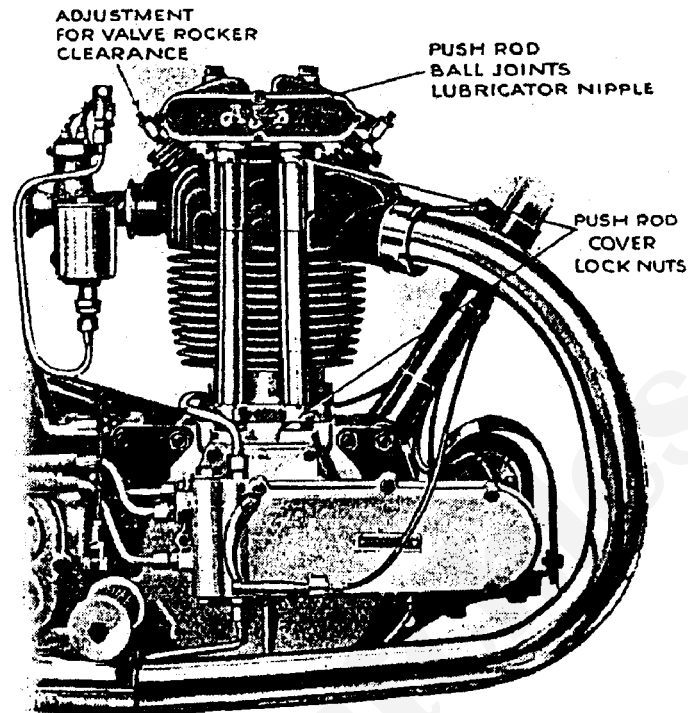

Illustration 5.

A.J.S. OVERHEAD VALVE ENGINE.

- (a) Turn on the petrol by pushing the tap to the "on" position, and when the float chamber needle has risen, give it one or two taps with the finger to flood the carburettor.
- (b) Shut the air lever.
- (c) Open the throttle very slightly, that is about $\frac{1}{8}$ in. pull on the wire after you have felt the resistance of the throttle spring.

On machines with twist-grip the right handlebar grip is moved inwards to open, *i.e.*, anti-clockwise when seated on the machine. Twist-grip control pulls the throttle wire like an ordinary lever, but working around the bar instead of on top of it. Open the throttle very slightly by twisting inwards about $\frac{1}{4}$ in. movement of the diameter of the rubber grip after you have felt the resistance of the throttle spring.

When Starting up—Twist Grip.—See that the position of the twist grip is not altered, this may easily take place by the movement of the body when depressing the footstarter pedal.

Footstarter.—Now lift the exhaust lever and turn the engine over, say twice with the footstarter, to get gas into the cylinder. Then give one smart kick downward, and the engine should start. Take the foot off the pedal immediately the engine fires, *but do not allow the footstarter to spring back with a bang.* Bring the foot back with the pedal and so prevent a heavy blow being given to the stop.

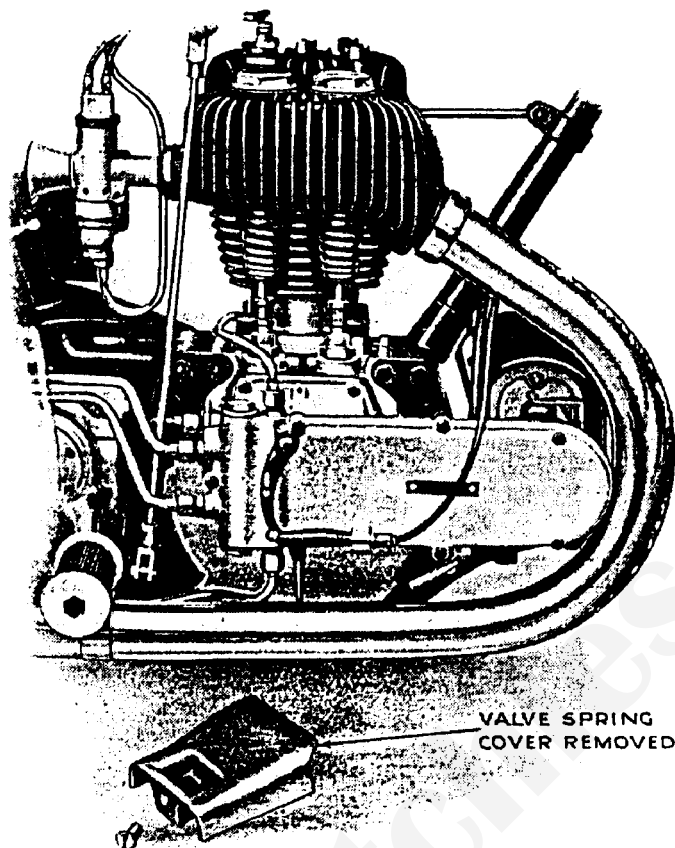

Illustration 6.

A.J.S. SINGLE CYLINDER SIDE VALVE ENGINE.

Carburettor Adjustment.—If the engine has been started with the air closed, it will be found that the mixture is very rich, so steadily open the air lever until the engine runs smoothly. After the engine has warmed up the lever can be left open.

The correct position of the air lever of course varies with atmospheric conditions, the quality of petrol, etc., but in a short time the rider should be able to get the correct setting of the air lever from the behaviour of the engine on the road. If the air lever is set properly, the carburettor should be practically automatic throughout its touring range.

If the engine does not start easily after the first attempt, the rider is usually inclined to heavily flood the carburettor, and so cause the mixture to be so rich that starting is impossible. If it is thought the mixture is too rich, open the throttle and air lever fully. Raise the exhaust valve lifter and turn the engine over a few times with the footstarter. This will get rid of the excessive petrol in the engine. Then proceed to start the engine again as described in the first part of these instructions.

To sum up for Starting.—Do not flood the carburettor except when cold or when petrol has been turned off for any length of time.

There is no need to shut the air lever if the engine is hot.

Do not open the throttle more than the slightest amount.

Set the ignition lever a quarter or half retard, and when the engine is started, advance the ignition fully.

Presuming these instructions have been carried out, and you are seated in the saddle, take out the clutch by means of the clutch lever on the left-hand side of the handlebar, place the gear lever in the low position, speed up the engine by opening the

DRIVING INSTRUCTIONS, ETC.—Continued.

throttle a little, and gently release the clutch lever. The machine will then move forward on the low gear. When the machine has attained a fair speed on this gear, again pull out the clutch and move the gear lever into second gear position, immediately re-engaging the clutch.

Repeat this operation to engage high gear. When running on high gear, the machine must be controlled by means of the throttle lever and brakes.

To stop, close the throttle, and when the machine is almost at a standstill, take out the clutch and apply the foot brake.

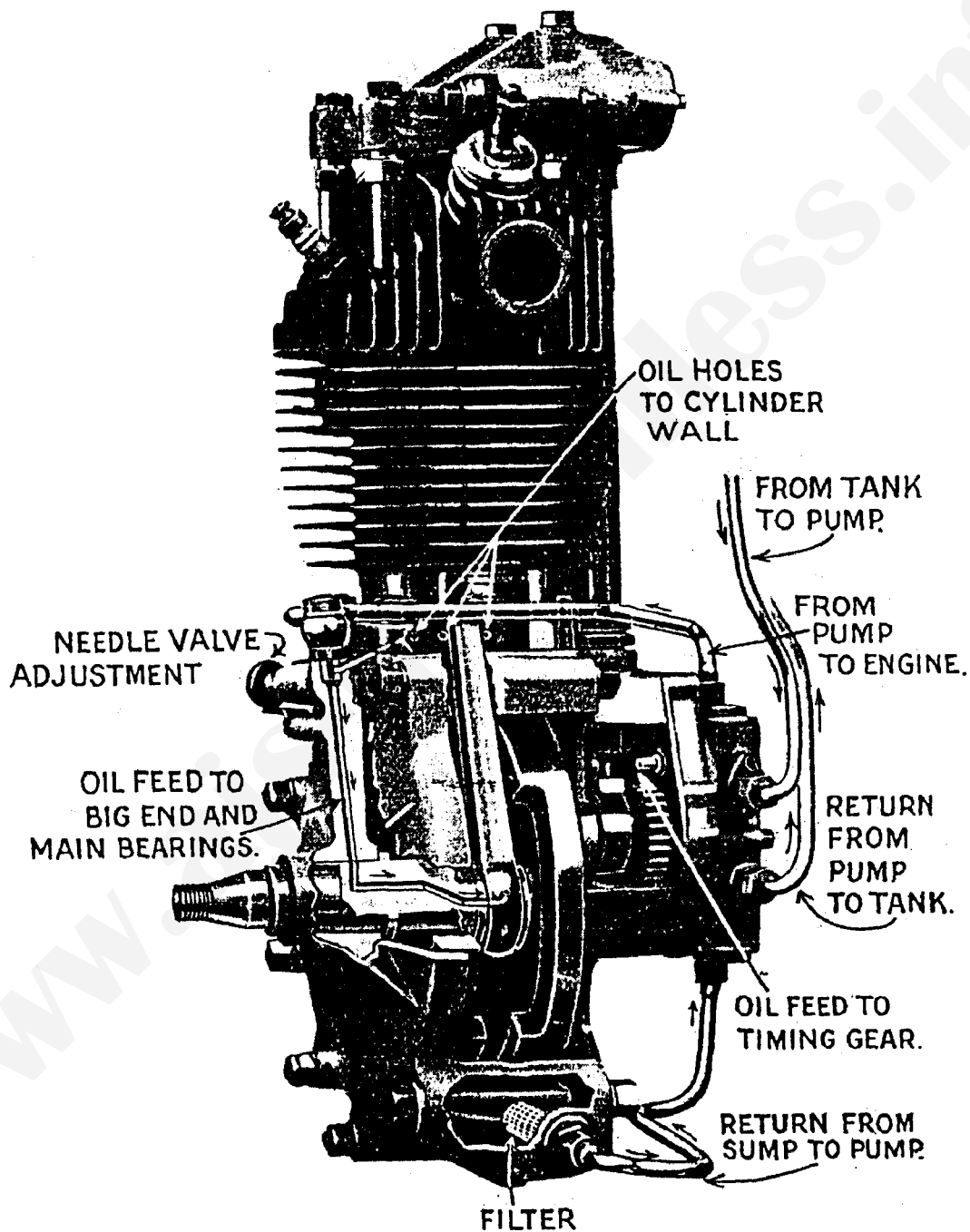

Illustration 7.

DRY SUMP LUBRICATION.

Sectional view of engine, showing circulation of oil.

CARE OF THE MACHINE. ENGINE.

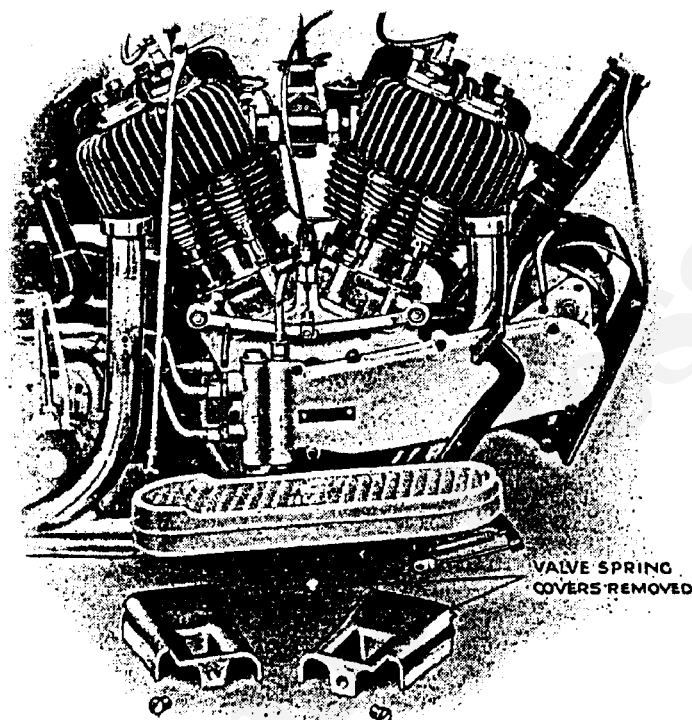

Illustration 8.

A.J.S. TWIN CYLINDER ENGINE.

Lubrication, Dry Sump.—Only best quality oils should be used. We use and recommend Wakefield Castrol "C," other suitable oils are Golden Shell, Mobiloil "B" Summer, Mobiloil "TT" Winter (for side valve engines); Mobiloil "D" Summer, Mobiloil "TT" Winter (for O.H.V. Engines); Price's Motorine "C" de Luxe Winter, Motorine "B" de Luxe Summer.

Lubrication of the engine is of the dry sump type. Driven by the half-time shaft is a double-acting pump, of which the feed side forces oil to the main bearings and thence by oil-ways to the big end. Oil is also forced to the timing gear case, lubricating all gears, cams and bearings. All oil pumped to the engine drains to the sump, from whence it is drawn by the other half of the pump and returned to the tank.

For every condition of touring, either fast or slow, the cylinder is correctly lubricated by oil thrown from the big end, but should the machine be used for road or track racing, oil can be fed direct to the piston by unscrewing one to two complete turns of the needle-valve fitted to the left-hand side of the crankcase at base of cylinder. Other than using this needle-valve for racing work, the lubrication system requires no adjustment whatever.

As is the case with all petrol engines, a sediment will gradually accumulate in the bottom of the oil tank and in the sump. This should be got rid of by draining the tank and sump every 4,000 miles, and at the same time thoroughly cleaning the filters fitted to each. The circulation of the oil can be seen by removing the oil tank filler cap, just underneath which is the return pipe from the sump. If, with the engine running, oil flows

ENGINE.—Continued.

from this pipe, the system is functioning properly. After the engine sump has been drained, it will be found that when the engine is started up again, oil will not immediately flow through the return pipe into the tank on account of the time which must necessarily elapse for the oil to circulate throughout the engine before being pumped back to the tank.

With this patented system of lubrication the rider has the satisfaction of knowing that a continuous flow of clean, cool oil is passing through his engine to suit every condition of road or load, with no trouble to himself, excepting keeping oil in the tank to the level shown thereon. **But be sure the tank is never allowed to run dry.**

Adjustments and Cleaning.—See that the valve tappets are always properly adjusted, .006 in. inlet and .008 in. exhaust is the correct clearance, or about the thickness of a visiting card between the tappet top and valve stem when the valve is on its seat. Check the clearance when the engine is hot, not when cold. Use two spanners to unlock the adjusting nuts on side valve models.

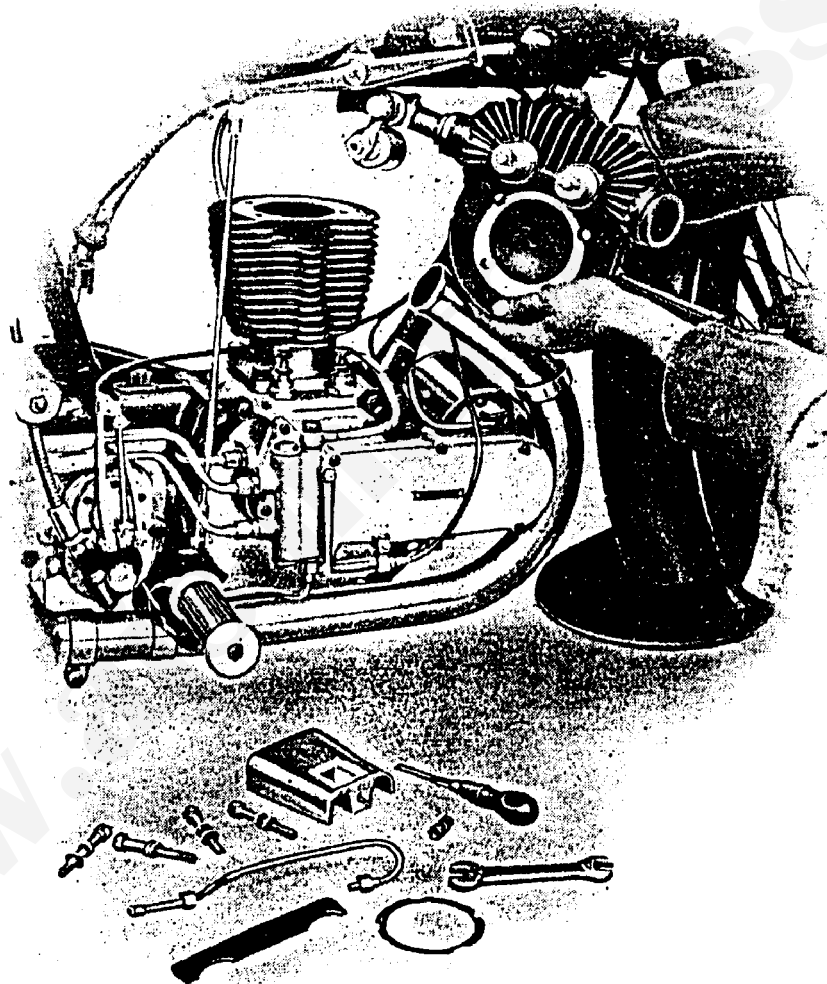

Illustration 9.

THIS SHOWS THE EASE WITH WHICH THE CYLINDER HEAD OF A.J.S. ENGINES CAN BE REMOVED.

To remove the cylinder for decarbonising, first disconnect the union on the exhaust pipe, using the special spanner supplied in the tool kit for this operation. Next remove the petrol pipe and slides from the carburettor, then undo the four holding-

down bolts on top of the cylinder head. To detach the head insert a screwdriver or similar tool between the top cylinder fin and the head, prising the head carefully off the barrel from both sides. Take great care not to break the radiating fins. **Prise upwards not downwards.** When quite free, the head can then be lifted off. If it is desired to remove the cylinder barrel as well, the four nuts situated at each corner of the base will have to be unscrewed from the studs, but before drawing off the cylinder barrel the engine should be turned over until the piston is at the lowest position of its stroke, and then lift off the the barrel carefully, taking care when the piston is free not to let it fall sharply against the connecting rod, as this may bruise or distort the skirt of the piston.

Having removed the cylinder, wrap a clean cloth or rag round underneath the piston to prevent any foreign matter or dirt getting into the crankcase. If the combustion head is badly carbonised this must be cleaned, the generally accepted method being to scrape the chamber free of the burnt charges, which can be done with an old screwdriver or similar tool. The top of the piston should also be scraped free of all deposit, using an old blunt knife or chisel, and while carrying out this operation see that no side strain is thrown on the piston. If the rings are quite free in their grooves they need not be removed, but if they are obviously choked up with burnt oil, loosen them very carefully, take them off the piston and clean the grooves thoroughly. Take the piston off the connecting rod to do this. First remove the gudgeon pin from the piston, take out the retaining springs, one of which will be found on either side of the gudgeon pin. These fit into recessed rings in the piston bosses and to withdraw must be squeezed together with the special small pliers provided. Afterwards the gudgeon pin can be pushed out.

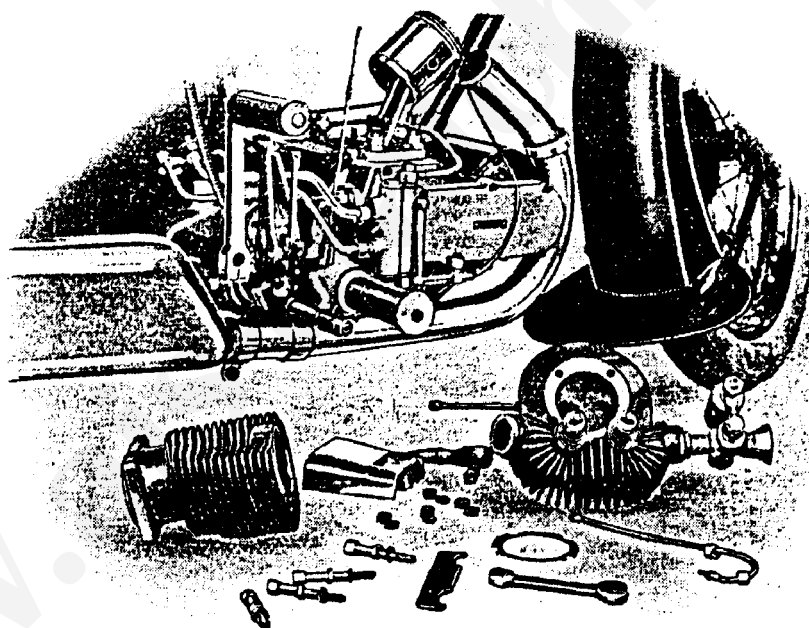

Illustration 10.

CYLINDER HEAD AND BARREL REMOVED.

When replacing the piston, see that both the gudgeon pin retaining springs are in place. Having got rid of all deposit from both the head and piston, wash all particles off with paraffin. Before replacing the cylinder after cleaning, carefully oil the piston and see that the joints of the piston rings are on opposite sides of the piston. Take care when replacing the cylinder on to the crankcase to see that the packing washer is inserted between the top of the crankcase and base of the cylinder. If the washer between the cylinder head and barrel has been damaged in detaching the head, replace with a new one. Smear the face of the cylinder head with a thin film of oil or vaseline. This will act as an adhesive to which the washer can be fixed, and will retain the washer in its

correct position whilst fitting the cylinder head on to the barrel. Place the cylinder head squarely on the barrel and then screw on the four holding-down bolts, afterwards tightening these evenly.

If it is required to remove the valves of side valve machines for inspection, etc., this can be done with the cylinder head still in position. All that has to be done is to unscrew and take out the valve cap, then place the hooked end of the special valve extractor, which is provided in every tool kit, on the top of the valve, using the valve cap spanner, which fits at the bottom of the hook, for the necessary leverage to lift the valve spring to allow the cotter to be withdrawn.

The valve can then be pushed up and drawn out of the head, via the valve cap aperture. If the valve seatings are at all pitted, grind in the valves with fine emery flour mixed with oil into a paste, taking care that all emery is cleared out of the valve chamber after the operation. The valves should, generally speaking, be ground in about every 1,500 miles.

Examine periodically the bolts which hold the engine in frame, and tighten any nuts that may have worked loose. Keep the engine clean externally, which can be done quickly and easily with a painter's brush and a pan of paraffin.

Removal of Cylinder on O.H.V. Models M 6 and M 8.—To remove the cylinder for cleaning, first disconnect all such fittings as exhaust pipe, carburettor slides, then proceed to remove the tubes which enclose the push rods, by telescoping them one inside the other. To do this the lock nuts at top and bottom of the tubes must be unscrewed. To detach the push rods the special extractor tool should be used, this is not supplied with the kit but can be had, Price 1/-. Place the end of the tool with the round hole over the rocker adjusting screw (see Illustration 11) and press down until the valve

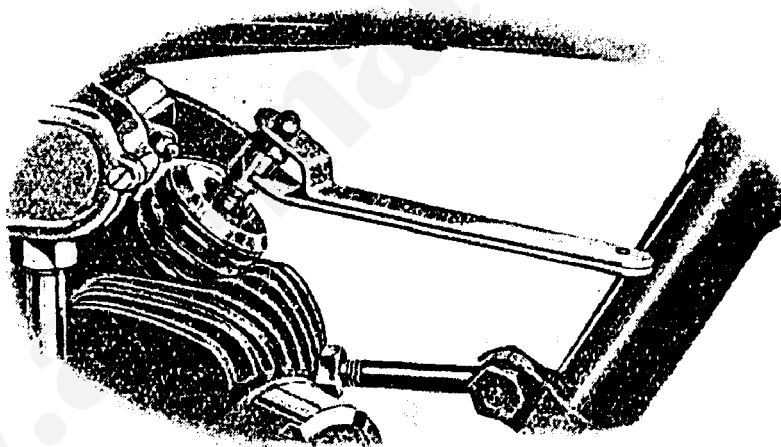

Illustration 11.

PUSH ROD EXTRACTOR.

spring is compressed. Hold down firmly and take hold of the bottom of the push rod which will be seen passing upwards from the crankcase to the rocker. Lift this up from its hollow cup and withdraw. Repeat the operation for the other push rod. To remove the rocker gear for the purpose of decarbonising, the locknuts at top and bottom of the push rod enclosing tubes will of course have to be dealt with as mentioned in the preceding paragraph. Next unscrew the four pins holding down the rocker box. The two pins at the right or push rod side of the rocker box need only be unscrewed until they are free, but those nearest to the valves must be withdrawn entirely. The rocker box can now be drawn off the cylinder head from the right hand side. Next unscrew and remove the four holding down bolts on top of cylinder head. To detach the head insert a screwdriver or similar tool between the top cylinder fin and the head, prising off carefully upwards from both sides.

ENGINE:—Continued.

The rocker gear can be inspected by removing the inspection cover, but this need not be taken off for the purpose of lubricating the upper ball joints of the push rods. In the centre of the inspection cover will be found a Tecalmitite nipple (see illustration 5). By means of the grease-gun force a very little grease through this nipple, which automatically finds its way to the push rod ball joints. It is important when this is being done that both valves are in the closed position.

Should it be desired to remove the valves when the head is detached, the special valve extractor should be used, Price 5/9 (see Illustration 12). This is a clamp-

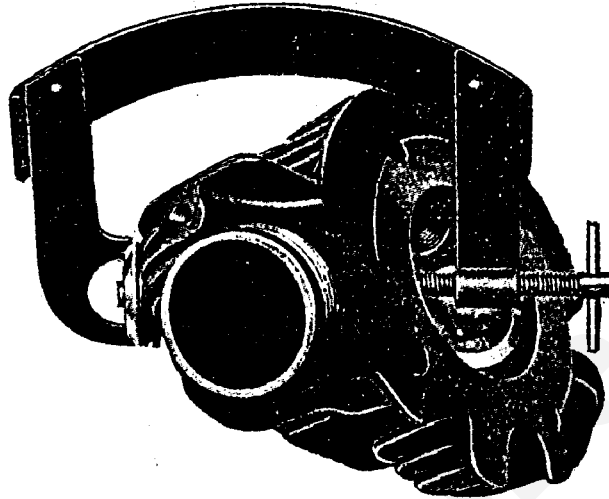

Illustration 12.

VALVE EXTRACTOR.

like tool to extract the valve from the cylinder head when the latter has been taken from the engine. For portability the tool is made to fold up. Unfold this and place the end opposite the screw over the valve spring, as shown in the illustration. Screw up until it presses inside the hollow of the valve head. Hold the cylinder head firmly, keep screwing, and it will be found that the spring is compressed so that the two small split cones can be taken away from the recess in the valve stem, and the valves withdrawn.

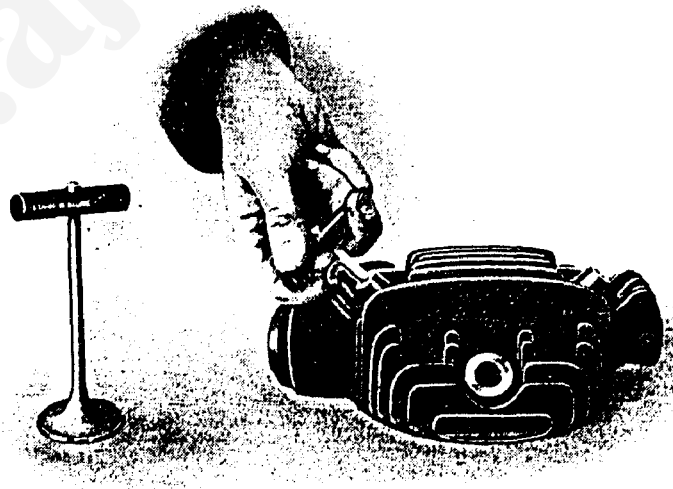

Illustration 13.

HOW TO USE THE A.J.S. VALVE GRINDING TOOL.

OVERHEAD CAMSHAFT ENGINE.

Removal of Cylinder on O.H.C. Models M 7 and M 10.—Remove exhaust pipe, carburettor connections, oil pipe to cam box, etc. Take out sparking plug. Then put piston on top dead centre with valves closed. Take away cap, also split cotter fixing nut on camshaft and remove the nut. Take off the washer; next remove the four pins holding the cam box on to cylinder head, and whilst an assistant holds and steadies the chain-wheel, carefully take away the cam box.

Unscrew the four pins holding cylinder head in position.

Take off cylinder head, then carefully turn engine until piston is on bottom of stroke. Whilst turning the engine, support the chain wheel, either with the fingers or some instrument that will allow the chain wheel to turn freely. The chain wheel must not be allowed to lock in the chaincase whilst the engine is being turned. **On no account must the chain wheel be allowed to fall out of the chain,** use the special supporting tool. For decarbonising see general instructions on page 14.

Fit the cylinder into the crankcase and tighten the four holding-down nuts evenly.

Next replace the cylinder head and tighten these nuts down.

When fitting the cam box, carefully place the chain-wheel on spigot of camshaft, then turn engine round slowly until hole in the camshaft sleeve is opposite hole in chain-wheel.

Now insert the washer with its special peg, and tighten up nut.

Fit split cotter.

Take away special tool that supported the chain-wheel and replace the inspection cap in chaincase.

Fit exhaust pipe, oil-pipe to cam box, carburettor connection, etc.

Should it be necessary at any time to take away the chains that drive the camshaft and magneto, see that the tooth marked with a dot on the timing pinion is opposite the dot on the larger pinion. Also see that the arrows on the chain-wheels are opposite each other (see Illustration 14).

Valve Clearance, Most Important.—When the engine is cold there must be a clearance of .018 between the end of the exhaust valve stem and the rocker stud, and .016 between the inlet valve and rocker stud. Gauges are supplied with each machine to show this clearance.

On no account must the clearance be less than stated above.

If the gauge should be mislaid, a rough setting may be obtained by turning the engine over until both valves are closed, then loosen the locking nut on rocker stud and screw down the stud until it just touches the end of the valve stem. Now unscrew the stud one half turn which will give approximately .018 clearance. Tighten up the locking nut again afterwards. These clearances may appear to be excessive, but with a camshaft engine such as the A.J.S., these are taken up when the engine gets warm. Conditions are different to those of a push-rod overhead valve or side valve engine.

Warning.—Do not take any metal from cylinder foot or top end of cylinder barrel to raise the compression, or put a thicker washer underneath cylinder barrel to lower the compression. If this is done it will alter the chain centre.

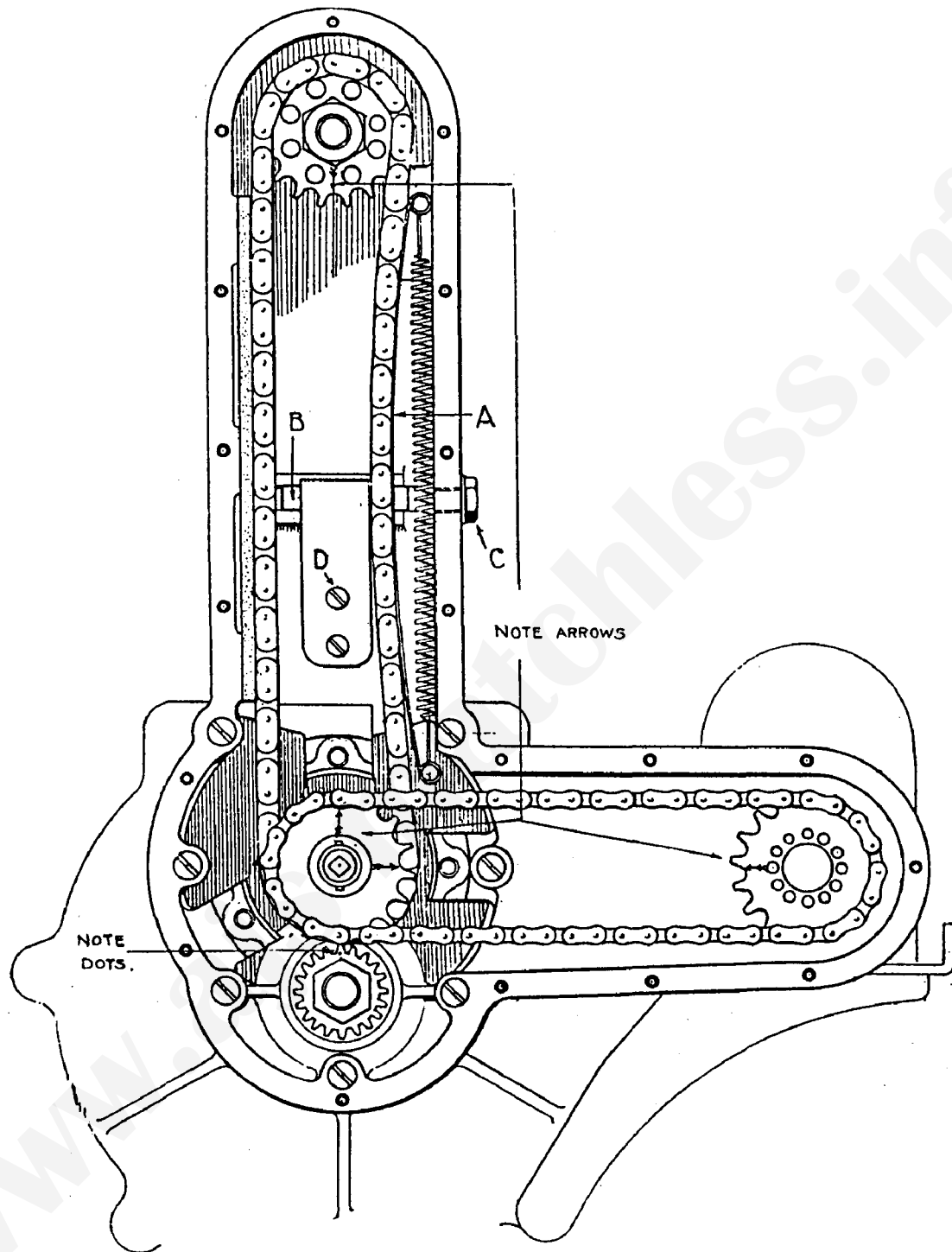

Illustration 14.

A.J.S. CAMSHAFT ENGINE,

Showing Chain Drive, Tensioning Device and Reaction Damper.

MAGNETO.

Lubrication.—The instrument is provided with ball bearings throughout, which are packed with grease before leaving the manufacturers. Fresh lubricant should not be required under normal circumstances until the machine has run from 10 to 12 thousand miles.

Adjustment.—The contact breaker points should be examined after 1,000 miles, and if the break should be more than the thickness of a visiting card they should be adjusted. The proper distance of the gap is 0.5 m.m. or roughly 1/64 in. full. Too great a gap will advance the timing. A special small spanner is provided with each machine, and the gauge of this is the correct distance for the break of the points. This adjustment, owing to the arrangement of the contact breaker, can be carried out without removing the contact breaker from the magneto. If it is necessary to take the contact breaker out, unscrew the long taper fixing screw, and pull the contact breaker off. The points only need attention at very long intervals, and we warn users against unnecessarily interfering with the setting. *The points only must be dressed with a dead smooth file if the surface has become at all pitted, and then the least possible amount taken off, the greatest care being exercised.*

Timing.—If the magneto has been removed from the machine it will be necessary to see that it is timed correctly after it is refitted. The engine magneto driving sprocket is secured to its shaft by means of castellations, which render wrong replacement impossible. The sprocket on the armature shaft of the magneto is supplied with a vernier timing

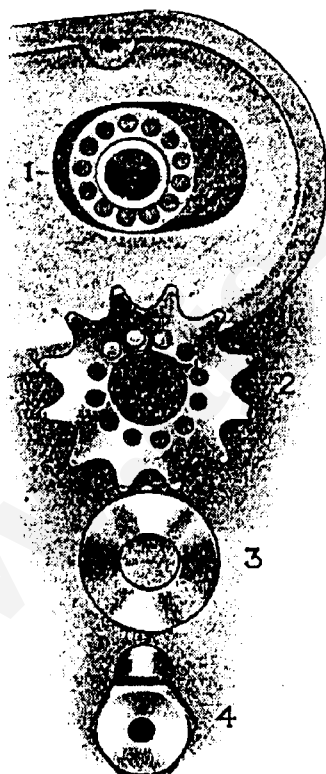

Illustration 15.

VERNIER TIMING ADJUSTMENT.

washer (3) into these holes, which effectively prevents the sprocket from moving from its correct setting, and tightly screw up the sleeve lock nut (4), which can be done without fear of the timing shifting in the process, as is often the case with other methods. As a means of verifying the timing, or if the sleeve (1) has been removed from the magneto armature

adjustment, which allows a very accurate and certain method of fixing the drive after the correct setting has been arrived at. The setting of this vernier adjustment may at first sound a trifle complicated, but in reality it is perfectly simple. Fitted to the armature shaft of the magneto is a sleeve (1), which has thirteen holes ranged in a circle. Fitting over a collar on this sleeve is the chain sprocket (2), which has twelve holes similarly arranged. Now on the sprocket on engine driving shaft and on the magneto shaft will be found an arrow. *These must point to each other before anything else is done.* The first thing then in timing up is to set these two arrows so that they face exactly towards each other. To do this turn engine over until the arrow on the driving sprocket is pointing directly towards the arrow on the magneto sprocket. This latter should be held free in the fingers and moved a tooth backwards or forwards in the chain until the correct setting is arrived at. When this is so, place the magneto sprocket on to the sleeve, and turn the armature shaft of magneto until a mark found punched over one of the twelve holes on the sprocket exactly registers with a similar mark on the outside of the collar of the sleeve. It will now be found that the marked holes in sleeve and sprocket respectively exactly coincide so that all that has to be done is to push the

shaft, set the piston its correct distance from top of compression stroke (see ignition timing for details of settings of each particular model), make sure it is not on the exhaust stroke. With the piston in this position take off the sleeve lock nut on magneto sprocket and remove the peg washer. This will leave the armature free from the engine drive, but still connected via the chain to the engine. See that the sprockets have their arrows facing as previously mentioned. Move the ignition control lever to the limit of its motion of advance. Remove the cover of contact breaker and slowly turn the armature till the fibre block of the make and break lever arises on the inclined plane of the steel segment just sufficient to separate the points. This is the firing point, and with the piston in the position referred to above the sleeve and sprocket should register if correctly fitted up. If so, the drive should be fixed up as before detailed. It is, however, always advisable to check the timing after tightening up.

It will prevent misfiring and make starting easier if the slip ring is cleaned occasionally. This is done by taking out the high tension terminal, and while the magneto is being revolved by slowly turning the engine round, insert a lead pencil, the end of which is covered with a clean rag moistened with petrol. The pencil should be pressed on the revolving slip ring.

Ignition Timing.—The spark is timed to take place $\frac{3}{8}$ in. before the top of compression stroke on Models M1, M2, M9 and M12, $\frac{1}{8}$ in. before top of compression stroke on Models M4, M5 and M8, $\frac{1}{8}$ in. before top of compression stroke on Model M6, and $\frac{3}{4}$ in. before top of compression stroke on Models MR6, M7, MR8 and M10. In all cases these are with the magneto control in the fully advanced position.

Magdyno.—Model M1 is fitted with a Lucas "Magdyno" as standard. This instrument provides ignition for the engine and generates current for the electric lamps, and although the two are retained as separate units they are housed so as to form one instrument. A full description of the working, care and maintenance of the "Magdyno" is contained in the Lucas Book of Running Instructions, a copy of which is sent out with each new A.J.S. machine.

The lubrication is the same as with the ordinary magneto. Usually sufficient grease works through from the gear wheel casing to lubricate all bearings on the driving end. The dynamo commutator end bearing can easily be lubricated by removing the hexagon nut securing end cover and placing a small quantity of grease or a few drops of oil in the bearing housing. The Magneto bearing at the contact breaker end should run perfectly without any attention, owing to the manner in which it is protected. Should the gears run completely dry they can be packed with a high melting point grease such as Price's H.M.P. grease.

When Ignition Trouble is Suspected.—Before interfering with the magneto verify that the sparking plug, the cable and connections are correct. If these are in order turn the engine over slowly and watch if the contact breaker arm works properly. This is bedded in a fibre insulating bush, and in moist weather there is an occasional danger of the material swelling. If this happens prise the rocker arm off its bearings and clean the steel pin on which it works with fine emery cloth, and smear a very small quantity of oil on it before replacing. Do not take the magneto to pieces needlessly. It is easily possible to damage it.

Most Important.—If it is necessary to take out the armature first see that the carbon collectors and safety gap screw are removed, or the collector ring will be broken during removal. Keep all parts clean and free from oil, particularly the contact breaker. Oil or dirt between the points will give instant trouble.

Magneto Adjustment.—Examine the driving chain occasionally, and if slack, tighten it by moving the magneto along the platform in a forward direction. Slacking off the platform adjusting pins allows this. When the correct tension has been obtained screw the pins up again tightly. It is not necessary to remove the magneto chain cover to do this, as the chain can be felt by inserting a finger through an aperture in the back of the cover. When adjusting, turn engine over slowly to check for any tight places in chain. Examine also the nuts securing the chain sprockets to the engine shaft and armature shaft of magneto respectively. After examination, before replacing the cover, oil the chain.

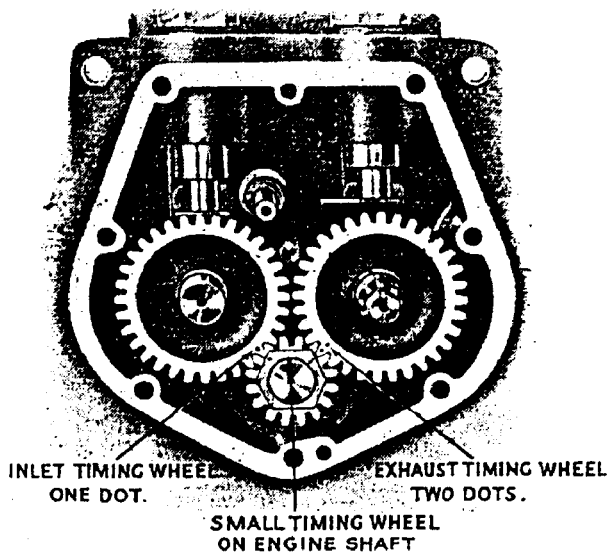

Illustration 16.

ARRANGEMENT OF TIMING GEAR,
Single Cylinder Models, except M7 and M10.

Engine Timing.—Models M3, M4, M5, M6, M8, M9 and M12.—Except in case of necessity we do not advise tampering with the valve timing arrangement. However, if the engine has been completely dismantled for any reason, we make it a practice to so mark the timing pinions that replacement is a matter of perfect ease if the following instructions are carried out. To facilitate correct setting and meshing of the pinions these are marked with a dot system of identification as shown in Illustration 16. On the small timing pinion will be found a single dot and a double dot. These dots correspond to similar marks on the inlet and exhaust valve timing pinions. To set the inlet valve, place the single dot found stamped thereon in register with the single dot on the small pinion, and similarly in the case of the exhaust wheel which has two dots stamped on it.

Engine Timing.—Models M1 and M2.—The registering marks for twin cylinder models are as follows:—small timing pinion—single dot and double dot. These marks register with corresponding dots on the back and front exhaust cam wheels, the back exhaust wheel being stamped with one and the front exhaust with two. The teeth of the back exhaust wheel must be meshed with those of the small pinion so that the single dot registers with the single dot on the small pinion, and the two dots on the front exhaust must register with the two dots on the small pinion. There now only remains the double inlet cam wheel which meshes with the front exhaust cam wheel. Upon this wheel a dash or stroke is marked which must be placed opposite the corresponding dash which will be found upon the front exhaust cam wheel. The correct setting of the valve timing is then arrived at.

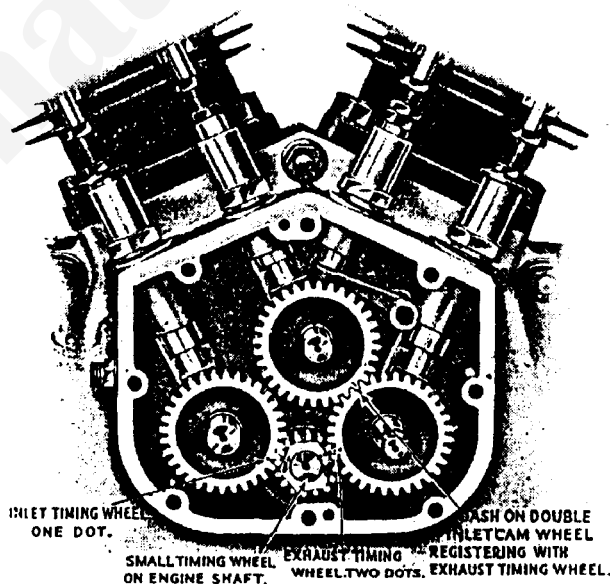

Illustration 17.

ARRANGEMENT OF TIMING GEAR,
9.96 h.p. Twin Cylinder Engine.

With the exception of carrying out the above instructions, do not tinker with the engine, nor fancy you can do better than the makers by tampering with the valve timing gear.

GEAR BOX.

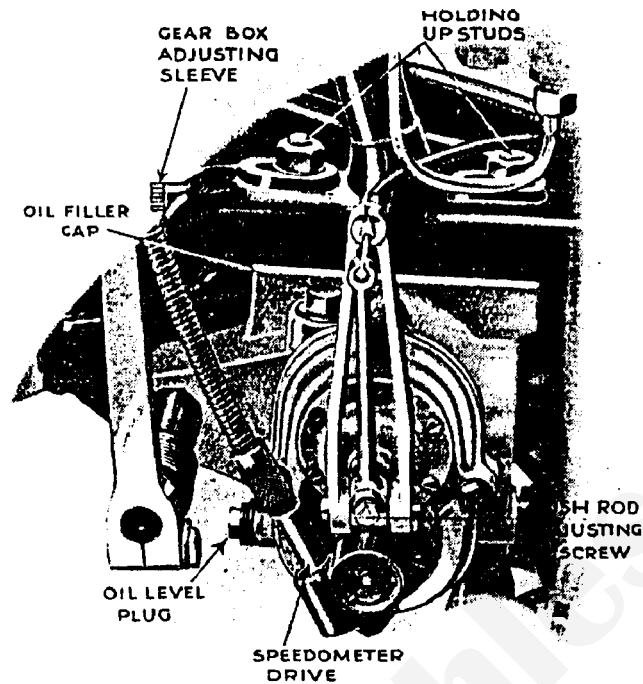

Illustration 18.

THE A.J.S. GEAR BOX.

Lubrication.—The gear box needs no attention whatever with the exception of replenishing with oil every 500 to 800 miles. Oil as used for the engine is suitable, but a very thick oil such as Castrolase "G" is most suitable.

An oil level indicator is provided in the form of a plug on the left hand side of the gear box, looking at it from the front. When pouring in oil leave the plug out, and as soon as oil begins to overflow, screw it in. This is the correct level and no more oil need be inserted.

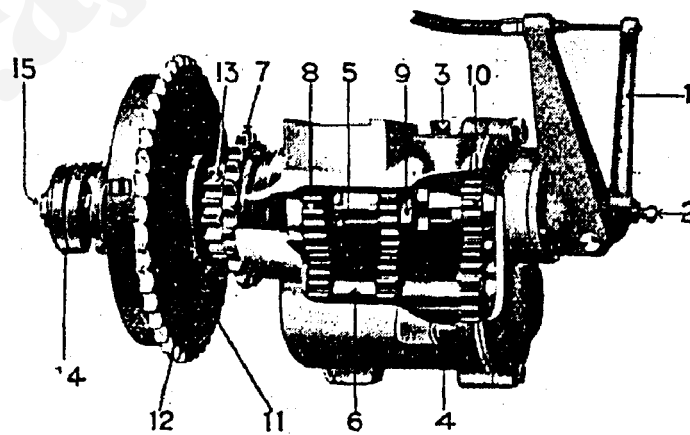

Illustration 19.

SECTIONAL VIEW OF GEAR BOX AS FITTED TO
9.96 H.P. AND 4.98 H.P. MODELS.

GEAR BOX.—Continued.

1. Clutch Operating Lever.
2. Push Rod Adjusting Screw.
3. Oil Filler Cap.
4. Oil Level Plug.
5. Main or Primary Shaft.
6. Lay or Secondary Shaft.
7. Sprocket, transmitting drive to road wheel.
8. High Gear Dog Wheel.
9. Sliding Sleeve.
10. Low Gear Dog Wheel.
11. Fixed Plate.
12. Clutch Sprocket, receiving drive from Engine.
13. Footstarter Ratchet Wheel.
14. Clutch Spring Adjusting Nut.
15. Clutch Spring.

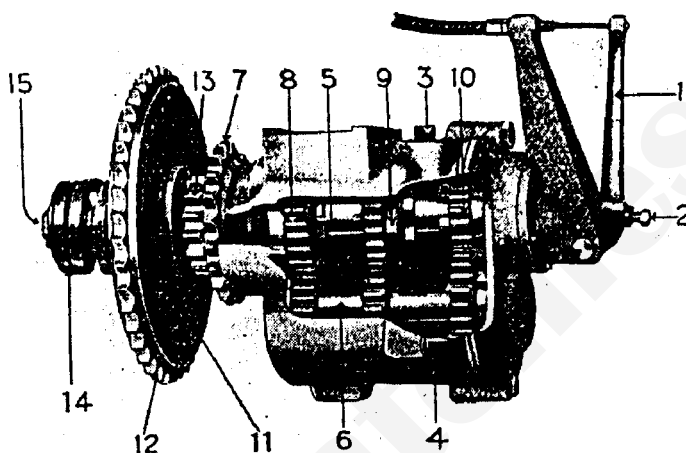

Illustration 20.

SECTIONAL VIEW OF GEAR BOX AS FITTED TO
3.49 H.P. AND 2.48 H.P. MODELS.

The descriptions corresponding to the various parts numbers are the same as in the case of Gear Box Illustration 19.

To dismantle the box the following procedure must be carried out :—

First disconnect the speedometer drive (fitted to all Models except M5 and M12) by unscrewing the lock ring of the cable at the gear box end. Next detach the Bowden cable from the clutch operating lever on gear box. To do this press the lever inwards sufficiently to allow the nipple of the cable to be slipped out of the slotted end. Next unscrew the six small pins round the cap which hold this to the gear box cover. The clutch operating mechanism can now be taken off entirely. Take care when doing this not to lose the short push rod. It will be found that on the end of the main shaft a thrust lock nut is fitted. This has a left-hand thread, and the punch provided in the tool kit should be employed to unfasten it. An arrow will be found on this nut pointing towards the right; this is the direction in which the nut must be unscrewed. Behind this will be found the ball thrust nut; remove this and the thrust washer. To take this out push the main shaft a little so as to allow the washer to be withdrawn. Now take out all bolts round the cover of the box and pull the cover off. The low gear dog wheel and lay shaft can then be taken out, also the sliding sleeve. The main shaft, complete with clutch, etc., can be drawn out from the opposite side of the box. To re-assemble simply reverse these operations.

N.B.—Be sure the Thrust Lock Nut is tight after replacing.

Do not forget to put fresh oil in the box after dismantling.

CLUTCH.

Adjustment.—If the clutch should slip when climbing steep hills, tighten up the clutch spring a little by means of the adjusting nut on the end of the clutch shaft, and adjust the Bowden cable until there is a little play in the lever. Do not tighten up the spring more than necessary to obtain a perfect grip, or unnecessary strain will be put on the Bowden control, etc., when the clutch is disengaged.

Do not put oil into the clutch under any circumstances.

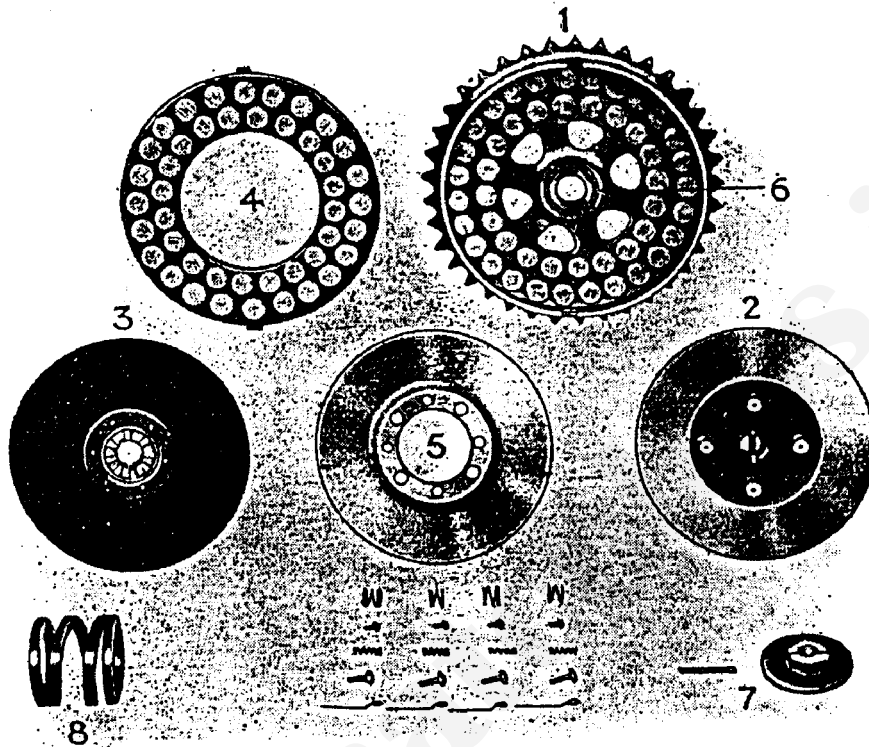

Illustration 21.

A.J.S. 7.99 H.P. AND 4.98 H.P. CLUTCH PARTS.

1. Clutch Sprocket fitted with Cork Inserts.
2. Sliding Plate (note key in centre which passes through gear box Main Shaft).
3. Fixed Plate.
4. Floating Plate, driven by No. 1.
5. Dished Plate with Adjusting Pins and Locking Device, driven by No. 2.
6. Ball Bearing on which No. 1 revolves when Clutch is disengaged.
7. Clutch Spring Adjusting Nut and Cotter Pin.
8. Clutch Spring.

To take up excessive backlash in Bowden lever on handlebar, adjust by means of the operating shaft adjusting screw No. 2 (Illustrations 19 and 20). A further adjustment is also provided at the point where the Bowden cable passes through the bracket. However, always allow a little backlash in the lever, or the clutch spring cannot exert all its pressure on the plates. If the clutch slips without any external reason, take it apart and ascertain if any portion of its mechanism is fouling another, and so keeping the plates apart. If the key in boss of clutch plate No. 2 (Illustrations 21 and 22) should foul the end of the slot in shaft it would prevent the clutch engaging.

To Dismantle the Clutch.—For Models M1 and M2, take off the front cover of the chain case by unscrewing the two pins. The cover can then be removed (see Illustration 23).

The above also applies in the case of Models M8, M9 and M10, but in addition the brake rod will have to be detached by taking out the cotter pin of the front yoke end and moving this out of the way.

CLUTCH.—Continued.

In the case of Models M3, M4, M5, M6, M7 and M12, the chaincase complete will have to be detached as well as detaching the brake rod. It will be perfectly obvious where the chain guards are fixed to the machine in order to remove the pins for detaching the guard.

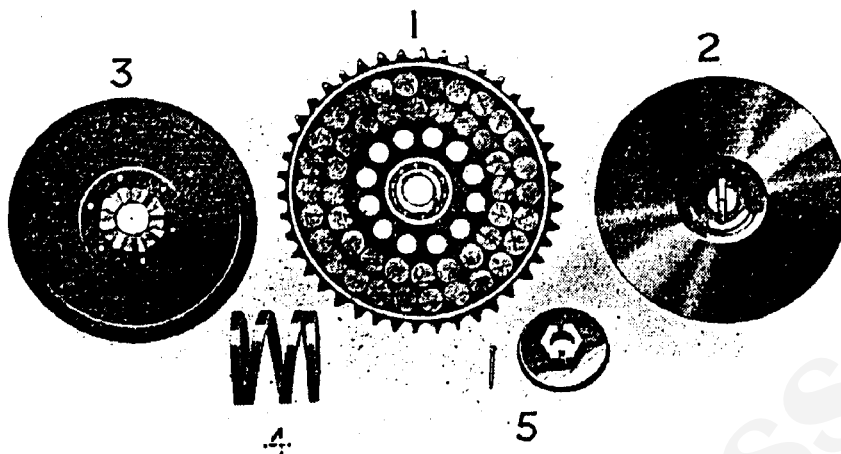

Illustration 22.

A.J.S. 3.49 H.P. AND 2.48 H.P. CLUTCH PARTS.

1. Clutch Sprocket with Cork Inserts.
2. Sliding Plate (note key in centre which passes through Gear Box Main Shaft).
3. Fixed Plate.
4. Clutch Spring.
5. Clutch Spring Adjusting Nut and Cotter Pin.

Now take out the split cotter which passes through the clutch spring adjusting nut No. 7 (Illustration 21) and No. 5 (Illustration 22) and remove the spring. This will allow the clutch plates to be drawn off the main shaft. Before replacing wipe the clutch plates clean and smear a thin film of oil on the portion of the shaft on which the outer plates slide. Also, before replacing, examine the lock nut which holds the fixed plate in position; if this is at all loose see that it is carefully tightened up again.

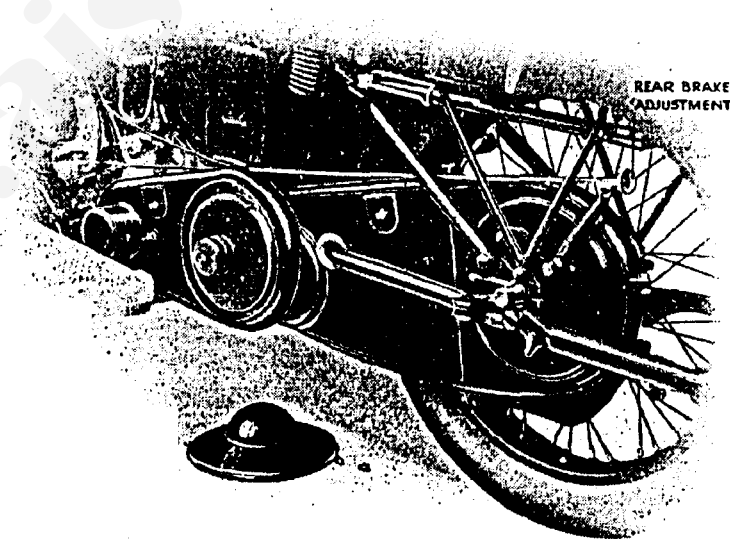

Illustration 23.

CHAIN CASE 9.96 H.P. MACHINE, SHOWING CLUTCH COVER REMOVED.

The 4.98 h.p. Models also have this detachable cover over the Clutch.

CLUTCH.—Continued.

It is of course necessary to take the chain off the clutch sprocket before this can be removed (see Illustration 27, page 28, for particulars of chain joint). It will be found that a flat key passes through a slot in the end of the clutch shaft, and fits in the boss of front or sliding plate. Great care must be taken to see that this key is in its proper position or the clutch cannot be disengaged. This key is clearly shewn in Fig. 2 (Illustrations 21 and 22), across the centre of the plate. To fit this key when re-assembling the clutch, turn the shaft till the slot is perfectly horizontal. Then put the key in slot with each end projecting equally on each side of the shaft. The sliding plate should then be slipped on shaft with its keyway in a corresponding horizontal position.

Difficulty in Disengaging Clutch.—If to disengage the clutch becomes difficult, smear a little oil on that portion of the shaft on which the outer plate slides.

If the clutch should "drag," even when fully disengaged, it will make gear changing very difficult, especially when changing down, for the reason that the drive is never properly taken off the gears, thus making it difficult to move the gear lever. This difficulty can be temporarily overcome by suddenly closing the throttle before changing down, immediately opening the throttle again after the change is made. The closing of the throttle takes the drive off the gears, and so allows easy disengagement. The cause of "drag" is usually that plate No. 5 (see Illustration 21) has too much lateral movement, and "follows up" the plate in front of it, when the clutch is disengaged.

Clutch Plate Adjustment.—Models M1, M2, M8, M9 and M10. If the clutch plates No. 1 and 3 are removed, it will be found that plate No. 5 is driven by four pegs on the sliding plate No. 2. There will also be seen four adjusting pins which are secured by a locking device consisting of four short lengths of spring wire, which fit into slots in the heads of the pins. The pins have two cross-cuts at right angles to each other, and the locking device wires are correctly



Illustration 24.

CLUTCH PLATE
ADJUSTMENT.

set when the clutch plates are assembled by us.

When the adjusting pins require attention, all that has to be done is to raise the spring wires out of their cross-cuts, and push on one side. If plate No. 4 has too much movement between plates 2 and 5, screw up the four adjusting pins until there is little or no movement, but be quite sure that plate No. 4 is free to revolve between plates 2 and 5. After adjustment see that the locking wires fit in the cross-cuts of the adjusting screws.

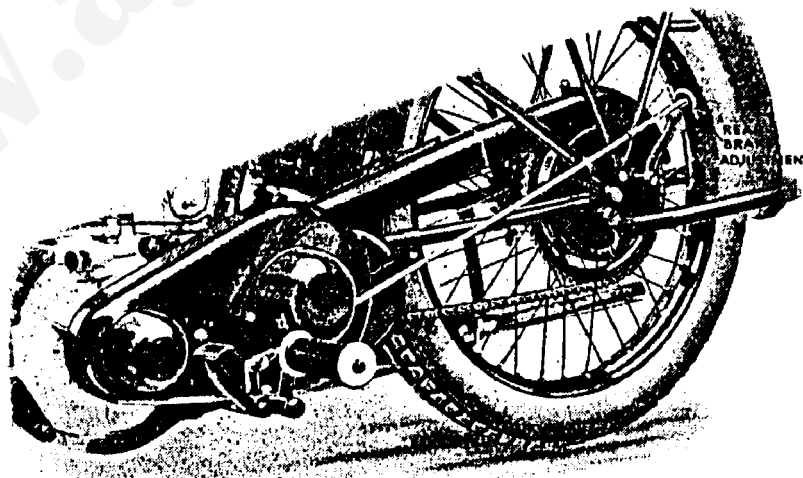

Illustration 25.

CHAIN CASE, AS FITTED TO 3.49 H.P. MODELS.

CARE OF CHAINS.

In the case of the 9.96 h.p. machines the chain drive is totally enclosed in weather-proof case. The top, bottom and back portion of the chain case can be detached independently, also a part of the front can be removed to expose the clutch (see Illustration 23). The rear part of the case is divided both horizontally and vertically. To remove the rear part unfasten the set pin which bolts together the top and bottom halves of the horizontal division, also unscrew similar pins holding the vertical division. Next take out the two small bolts which will be found to pass through slots cut in the rear part of the chain case. These bolts screw into the anchor plate and must be removed entirely to allow the rear of the case to come away. Having done this the case end can now be withdrawn. To remove the whole of the lower half of the chain case carry out the same operations as detailed above, but in addition, take off the nut on the end of the left hand rear foot-board rod and push rod through the lug of crankcase, just sufficient to allow the chain case to drop away. The front portion previously alluded to is readily removed by partly slacking off the small screws round its outer edge. Also, after these portions have been removed, the top half is quickly detached by simply taking off the nut on the end of the distance bolt which projects from the crankcase of engine through the chain case.

On the 2.48 h.p., 3.49 h.p. and 4.98 h.p. machines the chains are only partly enclosed, therefore it is a good plan to make a point of oiling the chains every day before starting out. One oiling will suffice for a day's riding whatever mileage is done. An oil gun is the best means of oiling the chains. With this instrument draw a charge of oil and insert spout of oiler into the chain case oil plug hole, which will be found on top of front of chain case above the front chain. Lift the exhaust valve and while pressing down plunger of oil gun, slowly turn the engine round with the foot-starter, taking care that the oil from the oil gun is falling on the chain. This ensures the whole chain being well lubricated. Treat the back chain in the same way by slowly revolving the back wheel.

Long life, less need of adjustment, and complete satisfaction with the transmission is assured if the rider will make a point of oiling his chains frequently, to say nothing of the knowledge that they are regularly having a supply of fresh clean oil.

CHAIN REPAIRS.

A chain hardly ever breaks if properly adjusted, since it is usually worn out long before the breaking point is arrived at.

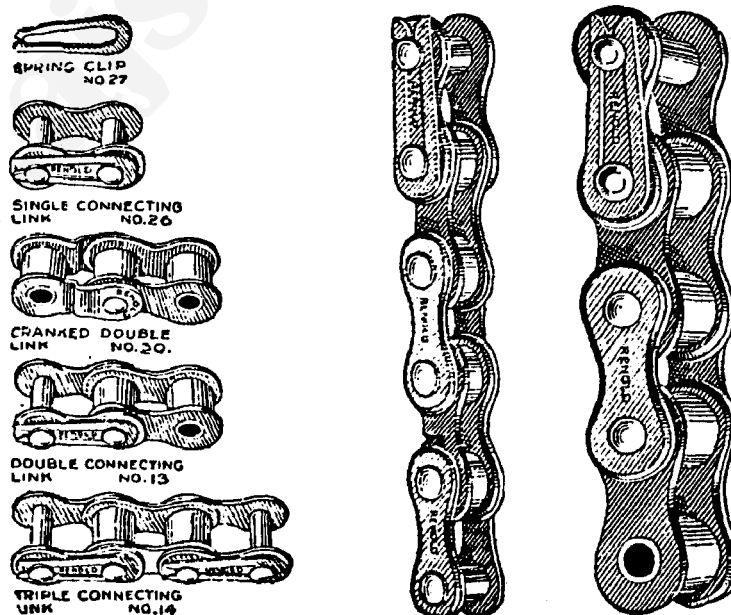

Illustration 27.

CHAIN REPAIR PARTS.

SPRING FORK ADJUSTMENT.

To take up any play which may have developed in the side links, unscrew the spindle lock nuts on the right hand side of the forks (looking at the machine from the front (see Illustration 29), and turn the spindles by means of the heads on the left-hand side until all slackness is taken up. Afterwards tighten up lock nuts.

REAR WHEEL ADJUSTMENT GAUGE.

On the right-hand side of the bottom chain stay will be found a piece of sheet metal, held in position by a clip which passes round the tube.

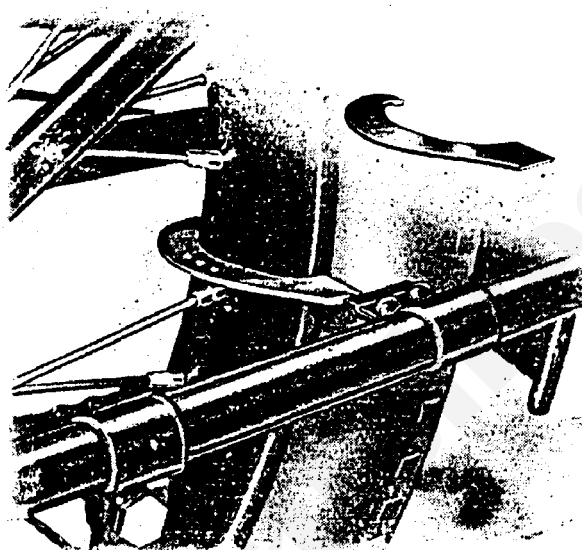

Illustration 30.

REAR WHEEL ADJUSTMENT GAUGE.

In the tool kit will be found a flat gauge that can be fitted round the rim (see Illustration 30). When replacing the rear wheel after removal, or after making adjustment to chain, place the gauge on the rim with the extension to the right, and set the wheel so that the edge of the gauge just touches the plate that is held by the clip on the chain stay. This ensures the wheel being correctly aligned and must be done before finally tightening up the spindle nuts. Do not attempt to unscrew the clip from the chain stay, as the position of the plate is set correctly before the machine leaves the factory.

It is important that this gauge should bed properly on to the rim on both sides ; the best method of ensuring this being to see that the hooked end is properly encircling the bead of the rim. Then pull the gauge end into place firmly.

DETACHABLE WHEELS.

With the exception of Models M7, M10 and M12, all A.J.S. Machines are fitted with quick detachable rear wheels, and in the case of Models M1 and M2 the front wheel also is quick detachable and interchangeable.

To remove proceed as follows.—Put the machine on the stand and with the box spanner provided *first unscrew the three sleeve nuts which pass through the hub flanges.* To prevent the wheel revolving while unscrewing the sleeve nuts, place foot against the tyre at bottom of wheel or the change speed lever can be placed in gear. The three sleeve nuts extend right through the wheel and near hub flange, and screw on to the three

DETACHABLE WHEELS.—Continued.

spring link, and unscrew the brake drum anchor pin which projects into slot of brake anchor plate, sufficient to clear. The wheel will then fall out of slots in fork-ends. The above remarks apply also for the removal of the rear wheel of Models M7, M10 and M12.

When the wheel is replaced, see that the brake anchor pin is screwed into the slot in anchor plate and spindle nuts are tight.

All wheels are disc-adjusting. Don't let the hubs run loosely, but take care that they are not adjusted too tightly.

This is a common cause of broken balls and cracked ball races. When properly adjusted, the weight of tyre valve should revolve the wheel if placed above the centre of wheel. At the same time the wheel should have no shake.

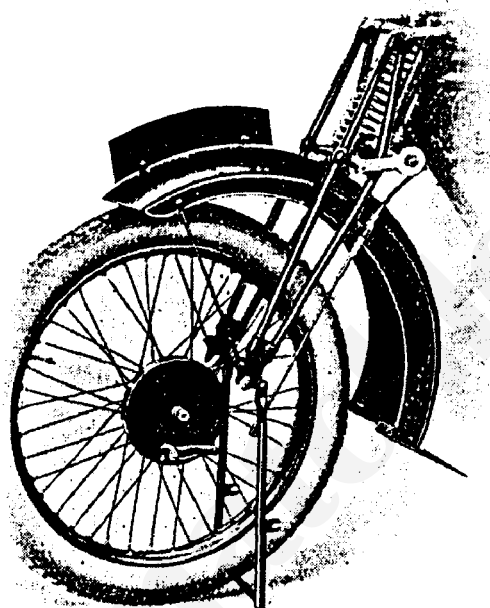

Illustration 32.

HOW THE FRONT WHEEL IS REMOVED ON ALL MODELS EXCEPT M1 AND M2.

All hubs before leaving the factory are packed with sufficient grease to last approximately two to three thousand miles. They should then be dismantled, thoroughly cleaned and replenished with Price's Hub Lubricant "Stiff" or other suitable grease.

When replacing the chain, it will facilitate the fitting of spring link if the ends of the chain are encircling an equal portion of the sprocket. This also applies to removing the spring link.

As previously mentioned, the front wheel of Model M1 and M2 being interchangeable with the back, the same system of attachment is provided, that is, three sleeve nuts and a centre pin. These are taken out in precisely the same way as in the case of the rear, when the wheel can be drawn off the driving studs on the brake drum. If the front wheel is to be removed, always place the machine on the rear stand before raising the front wheel on to its stand, or the machine may roll forward and damage the forks.

To remove Front Wheel.—Models M3, M4, M5, M6, M7, M8, M9, M10 and M12. Disconnect the yoke end of the brake operating rod from the lever, remove anchor plate bolt from fork-end, and after slackening off spindle nuts on either side, the wheel will then fall out of the slots in forks ends.

When the wheel is replaced, see that the brake anchor pin is screwed into the slot in anchor plate and spindle nuts are tight.

BRAKE ADJUSTMENT.

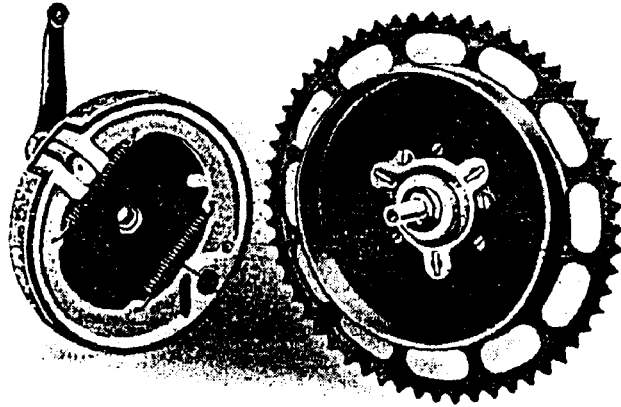

Illustration 33.

INTERNAL EXPANDING REAR BRAKE.

The brakes of A.J.S. machines require no attention with the exception of occasional adjustment of the control mechanism. In the case of the rear brake this is effected by giving a few turns to the adjusting disc, turning to the right to take up slack and vice versa. The front is carried out in the same manner.

GENERAL.

Remember you have a bicycle as well as a power plant. Frequently with the grease gun lubricate the links of spring fork and any little moving parts about the machine, such as brake shackles, Bowden levers, joints of control rods, change speed lever, gear box, clutch lever, etc. Lubricator nipples are fitted to all important moving parts. An oil gun is a most useful accessory. A charge of oil can be drawn out of the oil tank and used for lubricating every part of the machine. If a sidecar is fitted, don't forget to lubricate the spring shackles, etc., if squeaks are to be avoided. If the leaves of the springs creak or squeak, separate them by inserting the end of a screwdriver, and force oil between with the oil gun.

Keep the machine clean. If mud, etc., is allowed to accumulate, it will work into bearings, especially the hubs, and cause undue wear. Do not wash the machine down with a hose pipe. By so doing it is easy to get water into the petrol tank or carburettor, and cause trouble. Remove mud by means of a sponge and a bucket of water.

Pack tools tightly in the tool case with cleaning cloths, and so prevent them rattling about. Treat spare parts the same, or better still, carry tools and spare parts in the locker of sidecar where they will not be subjected to such punishment as when packed in the pannier bag on carrier. The pannier bags can be used for carrying spare tubes if they are carefully and tightly packed, but it means certain destruction if they are not.

Keep the back tyre fully inflated, but not board hard. It is not necessary to have the front tyre inflated as hard as the back.

Do not test the compression of your engine by standing on the footstarter pedal. Put the machine on the rear stand, place the gear lever in "top" position, and pull the rear wheel over by hand.

Any further information required we shall only be too happy to give if communicated with direct, but it will save unnecessary correspondence if our patrons will ascertain first that the information is not already given in this booklet.

SIDECAR HINTS—Continued.

The old saying "the race is not always to the swift," is very true, when applied to motoring. The careful driver who keeps up a consistent reasonable speed is usually much more certain of reaching his destination, not only in good time, but in comfort and safety.

As a last word on sidecars, we would earnestly advise our friends to order the complete combination (if this has not already been done), and not fit one of the ultra cheap sidecars with which the market is flooded (some of the expensive ones are very badly designed). They not only give continual trouble but in some cases are positively dangerous. However reliable the motor cycle may be, a sidecar which is always giving trouble spoils the whole combination.

HINTS AND TIPS FOR HILL CLIMBS AND SPEED EVENTS.

As regards Hill Climbs, it is very difficult to give any definite information regarding gear ratios, as everything depends upon the steepness of the hill, but a 19 tooth sprocket on the engine shaft will suit the average hill, but if the hill be fairly steep, an 18 tooth sprocket on the engine shaft would be faster, and as a rule in a hill climb it is better to gear too low than too high. Deciding on a suitable gear for any particular hill can only come from experience. Where the rider is continually competing in hill climb events, it is a great advantage to have different engine sprockets with a chain for each gear, so that an alteration in the gear ratio can be effected with the minimum of trouble. For 3.49 h.p. machines we advise from 18 tooth to 22 tooth and for 4.98 h.p. machines from 16 tooth to 20 tooth.

Lubricating Oil. For racing, the oil we use and recommend is Wakefield Castrol "R," other first-class oils are Shell Super Heavy Oil, Mobilol "D," or Price's Motorine "B" de Luxe.

Fuel. In the case of the "M6" models, we have found an advantage by using a mixture of first-class Petrol and Benzole in equal proportions, and possibly some little advantage would be derived from this mixture on the other models. There are now several mixtures of motor spirit on the market, some containing alcohol, but we are not in a position to give any advice on these fuels—it is all a matter for individual experiment.

Sparking Plugs. A high-class plug is absolutely essential. There are many good plugs on the market, particularly the K.L.G., Type 341. A cheap unsuitable plug usually causes pre-ignition, giving symptoms of the engine apparently seizing up. The engine suddenly falling off in power, as though a piston seizure is taking place, is usually caused by an unsuitable plug.

Carburettor. To get maximum power fit a jet large enough to give a correct mixture with the throttle and air levers wide open. The jet, large enough to give best results with full throttle and full air, would probably cause erratic running at slow speeds, but in speed events and hill climbs one is more concerned with high speeds than slow speeds.