

aprilia

1199 4

00/2004-06

Engines 3AS - 4AS

www.serviceaprilia.com

workshop manual



8140787

INTRODUCTION

0

SUMMARY

0.1. INTRODUCTION 3
0.1.1. INTRODUCTION 3
0.1.2. REFERENCE MANUALS 4
0.1.3. ABBREVIATIONS/SYMBOLS/CONVENTIONS 5

0.1. INTRODUCTION

0.1.1. INTRODUCTION

- This manual provides the information required for normal servicing.
- This publication is intended for use by **aprilia** dealerships and their qualified mechanics; many concepts have been omitted inasmuch as their inclusion would be superfluous for such an audience. Since complete mechanical explanations have not been included in this manual, the reader must be familiar with basic notions of mechanics, as well as with basic repair procedures. Without such familiarity, repairs and checks could be ineffective and even hazardous. Since the repair and vehicle check instructions are not exhaustive, special care must be taken to avoid damage and injury. To ensure maximum customer satisfaction with the vehicle, **aprilia spa** continuously improves its products and their documentation. The main technical modifications and changes in repair procedures are communicated to all **aprilia** dealerships and agencies worldwide. Such modifications will be entered in subsequent editions of the manual. In case of doubt regarding specific repairs or checks, contact the **aprilia** SERVICE DEPARTMENT; we will be pleased to provide all necessary information and assistance as well as keeping you updated on changes and modifications to the vehicle.

aprilia s.p.a. reserves the right to make changes to its products at any time, barring any such changes as may alter the essential features of a product as specified in the relevant manual.

All rights of storage using electronic means, reproduction and total or partial adaptation, whatever the means adopted, are reserved in all countries.

The mention of third parties' products is only made for information purposes, and constitutes no engagement.

aprilia spa is not liable in any way for the performance or use of its products.

For more details see (REFERENCE MANUALS).

First edition: June 2004

Designed and printed by:

DECA srl

via Risorgimento, 23/1 - 48022 Lugo (RA) - Italy

Tel. +39 - 0545 35235

Fax +39 - 0545 32844

E-mail: deca@decaweb.it

www.decaweb.it

On behalf of:

aprilia S.p.A.

Via G. Galilei, 1 – 30033 Noale (VE) – Italy

Tel. +39 – (0)41 58 29 111

Fax +39 – (0)41 58 29 190

www.aprilia.com

www.serviceaprilia.com

0.1.2. REFERENCE MANUALS

ENGINE WORKSHOP MANUALS

aprilia part# (description)	
8140783 (1195)	I
8140786 (1198)	E
8140784 (1196)	F
8140785 (1197)	D
8140787 (1199)	UK
CD 8CM0051	I E F D UK

CYCLE PARTS WORKSHOP MANUALS

aprilia part# (description)	
8140778 (1190)	I
8140779 (1191)	E
8140780 (1192)	F
8140781 (1193)	D
8140782 (1194)	UK
CD 8CM0062	I E F D UK

PARTS CATALOGUES

aprilia part# (description)	
6572 rel 02	I F D E UK

SPECIAL TOOLS CATALOGUES

aprilia part# (description)	
001E01	I F D E UK

0.1.3. ABBREVIATIONS/SYMBOLS/CONVENTIONS

#	= number
<	= less than
>	= greater than
≤	= less than or equal to
≥	= more than or equal to
~	= approximately
∞	= infinity
°C	= degrees Celsius (centigrade)
°F	= degrees Fahrenheit
±	= plus or minus
AC	= alternating current
A	= Ampere
Ah	=Ampere per hour
API	= American Petroleum Institute
HV	= high voltage
AV/DC	= Anti-Vibration Double Countershaft
bar	= pressure measurement (1 bar =100 kPa)
DC.	= Direct Current
cc	= cubic centimetres
CO	= carbon monoxide
CPU	= Central Processing Unit
DIN	= German industrial standards (Deutsche Industrie Norm)
DOHC	= Double Overhead Camshaft
ECU	= Electronic Control Unit
rpm	= revolutions per minute
HC	= unburnt hydrocarbons
ISC	= Idle Speed Control
ISO	= International Standardization Organization
Kg	= kilograms
Kgm	= kilogram metre (1 kgm =10 Nm)
km	= kilometres
kph	= kilometres per hour
kΩ	= kilo Ohm
kPa	= kiloPascal (1 kPa =0.01 bar)
KS	= clutch side (from the German "Kupplungseite")
kW	= kiloWatt
/	= litres
LAP	= racetrack lap
LED	= Light Emitting Diode
LEFT	
SIDE	= left side
m/s	= metres per second
max	= maximum
mbar	= millibar (1 mbar =0.1 kPa)
mi	= miles
MIN	= minimum
MPH	= miles per hour
MS	= flywheel side (from the German "Magnetoseite")
MΩ	= megaOhm
N.A.	= Not Available
N.O.M.M.	= Motor Octane Number
N.O.R.M.	= Research Octane Number
Nm	= Newton metre (1 Nm =0.1 kgm)
Ω	= ohm
PICK-UP	= pick-up
BDC	= Bottom Dead Centre
TDC	= Top Dead Centre
PPC	= Pneumatic Power Clutch

RIGHT	
SIDE	= right side
SAE	= Society of Automotive Engineers
TEST	= diagnostic check
T.B.E.I.	= crown-head Allen screw
T.C.E.I.	= cheese-head Allen screw
T.E.	=hexagonal head
TP	= flat head screw
TSI	= Twin Spark Ignition
UPSIDE-	
DOWN	= inverted fork
V	= Volt
W	= Watt
Ø	= Diameter

GENERAL INFORMATION

1

SUMMARY



1.1.	STRUCTURE OF THE MANUAL.....	3
1.1.1.	CONVENTIONS USED IN THE MANUAL	3
1.1.2.	SAFETY WARNINGS.....	4
1.2.	GENERAL RULES.....	5
1.2.1.	BASIC SAFETY RULES.....	5
1.3.	DANGEROUS ELEMENTS	8
1.3.1.	WARNINGS	8
1.4.	RUNNING-IN	12
1.4.1.	RUNNING-IN RECOMMENDATIONS.....	12
1.5.	USING TOOLS AND SPARE PARTS.....	13
1.5.1.	SPARE PARTS	13
1.6.	SPECIFICATIONS	14
1.6.1.	TECHNICAL SPECIFICATIONS OF 4-STROKE 2-VALVE 250 CC ENGINE, LIQUID-COOLED.....	14
1.6.2.	TECHNICAL SPECIFICATIONS OF 4-STROKE 2-VALVE 300 CC ENGINE, LIQUID-COOLED.....	15
1.7.	PRODUCTS.....	16
1.7.1.	TABLE OF LUBRICANTS	16
1.8.	FASTENERS	17
1.8.1.	GENERAL TORQUE SPECIFICATIONS	17
1.8.2.	TIGHTENING TORQUE SETTINGS.....	18

1.1. STRUCTURE OF THE MANUAL



























1.1.1. CONVENTIONS USED IN THE MANUAL

- This manual is divided in sections and subsections, each covering a set of the most significant components. Refer to the index of sections when consulting the manual.
- Unless expressly specified otherwise, assemblies are reassembled by reversing the dismantling procedure.
- The terms "right" and "left" are referred to the rider seated on the vehicle in the normal riding position.
- Motorcycle operation and basic maintenance are covered in the «OWNER'S MANUAL».

In this manual any variants are identified with these symbols:

	optional
	catalytic version
-	all versions
MP	national certification
SF	European certification (EURO 1 limits)

VERSION:

	Italy		Greece		Malaysia
	United Kingdom		Holland		Chile
	Austria		Switzerland		Croatia
	Portugal		Denmark		Australia
	Finland		Japan		United States of America
	Belgium		Singapore		Brazil
	Germany		Slovenia		South Africa
	France		Israel		New Zealand
	Spain		South Korea		Canada

1.1.2. SAFETY WARNINGS

The following precautionary warnings are used throughout this manual in order to convey the following messages:



Safety warning. This symbol appears, whether in the manual or on the vehicle itself, to indicate a personal injury hazard. Non-compliance with the indications given in the messages preceded by this symbol may result in grave risks for your and other people's safety and for the vehicle!

**WARNING**

Indicates a potential hazard which may result in serious injury or even death.

**CAUTION**

Indicates a potential hazard which may result in minor personal injury or damage to the vehicle.

IMPORTANT: The word "IMPORTANT" in this manual precedes important information or instructions

1.2. GENERAL RULES

1.2.1. BASIC SAFETY RULES

CARBON MONOXIDE

Should it be necessary to perform some operations with the vehicle running, make sure to work outdoors or in a well-aerated room.

Avoid starting the engine in closed or badly-ventilated rooms.

In case you are working indoors, make use of an exhaust gases scavenging system.



DANGER

Exhaust gases contain carbon monoxide, which is extremely toxic if inhaled and may cause loss of consciousness or even lead to death by asphyxia.

FUEL



DANGER

The fuel used to operate engines is highly flammable and becomes explosive under particular conditions. Refuelling and engine service should take place in a well-ventilated area with the engine stopped. Do not smoke when refuelling or in the proximity of sources of fuel vapours, avoid flames, sparks and any element that could ignite fuel or provoke explosions.

DO NOT DISPOSE OF FUEL IN THE ENVIRONMENT.

KEEP AWAY FROM CHILDREN.

HIGH-TEMPERATURE COMPONENTS

The engine and the exhaust system parts become hot and continue to be hot even for some time after the engine has been stopped.

Before handling these parts, wear insulating gloves or wait for the engine and the exhaust system to cool completely down.

USED GEARBOX AND FORK OILS



DANGER

In case any maintenance operation should be required, it is advisable to use latex gloves.

Gear oil may cause serious damage to the skin if handled daily and for long periods.

Wash your hands carefully after use.

Put it in a sealed container and take it to the filling station where you usually buy it or to an oil salvage center.

In case any maintenance operation should be required, it is advisable to use latex gloves.

DO NOT DISPOSE OF OIL IN THE ENVIRONMENT

KEEP AWAY FROM CHILDREN.

BRAKE FLUID



WARNING

When using the brake fluid, take care not to spill it on the plastic, rubber or painted parts, since it can damage them.

When carrying out the maintenance operations on the braking system, use a clean cloth to cover these parts.

Always wear safety goggles when working on the braking system.

The brake fluid is highly irritant. Avoid contact with your eyes.

If the brake fluid gets in contact with the skin or the eyes, carefully wash the parts of your body that get in contact with the fluid and consult a doctor.

KEEP AWAY FROM CHILDREN.

COOLANT

The coolant is composed of ethylene glycol that, under certain conditions, can become inflammable and send out invisible flames causing severe burns.

**DANGER**

Be careful not to spill the coolant on the red-hot parts of the engine and the exhaust system: it may catch fire and send out invisible flames.

In case any maintenance operation should be required, it is advisable to use latex gloves.

Even if toxic, coolant has a sweet flavour. Never leave it inside open containers or within the reach of animals to prevent the risk of drinking.

KEEP AWAY FROM CHILDREN.

Do not remove the radiator plug when the engine is hot. The coolant is under pressure and could cause severe burns.

HYDROGEN GAS AND BATTERY ELECTROLYTE**DANGER**

The battery electrolyte is a toxic, caustic substance containing sulphuric acid and thus able to cause severe burns in case of contact.

Always wear tight gloves and protective clothes when handling this fluid.

If the electrolyte gets in contact with the skin, carefully wash the parts of your body that get in contact with the fluid with abundant fresh water.

Always use a protection for your eyes since also a very small amount of the battery fluid can cause blindness. In the event of contact with your eyes, carefully wash them with water for fifteen minutes and then consult immediately an eye specialist.

Should you accidentally drink some fluid, drink abundant water or milk, then drink magnesia milk or vegetable oil and consult immediately a doctor. Battery releases explosive gases. Keep flames, sparks, cigarettes and any other heat source away from the battery. Make sure the room is well-aerated when servicing or recharging the battery.

KEEP AWAY FROM CHILDREN.

The battery fluid is corrosive

Do not pour it on the plastic parts.

Make sure that the electrolyte acid is suitable for the type of battery used.

GENERAL PRECAUTIONS AND INFORMATION

Follow these instructions closely when repairing, disassembling or reassembling the motorcycle or its components.

**DANGER**

Using bare flames is strictly forbidden when working on the motorcycle. Before servicing or inspecting the motorcycle: stop the engine and remove the key from the ignition switch; allow for the engine and exhaust system to cool down; where possible, lift the motorcycle using adequate equipment placed on firm and level ground. Be careful of any parts of the engine or exhaust system which may still be hot to the touch to avoid scalds or burns.

Never put any mechanical parts or other vehicle components in your mouth when you have both hands busy. None of the motorcycle components is edible. Some components are harmful to the human body or toxic.

Unless expressly specified otherwise, motorcycle assemblies are refitted or re-assembled by reversing the removal or dismantling procedure. Where a procedure is cross-referred to relevant sections in the manual, proceed sensibly to avoid disturbing any parts unless strictly necessary. Never attempt to polish matte-finished surfaces with lapping compounds.

Never use fuel instead of solvent to clean the motorcycle.

Do not clean any rubber or plastic parts or the seat with alcohol, petrol or solvents. Clean with water and neutral detergent.

Always disconnect the battery negative (-) lead before soldering any electrical components.

When two or more persons service the same motorcycle together, special care must be taken to avoid personal injury.

BEFORE DISASSEMBLING ANY COMPONENTS

Clean off all dirt, mud, and dust and clear any foreign objects from the vehicle before disassembling any components.

Use the model-specific special tools where specified.

DISASSEMBLING THE COMPONENTS

- Never use pliers or similar tools to slacken and/or tighten nuts and bolts. Always use a suitable spanner.
- Mark all connections (hoses, wiring, etc.) with their positions before disconnecting them. Identify each connection using a distinctive symbol or convention.
- Mark each part clearly to avoid confusion when refitting.
- Thoroughly clean and wash any components you have removed using a detergent with low flash point.
- Mated parts should always be refitted together. These parts will have seated themselves against one another in service as a result of normal wear and tear and should never be mixed up with other similar parts on refitting.
- Certain components are matched-pair parts and should always be replaced as a set.
- Keep the motorcycle and its components well away from heat sources.

REASSEMBLING THE COMPONENTS**DANGER**

Never reuse a circlip or snap ring. These parts must always be renewed once they have been disturbed. When fitting a new circlip or snap ring, take care to move the open ends apart just enough to allow fitment to the shaft.

Make a rule to check that a newly-fitted circlip or snap ring has located fully into its groove.

Never clean a bearing with compressed air.

NOTE All bearings must rotate freely with no hardness or noise. Replace any bearings that do not meet these requirements.

- Use ORIGINAL **aprilia** SPARE PARTS only.
- Use the specified lubricants and consumables.
- Where possible, lubricate a part before assembly.
- When tightening nuts and bolts, start with the largest or innermost nut/bolt and observe a cross pattern. Tighten evenly in subsequent steps until achieving the specified torque.
- Replace any self-locking nuts, gaskets, seals, circlips or snap rings, O-rings, split pins, bolts and screws which have a damaged thread.
- Lubricate the bearings abundantly before assembly.
- Make a rule to check that all components you have fitted are correctly in place.
- After repairing the motorcycle and after each service inspection, perform the preliminary checks, and then operate the motorcycle in a private estate area or in a safe area away from traffic.
- Clean all joint surfaces, oil seal edges and gaskets before assembly. Apply a light coat of lithium grease along the edges of oil seals. Fit oil seals and bearings with the marking or serial number facing outwards (in view).

ELECTRICAL CONNECTORS

To disconnect the electrical connector, follow the procedures below. Failure to comply with these procedures may lead to irreparable damages to the connector and the wiring as well. If present, press the special safety hooks.

**WARNING**

Do not pull cables to disconnect the two connectors.

- Grasp the two connectors and disconnect them by pulling them in the two opposite directions.
- In case of dirt, rust, moisture, etc., thoroughly clean the inside of the connectors with compressed air.
- Make sure that the cables are correctly fitted inside the connectors terminals.

NOTE The two connectors have just one correct positioning. Make sure to position them in the right direction.

- Then fit the two connectors. Make sure they are correctly coupled (a click will be heard).

TIGHTENING TORQUE SETTINGS**DANGER**

Always remember that the tightening torque settings of all wheel, brake, wheel shaft and other suspension parts play a fundamental role to ensure vehicle safety. Make sure that these values are always within the specified limits.

Check fastening parts tightening torque settings at regular intervals. Upon reassembly, always use a torque wrench.

Failure to comply with these recommendations could lead to the loosening and detachment of one of these parts with a consequent locking of the wheel or other serious troubles affecting the vehicle maneuverability, and thus the risk of falls and serious injuries or death.

1.3. DANGEROUS ELEMENTS

1.3.1. WARNINGS

FUEL

**DANGER**

The fuel used to operate engines is highly flammable and becomes explosive under particular conditions.

Refuelling and engine service should take place in a well-ventilated area with the engine stopped. Do not smoke when refuelling or in the proximity of sources of fuel vapours. Avoid contact with bare flames, sources of sparks or any other source which may ignite the fuel or lead to explosion.

Take care not to spill fuel out of the filler, or it may ignite when in contact with hot engine parts. In the event of accidental fuel spillage, make sure the affected area is fully dry before starting the engine. Fuel expands from heat and when left under direct sunlight.

Never fill the fuel tank up to the rim. Tighten the filler cap securely after each refuelling.

Avoid contact with skin. Do not inhale vapours. Do not swallow fuel. Do not transfer fuel between different containers using a hose.

DO NOT RELEASE FUEL INTO THE ENVIRONMENT.

KEEP AWAY FROM CHILDREN.

Use only premium grade unleaded petrol, min. O.N. 95 (N.O.R.M.) and 85 (N.O.M.M.).

LUBRICANTS

**DANGER**

A good lubrication ensures the vehicle safety.

Failure to keep the lubricants at the recommended level or the use of a non-suitable new and clean type of lubricant can lead to the engine or gearbox seizure, thus leading to serious accidents, personal injury or even death.

Gear oil may cause serious damage to the skin if handled daily and for long periods.

Wash your hands carefully after use.

Do not dispose of oil into the environment.

Take it to the filling station where you usually buy it or to an oil salvage center.

**WARNING**

When filling the vehicle with this oil, take care not to spill it out since it could damage the vehicle paintwork.

In case of contact with oil, the tyres surface will become very slippery, thus becoming a serious danger for your safety.

In case of leaks, do not use the vehicle. Check and trace the cause of leaks and proceed to repair.

ENGINE OIL

**DANGER**

Prolonged or repeated contact with engine oil may cause severe skin damage.

Wash your hands thoroughly after handling engine oil.

Do not release into the environment.

Dispose of engine oil through the nearest waste oil reclamation firm or through the supplier.

Wear latex gloves during servicing

FRONT FORK FLUID

**DANGER**

Front suspension response can be modified to a certain extent by changing damping settings and/or selecting a particular grade of oil. Standard oil grade is SAE 20 W. Different oil grades can be selected to obtain a particular suspension response. (Choose SAE 5W for a softer suspension, 20W for a stiffer suspension).

The two grades can also be mixed in varying solutions to obtain the desired response.

BRAKE FLUID

NOTE This vehicle is fitted with front and rear disc brakes. Each braking system is operated by an independent hydraulic circuit. The information provided below applies to both braking systems.

**DANGER**

Do not use the vehicle in case brakes are worn out or do not work properly! The brakes are the parts that most ensure your safety and for this reason they must always be perfectly working. Failure to comply with these recommendations will probably lead to a crash or an accident, with a consequent risk of personal injury or death.

A wet surface reduces brakes efficiency.

**DANGER**

In case of wet ground the braking distance will be doubled, since both brakes and tyres drives on the road surface are extremely reduced by the water present on the road surface.

Any water on brakes, after washing the vehicle or driving on a wet road surface or crossing puddles or gips, can wet brakes so as to greatly reduce their efficiency.

Failure to comply with these recommendations may lead to serious accidents, with a consequent risk of severe personal injuries or death.

Brakes are critical safety components. Do not ride the vehicle in case brakes are not working at their best.

Check for brakes proper operation before every trip.

Brake fluid is an irritant. Avoid contact with eyes or skin.

In the event of accidental contact, wash affected body parts thoroughly. In the event of accidental contact with eyes, contact an eye specialist or seek medical advice.

DO NOT RELEASE BRAKE FLUID INTO THE ENVIRONMENT.KEEP AWAY FROM CHILDREN.

When handling brake fluid, take care not to spill it onto plastic or paint-finished parts or they will damage.

**DANGER**

Do not use any brake fluids other than the specified type. Never mix different types of fluids to top up level, as this will damage the braking system.

Do not use brake fluid from containers which have been kept open or in storage for long periods.

Any sudden changes in play or hardness in the brake levers are warning signs of problems with the hydraulic circuits.

Ensure that the brake discs and brake linings have not become contaminated with oil or grease. This is particularly important after servicing or inspections.

Make sure the brake lines are not twisted or worn.

Prevent accidental ingress of water or dust into the circuit.

Wear latex gloves when servicing the hydraulic circuit.

DISC BRAKES**DANGER**

The brakes are the parts that most ensure your safety and for this reason they must always be perfectly working; check them before every trip.

A dirty disc soils the pads.

Dirty pads must be replaced, while dirty discs must be cleaned with a high-quality degreaser.

Perform the maintenance operations with half the indicated frequency if the vehicle is used in rainy or dusty areas, on uneven surfaces or on racetracks.

When the disc pads wear out, the level of the fluid decreases to automatically compensate for their wear. The front brake fluid reservoir is located on the right handlebar, near the front brake lever.

The rear brake fluid reservoir is located under the right fairing.

Do not use the vehicle if the braking system leaks fluid.

COOLANT

**DANGER**

Coolant is toxic when ingested and is an irritant, contact with eyes or skin may cause irritation. In the event of contact with eyes, rinse repeatedly with abundant water and seek medical advice. In the event of ingestion, induce vomiting, rinse mouth and throat with abundant water and seek medical advice immediately.

**DO NOT RELEASE INTO THE ENVIRONMENT.
KEEP AWAY FROM CHILDREN.**

**DANGER**

Take care not to spill coolant onto hot engine parts. It may ignite and produce invisible flames. Wear latex gloves when servicing.

Do not ride when coolant is below the minimum level.

Coolant mixture is a 50% solution of water and anti-freeze. This is the ideal solution for most operating temperatures and provides good corrosion protection.

This solution is also suited to the warm season, as it is less prone to evaporative loss and will reduce the need for top-ups.

In addition, less water evaporation means fewer minerals salts depositing in the radiator, which helps preserve the efficiency of the cooling system.

When temperature drops below zero degrees centigrade, check the cooling system frequently and add more anti-freeze (up to 60% maximum) to the solution.

Use distilled water in the coolant mixture. Tap water will damage the engine.

Refer to the chart given below and add water with the quantity of anti-freeze to obtain a solution with the desired freezing point:

Freezing point °C (°F)	Coolant % of volume
-20° (- 4°)	35
-30° (- 22°)	45
-40° (- 40°)	55

NOTE Coolants have different specifications. The protection degree is written on the label.

**WARNING**

Use nitrate-free coolant only, with a protection until at least -35°C (-31°F).

DRIVE CHAIN

Check drive chain operation, slack and lubrication at regular intervals.

The vehicle is equipped with an endless chain with a joint link.

**WARNING**

If too slack, the chain can come off the front or rear sprockets thus leading to serious accidents and damage to the vehicle, with consequent serious personal injury or death.

Do not use the vehicle if the chain tension has not been correctly adjusted.

To check chain, take it with your hand where it turns on the rear sprocket and pull it as to separate it from the crown itself.

If you can move the chain apart of the front sprocket for more than 3 mm (0.125 in), change chain, crown and pinion.

**DANGER**

If not properly maintained, chain can early wear out and lead to the damage of both crown and pinion.

Perform chain maintenance operations more frequently if the vehicle is used on rainy or dusty areas.

TYRES

**WARNING**

If tyres are excessively inflated, the vehicle will be hard and uneasy to ride, thus making you feel not at your ease.

In addition the roadworthiness, mainly on wet surfaces and during cornering, will be impaired.

Flat tyres (insufficient pressure) can slip on the rim and make you lose the control of the vehicle.

In this case too, both vehicle roadworthiness, maneuverability and brake efficiency will be impaired.

Tyres changing, repair, maintenance and balancing must be carried out by specialized technicians using suitable equipment.

When new, tyres can have a thin slippery protective coating. Drive carefully for the first kilometers (miles). Never use rubber treating substances on tyres.

In particular, avoid contact with fluid fuels, leading to a rapid wear.

In case of contact with oil or fuel, do not clean but change tyres.

**DANGER**

Some of the factory-assembled tyres of this vehicle are provided with wear indicators.

There are several kinds of wear indicators.

For more information on how to check the wear, contact your Dealer.

Visually check if the tyres are worn and in this case have them changed.

If a tyre deflates while driving, stop immediately.

Avoid hard brakings or moves and do not close throttles too abruptly.

Slowly close throttle grip, move to the edge of the road and make use of the engine brake to slow down until coming to a halt.

Failure to comply with these recommendations can lead to serious accidents and consequent personal injuries or death.

Do not install tyres with air tube on rims for tubeless tyres and viceversa.

1.4. RUNNING-IN

1.4.1. RUNNING-IN RECOMMENDATIONS

The running-in of the engine is essential to ensure its duration and correct functioning.

If possible, drive on hilly roads and/or roads with many bends, so that the engine, the suspensions and the brakes undergo a more effective running-in.

During running-in, change speed.

In this way the components are first "loaded" and then "relieved" and the engine parts can thus cool down.

Even if it is important to stress the engine components during running-in, take care not to exceed.



WARNING

Only after the first 500 km (312 mi) of running-in you can expect the best performance levels from the vehicle.

Keep to the following indications:

- Do not open the throttle completely if the speed is low, both during and after the running-in.
- During the first 100 km (62 mi) pull the brakes with caution, avoiding sharp and prolonged brakings. This ensures a correct bedding-in of the pads on the brake disc.
- During the first 500 km (312 mi), never use the vehicle beyond 80% of the max. speed, do not fully open throttle and do not keep the vehicle at a constant speed for a long time.



WARNING

After the first 1000 km (621 mi), Dealer carry out the checks indicated in the column "After running-in", in order to avoid hurting yourself or other people and/or damaging the vehicle.

- After the first 1000 km (621 mi) you can expect better performance from the engine, however, without exceeding the maximum allowed

1.5. USING TOOLS AND SPARE PARTS

1.5.1. SPARE PARTS

Should some parts be replaced, use **aprilia** Original Spare Parts only.
aprilia high-quality Original Spare Parts have been expressly designed and manufactured for **aprilia** vehicles.

**WARNING**

The use of **aprilia** non-original spare parts can impair the vehicle performance or cause serious damage to the vehicle itself.

1.6. SPECIFICATIONS**1.6.1. TECHNICAL SPECIFICATIONS OF 4-STROKE 2-VALVE 250 CC ENGINE, LIQUID-COOLED****ENGINE**

Type	4-stroke 2-valve single-cylinder OHC engine
Bore	69.0 mm (2.716 in.)
Stroke	66.8 mm (2.630 in.)
Total displacement	249.78 cu cm (15.242 cu in)
Compression ratio	10 ± 0.5:1
Starting	Electric starter
Engine idling speed	1500 ± 100 rpm
Clutch	Automatic dry centrifugal clutch
Gearbox	Automatic
Lubricating system	Wet-sump, forced lubrication with mechanical pump; oil dipstick to check level
Cooling system	Liquid cooling, forced circulation through centrifugal pump
Valve clearances (from cold)	Intake: 0.08 – 0.12 mm (0.00315 – 0.0047 in.) Exhaust: 0.16 – 0.20 mm (0.006230 – 0.0078 in.)

TRANSMISSION SYSTEM

Converter	Stepless automatic converter
Primary	V belt
Final	Gears
Total engine/wheel ratio	Minimum 15.808 Maximum 5.539

CARBURETTOR

Model	TEI KEI 5GM1A
Throttle	Equivalent diameter 28 mm (1.1 in)

FUEL SYSTEM

Type	Vacuum pump
Fuel	Premium-grade unleaded petrol, minimum octane rating 91 (RON) and 81 (MON)

IGNITION

Type	C.D.I. / inductive
Spark advance	Minimum 10° at 1500 rpm Maximum 32° at 5000 rpm

SPARK PLUG

Standard	NGK DR8EA
Electrode gap	0.6 – 0.7 mm (0.02362 – 0.02755 in.)

CAPACITIES

Engine oil (change)	1200 cu cm (73.228 cu in)
Engine oil (change for engine overhaul)	1400 cu cm (85.433 cu in)
Gearbox oil	250 cu cm (15.255 cu in)
Coolant (50% water + 50% ethylene glycol anti-freeze)	1.3 litres (0.343 gallons)

1.6.2. TECHNICAL SPECIFICATIONS OF 4-STROKE 2-VALVE 300 CC ENGINE, LIQUID-COOLED

ENGINE

Type	4-stroke 2-valve single-cylinder OHC engine
Bore	71.0 mm (2.795 in.)
Stroke	66.8 mm (2.630 in.)
Total displacement	264.47 cu cm (16.139 cu in)
Compression ratio	10 : 1
Starting	Electric starter
Engine idling speed	1500 ± 100 rpm
Clutch	Automatic dry centrifugal clutch
Gearbox	Automatic
Lubricating system	Wet-sump, forced lubrication with mechanical pump; oil dipstick to check level
Cooling system	Liquid cooling, forced circulation through centrifugal pump
Valve clearances (from cold)	Intake: 0.08 – 0.12 mm (0.00315 – 0.0047 in.) Exhaust: 0.16 – 0.20 mm (0.006230 – 0.0078 in.)

TRANSMISSION SYSTEM

Converter	Stepless automatic converter
Primary	V belt
Final	Gears
Total engine/wheel ratio	Minimum 15.808 Maximum 5.539

CARBURETTOR

Model	TK 5SE
Throttle	28 mm (1.102 in.)

FUEL SYSTEM

Type	Vacuum pump
Fuel	Premium-grade unleaded petrol, minimum octane rating 91 (RON) and 81 (MON)

IGNITION

Type	4 AS-AP
Spark advance	Minimum 2° at 1500 rpm Maximum 32° at 8250 rpm

SPARK PLUG







Standard	NGK DR8EA
Electrode gap	0.6 – 0.7 mm (0.02362 – 0.027559 in.)

CAPACITIES

Engine oil (change)	1200 cu cm (73.228 cu in)
Engine oil (change for engine overhaul)	1400 cu cm (85.433 cu in)
Gearbox oil	250 cu cm (15.255 cu in)
Coolant (50% water + 50% ethylene glycol anti-freeze)	1.3 litres (0.343 gallons)

1.7. PRODUCTS

1.7.1. TABLE OF LUBRICANTS

LUBRICANT	PRODUCT
Engine oil	RECOMMENDED:  SUPERBIKE 4, SAE 5W – 40 or  Agip 4T FORMULA RACING, SAE 5W - 40. Alternatively, use brand name oil complying with or exceeding the CCMC G-4, A.P.I. SG specifications.
Transmission oil	RECOMMENDED:  F.C., SAE 75W - 90 or  Agip GEAR SYNTH, SAE 75W - 90. Alternatively, use brand name oil complying with or exceeding the API GL-4 specifications
Bearings and other lubrication points	RECOMMENDED:  AUTOGREASE MP.+  Agip GREASE SM2. As an alternative to recommended grease, use top brand rolling bearing grease that will resist a temperature range of -30°C...+140°C, with dropping point 150°C...230°C, high corrosion protection, good resistance to water and oxidation.
Battery poles	use neutral grease or vaseline.

1.8. FASTENERS

1.8.1. GENERAL TORQUE SPECIFICATIONS

Torque figure table for fasteners class 8.8, steel/aluminium or materials with similar strength.

Screw or bolt thread	Spanner	Tightening torque	
		Nm	kgm
M 4	7	3	0.3
M 5	8	6	0.6
M 6	10	10	1.0
M 8	12	25	2.5
M 10	14	50	5.0
M 12	17	80	8.0
M 14	19	135	13.5
M 16	22	210	21.0

Unless otherwise specified, torque figures are intended for application to clean, dry threads at room temperature.

CAUTION Follow the instructions below to avoid distortion and/or improper fit:

- Screw all fasteners finger-tight.
- Tighten fasteners in a cross pattern - (A) and (B); (C) and (D) - to half the specified torque.
- Repeat sequence tightening to specified torque.

CAUTION This way, the load generated by the fasteners is applied evenly across joint surface.

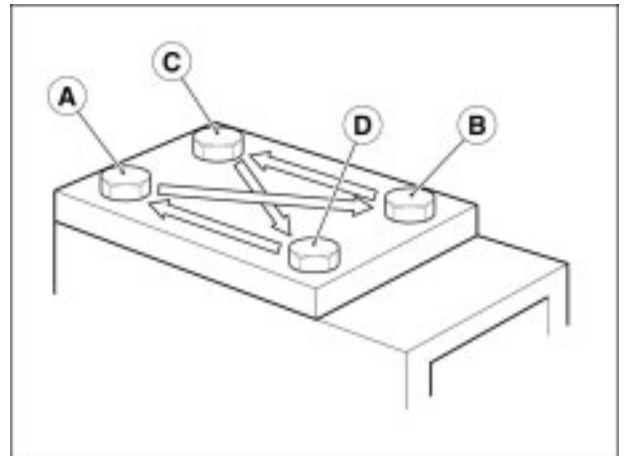

1.8.2. TIGHTENING TORQUE SETTINGS

DESCRIPTION		TIGHTENING TORQUE SETTINGS	
ENGINE			
TRANSMISSION SYSTEM		QTY	(Nm)
			(ft-lb)
Transmission cover (screw)	6	16	11.801
Rear cover (screw)	11	10	7.376
Air filter cover (screw)	3	7	5.163
Crankcase cover guard (bolt)	2	7	5.163
Unidirectional clutch	3	30	5.163
Driven pulley (nut)	1	60	44.254
Clutch assembly (nut)	1	90	66.380
Drive pulley (nut)	1	60 ÷ 80	44.254 ÷ 59.005
Stop ring (screw)	4	3	2.213
FLYWHEEL		QTY	(Nm)
			(ft-lb)
Flywheel nut	1	80	59.005
Oil cap with dipstick	1	7	5.163
Flywheel cover (screw)	10	10	7.376
Stator (screw)	3	7 ÷ 10	5.163 ÷ 7.376
Pick-up (screw)	2	7	5.163
LUBRICATION		QTY	(Nm)
			(ft-lb)
Oil pump baffle plate (screw)	2	12	8.851
Oil pump cover (screw)	1	1	0.737
Oil pump (screw)	2	7	5.163
Oil drain cap	1	32	23.602
COOLING SYSTEM		QTY	(Nm)
			(ft-lb)
Coolant pump (screw)	2	10	7.376
System drain (screw)	1	10	7.376
Coolant pump hose (screw)	2	7	5.163
CRANKCASE		QTY	(Nm)
			(ft-lb)
Starter motor (screw)	2	10	7.376
Crankcase	9	10	7.376
CYLINDER HEAD		QTY	(Nm)
			(ft-lb)
Spark plug tightening	1	18	13.276
Cylinder head stud bolt (screw)	4	13	9.588
Cylinder head nut	4	22	16.226
Cylinder head bolt	2	10	7.376
Tappet covers (screw)	5	10	7.376
Rotor nut	1	80	59.005
Valve clearance adjuster check nut	2	14	10.326
Camshaft retaining plate / washer (screw)	2	8	5.900
Pulley / breather plate (screw)	1	60	44.254
Timing chain tensioner fastener (screw)	2	10	7.376
Timing chain tensioner adjustment (screw)	1	8	5.900
Oil vapour recovery system cover (blow-by) (screw)	2	10	7.376
Thermostat fitting (screw)	2	10	7.376
Spark advance inspection hole cap	1	8	5.900
Thermal switch	2	23	16.964
Thermal unit	1	8	5.900

SPECIFIC TOOLS

2

SUMMARY

2.1. SPECIFIC TOOLS 3
2.1.1. SPECIAL TOOLS 3

2.1. SPECIFIC TOOLS

2.1.1. SPECIAL TOOLS

In order to perform assembly, reassembly and settings correctly, special tools suitable for the task must be used. The use of special tools avoids the potential risk of damage as a result of inappropriate tools and/or improvised methods. The special tools developed specifically for this engine are listed below.

Other special tools available not specific to this engine are listed in the Special Tools Catalogue.



WARNING

Before using the special tools, consult any documents attached.

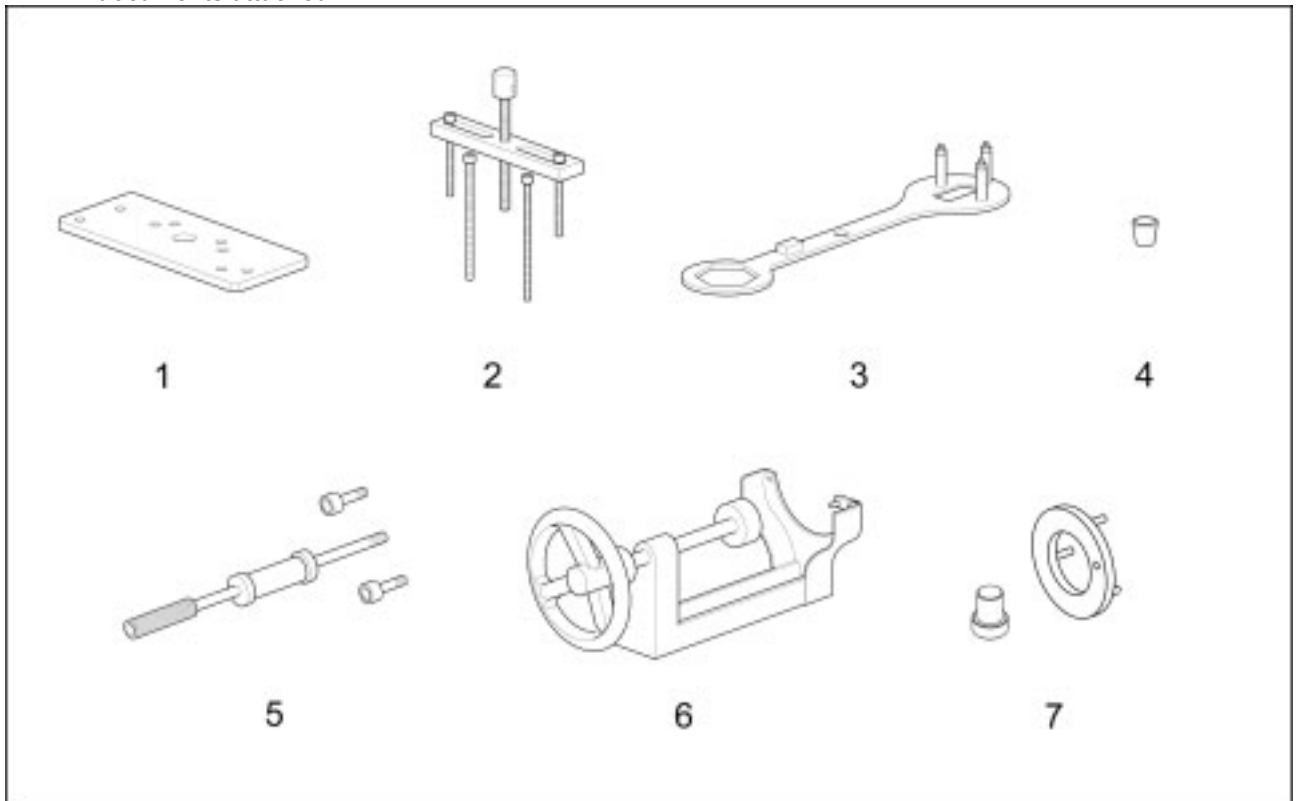

Key:

Reference	Tool designation and application	Part number
1	Flywheel extractor plate	8140228
2	Extractor	8106698
3	Multipurpose spanner	8140252
4	Bush to protect crankshaft	8140393
5	Slide hammer with adapters	8140432
6	Universal tool for clutch assembly	8140259
7	Adapters for clutch disassembly	8140789

ENGINE

3

SUMMARY

3.1.	TRANSMISSION SYSTEM.....	4
3.1.1.	TRANSMISSION COVER REMOVAL.....	4
3.1.2.	DRIVE PULLEY REMOVAL.....	6
3.1.3.	DRIVEN PULLEY REMOVAL.....	7
3.1.4.	CLUTCH HOUSING.....	8
3.1.5.	CLUTCH DISASSEMBLY.....	9
3.1.6.	PIN RETAINING COLLAR.....	10
3.1.7.	FIXED DRIVEN HALF PULLEY BEARINGS.....	11
3.1.8.	FIXED DRIVEN HALF PULLEY.....	12
3.1.9.	MOBILE DRIVEN HALF PULLEY.....	13
3.1.10.	INSTALLING THE FIXED DRIVEN HALF PULLEY BEARINGS.....	14
3.1.11.	DRIVEN PULLEY ASSEMBLY.....	15
3.1.12.	SPRING.....	16
3.1.13.	CLUTCH WEIGHTS.....	17
3.1.14.	CLUTCH INSTALLATION.....	18
3.1.15.	DRIVE BELT.....	19
3.1.16.	MOBILE DRIVE HALF PULLEY.....	20
3.1.17.	MOBILE DRIVE HALF PULLEY AND BUSH ASSEMBLY.....	21
3.1.18.	INSTALLING THE DRIVEN PULLEY AND FIXED DRIVE HALF PULLEY.....	23
3.1.19.	TRANSMISSION COVER INSTALLATION.....	24
3.1.20.	REAR TRANSMISSION DISASSEMBLY.....	26
3.1.21.	TRANSMISSION BEARINGS AND SHAFTS.....	27
3.1.22.	REAR TRANSMISSION ASSEMBLY.....	28
3.1.23.	TIGHTENING TORQUE SETTINGS.....	30
3.2.	FLYWHEEL.....	31
3.2.1.	FLYWHEEL COVER REMOVAL.....	31
3.2.2.	FLYWHEEL DISASSEMBLY.....	33
3.2.3.	STATOR REMOVAL.....	34
3.2.4.	FLYWHEEL INSPECTION.....	35
3.2.5.	STATOR INSTALLATION.....	36
3.2.6.	FLYWHEEL INSTALLATION.....	37
3.2.7.	FLYWHEEL COVER INSTALLATION.....	39
3.2.8.	TIGHTENING TORQUE SETTINGS.....	41
3.3.	LUBRICATION.....	42
3.3.1.	OIL PUMP REMOVAL.....	42
3.3.2.	OIL PUMP INSPECTION.....	43
3.3.3.	OIL PUMP INSTALLATION.....	45
3.3.4.	TIGHTENING TORQUE SETTINGS.....	46
3.4.	COOLING SYSTEM.....	47
3.4.1.	COOLANT PUMP REMOVAL AND DISASSEMBLY.....	47
3.4.2.	COMPONENT INSPECTION.....	49
3.4.3.	COOLANT PUMP DRIVE GEAR INSPECTION.....	50
3.4.4.	COOLANT PUMP ASSEMBLY AND INSTALLATION.....	51
3.4.5.	THERMOSTAT INSPECTION.....	53
3.4.6.	TIGHTENING TORQUE SETTINGS.....	54
3.5.	ENGINE CASING AND CRANKSHAFT.....	55
3.5.1.	STARTER MOTOR REMOVAL.....	55
3.5.2.	SPLITTING THE CRANKCASE.....	56
3.5.3.	CRANKCASE HALF INSPECTION.....	59
3.5.4.	REASSEMBLING THE CRANKCASE.....	60
3.5.5.	STARTER MOTOR INSTALLATION.....	61
3.5.6.	TIGHTENING TORQUE SETTINGS.....	62
3.6.	CYLINDER, HEAD AND TIMING SYSTEM.....	63
3.6.1.	VALVE TAPPET COVER REMOVAL.....	63
3.6.2.	ENGINE TIMING INSPECTION.....	64
3.6.3.	VALVE CLEARANCE INSPECTION/ADJUSTMENT.....	65
3.6.4.	VALVE TAPPET COVER INSTALLATION.....	66
3.6.5.	CHECKING PRESSURE AT THE END OF COMPRESSION STROKE.....	67
3.6.6.	INTAKE MANIFOLD REMOVAL.....	68
3.6.7.	THERMOSTAT REMOVAL.....	69
3.6.8.	CYLINDER HEAD REMOVAL.....	70
3.6.9.	CAMSHAFT AND ROCKER ARM REMOVAL.....	72
3.6.10.	VALVE REMOVAL.....	73
3.6.11.	CYLINDER AND PISTON REMOVAL.....	74
3.6.12.	CONNECTING ROD SMALL END INSPECTION.....	76
3.6.13.	PISTON PIN DIAMETER.....	77
3.6.14.	PISTON.....	79
3.6.15.	PISTON RINGS.....	80
3.6.16.	INSTALLING THE PISTON.....	81

Engines 3AS / 4AS

3.6.17.	PISTON RING INSTALLATION	82
3.6.18.	CYLINDER INSTALLATION	83
3.6.19.	HEAD INSPECTION	84
3.6.20.	CHECKING VALVES FOR WEAR.....	85
3.6.21.	CHECKING VALVE SEAT WEAR	86
3.6.22.	VALVE LEAK TEST	87
3.6.23.	CHECKING SPRINGS, RETAINERS AND COTTERS.....	88
3.6.24.	VALVE INSTALLATION.....	89
3.6.25.	TIMING COMPONENT INSPECTION	90
3.6.26.	CHECKING CAMSHAFT AND ROCKER ARMS	91
3.6.27.	CAMSHAFT AND ROCKER ARM INSTALLATION.....	93
3.6.28.	INSTALLING THE CYLINDER HEAD AND TIMING COMPONENTS	94
3.6.29.	TIMING COMPONENT INSTALLATION.....	95
3.6.30.	THERMOSTAT INSTALLATION.....	97
3.6.31.	INTAKE MANIFOLD INSTALLATION	98
3.6.32.	TIGHTENING TORQUE SETTINGS.....	99
3.7.	SECONDARY AIR SYSTEM	100
3.7.1.	SAS.....	100

3.1. TRANSMISSION SYSTEM

3.1.1. TRANSMISSION COVER REMOVAL

- Remove the retaining screws and collect the spacers.
- Remove the air box cover.



- Remove the air filter.

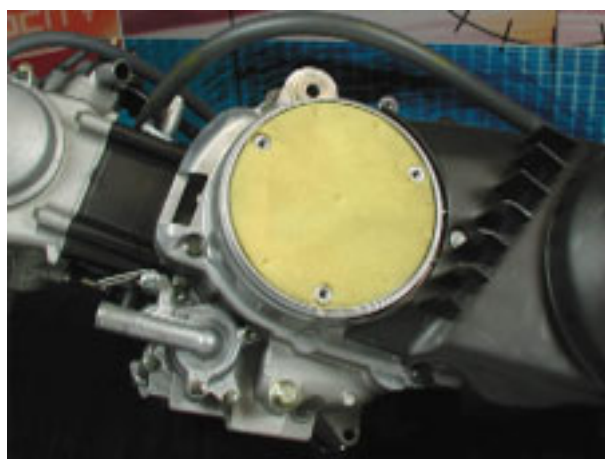

- Remove the retaining screws and collect the spacers.
- Remove the rear cover.



- Unscrew the retaining screws.
- Remove the transmission cover.



Engines 3AS / 4AS

- Remove the seal and the locating pins.



3.1.2. DRIVE PULLEY REMOVAL

- Remove the locknut using the specific tool.
- Multipurpose spanner: 8140252
- Remove the spacer.
- Remove the fixed drive half pulley and the rear spacer.



- Move the timing belt aside.
- Remove the mobile half pulley and the bush.



- Remove the retaining screws and collect the washers.
- Remove the retaining ring.
- Remove the roller guide plate and its sliders.
- Remove the rollers.
- Remove the O-ring.



Engines 3AS / 4AS**3.1.3. DRIVEN PULLEY REMOVAL**

- Use the tool to prevent rotation of the pulley.
- Multipurpose spanner: 8140252
- Unscrew the retaining nut.

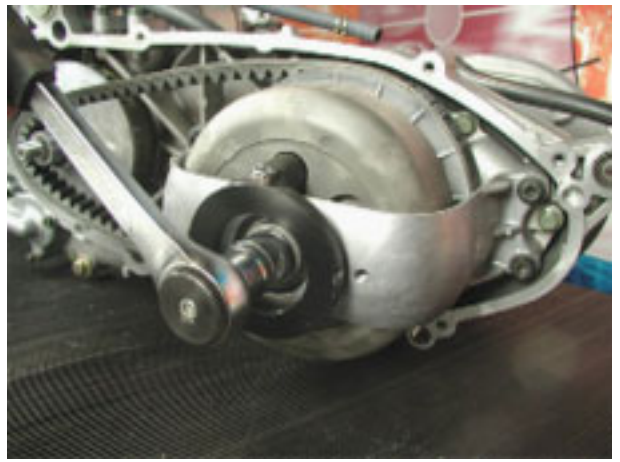

- Unscrew the bracket retaining screws.
- Remove the bracket and its bush.



- Remove the clutch housing.

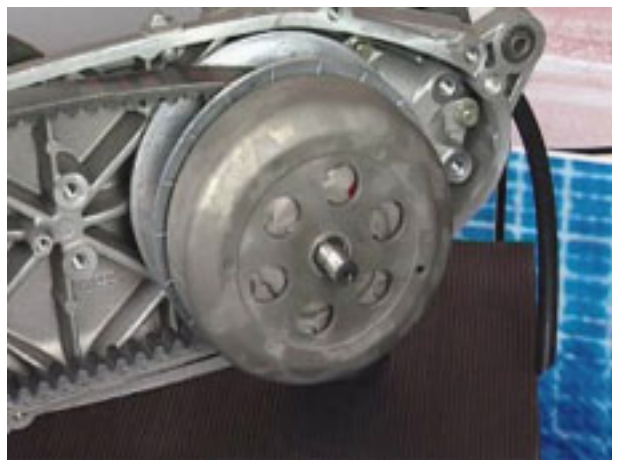

- Remove the driven pulley and the drive belt.



3.1.4. CLUTCH HOUSING

- Check the clutch housing for wear or damage.
- Measure the inner diameter of the clutch housing:

Engine 3AS (250 cc)

- Standard value: Ø 135 mm (5.315 in.)
- Max value: Ø 135.5 mm (5.335 in.)

Engine 3AS (300 cc)

- Standard value: Ø 145 mm (5.709 in.)
- Max value: Ø 145.5 mm (5.728 in.)

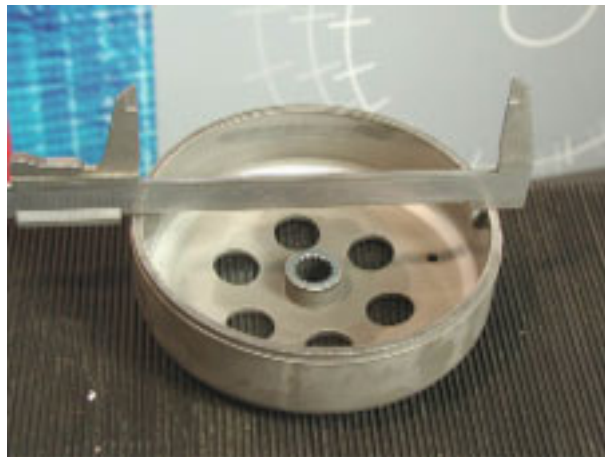

Engines 3AS / 4AS

3.1.5. CLUTCH DISASSEMBLY

- Position the adapter ring so the pins are facing the clutch body and the rear guide pin and then install the clutch body to the tool.
- Universal tool for clutch units: 8140259
- Adapter for 8140259: 8140789
- Ensure that the clutch is fully located in the adapter ring and on the rear guide pin before proceeding to release the clutch nut.
- Insert the lever pin into the hole of the adapter ring.

**WARNING**

The tool must be clamped tightly in a vice and the centre bolt with the guide pin must be inserted into the needle roller bearing of the driven pulley. Do not overtighten or you may distort the tool.

- Remove the retaining nut, release the tool and remove clutch, spring and driven pulley assembly.



3.1.6. PIN RETAINING COLLAR

- Prise off the collar using two flat-blade screwdrivers.



- Remove the guide pins.



- Remove the mobile half pulley.



Engines 3AS / 4AS**3.1.7. FIXED DRIVEN HALF PULLEY BEARINGS**

- Check for signs of wear or noise; replace as required.
- Knock out the needle roller bearing using a suitable slide hammer tool.



- Working from inside the half pulley, remove the circlip.



- Knock out the ball bearing using a suitable slide hammer tool.



3.1.8. FIXED DRIVEN HALF PULLEY

- Check the bush of the fixed half pulley for wear and damage and measure its outer diameter.



3.1.9. MOBILE DRIVEN HALF PULLEY

- Remove the two snap rings and the two O-rings.
- Measure the inner diameter of the mobile half pulley bush.



3.1.10. INSTALLING THE FIXED DRIVEN HALF PULLEY BEARINGS

- Drive the ball bearing into place using a suitable slide hammer tool while holding the cage from the outer side of the half pulley.
- Fit the circlip to the inside of the half pulley.

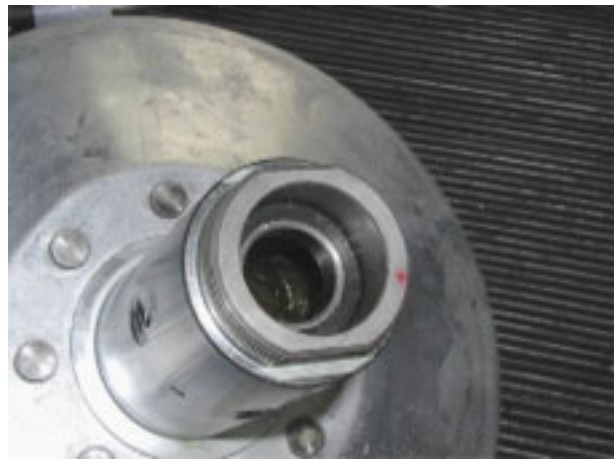

- Drive the roller bearing into place using a suitable slide hammer and holding the cage from the outer side of the half pulley.
- Grease the inside of the half pulley.



Engines 3AS / 4AS

3.1.11. DRIVEN PULLEY ASSEMBLY

- Check the surfaces that contact the belt.



- Fit new oil seals and O-rings to the mobile half pulley.
- Grease the inside of the mobile driven half pulley.



- Assemble the half pulleys.
- Check pins and collar for wear.



- Fit pins and collar.



3.1.12. SPRING

- Measure the free length of the mobile driven half pulley spring.
- Free length of spring: 102.4 mm (4.03148 in.)
- Service limit: 90 mm (3.54330 in.)

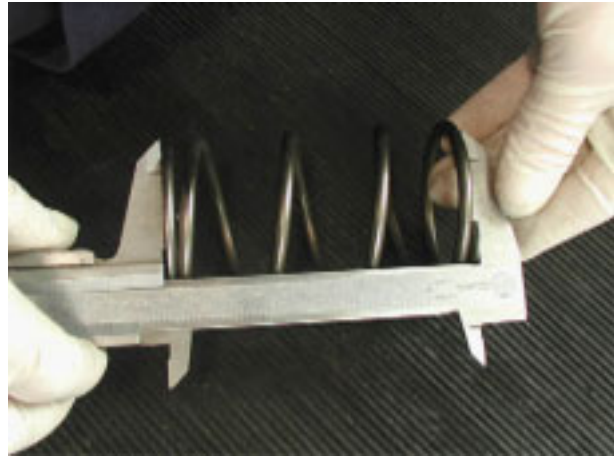

Engines 3AS / 4AS**3.1.13. CLUTCH WEIGHTS**

- Check the thickness of the friction material of clutch weights.

Engine 3AS (250 cc)

- Standard thickness: 3 mm (0.11811 in.)
- Minimum thickness allowed: 2 mm (0.07873 in.)

Engine 4AS (300 cc)

- Standard thickness: 3.3 mm (0.12992 in.)
- Minimum thickness allowed: 2 mm (0.07873 in.)



- Clutch weights must show no traces of lubricants; if they do, check the seals of the driven pulley assembly.

CAUTION During break-in, weights must show a witness mark in the centre and must not differ from one another. Any conditions other than specified may lead to jerkiness in the clutch.

**WARNING**

Do not pry the weights apart with any tools as this would alter return spring load.

3.1.14. CLUTCH INSTALLATION

- Install the adapter ring to the clutch.
- Assemble spring, driven pulley assembly and clutch and install to tool.
- Universal tool for clutch units: 8140259
- Adapter for 8140259: 8140789
- Insert the lever pin into the hole of the adapter ring.
- Tighten the tool until inserting the fixed half pulley into the seat in the clutch.
- Position the retaining nut and tighten to the specified torque.
- Unscrew the tool and remove the driven pulley.
- Remove the adapter ring.



Engines 3AS / 4AS**3.1.15. DRIVE BELT**

- Check the drive belt for damage.
- Measure belt width:
 - Standard width: 22.6 mm (0.88976 in.)
 - Minimum width: 21.0 mm (0.82676 in.)

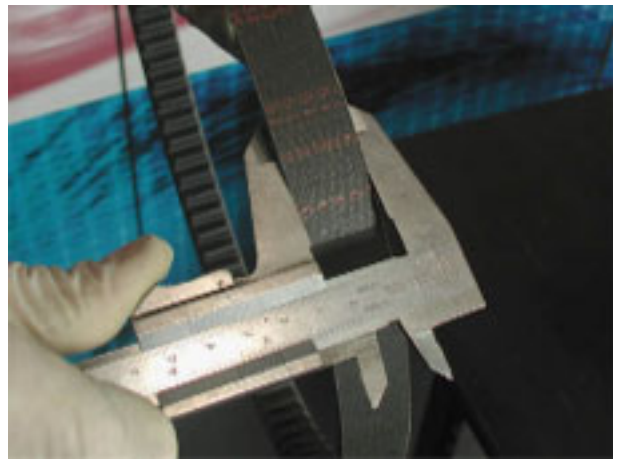

3.1.16. MOBILE DRIVE HALF PULLEY

- Check the slide bush of the pulley for wear and damage and measure its outer diameter.



- Check the needle rollers for wear and damage and measure their outer diameter.
 - Minimum diameter allowed: $\varnothing 20.0$ mm (0.78740 in.)
 - Service limit: $\varnothing 19.5$ mm (0.76771 in.)

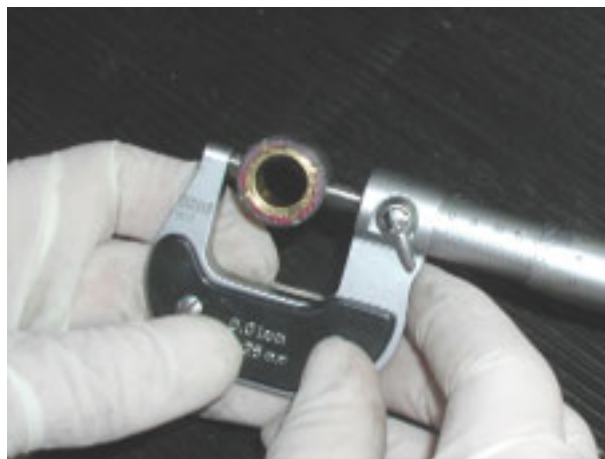

- Check the sliders of the roller guide plate for wear.
- Check the roller seats and the belt contact areas for wear on both pulleys.



Engines 3AS / 4AS

3.1.17. MOBILE DRIVE HALF PULLEY AND BUSH ASSEMBLY

- Grease the inside of the roller seat of the mobile half pulley.
- Fit the rollers to the half pulley.



- Fit the sliders to the roller guide plate.



- Fit the roller guide plate to the half pulley.
- Fit a new O-ring.



- Fit the retaining ring and tighten the screws with washer to the specified torque.



- Assemble half pulley and bush and refit them to the crankshaft.



Engines 3AS / 4AS

3.1.18. INSTALLING THE DRIVEN PULLEY AND FIXED DRIVE HALF PULLEY

- Slide the driven pulley and the drive belt on the clutch shaft.



- Fit the spacer.
- Slide the fixed drive half pulley to the crankshaft.
- Use the suitable tool to prevent crankshaft rotation.

- Multipurpose spanner: 8140252

- Position the spacer and a new retaining nut and tighten to the specified torque.

**WARNING**

It is essential to ensure free rotation of the belt during fixed drive half pulley installation; this is critical to correct tightening of the retaining nut.



- Install the clutch housing.
- Install the bracket and its bush.
- Apply Loctite 242 speed bonder and tighten the bracket retaining screws.
- Position a new retaining nut.



- Use the suitable tool to prevent rotation of the driven pulley.

- Multipurpose spanner: 8140252

- Tighten the retaining nut to the specified torque.



3.1.19. TRANSMISSION COVER INSTALLATION

- Fit the locating dowels.
 - Check the seal and replace as required.
 - Fit the seal to the cover.
-
- Install the transmission cover and tighten the retaining screws to the specified torque.
-
- Inspect the air filter and clean or replace as required.
 - Install the air filter.
 - Install the rear cover.
 - Tighten the retaining screws with the spacers to the specified torque.
-
- Check the O-ring and replace as required.



Engines 3AS / 4AS

- Install the air box cover.
- Tighten the retaining screws with the spacers to the specified torque.



3.1.20. REAR TRANSMISSION DISASSEMBLY

- Remove the oil filler cap.
 - Remove the screw plug and drain the transmission oil.
 - Unscrew the retaining screws.
-
- Remove the transmission cover complete with driven pulley shaft.
-
- Remove the spacers from the intermediate and wheel shafts.
 - Remove the locating dowels.
 - Remove the seal.
-
- Remove the wheel shaft gear and its thrust washer.
 - Remove the intermediate shaft, its thrust washer, the gear and the rear spacer.
 - Remove the wheel shaft.
 - Remove the oil seal from the transmission cover.

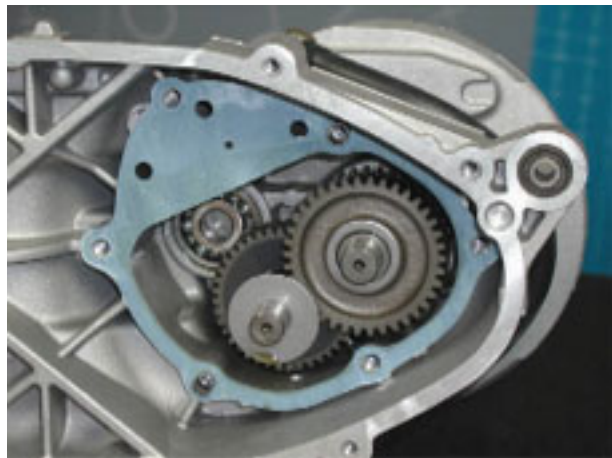

Engines 3AS / 4AS**3.1.21. TRANSMISSION BEARINGS AND SHAFTS**

- Inspect the bearings for wear, play and noise; check the oil seal for wear and leaks.
- Remove any damaged bearings or seals and fit a new component using a suitable extractor or drift, respectively.

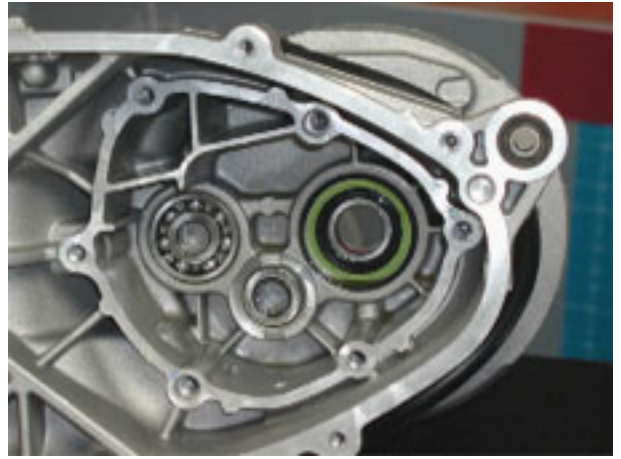

- Check the bearing for wear, play and noise.
- If you find an abnormal condition, remove the driven pulley shaft and the bearings after heating the transmission cover with a heat gun.

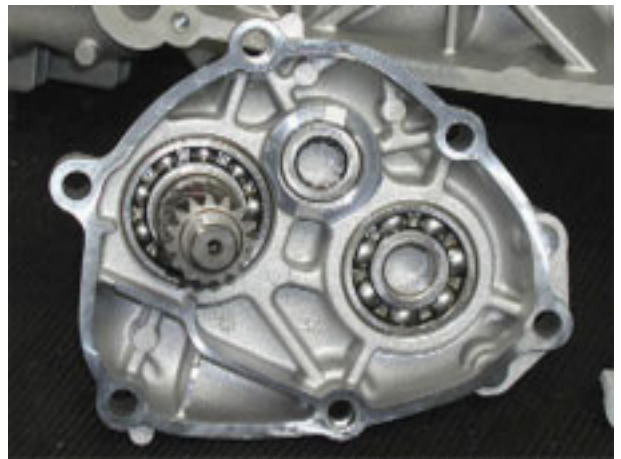

- Check the mating faces of the transmission cover for denting or distortion.
- Check the bearing sites.
- Check the splines, bearing sites and oil seals of the three shafts for wear and distortion.
- Replace any damaged parts.

3.1.22. REAR TRANSMISSION ASSEMBLY

- Clean all contact surfaces thoroughly before assembling the transmission.
- Install the wheel shaft.



- Assemble intermediate shaft, thrust washer with the letter "M" facing away from the transmission case, idler gear and rear spacer.
- Fit the intermediate shaft assembly into place.



- Slide the thrust washer onto the wheel shaft with the letter "D" facing away from the transmission case.



- Fit the wheel shaft gear and its spacer.
- Fit the spacer to the intermediate shaft.



Engines 3AS / 4AS

- Fit the locating dowels.
- Install a new seal.

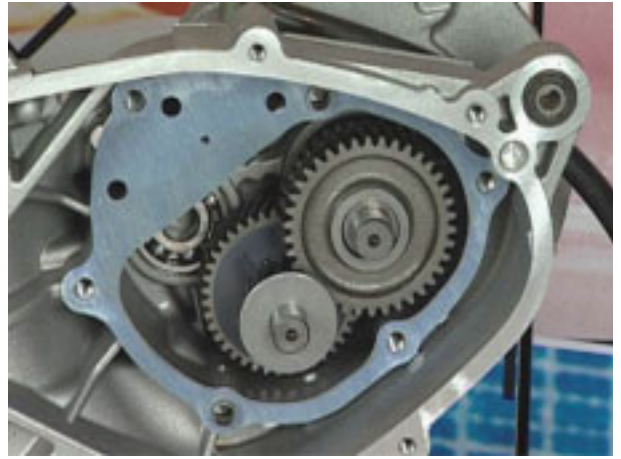

- Fit the transmission cover complete with the driven pulley shaft and tighten the retaining screws.



- Check transmission for proper operation.
- Install the new oil seal to the driven pulley shaft.
- Tighten the transmission oil drain screw/plug.
- Top up transmission oil to correct level and tighten the transmission oil filler cap.



3.1.23. TIGHTENING TORQUE SETTINGS

TRANSMISSION SYSTEM	QTY	(Nm)	(ft-lb)
Transmission cover (screw)	6	16	11.801
Rear cover (screw)	11	10	7.376
Air filter cover (screw)	3	7	5.163
Crankcase cover guard (bolt)	2	7	5.163
Unidirectional clutch	3	30	5.163
Driven pulley (nut)	1	60	44.254
Clutch assembly (nut)	1	90	66.380
Drive pulley (nut)	1	60 ÷ 80	44.254 ÷ 59.005
Stop ring (screw)	4	3	2.213

Engines 3AS / 4AS

3.2. FLYWHEEL**3.2.1. FLYWHEEL COVER REMOVAL**

- Drain the engine oil.
 - Remove the clamp and disconnect the secondary air system hose from the intake manifold.
-
- Unscrew the nuts securing the secondary air system rigid tube to cylinder head.
 - Disconnect the tube and collect the gasket.
-
- Unscrew the retaining screws.
 - Remove the secondary air system valve complete with mount and tubes.
-
- Remove the oil dipstick.
 - Unscrew the retaining screws.
 - Remove the flywheel cover complete with stator.



- Remove the locating dowels.
- Remove the seal.



Engines 3AS / 4AS

3.2.2. FLYWHEEL DISASSEMBLY

- Fit the suitable locking tool to the drive pulley to prevent crankshaft rotation.
- Multipurpose spanner: 8140252
- Unscrew the nut and remove the spacer.



- Position the tools.
- Flywheel extractor plate: 8140228
- Extractor: 8106698
- Bush to protect crankshaft: 8140393



CAUTION
Tighten the screws onto the flywheel taking care not to damage the freewheeling clutch.

- Pull out the flywheel.



- Remove the key.
- Remove the starter sprocket.



- Remove shaft, washer and starter motor idler gear.



3.2.3. STATOR REMOVAL

- Loosen the pick-up retaining screws.
- Unscrew the stator retaining screws.
- Disconnect the wiring from the flywheel cover and remove the stator complete with pick-up.



Engines 3AS / 4AS**3.2.4. FLYWHEEL INSPECTION**

- Check flywheel and pick-up operating plate for damage.



3.2.5. STATOR INSTALLATION

- Fit the stator into place.
- Apply Loctite 242 speed bonder and tighten the stator retaining screws to the specified torque.
- Place the pick-up into its seat.
- Apply Loctite 242 speed bonder and tighten the pick-up retaining screws to the specified torque.
- Apply sealing compound to the seat of the wire rubber gaiter.
- Fit the rubber gaiter securely in place in the flywheel cover.



Engines 3AS / 4AS

3.2.6. FLYWHEEL INSTALLATION

- Assemble shaft, washer and starter motor idler gear and fit them into place.



- Hold the starter clutch.
- When you rotate the starter sprocket clockwise (A), starter clutch and starter sprocket must be meshed together.
- If not so, the starter clutch is faulty and must be replaced.
- When rotated anticlockwise (B), the starter sprocket must rotate freely.
- If not so, the starter clutch is faulty and must be replaced.

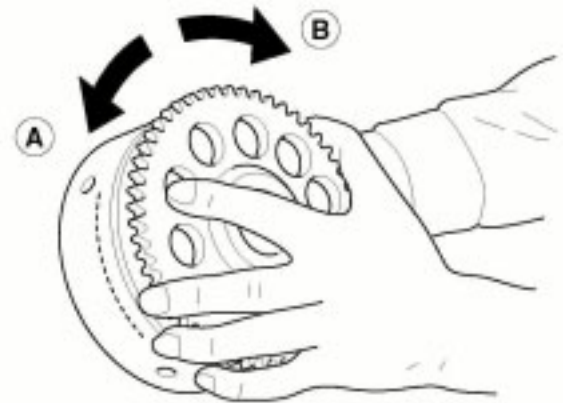

- Install the starter sprocket.
- Fit the key into the crankshaft.



- Install the flywheel making sure the key is in the correct position.



- Fit the spacer and the flywheel locknut.
- Fit the suitable locking tool to the drive pulley to prevent crankshaft rotation.
- Multipurpose spanner: 8140252
- Tighten the locknut to the specified torque.



Engines 3AS / 4AS

3.2.7. FLYWHEEL COVER INSTALLATION

- Fit the locating dowels.
- Install a new seal.



- Install the flywheel cover.
- Tighten the retaining screws to the specified torque.
- Fit the oil dipstick.



- Position the secondary air system valve complete with mount and tubes.
- Tighten the retaining screws.



- Position the gasket and connect the secondary air system rigid tube to the cylinder head.
- Tighten the locknuts.



- Connect the secondary air system hose to the intake manifold and fit the clamp to secure.



3.2.8. TIGHTENING TORQUE SETTINGS

FLYWHEEL	QTY	(Nm)	(ft-lb)
Flywheel nut	1	80	59.005
Oil cap with dipstick	1	7	5.163
Flywheel cover (screw)	10	10	7.376
Stator (screw)	3	7 ÷ 10	5.163 ÷ 7.376
Pick-up (screw)	2	7	5.163

3.3. LUBRICATION

3.3.1. OIL PUMP REMOVAL

- Drain the engine oil.
- Before proceeding, remove the secondary air system valve complete with mount and tubes, the flywheel cover, the flywheel, the key and the starter sprocket.
- Loosen the retaining screws and remove the baffle plate.



- Remove the circlip and the washer.
- Remove the oil pump drive gear and its locating pin.

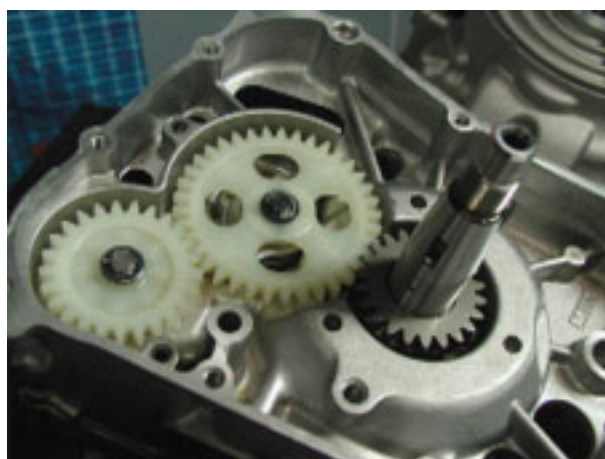

- Loosen the retaining screws and remove the oil pump.







- Remove the seal.



Engines 3AS / 4AS

3.3.2. OIL PUMP INSPECTION

- Loosen the screw and remove the oil pump cover.
- 
- Remove the oil pump shaft and the retaining pin.
- 
- Remove the rotors and clean thoroughly with petrol and compressed air.
 - Check shaft and pump body for wear.
 - Check the pump cover for wear and scoring.
 - Replace any parts that are worn or damaged, or the whole assembly, as required.
- 
- Install the outer rotor so the mark is visible.
 - Fit the pin into the pump shaft.
 - Fit the shaft to the inner rotor.
 - Fit inner rotor and shaft to pump body so the mark is visible.
 - Check clearance between the two rotors using a feeler gauge.
- Correct clearance: 0.10 - 0.34 mm (0.00394 - 0.01338 in.)
 - Maximum clearance allowed: 0.40 mm (0.01574 in.)
- 

- Check clearance between outer rotor and pump body using a feeler gauge.
- Correct clearance: 0.013 - 0.036 mm (0.00051 - 0.00142 in.)
- Maximum clearance allowed: 0.15 mm (0.00590 in.)



- Check side play of rotors using a grind-finished bar and a feeler gauge.
- Correct side play: 0.04 - 0.09 mm (0.00157 - 0.00354 in.)
- Service limit: 0.15 mm (0.00590 in.)
- Install the pump cover and tighten the retaining screw to the specified torque.



Engines 3AS / 4AS

3.3.3. OIL PUMP INSTALLATION

- Fit a new seal.
- Install the oil pump and tighten the retaining screws to the specified torque.
- Fit the pin, the gear, the washer and the circlip.
- Install the baffle plate and tighten the retaining screws to the specified torque.
- Refit the parts you had removed previously: starter sprocket, key, flywheel, flywheel cover, secondary air system valve complete with mount and tubes.
- Top up level with the specified oil.

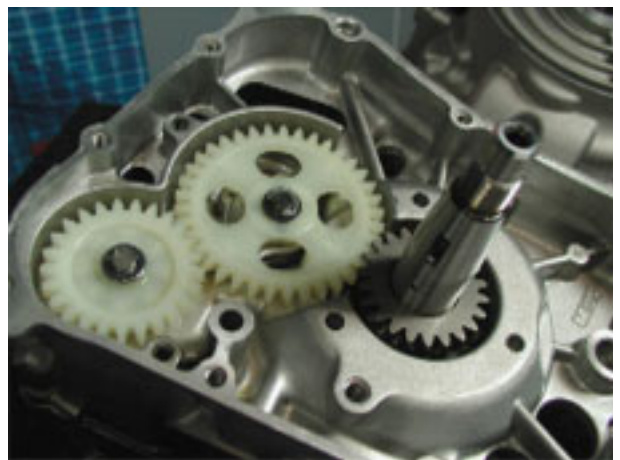

3.3.4. TIGHTENING TORQUE SETTINGS

LUBRICATION	QTY	(Nm)	(ft-lb)
Oil pump baffle plate (screw)	2	12	8.851
Oil pump cover (screw)	1	1	0.737
Oil pump (screw)	2	7	5.163
Oil drain cap	1	32	23.602

Engines 3AS / 4AS

3.4. COOLING SYSTEM**3.4.1. COOLANT PUMP REMOVAL AND DISASSEMBLY**

- Loosen the retaining screws of the cylindrical fitting.



- Unscrew the retaining screws.
- Remove the coolant pump complete with fitting.



- Remove the cylindrical fitting.
- Remove the O-rings from the cylindrical fitting.
- Remove the O-ring from the pump body.



- Unscrew the retaining screws.
- Unscrew the drain screw of the cooling system and collect the washer.
- Remove the coolant pump cover.



- Remove the seal.



- Remove the circlip and pull out the rotor.



Engines 3AS / 4AS**3.4.2. COMPONENT INSPECTION**

- Check the rotor shaft for oxidation.
- Check the rotor for abnormal wear or crazing.
- Inspect the mechanical seals fitted to rotor and pump body and the bearing and oil seal installed to pump body; replace as required.
- Check bearing housing and the seats for the mechanical seals for oxidation.



3.4.3. COOLANT PUMP DRIVE GEAR INSPECTION

- Remove the flywheel cover.
- Unscrew the retaining screws.
- Remove the baffle plate.
- Remove the coolant pump drive gear together with its shaft.



- Check gear and shaft for wear and crazing.
- If needed, remove circlip, upper washer, gear, retaining pin and lower washer and replace any damaged parts.



- Install lower washer, retaining pin, gear, upper washer and circlip.
- Fit the coolant pump drive gear together with its shaft into its seat in the engine casing.

Engines 3AS / 4AS

3.4.4. COOLANT PUMP ASSEMBLY AND INSTALLATION

- Grease the end of the rotor shaft lightly.
- To install the rotor shaft, push the shaft into place while rotating it.
- Install a new circlip.

**WARNING**

Use great care to avoid damaging the edge of the oil seal and make sure the spring does not slip off its seat.

- Check the rotor for proper operation.
- Install a new seal.
- Install the coolant pump cover.
- Position the retaining screws and the drain screw with its washer and tighten.
- Fit the new O-ring to the pump body.



- Fit new O-rings to the cylindrical fitting.
- Fit the cylindrical fitting to the pump body.



- Install the coolant pump complete with fitting making sure the cutout in the rotor shaft is properly aligned with the drive shaft projecting part.
- Tighten the retaining screws of the coolant pump to the specified torque.



- Tighten the retaining screws of the cylindrical fitting to the specified torque.



Engines 3AS / 4AS

3.4.5. THERMOSTAT INSPECTION

- Visually check that the thermostat (1) is not damaged.
- Take a metal container with approx. 1 litre of water.
- Immerse the thermostat (1) and keep it at the centre of the container.
- Immerse the multimeter thermal gauge close to the thermostat.
- Heat up the container using a heat gun.
- Check the temperature when thermostat starts opening:

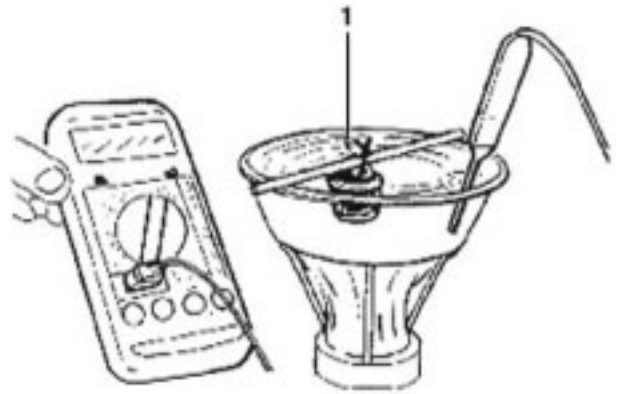

Start opening temperature: 80.5 - 83.5°C (176.9 - 185.9°F)

- Heat it up until obtaining thermostat complete opening:
 - **A** CLOSED
 - **B** OPEN

Opening travel: 3 mm at 95°C (0.11811 in. at 203°F)

CAUTION The thermostat is sealed and adjustment requires specific technical skills. Replace the valve in case of doubts on its accuracy. A faulty device could overheat or cool down the engine too much, thus causing damages.

**WARNING**

The test is correctly carried out when the thermostat never touches the container.

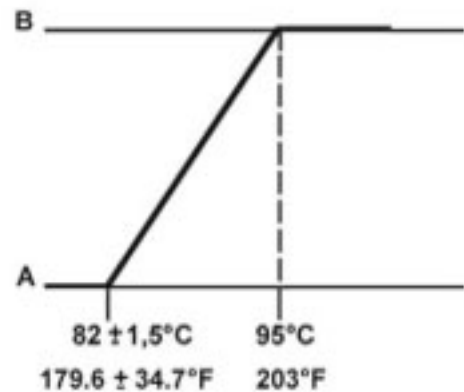

3.4.6. TIGHTENING TORQUE SETTINGS

COOLING SYSTEM	QTY	(Nm)	(ft-lb)
Coolant pump (screw)	2	10	7.376
System drain (screw)	1	10	7.376
Coolant hose (screw)	2	7	5.163

3.5. ENGINE CASING AND CRANKSHAFT

3.5.1. STARTER MOTOR REMOVAL

- The following assemblies need to be removed first: transmission, cylinder head, cylinder, flywheel, oil pump and coolant pump.
- Loosen the retaining screws and remove the starter motor.



- Remove the O-ring.



3.5.2. SPLITTING THE CRANKCASE

- Unscrew the crankcase bolts.
- Position the tools to the flywheel-side crankcase.

- Extractor: 8106698
- Bush to protect crankshaft: 8140393



- Tighten the tool and remove the flywheel-side crankcase.
- Remove the locating dowels.



- Take the timing drive chain off the crankshaft sprocket.



- Position the tools to the transmission-side crankcase.

- Extractor: 8106698
- Bush to protect crankshaft: 8140393

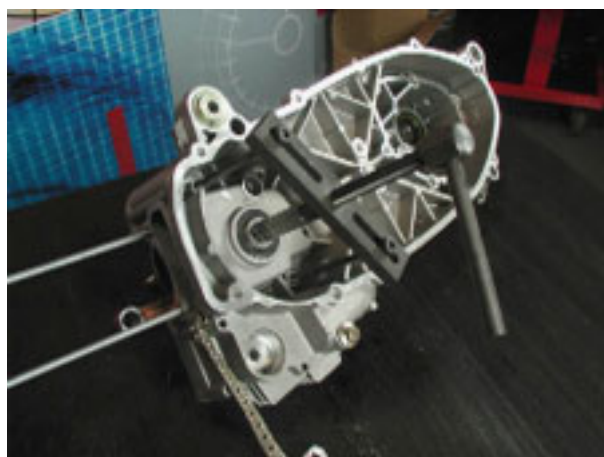

Engines 3AS / 4AS

- Tighten the tool and remove crankshaft and timing chain.



WARNING
Be careful not to drop the crankshaft.



- Remove the oil seal from the transmission-side crankcase.

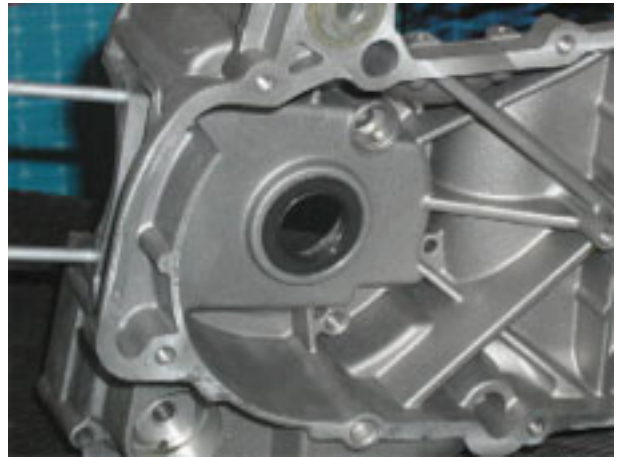

- Check connecting rod axial play.
 - Correct play:
0.35 – 0.85 mm (0.01378 – 0.03346 in.)



- Check connecting rod radial play.
 - Correct play:
0.010 – 0.026 mm (0.00039 – 0.00102 in.)

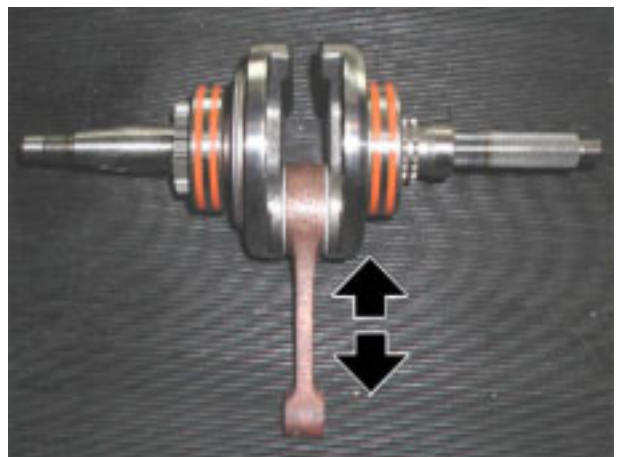

- Check the surfaces designed to limit axial play for scoring and measure crank web width.
- Correct size:
59.95 – 60.00 mm (2.360 – 2.362 in.)

**WARNING**

Crankshaft may be reused when width is within the specified range and no surfaces are scored.



- Exceeding crankshaft end play when the crankshaft is within specifications is certainly due to a worn or incorrectly machined crankcase.

- Rotate the crankshaft slowly to measure crankshaft misalignment.
- Max. misalignment allowed: 0.03 mm (0.001181 in.)
- Ensure that the following components are in good condition: crankshaft sprocket, bearings, pump drive gear, crankshaft taper, keyway, oil seal seat, crankshaft spline and threaded ends.
- If you find any abnormal condition, replace the crankshaft.
- Thoroughly clean the crankshaft oil hole using compressed air.



CAUTION *The main bearing locations cannot be ground. The connecting-rod big end bearings cannot be replaced.*

For the same reason, the connecting rod cannot be replaced; use great care when cleaning the crankshaft to prevent dirt or debris entering the crankshaft oil hole.

Never attempt to clean the oil passage using compressed air, as this will damage the connecting-rod bearings.

- Ensure that both pads are installed correctly to the crankpin.
- An incorrectly mounted pad may greatly reduce oil supply pressure, leading to poor lubrication of connecting rod bearings.

3.5.3. CRANKCASE HALF INSPECTION

- Remove all traces of sealing compound from the contact faces and clean both crankcase halves thoroughly.
- Check contact faces for denting or distortion paying particular attention to the contact faces of crankcase and cylinders and the crankcase mating faces.
- Check the surfaces designed to limit crankshaft end play for wear. For a dimensional check, please see the crankshaft end play and dimensional check procedures.



3.5.4. REASSEMBLING THE CRANKCASE

- Heat up the flywheel-end crankcase half using a heat gun.
- Lubricate the crankshaft bearings.
- Assemble the crankshaft into the crankcase half.
- Apply an adequate layer of sealing compound to the contact faces of the flywheel-end crankcase half.
- Fit the locating dowels.
- Heat up the timing-end crankcase half using a heat gun.
- Thread the timing drive chain through its seat in the timing-end crankcase half so the chain is not visible through the oil seal seat.
- Assemble the two crankcase halves and the crankshaft.
- Tighten the crankcase bolts to the specified torque.

CAUTION Remove any excess sealing compound from the cylinder face to ensure correct sealing.

- Lubricate and install the oil seal at transmission end.
- Wrap the timing drive chain around the crankshaft sprocket.

Engines 3AS / 4AS**3.5.5. STARTER MOTOR INSTALLATION**

- Fit a new O-ring to the starter motor and lubricate.
- Install the starter motor to the crankcase and tighten the retaining screws to the specified torque.
- Refit the assemblies you had removed previously: transmission, cylinder head, cylinder, flywheel, oil pump and coolant pump.



3.5.6. TIGHTENING TORQUE SETTINGS

CRANKCASE	QTY	(Nm)	(ft-lb)
Starter motor (screw)	2	10	7.376
Crankcase	9	10	7.376

3.6. CYLINDER, HEAD AND TIMING SYSTEM

3.6.1. VALVE TAPPET COVER REMOVAL

- Loosen the retaining screws and take off the valve tappet covers.
- Remove the O-rings.

CAUTION *The valve tappet cover on the intake side is retained by two screws, whereas the tappet cover on the exhaust side has three retaining screws.*



3.6.2. ENGINE TIMING INSPECTION

- Remove the inspection hole plug from the flywheel cover.
- Rotate the crankshaft until the flywheel mark lines up with the mark on flywheel cover (TDC mark).
- Remove the clip and disconnect the oil vapour recovery tube (blow-by).
- Unscrew the retaining screws and remove the oil vapour recovery system cover (blow-by).
- Ensure that the timing pulley mark is aligned with the mark on the head. If the pulley mark is at the opposite end from the head mark, rotate the crankshaft through one additional full turn.
- Refit any parts you have removed previously.



Engines 3AS / 4AS**3.6.3. VALVE CLEARANCE
INSPECTION/ADJUSTMENT**

- Valve clearances must be checked with the engine timing marks lined up.
- Remove the valve tappet covers.
- Use a feeler gauge to measure clearance between valve and shim and make sure it conforms to specifications. If valve clearances are outside the specified ranges, loosen the check nut and work the shim to set the correct clearance.
- Tighten the check nut to the specified torque.

Engine 3AS (250 cc)

- Intake: 0.08 – 0.12 mm (0.00314 – 0.00472 in.)
- Exhaust: 0.12 – 0.16 mm (0.00472 – 0.00629 in.)

Engine 4AS (300 cc)

- Intake: 0.08 – 0.12 mm (0.00314 – 0.00472 in.)
- Exhaust: 0.16 – 0.20 mm (0.00472 – 0.00787 in.)

**WARNING**

Valve clearances must be checked and adjusted with a cold engine.

- Install the valve tappet covers.

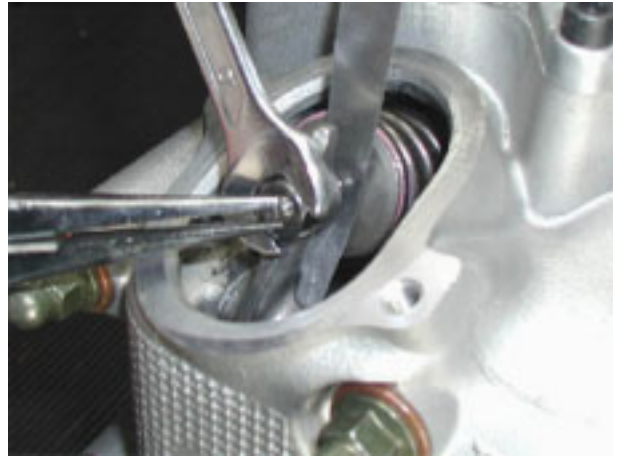

3.6.4. VALVE TAPPET COVER INSTALLATION

- Fit new O-rings.
- Position the valve tappet covers and tighten the retaining screws to the specified torque.

CAUTION The valve tappet cover on the intake side is retained by two screws, whereas the tappet cover on the exhaust side has three retaining screws.



3.6.5. CHECKING PRESSURE AT THE END OF COMPRESSION STROKE

- Check valve clearances and adjust as required.
- When the engine is cold, remove the spark plug cap.
- Remove the spark plug.

**WARNING**

Before removing the spark plug, use compressed air to dislodge any dirt that might be in the plug sleeve to prevent it from falling into the cylinder when you remove the spark plug.

- Install a compression test gauge using a spark plug fitting screwed into the spark plug hole and tightened to the correct torque.
- Crank the engine with the starter motor and the carburettor fully open until gauge reading becomes stable.

**WARNING**

To avoid producing sparks, ground the spark plug wire before cranking the engine.

- Measure compression pressure (at sea level):
 - Minimum pressure: 11.2 bar
 - Standard pressure: 14.0 bar
 - Maximum pressure: 15.7 bar
- If pressure is within the specified limits, remove the gauge and refit by reversing the removal procedure.
- If compression pressure exceeds the upper limit, look for carbon deposits on cylinder head, valve contact faces and piston crown. Clean off any carbon deposits and repeat test.
- If compression pressure is less than the lower limit, pour one spoonful of engine oil into the spark plug hole and measure pressure again.
 - If reading is higher than the first test (before adding the oil), change the piston rings.
 - If reading is the same as before, check the following components and replace as required: piston, valves, cylinder head and gasket.
- Remove the compression test gauge and the spark plug fitting.
- Refit the spark plug and tighten to the specified torque.

3.6.6. INTAKE MANIFOLD REMOVAL

- Unscrew the retaining screws.
- Remove the intake manifold and the spacer.
- Remove the O-rings fitted to the intake manifold and the spacer.



3.6.7. THERMOSTAT REMOVAL

- Unscrew the retaining screws.
- Remove fitting and thermostat together and then separate them.



3.6.8. CYLINDER HEAD REMOVAL

- Remove intake manifold and thermostat first.
- Loosen the retaining screws and take off the timing covers.
- Remove the clip and disconnect the oil vapour recovery tube (blow-by).
- Unscrew the retaining screws and remove the oil vapour recovery system cover (blow-by).



- Remove the centre screw of the tensioner.
- Unscrew the retaining screws.



- Remove the tensioner and its gasket.



- Temporarily install the drive pulley and use the suitable tool to prevent crankshaft rotation.
- Multipurpose spanner: 8140252



Engines 3AS / 4AS

- Remove the screw, the washer and the breather plate.
- Remove the camshaft drive pulley.



WARNING
Tie the timing chain to prevent it jumping off the crankshaft sprocket.



- Loosen the cylinder head nuts and bolts in two or three steps following a cross sequence.
- Collect the washers.
- Remove the cylinder head.



WARNING
Use great care to prevent the timing chain accidentally jumping off the crankshaft sprocket.



- Remove the locating dowels.
- Remove the seal.
- Remove the chain guide slider.



WARNING
Use great care to prevent the timing chain accidentally jumping off the crankshaft sprocket.



3.6.9. CAMSHAFT AND ROCKER ARM REMOVAL

- Remove the squashed metal on the lock washer.
- Unscrew the retaining screws.
- Remove the lock washer and the camshaft retaining plate.



- Fit the M6x1 adapter to the tool and remove the intake rocker arm shaft.
- Use the tool with the M6x1 adapter to remove the exhaust rocker arm shaft.

- Slide hammer with adapters: 8140432



- Use the tool fitted with the M10x1.25 adapter to remove the camshaft.

- Slide hammer with adapters: 8140432



- Remove the exhaust rocker arm.
- Remove the intake rocker arm.



Engines 3AS / 4AS

3.6.10. VALVE REMOVAL

- Place the cylinder head in a vice.
- Use the specific tool fitted with a suitable adapter to remove the cotters.



- Remove the upper retainers.
- Remove the outer and inner springs.
- Remove the valves.
- Remove the oil seals.
- Remove the lower retainers.



3.6.11. CYLINDER AND PISTON REMOVAL

- Lift off the cylinder.



WARNING
Hold the piston to avoid damage during cylinder removal.



WARNING
Use great care to prevent the timing chain accidentally jumping off the crankshaft sprocket.

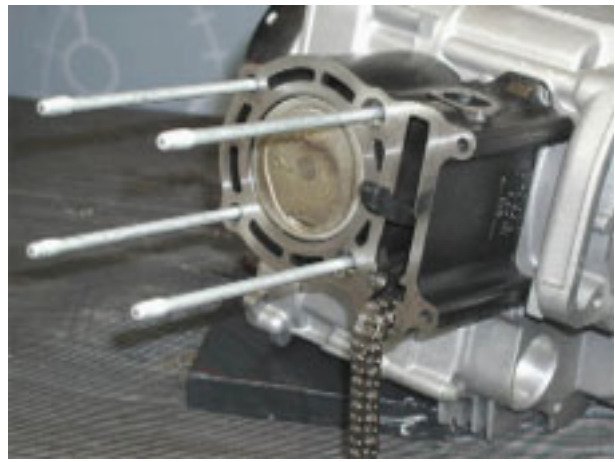

- Remove the locating dowels.
- Remove the cylinder base gasket.



WARNING
Use great care to prevent the timing chain accidentally jumping off the crankshaft sprocket.



- Protect the seating area of the crankshaft adequately.
- Remove the two retaining rings, the piston pin and the piston.

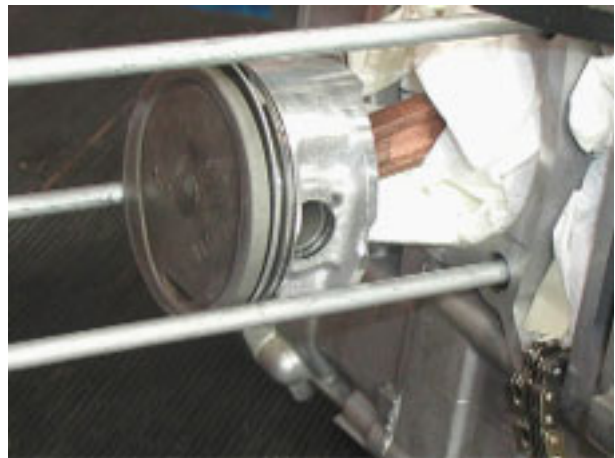

- Loosen the retaining screw and remove the chain tensioner/slider.

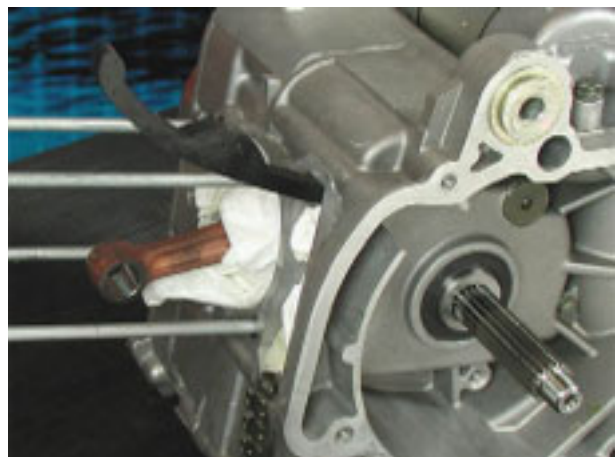

Engines 3AS / 4AS

- Remove the piston rings.

CAUTION Take care not to damage the piston rings during removal.

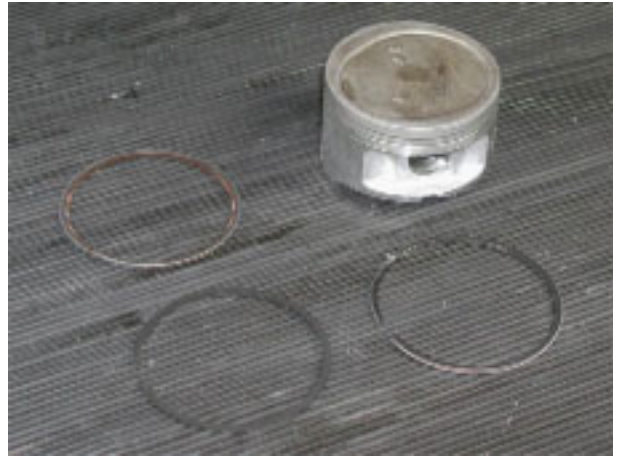

3.6.12. CONNECTING ROD SMALL END INSPECTION

- Check the connecting rod small end for wear or damage and measure its bore with an inside micrometer calliper.

CAUTION *If small end diameter exceeds the allowed range, is worn or shows traces of overheating, replace crankshaft and connecting rod.*



Engines 3AS / 4AS

3.6.13. PISTON PIN DIAMETER

- Check the outside diameter of the piston pin.
 - Correct diameter:
16.991 – 17.000 mm (0.66893 – 0.66929 in.)
 - Minimum diameter allowed: 16.975 mm (0.66830 in.)
- Calculate piston pin-to-con rod-small end clearance.
 - Correct diameter:
17.004 – 17.015 mm (0.66944 – 0.66987 in.)
 - Maximum diameter allowed: 17.045 mm (0.67106 in.)
 - Offset (intake side): 0.5 mm (0.01968 in.)
- Calculate piston-to-piston pin fit.
 - Correct clearance: 0.004 - 0.024 mm (0.00016 - 0.00094 in.)
- Measure piston outer diameter at right angles to piston pin axis.
 - Piston diameter (Engine 3AS) (250 cc) = 68.965 - 68.980 mm (2.71514 - 2.715740 in.)
 - Piston diameter (Engine 4AS) (300 cc) = 70.965 - 70.980 mm (2.79389 - 2.79448 in.)
- Using a bore gauge, measure cylinder bore diameter at two positions perpendicular to each other and repeat measurement at three different heights.
 - Correct bore diameter (Engine 3AS) (250 cc) 69.000 - 69.005 mm (2.71653 - 2.71672 in.)
 - Service limit: 69.100 mm (2.72046 in.)
 - Correct bore diameter (Engine 4AS) (300 cc) 71.000 - 71.005 mm (2.79526 - 2.79546 in.)
 - Service limit: 71.1 mm (2.7992 in.)
 - Maximum oval: 0.03 mm (0.00118 in.)
- Check the mating face that contacts the head for wear or distortion.
 - Maximum flatness error allowed: 0.05 mm (0.00197 in.)

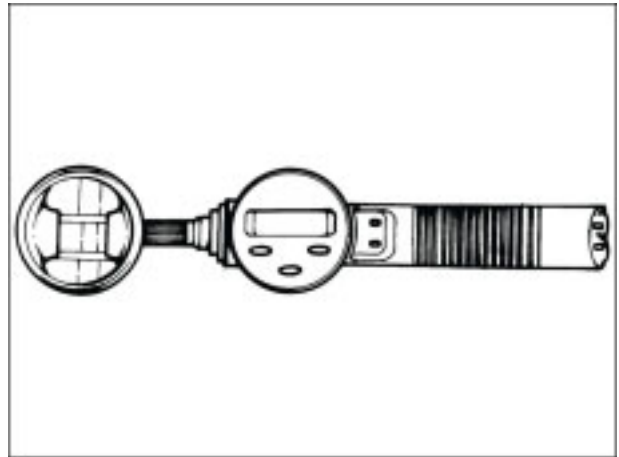

- Pistons and cylinders are grouped in different classes according to their diameter. For correct fit, always match components from the same class (A-A, B-B, C-C, D-D).
- When the cylinder is ground, finish must conform to original angle.
- Cylinder surface roughness must be 0.9 micron (0.000354 in.).
- This is critical to correct seating of the piston rings, which ensures lower oil consumption and optimal performance.

Engines 3AS / 4AS

3.6.14. PISTON

- Clean the piston ring grooves thoroughly.
- Measure ring-to-groove clearance using suitable gauges.
- When clearances are outside specifications, change the piston.



	Correct end gap	Service limit
1st ring (top ring)	0.04 - 0.08 mm	0.12 mm
2nd ring (bottom ring)	0.03 - 0.07 mm	0.12 mm

	Correct end gap	Service limit
1st ring (top ring)	0.00157 - 0.00315 in.	0.00472 in.
2nd ring (top ring)	0.00118 - 0.00275 in.	0.00472 in.

3.6.15. PISTON RINGS

- Insert the two piston rings alternately into the cylinder. Use the piston to push the rings into the cylinder so they are square in the bore.
- Measure ring end gap with a feeler gauge.
- Change the piston rings if end gap exceeds the maximum gap allowed.



	Correct clearance	Maximum running clearances
1st ring	0.15 - 0.30 mm	0.45 mm
2nd ring	0.30 - 0.45 mm	0.70 mm
oil scraper ring	0.20 - 0.70 mm	-

	Correct clearance	Maximum running clearances
1st ring	0.00590 - 0.01181 in.	0.01772 in.
2nd ring	0.01181 - 0.01772 in.	0.02756 in.
oil scraper ring	0.00787 - 0.02756 in.	-

Engines 3AS / 4AS

3.6.16. INSTALLING THE PISTON

- Protect the seating area of the crankshaft adequately.
- Lubricate connecting rod small end.
- Assemble piston and piston pin to the connecting rod so the piston arrow is pointing towards the exhaust end.
- Install the piston pin retaining rings.

**WARNING**

Be especially careful not to scratch or damage the ring grooves or the inner surfaces.



3.6.17. PISTON RING INSTALLATION

- Install the top ring (A).
- Install the second ring (B).
- Install the oil scraper ring rails (C).
- Install the oil scraper ring (D).

CAUTION The piston rings must be installed with the manufacturer's letters or numbers pointing towards the piston crown.

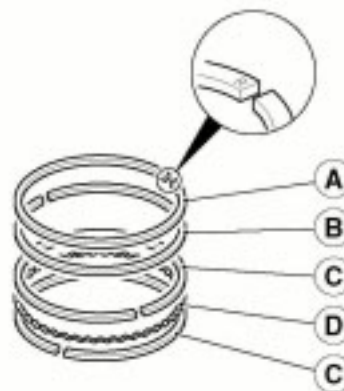

- Position the rings so that their gaps are staggered as shown in the figure.
 - a = top ring end
 - b = bottom oil scraper ring end
 - c = top oil scraper ring end
 - d = second ring end
- Lubricate all parts with abundant engine oil.

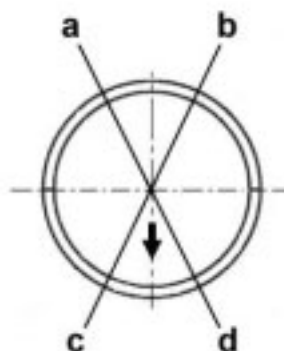

Engines 3AS / 4AS

3.6.18. CYLINDER INSTALLATION

- Clean the contact faces and the oil channels thoroughly.
- Fit the locating dowels.
- Install a new cylinder base gasket.

**WARNING**

Be especially careful not to scratch or damage the ring grooves or the inner surfaces.

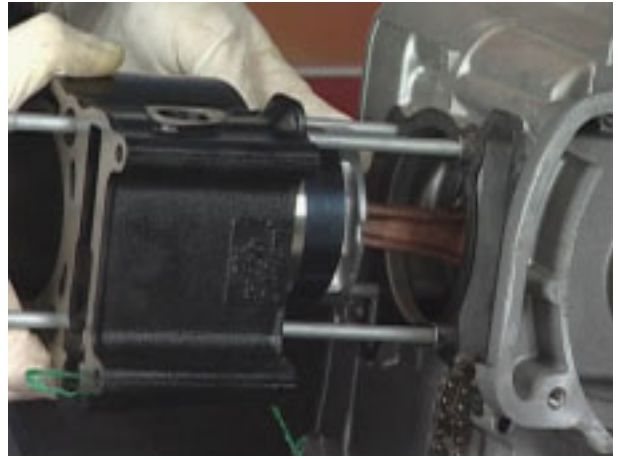

- Smear cylinder liner with oil.
- Make sure to have a suitable ring compressor ready at hand.
- Use the ring compressor to install the cylinder.

**WARNING**

Thread the timing drive chain through the seating in the cylinder taking care to prevent the chain from accidentally jumping off the crankshaft sprocket.

3.6.19. HEAD INSPECTION

- Using a grind-finished bar and a feeler gauge, check the head face for wear or distortion.

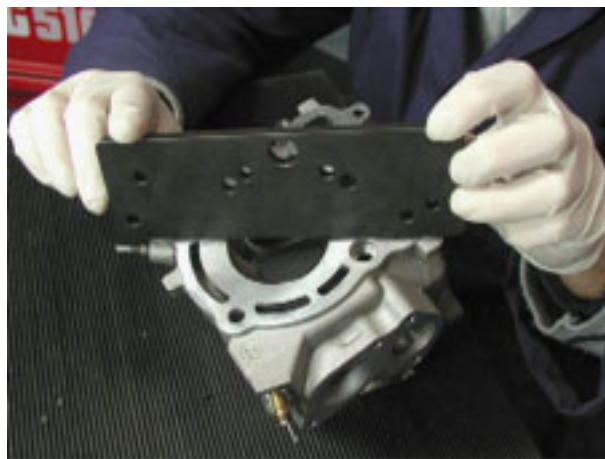

- Check the camshaft and rocker arm shaft locations for wear.
- Check the mating faces of valve tappet covers, intake manifold, exhaust manifold and thermostat for wear.



3.6.20. CHECKING VALVES FOR WEAR

- Clean off any carbon deposits from the valve.
- Measure valve stem diameter at three different heights.

Valve stem diameter (d)

Intake: 5.975 – 5.990 mm (0.23523 – 0.23582 in.)

Exhaust: 5.960 – 5.975 mm (0.23464 – 0.23523 in.)

Service limit for valve stem diameter (d)

Intake: 5.940 mm (0.23385 in.)

Exhaust: 5.920 mm (0.23307 in.)

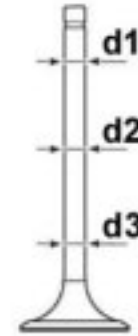

- Check the size of valve head.

Face width (A)

Intake and exhaust: 3.394 – 3.960 mm (0.1336216 – 0.155905 in.)

Valve seat width (B)

Intake and exhaust: 0.9 – 1.1 mm (0.03543 – 0.04331 in.)

Service limit: 1.6 mm (0.06299 in.)

Valve head diameter (C)

Intake: 33.900 – 34.100 mm (1.33464 – 1.34251 in.)

Exhaust: 28.4 – 28.6 mm (1.11810 – 1.12598 in.)

Thickness of valve head edge (D)

Intake and exhaust: 0.8 – 1.2 mm (0.03149 – 0.04724 in.)

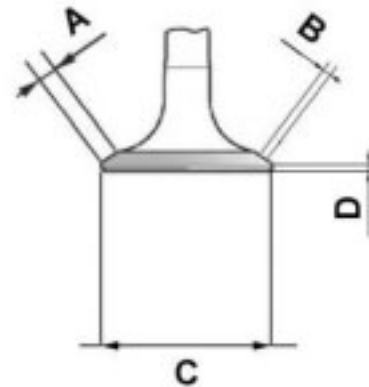

- Measure the valve stem out-of-round.

Maximum out-of-round allowed: 0.01 mm (0.00039 in.)

- Change the valve if valve wear exceeds the specified range.

3.6.21. CHECKING VALVE SEAT WEAR

- Clean off any carbon deposits on the valve guides.
- Measure the inner diameter of all valve guides.
- Measure at three different heights in the same direction as rocker arm thrust motion.

Correct inner diameter of valve guide

Intake and exhaust: 6.000 – 6.012 mm (0.23621 – 0.23669 in.)

Service limit for inner diameter

Intake and exhaust: 6.05 mm (0.23819 in.)

If the width of the valve seating surface on the valve seat or the valve guide diameter exceed the specified limits, change the cylinder head.



- Calculate valve stem-to-valve guide clearance.

Valve stem-to-valve guide clearance

Intake: 0.010 – 0.037 mm (0.00314 – 0.00472 in.)

Exhaust: 0.025 – 0.052 mm (0.00472 – 0.00787 in.)

Valve stem-to-valve guide clearance limit

Intake: 0.08 mm (0.00314 in.)

Exhaust: 0.10 mm (0.00394 in.)

- Check the surface that contacts the shim end for wear.
- If after the above inspections all parts proved within specifications, you may reuse the valves. To achieve optimal sealing, it is advisable to grind the valves. Grind gently with fine emery. While grinding the valves, hold the head so to keep valve axes horizontal otherwise grit could get between stem and guide.



WARNING

Stop rubbing the valve when emery is finished or you will score the contact face. Thoroughly clean head and valves with a cleaning agent suitable for the type of emery used.

3.6.22. VALVE LEAK TEST

- Insert the valve into the head.
- Test the intake and exhaust valves alternately.
- Test procedure is as follows: fill manifold with petrol, push down valve with your fingers and look for petrol oozing past the valve.

3.6.23. CHECKING SPRINGS, RETAINERS AND COTTERS

- Check the spring upper and lower retainers and the cotters for abnormal wear.
- If you find an abnormal condition or abnormal wear, change the affected parts.



Engines 3AS / 4AS

3.6.24. VALVE INSTALLATION

- Install the lower retainers.
- Install the oil seals.
- Insert the valves.
- Install the outer and inner springs.
- Install the upper retainers.

CAUTION For valve spring installation, refer to the colour-coded end that must be facing the upper cotters (coils farther apart).



- Attach the suitable adapter to the specific tool and use it to compress the springs and fit the cotters into their seats.



3.6.25. TIMING COMPONENT INSPECTION

- Check the chain for wear.
- Check the guide slider and the tensioner/slider for excessive wear.
- Check the camshaft drive pulley for wear.
- Replace any worn parts; if the chain or the pulley are worn, replace the whole assembly as a set.



- Remove the centre screw and the tensioner spring. Check the non-reverse mechanism for wear.
- Ensure that the tensioner spring is in good condition.
- If any part is worn, replace the whole assembly as a set.
- Work the retainer and ensure the chain tensioner slides properly.

Engines 3AS / 4AS

3.6.26. CHECKING CAMSHAFT AND ROCKER ARMS

- Check the bearings for wear and measure cam height.

Intake = 37.051 – 37.151 mm (1.45870 – 1.46263 in.)
 Exhaust = 37.053 – 37.153 mm (1.45877 – 1.46271 in.)
 Service limit = 36.956 mm (1.45496 in.)

- Clean the lubrication holes with compressed air.



- Measure cam width.

Intake = 30.074 – 30.174 mm (1.18401 – 1.18795 in.)
 Service limit = 29.973 mm (0.11705 in.)
 Exhaust = 30.091 – 30.191 mm (1.18468 – 1.18862 in.)
 Service limit = 23.194 mm (0.91315 in.)



- Check the rocker arm shafts for scoring or wear and measure their diameter.

Intake = 11.981 – 11.991 mm (0.47169 – 0.47208 in.)
 Service limit = 11.950 mm (0.47047 in.)



Exhaust = 11.981 – 11.991 mm (0.47169 – 0.47208 in.)
 Service limit = 11.950 mm (0.47047 in.)



- Check the slider that contacts the cam and the shim for wear.
- Measure the inner diameter of all rocker arms.

Intake and exhaust = 12.000 – 12.018 mm (0.47243 – 0.47314 in.)

Service limit = 12.030 mm (0.47362 in.)

- Clean the lubrication holes with compressed air.
- Replace any worn parts or parts that fall outside the specified limits.



Engines 3AS / 4AS

3.6.27. CAMSHAFT AND ROCKER ARM INSTALLATION

- Lubricate the rocker arms and fit them into place in the correct positions.

**WARNING**

The rocker arms have numbers etched in relief to identify their positions: "6" stands for exhaust end, "5" for intake end.



- Lubricate and install the camshaft.
- Change the O-ring at the exhaust end of the shaft.
- Lubricate the exhaust end shaft and install it using a suitable slide hammer tool.
- Lubricate the intake end shaft and install it using a suitable slide hammer tool.

**WARNING**

Locate the slot in the intake end shaft into the stud bolt seat in the cylinder head.



- Install a new camshaft retaining plate and a new stop washer.
- Tighten the retaining screws to the specified torque.
- Squash the lock washer.



3.6.28. INSTALLING THE CYLINDER HEAD AND TIMING COMPONENTS

- Fit the locating dowels.
- Install a new seal.
- Fit the chain tensioner/slider and tighten the retaining screw.
- Install the chain guide slider.

**WARNING**

Use great care to prevent the timing chain accidentally jumping off the crankshaft sprocket.



CAUTION Before installing the cylinder head, ensure that the mating face and the oil channels are clean. Clean with compressed air.

- Install the cylinder head threading the timing chain into its seat.

**WARNING**

Thread the timing drive chain through the seat in the head taking care to prevent it jumping off the crankshaft sprocket.

- Snug the nuts with washers and the screws on timing-chain side and tighten them to the specified torque in a cross sequence, in two or three steps.



Engines 3AS / 4AS

3.6.29. TIMING COMPONENT INSTALLATION

- Rotate the crankshaft until the flywheel mark lines up with the mark on flywheel cover (TDC mark).
- Install the camshaft drive pulley so that the mark aligns with the mark on the cylinder head.
- Install the breather plate, the washer and the screw.
- Fit the suitable locking tool to the drive pulley to prevent crankshaft rotation.
- Multipurpose spanner: 8140252
- Tighten the retaining screw for pulley/breather plate to the specified torque.
- Fit a new seal.
- Press the locking tab until the tensioner retracts fully.



- Install the chain tensioner and tighten the retaining screws to the specified torque.
- Change the tensioner O-ring.
- Position the spring and tighten the centre screw of the tensioner to the specified torque.

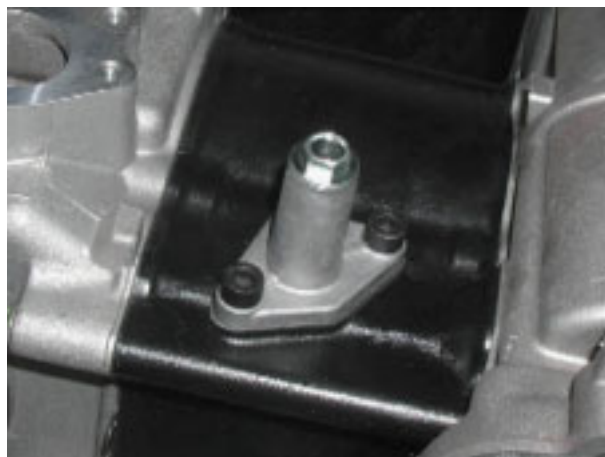

- Fit the oil vapour recovery system cover (blow-by) and tighten the retaining screws to the specified torque.
- Connect the oil vapour recovery tube (blow-by) and secure it with a clip.
- Fit the timing covers and tighten the retaining screws to the specified torque.
- Install the intake manifold and the thermostat.



3.6.30. THERMOSTAT INSTALLATION

- Assemble thermostat and fitting and install them to cylinder head.
- Tighten the retaining screws to the specified torque.



3.6.31. INTAKE MANIFOLD INSTALLATION

- Fit new O-rings to spacer and intake manifold.
- Install spacer and manifold.
- Tighten the retaining screws.

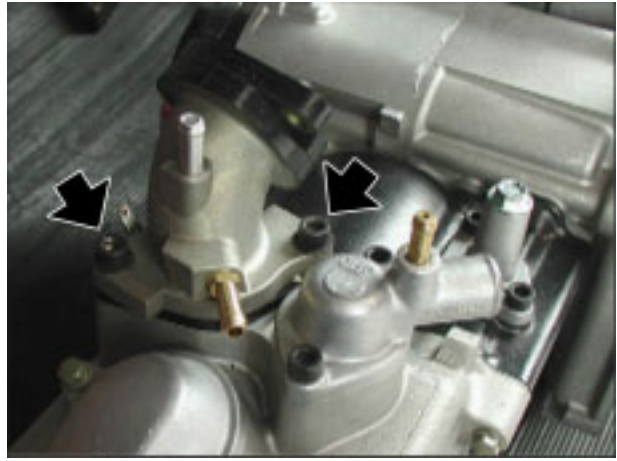

3.6.32. TIGHTENING TORQUE SETTINGS

CYLINDER HEAD	QTY	(Nm)	(ft-lb)
Spark plug tightening	1	18	13.276
Cylinder head stud bolt (screw)	4	13	9.588
Cylinder head nut	4	22	16.226
Cylinder head bolt	2	10	7.376
Tappet covers (screw)	5	10	7.376
Rotor nut	1	80	59.005
Valve clearance adjuster check nut	2	14	10.326
Camshaft retaining plate / washer (screw)	2	8	5.900
Pulley / breather plate (screw)	1	60	44.254
Timing chain tensioner fastener (screw)	2	10	7.376
Timing chain tensioner adjustment (screw)	1	8	5.900
Oil vapour recovery system cover (blow-by) (screw)	2	10	7.376
Thermostat fitting (screw)	2	10	7.376
Spark advance inspection hole cap	1	8	5.900
Thermal switch	2	23	16.964
Thermal unit	1	8	5.900

3.7. SECONDARY AIR SYSTEM

3.7.1. SAS

The Secondary Air System (SAS) has been developed to reduce carbon oxide and unburnt hydrocarbon emissions in vehicles that are not equipped with a lambda sensor. Natural air (which is rich in oxygen) is channelled into the exhaust stream to trigger a post-combustion process that raises the temperature of the exhaust gasses for a quick light-off of the catalyst.

The secondary air system is especially useful when the engine is idling and during warm-up, as the catalyst alone is not capable of triggering post-combustion under these operating conditions.

DESCRIPTION OF THE SYSTEM

The secondary air system operates on pressure fluctuation in the exhaust system. During depression stages, the exhaust takes in oxygen-rich air from the secondary air system so unburnt gasses in the exhaust stream can complete the combustion.

During overpressure stages, the secondary air reed valve cuts air supply to prevent backflow.

On 4-stroke engines, the reed valve is equipped with a cut-off device that shuts down additional air during cut-off stages, as exceedingly lean exhaust gasses would lead to exhaust blowing, resulting in exhaust valve and catalytic converter damage.

DETAILS OF SAS

- Natural air is taken in through a tube (1) placed on the left side of the vehicle (under the tail end) and is made to pass through a suitable filter (2).
- To gain access to the filter, remove the tail end (see manual, CHASSIS).
- Remove the clips (3).
- Loosen and remove the screws (4).
- Remove the filter (2); clean or replace as required.



Engines 3AS / 4AS

- Another tube (5) conveys filtered air to the secondary air valve (6) mounted to right side of engine; air is channelled through a tube (7) to cylinder head.

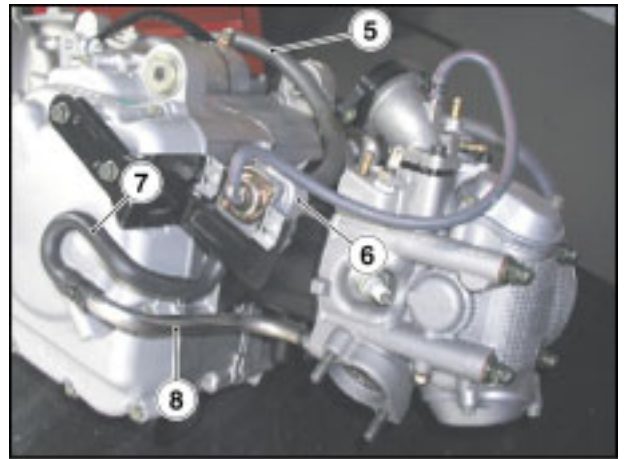

- The secondary air tube (7) is connected to a flanged metal fitting (8) attached directly to the head exhaust duct.



- The secondary air valve is fitted with a cut-off device (9), that is operated through the vacuum take-up point in the intake manifold (10) and cuts air supply during the cut-off stage to prevent exhaust blowing.

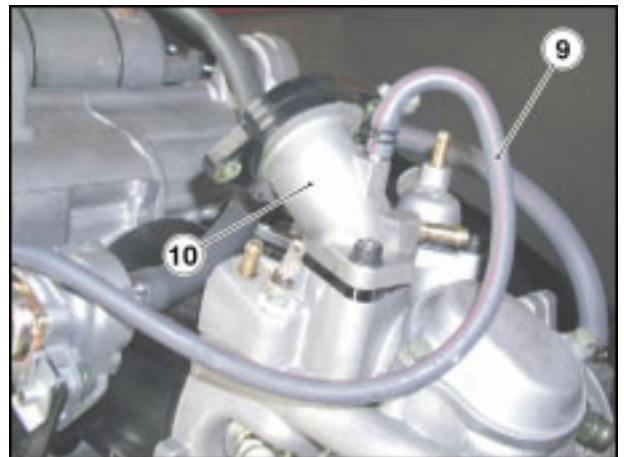



aprilia s.p.a.
via G. Galilei, 1
30033 Noale (VE) Italy
tel. +39 041.5829111
fax +39 041.5829190
www.aprilia.com
www.serviceaprilia.com