

Repair Manual

R 80 GS – R 100 R



BMW Motorrad GmbH + Co.
Service Department

Contents

- 0 Introduction
- 1 Completing the motorcycle and pre-delivery check
- 2 Maintenance and inspection
- 3 Operating media and servicing data
- 4 Electrics
- 5 Brake system
- 6 Suspension
- 7 Frame attachments
- 8 Exhaust system
- 9 Gearbox
- 10 Clutch
- 11 Engine
- 12 Technical data

Introduction

This Workshop Manual is intended to ensure that all major maintenance and repair work is carried out expertly. If used regularly by workshop personnel, it will add to the practical and theoretical knowledge provided by the Service Training School, and therefore make it easier to achieve the required high service quality standards.

A new edition will be issued if amendments or additions (supplements) are needed. The sections of the manual concerned will be marked with the new issue date. Microfiches which are rendered out of date as a result should be destroyed without delay.

All information contained in illustrations or descriptions refers to standard production motorcycles or those fitted with Original BMW Accessories and not modified in any other way.

- The Workshop Manual is laid out in the logical working order: removal, stripping down (dismantling), repair, assembly, installation.
- The contents are divided up into separate chapters. The page numbering means:

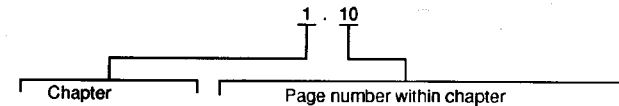

- The work to be performed during an Inspection is stated in an Inspection and Maintenance Schedule. The various levels of Inspection work are designated with Roman figures: I, II, III. The same designations are used in the work descriptions which follow, so that a continuous work sequence is assured.
- Where necessary, the work descriptions state which BMW special tools are to be used.

When the need arises, repair instructions are also issued in the form of Service Information bulletins. Their contents are incorporated into the next issue of the Workshop Manual. In addition, you are recommended to refer to the illustrated Parts microfiche as a further source of information.

BMW Motorrad GmbH + Co.
Service Department – Technical

Published by: BMW Motorrad GmbH + Co.
Triebstraße 32
8000 München 50
Federal Republic of Germany

All rights reserved. Not to be reprinted, translated or reproduced wholly or in part without prior written permission.
Subject to technical amendments; errors and omissions excepted.
Printed in Western Germany

SUMMARY OF MAIN GROUPS

| New Old | 1-3 | 4 | 5 | 6 | 7 | 8 | 9 | 10 | 11 | 12 | 13 | 14 |
|------------|-----|---|---|---|---|---|---|----|----|----|----|----|
| 00 | | | | | | | | | | | | |
| 11 | | | | | | | | | | | | |
| 12 | | | | | | | | | | | | |
| 13 | | | | | | | | | | | | |
| 16 | | | | | | | | | | | | |
| 17 | | | | | | | | | | | | |
| 18 | | | | | | | | | | | | |
| 21 | | | | | | | | | | | | |
| 23 | | | | | | | | | | | | |
| 31 | | | | | | | | | | | | |
| 32 | | | | | | | | | | | | |
| 33 | | | | | | | | | | | | |
| 34 | | | | | | | | | | | | |
| 36 | | | | | | | | | | | | |
| 46 | | | | | | | | | | | | |
| 51 | | | | | | | | | | | | |
| 52 | | | | | | | | | | | | |
| 61 | | | | | | | | | | | | |
| 62 | | | | | | | | | | | | |
| 63 | | | | | | | | | | | | |

Note:

The form and structure of the Workshop Manual have been revised; the main groups and their numbering have also changed.

Since the contents of individual main groups are closely related, they have now been grouped together into chapters of their own. This makes it easier to locate the required information and gain access to the group concerned.

The old and new main group numbers are compared in this summary. The black areas indicate the actual status of the manual.

**1. FITTING OUT
MOTOR CYCLE AND
DELIVERY INSPECTION**

Contents **Page**

1.1 FITTING OUT MOTOR CYCLE **1.5**
INSTALLING WINDSHIELD 1.5
AFFIXING HELMET STICKER 1.5
TIGHTENING HANDLEBAR CONTROLS 1.5
INSTALLING REAR-VIEW MIRRORS 1.5

1.2 DELIVERY INSPECTION **1.6**
REMOVING BATTERY 1.6
FILLING BATTERY WITH ELECTROLYTE 1.6
CHARGING BATTERIES 1.7
CHECKING REAR WHEEL BOLTS ARE TIGHT 1.7
CHECKING/CORRECTING TIRE INFLATION PRESSURE 1.7
CHECKING LIGHTING AND SIGNAL SYSTEM 1.7
CHECKING/TOPPING UP BRAKE FLUID 1.8
PERFORMING OPERATIONAL CHECK 1.8
FINAL VISUAL INSPECTION FOR LEAKS ON: 1.8

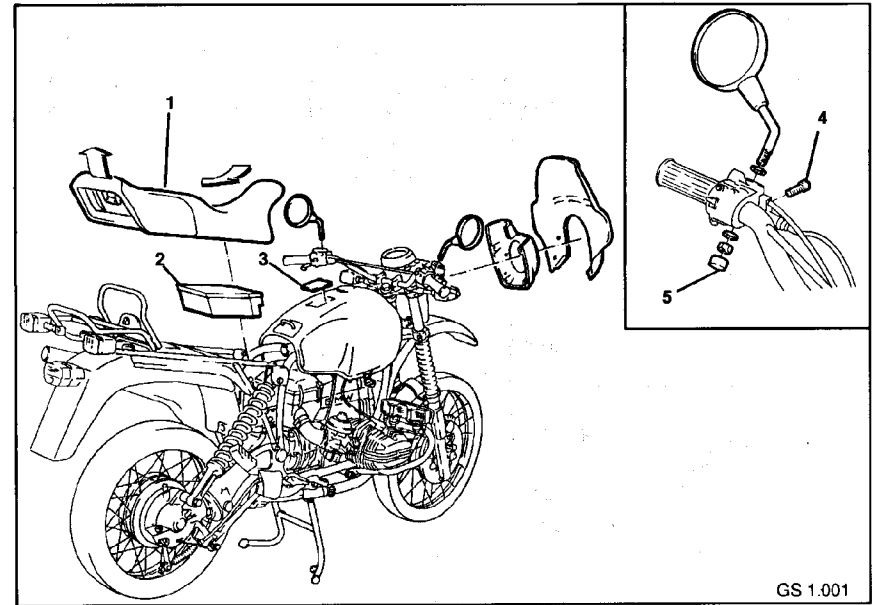

GS 1.001

1.1 FITTING OUT MOTOR CYCLE

INSTALLING WINDSHIELD

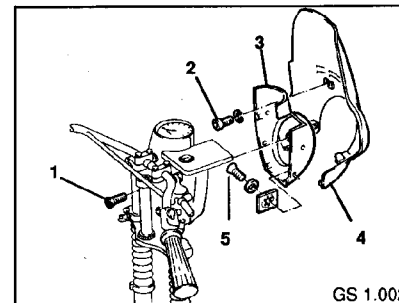

GS 1.002

- Remove windshield (4) from the enclosed carton.
- After slackening the 4 fastening screws (1), take off front section (3) of the headlamp fairing.
- Screw windshield to the front section of the headlamp fairing with 4 fastening screws (5, 2).

- Screw front section of headlamp fairing together with windshield to rear section with four fastening screws (1).

AFFIXING HELMET STICKER

- Affix helmet sticker (3) to the middle of the top of the fuel tank behind the tank cap.

TIGHTENING HANDLEBAR CONTROLS

- Align lefthand and righthand handlebar controls ergonomically (fitted on loosely).
- Clamp tight by tightening each on the fastening screws (4).

INSTALLING REAR-VIEW MIRRORS

- Install lefthand/righthand rear-view mirrors in the order shown in illustration.
- Fit on protective cap (5).
- Take off seat (1) after releasing seat lock.
- Check contents of stowage dish (2).
- Checking whether tools in stowage dish and documentation are complete.

Contents of dish: bike tools, breakdown assistance kit, 3 bike keys (1 folding key, 2 ridged keys).

Documentation: Owner's Manual, List of Dealers, First-Aid Guide.

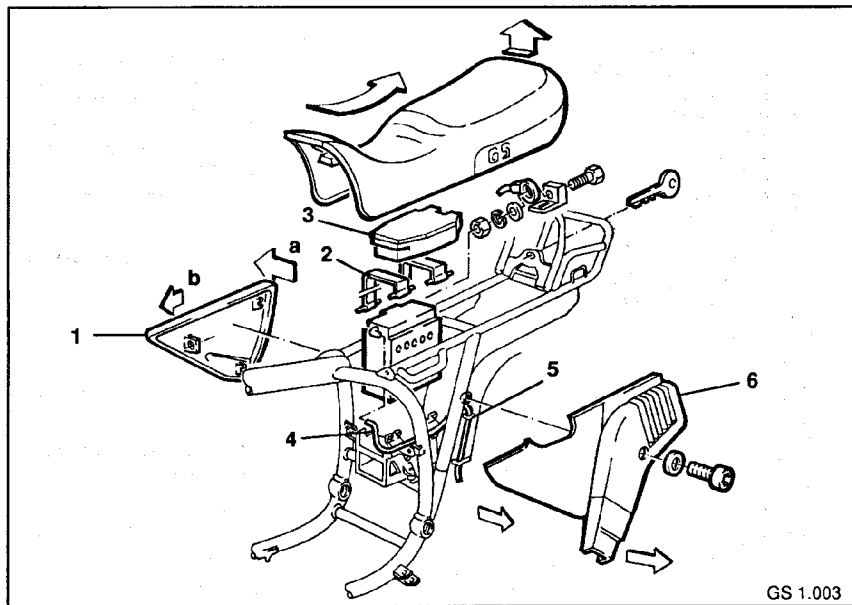

1.2 DELIVERY INSPECTION

NOTE:

The delivery inspection should be performed immediately before handing over the motor cycle to the customer.

REMOVING BATTERY

- Take off seat.
- Remove stowage dish (3).
- Take off righthand battery cover (1) in direction of arrow.
- Lift off left battery cover (6) in direction of arrow, and loosen screw (GS only).
- Detach battery tensiing straps (2).
- Unscrew negative terminal on battery.
- Lift battery up out of mount (withdraw angled vent pipe (4) from battery if necessary).

FILLING BATTERY WITH ELECTROLYTE

CAUTION:

The battery contains sulfuric acid. Avoid acid coming into contact with eyes and skin or clothing. Remedy: wash contact areas with water. If acid has been swallowed, drink large quantities of milk or water.

Contact a doctor without delay. Wash out eyes with water and obtain medical treatment.

Battery gives off explosive gases. Avoid sparking, naked flames and smoking. When working close to batteries, always wear protective goggles.

STORE BATTERIES AWAY FROM THE REACH OF CHILDREN!

Store batteries only in well-ventilated rooms. The filler caps must always be removed.

- Remove plugs from battery.

- Fill battery with pure electrolyte (conforming to VDE 0510, Density: 1.28 kg/l, for tropical countries 1.25 kg/l (related to electrolyte temperature of 20°C) up to specified level ("Max" mark).
- Leave battery to stand for approx. 1 hour, then shake slightly or tip (to vent) and top up electrolyte level to "Max" mark if necessary.
- Screw in plugs loosely (do not tighten fully until after battery is charged).

CAUTION:

After being filled, the dry-charged battery attains only 60% of its rated capacity. It is therefore essential to charge battery. Avoid allowing filled batteries to stand for lengthy period when not in use. Do not fill battery with electrolyte until just before it is to be used.

CHARGING BATTERIES

CAUTION:

Do not exceed a maximum charging current of 10% of battery capacity.

Maximum charging temperature = 40°C.

Example:

25 Ah-battery = charging current 2.5 Amperes
Charging time = 5 ... 10 hours

The charged state of the battery can be checked by measuring the electrolyte density.

Electrolyte density of fully-charged battery = 1.256 ... 1.30 kg/l related to 20°C.

- Shake battery slightly after charging – gas bubbles rise to the surface.
- After the electrolyte has settled, top up with distilled water to "Max" mark, if necessary.
- Screw in plugs tight.
- Install battery.

NOTE:

Ensure vent hose (5) is correctly routed.

CAUTION:

Connect battery positive terminal first, then negative terminal.

- Connect vent line.

CHECKING REAR WHEEL BOLTS ARE TIGHT

Tightening torque:
rear wheel bolt

105 Nm

CHECKING/CORRECTING TIRE INFLATION PRESSURE

Check tire inflation pressure when tires are cold; correct if necessary.

| | | |
|------------------------|-------|---------|
| Solo | front | 2.2 bar |
| | rear | 2.5 bar |
| with pillion passenger | front | 2.4 bar |
| | rear | 2.9 bar |

CHECKING LIGHTING AND SIGNAL SYSTEM

- Main beam, dipped beam, and parking lights;
- Stop, licence plate and turn signal lamps;
- Main beam, battery charge, idling and oil pressure indicator lamps;
- Horn and any optional equipment fitted.

CHECKING/TOPPING UP BRAKE FLUID

Checking brake fluid:

CAUTION:

Brake fluid is caustic. Avoid contact with eyes and skin and also with clothing. Protect paintwork from contact with brake fluid.

CAUTION:

The brake fluid level must extend to below "MAX" mark when the reservoir is closed. The brake fluid level must never drop below the "MIN" mark.

Take care when pouring in brake fluid.

Topping up brake fluid

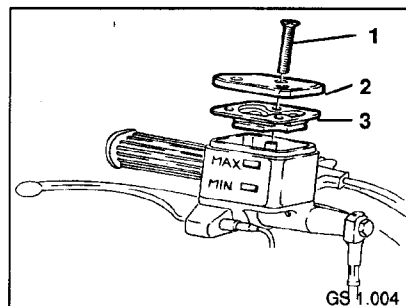

- Slacken the 3 fastening screws (1) and carefully lift lid (2) off the brake fluid reservoir.
- Take off bellows (3).

NOTE:

Use only brake fluid conforming to quality DOT 4 (e.g. ATE brake fluid "SL").

- Top up brake fluid until just below the "MAX" mark.
- Insert bellows, fit on cover and tighten gently with 3 fastening screws.

PERFORMING OPERATIONAL CHECK

- Clutch
- Gearshift
- Steering
- Footbrake
- Handbrake
- Operational instruments; perform test run, if necessary
- Following this, check idle setting of engine, correct if necessary; refer to adjusting carburetor (engine at normal operating temperature).

FINAL VISUAL INSPECTION FOR LEAKS ON:

- Engine
- Transmission
- Rear axle housing
- Telescopic forks and
- Fuel system

Stamp and sign Owner's Manual as confirmation that delivery inspection has been performed.

2. MAINTENANCE AND INSPECTION

| Contents | Page |
|--|-------------|
| BMW Maintenance and Inspection Schedule | 2.5 |
| 2.1 TIGHTENING CYLINDER HEAD NUTS | 2.7 |
| TIGHTENING CYLINDER HEAD NUTS (INSPECTION I) | 2.7 |
| CHECKING/ADJUSTING END PLAY OF ROCKER ARM (Inspection III) | 2.8 |
| ADJUSTING VALVE CLEARANCE (Inspection I, II, III) | 2.9 |
| 2.2 TESTING COMPRESSION PRESSURE | 2.10 |
| 2.3 SPARK PLUGS | 2.11 |
| CONDITION OF SPARK PLUGS | 2.11 |
| ELECTRODE GAP | 2.12 |
| CHECKING SPARK PLUGS AND ELECTRODE GAP (INSPECTION II) | 2.12 |
| 2.4 RENEWING AIR FILTER | 2.13 |
| 2.5 CLEANING FUEL COCKS | 2.13 |
| 2.6 CLEANING CARBURETTOR FLOAT HOUSING (Inspection II,III) | 2.14 |
| 2.7 CHECKING/ADJUSTING CLUTCH PLAY (Inspection I, III) | 2.14 |
| 2.8 CHECKING/ADJUSTING FIRING POINT | 2.15 |
| CHECKING/ADJUSTING FIRING point (Static) | 2.15 |
| CHECKING/SETTING FIRING POINT (Dynamic) | 2.16 |
| 2.9 SYNCHRONISING CARBURETTORS ADJUSTING CABLES (Inspection I, II, III) | 2.17 |
| BASIC SETTING OF CARBURETTOR | 2.17 |
| SYNCHRONISING CARBURETTORS WITHOUT CO MEASUREMENT | 2.18 |
| SYNCHRONISING CARBURETTORS WITH CO MEASUREMENT | 2.18 |
| SYNCHRONIZING CARBURETTORS WITH CO MEASUREMENT FOR PAS | 2.19 |
| FINAL SETTING OF THROTTLE CABLES | 2.19 |
| 2.10 CHANGING OIL AND OIL FILTER IN ENGINE (Inspection I, II, III) | 2.20 |
| DRAINING ENGINE OIL | 2.20 |
| CHANGING OIL FILTER | 2.20 |
| POURING IN ENGINE OIL | 2.21 |
| 2.11 CHANGING OIL IN TRANSMISSION (Inspection I, III) | 2.21 |
| 2.12 CHANGING TRANSMISSION OIL IN REAR WHEEL DRIVE (Inspection I, III) | 2.22 |
| 2.13 CHANGING OIL IN TELESCOPIC FORK (Inspection I, III) | 2.23 |

Contents **Page**

2.14 CHECKING FRONT BRAKE PADS FOR WEAR/RENEWING (Inspection III) 2.24

2.15 CHECKING BRAKE DISCS (Inspection II) 2.27

2.16 CHECKING/TOPPING UP BRAKE FLUID LEVEL (Inspection I, III) 2.27

2.17 CHANGING BRAKE FLUID 2.28

2.18 BLEEDING FRONT WHEEL BRAKE SYSTEM 2.29
 BLEEDING FRONT WHEEL BRAKE SYSTEM WITH BLEEDER 2.29
 BLEEDING FRONT WHEEL BRAKE USING HANDBRAKE LEVER 2.30

2.19 CHECKING REAR BRAKE PADS FOR WEAR/RENEWING BRAKE SHOE IF NECESSARY (Inspection III) 2.31
 CHECKING REAR BRAKE PADS FOR WEAR 2.31
 RENEWING REAR BRAKE SHOE 2.31

2.20 CHECKING/ADJUSTING FOOT BRAKE LEVER PLAY (Inspection III) 2.33

2.21 CHECKING REAR WHEEL FOR TILT PLAY (Inspection III) 2.33

2.22 CHECKING FRONT WHEEL BEARING (Inspection III) 2.33

2.23 CHECKING/ADJUSTING STEERING BEARING PLAY (Inspection III) 2.34

2.24 GREASING CLUTCH CABLE NIPPLES (Inspection II, III) 2.35

2.25 ADJUSTING SWING ARM BEARING PLAY (Inspection III) 2.35

2.26 BATTERY MAINTENANCE 2.35
 BATTERY FAULTS 2.35
 COMMISSIONING BATTERY 2.36
 CHARGING BATTERIES 2.36
 CHECKING /TOPPING UP ELECTROLYTE LEVEL OF BATTERY (INSPECTION III) 2.36
 BATTERY CARE WHEN MOTOR CYCLE STORED OUT OF USE 2.37

2.27 CHECKING NUTS AND BOLTS FOR TIGHT FIT (Inspection I, II, III) 2.37

2.28 CONSCIENTIOUSLY PERFORMING FINAL INSPECTION WITH CHECK OF ROAD/OPERATIONAL SAFETY (Inspection I, II, III) 2.37

BMW Maintenance and Inspection Schedule

ENGINE AND TRANSMISSION

| | I | II | III | Page |
|--|---------------------------|---|---|------|
| | BMW inspection at 1000 km | BMW inspection at 7500 km and every additional 15000 km | BMW service at 15000 km and every additional 15000 km | |
| Tightening cylinder head nut | X | | | 2.7 |
| Checking rocker arm and play, adjusting if necessary | | | X | 2.8 |
| Adjusting valve clearance | X | X | X | 2.9 |
| Checking spark plug electrode gap | | X | | 2.12 |
| Renewing spark plugs | | | X | 2.12 |
| Renewing intake filter | | | X3) | 2.13 |
| Cleaning carburettor float chamber | | X | X | 2.14 |
| Cleaning fuel cocks4) | | | X | 2.13 |
| Checking clutch play, adjusting if necessary | X | | X | 2.14 |
| Setting filling point | X | | X | 2.15 |
| Synchronising carburetors, adjusting cables | X | X | X | 2.17 |
| Renewing oil filter | X | X | X1) | 2.19 |
| Replacing engine oil at normal operating temperature | X | X | X1) | 2.19 |
| Replacing transmission oil at normal operating temperature | X | X | X2) | 2.20 |
| Replacing transmission oil in rear wheel drive at normal operating temperature | X | | X2) | 2.21 |

Recommendation: Re-grease throttle control and handlebar bearings at least every 3000 km if motor cycle used in extreme conditions*).

*) Invoiced separately

1) at least every six months, every 3 months or at least every 3000 km if motor cycle used only for short trips or at outside temperatures below 0°C

2) at least once a year

3) renew intake filter every 7500 km, or more often if necessary, if motor cycle used in extremely dusty or dirty conditions

4) as a rule every 30,000 km, every 15,000 km if fuel conditions poor

5) at least every 3 months

RUNNING GEAR

| | I | II | III | Page |
|--|---------------------------|---|---|------|
| | BMW inspection at 1000 km | BMW inspection at 7500 km and every additional 15000 km | BMW service at 15000 km and every additional 15000 km | |
| Replacing telescopic fork oil | X | | X2) | 2.21 |
| Checking brake pads and disc for wear, renewing if necessary*) | | | X | 2.22 |
| Checking brake calber for proper operation/leaks, repairing/renewing if necessary | X | | X | |
| Checking/topping up brake fluid level. Changing brake fluid at least once a year*) | X | | X | 2.24 |
| Checking connections and lines of brake system for leaks, signs of damage and correct position | X | | X | |
| Checking rear brake shoe for wear, renewing if necessary*) | | | X | 2.28 |
| Checking idle travel of rear wheel brake, adjusting if necessary | | | X | 2.30 |
| Checking wheel bearing, renewing if necessary*) | | | X | 2.30 |
| Checking handlebar bearing, adjusting if necessary*) | | | X | 2.31 |
| Adjusting swing arm bearing play | | | X | 2.32 |
| Greasing side stands and 2 nipples for clutch cable | | X | X | 2.32 |
| Checking electrolyte level of battery, topping up distilled water 5) | | | X | 2.33 |
| Cleaning and greasing battery terminals *) | | | X | |
| Checking nuts and bolts for tight fit | X | | X2) | 2.34 |
| Checking rear wheel bolts for tight fit | X | X | X2) | |
| Final inspection with examination of road/operational safety | X | X | X2) | 2.34 |

Recommendation: Re-grease throttle control and handlebar bearings at least every 3000 km if motor cycle used in extreme conditions*)

*) Invoiced separately

- at least every six months, every 3 months or at least every 3000 km if motor cycle used only for short trips or at outside temperatures below 0°C
- at least once a year
- renew intake filter every 7500 km, or more often if necessary, if motor cycle used in extremely dusty or dirty conditions
- as a rule every 30,000 km, every 15,000 km if fuel conditions poor
- at least every 3 months

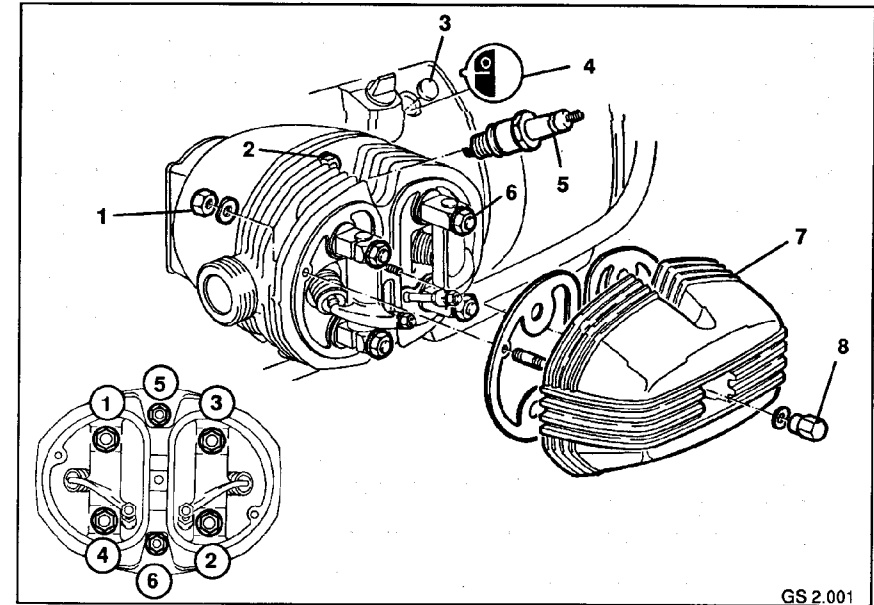

GS 2.001

2.1 TIGHTENING CYLINDER HEAD NUTS

Tightening cylinder head nuts to the specified tightening torque comprises:

- Checking/adjusting end play of rocker arms (Inspection III)
- Tightening cylinder head nut (Inspection I)
- Adjusting valve (Inspection I, II, III)

TIGHTENING CYLINDER HEAD NUTS (INSPECTION I)

CAUTION:

Engine must be cold (room temperature). After tightening the cylinder heads, always examine valve clearance, adjust if necessary. If leaks are detected between cylinder and cylinder head, examine cylinder head for signs of twisting and scorching on the sealing surfaces.

NOTE:

Collect leak oil in a suitable vessel.

- Slacken cap nut (8) on cylinder head cover (7).
- Slacken two side nuts (1) and take off cylinder head cover.
- Unscrew both spark plugs (5).
- Engage 5th gear.
- Position appropriate piston to compression TDC (TDC = Top Dead Centre) by turning rear wheel.

NOTE:

Compression TDC is reached when:

- The TDC mark (4) appears in inspection hole (3) on the bell housing and
- Inlet and exhaust valves are closed.

- Tighten collar nuts (6) and fastening nuts (2) in stages, in 3 steps, to specify tightening torque and in the order shown in tightening diagram.
- Repeat operation on 2nd cylinder.

Tightening torque:
Cylinder head nuts

15/25/35 Nm

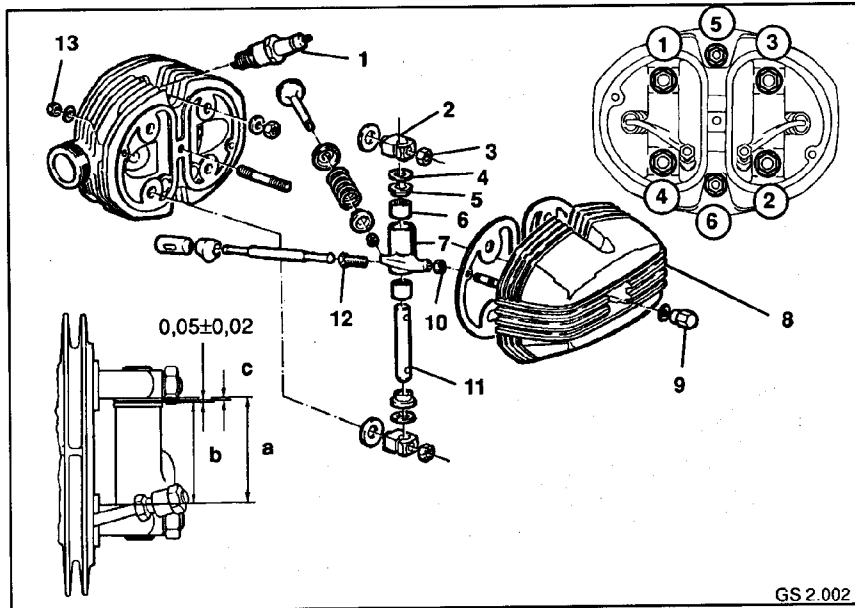

GS 2.002

**CHECKING/ADJUSTING END PLAY OF
ROCKER ARM (INSPECTION III)**

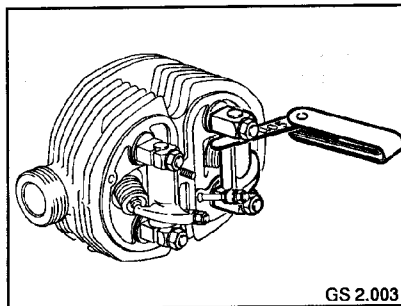

GS 2.003

a) Checking end play:

- Appropriate piston is set to compression in TDC.
- Use feeler gauge to check end play between Pertinax disc (5) and shim (6).

End play: 0.05 ± 0.02 mm

b) Adjusting end play:

- Measure distance (a) of clamp blocks (2) and note distance.

- Set piston to compression TDC.
- Slacken locking nuts (10) on the rocker arms (7).
- Turn back adjusting screws (12) of the valves far enough to fully relieve both rocker arms.
- Slacken 4 collar nuts (3) on the clamping blocks.
- Take off rocker arm shafts (11) together with clamping blocks and rocker arms.
- Take off clamping blocks and shims (4).
- Measure rocker arm together with Pertinax discs. Note measurement (b).
- Calculate thickness of spacer disc (c).

$$c = a - b - 0.05 \text{ (End play)}$$

CAUTION:

Ensure rocker armshafts and axle clamping blocks are correctly fitted. The punch marking (1) on each shaft must be pointing up and away from the cylinder.

The grooves (2) of the axle clamping blocks must be pointing out the way.

- Tighten collar nut (3) in stages in 3 steps to the specified tightening torque and in the order as shown in the tightening diagram.
 - Re-check end play.
- Repeat operation on second cylinder.

Tightening torque:
Cylinder head nuts

15/25/35 Nm

ADJUSTING VALVE CLEARANCE (Inspection I, II, III)

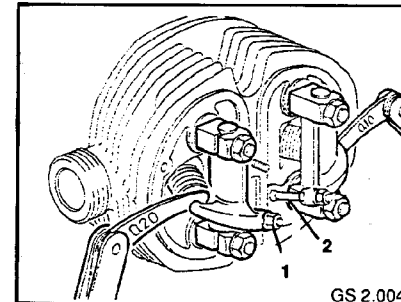

GS 2.004

- The valve clearance compensates for the different thermal expansions and wear to the individual engine components:
- Incorrect valve clearance is indicated by:
- Poor cold starting behaviour,
- Irregular idling,
- Lack of performance when engine at normal operating temperature and/or
- increased engine noises.

CAUTION:

Adjust valve clearance only when engine cold (room temperature).

- Cylinder head cover is removed.
- Appropriate piston is set to compression TDC.
- Check valve clearance between valve stem and rocker arm with feeler gauge, as shown.
- Slacken locking nut (1).
- Correct valve clearance by turning adjusting screw (2).
- Use combination wrench to prevent adjusting screw (2) from moving.
- Tightening locking nut (1).
- Re-check valve clearance. It must be possible to pull feeler gauge through between valve stem and rocker arm with slight resistance.

Valve clearance:

(Adjust when engine cold)

| up to 1000 km | | | |
|---------------|----|--|------|
| Inlet valve | mm | | 0.15 |
| Exhaust valve | mm | | 0.25 |
| from 1000 km | | | |
| Inlet valve | mm | | 0.10 |
| Exhaust valve | mm | | 0.20 |

CAUTION:

Clean sealing surface. Install cylinder head cover with gasket in perfect condition. Do not forget washers below the three fastening nuts. Screw in spark plugs in perfect condition.

Repeat operation at other cylinder.

Tightening torque:

| | |
|--------------------------------------|-------|
| Locking nut of valve adjusting screw | 20 Nm |
| Cap nut of cylinder head cover | 24 Nm |
| Spark plug | 25 Nm |

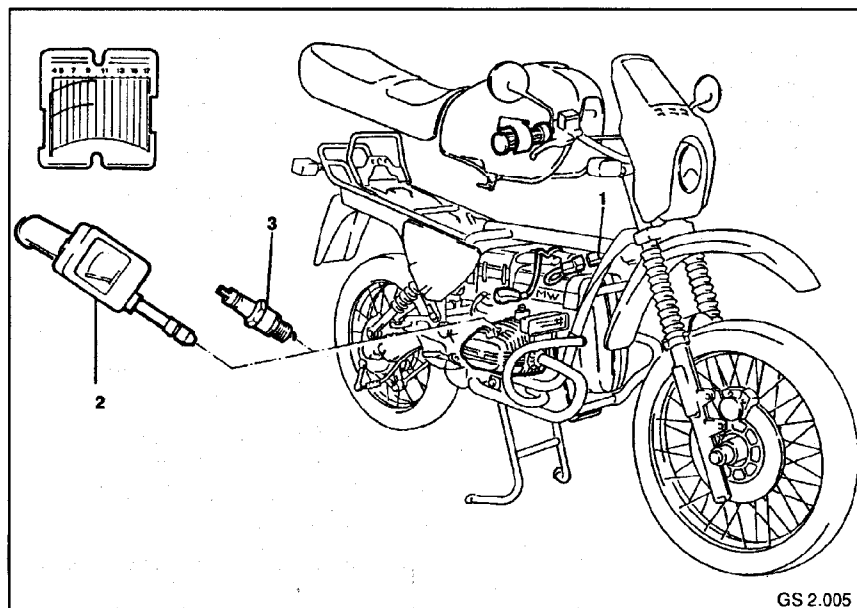

2.2 TESTING COMPRESSION PRESSURE

NOTE:

- Perform test only when:
1. valves correctly set,
 2. engine at normal operating temperature (to ensure seal between piston, piston rings and cylinder liner) and
 3. battery charged.

CAUTION:

It is essential to interrupt ignition otherwise ignition coil could be destroyed.

- Remove seat.
- Slacken locking clamp of fuel tank mounting (rear).
- Lift off fuel tank rear and prop up.
- Interrupt ignition by disconnecting three-pin plug (1).

- Unscrew spark plugs (3) on both cylinders.
- Hold throttle control in full throttle position.
- Press compression pressure tester (2) firmly into spark plug hole.
- Crank engine with starter until indicated pressure no longer rises.
- Repeat operations on other cylinder.
- Pressure difference between both cylinders must not exceed 1 bar.

Compression pressures:

| | | |
|---------------|------------------|----------------------|
| <i>good</i> | <i>more than</i> | <i>9 bar</i> |
| <i>normal</i> | | <i>7.5 ... 9 bar</i> |
| <i>poor</i> | <i>less than</i> | <i>7.5 bar</i> |

Compression pressure too low:

- Pour a few drops of engine oil into the cylinder.
- Repeat test procedure.
- If compression pressure rises: piston ring is probably worn.

Compression pressure constant:

- Valves and/or piston rings worn.

Compression pressure on both cylinders evenly too low:

- Parts of both cylinders are evenly worn.
- Following completion of test:
- Screw in spark plug on both cylinders.
 - Fit on spark plug connector.
 - Connect three-pin plug.
 - Insert fuel tank into rear lock.
 - Close locking bar.
 - Insert seat into locks at front and rear (lock if necessary).

Tightening torque:

Spark plugs

25 Nm

2.3 SPARK PLUGS

- The spark plug can provide information regarding the ignition and carburettor settings as well as regarding the state and operating conditions of the engine.
- The following procedure should be adopted for examining the spark plug pattern:
- Warm up engine by running for approx. 10 km in medium rpm range.
- Switch off engine before motor cycle has come to a stop.
- Avoid the engine running for a lengthy period at idle throttle before switching off.
- Unscrew spark plugs.

CONDITION OF SPARK PLUGS

Normal:

Insulator base is light-grey to fawn-brown. The thermal state of the spark plug is correct. Engine state, combustion and combustion temperature are in proper order. Carburettor and ignition are correctly set.

Carbon-fouled:

Spark plug covered with soft, dry deposits of soot.

Effects when driving:

- Poor cold starting behaviour.
- Misfiring (creep currents).
- Dark exhaust.

Possible sources of fault:

- Incorrect setting/type of carburettor (too rich mixture).
- Air filter fouled.
- Spark plug too "cold" (incorrect heat rating).
- Frequent short trips.
- Choke does not open fully.

Oil-fouled:

- Electrodes and interior of spark plug coated with black film of oil.

Effects when driving:

- Poor cold starting behaviour.
- Misfiring.

Possible sources of fault:

- Oil in combustion chamber.
- Wear or damage to piston rings, cylinder or valve guides.

Bright (overheated):

Electrode and base of insulator snow-white despite lengthy operation. If severely overheated, centre and ground electrodes will show signs of melting as a result of auto-ignition.

Effects when driving:

- Loss of power.
- Misfiring.
- Total failure (engine damage).

Possible sources of fault:

- Incorrect setting/type of carburettor (mixture too "lean").
- Incorrect ignition setting (ignition excessively advanced).
- Deposits in combustion chamber (which may cause auto-ignition).
- Spark plug too "hot" (incorrect heat rating).

Worn Electrode:

Effects when driving:

- Poor cold starting behaviour.
- Misfiring, principally when accelerating.

Possible sources of fault:

- Spark plugs not changed at correct interval.

ELECTRODE GAP

The electrode gap essentially determines the ignition voltage requirements of the spark plug.

Electrode gap too small:

- Excessive voltage reserve.
- Insufficient mixture reaches the spark gap, resulting in misfiring.

Electrode gap too wide:

- High ignition voltage, low voltage reserves.
- This may cause misfiring.

CHECKING SPARK PLUGS AND ELECTRODE GAP (INSPECTION II)

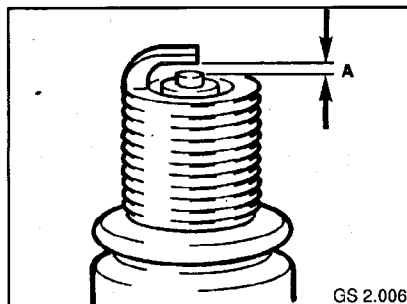

- Unscrew spark plug.
- Examine spark plug in respect of colour/appearance and for signs of damage.
- Clean spark plug with copper-bristle brush.

CHECKING ELECTRODE GAP WITH FEELER GAUGE OR SPARK PLUG GAUGE:

- Electrode gap is correct if the specified gauge thickness can be drawn through between the electrodes with scarcely perceptible resistance.

Electrode gap $A = 0.6 + 0.1 \text{ mm}$
Wear limit $A \text{ max} = 0.9 \text{ mm}$

- Once the wear limit (A max) has been reached, replace spark plug.

CAUTION:

Do not bend electrode. Risk of electrode fracturing when engine running.

- Screw in spark plug.

Tightening torque:
Spark plug (dry)

25 Nm

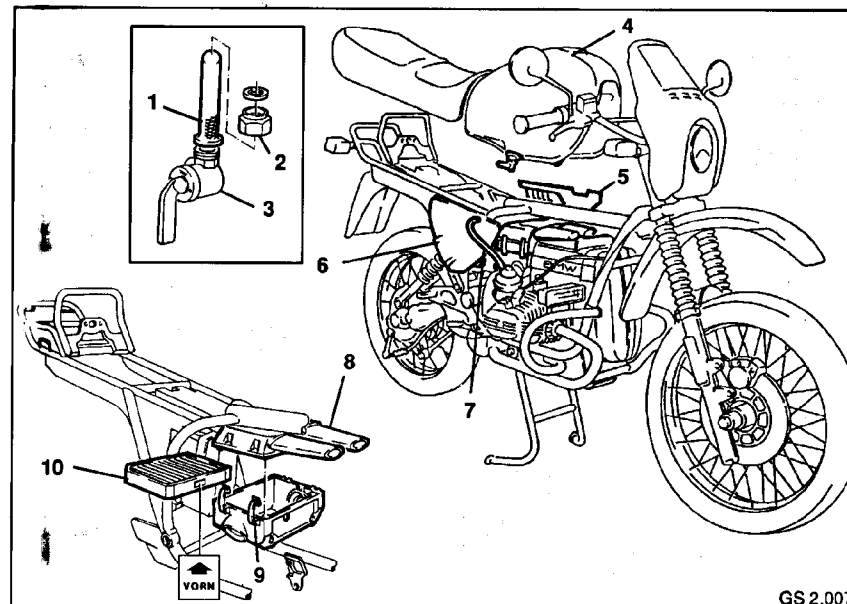

2.4 RENEWING AIR FILTER

- Remove lefthand battery cover (5) and righthand cover (6).
- Open the 4 spring clips (9) and lift off top section of air filter (8).
- Take out air cleaner element (10).

NOTE:

Install new air filter element with lettering "vorn" in direction of travel and arrow marking pointing upward.

- Install new air filter element.
- Fit on air filter top section and secure with four spring clips.

2.5 CLEANING FUEL COCKS

- Drain fuel tank (4).
- Slacken the union nut (2) and take fuel cock (3) off the fuel line.
- Unscrew union nut from fuel cock and take off fuel strainer (1).
- Clean fuel strainer with fuel.

CAUTION:

Examine sealing ring for possible signs of damage.

- Blow fuel strainer dry with compressed air and re-install.

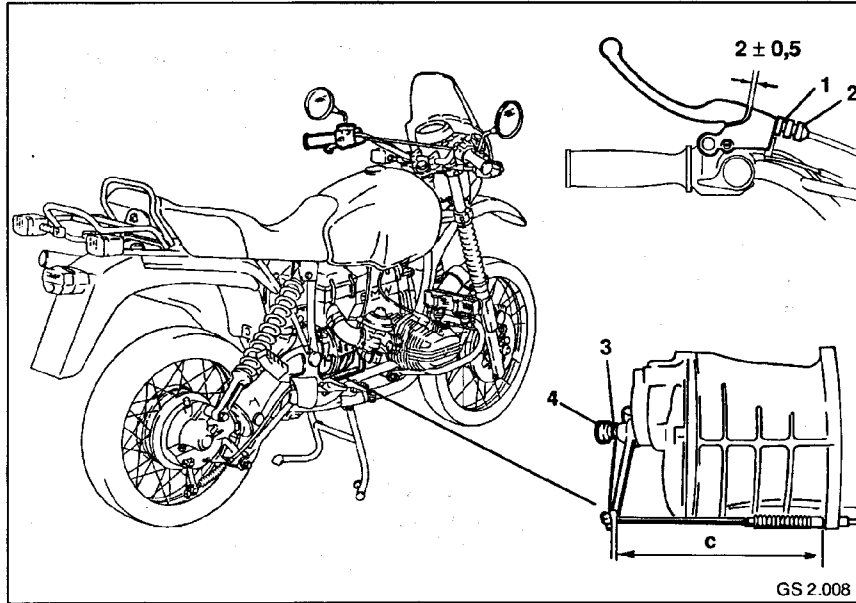

GS 2.008

2.6 CLEANING CARBURETTOR FLOAT HOUSING (Inspection II, III)

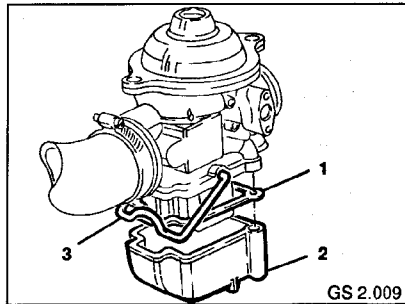

GS 2.009

- Use a screwdriver to lever spring clamp (3) on the carburettor down off the float housing (2).
- Take off float housing, drain and clean.
- Install float housing, ensuring gasket (1) is in proper condition.

2.7 CHECKING/ADJUSTING CLUTCH PLAY (Inspection I, III)

CHECKING CLUTCH PLAY AT HAND LEVER:

Specified clutch play 2 ± 0.5 mm

ADJUSTING CLUTCH PLAY:

- Slacken locking nut (1) of the Bowden cable adjusting screw (2) at the clutch lever.
- Turn adjusting screw until size "C" is set at the clutch lever at transmission end.
- Setting "C" = $201 + 1$ mm
- Tighten locking nut (1) of the Bowden cable adjusting screw.
- Slacken locking nut (3) of the adjusting screw (4) at transmission end.
- Turn adjusting screw until clutch play at hand lever is 2 ± 0.5 mm.
- Tighten locking nut (3).

Size C

$201 + 1$ mm

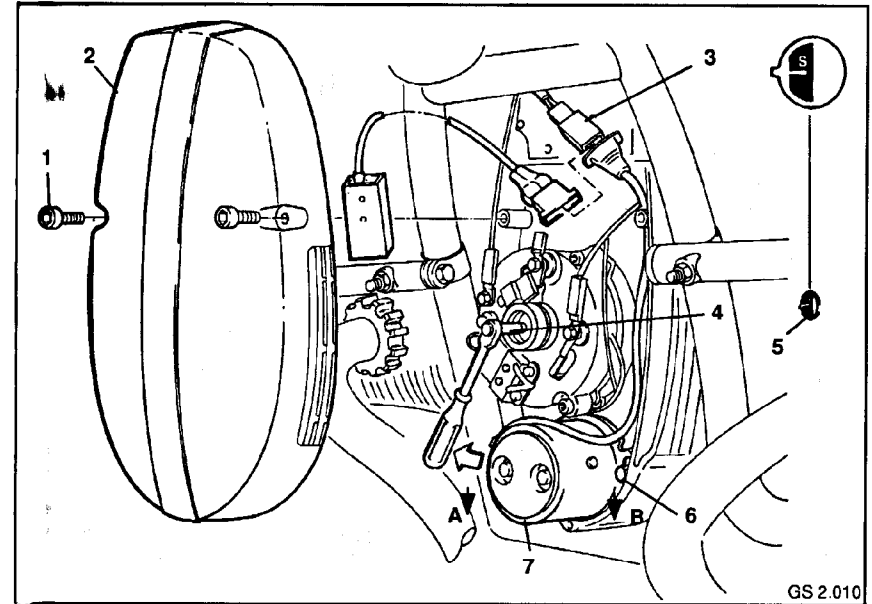

GS 2.010

2.8 CHECKING/ADJUSTING FIRING POINT

These motor cycles are fitted with a transistorized coil ignition (TSZ) a performance-enhanced ignition system.

WARNING:

Avoid touching life parts when engine is running. Hazardous!

CHECKING/ADJUSTING FIRING POINT (Static)

- Take off engine guard cover (2) after slackening the 2 hexagon socket screws (1).
- Remove wire clip of 3-pin plug connection (3) (Ignition box).
- Detach plug connection.
- Connect ignition timing device, BMW No. 12 3 650, to the ignition box.
- Unscrew spark plugs.
- Slowly crank engine in direction of arrow at the rotor fastening screw (4) until diode just lights up.

a. Checking firing point:

- Remove protective cap from inspection hole (5) on engine housing.
- Middle stroke of flywheel marking "S" must be aligned with the inspection hole marking (notch on engine housing) once the diode on the ignition timing device just lights up.

b. Settling firing point:

- Crank engine in direction of arrow at rotor fastening screw (4) until inspection hole marking and flywheel "S" are aligned.
- Slacken 2 fastening screws (6) on ignition box (7).
- Turn ignition box until diode on ignition timing device just lights up.

Turning in direction A = Ignition advanced
Turning in direction B = Ignition retarded

- Tighten both fastening screws.
- Re-check firing point.

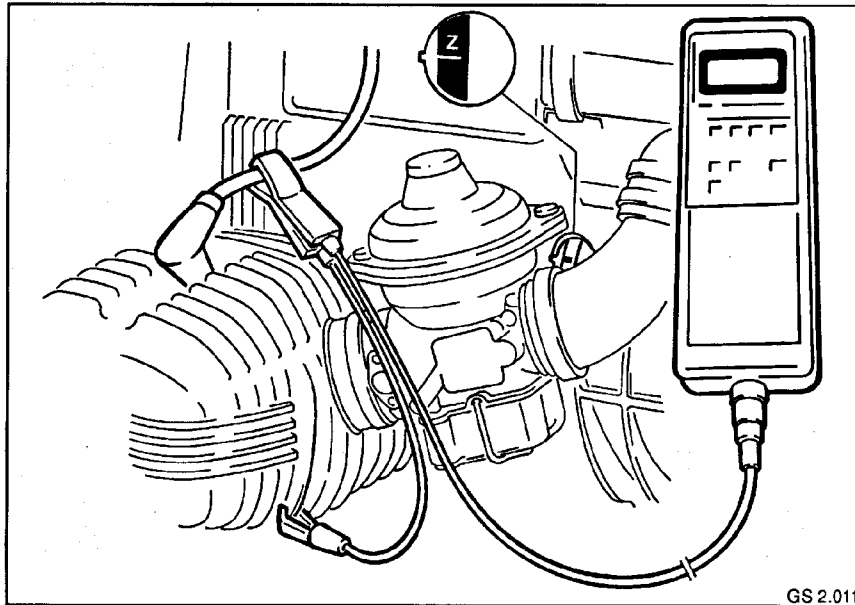

Following end of adjustment and check:

- Detach ignition timing device/ignition box plug connection.
- Re-create plug connection to engine cable harness.
- Fit on wire clip.
- Attach engine guard cover with two hexagon sockets.
- Screw in spark plugs and tighten to specified tightening torque.
- Plug in spark plug connector.
- Close inspection hole with protector cap.

Tightening torque:

Spark plug (dry)

25 Nm

CHECKING/SETTING FIRING POINT (Dynamic)

a. Checking firing point:

- Clip trigger sensor of BMW Diagnosis Tester over ignition cable.
- Connect ground cable to chassis with clamping tongues.
- Remove protective rubber cap from inspection hole in engine housing.
- Start engine.
- Maintain engine speed at 3500 rpm.
- Strobe flywheel with timing strobe through inspection hole.

- Line of flywheel marking "Z" must be aligned with inspection hole marking (notch).

Line above notch = Ignition advanced
Line below notch = Ignition retarded

Full ignition advance (from 3000 rpm) = 32° BTDC

- Again strobe flywheel with timing strobe at idling speed (800 ... 1100 rpm).
- Line of flywheel marking "S" must be aligned with inspection hole marking (notch).

Static firing point = 6° BTDC (at idling speed)

b. Setting firing point:

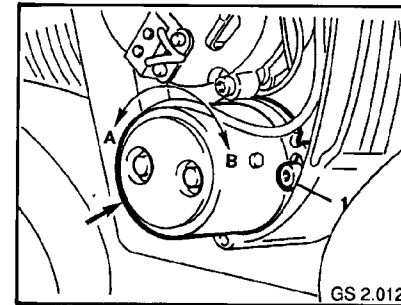

- Remove engine protective cover.
- Slacken 2 fastening screws (1) of the ignition box.
- Turn ignition box until marking (flywheel/inspection hole) are aligned when strobed with timing strobe.

Turning in direction A = Ignition advanced
Turning in direction B = Ignition retarded

- Tighten fastening screws of the ignition box.
- Attach engine protective cover.
- Seal inspection hole with protective cap.

2.9 SYNCHRONISING CARBURETTORS ADJUSTING CABLES (Inspection I, II, III)

BASIC SETTING OF CARBURETTOR

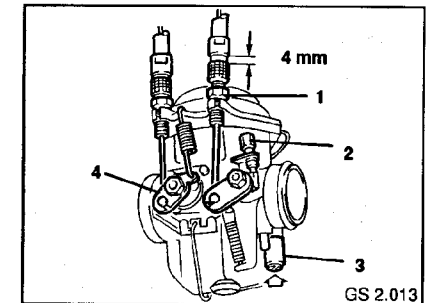

- Warm up engine until it is at normal operating temperature (approx. 80°C oil temperature e.g. measured at dipstick).
- Provisionally set throttle cable play of both carburettors to approx. 4 mm with adjusting screw (1) (to ensure throttle valves do not stick on the throttle cables but close fully).
- Adjust cable of starter device of both carburettors so that the starter lever (4) is pushed into its end position when choke is closed.
- Gently screw in idle mixture regulating screw (3) on both carburettors as far as the stop.
- Following this, unscrew both regulating screws evenly approx. 3/4 turns.
- Unscrew throttle valve stop screw (2) of both carburettors until they are touching the throttle valve lever.
- Following this, screw in both stop screws evenly approx. 1/2 turns.

SYNCHRONISING CARBURETTORS WITHOUT CO MEASUREMENT

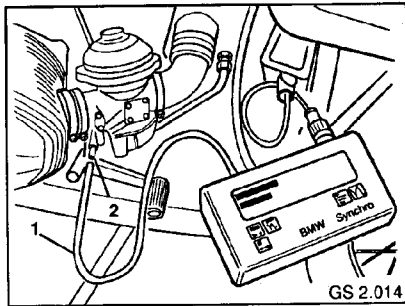

- Remove screw plug on both carburetors from the vacuum connection or detach PAS hose.
- Attach synchrotest connecting hoses (1), BMW No. 13 0 800, to both carburetors' vacuum connection (2).
- Connect synchrotester to the motorcycle battery via the appropriate adapter cable.
- Start engine and run at idle throttle.
- Set provisional idling speed to approx. 900 rpm by evenly turning the throttle valves top screw.

NOTE:

The idle mixture can be most accurately adjusted in this rpm range, i.e. the engine reacts very sensitively to adjustment of the idle mixture regulating screw.

- Check synchronous operation of carburetors with Synchrotester.
- Screw in idle mixture regulating screw until engine speed begins to drop.
- Following this, unscrew idle mixture screw 1/8 ... 1/4 turns.
- Repeat adjustment operation on second carburettor.
- When doing this, continuously check synchronous operation of carburetors with Synchrotester.

If idling speed is not in the specified range of 800 ... 1100 rpm, repeat adjustment operation (correcting idling speed / adjusting idle mixture).

SYNCHRONISING CARBURETTORS WITH CO MEASUREMENT

- Perform basic carburettor adjustment.
- Switch CO analyzer as stated in manufacturer's instructions.
- Insert probe approx. 30 cm into final silencer.
- Screw in or unscrew idle mixture regulating screw until specified CO reading is obtained.
- Repeat adjustment operation on second carburettor.
- Continuously check synchronous operation of carburetors with Synchrotester when adjusting.

If the idling speed is now not in the specified range of 800 ... 1100 rpm, repeat adjustment operation (correctly idling speed / adjusting idle mixture).

Idle CO-level

R 80 GS

R 100 GS, R 100 R

2,5 ± 1,5% by vol.

1,0 ± 0,5% by vol.

SYNCHRONIZING CARBURETTORS WITH CO MEASUREMENT FOR PAS

- The engine must be at its regular operating temperature.
- Perform basic carburettor adjustment.
- Detach both PAS lines from the air cleaner housing.

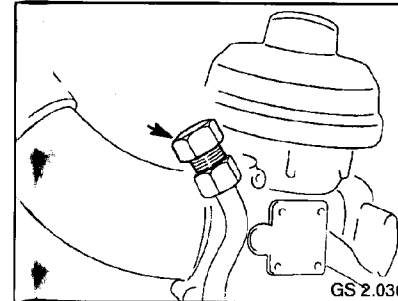

- Use screw plug, BMW No. 13 0 900, (arrow) to seal one line.

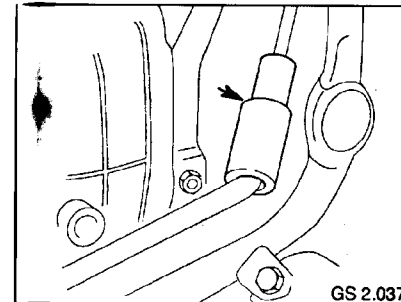

- Connect the open line with adapter, BMW No. 13 0 910 (arrow), to the CO tester measuring probe.
- Tighten idle mixture adjustment screw (leaner mixture) or loosen it (richer mixture) at the corresponding carburettor until the specified CO value is reached.
- Move to the other side of the motorcycle and adjust the second carburettor in the same way.
- Use the synchrotester to check carburettor synchronization continuously.

If the idling speed is not in the specified range, repeat the adjustment procedure (correcting idling speed / adjusting idle mixture).

Idle speed CO value

11100 GS

11 80 GS2.5

Idle speed

1 ± 0.5 Vol %

+/- 1.5 Vol %

800...1100 min⁻¹

FINAL ADJUSTMENT OF THE THROTTLE CABLES

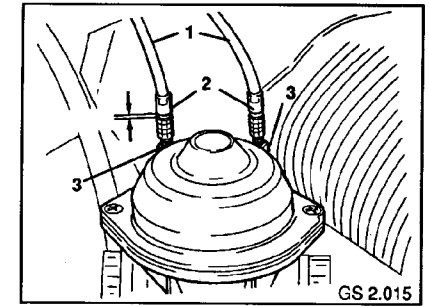

- Adjust both carburetors' throttle cables (1) to 0.5 ... 1.0 mm play at adjusting screw (2).
- Slightly increase engine speed using the twistgrip.
- Use adjusting screw (2) to adjust both carburetors' throttle cables so that the mercury columns in the synchrotester show the same level.
- Tighten adjusting screw with locknut (3).

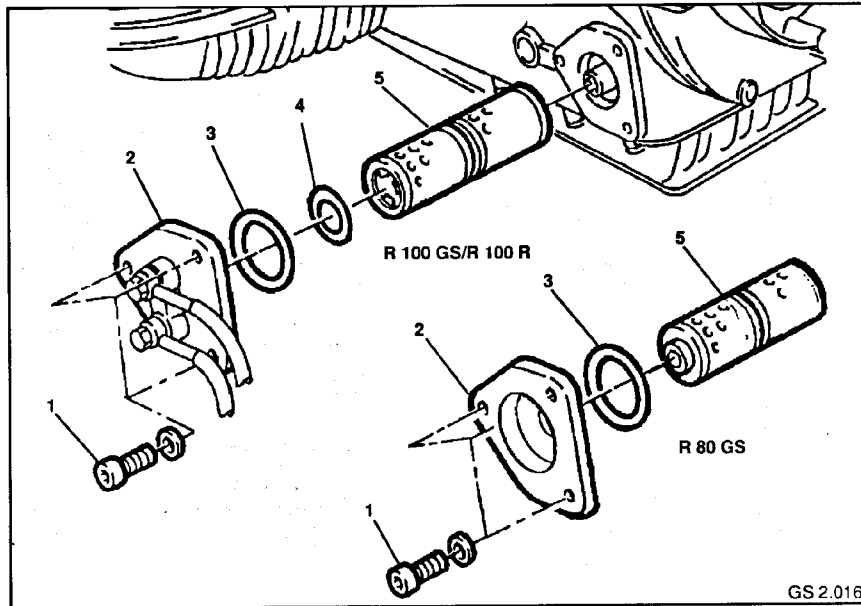

2.10 CHANGING OIL AND OIL FILTER IN ENGINE (Inspection I, II, III)

DRAINING ENGINE OIL

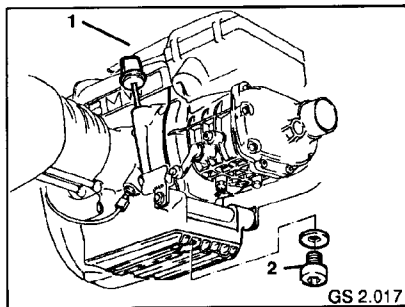

NOTE:

Change engine oil only when engine at normal operating temperature.

- Unscrew dipstick (1).
- Place suitable draining vessel below oil opening.

- Allow engine oil to flow out.
- Screw in oil drain plug with new sealing ring and tighten to specified tightening top.

CHANGING OIL FILTER

- Slacken the 3 fastening screws (1) and take cover (2) off oil filter housing.
- Drain oil from oil cooler (use compressed air, if necessary, to force out oil).
- Take O-ring (3,4) off cover.
- Withdraw oil filter cartridge (5) from the intake manifold.
- Fit new oil filter cartridge onto intake manifold with collar (5) facing engine.
- Fit on cover with new O-ring (3,4) and tighten with three fastening screws.
- Change the oil filter in the same way on the R 80 GS, but note that O-ring (4) is not fitted.

POURING IN ENGINE OIL

- Pour in specified quantity of fresh engine oil.
- Screw in dipstick (1)
- Run engine briefly.

NOTE:

Dipstick is only inserted into filler opening for checking oil level, and not screwed in.

- Wait approximately 5 minutes and then check oil level on dipstick.

CAUTION:

Never pour in engine oil to above "MAX" mark.

- Top up missing quantity of oil.
- Quantity of oil between "MIN" and "MAX" marks = 0.85 l.

Capacity of engine:

| | |
|---|--------|
| R 80 GS/R 100 GS | 2.00 l |
| with oil filter change R 80 GS/R 100 GS | 2.25 l |

Tightening torque:

| | |
|-------------------------|-------|
| Oil drain plug (engine) | 30 Nm |
|-------------------------|-------|

torque.

- Pour in fresh transmission oil to bottom edge of filler hole.
- Screw in oil filler plug and tighten to specified tightening torque.

Capacity of transmission

0.80 l

Tightening torque:

| | |
|--------------------------------|-------|
| Oil drain plug (transmission) | 26 Nm |
| Oil filter plug (transmission) | 31 Nm |

Grades of transmission oil: Proprietary Hypoid transmission oil of API Class GL 5. Useability of the particular viscosity classes is limited by the ambient temperature:

| | | |
|----------------------------|------|--------|
| above | 5 °C | SAE 90 |
| below | 5 °C | SAE 80 |
| or alternatively SAE 80W90 | | |

CAUTION:

Use of other grades and classes of oil in the transmission may result in premature damage to the gears.

2.11 CHANGING OIL IN TRANSMISSION (Inspection I, II)

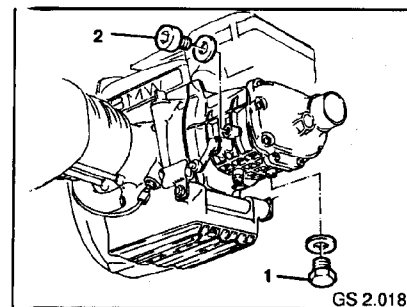

NOTE:

Change transmission oil only when transmission at normal operating temperature.

- Place suitable collecting vessel below oil drain opening.
- Slacken oil drain plug (1).
- Slacken oil filler plug (2).
- Allow transmission oil to flow out.
- Fit new sealing ring to oil drain plug, screw in oil drain plug and tighten to specified

2.12 CHANGING TRANSMISSION OIL IN REAR WHEEL DRIVE (Inspection I, III)

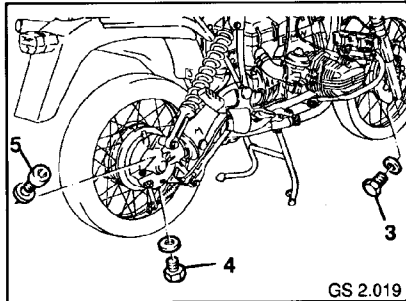

NOTE:

Change rear wheel drive oil only when rear wheel drive at normal operating temperature.

- Place suitable collecting vessel below oil drain opening.

- Unscrew oil drain plug (4).
- Unscrew oil inspection and filler plug (5).
- Allow transmission oil to flow out.
- Fit new sealing ring onto oil drain plug, screw in oil drain plug and tighten to specified torque.
- Pour specified quantity of transmission oil into rear wheel drive.
- Fit new sealing ring onto oil inspection and filler plug and screw in plug. Tighten to specified tightening torque.

Capacity of rear wheel drive 0.26 l

Tightening torque:
 Oil drain plug (rear wheel drive) 23 Nm
 Oil filler plug (rear wheel drive) 23 Nm

2.13 CHANGING OIL IN TELESCOPIC FORK (Inspection I, III)

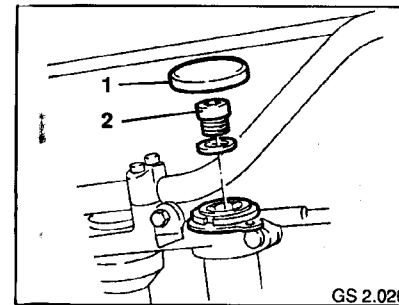

- Fit on fuel tank guard, BMW No. 16 1 600.
- Take off protective caps (1) on the top of the stanchions.
- Unscrew oil filler plugs (2) on left and right and take off sealing rings.
- Place suitable collecting vessels below the lefthand and righthand oil drain openings.
- Unscrew lefthand and righthand oil drain plugs (3).
- Allow telescopic fork oil to drain out.
- Following this, compress telescopic forks several times to pump out remaining oil.
- Fit new sealing ring onto oil drain plugs and screw in plugs.
- Tighten oil drain plugs gently to specified tightening torque.
- Pour in precisely gauged, specified quantities of fork oil into righthand and lefthand telescopic forks using a funnel.
- Fit new sealing ring onto oil filler plug and screw in plug. Tighten to specified tightening torque.

NOTE:

After filling the telescopic forks, bleed shock absorbers by compressing and releasing (5 ... 10 strokes) until full damping is felt).

Oil grades for telescopic forks:
 Esso Komfort

Capacity of telescopic forks:GS
 left 0.41 l
 right 0.44 l

Tightening torque:GS

Oil filler plug (telescopic fork) 10.5 Nm
 Mod.91 14 Nm
 Oil drain plug (telescopic fork) 6 Nm
 Mod.91 5 Nm

Capacity of telescopic forks:R 100 R
 left, right 0.41 l

Tightening torque:R 100 R

Oil filler plug (telescopic fork) 10 Nm
 Oil drain plug (telescopic fork) 9 Nm

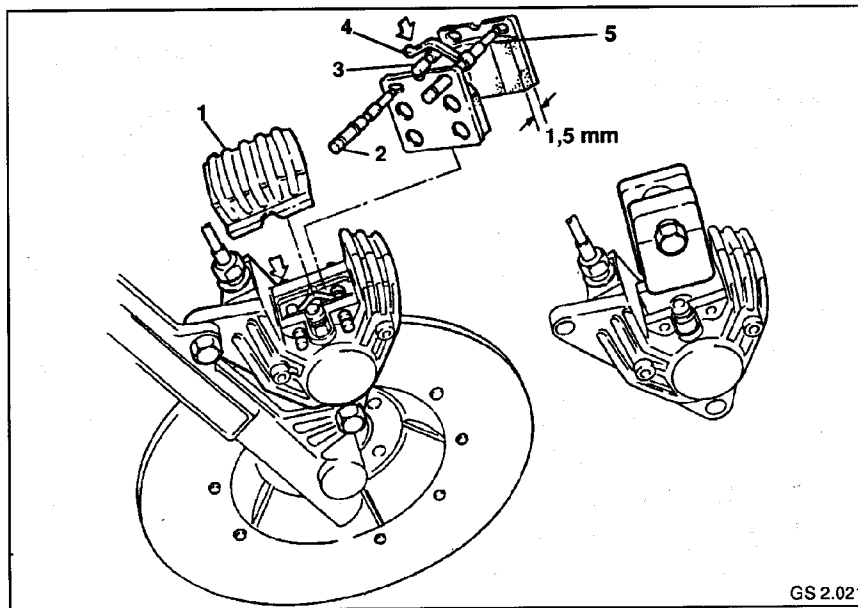

2.14 CHECKING FRONT BRAKE PADS FOR WEAR/RENEWING (Inspection III)

CHECKING BRAKE PAD FOR WEAR

- Use a screwdriver to lever plastic cap (1) off the brake caliper.
- Perform a visual check of brake pad thickness.

Minimum pad thickness

1.5 mm

NOTE:

The brake pad must be replaced in time to avoid scoring on the brake disc!

INSTALLING BRAKE PADS GS

NOTE:

New brake pads have to match to the brake surface. Good brake pad contact pattern is achieved by breaking frequently and cautiously in the initial phase. This avoids a glazed surface resulting from local excess of stresses.

- Use piston resetting device, BMW No. 34 1 500, to press back brake piston.

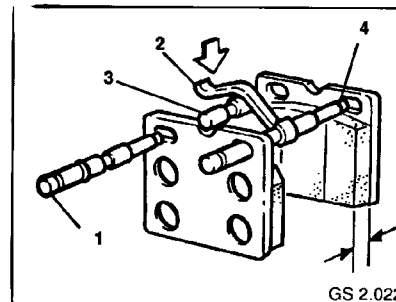

- Clean seat of brake pads.

- Insert brake pads in brake caliper.
- Insert spring clip (2) and push locking pin (4) through brake pads and eye of spring clip. Knock in with punch.
- Insert pin (3).
- Press down spring clip and insert pin (1). Knock in punch.
- Fit plastic cap (1) onto brake caliper.

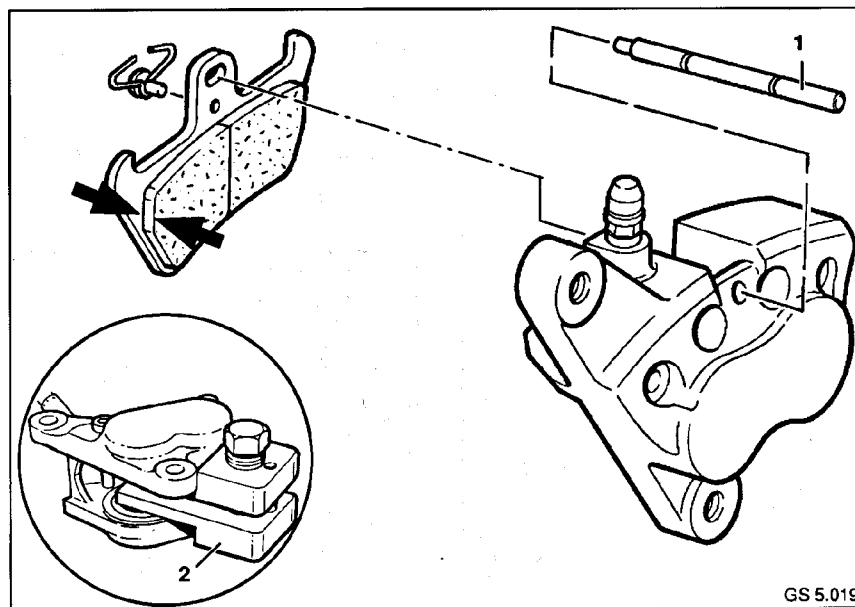

REMOVING / FITTING FRONT BRAKE PADS – R 100R

- Remove brake caliper.
- Knock out retaining pin (1).
- Press brake pads down and remove.

CAUTION:

Do not continue to use below minimum brake pad thickness (arrow)!
Replace pads in pairs!

*Minimum brake pad thickness:
Thickness on backing plate*

1.5 mm

- Install pads in reverse order of work.

NOTE:

Installation:
Press brake pistons back fully using piston reset device, BMW No. 34 1 500 (2).

*Tightening torque:
Brake caliper to slider tube*

32 Nm

2.15 CHECKING BRAKE DISCS (Inspection II)

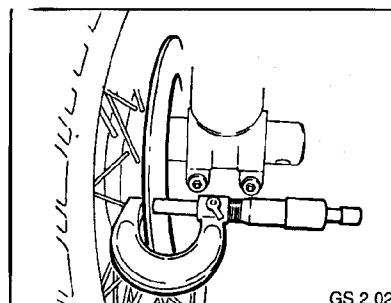

GS 2.023

NOTE:

Brake discs as a rule have a long life and only require to be replaced if they show signs of severe scoring or deformation.

- Examine brake discs carefully for signs of cracks or other damage.

CHECKING THICKNESS OF BRAKE DISCS:

- Measure thickness of brake discs at various points with a micrometer screw.

| | |
|--------------------------------|---------------------|
| <i>Thickness of brake disc</i> | <i>5.0 + 0.4 mm</i> |
| <i>Wear limit</i> | <i>4.4 mm</i> |
| <i>Mod.91, R 100 R</i> | <i>4.5 mm</i> |

Following this, check brake and brake lines to ensure that they operate properly, are correctly laid and do not show signs of leaks. Repair/renew any damaged parts.
(Inspection I, III)

2.16 CHECKING/TOPPING UP BRAKE FLUID LEVEL (Inspection I, III)

WARNING:

Brake fluid is extremely harmful to health and must therefore never be stored in beverage bottles. If brake fluid is inadvertently swallowed, the person concerned should receive medical attention without delay.

CAUTION:

Brake fluid is hygroscopic (absorbs water), and should therefore be renewed annually. Brake fluid which has run out or has been pumped out should never be used for replenishing system (impurities). Keep brake fluid away from paintwork and painted surfaces. Brake fluid contains elements which act as effective paint strippers.

a. Checking brake fluid level:

- Check brake fluid level at transparent reservoir.
- Never allow the brake fluid to drop below "MIN" mark to prevent air being pumped into the brake system.

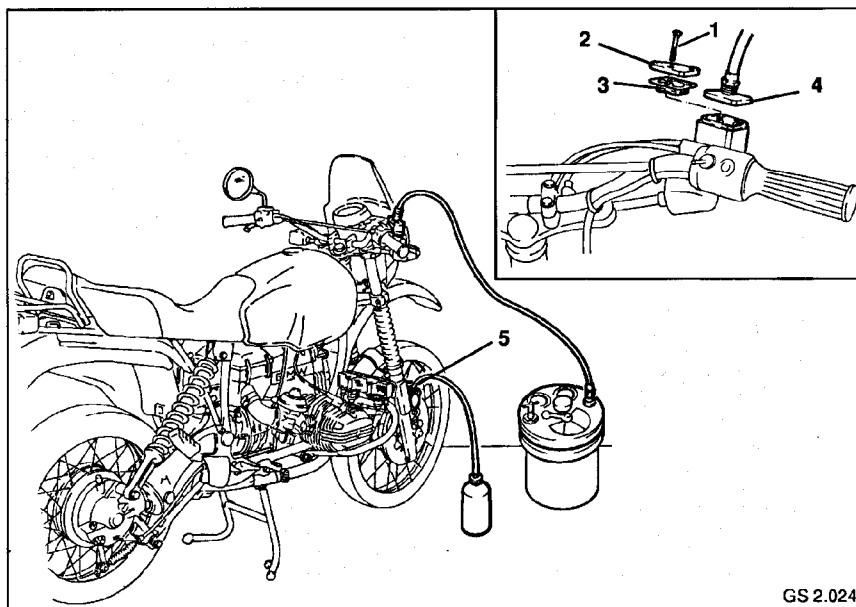

GS 2.024

b. Topping up brake fluid level:

CAUTION:

Do not allow brake fluid to come into contact with the paintwork of the motorcycle. Brake fluid strips the paint.

- Slacken three fastening screws (1) of the reservoir cover.
- Take off reservoir cover (2) and diaphragm (3).
- Top up brake fluid as far as the "MAX" mark.
- Fit on diaphragm and reservoir cover.
- Tighten three fastening screws gently.

Grade of brake fluid:

Only brake fluids of quality class DOT 4 (e.g. ATE brake fluid "SL" may be used).

2.17 CHANGING BRAKE FLUID

CAUTION:

For safety reasons, the brake fluid must be replaced at least once a year.

Brake fluid is subject to high thermal stresses (alternating effect), which promotes a natural ageing process.

By virtue of its hygroscopic nature, brake fluid absorbs moisture from the surrounding air, which can result in its boiling point dropping to a dangerous level.

- Remove front brake pads.
- Take the three fastening screws (1) out of cover (2) of the brake fluid reservoir.

- Take off cover and diaphragm (3).
- Screw appropriate adaptor (4) with rubber seal onto brake fluid reservoir.
- Connect hose of bleeder to brake fluid reservoir.
- Connect line from overflow reservoir to bleeder screw (5).

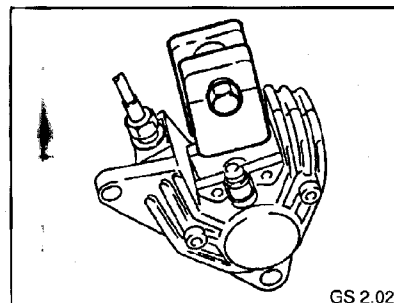

GS 2.025

- Use piston resetting device, BMW No. 34 1 500, to press back brake piston fully.
- Use spacer, BMW No. 34 1 510 (GS) or BMW No. 34 1 520 (R 100R) to secure brake piston in this position.
- Connect hose of bleeder to brake fluid reservoir.
- Move lever of bleeder to operating position (A) "Operating with compressed air".
- Open bleeder screw (5).
- Allow all of the brake fluid to flow out.
- Move lever on bleeder to operating position (B) "Operating with brake fluid".
- Open bleeder screw and hold open until brake fluid flows out free of bubbles.
- Close bleeder screw.
- Drain pressure from bleeder.
- Install brake pads.
- Move handlebar to full left and right lock while at the same time operating the brakes several times.
- Perform operational check of brake system.

2.18 BLEEDING FRONT WHEEL BRAKE SYSTEM

BLEEDING FRONT WHEEL BRAKE SYSTEM WITH BLEEDER

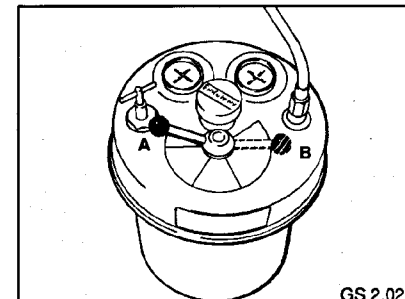

GS 2.026

CAUTION:

Do not allow brake fluid to come into contact with the paintwork of the motorcycle. Brake fluid strips the paint.

- Remove brake pads.
- Connect up bleeder as described in 2.18.
- Connect line from overflow reservoir to bleeder screw (5).
- Use piston resetting device, BMW No. 34 1 500, to press back brake piston fully.
- Use spacer, BMW No. 34 1 510, to fix brake piston in this position.
- Connect hose of bleeder to brake fluid reservoir.
- Move lever on bleeder to operating position (B) "Operating with brake fluid".
- Open bleeder screw and hold open until brake fluid flows out free of bubbles.
- Close bleeder screw.
- Drain pressure from bleeder.
- Repeat procedure on the second bleeder screw.
- Install brake pads.
- Turn handlebars from left to right lock while at the same time operating the brakes several times.
- Perform operational check of the brake system.

BLEEDING FRONT WHEEL BRAKE USING HANDBRAKE LEVER

CAUTION:

Do not allow brake fluid to come into contact with the paint work of the motorcycle. Brake fluid strips the paint.

- Remove front brake pads.
- Slacken 3 fastening screws on the brake fluid reservoir.
- Take off cover and diaphragm.
- Fill up brake fluid to the "MAX" mark.
- Connect line from overflow reservoir to bleeder screw (5).
- Use piston resetting device, BMW No. 34 1 500, to press back brake piston fully.
- Use spacer, BMW No. 34 1 510, to fix brake piston in this position.
- Apply handbrake lever several times until brake pressure can be felt.
- Hold handbrake lever under pressure, open bleeder screw while at the same time firmly pulling on handbrake lever.

CAUTION:

Do not release handbrake lever until bleeder screw is closed.

- Close bleeder screw (5) and release handbrake lever.
- Repeat this operation until brake fluid flows out at the bleeder screw free of bubbles.
- Tighten bleeder screw.
- Install brake pads.
- Perform operational check.

CAUTION:

The brake fluid must not drop below the "MIN" mark during the bleeding operation otherwise air will be drawn into the brake system. In this case, the bleeding operation has to be repeated.

2 19 CHECKING REAR BRAKE PADS FOR WEAR/RENEWING BRAKE SHOE IF NECESSARY (Inspection III)

CHECKING REAR BRAKE PADS FOR WEAR

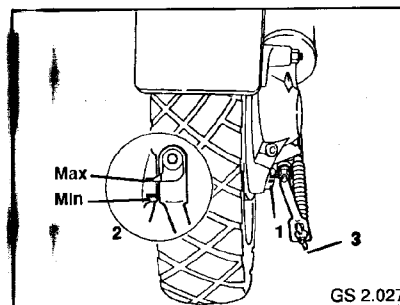

- Check wear indicator on rear wheel drive.
- If, by adjusting the brake with the wing nut (3), the arrow (1) is pointing to the mark (2) on the rear wheel drive, it is necessary to check the thickness of the brake pads.

- Withdraw 3 protective caps (8) from hub and perform a visual check of brake pad thickness.

Minimum pad thickness 1.5 mm

NOTE:

The brake pads must be renewed in time to prevent scoring on the brake drum.

RENEWING REAR BRAKE SHOE

a. Removing rear wheel

- Place motorcycle on kickstands.
- Place a support below the leading silencer to prevent motorcycle from toppling over.
- Slacken wing nut (5) of the brake linkage.
- Engage 1st gear.
- Slacken four wheel bolts (1).
- Withdraw rear wheel to the rear left.

NOTE:

If gear bag mounts are fitted, either remove rear wheel down the way (hoist) or remove the left hand gear bag mount.

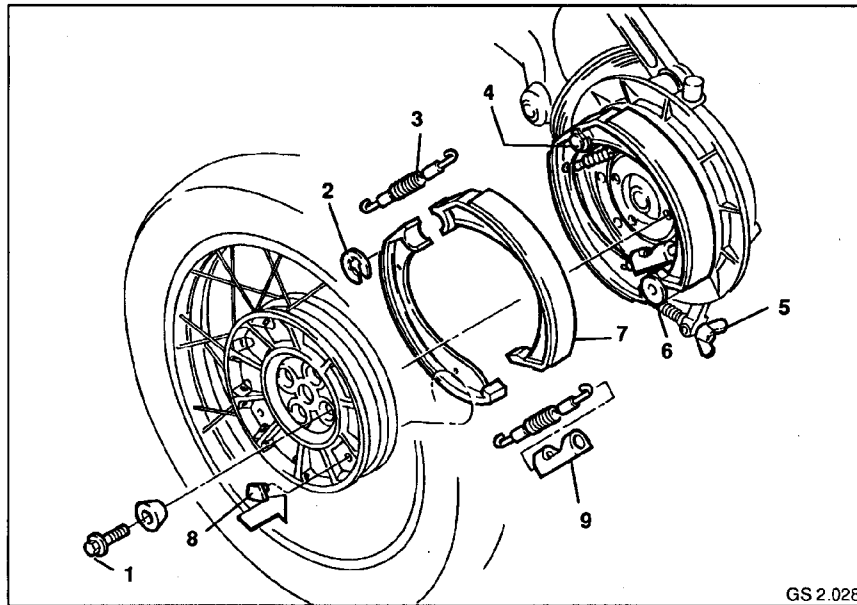

WARNING:

If the following method is employed, it is essential to ensure that the kickstands cannot fold up (e.g. by tying to front wheel).

If two persons are available, it is then possible to tilt the motorcycle to the right on its front wheel and kickstands. The rear wheel can then be removed to the bottom left.

b. Renewing rear brake shoe:

- Rear wheel is removed.
- Unscrew wing nut (5) on brake linkage completely.
- Remove locking ring (2) from brake anchor (4).
- Use a screwdriver to lever top brake shoe off rear wheel drive.
- Take off brake shoe (7) together with springs (3) and damping rubber.
- Apply a light coat of Molykote grease to brake anchor (4) and brake cam (6).

CAUTION:

Attach external tension springs!

- Fit damping rubber (9) onto rear tension springs. The rear flat side rests against the brake shoes and the brake cam.
- Connect brake shoes with tension springs.
- Fit brake shoes onto brake anchor (4) and brake cam at the same time.
- Open up brake shoes against the spring pressure and push onto brake anchor and brake cam.
- Fit locking ring onto brake anchor (4).

c. Checking brake drum for wear:

- Clean brake drum in rear wheel and check for signs of wear and scoring.
- If severe scoring is present, re-turn the brake drum.
- Pay attention to wear limits.

Brake drum dia.: 200 + 0.185 mm (H10)
Wear limit dia.: 201.2 mm

d. Installing rear wheel:

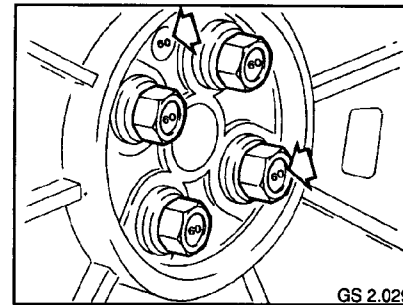

- Thoroughly clean hub centre ring and contact surfaces of wheel hub.

CAUTION:

Use only wheel bolts with the length index 60 (arrow). Rear wheel and wheel bolt heads are marked accordingly.

- Tighten wheel bolts to specified tightening torque.
- Adjust play of foot brake lever.

Tightening torque:

Rear wheel bolts

105 Nm

2.20 CHECKING/ADJUSTING FOOT BRAKE LEVER PLAY (Inspection III)

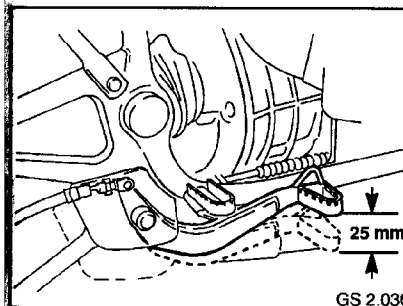

CHECKING FOOT BRAKE LEVER PLAY:

- Foot brake lever play is measured between rest position and braking point.

Foot brake lever play

approx. 25 mm

ADJUSTING FOOT BRAKE LEVER PLAY

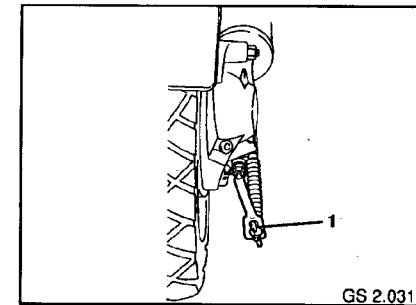

- Turn wing nut (1) on brake tie rod clockwise until the rear wheel just begins to brake.
- Turn wing nut back 3 ...4 turns (corresponds to approx. 25 mm foot brake lever travel).

2.21 CHECKING REAR WHEEL FOR TILT PLAY (Inspection III)

NOTE:

Do not check tilt play when rear wheel drive is at normal operating temperature.

- Tilt rear wheel back and forward over wheel axis.
- If play is perceptible, re-space rear wheel or replace bearings.

2.22 CHECKING FRONT WHEEL BEARING (Inspection III)

- Relieve load on front wheel.
- Tilt front wheel back and forward over wheel axis.
- There must not be any play perceptible.
- If play is determined in the wheel bearing, replace the bearings.

2.23 CHECKING/ADJUSTING STEERING BEARING PLAY (Inspection III)

CHECKING STEERING BEARING PLAY

- Place motorcycle on kickstands.
- Front wheel and steering free to move.
- If steering is knocked slightly, it must move by itself to left/right.
- If the steering stops
 - bearing too tight, adjust bearing play.
 - Steering locks in middle position
 - bearing faulty. Renew steering bearings.

ADJUSTING STEERING BEARING PLAY

WARNING:

Bearing play which is too loosely set causes shimmy at low speeds.

Bearing play which is too tightly set causes hunting at high speeds.

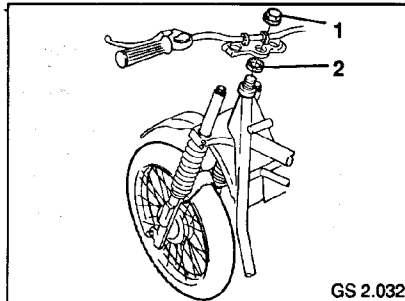

- Take off fuel tank. Slacken cap nut (1).
- Slacken slotted nut (2) with hook wrench.
- Relieve stress on bearings by striking the cap nut (with plastic-headed hammer).
- Tighten slotted nut (2) gently with hook wrench until steering bearings are located free of play in the bearing shells.
- Steering bearing is exactly set if
 - no tilt play is perceptible around the vertical axis.
 - the front wheel falls easily away from middle position to right/left lock (when motor cycle on stands). Ensure steering moves freely (cable harness, Bowden cables etc.).

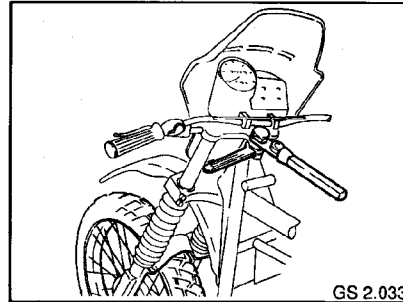

- Tighten cap nut with special tool BMW No. 31 4 850, and torque wrench. Hold slotted nut in place with hook wrench.
- Re-check steering bearing play, adjust if necessary.

Tightening torque:

Cap nut
Slotted nut

107 Nm

free of play max. 0.5 Nm

ADJUSTING STEERING BEARING CLEARANCE – MOD. 91, R 100R

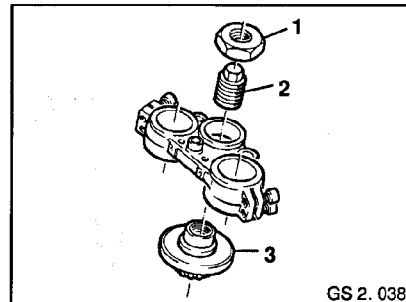

- Use special wrench, BMW No. 31 4 870, to loosen hex nut (1); loosen counter tube (2).
- Use adjusting ring (3) to adjust bearing play; handlebar must swing round easily from the central position to the left or right (motorcycle raised clear of ground).
- Tighten locking tube and secure with hex nut.

Tightening torque:

Locking tube
Hex nut

65 Nm
65 Nm

2.24 GREASING CLUTCH CABLE NIPPLES (Inspection II, III)

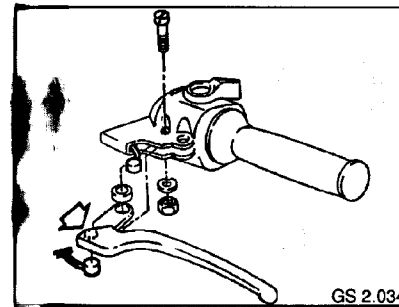

- Grease bearing points (arrow) of the clutch cable nipples at top and bottom (e.g. Shell Retinax A).
- Slacken bearing screw for clutch hand lever, if necessary.
- Withdraw lever from guide and turn through 180°.

2.25 ADJUSTING SWING ARM BEARING PLAY (Inspection III)

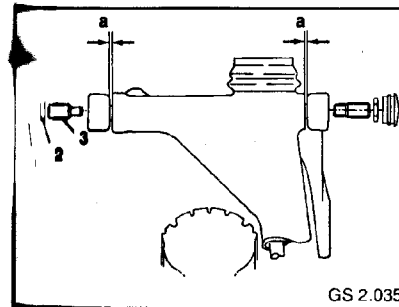

- Lever off cover caps (1) on the swing arm bearings.
- Slacken locking nuts (2) on left and right.
- Tighten both bearing journals (3) to the specified tightening torque to preload bearing.

Tightening torque:

Bearing journal preload

20 Nm

- Slacken both bearing journals and tighten once again to the final tightening torque.

Tightening torque:

Bearing journals

10 Nm

- Tighten locking nuts to specified tightening torque without twisting the bearing journals.

Tightening torque:

Locking nuts

107 Nm

CAUTION:

When performing the adjustment operation, it is essential that the gap size "a" between frame and swing arm is identical on left and right (max. difference = 0.5 mm)

2.26 BATTERY MAINTENANCE

BATTERY FAULTS

Faults in a battery may be caused by an internal short-circuit resulting from a plate short or an interruption in the connections between cells or plates.

An internal short-circuit can be detected by comparing the electrolyte density levels of the individual cells. If sharply fluctuating electrolyte density levels with a density difference > 0.03 kg/l are determined, this indicates a short-circuit. An interruption to the cell or plate connections is recognizable from the voltage collapsing during starting despite the battery being properly charged.

If there is no indication of a battery fault, yet the battery is either always discharged, this indicates:

- low electrolyte density
- no starting power,

or overcharged, this indicates:

- high water consumption,
- there is then a fault in the electrical system. Check alternator, regulator and relays.

COMMISSIONING BATTERY

CAUTION:

The battery contains sulfuric acid. Avoid acid coming into contact with eyes and skin or clothing. Remedy: wash contact areas with water. If acid has been swallowed, drink large quantities of milk or water. Contact a doctor without delay.

Wash out eyes with water and obtain medical treatment.

Battery gives off explosive gases. Avoid sparking, naked flames and smoking. When working close to batteries, always wear protective goggles.

STORE BATTERIES AWAY FROM THE REACH OF CHILDREN!

Store batteries only in well-ventilated rooms. The filler caps must always be removed.

- Remove plugs from battery.
- Fill battery with pure electrolyte (conforming to VDE 0510, Density: 1.28 kg/l, for tropical countries 1.25 kg/l (related to electrolyte temperature of 20°C) up to specified level ("Max" mark).
- Leave battery to stand for approx. 1 hour, then shake slightly or tip (to vent) and top up electrolyte level to "Max" mark if necessary.
- Screw in plugs loosely (do not tighten fully until after battery is charged).

CAUTION:

After being filled, the dry-charged battery attains only 60% of its rated capacity. It is therefore essential to charge battery.

Avoid allowing filled batteries to stand for lengthy period when not in use. Do not fill battery with electrolyte until just before it is to be used.

CHARGING BATTERIES

CAUTION:

Do not exceed a maximum charging current of 10% of battery capacity.

Example:

25 Ah-battery = charging current 2.5 Amperes
Charging time = 5 ... 10 hours

- The charged state of the battery can be checked by measuring the electrolyte density.
- Electrolyte density of fully-charged battery = 1.256 ... 1.30 kg/l related to 20°C.
- Shake battery slightly after charging
 - gas bubbles rise to the surface.
- After the electrolyte has settled, top up with distilled water to "Max" mark, if necessary.
- Screw in plugs tight.

CHECKING /TOPPING UP ELECTROLYTE LEVEL OF BATTERY (INSPECTION III)

- Remove battery.
- Check electrolyte level of battery (visual check).
- If necessary top up electrolyte level with distilled water to the "MAX" mark.
- Check electrolyte level approx. every 3 months.

CAUTION:

It may be necessary to check the electrolyte level more often in warmer climates with higher ambient temperatures in view of the greater losses from evaporation.

- Coat battery terminals with acid protection grease (e.g. Bosch Ft 40 V1).
- Install battery.

CAUTION:

Connect battery positive terminal first of all, then negative terminal.

BATTERY CARE WHEN MOTOR CYCLE STORED OUT OF USE.

- Charge battery with a suitable charger.

CAUTION:

The maximum charge current must not exceed 10% of the battery capacity.

Example:

25 Ah battery = max. charge current 2.5 Amperes
Charging time = 5 ... 10 hours

- Detach ground cable on righthand side of transmission (cardan drive/speedometer output) and isolate.

CAUTION:

If the battery terminals are not disconnected, the motor cycle electronics (clock etc.) will discharge the battery. This may result in the battery being fully discharged and rendered unsuitable for use.

- If the motor cycle is out of use for a lengthy period, re-charge battery every 4 months.
- If the battery terminals have not been disconnected, re-charge at least every 2 months.
- Store batteries in a cool place when not in use.
- Never store batteries when discharged.
- Before re-using battery, it must be fully charged again and the distilled water topped up if necessary.

27 CHECKING NUTS AND BOLTS FOR TIGHT FIT (Inspection I, II, III)

Tightening torque:

| | |
|----------------------|--------|
| Hub axle | 33 Nm |
| Top bolt (stub axle) | 15 Nm |
| Wheel bolts | 105 Nm |
| Pin front/rear | 54 Nm |
| Top | 87 Nm |
| Strut top/bottom | 29 Nm |
| Bottom | 47 Nm |

In addition, check that the hose strap fastenings on carburetors and bellows of the propeller shaft are tight.

2.28 CONSCIENTIOUSLY PERFORMING FINAL INSPECTION WITH CHECK OF ROAD/OPERATIONAL SAFETY (Inspection I, II, III)

Check of condition:

- Check wheels and tyres.
- Check tyre inflation pressure/correct.

Tyre Inflation pressures (bar):

| | front | rear |
|------------------------|-------|------|
| Solo | 2.2 | 2.5 |
| with pillion passenger | 2.4 | 2.9 |

Functional check:

Electrical system

- Main beam, dipped beam and parking light.
- Stop, licence plate and turn signal lamps.
- Main beam, battery charge, idling and oil pressure indicator lamps.
- Horn.
- Optional equipment.

Engine, transmission, running gear (conduct test run if necessary)

- Clutch
- Gear shift
- Steering
- Footbrake and handbrake
- Instruments

**3. FUEL, OIL AND
LUBRICANTS
AND
SERVICE DATA
FOR
MAINTENANCE**

| | |
|--|-------------|
| Contents | Page |
| 3.1 FUEL, OILS AND LUBRICANTS | 3.5 |
| 3.2 SERVICE DATA | 3.6 |
| 3.3 TIGHTENING TORQUES | 3.7 |

| 3.1 FUEL, OILS AND LUBRICANTS | ALL MODELS |
|--|---|
| Fuel | Regular unleaded fuel DIN 51607 Minimum octane number 91 (RON) and 82.5 (MON) |
| Engine oil grades | Proprietary - HD - Oil for spark ignition engines API - Classes SE/CC and SF/CC (refer to viscosity diagram) |
| Transmission oil grades | Proprietary - Hypoid - Gear oil API - Class GL5 (above 5°C SAE 90, below 5°C SAE 80, or optionally SAE 80W90) |
| Telescopic fork oil | Esso Komfort |
| Wheel bearings, steering head bearings, telescopic forks | Retinax A (Taper) roller bearing grease |
| Dust seals, telescopic forks | Gleitmo 805 |
| Clutch | Staburags NBU 30 PTM (high-performance lubricating paste) |
| Battery terminals | Acid protection grease (e.g. Bosch Ft 40 V 1) |
| Brake anchor and brake cam | Molykote grease |
| Brake fluid grades | DOT 4 (z.B. ATE "SL") |
| Electrolyte | (conforming to VDE 0510, Density: 1.28 kg/l, for tropical countries 1.25 kg/l, related to 20°C electrolyte temperature) |

Engine oil Viscosity diagram
as a function of outside temperature

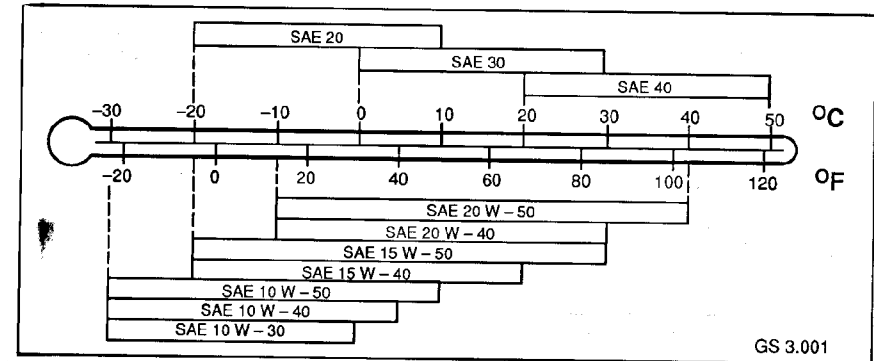

Operating materials

| Application/term | Instance of use | Order No. | Quantity |
|------------------|-----------------|-----------|----------|
|------------------|-----------------|-----------|----------|

Lubricants

| | | | |
|--|--|---------------------|--------------|
| Staburags NBU 30 PTM high-performance lubricating paste | serrations underhigh stress and pressure pointson clutch and drive shaft | 07 55 9 056 992 | 75 gr tube |
| | | 07 55 9 056 993 | 400 ml spray |
| Never-Seeze assembly paste, resistant to high temperatures | Inner bearing races in swinging arm | 8 21 1 337 498 | 30 gr tube |
| | | 18 21 1 337 499 | 250 gr can |
| Retinax A, (Taper) roller bearing grease | Wheel bearings, steering head bearings | HWB 81 22 9 407 302 | 900 gr can |
| | | HWB 81 22 9 407 303 | 150 gr tube |
| CRC spray | Water repellant and anti-friction protection on plugs, preservation | HWB 81 22 9 400 208 | 300 ml spray |

Sealants

| | | | |
|-------------------------------|--|---------------------|-------------|
| 3 - Bond 1209 Surface sealing | All metal sealing surfaces, cylinder base (without O-ring) | 07 58 9 062 376 | 30 ml tube |
| Loctite 574 surface sealing | on gearbox and rear wheel drive | HWB 81 22 9 407 301 | 50 ml tube |
| Dirko | Cylinder base | 11 12 1 262 571 | 100 gr tube |
| Curil K2 | Ignition output stage | HWB 81 22 9 400 243 | 250 gr can |

Adhesives and locking devices

| | | | |
|---|---|---------------------|--------------|
| Loctite 242 thread locking agent, medium strength | Damper pistons on piston rod (telescopic fork), Fixed bearing journal in swinging arm, rear wheel drive | 07 58 9 056 031 | 10 ml bottle |
| Loctite 270, thread locking agent high strength | Spring strut eye on piston | HWB 81 22 9 400 086 | 10 ml bottle |
| Sicomet | Fairing sections and handlebar grips, Adapter PD tank | 16 11 1 235 651 | 10 ml bottle |
| Loctite 454 | | 07 85 9 062 157 | 20 gr tube |
| Loctite 638 | Rear wheel drive at swinging arm (only Monolever) | 07 58 9 056 030 | 10 ml bottle |

| 3.2 Service Data | | R 80 GS /91 | R 100 GS /91 | R 100 GS PD | R 100 R |
|-------------------------|-----------------------|-------------------|------------------|-------------|-------------|
| Engine | | | | | |
| Oil capacity | with filter change | l | 2.25 | 2.25 | |
| | without filter change | l | 2.00 | 2.00 | |
| Valve clearance | Inlet | mm | 0.10 | | |
| | Exhaust | mm | 0.20 | | |
| Rocker arm end play | | mm | 0.05 ± 0.02 | | |
| Compression pressure | | bar | good more than 9 | | |
| | | bar | normal 7.5...9 | | |
| | | bar | poor below 7.5 | | |
| Clutch | | | | | |
| Bowden cable setting | at transmission | mm | 201 + 2 | | |
| | at hand lever | mm | 2 ± 0.5 | | |
| Transmission | | | | | |
| Oil capacity | | l | 0.8 | | |
| Rear wheel drive | | | | | |
| Oil capacity | | l | 0.26 | | |
| Carburettor | | | | | |
| Idling speed | | min ⁻¹ | 800...1000 | | |
| Idle CO level | | Vol% | 2 ± 1 | | |
| Throttle cable play | | mm | 0.5...1.0 | | |
| Ignition | | | | | |
| Timing range | Start of advance | min ⁻¹ | 1 500 | | |
| | End of advance | min ⁻¹ | 3 000 | | |
| Firing point | Static timing | °BTDC | 6 | | |
| | Dynamic timing | °BTDC | 32 | | |
| Timing range | | °CS | 26 | | |
| Spark plugs | | | | | |
| | | | Bosch W 7 DC | | |
| | | | Beru 14-7 DU | | |
| Electrode gap | | mm | 0.6 + 0.1 | | |
| Wear limit | | mm | 0.9 | | |
| Telescopic fork | | | | | |
| Oil capacity | left | l | 0.41 - 0.01 | | 0,41 - 0,01 |
| | right | l | 0.44 - 0.01 | | 0,41 - 0,01 |
| Tyres | | | | | |
| Tyre size | front | | 90/90-21S | 90/90-21T | 110/80V18 |
| | rear | | 130/80-17S | 130/80-17T | 140/80 V17 |
| Tyre inflation pressure | | bar | front | rear | |
| | Solo | bar | 2.2 | 2.4 | |
| | Pillion passenger | bar | 2.5 | 2.9 | |
| Brake system | | | | | |
| Brake disc | | | | | |
| | wear limit | mm | 5.4/45 | | 4.5 |
| | max. lateral runout | mm | 0.3 | | 0,3 |
| Thickness of brake pads | | | | | |
| | wear limit | front | mm | 1.5 | |
| | rear | mm | 1.5 | | |
| Foot brake lever play | | mm | 25 | | |

| 3.3 TIGHTENING TORQUES (Nm) | ALL MODELS |
|---------------------------------------|----------------------------------|
| Engine | |
| Engine pin | 54/ 77(Mod.91) |
| Spark plug (dry) | 25 |
| Cylinder head nut (three steps) | 15/25/35 |
| Locking nut of valve adjusting screw | 20 |
| Cap nut of cylinder head cove | 24 |
| Oil drain plug | 30 |
| Transmission | |
| Oil drain plug | 26 |
| Oil filler plug | 31 |
| Rear wheel | |
| Wheel bolts | 105 |
| Rear wheel drive | |
| Oil drain plug | 23 |
| Oil filler plug | 23 |
| Swing arm | |
| Spring strut fastening bolts | 29/ 47(Mod.91) |
| Bearing journal right preload | 20, slacken and tighten with 10 |
| Locking nut | 105 |
| Bearing journal right (fixed bearing) | 105 |
| Front wheel | |
| Stub axle | 33 |
| Axle clamping bolts | 15 |
| Brake caliper to sliding tube | 32 |
| Brake disc | 29 |
| Telescopic fork | |
| Oil drain plug | 10.5/ 14 (Mod.91)/ 3,5 (R 100 R) |
| Oil filler plug | 6.2/ 10 (R 100 R) |
| Cap nut (steering bearing) | 107 |
| Slotted nut (steering bearing) | free of play (max. 0.5) |
| Locking tube | 65 |
| Hex nut | 65 |
| Fastening bolts (rear frame section) | 16/ 24(Mod.91, R 100 R) |
| Caulked nut of exhaust system | tighten until gastight |

4. ELECTRICS

| Contents | Page |
|---|-------------|
| 4.1 REMOVING AND INSTALLING HEADLAMP | 4.5 |
| REMOVING AND INSTALLING HEADLIGHT (PARIS-DAKAR) | 4.5 |
| Removing windscreen | 4.5 |
| Removing flashing turn indicators with holders | 4.5 |
| Removing side section of instrument carrier | 4.6 |
| Removing the speedometer | 4.6 |
| Removing the instrument carrier | 4.7 |
| Removing the headlight | 4.7 |
| Installing the headlight | 4.8 |
| Installing the instrument carrier | 4.8 |
| Installing the speedometer | 4.9 |
| Installing side section of instrument carrier | 4.9 |
| Installing flashing turn indicator with holder | 4.10 |
| Installing the windscreen | 4.10 |
| REMOVING AND INSTALLING THE HEADLIGHT (1991 MODELS) | 4.10 |
| Removing the windscreen | 4.10 |
| Removing side section of instrument carrier | 4.10 |
| Removing the speedometer | 4.11 |
| Removing the revolution counter | 4.12 |
| Removing the ignition switch | 4.12 |
| Removing the headlight | 4.12 |
| Installing the headlight | 4.13 |
| Installing the instrument carrier | 4.13 |
| Installing the ignition switch | 4.14 |
| Installing the revolution counter | 4.14 |
| Tachometer einbauen | 4.14 |
| Installing side section of instrument carrier | 4.14 |
| Installing the windscreen | 4.15 |
| REMOVING AND INSTALLING HEADLIGHT – R 100R | 4.16 |
| 4.2 ADJUSTING HEADLAMP | 4.17 |
| ADJUSTING HEADLAMP WITHOUT BEAM ADJUSTER | 4.17 |
| ADJUSTING HEADLAMP WITH BEAM ADJUSTER | 4.17 |
| 4.3 REMOVING AND INSTALLING TURN SIGNALS | 4.18 |
| 4.4 REMOVING AND INSTALLING REAR LIGHT | 4.18 |
| 4.5 REMOVING AND INSTALLING SPEEDOMETER | 4.19 |
| DISMANTLING AND INSTALLING SPEEDOMETER / REVOLUTION COUNTER – R 100R | 4.20 |
| 4.6 REMOVAL DISPLAY PANEL WITH IGNITION LOCK | 4.21 |
| 4.7 DISASSEMBLING AND ASSEMBLING, INSTALLING DISPLAY PANEL | 4.21 |
| 4.8 REMOVING AND INSTALLING HANDLEBAR CONTROLS | 4.22 |
| 4.9 TESTING OPERATION OF ALTERNATOR, REGULATOR AND DIODE PLATE | 4.22 |
| TESTING REGULATOR | 4.22 |

| | | | | | |
|------|---|------|------|--|------|
| 4.10 | QUICK TEST OF ALTERNATOR AND REGULATOR | 4.23 | 4.25 | REMOVING AND INSTALLING REAR STOP LIGHT SWITCH. | 4.40 |
| 4.11 | REMOVING AND INSTALLING BATTERY | 4.24 | 4.26 | REMOVING AND INSTALLING FRONT STOP LIGHT SWITCH | 4.40 |
| 4.12 | REMOVING AND INSTALLING FUSE BOX | 4.25 | 4.27 | REMOVING AND INSTALLING CLUTCH SWITCH | 4.41 |
| 4.13 | REMOVING, TESTING AND INSTALLING RELAYS | 4.26 | 4.28 | REMOVING AND INSTALLING HORN | 4.41 |
| | TESTING OPERATION OF TURN SIGNAL RELAY (A) | 4.26 | 4.29 | REMOVING AND INSTALLING ENGINE CABLE HARNESS | 4.41 |
| | TESTING OPERATION OF STARTER RELAY (B) | 4.27 | 4.30 | REMOVING AND INSTALLING CHASSIS CABLE HARNESS SECTION | 4.42 |
| | TESTING DIODE OF STARTER RELAY | 4.27 | 4.31 | REMOVING AND INSTALLING REAR CABLE HARNESS SECTION | 4.43 |
| | TESTING OPERATION OF LIGHT RELAY (C) | 4.27 | 4.32 | TROUBLESHOOTING | 4.44 |
| 4.14 | REMOVING AND INSTALLING REGULATOR | 4.28 | | TROUBLESHOOTING IGNITION SYSTEM | 4.44 |
| 4.15 | REMOVING AND INSTALLING IGNITION CONTROL UNIT | 4.28 | | TROUBLESHOOTING ALTERNATOR | 4.46 |
| 4.16 | REMOVING, TESTING AND INSTALLING IGNITION COIL | 4.29 | | TROUBLESHOOTING STARTER | 4.48 |
| | TESTING RESISTANCES OF IGNITION COIL | 4.29 | | | |
| 4.17 | REMOVING, TESTING AND INSTALLING DIODE PLATE | 4.30 | | | |
| 4.18 | REMOVING AND INSTALLING IGNITION TRIGGER | 4.31 | | | |
| 4.19 | REPLACING CARBON BRUSHES | 4.31 | | | |
| 4.20 | REMOVING, TESTING, DISASSEMBLING AND ASSEMBLING ALTERNATOR .. | 4.32 | | | |
| | REMOVING ALTERNATOR | 4.32 | | | |
| | TESTING ALTERNATOR | 4.33 | | | |
| | A Testing exciter winding on slip rings: | 4.33 | | | |
| | B Testing rotor for short to ground: | 4.33 | | | |
| | C Testing stator winding: | 4.33 | | | |
| | D Testing stator winding for short to ground: | 4.33 | | | |
| | DISASSEMBLING STATOR | 4.34 | | | |
| | ASSEMBLING STATOR | 4.34 | | | |
| | INSTALLING ALTERNATOR | 4.34 | | | |
| 4.21 | TESTING STARTER | 4.35 | | | |
| | TESTING WITH VOLTMETER | 4.35 | | | |
| | TESTING WITH AMPEREMETER | 4.35 | | | |
| 4.22 | REMOVING, DISASSEMBLING, ASSEMBLING AND INSTALLING STARTER .. | 4.36 | | | |
| | REMOVING STARTER | 4.36 | | | |
| | REPLACING CARBON BRUSHES | 4.37 | | | |
| | DISASSEMBLING STARTER | 4.37 | | | |
| | ASSEMBLING STARTER | 4.38 | | | |
| | INSTALLING STARTER | 4.38 | | | |
| 4.23 | REMOVING AND INSTALLING SWITCH FOR IDLE DISPLAY | 4.39 | | | |
| 4.24 | REMOVING AND INSTALLING OIL PRESSURE SWITCH | 4.39 | | | |

4.1 REMOVING AND INSTALLING HEADLAMP

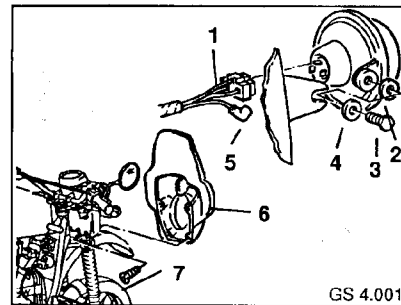

- Slacken 4 fastening screws (7) on the rear section of the headlamp fairing.
- Take off windshield (6) together with front section of headlamp fairing.
- Slacken left/right fastening screws (3) on the headlamp and take off together with washers (2,4).
- Disconnect 3-pin plug (1) as well as flat pin plug (5) and remove headlamp.
- The headlamp is installed in the reverse order by analogy to removal.

NOTE:

After being installed, the headlamp requires to be adjusted.

REMOVING AND INSTALLING HEADLIGHT (PD)

Removing windscreen

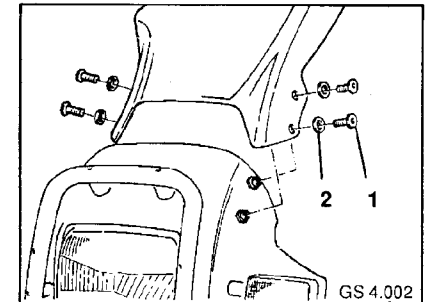

- Take out the screws (1) holding the windscreen.

Removing flashing turn indicators with holders

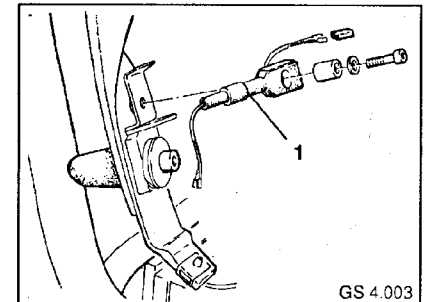

- Remove the left and right flashing turn indicators.
- Detach the flashing turn indicator holder (1) at the retaining bracket.
- Pull the flashing turn indicator housing with holder out of the fairing.
- Disconnect the electric wiring.

Removing side section of instrument carrier

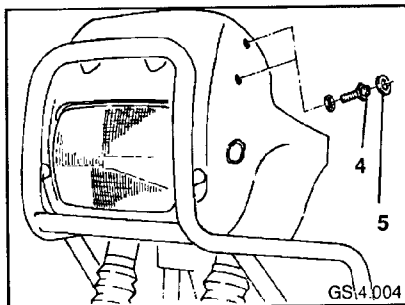

- Take out the upper left and right retaining screws (4).

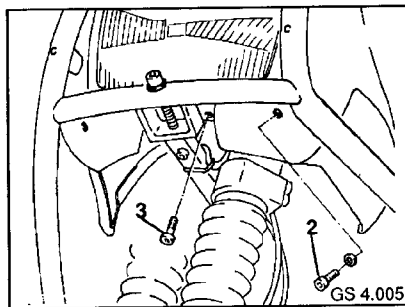

- Take out the lower left and right retaining screws (2) and screw (3).

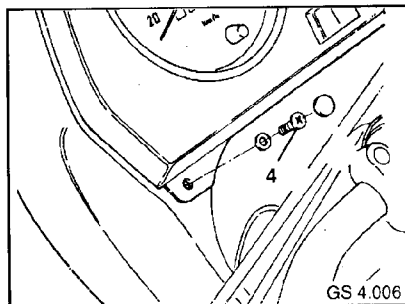

- Take out the retaining screws (2) under the instruments at left or right.
- Unclip the speedometer drive shaft inside the left side section.
- Pull the left and right side sections forward slightly and take them off.

Removing the speedometer

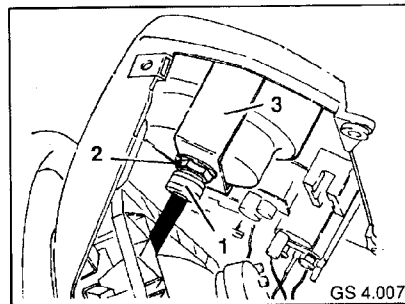

- Unscrew the knurled nut (1) for the speedometer shaft.
- Unscrew the retaining nut (2) for the speedometer.
- Take off the retaining hoop (3), pull out the bulb and lift out the speedometer

Removing the instrument carrier

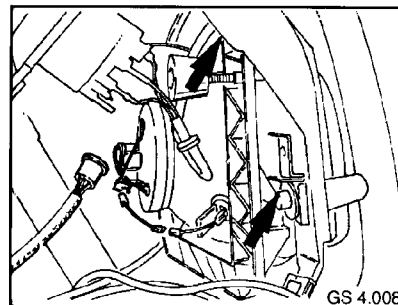

- Take out the instrument carrier retaining screws (arrows) at left and right.

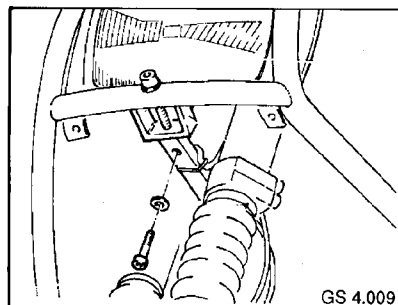

- Take out the headlight retaining screw at the fairing holder (remove the screw cover).
- Open the cable straps at the headlight frame and the fairing holder.
- Tilt the instrument carrier with headlight to one side to remove.

Removing the headlight

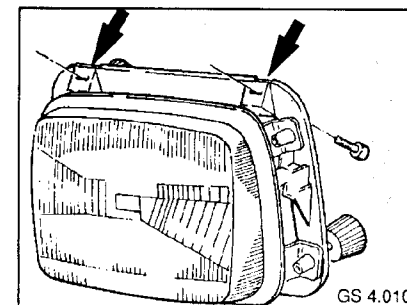

- Take out the retaining screws (arrows) for the frame at the instrument carrier.
- Pull the bulbs out of the reflector.

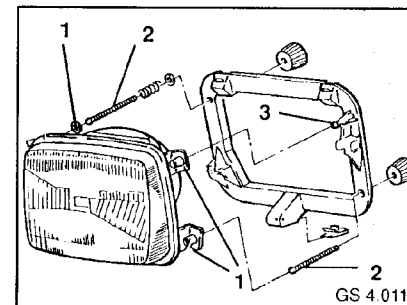

- Set the headlight down on a soft cloth.
- Using two screwdrivers, lever the threaded rods (1) and reaction mount (2) out of the plastic bushings on the headlight.

Installing the headlight

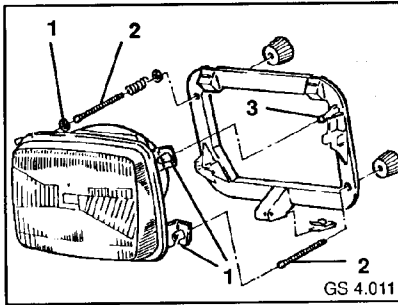

- Press the plastic bushings (1) into the headlight (applies only to a new headlight).
- Press the threaded rods (2) and reaction mount (3) on the headlight frame into the plastic bushings on the headlight.

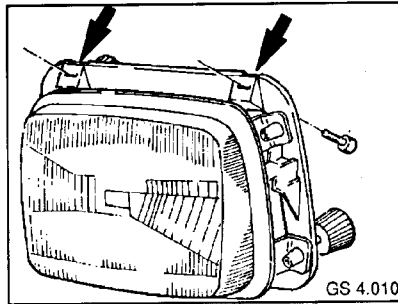

- Attach the headlight with frame to the instrument carrier (arrows).
- Insert the bulbs and connect the electric wiring.

Installing the instrument carrier

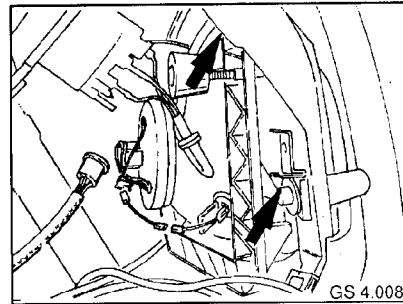

- Attach the headlight with instrument carrier loosely to the left and right protective hoops (arrows).

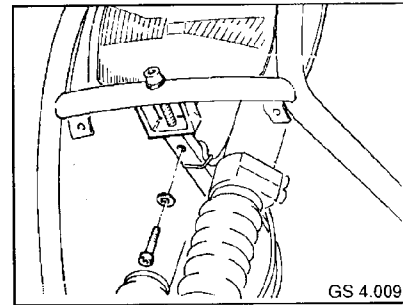

- Secure the headlight frame to the fairing holder.
- Tighten all screws firmly.
- Press in the screw cover.

Installing the speedometer

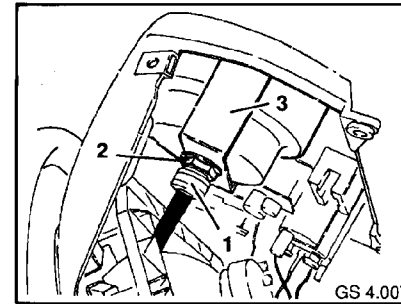

- Insert the speedometer into the instrument carrier.
- Press in the bulb with holder.
- Attach retaining hoop (3) and secure with hex nut (2).
- Run the speedometer cable between the reflector and the frame and tighten knurled nut (1).

Installing side section of instrument carrier

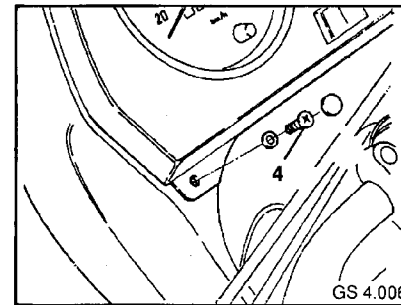

- Offer up left and right side sections to fuel tank and insert the retaining screws below the instruments, but do not tighten them yet.

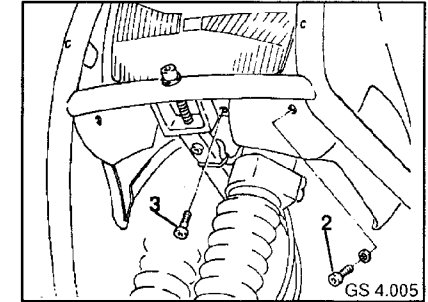

- Insert retaining screws (2, 3) at the bottom left and right, but do not tighten them yet.
- Make sure that the clamp is correctly located at the joint line between the side sections.

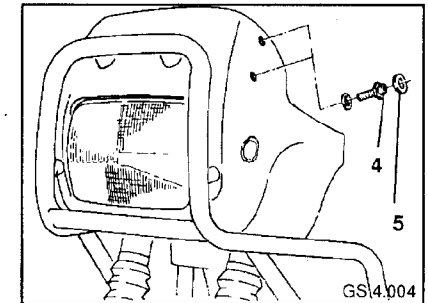

- Insert retaining screws (4) with plastic washers, and tighten carefully.
- Attach rubber washers (5).
- Tighten all screws.

Installing flashing turn indicator with holder

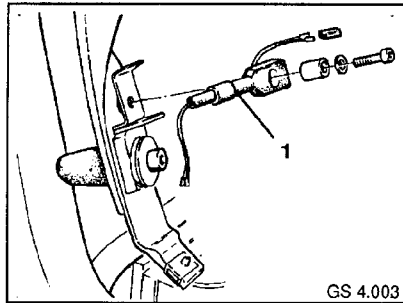

GS 4.003

- Make the electrical connection to the flashing turn indicator with holder.
- Insert the holder through the side section from the outside, and screw on tightly.

Installing the windscreen

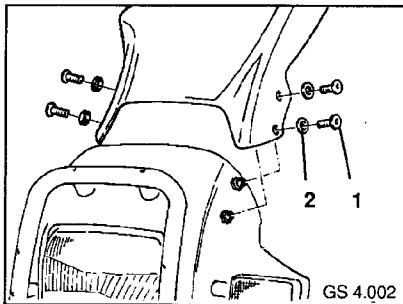

GS 4.002

- Install rubber washers at the 4 attachment points.
- Place the windscreen in position.
- Insert retaining screws (1) with plastic washers (2), but do not tighten yet.
- Make sure that there are no trapped stresses in the windscreen, and tighten the screws.

REMOVING AND INSTALLING THE HEADLIGHT (1991 MODELS)

Removing the windscreen

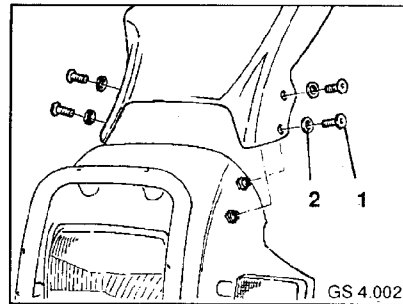

GS 4.002

- Unscrew and remove the windscreen retaining screws.

Removing side section of instrument carrier

- Take off the flashing turn indicator glass.
- Pull the wires off at the reflector.

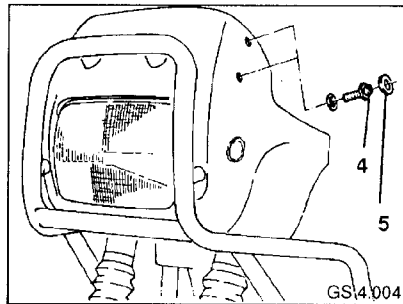

GS4.004

- Remove the flashing turn indicator housing.
- Remove the upper left and right retaining screws.

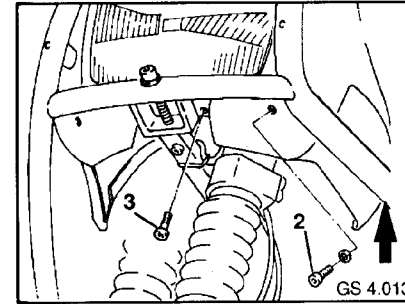

GS 4.013

- Remove the lower left and right retaining screws (2) and screw (3).
- Remove the retaining screws (arrow) at the bottom left and right of the protective hoop.

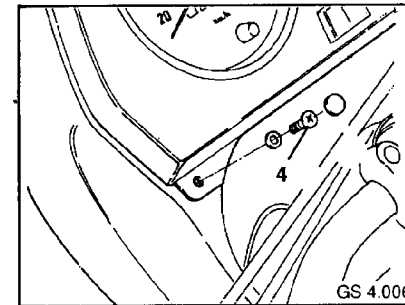

GS 4.006

- Remove the retaining screws (2) at the left and right under the instruments.

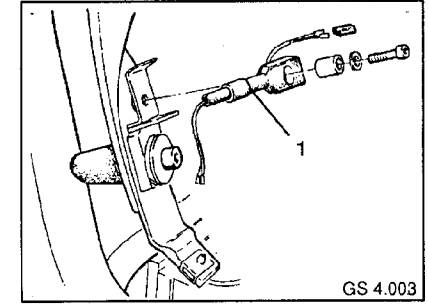

GS 4.003

- Pull the side section of the fairing away slightly.
- Unclip the speedometer drive shaft from the inside of the side section.
- Detach the flashing turn indicator holder (1) from the retaining bracket, and take off the side section.
- Pull off the flashing turn indicator holder.

Removing the speedometer

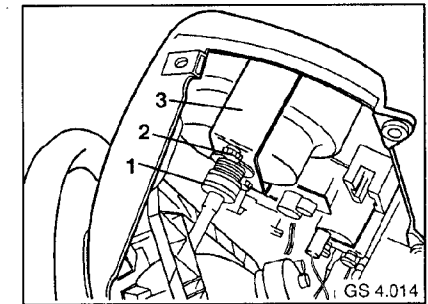

GS 4.014

- Unscrew the knurled nut (1) for the speedometer shaft.
- Unscrew the speedometer retaining nut (2).
- Remove the retaining hoop (3). Pull out the bulb and lift out the speedometer.

Removing the revolution counter

- Remove the retaining hoop.

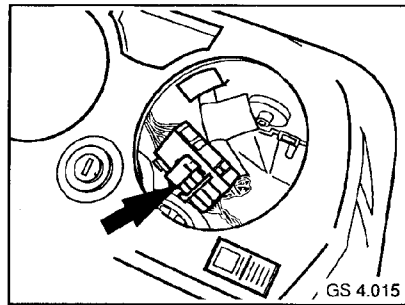

- Separate the plug connection (arrow) for the revolution counter.
- Raise the revolution counter slightly when lifting it out. Cut through one cable strap if necessary.
- Pull out the bulb.

Removing the Ignition switch

- Lever out the position mark ring with a small screwdriver.

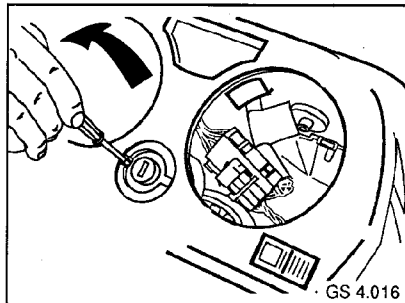

- Press the clamp loop at the ignition switch in and press the ignition switch out downwards.

Removing the headlight

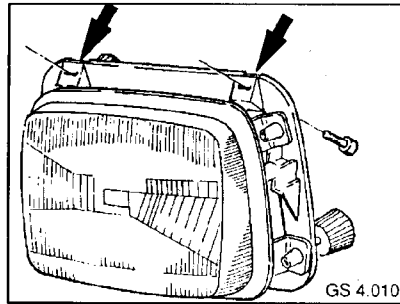

- Remove the headlight frame retaining screws (arrows) at the instrument carrier.

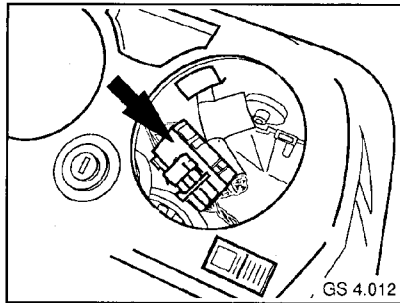

- Separate the plug connection (arrow) for the telltale lamp unit.
- Pull the instrument holder off upwards.
- Cut through the cable strap at the headlight frame.

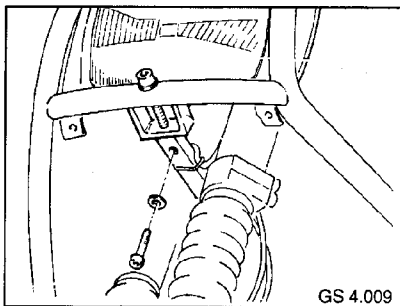

- Take out the headlight retaining screw at the fairing holder (first remove the screw cover).
- Pull the bulbs out of the reflector.

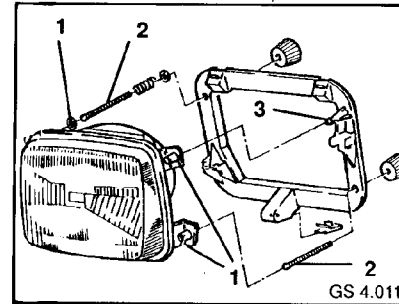

- Lay the headlight on a soft cloth.
- Using two screwdrivers, lever the threaded rods (2) and reaction mount (3) out of the plastic bushing (1) on the headlight.

Installing the headlight

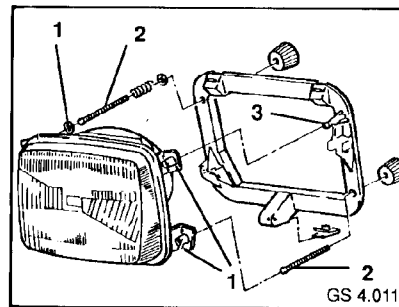

- Press plastic bushings (1) into headlight (new headlight only).
- Press threaded rods (2) and reaction mount (2) on headlight frame into plastic bushings on headlight.

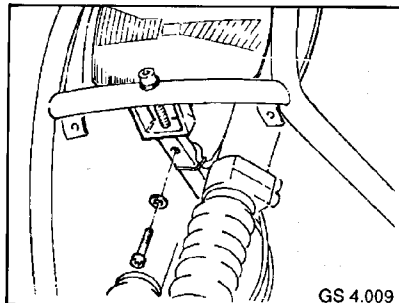

- Attach headlight frame loosely to fairing holder.

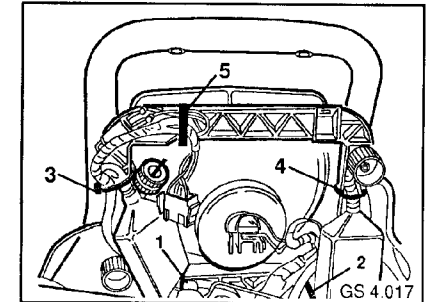

- Secure the wiring to the headlight frame with five cable straps.

Installing the instrument carrier

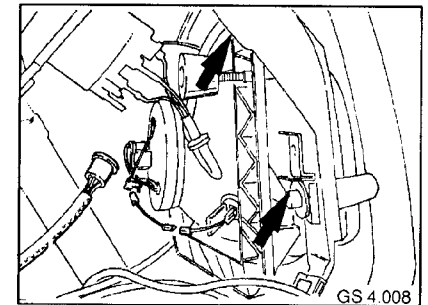

- Install the instrument carrier from the top.
- Insert the instrument carrier retaining screws (arrows) to the protective hoop at left and right, but do not tighten yet.

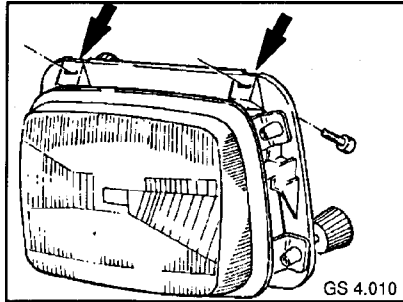

- Insert the headlight frame retaining screws (arrows) at the instrument carrier, but do not tighten yet.
- Tighten all headlight and instrument carrier retaining screws.
- Make the plug connection for the telltale lamp unit.
- Connect the telltale lamp unit to the wiring harness at the plug (arrow).

Installing the Ignition switch

- Press the ignition switch into the instrument carrier from below, noting the correct position.
- Press the position mark ring in from the top.

Installing the revolution counter

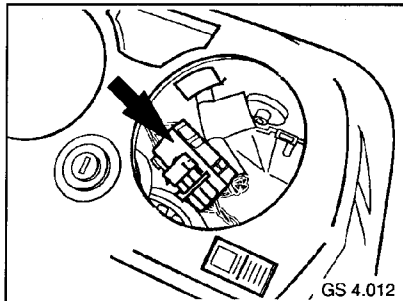

- Insert the revolution counter from the top, at the same time inserting the bulb in its holder.
- Install the retaining hoop.
- Make the plug connection for the revolution counter.
- Fix the wiring of the revolution counter with cable straps at the frame of the headlight.

Tachometer einbauen

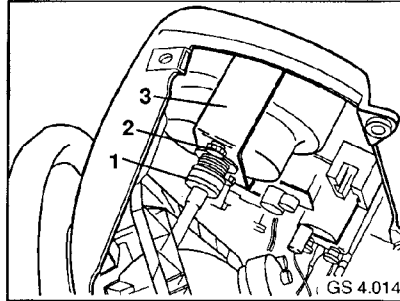

- Insert the speedometer from the top, at the same time inserting the bulb in its holder.
- Install the retaining hoop (3).
- Run the speedometer drive shaft between the reflector and the headlight frame and tighten knurled nut (1).

Installing side section of instrument carrier

- Insert the side section loosely.

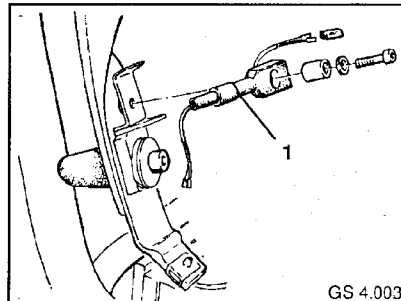

- Insert the flashing turn indicator holder (1) through the side section from the inside, and secure it to the instrument carrier.
- Clip the speedometer drive shaft to the inside of the left side section.

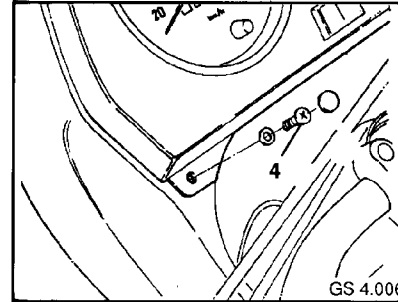

- Insert the retaining screws (arrow) at the left and right under the instruments, but do not tighten them yet..

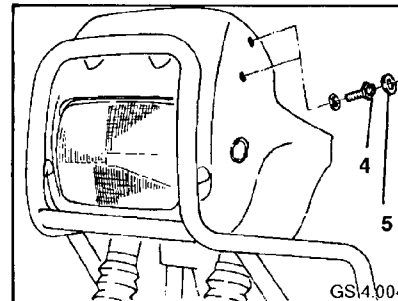

- Insert the upper left and right retaining screws (4).

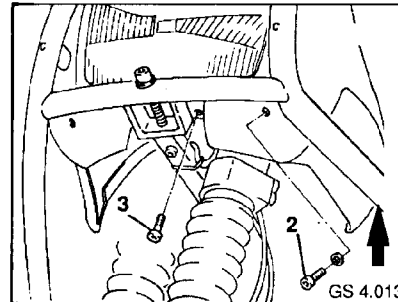

- Insert the lower left and right retaining screws (1) and screw (2), but do not tighten yet.

- Insert retaining screws (arrow) at bottom left and right of protective hoop, but do not tighten yet.
- Align the side sections and tighten all screws.
- Align the headlight and tighten the retaining screw at the holder. Press in the cover.
- Install the flashing turn indicator and connect the wires.
- Install the flashing turn indicator glass.

Installing the windscreen

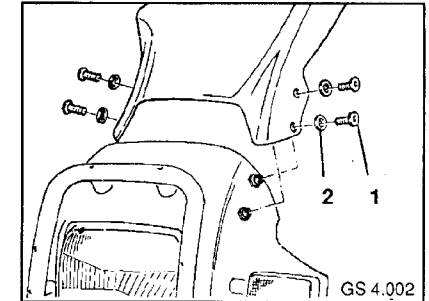

- Place rubber washers in position at the 4 retaining points.
- Offer up the windscreen.
- Insert the retaining screws with plastic washers, but do not tighten yet.
- Tighten the screws, avoiding trapped stresses in the windscreen.

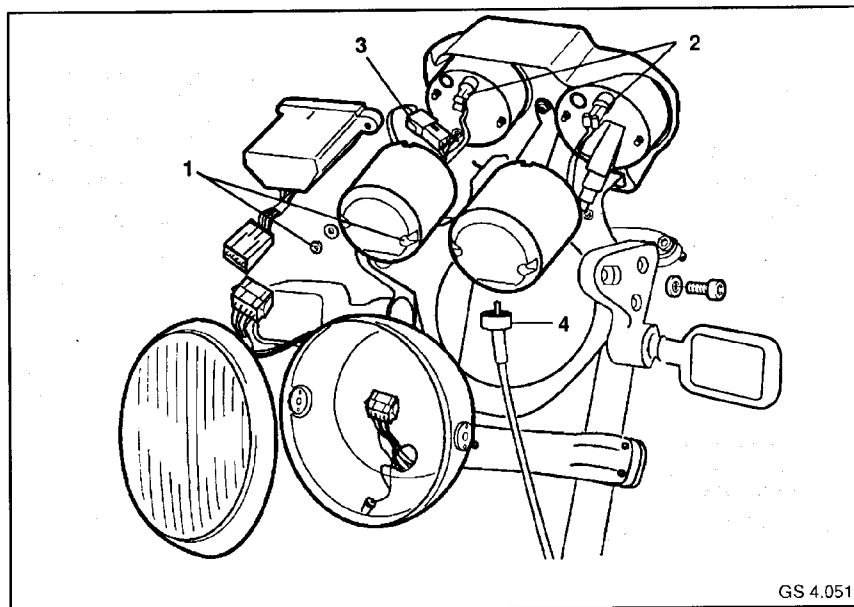

GS 4.051

REMOVING AND INSTALLING HEADLIGHT - R 100R

- Loosen headlight insert mount (arrow)
- Detach plug base from bulb, earth (ground) wire and side light bulb.
- Pull wire with plug base backwards and remove from headlight.
- Loosen headlight housing attachment screw (1) at left and right.

4.2 ADJUSTING HEADLAMP

ADJUSTING HEADLAMP WITHOUT BEAM ADJUSTER

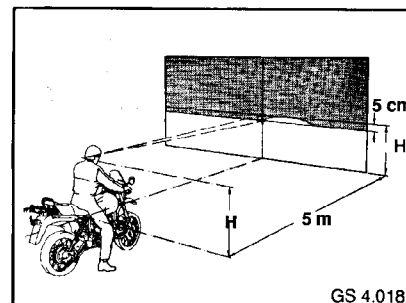

- If no beam adjuster is available, the work can be performed by adopting the following procedure:
- Check tyre pressure, correct if necessary.
- Spring strut set for solo driving.
- Park motorcycle on a flat surface 5 meters away from a light coloured wall and sit on the seat.

NOTE:

Obere Gabelbrücke muß sich leicht auf Standrohre/Lenkrohr aufschieben lassen.

- Measure distance "H" from ground to centre of headlamp.
- Transfer height "H" onto wall and mark with a cross.
- Mark a second cross 50 mm below this.
- Switch on dipped beam.
- Align headlamp so that the cut-off begins in the middle of the bottom cross, rising to the right up to the height of the top cross and then dropping off again.

ADJUSTING HEADLAMP WITH BEAM ADJUSTER

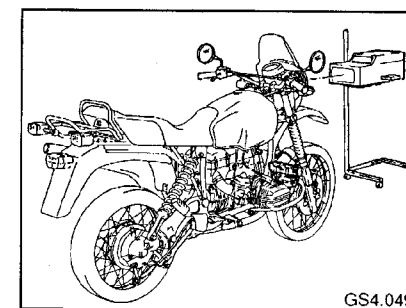

Perform adjustment of headlamp with an optical instrument as stated in the manufacturer's instructions.

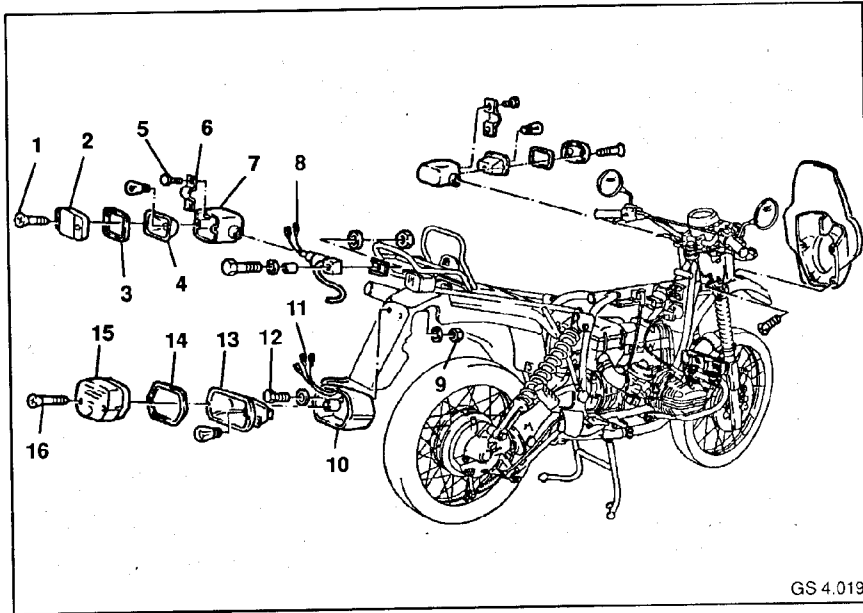

GS 4.019

4.3 REMOVING AND INSTALLING TURN SIGNALS

NOTE:

The same procedure is applied by analogy for removing all four turn signals.

- Slacken 2 fastening screws (1).
- Take off lens (2) together with gasket (3).
- Remove reflector (4/3/4) from turn signal housing (7).
- Detach plug connections (8) and remove.
- Slacken 2 screws (5) of the clamping bar (6) and withdraw turn signal housing from mounting bracket.

The turn signals are **installed** in reverse order by analogy to removal.

4.4 REMOVING AND INSTALLING REAR LIGHT

- unscrew 2 fastening screws (16) on the rear light and take off lens (15) together with sealing ring (14).
- Take out reflector (13).
- Detach plug connection (11) and take off reflector.
- Unscrew fastening screws/nuts (12,9) and take lamp housing (10) off the rear mudguard.

The rear light is **installed** in the reverse order by analogy to removal.

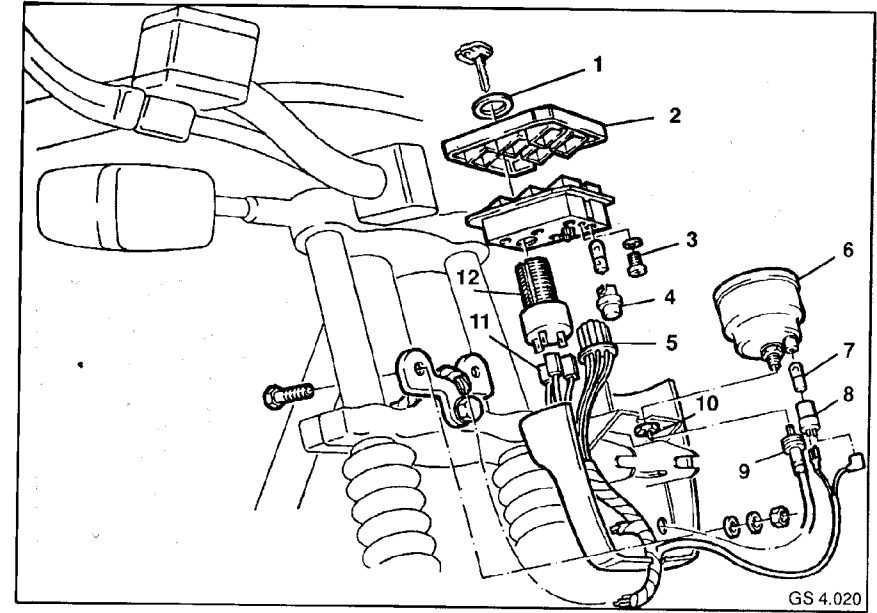

GS 4.020

4.5 REMOVING AND INSTALLING SPEEDOMETER

- Remove headlamp.
- Withdraw bulb (7) together with base (44/8) from speedometer housing (6).
- Slacken knurled nut (9) and take off speedometer shaft.
- Unscrew fastening nut (10) on the speedometer housing.
- Withdraw speedometer from mounting bracket to the front.

The speedometer is **installed** in the reverse order by analogy to removal.

NOTE:

After installing speedometer, the headlamp must be adjusted.

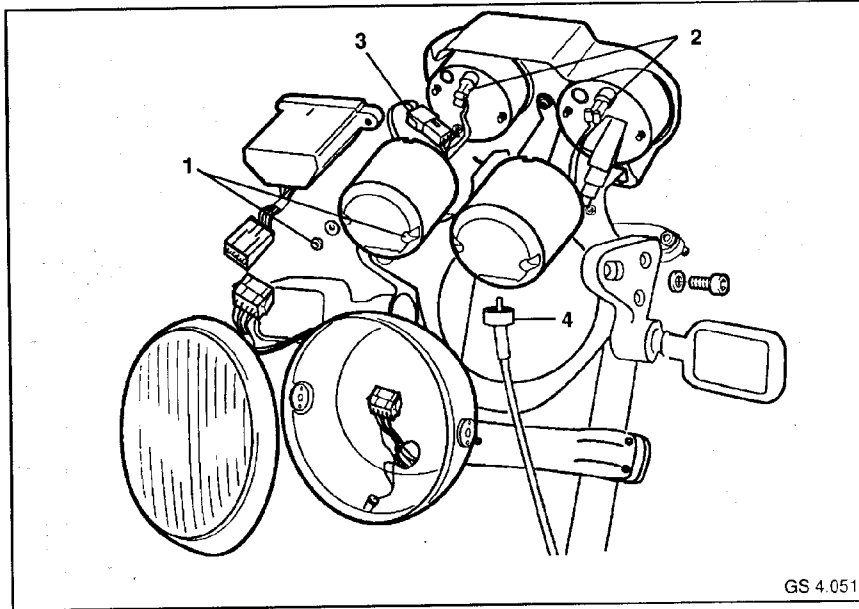

GS 4.051

DISMANTLING AND INSTALLING SPEEDOMETER/REVOLUTION COUNTER – R 100R

- Remove headlight
- Loosen attachment screws (1) for the relevant casing cover.
- Remove bulb with socket (2) from instrument; separate electrical plug connection (3).
- Remove speedometer shaft (4).
- Remove instrument from instrument carrier.

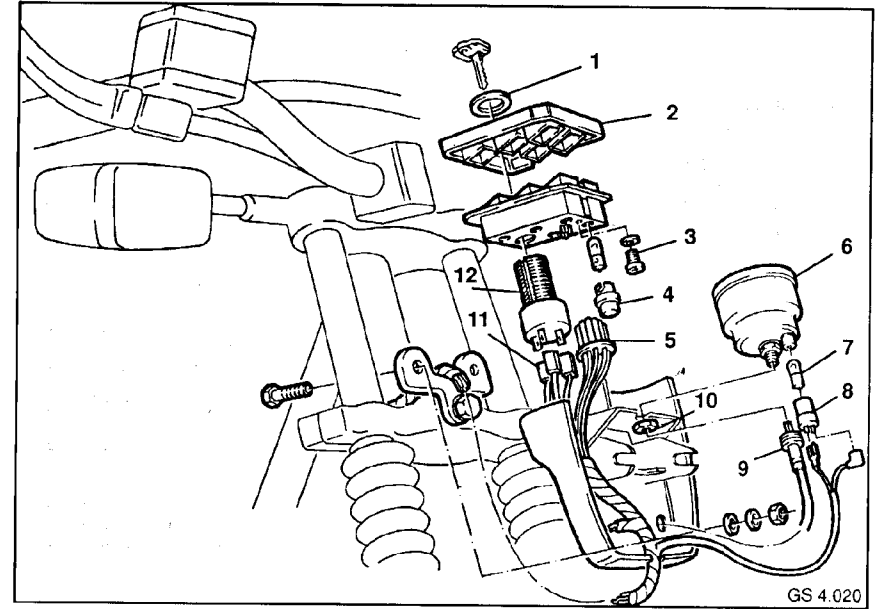

GS 4.020

4.6 REMOVAL DISPLAY PANEL WITH IGNITION LOCK

- Withdraw display panel (13) from the guide.
- Detach plug (5).
- Detach three plug contacts (11) from ignition lock (12) and take off display panel.
- Removing and installing headlight mod.91 look 4.1.
- R100R: remove headlight and loosen instrument cluster screws.
- Separate the plug connections for the electric wiring.

4.7 DISASSEMBLING AND ASSEMBLING, INSTALLING DISPLAY PANEL

- Slacken locking nut (1) and withdraw ignition lock (12).
- Slacken two fastening screws (3) and take off screen panel (2).
- Turn lamp base (4) 1/4 turns to release it and take off bulb.

The display panel is **assembled** in the reverse order by analogy to disassembly. The display panel is **installed** in the reverse order by analogy to removal.

4.8 REMOVING AND INSTALLING HANDLE-BAR CONTROLS

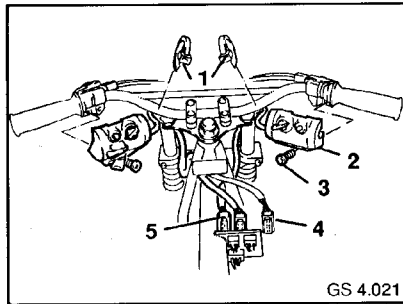

- Remove seat.
 - Remove fuel tank.
 - Cut through cable strap (1).
 - Disconnect 2 plugs (4) of the lefthand and plug (5) of the righthand handle bar control (2).
 - Slacken one fastening screw (3) on each side and take off handlebar controls.
- The handle bar controls are installed in the reverse order by analogy to removal.

4.9 TESTING OPERATION OF ALTERNATOR, REGULATOR AND DIODE PLATE.

CAUTION:

Cables between batteries, alternator and regulator must only be disconnected when the engine is not running.

The positive and negative cables of the battery must be disconnected before charging the battery in the motorcycle with a charger. The alternator will be only be correctly pre-excited if the charge indicator lamp is intact.

The positive and negative cables of the battery must be disconnected before charging the battery in the motorcycle with a charger. The alternator will be only be correctly pre-excited if the charge indicator lamp is intact.

TESTING REGULATOR

- Connect voltmeter to positive and negative terminals of the charged battery.
- Start engine and run at a speed of 3000 ... 4000 rpm. The voltage at the battery must rise to 13.5 ... 14.2 V.
- If the voltage reading is significantly below 13.5 V, examine the cable connection. If this is in proper order, either the regulator or the alternator is faulty.
- If the voltage reading is significantly greater than 14.2 V, the regulator is faulty.

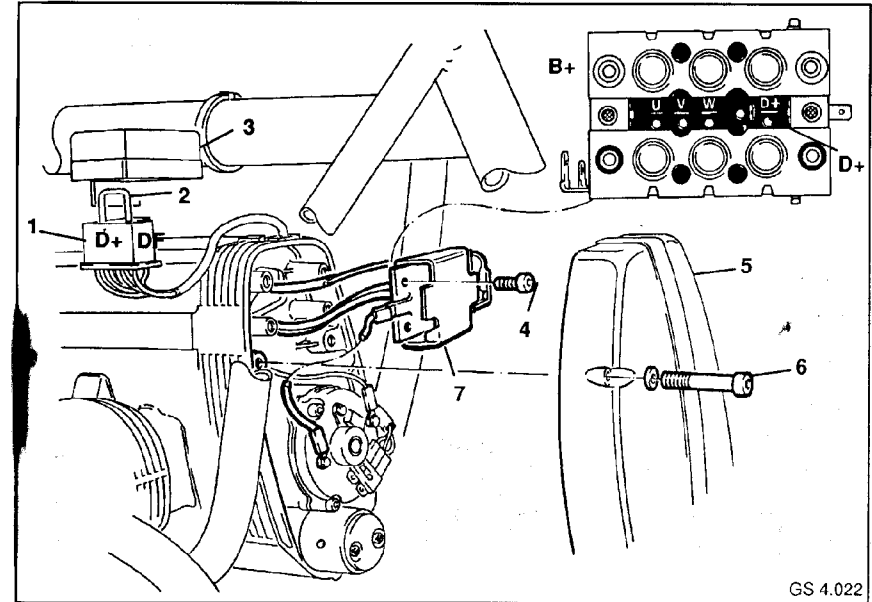

4.10 QUICK TEST OF ALTERNATOR AND REGULATOR

NOTE:

Only perform this test if the charge indicator lamp shows a steady light when the engine is running.

- Remove seat.
- Remove fuel tank.
- Disconnect multiple plug (1) from regulator (3) when the engine is not running.
- Connect cable D+ (blue) to cable DF (black) with a wire jumper (2).
- Start engine and run at 1000 ... 2000 rpm.
- If the charge indicator lamp goes out immediately, the regulator is faulty.
- If the charge indicator lamp glows faintly or continues to show a bright light, the alternator is faulty.

NOTE:

The quick test can also be conducted directly at the diode plate by comparing the voltages at D+ and B+ of the diode plate.

- Slacken 2 hexagon socket screws (6) and lift off engine guard cover (5).
- Slacken 4 hexagon socket screws (4) and take off diode plate (7).
- Connect voltmeter to chassis and D+ or B+ to diode plate.
- Start engine.
- Perform voltage measurements successively at B+ and D+.
- If there is a difference in voltage of up to 0.5 V, the regulator is faulty.
- If there is a voltage difference of 1.5 V to 4 V, the diode plate is faulty.

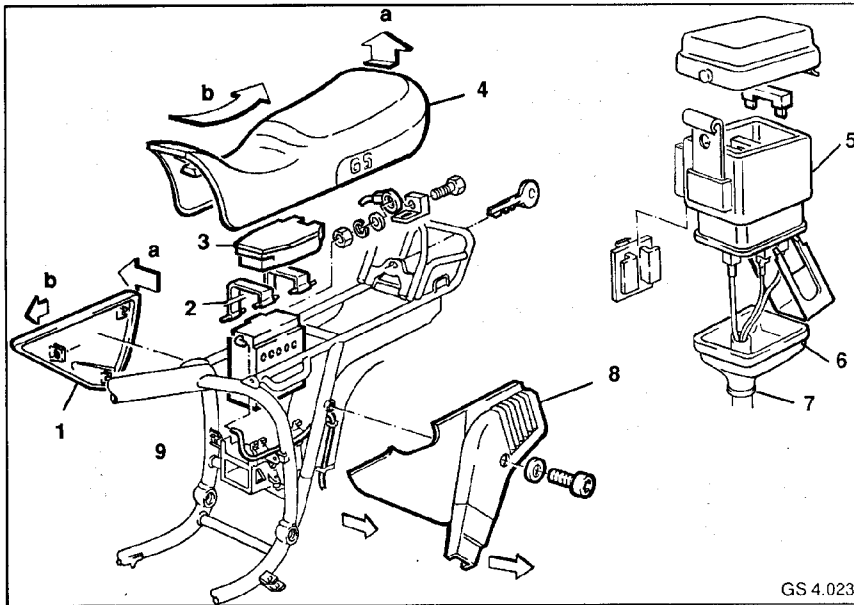

GS 4.023

4.11 REMOVING AND INSTALLING BATTERY

- Remove seat.
- Remove fuel tank.
- Take off battery cover on left side (8) and on right side (1).
- Lift tool tray (3) off up the way.
- Detach tensioning strap (2).

CAUTION:

Always disconnect the negative terminal first.

- Detach negative and positive cables from the battery terminals.
- Pull off battery breather (9).
- Lift out battery up the way.

The battery is **installed** in the reverse order by analogy to removal.

CAUTION:

Always connect the positive terminal first.

NOTE:

After connecting the positive and negative terminals of the battery, coat them with terminal post grease.

4.12 REMOVING AND INSTALLING FUSE BOX

- Turn fuse box (5) counter-clockwise and lift of battery mount.
- Push back protective rubber cap (7).

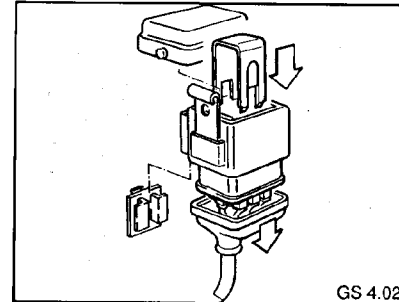

GS 4.024

- Use special tool, BMW No. 61 0 500, to release lock and disconnect fuse box from plug (6).
- The job of installing an additional cable can be performed at this stage.

The fuse box is **installed** in the reverse order by analogy to removal.

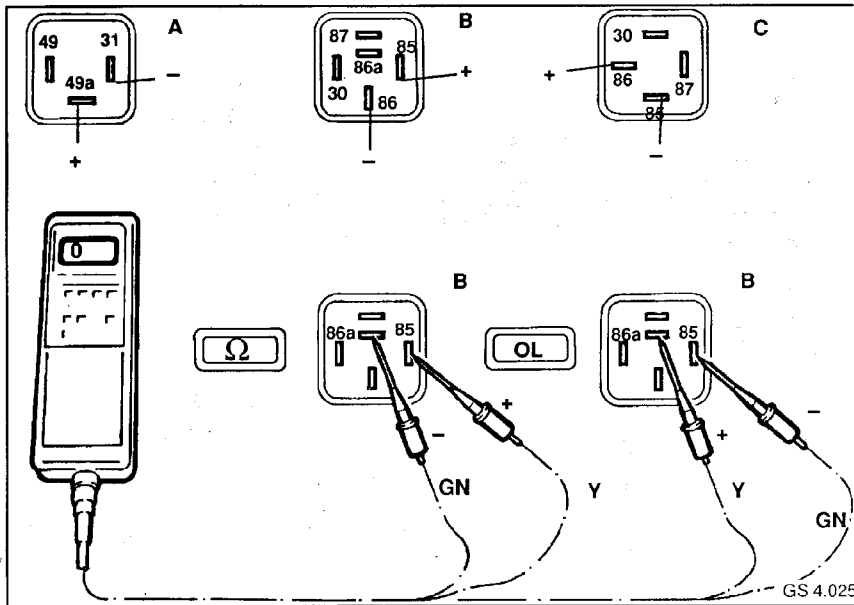

4.13 REMOVING, TESTING AND INSTALLING RELAYS

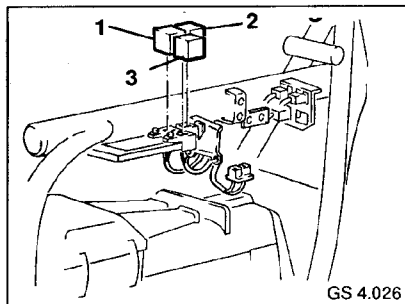

- Remove seat.
- Remove fuel tank.
- Withdraw turn signal (2), starter (1) and light relay (3) from their base.

TESTING OPERATION OF TURN SIGNAL RELAY (A)

- Positive cable connected to terminal 49 a.
- Negative cable connected briefly to terminal 31.
- Switching noise must be audible; if not, the relay is faulty.

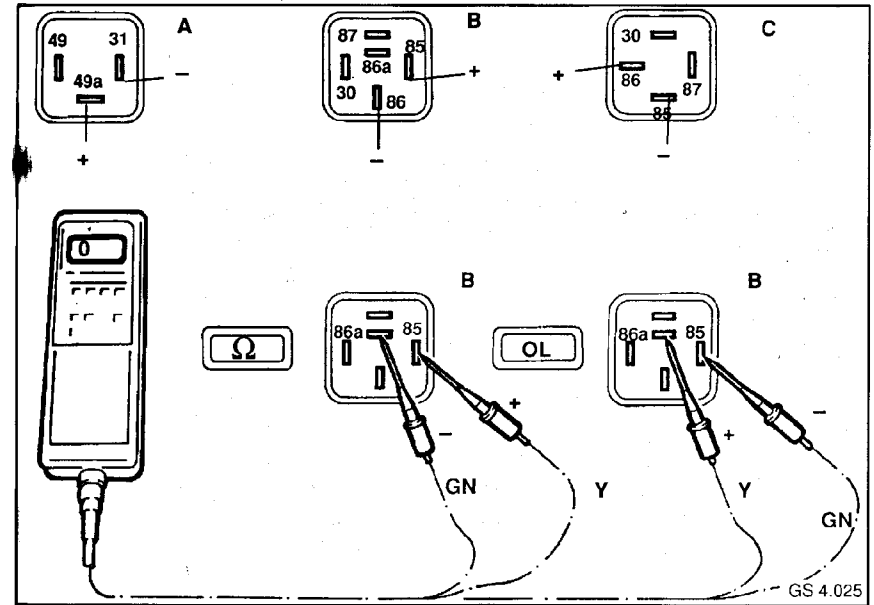

TESTING OPERATION OF STARTER RELAY (B)

- Positive cable connected to terminal 85.
- Negative cable connected briefly in turn to terminals 86 and 86a.
- Switching noise must be audible in both cases; if not, the relay is faulty.

TESTING DIODE OF STARTER RELAY

NOTE:

A zero adjustment must be performed prior to each measurement with the BMW Diagnosis Tester. This is done by connecting positive (yellow) and negative (green) cables. Press Ω button until digital display 0.00 Ω appears.

NOTE:

A zero adjustment must be performed prior to each measurement with the BMW Diagnosis Tester. This is done by connecting positive (yellow) and negative (green) cables. Press Ω button until digital display 0.00 Ω appears.

- Perform test as shown in Fig. 49.

TESTING OPERATION OF LIGHT RELAY (C)

- Positive cable connected to terminal 86.
- Negative cable connected briefly to terminal 85.
- Switching noise must be audible; if not, the relay is faulty.

The relays are installed in the reverse order by analogy to removal.

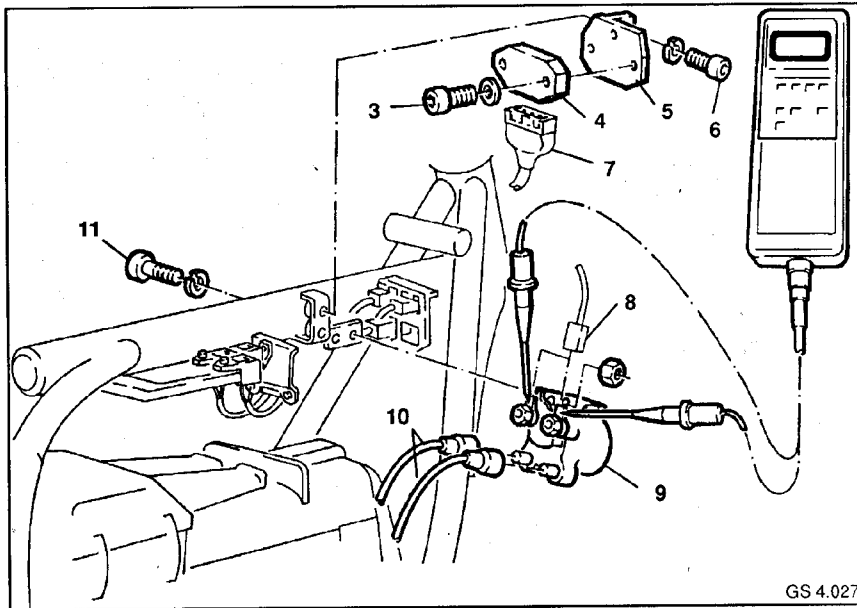

GS 4.027

4.14 REMOVING AND INSTALLING REGULATOR

- Remove seat.
 - Remove fuel tank.
 - Detach plug connection from regulator (1).
 - Slacken the 2 fastening screws (2) and take off regulator.
- The regulator is installed in the reverse order by analogy to removal.

4.15 REMOVING AND INSTALLING IGNITION CONTROL UNIT

- Remove seat.
- Remove fuel tank.
- Detach plug connection (7) from the ignition control unit (4).
- Slacken the two fastening screws (6) and take ignition control unit together with heat sink (5) off the frame.
- Slacken 2 fastening screws (3) and take heat sink (5) off the control unit.

NOTE:

When installing the heat sink, coat contact surfaces between control unit and heat sink with Curil K2 sealing compound.

The ignition control unit is installed in the reverse order by analogy to removal.

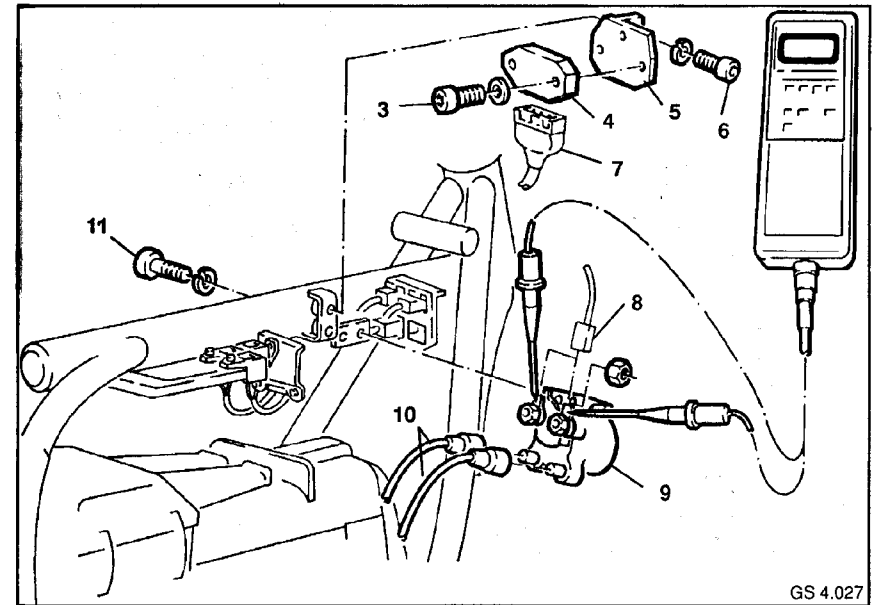

GS 4.027

4.16 REMOVING, TESTING AND INSTALLING IGNITION COIL

- Remove seat.
- Remove fuel tank.
- Disconnect ignition cables (10).
- Detach 2 plug connections (8) from ignition coil (9).
- Slacken the 2 fastening screws (11) and take ignition coil off the frame.

TESTING RESISTANCES OF IGNITION COIL

- Perform zero adjustment on BMW Diagnosis Tester.

- Perform resistance measurements as shown in illustration.
- The ignition coil is installed in the reverse order by analogy to removal.

Resistances:

Primary

between terminals 15 and 1 1.10 ... 1.32 Ω

Secondary

between terminals 4a and 4b 7.5 ... 9.15 Ω

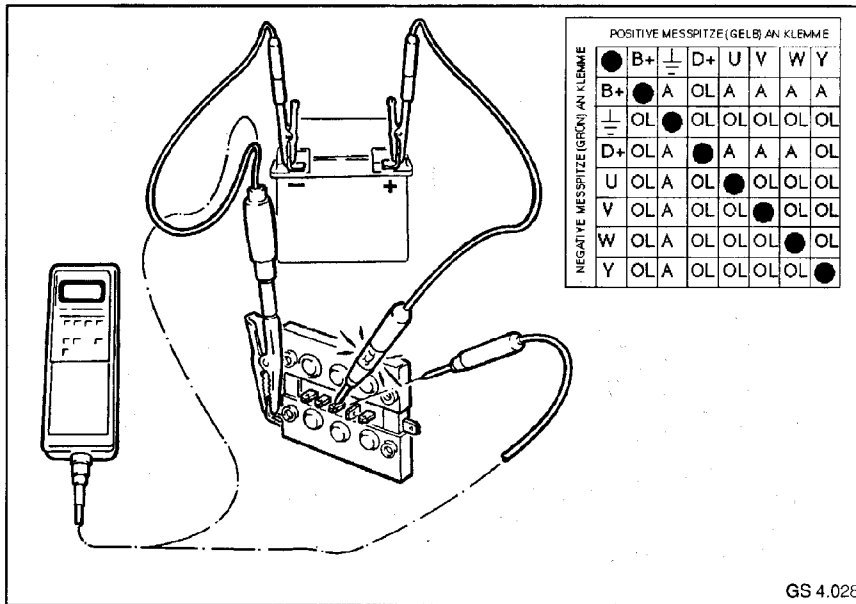

GS 4.028

4.17 REMOVING, TESTING AND INSTALLING DIODE PLATE

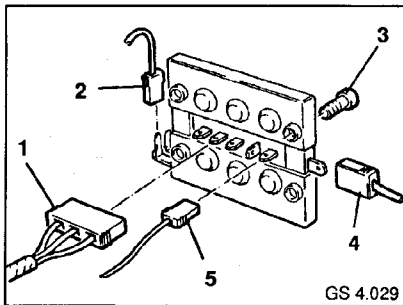

GS 4.029

- Take off engine protective cover.
- Disconnect diagnosis plug (2) and (4) from diode plate.
- Slacken the 4 fastening screws (3) and pull diode plate forward.
- Disconnect 3-pin (1) and 1-pin (5) plugs and take off diode plate.

NOTE:

The diode plate can be tested either with the test lamp or with an Ohmmeter (BMW Diagnosis Tester).

- Test diode plates fully as specified in test table.

NOTE:

The zero adjustment requires to be performed at the diagnosis tester before each test step.

Test lamp lights up

or

Ω display (A)

Test lamp off

or

OL display

continuity free

continuity blocked.

NOTE:

If the tester indicates a reading instead of "OL" repeat zero adjustment. If a reading is again obtained, the diode plate is faulty.

The diode plate is **Installed** in the reverse order by analogy to removal.

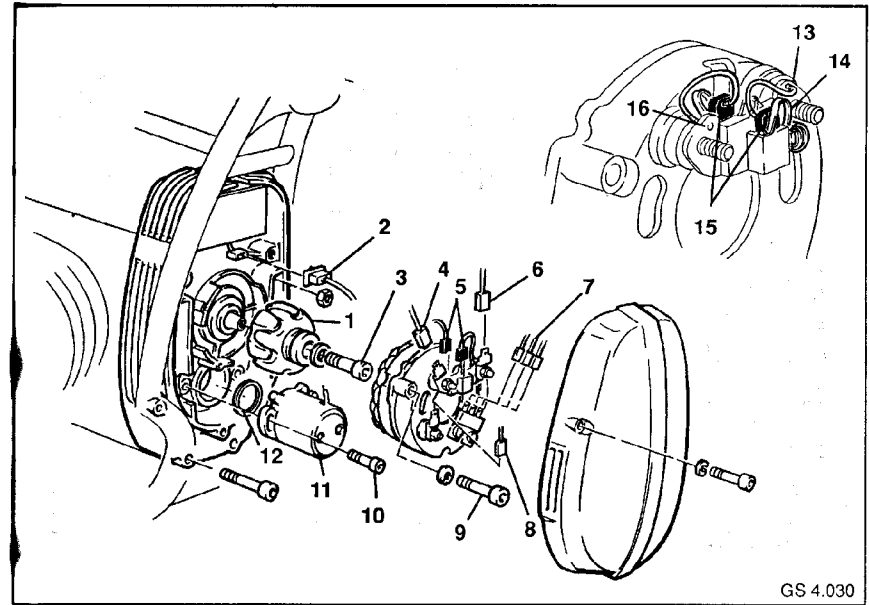

GS 4.030

4.18 REMOVING AND INSTALLING IGNITION TRIGGER

- Slacken the 2 fastening screws (10) and withdraw ignition trigger (11) from the chain box cover.
- Take 3-pin plug (2) off wire clamp and detach plug connection.

NOTE:

Before installing, renew sealing ring (12) of the ignition trigger.

The ignition trigger is **Installed** in the reverse order by analogy to removal.

NOTE:

After installing the ignition trigger, the firing point has to be set.

4.19 REPLACING CARBON BRUSHES

- Carefully move compression springs (14) sideways to the edge of the carbon brush guide.

NOTE:

When moving the compression spring facing the starter, ensure that it does not slip off the mount.

- Unsolder terminals (13,16) of the carbon brusher (15).
- Withdraw carbon brushes from holder.

The carbon brushes are installed in the reverse order by analogy to removal.

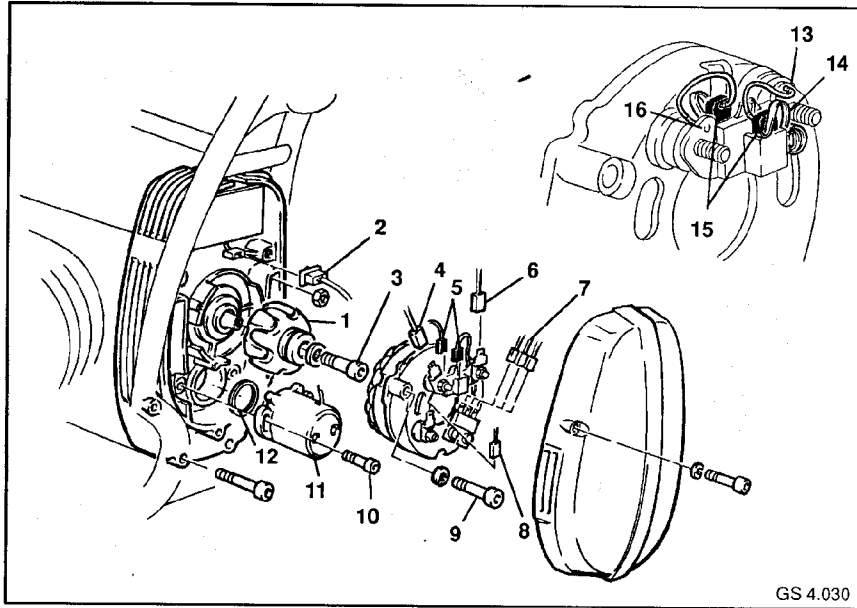

GS 4.030

4.20 REMOVING, TESTING, DISASSEMBLING AND ASSEMBLING ALTERNATOR

REMOVING ALTERNATOR

- Remove engine protective cover
- Disconnect 6 flat pin plugs (4,6,7,8) from the stator.
- Push carbon brushes (5) up slightly and fix in this position with compression springs (14).
- Slacken the 3 fastening screws (9) and take off stator.
- Slacken fastening screw (3) on the rotor (1).

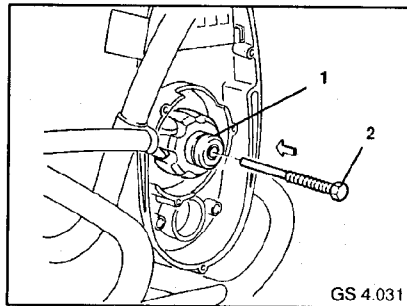

GS 4.031

- Press rotor (1) off crankshaft with forcing screw (2), BMW No. 12 3 600.

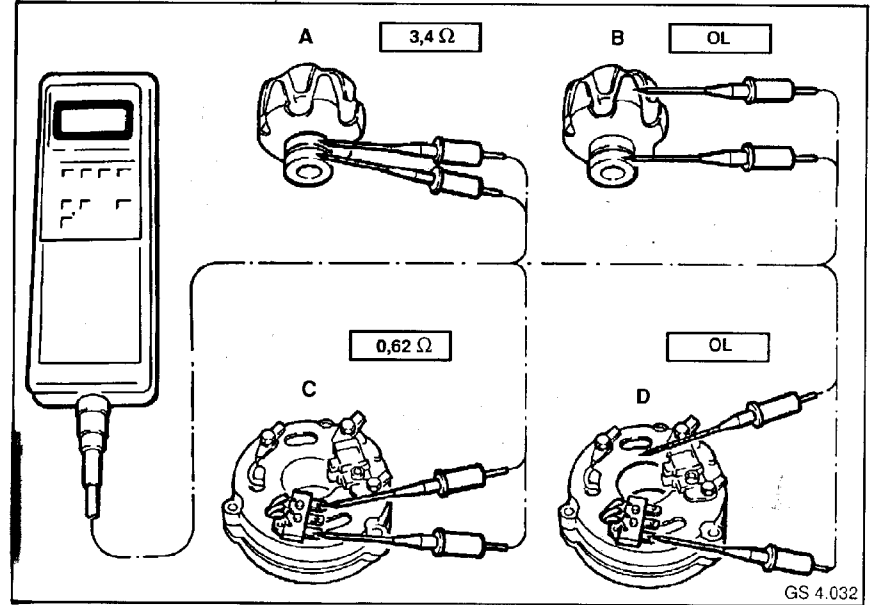

GS 4.032

TESTING ALTERNATOR

NOTE:

A zero adjustment requires to be performed before each measurement with the BMW Diagnosis Tester.

A Testing exciter winding on slip rings:

- Perform measurement A and take Ω-reading.
- If the display "OL" appears, the rotor is faulty.

B Testing rotor for short to ground:

- Perform measurement B.
- Display "OL" must appear.

C Testing stator winding:

- When performing measurement C, test resistance alternately between phase outputs (U,V,W) and take Ω readings.

NOTE:

As the resistance between the phase outputs is very low impedance, variations of 20 ... 30% to the resistance stated may be possible as a result of temperature differences and manufacturing tolerances. The rule which applies is: The starter winding is in proper order if the reading is less than 1.0 Ω.

D Testing stator winding for short to ground:

- Measure each U, V, W to chassis.
- The display "OL" must appear.

Resistances:

Max. resistance between slip rings 3.4 + 0.34 Ω
Resistance between phase outputs 0.62 Ω

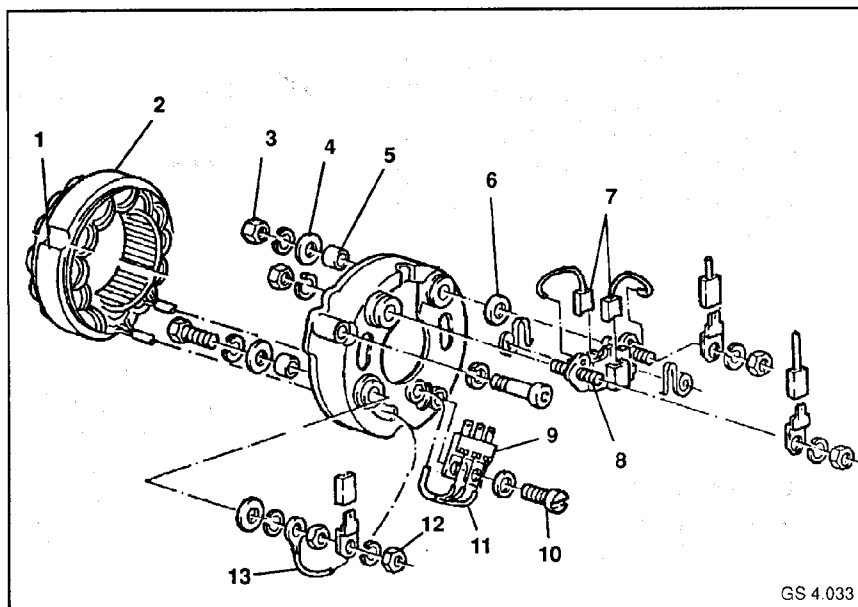

GS 4.033

DISASSEMBLING STATOR

- Mark the 3 wire connections (11) and unsolder from connector (57/9).
- Slacken nut (12) and take cable (13) off terminal "Y".
- Withdraw stator winding (2) from housing.
- Slacken 2 screws (10) and take off connector (11).
- Slacken 2 nuts (3,15) and take off holder (8) for carbon brushes (7).
- Take insulating discs (4,6) and insulating bush (5) off terminal DF.
- Unsolder terminals and take off carbon brushes (7).

ASSEMBLING STATOR

- Insert carbon brushes in holder and solder.
- Fit on insulating disc (6).
- Attach brush holder (8), fit on insulating bush (5) and insulating disc (4) to terminal DF.

- Screw on nuts (3,15).
- Attach connector and screw tight.

NOTE:

Align stator coils so that the milled surfaces (1) on the stator ring are aligned with the hold (14) in the housing.

- Insert stator coil (2) in housing, guiding cable through the openings as shown.
- Solder wire connections (11) to the connections O,V,W, according to the markings made when removing.
- Screw connection (13) to terminal "Y" with fastening nut.

INSTALLING ALTERNATOR

The alternator is installed in the reverse order by analogy to removal.

Tightening torque:

Fastening screw for rotor

25 Nm

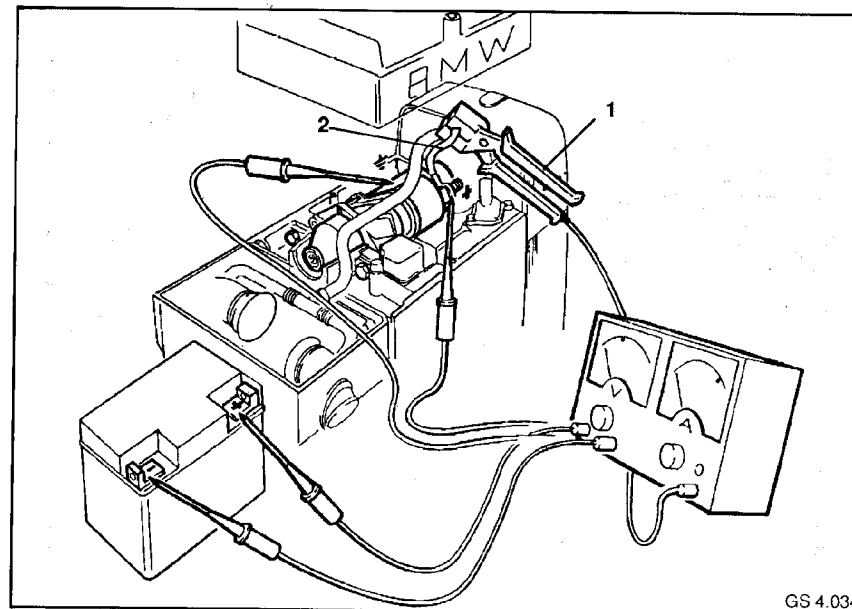

GS 4.034

4.21 TESTING STARTER

- Starter turns too slowly, does not crank engine.
- Test charging state of battery.

TESTING WITH VOLTMETER

- Connect voltmeter between positive and negative terminals of battery.
- Operate starter for 2 ... 3 seconds.
- If the battery voltage drops clearly below 8 V, battery is faulty.
- If the reading is greater than 8 V, note reading.
- Connect voltmeter between solenoid switch terminal 30 and starter ground.
- Operate starter for 2 ... 3 seconds.
- Take reading and compare with the reading noted above.
- If the difference is more than 0.5 V, test connections and cables between starters and battery.
- If these are in proper order, the starter is faulty.

TESTING WITH AMPEREMETER

NOTE:

Engine must be at normal operating temperature.

- Connect amperemeter to positive and negative terminals of battery.
- Clip trigger sensor (1) over starter cable (2) (to terminal 30).
- Operate starter for 2 ... 3 seconds.
- After briefly deflecting, the pointer falls back to a constant reading.

NOTE:

The reading depends on the output required of the starter.

The following readings apply as a guide:

Reading

100 A

100 ... 130 A

> 130 A

Starter in proper order
Starter still in proper order, starting problems may be encountered.
Starter faulty.

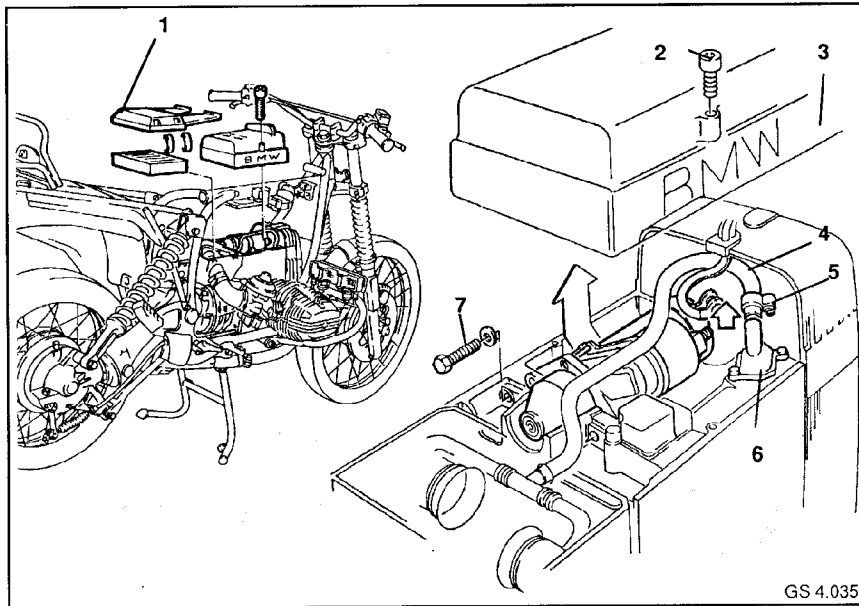

GS 4.035

4.22 REMOVING, DISASSEMBLING, ASSEMBLING AND INSTALLING STARTER

REMOVING STARTER

- Remove seat.
- Remove fuel tank.
- Take off top section of air filter housing (59/1).
- Take out filter element.
- Slacken the 2 fastening screws (59/2) and take off starter cover (59/3).
- Use a screwdriver to slacken clip (59/5) at the vent dome (59/6) and detach vent hose (59/4).

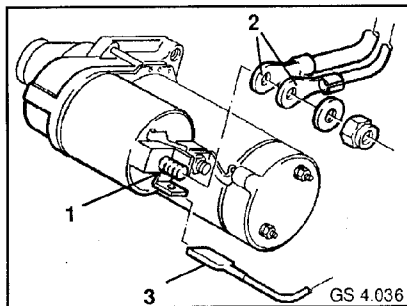

GS 4.036

- Detach positive cables (2) from starter terminal 30 (1).
- Detach cable (3) to the starter relay.
- Slacken rear starter fastening screws (7).
- Take starter out of housing.

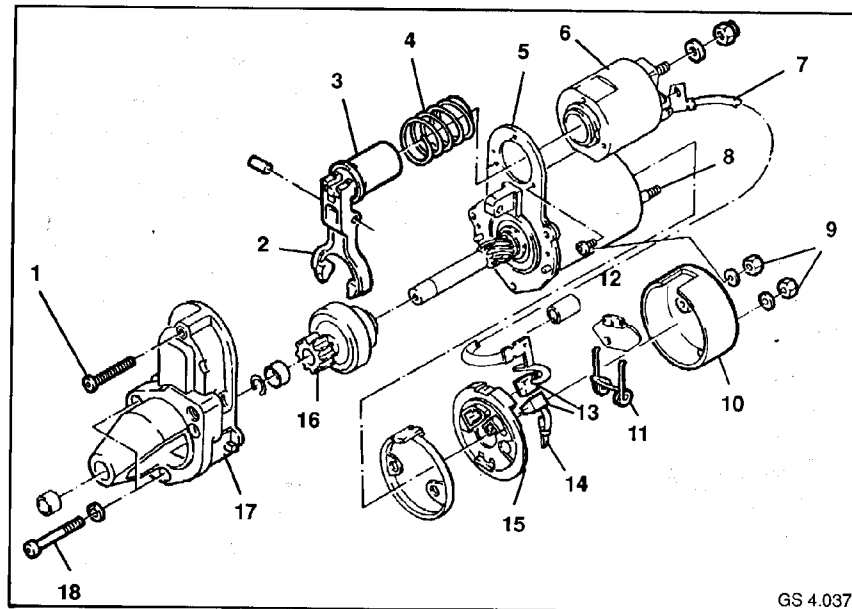

GS 4.037

REPLACING CARBON BRUSHES

- Slacken nut on solenoid switch (6) and take off cable (7).
- Slacken 2 fastening nuts (9) on the rear starter cover (10).
- Take off rear starter cover.
- Take off holder (15) for carbon brushes.
- Raise retaining springs (11) of the carbon brushes and take carbon brushes off the holder.
- Insert new carbon brushes in holder.
- Insert holder onto threaded pins (8) in the rear of the starter housing.
- Fit short cable (14) onto threaded pin.
- Fit on rear starter cover and screw tight with 2 fastening nuts.
- Attach cable (7) to the solenoid switch and screw tight with nut.

DISASSEMBLING STARTER

- Unscrew cable (7) to the excitor winding.
- Slacken fastening screw of solenoid switch (1).
- Slacken the 3 fastening screws (18) and take off starter cover (17).
- Slacken the 3 fastening screws (12) and take of solenoid switch (6).
- Remove release lever (2) and spiral spring (4) from the solenoid switch plunger (3).
- Take starter gear (16) off the shaft.
- Remove rear starter housing cover (10).
- Raise retaining springs (11) of the brushes (13) and remove brushes.

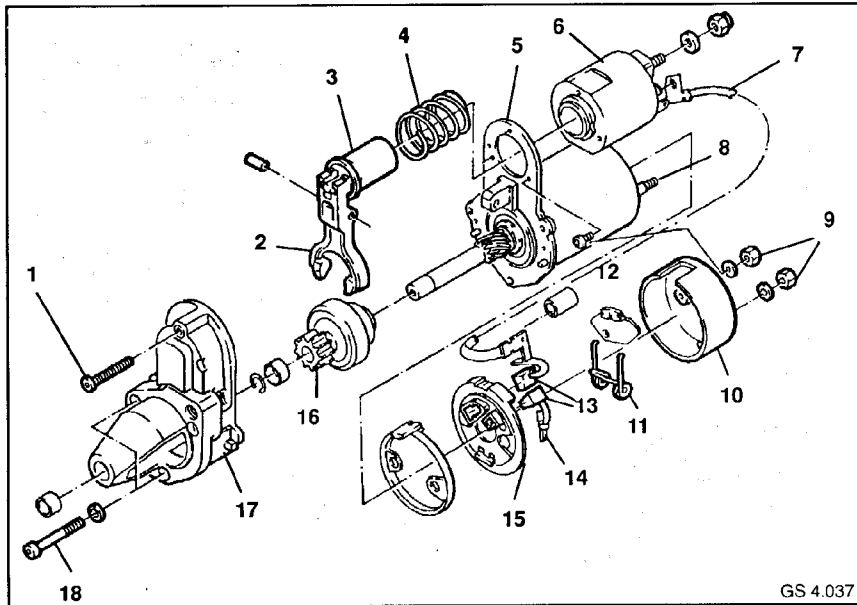

GS 4.037

ASSEMBLING STARTER

- Install carbon brushes with retaining plate.
- Install rear starter housing cover (10).
- Install solenoid switch (6).
- Coat spiral spline and engaging ring with silicone grease Bosch PZ 2 V3.
- Install release lever (2) and plunger (3) of the solenoid switch (6).

- Install solenoid switch housing (6) and spiral spring (4) and screw tight to housing (5).
- Fit on starter cover (17) and screw tight.

INSTALLING STARTER

The starter is **installed** in the reverse order by analogy to removal.

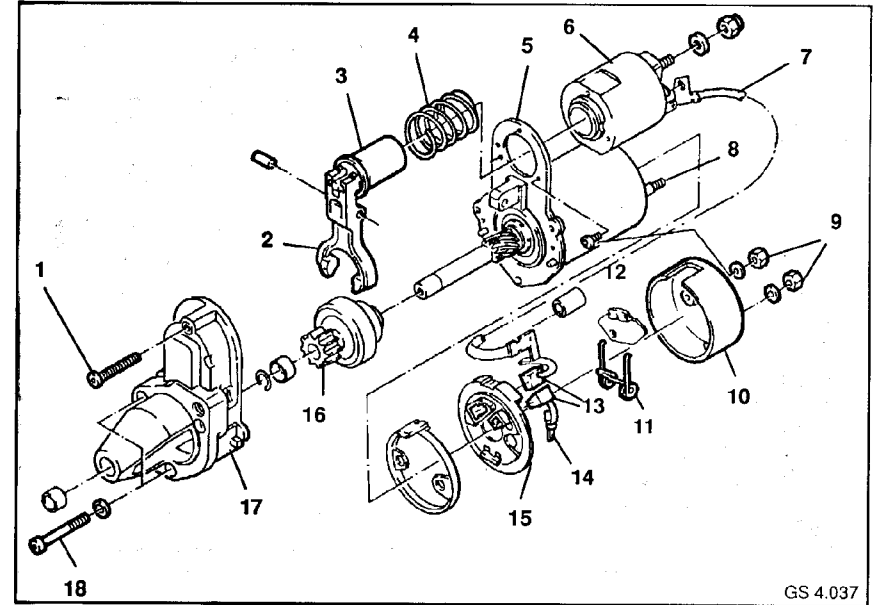

GS 4.037

4.23 REMOVING AND INSTALLING SWITCH FOR IDLE DISPLAY

- Remove front silencer.
- Slacken left/right fastening nut (3) on the rear engine pin(2).
- Withdraw engine pin.
- Use plastic-headed hammer to knock spacer tube (4) out of engine housing.
- After detaching the 2 connections (5), unscrew idle switch(1).

- The switch for the Idle display is installed in the reverse order by analogy to removal.

4.24 REMOVING AND INSTALLING OIL PRESSURE SWITCH

- After detaching the plug connection (8), unscrew oil pressure switch (7) from engine block.
- The oil pressure switch is **installed** in the reverse order by analogy to removal.

4.25 REMOVING AND INSTALLING REAR STOP LIGHT SWITCH.

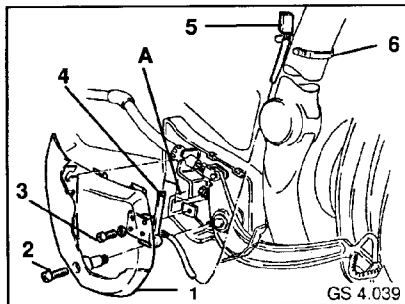

- After slackening the fastening screw (2), take off protective cover (1).
- Cut through cable strap (6) and detach plug connection (5).
- After slackening the fastening screw (3), remove stop light switch (4) from housing.

The stop light switch is installed in the reverse order by analogy to removal.

NOTE:

Following installation, size "A" must be set to 11.5 mm.

4.26 REMOVING AND INSTALLING FRONT STOP LIGHT SWITCH

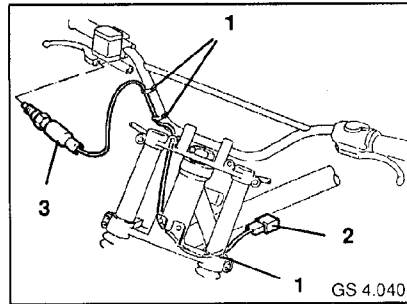

- Remove seat.
- Remove fuel tank.
- Cut through three cable straps (1) and detach plug connection (2).
- Unscrew stop light switch (3) from grip. The stop light switch is installed in the reverse order by analogy to removal.

4.27 REMOVING AND INSTALLING CLUTCH SWITCH

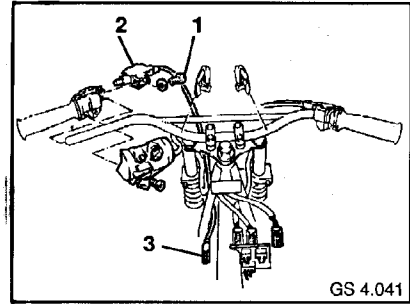

- Remove seat.
- Remove fuel tank.
- Detach plug connection (3).
- Remove left grip unit.
- After slackening the fastening screw (1), take clutch switch (2) off grip unit.

The clutch switch is installed in the reverse order by analogy to removal.

4.28 REMOVING AND INSTALLING HORN

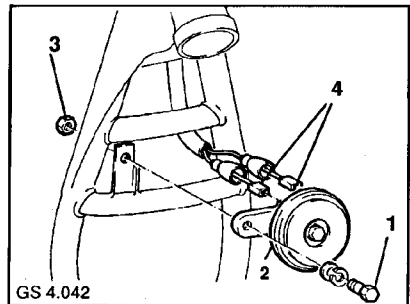

- Detach plug connection (4).

- After slackening the fastening screw/nut (1,3), take off horn (2). The horn is installed in the reverse order by analogy to removal.

4.29 REMOVING AND INSTALLING ENGINE CABLE HARNESS

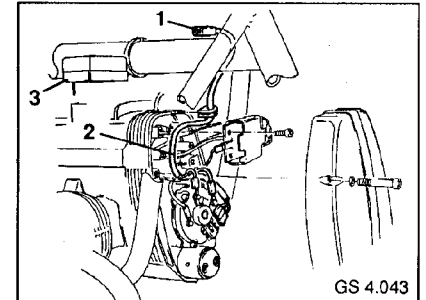

- Remove fuel tank.
- Remove engine protective cover.
- Remove diode plate.
- Detach plug connection (1) to main cable harness.
- Detach cables (2) to the alternator.
- Detach cable to the starter.
- Detach plug connection (3) from the regulator.
- Withdraw engine cable harness from the housing.

The engine cable harness is installed in the reverse order by analogy to removal.

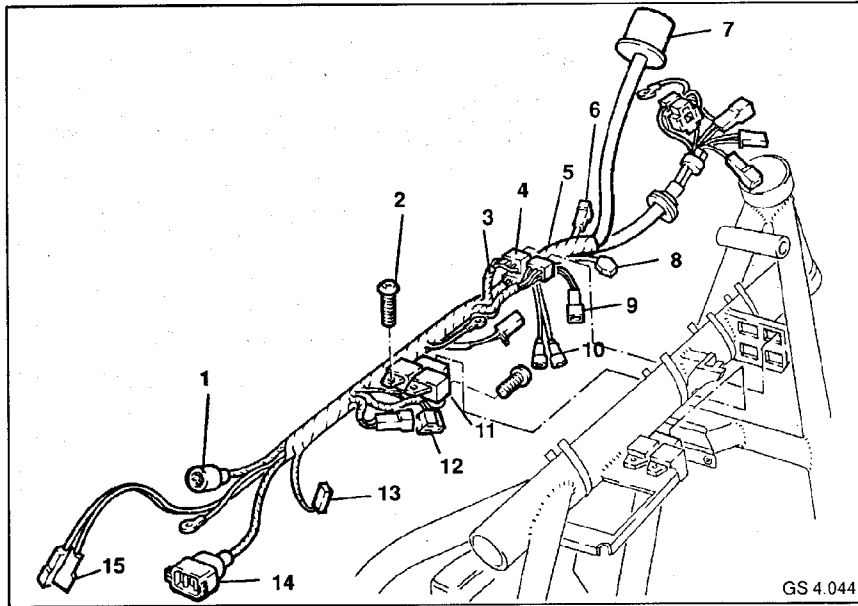

4.30 REMOVING AND INSTALLING CHASSIS CABLE HARNESS SECTION

- Remove seat.
- Remove fuel tank.
- Remove tool dish.
- Disconnect battery terminals.
- Remove ignition coil.
- Remove relays.
- Remove ignition control unit complete with heat sink.
- Remove headlamp.
- Remove front turn signal lamps.
- Cut through all cable straps (arrows).
- Detach the plug connections listed below
- 1. Rear cable harness section connection.
- 3. Left handlebar switch connection (red).
- 4. Left handlebar switch connection (black).
- 5. Right handlebar switch connection (white).

- 6. Engine cable harness connection.
- 7. Instrument connection.
- 8. Clutch switch connection.
- 9. Front stop light switch connection.
- 10. Connection for horn.
- 12. Connection for ignition switch.
- 13. Connection for rear stop light switch.
- 14. Connection for fuse box.
- 15. Connection for oil pressure and idle switch.
- Press plug connections (68/3,4,5) out off mount on frame, and lead through below the frame bar to the lefthand side of the motorcycle.
- Unscrew a cross-head screw (68/2) for each relay base (68/11) and move relay bases to the lefthand side of the motorcycle as shown.
- Take chassis cable harness section off the frame.
- The cable harness is **installed** in the reverse order by analogy to removal.

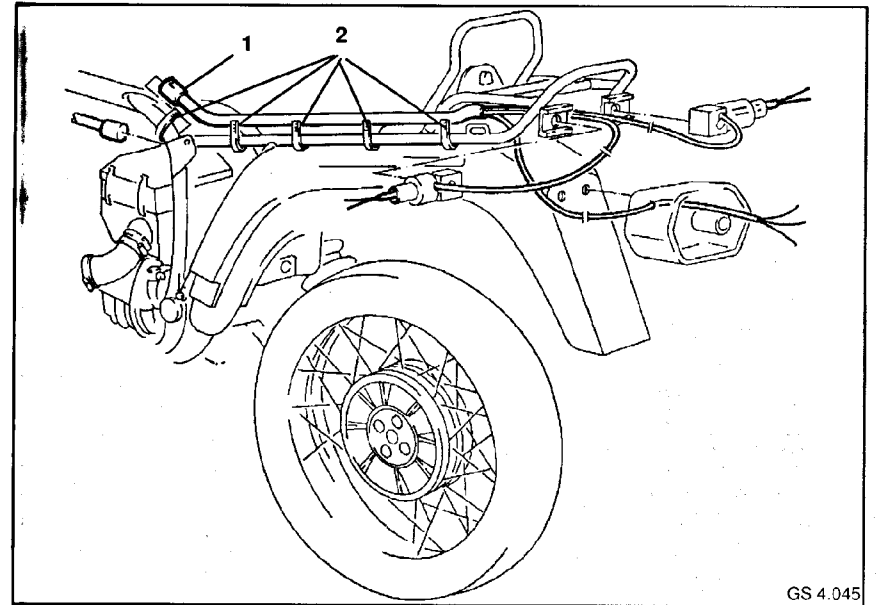

4.31 REMOVING AND INSTALLING REAR CABLE HARNESS SECTION

- Detach connections of the rear turn signal lamps.
- Detach connection for rear light.

- Take off seat.
 - Cut through 5 cable straps (69/2).
 - Detach plug connection (69/1) to the chassis cable harness section and take off rear cable harness section.
- The rear cable harness section is **installed** in the reverse order by analogy to removal.

4.32 TROUBLESHOOTING

TROUBLESHOOTING IGNITION SYSTEM

NOTE:

The control unit switches off again approx. 5 sec. after the ignition lock is switched on. The ignition lock must be switched off and switched on again to perform measurements at terminal 1.

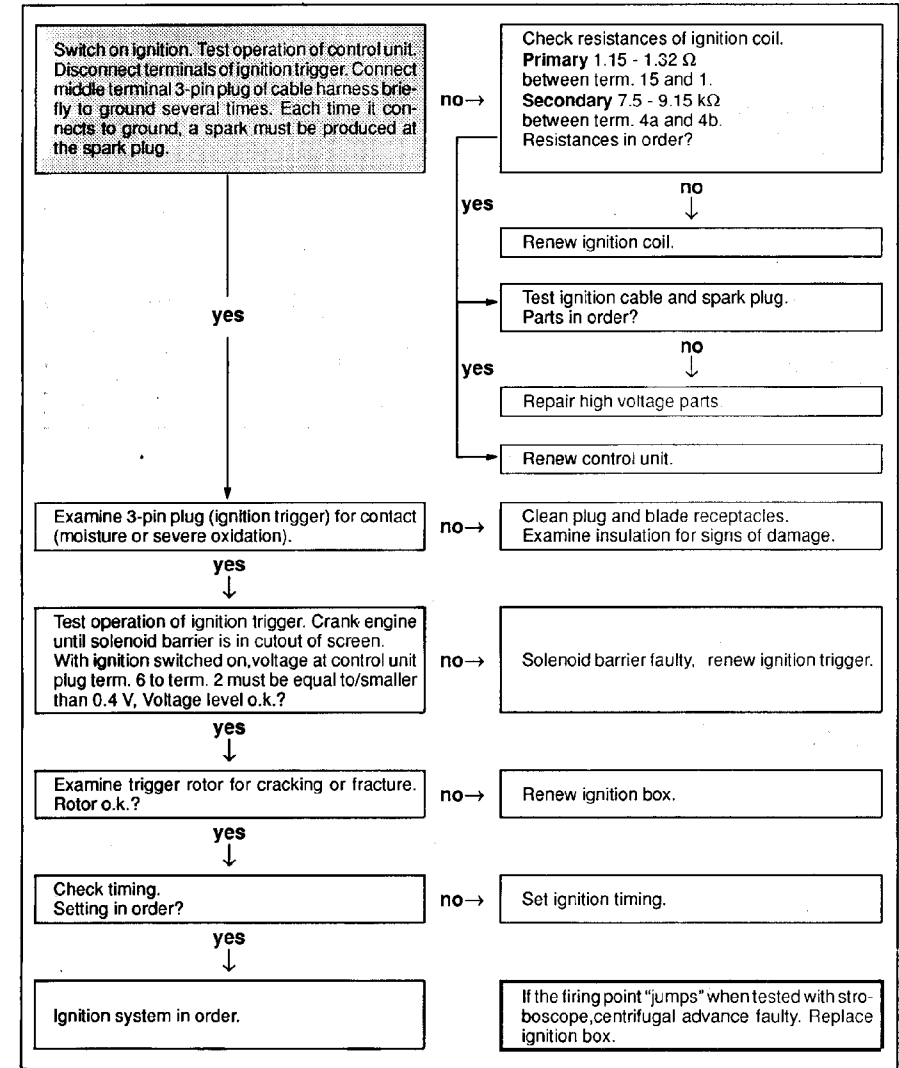
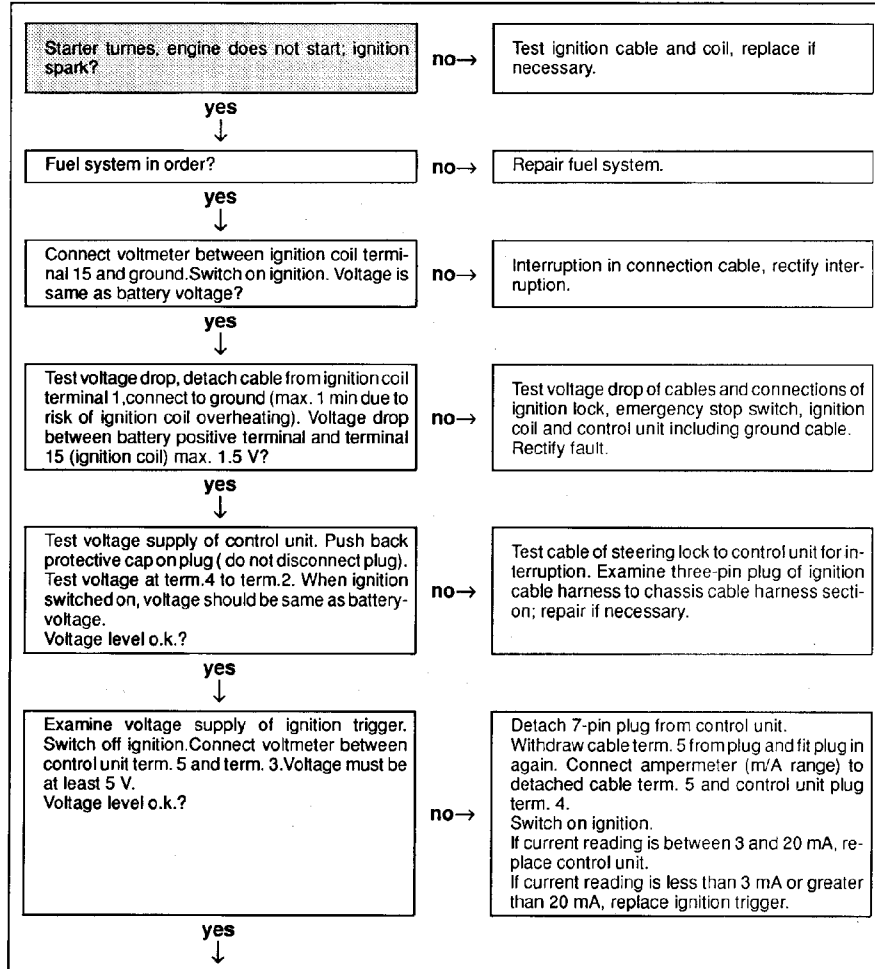

TROUBLESHOOTING ALTERNATOR

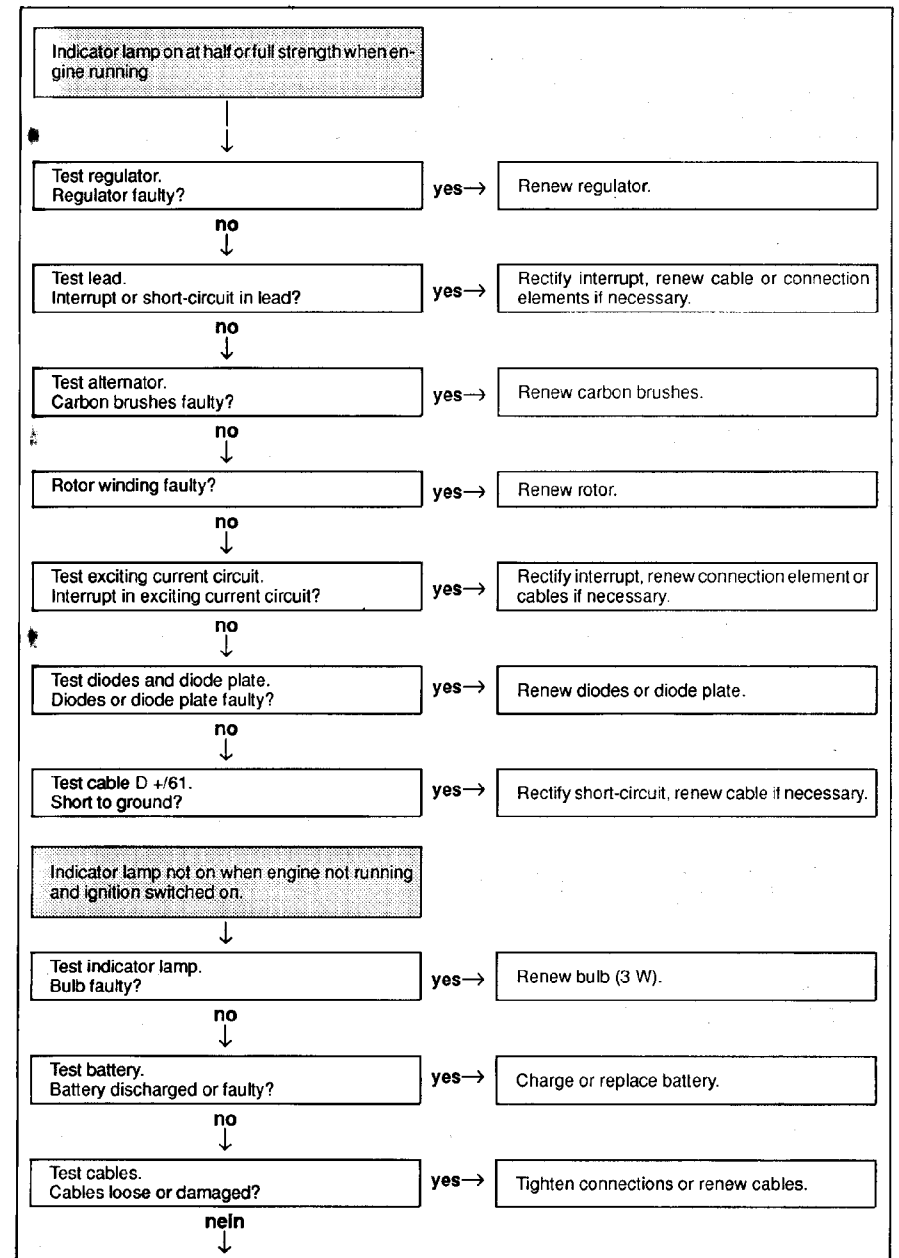
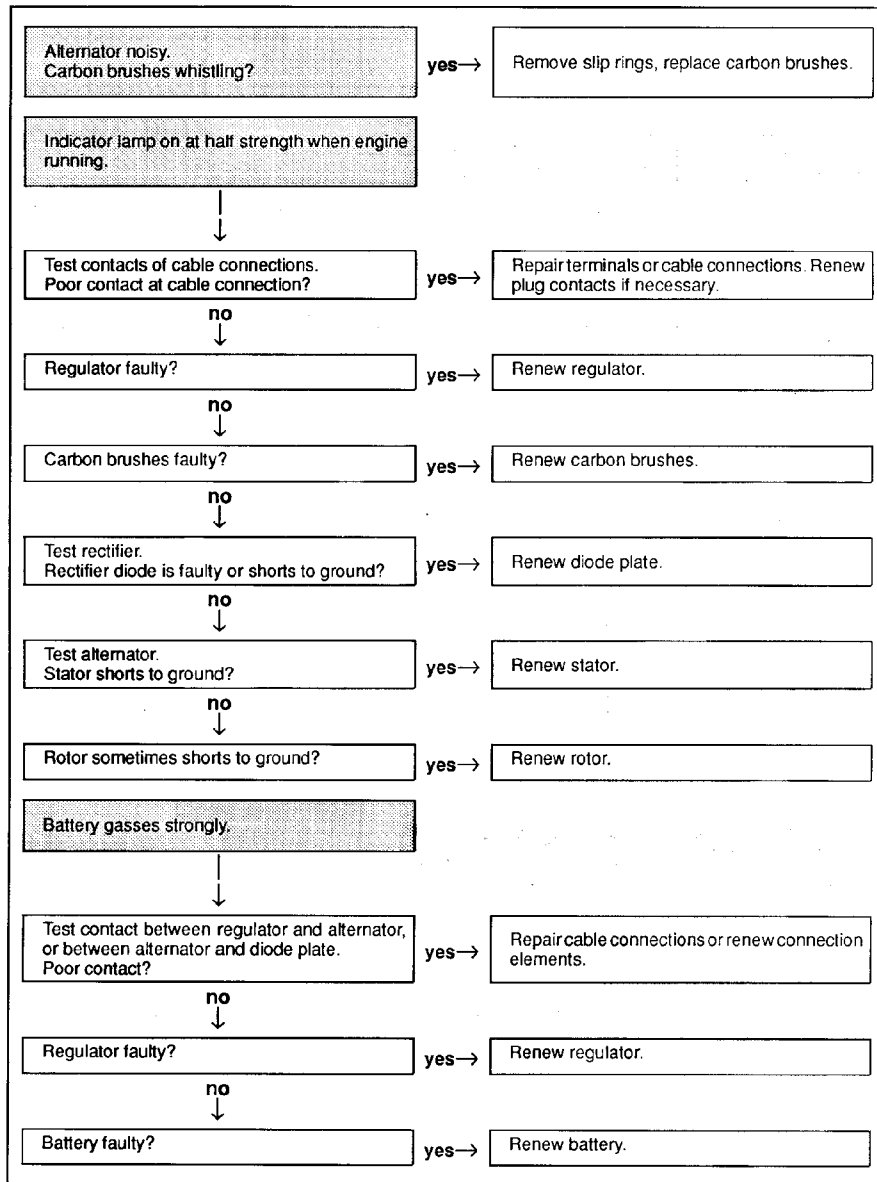

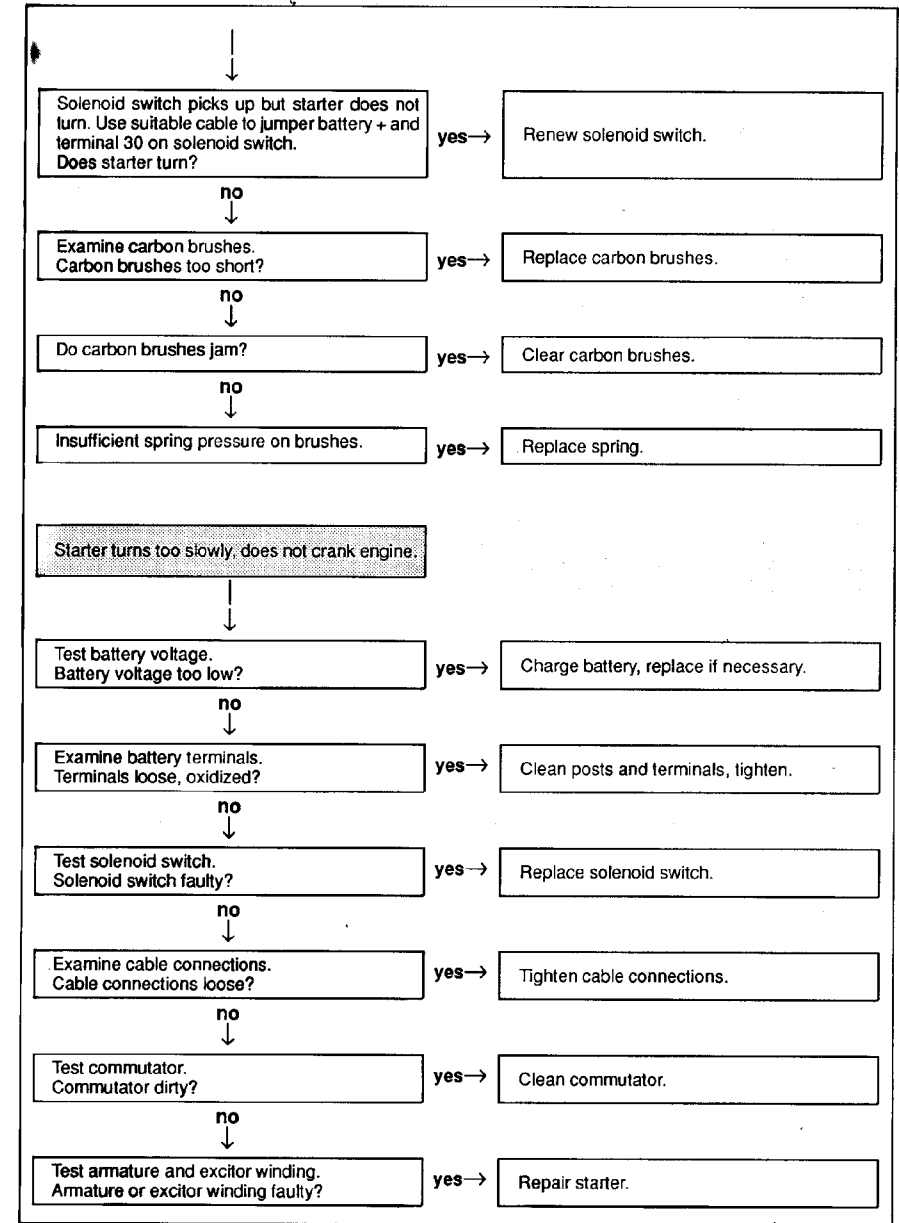
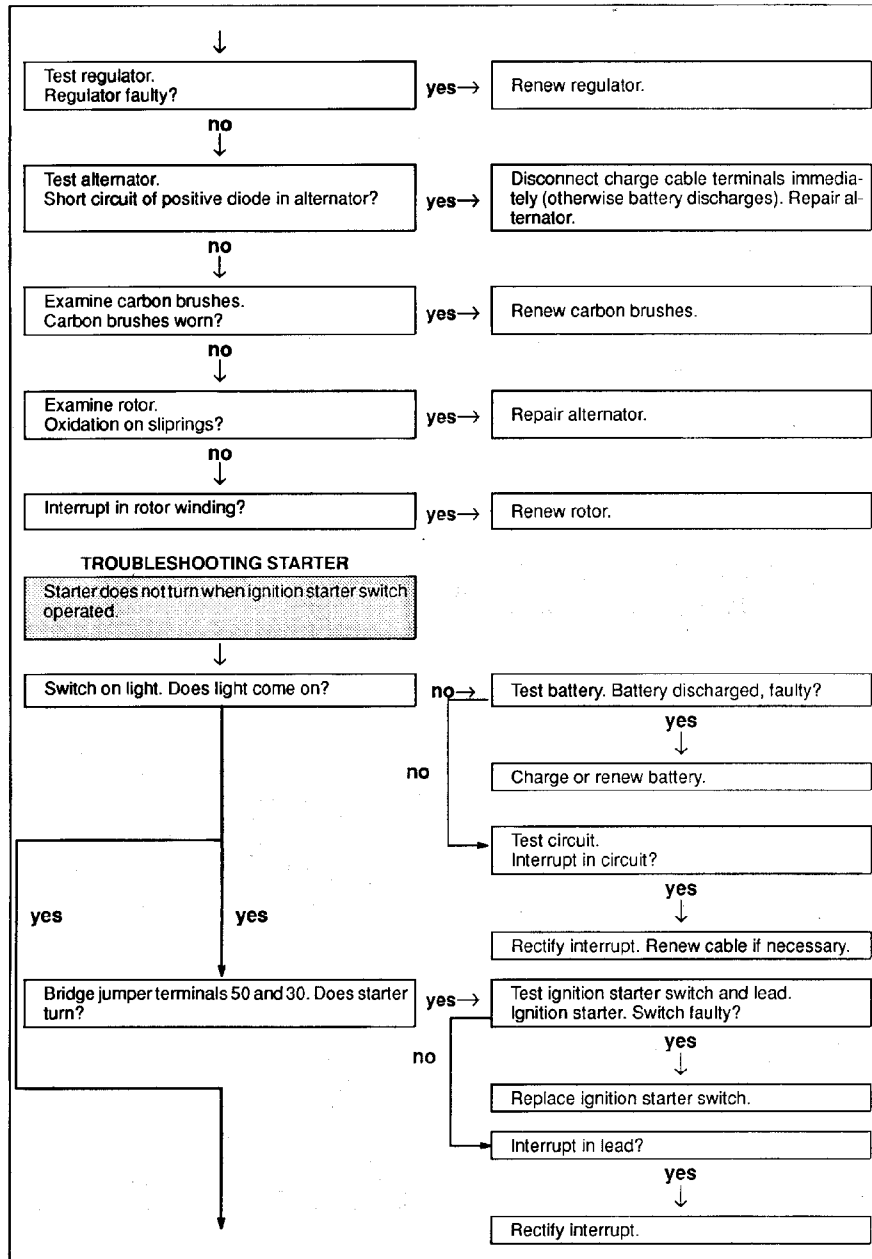

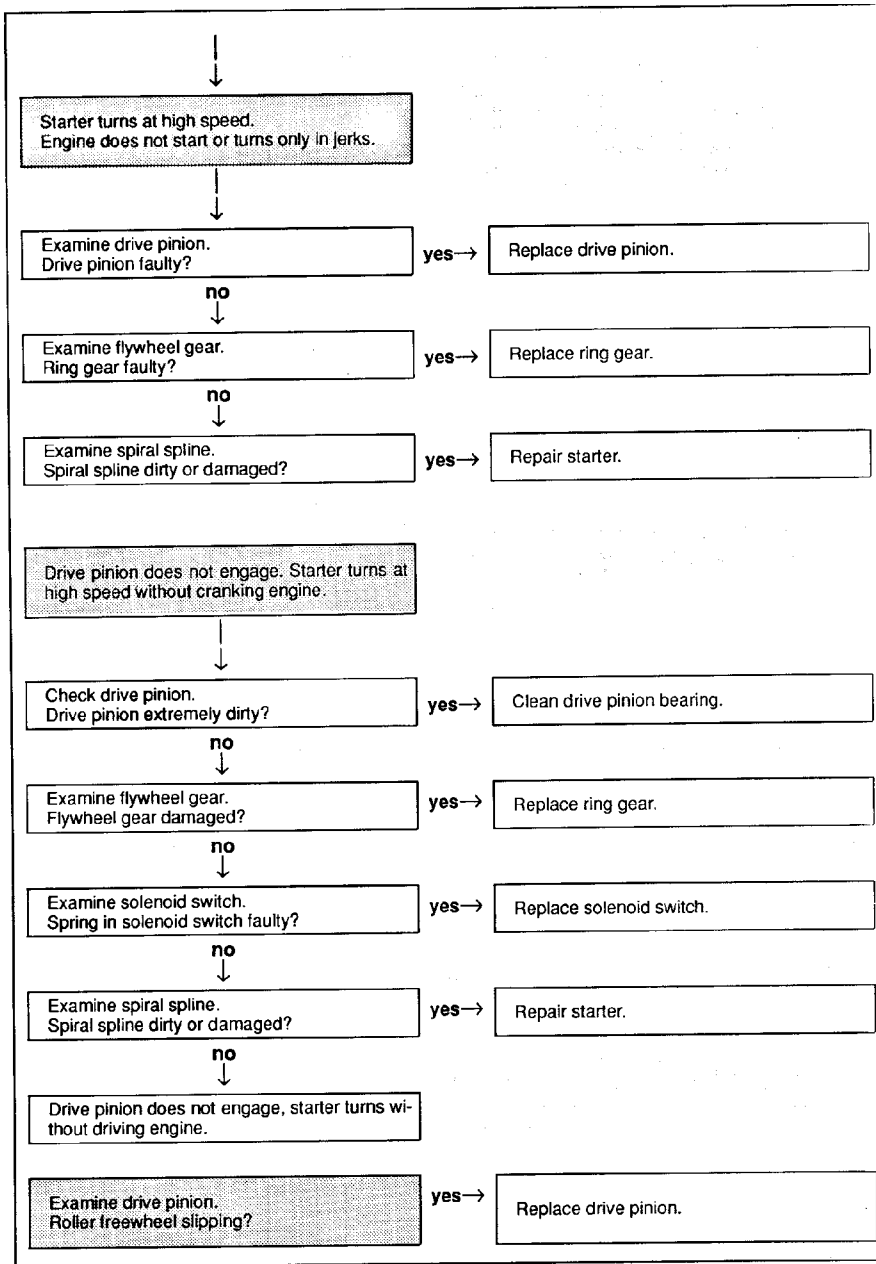

5. BRAKE SYSTEM

Contents

| | | |
|------------|---|-------------|
| 5.1 | REMOVING FRONT WHEEL BRAKE | 5.5 |
| | REMOVING BRAKE CALIPER | 5.5 |
| | REMOVING FRONT WHEEL | 5.5 |
| | REMOVING BRAKE DISC | 5.5 |
| | DISASSEMBLING BRAKE CALIPER GS | 5.6 |
| | ASSEMBLING BRAKE CALIPER GS | 5.7 |
| | REMOVING AND INSTALLING BRAKE FRONT PADS R 100R | 5.8 |
| | STRIPPING DOWN BRAKE CALIPER R 100 R | 5.9 |
| | ASSEMBLING BRAKE CALIPER R 100 R | 5.10 |
| | REMOVING BRAKE LINE | 5.11 |
| | REMOVING BRAKE FLUID RESERVOIR AND MASTER BRAKE CYLINDER | 5.12 |
| | DISASSEMBLING AND ASSEMBLING BRAKE FLUID RESERVOIR AND MASTER BRAKE CYLINDER | 5.13 |
| 5.2 | INSTALLING FRONT WHEEL BRAKE | 5.14 |
| | INSTALLING BRAKE CALIPER | 5.15 |
| | INSTALLING MASTER BRAKE CYLINDER AND BRAKE FLUID RESERVOIR | 5.15 |
| | INSTALLING BRAKE LINE | 5.16 |
| 5.3 | REMOVING REAR WHEEL BRAKE | 5.7 |
| | REMOVING REAR WHEEL | 5.17 |
| | REMOVING BRAKE SHOES | 5.18 |
| | EXAMINING BRAKE DRUM FOR WEAR | 5.18 |
| | REMOVING BRAKE LEVER | 5.19 |
| | REMOVING FOOT BRAKE LEVER | 5.20 |
| 5.4 | INSTALLING REAR WHEEL BRAKE | 5.20 |
| | INSTALLING FOOT BRAKE LEVER | 5.20 |
| | INSTALLING BRAKE KEY AND BRAKE LEVER | 5.21 |
| | INSTALLING BRAKE SHOES | 5.21 |
| | INSTALLING REAR WHEEL | 5.21 |
| | ADJUSTING FOOT BRAKE LEVER PLAY | 5.22 |
| 5.5 | TROUBLESHOOTING | 5.23 |
| | HANDBRAKE | 5.23 |
| | FOOT BRAKE | 5.24 |

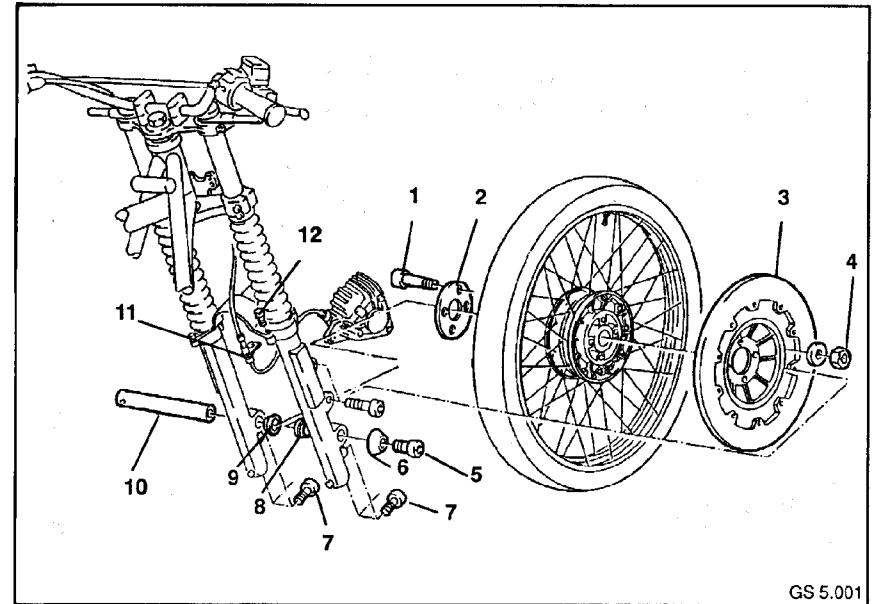

GS 5.001

5.1 REMOVING FRONT WHEEL BRAKE

REMOVING BRAKE CALIPER

WARNING:

Brake fluid is extremely harmful to health and must never be stored in beverage bottles. If brake fluid has been inadvertently swallowed, medical attention should be obtained immediately.

- Take off brake line at brake caliper; seal brake line.
- Loosen brake caliper attachment screws at the slider tube.
- Carefully remove brake caliper from the brake disc; do not tilt.

REMOVING FRONT WHEEL

CAUTION:

Do not operate hand brake lever when front wheel removed.

- Slacken retaining screw (5) at stub axle (10) and take off together with washer (6).
- Slacken 2 clamping screws (7) on each side of the stub axle at the slide tube.
- Withdraw stub axle and take off spacer sleeves.
- Take out wheel to the front.

REMOVING BRAKE DISC

- Take off brake disc (3) after slackening the 4 fastening screws (1) and nuts (4) together with locking washer (2).

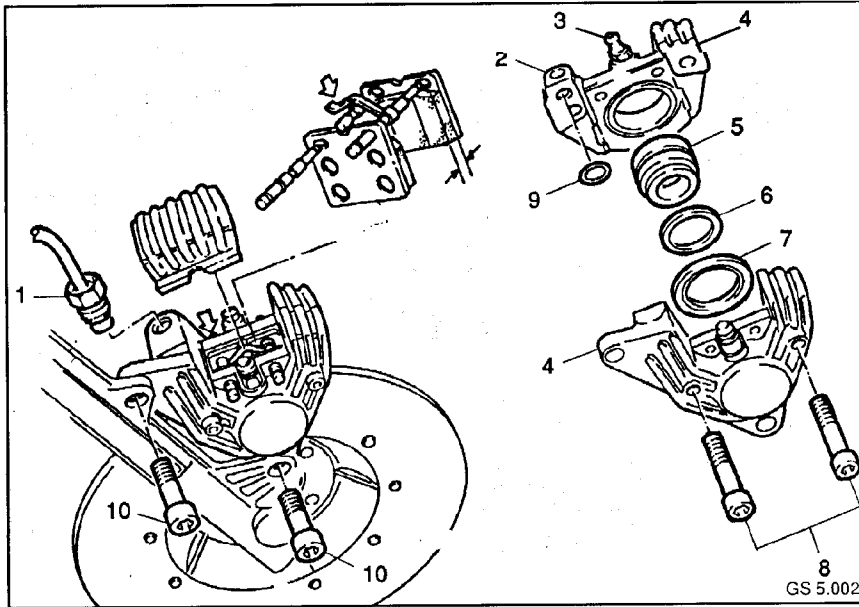

- Slacken union nut (1) of brake line at brake caliper.
- Take brake line off the brake caliper.
- Take caliper off the right slide tube after slackening the 2 fastening screws (10).

CAUTION:

Brake fluid is hygroscopic (absorbs water), and should therefore be renewed annually. Brake fluid which has been drained or pumped out must not be used for refilling (impurities). Keep brake fluid away from paint and painted surfaces. Brake fluids contain elements which act as paint strippers.

DISASSEMBLING BRAKE CALIPER GS

- Remove brake pads.
- Slacken 2 fastening screws (8) at brake caliper and separate brake caliper halves (4).
- Remove O-ring (9) from connecting hole.
- Take dust cap (7) out of left/right brake caliper half.
- Close right/left bleeder screws (3).
- Attach compressed air gun to connecting hole (2) of respective caliper half.
- Press out brake plunger (5) with light air pressure.
- Take sealing ring (6) off the left/right brake plunger.

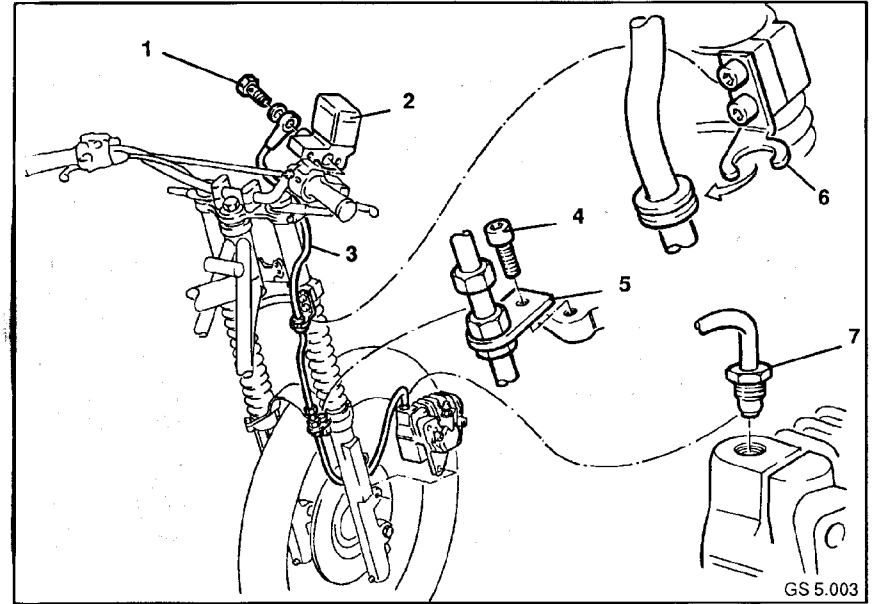

ASSEMBLING BRAKE CALIPER GS

- Insert sealing ring into left/right brake caliper half.
- Carefully press in left/right plunger.
- Fit on dust caps.
- Insert new O-rings into connecting hole.
- Screw together caliper halves.

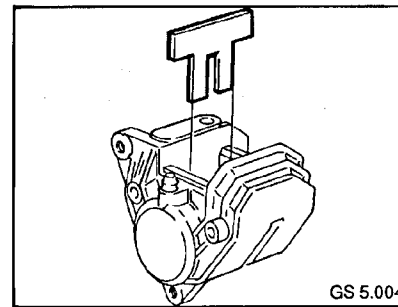

- Use spacer, BMW No. 34 1 510, to fix brake plungers in this position.

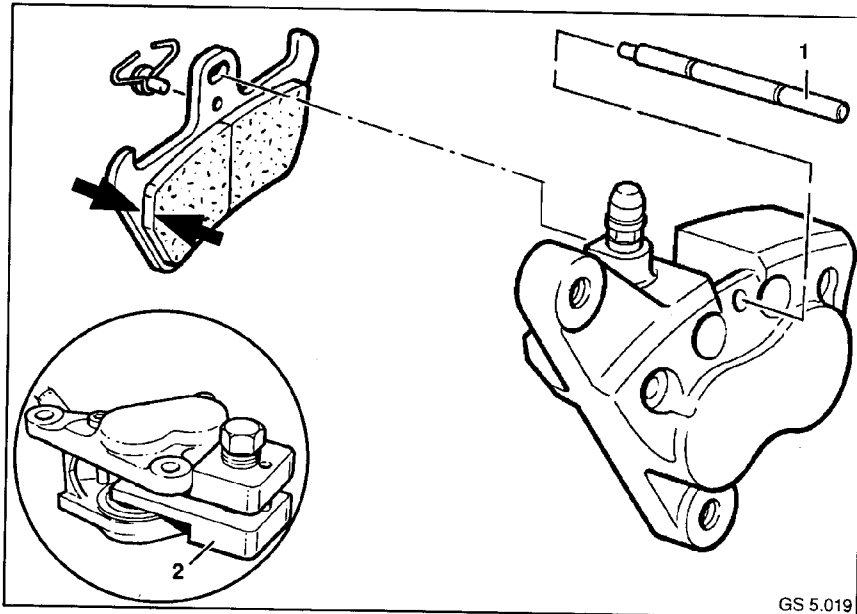

REMOVING AND INSTALLING FRONT BRAKE PADS – R 100R

NOTE:
Removing:
Only remove brake caliper. Do not detach brake line.

- Remove brake caliper.
- Knock safety pin (1) out.
- Remove brake pads downwards.

CAUTION:
Do not use if below minimum brake pad thickness (arrow)!
Replace pads in pairs!

Minimum brake pad thickness:
Thickness on backing plate 1.5 mm

- Install in reverse order of work.

NOTE:
Installation:
Press back brake pistons fully using piston reset device, BMW No. 34 1 500 (2).

Tightening torque:
Brake caliper to slider tube 32 Nm

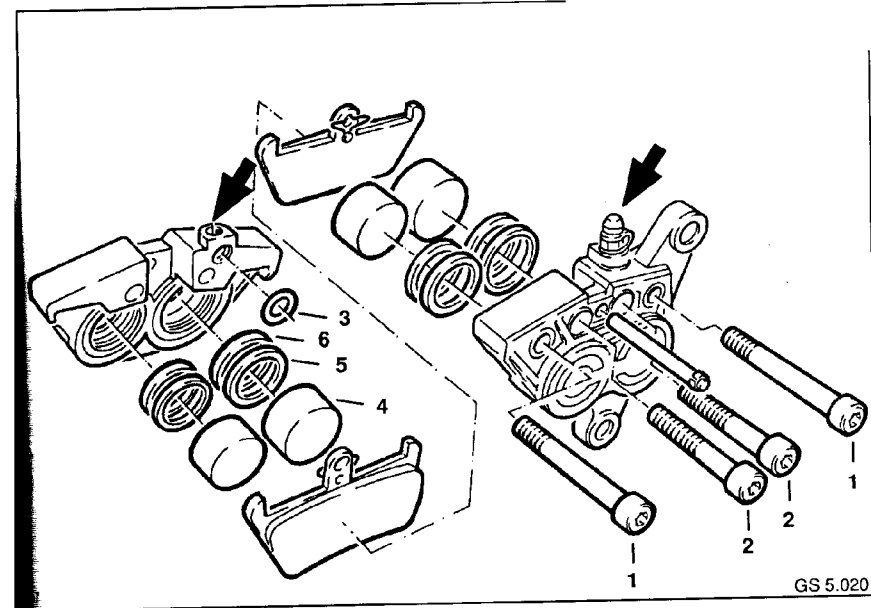

STRIPPING DOWN R 100R BRAKE CALIPER

- Loosen 4 attachment screws (1/2) in the brake caliper.

NOTE:
Attachment screws (1) are micro-encapsulated.
Use thread tap to recut thread holes. Blow through them. Clean screws with steel brush.

- Separate brake caliper halves.
- Remove O-ring (3) from connecting bore.

- Close bleed screw/brake line connections (arrows).
- Hold a cloth over the brake pistons.
- Use a compressed air gun at the connecting bores to press out brake pistons (4) carefully.
- Remove 2 sealing rings (5/6) from the left/right brake piston bores.
- Check brake piston for hairline fractures/score marks/damage.

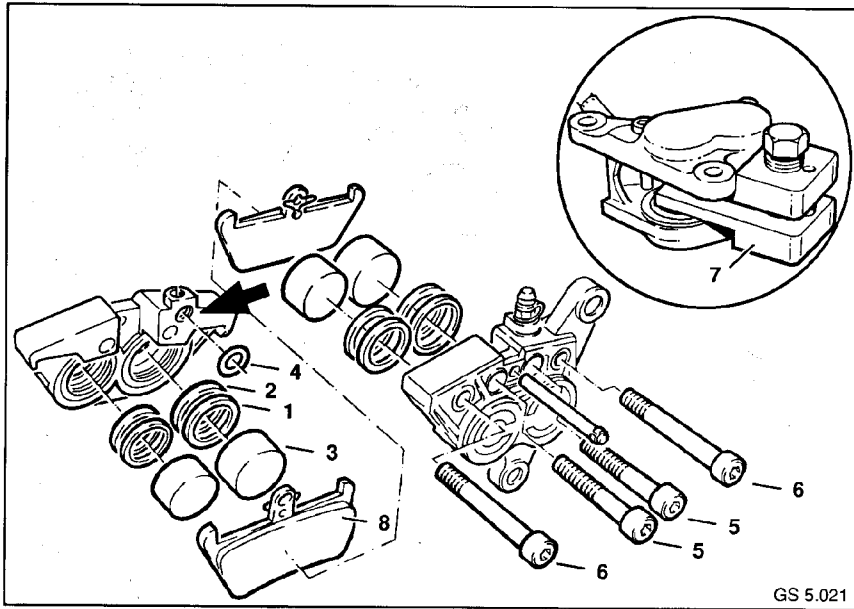

ASSEMBLING R 100R BRAKE CALIPER

CAUTION

Brake pistons are easily tilted. Take great care when inserting. Apply a thin film of brake fluid to the brake pistons/sealing rings!

- Insert 2 new sealing rings (1/2) in left and right brake piston bores.
- Gently press in brake pistons (3) at left and right.

- Fit new O-ring (4) into connecting bore (arrow).
- Use 2 attachment screws (5) to join up brake caliper halves.
- Tighten attachment screws to the specified tightening torque.
- After cleaning the 2 attachment screws (6), secure and tighten them with LOCTITE 273.

Tightening torque:
Outer connecting screws
Inner connecting screws

10 + 5 Nm
30 + 5 Nm

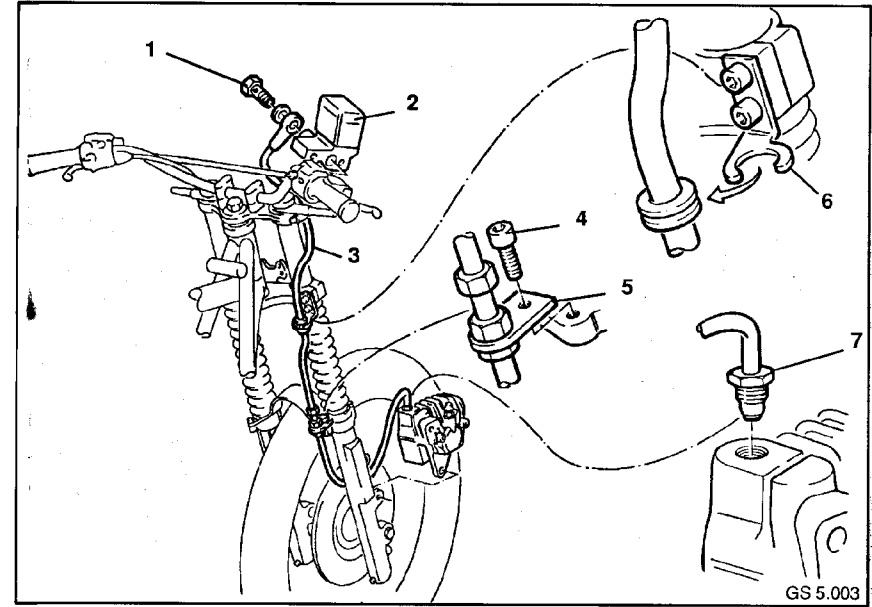

REMOVING BRAKE LINE

CAUTION:

Collect brake fluid flowing out in a suitable vessel.
Brake fluid strips paint work!

- Slacken hollow screw connection (1) at brake fluid reservoir(2).
- Take brake line (3) off the brake fluid reservoir.

- Slacken fastening screw (4) and take brake line off the anti-roll bar,GS.
- Loosen screw connection in the mud-guard (Mod. 91)
- Remove rear section from front mud-guard (R100R).
- Slacken screw connection (6) on the brake calliper.
- Withdraw brake line from mounting bracket (5) on bottom fork bridge and take brake line off motor cycle.

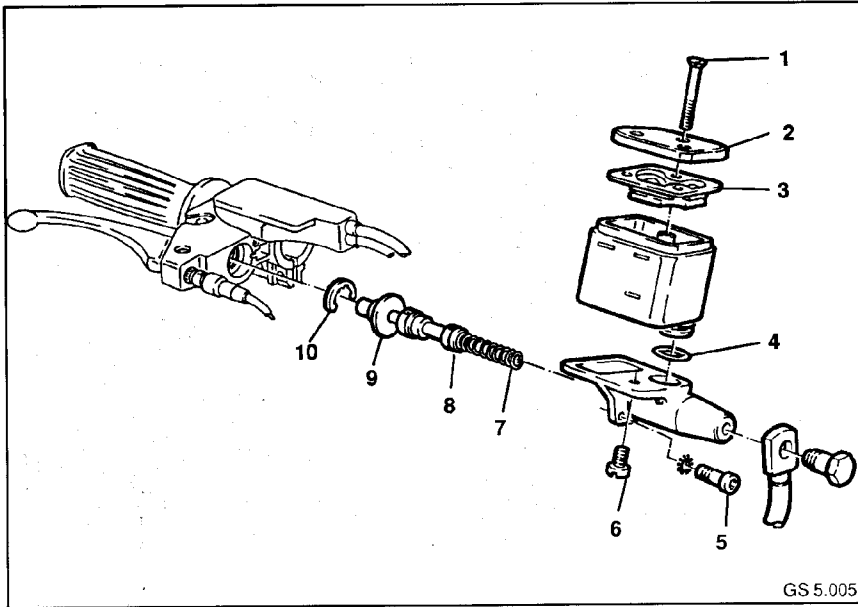

REMOVING BRAKE FLUID RESERVOIR AND MASTER BRAKE CYLINDER

CAUTION:

Do not allow brake fluid to come into contact with the paintwork of the motor cycle. Brake fluid strips paintwork.

CAUTION:

Collect brake fluid flowing out in a suitable vessel.

- Remove brake line.
- Slacken 2 fastening screws (5) on the brake fluid reservoir.
- Take brake fluid reservoir complete with master brake cylinder off the grip unit.

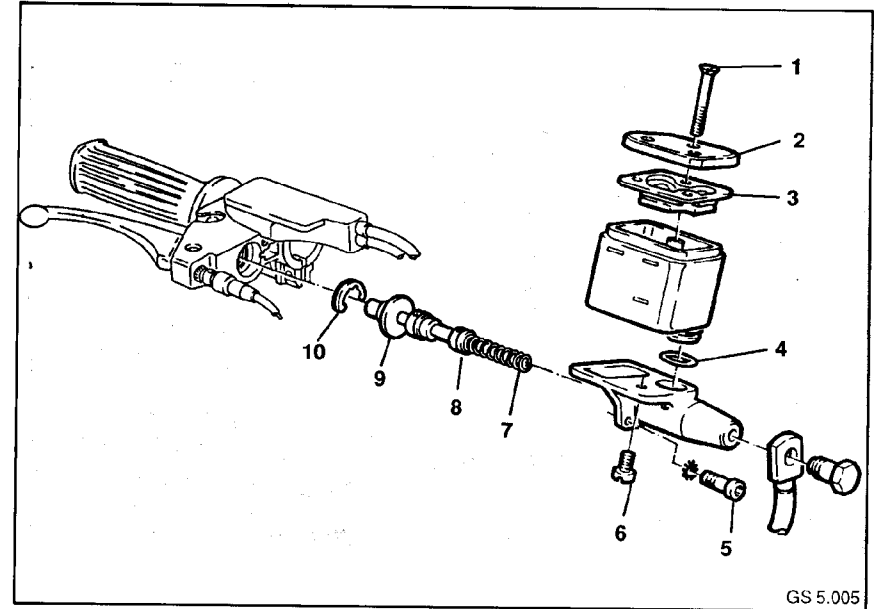

DISASSEMBLING AND ASSEMBLING BRAKE FLUID RESERVOIR AND MASTER BRAKE CYLINDER

CAUTION:

Collect brake fluid flowing out in a suitable vessel.

- Slacken 3 fastening screws (1) on the brake fluid reservoir cover.
- Take cover (2) and bellows (3) off the brake fluid reservoir.
- Drain brake fluid reservoir.
- Slacken fillister-head screw (6) and take brake fluid reservoir off the master brake cylinder.
- Take off O-ring (4).

CAUTION:

Cylinder is held by spring pressure.

- Press cylinder (9) back in the master brake cylinder housing.
- Release locking ring (10).
- Carefully release pressure on cylinder and withdraw from housing together with plunger (8) and spring (7).

The reservoir and the master brake cylinder are assembled in the reverse order by analogy to disassembly.

CAUTION:

Install new O-ring between cylinder housing and reservoir.

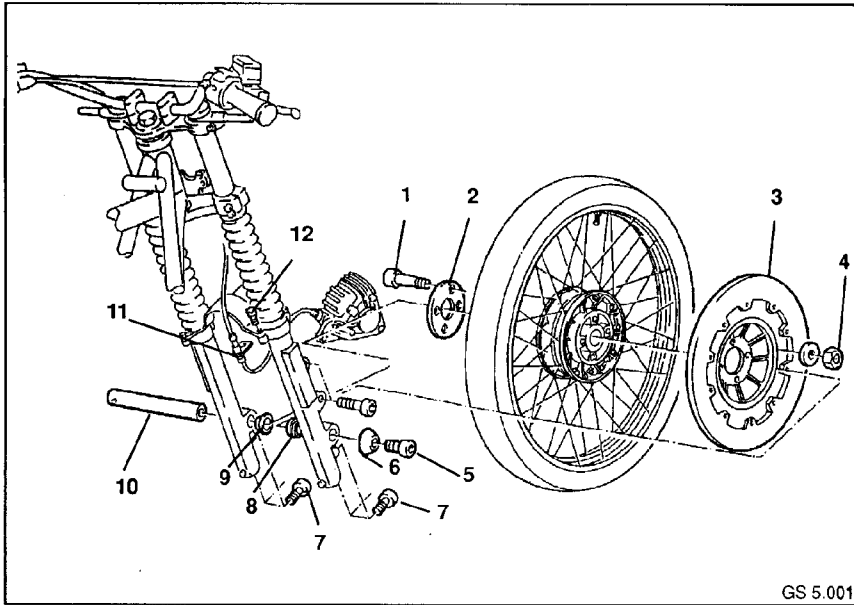

GS 5.001

INSTALLING BRAKE CALIPER

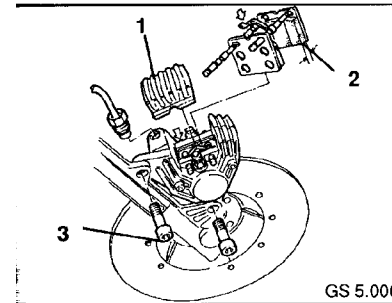

GS 5.006

- Attach brake caliper to slide tube and tighten with 2 fastening screws (3).
- Tighten fastening screws to specified tightening torque.
- Take spacer BMW No. 34 1 510 off brake caliper.
- Install brake pads (2).
- Fit on plastic protective cap (1).

Tightening torque:
 Brake caliper to slide tube

32 Nm

INSTALLING MASTER BRAKE CYLINDER AND BRAKE FLUID RESERVOIR

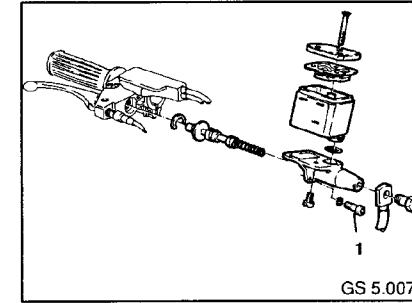

GS 5.007

- Attach brake fluid reservoir and master brake cylinder complete to right grip unit.
- Tighten with 2 fastening screws (1).

5.2 INSTALLING FRONT WHEEL BRAKE

INSTALLING BRAKE DISC

CAUTION:

Carefully remove grease from brake disc before installing.

- Attach brake disc (3) to hub of front wheel, fit on locking washer (2) and screw in 4 fastening screws (1) and tighten to specified torque.
- Insert front wheel in telescopic forks.
- Apply a light coating of Molykote grease to stub axle (10).
- Insert stub axle from the left and at the same time insert spacer sleeves.

CAUTION:

Insert spacer sleeves (8,9) with large OD facing wheel and spacer sleeve (9) with long collar on the left side.

- Attach washer (6) to stub axle (10) and screw in fastening screw (5).
- Tighten fastening screw to specified torque.
- Screw in 4 clamping screws (7) in slide tube and tighten to specified torque.

Tightening torque:

| | |
|------------------------------|--------|
| Stub axle | 33 Nm |
| Clamping screws of stub axle | 14 Nm |
| Brake caliper to slide tube | 32 Nm |
| Brake line to brake caliper | 7.3 Nm |
| Brake line to brake hose | 7.3 Nm |
| Brake disc to front wheel | 32 Nm |

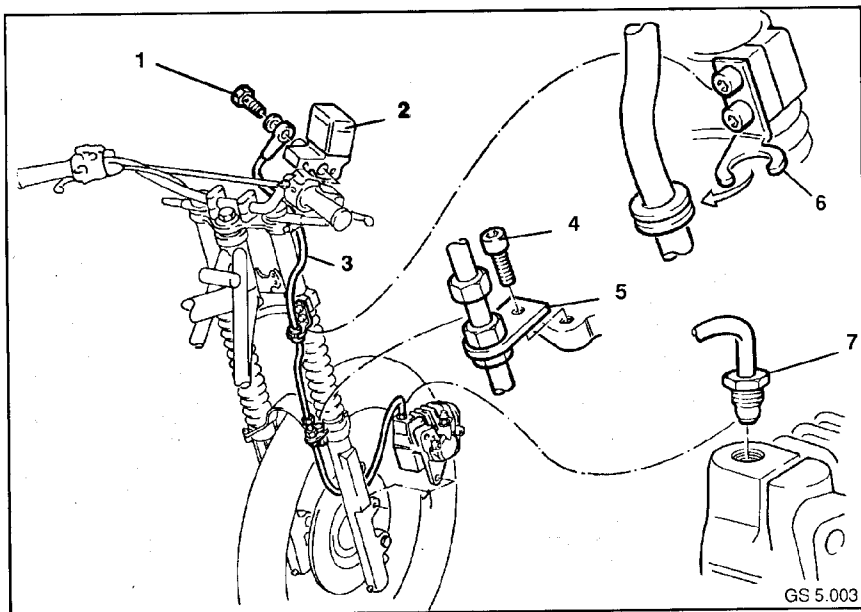

GS 5.003

INSTALLING BRAKE LINE

- Screw brake line onto master brake cylinder with hollow screw(1).
- Tighten hollow screw to specified tightening torque.
- Insert brake line into mounting bracket (2) on bottom fork bridge and screw tight with bracket (3) to anti-roll bar.
- Screw brake line into brake calliper with union nut (4).
- Tighten union nut to specified tightening torque.

NOTE:

The front wheel brake must be bled each time after it has been opened.

| | |
|-------------------------------------|--------|
| <i>Tightening torque:</i> | |
| Brake line to brake caliper | 7.3 Nm |
| Brake line to brake hose | 7.3 Nm |
| Brake line to master brake cylinder | 7.3 Nm |

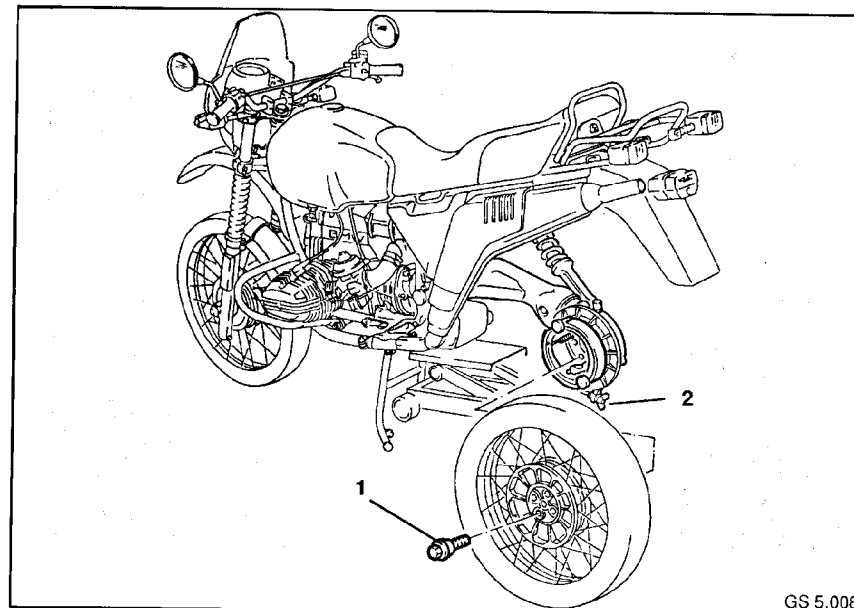

GS 5.008

5.3 REMOVING REAR WHEEL BRAKE

REMOVING REAR WHEEL

- Position motorcycle on kickstands.
- Place a support below front silencer to prevent motorcycle from toppling over.
- Slacken wing nut (2) on brake lever.
- Engage 1st gear.
- Slacken 4 wheel bolts (1).
- Take out rear wheel to the rear left.

NOTE:

If gear bags are fitted, either withdraw the rear wheel down the way (hoist platform) or remove the left gear bag.

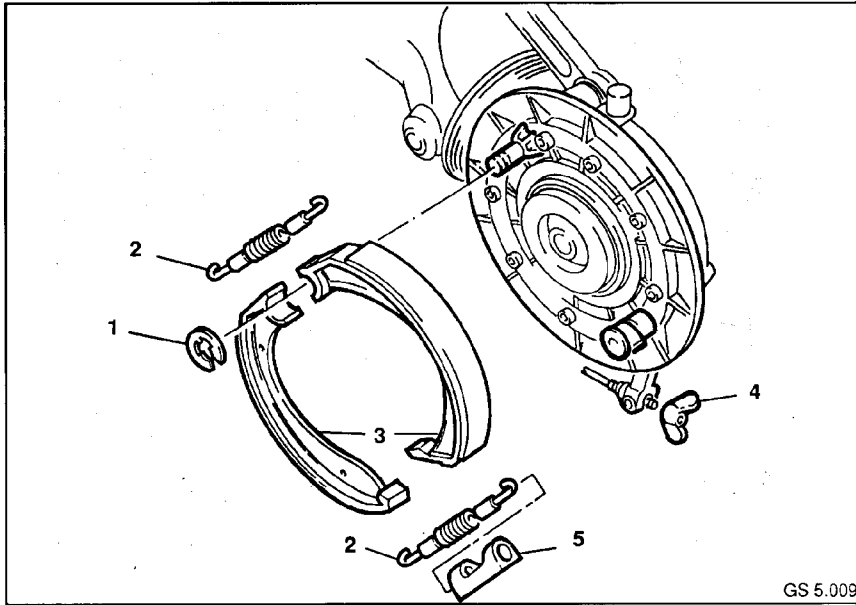

REMOVING BRAKE SHOES

- Slacken wing nut (4) on brake lever fully.
- Take locking ring (1) off the brake anchor.
- Use screwdriver to lever top brake shoe off the rear wheel drive.
- Take off brake shoes (3) with springs (2) and rubber damper (5).

- Clean brake drum (1) in the rear wheel and examine for signs of wear and scoring.
- If severe scoring is present, the brake drum must be turned to size.

Pay attention to wear limits.

Wear limits
 Brake drum dia. 200 + 0.185 mm (H10)
 Wear limit dia. 201.5 mm

EXAMINING BRAKE DRUM FOR WEAR

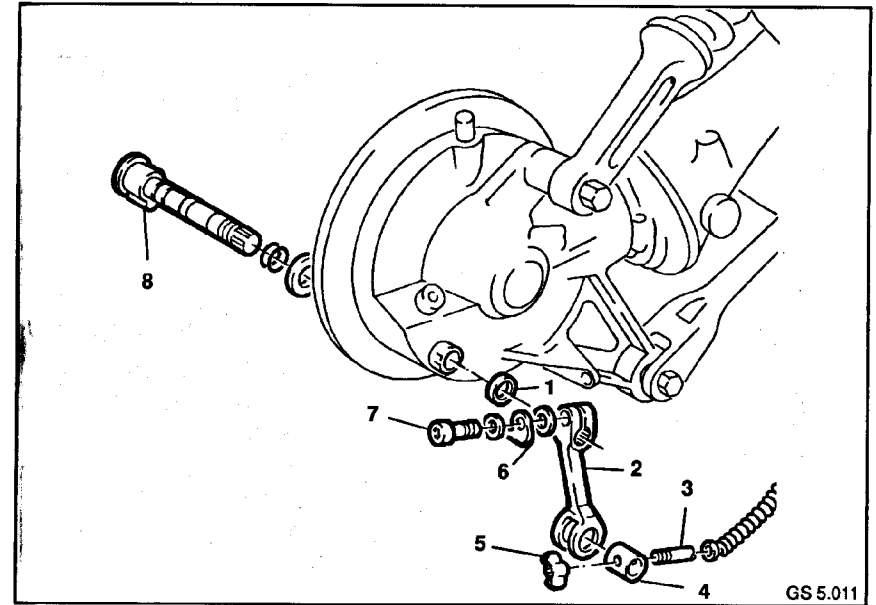
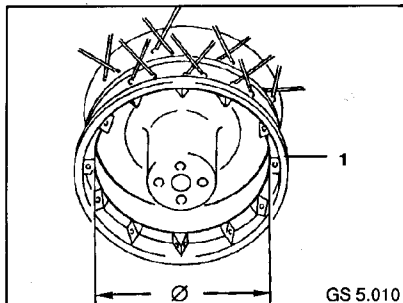

REMOVING BRAKE LEVER

NOTE:

Mark the position of the brake lever before removing.

- After slackening the wing nut (5), remove cable (3) and sleeve (4) from the brake lever (2).
- Slacken fastening screw (7) on the brake lever (2) and take off together with wear indicator (6).
- Withdraw brake lever from brake key (8).
- Take off felt seal (1).
- Withdraw brake key (8) from rear wheel drive.

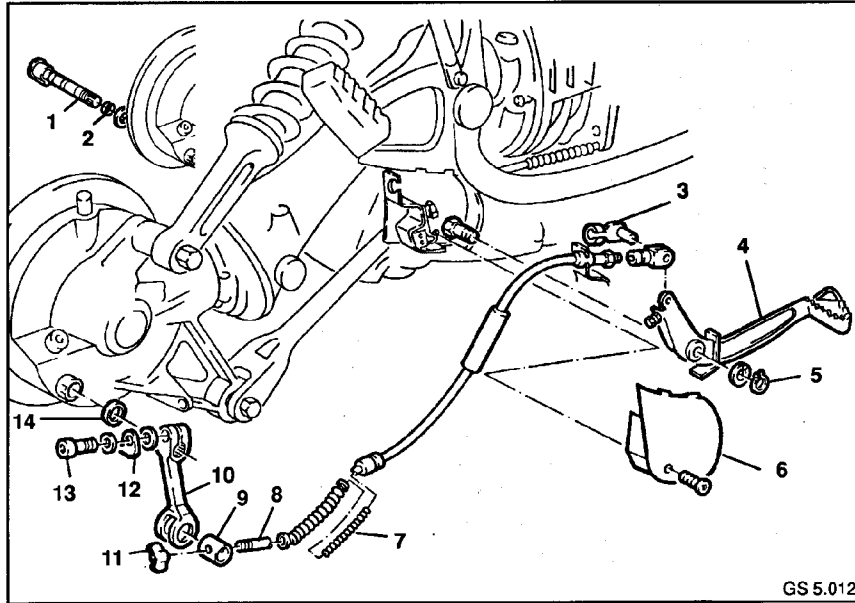

REMOVING FOOT BRAKE LEVER

- Remove protective cap (6).
- Take locking pin (3) off the foot brake lever (4) and remove Bowden cable.
- Release locking ring (5) on the foot brake lever and take off foot brake lever.

5.4 INSTALLING REAR WHEEL BRAKE

INSTALLING FOOT BRAKE LEVER

The foot brake lever is installed in the reverse order by analogy to removal.

NOTE:

Before installing the foot brake lever, apply a light coating of Molykote grease to the bearing pins of the brake lever.

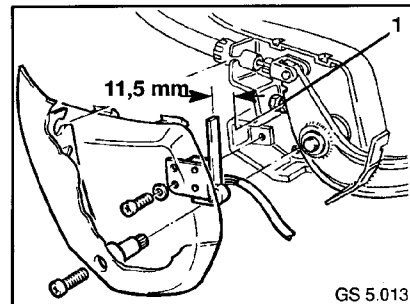

NOTE:

After installing the foot brake lever, the distance between brake lever and stop light switch must be set to 11.5 mm with the adjusting screw (1).

INSTALLING BRAKE KEY AND BRAKE LEVER

NOTE:

Fit new O-rings (1) when installing the brake key (1).

- Apply a light coating of Molykote grease to brake key and insert into rear wheel drive.
- Fit felt ring (14) onto brake key.
- Align brake lever (10) to the marking made during removal and fit onto brake key.
- Screw in fastening screw (13) together with wear indicator (12) and washer.
- Tighten fastening screw to specified tightening torque.
- Insert sleeve (9), introduce cable and screw on wing nut.

INSTALLING BRAKE SHOES

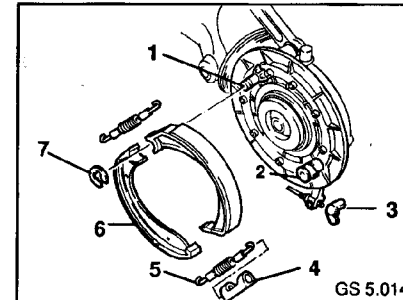

- Apply a light coating of Molykote grease to brake anchor (1) and brake key (2).

CAUTION:

Attach springs on the outside!

NOTE:

Align rubber damper (4) onto rear spring so that the rear flatside is resting on the brake shoes and on the brake key.

- Examine rubber damper on bottom spring; renew if necessary.
- Connect brake shoes (6) with springs (5).
- Attach brake shoes simultaneously to brake anchor and brake key.
- Fold brake shoes open against spring pressure and push onto brake anchor and brake key.
- Fit locking ring (7) onto brake anchor.

INSTALLING REAR WHEEL

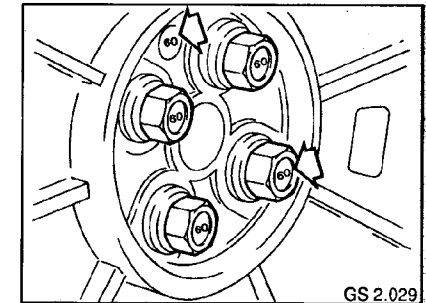

CAUTION:

Use only wheel bolts (1) with length code 60. Rear wheel and wheel bolt heads are marked accordingly. Ensure wheel studs are dry when inserting!

- Attach rear wheel to rear wheel drive.
- Screw in wheel bolt and tighten cross-wise to specified tightening torque.

Tightening torque:
Rear wheel bolts

105 Nm

ADJUSTING FOOT BRAKE LEVER PLAY

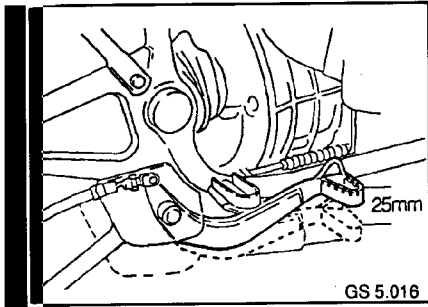

- Turn wing nut (3) on brake tie rod until the rear wheel begins to brake.
- Turn wing nut back 3..4 turns (corresponds to approx. 25 mm foot brake lever travel).

Foot brake lever play approx. 25 mm

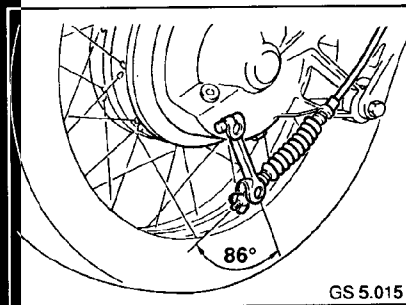

NOTE:

The angle between brake lever and cable must be approx. 86° when brake is released and correctly set.

Tightening torque:
Brake lever to brake key
Mod.91

6.2 Nm
10 Nm

5.5 TROUBLESHOOTING

HANDBRAKE

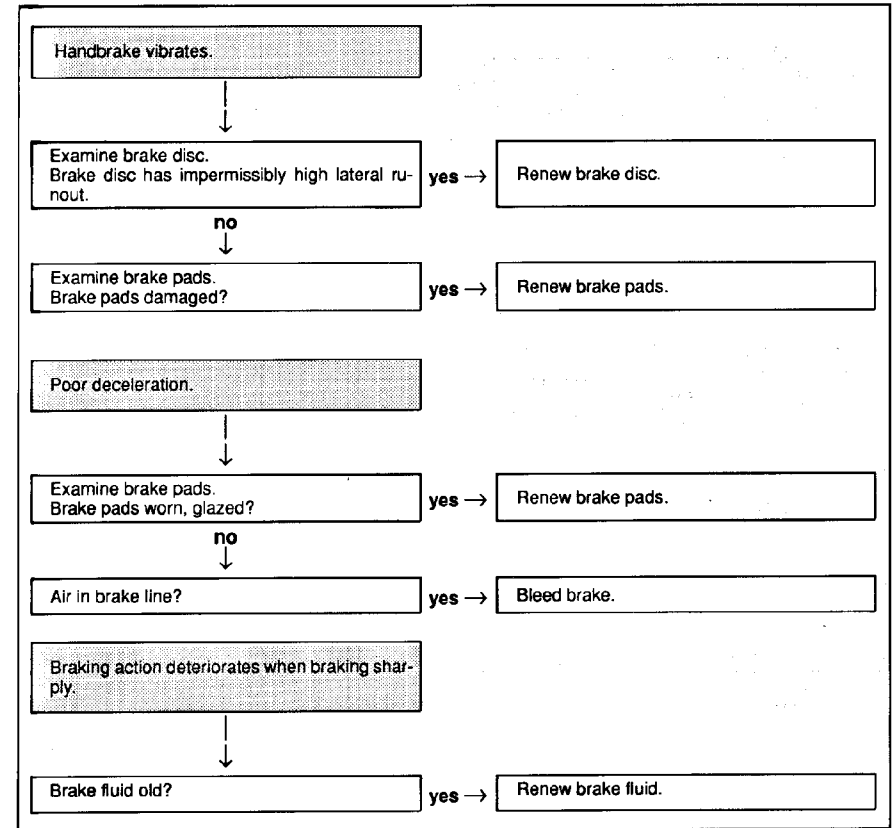

FOOT BRAKE

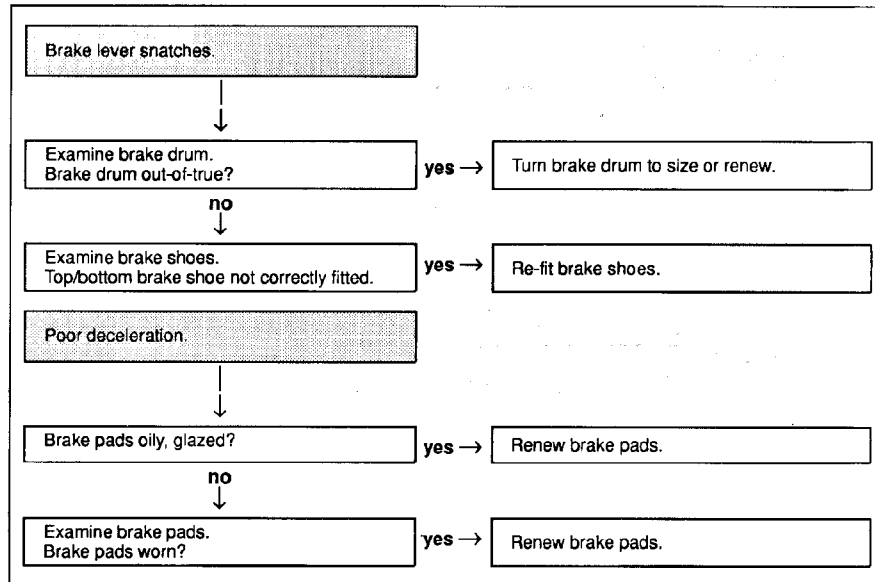

6. SUSPENSION

- Steering
- Telescopic fork
- Frame
- Wheels and tyres
- Rear wheel drive

| Contents | Page |
|--|-------------|
| 6.1 REMOVING FRONT WHEEL AND REPLACING WHEEL BEARINGS | 6.3 |
| REMOVING WHEEL BEARINGS | 6.3 |
| INSTALLING WHEEL BEARINGS | 6.3 |
| 6.2 REMOVING HANDLEBARS | 6.4 |
| REMOVING HANDLEBARS | 6.4 |
| 6.3 DISASSEMBLING AND ASSEMBLING GRIP UNITS | 6.5 |
| DISASSEMBLING RIGHT GRIP UNIT | 6.5 |
| ASSEMBLING RIGHT GRIP UNIT | 6.5 |
| DISASSEMBLING LEFT GRIP UNIT | 6.6 |
| ASSEMBLING LEFT GRIP UNIT | 6.6 |
| 6.4 REMOVING AND INSTALLING, DISASSEMBLING AND ASSEMBLING TELESCOPIC FORK | 6.8 |
| REMOVING TELESCOPIC FORK (1988 models) | 6.8 |
| Removing the telescopic fork (1991 models) | 6.8 |
| Removing telescopic fork – R 100 R | 6.9 |
| DISASSEMBLING TELESCOPIC FORK GS | 6.10 |
| REMOVING AND INSTALLING SHAFT SEAL AND SLIDING BUSH IN SLIDING TUBE | 6.12 |
| STRIPPING DOWN TELESCOPIC FORK R 100 R | 6.14 |
| Standrohr ausbauen | 6.14 |
| Stripping down the fixed tube | 6.15 |
| Damper components | 6.16 |
| MEASURING TELESCOPIC FORK ALIGNMENT | 6.17 |
| EXAMINING STANCHIONS | 6.17 |
| EXAMINING BOTTOM FORK BRIDGE | 6.17 |
| Examine parallelisms of the stanchions | 6.17 |
| ASSEMBLING TELESCOPIC FORK GS | 6.18 |
| ASSEMBLING TELESCOPIC FORK R 100 R | 6.19 |
| ASSEMBLING STANCHIONS | 6.21 |
| REMOVING AND INSTALLING STEERING HEAD BEARING | 6.23 |
| REMOVING AND INSTALLING BOTTOM TAPER ROLLER BEARING | 6.23 |
| Removing and installing the upper taper roller bearing (1991 models, R 100 R) | 6.23 |
| EXAMINING FRONT FRAME SECTION | 6.24 |
| INSTALLING TELESCOPIC FORK | 6.26 |
| Mod.88 | 6.26 |
| Mod. 91 and R 100R | 6.27 |
| Installing headlight and instruments | 6.28 |

| Contents | Page |
|---|------|
| 6.5 INSTALLING HANDLEBARS | 6.29 |
| 6.6 INSTALLING FRONT WHEEL | 6.30 |
| 6.7 MEASURING TRACK ALIGNMENT | 6.31 |
| 6.8 REMOVING REAR WHEEL | 6.33 |
| 6.9 REMOVING AND INSTALLING SPOKES | 6.34 |
| REMOVING SPOKES | 6.34 |
| INSTALLING SPOKES | 6.34 |
| 6.10 EXAMINING RIMS FOR RUNOUT, CENTERING | 6.35 |
| EXAMINING RIMS FOR VERTICAL AND LATERAL RUNOUT | 6.35 |
| a. Front wheel rim | 6.35 |
| b. Rear wheel rim | 6.35 |
| CENTERING LATERAL RUNOUT | 6.36 |
| 6.11 STATIC WHEEL BALANCING | 6.37 |
| 6.12 REMOVING, DISASSEMBLING AND ASSEMBLING REAR SPRING STRUT | 6.38 |
| REMOVING AND INSTALLING REAR SPRING STRUT | 6.38 |
| DISASSEMBLING AND ASSEMBLING REAR SPRING STRUT | 6.38 |
| 6.13 REMOVING AND INSTALLING, DISASSEMBLING AND ASSEMBLING REAR WHEEL DRIVE | 6.42 |
| removing rear wheel drive | 6.42 |
| REMOVING, STRIPPING AND ASSEMBLING THE INPUT BEVEL PINION | 6.43 |
| Removing the input bevel pinion | 6.43 |
| Stripping down the input bevel pinion | 6.44 |
| Removing the needle roller bearing | 6.45 |
| Installing the needle roller bearing | 6.45 |
| Assembling the input bevel pinion | 6.46 |
| INSTALLING THE INPUT BEVEL PINION | 6.47 |
| REMOVING AND INSTALLING TAPER NEEDLE ROLLER BEARING | 6.48 |
| REMOVING THE CROWN WHEEL | 6.49 |
| INSTALLING CROWN WHEEL | 6.50 |
| Shimming the crown wheel | 6.50 |
| Adjusting tooth backlash | 6.51 |
| CHECKING TOOTH CONTACT PATTERN | 6.52 |
| INSTALLING THE HOUSING COVER | 6.53 |
| Shimming the housing cover | 6.53 |
| Installing the housing cover | 6.53 |
| 6.14 REMOVING AND INSTALLING, DISASSEMBLING AND ASSEMBLING REAR WHEEL SWING ARM | 6.54 |
| REMOVING AND INSTALLING TAPER ROLLER BEARINGS | 6.54 |
| INSTALLING SWING ARM AND ADJUSTING BEARING PLAY | 6.55 |

| Contents | Page |
|--|------|
| 6.15 INSTALLING REAR WHEEL DRIVE | 6.56 |
| 6.16 INSTALLING SPRING STRUT | 6.57 |
| 6.17 INSTALLING REAR WHEEL | 6.58 |

6.1 REMOVING FRONT WHEEL REPLACING WHEEL BEARING

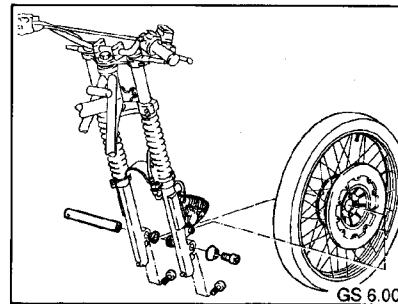

- Remove brake caliper.
- Slacken retaining screw on stub axle and take off together with washer.
- Slacken 2 clamping screws on each side of stub axle at the slide tubes.
- Withdraw stub axle and at the same time take off spacer sleeves.
- Take front wheel out of telescopic forks, to the front.

Use internal extractor, BMW No. 00 8 573,
and counter-support, BMW No. 00 8 570.

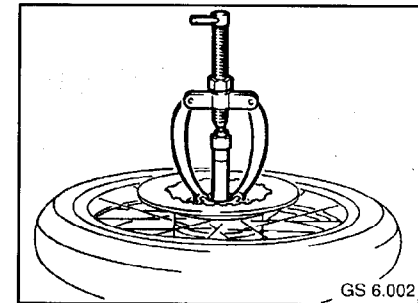

INSTALLING WHEEL BEARINGS

CAUTION:

Remove brake disc before heating hub.

- Heat hub to approx. 100 °C.
- Insert new bearings.

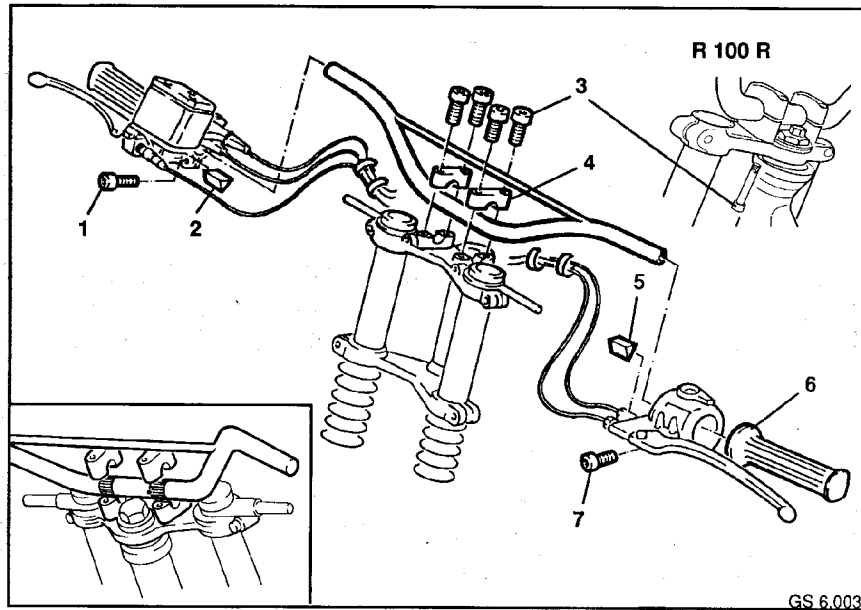

6.2 REMOVING HANDLEBARS

REMOVING HANDLEBARS

NOTE:

Take off fuel tank or use protective cover, BMW No. 16 1 600, to avoid damage to fuel tank.

- Cut through 2 cable straps each on the handlebars.
- Slacken clamping screw (7) on left grip unit and push grip unit to middle of handlebar.
- Insert a small screwdriver below the rubber grip (6).

- Spray creep oil below the rubber.
- Pull off rubber grip, turning it slightly.
- After loosening the 4 attachment screws (3), detach clamp mounts (4); loosen the R 100R's clamp mounts from underneath.
- Push handlebars to the right.

NOTE:

Pay attention to the clamping wedges (2,5) when pulling off the grip unit.

- Pull left grip unit off handlebars.
- Slacken clamping screw (1) on the right grip unit.
- Push handlebars to the left and pull right grip unit off handlebars.
- Take handlebars off fork bridge.

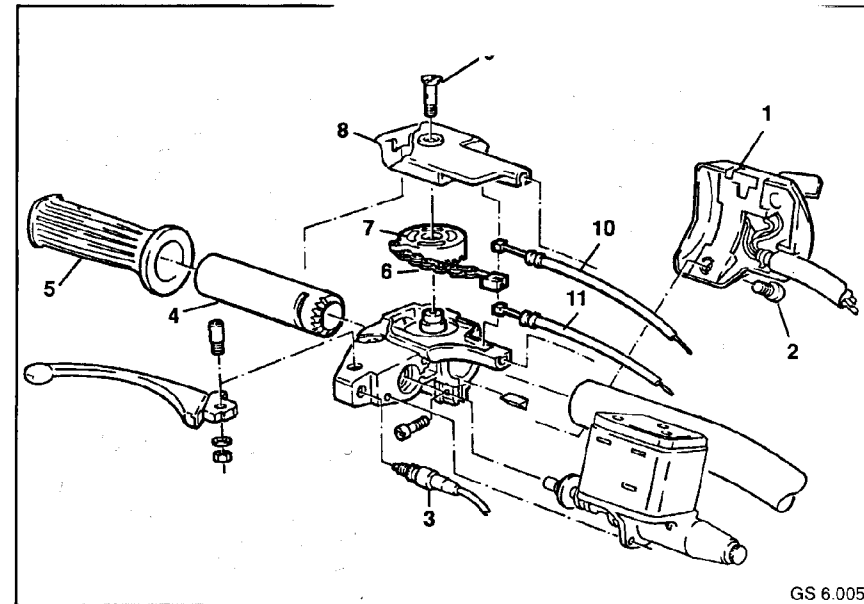

6.3 DISASSEMBLING AND ASSEMBLING GRIP UNITS

DISASSEMBLING RIGHT GRIP UNIT

- Remove brake fluid reservoir and main brake piston.
- Slacken stop light switch (3).
- After slackening the fastening screw (2), take off handlebar controls (1).
- Slacken fastening screw (9) at the throttle control.
- Carefully remove protective cover (8).
- Detach top cable (10) from chain (6) and remove from protective cap.
- Detach bottom cable (11) from chain and withdraw adjusting cam (7) from grip unit.
- Pull twist tube (4) together with rubber grip (5) off handlebars.

ASSEMBLING RIGHT GRIP UNIT

NOTE:

If the rubber grip (5) has been removed from the twist tube (4), use suitable adhesive when installing rubber grip to prevent it turning.

- Insert top cable (10) of throttle control into protective cover (8) and bottom cable (11) into guide of grip unit.

NOTE:

Before installing, grease adjusting cam and serrations on twist tube.

- Insert adjusting cam (7) and attach both cables of throttle control to chain (6).

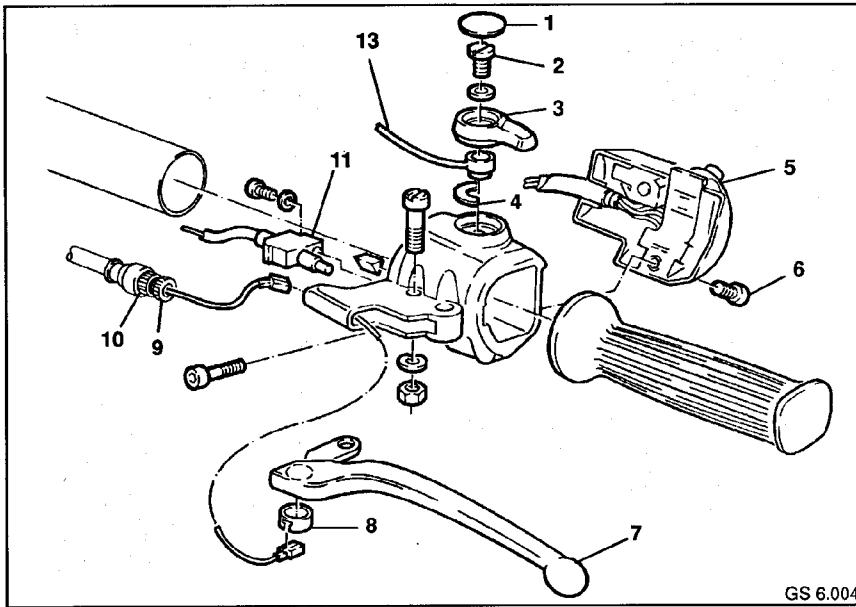

GS 6.004

DISASSEMBLING LEFT GRIP UNIT

- Take cover (1) off cold start lever (3).
- Slacken fastening screw (2).
- Detach cable (13) from cold start lever and take off lever.
- Remove plate (4) from grip unit.
- Slacken the fastening screw (6) and take off handle bar controls (5).
- Slacken locking nut (9) from clutch cable and screw in adjusting screw (10) of the clutch cable fully.
- Use screwdriver to operate release lever on transmission.
- Remove the sleeve (8) and pull clutch cable out of grip unit.

- Slacken the fastening screw (12) and withdraw clutch switch(11) from grip unit.

ASSEMBLING LEFT GRIP UNIT

The left grip unit is assembled in the reverse order by analogy to disassembly.

NOTE:

Before installing grip unit, apply a light coating of grease to the seat of the lever of the cold start control and to nipple with sleeve (8) on the clutch cable.

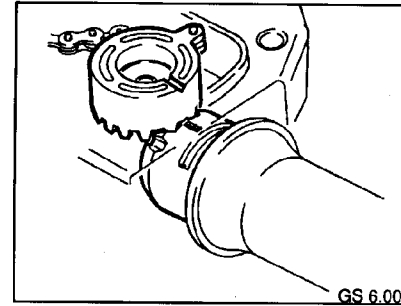

NOTE:

When assembling, ensure that the mark on the serrations of the twist tube is aligned with the mark on the adjusting cam.

- Push on twist tube.
- Fit on protective cover and screw tight with fastening screw.

air control and tighten with

- Screw in stop light switch.
- Install brake fluid reservoir with master brake cylinder.

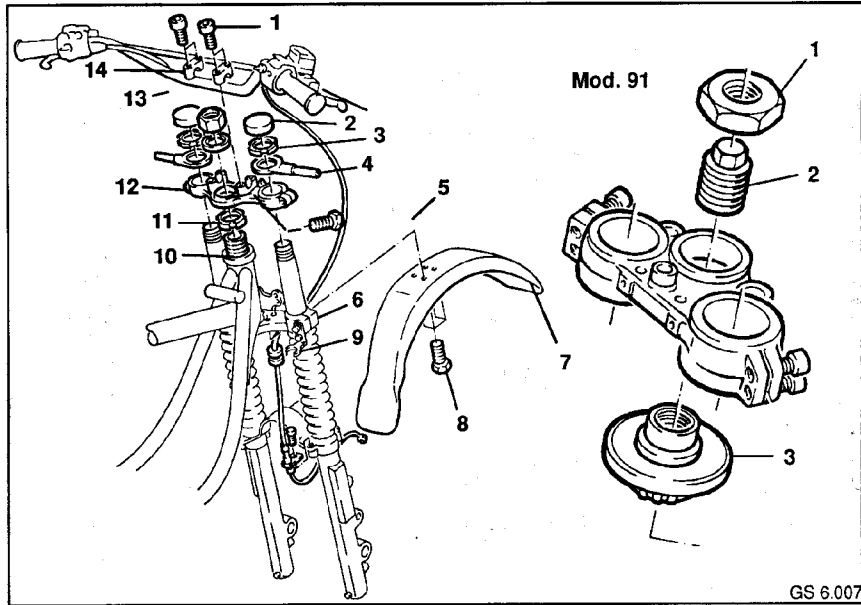

GS 6.007

6.4 REMOVING AND INSTALLING, DISASSEMBLING AND ASSEMBLING TELESCOPIC FORK

REMOVING TELESCOPIC FORK (1988 MODELS)

NOTE:

Take off fuel tank or use protective cover, BMW No. 16 1 600, to avoid damage to the fuel tank.

- Remove headlamp complete with head lamp fairing and instruments.
- Remove brake caliper.
- Remove front wheel.
- Take brake line off mounting bracket (9) on bottom fork bridge (6).
- After slackening the 4 fastening screws (8), take mudguard (7) off bottom fork bridge.
- Slacken end screw (13) on the control tube.
- Remove protective caps (2) from the top of the stanchions.

- Use hooked wrench to slacken slotted nuts (3).
- Remove left/right turn signal mounting bracket (4).
- Slacken the 2 clamping screws (5) and take off top fork bridge (12).
- Use hooked wrench to slacken slotted nut (11).
- Slacken telescopic fork by applying light blows (with plastic-headed hammer) to the control tube (10) and withdraw from the control head.

Removing the telescopic fork (1991 models)

- Slacken off locknut (1).
- Unscrew locking tube (2) and remove it complete with the hex nut.
- Detach the spring mount.
- Unscrew the fork bridge clamp bolts.
- Take off the upper fork bridge.
- Unscrew ring nut (3) and take it off complete with the bearing.
- Loosen the telescopic fork with light blows of a plastic-faced hammer on the steering head tube (10), and remove it from the steering head.



GS 6.096

REMOVING TELESCOPIC FORK - R 100 R

- Remove fuel tank.
- Detach mudguard and brake caliper.
- Separate plug connections for electric wires:
 - brake light switch
 - clutch switch
 - left/right instrument switch
 - ignition switch
- Remove headlight.
- Loosen speedometer shaft at instrument panel.
- Remove instrument covers.
- Remove bulbs.
- Separate plug connections for electric wires:
 - revolution counter
 - display panel
- Remove instruments from cover plate.
- Detach flashing turn indicator connecting wires (1) in the indicator housing at the left and right.
- Remove headlight/instrument holder (2).
- Loosen attachment screws (arrow) for the handlebar clamp blocks and set the handlebar down on the frame.

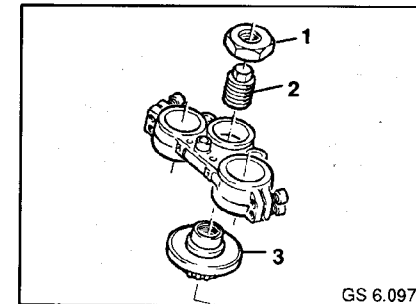

GS 6.097

- Slacken off locknut (1).
- Unscrew locking tube (2) and remove it complete with the hex nut.
- Unscrew the fork bridge clamp bolts.
- Take off the upper fork bridge.
- Unscrew ring nut (3) and take it off complete with the bearing.
- Loosen the telescopic fork with light blows of a plastic-faced hammer on the steering head tube (10), and remove it from the steering head.

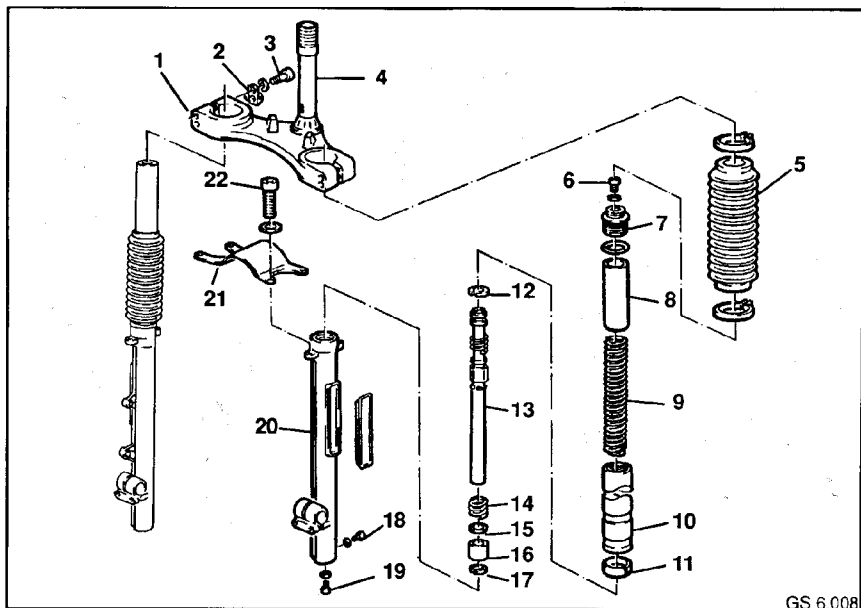

GS 6.008

DISASSEMBLING TELESCOPIC FORK GS

- Slacken oil drain plug (18) on both sides.
- Slacken oil filler plug (6).
- Allow fork oil to drain into suitable vessel.
- Insert protective jaws in vice and clamp telescopic fork in vice at control tube (4).
- After slackening the remaining 3 fastening screws (22), take off fork stabilizer (21).
- Slacken 4 clamping screws (3) on bottom fork bridge.
- Remove bracket for brake line (2) (1) from the righthand side of the bottom fork bridge.
- Withdraw left and right stanchions complete from bottom fork bridge.

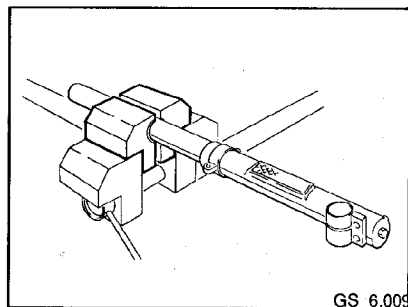

GS 6.009

- Clamp left stanchion in vice with clamping block, BMW No. 31 4600, at stanchion.

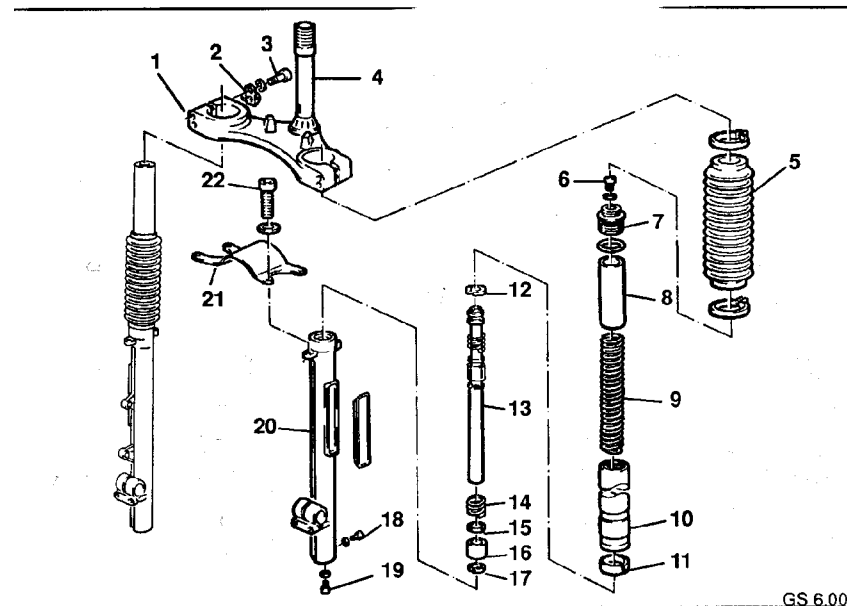

GS 6.008

CAUTION:

Spring bearing is pressurized.

- Slacken fastening screw (19) at base of sliding tube(20). Compress telescopic fork, if necessary.
- Slacken top spring bearing (7) with hexagon socket range.
- Remove spacer tube (8) and spring (9) from stanchion(10).
- Slacken tensioning straps of bellows (5) and take off bellows.

- Pull sliding tube off stanchion.
- Take sliding ring (11) off stanchion.
- Release locking ring (17) at the base of the stanchion and withdraw damper tube (13) complete from stanchion.

Remove the following parts from the left damper tube in the order stated

- Throttle bush (16)
- Throttle disc (15)
- Spring (14)
- Spring pad (12)

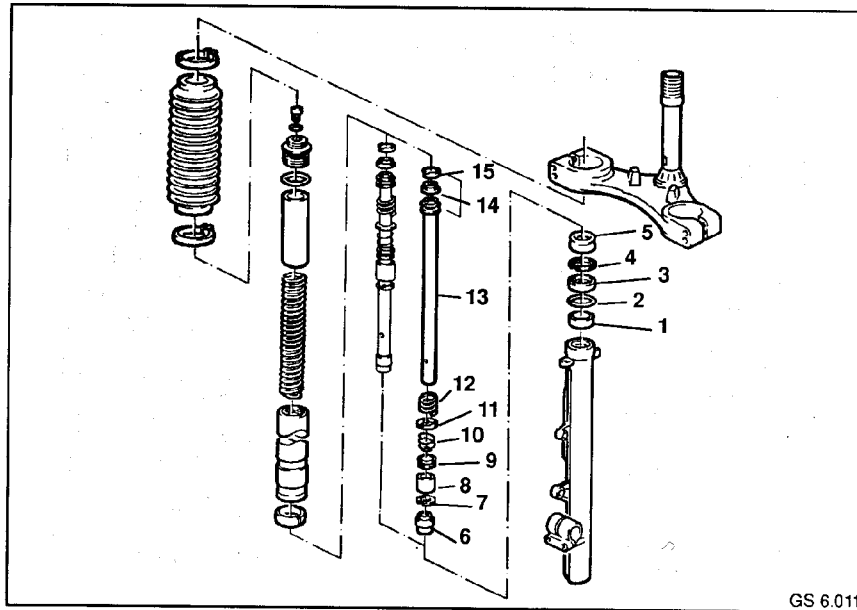

GS 6.011

- Following this, disassemble right stanchion.

NOTE:

Disassembly of the right stanchion is identical to disassembly of the left one up to removal of the sliding tube.

- Take guide bush (6) off bottom of stanchion.
- Release locking ring (7) at the base of the stanchion and withdraw right damper tube (13) complete from stanchion.

Remove the following parts from the right damper tube in the order stated:

- Valve housing (8)
- Spring bearing (9)
- Spring (10)
- Spring pad (11)
- Spring (12)
- Spring guide (13)
- Piston ring (14)
- Spring pad (15)

REMOVING AND INSTALLING SHAFT SEAL AND SLIDING BUSH IN SLIDING TUBE

- Clamp sliding tube in vice using protective jaws.
- Use small screwdriver to lever dust seal (5) and locking ring (4) out of top of sliding tube.
- Clamp sliding tube in vice with protective jaws at eye for brake caliper fixture.

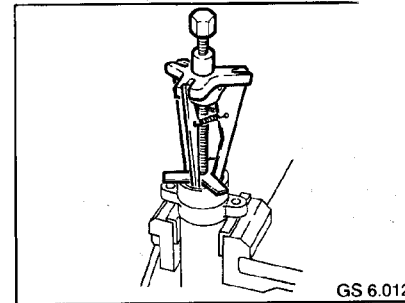

GS 6.012

- Withdraw shaft seal (3) from sliding tube using internal extractor BMW No. 00 5 010, and base, BMW No. 31 4 630.
- Withdraw washer (2).

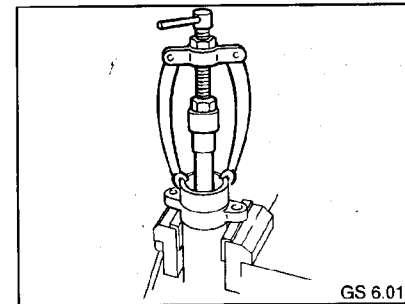

GS 6.013

- Withdraw sliding bush (1) from sliding tube using internal extractor, BMW No. 00 8 560.

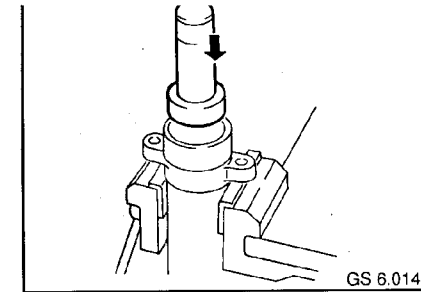

GS 6.014

- Use impact drift, BMW No. 11 1 850, and grip, BMW No. 00 5 500 to knock in bush if necessary.
- Insert washer (2) in sliding tube.
- Grease inside and outside of shaft seal with Shell Retinax A and knock in with impact drift, BMW No. 31 4 680, and grip, BMW No. 00 5 500.
- Insert locking ring (4).
- Grease shaft seal.
- Insert dust seal (5) by hand.

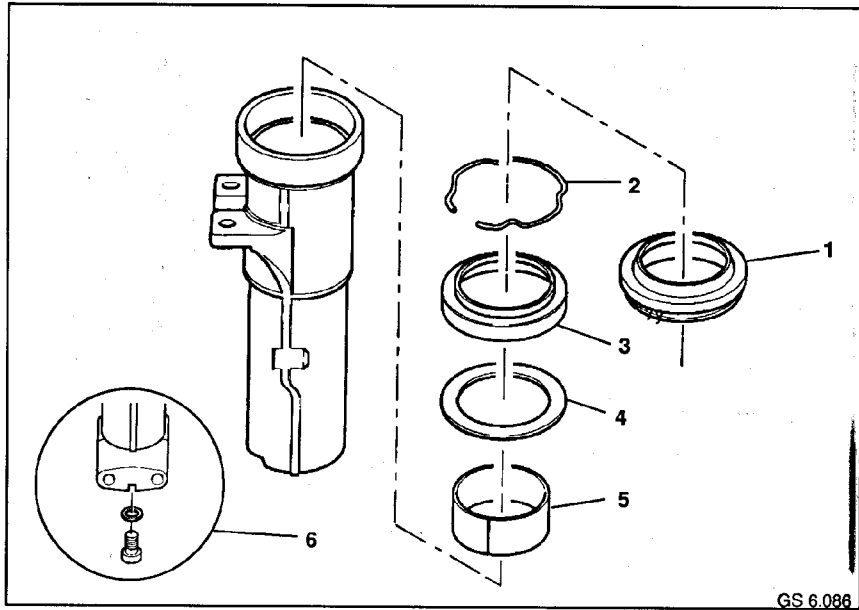

**STRIPPING DOWN TELESCOPIC FORK
R 100 R**

Removing the fixed tube

- Loosen clamp screws on lower fork bridge.
- Remove fixed tube with slider tube from fork bridge.
- Remove protective cap inside fixed tube.

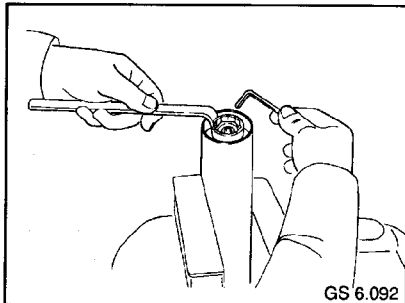

- Take out oil filling screw in the upper spring bearing.

- Loosen oil drain screw in the slider tube and drain off oil.
- Use protective jaws to clamp the slider tube into the vice at both brake caliper attachment lugs.
- Remove dust cap (1).
- Use screwdriver to lever out securing ring (2).
- Loosen shock absorber base screw connection (3) in the slider tube.
- Insert fixed tube a short distance into slider tube and pull sharply to extract fixed tube, sealing ring (2), intermediate ring (3) and sliding bushing (4) from the slider tube.

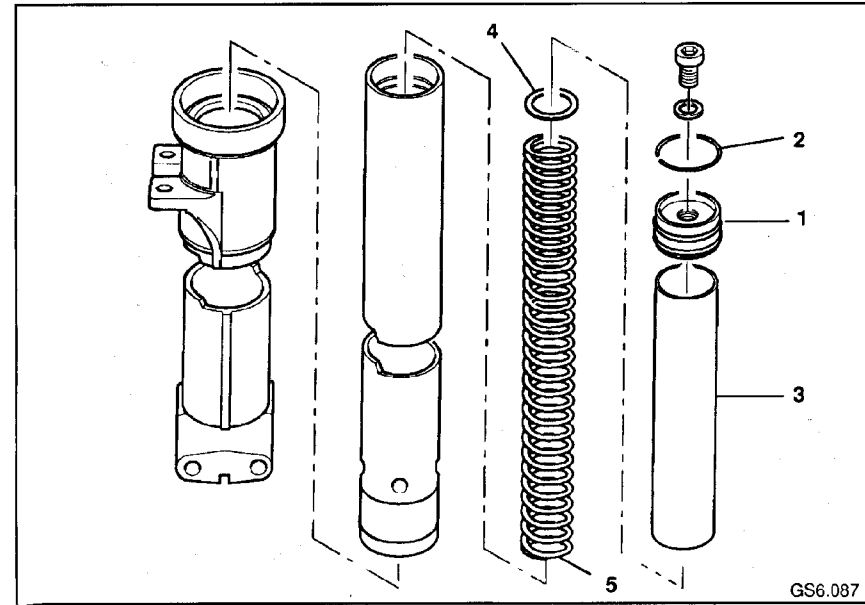

Stripping down the fixed tube

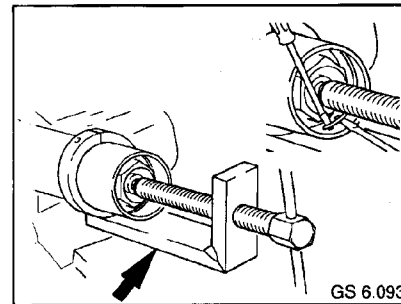

- Secure clamping device (arrow), BMW No. 31 5 550, to the fixed tube and insert BMW No. 31 5 552.
- Gently press spring bearing (1) downwards; use two screwdrivers to lever out securing ring (2).
- Remove spacer (3), mount (4) and suspension spring (5).

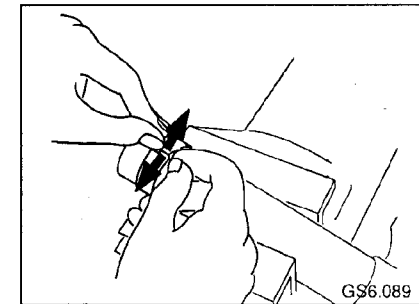

- Use two fingers to press sliding bushing apart and remove it from fixed tube.

NOTE:

Replace sliding bushings if damaged.

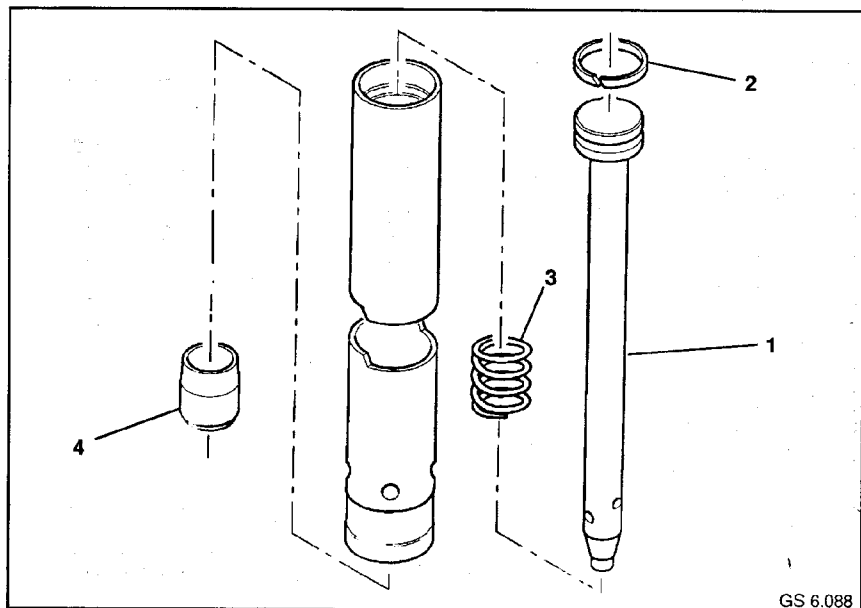

Damper components

- 1) Damper tube
- 2) Piston ring
- 3) Spring
- 4) Guide

GS 6.088

MEASURING TELESCOPIC FORK ALIGNMENT

NOTE:

It is particularly important to carefully examine the bottom fork bridge, the stanchions as well as the sliding tubes for any signs of cracking if the fork has been damaged.

EXAMINING STANCHIONS

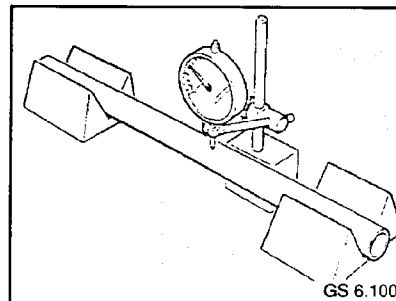

GS 6.100

- Examine both ends of the removed stanchions for runout in prisms or in the pivot block.

Permissible runout of fork stanchion 0.1 mm

CAUTION:

Bent stanchions must not be straightened. Risk of permanent fracture.

EXAMINING BOTTOM FORK BRIDGE

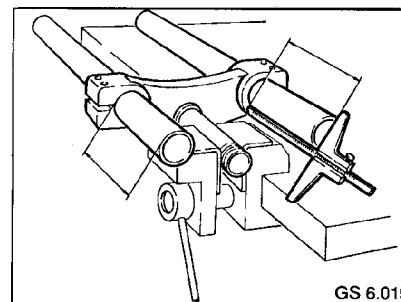

GS 6.015

- Install two new stanchions in the fork bridge for this examination. Installed

length approx. 180 mm measured from top end of stanchion to top end of fork bridge.

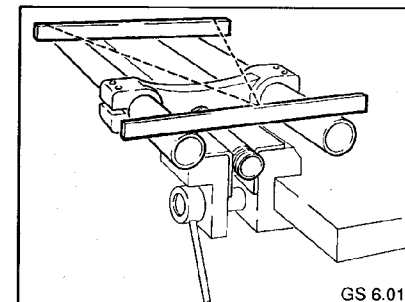

GS 6.016

- Place two straightedges BMW No. 31 4 620, over the ends of the stanchions and determine any possible distortion by visual inspection.

EXAMINE PARALLELISMS OF THE STANCHIONS

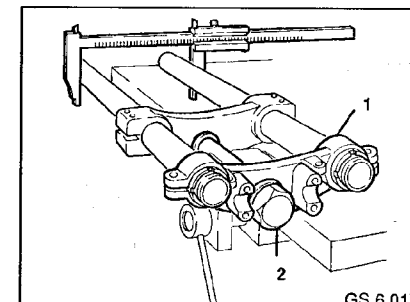

GS 6.017

- Examine parallelism of the stanchions with sliding calliper.
- Examine steering tube (1) for precise alignment relative to stanchions by fitting on top fork bridge (2).
- Screw in spring pad.
- Screw cap nut (3) on to control tube.

NOTE:

Centering collar of cap nut must screw easily into the fork bridge.

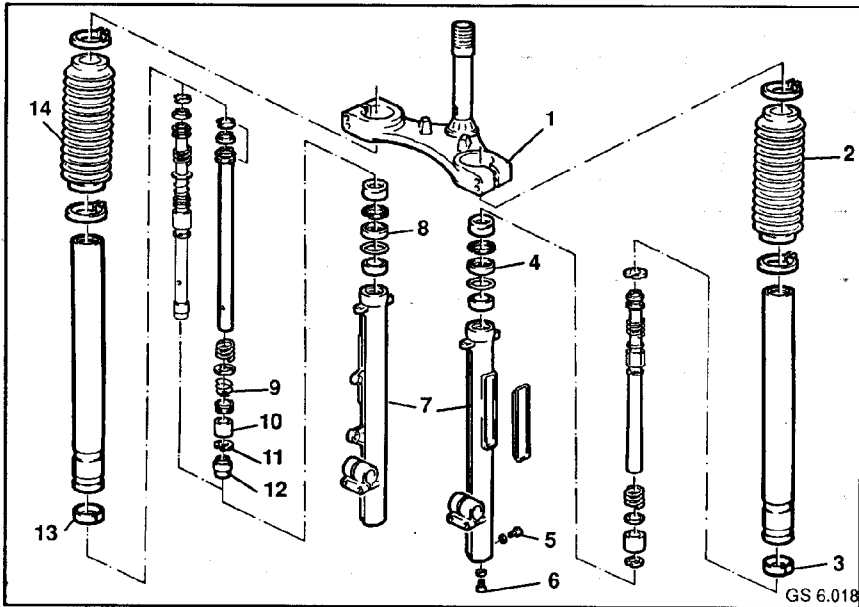

ASSEMBLING TELESCOPIC FORK GS

NOTE:

When assembling the right damper, ensure that the small spring (9) is clamped fully into the valve housing. If not, it is not possible to install locking ring in stanchion.

- Push parts over damper tube in the reverse order to removal.
- Push damper tube complete over inner edge into stanchion.
- Secure valve housing (10) of the right-hand stanchion in the stanchion with locking ring (11).
- Insert guide bush (12) in stanchion.

NOTE:

Use a screwdriver, if necessary, to push locking ring in further until it is fully engaged in the slot.

- Lightly grease shaft seals (4,8).

NOTE:

Deburr new sliding bushes (3,13), if necessary.

The chamfered side of bushes must face end of stanchion.

- Fit new sliding bush onto stanchion.
- Fit sliding tube (7) onto stanchions by slightly rotating them.
- Screw fastening screws (6) into the bottom of the sliding tube.
- Screw oil drain plugs (5) with new sealing ring into sliding tubes.
- Tighten oil drain plugs to specified tightening torque.
- Fit rubber seals (2,14) onto sliding tubes and secure with tensioning straps.
- Clamp bottom fork bridge (1) in vice at steering tube.
- Insert left and right stanchions into bottom fork bridge.

Tightening torque:

Oil drain plug

Mod.91

Damper to sliding tube

6 Nm

5 Nm

15 Nm

GS 6.018

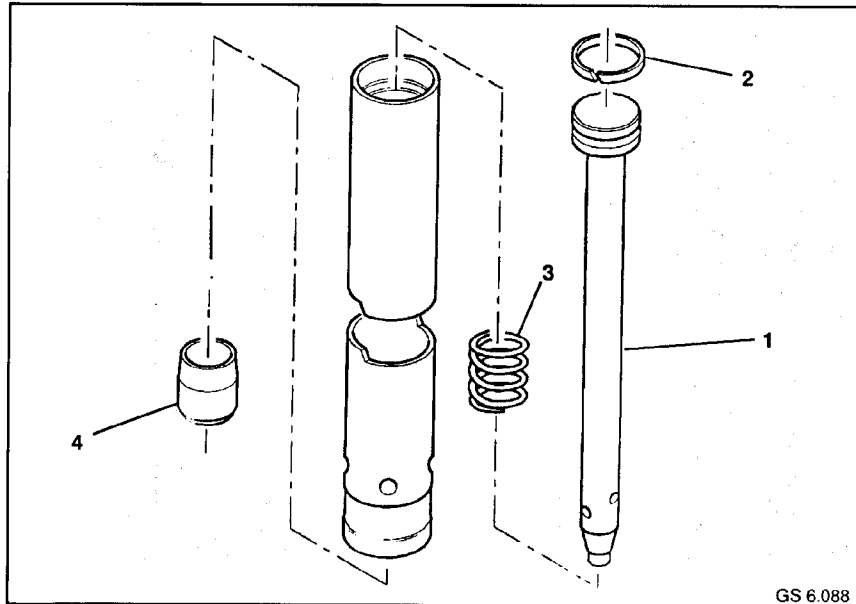

ASSEMBLING TELESCOPIC FORK R 100 R

- Insert damper tube (1) with piston ring (2) and spring (3) into fixed tube.
- Attach guide (4) to damper tube.
- Insert fixed tube and sliding bushing into fork slider tube.

- Insert attachment screw for damper with new sealing ring, without tightening.
- Place slider tube on work bench.

NOTE:

Lightly coat the sliding bushings with fork oil before assembly.

GS 6.088

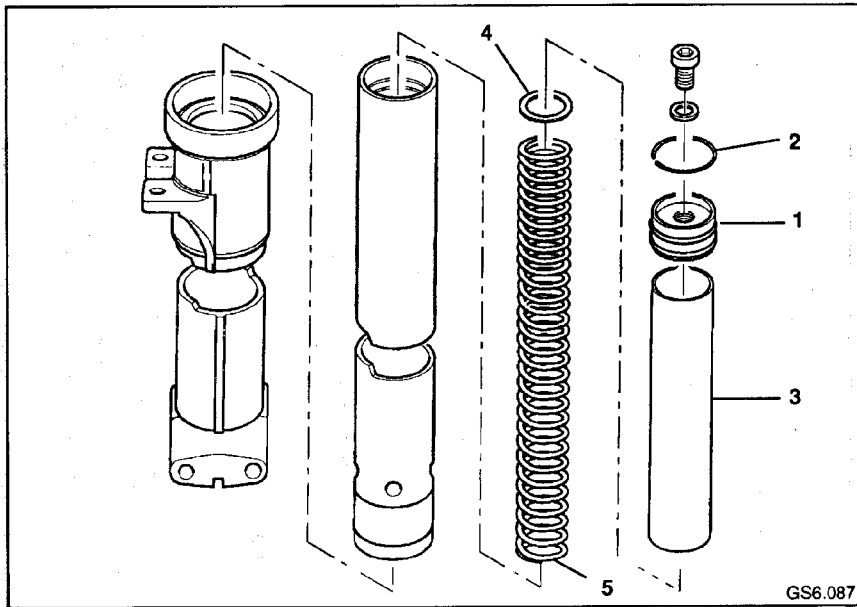

GS6.087

ASSEMBLING STANCHIONS

- Insert fork suspension spring (5) into fixed tube with more closely spaced coils facing up.
- Fit mount (4); attach spacer (3).

- Insert oil drain screw on slider tube with new sealing ring and tighten.

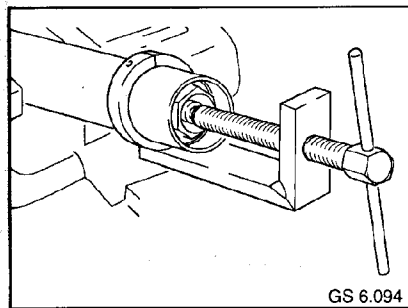

GS 6.094

- Use tensioning device, BMW No. 31 5 550 and insert BMW No. 31 5 552 to press in spring bearing (1) and insert snap ring (2).

NOTE:

Replace O-ring on spring bearing if damaged.

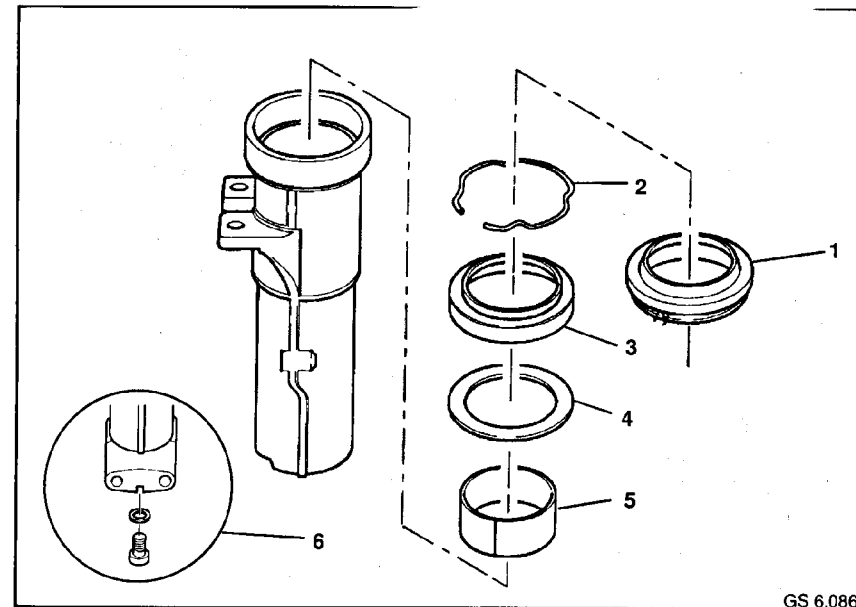

GS 6.086

- Fit upper sliding bushing (5) over fixed tube and gently press into slider tube.

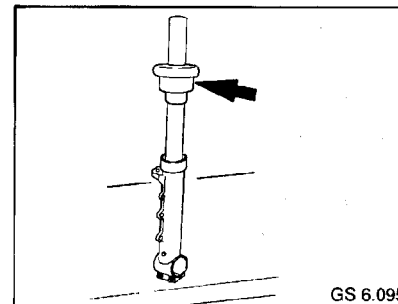

GS 6.095

- Push arbor, BMW No. 31 3 650, (arrow) on to fixed tube and release.
- Insert intermediate ring (4).
- Drive in radial sealing ring (3) in the same way.
- Fit securing ring (2) in groove above the sealing ring.

NOTE:

Lightly coat outside of radial sealing ring with tyre fitting fluid before assembly. Installed position: large groove facing down, lettering on top.

- Drive dust sleeve (1) into the slider tube, also with the convex end of the arbor, BMW No. 31 3 650.

NOTE:

Fill grease pocket in dust sleeve with Shell Retinax "A".

- Fill up with BMW-approved oil.
- Insert oil filler screw with new sealing ring and tighten.
- Press in fixed tube cover.

Oil quantity 0,420 L

Tightening torque:
 Damper attachment in slider tube 20 Nm
 Oil drain screw 6.5 Nm
 Oil filling screw 10 Nm

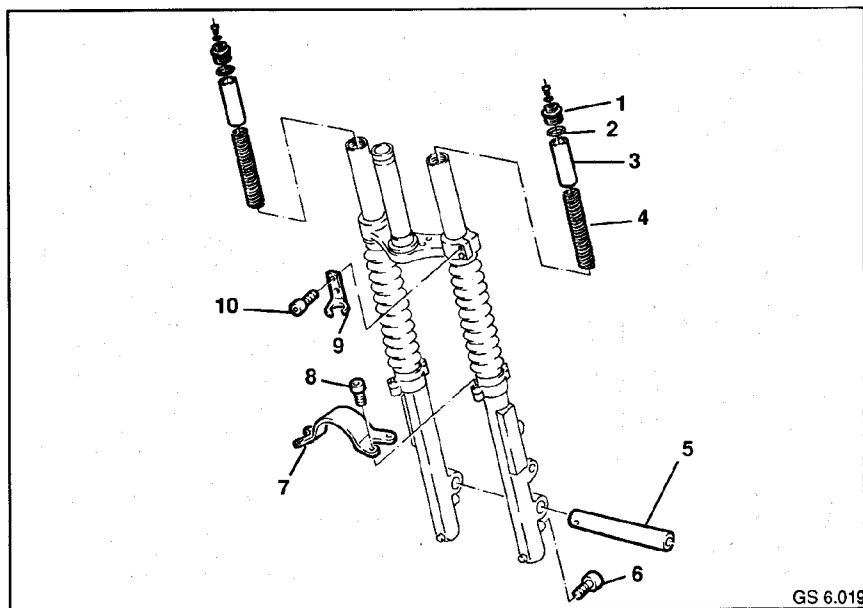

GS 6.019

NOTE:

The stanchions must both project evenly 176 mm over the bottom fork bridge.

- Adjust distance (176 mm) from top edge of stanchion to top end of fork bridge.

NOTE:

Install bracket (9) for brake line to the right-hand side of the fork bridge.

- Screw 4 clamping screws (10) into bottom fork bridge and tighten slightly.
- Insert stub axle (5) into telescopic fork and fix in position on lefthand side with clamping screws (6).
- Push up sliding tubes fully.
- Fix stub axle on righthand side with clamping screws.
- Insert fork stabilizer (7), screw in 4 fastening screws (8) and tighten to specified tightening torque.

- Tighten clamping screws of bottom fork bridge to specified tightening torque.
- Allow sliding tubes to slide down.

NOTE:

If the forks are found to be sticking, perform assembly of fork stabilizer once again as described.

- Insert springs (4) into stanchions.
- Insert spacer tubes (3).
- Fit new O-ring (2) onto spring bearing (1).
- Apply a light coating of oil to thread of spring pad.
- Screw in spring pad and tighten to specified tightening torque.
- Tighten fastening screws on bottom of sliding tube to specified tightening torque.

Tightening torque:
 Spring pads 20 Nm
 Fork stabilizer 15 Nm
 Clamp at bottom of fork bridge /R 100 R 15/21 Nm

REMOVING AND INSTALLING STEERING HEAD BEARING

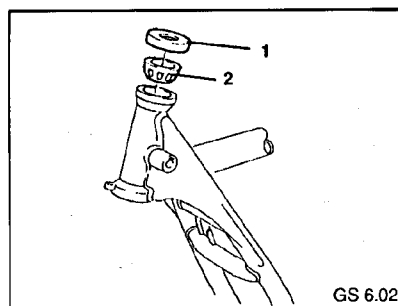

GS 6.020

- Take dust ring (1) of steering head and withdraw top taper roller bearing (2) from steering head.

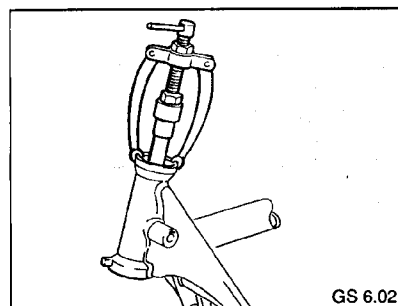

GS 6.021

- Withdraw bearing outer race using Kukko extractor, BMW No. 00 5560, in combination with supporting ring, BMW No. 31 4 800.

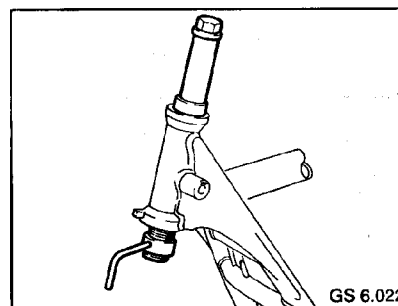

GS 6.022

- Pull in new bearing outer race with washer and nut as far as base of seat using the spindle of the frame alignment gauge in combination with spacer, BMW No. 31 4 820.

bearing
 k pro-

secure as appropriate.

REMOVING AND INSTALLING BOTTOM TAPER ROLLER BEARING

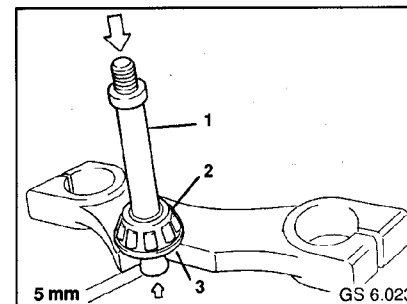

GS 6.023

- Press down steering tube (1) a little (approx. 5 mm) out of fork bridge and push back again.
- Pull taper roller bearing (2) off steering tube with a suitable puller.
- Take dust ring (3) off steering tube.
- Heat bearing to 80°C and fit on with dust ring. Knock on bearing with tube evenly until the abut, if necessary.

Removing and installing the upper taper roller bearing (1991 models, R 100 R)

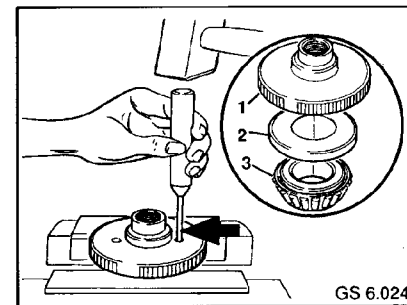

GS 6.024

- Drive taper roller bearing (3) and dust protection ring (2) down off adjusting ring (1) with a suitable drift.

NOTE:

To install, heat the taper roller bearing to approx. 80 C. The dust protection ring must be installed without any play between the bearing and the adjusting ring.

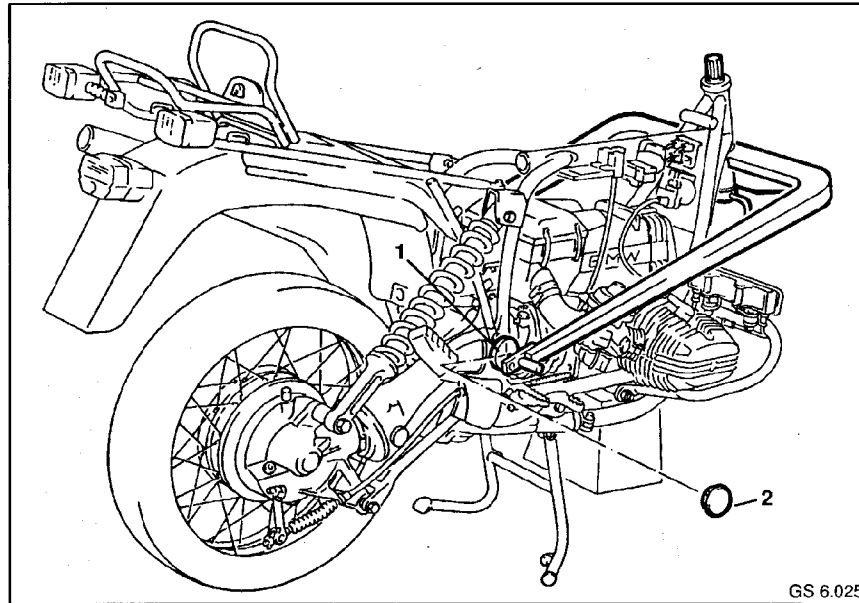

EXAMINING FRONT FRAME SECTION

NOTE:

In the event of an accident or fall, the forces acting on the motorcycle frame are in excess of those in normal motor cycling. If such a case has occurred and an inspection of the frame with the naked eye does not reveal any change, the frame can be checked with the frame alignment gauge, BMW No. 46 5 600.

- Remove taper roller bearing from steering head.
- Take cap (2) out of the swing arm bearing and slacken locking nut.
- Screw gauging discs BMW No. 46 5 603, into left and right swing arm bearing pins to an equal extent.
- Position the reticule vertically.

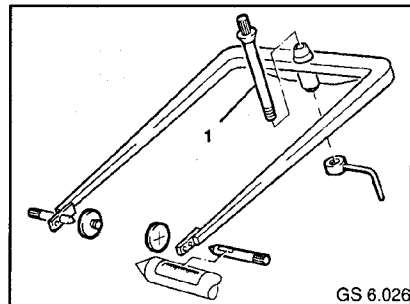

- Offer up the frame alignment gauge from below to the steering head, and clamp frame and gauge together with spindle (1).

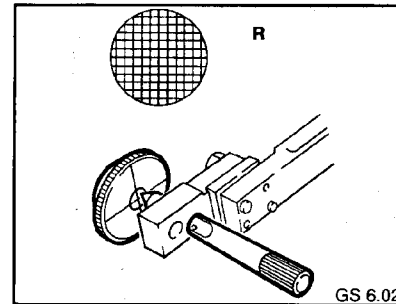

- Slightly grease plug gauges and insert into the front hose (A) of the frame alignment gauge.

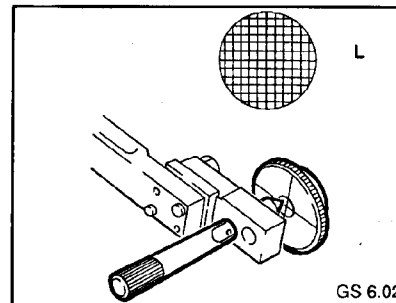

- Align gauge so that the same reading is obtained on the left and right of the plugg gauge scale when the tips make slight contact with the gauging discs.

NOTE:

The frame is in proper order if the tips on the left and right are approx. at the same point within the tolerance circle (maximum deviation from left to right 2 mm = 2 boxes).
If the tips are far apart ⇒ align frame.
If the tips are outside of the tolerance circle, it is no longer possible to align frame!

- If the frame is within the tolerance range, examine top tube of frame for parallelism.
- If the frame top tube is twisted, the frame cannot be aligned.
- After examining frame top tube, examine gusset plates for buckling.
- If the plates are buckled, the frame cannot be aligned.

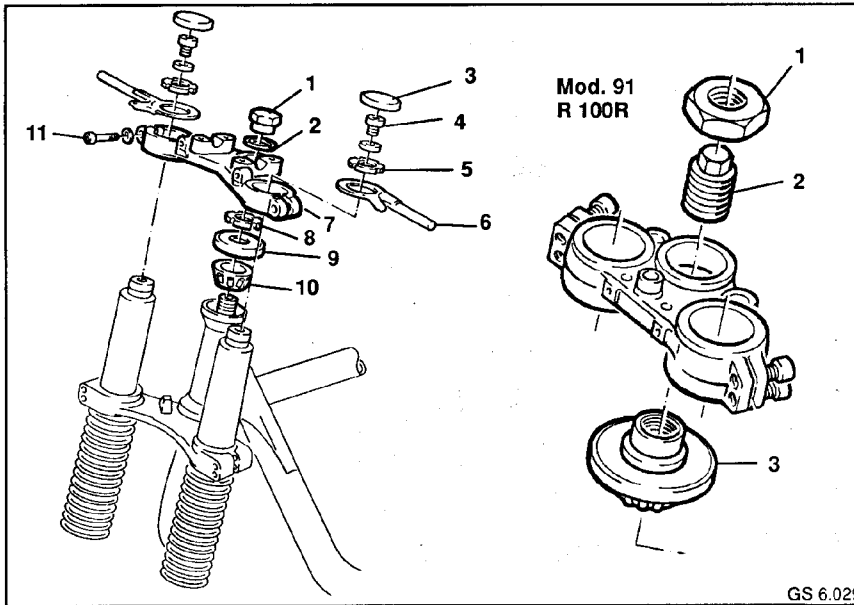

INSTALLING TELESCOPIC FORK

Mod.88

- Insert telescopic fork into steering head.

CAUTION:

Before installing telescopic fork grease upper (10) and bottom taper roller bearing with "Shell Retinax A".

- Fit on top taper roller bearing.
- Fit dust cap (9) onto steering tube.
- Fit on slotted nut (8) and tighten slightly (max. 0.6 Nm) until there is no play at steering head bearing.
- Examine steering bearing play.

NOTE:

If bearing play is too great, the steering will shake at low speeds; if it is too low, the motorcycle will tend to snake at high speeds.

NOTE:

If the steering bearings are correctly adjusted and the wire cables run correctly, the front wheel will drop to the full left or right steering lock position easily when clear of the ground (motorcycle on stand).

- Fit top fork bridge (7) onto telescopic fork.
- Screw in clamping screws (11) to top fork bridge and tighten to specified tightening torque.
- Fit washer (2) onto steering tube and fit on screw (1).
- Use hooked wrench to hold slotted nut (8) in position and tighten screw (1) with special tool, BMW no. 31 4 850, to specified tightening torque.
- Re-check steering bearing play; adjust if necessary.
- Fit on turn signal mounting (6) and screw on slotted nut (5).
- Tighten slotted nuts to specified tightening torque.
- Unscrew left/right oil filler plugs (4) out of top spring bearings.
- Pour precisely gauged, specified quantities of fork oil into left and right telescopic forks, using a funnel.
- Fit new sealing ring onto oil filler plugs and screw in plugs. Tighten to specified tightening torque.
- Fit on protective caps (3).

Mod. 91 and R 100R

- Insert the lower fork bridge with steering tube into the steering head.
- Screw on adjusting ring (3) with the taper roller bearing.
- Attach the upper fork bridge and screw in locking tube (2) with hex nut (1) loosely at first.
- Insert the fixed fork tubes fully into the upper fork bridge and screw in the spring mounts without tightening them at this stage.
- Turn the adjusting ring to eliminate bearing play.
- Tighten the locking tube and hex nut.
- Tighten the spring mounts and clamp bolts in the fork bridge.

NOTE:

After filling the telescopic forks, bleed shock absorbers by compressing and extending forks (5 strokes) – full damping perceptible.

| | |
|---|--------------|
| Oil grade for telescopic fork | Esso Komfort |
| Capacity of telescopic fork: GS following disassembly | |
| left | 0.47 – 0.1 l |
| right | 0.47 – 0.1 l |
| with oil change | |
| left | 0.41 – 0.1 l |
| right | 0.44 – 0.1 l |

| | |
|------------------------------------|--------------|
| End screw | 15 Nm |
| Slotted nut (taper roller bearing) | 107 Nm |
| Slotted nut (fork bridge) | free of play |
| Oil filler plug | 40 Nm |
| Locking tube | 14 Nm |
| Hex nut | 65 Nm |
| Spring bearing | 20 Nm |
| Locking tube | 65 Nm |
| Hex nut | 65 Nm |
| Spring mount | 20 Nm |

| | |
|--|---------|
| Capacity of telescopic fork: R 100 R following disassembly with oil change | |
| | 0.420 L |
| | 0.410 L |

| | |
|--------------------------------------|-----------|
| Tightening torque: R 100 R | |
| Upper fork bridge on telescopic fork | 21 Nm |
| Collar nut (taper roller bearing) | zero play |
| Oil filler plug | 10 Nm |
| Oil drain plug | 6.5 Nm |
| Locking tube | 65 Nm |
| Hex nut | 65 Nm |

Installing headlight and Instruments

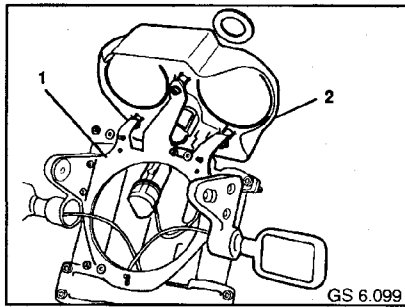

- Install headlight and instrument holder with cover plate.

NOTE:

Run all electrical wiring and wire cables between the frame and the holder.

- Make all the plug connections:
 - left and right instrument switches
 - ignition lock
 - clutch switch
 - brake light switch
- Connect up flashing turn indicators.
- Install ignition lock.
- Install display panel.
- Install revolution counter and speedometer.
- Insert bulbs and make plug connections.
- Install instrument cover.
- Install headlight.

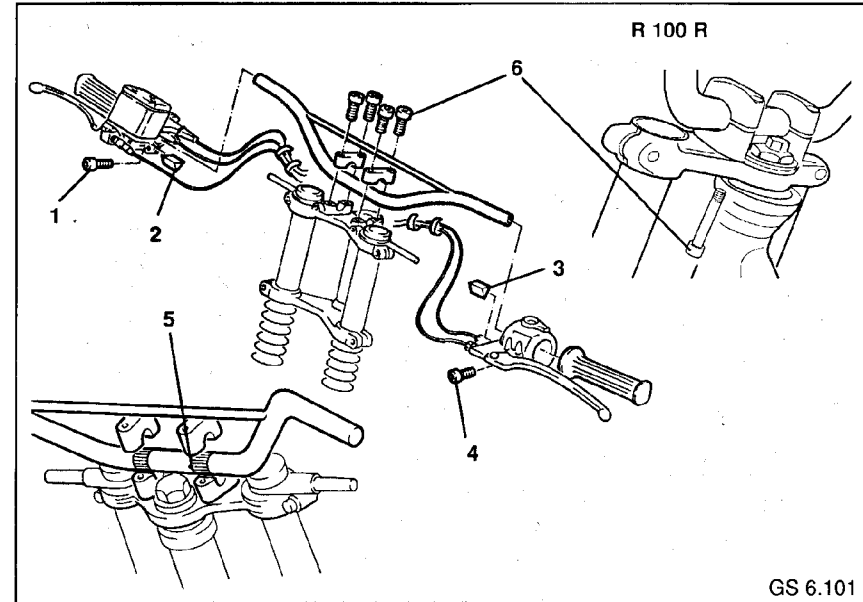

6.5 INSTALLING HANDLEBARS

NOTE:

When installing the handlebars, ensure that the cables and wires are correctly routed.

- Insert clamping wedges (2,3) in grip units.
- Fit left grip unit onto handlebars.
- Fit right grip unit onto handlebars.
- Place handlebars onto fork.
- Fit on clamping block and screw in 4 clamping screws loosely.

NOTE:

The punch markings (5) must be positioned exactly between the top and bottom halves as well as in the middle of the clamping blocks.

- Align handlebars and tighten clamping screws(6) to specified tightening torque.

- Align grip unit ergonomically and tighten clamping screws (6).
- Coat inside of left rubber grip with suitable adhesive and fit rubber grip onto handlebars.
- Position left/right electrical cables on handlebars with 2 cable straps.

CAUTION:

The clutch play must be set after installing the left grip unit.

Tightening torque:
Clamp screws

22 Nm

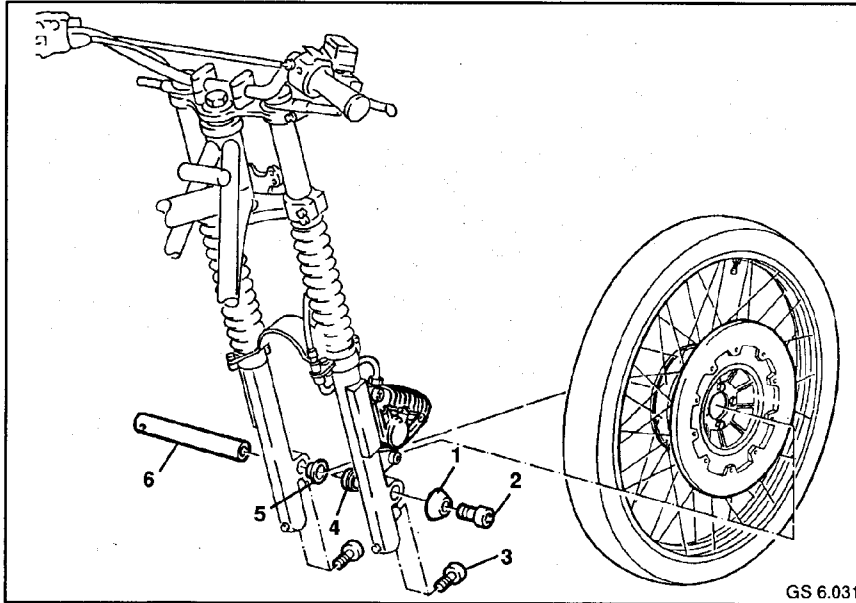

GS 6.031

6.6 INSTALLING FRONT WHEEL

- Insert front wheel into telescopic forks, carefully introducing brake disc into brake caliper.
- Apply a light coating of Molykote grease to stub axle.
- Insert stub axle (6) from the left, inserting spacer sleeves at the same time.

NOTE:

Insert spacer sleeves (4,5) with large OD facing the wheel and spacer sleeve (5) with long collar on the left side.

- Attach washer (1) to stub axle (6) and screw in fastening screw (2).

- Tighten fastening screw to specified fastening torque.
- Screw 4 clamping screws into stanchions and tighten to specified tightening torque.

Tightening torque:
Clamping screws
Fastening screw of stub axle

14 Nm
29 Nm

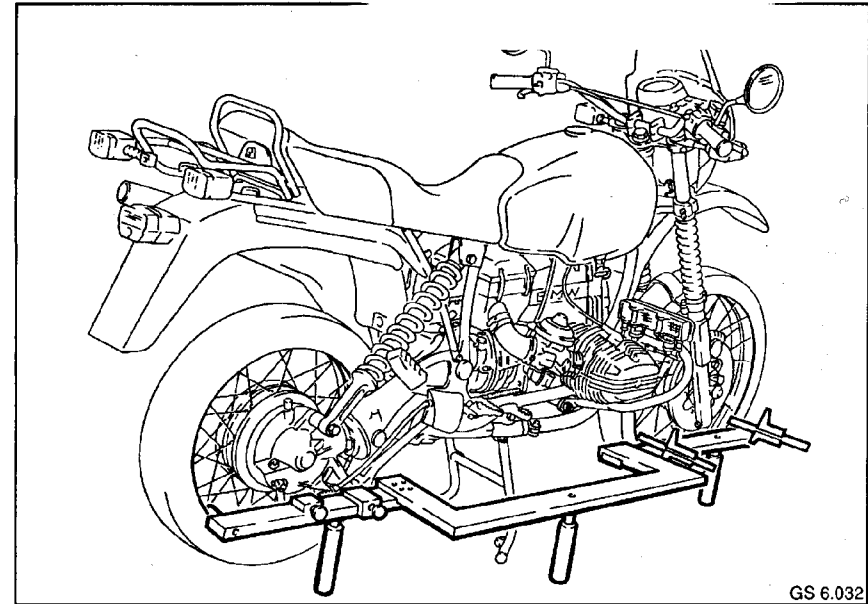

GS 6.032

6.7 MEASURING TRACK ALIGNMENT

NOTE:

It is an extremely simple matter to examine the motorcycle geometry using the BMW Track Alignment Gauge BMW No. 36 3 920. Deviations and variations to the frame or in the telescopic forks (resulting from an accident) usually show themselves most clearly when riding.

The track alignment measurement indicates whether there has been any change to the geometry of the motorcycle.

- Position motorcycle on a flat surface or on a hoist platform.
- Attach track alignment gauge to the right-hand side of the motorcycle.

CAUTION:

Adjust height with variable supports so that the measuring level is as close as possible to the centre point of the wheel and the gauge can still be freely pushed up against the motorcycle.

The measuring stops (1) must only be resting against the outer edge of the rim, not against the tyre.

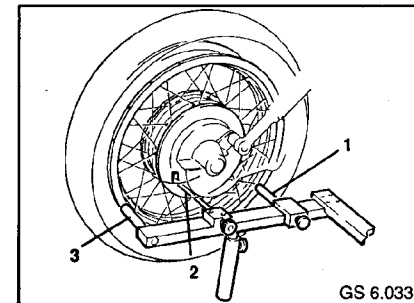

GS 6.033

- Attach hook (2) to the hub and carefully tighten gauge until it is resting free of play against the rear wheel.

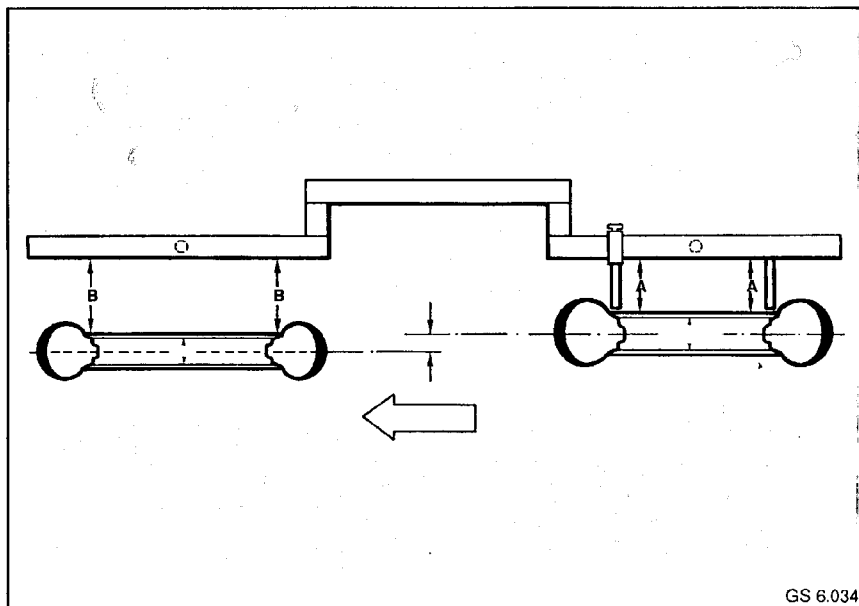

Outer width of rim at front $68 \pm 0.5 \text{ mm}$
 Outer width of rim at rear $92 \pm 0.5 \text{ mm}$

CAUTION:

The figures are only guidelines and are not a substitute for proper measurement!

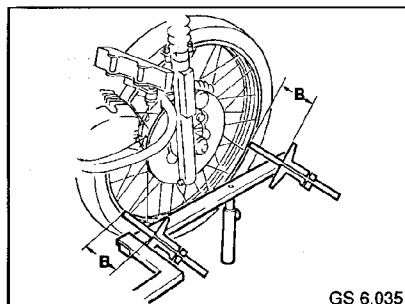

- Size A is a fixed size = 90 mm

- Determine size A and size B using depth gauge.
- Then, calculate track misalignment "S" using the following formula.

EXAMPLE:

Front and rear wheels with different rim widths.

$$\text{Formula } A + \frac{F_f}{2} - \left(B + \frac{F_r}{2} \right) = S$$

For example:

| | | | |
|----------------|---------------------|---|----------|
| Fixed size | A | = | 90,0 mm |
| Half rim width | + F _f /2 | = | 46,0 mm |
| | | = | 136,0 mm |

| | | | |
|----------------|---------------------|---|----------|
| Size measured | B | = | 100,5 mm |
| Half rim width | + F _r /2 | = | 34,0 mm |
| | | = | 134,5 mm |

Misalignment "S":
 $136,0 - 134,5 = 1,5 \text{ mm}$

Permissible misalignment max. 5 mm

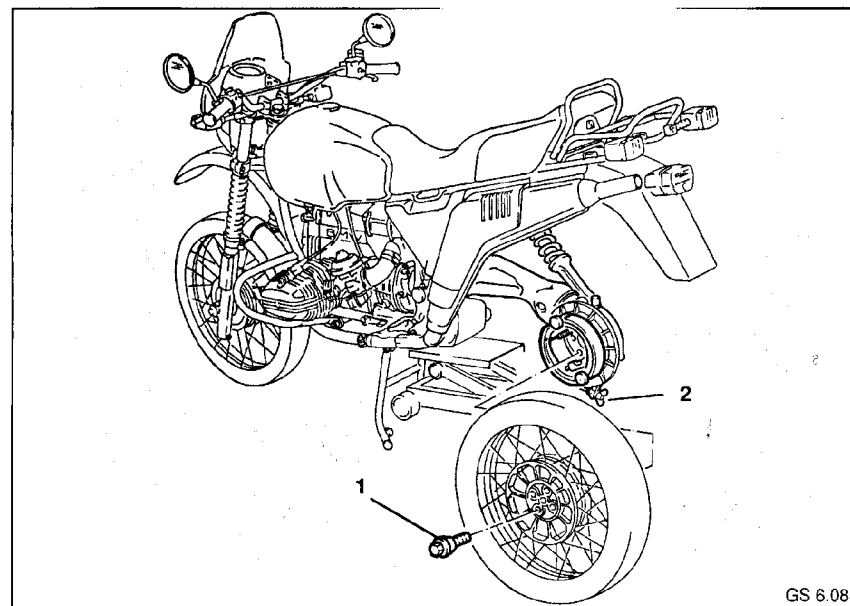

6.8 REMOVING REAR WHEEL

- Slacken 4 wheel bolts (1).
 - Take out rear wheel to the rear left.
- Position motorcycle on kickstands.
 - Place a support below front silencer to prevent motorcycle from toppling over.
 - Remove silencer (R 100R).
 - Slacken wing nut (2) on brake lever.
 - Engage 1st gear.

NOTE:

If gear bags are fitted, either take out the rear wheel down the way (hoist platform), or remove the left gear bag.

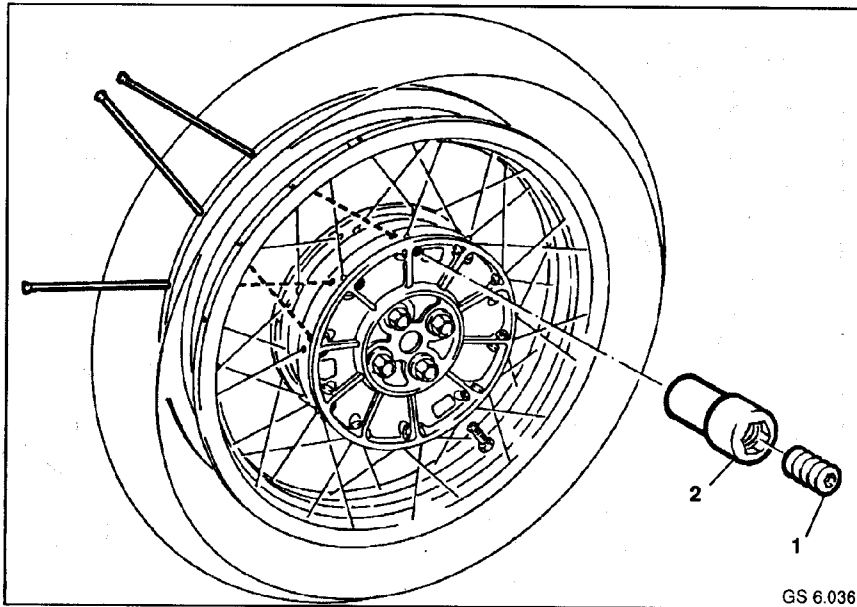

GS 6.036

6.9 REMOVING AND INSTALLING SPOKES

REMOVING SPOKES

CAUTION:

Do not replace more than one spoke.

- Slacken grub screw (1).
- Slacken spoke nipple (2) and remove spoke through rim flange as shown.

INSTALLING SPOKES

CAUTION:

If a spoke is replaced, the rim requires to be centered afterwards.

- Insert spoke as shown and screw on spoke nipple. Tighten spoke nipple with straight hexagon socket screwdriver.
- Centre rim.

Tightening torque:
Spoke nipple

max. 5 Nm

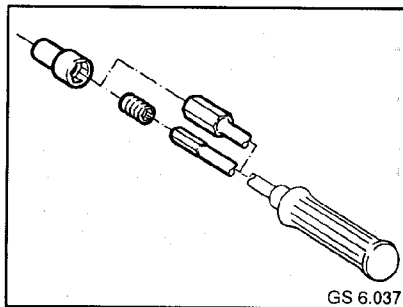

GS 6.037

CAUTION:

Tubeless tyres must not be fitted to rims without hump. Such rims were used up to Chassis No. 6 245 617.

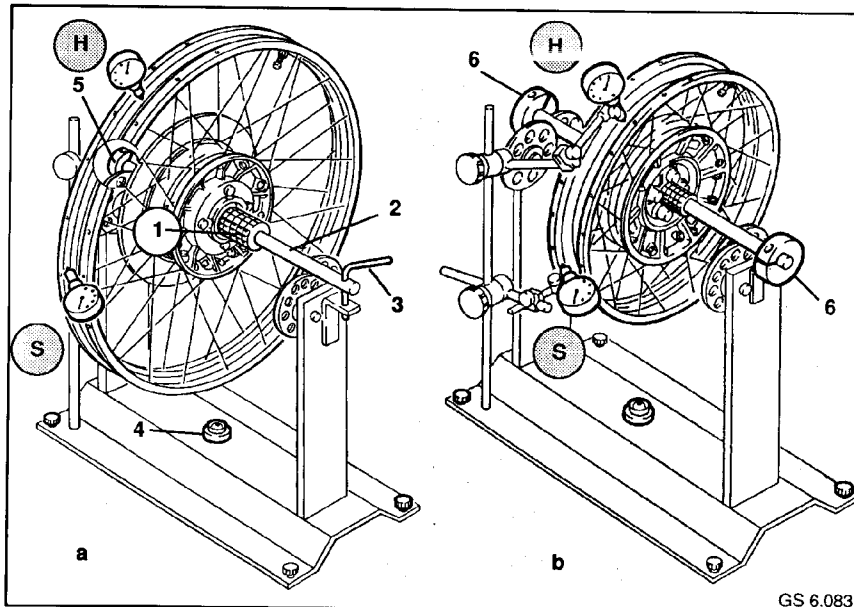

GS 6.083

6.10 EXAMINING RIMS FOR RUNOUT, CENTERING

EXAMINING RIMS FOR VERTICAL AND LATERAL RUNOUT

NOTE:

The tyre requires to be removed for measuring vertical and lateral runout.

a. Front wheel rim

- Insert balancing axle (2), BMW No. 36 3 614, through wheel bearings.
- Slightly pre-tension bearing with knurled nut (1).
- Align balancing device, BMW No. 26 3 600, in the base plate with the spirit level (4).
- Mount wheel on balancing device.
- Lock balancing axle with lever (3).
- Fit fixing plate (5), BMW No. 36 3 615, onto balancing axle opposite lever (3) until balancing axle runs free of play.
- Measure vertical "H" and lateral "S" runout with dial gauge, BMW No. 00 2 510, as shown.

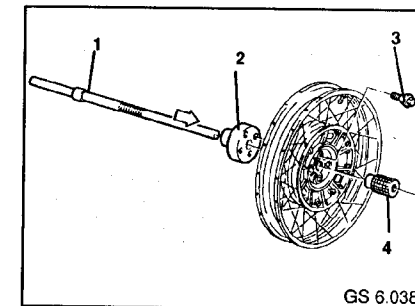

GS 6.038

b. Rear wheel rim

- Screw balancing adaptor (2), BMW No. 36 3 613, onto centering collar with 4 wheel bolts (3).
- Insert balancing axle (1) through the wheel in direction of arrow and slightly pre-tension with knurled nut (4).
- Fit fixing plate (5), BMW No. 36 3 615, onto both sides of the balancing axle until balancing axle runs free of play.
- Remaining procedure as described in a.

| | Maximum deviation: | |
|------------------------------------|---------------------|----------------------|
| | lateral runout (mm) | vertical runout (mm) |
| Specification | 1,0 | 1,0 |
| Centering required if greater than | 1,3 | 1,3 |
| Can be centered up to | 2,0 | — |

It is not possible to compensate for vertical runout by centering.

CENTERING LATERAL RUNOUT

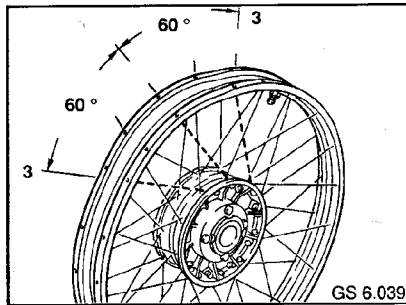

- Determine maximum deviation plus (+) and minus (-).
- The spoke nipples on the side opposite the maximum deviation require to be tightened in order to centre the wheel.
- Unscrew the grub screw from the appropriate spoke nipple before tightening.
- Tighten the nipple of the 3rd spoke in each case starting from the point of the maximum plus and minus value to the front and rear.
- Tighten 2 spokes in each case at the maximum plus and minus deviation.
- This involves tightening 4 spokes for each centering operation.
- Examine lateral runout with dial gauge.
- Repeat centering operation, if necessary.

CAUTION:

Never eliminate the entire lateral runout with one or two spokes!

NOTE:

Vertical runout requires to be re-checked after each correction to lateral runout. Lock tensioned spokes in place with grub screw.

Tightening torque:
Tightening spokes
Grub screw

max. 5 Nm
max. 1.3 Nm

6.11 STATIC WHEEL BALANCING

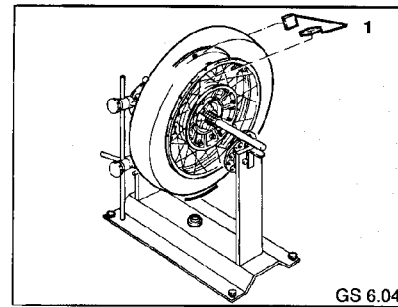

- Align balancing device.
- Mount front or rear wheel complete with tyre onto balancing device as described in

6.7
BM

- Allow wheel to come to rest.

NOTE:

The heaviest point on the wheel is now at the bottom. The balancing weight must be fitted opposite this point, at the top.

- Clean rim at this point and remove grease.

CAUTION:

The balancing weight fitted must not exceed 60 g.

- Attach self-adhesive weights (1) in pairs on left and right.
- Turn wheel and repeat balancing operation, if necessary.

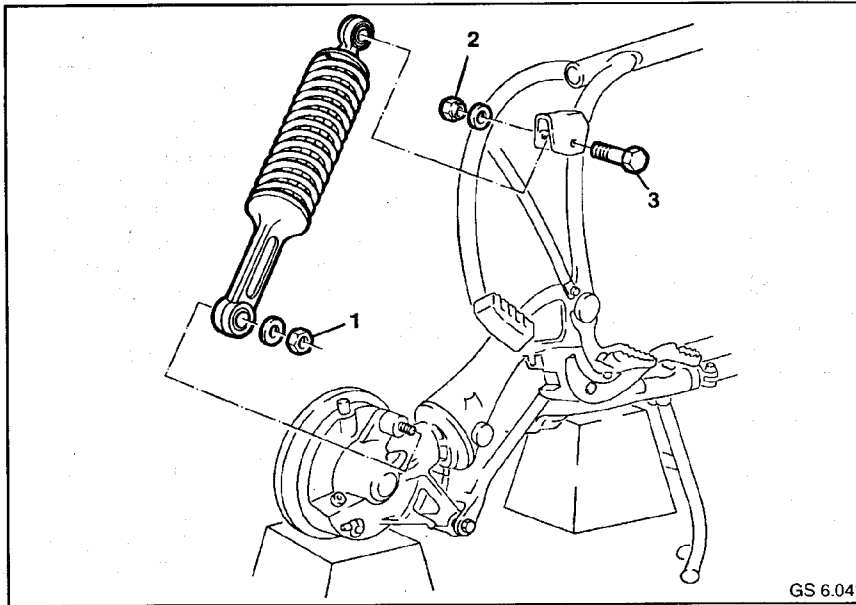

GS 6.041

6.12 REMOVING, DISASSEMBLING AND ASSEMBLING REAR SPRING STRUT

REMOVING AND INSTALLING REAR SPRING STRUT

- Take off right battery cover.
- Slacken bottom fastening nut (1) on spring strut.
- Slacken top fastening nut (2) of the spring strut.
- Use a plastic-headed hammer to slightly knock back top fit bolt.
- Take off spring strut.

DISASSEMBLING AND ASSEMBLING REAR SPRING STRUT

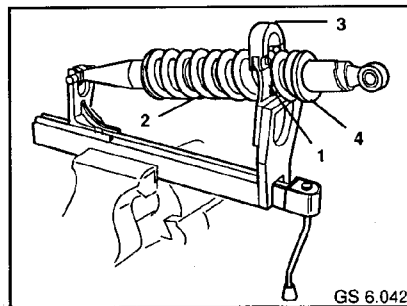

GS 6.042

- Secure the clamping fixture, BMW No. 33 5 600, into the vise.
- Insert adaptor (1), BMW-Nr 33 5 640, into the clamping fixture.
- Locate the lower spring strut pivot eye with the pin of the clamping fixture.
- Insert coil spring (2) into the adapter at a point between the 5th and 6th turns of the spring, and close safety hoop (3).
- Preload the spring strut until the split clamping washer (4) is exposed.

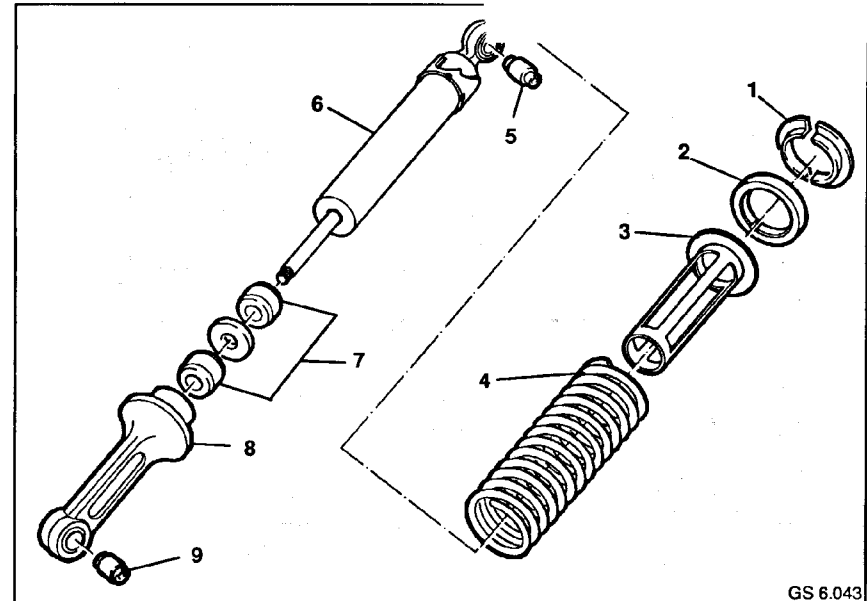

GS 6.043

- Take split conical spring washer (1) off the top of spring strut.
- Align retaining ring (2) with groove facing weld point and take off retaining ring.
- Withdraw chafe protector (3) between spiral spring (4) and shock absorber (6).
- Slowly release tension of spiral spring and remove from shock absorber.
- Take spring strut out of retaining device and examine silentblocks (5,9) in spring strut eyes for signs of damage.
- If damage present, press silentblocks out of spring strut eyes with a suitable bush.

WARNING:

Wear protective gloves when handling heated parts.

CAUTION:

Push rubber bearing (7) towards shock absorber before heating the bottom spring strut eye.

- Heat bottom spring strut eye (8) to 140°C.
- Check temperature with thermochrome pens.
- Unscrew spring strut eye from shock absorber.
- Take off rubber bearing.

The spring strut is assembled in the reverse order by analogy to disassembly.

NOTE:

Clean the first threads of the piston rod, remove grease and coat with Loctite 270 when installing.

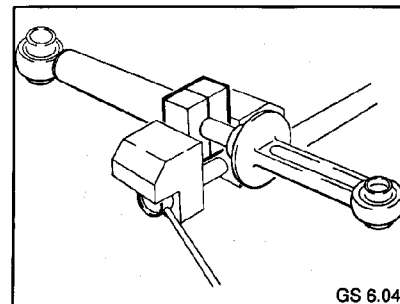

GS 6.044

- Clamp spring strut in vise at piston rod with the two clamps, BMW No. 33 5 642.

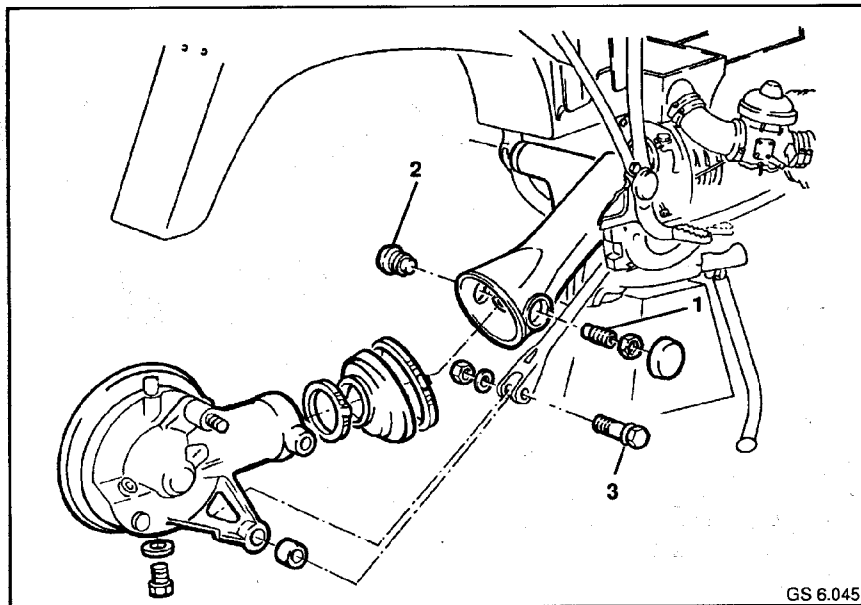

6.13 REMOVING AND INSTALLING, DISASSEMBLING AND ASSEMBLING REAR WHEEL DRIVE

REMOVING REAR WHEEL DRIVE

- Drain oil from rear wheel drive.
- Remove rear wheel.
- Remove brake shoes.

CAUTION:

Support rear wheel drive before removing spring strut to avoid damage to the bellows. Support rear wheel drive before removing spring strut to avoid damage to the bellows.

- Remove spring strut.
- Detach cable for brake control.
- Take off strut (6) by slackening the fastening screw (5).
- Remove rubber bearing (10) from the mounting bracket of the strut in the rear wheel drive.
- Slacken tensioning strap (7) of the bellows (8) at the swing arm housing.
- Take protective cap (4) off the right bearing journal (2) and slacken locking nut (3).
- Heat left bearing journal (1) to 130°C (thermochrome pen) and then release.
- Release right bearing journal (2).
- Pull rear wheel drive (11) off drive shaft.
- Slacken tensioning strap (136/9) at the wheel drive housing.
- Take off bellows (136/8) from the wheel drive housing.

GS 6.045

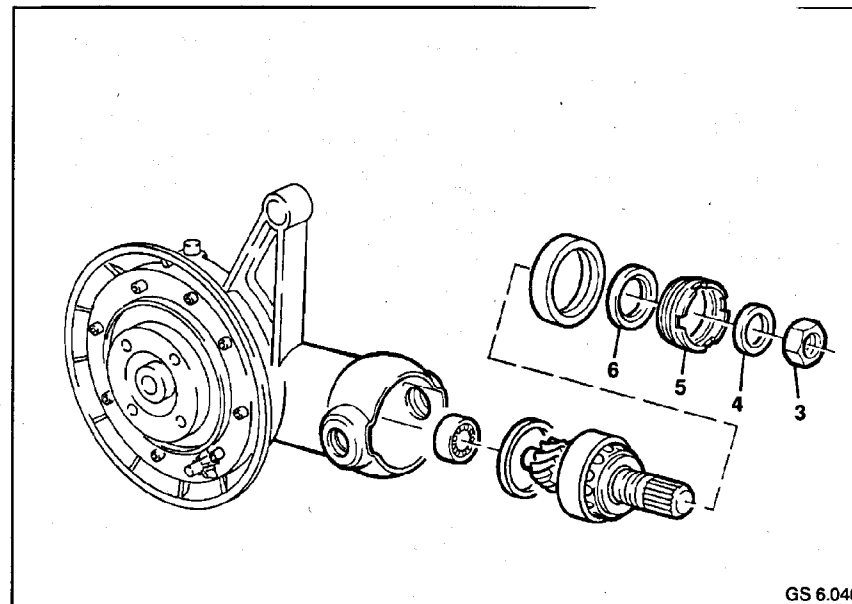

REMOVING, STRIPPING AND ASSEMBLING THE INPUT BEVEL PINION

Removing the input bevel pinion

- Clamp the retaining fixture, BMW-No. 33 1 500, into the vise.

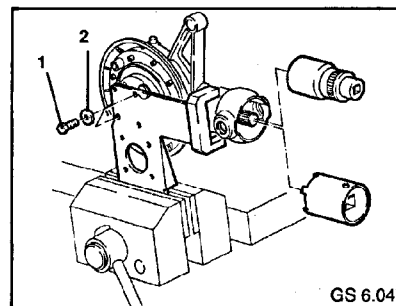

- Secure the crown wheel to the fixture with 2 retaining bolts (1).

GS 6.047

- Tighten the retaining bolts to the specified torque.

Tightening torque:
Fastening screws

100 Nm

- Heat nut (3) on the input bevel pinion to approx. 100 °C and unscrew it.

NOTE:

Never use a hammer to loosen the nut, or the splines may be damaged.

- Remove thrust ring (4) from the input bevel pinion shaft.
- Heat the neck of the housing to approx. 120 °C and unscrew threaded ring (5) with a pin wrench, BMW No. 33 1 700.
- Take off the threaded ring together with shaft sealing ring (6).

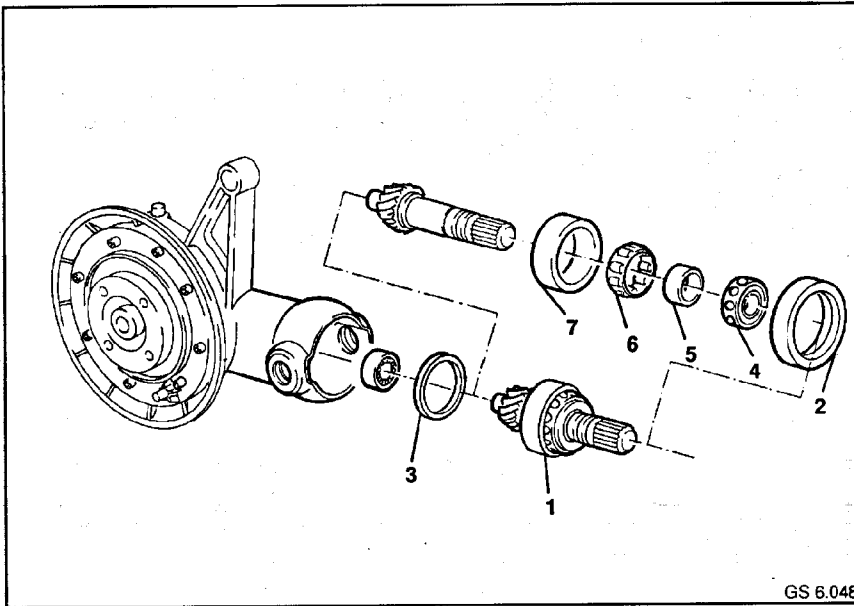

GS 6.048

Stripping down the input bevel pinion

- Heat the input bevel pinion bearing seat to approx. 120 ... 130 °C.
- Pull out the complete input bevel pinion (1).
- Remove the outer race (2) of the combined radial and thrust bearing.
- Remove the spacing washer (3) from the neck of the housing.
- Clamp the input bevel pinion into the vise using soft jaws (with spline tracks at top).

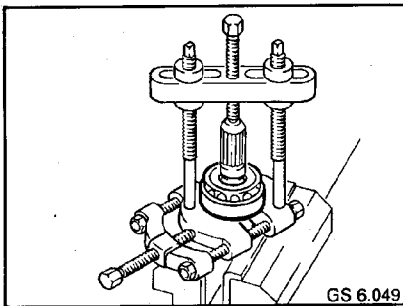

GS 6.049

- Attach a Kukko puller, BMW No. 00 7500, under the roller bearing and pull both

bearings off the input bevel pinion together.

- Remove the combined radial and thrust bearing (4), the inner roller bearing race (5), the roller bearing cage (6) and the outer roller bearing race (7) from the input bevel pinion.

Removing the needle roller bearing

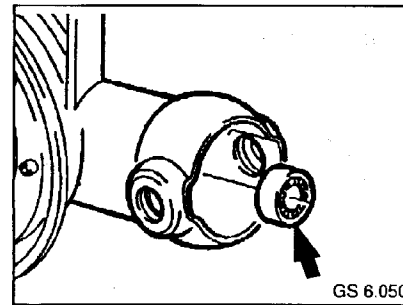

GS 6.050

- Break open the needle roller bearing cage.
- Heat housing of rear wheel drive to approx. 120°C.

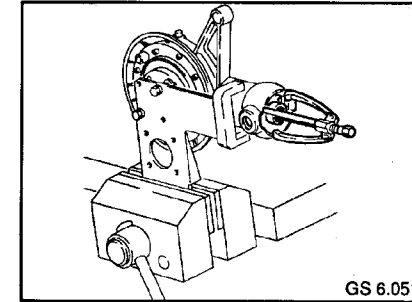

GS 6.051

- Using Kukko internal puller, BMW No. 00 8573, and counter-holder, BMW No. 00 8570, pull the needle roller bearing (arrow) out of the housing.

Installing the needle roller bearing

- Heat the seat of the needle roller bearing for the input bevel pinion to approx. 120 °C.
- Place the needle roller bearing in with a suitable drift, or use the input bevel pinion.

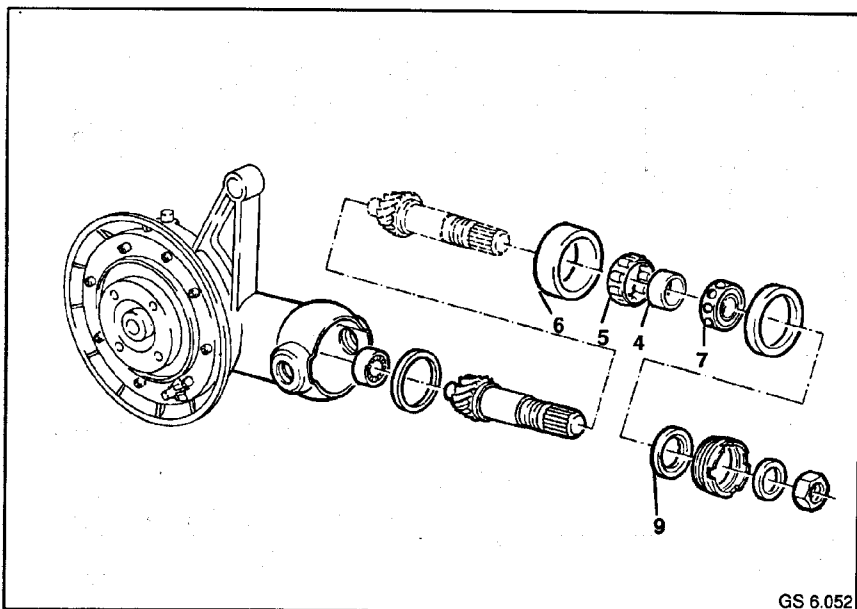

GS 6.052

Assembling the input bevel pinion

- Heat the inner race of roller bearing (4) to approx. 100 °C
- Place the inner race on input bevel pinion (3) and slide it fully on.
- Place roller bearing outer race (6) with roller bearing cage (5) over the inner bearing race.
- Heat ball bearing (7) to approx. 100 °C and place on input bevel pinion.
- Heat thrust ring to approx. 100 °C and place on input bevel pinion.
- Allow the input bevel pinion to cool down.

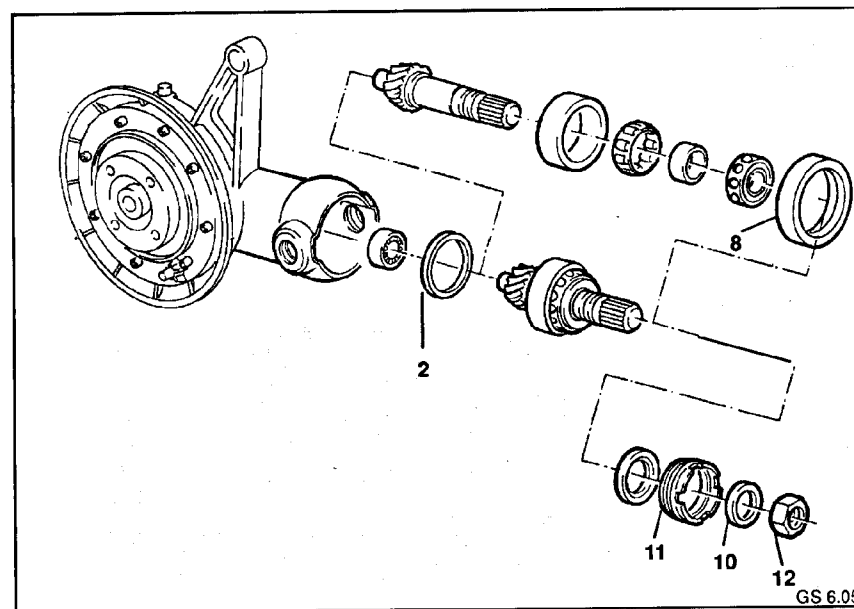

GS 6.053

INSTALLING THE INPUT BEVEL PINION

- Insert a spacing washer (2) of the previously determined thickness in the neck of the housing.
- Heat the neck of the housing to approx. 120 °C.
- Insert the complete input bevel pinion with combined radial and thrust bearing.
- Insert the outer ball bearing race (8).

NOTE:

The housing must still be at a temperature of 80 – 100 °C. Make sure that the shaft sealing ring lip makes proper contact with the thrust ring.

- Screw in the threaded ring with pin wrench, BMW No. 33 1 700, and tighten to the specified torque.

Tightening torque:

Threaded ring 105/118(mod.91) Nm

- Coat hex nut (12) for the input bevel pinion with Loctite 273 (use approx. 0.1 g). Do not coat the threads.

CAUTION:

The nut must not damage the shaft sealing ring.

- Screw on the nut and tighten it to the specified torque.

Tightening torque:

Nut for input bevel pinion 200 Nm

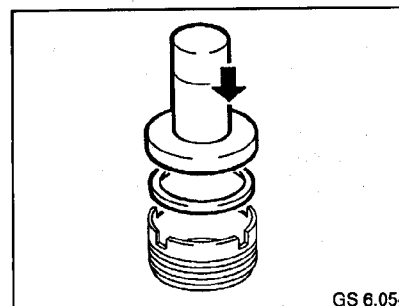

GS 6.054

- Drive a new sealing ring (10) into threaded ring (11) with drift, BMW No. 33 1 760, and handle, BMW No. 00 5 500.
- Degrease the threads and coat the threaded ring with Hylomar SQ 32 M.

- Attach a three-arm puller, BMW No. 33 1 830, to the deep-groove ball bearing and pull it off.

NOTE:

Sharp taps with a hammer on the spindle head of the puller make it easier to dislodge the bearing.

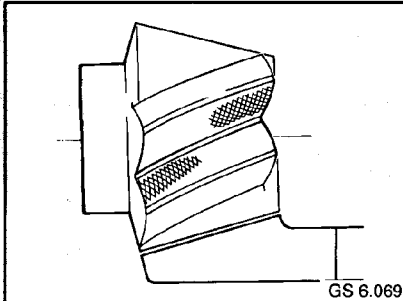

GS 6.069

- Pull the taper roller bearing off the crown wheel with Kukko puller, BMW No. 00 7 500.

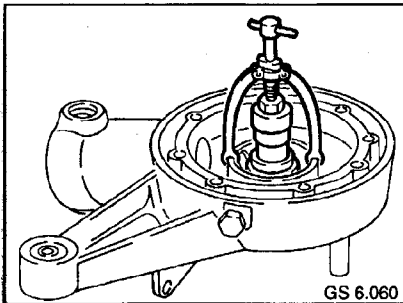

GS 6.060

- Pull out taper roller bearing race with Kukko internal puller, BMW No. 00 8 560.

Available shim thicknesses:

Taper roller bearing 1.50 ... 2.10 mm

INSTALLING CROWN WHEEL

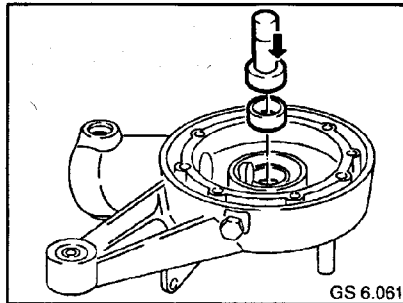

GS 6.061

- Heat housing to approx. 80 °C.
- Press the bearing race into the bearing seat with drift, BMW No. 33 1 880, and handle, BMW No. 00 5 500.

NOTE:

Tap lightly to ensure correct seating

Shimming the crown wheel

- The crown wheel must be reshimmed if any new parts are installed, for example the taper roller bearing.

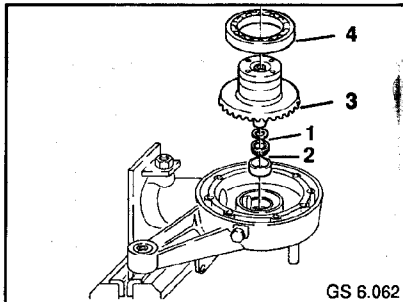

GS 6.062

- Place the existing spacing ring (1) on the crown wheel.
- Heat taper roller bearing (2) to 80 °C and place it on the crown wheel.
- Place crown wheel (3) in the housing.
- Heat deep-groove ball bearing (4) to approx. 80 °C and place it on crown wheel (3).

Adjusting tooth backlash

NOTE:

Tooth backlash must be checked and correct if necessary whenever the taper roller bearing is replaced.

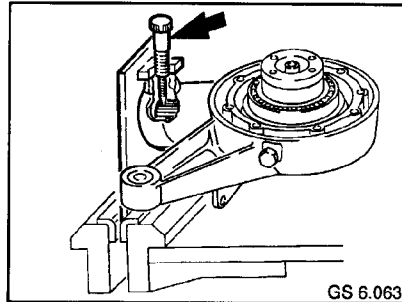

GS 6.063

- Clamp the rear wheel drive assembly into the retaining fixture, BMW No. 33 1 520, with bearing pin and locknut.
- Prevent the input bevel pinion from moving with the knurled locking screw (arrow).

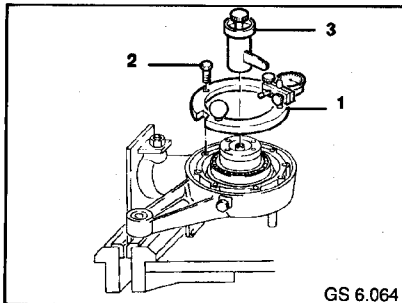

GS 6.064

- Attach measuring device BMW No. 33 2 600 with a dial gauge to the crown wheel.
- Attach measuring ring (1) to the housing with knurled screw (2).
- Attach measuring arm, BMW No. 33 2 604, centrally to the crown wheel.

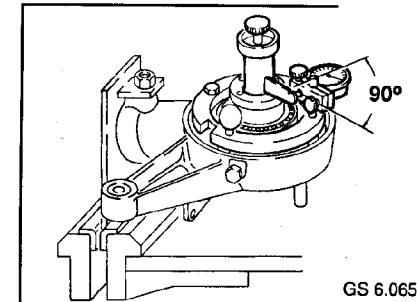

GS 6.065

- Align the dial gauge and the measuring stop until the dial gauge feeler is at a right angle to the measuring stop.
- Press the crown wheel into the housing with the ball of the thumb.
- Measure tooth backlash at the measuring stop while turning the crown wheel to and fro slightly.

NOTE:

Measure tooth backlash at three points 120 degrees apart. To do this, loosen the measuring stop, bearing pin and knurled screw, turn the crown wheel by the necessary amount, then retighten all components.

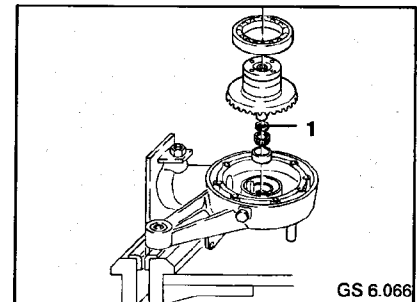

GS 6.066

- Compensate for excessive tooth flank backlash by inserting thinner shims, or for too little backlash by inserting thicker shims. Compensate for play by inserting thicker spacing rings (1) under the taper roller bearing for the crown wheel.

Tooth backlash

(adjust without oil): 0.07 ... 0.16 mm
Available shims (5/100 mm intervals): 1.95 ... 2.80 mm

CHECKING TOOTH CONTACT PATTERN

- If the combined radial and thrust bearing at the input bevel pinion is renewed, the tooth contact pattern must be checked again afterwards.

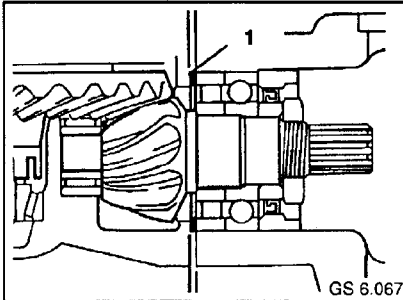

NOTE:

The tooth contact pattern is adjusted by means of the shim washer (1) at the input bevel pinion.

- Degrease the crown wheel teeth and coat with Paris blue or a small amount of white oilbound paint.
- Degrease the teeth on the input bevel pinion as well.
- Install the crown wheel and press it into the housing with the ball of the thumb, at the same time turning it to and fro several times.

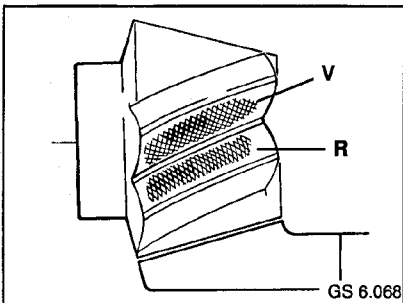

- The above contact pattern will be obtained off-load if the pinion is installed with a shim of the correct thickness.

The contact mark is in the centre of the leading tooth flank V.
The contact mark is closer to the larger diameter of the pinion on the trailing flank R..

CAUTION:

The teeth must NEVER make contact at the smaller-diameter end of the pinion.

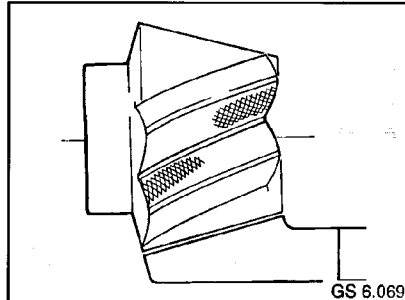

- If the contact pattern is as shown above, fit a thinner shim washer.

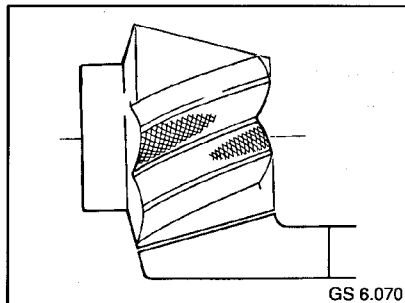

- If the contact pattern is as shown above, fit a thicker shim washer.

INSTALLING THE HOUSING COVER

Shimming the housing cover

- The housing cover must be installed with a shim of the correct thickness, in order to obtain the required taper roller bearing preload.

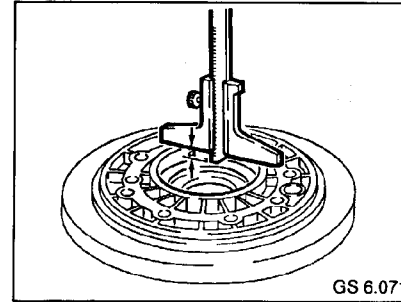

- Using a depth gauge, BMW No. 00 2 500, determine distance a from the cover joint face to the base of the ball bearing seat.

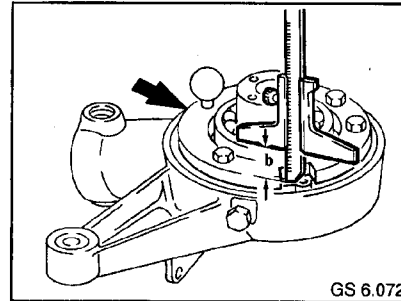

- Attach measuring ring (arrow), BMW No. 33 2 601, and lock into position.
- Measure from the outer ball bearing race through the cutout in the measuring ring to the housing joint face, and determine distance b.
- Deduct distance b from distance a to obtain the required spacing washer thickness without preload.

Preload:
0.05 ... 0.1 mm = 600 ... 1600 N

Installing the housing cover

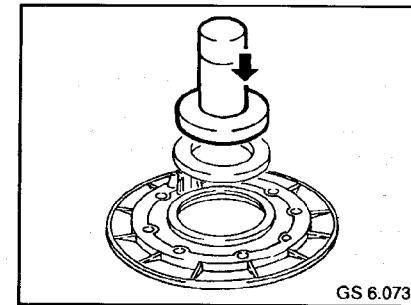

- Using drift, BMW No. 33 1 860, and handle, BMW No. 00 5 500, force a new sealing ring into the cover
- Insert the cord ring seal.
- Coat the edge of the cover seal with Loctite 574 seaiant.
- Heat the housing cover to approx. 80 °C.
- Place the cover on the housing.
- Tighten the retaining bolts in a crosswise pattern to the specified torque.

Tightening torque:
Retaining bolts

21 Nm

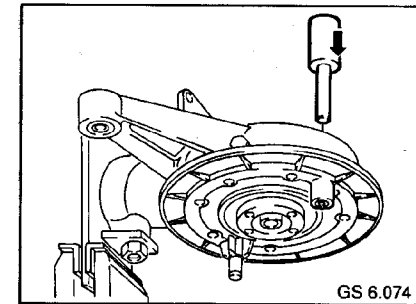

- Heat the housing and cover in the bushing area to 80 °C.
- Using a drift, BMW No. 33 2 640, drive the brake backplate bushing back into the housing cover.
- Allow bush for brake key to cool to 35°C before installing.
- Heat housing in area of bush to 80°C.

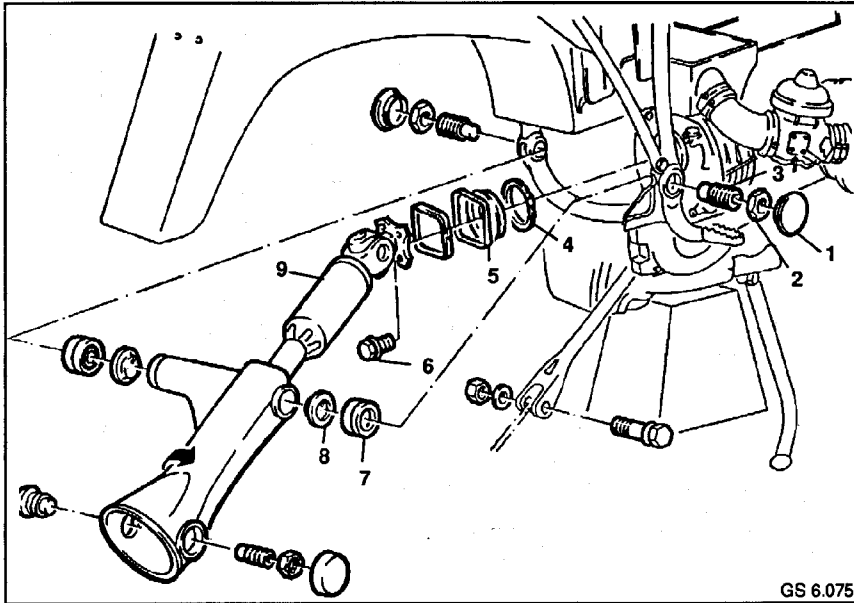

6.14 REMOVING AND INSTALLING, DISASSEMBLING AND ASSEMBLING REAR WHEEL SWING ARM

- Remove rear wheel drive.
- Slacken tensioning strap (4) on bellows (5) at transmission end.

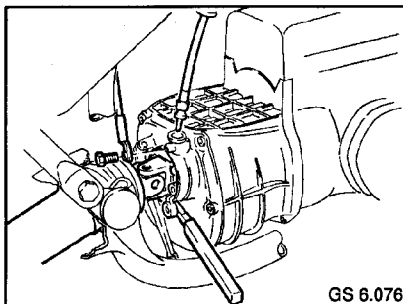

- Engage first gear to prevent transmission rotating.
- Unscrew drive shaft (9) from transmission output flange by slackening the 4 fastening screws (6) with special range, BMW No. 33 1 620.

- Remove left/right protective cap (1) on bearing journals.
- Slacken locking nut (2) of the bearing journals (3).
- Slacken left/right bearing journals.
- Move swing arm to the side and lift it out of the frame.
- Withdraw propeller shaft from swing arm.

REMOVING AND INSTALLING TAPER ROLLER BEARINGS

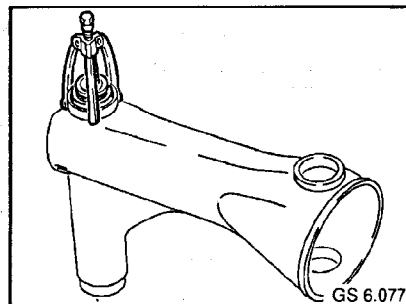

NOTE:

Mark taper roller bearings before removing them to avoid any mix-up.

- Withdraw swing arm bearings (7) with Kukko internal extractor, No. 21/2, and counter-support, 22-1.
- Remove left/right inner cover discs (8) from bearing seat.
- (Left cover disc not fitted with effect from model 1989).

New taper roller bearings are installed in the reverse order by analogy to removal.

CAUTION:

The bearings are greased for life. A vent is necessary due to the change in volume of the bellows when the swing arm compresses. This vent is provided at the front swing arm bearings by means of holes in the inner cover discs and the swing arm bearing pins. No additional grease may be applied to this point to ensure that the holes always remain clear.

INSTALLING SWING ARM AND ADJUSTING BEARING PLAY

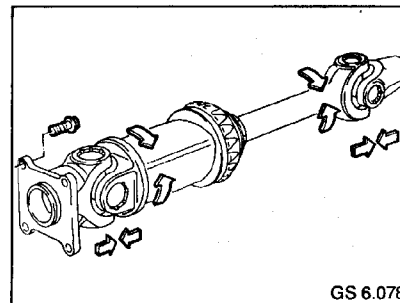

NOTE:

Examine propeller shaft for signs of wear before installing.
 - Determine radial play by alternately turning flange and propeller shaft.
 - Determine axial play by shifting in axial direction.
 If play is determined, replace propeller shaft.

- Introduce propeller shaft into swing arm.

- Fit bellows onto swing arm and secure with tensioning strap.
- Move swing arm to the side and insert into the frame.
- Screw bearing journals.

CAUTION:

When adjusting bearing play, ensure that the gap "a" on left and right between frame and swing arm is identical (max. difference = 0.5 mm).

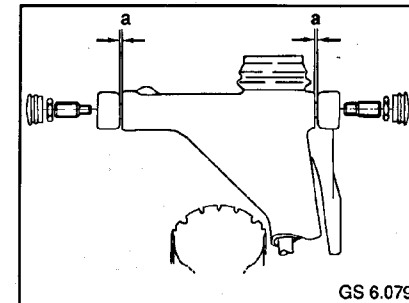

- Adjust gap "a".
- Tighten one bearing journal to specified tightening torque to pre-load bearings.
- Slacken bearing journals and tighten again to final tightening torque.
- Tighten locking nuts to specified tightening torque without twisting the bearing journals.
- Press on caps.
- Screw in fastening screws on transmission output flange using special range, BMW No. 33 1 620, and tighten to specified tightening torque.
- Tighten bellows at transmission end with tensioning strap.
- Check that swing arm moves freely by moving up and down.

Tightening torque:

| | |
|---------------------------------|--------|
| Pre-load of bearing journals | 20 Nm |
| Re-tightening bearing journals | 10 Nm |
| Locking nut | 107 Nm |
| Propeller shaft to transmission | 40 Nm |

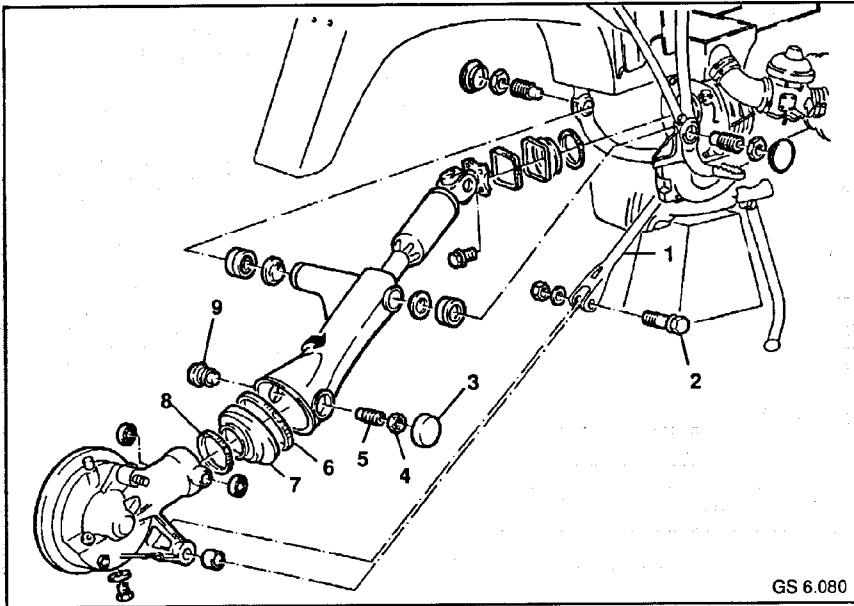

GS 6.080

6.15 INSTALLING REAR WHEEL DRIVE

- Fit bellows (174/7) onto swing arm and tighten tensioning strap (174/6) on swing arm housing.
- Grease teeth of drive pinion with approx. 4g Staburags NBU 30PTM high performance lubricating paste.

CAUTION:

Support rear wheel drive after fitting it onto propeller shaft.

- Fit rear wheel drive onto propeller shaft.

NOTE:

Nut of fastening screw must be facing wheel.

- Screw strut (1) onto rear wheel drive with fastening screw (2).
- Tighten fastening screw to specified tightening torque.

NOTE:

Apply a light coating of Never Seeze to right bearing journal before screwing in. The left bearing journal (9) is micro-encapsulated.

When re-using, remove locking agent in the threads (bearing journal and transmission housing).

- Coat thread of left bearing journal (9) with Loctite 242.
- Screw in left bearing journal and tighten to specified tightening torque.
- Screw in right bearing journal and pre-load to specified tightening torque.
- Slacken bearing journal once again and tighten to specified tightening torque.
- Screw locking nut (4) onto right bearing journal (5) and tighten to specified tightening torque.
- Fit on right protective cap (3).
- Tighten tensioning strap (8) on rear wheel drive housing.
- Fill rear wheel drive with specified quantity of oil.

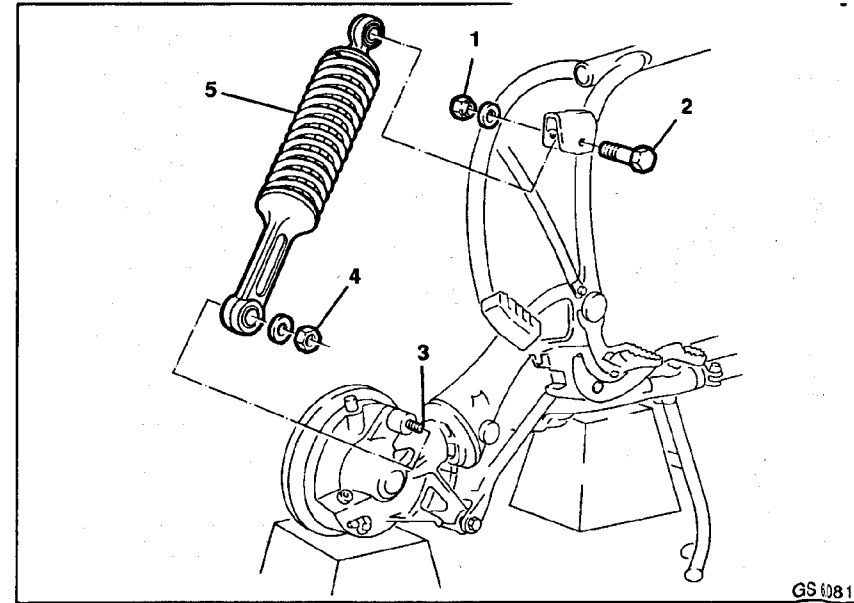

GS 6.081

Tightening torque:

| | |
|--------------------------------------|--------------|
| Pre-load of right bearing journal | 5 Nm |
| Right bearing journal | 7.3 ± 0.5 Nm |
| Locking nut | 105 ± 7 Nm |
| Left bearing journal (fixed bearing) | 105 ± 7 Nm |
| Strut on rear wheel drive | 33 ± 2 Nm |
| Strut on frame | 42 ± 4 Nm |
| Oil filler plug | 20 ± 2 Nm |

Oil grades and capacities:

| | |
|-----------------------|-------------|
| Oil grade above 5°C | SAE 90 |
| Oil grade below 5°C | SAE 80 |
| Oil grade all-seasons | SAE 80 W 90 |

Capacity 0.26 l

6.16 INSTALLING SPRING STRUT

NOTE:

When tightening the screw connection, ensure that the rubber bearing is not twisted.

- Fit spring strut (5) onto threaded pin on rear axle drive housing.
- Insert top fit bolt (2) and tighten spring strut to specified tightening torque with fastening nut (1).
- Tighten bottom fastening nut (4) to specified tightening torque.

Tightening torque:

| | |
|----------------------------------|-----------|
| Spring strut on rear wheel drive | 29 ± 3 Nm |
| Spring strut on frame | 29 ± 3 Nm |

6.17 INSTALLING REAR WHEEL

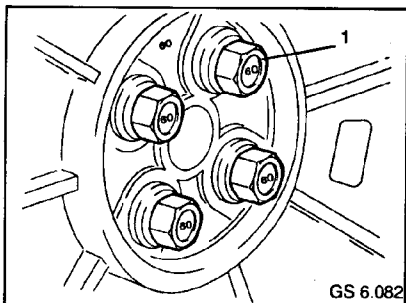

CAUTION:

Use only wheel bolts (1) with length code 60. Rear wheel and wheel bolt heads are marked accordingly.

- Attach rear wheel to rear wheel drive.
- Screw in wheel bolts and tighten to specified tightening torque.

Tightening torque:

Rear wheel bolts 105 Nm

CAUTION:

The foot brake lever play must be re-set after working on the rear wheel drive.

7. FRAME ATTACHMENTS

| Contents | Page |
|--|-------------|
| 7.1 REMOVING AND INSTALLING REAR MUDGUARD | 7.5 |
| 7.2 REMOVING, DISASSEMBLING AND ASSEMBLING, INSTALLING REAR FRAME SECTION | 7.5 |
| 7.3 REMOVING AND INSTALLING SIDE STAND | 7.7 |
| 7.4 REMOVING AND INSTALLING CYLINDER GUARD | 7.7 |
| 7.5 REMOVING AND INSTALLING KICKSTAND | 7.8 |
| 7.6 REMOVING, DISASSEMBLING AND ASSEMBLING, INSTALLING FOOT RESTS | 7.9 |
| 7.7 REMOVING AND INSTALLING AIR FILTER BOX | 7.11 |
| REMOVING AND INSTALLING AIR FILTER BOX (WITH PAS) – ADDITIONALLY: | 7.11 |
| 7.8 REMOVING AND INSTALLING BATTERY MOUNT | 7.12 |
| 7.9 REMOVING AND INSTALLING STEERING LOCK | 7.12 |

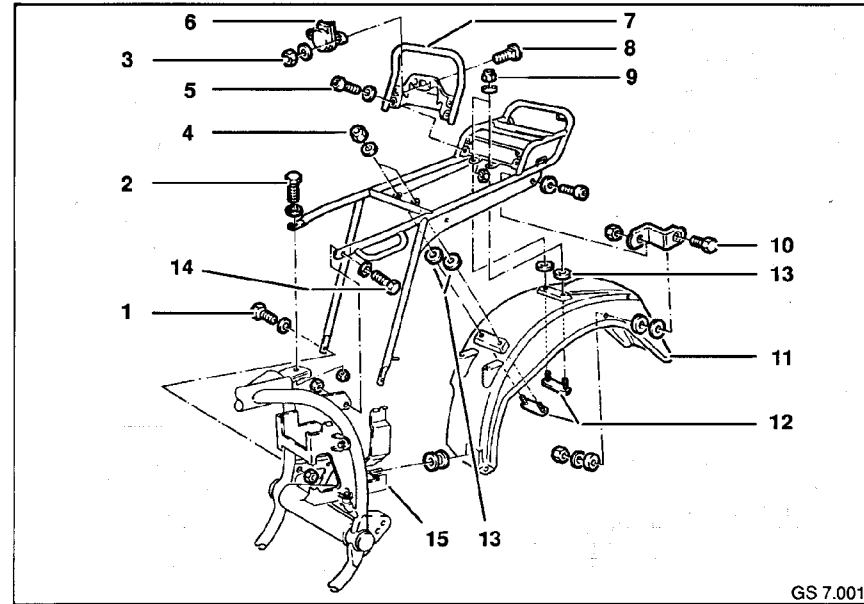

GS 7.001

7.1 REMOVING AND INSTALLING REAR MUDGUARD

REMOVING REAR MUDGUARD

- Remove seat.
- Remove rear light.
- Slacken fastening screw/nut (10) on mounting bracket for rear mudguard.
- Slacken 4 fastening nuts (4,9) on rear mudguard and take off the two base plates (12).
- Detach rear mudguard (11) from the mounting bracket(15) on the battery compartment and take off from motor-cycle.

The rear mudguard is **installed** in the reverse order by analogy to removal.

NOTE:

Pay attention to the rubber washers (13) between rear mudguard and frame when installing parts.

7.2 REMOVING, DISASSEMBLING AND ASSEMBLING, INSTALLING REAR FRAME SECTION

REMOVING REAR FRAME SECTION

- Remove seat.
- Remove left/right battery cover.
- Remove rear silencer. (GS only).
- Remove rear mudguard.
- Remove rear cable harness section.
- Detach rear frame section from frame connection after slackening the fastening screws/nuts (1,2,14) and take off rear frame section.

Tightening torque:
Rear mudguard to frame

3 Nm

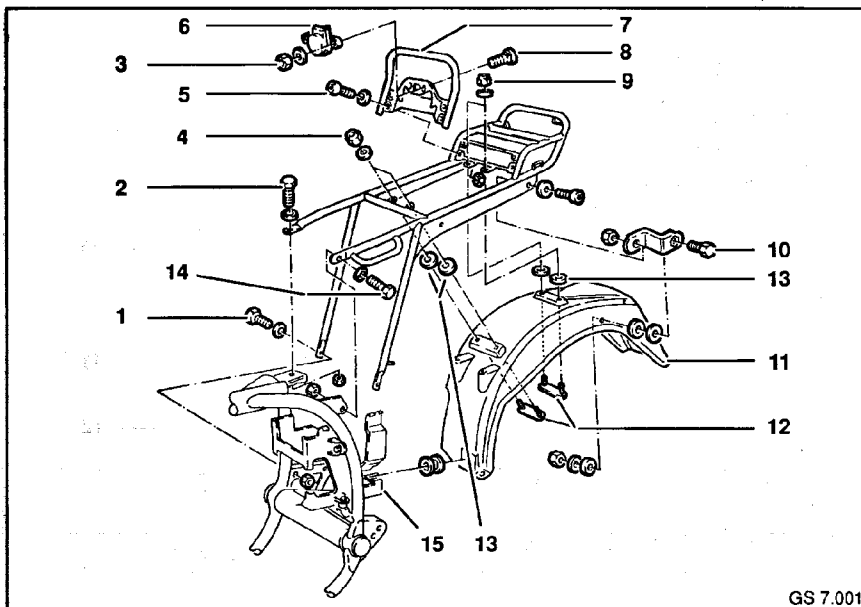

GS 7.001

DISASSEMBLING REAR FRAME SECTION

- Slacken two fastening nuts (3) on seat lock.
- Remove seat lock (6) together with smooth-head screws(8) from grab handle.
- Detach grab handle (7) after slackening the 4 fastening screws (5) and nuts.
- Take grab handle of rear frame section.

The attachments of the rear frame are **assembled and installed** in the reverse order by analogy to removal and disassembly.

Tightening torque:
Rear frame section to frame
Mod.91

16 Nm
24 Nm

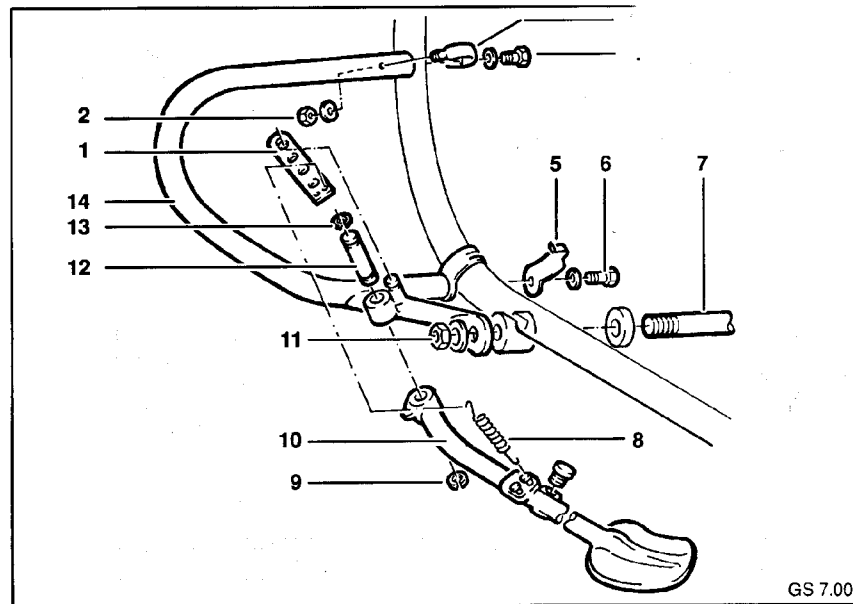

GS 7.002

7.3 REMOVING AND INSTALLING SIDE STAND, GS

REMOVING SIDE STAND

- Detach both springs (8) and remove.
- Take spring bracket (1) off the left engine guard.
- Remove side stand (10) after releasing the locking rings(9,13) at top and bottom of pin (12).
- Press out pin.

The side stand is **installed** in the reverse order by analogy to removal.

NOTE:

Grease bearing pin with approved lubricant before installing (e.g. Shell Retinax A).

7.4 REMOVING AND INSTALLING CYLINDER GUARD

REMOVING CYLINDER GUARD

- Slacken fastening screw (4) and nut (2) at the top mounting point of the engine guard.
- Take off retaining clamp (3).
- Slacken the fastening screw (6) and take off clip (5) at the bottom mounting point.
- Slacken fastening nut (11) on the front engine pin (7).
- Take off cylinder guard (14).

The cylinder guard is **installed** in the reverse order by analogy to removal.

Tightening torque:
Hexagon nut (engine pin)
Mod.91

54 Nm
87 Nm

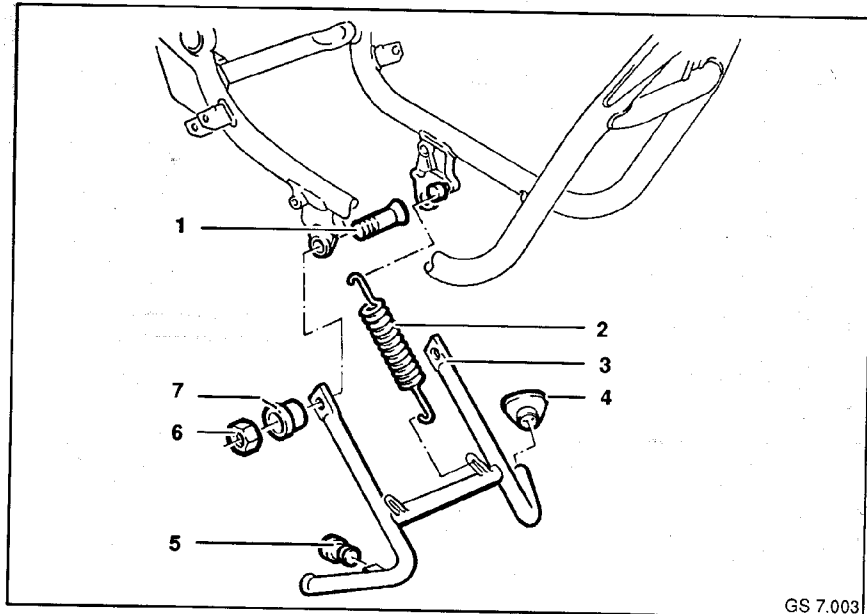

GS 7.003

7.5 REMOVING AND INSTALLING KICKSTAND

REMOVING KICKSTAND

- Detach both springs (2).
- Slacken fastening screws (6) and nuts (1) on both sides of the frame.
- Press out fastening screws and bushes (7) and take off stand (3) down the way.
- Renew stopper (5), plug (4) and bushes if damaged.

The kickstand is **installed** in the reverse order by analogy to removal.

NOTE:

Grease bearing bush with approx. 4g Shell Retinax A.

Tightening torque:
Hexagon nut (kickstand)
Hexagon nut (engine pin)
Mod.91

47 Nm
54 Nm
87 Nm

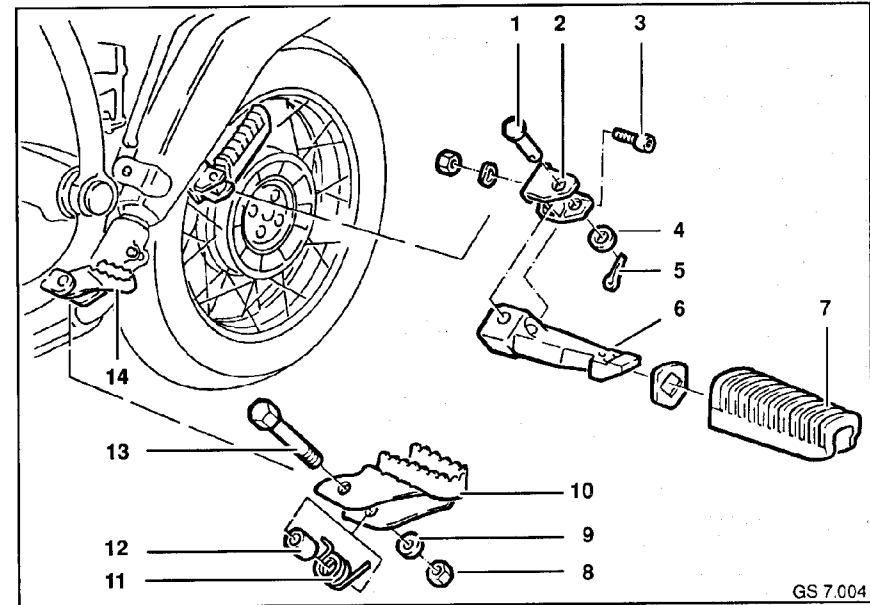

GS 7.004

7.6 REMOVING, DISASSEMBLING AND ASSEMBLING, INSTALLING FOOT RESTS

REMOVING AND DISASSEMBLING FOOT RESTS

- Slacken fastening screw (13) and nut (8) on front footrest.
- Remove foot rest from mounting bracket (14).
- Press bush (12) and spring (13) out of rest.

CAUTION:

Foot rests are slightly spring-tensioned.

- Remove split pin (5) from bolt (1) on rear foot rest.

- Press bolt out of mounting bracket (2).
- Pull foot rest (6) out of bracket.
- Remove foot rest mounting (2) from rear silencer after slackening the fastening screw (3).

NOTE:

Replace foot rest pad (7) and bolt if worn.

The foot rests are **assembled** in the reverse order by analogy to disassembly.

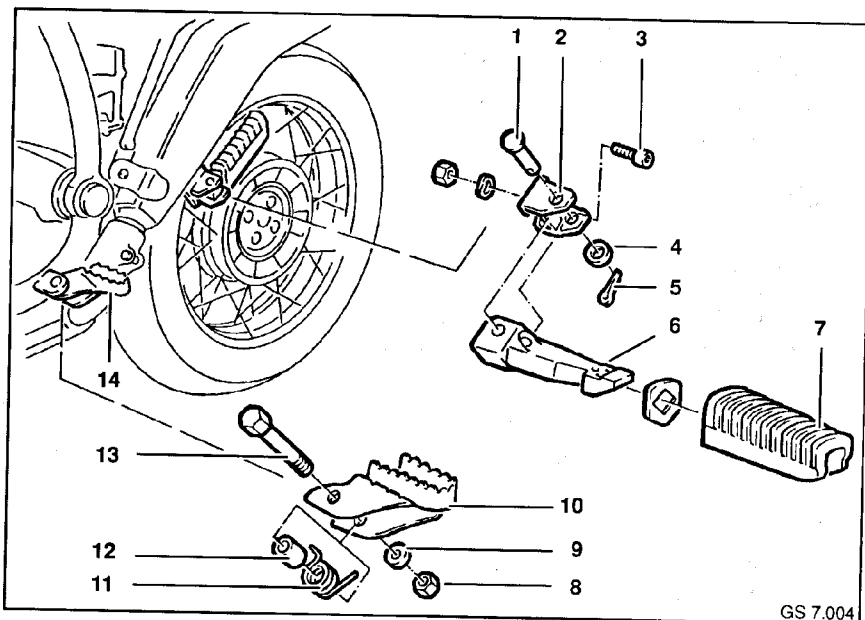

GS 7.004

INSTALLING FOOT RESTS

- Insert bush (12) of front foot rest into spring (11).
- Introduce front foot rest (10) into mounting bracket (14).
- Insert fastening screw (13) into mounting bracket and foot rest, at the same time pushing on bush and spring.

NOTE:

Tighten nut sufficiently that foot rest still rotates freely.

- Tighten nut (8) to specified tightening torque.

- Install mounting bracket (2) of rear foot rest.
- Insert foot rest (6) into bracket.
- Push in bolt (1) and fit new split pin (5) and washer (4).

NOTE:

Grease bolt and bushes with e.g. Shell Retinax A.

Tightening torque:
Foot rest mounting (at rear)

47 Nm

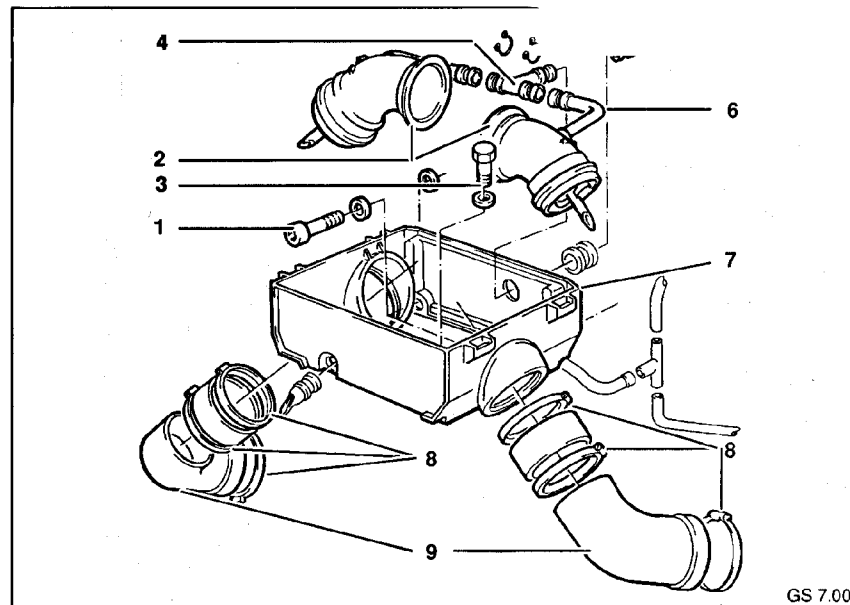

GS 7.005

7.7 REMOVING AND INSTALLING AIR FILTER BOX

REMOVING AIR FILTER BOX

- Remove seat.
- Remove fuel tank.
- Remove battery.
- Remove air filter housing top section and air filter element.
- Detach intake lines (9) after slackening the hose clips (8).
- Remove intake lines on both sides.
- Remove crankshaft breather hose (5) from Tee piece (4) in air filter box.
- Remove both intake connection fittings (2) together with hose sections (6) from the housing.
- Slacken fastening screw (1) in air filter box.
- Slacken hexagon screw (3) in air filter box.
- Remove air filter box.

The air filter box is installed in the reverse order by analogy to removal.

REMOVING AND INSTALLING AIR FILTER BOX (WITH PAS) – additionally:

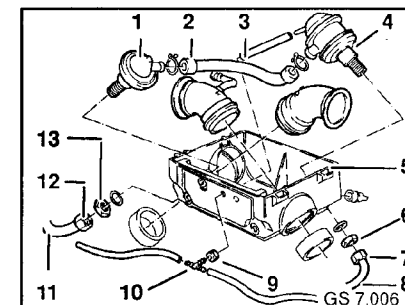

GS 7.006

- Detach 2 air lines (7,11) from the air filter box (5) after slackening the union nuts (7,12).
- Slacken 2 fastening nuts (6,13) of the valves (1,4) on the air filter box.
- Detach hose connection (3) from the Tee piece (10).
- Take off valves with connecting hose (2).
- Withdraw Tee piece from grommet (9) in the air filter box.

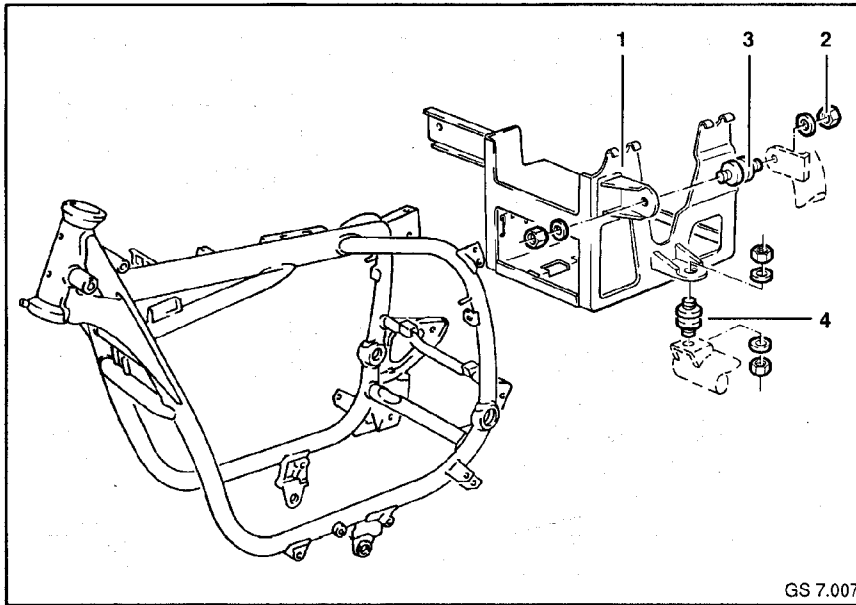

GS 7.007

7.8 REMOVING AND INSTALLING BATTERY MOUNT

REMOVING BATTERY MOUNT

NOTE:

When removing the battery mount, ensure that the two bottom damper elements (4) are screwed in with a headless set screw; the two top damper elements (3) are secured with a locking nut (2).

- Remove seat.
- Remove battery.
- Remove battery mount (1) in the order shown in the drawing.

The battery mount is **installed** in the reverse order by analogy to removal.

7.9 REMOVING AND INSTALLING STEERING LOCK

REMOVING STEERING LOCK

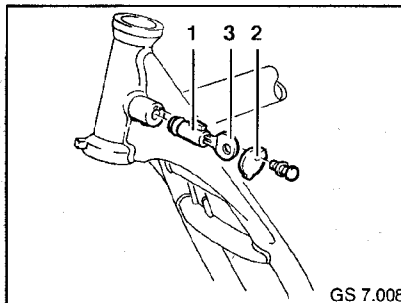

GS 7.008

- Use screwdriver to lift off cover plate (3).
- Insert key (2) into lock.
- Turn counter-clockwise as far as the stop.
- Withdraw locking cylinder (1).

The steering lock is **installed** in the reverse order by analogy to removal.

8. EXHAUST SYSTEM

Contents Page

8.1 REMOVING AND INSTALLING EXHAUST SYSTEM **8.5**
REMOVING MAIN SILENCER GS 8.5
REMOVING MAIN SILENCER R100R 8.5
REMOVING FRONT SILENCER AND EXHAUST MANIFOLD 8.6
INSTALLING FRONT SILENCER AND EXHAUST MANIFOLD 8.6
INSTALLING MAIN SILENCER GS 8.7
INSTALLING MAIN SILENCER R100R 8.7

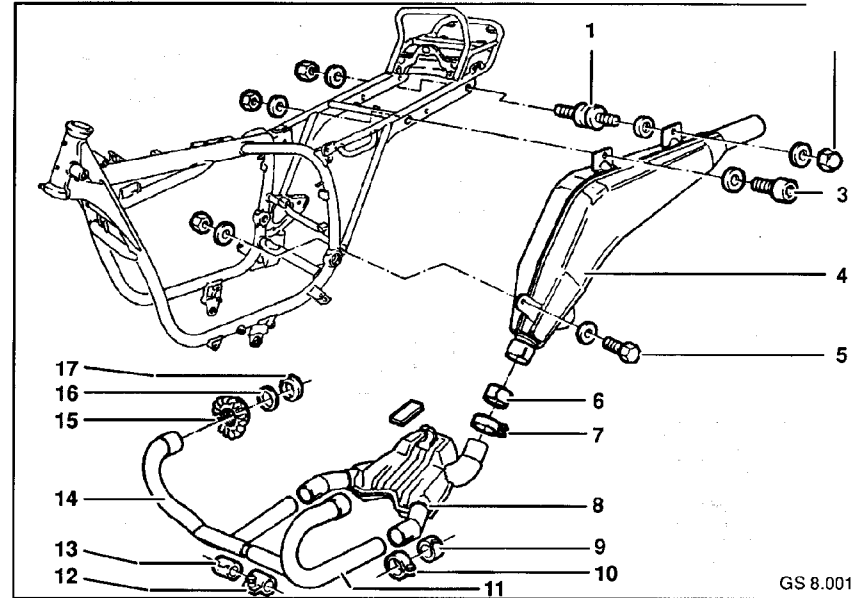

GS 8.001

8.1 REMOVING AND INSTALLING EXHAUST SYSTEM

REMOVING MAIN SILENCER GS

- Remove rear left foot rest.
- Slacken clip (7) at the joint between front and rear silencers.
- Slacken cap nut (2) and fastening screws (3,5) on the rear silencer.
- Pull rear silencer (4) out of front silencer (8) and take off.
- Remove gasket (6) from rear silencer.

REMOVING MAIN SILENCER R100R

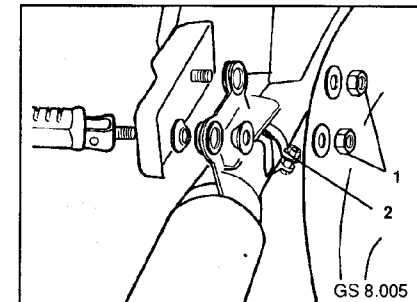

GS 8.005

- Remove silencer attachment (1) at frame.
- Loosen clip (2) on the front silencer.

REMOVING FRONT SILENCER AND EXHAUST MANIFOLD

- Slacken left/right clips (10) at joint between front silencer and exhaust pipes.
- Pull off front silencer.
- Remove gaskets (9).

NOTE:

The gasket (9) may either be located in the front silencer or be fitted to the exhaust pipes (11,14).

- Slacken clip (12) of the interference pipe.

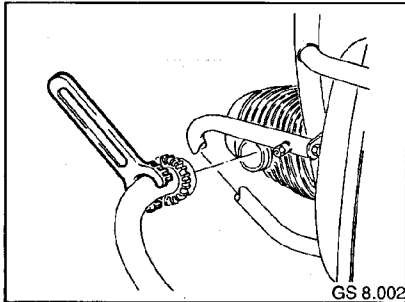

- Slacken both exhaust nuts (15) with exhaust range, BMW No.18 0 600.
- Remove left and right exhaust pipes (11,14) together.
- Separate left and right exhaust pipes and take off gasket(13).
- Remove left/right clamp (17) and thrust ring (16) from exhaust nuts.

NOTE:

Replace rubber bearing (1) and pad (18) if damaged.

INSTALLING FRONT SILENCER AND EXHAUST MANIFOLD

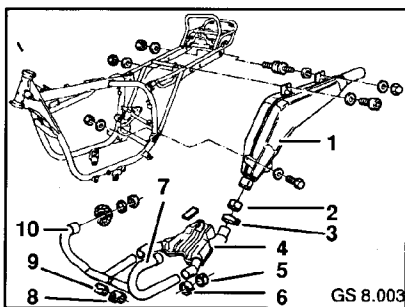

NOTE:

Coat all exhaust clamp points with anti-corrosion paste prior to assembly.

Fit new gasket each time after disassembling part.

Coat thread of exhaust nuts with high-temperature assembly paste.

- Insert new gasket (9) in interference pipe.
- Fit clip (8) onto interference pipe and fit together the two exhaust pipes. Do not tighten clip at this stage.

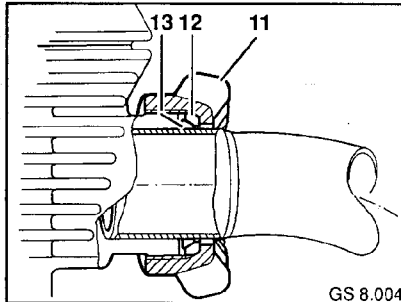

- Align and insert thrust (2) and clamp ring (3) in exhaust nuts (1) in the order shown.
- Fit exhaust nuts onto left and right exhaust pipe.
- Insert both exhaust pipes into cylinder head and screw on exhaust nuts.

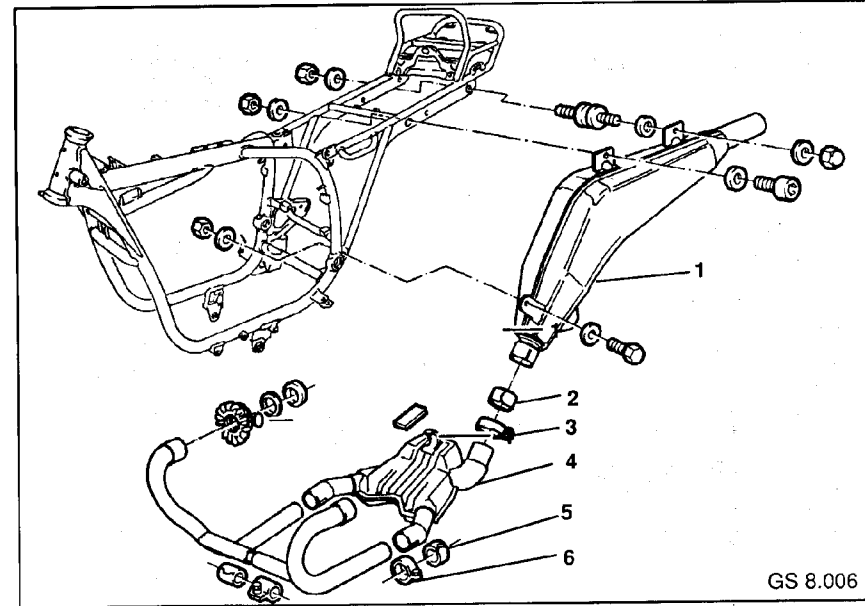

- Insert new gasket (5) into front silencer (4) and fit clips (6) onto ends of exhaust pipe.
- Fit on front silencer (4). Do not tighten clip at this stage.

INSTALLING MAIN SILENCER GS

- Insert gasket (2) into rear silencer.
- Push clip (3) onto front silencer flange and fit on rear silencer.
- Screw rear silencer onto rear section of frame.

INSTALLING MAIN SILENCER R100R

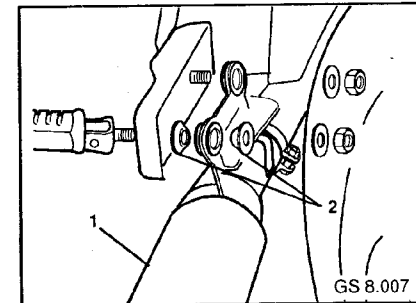

- Attach main silencer (1) without gasket to front silencer.
- Secure main silencer to frame, noting shaped discs (2) at left and right

- Tighten all clips.
- Tighten exhaust nuts as far as necessary until gastight, with engine running.

9. GEARBOX

| Contents | Page |
|---|-------------|
| 9.1 REMOVING TRANSMISSION | 9.5 |
| 9.2 DISASSEMBLING TRANSMISSION | 9.7 |
| REMOVING, DISASSEMBLING AND ASSEMBLING TRANSMISSION COVER | 9.7 |
| REMOVING AND INSTALLING KICK STARTER | 9.10 |
| ASSEMBLING BEARING BLOCK | 9.11 |
| ASSEMBLING INPUT SHAFT | 9.13 |
| REMOVING OUTPUT AND INTERMEDIATE SHAFTS | 9.15 |
| DISASSEMBLING OUTPUT SHAFT | 9.16 |
| ASSEMBLING OUTPUT SHAFT | 9.17 |
| DISASSEMBLING AND ASSEMBLING INTERMEDIATE SHAFT | 9.17 |
| REPLACING RADIAL SEAL FOR INPUT SHAFT | 9.17 |
| REPLACING ROLLER BEARING OF INPUT SHAFT | 9.17 |
| REPLACING RADIAL PIVOT BEARING AND SEALING RING FOR SHIFT LEVER | 9.17 |
| 9.3 ASSEMBLING TRANSMISSION | 9.18 |
| CALCULATING THICKNESS OF SPACER RING FOR END PLAY | 9.19 |
| EXAMPLE OF CALCULATION: | 9.19 |
| 9.4 INSTALLING TRANSMISSION | 9.22 |
| DISASSEMBLING AND ASSEMBLING GEAR SHIFT LINKAGE | 9.24 |
| INSTALLING SHIFT LEVER | 9.24 |
| 9.5 TROUBLESHOOTING TRANSMISSION | 9.25 |

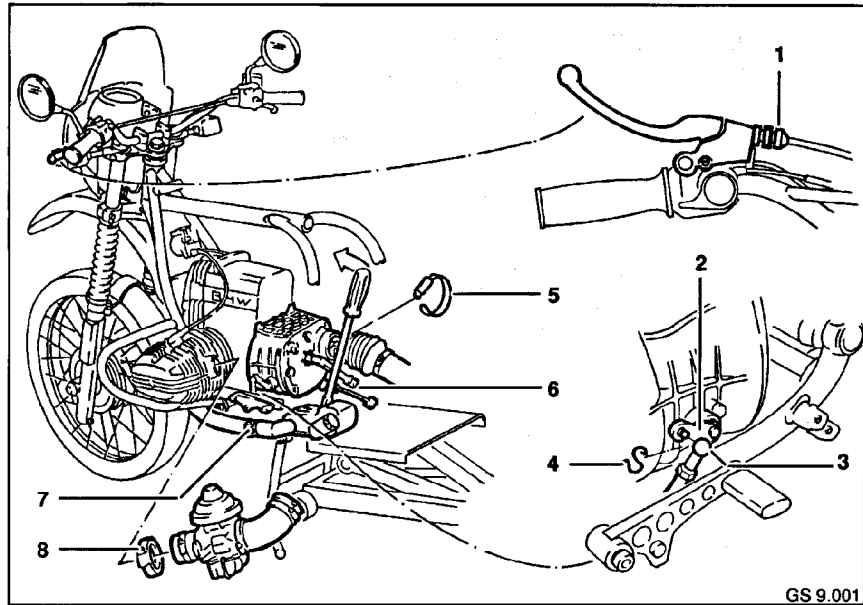

GS 9.001

9.1 REMOVING TRANSMISSION

- Remove seat.
- Remove fuel tank.
- Remove battery.
- Remove battery mount.
- Remove air filter housing.
- Slacken hose clip (8) and remove left carburettor from cylinder head.
- Remove left/right exhaust pipes (7).
- Drain oil from transmission.
- Take locking element (4) off the ball head of the gearshift lever (2).
- Detach pivot lever (3).
- Relieve tension on clutch cable by slackening the adjusting screw (1) on the left grip unit.
- Use large screwdriver to lever forward clutch release (6) on transmission and detach clutch cable.
- Slacken clip of bellows (5) on the output flange at transmission end.
- Push back bellows.

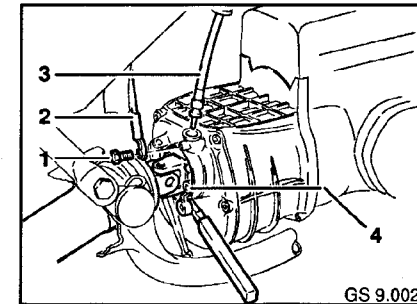

GS 9.002

- Slacken the fastening bolt (1) and detach earth cable (2) from transmission housing.
- Pull speedometer shaft (3) out of transmission.
- Slacken fastening bolts (4) of propeller shaft with special wrench, BMW No. 00 2 560.
- Take propeller shaft off output flange.

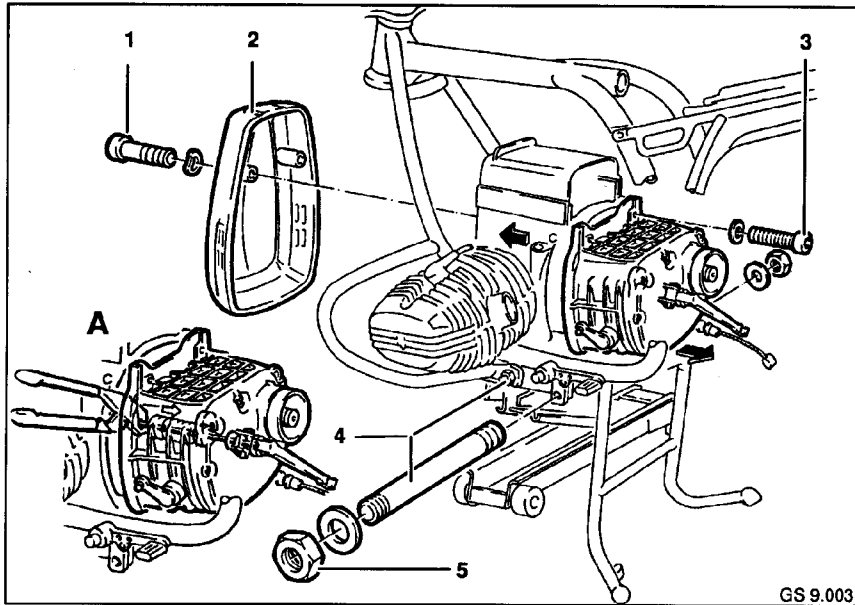

GS 9.003

- Slacken 4 transmission fastening bolts (3).
- Use plenty of protective foil to cover the frame ties in the area of the tappet rod protective tubes.
- Slacken nuts (5) on both engine pins (4).
- Jack up engine with vehicle jack.
- Withdraw engine pins, paying attention to the spacer rings.
- Slacken the two fastening bolts (1) and remove engine guard cover (2).
- Pull engine forward up to frame ties.
- Remove transmission from engine to the rear.
- Turn transmission to the side (clockwise) in direction of arrow.
- Detach plug connection (1) from idle switch.
- Withdraw transmission to the left side, pushing clutch thrust rod down the way (detail A).

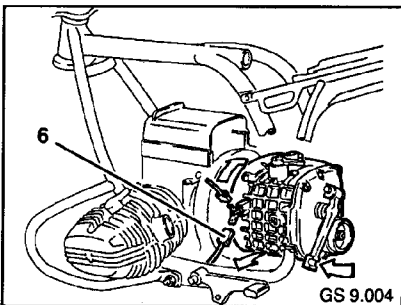

GS 9.004

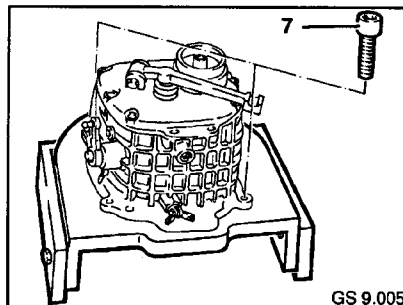

GS 9.005

- Mount transmission in assembly device, BMW No. 11 0 600.
- Secure with two bolts (7), tightened cross-wise.

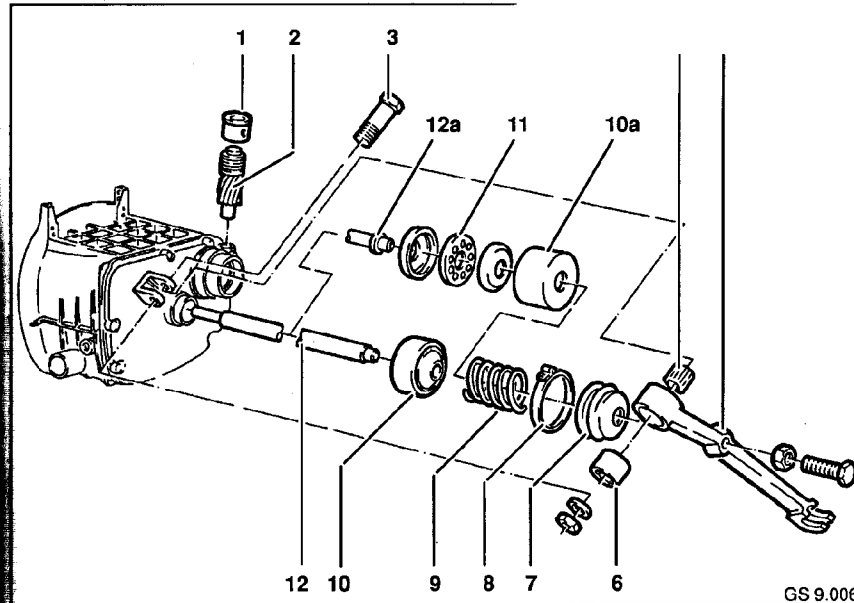

GS 9.006

9.2 DISASSEMBLING TRANSMISSION

REMOVING, DISASSEMBLING AND ASSEMBLING TRANSMISSION COVER

- Slacken the fastening nut/bolt (3) and take release lever (5) off the bearing block.
- Slacken the clip (8) and take off cup seal (7).
- Depending on version:
 - Remove spring (9) and piston (10) together with integrated plastic bearing and clutch thrust rod (12) or
 - Remove piston (10a), clutch bearing (11) and clutch thrust rod (12a).
- Use suitable drift to press bearing (6) and bush (4) out of release lever (5).
- Withdraw guide sleeve (1) from connection of speedometer shaft.
- Take out speedometer helical gear (2).

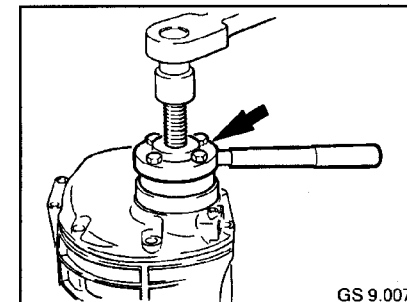

GS 9.007

CAUTION:

Place washers below bolt head of fastening bolts of holding device to avoid damage to the sealing ring.

- Attach holding device, BMW No. 23 1 700, to output flange without forcing spindle.

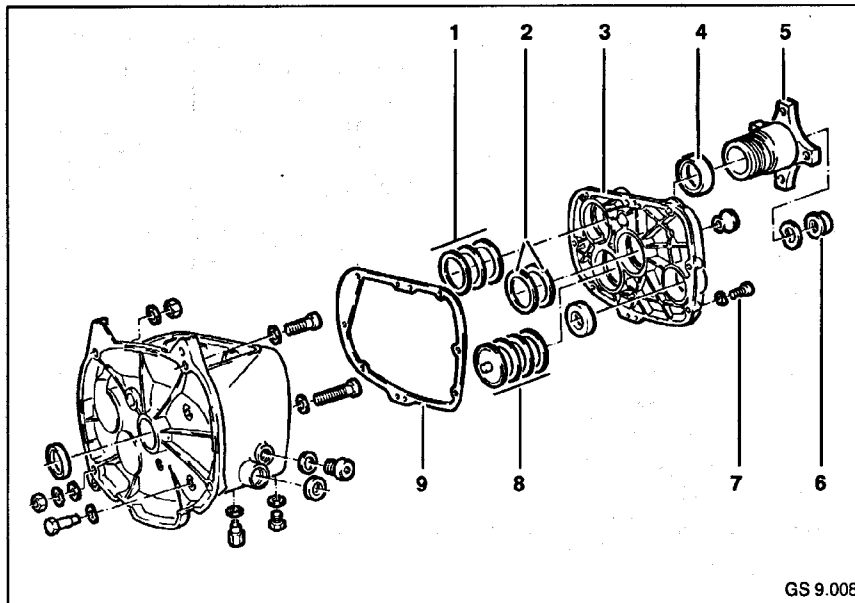

GS 9.008

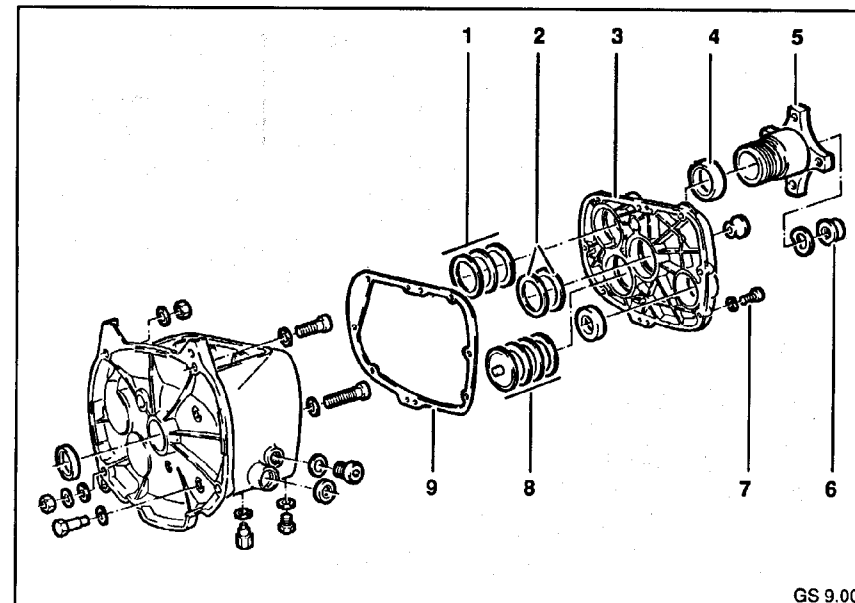

GS 9.008

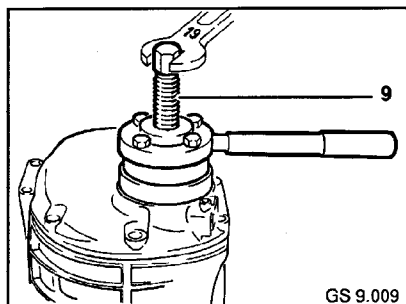

GS 9.009

- Slacken fastening nut (6) on output flange (5).
- Unscrew holding device and screw on again tight with forcing spindle inserted.

- Force off output flange. Slacken tapered seat with a light blow to the spindle head, if necessary.
- Slacken fastening bolts (7) of transmission cover.

WARNING:

Wear protective gloves when handling heated parts.

- Attach forcing device, BMW No. 23 1 630.

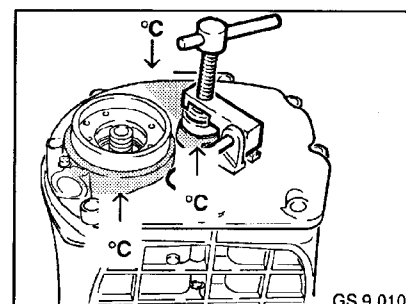

GS 9.010

- Heat transmission cover in the area of the bearing seats to approx. 100...120°C with hot-air fan or gentle flame.

- Press off transmission cover with forcing device.
- Take shim rings (1,2,8) for shaft end play off the bearings.

NOTE:

Mark the shim ring matching the 3 bearings.

- Examine sealing ring (4) of output shaft for signs of damage.
- If necessary, use a drift to knock sealing ring out of transmission cover.

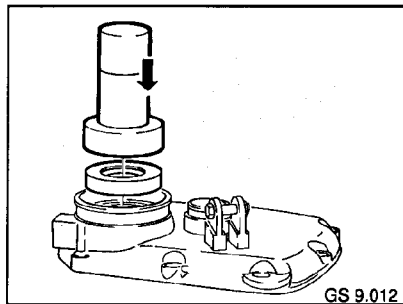
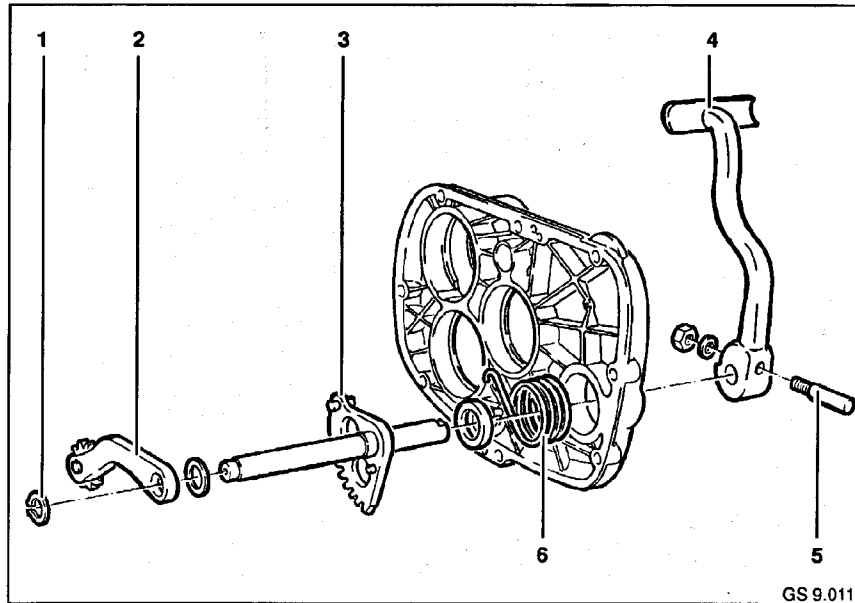

REMOVING AND INSTALLING KICK STARTER

- Withdraw intermediate gear (2) from kick starter shaft (3) after removing the locking ring (1).
- Slacken splined screw (5) on the kick starter lever (4) and knock out with sharp blows from a hammer.
- Pull off lever.
- Withdraw kick starter shaft from transmission cover.
- Take off spring (6).

The kick starter is installed in the reverse order by analogy to removal.

Tightening torque:

Splined screw of kick starter lever

22 Nm

NOTE:

Open side of sealing ring must be facing output flange.

CAUTION:

It is essential to pre-shape the sealing ring otherwise the sealing lid will be damaged on the worm of the speedometer drive.

- Knock in new shaft seal with special tool, BMW No. 23 1 750.

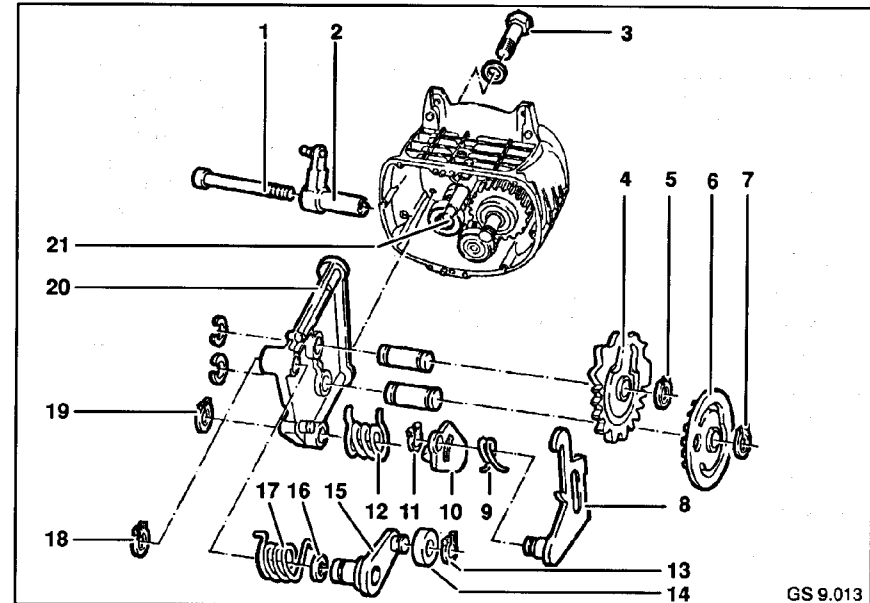

REMOVING BEARING BLOCK FOR SHIFT DISCS

- Slacken the fastening bolt (1) and withdraw shift lever (2).
- Slacken the 2 fit bolts (3) and tilt bearing block (20) so that the shift forks (21) are released.
- Withdraw bearing block from transmission housing.

DISASSEMBLING BEARING BLOCK

- After releasing the locking rings (5,7), take off shift discs (4,6).
- Release the locking ring (19) and take off shift segment (8).

NOTE:

Leave spring (12) on bearing block.

- Release the locking ring (11) and pull segment shaft (8) off ratchet (10).

- Release the locking ring (18) and withdraw gear lock (15) from bearing block.
- Take spring (17) and spacer ring (16) off lever for gear lock.
- Release the locking ring (13) and take roller (14) off lever for gear lock.

ASSEMBLING BEARING BLOCK

- Fit roller (14) onto lever of gear lock (15).
- Fix roller in place with locking ring (13).
- Insert gear lock (15) complete with spacer ring (16) and spring (17) in bearing block.
- Fix gear lock in place with locking ring (18).
- Attach spring (17).
- Fit spring (9) onto segment shaft (8).
- Fit segment shaft onto ratchet (10).

- Secure ratchet with locking ring (11).
- Fit complete shift segment onto bearing block and insert locking ring (19).

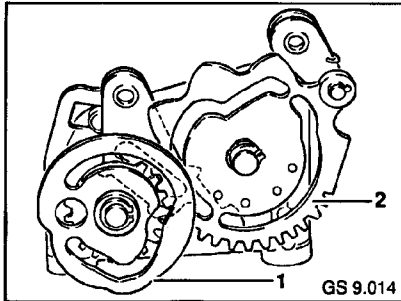

NOTE:

When installing the shift discs (1,2), ensure that the first teeth of the shift discs

- Mount shift discs on bearing block and insert locking rings.

REMOVING AND DISASSEMBLING INPUT SHAFT

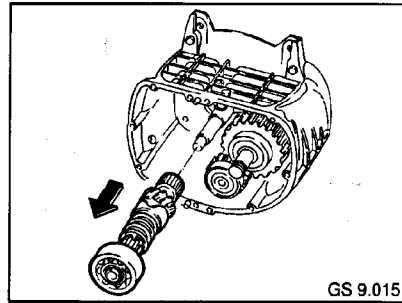

- Knock on the front end of shaft with a plastic-headed hammer.
- Withdraw input shaft complete from transmission housing.

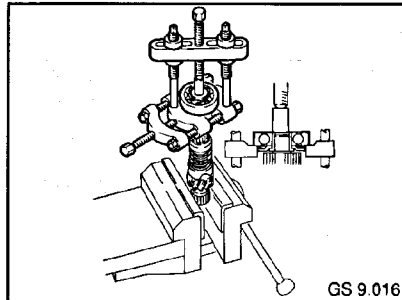

NOTE:

When removing the ball bearing (1) of the input shaft, the bearing bush (2) must not be removed as well.

- Insert thrust plate, BMW No. 23 2 670, in input shaft.
- Use universal puller, BMW No. 00 7 500, to pull off ball bearing (1) of input shaft and cover plate (2).

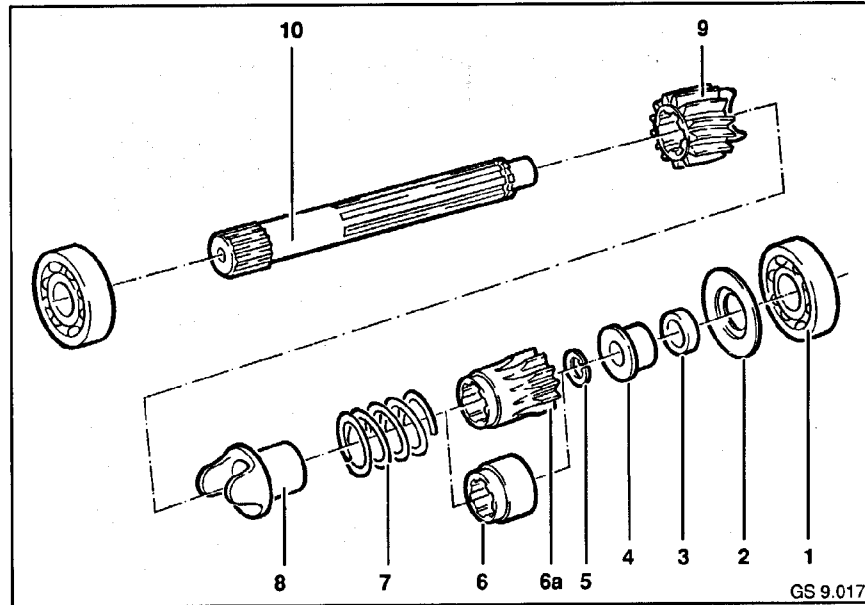

- Use screwdriver to lever small shaft seal (5) out of bearing bush (4).

NOTE:

Shaft seal may be destroyed when removing.

- Use universal puller, BMW No. 00 7 500, and thrust plate, BMW No. 23 2 670, to remove bearing bush (4).

- Compress helical spring (7) with universal puller, BMW No. 00 7 500, in combination with assembly bush, BMW No. 23 2 650.
- Release locking ring (5) on intermediate piece (6).
- Release tension on spring by slackening puller device.
- Remove intermediate piece (6) (on version with kick starter (6a)), helical spring (7), thrust piece (8) and spur gear (9) from input shaft.

ASSEMBLING INPUT SHAFT

- Fit parts (9 to 6) onto input shaft (10) in this order.
- Compress spring (7) with assembly bush, BMW No. 23 2 650, and universal puller (BMW No. 00 7 500).

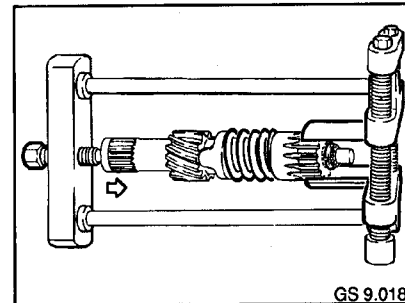

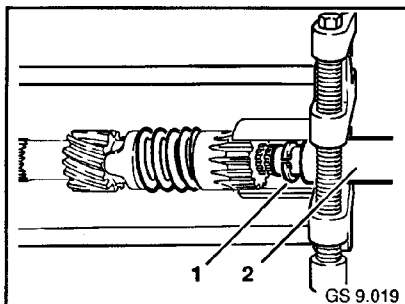

- Fit locking ring (1) onto guide bush of tool, BMW No. 23 2 650, and press forward as far as the groove with slip sleeve (2).

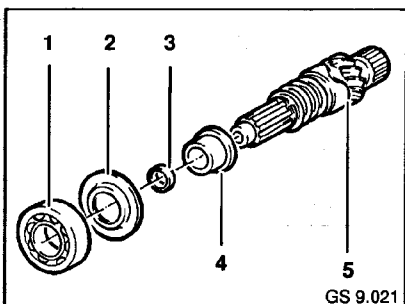

NOTE:

Press bearing onto shaft together with bush.

- Fit cover plate (2) onto bush (4).
- Heat bearing (1) to approx. 80°C and press bush (4) into bearing together with cover plate.

- Heat bearing bush and bearing to approx. 80°C.
- Press bearing together with bearing bush onto input shaft.
- Knock new shaft seal (3) into bush with suitable pipe section.

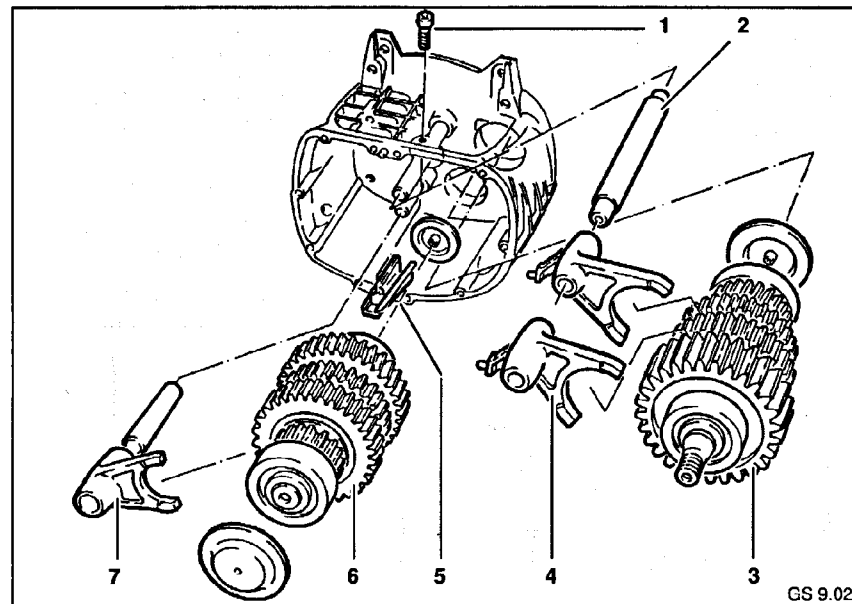

REMOVING OUTPUT AND INTERMEDIATE SHAFTS

- Slacken the fastening screw (1) and take off oil baffle (5).
- Withdraw shaft (2) from shift forks (4) for 1st, 2nd, 5th gear.
- Remove shift forks.

- Heat transmission housing at bearing seat of output shaft (3) and intermediate shaft (6) to 100°C.
- Withdraw both shafts with shift fork (7) for 3rd and 4th gear.
- Take guard plates out of transmission housing.

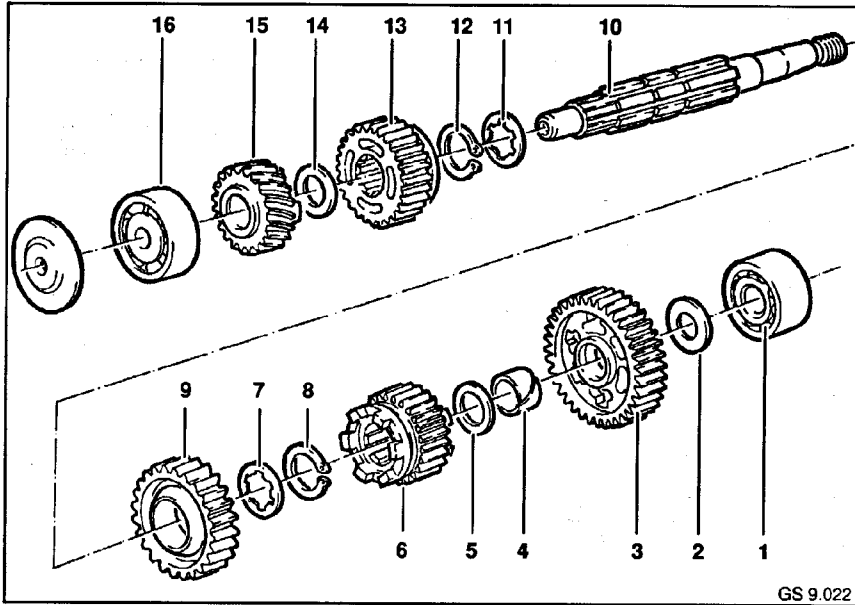

GS 9.022

DISASSEMBLING OUTPUT SHAFT

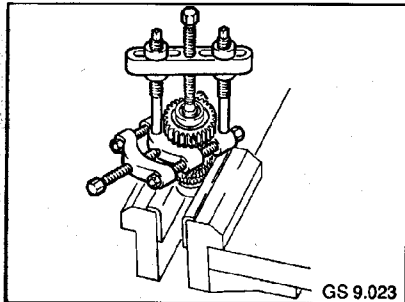

GS 9.023

- Remove 1st gear wheel (3) together with bearing (1) with universal puller, BMW No. 00 7 500.
- Take off disc (2) between bearing and 1st gear wheel.
- Take off 4th gear wheel (6) and disc (5).

- Clamp output shaft in vice using protective jaws.
- Pull off 5th gear wheel (15) together with bearing (16) using universal puller, BMW No. 00 7 500.
- Remove disc (14) and 3rd gear wheel (13).
- Remove locking ring (12) ahead of 2nd gear wheel (9).
- Pull gear wheel with disc (11) off shaft.
- Take disc (8) and locking ring (7) off shaft (10).

NOTE:

Output shaft must be replaced if the bush (4) which is press-fitted onto shaft is faulty.

ASSEMBLING OUTPUT SHAFT

The output shaft is assembled in the reverse order by analogy to disassembly.

DISASSEMBLING AND ASSEMBLING INTERMEDIATE SHAFT

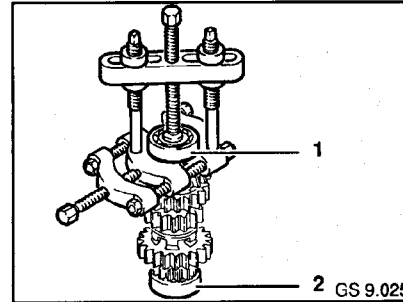

GS 9.025

NOTE:

With the exception of the two bearings (1,2), the intermediate shaft is replaced as a complete unit, if faulty. Remove the two bearings with universal puller, BMW No. 00 7 500.

REPLACING RADIAL SEAL FOR INPUT SHAFT

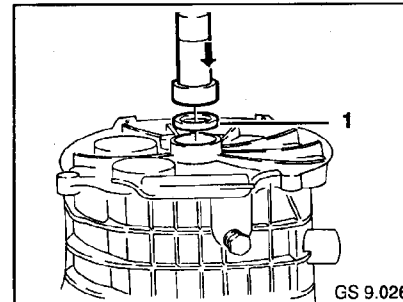

GS 9.026

- Use screwdriver to lever out seal (1).
- Knock in new seal with impact drift, BMW No. 23 1 650, in combination with handle, BMW No. 00 5 500.

REPLACING ROLLER BEARING OF INPUT SHAFT

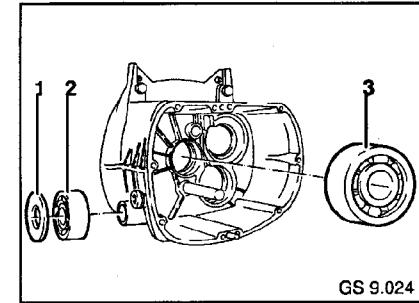

GS 9.024

- Heat transmission housing to approx. 100°C.
- Use suitable tool (hook) to remove roller bearing (3).
- Insert new bearing into warm housing.

REPLACING RADIAL PIVOT BEARING AND SEALING RING FOR SHIFT LEVER

- Use screwdriver to lever out sealing ring (1).
- Withdraw bearing (2) from housing.

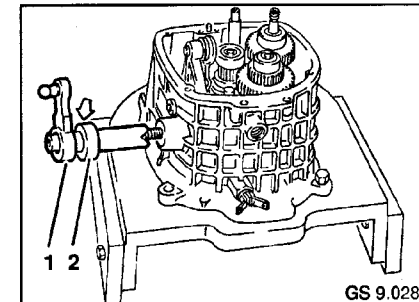

GS 9.028

- Lightly oil new bearing.
- Press in bearing.
- Fit new sealing ring (2) onto shift lever (1) and press this into housing with light blows.

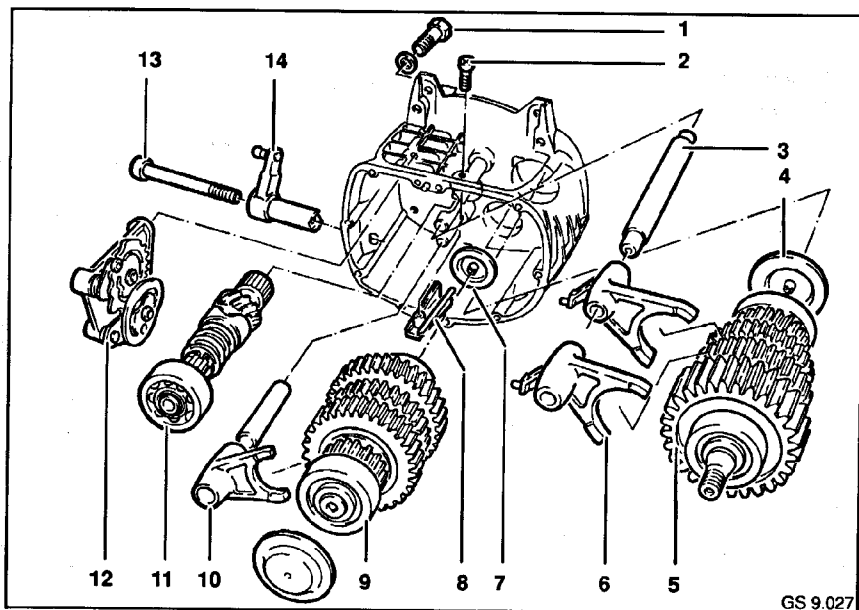

9.3 ASSEMBLING TRANSMISSION.

- Place guard plates (4,7) into the ball bearing bores of the housing.
- Heat transmission housing in the area of the bearing seats to approx. 80...100°C.
- Insert output shaft (5) and intermediate shaft (9) together with 3rd and 4th gear shift fork (10) into housing with long guide end facing down.

CAUTION:

Shift forks must not jam.

- Insert 1st, 2nd and 5th gear shift fork (6) with the short guide ends facing each other and fix in place with shaft (3).

NOTE:

Secure fastening screw with Loctite 270.

- Insert oil baffle (8) and tighten with fastening screw (2).
- Install bearing block (12) into neutral position.
- Tighten fastening screws of bearing block to specified tightening torque.
- Tighten shift lever (14) with fastening screw (13).
- Insert input shaft (11).

Tightening torque:
Shift block mounting

24 Nm

CALCULATING THICKNESS OF SPACER RING FOR END PLAY

NOTE:

If a paper gasket is used for the transmission cover seal, this should be placed below the measuring plate when performing this measurement.

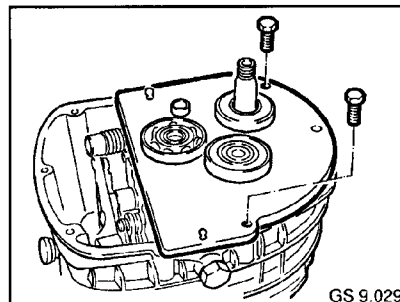

- Place measuring plate, BMW No. 23 3 650, onto the transmission housing.
- Fix measuring plate in place with two bolts.

NOTE:

Permissible play when using old bearings
0.00 ... 0.05.

Permissible play when using new bearings
0.05 ... 0.10.

It is recommended to enter the calculated values in the table (see example).

EXAMPLE OF CALCULATION:

| | | Input shaft | Interm. shaft | Output shaft |
|---|----|-------------|---------------|--------------|
| 1. Size of cover | mm | 15,35 | 15,75 | 15,35 |
| 2. Housing | mm | 7,25 | 7,30 | 7,30 |
| + Measuring plate | mm | 7,50 | 7,50 | 7,50 |
| 3. Total size of housing | mm | 14,75 | 14,80 | 14,80 |
| 4. Difference (1. - 3.) | mm | 0,60 | 0,95 | 0,55 |
| 5. Average end play | mm | 0,05 | 0,05 | 0,05 |
| 6. Thickness of spacer incl. oil baffle (4. Difference - 5. Average end play) | mm | 0,55 | 0,90 | 0,50 |

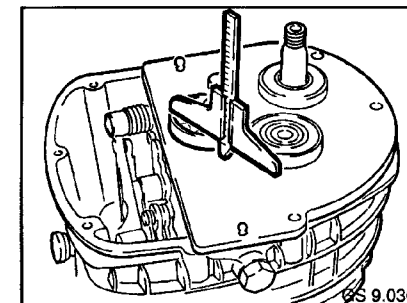

- Measure distance between ball bearing outer race and measuring plate using depth gauge, BMW No. 00 2 550.

Actual distance = size measured + thickness of measuring plate

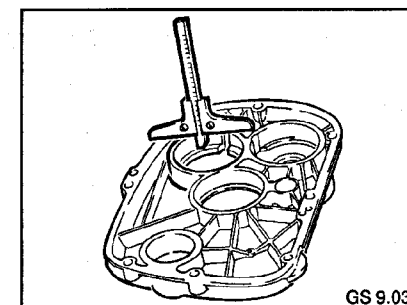

- Calculate depth of ball bearing seat in housing cover (size of cover).

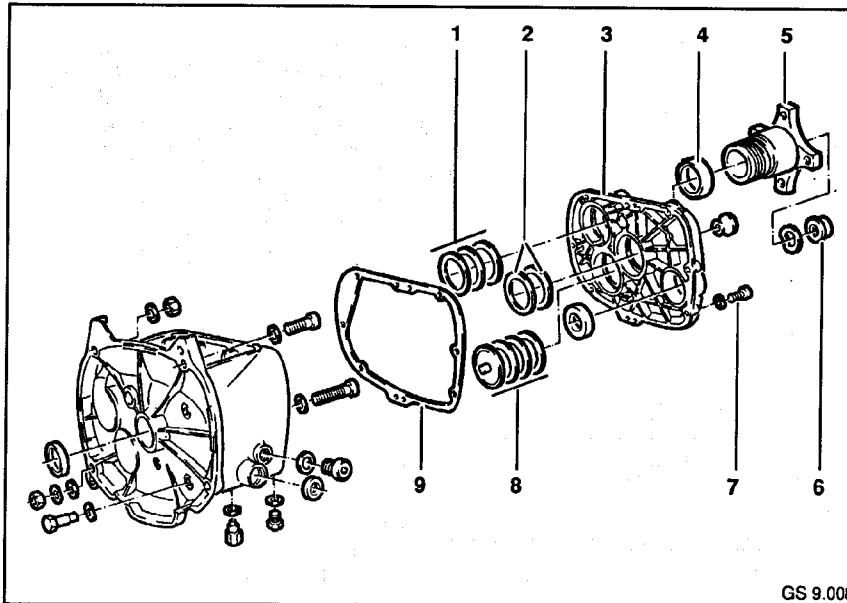

GS 9.008

- Fit on new transmission cover gasket (1).
- Fit required spacer rings onto the bearings.
- Fit on housing cover (2).
- Heat housing cover in area of bearing seats to approx. 100 °C with hot-air fan.

NOTE:

Place two washers below the top centre fastening bolt.

- Tighten housing cover with fastening bolt (5).
- Tighten fastening bolts to specified tightening torque.
- Clean tapered seat of output flange with grease-free cleaning agent and dry.
- Mount output flange (3) onto taper of output shaft.

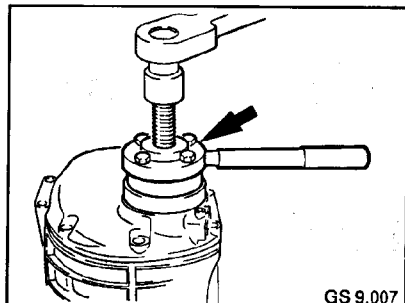

GS 9.007

- Screw holding device, BMW No. 23 1 700, onto output flange with four fastening bolts.
- Oil nut (4) of the output flange with viscous oil.
- Screw on nut and tighten to specified torque.

Tightening torque:
Driving flange
Housing cover bolts

220 Nm
10 Nm

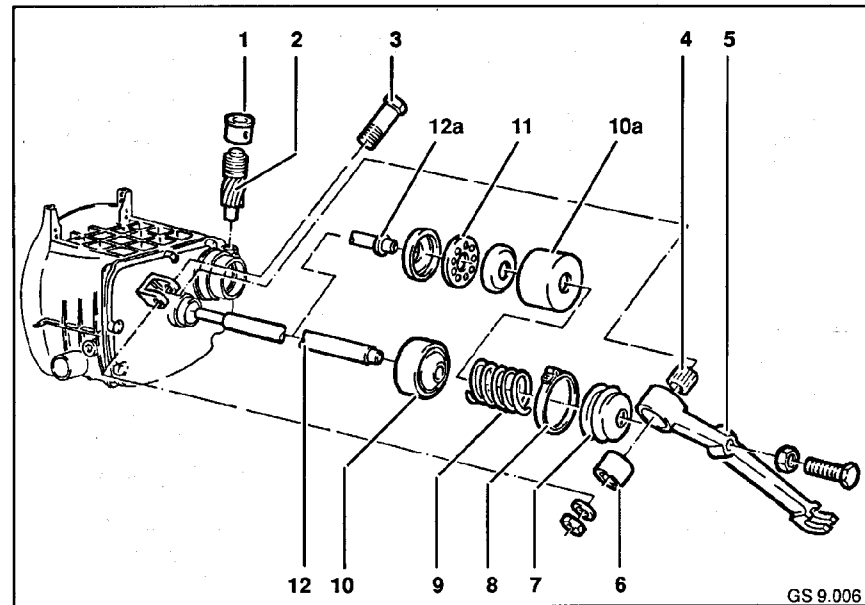

GS 9.006

- Insert speedometer helical gear (2) into transmission housing.
- Insert guide sleeve (1).
- Depending on version, introduce clutch thrust rod (12 or 12a) into transmission.
- Depending on version:
 - Insert clutch bearing (11) and piston (10a) or
 - Piston (10) with integrated plastic bearing into transmission cover.
- Insert spring (9).

- Fit cup seal (7) of clutch control, screw tight with clip (8).
- Press needle sleeve (6) and bush (4) into release lever (5).
- Screw release lever onto bearing block with fastening bolt (3).
- Tighten fastening bolt to specified tightening torque.
- Install electric idle indicator.

Tightening torque:
Clutch control lever

10 Nm

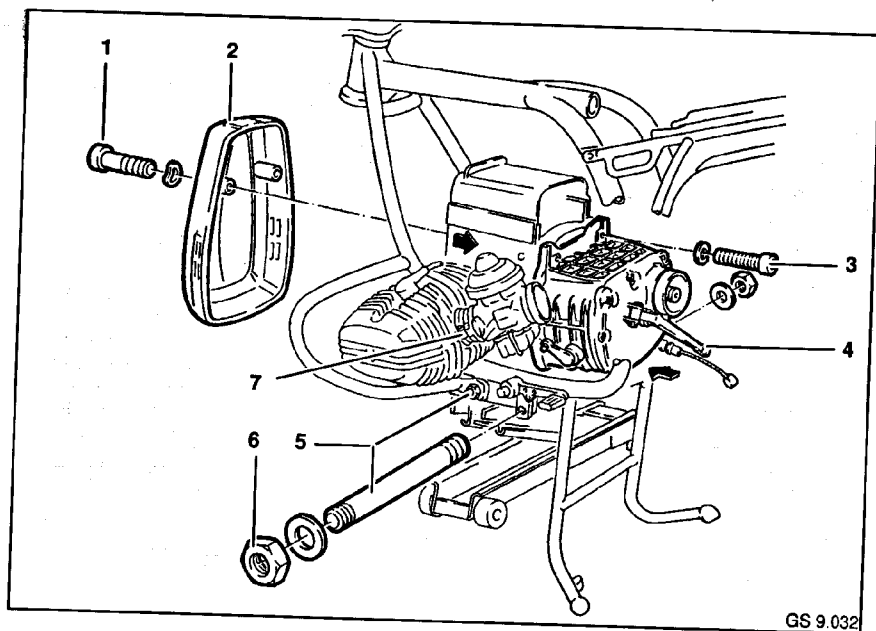

9.4 INSTALLING TRANSMISSION

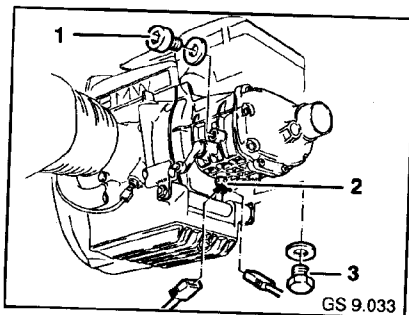

- Insert oil drain plug (3) with new gasket and tighten to specified tightening torque.
- Fill transmission with specified quantity and grade of oil.
- Insert oil filler plug (1) and tighten to specified tightening torque.
- Insert transmission into the frame turned to the side.
- Connect neutral switch (2).

NOTE:

Coat teeth of input shaft with Molykote paste before installing transmission.

- Carefully insert longitudinal teeth of the input shaft into the clutch plate.
- Align transmission to engine housing.
- Screw transmission to engine with 4 fastening bolts (3).
- Move engine to the back.
- Insert engine fastening pin (5), screw tight with fastening nuts (6).
- Tighten fastening nuts to specified tightening torques.
- Push back release lever (4) with large screwdriver.
- Attach clutch cable to release lever.
- Fit carburettor onto cylinder head and tighten clip (7).
- Fit on engine guard cover (2) and screw tight with 2 fastening screws (1).

Transmission oil grades:
 up to 5°C SAE 90
 below 5°C SAE 80
 or optionally SAE 80 W 90
 Transmission oil capacity 0.8 l

Tightening torque:
 Oil drain plug 26 Nm
 Oil filler plug 31 Nm
 Transmission to engine 33 Nm

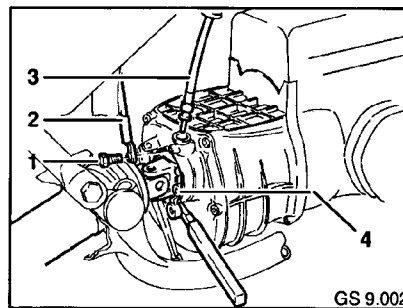

- Screw input shaft to output flange with 4 fastening bolts.

- Tightening torque.
- Fit bellows onto transmission housing.
- Tighten tensioning strap.
- Insert speedometer shaft (3) in transmission cover.
- Fit battery earth cable (2) to clamp screw (1) for speedometer drive shaft.
- Screw clamp screw into transmission housing.

NOTE:

Coat threads of exhaust nuts with anti-corrosion paste before fitting them.

- Install exhaust pipes.
- Install air filter housing.
- Install battery mount.
- Install battery.
- Install side fairings.
- Adjust clutch play.

Tightening torque:
 Propeller shaft to transmission

40 Nm

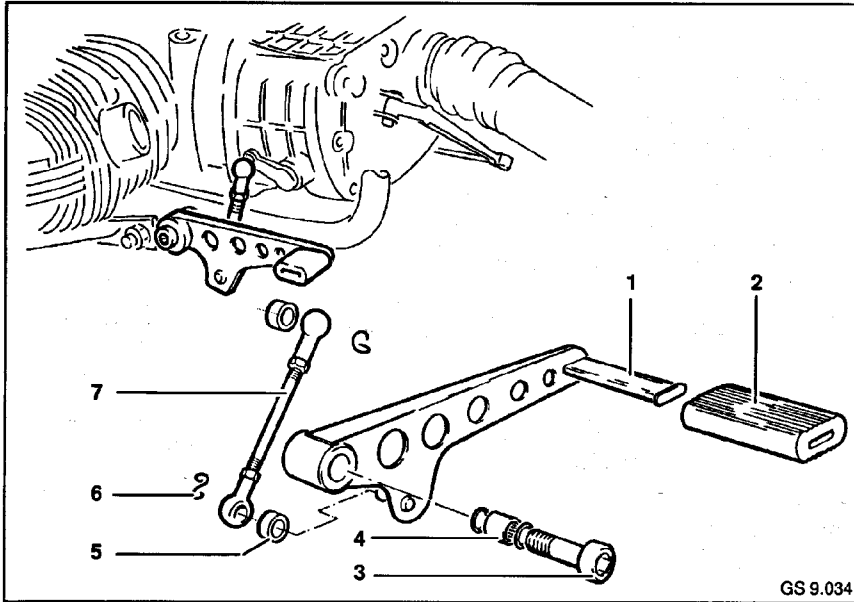

DISASSEMBLING AND ASSEMBLING GEAR SHIFT LINKAGE

- Remove locking ring (6).
- Take pivot lever (7) off bottom ball head.
- Slacken fastening screw (3) and take off shift lever (1).
- Use suitable drift to press bearing bush (4) out of shift lever.
- Lever Teflon bush (5) out of pivot lever.
- Lever rubber sleeve (2) out of shift lever.

NOTE:

Renew bushes and rubber sleeve if worn.

The gear shift linkage is **assembled** in the reverse order by analogy to disassembly.

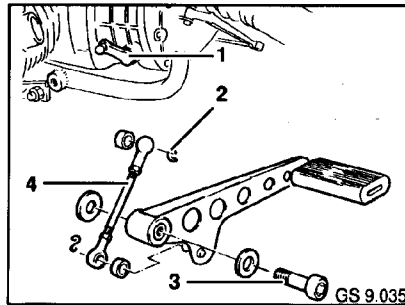

INSTALLING SHIFT LEVER

- Screw shift lever to frame with fastening screw (3).
- Push pivot lever (4) onto gear shift linkage (1) and fix lock in place (2).

9.5 TROUBLESHOOTING TRANSMISSION

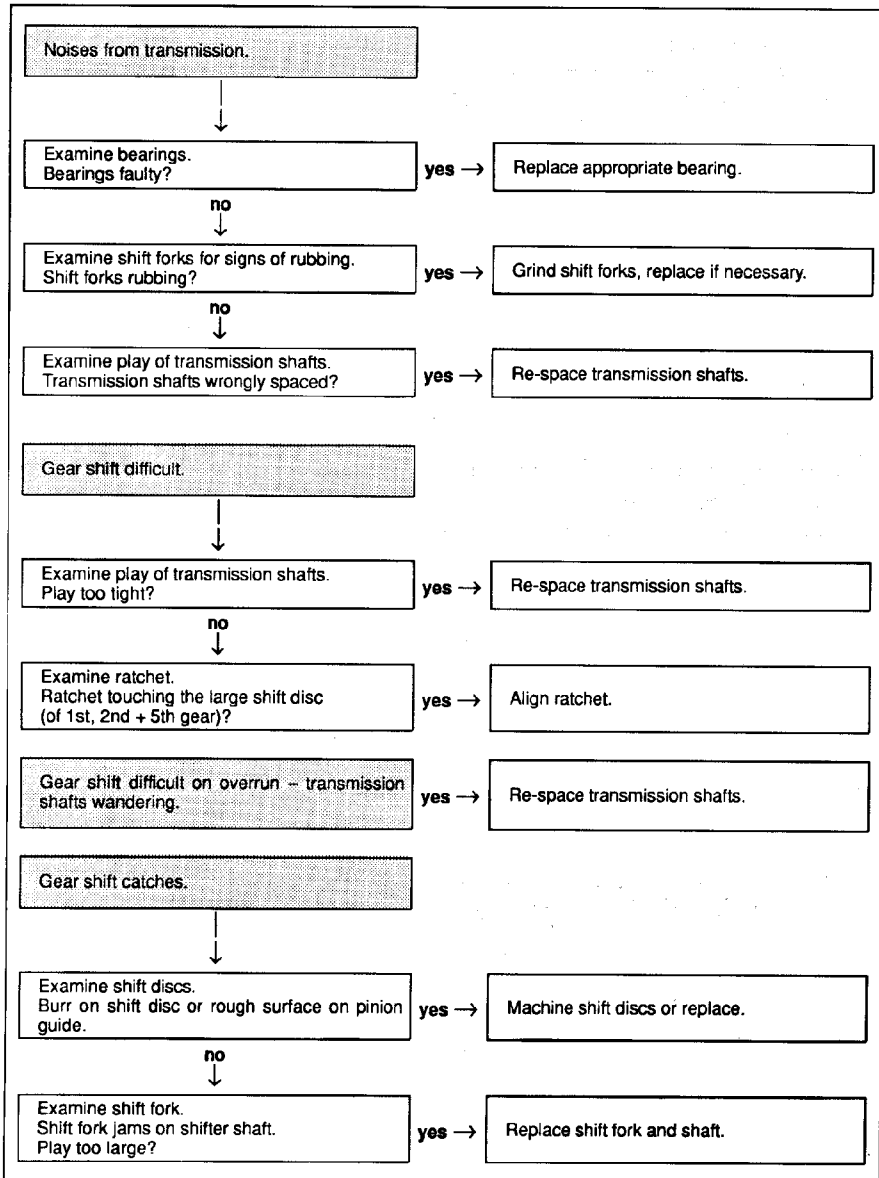

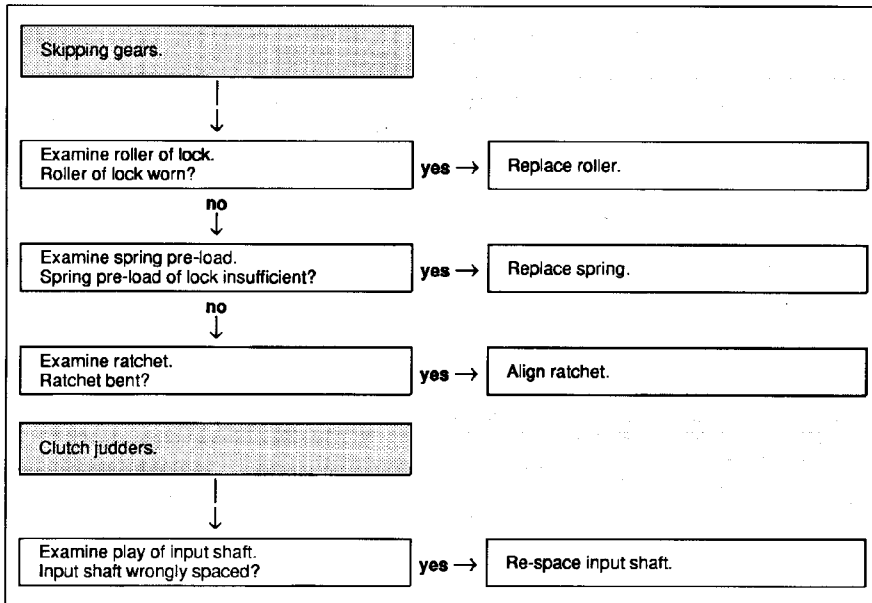

10. CLUTCH

Contents

10.1 REMOVING AND INSTALLING CLUTCH **10.5**
 REMOVING CLUTCH 10.5
 INSTALLING CLUTCH 10.5

10.2 TROUBLESHOOTING **10.7**

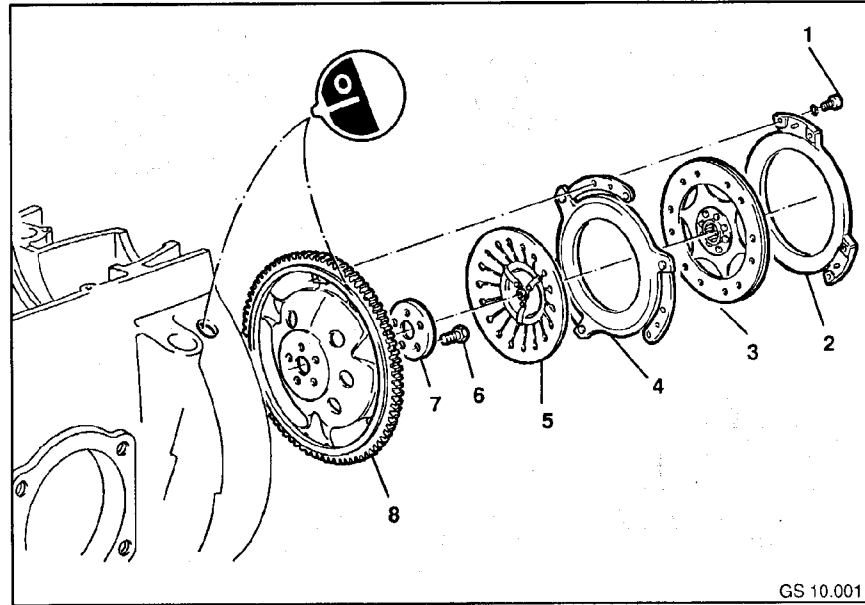

GS 10.001

10.1 REMOVING AND INSTALLING CLUTCH

REMOVING CLUTCH

- Remove transmission.
- After slackening the 6 fastening screws (1), take off housing cover (2), clutch disc (3), plate (4) and diaphragm spring (5).

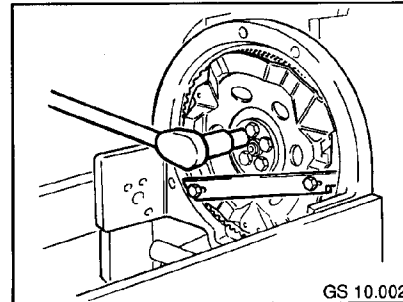

GS 10.002

- Attach holding device, BMW No. 11 2800, to clutch housing.

- After slackening the five fastening bolts (6), take steel disc (7) off the clutch housing.
- Remove holding device.
- Take off clutch housing.

INSTALLING CLUTCH

NOTE:

Turn engine to TDC. Install clutch housing so that TDC marking is facing inspection hole.

- Mount clutch housing (8) on crank shaft.
- Attach holding device to clutch housing.

CAUTION:

Screws and contact surfaces must be free of oil and grease.

- Screw steel disc (7) tight with 5 fastening bolts.

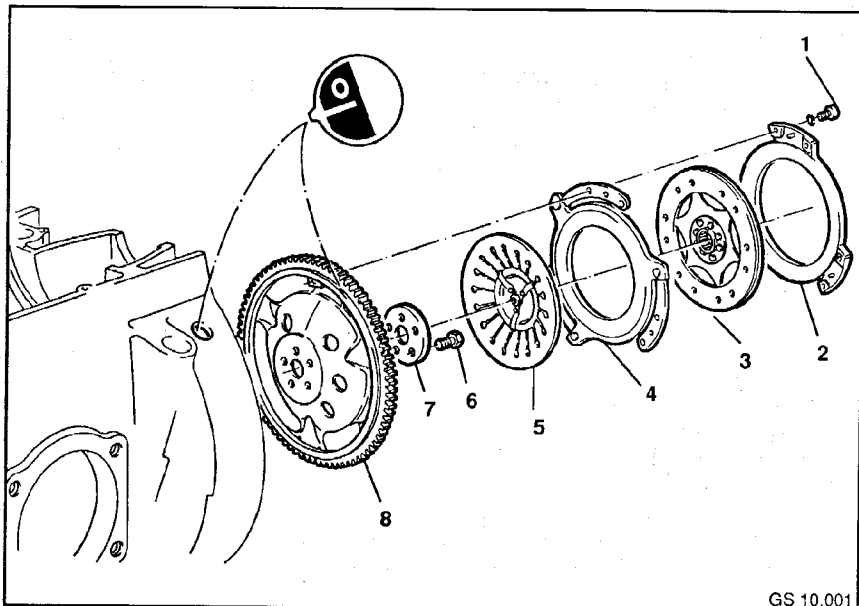

GS 10.001

- Tighten fastening bolts to specified tightening torque.
- Remove holding device.

CAUTION:

When assembling, ensure that the coloured balancing markings on diaphragm spring, pressure plate and housing cover are offset by 120°.

- Insert diaphragm spring (5), plate (4), clutch disc (3) and cover (2).
- Fix aligned clutch components in position on clutch housing with 6 fastening screws (1).

- Center clutch disc with centering drift, BMW No. 21 2 660.
- Tighten fastening screws to specified tightening torque.

NOTE:

Coat driven gears of clutch disc with Molykote "U".

Tightening torque:
 Clutch housing to crank shaft 100 Nm
 Housing cover to flywheel 20 Nm

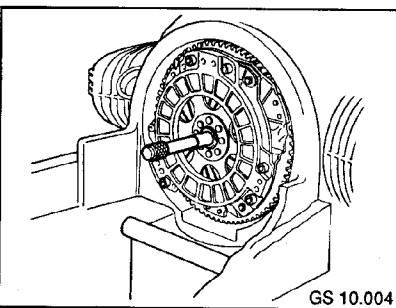

GS 10.004

10.2 TROUBLESHOOTING

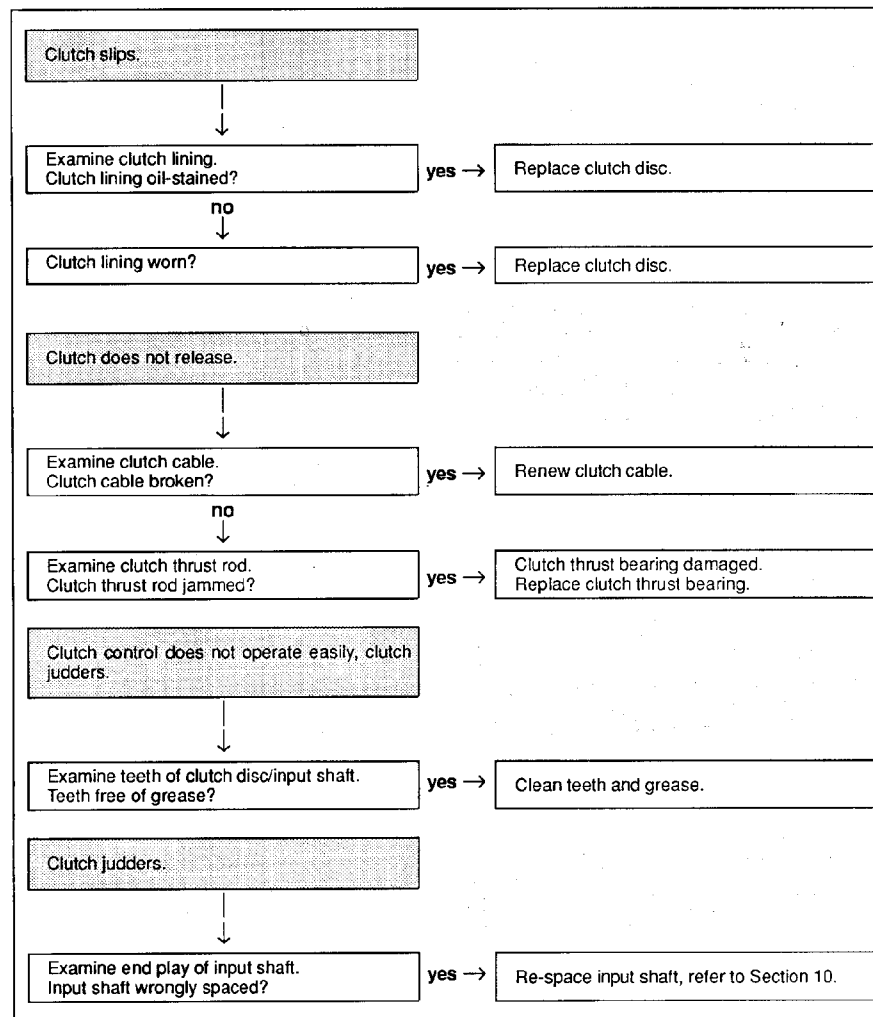

11. ENGINE

Contents Page

| | |
|--|--------------|
| 11.1 FUEL PREPARATION | 11.5 |
| REMOVING AND DISASSEMBLING FUEL TAP | 11.5 |
| REMOVING AND INSTALLING BOWDEN CABLE FOR COLD START DEVICE | 11.5 |
| REMOVING AND INSTALLING BOWDEN CABLES FOR THROTTLE CONTROL | 11.6 |
| REMOVING CARBURETTOR | 11.7 |
| DISASSEMBLING CARBURETTOR | 11.8 |
| REMOVING NOZZLE SET | 11.8 |
| ASSEMBLING CARBURETTOR | 11.10 |
| REMOVING SHED FUEL SYSTEM (USA) | 11.13 |
| SYSTEM DIAGRAM OF SHED FUEL SYSTEM (USA) | 11.14 |
| 11.2 TROUBLESHOOTING SHED-SYSTEM | 11.15 |
| 11.3 REMOVING ENGINE | 11.16 |
| 11.4 DISASSEMBLING ENGINE | 11.18 |
| REMOVING CYLINDER HEAD | 11.18 |
| DISASSEMBLING CYLINDER HEAD | 11.19 |
| Removing valves | 11.19 |
| EXAMINING AND REPAIRING CYLINDER HEAD | 11.19 |
| Examining cylinder head | 11.19 |
| Examining valves and valve guides for wear | 11.19 |
| CHECKING VALVE GUIDE FOR WEAR | 11.20 |
| Measuring valve tilt angle (at rocker end) | 11.20 |
| Measuring valve tilt angle (at combustion chamber end) | 11.21 |
| Reaming out valve guide | 11.22 |
| Replacing valve guides | 11.23 |
| INSTALLING VALVES | 11.25 |
| REMOVING CYLINDER | 11.26 |
| REMOVING CONROD | 11.27 |
| EXAMINING PISTON AND CYLINDER | 11.27 |
| EXAMINING AND REPAIRING CONROD | 11.29 |
| EXAMINING CONROD FOR PARALLELISM AND TWISTING | 11.30 |
| REMOVING OIL PUMP | 11.32 |
| EXAMINING OIL PUMP | 11.32 |
| ASSEMBLING OIL PUMP | 11.33 |
| REPLACING RADIAL SEAL FOR CRANK SHAFT SEAL | 11.33 |
| Removing seal | 11.33 |
| Installing seal | 11.34 |
| REMOVING CHAIN BOX COVER | 11.35 |
| REPLACING RADIAL SEAL FOR CRANKSHAFT SEAL | 11.36 |
| REMOVING CAMSHAFTS | 11.36 |
| EXAMINING CAMSHAFT | 11.37 |
| REMOVING CRANK SHAFT | 11.38 |
| DETERMINING CRANKSHAFT BEARING PLAY | 11.39 |
| REMOVING CRANKSHAFT BEARING | 11.40 |
| Removing crankshaft bearing bush from engine housing | 11.40 |
| Removing crankshaft bearing bush from bearing cover | 11.40 |

| | |
|--|--------------|
| REMOVING OIL SUMP AND INTAKE BELL | 11.41 |
| REMOVING AND INSTALLING VENT COVER | 11.41 |
| REMOVING AND INSTALLING BYPASS VALVE | 11.41 |
| 11.5 ASSEMBLING ENGINE | 11.42 |
| INSTALLING CRANK SHAFT BEARING BUSH IN ENGINE HOUSING | 11.42 |
| INSTALLING NEW CRANKSHAFT BEARING BUSH IN BEARING COVER | 11.43 |
| EXAMINING CONROD BEARING PLAY | 11.44 |
| INSTALLING CRANKSHAFT | 11.45 |
| INSTALLING CAMSHAFT | 11.47 |
| ATTACHING CHAIN BOX COVER | 11.48 |
| INSTALLING OIL PUMP | 11.49 |
| INSTALLING PISTON | 11.49 |
| INSTALLING CYLINDER | 11.50 |
| ATTACHING CYLINDER HEAD | 11.51 |
| INSTALLING INTAKE BELL AND OIL SUMP | 11.52 |
| 11.6 INSTALLING ENGINE | 11.53 |
| 11.7 REMOVING AND DISASSEMBLING, ASSEMBLING AND INSTALLING OIL COOLER | 11.55 |
| REMOVING AND DISASSEMBLING OIL COOLER | 11.55 |
| 11.8 TROUBLESHOOTING ENGINE | 11.56 |

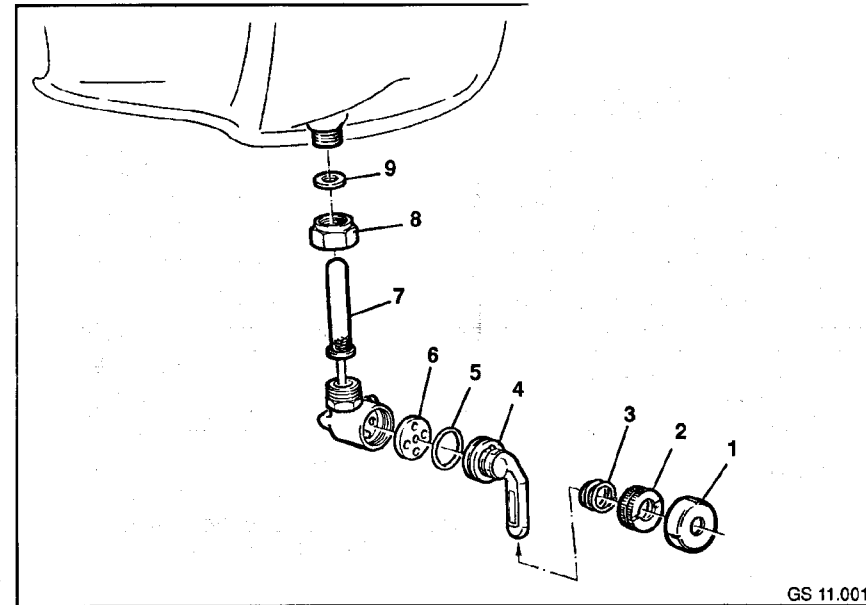

GS 11.001

11.1 FUEL PREPARATION

- Remove seat.
- Remove fuel tank.

REMOVING AND DISASSEMBLING FUEL TAP

- Drain fuel tank.
- Slacken the union nut (8) and take fuel tap off fuel tank.
- Remove fuel strainer (7) and seal (9).
- Slacken knurled nut (2) after taking off cap (1).
- Remove spring (3) and operating lever (4).
- Examine O-ring (5) and seal (6) for signs of damage.

The fuel tap is assembled and installed in the reverse order by analogy to disassembly and removal.

REMOVING AND INSTALLING BOWDEN CABLE FOR COLD START DEVICE

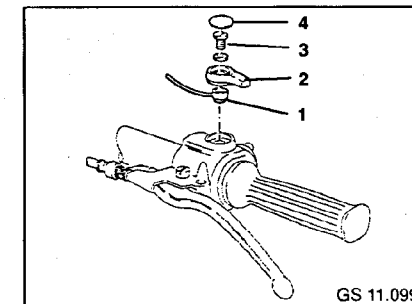

GS 11.099

- Take protective cap (4) off lever (2) of the cold start device.
- Slacken the fastening screw (3) and take off lever of cold start device.
- Detach cable (1).

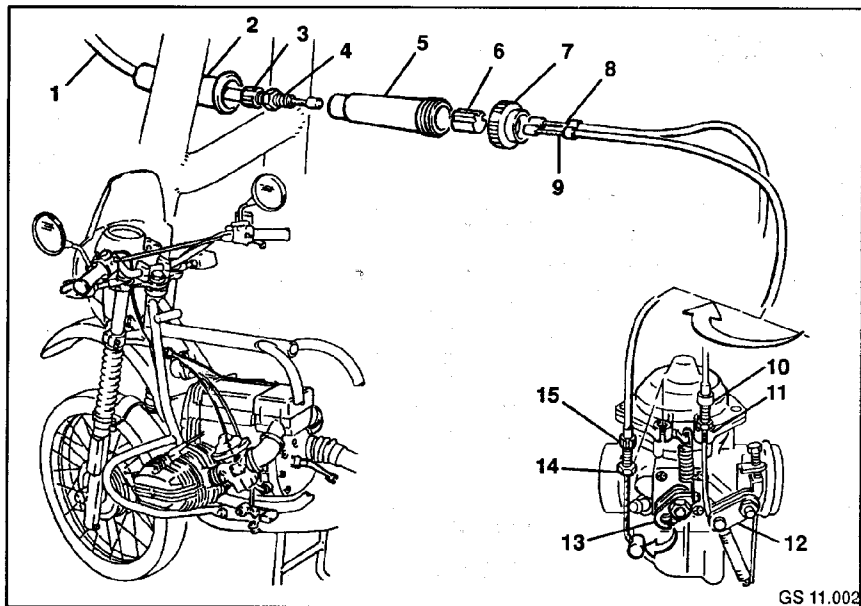

GS 11.002

- Push back protective cap (2) of distributor.
- Slacken locking nut (4) on cable (1).
- Screw in adjusting screw (3) fully.
- Turn sleeve (5) of the distributor, holding the knurled section (7) at the same time.
- Detach cable (8,9) from distributor and remove.
- Slacken locking nuts (14) at the carburetors.
- Unscrew adjusting screws (15) fully.
- Detach left/right cables at the levers (13) of the cold start device.

The Bowden cables of the cold start device are installed in the reverse order by analogy to removal.

NOTE:

After installing, adjust Bowden cables so that the cold start device opens fully.

REMOVING AND INSTALLING BOWDEN CABLES FOR THROTTLE CONTROL

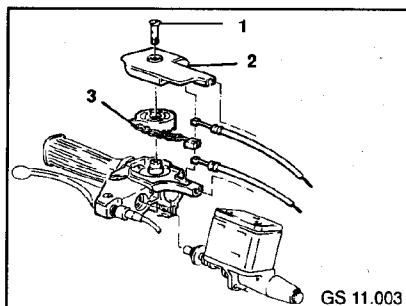

GS 11.003

- Remove seat.
- Remove fuel tank.
- Cut through cable strap on handle bars.

- After slackening the fastening screw (1), take off cover (2) on the right handle bar control.
- Detach cables from chain (3).
- Slacken locking nuts (11) on the carburetors.
- Unscrew adjusting screws (10) fully.
- Detach throttle cables at lever (12) of the throttle control and remove.

The Bowden cables for the throttle control are installed in the reverse order by analogy to removal.

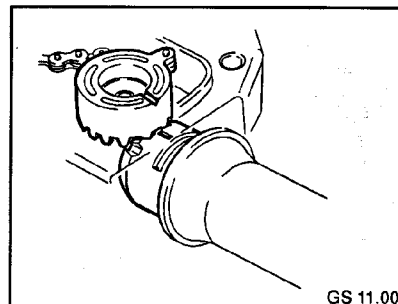

GS 11.004

CAUTION:

When installing the cables at the grip unit, ensure that the marking on the adjusting cam is aligned with the marking on the throttle twist grip (refer also to Installing grip unit, Section 6).

REMOVING CARBURETTOR

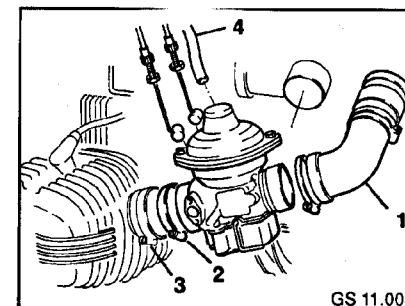

GS 11.005

- Remove air line (1) after slackening the hose clips and pushing back the rubber sleeve.
- Withdraw carburetors complete from intake line after slackening the hose clips (2,3).
- Detach petrol line (4) from carburetor.
- Remove Bowden cables for cold start device and throttle control of carburetors.

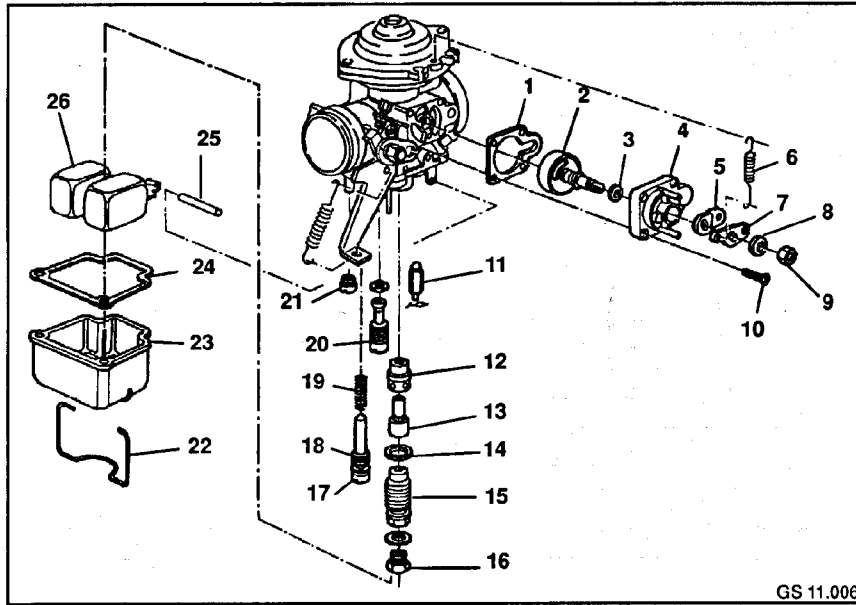

GS 11.006

DISASSEMBLING CARBURETTOR

NOTE:

Clean components with cleaning fluid and blow out nozzles with compressed air.

- Slacken the clamp (22) and take off float housing (23).
- Knock out float pin (25) with punch (dia. 2 mm) and take off float.
- Take off float needle (11).
- Examine float (26) for signs of damage:
 - parallelism of float bodies.
 - weight of float (leaks).
 - jamming float pin.
- Examine float needle (11) for signs of damage:
 - damage (notch) to float needle tip.
 - dirt on tip or seat in carburettor.

- Examine float pin for bending.
- Examine cork seal (24), renew if necessary.

REMOVING NOZZLE SET

- Slacken oval-head screw (21).
- Slacken main nozzle (16).
- Slacken idle nozzle (20).
- Slacken mixture adjusting screw (17).
- After slackening the nozzle assembly (15), remove atomizer (12) and needle nozzle (13).
- Examine sealing rings (14,18), renew if necessary.
- Detach spring (6) at starter lever (7).
- After slackening the nut (9) on shaft of start carburettor (2), take off spring washer (8) and both levers (5,7).
- Slacken the 4 fastening screws (10) and take off start carburettor housing (4) and gasket (1).
- Take off start carburettor and clean.
- Examine gasket (1) and O-ring (3), replace if necessary.

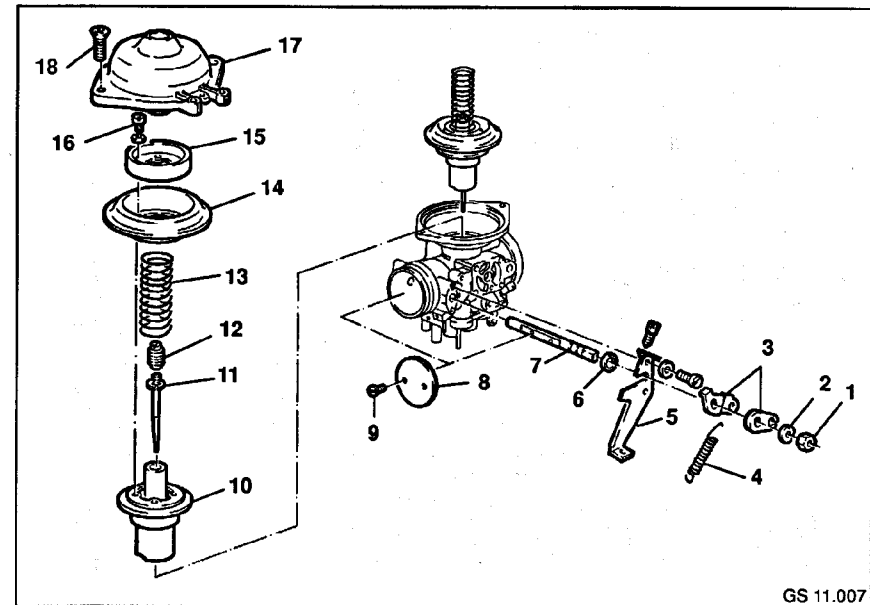

GS 11.007

- Slacken the 2 fastening screws (18) and take off carburettor cover (17).
- Withdraw spring (13) from carburettor housing.
- Remove piston (10) complete with diaphragm (14) from carburettor housing.
- After slackening the 4 fastening screws (16), separate retaining ring (15) and diaphragm (14) from piston.
- Unscrew nozzle needle screw (12) from piston.
- Remove nozzle needle (11).
- Clean carburettor housing with cleaning agent.
- Clean all bores with compressed air.

- Examine diaphragm (14) for cracking and porous points.
- Check needle position.
- Detach spring (4) from throttle lever (3).
- After slackening the nut (1), take nozzle lever (3) together with spring washer (2) off the shaft (7).
- After slackening the 2 fastening screws, take off mounting bracket (5).
- After slackening the 2 fastening screws (9), take throttle valve (8) off shaft.
- Withdraw shaft and examine O-rings (6); replace if necessary.

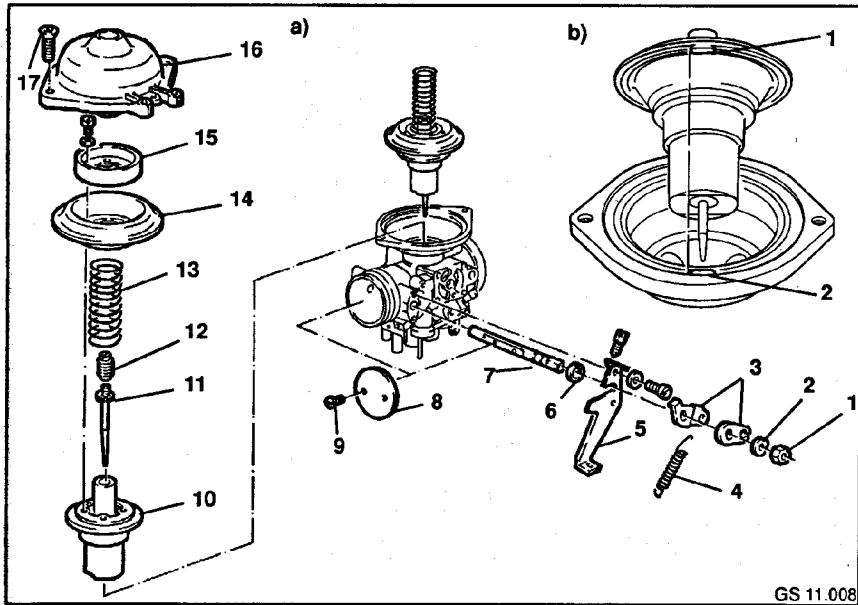

GS 11.008

ASSEMBLING CARBURETTOR

- Insert throttle valve shaft (a/7) complete with both O-rings (a/6) in carburettor housing.
- Attach throttle valve (a/8) to shaft and screw tight with two fastening screws.
- Screw mounting bracket tight (a/5) with 2 fastening screws.
- Fit both throttle adjusting levers (a/3) and spring washer onto throttle valve shaft.
- Screw adjusting levers tight with nut (a/1).
- Attach spring (a/4) into adjusting levers and mounting bracket.
- Insert nozzle needle (a/11) into piston (a/10) and screw in nozzle needle screw (a/12).

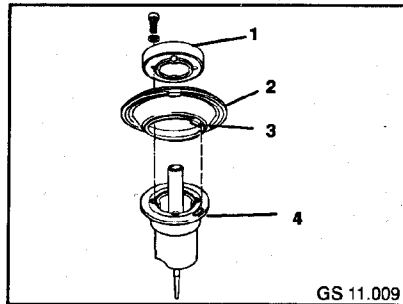

GS 11.009

NOTE:

The lug (3) on the inner collar of the diaphragm must be located in the piston groove (4).

- Mount diaphragm (2) onto piston.

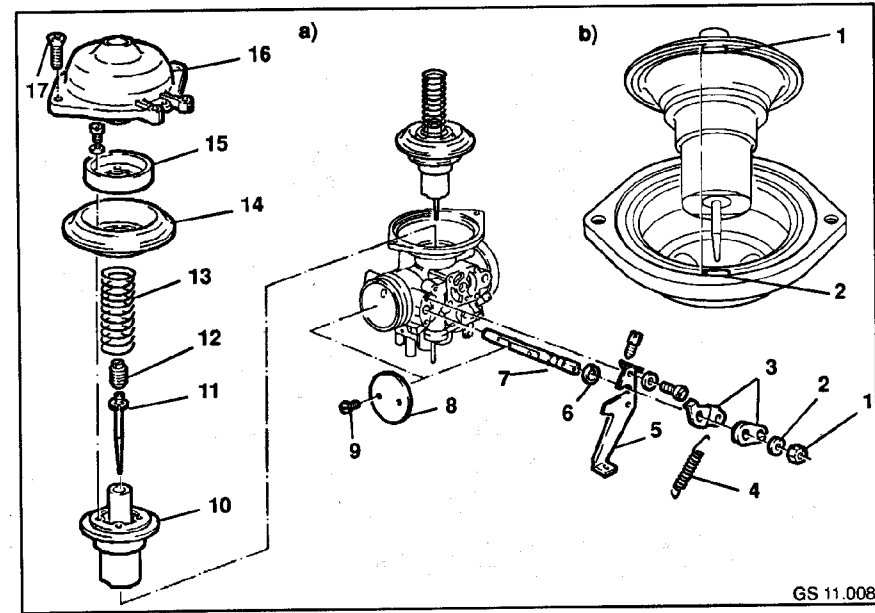

GS 11.008

- Screw retaining ring (1) tight with four fastening screws.

NOTE:

When inserting the piston in the carburettor housing, the lug (b/1) on the outer collar of the diaphragm must be inserted into the groove (b/2) of the carburettor housing.

- Insert piston with diaphragm into the carburettor housing.
- Insert spring (a/13).

- Screw carburettor cover (a/16) tight with two fastening screws (a/17).

NOTE:

Grease shaft of start carburettor with Graphite grease. Starter disc and shaft must move freely.

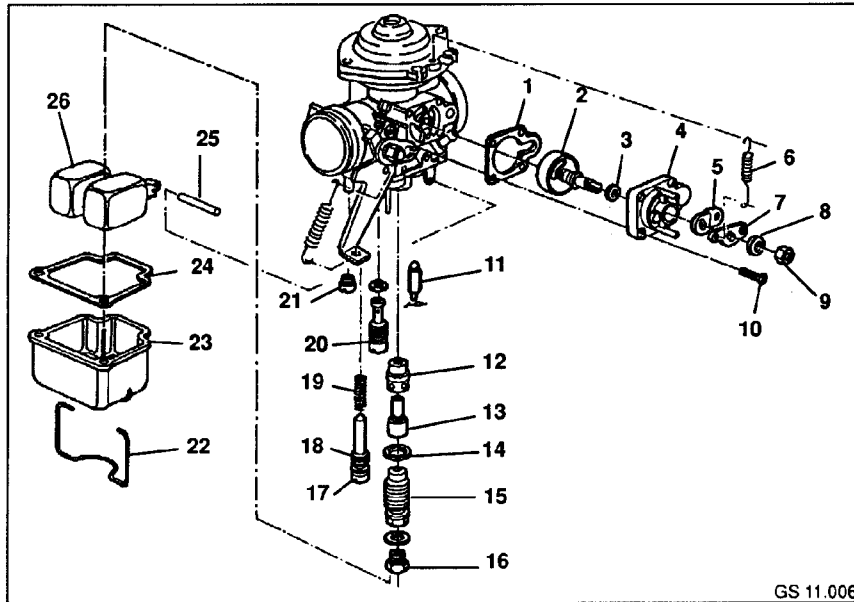

GS 11.006

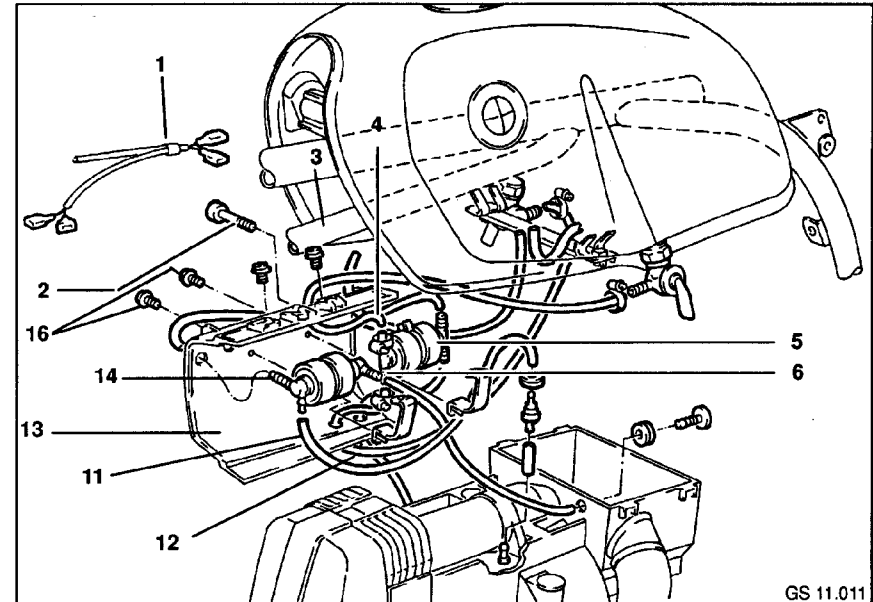

GS 11.011

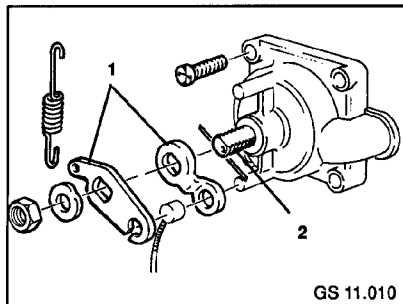

GS 11.010

CAUTION:

When installing the starter levers (1), pay attention to the position of the starter shaft. The punch point (2) must be facing in the direction of the opening for attaching cable.

- Insert start carburettor (2) in housing (3).
- Fit on gasket (1) for start carburettor.

- Fit start carburettor (2) onto carburettor.
- Screw start carburettor tight with four fastening screws (7).
- Fit both starter levers (8) and one spring washer (5) onto shaft.
- Screw starter levers tight with nut (6).
- Attach spring (4) to starter lever.
- Insert float needle (9) and float (19).
- Secure float by knocking in pin (8).
- Fit on gasket (20).
- Insert needle nozzle (11) and atomizer (10) into carburettor.
- Insert sealing ring (12) and screw in nozzle assembly (13).
- Fit spring onto mixture adjusting screw (15).
- Screw in mixture adjusting screw.
- Screw in idle nozzle (17).
- Fit washer to main nozzle (14) and screw in nozzle.
- Fit on float housing (21) together with gasket (20).
- Close clamp (22).

ANNEX TO SECTION 11.1

REMOVING SHED FUEL SYSTEM (USA)

- After slackening 2 fastening screws (2), turn starter cover (13) to the right side.
- After slackening 2 hose clips of the solenoid fuel shut-off valve (5), withdraw 4 fuel hoses (4,6,11,12).
- Detach cable connections (1).
- After slackening the 2 fastening screws (3), remove solenoid fuel shut-off valve with clip (6) from the starter cover.

- Take off clip.
- After slackening 2 hose clips, detach 3 vent hoses (10,11,15) from the solenoid air valve (14).
- After slackening the 2 fastening screws (16), take solenoid air valve with clip (9) off the starter cover.
- Remove clip.

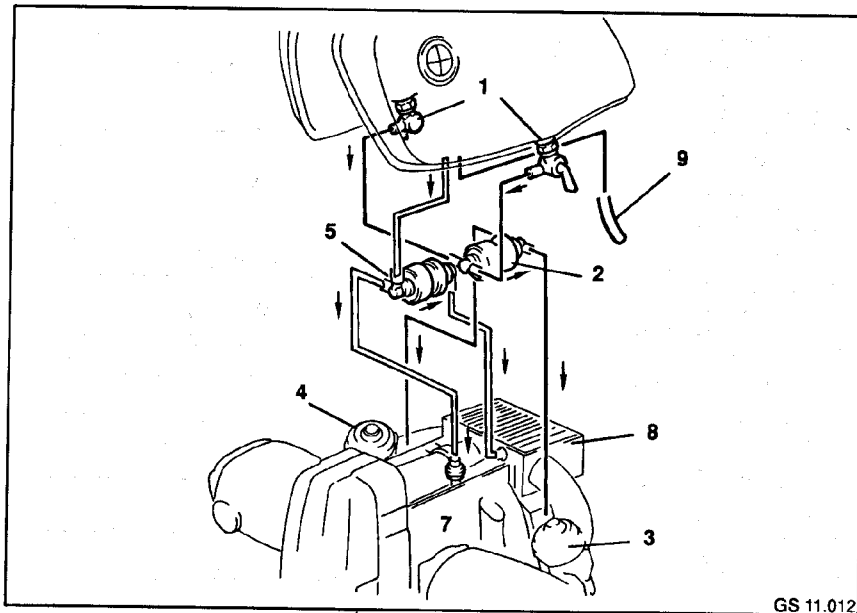

GS 11.012

- Detach pressure relief valve (7) from vent line (12) and engine housing. The fuel system is **Installed** in the reverse order by analogy to removal.

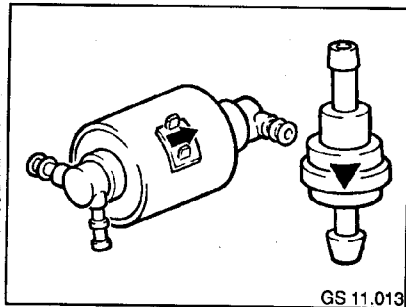

GS 11.013

CAUTION:

Pay attention to flow direction of valves when installing. Failure to do so may result in the fuel system being damaged.

SYSTEM DIAGRAM OF SHED FUEL SYSTEM (USA)

- 1 Fuel tap
- 2 Solenoid fuel shut-off valve
- 3 Carburettor, left
- 4 Carburettor, right
- 5 Vapour/vent hose
- 6 Solenoid air valve
- 7 Pressure relief valve
- 8 Air cleaner element
- 9 Drainage hose

11.2 TROUBLESHOOTING SHED-SYSTEM

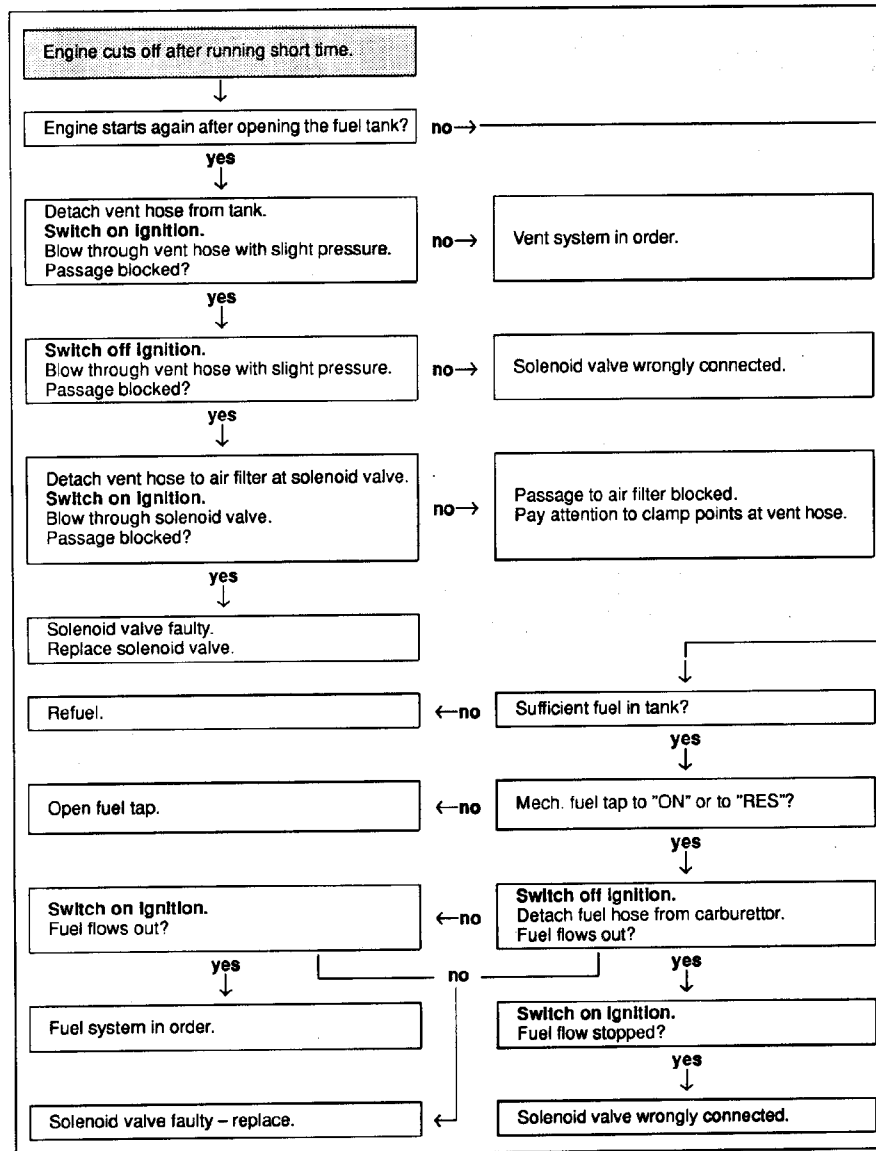

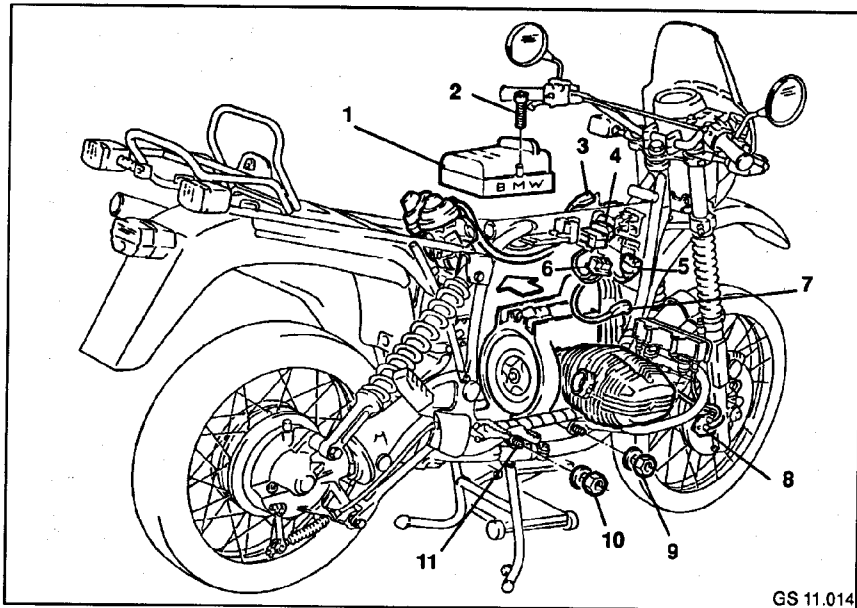

GS 11.014

11.3 REMOVING ENGINE

NOTE:

Repair work and disassembly of cylinder heads, cylinders, pistons, conrod and conrod bearings can be performed when the engine is fitted.

- Remove seat.
- Remove fuel tank.
- Remove battery.
- Remove battery mount.
- Remove air filter housing.
- Remove exhaust pipes and front silencer.
- Slacken both carburetors on cylinder head and detach fuel lines.
- Place down carburettor above battery.
- Drain engine oil.
- Detach plug of engine cable harness (3).
- Detach plug (5) from control unit (4).

- Detach multi-contact plug (6) from regulator.
- Detach spark plug connector (7) and place above frame.
- Slacken the 2 fastening screws (2) and take off starter cover (1).

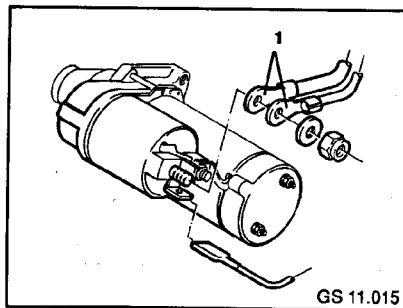

GS 11.015

- Detach battery positive cables (1) from starter.

- Remove transmission.

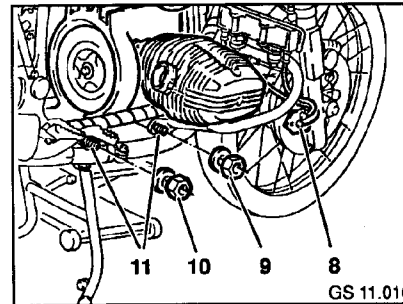

GS 11.016

NOTE:

Protect frame ties from damage by covering over with cut-open hose or similar. Collect leaked oil in suitable vessel and seal engine after removing oil filter cover.

- Slacken the 3 fastening screws and take off oil filter cover (8).
- Slacken nuts on 2 engine pins (9,10).
- Remove motor-spoiler (Paris Dakar).

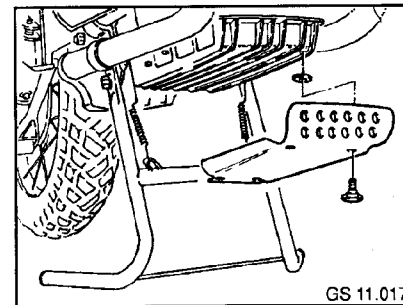

GS 11.017

- Remove engine guard (Paris Dakar).

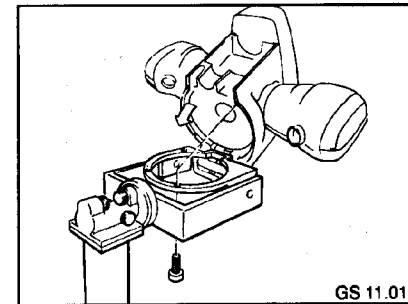

GS 11.018

- Mount engine in assembly stand, BMW No. 00 1 490, on device, BMW No. 11 0 600.
- Attach engine block to device, BMW No. 11 0 600, with three bolts.

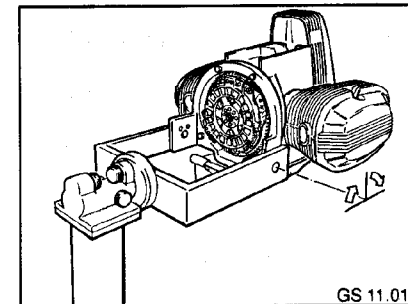

GS 11.019

- Swivel engine with device.

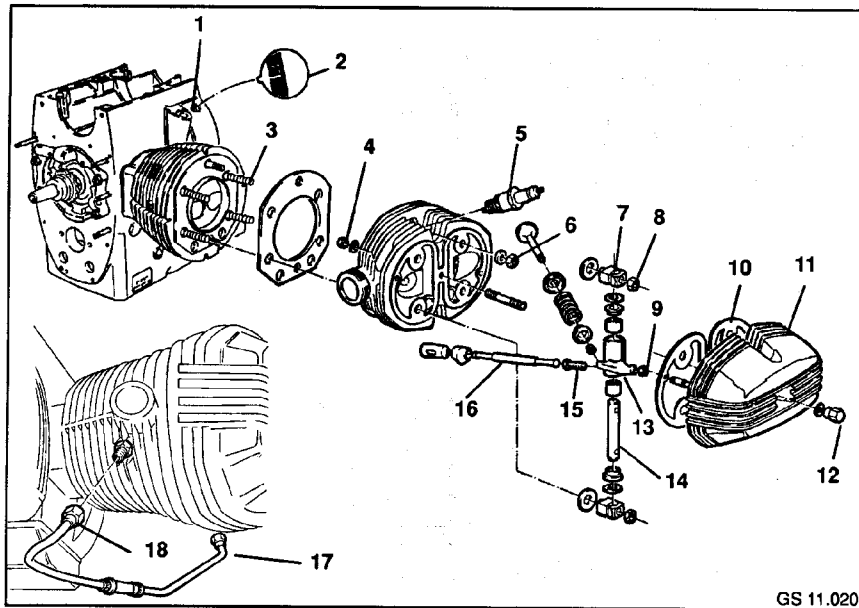

GS 11.020

11.4 DISASSEMBLING ENGINE

NOTE:

The engine does not require to be removed for performing repair work and disassembly of cylinder head, cylinders, pistons, conrod and conrod bearings.

REMOVING CYLINDER HEAD

- Take off cylinder head cover (11) after slackening the cap nut (12) and the 2 fastening nuts (4).
- Remove gasket (10) of cylinder head cover.
- Slacken spark plug (5).
- Turn clutch flange to position piston at compression TDC.
- With engine installed, engage 5th gear and set TDC by turning rear wheel.

NOTE:

Compression TDC is reached when

1. The TDC mark (2) appears in the inspection hole on the left engine housing (1) and
2. Inlet and exhaust valves of the appropriate cylinder are closed (play can be felt at rocker arm).

- Slacken locking nuts (9) at adjusting screws (15).
- After slackening the 4 collar nuts (8), take off rocker arm (13) together with clamping blocks (7) and rocker arm shafts (14).
- Withdraw tappet rods (16).
- Slacken cylinder head nuts (6).
- Detach cylinder head from cylinder with light blows from a plastic-headed hammer.
- Pull cylinder head off the tie-bolts (3).

NOTE:

On the USA engine version, slacken union nut (18) and take air line (16) off the cylinder head before removing the cylinder head.

DISASSEMBLING CYLINDER HEAD

Removing valves

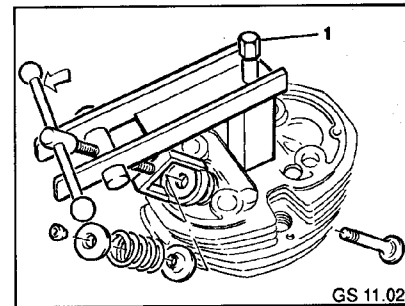

GS 11.021

- Mount valve spring tensioning device, BMW No. 11 12 750, onto cylinder head.
- Clamp tensioning device tight with central nut (1).
- Press valve spring down by turning spindle.
- Separate valve cone from spring plate by light blows to the bottom of the valve (valve head).
- Use a magnet or pincers to remove valve collets (5).
- Release pressure on device.
- Take off valve spring (3), top and bottom spring plates (2,4).
- Withdraw valves down the way.

Examining cylinder head.

- Carefully clean combustion residues off combustion chamber and quench edge.
- Examine combustion chamber in area of spark plug bore/seat for signs of cracking.
- Examine sealing surface for signs of damage, smooth off if necessary.

Examining valves and valve guides for wear

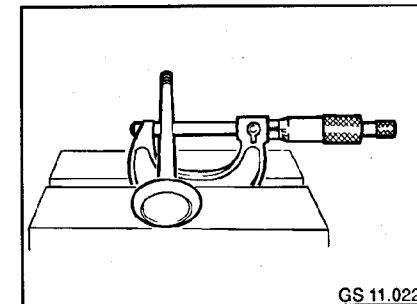

GS 11.022

- Clean combustion residues of valves.
- Check diameter of valve stem (Vs) with external micrometer.

Wear limit for valve stem diameter (Vs min):

| | |
|---------|----------|
| Inlet | 7.925 mm |
| Exhaust | 7.915 mm |

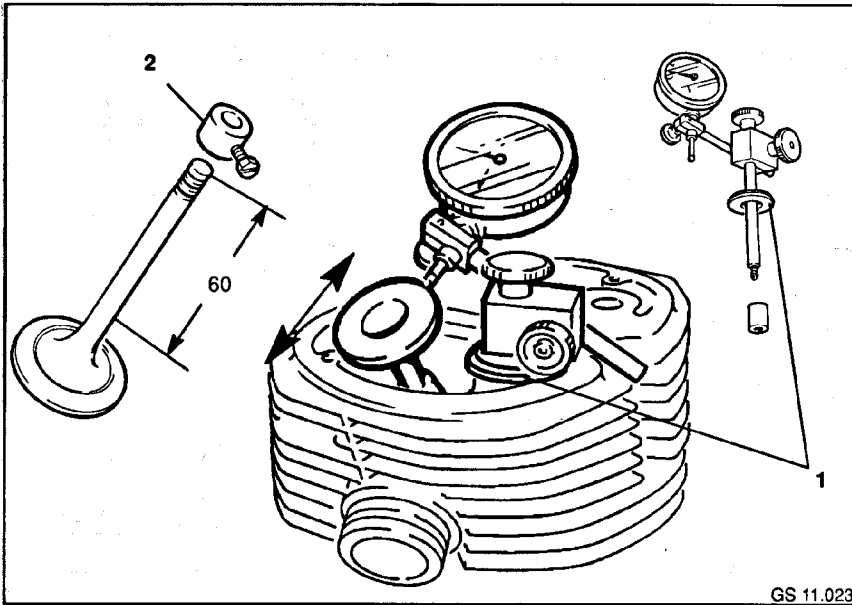

GS 11.023

CHECKING VALVE GUIDE FOR WEAR

Measuring valve tilt angle (at rocker end)

- Attach measuring device BMW No. 00 2 500 with a 4 mm washer (1) to the tierod hole in the cylinder head.
- Make up a clamp from an old valve guide and attach it at the correct distance to the stem of a new valve.

NOTE:

Always use a new valve to measure the tilt angle.

- Insert the valve from the rocker side.
- The valve stem must enter the guide by 60 mm.

- Insert the dial gauge, BMW No. 00 2 510, into the dial gauge holder and align the sensing pin with the longitudinal axis of the cylinder head.
- Allow the sensing pin to contact the edge of the valve head.
- Hold the valve head at the side, press the valve forwards along the line of the cylinder head and set the dial gauge to zero.
- Move the valve head to and fro, and note the reading at the dial gauge pointer.
- Pull out the valve.

NOTE:

Always measure valve stem tilt angle at the rocker end and at the combustion chamber end.

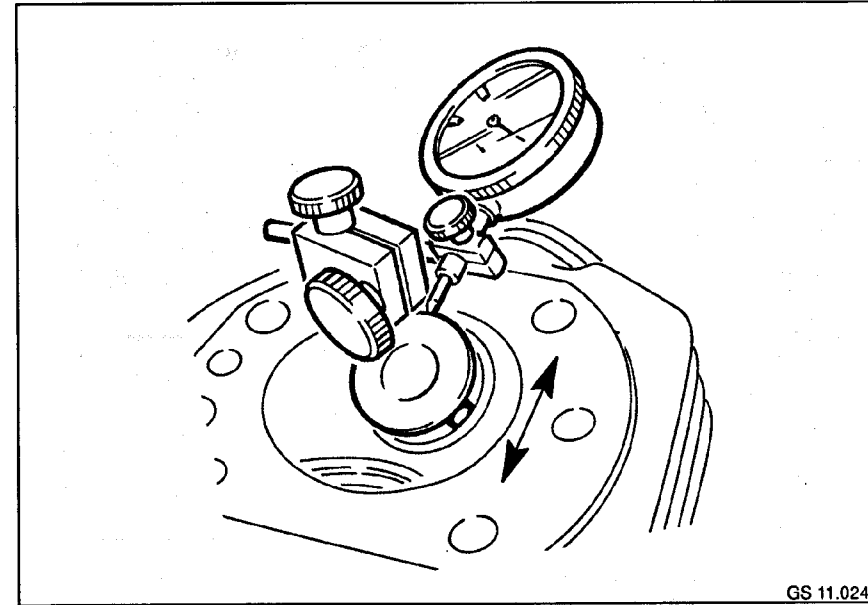

GS 11.024

Measuring valve tilt angle (at combustion chamber end)

- Secure the measuring device, BMW No. 00 2 500, to the tierod hole in the cylinder head without the washer.
- Insert the valve into the valve guide with the clamping device.
- Attach the dial gauge, BMW No. 00 2 510, to the dial gauge holder.
- Align the sensing pin with the longitudinal axis of the cylinder head.
- Zero the dial gauge and determine the valve stem tilt angle on the longitudinal axis.

*Permissible valve stem tilt angle:
If the angle exceeds 0.7 mm at either of the two measuring points, the valve guide must be remachined or renewed.*

- If the valve guide is remachined, the diameter at the upper and lower ends must not exceed 8.3 mm (size of reamer).

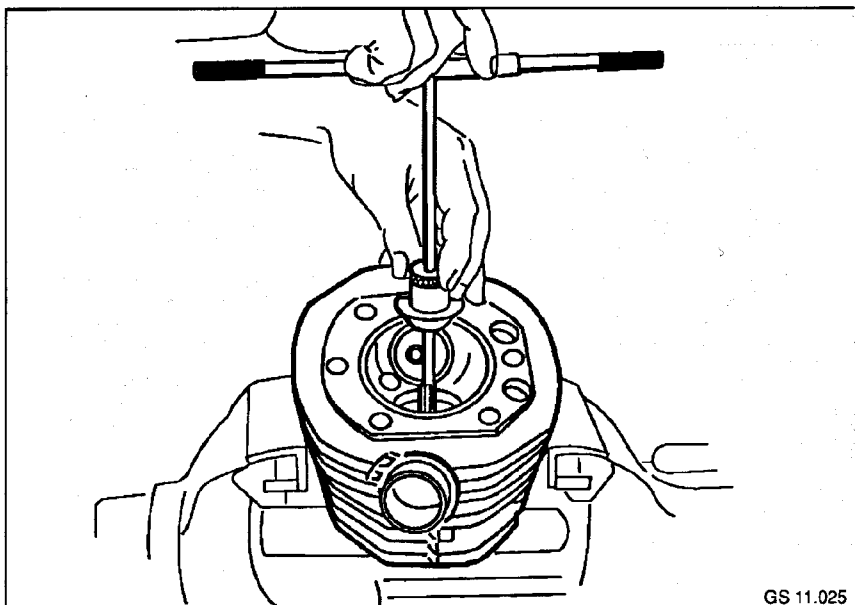

GS 11.025

Reaming out valve guide

- With the combustion chamber facing upwards, clamp the cylinder head firmly in a vise, using soft jaws.
- The valve guide to be machined must be vertical.
- Place reamer guide head (1), BMW No. 00 4 603, on the valve seat.
- Begin reaming out with reamer BMW No. 00 4 601.

NOTE:

Use only thread cutting oil to lubricate the reamer.

CAUTION:

Turn the reamer clockwise only, in the cutting direction, never in the opposite direction.

- At frequent intervals, pull the reamer out (still turning only in the cutting direction) and clean off swarf.

- While reaming, press the reamer guide head into the valve seat with two fingers.
- When the valve guide is fully reamed out, take the reamer out downwards.
- Finish the bore of the valve guide with finish reamer, BMW No. 00 4 602, working in the same manner as described above.

CAUTION:

After reaming out the valve guide, the valve seat must be corrected with a suitable turning tool.

Replacing valve guides

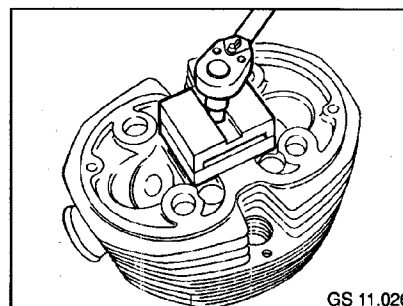

GS 11.026

WARNING:

Wear protective gloves when handling heated parts.

CAUTION:

Heat cylinder head slowly and evenly in heating oven or similar to 230°C.

NOTE:

The time required for heating cylinder head is at least 2.5 hours.

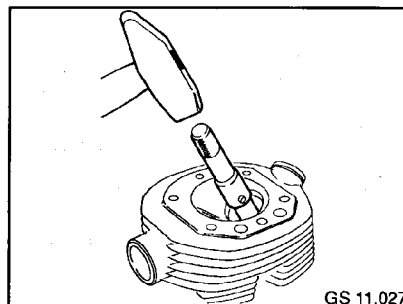

GS 11.027

- Use impact drift, BMW No. 11 1 780, to knock out valve guides as follows:
 - Slacken valve guide with vigorous blow,
 - Knock out valve guide with rapid light blows.

- Examine valve guide bore for:
 - material abrasion,
 - conical widening and
 - dimensional tolerance in H7 tolerance range (14.00 + 0.018 mm).

CAUTION:

The valve guides are inserted into the cylinder head with an overlap of 3/100 ... 6/100 mm.
It has proven ideal to maintain an overlap of 4/100 mm when performing repairs.

- Use oversize valve guide (14.25 + 0.011 mm).
- Determine actual diameter (dia. Vf) of valve guide with micrometer.
- Calculate specified diameter (dia. B) of valve guide bore:
 - dia. B = dia. Vf - 4/100 mm (overlap).
- Carefully widen bore with 14.2H7 mm reamer to the desired size.
- Determine actual diameter (dia. B) of bore with internal micrometer.
- Calculate specified diameter (dia. Vf) of valve guide:
 - dia. Vf = dia. B + 4/100 mm (overlap).
- Use oversize valve guide (14.25 + 0.011 mm).
- Turn oversize valve guide to specified size (dia. Vf).
- Valve guide bore is free of damage and dimensionally accurate in 14H7-tolerance range (14.06 + 0.018 mm) or slightly larger (max. 14.025 mm).
- Use substitute valve guide (dia. 14.06 + 0.011 mm).
- Determine actual size (dia. B) with internal micrometer.
- As a rule the bore diameter (dia. B) is between 14.018 ... 14.022 mm, so that the substitute valve guide is always within the overlap range of 3...6/100 mm and can be used without the need for reworking.

- The tolerance range of the substitute valve guide is 14.060 ... 14.071 mm.
- Measure valve guides with micrometer.
- Use the valve guide which is closest to the ideal size.

NOTE:

The time required for heating the cylinder head is at least 2.5 hours.

- Slowly heat cylinder head in heating oven or similar to a temperature of approx. 220°C.

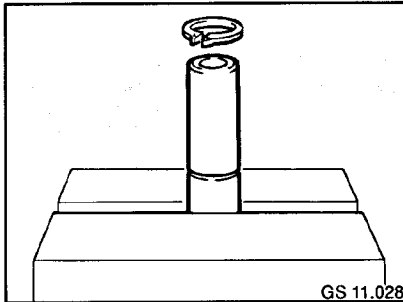

- Fit spring lock washer onto valve guide.
- Immerse valve guide in liquid grinder talc.
- Supercool valve guide with dry ice (CO₂).

NOTE:

The temperature immediately before press-fitting must be -40°C.

- Place heated cylinder head evenly on workbench or similar.

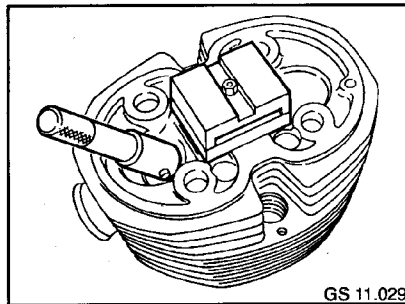

- Mount supercooled valve guide onto impact drift, BMW No. 11 1 780.
- Knock valve guide rapidly and smoothly into cylinder head until it abuts spring lock washer.
- Knock in second valve guide immediately afterwards.
- Allow cylinder head to cool to room temperature, approx. 20°C.

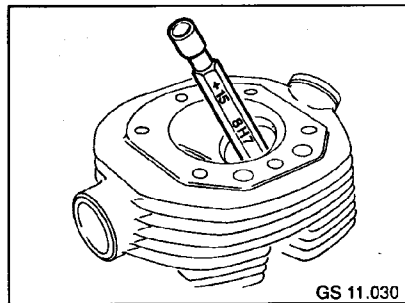

- Examine inner bore of valve guide with 8H7 plug limit gauge.

NOTE:

Valve guides for repairs are manufactured to an inner size of 8.01 H7 mm. In most cases the bore is within the 8.00 H7 mm-tolerance range after press-fitting the valve guide. If the bore is too tight, it can be widened with a mechanical reamer.

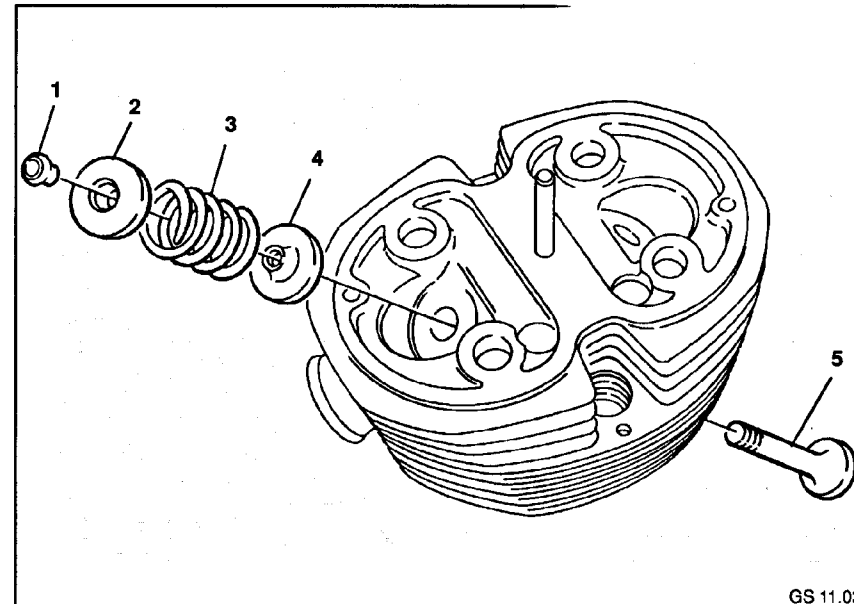

INSTALLING VALVES

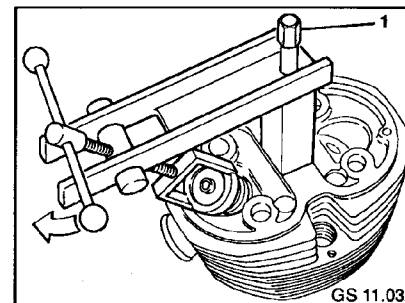

- Fit valve spring tensioning device, BMW No. 11 1 750, onto cylinder head with central nut (1).
- Insert valve (5) into valve guide.

NOTE:

Valve springs have slightly progressive windings and should therefore be installed with the coloured marking at the bottom (cylinder head end).

- Fit on bottom spring plate (4).

- Fit on spring (3).
- Fit on top springs plate (2).
- Compress valve spring with tensioning device.
- Insert valve collets (1) between top spring plate and valve stem.
- Slowly relieve pressure on valve spring.

NOTE:

Pay attention to ensuring that the valve collets are properly located in the valve stem grooves.

- Examine valves for leaks.
- Shake small quantities of fuel into inlet and exhaust passages.
- Check whether fuel flows out at combustion chamber end.

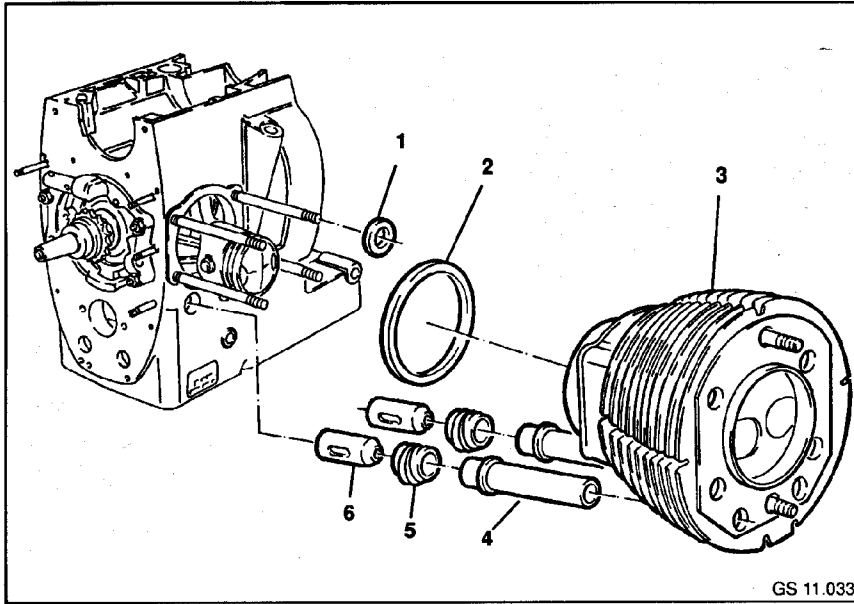

GS 11.033

REMOVING CYLINDER

CAUTION:

When removing cylinder, ensure that the piston does not strike the engine housing.

- Slacken cylinder (3) with blows from plastic-headed hammer.
- Detach cylinder from housing.

- Withdraw tappets (6) from the guides.
- Remove rubber seals (5) from tappet rod tubes (4).
- Take O-ring (2) off base of cylinder.
- Take off O-rings (1) on the top tie-bolts.

NOTE:

The O-rings mentioned should always be replaced after removing cylinder.

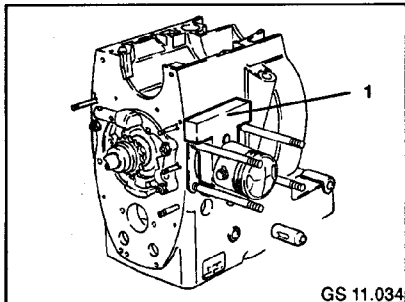

GS 11.034

- Insert protective wooden block for piston (1) behind the piston between the tie-bolts.

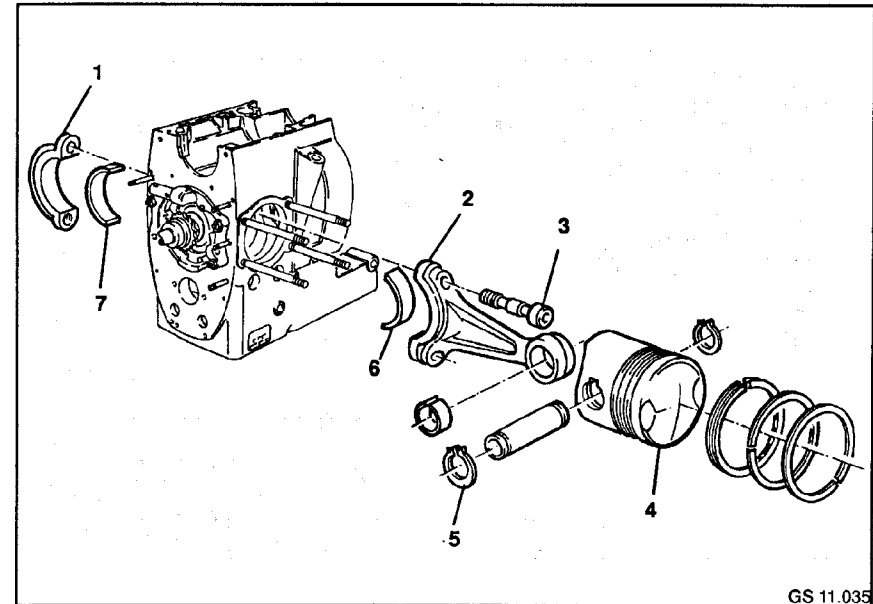

GS 11.035

REMOVING CONROD

- Release locking ring (5) on piston pin with locking ring pliers.
- Press piston pin out of conrod and piston by hand or with impact drift, BMW No. 11 2 920.
- Take off piston (4).

NOTE:

The conrod is removed with the crankshaft in the TDC position.

- Take off conrod (2) and conrod bearing cap (1) together with bearing shells (6,7).

EXAMINING PISTON AND CYLINDER

NOTE:

Reference temperature for dimensional tolerance: 20°C.

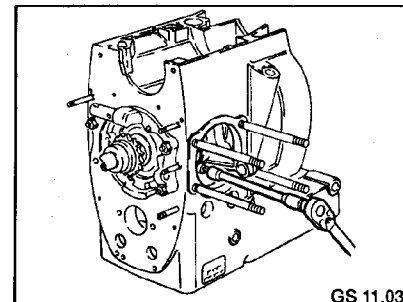

GS 11.036

- Slacken conrod bolts (3) with key for screws with internal serrations, BMW No. 11 2 860.

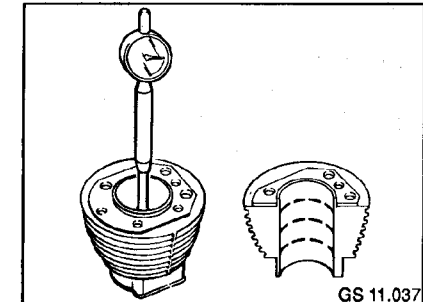

GS 11.037

CAUTION:

Use piston and cylinder of the same weight class in an engine.

- Measure cylinder bore at three levels:
 - 10 mm from above,
 - in the middle,
 - and at the bottom with internal calipers in each case in piston pin direction and at right angles thereto.

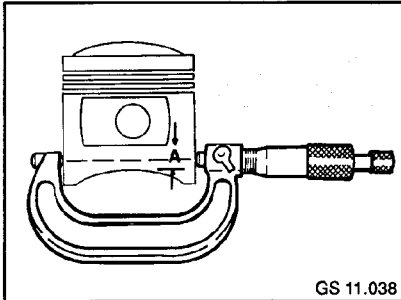

- Measure piston diameter at piston skirt with external micrometer.
- Piston outer diameter: refer to Technical Data.

Measuring level A:
R 80 GS 27 mm, R 100 GS 18 mm

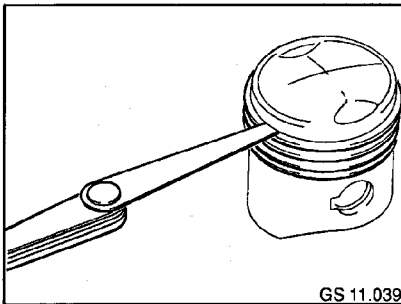

- Determine flank clearance of piston rings using feeler gauge.

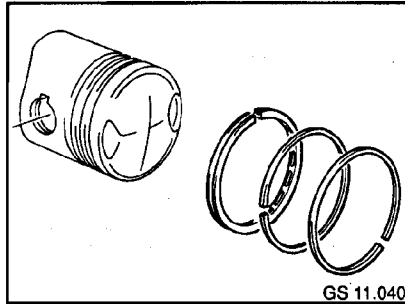

CAUTION:

Oil scraper ring and piston rings are fragile.

- Remove piston rings from piston with suitable pliers.

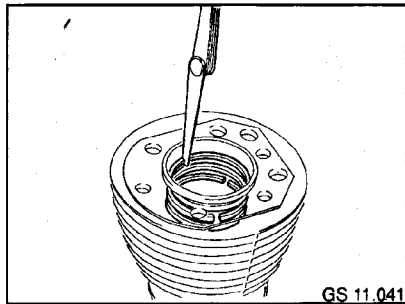

- Insert piston rings in cylinder.
- Determine clearance of piston rings with feeler gauge.
- Fit piston rings onto piston in the following order:
 - 3rd groove oil scraper ring (1)
 - 2nd groove taper face ring (2)
 - 1st groove taper face ring (3)

Clearances:

| | |
|--|----------|
| Max. total clearance for wear of piston and cylinder | 0.08 mm |
| Perm. out-of-round of cylinder bore | |
| 20 mm from top edge | 0.005 mm |
| 115 mm from top edge | 0.01 mm |

Clearance of piston rings

| | |
|----------------------------|------------------|
| Taper face ring 1st groove | 0.30 ... 0.50 mm |
| Taper face ring 2nd groove | 0.30 ... 0.50 mm |
| Oil scraper ring | 0.25 ... 0.40 mm |

Flank clearance of piston rings

| | |
|----------------------------|--------------------|
| Taper face ring 1st groove | 0.050 ... 0.082 mm |
| Taper face ring 2nd groove | 0.040 ... 0.072 mm |
| Oil scraper ring | 0.030 ... 0.062 mm |

EXAMINING AND REPAIRING CONROD

CAUTION:

Both conrods within an engine must have the same weight and colour markings.

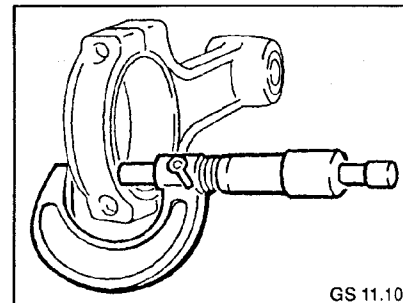

- Measure conrod width at big-end bearing with micrometer screw.

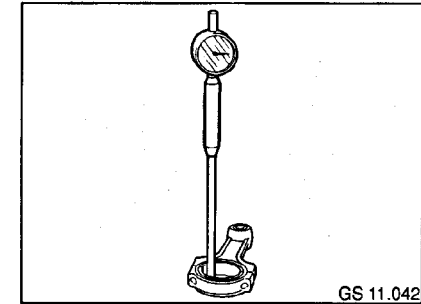

- Use internal calipers to check that piston bush is tightly located and has correct dimensional tolerance.
- If wear limit is exceeded, press out piston bush.

NOTE:

If a new bush is fitted, it must be possible to push in the piston pin by hand.

Conrod dimensions:

| | |
|---------------------------------|--|
| Conrod bush OD | 24.060 ... 24.100 mm |
| Wear limit ID | |
| Conrod bush | 22 + 0.040 mm |
| Conrod width at big-end bearing | 22 ^{-0.065} _{0.017} mm |

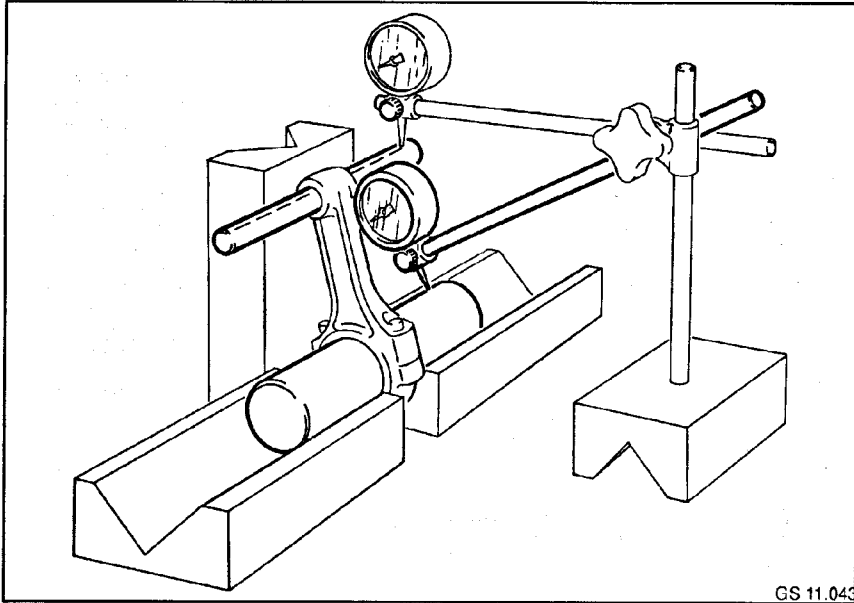

GS 11.043

EXAMINING CONROD FOR PARALLELISM AND TWISTING

- Press in bearing shells which are intended to be used in conrod for examination.

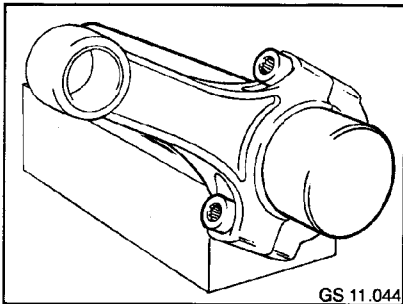

GS 11.044

- Mount conrod on hardened and ground inspection mandrel.
- Tighten conrod bolt.

CAUTION:

The inspection mandrel must not have any radial play in the big-end bearing bore.

- Insert a ground plug gauge (269/1), approx. 300 mm long, into piston pin bush.
- Align plug gauge so that it projects equally at both ends.
- Fit two equally large Vee blocks onto an alignment plate.
- Place inspection mandrel with conrod onto the Vee blocks.
- Position conrod vertically at the third, upright Vee block.
- Use a bench dial gauge to measure the parallelism of the piston pin axis to the big-end bearing journal axis.

Conrod dimensions:

Max. term. variation in parallelism of conrod bores 0.04 mm

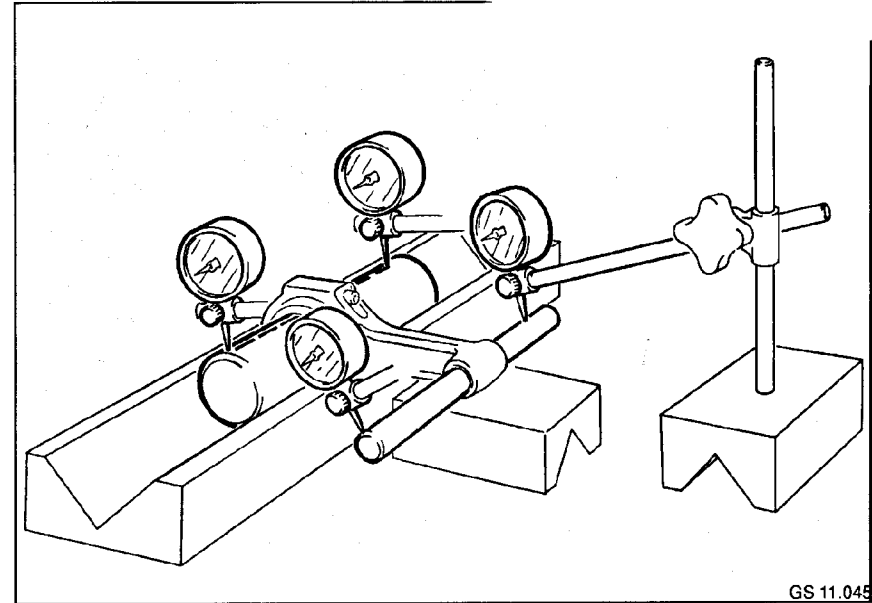

GS 11.045

- Place inspection mandrel with conrod onto two equally large Vee blocks.
- Support conrod at piston pin boss so that the piston from the alignment plate to the middle of the big-end bearing and piston pin bore is approximately the same.
- Use dial gauge to examine conrod for twisting (at ends of plug gauge).
- If excessive twisting (out-of-tolerance) is present, replace conrod.

CAUTION:

Carefully clean conrod bearing basic bore before assembly.

- Insert bearing shells in conrod bearing basic bore.

Conrod dimensions:

Max. variation in twisting of conrod bores 1.5 mm

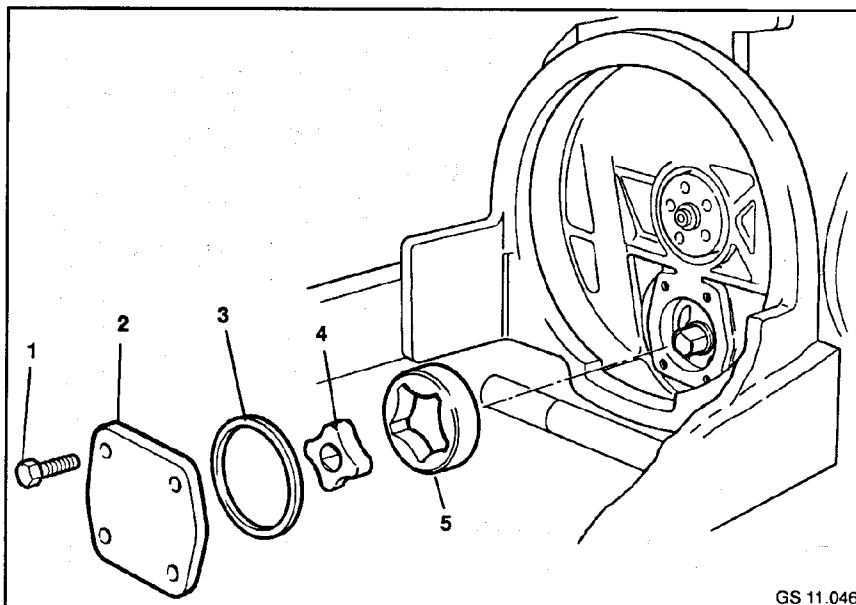

GS 11.046

REMOVING OIL PUMP

- Remove clutch housing.
- Slacken the 4 slackening bolts (1) and take off oil pump housing cover (2).
- Use wire hook or similar to pull inner rotor (4) out of pump housing.
- Withdraw outer rotor (5) by analogy.

EXAMINING OIL PUMP

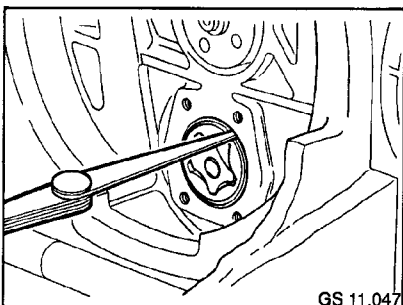

GS 11.047

- Determine clearance between outer rotor and pump housing using feeler gauge.

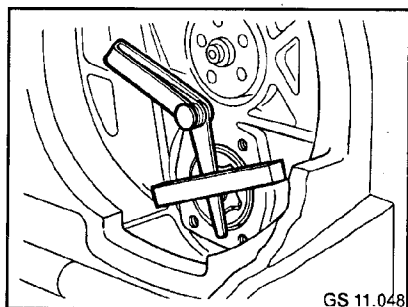

GS 11.048

- Determine clearance between mating surface (pump housing) and sealing surface (rotor) using feeler gauge.

Oil pump clearances:

| | |
|--|---------------------------|
| <i>Outer rotor/pump housing</i> | <i>0.15 ... 0.29 mm</i> |
| <i>Mating surface (pump housing)/sealing surface (rotor)</i> | <i>0.025 ... 0.070 mm</i> |

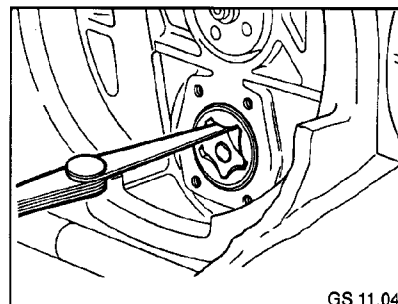

GS 11.049

- Determine size of gap between inner and outer rotors using feeler gauge.

ASSEMBLING OIL PUMP

- Replace O-ring (3) in the end cover.

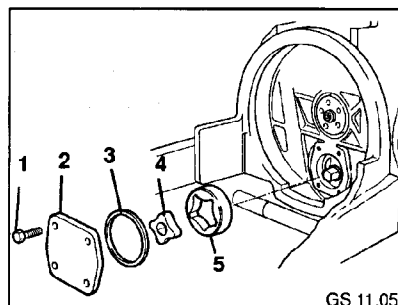

GS 11.050

NOTE:

When assembled, the O-ring (3) must be pressed far enough into the groove of the housing cover for the housing cover to be positioned flat against housing mating surface.

- Fit on oil pump housing cover.
- Tighten four fastening bolts.

Oil pump clearance:

Gap inner/outer rotor

0.12 ... 0.20 mm

REPLACING RADIAL SEAL FOR CRANK SHAFT SEAL

Removing seal

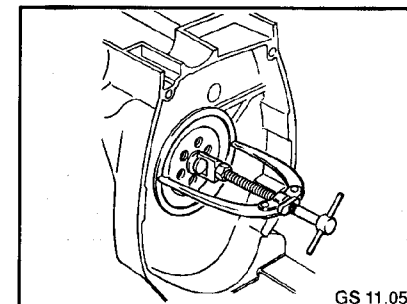

GS 11.051

- Remove thrust ring with extract device, BMW No. 11 1 870, in combination with supporting bridge, BMW No. 00 8 560.
- Take O-ring off thrust ring.

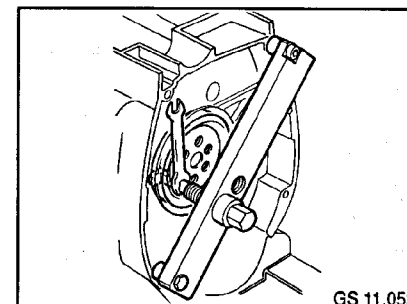

GS 11.052

- Cut into lip of sealing ring at bottom over a length of approx. 5 cm.
- Attach extractor tool, BMW No. 11 1 890, to engine housing.
- Insert extractor spindle.
- Push eccentric lug through cut in seal until it touches friction washer.

NOTE:

Eccentric lug must be facing down the way.

- Hold tight at extractor spindle and withdraw seal by turning the nut clockwise.

Installing seal

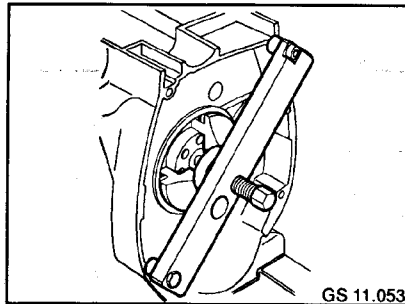

GS 11.053

NOTE:

The seal should be fitted onto the impact drift, BMW No. 11 1 880, approx. 2 hours before being installed, in order to pre-shape it.

- Attach extractor tool, BMW No. 11 1 890, to engine housing.
- Fit new seal onto impact drift, BMW No. 11 1 880.
- Fit on thrust piece.
- Move impact drift up against engine housing.
- Press in seal by screwing in spindle.

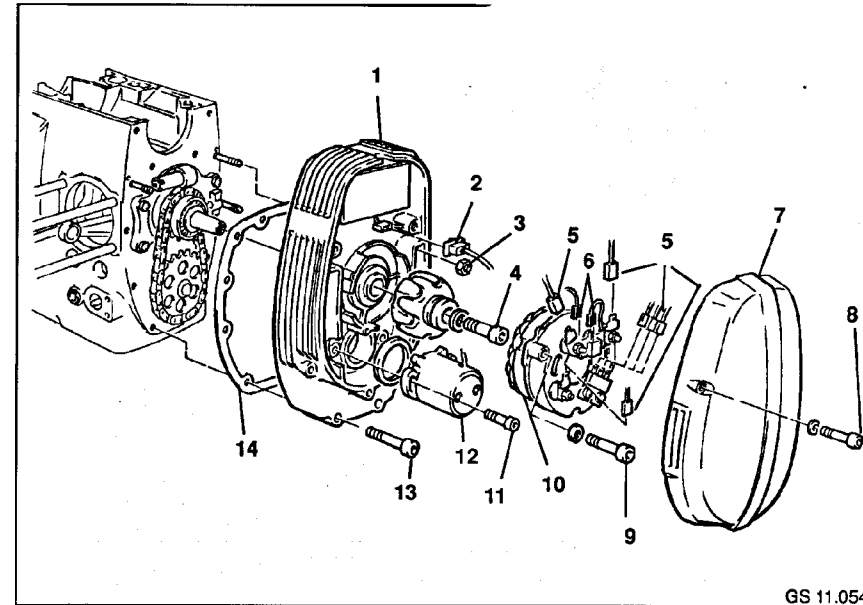

GS 11.054

REMOVING CHAIN BOX COVER

- Take off engine guard cover (7) after slackening the 2 fastening screws (8).
- Detach plug connection of ignition trigger (2) after removing the wire clamp.
- Take off ignition trigger (12) after slackening the 2 fastening screws (11).
- Detach 6 flat-blade plugs (5) from alternator.
- Raise carbon brushes (6) slightly and fix in this position with springs.
- Take off pole housing (10) after slackening the three fastening screws (9).

- Use forcing screw, BMW No. 12 3 600, to press rotor (1) off crank shaft.
- Slacken 9 fastening screws (13) and 3 fastening nuts (3) on chain box cover (1).

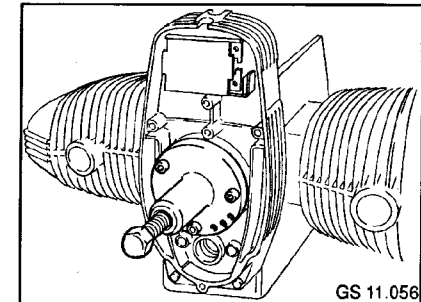

GS 11.056

- Screw puller device, BMW No. 11 1 800, onto the tapped holes for securing the alternator housing.
- Fit on thrust plate for puller.
- Pull off chain box cover.
- Remove gasket (14).

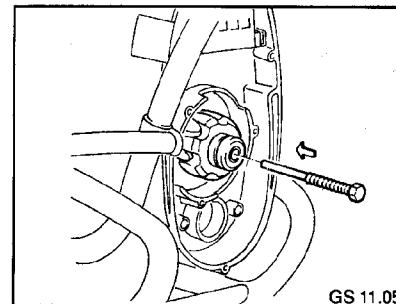

GS 11.055

- Slacken rotor fastening screw (4).

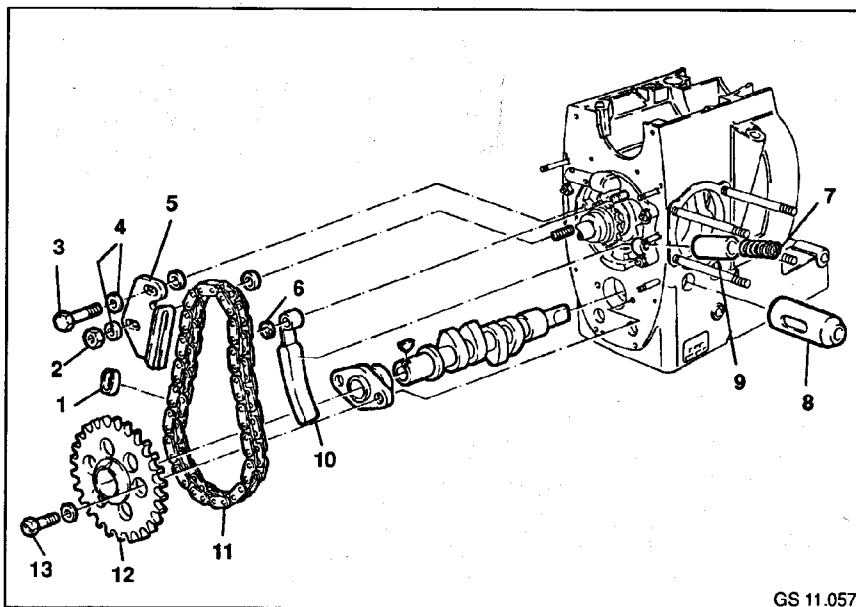

GS 11.057

REPLACING RADIAL SEAL FOR CRANK-SHAFT SEAL

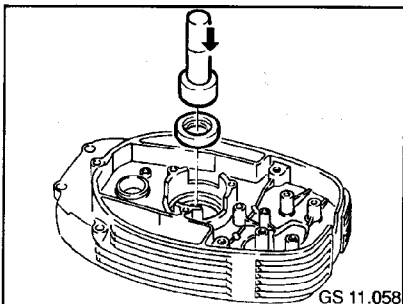

GS 11.058

- Knock out radial seal for front crankshaft journal with impact drift, BMW No. 11 1 850.
- Insert new seal with impact drift.

REMOVING CAMSHAFTS

- Take off chain guide bar (5) after slackening the fastening bolt (3) and nut (2).
- Take off spacer rings (4).
- Remove chain tensioning lever (10) after releasing the locking ring (6).

NOTE:

If a chain without chain joint is fitted, the chain must be removed together with the corresponding sprocket wheel.

- Open chain joint (1) and slowly release tension on chain (11).
- Take off chain, piston (9) and spring (7) of chain tensioner.
- Withdraw tappet (8) from engine block using wire hook or magnet.

- Turn sprocket wheel (12) so that the fastening bolts of the camshaft are visible.
- Slacken 2 fastening bolts (13) on the camshaft flange.

CAUTION:

Do not damage sealing surface.

- Use two screwdrivers to lever out camshaft at sprocket wheel.
- Withdraw camshaft complete from engine housing.

EXAMINING CAMSHAFT

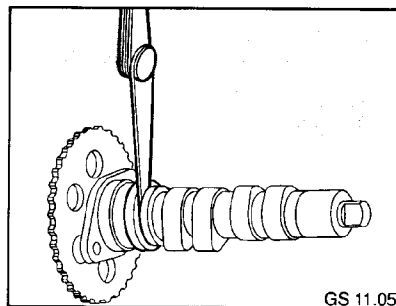

GS 11.059

- Examine end play of camshaft flange bearing with feeler gauge.

Camshaft play:

End play camshaft flange bearing $0.1 \pm 0.02 \text{ mm}$

NOTE:

If there has been a change to the end play in use, the sprocket wheel must be additionally secured to the interference fit with Loctite.

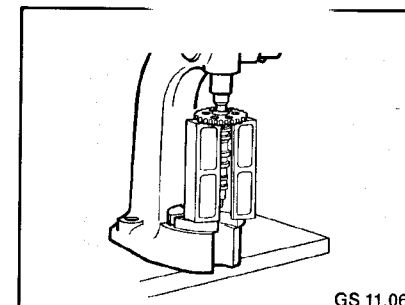

GS 11.060

- Press sprocket wheel off camshaft.

CAUTION:

Pay attention to half-moon wedge. If Loctite is used as an additional safeguard, the bearing flange must be oiled beforehand.

- Position feeler gauge (thickness 0.1 mm) between camshaft thrust collar and flange bearing.
- Press sprocket wheel onto camshaft.
- Re-check end play of camshaft flange bearing.

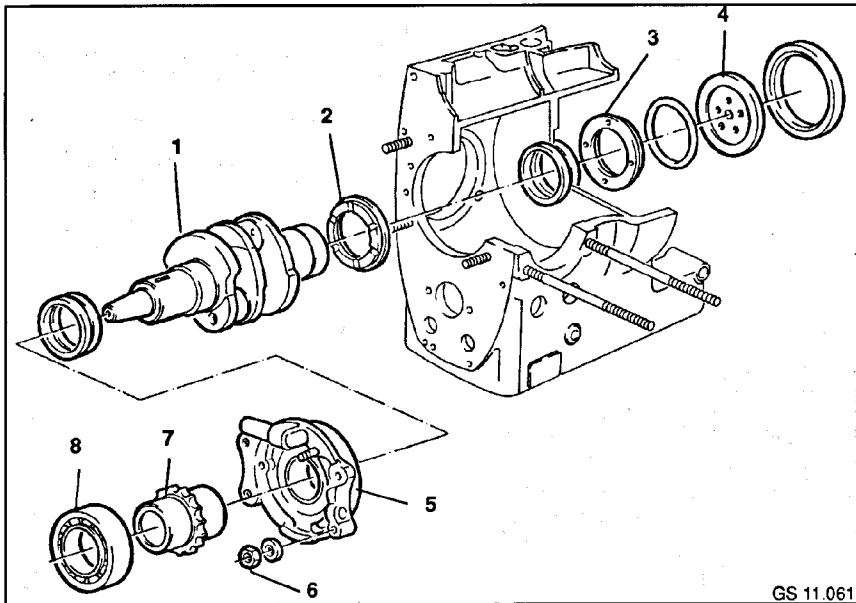

GS 11.061

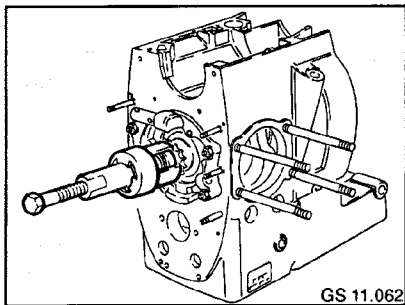

GS 11.062

REMOVING CRANK SHAFT

- Fit on puller device, BMW No. 11 2 600, and puller shells, BMW No. 11 2 606, (without groove).
- Pull sprocket wheel (7) together with bearing (8) off crankshaft.
- Slacken 4 fastening nuts (6) on crankshaft bearing cover (5).
- Place engine upright.

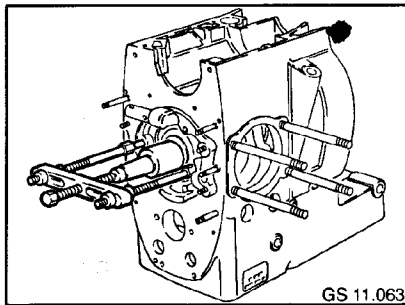

GS 11.063

- Screw two bolts of universal puller, BMW No. 00 7 500, into the tapped holes provided for this purpose in the crankshaft bearing cover.
- Fit on thrust plate for puller.
- Pull off crankshaft bearing cover (5).
- Withdraw crankshaft from engine housing.
- Use screwdriver to lever both thrust discs (2,3) off the locating pins in the crankcase.

DETERMINING CRANKSHAFT BEARING PLAY

CAUTION:

Determine crankshaft bearing play solely with "Report for Measuring Crank Shaft Bearing Play", refer to Technical Data.

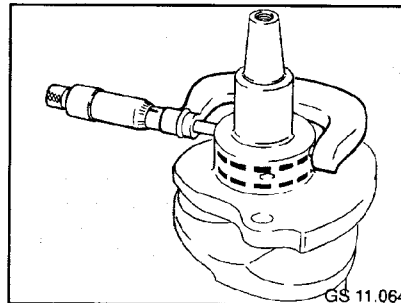

GS 11.064

- Measure crankshaft bearing journals at two levels A and B crosswise with external micrometer.
- Enter sizes obtained in report.

NOTE:

Measure front crankshaft bearing only when bearing cover installed.

- Heat engine housing to 100 ... 120°C.
- Insert bearing cover in housing.

CAUTION:

Allow housing to cool to room temperature before performing measurements.

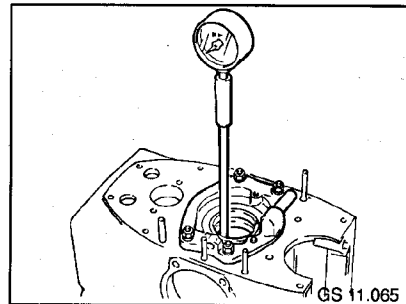

GS 11.065

- Measure front crankshaft bearing.
- Measure rear crankshaft bearing.

NOTE:

Measure front and rear crankshaft bearings as stated Report for Measuring Crankshaft Bearing Play.

- Enter sizes obtained in report and determine crankshaft bearing plays.

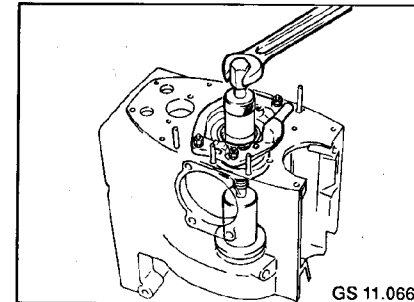

GS 11.066

- Press off bearing cover when crankshaft removed as follows:
- Insert removing drift for crankshaft bearings, BMW No. 11 2 720, into rear bearing.
- Press off bearing cover with screw nipple, BMW No. 11 1 710, and forcing bridge with spindle of universal puller Kukko 17 K.

Crank shaft play:

Radial play of main bearing journal
 (red) 0.017 ... 0.066 mm
 (blue) 0.019 ... 0.067 mm

Conrod bearing play:

Radial play 0.023 ... 0.069mm

REMOVING CRANKSHAFT BEARING

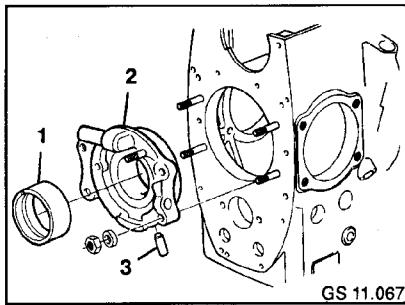

GS 11.067

Removing crankshaft bearing bush from engine housing

- Heat engine housing to 100 ... 120°C.

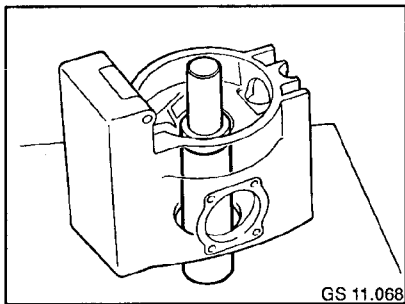

GS 11.068

- Place engine housing over cylinder of removal device, BMW No. 11 2 710.

CAUTION:

Locating pins for inner thrust washer must engage in the holes of the cylinder provided for this purpose.

- Use removal drift, BMW No. 11 2 700, to press bearing bush out with hand lever press.

Removing crankshaft bearing bush from bearing cover

- Knock locating pin (3) for bearing bush (1) out from inside to outside.
- Heat bearing cover (2) to 100 ... 120°C.

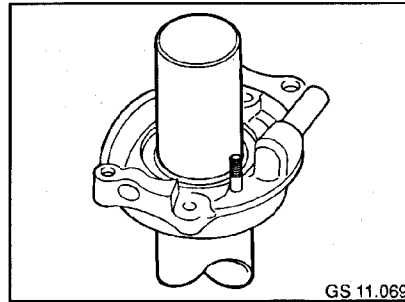

GS 11.069

- Place bearing cover on to cylinder of removal device, BMW No. 11 2 710.
- Press out bearing bush with drift, BMW No. 11 2 700, on hand lever press or knock out with hammer.

REMOVING OIL SUMP AND INTAKE BELL

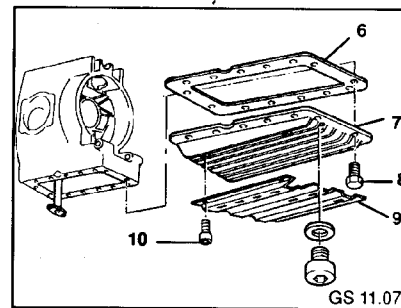

GS 11.070

- Unscrew 4 screws (10) from oil sump guard (9).
- Take off oil sump guard.
- Slacken 14 fastening bolts (8) on oil sump (7).
- Take off oil sump.
- Remove oil sump gasket (6).

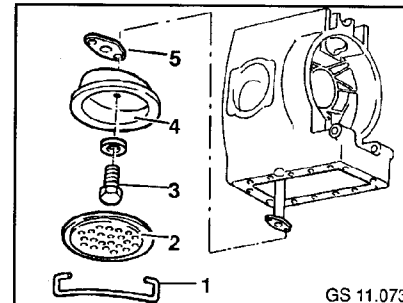

GS 11.073

- Detach clamp (1) on oil intake bell (4) and remove filter strainer (2).
- Slacken the 2 fastening bolts (3) and remove intake bell.
- Take off gasket (5).

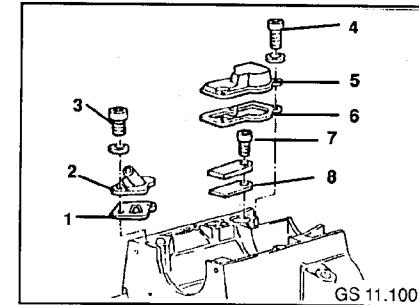

GS 11.100

REMOVING AND INSTALLING VENT COVER

- Slacken the 2 fastening screws (3) and take vent cover (2) off engine housing.
- Replace paper gasket (1).
- Attach vent cover.

REMOVING AND INSTALLING BYPASS VALVE

- Slacken 2 fastening screws (4) and take off bypass valve cover (5).
- Slacken the fastening screw (7) and replace valve tongue (8).
- Replace paper gasket (6).
- Attach bypass valve cover.

11.5 ASSEMBLING ENGINE

INSTALLING CRANK SHAFT BEARING BUSH IN ENGINE HOUSING

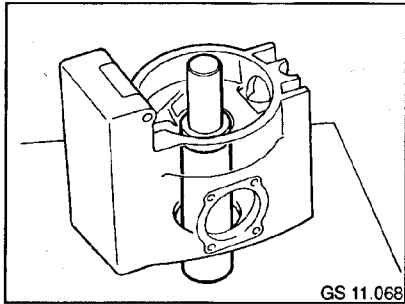

GS 11.068

- Heat engine housing to 100 ... 120°C.
- Fit aluminium plate of special tool, BMW No. 11 2 710, on to removal cylinder.

CAUTION:

The locating pins must slip into the holes provided in the aluminium plate.

- Fit engine over removal device.
- Use aluminium part, BMW No. 11 2 710, together with pipe section as counter bearing.
- Fit new bearing bush of calculated thickness onto bearing seat.

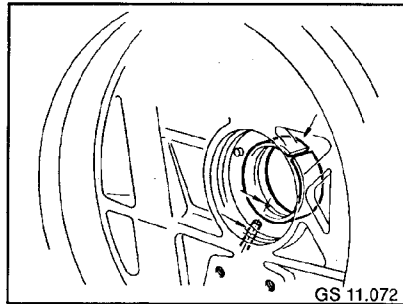

GS 11.072

CAUTION:

The bearing bush joint must be at the top right, looking from the clutch housing end, and the oil bores of the bearing bush at the bottom left aligned with the bore in the housing.

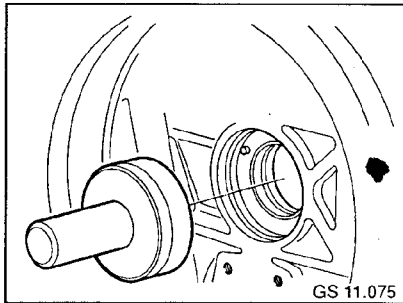

GS 11.075

CAUTION:

The locating pins projected in the housing must extend into the recesses around the fitting drift when the bearing bush is pressed in.

- Insert fitting drift with plastic bush of special tool, BMW No. 11 2 710, into bearing bush.

NOTE:

The bearing bush is dimensioned in such a way that it stand back slightly on both sides in the bearing bore in the housing.

- Press in bearing bush.

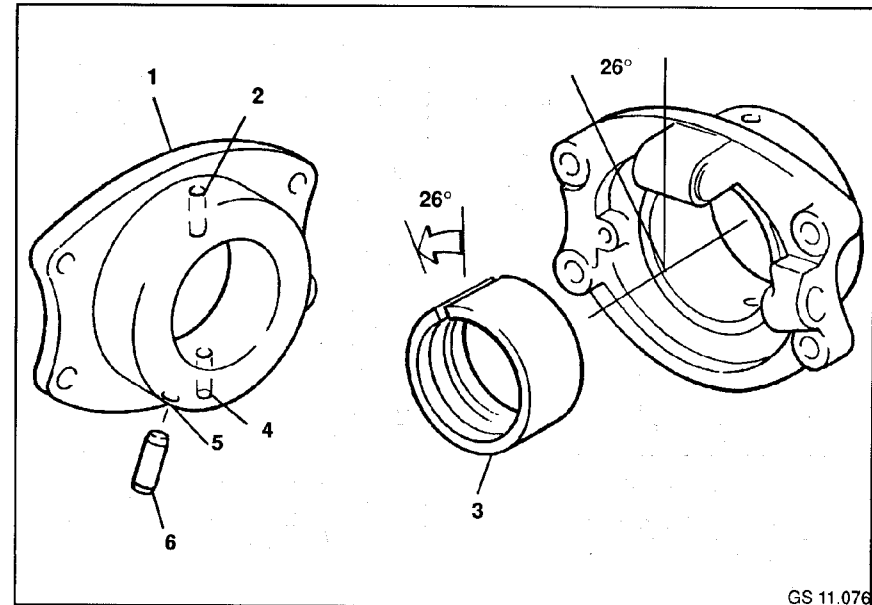

GS 11.076

INSTALLING NEW CRANKSHAFT BEARING BUSH IN BEARING COVER

- Heat bearing cover (1) to 100 ... 120°C.

CAUTION:

The bearing bush joint must be offset approx. 26° to the left of the vertical oil bores when installed.

- Press in bearing bush.
- Clamp bearing cover in vice between soft protective jaws.
- Drill 2 additional holes 3.2 mm in the bearing bush through the two holes in the bearing cover (2,4).
- Deburr holes drilled in the bearing bush.
- Make centering hole in bearing bush with 3.9 mm drill through the locating pin hole (5) in the bearing cover.
- Widen bearing bush to 3.8 mm, basic reaming size.

CAUTION:

Do not ream bearing bush through fully with hand reamer to prevent the locking pin subsequently moving through to the inside.

- Widen bearing bush with hand reamer 4H8 mm.
- Deburr hole.

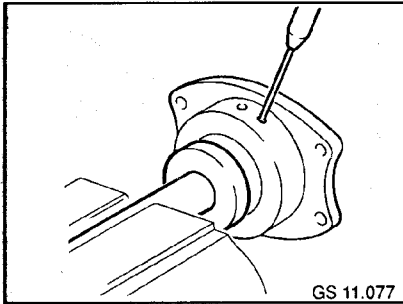

GS 11.077

- Clamp fitting drift, BMW No. 11 2 710, in vice.
- Fit on bearing cover.
- Knock in locking pin (6) far enough for it to still stand back 0.5 to 1.0 mm from the bearing bush hole.
- Secure pin with three notch blows.

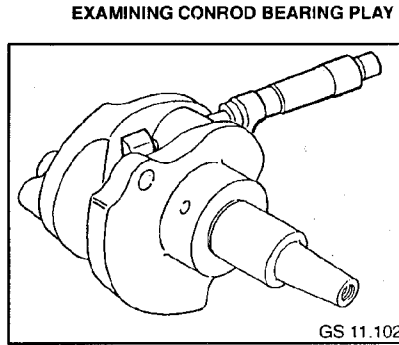

GS 11.102

- Measure crankshaft journals with external micrometer.

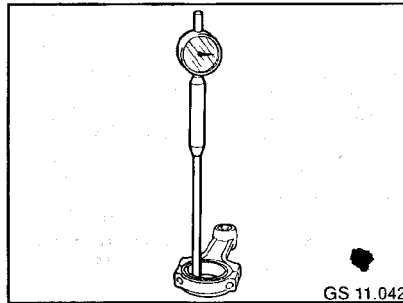

GS 11.042

- Screw conrod bearing cover with bearing shell onto conrod.
- Measure conrod bearing with internal calipers.
- Calculate conrod bearing play.
- If play excessive, renew conrod bearing shells, or replace crankshaft.

Conrod bearing radial play 0.023 ... 0.069 mm

EXAMINING CONROD BEARING PLAY

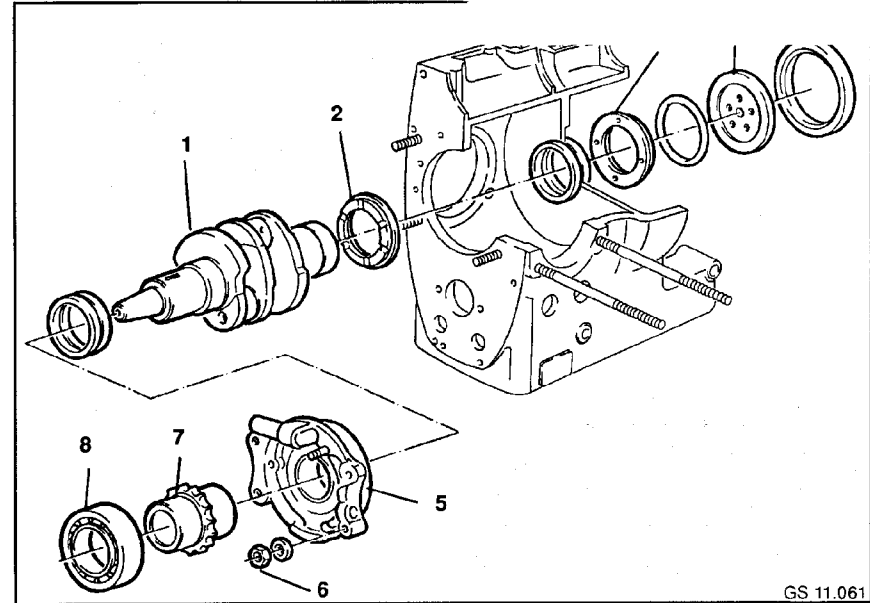

GS 11.061

INSTALLING CRANKSHAFT

- Re-set end play of crankshaft.

NOTE:

Refer to Technical Data for selection table for thrust washers.

The end play can be easily set by fitting a red-marked thrust washer (2,3) onto the locating pins (4) on the inside and outside.

CAUTION:

Both locating pins must project evenly in the housing at the clutch and alternator ends. Heat the engine housing to align or insert the locating pins.

- Fit red-marked thrust washers onto locating pins.
- Position engine housing vertically in assembly stand.
- Heat engine housing to 100 ... 120°C.
- Introduce crankshaft (1) into housing.

- Fit on bearing cover (5).
- Tighten bearing cover with 4 fastening nuts (6).
- Rotate crankcase through 180°.

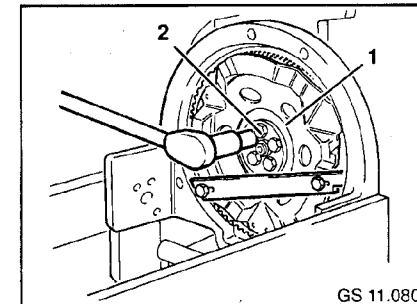

GS 11.080

- Mount clutch housing onto crankshaft.
- Attach holding device, BMW No. 11 2 800, to clutch housing.
- Screw steel disc (1) tight with 5 fastening bolts (2).
- Remove holding device.

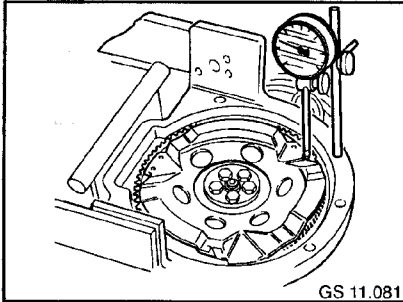

GS 11.081

- Screw dial gauge holder, BMW No. 00 2 500, onto transmission flange of engine housing.
- Determine end play by moving crankshaft by hand.
- Remove dial gauge holder.
- Remove clutch housing.
- Withdraw red-marked thrust washer.
- Measure thrust washer with micrometer screw.

EXAMPLE:

| | |
|---|-----------------|
| End play determined | 0.18 mm. |
| Desired end play | <u>0.12 mm.</u> |
| Resulting difference | 0.06 mm. |
| Determined thickness of removed thrust washer | 2.48 mm |
| plus difference | <u>0.06 mm.</u> |
| Thrust washer to be used: | <u>2.54 mm.</u> |

NOTE:

Select thrust washer which does not vary from size determined by more than +0.03 mm and -0.04 mm.

- Fit determined size of thrust washer onto locating pins.

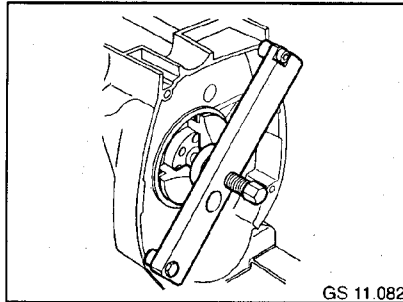

GS 11.082

CAUTION:

Place radial seal in oil for approx. 2 hours before fitting.

- Press in with special tool, BMW No. 11 1 890, in combination with impact drift, BMW No. 11 1 880, into crankcase.

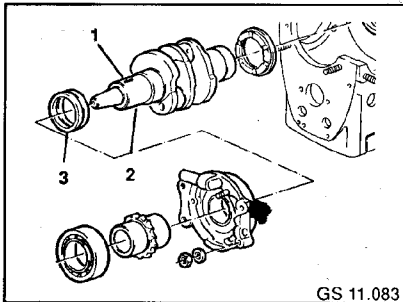

GS 11.083

NOTE:

Align groove in sprocket wheel to match spring (1).

- Heat sprocket wheel (2) to 80°C and press onto crankshaft.
- Heat crankshaft bearing (3) at alternator end to approx. 80°C (bearing inner race) and press onto crankshaft.

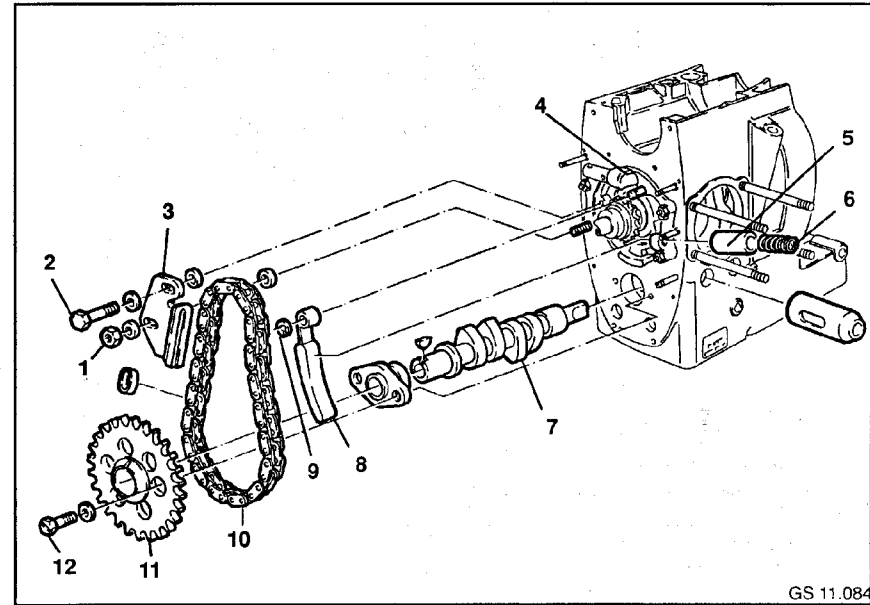

GS 11.084

INSTALLING CAMSHAFT

NOTE:

If a timing chain without chain joint is used, the timing chain must be fitted together with the camshaft.

CAUTION:

Align camshaft and crankshaft sprocket wheels, so that the teeth markings are precisely aligned.

- Insert camshaft (7).
- Turn camshaft sprocket wheel (11) so that access can be gained to the tapped holes for the camshaft flange.
- Screw camshaft onto flange with 2 fastening screws (12).
- Insert spring (6) and piston (5) of chain tensioner into housing at bearing cover (4).
- Push back piston of chain tensioner, fix in this position and insert timing chain.

CAUTION:

Chain joint (13) must be closed in direction of travel.

- Hold together chain ends with right-angled pointed pliers.
- Introduce chain joint from below.
- Close chain joint.
- Fit chain tensioner lever (8) onto guide.
- Insert locking ring (9).
- Fit chain guide bar (3) onto headless set screw.

CAUTION:

Chain preload must be max. 0.5 mm.

- Fit chain guide bar onto chain, paying attention to preload.
- Tighten with fastening nut (1) and bolt (2).

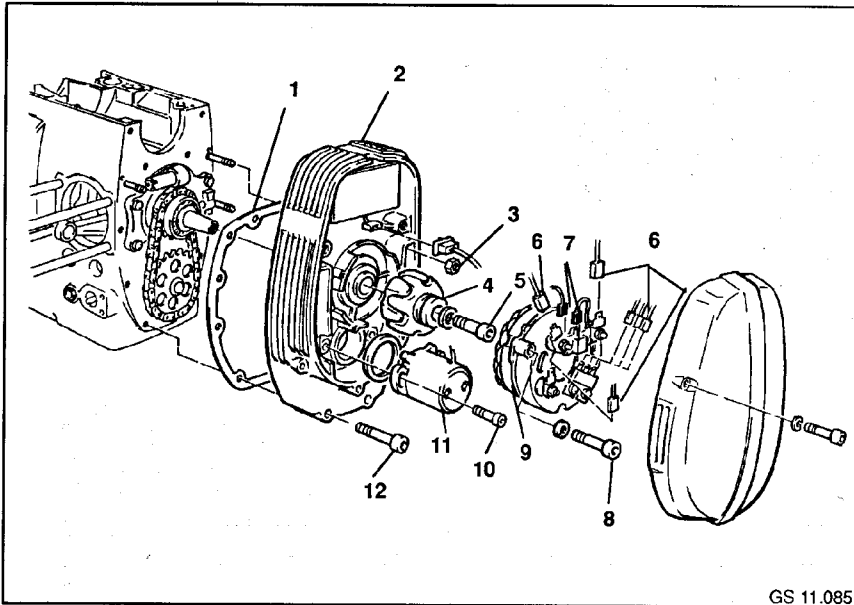

ATTACHING CHAIN BOX COVER

- Heat bearing seat of chain box cover (2) to approx. 80°C.
- Fit on gasket (1).
- Fit chain box cover onto engine.
- Tighten 9 fastening screws (12) and 3 nuts (3), starting from the middle.

CAUTION:

Relieve stress of grooved ball bearing on bearing seat by striking a few times with a plastic-headed hammer.

- Press rotor (4) onto crankshaft.
- Screw in rotor fastening screw (5) and tighten to specified torque.

- Slightly raise carbon brushes (7) at stator (9) and fix in this position with springs.
- Fit stator onto rotor and screw tight with 3 fastening screws (8).
- Insert carbon brushes and fit springs onto carbon brushes.
- Push in 6 plug connections (6).
- Fit new O-ring (13) to ignition trigger (11).
- Insert ignition trigger into chain box cover.
- Screw ignition trigger tight with 2 fastening screws (10).

NOTE:

Do not install engine guard cover until engine has been installed and adjusted.

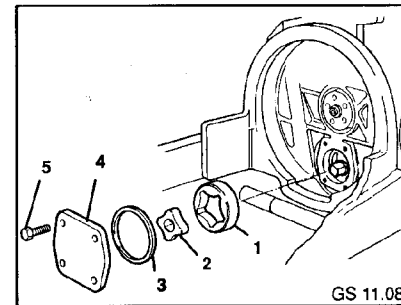
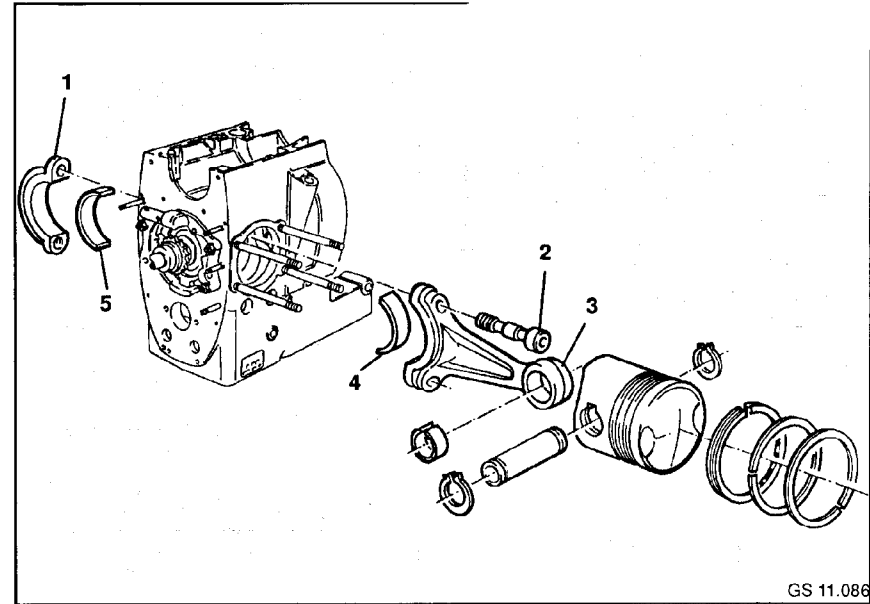

INSTALLING OIL PUMP

- Insert outer rotor (1) into oil pump housing.
- Insert inner rotor (2).
- Insert new O-ring (3) into cover (4).

NOTE:

When installed, the O-ring must be pressed far enough into the groove for the end cover to lie flat on the mating surface of the housing.

- Screw cover tight with 4 fastening bolts (5).

INSTALLING PISTON

- Clean conrod bearing bore.
- Press bearing shells (4,5) of the calculated thickness into conrod bearing basic bore.

CAUTION:

Use only conrods of the same weight class. Install both conrods so that the locating pins of the conrod bearings are positioned at the alternator end.

NOTE:

The parts are installed with the crankshaft in TDC position. Apply a light coating of Molykote paste G to conrod bearing shells before installing.

- Fit conrod (3) and conrod bearing cover (1) onto crankshaft.

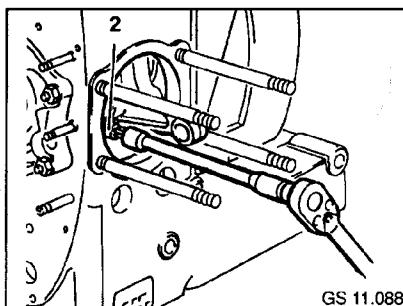

GS 11.088

- Screw in conrod bolts (2) with key for screws with internal serrations, BMW No. 11 2 860, and tighten to specified tightening torque.

Tightening torque:

Conrod bolts

Preload

Tightening angle

20 Nm

40° + 5°

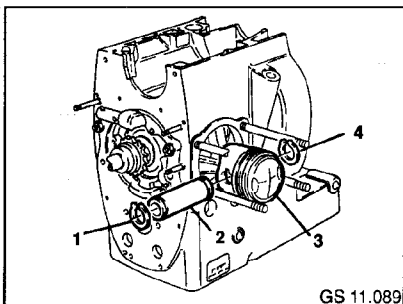

GS 11.089

CAUTION:

Install pistons so that the arrow mark on the piston crown is pointing in direction of travel.

Only pistons of the same weight group may be used within an engine.

NOTE:

The piston does not require to be heated for inserting the piston pin.

- Fit piston (3) onto conrod and introduce piston pin (2).
- Insert locking rings (1,4) into annular groove on piston pin.

INSTALLING CYLINDER

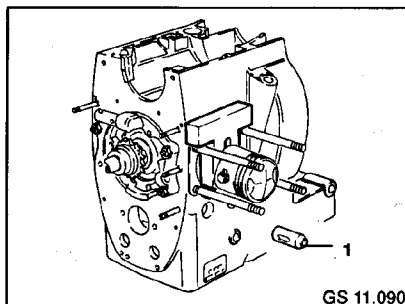

GS 11.090

NOTE:

Base of cylinder and cylinder sealing surfaces on engine housing must be free of grease.

- Insert protective wooden block for piston behind the piston between the tiebolt.
- Insert tappet (1) into guides.

CAUTION:

When introducing the cylinder into the engine housing, ensure that the O-rings are not crushed.

Turn piston ring joints so that they are offset by 120° before attaching the piston ring tensioner, BMW No. 11 2 905.

Tightening torque:

Oil pan to engine block

10 Nm

Oy

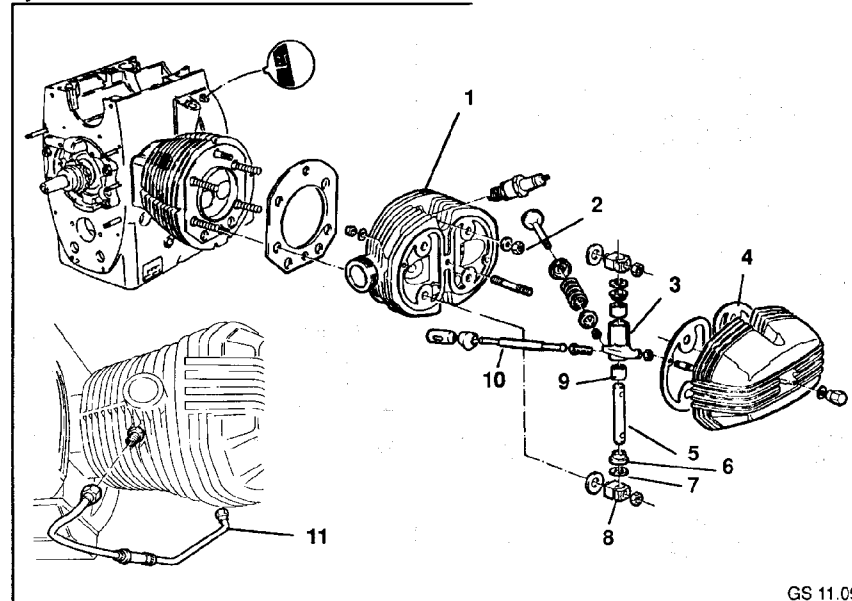

GS 11.091

NOTE:

If problems exist with sealing of cylinder base, use oversize O-rings (refer to parts film).

- Fit cylinder (1) onto the 4 tiebolts.

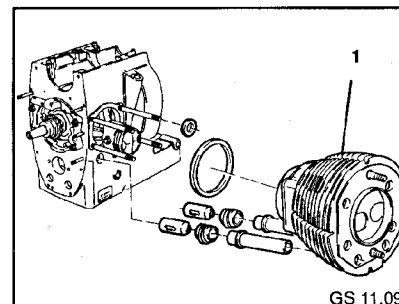

GS 11.092

- Compress piston rings with piston ring tensioner, BMW No. 11 2 905.

- Push cylinder over piston and introduce into engine housing, at the same time removing protective wooden block and piston ring tensioner.

ATTACHING CYLINDER HEAD

- Attach cylinder head gasket (4).
- Fit cylinder head (1) onto the 4 tiebolts.
- Screw cylinder head tight with 2 nuts (2) onto cylinder.
- Introduce tappet rod (10).
- Fit rocker arm (3) complete with rocker arm shaft (5), Pertinax disc (6), shim(s) (7), bearings (9) and clamping blocks (8) onto the tiebolts and screw tight.

CAUTION:

Following assembly and installation of the engine, adjust end play of rocker arms and valve clearance.

Following this, tighten cylinder head nuts to specified tightening torque in three steps in the specified order.

NOTE:

Do not install cylinder head cover until the adjustment work has been completed.

NOTE:

In the case of motor version USA tighten air conduit (11) onto cylinder head.

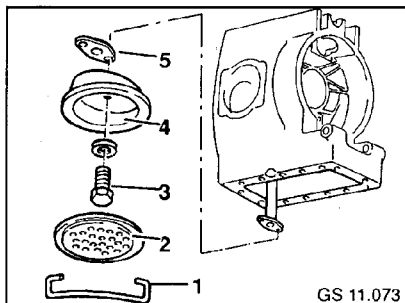
INSTALLING INTAKE BELL AND OIL SUMP

GS 11.073

- Fit new gasket (5) to intake pipe (6).
- Fit on intake bell (4) and screw tight with 2 fastening bolts (3).
- Fit filter strainer (2) to intake bell and secure with clamp (1).

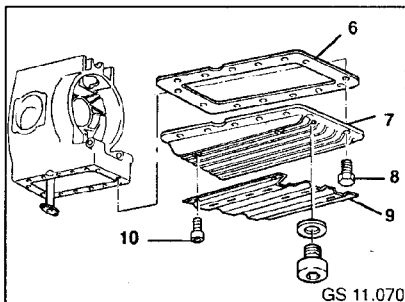

GS 11.070

- Fit on new oil sump gasket (6).
- Fit on oil sump (7) and screw tight with 14 fastening bolts (8).
- Tighten fastening bolts to specified tightening torque.
- Fit on oil sump guard (9) and tighten with 4 fastening screws (10).
- Install clutch.

11.6 INSTALLING ENGINE**NOTE:**

After inserting engine, support at oil sump with scissors or hydraulic jack.

- Tilt engine slightly and insert into frame from the left.
- Move engine fully forward.
- Install transmission.
- Align engine with transmission to the bores of the engine pins.

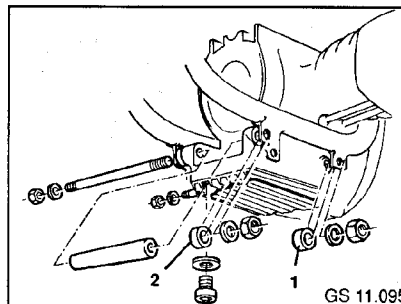

GS 11.095

NOTE:

Insert the wider spacer rings (1) on the front engine pin and the thinner spacer rings (2) on the rear engine pin.
On R 100 R, insert wide shim at front left.

- Insert spacer rings, insert front and rear engine pins.

- Screw in spark plugs and tighten to specified tightening torque.

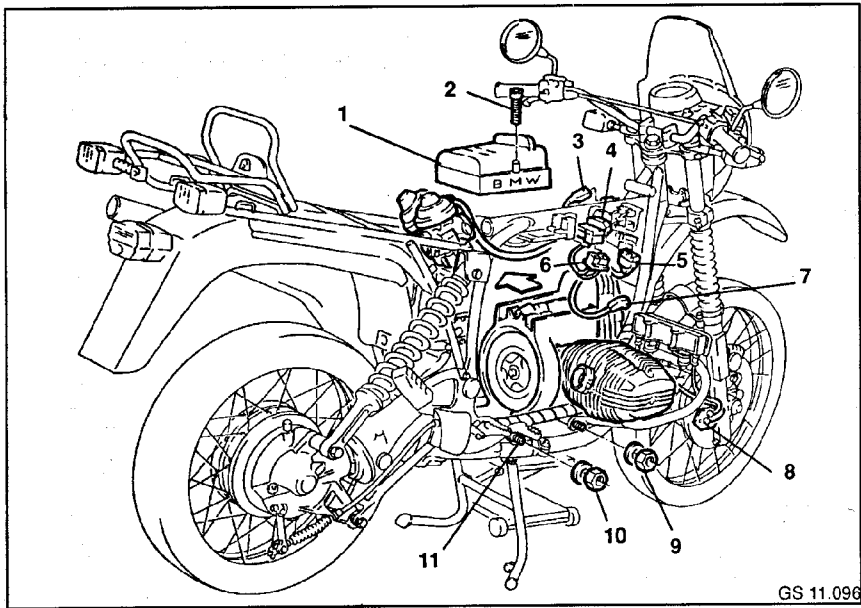

GS 11.096

- Fit on spark plug connector (7).
- Attach oil filter cover (8) and tighten with 3 fastening screws.
- Connect plug (3) of engine cable harness.
- Connect plug (5) to control unit (4).
- Connect multi-point plug (6) to regulator.
- Screw on fastening nut (9,10) of engine pins (11) and tighten to specified tightening torque.

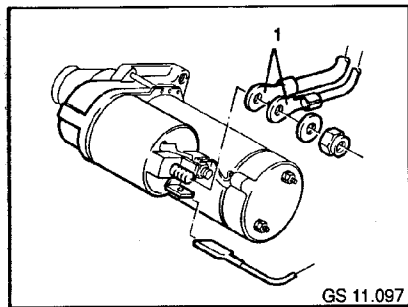

GS 11.097

- Connect battery positive cable (1) to starter.

- Fit on starter cover (1) and tighten with 2 fastening screws (2).
- Screw in oil drain plug.
 - Install exhaust pipe.
 - Install air filter housing.
 - Install battery mount.
 - Install battery.
 - Install fuel tank.
 - Install seat.
 - Fill engine with oil of specified grade and quantity.
 - Connect input shaft.

CAUTION:

After installing engine, set ignition, carburettor, valve clearance and rocker arm end play.

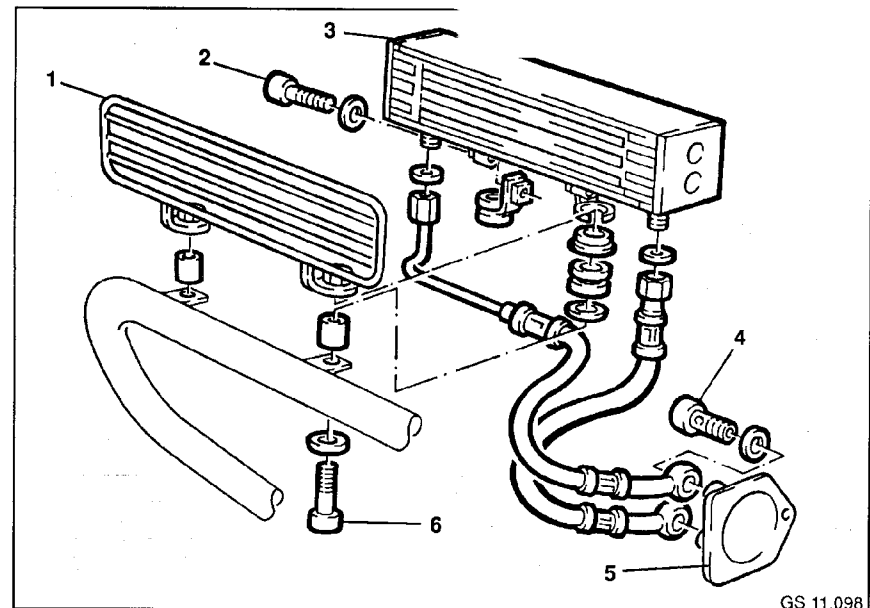

GS 11.098

11.7 REMOVING AND DISASSEMBLING, ASSEMBLING AND INSTALLING OIL COOLER

REMOVING AND DISASSEMBLING OIL COOLER

- Unscrew 2 hollow screws (4) on the cover (5) of the oil filter.
- Unscrew oil hoses with seals at oil filler head.

NOTE:

Collect leak oil in a suitable vessel. Force out oil with compressed air if necessary.

- Slacken 2 fastening screws (6) on the oil cooler guard grill (1).
- Remove oil cooler (3) complete with guard grill and hoses.
- Remove rubber grommets and bushes.
- Slacken the 2 fastening screws (2) and take grill off oil cooler.

11.8 TROUBLESHOOTING ENGINE

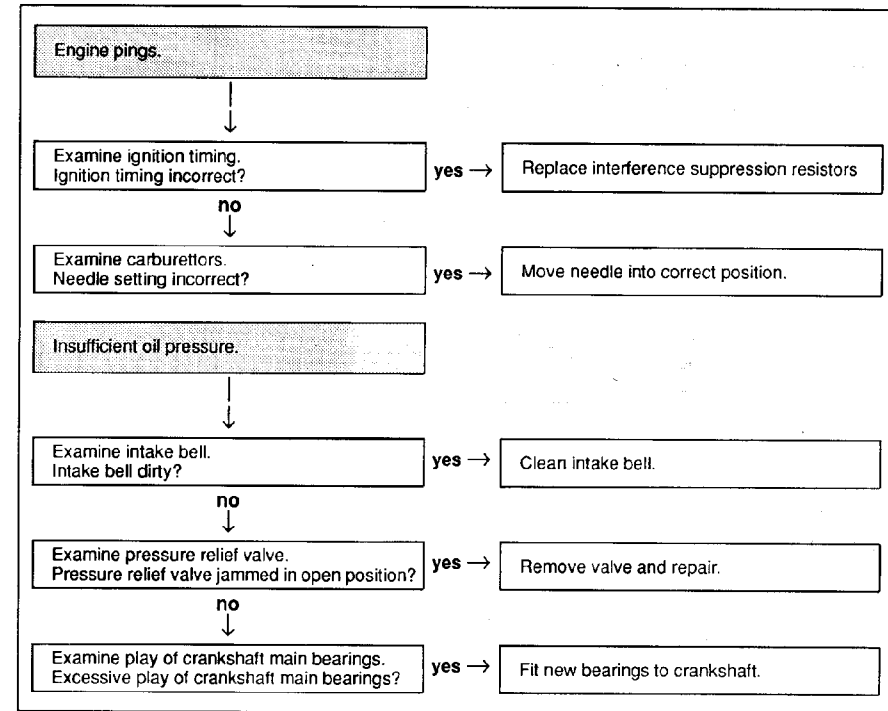
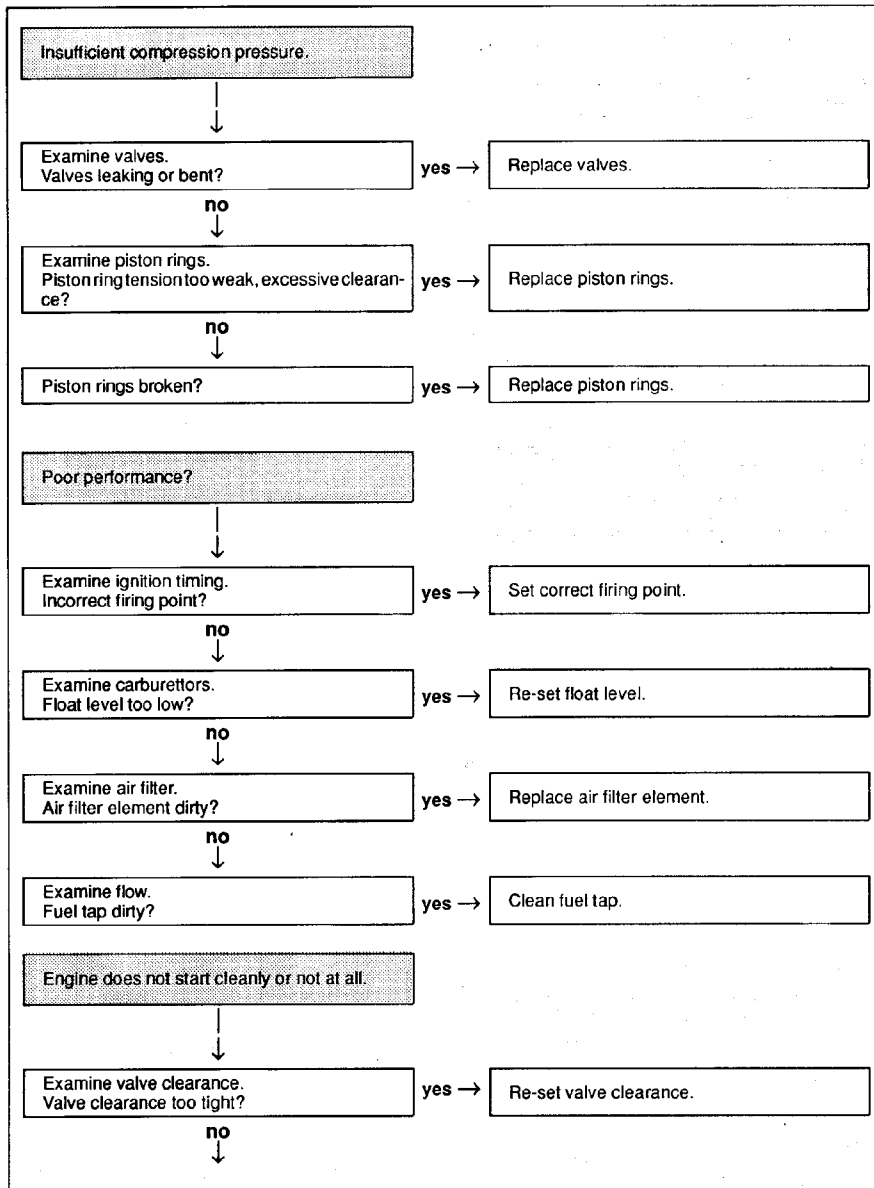

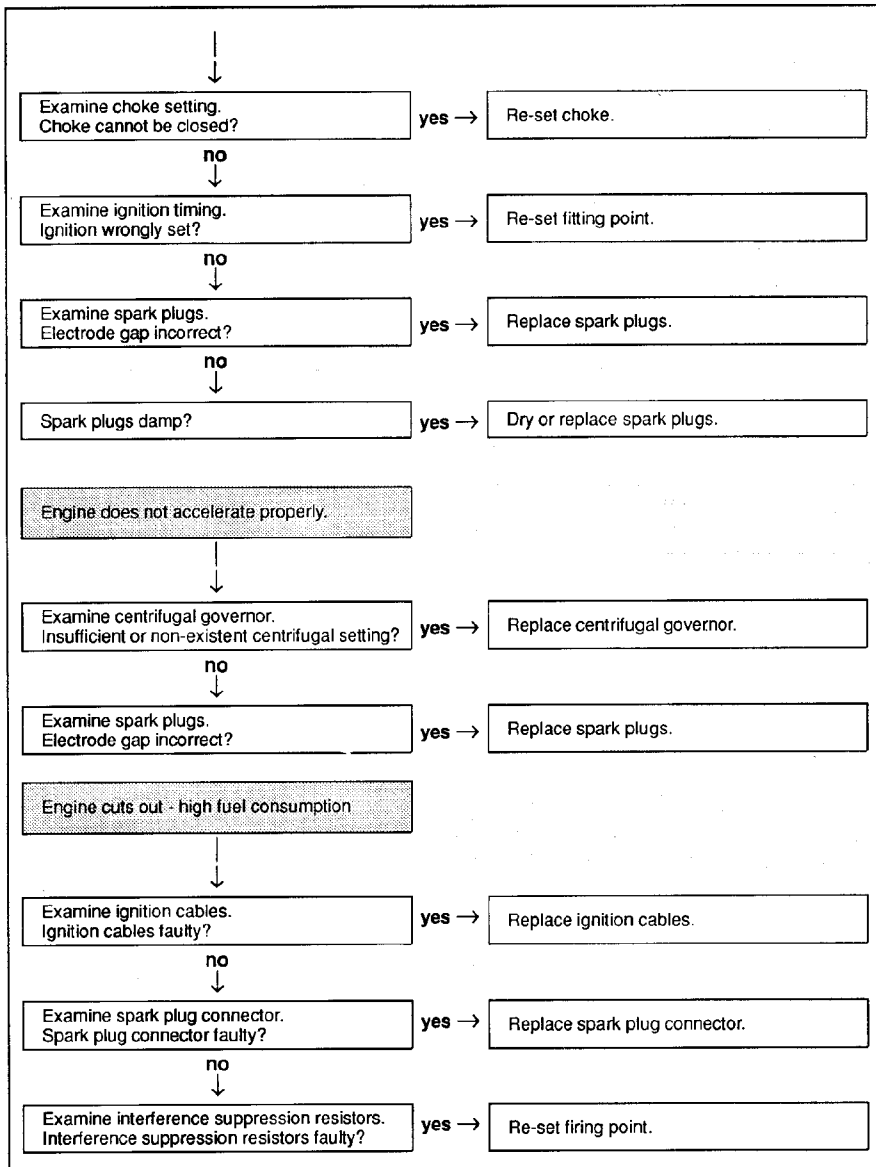

12. TECHNICAL DATA

Technical Data

CONVERSION TABLE

| From metric system: | mm | To British (Imp.)/US system | Multiply by conversion factor: |
|----------------------------------|---------------------|--|--------------------------------|
| Length | | | |
| Millimetres | mm | Inches in | 0.039 |
| Centimetres | cm | Inches in | 0.394 |
| Metres | m | Feet ft | 3.281 |
| Kilometres | km | Miles mile | 0.621 |
| Area | | | |
| Square centimetres | cm ² | Square inches sq.in, in ² | 0.155 |
| Volume | | | |
| Cubic centimetres | cc, cm ³ | Cubic inches cu.in, in ³ | 0.061 |
| Litres | l | Fluid ounces (US) US fl. oz | 33.813 |
| | | Fluid ounces (Imp.) Imp. fl. oz | 35.195 |
| | | Pints (US) US pt | 2.113 |
| | | Pints (Imp.) Imp. pt | 1.760 |
| | | Quarts (US) US qt | 1.057 |
| | | Quarts (Imp.) Imp. qt | 0.880 |
| | | Gallons (US) US gal | 0.264 |
| | | Gallons (Imp.) Imp. gal | 0.220 |
| Weight | | | |
| Kilogrammes | kg | Pounds lb | 2.205 |
| Pressure | | | |
| Bar | bar | Pounds force/square inch psi (lb.f/in ²) | 14.504 |
| Power | | | |
| Kilowatts | kW | Horsepower hp | 1.341 |
| Torque | | | |
| Newton metres | Nm | Footpounds ft.lb | 0.723 |
| Speed | | | |
| Kilometres/hour | km/h | Miles/hour mile/h (mph) | 0.621 |
| Metres/second | m/s | Feet/second ft/s | 3.281 |
| Consumption | | | |
| Litres/kilometre | l/100 km | Miles/gallon (US) mile/gal (US) | 235.21 |
| | | | value in l/100km |
| | | Miles/gallon (Imp.) mile/gal (Imp.) | 284.48 |
| | | | value in l/100km |
| | | Miles/pint (US) mile/pt (US) | 29.40 |
| | | | value in l/100km |
| Miles/pint (Imp.) mile/pt (Imp.) | 35.30 | | |
| | value in l/100km | | |
| Weight per unit power | | | |
| Kilogrammes/kilowatt | kg/kW | Brake horsepower/ton bph/ton (US) | 1216.55 |
| | | | value in kg/kW |
| | | Brake horsepower/ton bph/ton (Imp.) | 1362.55 |
| | | | value in kg/kW |

| Technical Data | | | |
|------------------------------|----------------------------|----------------------|--------------------------------------|
| CONVERSION TABLE | | | |
| From | | To | Multiply by conversion factor: |
| British (Imp.)/US system: | | metric system: | |
| Length | | | |
| Inches | in | Millimetres | mm 25.400 |
| Inches | in | Centimetres | cm 2.540 |
| Feet | ft | Metres | m 0.305 |
| Miles | mile | Kilometres | km 1.609 |
| Area | | | |
| Square inches | sq.in, in ² | Square centimetres | cm ² 6.452 |
| Volume | | | |
| Cubic inches | cu.in, in ³ | Cubic centimetres | cc, cm ³ 16.387 |
| Fluid ounces (US) | US fl. oz | Litres | l 0.030 |
| Fluid ounces (Imp.) | Imp. fl. oz | Litres | l 0.028 |
| Pints (US) | US pt | Litres | l 0.473 |
| Pints (Imp.) | Imp. pt | Litres | l 0.568 |
| Quarts (US) | US qt | Litres | l 0.946 |
| Quarts (Imp.) | Imp. qt | Litres | l 1.137 |
| Gallons (US) | US gal. | Litres | l 3.785 |
| Gallons (Imp.) | Imp. gal | Litres | l 4.546 |
| Weight | | | |
| Pounds | lb | Kilogrammes | kg 0.454 |
| Pressure | | | |
| Pounds force/square inch | psi (lb./in ²) | Bar | bar 0.069 |
| Power | | | |
| Horsepower | hp | Kilowatts | kW 0.746 |
| Torque | | | |
| Footpounds | ft.lb | Newton metres | Nm 1.383 |
| Speed | | | |
| Miles/hour | mile/h (mph) | Kilometres/hour | km/h 1.610 |
| Feet/second | ft/s | Metres/second | m/s 0.305 |
| Consumption | | | |
| Miles/gallon (US) | mile/gal (US) | Litres/kilometre | l/100 km 235.21 value in mile/gal |
| Miles/gallon (Imp.) | mile/gal (Imp.) | Litres/kilometre | l/100 km 282.48 value in mile/gal |
| Miles/pint (US) | mile/pt (US) | Litres/kilometre | l/100 km 29.40 value in mile/pt |
| Miles/pint (Imp.) | mile/pt (Imp.) | Litres/kilometre | l/100 km 35.30 value in mile/pt |
| Weight per unit power | | | |
| Brake horsepower/ton | bph/ton (US) | Kilogrammes/kilowatt | kg/kW 1216.55 value in bph/ton |
| Brake horsepower/ton | bph/ton (Imp.) | Kilogrammes/kilowatt | kg/kW 1362.55 value in bph/ton |

Technical Data

Report for Measuring Crankshaft Main Bearing Play (Refer also to Service Information, group engine, No. 11 015 80 (146 R)).

Model _____ Chassis No. _____ Odometer reading _____

Order No. _____ Annex to GA No. _____

Measuring main bearing journal:

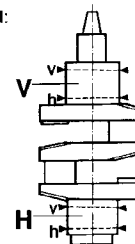
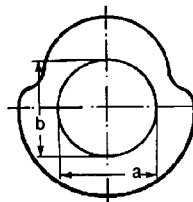

Measure front bearing journal V and rear bearing journal H in the directions A and B (3 times each at the same point) with external micrometer, translated to the levels Vv, Vh, Hv, Hh. This results in 24 individual measurements which should be entered in the table below. Calculate the mean values using the specified formula.

| Meas. levels | a | b | Cross addition | :6 = | Mean value |
|--------------|---|---|----------------|------|--------------|
| V | v | | | | △ 59. ... mm |
| 59. ... | h | | | | △ 59. ... mm |
| H | v | | | | △ 59. ... mm |
| | h | | | | △ 59. ... mm |

Measuring main bearing shells:

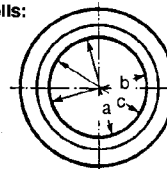

Measure main bearing shells in the directions a, b and c. This is done by applying markings with felt pen on to engine housing and bearing cover, exactly as shown. Otherwise, proceed as described above. This produces 36 individual measurements which should be entered in the table below. Calculate the mean values with the formula specified.

| Meas. levels | a | b | Cross addition | :9 = | Mean value |
|--------------|---|---|----------------|------|-------------|
| V | v | | | | △ 60.0.. mm |
| 60.0.. | h | | | | △ 60.0.. mm |
| H | v | | | | △ 60.0.. mm |
| | h | | | | △ 60.0.. mm |

Calculating main bearing play

Specified = 0.020...0.065 mm

| Results | ∅ bearing shells | ∅ CS bearing journal | bearing play |
|---------|------------------|----------------------|--------------|
| V | v | minus | = mm |
| | h | minus | = mm |
| H | v | minus | = mm |
| | h | minus | = mm |

Date _____

Signature _____

| Technical Data | |
|---|---|
| FUEL, OILS AND LUBRICANTS | |
| Fuel | Unleaded regular fuel DIN 51607 Minimum octane number 91 (RON) 82.5 (MON) (Leaded fuel may also be used) |
| Engine oil grades | Proprietary HD oil for spark-ignition engines API Classes SE/CC and SF/CC (refer to viscosity diagram) |
| Transmission oil grades | Proprietary Hypoid Transmission oil API Class GL 5 (above 5°C SAE 90, below 5°C SAE 80, or optionally SAE 80W90)) |
| Telescopic fork oil | Esso Komfort |
| Wheel bearings, steering head bearing, telescopic forks, gear shift linkage, orks, gear shift linkage, kick and side stands | Retinax A (taper) roller bearing grease |
| Dust seals, telescopic forks | Gleitmo 805 |
| Clutch and rear wheel drive, serrations | Staburags NBU 30 PTM (high-performance lubricating paste) |
| Silencers | Never-Seeze (high-temperature assembly paste) |
| Metal sealing surfaces (except transmission and rear wheel drive) | 3-Bond 1207 B |
| Metal sealing surfaces (transmission and rear wheel drive) | Loctite 574 |
| Ignition control unit | Curil K2 (Heat-conducting sealant) |
| Adhesers and locking elements: | |
| Telescopic forks, damper pistons | Loctite 242 |
| Oil intake bell of engine, oil baffle of transmission, springstrut eye | Loctite 270 |
| Bearing journal left, rear wheel drive | Loctite 273 |
| Supporting element, fuel tank | Herberts adhesive |
| Battery posts | Anti-acid grease (e.g. Bosch Ft 40 V 1) |
| Plug connectors | CRC-Spray (water displacement) and HWB 81 (friction protection) |
| Brake anchor and brake cam | Molykote grease |
| Brake fluid grades | DOT 4 (e.g. ATE "SL") |
| Battery electrolyte | (Conf. to VDE 0510, Density: 1,28 kg/l, for tropical countries 1.25 kg/l, based on electrolyte temperature of 20°C.) |

Technical Data

Engine oil Viscosity Diagram
As a function of outside temperature

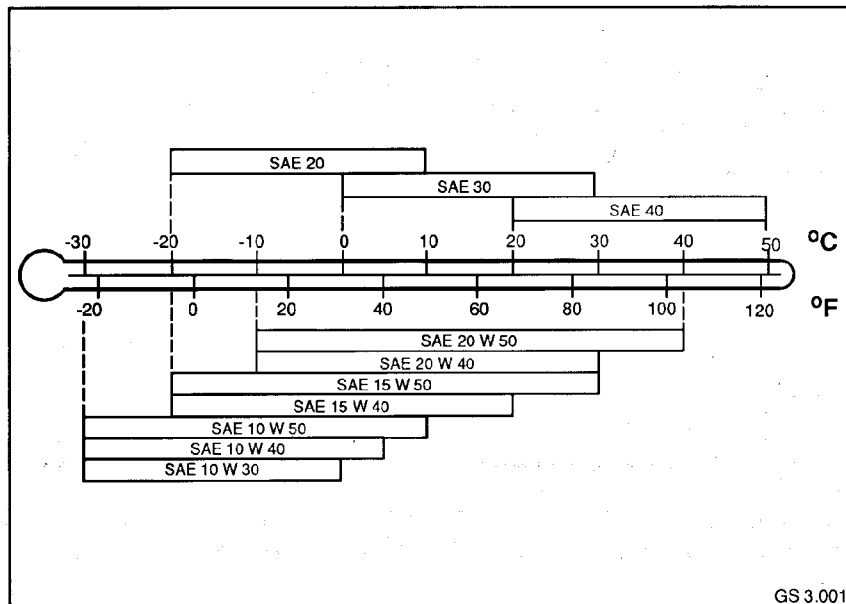

GS 3.001

| Technical Data | |
|--|---------------------------|
| ELECTRICAL SYSTEM | |
| Starter: | |
| Type | D 6 RA |
| Racial | Planetary gear 5.5 : 1 |
| Output | kW 1.1 |
| Torque | kpm 1.179 |
| Starter relay | Wehrle |
| Alternator: | |
| Type | Bosch G1 14V 20A 21/280 W |
| Maximum rating | W/V 280/14 |
| Maximum amperage | A 20 |
| Resistance between phase output | Ω 0.62 |
| Starter charging | min ⁻¹ 980 |
| Max. speed | min ⁻¹ 10 000 |
| Max. runout at sliprings | mm 0.06 |
| Minimum diameter of sliprings | mm 26.8 |
| Max. resistance between sliprings | Ω 3.4 + 0.34 |
| Voltage regulator: | |
| Type (Wehrle) | E 1051 B/14 V |
| Regulated voltage (engine at operating temperature, ambient temperature 20°C, at 5000 rpm) | V 13.5 ... 14.2 |
| Diode plate: | |
| Type (Bosch) | D 120 915 158 14V 20A |
| Ignition coil: | |
| Type (Bosch) | |
| Spark plugs: | |
| Thread | M 14 X 1.25 |
| Bosch | W 7 DC |
| Beru | 14 - 7 DV |
| Electrode gap | mm 0.6 + 0.1 |
| Elektrode wear limit | mm 0.9 |

| Technical Data | |
|--|---|
| ELECTRICAL SYSTEM | |
| Ignition trigger: | |
| Ignition switch gear | |
| Version without kick starter | Bosch No. 0227 100 103 or |
| Switching duration 1.2 sec | Telefunken 12.14 -1244 477 |
| Version with kick starter | Bosch No. 0227 100 116 or |
| Switching duration 5 sec | Telefunken 12.14 -1244 478 |
| Firing point (related to speed) | $^{\circ}\text{CS}$ 6 ... 32 (advance) |
| Static timing | $^{\circ}\text{CS}$ 6 BTDC |
| Timing advance range | $^{\circ}\text{CS}$ 26 |
| Start of advance | mm ⁻¹ 1500 |
| End of advance | mm ⁻¹ 3000 |
| General electrical system: | |
| Horn (Bosch) | 335 Hz \pm 20 Hz (Type 0320 043 029) |
| Fuse, 2 off. | A 7.5 |
| Battery: | |
| Voltage | V 12 |
| Capacity | Ah 25 |
| Electrolyte density fully charged | g/ml 1.256 ... 1.30 |
| Electrolyte density tolerance | g/ml 0.03 |
| Charging current Max. | A 2.5 |
| Charging time | h 5 ... 10 |
| Turn signal flasher (Bosch) | 0335 200 043 12 V 2 (4) x 21 W 13 ... 7 W |
| Foot brake light switch, setting | mm 11.5 |
| Lights: | |
| Head lamp (Bosch) | Type 1 305 601 129 |
| Head lamp dia. | mm 140 / 180 (R 100 R) |
| Main and dipped beam | 12 V / 60 / 55 W |
| Parking light | 12 V / 4 W |
| Idle indicator lamp (green) | 12 V / 1.2 W |
| Charge indicator lamp (red) | 12 V / 3 W |
| Oil pressure indicator lamp (red) | 12 V / 1.2 W |
| Main beam indicator lamp (blue) | 12 V / 1,2 W |
| Turn signal indicator lamp (green) | 12 V / 3 W |
| Speedometer lighting | 12 V / 3 W |
| Tail lamp / Stop lamp | 12 V / 5 W / 21 W |
| Turn signal lamp (2 yellow lamps each at front and rear) | 12 V / 21 W |

| Technical Data | |
|---|----------------------------------|
| BRAKE SYSTEM | |
| Front wheel: | |
| Brake disc dia. | mm 285 |
| Brake disc thickness | mm 6/5 (Mod. 91, R 100 R) |
| Brake disc wear limit | mm 5.4/4.5 (Mod.91, R 100 R) |
| Effective brake pad area | cm ² 44/50 (R100 R) |
| Minimum thickness of brake pads | mm 1.5 |
| Max. permissible runout of brake disc relative to wheel hub | mm 0.03 |
| Max lateral runout of brake disc | mm 0.3 |
| Dia. of piston of master brake cylinder | mm 13 |
| Dia. of piston of wheel brake cylinder | mm 48 |
| Brake fluid for disc brake | DOT 4, e.g. ATE brake fluid "SL" |
| Capacity, total volume if brake fluid changed by flushing approx. | l 0.20 |
| Rear wheel: | |
| Brake drum dia. | mm 200 + 0.185 (H 10) |
| Brake drum, max perm. wear dia. | mm 201.5 |
| Width of pad | mm 25 |
| Effective brake pad area | cm ² 89 |
| Minimum thickness of brake pads | mm 1.5 |
| Foot brake lever play | mm 25 |

| Technical Data | | | |
|---|---|---|-------|
| RUNNING GEAR | | | |
| Telescopic fork: | | | |
| Front wheel caster | mm 101 | | |
| Handle bar lock angle on each side | ° 45 | | |
| Spring travel (loads 75 kg) | mm 225/135 (R 100 R) | | |
| Inspection installed length | mm ca. 180 | | |
| Stanchion OD | mm 40/41 (R 100 R) | | |
| Fork sliding tube ID | mm 40.16 | | |
| Max. perm. runout of fork stanchion | mm 0.1 | | |
| Length of fork supporting spring | mm 445 | | |
| Wire diameter of fork supporting spring | mm 4.7 ± 0.03 | | |
| Telescopic fork oil – approved grades | Esso Komfort | | |
| Oil capacity per fork | Refilling after disassembly | 0.47 -0.01 | 0,420 |
| | with oil change | 0.41 -0.01 left, 0.44 -0.01 right | 0.410 |
| Rear wheel drive: | | | |
| Number of teeth | 32/10 | 34/11 | |
| Transmission racial | 3.2 : 1 | 3.09 : 1 | |
| Backlash | mm 0.07 ... 0.16 | | |
| available spacer rings (in jumps of 5/100 mm) | Crown wheel | mm 1.95 ... 2.80 | |
| | Pinion | mm 1.50 ... 2.10 | |
| Preload of taper roller bearings | mm 0.05 ... 0.1 ⇒ 600 ... 1600 N pre-load | | |
| Available shims | mm 0.18 / 0.28 / 0.38 / 0.50 / 0.63 / 0.75 / 0.88 | | |
| Oil grade | above 5°C | Proprietary Hypoid gear oil SAE 90 | |
| | below 5°C | Proprietary Hypoid gear oil SAE 80 | |
| | all-seasons | Proprietary Hypoid gear oil SEA 80 W 90 | |
| Capacity | l 0.26 | | |

| Technical Data | R 80 GS | R 100 GS / PD | R 100 R |
|--------------------------------------|-----------------|--|---------------------|
| RUNNING GEAR | | | |
| Rear wheel suspension: | | | |
| Spring travel | mm | 180 | 135 |
| Spring length | untensioned | mm | 308 |
| Wire dia. | mm | 11.8 ± 0.09 | |
| Length of swing arm | mm | 450 | |
| Difference in size of gap | frame/swing arm | mm | 0.5 (on both sides) |
| Frame: | | | |
| Max. permissible track misalignment | mm | 5 | 10 |
| Steering: | | | |
| Handle bar lock | ° | 43 | |
| Handle bar width | mm | 830 | 720 |
| Handle bar tube dia. | mm | 22 | |
| Wheels and tires: | | | |
| Size of rim | front | 1.85 - 21 MTH 2 | 1,85 - 18 MT H2 |
| | rear | 2.50 - 17 MTH 2 | 2,50 - 17 MT H2 |
| Outer rim width | front | mm | 68 ± 0,5 |
| | rear | mm | 92 ± 0,5 |
| Max. track misalignment | mm | 5 | 10 |
| Max. radial runout | mm | 1.3 - measured at rim flange, without tire | |
| Max. axial runout | mm | 1.3 - measured at rim flange, without tire | |
| Tire size | front | 90/90 - 21 S | 90/90 - 21 T |
| | rear | 130/80 - 17 S | 130/80 - 17 T |
| | | TUBELESS | |
| Tire inflation pressure (tires cold) | front | | |
| | rear | | |
| Solo | bar | 2.2 | |
| | | 2.4 | |
| Pillion | bar | 2.5 | |
| | | 2.9 | |

| Technical Data | R 80 GS | R 100 GS / PD | R 100 R |
|--|-------------|---|--|
| EXHAUST SYSTEM | | | |
| Exhaust pipe dia. | front | mm | 36.05 |
| | rear | mm | 38.05 |
| TRANSMISSION | | | |
| Racials | | | |
| | 1st gear | | 4.40 |
| | 2nd gear | | 2.86 |
| | 3rd gear | | 2.07 |
| | 4th gear | | 1.67 |
| | 5th gear | | 1.50 |
| Oil grade | above 5°C | | Proprietary Hypoid gear oil SAE 90 API class |
| | below 5°C | | Proprietary Hypoid gear oil SAE 80 GL 5 |
| | all-seasons | | Proprietary Hypoid gear oil SAE 80W90 |
| Capacity | l | 0.8 | |
| Input shaft: | | | |
| End play | mm | 0.05 ... 0.15 (set with shims) | |
| Intermediate shaft: | | | |
| End play | mm | 0.05 ... 0.15 (set with shims) | |
| Output shaft: | | | |
| End play | mm | 0.05 ... 0.15 (set with shims) | |
| Ball bearing seat in housing | | Interference fit (heat housing to approx. 100°C for assembly) | |
| End play of idler gears on shaft | mm | 0.15 ... 0.30 | |
| Play of bushes on output shaft | mm | 0.005 ... 0.035 | |
| Driven flange: | | | |
| Radial runout | mm | ± 0.05 | |
| Axial runout | mm | ± 0.05 | |
| Foot shift lever shaft: | | | |
| End play | mm | 0.1 | |
| CLUTCH | | | |
| Total thickness of clutch disc (disc and lining) | mm | 5.5 ± 0.25 | |
| OD of clutch disc | mm | 165 ± 1 | |
| Play at hand lever (cable) | mm | 2 ± 0.5 | |

| Technical Data | | R 80 GS | R 100 GS / PD | R 100 R |
|--|---------------------------|---------------------------------|---------------|---------|
| ENGINE | | | | |
| Cylinder bore | mm | 84.8 | 94.0 | |
| Piston stroke | mm | 70.6 | | |
| Bore/stroke racial | | 0.83 | 0.75 | |
| Effective displacement | cm ³ | 797.5 | 979.9 | |
| Compression racial | | 8.2 : 1 | 8.5 : 1 | |
| Maximum useful output | kW | 37 | 44 | |
| | HP | 50 | 60 | |
| | at rpm | 6500 | | |
| Permissible continuous engine speed | rpm | 7000 | | |
| Permissible maximum engine speed | rpm | 7250 | | |
| Idling speed | rpm | 800 ... 1100 | | |
| Permissible maximum engine speed during running-in | | | | |
| | up to 1000 km bis 1000 km | rpm | 4000 | |
| | up to 2000 km bis 2000 km | rpm | 4500 | |
| Direction of rotation | | clockwise looking at alternator | | |
| Max. torque | Nm | 61 | 76 | |
| | kpm | 6.20 | 7.75 | |
| | at rpm | 3750 | | |
| Mean piston speed | m/s | 17.4 | | |
| | at rpm | 7400 | | |
| Compression pressure | good | bar | above 9.0 | |
| | normal | bar | 7.5 ... 9.0 | |
| | poor | bar | below 7.5 | |
| Pressure difference for opening of bypass valve | bar | 1.5 | | |
| Oil pressure indicator lamp lights up below | bar | 0.2 ... 0.5 | | |

| Technical Data | | R 80 GS | R 100 GS / PD | R 100 R |
|---|-----------------------|-----------------|---------------|---------------------|
| ENGINE | | | | |
| Engine lubrication system: | | | | |
| Opening pressure of pressure relief valve | bar | approx. 5.0 | | |
| Length of pressure relief spring untensioned | mm | 68 | | |
| Oil capacity | without filter change | l | | 2.0/2.25 (Mod. 91) |
| | with filter change | l | | 2.25/2.5 (Mod. 91) |
| Oil consumption | max. | l/100 km | 0.10 | |
| Oil pump: | | | | |
| Delivery | l/h | 1320 | | |
| at engine speed | rpm | 6000 | | |
| Operating pressure | bar | 6 | | |
| Rotor OD | mm | 57.1 | | |
| | | -0.025 | | |
| Housing ID | mm | 57.2 | | |
| | | +0.046 | | |
| Clearance outer rotor/pump housing | mm | 0.15 ... 0.29 | | |
| | | -0.015 | | |
| Height of rotor | mm | 14 | | |
| | | -0.045 | | |
| Depth of housing | mm | 14 | | |
| | | +0.025 | | |
| | | +0.010 | | |
| Clearance between mating surface (pump housing) and sealing surface (rotor) | mm | 0.025 ... 0.070 | | |
| Gap between inner-outer rotors | mm | 0.12 ... 0.20 | | |
| Inlet depth in cover max. | mm | 0.05 | | |
| Valves: | | | | |
| Valve clearance | | | | |
| Setting when engine cold (20°C) | | | | up to 1000 km |
| | Inlet valve | mm | 0.10 | 0.15 |
| | Exhaust valve | mm | 0.20 | 0.25 |
| Valve timing | | | | |
| Timing shaft setting at 2 mm valve clearance 308° Camshaft | | | | |
| | Inlet valve opens | | 16° BTDC | |
| | Inlet valve closes | | 44° BBDC | |
| | Exhaust valve opens | | 56° BBDC | |
| | Exhaust valve closes | | 4° ATDC | |
| Overall length of valve | | | | |
| | Inlet | mm | 98.8 - 0.4 | |
| | Exhaust | mm | 98.7 ± 0.2 | |
| Valve plate dia. | Inlet | mm | 42 | |
| | Exhaust | mm | 40 | |

| Technical Data | | R 80 GS | R 100 GS / PD | R 100 GS / PD |
|--|----------------|---------|--|-------------------------------------|
| ENGINE | | | | |
| Stem dia. | Inlet | mm | 7.95 - 0.015 | |
| | Exhaust | mm | 7.95 - 0.015 | |
| Min edge thickness of valve plate | | | | |
| | Inlet | mm | 1.2 - 0.2 | |
| | Exhaust | mm | 1.2 - 0.02 | |
| Max. runout of valve seat relative to stem | | mm | 0.02 | |
| Valve seat ring: | | | | |
| | Inlet | mm | 43.2 ⁰ _{-0.025} | 45.2 ⁰ _{-0.025} |
| | Exhaust | mm | 45.2 ^{+0.025} _{-0.009} | |
| Bore in cylinder head for valve seat ring: | | | | |
| | Inlet | mm | 43 ^{+0.025} ₀ | 45 ^{+0.025} ₀ |
| | Exhaust | mm | 45 ^{+0.025} ₀ | |
| Valve seat angle | Inlet | degrees | 45° | |
| | Exhaust | degrees | 30° | |
| Valve seat width (reference values): | | | | |
| | Inlet | mm | 1.2+ 0.3 | |
| | Exhaust | mm | 2.0+ 0.4 | |
| Oversizes of valve seat rings | | mm | 0.2 / 0.4 | |
| Valve guides: | | | | |
| Overall length | Inlet | mm | 46.5 | |
| | Exhaust | mm | 46.5 | |
| Valve guides | OD | mm | 14 ^{+0.061} _{+0.050} | |
| | | mm | 8 ^{+0.015} ₀ | |
| | ID | mm | 8 ^{+0.015} ₀ | |
| Bore in cylinder head | | mm | 14 ^{+0.015} ₀ | |
| Oversizes | 1st stage dia. | mm | 14.1 ^{+0.061} _{+0.050} | |
| | | mm | 14.2 ^{+0.061} _{+0.050} | |
| | Inlet | mm | 0.7 | |
| | Exhaust | mm | 0.7 | |
| Max. perm. wear clearance | | | | |
| | Inlet | mm | 0.15 | |
| | Exhaust | mm | 0.15 | |

| Technical Data | | | | |
|--|--|--------|--|--|
| ENGINE | | | | |
| Valve spring: | | | | |
| Wire gauge | | mm | 4.25 | |
| Length of spring untensioned | | mm | brown colour coat 43.5; blue 46 | |
| Direction of winding | | | right hand | |
| Number of windings resilient | | | 4.6 | |
| Number of windings total | | | 6 | |
| Block length | | mm | 25 | |
| Installed direction | | | coloured marks facing cylinder head end | |
| Rocker arm: | | | | |
| End play of rocker arm | | mm | 0.05 ± 0.02 | |
| Camshaft: | | | | |
| Camshaft drive | | inches | Single-roller chain 3/8 x 7/32 with removable link | |
| Number of links | | | 50 | |
| Flange bearing bore dia. in engine housing | | mm | 40 ^{+0.039} ₀ | |
| Flange bearing OD | | mm | 40 ⁰ _{-0.016} | |
| Flange bearing bore dia. | | mm | 25 ^{+0.013} ₀ | |
| Camshaft bearing journal dia. at alternator end | | mm | 25 ^{-0.020} _{-0.033} | |
| Camshaft bearing bore dia. at flywheel end in engine housing | | mm | 24 ^{+0.021} ₀ | |
| Camshaft bearing journal dia. at flywheel end | | mm | 24 ^{-0.020} _{-0.033} | |
| Camshaft radial play at alternator end | | mm | 0.020 ... 0.046 | |
| Camshaft radial play at flywheel end | | mm | 0.020 ... 0.054 | |
| End play (between camshaft thrust collar/flange bearing) | | mm | 0.10 ± 0.02 | |
| Cam base circle dia. | | mm | 28 | |
| Cam stroke | | mm | 6.756 | |
| Tappet OD | | mm | 22 ^{-0.025} _{-0.045} | |
| Dia. of bore for tappet in engine housing | | mm | 22 ^{+0.006} _{-0.015} | |
| Radial play of tappets | | mm | 0.01 ... 0.051 | |
| Max. perm. wear clearance of tappets | | mm | 0.03 | |

| Technical Data | | R 80 GS | R 100 GS / PD | R 100 R |
|---|------|--------------------------------------|------------------------|-------------------|
| ENGINE | | | | |
| Crankshaft and bearings: | | Main bearing journals dia. mm | | |
| Marking of crankshaft | | Alternator end Flywheel end | | |
| Standard | 0 | red/red | 59.980 ... 59.990 | 59.980 ... 59.990 |
| | | red/blue | 59.980 ... 59.990 | 59.971 ... 59.980 |
| | | blue/red | 59.971 ... 59.980 | 59.980 ... 59.990 |
| | | blue/blue | 59.971 ... 59.980 | 59.971 ... 59.980 |
| 1st stage | 0.25 | red/red | 59.730 ... 59.740 | 59.730 ... 59.740 |
| | | red/blue | 59.730 ... 59.740 | 59.721 ... 59.730 |
| | | blue/red | 59.721 ... 59.730 | 59.730 ... 59.740 |
| | | blue/blue | 59.721 ... 59.730 | 59.721 ... 59.730 |
| Dia. of bore for crankshaft main bearing bush in engine housing | mm | + 0.019 65 0 | | |
| Dia. of bore for crankshaft main bearing bush in bearing cover | mm | + 0.019 65 0 | | |
| Radial play of main bearing journal at 20°C | mm | red | blue | |
| | | 0.017 ... 0.066 | 0.019 ... 0.067 | |
| Dia. of bearing seat for grooved bearings of front crank shaft mounting | mm | + 0.020 35.003 + 0.009 | | |
| Dia. of bore (bearing seat) for grooved bearings in chain box cover | mm | - 0.009 62 - 0.039 | | |
| Main bearing bush: | | | | |
| Wall thickness in | mm | | | |
| Standard | 0 | red | 2.500 ... 2.510 | |
| | | blue | 2.504 ... 2.514 | |
| 1st stage | 0.25 | red | 2.625 ... 2.635 | |
| | | blue | 2.629 ... 2.639 | |
| 2nd stage | 0.50 | red | 2.750 ... 2.760 | |
| | | blue | 2.754 ... 2.764 | |
| 3rd stage | 0.75 | red | 2.875 ... 2.885 | |
| | | blue | 2.879 ... 2.889 | |
| Engine housing | | | 65 H 6 | |
| Crankshaft bearing bore dia. | mm | | 65.000 ... 65.019 | |
| Bearing cover bore dia. | mm | | 130 + 0.026 - 0.007 | |
| Bearing cover OD | mm | | 130.003 ... 130.028 | |
| Crankshaft bearing dia. when bearing press fitted | mm | red | blue | |
| | | 60.007 ... 60.046 | 59.999 ... 60.038 | |
| Dia. of crankshaft seat for sprocket wheel | mm | + 0.020 35.003 - 0.009 | | |
| Dia. of mounting bore for sprocket wheel | mm | + 0.003 35.003 - 0.013 | | |

| Technical Data | | | | |
|---|------|--------|--------------------------|--|
| ENGINE | | | | |
| Crankshaft end play | mm | | 0.08 ... 0.15 | |
| Thrust washer thickness | mm | red | 2.483 ... 2.530 | |
| | | blue | 2.530 ... 2.578 | |
| | | green | 2.578 ... 2.626 | |
| | | yellow | 2.626 ... 2.673 | |
| Max. perm. wear clearance | mm | | - 0.20 | |
| Max. perm. runout at shaft journal (at alternator end) on outside when supported on main bearing points | mm | | 0.02 | |
| Max. perm. unbalance of crankshaft (dynamic) | cmp | | 20 | |
| Conrod and bearings: | | | | |
| Conrod bearing journal dia. | mm | | | |
| Standard | 0 | | 48,00 - 0.009 - 0.025 | |
| Stage | 0.25 | | 47,75 - 0.009 - 0.025 | |
| Stage | 0.50 | | 47,50 - 0.009 - 0.025 | |
| Stage | 0.75 | | 47,25 - 0.009 - 0.025 | |
| Dia. of conrod bearing basic bore, big-end bearing | mm | | + 0.019 52 0 | |
| Conrod bearing radial play | mm | | 0.023 ... 0.069 | |
| Conrod bearing width, big-end bearing | mm | | 22 - 0.065 - 0.117 | |
| Conrod journal bearing width | mm | | 22 + 0.149 + 0.065 | |
| Axial conrod play | mm | | 0.130 ... 0.266 | |
| Max. perm. axial wear play | mm | | 0.32 | |
| Centre-to-centre distance of bores | mm | | 135 | |
| Conrod bore, small-end bearing (basic bore) dia. | mm | | 24 + 0.019 0 | |
| Conrod bush OD | mm | | 24.060 ... 24.100 | |
| Dia. of bore in conrod bush for piston pin | mm | | 22 + 0.149 + 0.065 | |
| Dia. of bore in conrod bush for piston pin, wear limit | mm | | 22 + 0.040 | |
| Max. perm. variation in parallelism of conrod bores with bearing shells at 150 mm distance | mm | | 0.04 | |

| Technical Data | R 80 GS | R 100 GS / PD | R 100 R |
|---|--|-----------------------------------|----------------------------------|
| ENGINE | | | |
| Max. variation in twisting of conrod bores at 150 mm distance | mm | 1.5 | |
| Perm. difference in weight of both conrods | g | ± 2 | |
| Piston rings: | | | |
| Weak taper face ring 1st groove * | | | |
| Height | mm | 1.75 ^{-0.010} - 0.022 | |
| Vertical clearance | mm | 0.30 ... 0.50 | |
| Flank clearance | mm | 0.050 ... 0.082 | |
| Taper face oil scraper ring 2nd groove * | | | |
| Height | mm | 2.00 ^{-0.010} - 0.022 | |
| Vertical clearance | mm | 0.30 ... 0.50 | |
| Flank clearance | mm | 0.040 ... 0.072 | |
| Narrow land drain hose spring oil control ring 3rd groove | | | |
| Height | mm | 3.5 ^{-0.010} - 0.022 | 4.0 ^{-0.010} - 0.022 |
| Vertical clearance | mm | 0.25 ... 0.40 | |
| Flank clearance | mm | 0.030 ... 0.062 | |
| Direction of installation of piston rings | with designation (Top) facing up (grooves 1 and 2) | | |
| * not DIN corresponding to BMW special version | | | |
| Piston pin: | | | |
| Piston pin offset from piston centre | mm | 1.0 | |
| Piston pin dia. 2) | mm | 22 ⁰ - 0.004 | 22 ⁰ - 0.005 |
| Bore dia. of piston pin bosses | mm | 22 ^{+0.004} 0 | 22 ^{+0.010} + 0.005 |
| Piston pin play 3) in piston | mm | 0 ... 0.008 | 0.005 - 0.015 |
| Play of piston pin in conrod bush | mm | 0.015 ... 0.025 | |
| 2) Use only piston pins marked in "white". | | | |
| 3) Always replace pistons and piston pins together. | | | |

| Technical Data | R 80 GS | R 100 GS / PD / R 100 R |
|--|---|-----------------------------------|
| ENGINE | | |
| Cylinder: | | |
| Bore dia. (original) | A mm | 84.788 } 93.983 |
| | B mm | 84.798 } ± 0.005 93.993 } ± 0.005 |
| | C mm | 84.808 } 94.003 |
| Surface roughness | µm | 1.5 |
| Perm. out-of-round of cylinder bore | mm | |
| Measured from top edge | distance 20 mm | 0.005 |
| | distance 115 mm | 0.01 |
| Piston: | | |
| Weight group of piston assembly | + or - stamped use only pistons of same weight class | |
| Piston dia. (original) | A mm | 84.765 } 93.967 |
| | B mm | 84.775 } ± 0.007 93.977 } ± 0.007 |
| | C mm | 84.785 } 93.987 |
| Installed clearance of piston | mm | 0.03 ... 0.04 |
| Perm. total wear clearance at piston and cylinder | mm | max. 0.08 |
| Direction of installation | Arrow with designation "vorn" in direction of travel | |
| <div style="display: flex; justify-content: space-around; align-items: flex-end;"> <div style="text-align: center;"> <p>R 80 GS</p> <p>measuring level 27 mm</p> </div> <div style="text-align: center;"> <p>R 100 GS</p> <p>measuring level 18 mm</p> </div> </div> | | |

| Technical Data | R 80 GS/ 20 KW | R 100 GS / PD | R 100R |
|---|-------------------|---|-----------|
| FUEL PREPARATION | | | |
| Carburettor: | | | |
| Carburettor type BING V 64 II | | | |
| left carburettor | 35 KW 20 KW | 64/32/349 /353 A | 94/40/123 |
| right carburettor | 35 KW 20 KW | 64/32/350 /354 A | 94/40/124 |
| Carburettor passage | mm | 32 | 40 |
| Main nozzle | | 135 | 150 |
| Needle nozzle | | 2.68 | 2.66 |
| Nozzle needle number | | 46-251 | 46-371 |
| Needle position | | 3 | 3 |
| Starter nozzle | | 66 | 80 |
| Starter air nozzle dia. (starter vessel breather) | mm | 2.0 | 1.0 |
| Dia. of mixing bores in rotary valve | mm | 2.0, 0.6 | |
| Idling nozzle | | 45 | |
| Dia. of idling nozzle | mm | 1.0 | 0.8 |
| Idle mixture adjusting screw open (turns) | | 3/4 turn | |
| Dia. of bypass bore 1 | mm | 0.7 | 0.8 |
| Dia. of bypass bore 2 | mm | 0.65 | 0.65 |
| Dia. of float valve | mm | 2.5 | |
| Float chamber vent bore | | 2 bores on out-sides | |
| Dia. of idle outlet bore | mm | 1.0 | |
| Piston | | 22 - 907 - 3 | 22 - 910 |
| Fuel system: | | | |
| Fuel tank | | 26 (24 Mod.91, R 100 R), of which 4.7 l reserve | |

| Technical Data | | | |
|--|------|-------------------|-------------------|
| GENERAL TECHNICAL DATA | | | |
| Dimensions: | | | |
| Length overall | mm | 2290 | 2210 |
| Maximum height (without mirrors) | mm | 1165 | 1190 |
| Width over handle bars (without mirrors) | mm | 830 | 720 |
| Width over foot rests (of driver) | mm | 525 | |
| Width over foot rests (Pillion passenger) | mm | 600 | |
| Wheelbase at kerb weight | mm | 1514 | 1495 |
| Wheelbase with driver (75 kg) | mm | 1513 | |
| Caster at kerb weight | mm | 99 | |
| Caster with driver | mm | 101 | |
| Steering head angle at kerb weight | ° | 62° | |
| Steering head angle with driver | ° | 61° 30' | |
| Height of seat at kerb weight | mm | 850 | 800 |
| Ground clearance with normal load | mm | 170 | |
| Turning circle | m | 4.68 | |
| Weights: | | | |
| Weight dry (without fuel, lubricant, tools) | kg | 187/192 Mod.91 | 197/207 Mod.91 |
| Kerb weight (ready for the road, fuel tank full) | kg | 210/215 Mod.91 | 220/236 Mod.91 |
| Perm. gross weight | kg | 420 | |
| Power-to-weight racial | | | |
| ready for the road, incl. driver 75 kg | | 7.70 | 6.48 |
| at perm. gross weight | | 11.35 | 9.55 |
| Perm. wheel load | | | |
| front at 2.2 bar gauge pressure | | 185 | |
| rear at 2.5 bar gauge pressure | | 270 | |
| Front/rear axle load distribution | | | |
| at kerb weight | | 46/54 | |
| in normal attitude with driver | | 43/57 | |
| Performance: | | | |
| Maximum speed | | | |
| "Type test" | km/h | 168 | 181 |
| two persons | | 162 | 174 |

| Technical Data | R 80 GS | R 100 GS / PD | R 100 R |
|--------------------------------------|----------------------------------|---------------|---------|
| TIGHTENING TORQUES | Nm | | |
| Engine | | | |
| Engine fastening bolt (engine pin) | 54/87(Mod.91) | 87 | |
| Conrod bolts | 20 preload, tightening angle 40° | | |
| Clutch housing to crankshaft | 100 | | |
| Screw connection for carburetors | 50 | | |
| Spark plug (dry) | 25 | | |
| Cylinder head nuts (three passes) | 15/25/35 | | |
| Locking nut of valve adjusting screw | 20 | | |
| Oil filter cover | 10 | | |
| Camshaft bearing | 24 | | |
| Crankshaft flange | 24 | | |
| Hose to oil cooler thermostat | 20 | | |
| Oil pump cover | 10 | | |
| Oil sump to engine housing | 10 | | |
| Oil intake bell | 10 | | |
| Oil pressure switch | 25 | | |
| Chain box cover to engine housing: | | | |
| Nut | 7 | | |
| Bolt | 10 | | |
| Slotted nut of cylinder head cover | 24 | | |
| Oil drain plug | 30 | | |
| Fastening screw of alternator rotor | 25 | | |
| Engine electrics | | | |
| Alternator rotor to crankshaft | 25 | | |
| Spark plugs | 25 | | |
| Clutch | | | |
| Clutch housing to crankshaft | 100 | | |
| Clutch housing cover | 20 | | |
| Transmission | | | |
| Oil drain plug | 26 | | |
| Oil filler plug | 31 | | |
| Transmission to engine | 33 | | |
| Gearshift bracket to housing | 24 | | |
| Output flange to input shaft | 220 | | |
| Transmission cover | 8/10(Mod.91) | 10 | |
| Propeller shaft | | | |
| Twelve-sided bolts | 40 | | |

| Technical Data | | |
|-------------------------------------|------------------|-----|
| TIGHTENING TORQUES | Nm | |
| Rear wheel | | |
| Wheel bolts | 105 | |
| Spokes | 5 Max. | |
| Frame | | |
| Rear frame section to frame | 16/24(Mod.91) | 24 |
| Rear mud guard | 3 | |
| Kickstands | 47 | |
| Foot rest mounting brackets | 47 | |
| Exhaust system | | |
| Cauked nut | gastight | |
| Front silencer, clips | 21/24(Mod.91) | 24 |
| Rear wheel drive | | |
| Bevel gear nut | 147/200(Mod.91) | 200 |
| Threaded ring | 105/118(Mod.91) | 118 |
| Housing cover | 15 /21(Mod.91) | 21 |
| Oil drain plug | 23 | |
| Oil filler plug | 23 | |
| Swing arm | | |
| Spring strut fastening bolts | 29/47 Mod.91 | 47 |
| Bearing journal preload | 20 | |
| Bearing journal | 10 | |
| Locking nut | 107 | |
| Brake system | | |
| Brake caliper to sliding tube | 32 | |
| Brake disc | 29 /42(Mod.91) | 42 |
| Brake line to brake caliper | 7.3 | |
| Brake line to brake hose | 7.3 | |
| Brake line to master brake cylinder | 7.3 | |
| Brake lever to brake key | 6 | |

| Technical Data | R 80 GS | R 100 GS / PD | R 100 R |
|--|----------------------------|---------------|---------|
| TIGHTENING TORQUES | Nm | | |
| Telescopic fork | | | |
| Oil filler plug | 10.5/14(Mod.91) | | 10 |
| Oil drain plug | 6 | | 6,5 |
| Damper to sliding tube | 52 | | 20 |
| Spring pad | 20 | | |
| Fork stabilizer | 15/19(Mod91) | | |
| Fork bridge clamp (bottom) | 15/19 (Mod.91) | | 21 |
| Fork bridge clamp (top) | 15/19 (Mod.91) | | 21 |
| Cap nut | 107 | | |
| Slotted nut (steering bearing) | free of play (max. 0.5) | | |
| Slotted nut (fork bridge) | 40 | | |
| Locking tube | 65 | | |
| Hex nut | 65 | | |
| Handle bar clamping blocks to fork bridge | 22 | | |
| Screw with hexagonal recessed hole (stub axle) | 33 | | |
| Clamping screw (stub axle) | 15 | | |