

HONDA

@ 125/150

@ 125/150 ES

OWNER'S MANUAL

MANUAL DEL PROPIETARIO

MANUAL DO PROPRIETÁRIO

© Honda ITALIA INDUSTRIALE S.p.A. - 2001

HONDA

@ 125/150

@ 125/150 ES

OWNER'S MANUAL 

© Honda ITALIA INDUSTRIALE S.p.A. - 2001

IMPORTANT NOTICE

OPERATOR AND PASSENGER

This scooter is designed to carry the operator and one passenger. Never exceed the maximum weight capacity as shown.

ON-ROAD USE

This scooter is designed for road use only.

READ THIS OWNER'S MANUAL CAREFULLY

Pay special attention to statements preceded by the following words:

⚠ WARNING

- Indicates a strong possibility of severe personal injury or death if instructions are not followed.

CAUTION

- Indicates a possibility of personal injury or equipment damage if instructions are not followed.

NOTE:

- Gives helpful information.

This manual must be considered part of the scooter and must be handed over with it when sold.

HONDA @125/150 - @ 125/150 ES OWNER'S MANUAL

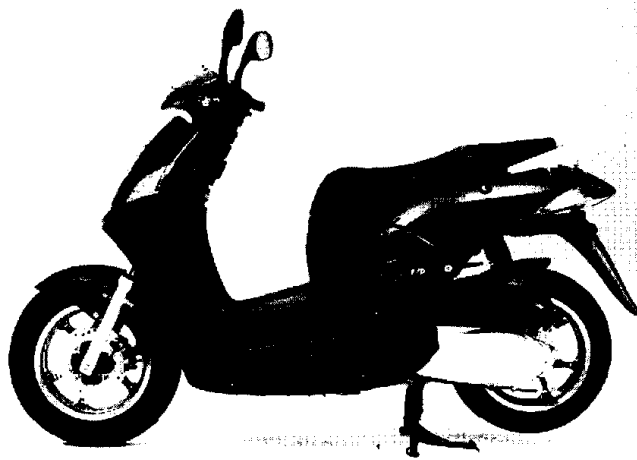

All information in this publication is based on the latest production information available at the time of approval for printing. HONDA ITALIA INDUSTRIALE S.p.A., reserves the right to make changes at any moment without prior warning and without having to fulfil any obligations. This publication cannot be reproduced in any part without written authorization from Honda Italia Industriale S.p.A. This manual is for the @125/150 - @ 125/150 ES scooter.

WELCOME

Thank you for purchasing this Honda scooter and we wish you many kilometers/miles of happy riding in the years to come. In order to enjoy safer riding and get more from your scooter read this manual carefully before taking to the road. Your safety depends not only on your own alertness and familiarity with the scooter, but also on the vehicles mechanical condition. A pre-ride inspection before every ride and regular maintenance are essential.

When you require maintenance or repairs remember that your Honda dealer knows how to help you get the best out of your scooter.

Thank you for choosing a Honda, and we wish you pleasant riding.

- The following codes used in this guide indicate the countries as shown:

@125 - @ 125 ES		@150 - @150 ES	
ED	ITALY, SPAIN, BELGIUM, PORTUGAL	ED	ITALY, SPAIN, HOLLAND
	GERMANY, HOLLAND	E	UNITED KINGDOM
	AUSTRIA, SWITZERLAND	F	FRANCE
F	FRANCE		
E	UNITED KINGDOM		

- Specifications may vary according to the country of destination.

CONTENTS

- 1 SCOOTER SAFETY
 - 1 Safe Riding Rules
 - 3 Protective Clothing
 - 4 Modifications
 - 4 Load and Accessories
- 7 LOCATION OF INSTRUMENTS
- 10 INSTRUMENTS AND INDICATORS
- 17 MAIN COMPONENTS (Information you need to operate this scooter)
 - 17 Suspension
 - 18 Brakes
 - 23 Liquid Coolant
 - 25 Fuel
 - 28 Engine Oil
 - 29 Tubeless Tires
- 33 ESSENTIAL COMPONENTS
 - 33 Ignition Switch
 - 34 Right Handlebar Controls
 - 35 Left Handlebar Controls
 - 36 Idle Stop Switch (@ 125/150 ES)
 - 37 Rear brake lock
- 38 FEATURES (Not required for operation)
 - 38 Steering Lock
 - 39 Seat Lock
 - 40 Helmet Holder
 - 41 Center Compartment
 - 42 Document Compartment
 - 43 Front Fairing
 - 43 Lower Central Cover
 - 44 Left/right side cover
 - 45 Headlight vertical Adjustment
 - 46 Idle stop (@ 125/150 ES)
- 52 RUNNING YOUR SCOOTER
 - 52 Pre-ride Inspection
 - 53 Starting the Engine
 - 56 Running in
 - 57 Riding
 - 64 When the Idle Stop Switch is Set in the IDLING STOP Position (@ 125/150 ES)
 - 67 Parking
 - 68 Anti-theft Advice

MAINTENANCE

69 MAINTENANCE

- 70 Maintenance schedule
- 73 Tool bag
- 74 Serial number
- 75 Color label
- 75 Maintenance precautions
- 76 Air cleaner
- 77 Belt case air cleaner
- 80 Breather separator
- 81 Engine oil
- 84 Spark plug
- 86 Idle speed
- 87 Side stand
- 88 Brake pad wear
- 89 Brake shoe wear
- 90 Battery
- 92 Changing fuses
- 95 Changing bulbs

99 TRANSPORTING

100 CLEANING

103 STORAGE GUIDE

103 Storage

104 After storage

105 SPECIFICATIONS

SAFE RIDING

⚠ WARNING

- **You must take all precautions necessary to ensure your safety when riding your scooter. Before riding make sure you know the following rules.**

SAFE RIDING RULES

1. Always make a pre-ride inspection (page 52) before you start the engine and then carry out any necessary repairs. You may prevent an accident or equipment damage.
2. Many accidents involve inexperienced riders. Most countries require a special scooter riding test or license. Make sure you are qualified before you ride. NEVER lend your scooter to an inexperienced rider.
3. Many automobile/scooter accidents happen because the car driver does not see the rider. Make yourself well visible to help avoid the accident which you were not responsible for:
 - Wear bright or reflective clothing.
 - Do not ride in another motorist "blind spot".
4. Obey all national and local laws and regulations.
 - Excessive speed is a factor in many accidents. Obey the speed limits and NEVER travel faster than is safe under the conditions you are riding in.
 - Always signal clearly your intention to change direction or lane. The size and agility of your scooter may confuse other drivers.

5. Do not let other motorists surprise you use extra caution at intersections, parking lot entrances and driveways.
6. Always keep both hands on the handlebars and both feet on the foot rests while driving.
7. Never leave the scooter unattended with the engine running.
8. Keep your speed low when riding on bumpy roads. Avoid hitting road hazards such as sharp bumps and holes in the road surface. These can cause loss of control or structural damage to the vehicle.

PROTECTIVE CLOTHING

ALWAYS WEAR A HELMET.
ALSO WEAR A VISA OR GLASSES.

WEAR BRIGHT OR
REFLECTIVE
CLOTHING



CLOTHES SHOULD BE
CLOSE FITTING

WEAR GLOVES

SHOES SHOULD BE CLOSE FITTING
WITH LOW HEALS AND MUST PROTECT
YOUR ANKLES.

MODIFICATIONS

⚠ WARNING

- **Modifications to the scooter or removal of any original equipment may make it unsafe or illegal. Obey all national and local equipment regulations.**

LOAD AND ACCESSORIES

⚠ WARNING

- **Honda original accessories have been designed specifically for this scooter. Other types of accessories have not been tested for this machine. Therefore you are responsible for the choice installation and use of non original Honda accessories. Always follow the instructions on weight:**

These guidelines may help you to decide whether or how to equip your scooter and how to load it safely.

1. The combined weight of the scooter, load, and any accessories must not exceed the maximum weight bearing capacity of 180 kg.

Never exceed the weight limits indicated below for the Front bag hook 1,5 kg
Rack 3,0 kg

- Do not exceed the following limits for the central compartment: 10 kg
 - Overloading any of these compartments will adversely affect the stability and handling of the scooter.
2. Do not install another fairing or modify the existing one.
 3. Do not carry items that protrude beyond the rack or block the taillight.
 4. Do not carry children or animals in the rear compartment.
 5. Keep load weight low and as close as possible to the center of the scooter. The further away the weight is from the center of gravity the harder the vehicle is to handle.
 6. Ensure that accessories do not completely or partly obscure any of the lights, they can reduce the light on the ground and the angle of inclination, or they limit travel on the suspension, the rotation of the handlebars and the control operations.

-
7. Badly fitted fairing or wind shields can cause aerodynamic resistance and make the scooter unstable to ride. Do not fit fairing that reduce or block the passage of air towards the engine.
 8. Do not fit accessories which alter the driving position, distancing hands or feet from the controls, these can increase reaction times in emergency situations.
 9. Don not fit electrical instruments which alter the scooter's electrical capacity. If a fuse blows it may cause a dangerous reduction in light or in engine performance.
 10. This scooter was not designed to pull side-cars and trailers. These, if installed, would seriously compromise the handling of the scooter.
 11. Any changes made to the cooling equipment may cause over heating and seriously damage the engine. Do not modify the radiator or install accessories which block or deviate the flow of air from the radiator.

Overloading the scooter makes it unstable and difficult to handle

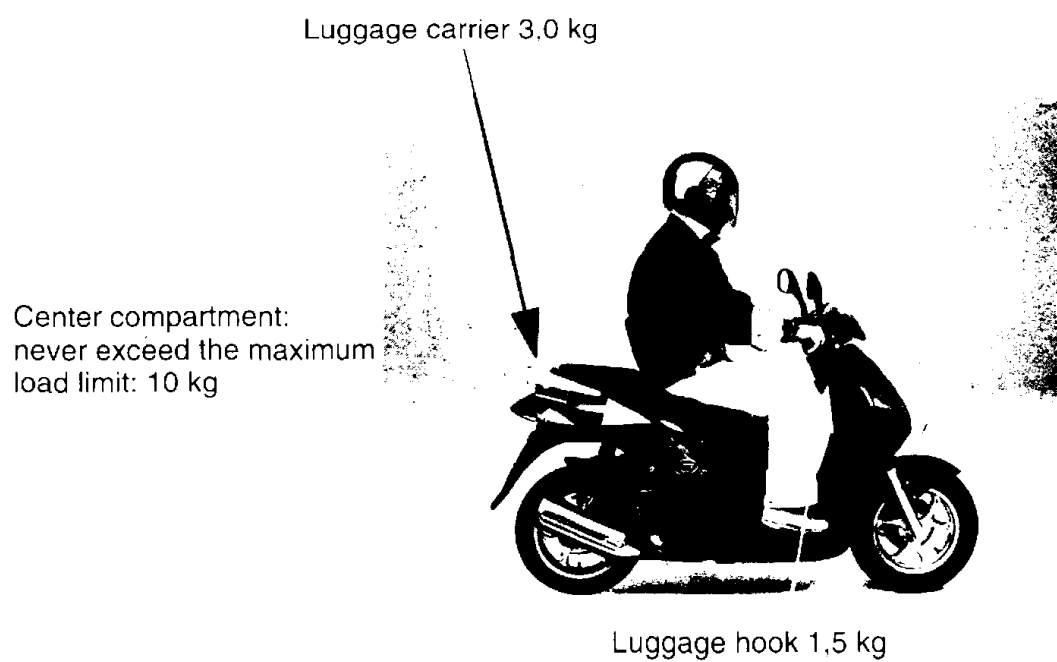

LOCATION OF INSTRUMENTS

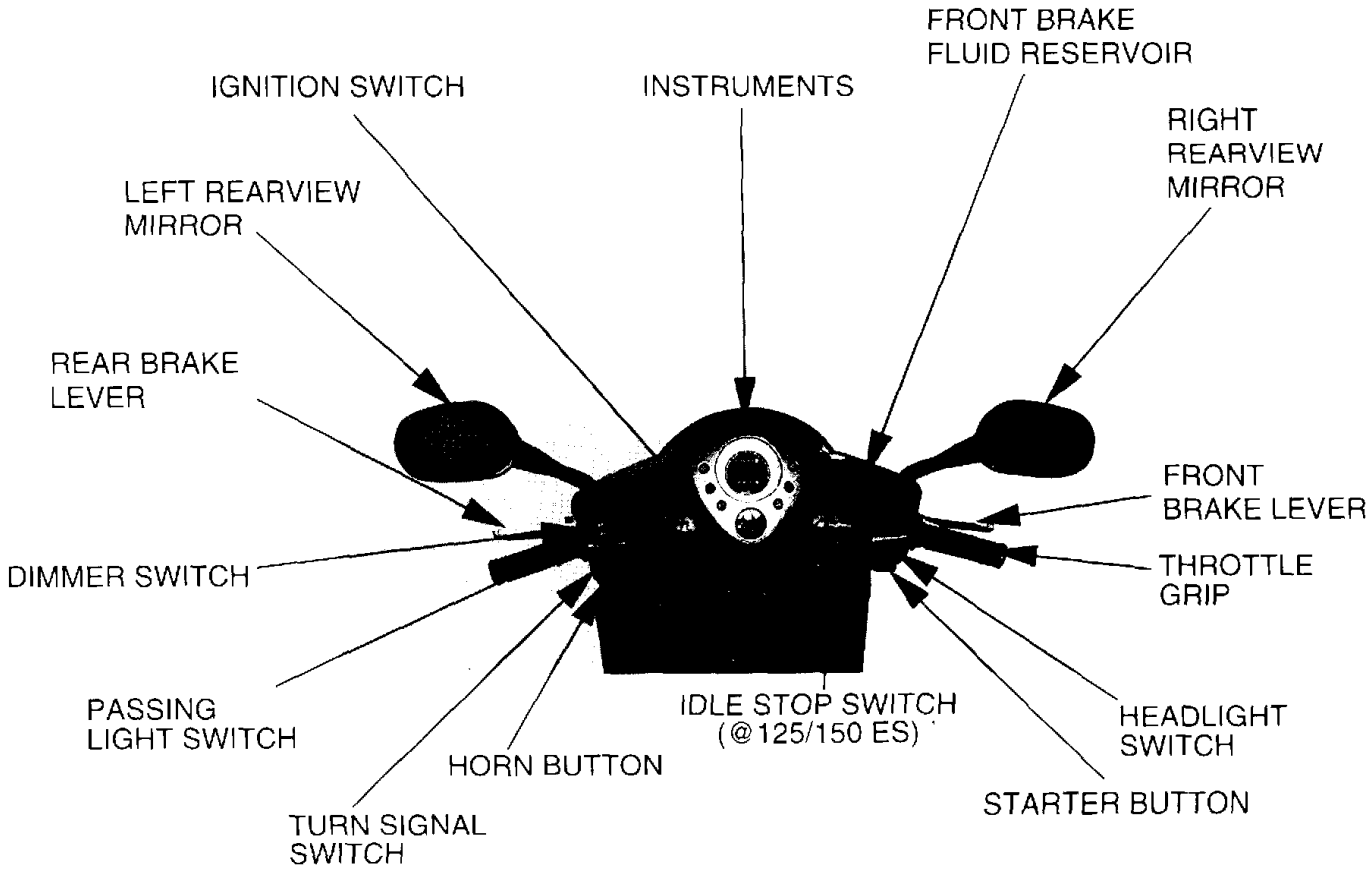

INSTRUMENTS AND INDICATORS

The indicators are contained in the instrument panel. Their functions are described in the tables on the following pages.

- (1) Fuel gauge
- (2) Left turn indicator
- (3) Speedometer
- (4) Odometer
- (5) Digital clock
- (6) High beam indicator
- (7) Right turn indicator
- (8) Coolant temperature gauge
- (9) Maintenance indicator
- (10) Tripmeter reset knob
- (11) Tripmeter
- (12) Standby indicator (@ 125/150 ES)

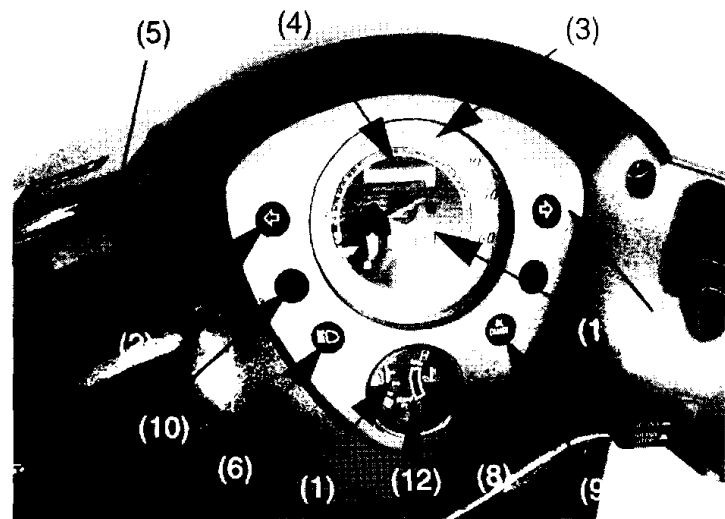

Rif. No.	Description	Function
1	Fuel gauge	Shows approximate fuel supply available (see page 14).
2	Left turn indicator	Flashes when left turn signal is used.
3	Speedometer	Indicates driving speed.
4	Odometer	Indicates total number of kilometers run.
5	Digital clock	Shows hours and minutes (see page15).
6	High beam indicator (blue)	Lights up when high beam is on.
7	Right turn signal indicator	Lights when the right light turn signal operates.
8	Coolant temperature gauge	Shows coolant temperature (see page 13).
9	Maintenance indicator	When the ignition is turned to ON the indicator lights up and after a few seconds turns off. If the indicator remains on, it means it is time to change the engine oil. Refer to the Maintenance Table (page 70). If the warning lamp does not come on it means there is a fault in the indicator signal system (page16).

Rif. No.	Description	Function
10	Tripmeter reset knob	Zero (0) the temporary odometer by pressing the button.
11	Tripmeter	Indicates the number of kilometers completed on the trip.
12	Standby indicator (@ 125/150 ES)	Flashes by the idle stop system when the idle stop is functioned.

Coolant temperature gauge

When the needle begins to move above the C (Cold) mark, the engine is warm enough for the motorcycle to be ridden. The normal operating temperature range is within the section between the H and C marks. If the needle reaches the H (Hot) mark, stop the engine and check the reserve tank coolant level. Read pages 23 and 24 and do not ride the motorcycle until the problem has been solved.

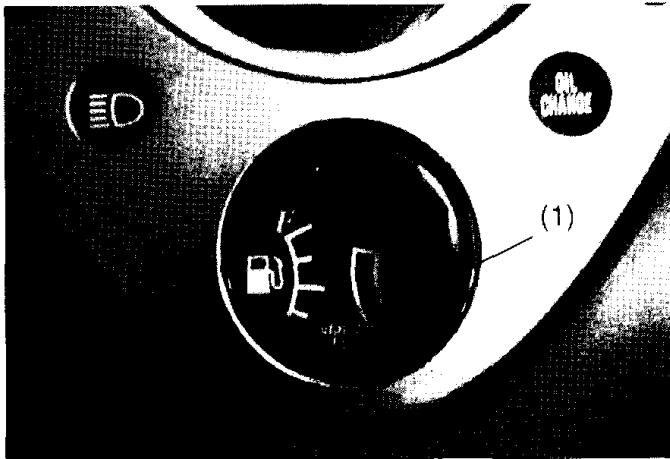

(1) Coolant temperature gauge

CAUTION

- Exceeding maximum running temperature may cause serious engine damage.

Fuel gauge (1)

When the gauge needle enters the red band (2), the fuel level is low and you must refill the tank as soon as possible.

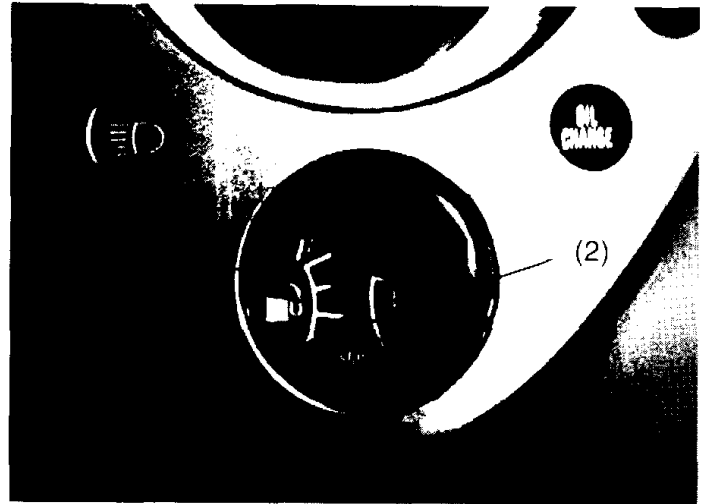

- (1) Fuel gauge
- (2) Red band

Digital clock (1)

Indicates the hours and minutes. To change the hour proceed as follows:

1. Turn the main switch to ON.
2. Press the "H" button (2). To move the time forward keep the button pressed until the hour desired is displayed.
3. Press the "M" button (3). To move the time forward keep the button pressed. When "60" minutes are reached the display will turn to "00" without affecting the hour display.

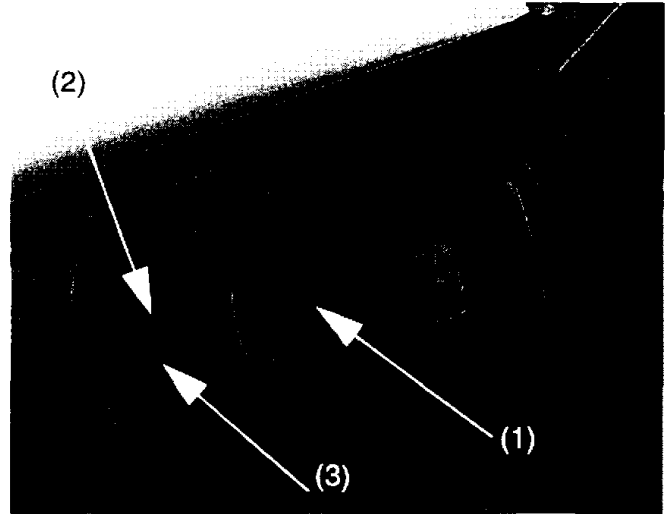

- (1) Digital clock
- (2) Hour button (H)
- (3) Minute button (M)

Maintenance indicator

When the mileage on your scooter approaches the specified maintenance interval to change the engine oil except for the first 1000 km, the maintenance indicator (1) will come on. After replacing the engine oil, reset the indicator to zero by following procedures given below.

Resetting

1. Turn the ignition switch "ON".
2. Press the reset button (3) using a screwdriver (2) or similar tool.
3. Keep it pressed for at least a second, until the indicator is turned off.
4. Then turn the ignition switch "OFF".



- (1) Indicator
- (2) Screwdriver
- (3) Reset button

16

NOTE:

- When the ignition switch is turned "ON", the indicator flashes.
- The indicator flashes twice when the reset switch is pressed for at least a second. This means that the indicator has been reset and zeroed.

When the scooter odometer reading reaches the oil replacement service limit (as indicated in the maintenance schedule page 70), the maintenance indicator will light up. Having replaced the engine oil, reset the indicator by pressing the reset button positioned above the indicator.

NOTE:

- The indicator lights up only if the scooter has run for approximately 5000 km, therefore once the engine oil has been changed (except for the first 1000 km) be sure to reset the indicators so that the following maintenance interval is indicated at the specified mileage limit.

MAIN COMPONENTS

(Essential information for running your scooter)

⚠ WARNING

- If you fail to carry out a pre-ride inspection (page 52), before starting out, severe personal injury or damage to the vehicle may result.

SUSPENSION

The shock absorber (1) pre-load has three adjustment positions for different load types and road conditions.

Use a hook spanner (2) to adjust the rear shock absorber.

Position A is for light loads and good road conditions. Position C increases spring pre-load for a more rigid rear suspension and is used when the motorcycle is heavily loaded.

Position A is standard.

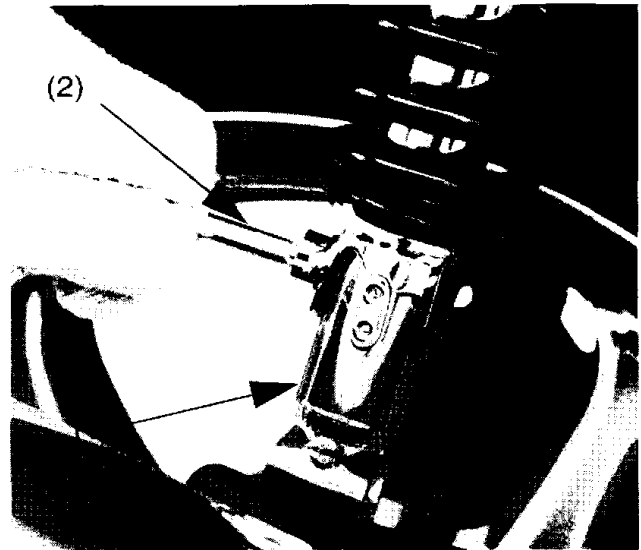

- (1) Shock absorber
- (2) Hook spanner

BRAKES

This scooter is equipped with a Combined Brake System. Operating the rear brake lever, applies the rear brake and a portion of the front brake. For full braking effectiveness, use both the front and the rear brake levers simultaneously, as you would with a conventional scooter braking system.

As with a conventional scooter braking system, excessively hard application of the brake controls may cause wheel lock, reducing control of the scooter.

For normal braking, apply both the front and the rear brake lever to match your road speed. For maximum braking, close the throttle and firmly apply the front and rear brake lever.

Front brake

The scooter front brake is a hydraulic disc brake. As the brake pads wear, brake fluid level drops.

There are no adjustments to perform, but fluid level and pad wear should be inspected periodically. The system should be inspected frequently to ensure there are no fluid leaks. If the control lever free travel becomes excessive and the brake pads are not worn beyond the recommended limit (page 88), there is probably air in the brake system and it must be bled. See your authorized Honda dealer for this service.

Brake fluid level:

⚠ WARNING

- **Brake fluid may cause irritation. Avoid contact with skin or eyes. In case of contact, flush thoroughly with water and call a doctor if fluid gets in your eyes.**
- **KEEP OUT OF REACH OF CHILDREN.**

CAUTION

- **Handle brake fluid with care because it can damage plastic and painted surfaces.**
- **When topping up the fluid ensure that the reservoir is horizontal before removing the cap or fluid may spill out.**
- **Use only DOT3 or DOT4 brake fluid from a sealed container.**
- **Keep water or dirt out of the brake fluid tank.**

Check that the fluid is always above the lower level mark (1) when the scooter is vertical. Add brake fluid to the reservoir when the level begins to reach the lower level mark (1). Remove the screws (2), the tank cover (3), the diaphragm plate (4) and diaphragm (5). Fill the reservoir with DOT3 or 4 from a sealed container and fill up to the upper level mark (6). Replace the diaphragm and cover. Tighten the screws securely.

Other checks:

Check that there are no fluid leaks. Check for wear and cracks in the hoses and fittings.

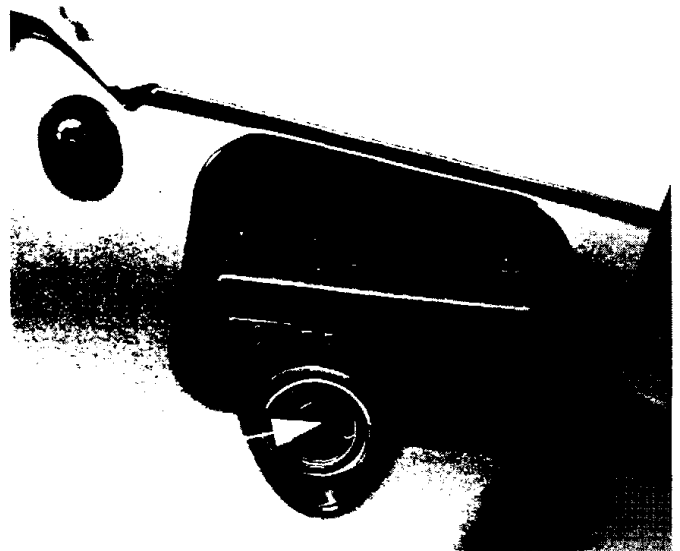

- (1) Lower level mark
- (2) Screws
- (3) Reservoir cover
- (4) Diaphragm support
- (5) Diaphragm
- (6) Upper level mark

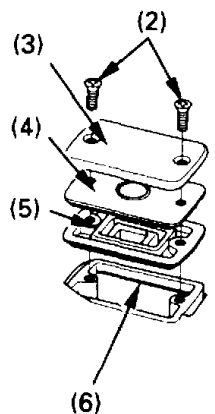

**Rear brake
Adjustment:**

1. Measure the distance of movement on the rear brake lever (1) before the brake starts to act. The play on the front brake lever before it starts braking must be 15 - 25 mm. If necessary adjust it, turn the rear brake adjusting nut (2).

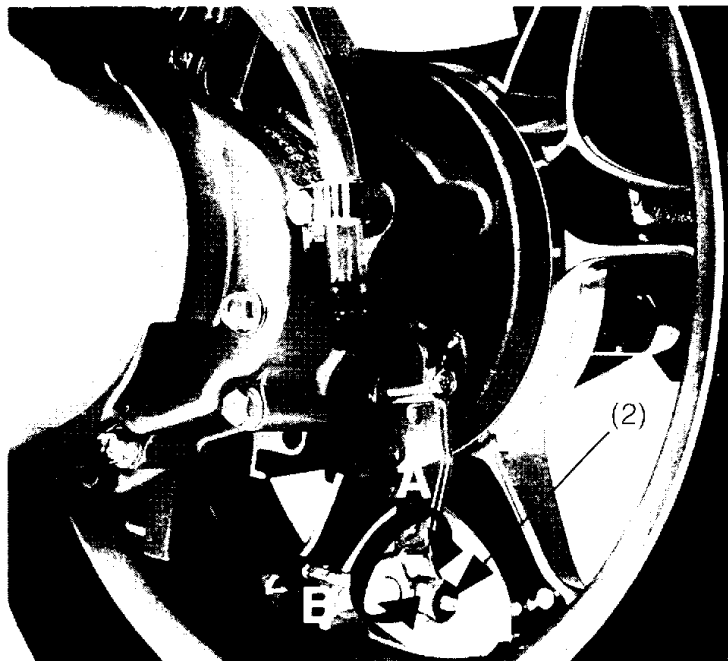
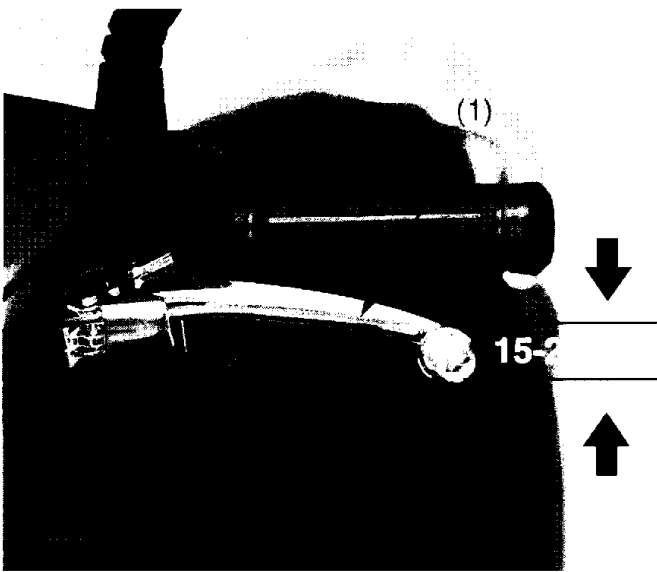

(A) Reducing play
(B) Increasing play

- (1) Rear brake lever
- (2) Adjusting nut

2. Put the brakes on a number of times and check that the wheels move freely when the brake lever is released.

NOTE:

- When the adjustment has been done check that the groove on the adjusting nut (2) fits snugly into the arm pin (3).
- If you are not able to carry out the adjustment in this way, contact your Honda dealer.

Other checks:

Check that the brake arm, the spring and the joints are all in good condition.

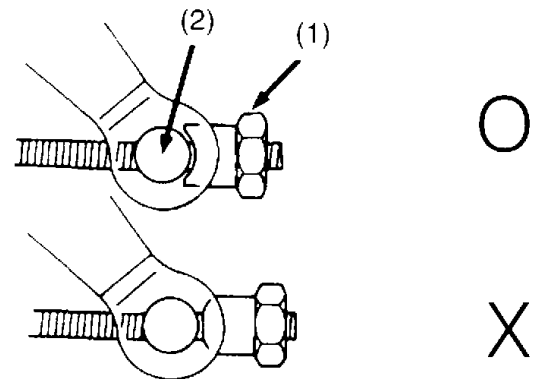

- (1) Adjusting nut
- (2) Arm pin

LIQUID COOLANT

How to use the coolant

The owner must properly maintain the coolant to prevent freezing, overheating and corrosion. Use only high quality ethylene glycol antifreeze containing corrosion protection inhibitors specifically recommended for use in aluminum engines.

(SEE ANTIFREEZE CONTAINER LABEL).

CAUTION

- **Use only low-mineral drinking water or distilled water as a part of the antifreeze solution. Water that is high in mineral content or salt may be harmful to the aluminum engine.**

The factory provides a 50/50 solution of antifreeze and distilled water in this motorcycle. This coolant solution is recommended for most operating temperatures and provides good corrosion protection. A higher concentration of antifreeze decreases the cooling system performance and is recommended only when additional protection against freezing is needed. A concentration of less than 40/60 (40% antifreeze) will not provide proper corrosion protection. During freezing temperatures, check the cooling system frequently and add higher concentration of antifreeze (up to a maximum of 60% antifreeze) if required.

Inspection

The reserve tank is located on front right side. Check the coolant level in the reserve tank (1) with the engine at normal temperature. If the liquid is below the "LOWER" level (2), remove the reserve tank cap (3) and add the coolant mixture until it reaches the "UPPER" mark (4). Always add coolant to the reserve tank. Do not attempt to add coolant by removing the radiator cap.

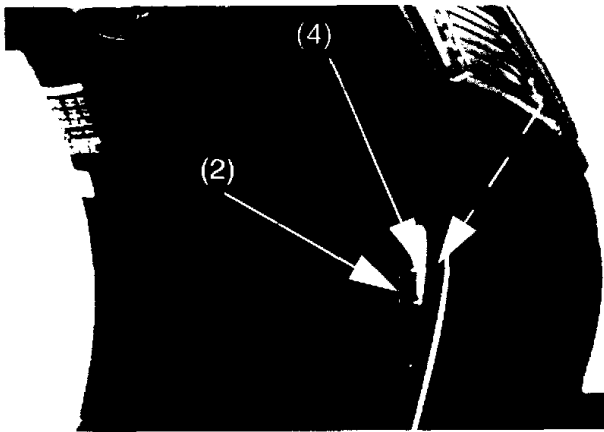

⚠ WARNING

- Do not remove the radiator cap when the engine is hot. The coolant is under pressure and could scald you.
- Keep hands and clothes away from the cooling fan, as it starts automatically.

If the reserve tank is empty, if coolant loss is excessive check for leaks and see your Honda dealer to carry out repairs.

- (1) Reserve tank
- (2) LOWER level mark (Low)
- (3) Reserve tank cap
- (4) UPPER level mark (Up)

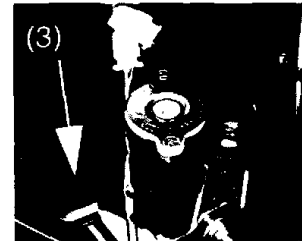

FUEL

Fuel tank

The fuel tank is situated under the seat. Fuel tank capacity is 9 liters.

Unlock and open the seat with the ignition key. Turn the fuel cap (1) anti-clockwise until it clicks then lift it off. Fill the tank and then replace the cap taking care to tighten it firmly turning it clockwise. Make sure that the symbols on the cap and tank (2) are aligned.

Use petrol with an octane number of 91 or higher.

Use unleaded petrol because it produces a lower level of deposits in the engine and spark plugs, and extends the life of the exhaust system components.

CAUTION

- If "spark knock" or "pinking" occurs at a steady engine speed under normal load, change brands of petrol. If spark knock or pinking persists, consult your Honda dealer. Failure to do so is considered misuse, and damage caused by misuse is not covered by Honda's Limited Warranty.

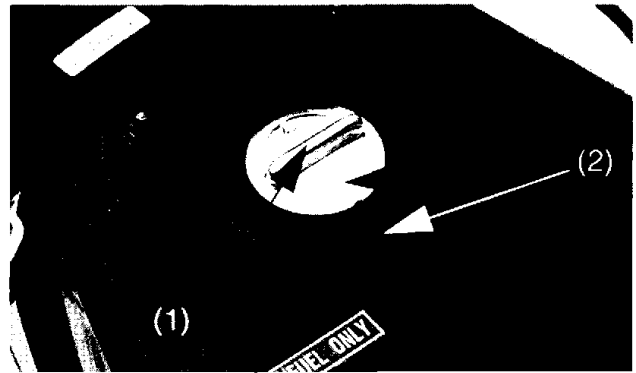

- (1) Filler cap
- (2) Symbols

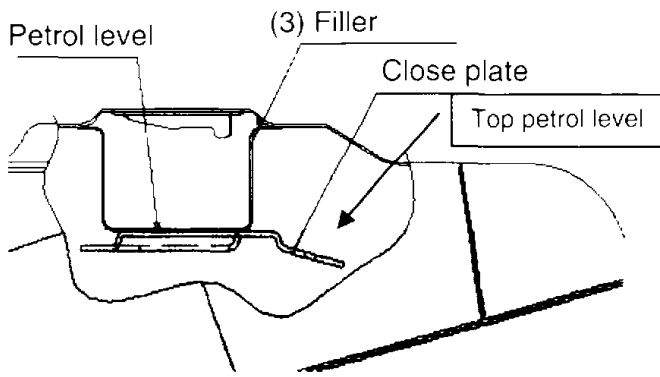

(3) Filler

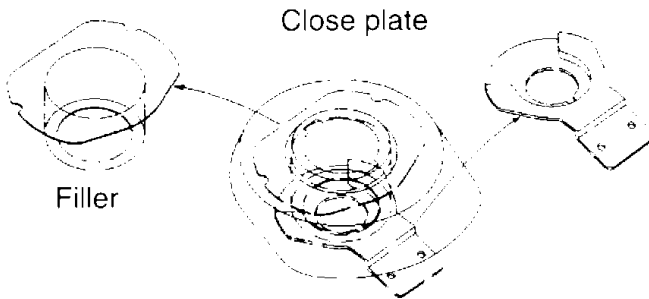

⚠ WARNING

- Petrol is extremely flammable and explosive under certain conditions. Refuel in a well-ventilated area with the engine stopped. Do not smoke or allow flames or sparks in the area where petrol is stored or where the fuel tank is refilled.
- Do not overfill the tank (there should be no fuel in the filler neck (3)). After refueling, make sure the fuel fill cap is closed securely.
- Be careful not to spill fuel when refueling. Spilled fuel or fuel vapor may ignite. If any fuel is spilled, make sure the area is dry before starting the engine.
- Avoid repeated or prolonged contact with skin or breathing in the petrol fumes. **KEEP OUT OF CHILDREN'S REACH.**

Petrol containing alcohol

If you decide to use as petrol containing alcohol, make sure that its octane rating is as least as high as that recommended by Honda. There are two types of this petrol one contains ethanol and the other methanol. Do not use petrol that contains more than 10% ethanol. Do not use petrol with methanol (methyl or wood alcohol) that does not also contain co-solvents and corrosion inhibitors for methanol. Never use petrol with more than 5% alcohol even if it has cosolvents and corrosion inhibitors.

NOTE:

- Damage to the fuel system or engine performance problems resulting from the use of fuels that contain alcohol are not covered under the warranty. Honda cannot authorize the use of fuels containing methanol since they have not yet been proved to be entirely suitable.
- Before buying fuel from an unfamiliar petrol station, try to find out if the fuel contains alcohol. If it does confirm the type and percentage of alcohol used. If you notice any operating problems while using a petrol that contains alcohol, switch to one that you know does not contain alcohol.

ENGINE OIL

Checking engine oil level

Check the engine oil level every day before riding your scooter.

The level must be between the upper (1) and lower (2) level marks on the dipstick (3).

1. Start the engine and let it idle for a few minutes.
2. Stop the engine and put the scooter on its a center stand on level ground.
3. After a few minutes, remove the oil filler cap/dipstick (3) wipe it clean, and reinsert the dipstick without screwing it in. Remove the dipstick. The oil level should be between the lower (1) and upper (2) level marks on the dipstick.
4. If required add the specified oil (see page 81) up to the upper level mark. Do not exceed the upper mark.
5. Replace the oil filler cap/dipstick. Check for oil leaks.

CAUTION

- **Running the engine with insufficient oil can cause serious damage.**



- (1) Level upper
- (2) Level lower
- (3) Dipstick

TUBELESS TIRES

This scooter is equipped with tubeless tires, valves, and wheel rims. Use on tires marked "TUBELESS" and tubeless valves on rims marked "TUBELESS TIRE APPLICABLE". Proper air pressure will provide maximum stability, riding comfort and tire life. Check tire pressure frequently and adjust if necessary.

NOTE:

- Tire pressure should be checked before you ride while the tires are "cold".
- Tubeless tires have some degree of self-sealing ability if they are punctured, and leakage is often very slow. Inspect very closely for punctures, especially if the tire is not fully inflated.

		Front	Rear
Tire size		110/90 13M/C 56L	130/70 13 M/C 57L
Cold tire pressure kPa (kgf/cm ²)	Rider only	175 (1,75)	200 (2,00)
	Rider and passenger	175 (1,75)	225 (2,25)
Make of tire (ONLY TUBELESS)			
Dunlop	Front		D305F
	Rear		D305
Bridgestone	Front		HOOP B03
	Rear		HOOP B02

Cracks and damage

Check the tire tread and sidewalls for cracks (1) or other damage (2).

⚠ WARNING

- Cracked or damaged tires are a safety hazard. They may lose pressure rapidly which could result in losing control of the vehicle.

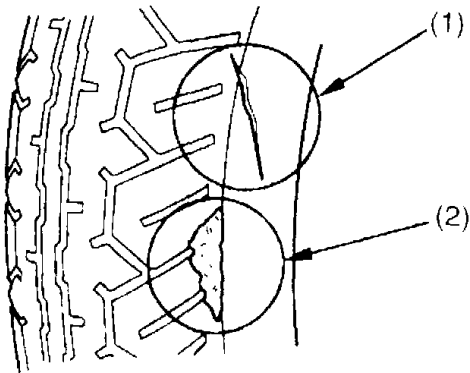

- (1) Cracks
- (2) Damage

Abnormal wear

Check for abnormal wear of the tire tread (1).

NOTE:

- Abnormal wear will adversely affect traction and handling.

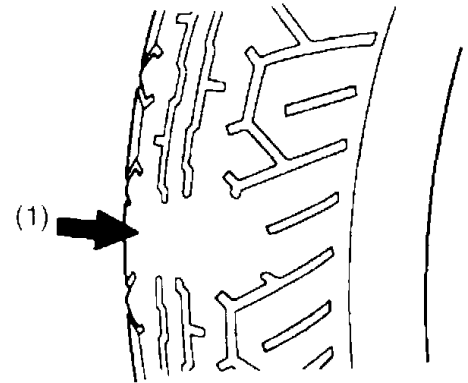

- (1) Abnormal wear

Nails rocks and other sharp objects

Check the tread and sidewalls for nails stones and other sharp objects (1).

⚠ WARNING

- Nails, rocks and other sharp objects may cause a puncture that could result in loss of vehicle control.

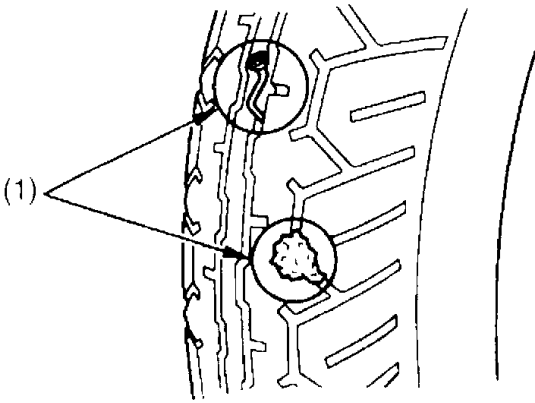

(1) Nails rocks and other sharp objects

Tread depth

Check the wear indicator (1) to check for insufficient tread depth. If the wear indicator is visible, change the tire.

⚠ WARNING

- Riding the scooter with excessively worn tires is dangerous and will adversely affect traction and handling.

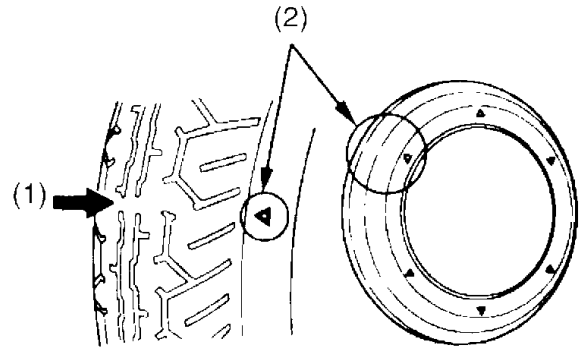

(1) Wear indicator
(2) Wear indicator position mark

Tire wear/replacement

See your Honda dealer

⚠ WARNING

- The use of tires other than those listed on the tire information label may adversely affect handling.
- Do not install tube-type tires on tubeless rims. The beads may not seat and the tires could slip on the rims, causing tire deflation that may result in a loss of vehicle control.
- Do not install a tube inside a tubeless tire. Excessive heat build-up may cause the tube to burst resulting in rapid tire deflation that may result in a loss of vehicle control.

⚠ WARNING

- Replace the tire if the sidewall is punctured or damaged. Sidewall flexing may cause repair failure and tire deflation may result in a loss of vehicle control.
- If nails or rocks are allowed to remain stuck in the tire's tread surface, performance will be reduced and late repair may not fully restore the tire's designed safety level.

CAUTION

- Do not try to remove tubeless tires without special tools and rim protectors. You may damage the rim sealing surface or disfigure the rim.

ESSENTIAL COMPONENTS

IGNITION SWITCH

The ignition switch (1) is on the right side below the steering stem.

You should receive a key number plate (2) with your key.

You will need this key number if you ever have to replace a lost key. Store this plate in a safe place.

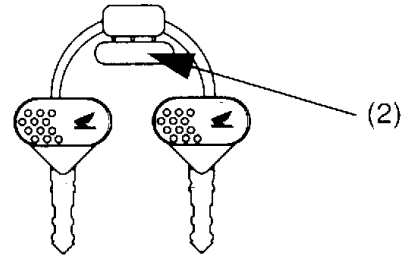

- (1) Ignition switch
- (2) Key number plate

Key position	Function	Key removal
LOCK	Steering is locked. Engine and lights cannot be operated.	The key can be removed.
OFF	Engine and lights cannot be operated.	The key can be removed.
ON	Engine and lights can be operated.	The key cannot be removed.

RIGHT HANDLEBAR CONTROLS

Headlight switch

	Headlight, position light, taillight and meter lights ON.
	Position light, taillight and meter lights ON.
•	All lights OFF

Starter button

The starter button (2) is below the headlights switch (1).

When the button is pressed, the starter motor cranks the engine.

See page 53 for how to start up.

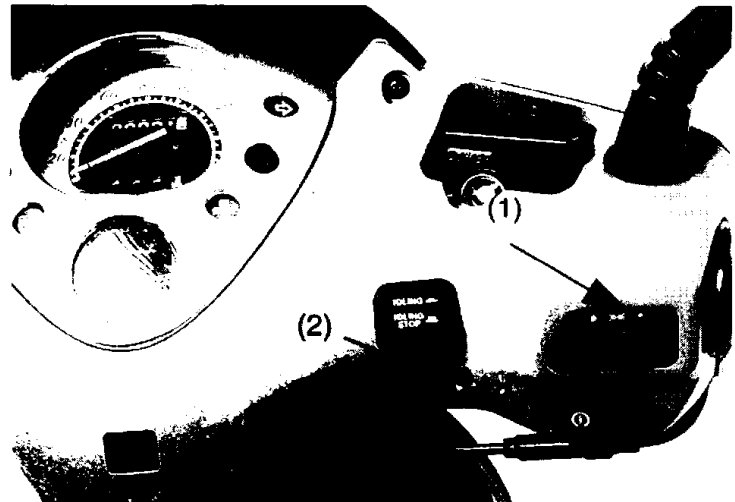



(1) Headlights switch

(2) Starter button

LEFT HANDLEBAR CONTROLS

Headlight dimmer switch (1)

	High beam
	Low beam

Passing light control switch (2) PASSING ↓

When this switch is pressed down the headlight flashes on to signal approaching cars or when passing.

Turn signal switch (3) ↔

Move left to signal a left turn, and move right to signal a right turn.

Press to turn the signal off.

Horn (4)

Press the button to sound the horn.

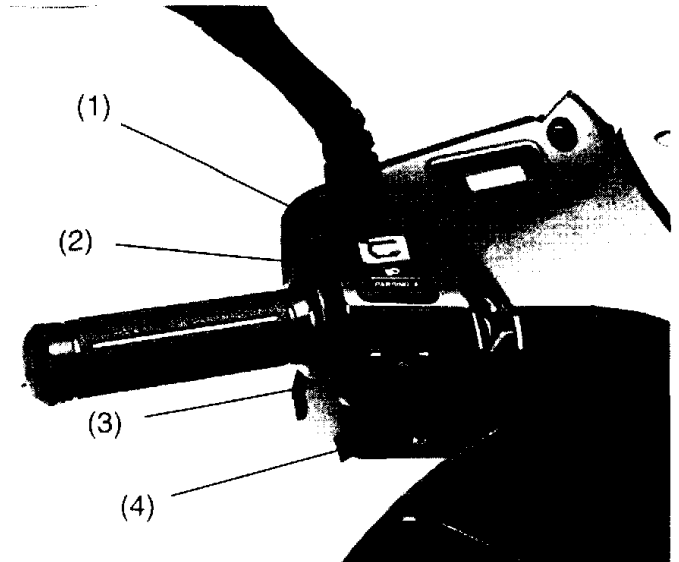

- (1) Headlight dimmer switch
- (2) Passing light switch
- (3) Turn signal switch
- (4) Horn button

IDLE STOP SWITCH (@ 125/150 ES)

Activates and releases the idle stop system.

IDLING STOP.... Idle stop system activated

IDLING Idle stop system released

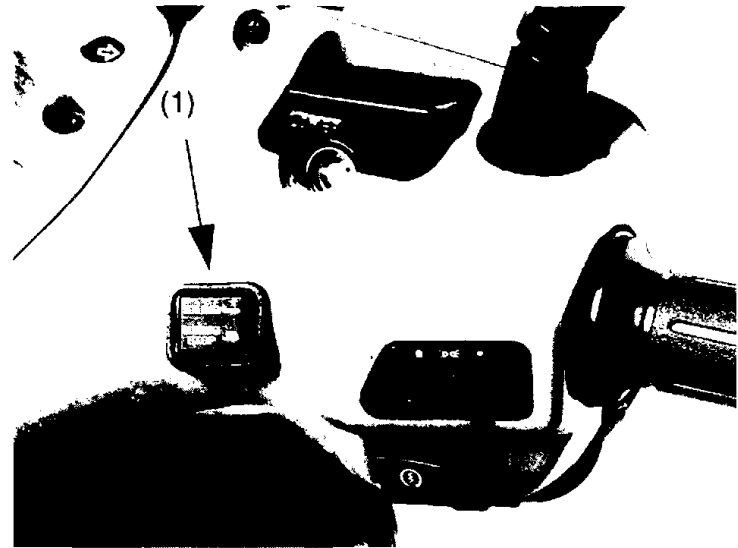

(1) Idle stop switch

REAR BRAKE LOCK

Be sure the rear brake lock is applied while warming up the engine.

To apply the brake lock:

1. While pushing the brake lock lever (1) in, pull in the rear brake lever (2).
2. To set the rear brake lever push the rear brake lever block back and pull on the rear brake lever.

NOTE:

- The rear brake lock will not be applied if the rear brake and brake lock cable are not adjusted properly.
- If your brake lock cable needs adjustment, see your Honda dealer.

To release the brake lock:

1. Unlock the brake lock lever by squeezing the rear brake lever.
2. Release the rear brake lever.

CAUTION

- Before riding, make sure that the rear brake is released fully and does not drag.

To apply



To release



- (1) Brake lock lever
- (2) Rear brake lever

FEATURES

(Not essential for running the motorcycle)

STEERING LOCK

To lock the steering, turn the handle bar all the way to the left and turn the key (1) to the "LOCK" position while pushing in. Remove the key.

⚠ WARNING

- Do not turn the key to LOCK while riding the scooter because you will lose control of the vehicle.

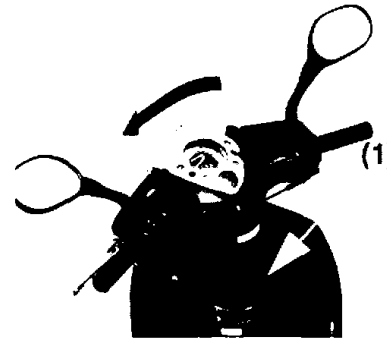

- (A) PUSH IN
- (B) TURN TO "LOCK"
- (C) TURN TO "OFF"

(1) Ignition key

TO LOCK

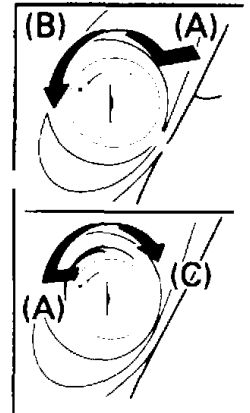

TO UNLOCK

SEAT LOCK

The seat lock (1) is on the left side below the seat.

To lift the seat, insert the ignition key (2) and turn it clockwise to unlock.

Pull the seat up while holding the key on unlock position.

To lock the seat, lower it and press down on it near the hook (3) until it locks.

NOTE:

- Before locking the seat check that you have not left the key in the compartment under the seat.

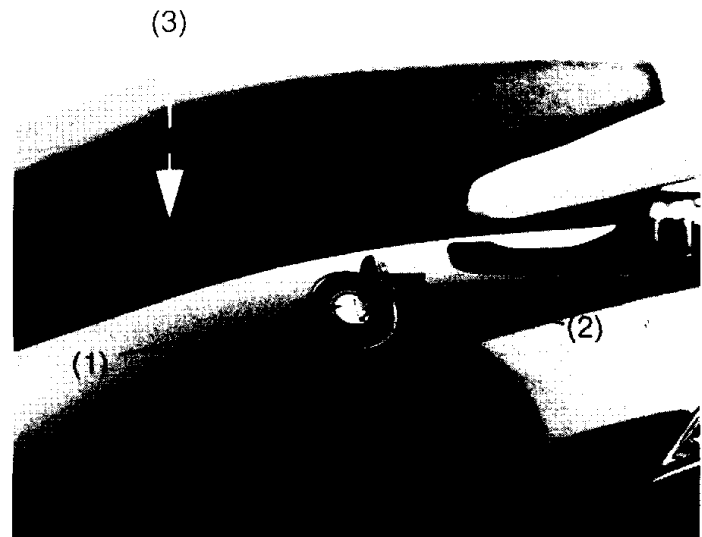

- (1) Seat lock
- (2) Ignition key
- (3) Hooks

HELMET HOLDER

The helmet holder means you do not need to carry your helmet after parking the scooter. Insert the ignition key into the seat lock, and turn it clockwise to unlock.

Hang the helmet by routing either end of the helmet holder wire through the helmet's D-ring.

Hook the loops of the wire onto the helmet holder (1) and lower the seat lock.

The helmet holder wire is furnished in the tool kit.

⚠ WARNING

- The helmet holder is designed for helmet security while the vehicle is parked. Do not ride with a helmet attached to the holder as the helmet may interfere with safe running and result in loss of control.

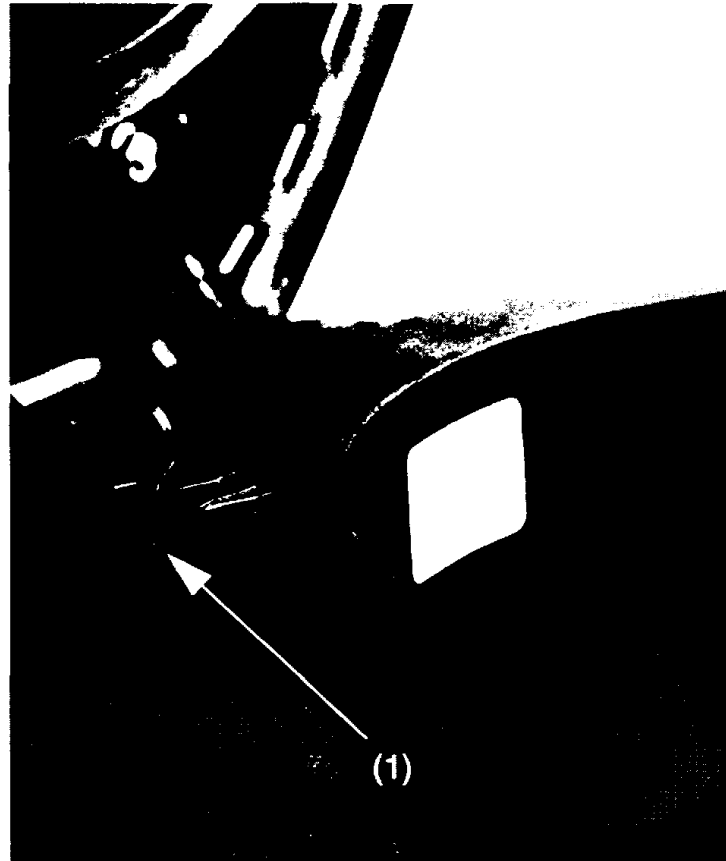

(1) Helmet holder

CENTER COMPARTMENT

The center compartment (1) is under the seat.

Maximum Weight Limit: 10 kg

▲ WARNING

- Never exceed the maximum weight limit, this could make the scooter unstable and difficult to handle.

CAUTION

- The center compartment may become heated by the engine. Do not put food, inflammable objects or anything which could be damaged by heat in this compartment.

NOTE:

- Do not direct water under pressure against this compartment as water will enter the compartment.

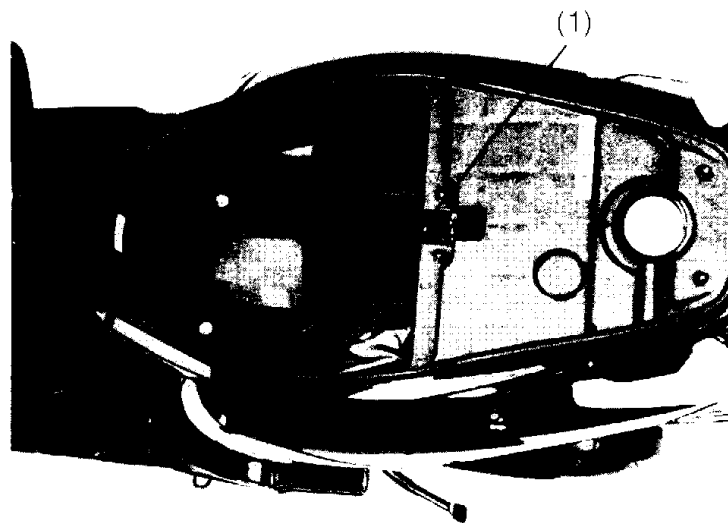

(1) Center compartment

DOCUMENT COMPARTMENT

The document compartment (1) is located to the front left of the handlebar.

Maximum weight limit: 0,5 kg

To open in turn the ignition key clockwise.

The use and maintenance manual and other documents must be kept in this compartment.

When washing the scooter take care not to flood this area with water.

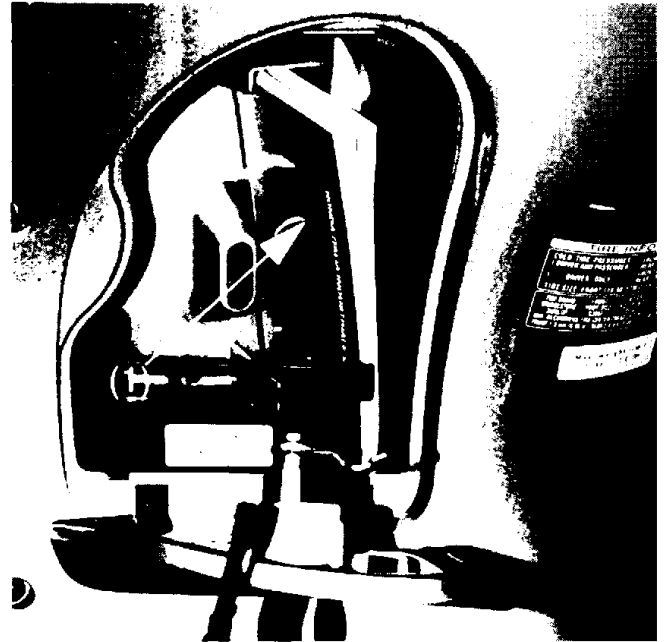
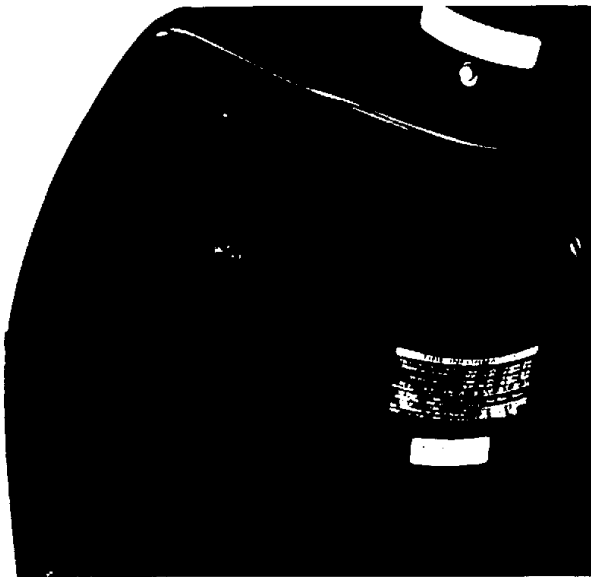

(1) Document compartment

FRONT FAIRING

To remove the front cover (1) remove the eight screws (2) securing the inner cover (3). Remove the inner cover. Remove the cover. Installation is in the reverse order of removal.

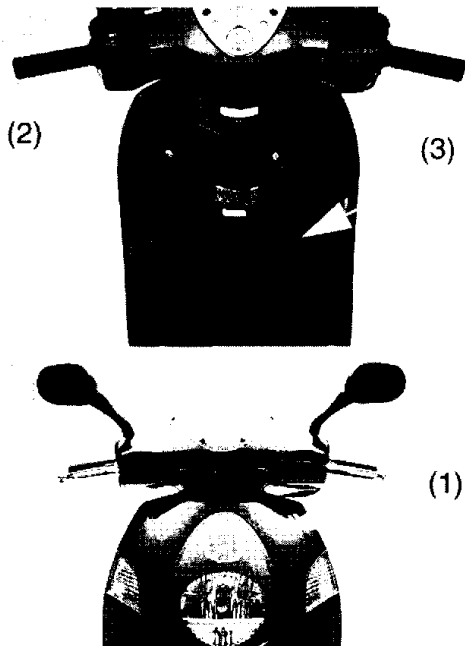

- (1) Front cover
- (2) Screws
- (3) Inner cover

LOWER CENTRAL COVER

Lift the seat up. Remove the center cover (2) screw (1). Remove the clips (3) from the right and left side of the cover. Remove the cover. Installation is in the reverse order of removal.



- (1) Screw
- (2) Center cover
- (3) Clips

LEFT AND RIGHT SIDE COVER

Unscrew the two screws (1) on the side cover bag. Unscrew the screws (2) behind the rear foot rest. Unscrew the screws (3) on the saddle bag after having removed the lower central cover (page. 43), remove the side saddle bag. To refit, carry out the removal procedure in reverse.

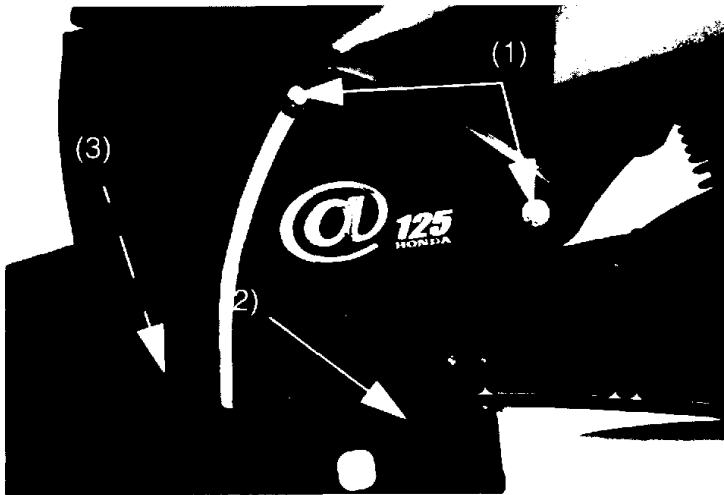

HEADLIGHT VERTICAL ADJUSTMENT

The vertical adjustment can be carried out by turning the screw (1) through the hole in the document compartment. Only the height can be adjusted.

Follow local laws and regulations.

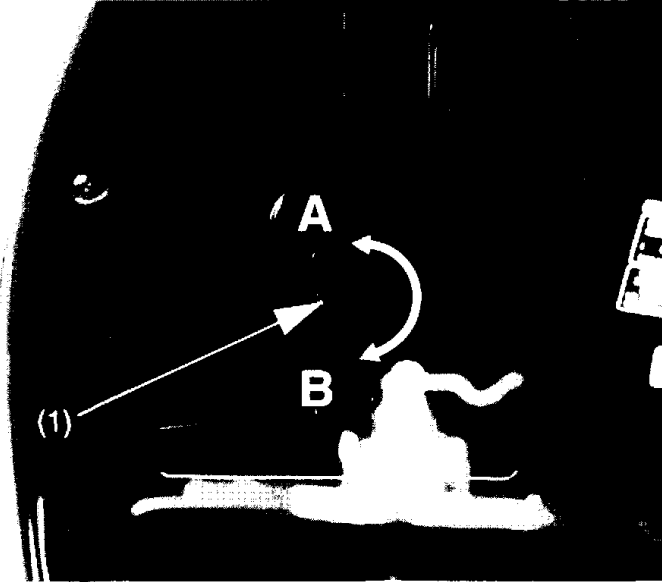

- (1) Adjustment screw
- (A) Up
- (B) Down

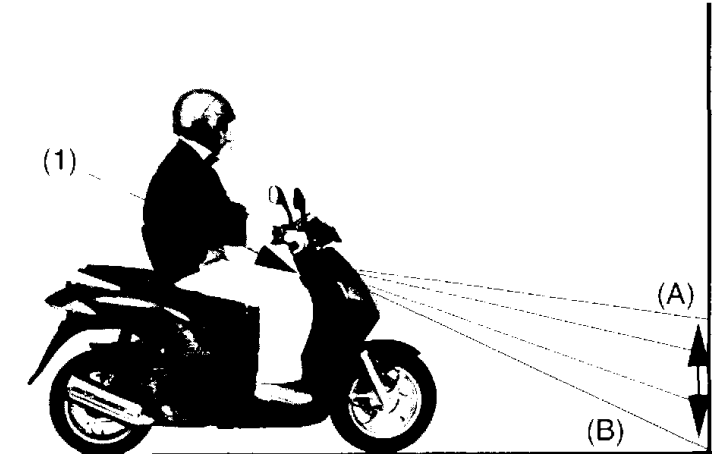

NOTE:

- Adjust the height of the light beam in compliance with local driving standards.

IDLE STOP (@125/150 ES)

Function of the Idle Stop System

The purpose of the idle stop system is to improve fuel economy and to reduce exhaust emissions and noises by stopping the engine automatically while waiting at the intersection (Idle Stop).

- The idle stop system comes into operation when the throttle closed and the scooter brought to a complete stop.
- The standby indicator will flash to indicate that the idle stop system in operation.
- The engine can be restarted by opening the throttle.

The idle stop operation can be cancelled by moving the idle stop switch to the IDLING position.

Operating Condition of the Idle Stop System

In order for the idle stop system to function properly, the following conditions must be met.

1. Before starting to ride the scooter.
 - Warm up the engine to the operating temperature. The idle stop system will not function when the engine is cold.
 - Set the idle stop switch to the IDLING STOP position.
 - Assume a proper posture on the seat. The system will not function when the seat is not loaded with weight properly.

Ride the scooter at speed higher than 10 km/h.

2. To stop the scooter.

- Throttle is closed. The idle stop system will not function when open the throttle.
- Bring the scooter to a complete stop. The idle stop system will not function unless the scooter is brought to a complete stop.

3. To restart the engine.

- Check that the standby indicator is flashing. The engine cannot be restarted even if the throttle is opened unless the standby indicator is flashing.
- The idle stop system will be released, and standby indicator turned off unless the rider sits in the seat for more than three minutes.
- Squeeze the brake lever and press the starter button when restarting the engine with the standby with indicator not flashing.

For Safety Riding (@125/150 ES)

Observe the followings to ensure safety in the operation of the idle stop system.

- Do not leave the scooter unattended with the idle stop system in operation. Be sure to remove the key from the ignition switch when the scooter is to be left unattended.



- Once you get off the scooter, do not hold your body or hand against the seat, or place cargo on it while the idle stop system is in operation. The engine may be restarted if the throttle grip is rotated accidentally.

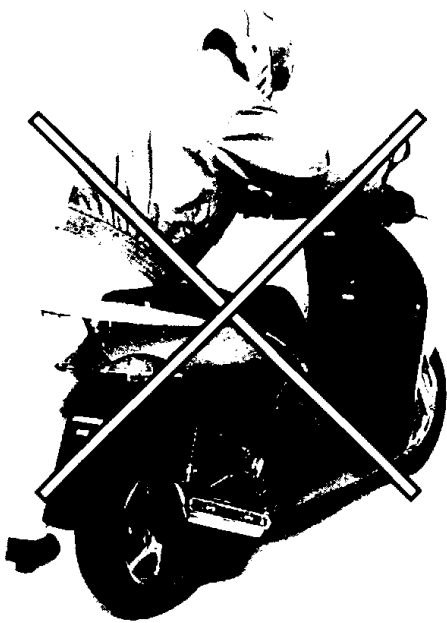

When the Idle Stop System Does Not Function (@125/150 ES)

Perform the following before taking your scooter to see your Honda dealer.

Symptom	Check	Remedy
Idle stop is not functioned	Is the idle stop switch set in the IDLING STOP position?	Set the idle stop switch in the IDLING STOP position.
	Is the engine cold ?	The idle stop system will not function when the engine is cold. Warm up the engine to the operating temperature.
	Is the scooter brought to a complete stop ?	The idle stop system will not function unless the scooter is run at speed 0 km/h.

Symptom	Check	Remedy
Idle stop is not functioned	Is the throttle opened ?	The idle stop system will not function if the throttle is opened . The throttle is closed.
	Has the scooter been run after it was stopped last?	The idle stop system will not function if the scooter has not been run at speed above 10 km/h after starting the engine last. Ride the scooter once again.
	Is the rider seated in the seat in proper posture?	The idle stop system will not function if the seat is not loaded with weight properly. Sit in the seat in proper posture.

Symptom	Check	Remedy
Engine is not started even when the throttle is opened.	Is the standby indicator flashing ? Check the following if it is turned OFF.	Perform the following if the standby indicator is turned OFF.
	Is the rider seated in the seat in proper posture?	The idle stop system does not function when the seat is not loaded with weight. The system will be released if the seat is not loaded with weight for more than about 3 minutes. Sit in the seat in proper posture.
	Is the idle stop switch set in the IDLING position ?	Set the idle stop switch in the IDLING STOP position.

RUNNING YOUR SCOOTER

PRE-RIDE INSPECTION

⚠ WARNING

- **Failure to carry out a pre-ride inspection may result in serious personal injury or damage to the scooter.**

Check the scooter every day before starting up and carry out any necessary adjustments or repairs. The following checks will only take a few minutes and in the long run they will save time, money and possibly your life.

1. Oil level - Check the oil level and if necessary top it up (page 28).
2. Fuel level - refill fuel tank when necessary (page 25) Check for leaks in the tank.
3. Coolant level - Add liquid coolant when necessary. Check that there are no leaks (page 23 - 24).
4. Brakes (front and rear) - Check their efficiency and if necessary adjust play (page 18 - 22).
5. Tires front and rear- Check their condition and pressure (page 29 - 32).

6. Throttle - Check for smooth opening and full closing in all steering positions.
 7. Lights and horn - Check that the (front and rear) lights, stop light, indicators, turn signals, and horn all work efficiently.
- Correct any fault before you ride. Contact your Honda dealer if there are any problems you cannot solve.

STARTING THE ENGINE

Always start the scooter as follows.

This scooter is equipped with a cut out system which blocks start up if the side stand is in the down position.

This scooter is equipped with an automatic starter and an auto cock, so no manual operations are necessary.

1. Place the scooter on its center stand.
2. Turn the ignition switch (1) to "ON".

⚠ WARNING

- **Never run the engine in a closed area. The exhaust contains poisonous carbon monoxide gas that can cause loss of consciousness and lead to death.**

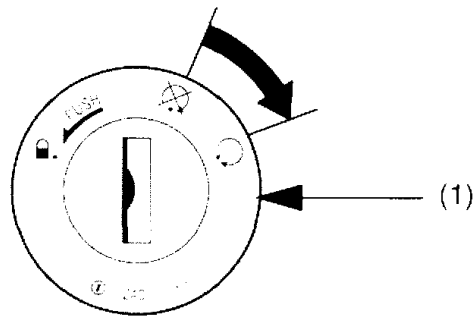

(1) Ignition switch

3. Lock the rear wheel by applying the brake lock lever (1).

⚠ WARNING

- **The rear wheel will spin if not restrained by the brake or contact with the ground. Accidental contact with a spinning wheel could cause death or injury.**

NOTE:

- Electric starter will work when the brake lever is squeezed and side stand is up.



- (1) Rear brake lever
(2) Starter button

4. With the throttle closed, push the starter button (2). Release the starter button as soon as the engine starts.

NOTE:

- Do not use the electric starter for more than 5 seconds at a time. Wait for about 10 seconds before pressing the starter button again.

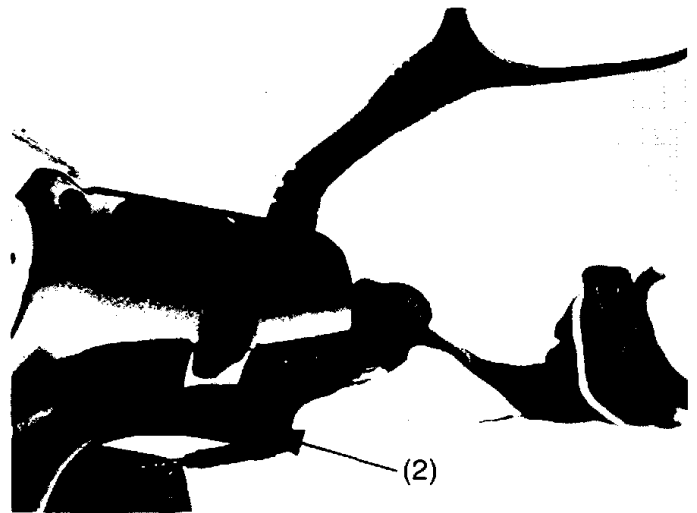

5. Be sure to keep the throttle closed and the rear brake (1) locked while the engine is warming up.
6. Allow the engine to warm up before riding. (See "RIDING" page 57).

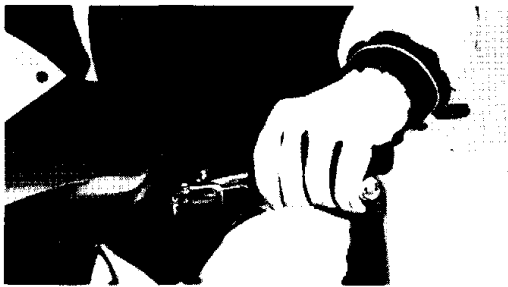

(1) Rear brake lever

⚠ WARNING

- Do not open and close the throttle rapidly as the scooter will lurch forward suddenly, causing possible loss of control.
- Do not leave the scooter unattended while the engine is warming up.

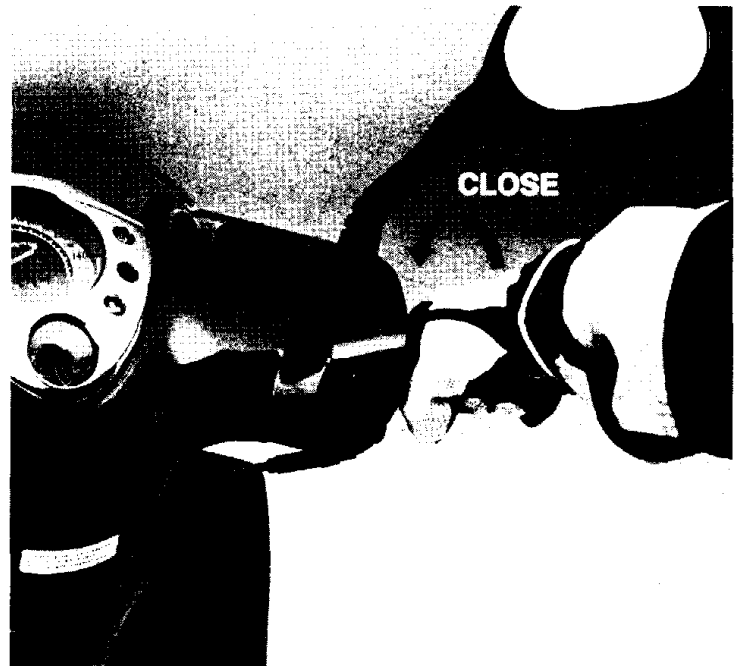

If you cannot restart a warm engine:

1. Place the scooter on its center stand and lock the rear brake lever.
2. Open the throttle (1) $1/8$ - $1/4$ turn while starting the engine.

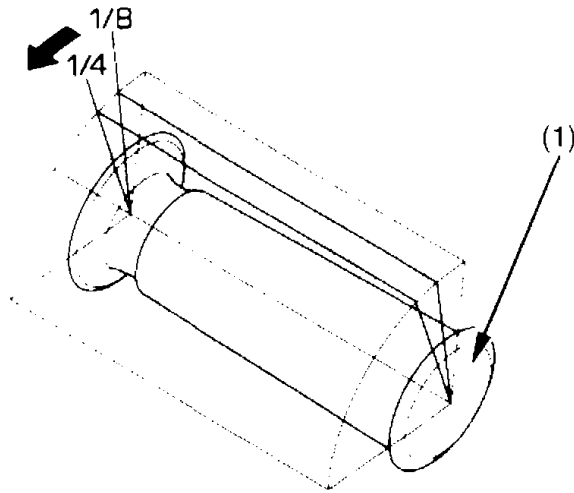

(1) Throttle

RUNNING IN

Help assure your scooter's future reliability and performance by paying extra attention to how you ride for the first 500 km (300 miles).

Do not exceed 80% of the machine's maximum allowed speed.

Avoid opening the throttle fully and maintaining the same speed for a long period. During the early running in period the new machined surfaces are in contact with each other and can wear quickly. The servicing 1.000 km after running in is to compensate for this initial wear. If you run your scooter in carefully you will ensure a long life and excellent performance from the engine.

RIDING

1. Make sure that the throttle is closed before taking the scooter off the center stand.

⚠ WARNING

- The rear wheel must be locked when taking the scooter off the center stand or you may lose control of the vehicle.
2. Stand on the left of the scooter and push it forward and off the center stand.

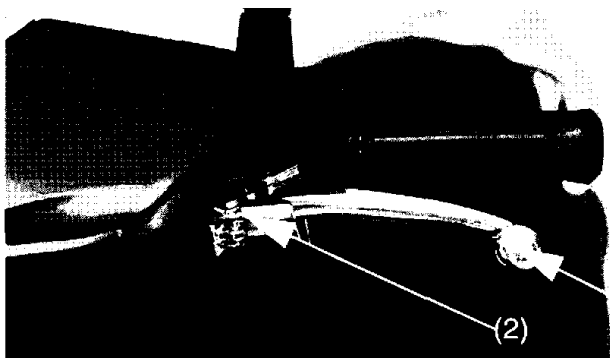

- (1) Rear brake lever
(2) Brake lock lever

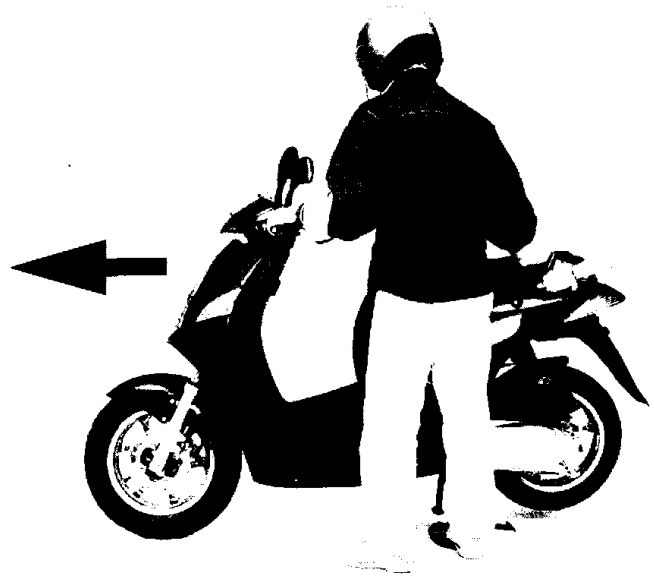

3. Mount the scooter from the left side keeping at least one foot on the ground to steady the it.



4. Unlock the rear wheel by releasing the rear brake lever (1).



- (1) Brake lock lever
- (2) Rear brake lever

5. Before starting off, indicate your direction with the turn signals, and check for safe traffic conditions.

Hold the handlebars firmly with both hands.

⚠ WARNING

- **Never ride with one hand, you may lose control of the vehicle.**

6. To accelerate, open the throttle (1) gradually the scooter will move forward.

⚠ WARNING

- **Do not open and close the throttle rapidly as the scooter will lurch forward suddenly, causing possible loss of control.**

7. To decelerate close the throttle.



(1) Throttle

8. When slowing down, coordination of the throttle (1) and the front and rear brakes (2) is very important.



- (1) Throttle
(2) Front and rear brakes

⚠ WARNING

- Both brakes (front and rear) must be applied together. Independent use of only the front or rear brake reduces stopping power. Excessive brake application, may cause either wheel to lock reducing control of the scooter.



9. When approaching a curve or a corner, close the throttle (1) and slow the scooter down by applying both brakes (front (3) and rear (2)) at the same time.

10. After completing a turn open the throttle gradually.

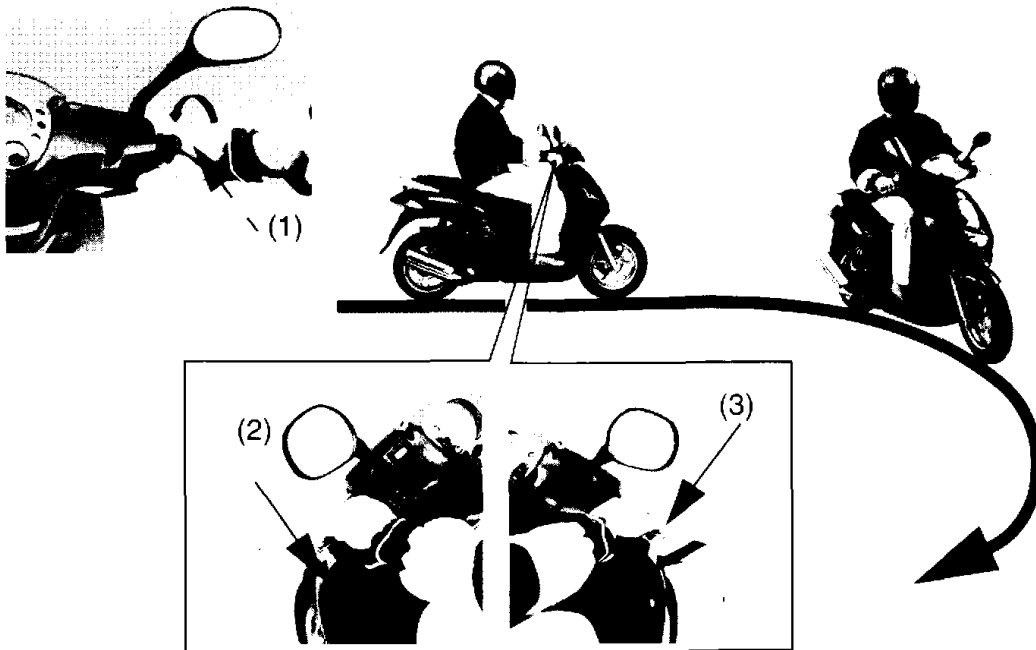

- (1) Throttle
- (2) Rear brake
- (3) Front brake

11. When descending a steep slope close the throttle fully (1) and apply both brakes to reduce speed.

CAUTION

- Avoid continuous use of the brakes, this may cause overheating and reduce braking efficiency.

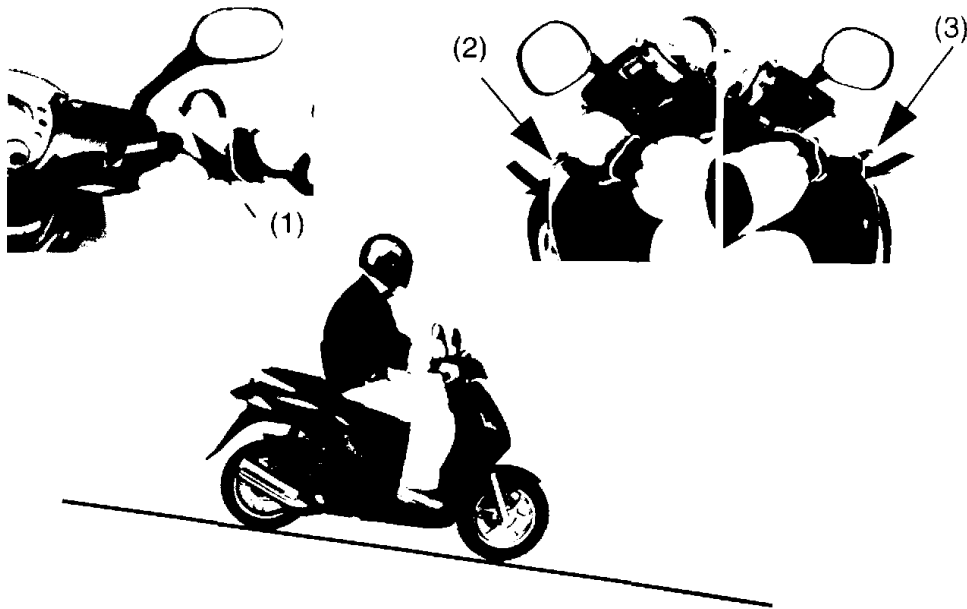

- (1) Throttle
- (2) Rear brake
- (3) Front brake

12. Be especially careful when riding on wet or loose surfaces.

⚠ WARNING

- When riding in wet or rainy conditions or on loose surfaces, the ability to maneuver and stop will be reduced.
For your safety:
- Exercise extreme caution when braking, accelerating or turning.
- Ride at slower speeds and allow for extra stopping distance.
- Keep the scooter as upright as possible.
- Use extreme caution when riding over slippery surfaces such as railroad tracks, iron plates, manhole covers, painted lines, etc.

WHEN THE IDLE STOP SWITCH IS SET IN THE IDLING STOP POSITION (@ 125/150 ES)

The engine will stop idling about 3 seconds after you have ridden the scooter at speed above 10 km/h, brought it to a complete stop, then closed the throttle completely with the engine warmed and the driver is seated.

The standby indicator will start flashing to indicate that the idle stop system is in operation.

NOTE:

- Sustained idle stop may cause the battery to run down.

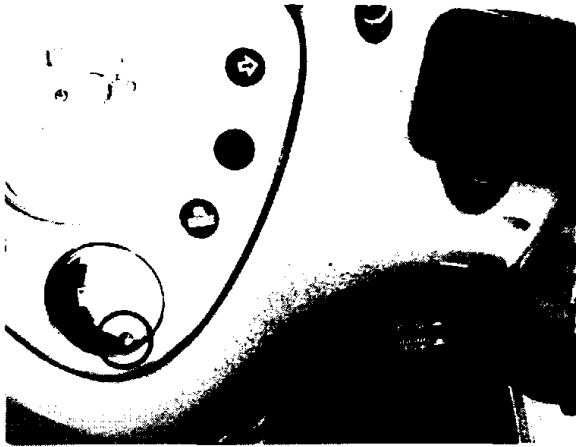

To restart the engine

The engine is restarted by opening the throttle.

The engine will not restart unless you place your weight on the seat in proper posture.

Check that the engine is started.

When restarting on upgrade, be sure to release the brake lever after making sure that the engine starts to lug against the load imposed on it.



The idle stop system is released when the idle stop mode switch is returned to the idling position. Setting the idle stop mode switch back in the idling stop position causes the system to resume its function.

The idle stop system will be released when the side stand is applied under the idle stop condition. It will resume its function when the side stand is stored.

PARKING

1. When the scooter has stopped turn the ignition switch to "OFF" and remove the key.
2. Lift the scooter onto the center stand to park it.

CAUTION

- Park on firm level ground so that it does not fall over.
3. Lock the steering to help prevent theft (page 38).

⚠ WARNING

- The exhaust pipe and muffler become very hot while the scooter is running and remain sufficiently hot to burn if touched even after shutting off the engine.
- USE THE CENTER STAND

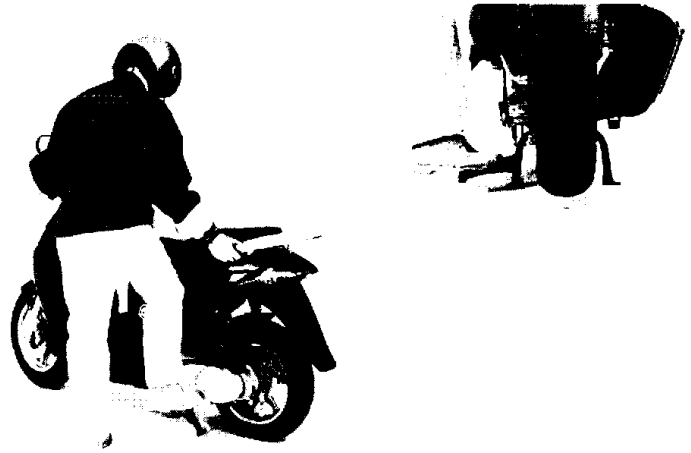

ANTI-THEFT ADVICE

1. Always lock the steering and never leave the key in the ignition switch. This sounds simple but people do forget.
2. Be sure that the registration information is accurate and current.
3. Whenever possible park your scooter in a locked garage.
4. Write your name address and telephone number in this use and maintenance manual and keep it on your scooter.
5. Stolen motorcycles are often identified by the information in the owner's manuals that are with them.

NAME: _____

ADDRESS: _____

TELEPHONE NO: _____

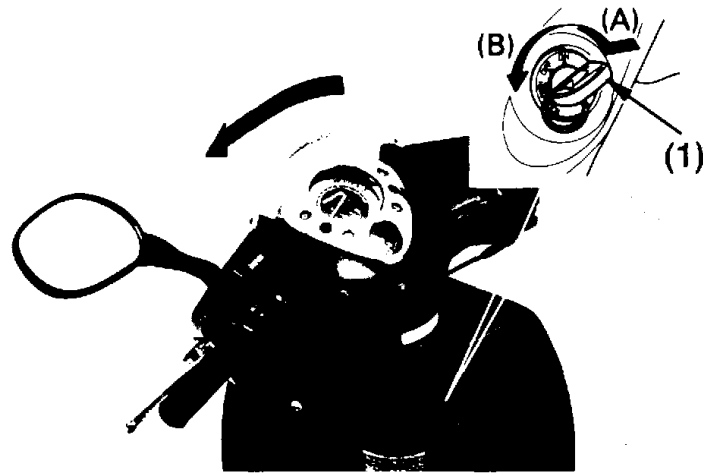

(1) Ignition key

(A) Push in

(B) Turn to lock

MAINTENANCE

1. When your scooter needs servicing remember that your authorized Honda dealer knows your scooter better than you do and has all the equipment necessary to carry out all maintenance and repairs. The maintenance schedule can also be followed by qualified mechanics who normally carry out this kind of work.
2. The maintenance schedule and time intervals indicated are applicable to normal riding conditions. Scooters constantly ridden at high speeds or in unusually wet and dirty conditions will need more frequent maintenance.
3. Consult your Honda dealer for advice specific to your needs.

MAINTENANCE SCHEDULE

The following maintenance schedule specifies all maintenance required to keep your scooter in peak operating condition. Maintenance work must be performed in accordance with standards and specifications of Honda by properly trained and equipped technicians. Your Honda dealer meets all of these requirements.

Perform the Pre-ride Inspection at each scheduled maintenance period.

I: Inspect and clean, adjust, lubricate or replace if necessary

C : Clean R: Replace A: Adjust L: Lubricate

Element	Frequency	Whichever comes first ↓	Odometer reading (Note 1)					See page
			→ x 1000 km x 1000 mi	1 0.6	4 2.5	8 5	12 7.5	
		Note	Month		6	12	18	
* Fuel line					I	I	I	—
* Throttle operation					I	I	I	—
* Air cleaner		Note 2					R	76
Crankcase breather		Note 3			C	C	C	—
Spark plug						R		84
* Valve clearance				I	I	I	I	—
Engine oil				R	R	R	R	81
Engine oil filter							C	82
* Engine idle speed				I	I	I	I	86
Radiator coolant		Note 4				I		—

Element	Frequency	Whichever comes first ↓	Odometer reading (Note 1)					See page
			→ x 1000 km x 1000 mi	1 0.6	4 2.5	8 5	12 7.5	
		Note	Month		6	12	18	
* Cooling system								—
* Secondary air supply system								—
* Drive belt		Every 8000 km I - Every 24000 km R						—
Belt case air cleaner					C	C	C	77
* Final drive oil		Note 4						—
Brakefluid		Note 4						19-20
Brake shoes/pads wear								88-89
Brake system								—
* Brake light switch								—
* Brake lock operation								18-22
* Headlight aim								—
** Clutch Shoes wear								—
Side stand								87
* Suspension								—
* Nuts, bolts, fasteners								—
** Wheels/Tires								29
** Steering head bearings								—

*Should be serviced by your Honda dealer unless the owner has the proper tools and qualifications to carry out the work. See the Honda shop manual.

**For safety reasons these items must be serviced by an authorized Honda shop. Honda recommends that your authorized dealer road tests your motorcycle after every periodic maintenance inspection.

Note 1. At higher odometer readings, repeat at frequency interval established here.

Note 2. Service more frequently when riding in the rain or at full throttle.

Note 3. Change every 2 years. Changing requires mechanical skill.

Note 4. Change every 2 years. Changing requires mechanical skill.

TOOL BAG

To get to the tool bag (1) open the seat. The tools are in the center compartment. With this kit you can carry out minor or emergency repairs and some maintenance.

- Pin wrench
- Spanner 8 x 12 mm
- Spanner 10 x 14 mm
- Screw driver 3
- Screw driver 1
- Grip, screw driver
- Hex. wrench 5
- Wrench plug
- Bar, handle
- Tool bag 160
- Blade fuse 30A



(1) Tool bag

SERIAL NUMBER

The frame and engine serial numbers are required when registering your scooter. They may also be required by your dealer when ordering spare parts. Record the numbers here for your reference.

FRAME NO. _____

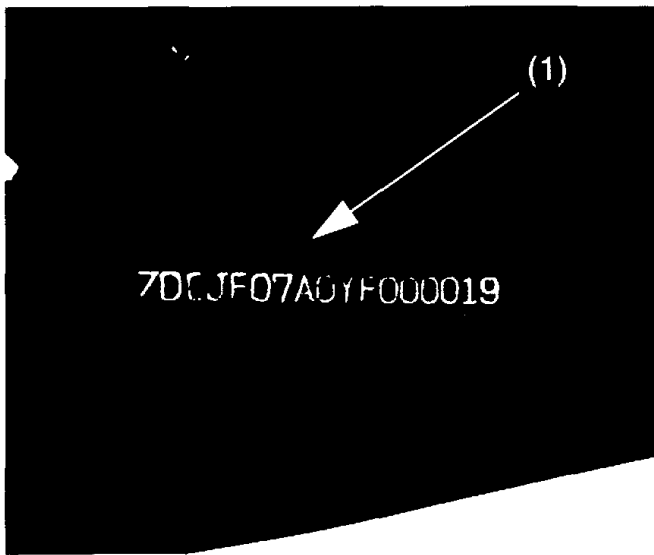

(1) Frame no.

The frame number (1) is stamped on the right side of the frame body.

The engine number (2) is stamped on the left side of the crank case near the rear wheel.

ENGINE NO. _____



(2) Engine no.

COLOR LABEL

The color label (1) is attached to the center compartment. It is helpful when ordering replacement parts. Record the color code here for your reference.

COLOR: _____

CODE: _____

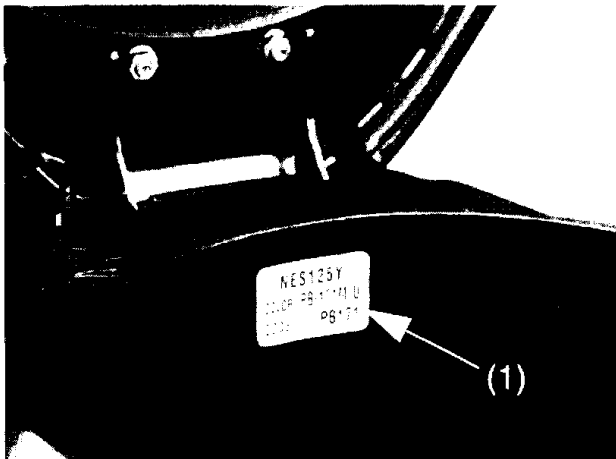

(1) Color label

MAINTENANCE PRECAUTIONS

⚠ WARNING

- If your scooter is overturned or involved in an collision, inspect control levers, brake hoses, calipers, accessories and other vital parts for damage. Do not ride the scooter if damage impairs safe riding. Have your Honda dealer inspect the major components including frame, suspension, and steering parts for misalignment and damage that you may not be able to detect.
- Before carrying out any maintenance, switch off the engine and place the scooter on the center stand on firm flat ground.
- Only use original Honda parts or an equivalent for maintenance and repairs. Parts of a lower quality may effect the safety of the scooter.

AIR CLEANER

(See "Maintenance precautions" on page 75)

The air cleaner must be serviced at regular intervals (page 70). Service more frequently when riding in unusually wet or dusty areas.

1. Remove the six screws (1) from the cover (2).
2. Remove the air cleaner cover and remove the air cleaner element (3).

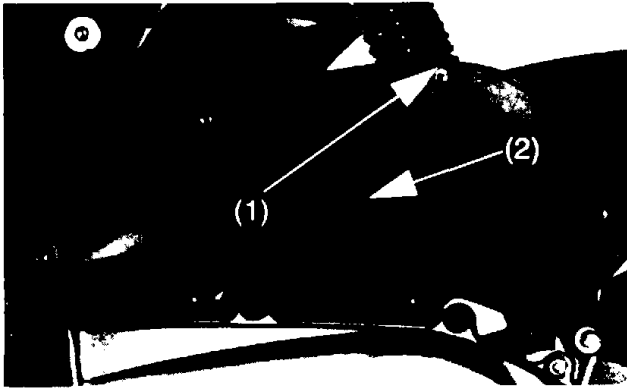

- (1) Screws
- (2) Cover air cleaner
- (3) Air cleaner cover

3. Use original Honda air cleaners or equivalent air cleaner specified for your model motorcycle. Using air cleaners different from those specified or non equivalent air cleaners, may cause premature engine wear or performance problems.
4. Install the removed part in the reverse order from which they were removed.

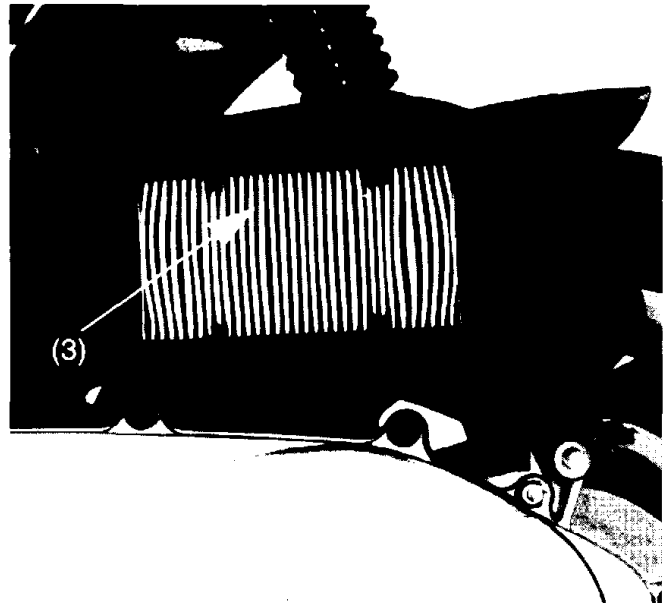

BELT CASE AIR CLEANER

(See "Maintenance precautions" on page 75).

1. Remove lower center cover (page 43).



- (1) Center cover
- (2) Screw

2. Remove left side cover (page 44).

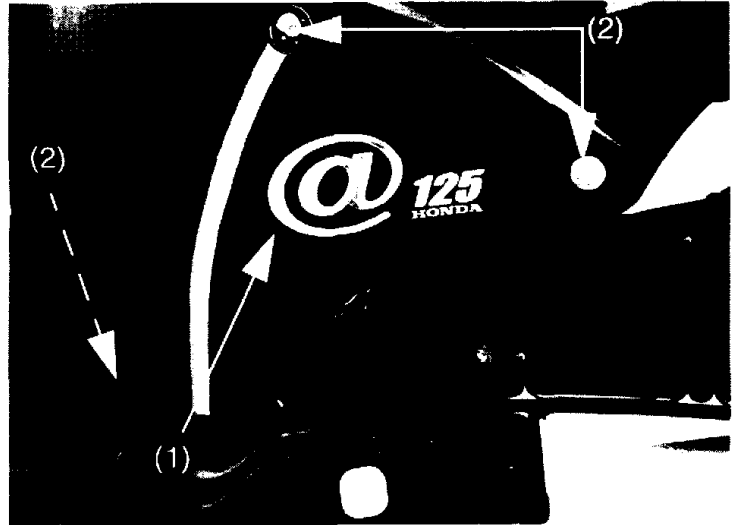

- (1) Side cover
- (2) Screws

3. Remove the two left side band screws, unscrew the two footrest bolts (1) and the two passenger footrest pedal rod bolts (2).

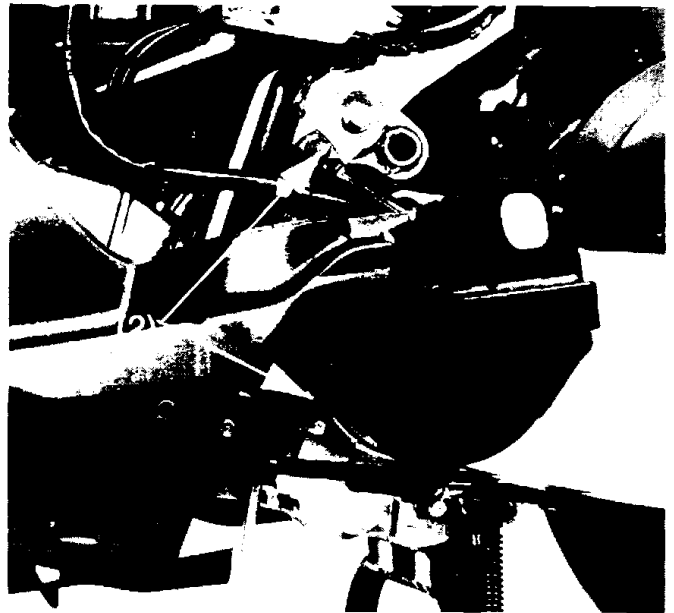
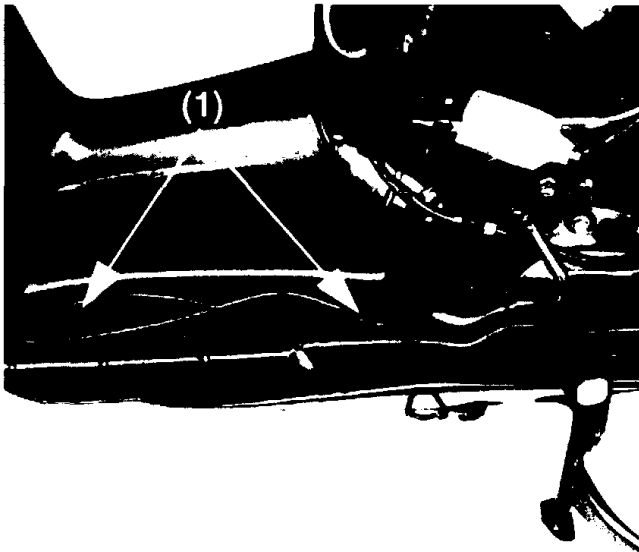

- (1) Screws footrest bolts
- (2) Footrest pedal rod bolts

4. Remove the belt cover duct assembly from the belt case (1) take out the bolts (2).
5. Remove the duct cover cap (3) releasing the tongue (4).
6. Remove the element (5).
7. Wash the element in a clean non-flammable solvent or high flash point solvent and let it dry thoroughly.

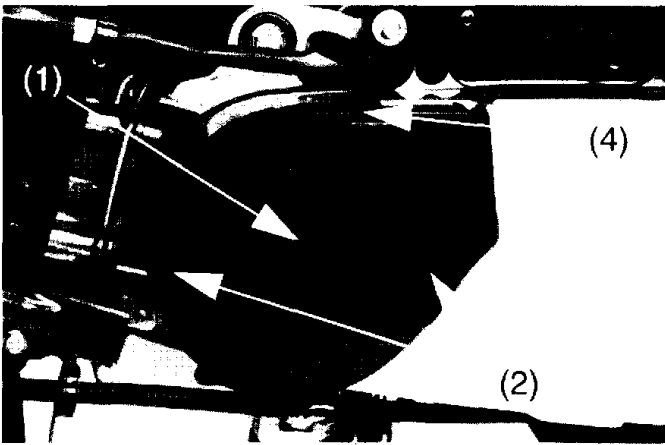

- (1) Belt cover duct assembly
- (2) Bolts
- (3) Duct cover cap
- (4) Tongue
- (5) Element

⚠ WARNING

- Never use petrol or low flash point solvents for cleaning the air cleaner. A fire or explosion could result.

CAUTION

- Allow the element to dry thoroughly before refitting.
 - Do not use oil on the element, this will damage the drive belt.
8. For installation carry out the removal procedure in reverse order.

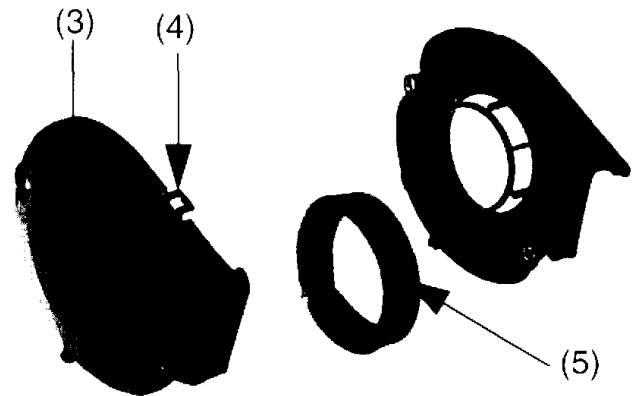

BREATHER SEPARATER

(See "Maintenance precautions" on page 75)
Remove the crankcase breather tube plug (1) from the tube and drain the deposits into a suitable container.

Replace the crankcase breather tube plug.

NOTE:

- Service more frequently when riding in rain at full throttle, or after the motorcycle is washed or overturned. Service if the deposit level can be seen in the transparent section of the drain tube.

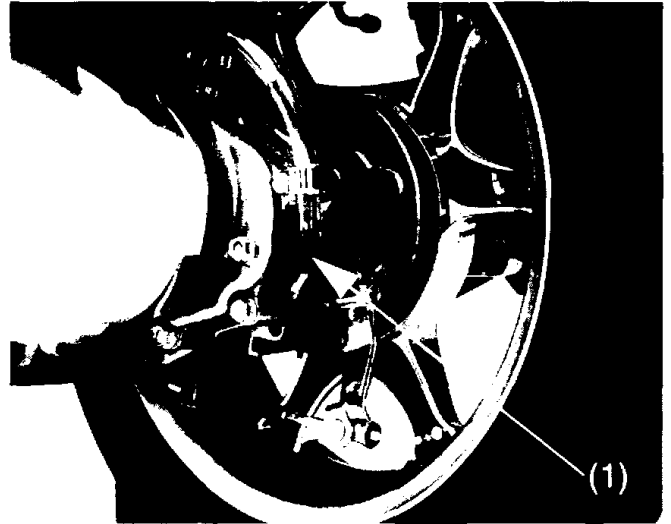

(1) Breather tube plug

ENGINE OIL

(See "Maintenance precautions" on page. 75)

Engine oil

Good engine oil has many different qualities. Use only high detergent, quality motor oil certified on the container to meet or exceed requirements for API Service Classification SE, SF or SG.

Viscosity:

Engine oil viscosity grade must be based on the average atmospheric temperature in your riding area. The following provides a guide to the selection of the proper grade or viscosity of oil to be used at various atmospheric temperatures.

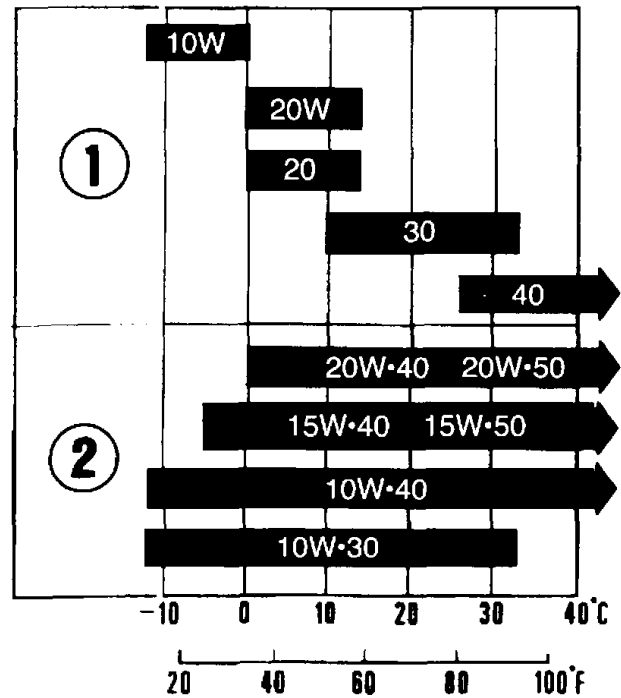

Engine oil strainer screen

Engine oil quality is the chief factor effecting the life of the engine. Change the oil as specified in the maintenance schedule (page 70).

NOTE:

- Change the oil with the engine at normal running temperature and the scooter on its stand to assure complete and rapid draining.

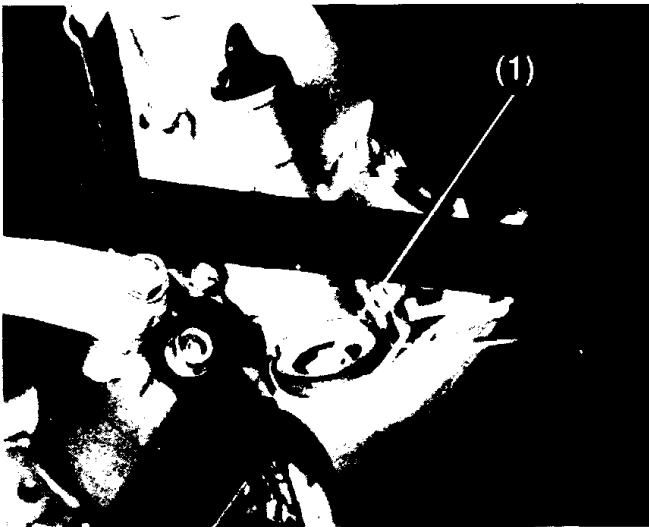

(1) Drain plug

1. Remove the oil filler cap from the right crankcase cover.
2. Place an oil pan under the crankcase and remove the oil drain plug (1).

NOTE:

- The spring (2) and the oil filter grill (3) come away when the drain cap is removed (1).
3. Check that the oil strainer screen, sealing rubber and drain plug O-ring are in good condition.

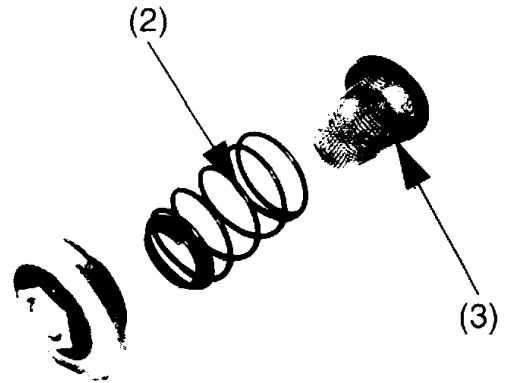

(2) Spring (3) Oil filter grill

4. Replace the oil strainer screen, spring and drain plug.
5. Fill the crankcase with the recommended grade oil: approximately 1,1 liters.
6. Replace the filler cap.
7. Start the engine and let it run for around 2-3 minutes.
8. Stop the engine and check that the oil level is at the upper level mark on the dipstick with the scooter upright on firm level ground.

NOTE:

- Check there are no oil leaks.
- Always dispose of used engine oil in a way that will not damage the environment. Take it to your local service station in a sealed container. Do not throw it in the rubbish or pour it on the ground or down a drain.

CAUTION

- **Used engine oil may cause skin cancer if repeatedly left in contact with the skin for long periods. Although this is unlikely, unless you handle used oil on a daily basis, it is still advisable to wash your hands thoroughly with soap and water as soon as possible after handling used oil.**

SPARK PLUG

(See "Maintenance precautions" on page. 75).

Recommended spark plugs:

Standard:	BR8ES (NGK) W24ESR-U (DENSO)
High speed riding	BR9ES (NGK) W27ESR-U (DENSO)

NOTE:

- Be careful not to damage the scooter parts when carrying out maintenance on the spark plug.

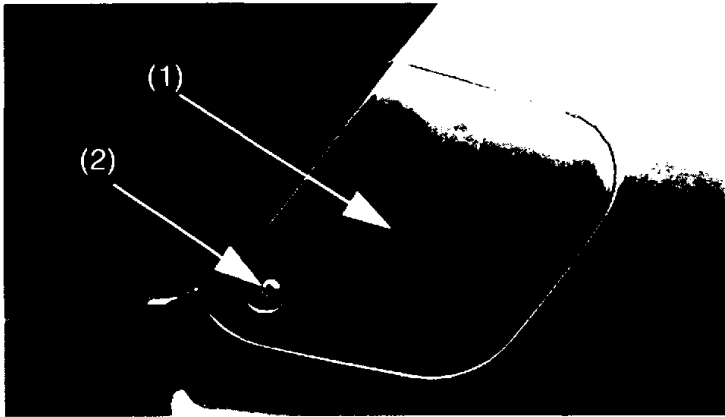

1. Remove the maintenance cover (1) remove the screws (2).
2. Disconnect the spark plug cap from the spark plug (3).
3. Clean any dirt from around the spark plug base. Remove the spark plug using the spark plug wrench in the tool kit.
4. Throw away the used spark plug

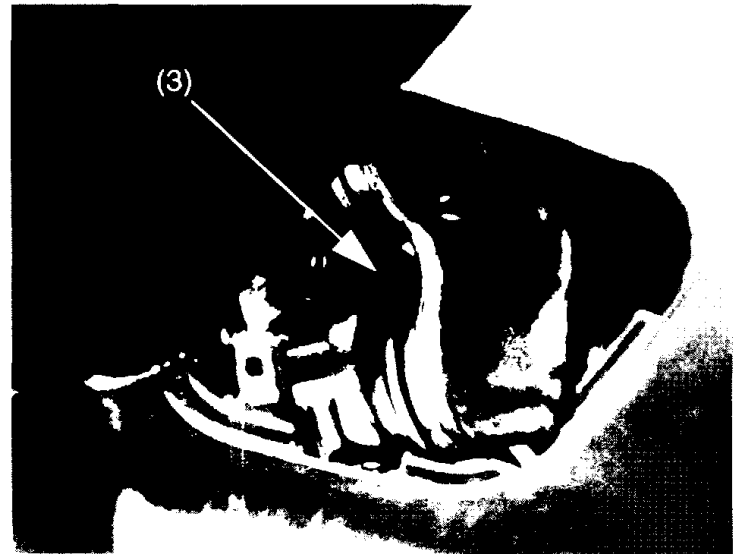

- (1) Maintenance lid
- (2) Screw
- (3) Spark plug cap

5. Check the new spark plug gap (1) using a wire-type feeler gauge. If adjustment is necessary, bend the side electrode carefully (2). The gap should be: 0,80 - 0,90 mm.

CAUTION

- **Make sure that the spark plug washer is in good condition.**

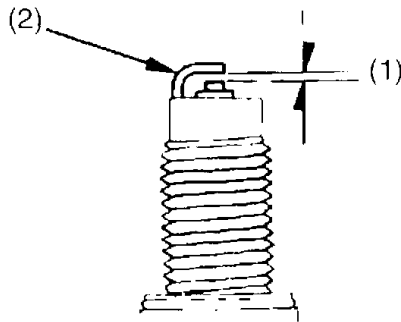

- (1) Spark plug gap
(2) Side electrode

6. With the plug washer attached, thread the spark plug in by hand to prevent cross-threading.
7. Tighten the new spark plug 1/2 turn with the spark plug wrench to compress the washer. If you are reusing a plug it should only take 1/8 or 1/4 turn to after the plug seat.
8. Replace the spark plug cap.

⚠ WARNING

- **Never leave shop towels in the engine area after cleaning the spark plug base. They may cause the engine to overheat and become damaged.**

CAUTION

- **Always tighten the spark plug securely. An improperly tightened plug can become very hot and may cause the engine damage.**
- **Never use spark plugs not of the right grade these could cause serious damage to the engine.**

IDLE SPEED

(See "Maintenance precautions" on page. 75). The engine must be at normal running temperature in order to carry out accurate idle speed adjustment. Ten minutes of stop-go riding is sufficient.

NOTE:

- Do not attempt to compensate for faults in other systems by adjusting the idle speed. See your Honda dealer for regular carburetor adjustments.
1. Warm up the engine place the scooter on its center stand.
 2. Connect a rev. counter to the engine.
 3. Adjust idle speed (A - B) with the throttle stop screw (1).

Idle speed:
1.600 rpm

▲ WARNING

- The rear wheel will spin if not stopped by the brake or contact with the ground. Accidental contact with a spinning rear wheel could cause personal injury.

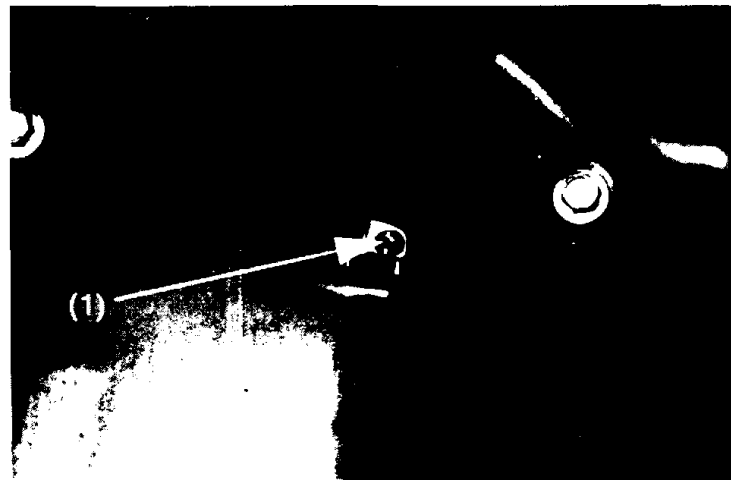

(1) Idle speed adjusting screw

SIDE STAND

(See "Maintenance precautions" on page 75).
Check that the side stand system is functioning correctly.

- Check the spring for damage or loss of tension and the side stand assembly for freedom of movement.
- Check the side stand ignition cut-off system:
 1. Place the scooter on the center stand.
 2. Put the side stand up and start the engine.
 3. Lower the side stand the engine should stop as you put the side stand down.

If your side stand system does not operate as described, see your Honda dealer for service.

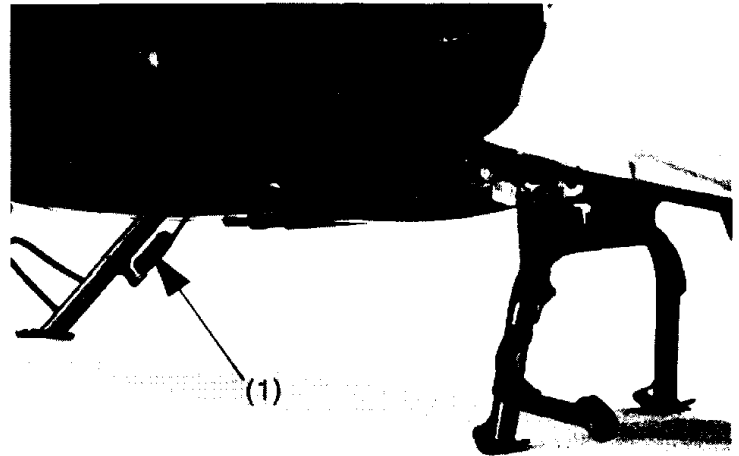

(1) Spring

BRAKE PAD WEAR

(See maintenance precautions on page 75).
Brake pad wear depends upon the severity of usage, the type of riding, and road conditions. Generally, the pads will wear faster on wet and dirty roads. Inspect the pads at each regular maintenance interval (page 71).

Front brake

Check the wear indicator mark (1) on each pad.

If either pad is worn to the wear indicator mark, replace both pads as a set. See your Honda dealer for this service.

NOTE:

- Only use original Honda pads or equivalent, on sale at authorized Honda dealers. When the brakes need servicing contact your Honda dealer.

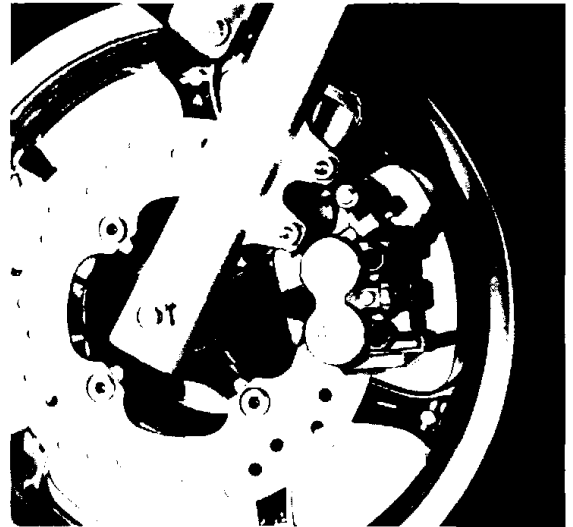

(1) Wear indicator mark

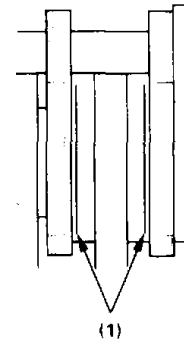

BRAKE SHOE WEAR

(Refer to the maintenance precautions on page 75).

The rear brake has a wear indicator mark.

When you brake, a reference symbol (1) moves towards an arrow (2) on the brake arm (3). If the arrow lines up with the reference symbol when the brake is fully on, the brake shoe needs to be changed.

Contact your Honda dealer to carry out this operation.

NOTE:

- Only use original Honda parts or equivalent, on sale at authorized Honda dealers. When the brakes need servicing contact your Honda dealer.

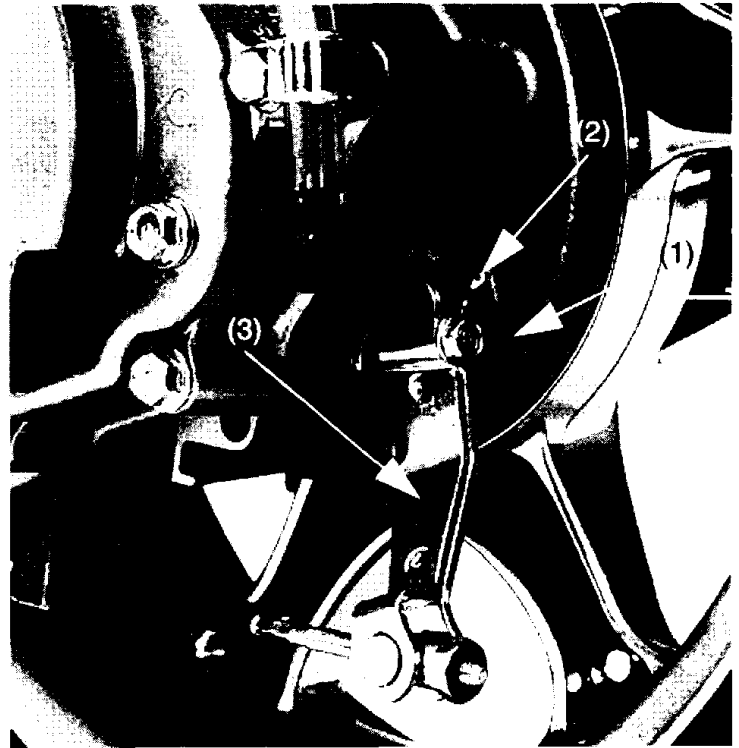

- (1) Reference symbol
- (2) Arrow
- (3) Brake arm

BATTERY

(Refer to the maintenance precautions on page 75).

It is not necessary to check the battery electrolyte level or add distilled water, as the battery is a maintenance-free (sealed) type. If your battery seems weak and/or is leaking electrolyte (causing hard starting or other electrical troubles), contact your Honda dealer.

CAUTION

- Removing the battery cap strip can damage the cap strip and result in leaks and eventual battery damage.
- When the scooter is to be stored for an extended period of time, remove the battery from the scooter and charge it fully.
- Then store it in a cool, dry place. If the battery is to be left in the scooter, disconnect the negative cable from the battery terminal.

⚠ WARNING

- The battery gives off explosive gases; keep sparks, flames and cigarettes away. Provide adequate ventilation when charging or using the battery in an enclosed space.
- The battery contains sulfuric acid (electrolyte). Contact with skin or eyes may cause severe burns. Wear protective clothing and a face shield.
- If electrolyte gets on your skin, flush with water.
- If electrolyte gets in your eyes, flush with water for at least 15 minutes and call a physician immediately.
- Electrolyte is poisonous.
- If swallowed, drink large quantities of water or milk of magnesium or vegetable oil and call a doctor.
- KEEP OUT OF CHILDREN'S REACH.

Removing the battery:

1. Remove the lower center cover (page 43).
2. Remove the battery support locking screws (1).
3. Disconnect the negative (-) terminal cable (3) then the positive one (+)(4).
4. Pull out the battery (5) from its container.

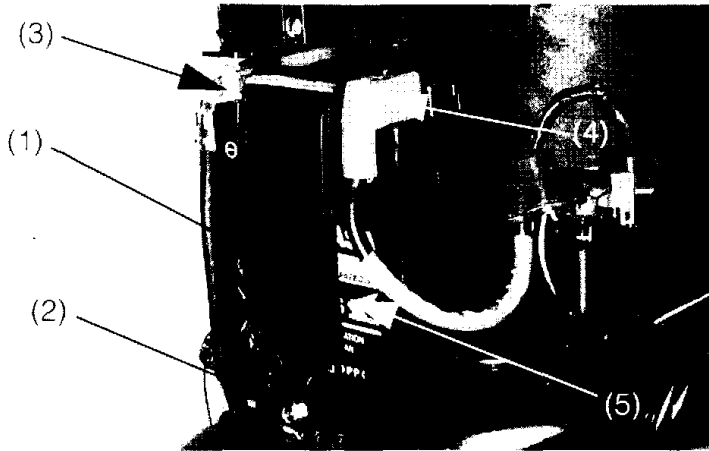

- (1) Battery container cover
- (2) Screws
- (3) Negative terminal cable (-)
- (4) Positive terminal cable (+)
- (5) Battery

CHANGING FUSES

(Refer to the maintenance precautions on page 75).

When frequent fuse failure occurs it usually means a short circuit or an overload in the electrical system. See your Honda dealer for repairs.

BROKEN FUSE

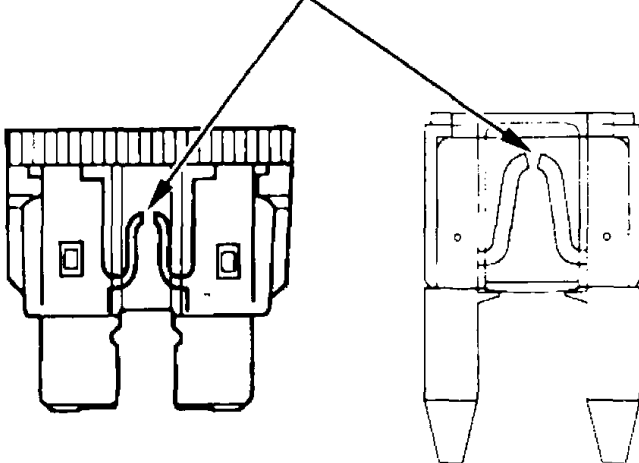

CAUTION

- Turn the ignition switch OFF before checking or changing fuses to prevent accidental short circuiting.

⚠ WARNING

- Never use a fuse with a different rating from that specified. This may cause serious damage to the electrical system or fire, causing a dangerous loss of lights or engine power.

Fuse box:

The fuse box is positioned behind the central cover on the right of the battery.

The specified fuses are:

10A x 4, 15A x 1

1. Remove the central lower cover (page 43).
2. Open the fuse box cover (1).
3. Take out the broken fuse and put in the new one. The spare fuses are in the fuse box.
4. Close the fuse box cover and reinstall the central cover.

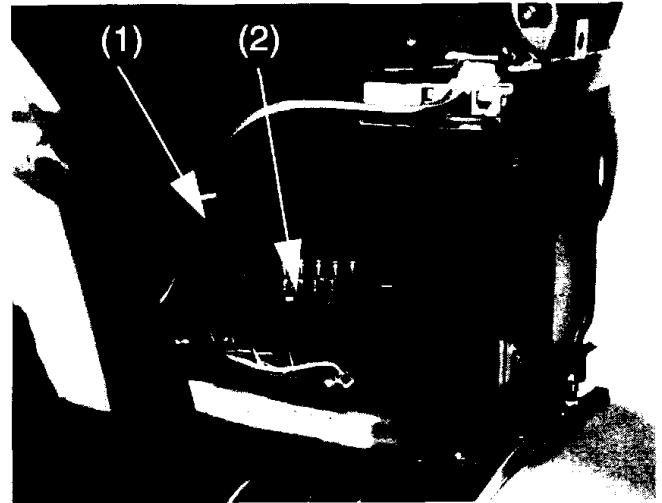

- (1) Fuse box
(2) Spare fuses

Main fuses:

The main fuse (1) is on the left of the battery behind the center cover.

The specified fuse is:

30A

1. Remove the center cover (page 43).
2. Disconnect the wire connector (2) from the magnetic starter switch.
3. Remove the old fuse and install a new one.
The spare fuse is kept in the tool bag (page 73).
4. Reconnect the connector and install the battery cover.

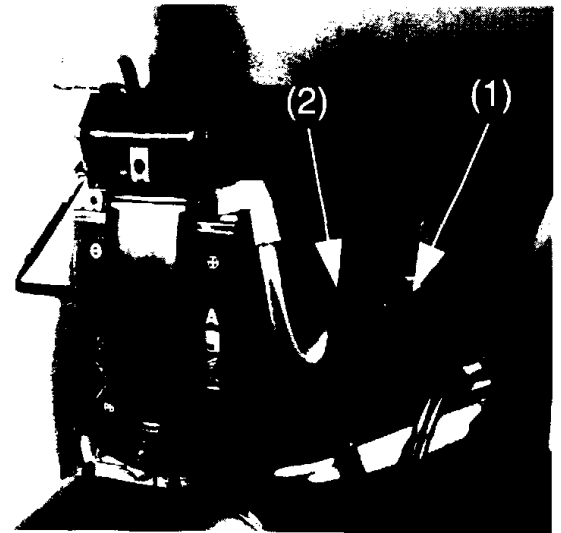

- (1) Main fuse
(2) Connector

CHANGING BULBS

(Refer to the maintenance precautions on page 65).

⚠ WARNING

- **The light bulb becomes very hot while the light is ON and stays hot for a while after it is turned OFF . Let it cool before touching it.**

CAUTION

- **Do not put finger prints on the bulb because they may create hot spots on the bulb and cause it to break. Wear clean gloves while replacing the bulb. If you touch the bulb with your bare hands, clean it with alcohol.**

NOTE:

- Turn the ignition switch OFF before changing the bulb.
- Do not use bulbs other than specified.
- After installing a new bulb, check that the light operates properly.

Headlight bulb

1. Remove the front cover (page 43).
2. Remove the two screws on the front headlight bar (1).
3. Remove the dust cover (2).
4. Take out the two connectors (3).
5. Release the catch (4).
6. Take out the bulb (5).
7. Fit a new bulb and reinstall in the reverse order of removal.

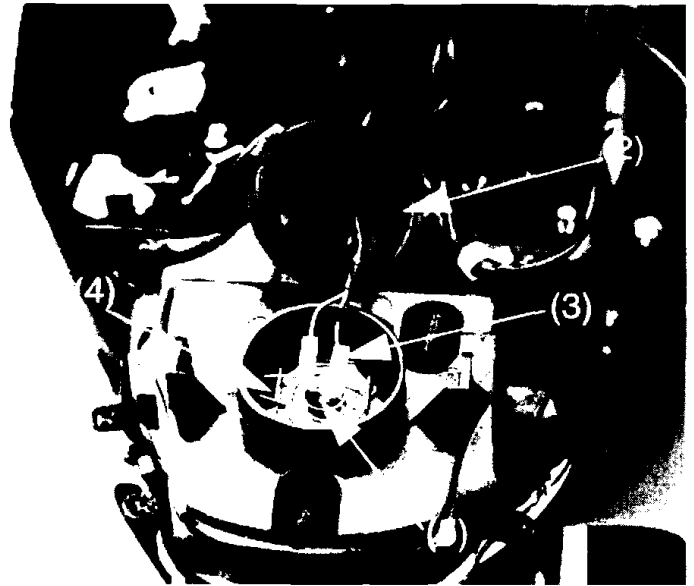

- (1) Screws
- (2) Dust cover
- (3) Connector
- (4) Catch
- (5) Bulb

Position light bulb

1. Pull out the position bulb holder (1) .
2. Pull out the bulb (2) without turning it.
3. Install a new bulb in the reverse order to removal.

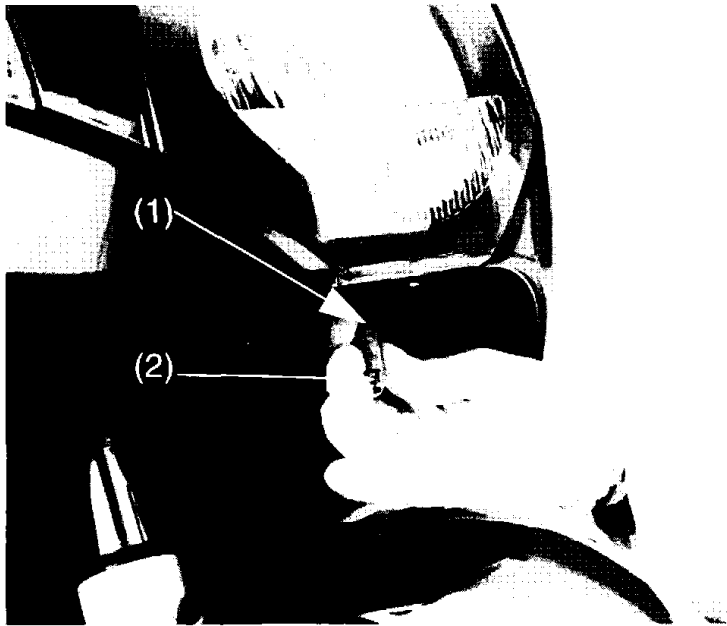

- (1) Position light bulb holder
(2) Bulb

Stop Taillight bulb

1. Remove the two screws (1) securing the rear light and remove the light.
2. Turn the connector by 90° counter clockwise and remove it.
3. Take out the bulb without turning it.
4. Install a new bulb following the removal procedure in reverse.

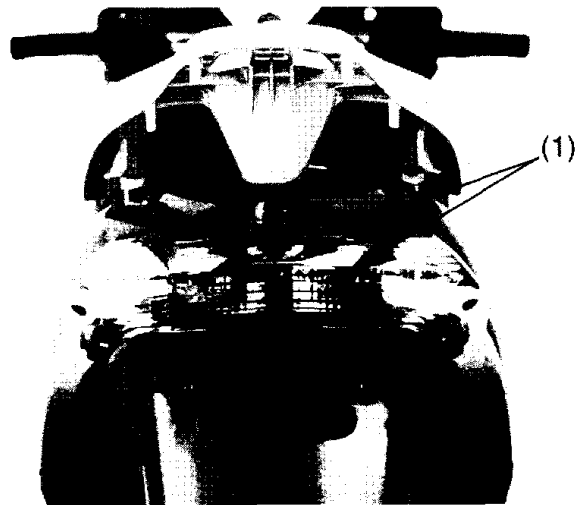

- (1) Screws light

Front turn signal bulb

1. Remove the indicator lamp glass (1).
2. Turn the connector by 90° counter clockwise and remove it.
3. Take out the bulb without turning it.
4. Install a new bulb following the removal procedure in reverse.

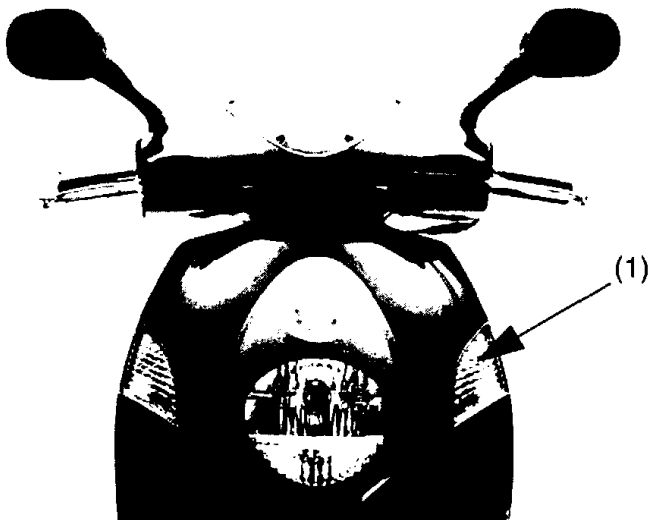

(1) Indicator lamp glass

Rear turn signal indicator light.

1. Remove the rear light (page 97).
2. Remove the turn signal cover.
3. Turn the left socket connector 90° counter-clockwise and the right one 90° clockwise and remove it.
4. Remove the bulb without turning it.
5. Fit a new bulb. Installation is in the reverse order of removal.

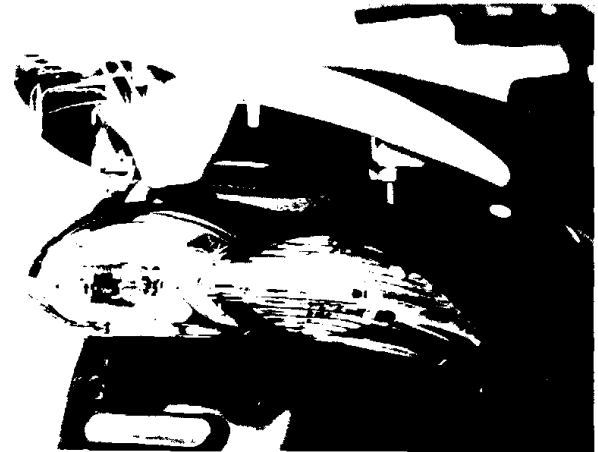

TRANSPORTING

⚠ WARNING

- To prevent fire or explosions while transporting the scooter, always:
- Drain the fuel tank and carburetor.
- Carry the motorcycle upright in its normal riding position to prevent oil from leaking out.

Draining the fuel

Always carry out this operation in a well ventilated area.

⚠ WARNING

- **Petrol is extremely flammable and explosive in certain conditions. Carry out this operation in a well ventilated area with the engine off. Do not smoke or allow flames or sparks in the area where fuel is being drained or refilled, or where fuel is stored.**

1. Stop the engine.
2. Empty the fuel tank using a commercially available hand siphon or other equivalent method.
3. Place the free end of the carburetor drainage pipe in a suitable container.
4. Open the carburetor breather pipe turning the drainage screw counter clockwise. Once the fuel is all drained out, turn the screw clockwise until it is tightened.

CLEANING

Clean your scooter regularly to protect its surface finish and check for damage, wear, oil or brake fluid leaks.

CAUTION

- **Water (or air) at high pressure may damage certain parts of the scooter.**

Avoid spraying high pressure water (typical in car washes) on the following parts:

- Wheel hubs
- Ignition switch
- Carburetor
- Brake master cylinder
- Instruments
- Handlebar switches
- Muffler outlet
- Under seat
- Air cleaner

1. After cleaning, rinse the scooter thoroughly with clean water as strong detergent can corrode alloy parts.

NOTE:

- Clean the plastic parts using a cloth or sponge dampened with a solution of mild detergent and water.
- Clean windshield with soft cloth or sponge and plenty of water. Dry with soft clean cloth. Remove minor scratches with commercially available plastic polishing compound. Replace wind-shield if scratches cannot be removed and they obstruct clear vision.
- The inside of the headlight lens may be clouded immediately after washing the motorcycle. Moisture condensation inside the headlight lens will disappear gradually by lighting the headlight in high beam. Run the engine with the headlight on.

2. Dry the scooter, start the engine, let it run for several minutes.

⚠ WARNING

- After washing the scooter the braking efficiency may be temporarily reduced.
- Anticipate longer stopping distances to avoid a possible accident.
- Do not clean the plastic parts with solvents that contain abrasives. They could cause the plastic to become opaque or streaked.

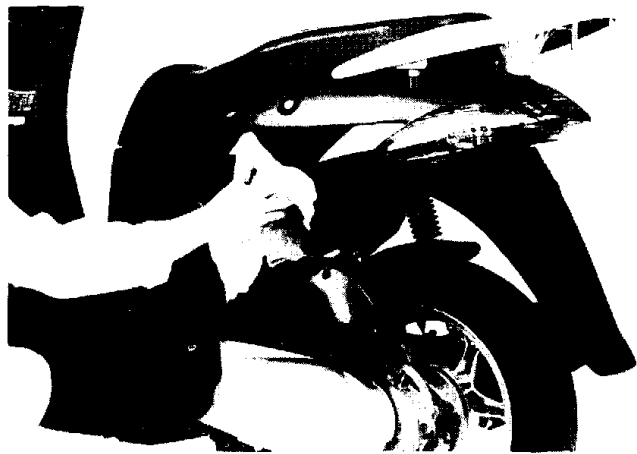

3. Test the efficiency of the brakes before using the scooter. Sever applications may be necessary to restore normal braking performance.

TESTING THE BRAKES

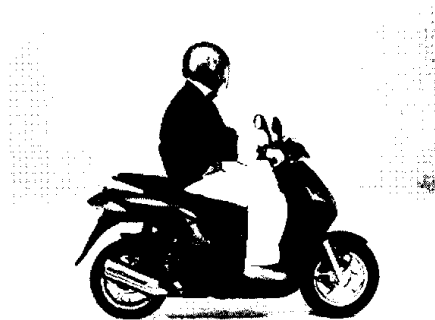
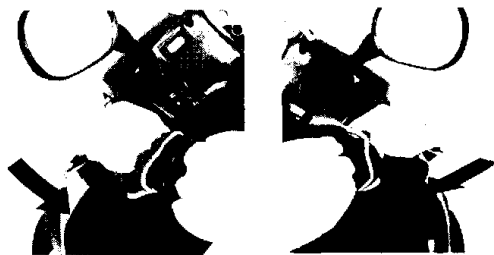

Painted aluminum wheels

Aluminum may corrode from contact with dirt, mud or road salt. Clean the wheels after riding through any of these substances. Use a wet sponge and mild detergent. Avoid stiff brushes, steel wool or cleaners containing abrasives or chemical compounds.

After washing, rinse with plenty of water and dry with a clean cloth.

Apply paint to touch up any damaged parts of the wheels.

STORAGE GUIDE

If the scooter is to stay off the road for a long period, such as for winter, you must take steps to reduce the effects of deterioration from non use of the scooter.

Any necessary repairs should be made **BEFORE** storing, otherwise these repairs may be forgotten by the time the scooter is removed from storage.

STORAGE

1. Change the engine oil.
2. Make sure that the cooling system is filled with a 50/50 antifreeze solution.
3. Empty the fuel tank into an approved petrol container using a commercially available hand siphon or an equivalent method.

NOTE:

- If the storage is going to last for more than a month, it is very important to drain the carburetor, to ensure proper performance after storage.

⚠ CAUTION

- **Petrol is extremely flammable and explosive in certain conditions. Carry out this operation in a well ventilated area with the engine off. Do not smoke or allow flames or sparks in the area where fuel is being drained or refilled, or where fuel is stored.**
4. Remove the spark plug cap from the spark plug and pour a tablespoon (15-20 cm³) of clean engine oil for four stroke engines. Crank the engine several times to distribute the oil.

NOTE:

- When carrying out this operation, the ignition switch must be OFF.
5. Remove the battery store it in an area protected from freezing temperatures and direct sunlight. Recharge the battery every month.

-
6. Wash and dry the scooter. Wax all painted surfaces.
 7. Cover chromed parts with rust proof oil.
 8. Inflate the tires up to the recommended standard pressure. Position the motorcycle on a support so that both wheels are off the ground.
 9. Cover the scooter (do not use plastic or water proof material) and in an unheated, damp-free place with minimum temperature variations. Do not leave the scooter in direct sunlight.

AFTER STORAGE

1. Uncover and clean the scooter.
2. Install the battery. If the battery is low contact your Honda dealer who is equipped to recharge it for you.
3. Refill the fuel tank with fresh petrol.
4. Carry out all pre-ride inspection checks (page 52). Test ride the scooter at low speeds in a safe riding area away from traffic.

SPECIFICATIONS

SPECIFICATIONS	@125/150	@ 125/150 ES
DIMENSIONS		
Overall length	1.937 mm	1.937 mm
Overall width	698 mm	698 mm
Overall height	1.174 mm	1.174 mm
Wheelbase	1.328 mm	1.328 mm
Ground clearance	141 mm	141 mm
Dry weight	122 kg	122 kg
CAPACITY		
Passenger capacity	Rider and passenger	Rider and passenger
Engine oil	1,0 liters	1,0 liters
Fuel tank	9,0 liters	9,0 liters
Cooling system capacity	0,95 liters	0,95 liters
Maximum weight capacity	180 kg	180 kg
ENGINE		
Bore and stroke	52,4 x 57,8 mm	58,0 x 57,8 mm
Displacement	124,6 / 152,7 cm ³	124,6 / 152,7 cm ³
Compression ratio	11,0 : 1	11,0 : 1
Idle speed	1.600 rpm	1.600 rpm

SPECIFICATIONS	@125/150	@ 125/150 ES
FRAME		
Frame type	Mono cradle	
Steering column angle	27° 00'	
Tail	80 mm	
Front suspension travel	Telescopic fork 89 mm	
Rear suspension travel	Floating engine with dual shock-absorbers 83 mm	
Front tire	110/90-13 M/C 56 L	
Rear tire	130/70-13 M/C 57 L	
TRANSMISSION		
Clutch	Automatic	Automatic
Final transmission	V belt	V belt
Gear ratio	2,64 : 1 ÷ 0,82 : 1	2,64 : 1 ÷ 0,82 : 1
Final reduction	9,2 / 10,109	9,2 / 10,109

SPECIFICATIONS	@125/150	@ 125/150 ES
ELECTRICAL SYSTEM		
Starting system	Electric	
Alternator	0,23 KW / 5.000 rpm	0,26 KW / 5.000 rpm
Battery	12 V - 6 Ah	
Main fuse	30 A	
Secondary fuses	15 A x 1, 10 A x 4	
Standard spark plug	CR8EH-9 (NGK), U24FER9 (DENSO)	
Spark plug for high speeds	CR9EH-9 (NGK), U27FER9 (DENSO)	
Distance electrodes	0,80 - 0,90 mm	
LIGHTS		
Front headlight	12V - 55W / 55W	12V - 55W / 55W
Stop / taillight	12V - 21W / 5W x 1	12V - 21W / 5W x 1
Turn signal lights	12V - 21W x 4	12V - 21W x 4
Position lights	12V - 5W	12V - 5W
Instrument lights	12V - 1,7W x 2	12V - 1,7W x 2
Turn signal lights	12V - 1,7W x 2	12V - 1,7W x 2
Headlight indicator	12V - 1,7W	12V - 1,7W
