

# HONDA

*Don Murphy Level 3*

## SHOP MANUAL NIGHTHAWK CB750SC

*Michelle  
Dion*

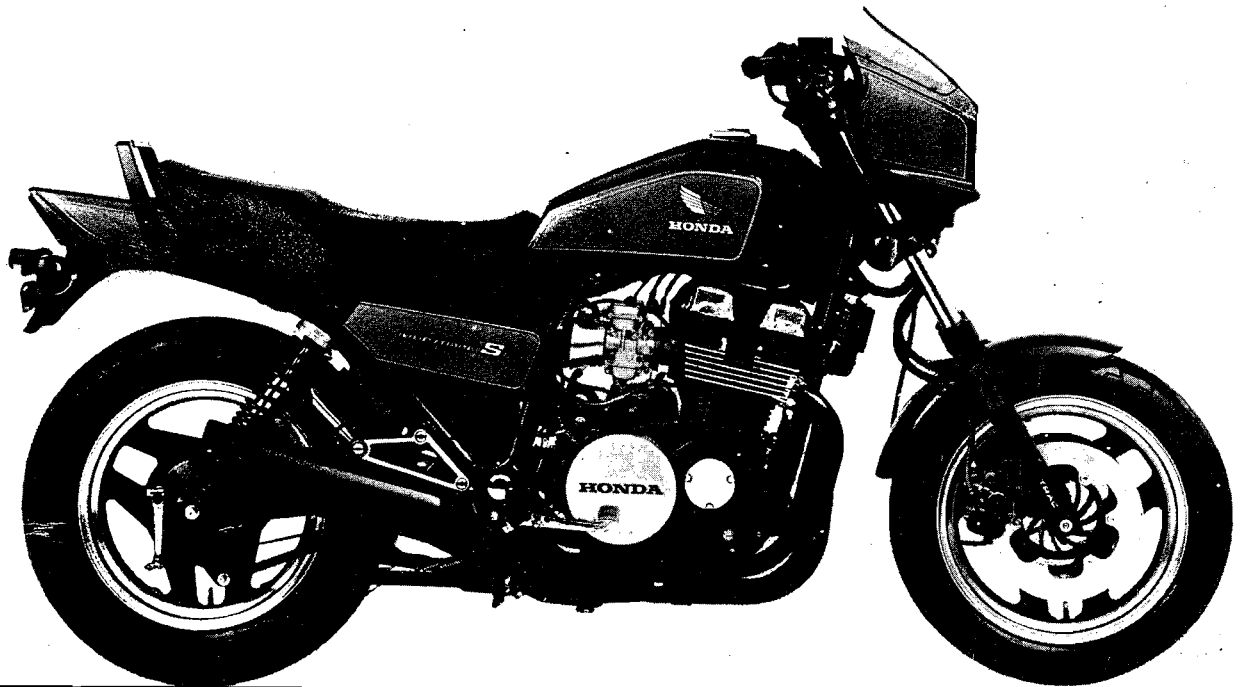

PART NO.-HM 1074

1984

## NIGHTHAWK CB750SC

## IMPORTANT SAFETY NOTICE

 **WARNING** *Indicates a strong possibility of severe personal injury or loss of life if instructions are not followed.*

**CAUTION:** *Indicates a possibility of personal injury or equipment damage if instructions are not followed.*

**NOTE:** Gives helpful information.

Detailed descriptions of standard workshop procedures, safety principles and service operations are not included. It is important to note that this manual contains *some* warnings and cautions against some specific service methods which could cause **PERSONAL INJURY** to service personnel or could damage a vehicle or render it unsafe. Please understand that those warnings could not cover all conceivable ways in which service, whether or not recommended by Honda might be done or of the possibly hazardous consequences of each conceivable way, nor could Honda investigate all such ways. Anyone using service procedures or tools, whether or not recommended by Honda *must satisfy himself thoroughly* that neither personal safety nor vehicle safety will be jeopardized by the service method or tools selected.



# HONDA CB750SC

## HOW TO USE THIS MANUAL

Follow the Maintenance Schedule (Section 3) recommendations to ensure that the vehicle is in peak operating condition and the emission levels are within the standards set by the U.S. Environmental Protection Agency. Performing the first scheduled maintenance is very important. It compensates for the initial wear that occurs during the break-in period.

Sections 1 through 3 apply to the whole motorcycle, while sections 4 through 21 describe parts of the motorcycle, grouped according to location.

Find the section you want on this page, then turn to the table of contents on page 1 of that section.

Most sections start with an assembly or system illustration, service information and troubleshooting for the section. The subsequent pages give detailed procedures.

If you are not familiar with this motorcycle, read the Technical Features in section 23.

If you don't know the source of the trouble, go to section 24, Troubleshooting.

All information, illustrations, directions and specifications included in this publication are based on the latest product information available at the time of approval for printing. HONDA MOTOR CO., LTD. reserves the right to make changes at any time without notice and without incurring any obligation whatever. No part of this publication may be reproduced without written permission.

HONDA MOTOR CO., LTD.  
Service Publications Office

## CONTENTS

	GENERAL INFORMATION	1
	LUBRICATION	2
	MAINTENANCE	3
ENGINE	FUEL SYSTEM	4
	ENGINE REMOVAL/INSTALLATION	5
	CYLINDER HEAD/VALVES	6
	CYLINDER/PISTON	7
	CLUTCH	8
	GEAR SHIFT LINKAGE	9
	CRANKCASE	10
	TRANSMISSION	11
	CRANKSHAFT/STARTER CLUTCH	12
	FINAL DRIVE	13
CHASSIS	FRONT WHEEL/SUSPENSION	14
	REAR WHEEL/SUSPENSION/BRAKE	15
	HYDRAULIC BRAKE	16
	MUFFLER/REAR FENDER	17
ELECTRICAL	BATTERY/CHARGING SYSTEM	18
	IGNITION SYSTEM	19
	ELECTRIC STARTER	20
	LIGHTS/INSTRUMENTS/SWITCHES	21
	WIRING DIAGRAM	22
	TECHNICAL FEATURES	23
	TROUBLESHOOTING	24



GENERAL SAFETY	1-1	TOOLS	1-7
SERVICE RULES	1-1	CABLE & HARNESS ROUTING	1-9
MODEL IDENTIFICATION	1-2	EMISSION CONTROL SYSTEMS	1-13
SPECIFICATIONS	1-3	EMISSION CONTROL INFORMATION	
TORQUE VALUES	1-5	LABELS	1-14

## GENERAL SAFETY

**WARNING**

*If the engine must be running to do some work, make sure the area is well-ventilated. Never run the engine in a closed area. The exhaust contains poisonous carbon monoxide gas.*

**WARNING**

*Gasoline is extremely flammable and is explosive under certain conditions. Do not smoke or allow flames or sparks in your working area.*

**WARNING**

*The battery electrolyte contains sulfuric acid. Protect your eyes, skin and clothing. In case of contact, flush thoroughly with water and call a doctor if electrolyte gets in your eyes.*

**WARNING**

*The battery generates hydrogen gas which can be highly explosive. Do not smoke or allow flames or sparks near the battery, especially while charging it.*

## SERVICE RULES

1. Use genuine HONDA or HONDA-recommended parts and lubricants or their equivalents. Parts that do not meet HONDA's design specifications may damage the motorcycle.
2. Use the special tools designed for this product.
3. Use only metric tools when servicing this motorcycle. Metric bolts, nuts, and screws are not interchangeable with English fasteners. The use of incorrect tools and fasteners may damage the motorcycle.
4. Install new gaskets, O-rings, cotter pins, lock plates, etc. when reassembling.
5. When tightening bolts or nuts, begin with the larger-diameter or inner bolts first, and tighten to the specified torque diagonally, unless a particular sequence is specified.
6. Clean parts in cleaning solvent upon disassembly. Lubricate any sliding surfaces before reassembly.
7. After reassembly, check all parts for proper installation and operation.



MODEL IDENTIFICATION

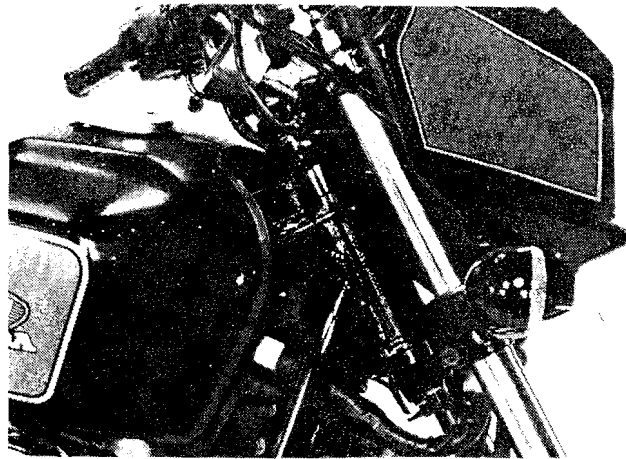
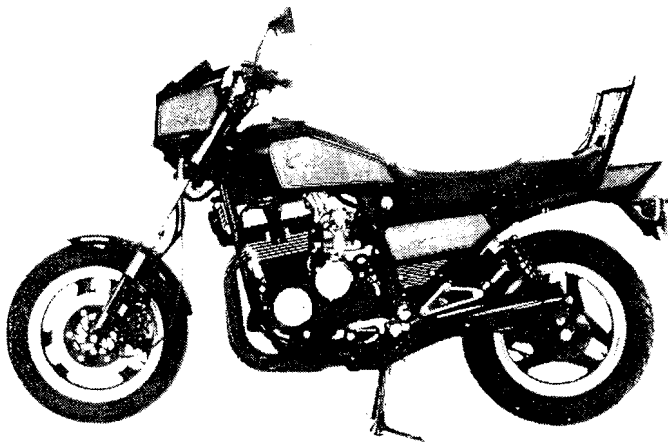

The frame serial number is stamped on the right side of the steering head.

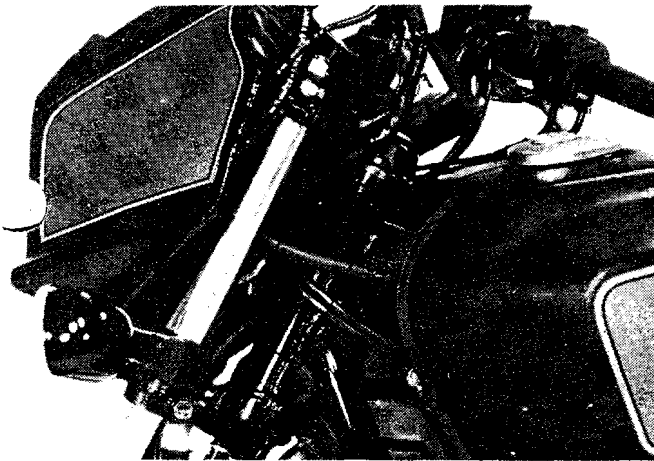

The vehicle identification number (VIN) is on the left side of the steering head.

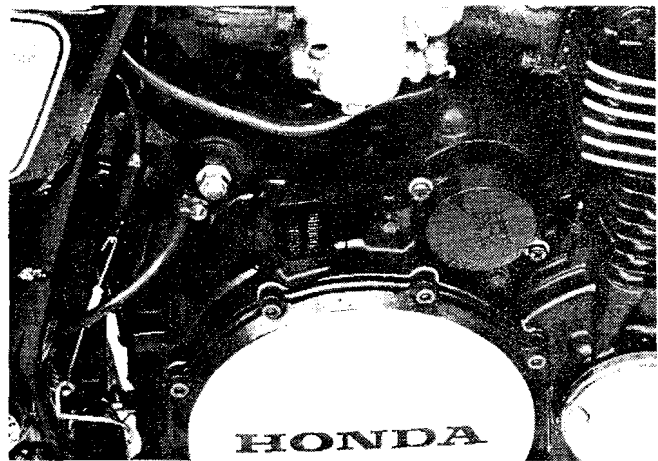

The engine serial number is stamped on the top right side of the crankcase.

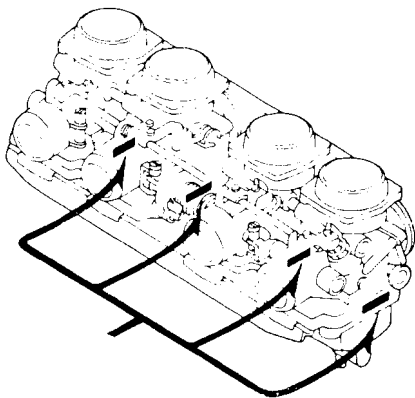

The carburetor identification numbers are on the left sides of the carburetor bodies.

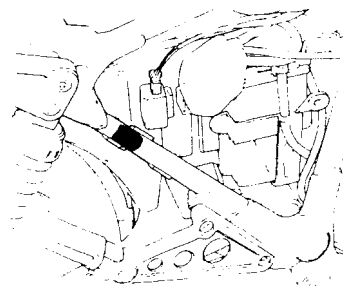

The color label is attached to the frame tube under the right side cover.



**SPECIFICATIONS**

ITEM			
DIMENSIONS	Overall length	2,155 mm (84.8 in)	
	Overall width	780 mm (30.7 in)	
	Overall height	1,195 mm (47.5 in)	
	Wheelbase	1,495 mm (58.9 in)	
	Seat height	795 mm (31.3 in)	
	Ground clearance	145 mm (5.7 in)	
	Dry weight	214 kg (471.8 lbs)	
FRAME	Type	Double cradle	
	Front suspension	Telescopic fork	
	Rear suspension	Swing arm/shock absorber	
	Front tire size	110/90-16 59H	
	Rear tire size	130/90-16 67H	
	Cold tire pressures	Driver only	Front 225 kPa (2.25 kg/cm <sup>2</sup> , 32 psi) Rear 225 kPa (2.25 kg/cm <sup>2</sup> , 32 psi)
		Driver and passenger	Front 225 kPa (2.25 kg/cm <sup>2</sup> , 32 psi) Rear 280 kPa (2.80 kg/cm <sup>2</sup> , 40 psi)
	Front brake, lining swept area	Disc brake, 904 cm <sup>2</sup> (140 sq in)	
	Rear brake, lining swept area	Drum brake, 198 cm <sup>2</sup> (31 sq in)	
	Fuel capacity	16 liters (4.2 US gal, 3.52 Imp gal)	
Fuel reserve capacity	2.5 liters (2.6 US qt, 2.2 Imp qt)		
Caster angle	60°		
Trail	122 mm (4.8 in)		
Front fork oil capacity			
	Right	423 cc (14.3 ozs)	
	Left	429 cc (14.5 ozs)	
ENGINE	Type	Air cooled 4-stroke, DOHC	
	Cylinder arrangement	Vertical in line four	
	Bore and stroke	67.0 x 53.0 mm	
	Displacement	747 cc	
	Compression ratio	9.3 : 1	
	Valve train	Chain driven DOHC, 4 valves per cylinder	
	Maximum horsepower	80 PS/10,000 rpm	
	Maximum torque	6.25 kg-m (45.20 lb-ft)/8,000 rpm	
	Oil capacity	3.6 liters (3.8 US qt, 3.2 Imp qt) after disassembly	
	Lubrication system	Wet sump	
	Air filtration	Paper	
	Cylinder compression	1200 ± 200 kPa (12.0 ± 2.0 kg/cm <sup>2</sup> , 170 ± 28 psi)	
	Intake valve	Opens 10° (BTDC) at 1 mm lift, 42° (BTDC) at 0 lift	
		Closes 40° (ABDC) at 1 mm lift, 80° (ABDC) at 0 lift	
	Exhaust valve	Opens 45° (BBDC) at 1 mm lift, 81° (BBDC) at 0 lift	
		Closes 5° (ATDC) at 1 mm lift, 51° (ATDC) at 0 lift	





### TORQUE VALUES

#### ENGINE

Item	Q'ty	Thread Dia (mm)	Torque N-m (kg-m, ft-lb)	Remarks	
Main oil gallery plug	1	—	25-35 (2.5-3.5, 18-25)	U.B.S., Apply a locking agent to the threads	
Camshaft holder	20	6	12-16 (1.2-1.6, 9-12)		
Cylinder head	12	9	26-30 (2.6-3.0, 19-22)		
Cam sprocket	4	7	18-20 (1.8-2.0, 13-14)		
Cam chain tensioner	4	8	10-14 (1.0-1.4, 7-10)	Apply engine oil to the threads	
Spark plug	4	—	12-18 (1.2-1.8, 9-13)		
Crankcase	8 mm	11	21-25 (2.1-2.5, 15-18)		
	7 mm	2	15-19 (1.5-1.9, 11-14)		
	6 mm	20	10-14 (1.0-1.4, 7-10)		
Connecting rod nut	8	8	30-34 (3.0-3.4, 22-25)		Apply engine oil to the O-ring Apply a liquid sealant to the threads
Pulse rotor	1	10	30-40 (3.0-4.0, 22-29)		
Alternator rotor bolt	1	10	30-38 (3.0-3.8, 22-28)		
Mainshaft lock nut	1	22	47-53 (4.7-5.3, 34-38)		
Oil filter	1	—	15-20 (1.5-2.0, 11-14)		
Oil pressure switch	1	—	10-14 (1.0-1.4, 7-10)		
Oil pipe bolt	7 mm	2	10-14 (1.0-1.4, 7-10)		
	8 mm	4	12-16 (1.2-1.6, 9-12)		
	10 mm	1	16-20 (1.6-2.0, 12-14)		
Oil drain plug	1	12	30-40 (3.0-4.0, 22-29)		
Pulse generator assembly	4	5	5-7 (0.5-0.7, 4-5)		
Alternator shaft lock nut	1	16	30-38 (3.0-3.8, 22-28)	Apply a liquid sealant to the threads	
Clutch lock nut	1	—	75-85 (7.5-8.5, 54-62)		
Output driven gear bearing holder	4	8	30-34 (3.0-3.4, 22-25)		
Countershaft bearing holder	3	8	30-34 (3.0-3.4, 22-25)		
Output gear bearing lock nut (outer)	2	—	90-110 (9.0-11.0, 65-80)		
	(inner)	2	70-80 (7.0-8.0, 51-58)		
Output gear case	8 mm	2	21-25 (2.1-2.5, 15-18)		
	6 mm	1	10-14 (1.0-1.4, 7-10)		
Oil chamber cover bolt	1	8	16-20 (1.6-2.0, 12-15)		
Main bearing bolt	10	8	21-25 (2.1-2.5, 15-18)		
Oil hose	6 mm	2	10-15 (1.0-1.5, 7-11)		
	8 mm	2	24-30 (2.4-3.0, 17-22)		

#### CHASSIS

Item	Q'ty	Thread Dia (mm)	Torque N-m (kg-m, ft-lb)	Remarks
Engine oil drain plug	2	8	24-30 (2.4-3.0, 17-22)	U nut U.B.S.
Steering stem nut	1	24	90-120 (9.0-12.0, 65-87)	
Handlebar holder	4	8	20-30 (2.0-3.0, 14-22)	
Front fork pinch bolt (upper)	2	7	9-15 (0.9-1.5, 6-11)	
Front fork pinch bolt (lower)	2	10	45-55 (4.5-5.5, 32-40)	
Front axle nut	1	12	65-75 (6.5-7.5, 48-54)	
Front axle holder nut	4	8	18-25 (1.8-2.5, 13-18)	
Engine mounting bolts	8 mm	8	20-30 (2.0-3.0, 14-22)	
	10 mm	5	45-60 (4.5-6.0, 32-43)	
Rear axle nut	1	18	85-105 (8.5-10.5, 62-77)	
Final gear case	3	10	60-70 (6.0-7.0, 43-51)	



GENERAL INFORMATION



**HONDA**  
**CB750SC**

Item	Q'ty	Thread Dia (mm)	Torque N·m (kg·m, ft·lb)	Remarks
Rear brake torque link	2	8	18-25 (1.8-2.5, 13-18)	
Rear shock (upper)	2	8	24-30 (2.4-3.0, 17-22)	
(lower)	2	10	30-40 (3.0-4.0, 22-29)	
Foot peg	2	10	30-40 (3.0-4.0, 22-29)	
Gearshift pedal	1	6	8-12 (0.8-1.2, 6-9)	
Rear axle pinch bolt	1	8	20-30 (2.0-3.0, 14-22)	
Swing arm pivot (right)	1	23	8-12 (0.8-1.2, 6-9)	
(left)	1	23	60-80 (6.0-8.0, 43-58)	
Swing arm pivot lock nut	1	23	80-120 (8.0-12.0, 58-87)	
Final drive case oil drain plug	1	10	10-14 (1.0-1.4, 7-10)	
Handlebar pinch bolt	2	8	24-30 (2.4-3.0, 17-22)	
Steering bearing adjustment nut	1	-	20-22 (2.0-2.2, 14-16)	Apply oil to the threads
Exhaust pipe joint nut	8	8	8-14 (0.8-1.4, 6-10)	
Brake and clutch master cylinder holder	4	6	10-14 (1.0-1.4, 7-10)	
Brake and clutch bleeder	2	8	4-7 (0.4-0.7, 3-5)	
Brake and clutch hose oil bolt	4	10	25-35 (2.5-3.5, 18-25)	
Brake pedal	1	8	20-28 (2.0-2.8, 14-20)	
Side stand (bolt)	1	10	10-20 (1.0-2.0, 7-14)	
(nut)	1	10	35-45 (3.5-4.5, 25-32)	
Main stand	2	10	35-45 (3.5-4.5, 25-32)	
Muffler clamp bolt	1	8	18-28 (1.8-2.8, 13-20)	
Muffler mount bolts	2	10	45-65 (4.5-6.5, 32-48)	U.B.S.
Front fork brace	4	6	10-15 (1.0-1.5, 7-11)	
Brake and clutch master cylinder cap	4	4	1-2 (0.1-0.2, 0.7-1.4)	
Final gear case oil filler cap	1	30	10-14 (1.0-1.4, 7-10)	
at brake disc	12	8	35-40 (3.5-4.0, 25-29)	Apply oil to the threads
ion bearing retainer	1	-	100-120 (10.0-12.0, 72-87)	
Pinion nut	1	-	100-120 (10.0-12.0, 72-87)	
Final gear case cover 10 mm	2	10	45-50 (4.5-5.0, 32-36)	Apply locking agent to the threads
8 mm	6	8	23-28 (2.3-2.8, 17-20)	
Front fork socket bolt	2	8	20-26 (2.0-2.6, 15-19)	
Front fork tube cap	2	-	15-30 (1.5-3.0, 11-25)	
Rear brake arm	1	8	24-30 (2.4-3.0, 17-22)	
Final driven flange	5	10	50-60 (5.0-6.0, 36-43)	
Brake caliper bracket bolt (right)	2	10	35-45 (3.5-4.5, 25-32)	
(left upper)	1	10	35-45 (3.5-4.5, 25-32)	
Brake caliper bolt	2	8	20-25 (2.0-2.5, 14-18)	
Brake caliper pivot bolt	2	8	25-30 (2.5-3.0, 18-22)	
Brake pad pin retainer bolt	2	6	8-13 (0.8-1.3, 6-9)	
Anti-dive piston pin bolt	1	6	10-14 (1.0-1.4, 7-10)	
Oil cooler elbow	4	6	10-15 (1.0-1.5, 7-11)	
Fuel strainer cup	1	-	3-5 (0.3-0.5, 2-4)	

- Torque specifications listed above are for important fasteners. Others should be tightened to the standard torque values below.

STANDARD TORQUE VALUES

Type	Torque N·m (kg·m, ft·lb)	Type	Torque N·m (kg·m, ft·lb)
5 mm bolt, nut	4.5-6 (0.45-0.6, 3.5-4.5)	5 mm screw	3.5-5 (0.35-0.5, 2.5-3.6)
6 mm bolt, nut	8-12 (0.8-1.2, 6-9)	6 mm screw	7-11 (0.7-1.1, 5-8)
8 mm bolt, nut	18-25 (1.8-2.5, 13-18)	6 mm flange bolt, nut	10-14 (1.0-1.4, 7-10)
10 mm bolt, nut	30-40 (3.0-4.0, 22-29)	8 mm flange bolt, nut	24-30 (2.4-3.0, 17-22)
12 mm bolt, nut	50-60 (5.0-6.0, 36-43)	10 mm flange bolt, nut	30-40 (3.0-4.0, 22-29)



**TOOLS**

**SPECIAL**

DESCRIPTION	PART NUMBER	ALTERNATIVE TOOL	PART NUMBER	REF. SECT.
Race remover attachment	07953-MJ1000A	U.S.A. only		14
Oil pressure gauge attachment	07510-MJ10000			2
Valve guide driver/remover	07942-MA60000			6
Hydraulic lifter bleeder	07973-MJ 00000			6
Valve guide reamer	07984-MA60000			6
Shaft holder	07923-6890101			11
Swing arm lock nut wrench	07908-ME90000			15
Rear shock compressor	07967-KC10000	Not available in U.S.A.		15
Oil pressure gauge	07506-3000000	Commercially available in U.S.A.		2
Vacuum gauge set	07404-0030100	Vacuum gauge set (U.S.A. only)	M937B-021-XXXXX or 07404-0020000	3
Compression gauge attachment	07510-MB00101	Equivalent commercially available in U.S.A.		3
Carburetor pilot screw wrench	07908-4220201			3,4
Piston ring compressor (2-required)	07954-2830000			7
Piston base (2-required)	07958-3000000			7
Snap ring pliers	07914-3230001	Commercially available in U.S.A.		8,16
Lock nut wrench, 30/64 mm	07916-MB00000			11,13
Remover handle	07936-3710100			11
Remover weight	07741-0010201	Remover weight	07936-3710200	11,15
Bearing remover, 17 mm	07936-3710300			11
Attachment	07945-3330300			11,13
Ring gear dis/assembly tool	07965-3710100			11
Shock absorber compressor attachment (collar)	07964-MB00100			13
Shock absorber compressor attachment (plate)	07964-MB00200			13
Pinion joint holder	07926-ME90000			13
Pinion puller	07935-MB00000	Pinion puller	07931-4630200	13
		Pinion puller attachment kit	07931-MB00000	13
Attachment	07945-3330100			13
Steering stem socket	07916-3710100			14
Steering stem driver	07946-MB00000			14
Race remover attachment	07946-3710500			14
Lock nut wrench	07910-ME80000			13
Socket bit, 17 mm	07703-0020500	Commercially available in U.S.A.		15
Socket bit, 10 mm	07917-3710000	Commercially available in U.S.A.		15
Ball race remover attachment	07946-3710500			14
Bearing driver attachment, 28 x 30	07946-1870100			11
Oil filter wrench	07912-6110001			2
Crankcase assembly pin (2-required)	07973-ME50000			10
Fork piston holder	07930-KA40200			14
Fork piston holder attachment	07930-KA50100			14

GENERAL INFORMATION



**HONDA**  
**CB750SC**

DESCRIPTION	PART NUMBER	ALTERNATIVE TOOL	PART NUMBER	REF. SECT.
Fork seal driver	07947-4630100	Swing arm pivot remover	07936-3710500	14
Swing arm bearing remover	07936-4150000			15
Shock absorber compressor attachment (extensions)	07959-MB10000			15
Rotor puller	07933-2160000	Driver	07949-3710000	18
Driver	07949-3710001			14

COMMON

DESCRIPTION	PART NUMBER	ALTERNATIVE TOOL	PART NUMBER	REF. SECT.
Float level gauge	07401-0010000	Valve spring compressor Equivalent commercially available in U.S.A.	07957-3290001	4
Valve spring compressor	07757-0010000			6
Lock nut wrench, 17 x 27 mm	07716-0020300			8
Extension bar	07716-0020500			2, 14
Attachment, 42 x 47 mm	07746-0010300	Driver	07949-6110000	11, 15
Pilot, 30 mm	07746-0040700			13, 14
Driver	07749-0010000	Driver	07945-3710200	11, 13
Attachment, 32 x 35 mm	07746-0010100			8, 10, 11, 13, 14, 15
Pilot, 17 mm	07746-0040400			13, 15
Attachment, 52 x 55 mm	07746-0010400			11
Driver	07746-0030100			11, 13, 14
Attachment, 25 mm I.D.	07746-0030200			11, 13
Attachment, 30 mm I.D.	07746-0030300			11
Pilot, 15 mm	07746-0040300			14
Shock absorber compressor	07959-3290001			13, 15
Lock nut wrench, 30 x 32 mm	07716-0020400			Equivalent commercially available in U.S.A.
Bearing remover expander	07746-0050100	Equivalent commercially available in U.S.A.		14, 15
Bearing remover, 15 mm	07746-0050400			14
Bearing remover, 20 mm	07746-0050600			15
Pilot, 20 mm	07746-0040500			15
Universal holder	07725-0030000			12
Attachment, 62 x 68 mm	07746-0010500			11
Attachment, 37 x 40 mm	07746-0010200	14		



### CABLE & HARNESS ROUTING

Note the following when routing cables and wire harnesses:

- A loose wire, harness or cable can be safety hazard. After clamping, check each wire to be sure it is secure.
- Do not squeeze wires against the weld or end of its clamp when a weld-on clamp is used.
- Secure wires and wire harnesses to the frame with their respective wire bands at the designated locations. Tighten the bands so that only the insulated surfaces contact the wires or wire harnesses.
- Route harnesses so they are neither pulled tight nor have excessive slack.
- Protect wires and harnesses with electrical tape or tube if they contact a sharp edge or corner. Clean the attaching surface thoroughly before applying tape.
- Do not use a wire or harness with a broken insulator. Repair by wrapping them with protective tape or replace them.
- Route wire harnesses to avoid sharp edges or corners.
- Also avoid the projected ends of bolts and screws.
- Keep wire harnesses away from the exhaust pipes and other parts that get hot.
- Be sure grommets are seated in their grooves properly.
- After clamping, check each harness to be certain that it is not interfering with any moving or sliding parts.
- After routing, check that the wire harnesses are not twisted or kinked.
- Wire harnesses routed along the handlebars should not be pulled taut, have excessive slack, be pinched by or interfere with adjacent or surrounding parts in all steering positions.

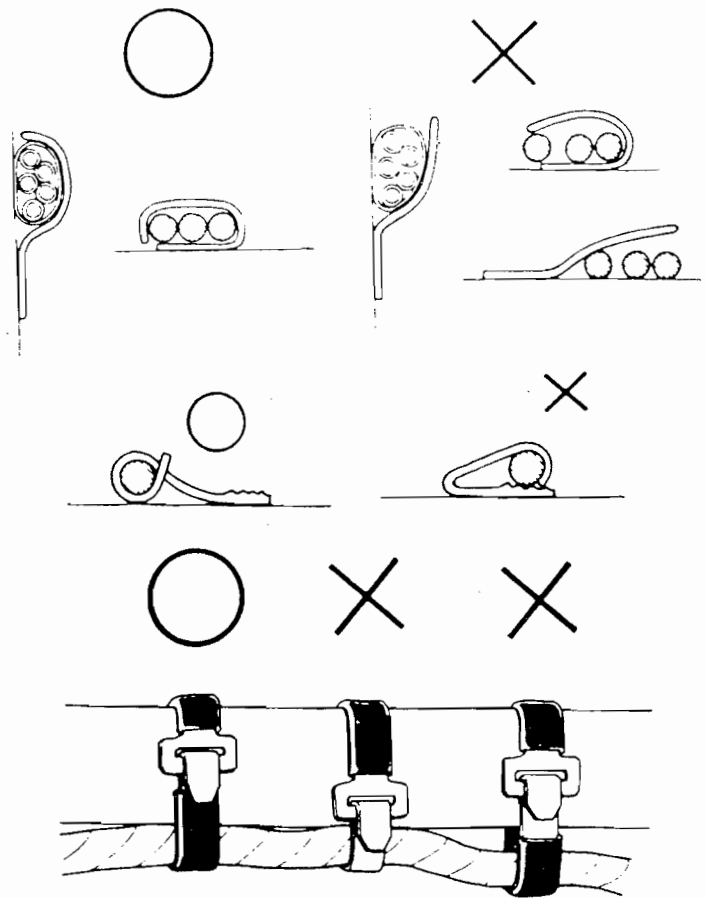

O: CORRECT  
X: INCORRECT

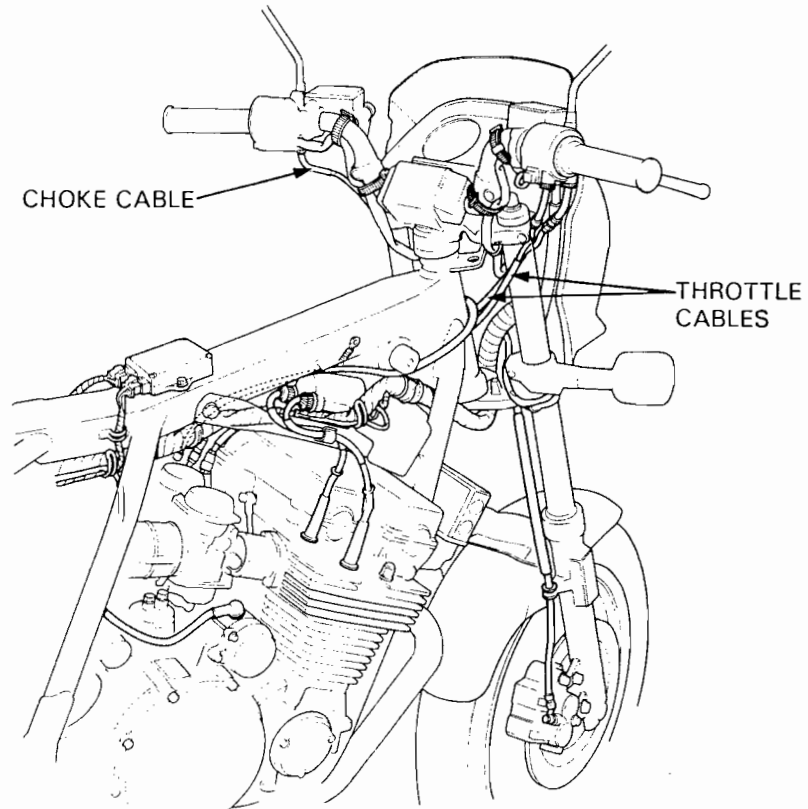
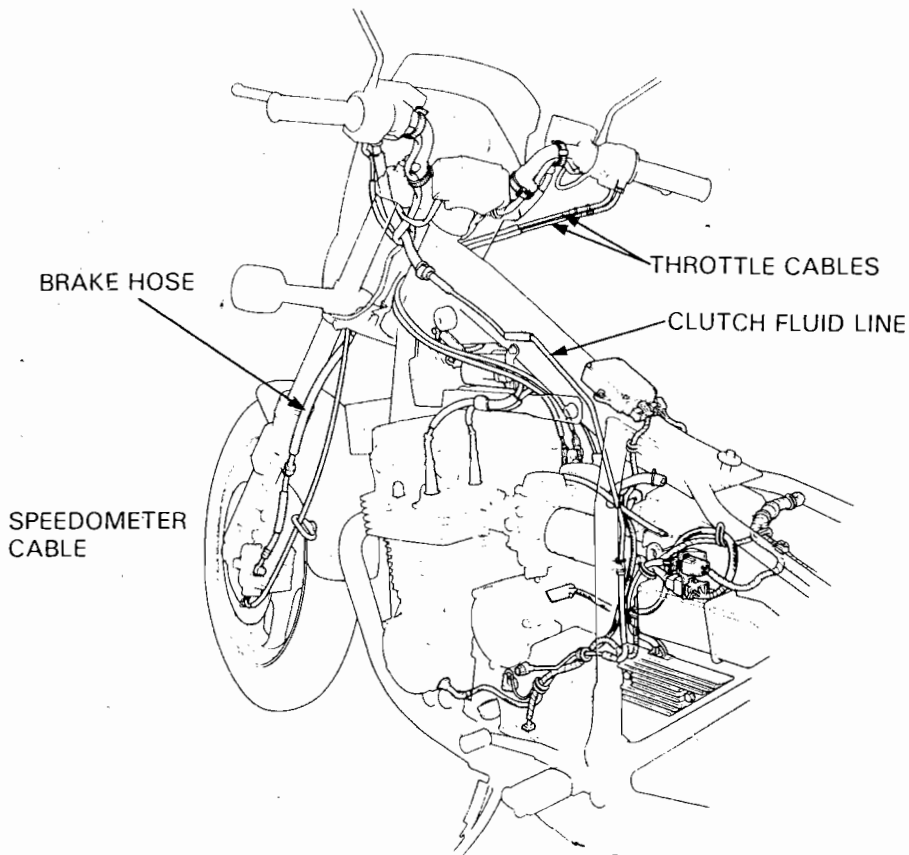

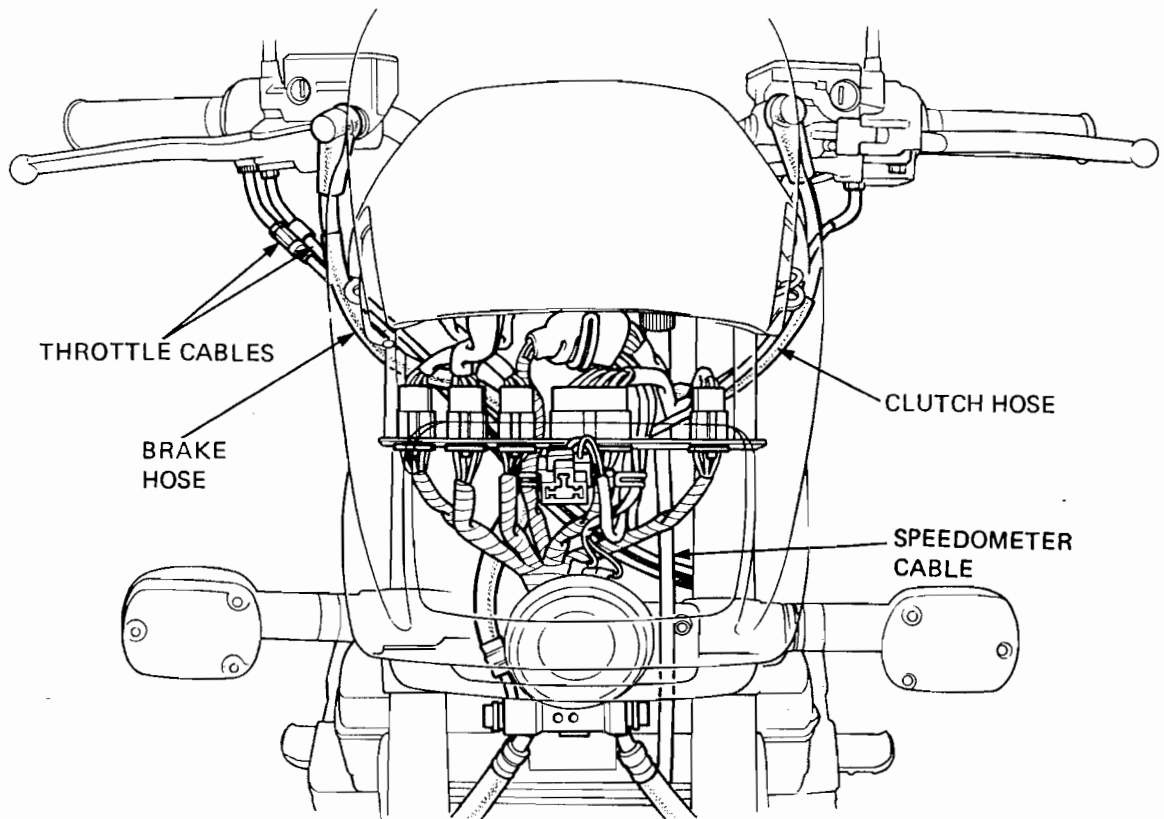
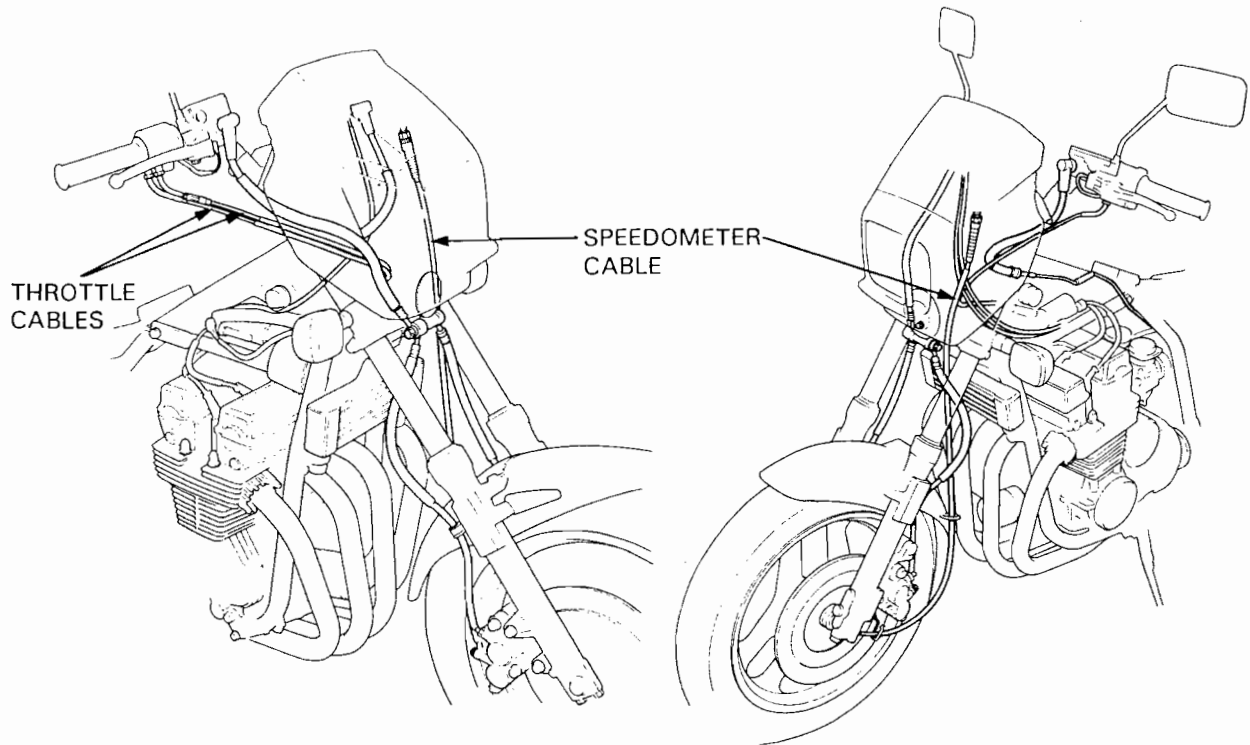

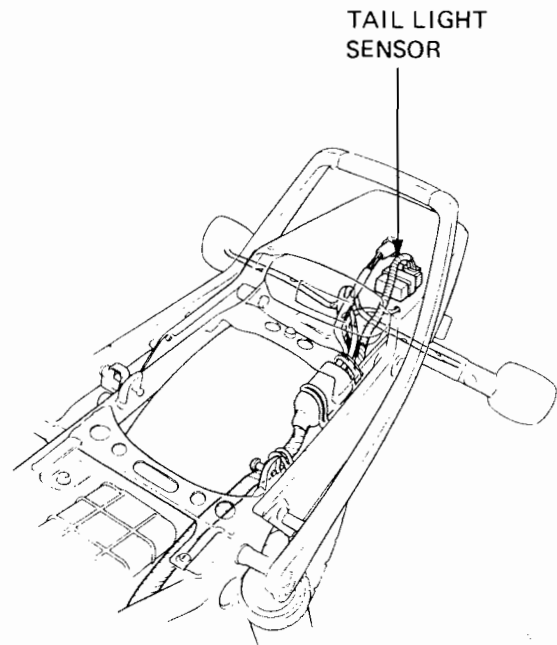
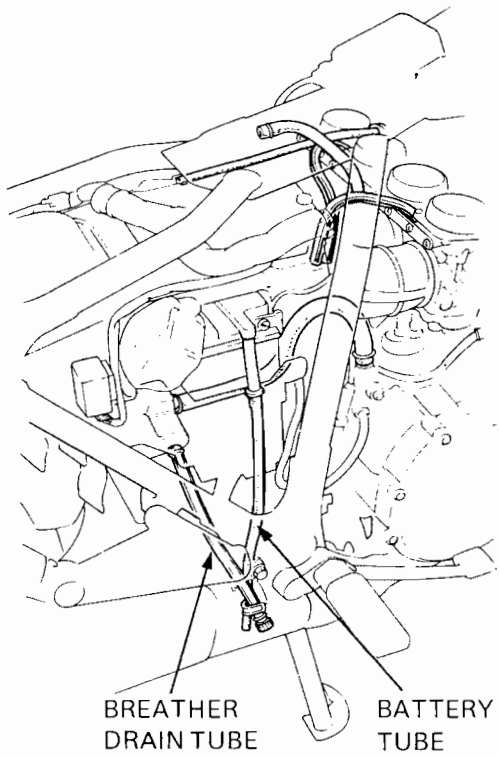
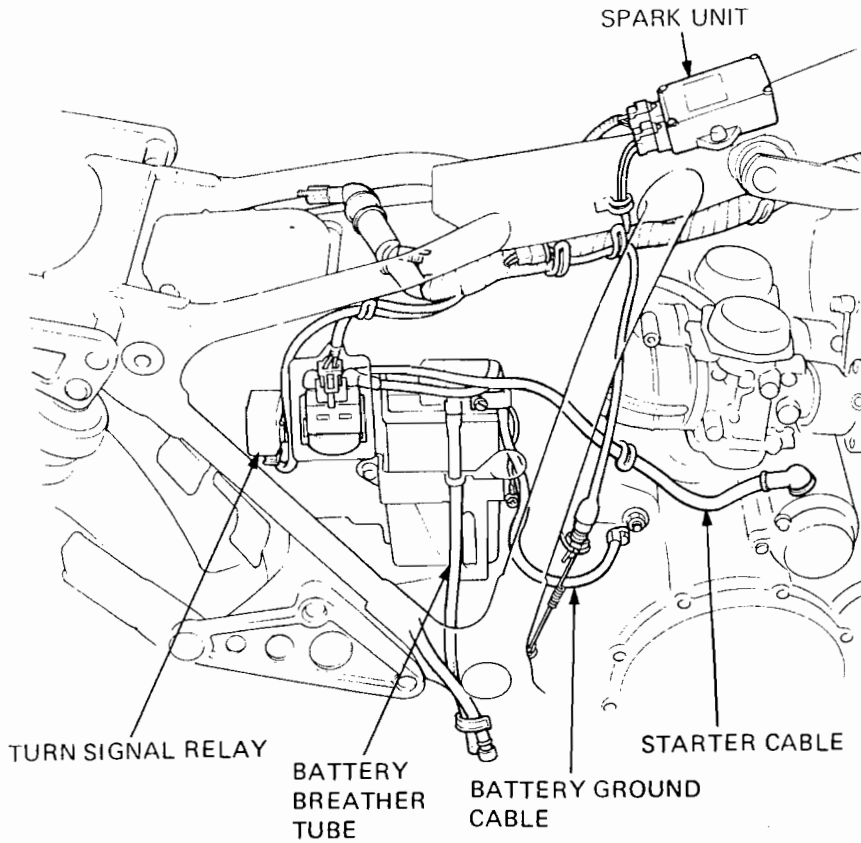



## EMISSION CONTROL SYSTEMS

The U.S. Environmental Protection Agency and California Air Resources Board (CARB) require manufacturers to certify that their motorcycles comply with applicable exhaust emissions standards during their useful life, when operated and maintained according to the instructions provided, and that motorcycles built after January 1, 1983 comply with applicable noise emission standards for one year or 6,000 km (3,730 miles) after the time of sale to the ultimate purchaser, when operated and maintained according to the instructions provided. Compliance with the terms of the Distributor's Warranties for Honda Motorcycle Emission Control Systems is necessary in order to keep the emissions system warranty in effect.

### SOURCE OF EMISSIONS

The combustion process produces carbon monoxide and hydrocarbons. Control of hydrocarbons is very important because, under certain conditions, they react to form photochemical smog when subjected to sunlight. Carbon monoxide does not react in the same way, but it is toxic.

Honda Motor Co., Ltd. utilizes lean carburetor settings as well as other systems, to reduce carbon monoxide and hydrocarbons.

### EXHAUST EMISSION CONTROL SYSTEM

The exhaust emission control system is composed of lean carburetor setting, and no adjustments should be made except idle speed adjustment with the throttle stop screw.

### CRANKCASE EMISSION CONTROL SYSTEM

The engine is equipped with a closed crankcase system which routes crankcase emissions through the air cleaner and into the combustion chamber. Condensed crankcase vapors are accumulated in a storage tank which must be emptied periodically. See the Maintenance Schedule in section 3.

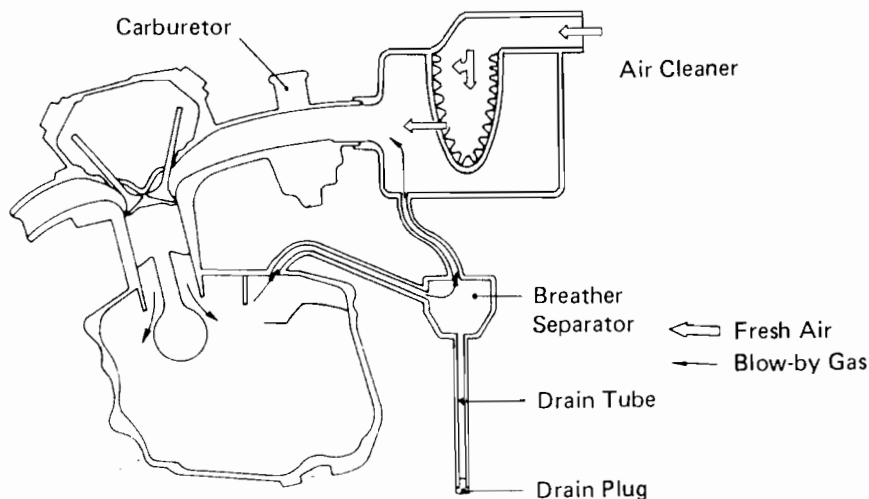





**GENERAL INFORMATION**

**EVAPORATIVE EMISSION CONTROL SYSTEM (California model only)**

This model complies with California Air Resources Board requirements for evaporative emission regulations. Fuel vapor from the fuel tank is routed into a charcoal canister where it is adsorbed and stored while the engine is stopped. When the engine is running and the purge control diaphragm valve is open, fuel vapor in the charcoal canister is drawn into the engine through the carburetor.

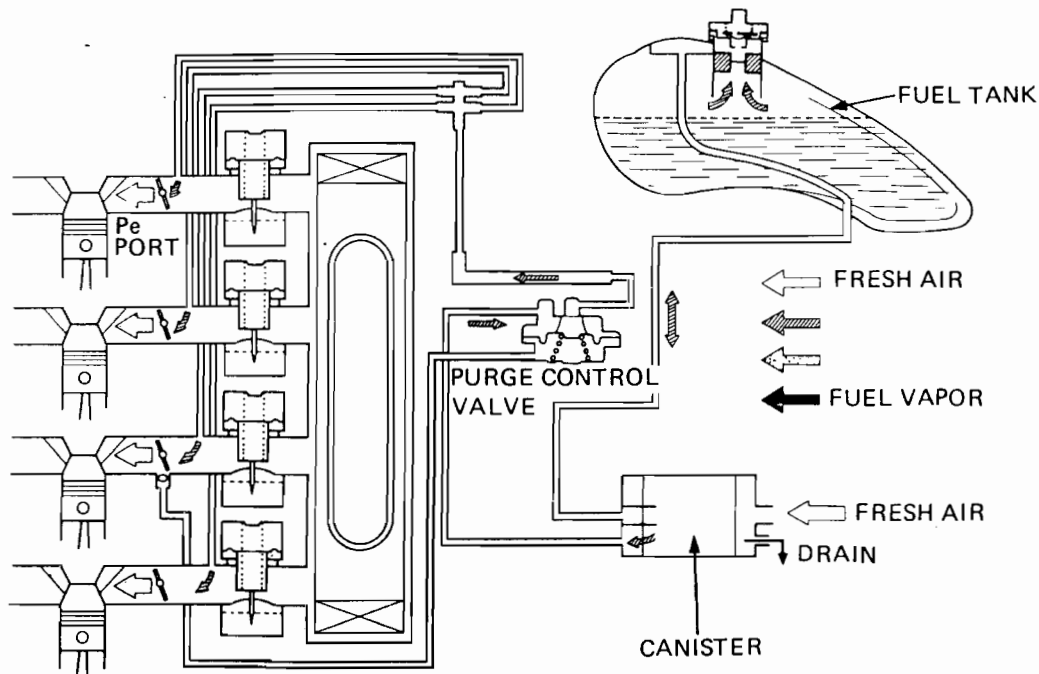

**NOISE EMISSION CONTROL SYSTEM**

**TAMPERING WITH THE NOISE CONTROL SYSTEM IS PROHIBITED:** Federal law prohibits the following acts or the causing thereof: (1) The removal or rendering inoperative by any person, other than for purposes of maintenance, repair or replacement, of any device or element of design incorporated into any new vehicle for the purpose of noise control prior to its sale or delivery to the ultimate purchaser or while it is in use; or (2) the use of the vehicle after such device or element of design has been removed or rendered inoperative by any person.

AMONG THOSE ACTS PRESUMED TO CONSTITUTE TAMPERING ARE THE ACTS LISTED BELOW:

1. Removal of, or puncturing the muffler, baffles, header pipes or any other component which conducts exhaust gases.
2. Removal of, or puncturing of any part of the intake system.
3. Lack of proper maintenance.
4. Replacing any moving parts of the vehicle, or parts of the exhaust or intake system, with parts other than those specified by the manufacturer.



### EMISSION CONTROL INFORMATION LABEL

An Emission Control Information Label is located on the frame side cover as shown. It contains basic tune-up specifications.

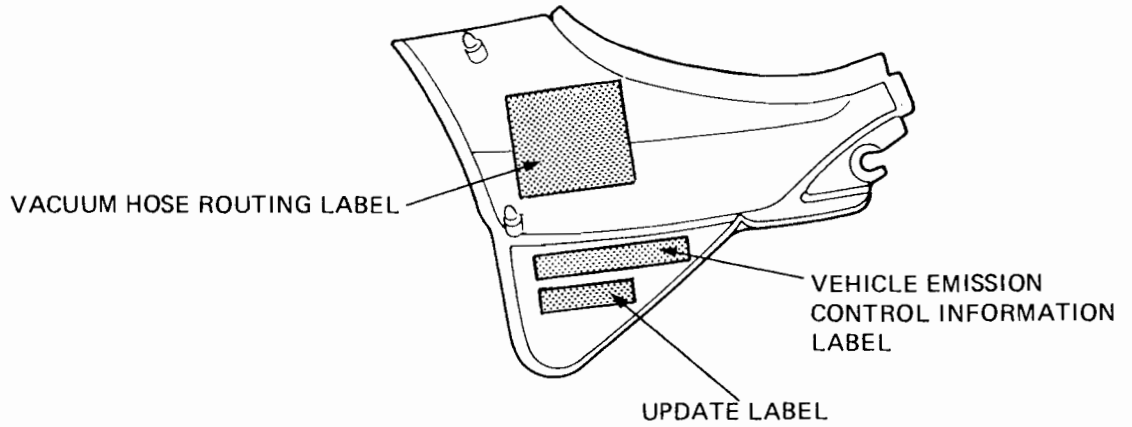

### EMISSION CONTROL INFORMATION UPDATE LABEL

After making a high altitude carburetor adjustment (Page 4-15), attach an update label on the frame side cover as shown. Instructions for obtaining the update label are given in Service Letter No. 132.

### VACUUM HOSE ROUTING DIAGRAM LABEL (California model only)

The Vacuum Hose Routing Diagram Label is attached to the frame side cover. Route the vacuum hoses as shown on this label, this label.

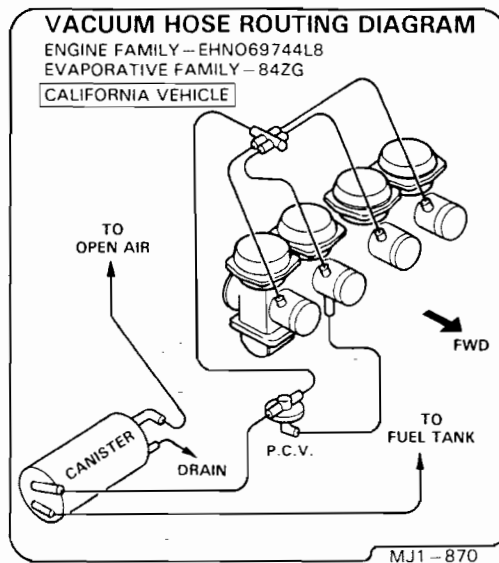



ENGINE LUBRICATION DIAGRAM

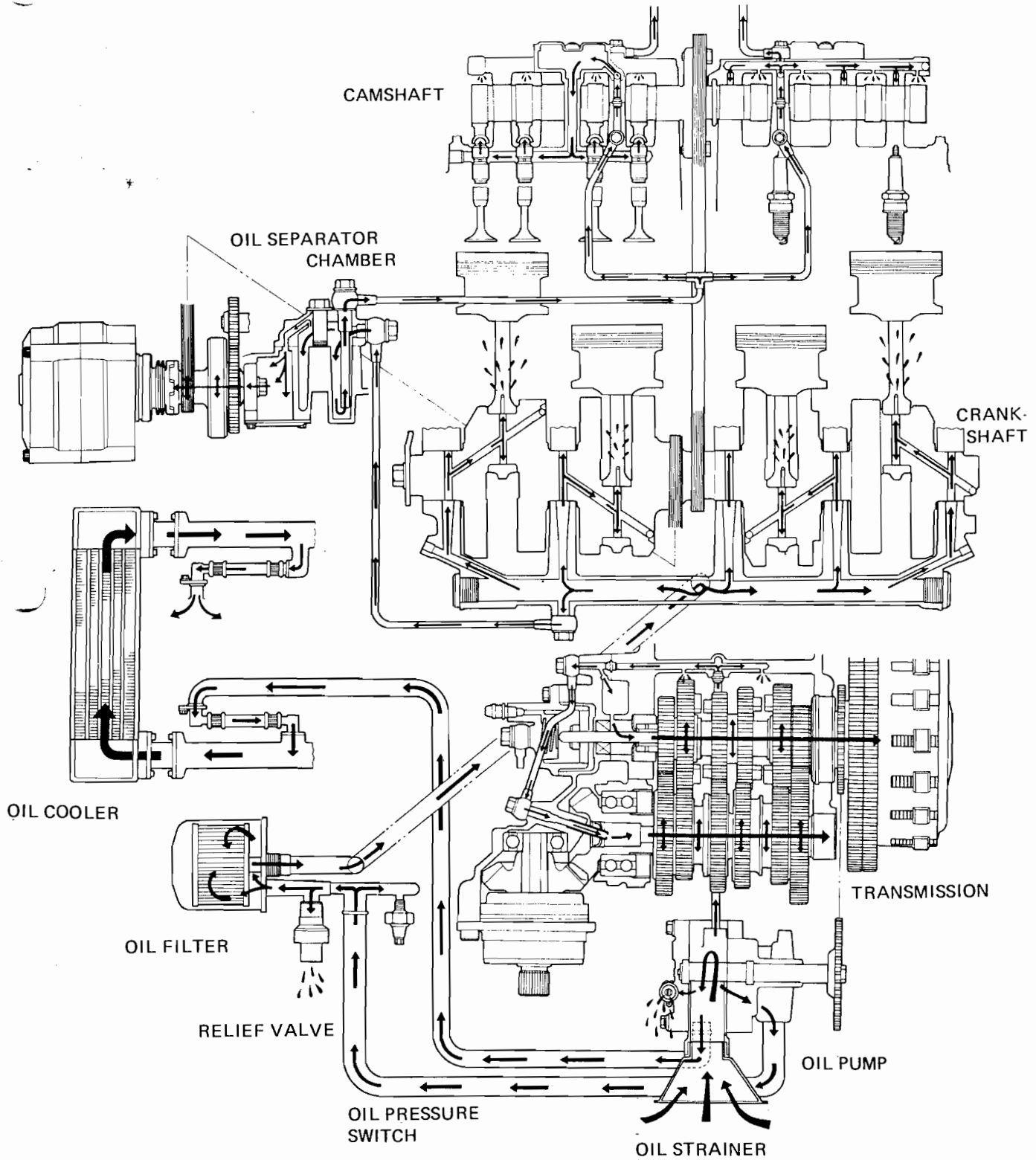



SERVICE INFORMATION	2-1	OIL PUMP	2-7
TROUBLESHOOTING	2-2	OIL COOLER	2-12
ENGINE OIL LEVEL	2-3	FINAL DRIVE OIL	2-13
ENGINE OIL & FILTER CHANGE	2-3	CONTROL CABLE LUBRICATION	2-13
OIL PRESSURE CHECK	2-4	LUBRICATION POINTS	2-14
PRESSURE RELIEF VALVE/ OIL STRAINER	2-5		

## SERVICE INFORMATION

### GENERAL

To remove the oil pump, the following parts must be removed:

- Exhaust pipes (Section 17).
- Clutch assembly (Section 8).

### SPECIFICATIONS

#### Engine oil

Oil capacity	2.8 liter (3.0 US qt, 2.5 Imp qt) after oil filter and oil change 2.5 liter (2.6 US qt, 2.2 Imp qt) after oil change 3.6 liter (3.8 US qt, 3.2 Imp qt) after disassembly
Oil recommendation	<p>Use Honda 4-Stroke Oil or equivalent. API Service Classification: SE or SF. Viscosity: SAE 10W-40</p> <p>Other viscosities shown in the chart may be used when the average temperature in your riding area is within the indicated range.</p> <div style="text-align: right;"> <p><b>OIL VISCOSITIES</b></p> </div>
Oil pressure (at main oil gallery)	630 kPa (6.3 kg/cm <sup>2</sup> , 90 psi)/6,000 rpm 80°C (176°F)

#### Oil pump service data

	STANDARD	SERVICE LIMIT
Rotor tip clearance	0.10 mm (0.004 in)	0.15 mm (0.006 in)
Pump body clearance	0.15-0.22 mm (0.006-0.009 in)	0.35 mm (0.014 in)
Pump end clearance	0.02-0.07 mm (0.001-0.003 in)	0.10 mm (0.004 in)

#### Final drive gear

Oil capacity	130 cc (4.4 oz) at oil change 150 cc (4.9 oz) after disassembly
Recommended oil	Hypoid gear oil: SAE #80



## LUBRICATION

### TORQUE VALUES

Engine oil drain plug	30–40 N·m (3.0–4.0 kg-m, 22–29 ft-lb)
Engine oil filter	15–20 N·m (1.5–2.0 kg-m, 11–14 ft-lb) — Apply engine oil to the O-ring
Right main oil gallery plug	25–35 N·m (2.5–3.5 kg-m, 18–25 ft-lb) — Apply 3-BOND® No. 1211 or its equivalent to the bolt threads
Oil cooler elbow socket bolt	10–15 N·m (1.0–1.5 kg-m, 7–11 ft-lb)

### TOOLS

#### Special

Oil pressure gauge	07506–3000000 or commercially available
Oil pressure gauge attachment	07510–MJ10100
Oil filter wrench	07912–MB00000

#### Common

Extension bar	07716–0020500 or commercially available
---------------	---

## TROUBLESHOOTING

### Oil level too low — high oil consumption

1. External oil leaks
2. Worn piston rings
3. Worn valve guide or seal

### Contamination

1. Oil or filter not changed often enough
2. Head gasket faulty
3. Worn piston rings

### Low oil pressure

1. Oil level low
2. Pressure relief valve stuck open
3. Plugged oil pick-up screen
4. Oil pump worn
5. External oil leaks

### High oil pressure

1. Pressure relief valve stuck closed
2. Plugged oil filter, gallery, or metering orifice
3. Incorrect oil being used

### No oil pressure

1. Oil level low
2. Oil pump drive gear broken
3. Oil pump faulty
4. Internal oil leakage



### ENGINE OIL LEVEL

Run the engine and allow it to idle for few minutes. Stop the engine and place the motorcycle on its center stand.

After 2-3 minutes, check the oil level with the filler cap/dipstick.

Do not screw it in when making this check.

If the oil level is below or near the lower level mark on the dipstick, add the recommended oil (Page 2-1) up to the upper level line.

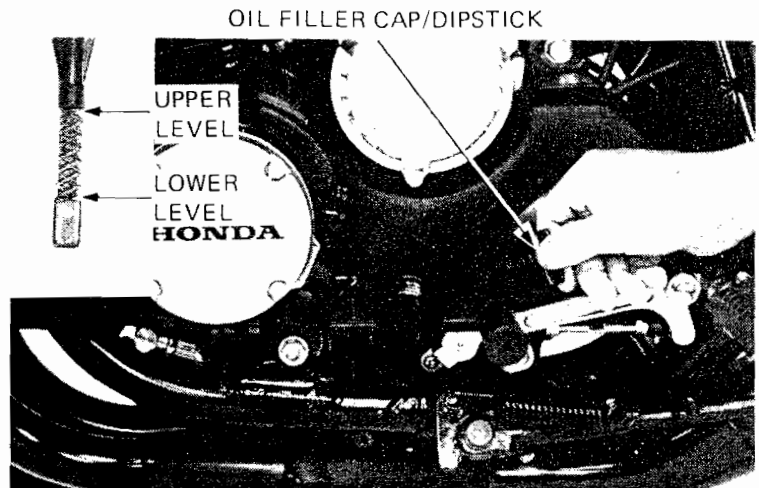

### ENGINE OIL & FILTER CHANGE

#### NOTE

Change engine oil with the engine warm and the motorcycle on its center stand to assure complete and rapid draining.

#### WARNING

*Do not touch the exhaust pipes and frame while they are hot.*

Remove the oil filler cap/dipstick.  
Remove the engine and frame drain plugs and drain the engine oil.

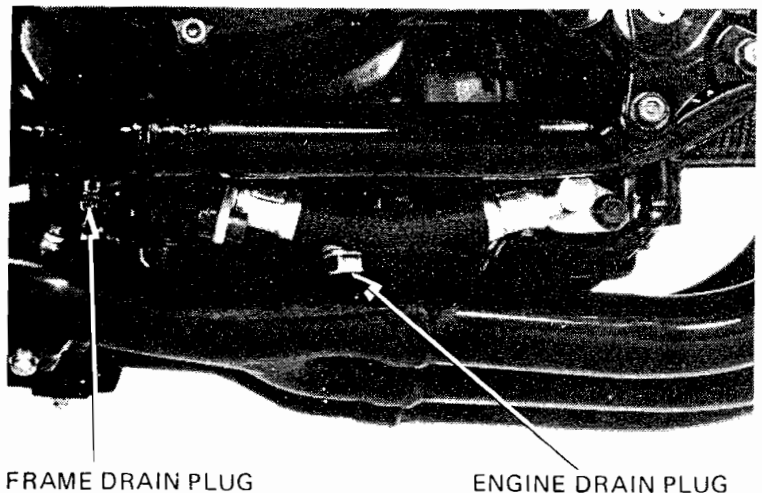

OIL FILTER WRENCH  
07912-MB00000

Loosen the oil filter with a filter wrench and extension bar and remove it between the No. 4 exhaust pipe and the frame.

Discard the oil filter.

Check that the sealing washers on the drain plugs are in good condition and install them.

#### TORQUE:

- Engine drain plug — 30-40 N·m  
(3.0-4.0 kg·m, 22-29 ft·lb)
- Frame drain plugs — 24-30 N·m  
(2.4-3.0 kg·m, 17-22 ft·lb)

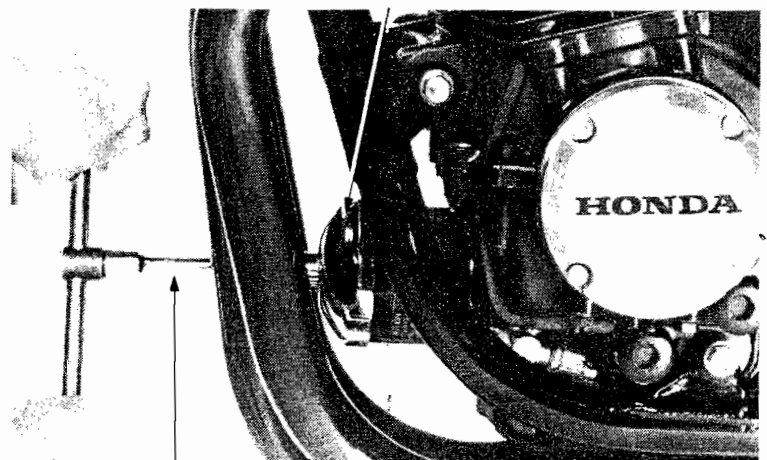



Apply oil to the new oil filter O-ring and install the new oil filter.

**NOTE**

Use only a Honda genuine oil filter for CB750SC.

Torque the oil filter with the filter wrench and extension bar.

**TORQUE:** 15–20 N·m  
(1.5–2.0 kg·m, 11–14 ft·lb)

Fill the crankcase with 2.8 liters (3.0 US qt, 2.5 Imp. qt.) of the recommended oil (Page 2–1). Install the oil filler cap/dipstick.

Wipe clean exhaust pipes from oil.

Start the engine and let it idle for few minutes. Stop the engine and place the motorcycle on its center stand. After 2–3 minutes, check that the oil level is at the upper level mark on the dipstick. Make sure there are no oil leaks.

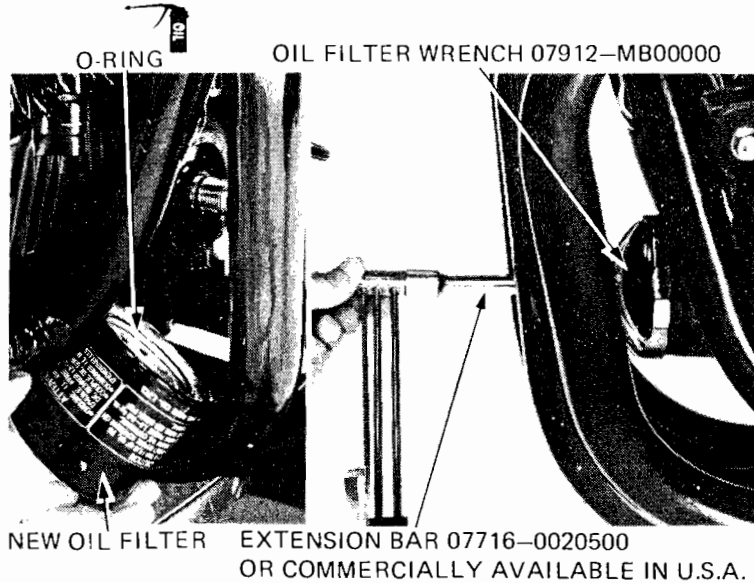

**OIL PRESSURE CHECK**

Warm the engine up to normal operating temperature (approximately 80°C/176°F). Stop the engine.

Place the motorcycle on its side stand. Remove the right main gallery plug.

Connect an oil pressure gauge to the right main gallery plug hole with a attachment. Place the motorcycle back on its center stand. Check the oil level (Page 2–3). Start the engine and check the oil pressure at 6,000 rpm.

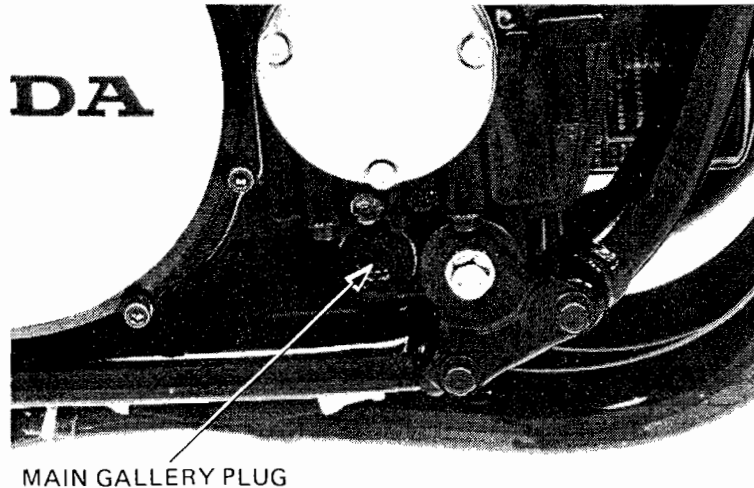

**OIL PRESSURE:** 630 kPa (6.3 kg/cm<sup>2</sup>, 90 psi)/  
6,000 rpm at 80°C (176°F)

PRESSURE GAUGE 07506-3000000  
(NOT AVAILABLE IN U.S.A.)

Remove the pressure gauge and attachment after placing the motorcycle on its side stand.

Apply 3-BOND<sup>®</sup> sealant or equivalent to the right main gallery plug threads and install the plug.

**TORQUE:** 25–35 N·m  
(2.5–3.5 kg·m, 18–25 ft·lb)

Start the engine.

Check that the oil pressure warning indicator goes out after one or two seconds. If the oil pressure warning indicator stays on, stop the engine immediately and determine the cause.

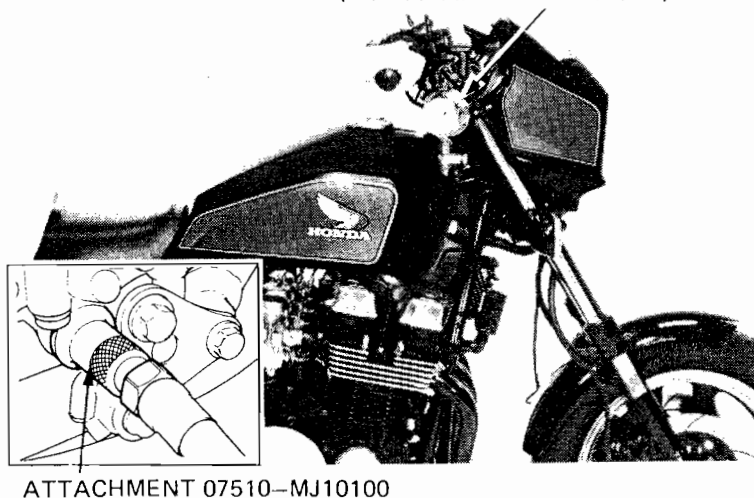



## PRESSURE RELIEF VALVE/OIL STRAINER

### NOTE

The oil strainer can be removed with the engine mounted in the frame.

### OIL PAN REMOVAL

Remove the exhaust pipes (Page 17-2).  
Drain the engine oil (Page 2-3).  
Remove the right and left oil hoses by removing the bolts.

Remove the oil pan bolts and oil pan.

Remove the oil pan gasket.

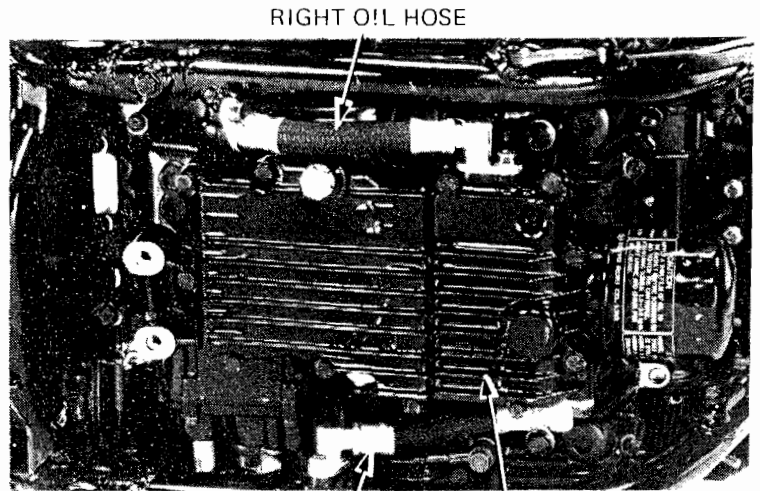

RIGHT OIL HOSE  
LEFT OIL HOSE OIL PAN

### RELIEF VALVE INSPECTION

Remove the pressure relief valve and check it for operation.

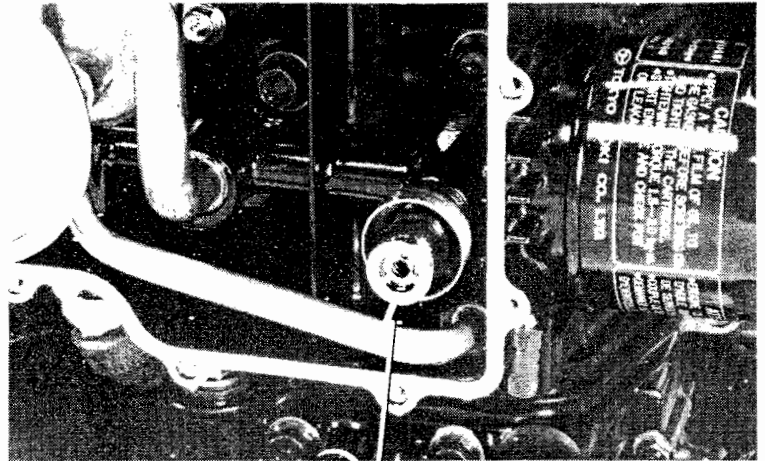

PRESSURE RELIEF VALVE

Remove the snap ring and disassemble the relief valve.

Check the valve for clogging or damage.  
Check the spring and piston for wear or damage.  
Assemble the parts in the reverse order of disassembly.

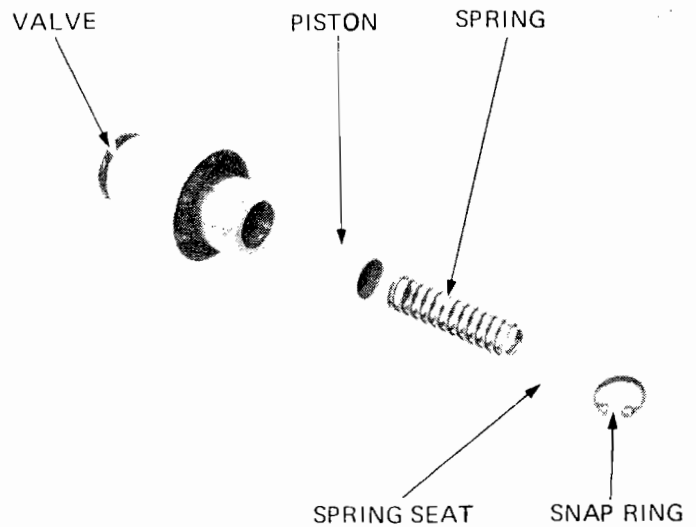





Replace the O-ring on the relief valve with a new one.  
Apply oil to the O-ring and install the relief valve.

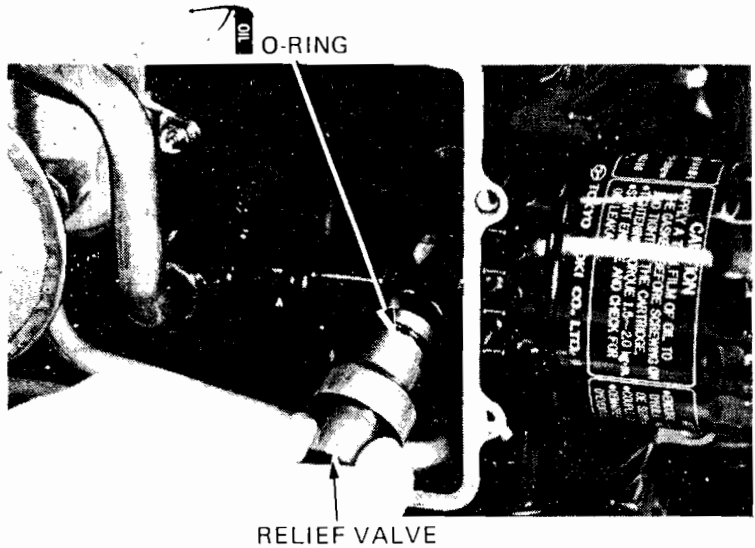

**OIL STRAINER CLEANING**

Remove and clean the oil strainer.

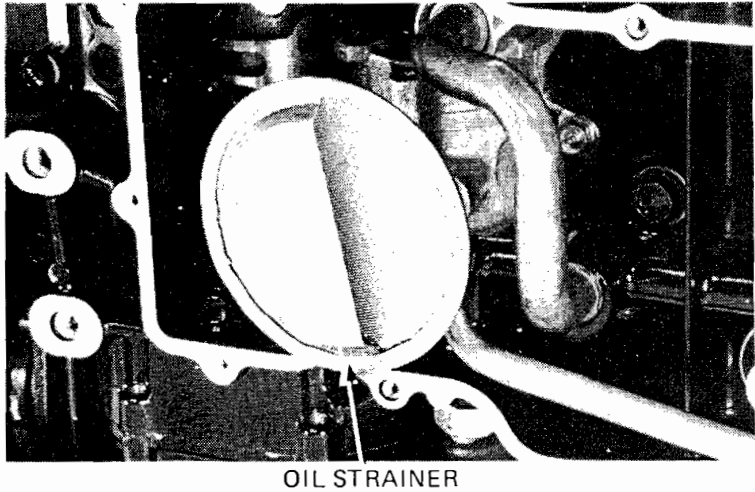

Replace the O-ring on the oil pump with a new one.  
Apply engine oil to the O-ring and install the oil strainer aligning its groove with the tab on the oil pump.

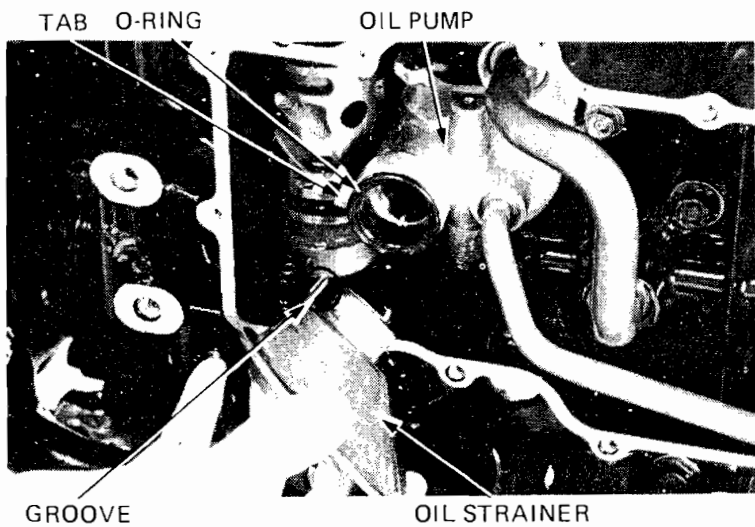



### OIL PAN INSTALLATION

Install the oil pan with a new gasket.

Tighten the oil pan bolts in 2-3 steps in a criss cross pattern.

Replace the O-rings on the right and left oil hoses with new ones.

Install the right and left oil hoses and tighten the bolts.

#### TORQUE:

8 mm socket bolts → 24-30 N·m  
(2.4-3.0 kg·m, 17-22 ft·lb)

6 mm SH bolts → 10-15 N·m  
(1.0-1.5 kg·m, 7-11 ft·lb)

Install the exhaust pipes (Page 17-2).

Fill the crankcase with the recommended oil (Page 2-1).

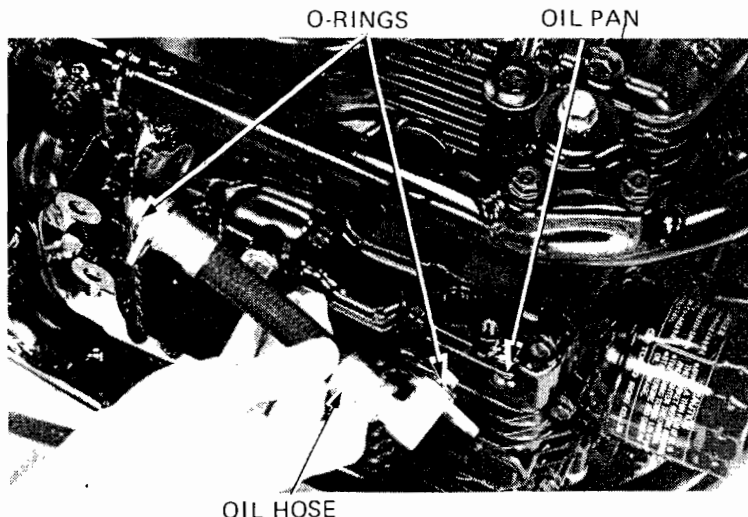

### OIL PUMP

#### REMOVAL

Remove the following parts:

- clutch assembly (Page 8-10).
- exhaust pipes (Page 17-2).
- oil pan (Page 2-5).
- oil strainer (Page 2-6).

Remove the bolt attaching the oil pump driven gear to the oil pump and the driven gear.

OIL PUMP DRIVEN GEAR

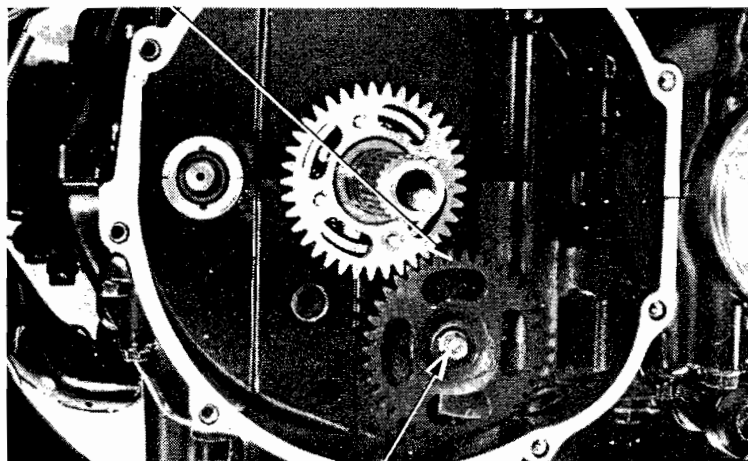

BOLT

Remove the oil pipes.

OIL PIPES

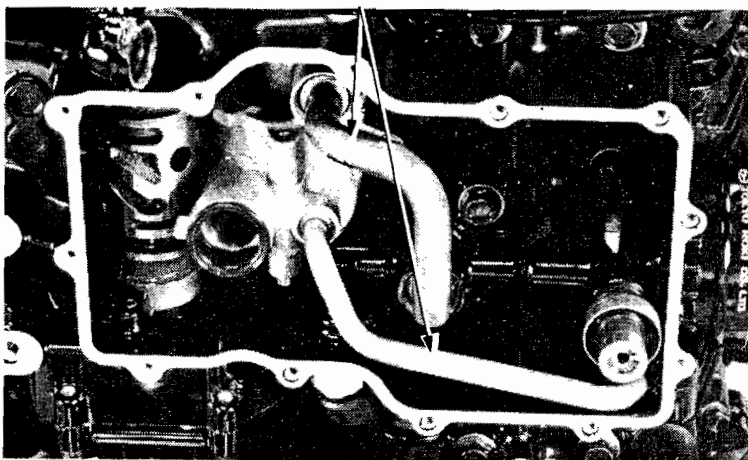



Remove the three oil pump mounting bolts and the oil pump.

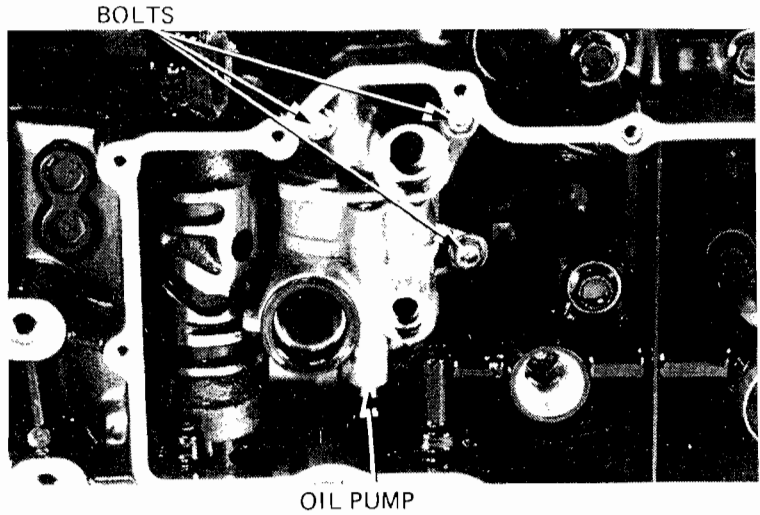

Check the operation of the pressure relief valve.

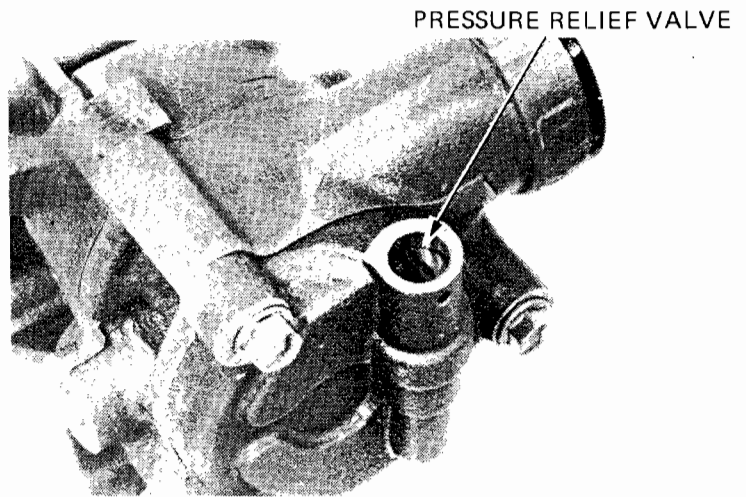

**DISASSEMBLY**

Remove the three bolts and oil pump cover B.

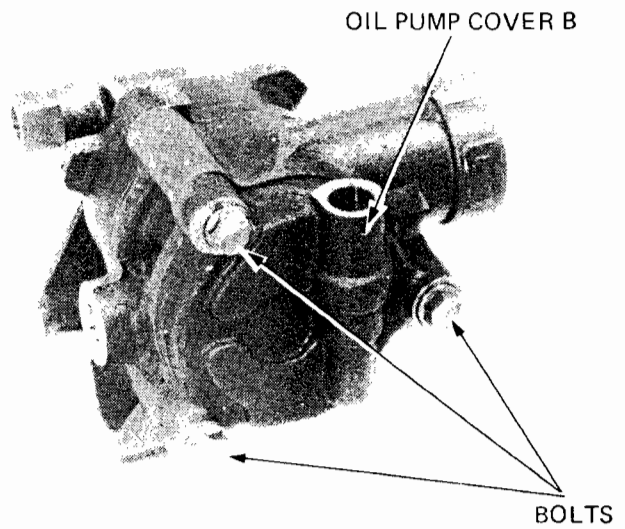



Remove the two dowel pins.  
 Remove the inner and outer rotors of the cooler pump.  
 Remove the pump drive pin.

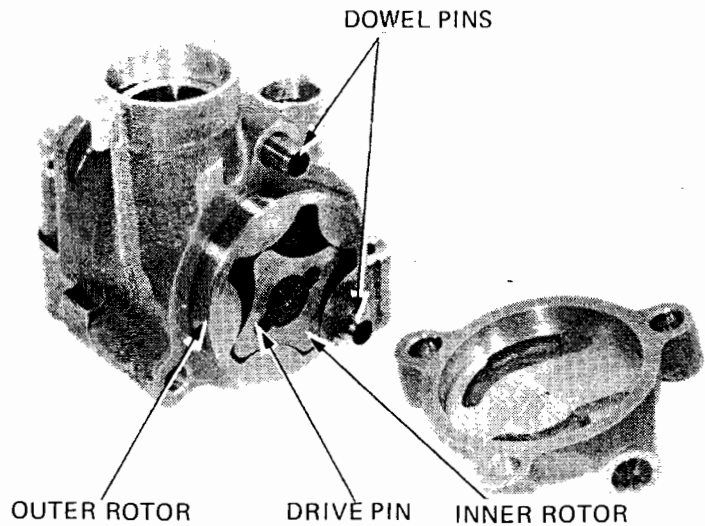

Remove the pump body from pump cover A.  
 Remove the dowel pin.  
 Remove the inner and outer rotors of the feed pump.  
 Remove the pump drive pin and thrust washer.  
 Remove the oil pump shaft from cover A.  
 Clean and dry all oil pump components.

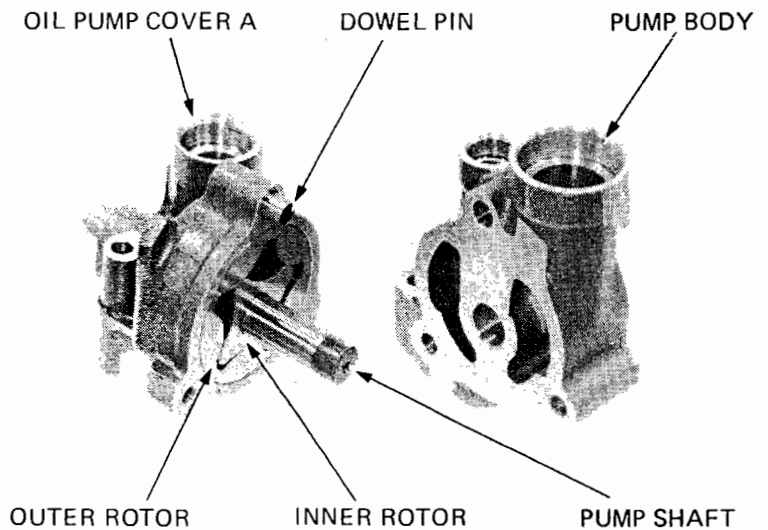

### INSPECTION

Install the feed pump inner and outer rotors, thrust washer and pump shaft into pump cover A.  
 Measure the pump tip clearance.

**SERVICE LIMIT: 0.20 mm (0.008 in)**

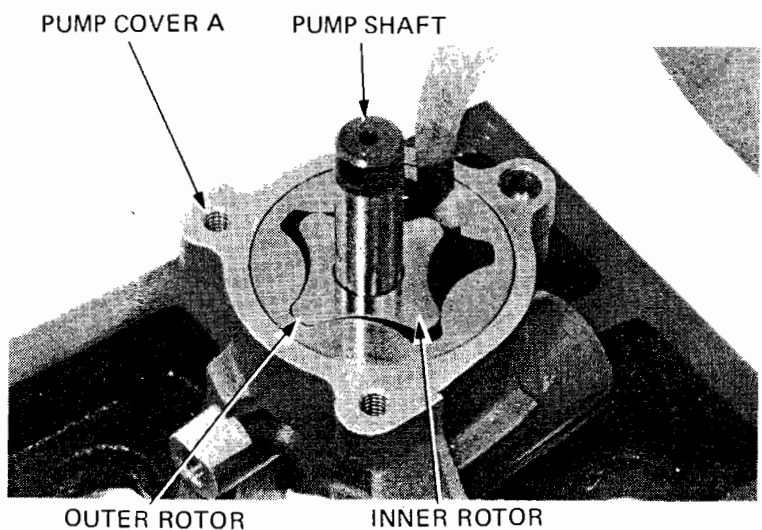



sure the pump body clearance.

**SERVICE LIMIT: 0.35 mm (0.014 in)**

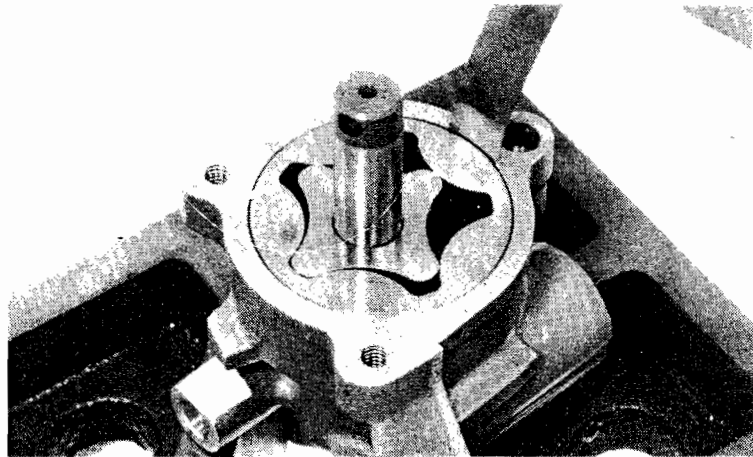

Remove the pump shaft and measure the pump end clearance.

**SERVICE LIMIT: 0.10 mm (0.004 in)**

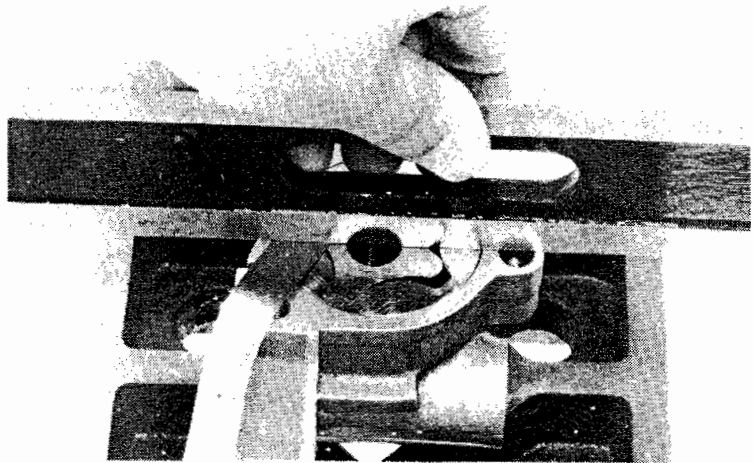

**ASSEMBLY**

Coat all components with clean engine oil and then assemble the oil pump in the reverse order of disassembly.

Make sure the oil pump shaft rotates freely after assembling the oil pump.

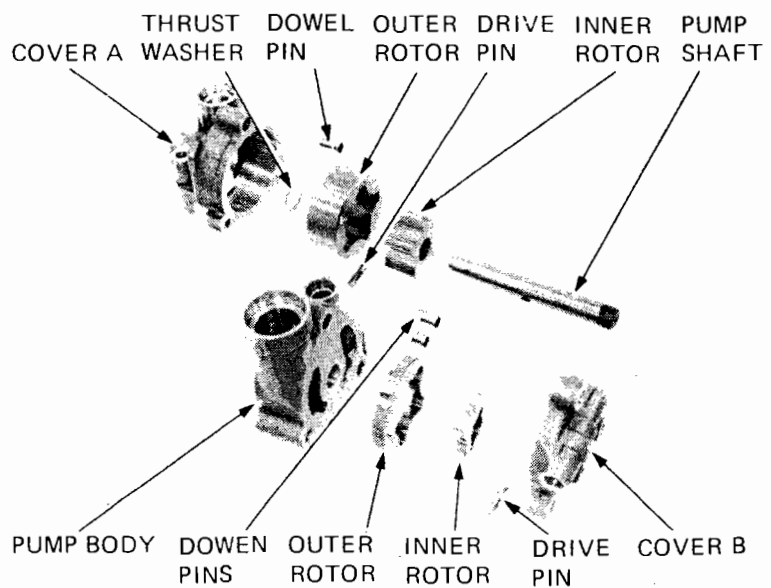



### INSTALLATION

Install the two dowel pins onto the lower crankcase. Make sure the orifice is not clogged. Install the orifice and a new O-ring.

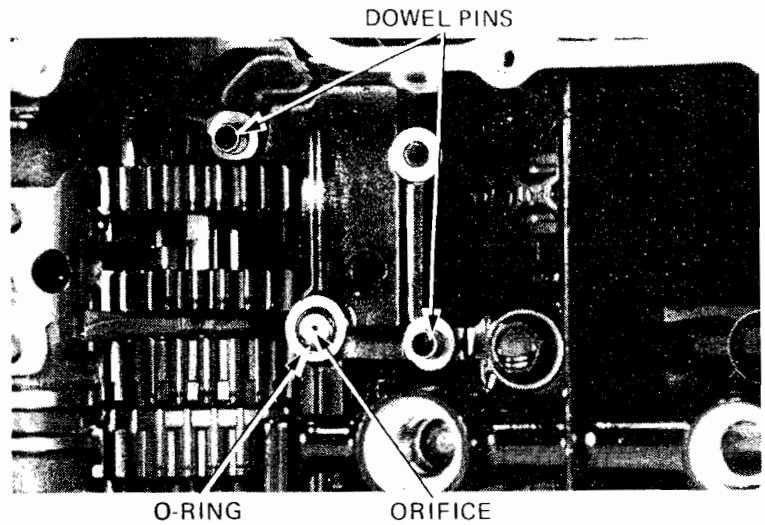

Install the oil pump onto the lower crankcase and tighten the three mounting bolts.

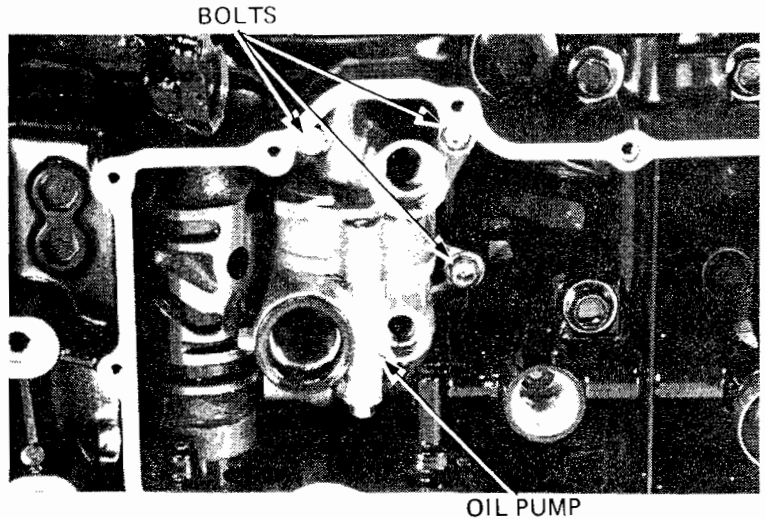

Replace the O-rings on the oil pipes with new ones. Apply engine oil to the O-rings and install the oil pipes.

Install the following parts:

- oil strainer (Page 2-6)
- oil pan (Page 2-7)
- exhaust pipes (Page 17-2)
- oil pump driven gear and clutch (Page 8-13)

Fill the crankcase with the recommended oil (Page 2-1).

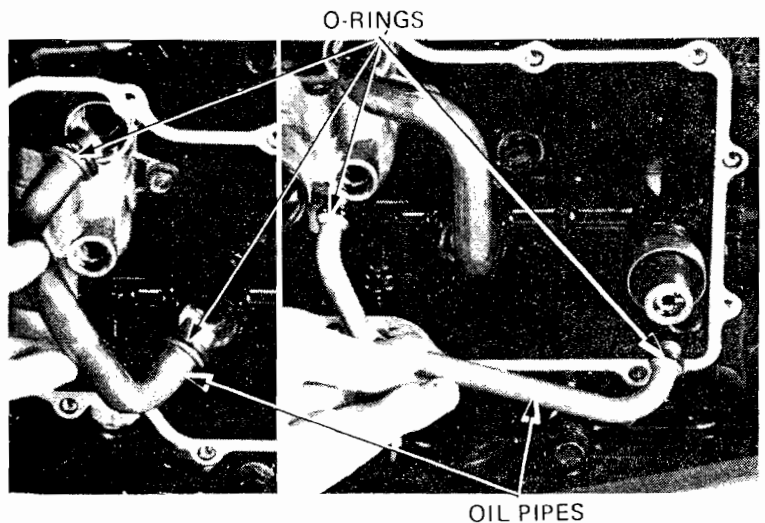



## COOLER

### INSPECTION

Inspect the oil cooler soldered joints and seams for leaks.

Blow dirt out from between core fins with compressed air. If insects, etc., are clogging the oil cooler, wash them off with low pressure water. Carefully straighten any bent fins.

### REMOVAL

Drain the engine oil (Page 2-3).

Disconnect the inlet and outlet elbows by removing the socket bolts.

Remove the oil cooler mounting bolt and the oil cooler from the frame.

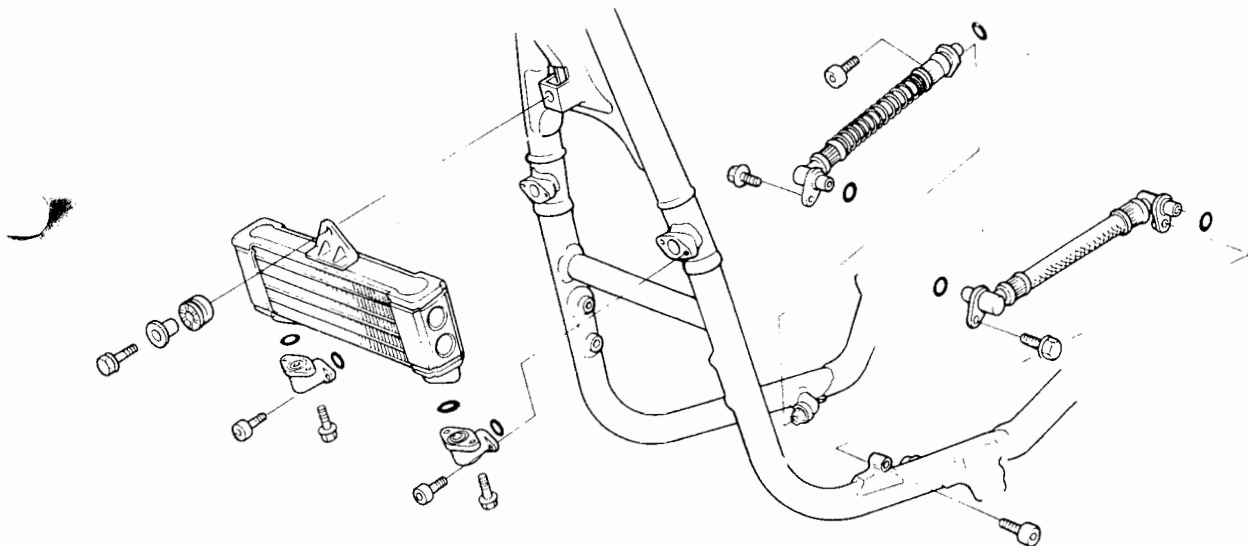
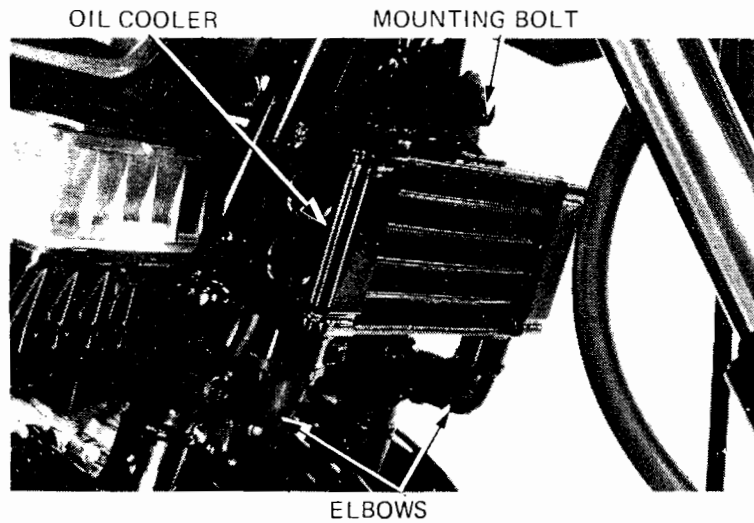

"UP" MARK

### INSTALLATION

Replace the O-rings on the elbows with new ones.

Install the oil cooler elbows to the oil cooler with their "UP" marks facing up.

Connect the oil cooler elbows to the frame down tubes and tighten the four socket bolts.

**TORQUE:** 10–15 N·m  
(1.0–1.5 kg·m, 7–11 ft·lb)

Tighten the oil cooler mounting bolt.

Fill the crankcase with the recommended oil (Page 2-3).

Start the engine and check for oil leaks.

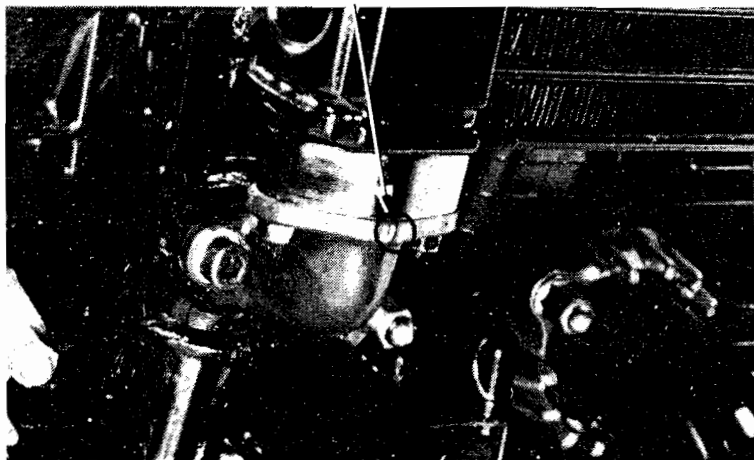



## FINAL DRIVE OIL

### CHECK

Place the motorcycle on its center stand on level ground.

Remove the oil filler cap.

Check that the oil level reaches the level mark in the oil filler cap hole.

Check for leaks if the level is low. Pour fresh oil through the oil filler hole until it reaches the oil level mark.

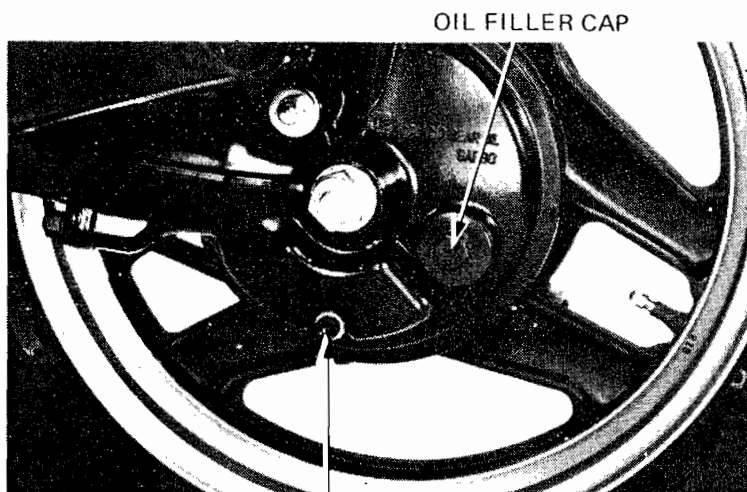

### CHANGE

Remove the oil filler cap and drain bolt to drain all oil from the final gear case.

Install the drain bolt securely.

Fill the gear case with the recommended oil (Page 2-2) up to the correct level (above).

**OIL CAPACITY: 130 cc (4.4 oz) after draining**

Install the oil filler cap securely.

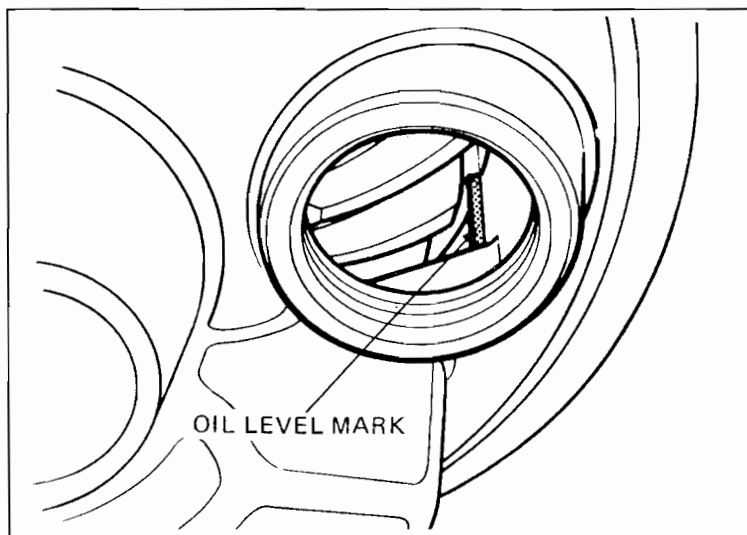

## CONTROL CABLE LUBRICATION

Periodically, disconnect the throttle cables at their upper ends. Thoroughly lubricate the cables and their pivot points with a commercially available cable lubricant or a light weight oil.





**LUBRICATION POINTS**

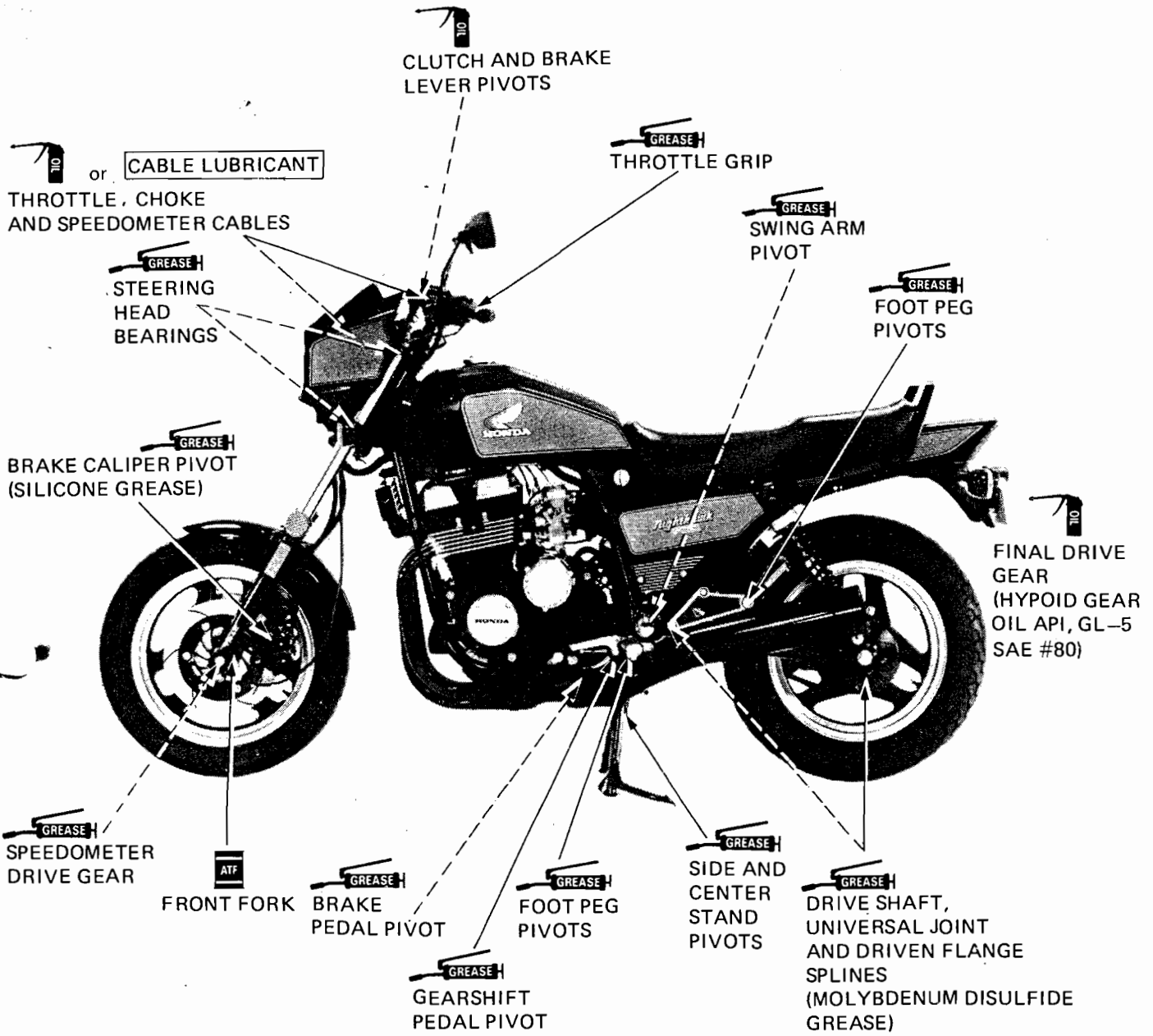



SERVICE INFORMATION	3-1	CYLINDER COMPRESSION	3-10
MAINTENANCE SCHEDULE	3-3	< CHASSIS >	
< ENGINE >		BATTERY	3-10
FUEL LINES	3-4	BRAKE FLUID	3-11
FUEL STRAINER	3-4	BRAKE SHOE/PAD WEAR	3-11
THROTTLE OPERATION	3-5	BRAKE SYSTEM	3-11
CARBURETOR CHOKE	3-6	BRAKE LIGHT SWITCH	3-13
AIR CLEANER	3-6	HEADLIGHT AIM	3-13
CRANKCASE BREATHER	3-7	CLUTCH	3-14
SPARK PLUGS	3-7	SIDE STAND	3-14
CARBURETOR SYNCHRONIZATION	3-8	SUSPENSION	3-14
CARBURETOR IDLE SPEED	3-9	NUTS, BOLTS, FASTENERS	3-16
IGNITION TIMING	3-9	WHEELS	3-16
EVAPORATIVE EMISSION CONTROL SYSTEM	3-9	STEERING HEAD BEARINGS	3-16

## SERVICE INFORMATION

### GENERAL

Engine oil See page 2-3  
 Engine oil filter See page 2-3  
 Final drive oil See page 2-13

**WARNING**

- Support the motorcycle on the center stand on a level surface before starting any work.
- When the engine must be running to do some work, make sure the area is well ventilated. Never run the engine in a closed area. The exhaust contains poisonous carbon monoxide gas.

### SPECIFICATIONS

< Engine >

Spark plugs:

Standard		For cold climate (below 5°C, 41°F)		For extended high speed riding	
NGK	ND	NGK	ND	NGK	ND
DPR8EA-9	X24EPR-U9	DPR7EA-9	X22EPR-U9	DPR9EA-9	X27EPR-U9

Spark plug gap: 0.8–0.9 mm (0.031–0.035 in)

Ignition timing

At idle: 10° BTDC  
 Full advance: 32° BTDC at 3,150 ± 250 rpm

Idle speed: 1,000 ± 100 rpm

Carburetor synchronization: All carburetors within 50 mm (2.0 in) Hg of each other

Cylinder compression: 1200 ± 200 kPa (12.0 ± 2.0 kg/cm<sup>2</sup>, 170 ± 28 psi)

Throttle grip free play: 2–6 mm (1/8–1/4 in)

Choke valve stroke: 5–7 mm (3/16–1/4 in)



CHASSIS >

Rear brake pedal free play: 20–30 mm (3/4 – 1-1/4 in)

Tire:

Tire size		Front	Rear
			110/90–16 59H
Cold tire pressure kPa (kg/cm <sup>2</sup> , psi)	UP to 90 kg (200 lbs) load	225 (2.25, 32)	225 (2.25, 32)
	90 kg (200 lbs) load to vehicle capacity load	225 (2.25, 32)	280 (2.80, 40)
Tire brand	Dunlop	K527A	K627
	Bridgestone	G511	G508

Suspension air pressure: Front 0–40 kPa (0 – 0.4 kg/cm<sup>2</sup>, 0 – 6 psi)

TOOLS

**Special**

- |                              |   |
|------------------------------|---|
| Vacuum gauge set             | 07404–0030100 or 07404–0020000 or M937B–021–XXXXX (U.S.A. only) |
| Vacuum gauge adaptor A       | 07510–3000100   |
| B                            | 07510–3000200   |
| Jeturetor pilot screw wrench | 07908–4220201   |
| Compression gauge attachment | 07510–MB00101—equivalent commercially available in U.S.A.       |



### MAINTENANCE SCHEDULE

Perform the PRE-RIDE INSPECTION in the Owner's Manual at each scheduled maintenance period.

I: INSPECT AND CLEAN, ADJUST, LUBRICATE, OR REPLACE IF NECESSARY.

C: CLEAN, R: REPLACE, A: ADJUST

ITEM	FREQUENCY	WHICHEVER COMES FIRST ↓	ODOMETER READING (NOTE 4)								
			EVERY	1,000 km (600 mi)	6,400 km (4,000 mi)	12,800 km (8,000 mi)	19,200 km (12,000 mi)	25,600 km (16,000 mi)	32,000 km (20,000 mi)	38,400 km (24,000 mi)	Refer to page
EMISSION RELATED ITEMS	* FUEL LINES			I	I	I	I	I	I	I	3-4
	* FUEL STRAINER		C	C	C	C	C	C	C	C	3-4
	* THROTTLE OPERATION		I	I	I	I	I	I	I	I	3-5
	* CARBURETOR CHOKE			I	I	I	I	I	I	I	3-6
	AIR CLEANER	NOTE 1			R		R		R		3-6
	CRANKCASE BREATHER	NOTE 2		C	C	C	C	C	C	C	3-7
	SPARK PLUGS			R	R	R	R	R	R	R	3-8
	ENGINE OIL	YEAR		R	R	R	R	R	R	R	2-3
	ENGINE OIL FILTER	YEAR		R	R	R	R	R	R	R	2-3
	* CARBURETOR SYNCHRONIZATION			I	I	I	I	I	I	I	3-8
	* CARBURETOR IDLE SPEED			I	I	I	I	I	I	I	3-9
* EVAPORATIVE EMISSION CONTROL SYSTEM	NOTE 3				I		I		I	3-10	
NON-EMISSION RELATED ITEMS	FINAL DRIVE OIL				I		I			R	2-14
	BATTERY	MONTH		I	I	I	I	I	I	I	3-12
	BRAKE FLUID (FRONT)	MONTH I 2 YEARS*R		I	I	I	I	I	I	*R	3-13
	BRAKE PAD/SHOE WEAR			I	I	I	I	I	I	I	3-13
	BRAKE SYSTEM			I	I	I	I	I	I	I	3-13
	BRAKE LIGHT SWITCH			I	I	I	I	I	I	I	3-15
	HEADLIGHT AIM			I	I	I	I	I	I	I	3-15
	CLUTCH FLUID	MONTH I 2 YEARS*R		I	I	I	I	I	I	*R	3-16
	CLUTCH SYSTEM			I	I	I	I	I	I	I	3-16
	SIDE STAND				I	I	I	I	I	I	3-16
	* SUSPENSION			I	I	I	I	I	I	I	3-16
	* NUTS, BOLTS, FASTENERS			I	I	I	I	I	I	I	3-18
	** WHEELS			I	I	I	I	I	I	I	3-18
** STEERING HEAD BEARINGS			I		I		I		I	3-18	

\* SHOULD BE SERVICED BY AN AUTHORIZED HONDA DEALER, UNLESS THE OWNER HAS PROPER TOOLS AND SERVICE DATA AND IS MECHANICALLY QUALIFIED.

\*\* IN THE INTEREST OF SAFETY, WE RECOMMEND THESE ITEMS BE SERVICED ONLY BY AN AUTHORIZED HONDA DEALER.

NOTES: 1. SERVICE MORE FREQUENTLY WHEN RIDING IN DUSTY AREAS.

2. SERVICE MORE FREQUENTLY WHEN RIDING IN RAIN OR AT FULL THROTTLE.

3. CALIFORNIA TYPE ONLY.

4. FOR HIGHER ODOMETER READINGS, REPEAT AT THE FREQUENCY INTERVAL ESTABLISHED HERE.



## FUEL LINES

Remove the fuel valve cover.  
Check the fuel lines for deterioration, damage, or leakage.

Replace if necessary.

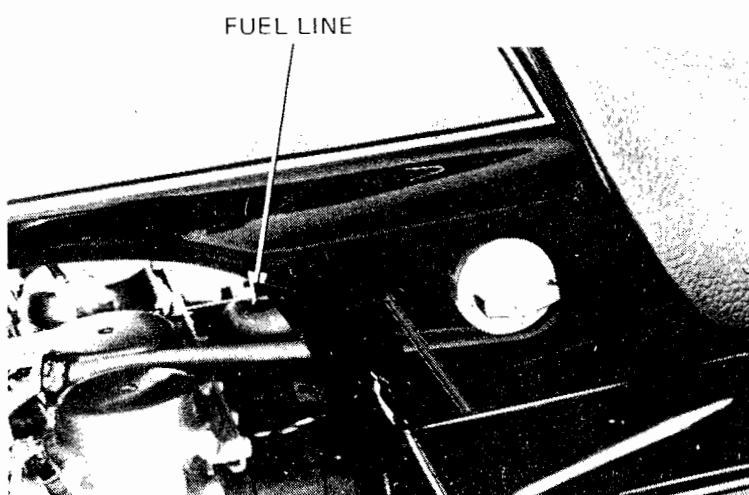

## FUEL STRAINER

Turn the fuel valve OFF and remove the fuel tank (Page 4-16).

Remove the fuel cup and empty the gasoline into a suitable container. Remove the O-ring and strainer.

**WARNING**

*Gasoline is flammable and is explosive under certain conditions. Do not smoke or allow flames or sparks near the equipment while draining fuel.*

Wash the cup and filter screen in clean nonflammable or high flash point solvent.

Reinstall the screen, aligning the index marks on the fuel valve body and filter screen. Install a new O-ring into the fuel valve body. Reinstall the fuel cup, making sure the new O-ring is in place. Hand tighten the fuel cup and torque to specification.

**TORQUE:** 3–5 N·m  
(0.3–0.5 kg·m, 2–4 ft·lb)

After installing and refilling the tank, turn the fuel valve ON and check that there are no leaks.

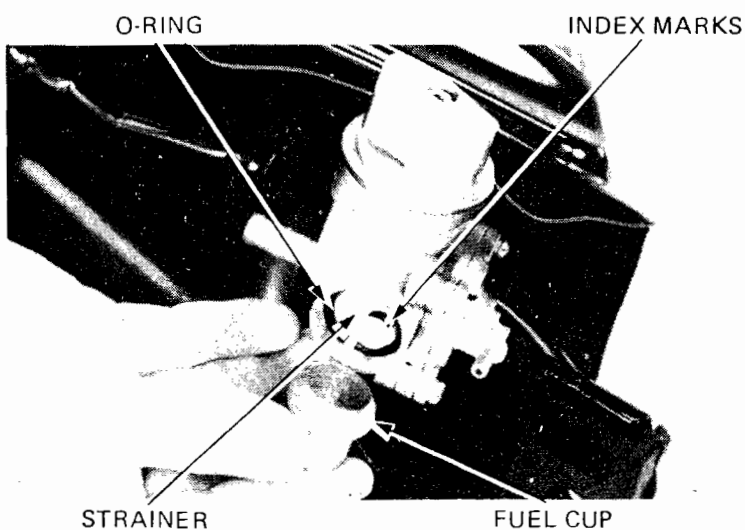
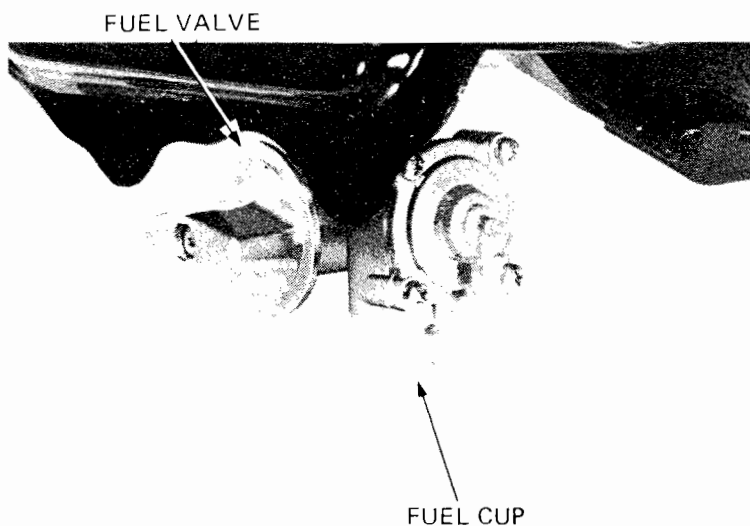



## THROTTLE OPERATION

Check for smooth throttle grip full opening and automatic full closing in all steering positions.

Make sure there is no deterioration, damage, or kinking in the throttle cables. Replace any damaged parts.

Lubricate the throttle cables (Page 2-13); if throttle operation is not smooth.

Measure throttle grip free play at the throttle grip flange.

**FREE PLAY: 2–6 mm (1/8–1/4 in)**

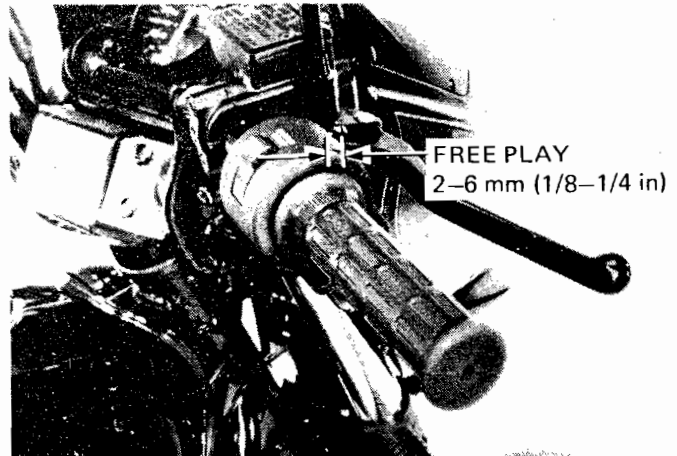

Throttle grip free play can be adjusted at either end of the throttle cable. Minor adjustments are made with the upper adjuster.

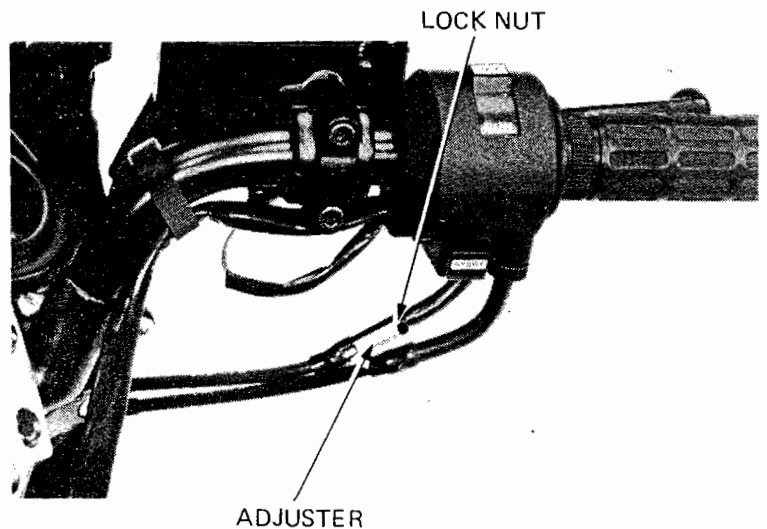

Major adjustments are made with the lower adjuster.

Adjust free play by loosening the lock nut and turning the adjuster. Tighten the lock nut.

Recheck throttle operation in all steering positions.

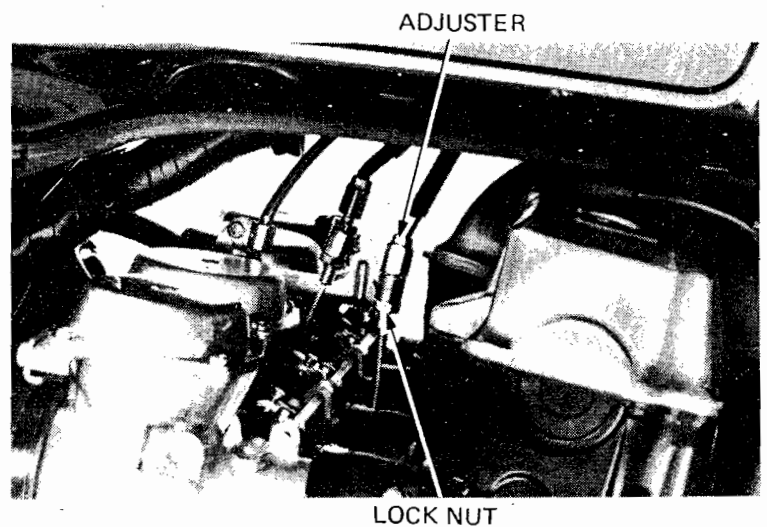



## CARBURETOR CHOKE

The CB700SC choke system uses a fuel enrichening circuit controlled by a bystarter valve. The bystarter valve opens the enrichening circuit via a cable when the choke lever on the handlebar is pulled down.

Check for smooth upper choke lever operation. Lubricate the choke cable if the operation is not smooth.

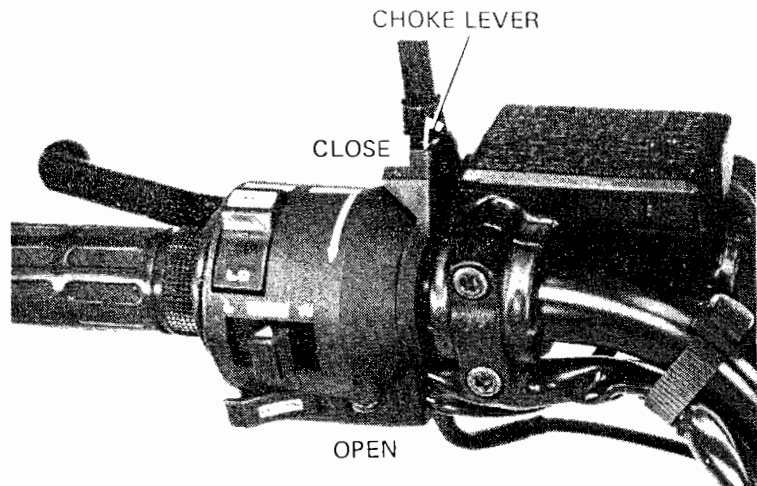

Pull the choke lever on the handlebar all the way back to the fully open position and measure the choke valve stroke at the No. 3 carburetor between the fully closed and fully open positions.

**CHOKE VALVE STROKE: 5–7 mm (3/16–1/4 in)**

just if necessary by loosening the choke cable clamp on the carburetor and moving the cable casing. Recheck the choke valve stroke.

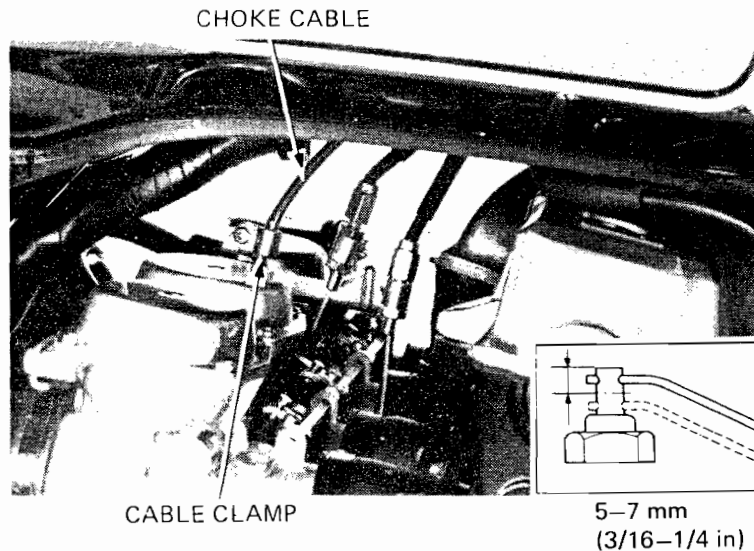

## AIR CLEANER

Remove the seat.  
Remove the four air cleaner cover screws and the cover.

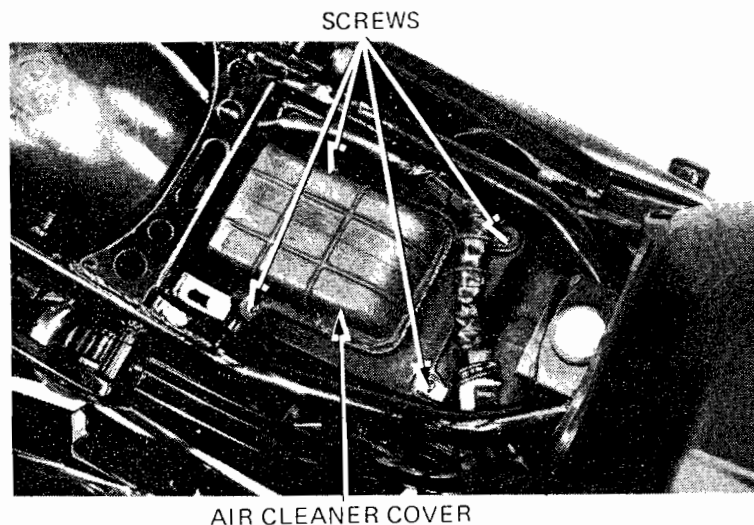



Remove and discard the air cleaner element.  
Install a new element, the air cleaner cover and seat.

ELEMENT

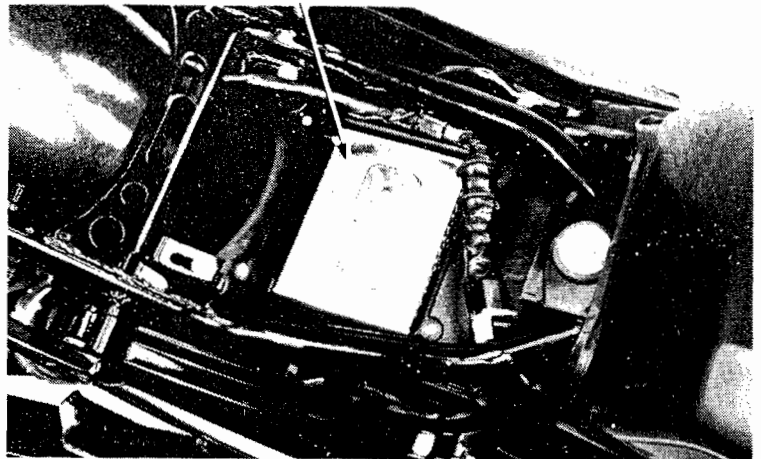

### CRANKCASE BREATHER

Remove the plug from the drain tube to empty any deposits.

Install the drain plug.

#### NOTE

Service more frequently when riding in rain or at full throttle, or if the deposit level can be seen in the transparent section of the drain tube.

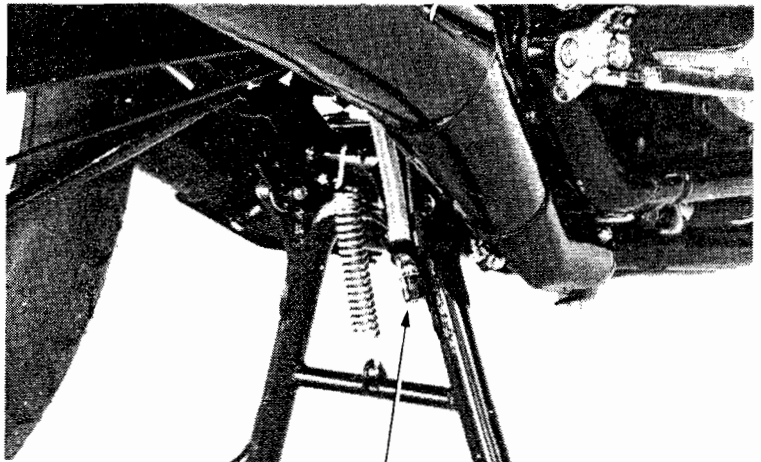

DRAIN PLUG

### SPARK PLUGS

#### RECOMMENDED SPARK PLUGS

	NGK	ND
Standard	DPR8EA-9	X24EPR-U9
For cold climate (Below 5°C, 41°F)	DPR7EA-9	X22EPR-U9
For extended high speed riding	DPR9EA-9	X27EPR-U9

Disconnect the spark plug caps and clean any dirt from around the spark plug bases.

Remove and discard the spark plugs.

Measure the new spark plug gaps using a wire-type feeler gauge.

**SPARK PLUG GAP: 0.8–0.9 mm (0.031–0.035 in)**

Adjust the spark plug gap by bending the side electrode carefully.

With the plug washer attached, thread each spark plug in by hand to prevent cross-threading. Tighten the spark plugs another 1/2 turn with a spark plug wrench to compress the plug washer. Connect the spark plug caps.

SIDE ELECTRODE

0.8–0.9 mm  
(0.031–0.035 in)

CENTER ELECTRODE

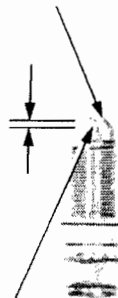





## CARBURETOR SYNCHRONIZATION

### NOTE

Synchronize the carburetors with the engine at normal operating temperature, transmission in neutral and motorcycle on the center stand.

Disconnect the fuel valve vacuum line at the No. 2 intake pipe.

Remove the plugs and vacuum line connector from the intake pipes and install the vacuum gauge adaptors.

Connect the vacuum gauges.

VACUUM LINE

ADAPTORS

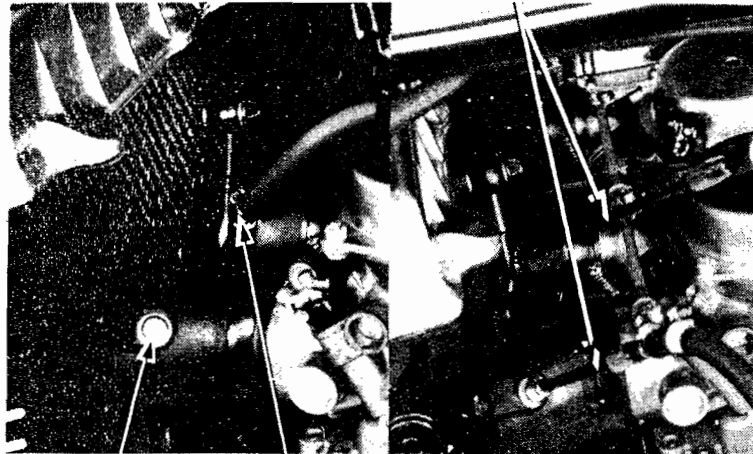

PLUG

CONNECTOR

Apply vacuum to the fuel valve vacuum line with a hand vacuum pump.

### NOTE

If a hand vacuum pump is not available, start the engine and pinch the vacuum line with a tube clamp before disconnecting the vacuum line.

VACUUM GAUGE 07404-0020000  
OR M937B-021-XXXXX (U.S.A. ONLY)

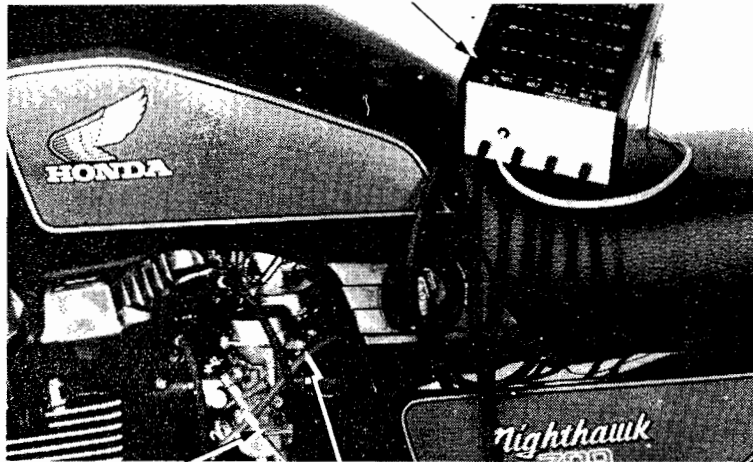

TUBE CLAMP

VACUUM LINE

Start and warm up the engine.

Adjust the idle speed with the throttle stop screw.

**IDLE SPEED: 1,000 ± 100 rpm**

Check that the differences in vacuum readings are 50 mm (2.0 in) Hg or less.

Adjust within specifications by turning the adjusting screws, if necessary.

The No. 2 carburetor cannot be adjusted. It is the base.

Recheck the idle speed and synchronization.

Stop the engine.

Disconnect the gauges and remove the gauge adaptors from the ports.

Install the removed parts in the reverse order of removal.

CARBURETOR PILOT SCREW WRENCH  
07908-4220201

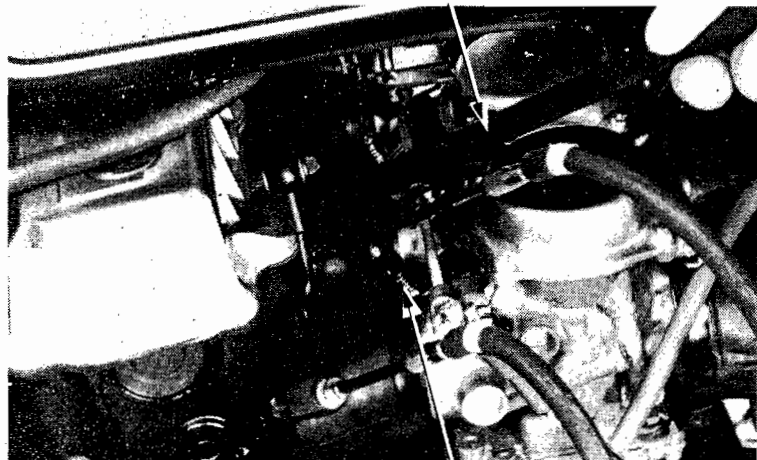

ADJUSTING SCREWS



### BRAKE FLUID

Check the front brake fluid reservoir level. If the level nears the lower level mark remove the cover and diaphragm. Fill the reservoir with DOT 3 or 4 Brake Fluid to the upper level mark located inside the reservoir.

Check the entire system for leaks, if the level is low.

#### CAUTION

- Be careful not to let dust or water enter the hydraulic system when filling the reservoir.
- Avoid spilling brake fluid on painted surfaces or instrument lenses, as severe damage can result.
- Do not remove the cover until the handlebar has been turned so that the reservoir is level.
- Do not mix different types of fluid, they are not compatible with each other.

Refer to section 16 for brake bleeding procedures.

### BRAKE SHOE/PAD WEAR

#### BRAKE PAD WEAR

Check the brake pads for wear by looking through the slot indicated by the arrow cast on the caliper assembly.

Replace the brake pads if the wear line on the pads reaches the edge of the brake disc (Page 16-5).

#### CAUTION

*Always replace the brake pads as a set to assure even disc pressure.*

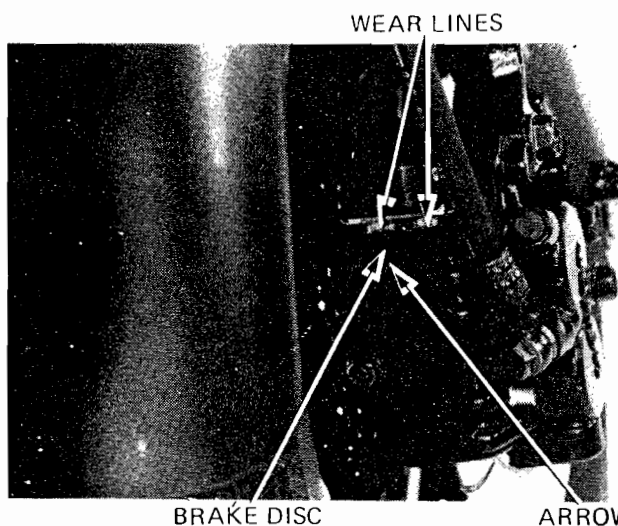
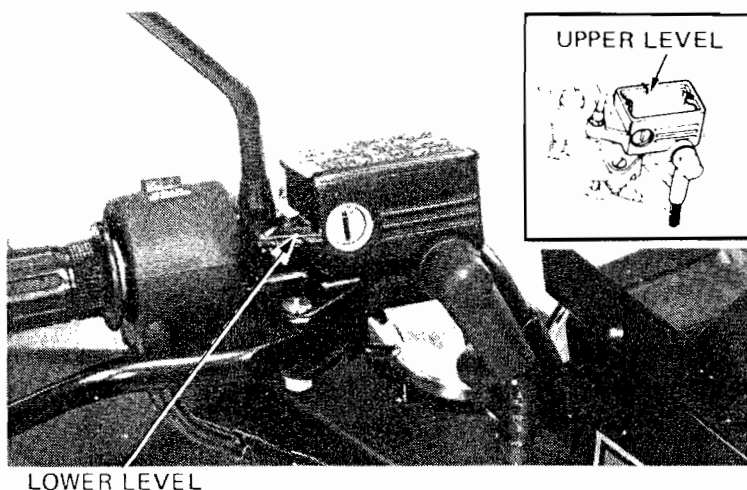

#### BRAKE SHOE INSPECTION

Replace the brake shoes if the arrow on the brake arm aligns with the reference mark "Δ" on full application of the rear brake pedal.

### BRAKE SYSTEM

Inspect the brake hoses and fittings for deterioration, cracks and signs of leakage. Tighten any loose fittings.

Replace hoses and fittings as required.

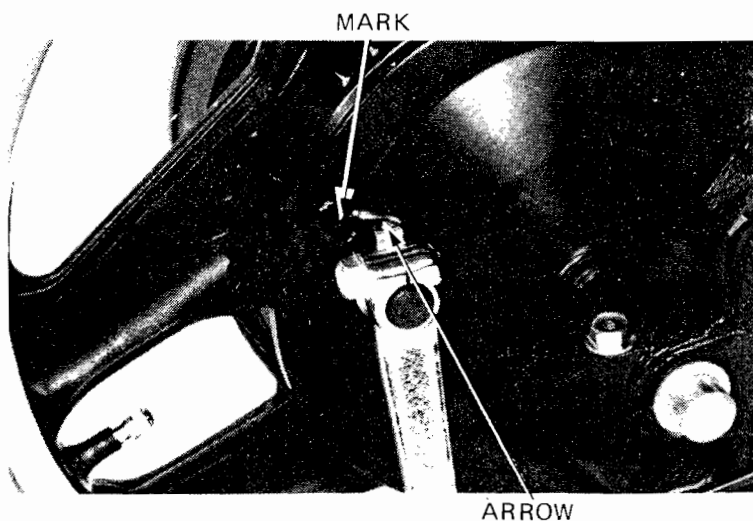



**MAINTENANCE**

**BRAKE PEDAL HEIGHT**

Adjust brake pedal height so the pedal is 7 mm (1/4 in) below the top of the foot peg.

**CAUTION**

*Incorrect brake pedal height can cause brake drag.*

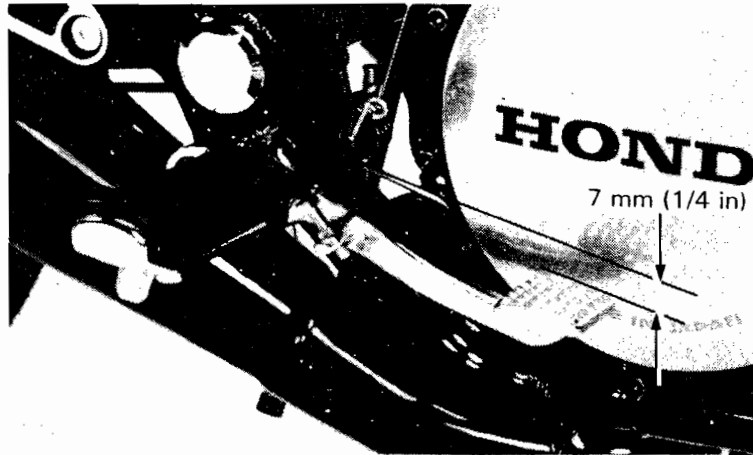

To Adjust:

Loosen the stopper bolt lock nut and turn the stopper bolt.

Retighten the lock nut.

**NOTE**

After adjusting the brake pedal height, check the rear brake light switch and brake pedal free play and adjust if necessary.

STOPPER BOLT

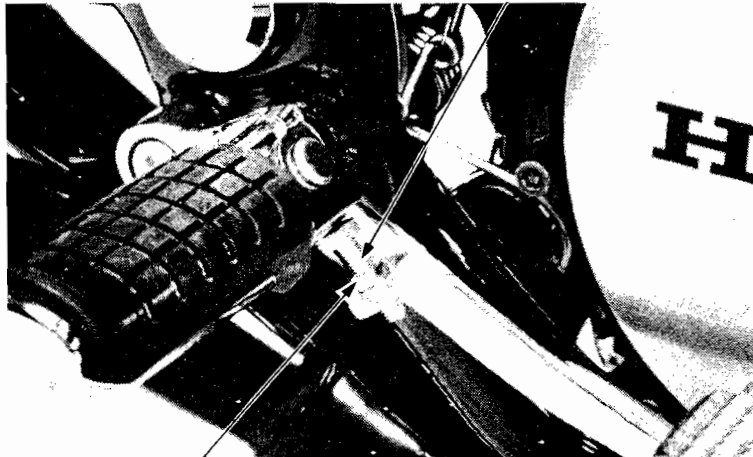

LOCK NUT

**BRAKE PEDAL FREE PLAY**

**NOTE**

Perform brake pedal free play adjustment after adjusting brake pedal height.

Check the brake pedal free play.

**FREE PLAY: 20–30 mm (3/4–1-1/4 in)**

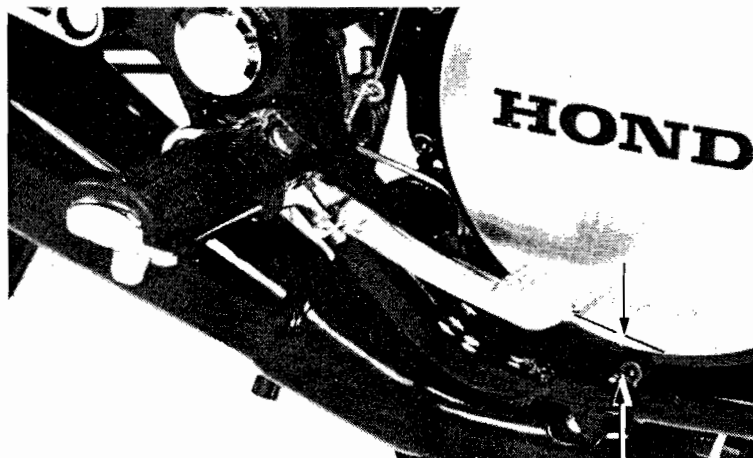

20–30 mm  
(3/4–1-1/4 in)



If adjustment is necessary, turn the rear brake adjusting nut.

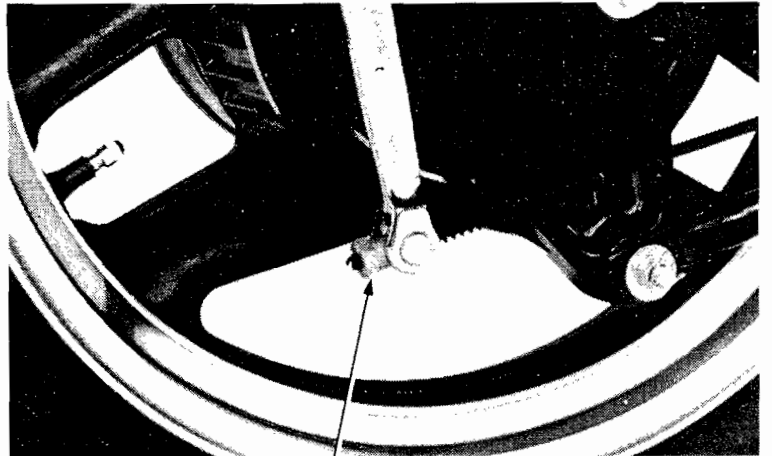

BRAKE ADJUSTING NUT

## BRAKE LIGHT SWITCH

### NOTE

- Perform rear brake light switch adjustment after adjusting the brake pedal free play and height.
- The front brake light switch does not require adjustment.

Adjust the brake light switch so that the brake light will come on when the brake pedal is depressed 20 mm (3/4 in), and brake engagement begins. Holding the switch body and turning the adjusting nut. Do not turn the switch body.

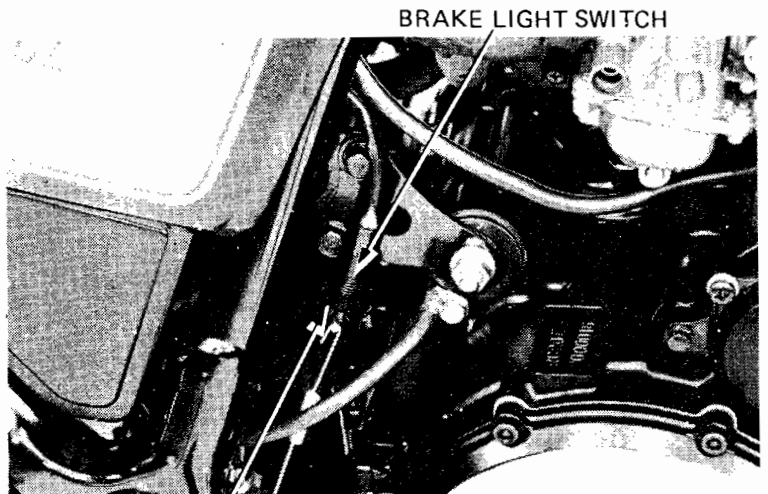

BRAKE LIGHT SWITCH

ADJUSTING NUT

## HEADLIGHT AIM

Remove the two headlight cover nuts and open the headlight cover.  
Adjust vertically by turning the vertical adjusting screw.  
Adjust horizontally by turning the horizontal adjusting screws.

### NOTE

Adjust the headlight beam as specified by local laws and regulations.

### WARNING

*An improperly adjusted headlight may blind oncoming drivers, or it may fail to light the road for a safe distance.*

HORIZONTAL ADJUSTING SCREWS

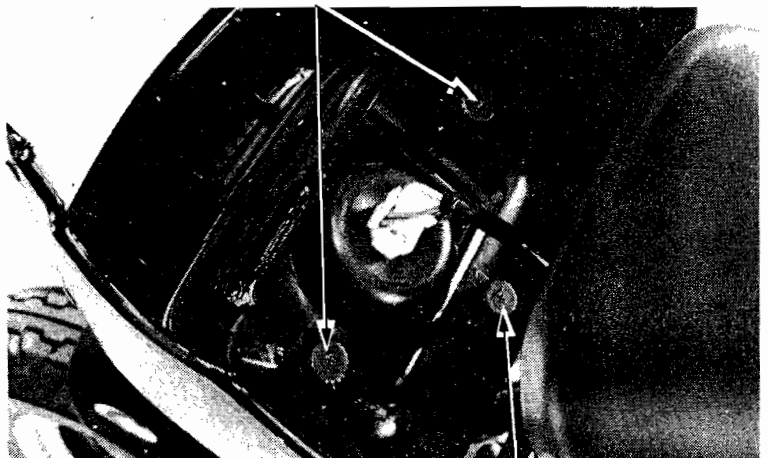

VERTICAL ADJUSTING SCREW



## CLUTCH

Check the clutch fluid level.

If the level is under the lower level mark, check the clutch system for leaks.

Remove the reservoir cap mount screws and cap. Fill the reservoir with DOT 3 or 4 Brake Fluid to the upper level mark inside the reservoir.

### CAUTION

- Be careful not to let dust or water enter the hydraulic system when filling the reservoir.
- Avoid spilling brake fluid on painted surfaces or instrument lenses, as severe damage can result.
- Do not remove the cover until the handlebar has been turned so that the reservoir is level.
- Do not mix different types of fluid, as they are not compatible with each other.

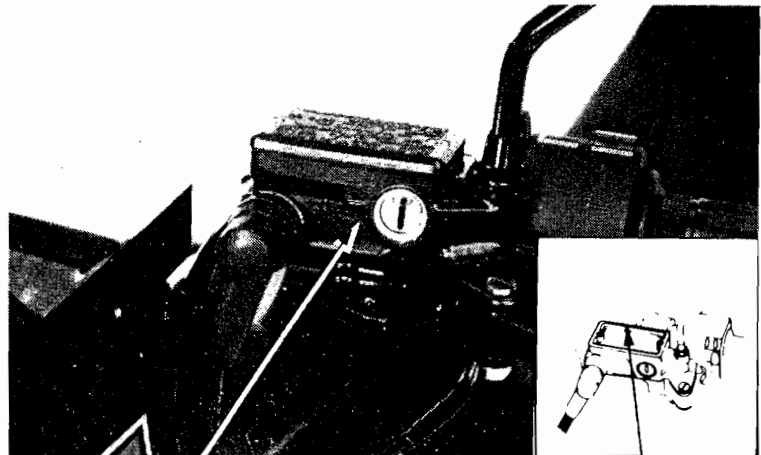

LOWER LEVEL MARK

UPPER LEVEL MARK

Refer to section 8 for clutch bleeding procedures.

## SIDE STAND

Check the rubber pad for deterioration or wear. Replace if any wear extends to wear line as shown.

Check the side stand spring for damage and loss of tension, and the side stand assembly for freedom of movement. Make sure the side stand is not bent.

### NOTE

- When replacing, use a rubber pad with the mark "Over 260 lbs ONLY".
- Spring tension is correct if the measurements fall within 2–3 kg (4.4–6.6 lb), when pulling the side stand lower end with a spring scale.

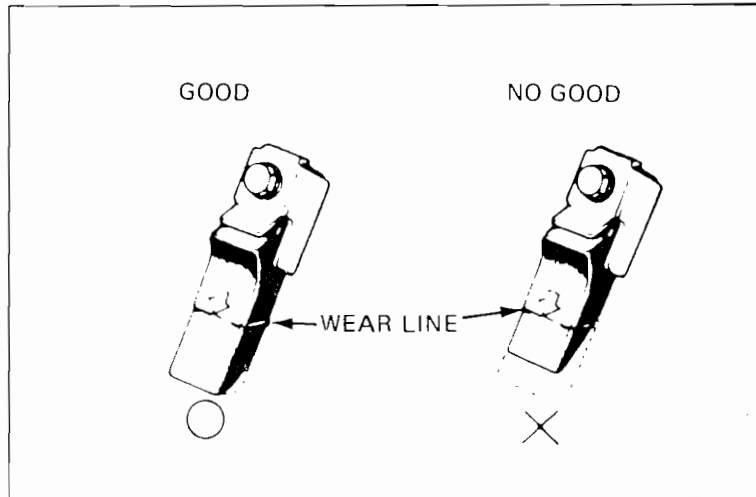

## SUSPENSION

### WARNING

*Do not ride a vehicle with faulty suspension. Loose, worn or damaged suspension parts impair vehicle stability and control.*

### FRONT

Check the action of the front forks by compressing them several times.

Check the entire fork assembly for leaks or damage. Replace damaged components which cannot be repaired.

Tighten all nuts and bolts.

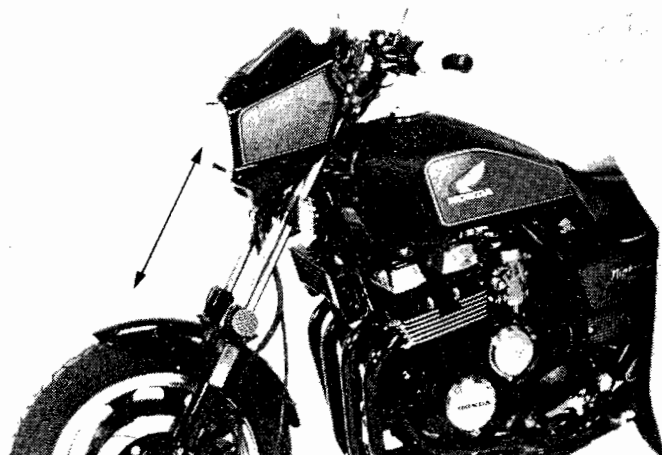



Check the front fork air pressure when the forks are cold.

Place the vehicle on its center stand.

Remove each air valve cap and measure the air pressure.

**AIR PRESSURE:**

0-6 psi (0-40 kPa, 0-0.4 kg/cm<sup>2</sup> )

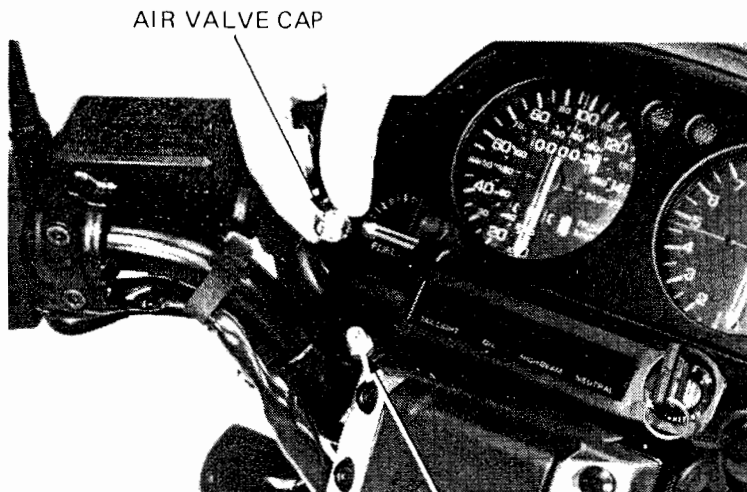

AIR VALVE CAP

AIR VALVE

**ANTI-DIVE SYSTEM INSPECTION**

Check the operation of the anti-dive system in all positions by riding the motorcycle and firmly applying the brakes.

Position	Anti-dive damper force
1	LIGHT ANTI-DIVE
2	MEDIUM
3	HARD
4	MAXIMUM ANTI-DIVE

Inspect and if necessary, repair the system (Refer to section 14).

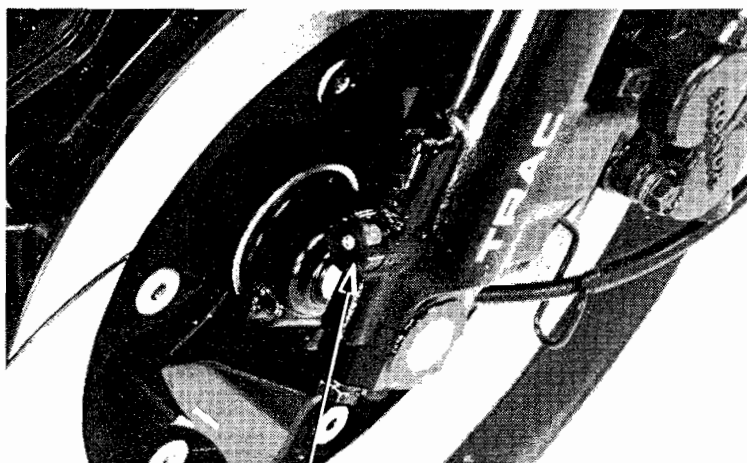

ADJUSTER

**REAR**

Place the motorcycle on its center stand.

Move the rear wheel sideways with force to see if the swing arm bearings are worn. Replace if excessively worn.

Check the shock absorbers for leaks or damage.

Tighten all rear suspension nuts and bolts.

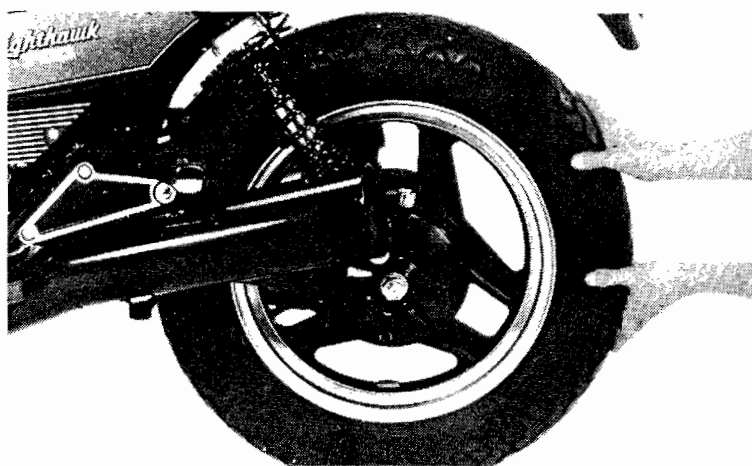



## NUTS, BOLTS, FASTENERS

Check that all chassis nuts and bolts are tightened to correct torque values (page 1-5).

Check that all cotter pins, safety clips, hose clamps and cable stays are in place.

## WHEELS

### TIRE PRESSURE

NOTE

Tire pressure should be checked when tires are COLD.

Check the tires for cuts, imbedded nails, or other sharp objects.

Recommended tire pressures and tire sizes:

		Front	Rear
Tire size		110/90-16 59H	130/90-16 67H
Cold tire pressure kPa (kg/cm <sup>2</sup> )	Up to 90 kg (200 lbs) load	225 (2.25, 32)	225 (2.25, 32)
	90 kg (200 lbs) load to vehicle capacity load	225 (2.25, 32)	280 (2.8, 40)
Tire brand	BRIDGE-STONE	G511	G508
	DUNLOP	K527A	K627

Check the front and rear wheels for trueness (Refer to section 14, 15).

Measure the tread depth at the center of the tires. Replace the tires if the tread depth reaches the following limit:

Minimum tread depth:

- Front: 1.5 mm (1/16 in)
- Rear: 2.0 mm (3/32 in)

## STEERING HEAD BEARINGS

NOTE

Check that the control cables do not interfere with handlebar rotation.

Raise the front wheel off the ground.

Check that the handlebar moves freely from side to side. If the handlebar moves unevenly, binds, or has abnormal movement, inspect the steering head bearings (Section 14).

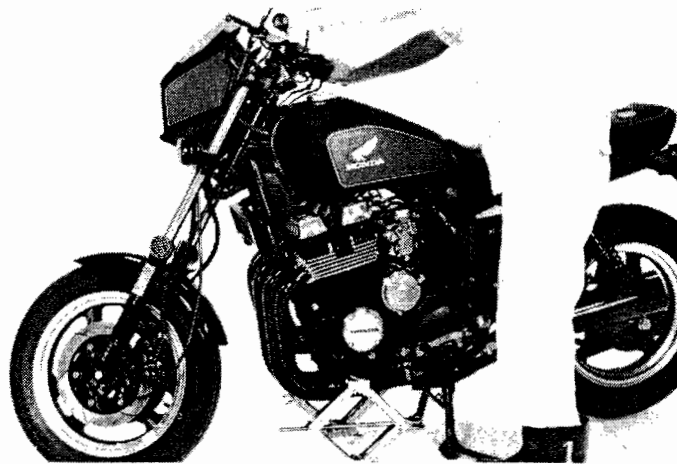
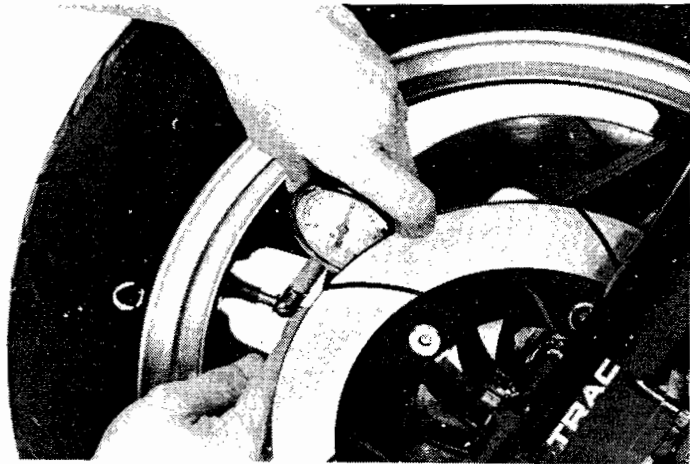



**HONDA**  
**CB750SC**

---

MEMO



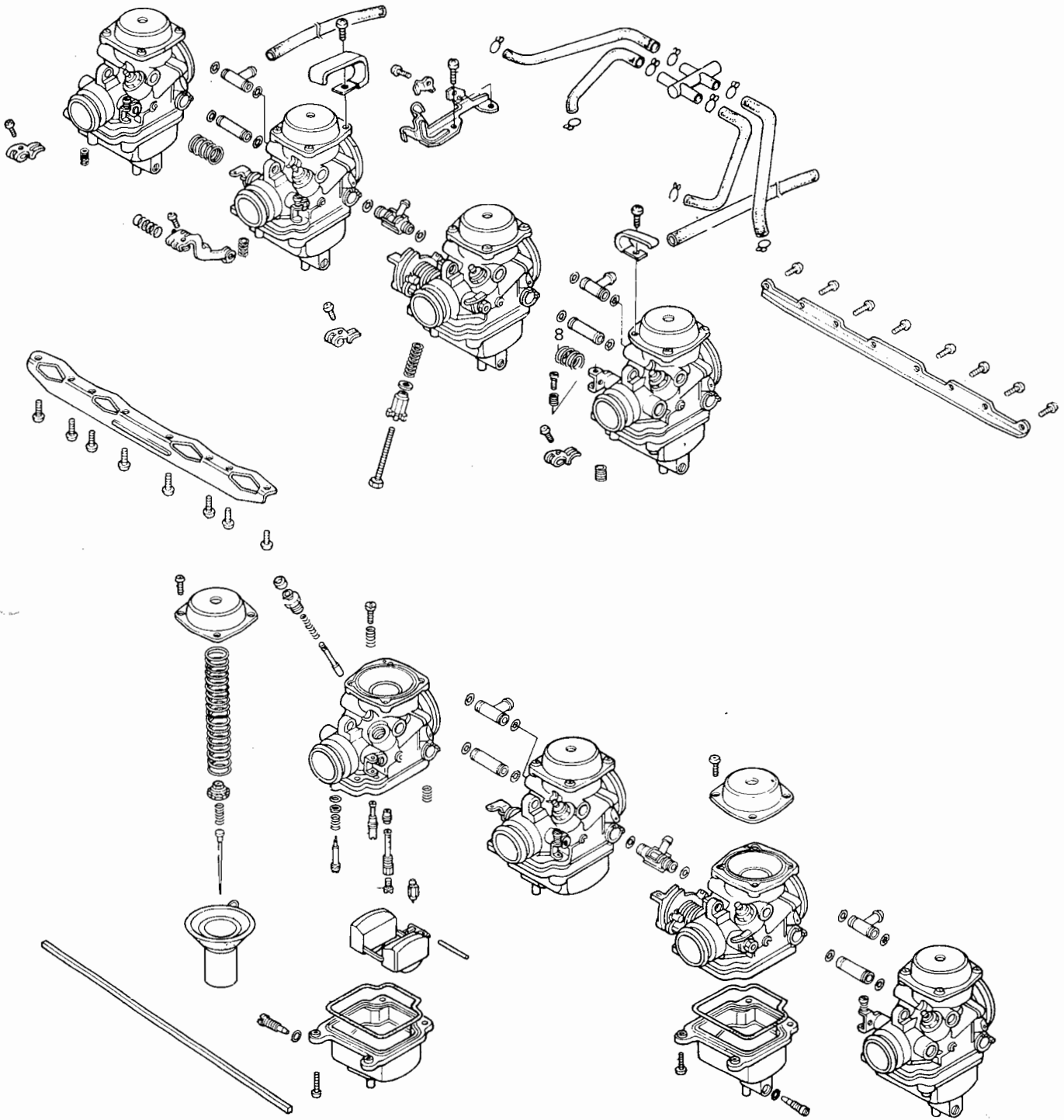



SERVICE INFORMATION	4-1	PILOT SCREW REMOVAL/ INSTALLATION	4-13
TROUBLESHOOTING	4-2	PILOT SCREW ADJUSTMENT	4-14
CARBURETOR REMOVAL	4-3	LIMITER CAP INSTALLATION	4-14
VACUUM CHAMBER	4-4	HIGH ALTITUDE ADJUSTMENT	4-15
FLOAT CHAMBER	4-6	FUEL TANK	4-16
CHOKE (BYSTARTER) VALVE	4-7	AIR CLEANER CASE	4-18
CARBURETOR SEPARATION	4-9	PURGE CONTROL VALVE INSPECTION	4-20
CARBURETOR ASSEMBLY	4-11		
CARBURETOR INSTALLATION	4-12		

## SERVICE INFORMATION

### GENERAL

**WARNING**

*Gasoline is extremely flammable and is explosive under certain conditions. Work in a well ventilated area. Do not smoke or allow flames or sparks in the work area.*

- When disassembling fuel system parts, note the locations of the O-rings. Replace them during assembly.
- The float bowls have drain plugs that can be loosened to drain residual gasoline.

### SPECIFICATIONS

ITEM	
Throttle bore	34 mm (1.34 in)
Venturi dia.	Primary: 10.1 mm (0.40 in) Secondary: 30.8 mm (1.21 in)
Identification mark	VE65A, California type: VE77A
Float level	18.5 mm (0.73 in)
Main jet	#115
Slow jet	#35
Idle speed	1,000 ± 100 rpm
Throttle grip free play	2-6 mm (0.08-0.24 in)
Fast idle	2,500 ± 500 rpm
Pilot screw opening	See page 4-13

### TOOLS

**Special**

Carburetor pilot screw wrench 07908-4220201

**Common**

Float gauge 07401-0010000



## DOUBLESHOOTING

### Engine cranks but won't start

1. No fuel in tank
2. No fuel to carburetor
3. Engine flooded with fuel
4. No spark at plug (ignition malfunction)
5. Air cleaner clogged
6. Intake air leak
7. Improper choke operation
8. Improper throttle operation

### Hard starting or stalling after starting

1. Improper choke operation
2. Ignition malfunction
3. Fast idle speed incorrect
4. Carburetor malfunction
5. Fuel contaminated
6. Intake air leak
7. Idle speed incorrect

### Rough idle

1. Ignition malfunction
2. Idle speed incorrect
3. Incorrect carburetor synchronization
4. Carburetor malfunction
5. Fuel contaminated

### Stalling during acceleration

1. Ignition malfunction

### Backfiring

1. Ignition malfunction
2. Carburetor malfunction

### Poor performance (driveability) and poor fuel economy

1. Fuel system clogged
2. Ignition malfunction

### Lean mixture

1. Clogged fuel jets
2. Piston stuck closed
3. Faulty float valve
4. Float level low
5. Fuel cap vent blocked
6. Fuel strainer screen clogged
7. Restricted fuel line
8. Air vent tube clogged
9. Intake air leak

### Rich mixture

1. Clogged air jets
2. Faulty float valve
3. Float level too high
4. Choke stuck closed
5. Dirty air cleaner



### CARBURETOR REMOVAL

Remove the seat, both frame side covers and fuel tank (Page 4-16).  
Loosen the air cleaner connecting tube and carburetor intake pipe bands.

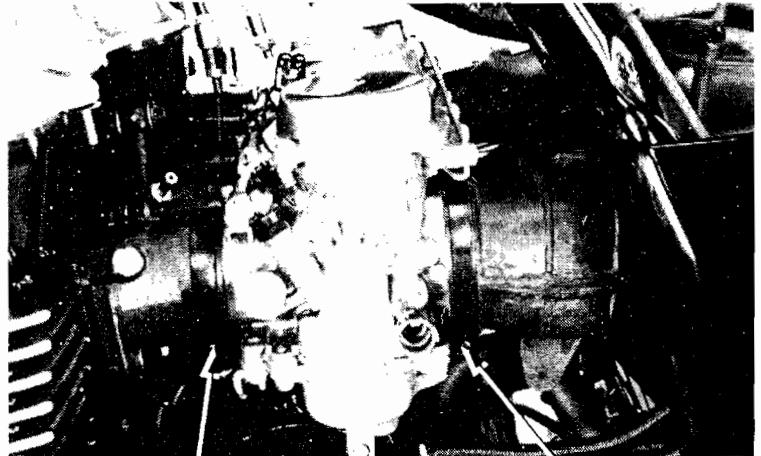

INTAKE PIPE BAND

CONNECTING TUBE BAND

Disconnect the couplers and remove the regulator/rectifier and tool box by removing the bolts.

Remove the left air cleaner case mounting bolt.

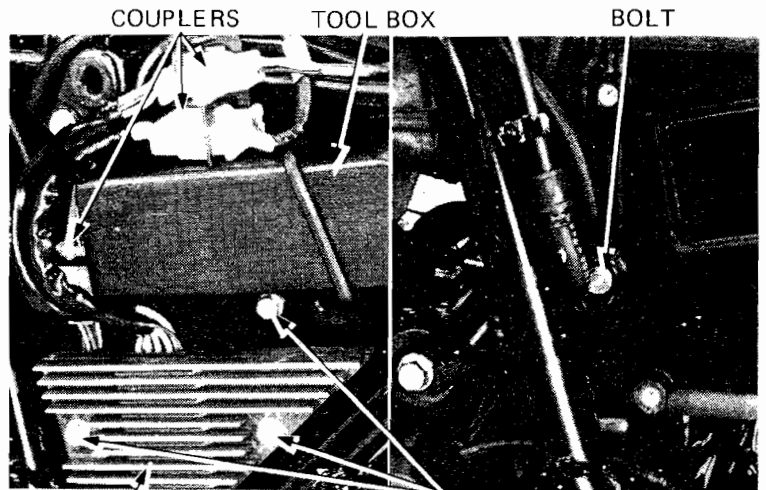

COUPLERS

TOOL BOX

BOLT

REGULATOR/RECTIFIER

BOLTS

Remove the front and lower battery holder bolts. Loosen the air cleaner case upper mounting bolts and move the air cleaner case to the rear.

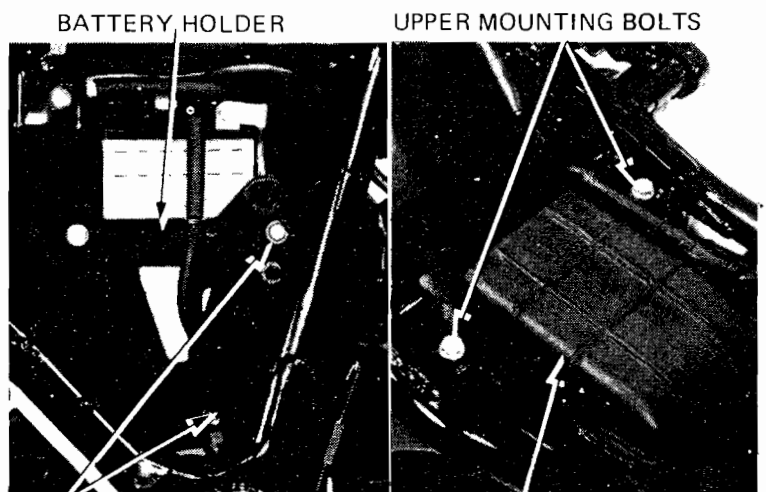

BATTERY HOLDER

UPPER MOUNTING BOLTS

BOLTS

AIR CLEANER CASE



Remove the carburetor assembly from the left side and disconnect the throttle and choke cables.

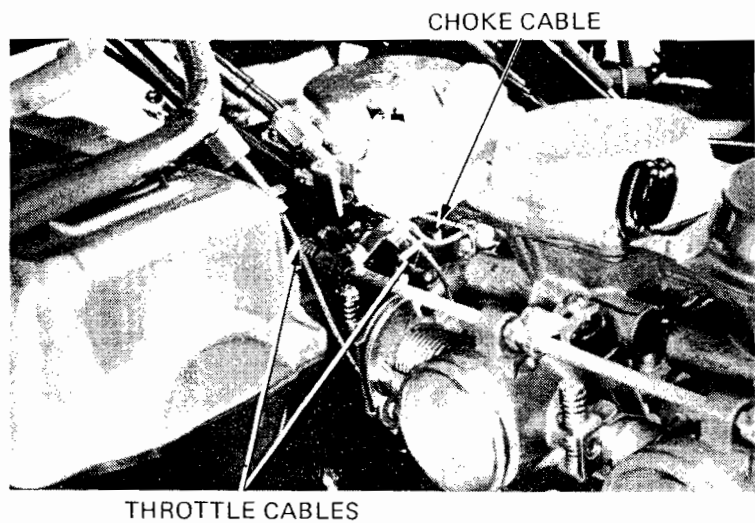

## VACUUM CHAMBER

### REMOVAL

Remove the four vacuum chamber cover screws and cover.

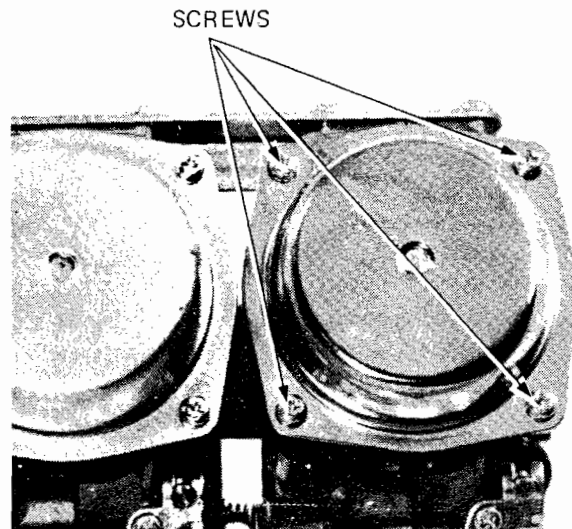

Remove the compression spring, diaphragm and vacuum piston.

Inspect the vacuum piston for wear, nicks, scratches or other damage. Make sure the piston moves up and down freely in the chamber.

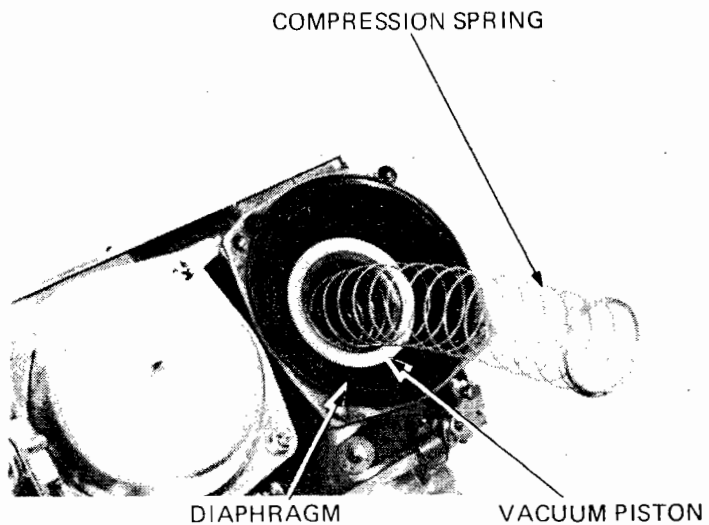



Push the needle holder in and turn it 60 degrees with an 8 mm socket. Then remove the needle holder, spring and needle from the piston.

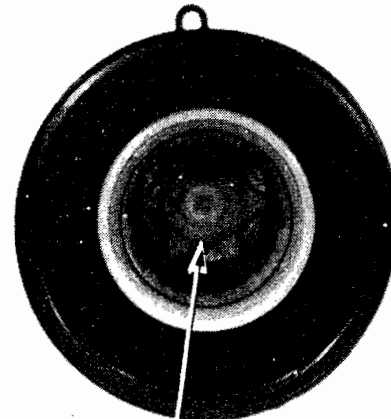

NEEDLE HOLDER

Inspect the needle for excessive wear at the tip and for bending, or other damage.

Check the diaphragm for deterioration and tears.

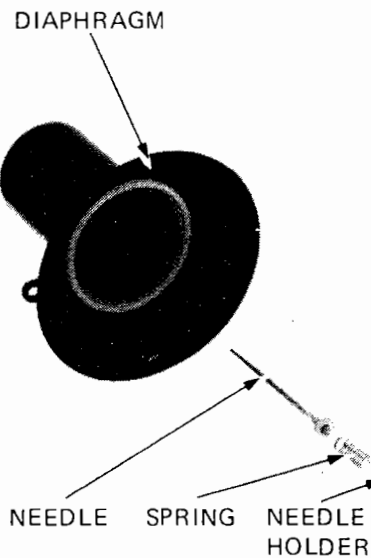

### INSTALLATION

Installation is essentially the reverse of removal. Install the chamber cover so that its cavity aligns with the hole in the diaphragm.

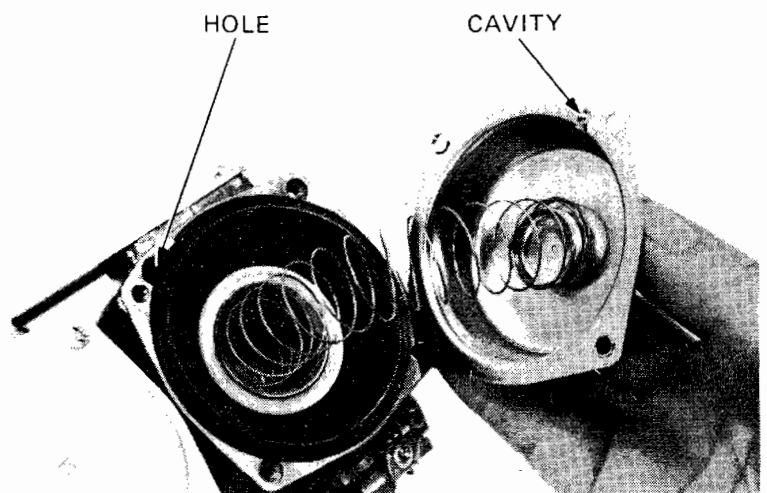



## FLOAT CHAMBER

### REMOVAL

Remove the four float chamber screws and the float chamber.

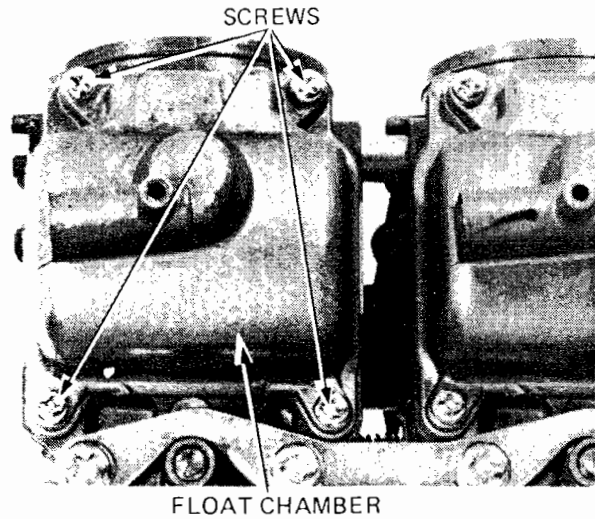

### FLOAT LEVEL

Measure the float level with the float tang just contacting the float valve.

**SPECIFICATIONS: 18.5 mm (0.61 in)**

Replace the float assembly, if it is not within specifications.

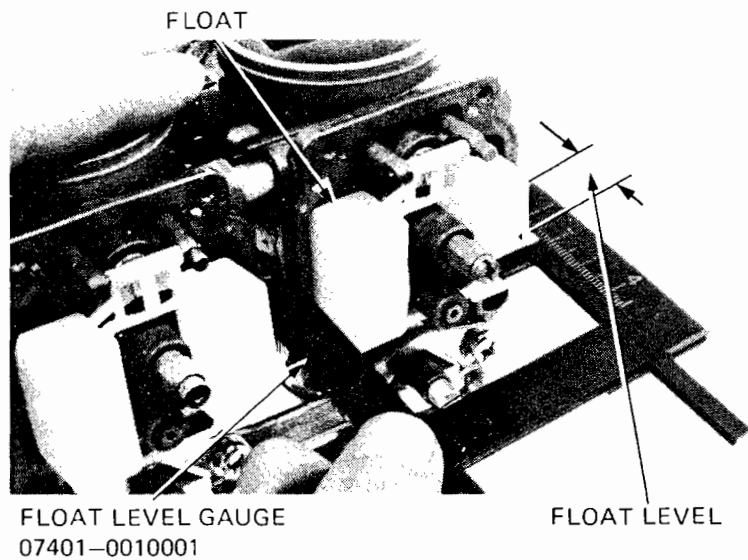

### FLOAT AND JETS

Remove the float pin, float and float valve.

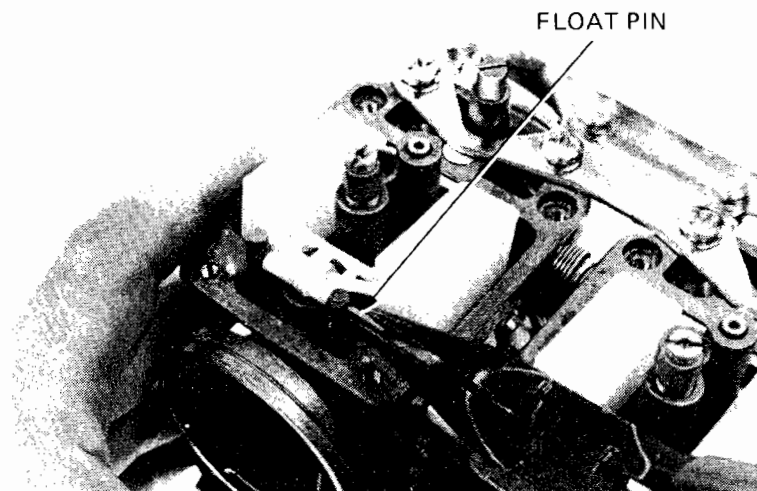



Inspect the float valve for grooves and nicks.

Inspect the operation of the float valve.

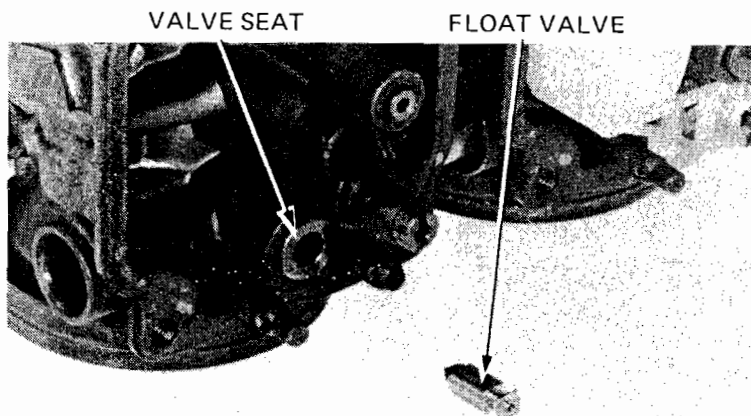

Remove the main jet, needle jet holder and slow jet.

**ASSEMBLY**

Assemble the float chamber components in the reverse order of disassembly.

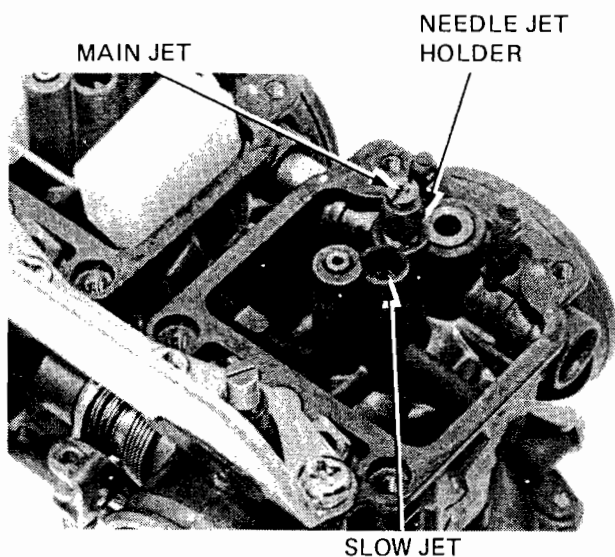

**CHOKE (BYSTARTER) VALVE**

**REMOVAL**

Unhook the choke (bystarter) relief spring.

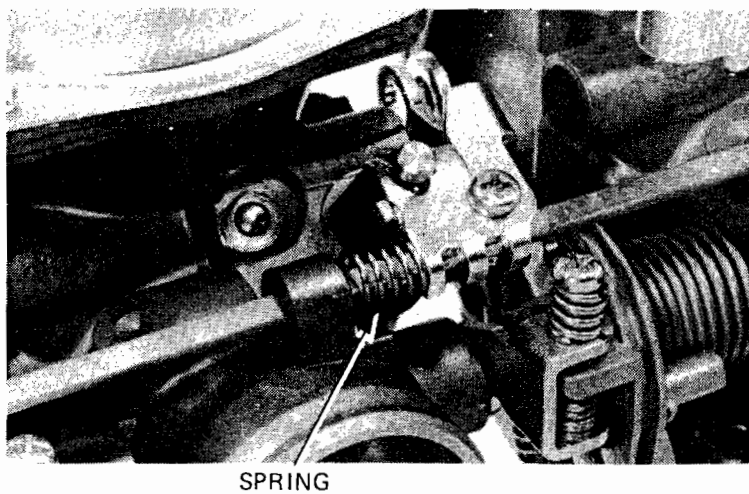



Loosen each choke (bystarter) arm locking screw.

Pull the choke shaft out and remove the choke arms.

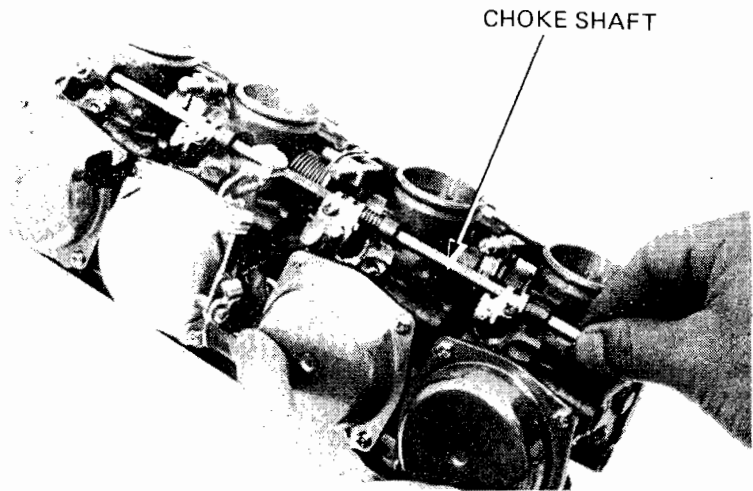

Loosen the choke (bystarter) valve nut and remove the valve assembly.

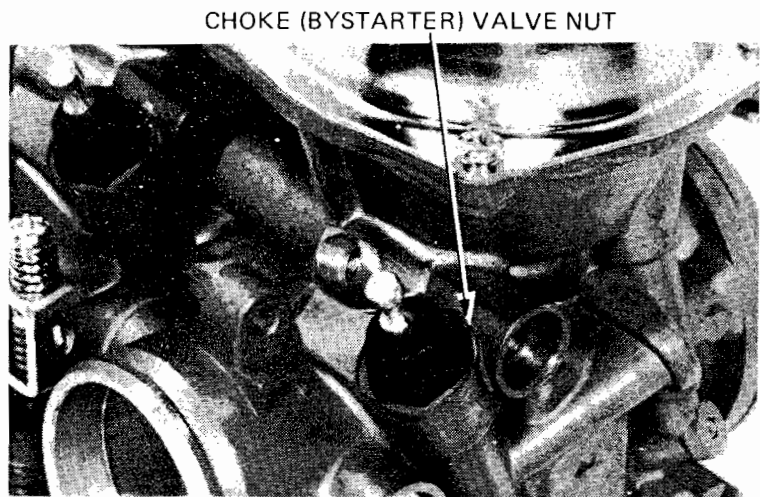

Check the choke (bystarter) valve and spring for nicks, grooves, or other damage.

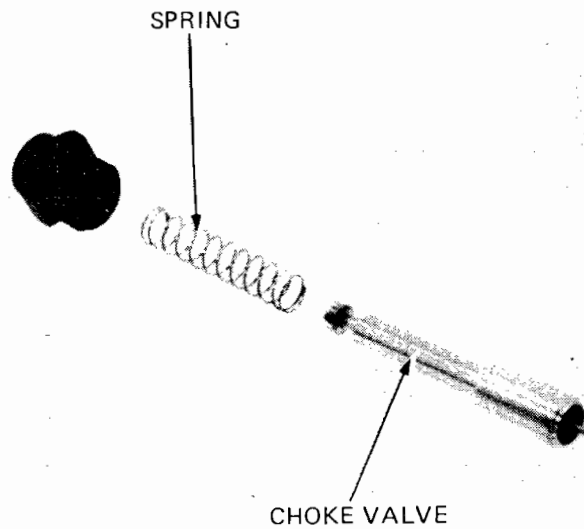



### INSTALLATION

Install the choke (bystarter) valve and linkage in the reverse order of removal.  
Make sure that the choke (bystarter) linkage operates smoothly by moving the choke lever.

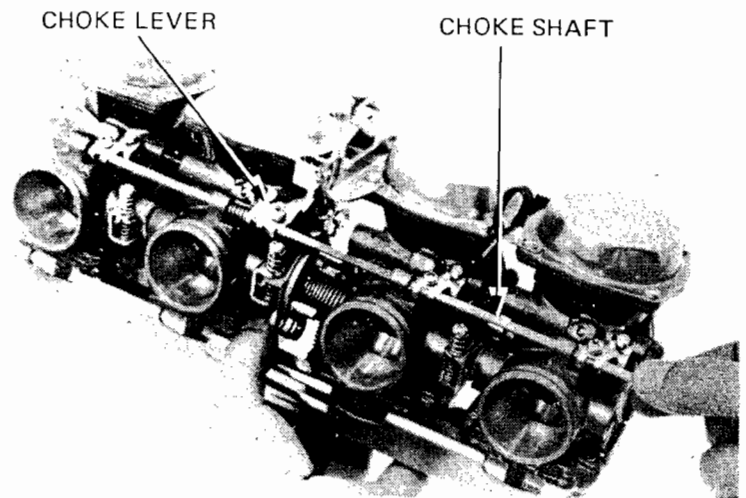

### CARBURETOR SEPARATION

Remove the choke (bystarter) shaft and arms (Page 4-7).

Loosen each carburetor's synchronization adjusting screw until there is no spring tension on it.

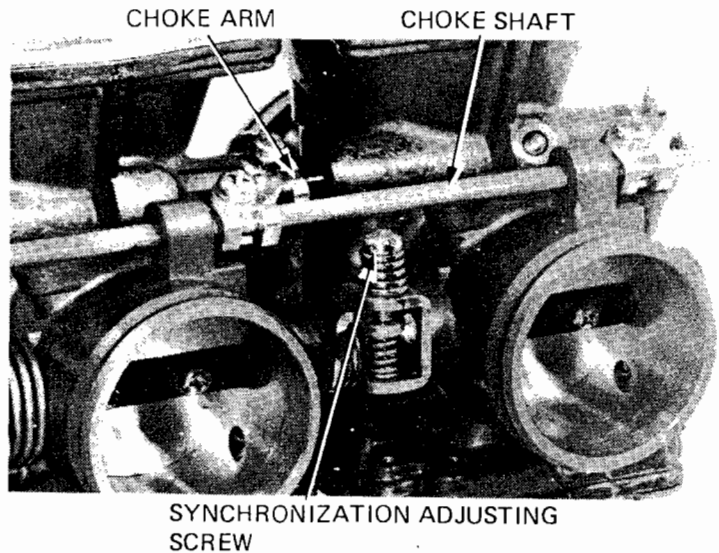

Remove the rear bracket.

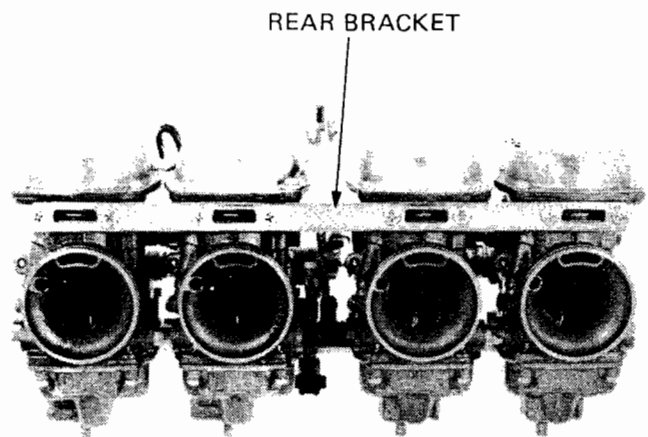

Remove the front bracket.

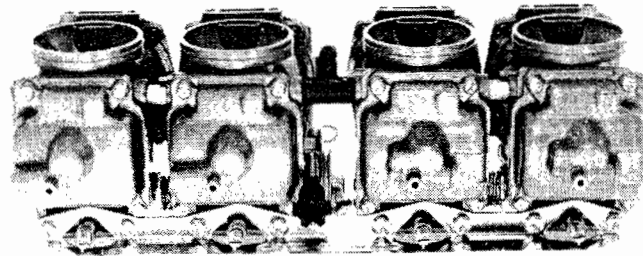

FRONT BRACKET

Carefully separate the carburetors.

**CAUTION**

*Separate the carburetors horizontally to prevent damage to the fuel and air joint pipes and to the choke linkage.*

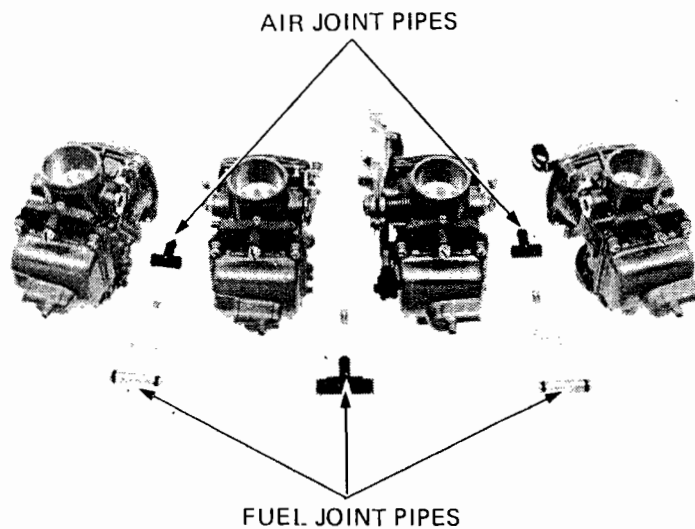

**CARBURETOR CLEANING**

- Remove the vacuum piston (Page 4-4).
- Remove the float chamber, float, valve and jets (Page 4-6).
- Remove the choke (bystarter) valve (Page 4-7).
- Clean all carburetor passages with compressed air.



## CARBURETOR ASSEMBLY

Install new O-rings onto the fuel joint and air pipes.

### NOTE

Apply a thin coating of oil to the O-rings.

Install the front bracket loosely.

Place the carburetors on a flat surface with the front side up.

Press the carburetors together carefully and evenly tighten the screws in the sequence shown in two or more steps to prevent carburetor misalignment.

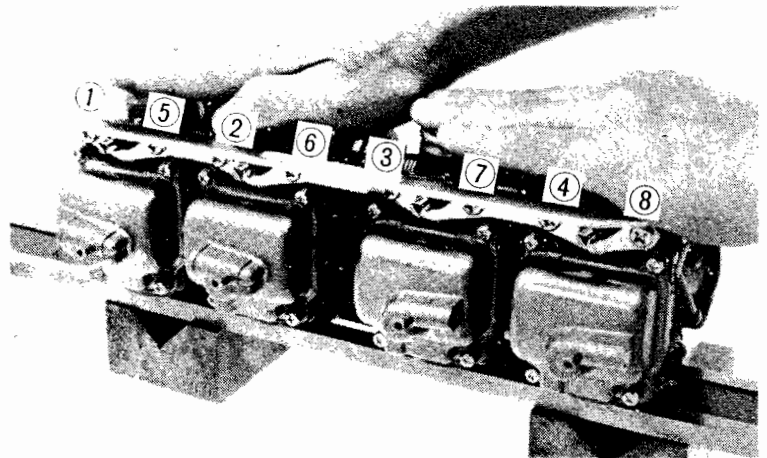

Install the rear bracket using the same procedure as for the front bracket with the rear side up.

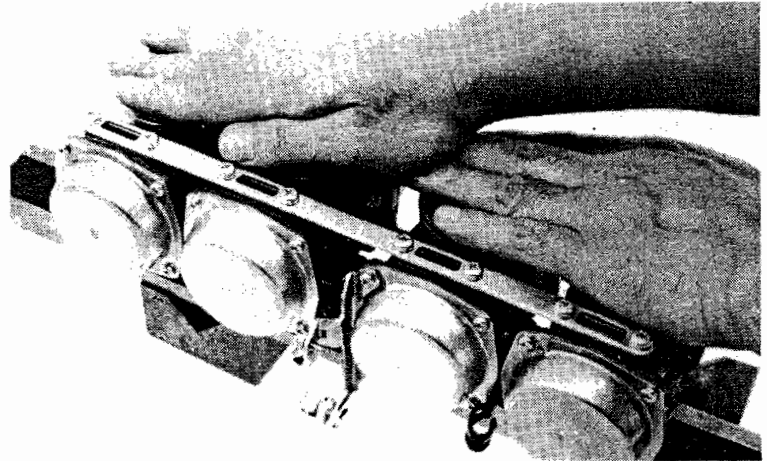

Install the choke (bystarter) arms onto the valves. Carefully insert the choke shaft through the arms from the left side.

Tighten the screws securely and hook the choke (bystarter) relief spring. Check the choke shaft for smooth operation.

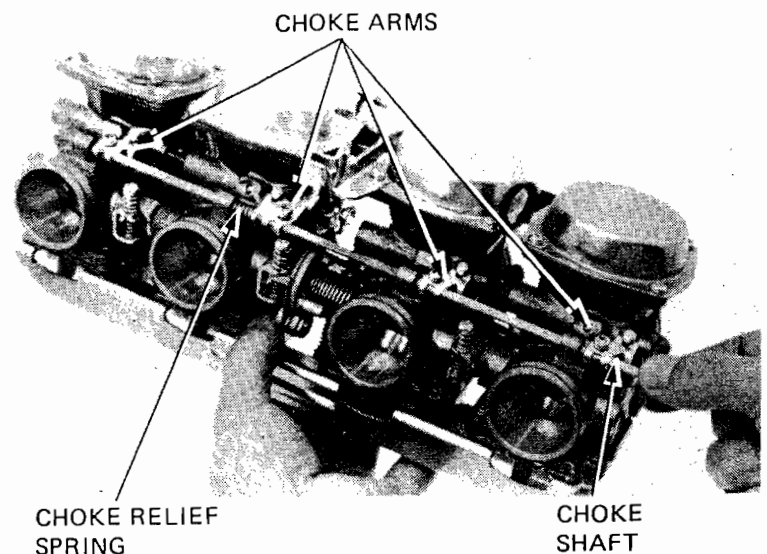



Make the distance between the by-pass hole in the carburetor body and throttle valve equal for each carburetor by turning the synchronization adjusting screws.

SYNCHRONIZATION ADJUSTING SCREW

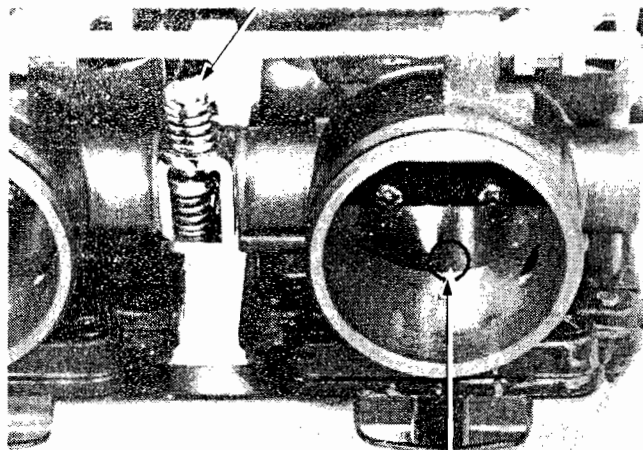

BY-PASS HOLE

Inspect the throttle operation as described below:

- Open the throttle slightly by pressing on the throttle linkage. Then release the throttle.
- Make sure that it returns smoothly.
- Make sure that there is no drag when opening and closing the throttle.

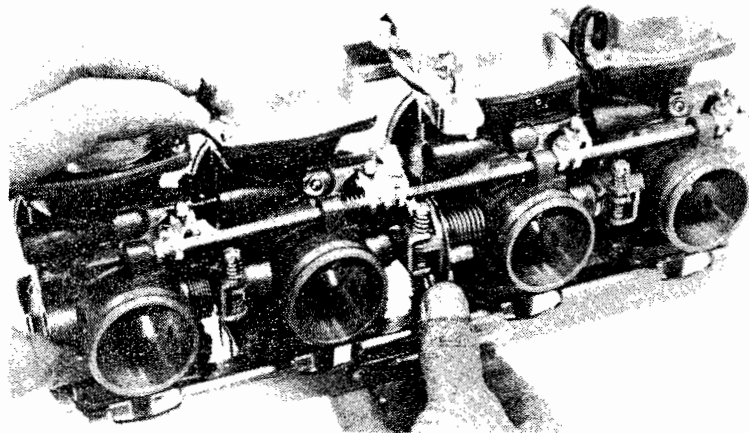

## CARBURETOR INSTALLATION

The installation sequence is the reverse of removal.

After installation, inspect the following items.

- Choke cable adjustment (Page 3-6).
- Throttle cable adjustment (Page 3-5).
- Carburetor synchronization adjustment (Page 3-8).
- Carburetor idle speed (Page 3-9).

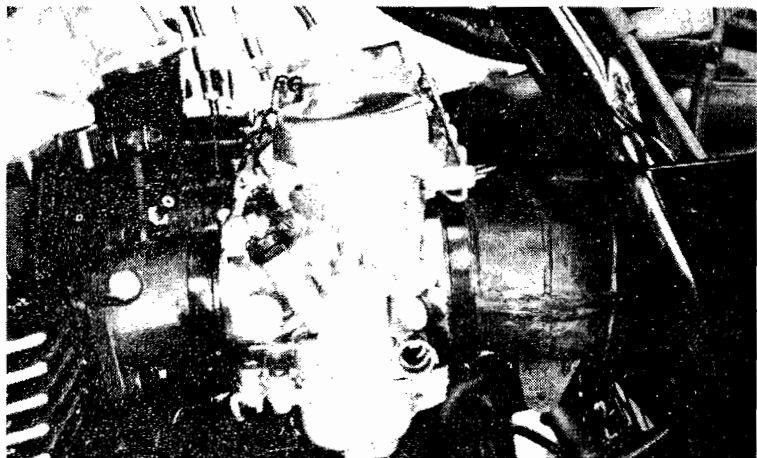



## PILOT SCREW REMOVAL/INSTALLATION

### NOTE

- The pilot screws are factory pre-set and should not be removed unless the carburetors are overhauled.
- The pilot screw limiter caps are factory installed and cemented in place to prevent pilot screw misadjustment.

Remove the carburetors (Page 4-3).  
Remove the front bracket (Page 4-10).  
Turn each pilot screw in and carefully count the number of turns before it seats lightly. Make a note of this to use as a reference when reinstalling the pilot screws.

### CAUTION

*Damage to the pilot screw seat will occur if the pilot screw is tightened against the seat.*

Remove the pilot screws.  
Inspect each pilot screw and replace if worn or damaged.  
Install the pilot screws and return them to their original positions as noted during removal. Perform pilot screw adjustment if a new pilot screw is installed (Page 4-14).

### NOTE

Do not install limiter caps on new pilot screws until after adjustment has been made (Page 4-14).

Install the front bracket (Page 4-11).  
Install the carburetors (Page 4-12).

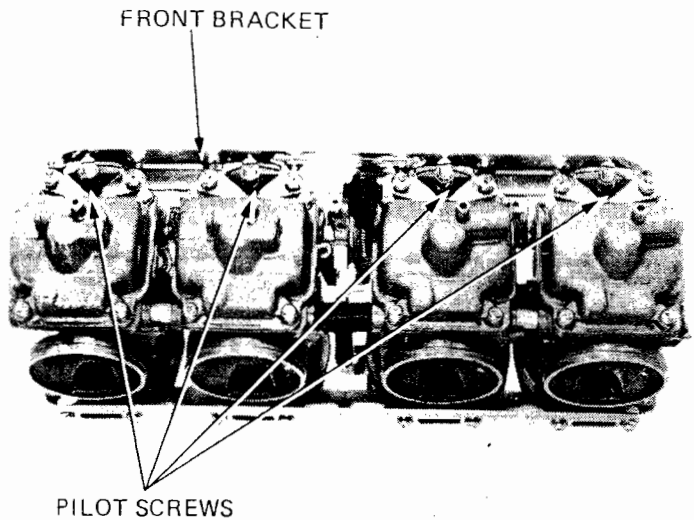



## PILOT SCREW ADJUSTMENT

### IDLE DROP PROCEDURE (U.S.A. ONLY)

#### NOTE

- The pilot screws are factory pre-set and no adjustment is necessary unless the pilot screw is replaced.
- Use a tachometer with graduations of 50 rpm or smaller that will accurately indicate a 50 rpm change.

1. Turn each pilot screw clockwise until it seats lightly and back it out to the specification given. This is an initial setting prior to the final pilot screw adjustment.

**INITIAL OPENING: 2 turns out**

#### CAUTION

*Damage to the pilot screw seat will occur if the pilot screw is tightened against the seat.*

2. Warm up the engine to operating temperature. Stop and go driving for 10 minutes is sufficient.
3. Attach a tachometer.
4. Adjust the idle speed with the throttle stop screw.

**IDLE SPEED: 1,000 ± 100 rpm**

5. Turn each pilot screw 1/2 turn out from the initial setting.
6. If the engine speed increases by 50 rpm or more, turn each pilot screw out by a continual 1/2 turn until it drops by 50 rpm or less.
7. Adjust the idle speed with the throttle stop screw.
8. Turn the No. 1 carburetor pilot screw in until the engine speed drops 50 rpm.
9. Turn the No. 1 carburetor pilot screw 1 turn out from the position obtained in step 8.
10. Adjust the idle speed with the throttle stop screw.
11. Perform steps 8, 9 and 10 for the No. 2, 3 and 4 carburetor pilot screws.

## LIMITER CAP INSTALLATION

If the pilot screw is replaced, a new limiter cap must be installed after pilot screw adjustment is completed.

After adjustment, cement the limiter caps over the pilot screws, using LOCTITE ® 601 or equivalent. The limiter cap should be placed against its stop, preventing further adjustment that would enrich the fuel mixture (limiter cap position permits clockwise rotation and prevents counterclockwise rotation).

#### NOTE

Do not turn the pilot screw when installing the limiter cap.

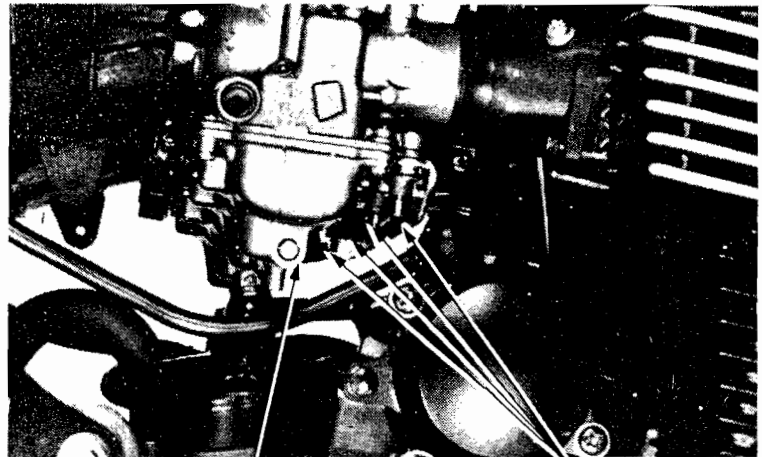

THROTTLE STOP SCREW      PILOT SCREWS

PILOT SCREW WRENCH  
07908-4220201

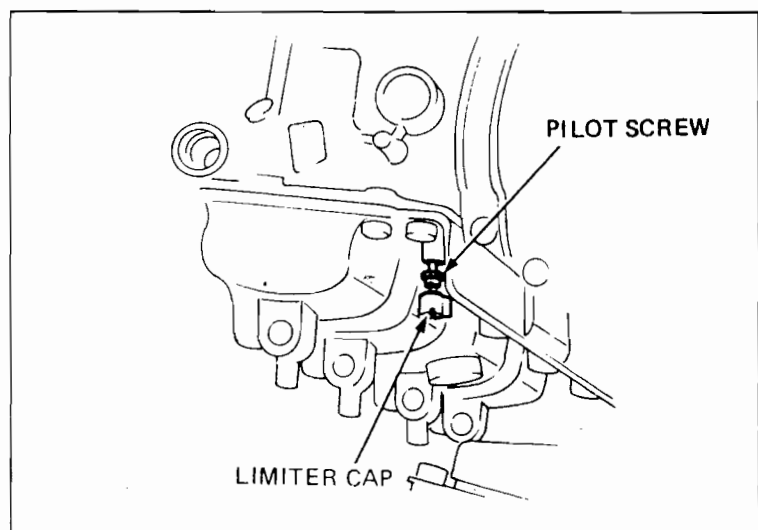
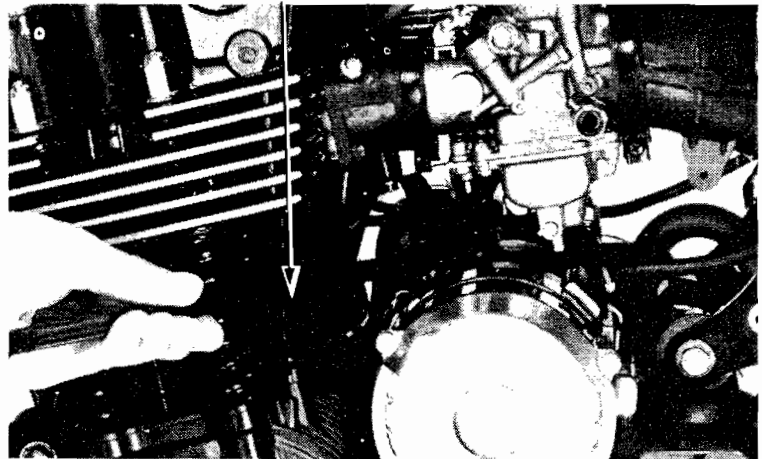



## HIGH ALTITUDE ADJUSTMENT

### NOTE

These adjustments must be made at high altitude to ensure proper high altitude operation.

When the vehicle is to be operated continuously above 6,500 ft (2,000 m) the carburetors must be readjusted as described below to improve driveability and decrease exhaust emissions.

1. Warm up the engine to operating temperature. Stop and go driving for 10 minutes is sufficient.
2. Turn the pilot screw clockwise 1/2 turn.
3. Adjust the idle speed to  $1,000 \pm 100$  rpm with the throttle stop screw.
4. Attach the Vehicle Emission Control Information Update Label.

### NOTE

Do not attach the label to any part that can be easily removed from the vehicle.

### WARNING

*Operation at an altitude lower than 5,000 ft (1,500 m) with the carburetors adjusted for high altitudes may cause the engine to idle roughly and stall.*

*When the vehicle is to be operated continuously below 5,000 ft (1,500 m), turn the pilot screw counterclockwise to its original position against its stop and adjust the idle speed to  $1,000 \pm 100$  rpm. Be sure to do these adjustments at low altitude.*

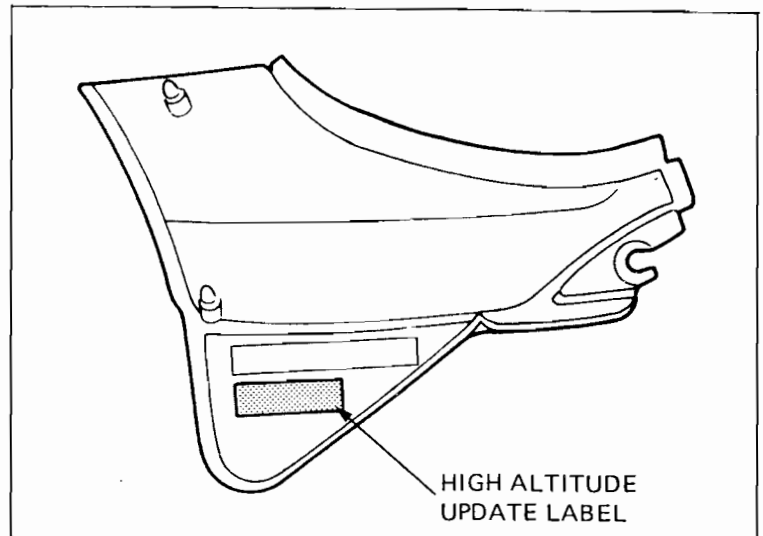





## FUEL TANK

**WARNING**

*Do not allow flames or sparks near gasoline.  
Wipe up spilled gasoline at once.*

### FUEL TANK REMOVAL

Remove the seat.  
Turn the fuel valve OFF and disconnect the fuel line at the fuel valve and vacuum line at the intake pipe.  
Remove the fuel tank mounting bolt and fuel tank.

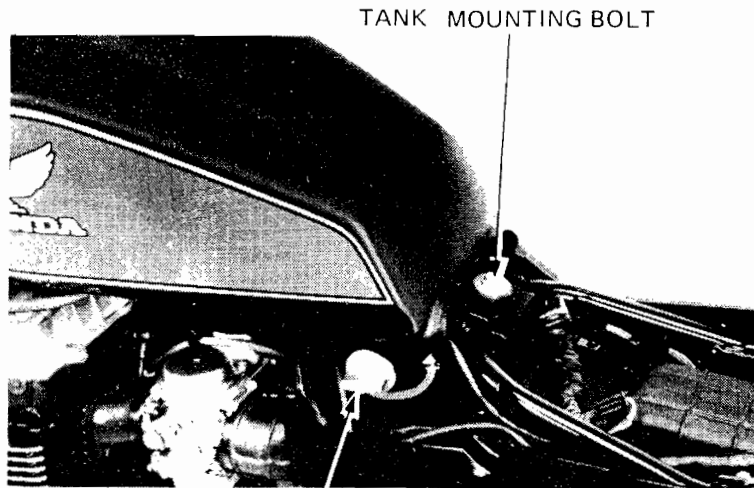

FUEL VALVE

### FUEL VALVE DIAPHRAGM TEST

Connect a fuel line to the fuel valve and place a container under the fuel line.  
Turn the fuel valve ON. If fuel comes out of the fuel line, replace the fuel valve diaphragms.

Connect a vacuum gauge to the diaphragm vacuum outlet. Fuel should flow from the fuel line when 12–20 mm Hg (0.48–0.8 in Hg) of vacuum is applied. If flow is restricted, inspect the fuel valve diaphragms and fuel strainer (Page 4-17).

FUEL LINE VACUUM PUMP

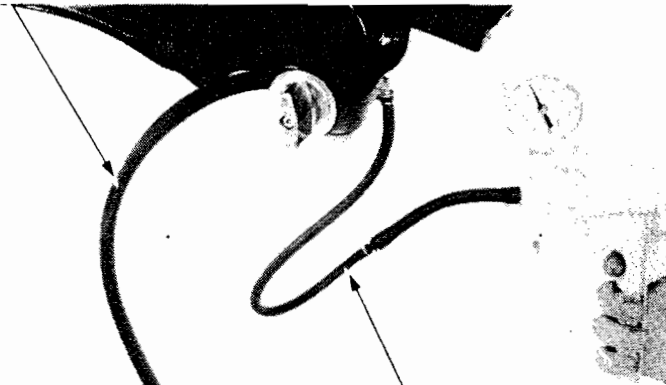

VACUUM LINE

### FUEL VALVE DIAPHRAGM REPLACEMENT

Drain the fuel from the fuel tank.  
Remove the four diaphragm cover screws, cover and spring.

DIAPHRAGM COVER

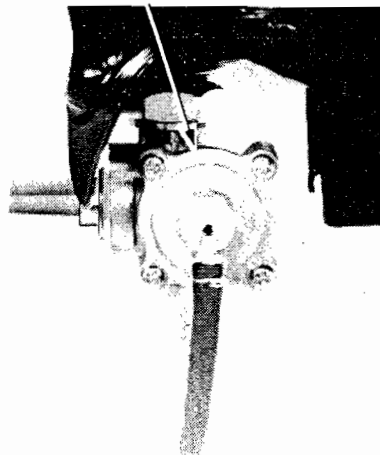

SPRING

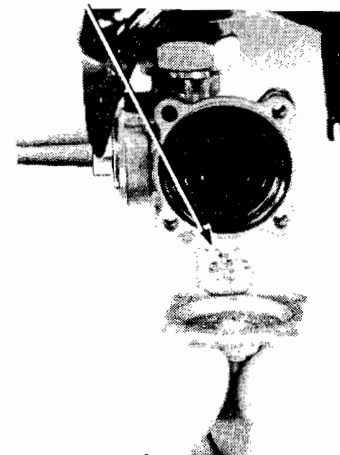



Remove the diaphragm base and remove the diaphragms.

DIAPHRAGM BASE

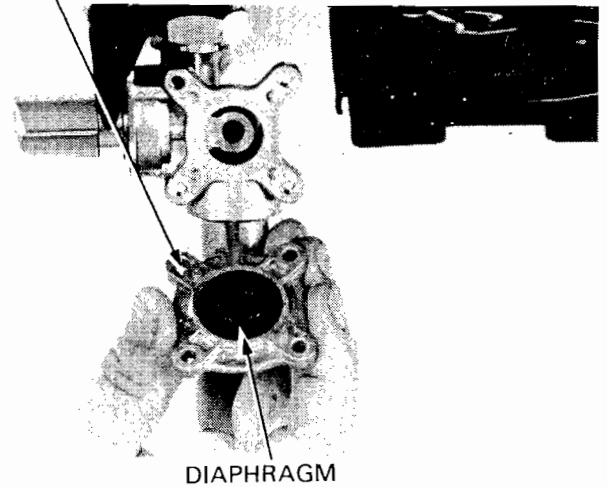

Install new diaphragms onto the base.  
Install the diaphragm base with its boss facing down.  
Install the diaphragm cover.  
Test the diaphragm operation (Page 4-16).

DIAPHRAGM BASE

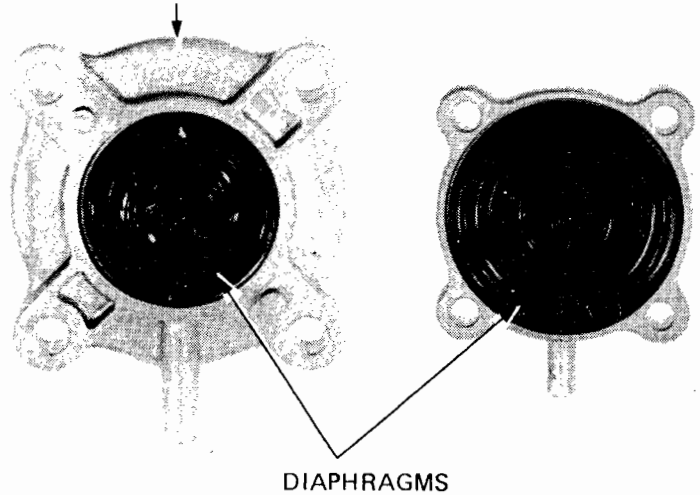

**FUEL STRAINER CLEANING**

Drain the fuel from the fuel tank.  
Loosen the fuel valve lock nut and remove the fuel valve.  
Remove the fuel strainer and O-ring.  
Clean the fuel strainer.  
Install the fuel strainer and O-ring onto the fuel valve.  
Install the fuel valve and tighten the lock nut.

**NOTE**

Do not over-tighten the lock nut.

Fill the fuel tank with gasoline and make sure there are no fuel leaks.

LOCK NUT

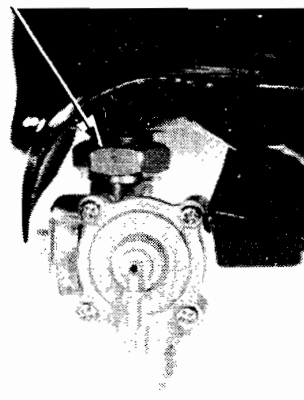

FUEL STRAINER

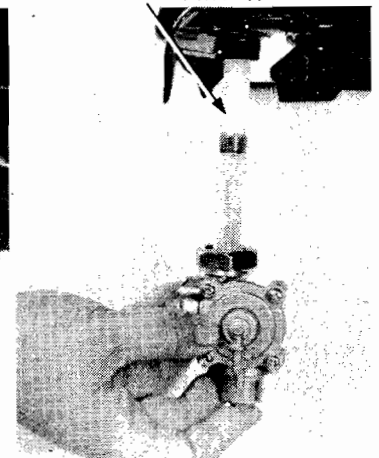

FUEL VALVE



FUEL TANK INSTALLATION

Install the fuel tank in the reverse order of removal.  
Make sure there are no fuel leaks after installation.

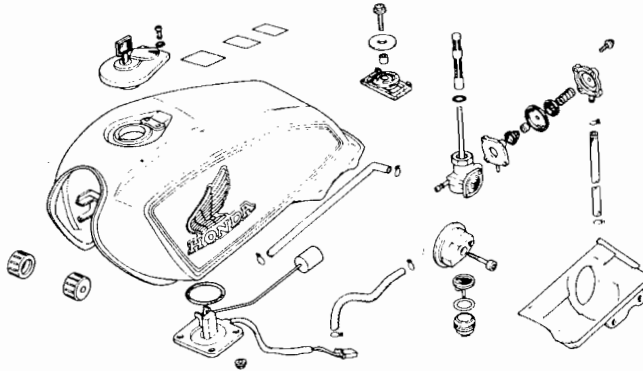

**AIR CLEANER CASE**

REMOVAL

Remove the seat and both frame side covers.

- Remove the rear wheel (Page 15-3).
- move rear fender A (Page 17-3).
- Remove the battery (Page 18-3).

Remove the tool box and regulator/rectifier by removing the bolts and disconnecting the couplers.

COUPLERS

TOOL BOX

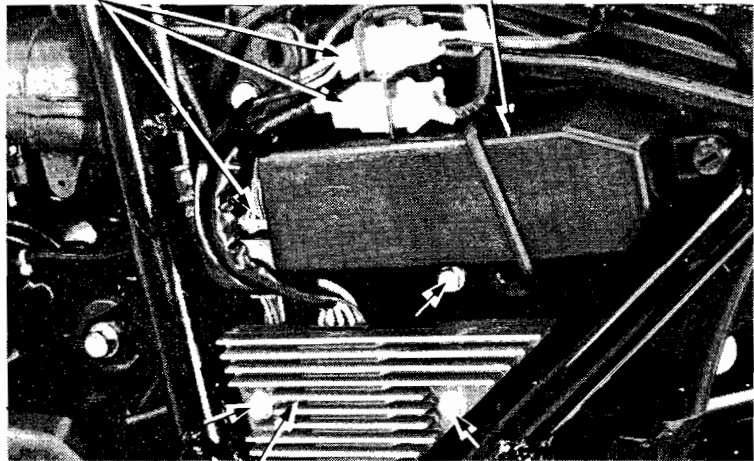

REGULATOR/RECTIFIER

Remove the starter and turn signal relays from the air cleaner case.

TURN SIGNAL RELAY



STARTER RELAY



Loosen the air cleaner connecting tube bands.  
Remove the three air cleaner mounting bolts and the air cleaner case.  
Check the air cleaner case for deterioration and replace if necessary.  
Check the breather tube for restriction.

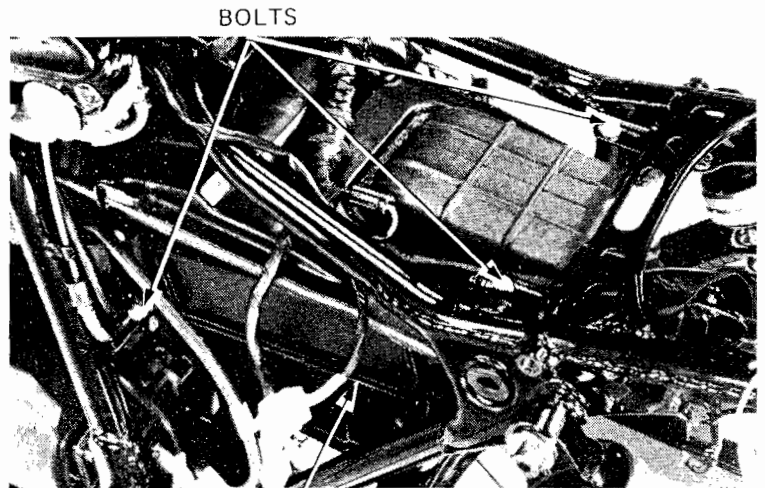

AIR CLEANER CASE

### INSTALLATION

Install the air cleaner case in the reverse order of removal.

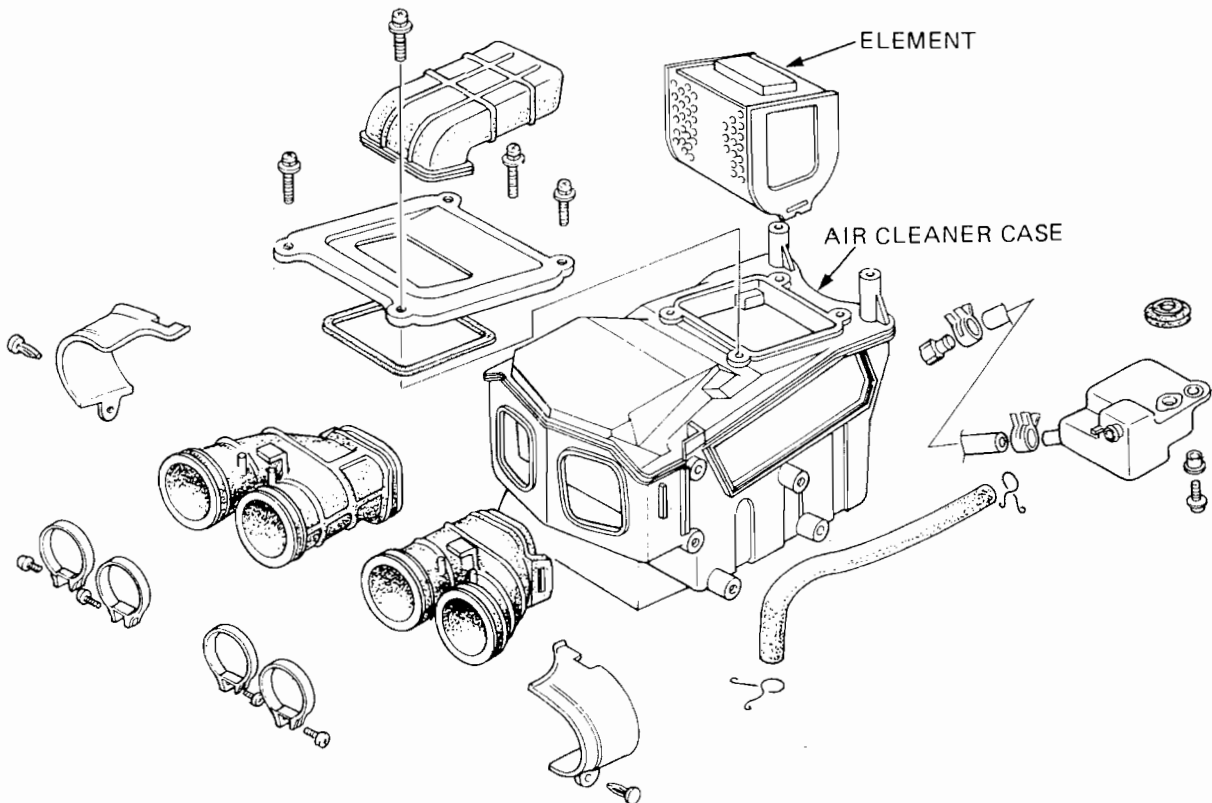



**PURGE CONTROL VALVE INSPECTION**  
**(CALIFORNIA MODEL)**

**NOTE**

The purge control valve should be inspected if hot restart is difficult.

Check all fuel tank, Purge Control Valve (PCV), and charcoal canister hoses to be sure they are not kinked and are securely connected. Replace any hose that shows signs of damage or deterioration.

**NOTE**

The PCV is located under the carburetor.

Disconnect the PCV hoses from their connections and remove the PCV from its mount. Refer to the routing label on the inside of the frame right side cover for hose connections.

Connect a vacuum pump to the 8 mm I.D. hose that goes to the carburetor body. Apply the specified vacuum to the PCV.

**SPECIFIED VACUUM: 250 mm (9.8 in) Hg**

The specified vacuum should be maintained. Replace the PCV if vacuum is not maintained.

Remove the vacuum pump and connect it to the hose that goes to the No. 3 carburetor. Apply the specified vacuum to the PCV.

**SPECIFIED VACUUM: 250 mm (9.8 in) Hg**

The specified vacuum should be maintained. Replace the PCV if vacuum is not maintained.

Connect a vacuum pump to the 8 mm I.D. hose that goes to the charcoal canister. While applying the specified vacuum to the PCV hose that goes to the No. 3 carburetor, pump air through the canister hose. Air should flow through the PCV and out the hose that goes to the carburetor body. Replace the PCV if air does not flow out.

**CAUTION**

To prevent damage to the purge control valve, do not use high air pressure sources. Use a hand operated air pump only.

Remove the pumps, install the PCV on its mount, route and reconnect the hoses according to the routing label.

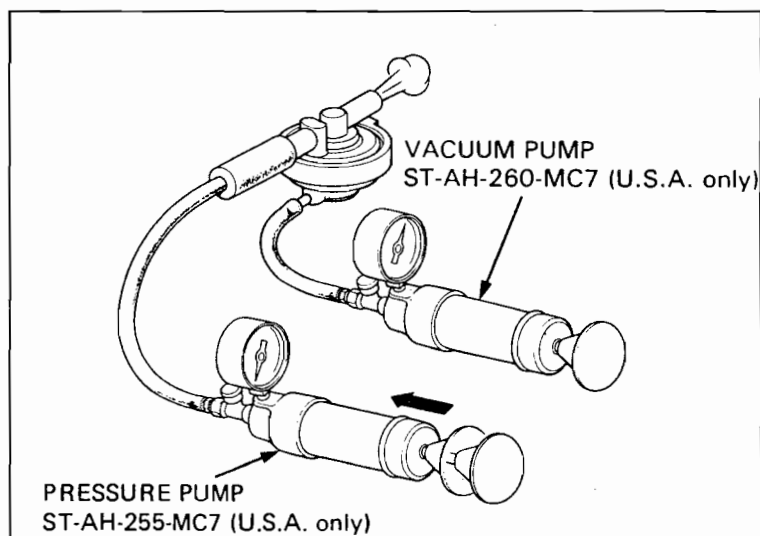
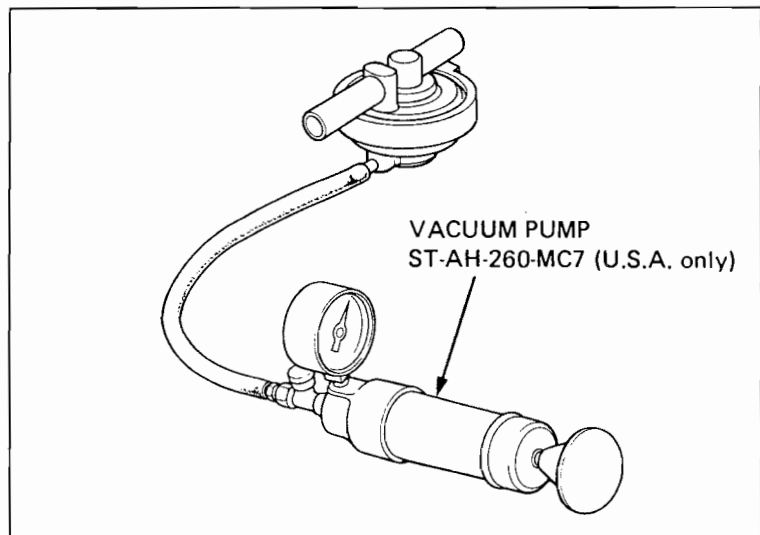
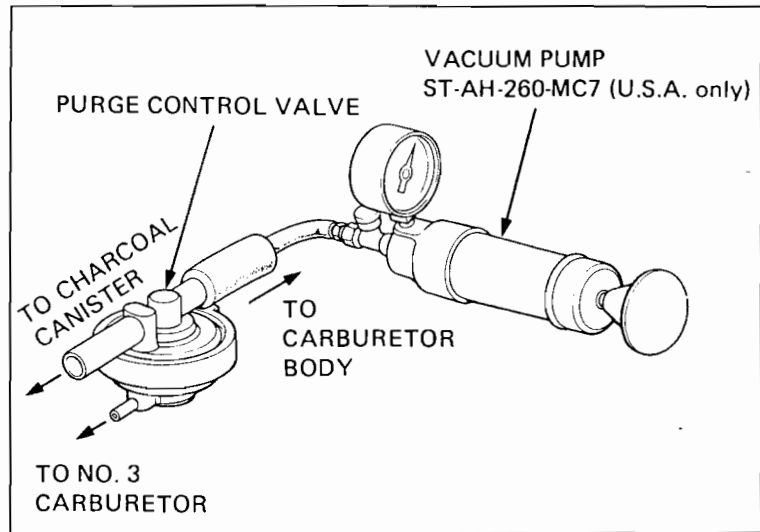



Route the vacuum tubes as described on the Vacuum Hose Routing Label.

**NOTE**

- Be careful not to bend, twist or kink the tubes when installing.
- Slide the end of each tube onto its fitting fully and secure with the hose clamps.
- Secure with the hose clamps whenever specified.
- Check that the hoses are not contacting sharp edges or corners.

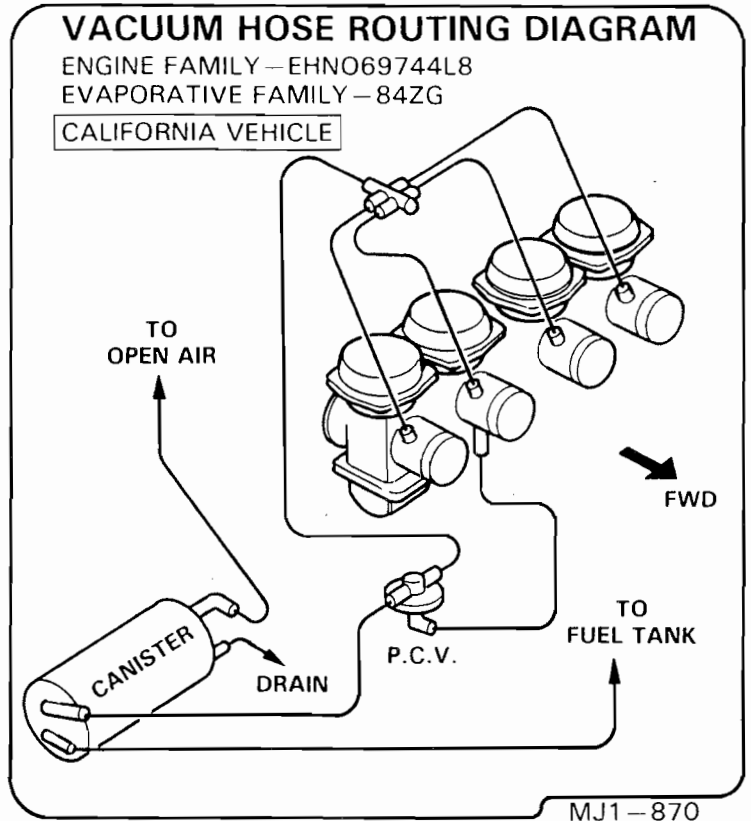

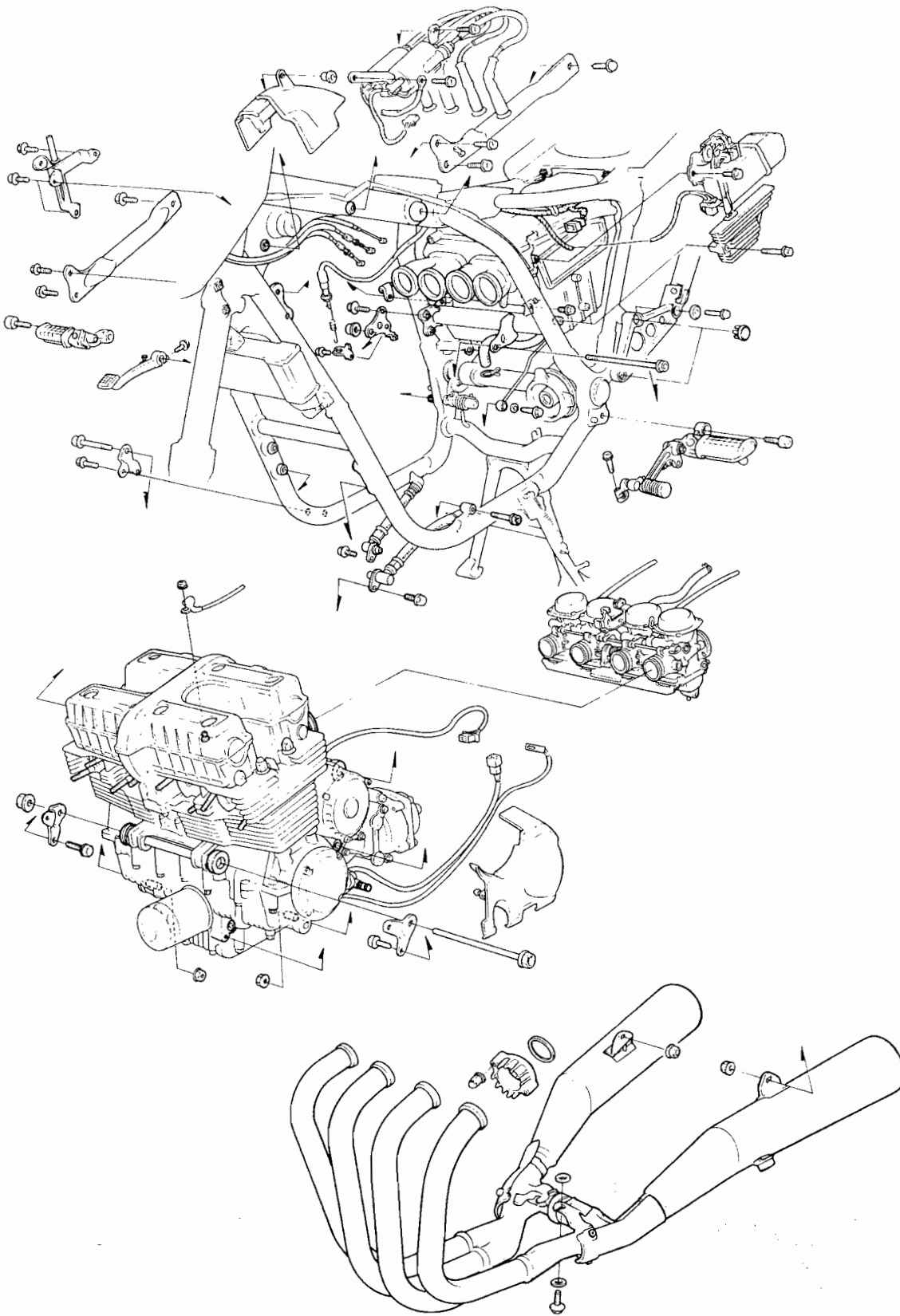



SERVICE INFORMATION	5-1
ENGINE REMOVAL	5-2
ENGINE INSTALLATION	5-5

## GENERAL

- A floor jack or other adjustable support is required to support and maneuver the engine.
- The following parts or components can be serviced with the engine installed in the frame:

- |                 |                 |
|-----------------|-----------------|
| • Clutch        | • Starter motor |
| • Shift linkage | • Cylinder head |
| • Camshaft      | • Alternator    |
| • Carburetor    | • Piston        |
| • Cylinder      |                 |

**5**

## SPECIFICATIONS

Engine dry weight	82 kg (181 lb)
Oil capacity	2.8 liter (3.0 US qt, 2.5 Imp qt) after oil filter and oil change 2.5 liter (2.6 US qt, 2.2 Imp qt) after oil change 3.6 liter (3.8 US qt, 3.2 Imp qt) after disassembly

## TORQUE VALUES

Engine mount	8 mm bolt	20-30 N·m (2.0-3.0 kg-m, 14-22 ft-lb)
	10 mm bolt	45-60 N·m (4.5-6.0 kg-m, 33-43 ft-lb)
Footpeg socket bolt		30-40 N·m (3.0-4.0 kg-m, 22-29 ft-lb)
Brake pedal bolt		20-28 N·m (2.0-2.8 kg-m, 14-20 ft-lb)





**ENGINE REMOVAL/INSTALLATION**

**ENGINE REMOVAL**

Place the motorcycle on its center stand.

Drain the engine oil (Page 2-3).

Remove the following components:

- seat and both frame side covers.
- fuel tank (Page 4-16).
- ignition coils (Page 19-2).
- carburetors (Page 4-3).
- exhaust pipes (Page 17-2).

Remove the bolt attaching the battery ground cable to the engine.

Disconnect the starter cable from the starter motor by removing the terminal nut.

Disconnect the crankcase breather tube from the crankcase.

CRANKCASE BREATHER TUBE

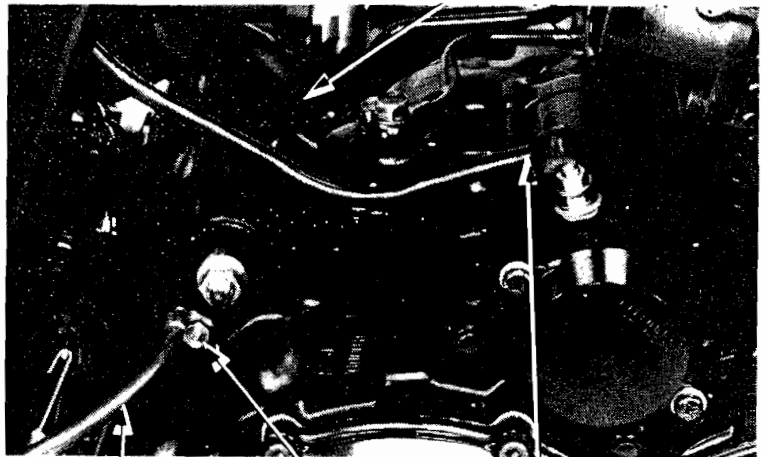

GROUND CABLE

BOLT

STARTER CABLE

Remove the brake pedal.  
Remove the right footpeg.

RIGHT FOOTPEG

BRAKE PEDAL

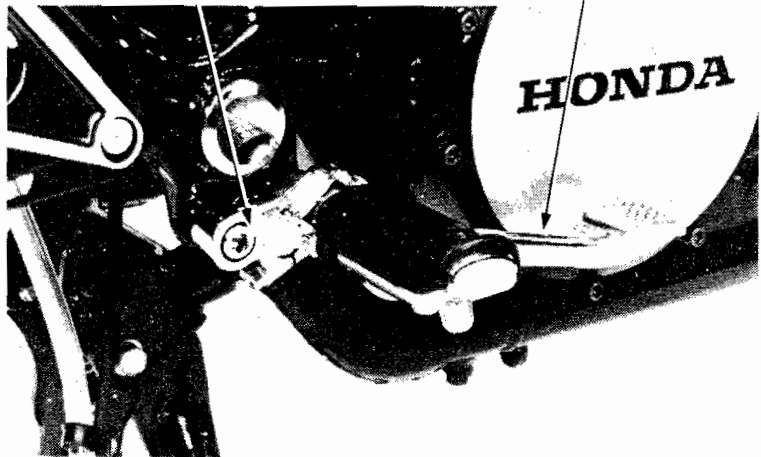

Remove the right and left oil hoses by removing the bolts.

Remove the oil filter (Page 2-3).

RIGHT OIL HOSE

OIL FILTER

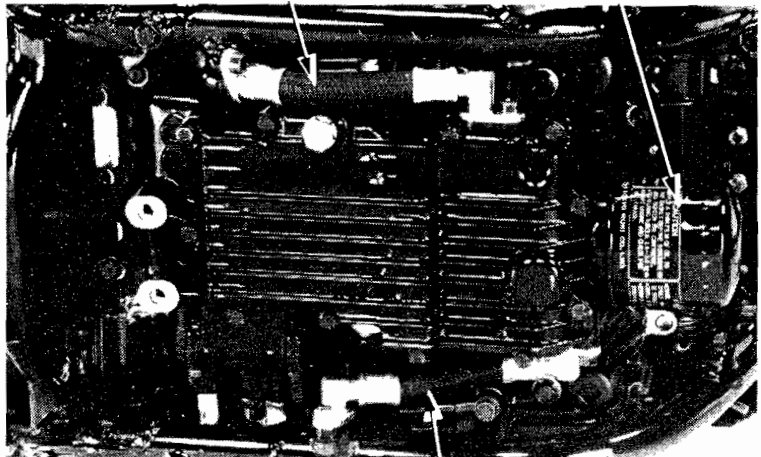

LEFT OIL HOSE



Remove the left crankcase rear cover.

LEFT CRANKCASE REAR COVER

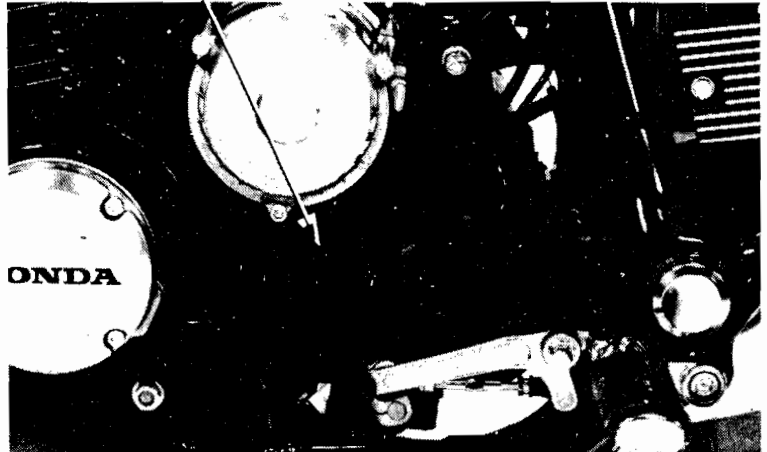

Remove the gearshift pedal and left footpeg assembly by removing the 10 mm socket bolt and 6 mm shift arm pinch bolt.

SHIFT ARM PINCH BOLT

10 MM SOCKET BOLT

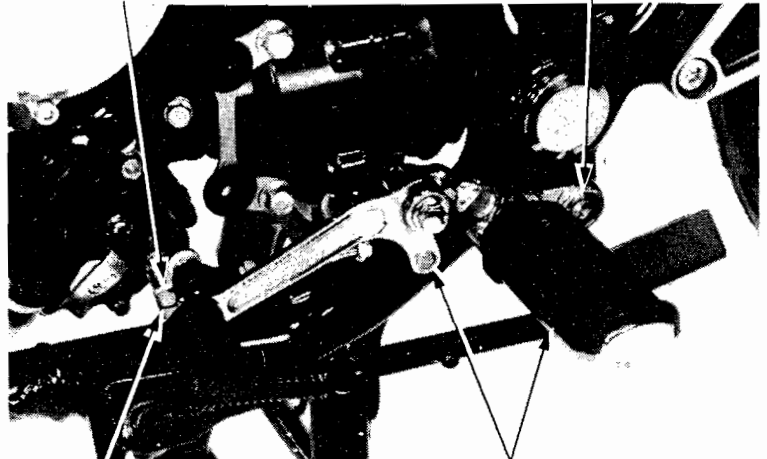

SHIFT ARM

GEARSHIFT PEDAL AND LEFT FOOTPEG ASSEMBLY

Remove the slave cylinder from the crankcase with the clutch pipe connected (Page 8-7).

**NOTE**

Do not operate the clutch lever after removing the clutch slave cylinder. To do so will cause difficulty in installing the slave cylinder.

SLAVE CYLINDER

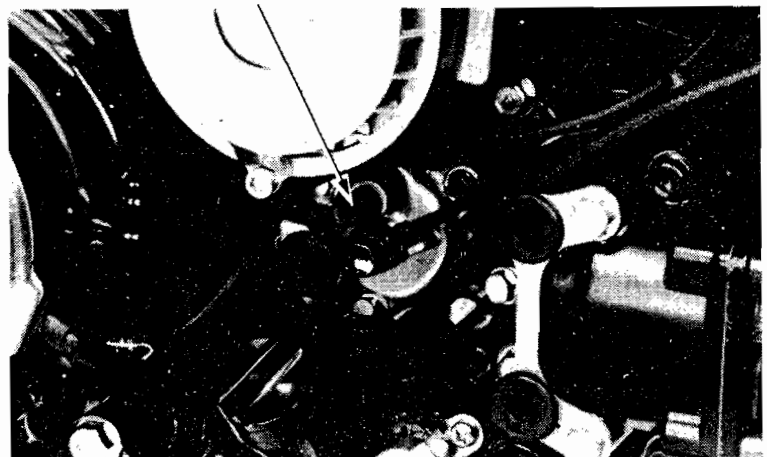



Disconnect the pulse generator, alternator, and oil pressure switch/gear position switch wire couplers.

PULSE GENERATOR WIRE COUPLER      GEAR POSITION SWITCH WIRE COUPLER

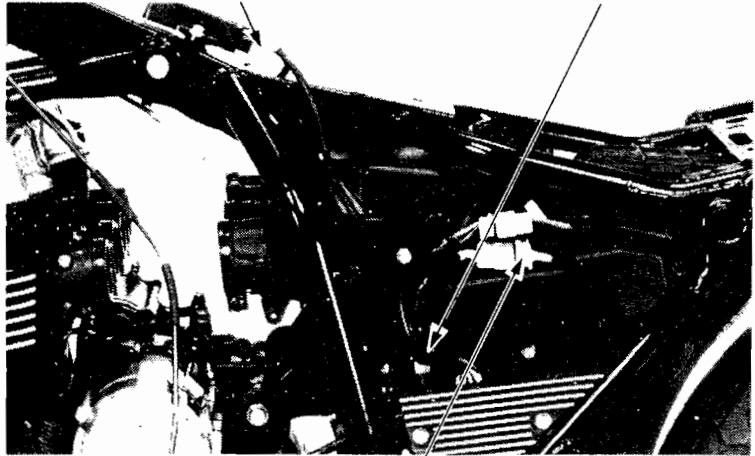

ALTERNATOR WIRE COUPLER

Remove the sub frame bolts and the sub frames.

SUB FRAMES      8 mm BOLTS

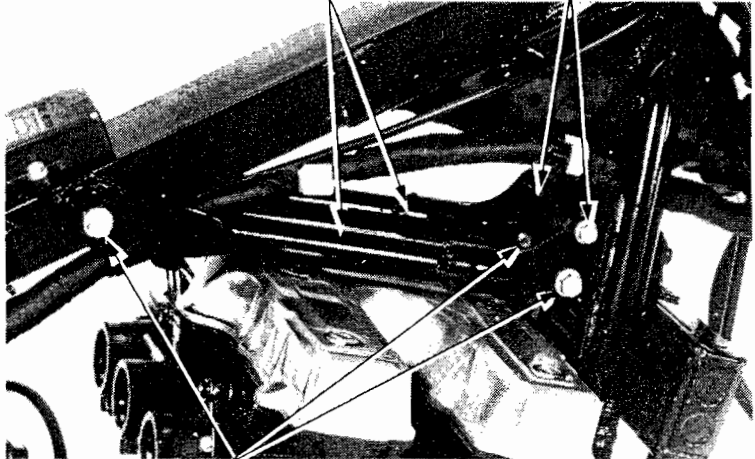

10 mm BOLTS

Pry the universal joint to the rear and hold it with a screwdriver through the hole in the left swing arm pivot bolt as shown.

UNIVERSAL JOINT      LEFT SWING ARM PIVOT BOLT

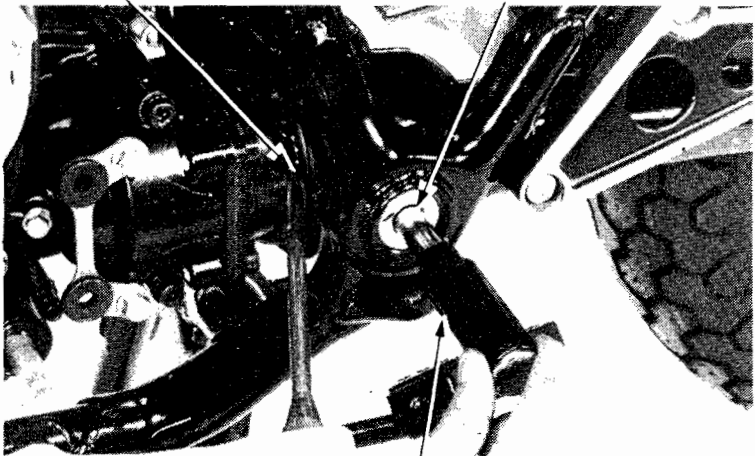

SCREWDRIVER



Place a floor jack or other adjustable support under the engine.

### NOTE

The jack height must be continuously adjusted so that the mounting bolts can be removed, and so stress is relieved from other bolts until they are removed.

Remove the engine mounting bolts and brackets.

Remove the engine from the right side.

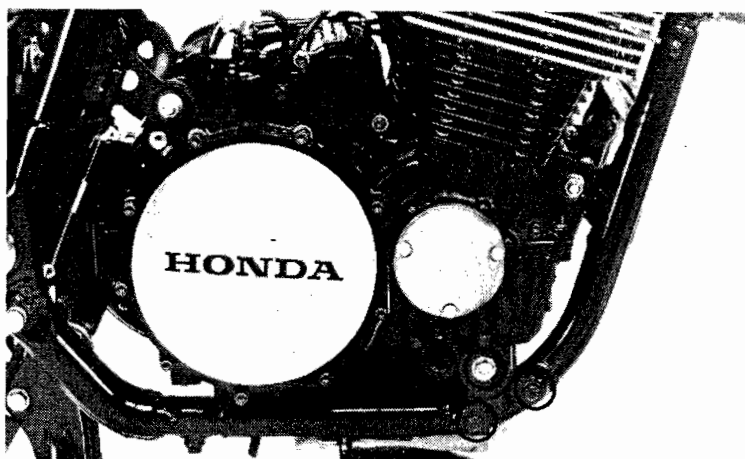

## ENGINE INSTALLATION

Engine installation is essentially the reverse of removal.

Use a floor jack or other adjustable support to carefully maneuver the engine into place.

### CAUTION

*Carefully align mounting points with the jack to prevent damage to mounting bolt threads, wire harness and cables.*

Tighten the all fasteners to the specified torque:

### ENGINE MOUNT BOLTS:

10 mm: 45–60 N·m  
(4.5–6.0 kg-m, 32–43 ft-lb)

8 mm: 20–30 N·m  
(2.0–3.0 kg-m, 14–22 ft-lb)

### NOTE

- The front hanger brackets have "R" (right) or "L" (left) marks on their inside surfaces.
- Route the wires and cables properly (Page 1-9).
- Fill the crankcase to the proper level with the recommended oil (Page 2-1).
- Perform the following inspection and adjustments:  
Throttle operation (Page 3-5).  
Clutch (Page 3-14).

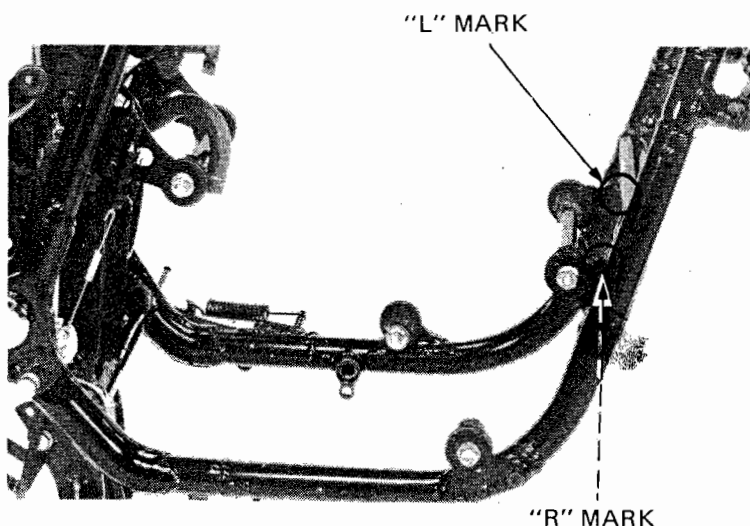

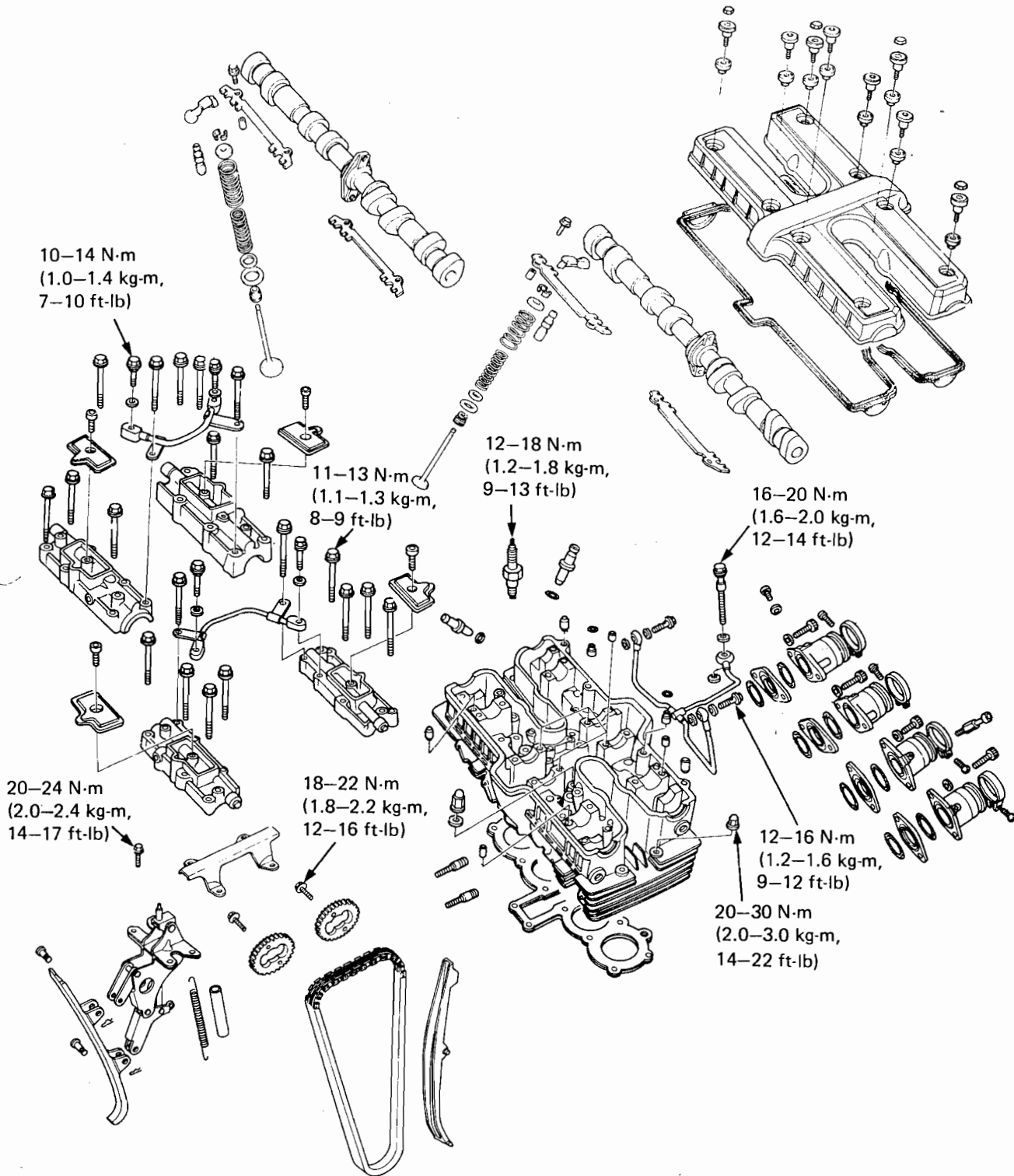



SERVICE INFORMATION	6-1	VALVE GUIDE REPLACEMENT	6-14
TROUBLESHOOTING	6-2	VALVE SEAT INSPECTION/REFACING	6-15
CAMSHAFT REMOVAL	6-3	CYLINDER HEAD ASSEMBLY	6-16
HYDRAULIC TAPPET REMOVAL	6-8	CYLINDER HEAD INSTALLATION	6-17
CYLINDER HEAD REMOVAL	6-9	HYDRAULIC TAPPET INSTALLATION	6-20
CYLINDER HEAD DISASSEMBLY	6-12	CAMSHAFT INSTALLATION	6-21

## SERVICE INFORMATION

### GENERAL

- The engine uses hydraulic valve tappets that eliminate manual valve adjustments.
- The hydraulic tappets have defoaming chambers. Before assembling, fill the chambers with clean engine oil.
- Do not turn the camshaft before installing all camshaft holders and filling the defoaming chambers with engine oil, when you adjust the valve timing.
- Whenever the camshaft is removed, bleed air from the tappets thoroughly (See page 6-20).
- Lubricate the camshaft journals and cam lobes with molybdenum disulfide grease for initial lubrication.
- The exhaust and intake camshaft holders are identified by the respective markings (EXR and EXL, for the exhaust camshaft holders and INR and INL, for intake camshaft holders).

**6**

### SPECIFICATIONS

ITEM		STANDARD	SERVICE LIMIT	
Compression pressure		1200 kPa (12 kg/cm <sup>2</sup> , 171 psi)	—	
Camshaft	Cam height	IN, EX 32.950 mm (1.2972 in)	32.90 mm (1.295 in)	
	Oil clearance	IN1,2,5,6,EX1,2,5,6	0.020–0.062 mm (0.0008–0.0024 in)	0.12 mm (0.005 in)
		IN3, 4, EX3, 4	0.055–0.097 mm (0.0022–0.0038 in)	0.14 mm (0.006 in)
	Runout	—	0.03 mm (0.001 in)	
Valve spring	Free length	IN, EX Outer	41.70 mm (1.642 in)	40.2 mm (1.58 in)
		IN, EX Inner	36.80 mm (1.449 in)	35.5 mm (1.40 in)
	Preload/ length	IN, EX Outer	29.5–33.5 kg/24.90 mm (65.0–73.9 lb/0.980 in)	—
		IN, EX Inner	12.5–14.5 kg/21.10 mm (27.6–32.0 lb/0.831 in)	—

**CYLINDER HEAD/VALVES**

ITEM			STANDARD	SERVICE LIMIT
Valve, valve guide	Valve stem O.D.	IN	4.975–4.990 mm (0.1959–0.1965 in)	4.97 mm (0.195 in)
		EX	4.955–4.970 mm (0.1951–0.1957 in)	4.94 mm (0.194 in)
	Valve guide I.D.	IN, EX	5.000–5.012 mm (0.1969–0.1973 in)	5.04 mm (0.198 in)
	Stem-to-guide clearance	IN	0.010–0.037 mm (0.0004–0.0146 in)	0.07 mm (0.003 in)
EX		0.030–0.057 mm (0.0012–0.0022 in)	0.09 mm (0.004 in)	
Cylinder head	Warpage		—	0.10 mm (0.004 in)
	Valve seat width IN/EX		0.9–1.1 mm (0.035–0.043 in)	1.5 mm (0.06 in)

**TORQUE VALUES**

Camshaft holder bolts	12–16 N·m (1.2–1.6 kg·m, 9–12 ft·lb)	Apply locking agent to threads
Cam sprocket bolts	18–20 N·m (1.8–2.0 kg·m, 13–14 ft·lb)	
Cam chain tensioner bolts	10–14 N·m (1.0–1.4 kg·m, 7–10 ft·lb)	
Cylinder head nuts	26–30 N·m (2.6–3.0 kg·m, 19–22 ft·lb)	
Spark plug	12–18 N·m (1.2–1.8 kg·m, 9–13 ft·lb)	
Oil pipe bolt 7 mm	10–14 N·m (1.0–1.4 kg·m, 7–10 ft·lb)	
8 mm	12–16 N·m (1.2–1.6 kg·m, 9–12 ft·lb)	
10 mm	16–20 N·m (1.6–2.0 kg·m, 12–14 ft·lb)	

**TOOLS**

<b>Special</b>	
Valve guide reamer	07984–MA60000
Valve guide driver/remover	07942–MA60000
Hydraulic tappet bleeder	07973–MJ 00000
<b>Common</b>	
Valve spring compressor	07757–0010000 or 07957–3290001

**TROUBLESHOOTING**

Engine top-end problems are usually performance-related and can be diagnosed by a compression test, or are engine noises which can be traced to the top-end with a sounding rod or stethoscope.

**Low compression or uneven compression**

1. Valves
  - Faulty hydraulic tappet
  - Burned or bent valves
  - Incorrect valve timing
  - Broken valve spring
2. Cylinder head
  - Leaking or damaged head gasket
  - Warped or cracked cylinder head
3. Cylinder and piston (Refer to Section 7)

**Compression too high**

- Excessive carbon build-up on piston head or combustion chamber

**Excessive noise**

1. Faulty hydraulic valve tappet system
  - Low engine oil level
  - Contaminated oil
  - Low oil pressure
  - Damaged hydraulic tappet
2. Sticking valve or broken valve spring
3. Damaged or worn camshaft
4. Loose or worn cam chain
5. Worn or damaged cam chain tensioner
6. Worn cam sprocket teeth



## CAMSHAFT REMOVAL

Remove the following components:

- seat and fuel tank (Page 4-16).
- ignition coils (Page 18-3).
- air guide.
- sub frames (Page 5-4).

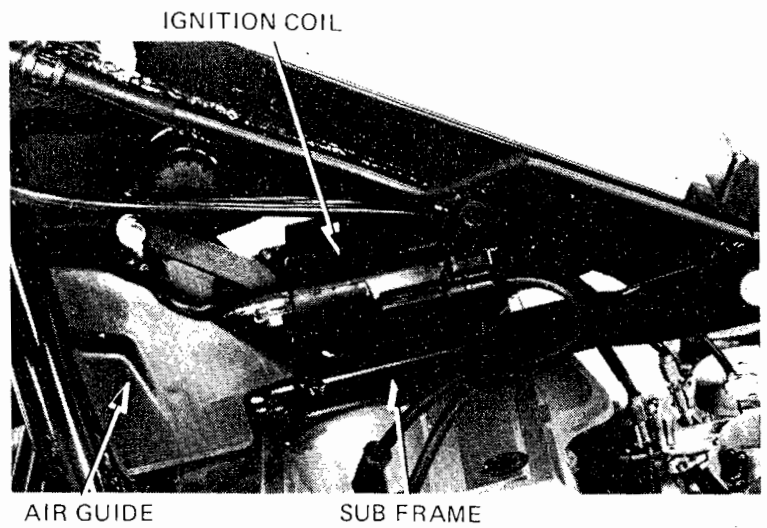

Remove the cylinder head cover bolts and the cover. Remove the dowel pins.

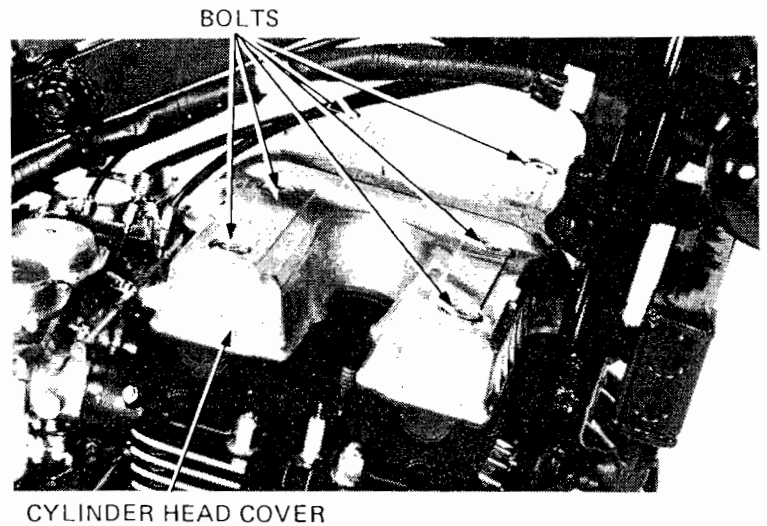

Check the cylinder head cover seal for deterioration or damage and replace if necessary.

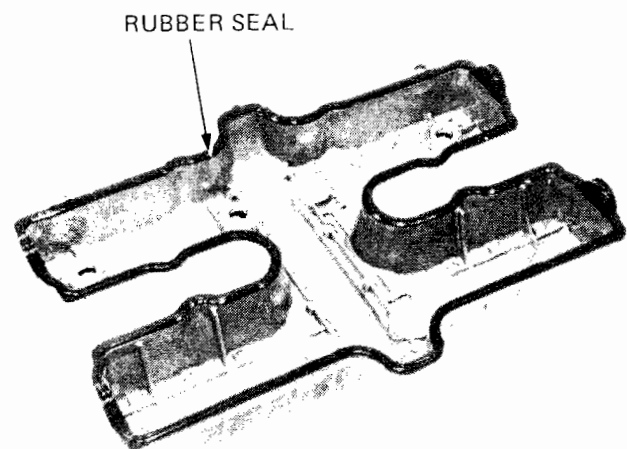





**CYLINDER HEAD/VALVES**

- Remove the four bolts attaching the cam chain guard and the guard.
- Remove the oil pipe bolts and oil pipes.
- Remove the socket bolts attaching the defoaming chamber covers and the covers.

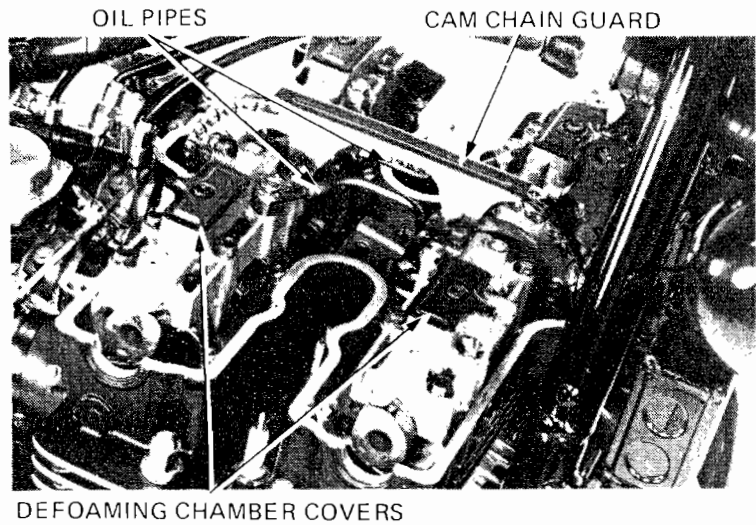

- Remove the cam sprocket bolts.

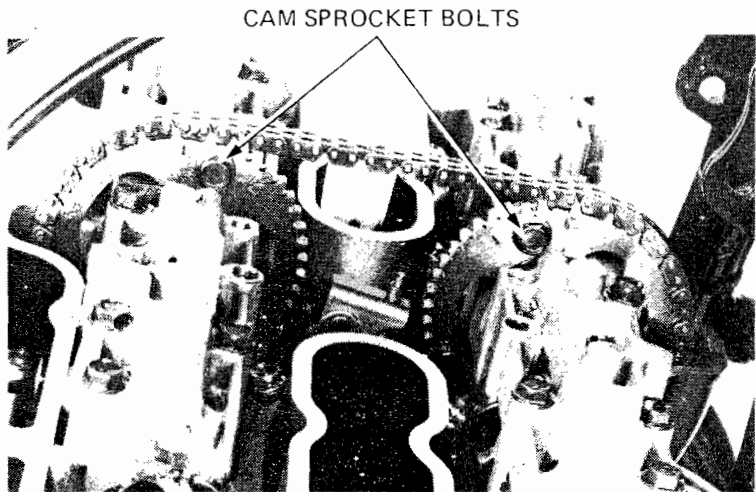

- Remove the right crankshaft cover.
- Turn the crankshaft counterclockwise and then remove the two other cam sprocket bolts.

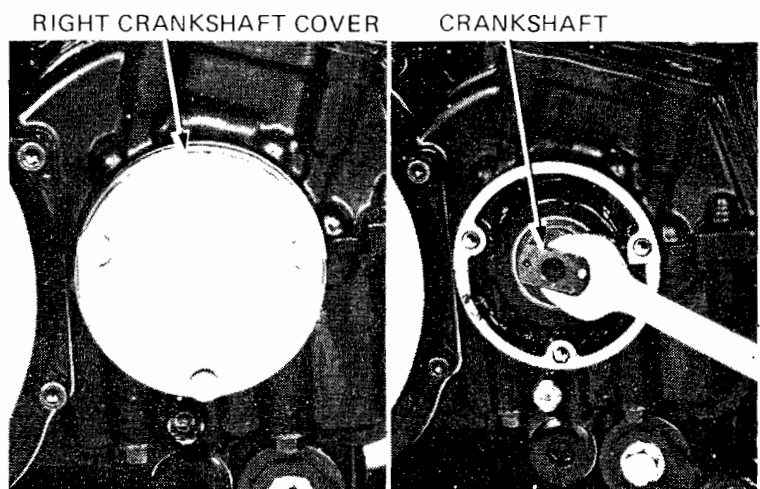



Loosen the cam chain by pushing the tensioner lock pin down and pulling the lock plate up as shown. Remove the cam sprockets from the camshaft flange shoulders.

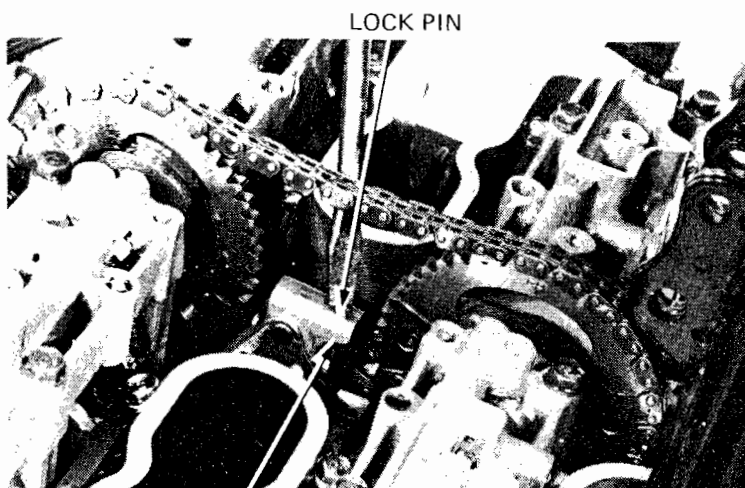

LOCK PIN

LOCK PLATE

Remove the cam chain from the sprockets. Remove the camshaft holder bolts and the holders.

**NOTE**

Loosen the holder bolts in 2-3 steps in criss-cross pattern.

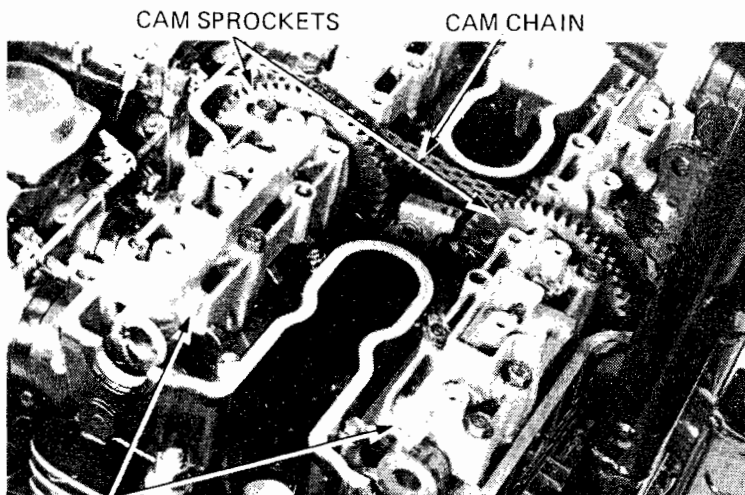

CAM SPROCKETS

CAM CHAIN

CAMSHAFT HOLDERS

Remove the camshafts and sprockets.

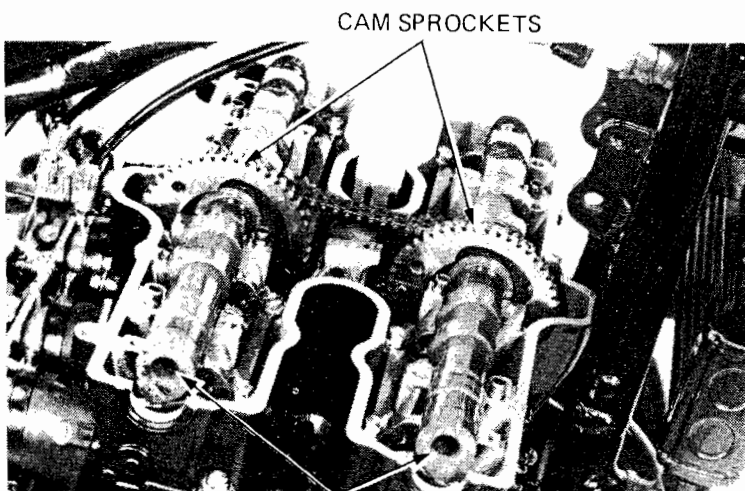

CAM SPROCKETS

CAMSHAFTS



ISPECTION

**CAMSHAFT BEARING SURFACES**

Inspect the cam bearing surfaces for scoring, scratches, or evidence of insufficient lubrication. Also, inspect the bearing surfaces of the camshaft holders.

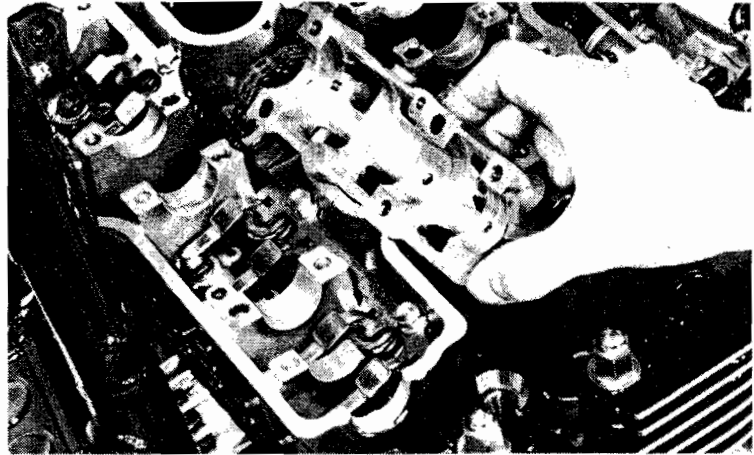

**CAMSHAFT RUNOUT**

Check camshaft run-out with a dial indicator. Support both ends of the camshaft with V-blocks.

**SERVICE LIMIT: 0.03 mm (0.001 in)**

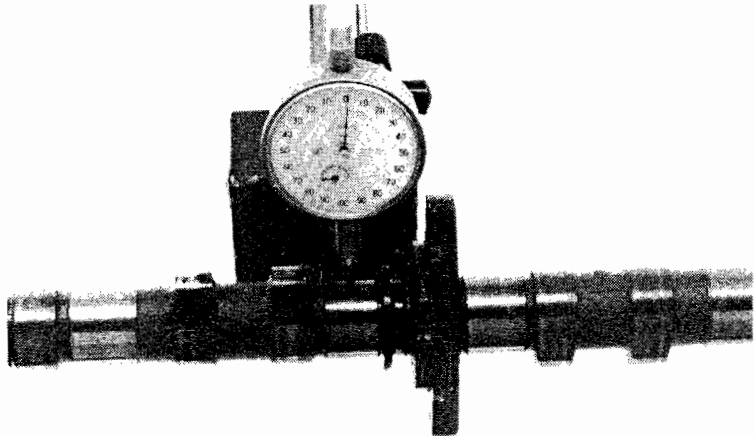

**CAM LOBE HEIGHT**

Check the camshaft lobes for wear or damage. If the lobes are scored, inspect the rocker arm surfaces also.

Measure the cam lobe height with a micrometer.

**SERVICE LIMIT: IN,EX: 32.90 mm (1.295 in)**

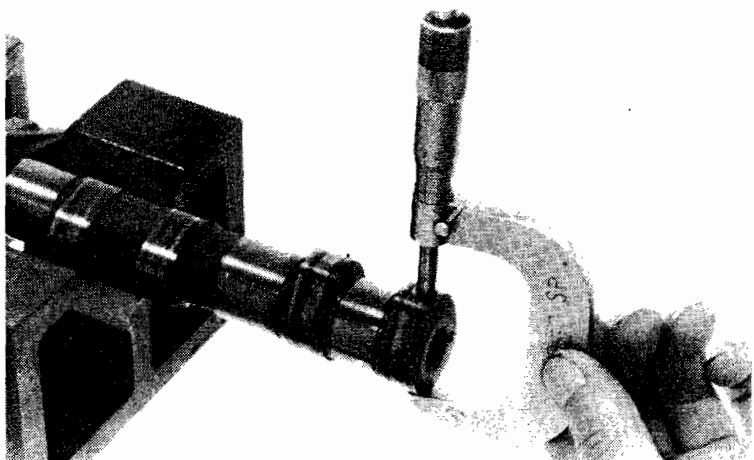



### CAMSHAFT OIL CLEARANCE

Wipe any oil from the camshaft journals.

Lay a strip of plastigauge lengthwise on top of each camshaft journal.

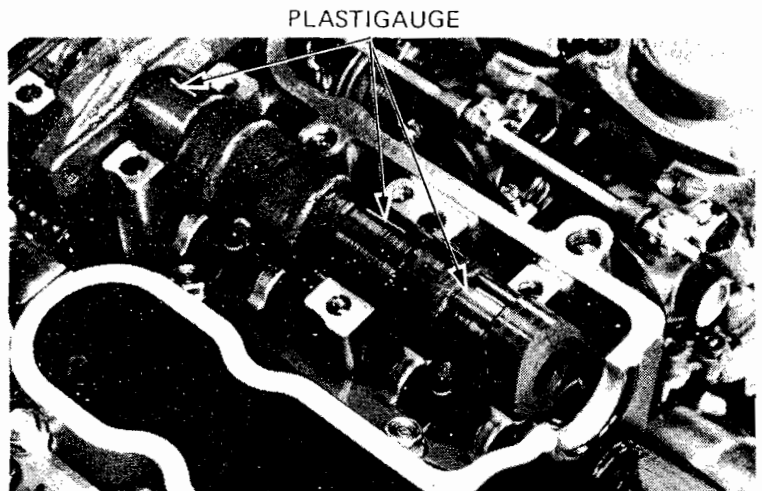

Install the camshaft holders and tighten in a criss-cross pattern.

#### NOTE

Do not rotate the camshaft when using plastigauge.

**TORQUE:** 12–16 N·m  
(1.2–1.6 kg·m, 9–12 ft·lb)

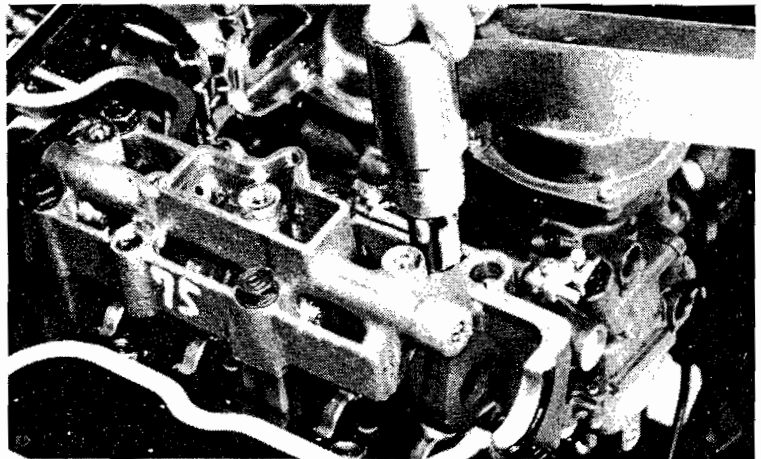

Remove the camshaft holders and measure the width of each plastigauge. The widest thickness determines the oil clearance.

#### SERVICE LIMITS:

IN1, 2, 5, 6, EX1, 2, 5, 6: 0.12 mm (0.005 in)  
IN3, 4, EX3, 4: 0.14 mm (0.006 in)

When the service limits are exceeded, replace the camshaft and recheck the oil clearance. Replace the cylinder head and camshaft holders if the clearance still exceeds service limits.

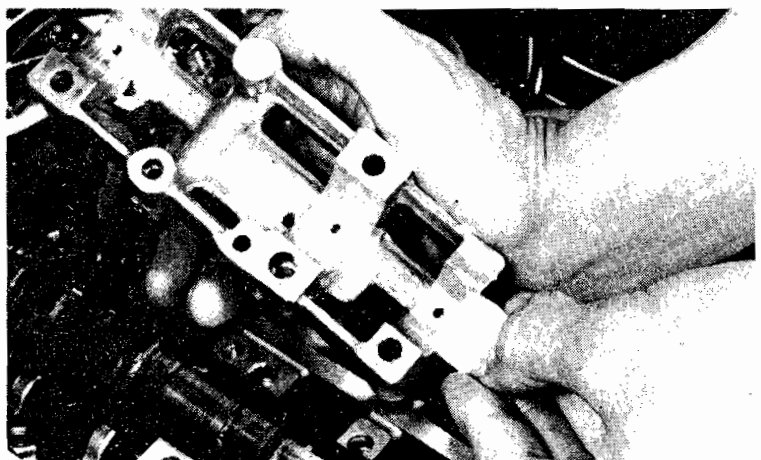



## HYDRAULIC TAPPET REMOVAL

Remove the camshafts (Page 6-3).  
Remove the rocker arm holder bolts, holders and rocker arms.  
Remove the dowel pins.

ROCKER ARM HOLDERS

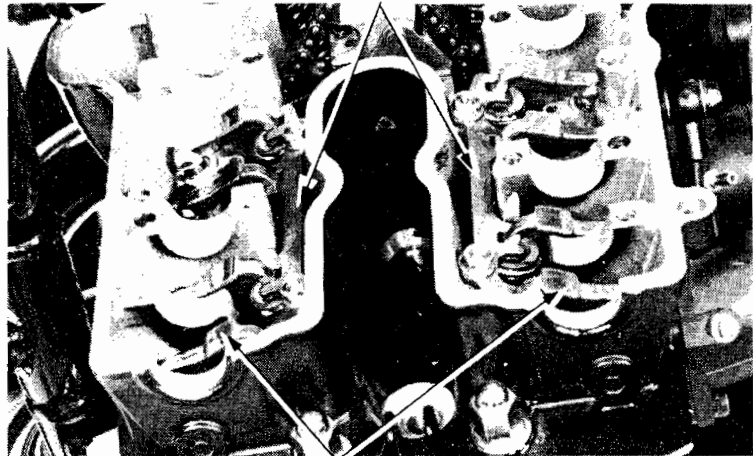

ROCKER ARMS

Remove the hydraulic tappets.

**NOTE**

Take care not to damage the pivot sphere end of the hydraulic tappet.

HYDRAULIC TAPPETS

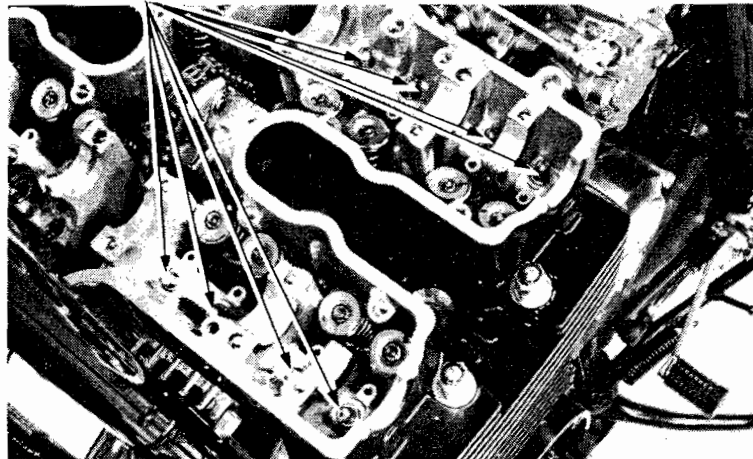

### INSPECTION ROCKER ARM

Inspect the rocker arm followers for damage or abnormal wear, and replace if necessary.

### HYDRAULIC TAPPET

Inspect the hydraulic tappet for wear or damage or for a clogged oil hole.

**CAUTION**

*Never attempt to disassemble the tappets. Always use the special tool when bleeding the tappets. Use of wire can cause damage to them.*





Measure the free length of each hydraulic tappet as follows:

Attach the Hydraulic Tappet Bleeder to the hydraulic tappet and compress and extend the hydraulic tappet bleeder slowly in a jar filled with kerosene.

**NOTE**

Hold the hydraulic tappet upright while compressing and extending the bleeder.

Continue operating the hydraulic tappet bleeder until there are no air bubbles from the hydraulic tappet.

Remove the hydraulic tappet and try to compress it quickly by hand. Measure the compression stroke with a dial gauge on a flat place.

**COMPRESSION STROKE: 0-0.2 mm**

**NOTE**

Keep the hydraulic tappet below the surface of kerosene while priming the hydraulic tappet.

HYDRAULIC TAPPET BLEEDER  
07973-MJ00000

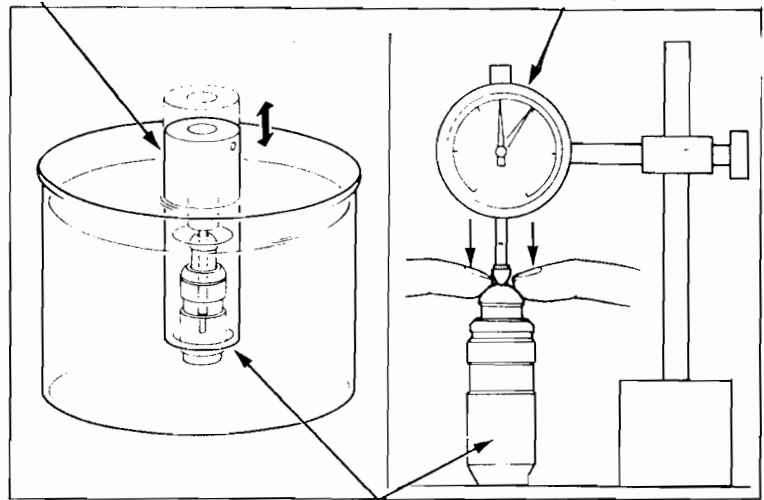

HYDRAULIC TAPPET

## CYLINDER HEAD DISASSEMBLY

- Remove the carburetor (Section 4).
- Remove the exhaust pipes (Section 17).
- Remove the camshafts (Page 6-3).
- Remove the hydraulic tappets (Page 6-8).

Place a floor jack or other adjustable support under the engine.

Remove the lower and rear engine mount bolts. Lower the engine onto the frame by pivoting it from the front engine mount bolt.

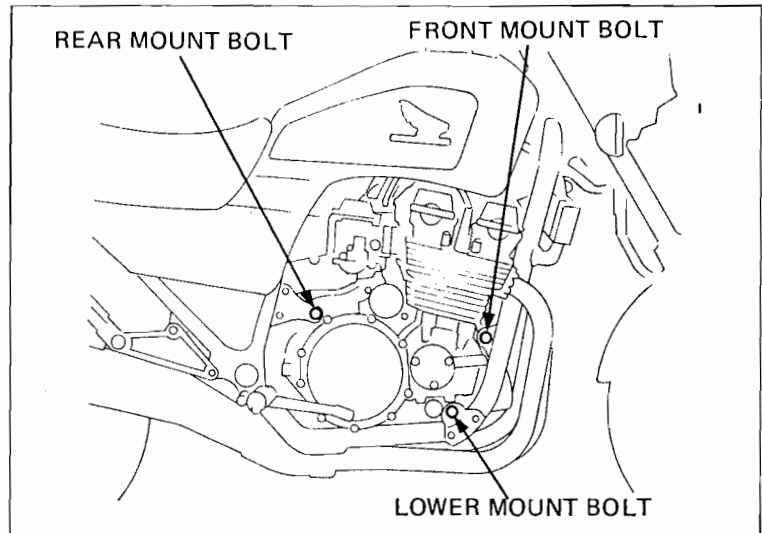

Remove the four bolts mounting the cam chain tensioner.

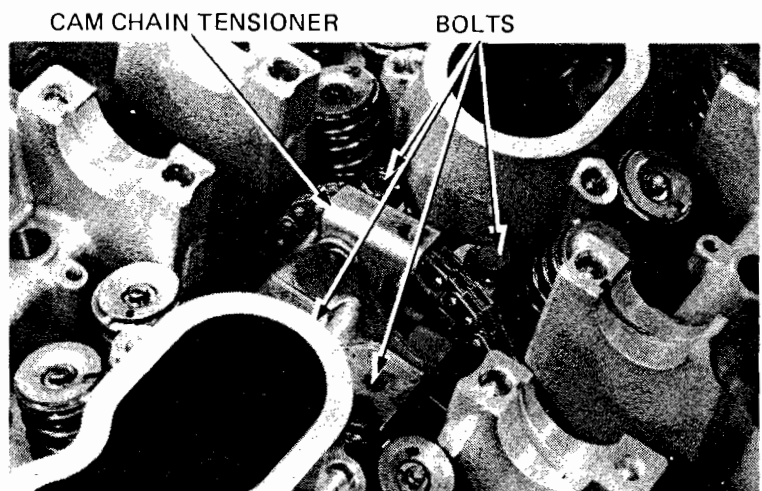



**CYLINDER HEAD/VALVES**

Remove the clips and pins from the tensioner.

**NOTE**

Use care when removing the clips and pins to prevent them from falling into the crankcase.

Place a piece of wire through the cam chain. Tie it so the chain does not fall into the crankcase. Separate the tensioner body and slider and remove them.

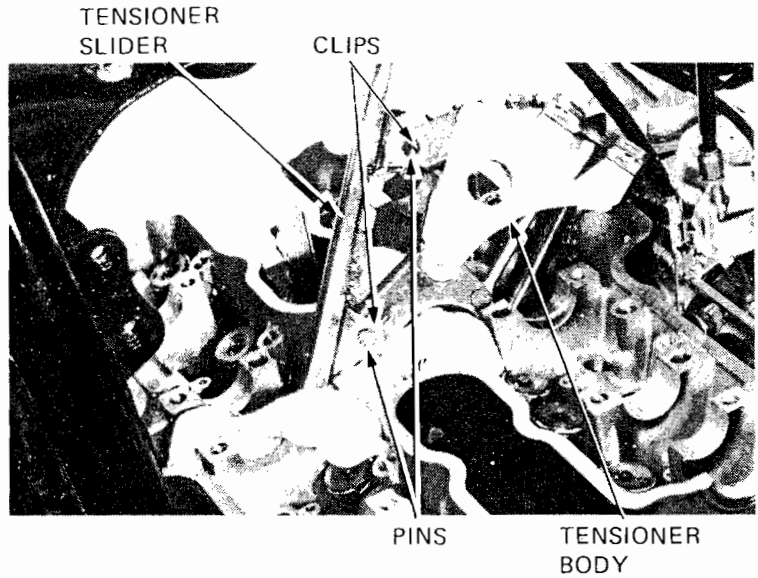

Remove the oil pipe bolts, sealing washers and oil pipe.

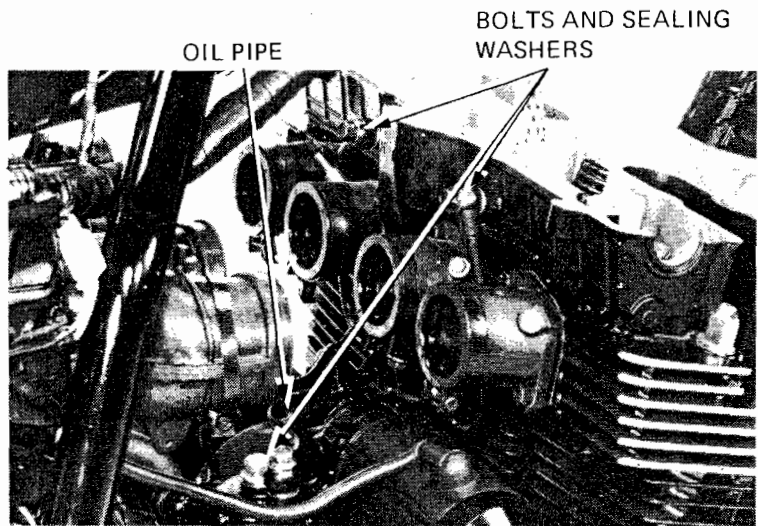

Remove the front and rear cylinder head bolts.

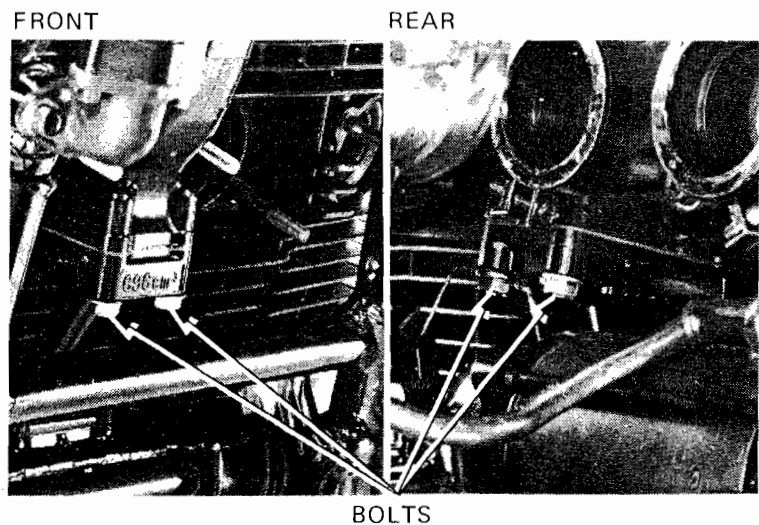



Remove the 12 cylinder head cap nuts and washers.

**NOTE**

Loosen the nuts in 2-3 steps in a crisscross pattern to prevent cylinder head warpage.

Remove the cylinder head.

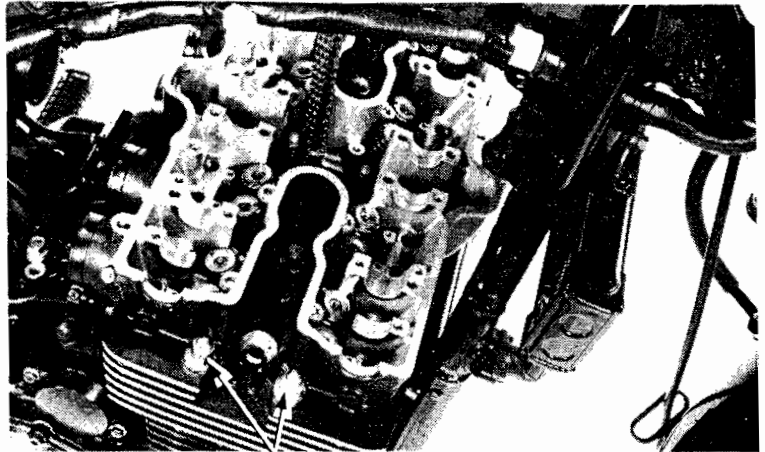

CAP NUTS

Remove the cylinder head gasket and dowel pins.  
Remove the cam chain guide.

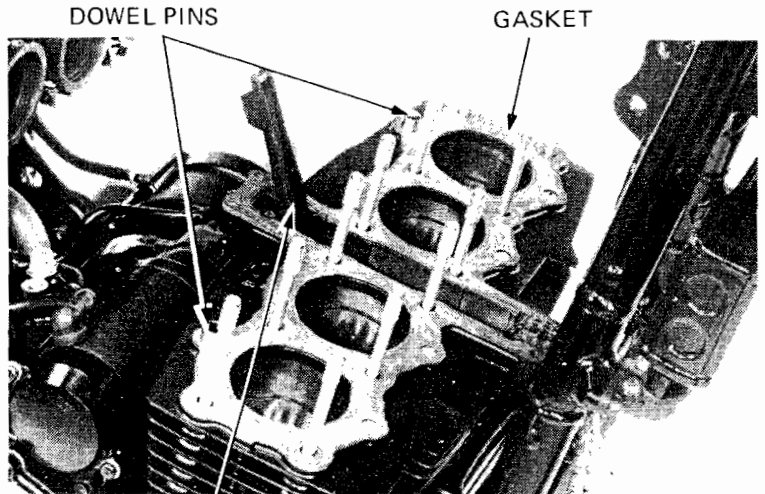

CAM CHAIN GUIDE

**CAM CHAIN GUIDE AND TENSIONER INSPECTION**

Inspect the cam chain guide and tensioner for damage or excessive wear.

Inspect the cam chain tensioner slipper for damage or excessive wear.

Replace the spring if it is weak or has been damaged.

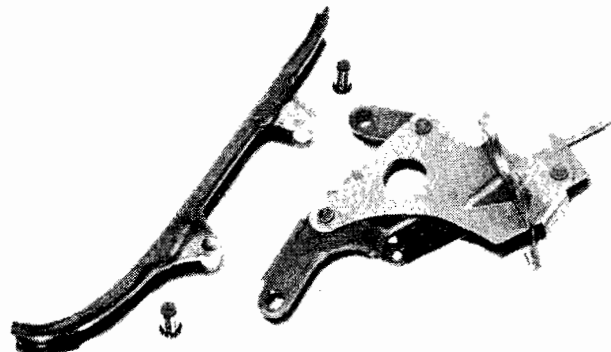





## CYLINDER HEAD DISASSEMBLY

Remove the valve cotters, retainers, springs and valves using a valve spring compressor.

### CAUTION

- To prevent loss of tension, do not compress the valve springs more than necessary to remove the cotters.
- Remove valve spring compressor large spring retainer before using to avoid damaging the cylinder head.

### NOTE

Mark all disassembled parts to ensure correct reassembly.

VALVE SPRING COMPRESSOR  
07757-0010000 or 07957-3290001

INLET PIPES

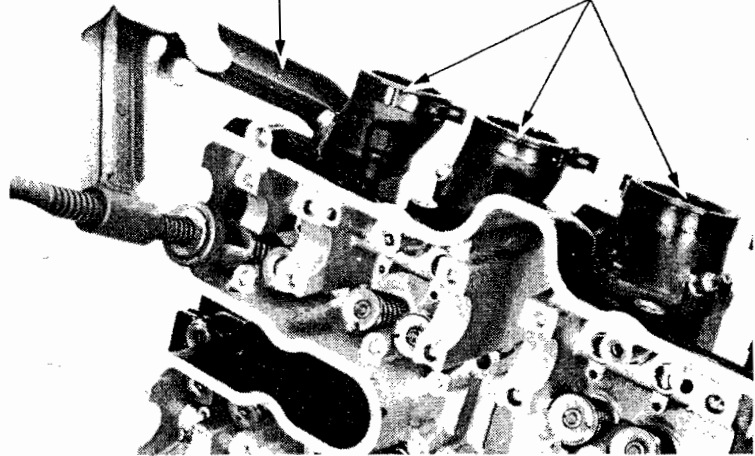

Remove the inlet pipes.

Remove carbon deposits from the combustion chamber and gasket material from the cylinder head.

Clean the head gasket surfaces thoroughly.

### NOTE

- Avoid damaging the gasket surfaces.
- The gasket will come off easier if it is soaked in solvent.

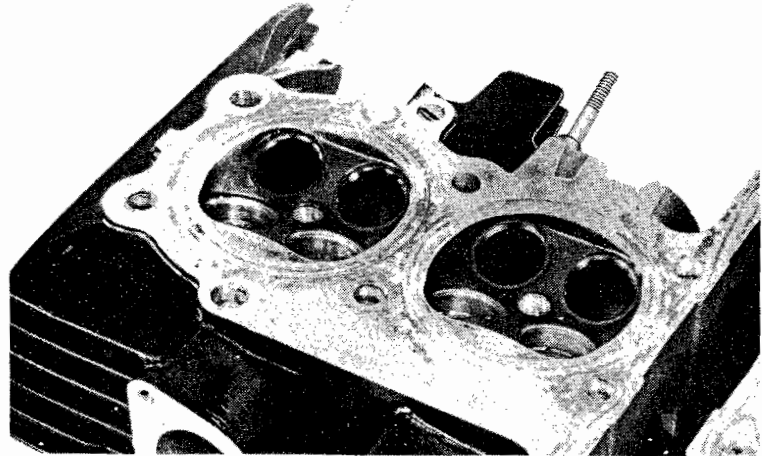

## INSPECTION

### CYLINDER HEAD

Check the spark plug holes and valve areas for cracks.

Check the cylinder head for warpage with a straight edge and a feeler gauge in an 'X' pattern.

**SERVICE LIMIT: 0.10 mm (0.004 in)**

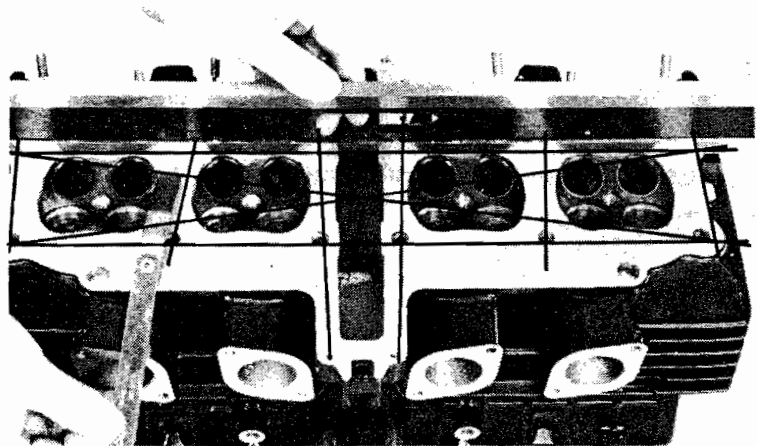



### VALVE SPRING FREE LENGTH

Measure the free length of the inner and outer valve springs.

**SERVICE LIMITS:**

**INNER SPRING: 35.5 mm (1.40 in)**

**OUTER SPRING: 40.2 mm (1.58 in)**

Replace them if they are shorter than the service limit.



### VALVE STEM-TO-GUIDE CLEARANCE

Inspect each valve for bending, burning, scratches or abnormal stem wear.

Check valve movement in the guide. Measure and record each valve stem O.D.

**SERVICE LIMITS:**

**IN: 4.97 mm (0.195 in)**

**EX: 4.94 mm (0.194 in)**

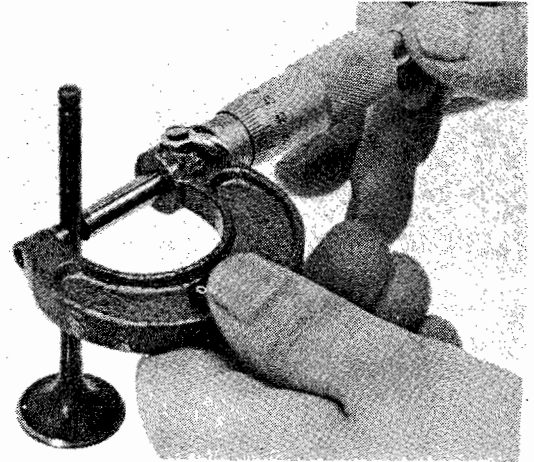

VALVE GUIDE REAMER  
07984-MA60000

Ream the guides to remove any carbon build-up before checking clearance.

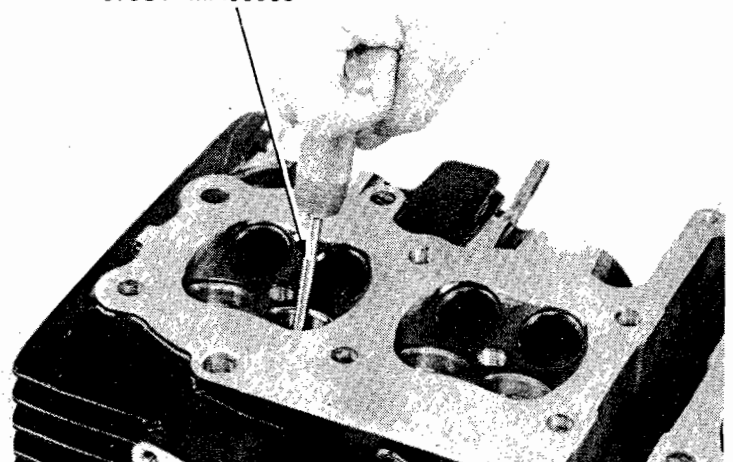



Measure and record each valve guide I.D. using a ball gauge or inside micrometer.

**SERVICE LIMIT:**

**IN:** 5.04 mm (0.198 in)

**EX:** 5.04 mm (0.198 in)

Subtract each valve stem O.D. from the corresponding guide I.D. to obtain the stem to guide clearance.

**SERVICE LIMITS:**

**IN:** 0.07 mm (0.003 in)

**EX:** 0.09 mm (0.004 in)

If the stem-to-guide clearance exceeds the service limits, determine if a new guide with standard dimensions would bring the clearance within tolerance. If so, replace any guides as necessary and ream to fit.

If the stem-to-guide clearance exceeds the service limits with new guides, replace the valves and guides.

**NOTE**

Reface the valve seats whenever the valve guides are replaced (Page 6-15).

**VALVE GUIDE REPLACEMENT**

Support the cylinder head and drive the guide from the valve port out.

**NOTE**

When driving out the valve guide, be careful not to damage the head.

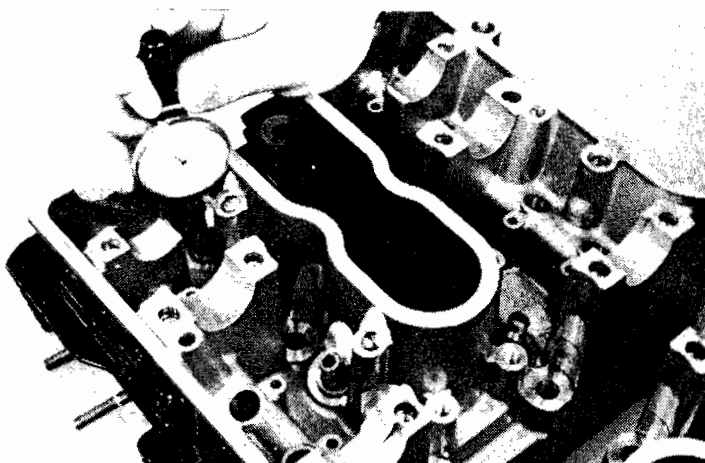

VALVE GUIDE REMOVER/DRIVER  
07942-MA60000

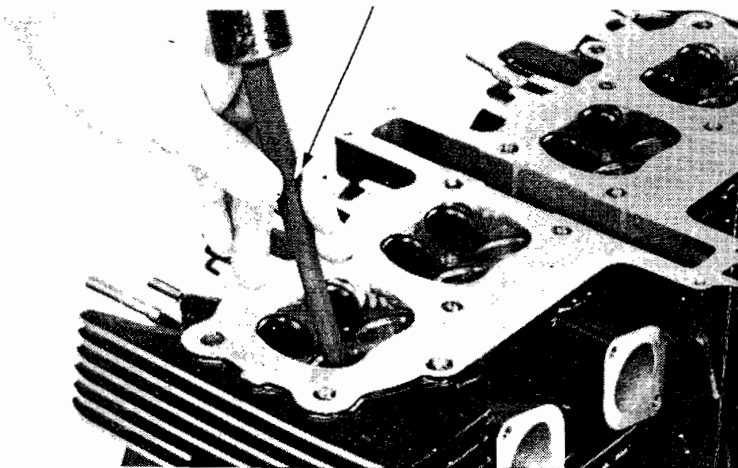

VALVE GUIDE REMOVER/DRIVER  
07942-MA60000

Install an oversize valve guide from the top of the head.

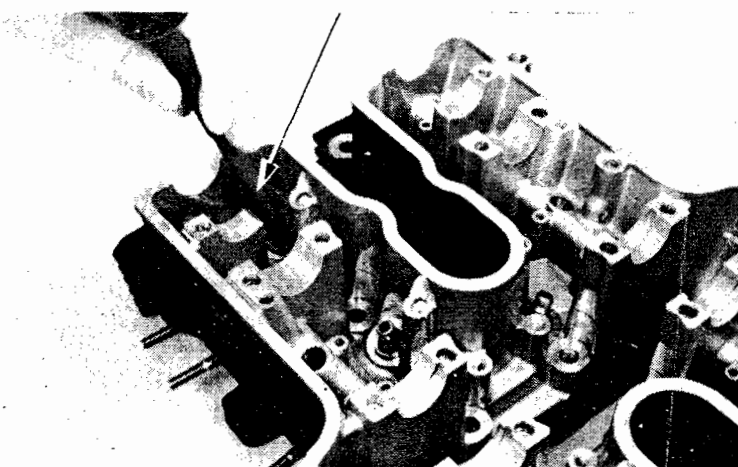



Ream the new valve guide after installation.

**NOTE**

- Use cutting oil on the reamer during this operation.
- Always rotate the reamer in the same direction when inserting and removing it.

Reface the valve seat.

Clean the cylinder head thoroughly to remove any metal particles.

VALVE GUIDE REAMER  
07984-MA60000

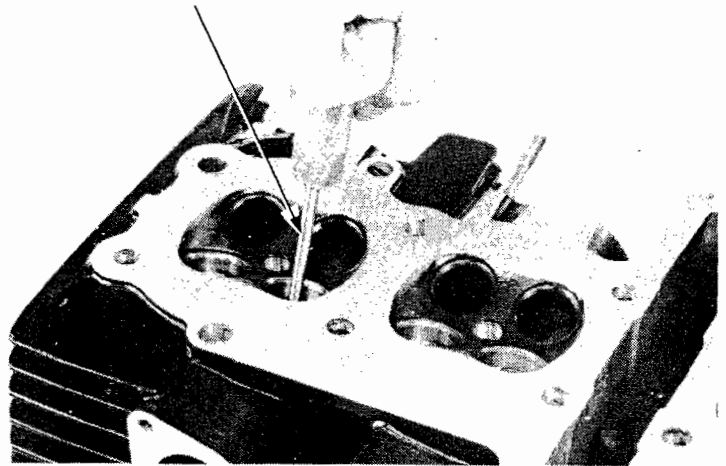

**VALVE SEAT INSPECTION/REFACING**

Clean all intake and exhaust valves thoroughly to remove carbon deposits.

Apply a light coating of valve lapping compound to each valve face. Lap each valve and seat a few times with light pressure using a rubber hose or other hand-lapping tool.

**NOTE**

Take care not to allow the compound to enter between the valve stem and guide. After lapping, wash out the compound completely and apply a coat of engine oil to the valve face and seat.

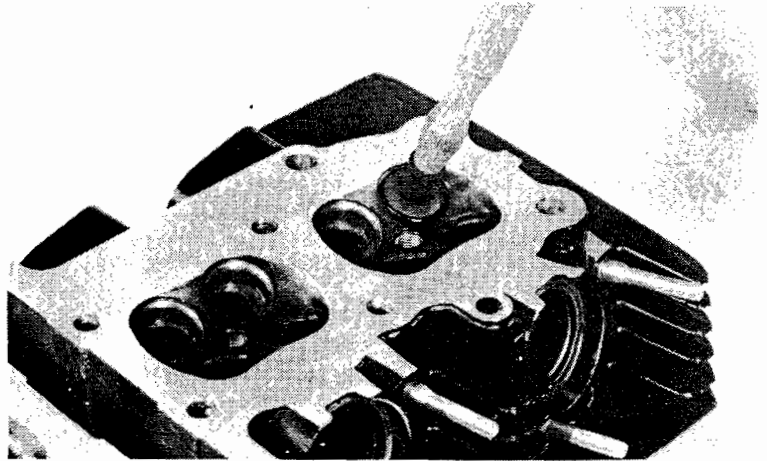

Reface the valve seat.

**CAUTION**

*The valves cannot be ground. If the valve face is rough, worn unevenly, or contacts the seat improperly, the valve must be replaced.*

Inspect the valve seat. If the seat is too wide, too narrow, or has low spots, the seat must be ground.

**NOTE**

Follow the refacer manufacturer's operating instructions.

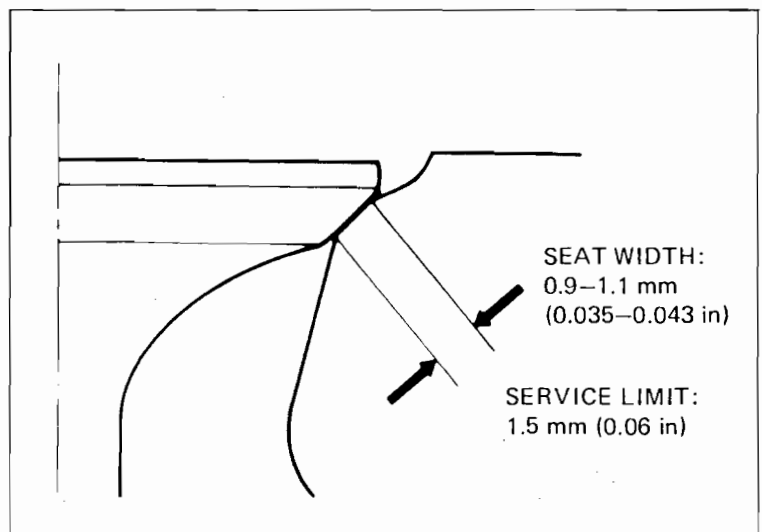



**CYLINDER HEAD/VALVES**

After cutting the seat, apply lapping compound to valve face, and lap the valve using light pressure. After lapping, wash any residual compound off the cylinder head and valve.

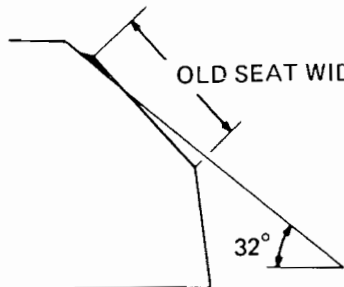

FLAT CUTTER 25 mm (IN)  
22.5 mm (EX)

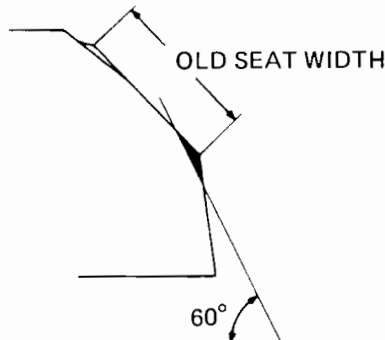

INTERIOR CUTTER 22.5 mm (IN. EX)

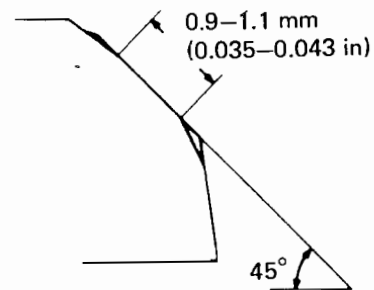

SEAT CUTTER 24.5 mm (IN)  
22.5 mm (EX)

**CYLINDER HEAD ASSEMBLY**

Clean the cylinder head assembly with solvent and blow through all oil passages with compressed air.

Install new valve stem seals.

Lubricate each valve stem with molybdenum disulfide grease and insert the valve into the valve guide.

**NOTE**

To avoid damage to the stem seal, turn the valve slowly when inserting.

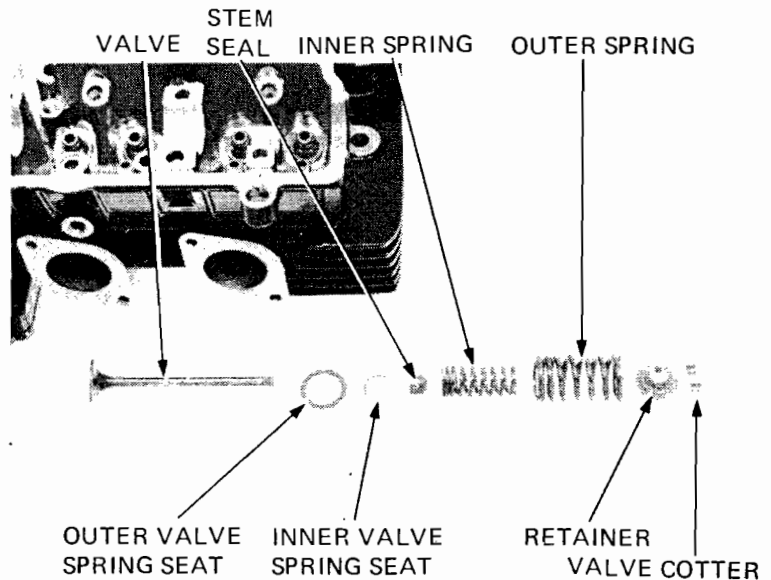

VALVE SPRING COMPRESSOR  
07757-0010000 or 07957-3290001

Install the valve springs and retainers.

**NOTE**

Install the valve springs with the tightly wound coils facing the cylinder head.

Install the valve cotters.

**CAUTION**

To prevent loss of tension, do not compress the valve spring more than necessary to install the valve cotters.

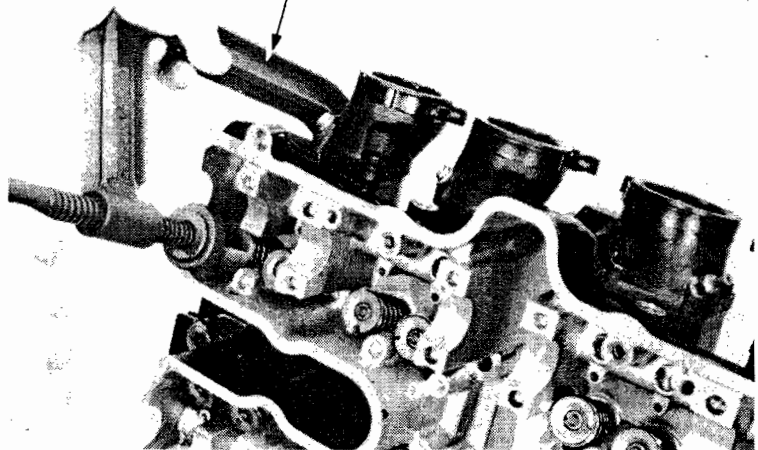



Tap the valve stems gently with a soft hammer to firmly seat the cotters.

**NOTE**

Support the cylinder head above the work bench surface to prevent possible valve damage.

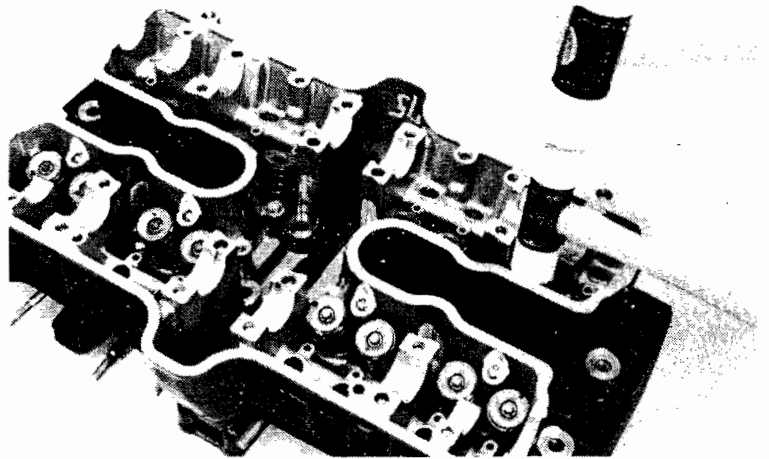

**CYLINDER HEAD INSTALLATION**

Clean the cylinder head surfaces of any gasket material.

Install the dowel pins and a new gasket.

Install the cam chain guide.

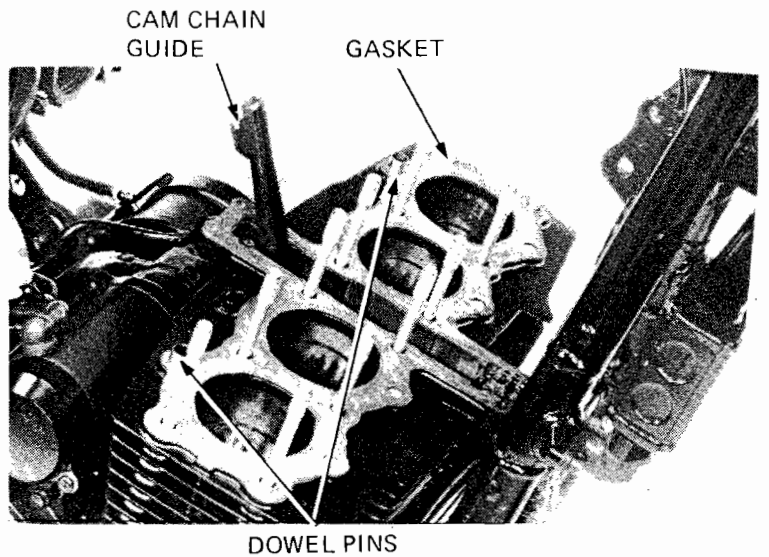

Push on the tensioner arm and lock the arm by setting the lock pin to the lock plate as shown.

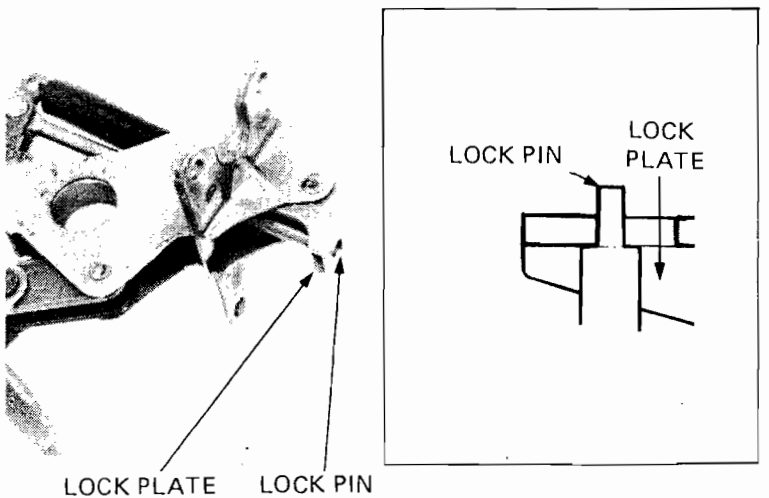



Slide the cam chain guide slightly and push it forward, then lower the cylinder head.

Set the cam chain guide properly and set the cylinder head.

Tighten the 12 cylinder head cap nuts in the sequence shown.

**TORQUE:** 26–30 N·m  
(2.6–3.0 kg-m, 19–22 ft-lb)

**NOTE**

Apply molybdenum disulfide grease to the threads of the cylinder studs.

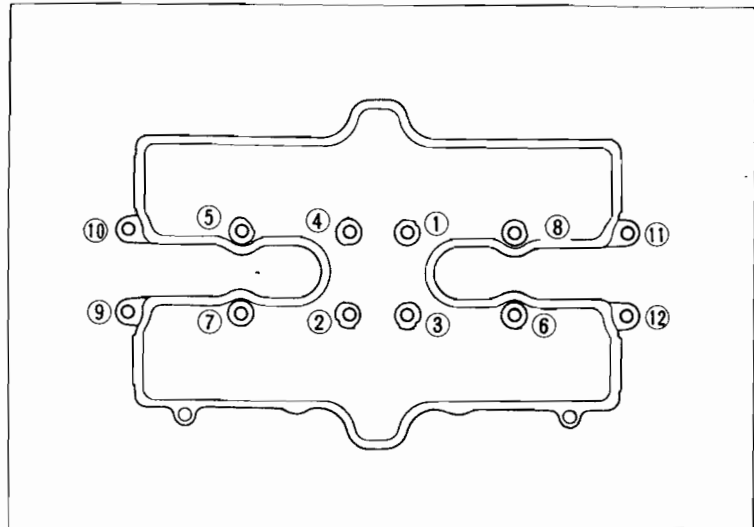

Tighten the front and rear cylinder head bolts.

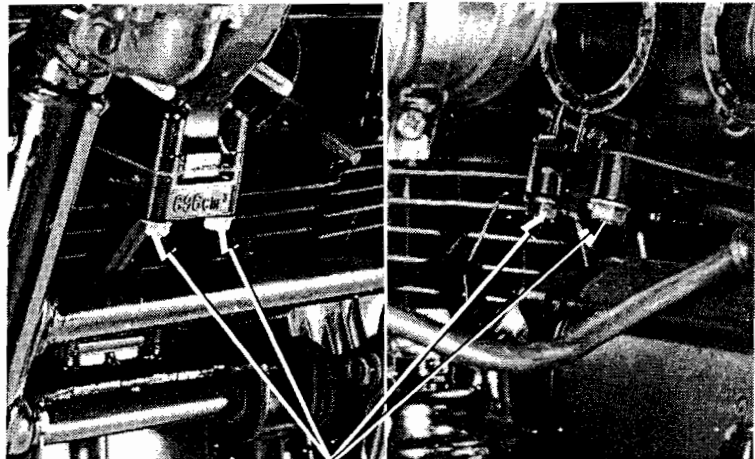

**BOLTS**

Blow the oil pipe and oil control bolt with compressed air.

Make sure that the sealing washers are in good condition.

Install the oil pipe with oil bolts and sealing washers.

Tighten the oil bolts.

**TORQUE:**

- 7 mm bolt: 10–14 N·m  
(1.0–1.4 kg-m, 7–10 ft-lb)
- 8 mm bolt: 12–16 N·m  
(1.2–1.6 kg-m, 9–12 ft-lb)
- mm bolt: 16–20 N·m  
(1.6–2.0 kg-m, 12–14 ft-lb)

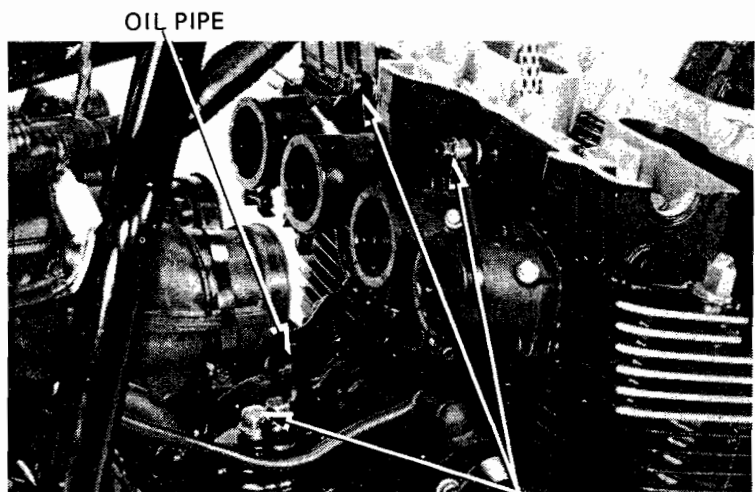

**OIL BOLTS**

Install the carburetors and exhaust system.



Put the cam chain over the tensioner body and install the tensioner slider with the clips and pins as shown.

**NOTE**

Be careful not to drop the pins and clips into the crankcase.

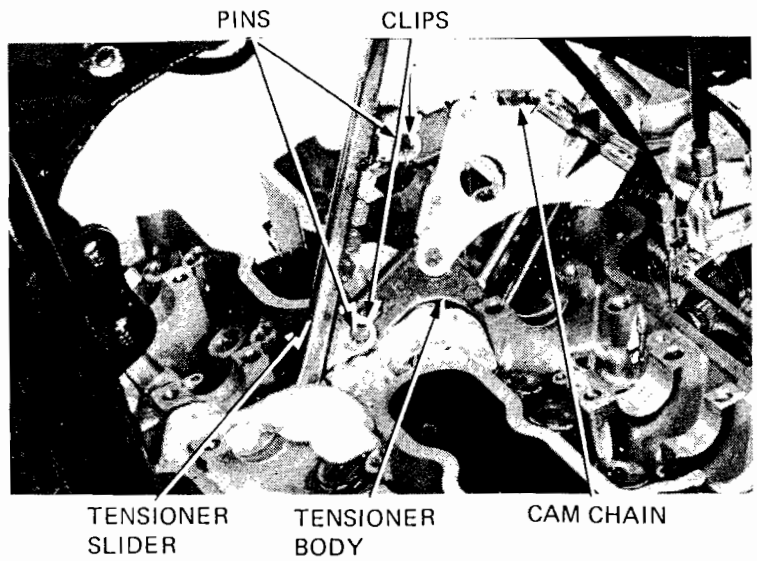

Tighten the cam chain tensioner with the four bolts.

**TORQUE:** 10–14 N·m  
(1.0–1.4 kg·m, 7–10 ft·lb)

Install the rear and lower engine mount bolts (Page 5-5).

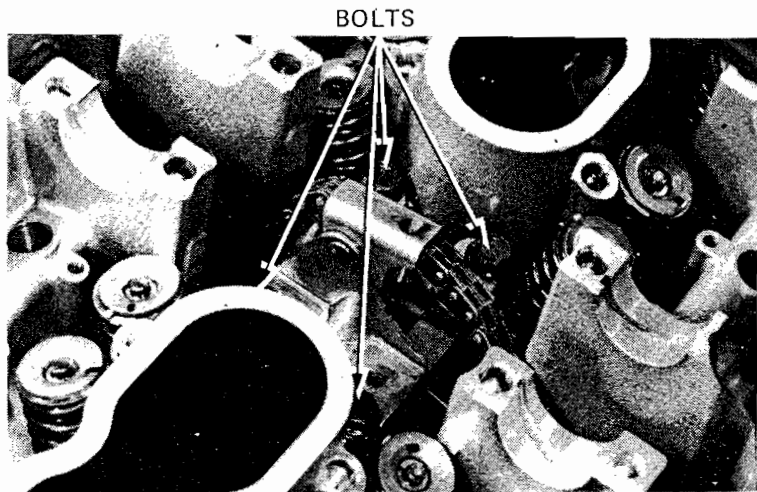





## HYDRAULIC TAPPET INSTALLATION

Place the tappet in a jar filled with kerosene.  
 Place the tappet bleeder into the tappet.  
 Hold the tappet upright and pump the tappet until air bubbles stop coming out. Remove the tool, and try to quickly compress the tappet by hand. You should not be able to compress it more than 0.2 mm (0.008 in).  
 Remove the tappet from the fluid keeping it upright.

HYDRAULIC TAPPET BLEEDER  
 07973 - MJ00000

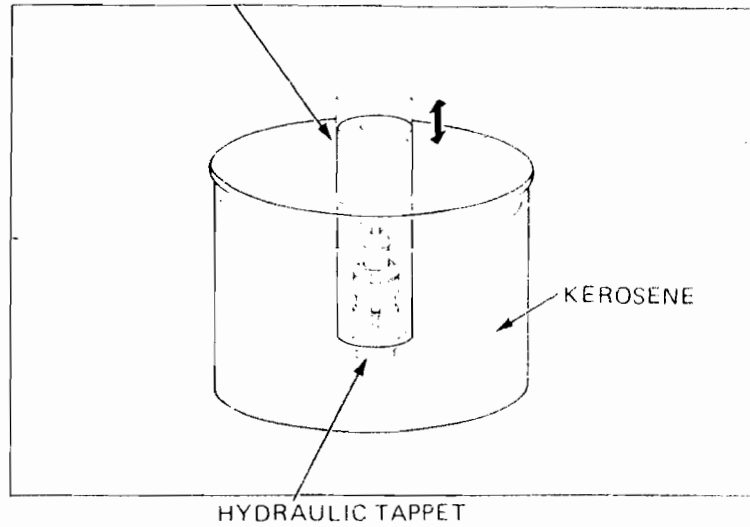

Fill all the tappet holes up with clean engine oil.  
 Install the bled hydraulic tappets as described in above procedure.

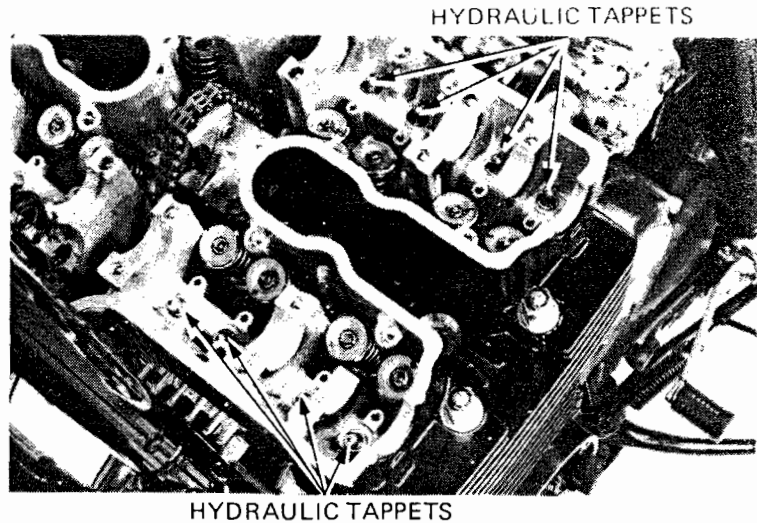

Install the dowel pins into the cylinder head.

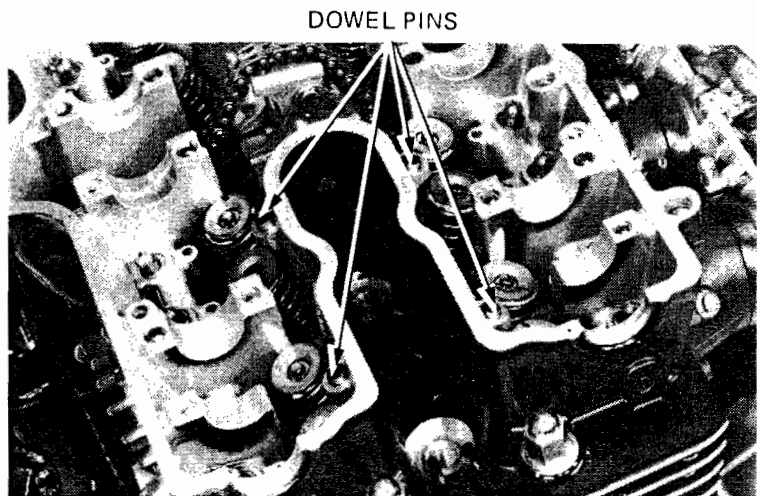



Install the rocker arms.  
Install the rocker arm holders and tighten the bolts.

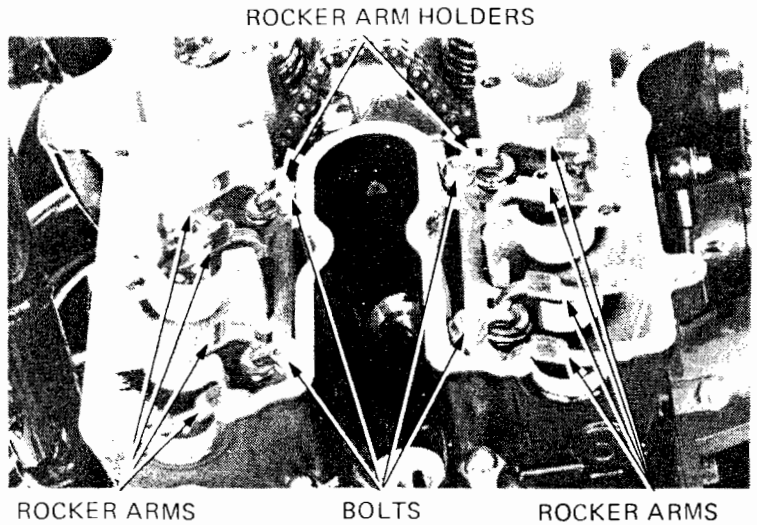

### CAMSHAFT INSTALLATION

Remove the pulse generator cover.  
Turn the crankshaft counterclockwise and align the "T" mark on the pulse rotor with the index mark on the crankcase.

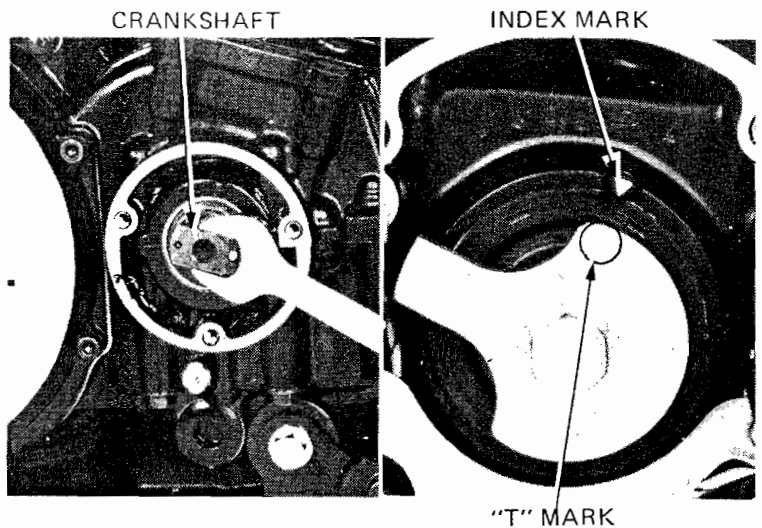

Lubricate the camshaft bearings with molybdenum disulfide grease.  
Position the cam sprockets onto the camshaft with the timing marks facing out.  
Place the intake and exhaust camshaft onto the cylinder head with the No. 1 cam lobes facing up as shown.

**NOTE**

The camshaft has an "IN" mark for intake, or an "EX" mark for exhaust.

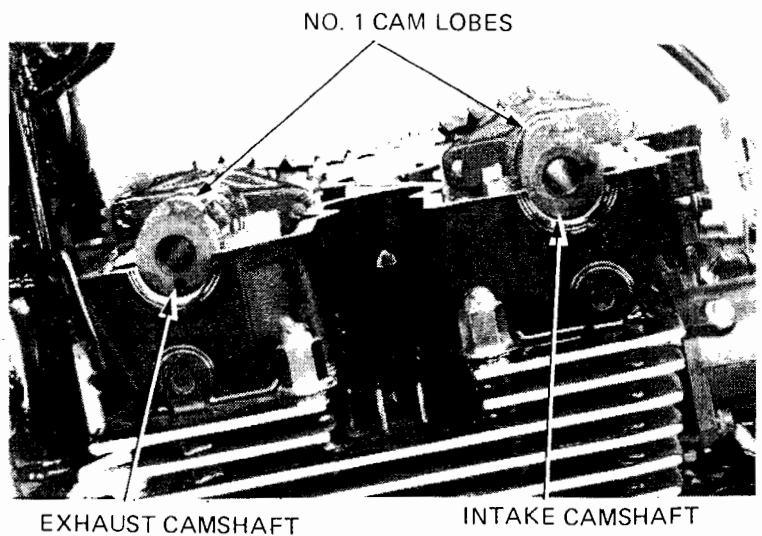



Install the two oil orifices and O-rings.  
Install the camshaft holder dowel pins.

OIL ORIFICES/O-RINGS

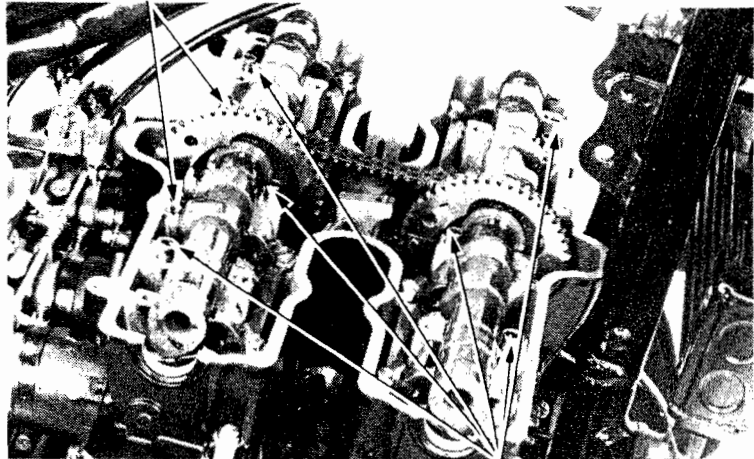

DOWEL PINS

Install each camshaft holder on its original position.

**NOTE**

The camshaft holders have their location marks.  
 "INR" mark: Intake right  
 "INL" mark: Intake left  
 "EXR" mark: Exhaust right  
 "EXL" mark: Exhaust left

Tighten the camshaft holder bolts to the specified torque in a crisscross pattern in 2-3 steps.

**TORQUE: 12-16 N·m**  
**(1.2-1.6 kg·m, 9-12 ft·lb)**

Align the "IN" marks on the intake cam sprocket and "EX" mark on the exhaust cam sprocket with the cylinder head upper surface.

The "RH" marks should be facing up and right side of the engine as shown.

Place the cam chain over the cam sprockets.

Install the cam sprockets onto the camshaft flange shoulders.

Align the cam sprocket bolt holes by turning the crankshaft slightly counterclockwise and install the cam sprocket bolts.

Tighten the sprocket bolts to the specified torque.

**TORQUE: 18-20 N·m**  
**(1.8-2.0 kg·m, 13-14 ft·lb)**

"IN" MARK "RH" MARK "EX" MARK

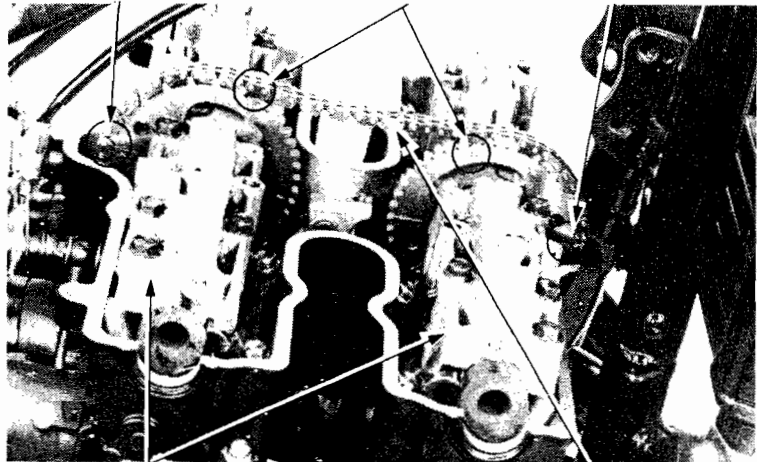

CAMSHAFT HOLDERS

CAM CHAIN

CAM SPROCKET BOLTS

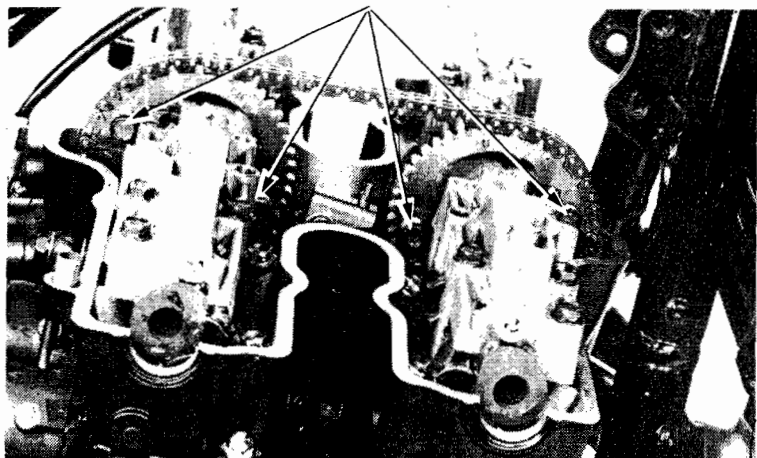



Fill the defoaming chambers in the camshaft holders with clean engine oil.

Realign the pulse rotor "T" mark with the index mark on the crankcase and make sure that the "IN" and "EX" marks align with the cylinder head upper surface.

Push the cam chain tensioner lock pin to the rear to free the cam chain tensioner.



Blow the oil pipes and oil bolts with compressed air. Make sure that the oil bolt sealing washers are in good condition and install the oil pipes.

**TORQUE:** 10–14 N·m  
(1.0–1.4 kg·m, 7–10 ft·lb)

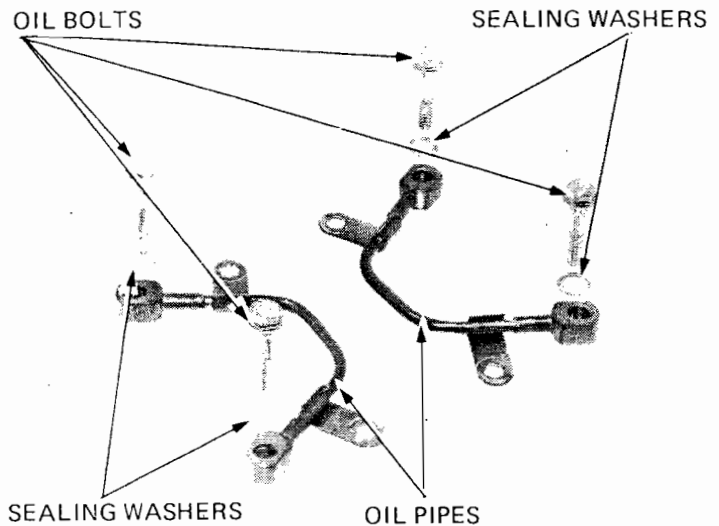

Install the defoaming chamber covers with the socket bolts.

Install the cam chain guard with four bolts.

**TORQUE:** 12–16 N·m  
(1.2–1.6 kg·m, 9–12 ft·lb)

Install the cylinder head cover dowel pins.

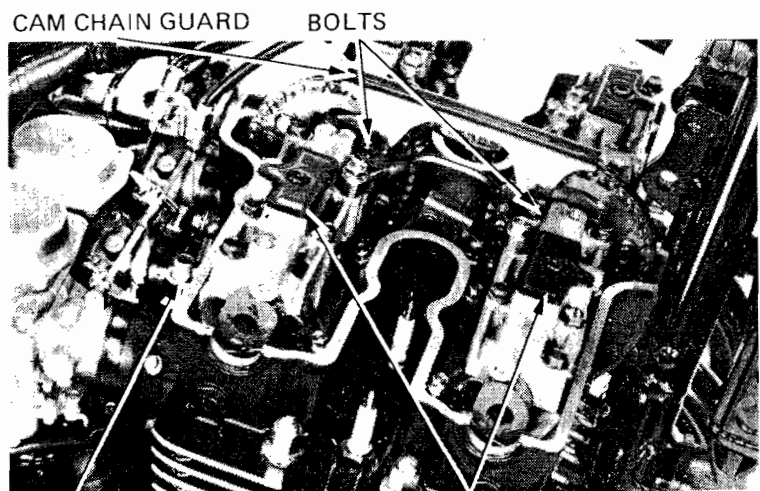



Install the cylinder head cover and tighten the cover bolts.

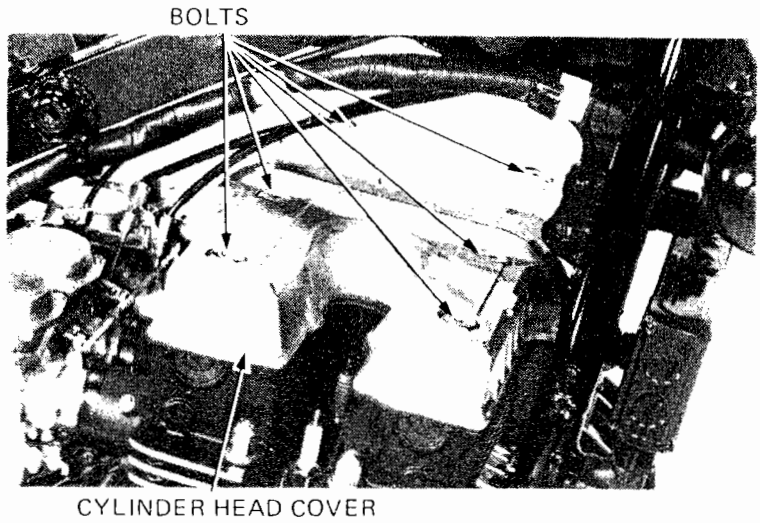

Install the sub frames and tighten the bolts.

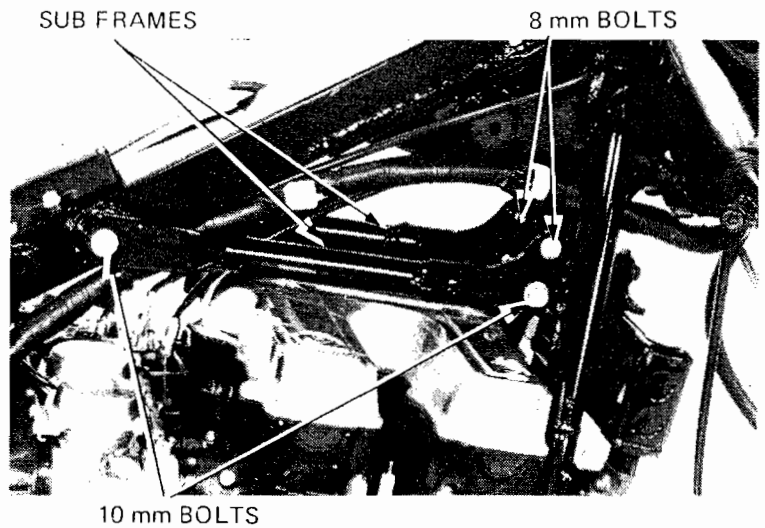

Install the air guide and ignition coils (Page 19-3).

Install the fuel tank and seat.

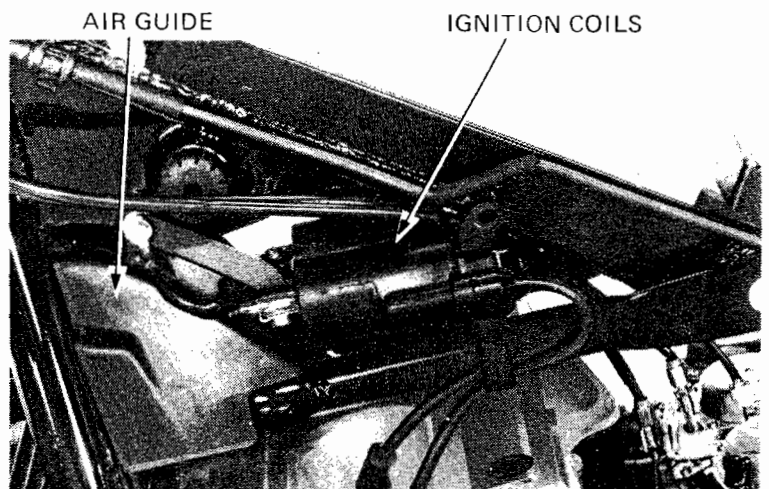



**HONDA**  
**CB750SC**

---

MEMO

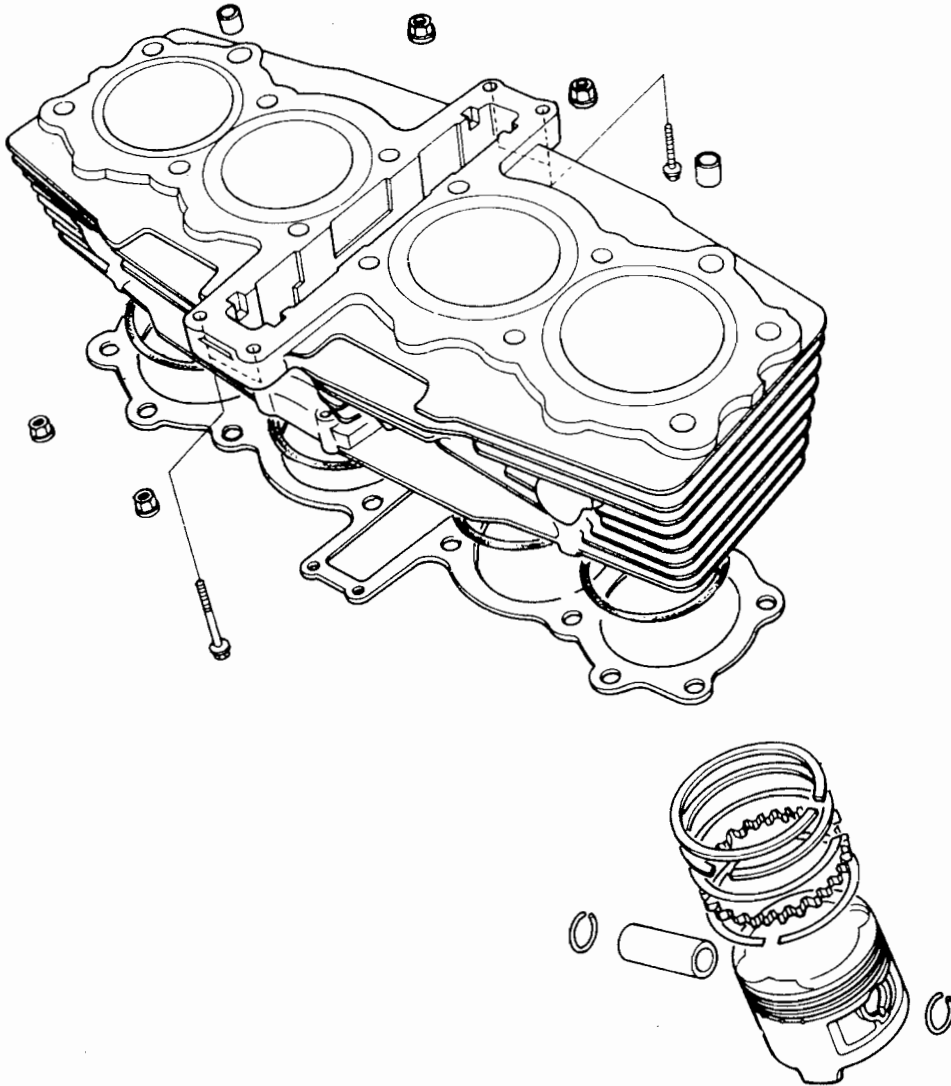



# 7. CYLINDER/PISTON

SERVICE INFORMATION	7-1	PISTON REMOVAL	7-3
TROUBLESHOOTING	7-1	PISTON INSTALLATION	7-7
CYLINDER REMOVAL	7-2	CYLINDER INSTALLATION	7-7

## SERVICE INFORMATION

### GENERAL

All cylinder/piston maintenance and inspection can be accomplished without removing the engine from the frame.

### SPECIFICATIONS

Cylinder		I.D.		STANDARD	SERVICE LIMIT
				67.000–67.010 mm (2.6378–2.6382 in)	67.10 mm (2.642 in)
		Warpage		—	0.10 mm (0.004 in)
Piston, piston rings and piston pin	Piston ring-to-ring groove clearance	TOP		0.015–0.045 mm (0.0006–0.0018 in)	0.06 mm (0.002 in)
		SECOND		0.015–0.045 mm (0.0006–0.0018 in)	0.06 mm (0.002 in)
	Ring end gap	TOP		0.15–0.30 mm (0.006–0.012 in)	0.5 mm (0.02 in)
		SECOND		0.15–0.30 mm (0.006–0.012 in)	0.5 mm (0.02 in)
		OIL (SIDE RAIL)		0.30–0.90 mm (0.012–0.035 in)	1.1 mm (0.04 in)
	Piston O.D.		66.970–66.990 mm (2.6366–2.6374)	66.90 mm (2.634 in)	
	Piston pin bore		17.002–17.008 mm (0.6694–0.6696 in)	17.05 mm (0.671 in)	
	Connecting rod small end I.D.		17.016–17.034 mm (0.6699–0.6706 in)	17.07 mm (0.672 in)	
	Piston pin O.D.		16.994–17.000 mm (0.6691–0.6693 in)	16.98 mm (0.669 in)	
	Piston-to-piston pin clearance		0.002–0.014 mm (0.0001–0.0006 in)	0.04 mm (0.002 in)	
	Connecting rod-to-piston pin clearance		0.016–0.040 mm (0.0006–0.0017 in)	0.06 mm (0.002 in)	
	Cylinder-to-piston clearance		0.010–0.050 mm (0.0003–0.0020 in)	0.10 mm (0.004 in)	

### TOOLS

#### Special

Piston base (2 required)	07958–3000000
Piston ring compressor (2 required)	07954–2830000

## TROUBLESHOOTING

#### Compression low

1. Worn cylinder or piston rings
2. Leaking valve seats

#### Excessive smoke

1. Worn cylinder or piston
2. Improper installation of piston rings
3. Scored or scratched piston or cylinder wall

#### Overheating

1. Excessive carbon build-up on the piston or combustion chamber wall
2. Incorrect spark plug

#### Knocking or abnormal noise

1. Worn piston and cylinder
2. Excessive carbon build-up
3. Low octane fuel





## CYLINDER REMOVAL

Remove the cylinder head (Section 6)

Remove the cam chain tensioner guide.

Remove the front and rear cylinder holding nuts and remove the cylinder.

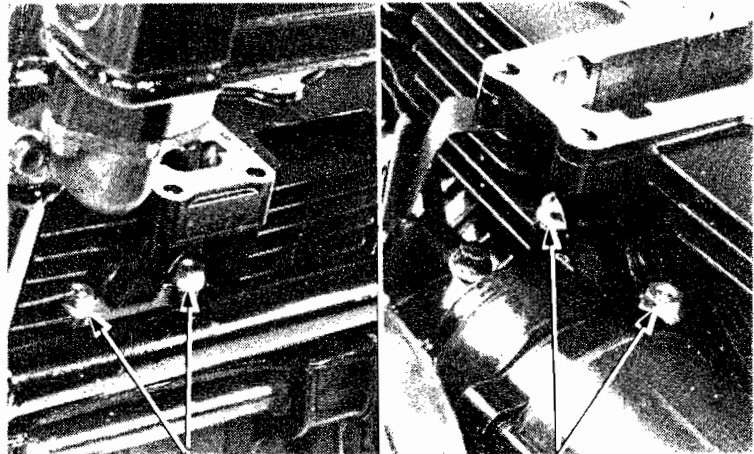

FRONT HOLDING NUTS

REAR HOLDING NUT

Remove the cylinder gasket and dowel pins.

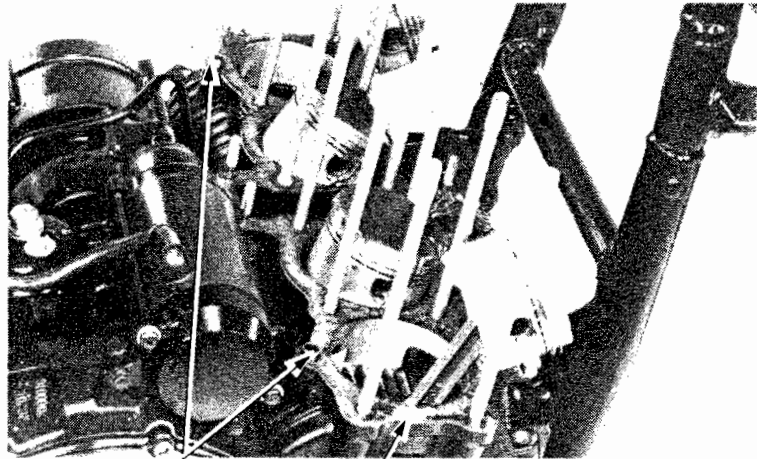

DOWEL PINS

GASKET

Remove gasket material from the cylinder surfaces.

### NOTE

- Avoid damaging the cylinder surfaces.
- Gaskets will come off easier if soaked in solvent.

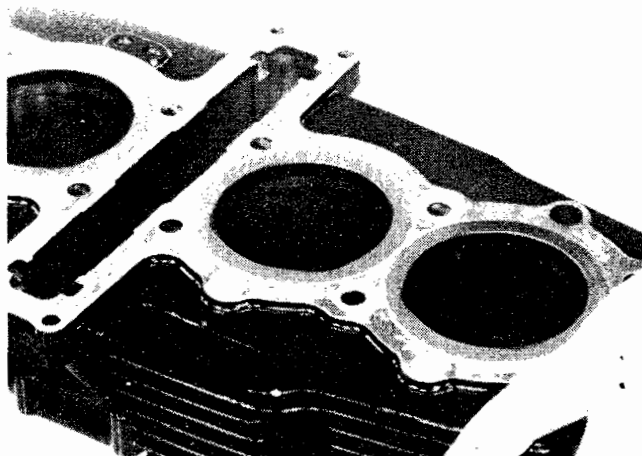



Inspect the top of the cylinder for warpage. Check in an X pattern as shown.

**SERVICE LIMIT: 0.10 mm (0.004 in)**

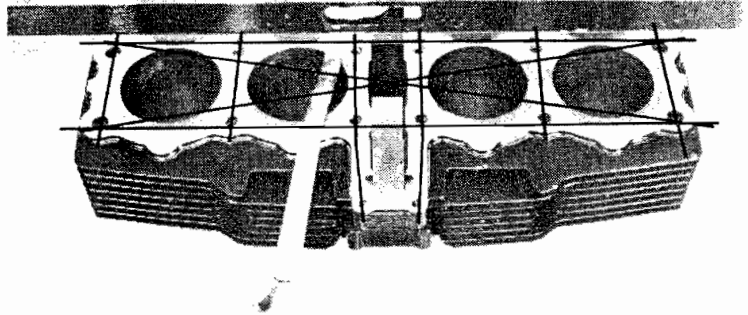

Inspect the cylinder bores for wear or damage.

Measure the cylinder I.D. at the three levels shown in both X and Y directions.

**SERVICE LIMIT: 67.10 mm (2.642 in)**

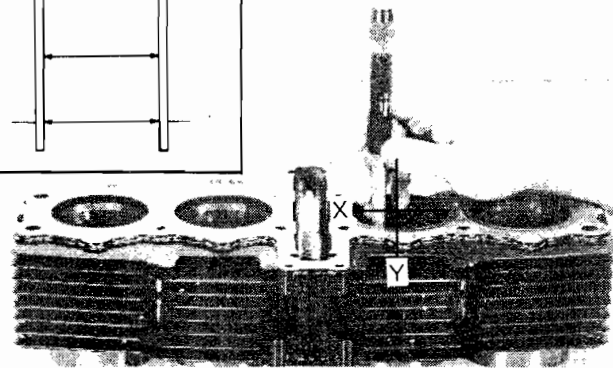
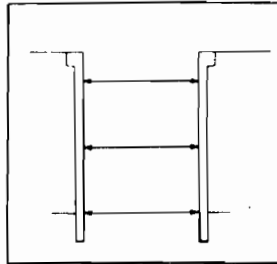

## PISTON REMOVAL

Place rags in the crankcase openings.  
Remove each piston pin clip with needle nose pliers being careful not to allow clips to fall into the crankcase.

Press the piston pins out.

Mark each piston to indicate its cylinder position for reassembly.





**INSPECTION**

**PISTON/PISTON RING**

Inspect the piston ring-to-groove clearance.

**SERVICE LIMIT:**

**TOP: 0.06 mm (0.002 in)**

**SECOND: 0.06 mm (0.002 in)**

Mark the rings so that they can be returned to correct piston during reassembly.

Inspect the pistons for damage and cracks; ring grooves for wear.



Insert each piston ring into the bottom of the cylinder, and inspect the end gap.

**SERVICE LIMITS:**

**TOP: 0.50 mm (0.020 in)**

**SECOND: 0.50 mm (0.020 in)**

**OIL (Side rail): 1.10 mm (0.043 in)**

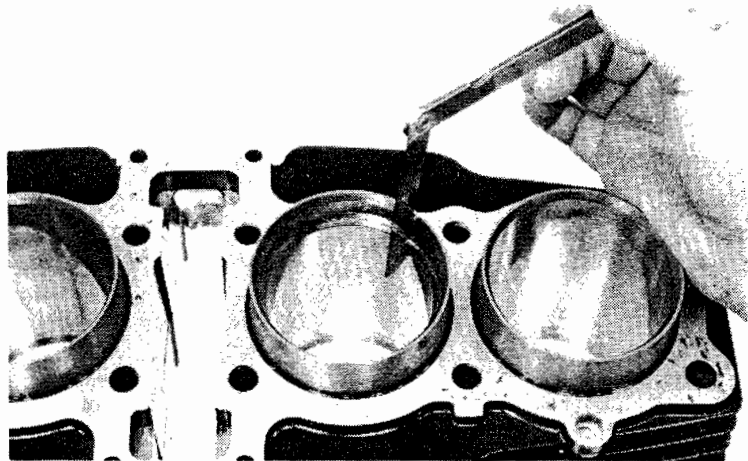

Measure the piston O.D. 14 mm (0.6 in) from the bottom of the skirt and 90° to the piston pin hole.

**SERVICE LIMIT: 66.90 mm (2.634 in)**

Calculate the cylinder-to-piston clearance.

**SERVICE LIMIT: 0.10 mm (0.004 in)**

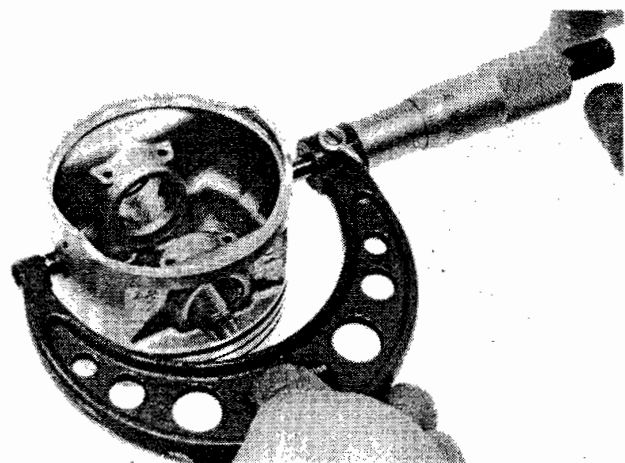



Measure the piston pin hole I.D.

**SERVICE LIMIT: 17.05 mm (0.671 in)**

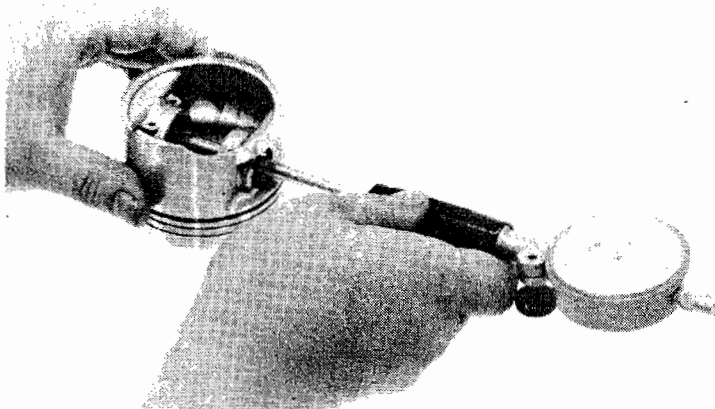

Measure the connecting rod small end I.D.  
(See Section 12 for replacement procedure)

**SERVICE LIMIT: 17.07 mm (0.672 in)**

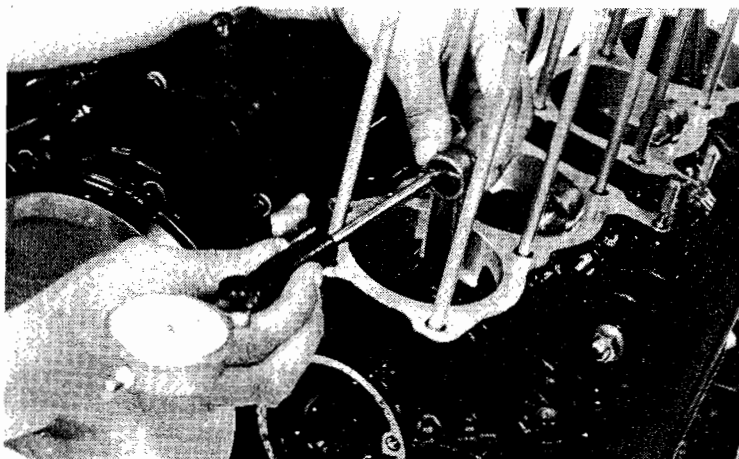

Measure the piston pin O.D.

**SERVICE LIMIT: 16.98 mm (0.669 in)**

Determine the piston-to-piston pin clearance.

**SERVICE LIMIT: 0.04 mm (0.002 in)**

Determine the connecting rod-to-piston pin clearance.

**SERVICE LIMIT: 0.06 mm (0.002 in)**

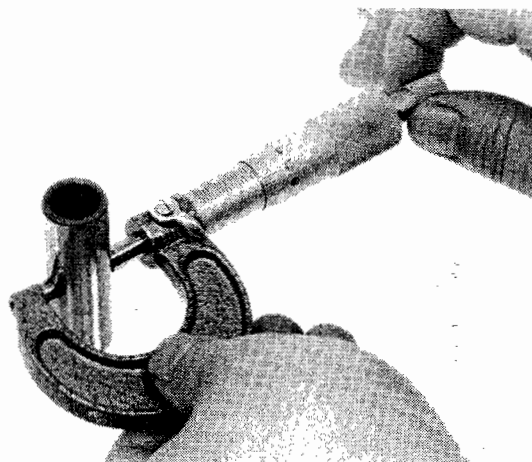



**PISTON RING INSTALLATION**

Install the piston rings with the markings facing up.

**NOTE**

After installation, the rings should rotate freely in the grooves.

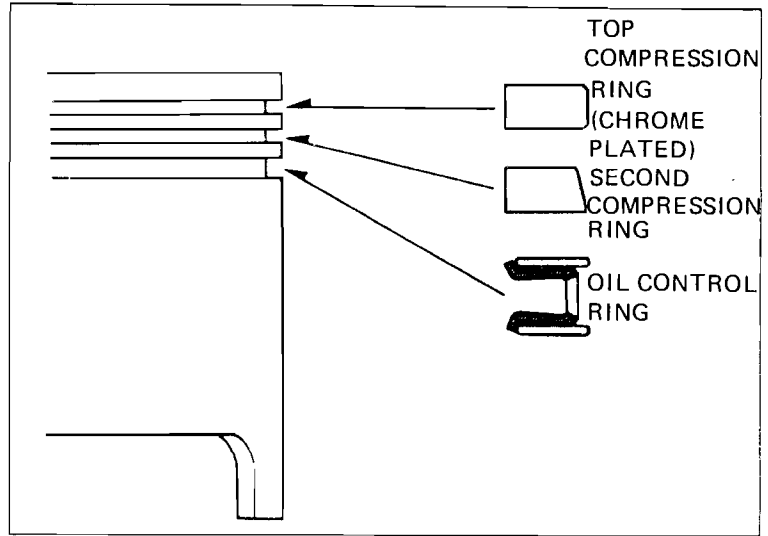

Space the piston ring end gaps 120 degrees apart.  
Do not align the gaps in the oil ring side rails.

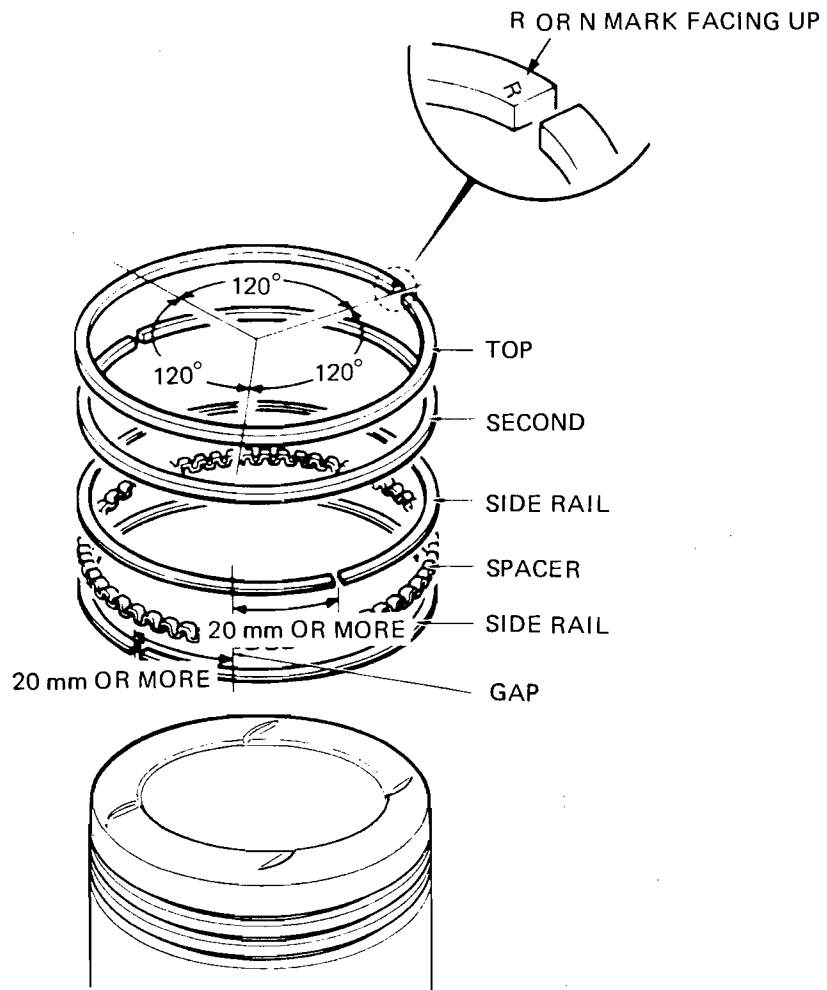



### PISTON INSTALLATION

Apply molybdenum disulfide grease to the connecting rod small ends.

Install the pistons, piston pins and clips. Be careful not to drop clips into the crankcase.

#### NOTE

- Position the "IN" mark on the piston crown toward the intake side.
- Install the pistons in their original positions.

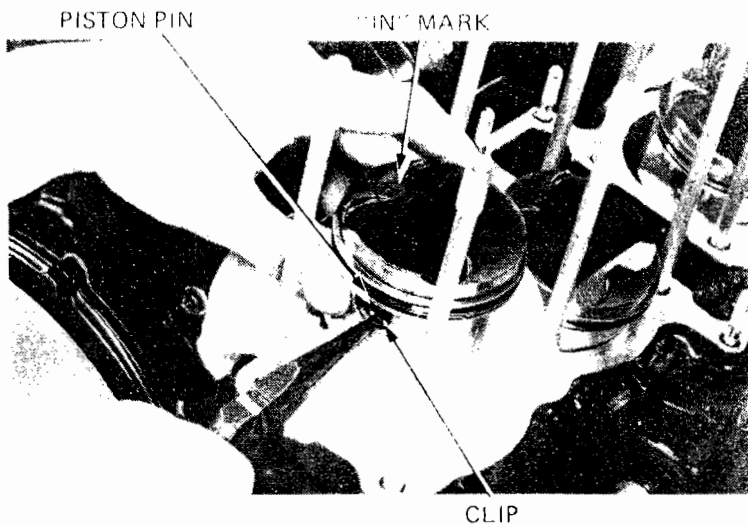

### CYLINDER INSTALLATION

Install the dowel pins and a new gasket

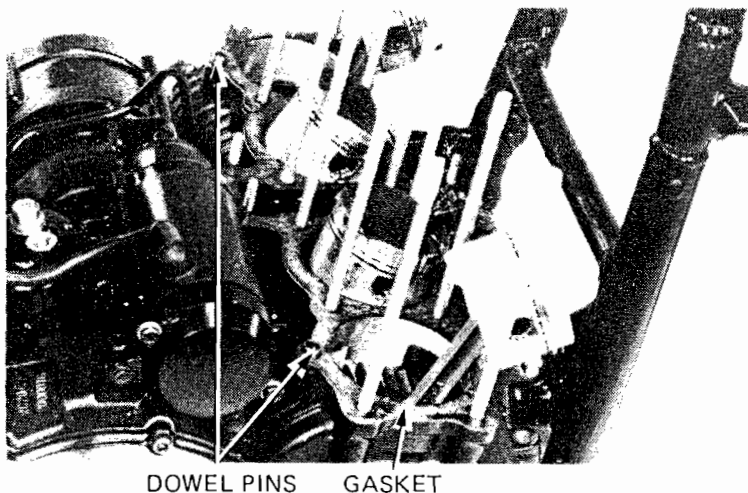

Position the No. 1 and No. 4 pistons at T.D.C.  
 Insert the piston bases under the pistons and attach piston ring compressors to the No. 1 and No. 4 pistons.  
 Slide the cylinder over the pistons.  
 Remove the piston bases and compressors.

PISTON RING COMPRESSOR (2 PCS)  
07954-2830000

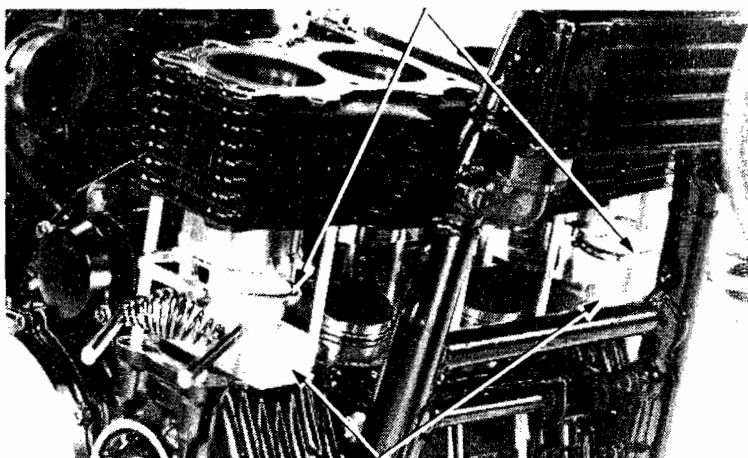

PISTON BASE (2 PCS)  
07958-3000000



Attach the piston ring compressors to the No. 2 and No. 3 pistons and slide the cylinder over the pistons.

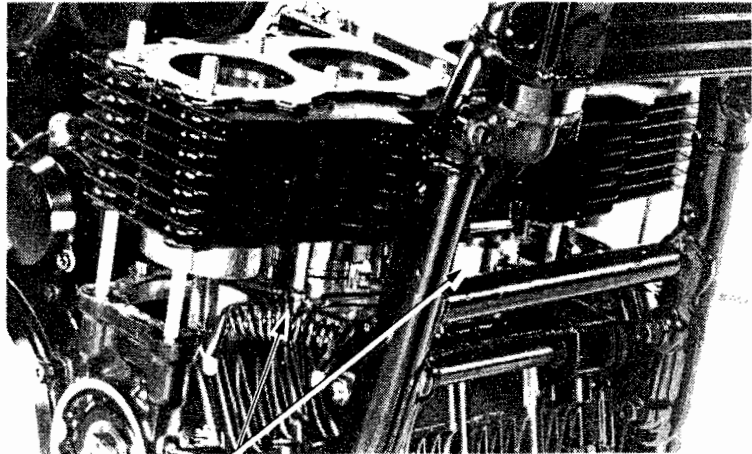

PISTON RING COMPRESSOR  
07954-2830000

Install the cylinder holding nuts securely.

Install the cylinder head (Section 6).

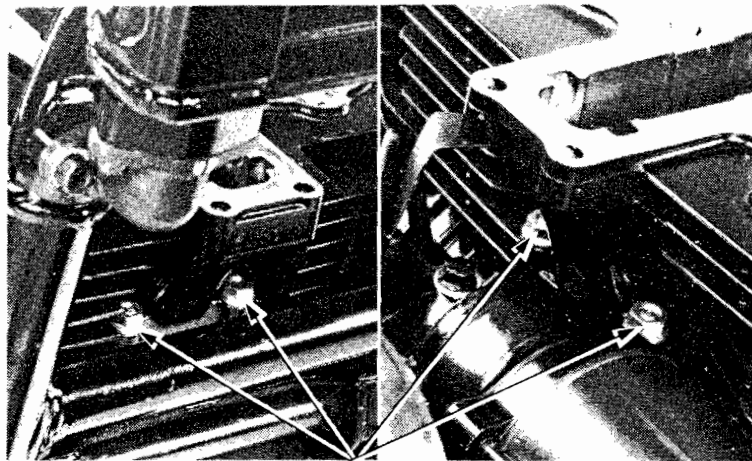

NUTS



**HONDA**  
**CB750SC**

---

MEMO



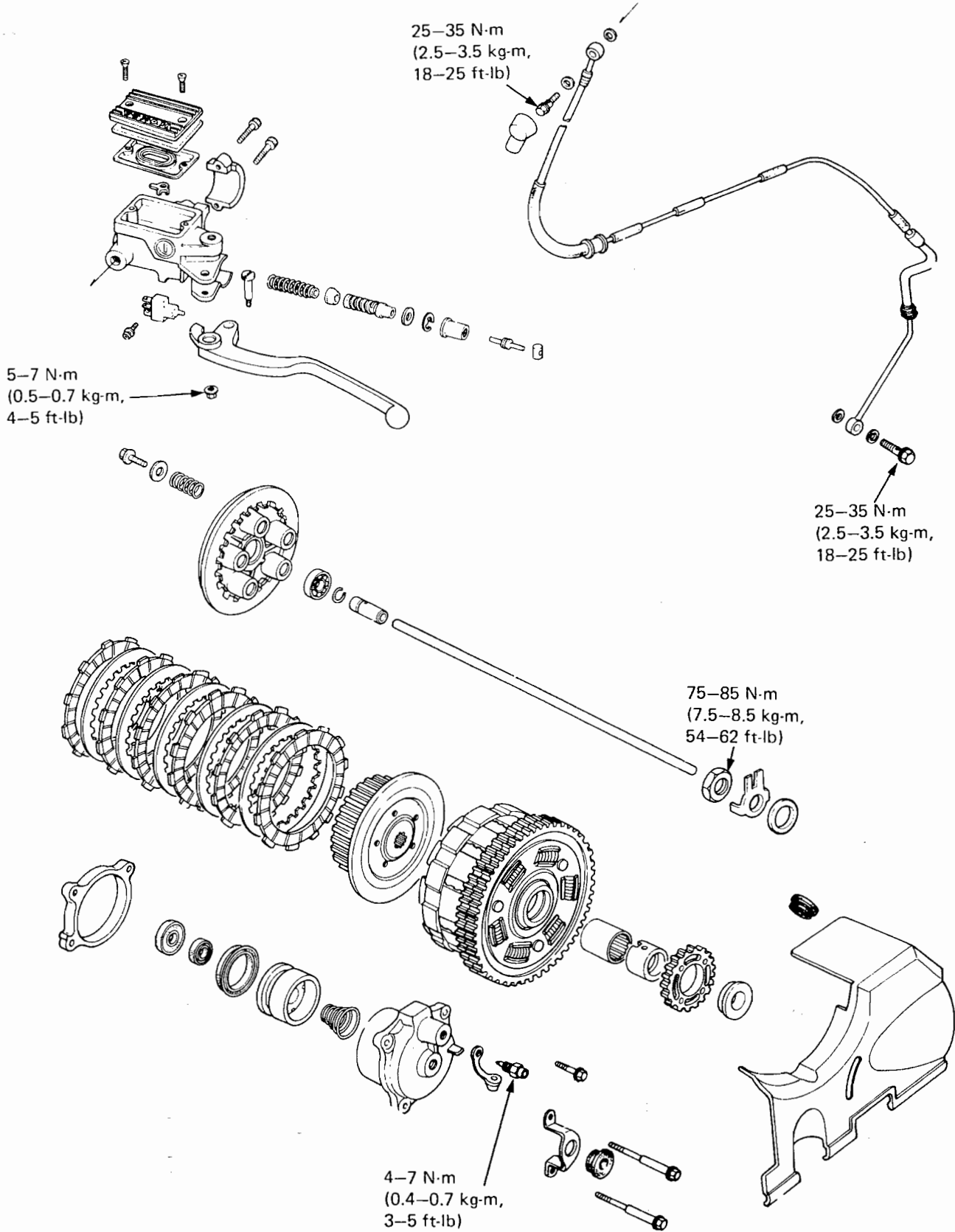



SERVICE INFORMATION	8-1	CLUTCH SLAVE CYLINDER	8-7
TROUBLESHOOTING	8-2	CLUTCH DISASSEMBLY	8-10
CLUTCH FLUID REPLACEMENT/ AIR BLEEDING	8-3	CLUTCH ASSEMBLY	8-13
CLUTCH MASTER CYLINDER	8-5		

## SERVICE INFORMATION

### GENERAL

- This section covers removal and installation of the clutch hydraulic system and the clutch.
- DOT 3 or 4 brake fluid is used for the hydraulic clutch and is referred to as clutch fluid in the section. Do not use other types of fluid as they are not compatible.
- Clutch maintenance can be done with the engine in the frame.

**8**

### SPECIFICATIONS

		STANDARD	SERVICE LIMIT
Clutch master cylinder	Cylinder I.D.	14.000–14.043 mm (0.5512–0.5524 in)	14.06 mm (0.553 in)
	Piston O.D.	13.957–13.984 mm (0.5495–0.5506 in)	13.94 mm (0.549 in)
Clutch slave cylinder	Cylinder I.D.	38.100–38.162 mm (1.5000–1.5024 in)	38.18 mm (1.503 in)
	Piston O.D.	38.036–38.075 mm (1.4975–1.4990 in)	38.02 mm (1.497 in)
Clutch	Spring free length	35.50 mm (1.398 in)	34.0 mm (1.21 in)
	Disc thickness	3.72–3.88 mm (0.147–0.153 in)	3.1 mm (0.12 in)
	Plate warpage	—	0.30 mm (0.012 in)

### TORQUE VALUES

Clutch hose oil bolt	25–35 N·m (2.5–3.5 kg·m, 18–25 ft·lb)
Clutch lock nut	75–85 N·m (7.5–8.5 kg·m, 54–62 ft·lb)

### TOOL

#### Special

Snap ring pliers  
07914–3230001 or equivalent commercially available in U.S.A.



**CLUTCH**

---

**TROUBLESHOOTING**

**Clutch lever soft or spongy**

1. Air bubbles in hydraulic system
2. Low fluid level
3. Hydraulic system leaking

**Clutch lever too hard**

1. Sticking piston(s)
2. Clogged hydraulic system

**Clutch slips**

1. Hydraulic system sticking
2. Discs worn
3. Springs weak

**Clutch will not disengage**

1. Air bubbles in hydraulic system
2. Low fluid level
3. Hydraulic system leaking
4. Hydraulic system sticking
5. Plates warped

**Motorcycle creeps with clutch disengaged**

1. Air bubbles in hydraulic system
2. Low fluid level
3. Hydraulic system leaking
4. Hydraulic system sticking
5. Plates warped

**Excessive lever pressure**

1. Hydraulic system sticking
2. Lifter mechanism damaged

**Clutch operation feels rough**

1. Outer drum slots rough
2. Sticking piston(s)



## CLUTCH FLUID REPLACEMENT/ AIR BLEEDING

Check the fluid level with the fluid reservoir parallel to the ground.

### CAUTION

- *Install the diaphragm on the reservoir when operating the clutch lever. Failure to do so will allow clutch fluid to squirt out of the reservoir during clutch operation.*
- *Avoid spilling fluid on painted surfaces. Place a rag over the fuel tank whenever the system is serviced.*

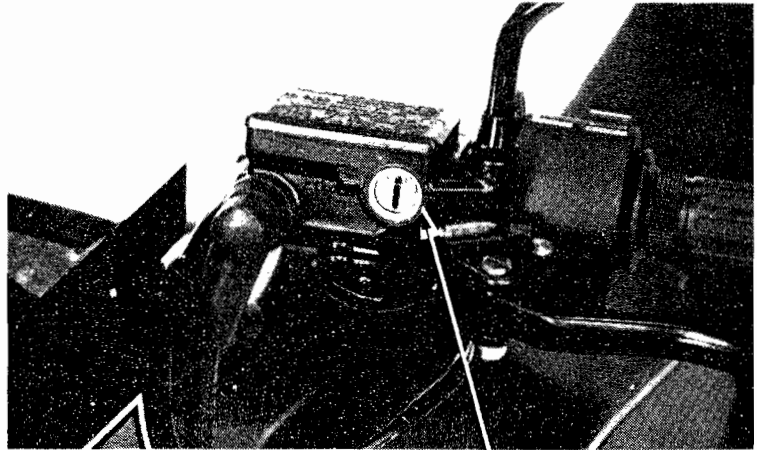

LOWER LEVEL

## CLUTCH FLUID DRAINING

Remove the left crankcase rear cover.  
Connect a bleed hose to the bleed valve.  
Loosen the slave cylinder bleed valve and pump the clutch lever.  
Stop operating the lever when no fluid flows out of the bleed valve.

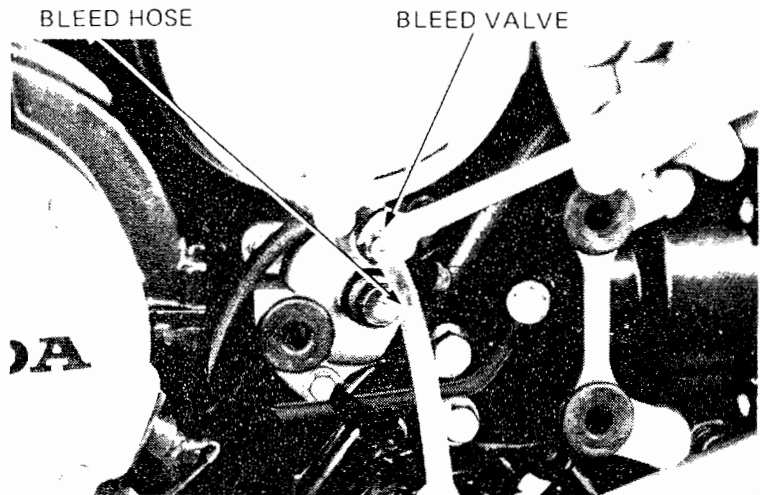

## CLUTCH FLUID FILLING

### NOTE

Do not mix different types of fluid since they may not be compatible.

Close the bleed valve, fill the reservoir, and install the diaphragm.

Pump up the system pressure with the lever until there are no air bubbles in the fluid flowing out of the reservoir small hole and lever resistance is felt. Then bleed the system.

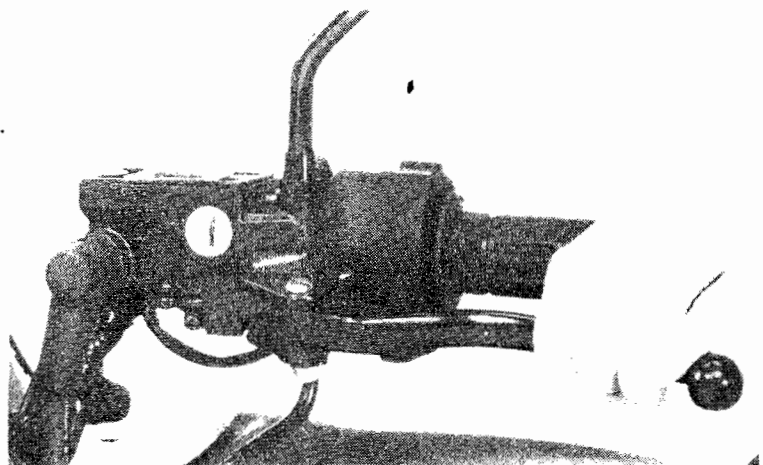



**AIR BLEEDING**

**NOTE**

- Check the fluid level often while bleeding the clutch to prevent air from being pumped into the system.
- Use only DOT 3 or 4 brake fluid from a sealed container.
- Do not mix brake fluid types and never reuse the fluid which has been pumped out during bleeding, or the efficiency of the clutch system will be impaired.

Remove the master cylinder cap and fill the reservoir to near full.  
 Connect the Mityvac Brake Bleeder or equivalent to the bleeder valve.  
 Pump the Mityvac Bleeder and loosen the clutch bleeder valve.  
 Add fluid when the fluid level in the master cylinder reservoir is low.

Repeat above procedures until air bubbles do not appear in the plastic hose.

**NOTE**

If air is entering the bleeder from around the bleeder valve threads, seal the threads with teflon tape.

If a Mityvac Brake Bleeder or equivalent not available, bleed the system as follows:

- 1) Connect a bleeder tube to the bleeder valve.
- 2) Squeeze the clutch lever, open the bleeder valve 1/2 turn and then close the valve.

**NOTE**

Do not release the clutch lever until the bleeder valve has been closed.

- 3) Release the clutch lever slowly and wait several seconds after it reaches the end of its travel.

Repeat steps 1 and 2 until bubbles cease to appear in the fluid at the end of the hose.

Fill the fluid reservoir to the upper level mark.

PLASTIC HOSE BLEEDER VALVE

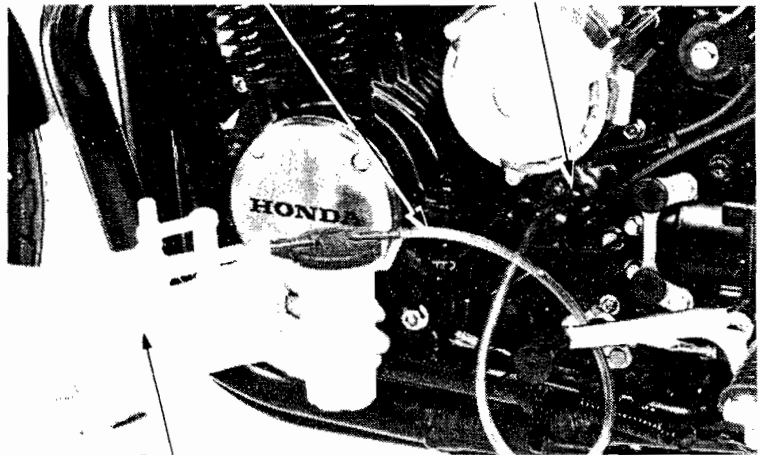

MITYVAC BRAKE BLEEDER  
 # 6860 Commercially Available in U.S.A.

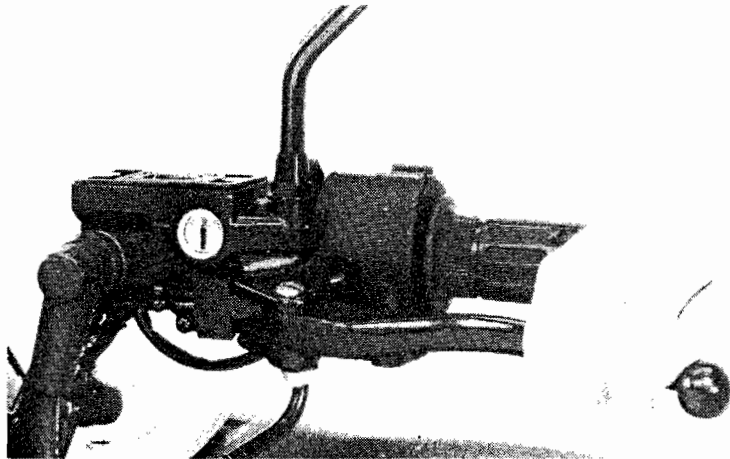

BLEEDER VALVE

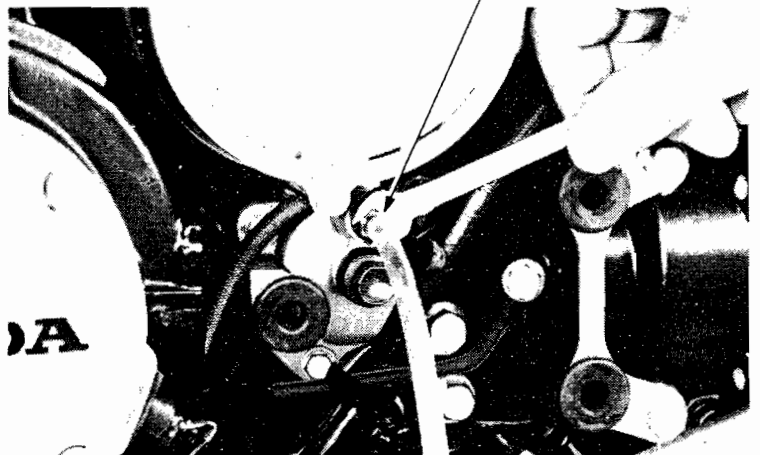



### CLUTCH MASTER CYLINDER

#### DISASSEMBLY

Drain clutch fluid from the hydraulic system. Remove the rear view mirror and clutch lever. Disconnect the clutch switch wires and remove the clutch hose.

#### CAUTION

*Avoid spilling clutch fluid on painted surfaces. Place a rag over the fuel tank whenever the clutch system is serviced.*

#### NOTE

When removing the oil bolt, cover the end of the hose to prevent contamination and secure the hose.

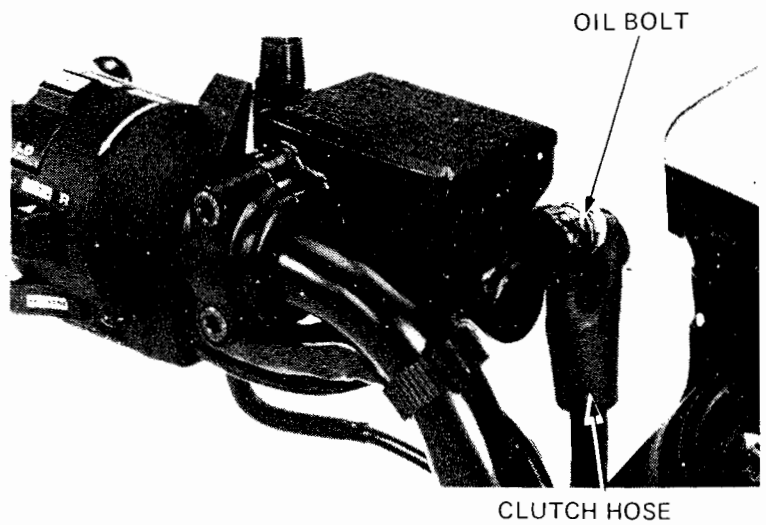

Remove the master cylinder.

Remove the push rod boot and snap ring from the master cylinder body.

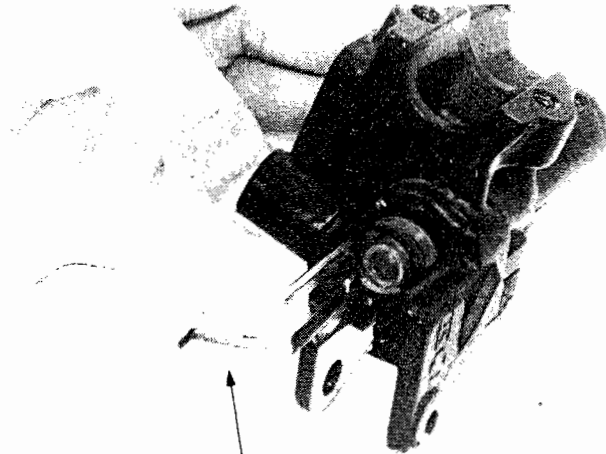

SNAP RING PLIERS  
07914-3230001 or EQUIVALENT COMMERCIALY  
AVAILABLE IN U.S.A.

Remove the following:

- piston and secondary cup.
- primary cup and spring.
- clutch switch, if necessary.

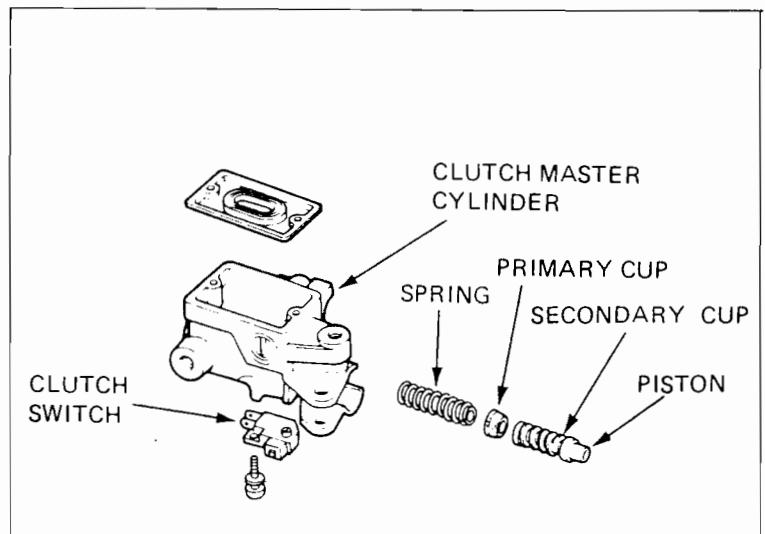

**MASTER CYLINDER I.D. INSPECTION**

Measure the master cylinder I.D.  
Check the master cylinder for scores, scratches or nicks.

**SERVICE LIMIT: 14.06 mm (0.553 in)**

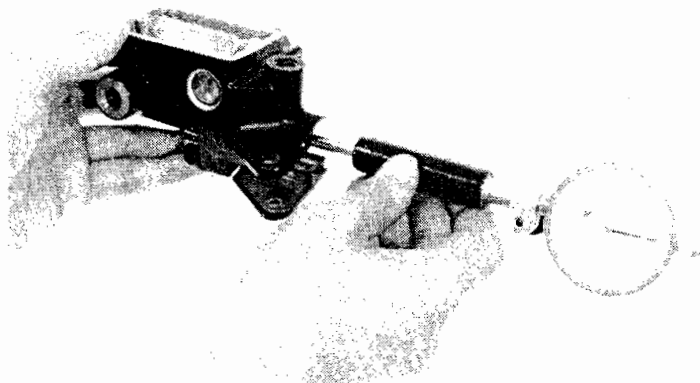

**MASTER PISTON O.D. INSPECTION**

Measure the master piston O.D.

**SERVICE LIMIT: 13.94 mm (0.549 in)**

Check the primary and secondary cups for damage before assembly.

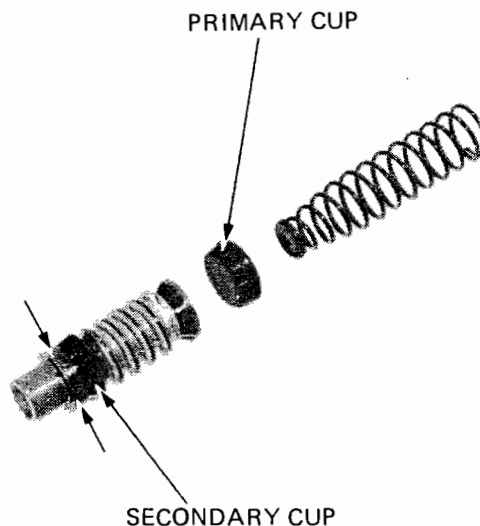

**ASSEMBLY**

**CAUTION**

*Handle the master piston, spring, primary cup and secondary cup as a set.*

Coat primary cup and master piston with clean brake fluid before assembly.  
Install the spring, primary cup and piston.

**CAUTION**

*When installing the cups, do not allow the lips to turn inside out.*

Install the snap ring making sure it is seated firmly in the groove. Then install the boot and push rod.  
Install the clutch switch, if it was removed.

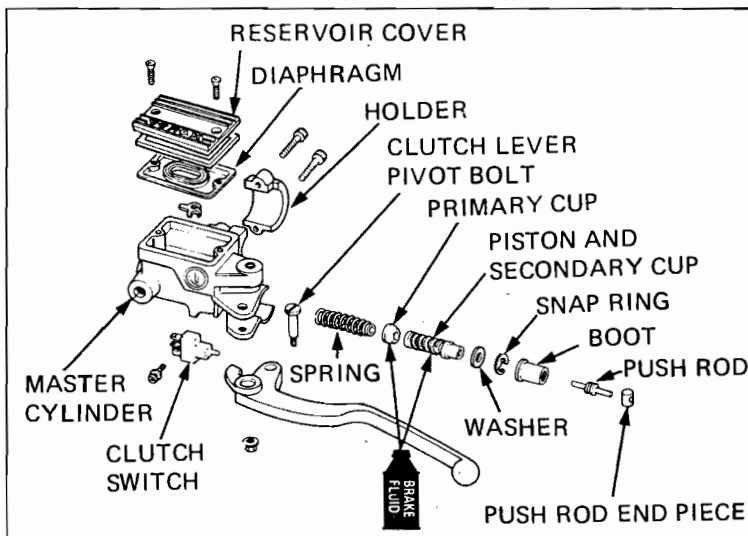



Place the master cylinder on the handlebar and install the holder with the "UP" mark facing up and the two mounting bolts.

Align the end of the holder with the handlebar punch mark.

Tighten the top bolt first, then the bottom bolt.

Install the clutch hose with the bolt and its two sealing washers.

**TORQUE:** 25–35 N·m  
(2.5–3.5 kg·m, 18–25 ft·lb)

Install the push rod end piece into the clutch lever hole and install the clutch lever.

Connect the clutch switch wires to the switch terminals.

Fill the reservoir and bleed the clutch system (Page 8-4).

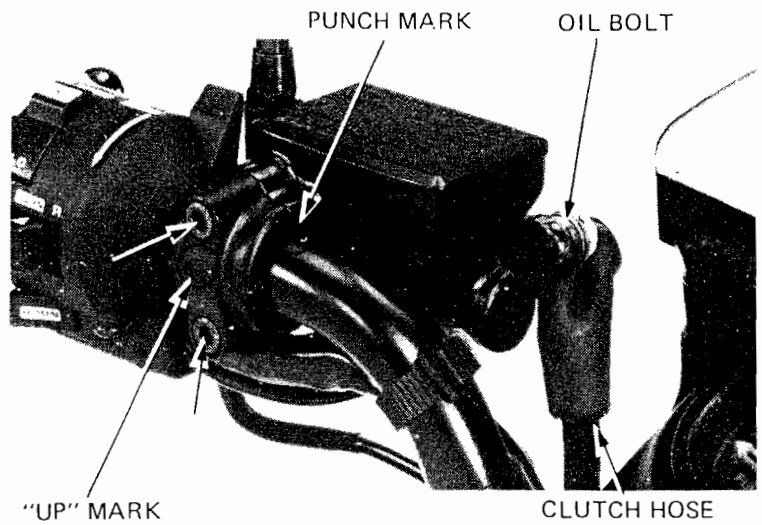

## CLUTCH SLAVE CYLINDER

### DISASSEMBLY

Drain the engine oil (Page 2-3).

Remove the left crankcase rear cover.

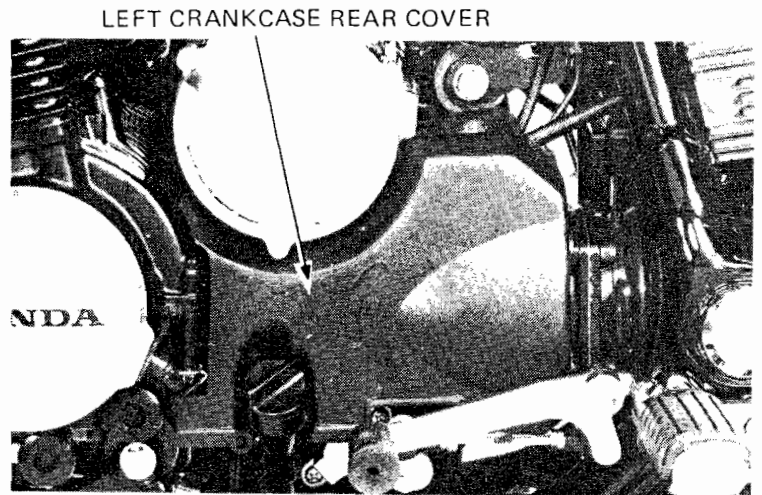

Remove the oil bolts and engine oil pipe.

Place a container under the slave cylinder, remove the oil bolt and disconnect the clutch pipe.

### NOTE

Avoid spilling clutch fluid on painted surfaces.

Remove the three slave cylinder mounting bolts and the slave cylinder.

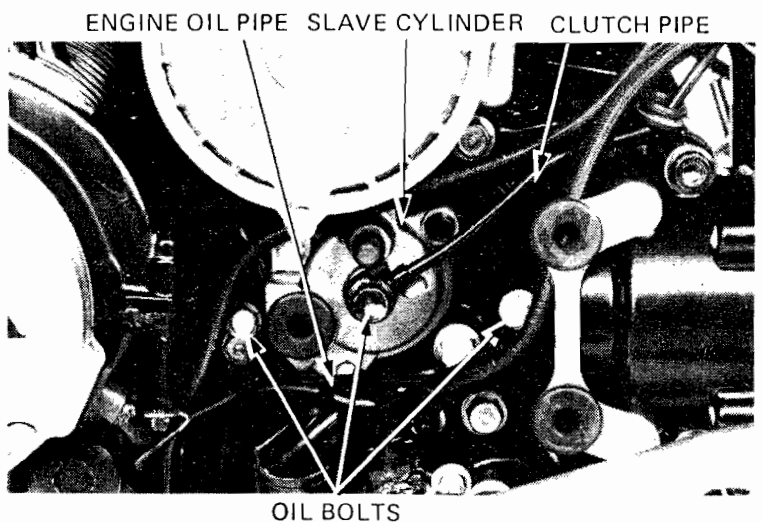





Remove the piston from the cylinder.

If piston removal is hard, place a shop towel over the piston to cushion the piston when it is expelled, and position the cylinder with the piston down.

Apply compressed air to the fluid inlet to remove the piston. Use the air in short spurts.

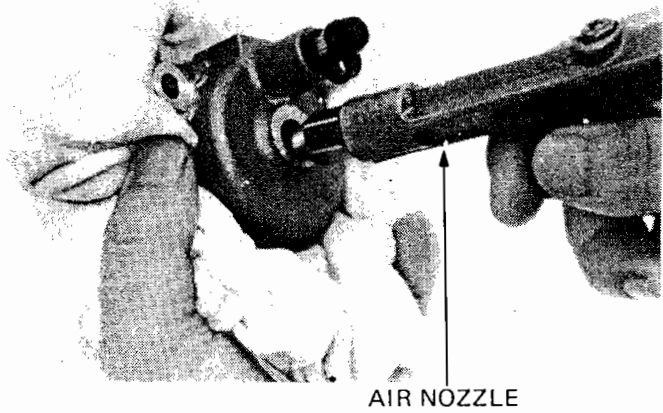

Remove the spring from the slave cylinder.

Remove the oil and piston seals.  
Clean the piston groove with clutch fluid.  
Check the piston spring for weakness or damage.

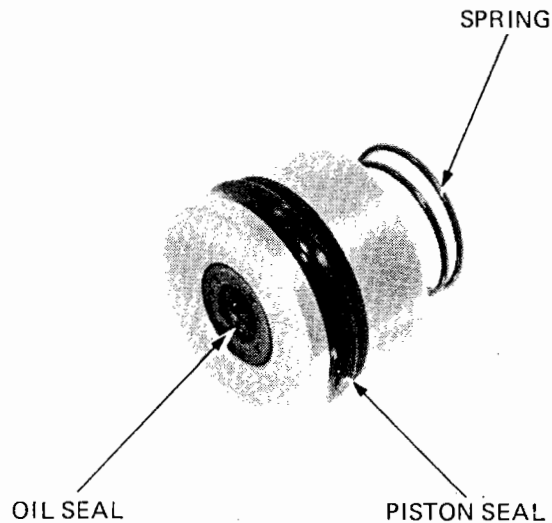

**PISTON O.D. INSPECTION**

Check the piston for scoring or scratches.  
Measure the outside diameter of the piston with a micrometer.

**SERVICE LIMIT: 38.02 mm (1.497 in)**

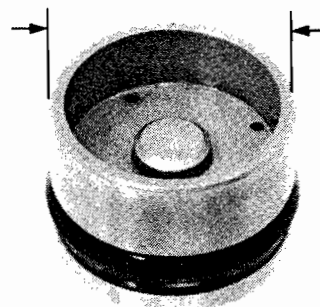



### CYLINDER I.D. INSPECTION

Check the slave cylinder for scoring or scratches. Measure the inside diameter of the cylinder bore.

**SERVICE LIMIT: 38.18 mm (1.503 in)**

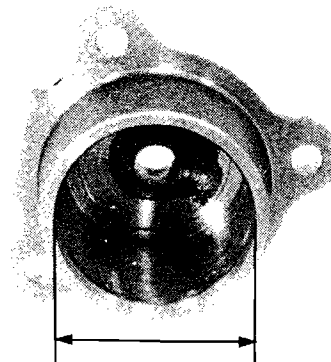

### ASSEMBLY

Assemble the slave cylinder in the reverse order of disassembly. The oil seals must be replaced with new ones whenever they have been removed.

Lubricate the piston and piston seal with a medium grade of Hi-Temperature silicone grease or brake fluid before assembly.

Be certain the piston seal is seated in the piston groove. Place the piston in the cylinder with the seal end facing out.

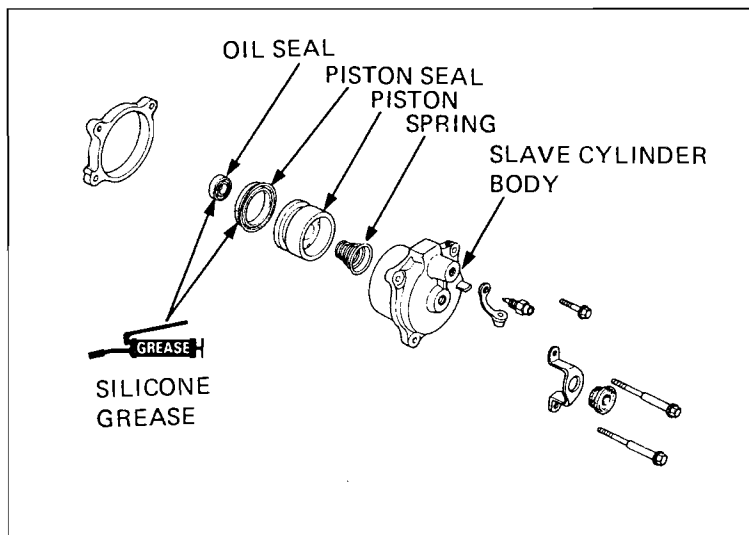

Install the insulator and slave cylinder. Connect the clutch hose with the oil bolt and the two sealing washers.

**TORQUE: 25–35 N·m  
(2.5–3.5 kg·m, 18–25 ft·lb)**

Make sure that the sealing washers are in good condition.

Install the engine oil pipe with the oil bolts and two sealing washers for each bolt after making sure that the sealing washers are in good condition.

Fill the clutch fluid reservoir and bleed the clutch system (Page 8-4).

Install the left crankcase rear cover.

Fill the crankcase with the recommended oil (Page 2-3).

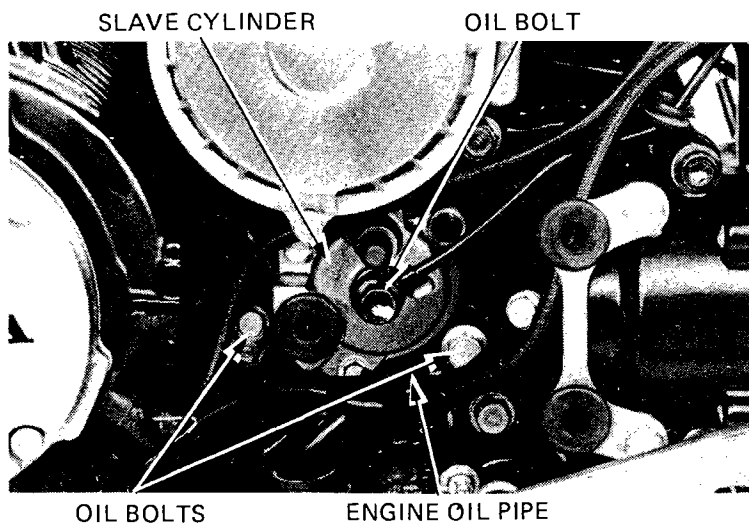



## CLUTCH DISASSEMBLY

**NOTE**

Do not operate the clutch lever after removing the clutch. To do so will cause difficulty in reassembling the clutch.

Drain the engine oil (Page 2-3).  
Remove the right footpeg and brake pedal (Page 15-10).

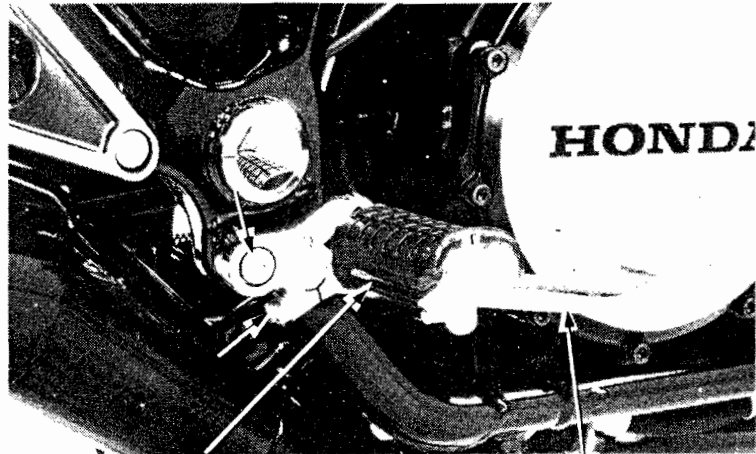

RIGHT FOOTPEG

BRAKE PEDAL

Remove the clutch cover bolts, cover and gasket.

CLUTCH COVER

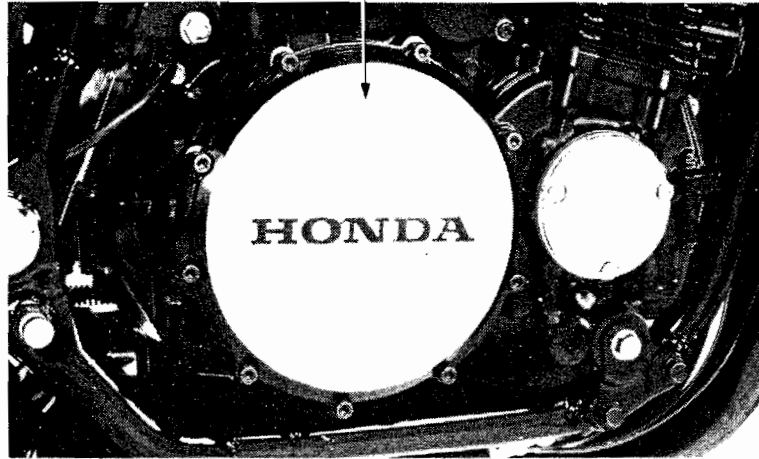

Remove the bolts and clutch springs.

**NOTE**

Loosen the bolts in a crisscross pattern in 2-3 steps.

Remove the clutch pressure plate with the clutch lifter guide and release bearing.

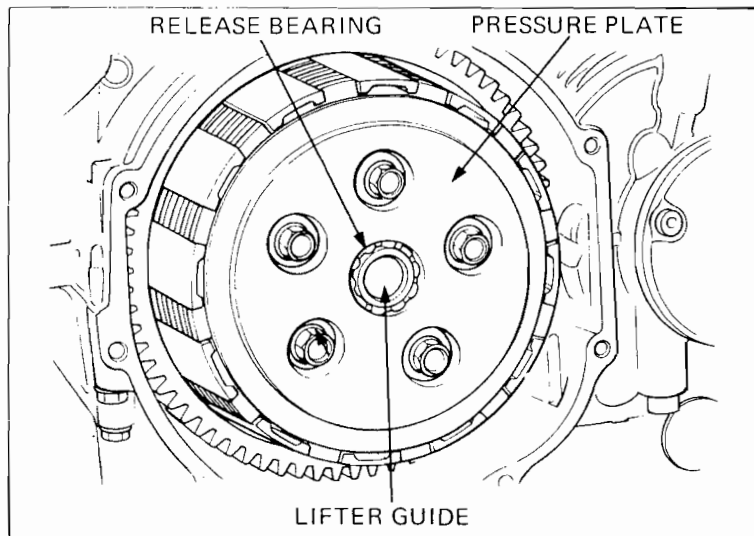



Remove the clutch lifter rod, clutch discs and plates.

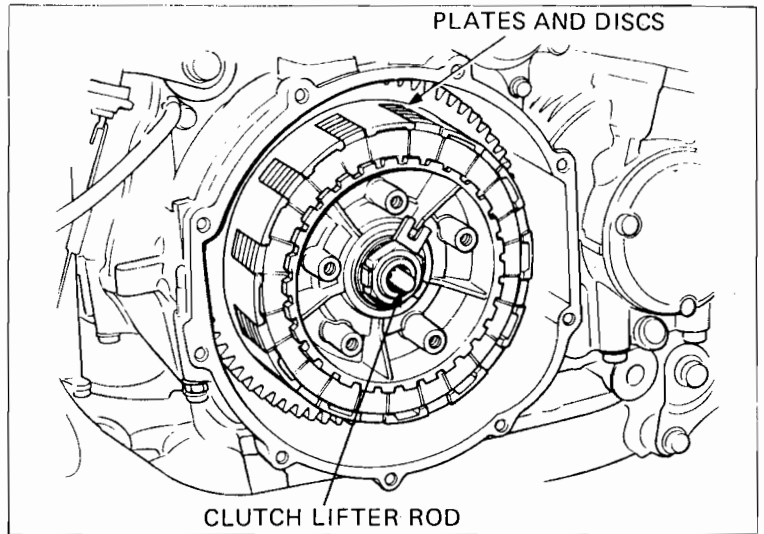

Shift the transmission into 6th gear.  
Temporarily install the brake pedal.  
Depress the brake pedal and remove the clutch lock nut and lock washers.

**NOTE**

If the engine is out of the frame, hold the output shaft with a shaft holder 07923-6890101.

Remove the clutch center.

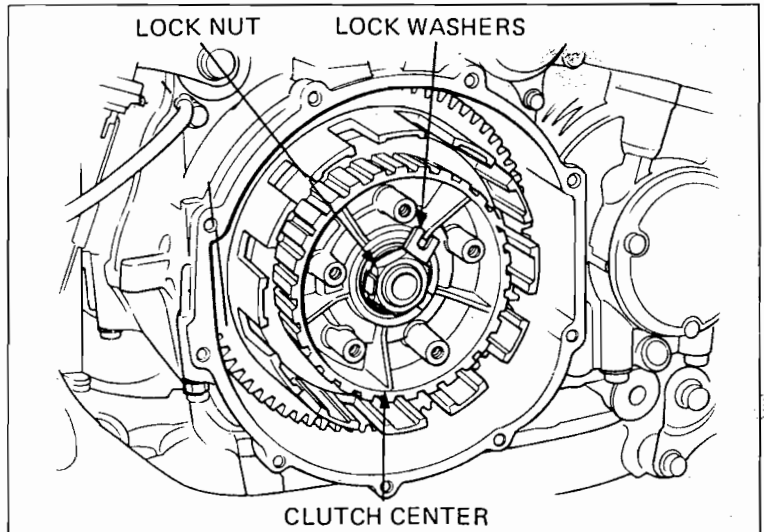

Remove the right crankshaft cover and turn the crankshaft until the No. 4 piston is at bottom dead center.  
Remove the clutch outer guide and clutch outer.

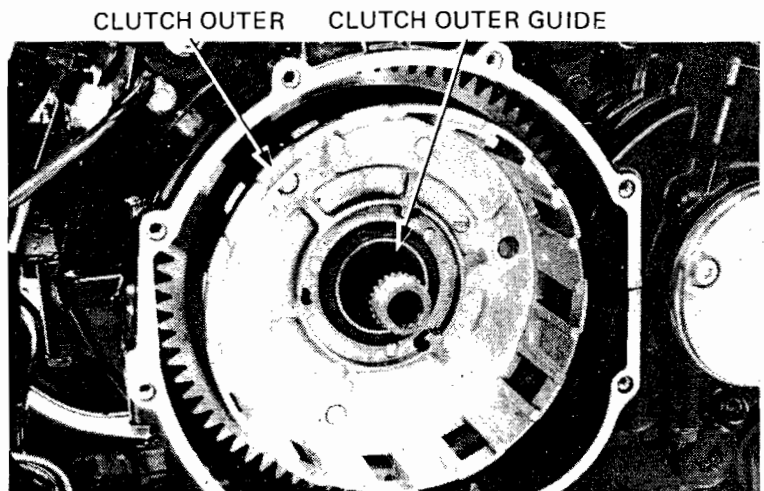



**CLUTCH**

**CLUTCH SPRING**

Measure the clutch spring free length.

**SERVICE LIMIT: 34.0 mm (1.34 in)**

Replace any spring that is shorter than the service limit.

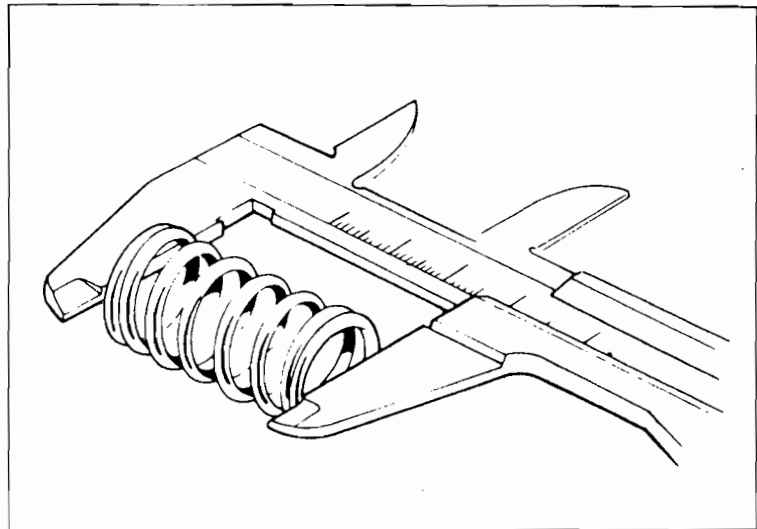

**CLUTCH DISC**

Replace the clutch discs if they show signs of scoring or discoloration.

Measure the thickness of each disc.

**SERVICE LIMIT: 3.1 mm (0.12 in)**

Replace any disc that is thinner than the service limit.

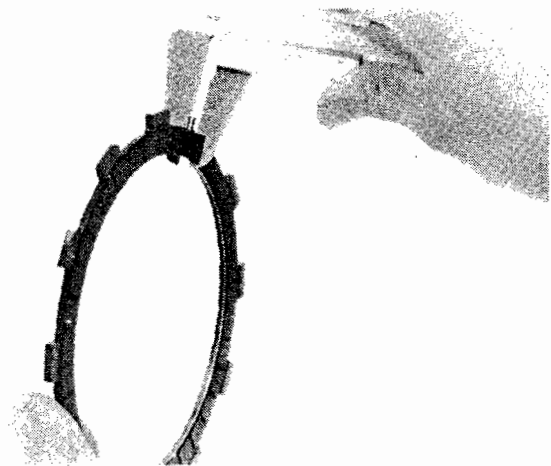

**CLUTCH PLATE**

Check the plate warpage on a surface plate, using a feeler gauge.

**SERVICE LIMIT: 0.30 mm (0.012 in)**

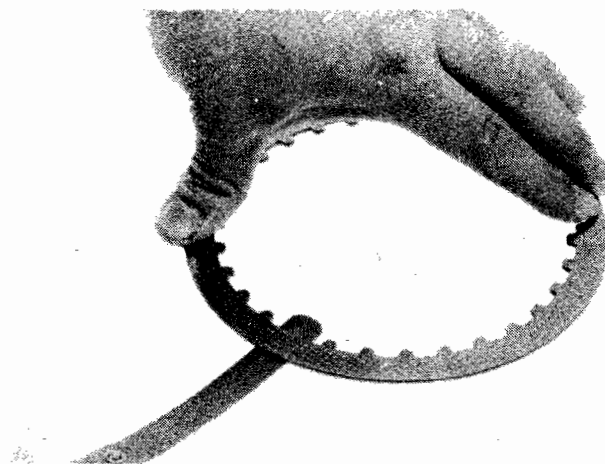



**CLUTCH OUTER**

Check the slots in the clutch outer for nicks, cuts or indentations made by the friction discs.

Check the clutch outer needle bearing for damage or excessive play.

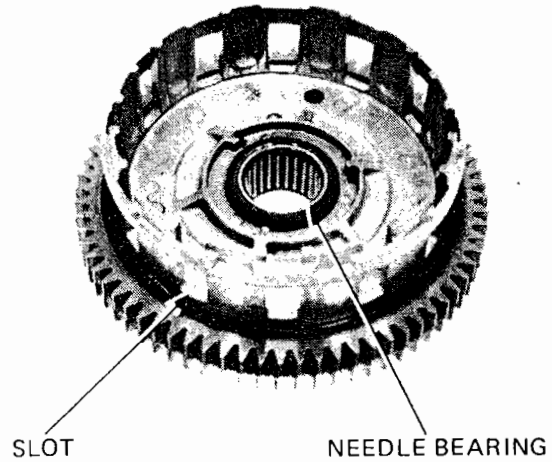

**CLUTCH ASSEMBLY**

Set the No. 4 piston at bottom dead center by rotating the crankshaft.

Install the clutch outer over the mainshaft and engage the primary driven gear on the clutch outer with the primary drive gear.

Install the needle bearing and clutch outer guide.

**NOTE**

Face the grooves in the clutch outer out.

Turn the oil pump driven gear and align the drive pins on the oil pump drive gear with the holes in the clutch outer.

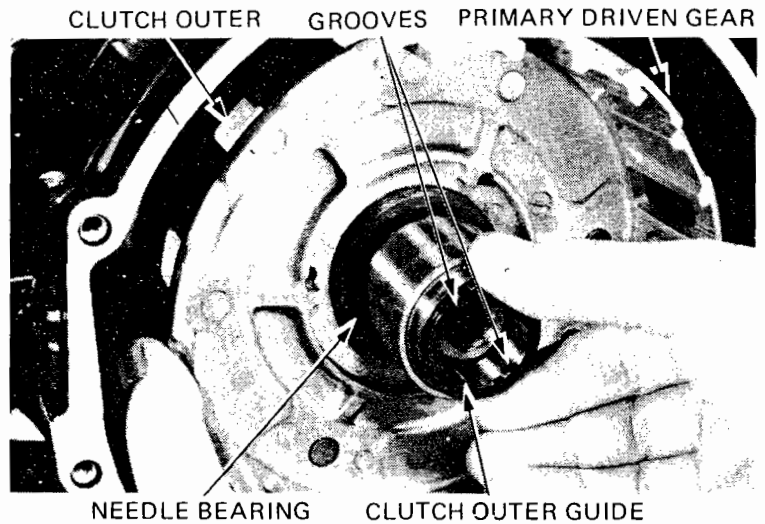

Install the lock washer with the dished side facing the inside, and install the tongued washer and lock nut.

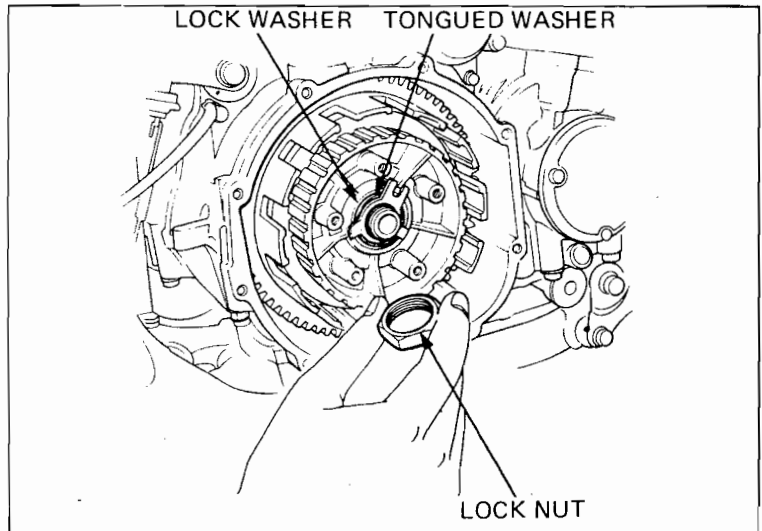



**CLUTCH**

Remove oil from the clutch lock nut and apply a locking agent to the nut threads.  
Shift the transmission into 6th gear.  
Depress the brake pedal and tighten the lock nut.

**TORQUE:** 75–85 N·m  
(7.5–8.5 kg·m, 54–62 ft·lb)

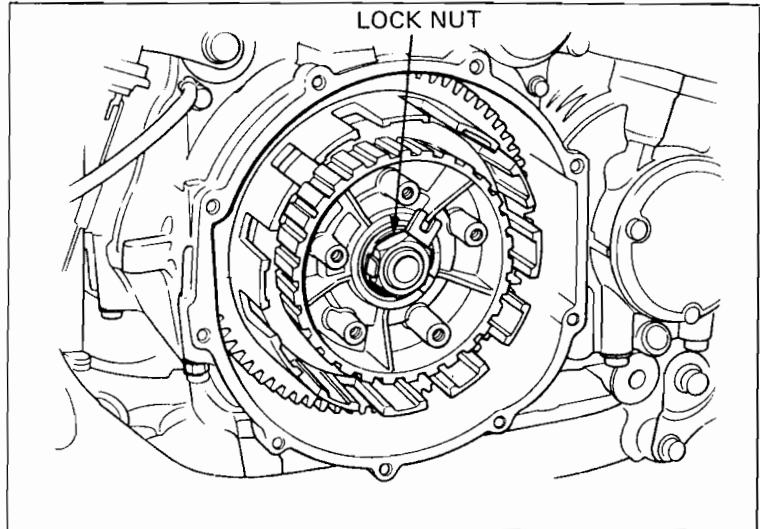

Coat the discs and plates with clean engine oil.

Install the clutch discs and plates as shown.

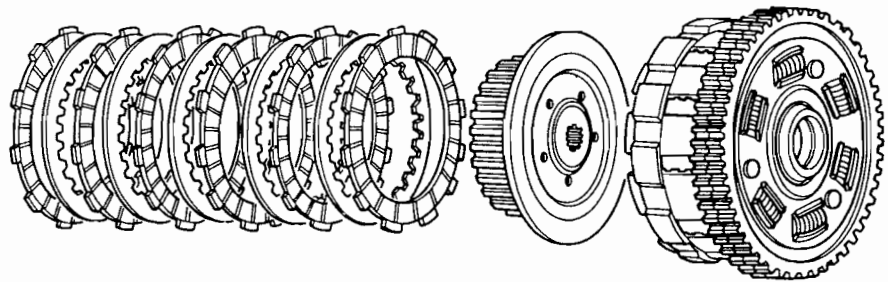

Insert the lifter rod into the mainshaft.

Install the clutch release bearing and lifter guide into the clutch pressure plate.

Install the clutch pressure plate.

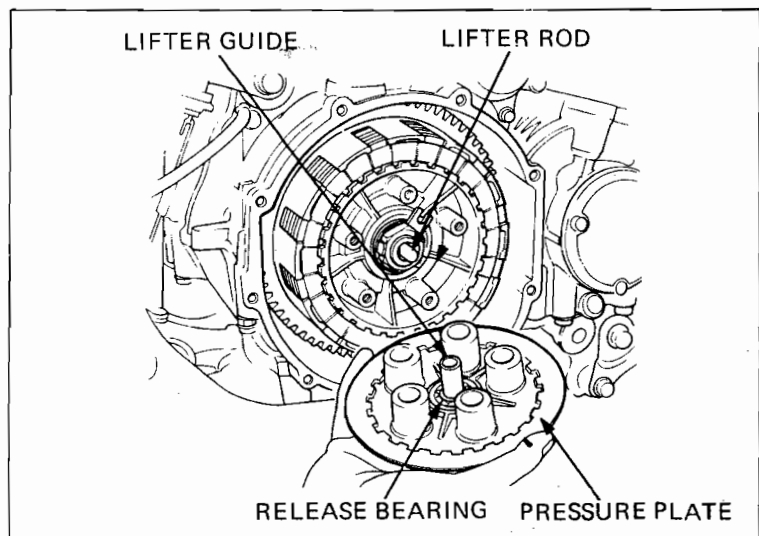



Install the clutch springs, plain washers and bolts.

**NOTE**

Tighten the bolts evenly in 2-3 steps in a crisscross pattern.

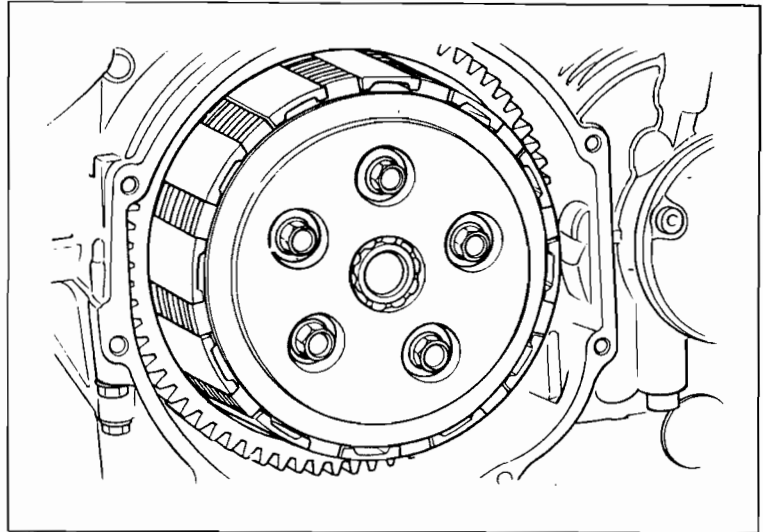

Install a new gasket onto the clutch cover.  
Install the clutch cover with the nine socket bolts.  
Install the brake pedal and right foot peg (Page 15-11).  
Fill the crankcase with the recommended oil (Page 2-3).

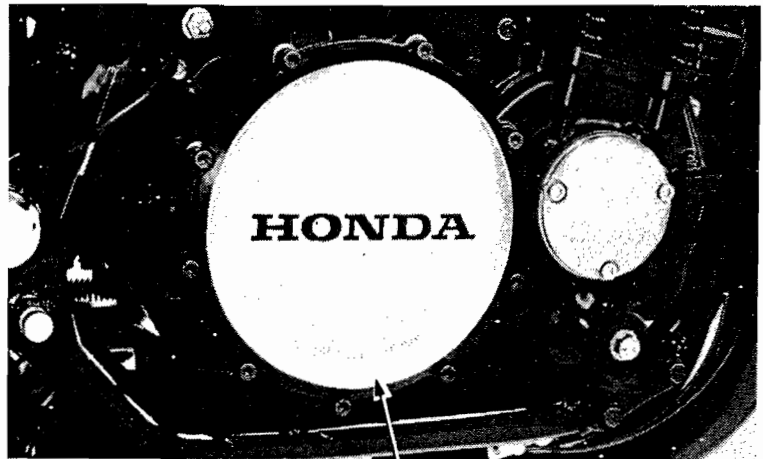

CLUTCH COVER



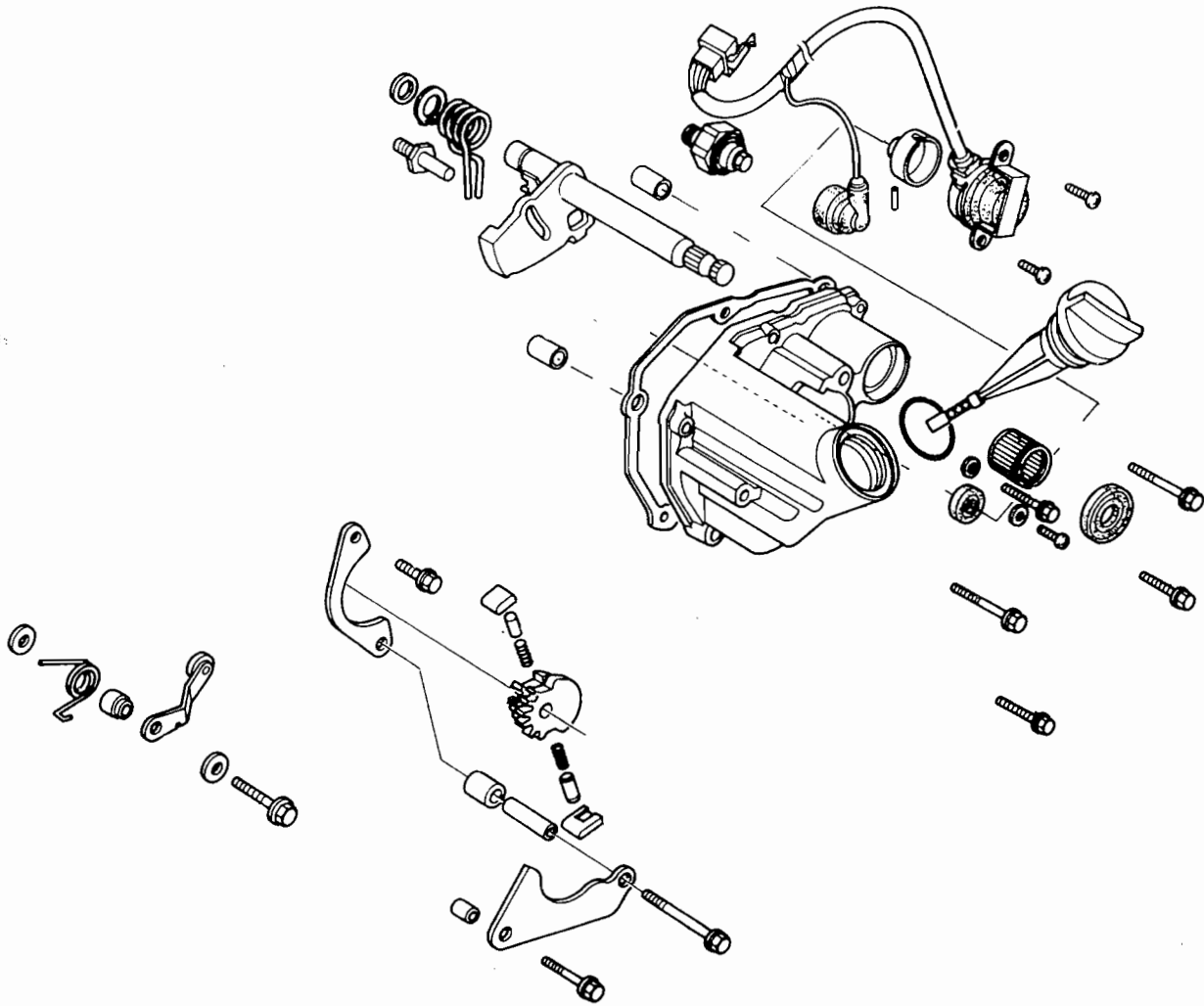



SERVICE INFORMATION	9-1
TROUBLESHOOTING	9-1
GEAR POSITION SWITCH	9-2
GEARSHIFT LINKAGE	9-4

## SERVICE INFORMATION

### GENERAL

- The gear position switch can be serviced with the engine in the frame. If the gearshift spindle, drum shifter and stopper arm require servicing, remove the engine from the frame (Section 5).  
If the shift forks, drum and transmission require servicing, remove the engine and separate the crankcase (Section 10).
- See Page 21-8 for gear position switch inspection.

### TORQUE VALUE

Footpeg	30-40 N·m (3.0-4.0 kg-m, 22-29 ft-lb)
Gearshift pedal	8-12 N·m (0.8-1.2 kg-m, 6-9 ft-lb)

## TROUBLESHOOTING

### Hard to shift

1. Improper clutch operation
2. Shift forks bent
3. Shift shaft bent
4. Shift claw bent
5. Shift drum cam grooves damaged

### Transmission jumps out gear

1. Gear dogs worn
2. Shift shaft bent
3. Shift drum stopper broken
4. Shift forks bent



**GEAR POSITION SWITCH**

**GEARSHIFT PEDAL REMOVAL**

Remove the left crankcase rear cover.  
Remove the gearshift pedal by removing the pivot bolt and arm pinch bolt.

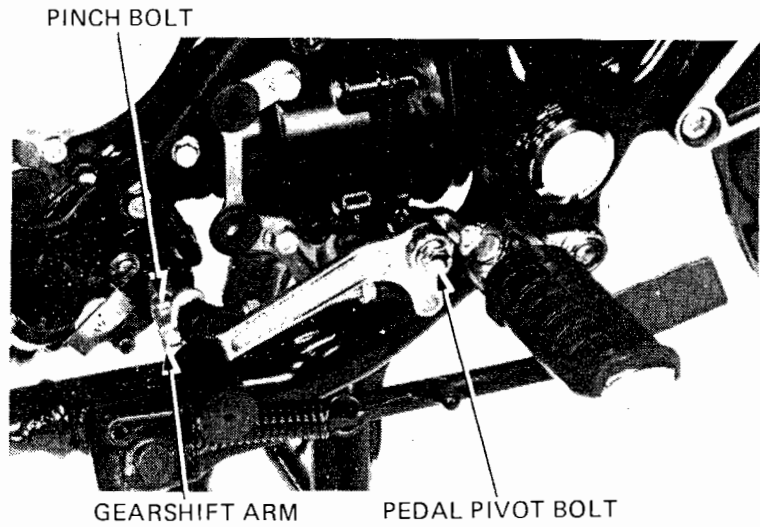

**GEAR POSITION SWITCH REMOVAL**

Remove the left frame side cover.  
Disconnect the gear position switch coupler from the wire harness.  
Remove the two switch mounting screws and the switch.

Slip the oil pressure switch cover off the switch.  
Remove the oil pressure switch terminal screw and disconnect the switch wire from the switch.

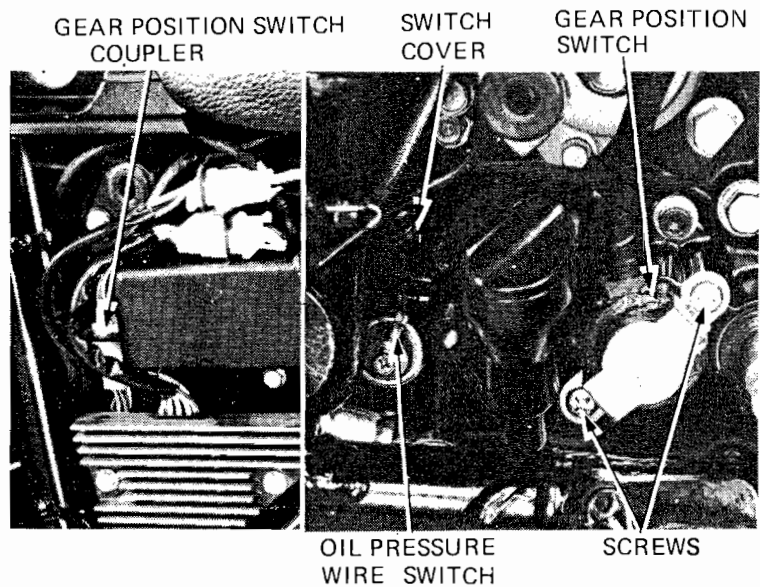

Remove the switch joint.

**GEAR POSITION SWITCH INSTALLATION**

Align the pin on the switch joint with the groove in the shift drum and install the joint.

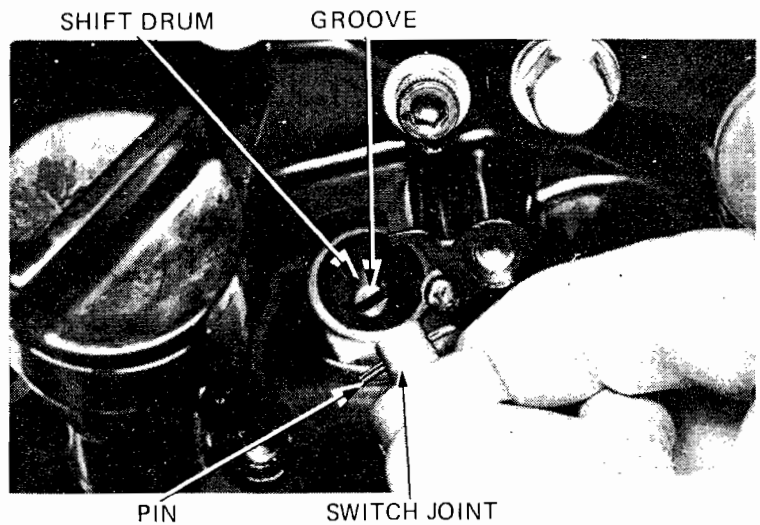



Align the pin on the gear position switch with the grooves in the switch joint and install the switch. Tighten the switch with the two screws securely. Connect the oil pressure switch wire to the switch with the terminal screw and slip the switch cover over the switch.

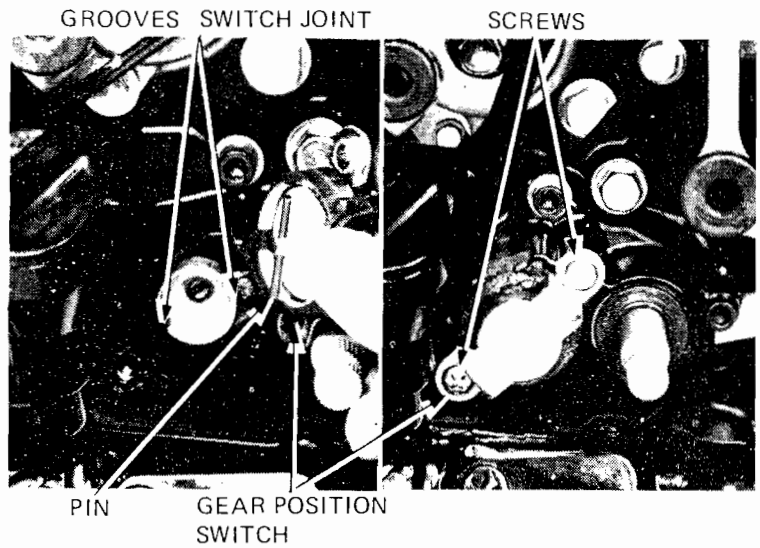

Connect the gear position switch wire coupler to the wire harness. Install the frame left side cover.

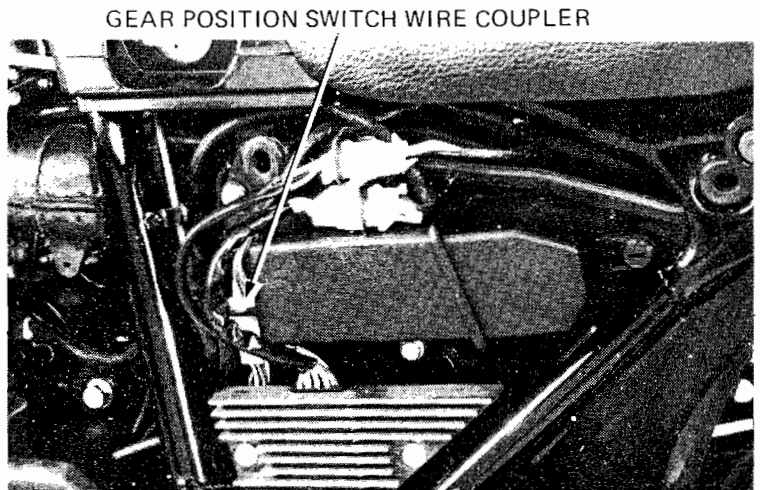

**GEARSHIFT PEDAL INSTALLATION**

Align the index mark on the gearshift arm with the punch mark on the gearshift spindle and install the arm. Tighten the arm pinch bolt.

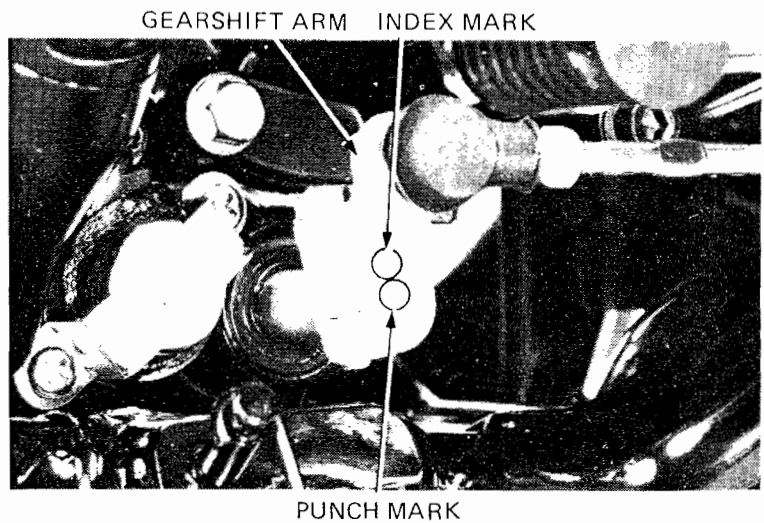

## GEARSHIFT LINKAGE



**HONDA**  
**CB750SC**

Apply grease to the gearshift pedal pivot and install the pedal onto the left footpeg with the pivot bolt.

**TORQUE:** 30–40 N·m  
(3.0–4.0 kg·m, 22–29 ft·lb)

Install the left crankcase rear cover.

Adjust the distance between the ball joints to 47.2 mm (1.86 in) by loosening the lock nuts and turning the shift rod. Tighten the lock nuts securely.

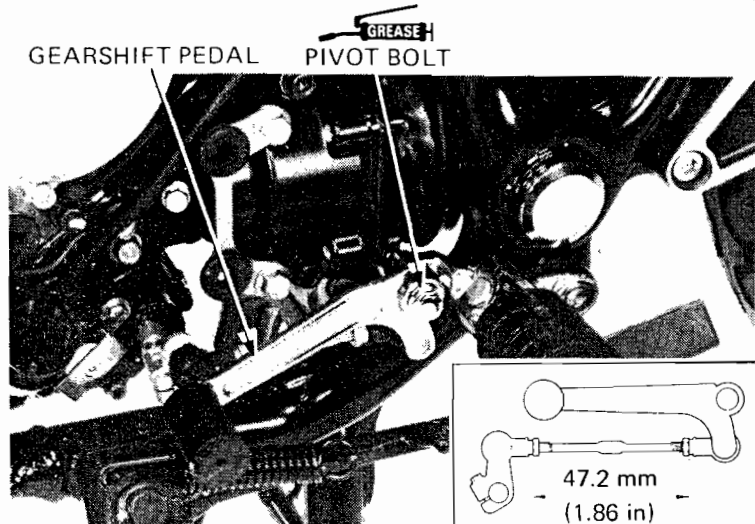

## GEARSHIFT LINKAGE

### REMOVAL

Remove the engine (Section 5).

Remove the gear position switch (Page 9-2).

Remove the five shift linkage cover bolts and remove the cover.

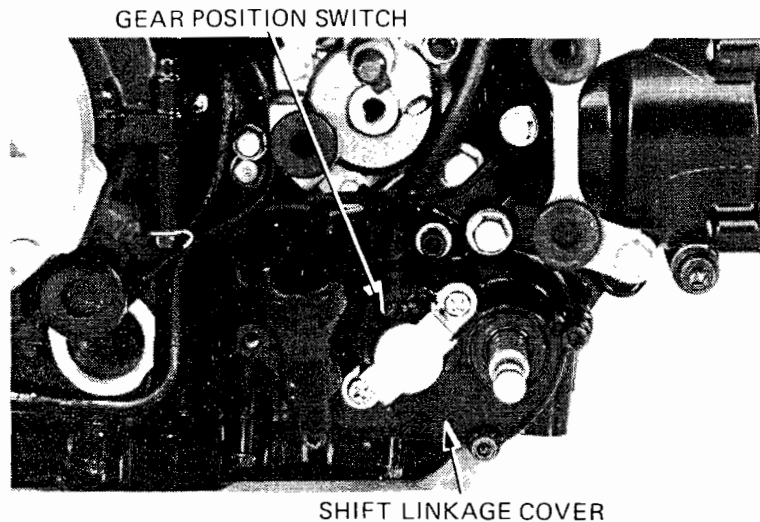

Remove the gasket and dowel pins.  
Remove the gearshift spindle.

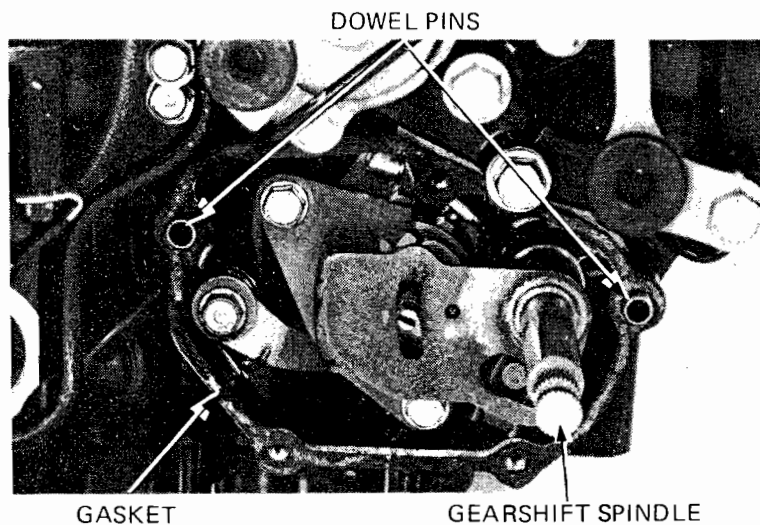



Remove the two guide plate bolts and the guide plate.

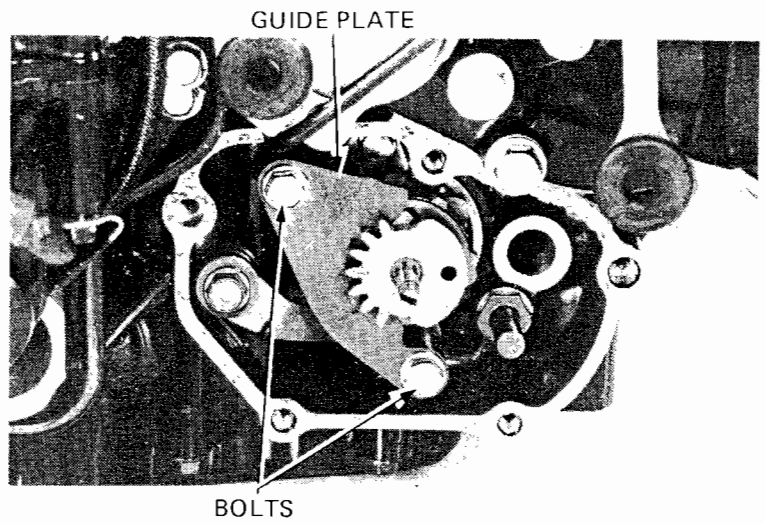

Remove the guide plate spacer and dowel pins. Remove the drum shifter, pawls, plungers and springs.

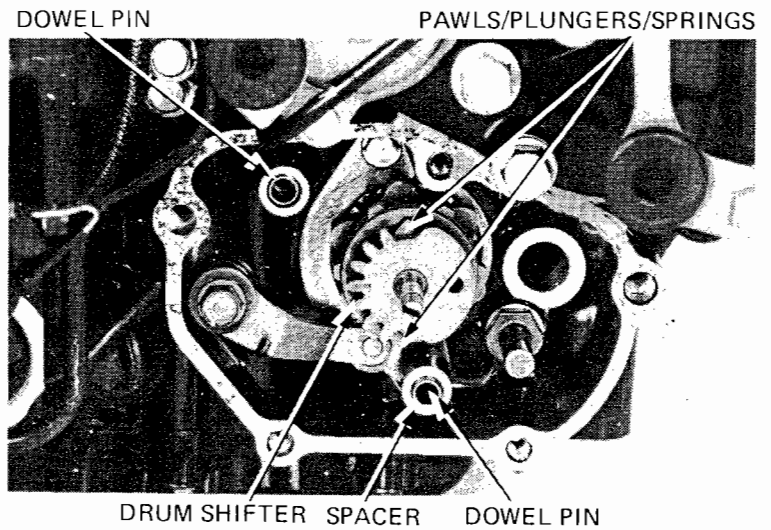

Remove the drum stopper arm bolt, arm and spring.

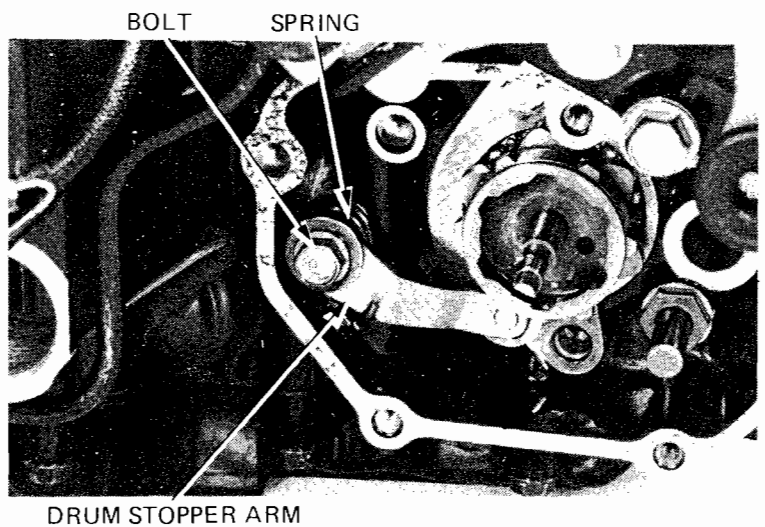



**INSPECTION**

Check the shift spindle needle bearing and oil seals for wear or damage and replace if necessary.

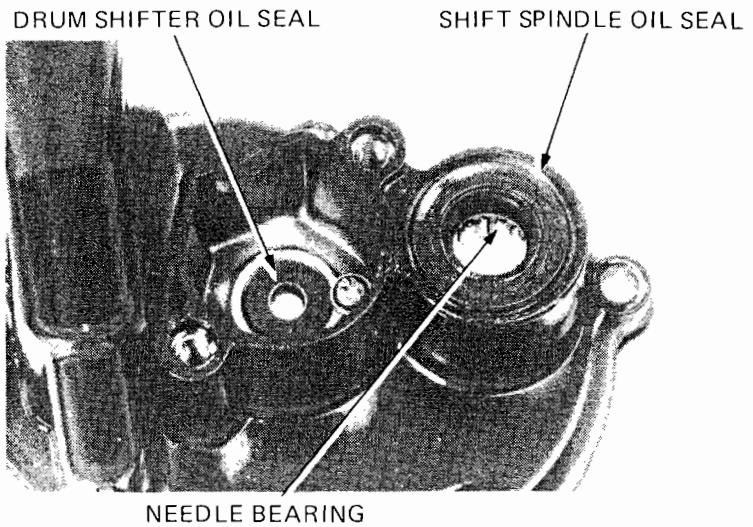

Check the gear on the shift spindle for wear or damage.  
Check the drum shifter gear for wear or damage.  
Check the drum shifter pawls, plungers and springs for wear, weakness or damage.

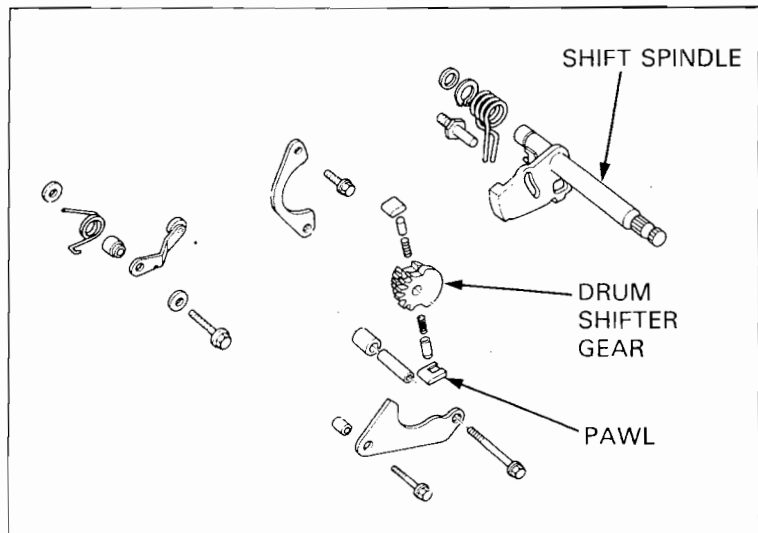

**ASSEMBLY**

Install the drum stopper arm, collar and spring onto the crankcase with the washer and bolt.

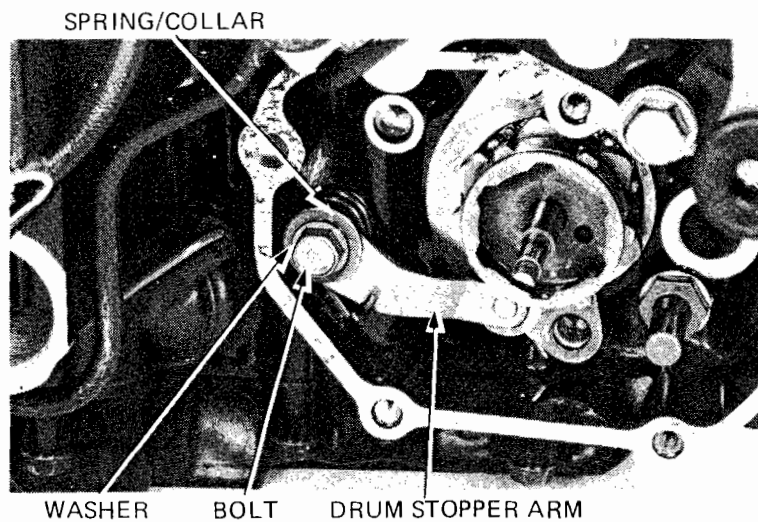



Install the plunger springs, plungers and pawls onto the drum shifter as shown.

Install the drum shifter assembly into the gear shift drum by aligning the holes in the drum and shifter.

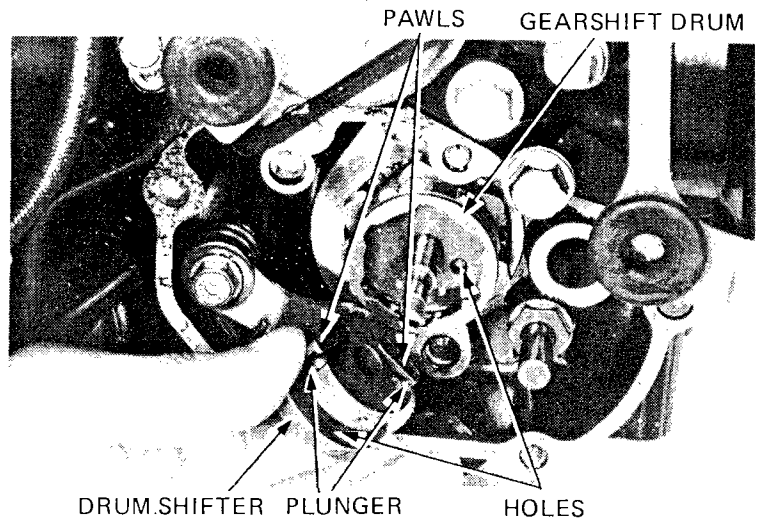

Install the dowel pins and spacer.

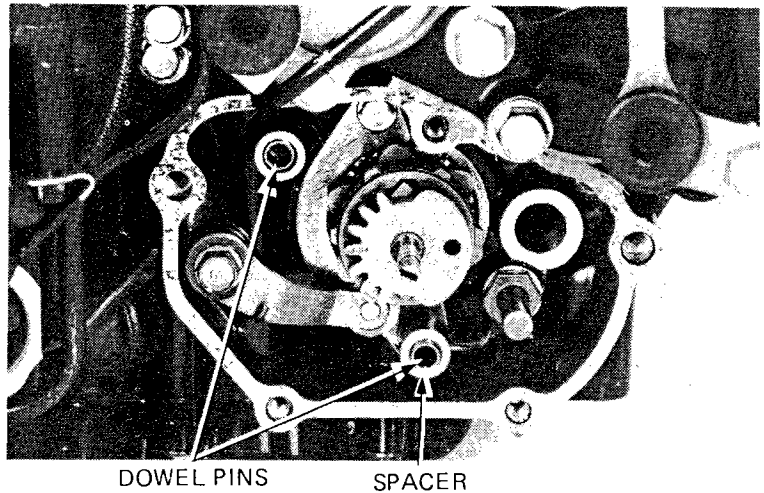

Install the guide plate and tighten it with the two bolts.

Install the spindle return spring and thrust washer onto the gearshift spindle.

Align the hole in the drum shifter with the hole in the spindle and install the spindle assembly.

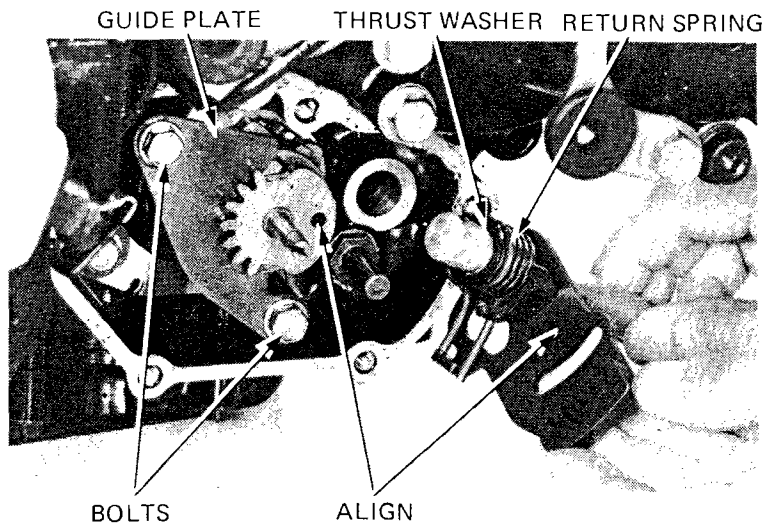





- Clean the gasket surfaces of the crankcase and shift linkage cover and install the two dowel pins and a new gasket.

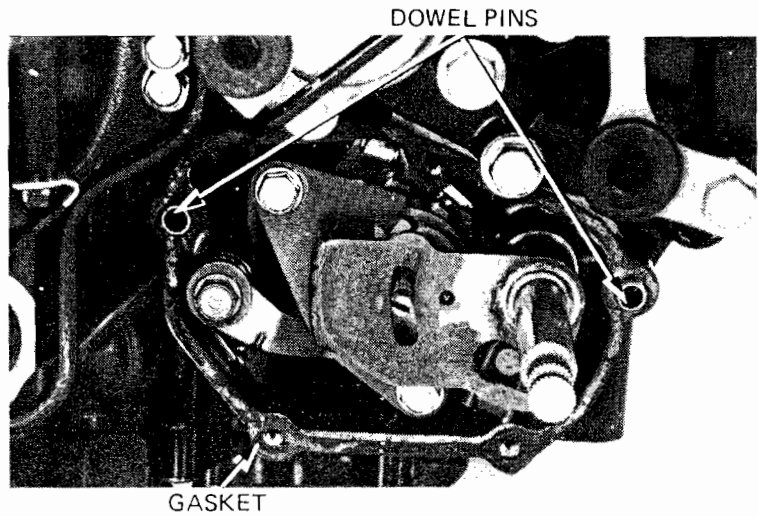

- Install the shift linkage cover with the five socket bolts. Use the copper washer on the socket bolt hole with the "Δ" mark on the cover.
- Temporarily install the gearshift arm and make sure that the shift linkage operates properly.
- Remove the gearshift arm.
- Install the gear position switch (Page 9-2).
- Install the engine into the frame (Page 5-5).
- Install the gearshift pedal (Page 9-3).

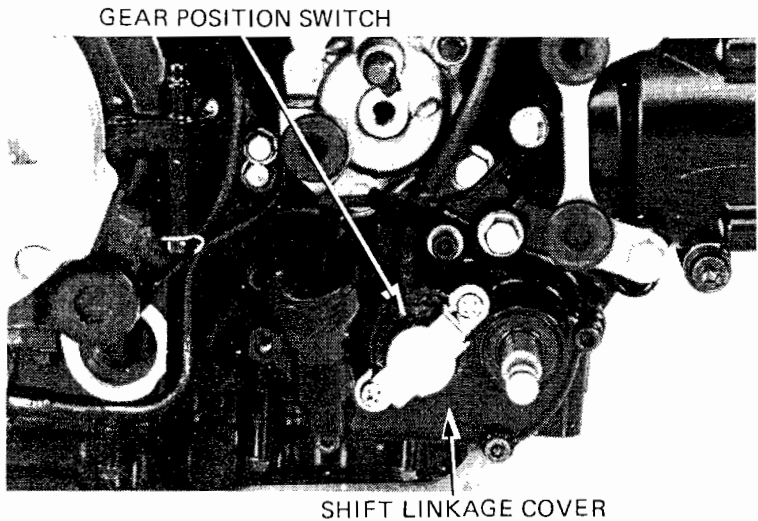



**HONDA**  
**CB750SC**

---

MEMO



6 mm: 10–14 N·m  
(1.0–1.4 kg·m,  
7–10 ft·lb)

7 mm: 15–19 N·m  
(1.5–1.9 kg·m, 11–14 ft·lb)

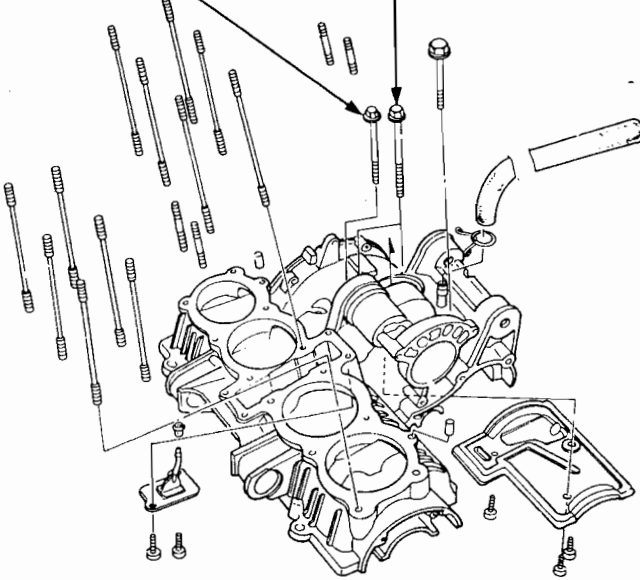

16–20 N·m  
(1.6–2.0 kg·m,  
12–15 ft·lb)

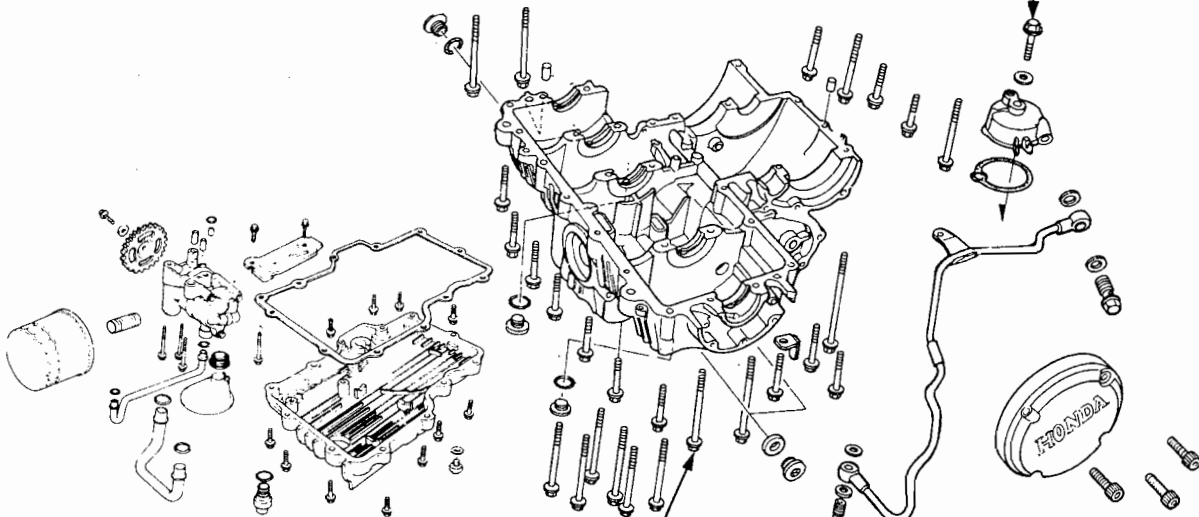

8 mm: 21–25 N·m  
(2.1–2.5 kg·m,  
15–18 ft·lb)

16–20 N·m  
(1.6–2.0 kg·m,  
12–14 ft·lb)



SERVICE INFORMATION	10-1
CRANKCASE DISASSEMBLY	10-2
CRANKCASE ASSEMBLY	10-4

## SERVICE INFORMATION

### GENERAL

- For crankshaft, connecting rod, starter clutch, gearshift drum and transmission servicing, the crankcase must be separated.
- The following parts must be removed before disassembling the crankcase.

For crankshaft and connecting rod services:

- Clutch/slave cylinder Section 8
- Oil pan/oil filter screen Section 2
- Cylinder head Section 6
- Cylinder/pistons Section 7
- Pulse generator Section 19
- Alternator Section 18
- Starter motor Section 20

For starter clutch service:

- Clutch/slave cylinder Section 8
- Oil pan/oil filter screen Section 2
- Pulse generator Section 19
- Alternator Section 18
- Starter motor Section 20

For gearshift drum and shift fork services:

- Clutch/slave cylinder Section 8
- Oil pan/oil filter screen Section 2
- Gearshift linkage Section 9
- Pulse generator Section 19
- Starter motor Section 20

For transmission service:

- Clutch/slave cylinder Section 8
- Oil pan/oil filter screen Section 2
- Pulse generator Section 19
- Starter motor Section 20

### TORQUE VALUES

Oil chamber cover bolt		16-20 N·m (1.6-2.0 kg-m, 12-15 ft-lb)
Crankcase bolt	8 mm	21-25 N·m (2.1-2.5 kg-m, 15-18 ft-lb)
	6 mm	10-14 N·m (1.0-1.4 kg-m, 7-10 ft-lb)
	7 mm	15-19 N·m (1.5-1.9 kg-m, 11-14 ft-lb)
Output gear case bolt	8 mm	21-25 N·m (2.1-2.5 kg-m, 15-18 ft-lb)
	6 mm	10-14 N·m (1.0-1.4 kg-m, 7-10 ft-lb)
Oil pipe bolt		16-20 N·m (1.6-2.0 kg-m, 12-14 ft-lb)

### TOOLS

#### Special

Crankcase assembly pin (2-required) 07973-ME50000



## CRANKCASE DISASSEMBLY

Remove the engine from the frame (Section 5).  
Remove the necessary parts before disassembling the crankcase (Page 10-1).  
Remove the oil pipe bolts and the oil pipe from the crankcase.  
Remove the special bolt and remove the oil chamber cover.

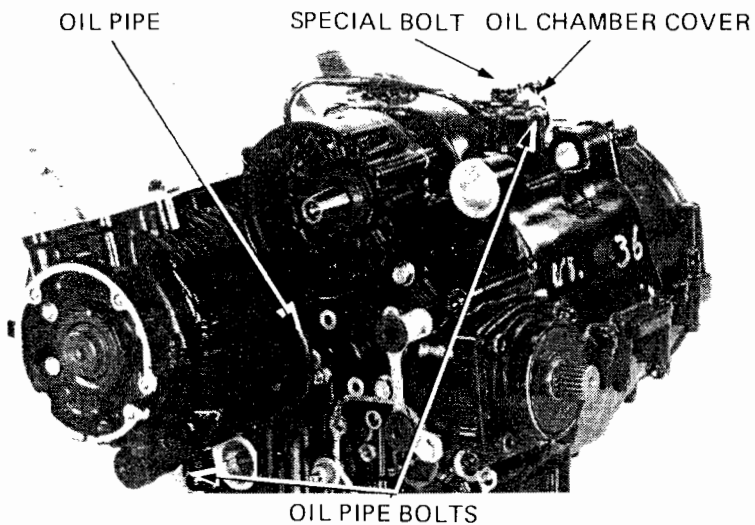

Remove the bolts attaching the output gear case to the crankcase.

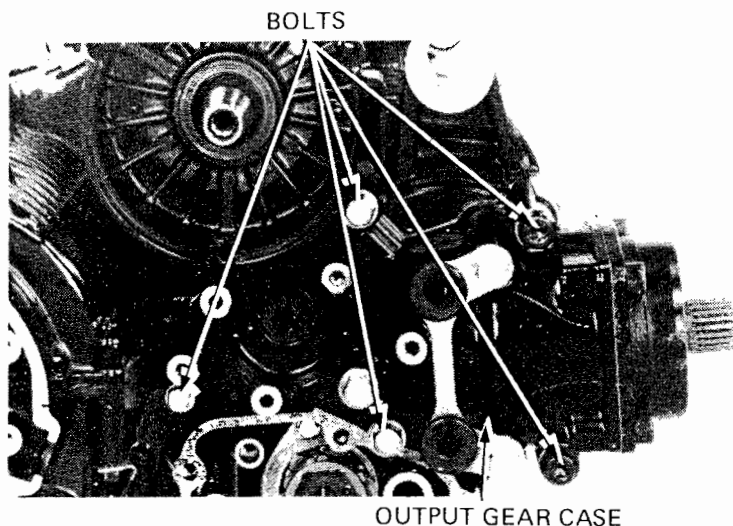

Remove the four upper crankcase bolts.

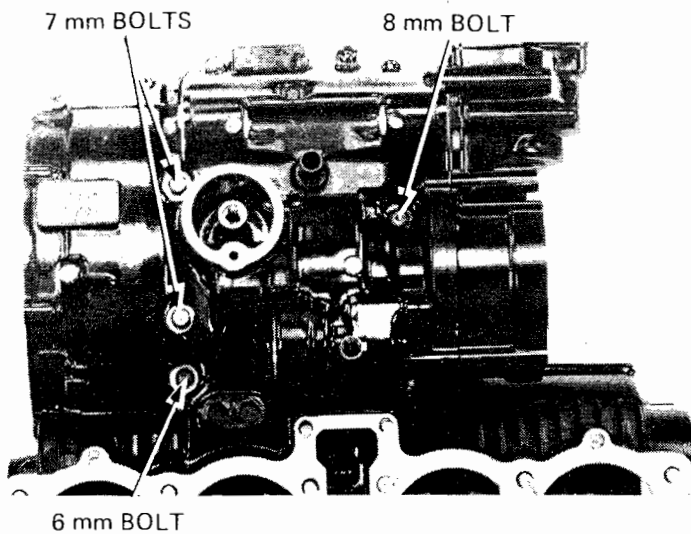



Turn the engine upside down and remove the crankcase lower bolts. Remove the 6 mm bolts (15) first and then remove the 8 mm bolts (11).

**NOTE**

Loosen the bolts in 2-3 steps and in a criss cross pattern to prevent case warpage.

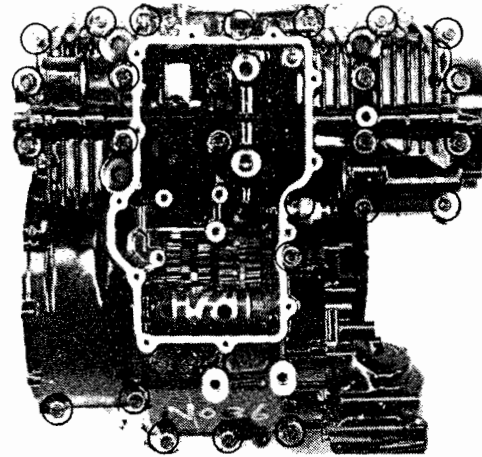

Remove the lower crankcase from the upper crankcase.

**CAUTION**

*Do not pry between the upper and lower cases.*

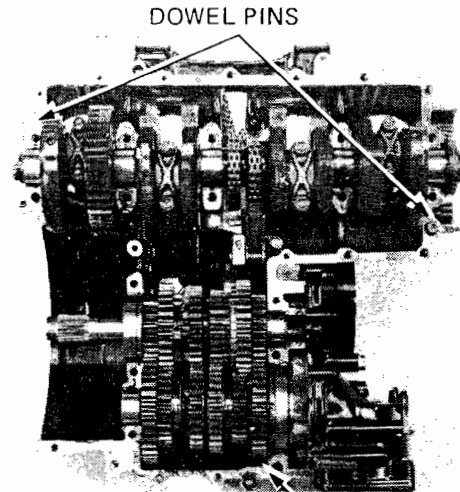

UPPER CRANKCASE

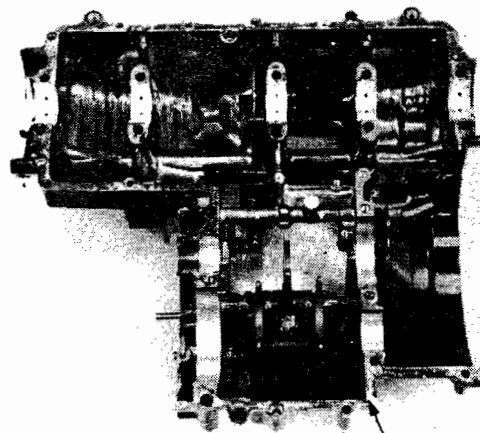

LOWER CRANKCASE



**CRANKCASE**

**CRANKCASE ASSEMBLY**

Apply molybdenum disulfide grease to the gear fork grooves and the crankshaft main bearings.

**GREASE** (MOLYBDENUM DISULFIDE)

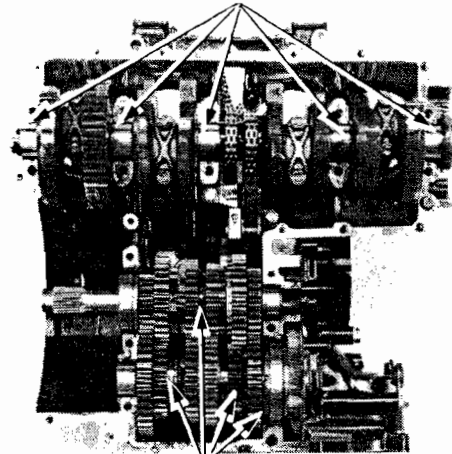

**GREASE** (MOLYBDENUM DISULFIDE)

Clean the crankcase mating surface and apply liquid sealant to the mating surface of the lower crankcase.

**CAUTION**

*Do not apply sealant to the area near the main bearings and tapered holes.*

Install the oil orifice and O-ring into the lower crankcase hole.

O-RING ORIFICE

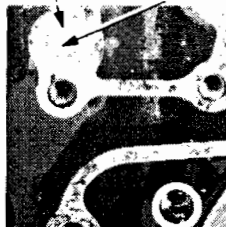

DO NOT COAT THIS AREA.

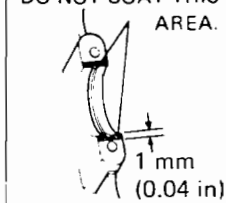

**GREASE** (MOLYBDENUM DISULFIDE)

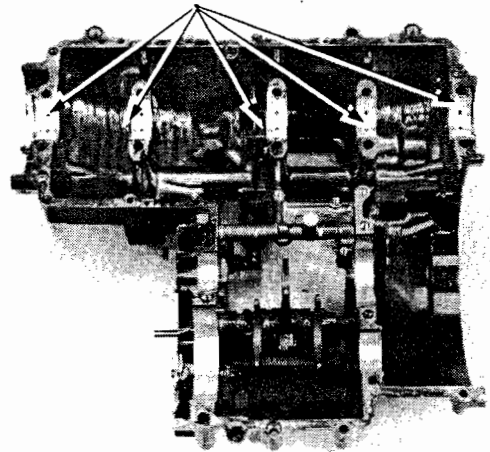

Install the two crankcase assembly pins (07973-ME50000) into the upper crankcase from the outside.

Shift the gearshift linkage into the neutral position for easier assembly, if the gearshift linkage is installed in the lower crankcase.

Place the lower crankcase onto the upper crankcase aligning the pins with the taper holes in the lower crankcase, and the shift fork claws with the transmission gear grooves.

TAPER HOLES

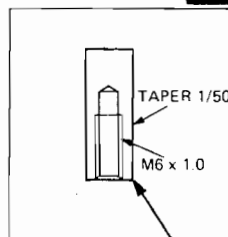
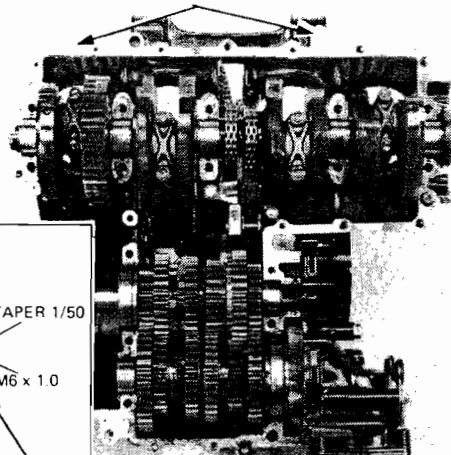

CRANKCASE ASSEMBLY PIN  
07973-ME50000



Apply molybdenum disulfide grease to the crankcase bolts threads and under the bolt heads. Tighten the lower crankcase bolts in the sequence shown in 2-3 steps.

**TORQUE:**

- 8 mm Bolt: 21-25 N·m  
(2.1-2.5 kg·m, 15-18 ft·lb)
- 6 mm Bolt: 10-14 N·m  
(1.0-1.4 kg·m, 7-10 ft·lb)

Drive the crankcase assembly pins out of the crankcase.

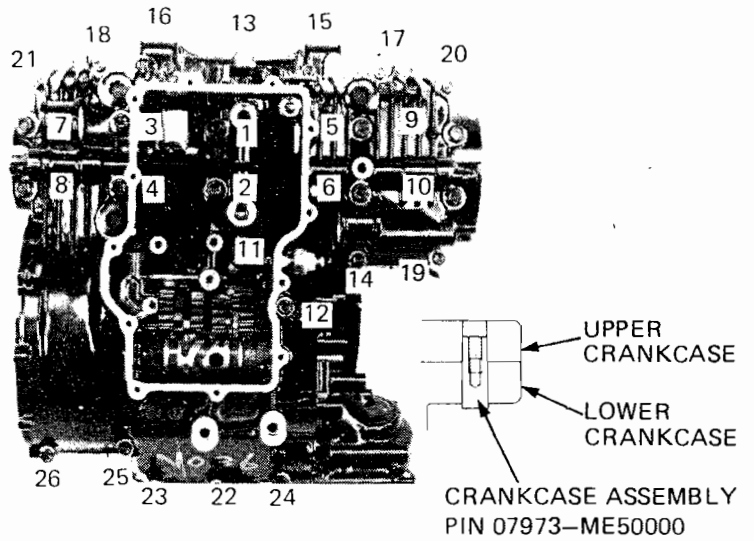

Turn the crankcase upright and tighten the upper crankcase bolts.

**TORQUE:**

- 8 mm Bolt: 21-25 N·m  
(2.1-2.5 kg·m, 15-18 ft·lb)
- 7 mm Bolt: 15-19 N·m  
(1.5-1.9 kg·m, 11-14 ft·lb)
- 6 mm Bolt: 10-14 N·m  
(1.0-1.4 kg·m, 7-10 ft·lb)

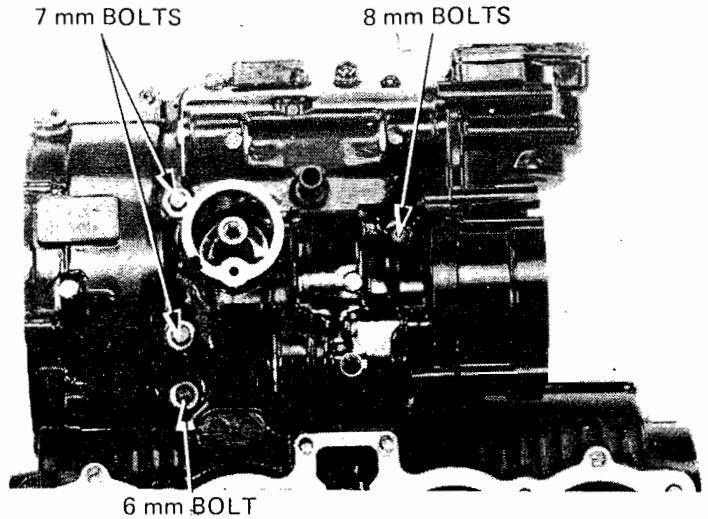

Tighten the output gear case mounting bolts.

**TORQUE:**

- 8 mm Bolts: 21-25 N·m  
(2.1-2.5 kg·m, 15-18 ft·lb)
- 6 mm Bolt: 10-14 N·m  
(1.0-1.4 kg·m, 7-10 ft·lb)

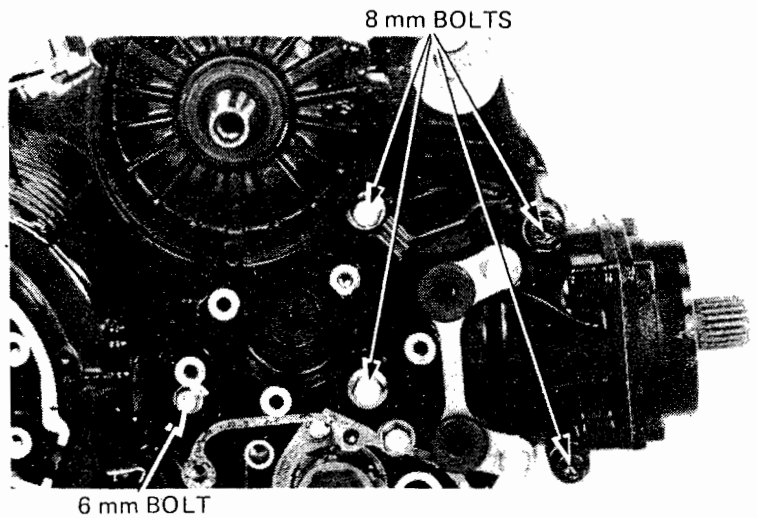





Clean the oil hole in the oil chamber cover with compressed air.  
Make sure the O-ring on the oil chamber cover is in good condition and install the cover onto the upper crankcase.

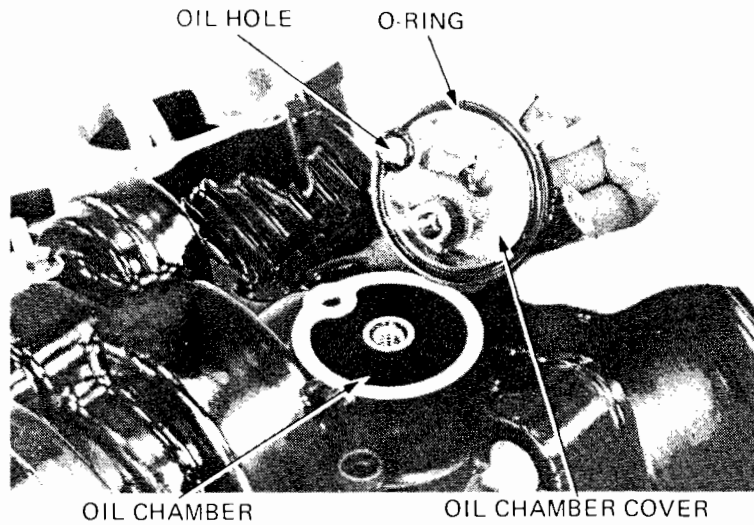

Tighten the oil chamber cover special bolt.

**TORQUE: 16–20 N·m**  
**(1.6–2.0 kg·m, 12–15 ft·lb)**

Clean the oil pipe and oil pipe bolts with compressed air to clean the holes.

Make sure the oil pipe sealing washers are in good condition.

Install the oil pipe with the oil pipe bolts and two sealing washers for each bolt.

**TORQUE: 16–20 N·m**  
**(1.6–2.0 kg·m, 12–14 ft·lb)**

Install the removed parts according to the corresponding sections (Page 10-1).  
Install the engine (Section 5).

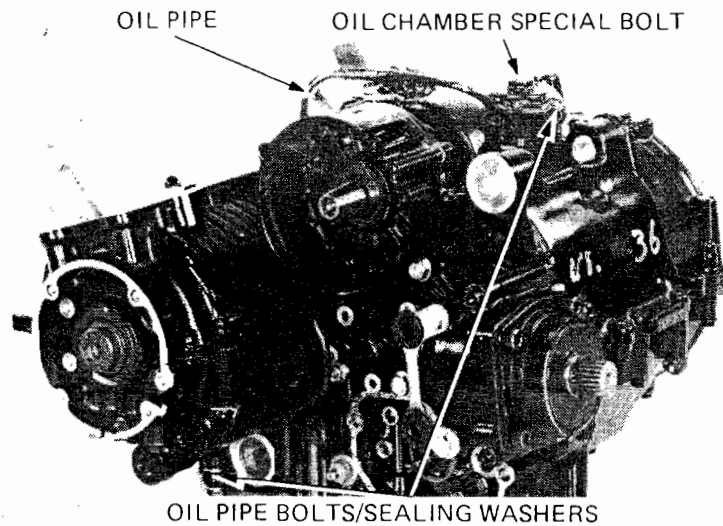



**HONDA**  
**CB750SC**

---

MEMO

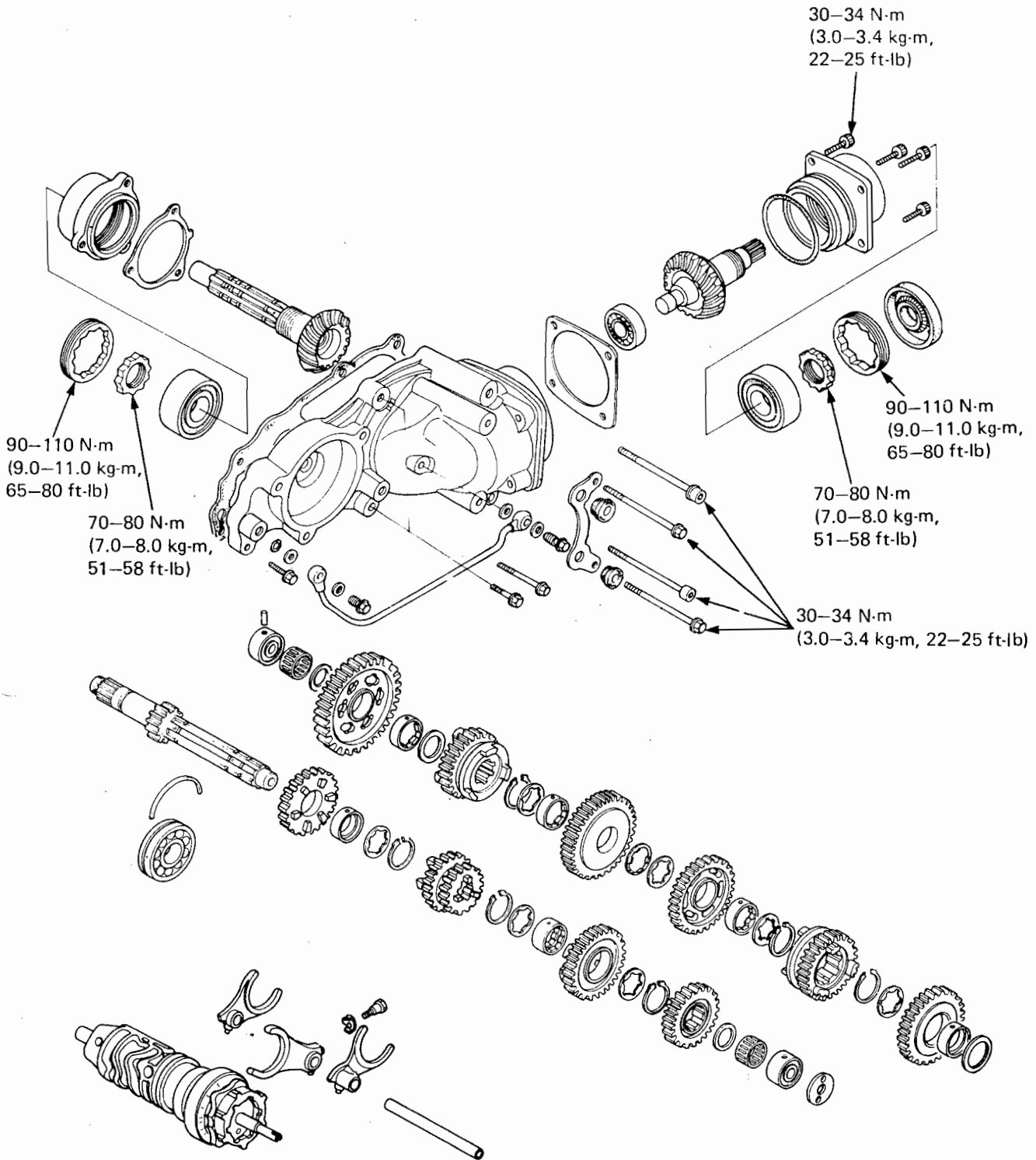



SERVICE INFORMATION	11-1	TRANSMISSION	11-5
TROUBLESHOOTING	11-2	OUTPUT GEAR CASE	11-10
SHIFT FORKS AND SHIFT DRUM	11-3		

## SERVICE INFORMATION

### GENERAL

- For internal transmission repairs, the crankcase must be separated (Section 10).
- Replace the countershaft and output driven gear as a set.
- When using the lock nut wrench, use a deflecting beam type torque wrench 35–51 cm (14–20 inches) long. The lock nut wrench increases the torque wrench's leverage, so the torque wrench reading will be less than the torque actually applied to the lock nut. The specification given is the actual torque applied to the lock nut, not the reading on the torque wrench when used with the lock nut wrench. The torque wrench scale reading is given with the actual torque specification.

### SPECIFICATIONS

Transmission			STANDARD	SERVICE LIMIT
Backlash	1st, 2nd, 3rd		0.089–0.179 mm (0.0035–0.0070 in)	0.22 mm (0.009 in)
	4th, 5th, 6th		0.068–0.136 mm (0.0013–0.0040 in)	0.18 mm (0.007 in)
Gear I.D.	M5, M6, C3, C4		28.000–28.021 mm (1.1024–1.1032 in)	28.04 mm (1.104 in)
	C1		24.000–24.021 mm (0.9449–0.9457 in)	24.04 mm (0.946 in)
	C2		29.000–29.021 mm (1.1417–1.1426 in)	29.04 mm (1.143 in)
Gear bushing O.D.	M5, M6, C3, C4		27.959–27.980 mm (1.1007–1.1016 in)	27.94 mm (1.100 in)
	C2		28.959–28.980 mm (1.1413–1.1409 in)	28.94 mm (1.139 in)
	C1		23.959–23.980 mm (0.9443–0.9451 in)	23.94 mm (0.944 in)
Gear bushing I.D.	M5, C2		24.985–25.006 mm (0.9837–0.9845 in)	25.04 mm (0.986 in)
	C1		20.016–20.037 mm (0.7880–0.7889 in)	20.06 mm (0.790 in)
Mainshaft O.D.	M5		24.959–24.980 mm (0.9826–0.9835 in)	24.90 mm (0.980 in)
Countershaft O.D.	C1		19.987–20.000 mm (0.7869–0.7874 in)	19.94 mm (0.785 in)
	C2		24.959–24.980 mm (0.9826–0.9835 in)	24.90 mm (0.980 in)
Gear-to-bushing or shaft clearance	M5, M6, C3, C4 gear to bushing		0.020–0.062 mm (0.0008–0.0024 in)	0.08 mm (0.003 in)
	M5, C2 bushing to shaft		0.005–0.047 mm (0.0002–0.0019 in)	0.07 mm (0.003 in)
	C1 gear to bushing		0.015–0.057 mm (0.0006–0.0022 in)	0.08 mm (0.003 in)
	C1 bushing to shaft		0.007–0.041 mm (0.0003–0.0016 in)	0.06 mm (0.002 in)
	C2 gear to bushing		0.020–0.062 mm (0.0008–0.0024 in)	0.08 mm (0.003 in)

**TRANSMISSION**

		STANDARD	SERVICE LIMIT
Gearshift fork	Claw thickness	6.43–6.50 mm (0.253–0.256 in)	6.1 mm (0.24 in)
	I.D. (right and left)	14.000–14.021 mm (0.5512–0.5520 in)	14.04 mm (0.553 in)
Shift fork shaft O.D.		13.966–13.984 mm (0.5498–0.5506 in)	13.90 mm (0.547 in)

**TORQUE VALUES**

Output gear case		30–34 N·m (3.0–3.4 kg-m, 22–25 ft-lb)	
Driven gear bearing holder		30–34 N·m (3.0–3.4 kg-m, 22–25 ft-lb)	Apply engine oil to the bolt threads
Countershaft bearing holder		30–34 N·m (3.0–3.4 kg-m, 22–25 ft-lb)	
Countershaft bearing lock nut	outer	90–110 N·m (9.0–11.0 kg-m, 65–80 ft-lb)	Apply engine oil to the threads
	inner	70–80 N·m (7.0–8.0 kg-m, 51–58 ft-lb)	
Driven gear bearing lock nut	outer	90–110 N·m (9.0–11.0 kg-m, 65–80 ft-lb)	
	inner	70–80 N·m (7.0–8.0 kg-m, 51–58 ft-lb)	

**TOOLS****Special**

Lock nut wrench, 30/64 mm	07916–MB00000
Shaft holder	07923–6890101
Attachment	07945–3330300
Bearing remover, 17 mm	07936–3710300
Remover handle	07936–3710100
Remover weight	07936–3710200 or 07741–0010201

**Common**

Driver	07749–0010000
Attachment, 52 x 55 mm	07746–0010400
Pilot, 17 mm	07746–0040400
Driver	07746–0030100
Attachment, 30 mm I.D.	07746–0030300
Pilot, 30 mm	07746–0040700

**TROUBLESHOOTING****Hard to shift**

1. Clutch slave cylinder sticking
2. Shift fork bent
3. Shift shaft bent
4. Shift claw bent
5. Shift drum cam grooves damaged

**Transmission jumps out of gear**

1. Gear dogs worn
2. Shift shaft bent
3. Shift drum stopper broken
4. Shift forks bent



## SHIFT FORKS AND SHIFT DRUM

### REMOVAL

Remove the required parts from the engine (Page 10-1) and separate the crankcase (Page 10-2).

Bend down the lock washer tabs and remove the center shift fork set bolt and lock washer.  
Remove the shift fork shaft and shift forks from the lower crankcase.

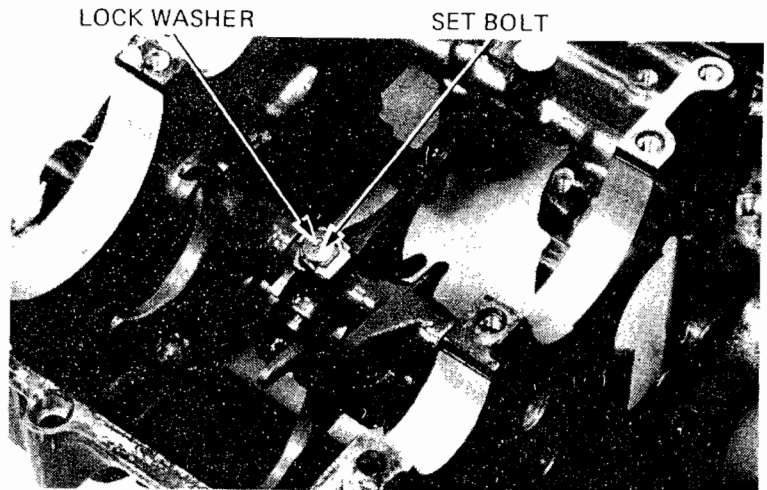

Remove the bearing set plate bolt and the plate.  
Remove the shift drum.

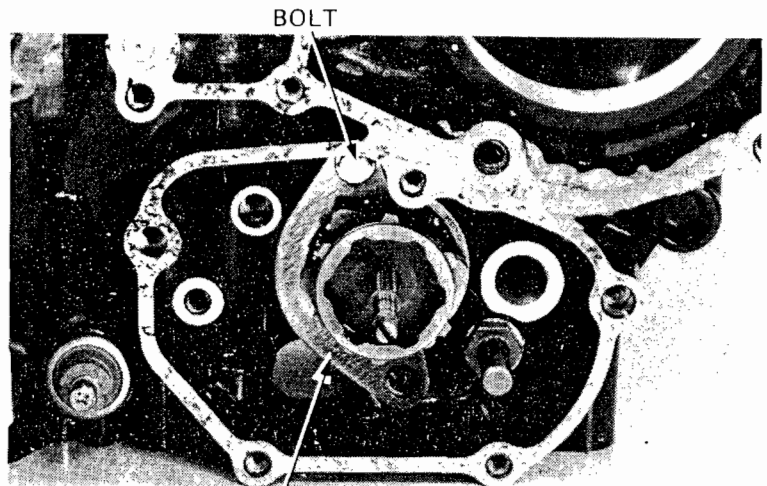

BEARING SET PLATE

### INSPECTION

Check the shift fork shaft for scratches, scoring or evidence of insufficient lubrication.  
Measure the O.D. of the shift fork shaft.

**SERVICE LIMIT: 13.90 mm (0.547 in)**

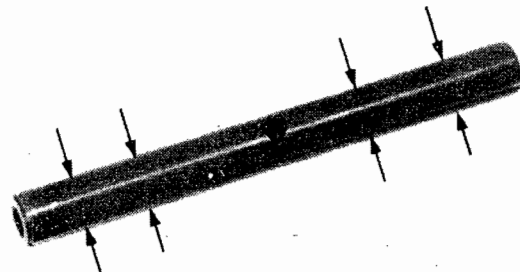



Measure the I.D. of the right and left shift forks.

**SERVICE LIMIT: 14.04 mm (0.553 in)**

Measure the shift fork claw thickness.

**SERVICE LIMIT: 6.1 mm (0.24 in)**

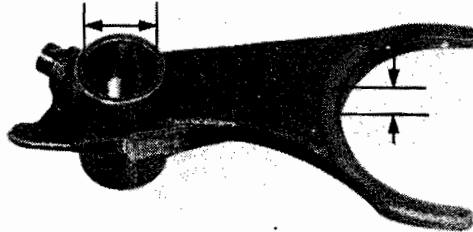

Inspect the shift drum bearing for excessive play, noise or damage.  
Check the shift drum guide grooves for wear or damage.  
Inspect the end of the shift drum for scoring, scratches, or evidence of insufficient lubrication.

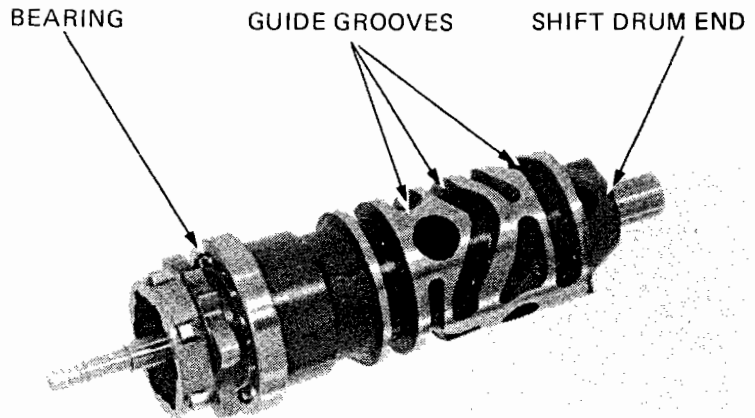

Inspect the shift drum and shift fork shaft holes in the lower crankcase for scoring, scratches or damage.

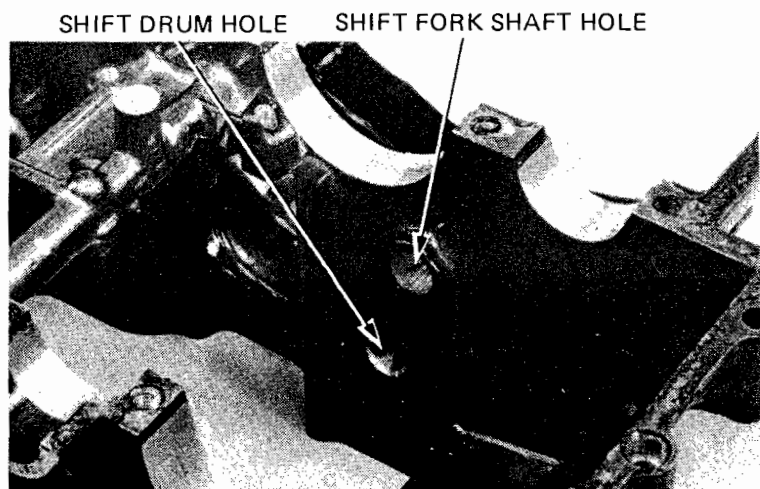



### INSTALLATION

Install the shift drum into the lower crankcase.  
Install the bearing set plate with the bolt.

#### NOTE

Do not tighten the bolt at this time. Tighten the bolt after installing the dowel pin (Page 9-7).

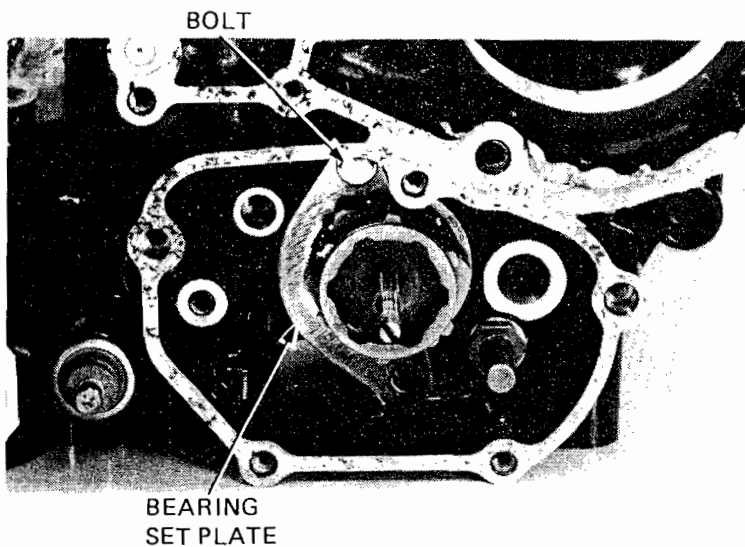

Install the shift forks and shift fork shaft.  
Align the set bolt holes in the fork shaft and center shift fork and tighten the center shift fork with the lock washer and set bolt.  
Bend up the lock washer tabs up against the bolt head.  
Assemble the crankcase (Page 10-4).

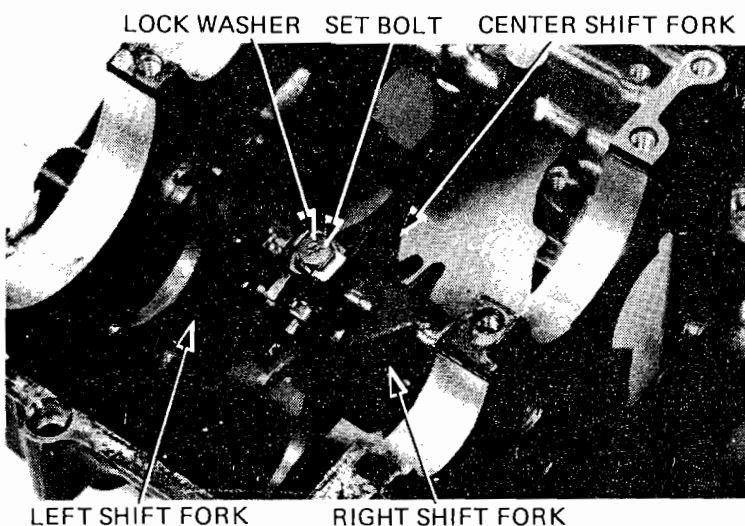

### TRANSMISSION

#### DISASSEMBLY

Remove the required parts (Page 10-1) and separate the crankcase (Page 10-2).  
Measure the backlash of each gear.

#### SERVICE LIMIT:

1st, 2nd, 3rd:	0.20 mm (0.008 in)
4th, 5th, 6th:	0.18 mm (0.007 in)

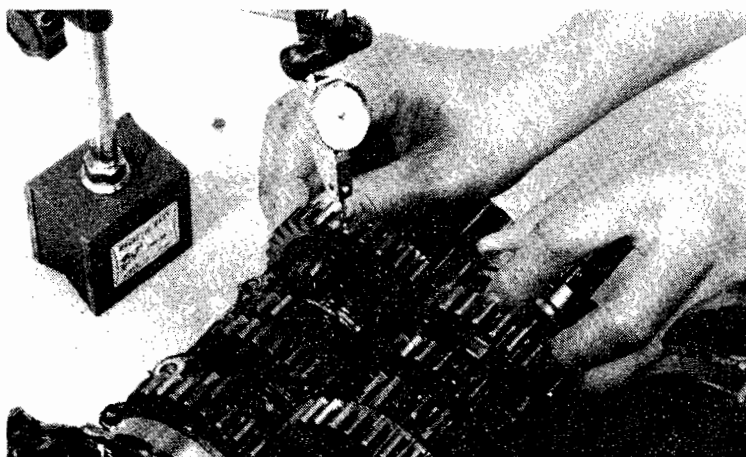



Remove and disassemble the mainshaft and countershaft.

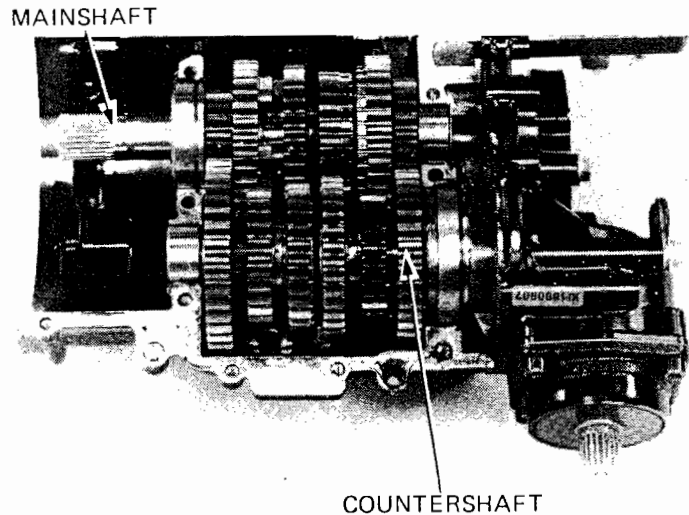

**INSPECTION**

Check the gear dogs, holes and teeth for excessive or abnormal wear, or evidence of insufficient lubrication.

Measure the I.D. of each gear.

**SERVICE LIMITS:**

- M5, M6, C3, C4: 28.04 mm (1.104 in)
- C1: 24.04 mm (0.946 in)
- C2: 29.04 mm (1.143 in)

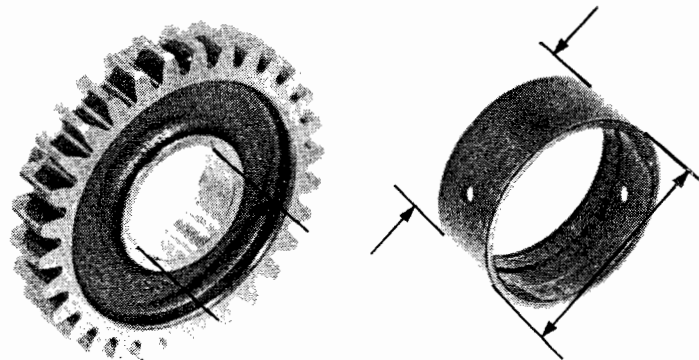

Measure the I.D. and O.D. of each gear bushing.

**SERVICE LIMITS:**

- M5, M6, C3, C4 O.D.: 27.94 mm (1.100 in)
- C2 O.D.: 28.94 mm (1.139 in)
- C1 O.D.: 23.94 mm (0.944 in)
- M5, C2 I.D.: 25.04 mm (0.986 in)
- C1 I.D.: 20.06 mm (0.790 in)

Measure the O.D. of the mainshaft and countershaft.

**SERVICE LIMITS:**

- M5: 24.90 mm (0.980 in)
- C1: 19.94 mm (0.785 in)
- C2: 24.90 mm (0.980 in)

Calculate the clearance between the gear bushing and the gear or shaft.

**SERVICE LIMITS:**

- M5, M6, C3, C4
  - gear-to-bushing: 0.08 mm (0.003 in)
  - M5, C2 bushing-to-shaft: 0.07 mm (0.003 in)
- C1 gear-to-bushing: 0.08 mm (0.003 in)
- C1 bushing-to-shaft: 0.06 mm (0.002 in)
- C2 gear-to-bushing: 0.08 mm (0.003 in)

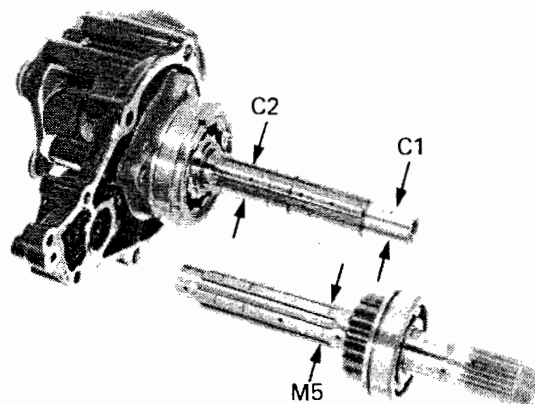



**ASSEMBLY**

**Mainshaft**

Check the gears for freedom of movement or rotation on the shaft.  
Check that the snap rings are seated in the grooves and that the snap ring ends are supported by shaft splines.

**NOTE**

Align the M6 gear bushing oil hole with the mainshaft oil hole.

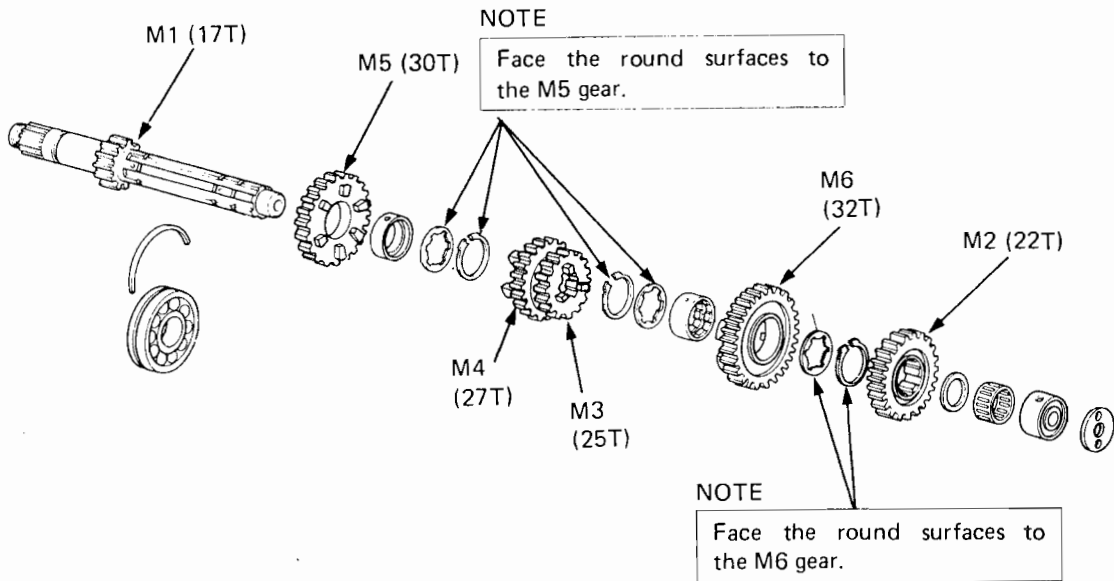
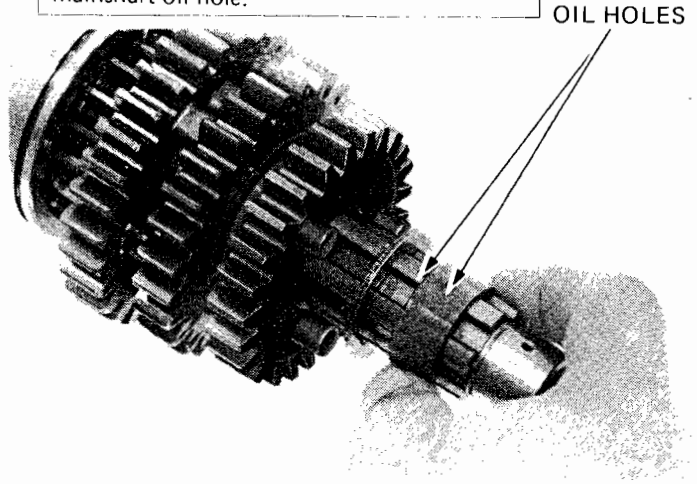



**TRANSMISSION**

**Countershaft**

Check the gears for freedom of movement or rotation on the shaft.

Check that the snap rings are seated in the grooves and that the snap ring ends are supported by shaft splines.

**NOTE**

Align the oil hole of the C3 and C4 gear bushings with the oil hole in the countershaft.

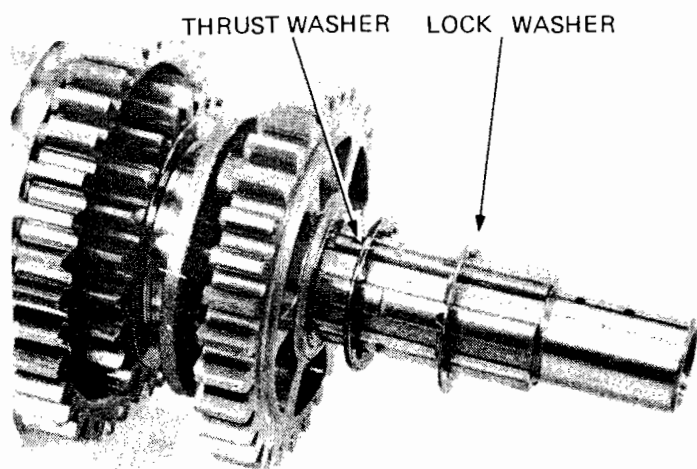
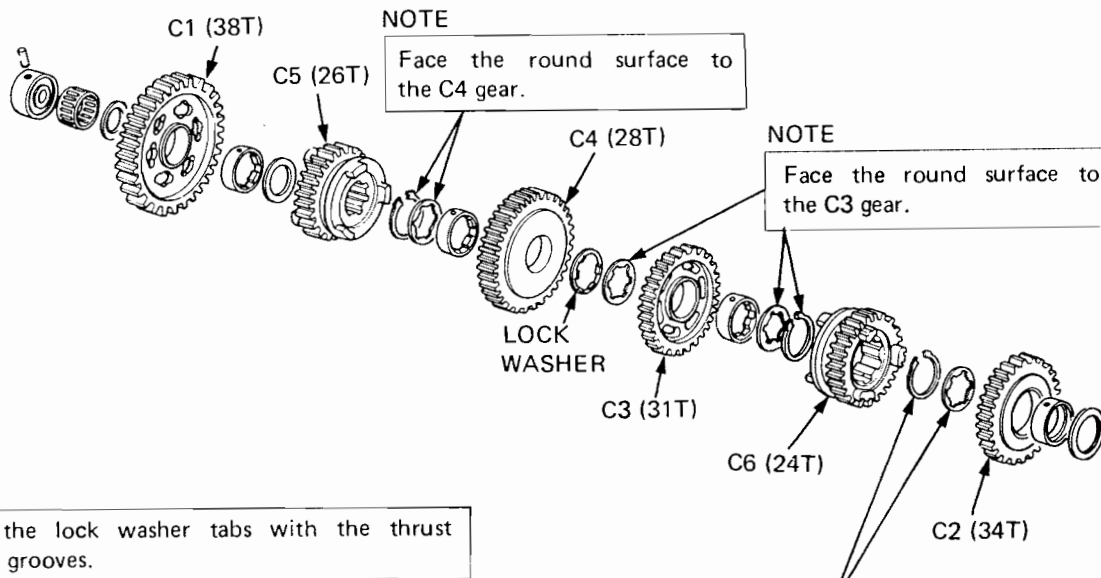
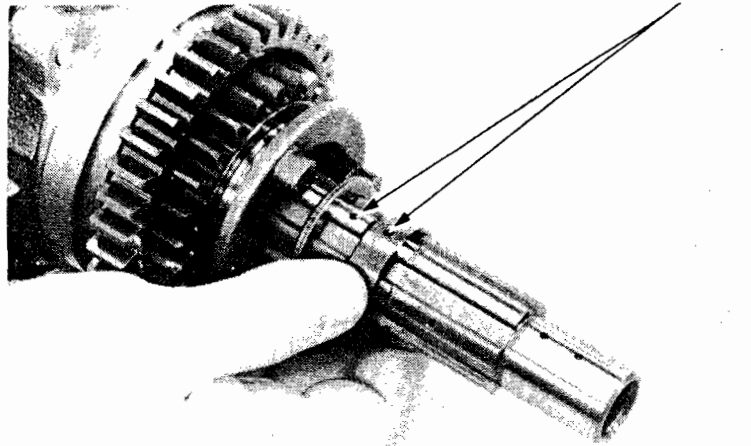



**INSTALLATION**

Install the bearing set ring and dowel pin into the upper crankcase.

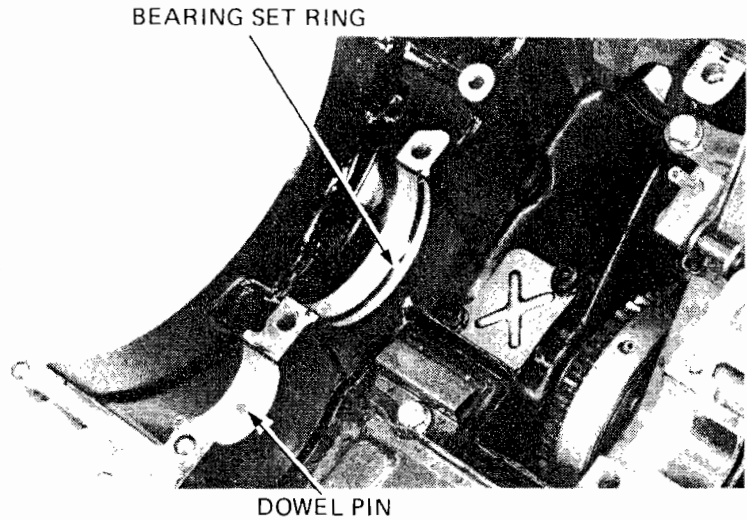

Install the mainshaft aligning the bearing groove with the bearing set ring.  
Install a new gasket onto the output gear case mounting surface.  
Install the countershaft assembly.

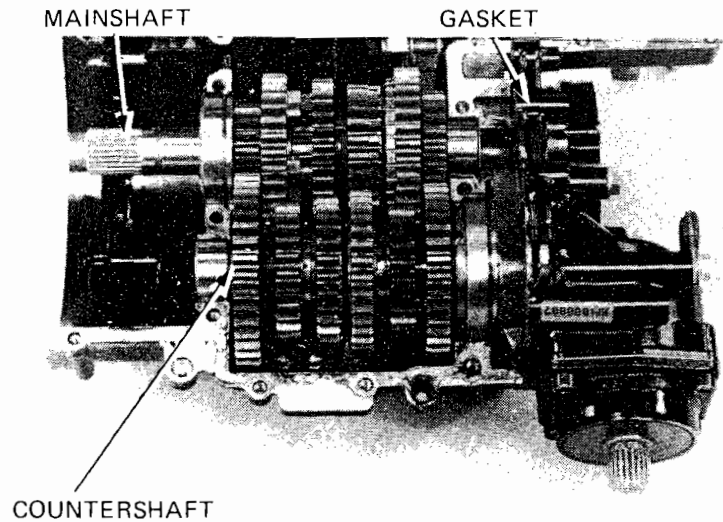

Align the hole in the needle bearing with the dowel pin by aligning the marks on the needle bearing with the crankcase mating surface.

Assemble the crankcase (Section 10).

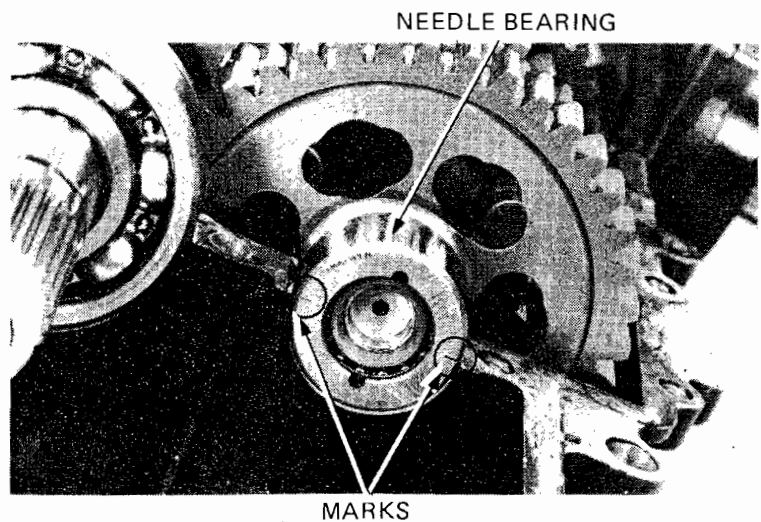



## OUTPUT GEAR CASE

### OUTPUT DRIVE GEAR (COUNTERSHAFT) REMOVAL

Disassemble the countershaft (Page 11-5).  
Place the output gear case in a vise with soft jaws,  
being careful not to distort it.

Place a holder tool on the output driven gear shaft,  
wedging it to lock the shaft.

Pry or drill the staked edge of lock nut flange up.

**NOTE**

Be careful that metal particles do not enter  
the bearing.

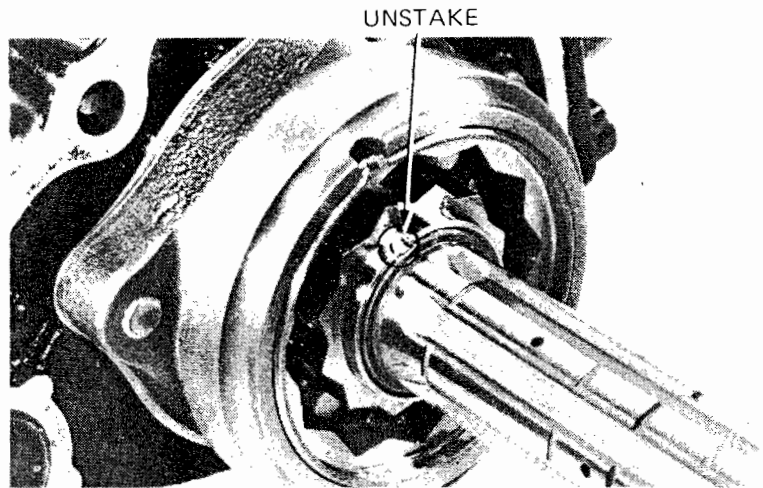

Remove the bearing inner race lock nut and discard  
the nut.

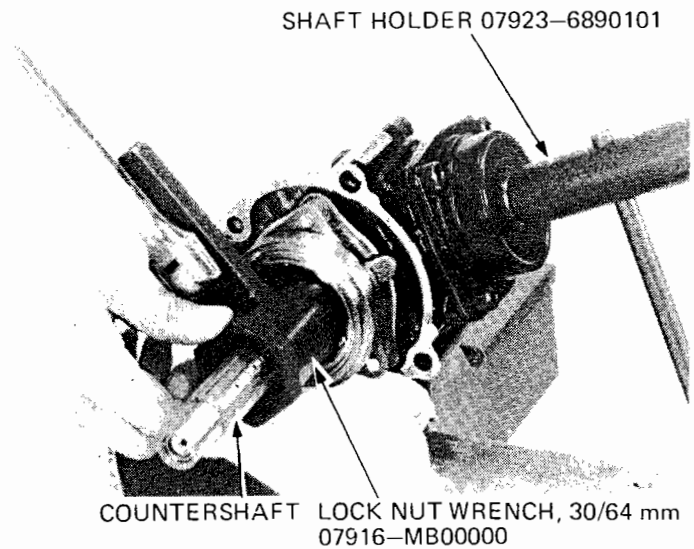

Remove the countershaft bearing holder bolts.

Remove the countershaft holder and shim.

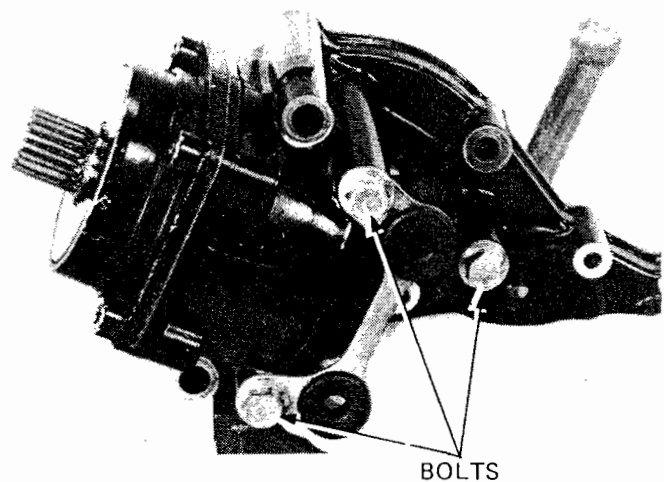



Place the countershaft/holder in a press.

Press the countershaft out of the bearing holder.

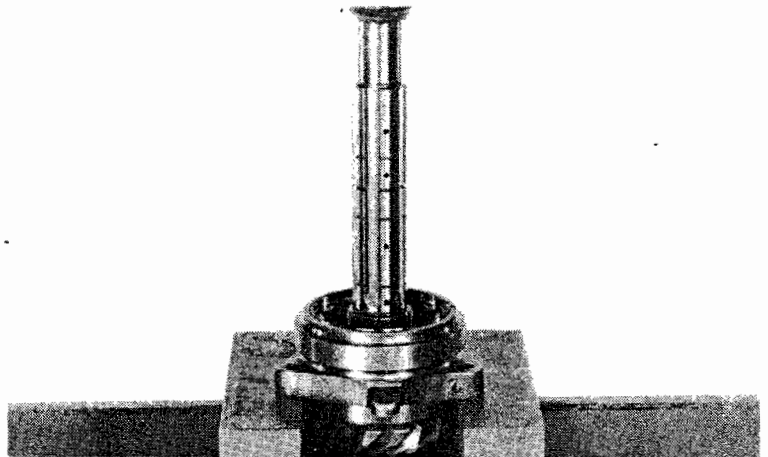

**COUNTERSHAFT BEARING REPLACEMENT**

Place the bearing holder in a vise with soft jaws or a shop towel.

**NOTE**

Be careful not to damage the bearing holder, especially the surface that fits against the crankcase.

Unstake the outer race lock nut with a punch.

Remove the bearing outer race lock nut with the special tool.

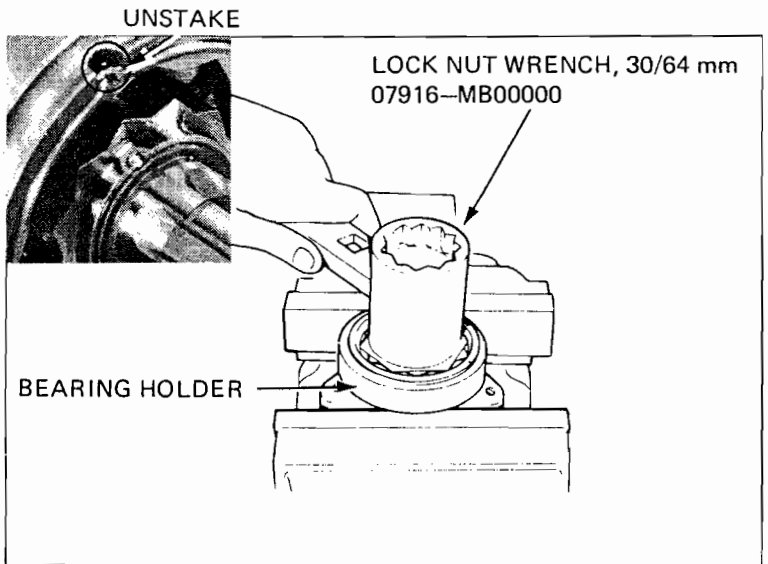

Place the bearing holder in a press and remove the bearing.

Press in a new bearing.

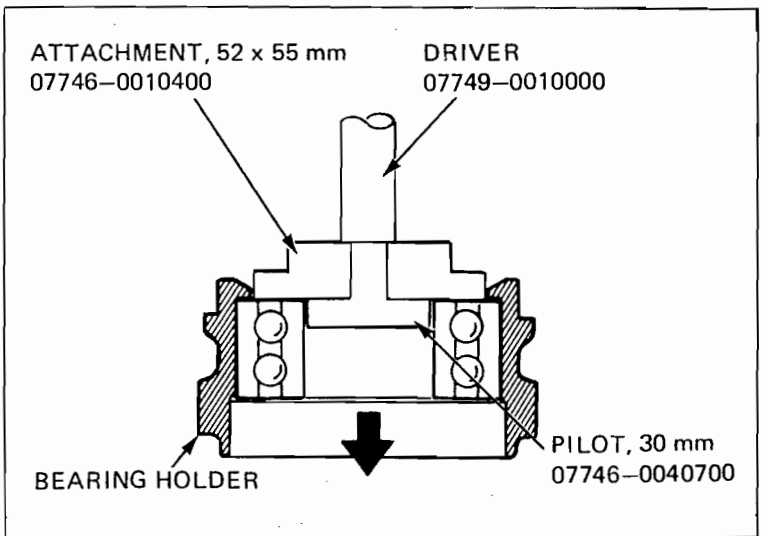

**INPUT DRIVE GEAR  
(COUNTERSHAFT) INSTALLATION**

**NOTE**

The countershaft and driven gear must be replaced as a set if they require replacement.

Place the bearing holder in a press and support the inner race with the special tool.  
Place the countershaft into the holder and press it in.

**NOTE**

Place the pilot's threaded end into the countershaft and be sure the attachment is aligned with the bearing inner race.

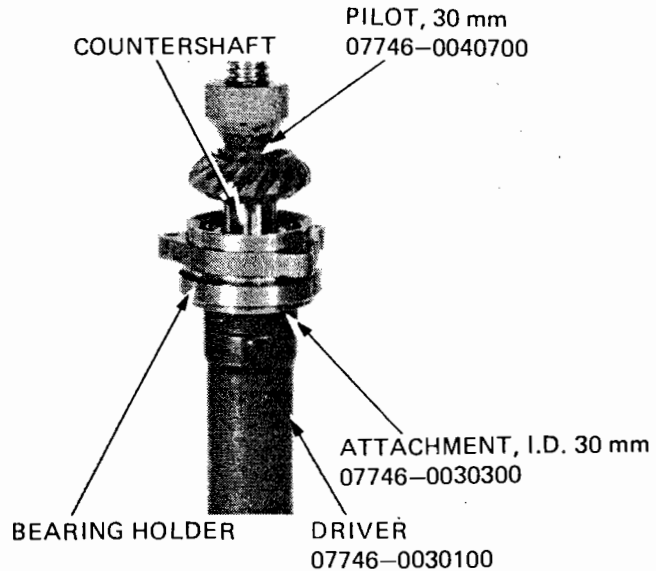

If the bearing outer race lock nut is removed, place the bearing holder in a vise with soft jaws and, apply engine oil to the bearing holder and lock nut threads. Tighten a new outer race lock nut to the specified torque value.

**TORQUE:** 90-110 N·m  
(9.0-11.0 kg·m, 65-80 ft·lb)

**Torque wrench scale reading:**  
80-100 N·m (8.0-10.0 kg·m, 58-72 ft·lb)

Then stake the new nut.

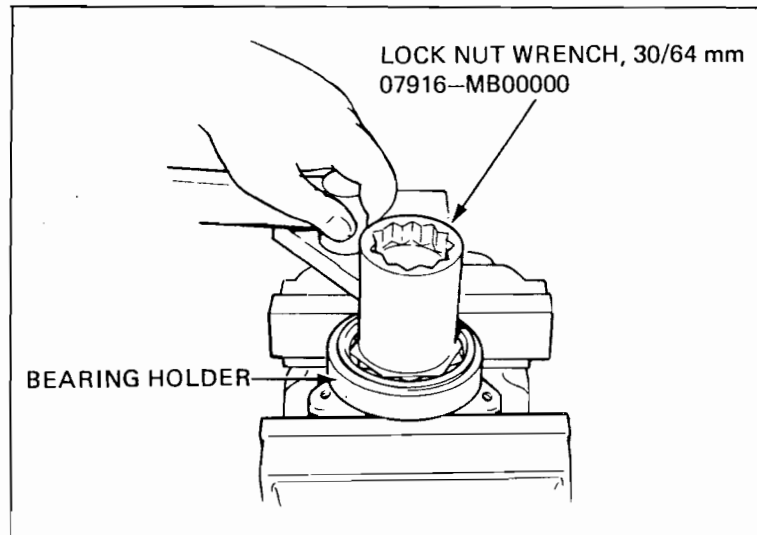

Place the adjustment shim over the bearing holder.

**NOTE**

If the countershaft/driven gear, gear case, and/or bearing are replaced, a new adjustment shim must be selected (Page 11-21 Backlash Inspection).

Apply engine oil to the bearings and gears.

Place the countershaft/bearing holder and correct shim (Page 11-22) into the output gear case.

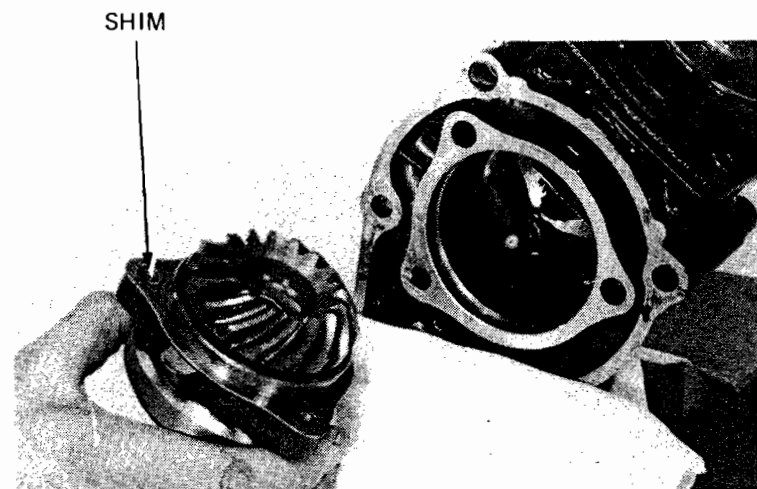



Apply oil to the threads of the mounting bolts and tighten them to the specified torque.

**TORQUE:** 30–34 N·m  
(3.0–3.4 kg·m, 22–25 ft·lb)

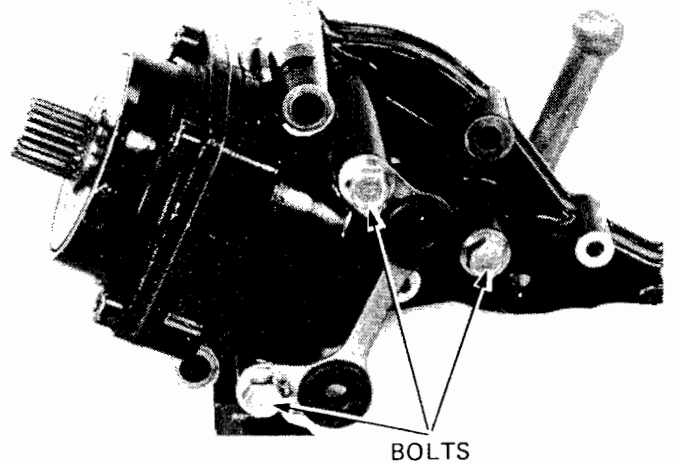

Place the output gear case in a vise with soft jaws, being careful not to distort it.

Set a shaft holder on the output driven gear shaft wedging it to lock the shaft.

Apply engine oil to the countershaft and the new lock nut threads.

Tighten the lock nut to specified torque.

**TORQUE:** 70–80 N·m  
(7.0–8.0 kg·m, 51–58 ft·lb)

**Torque wrench scale reading:**  
64–73 N·m (6.4–7.3 kg·m, 46–53 ft·lb)

SHAFT HOLDER 07923–6890101

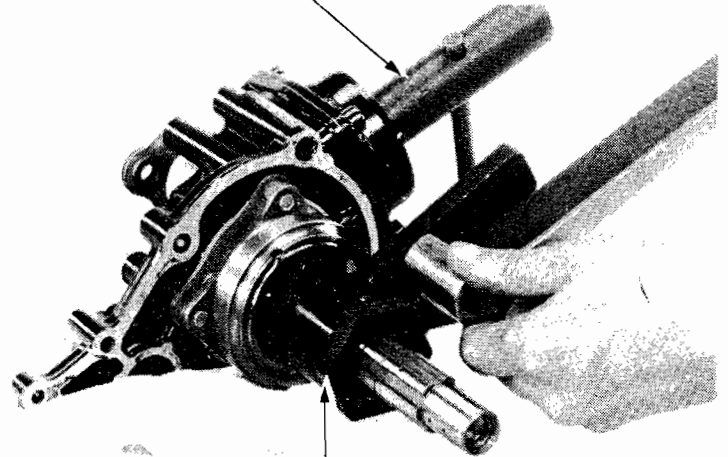

LOCK NUT WRENCH, 30/64 mm  
07916–MB00000

Stake the lock nut into the countershaft hole.

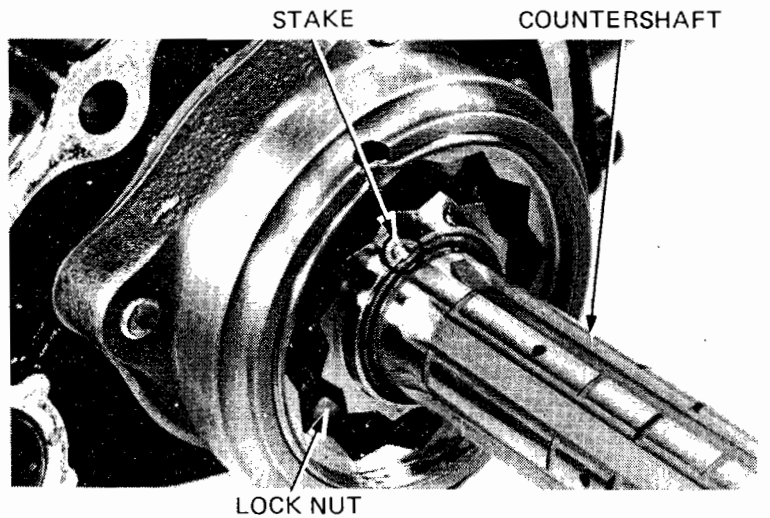





**OUTPUT DRIVEN GEAR REMOVAL**

Remove the output driven gear oil seal from the output gear case.

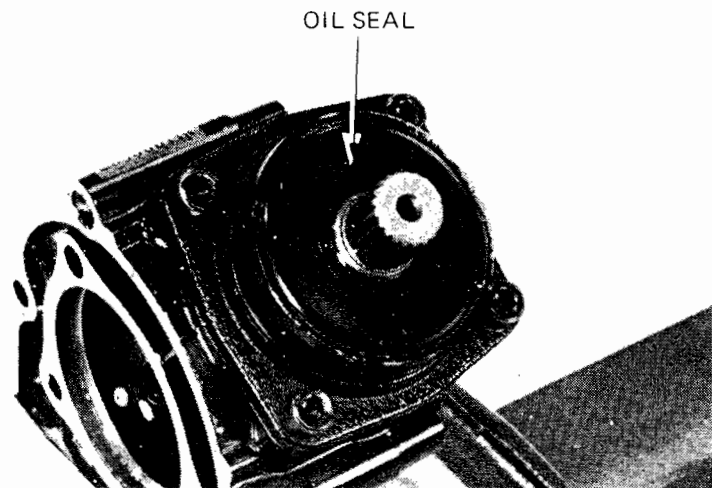

Pry or drill the staked edge of the output driven gear bearing inner race lock nut.

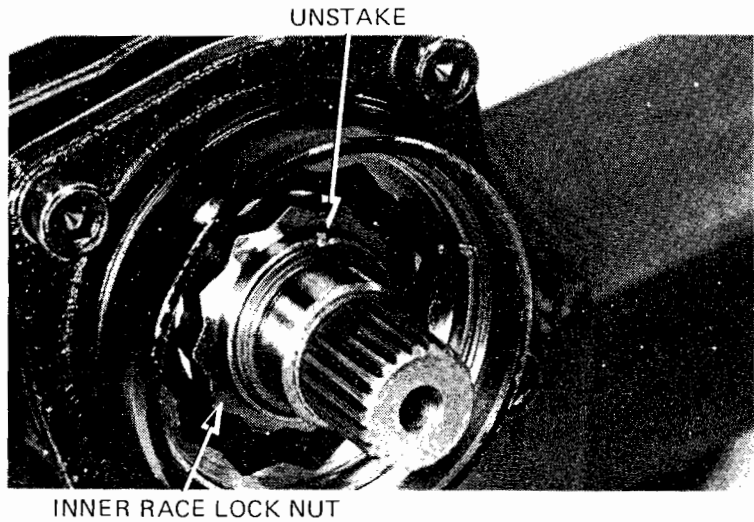

Remove the inner race lock nut and discard it.

LOCK NUT WRENCH, 30/64 mm  
07916-MB00000

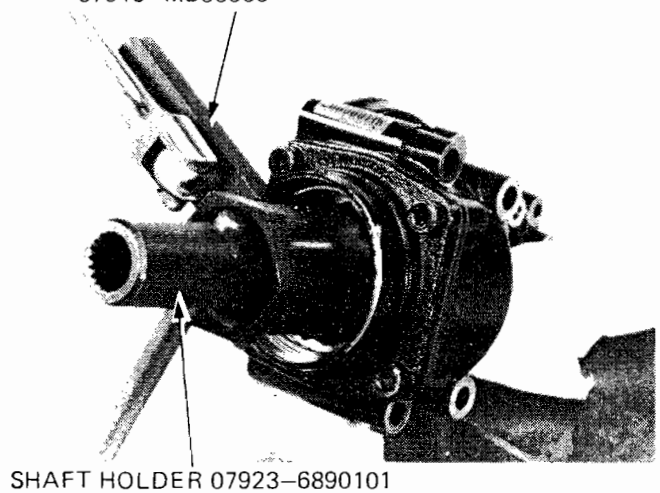



Remove the driven gear bearing holder mounting bolts.

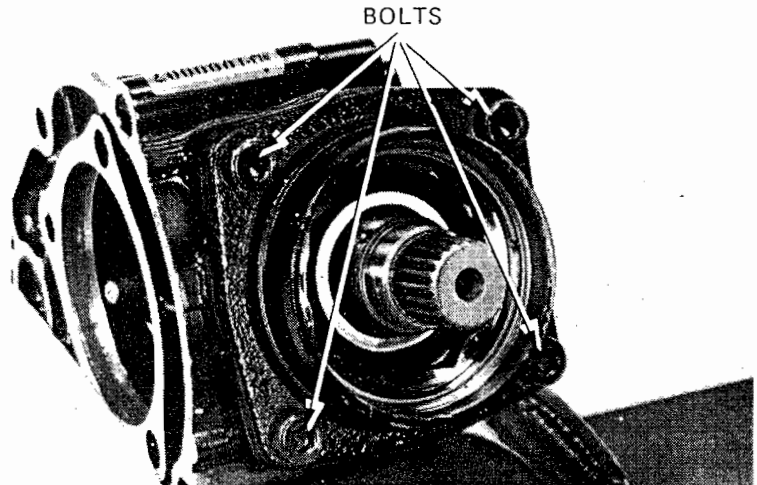

Pry the driven gear from inside the case and remove the driven gear.  
Remove the shim and O-ring from the bearing holder.

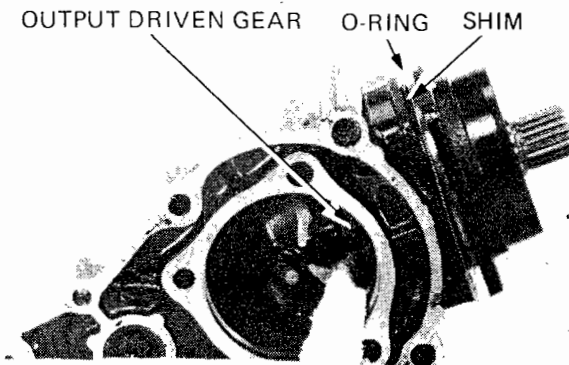

Place the output driven gear/bearing holder in a press.  
Press the output driven gear out of the bearing holder.

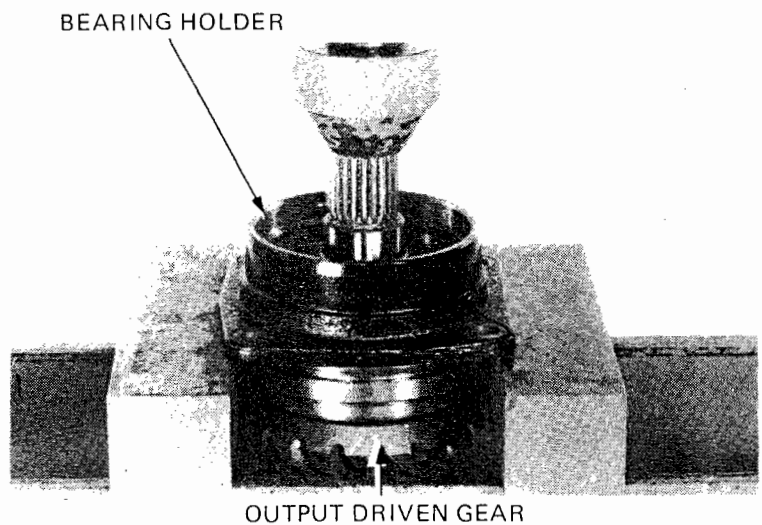



**OUTPUT DRIVEN GEAR BEARING  
REPLACEMENT**

Place the output driven gear bearing holder into a vise with soft jaws. Unstake and remove the output driven gear bearing outer race lock nut from the holder.

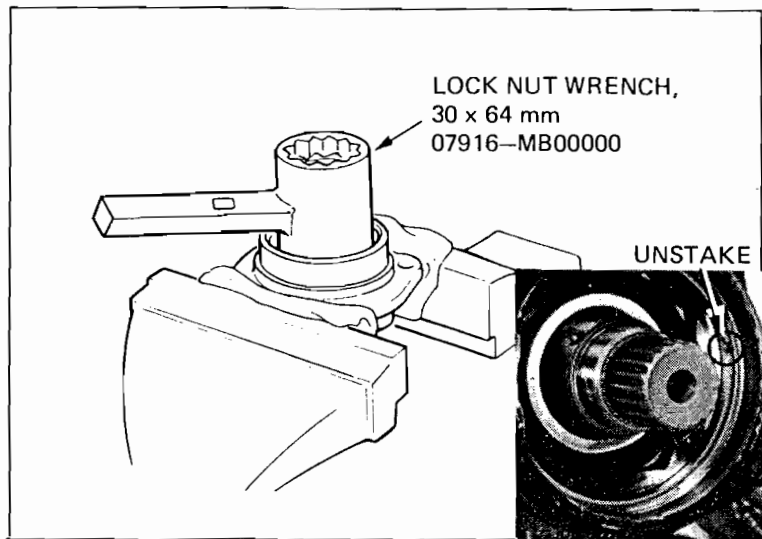

Place the bearing holder in a press and press the bearing out.

**NOTE**

Be careful not to damage the bearing holder gear case mating surface.

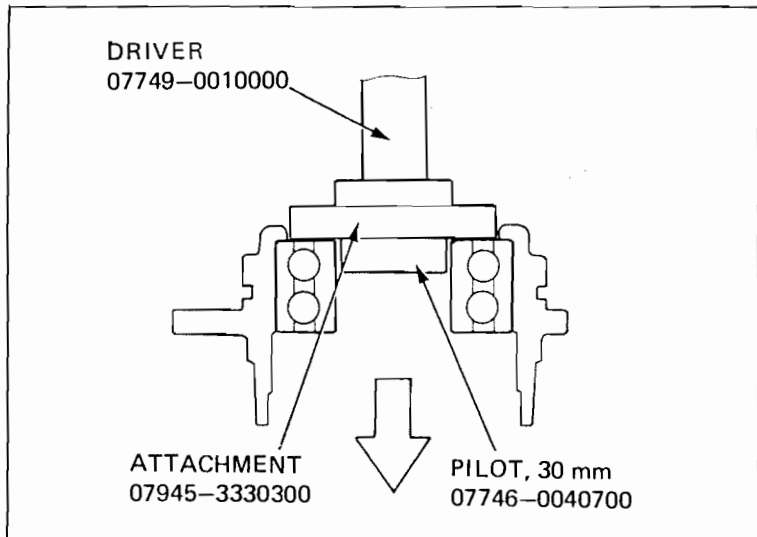

Press in a new bearing and make sure it rotates freely.

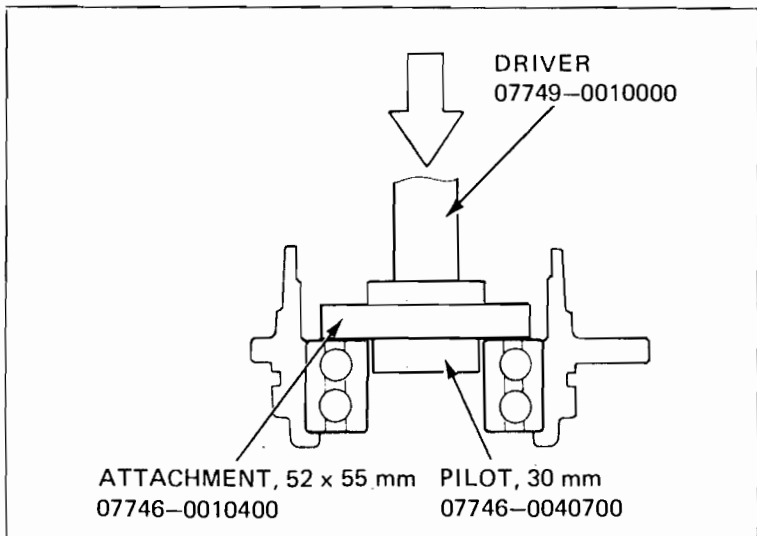



**OUTPUT DRIVEN GEAR CASE BEARING REPLACEMENT**

Heat the output gear case around the bearing to 80°C (176°F).

**CAUTION**

*Always wear gloves when handling a heated gear case.*

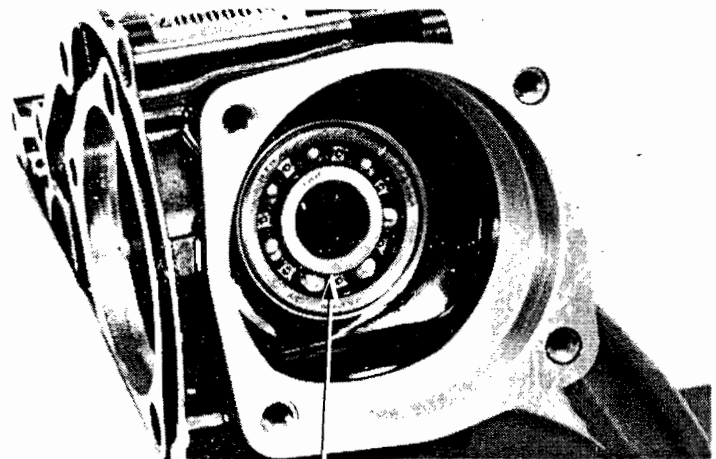

BEARING

Remove the bearing with the special tools.

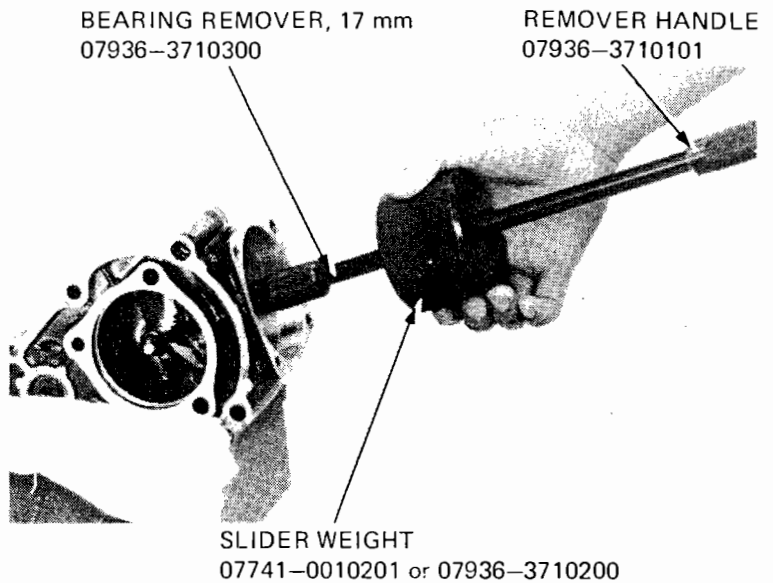

BEARING REMOVER, 17 mm  
07936-3710300

REMOVER HANDLE  
07936-3710101

SLIDER WEIGHT  
07741-0010201 or 07936-3710200

Drive a new bearing into the output gear case.

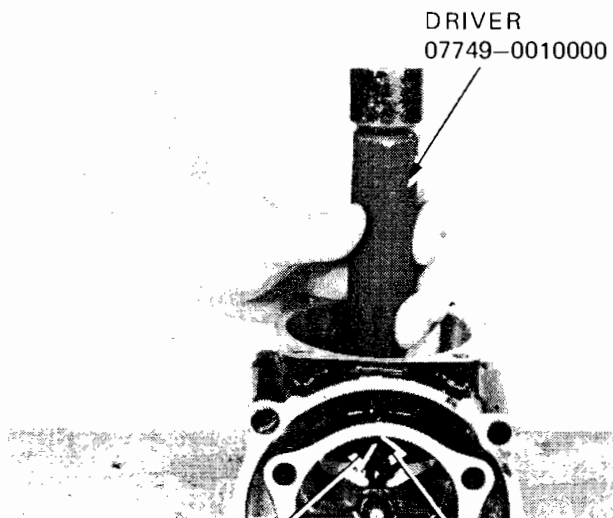

DRIVER  
07749-0010000

ATTACHMENT, 42 x 47 mm  
07746-0010300

PILOT, 17 mm  
07746-0040400

**OUTPUT DRIVEN GEAR INSTALLATION**

Apply engine oil to the threads of a lock nut and driven gear shaft. Install the lock nut and tighten by hand.

Place the output driven gear bearing holder into a press. Support the inner race with the special tool. Then press in the output driven gear.

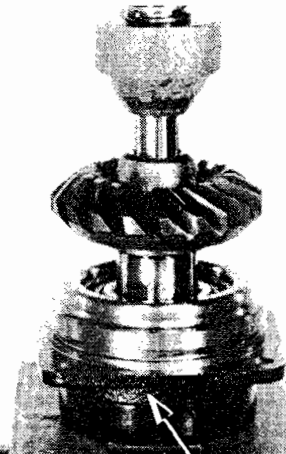

DRIVER 07746-0030100  
ATTACHMENT, 30 mm I.D. 07746-0030300

If the outer race lock nut is removed, place the bearing holder into a vise with soft jaws. Apply engine oil to the bearing holder and the new lock nut threads. Tighten the new lock nut to the specified torque value.

**TORQUE:** 90-110 N·m  
(9.0-11.0 kg·m, 65-80 ft·lb)

**Torque wrench scale reading:**  
80-100 N·m (8.0-10.0 kg·m, 58-72 ft·lb)

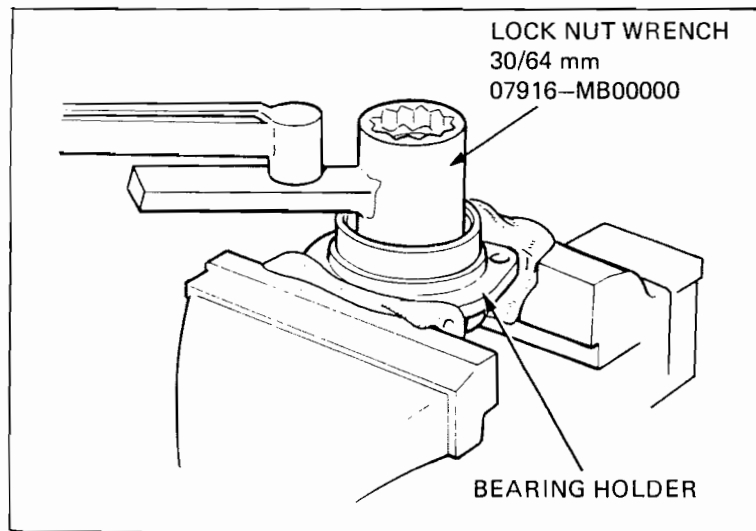

Blow compressed air through the oil nozzle to make sure the oil passage is not clogged.  
Install the correct shim and new O-ring.

**NOTE**

When the gear set, driven gear bearing and/or gear case has been replaced, use the 0.50 mm (0.020 in) shim for initial reference.

Attach the bearing holder onto the gear case.

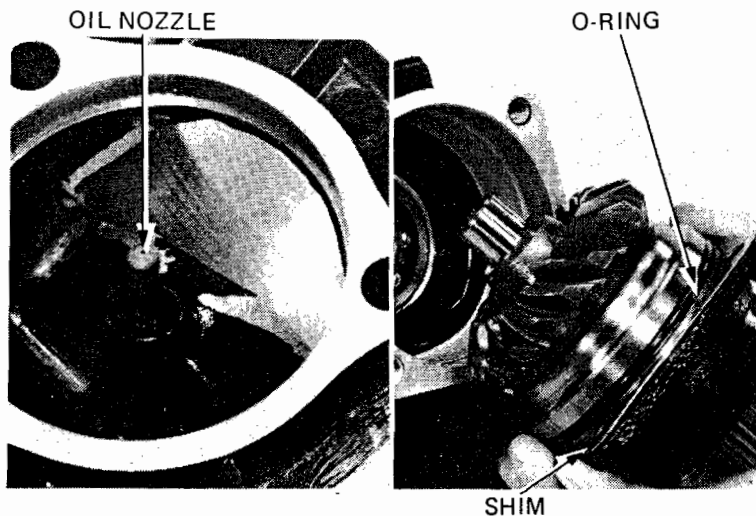



Apply engine oil to the bolt threads and tighten the bolts to the specified torque.

**TORQUE:** 30–34 N·m  
(3.0–3.4 kg·m, 22–25 ft·lb)

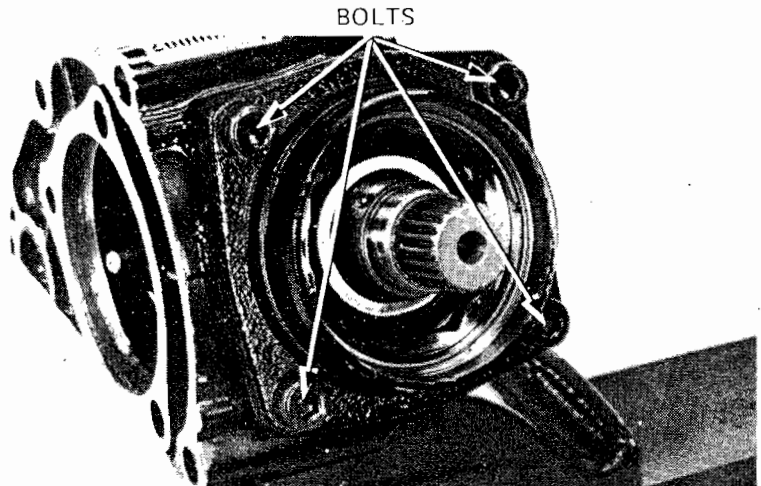

Tighten the lock nut to specified torque.

**TORQUE:** 70–80 N·m  
(7.0–8.0 kg·m, 51–58 ft·lb)

Torque wrench scale reading:  
64–73 N·m (6.4–7.3 kg·m, 46–53 ft·lb)

Stake the new lock nut into the hole in the output driven gear shaft.

LOCK NUT WRENCH, 30/64 mm 07916–MB00000

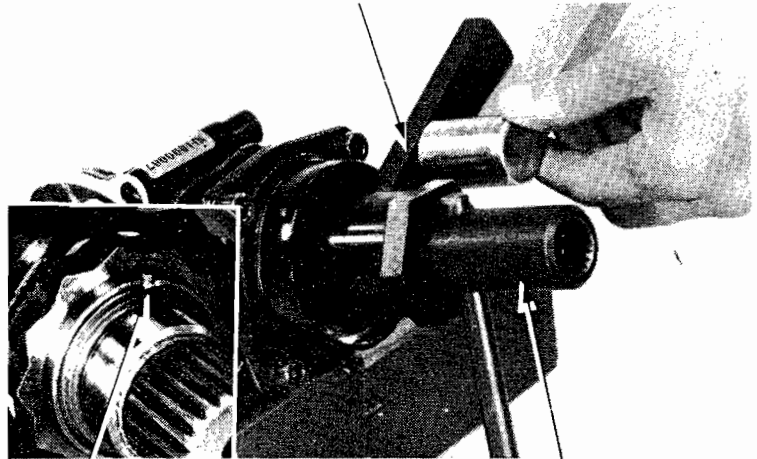

STAKE

SHAFT HOLDER 07923–6890101

Install a new oil seal with special tool 07947–3710200.

OIL SEAL

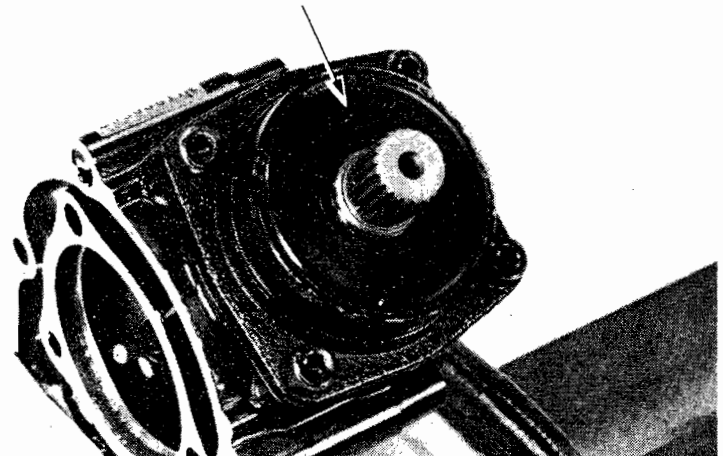



### GEAR TOOTH CONTACT PATTERN CHECK

Remove the drive and driven gears (Page 11-10, 11-14).

Apply Prussian Blue to the driven gear teeth.

Install the drive and driven gears with the standard shims.

Rotate the drive gear several times in the normal direction of rotation.

Check the gear tooth contact pattern after removing the drive gear.

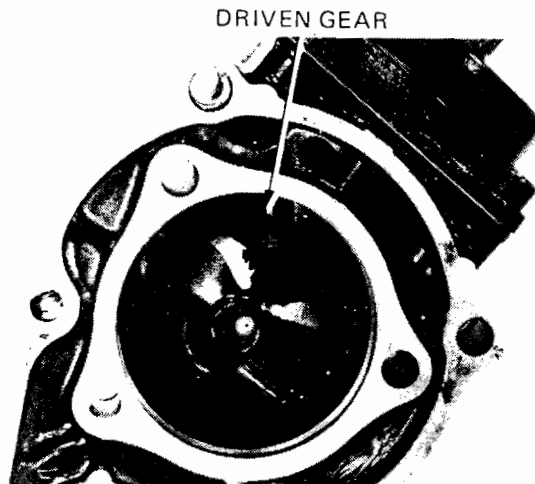

Contact is normal if Prussian Blue is transferred to the approximate center of each tooth and slightly to the side.

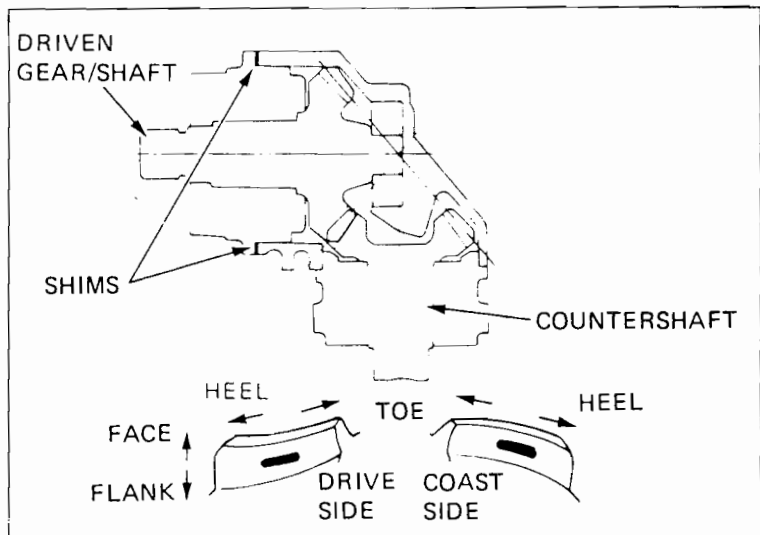

If the pattern is not correct, remove and replace the driven gear adjustment shim. Replace the shim with a thinner one if the contact pattern is too high.

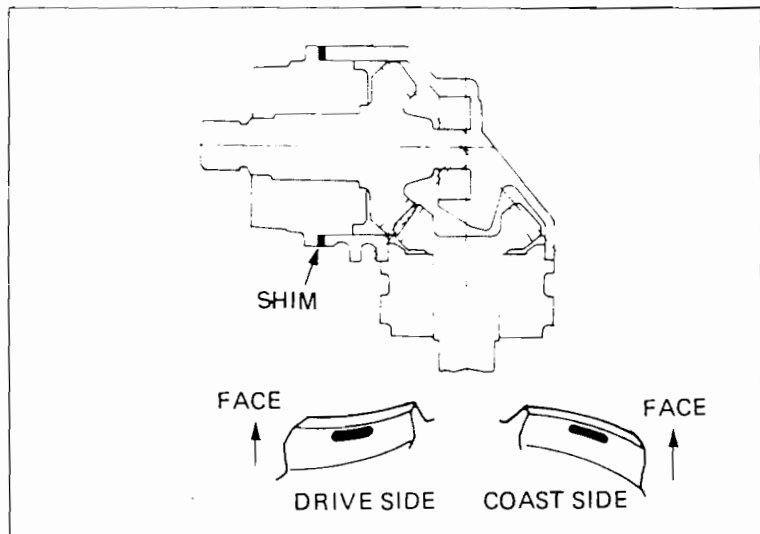



Replace the driven gear adjustment shim with a thicker one if contact is too low.

The pattern will shift about 1.5–2.0 mm (0.06–0.08 in) when the thickness of the shim is changed by 0.10 mm (0.04 in).

**OUTPUT DRIVEN GEAR ADJUSTMENT SHIM:**

- 1: 0.40 mm (0.016 in)
- 2: 0.45 mm (0.018 in)
- 3: 0.50 mm (0.020 in)     **Standard**
- 4: 0.55 mm (0.022 in)
- 5: 0.60 mm (0.024 in)

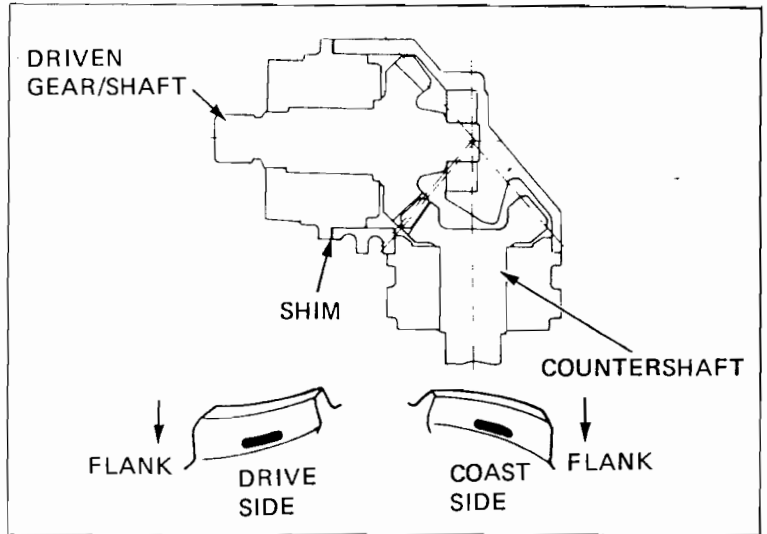

**BACKLASH INSPECTION**

Place the output gear case in a vise with soft jaws or a shop towel.

Set a horizontal type dial indicator on the countershaft as shown.

Hold the driven gear with special tool and rotate the countershaft until gear slack is taken up.

Turn the countershaft back and forth to read backlash.

- STANDARD:**     0.04–0.09 mm  
                          (0.002–0.004 in)
- SERVICE LIMIT:** 0.20 mm (0.008 in)

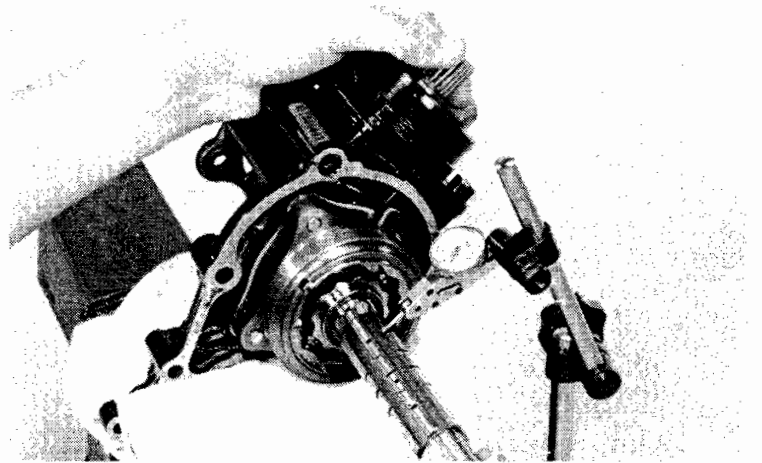

Remove the dial indicator. Turn the countershaft 120° and measure backlash. Do this once more. Compare the difference of the three measurements.

- DIFFERENCE OF MEASUREMENT**
- SERVICE LIMIT:** 0.10 mm (0.004 in)





**GENERAL INFORMATION**

If the difference in measurements exceeds the service limit, it indicates that the bearing is not installed squarely. Inspect the bearings and reinstall if necessary.

If backlash is excessive, replace the countershaft gear adjustment shim with a thinner one.

If backlash is too small, replace the countershaft shim with a thicker one.

Backlash is changed by about 0.06–0.07 mm (0.002–0.003 in) when the thickness of the shim is changed by 0.10 mm (0.004 in).

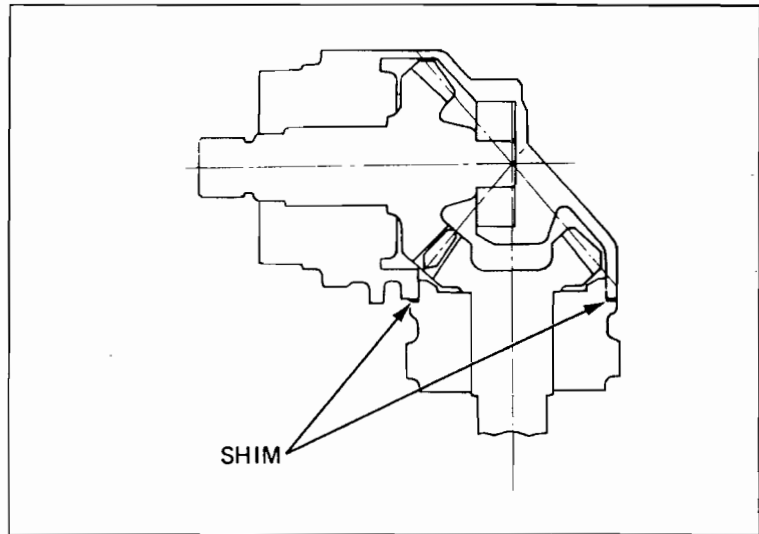

**COUNTERSHAFT/OUTPUT DRIVE GEAR ADJUSTMENT SHIMS:**

- 1: 0.40 mm (0.016 in)
- 2: 0.45 mm (0.018 in)
- 3: 0.50 mm (0.020 in) Standard
- 4: 0.55 mm (0.022 in)
- 5: 0.60 mm (0.024 in)

When the shim is replaced, remark the shim number on the output gear case as shown.

Clean the case gasket surfaces of any gasket material.

Reassemble and install the countershaft (Pages 11-8 and 11-9).

SHIM NUMBER

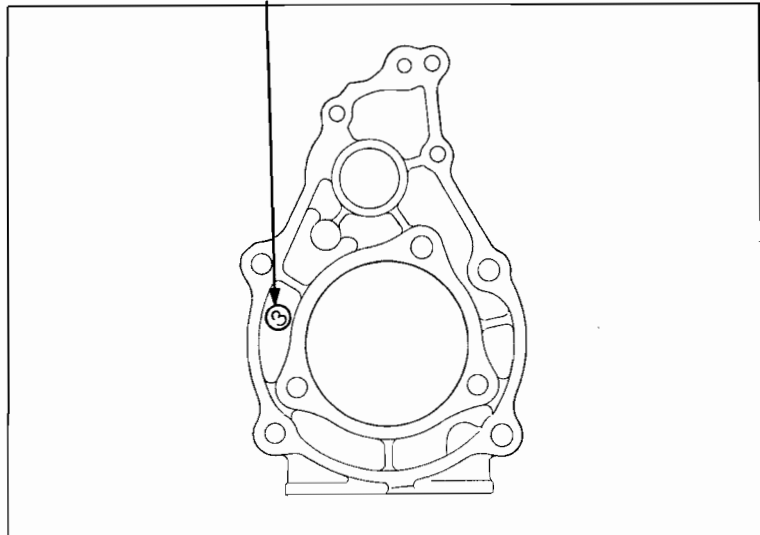



**HONDA**  
**CB750SC**

---

MEMO

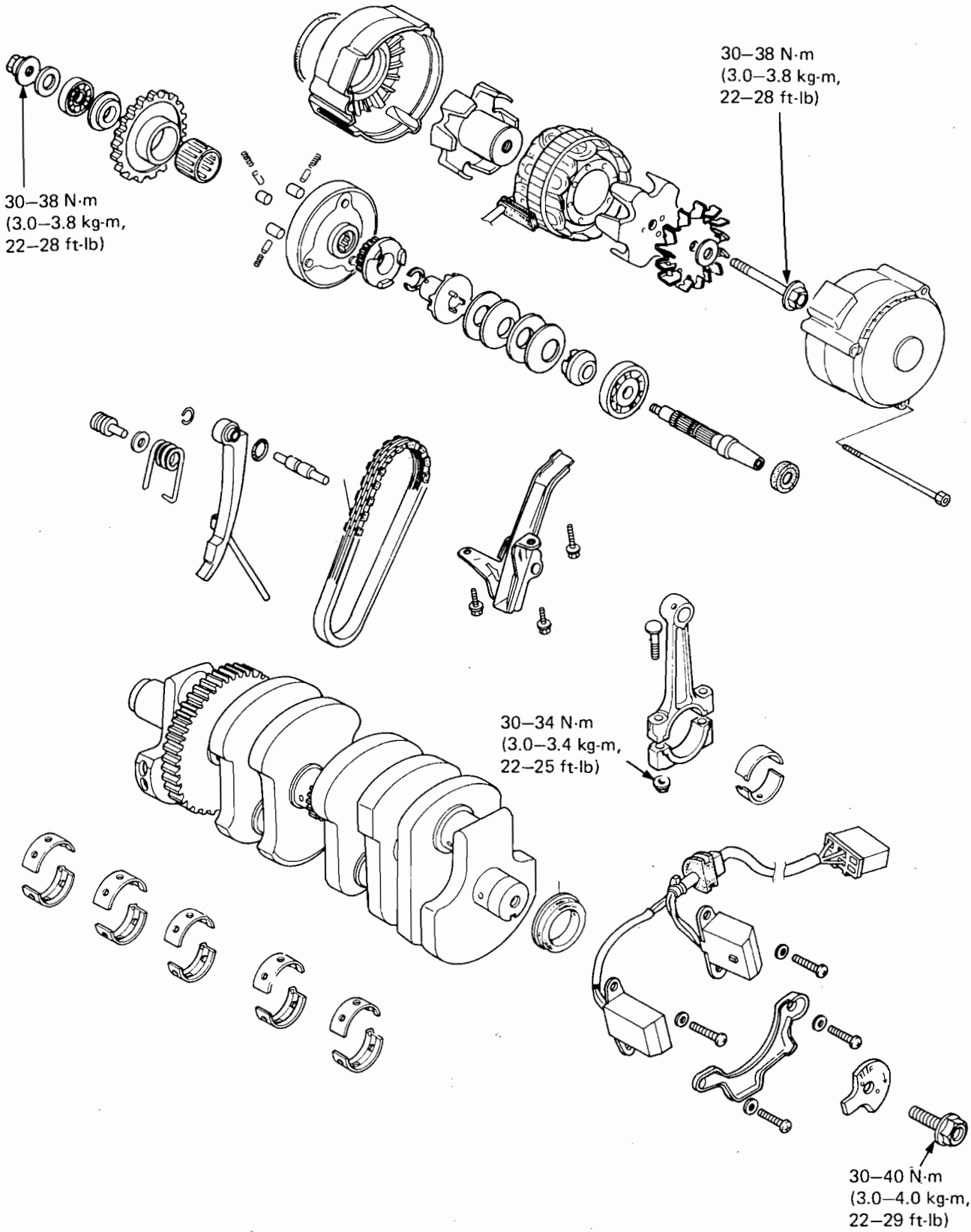



SERVICE INFORMATION	12-1
TROUBLESHOOTING	12-1
STARTER CLUTCH/ALTERNATOR SHAFT	12-2
CONNECTING ROD/CRANKSHAFT REMOVAL	12-11
BEARING INSPECTION	12-13
BEARING SELECTION	12-15
CRANKSHAFT/CONNECTING ROD INSTALLATION	12-17

## SERVICE INFORMATION

### GENERAL

- All bearing inserts are a select fit and are identified by color codes. Select replacement bearings from the code tables. After installing new bearings, recheck them with plastigauge to verify clearance. Apply molybdenum disulfide grease to the main journals and crankpins during assembly.
- The crankcase assembly must be separated (Section 10) to service the crankshaft and starter clutch.
- Refer to section 20 for starter system troubleshooting.

### SPECIFICATIONS

		STANDARD	SERVICE LIMIT
Crankshaft	Connecting rod big end side clearance	0.05–0.20 mm (0.002–0.008 in)	0.3 mm (0.01 in)
	Runout	—	0.03 mm (0.001 in)
	Crankpin oil clearance	0.024–0.057 mm (0.0009–0.0022 in)	0.07 mm (0.003 in)
	Main journal oil clearance	0.019–0.043 mm (0.0007–0.0017 in)	0.06 mm (0.002 in)
Cam chain	Length	336.55–337.00 mm (13.250–13.268 in)	339.0 mm (13.35 in)
Alternator chain	Length	149.01–149.21 mm (5.867–5.874 in)	150.5 mm (5.93 in)

### TORQUE VALUES

Connecting rod cap nut	30–34 N·m (3.0–3.4 kg·m, 22–25 ft·lb)
Main bearing bolt	21–25 N·m (2.1–2.5 kg·m, 15–18 ft·lb)
Pulse generator rotor bolt	30–40 N·m (3.0–4.0 kg·m, 22–29 ft·lb)
Alternator shaft nut	30–38 N·m (3.0–3.8 kg·m, 22–28 ft·lb)

### TOOLS

#### Special

Bearing remover, 17 mm	07936–3710300
Remover handle	07936–3710100
Remover weight	07936–3710200 or 07741–0010201

#### Common

Universal holder	07725–0030000	Attachment, 42 x 47 mm	07746–0010300
Attachment, 37 x 40 mm	07746–0010200	Pilot, 20 mm	07746–0040500
Pilot, 17 mm	07746–0040400	Driver	07746–0020100
Driver	07749–0010000	Attachment, 20 mm I.D.	07746–0020400

## TROUBLESHOOTING

### Excessive noise

- Worn main journal bearing
- Worn crank pin bearing

### STARTER CLUTCH/ALTERNATOR SHAFT

Remove the required parts (Page 10-1) and separate the crankcase (Page 10-2).

Loosen the alternator drive chain by pushing the tensioner lock pin and pulling the lock plate up as shown.

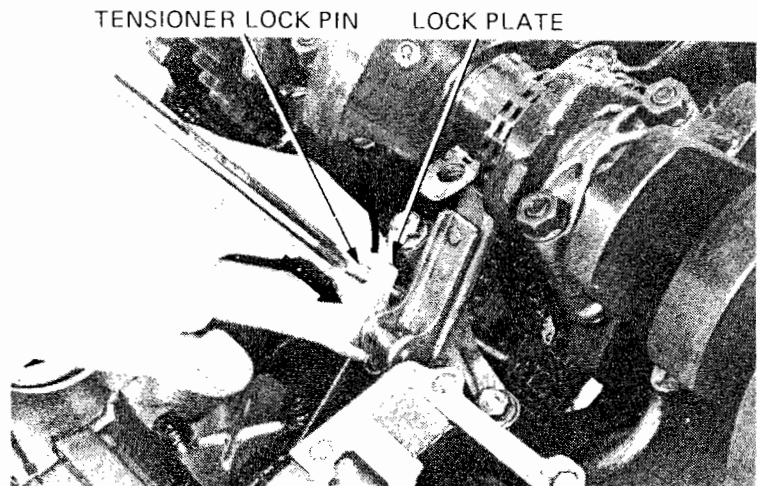

Remove the two oil chamber cover bolts and the cover.

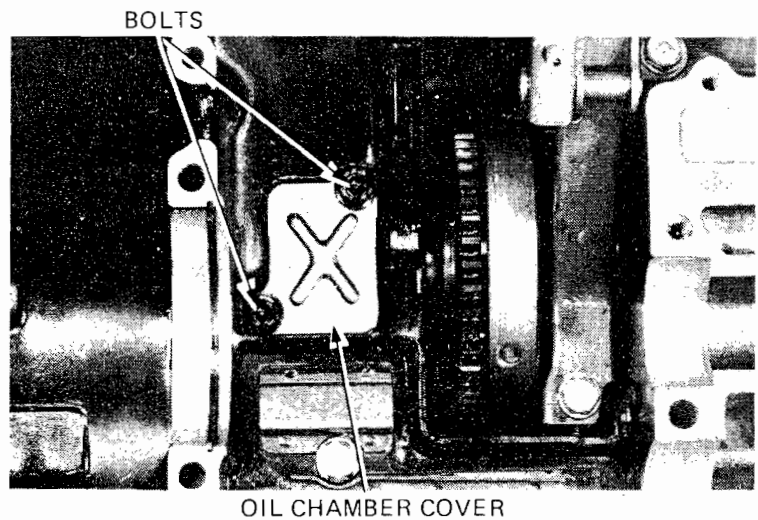

Temporarily install the alternator rotor (Page 18-6) and hold the rotor with the universal holder. Remove the alternator shaft nut.

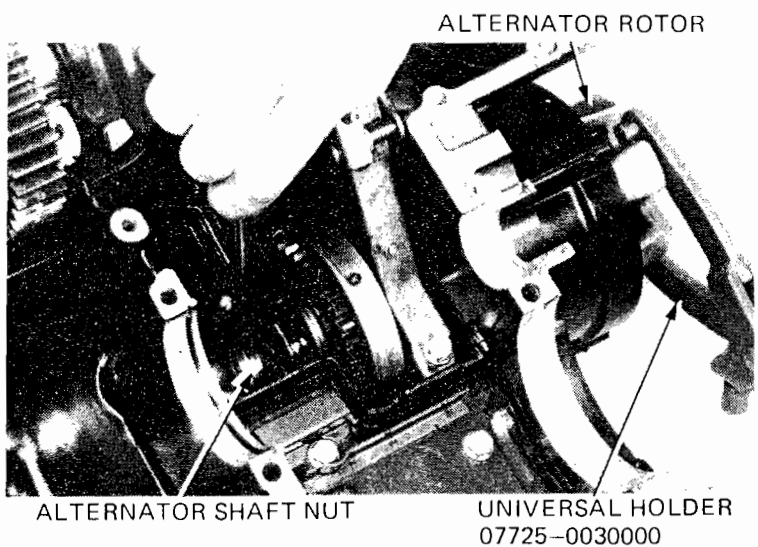



Remove the alternator shaft, alternator driven sprocket and starter clutch.

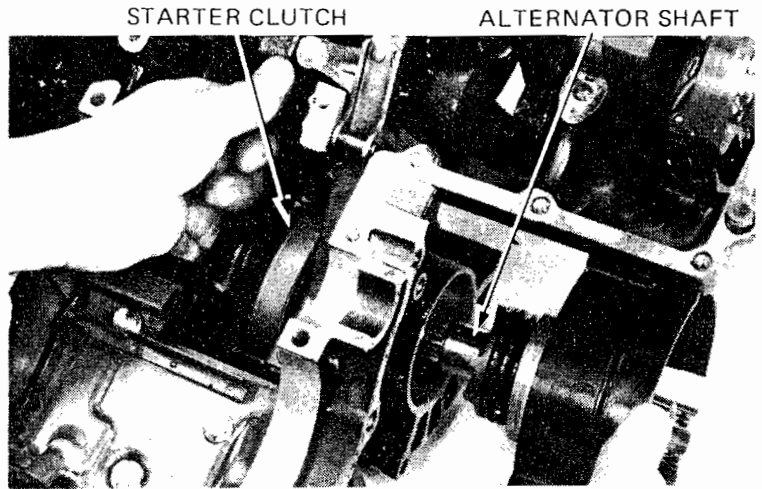

**STARTER CLUTCH DISASSEMBLY/  
INSPECTION**

Check the starter clutch for smooth operation by turning the starter driven gear. The starter driven gear should turn clockwise freely and should not turn counterclockwise.

STARTER DRIVEN GEAR

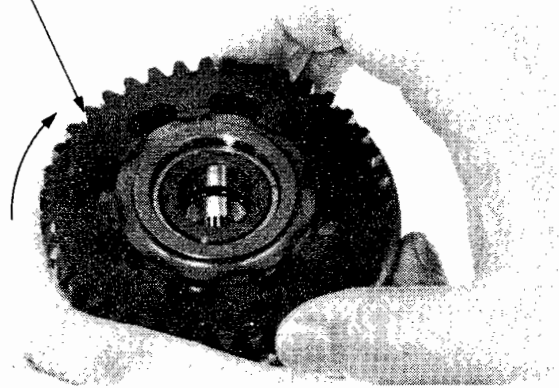

Remove the starter driven gear, needle bearing and collar. Check the driven gear, needle bearing and collar for excessive or abnormal wear, or damage.

STARTER DRIVEN GEAR

NEEDLE BEARING

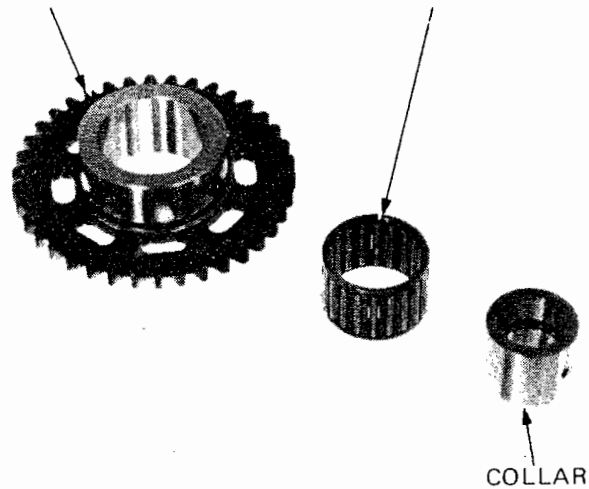



Remove the rollers, plungers and springs from the starter clutch.  
Check the rollers, plungers and springs for excessive wear or damage.

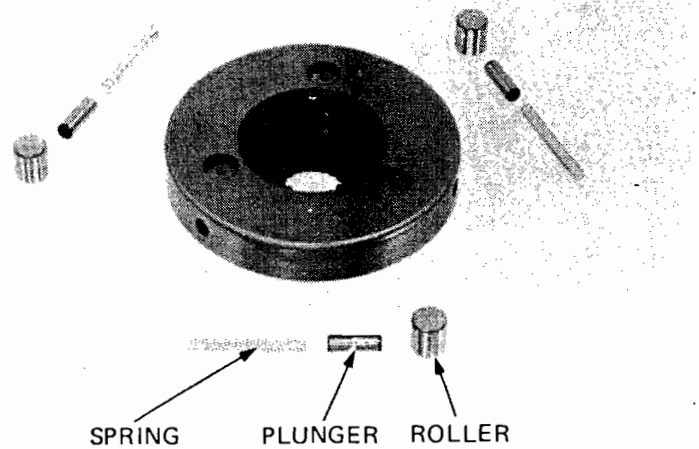

**ALTERNATOR SHAFT  
DISASSEMBLY/INSPECTION**

Check the alternator driven sprocket and damper cam for excessive or abnormal wear.  
Remove the damper cam and damper springs from alternator shaft.

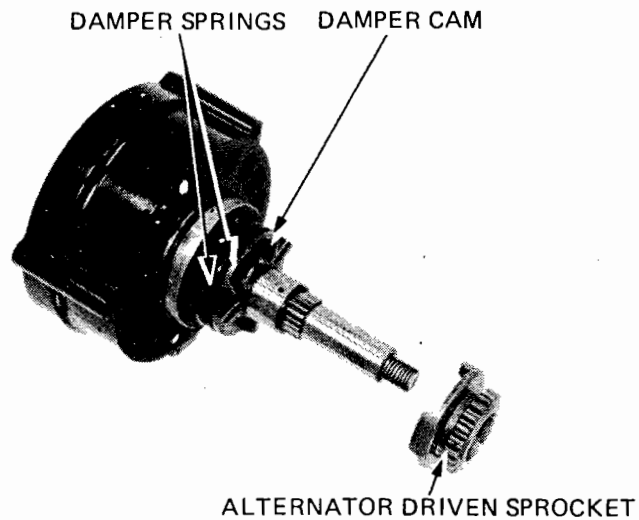

Place the alternator shaft/case in the press so that the case, not the bearing, rests on the press.  
Press the alternator shaft/bearing out of the alternator case.

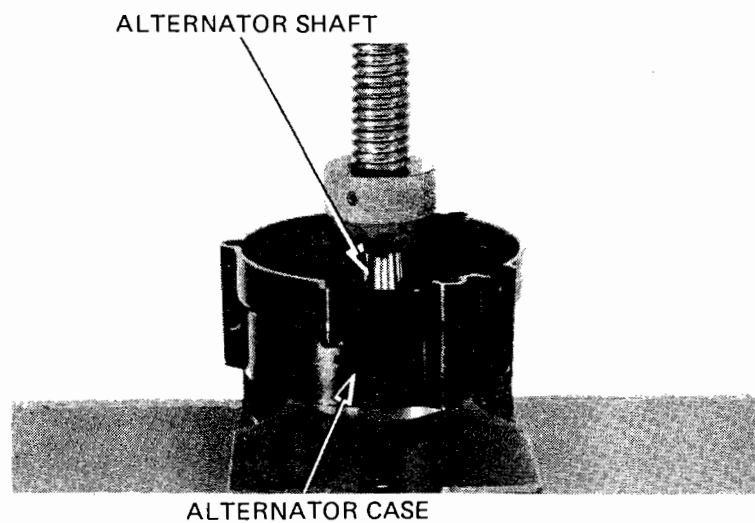



Place the alternator shaft in the press and press the alternator shaft from the bearing and collar.

**NOTE**

Replace the bearing with a new one if it is removed.

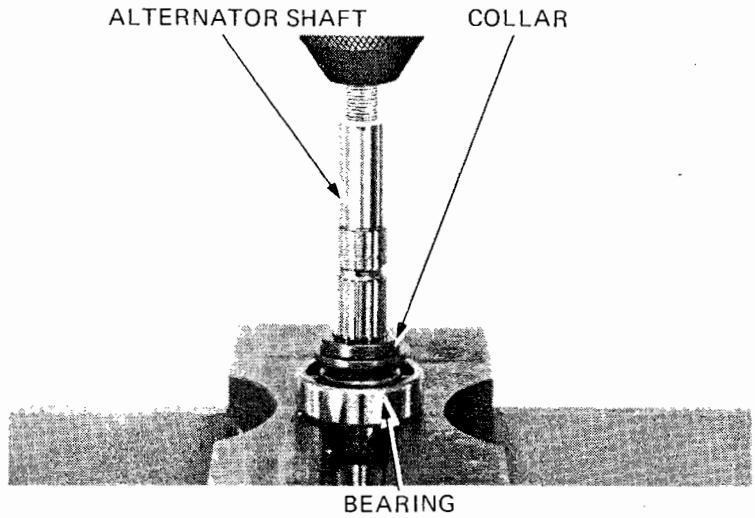

Check the alternator shaft oil seal for wear or damage and replace if necessary.

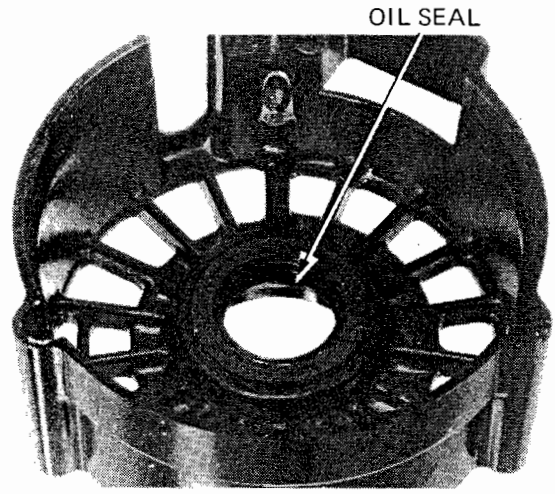

**CRANKCASE BEARING REPLACEMENT**

Remove the bearing with the special tools shown.

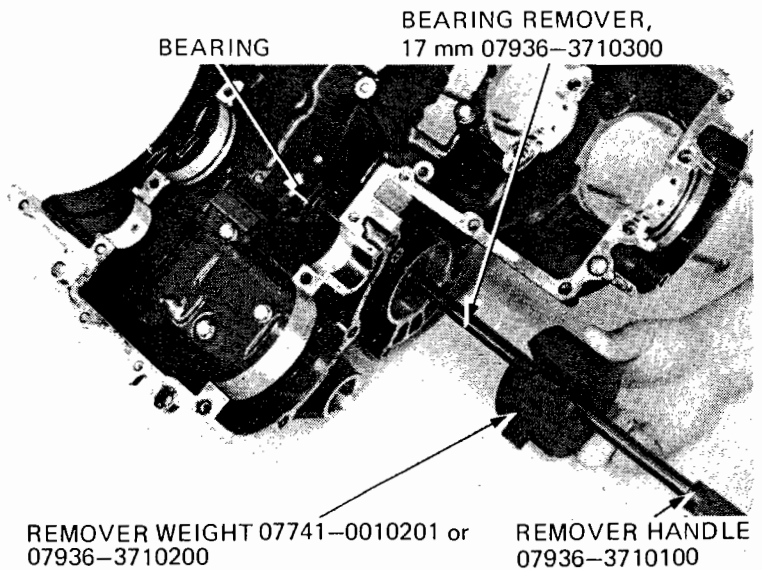





Install a new bearing into the crankcase.

DRIVER 07749-0010000

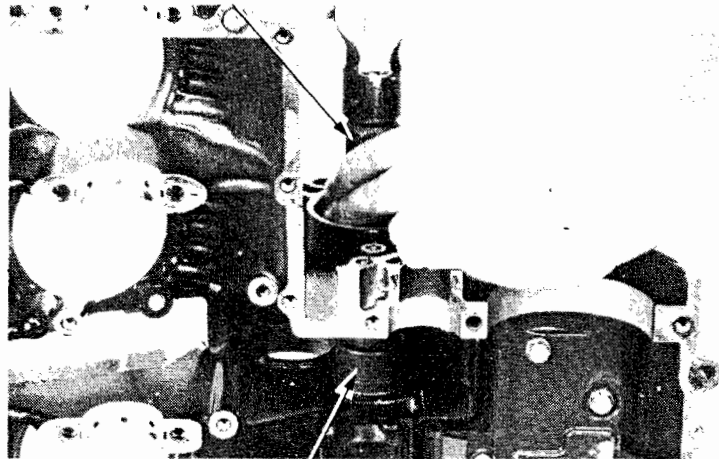

ATTACHMENT, 37 x 40 mm 07746-0010200  
PILOT, 17 mm 07746-0040400

**ALTERNATOR DRIVE CHAIN  
TENSIONER DISASSEMBLY/INSPECTION**

Remove the tensioner base by removing the three bolts.

BOLTS

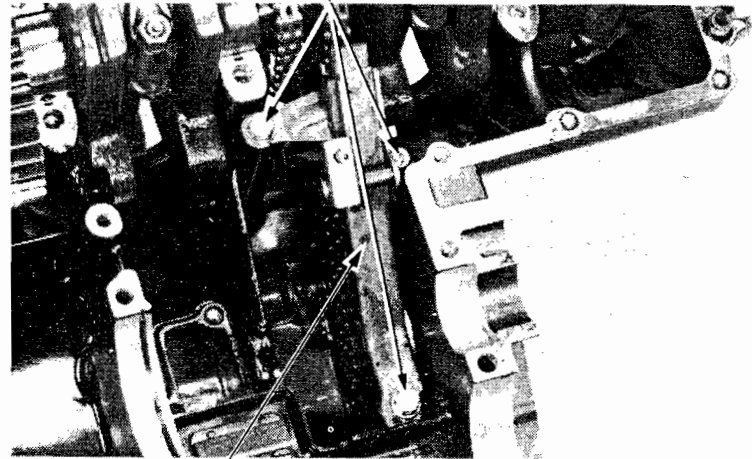

TENSIONER BASE

Remove the lock pin and washer securing the tensioner.  
Remove the tensioner shaft and tensioner from the crankcase.

TENSIONER SHAFT TENSIONER

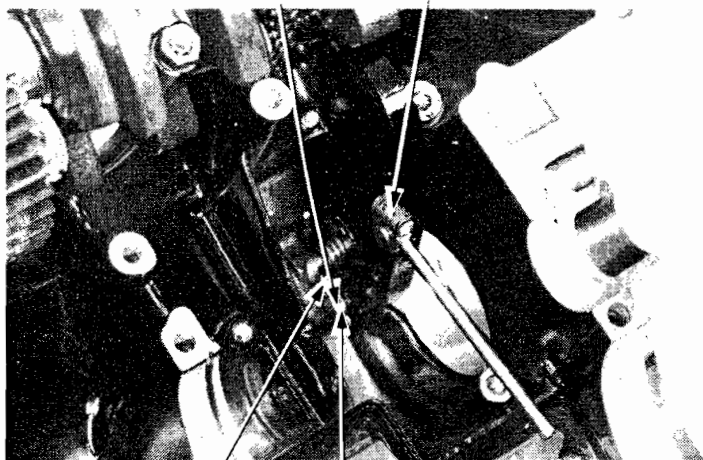

LOCK PIN WASHER



Check the tensioner base and tensioner for excessive wear or damage.

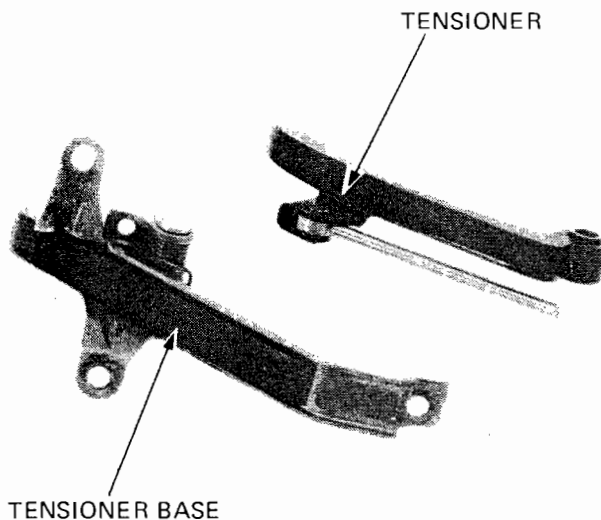

Remove the tensioner spring pin set bolt.  
Remove the tensioner spring pin and spring.

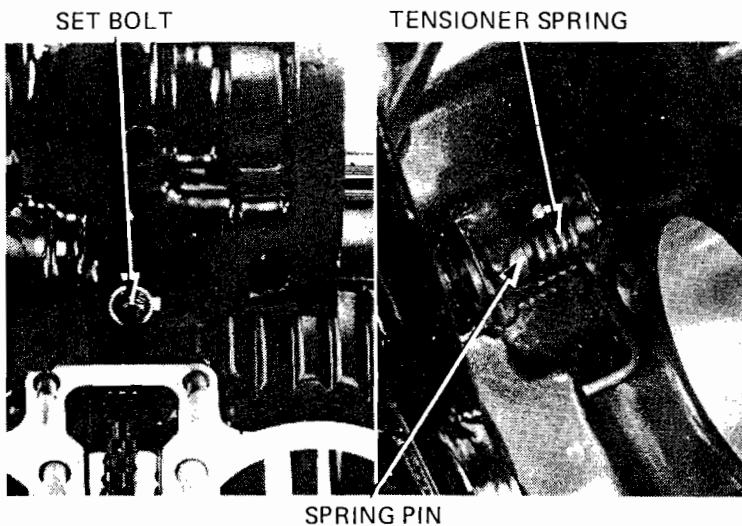

### ALTERNATOR DRIVE CHAIN TENSIONER ASSEMBLY

Install the tensioner spring and spring pin in the crankcase.  
Align the holes in the spring pin and the crankcase and install the set bolt. Tighten the bolt securely.

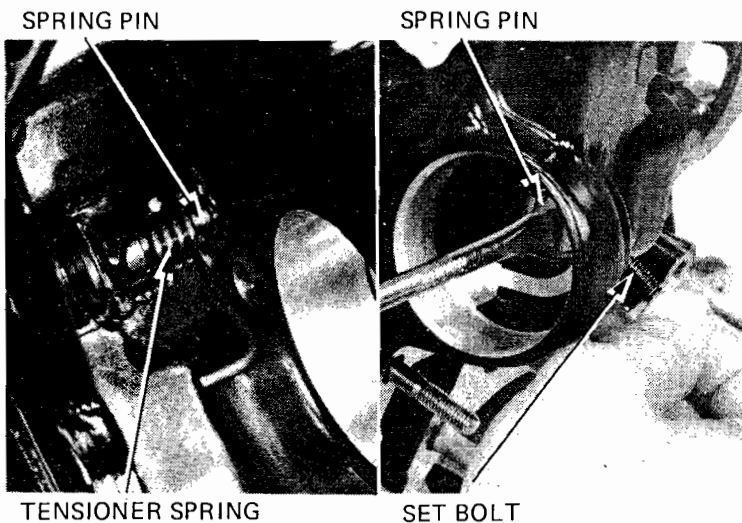



Place the tensioner into the crankcase.  
Install a new O-ring in the groove of the tensioner shaft and apply oil to the O-ring.  
Insert the shaft through the crankcase into the tensioner.  
Install the washer and lock pin.

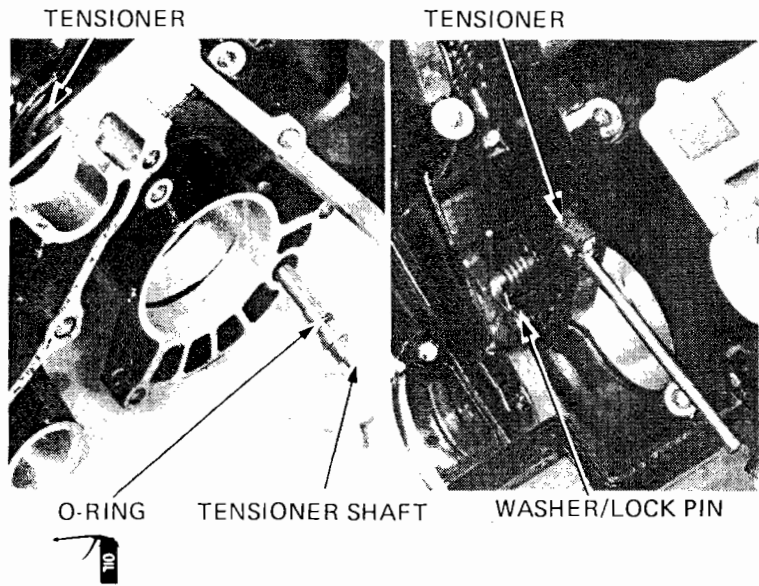

Apply a locking agent to the tensioner base bolt threads.  
Position the alternator drive chain over the tensioner and install the tensioner base with the three bolts.  
Push the tensioner lock pin down while pulling the lock plate up to loosen the tensioner.

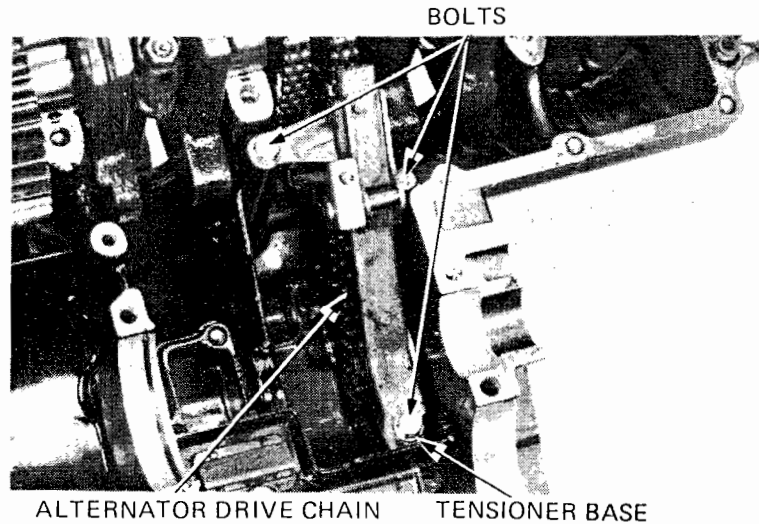

**ALTERNATOR SHAFT ASSEMBLY**

Install a new bearing into the alternator case.

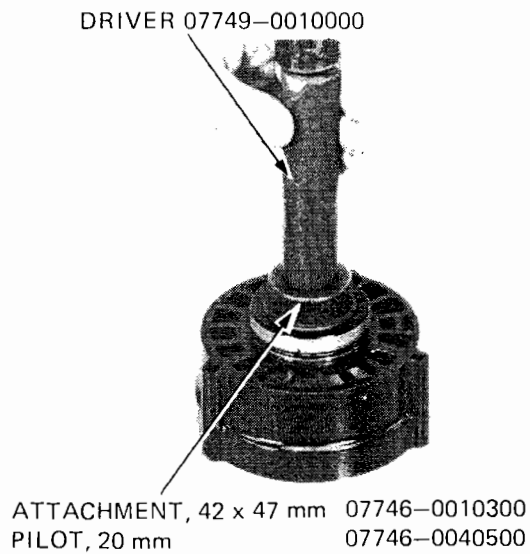



Support the collar and case bearing with the special tools and press the alternator shaft into them.

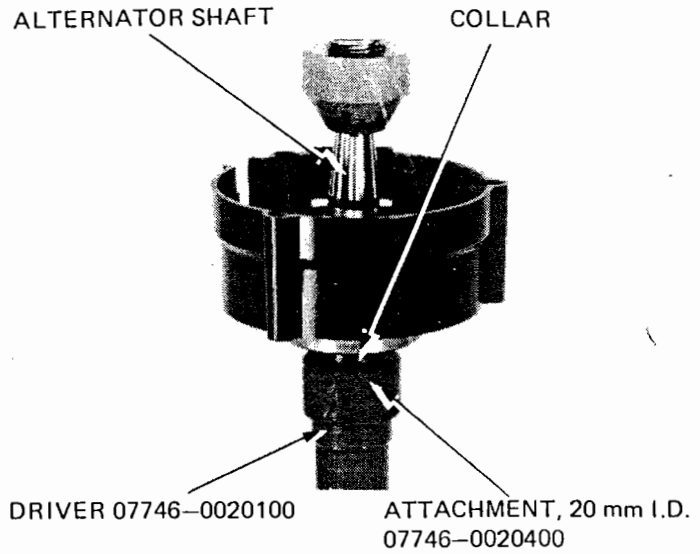

Install a new O-ring in the groove of the alternator case.

Install the four damper springs alternately as shown. Align the oil holes in the alternator shaft and damper cam and install the damper cam over the alternator shaft.

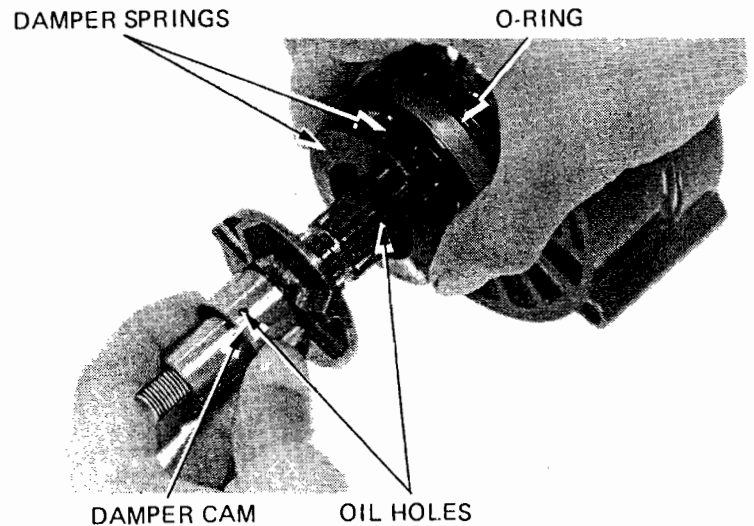

### STARTER CLUTCH ASSEMBLY

Install the springs, plungers and rollers into the starter clutch.

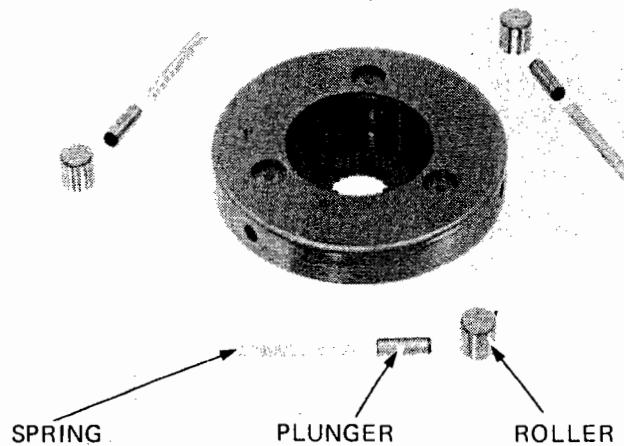



Install the collar, needle bearing, starter driven gear and spacer into the starter clutch.

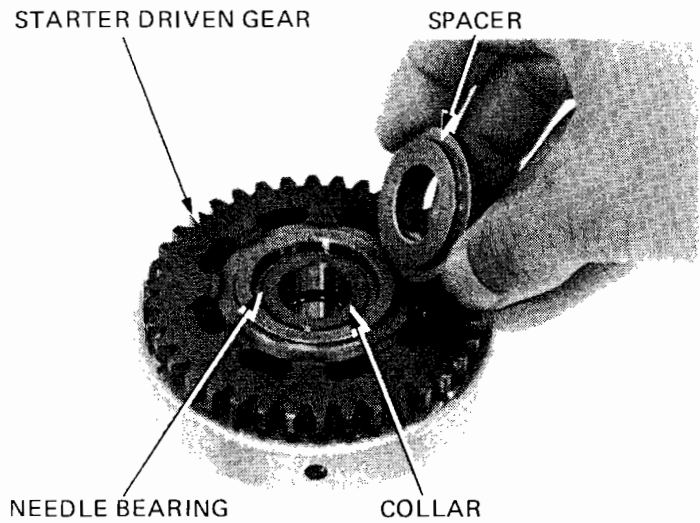

**STARTER CLUTCH/ALTERNATOR SHAFT INSTALLATION**

Place the alternator drive chain over the alternator driven sprocket.

Position the starter clutch assembly into the crankcase.

Apply engine oil to the alternator case O-ring and insert the alternator shaft into the alternator driven sprocket and starter clutch through the crankcase.

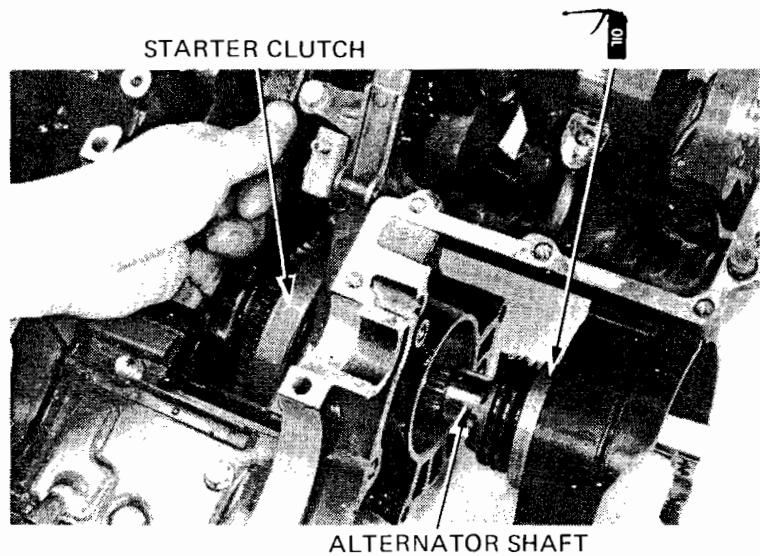

Temporarily install the alternator rotor (Page 18-7) and hold the rotor with the universal holder. Tighten the alternator shaft nut.

**TORQUE:** 30–38 N·m  
(3.0–3.8 kg·m, 22–28 ft·lb)

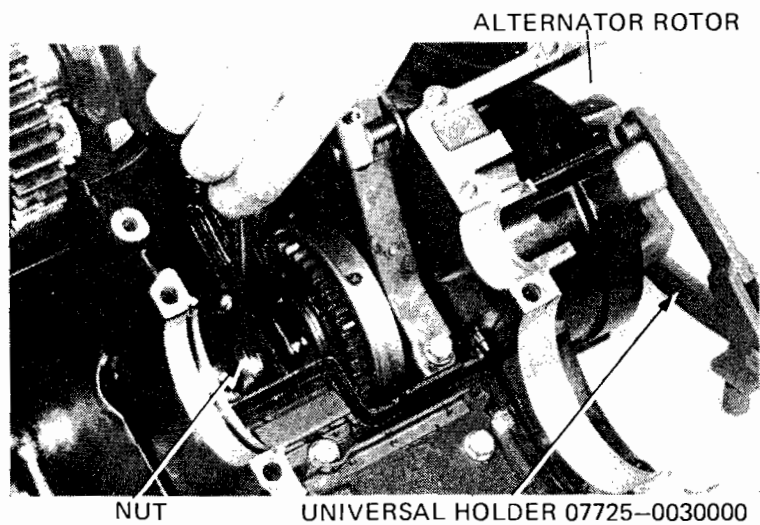



Push the chain tensioner lock plate in to free the tensioner.

Apply locking agent to the socket bolt threads. Install the oil chamber cover with the two socket bolts.

Assemble the crankcase (Page 10-4).

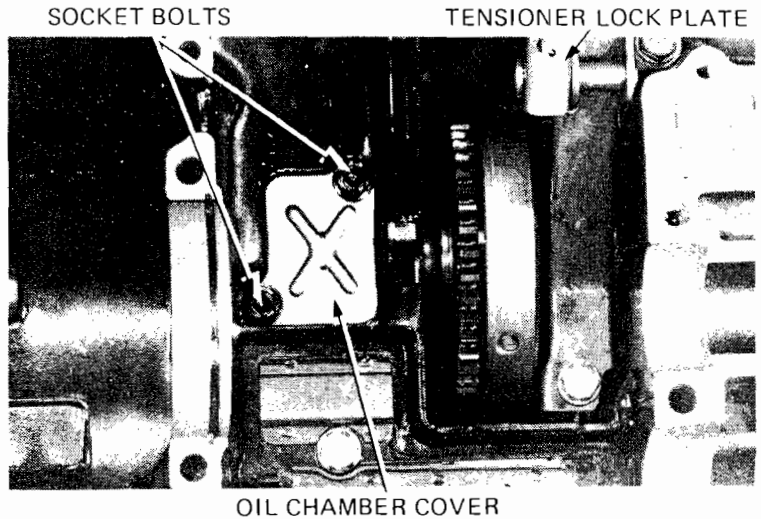

## CONNECTING ROD/CRANKSHAFT REMOVAL

Separate the crankcase (Section 10).

Remove the transmission (Section 11).

Remove the starter clutch and alternator shaft (Page 12-2).

Remove the alternator drive chain tensioner (Page 12-6).

Check the connecting rod side clearance with a feeler gauge.

**SERVICE LIMIT: 0.3 mm (0.01 in)**

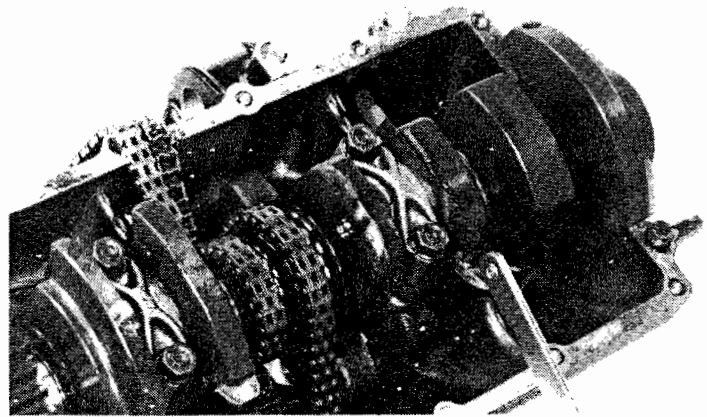

Remove the bearing cap nuts, bearing caps and connecting rods.

Mark the rods, bearings and bearing caps to indicate their cylinder position for correct reassembly.

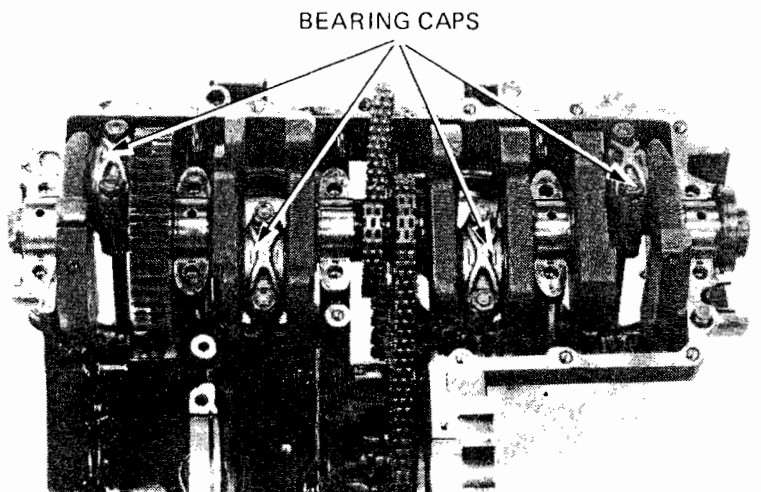



Remove the crankshaft.  
Remove the cam and alternator chains.

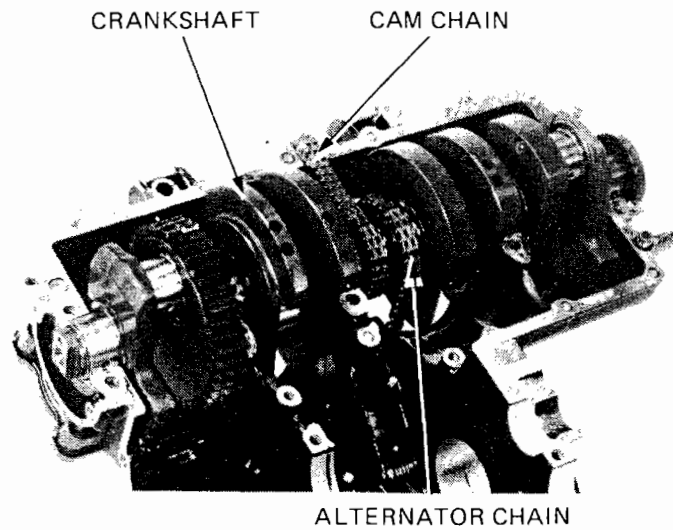

**INSPECTION**

**CRANKSHAFT RUNOUT**

Place the crankshaft on a stand or V-blocks.

Set a dial indicator on the center main journal of the crankshaft. Rotate the crankshaft two revolutions and read runout at the center journal.

**SERVICE LIMIT: 0.03 mm (0.001 in)**

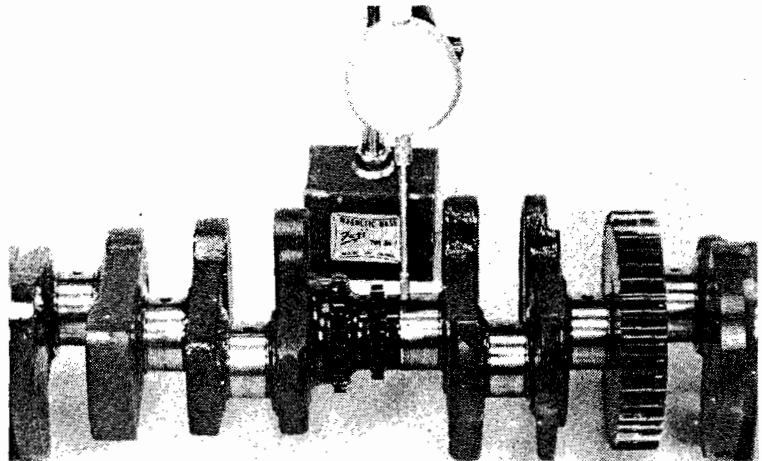

**CAM CHAIN LENGTH**

Place the cam chain over the intake and exhaust camshaft sprockets with the bolt holes and punch marks positioned as shown. Secure one sprocket. Apply 13 kg (29 lb) of tension with a spring scale to the other sprocket.

Measure the chain length between the index marks on the sprockets.

**SERVICE LIMIT: 339.0 mm (13.35 in)**

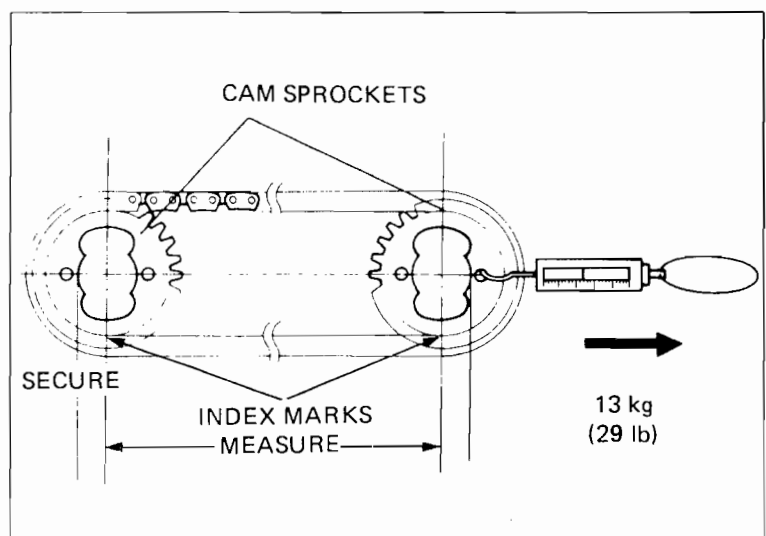



### ALTERNATOR CHAIN LENGTH

Place the alternator chain over the alternator drive and driven sprockets. Secure the crankshaft. Apply 13 kg (29 lb) of tension with a spring scale to the driven sprocket. Measure the chain length as shown.

**SERVICE LIMIT: 150.5 mm (5.93 in)**

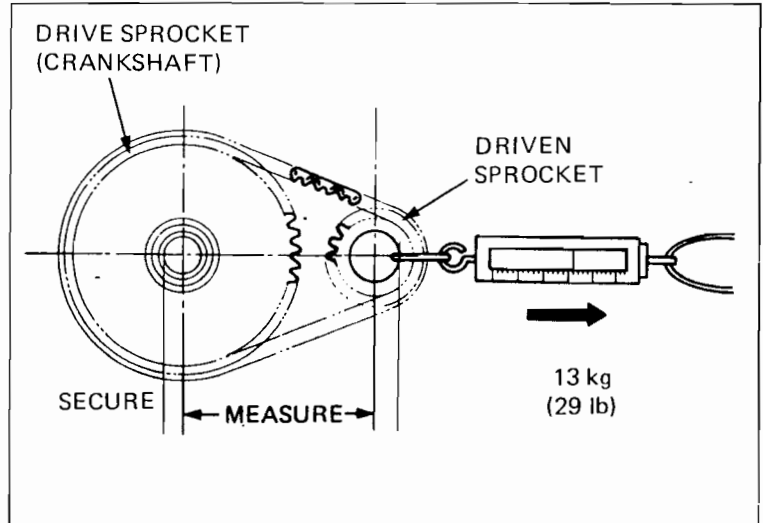

### BEARING INSPECTION

#### CONNECTING RODS

Inspect the bearing inserts for damage or separation.

Clean all oil from the bearing inserts and crankpins.

Put a piece of plastigauge on each crankpin, avoiding the oil hole.

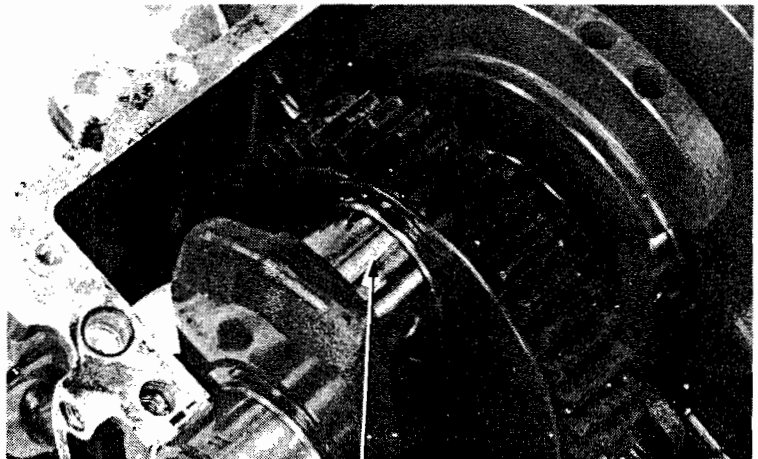

PLASTIGAUGE

Install the bearing caps and rods on the correct crankpins, and tighten them evenly.

**TORQUE: 30–34 N·m**  
**(3.0–3.4 kg·m, 22–25 ft·lb)**

#### NOTE

Do not rotate the crankshaft during inspection.

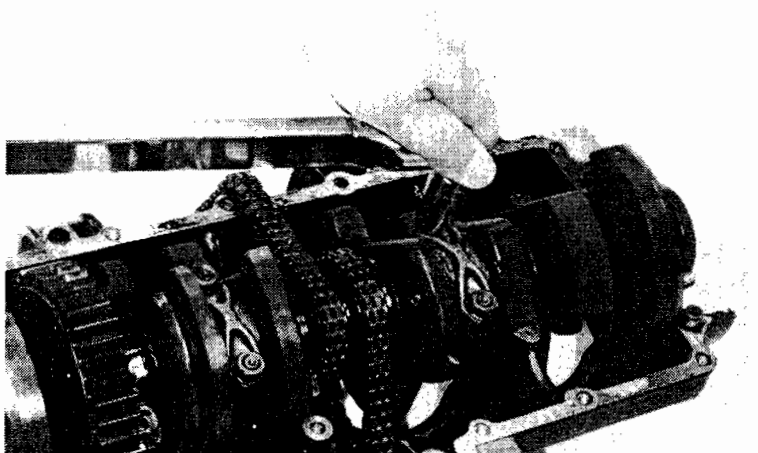





Remove the caps and measure the compressed plastigauge on each crankpin.

**OIL CLEARANCE SERVICE LIMIT:**  
0.07 mm (0.003 in)

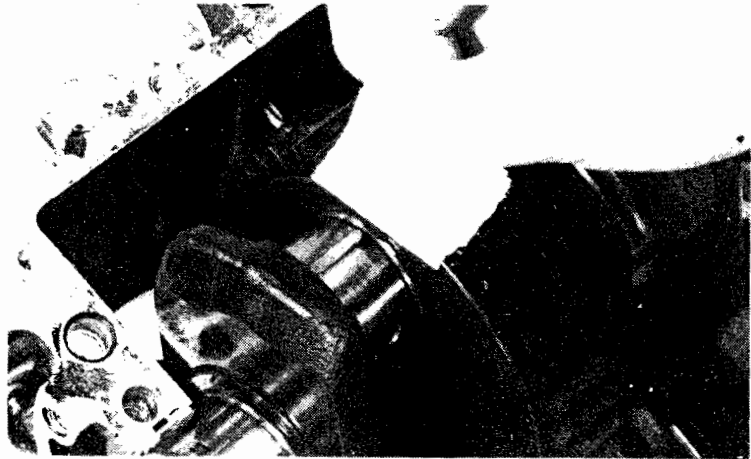

### MAIN BEARINGS

Inspect the bearing inserts for damage or separation.

Clean all oil from the bearing inserts and journals.

Apply a piece of plastigauge on each journal, avoiding the oil holes.

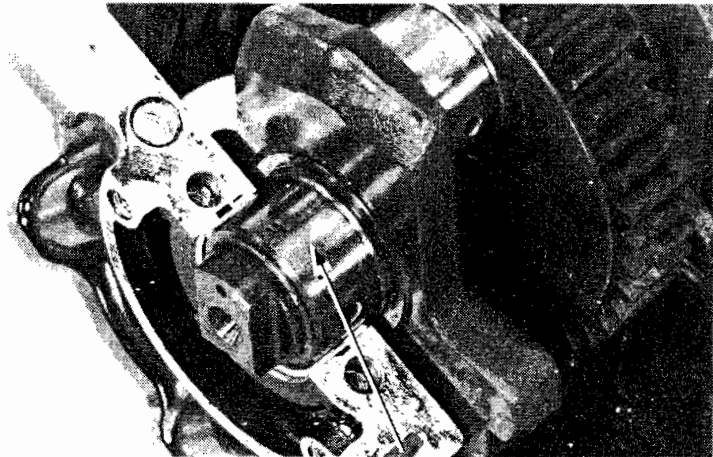

PLASTIGAUGE

Install the main bearings on the correct journals on the lower crankcase and tighten them evenly in the sequence shown in 2-3 steps.

**TORQUE VALUE:** 21–25 N·m  
(2.1–2.5 kg·m, 15–18 ft·lb)

#### NOTE

Do not rotate the crankshaft during inspection.

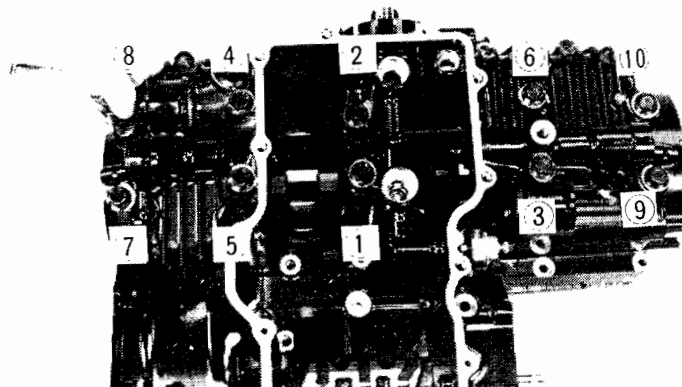



Remove the lower crankcase and measure the compressed plastigauge on each journal.

**OIL CLEARANCE SERVICE LIMIT:**  
0.06 mm (0.002 in)

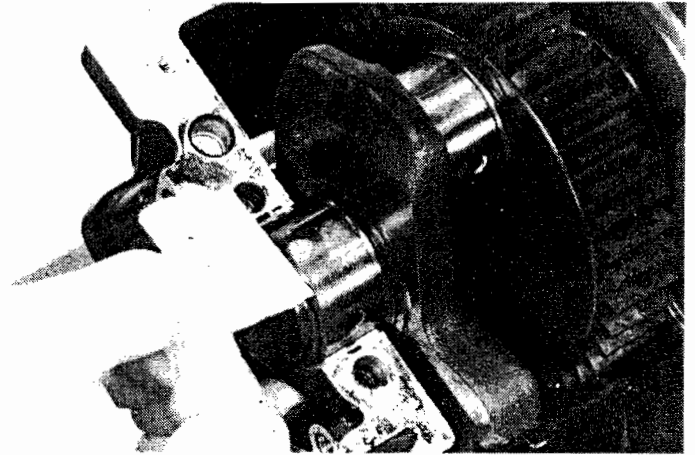

## BEARING SELECTION

If rod bearing clearance is beyond tolerance, select replacement bearings as follows:

### CONNECTING ROD BEARING INSERTS

Determine and record the corresponding rod I.D. code number.

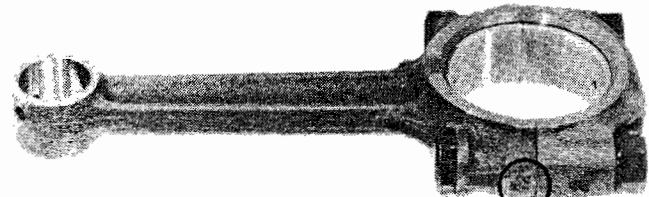

I.D. CODE

Determine and record the corresponding crankpin O.D. code letter (or measure the crankpin O.D.).

#### NOTE

The letter A or B on the outside crankshaft weight is the code for each crank pin O.D. from left-to-right.

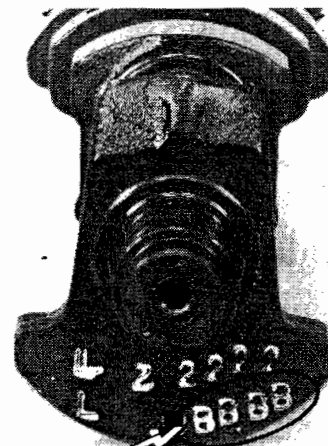

O.D. CODE



## CRANKSHAFT/STARTER CLUTCH

Cross reference the crankpin and connecting rod codes to determine the replacement bearing color.

		CRANKPIN O.D. CODE	
		A	B
CONNECTING ROD I.D. CODE NO.	1	35.992–36.000 mm (1.4170–1.4173 in)	35.984–35.992 mm (1.4161–1.4170 in)
	2	39.000–39.008 mm (1.5354–1.5357 in)	39.008–39.016 mm (1.5357–1.5361 in)
		Yellow	Green
		Green	Brown

### BEARING INSERT THICKNESS:

Brown : 1.494–1.498 mm (0.0588–0.0590 in)  
 Green : 1.490–1.494 mm (0.0587–0.0588 in)  
 Yellow : 1.486–1.490 mm (0.0585–0.0587 in)

### IN BEARING

Determine and record crankcase I.D. code letter on the upper crankcase.

#### NOTE

The letters A or B on the upper crankcase are the codes for the main journal I.D.'s from left-to-right.

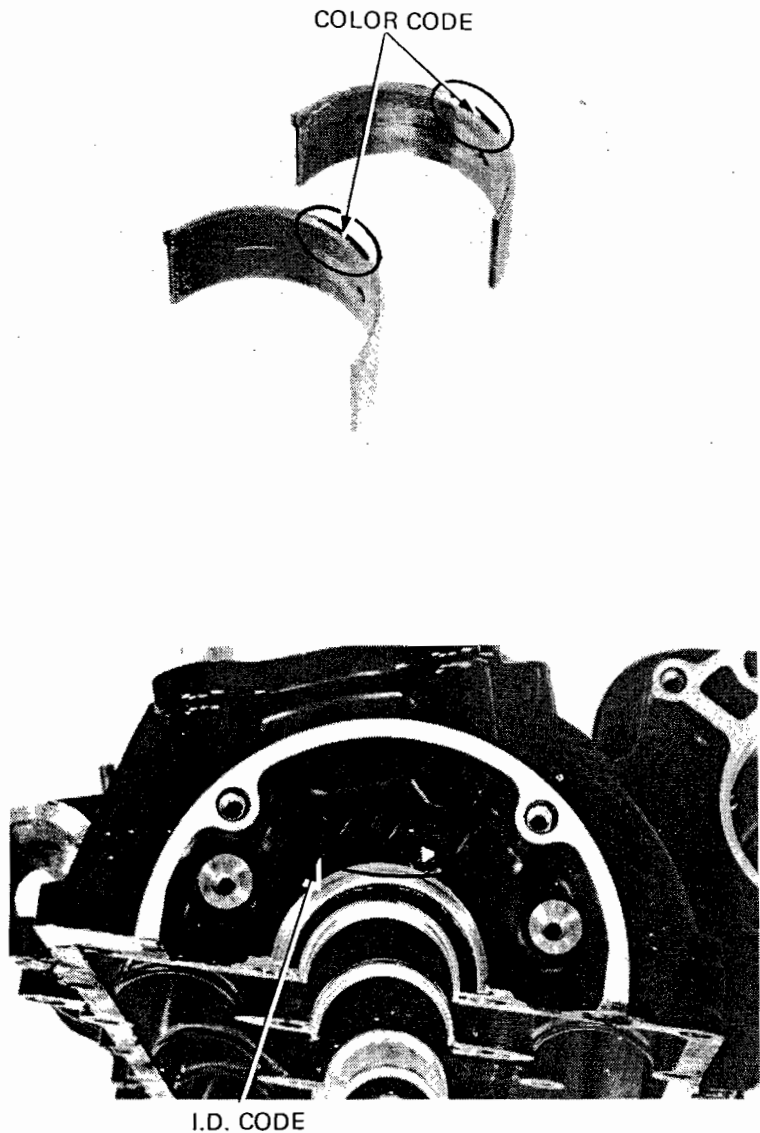

Determine and record the corresponding main journal O.D. code numbers (or measure the main journal O.D.).

#### NOTE

The numbers 1 or 2 on the crank weight are the codes for the main journal O.D.'s from left-to-right.

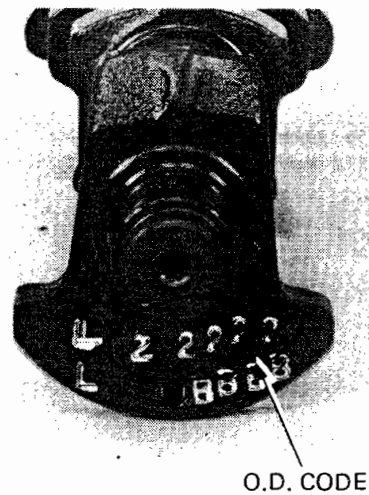



Cross reference the case and journal codes to determine the replacement bearings.

		MAIN JOURNAL O.D. CODE NO.	
		1	2
CRANKCASE I.D. CODE	A	35.992–36.000 mm (1.4170–1.4173 in)	35.984–35.992 mm (1.4161–1.4170 in)
	B	39.000–39.008 mm (1.5354–1.5357 in)	39.008–39.016 mm (1.5357–1.5361 in)
		Pink	Yellow
		Yellow	Green

**MAIN BEARING INSERT THICKNESS:**

Green : 1.504–1.508 mm (0.0592–0.0594 in)  
 Yellow : 1.500–1.504 mm (0.0591–0.0592 in)  
 Pink : 1.496–1.500 mm (0.0589–0.0591 in)

### CRANKSHAFT/CONNECTING ROD INSTALLATION

Install the main bearings into the upper and lower crankcases.

Apply molybdenum disulfide grease to the upper and lower main bearings.

Install the cam and alternator drive chains over the crankshaft.

Install the crankshaft into the upper crankcase.

COLOR CODES

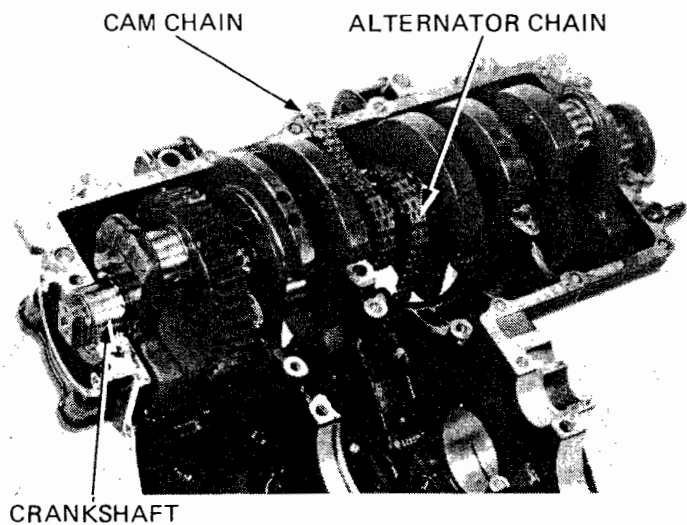
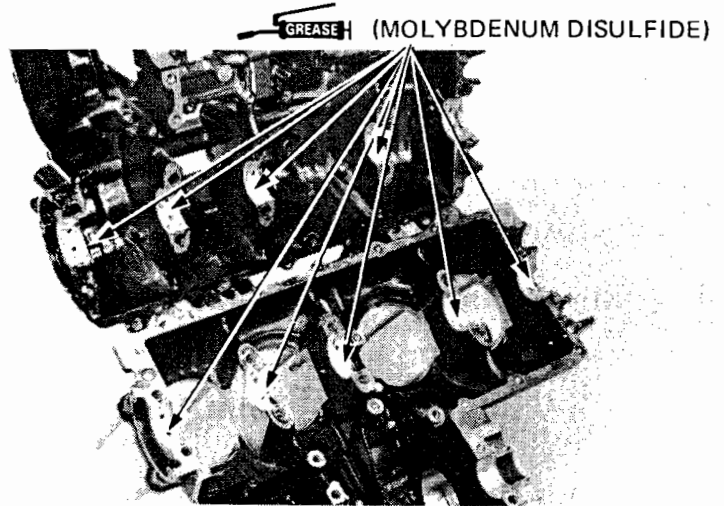
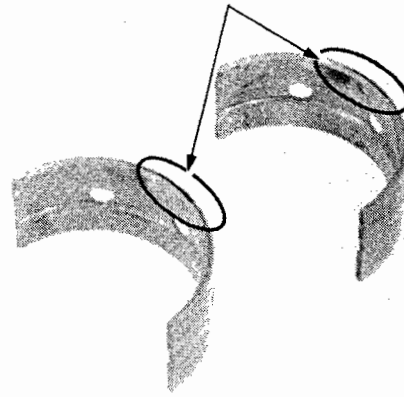



Before installing the connecting rods, make sure that the weight code combination is correct.

Factory set code

Available code

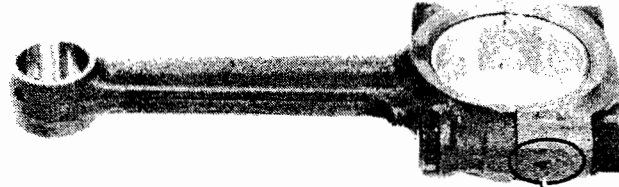
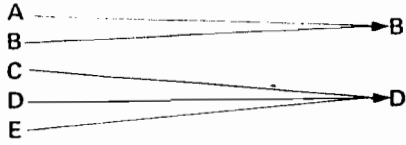

WEIGHT CODE

**NOTE**

Do not assemble the connecting rods which differ two ranks or more each other.

Align the boss on the bearing insert with the groove in the rod or cap and install the bearing inserts on the rods and caps.  
Apply molybdenum disulfide grease to the bearing inserts.

GREASE (MOLYBDENUM DISULFIDE)

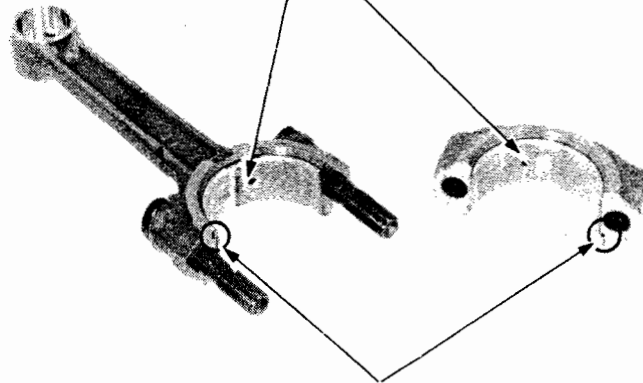

BOSSSES AND GROOVES

Install the connecting rods and bearing caps.

**NOTE**

- Be sure the connecting rods are installed in their correct positions and the oil holes point to the front.
- Cross reference the connecting rod and cap I.D. codes to insure correct assembly.

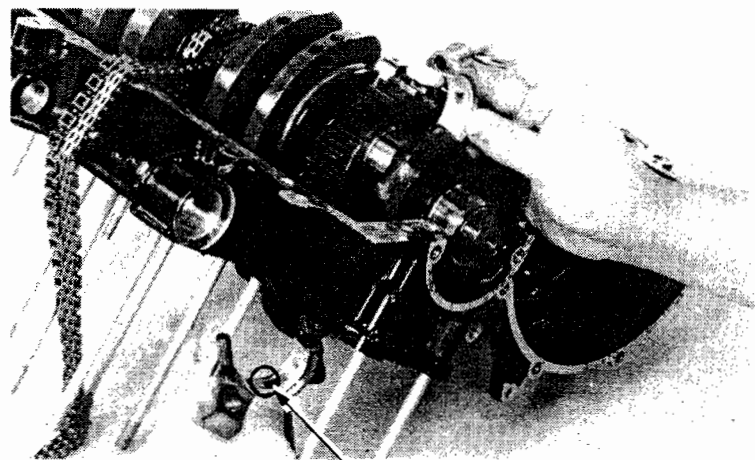

OIL HOLE



Tighten the connecting rod bearing cap nuts, in 2-3 steps.

**TORQUE:** 30–34 N·m  
(3.0–3.4 kg·m, 22–25 ft·lb)

**NOTE**

After tightening the nuts, check that the connecting rod moves freely without binding.

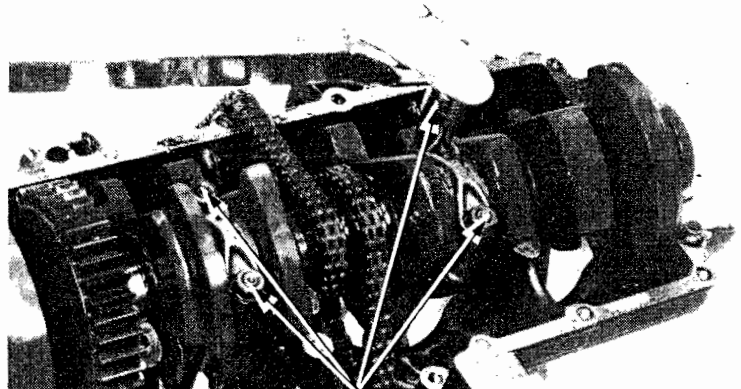

ROD BEARING  
CAP NUTS

Install the alternator drive chain tensioner (Page 12-7), starter clutch and alternator shaft (Page 12-10).

If the pulse generator rotor was removed from the crankshaft, align the rotor tip-side boss with the hole in the crankshaft and the other boss with the groove in the crankshaft.

Tighten the rotor bolt to the specified torque.

**TORQUE:** 30–40 N·m  
(3.0–4.0 kg·m, 22–29 ft·lb)

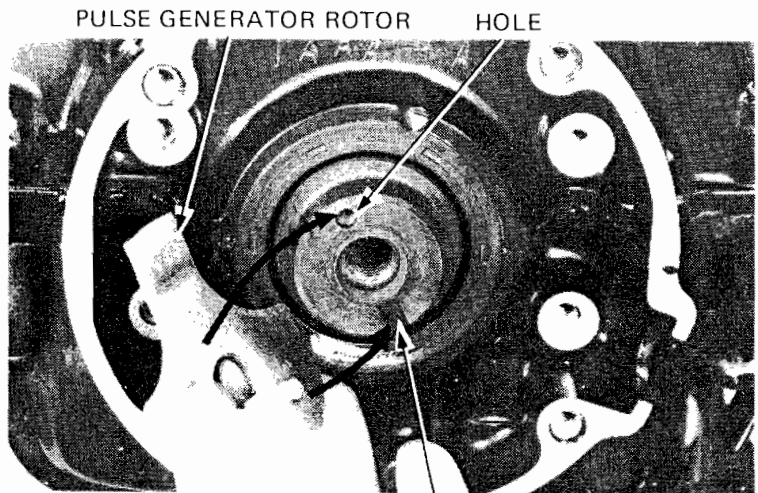

PULSE GENERATOR ROTOR HOLE

GROOVE



**FINAL DRIVE**

8 mm: 23–28 N·m  
(2.3–2.8 kg·m, 17–20 ft·lb)  
10 mm: 45–50 N·m  
(4.5–5.0 kg·m, 32–36 ft·lb)

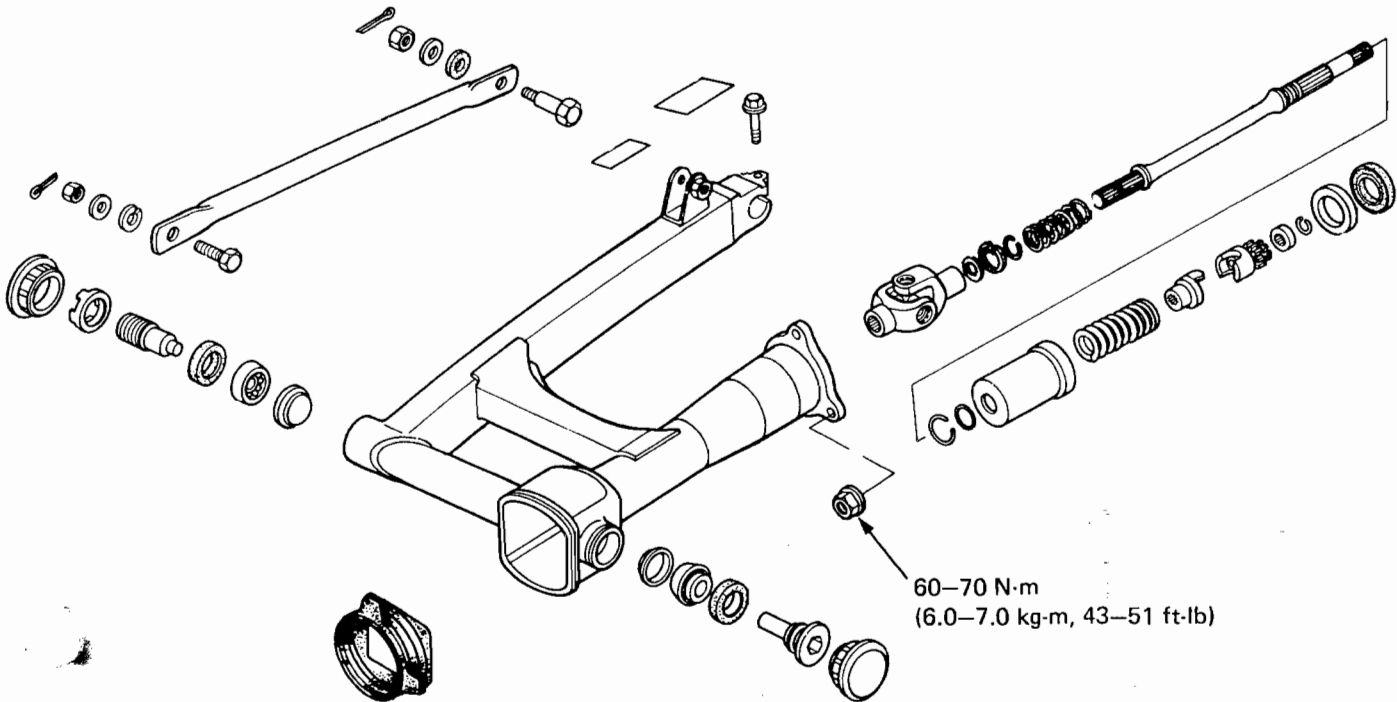
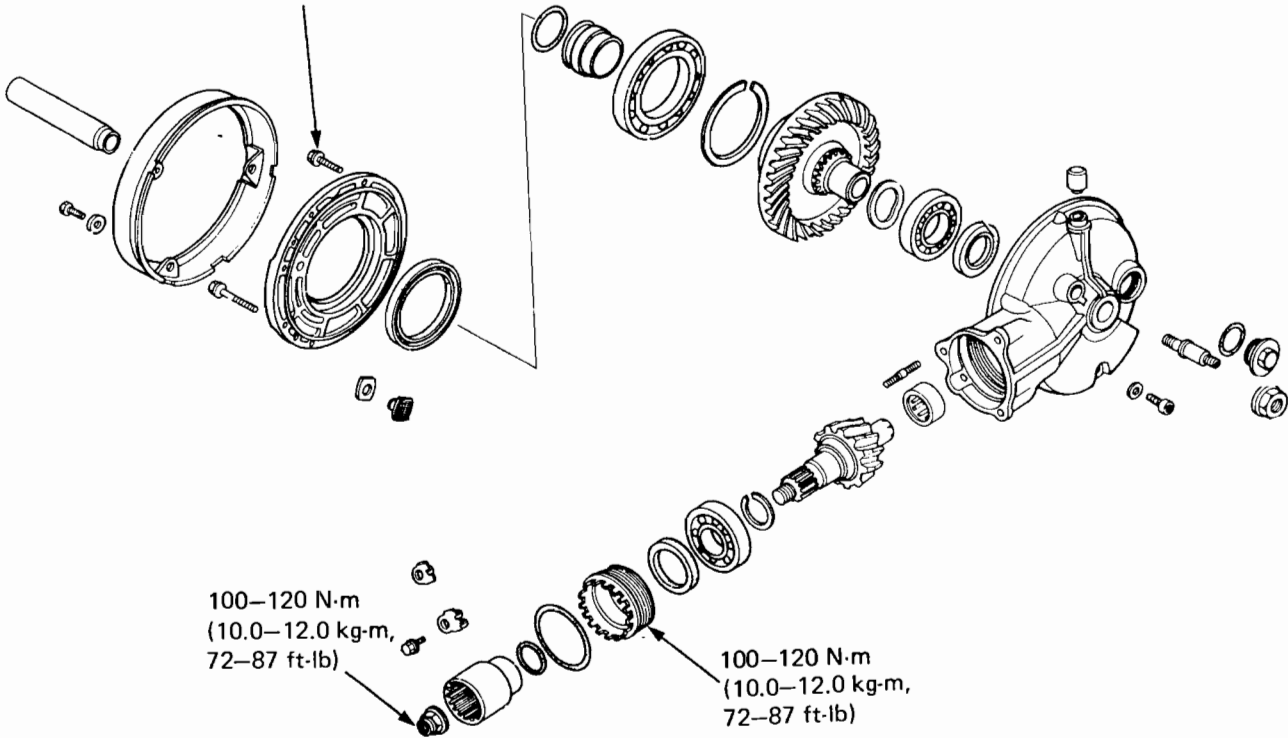



SERVICE INFORMATION	13-1
TROUBLESHOOTING	13-2
FINAL DRIVE REMOVAL	13-3
DRIVE SHAFT	13-3
UNIVERSAL JOINT	13-6
FINAL DRIVE GEAR	13-7
FINAL DRIVE INSTALLATION	13-19

## SERVICE INFORMATION

### GENERAL

- The final drive gear assembly must be removed together with the drive shaft.
- Replace all oil seals and O-rings whenever the final drive gear assembly is disassembled.
- Check gear tooth contact pattern and gear backlash when the bearing, gear set and/or gear case has been replaced.

### SPECIFICATIONS

		STANDARD	SERVICE LIMIT
Final gear oil	Capacity	150 cc (5.07 oz)	—
	Recommended oil	Hypoid-gear oil API, GL-5 SAE #80	—
Gear backlash		0.08–0.18 mm (0.003–0.007 in)	0.30 mm (0.012 in)
Gear assembly preload		0.2–0.4 N·m (2–4 kg-cm, 1.7–2.9 in-lb)	—
Damper case oil capacity		20 cc (0.71 oz)	—
Damper cam spring free length		53 mm (2.1 in)	51.5 mm (2.03 in)
Ring gear-to-stop pin clearance		0.3–0.6 mm (0.01–0.02 in)	—

### TORQUE VALUES

Pinion bearing retainer	100–120 N·m (10.0–12.0 kg-m, 72–87 ft-lb)
Pinion nut	100–120 N·m (10.0–12.0 kg-m, 72–87 ft-lb)
Gear case cover bolt 10 mm (locking agent)	45–50 N·m (4.5–5.0 kg-m, 32–36 ft-lb)
8 mm	23–28 N·m (2.3–2.8 kg-m, 17–20 ft-lb)
Final gear case attaching nut	60–70 N·m (6.0–7.0 kg-m, 43–51 ft-lb)
Oil filler cap	10–14 N·m (1.0–1.4 kg-m, 7–10 ft-lb)
Oil drain plug	10–14 N·m (1.0–1.4 kg-m, 7–10 ft-lb)





**FINAL DRIVE**

---

**TOOLS**

**Special**

Lock nut wrench	07910-ME80000
Shock absorber compressor attachment collar	07964-MB00100
Shock absorber compressor attachment plate	07964-MB00200
Attachment	07945-3330300
Attachment	07945-3330100
Pinion puller	07931-4630200 and 07931-MB00000 or 07935-MB00000
Pinion joint holder	07926-ME90000
Driver	07931-4630300

**Common**

Driver	07749-0010000
Attachment, 42 x 47 mm	07746-0010300
Attachment, 52 x 55 mm	07746-0010400
Driver	07746-0030100
Attachment, 25 mm I.D.	07746-0030200 } or Driver 07945-3710200
Shock absorber compressor	07959-3290001
Attachment, 32 x 35 mm	07746-0010100
Pilot, 30 mm	07746-0040700

**TROUBLESHOOTING**

**Excessive noise**

1. Worn or scored ring gear shaft and driven flange
2. Scored driven flange and wheel hub
  - Worn or scored drive pinion and splines
4. Worn pinion and ring gears
5. Excessive backlash between pinion and ring gear
6. Oil level too low

**Oil leak**

1. Clogged breather
2. Oil level too high
3. Seals damaged



## FINAL DRIVE REMOVAL

Place the motorcycle on its center stand.  
Drain the final gear oil (Page 2-14) and remove the rear wheel (Page 15-3).  
Remove the left shock absorber lower bolt.  
Remove the final gear case and drive shaft assembly.

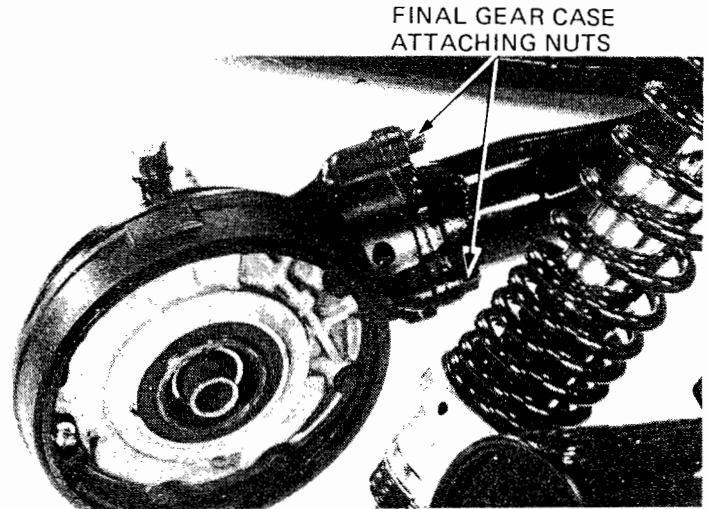

## DRIVE SHAFT

### REMOVAL

If the drive shaft came out of the swing arm attached to the final gear case when it was removed, do the following:

Insert the axle through the gear case and secure the case in a vise with soft jaws or shop rags by clamping the axle. Place the oil drain between the jaws for stability.

Place an oil drain pan under the damper case to catch the damper oil that will spill out.

Separate the damper unit from the gear case by gently revolving the damper in a circular motion while tugging slightly.

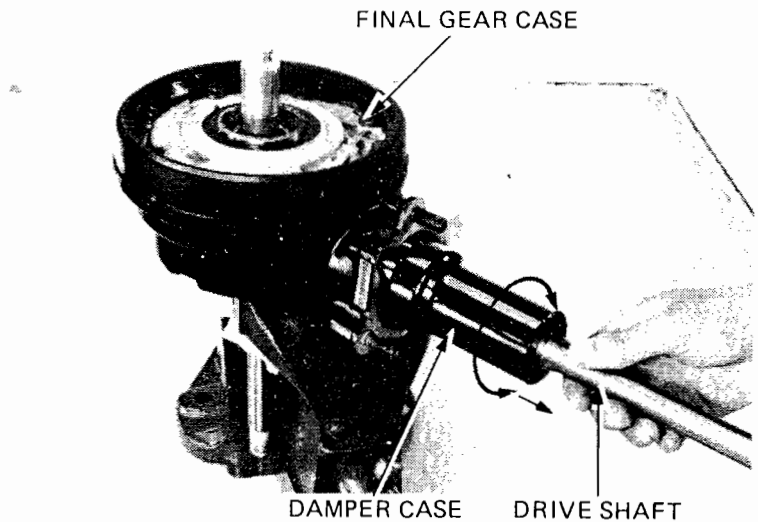

### DISASSEMBLY

Remove the joint stop ring from the damper cam and discard it.

Compress the drive shaft with the rear shock absorber compressor and attachment tools.

Drain the gear oil from the damper case.

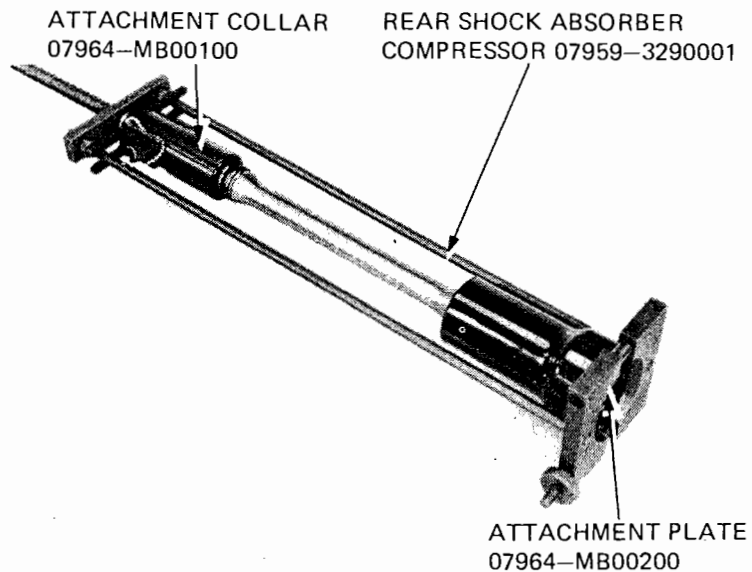



**FINAL DRIVE**

Remove the spring stop ring and drive shaft from the compressor.

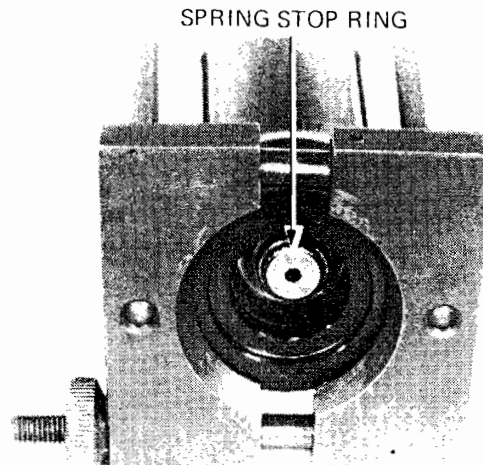

Remove the spring stop, damper cam, damper lifter, damper spring and damper case from the drive shaft.

Check the damper lifter and cam for wear or damage.

**NOTE**

Install a new stop ring on reassembly.

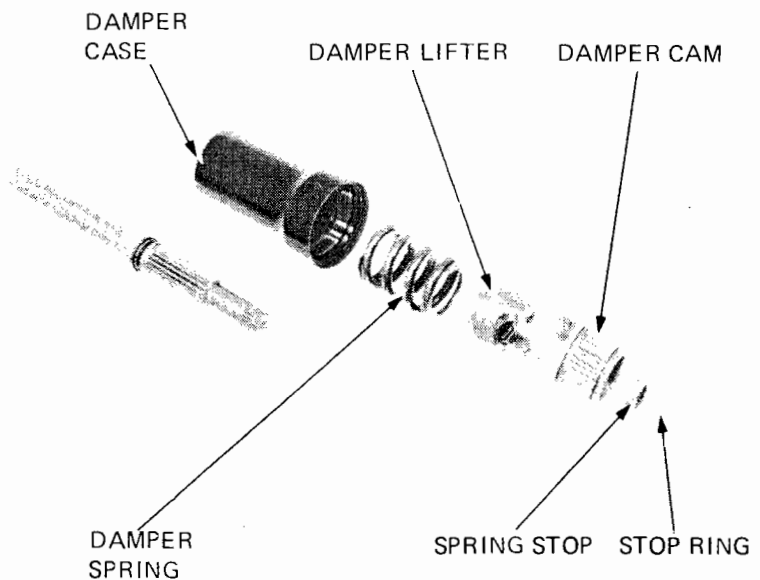

Measure the damper spring free length.

**SERVICE LIMIT: 51.5 mm (2.03 in)**

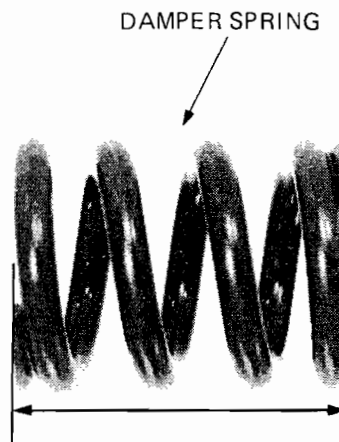



Remove the O-ring and stop ring from the drive shaft.

Remove the circlip, spring seat and spring.

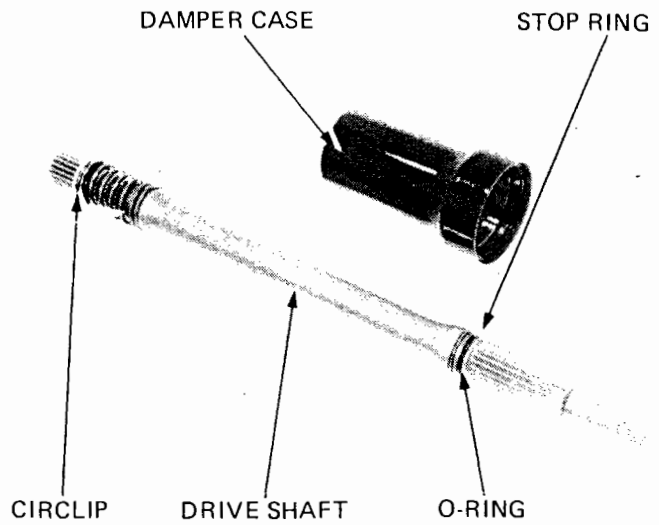

Remove the oil seal and oil seal guide from the damper case.

**NOTE**

Replace the oil seal with a new one if it is removed.

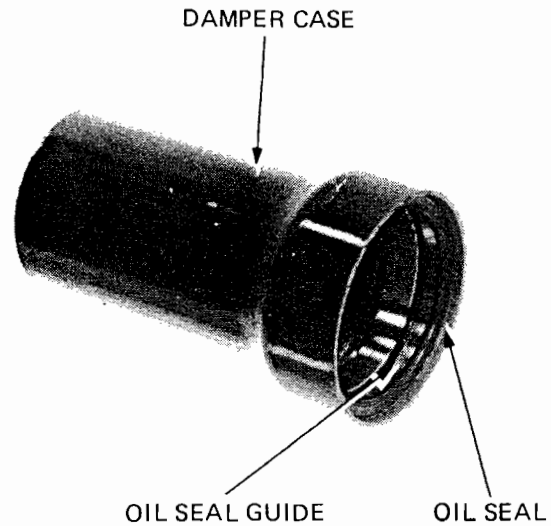

**ASSEMBLY**

Drive the oil seal guide and oil seal in with the driver attachment and driver.

Assemble the remaining parts in the reverse order of disassembly.

**NOTE**

Replace the O-ring, oil seal and stop rings with new ones when reassembling the drive shaft.

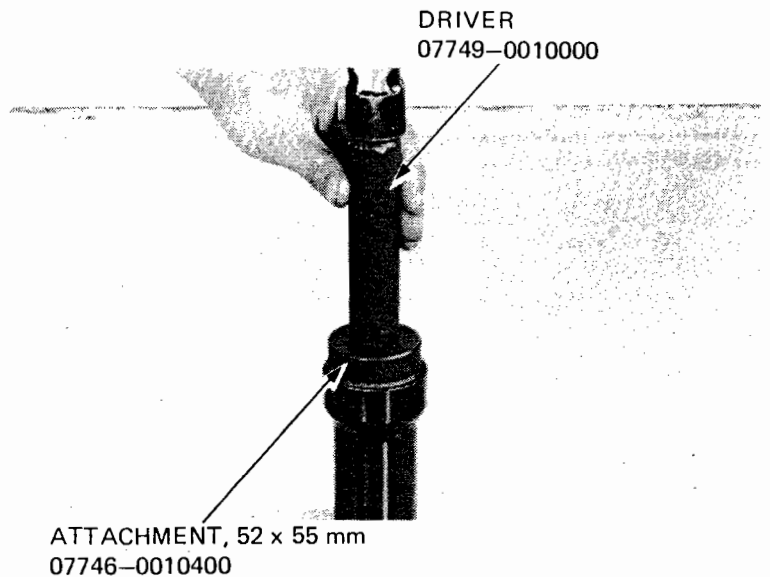



## UNIVERSAL JOINT

### REMOVAL/INSTALLATION

Remove the swing arm (Page 15-16).  
Remove the universal joint from the engine output shaft.

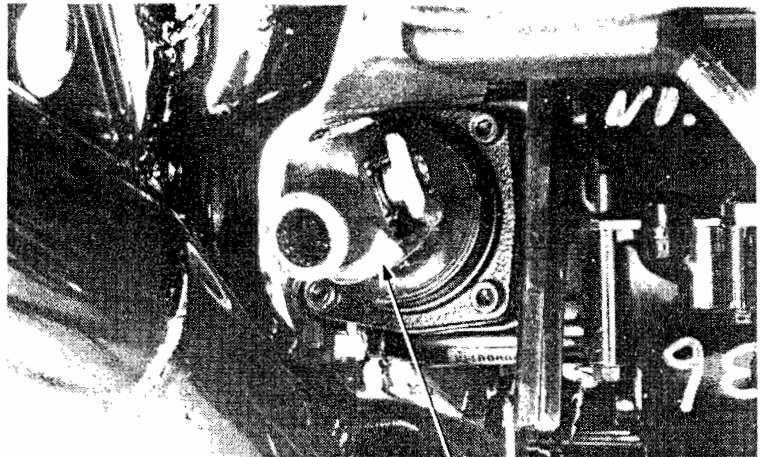

UNIVERSAL JOINT

Check the universal joint and drive shaft splines for wear or damage.  
Inspect the universal joint bearings for excessive play or damage.  
Apply molybdenum disulfide grease to the splines and install the universal joint.

UNIVERSAL JOINT

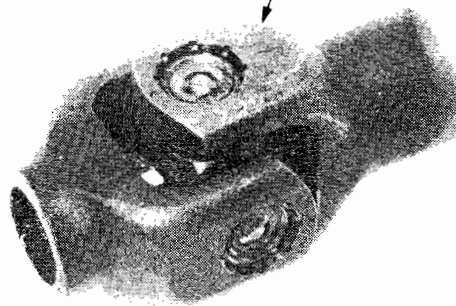

DRIVE SHAFT

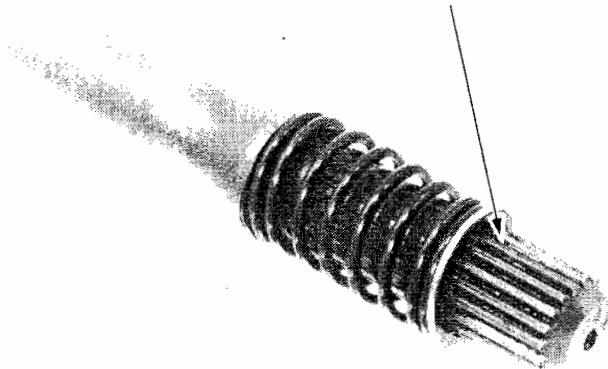



## FINAL DRIVE GEAR

### RING GEAR REMOVAL

Remove the distance collar and dust guard plate.

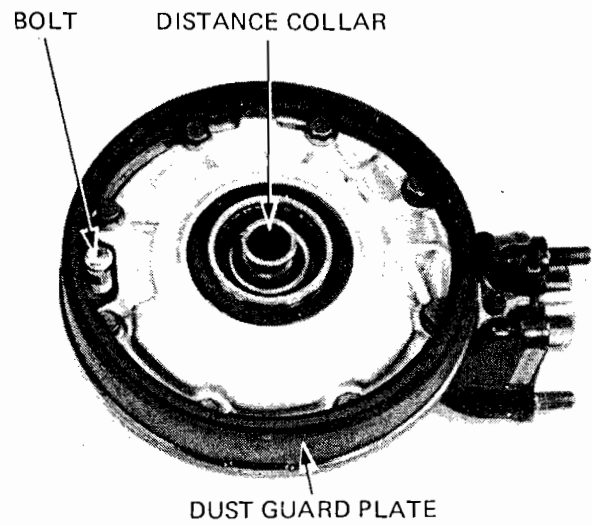

Remove the eight case cover bolts and cover.

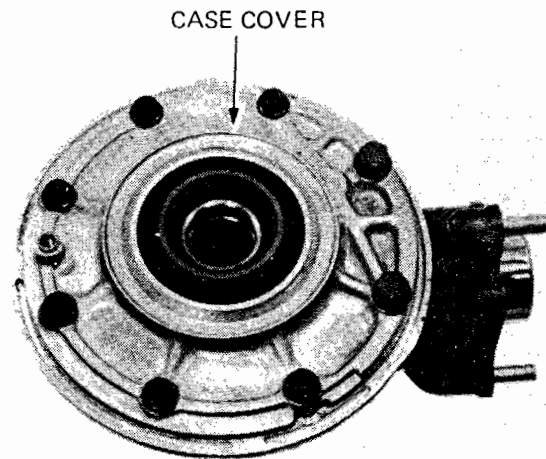

Remove the ring gear from the final drive case.

Remove the O-ring guide by tapping it from the opposite side with a plastic hammer.

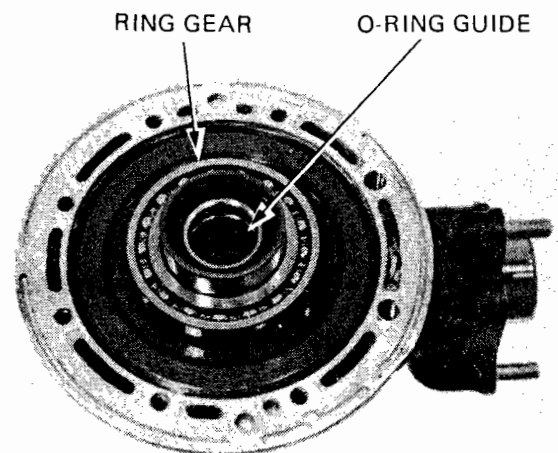



**RING GEAR BEARING REMOVAL**

Remove the ring gear bearing and gear adjusting spacer.

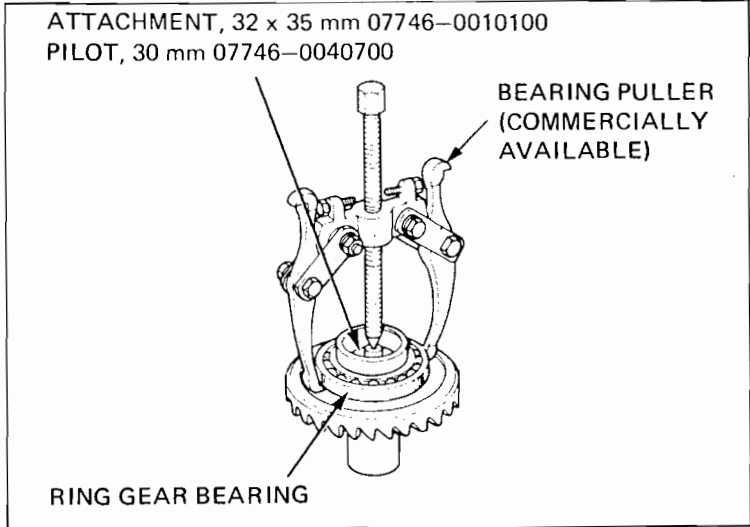

**CASE COVER OIL SEAL REPLACEMENT**

Remove the oil seal from the case cover and drive in a new oil seal.

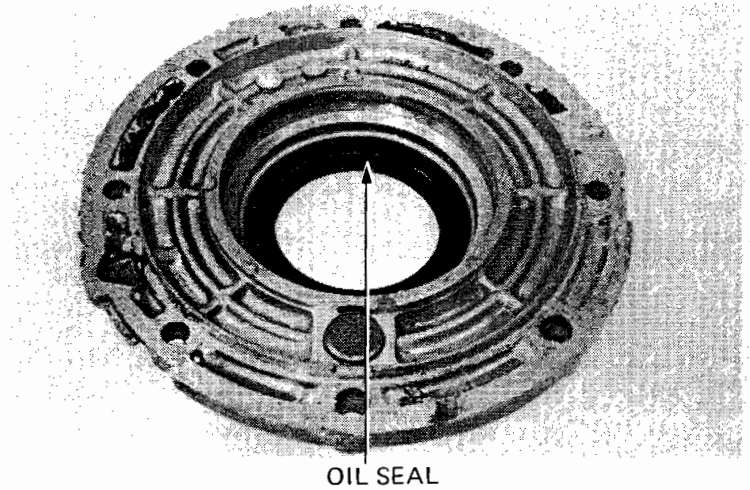

**PINION GEAR REMOVAL**

Install the pinion joint holder onto the pinion joint and remove the pinion shaft nut. Remove the tool and pinion joint.





Remove the retainer lock tab.

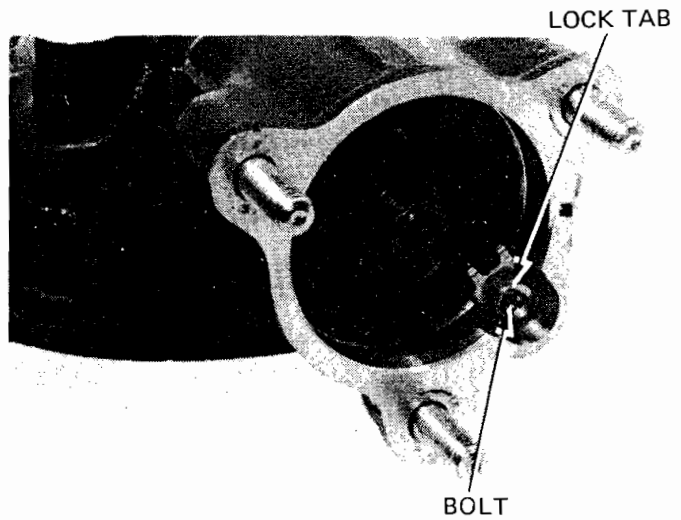

Remove the pinion retainer with the retainer wrench.

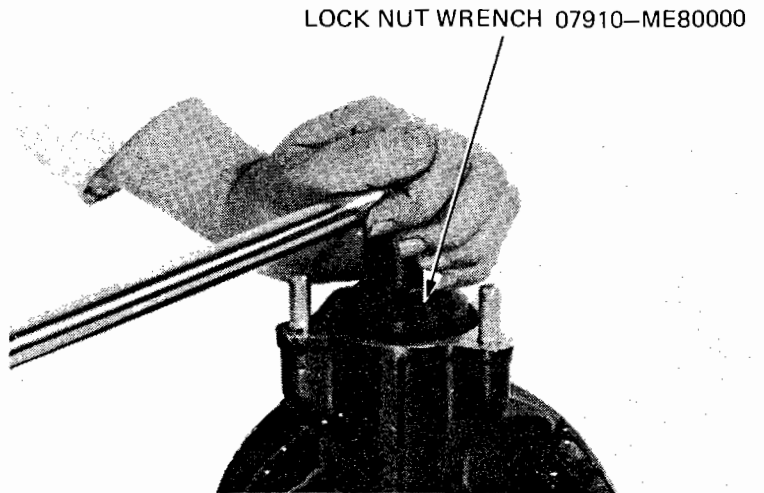

Pull the pinion assembly off with the pinion puller.

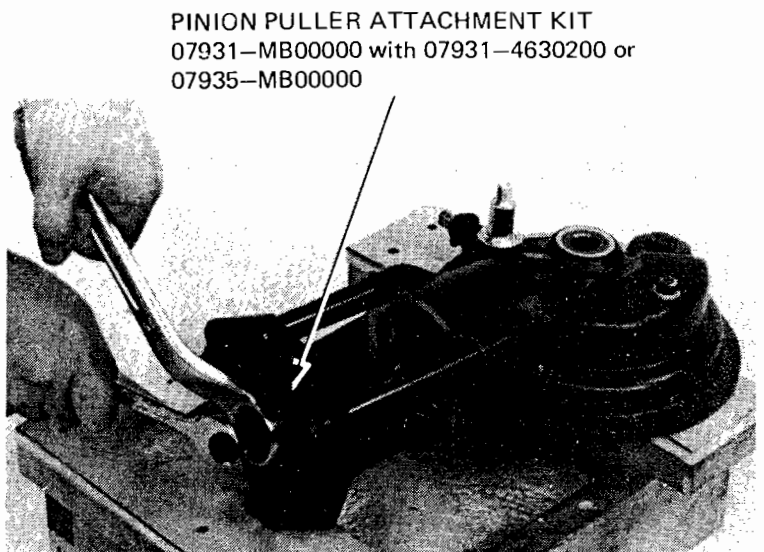





**PINION BEARING REMOVAL**

Remove the O-ring.  
Pull the bearing outer and inner races off with a bearing puller.

Pull the other inner race off with the same tool and remove the pinion adjustment spacer.

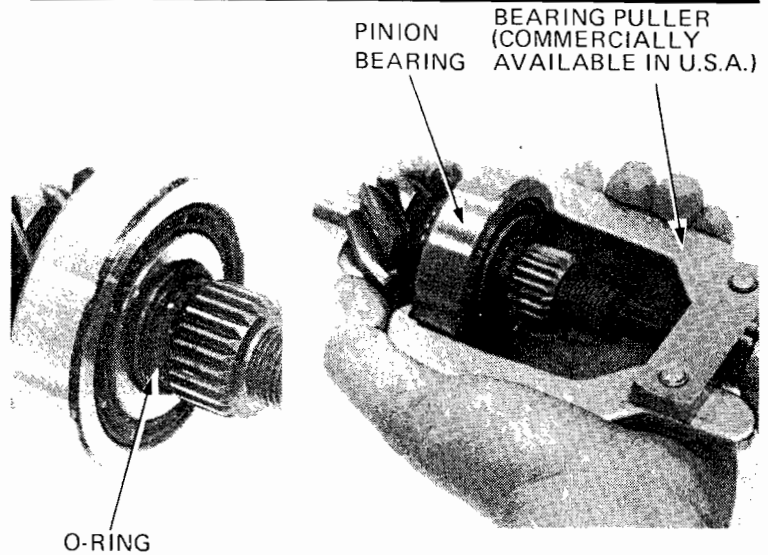

**PINION RETAINER OIL SEAL REPLACEMENT**

Remove the O-ring and oil seal from the pinion retainer.

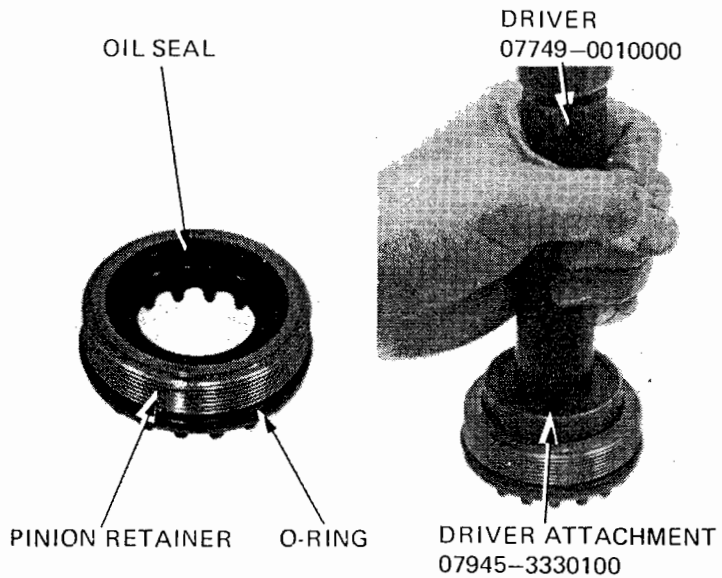

Drive a new oil seal into the retainer.

Coat a new O-ring with oil and install it onto the retainer.

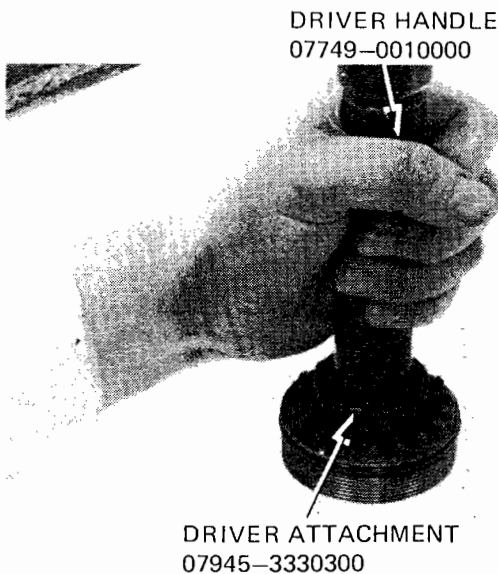



### CASE BEARING AND OIL SEAL REPLACEMENT

Heat the gear case to 80°C (176°F).

Tap the gear case with a plastic hammer and remove the ring gear and pinion bearings.

**WARNING**

*Always wear gloves when handling the gear case after it has been heated.*

**NOTE**

Use bearing remover, 35 mm, 07936-3710400 to remove the ring gear bearing if necessary.

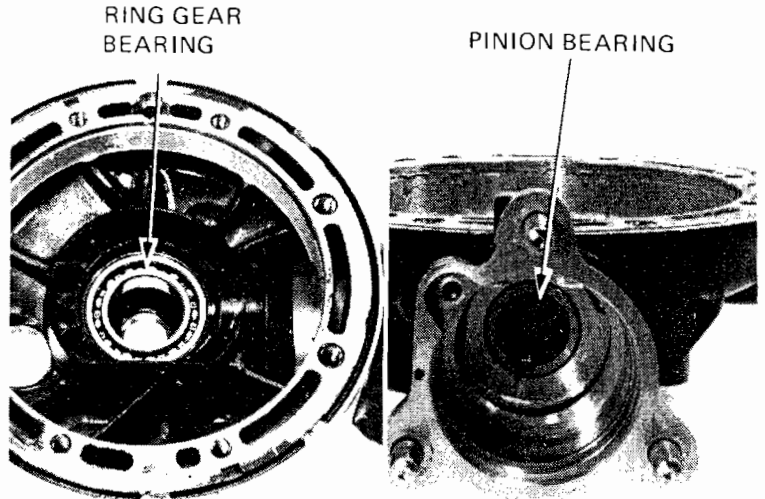

Remove the ring gear shaft oil seal.  
Drive a new oil seal into the case, with the special tools.

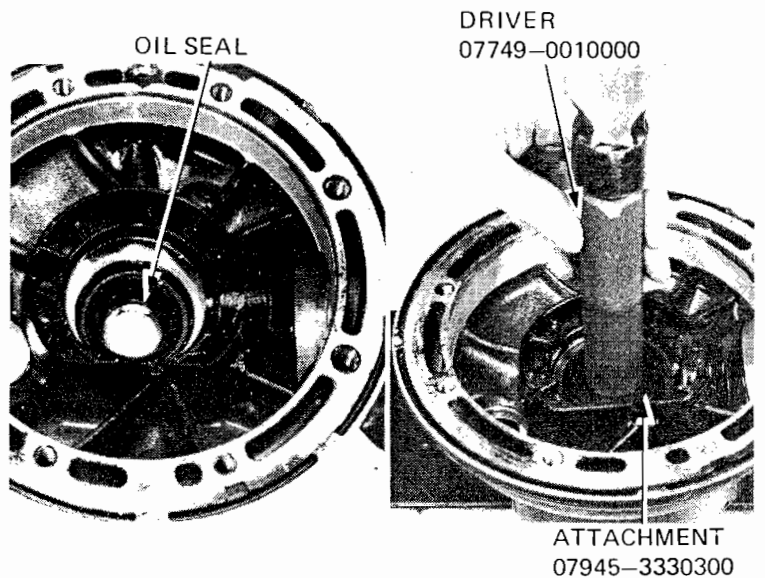

Drive new pinion and ring gear bearings into the case.

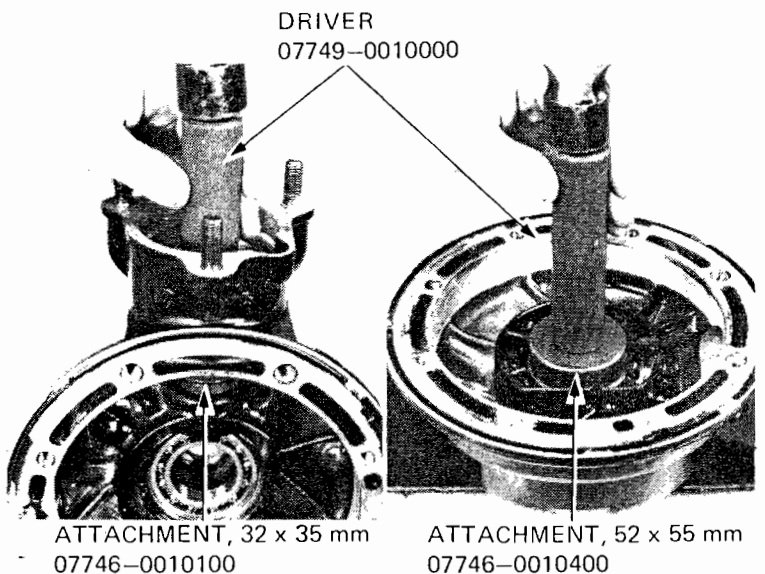

**BREATHER HOLE CLEANING**

Remove the breather hole cap and blow through the breather hole with compressed air.

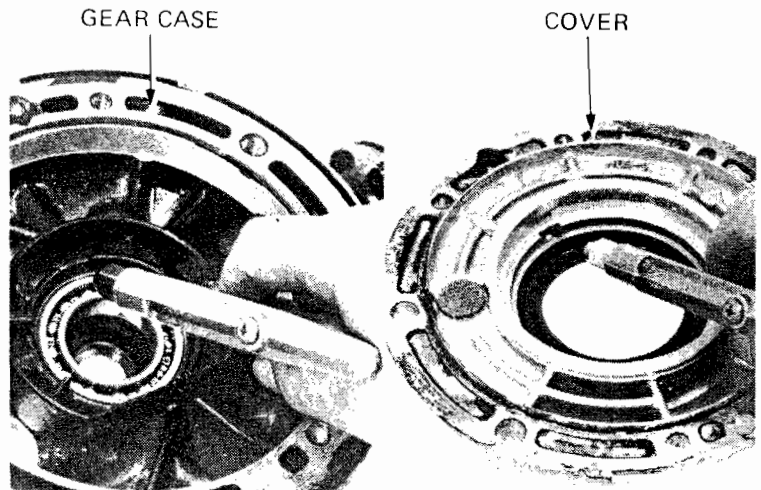

**PINION GEAR ASSEMBLY**

Install the original pinion gear spacer.

**NOTE**

When the gear set, pinion bearing and/or gear case has been replaced, use a 2.0 mm thick spacer.

PINION SPACER

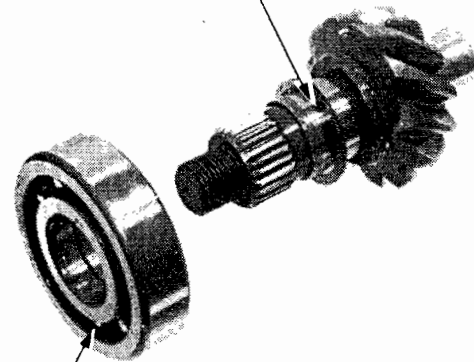

PINION BEARING

DRIVER  
07746-0030100  
or 07945-3710200

Press the pinion bearing onto the shaft until it seats. Press only on the inner race. Install the O-ring.

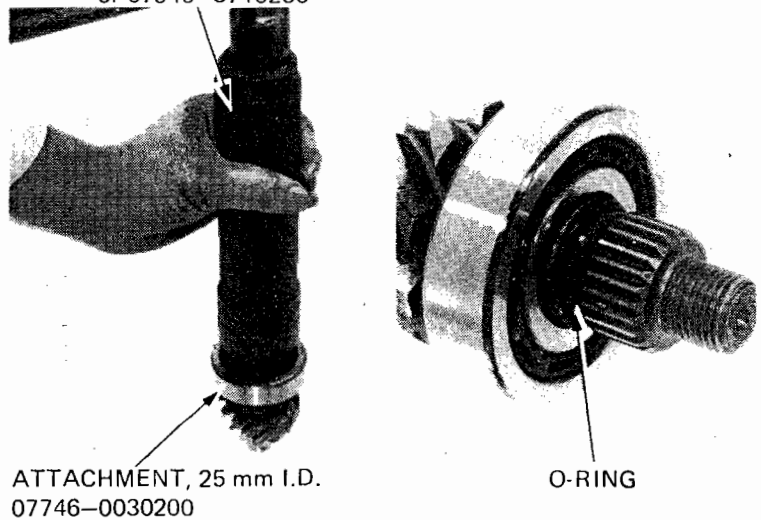



Place the pinion assembly into the gear housing. Drive the pinion assembly into the gear case just until enough threads are visible to engage the pinion retainer.

Apply gear oil to the O-ring and threads on the pinion retainer.

Screw in the pinion retainer to press the pinion bearing in place, then tighten it to the specified torque.

**TORQUE:** 100–120 N·m  
(10.0–12.0 kg·m, 72–87 ft·lb)

DRIVER  
07931-4630300

LOCK NUT WRENCH  
07910-ME80000

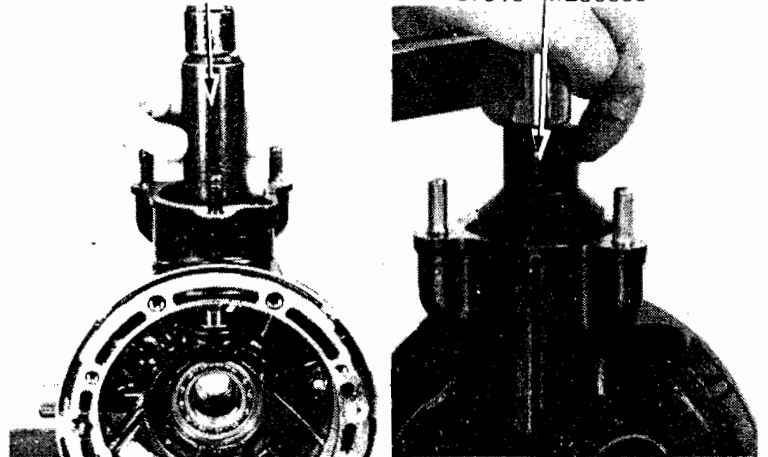

### RING GEAR ASSEMBLY

Install the original spacer onto the ring gear.

#### NOTE

If the gear set, pinion bearing, ring gear bearing and/or gear case is replaced, install a 2.0 mm thick spacer.

RING GEAR BEARING

RING GEAR SPACER

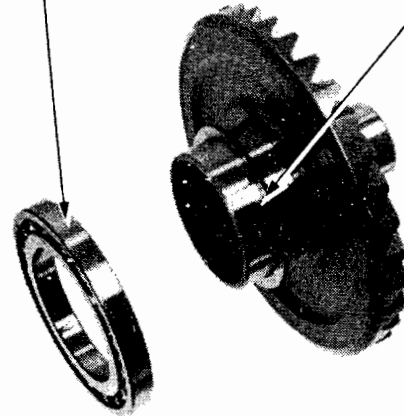

Place a new ring gear bearing on the ring gear shaft. Place the old bearing on top of it. Then, drive the new bearing onto the shaft with the old bearing and attachment. Then remove the old bearing.

ATTACHMENT  
07947-6340201

DRIVER  
07749-0010000

OLD BEARING

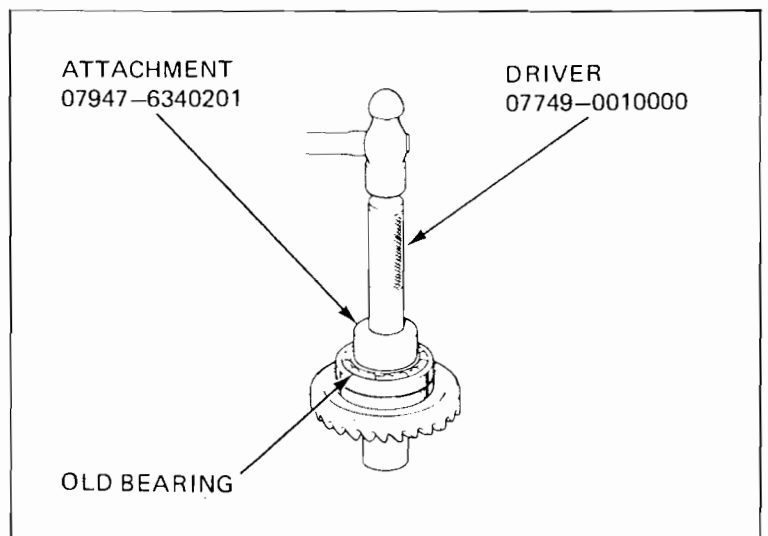



Install a new O-ring on the O-ring guide.  
Apply grease to the O-ring and drive the O-ring guide onto the ring gear shaft.

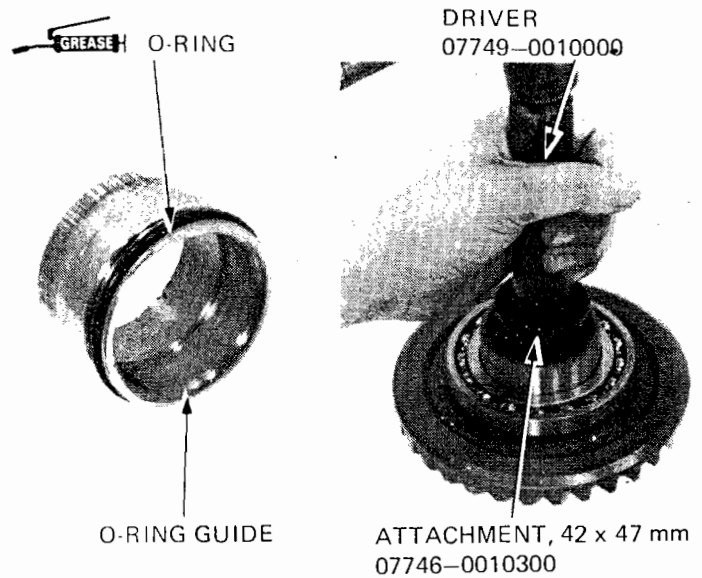

Install the ring gear into the gear case cover.

Measure the clearance between the ring gear and the ring gear stop pin with a feeler gauge.

**CLEARANCE:** 0.30–0.60 mm (0.012–0.024 in)

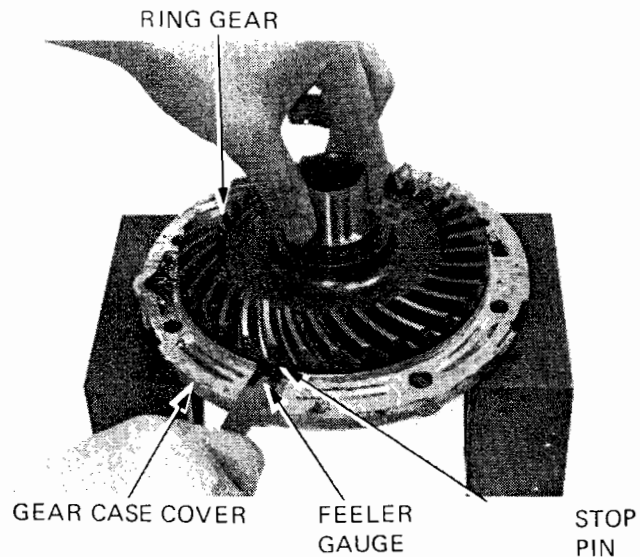

Remove the ring gear.

If the clearance exceeds the limit, heat the gear case cover to approximately 80°C (176°F) and remove the stop pin by tapping the cover behind the pin.

**WARNING**

*Always wear gloves when handling the gear case after it has been heated.*

Install a stop pin shim to obtain the correct clearance.

**SHIM THICKNESS:** A 0.10 mm (0.004 in)  
B 0.15 mm (0.006 in)

Install the shim and drive the stop pin into the case cover.

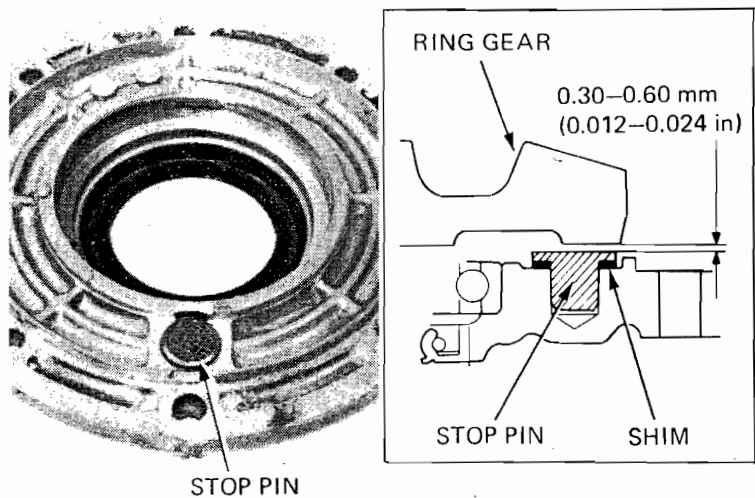



Clean all sealing material off the mating surfaces of the gear case and cover.

### NOTE

- Keep dust and dirt out of the gear case.
- Be careful not to damage the mating surfaces.

Apply liquid sealant to the mating surface of the gear case cover.

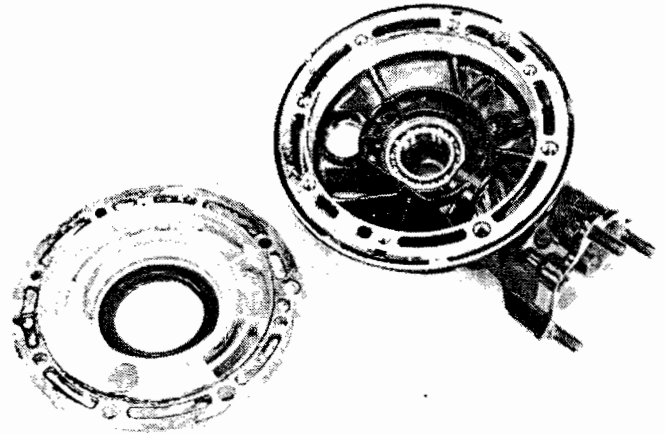

Apply a thin coat of Prussian Blue to the pinion gear teeth for a gear tooth contact pattern check.

Place the wave washer and ring gear into the gear case.

Apply gear oil to the lip of the oil seal on the gear case cover and install the gear case cover.

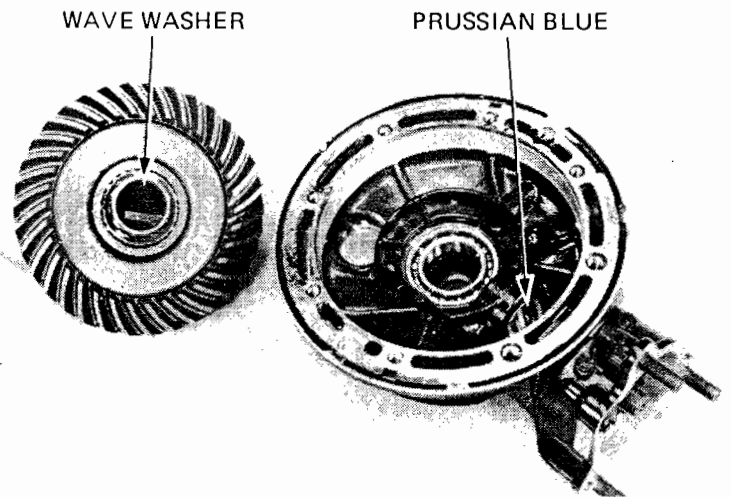

Tighten the cover bolts in 2–3 steps until the cover evenly touches the gear case, then tighten the 8 mm bolts to the specified torque in a crisscross pattern in the two or more steps.

**TORQUE:** 23–28 N·m  
(2.3–2.8 kg·m, 17–20 ft·lb)

Then tighten the 10 mm bolts.

**TORQUE:** 45–50 N·m  
(4.5–5.0 kg·m, 32–36 ft·lb)

### NOTE

Apply a locking agent to the 10 mm bolt threads.

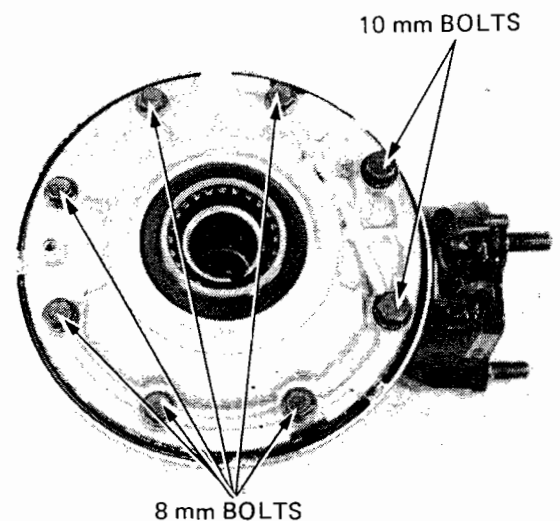



## FINAL DRIVE

### GEAR TOOTH CONTACT PATTERN CHECK

Remove the oil filler cap from the final gear case.

Rotate the ring gear several times in both direction of rotation.

Check the gear tooth contact pattern through the oil filler hole. The pattern is indicated by the Prussian Blue applied to the pinion before assembly. Contact is normal if Prussian Blue is transferred to the approximate center of each tooth and slightly towards the face.

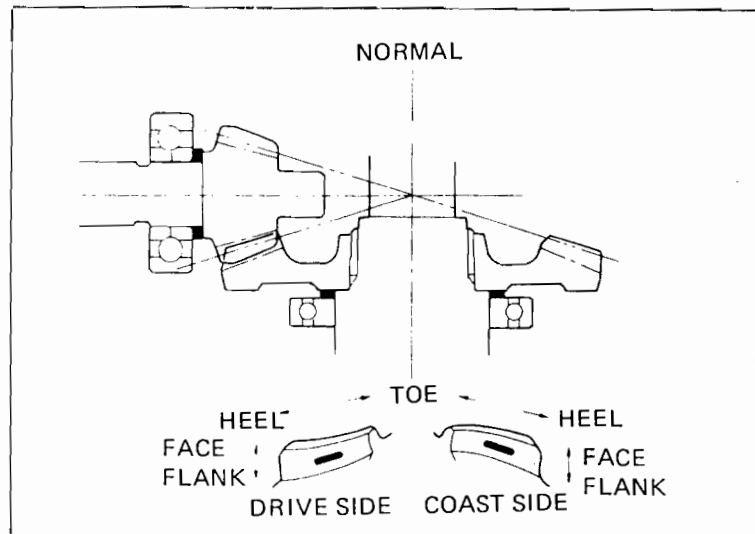

If the patterns are not correct, remove and replace the pinion spacer.

Replace the pinion spacer with a thicker one if the contacts are too high.

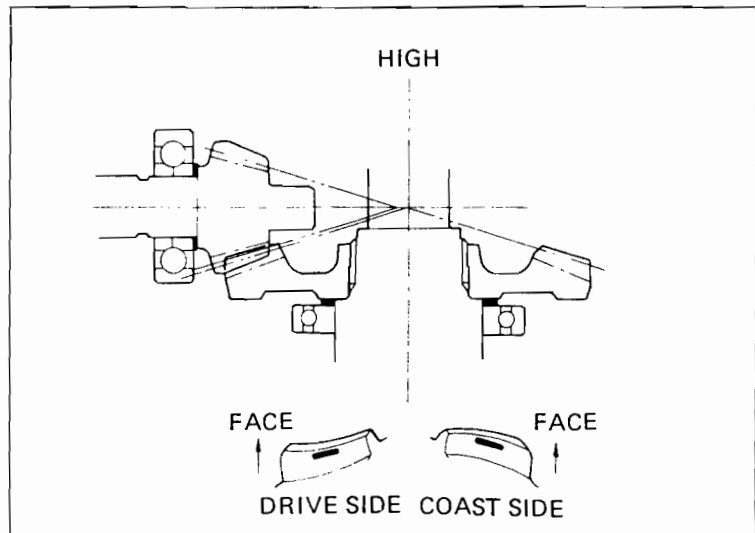

Replace the pinion spacer with a thinner one if the contacts are too low.

The patterns will shift about 1.5–2.0 mm (0.06–0.08 in) when the thickness of the spacer is changed by 0.1 mm (0.004 in).

#### PINION SPACER:

- A 1.82 mm (0.072 in)
- B 1.88 mm (0.074 in)
- C 1.94 mm (0.076 in)
- D 2.00 mm (0.079 in) **standard**
- E 2.06 mm (0.081 in)
- F 2.12 mm (0.083 in)
- G 2.18 mm (0.086 in)

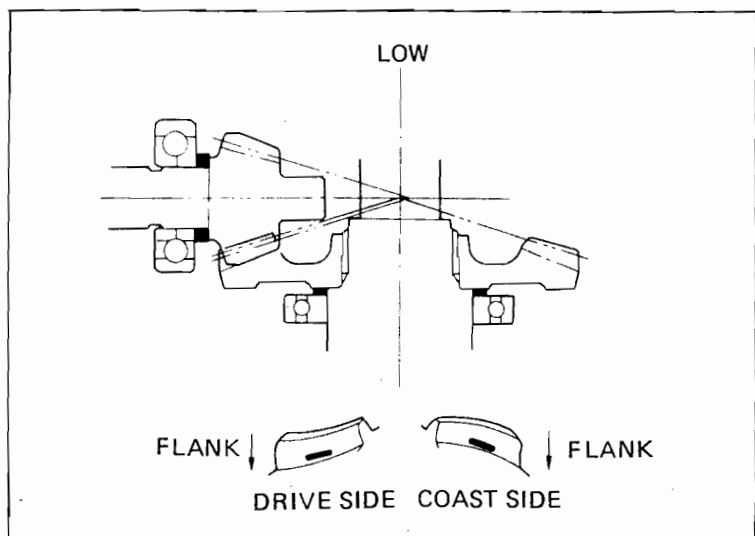



**BACKLASH INSPECTION**

Remove the oil filler cap.

Set the final gear assembly into a jig or stand to hold it steady.

Set a horizontal type dial indicator on the ring gear, through the oil filler hole.

Hold the pinion gear spline by hand. Rotate the ring gear by hand until gear slack is taken up.

Turn the ring gear back and forth to read backlash.

**STANDARD: 0.08–0.18 mm (0.003–0.007 in)**

**SERVICE LIMIT: 0.30 mm (0.02 in)**

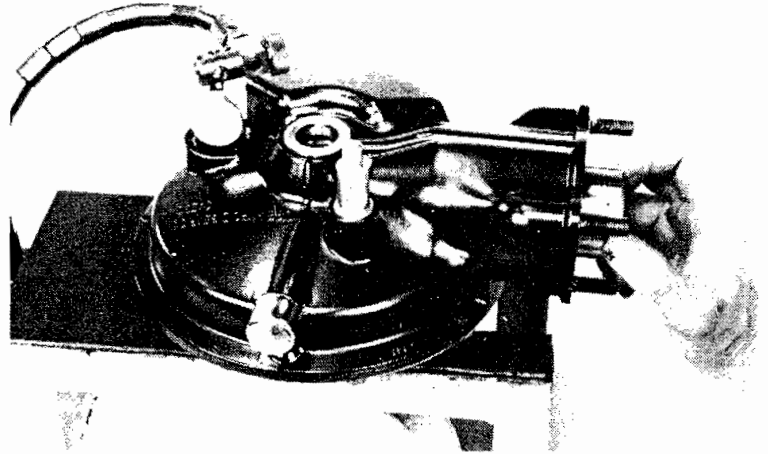

Remove the dial indicator. Turn the ring gear 120° and measure backlash. Repeat this procedure once more.

Compare the difference of the three measurements.

**DIFFERENCE OF MEASUREMENT**  
**SERVICE LIMIT: 0.10 mm (0.004 in)**

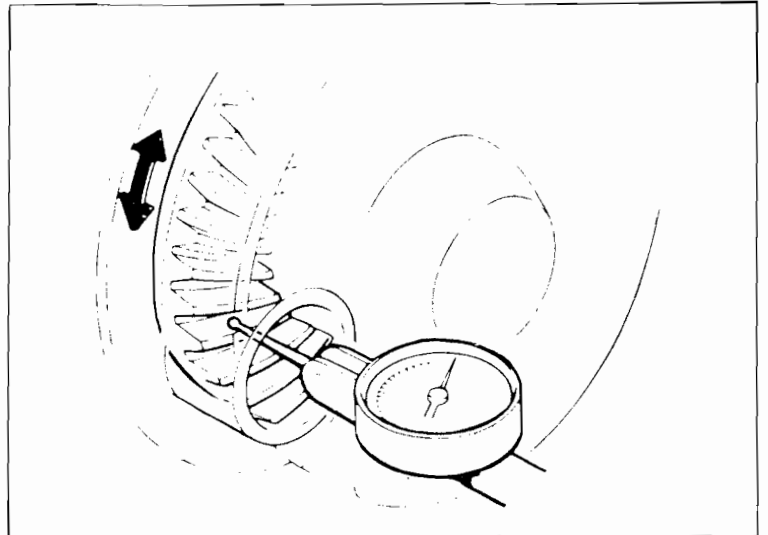

If the difference in measurements exceeds the limit, it indicates that the bearing is not installed squarely. Inspect the bearings and reinstall if necessary.

If backlash is excessive, replace the ring gear spacer with a thicker one.

If the backlash is too small, replace the ring gear spacer with a thinner one.

Backlash is changed by about 0.06–0.07 mm (0.002–0.003 in) when thickness of the spacer is changed by 0.10 mm (0.004 in).

**RING GEAR SPACER:**

- A 1.82 mm (0.072 in)
- B 1.88 mm (0.074 in)
- C 1.94 mm (0.076 in)
- D 2.00 mm (0.079 in) **standard**
- E 2.06 mm (0.081 in)
- F 2.12 mm (0.083 in)
- G 2.18 mm (0.086 in)
- H 2.24 mm (0.088 in)
- I 2.30 mm (0.091 in)

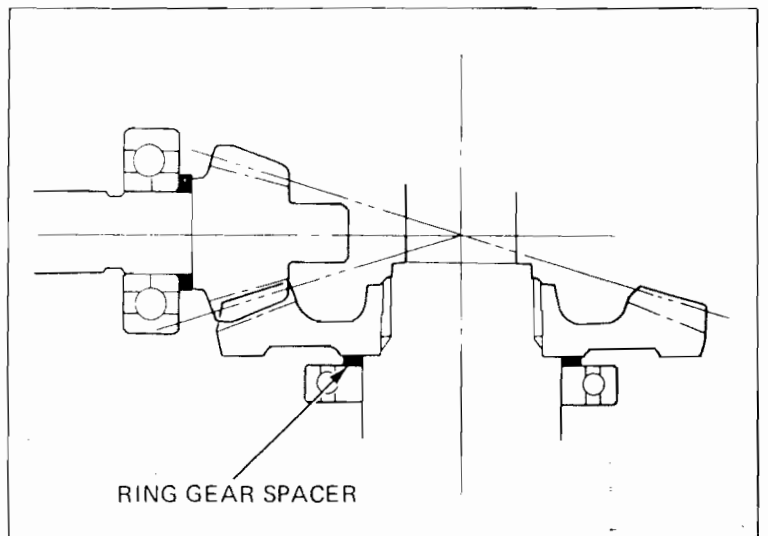



**PINION JOINT INSTALLATION**

Install the appropriate pinion lock tab.

**NOTE**

There are two types of lock tabs.

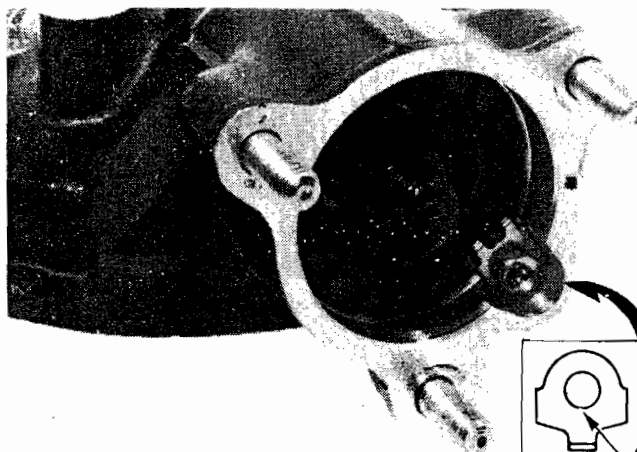

LOCK TABS

Apply gear oil to the oil seal lip contact surface of the pinion joint and install the pinion joint.

Install the pinion joint holder tool and tighten the pinion nut.

**TORQUE:** 100–120 N·m  
(10.0–12.0 kg·m, 72–87 ft·lb)

Remove the pinion joint holder tool.

PINION JOINT HOLDER  
07926-ME90000

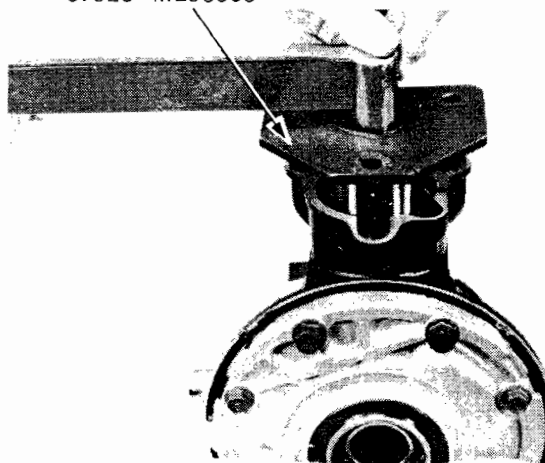

Make sure that the gear assembly rotates smoothly without binding by turning the pinion joint.

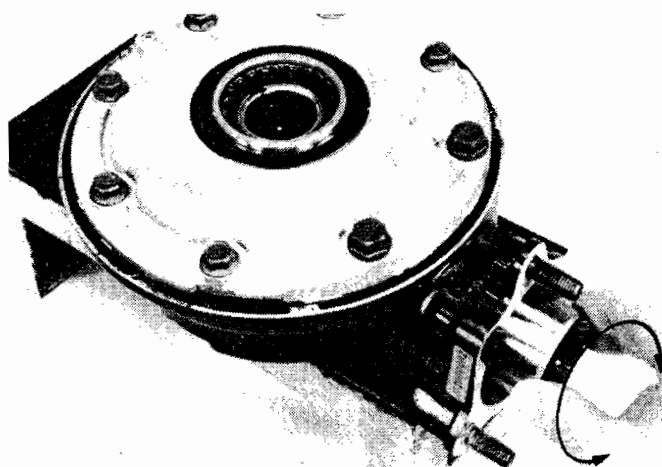



Measure the gear assembly preload.

**PRELOAD:** 0.2–0.4 N·m  
(2–4 kg·cm, 1.7–3.4 in·lb)

If the preload reading does not fall within the limit, disassemble the final gear and check the bearings for installation condition.

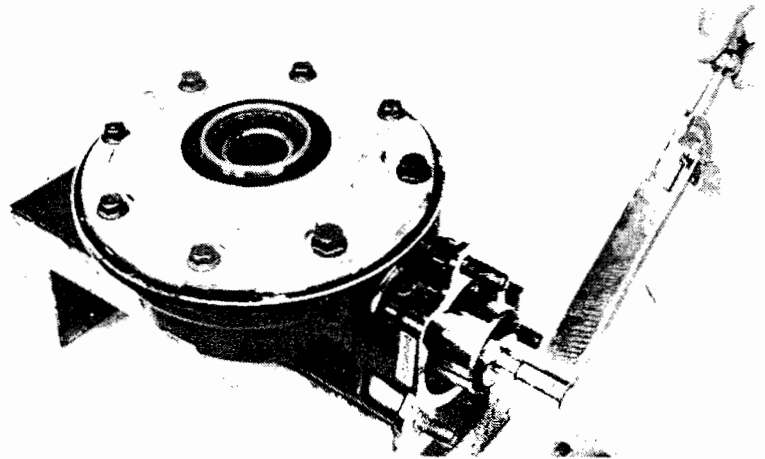

Install the dust guard plate and torque the bolts.  
Install the distance collar.

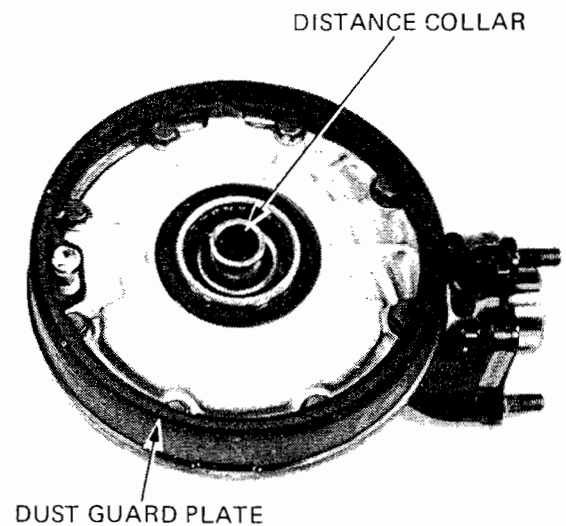

## FINAL DRIVE INSTALLATION

Fill the damper case with the recommended type and amount of lubricant.

**RECOMMENDED OIL:** HYPOID GEAR OIL API,  
GL-5, SAE #80

**OIL CAPACITY:** 20 cc (0.71 oz)





## FINAL DRIVE

Keep the damper case vertical and install the final drive gear case over the damper cam.

### NOTE

- Be careful not to damage the drive shaft oil seal.
- Do not let the gear case separate from the damper case or the oil will spill out.

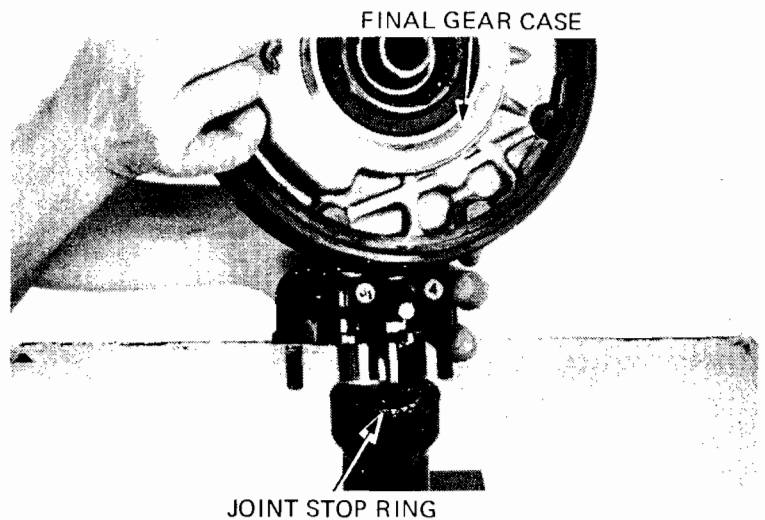

Apply molybdenum disulfide grease to the drive shaft splines.

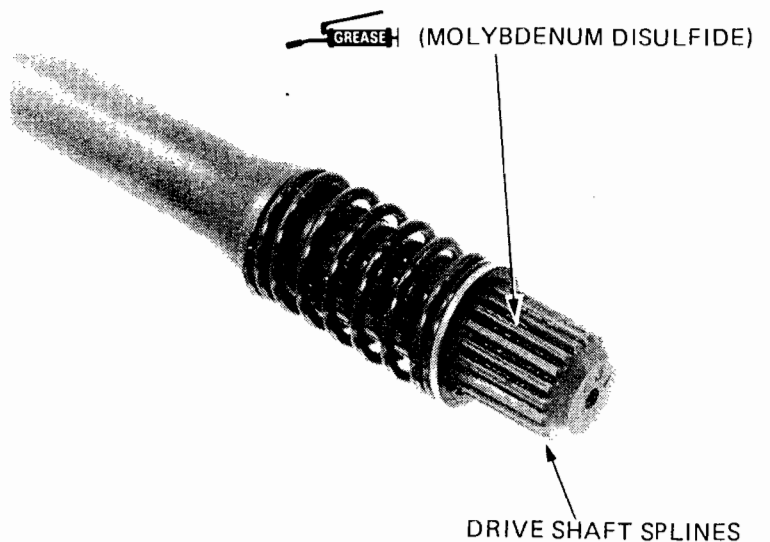

Insert the drive shaft assembly into the swing arm and align its splines with the universal joint.

Attach the gear case onto the swing arm loosely.

### NOTE

- To ease axle installation, do not tighten the gear case nuts until after the axle is installed.

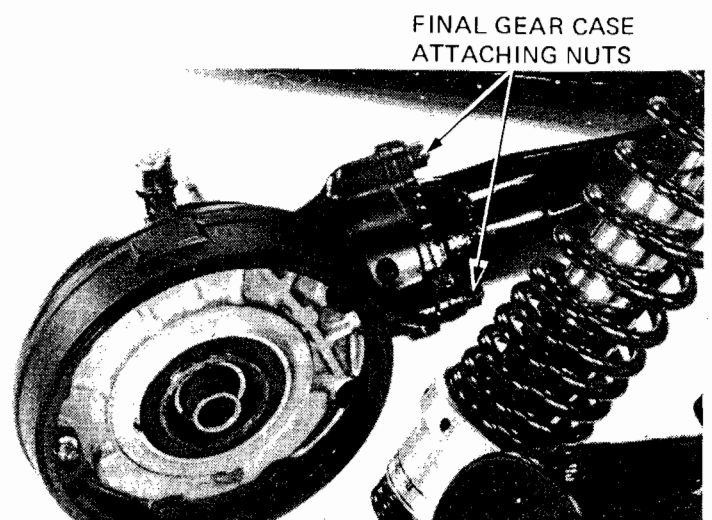



Install the rear wheel (Page 16-7).

Tighten the axle nut.

**TORQUE:** 60–80 N·m  
(6.0–8.0 kg·m, 43–58 ft·lb)

Tighten the three final gear case attaching nuts.

**TORQUE:** 60–70 N·m  
(6.0–7.0 kg·m, 43–51 ft·lb)

Tighten the axle pinch bolt.

**TORQUE:** 20–30 N·m  
(2.0–3.0 kg·m, 14–22 ft·lb)

Install the left shock absorber (Page 16-12).

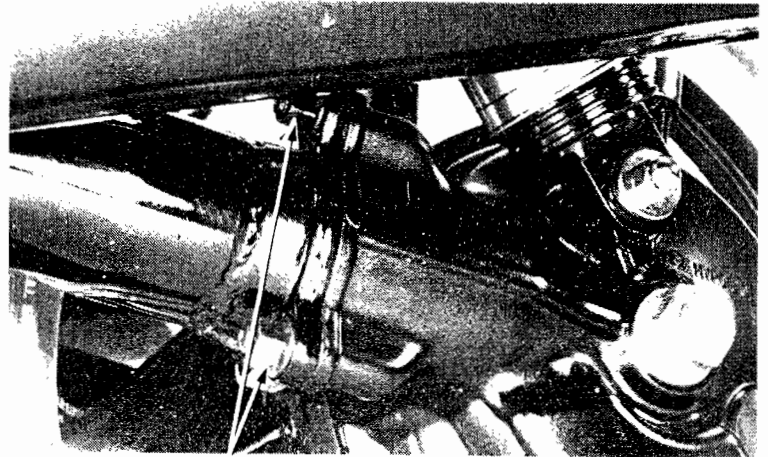

FINAL GEAR CASE  
ATTACHING NUTS

Place the motorcycle on its center stand.

Make sure that the drain bolt is tightened.

Remove the oil filler cap and pour the specified amount of recommended oil up to the level mark.

**RECOMMENDED OIL: HYPOID GEAR OIL  
SAE 80  
OIL CAPACITY: 150 cc (5.07 oz)**

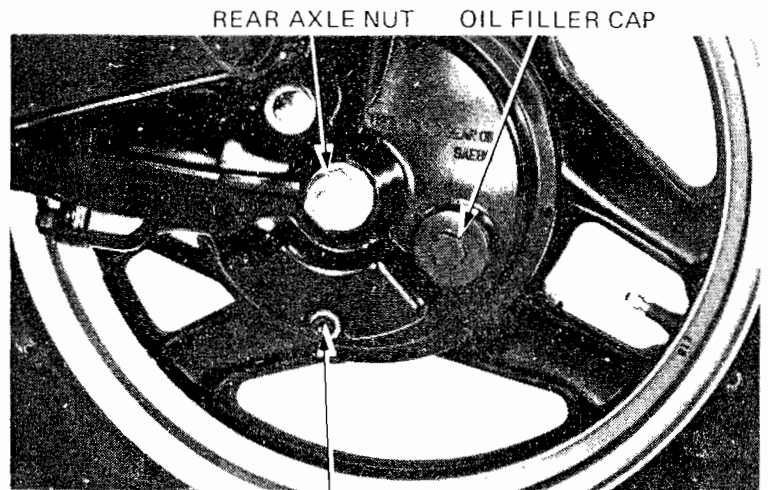

DRAIN BOLT

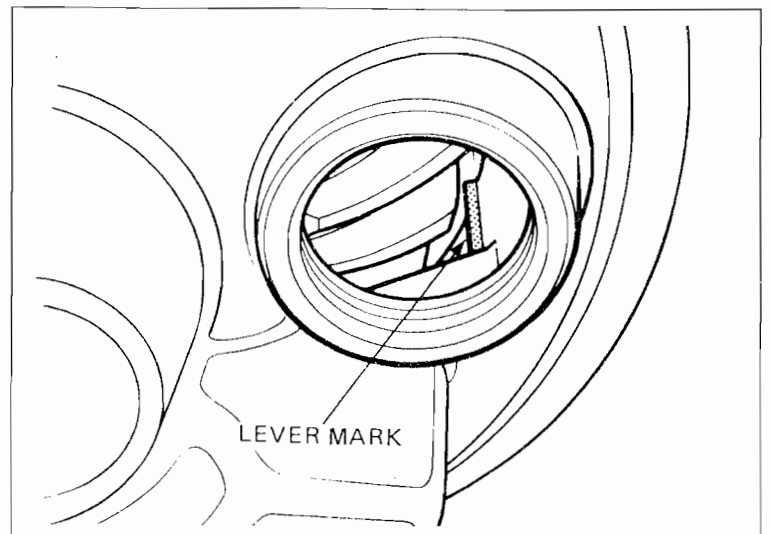

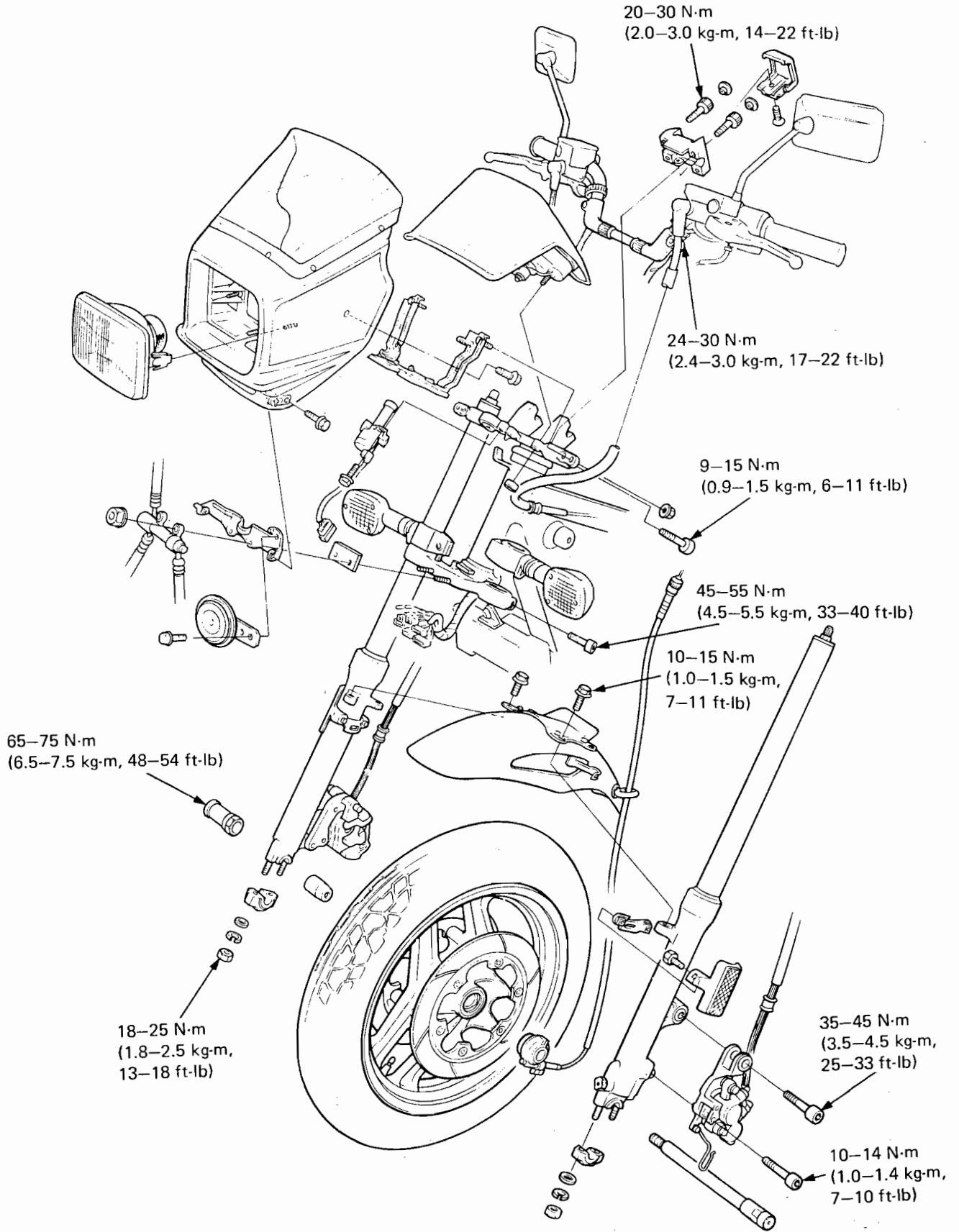



SERVICE INFORMATION	14-1	FRONT WHEEL	14-9
TROUBLESHOOTING	14-2	FRONT FORK	14-17
HANDLEBARS	14-3	STEERING STEM	14-28

## SERVICE INFORMATION

### GENERAL

- A jack or other support is required to support the motorcycle for some service operations.
- Never ride on the rim or try to bend the wheel.
- For front brake service information, refer to section 16, Hydraulic Brake.

### SPECIFICATIONS

		STANDARD	SERVICE LIMIT
Axle shaft runout		—	0.2 mm (0.01 in)
Front wheel rim runout	Radial	0.3 mm (0.01 in) max.	2.0 mm (0.08 in)
	Axial	0.3 mm (0.01 in) max.	2.0 mm (0.08 in)
Fork spring free length		437 mm (17.2 in)	428 mm (16.9 in)
Fork tube runout		—	0.2 mm (0.01 in)
Front fork fluid capacity		Right 423 cc (14.3 oz)	—
		Left 429 cc (14.5 oz)	—
Front fork air pressure		0 – 40 kPa (0 – 0.4 kg/cm <sup>2</sup> , 0 – 6 psi)	—
Steering bearing preload		1.0 – 1.6 kg (2.21 – 3.53 lb)	—

### TORQUE VALUES

Handlebar upper holder	20–30 N·m (2.0–3.0 kg·m, 14–22 ft·lb)
Handlebar pinch bolt	24–30 N·m (2.4–3.0 kg·m, 17–22 ft·lb)
Axle holder nut	18–25 N·m (1.8–2.5 kg·m, 13–18 ft·lb)
Front axle nut	65–75 N·m (6.5–7.5 kg·m, 48–54 ft·lb)
Caliper mounting bolt	35–45 N·m (3.5–4.5 kg·m, 25–33 ft·lb)
Anti-dive piston pin bolt	10–14 N·m (1.0–1.4 kg·m, 7–10 ft·lb)
Front fork socket bolt	20–26 N·m (2.0–2.6 kg·m, 15–19 ft·lb)
Fork tube cap	15–30 N·m (1.5–3.0 kg·m, 11–22 ft·lb)
Steering stem nut	90–120 N·m (9.0–12.0 kg·m, 65–87 ft·lb)
Brake disc	35–40 N·m (3.5–4.0 kg·m, 25–29 ft·lb)
Fork brace	10–15 N·m (1.0–1.5 kg·m, 7–11 ft·lb)
Front fork upper pinch bolt	9–15 N·m (0.9–1.5 kg·m, 6–11 ft·lb)
Front fork lower pinch bolt	45–55 N·m (4.5–5.5 kg·m, 33–40 ft·lb)
Steering bearing adjustment nut	20–22 N·m (2.0–2.2 kg·m, 14–15 ft·lb)
Master cylinder holder bolt	10–14 N·m (1.0–1.4 kg·m, 7–10 ft·lb)



**FRONT WHEEL/SUSPENSION**

**TOOLS**

**Special**

Fork piston holder	07930-KA40200
Holder attachment	07930-KA50100
Fork seal driver	07947-4630100
Race remover attachment	07953-MJ1000A U.S.A. only
Race remover attachment	07946-3710500
Steering stem socket	07916-3710100
Steering stem driver	07946-MB00000 or 07946-3710601 and 07964-MB00200
Driver	07949-3710001 or 07949-3710000

**Common**

Driver	07749-0010000
Attachment, 42 x 47 mm	07746-0010300
Pilot, 15 mm	07746-0040300
Lock nut wrench, 30 x 32 mm	07716-0020400 or commercially available
Extension bar	07716-0020500 or commercially available
Bearing remover expander	07746-0050100
Bearing remover collet, 15 mm	07746-0050400
Attachment, 52 x 55 mm	07746-0010400
Attachment, 37 x 40 mm	07746-0010200

**TROUBLESHOOTING**

**Hard steering**

1. Steering bearing adjustment nut too tight
2. Faulty steering stem bearings  
    Damaged steering stem bearings
4. Insufficient tire pressure

**Steers to one side or does not track straight**

1. Unevenly adjusted right and left shock absorbers
2. Bent front forks
3. Bent front axle; wheel installed incorrectly

**Front wheel wobbling**

1. Bent rim
2. Worn front wheel bearings
3. Faulty tire
4. Axle nut not tightened properly
5. Wheel out of balance

**Soft suspension**

1. Weak fork springs
2. Insufficient fluid in front forks

**Hard suspension**

1. Incorrect fluid weight in front forks
2. Front fork air pressure incorrect
3. Bent fork tubes
4. Clogged fluid passage
5. Clogged anti-dive orifice

**Front suspension noise**

1. Worn slider or guide bushings
2. Insufficient fluid in forks
3. Loose front fork fasteners
4. Lack of grease in speedometer gearbox



## HANDLEBARS

Disconnect the clutch switch wires from the switch. Remove the left handlebar switch by removing the two screws.

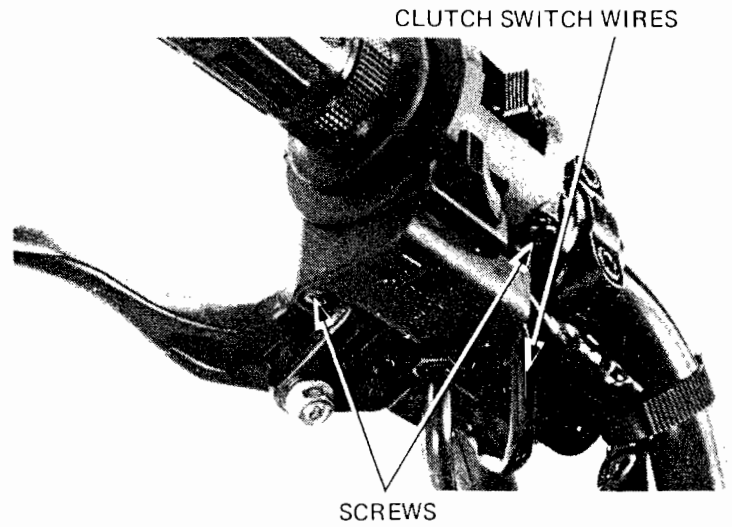

Disconnect the choke cable from the choke lever.

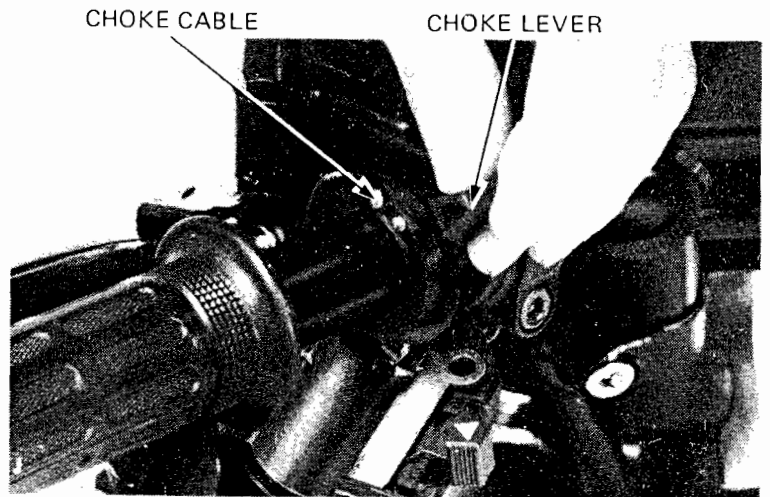

Remove the clutch master cylinder.

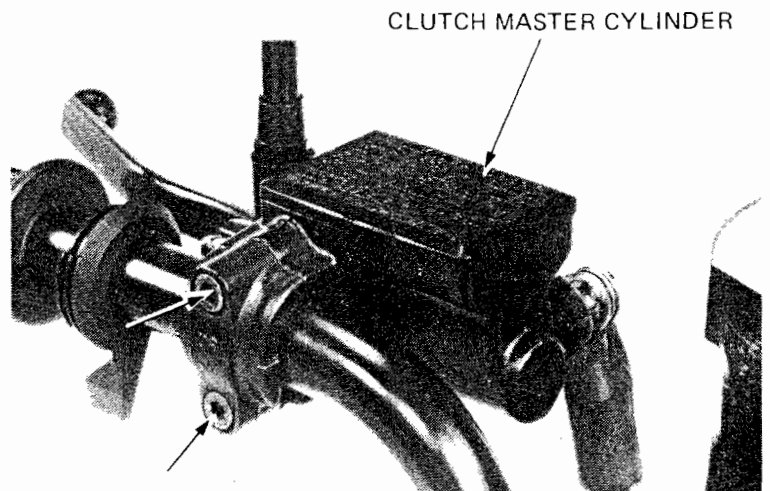





**FRONT WHEEL/SUSPENSION**

Disconnect the front brake light switch wires.  
Remove the right handlebar switch by removing the two screws.  
Disconnect the throttle cables from the throttle grip and remove the throttle grip.

THROTTLE GRIP

RIGHT HANDLEBAR SWITCH

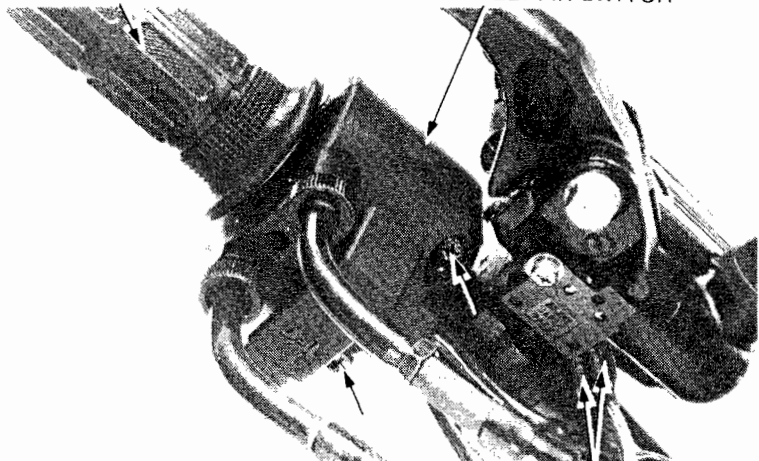

FRONT BRAKE LIGHT SWITCH WIRES

Remove the front brake master cylinder.

FRONT BRAKE MASTER CYLINDER

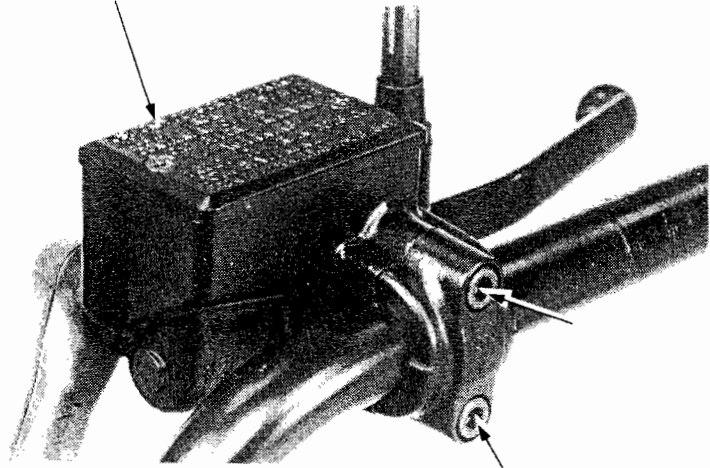

Loosen the right and left handlebar pinch bolts.  
Remove the handlebar set screws and the handlebars.

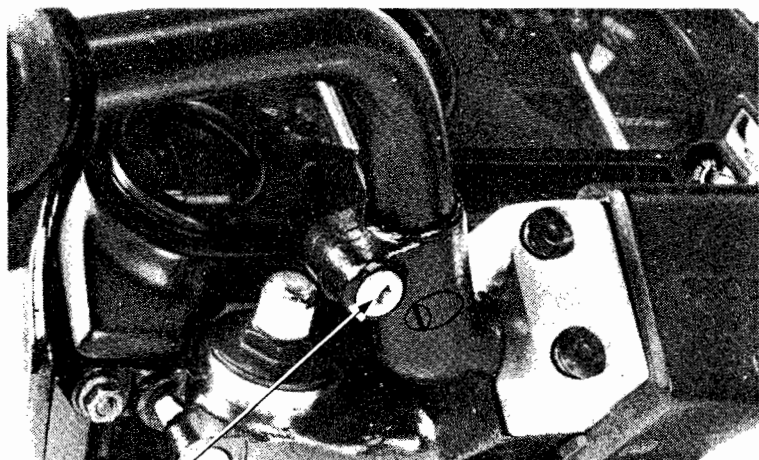

HANDLEBAR PINCH BOLT

SET SCREW



Remove the handlebar upper holder bolt caps and bolts.  
Remove the handlebar upper holder and center handlebar.

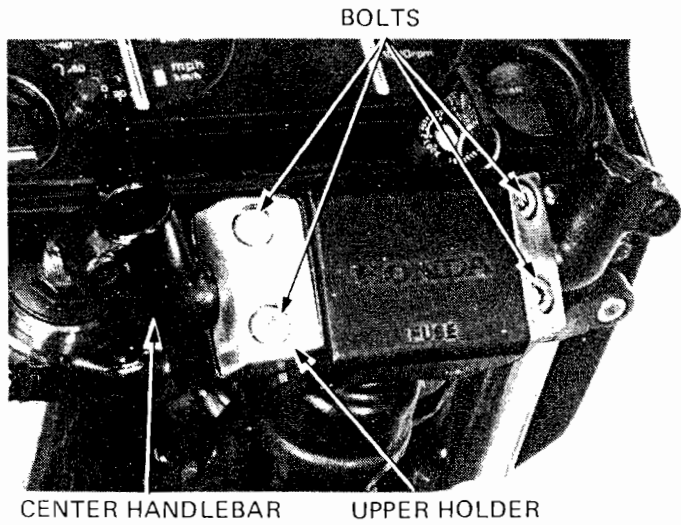

**INSTALLATION**

Place the center handlebar onto the lower holders aligning the dowel pin with the hole in the handlebar lower holder.

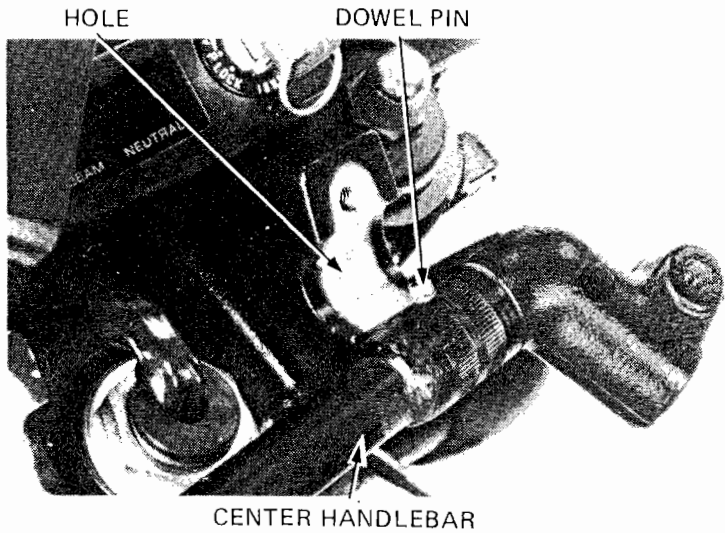

Align the punch mark on the center handlebar with the upper surface of the lower holder.

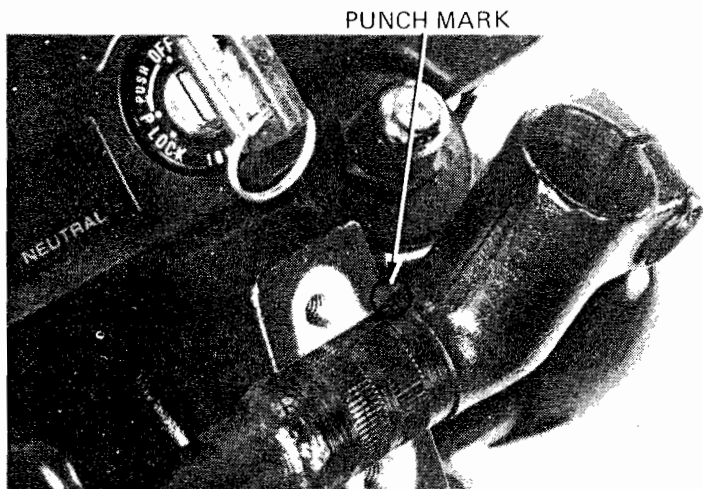

Place the upper holder onto the lower holder.  
Tighten the forward bolts first, then tighten the rear bolts.

**TORQUE:** 20–30 N·m  
(2.0–3.0 kg-m, 14–22 ft-lb)

Install the bolt caps.

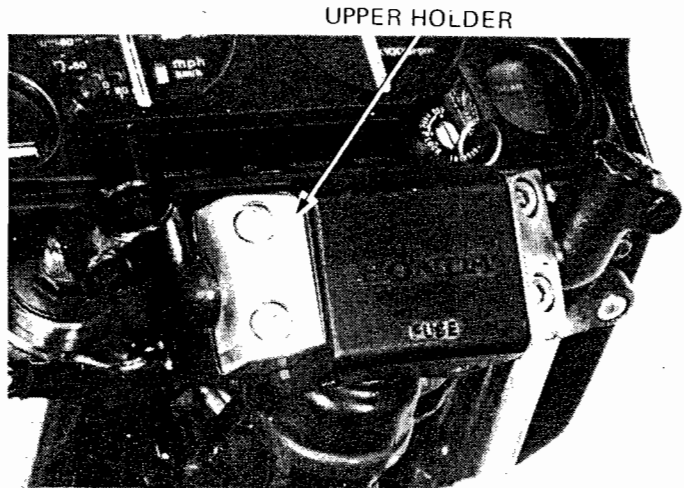

Install the right and left handlebars into the center handlebar.

Apply a thread locking agent to the set screw threads and install them.

Adjust both handlebars to the same position, using the set screws in the left and right handlebars and the holes in the center handlebar as a reference.

Apply grease to the handlebar pinch bolts and then tighten them to the specified torque.

**TORQUE:** 24–30 N·m  
(2.4–3.0 kg-m, 17–22 ft-lb)

**WARNING**

*Check the security of the handlebars by turning them all the way to the left and right and pushing and pulling on them with force.*

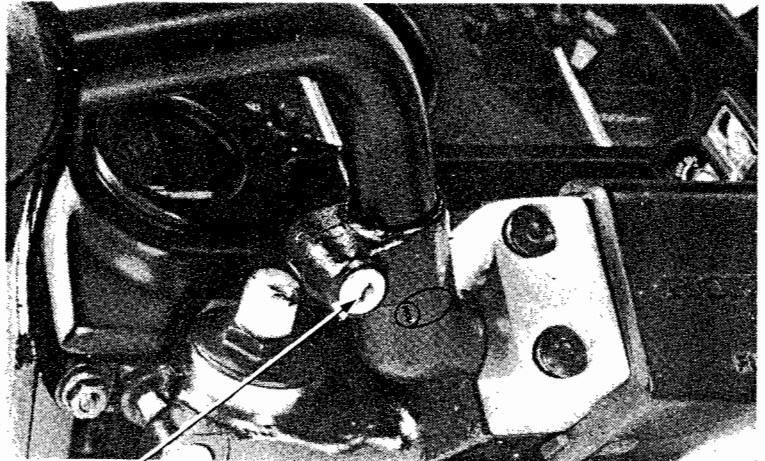

MASTER CYLINDER

HOLDER

Install the front brake master cylinder and holder with holder "UP" mark facing up.

Align the end of the holder with the handlebar punch mark.

Tighten the upper bolt first, then the lower bolt.

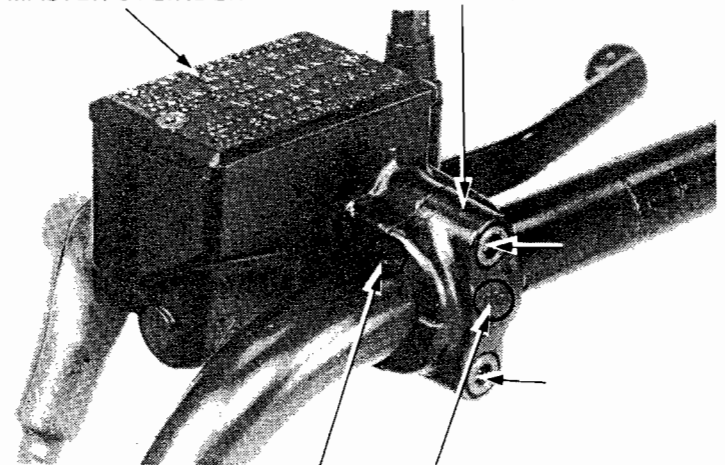

PUNCH MARK "UP" MARK



Apply grease to the throttle grip sliding surface.  
Install the throttle grip over the handlebar and connect the throttle cables.

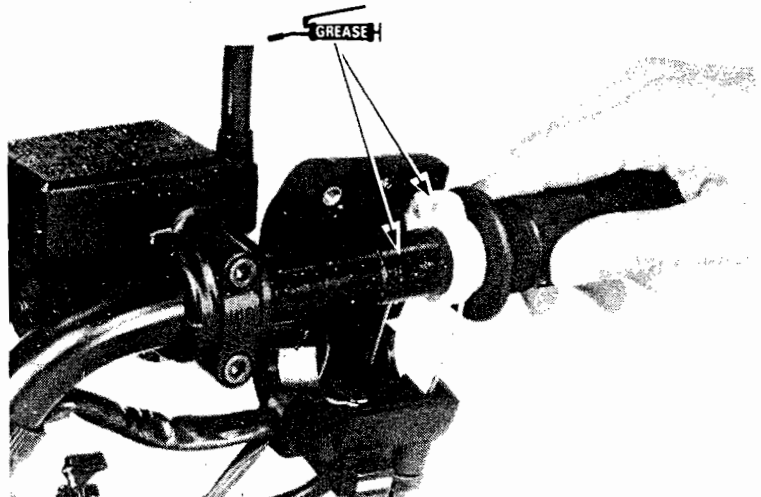

Align the right switch locating pin with the hole in the handlebar and install the right switch.

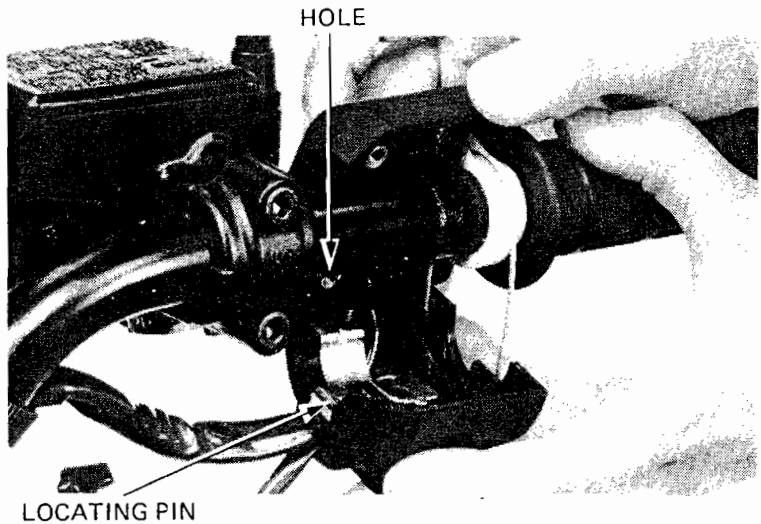

Tighten the forward switch screw first, then tighten the rear screw.  
Connect the brake light switch wires.

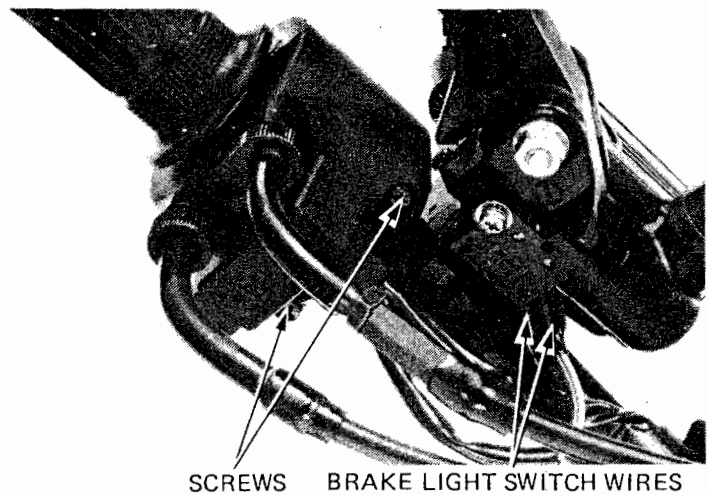

Install the clutch master cylinder and holder with holder "UP" mark facing up. Align the end of the holder with the punch mark on the handlebar. Tighten the upper bolt first, then the lower bolt.

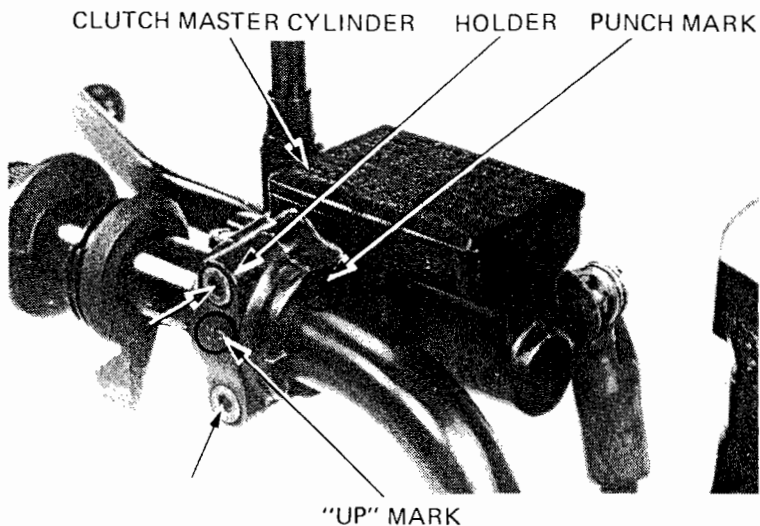

Apply grease to the sliding surface on the choke lever and connect the choke cable to the lever.

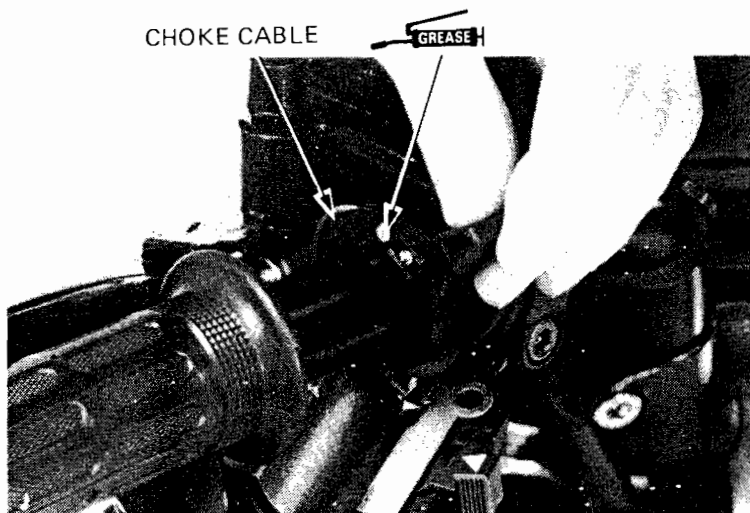

Align the left switch locating pin with the hole in the handlebar and install the left switch.

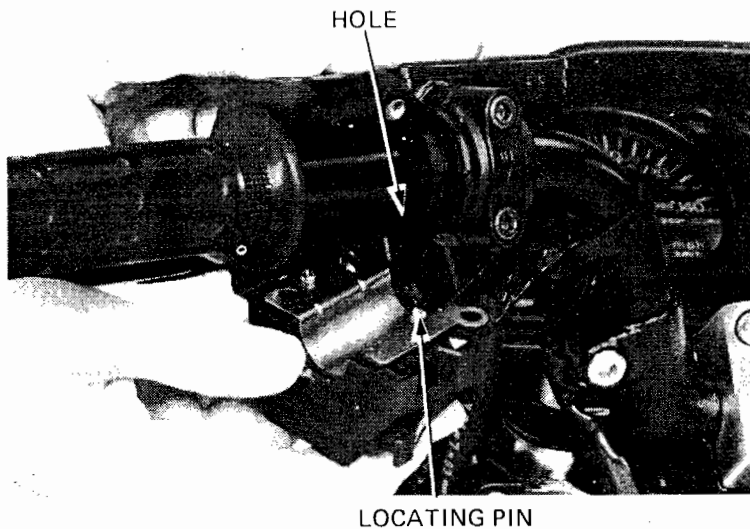



Tighten the forward switch housing screw first, then the rear screw.  
Connect the clutch switch wires.

**WARNING**

*Check to be sure that the wires, hoses and cables are not kinked or pulled taut, and are free to move in all steering positions.*

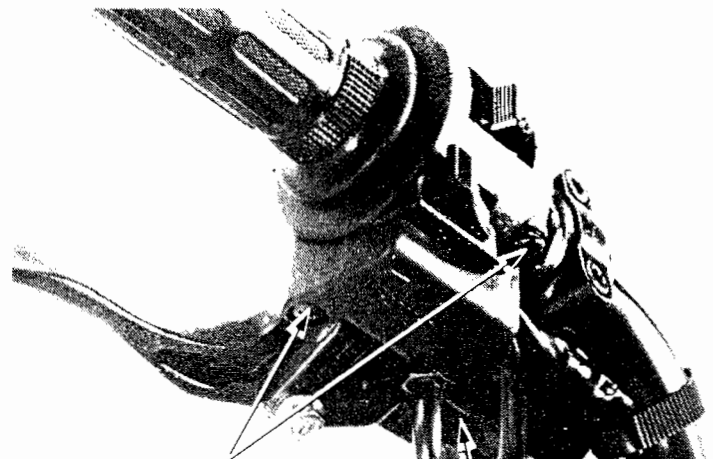

SCREWS

CLUTCH SWITCH WIRES

## FRONT WHEEL

### REMOVAL

Remove the speedometer cable set screw and the speedometer cable.

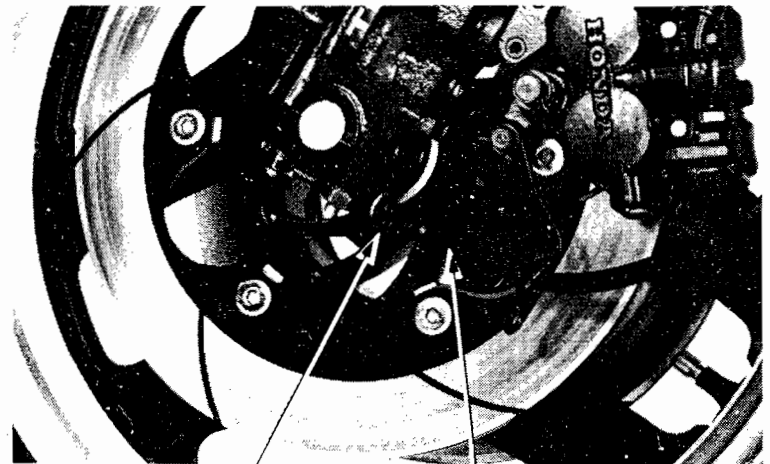

SET SCREW

SPEEDOMETER CABLE

Remove the right caliper assembly by removing the two bolts.

**NOTE**

Do not operate the front brake lever after removing the front wheel. To do so will cause difficulty in fitting the brake disc between the brake pads.

Remove the right and left axle holders.

Jack up the engine until the forks clear the front axle and remove the front wheel.

### RIGHT CALIPER ASSEMBLY

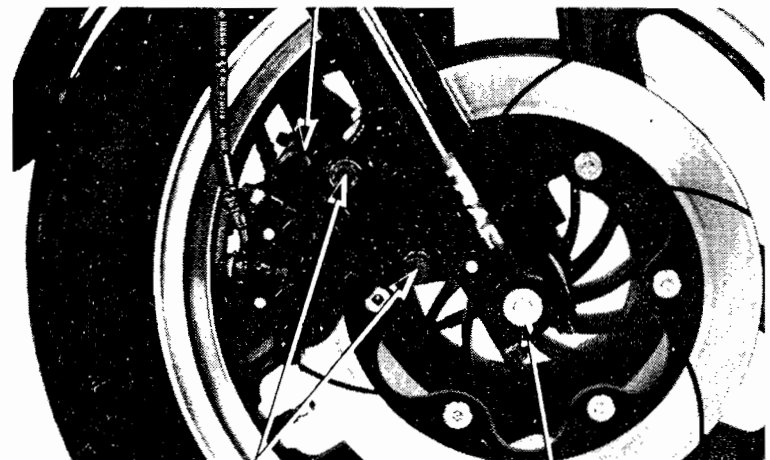

BOLTS

AXLE HOLDER



Remove the front axle nut and axle.

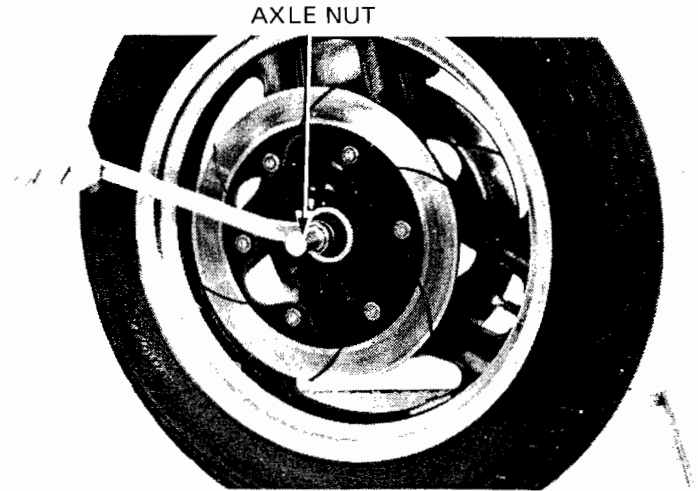

**INSPECTION**

Set the axle in V blocks and measure the runout.

**SERVICE LIMIT: 0.2 mm (0.01 in)**

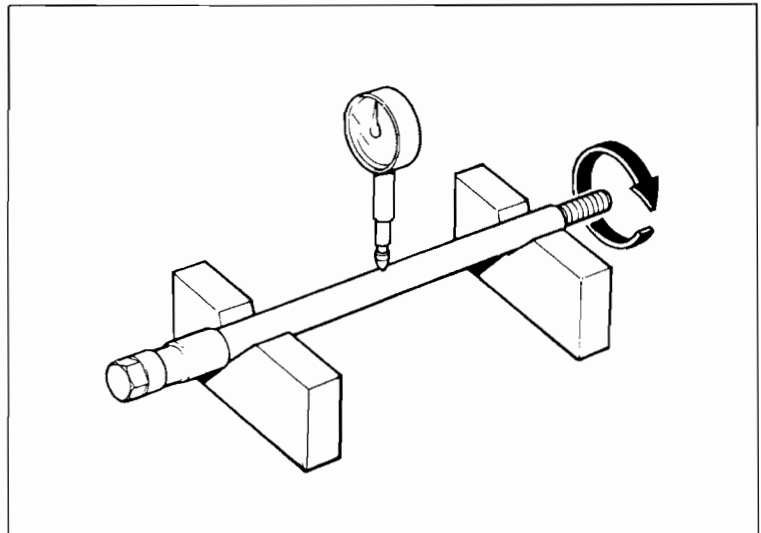

**WHEEL**

Check the rim runout by placing the wheel in a truing stand. Spin the wheel slowly and read the runout using a dial indicator.

**SERVICE LIMITS:**

**RADIAL RUNOUT: 2.0 mm (0.08 in)**

**AXIAL RUNOUT: 2.0 mm (0.08 in)**

**NOTE**

The wheel cannot be repaired and must be replaced with a new one if the service limits are exceeded.

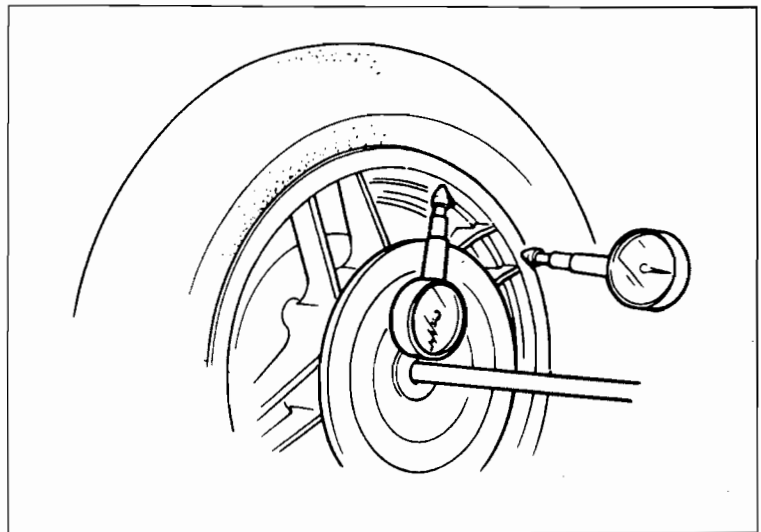



### WHEEL BEARING

Check wheel bearing play by placing the wheel in a truing stand and spinning the wheel by hand. Replace the bearings with new ones if they are noisy or have excessive play.

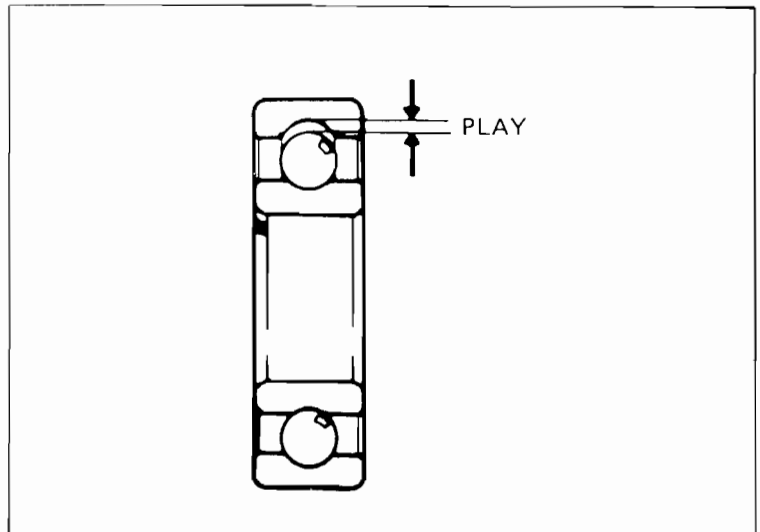

### WHEEL BALANCE

#### CAUTION

*Wheel balance directly affects the stability, handling and overall safety of the motorcycle. Always check balance when the tire has been removed from the rim.*

#### NOTE

For optimum balance, the tire balance mark (a paint dot on the side wall) must be located next to the valve stem. Remount the tire if necessary.

TIRE BALANCE MARK

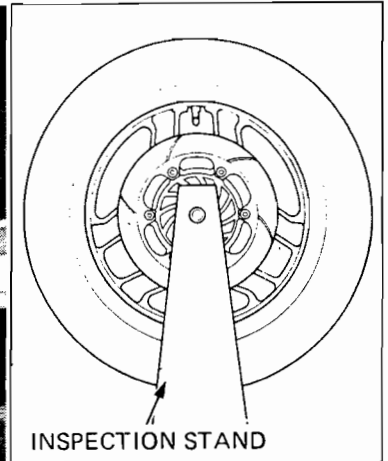
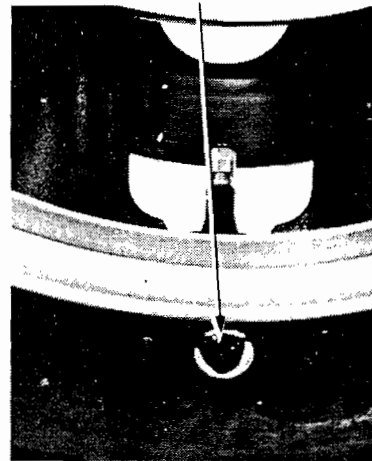

Remove the dust seal and speedometer gearbox from the wheel.

Mount the wheel, tire and brake disc assembly in an inspection stand.

Spin the wheel, allow it to stop, and mark the lowest (heaviest) part of the wheel with chalk. Do this two or three times to verify the heaviest area. If the wheel is balanced, it will not stop consistently in the same position.

To balance the wheel, install wheel weights on the highest side of the rim, the side opposite the chalk marks. Add just enough weight so the wheel will no longer stop in the same position when it's spun. Do not add more than 60 grams to the front wheel (rear wheel: 70 grams).



WHEEL WEIGHT





Remove the speedometer gearbox and axle side collar.

Remove the brake disc mounting bolts and discs.

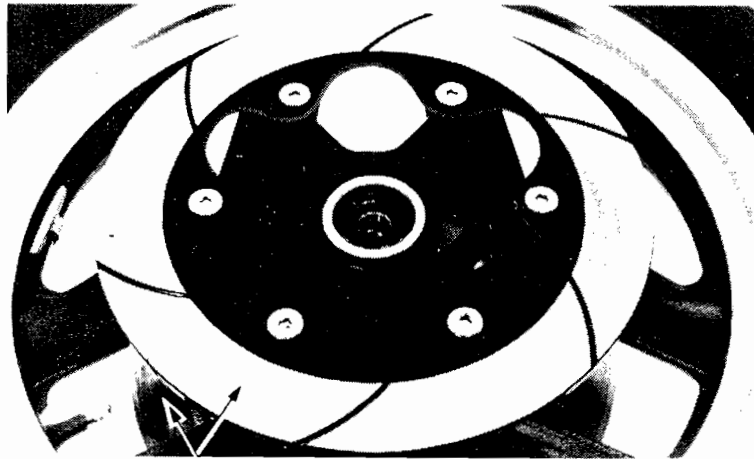

BRAKE DISCS

Remove the right and left seals and speedometer gear retainer from the hub.

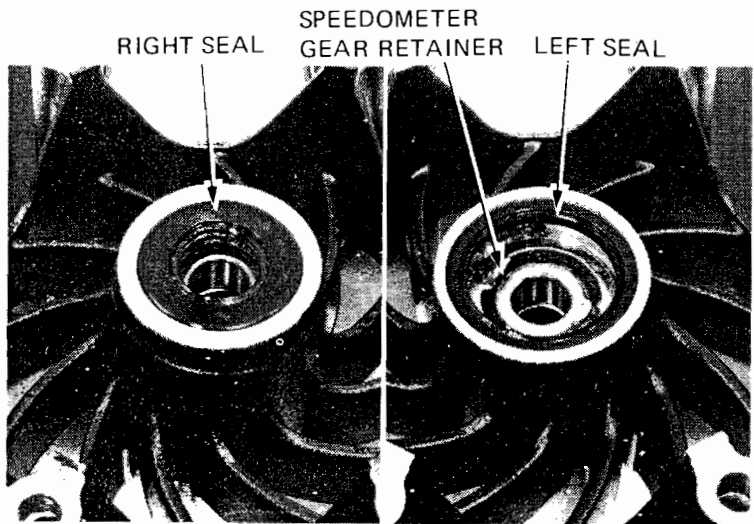

Remove the wheel bearings and distance collar from the hub.

**NOTE**

If the bearings are removed, they must be replaced with new ones.

BEARING REMOVER EXPANDER  
07746-0050100

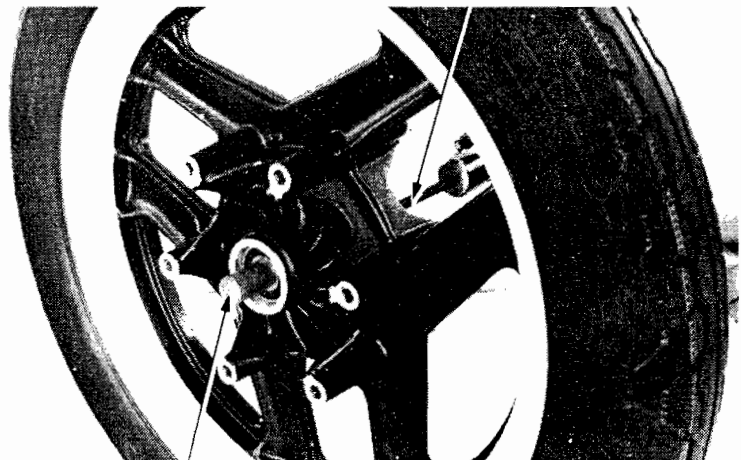

BEARING REMOVER COLLET, 15 mm  
07746-0050400



### ASSEMBLY

**WARNING**

*Do not get grease on the brake disc or stopping power will be reduced.*

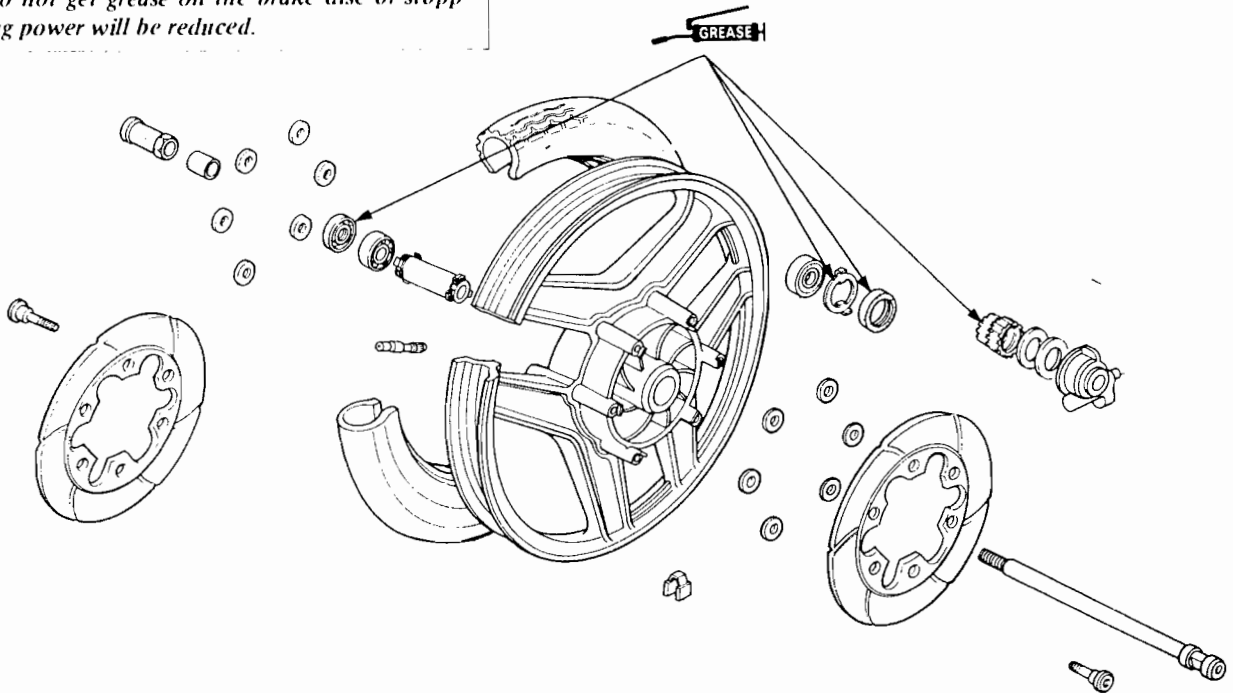
**NOTE**

- The cast wheel has no rim band.
- This motorcycle uses tubeless tires. For tubeless tire repair, refer to the Honda Tubeless Tire Manual.

Drive in the right bearing first and press the distance collar into place.

**NOTE**

Be certain the distance collar is in position before installing the left bearing.

Drive in the left bearing squarely.

**NOTE**

Drive the bearing into position, making sure that it is fully seated.

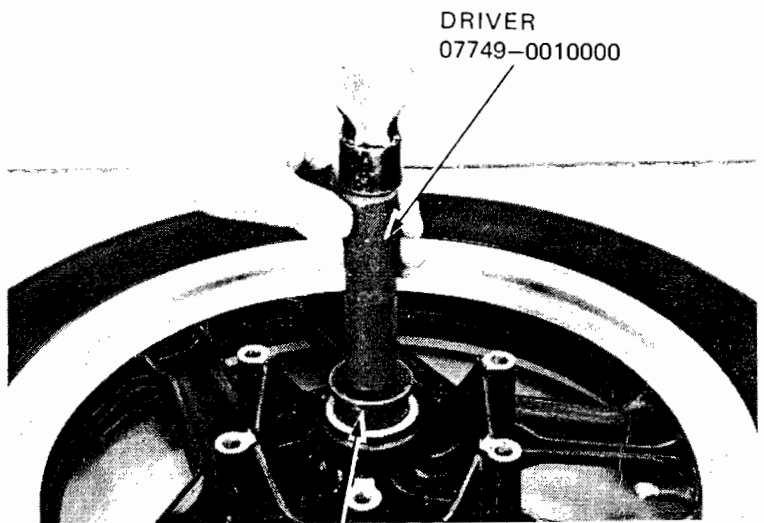

ATTACHMENT, 42 x 47 mm 07746-0010300  
PILOT, 15 mm 07746-0040300



**FRONT WHEEL/SUSPENSION**

1. Slide the speedometer gear retainer into the wheel hub, aligning the tangs with the slots.

Install the left seal.

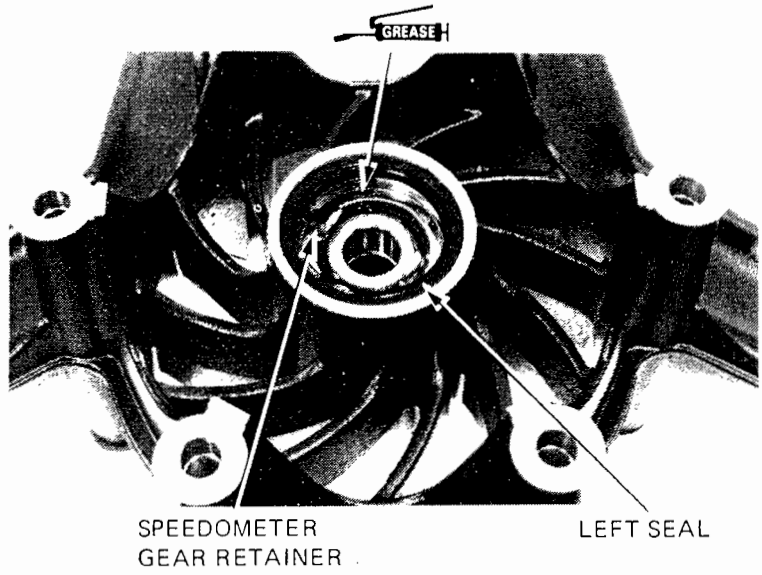

Install the right seal and side collar.

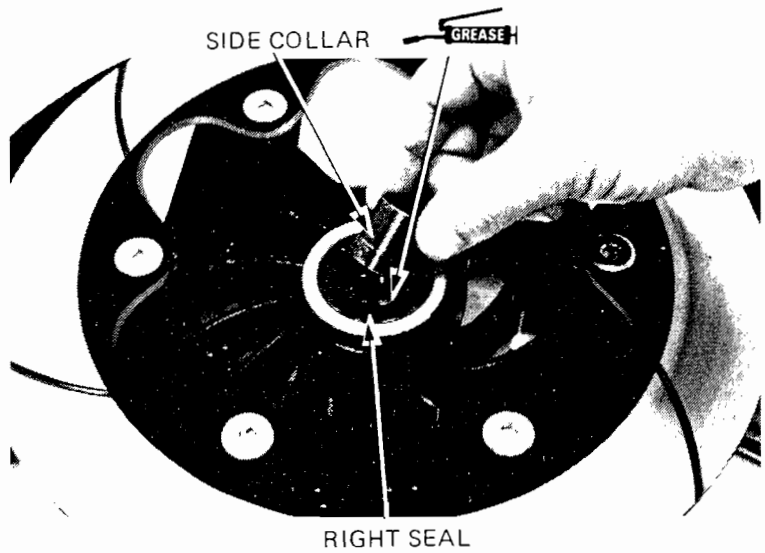

Install new gaskets onto the wheel hub.

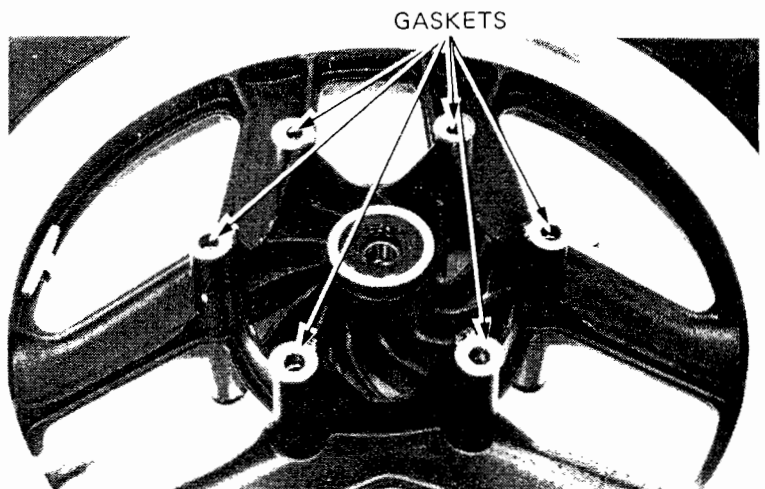



Apply oil or grease to the brake disc bolt threads. Install the brake disc with the "R" mark on the right and the disc with the "L" mark on the left.

**TORQUE:** 35–40 N·m  
(3.5–4.0 kg·m, 25–29 ft·lb)

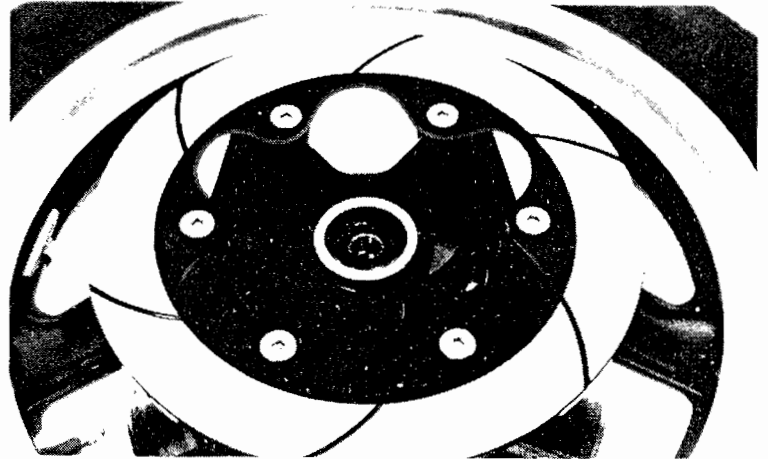

Fill the speedometer gearbox with grease and install the plain washer and drive gear.

Install the speedometer gearbox in the wheel hub, aligning the tangs with the slots.



Install the front axle and axle nut.

**TORQUE:** 65–75 N·m  
(6.5–7.5 kg·m, 48–54 ft·lb)

Clean the brake discs with a high quality degreasing agent.

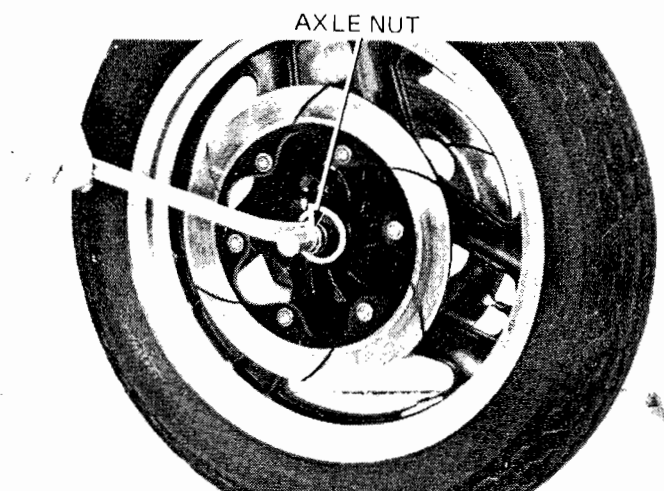



## INSTALLATION

Position the wheel between the fork legs.  
Lower the engine so the fork legs rest on the top of the axle.

### CAUTION

*When installing the wheel, fit the left brake disc carefully between the brake pads to avoid damaging the pads.*

Position the tang on the speedometer gearbox against the back of the lug on the left fork leg.  
Install the right brake caliper assembly and tighten the caliper bracket mounting bolts.

**TORQUE:** 35–45 N·m  
(3.5–4.5 kg·m, 25–33 ft·lb)

Loosely install the axle holders with the "F" arrow forward.  
Tighten the right axle holder nuts to the specified torque, starting with the forward nuts.

**TORQUE:** 18–25 N·m  
(1.8–2.5 kg·m, 13–18 ft·lb)

Measure the clearance between each surface of the left brake disc and the left caliper holder with a 0.7 mm (0.028 in) feeler gauge. If the gauge inserts easily, tighten the forward left axle holder nut to the specified torque, then tighten the rear nut. If the feeler gauge cannot be inserted easily, pull the left fork out or push it in until the gauge can be inserted.

After installing the wheel, apply the brake several times, then recheck both discs for caliper holder to disc clearance.

### WARNING

*Failure to provide adequate disc to caliper holder clearance may damage the brake disc and impair brake efficiency.*

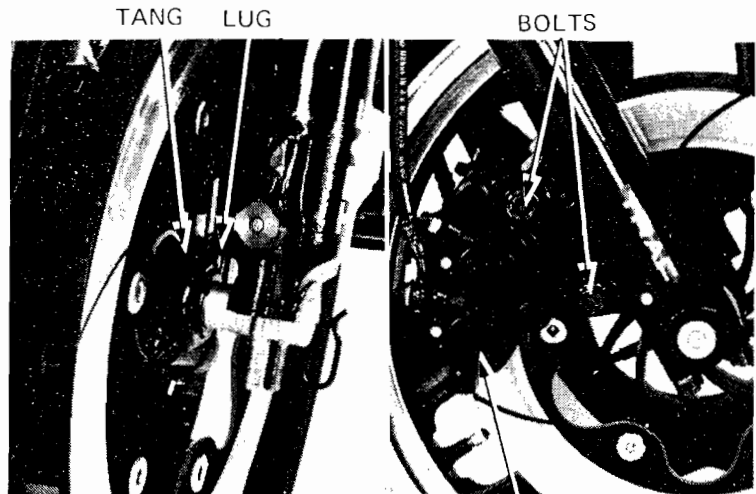

RIGHT CALIPER  
ASSEMBLY

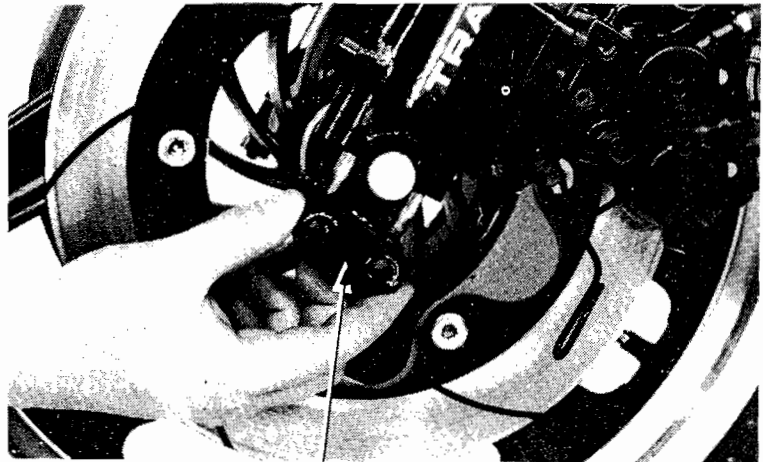

"F" ARROW MARK

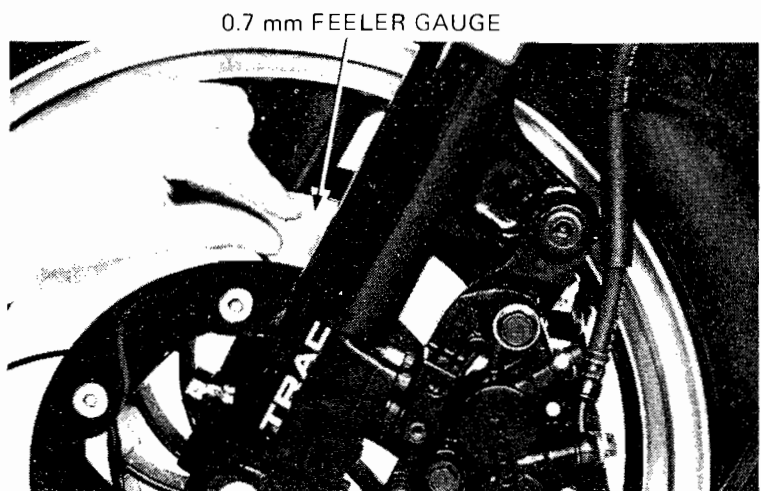

0.7 mm FEELER GAUGE



Connect the speedometer cable to the gearbox and tighten the set screw.

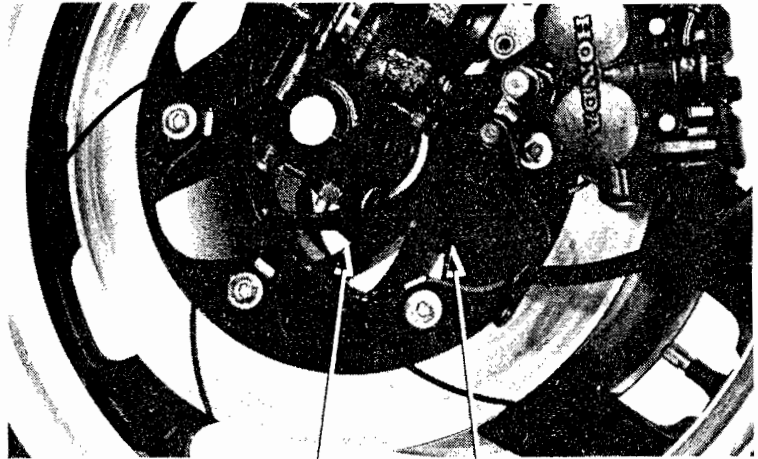

SET SCREW    SPEEDOMETER CABLE

## FRONT FORK

### REMOVAL

Remove the front wheel (Page 14-9).  
Remove the brake calipers and brackets.  
Remove the fender.  
Remove the fork brace.

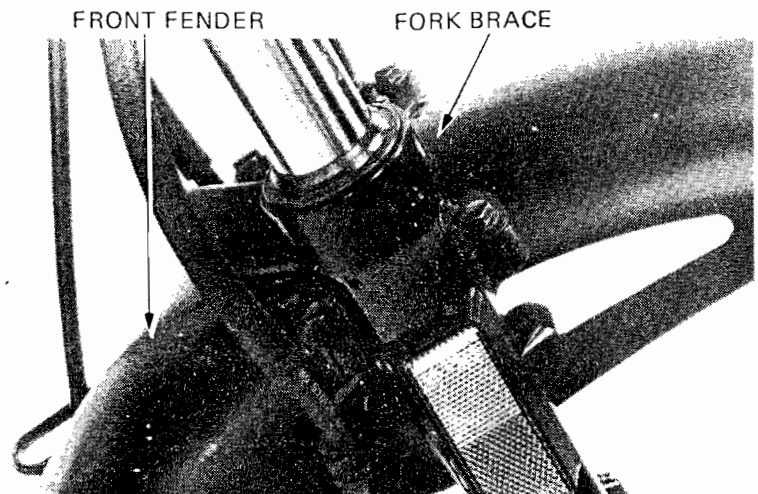

FRONT FENDER

FORK BRACE

Loosen the fork upper and lower pinch bolts.  
Pull the fork tubes down and out while twisting to remove them.

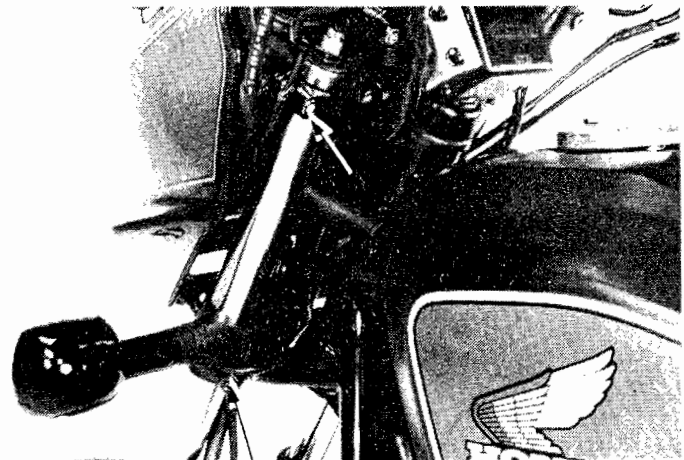

**DISASSEMBLY**

Remove the reflector bolts and reflector from the fork leg.

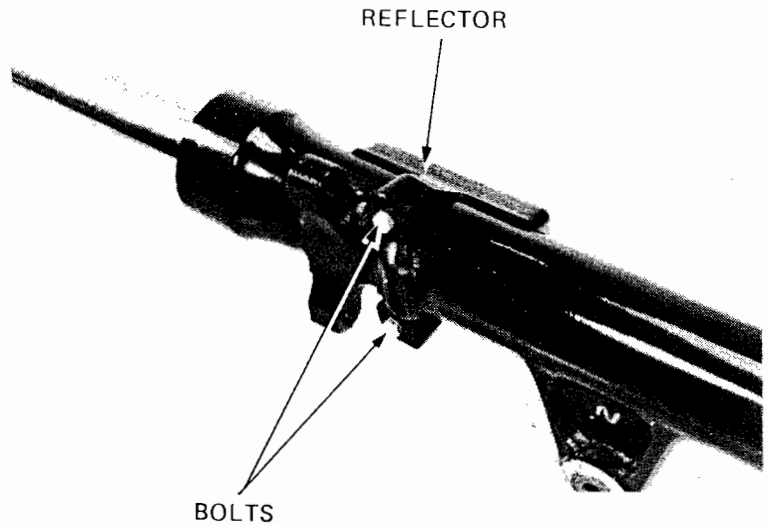

Depress the air valve and release front fork air pressure.

**CAUTION**

- *If air pressure is not released before disassembling, the fork cap may become a projectile.*
- *The cap is also under spring pressure. Use care when removing and wear eye and face protection.*

Hold the fork tube in a vise with soft jaws or a shop towel and remove the fork tube cap.

**CAUTION**

*Do not damage the sliding surface.*

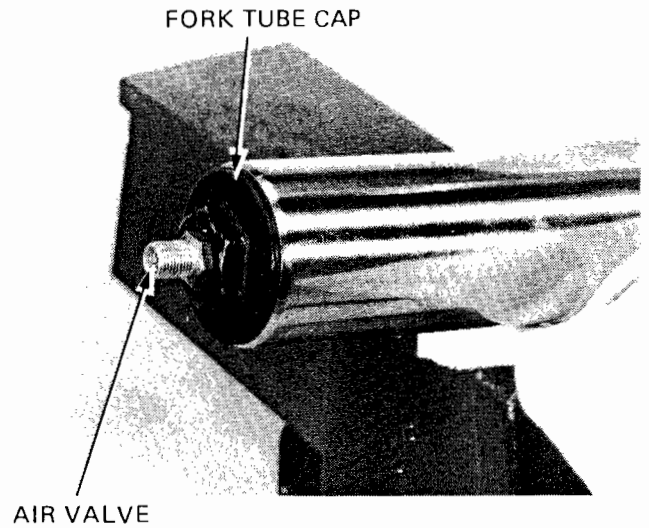

Remove the spacer, washer and fork spring.

Pour the fork fluid out.

Pour the remaining fork fluid out by pumping the fork tube several times.

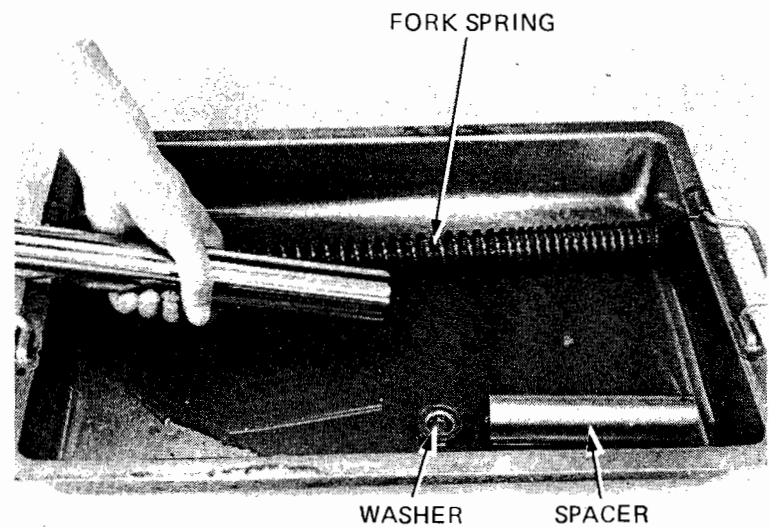



Hold the fork piston with the special tools.

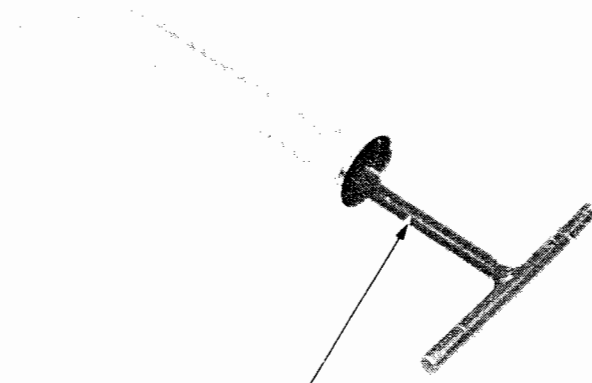

FORK PISTON HOLDER 07930-KA40200  
ATTACHMENT 07930-KA50100

Hold the fork slider in a vise with soft jaws or a shop towel.  
Remove the socket bolt with a 8 mm hex wrench.

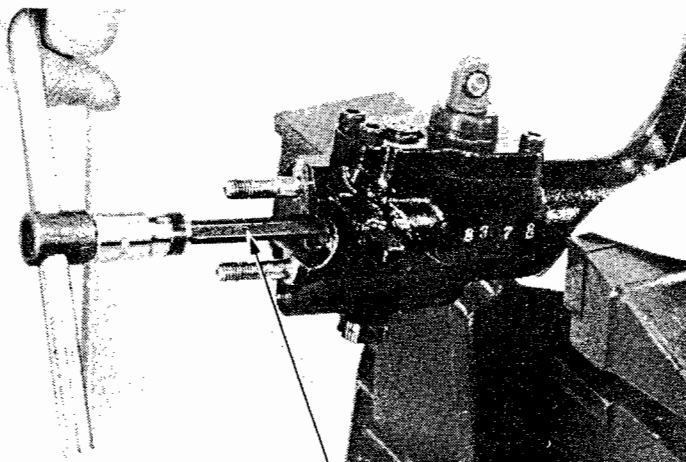

8 mm HEX WRENCH

Remove the dust seal, snap ring and washer.

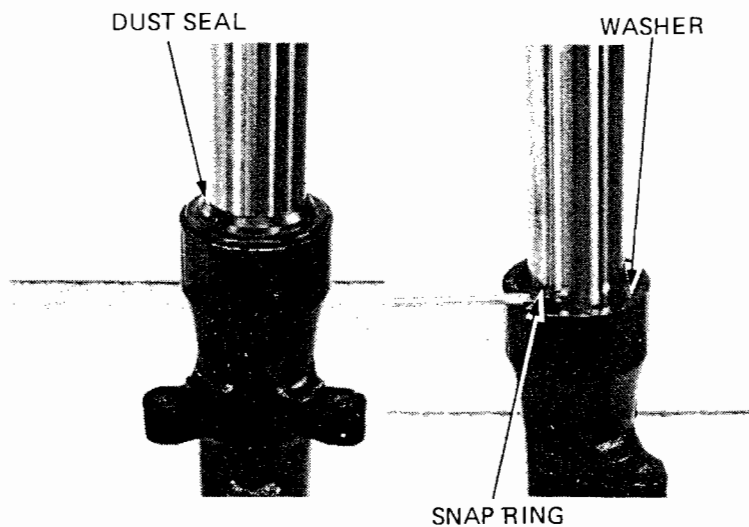



Pull the fork tube out until resistance from the slider bushing is felt. Then move it in and out, tapping the bushing lightly until the fork tube separates from the slider. The slider bushing will be forced out by the fork tube bushing.

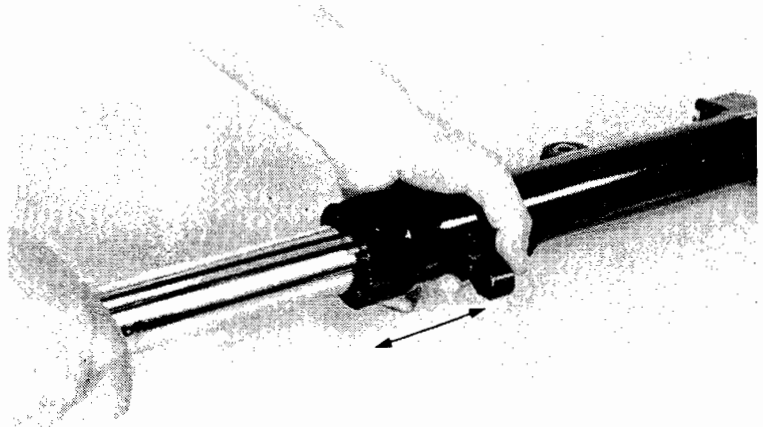

On the left fork, remove the spring seat, spring and oil lock valve from inside the slider. Remove the oil lock piece from inside the slider.

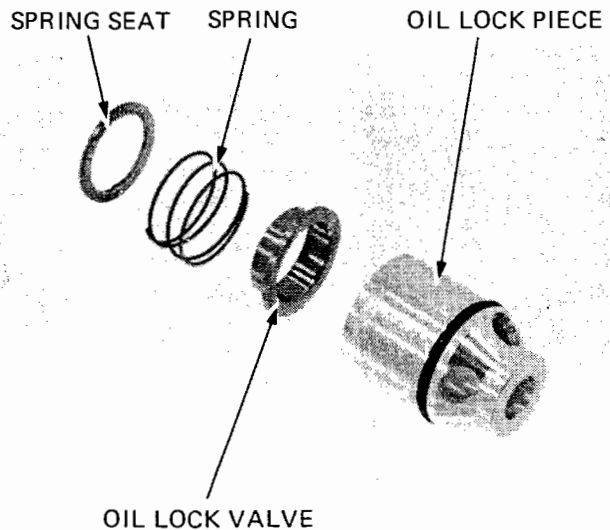

Remove the oil seal, back-up ring and slider bushing from the fork tube.

**NOTE**

Do not remove the fork tube bushing unless it is necessary to replace it with a new one. See inspection on Page 14-22.

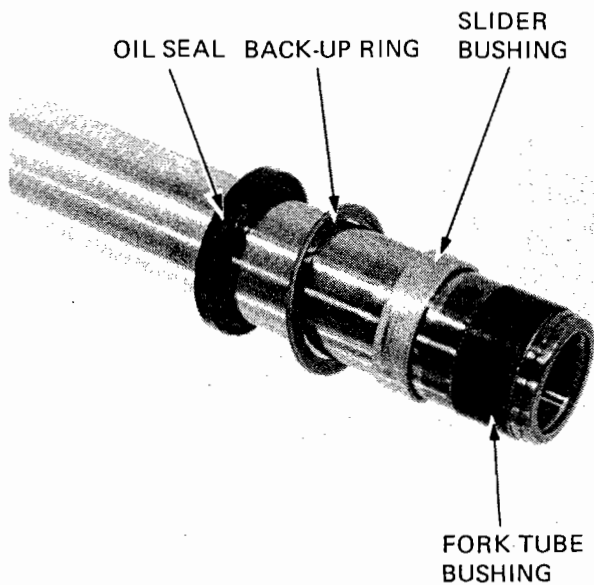



**INSPECTION**

Measure the fork spring free length.

**SERVICE LIMIT: 428 mm (16.9 in)**

Replace the spring if it is shorter than the service limit.

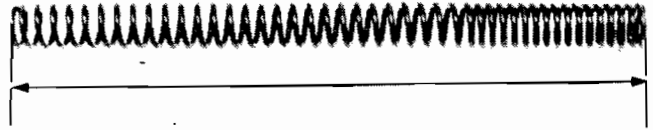

Check the fork tube, fork slider and piston for score marks, scratches, or excessive or abnormal wear. Replace any components which are worn or damaged.

Check the fork piston ring for wear or damage.  
Check the rebound spring for fatigue or damage.

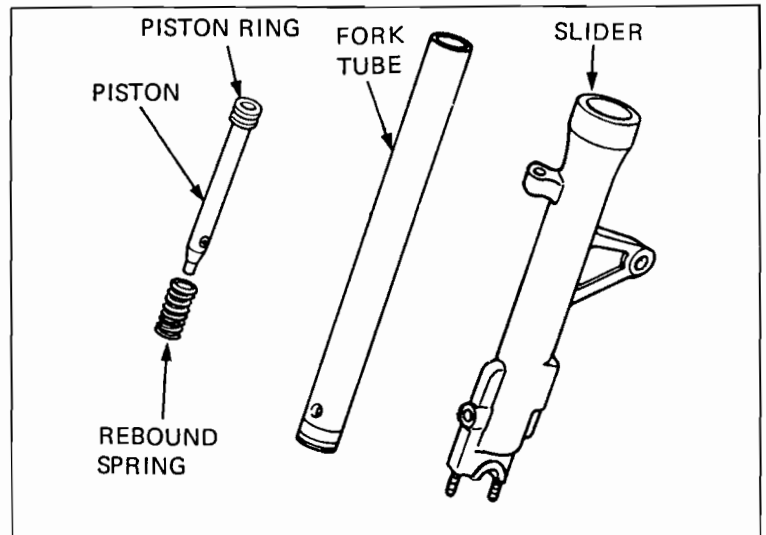

Set the fork tube in V blocks and read the runout.

**SERVICE LIMIT: 0.2 mm (0.01 in)**

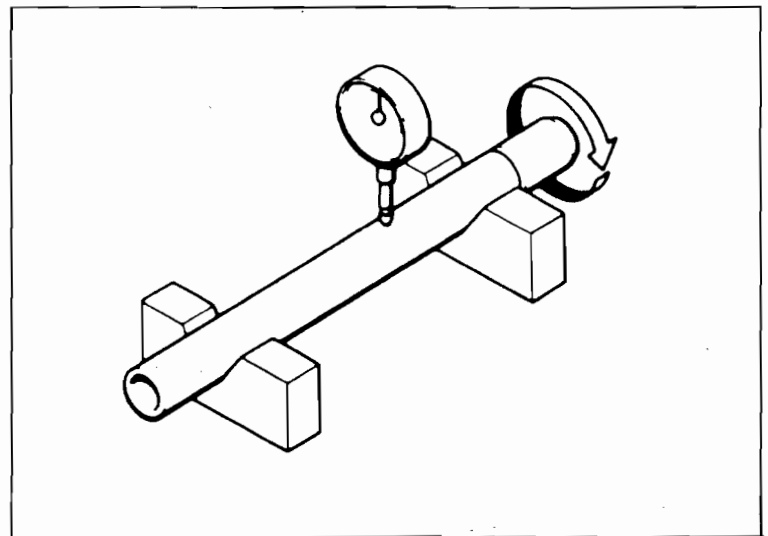



**FRONT WHEEL/SUSPENSION**

Visually inspect the slider and fork tube bushings. Replace the bushings if there is excessive scoring or scratching, or if the teflon is worn so that the copper surface appears on more than 3/4 of the entire surface.

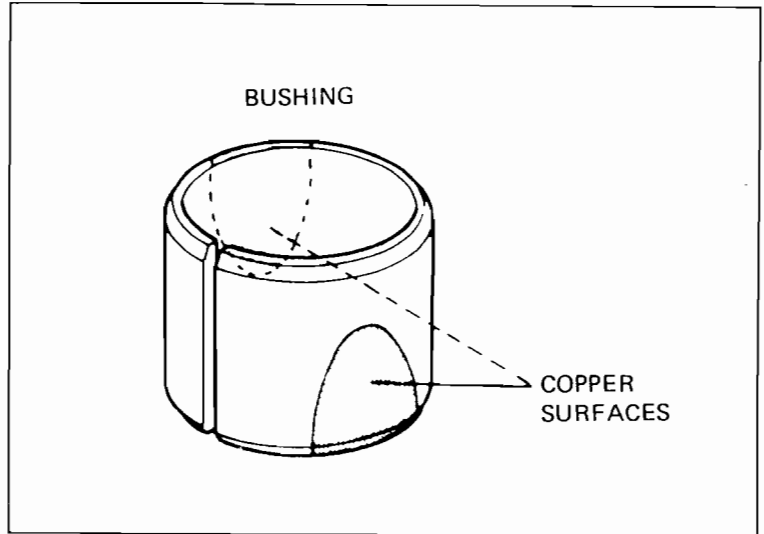

**ANTI-DIVE CASE**

Remove the four socket bolts and remove the antidive case.

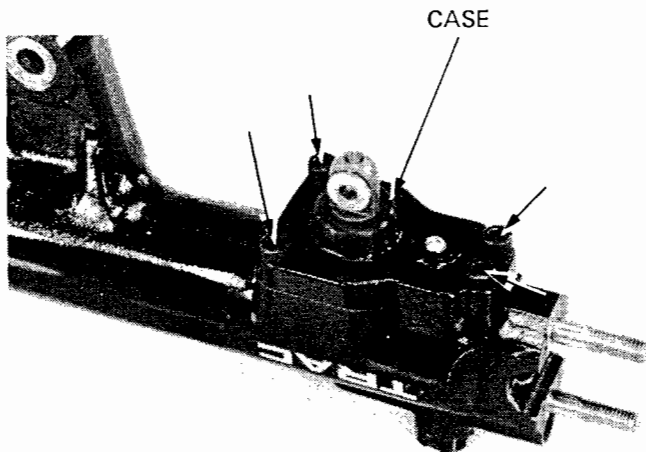

Remove the piston and spring.

Remove the boot, pivot bolt collar and rubber bushing.

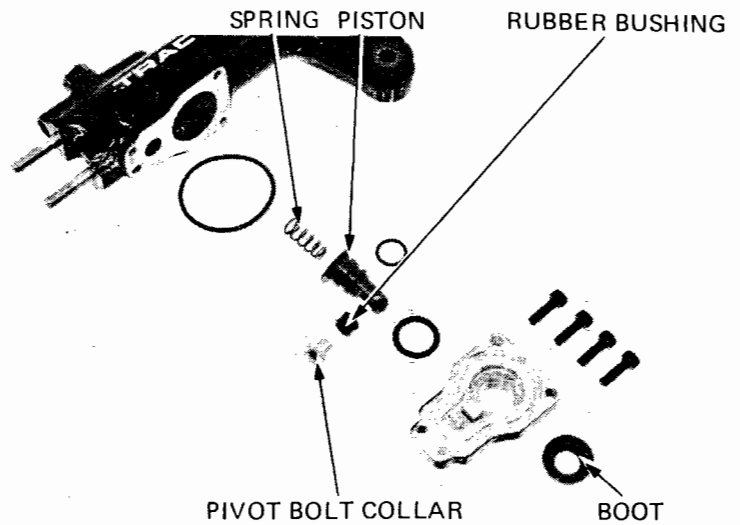



Check the spring and piston for wear or damage.

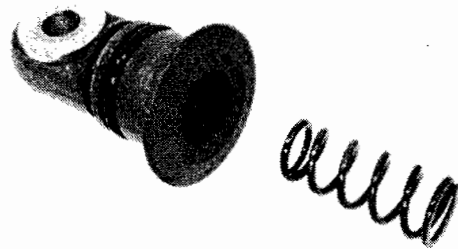

Remove the screw attaching the anti-dive adjuster knob, knob and orifice.

Remove the check ball screw, spring and ball.

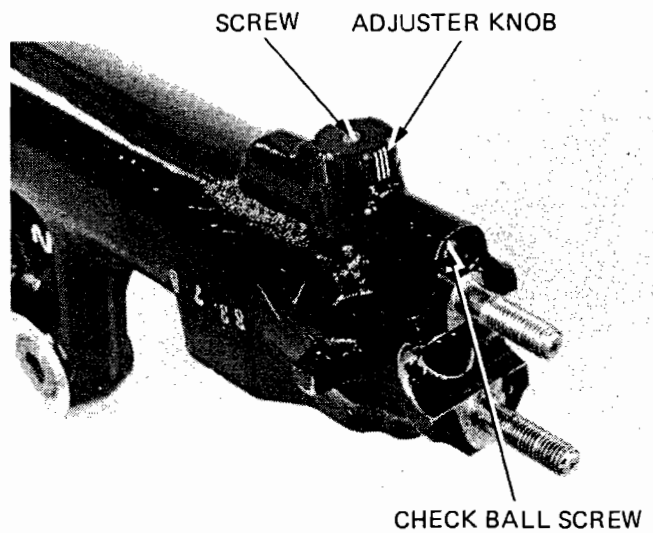

Check the orifice for clogging, scoring, excessive wear or damage.

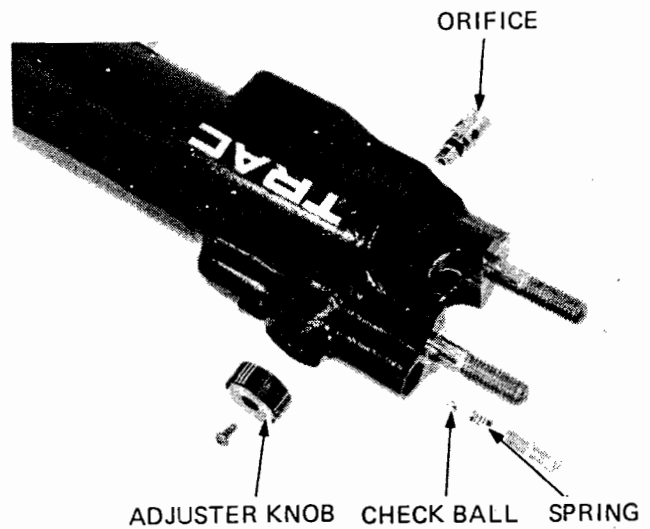

Assemble the anti-dive case in the reverse order of disassembly.

**NOTE**

- Replace the O-rings with new ones.
- Apply locking agent to the threads of the screws and socket bolts before assembly.

Apply ATF to the piston and piston O-ring.  
Apply silicone grease to the pivot bolt collar.  
Check the operation of the piston.

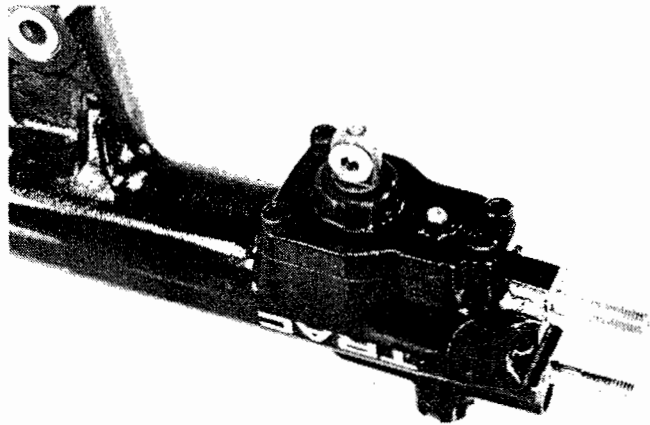

**ASSEMBLY**

Before assembly, wash all parts with a high flash point or non-flammable solvent and wipe them off completely.

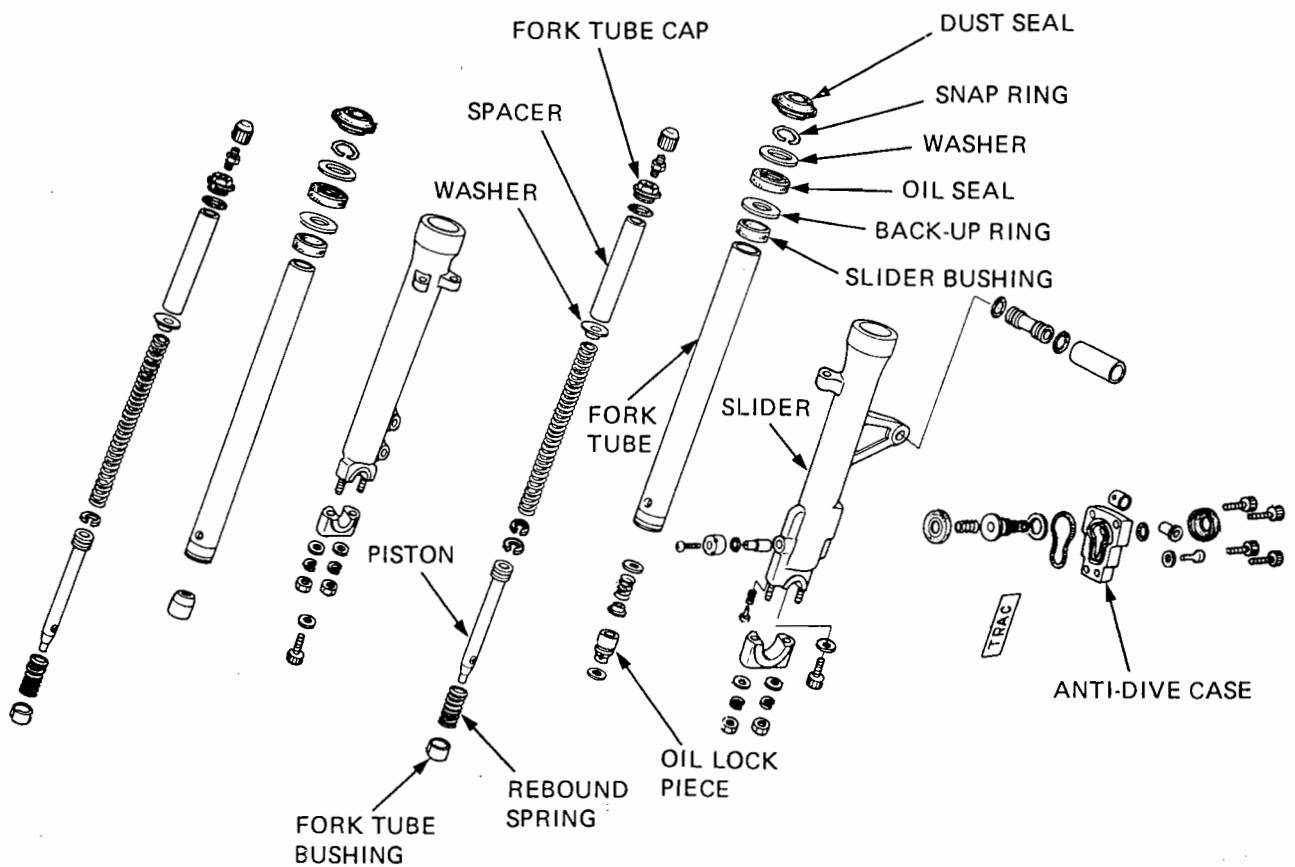



Insert the rebound spring and piston into the fork tube.

On the left fork, install the spring seat, spring and oil lock valve on the piston.

Place the oil lock piece on the end of the piston and insert the fork tube into the slider.

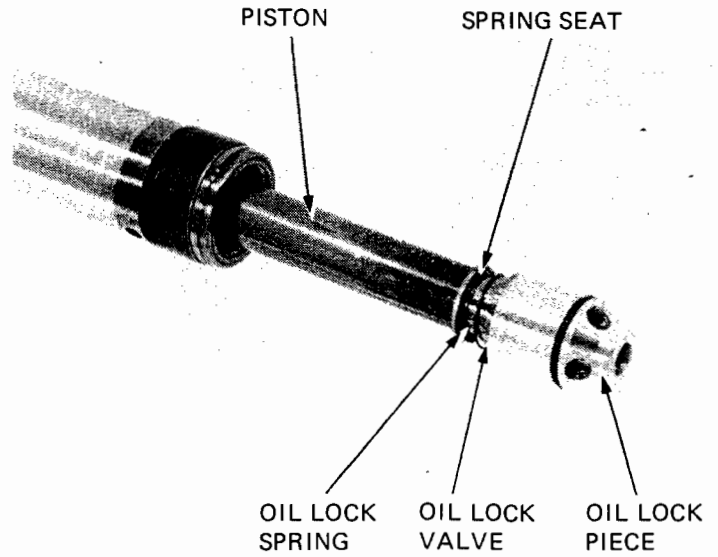

Hold the piston with the special tools.  
Place the fork slider in a vise with soft jaws or a shop towel.  
Apply a locking agent to the socket bolt and thread it into the piston. Tighten with a 8 mm hex wrench.

**TORQUE:** 20–26 N·m  
(2.0–2.6 kg·m, 15–19 ft·lb)

PISTON HOLDER 07930-KA40200  
ATTACHMENT 07930-KA50100

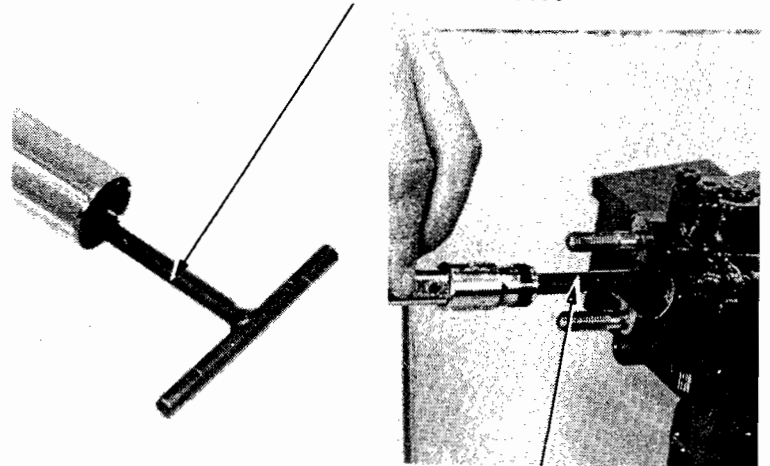

8 mm HEX WRENCH

Place the slider bushing over the fork tube and rest it on the slider.

Put the back-up ring and an old bushing or equivalent tool on top.

Drive the new bushing into place with the seal driver and remove the old bushing or equivalent tool.

Coat a new oil seal with ATF and install it with the seal markings facing up. Drive the seal in with the seal driver.

Install the washer, snap ring and dust seal.

FORK SEAL DRIVER  
07947-4630100

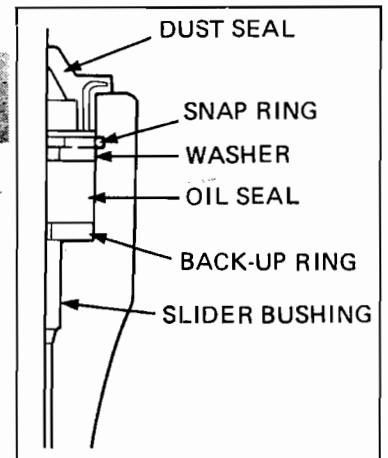
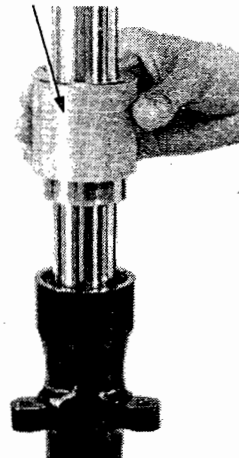

## FRONT WHEEL/SUSPENSION



# HONDA CB750SC

Compress the front fork and pour ATF into the fork tube.

### SPECIFIED LEVEL:

Right: 143 mm (5.63 in)  
Left: 141 mm (5.55 in)

### CAPACITY:

Right fork: 423 cc (14.3 ozs)  
Left fork: 429 cc (14.5 ozs)

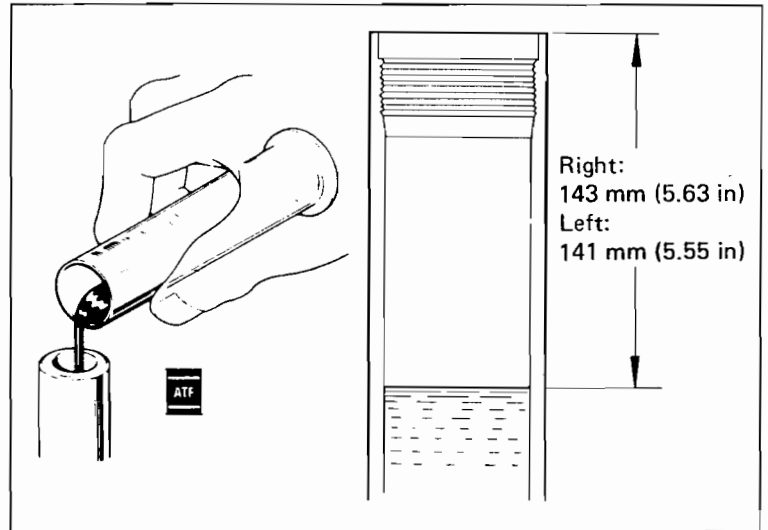

Place the fork spring, washer and spacer into the fork tube.

### NOTE

Note the spring direction, the tight windings should face toward the top.



Install and torque the fork tube cap.

**TORQUE:** 15–30 N·m  
(1.5–3.0 kg·m, 11–22 ft·lb)

Install the reflector.

FORK TUBE CAP

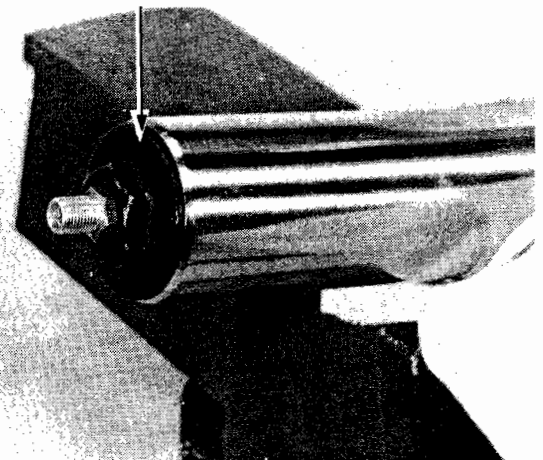



### INSTALLATION

Install the front forks.

Tighten the bottom pinch bolts.

**TORQUE:** 45–55 N·m  
(4.5–5.5 kg-m, 32–40 ft-lb)

Tighten the top pinch bolts.

**TORQUE:** 9–15 N·m  
(0.9–1.5 kg-m, 7–11 ft-lb)

Loosely install the front fork brace.

#### NOTE

Do not install the fork brace before torquing the front fork pinch bolts.

Install the removed parts in the reverse order of removal.

- front fender.
- brake calipers (Page 16-12).
- front wheel (Page 14-16).

Tighten the front fork brace to the specified torque.

**TORQUE:** 10–15 N·m  
(1.0–1.5 kg-m, 7–11 ft-lb)

Fill the fork tubes with air to 0–40 kPa (0–0.4 kg/cm<sup>2</sup>, 0–6 psi).

#### CAUTION

- Use only a hand operated air pump to fill the fork tubes. Do not use compressed air.
- Maximum pressure is 300 kPa (3 kg/cm<sup>2</sup>, 43 psi). Do not exceed this or fork tube component damage may occur.

With the front brake applied, pump the front forks up and down several times. Place the motorcycle on its center stand. Check the air pressure and adjust if necessary.

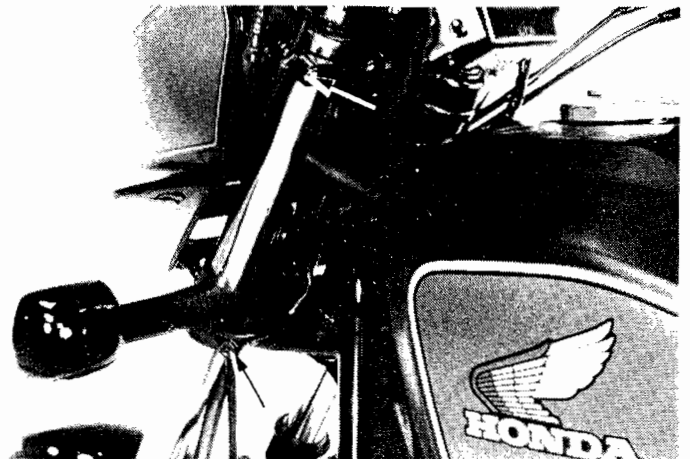

FRONT FORK BRACE

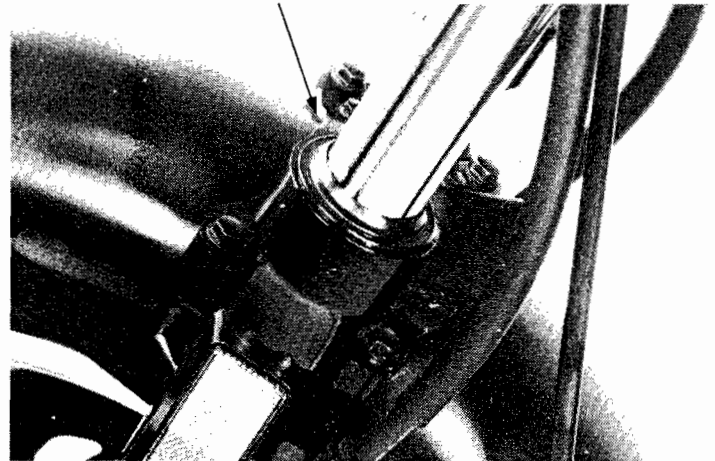

AIR VALVE

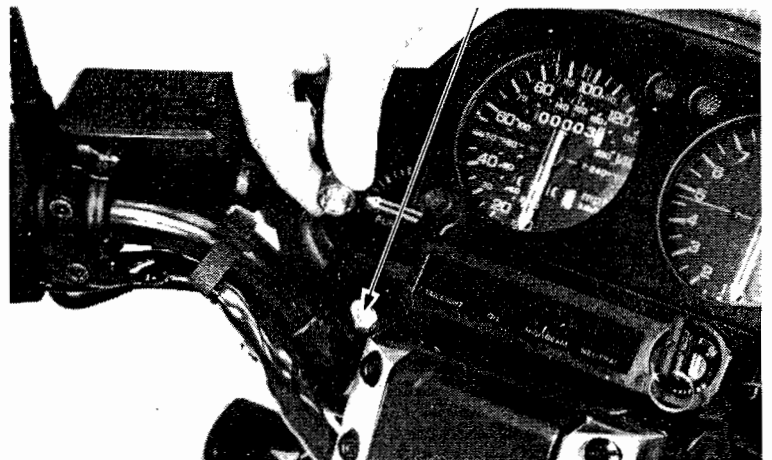





## STEERING STEM

### REMOVAL

Remove the following components:

- headlight case (Page 21-2).
- instruments (Page 21-3).
- handlebars (Page 14-3).
- front wheel (Page 14-9).
- brake caliper assemblies (Page 16-10) and brackets (Page 16-13).
- instrument bracket.
- ignition switch (Page 21-5).
- horn.

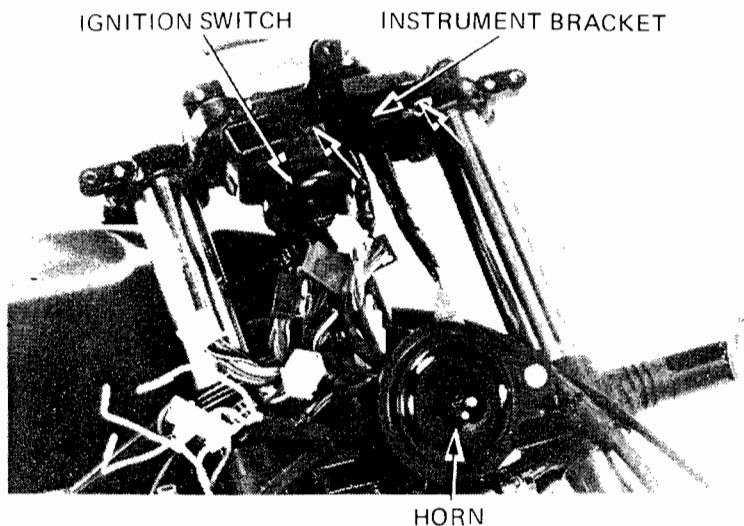

- brake three way joint.

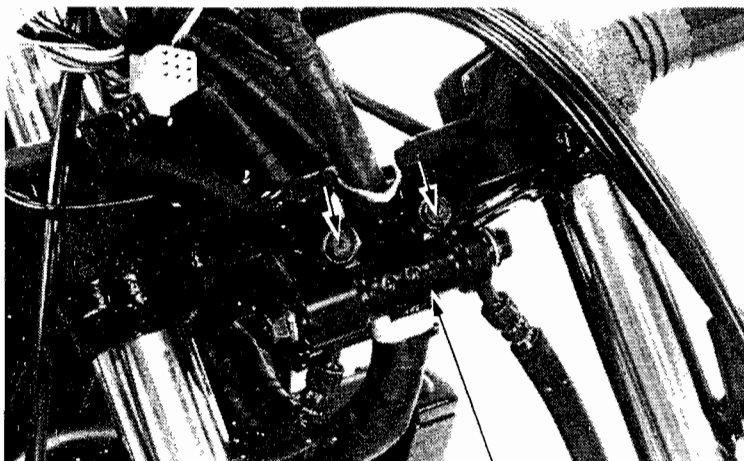

- steering stem nut.
- fork top bridge.
- front forks (Page 14-17).

EXTENSION BAR 07716-0020500 or COMMERCIALY AVAILABLE in U.S.A.

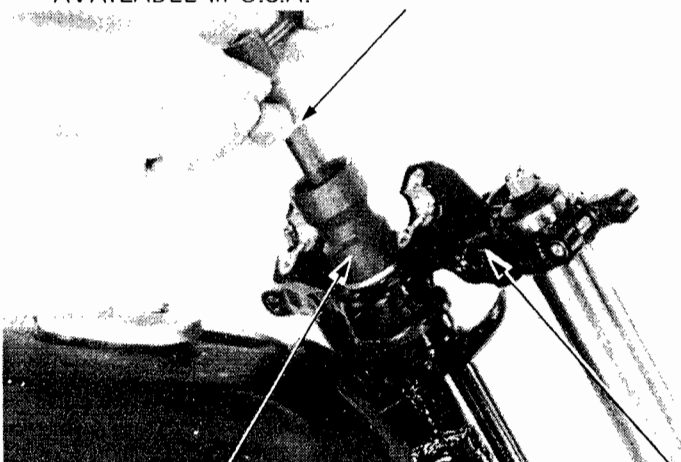



Bend down the lock washer tab and remove the lock nut and lock washer.  
Remove the bearing adjustment nut with the steering stem socket (07916-3710100).

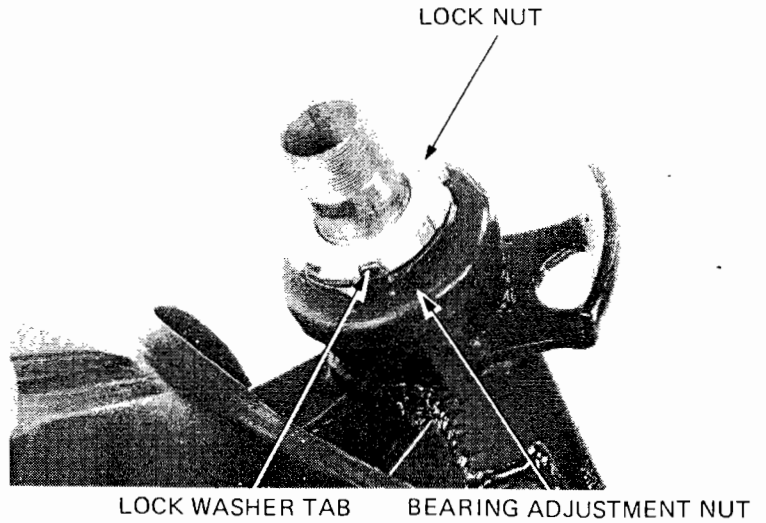

Remove the dust seal, bearing inner race and upper bearing.

Remove the steering stem, grease retainer and lower bearing.

Check the bearings, outer and inner races for wear or damage and replace if necessary.

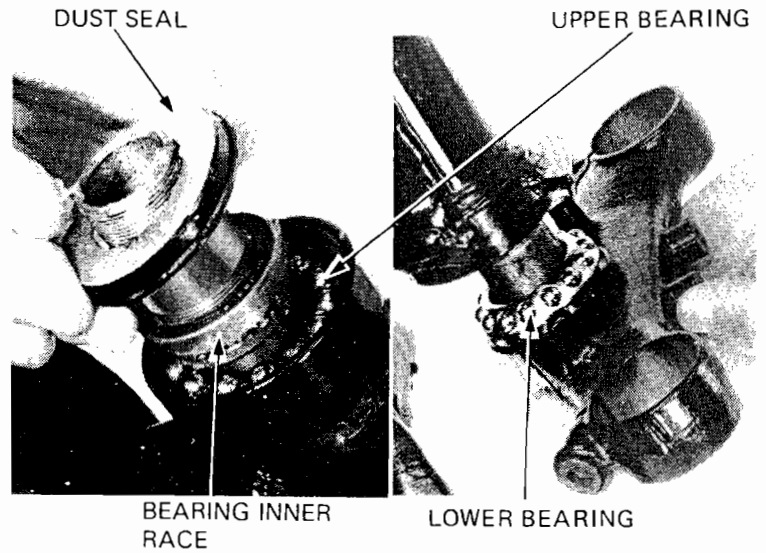

**BEARING REPLACEMENT**

**NOTE**

Always replace the bearing, inner and outer races as a set.

Remove the upper and lower bearing inner races.

**NOTE**

Use side "A" of the race remover attachment 07953-MJ1000A.

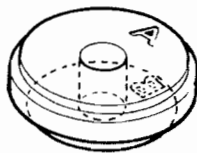

RACE REMOVER ATTACHMENT  
07953-MJ1000A (U.S.A. only)

DRIVER  
07949-3710001 OR  
07949-3710000

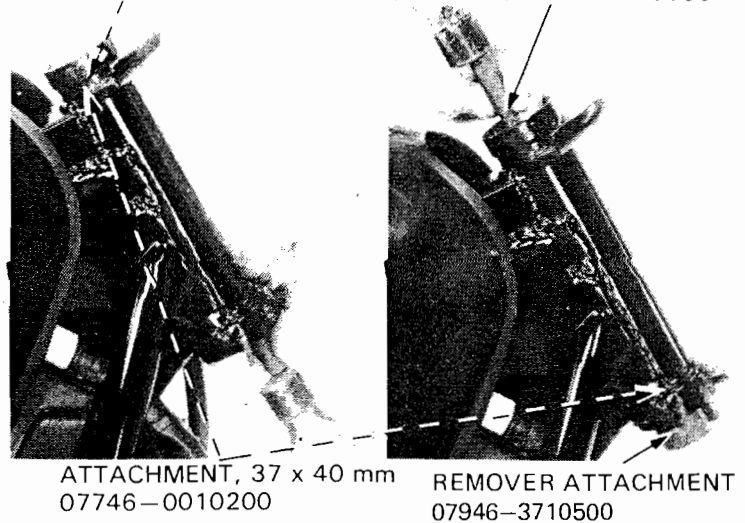



**FRONT WHEEL/SUSPENSION**

Remove the lower bearing inner race and dust seal from the steering stem.

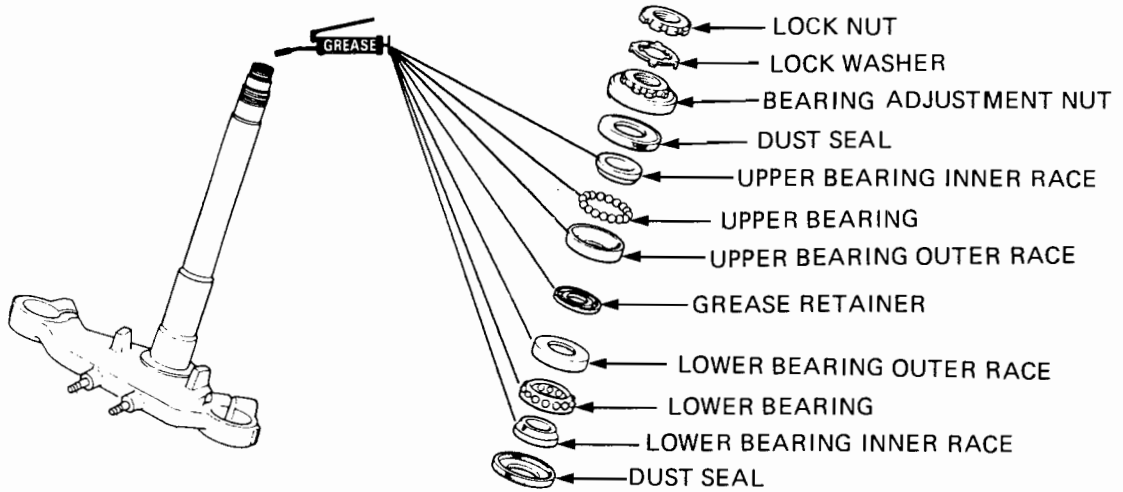
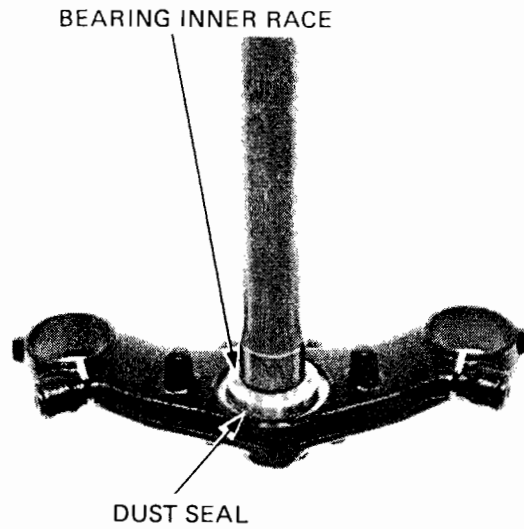

Install a new dust seal over the steering stem.  
Install a new lower bearing inner race over the steering stem using a press.

STEERING STEM DRIVER 07946-MB00000

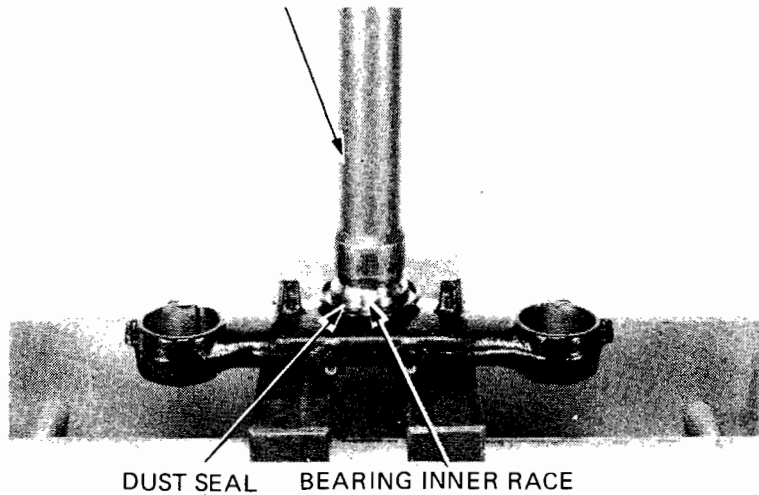



Install new upper and lower bearing outer races into the head pipe.

ATTACHMENT, 52 x 55 mm  
07746-0010400

ATTACHMENT, 42 x 47 mm  
07746-0010300

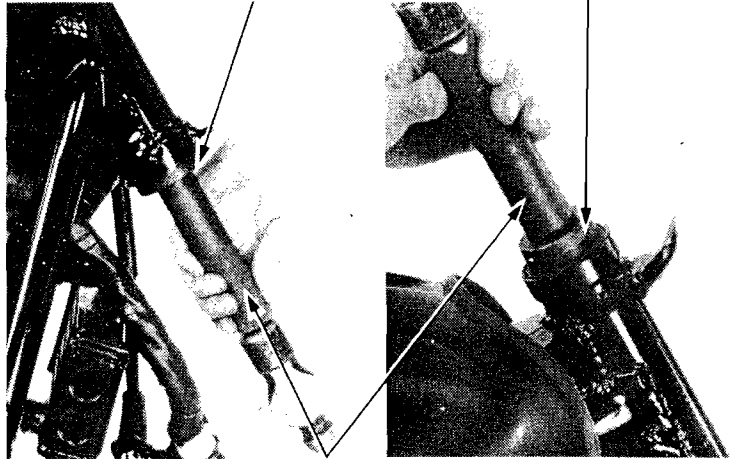

DRIVER 07749-0010000

**INSTALLATION**

Pack the bearing cavities with grease.  
Install the steering stem and lower bearing.

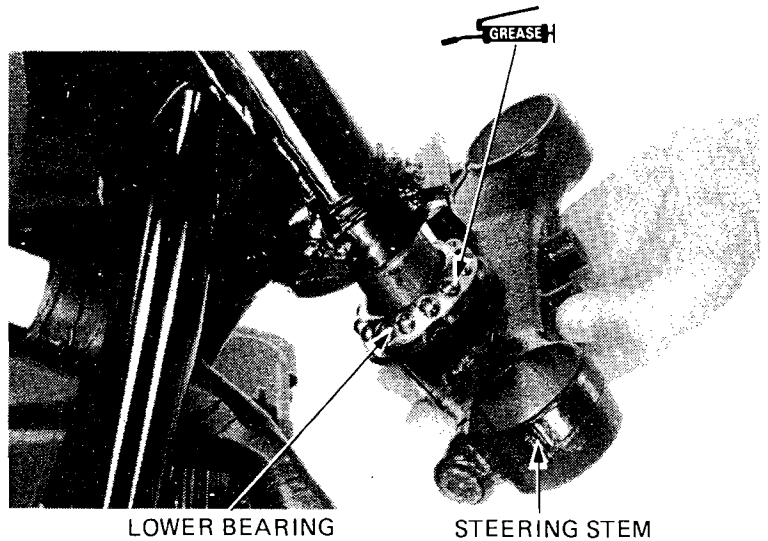

Install the grease retainer, upper bearing, bearing inner race and dust seal.

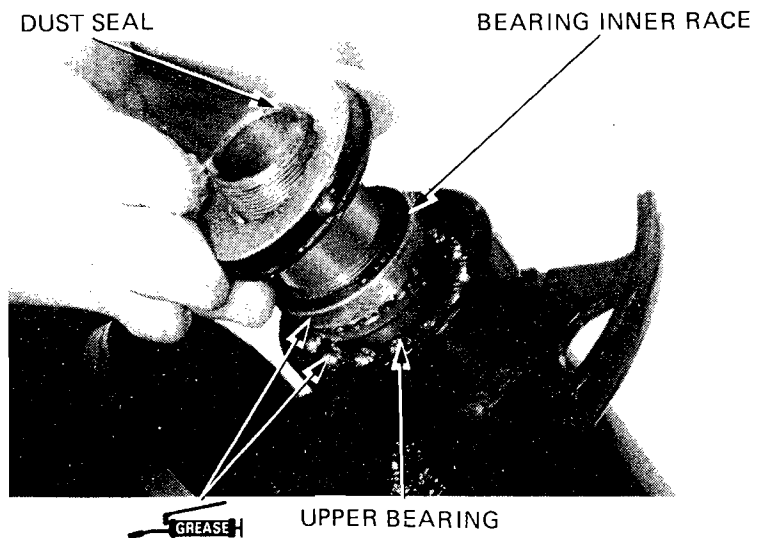



**FRONT WHEEL/SUSPENSION**

STEERING STEM SOCKET 07916-3710100

- Install the bearing adjustment nut and tighten it to the specified torque:

**TORQUE:** 20–22 N·m  
(2.0–2.2 kg·m, 14–16 ft·lb)

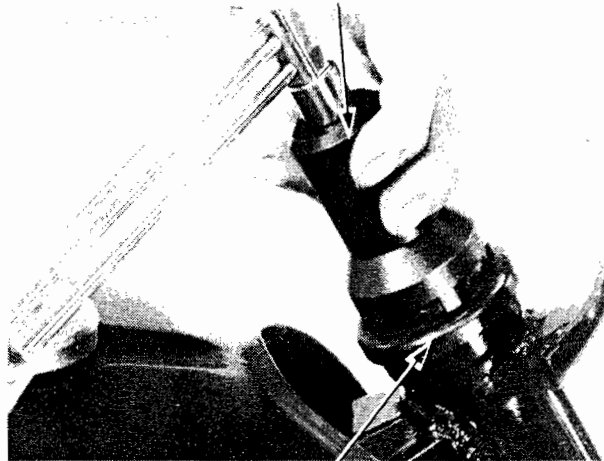

STEERING ADJUSTMENT NUT

Turn the steering stem all the way right and left five times to seat the bearings.  
Retighten the adjustment nut to the same torque.  
Turn the steering stem to seat the bearings.

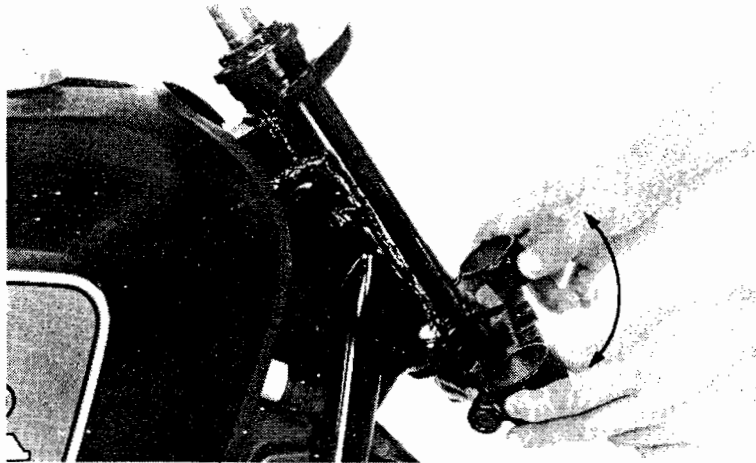

Install a new lock washer by aligning its tab with the groove of the adjustment nut.  
Finger tighten the lock nut all the way.  
Hold the bearing adjustment nut and tighten the lock nut, within 90 degrees, to align its groove with the tab of the lock washer.  
Bend up the lock washer tab into the groove of the lock nut.

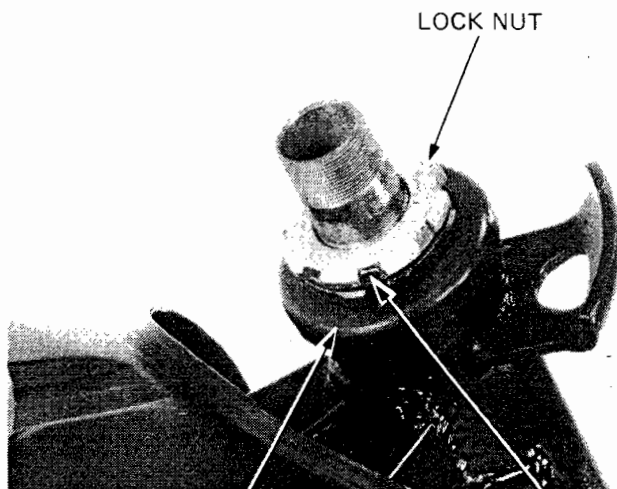

BEARING ADJUSTMENT NUT    LOCK WASHER TAB



Temporarily install the front forks.  
Install the fork top bridge and tighten the steering stem nut.

**TORQUE:** 90–120 N·m  
(9.0–12.0 kg·m, 65–87 ft·lb)

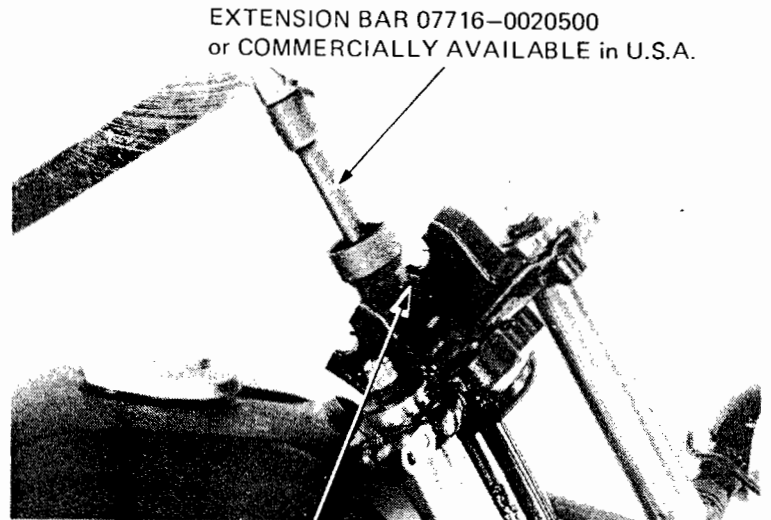

LOCK NUT WRENCH, 30 x 32 mm 07716-0020400  
or COMMERCIALLY AVAILABLE in U.S.A.

### STEERING HEAD BEARING PRELOAD

Install the front forks (Page 14-27).  
Install the front wheel (Page 14-16).  
Place a stand under the engine and raise the front wheel off the ground.  
Position the steering stem to the straight ahead position.  
Hook a spring balancer to the fork tube and measure the steering head bearing preload.

#### NOTE

Make sure that there is no cable or wire harness interference.

The preload should be within 1.0–1.6 kg (2.21–3.53 lb) for right and left turns.

If the readings do not fall within the limits, lower the front wheel on the ground and adjust the bearing adjustment nut.

After making sure the bearing preload, install the removed parts in the reverse order of removal.

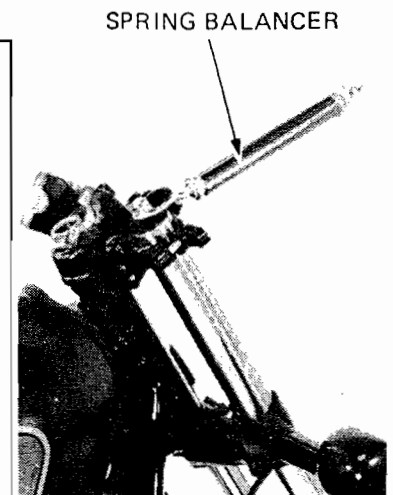
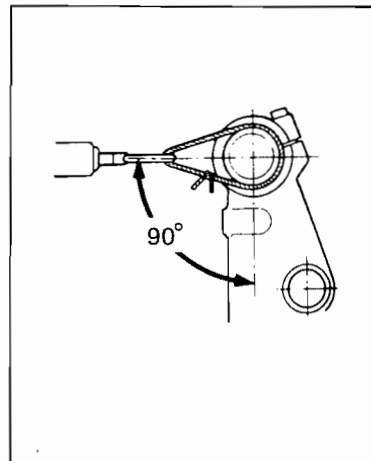



**HONDA**  
**CB750SC**

---

MEMO

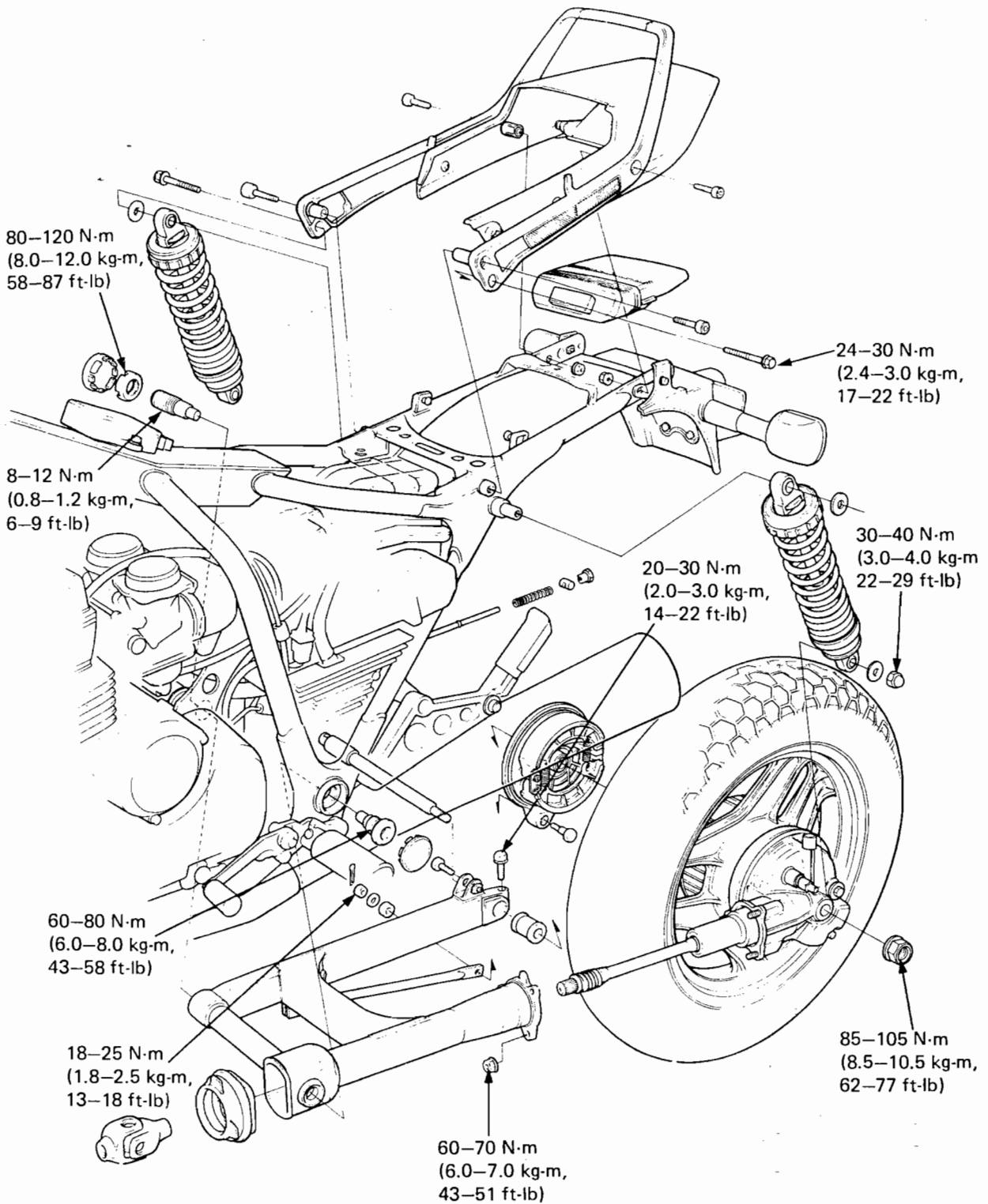





SERVICE INFORMATION	15-1	REAR BRAKE	15-7
TROUBLESHOOTING	15-2	SHOCK ABSORBER	15-12
REAR WHEEL	15-3	SWING ARM	15-16

## SERVICE INFORMATION

### GENERAL

- The rear wheel uses a tubeless tire. For tubeless tire repairs, refer to the Tubeless Tire Manual.
- Never ride on the rim or try to bend wheel.
- For wheel balancing, refer to Page 14-11.

#### WARNING

*Brake dust may contain asbestos which can be harmful to your health. Do not use compressed air to clean brake drums or brake panels. Use a vacuum with a sealed dust collector. Wear a protective face mask and thoroughly wash hands when finished.*

## SPECIFICATIONS

		STANDARD	SERVICE LIMIT
Axle runout		—	0.2 mm (0.01 in)
Rear wheel rim runout	Radial	—	2.0 mm (0.08 in)
	Axial	—	2.0 mm (0.08 in)
Shock absorber spring free length		266.5 mm (10.49 in)	261 mm (10.3 in)
Brake drum I.D.		180.0 – 180.3 mm (7.09 – 7.10 in)	181 mm (7.13 in)
Rear brake lining thickness		5.3 mm (0.21 in)	2.0 mm (0.08 in)

## TORQUE VALUES

Rear axle nut	85–105 N·m (8.5–10.5 kg·m, 62–77 ft·lb)
Axle pinch bolt	20–30 N·m (2.0–3.0 kg·m, 14–22 ft·lb)
Brake arm	24–30 N·m (2.4–3.0 kg·m, 17–22 ft·lb)
Final gear case attaching nuts	60–70 N·m (6.0–7.0 kg·m, 43–51 ft·lb)
Swing arm left pivot bolt	60–80 N·m (6.0–8.0 kg·m, 43–58 ft·lb)
Swing arm right pivot bolt	8–12 N·m (0.8–1.2 kg·m, 6–9 ft·lb)
Swing arm pivot lock nut	80–120 N·m (8.0–12.0 kg·m, 58–87 ft·lb)
Brake torque link	18–25 N·m (1.8–2.5 kg·m, 13–18 ft·lb)
Final driven flange bolt	50–60 N·m (5.0–6.0 kg·m, 36–43 ft·lb)
Brake pedal bolt	20–28 N·m (2.0–2.8 kg·m, 14–20 ft·lb)
Right footpeg bolt	30–40 N·m (3.0–4.0 kg·m, 22–29 ft·lb)
Shock absorber mount (upper)	24–30 N·m (2.4–3.0 kg·m, 17–22 ft·lb)
(lower)	30–40 N·m (3.0–4.0 kg·m, 22–29 ft·lb)



**REAR WHEEL/SUSPENSION/BRAKE**

**TOOLS**

**Special**

Attachment	07967-KC10000
Shock absorber compressor attachment	07959-MB10000
Swing arm lock nut wrench	07908-ME90000
Swing arm bearing remover	07936-4150000 or 07936-3710500
Sliding hammer	07936-3710200 or 07741-0010201
Bearing remover handle	07936-3710100
Socket bit, 17 mm	07703-0020500
Socket bit, 10 mm	07917-3710000 } or commercially available in U.S.A.

**Common**

Driver	07749-0010000
Attachment, 42 x 47 mm	07746-0010300
Pilot, 20 mm	07746-0040500
Attachment, 32 x 35 mm	07746-0010100
Shock absorber compressor	07959-3290001
Bearing remover collet, 20 mm	07746-0050600
Bearing remover expander	07746-0050100

**TROUBLESHOOTING**

**Wobble or vibration in motorcycle**

1. Tire pressure incorrect
2. Faulty tire
3. Bent rim
  - Loose wheel bearing
4. Swing arm bushing worn
6. Wheel out of balance

**Soft suspension**

1. Weak springs
2. Shock absorbers improperly adjusted

**Hard suspension**

1. Shock absorbers improperly adjusted
2. Bent shock absorber rod

**Suspension noise**

1. Loose fasteners
2. Worn shocks



## REAR WHEEL

### REMOVAL

Place the motorcycle on its center stand and remove the axle nut.

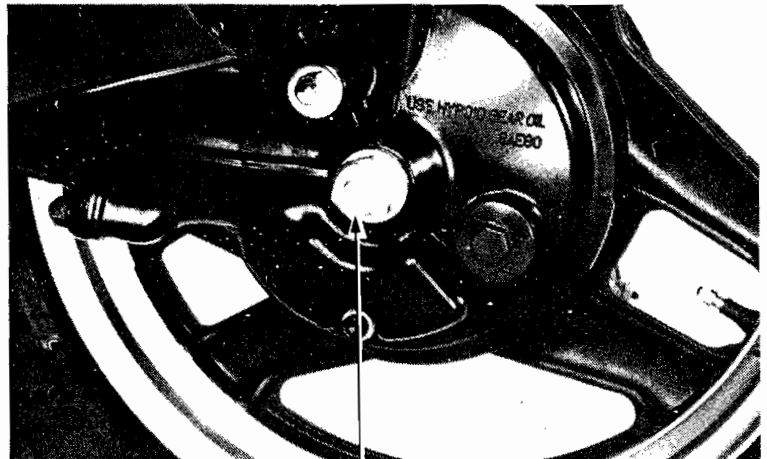

AXLE NUT

Disconnect the brake torque link from the brake panel by removing the cotter pin, nut and bolt.

Remove the brake adjusting nut and disconnect the brake rod from the brake arm.

Loosen the axle pinch bolt and remove the rear axle.

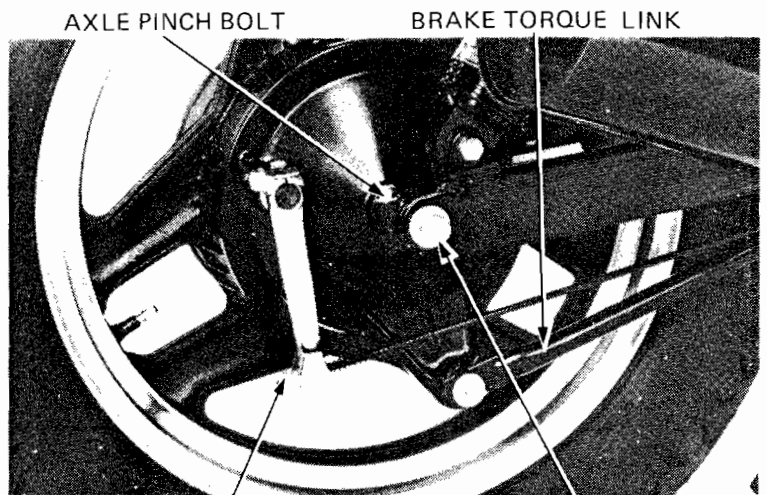

BRAKE ADJUSTING NUT

REAR AXLE

Move the wheel to the right to separate it from the final drive gear case and remove the rear wheel.

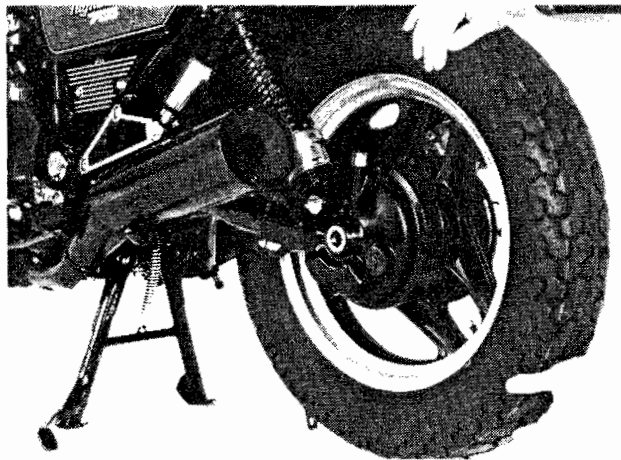



**REAR WHEEL/SUSPENSION/BRAKE**

**INSPECTION**

**AXLE**

Set the axle in V blocks and read the axle runout with a dial indicator.

**SERVICE LIMIT: 0.2 mm (0.01 in)**

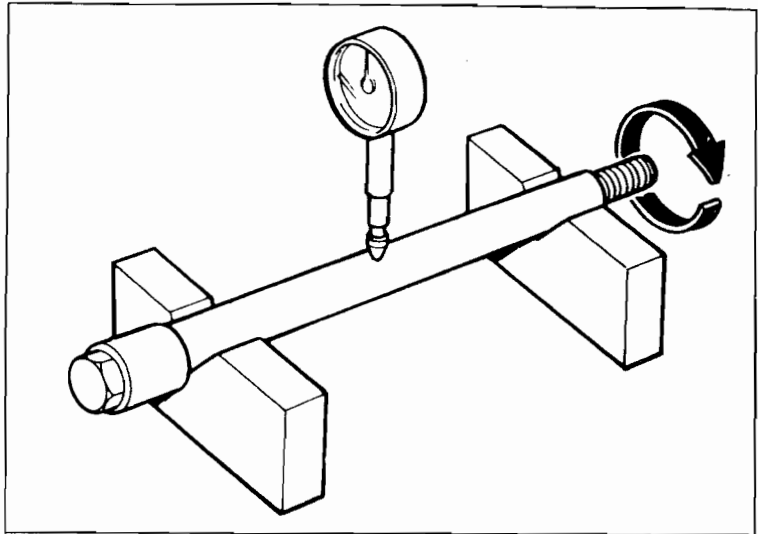

**WHEEL RIM RUNOUT**

Check the rim for runout by placing the wheel in a truing stand. Spin the wheel slowly, and read the runout using a dial indicator.

**SERVICE LIMITS:**

**RADIAL RUNOUT: 2.0 mm (0.08 in)**

**AXIAL RUNOUT: 2.0 mm (0.08 in)**

The wheel cannot be serviced and must be replaced if the above limits are exceeded.

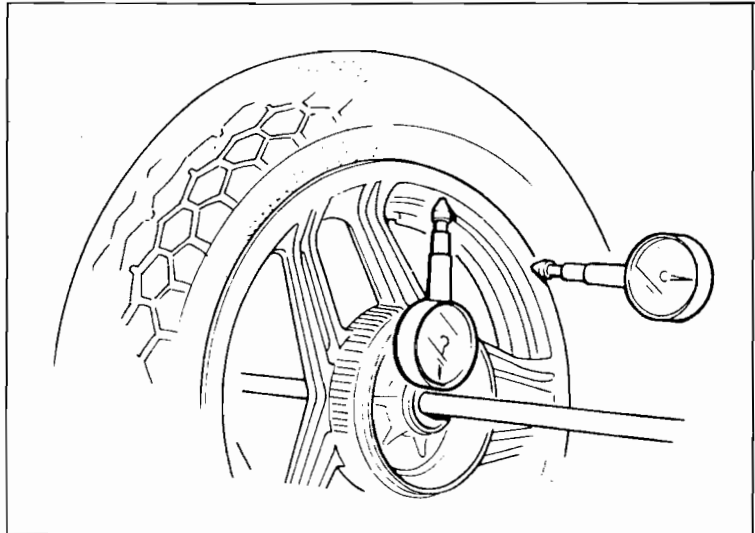

**WHEEL BEARINGS**

Place the wheel in a truing stand and check the wheel bearing play by rotating the wheel by hand. Replace the bearings with new ones if they are noisy or have excessive play.

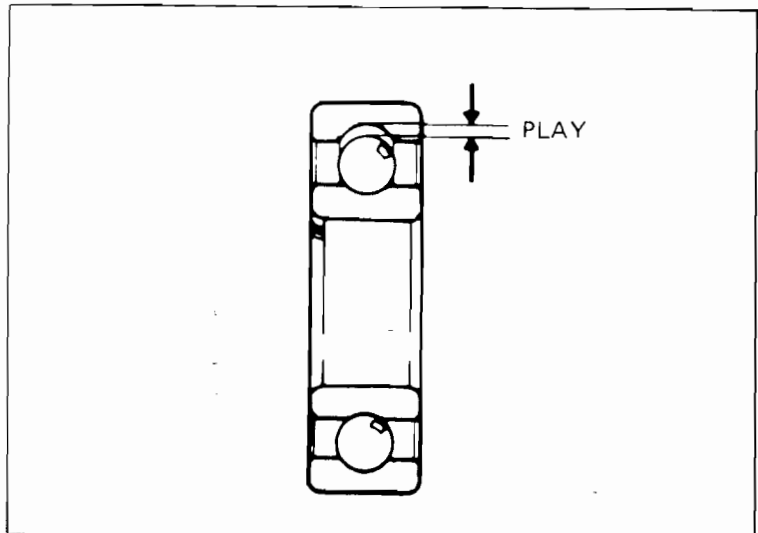



### DISASSEMBLY

Remove the final driven flange from the hub.

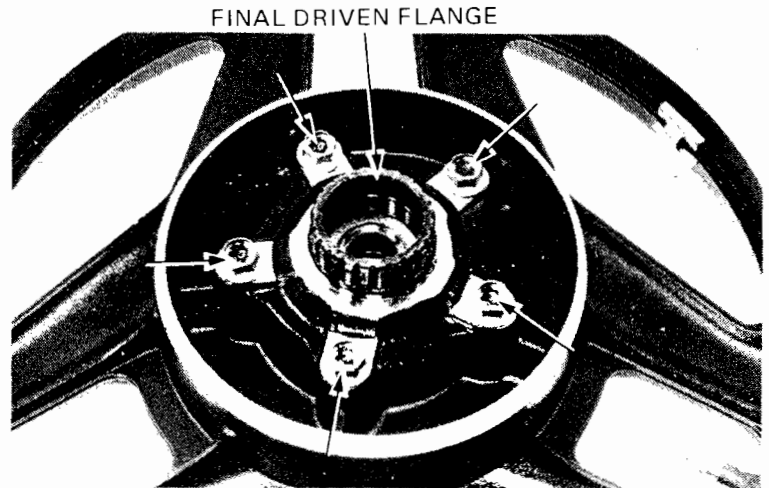

Remove the wheel bearings and the distance collar from the hub with the special tools.

BEARING REMOVER EXPANDER 07746-0050100  
or **COMMERCIALLY AVAILABLE** in U.S.A.

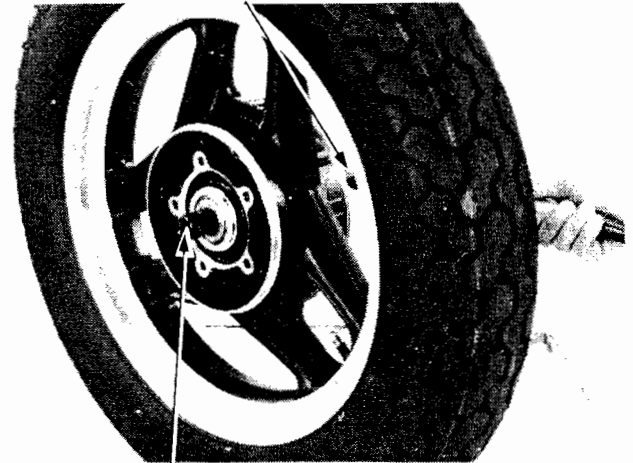

BEARING REMOVER COLLET, 20 mm 07746-0050600  
or **COMMERCIALLY AVAILABLE** in U.S.A.

### ASSEMBLY

#### NOTE

The wheel uses a tubeless tire. For tubeless tire repairs, refer to the Tubeless Tire Manual.

#### NOTE

Use lithium-based multipurpose grease with MoS<sub>2</sub>-additive as follows:

- Molykote BR2-PLUS manufactured by Dow Corning, U.S.A.
- Multipurpose M-2 manufactured by Mitsubishi Oil, Japan
- Sta-lube NLGI #2.
- Other lubricants of equivalent quality.

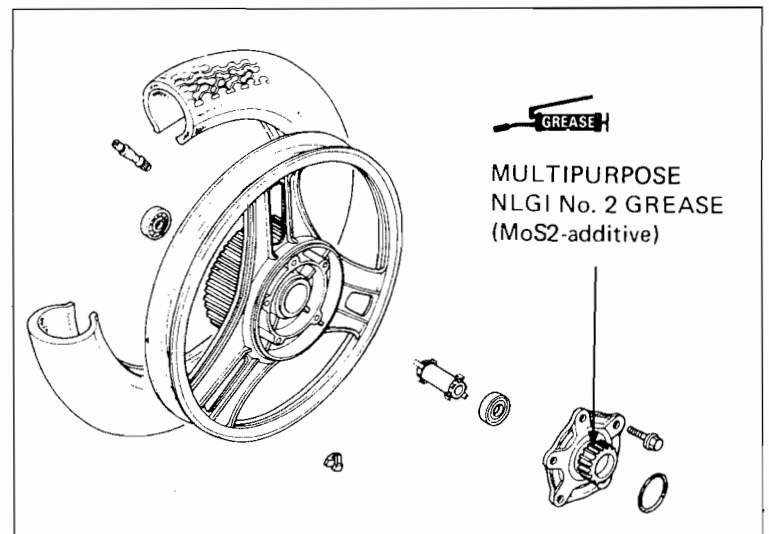



Press the distance collar into place from the left side. Drive the right ball bearing in first, then the left ball bearing.

**CAUTION**

*Drive the bearings in squarely, making sure they are fully seated.*

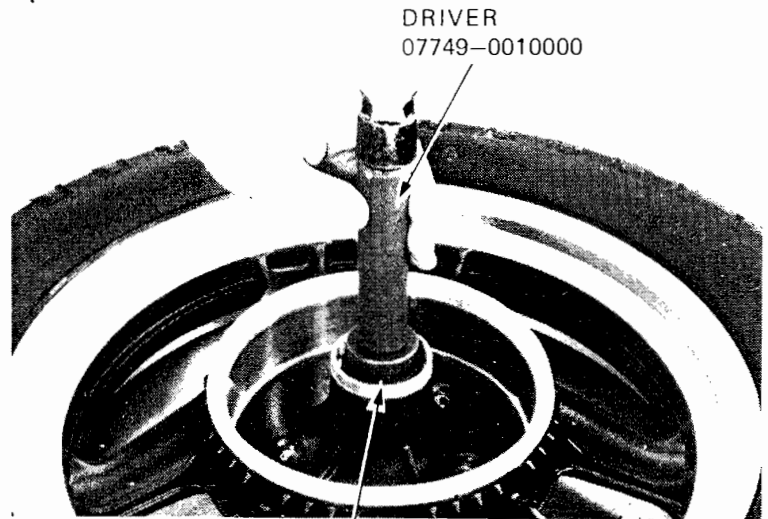

DRIVER  
07749-0010000

ATTACHMENT, 42 x 47 mm 07746-0010300  
PILOT, 20 mm 07746-0040500

Install the final driven flange onto the rear wheel and tighten the bolts.

**TORQUE:** 50-60 N·m  
(5.0-6.0 kg·m, 36-43 ft·lb)

Install a new O-ring in the groove of the final driven flange.

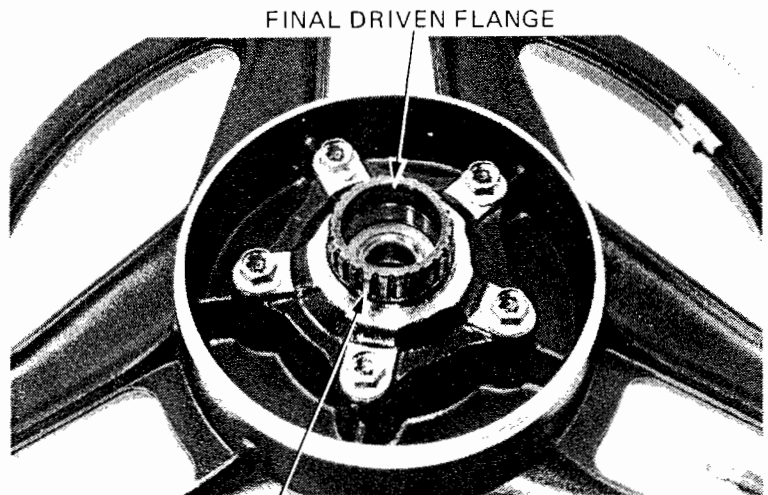

FINAL DRIVEN FLANGE

O-RING

**INSTALLATION**

Apply Multipurpose NLGI No. 2 grease (MoS2-additive) to the final driven flange and ring gear engagement splines.

Loosen the final gear case attaching nuts to ease axle installation and to assure proper driven flange alignment.

Engage the rear wheel with the final drive case, making sure the splines are correctly aligned.

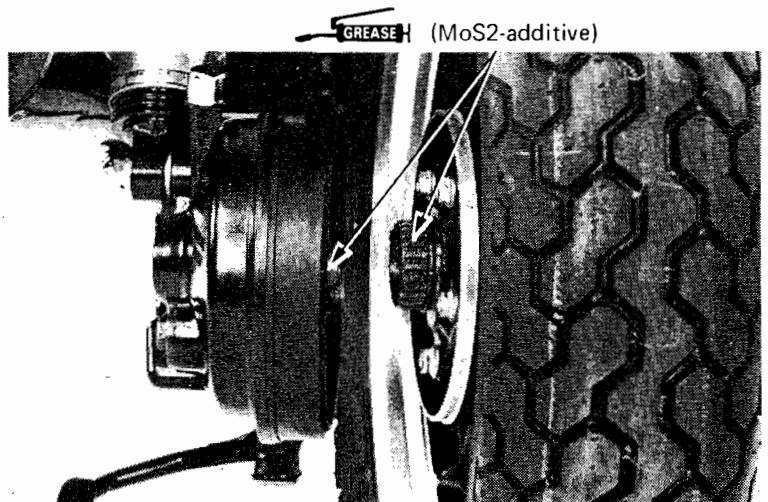

GREASE (MoS2-additive)



Insert the rear axle from the right side through the swing arm, side collar, brake panel, hub and final drive gear.

Tighten the axle nut.

**TORQUE:** 60–80 N·m  
(6.0–8.0 kg-m, 43–58 ft-lb)

Tighten the final gear case attaching nuts.

**TORQUE:** 60–70 N·m  
(6.0–7.0 kg-m, 43–51 ft-lb)

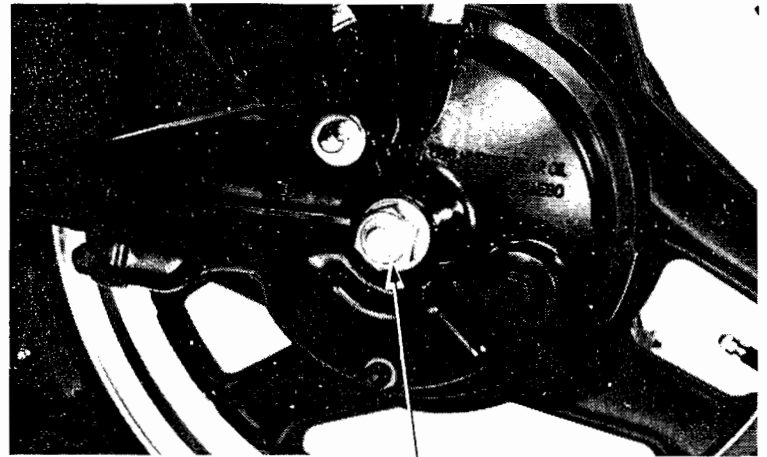

AXLE NUT

Tighten the axle pinch bolt.

**TORQUE:** 20–30 N·m  
(2.0–3.0 kg-m, 14–22 ft-lb)

Place the brake rod through the brake arm pin and install the brake adjusting nut.

Connect the brake torque link to the brake panel with bolt, rubber washer, plain washer and nut. Install a new cotter pin. Adjust the rear brake (Page 3-11).

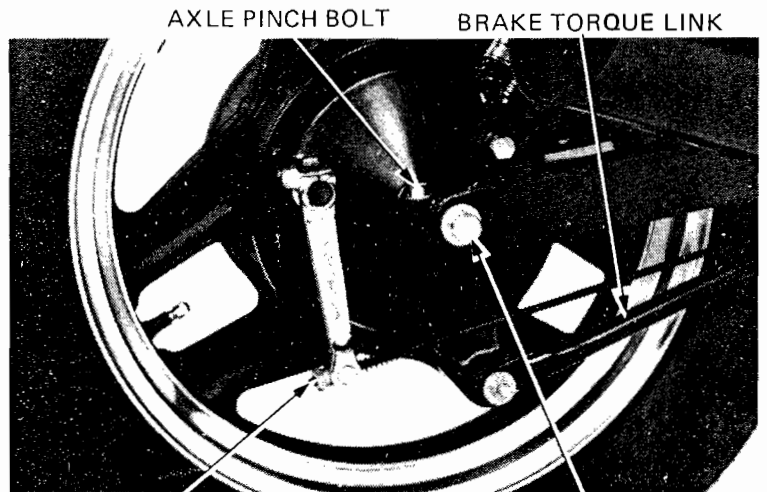

AXLE PINCH BOLT

BRAKE TORQUE LINK

BRAKE ADJUSTING NUT

REAR AXLE

## REAR BRAKE

Remove the rear wheel (Page 15-3).  
Remove the brake panel from the wheel hub.

### BRAKE DRUM INSPECTION

Measure the brake drum I.D.

**SERVICE LIMIT:** 181 mm (7.13 in)

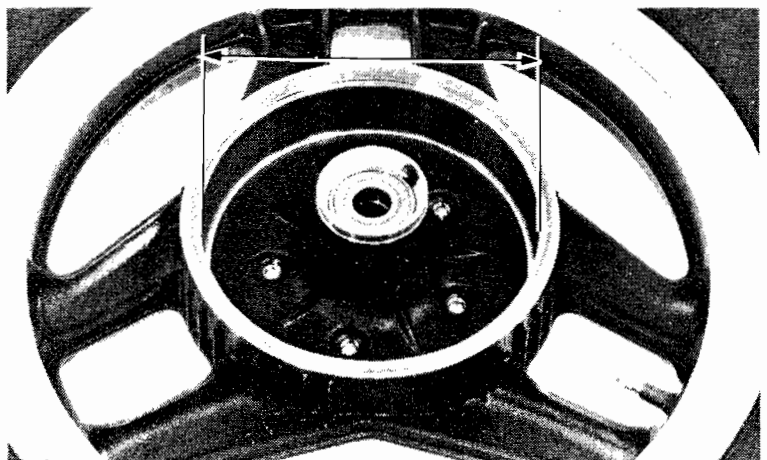



### LINING THICKNESS INSPECTION

Measure the rear brake lining thickness.

**SERVICE LIMIT: 2.0 mm (0.08 in)**

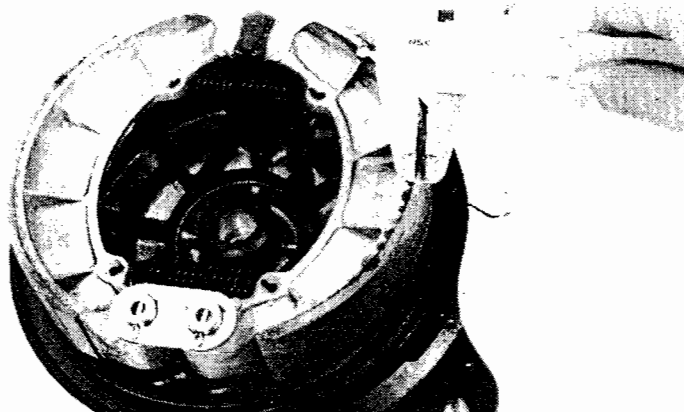

### DISASSEMBLY

Remove the rear brake arm.

Remove the cotter pins, brake shoes, springs and brake cam.

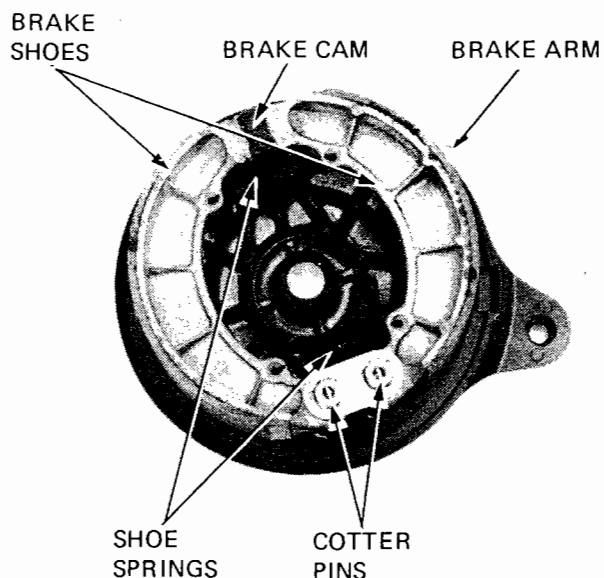

### ASSEMBLY

Apply grease to the anchor pins and brake cam.

**WARNING**

*Contaminated brake linings reduce stopping power. Keep grease off the brake linings. Wipe any excess grease off the cam.*

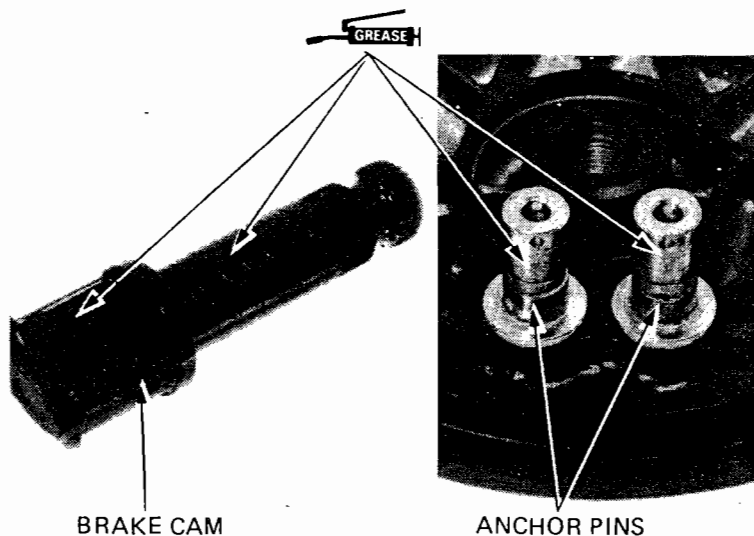





Assemble the brake shoes, springs and brake cam as shown and install the assembly onto the brake panel.

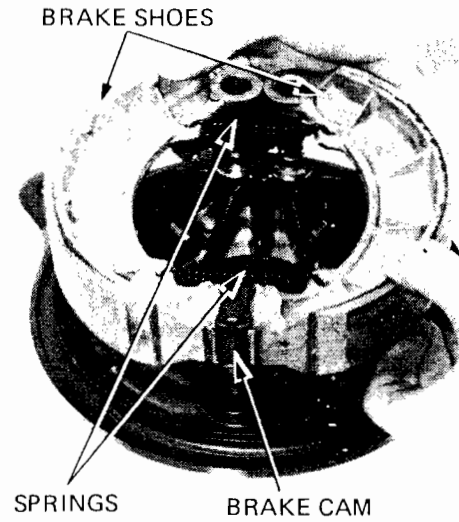

Install the anchor pin plate and new cotter pins.

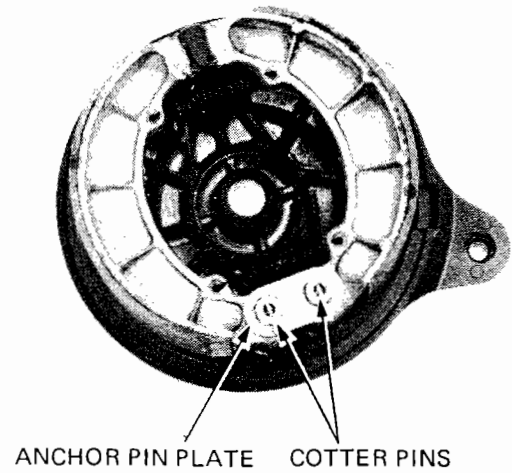

Install the felt seal.  
Install the wear indicator aligning its tab with the slot in the brake cam.

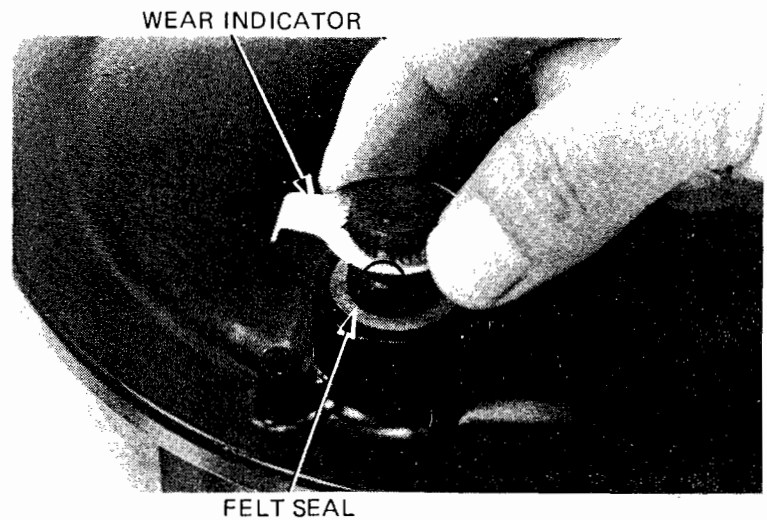



Align the index mark on the brake arm with the punch mark on the brake cam and install the brake arm.  
Tighten the brake arm bolt.

**TORQUE:** 24–30 N·m  
(2.4–3.0 kg·m, 17–22 ft·lb)

Place the brake panel into the rear wheel hub and install the rear wheel (Page 15-6).

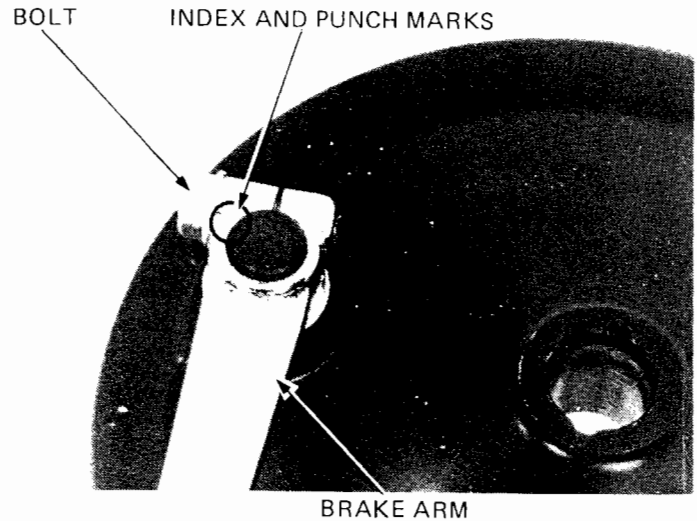

**REAR BRAKE LINKAGE REMOVAL**

Remove the right footpeg bolt and footpeg.  
Remove the brake pedal bolt and brake pedal.

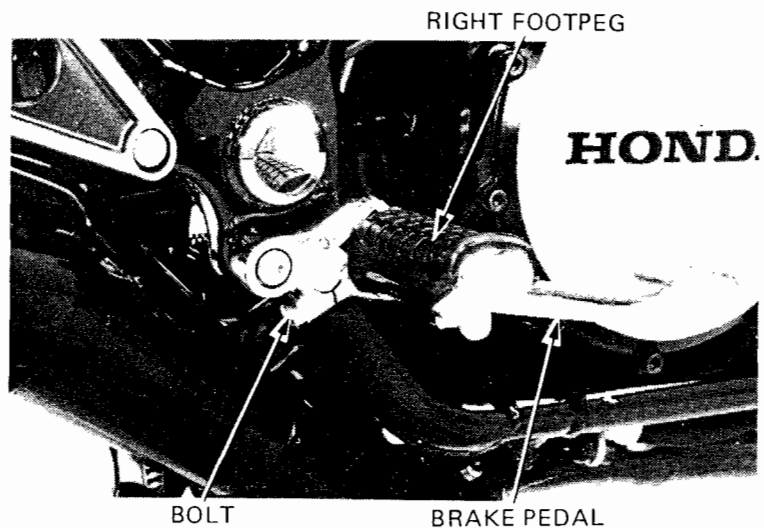

Remove the rear wheel (Page 15-3) and swing arm (Page 15-16).  
Remove the brake pedal shaft.  
Remove the brake pedal return spring and brake rod from the pedal shaft.

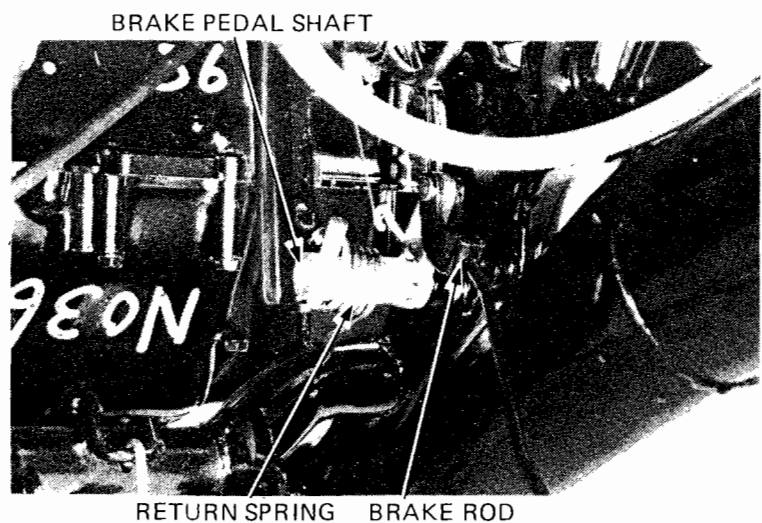



### REAR BRAKE LINKAGE INSTALLATION

Install the brake rod and return spring onto the brake pedal shaft.  
Apply grease to the brake pedal shaft and insert it into the frame.

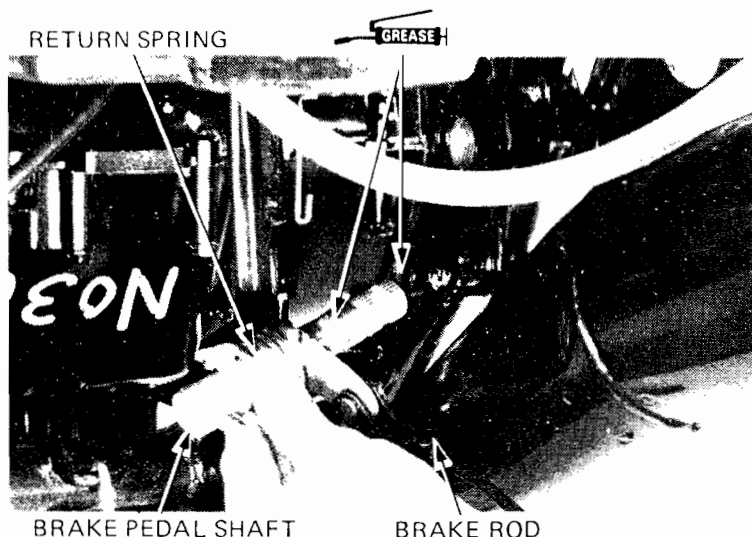

Rest the return spring end on the frame as shown.  
Hook the brake light switch spring to the return spring.  
Install the swing arm (Page 15-18) and rear wheel (Page 15-6).

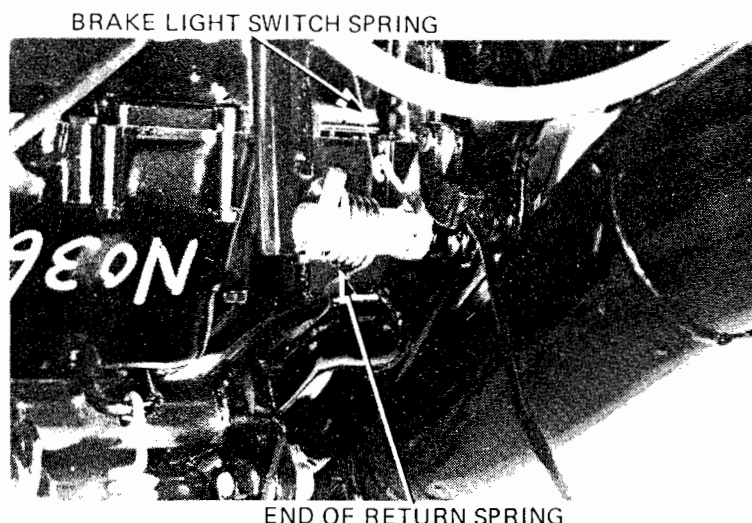

Install the brake pedal over the pedal shaft aligning the punch marks.  
Tighten the brake pedal bolt.

**TORQUE:** 20–28 N·m  
(2.0–2.8 kg·m, 14–20 ft·lb)

Install the right footpeg and tighten the socket bolt.

**TORQUE:** 30–40 N·m  
(3.0–4.0 kg·m, 22–29 ft·lb)

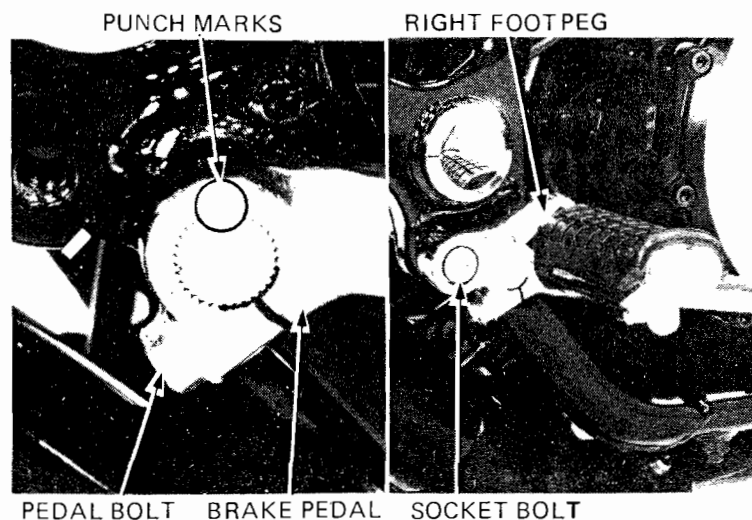

## SHOCK ABSORBER

### REMOVAL

#### NOTE

Remove one shock absorber at a time to facilitate removal and installation.

Remove the seat.

Remove the four handrail mounting bolts and the handrail.

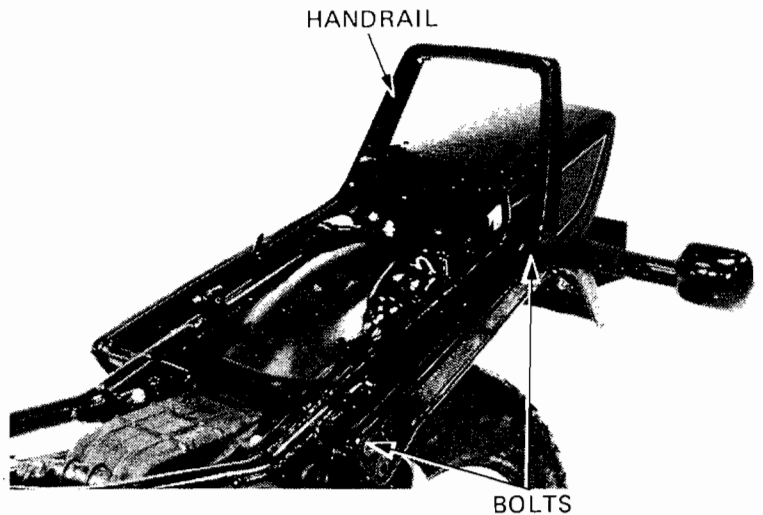

Remove the shock absorber upper and lower mounts.

Remove the shock absorber.

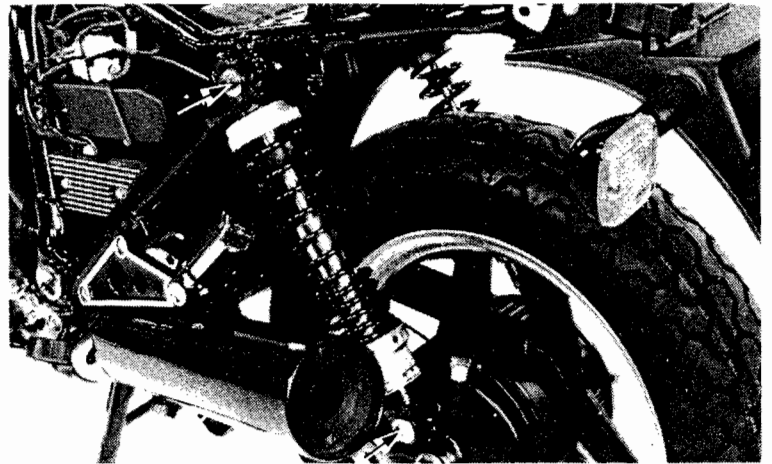

### DISASSEMBLY

Replace base of shock compressor, 07959-3290001 with 07959-MB10000. Be sure to replace the spring compressor guides with the ones supplied with 07959-MB10000.

Install the attachment onto the spring.

Set the shock in the compressor as shown and compress the spring 30 mm by turning the compressor handle.

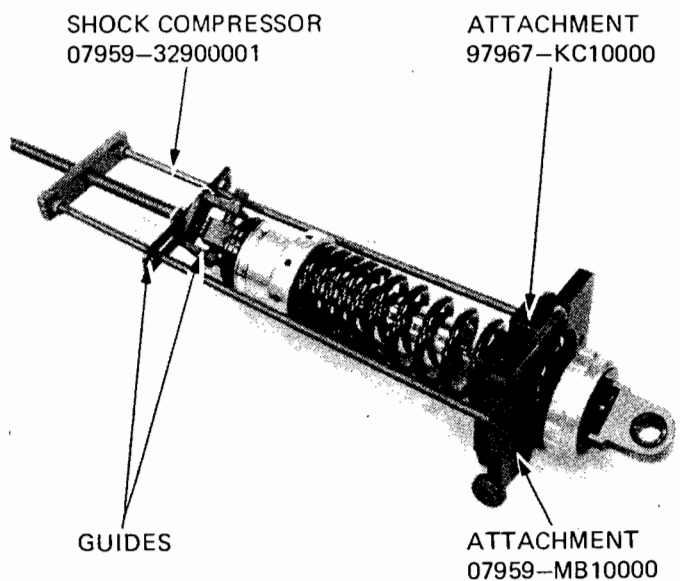



Pull the lock seat out of the shock absorber.  
Remove the compressor.

Remove the upper spring seat, spring, lower spring seat and spring adjuster.

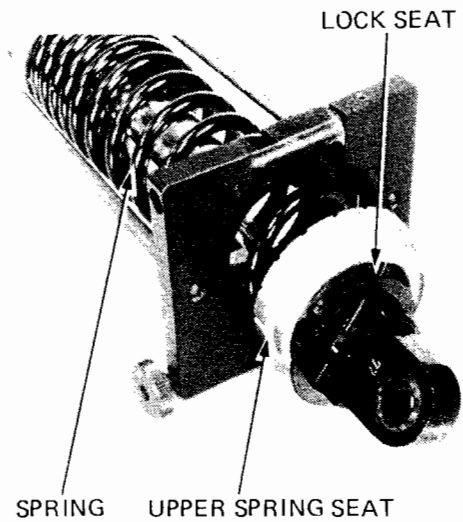

### SPRING FREE LENGTH

Measure the rear shock absorber spring free length.

**SERVICE LIMIT: 261 mm (10.3 in)**





ASSEMBLY

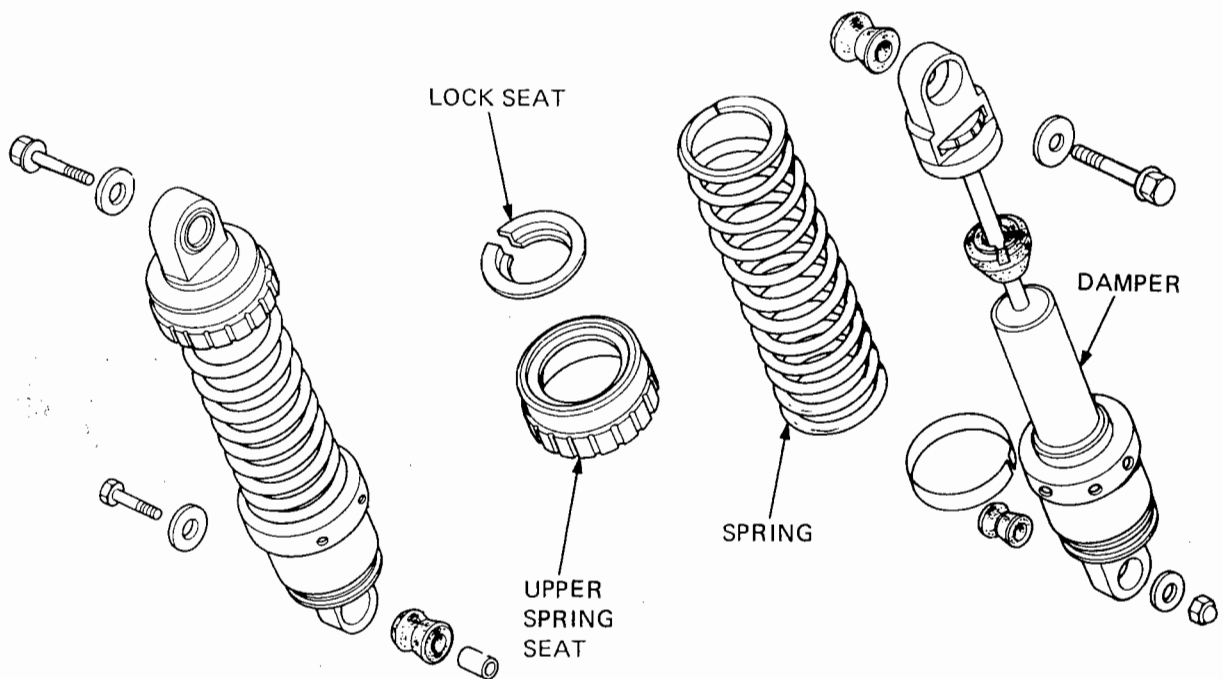



Place the spring adjuster in softest position and install the lower spring seat aligning its "1" mark with the index mark on the lower joint.

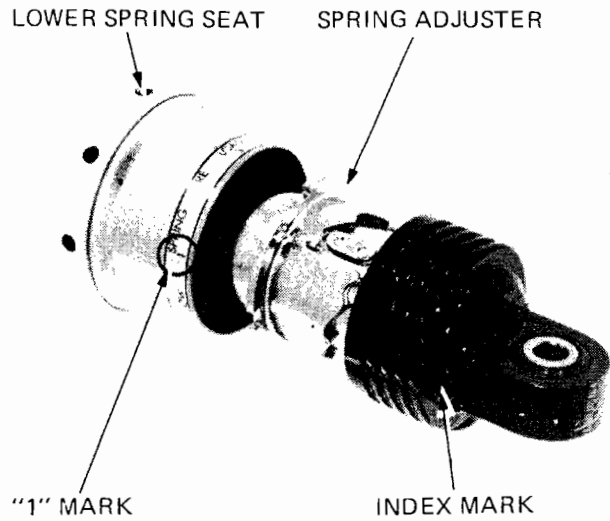

Install the spring with the tightly wound end facing down.

Install the upper spring seat.

Compress the spring with the compressor and attachment tools and install the lock seat.

Remove the compressor.

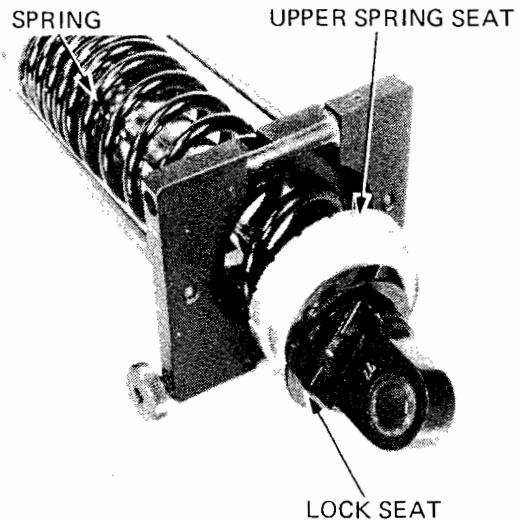

### INSTALLATION

Install the shock absorber onto the frame and swing arm.

Tighten the upper and lower mounts.

#### TORQUE:

UPPER: 24–30 N·m  
(2.4–3.0 kg·m, 17–22 ft·lb)

LOWER: 30–40 N·m  
(3.0–4.0 kg·m, 22–29 ft·lb)

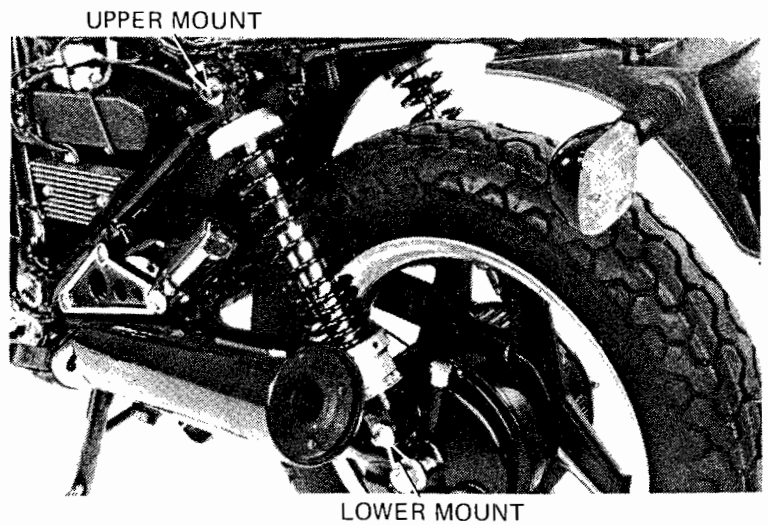



**REAR WHEEL/SUSPENSION/BRAKE**

Install the handrail with the four socket bolts.  
Install the seat.

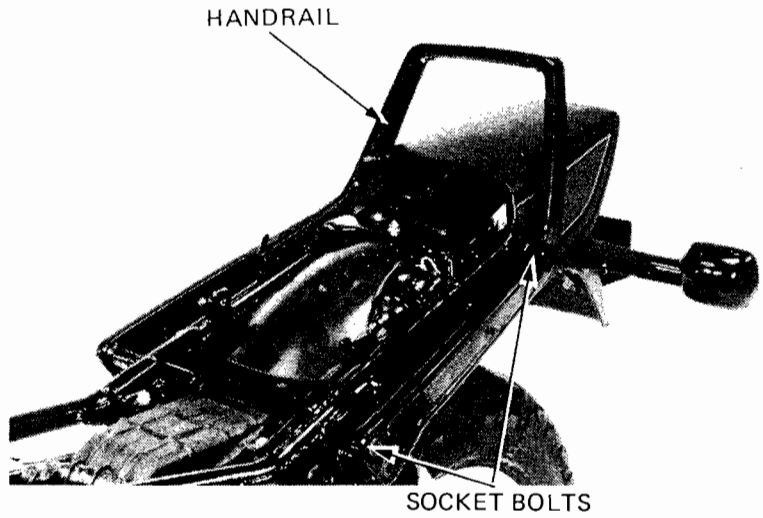

SWING ARM PIVOT LOCK NUT WRENCH  
07908-ME90000

**SWING ARM**

**REMOVAL**

- Remove the following parts:
- rear wheel (Page 15-3).
  - final drive case (Page 13-3).
  - shock absorbers (Page 15-12).

Remove the swing arm pivot caps and loosen the right pivot bolt lock nut.

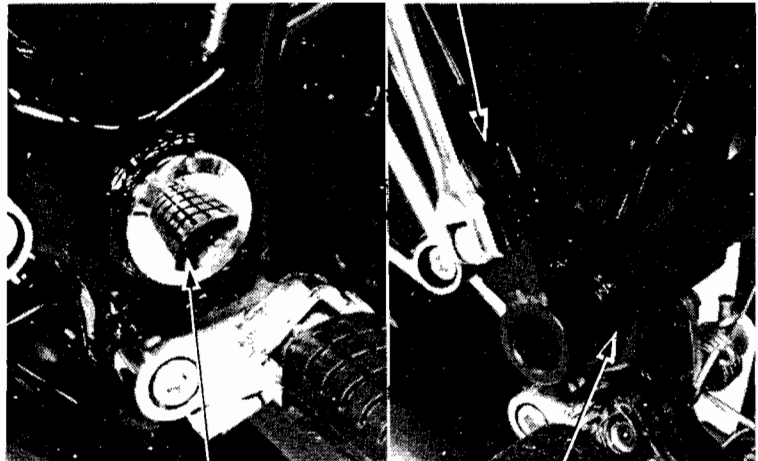

PIVOT CAP

LOCK NUT

RIGHT PIVOT BOLT

Remove the right pivot bolt, using the socket bit.

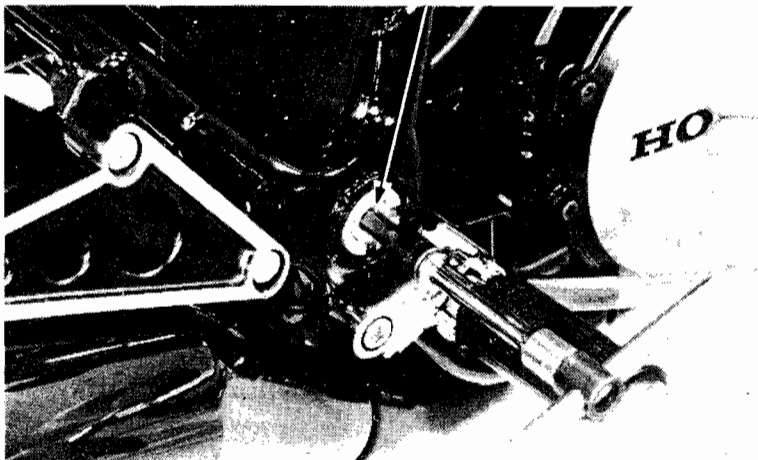





Remove the left pivot bolt and remove the swing arm.

Remove the boot from the swing arm.

LEFT PIVOT BOLT

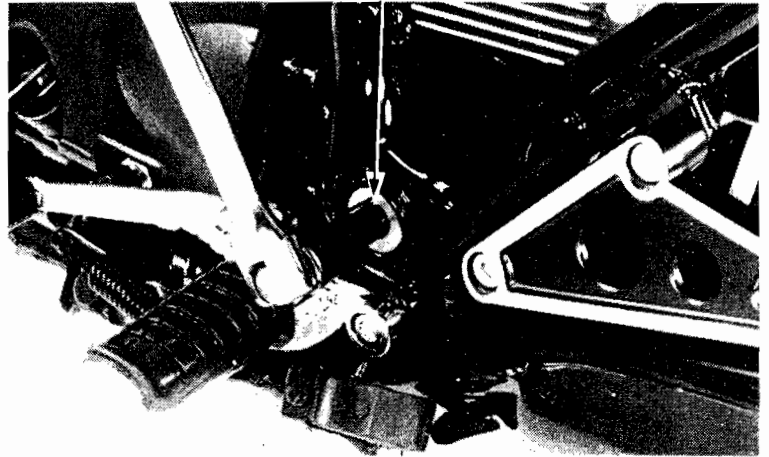

**BEARING REPLACEMENT**

Remove the attachment from the special tool, 07936-4150000. Slide the shaft through the left hole and install the attachment onto the shaft. Install the sliding hammer.

Remove the race.

Drive out the right bearing race through the left bearing bore.

BEARING REMOVER  
07936-4150000

SLIDING HAMMER  
07936-3710200 or 07741-0010200

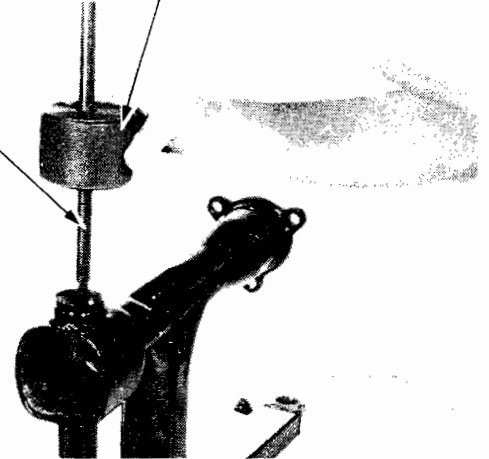

DRIVER  
07749-0010000

ATTACHMENT, 32 x 35 mm  
07746-0010200

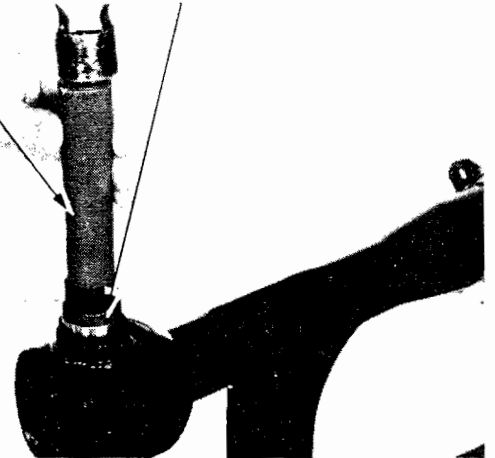

Install new grease retainer plates and drive new bearing outer races into the swing arm.

**NOTE**

The left grease retainer has a hole to hold the universal joint when removing and installing the engine.



**REAR WHEEL/SUSPENSION/BRAKE**

**INSTALLATION**

Apply grease to the pivot bearings dust seals and pivot bolt tips.

Install the bearings and dust seals.

Install the boot onto the swing arm with the "UP" mark facing up.

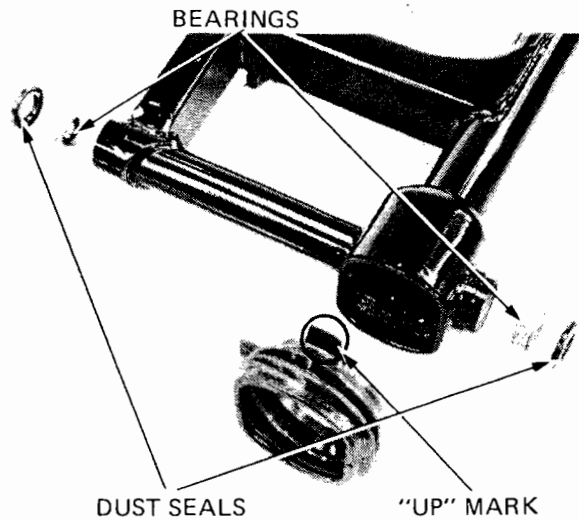

Install the swing arm and pivot bolts.

Tighten the left pivot bolt to the specified torque.

**TORQUE:** 60–80 N·m  
(6.0–8.0 kg·m, 43–58 ft·lb)

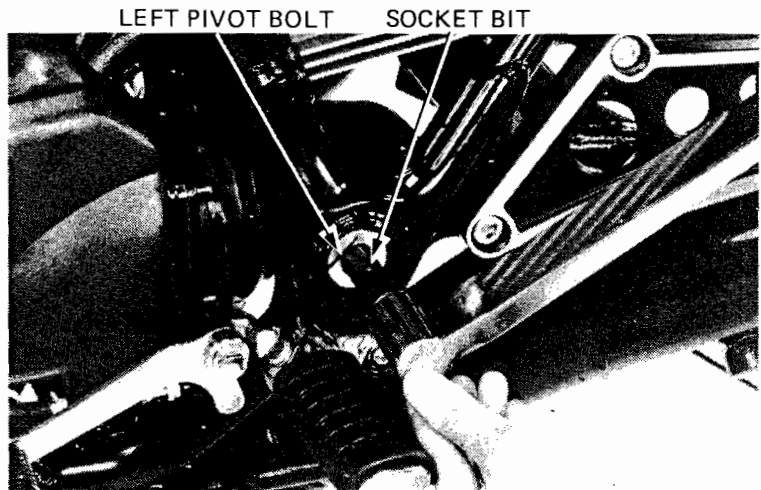

Tighten the right pivot bolt to 40 N·m (4.0 kg·m, 29 ft·lb), loosen it and retighten to the specified torque.

**TORQUE:** 8–12 N·m  
(0.8–1.2 kg·m, 6–9 ft·lb)

Move the swing arm up and down several times. Then, retighten the right pivot bolt to the specified torque.

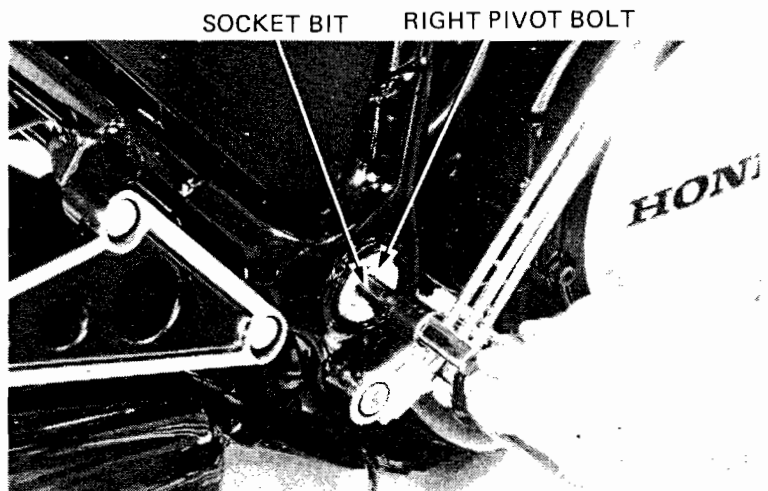



Tighten the lock nut while holding the right pivot bolt.

**TORQUE:** 80–120 N·m  
(8.0–12.0 kg·m, 58–87 ft·lb)

Install the following parts:

- shock absorbers (Page 15-15).
- final drive case (Page 13-19).
- rear wheel (Page 15-6).

SWING ARM PIVOT LOCK NUT WRENCH  
07908–ME90000

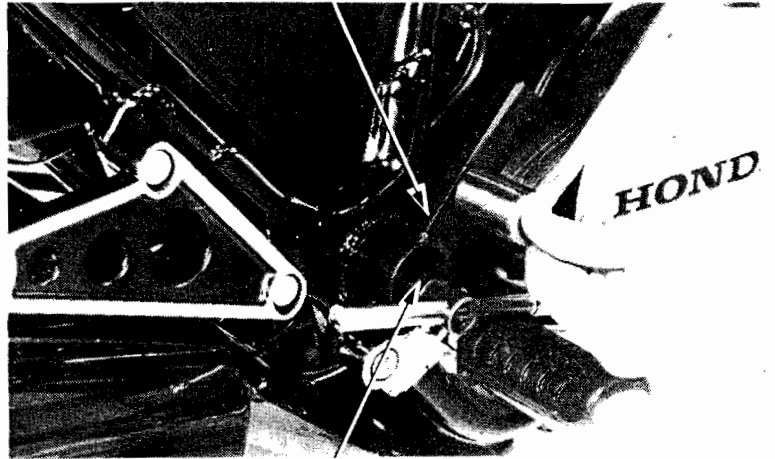

SOCKET BIT

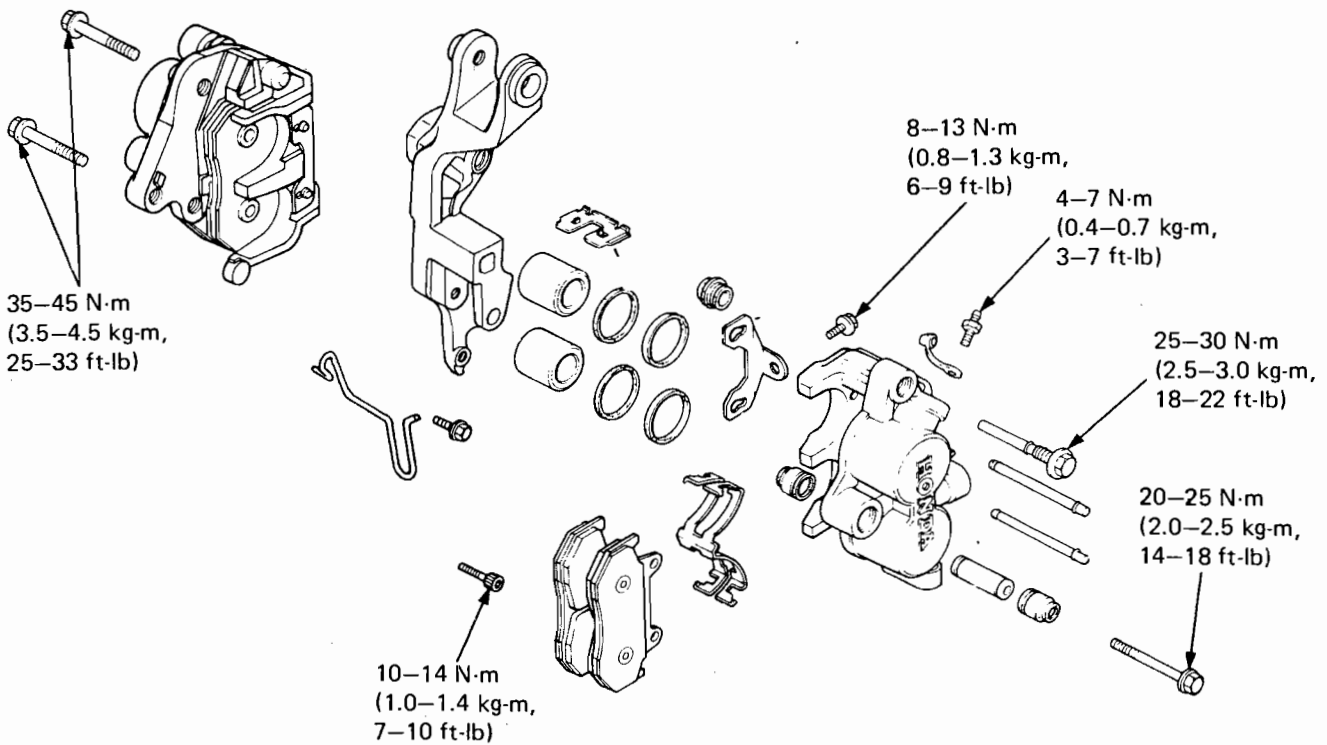
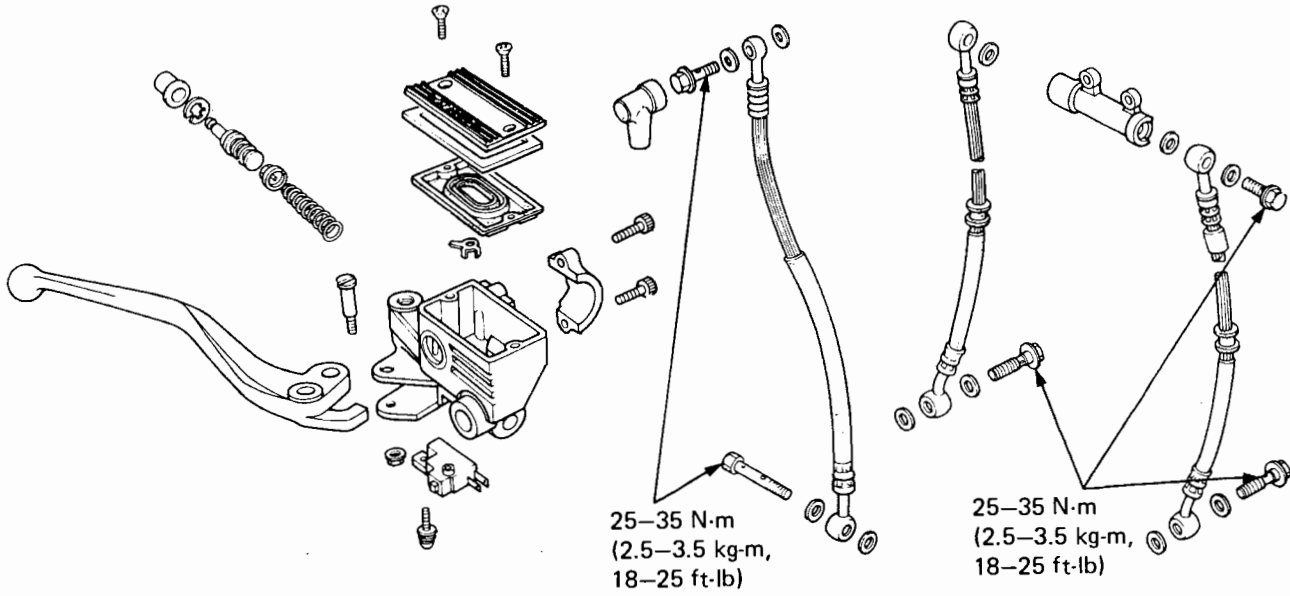



SERVICE INFORMATION	16-1
TROUBLESHOOTING	16-2
BRAKE FLUID REPLACEMENT/AIR BLEEDING	16-3
BRAKE PAD/DISC	16-5
MASTER CYLINDER	16-7
BRAKE CALIPERS	16-10

## SERVICE INFORMATION

### GENERAL

- The brake calipers can be removed without disconnecting the hydraulic system.
- Bleed the hydraulic system if it is disassembled or if the brake feels spongy.
- Do not allow foreign material to enter the system when filling the reservoir.
- Avoid spilling brake fluid on painted surfaces or instrument lenses, as severe damage can result.
- Always check brake operation before riding the motorcycle.
- Use DOT 3 or 4 brake fluid. Do not mix different types of brake fluid since they are not compatible.

### SPECIFICATIONS

	STANDARD	SERVICE LIMIT
Front disc thickness	4.8–5.2 mm (0.19–0.20 in)	4.0 mm (0.16 in)
Front disc runout	—	0.30 mm (0.012 in)
Front master cylinder I.D.	15.870–15.913 mm (0.6248–0.6265 in)	15.93 mm (0.627 in)
Front master piston O.D.	15.827–15.854 mm (0.6231–0.6242 in)	15.82 mm (0.623 in)
Front caliper piston O.D.	31.948–31.998 mm (1.2578–1.2598 in)	31.940 mm (1.2578 in)
Front caliper cylinder I.D.	32.030–32.080 mm (1.2610–1.2630 in)	32.090 mm (1.2634 in)

### TORQUE VALUES

Brake hose bolt	25–35 N·m (2.5–3.5 kg·m, 18–25 ft·lb)
Brake caliper bracket bolt (Right)	35–45 N·m (3.5–4.5 kg·m, 25–33 ft·lb)
Brake caliper bolt	20–25 N·m (2.0–2.5 kg·m, 14–18 ft·lb)
Brake caliper pivot bolt	25–30 N·m (2.5–3.0 kg·m, 18–22 ft·lb)
Brake caliper bracket bolt (Left upper)	35–45 N·m (3.5–4.5 kg·m, 25–33 ft·lb)
Piston pin bolt (Left)	10–14 N·m (1.0–1.4 kg·m, 7–10 ft·lb)
Pad pin retainer bolt	8–13 N·m (0.8–1.3 kg·m, 6–9 ft·lb)

### TOOL

<b>Special</b>	
Snap ring pliers	07914–3230001



## TROUBLESHOOTING

### Brake lever action soft or spongy

1. Air bubbles in hydraulic system
2. Low fluid level
3. Hydraulic system leaking

### Brake lever action too hard

1. Sticking piston(s)
2. Clogged hydraulic system
3. Pads glazed or worn excessively

### Brakes drag

1. Hydraulic system sticking
2. Sticking piston(s)

### Brake grab or pull to one side

1. Pads contaminated
2. One side of front brake faulty
3. Disc or wheel misaligned

### Brake chatter or squeal

1. Pads contaminated
2. Excessive disc runout
3. Caliper installed incorrectly
4. Disc or wheel misaligned



## BRAKE FLUID REPLACEMENT/AIR BLEEDING

Check the fluid level with the fluid reservoir parallel to the ground.

### CAUTION

- Install the diaphragm on the reservoir when operating the brake lever. Failure to do so will allow brake fluid to squirt out of the reservoir during brake operation.
- Avoid spilling fluid on painted surfaces. Place a rag over the fuel tank whenever the system is serviced.

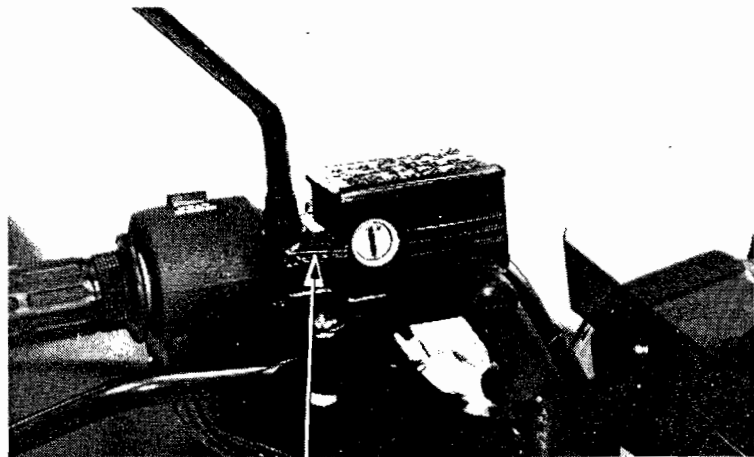

LOWER LEVEL

## BRAKE FLUID DRAINING

Remove the master cylinder reservoir cap. Connect a bleed hose to the bleed valve.

Loosen the caliper bleed valve and pump the brake lever. Stop operating the lever when fluid stops flowing out of the bleed valve.

### WARNING

*A contaminated brake disc or pad reduces stopping power. Discard contaminated pads and clean a contaminated disc with a high quality brake degreasing agent.*

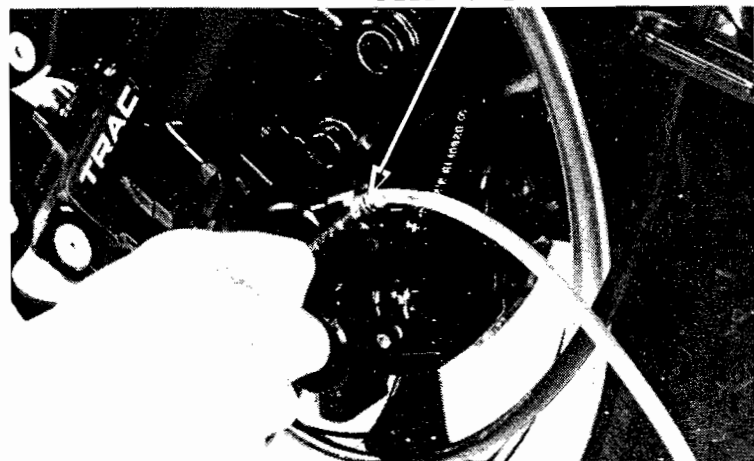

BLEED VALVE

## BRAKE FLUID FILLING

### NOTE

- Do not mix different types of fluid since they are not compatible.
- Do not allow foreign material to enter the system when filling the reservoir.

Close the bleed valve, fill the reservoir, and install the diaphragm.

Pump up the system pressure with the lever until there are no air bubbles in the fluid flowing out of the reservoir small hole and lever resistance is felt.

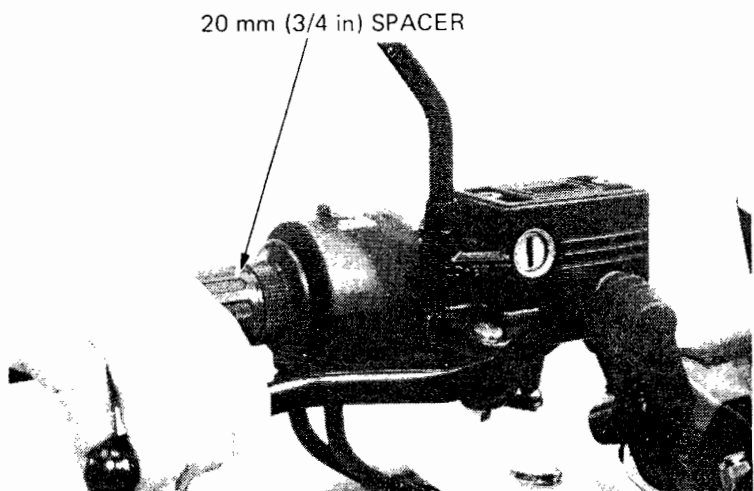

20 mm (3/4 in) SPACER

**AIR BLEEDING**

**NOTE**

- Check the fluid level often while bleeding the brakes to prevent air from being pumped into the system.
- When using the Mityvac Brake Bleeder, follow the manufacturer's instructions.

**CAUTION:**

- Use only DOT3 or 4 brake fluid from a sealed container.
- Do not mix brake fluid types and never reuse the contaminated fluid which has been pumped out during brake bleeding, because this will impair the efficiency of the brake system.

Pump the brake lever to bring the caliper pads in contact with the disc.  
 Remove the master cylinder cap and fill the reservoir to near full.  
 Connect the Mityvac Brake Bleeder or equivalent to the bleeder valve.  
 Pump the brake bleeder and loosen the bleeder valve.  
 Add fluid when the fluid level in the master cylinder reservoir is low.  
 Repeat above procedures until air bubbles do not appear in the plastic hose.

**NOTE**

If air is entering the bleeder from around the bleeder valve threads, seal the threads with teflon tape.

If a Mityvac Brake Bleeder or equivalent not available, bleed the system as follows:

- 1) Connect a bleeder tube to the bleeder valve.
- 2) Squeeze the brake lever, open the bleed valve 1/2 turn and then close the valve.

**NOTE**

Do not release the brake lever until the bleed valve has been closed.

- 3) Release the brake lever slowly and wait several seconds after it reaches the end of its travel.

\*Repeat steps 1 and 2 until bubbles cease to appear in the fluid at the end of the hose.  
 Fill the fluid reservoir to the upper level mark.

**WARNING**

A brake fluid contaminated brake disc or pad reduces stopping power. Discard contaminated pads and clean a contaminated disc with a high quality brake degreasing agent.

PLASTIC HOSE BLEEDER VALVE

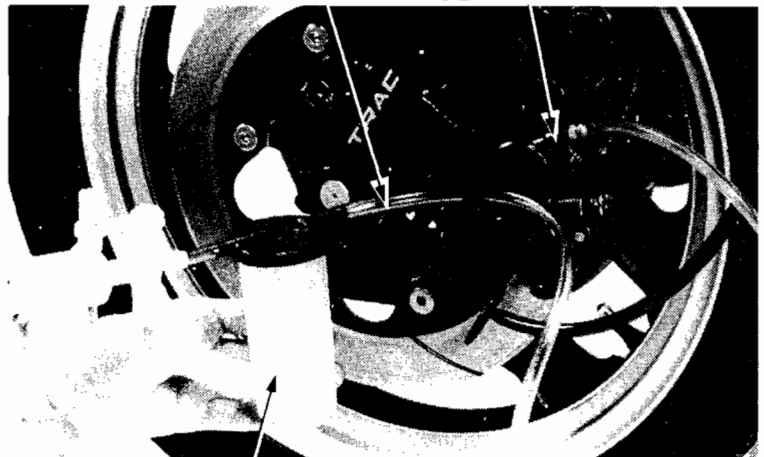

MITYVAC BRAKE BLEEDER  
# 6860 Commercially Available in U.S.A.

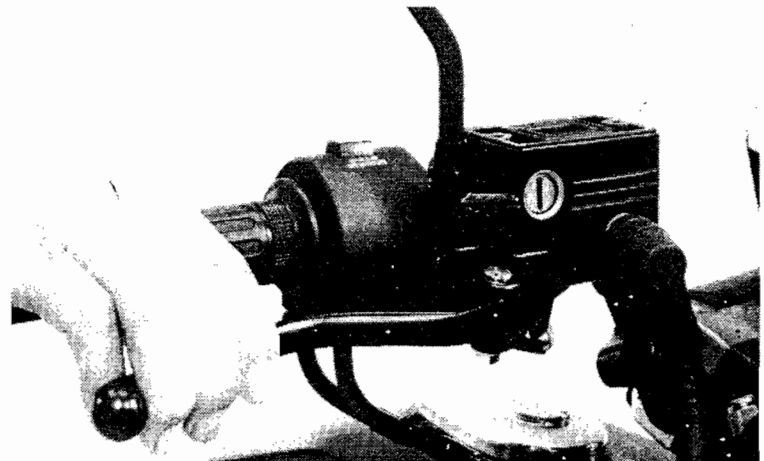

BLEEDER VALVE

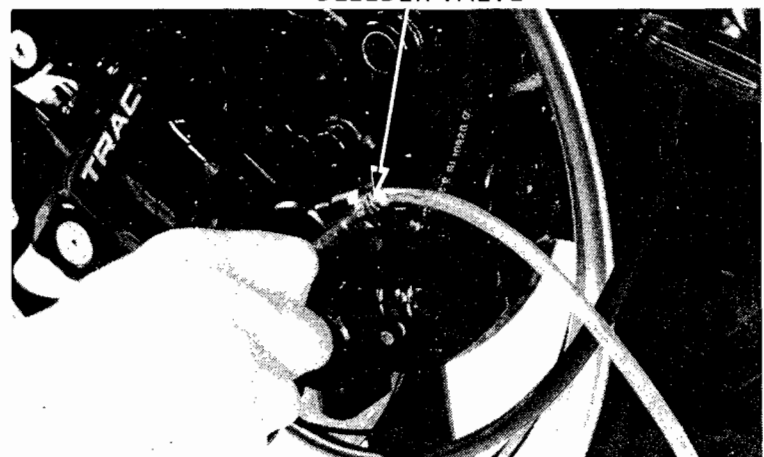





## BRAKE PAD/DISC

### PAD REPLACEMENT

#### NOTE

Always replace the brake pads as a set to assure even disc pressure.

Remove the pad pin retainer bolt.  
Remove the caliper bolt and pivot bolt.  
Remove the caliper.

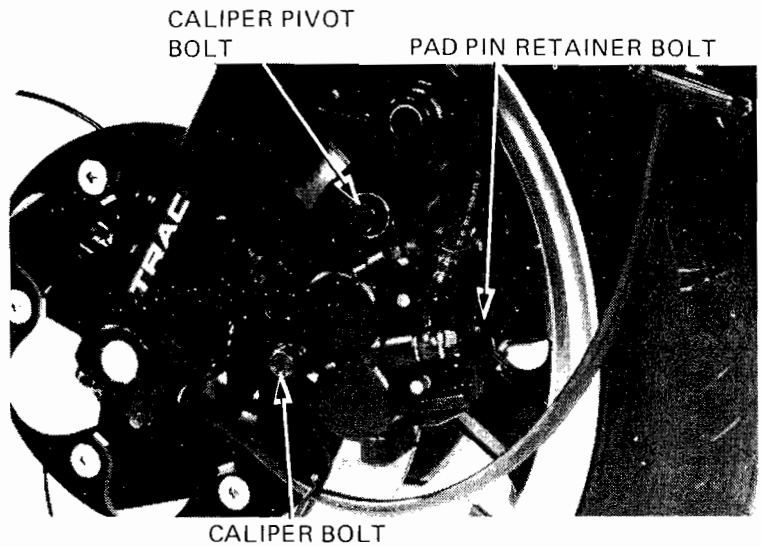

Remove the pad pin retainer and pull the pad pins out of the caliper.

Remove the brake pads.

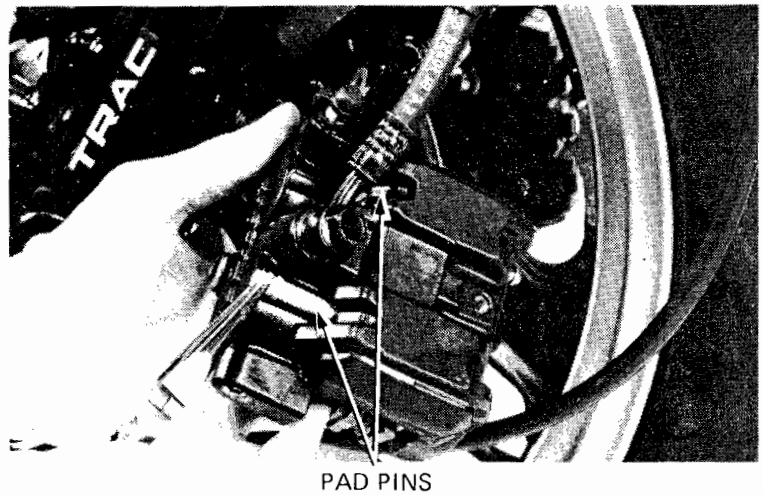

Position the pad spring in the caliper as shown and push the caliper pistons in all the way.

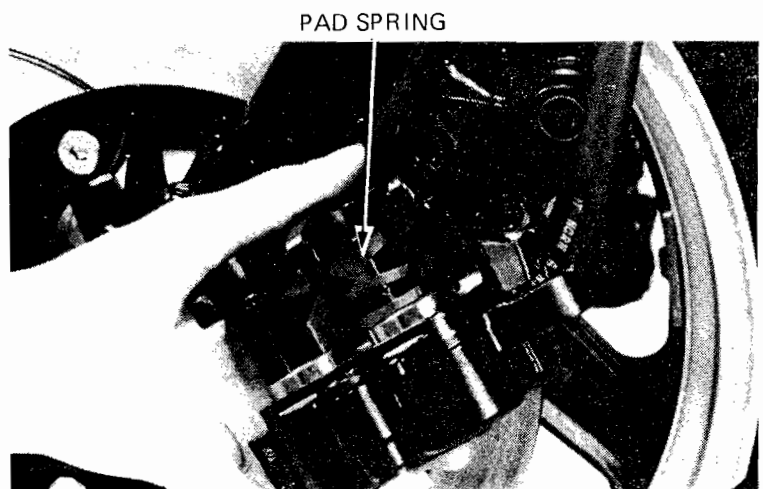



Install the new pads in the caliper.  
Install the pad pins, one pad pin first, then install the other pin by pushing the pads against the caliper to depress the pad spring.

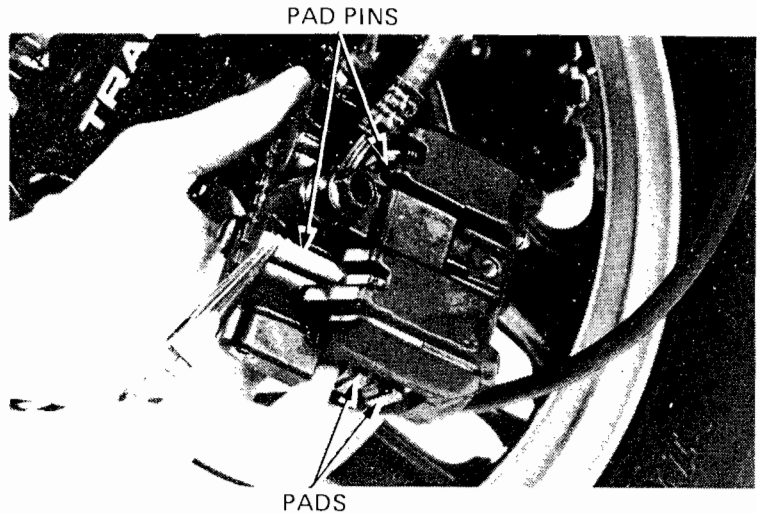

Place the pad pin retainer over the pad pins. Push the retainer down to secure the pins.  
Install the retainer bolt loosely.  
Apply silicone grease to the caliper pivot bolt, inside the pivot bolt boot, caliper bolt boots and collar.

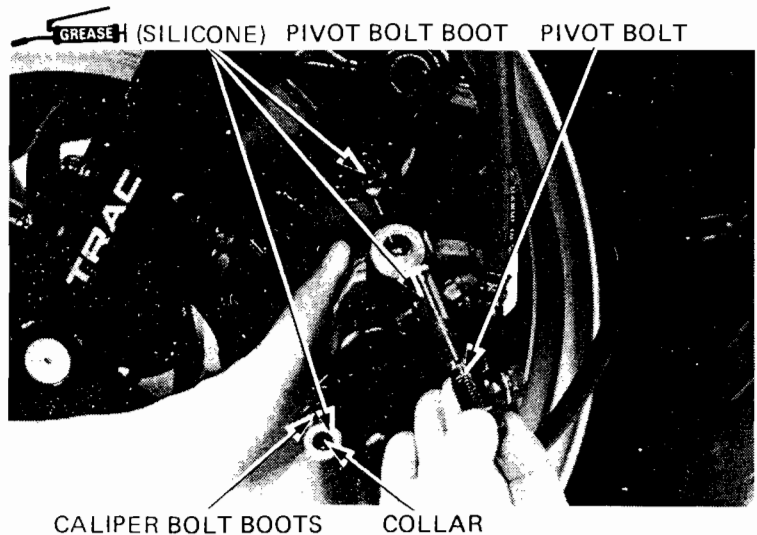

Install the caliper to the bracket so the disc is positioned between the pads, being careful not to damage the pads.  
Install and tighten the caliper bolt and pivot bolt.

**TORQUE:**  
**PIVOT BOLT:** 25–30 N·m  
 (2.5–3.0 kg·m, 18–22 ft·lb)  
**CALIPER BOLT:** 20–25 N·m  
 (2.0–2.5 kg·m, 14–18 ft·lb)

Tighten the pin retainer bolt.

**TORQUE:** 8–13 N·m  
 (0.8–1.3 kg·m, 6–9 ft·lb)

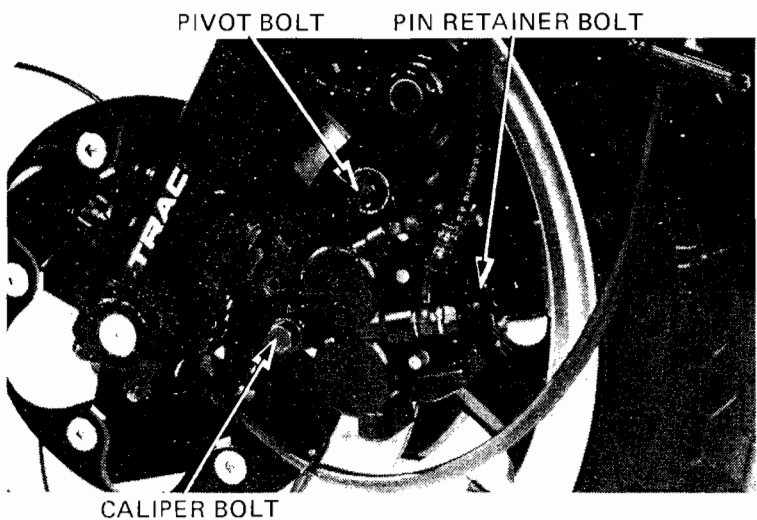



### DISC THICKNESS

Measure the thickness of each disc.

**SERVICE LIMIT: 4.0 mm (0.16 in)**

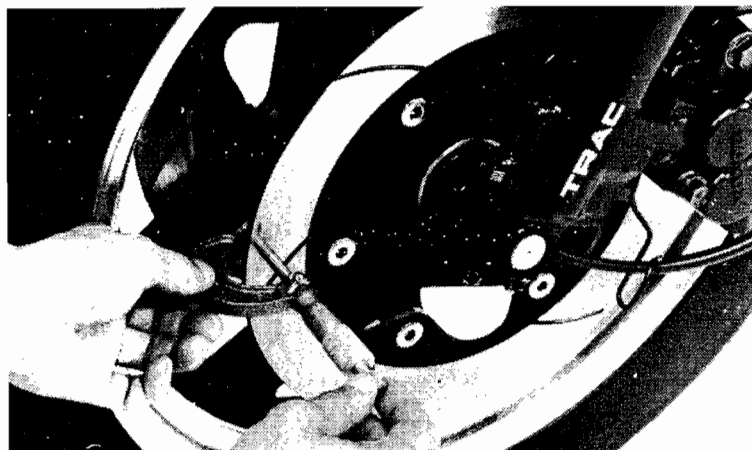

### BRAKE DISC WARPAGE

Measure brake disc for warpage.

**SERVICE LIMIT: 0.30 mm (0.012 in)**

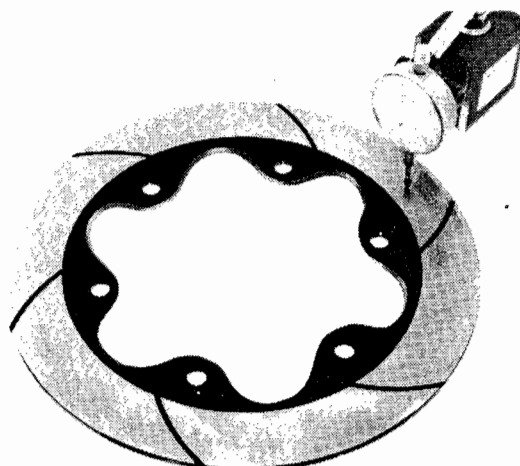

## MASTER CYLINDER

### DISASSEMBLY

Drain brake fluid from the hydraulic system.  
Remove the brake lever and rear view mirror from the master cylinder. Disconnect the brake hose.

**CAUTION**

*Avoid spilling brake fluid on painted surfaces.  
Place a rag over the fuel tank whenever the  
brake system is serviced.*

**NOTE**

*When removing the hose bolt, cover the end  
of the hose to prevent contamination.  
Secure the hose to prevent fluid from leaking  
out.*

Disconnect the front brake switch wires.  
Remove the front brake master cylinder.

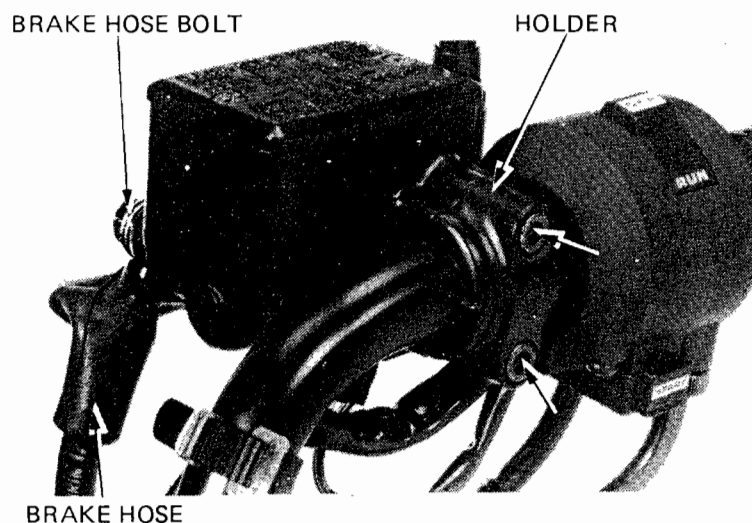



Remove the piston boot and the snap ring from the master cylinder body.

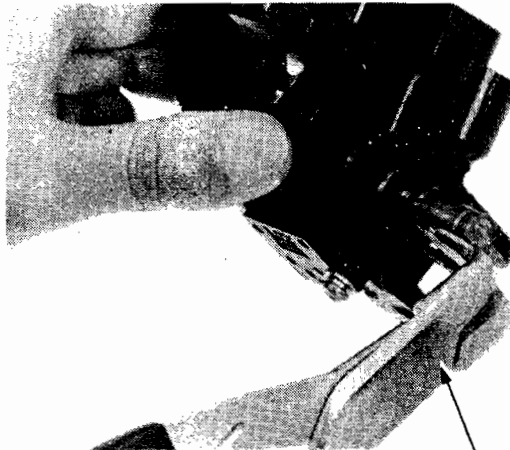

SNAP RING PLIERS or EQUIVALENT COMMERCIALLY AVAILABLE in U.S.A. 07914-3230001

Remove the secondary cup and piston. Then remove the primary cup and spring.

Remove the brake light switch from the master cylinder body, if necessary.

Clean the inside of the master cylinder and reservoir with brake fluid.

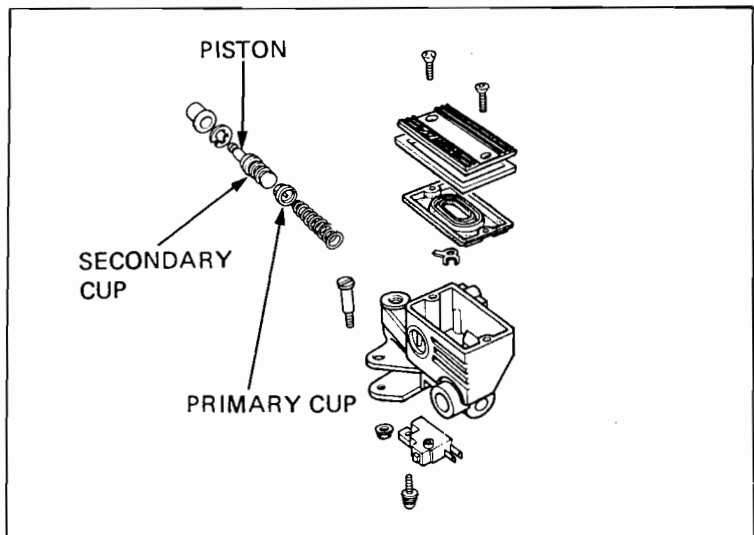

**INSPECTION**

Check the master cylinder for scores, scratches or nicks.

Measure the master cylinder I.D.

**SERVICE LIMIT: 15.93 mm (0.627 in)**

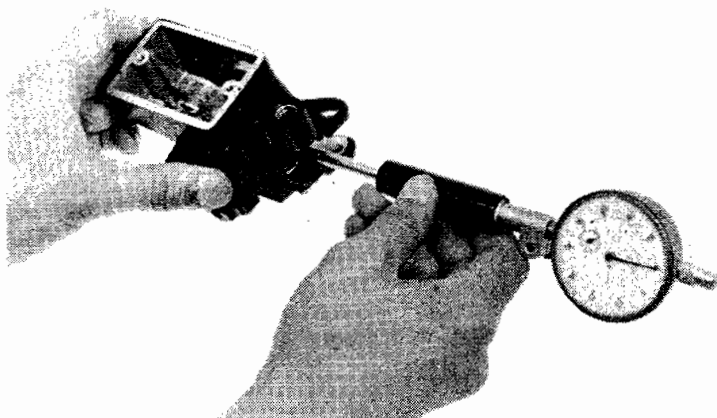



Measure the master cylinder piston O.D.

**SERVICE LIMIT: 15.82 mm (0.623 in)**

Check the primary and secondary cups for damage before assembly.

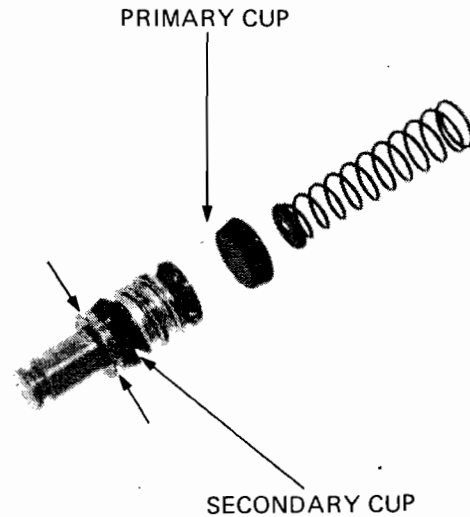

**ASSEMBLY**

**CAUTION**

*Keep the master cylinder piston, cylinder and spring as a set; don't substitute individual parts.*

Assemble the master cylinder. Coat the primary cup and master piston with clean brake fluid before assembly. Install the spring and primary cup together.

**CAUTION**

*When installing the cups, do not allow the lips to turn inside out and be certain the snap ring is firmly seated in the groove.*

Install the piston and snap ring.  
Install the boot.

Place the front master cylinder on the handlebar and install its holder and two mounting bolts. Align the end of the holder with the punch mark on the handlebar. Tighten the upper bolt first, then tighten the lower bolt.  
Install the brake hose with the bolt and two sealing washers.

**TORQUE: 25–35 N·m**  
**(2.5–3.5 kg·m, 18–25 ft·lb)**

Install the brake lever.  
Install the rear view mirror.  
Connect the front brake switch wires.  
Fill the reservoir to the upper level and bleed the brake system according to Page 16-4.

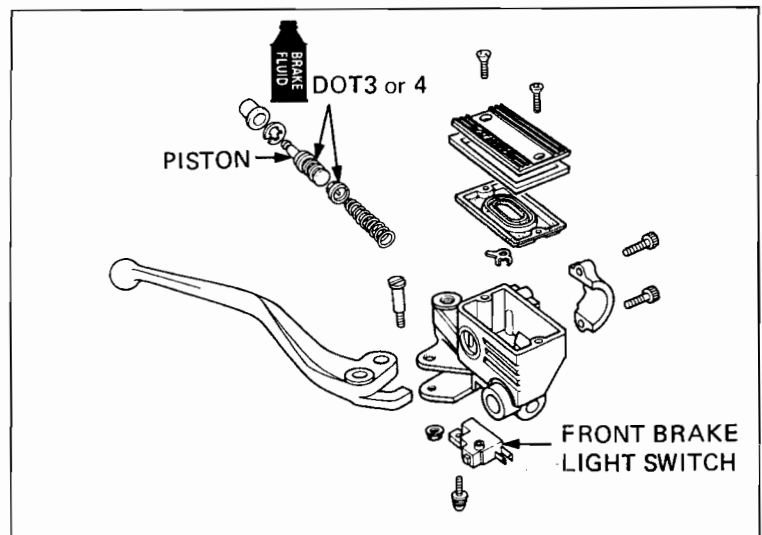

**BRAKE HOSE BOLT/SEALING WASHERS HOLDER**

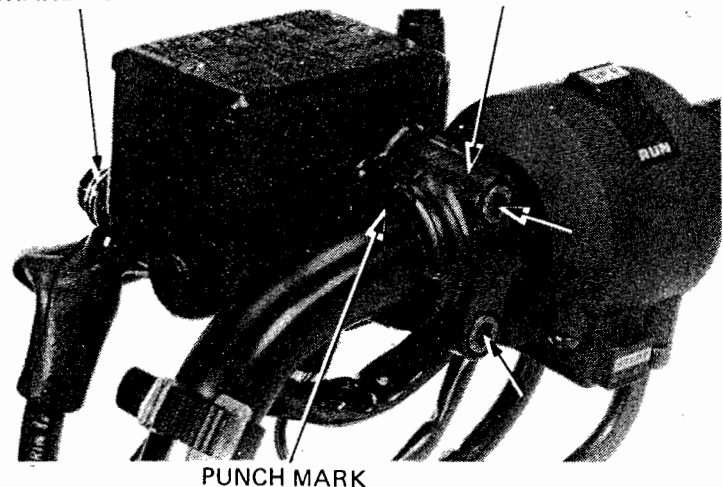



## BRAKE CALIPERS

### REMOVAL

Place a clean container under the caliper and disconnect the brake hose from the caliper.

**CAUTION**

*Avoid spilling brake fluid on painted surfaces.*

Remove the caliper pivot bolt and caliper bolt, and remove the caliper.

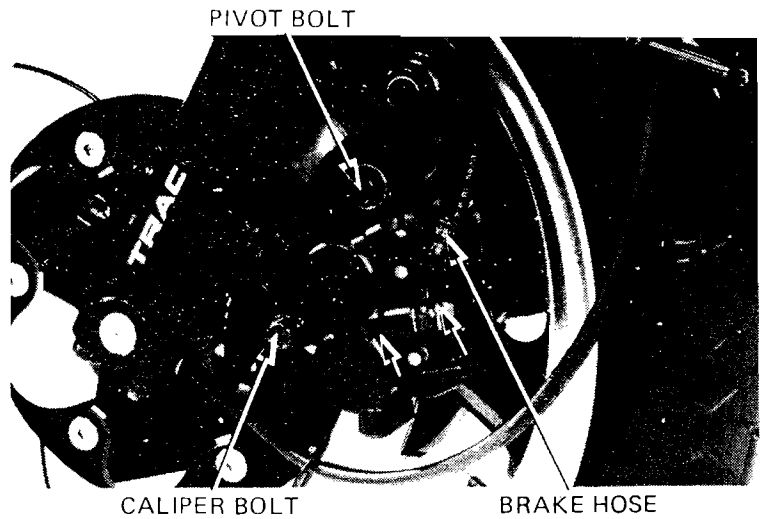

### DISASSEMBLY

Remove the pads and pad spring.

Remove the caliper bolt collar and boots.

Remove the pistons from the caliper.

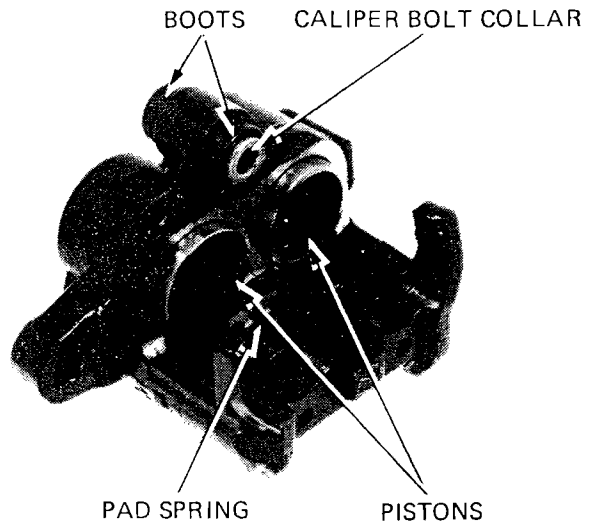

If necessary, apply compressed air to the caliper fluid inlet to get the piston out. Place a shop rag under the caliper to cushion the piston when it is expelled. Use the air in short spurts.

**WARNING**

*Do not bring the nozzle too close to the inlet.*

Examine the pistons and cylinders for scoring, scratches or other damage and replace if necessary.





Push the piston seals in and lift them out, then discard them.  
Clean the piston seal grooves with brake fluid.

**CAUTION**

*Be careful not to damage the piston sliding surfaces.*

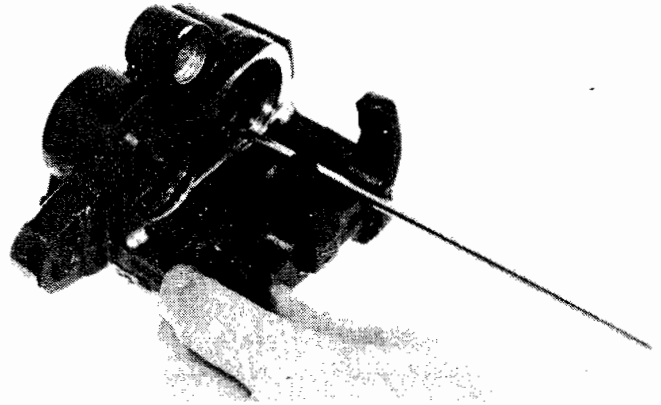

**PISTON INSPECTION**

Check the pistons for scoring, scratches or other faults. Measure the piston diameter with a micrometer.

**SERVICE LIMIT: 31.940 mm (1.2578 in)**

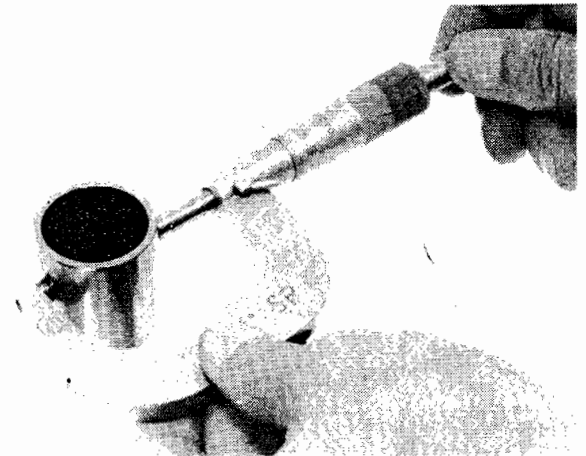

**CYLINDER INSPECTION**

Check the caliper cylinder for scoring, scratches or other faults. Measure the caliper cylinder bore.

**SERVICE LIMIT: 32.090 mm (1.2634 in)**

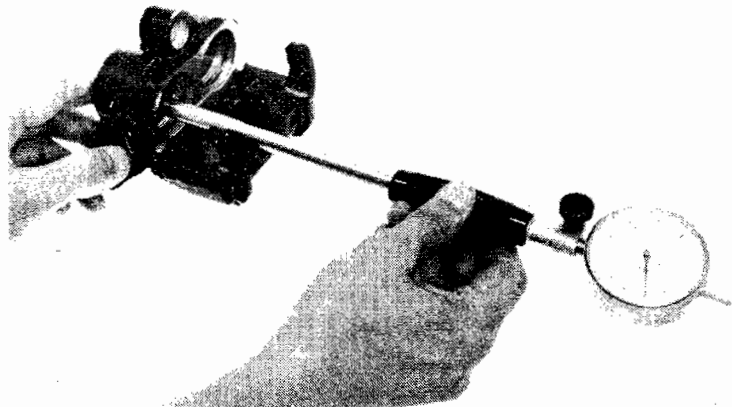



**ASSEMBLY**

If the collar boots are hardened or deteriorated, replace them with new ones.

The piston and dust seals must be replaced with new ones whenever they are removed. Coat the seals with brake fluid before assembly.

**NOTE**

Install the piston and dust seals with their small I.D. sides facing in.

Install the pistons with the dished ends toward the pads.

Apply silicone grease to the collar and boots.

Install the collar boots and collar making sure that the boots are seated in the collar and caliper grooves properly.

Install the pad spring.

Install the pads (Page 16-5).

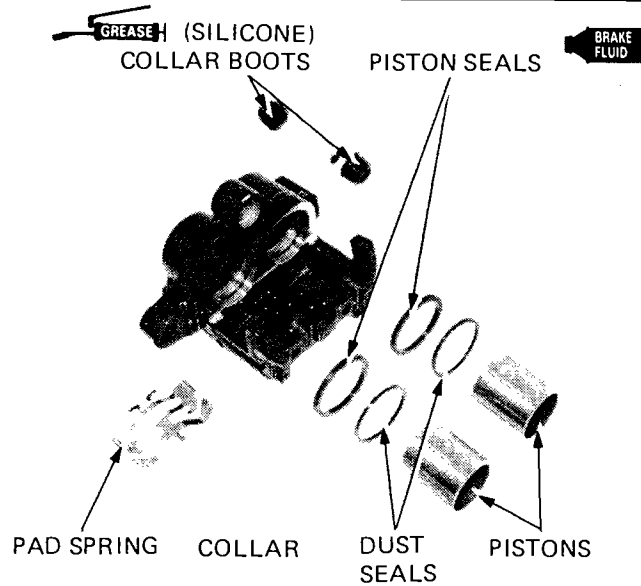

**INSTALLATION**

Make sure that the retainer clip is in position on the caliper bracket.

Inspect the condition of the caliper pivot boot. Apply silicone grease to the caliper pivot bolt and inside the pivot boot.

CALIPER PIVOT BOOT

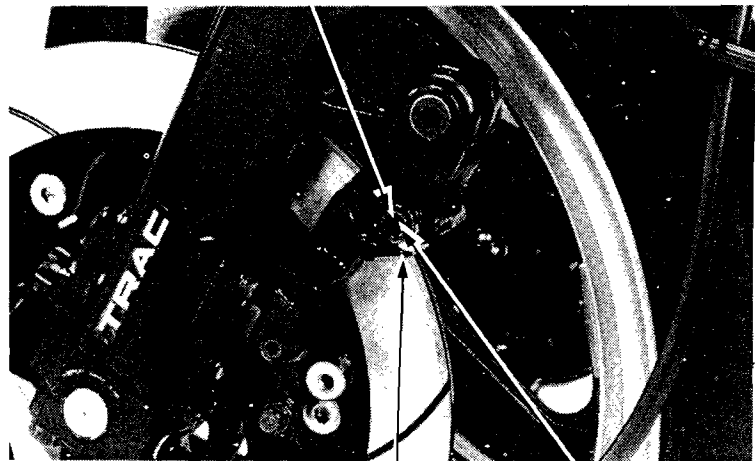

RETAINER CLIP

GREASE (SILICONE)

Install the caliper assembly over the brake disc so that the disc is positioned between the pads.

**CAUTION**

*Be careful not to damage the pads.*

Install and tighten the pivot bolt and caliper bolt.

**TORQUE:**

**PIVOT BOLT:** 25–30 N·m  
(2.5–3.0 kg·m, 18–22 ft·lb)

**CALIPER BOLT:** 20–25 N·m  
(2.0–2.5 kg·m, 14–18 ft·lb)

Connect the brake hose to the caliper with the bolt and two sealing washers.

**TORQUE:** 25–35 N·m  
(2.5–3.5 kg·m, 18–25 ft·lb)

Fill the brake fluid reservoir and bleed the brake system (Page 16-4).

PIVOT BOLT

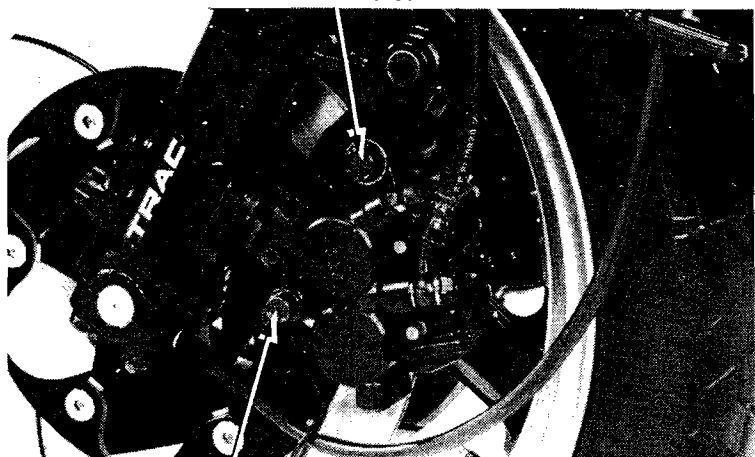

CALIPER BOLT





**CALIPER BRACKET REMOVAL**

Remove the caliper (Page 16-10).

Right caliper bracket: Remove the two caliper bracket bolts and bracket from the right fork leg.

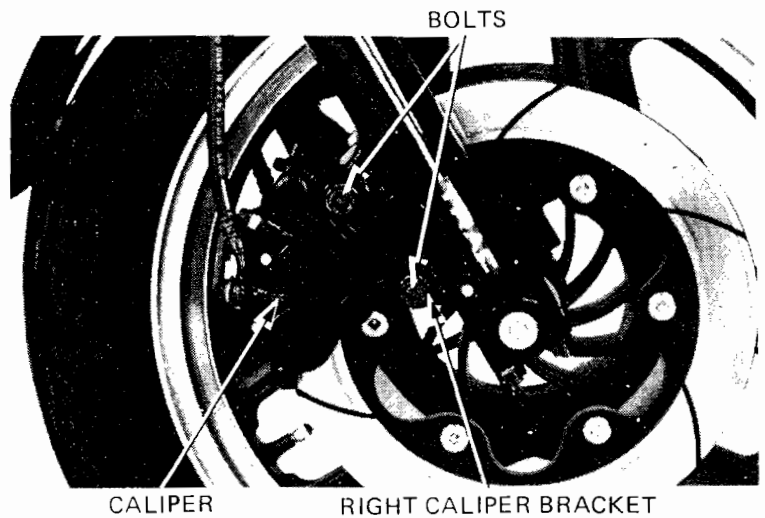

Left caliper bracket: Remove the upper mount socket bolt, anti-dive piston pin bolt and bracket. Remove the bracket pivot pin from the fork leg upper mount.

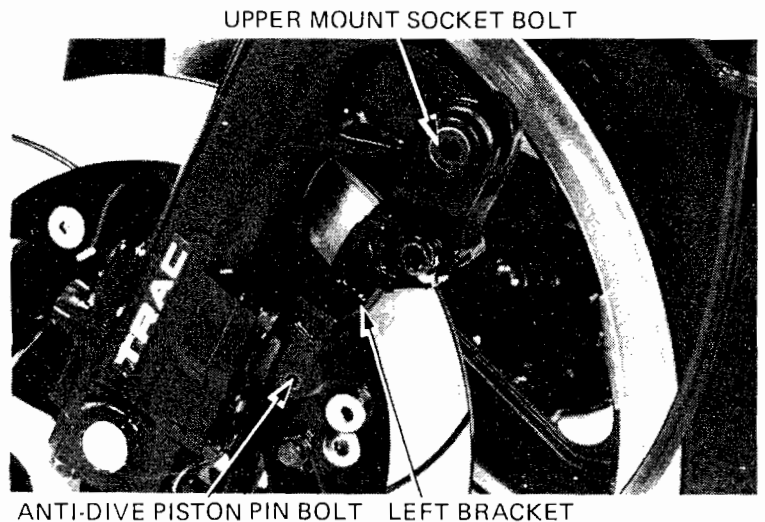

**CALIPER BRACKET INSTALLATION**

Install the caliper bracket in the reverse order of removal.  
Replace the O-rings on the left bracket pivot pin with new ones.  
Apply grease to the left bracket pivot pin before installation.

**TORQUE:**

- RIGHT BRACKET MOUNT BOLTS:**  
35–45 N·m (3.5–4.5 kg·m, 25–33 ft·lb)
- LEFT BRACKET UPPER MOUNT BOLT:**  
35–45 N·m (3.5–4.5 kg·m, 25–33 ft·lb)
- ANTI-DIVE PISTON PIN BOLT:**  
10–14 N·m (1.0–1.4 kg·m, 7–10 ft·lb)

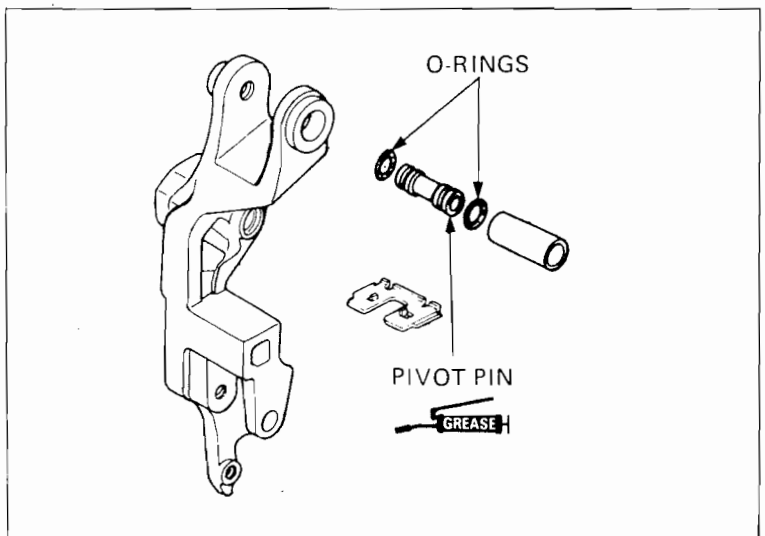



**HONDA**  
**CB750SC**

---

MEMO

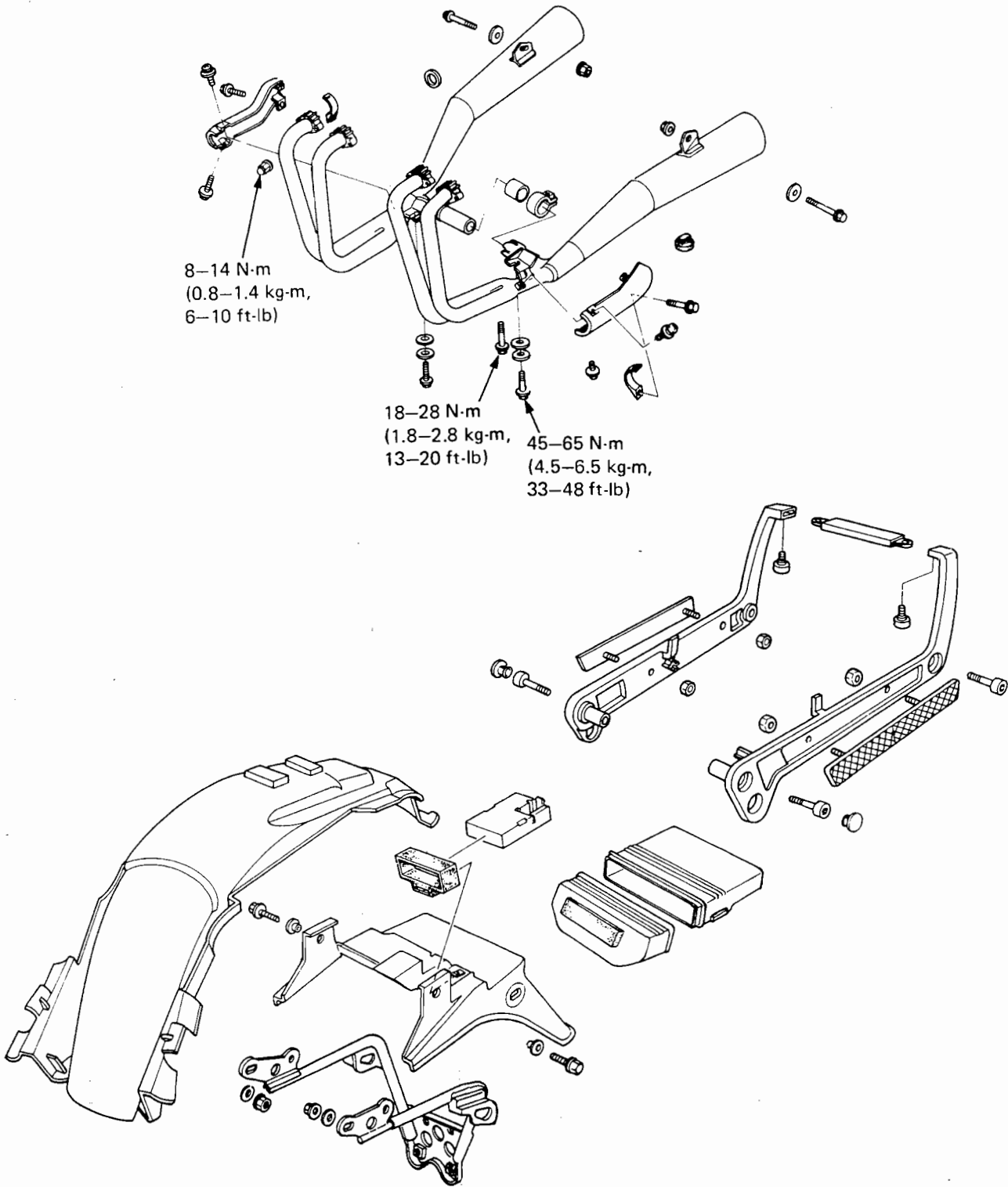



SERVICE INFORMATION	17-1
MUFFLER	17-2
REAR FENDER	17-3

## SERVICE INFORMATION

### GENERAL

- Do not service the exhaust system when it is hot.
- Check the exhaust system for leaks after installation.

### TORQUE VALUES

Exhaust pipe joint nut	8-14 N·m (0.8-1.4 kg·m, 6-10 ft·lb)
Exhaust pipe clamp bolt	18-28 N·m (1.8-2.8 kg·m, 13-20 ft·lb)
Muffler lower mounting bolt	45-65 N·m (4.5-6.5 kg·m, 33-48 ft·lb)



**MUFFLER**

**REMOVAL**

Remove the exhaust pipe joint nuts.

EXHAUST PIPE JOINT NUTS

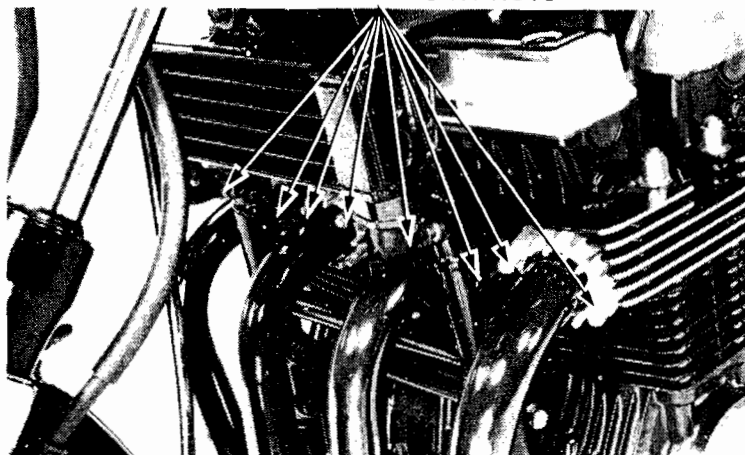

Loosen the exhaust pipe clamp bolt.  
Remove the muffler bracket bolts, rear muffler mount bolts and brackets.  
Remove the lower muffler mount bolts and remove the right and left mufflers.

LOWER MUFFLER  
MOUNT BOLTS

REAR MUFFLER MOUNT BOLT

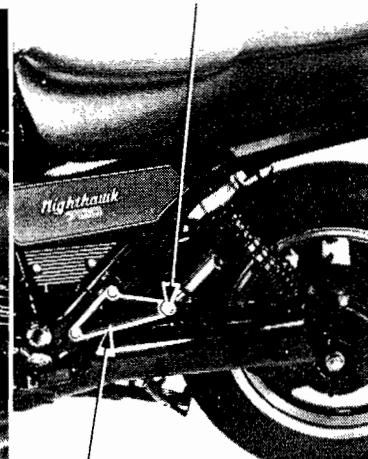
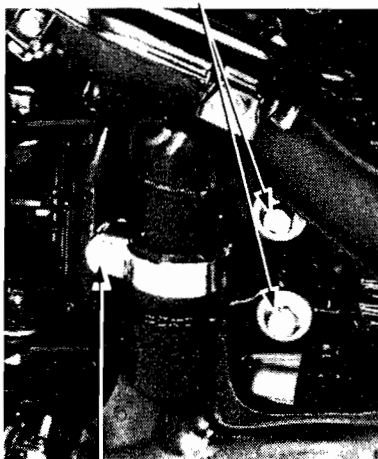

**INSTALLATION**

Check the muffler joint gasket for damage and replace if necessary.

Temporarily install the mufflers in the reverse order of removal.

Tighten the exhaust pipe joint nuts.

**TORQUE:** 8–14 N·m  
(0.8–1.4 kg-m, 6–10 ft-lb)

Tighten the exhaust pipe clamp bolt.

**TORQUE:** 18–28 N·m  
(1.8–2.8 kg-m, 13–20 ft-lb)

Tighten the rear muffler mount bolts.  
Tighten the muffler lower mount bolts.

**TORQUE:** 45–65 N·m  
(4.5–6.5 kg-m, 33–48 ft-lb)

Start the engine and make sure that there are no exhaust leaks.

EXHAUST PIPE CLAMP BOLT

MUFFLER BRACKET

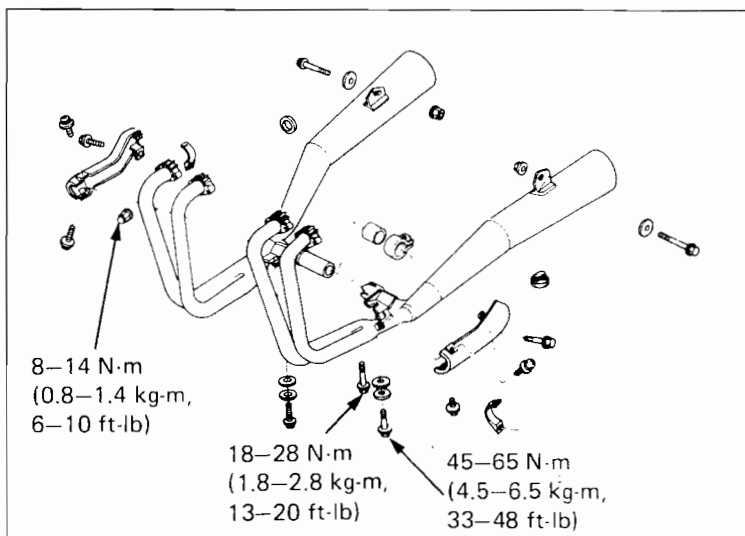



## REAR FENDER

### REMOVAL

Remove the seat.  
Remove the four socket bolts attaching the handrail and rear cowl.

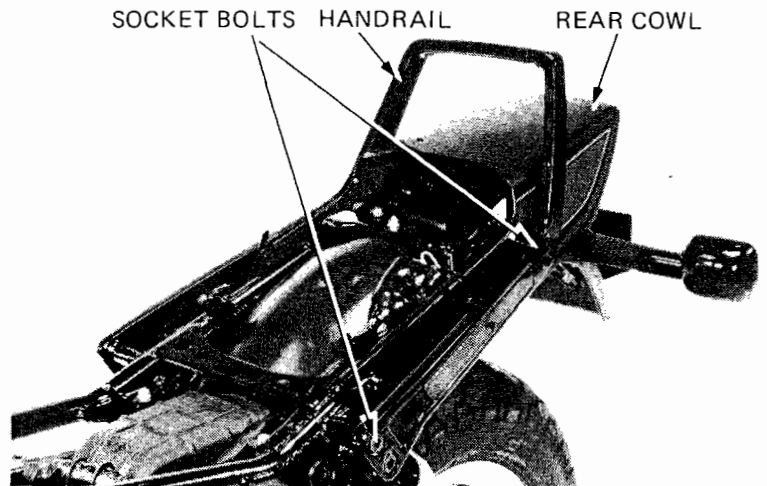

Remove the nut mounting rear fender A and fender B.  
Disconnect the taillight coupler, rear turn signal and license light wire connectors.  
Remove the two rear fender B mounting bolts and rear fender B.

### INSTALLATION

Install rear fenders A and B in the reverse order of removal.

#### NOTE

Be careful not to pinch the wires between the parts.

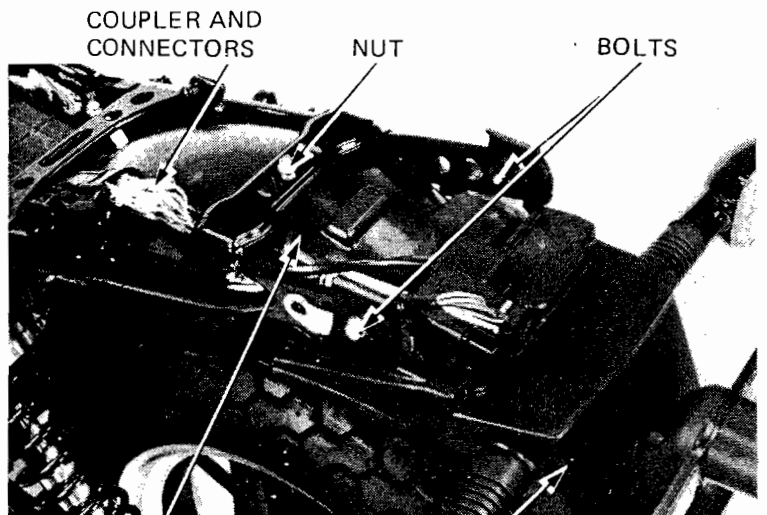

REAR FENDER A

REAR FENDER B

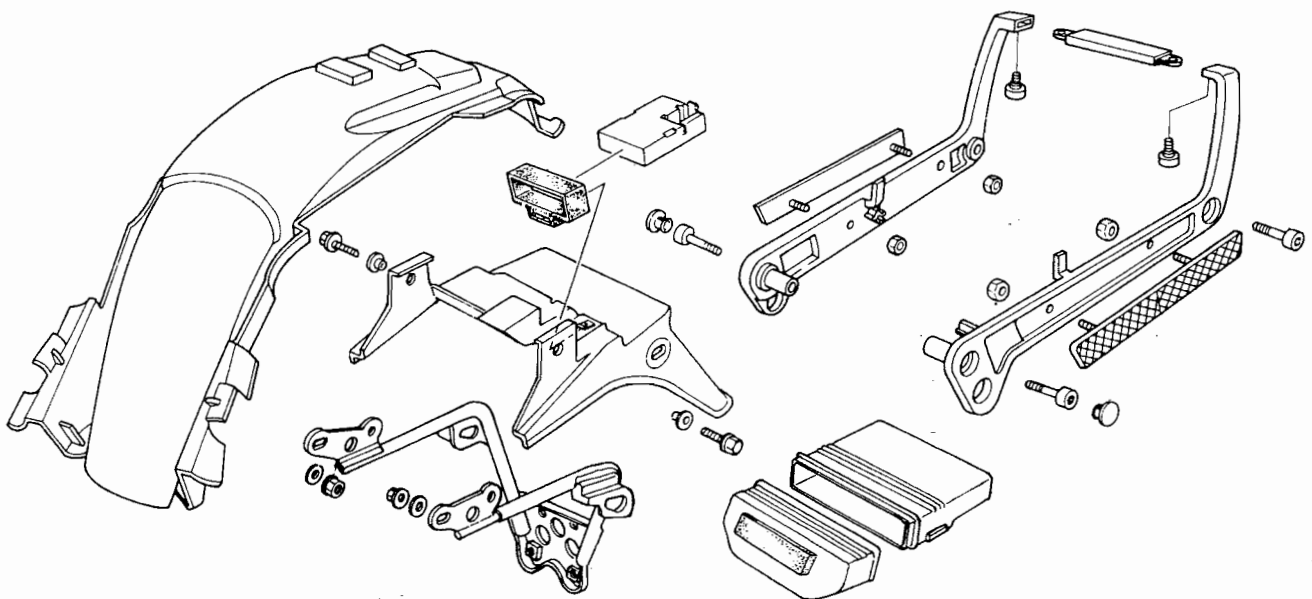



**BATTERY/CHARGING SYSTEM**

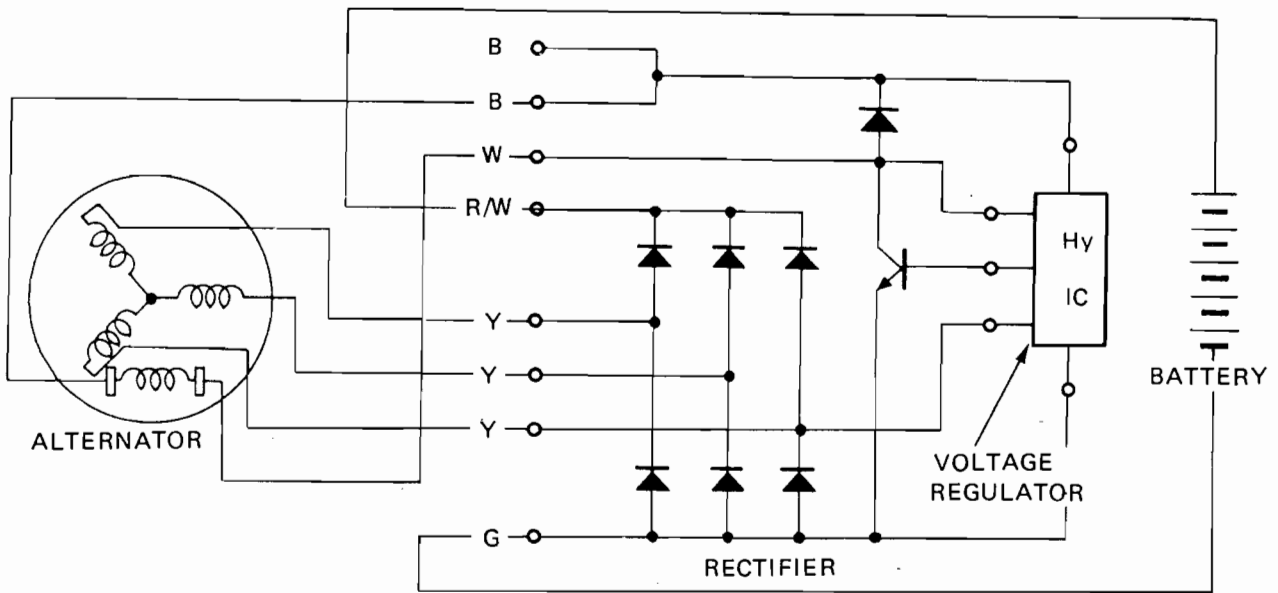
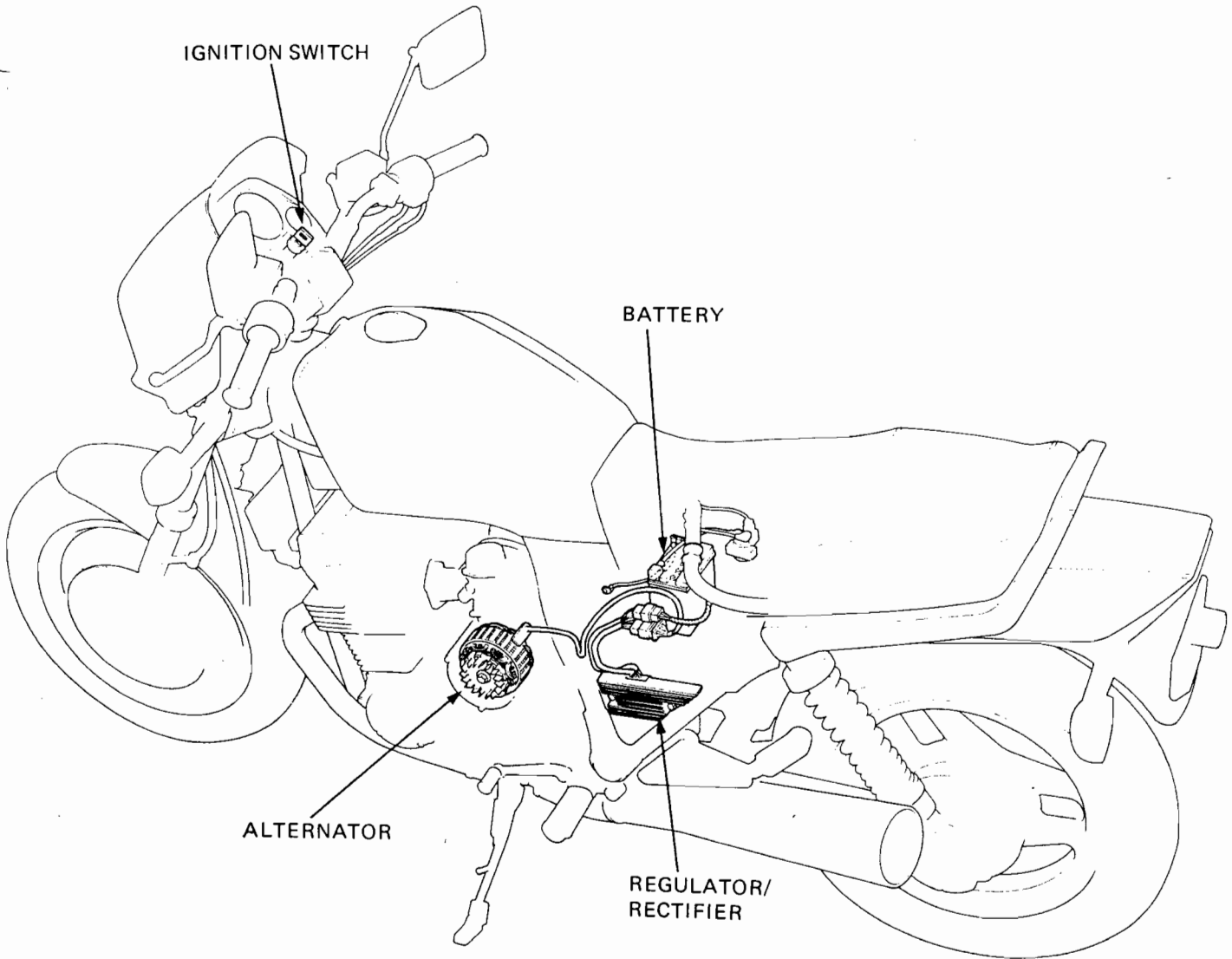

**BATTERY CHARGING SYSTEM**



SERVICE INFORMATION	18-1
TROUBLESHOOTING	18-2
BATTERY	18-3
CHARGING SYSTEM	18-4
ALTERNATOR	18-5
VOLTAGE REGULATOR/RECTIFIER	18-9

## SERVICE INFORMATION

### GENERAL

- Battery fluid level should be checked regularly. Fill with distilled water when necessary.
- Quick charge a battery, only in an emergency. Slow-charging is preferred.
- Remove the battery from the motorcycle for charging. If the battery must be charged on the motorcycle, disconnect the battery cables.

**WARNING**

*Do not smoke, and keep flames away from a charging battery. The gas produced by a battery will explode if a flame or spark is brought near.*

- All charging system components can be tested on the motorcycle.

### SPECIFICATIONS

Battery	Capacity	12V 14 AH
	Specific gravity	1.270-1.290/20°C (68°F)
	Charging rate	1.4 amperes maximum
Alternator capacity		5 A min. at 2,000 rpm
Voltage regulator		Transistorized non-adjustable

### TOOLS

Special Rotor puller 07933-2160000

### TORQUE VALUE

Alternator rotor bolt 30-38 N·m (3.0-3.8 kg·m, 22-28 ft·lb)





## TROUBLESHOOTING

### No power — key turned on

1. Dead battery
  - Low fluid level
  - Low specific gravity
  - Charging system failure
2. Disconnected battery cable
3. Main fuse burned out
4. Faulty ignition switch

### Low power — key turned on

1. Weak battery
  - Low fluid level
  - Low specific gravity
  - Charging system failure
2. Loose battery connection

### Low power — engine running

1. Battery undercharged
  - Low fluid level
  - One or more dead cells
2. Charging system failure

### Intermittent power

1. Loose battery connection
2. Loose charging system connection
3. Loose starting system connection
4. Loose connection or short circuit in ignition system

### Charging system failure

1. Loose, broken, or shorted wire or connection
2. Faulty voltage regulator
3. Faulty rectifier
4. Faulty alternator



### BATTERY

#### REMOVAL

Remove the frame right side cover.  
 Disconnect the negative cable at the battery.  
 Remove the three battery holder bolts, disconnect the battery breather tube at the battery and pull the battery out.

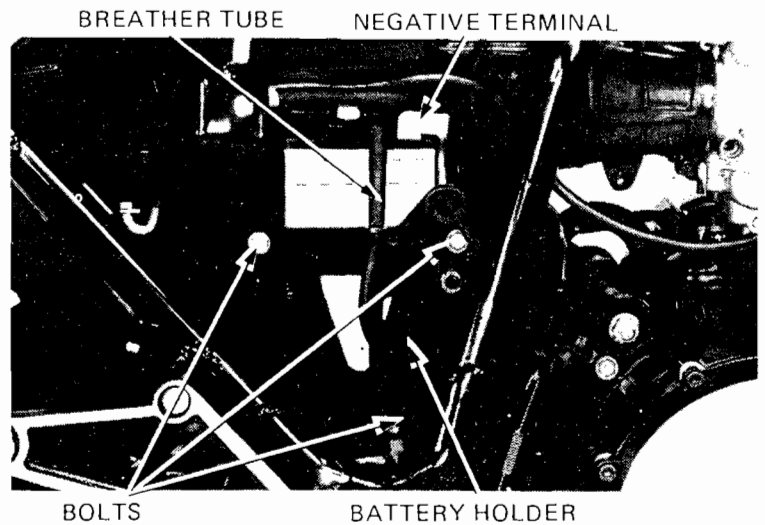

Disconnect the positive cable at the battery and remove the battery.

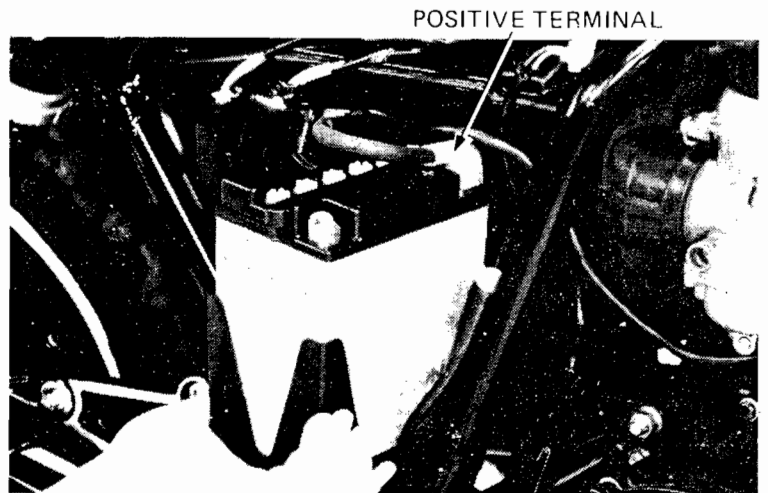

#### TESTING SPECIFIC GRAVITY

Test each cell with a hydrometer.

**SPECIFIC GRAVITY:**  
(20°C, 68°F)

1.270 – 1.290	Fully charged
Below 1.260	Undercharged

#### NOTE

The battery must be recharged if the specific gravity is below 1.230.

The specific gravity varies with the temperature as shown in the accompanying table.

Replace the battery if sulfation is evident or if the space below the cell plates is filled with sediment.

#### WARNING

*The battery contains sulfuric acid. Avoid contact with skin, eyes, or clothing.  
 Antidote: Flush with water and get prompt medical attention.*

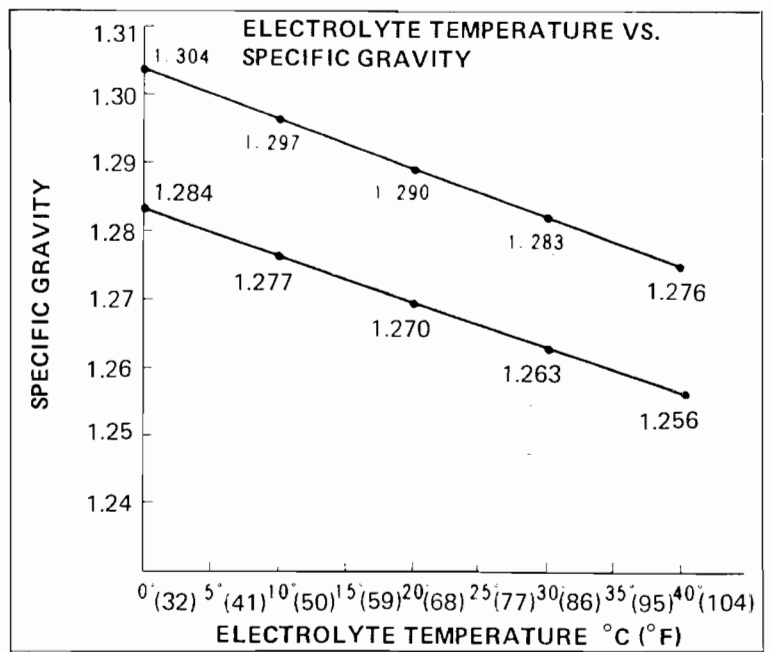



**BATTERY/CHARGING SYSTEM**

**BATTERY CHARGING**

Connect the charger positive (+) cable to the battery positive (+) terminal.

Connect the charger negative (-) cable to the battery negative (-) terminal.

**Charging current:**  
1.4 amperes max.

**Charging:**  
Charge the battery until specific gravity is 1.270 - 1.290 at 20°C (68°F).

**WARNING**

- Before charging a battery, remove the cap from each cell.
- Keep flames and sparks away from a charging battery.
- Turn power ON/OFF at the charger, not at the battery terminals.
- Discontinue charging if the electrolyte temperature exceeds 45°C (113°F).

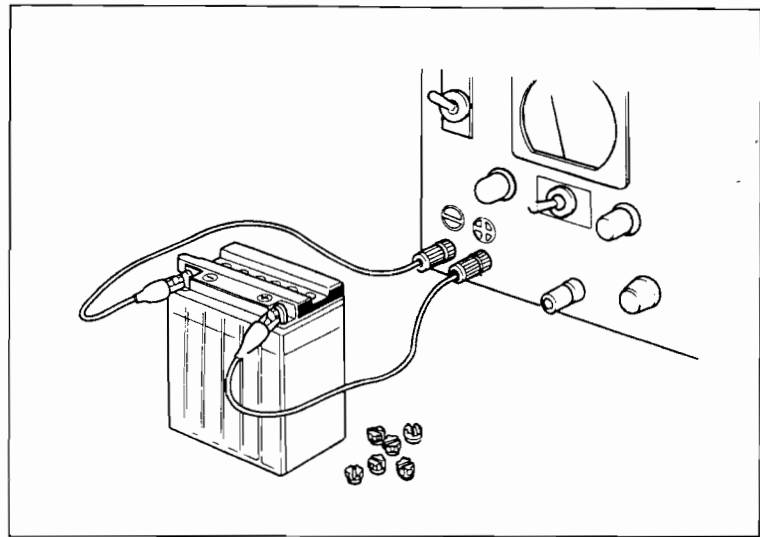

**CAUTION**

Quick-charging should only be done in an emergency; slow-charging is preferred.

After installing the battery, coat the terminals with clean grease.

**CAUTION**

Route the breather tube as shown on the battery caution label.

**CHARGING SYSTEM**

**CURRENT TEST**

**NOTE**

Be sure the battery is in good condition before performing this test.

Warm up the engine.

Remove the frame right side cover.  
Remove the fuse and connect the ammeter positive wire to the fuse holder negative terminal and ammeter negative wire to the fuse holder positive terminal.

Connect the voltmeter across the battery negative and starter relay positive terminals.  
Start the engine, gradually increase engine speed and read the ammeter and voltmeter.

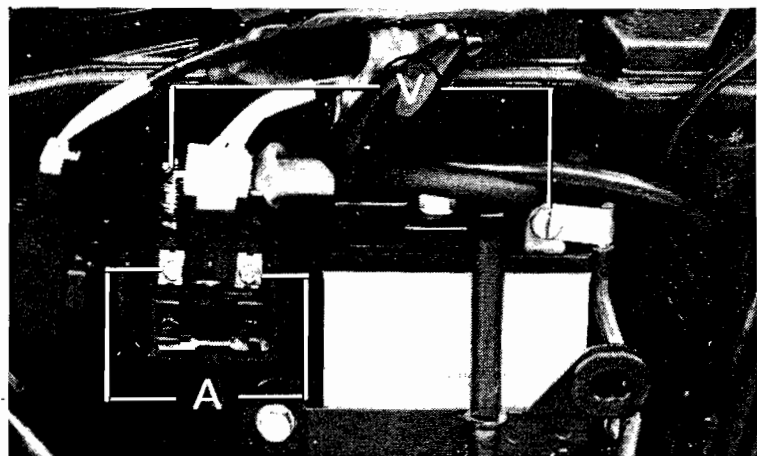



Ampere and voltage should be controlled to 0 A and 14–15 V.

If the readings do not meet the specifications, check the wires for loose connection and repair if necessary.

If the wires are in good condition, replace the regulator/rectifier with a new one and retest.

If the readings still do not meet the specifications, perform the alternator output test.

### ALTERNATOR OUTPUT TEST

Disconnect the regulator/rectifier couplers.

Disconnect the white wire from the alternator coupler, connect it to the green wire terminal of the regulator/rectifier coupler and reconnect the couplers.

Connect the ammeter and voltmeter as the same as the current test (Page 18-4).

Start the engine and gradually increase the engine speed.

ENGINE SPEED	2,000 min <sup>-1</sup> (rpm)
OUTPUT	5 A min.

## ALTERNATOR

### STATOR COIL CONTINUITY TEST

#### NOTE

It is not necessary to remove the stator to make this test.

Check the yellow leads to the alternator stator for continuity with each other. Replace the stator if any yellow lead is not continuous with the other.

Check each yellow lead to ground.

There should be no continuity. Replace the stator if there is continuity.

### FIELD COIL CONTINUITY TEST

Check the B and W terminals of the alternator coupler for continuity. Replace the stator, if there is no continuity between them.

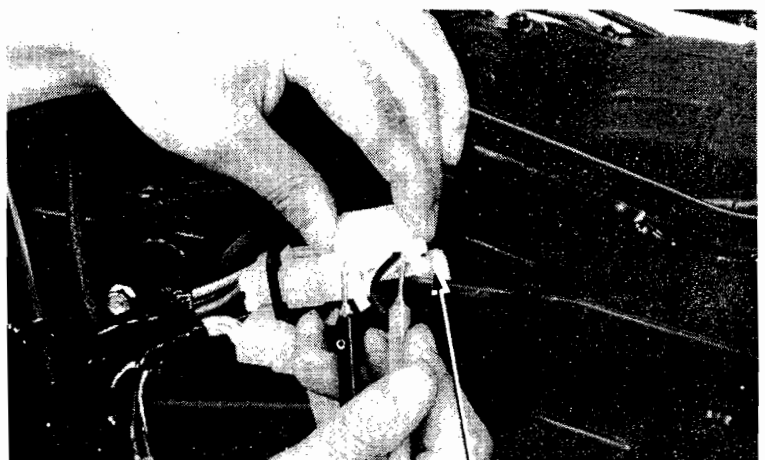

ALTERNATOR COUPLER



**ALTERNATOR REMOVAL**

Remove the frame left side cover.  
Disconnect the alternator coupler.

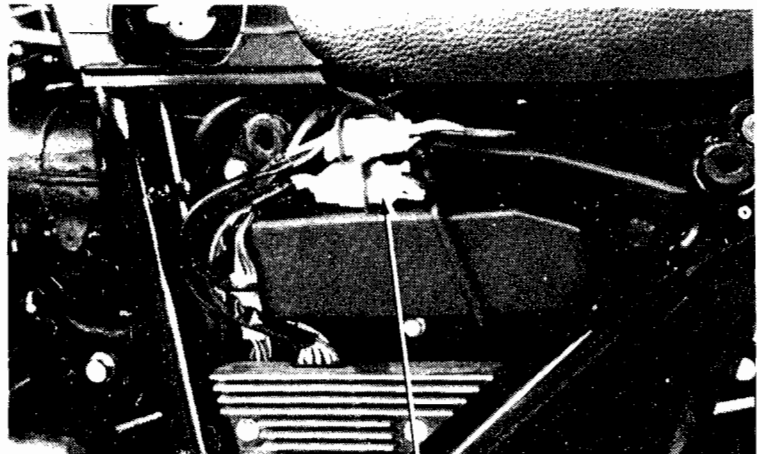

ALTERNATOR COUPLER

Remove the alternator cover by loosening three bolts.

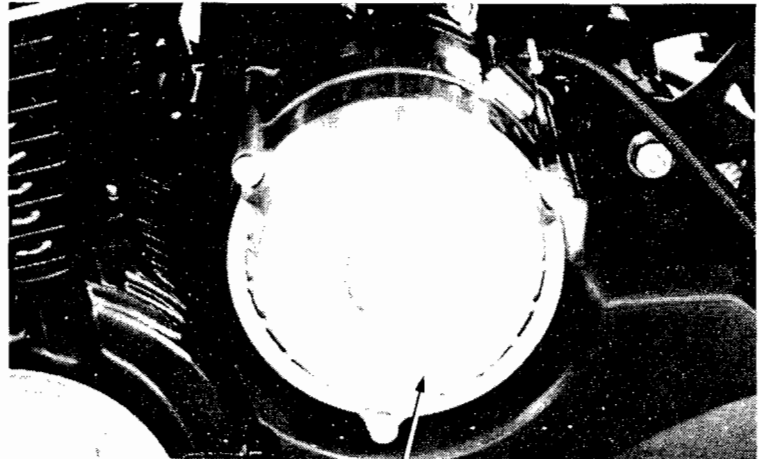

ALTERNATOR COVER

Shift the transmission into gear and apply the rear brake.  
Remove the alternator rotor bolt, fan, rotor B and stator.

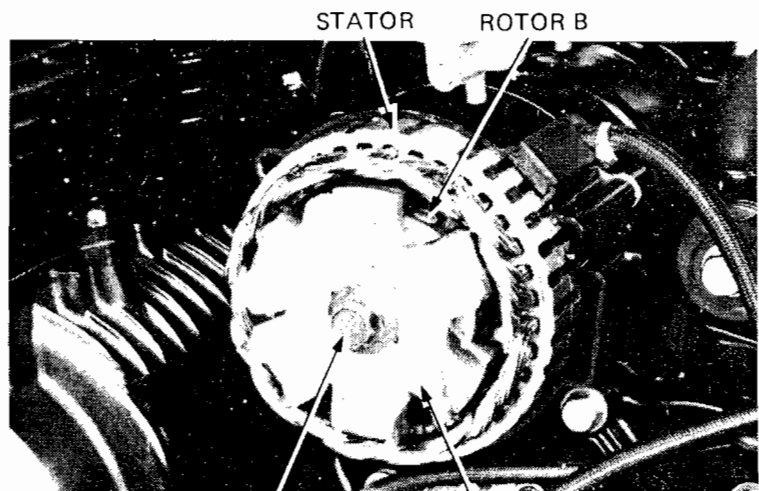

STATOR      ROTOR B

ROTOR BOLT      FAN



Remove alternator rotor A while applying the rear brake.



ROTOR PULLER  
07933-2160000

**ALTERNATOR ASSEMBLY**

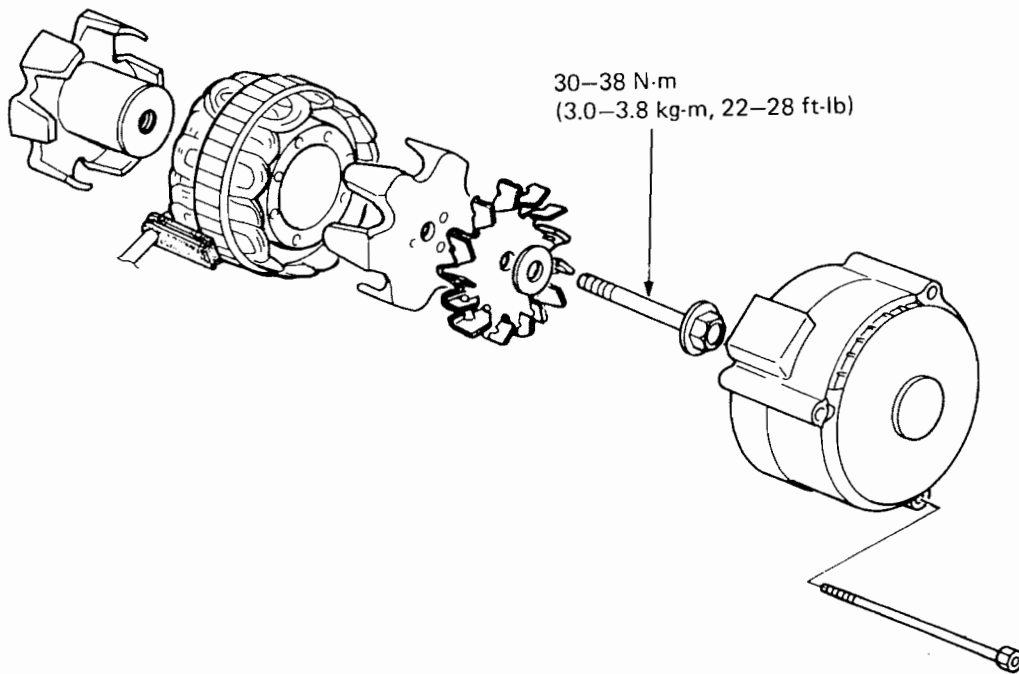



**BATTERY/CHARGING SYSTEM**

Install alternator rotor A.

Install the alternator stator with the painted groove on the stator coil aligned with upper left groove for the alternator cover mounting bolts.

Install rotor B with its hole aligned with the boss on rotor A.

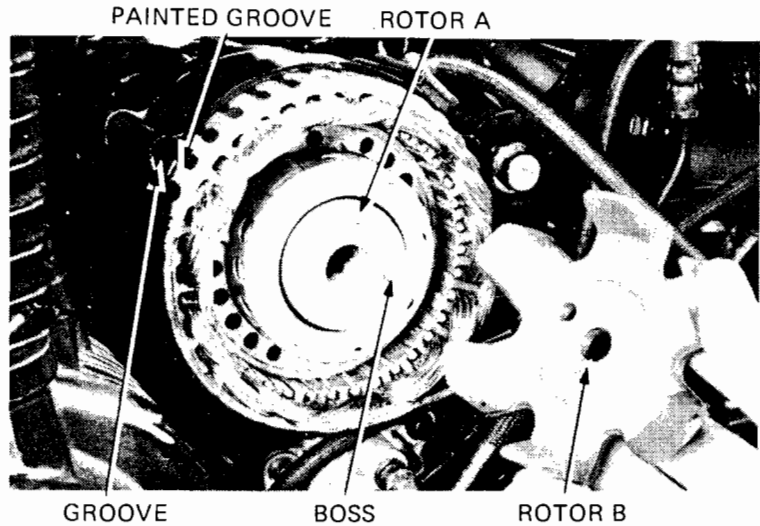

Install the alternator fan with its holes aligned with the pins on rotor B.

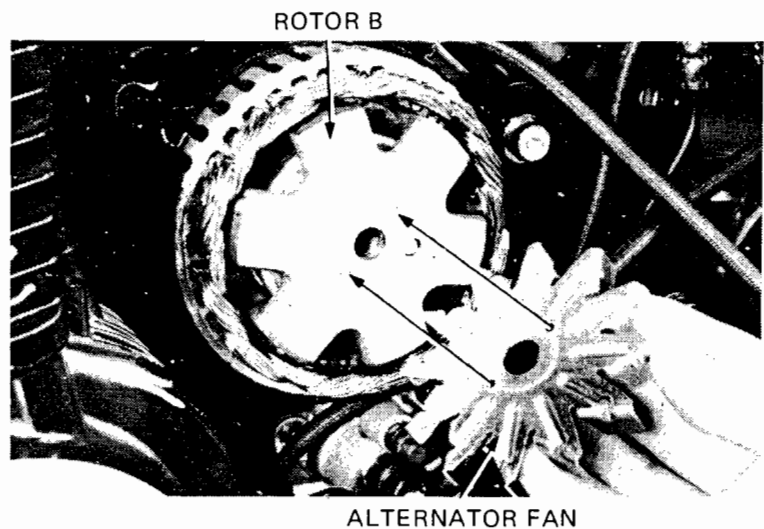

Install and tighten the alternator bolt to the specified torque.

**TORQUE:** 30–38 N·m  
(3.0–3.8 kg·m, 22–28 ft·lb)

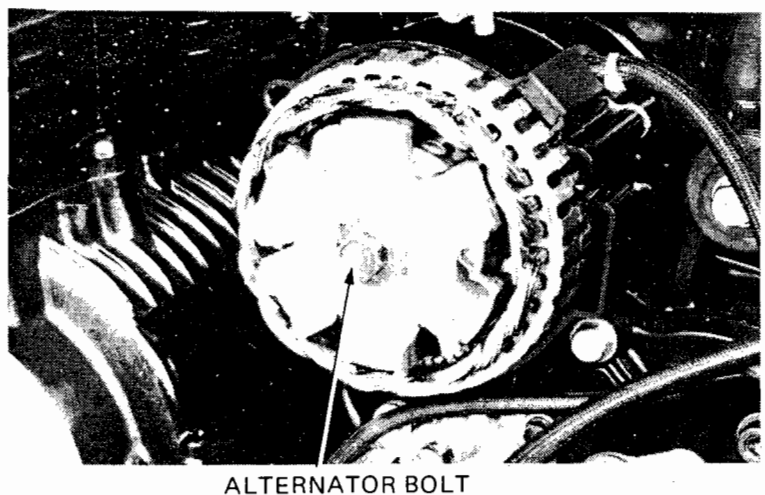



Install the alternator cover.

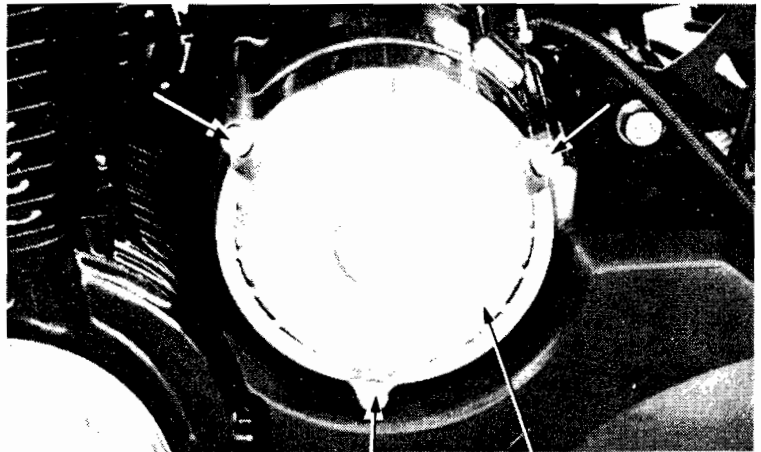

ALTERNATOR COVER

### VOLTAGE REGULATOR/RECTIFIER

#### REGULATOR/RECTIFIER TEST

Disconnect the two regulator/rectifier couplers.

Check the resistances between the leads with an ohmmeter. If the resistance is out of the specifications, replace the regulator rectifier.

#### NOTE

- Use a SANWA [SP-10D] or KOWA [TH-5H] tester or KOWA DIGITAL VOLTOMETER (07411-0020000).
- The regulator/rectifier has a semi-conductor, that if using a different tester the test results will be out of specification.

#### REGULATOR/RECTIFIER COUPLERS

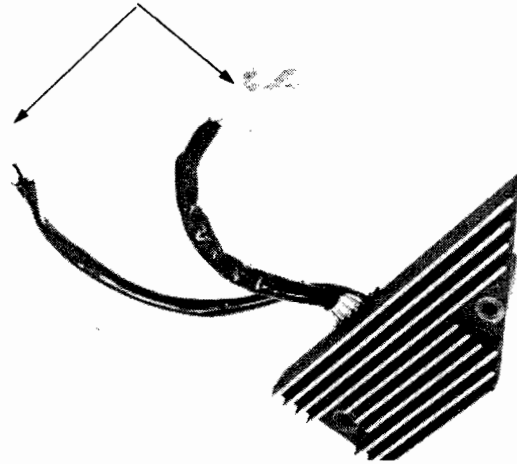

#### RECTIFIER

kΩ

+Probe -Probe	Red/ White	Green	Yellow 1	Yellow 2	Yellow 3
Red/White		∞	∞	∞	∞
Green	5 ~ 40		5 ~ 40	5 ~ 40	5 ~ 40
Yellow 1	5 ~ 40	∞		∞	∞
Yellow 2	5 ~ 40	∞	∞		∞
Yellow 3	5 ~ 40	∞	∞	∞	





**IGNITION SYSTEM**

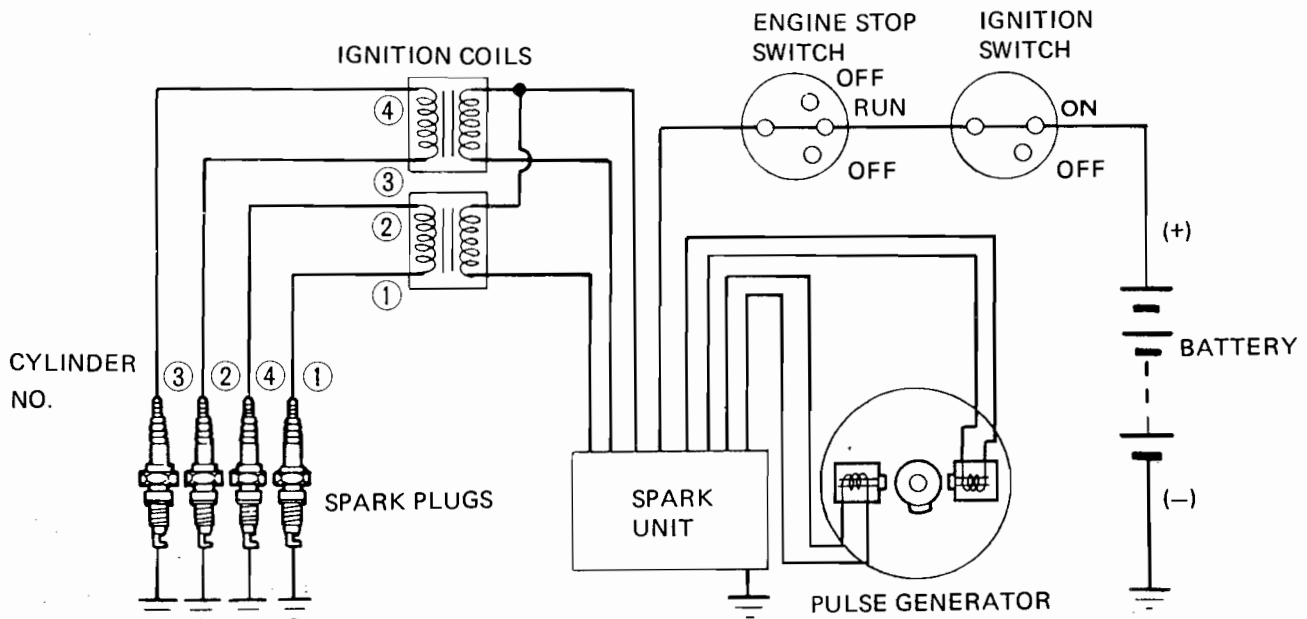
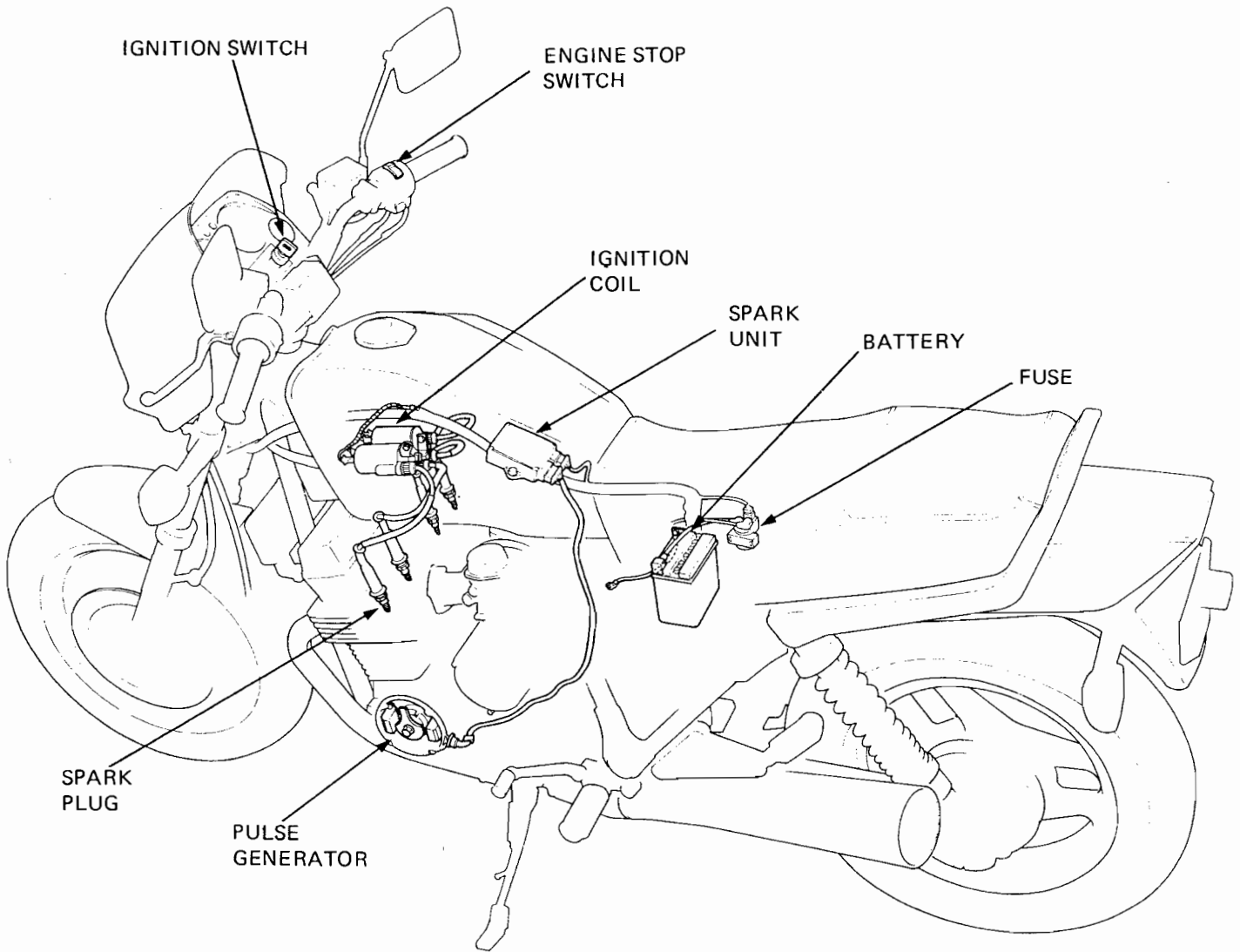



SERVICE INFORMATION	19-1
TROUBLESHOOTING	19-1
IGNITION COIL	19-2
TRANSISTORIZED IGNITION SYSTEM (Pulse Generator, Spark Unit)	19-3

## SERVICE INFORMATION

### GENERAL

A transistorized ignition system is used and it cannot be adjusted.

### SPECIFICATIONS

Spark plug (std.)	ND	X24EPR-U9
	NGK	DPR8EA-9
Spark plug gap		0.8 – 0.9 mm (0.031 – 0.035 in)
Ignition timing	At idle	10° (BTDC)
	Full advance	32° BTDC/3,150 rpm
Ignition coil	Primary coil resistance	2.7 ohms ± 10%
	Secondary coil resistance	14 k ohms ± 10%
	Plug cap resistance	5 ± 1.25 k ohms
Pulse generator	Resistance	330 ohms ± 10%
	Air gap	0.4 – 1.1 mm (0.02 – 0.04 in)

## TROUBLESHOOTING

### NOTE

The ignition system has two sub-systems; one for the No. 1 and No. 4 cylinders and one for No. 2 and No. 3 cylinders. Determine which sub-system is faulty, then refer to the charts below.

#### Engine cranks but will not start

1. Engine stop switch OFF
2. No spark at plugs
3. Faulty transistorized spark unit
4. Faulty pulse generator

#### No spark at plug

1. Engine stop switch OFF
2. Poorly connected, broken or shorted wires
  - Between ignition switch and engine stop switch
  - Between spark unit and engine stop switch
  - Between spark unit and ignition coil
  - Between ignition coil and plug
  - Between spark unit and pulse generator
3. Faulty ignition coil
4. Faulty ignition switch
5. Faulty spark unit
6. Faulty pulse generator

#### Engine starts but runs poorly

1. Ignition primary circuit
  - Faulty ignition coil
  - Loose or bare wire
  - Intermittent short circuit
2. Secondary circuit
  - Faulty plug
  - Faulty spark plug wire

#### Timing advance incorrect

- Faulty spark unit



## IGNITION COIL

### CONTINUITY TEST

Remove the fuel tank and disconnect the ignition coil wire leads.

Measure the primary coil resistance between the wire coupler terminals.

**RESISTANCE: 2.7 ohms  $\pm$  10%**

If the reading does not meet the specification, disconnect the primary wires from the coil terminals and measure the resistance between the primary terminals.

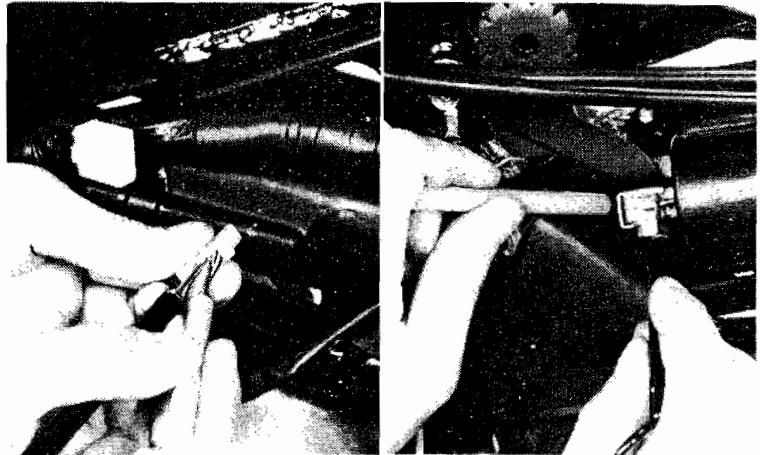

Measure the secondary coil resistance with the spark plug caps in place.

**RESISTANCE: 16.3–21.7 k ohms**

If the reading does not fall within the limit, remove the ignition coils by removing the bolts.

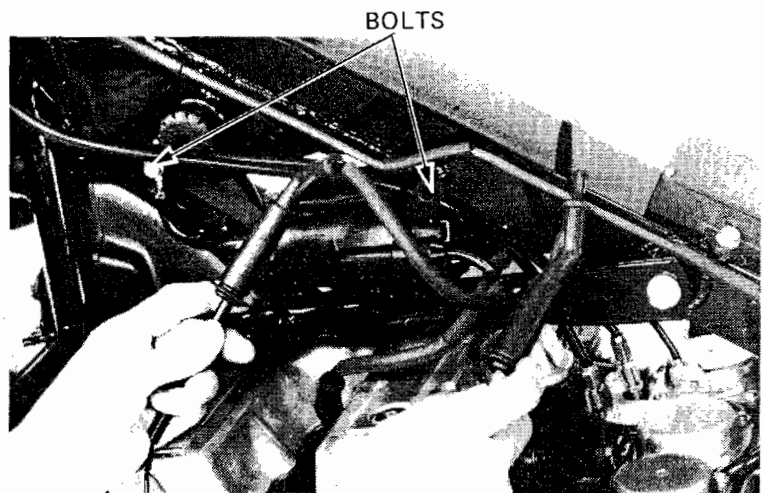

Remove the spark plug wires by loosening the wire retaining nuts.

Measure the secondary coil resistance.

**RESISTANCE: 14 k ohms  $\pm$  10%**

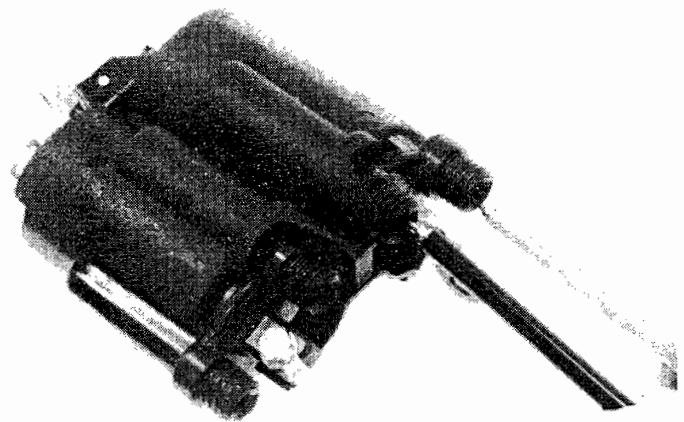



## TRANSISTORIZED IGNITION SYSTEM

### PULSE GENERATOR TEST

Remove the seat.  
Disconnect the pulse generator coupler and measure coil resistance between the white and yellow leads (2, 3 cylinders) and between the white and blue leads (1, 4 cylinders).

**RESISTANCE: 330 ohms  $\pm$  10%**



### PULSE GENERATOR REPLACEMENT

Remove the seat and fuel tank.  
Disconnect the pulse generator wire coupler from the spark unit.

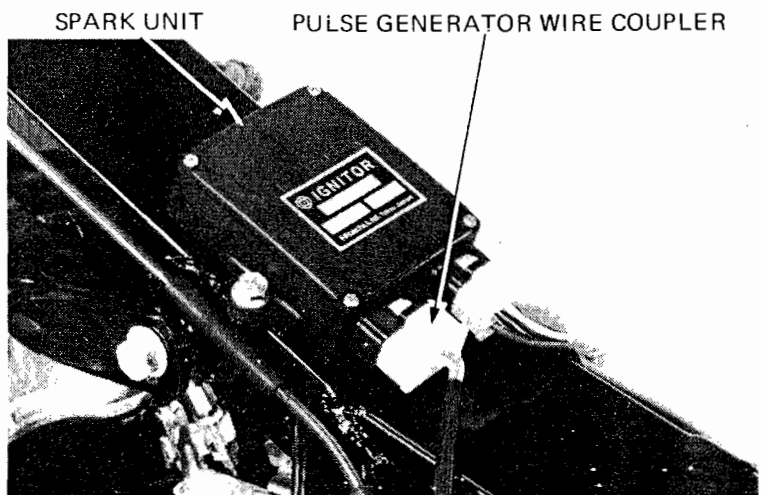

Remove the pulse generator and left crankcase rear covers.

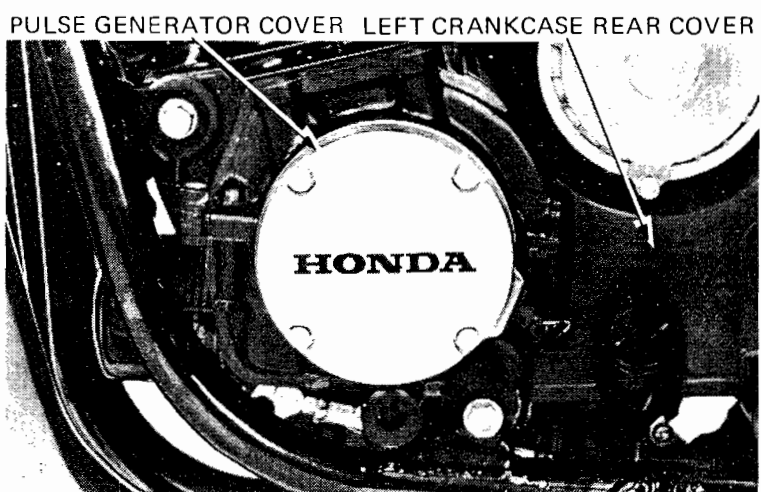



## IGNITION SYSTEM

Remove the pulse generator mounting screws, pulse generators and wire guide.

Install new pulse generators and wire guide.

Align the pulse rotor tip with the pulse generator magnet and measure the air gap with a feeler gauge.

**AIR GAP: 0.4 – 1.1 mm (0.02 – 0.04 in)**

Check the ignition timing (Page 3-9).

Install the left crankcase rear cover and pulse generator cover.

### PULSE GENERATORS

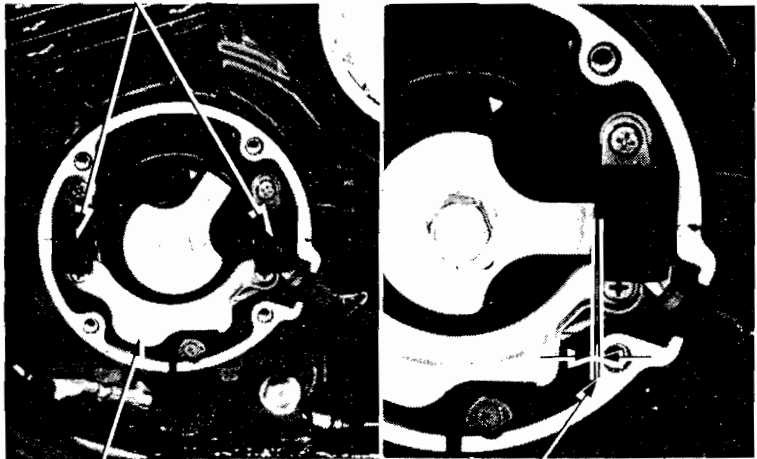

WIRE GUIDE

AIR GAP

### SPARK UNIT

If the pulse generators, ignition coils and wiring are good, and the ignition timing is not within specification; replace the spark unit with a new one and recheck the ignition timing.

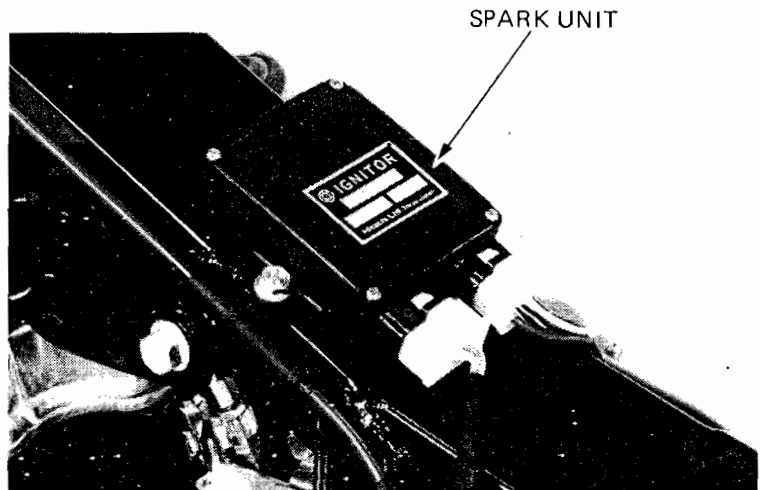



**HONDA**  
**CB750SC**

---

MEMO

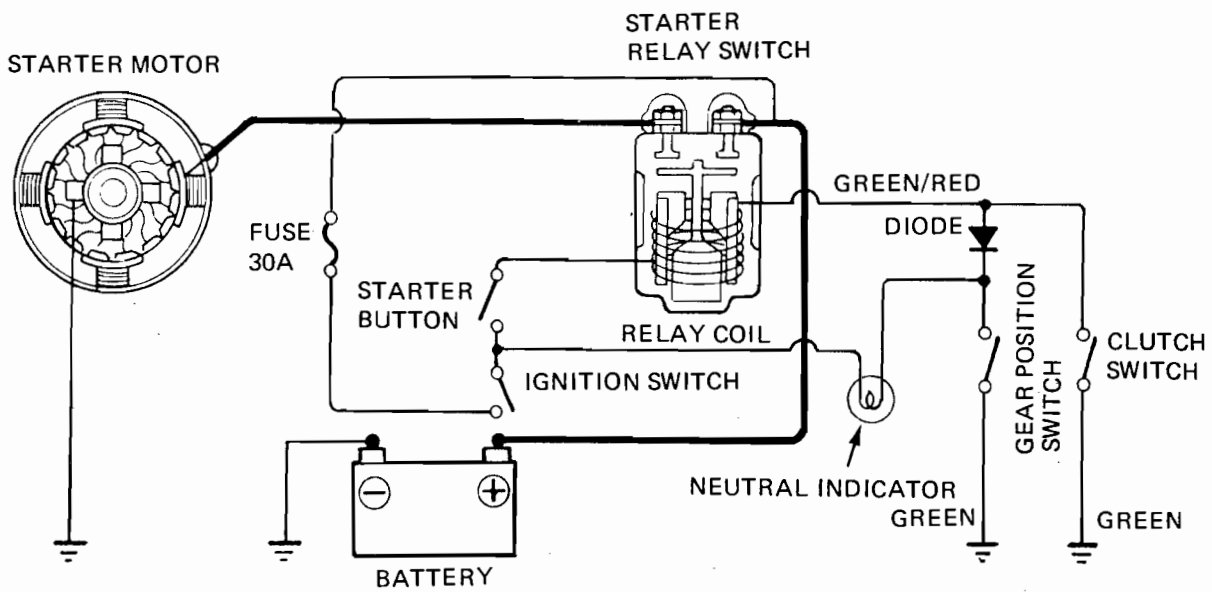
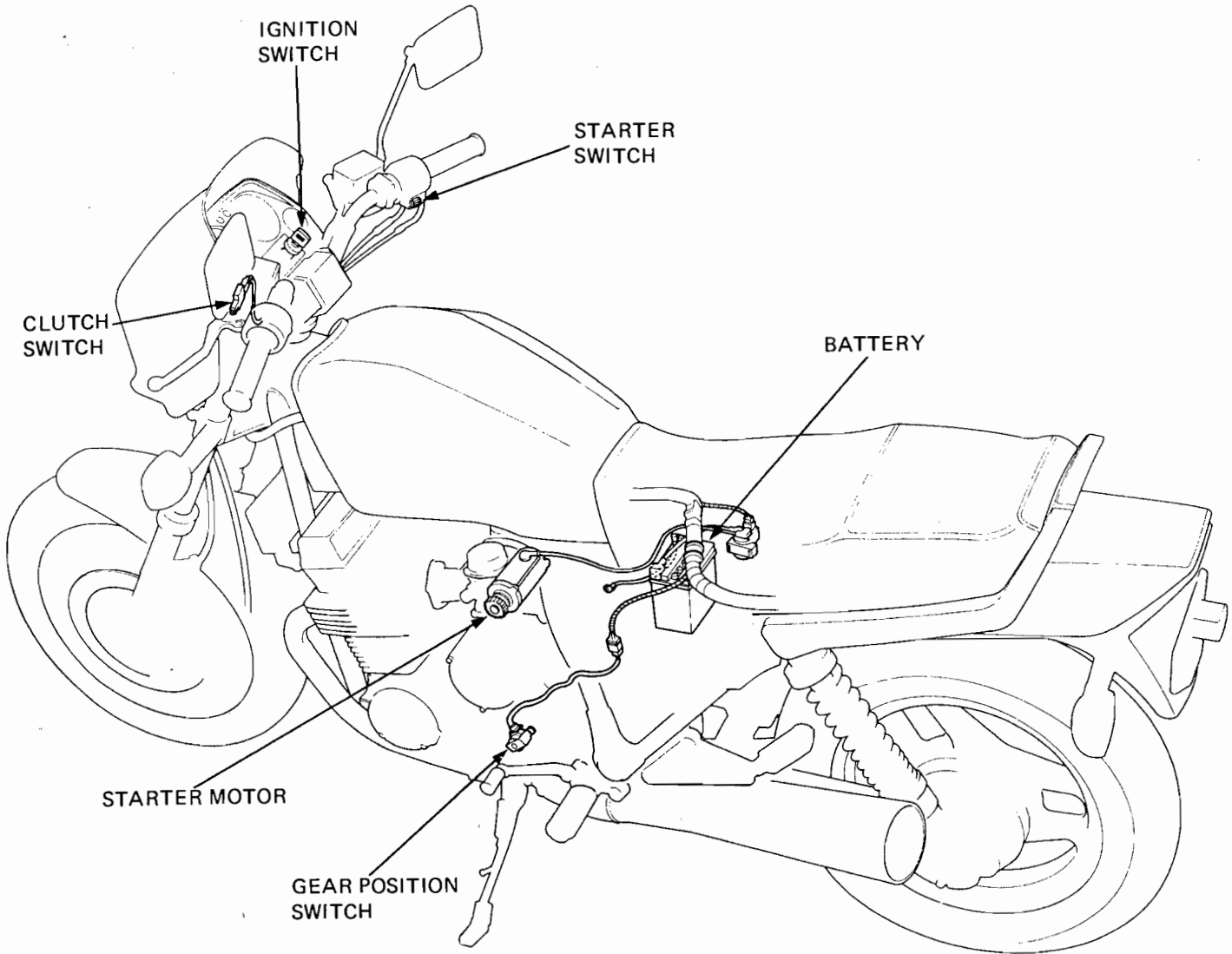



SERVICE INFORMATION	20-1
TROUBLESHOOTING	20-1
STARTER MOTOR	20-2
STARTER RELAY SWITCH	20-5

## SERVICE INFORMATION

### GENERAL

The starter motor can be removed with the engine in the frame.

### SPECIFICATIONS

		STANDARD	SERVICE LIMIT
Starter motor	Brush spring tension	800 ± 120 g (28.2 ± 4.2 oz)	680 g (24.0 oz)
	Brush length	12.0 – 13.0 mm (0.47 – 0.51 in)	6.5 mm (0.26 in)

## TROUBLESHOOTING

### Starter motor will not turn

1. Battery discharged
2. Faulty ignition switch
3. Faulty starter switch
4. Faulty neutral switch
5. Faulty starter relay switch
6. Loosen or disconnected wire or cable
7. Neutral diode open

### Starter motor turns engine slowly

1. Low specific gravity
2. Excessive resistance in circuit
3. Binding in starter motor

### Starter motor turns, but engine does not turn

1. Faulty starter clutch
2. Faulty starter motor gears
3. Faulty starter motor or idle gear

### Starter motor and engine turns, but engine does not start

1. Faulty ignition system
2. Engine problems





## STARTER MOTOR

### REMOVAL

**WARNING**

*With the ignition switch OFF, remove the negative cable at the battery before servicing the starter motor.*

Remove the starter cable from the starter motor.

Remove the bolts and starter motor.

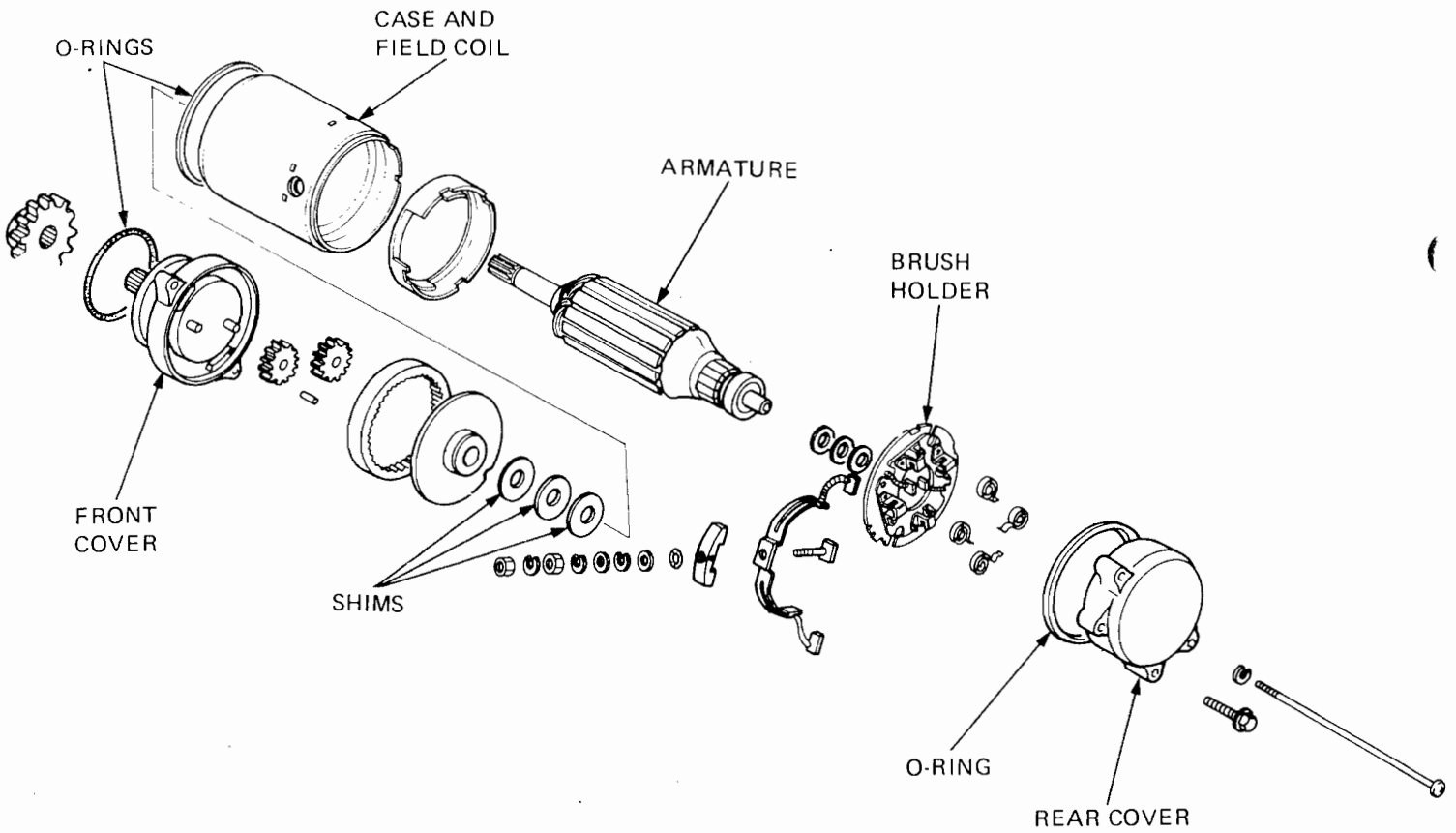
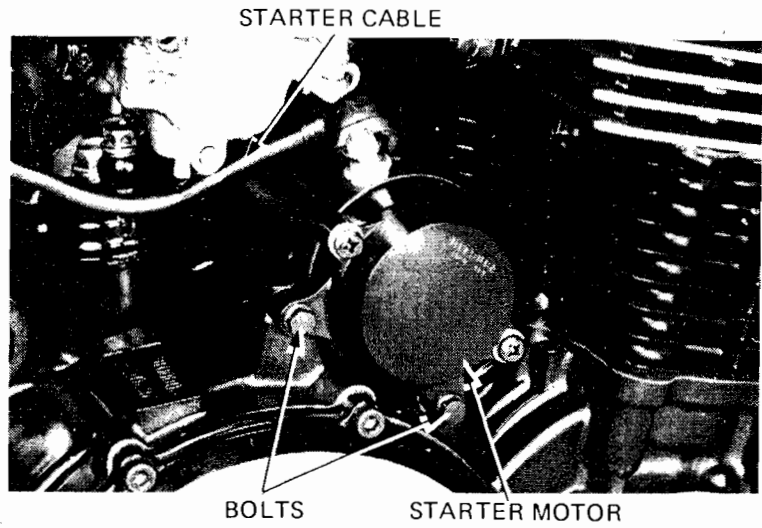



### BRUSH INSPECTION

Remove the starter motor case screws.

Inspect the brushes and measure the brush length.

Measure brush spring tension with a spring scale.

#### SERVICE LIMITS:

Brush length:	6.5 mm (0.26 in)
Brush spring tension:	680 g (24.0 oz)

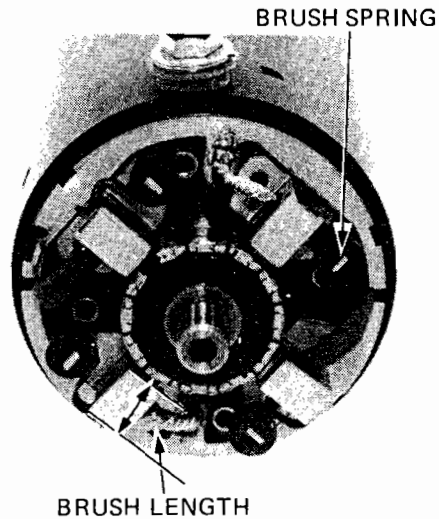

### COMMUTATOR INSPECTION

Remove the starter motor case.

#### NOTE

Record the location and number of thrust washers for correct reassembly.

Inspect the commutator bars for discoloration. Bars discolored in pairs indicate grounded armature coils.

#### NOTE

Do not use emery or sand paper on the commutator.

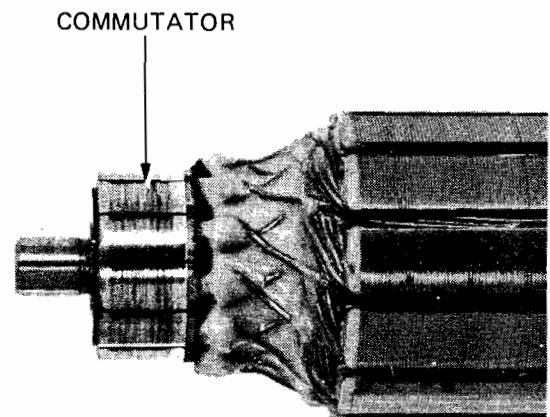

Check for continuity between pairs of commutator bars; there should be continuity.

Also, check for continuity between individual commutator bars and armature shaft; there should be no continuity.

CONTINUITY BETWEEN  
COMMUTATOR BAR PAIRS: NORMAL

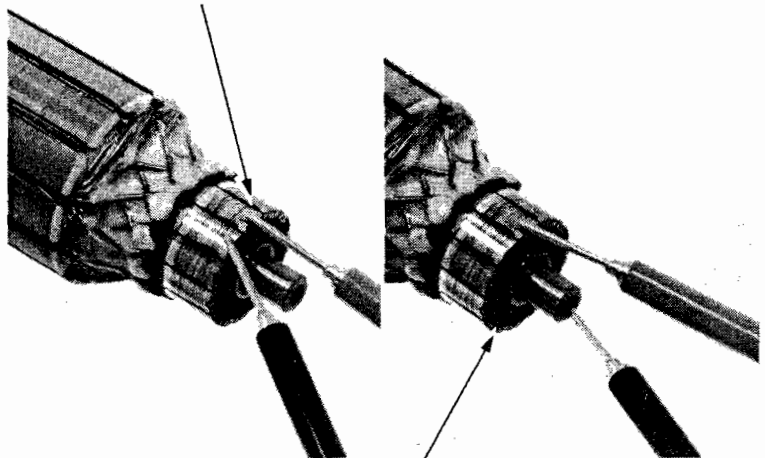

NO CONTINUITY BETWEEN  
COMMUTATOR BARS AND ARMATURE SHAFT: NORMAL



**ELECTRIC STARTER**

**FIELD COIL INSPECTION**

Check for continuity from the cable terminal to the motor case and from the cable terminal to the brush wire. Replace the starter motor if the field coil is not continuous or if it is shorted to the motor case.

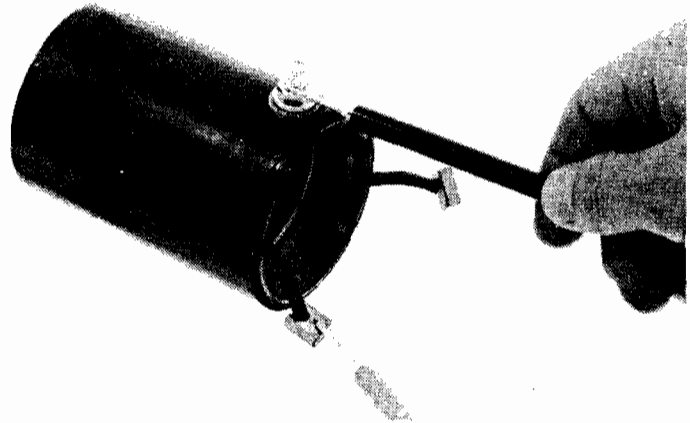

**ASSEMBLY/INSTALLATION**

Assemble the starter motor. Align the case notch with the brush holder pin.

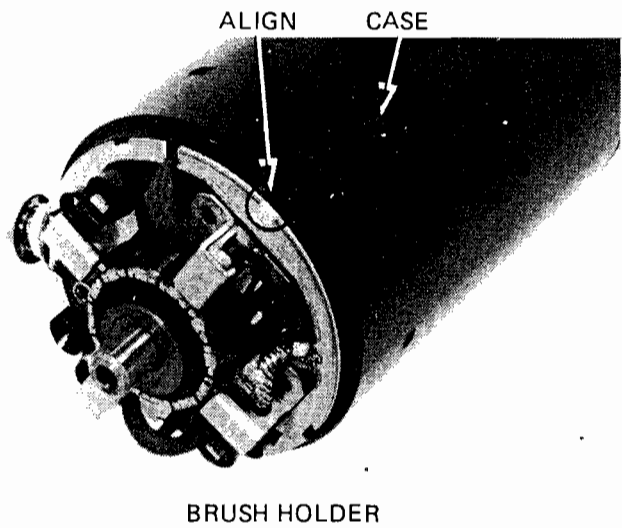

Install the rear cover aligning its slot with the brush holder pin.

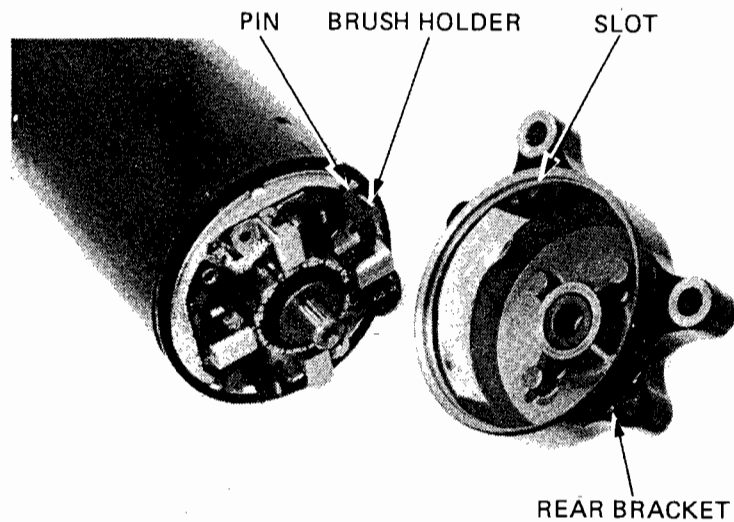



Install the rear cover with its index mark aligned with the index mark on the case.

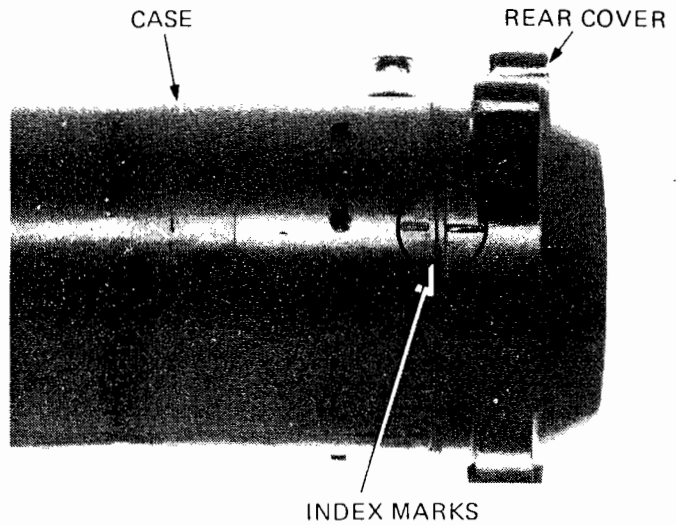

Install the starter motor.

Connect the starter cable and battery ground cable.

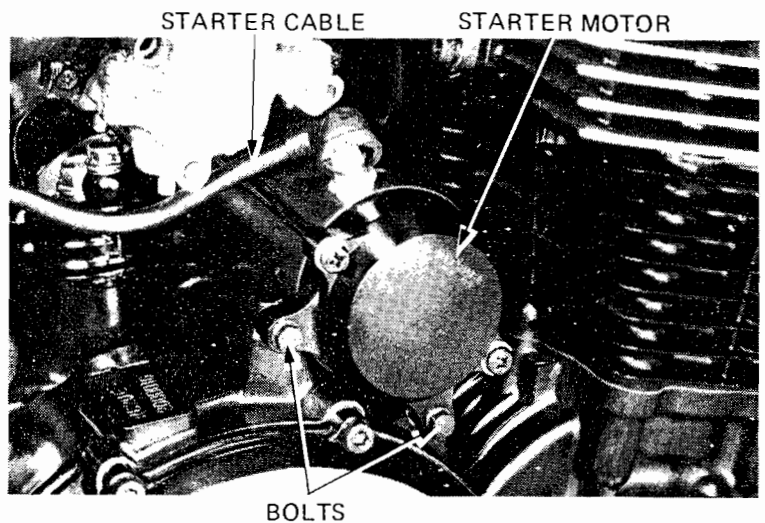

## STARTER RELAY SWITCH

### INSPECTION

Depress the starter switch button with the ignition ON. The coil is normal if the starter relay switch clicks.

Connect an ohmmeter to the starter cable terminals.

Connect a 12 V battery to the switch primary terminals.

The switch is normal if there is continuity.

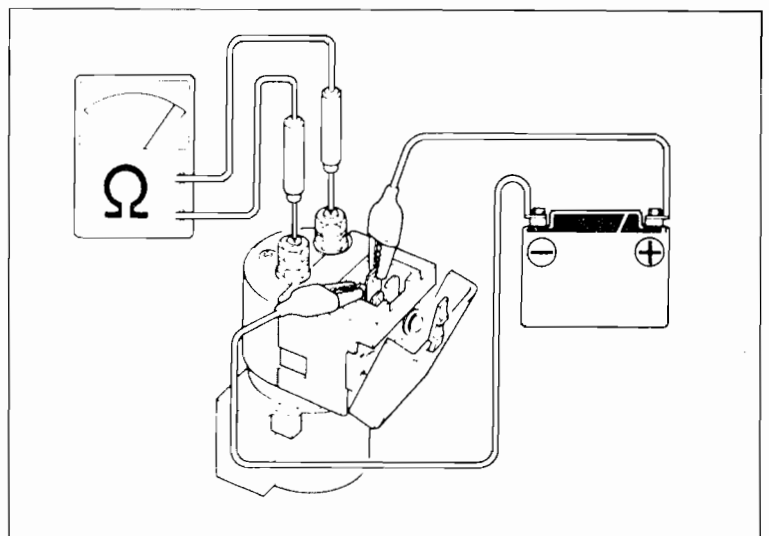



## CLUTCH DIODE

### REMOVAL

Remove the fuel tank.

Remove the clutch diode from the wire harness.

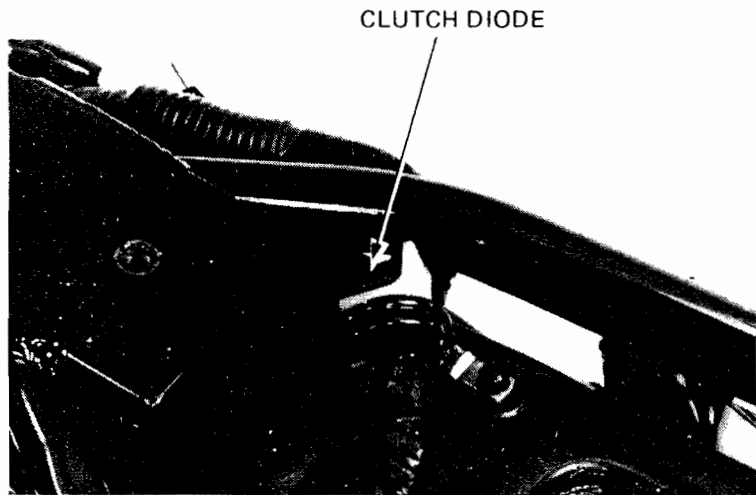

### INSPECTION

Check for continuity with an ohmmeter.

**NORMAL DIRECTION: CONTINUITY**  
**REVERSE DIRECTION: NO CONTINUITY**

Replace the diode if it does not meet specifications.

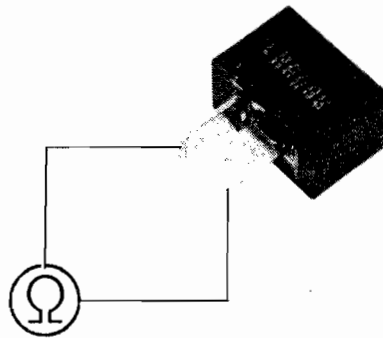



SERVICE INFORMATION	21-1	HANDLEBAR SWITCHES	21-9
HEADLIGHT	21-2	FUEL SENSOR/METER	21-10
INSTRUMENTS	21-3	TACHOMETER	21-11
IGNITION SWITCH	21-5	HORN	21-11
OIL PRESSURE WARNING SYSTEM	21-7	TAILLIGHT SENSOR	21-12
BRAKE LIGHT SWITCHES	21-8	TURN SIGNAL	21-12
GEAR POSITION SWITCH	21-8	TAIL/BRAKE LIGHT	21-13
CLUTCH SWITCH	21-9	LICENSE LIGHT	21-14

## SERVICE INFORMATION

### GENERAL

- Some wires have different colored bands around them near the connector. These are connected to other wires which correspond with the band color.
- All plastic plugs have locking tabs that must be released before disconnecting, and must be aligned when reconnecting.
- The following color codes used are indicated throughout this section and on the wiring diagram.

B =Blue  
Bk =Black  
Br =Brown

G =Green  
Gr =Grey  
LB =Light Blue

LG =Light Green  
O =Orange  
P =Pink

R =Red  
W =White  
Y =Yellow

- To isolate an electrical failure, check the continuity of the electrical path through the part. A continuity check can usually be made without removing the part from the motorcycle. Simply disconnect the wires and connect a continuity tester or volt-ohmmeter to the terminals or connections.
- A continuity tester is useful when checking to find out whether or not there is an electrical connection between the two points. An ohmmeter is needed to measure the resistance of a circuit, such as when there is a specific coil resistance involved, or when checking for high resistance caused by corroded connections.

### SPECIFICATIONS

Headlight (High/Low beam)	12V 60/55W
Tail/brake light	12V 3/32 cp
Turn signal light (Front/Rear)	12V 3/32 cp/12V 32 cp
Instrument lights	12V 3.4W
Neutral indicator	12V 3.4W
Turn signal indicators	12V 3.4W
High beam indicator	12V 3.4W
Oil pressure warning light	12V 3.4W
Taillight warning light	12V 3.4W
License light	12V 3 cp

### TORQUE VALUE

Oil pressure switch 10-14 N·m (1.0-1.4 kg-m, 7-10 ft-lb)



**HEADLIGHT**

**BULB REPLACEMENT**

Remove the two headlight case nuts and open the headlight case.

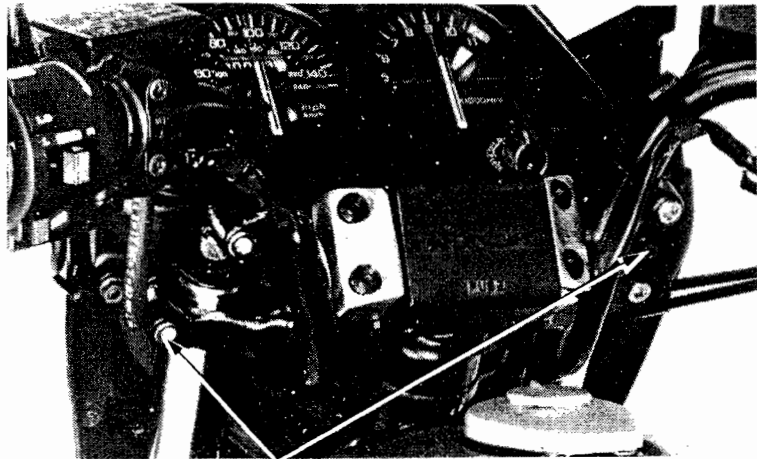

NUTS

Disconnect the headlight coupler and remove the boot.  
Remove the clip and remove the headlight bulb.  
Replace the bulb with a new one.

HEADLIGHT COUPLER

CLIP

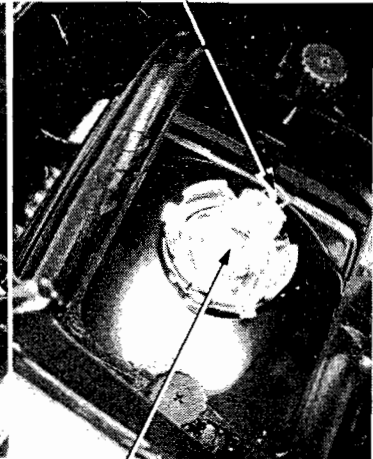
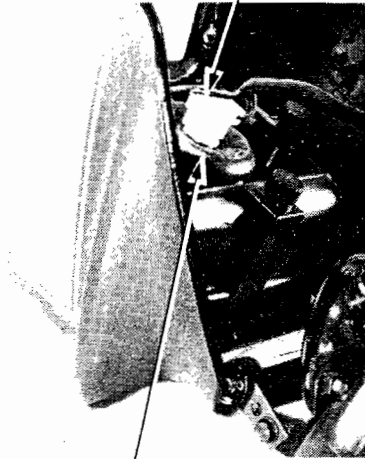

BOOT

BULB

**HEADLIGHT REMOVAL**

Open the headlight case and disconnect the headlight coupler.  
Remove the headlight case mounting bolts and the case.

HEADLIGHT COUPLER

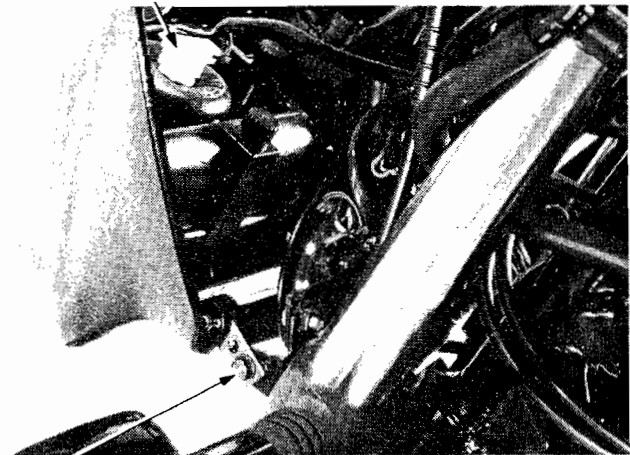

BOLT



Remove the headlight adjusting screws and head-  
lights from the case.

### HEADLIGHT INSTALLATION

Install the headlight in the reverse order of removal.  
Install the headlight boot with its "UP" mark  
facing up.  
Adjust headlight aim (Page 3-13).

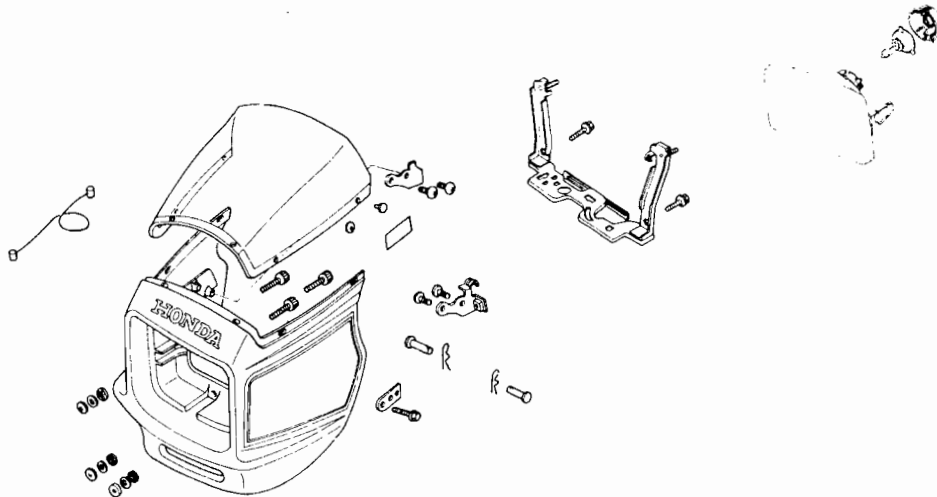
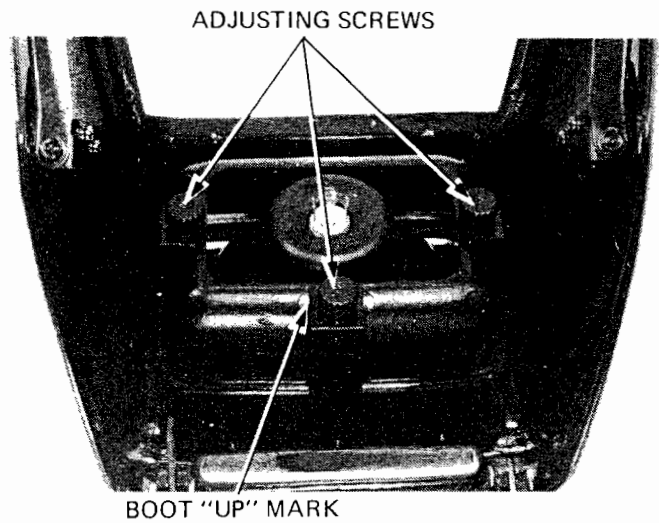

### INSTRUMENTS

#### REMOVAL

Open the headlight case.  
Disconnect the speedometer cable, instrument  
coupler and connectors.  
Remove the three instrument mounting cap nuts  
and the instruments.

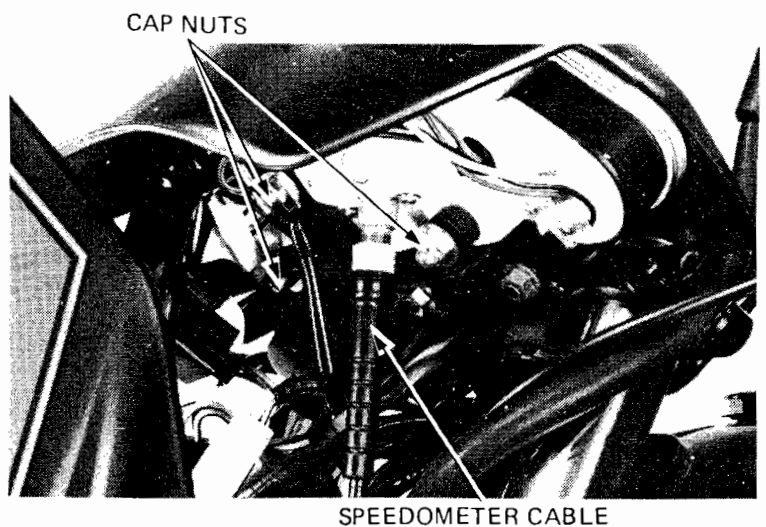





DISASSEMBLY

**CAUTION**

*Do not leave the instruments upside down or damping fluid will leak onto the inside of the lens.*

Remove the odometer reset knob.

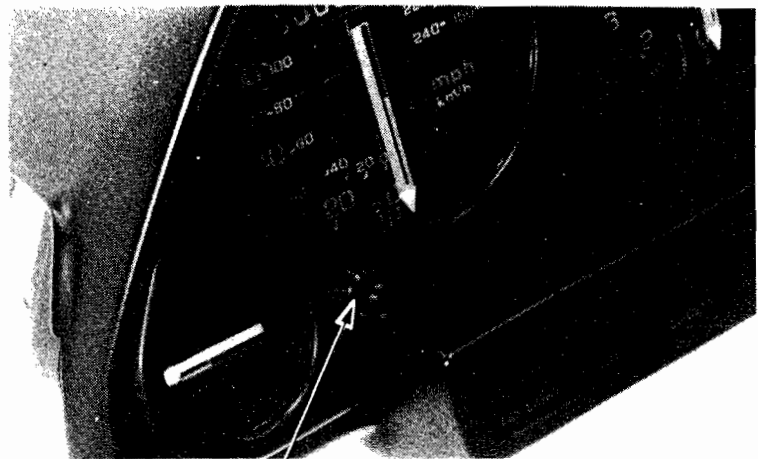

ODOMETER RESET KNOB

Remove the cover from the instruments by removing the screws.

INSTRUMENT COVER

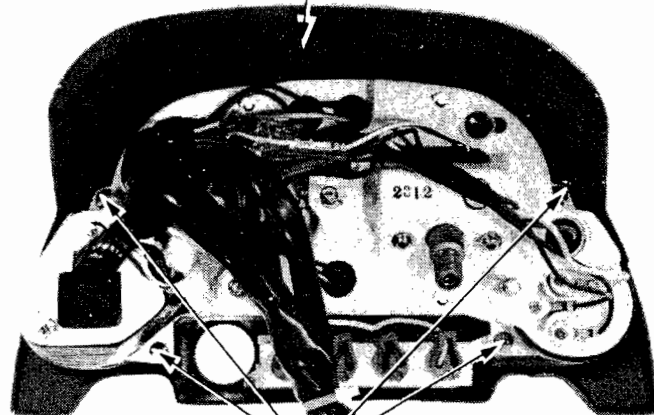

SCREWS

Remove the each instrument by removing the screws and bulb sockets.

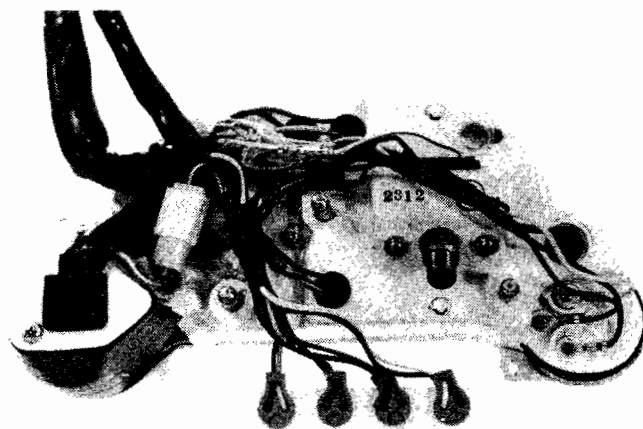



### ASSEMBLY/INSTALLATION

Lubricate the speedometer cable before reconnecting.

Reassemble and install in the reverse order of removal and disassembly.

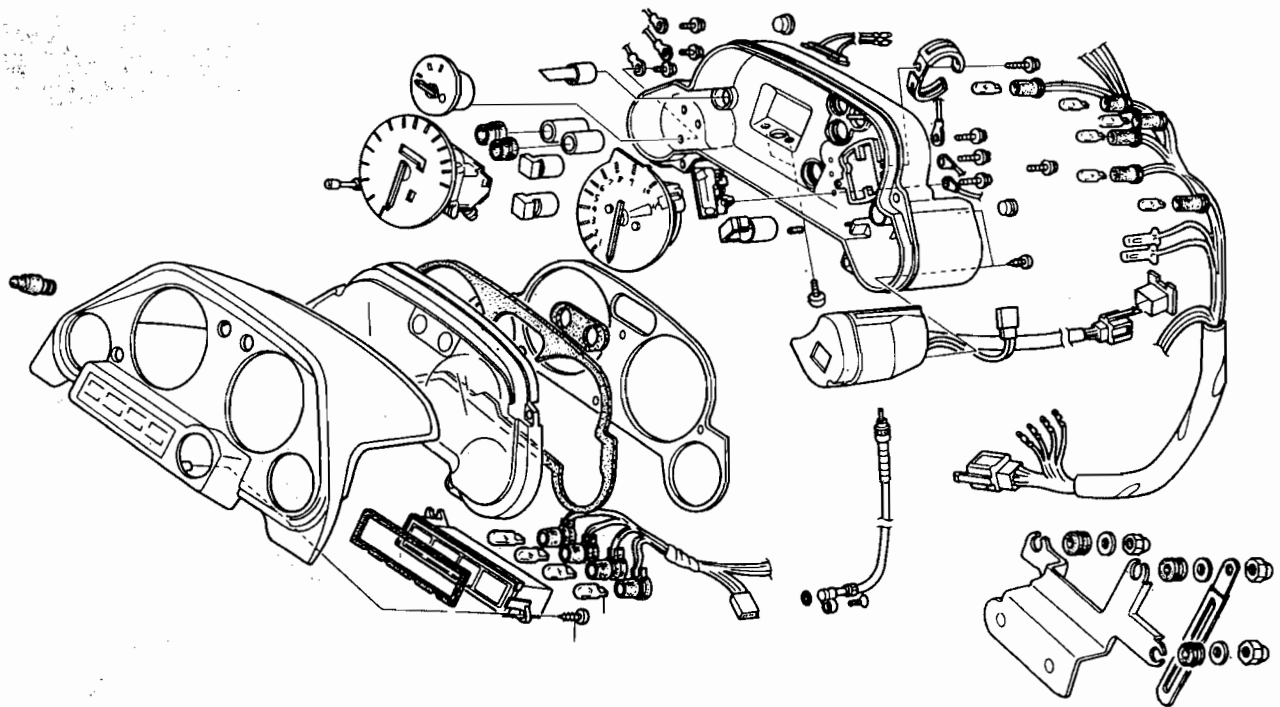

### IGNITION SWITCH

Open the headlight case and disconnect the ignition switch coupler.

Check continuity between the color coded wires in the chart below.

Color code	R	R/Bk	Br/W	Br	Y/Bk
Terminal	BAT	IGN	TL1	TL2	P
ON	○	○	○	○	
OFF					
P	○				○
LOCK					

IGNITION SWITCH

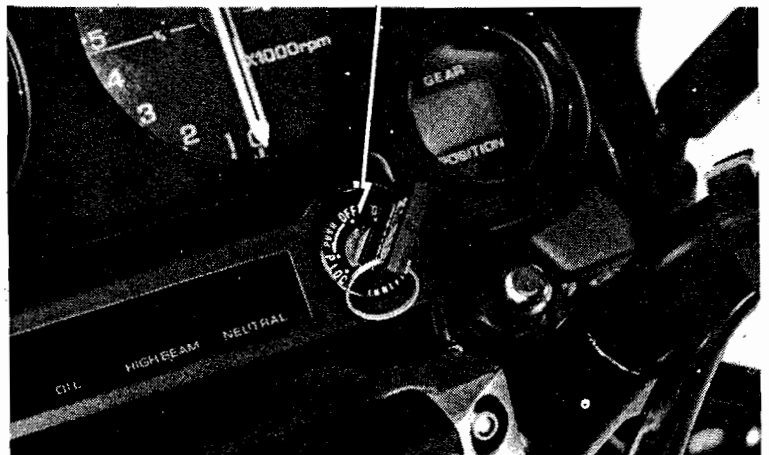



**LIGHTS/INSTRUMENTS/SWITCHES**

**REMOVAL/INSTALLATION**

Remove the headlight (Page 21-2) and instruments (Page 21-3).

Disconnect the ignition switch wire coupler. Remove the two ignition switch mounting bolts and the switch.

Install the ignition switch in the reverse order of removal.

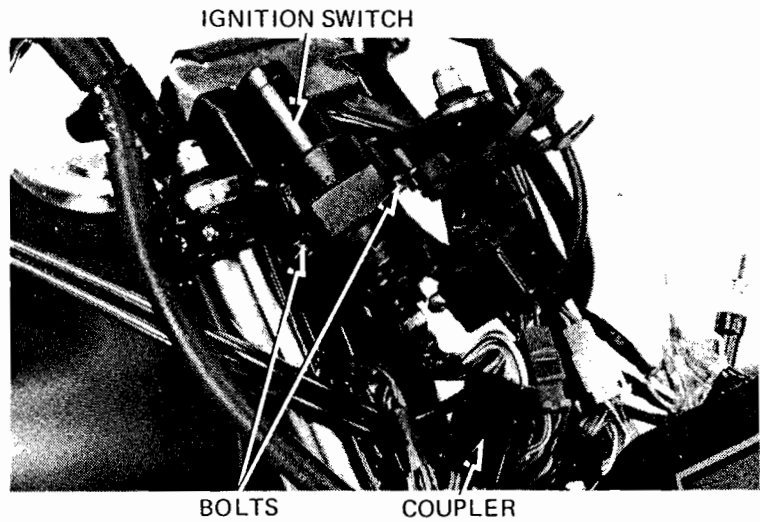

**DISASSEMBLY/ASSEMBLY**

Open the wire clamp tongue up and remove the clamp.

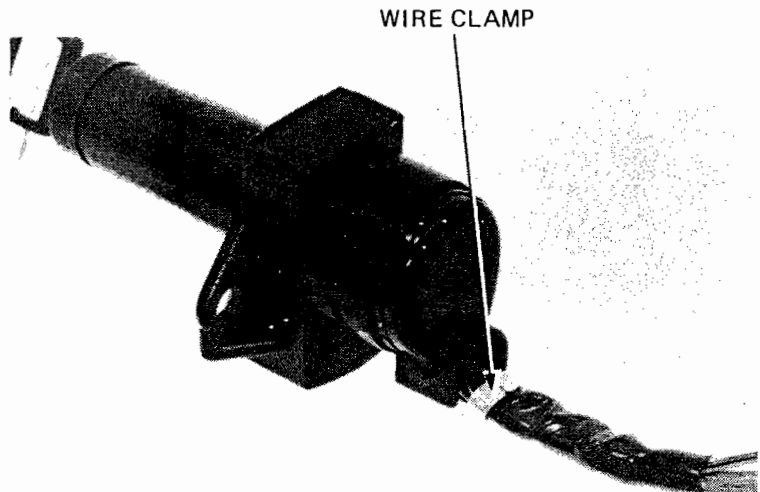

Insert the ignition key and turn it to between the ON and OFF detent positions.

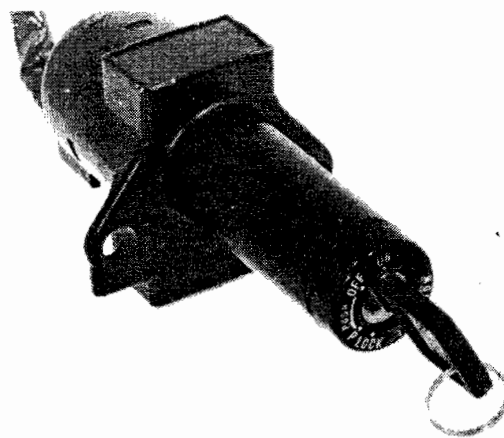



Push in the lugs in the slots and pull the contact base from the switch.

Assemble the ignition switch in the reverse order of disassembly.

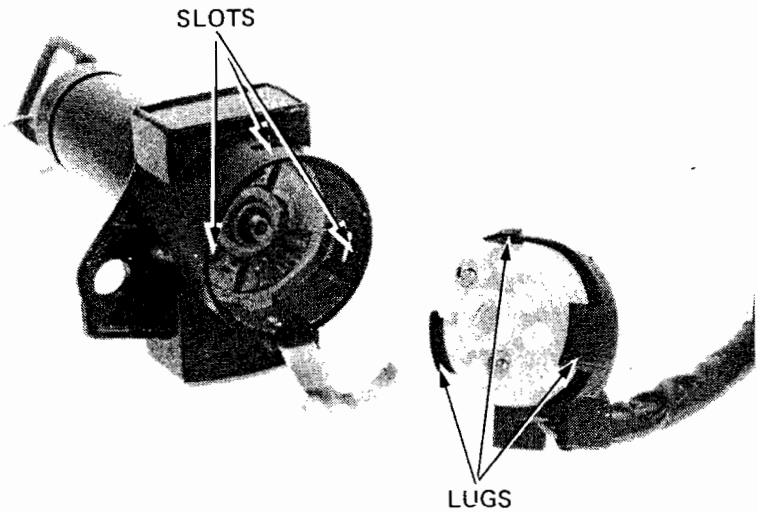

## OIL PRESSURE WARNING SYSTEM

### INSPECTION

Disconnect the oil pressure switch wire from the switch by removing the terminal screw.

Turn the ignition switch ON.

Ground the oil pressure switch wire to the engine. The oil pressure warning light should come on. If the light does not come on, check the wires for loose connections or an open circuit and check that the bulb is not burned out. Replace or repair if necessary.

If the oil pressure and warning systems are normal pressure switch with a new one.

OIL PRESSURE WARNING LIGHT



### OIL PRESSURE SWITCH REPLACEMENT

Remove the mufflers (Page 17-2).

Disconnect the switch wire from the switch by removing the terminal screw.

Remove the switch.

Apply sealing agent to a new switch threads and install the switch.

**TORQUE:** 10–14 N·m  
(1.0–1.4 kg-m, 7–10 ft-lb)

SWITCH WIRE      SCREW

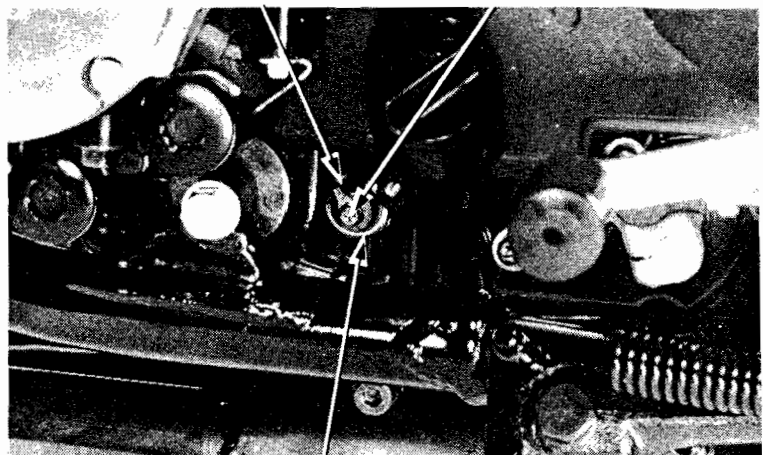

OIL PRESSURE SWITCH



## BRAKE LIGHT SWITCHES

### FRONT

Disconnect the wires from the front brake light switch.

Check the front brake light switch for continuity with the front brake applied.

Replace the switch if necessary.

**BRAKE APPLIED: CONTINUITY**  
**BRAKE NOT APPLIED: NO CONTINUITY**

FRONT BRAKE LIGHT SWITCH

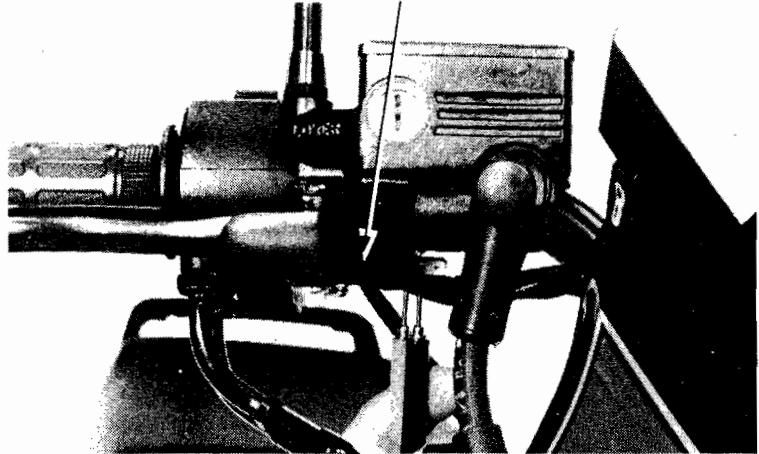

### REAR

Remove the right side cover.  
Disconnect the switch wire coupler.

Check the rear brake light switch for continuity with the rear brake applied.

**BRAKE APPLIED: CONTINUITY**  
**BRAKE NOT APPLIED: NO CONTINUITY**

REAR BRAKE LIGHT SWITCH COUPLER

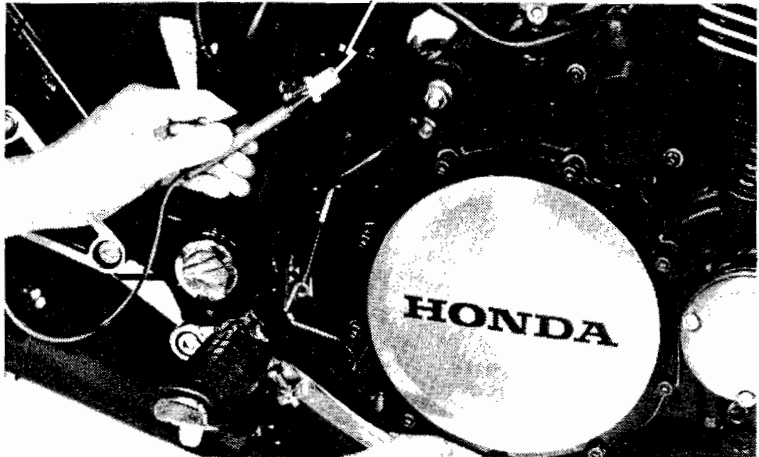

## GEAR POSITION SWITCH

Remove the left side cover and disconnect the gear position switch coupler.  
Check for continuity between each terminal and ground in each gear position.

Color Code	Y	G	Bk.	W	R	Br	B	Ground
1st	○	---	---	---	---	---	---	○
N		○	---	---	---	---	---	○
2nd			○	---	---	---	---	○
3rd				○	---	---	---	○
4th					○	---	---	○
5th						○	---	○
OD							○	○

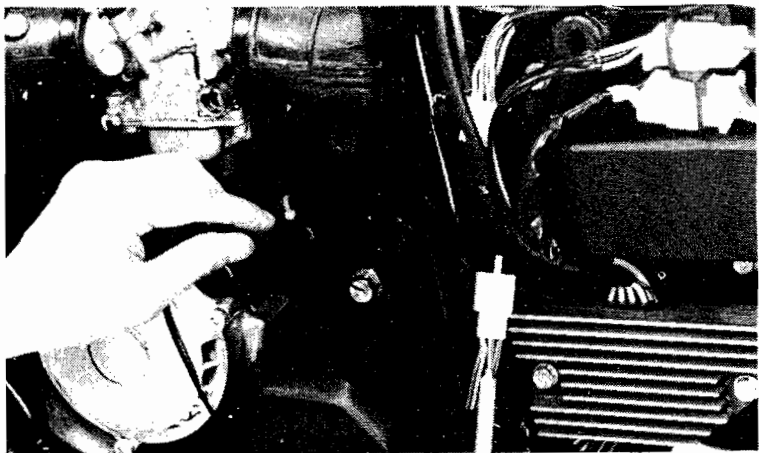

Refer to Page 9-2 for gear position switch replacement.



### CLUTCH SWITCH

Disconnect the wire leads from the clutch switch.

Check the continuity of the clutch (safety) switch with the clutch released and applied.

Replace if necessary.

**LEVER APPLIED: CONTINUITY**

**LEVER NOT APPLIED: NO CONTINUITY**

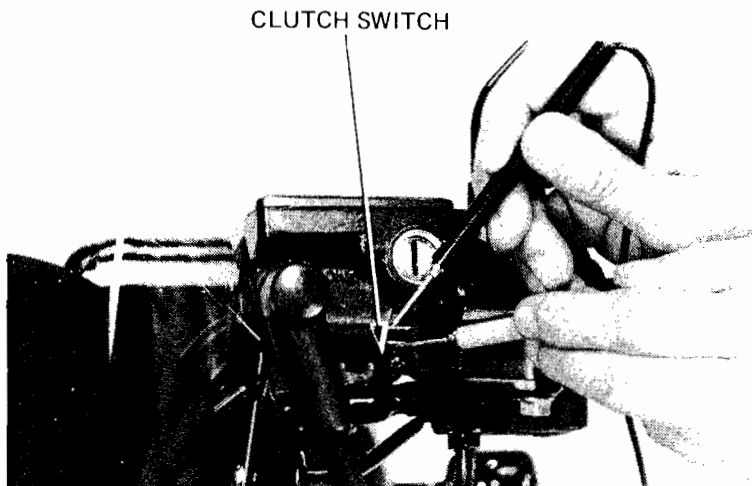

### HANDLEBAR SWITCHES

Open the headlight cover.

Disconnect the couplers and connectors.

Check continuity between the color coded wires in each chart.

#### TURN SIGNAL/PASSING SWITCH

Color Code	Gr	LB	O	Br/B	LB/W	O/W	P	LG/W
Terminal	W	R	L	P	PR	PL	E	W OFF
R	○	○		○	○		○	○
L	○		○				○	○
PUSH								○

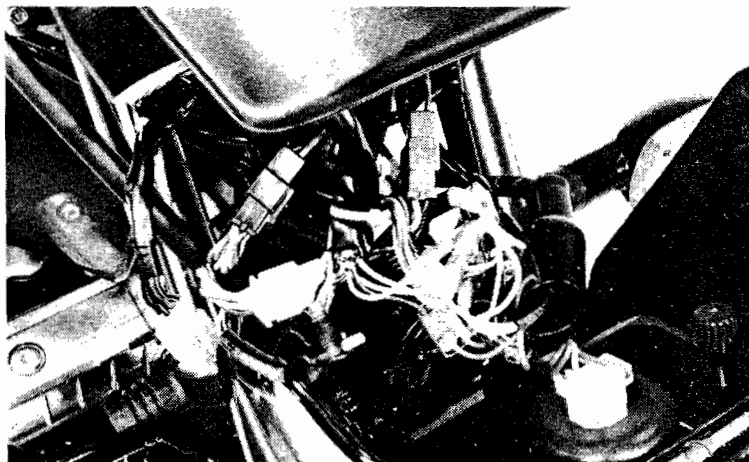

Color Code	B/W	W	B
Terminal	HL	Lo	Hi
Lo	○	○	
(N)	○	○	○
Hi	○		○

#### HORN BUTTON

Color Code	LG	W/G
Terminal	Ho	BAT3
BUTTON OUT		
PUSHED	○	○

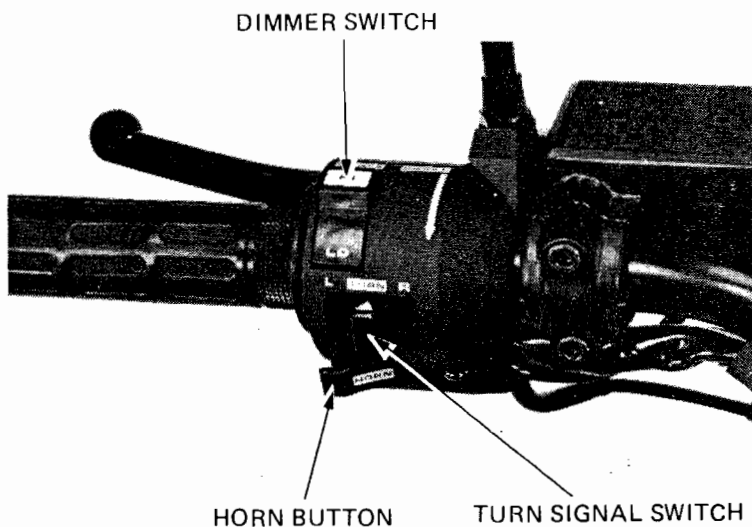



## LIGHTS/INSTRUMENTS/SWITCHES

### ENGINE STOP SWITCH

Color Code	Bk/W	Bk
Terminal	IGN	BAT2
OFF		
RUN	○ — ○	○
OFF		

### STARTER BUTTON

Color Code	Bk	Y/R	B/W	Bk/R
Terminal	BAT2	ST	HL	BAT5
BUTTON OUT			○ — ○	
PUSHED	○ — ○			

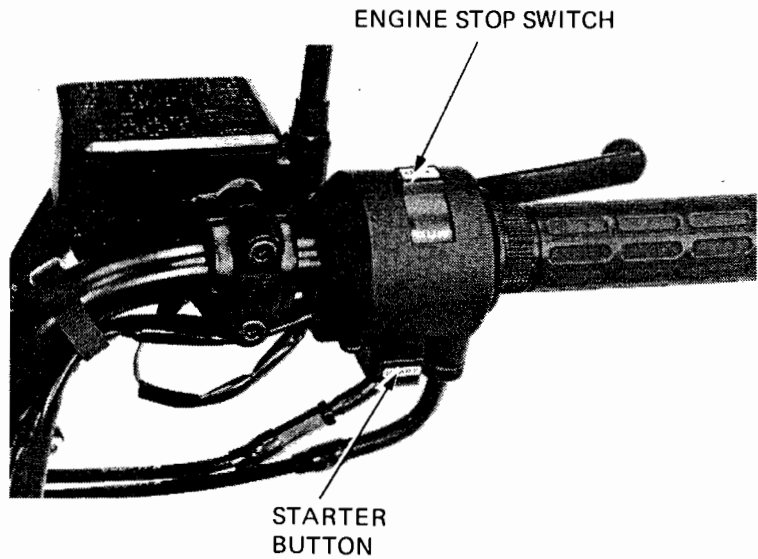

## FUEL SENSOR/METER

Remove the fuel tank.

Remove the fuel sensor nuts and remove the sensor.

### NOTE

Be careful not to bend the float arm.

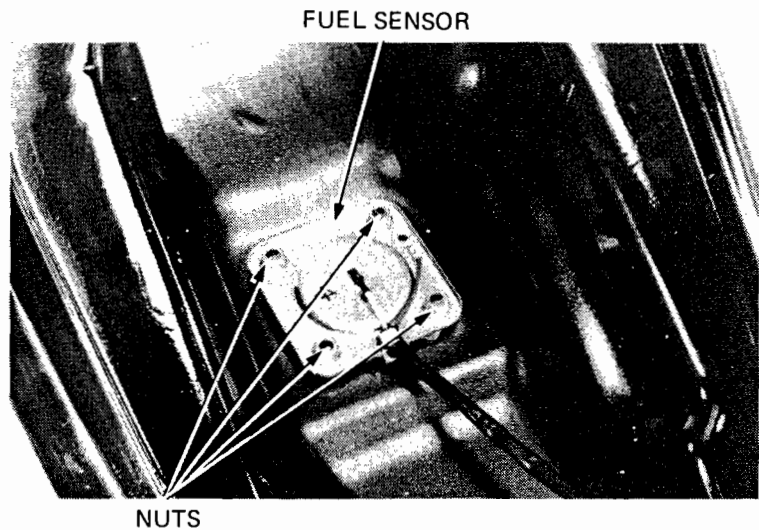

### FUEL SENSOR INSPECTION

Connect the ohmmeter to the fuel sensor coupler.

Inspect the resistance of the float at the top and bottom positions.

FLOAT POSITION	RESISTANCE
TOP (FULL)	4 – 10 Ω
BOTTOM (EMPTY)	90 – 100 Ω

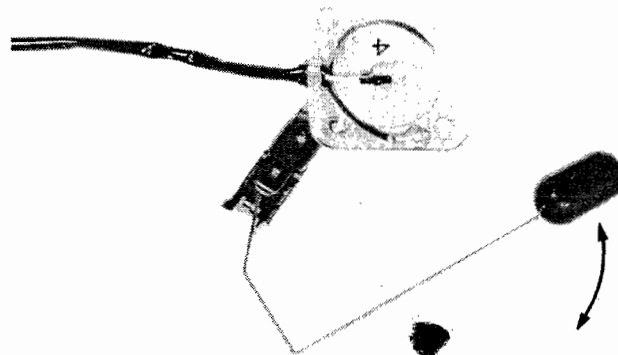



### FUEL METER INSPECTION

Connect the fuel sensor coupler to the wire harness and move the float from empty to full to check the fuel meter indication.

If the fuel meter does not indicate properly, check the wiring for an open or short circuit.

If the wiring is good, replace the fuel meter with a new one and retest.

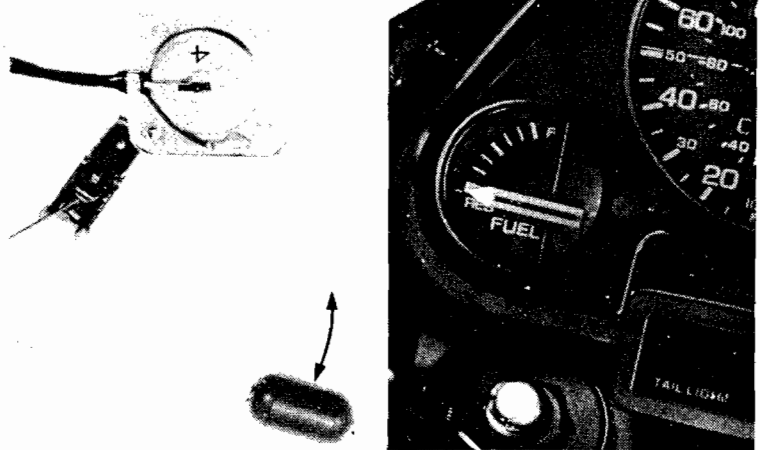

### TACHOMETER

If the tachometer does not indicate properly, check and repair the 2-3 cylinder ignition system.

If the problem still appears, check continuity between the yellow wire terminal of the wire harness instrument coupler and the yellow wire of the 2-3 cylinder ignition coil. Repair the circuit, if necessary.

If there is continuity, replace the tachometer with a new one.

WIRE HARNESS INSTRUMENT COUPLER (YELLOW TERMINAL)

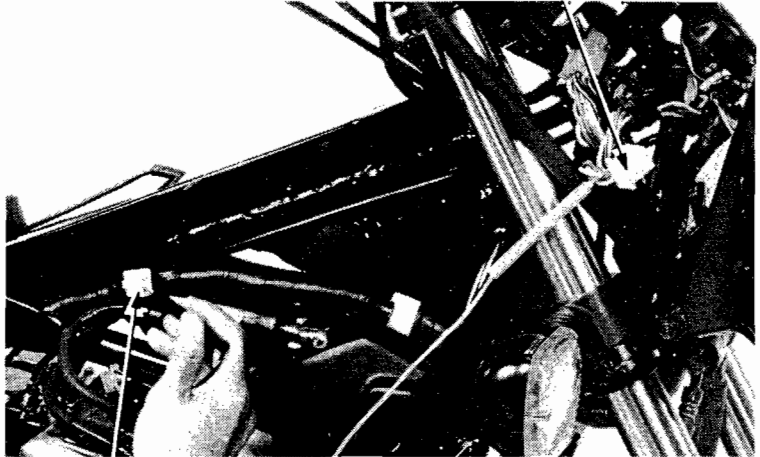

WIRE HARNESS IGNITION COIL COUPLER (YELLOW WIRE)

### HORN

Open the headlight case and disconnect the horn wires from the horn.

Connect a 12V battery across the horn terminals to check that the horn sounds.

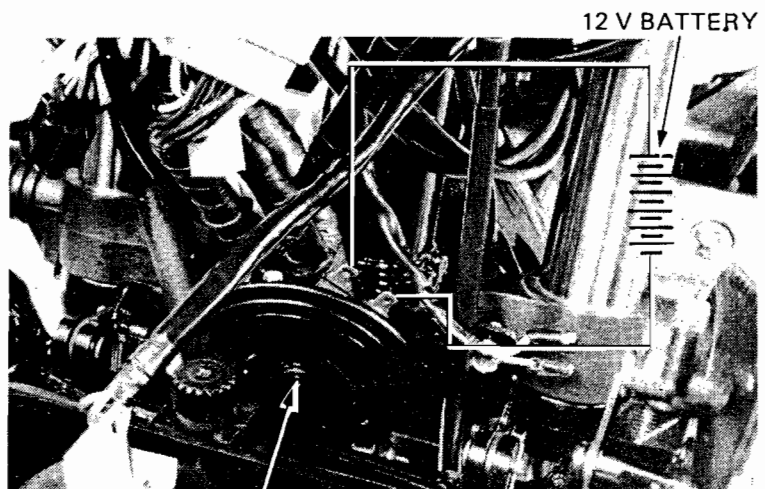

12 V BATTERY

HORN





## TAILLIGHT SENSOR

Remove the seat, handrail and rear cowl (Page 17-3).

Disconnect the taillight sensor coupler.

Turn the ignition switch ON and check that the taillight warning light comes on.

If the warning light does not come on, check voltage at the black/brown and green terminals of the taillight sensor coupler.

If there is no voltage, check and repair the circuit wiring and connections.

If there is voltage, measure the voltage at the white/yellow (positive) and green (negative) terminals.

**VOLTAGE: 9-14 V**

If there is no voltage between these terminals, replace the taillight sensor with a new one.

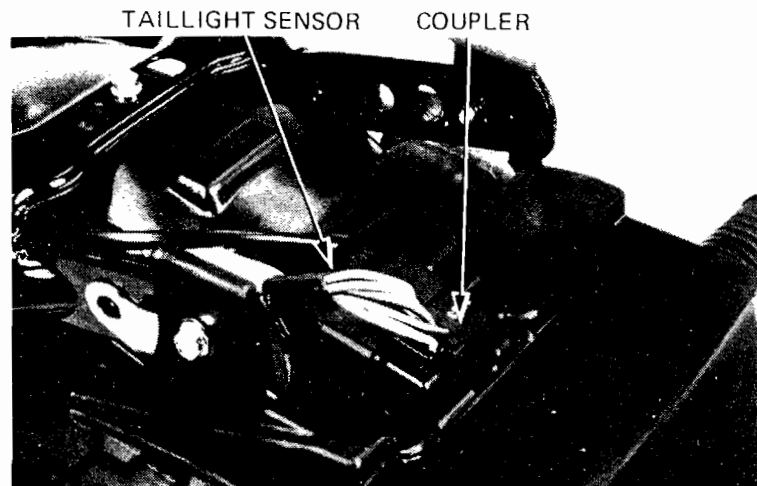

## TURN SIGNAL

### BULB REPLACEMENT

Remove the lens screws and lens.

Replace the bulb.

Install the lens and tighten the screws.

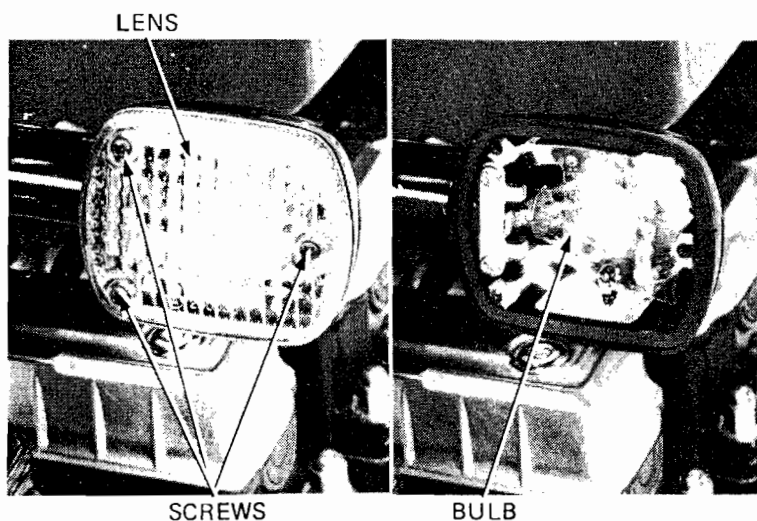



## TAIL/BRAKE LIGHT

### BULB REPLACEMENT

Remove the two taillight lens mounting screws and lens.

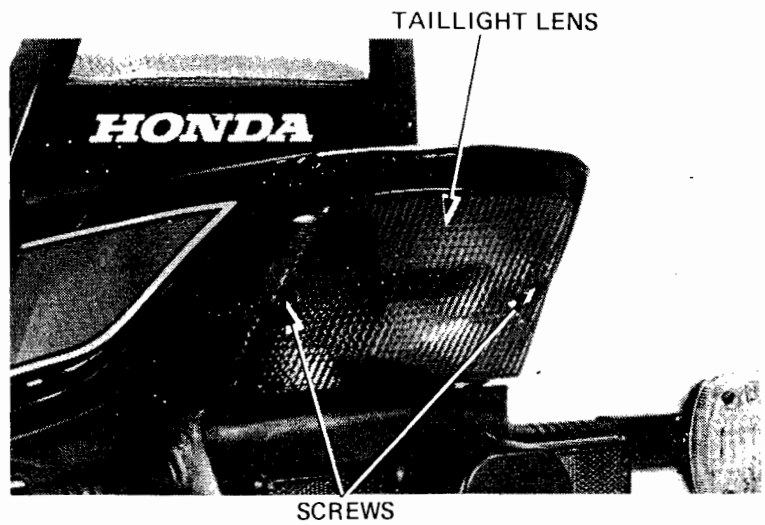

Replace the bulb with a new one.  
Install the taillight lens and tighten the screws.

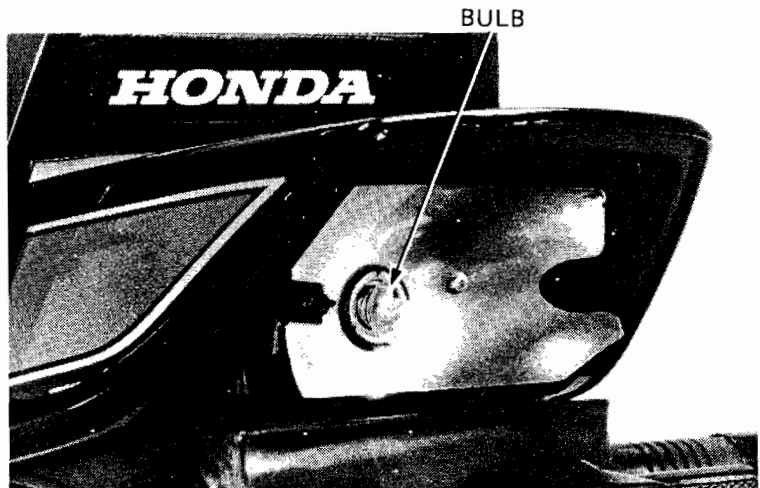

### REMOVAL/INSTALLATION

Disconnect the taillight wire coupler.  
Remove the taillight mounting screw and the taillight assembly.

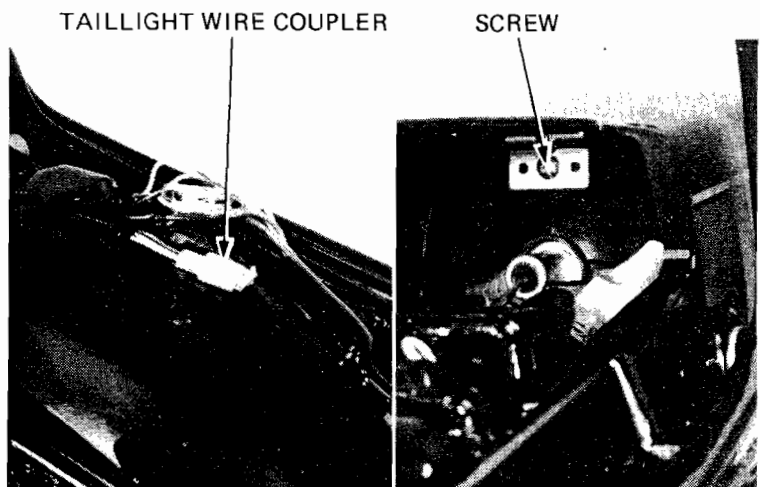



## LICENSE LIGHT

### BULB REPLACEMENT

Remove the two license plate bracket bolts and bracket.

Remove the two license light mounting nuts.

LICENSE PLATE BRACKET

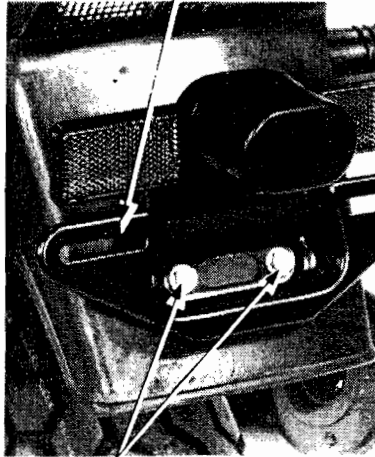

BOLTS

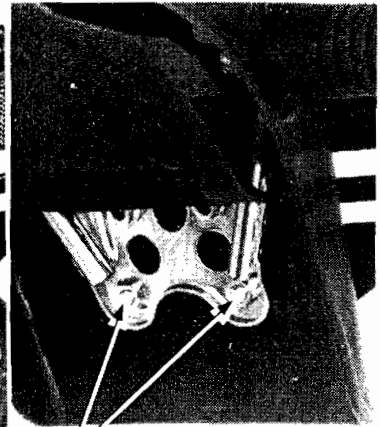

NUTS

Remove the two screws attaching the lens and the lens.

Replace the bulb with a new one.

Install the lens onto the light and tighten the two screws.

Install the light and bracket in the reverse order of removal.

SCREWS

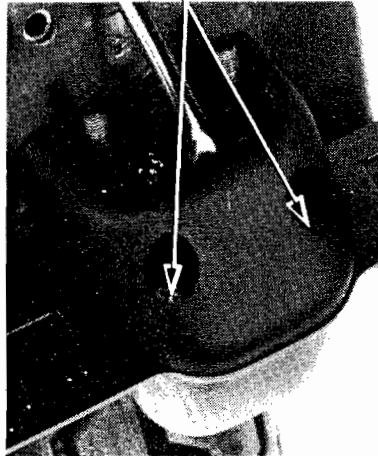

BULB

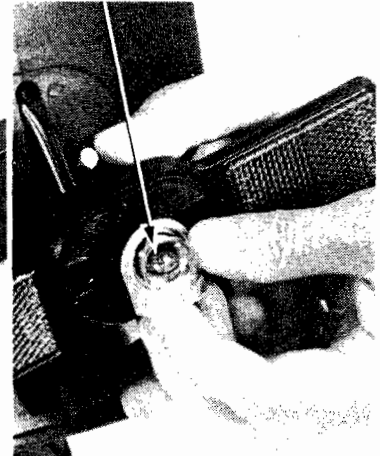

### REMOVAL/INSTALLATION

Remove the seat and disconnect the license light connectors.

WIRE CONNECTORS

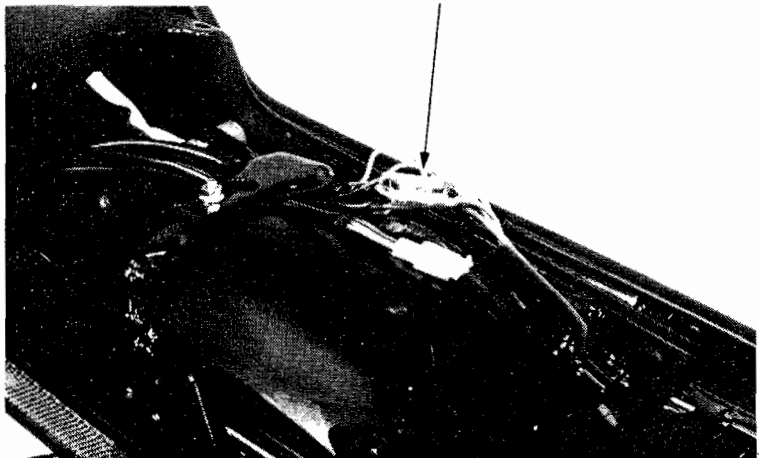



Remove the two license plate bracket mounting bolts and the bracket.

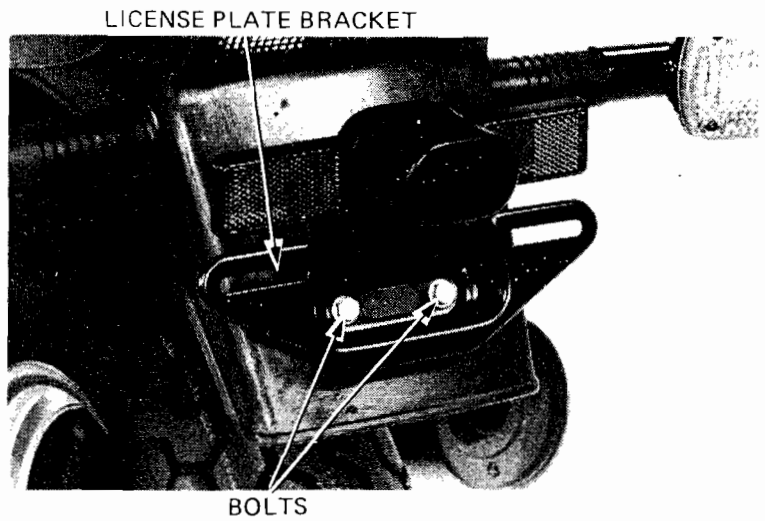

Remove the two license light mounting nuts and the light assembly.

Install in the reverse order.

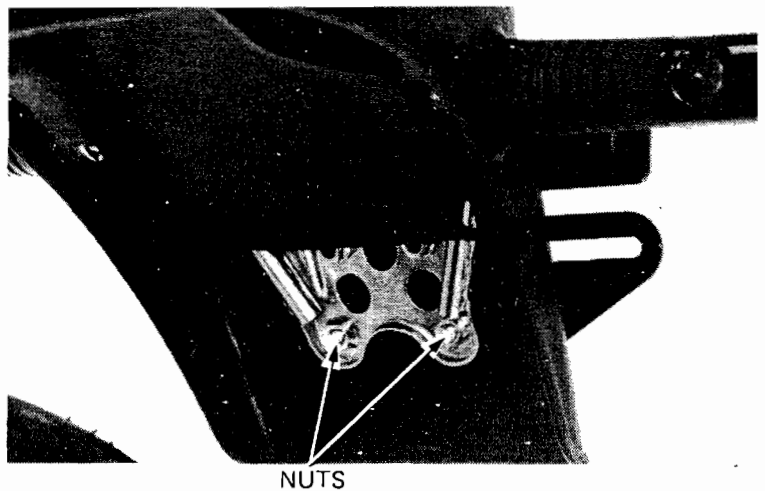



**HONDA**  
**CB750SC**

---

MEMO





HYDRAULIC TAPPETS

23-1

NEW TRAC FRONT SUSPENSION

23-3

## HYDRAULIC TAPPETS

### GENERAL

This motorcycle uses hydraulic tappets. Hydraulic tappets do not require adjustment and help the engine to run quieter by keeping valve clearance at zero at all engine temperatures.

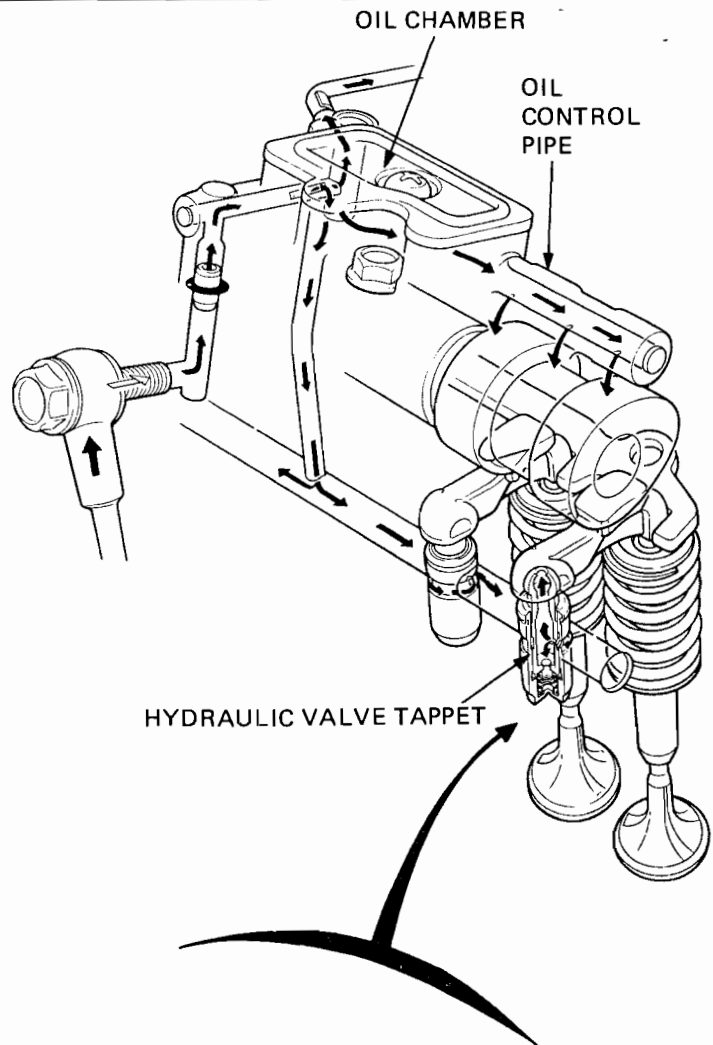

### OPERATION

When the camshaft lobe does not push the rocker arm the tappet plunger is at rest. In this position its oil inlet hole aligns with the tappet body oil inlet hole. Oil enters the tappet reservoir through these holes.

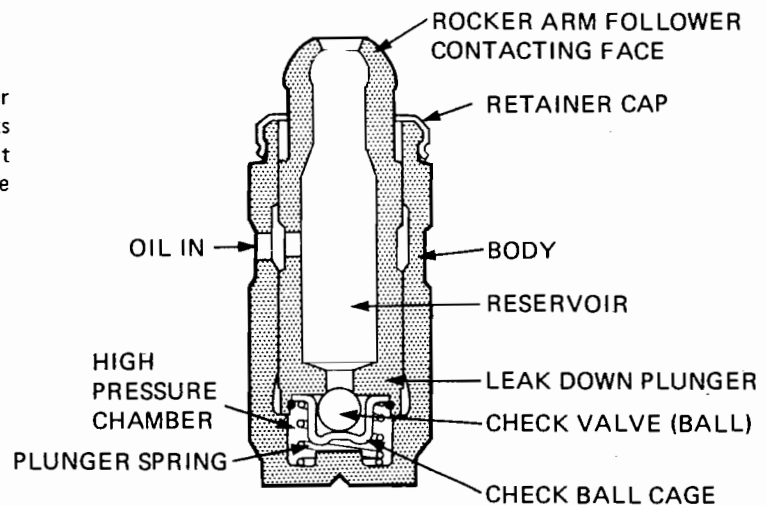



## TECHNICAL FEATURES

As the camshaft turns and pushes on the rocker arm slipper, the rocker arm pushes the tappet plunger down and oil pressure in the tappet high pressure chamber increases causing the check valve to close. During the short time it takes the check valve to close, a small amount of oil leaks out of the chamber causing the tappet to compress.

As the cam lobe continues to push on the rocker arm, oil pressure in the high pressure chamber increases rapidly (because the check valve is closed). The high oil pressure keeps the tappet from compressing any further which then allows the rocker arm to pivot and open the engine valve. As the cam lobe nears maximum lift, oil pressure in the high pressure chamber becomes high enough to cause a very small amount of oil to leak out of the high pressure chamber between the plunger and body. This allows the plunger to absorb the shock from the effects of the cam lobe reaching maximum lift.

After the cam lobe passes maximum lift, the engine valve springs force the engine valve to close.

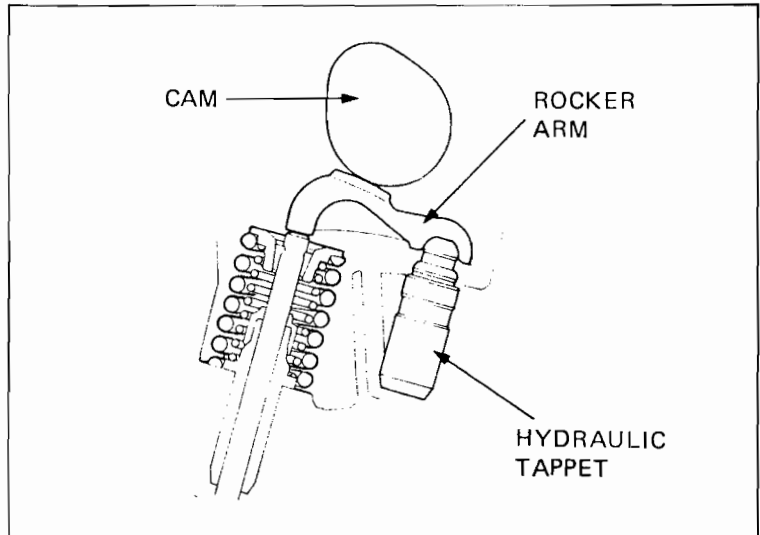
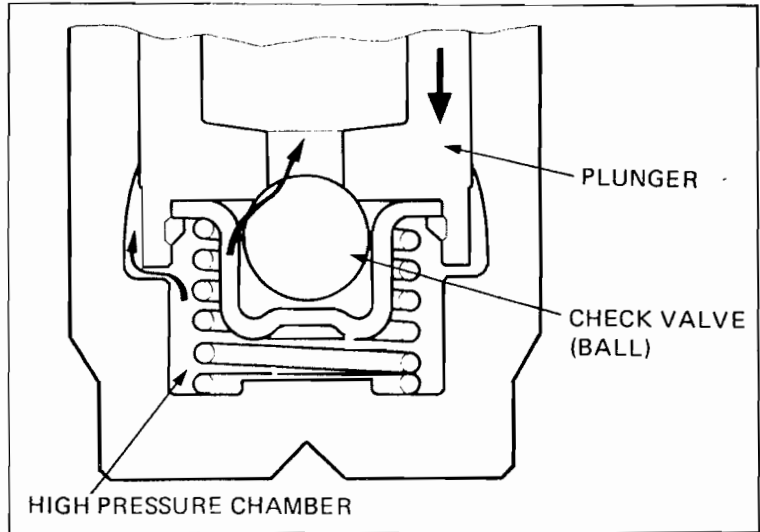

When the valve closes completely, the plunger is pushed up by the spring in the high pressure chamber. Oil pressure decreases and as a result the check valve opens and allows oil to re-enter the high pressure chamber from the reservoir.

All of the above actions keep valve clearance at zero under all normal operating conditions.

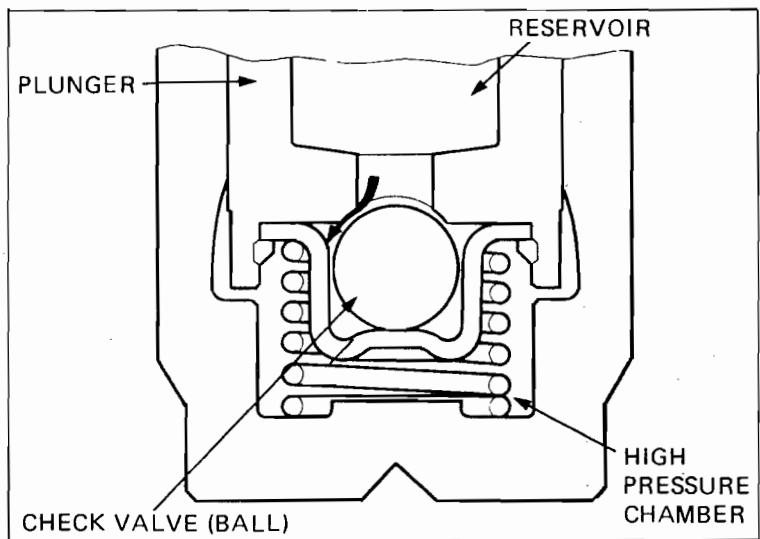





## NEW TRAC (Torque Reactive Anti-dive Control) FRONT SUSPENSION

### GENERAL

This motorcycle has an anti-dive front suspension system with four-way adjustability to provide the desired ride under various braking conditions. The system consists of a piston, return spring, oil control orifice and body.

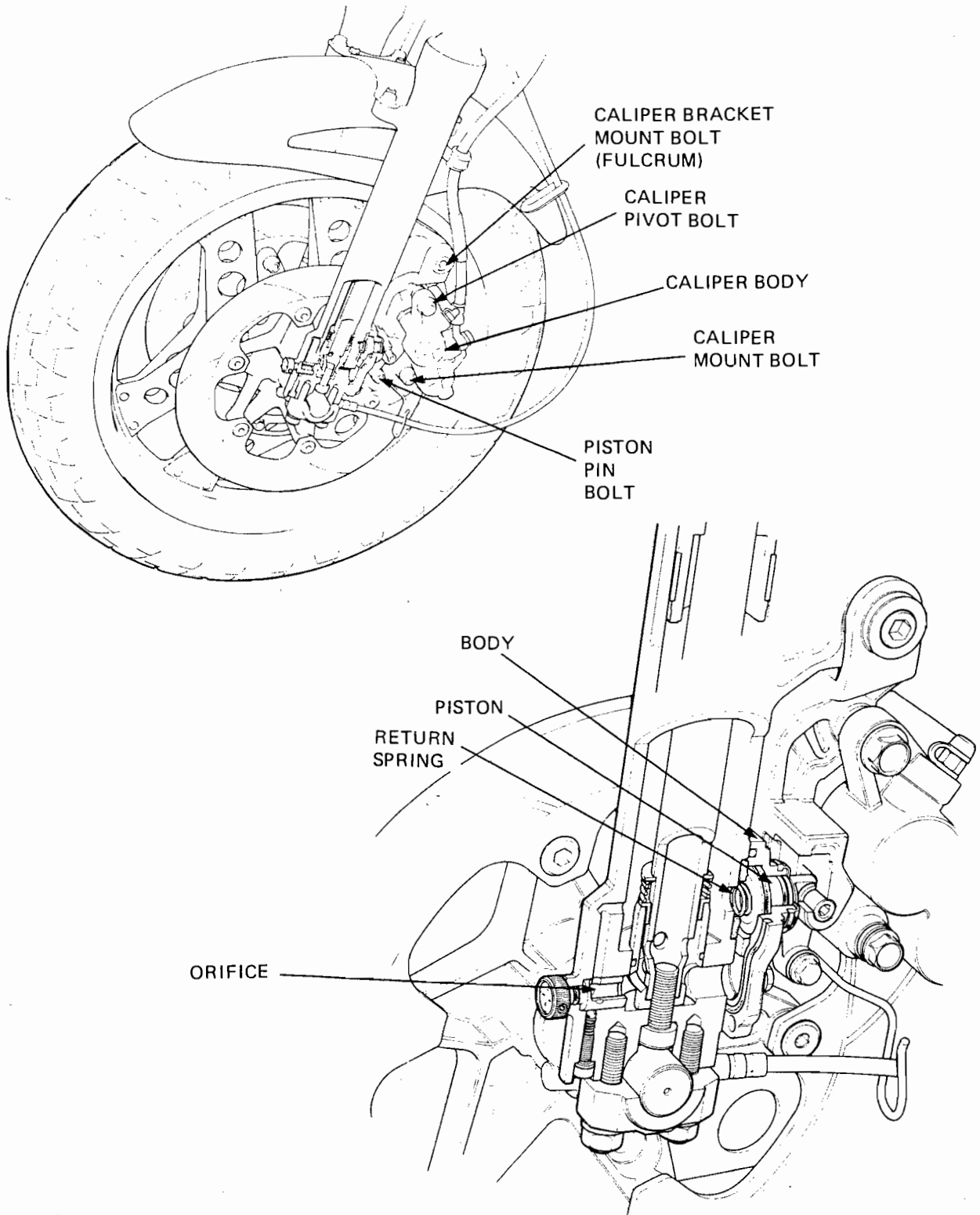



**TECHNICAL FEATURES**

**OPERATION**

When the motorcycle is slowed or stopped, the brake disc is squeezed by the brake pads, causing the brake caliper to pivot on its bracket mounting bolt.

This movement causes the pivot bolt to push the piston in, uncovering the oil control orifice.

Since the orifice has four oil passages of different diameters, the desired damping can be selected by turning it. Always adjust the right and left to the same position.

Front Suspension Adjustment Chart

PISTON	DAMPING EFFECT
1	SOFT
2	STANDARD
3	FIRM
4	EXTRA FIRM

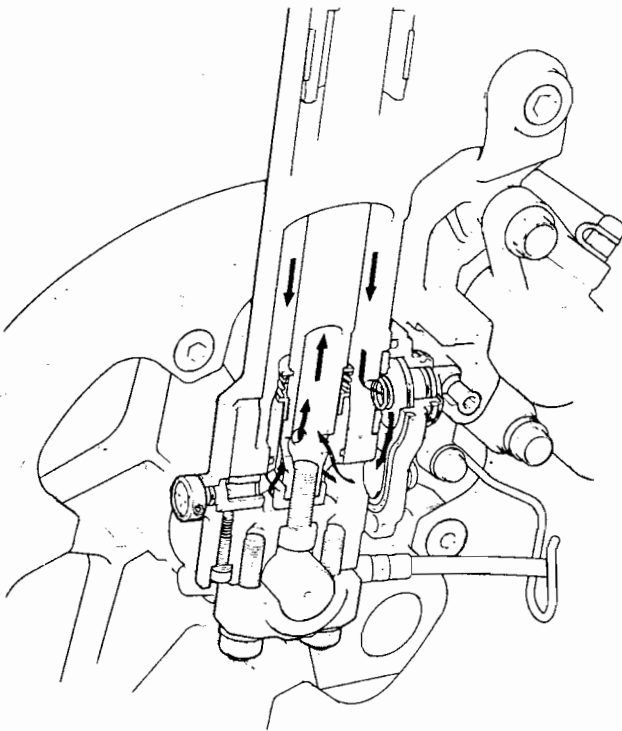

NORMAL CONDITION

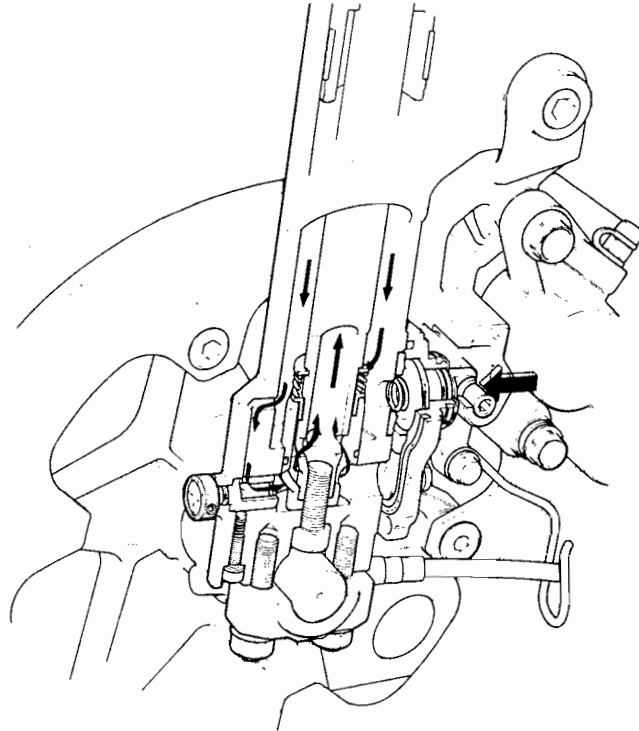

BRAKING



ENGINE DOES NOT START OR IS HARD TO START	24-1
ENGINE LACKS POWER	24-2
POOR PERFORMANCE AT LOW AND IDLE SPEED	24-3
POOR PERFORMANCE AT HIGH SPEED	24-3
HYDRAULIC TAPPET	24-4
POOR HANDLING	24-5

## ENGINE DOES NOT START OR IS HARD TO START

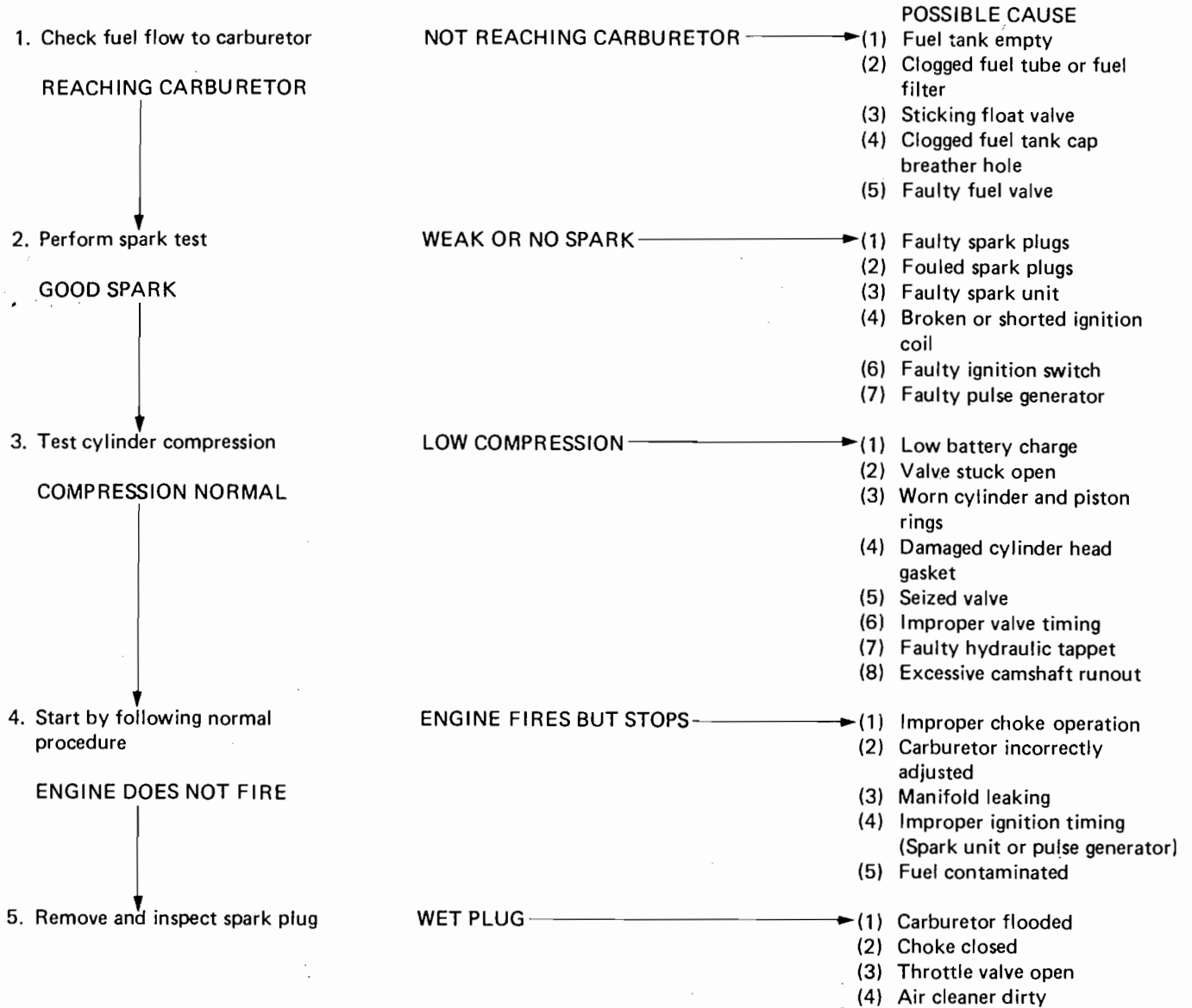



**ENGINE LACKS POWER**

1. Raise wheels off ground and spin by hand  
WHEEL SPINS FREELY
2. Check tire pressure  
PRESSURE NORMAL
3. Check clutch for slipping  
CLUTCH ENGAGED PROPERLY
4. Accelerate lightly  
ENGINE SPEED INCREASES
5. Check ignition timing  
CORRECT
6. Test cylinder compression  
NORMAL
7. Check carburetor for clogging  
NOT CLOGGED
8. Remove spark plug  
NOT FOULED OR DISCOLORED
9. Check oil level and condition  
CORRECT
10. Remove cylinder head cover and inspect lubrication  
VALVE TRAIN LUBRICATED PROPERLY
11. Check for engine overheating  
NOT OVERHEATING
12. Accelerate or run at high speed  
ENGINE DOES NOT KNOCK

- |                                     |   |   |
|-------------------------------------|---|---|
| WHEELS DO NOT SPIN FREELY           | → | POSSIBLE CAUSE  |
|                                     |   | (1) Brake dragging  |
|                                     |   | (2) Worn or damaged wheel bearing                                       |
|                                     |   | (3) Wheel bearing needs lubrication                                     |
|                                     |   | (4) Faulty drive train  |
| PRESSURE LOW                        | → | (1) Punctured tire  |
|                                     |   | (2) Faulty tire valve   |
| CLUTCH SLIPS                        | → | (1) Faulty clutch spring  |
|                                     |   | (2) Worn clutch disc/plate  |
|                                     |   | (3) Warped clutch disc/plate  |
| ENGINE SPEED DOES NOT INCREASED     | → | (1) Carburetor choke closed   |
|                                     |   | (2) Clogged air cleaner   |
|                                     |   | (3) Restricted fuel flow  |
|                                     |   | (4) Clogged fuel tank breather tube                                     |
|                                     |   | (5) Clogged muffler   |
| INCORRECT                           | → | (1) Faulty spark unit   |
|                                     |   | (2) Faulty pulse generator  |
| TOO LOW                             | → | (1) Valve stuck open  |
|                                     |   | (2) Worn cylinder and piston rings                                      |
|                                     |   | (3) Leaking head gasket   |
|                                     |   | (4) Improper valve timing   |
|                                     |   | (5) Excessive camshaft runout   |
| CLOGGED                             | → | Carburetor not serviced frequently enough                               |
| FOULED OR DISCOLORED                | → | (1) Plugs not serviced frequently enough                                |
|                                     |   | (2) Spark plug with incorrect heat range                                |
| INCORRECT                           | → | (1) Oil level too high  |
|                                     |   | (2) Oil level too low   |
|                                     |   | (3) Contaminated oil  |
| VALVE TRAIN NOT LUBRICATED PROPERLY | → | (1) Clogged oil passage   |
|                                     |   | (2) Clogged oil control orifice   |
| OVERHEATING                         | → | (1) Excessive carbon build-up in combustion chamber                     |
|                                     |   | (2) Use of poor quality fuel  |
|                                     |   | (3) Clutch slipping   |
| ENGINE KNOCKS                       | → | (1) Worn piston and cylinder  |
|                                     |   | (2) Wrong type of fuel  |
|                                     |   | (3) Excessive carbon build-up in combustion chamber                     |
|                                     |   | (4) Ignition timing too advanced (Faulty spark unit or pulse generator) |



### POOR PERFORMANCE AT LOW AND IDLE SPEED

<p>1. Check ignition timing and camshaft</p> <p style="text-align: center;">CORRECT</p> <p>↓</p> <p>2. Check carburetor pilot screw adjustment</p> <p style="text-align: center;">CORRECT</p> <p>↓</p> <p>3. Check for leaking intake pipe</p> <p style="text-align: center;">NO LEAKS</p> <p>↓</p> <p>4. Perform spark test</p> <p style="text-align: center;">GOOD SPARK</p>	<p>INCORRECT →</p> <p>INCORRECT      See Fuel System Section</p> <p>LEAKING →</p> <p>WEAK OR INTRRMITTENT SPARK →</p>	<p>POSSIBLE CAUSE</p> <p>(1) Improper ignition timing (Faulty spark unit or pulse generator)</p> <p>(2) Faulty camshaft journal</p> <p>(1) Deteriorated insulator O-ring</p> <p>(2) Loose carburetor</p> <p>(1) Faulty, carbon or wet fouled spark plug</p> <p>(2) Faulty spark unit</p> <p>(3) Faulty ignition coil</p> <p>(4) Faulty pulse generator</p>
--	---	--

### POOR PERFORMANCE AT HIGH SPEED

<p>1. Check ignition timing</p> <p style="text-align: center;">CORRECT</p> <p>↓</p> <p>2. Disconnect fuel tube at carburetor</p> <p style="text-align: center;">FUEL FLOWS FREELY</p> <p>↓</p> <p>3. Remove carburetor and check for clogged jet</p> <p style="text-align: center;">NOT CLOGGED</p> <p>↓</p> <p>4. Check valve timing</p> <p style="text-align: center;">CORRECT</p> <p>↓</p> <p>5. Check valve spring tension</p> <p style="text-align: center;">NOT WEAKENED</p>	<p>INCORRECT →</p> <p>FUEL FLOW RESTRICTED →</p> <p>CLOGGED →</p> <p>INCORRECT →</p> <p>WEAK →</p>	<p>(1) Faulty spark unit</p> <p>(2) Faulty pulse generator</p> <p>(1) Lack of fuel in tank</p> <p>(2) Clogged fuel line</p> <p>(3) Clogged fuel tank breather hole</p> <p>(4) Clogged fuel cock</p> <p>Clean</p> <p>Cam sprocket not installed properly</p> <p>Faulty spring</p>
--	--	--



**TROUBLESHOOTING**

**HYDRAULIC TAPPET**

**TAPPET NOISE**

Snap ten times or ride for five minutes with the engine speed 3,000 rpm.

1. Check oil level and condition

CORRECT

2. Check oil pressure

CORRECT

3. Remove cylinder head cover and oil hole caps and check lubrication

CORRECT

4. Remove hydraulic tappet and check

CORRECT

INCORRECT

- (1) Oil level too low
- (2) Contaminated oil
- (3) Contaminated oil filter

TOO LOW

- (1) Clogged oil passage
- (2) Defective O-ring
- (3) Defective oil hole cap

NOT LUBRICATED PROPERLY

- (1) Clogged oil pipe
- (2) Defective O-ring
- (3) Defective oil hole cap

INCORRECT

- (1) Plunger stick
- (2) Defective tappet
- (3) Defective one way valve

**ENGINE LACKS POWER**

1. Turn the engine for a few minute with starter

ENGINE DOES NOT START

2. Check oil pressure

CORRECT

3. Remove tappet and check

ENGINE START

Bubbly engine oil with over rev up

TOO LOW

- (1) Oil level too low
- (2) Clogged oil passage
- (3) Contaminated oil
- (4) Contaminated oil filter

INCORRECT

Defective tappet



**POOR HANDLING**

- |  | <b>POSSIBLE CAUSE</b>   |
|--|---|
| 1. If steering is heavy                | (1) Steering stem adjustment too tight<br>(2) Damaged steering head bearings  |
| 2. If either wheel is wobbling         | (1) Excessive wheel bearing play<br>(2) Bent rim<br>(3) Improperly installed wheel hub<br>(4) Swing arm pivot bearing excessively worn<br>(5) Bent frame<br>(6) Swing arm pivot adjusting bolt (right side) too tight<br>(7) Wheel out of balance |
| 3. If the motorcycle pulls to one side | (1) Improperly adjusted shock absorber<br>(2) Front and rear wheels not aligned<br>(3) Bent front fork<br>(4) Bent swing arm<br>(5) Improperly installed front fork brace   |