

HYOSUNG

HYOSUNG

HYOSUNG MOTORS & MACHINERY INC.

sense

sense

SERVICE MANUAL

SERVICE MANUAL

99000-91201

## FOREWORD

This service manual has been specially prepared to provide all the necessary information for the proper maintenance and repair of the SD-50.

The SD-50 is a new type of motorcycle that has many technical features such as :

- ※ V-belt drive automatic transmission
- ※ Forced air-cooling system
- ※ P.E Ignition system
- ※ Electric starter system

The SD-50 fits the needs of a wide variety of motorcycle users. Those who will be servicing this motorcycle should carefully review this manual before performing any repair or services.

Information of this manual is up-to-date at the time of issue. Major modification and changes incorporated later will be advised to HYOSUNG product distributor in each market. Therefore, if newest information is requested in the future, please contact the local HYOSUNG distributor.

The SD-50 motorcycles distributed in your county might differ in minor respects from the standard specification and, if they do, it is because some minor modifications (which are of no consequence in most cases as far as servicing is concerned) has to be made to comply with the statutory requirements of your country.

## GROUP INDEX

<b>GENERAL INFORMATION</b>	<b>1</b>
<b>PERIODIC MAINTENANCE AND TUNE-UP PROCEDURE</b>	<b>2</b>
<b>ENGINE</b>	<b>3</b>
<b>FUEL AND LUBRICATION SYSTEM</b>	<b>4</b>
<b>ELECTRICAL SYSTEM</b>	<b>5</b>
<b>CHASSIS</b>	<b>6</b>
<b>SERVICING INFORMATION</b>	<b>7</b>

## HYOSUNG MOTORS & MACHINERY INC.

*Overseas Service*

# GENERAL INFORMATION

1

## CONTENTS

<i>MODEL IDENTIFICATION</i> .....	<i>1-1</i>
<i>FUEL AND OIL RECOMMENDATIONS</i> .....	<i>1-1</i>
<i>BREAKING-IN PROCEDURE</i> .....	<i>1-1</i>
<i>PRECAUTIONS AND GENERAL INSTRUCTIONS</i> .....	<i>1-2</i>
<i>SPECIAL MATERIALS</i> .....	<i>1-3</i>
<i>SPECIFICATIONS</i> .....	<i>1-4</i>

## 1-1 GENERAL INFORMATION

---

### MODEL IDENTIFICATION

#### FRAME NUMBER

The frame number ① or VIN is stamped on the right side of the under center in the frame.

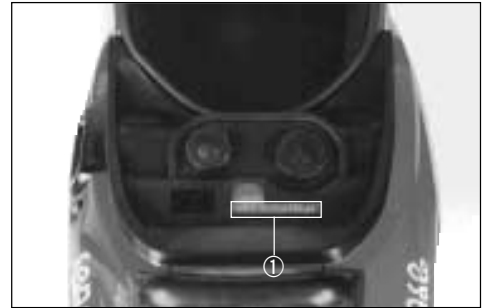

#### ENGINE NUMBER

The engine serial number ② is stamped on the crankcase.

These numbers are required especially for registering the motorcycle and ordering spare parts.

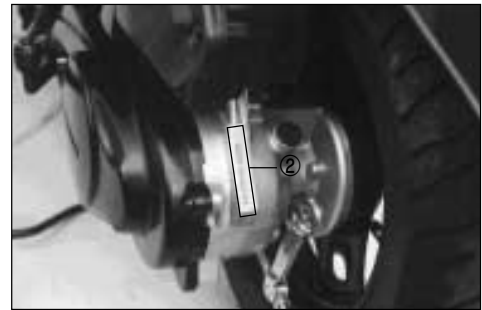

### FUEL AND OIL RECOMMENDATIONS

Be sure to use the specified fuel and oils.

The following are the specifications.

#### FUEL

Gasoline used should be graded 85-95 octane or higher.

Unleaded gasoline is recommended.

#### ENGINE OIL

For the HYOSUNG CCI system, use of "APOLLOIL BIKE-K" or "HYPOL HS" is highly recommended, but if they are not available, a good quality two-stroke oil (non-diluent type) should be used.

#### FINAL GEAR OIL

Use a good quality SAE 10W/40 multi-grade motor oil.

### BREAKING-IN PROCEDURE

During manufacture only the best possible materials are used and all machined parts are finished to a very high standard but it is still necessary to allow the moving parts to "BREAK-IN" before subjecting the engine to maximum stresses. The future performance and reliability of the engine depends on the care and restraint exercised during its early life. The general rules are as follows :

- Keep to these breaking-in speed limits:  
Up to 1000 km(600 miles): Less than 4/5 throttle
- Upon reaching an odometer reading of 1000km(600 miles) you can subject the motorcycle to full throttle operation.
- Do not maintain constant engine speed for an extended time period during any portion of the break-in.  
Try to vary the throttle position.

## PRECAUTIONS AND GENERAL INSTRUCTIONS

Observe the following items without fail when disassembling and reassembling motorcycles.

- Do not run engine indoors with little or no ventilation.
- Be sure to replace packing, gaskets, circlips, O-rings and cotter pins with new ones.

### CAUTION:

Never reuse a circlip after it has been removed from a shaft, it should be discarded and a new circlip must be installed.

When installing a new circlip, care must be taken not to expend the end gap larger than required to slip the circlip over the shaft.

After installing a circlip, always insure that it is completely seated in its groove and securely fitted.

- When tightening cylinder head or a case, torque the bolt or nut of larger thread diameter first and then proceed to that of smaller diameter. They should also be tightened crosswise from inside to outside to the specified torque.
- Use special tools where specified.
- Use genuine parts and recommended oils.
- When two or more persons work together, pay attention to safety of each other.
- After the reassembly, check parts for tightness and operation.
- Treat gasoline, which is extremely flammable and highly explosive, with greatest care. Never use gasoline as cleaning solvent.

Warning, Caution and Note are included in this manual occasionally, describing the following contents.

**WARNING** ..... The personal safety of the rider may be involved. Disregarding this information could result in injury to rider.

**CAUTION** ..... These instructions point out special service procedures or precautions that must be followed to avoid damaging the machine.

**NOTE** ..... This provides special information to make maintenance easier or important instructions clearer.

## REPLACEMENT PARTS

When you replace any parts, use only genuine HYOSUNG replacement parts, or their equivalent. Genuine HYOSUNG parts are high quality parts which are designed and built specifically for HYOSUNG vehicles.

### CAUTION:

Use of replacement parts which are not equivalent in quality to genuine HYOSUNG parts can lead to performance problems and damage.









## 1-3 GENERAL INFORMATION

### SPECIAL MATERIALS

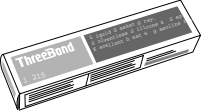
The materials shown are required for maintenance works on the Model SD-50 and should be kept on hand for ready use. In addition, such standard materials as cleaning fluids, lubricants, etc., should also be available.

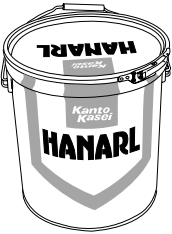
Methods of use are discussed in the text of this manual on later pages.

Material	use	Material	use
 <p>GREASE "G2" 99000-07C00</p>	<ul style="list-style-type: none"> <li>● Oil seal</li> <li>● Throttle grip</li> <li>● Speedometer cable</li> <li>● Oil pump drive/driven gear</li> <li>● Kick starter gear</li> <li>● Kick starter shaft</li> <li>● Movable driven face</li> <li>● Fixed driven face</li> <li>● Starter pinion</li> <li>● Starter motor</li> <li>● Wheel bearing</li> <li>● Brake camshaft</li> <li>● Steering stem bearing</li> </ul>	 <p>THREAD LOCK "1342" 99000-32050</p>	<ul style="list-style-type: none"> <li>● Reed valve securing screw</li> <li>● Crankshaft oil seal outer surface</li> </ul>
 <p>THREE BOND No. 1215 99000-31110</p>	<ul style="list-style-type: none"> <li>● Crankcase mating surface</li> <li>● Final gear cover</li> </ul>	 <p>THREAD LOCK "1324" 99000-32030</p>	<ul style="list-style-type: none"> <li>● Front fork socket bolt</li> </ul>
 <p>SILICONE GREASE 99000-25110</p>	<ul style="list-style-type: none"> <li>● Front brake caliper</li> </ul>		
 <p>THREAD LOCK SUPER "1322" 99000-32110</p>	<ul style="list-style-type: none"> <li>● Magneto rotor nut</li> </ul>		

**SPECIFICATIONS**

**DIMENSIONS AND DRY MASS**

Overall length	1,780 mm(70.1 in)
Overall width	660 mm(26.0 in)
Overall height	1,065 mm(41.9 in)
Wheelbase	1,221 mm(48.1 in)
Ground clearance	112 mm (4.4 in)
Dry mass	84 kg(185 lbs)

**ENGINE**

Type	Two-stroke, forced air-cooled
Intake system	Reed valve
Number of cylinder	1
Bore	41.0 mm(1.614 in)
Stroke	37.4 mm(1.472 in)
Piston displacement	49 cm <sup>3</sup> (3.0 cu.in)
Corrected compression ratio	7.4:1
Carburetor	SIDEDRAFT V.V.
Air cleaner	Polyurethane foam element
Starter system	Electric and kick
Lubrication system	HYOSUNG "CCI"

**TRANSMISSION**

Clutch	Dry shoe, automatic, centrifugal type
Reduction ratio	2.815-0.866 (Variable)
Drive system	V-belt drive

**CHASSIS**

Front suspension	Telescopic, coil spring, oil dampened
Rear suspension	Swingarm type, coil spring, oil damped
Caster	25 °
Trail	70 mm(2.75 in)
Steering angle	45 ° (right & left)
Turning radius	1.9 mm(6.2 ft)
Front tire size	100/80-10 53J
Rear tire size	100/80-10 53J
Front brake	Disc
Rear brake	Internal expanding

**ELECTRICAL**

Ignition type	HYOSUNG "CDI"
Ignition timing	23 ° B.T.D.C.at 4,000 r/min
Spark plug	GOLDEN: BP6HS
Battery	12V 3Ah/10HR
Generator	Magneto
Fuse	10 A
Headlight	12V 15/15 W × 2
Front turn signal light	12V 21 W
Rear turn signal light	12V 10 W
Tail/Brake light	12V 5/21 W
Speedometer light	12V 3.4 W × 2
Oil level indicator light	12V 1.7 W
Turn signal indicator light	12V 1.7W
Trunk light	12V 2 W

**CAPACITIES**

Fuel tank	4.8 L(1.3/1.1 US/Imp gal)
Engine oil tank	1.2 L(1.2/1.0 US/Imp qt)
Final gear oil	80 ml(2.7/2.8 US/Imp oz)

\* The specifications are subject to change without notice.

# PERIODIC MAINTENANCE AND TUNE-UP PROCEDURES

## CONTENTS

<b>PERIODIC MAINTENANCE SCHEDULE</b> .....	<b>2- 1</b>
<b>MAINTENANCE AND TUNE-UP PROCEDURE</b> .....	<b>2- 2</b>
<b>BATTERY</b> .....	<b>2- 2</b>
<b>CYLINDER HEAD NUTS AND EXHAUST PIPE BOLTS</b> .....	<b>2- 3</b>
<b>CYLINDER HEAD AND CYLINDER</b> .....	<b>2- 3</b>
<b>SPARK PLUG</b> .....	<b>2- 4</b>
<b>FUEL LINE</b> .....	<b>2- 4</b>
<b>AIR CLEANER</b> .....	<b>2- 5</b>
<b>THROTTLE CABLE</b> .....	<b>2- 5</b>
<b>ENGINE IDLE SPEED</b> .....	<b>2- 5</b>
<b>OIL PUMP</b> .....	<b>2- 6</b>
<b>FINAL GEAR OIL</b> .....	<b>2- 7</b>
<b>BRAKES</b> .....	<b>2- 7</b>
<b>TIRES</b> .....	<b>2-10</b>
<b>STEERING</b> .....	<b>2-10</b>
<b>FRONT SUSPENSION</b> .....	<b>2-11</b>
<b>REAR SUSPENSION</b> .....	<b>2-11</b>
<b>CHASSIS BOLTS AND NUTS</b> .....	<b>2-11</b>
<b>GENERAL LUBRICATIONS</b> .....	<b>2-13</b>



## 2-1 PERIODIC MAINTENANCE AND TUNE-UP PROCEDURES

### PERIODIC MAINTENANCE SCHEDULE

The chart below lists the recommended intervals for all the required periodic service work necessary to keep the motorcycle operating at peak performance and economy. Mileages are expressed in terms of miles, kilometers and months.

**NOTE:**

More frequent servicing may be performed on motorcycles that are used under severe conditions.

### PERIODIC MAINTENANCE CHART

INTERVAL: This intervals judged by odometer reading or month whichever comes first	miles	Initial 600	Every 2400	Every 4800
	km	Initial 1000	Every 4000	Every 8000
	months	2	6	12
Battery		I	I	-
Cylinder head nuts and exhaust pipe nuts		T	T	-
Cylinder head and cylinder		-	-	C
Spark plug		-	C	R
Fuel line		I	I	-
		Replace every 4 years		
Air cleaner		-	C	-
Throttle cable play		I	I	-
Engine idle rpm		I	I	-
Oil pump		I	I	-
Final gear oil		I	-	I
Brakes		I	I	-
Brake hose		I	I	-
		Replace every 4 years		
Brake fluid		I	I	-
		Replace every 2 years		
Tire		I	I	-
Steering		I	I	-
Front suspension		I	-	I
Rear suspension		I	-	I
Chassis bolts and nuts		T	T	-

**NOTE:** I = Inspect and clean, adjust, lubricate or replace, if necessary.

A = Adjust, C = Clean, R = Replace, T = Tighten

## MAINTENANCE AND TUNE-UP PROCEDURE

This section describes the servicing procedures for each item of the Periodic Maintenance requirements.

### BATTERY

**Inspect at Initially 1000km (600miles, 2months), and Every 4000km (2400miles, 6months) thereafter**

- Remove the battery cover ① from the leg shield mounting screws.

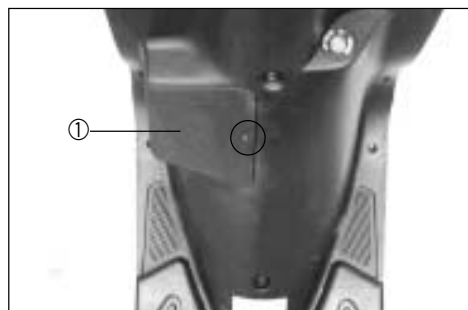

- Remove the battery  $\ominus$  lead and then  $\oplus$  lead at the battery terminals and remove the battery.



- Check the battery voltage with the pocket tester.  
If the voltage reading is below 12.0V, this battery needs recharging. (Refer to page 5-10)

Battery voltage	Minimum 12.0V
09900-25002	Pocket tester

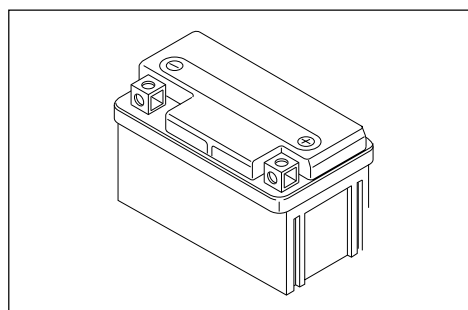

## 2-3 PERIODIC MAINTENANCE AND TUNE-UP PROCEDURES

### CYLINDER HEAD NUT AND EXHAUST PIPE BOLTS

**Tighten at Initially 1000km (600miles, 2months), and Every 4000km (2400miles, 6months) thereafter**

Cylinder head nuts, when they are not tightened to the specified torque, may result in leakage of the compressed mixture and reduce output. Tighten the cylinder head nuts in the following procedure.

- Remove the frame side cover.(Refer to page 6-3)
- Remove the spark plug cap.
- Remove the cylinder head cover bolts.  
(Refer to page 3-5)
- Tighten the nuts evenly one by one in stages until each one is tightened to the specified torque. Tighten the nuts in the order indicated.

#### Tightening torque

Cylinder head nut	8-12 N · m (0.8-1.2 kg-m, 6.0-8.5 lb-ft)
Exhaust pipe nut	8-12 N · m (0.8-1.2 kg-m, 6.0-8.5 lb-ft)

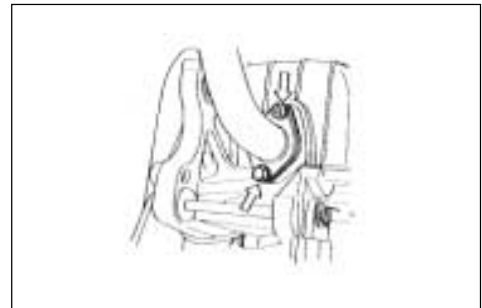
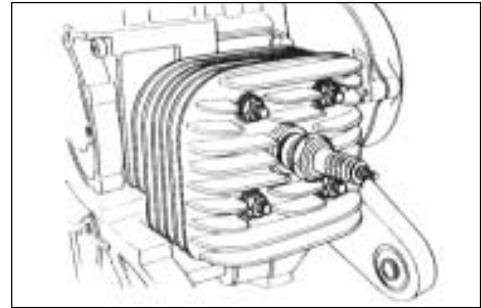

### CYLINDER HEAD AND CYLINDER

**Remove carbon Every 8000km (4800miles, 12months)**

Carbon deposits in the combustion chamber and the cylinder head will raise the compression ratio and may cause preignition or overheating. Carbon deposited at the exhaust port of the cylinder will prevent the flow of exhaust gases, reducing the output. Remove carbon deposits periodically.

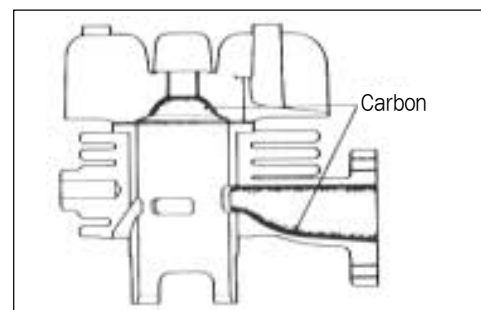

### SPARK PLUG

**Clean Every 4000km (2400miles, 6months) and  
Replace Every 8000km (4800miles, 12months)**

Neglecting the spark plug maintenance eventually leads to difficult starting and poor performance. If the spark plug is used for a long period, the electrode gradually burns away and carbon builds up along the inside part. In accordance with the Periodic Inspection Chart, the plug should be removed for inspection, cleaning and to reset the gap.

- Carbon deposits on the spark plug will prevent good sparking and cause misfiring. Clean the deposits off periodically.
- If the center electrode is fairly worn down, the plug should be replaced and the plug gap set to the specified gap using a thickness gauge.

09900-20804	Thickness gauge
Spark plug gap	0.6-0.7 mm(0.024-0.028 in)

- Check the spark plug for burnt condition. If abnormal, replace the plug as indicated in the chart.

GOLDEN	REMARKS
BP5HS	If the standard plug is apt to get wet, replace with this plug.
BP6HS	Standard
BP7HS	If the standard plug is apt to get overheat, replace with this plug.

- Tighten the spark plug to the specification.

#### Spark plug

Tightening torque	25-30 N · m (2.5-3.0 kg-m, 18.0-21.0 lb-ft)
-------------------	--

**NOTE:**

- To check the spark plug, first make sure that the fuel used is unleaded gasoline, and if plug is either sooty with carbon or burnt white, replace it.
- Confirm the thread size and reach when replacing the plug.

### FUEL LINE

**Inspect at Initially 1000km (600miles, 2months), and  
Every 4000km (2400miles, 6months) thereafter  
Replace Every 4 years.**

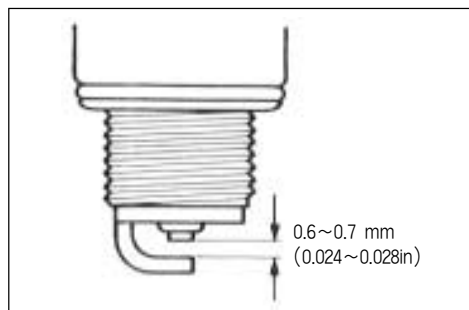
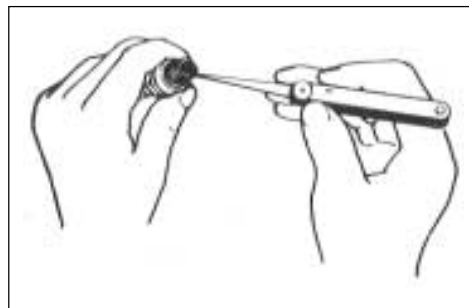

## 2-5 PERIODIC MAINTENANCE AND TUNE-UP PROCEDURES

### AIR CLEANER

**Clean Every 4000km (2400miles, 6months)**

If the air cleaner is clogged with dust, intake resistance will be increased with a resultant decrease in power output and an increase in fuel consumption. Check and clean the element in the following manner.

- Remove the frame side cover.(Refer to page 6-3)
- Remove the cleaner cover by removing the screw.
- Remove the element ①.
- Fill a washing pan of a proper size with non-flammable cleaning solvent. Immerse the element in the cleaning solvent and wash them clean.
- Squeeze the cleaning solvent out of the washed element by pressing it between the palms of both hands: do not twist or wiring the element or it will develop tears.
- Immerse the element in SAE 10/W40 oil, and squeeze the oil out of the element leaving it slightly wet with oil.
- Fit the elements to the cleaner case properly.

#### CAUTION:

- Before and during the cleaning operation, inspect the element for tears. A torn element must be replaced.
- Be sure to position the element snugly and correctly, so that no incoming air will bypass it. Remember, rapid wear of piston rings and cylinder bore is often caused by a defective or poorly fitted element.

Ⓐ Non-flammable cleaning solvent

Ⓑ SAE 10W40

### THROTTLE CABLE

**Adjust at Initially 1000km (600miles, 2months), and Every 4000km (2400miles, 6months) thereafter**

- Loosen the lock nut ① and adjust the cable play ② by turning adjuster ③ in or out to obtain the following cable play. After adjusting play, tighten the lock nut.

Cable play	0.5 – 1.0 mm(0.020 – 0.040 in)
------------	--------------------------------

### ENGINE IDLE SPEED

**Adjust at Initially 1000km (600miles, 2months), and Every 4000km (2400miles, 6months) thereafter**

- Adjust the throttle cable play.
- Remove the frame side cover.(Refer to page 6-3)
- Warm up the engine.

#### NOTE:

A warm engine means an engine that has been run for 10 minutes.

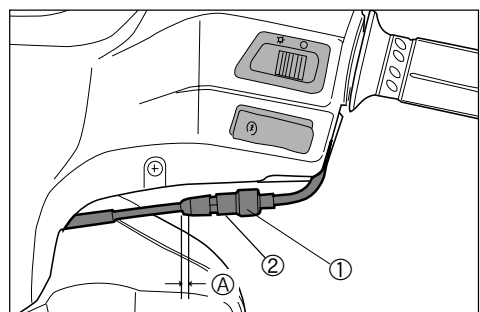
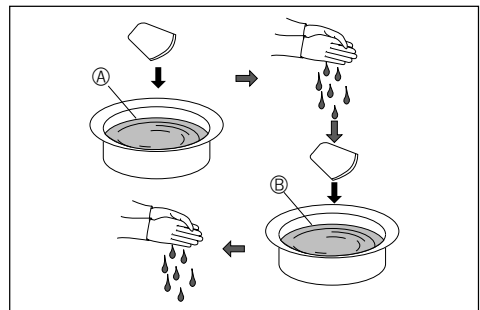
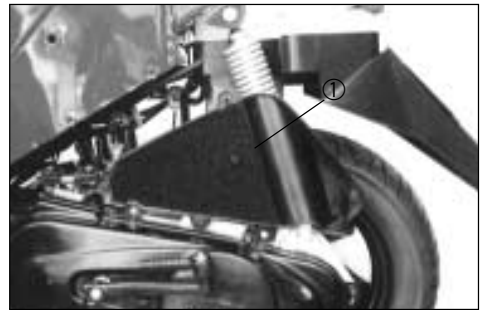
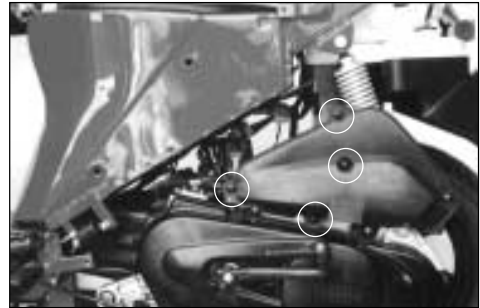

- Connect an electric tachometer to the connecting portion of the high tension lead. Use the selector key "C" position.

09900-26006	Tachometer
-------------	------------

- Adjust the throttle stop screw to obtain the idle r/min as follows.

Idle r/min	1800 ± 50 r/min
------------	-----------------

- Finally adjust the throttle cable play.

## OIL PUMP

**Inspect at Initially 1000km (600miles, 2months), and Every 4000km (2400miles, 6months) thereafter**

The engine oil is fed by the oil pump to the engine. The amount of oil fed to it is regulated by engine speed and oil pump control lever which is controlled by amount of throttle opening.

Check the oil pump in the following manner to confirm correct operation for throttle valve full opening position.

- Turn the throttle grip full open.
- Check whether the mark ① on the oil pump control lever is aligned with the index mark ② when the throttle valve is positioned as above.
- If the marks are not aligned, loosen lock nuts ③ and turn the adjuster ④ in or out to align the marks.
- After aligning the marks, tighten the lock nuts.

### CAUTION:

**Oil pump cable adjustment must be done after throttle cable adjustment.**

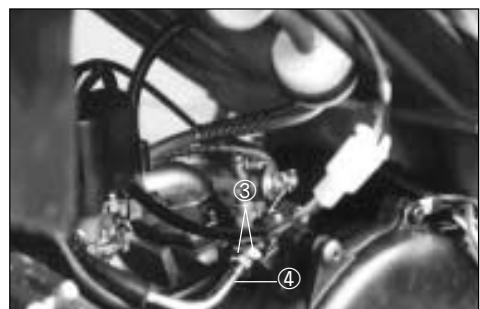
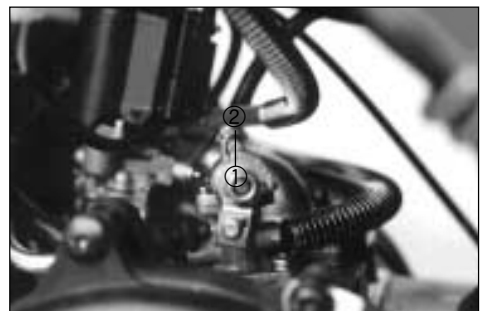

## 2-7 PERIODIC MAINTENANCE AND TUNE-UP PROCEDURES

### FINAL GEAR OIL

**Inspect at Initially 1000km (600miles, 2months), and Every 8000km (4800miles, 12months) thereafter**

Inspect final gear oil periodically following procedure below.

- Remove the side cover.(Refer to page 6-3)
- Remove the clutch cover.(Refer to page 3-5)
- Remove the oil level bolt ① and inspect oil level.  
If the level is below the level hole, add oil until oil flows from the level hole.
- Tighten the oil level bolt to the specified torque.

Tightening torque	9–15 N·m (0.9–1.5 kg-m, 6.5–11.0 lb-ft)
-------------------	--

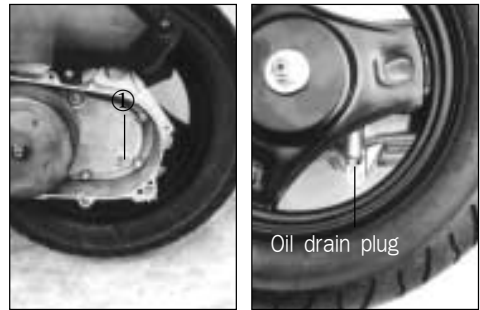

### BRAKES

**Inspect at Initially 1000km (600miles, 2months), and Every 4000km (2400miles, 6months) thereafter**  
**Replace(change) brake fluid Every 2 years**  
**Replace brake hose Every 4 years**

#### FRONT BRAKE FLUID LEVEL

- Keep the motorcycle upright and place the handlebar straight.
- Check brake fluid level by observing the lower limit line on the brake fluid reservoir.
- When the level is below the lower limit line, replenish with brake fluid that meets the following specification.

Specification and classification	DOT4
----------------------------------	------

#### WARNING:

The brake system of this motorcycle is filled with a glycolbased brake fluid. Do not use or mix different type of fluid such as silicone-based and petroleum-based. Do not use any brake fluid taken from old, used or unsealed containers. Never re-use the brake fluid left over from the last servicing and stored for long periods.

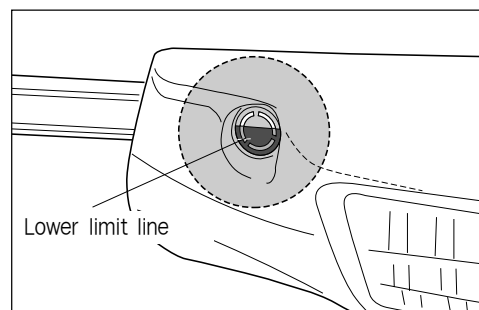

**WARNING:**

Brake fluid, if it leaks, will interfere with safe running and immediately discolor painted surfaces.

Check the brake hoses for cracks and hose joints for leakage before riding.

**BRAKE PADS**

Wearing condition of brake pads can be checked by observing the limit line ① marked on the pad. When the wear exceeds the limit mark, replace the pads with new ones.(Refer to page 6-13.)

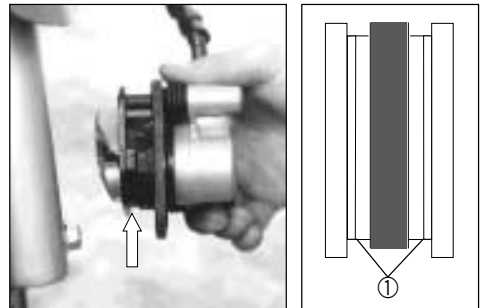

**BLEEDING AIR FROM THE BRAKE FLUID CIRCUIT**

Air trapped in the fluid circuit acts like a cushion to absorb a large proportion of the pressure developed by the master cylinder and thus interferes with the full braking performance of the brake caliper. The presence of air is indicated by “sponginess” of the brake lever and also by lack of braking force. Considering the danger to which such trapped air exposes the machine and rider, it is essential that, after remounting the brake and restoring the brake system to the normal condition, the brake fluid circuit be purged of air in the following manner:

- Fill up the master cylinder reservoir to the upper end of the inspection window. Replace the reservoir cap to prevent entry of dirt.
- Attach a pipe to the caliper bleeder valve, and insert the free end of the pipe into a receptacle.
- Bleed air from the bleeder valve.
- Squeeze and release the brake lever several times in rapid succession, and squeeze the lever fully without releasing it. Loosen the bleeder valve by turning it a quarter of a turn so that the brake fluid runs into the receptacle: this will remove the tension of the brake lever causing it to touch the handlebar grip. Then, close the valve, pump and squeeze the lever, and open the valve. Repeat this process until the fluid flowing into the receptacle no longer contains air bubbles.

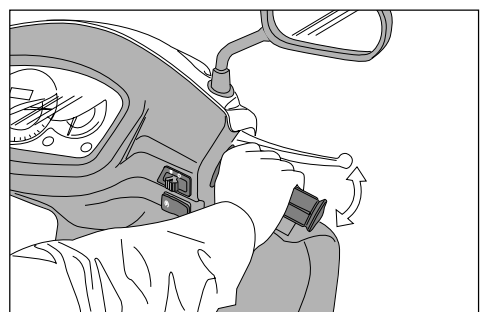



## 2-9 PERIODIC MAINTENANCE AND TUNE-UP PROCEDURES

**NOTE:**

Replenish the brake fluid reservoir as necessary while bleeding the brake system.  
Make sure that there is always some fluid visible in the reservoir.

- Close the bleeder valve, and disconnect the pipe. Fill the reservoir to the upper end of the inspection window.

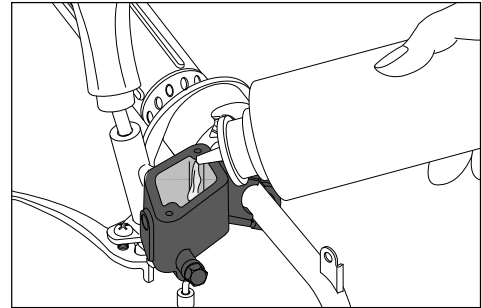

**Bleeder valve**

Tightening torque	6–9 N·m (0.6–0.9 kg-m, 4.5–6.5 lb-ft)
-------------------	--

**CAUTION:**

Handle the brake fluid with care: the fluid reacts chemically with paint, plastics, rubber materials, etc.

**REAR BRAKE**

Adjust by turning the adjusting nut ① so that the play ② is 15–25 mm (0.6–1.0 in) as shown in the illustration.

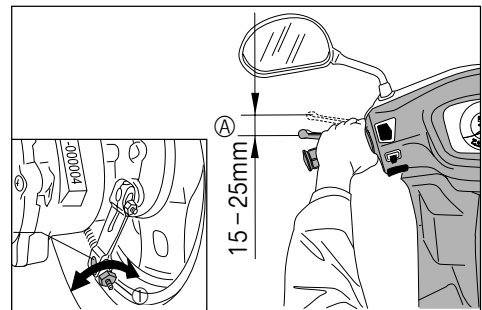

**Brake lining wear limit**

This motorcycle is equipped with the brake lining wear limit indicator on the rear brake. As shown in the illustration at right, at the condition of normal lining wear, an extended line from the index mark on the brake camshaft should be within the range embossed on the crankcase. To check wear of the brake lining, follow the steps below.

- First check if the brake system is properly adjusted.
- While operating the brake, check to see that the extension line from the index mark is within the range on the crankcase.
- If the index mark is outside the range as shown in the illustration at right, the brake shoe assembly should be replaced to ensure safe operation.

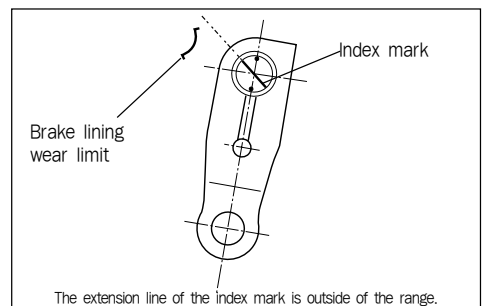
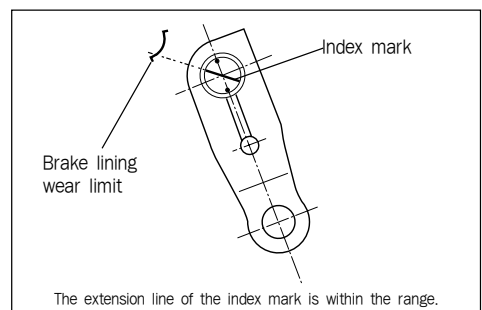

## TIRES

**Inspect at Initially 1000km (600miles, 2months), and Every 4000km (2400miles, 6months) thereafter**

### TIRE PRESSURE

If the tire pressure is too high, the motorcycle will tend to ride stiffly and have poor traction. Conversely, if the tire pressure is too low, stability will be adversely affected. Therefore, maintain the correct tire pressure for good roadability and to prolong tire life.

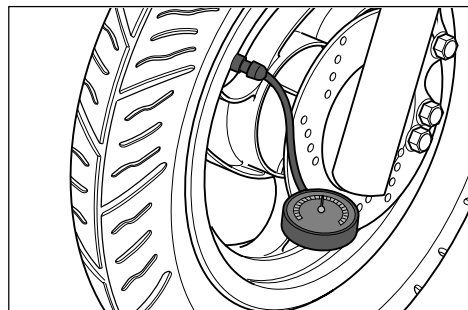

### CAUTION:

**The standard tire fitted on this motorcycle is 100/90-10 56J for front and rear. The use of a tire other than the standard may cause handling instability. It is highly recommended to use a HYOSUNG Genuine Tire.**

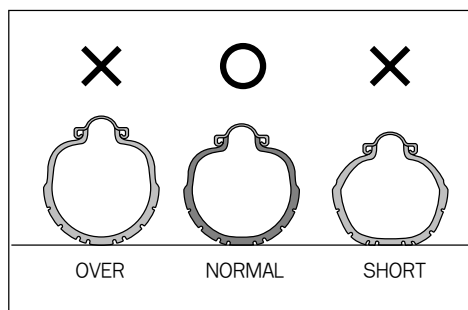

COLD INFLATION TIRE PRESSURE	SOLO RIDING			DUAL RIDING		
	kPa	kg/cm <sup>2</sup>	psi	kPa	kg/cm <sup>2</sup>	psi
FRONT	125	1.25	18	-	-	-
REAR	200	2.00	29	-	-	-

### TIRE TREAD CONDITION

Operating the motorcycle with the excessively worn tires will decrease riding stability and consequently invite a dangerous situation. It is highly recommended to replace the tire when the remaining depth of tire tread reaches the following specification.

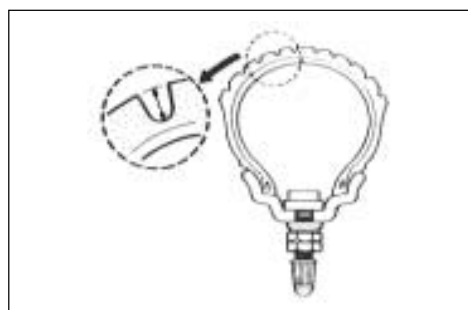

Front and Rear	1.6 mm (0.064 in)
09900-20805	Tire depth gauge

## STEERING

**Inspect at Initially 1000km (600miles, 2months), and Every 4000km (2400miles, 6months) thereafter**

Steering should be adjusted properly for smooth turning of handlebars and safe running. Too stiff steering prevents smooth turning of handlebars and too loose steering will cause poor stability.

Check that there is no play in the front fork assembly by supporting the machine so that the front wheel is off the ground, with wheel straight ahead, grasp lower shock absorber near the axle and pull forward. If play is found, perform steering bearing adjustment. (Refer to page 6-24)



## 2-11 PERIODIC MAINTENANCE AND TUNE-UP PROCEDURES

### FRONT SUSPENSION

**Inspect at Initially 1000km (600miles, 2months), and Every 8000km (4800miles, 12months) thereafter**

Inspect the front shock absorber for oil leakage or other damage, and replace the defective parts, if necessary.

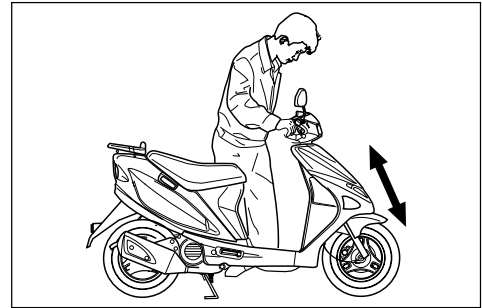

### REAR SUSPENSION

**Inspect at Initially 1000km (600miles, 2months), and Every 8000km (4800miles, 12months) thereafter**

Inspect the rear shock absorber for oil leak and the mounting rubbers including engine mountings for wear and damage. Replace the defective part if necessary.

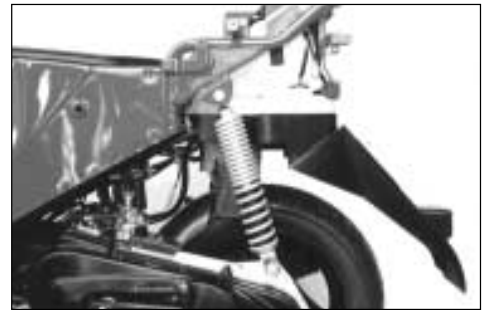

### CHASSIS BOLTS AND NUTS

**Tighten at Initially 1000km (600miles, 2months), and Every 4000km (2400miles, 6months) thereafter**

These bolts and nuts listed below are important safety parts. They must be loosened first and retightened, to the specified torque with a torque wrench.

No.	ITEM	N · m	kg · m	lb · ft
①	Front axle nut	33 - 52	3.3 - 5.2	24.0 - 37.5
②	Steering stem lock nut	60 - 100	6.0 - 10.0	43.5 - 72.5
③	Handlebar clamp nut	48 - 52	4.8 - 5.2	34.5 - 37.5
④	Handlebar set bolt	22 - 28	2.2 - 2.8	16.0 - 20.0
⑤	Front brake master cylinder bolt	8 - 12	0.8 - 1.2	6.0 - 8.5
⑥	Front brake hose union bolt	20 - 25	2.0 - 2.5	14.5 - 18.0
⑦	Front brake caliper mounting bolt	18 - 28	1.8 - 2.8	13.0 - 20.0
⑧	Front brake air bleeder valve	6 - 9	0.6 - 0.9	4.5 - 6.5
⑨	Rear axle nut	60 - 90	6.0 - 9.0	43.5 - 65.0
⑩	Rear shock absorber bolt (upper and lower)	22 - 35	2.2 - 3.5	16.0 - 25.5
⑪	Rear brake cam lever nut	6 - 9	0.6 - 0.9	4.5 - 6.5
⑫	Engine mounting bracket nut	48 - 72	4.0 - 6.0	34.5 - 52.0
⑬	Engine mounting nut	40 - 60	7.0 - 10.0	29.0 - 43.5

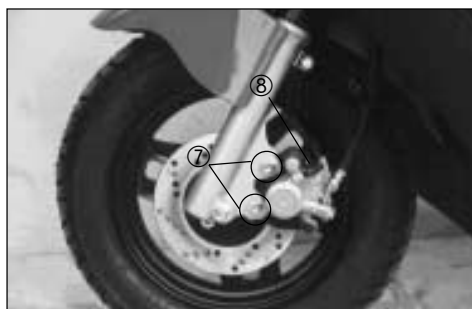
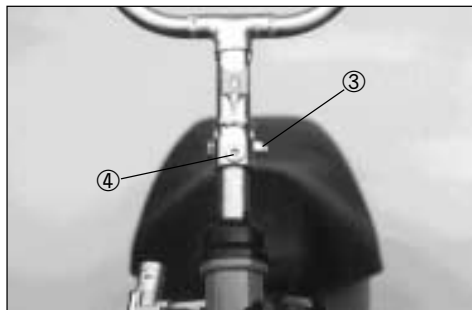
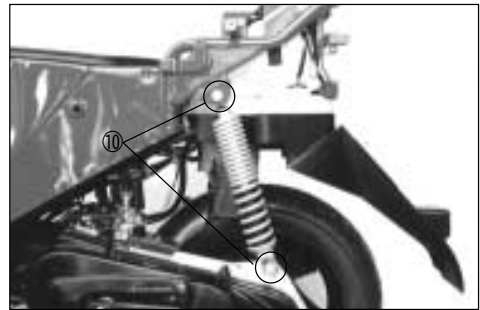
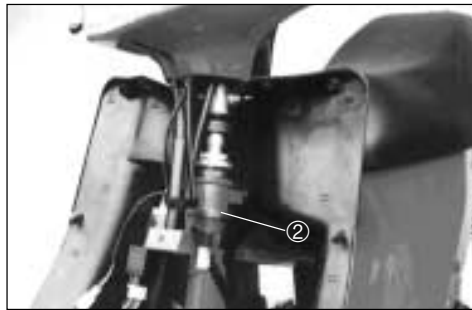
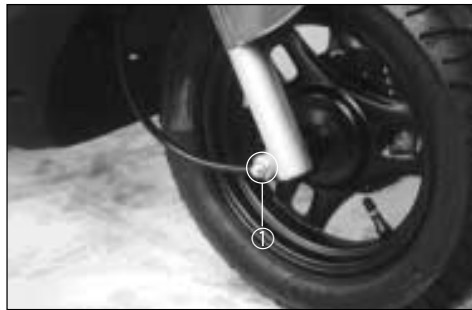

## 2-13 PERIODIC MAINTENANCE AND TUNE-UP PROCEDURES

### GENERAL LUBRICATIONS

Proper lubrication is important for smooth operation and long life of each working part of the motorcycle. The major lubrication points are indicated below.

**NOTE:**

\* Lubricate exposed parts which are subject to rust with motor oil grease.

\* Before lubricating each part, clean off any rusty spots and wipe off any grease, oil dirt or grime.

**WARNING:**

Be careful not to apply too much grease to the rear brake camshaft. If grease gets on the linings, brake slippage will result.

- ① Steering stem bearing
- ② Speedometer cable and drive gear box
- ③ Throttle grip
- ④ Throttle cable
- ⑤ Wheel bearing
- ⑥ Center stand
- ⑦ Engine mounting bracket pivoting portion
- ⑧ Rear brake lever and cable
- ⑨ Rear brake camshaft

**G** : Grease

**O** : Oil

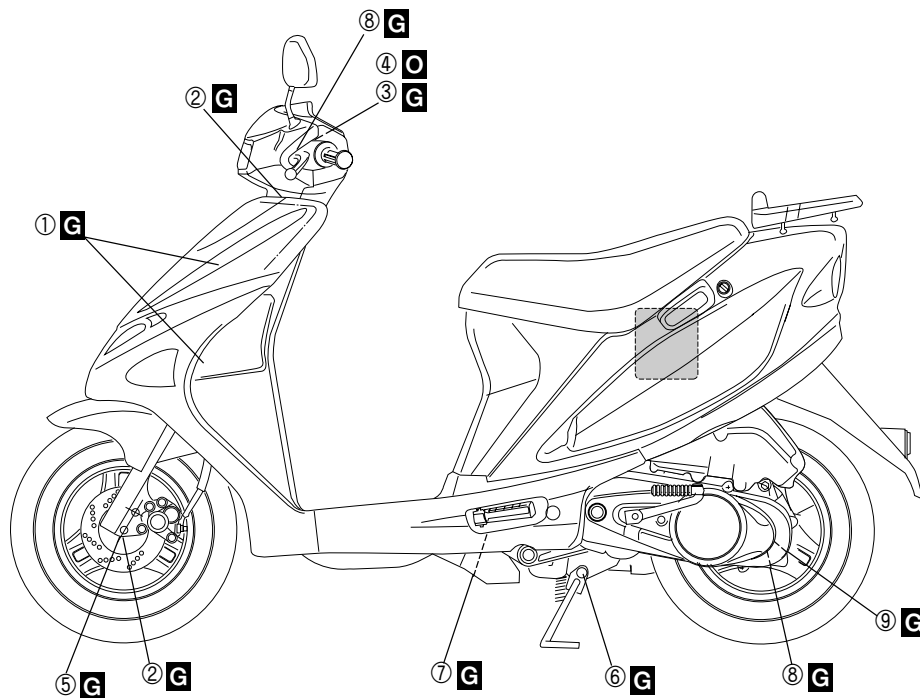

# ENGINE

## CONTENTS

<b>ENGINE REMOVAL AND REMOUNTING</b> .....	<b>3- 1</b>
<b>ENGINE REMOVAL</b> .....	<b>3- 1</b>
<b>ENGINE REMOUNTING</b> .....	<b>3- 3</b>
<b>ENGINE DISASSEMBLY</b> .....	<b>3- 4</b>
<b>ENGINE COMPONENTS INSPECTION AND SERVICING</b> .....	<b>3-13</b>
<b>BEARINGS</b> .....	<b>3-13</b>
<b>OIL SEALS</b> .....	<b>3-13</b>
<b>CRANKSHAFT</b> .....	<b>3-13</b>
<b>AUTOMATIC CLUTCH INSPECTION</b> .....	<b>3-14</b>
<b>CYLINDER HEAD</b> .....	<b>3-16</b>
<b>CYLINDER</b> .....	<b>3-17</b>
<b>PISTON</b> .....	<b>3-17</b>
<b>REED VALVE</b> .....	<b>3-19</b>
<b>ENGINE REASSEMBLY</b> .....	<b>3-20</b>
<b>OIL SEALS</b> .....	<b>3-20</b>
<b>BEARINGS</b> .....	<b>3-20</b>
<b>BUSHINGS</b> .....	<b>3-21</b>
<b>CRANKSHAFT</b> .....	<b>3-22</b>
<b>CRANKCASE</b> .....	<b>3-23</b>
<b>CENTER STAND</b> .....	<b>3-24</b>
<b>REAR AXLE SHAFT, BRAKE AND WHEEL</b> .....	<b>3-25</b>
<b>TRANSMISSION</b> .....	<b>3-27</b>
<b>STARTER DRIVEN GEAR AND STARTER MOTOR</b> .....	<b>3-29</b>
<b>MOVABLE DRIVEN AND CLUTCH</b> .....	<b>3-30</b>
<b>MOVABLE DRIVE</b> .....	<b>3-33</b>
<b>KICK STARTER</b> .....	<b>3-35</b>
<b>PISTON</b> .....	<b>3-36</b>
<b>OIL PUMP AND INTAKE PIPE</b> .....	<b>3-38</b>
<b>MAGNETO</b> .....	<b>3-39</b>
<b>MUFFLER</b> .....	<b>3-40</b>

## 3-1 ENGINE

---

### ENGINE REMOVAL AND REMOUNTING

#### ENGINE REMOVAL

Before taking the engine out of the frame, thoroughly clean the engine with a suitable cleaner. The procedure of engine removal is sequentially explained as follows.

- Remove the frame side covers. (Refer to page 6-3)
- Remove the air cleaner by removing the mounting bolts and clamp screw.

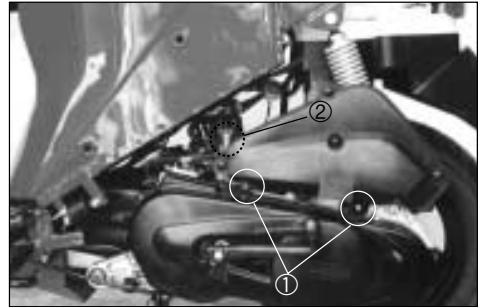

- Disconnect the ignition coil lead wires and spark plug cap.

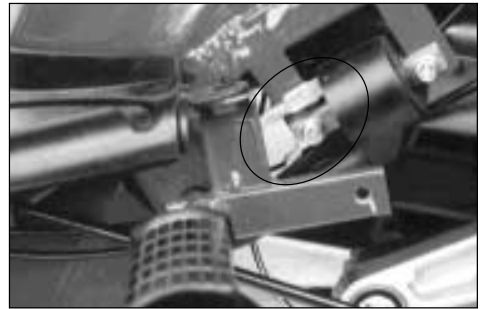

- Disconnect the oil pump cable ③ and the thermoelement lead coupler ④.
- Disconnect the throttle cable. (Refer to page 4-2)

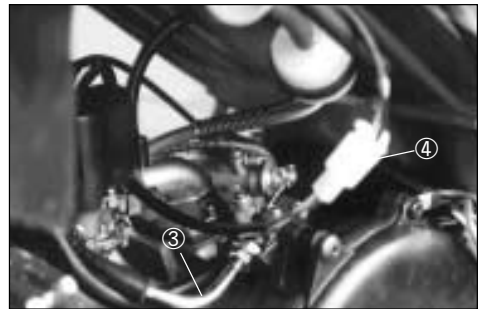

- Disconnect the carburetor hoses and oil hose.  
Vacuum hose ⑤.  
Fuel hose ⑥.  
Oil hose ⑦.

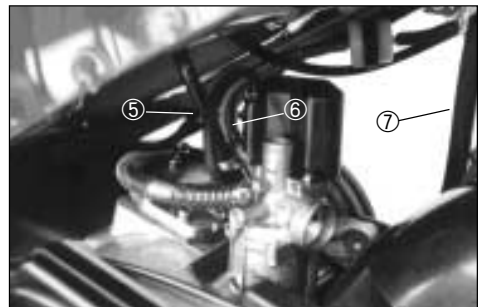

- Disconnect the magneto lead wire and starter lead wire.

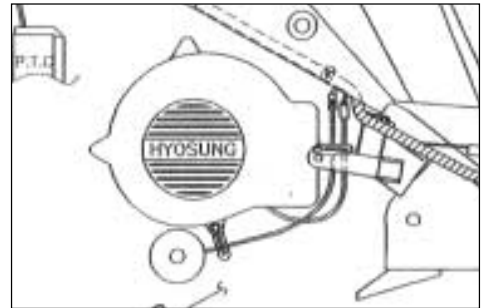

- Remove the rear brake cable ② by removing the bolt ①, bolt ③ and adjuster nut.

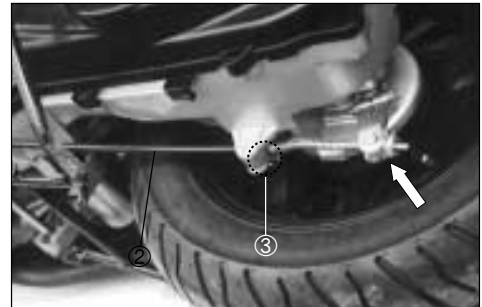
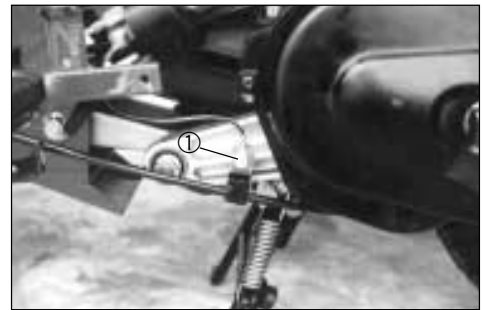

- Remove the rear shock absorber mounting lower bolt.

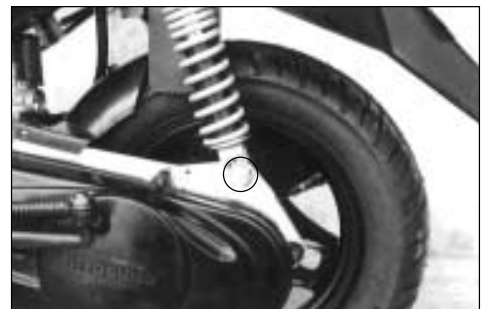

- Remove the engine mounting shaft and remove the engine from the frame.





### 3-3 ENGINE

#### ENGINE REMOUNTING

The engine can be mounted in the reverse order of removal.

- Install the damper to the crankcase bracket as shown in the illustration.
- With "UP" mark faced upward, install the crankcase bracket ① on the frame. Do not tighten the bracket bolt ② at this stage. Pull up on the rear part of crankcase bracket and while holding it, tighten the bracket bolt ② to specification. Tighten both the rear shock absorber bolt ④ and engine mounting bolt ③ to specification.

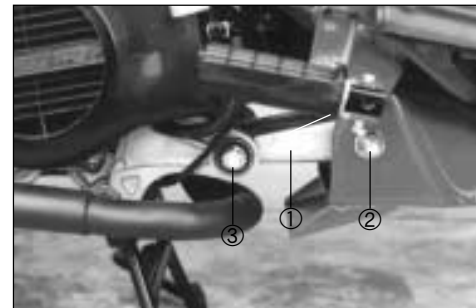
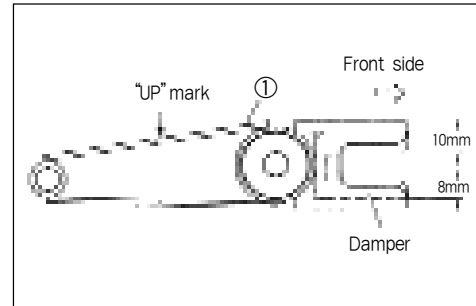

#### Tightening torque

	N · m	kg · m	lb-ft
②	48-72	4.8-7.2	34.5-52.0
③	40-60	4.0-6.0	29.0-43.5
④	20-30	2.0-3.0	14.5-21.5

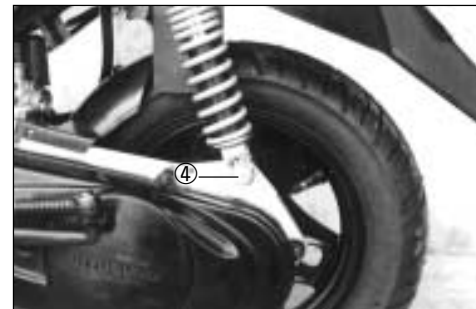

- Install the magneto lead wire and starter motor lead wire correctly.

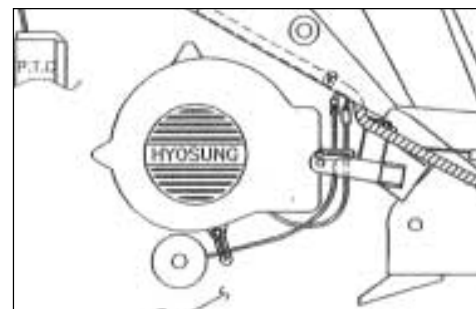

After remounting the engine, route the wiring harness properly (Refer to page 6) and following adjustments are necessary.

	Page
· Throttle cable play	2-5
· Idling adjustment	2-5
· Oil pump cable paly	2-6
· Rear brake cable adjustment	2-9
· Air bleeding at oil pump	4-8



## ENGINE DISASSEMBLY

### MUFFLER

- Remove the muffler by removing the bolts and nuts.

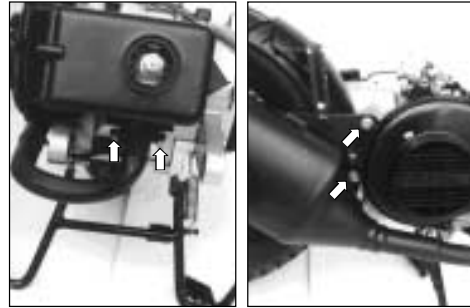

### MAGNETO

- Remove the cooling fan.
- Remove the magneto rotor nut ① with the special tool.

09930-40113	Rotor holder
-------------	--------------

- Remove the magneto rotor with the special tool.

09930-30163	Rotor remover
-------------	---------------

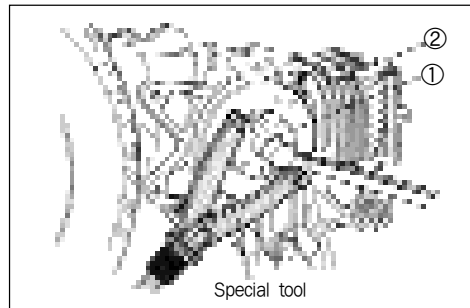

- Remove the magneto stator and key.

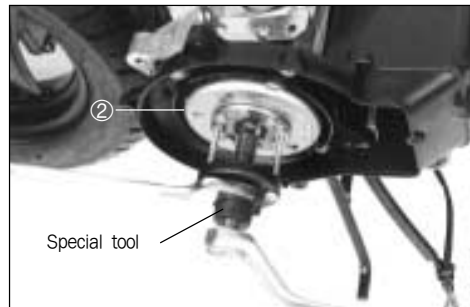

### REED VALVE

- Remove the intake pipe ① with reed valve.

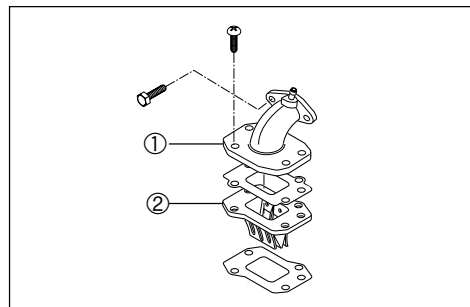

### OIL PUMP

- Remove the oil pump ①.
- Remove the oil pump driven gear ②.

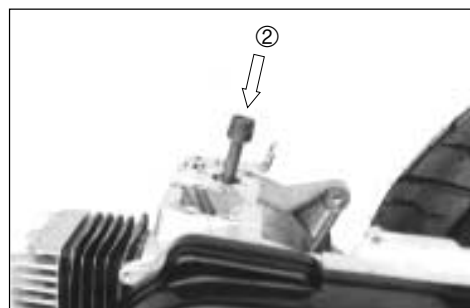
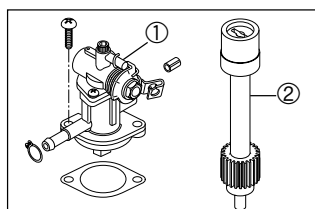

## 3-5 ENGINE

### CYLINDER

- Remove the cylinder cowling.
- Remove the cylinder head ① and cylinder ②.

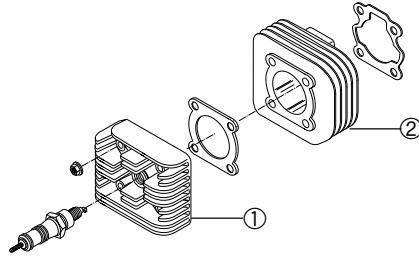

### PISTON

- Place a cloth beneath the piston and remove the circlip ① with a pliers.
- Remove the piston pin ② and piston ③.
- Remove the piston pin bearing ⑤.

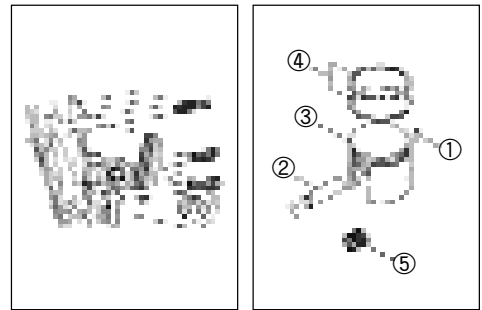

### KICK STARTER

- Remove the kick starter lever ①.
- Remove the clutch cover ②.

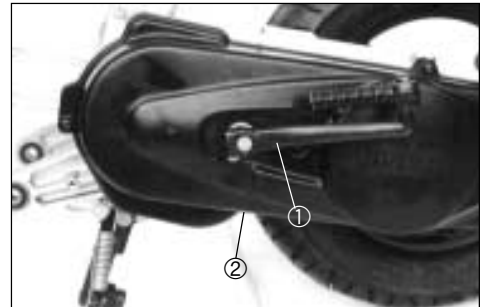

- Remove the crankcase left cover ③.

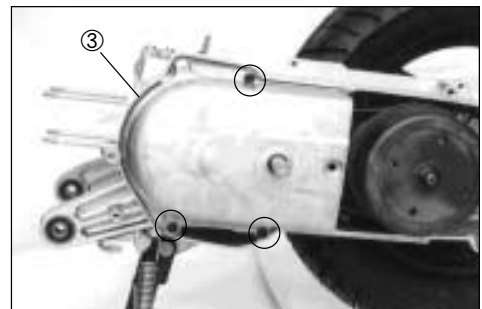

- Remove the kick starter shaft spring ④ and kick starter shaft ⑤.

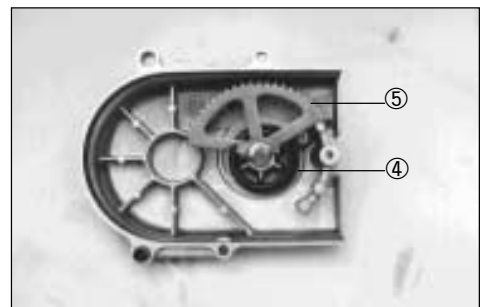

**KICK STARTER DRIVEN GEAR**

- Remove the E-ring ① with the long nose plier.
- Remove the spacer ②, spring ③ and kick starter driven gear ④.

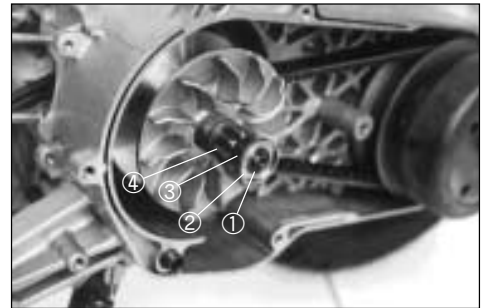
**MOVABLE DRIVE FACE**

- Remove the kick starter driven nut with the special tool.

**CAUTION:**  
This nut has left-hand thread.

09910-20115

Conrod holder

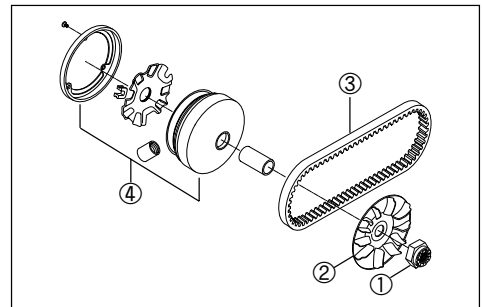

- Remove the fixed drive face ② and V-belt ③.
- Disassemble the movable drive face ④.

**STARTER DRIVEN GEAR**

- Remove the starter driven gear ①.

**MOVABLE DRIVEN FACE**

- Remove the clutch housing with the special tool.

09930-40113

Rotor holder



### 3-7 ENGINE

- Loosen the clutch shoe nut with the special tool.

09930-40113	Rotor holder
-------------	--------------

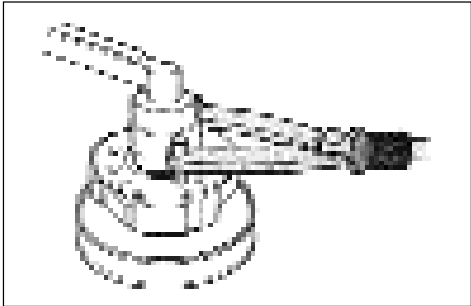

- Remove the nut while holding down the clutch shoe assembly by both hands as shown in the illustration.

**WARNING:**  
**Gradually back off the clutch shoe assembly pressed down by hand to counter the clutch spring load. Releasing the hand suddenly may cause the parts to fly apart.**

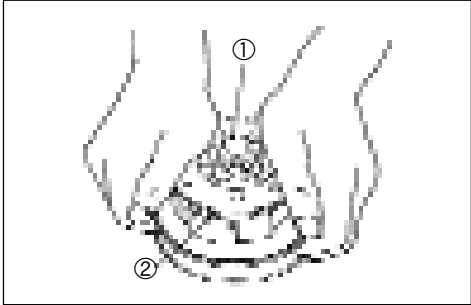

- ① Nut
- ② Clutch shoe assembly
- ③ Spring

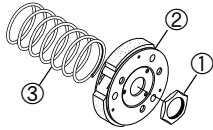

**CAUTION:**  
**Do not attempt to disassemble the clutch shoe assembly. It is not serviceable.**

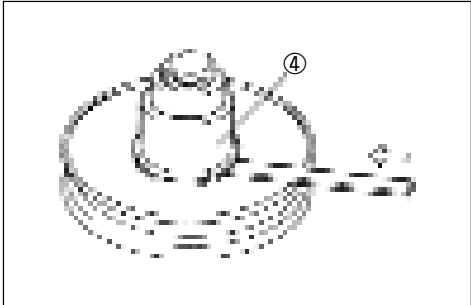

- Using a thin blade screwdriver or the like, pry up the movable driven face spring guide ④.

- Remove the pins ⑤, movable driven face ⑥ and fixed driven face ⑦.

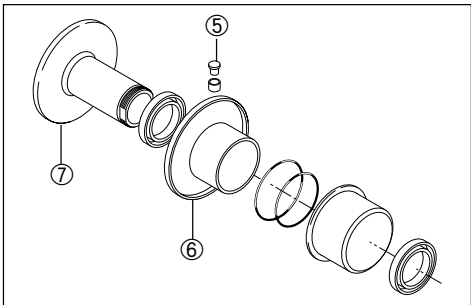

- Remove the roller bearing (A) with the special tools.

09923-73210	Bearing remover
09930-30102	Sliding shaft

**CAUTION:**  
**The removed bearing should be replaced with a new one.**

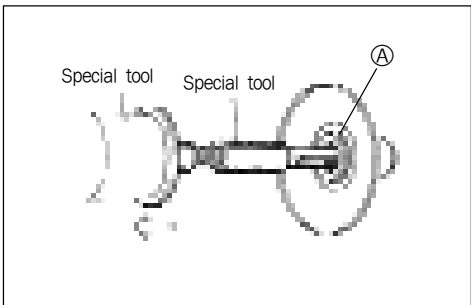

- Remove the circlip ②.

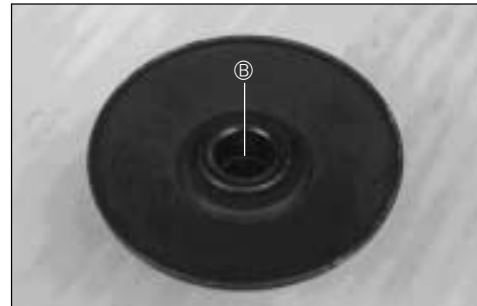
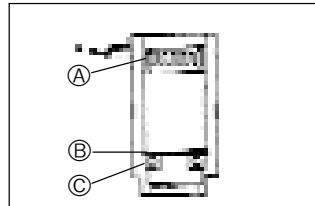

- Remove the bearing ③ with the special tool.

09941-50111	Wheel bearing remover
-------------	-----------------------

**CAUTION:**  
The removed bearing should be replaced with a new one.

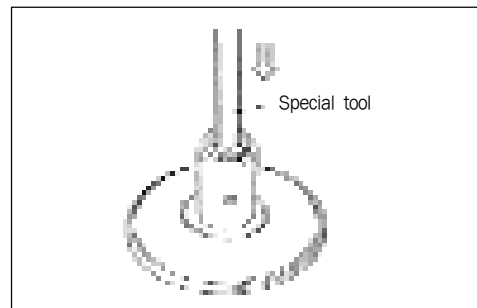

**TRANSMISSION**

- Drain gear oil.
- Remove the gear box cover ①.
- Remove the driveshaft ②.

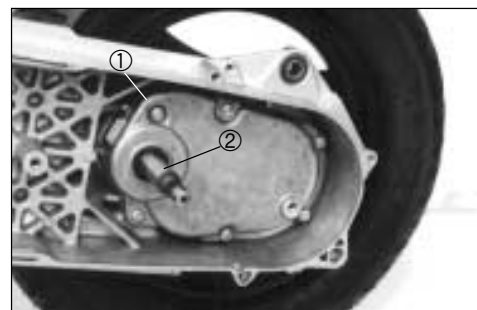

- Remove the oil seal ③ from the gear box cover with the special tool.

09913-50121	Oil seal remover
-------------	------------------

**CAUTION:**  
The removed oil seal should be replaced with a new one.

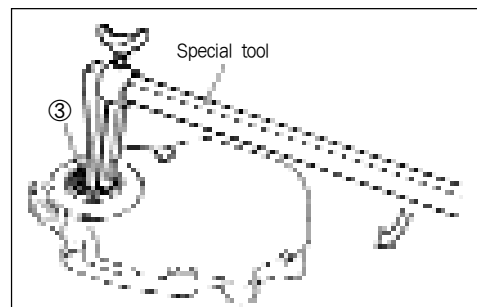

- Remove the bearing ④ with the special tool.

09943-88211	Bearing remover (Bearing installer)
-------------	--

**CAUTION:**  
The removed bearing should be replaced with a new one.

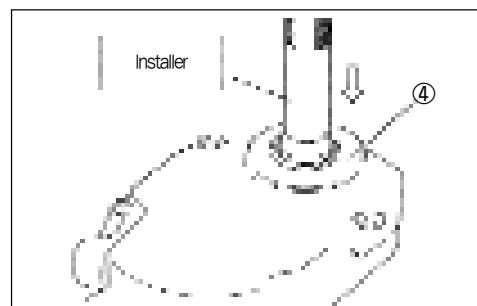

## 3-9 ENGINE

- Remove the circlip ④ and final driven gear ⑤.
- Remove the idle shaft ⑥.

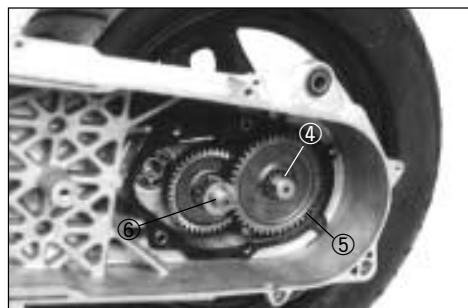

- Remove the drive shaft bearing ⑦.

09930-30102	Sliding shaft
09921-20210	Bearing remover

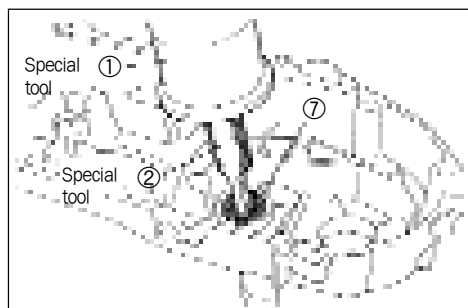

### WHEEL, BRAKE

- Remove the rear axle nut ① and washer ②.
- Remove the rear wheel ③.



- Remove the brake shoes ⑤ and rear axle shaft ④.

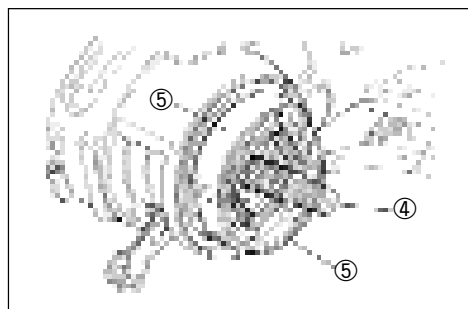

- Remove the bearing retainer ⑥.

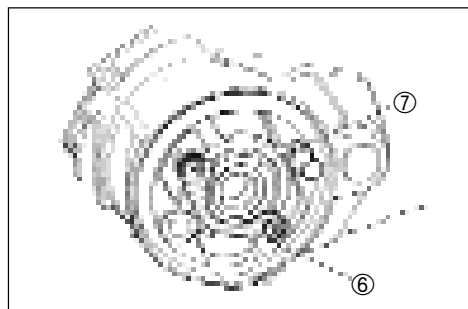

- Remove the bearing ⑦ with the special tool.

09913-75820	Bearing remover (Bearing installer)
-------------	--

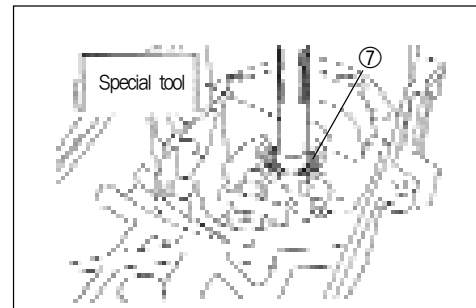

- Remove the oil seal ⑧ with the special tool.

09913-50121	Oil seal remover
-------------	------------------

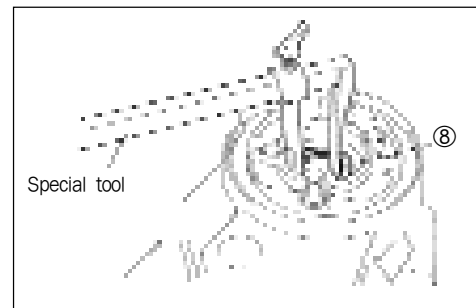

**CENTER STAND**

- Remove the return spring ①.

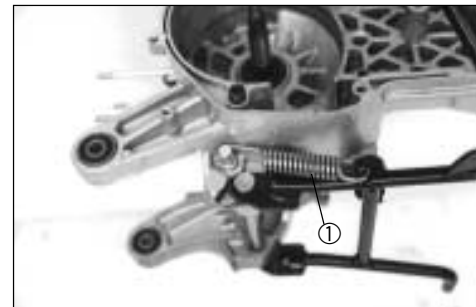

- Remove the cotter pin ②, washer ③ and shaft ④.
- Remove the center stand ⑤.

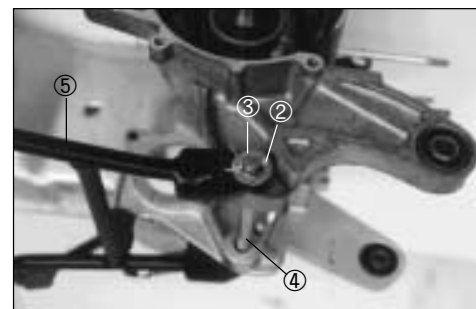

**CRANKCASE**

- Remove the crankcase securing screws.

<b>NOTE:</b> Loosen the crankcase nuts diagonally.	
---	--

09920-13120	Crankcase separation tool
-------------	---------------------------





## 3-11 ENGINE

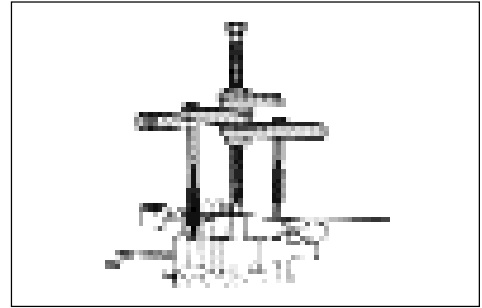

- Remove the crankshaft with the special tool.

09920-13120	Crankshaft remover (Crankcase separating tool)
-------------	---

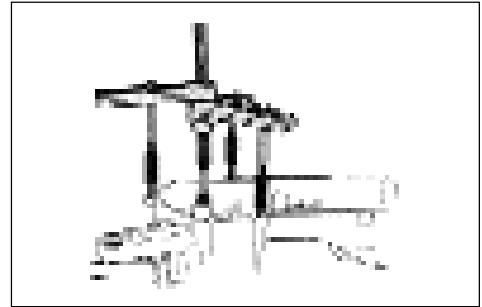

- Remove the bearings, oil seals and bushing.

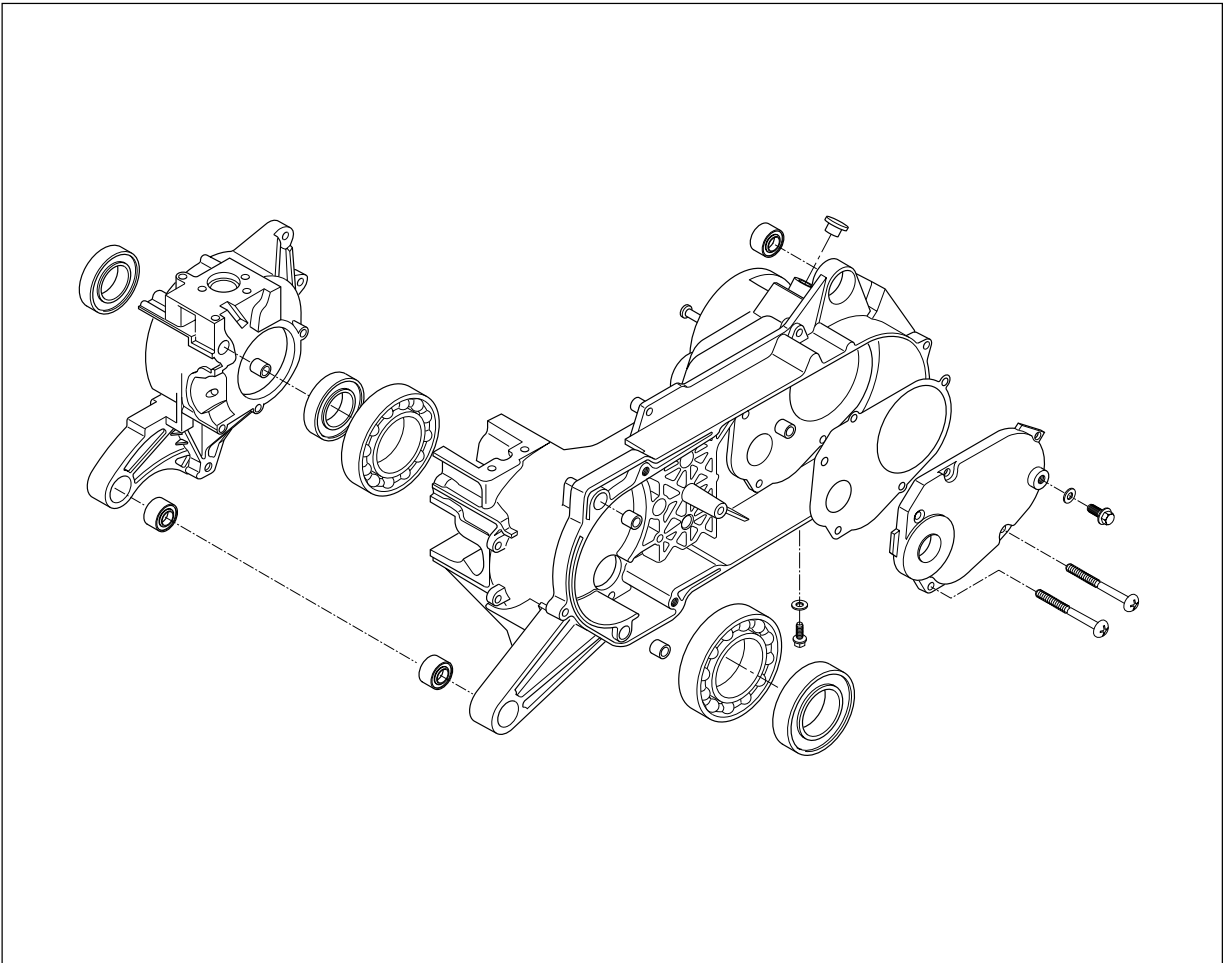

- Using two steel tubes of appropriate size, press out the engine mounting bushings on a vise as shown in the illustration.

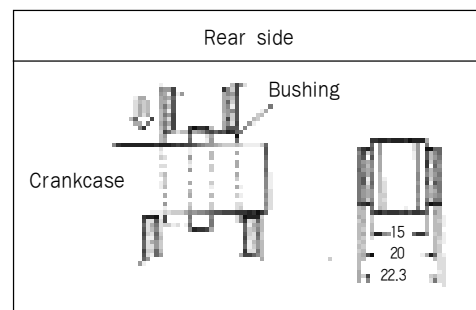
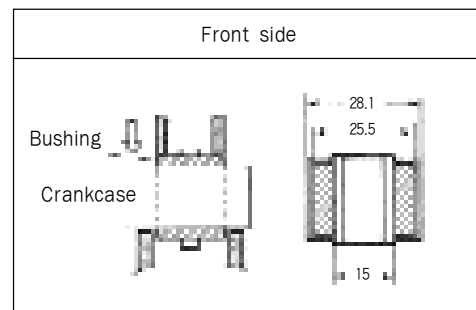
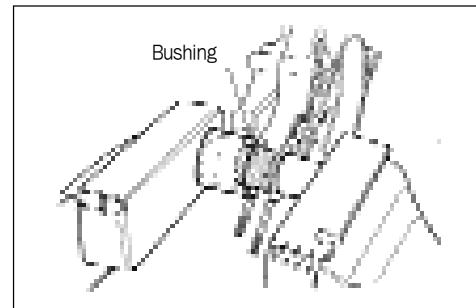

## 3-13 ENGINE

### ENGINE COMPONENTS INSPECTION AND SERVICING

#### BEARINGS

Wash the bearing with cleaning solvent and lubricate with motor oil before inspecting.

Turn the inner ring and check to see that the inner ring turns smoothly. If it does not turn lightly, quietly and smoothly, or if noise is heard, the bearing is defective and must be replaced with a new one.

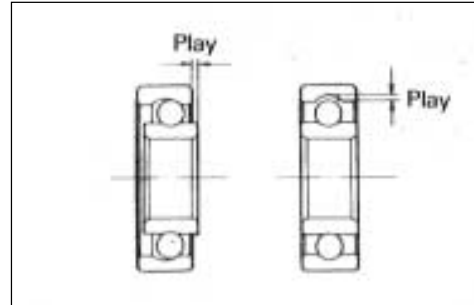

#### OIL SEAL

Damage to the lip of the oil seal may result in leakage of the fuel-air mixture or oil. Inspect for damage and be sure to replace the damaged seal if found.



#### CRANKSHAFT

##### CRANKSHAFT RUNOUT

Support crankshaft by "V" blocks, with the dial gauge rigged to read the runout as shown.

Service limit	0.05 mm(0.002 in)
---------------	-------------------

Excessive crankshaft runout is often responsible for abnormal engine vibration. Such vibration shortens engine life.

09900-21304	V-block(100 mm)
-------------	-----------------

09900-20701	Magnetic stand
-------------	----------------

09900-20206	Dial gauge(1/100 mm)
-------------	----------------------

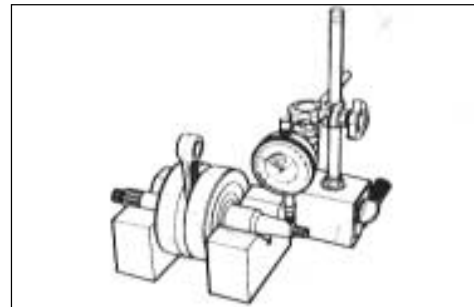

##### CONDITION OF BIG END BEARING

Turn the crankshaft with the conrod to feel the smoothness of rotary motion in the big end. Move the rod up and down while holding the crankshaft rigidly to be sure that there is no rattle in the big end.

Wear on the big end of the conrod can be estimated by checking the movement of the small end of the rod. This method can also check the extent of wear on the parts of the conrod's big end.

If wear exceeds the limit, conrod, crank pin and crank pin bearing should all be replaced.

Service limit	3.0 mm(0.12 in)
---------------	-----------------

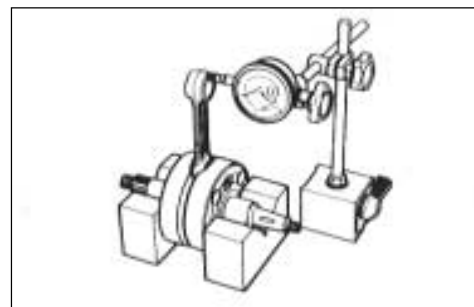

**CONROD SMALL END BORE I.D.**

Measure the conrod small end diameter with a caliper gauge.

Service limit	14.047 mm(0.5530 in)
09900-20605	Dial calipers

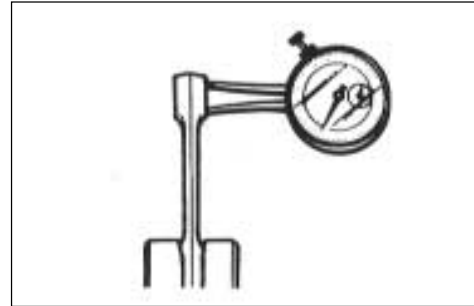

**AUTOMATIC CLUTCH INSPECTION**

This motorcycle is equipped with an automatic clutch and variable ratio belt drive transmission. The engagement of the clutch is governed by engine RPMs and centrifugal mechanism located in the clutch.

To insure proper performance and longevity of the clutch assembly it is essential that the clutch engages smoothly and gradually. Two inspection checks must be performed to thoroughly check the operation of the drivetrain. Follow the procedures listed.

**1. INITIAL ENGAGEMENT INSPECTION**

Warm up the motorcycle to normal operating temperature.

Remove the right frame side cover.

Connect an electric tachometer to the engine.

Seated on the motorcycle with the motorcycle on level ground, increase the engine RPMs slowly and note the RPM at which the motorcycle begins to move forward.

09900-26006	Tachometer
-------------	------------



**ENGAGEMENT R/MIN**

STD	3300 r/min
Tolerance	± 300 r/min

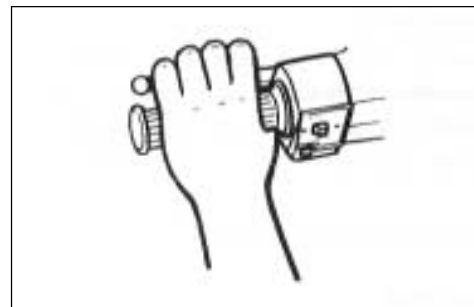

**2. CLUTCH "LOCK-UP" INSPECTION**

Perform this inspection to determine if the clutch is engaging fully and not slipping.

Warm the engine to normal operating temperatures.

Connect an electric tachometer to the engine.

Apply the rear brake as firm as possible.

Briefly open the throttle fully and note the maximum engine RPMs sustained during the test cycle.

**CAUTION:**  
 Do not apply full power for more than 10 seconds or damage to the clutch or engine may occur.

**LOCK-UP R/MIN**

STD	5800 r/min
Tolerance	± 500 r/min

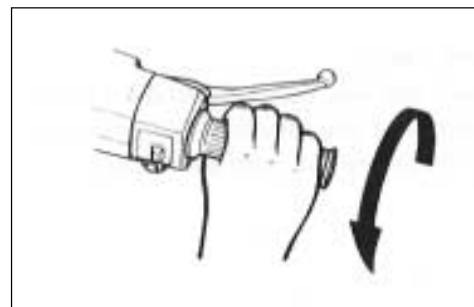

### 3-15 ENGINE

If the engine r/min does not coincide with the specified r/min range, then disassemble the clutch.

Clutch shoe - inspect the shoes visually for chips, cracking, uneven wear and burning, and check the thickness of the shoes with vernier calipers. If the thickness is less than the following service limit, replace them as a set.

Clutch springs - visually inspect the clutch springs for stretched coils or broken coils.

Service limit	2.0 mm(0.08 in)
---------------	-----------------

**CAUTION:**

**Clutch shoes or springs must be changed as a set and never individually.**

Clutch wheel - inspect visually the condition of the inner clutch wheel surface for scrolling, cracks, or uneven wear. Measure inside diameter of the clutch wheel with inside calipers. Measure the diameter at several points to check for an out-of-round condition as well as wear.

Service limit	110.35 mm(4.344 in)
---------------	---------------------

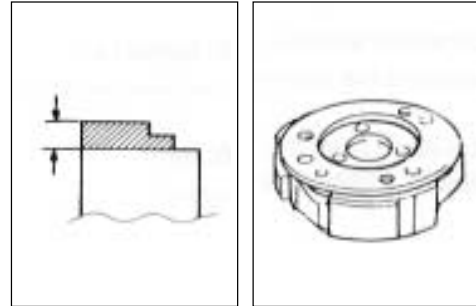

Measuring clutch wheel I.D.

#### DRIVE BELT

Remove the drive belt and check for cracks, wear and separation. Measure the drive belt width with a vernier calipers. Replace it if the belt width is less than the service limit or any defect has been found.

Service limit	15.3 mm(0.602 in)
---------------	-------------------

**CAUTION:**

**Always keep the drive belt away from any greasy mater.**

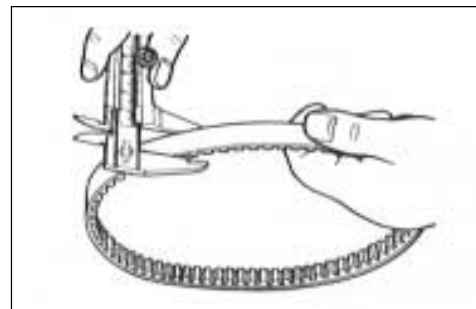

#### DRIVE FACE

Inspect the belt contact surface of the drive faces for wear, scratches or any abnormality. If there is something unusual, replace the drive face with a new one.

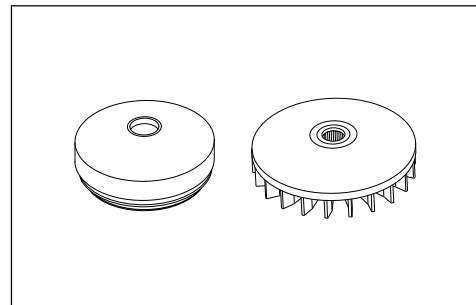

**ROLLER AND SLIDING SURFACE**

Inspect each roller and sliding surface for wear or damage.

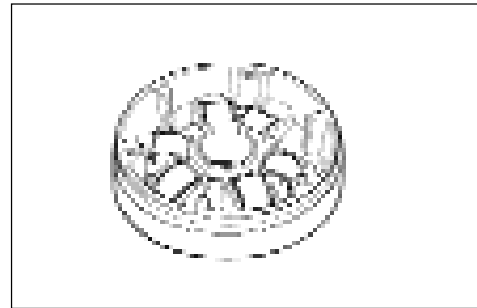

**DRIVEN FACE SPRING**

Measure the free length of the driven face spring. If the length is shorter than the service limit, replace the spring with a new one.

Service limit	104.5 mm(4.11 in)
---------------	-------------------

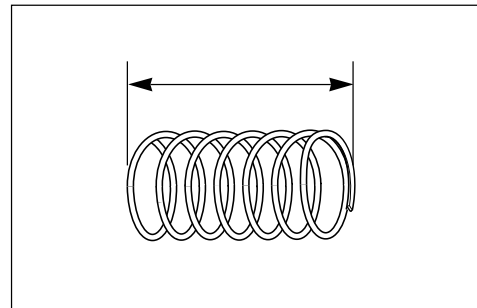

**DRIVEN FACE PIN AND OIL SEAL**

Turn the driven faces and check to see that the driven faces turn smoothly.

If any stickness or hitches are found, visually inspect the lip of oil seal, driven face sliding surface and sliding pins for wear or damage.

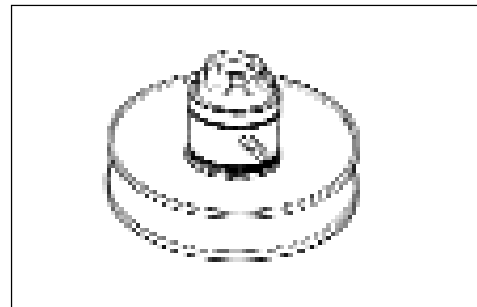

**DRIVEN FACE**

Inspect the belt contacting surface of both driven faces for any scratches, wear and damage.

Replace driven face with new one if there are any abnormality.

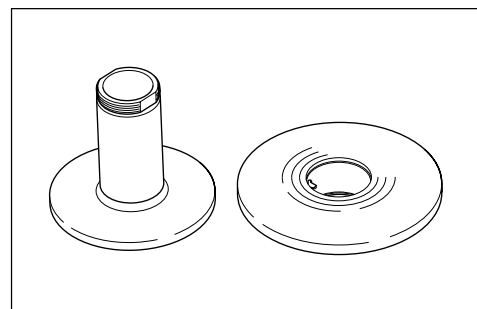

**CYLINDER HEAD**

Decarbon the combustion chamber.

Check the gasketed surface of the cylinder head for distortion with a straightedge and thickness gauge, taking a clearance reading at several places.

09900-20803	Thickness gauge
-------------	-----------------

Service limit	0.1 mm(0.004 in)
---------------	------------------

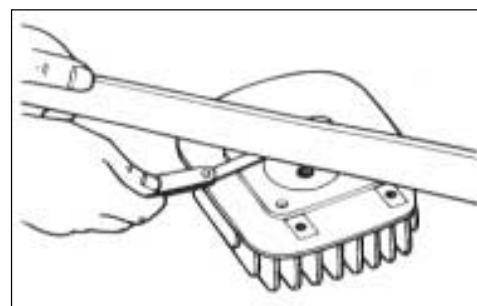

## 3-17 ENGINE

If the largest reading at any portion of the straightedge exceeds the limit, rework the surface by rubbing it against emery paper (of about # 400) laid flat on the surface plate in a lapping manner. The gasketed surface must be smooth and perfectly flat in order to secure a tight joint: a leaky joint can be the cause of reduced power output and increased fuel consumption.

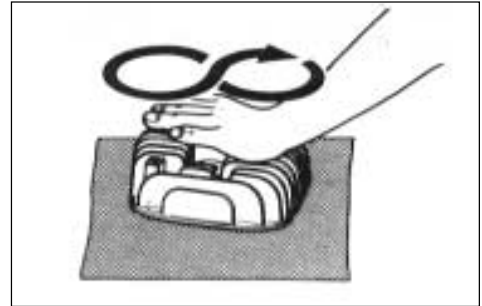

### CYLINDER

Decarbon exhaust port and upper part of the cylinder, taking care not to damage the cylinder wall surface.

The wear of the cylinder wall is determined from diameter reading taken at 20 mm from the top of the cylinder with a cylinder gauge. If the wear thus determined exceeds the limit indicated below, rework the bore to the next oversize by using a boring machine or replace the cylinder with a new one. Oversize piston is available in one size: 0.5 mm oversize.

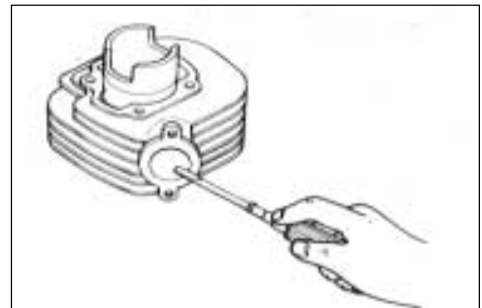

09900-20508	Cylinder gauge set
Service limit	41.070 mm(1.6169 in)

After reworking the bore to an oversize, be sure to chamfer the edges of ports and smooth the chamfered edges with emery paper. To chamfer, use a scraper, taking care not to nick the wall surface.

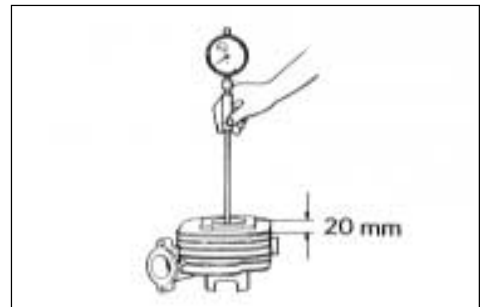

#### NOTE:

**Minor surface flaws on the cylinder wall due to seizure or similar abnormalities can be corrected by grinding the flaws off with fine-grain emery paper. If the flaws are deep grooves or otherwise persist, the cylinder must be reworked with a boring machine to the next oversize.**

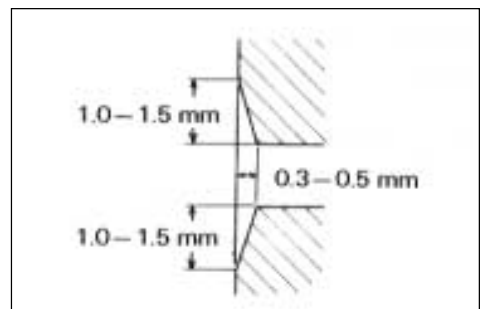

### PISTON

#### CYLINDER TO PISTON CLEARANCE

Cylinder-to-piston clearance is the difference between piston diameter and cylinder bore diameter. Be sure to take the measured diameter at right angles to the piston pin. The value of elevation (A) is prescribed to be 15 mm from the skirt end.

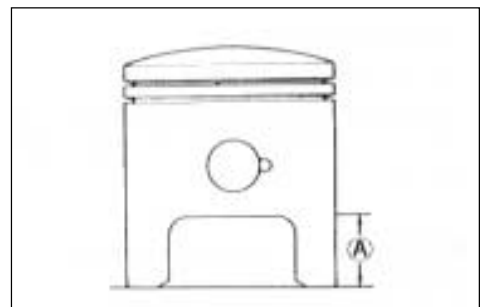

09900-20202	Micrometer(25-50 mm)
Service limit	40.885 mm(1.6096 in)

As a result of the above measurement, if the piston-to-cylinder clearance exceeds the following limit, overhaul the cylinder and use an oversize piston, or replace both cylinder and piston. The measurement for the bore diameter should be taken in the intake-to-exhaust port direction and at 20mm from the cylinder top surface.

Unit: mm

	STD	Service Limit
Cylinder	41.005-41.020	41.070
Piston	40.935-40.950	40.885
Cylinder to piston	0.065-0.075	0.120

**DE-CARBONING**

De-carbon the piston and piston ring grooves, as illustrated. After cleaning the grooves, fit the rings and rotate them in their respective grooves to be sure that they move smoothly.

Carbon in groove is liable to cause the piston ring to get stuck in the groove, and this condition will lead to reduced engine power output.

A piston whose sliding surface is badly grooved or scuffed due to overheating must be replaced. Shallow grooves or minor scuff can be removed by grinding with emery paper of about # 400.

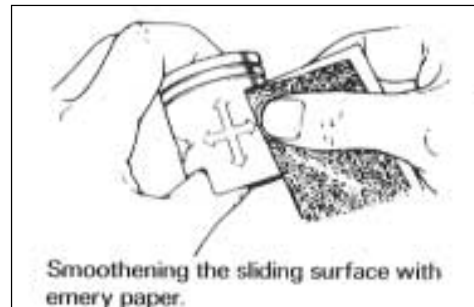

**PISTON PIN BORE**

Using a caliper gauge, measure the piston pin bore inside diameter. If reading exceeds the following service limit, replace it with a new one.

09900-20605	Dial calipers
Service limit	10.036 mm(0.4079 in)

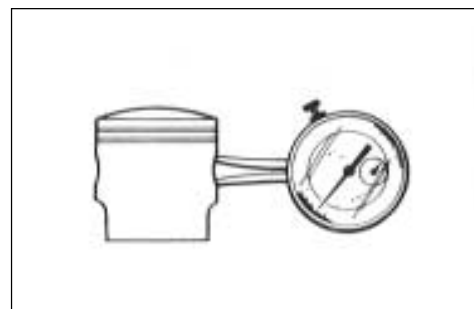

**PISTON PIN O.D.**

Using a micrometer, measure the piston outside diameter at three positions.

09900-20205	Micrometer(0-25 mm)
Service limit	9.980 mm(0.3929 in)

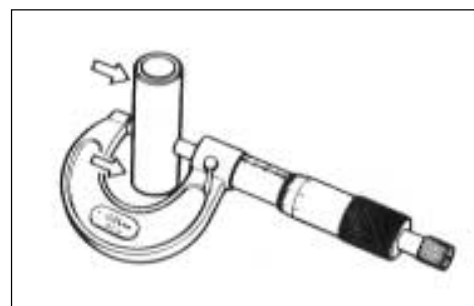



## 3-19 ENGINE

### PISTON RINGS

Check each ring for end gap, reading the gap with a thickness gauge shown in the illustration. If the end gap is found to exceed the limit, indicated below, replace it with a new one.

The end gap of each ring is to be measured with the ring fitted squarely into the cylinder bore and held at the least worn part near the cylinder bottom, as shown in the illustration.

09900-20803	Thickness gauge
Service limit	0.75 mm(0.030 in)

As the piston ring wears, its end gap increases reducing engine power output because of the resultant blow by through the enlarged gap. Here lies the importance of using piston rings with end gaps within the limit.

Measure the piston ring free end gap to check the spring tension.

Service Limit	1st	3.7 mm(0.15 in)
	2nd	3.5 mm(0.14 in)

Fix the piston ring in the piston ring groove, measure the ring side clearance with the thickness gauge while matching the sliding surfaces of piston and ring.

STD clearance	0.020-0.060 mm (0.0008-0.0024 in)
---------------	--------------------------------------

### REED VALVE

When reinstalling the reed valve and stopper plate to the body, align the both cut on the reed valve and stopper plate.

Apply Thread Lock "1324" to the stopper plate securing screws.

99000-32030	Thread Lock "1324"
-------------	--------------------

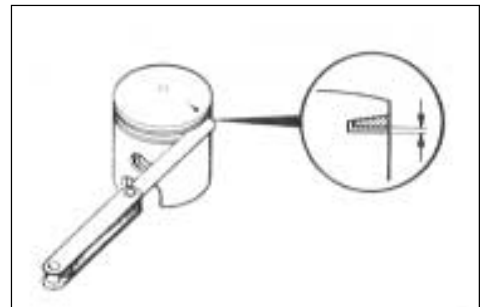
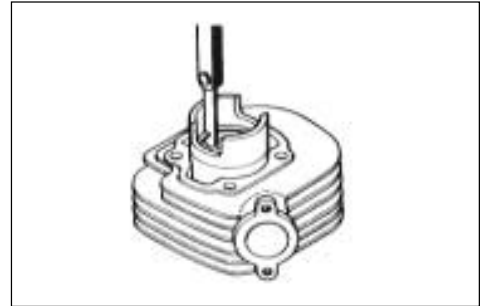

## ENGINE REASSEMBLY

Reassembly is generally performed in the reverse order of disassembly, but there are a number of reassembling steps that demand or deserve detailed explanation or emphasis. These steps will be taken up for respective parts and components.

### OIL SEALS

Fit the oil seals to the crankcase following the procedure below. Replace removed oil seals with new ones.

- Apply grease to the lip of the oil seals.

99000-07000	Grease "G <sub>2</sub> "
-------------	--------------------------

- Be sure to apply Thread Lock "1324" to outer surfaces of right and left crankshaft oil seals to prevent them from moving.

99000-32030	Thread Lock "1324"
-------------	--------------------

- When fitting the oil seal in the crankcase, insert it slowly with the special tools.

09913-75830	Oil seal installer
-------------	--------------------

09924-74510	Oil seal installer handle
-------------	---------------------------

09924-74540	Oil seal installer attachment
-------------	-------------------------------

#### NOTE:

Align the oil seal with edge **A** of the crankcase as shown in the illustration.

### BEARINGS

Install new bearings with the special tool.

09913-75810	Bearing installer
-------------	-------------------

09913-76010	Bearing installer
-------------	-------------------

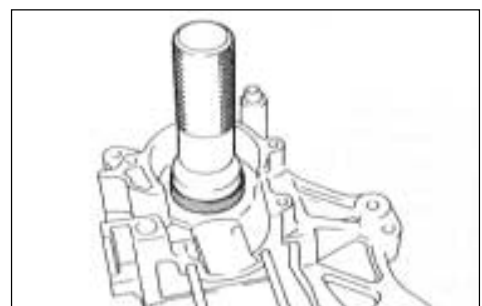
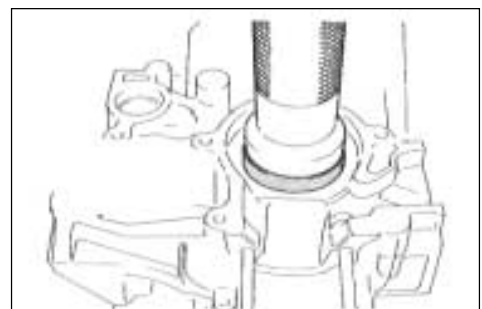
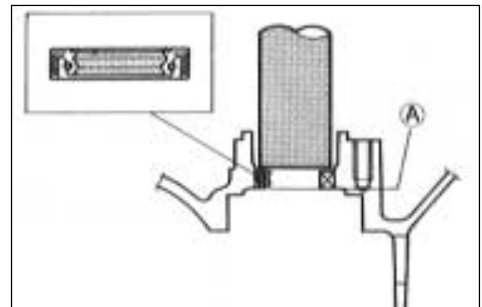
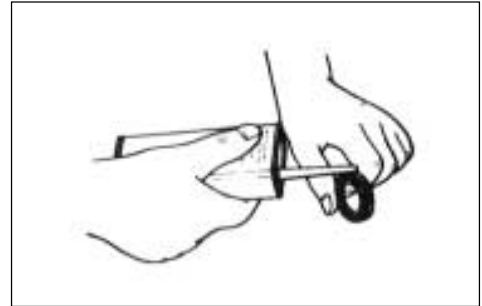

## 3-21 ENGINE

### BUSHINGS

Using two steel tubes of appropriate size and a vise, press the mounting bushings ① and ② into the crankcase holes as shown in the illustration.

**NOTE:**

Knurled end ③ should face inside. Protrusion A and B should be in the same dimension.

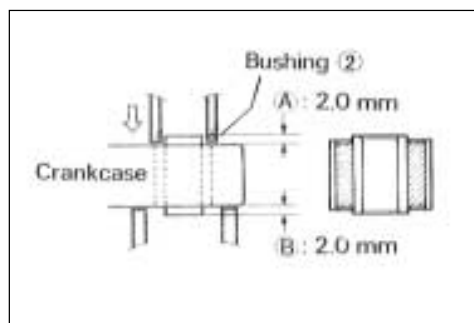
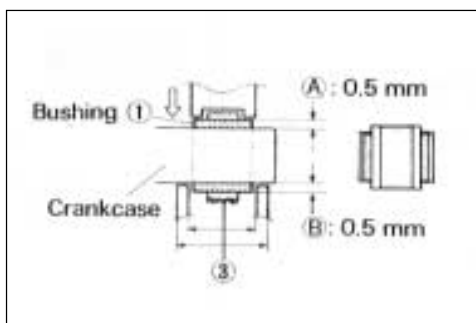
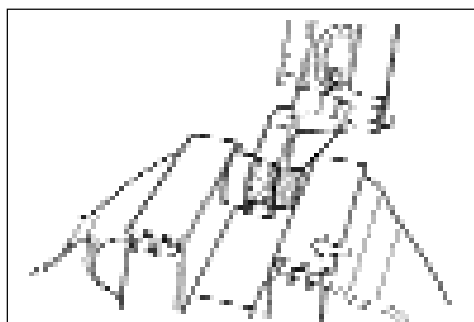
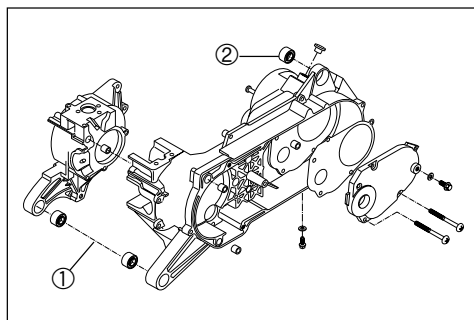

## CRANKSHAFT

- ①Crankshaft
- ②Crankcase(R)
- ③Oil seal
- ④Oil seal
- ⑤Oil pump drive gear
- ⑥Oil pump drive gear
- ⑦Oil

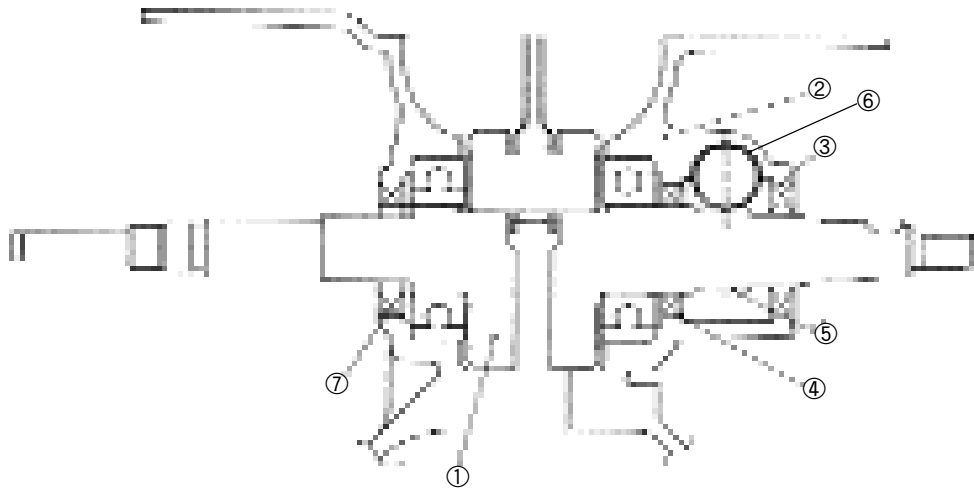

- Decide the length between the webs referring to the figure at right when rebuilding the crankshaft.

Standard width between webs	$35.0 \pm 1.0 \text{ mm}$ $(1.378 \pm 0.004 \text{ in})$
-----------------------------	---

- When mounting the crankshaft into the crankcase, it is necessary to pull its left end into the crankcase with the special tool.

09910-32812	Crankshaft installer
-------------	----------------------

**CAUTION:**

**Never fit the crankshaft into the crankcase by driving it with a plastic hammer. Always use the special tool, otherwise crankshaft alignment accuracy will be affected.**

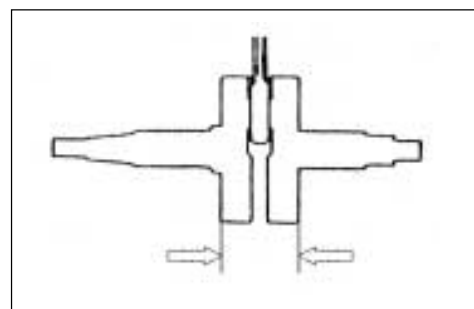
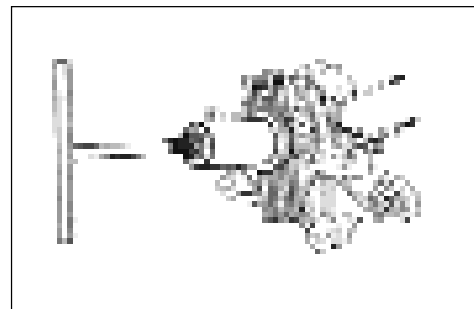

## 3-23 ENGINE

### CRANKCASE

- Wipe the crankcase mating surfaces(both surfaces)with cleaning solvent.
- Apply THREE BOND NO.1215 uniformly to the mating surface of the left half of the crankcase, and install the dowel pins.

99000-31110	THREAD BOND NO.1215
-------------	---------------------

- Install the two dowel pins.
- Tighten the crankcase screws securely.
- Check if crankshaft rotates smoothly.

- Install the new oil seal ① to the crankcase with the special tool.

#### NOTE:

Align the oil seal with edge ④ of the crankcase as shown in the illustration.

09913-85210	Bearing installer
-------------	-------------------

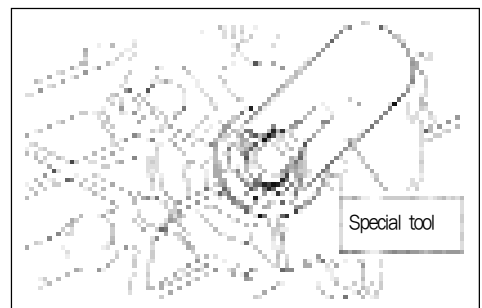
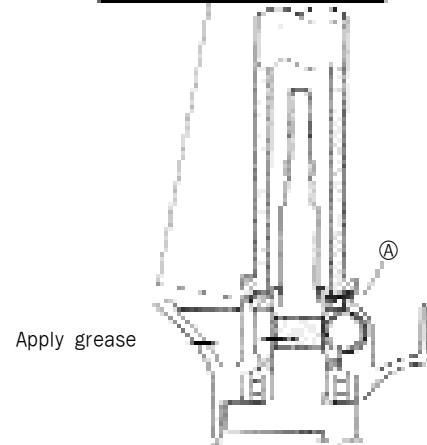
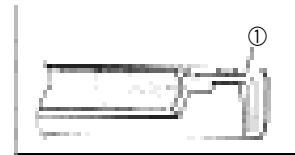
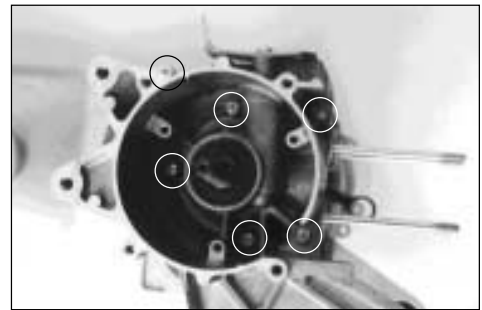
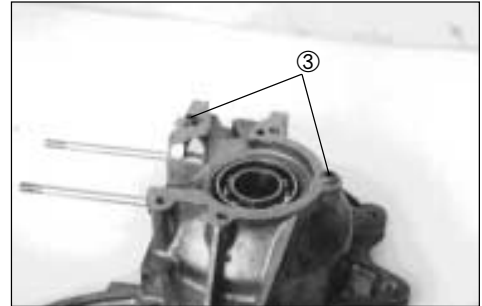

**CENTER STAND**

- Install the center stand ①.
- Install the shaft ②, washer ③ and cotter pin ④.
- Hook center stand spring ⑤ into the crankcase.

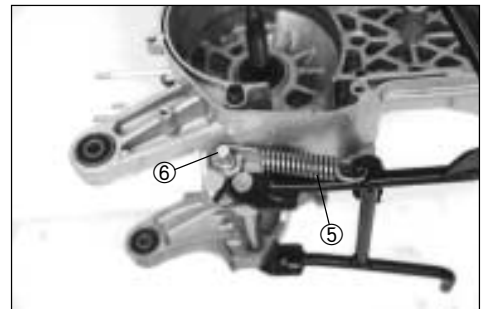
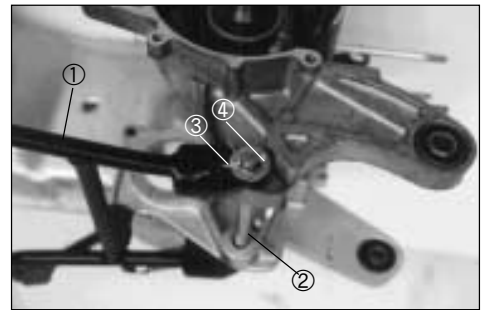
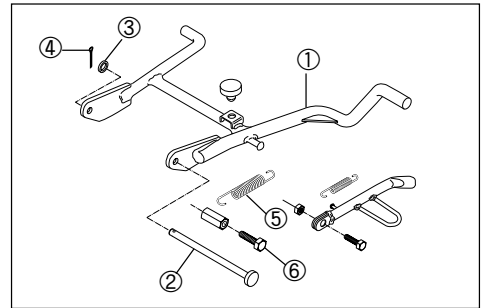

## 3-25 ENGINE

### REAR AXLE SHAFT, BRAKE AND WHEEL

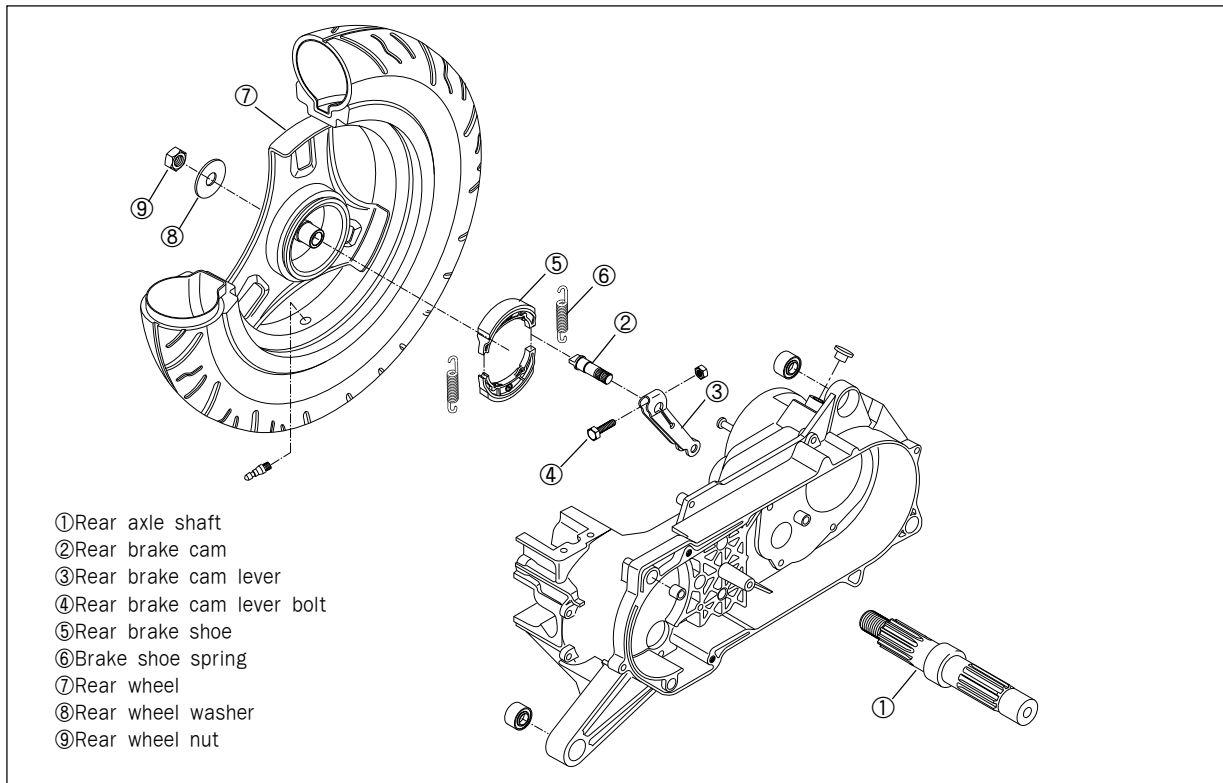

- Install the rear axle shaft ① into the crankcase by tapping its end lightly.
- Apply engine oil on the left end of the rear axle shaft being inserted later in the reduction rear box cover.

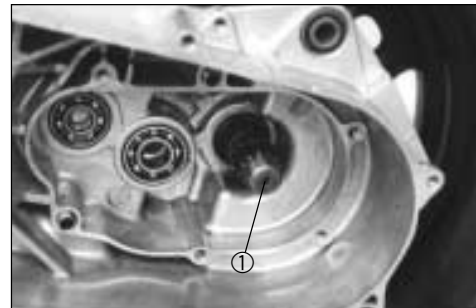

- Apply grease lightly on the rear brake cam pivot part and install it to the crankcase.

99000-07000	Grease "G2"
-------------	-------------

- Turn to position the cam where the punched mark (A) on the end face is directed toward the axis of the rear axle shaft.

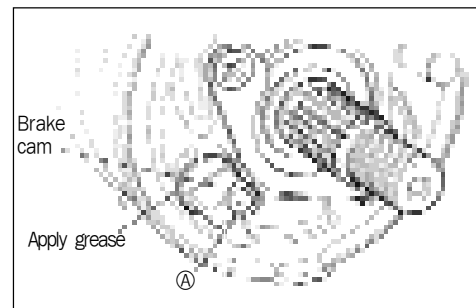

- When installing the cam lever ④ to the cam, align the punched mark with the slit of cam lever.

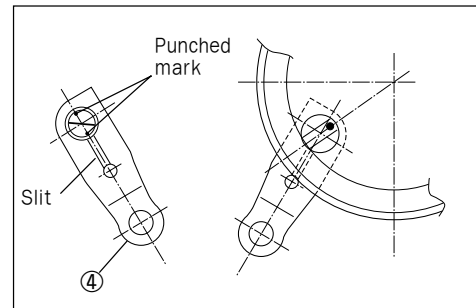

- Tighten the cam lever nut ⑤ to the specified torque.

Tightening torque	6-9 N · m (0.6-0.9 kg-m, 4.5-6.5 lb-ft)
-------------------	--

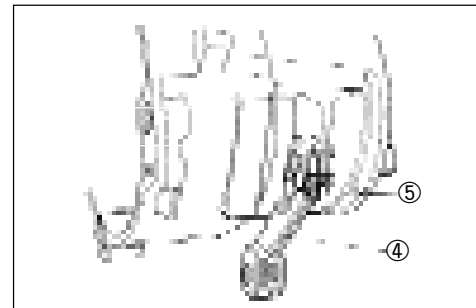

- Install the brake shoes.
- Apply grease to the camshaft and pin before installing the brake shoes.

99000-07000	Grease "G2"
-------------	-------------

**CAUTION:**

Be careful not to apply too much grease to the camshaft and pin. If grease gets on the lining, brake effectiveness will be lost.

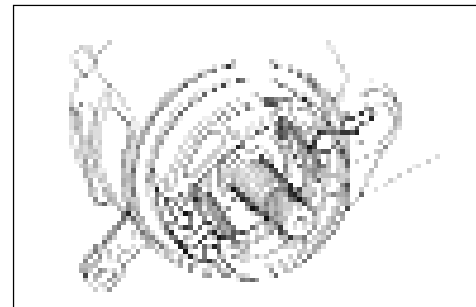

- Install the rear wheel and nut.

Tightening torque	60-90 N · m (6.0-9.0 kg-m, 43.5-65.0 lb-ft)
-------------------	--





## 3-27 ENGINE

### TRANSMISSION

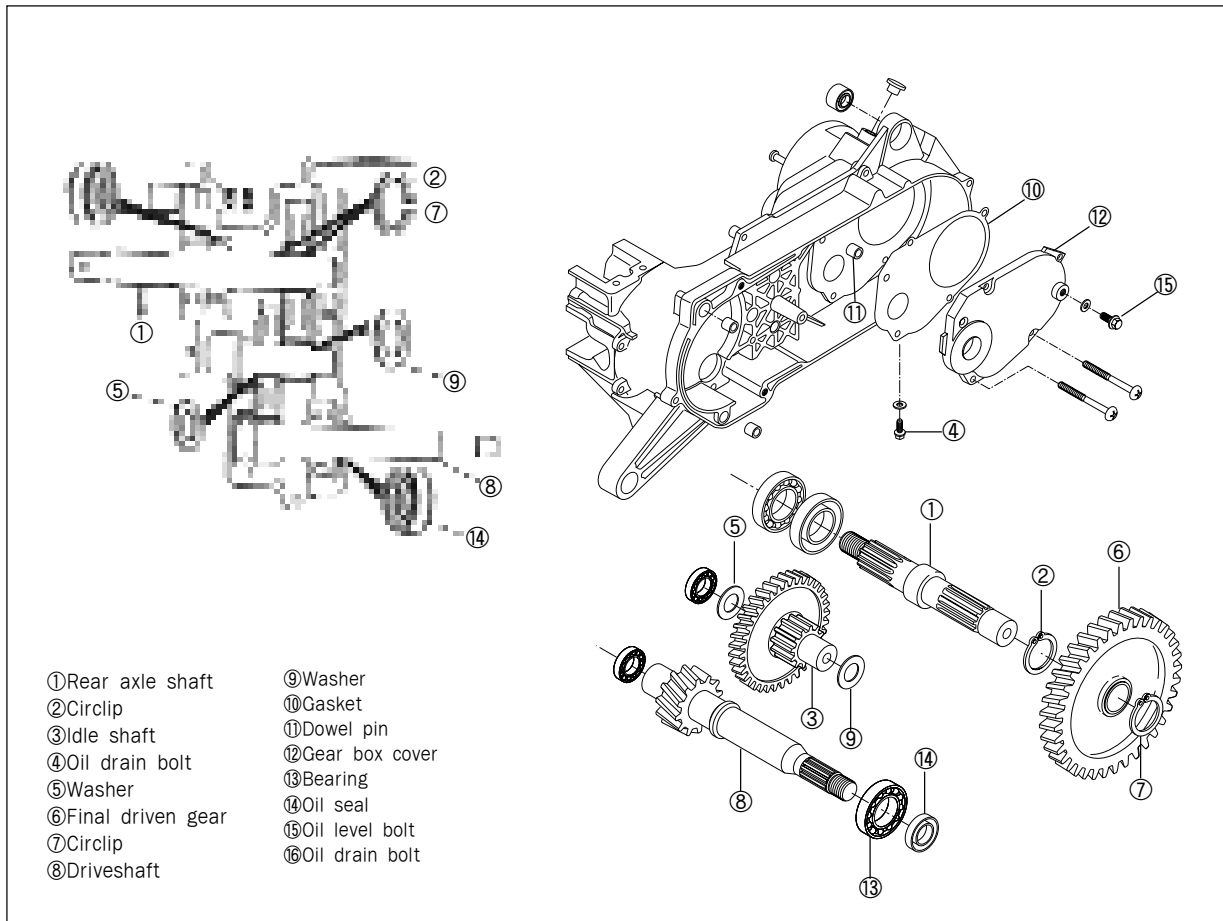

- Install the circlip ① on to the rear axle shaft ②.
- Assemble the idle shaft subassembly using the idle shaft ③ and thrust washer ④, then install the subassembly on the gear box.

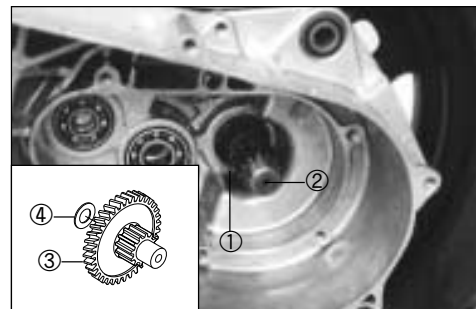

- Install the final driven gear ⑤ on the rear axle shaft using the circlip ⑥.

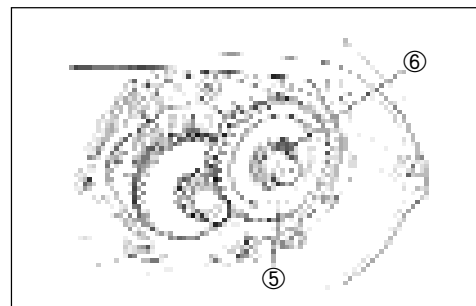
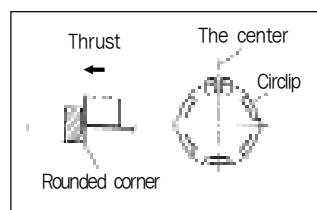

- Install the new bearing ⑦ to the gear box cover ⑧ with the special tool.

09913-70610	Bearing installer
-------------	-------------------

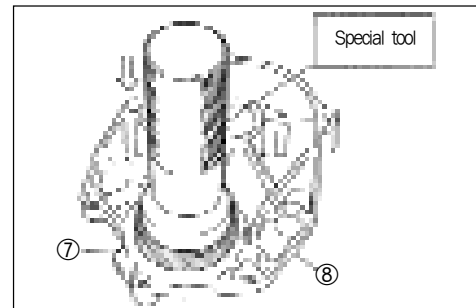

- Apply grease to the lip of the oil seal ⑨ and install it to the gear box cover with the special tool.

99000-07000	Grease "Gz"
-------------	-------------

09914-05210-005	Bearing installer
-----------------	-------------------

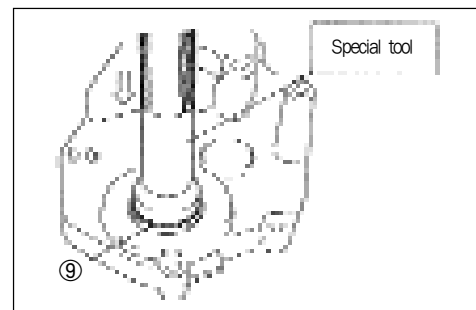
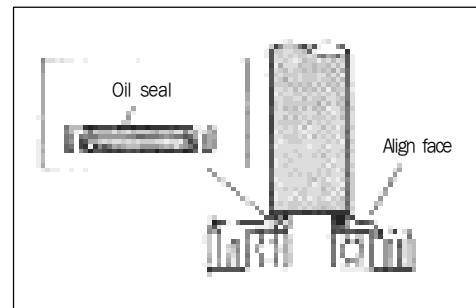

- Install the washer ⑩, new gasket and dowel pin ⑪.
- Install the driveshaft ⑫ to the gear box cover.

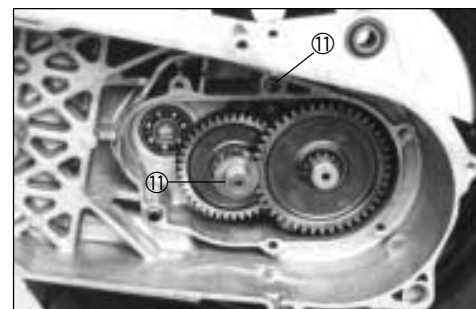
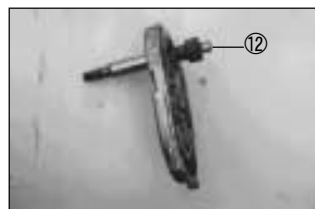

- Apply THREE BOND NO.1215 at the hatched area shown in the illustration and install the gear box cover ⑬ on the crankcase.

99000-31110	Three Bond No. 1215
-------------	---------------------

- Tighten all the screws evenly one by one in a diagonal fashion.

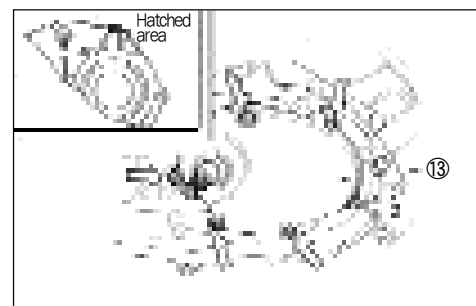

## 3-29 ENGINE

### STARTER DRIVEN GEAR AND STARTER MOTOR

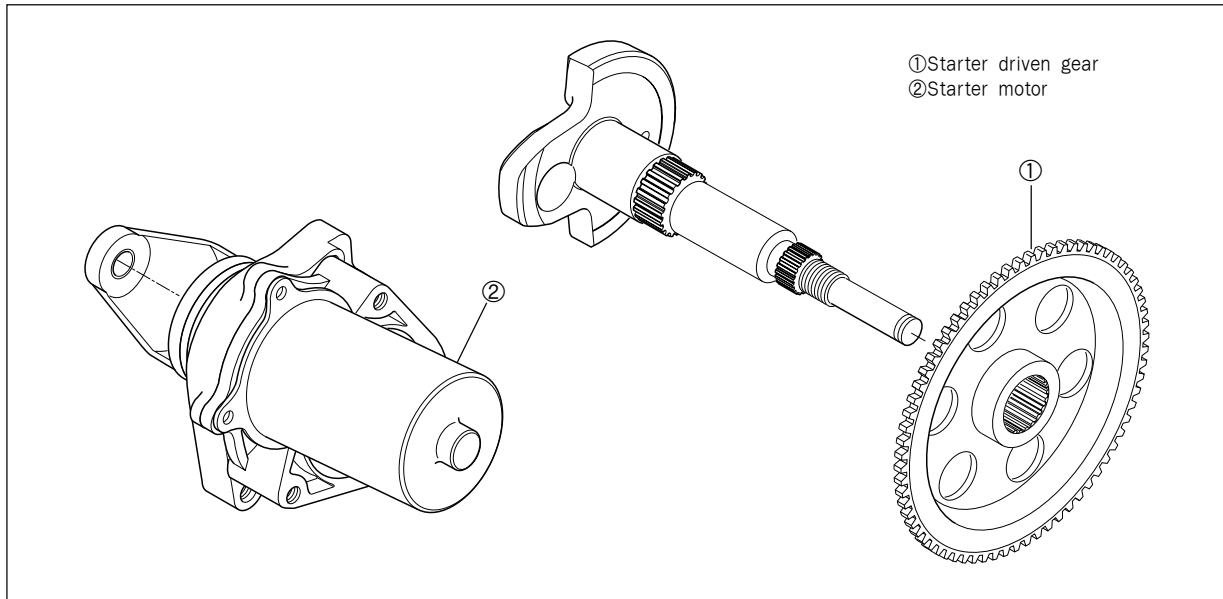

- Install the starter driven gear ① over the left crankshaft end.

**NOTE:**

The convex side of hub should face outside when installed in proper position.



- Install the starter motor ②.

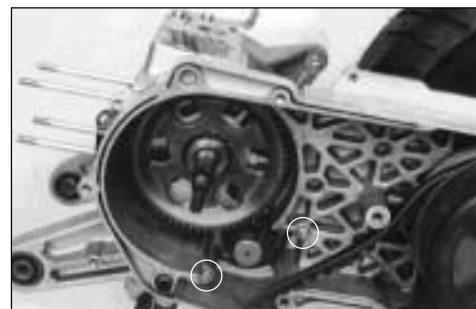
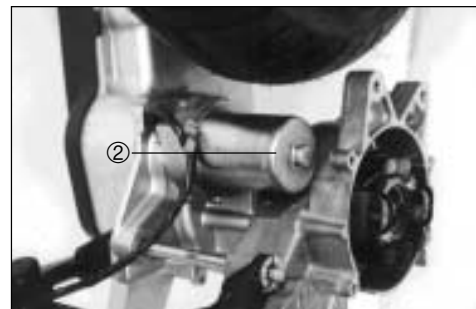

MOVABLE DRIVEN AND CLUTCH

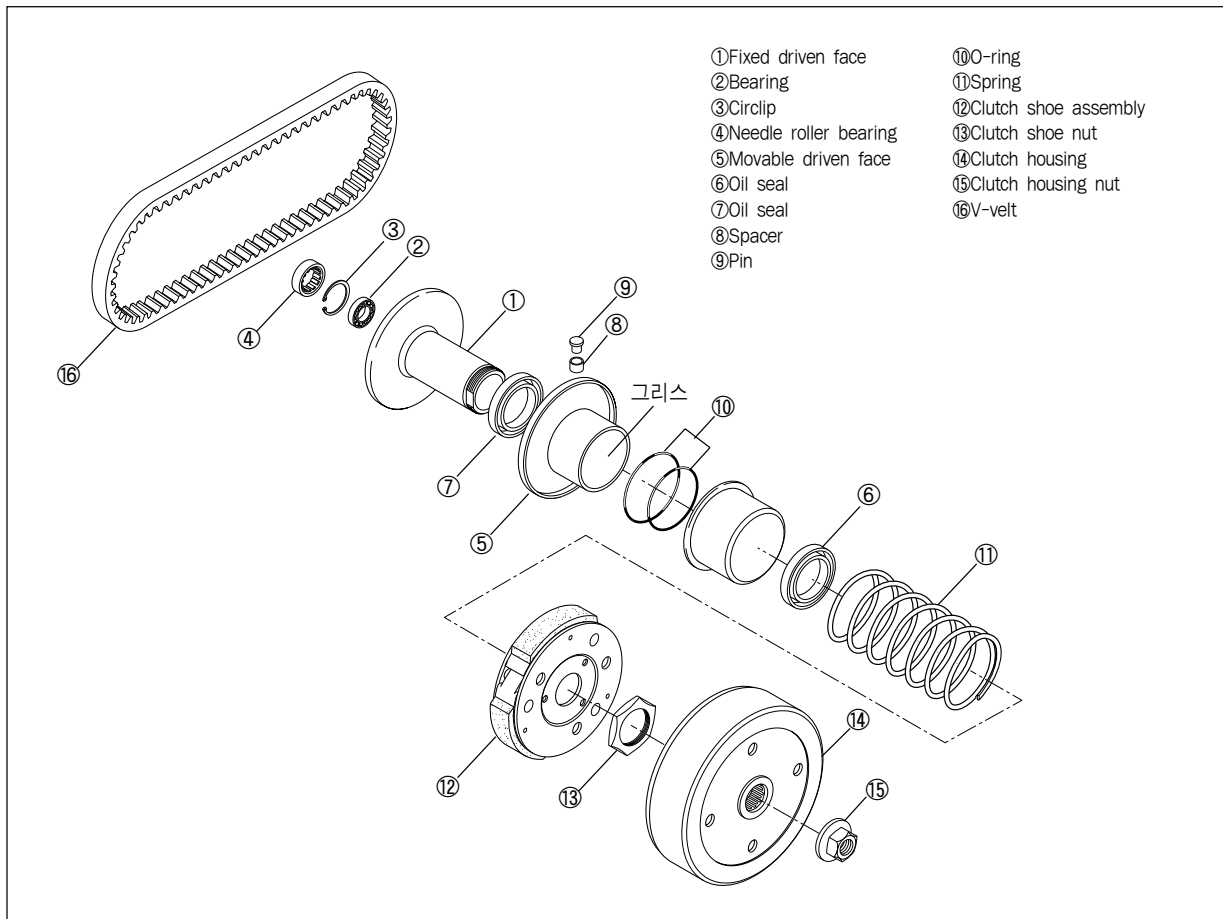

- ① Fixed driven face
- ② Bearing
- ③ Circlip
- ④ Needle roller bearing
- ⑤ Movable driven face
- ⑥ Oil seal
- ⑦ Oil seal
- ⑧ Spacer
- ⑨ Pin
- ⑩ O-ring
- ⑪ Spring
- ⑫ Clutch shoe assembly
- ⑬ Clutch shoe nut
- ⑭ Clutch housing
- ⑮ Clutch housing nut
- ⑯ V-belt

- Install the bearing ② in the fixed driven face ① with the special tool.

09943-88211	Bearing installer
-------------	-------------------

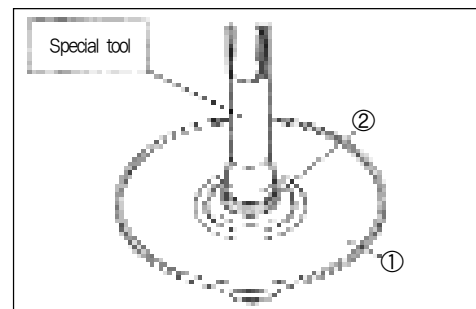

- Install the circlip ③.

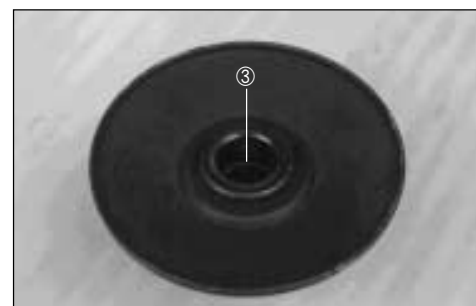
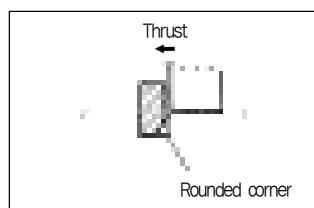

### 3-31 ENGINE

- Install the bearing with the special tool.

09943-88210	Bearing installer
-------------	-------------------

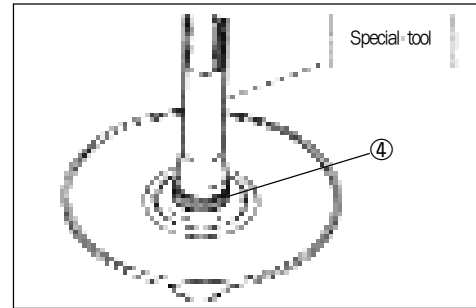

- Install the new oil seals (5, 6) to the movable driven face with the special tool.

09913-76010	Bearing installer
-------------	-------------------

- Apply grease to the lip of oil seals and groove of inside of movable driven face.

99000-07000	Grease "G2"
-------------	-------------

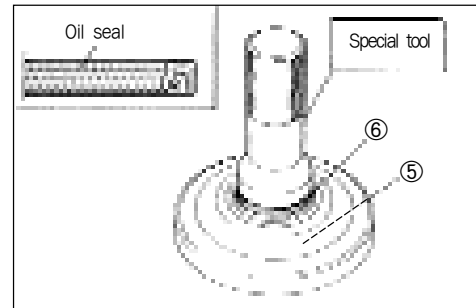

- Install the movable driven (7) to the fixed driven face (8).

**NOTE:**  
When reinstalling the movable face to the fixed face, make sure that the oil seal is positioned properly.

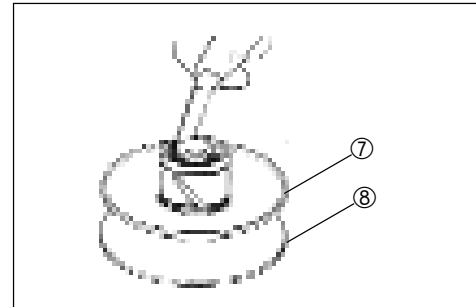

- Install the pin (9) at three places on the driven face hub.
- Apply grease lightly to the cam part where the pins are placed.
- Position two O-ring (10).

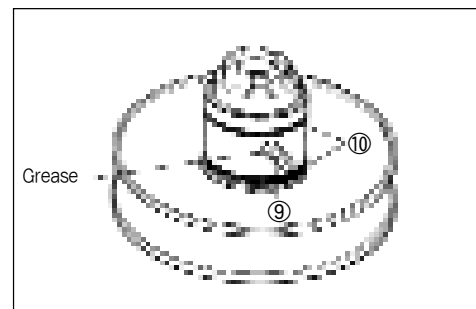
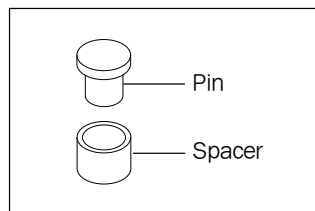

- Install the movable driven face seat (11).

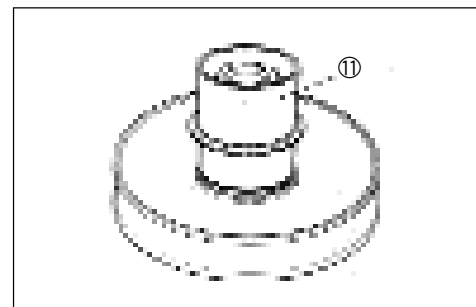

- Install the spring ⑫.
- Install the clutch shoe assembly ⑬ and nut ⑭.

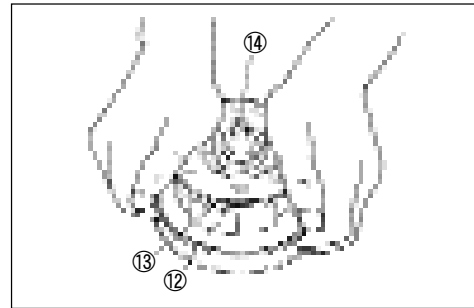

- Tighten the nut to the specified torque with the special tool.

09930-40113	Rotor holder
Tightening torque	40-60 N · m (4.0-6.0 kg-m, 29.0-43.5 lb-ft)

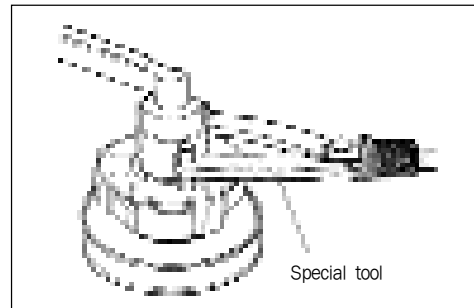

- Insert the V-belt between the driven faces as deep inside as possible while pulling the movable driven face all the way outside to provide the maximum belt clearance.

**CAUTION:**

The belt should be positioned so that the arrows on the belt periphery point the normal turning direction. The V-belt contact face on the driven faces should be thoroughly cleaned to be free from oil.

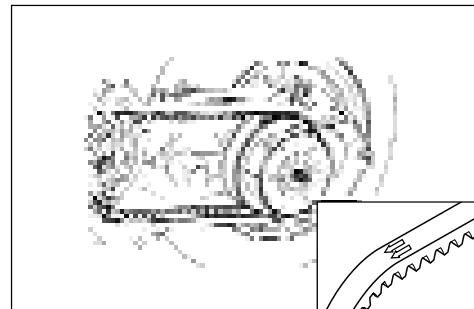

- Thoroughly clean the clutch housing ⑬ to be free from oil and position it over the clutch shoe assembly.
- Tighten the clutch housing nut ⑭ to the specified torque with the special tool.

09930-40113	Rotor holder
Tightening torque	40-60 N · m (4.0-6.0 kg-m, 29.0-43.5 lb-ft)

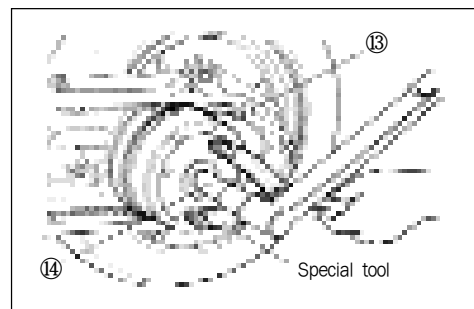

## 3-33 ENGINE

### MOVABLE DRIVE

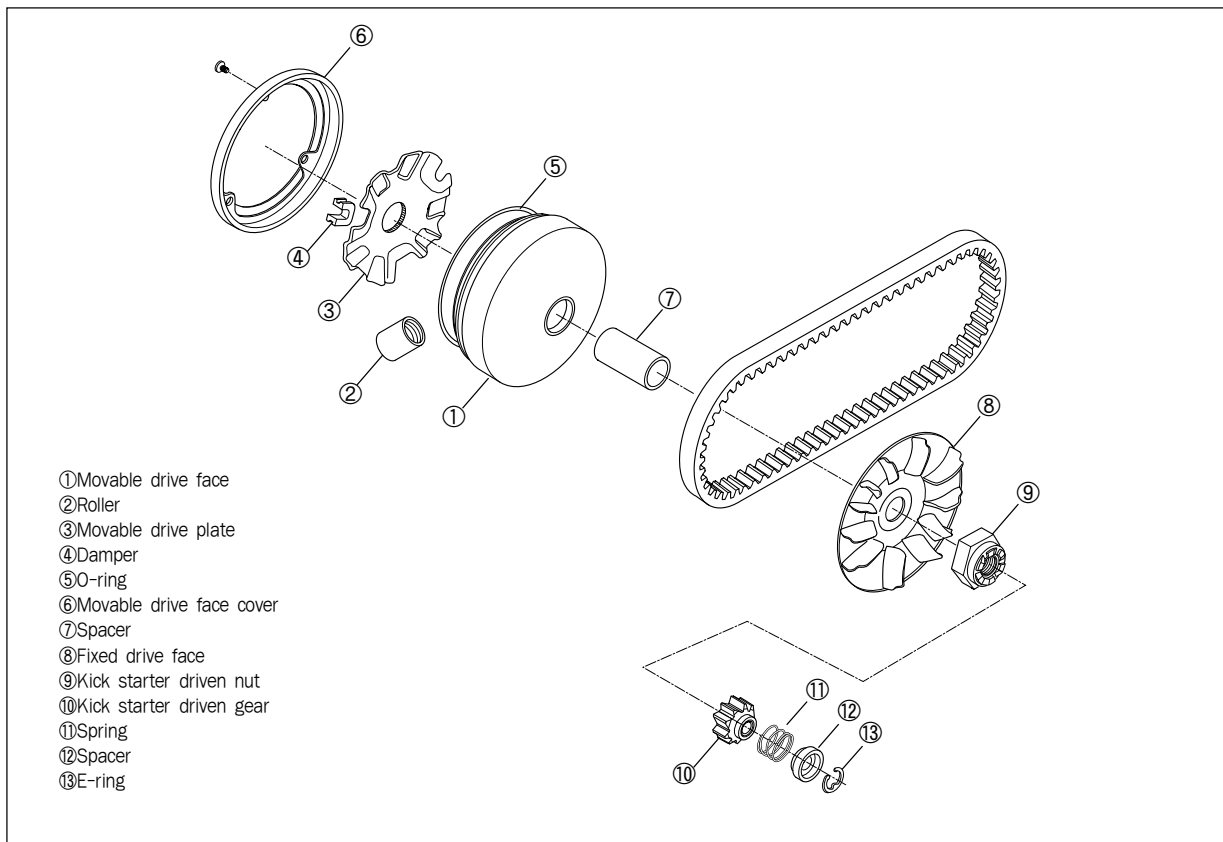

- Install the roller ② to the movable drive face ①.

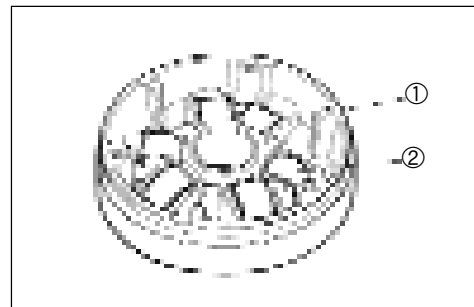

- Mount the three dampers ④ on the movable drive plate ③ and install it on the movable drive face ⑤.
- Position the O-ring ⑥ on the movable drive face.

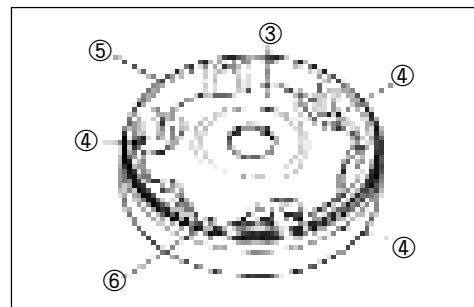

- Install the movable drive face cover ⑦.

**NOTE:**  
 Make sure that the movable drive plate is fully positioned inside, or the weight roller may come off.

- Insert the spacer.

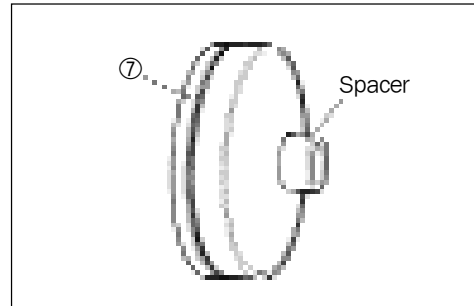

- Position the movable drive face subassembly on the crankshaft as shown in the photo.

**NOTE:**  
 Thoroughly clean the belt contact to be from oil.



- Install the fixed drive face ⑧.
- Tighten the nut ⑨ to the specified torque with the special tool.

09910-20115	Conrod holder
-------------	---------------

Tightening torque	40-60 N · m (4.0-6.0 kg-m, 29.0-43.5 lb-ft)
-------------------	--

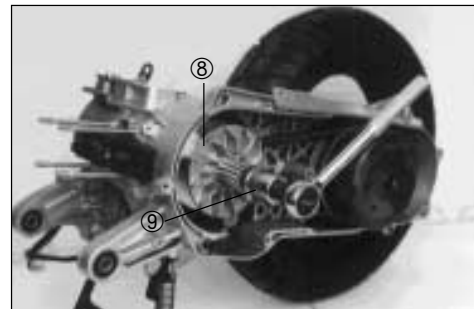

- Fill grease in the groove provided inside sliding surface of the kick driven gear and install it ⑩ on the end of the crankshaft. Wipe off excess grease.

99000-07000	Grease "Gz"
-------------	-------------

- Install the spring ⑪ and spacer ⑫.

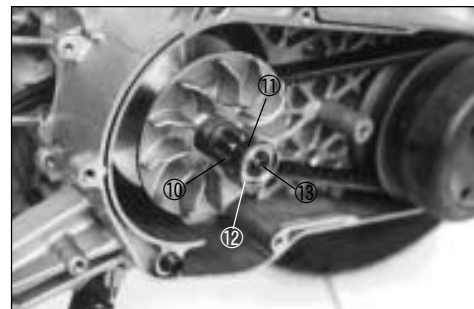

- Install the E-ring ⑬.

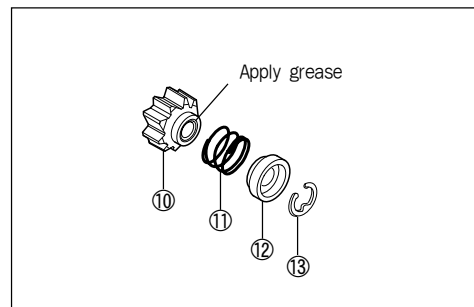



### 3-35 ENGINE

- Continue turning the fixed drive face ⑭ by hand until the belt is seated in and both the drive and driven faces ⑮ will move together smoothly without slip.
- Fill the final gear box with engine oil up to the level hole.

Oil Capacity	90 ml
--------------	-------

- Tighten the oil level bolt to the specified torque.

Tightening torque	9-15 N · m (0.9-1.5 kg-m, 4.5-11.0 lb-ft)
-------------------	--

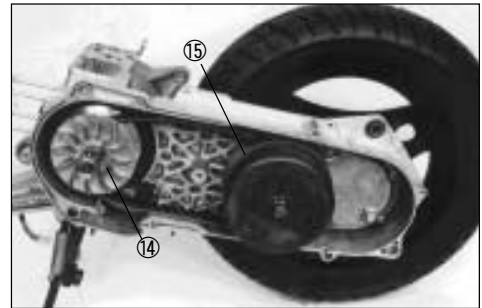

### KICK STARTER

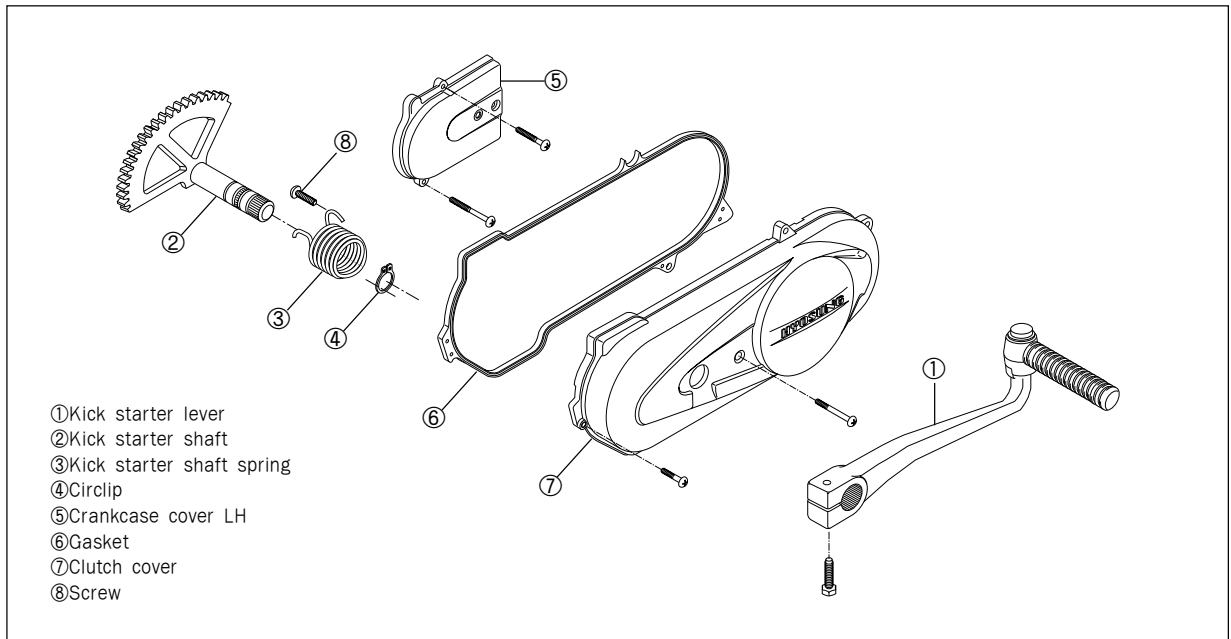

- Apply grease lightly on the rolling surface and install it on the crankcase cover.

99000-07000	Grease "G2"
-------------	-------------

- Position the kick starter shaft return spring and hook the spring end on the crankcase cover boss ①.

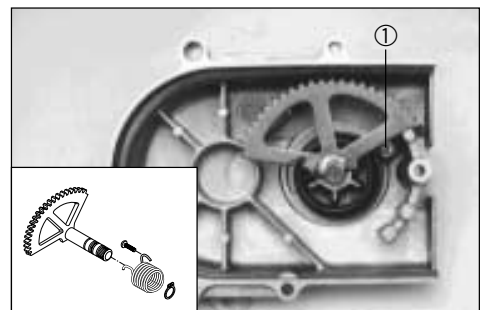

- Install the dowel pin and crankcase cover ②.

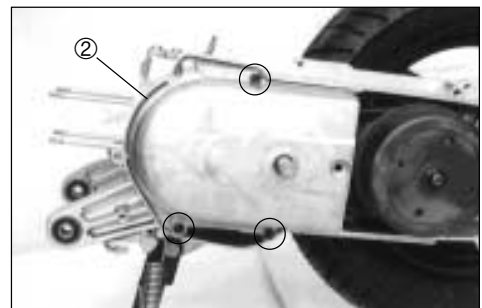

- Install the clutch cover and kick starter lever ①.

**NOTE:**

Install the kick starter lever as shown in the illustration.

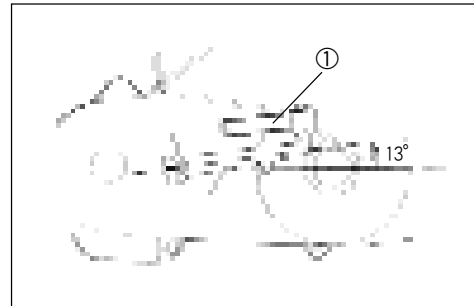

- Tighten the kick starter lever bolt to the specified torque.

Tightening torque	8-12 N · m (0.8-1.2 kg-m, 6.0-8.5 lb-ft)
-------------------	---



**PISTON**

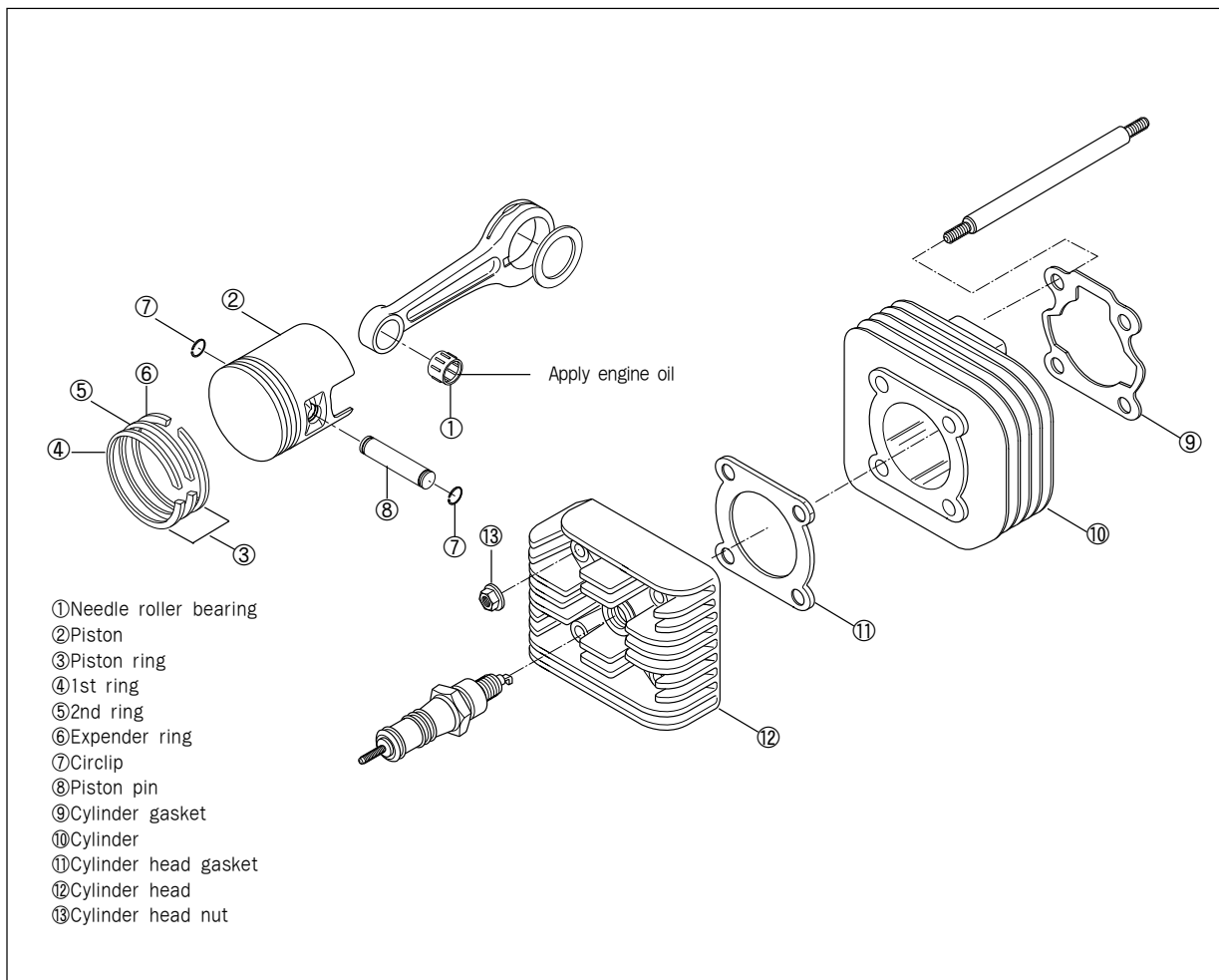

### 3-37 ENGINE

- Install the piston rings on the piston.
  - 1st - Keystone ring
  - 2nd - Rectangular ring
    - ↳ Expander ring

**NOTE:**

**Position the ring so that the marking is on upside.**

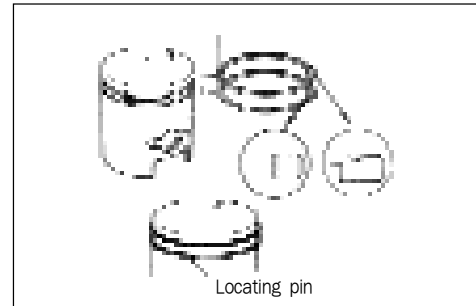

- It is extremely important that, when the piston is fed into the cylinder, each ring in place should be so positioned as to hug the locating pin as shown in the illustration.

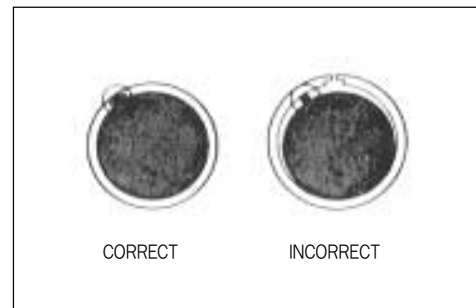

- Apply engine oil on the piston pin and install the piston to the conrod.

**NOTE:**

**The arrow mark ① on the piston head should point the exhaust side.**

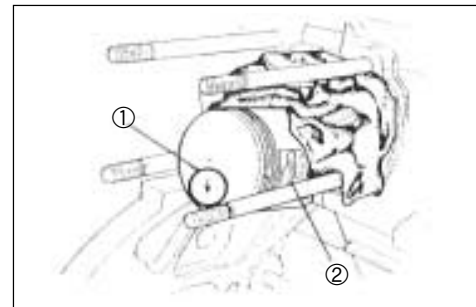

- The circlip should be mounted in such a position ② that the mating ends of the circlip do not coincide with the groove portion of the piston.
- Position the cylinder base gasket.
- Apply engine oil on the piston and cylinder wall surfaces and install the cylinder over the piston carefully.

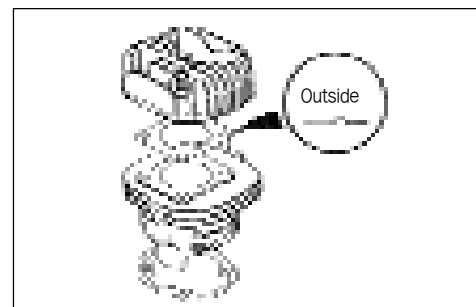

- Tighten the cylinder head nut to the specification.

Tightening torque	8-12 N · m (0.8-1.2 kg-m, 6.0-8.5 lb-ft)
-------------------	---



OIL PUMP AND INTAKE

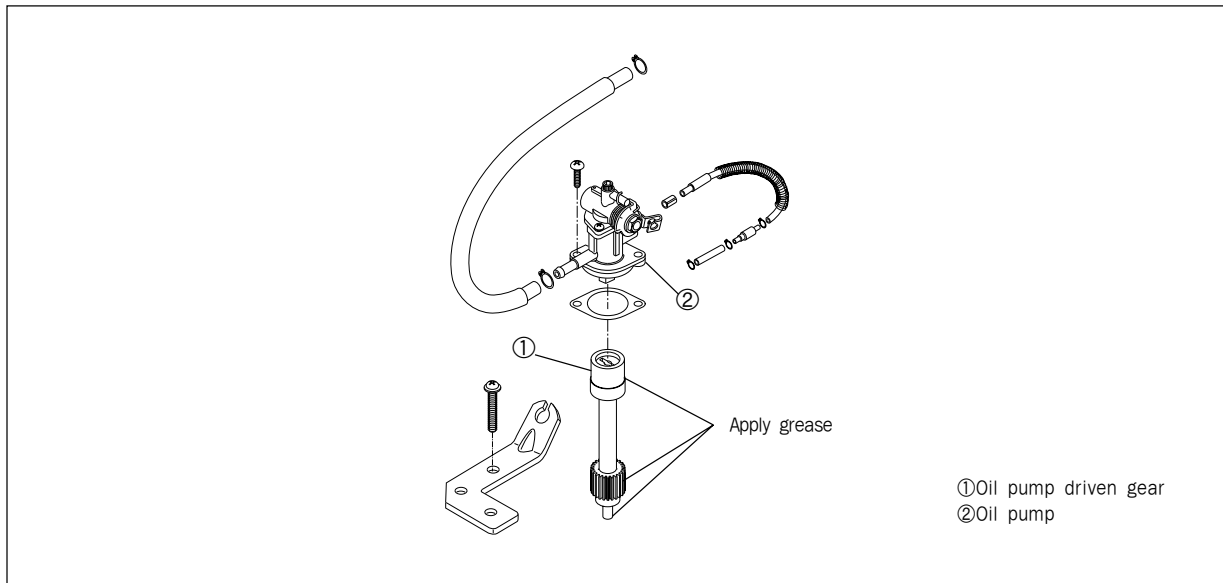

- Apply grease to the oil pump driven gear ① and install it to the crankcase.

99000-07000	Grease "G <sub>2</sub> "
-------------	--------------------------

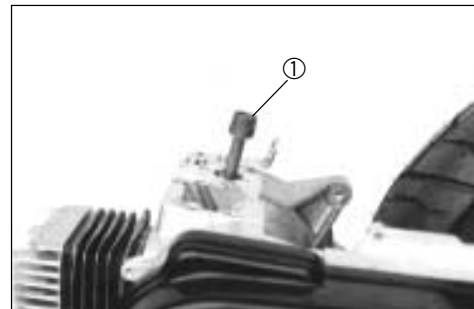

- Install the oil pump ② and tighten it to the specified torque.

Tightening torque	3-5 N · m (0.3-0.5 kg-m, 2.0-3.6 lb-ft)
-------------------	--

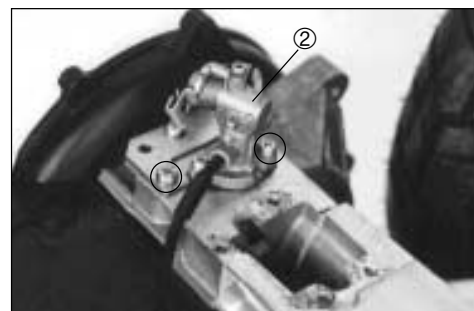

- Install the gaskets (③, ④) and intake pipe ⑥ with reed valve ⑤ to the crankcase.

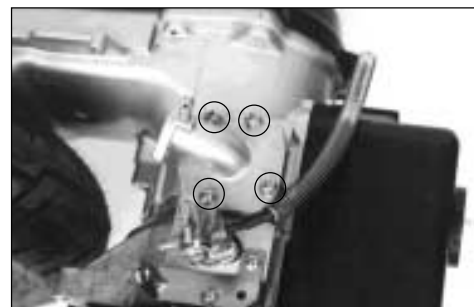
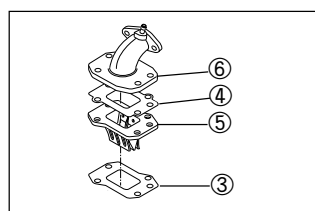

## 3-39 ENGINE

### MAGNETO

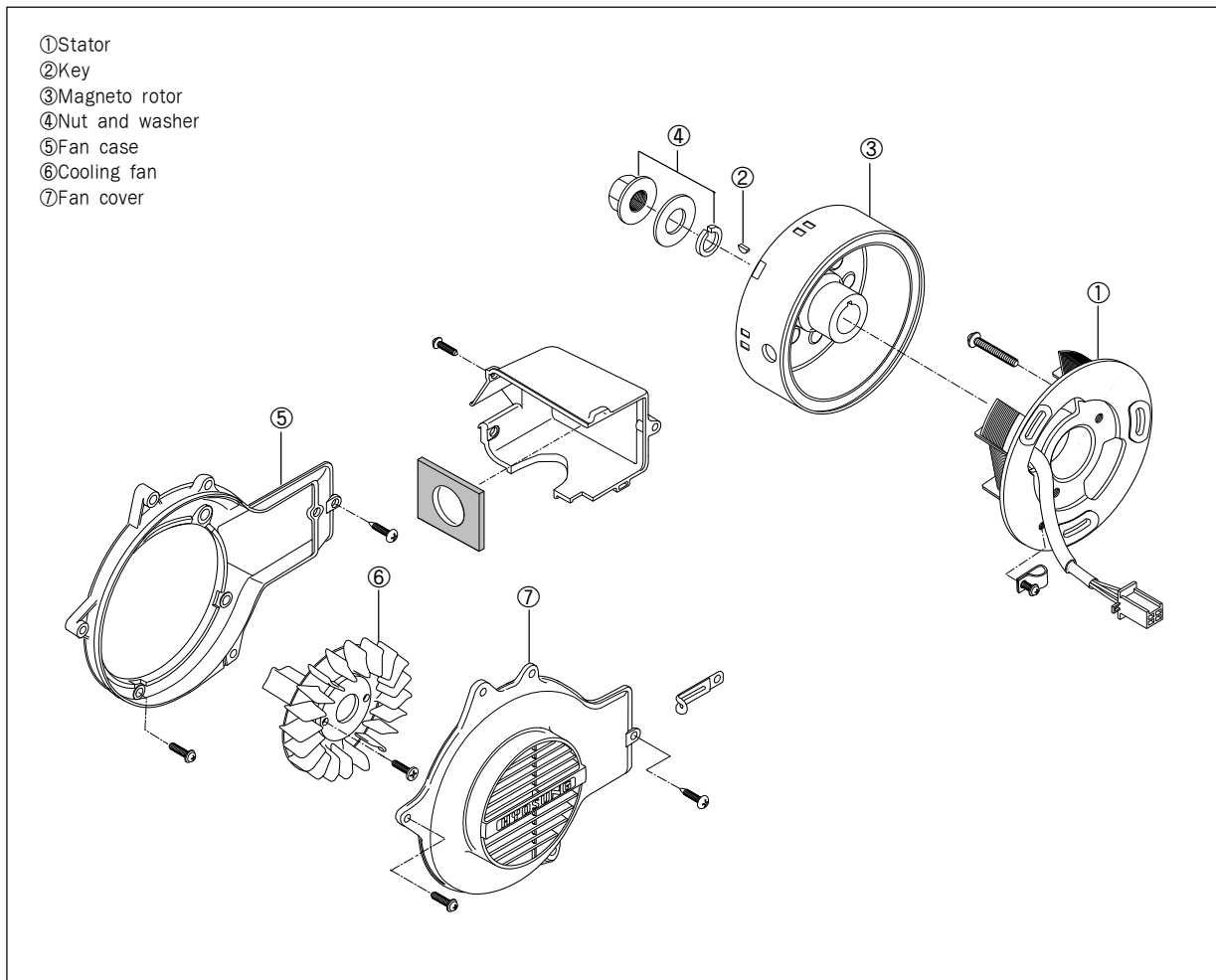

- Degrease the tapered portion of the crankshaft and also the magneto rotor.
- Install the stator ①.
- Install the key ②.
- Install the rotor ③.

- Apply THREAD LOCK "1324" to the rotor nut ④ and tighten it to the specified torque with the special tool.

99000-32030	THREAD LOCK "1324"
09930-40113	Rotor holder
Tightening torque	35-45 N · m (3,5-4,5 kg-m, 25,5-31,0 lb-ft)

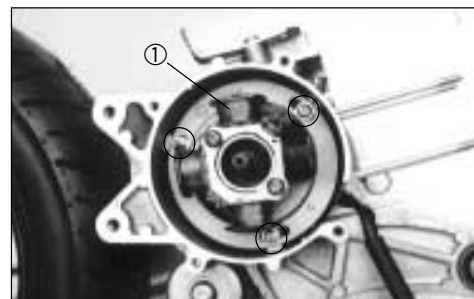

- Install the fan case ⑤.
- Install the magneto lead wire and starter motor lead wire.

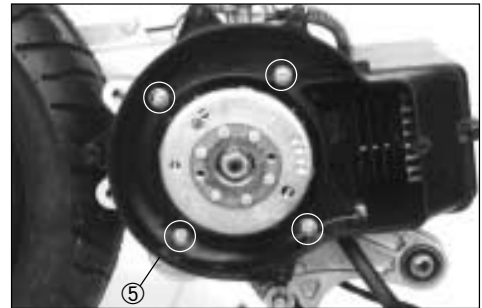

- Install the cooling fan ⑥.

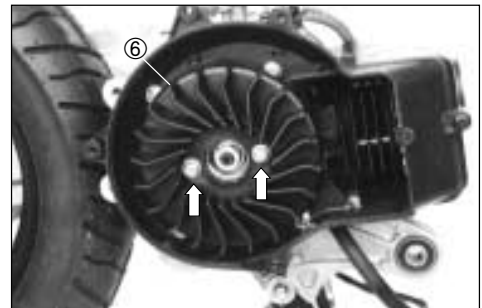

- Install the cooling fan cover ⑦.

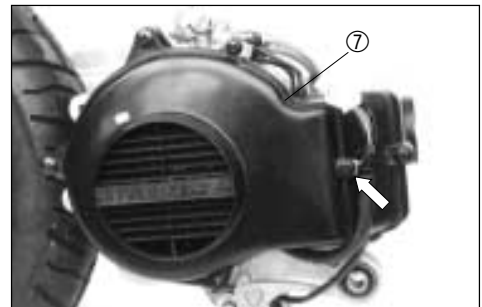

**MUFFLER**

- Tighten the exhaust pipe bolts ① and muffler mounting bolts ② to the specified torque.

Tightening torque	8-12 N · m (0.8-1.2 kg-m, 6.0-8.5 lb-ft)
-------------------	---

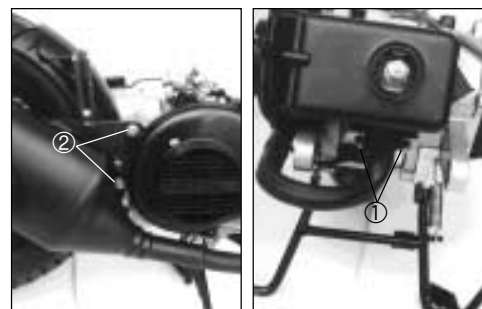

# FUEL AND LUBRICATION SYSTEM

## CONTENTS

<b>CARBURETOR</b> .....	<b>4- 1</b>
<b>REMOVAL</b> .....	<b>4- 1</b>
<b>DISASSEMBLY</b> .....	<b>4- 2</b>
<b>INSPECTION</b> .....	<b>4- 4</b>
<b>REASSEMBLY AND REMOUNTING</b> .....	<b>4- 4</b>
<b>FUEL TANK</b> .....	<b>4- 6</b>
<b>REMOVAL</b> .....	<b>4- 6</b>
<b>REMOUNTING</b> .....	<b>4- 7</b>
<b>OIL PUMP</b> .....	<b>4- 8</b>

## 4-1 FUEL AND LUBRICATION SYSTEM

### CARBURETOR

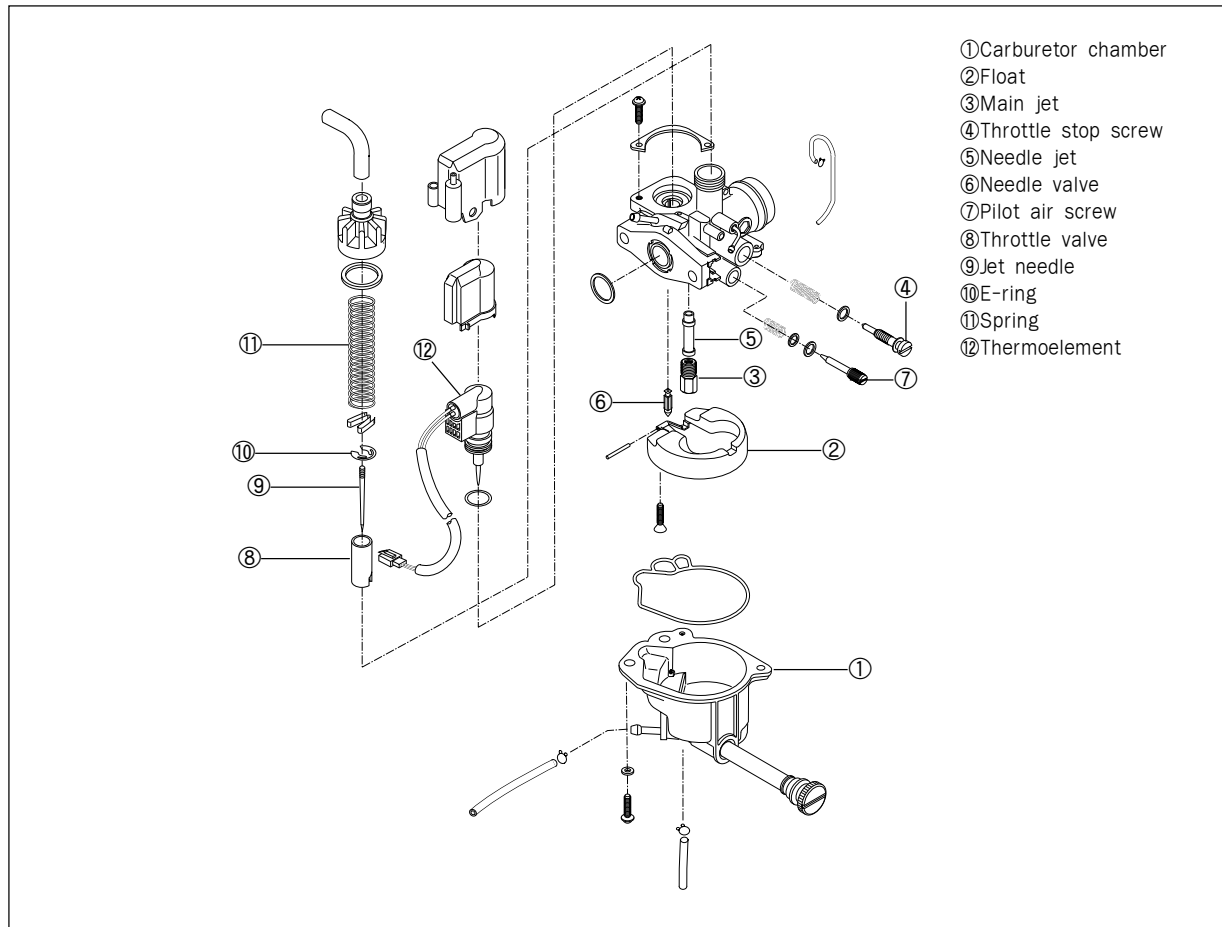

### REMOVAL

- Remove the side cover. (Refer to page 6-3)
- Remove the absorber mounting lower bolt.





- Remove the carburetor top cap ①, and disconnect the throttle cable ②.

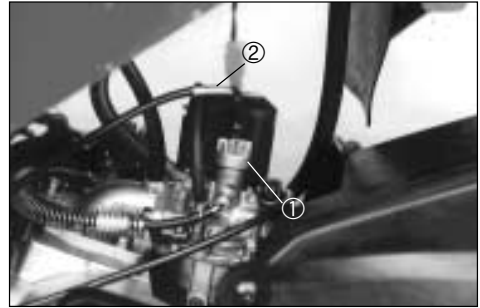

- Disconnect the carburetor hoses and oil hose.  
Vacuum hose ③.  
Oil hose ④.  
Fuel hose ⑤.

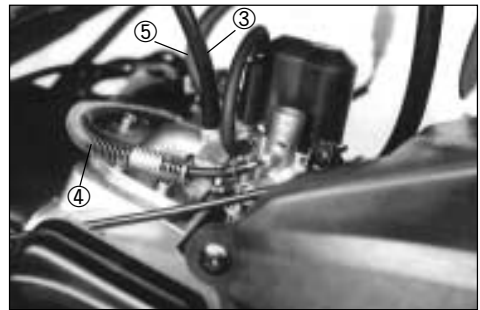

- Remove the carburetor by loosening the mounting bolts ⑥ and clamp screw ⑦.

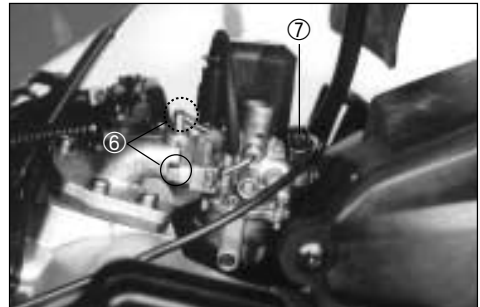

### DISASSEMBLY

- Remove the thermoelement assembly.



**CAUTION:**  
Do not attempt to disassemble the thermoelement assembly.  
It is not serviceable.



## 4-3 FUEL AND LUBRICATION SYSTEM

- Remove the float chamber ①.

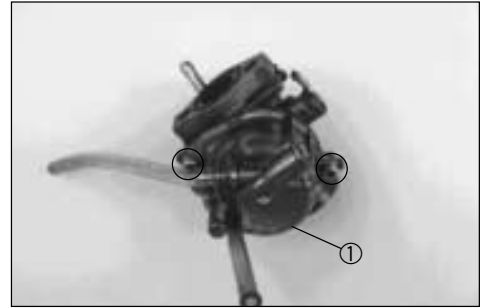

- Remove the float ③ by removing the screw and pin ②.

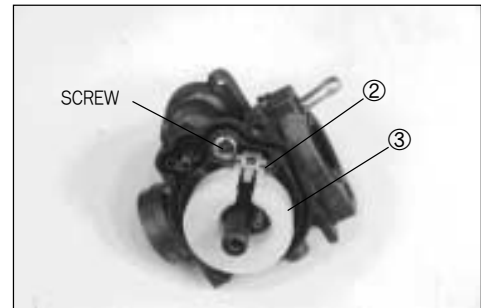

- Remove the needle valve ④.

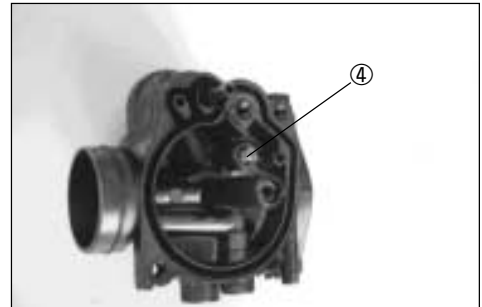

- Remove the throttle stop screw ⑤ and pilot air screw ⑥.

**NOTE:**

When removing the pilot air screw, record the revolutions until tighten completely.

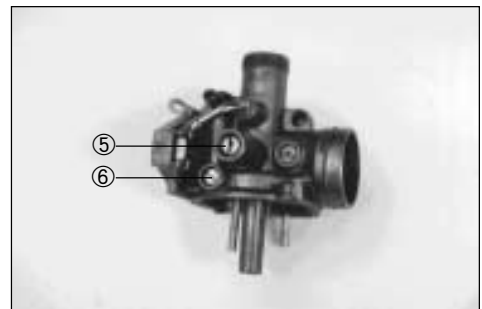
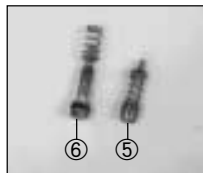

- Remove the main jet ⑦ and needle jet ⑧.

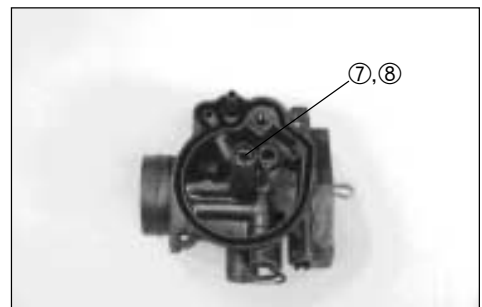
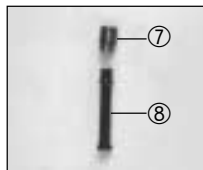

**INSPECTION**

Check following items for any damage or clogging.

- Pilot jet
- Main jet
- Pilot air screw
- Needle jet air bleeding hole
- Float
- Gasket
- Pilot outlet and bypass holes

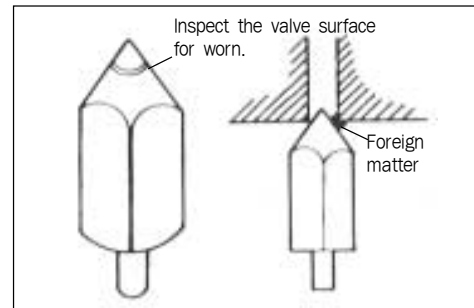

**NEEDLE VALVE INSPECTION**

If foreign matter is caught between the valve seat and the needle, the gasoline will continue flowing and cause it to overflow. If the seat and needle are worn beyond the permissible limits, similar trouble will occur. Conversely, if the needle sticks, the gasoline will not float chamber. Clean the float chamber and float parts with gasoline. If the needle is worn as shown in the illustration, replace it together with a valve seat. Clean the fuel passage of the mixing chamber with compressed air.

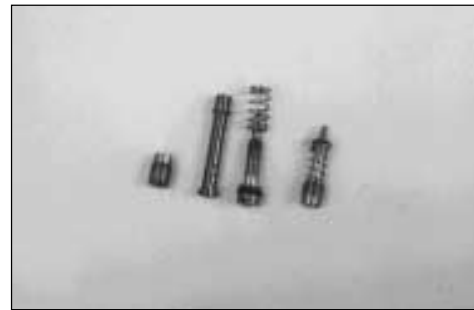

**REASSEMBLY AND REMOUNTING**

- Reassemble following items.
  - ① Pilot air screw
  - ② Throttle stop screw
  - ③ Main jet
  - ④ Needle jet
  
- Install the needle ⑤ and float ⑥ on the carburetor body.

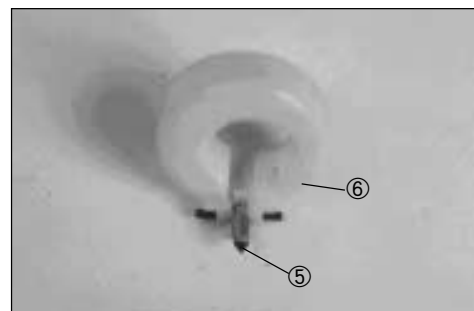
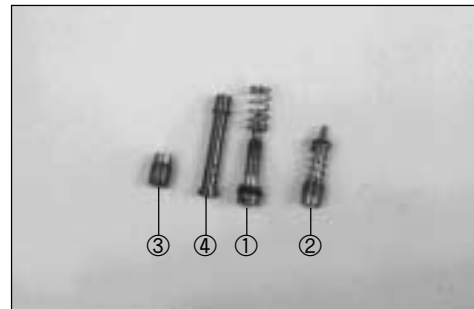

- Install the float pin and tightened the screw ⑦.
- Install the gasket and float chamber.

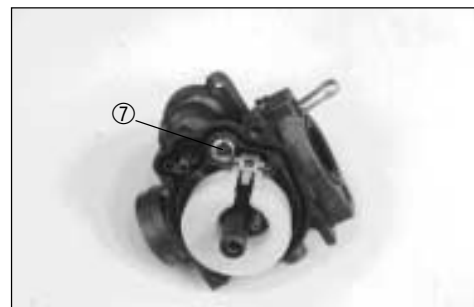

## 4-5 FUEL AND LUBRICATION SYSTEM

---

- Install the thermoelement assembly.



- Install the carburetor assembly.

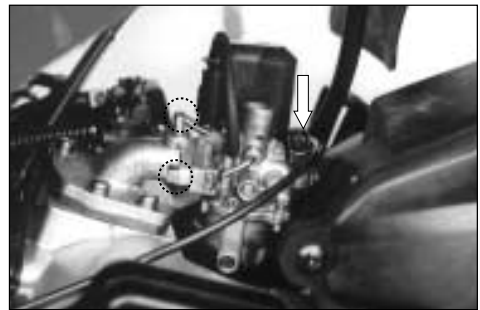

- Install the vacuum hose ①, oil hose ② and fuel hose ③.

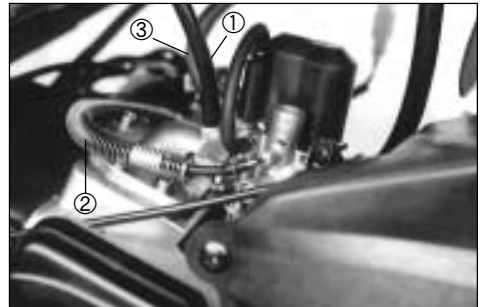

- Install the carburetor top cap.

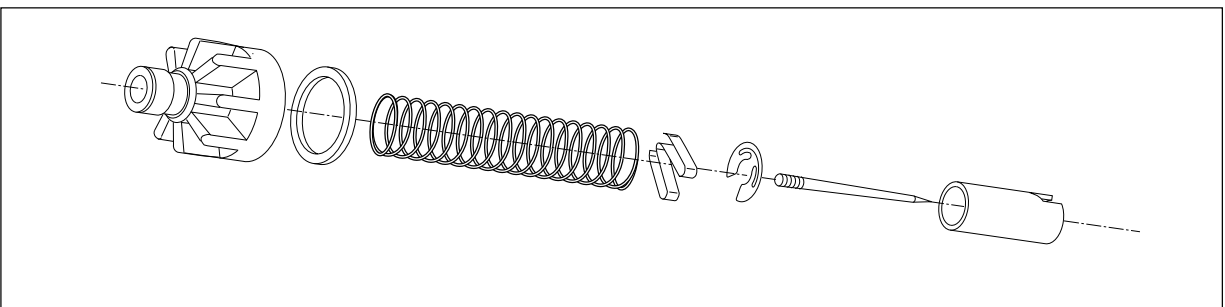

## FUEL TANK

### REMOVAL

- Remove the side covers. (Refer to page 6-3)
- Remove the rear center cover ①.

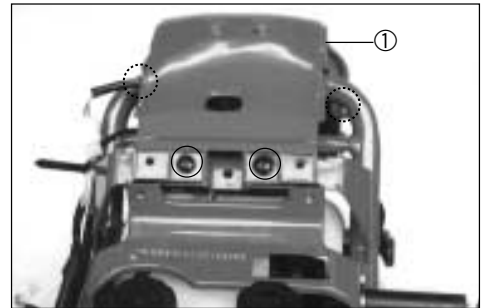

- Disconnect the fuel hose ②.

**NOTE:**

To prevent fuel flow, connect the suitable cap to the fuel tank outlet.

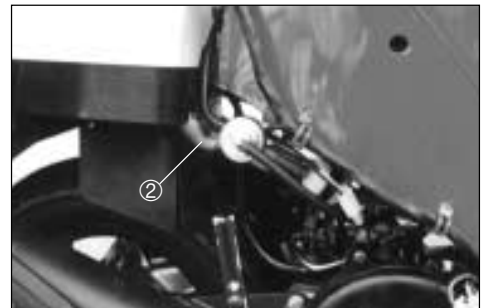

- Disconnect the oil gauge lead wire ③.

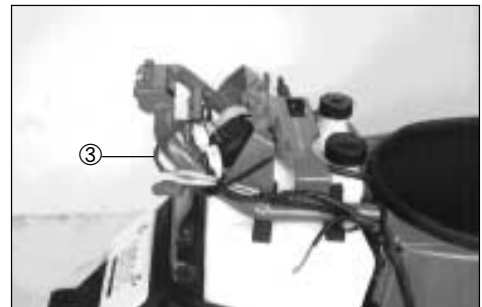

- Remove the shock absorber mounting lower bolt.
- Remove the rear fender bolts, then take off the rear fender.



### CLEANING

Dust from the fuel tank tends to build up in the fuel filter which, when the fuel filter has been neglected for a long period, inhibits the flow of fuel.

Remove the dust from the fuel filter ① using compressed air.

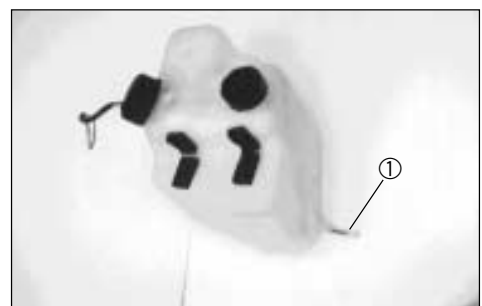

## 4-7 FUEL AND LUBRICATION SYSTEM

### REMountING

Remount the fuel tank in the reverse of removal.

- ① Fuel tank
- ② Fuel level gauge
- ③ Fuel level gauge cap
- ④ Fuel tank cap
- ⑤ Vacuum hose
- ⑥ Inlet hose
- ⑦ Outlet hose No.1
- ⑧ ⑨ Cushion
- ⑩ Fuel strainer
- ⑪ Outlet hose No.2

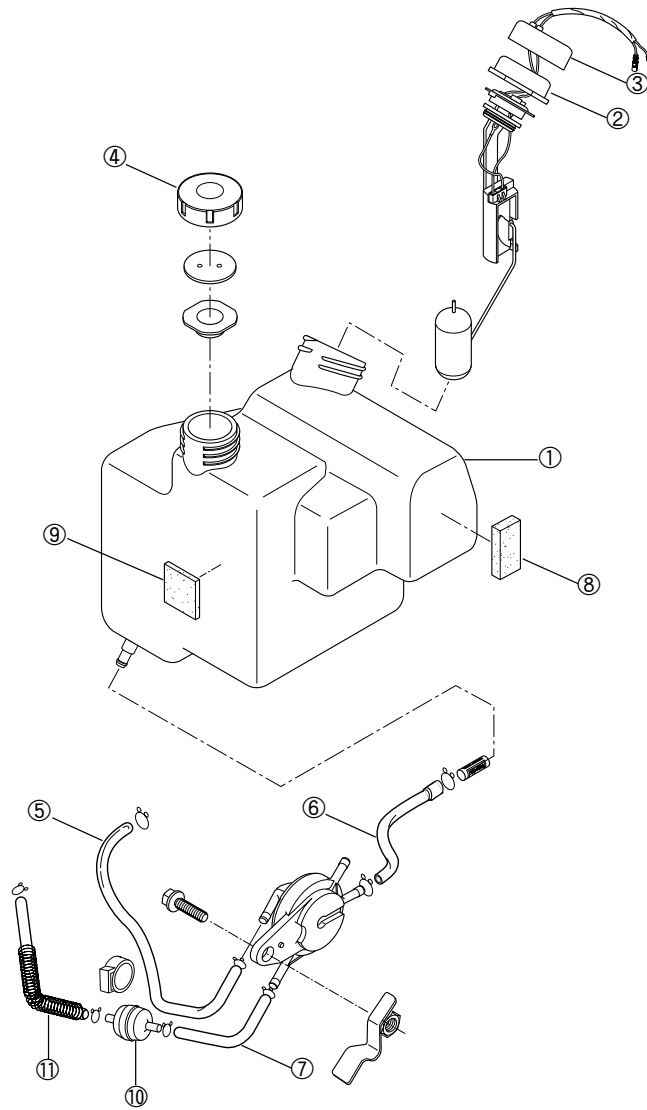

## OIL PUMP

### AIR BLEEDING

Whenever evidence is noted of some air having leaked into the oil pipe from the oil tank in a machine brought in for servicing, or if the oil pump has to be removed for servicing, be sure to carry out an air bleeding operating with the oil pump in place before returning the machine to the user.

To bleed air, hold the machine in standstill condition. Loosen the screw ① to let out air and after making sure that the trapped air has all been bled, tighten the screw good and hare.

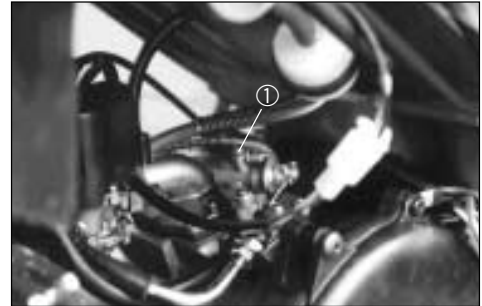

### CHECKING OIL PUMP

Use the special tool, to check the pump for capacity by measuring the amount of oil the pump draws during the specified interval.

- Remove the left side cover.
- Have the tool filled with HYOSUNG HYPOL OIL and connect it to the suction side of the pump.
- Run the engine at 3000 r/min.
- Holding engine speed at the same 3000 r/min., let the pump draw for 5 minutes. For this operation, the reading taken on the device should be 0.9~1.1 ml.

09900-21602	CCI oil gauge
-------------	---------------

Oil discharge amount	0.9-1.1 ml at 3000 r/min. for 5 minutes.
----------------------	---

**CAUTION:**

**During this inspection, strictly follow the following points.**

- \* **The machine should be rested on the center stand.**
- \* **Do not touch the rear wheel while running the engine.**

# ELECTRICAL SYSTEM

## CONTENTS

<b>ELECTRICAL PARTS</b> .....	<b>5- 1</b>
<b>IGNITION/CHARGING SYSTEM</b> .....	<b>5- 2</b>
<b>IGNITION COIL</b> .....	<b>5- 2</b>
<b>STATOR COILS</b> .....	<b>5- 3</b>
<b>REGULATOR/RECTIFIER</b> .....	<b>5- 3</b>
<b>STARTER SYSTEM</b> .....	<b>5- 4</b>
<b>STARTER MOTOR INSPECTION</b> .....	<b>5- 5</b>
<b>STARTER RELAY INSPECTION</b> .....	<b>5- 5</b>
<b>FUEL LEVEL GAUGE</b> .....	<b>5- 6</b>
<b>OIL LEVEL CHECK LIGHT</b> .....	<b>5- 7</b>
<b>THERMOELEMENT</b> .....	<b>5- 8</b>
<b>SWITCHES</b> .....	<b>5- 9</b>
<b>BATTERY</b> .....	<b>5-10</b>



## 5-1 ELECTRICAL SYSTEM

### ELECTRICAL PARTS

- ① Ignition coil
- ② Thermostatic assembly
- ③ Trunk box lamp
- ④ Fuel level gauge
- ⑤ Oil level gauge

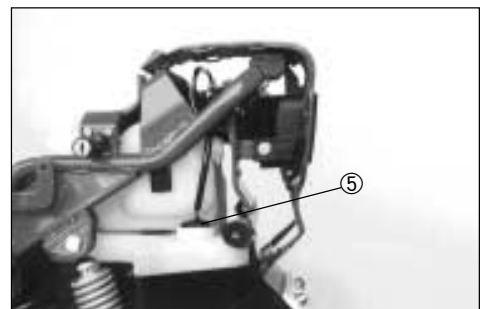
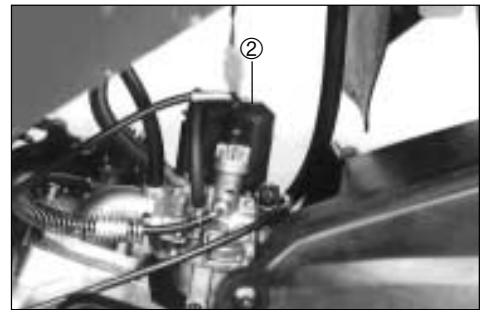
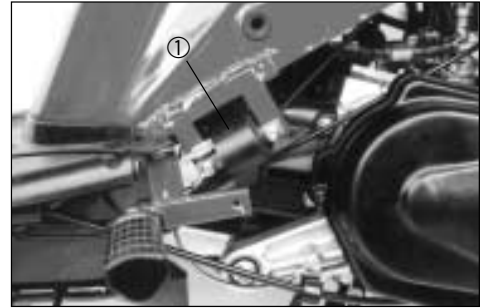
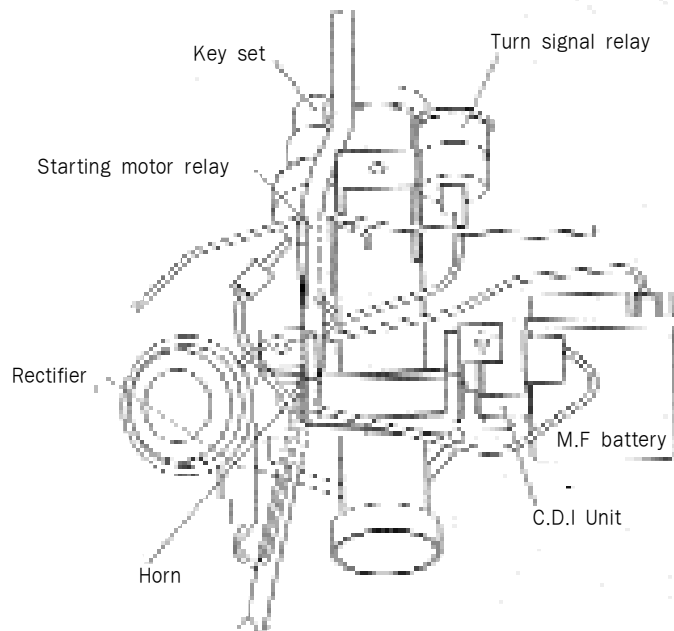

**IGNITION/CHARGING SYSTEM**

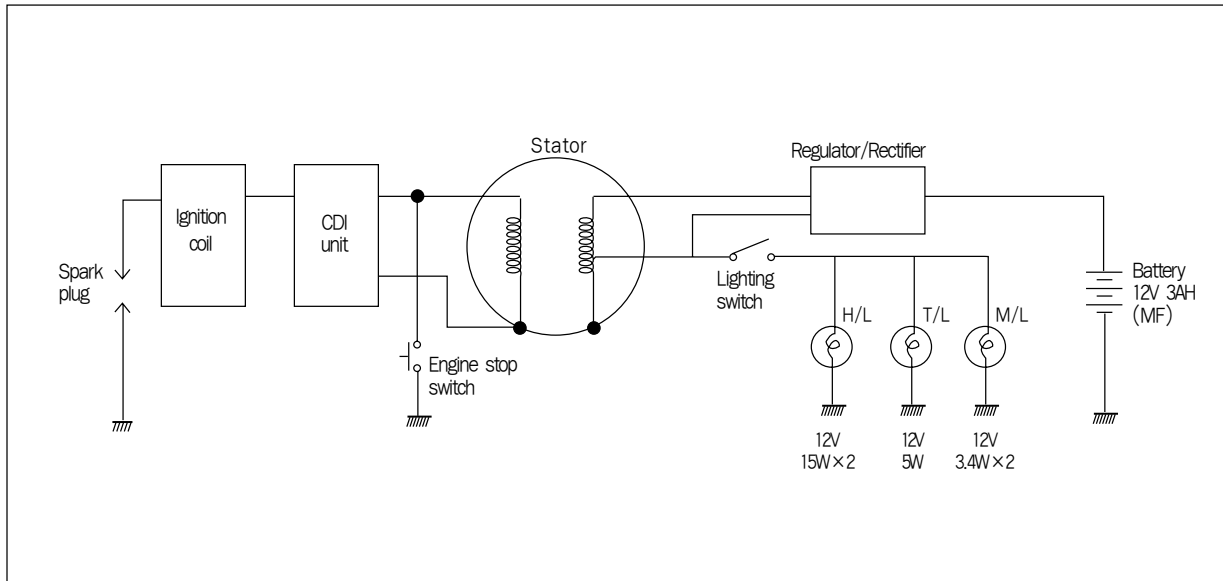

**IGNITION COIL**

- Check the ignition coil with electro tester.
- Test the ignition coil for sparking performance. Test connection is as indicated. Make sure that the three-needle sparking distance is at least 8mm. Test it at least for 5 minutes.

09900-28106	Electro tester
-------------	----------------

STD spark performance	8 mm
-----------------------	------

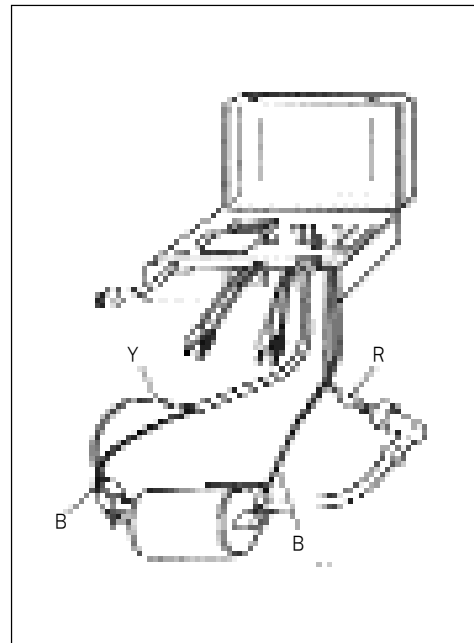
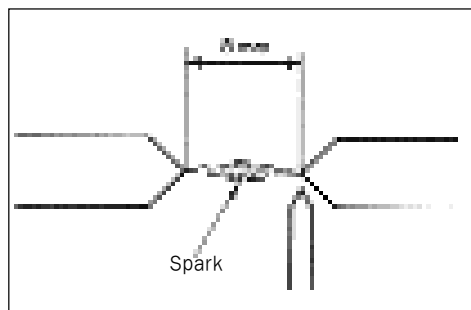

- Check the ignition coil with pocket tester.

09900-25002	Pocket tester
-------------	---------------

**IGNITION COIL RESISTANCE**

Primary	W/L-Ground Approx. 0.15-0.28 Ω
Secondary	Plug cap-Ground Approx. 14-20 KΩ

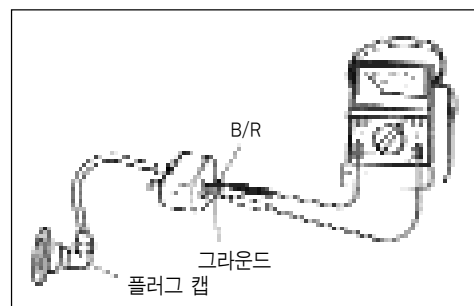

## 5-3 ELECTRICAL SYSTEM

### STATOR COILS

- Using a pocket tester, measure the resistance between the lead wire and ground. If the resistance checked is incorrect, replace the coil.

		Standard resistance	
Y/W	Ground	Lighting	0.6-1.4 $\Omega$
W/R	Ground	Charging	0.6-1.4 $\Omega$
B/R	Ground	Exciting	180-230 $\Omega$

### CHARGING OUTPUT CHECK

Start the engine and keep it running at 5000 r/min with lighting switch turned ON.

Measure the DC voltage between the battery terminal  $\oplus$  and  $\ominus$  with a pocket tester.

If the tester reads under or over following specification, check the no-load performance or replace the regulator/rectifier.

#### NOTE:

**When making this test, be sure that the battery is in fully-charged condition.**

09900-25002	Pocket tester
09900-26006	Tachometer
STD charging output	14-15V at 5000 r/min

### NO-LOAD PERFORMANCE

- Disconnect the magneto lead wire coupler.
- Start the engine and keep it running at 5000 r/min.
- Using a pocket tester, measure the AC voltage between the White with Red tracer white lead wire and ground. If the tester reading is as follows, magneto is in good condition.

STD No-load performance	More than 100 V(AC) at 5000 r/min
-------------------------	-----------------------------------

### REGULATOR/RECTIFIER

- Disconnect the coupler.
- Using the pocket tester ( $\times 1 \text{ k}\Omega$  range), measure the resistance between the terminals as shown in the following table. If the resistance checked is incorrect, replace the regulator/rectifier.

09900-25002	Pocket tester
-------------	---------------

Unit: Approx.  $\text{k}\Omega$

		$\oplus$ Probe of tester to:			
		①	②	③	④
$\oplus$ Probe of tester to:	①		50-260	$\infty$	$\infty$
	②	50-230		$\infty$	$\infty$
	③	$\infty$	$\infty$		$\infty$
	④	$\infty$	$\infty$	10-100	

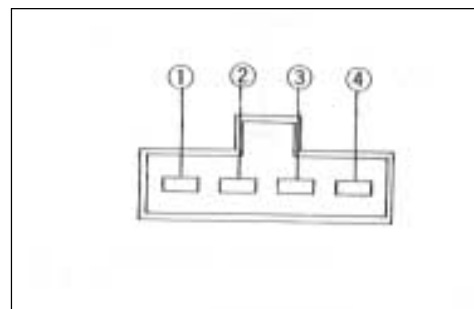
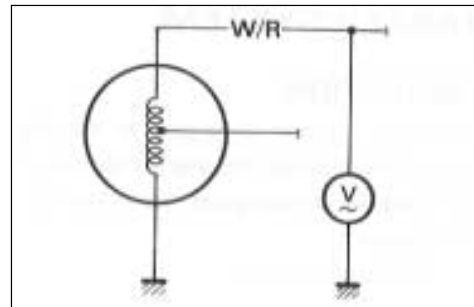
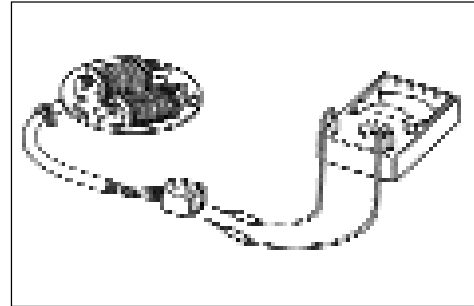

## STARTER SYSTEM

### DESCRIPTION

The starter system is shown in the diagram below: namely, the starter motor, relay, starter switch and battery. Depressing the starter button (on the right handlebar switch box) while squeezing the front or rear brake lever energizes the relay, causing the contact points to close which connects the starter motor to the battery.

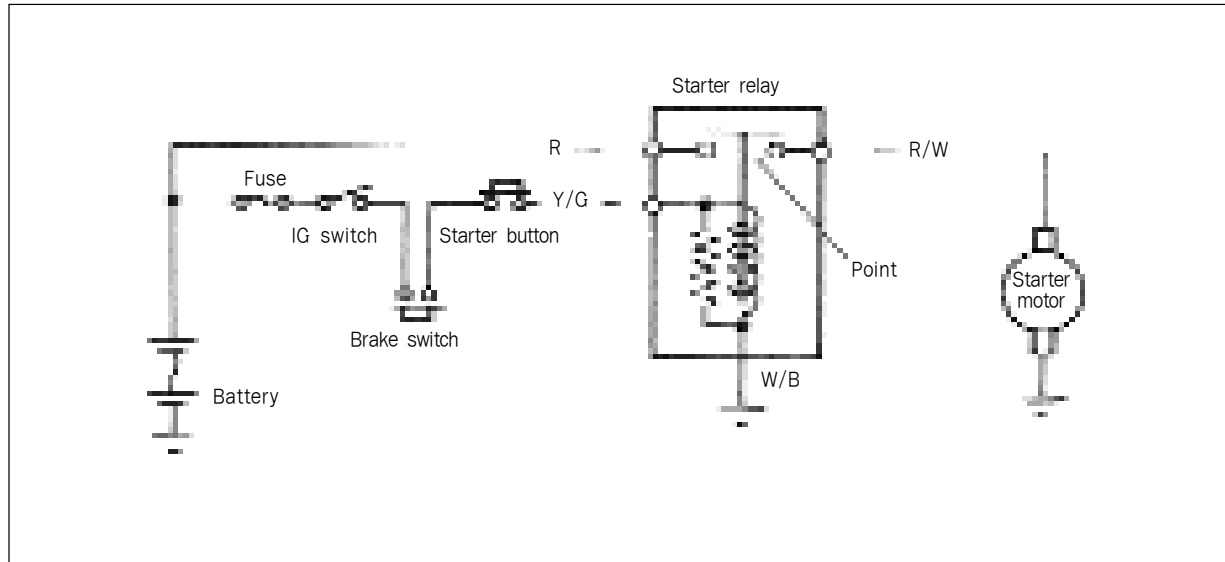

### STARTER MOTOR REMOVAL AND DISASSEMBLY

Remove the starter motor.

Disassemble the starter motor as shown in the illustration.

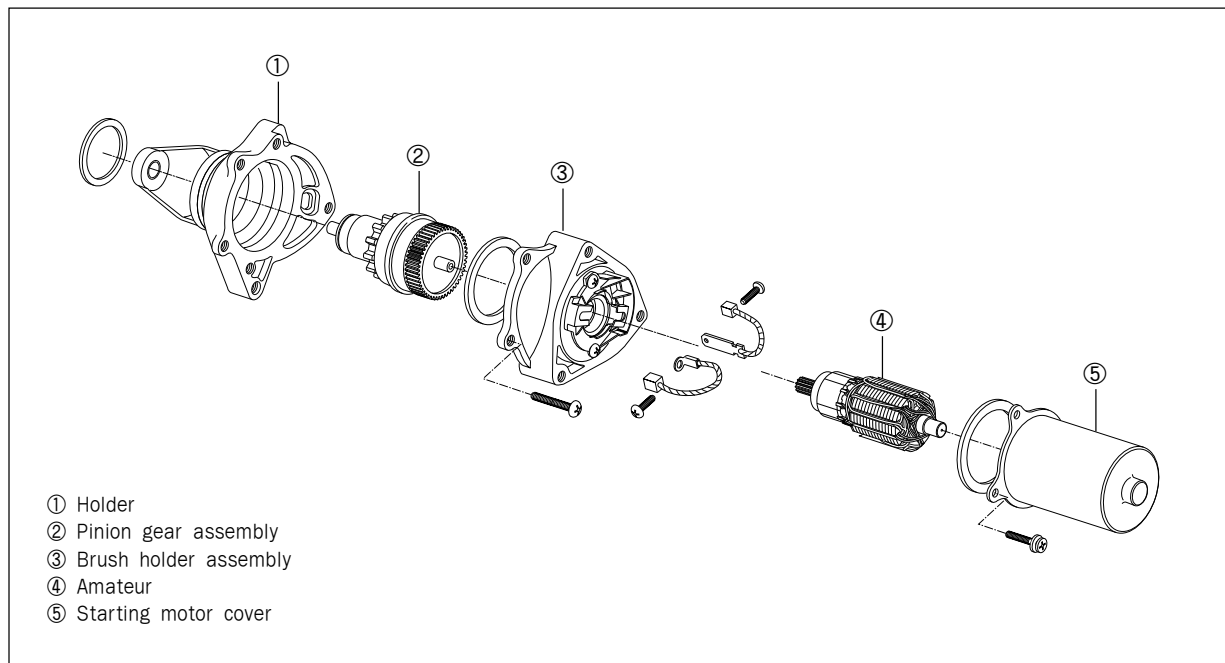

## 5-5 ELECTRICAL SYSTEM

### STARTER MOTOR INSPECTION

#### CARBON BRUSHES

When the brushes are worn, the motor will be unable to procedure sufficient torque, and the engine will be difficult to turn over. To prevent this, periodically inspect the length of the brushes and replace them when they are too short or chipping.

Service Limit	4mm(0.16in)
---------------	-------------

#### COMMUTATOR

If the commutator surface is dirty, starting performance will decrease. Polish the commutator with #400 or similar fine emery paper when it is dirty. After polishing wipe the commutator with a clean dry cloth.

Measure the commutator under cut ①.

Service Limit	4mm(0.16in)
---------------	-------------

#### ARMATURE COIL

Using the pocket tester, check the coil for open and ground by placing probe pins on each commutator segment and rotor core (to test for ground) and on any two segments at various places (to test for open), with the brushes lifted off the commutator surface.

If the coil is found to be open-circuited or grounded, replace the armature. Continuous use of a defective armature will cause the starter motor to suddenly fail.

09900-25002	Pocket tester
-------------	---------------

### STARTER RELAY INSPECTION

- Disconnect the starter relay lead wire coupler. Check the coil for "open", "ground" and ohmic resistance. The coil is in good condition, if the resistance is as follows.

09000-25002	Pocket tester
-------------	---------------

STD resistance	0-70 Ω
----------------	--------

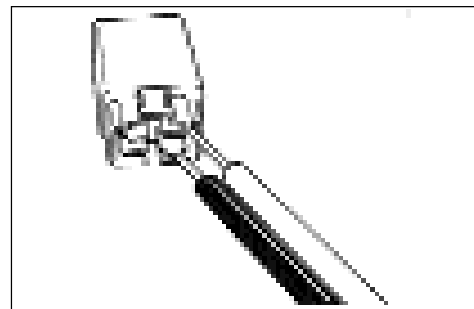
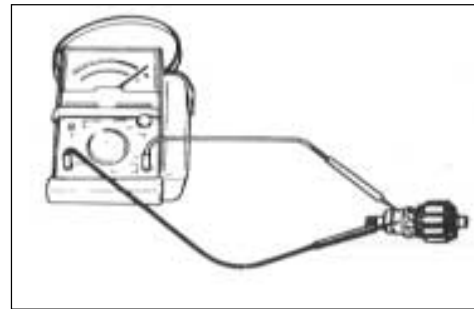
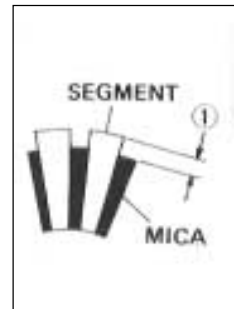
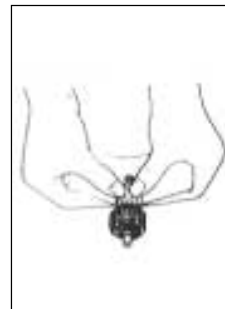
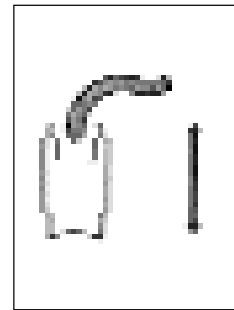
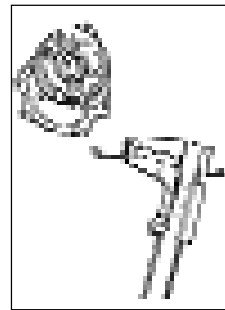

## FUEL GAUGE

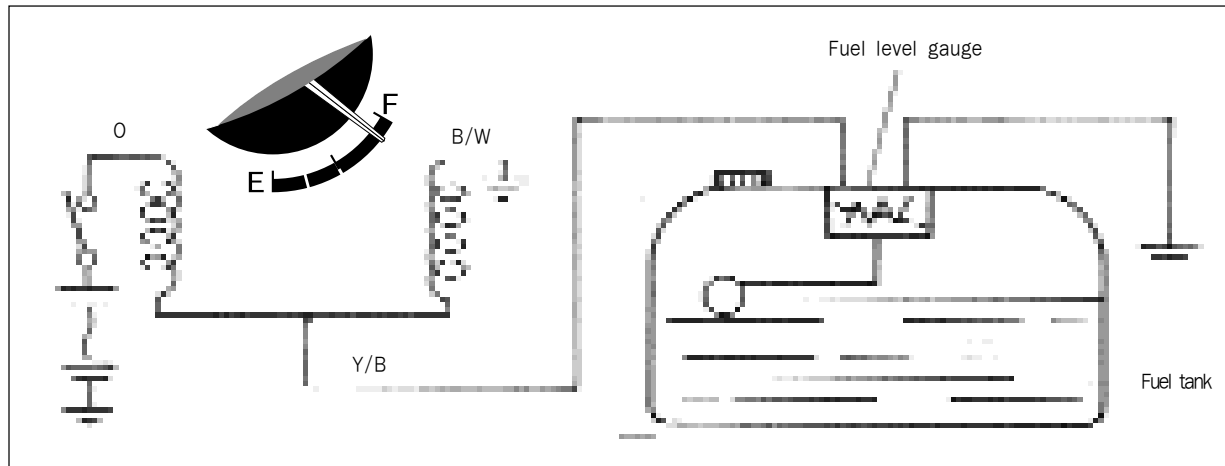

## FUEL LEVEL METER/GAUGE

### FUEL METER INSPECTION

To test the Fuel Meter two different checks may be used. The first, and simplest test will tell if the meter is operating but will not indicate the meters accuracy throughout the range. To perform this test, lift the seat and remove the right frame cover, then disconnect the B/W and Y/B lead connector of the fuel gauge sending unit. Connect a jumper wire between B/W and Y/B wires coming from the main wiring harness. With the ignition switch turned ON, the fuel meter should indicate "F".

The second test will check the accuracy of the meter in the full and empty positions. Connect a 90-ohm resistor between the Y/B and B/W lead wires. The fuel meter is normal if its pointer indicates the E(empty) position when the specified voltage is applied to the circuit and if its pointer indicates the F(full) position when the resistor is changed to 10 ohms.

If either one or both indications are abnormal, replace the fuel meter with a new one.

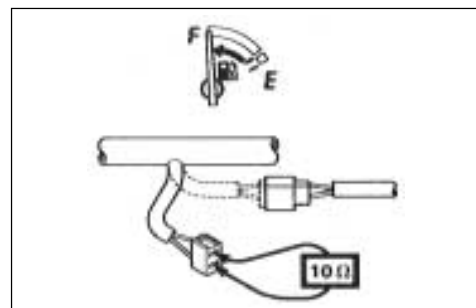
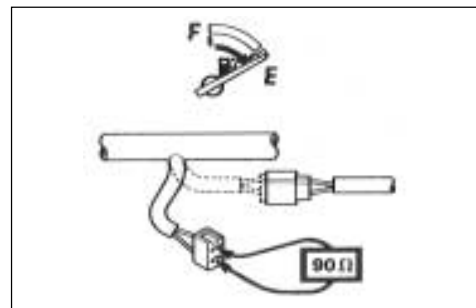
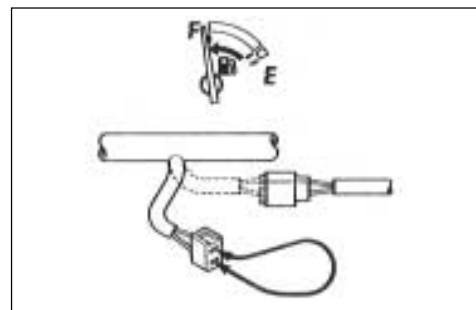

## 5-7 ELECTRICAL SYSTEM

### FUEL GAUGE SENDING UNIT INSPECTION

- Disconnect the lead wires coming out of the fuel gauge and check resistance of each position.
- If the resistance measured is incorrect, replace the fuel gauge assembly with a new one.
- The relation between the position of the fuel gauge float and resistance is shown in the following table.

Float position	Resistance
F(Full)	Approx. 10 Ω
1/2	Approx. 38 Ω
E(Empty)	Approx. 90 Ω

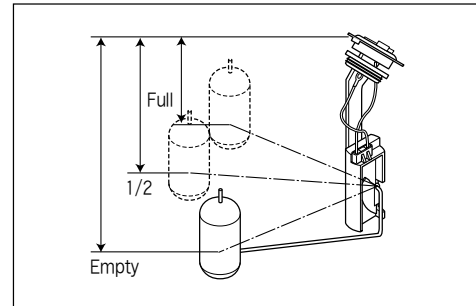

### OIL LEVEL CHECK LIGHT

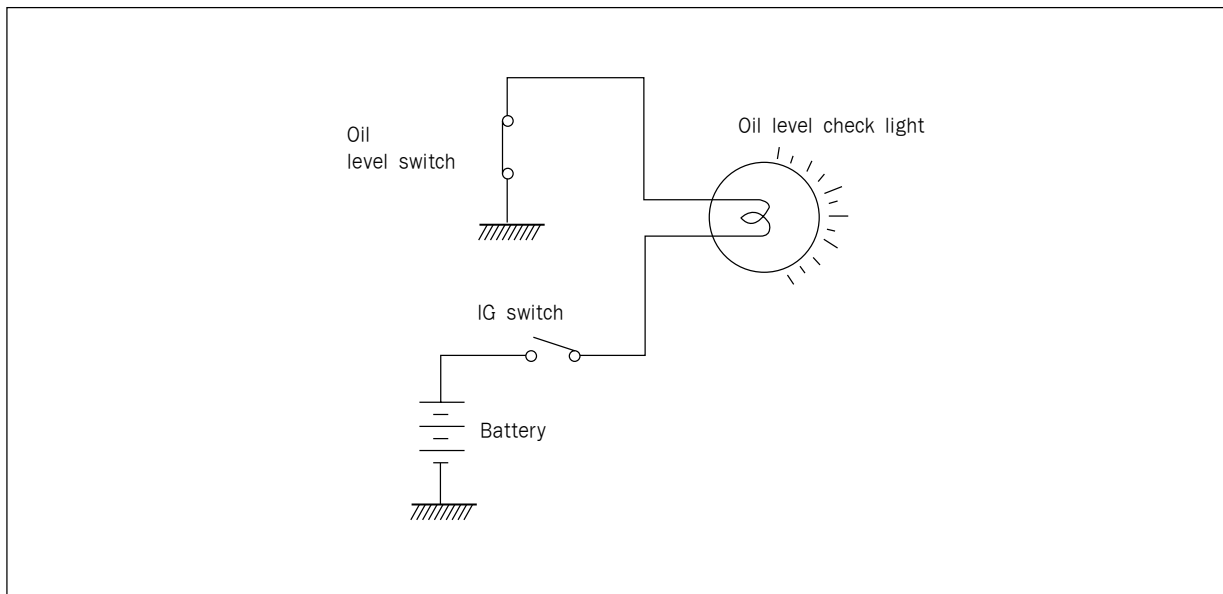

### OIL LEVEL SWITCH INSPECTION

Check the oil level switch for continuity between the lead wire. If the tester does not show the value of 0-1 ohm when the switch ring is in bottom position, file the contact surface or replace the unit.

09900-25002	Pocket tester
-------------	---------------

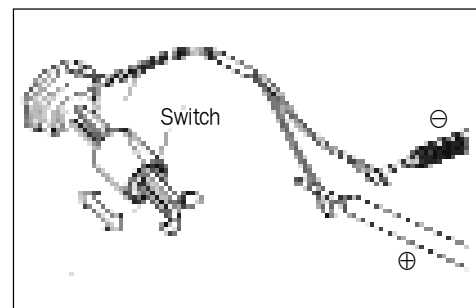

**OIL LEVEL CHECK LIGHT INSPECTION**

Disconnect the L/W and B/W lead connector ① of the oil level check light.

Connect a jumper wire between L/W and B/W wires coming from the main wiring harness. With the ignition switch turned ON, the oil level check light should flash.

If there is no flash, check the wiring harness continuity and the bulb blown out.

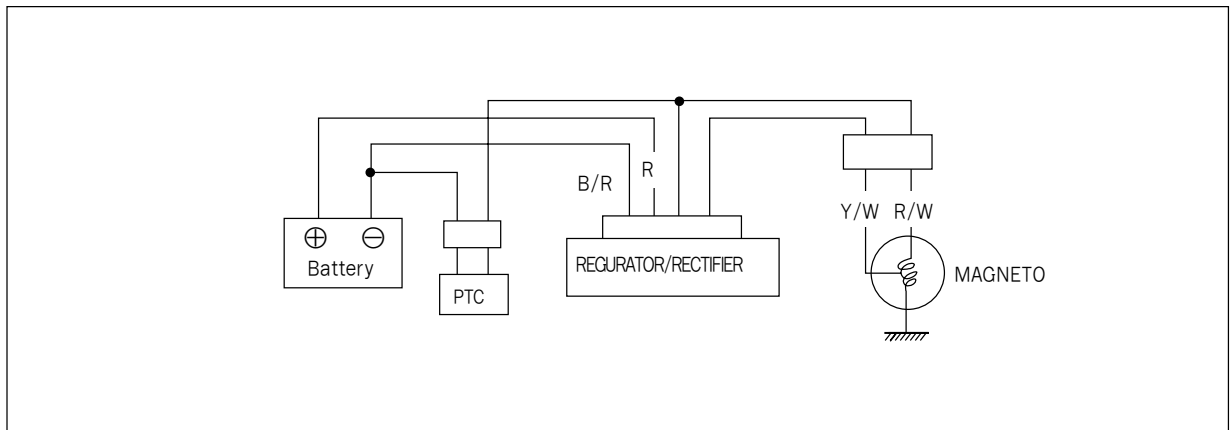
**THERMOELEMENT****INSPECTION**

- Disconnect the thermoelement coupler.
- Connect the thermoelement coupler ① to a 12V battery and touch the thermoelement ② to check the temperature being raised.

The thermoelement ② should become heated to a temperature more than that of human body within five minutes. If not, replace with new one.

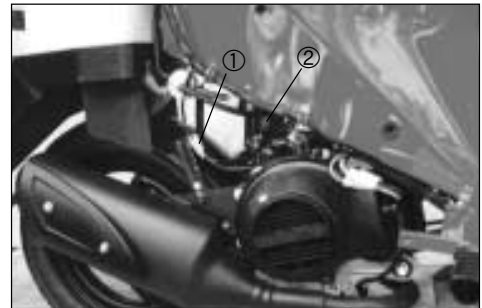
**NOTE:**

This check should be carried out when the carburetor is cold.



## 5-9 ELECTRICAL SYSTEM

### SWITCHES

Inspect each switch for continuity with the pocket tester referring to the chart. If it is found any abnormality, replace the repective switch assembly with new one.

#### WIRE COLOR

B	.....	Black
G	.....	Green
Gr	.....	Gray
Sb	.....	Light blue
Lg	.....	Light green
O	.....	Orange
R	.....	Red
W	.....	White
Y	.....	Yellow
B/R	.....	Black with Red tracer
B/W	.....	Black with White tracer
W/B	.....	White with Black tracer
Y/W	.....	Yellow with white tracer

LIGHTING SWITCH		
	Gr	YW
ON	○ — ○	○ — ○
OFF		

STARTER BUTTON		
	BW	YG
ON	○ — ○	○ — ○
OFF		

FRONT AND REAR BRAKE LIGHT SWITCH		
	O	WB
ON	○ — ○	○ — ○
OFF		

DIMMER SWITCH			
	W	Y	Gr
LO	○ — ○		○ — ○
HI		○ — ○	○ — ○

TURN SIGNAL LIGHT SWITCH			
	Lg	B	Sb
L		○ — ○	○ — ○
.			
R	○ — ○		○ — ○

HORN BUTTON		
	BW	G
ON	○ — ○	○ — ○
OFF		

IGNITION SWITCH				
	BW	BR	R	O
LOCK	○ — ○	○ — ○		
OFF	○ — ○	○ — ○		
ON			○ — ○	○ — ○

## BATTERY

### SPECIFICATION

Type designation	YTX4L-BS
Capacity	12V, 3AH/10HR
Standard electrolyte S.G.	1.32 at 20 °C (68°F)

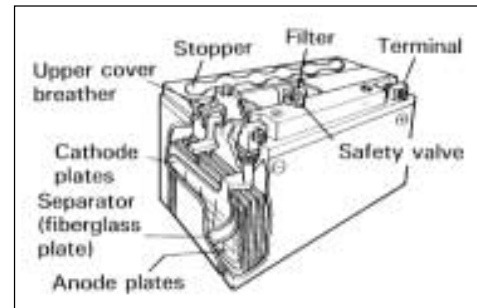

### INITIAL CHARGING

#### FILLING ELECTROLYTE

- Remove the aluminum tape ① sealing the battery electrolyte filler holes.

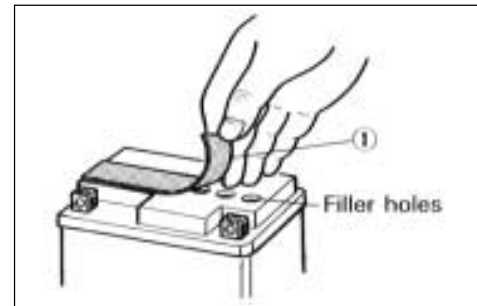

- Remove the caps ②.

#### NOTE:

After filling the electrolyte completely, use the removed cap ② as the sealed caps of battery-filler holes.

Do not remove or pierce the sealed areas ③ of the electrolyte container.

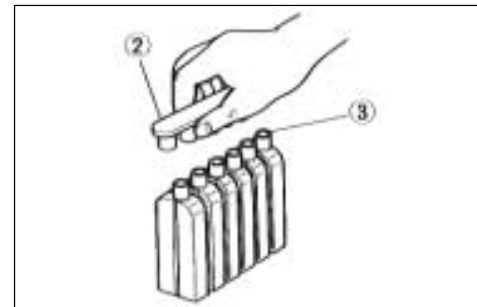

- Insert the nozzels of the electrolyte container into the battery's electrolyte filler holes, holding the container firmly so that it does not fall. Take precaution not to allow any of the fluid to spill.

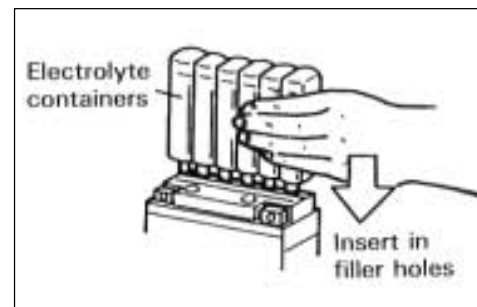

- Make sure air bubbles are coming up each electrolyte container, and leave in this position for about more than 20 minutes.

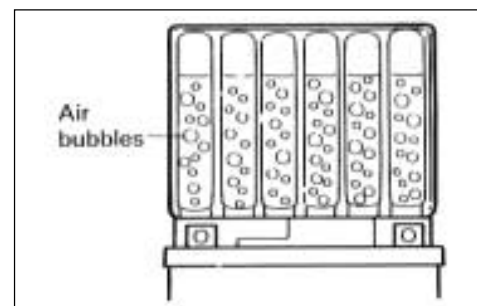

## 5-11 ELECTRICAL SYSTEM

**NOTE:**

If no air bubbles are coming up from a filler port, tap the bottom of the two or three times.  
Never remove the container from the battery.

- After confirming that the electrolyte has entered the battery completely, remove the electrolyte containers from the battery. Wait for around 20 minutes.
- Insert the caps into the filler holes, pressing in firmly so that the top of the caps do not protrude above the upper surface of the battery's top cover.

**CAUTION:**

Never use anything except the specified battery.  
Once install the caps to the battery, do not remove the caps.

- Using HYOSUNG pocket tester, measure the battery voltage. The tester should indicate more than 12.5-12.6 V(DC) as shown in the Fig. If the battery voltage is lower than the specification, charge the battery with a battery charger.

**NOTE:**

Initial charging for a new battery is recommended if two years have elapsed since the date of manufacture.

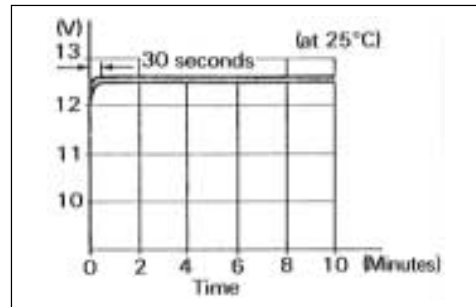
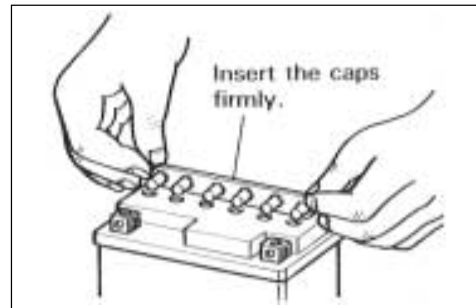
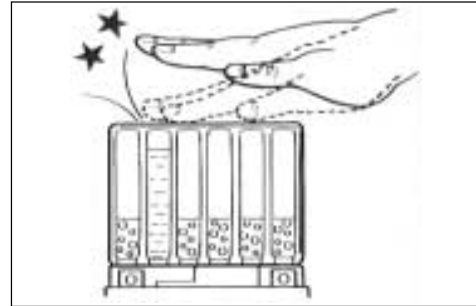

### SERVICING

Visually inspect the surface of the battery container. If any signs of cracking or electrolyte leakage from the sides of the battery have occurred, replace the battery with a new one. If the battery terminals are found to be coated with rust or an acidic white powdery substance, then this can be cleaned away with sandpaper.

**RECHARGING OPERATION**

- Using the pocket tester, check the battery voltage. If the voltage reading is less than 12.0V(DC), recharge the battery with a battery charger.

**CAUTION:**

When recharging the battery, remove the battery from the motorcycle.

**NOTE:**

Do not remove the sealing cap off the battery top while recharging.

Recharging time	0.4A for hours or 4.0A for half an hour
-----------------	--

**CAUTION:**

Be careful not to allow the charging current to exceed 4A at any time.

- After recharging, wait for more than 30 minutes and check the battery voltage with a pocket tester.
- If the battery voltage is less than 12.5V, recharge the battery again.
- If the battery voltage is still less than 12.5V after recharging, replace the battery with a new one.
- When a battery is left for a long term without using, it is subject to discharge. When the motorcycle is not used for more than 1 month(especially during the winter season), recharge the battery once a month at least.

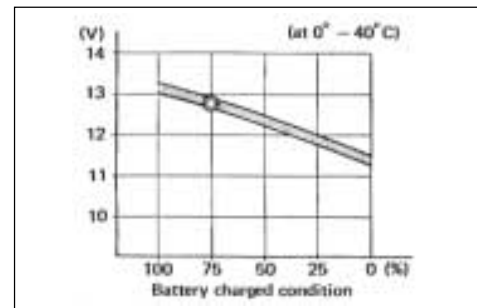
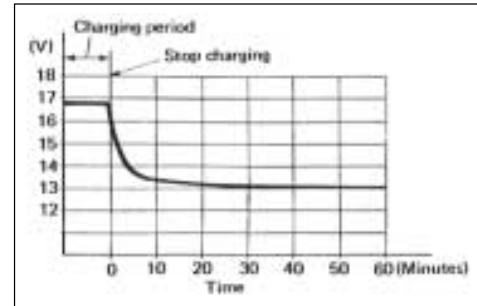

# CHASSIS

## CONTENTS

<b>HANDLE BAR COVERS</b> .....	6- 1
<b>REMOVAL</b> .....	6- 2
<b>REMOUNTING</b> .....	6- 2
<b>LEG SHIELD AND SIDE COVERS</b> .....	6- 3
<b>REMOVAL</b> .....	6- 4
<b>REMOUNTING</b> .....	6- 7
<b>FRONT WHEEL</b> .....	6- 8
<b>REMOVAL AND DISASSEMBLY</b> .....	6- 8
<b>INSPECTION</b> .....	6-10
<b>REASSEMBLY AND REMOUNTING</b> .....	6-10
<b>FRONT BRAKE</b> .....	6-13
<b>BRAKE PAD REPLACEMENT</b> .....	6-13
<b>CALIPER REMOVAL AND DISASSEMBLY</b> .....	6-14
<b>CALIPER INSPECTION</b> .....	6-15
<b>CALIPER REASSEMBLY</b> .....	6-15
<b>DISC PLATE REMOVAL AND DISASSEMBLY</b> .....	6-16
<b>DISC PLATE INSPECTION</b> .....	6-16
<b>MASTER CYLINDER REMOVAL AND DISASSEMBLY</b> .....	6-16
<b>MASTER CYLINDER INSPECTION</b> .....	6-18
<b>MASTER CYLINDER REASSEMBLY AND REMOUNTING</b> .....	6-18
<b>FRONT FORK</b> .....	6-19
<b>REMOVAL AND DISASSEMBLY</b> .....	6-19
<b>INSPECTION</b> .....	6-21
<b>REASSEMBLY AND REMOUNTING</b> .....	6-21
<b>STEERING</b> .....	6-22
<b>REMOVAL AND DISASSEMBLY</b> .....	6-22
<b>INSPECTION</b> .....	6-23
<b>REASSEMBLY AND REMOUNTING</b> .....	6-23
<b>REAR WHEEL AND BRAKE</b> .....	6-25
<b>REMOVAL AND DISASSEMBLY</b> .....	6-25
<b>INSPECTION</b> .....	6-25
<b>REASSEMBLY AND REMOUNTING</b> .....	6-26

HANDLEBAR COVERS

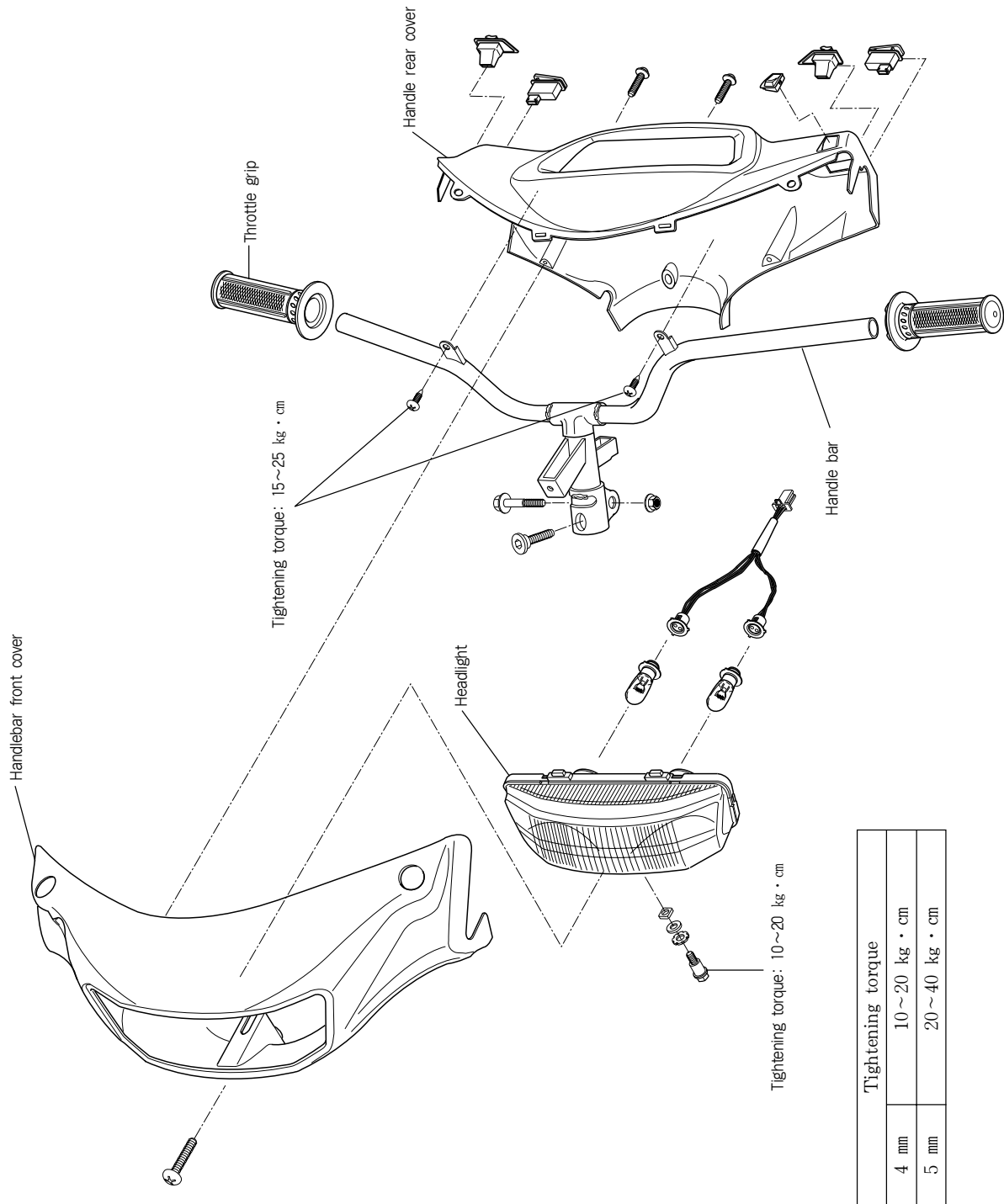

**REMOVAL****HANDLEBAR FRONT COVER**

- Remove the handlebar front cover by removing the mounting screws and disconnecting the lead wires.

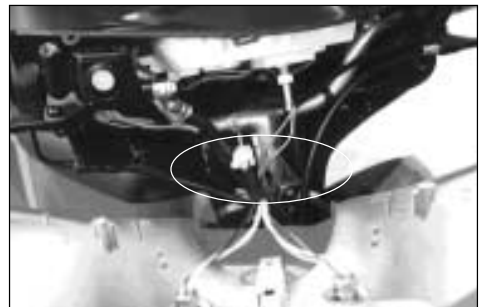
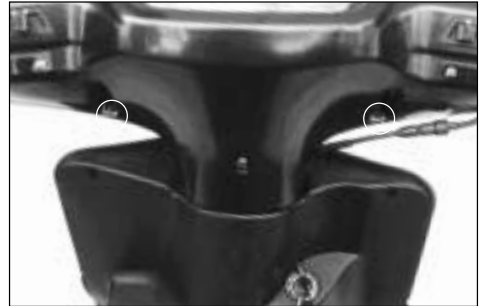
**HANDLEBAR REAR COVER**

- Disconnect the lead wire couplers and speedometer cable.

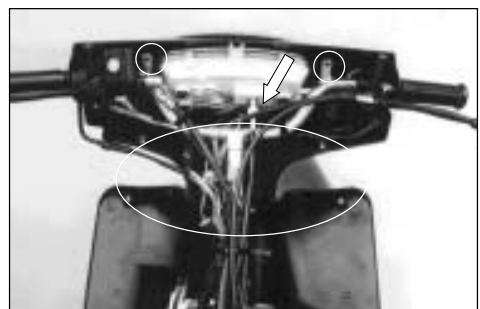

- Remove the handlebar rear cover by removing the mounting screws.

**REMOUNTING**

- Remount the handlebar covers in the reverse order of removal.



LEG SHIELD AND SIDE COVERS

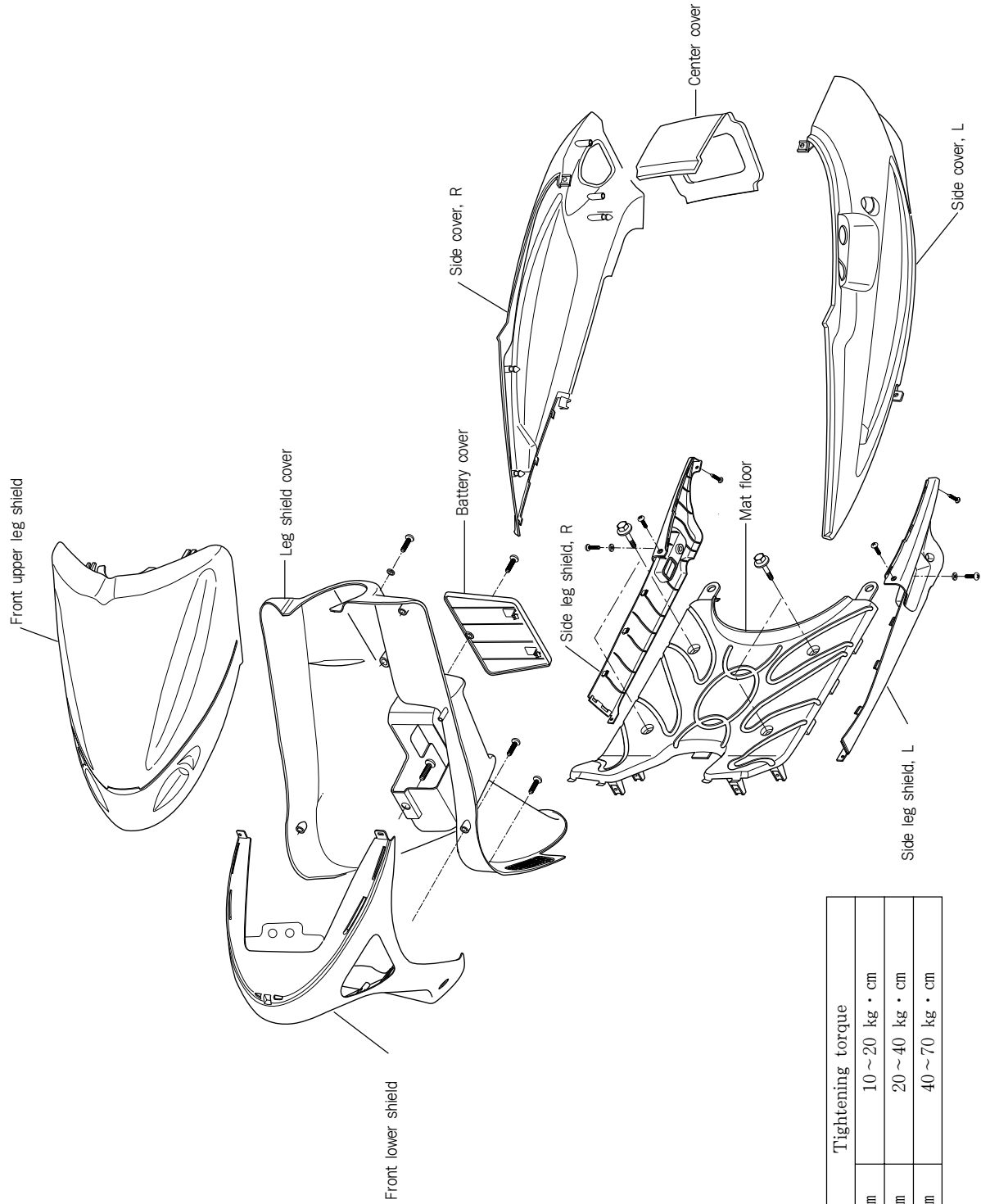

Tightening torque	
4 mm	10 ~ 20 kg · cm
5 mm	20 ~ 40 kg · cm
6 mm	40 ~ 70 kg · cm



**REMOVAL****FRONT LEG SHIELD UPPER**

- Loosen the mounting screws.

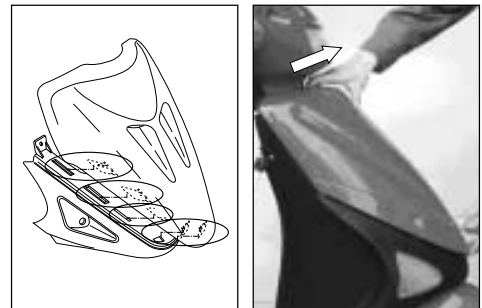

- Remove the front leg shield upper by pull out it forward.

**FRONT LEG SHIELD LOWER**

- Loosen the mounting screws.

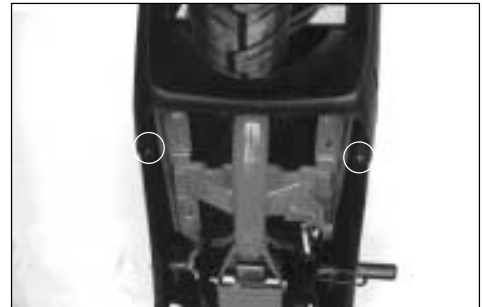

- Remove the front leg shield lower.



## 6-5 CHASSIS

---

### REAR CARRIER

- Open the seat.
- Remove the rear carrier by removing the bolts and screw.



### RIGHT SIDE COVER, RIGHT SIDE LEG SHIELD

- Loosen the mounting screws.



- Remove the right side cover and right side leg shield at the same time.

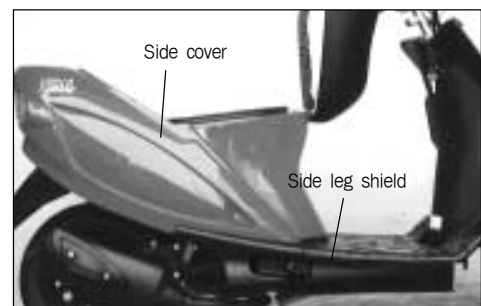

**LEFT SIDE COVER, LEFT SIDE LEG SHIELD**

- Loosen the mounting screws.



- Remove the handle grip ① by removing the bolts.

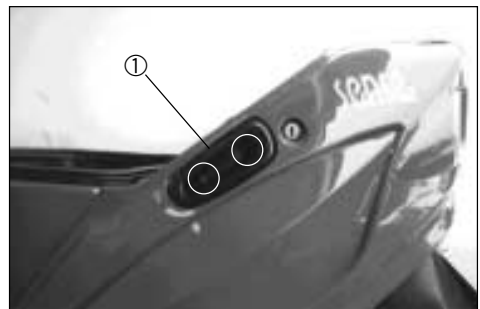

- Remove the left side cover and left side leg shield at the same time.

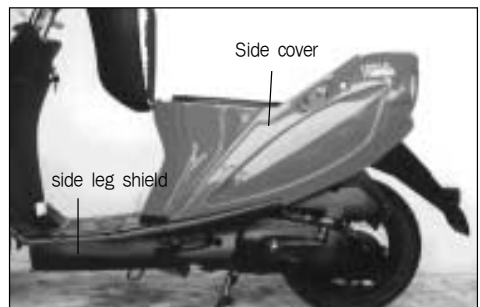

## 6-7 CHASSIS

### REAR CENTER COVER

- Remove the rear center cover by removing the bolts.

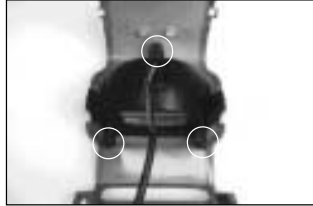

### COVER LEG SHIELD REAR AND LEL SHIELD REAR

- Remove the ignition cap.
- Remove the battery cover by removing the screw.

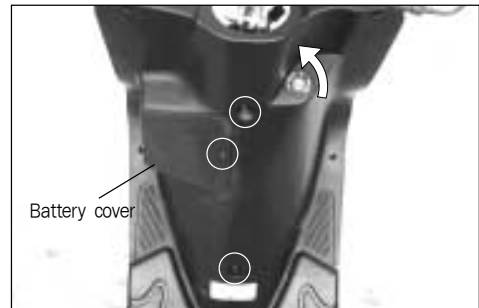

- Loosen the screw and bolts.



- Remove the cover leg shield ① rear and leg shield rear ② at the same time.

### REMOUNTING

- Remount the leg shield and side covers in the reverse orders of removal.



## FRONT WHEEL

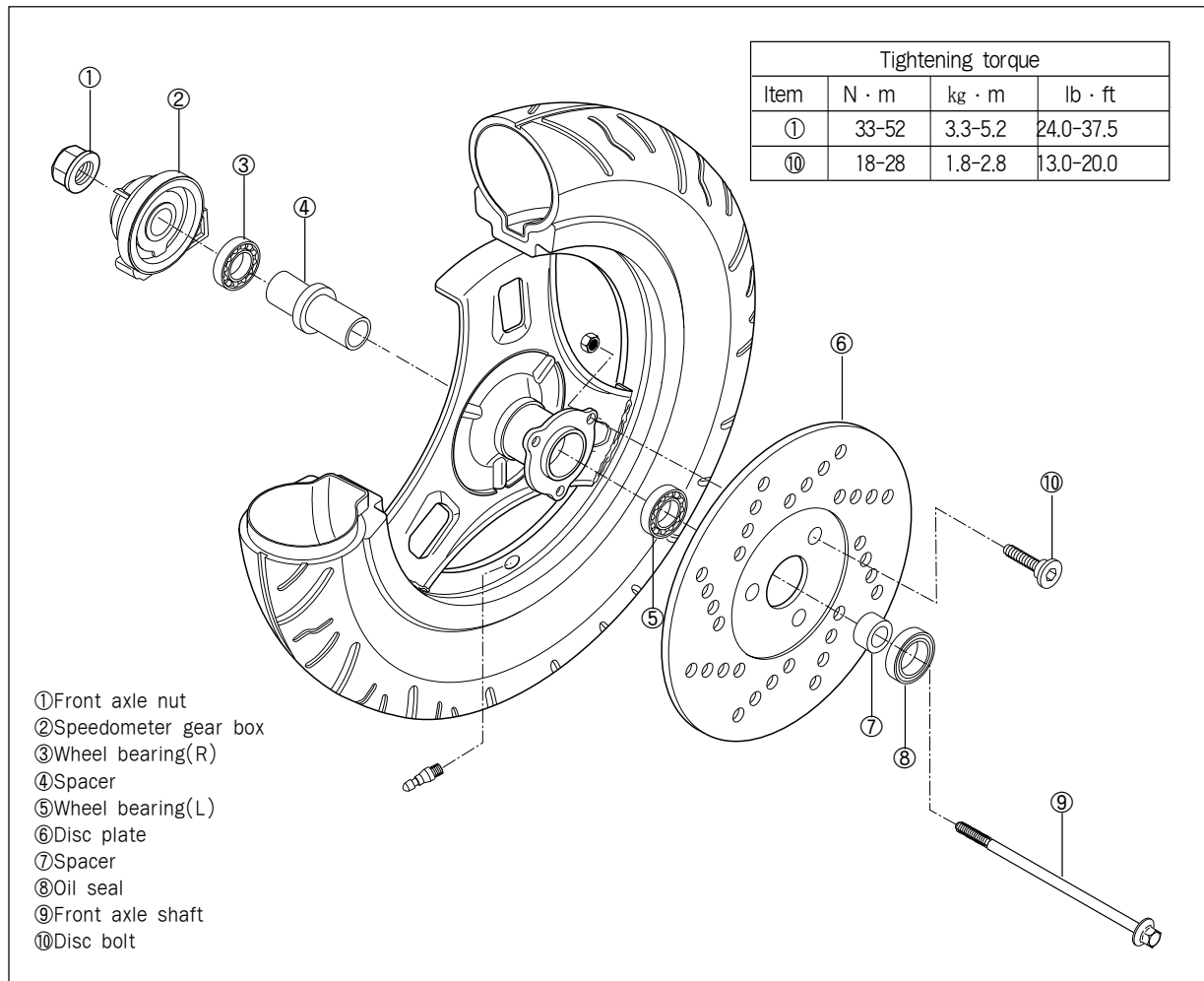

## REMOVAL AND DISASSEMBLY

- Remove the front brake caliper by removing the mounting bolts.

**NOTE:**

**Do not operate the front brake lever while dismantling the caliper.**



- Remove the front axle nut.
- Support the motorcycle by jack or wooden block.
- Remove the front wheel by removing the front axle shaft.



## 6-9 CHASSIS

- Remove the disc plate ① by removing the bolts.



- Remove the spacer.



- Remove the dust seal ③ with the special tool.

09913-50121	Oil seal remover
-------------	------------------



- Drive out the both bearing with the special tool in the following procedures.
- Insert the adapter into the bearing.
- After inserting the wedge bar from the opposite side, lock the wedge bar in the slit of the adapter.
- Drive out the bearing by knocking the wedge bar.

09941-50110	Bearing remover
-------------	-----------------

### CAUTION:

The removed dust seal and bearing should be replaced with new ones.

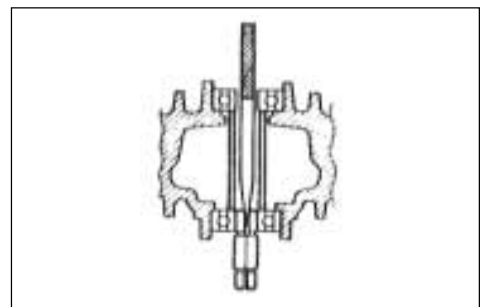

**INSPECTION**

**WHEEL RIM**

Make sure that the wheel rim runout does not exceed the service limit when checked as shown.

An excessive runout is usually due to worn or loose wheel bearings and can be reduced by replacing the bearings. If bearing replacement fails to reduce the runout, replace the wheel.

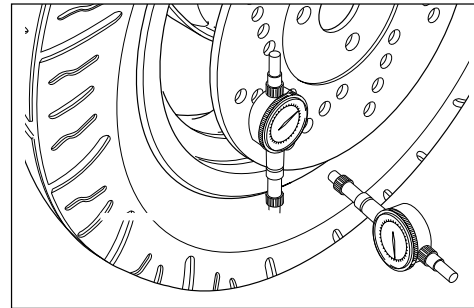

Service limit (Axle and Radial)	3.0 mm(0.12 in)
------------------------------------	-----------------

**TIRE**

Inspect the tires for wear and damage;and check the tire tread depth as shown. Replace a badly worn or damaged tire. A tire with its tread worn down to the limit(in terms of tread depth)must be replaced.

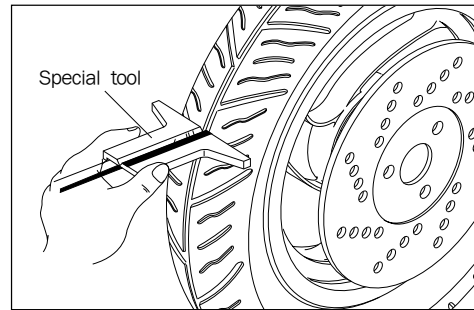

**TIRE DEPTH SERVICE LIMIT**

Front & Rear	1.6 mm(0.064 in)
--------------	------------------

Check the tire pressure, and examine the value for evidence of air leakage.

**TIRE DEPTH SERVICE LIMIT**

COLD INFLATION TIRE PRESSURE	NORMAL RIDING			
	SOLD RIDING		DUAL RIDING	
	kPa	kg/cm <sup>2</sup>	kPa	kg/cm <sup>2</sup>
FRONT	125	1.25	-	-
REAR	200	2.00	-	-

**REASSEMBLY AND REMOUNTING**

Reassemble and remount the front wheel in the reverse order disassembly and removal, and also carry out the following steps.

**WHEEL BEARING**

- Apply grease to the bearings before installing.



99000-07C00	Grease "G2"
-------------	-------------

- Install the wheel bearings by using the special tool.

09924-84520	Bearing installer
-------------	-------------------

**CAUTION:**

First install the wheel bearing for left side.



## 6-11 CHASSIS

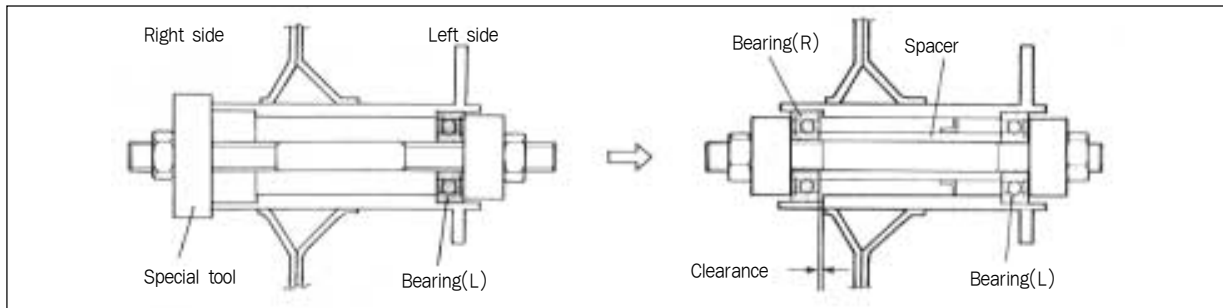

### OIL SEAL

- Install the oil seal ① with the special tool.

09922-55131	Oil seal installer
-------------	--------------------



- Install the spacer ②.



### DISC PLATE

- Install the disc plate and tighten them to the specified torque.

Tightening torque	18-28 N · m (1.8-2.8 kg · m, 13-20 lb-ft)
-------------------	--





**SPEEDOMETER GEAR BOX**

- When installing the speedometer gear box, align the two drive pawls **A** with the two recesses **B** of the wheel hub.

**CAUTION:**  
 After touching the speedometer gear box **C** to the stopper **D**, tighten the axle shaft.

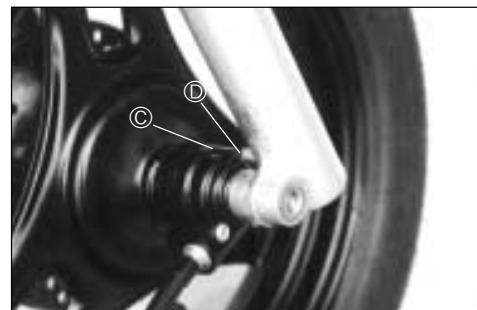
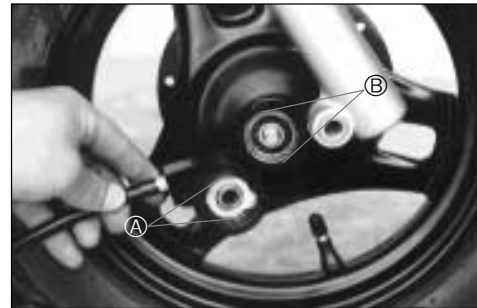

**FRONT WHEEL**

- Tighten the front axle nut to the specified torque.

Tightening torque	33-52 N · m (3.3-5.2 kg · m, 24-38 lb · ft)
-------------------	--



- Tighten the caliper mounting bolts to the specified torque.

Tightening torque	18-28 N · m (1.8-2.8 kg · m, 13-20 lb · ft)
-------------------	--



FRONT BRAKE

Apply silicone grease

① Master cylinder bolt  
 ② Master cylinder  
 ③ Brake hose union bolt  
 ④ Brake hose  
 ⑤ Pad  
 ⑥ Air bleeder valve  
 ⑦ Dust seal  
 ⑧ Piston  
 ⑨ Piston seal  
 ⑩ Caliper

Tightening torque			
Item	N · m	kg · m	lb-ft
①	8-12	0.8-1.2	6.0-8.5
③	20-25	2.0-2.5	14.5-18.0
⑥	6-9	0.6-0.9	4.5-6.5

**BRAKE PAD REPLACEMENT**

- Remove the caliper by removing the mounting bolts ①.

**NOTE:**  
 Do not operate the front brake lever while dismantling the caliper.

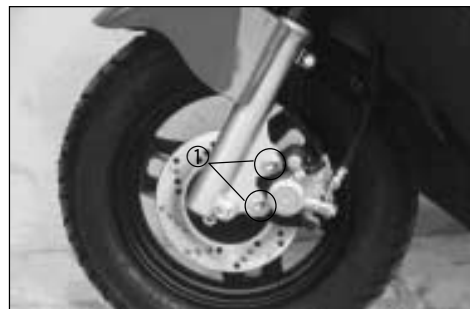

- Remove the brake pads ②.

**CAUTION:**  
 Replace the brake pads as a set, otherwise braking performance will be adversely affected.



**CALIPER REMOVAL AND DISASSEMBLY**

- Remove the brake hose and catch the brake fluid in a suitable receptacle.

**CAUTION:**

Never re-use the brake fluid left over from the last servicing and stored long periods.

- Remove the caliper.
- Remove the brake pads.
  
- Remove the pad holder ① and spring ②.



- Place a rag over the piston to prevent popping up. Force out the piston with an air gun.

**CAUTION:**

Do not use high pressure air to prevent piston damage.



- Remove the dust seal ③ and piston seal ④.

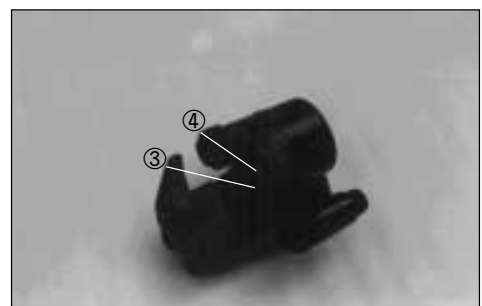

## 6-15 CHASSIS

### CALIPER INSPECTION

Inspect the caliper cylinder bore wall for nicks, scratches or other damage.

Inspect piston for damage and wear.



Inspect each rubber part for damage and wear.



### CALIPER REASSEMBLY

Reassemble and remount the caliper in the reverse order of removal and disassembly, and also carry out the following steps.

#### CAUTION:

Wash the caliper components with fresh brake fluid before reassembly. Never use cleaning solvent or gasoline to wash them. Apply brake fluid to the caliper bore and piston to be inserted into the bore.

- Apply silicone grease to the caliper holder.

99000-25100	Silicone grease
-------------	-----------------

- Tighten the each bolts.

Item	N · m	kg · m	lb-ft
③	18-28	1.8-2.8	13-20
④	20-25	2.0-2.5	14-18

#### WARNING:

Bleed the air from brake fluid circuit after reassembling caliper(See page 2-8)

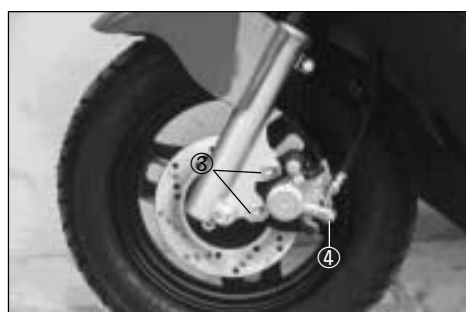
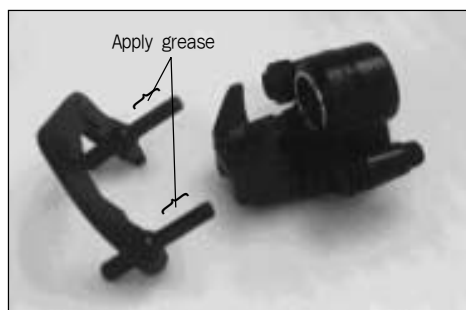

**DISC PLATE REMOVAL AND DISASSEMBLY**

- Remove the front wheel(Refer to page 6-8)
- Remove the disc plate(Refer to page 6-9)
- Install the disc plate(Refer to page 6-11)

**DISC PLATE INSPECTION**

- Check the disc for wear with a micrometer. Its thickness can be checked with disc and wheel in place. Replace the disc if the thickness exceeds the service limit.

Service Limit	3.5 mm(0.14 in)
09900-20205	Micrometer(0-25 mm)

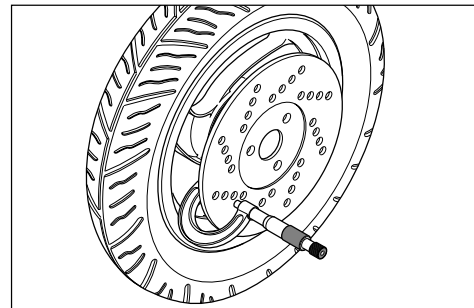

- With the disc mounted on the wheel, check the disc for face runout with a dial gauge as shown. Replace the disc if the runout exceeds the service limit.

Service Limit	0.3 mm(0.012 in)
09900-20606	Dial gauge(1/100 mm)
09900-20701	Magnetic stand

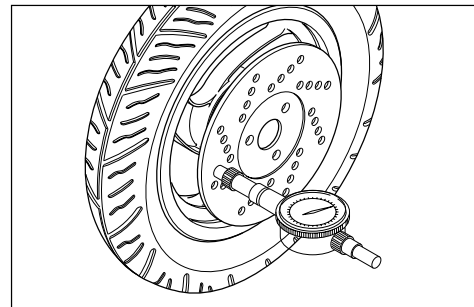

**MASTER CYLINDER REMOVAL AND DISASSEMBLY**

- Remove the handlebar cover(Refer to page 6-1)
- Disconnect the front brake light switch lead wires.

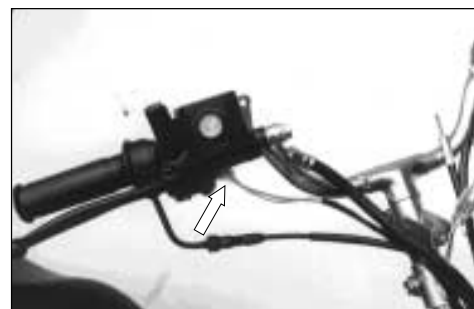

- Place a cloth underneath the union bolt on the master cylinder to catch spilled drops of brake fluid. Unscrew the union bolt and disconnect the brake hose/master cylinder joint.

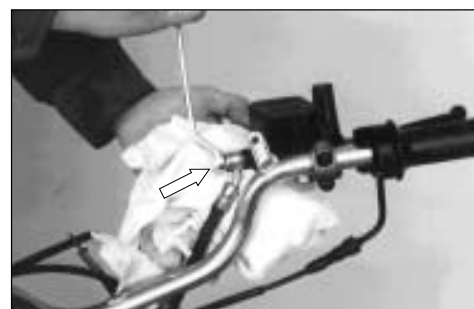

**CAUTION:**  
 Completely wipe off any brake fluid adhering to any part of motorcycle. The fluid reacts chemically with paint, plastics, rubber materials, etc.

## 6-17 CHASSIS

- Remove the master cylinder.



- Remove the brake lever ① and brake switch ②.

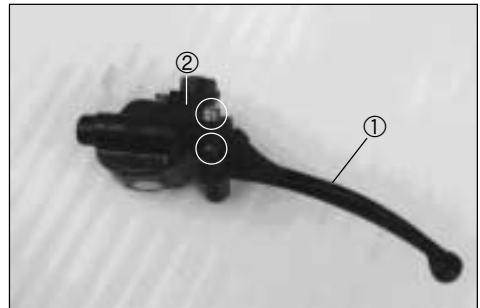

- Remove the dust boot ③.



- Remove the circlip ④ with the special tool.

09900-06108	Snapping pliers
-------------	-----------------

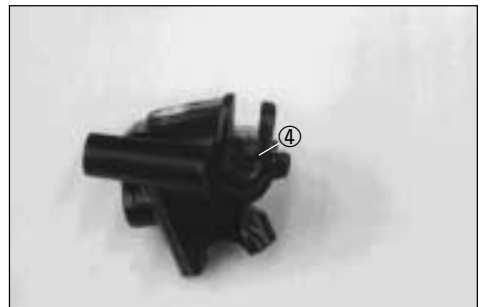

- Remove the piston/primary cup with return spring ⑤.
- Remove the reservoir cap ⑥ and diaphragm ⑦.
- Drain brake fluid.

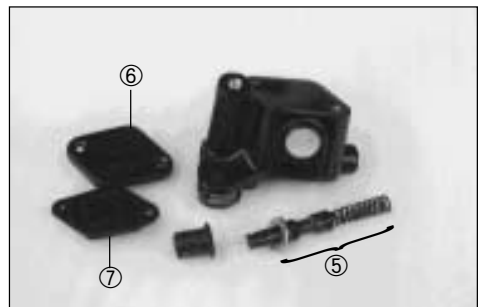

**MASTER CYLINDER INSPECTION**

Inspect the master cylinder bore for any scratches or other damage.  
 Inspect the piston surface for scratches or other damage.  
 Inspect the primary cup and dust boot for wear or damage.

**MASTER CYLINDER REASSEMBLY AND REMOUNTING**

Reassemble and remount the master cylinder in the reverse order of removal and disassembly, and also carry out the following steps.

**CAUTION:**

**Wash the master cylinder components with fresh brake fluid before reassembly. Never use cleaning solvent or gasoline to wash them.**

**Apply brake fluid to the cylinder bore and all the internals to be inserted into the bore.**

- Reassemble and remount the master cylinder.(Refer to page 6-13)
- When remounting the master cylinder on the handlebar, first tighten the clamp bolt for upside.

**CAUTION:**

**Bleed air after remounting the master cylinder.(Refer to page 2-8)**

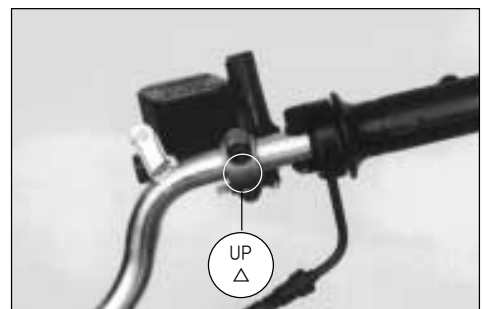
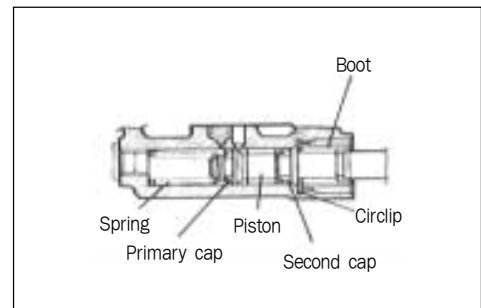

## 6-19 CHASSIS

### FRONT FORK

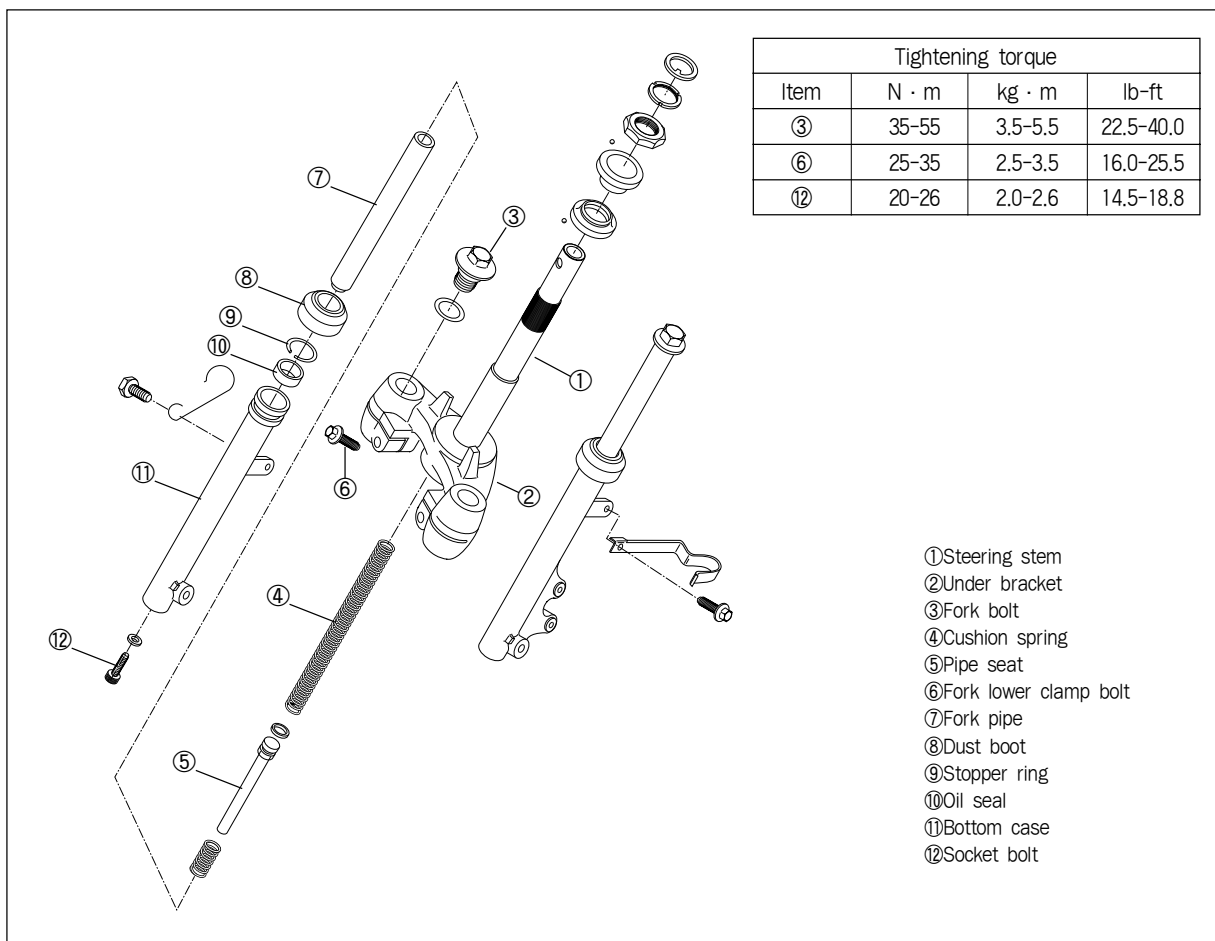

#### REMOVAL AND DISASSEMBLY

- Remove the front leg shield(Refer to page 6-3).
- Remove the front brake caliper by removing the mounting bolts.

#### NOTE:

**Do not operate the front brake lever while dismantling the caliper.**

- Remove the front axle nut.
- Remove the motorcycle by jack or wooden block.
- Remove the front wheel by removing the front axle shaft.





- Loosen the front fork bolt, then draw out the fork spring.
- Loosen the front fork lower clamp bolts.

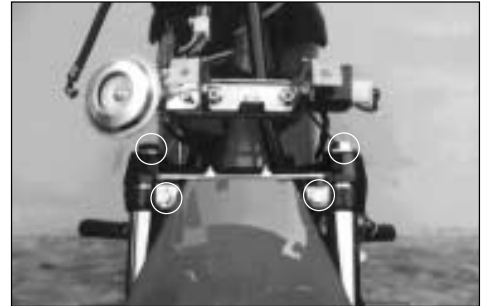
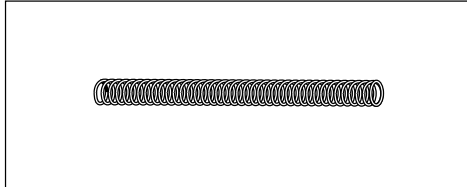

- Invert the fork and stroke it several times to remove the oil.
- Hold the fork inverted for a few minutes.

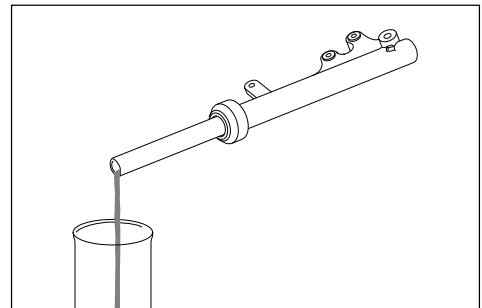

- Remove the socket bolt ① with the hexagon wrench.
- Separate the fork pipe ② and pipe seat ③.

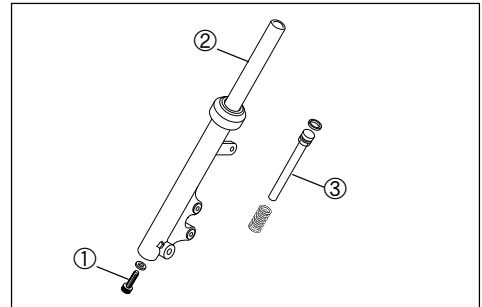

- Remove the dust boot ④ and stopper ring ⑤.

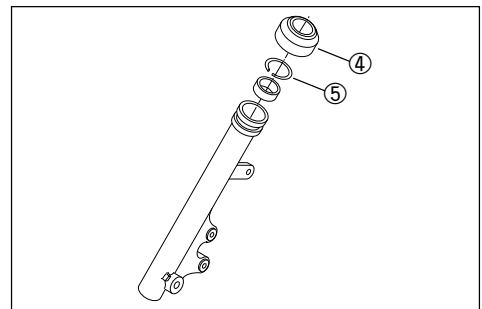

- Remove the oil seal by using the special tool.

**CAUTION:**

The oil seal removed should be replaced with a new oil seal.



## 6-21 CHASSIS

### INSPECTION

Inspect pipe seat for wear and damage.

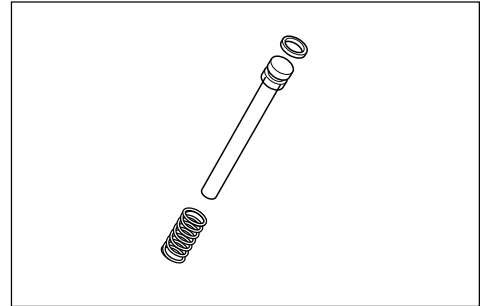

Inspect fork pipe and bottom case sliding surfaces for any scuffing or flaws.

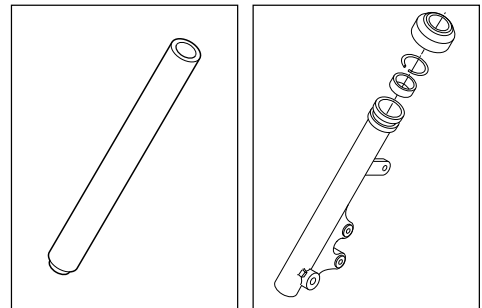

### CUSHION SPRING

Measure the cushion spring free length, if it is shorter than the service limit, replace it.

Service limit	240 mm(9.45 in)
---------------	-----------------

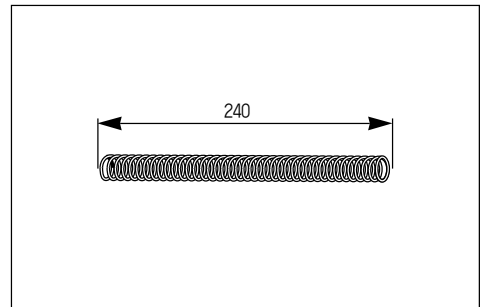

### REASSEMBLY AND REMOUNTING

Reassemble and remount the fork in the reverse order of removal and disassembly, and also carry out the following steps.

#### FRONT FORK BOLT

- Apply thread lock "1324" to the fork bolt and tighten the bolt with specified torque.

99000-32030	Thread lock "1324"
Tightening torque	35-55 N · m(3.5-5.5 kg · m 25.3-40.0 lb-ft)

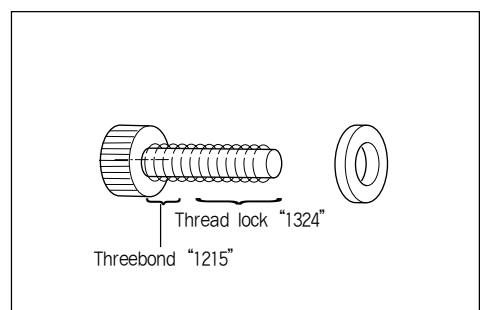

#### FORK OIL

- For the fork oil, be sure to use a front fork oil whose viscosity rating meets specification below.

Fork oil type	TELLUS #22
Capacity	50 ml

#### FORK SPRING

- When installing the front fork spring, the close end should position upside.

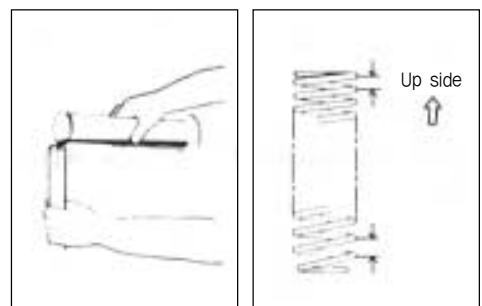

## STEERING

### REMOVAL AND DISASSEMBLY

- Remove the handlebar cover.(Refer to page 6-1)
- Remove the handlebar by removing the clamp bolt ① and set bolt ②.

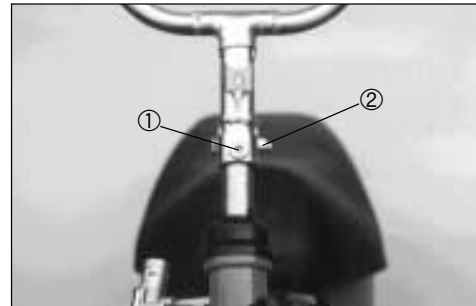

- Loosen the steering stem lock nut ③ with the special tool.

09910-60611	Universal clamp wrench
-------------	------------------------

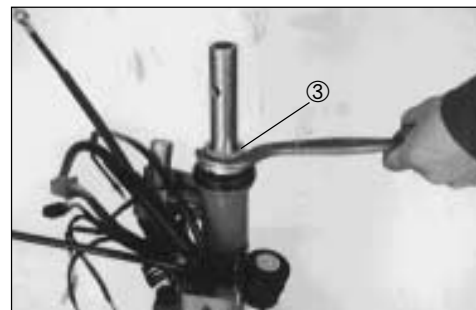

- Remove the front fork assembly by removing the lock washer ④, steering outer upper race ⑤ and dust seal ⑥.

**CAUTION:**  
Do not drop the steering stem steel balls.

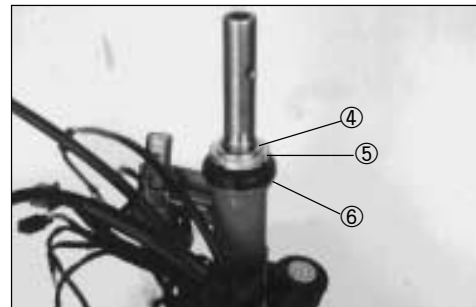

- Remove the lower bearing outer race ⑦ with a chisel.

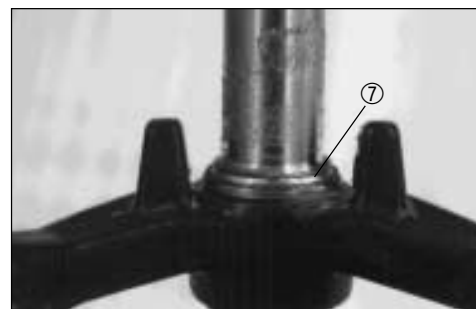

- Remove the steering stem steel balls ⑧.

#### Number of steel balls

Upper	22 pcs
Lower	25 pcs

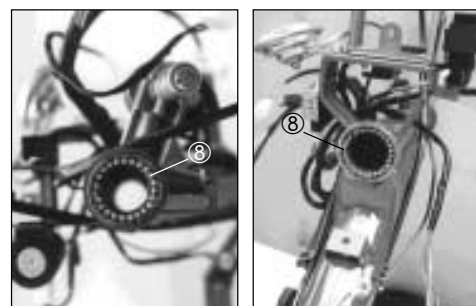

## 6-23 CHASSIS

- Remove the upper and lower bearing inner race with a appropriate bar.



### INSPECTION

Inspect the removed parts for the following abnormalities.

- Bearing race wear and brinelling.
- Worn and damaged steel balls.
- Distortion of steering stem or handlebar.



### REASSEMBLY AND REMOUNTING

Reassemble and remount the steering stem, handlebar and front fork in the reverse order of disassembly and removal, and also carry out the following steps.

#### OUTER LOWER RACE

- Press in the outer lower race.



#### INNER RACE

- Press in the upper and lower inner races with special tool.

09941-34513	Steering inner race installer
-------------	-------------------------------



#### STEEL BALL

- Apply grease when installing the upper and lower steel balls.

99000-07C00	Grease "G2"	
Number of steel balls	Upper	22 pcs
	Lower	25 pcs

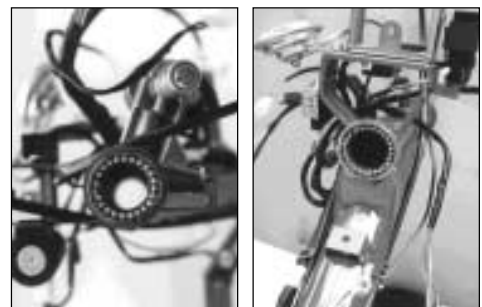

**STEERING OUTER RACE NUT**

- Tighten the steering outer race ① until resistance is felt, then loosen it 1/8-1/4 turn.

**NOTE:**

This adjustment will vary from motorcycle to motorcycle. Make sure that the steering turns smoothly and easily, left to right.

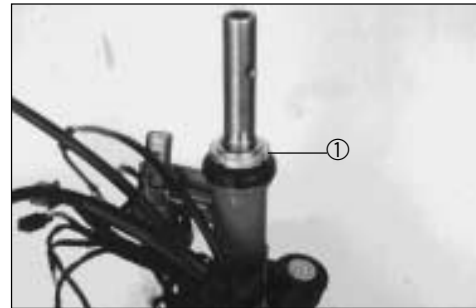

- Tighten the steering stem lock nut ② with the special tool.

Tightening torque	60-100 N · m (6.0-10.0 kg · m, 43.5-72.5 lb-ft)
09910-60611	Universal clamp wrench

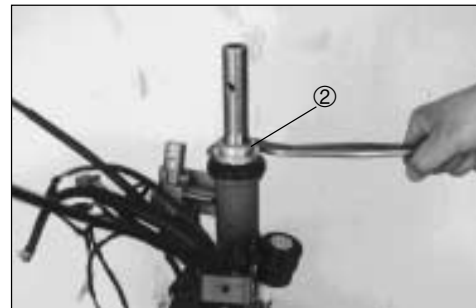

- Install the handlebar and tighten the set bolt ③ and clamp nut ④ to the specified torque.

③	Tightening torque	22-28 N · m (2.2-2.8 kg · m, 15.9-20.3 lb-ft)
---	-------------------	--

④	Tightening torque	48-52 N · m (4.8-5.2 kg · m, 34.5-37.5 lb-ft)
---	-------------------	--

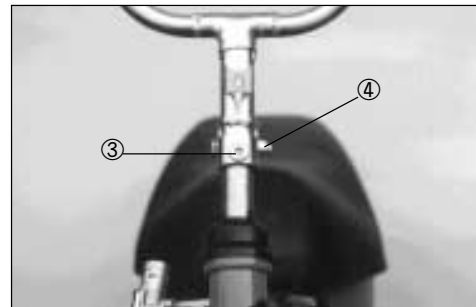

**CAUTION:**

After performing the adjustment and installing the handlebar, "rock" the front wheel assembly forward and backward to ensure that there is no play and that the procedure was accomplished correctly. If play is noticeable, readjust the steering outer race nut.



**REAR WHEEL AND BRAKE**

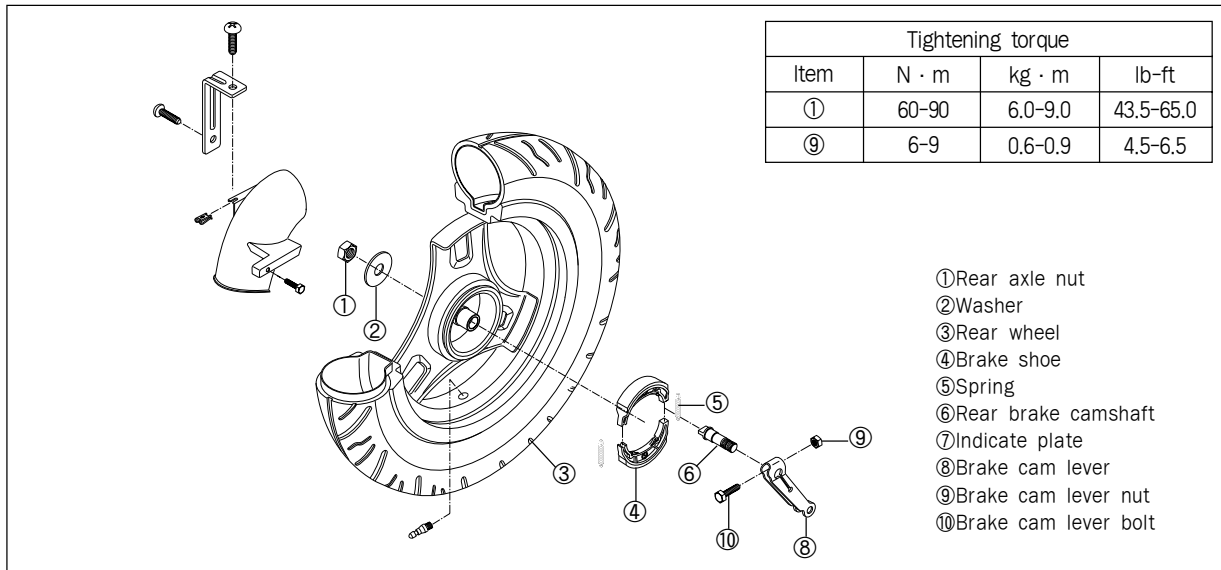

- ①Rear axle nut
- ②Washer
- ③Rear wheel
- ④Brake shoe
- ⑤Spring
- ⑥Rear brake camshaft
- ⑦Indicate plate
- ⑧Brake cam lever
- ⑨Brake cam lever nut
- ⑩Brake cam lever bolt

**REMOVAL AND DISASSEMBLY**

- Place the motorcycle on level ground.
- Remove the muffler.(Refer to page 3-4)
- Remove the rear wheel by removing the axle nut ①.



**INSPECTION**

**BRAKE DRUM**

Measure the brake drum I.D. to determine the extent of wear and, if the limit is exceeded by the wear noted, replace the drum. The value of this limit is indicated inside the drum.

Service Limit	100.7 mm(3.96 in)
---------------	-------------------

**BRAKE SHOE**

Using a vernier calipers, measure the brake shoe outside diameter at the place as shown in the photo. If the measurement is less than the limit, replace the brake shoe.

Service Limit	96.6 mm(3.78 in)
---------------	------------------

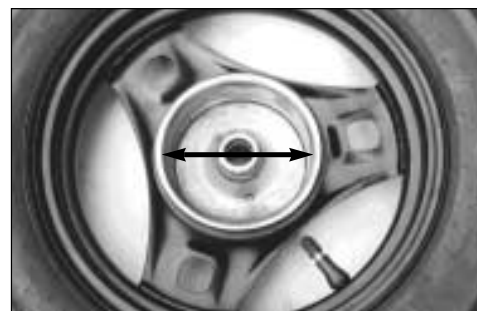

**CAUTION:**  
 Replace the brake shoe with a set, otherwise braking performance will be adversely affected.



**WHEEL**

Refer to page 6-10.

**TIRE**

Refer to page 6-10.

**REASSEMBLY AND REMOUNTING**

Reassemble and remount the rear wheel and brake in the reverse order of removal, and disassembly.

**BRAKE CAM LEVER**

- When installing the brake cam lever, align the punched mark ① of camshaft with the slit ② on cam lever.

Tightening torque	6-9 N · m (0.6-0.9 kg · m, 4.5-6.5 lb-ft)
-------------------	--

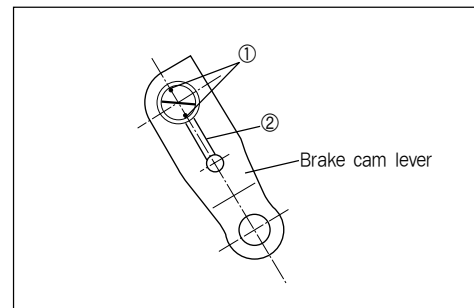

**BRAKE SHOE**

- Apply grease to the camshaft and pin before installing the brake shoes.

99000-07C00	Grease "G2"
-------------	-------------

**CAUTION:**  
**Be careful not to apply too much grease to the camshaft and pin. If grease gets on the lining, brake effectiveness will be lost.**



**REAR AXLE NUT**

- Tighten the rear axle nut to the specified torque.

Tightening torque	60-90 N · m (6.0-9.0 kg · m, 43.5-65.0 lb-ft)
-------------------	--



# SERVICING INFORMATION

## CONTENTS

<i>SPECIAL TOOLS</i> .....	7- 1
<i>TIGHTENING TORQUE</i> .....	7- 3
<i>WIRING DIAGRAM</i> .....	7- 5
<i>WIRE ROUTING</i> .....	7- 6
<i>SERVICE DATA</i> .....	7- 7
<i>TROUBLESHOOTING</i> .....	7-11



## 7-1 SERVICING INFORMATION

### SPECIAL TOOLS



















FIG	PART No.	PART NAME	FIG	PART No.	PART NAME
	09900-00401	Hexagon wrench set		09910-20116	Conrod holder
	09900-06107	Snap ring pliers (opening type)		09910-32812	Crank shaft installer
	09900-06108	Snap ring pliers (closing type)		09910-60611	Universal clamp wrench
	09900-09003	Impact driver set		09913-50121	Oil seal remover
	09900-20804	Thickness gauge		09913-75810	Bearing remover/ installer
	09900-20805	Tire depth gauge		09913-75820	Bearing remover/ installer
	09900-21602	CCI oil gauge		09913-75830	Bearing remover/ installer
	09900-25002	Pocket tester		09913-76010	Bearing remover/ installer
	09900-26006	Tachometer		09913-84510	Bearing remover/ installer

















FIG	PART No.	PART NAME
	09913-85210	Bearing remover/ installer
	09914-05210-005	Bearing remover/ installer
	09920-13120	Crankcase separating tool
	09921-20210	Bearing remover
	09923-73210	Bearing remover
	09923-74510	Bearing remover
	09924-74510	Bearing installer handle
	09924-74540	Bearing installer attachment
	09924-84520	Bearing installer set

FIG	PART No.	PART NAME
	09925-98220	Bearing installer
	09930-30102	Sliding shaft
	09930-30163	Rotor remover
	09930-40113	Rotor holder
	09941-34513	Bearing installer
	09941-50110	Bearing remover
	09941-74910	Bearing installer
	09943-88211	Bearing installer

## 7-3 SERVICING INFORMATION

### TIGHTENING TORQUE

#### CHASSIS

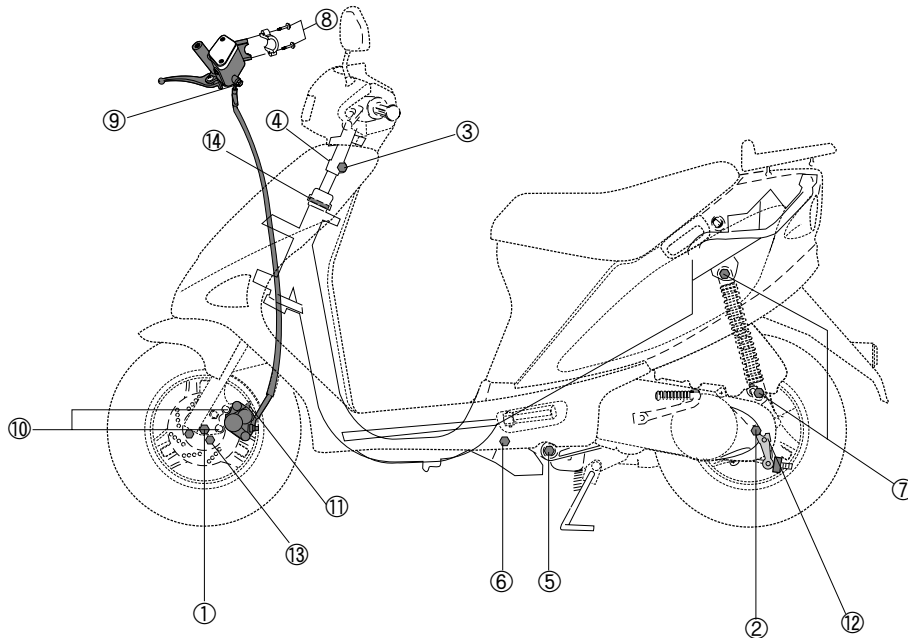

No	Item	N · m	kg · m	lb-ft
1	Front axle nut	33~52	3.3~5.2	24.0~37.5
2	Rear axle nut	60~90	6.0~9.0	43.5~65.0
3	Handle bar clamp nut	48~52	4.8~5.2	34.5~37.5
4	Handle bar set bolt	22~28	2.2~2.8	16.0~20.0
5	Engine mount nut	40~60	4.0~6.0	29.0~43.5
6	Engine mounting bracket nut	48~72	4.8~7.2	34.5~52.0
7	Rear shock absorber bolt	20~30	2.0~3.0	14.5~21.5
8	Front brake master cylinder bolt	8~12	0.8~1.2	6.0~8.5
9	Front brake hose union bolt	20~25	2.0~2.5	14.5~18.0
10	Front brake caliper mounting bolt	18~28	1.8~2.8	13.0~20.0
11	Front brake air bleeder valve	6~9	0.6~0.9	4.5~6.5
12	Rear brake cam lever nut	6~9	0.6~0.9	4.5~6.5
13	Front brake disc bolt	18~28	1.8~2.8	13.0~20.0
14	Steering stem lock nut	60~100	6.0~10.0	43.5~72.5

**ENGINE**

No	Item	N · m	kg · m	lb-ft
1	Spark plug	25~30	2.5~3.0	18.0~21.5
2	Magneto rotor nut	35~45	3.5~4.5	25.5~31.0
3	Kick starter driven nut	40~60	4.0~6.0	29.0~43.5
4	Clutch shoe nut	40~60	4.0~6.0	29.0~43.5
5	Clutch housing nut	40~60	4.0~6.0	29.0~43.5
6	Kick starter lever bolt	8~12	0.8~1.2	6.0~8.5
7	Final gear oil drain plug	4~7	0.4~0.7	3.0~5.0
8	Final gear oil level bolt	9~15	0.9~1.5	6.5~11.0
9	Cylinder head nut	8~12	0.8~1.2	6.0~8.5
10	Muffler mounting bolt	8~12	0.8~1.2	6.0~8.5
11	Exhaust pipe nut	8~12	0.8~1.2	6.0~8.5

**TIGHTENING TORQUE CHART**

For other bolts and nuts not listed in the preceding page, refer to this chart.

Bolt Diameter Ⓐ (mm)	Conventional or "4" marked bolt			"7" marked bolt		
	N · m	kg · m	lb-ft	N · m	kg · m	lb-ft
4	1~2	0.1~0.2	0.7~1.5	1.5~3	0.15~0.3	1.0~2.0
5	1~4	0.2~0.4	1.5~3.0	3~6	0.3~0.6	2.0~4.5
6	4~7	0.4~0.7	3.0~5.0	8~12	0.8~1.2	6.0~8.5
8	10~16	1.0~1.6	7.0~11.5	18~28	1.8~2.8	13.0~20.0
10	22~35	2.2~3.5	16.0~25.5	40~60	4.0~6.0	29.0~43.5
12	35~55	3.5~5.5	25.5~40.0	70~100	7.0~10.0	50.5~72.5
14	50~80	5.0~8.0	36.5~58.0	110~160	11.0~16.0	79.5~115.5
16	80~130	8.0~13.0	58.0~94.0	170~250	17.0~25.0	123.0~181.0
18	130~190	13.0~19.0	94.0~137.5	200~280	20.~28.0	144.5~202.5



Conventional bolt

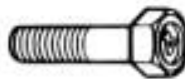

"4" marked bolt



"7" marked bolt

WIRING DIAGRAM

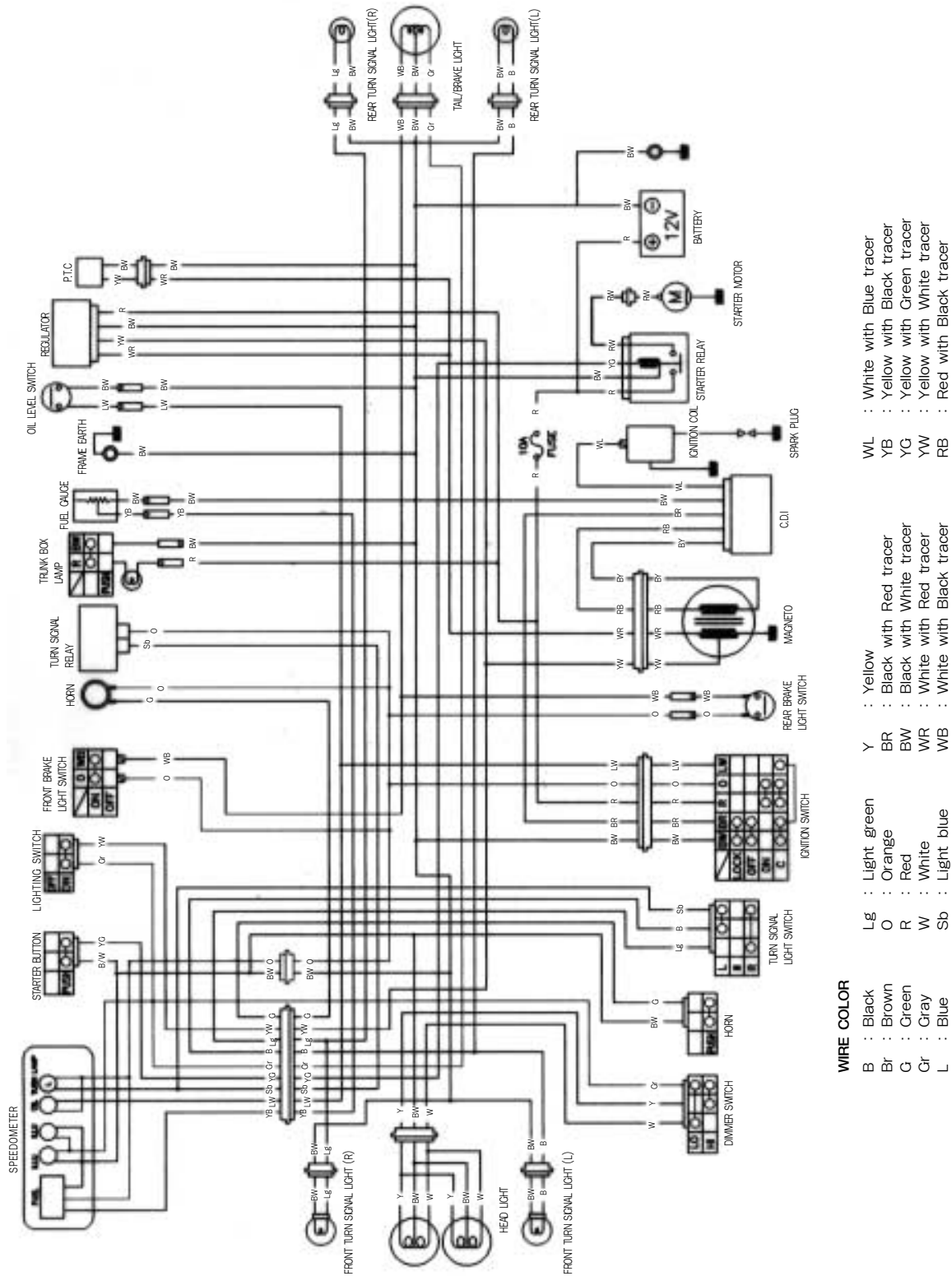

WIRE COLOR

- B : Black
- Br : Brown
- G : Green
- Gr : Cray
- L : Blue
- Lg : Light green
- O : Orange
- R : Red
- W : White
- Sb : Light blue
- Y : Yellow
- BR : Black with Red tracer
- BW : Black with White tracer
- WR : White with Red tracer
- WB : White with Black tracer
- WL : White with Blue tracer
- YG : Yellow with Green tracer
- YW : Yellow with White tracer
- RB : Red with Black tracer

# WIRE, CABLE AND HOSE ROUTING

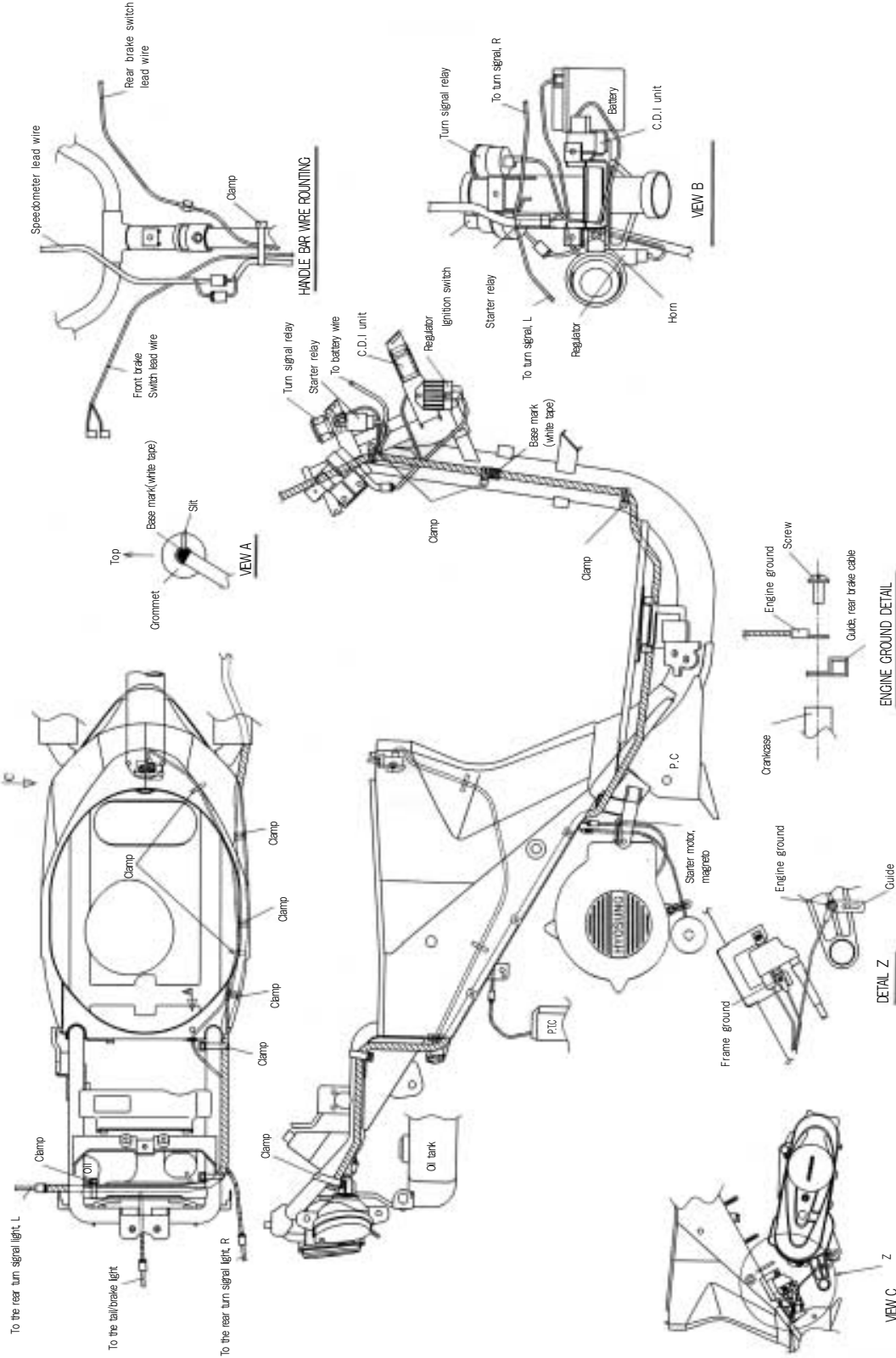

## 7-7 SERVICING INFORMATION

### SERVICE DATA

#### CYLINDER + PISTON + PISTON RING

Unit : mm (in)

ITEM	STANDARD		LIMIT
Piston to cylinder clearance	0.065-0.075 (0.0026-0.0030)		0.120 (0.0047)
Cylinder bore	41.005-41.020 (1.6143-1.6120) Measure at 20(0.8) from the top surface		41.07 (1.6169)
Piston diam	40.935-40.950 (1.6116-1.6122) Measure at 20(0.8) from the skirt end		40.885 (1.6096)
Cylinder distortion	—————		0.1 (0.004)
Cylinder head distortion	—————		0.1 (0.004)
Piston ring free end gap	1st	R Apporox. 4.5(0.18)	3.7(0.15)
	2nd		
Piston ring end gap	0.10-0.25 (0.004-0.010)		0.75 (0.030)
Piston ring groove clearance	1st	0.02-0.06 (0.0008-0.0024)	—————
	2nd	0.02-0.06 (0.0008-0.0024)	—————
Piston pin bore	(0.002-10.010 (0.3938-0.3941)		10.036 (0.4079)
Piston pin O.D.	9.995-10.000 (0.3935-0.3937)		9.980 (0.3929)

#### CONROD + CRANKSHAFT

Unit : mm (in)

ITEM	STANDARD	LIMIT
Conrod small end I.D.	14.003-14.011 (0.5513-0.5516)	14.047 (0.5530)
Conrod deflection	—————	3.0 (0.12)
Crank web to wed width	35±0.1 (1.378±0.004)	—————
Crankshaft runout	—————	0.05 (0.002)

#### OIL PUMP

ITEM	STANDARD
Oil pump reduction ratio	30.000(30/1)
CCI pump discharge rate (Full open)	0.9-1.1 ml (0.030/0.032-0.037/0.039 US/Imp oz) for 5 minutes at 3000 r/min

**CLUTCH**

Unit : mm (in)

ITEM	STANDARD	LIMIT
Clutch Wheel I.D.	110-110.15 (4.3307-4.3366)	110.35 (4.344)
Clutch shoe thickness	3.0 (0.118)	2.0 (0.08)
Clutch engagement	3300±300 r/min	————
Clutch lock-up	5800±500 r/min	————

**TRANSMISSION+DRIVE CHAIN**

Unit : mm (in) Except ratio

ITEM	STANDARD	LIMIT
Final reduction ratio	12.0	————
Gear ratio	Variable 2.815-0.866	————
Drive belt width	16.5 (0.650)	15.3 (0.602)
Driven face spring free length	110.0 (4.33)	104.5 (4.11)

**CARBURETOR**

ITEM	SPECIFICATION
Carburetor type	SIDERAFT VARIABLE VENTURI
Bore size	14 mm
I.D. No.	PA35E
Idle r/min	1800±50 rpm
Pilot air jet (P.A.T.)	1.0mm
Main jet (M.J.)	# 76
Main air jet (M.A.J.)	φ 2.0
Jet needle (J.N.)	J68A-2
Needle jet (N.J.)	φ 2.1
Cut-away(C.A.)	# 3.5
Pilot jet (P.J.)	# 3.5
Throttle cable play	0.5-1.0mm(0.02-0.04in)

**ELECTRICAL**

Unit : mm (in)

ITEM	SPECIFICATION	NOTE
Ignition timing	B.T.D.C. 23° at 4000 r/min	
Spark plug	Type	L87YC BP6HS
	Gap	0.6-0.7 (0.024-0.028)



## 7-9 SERVICING INFORMATION

ITEM		SPECIFICATION		NOTE
Spark performance		Over 8(0.3) at 1 atm		
Ignition coil resistance		Secondary	14-20 k $\Omega$	
Magneto coil resistance		Lighting	0.6-1.4 $\Omega$	Y/W-Ground
		Charging	0.6-1.4 $\Omega$	W/R-Ground
		Exciting	180-230 $\Omega$	R/B-Ground
Regulated voltage		14-15V at 5000 r/min		
Starter motor brush length		Limit: 4.0(0.15)		
Commutator under-cut		Limit: 0.2(0.008)		
Starter relay resistance		0-70 $\Omega$		
Battery	Type designation	YTX4L-BS		
	Capacity	12V 3Ah/10HR		
	Standard electrolyte S.G.	1.32 at 20°C(68°F)		
Fuse size		10A		

### WATTAGE

Unit : W

ITEM		SPECIFICATION
Headlight	POSITION	3 × 2 EA
	LO	15 × 2 EA
Tail/ Brake light		5/21
Front turn signal light		21
Rear turn signal light		10
Speedometer light		3.4 × 2 EA
Oil level indicator light		1.7
Turn signal indicator light		1.7
Trunk light		2

### BRAKE+WHEEL

Unit : mm (in)

ITEM		STANDARD	LIMIT
Brake lever play	Front	5-20(0.2-0.8)	————
	Rear	15-25(0.6-1.0)	————
Brake drum I.D.	Rear	100 (3.94)	100.7 (3.96)
Brake lining thickness	Rear	99.2 (3.91)	96 (3.78)
Brake disc thickness	Front	4.0±0.2 (0.157±0.008)	3.5 (0.14)
Brake disc runout	Front	————	0.30 (0.012)
Master cylinder bore	Front	11.000-11.043 (0.4331-0.4348)	————
Master cylinder piston diam.	Front	10.957-10.984 (0.4314-0.4324)	————

## SERVICING INFORMATION 7-10

ITEM	STANDARD		LIMIT
Brake caliper cylinder bore	Front	30.230-30.306 (1.1902-1.1931)	—————
Brake caliper piston diam.	Front	30.150-30.200 (1.1870-1.1890)	—————
Wheel rim runout	Axial	—————	3.0 (0.12)
	Radial	—————	3.0 (0.12)
Wheel axle runout	Front	—————	0.25 (0.010)
Tire size	Front	100/80-10 53J	—————
	Rear	100/80-10 53J	—————
Tire tread depth	Front	—————	1.6 (0.06)
	Rear	—————	1.6 (0.06)

### SUSPENSION

Unit: mm (in)

ITEM	SPECIFICATION	LIMIT	NOTE
Front fork stroke	70 (2.7)	—————	
Rear wheel travel	65 (2.6)	—————	

### TIRE PRESSURE

COLD INFLATION TIRE PRESSURE	SOLO RIDING			DUAL RIDING		
	kPa	kg/cm <sup>2</sup>	psi	kPa	kg/cm <sup>2</sup>	psi
FRONT	125	1.25	18	—	—	—
REAR	200	2.00	29	—	—	—

### FUEL + OIL

ITEM	SPECIFICATION		NOTE
Fuel type	Gasoline used should be graded 85-95 octane or higher. An unleaded gasoline is recommended.		
Fuel tank capacity	4.8 L (1.3/1.1 US/Imp gal)		
Engine oil type	Use APOLLOIL BIKE-K or HYPOL HS or an equivalent good quality synthetic based 2-cycle oil.		
Engine oil tank capacity	1.2 L (1.2/1.0 US/Imp qt)		
Final gear oil type	SAE 10W/40		
Final gear oil capacity	Change	80 ml (2.7/2.8 US/Imp oz)	
	Overhaul	90 ml (3.0/3.2 US/Imp oz)	
Brake fluid type	DOT4		

## 7-11 SERVICING INFORMATION

### TROUBLESHOOTING

#### ENGINE

Complaint	Symptom and possible causes	Remedy
<b>Engine does not start, or is hard to start.</b>	<p><b>Compression too low</b></p> <ol style="list-style-type: none"> <li>1. Excessively worn cylinder or piston rings.</li> <li>2. Stiff piston ring in place.</li> <li>3. Gas leaks from the joint in crankcase, cylinder or cylinder head.</li> <li>4. Damaged reed valve.</li> <li>5. Spark plug too loose.</li> <li>6. Broken, cracked or otherwise failed piston.</li> </ol> <p><b>Plug not sparking</b></p> <ol style="list-style-type: none"> <li>1. Damaged spark plug or spark plug cap.</li> <li>2. Dirty or wet spark plug.</li> <li>3. Defective CDI &amp; Ignition coil unit or stator coil.</li> <li>4. Open or short in high-tension cord.</li> <li>5. Defective ignition switch.</li> </ol> <p><b>No fuel reaching the carburetor</b></p> <ol style="list-style-type: none"> <li>1. Clogged hole in the fuel tank cap.</li> <li>2. Clogged or defective fuel cock.</li> <li>3. Defective carburetor float valve.</li> <li>4. Clogged fuel hose or defective vacuum hose.</li> </ol>	<p>Replace. Repair or replace. Repair or replace. Replace. Tighten. Replace.</p> <p>Replace. Clean and dry. Replace. Replace. Replace.</p> <p>Clean. Clean or replace. Replace. Clean or replace.</p>
<b>Engine stalls easily.</b>	<ol style="list-style-type: none"> <li>1. Carbon deposited on the spark plug.</li> <li>2. Defective CDI &amp; Ignition coil unit.</li> <li>3. Clogged fuel hose.</li> <li>4. Clogged jets in carburetor.</li> <li>5. Clogged exhaust pipe.</li> </ol>	<p>Clean. Replace. Clean. Clean. Clean.</p>
<b>Noisy engine.</b>	<p><b>Noise appears to come from piston</b></p> <ol style="list-style-type: none"> <li>1. Piston or cylinder worn down.</li> <li>2. Combustion chamber fouled with carbon.</li> <li>3. Piston pin, bearing or piston pin bore worn.</li> <li>4. Piston rings or ring grooves worn.</li> </ol> <p><b>Noise seems to come from crankshaft</b></p> <ol style="list-style-type: none"> <li>1. Worn or brunt crankshaft bearings.</li> <li>2. Worn or brunt conrod big-end bearings.</li> </ol> <p><b>Noise seems to come from final gear box</b></p> <ol style="list-style-type: none"> <li>1. Gears worn or rubbing.</li> <li>2. Badly worn splines.</li> <li>3. Worn or damaged bearings of drive shaft for rear axle shaft.</li> </ol>	<p>Replace. Clean. Replace. Replace.</p> <p>Replace. Replace.</p> <p>Replace. Replace. Replace.</p>
<b>Slipping clutch</b>	<ol style="list-style-type: none"> <li>1. Worn or damaged clutch shoes.</li> <li>2. Worn clutch drum.</li> </ol>	<p>Replace. Replace.</p>
<b>Engine idles poorly.</b>	<ol style="list-style-type: none"> <li>1. Excessively worn cylinder or piston rings.</li> <li>2. Stiff piston ring in place.</li> <li>3. Gas leaks from crankshaft oil seal.</li> <li>4. Spark plug gaps too wide.</li> <li>5. Defective CDI &amp; Ignition coil unit.</li> <li>6. Defective magneto stator coil.</li> <li>7. Float-chamber fuel level out of adjustment in carburetor.</li> <li>8. Clogged jets in carburetor.</li> <li>9. Broken or damaged reed valve.</li> </ol>	<p>Replace. Replace. Replace. Adjust or replace. Replace. Replace. Replace. Clean or adjust. Replace.</p>

Complaint	Symptom and possible causes	Remedy
<b>Engine runs poorly in high-speed range.</b>	<ol style="list-style-type: none"> <li>1. Excessively worn cylinder or piston rings.</li> <li>2. Stiff piston ring in place.</li> <li>3. Spark plug gaps too narrow.</li> <li>4. Ignition not advanced sufficiently due to poorly working CDI &amp; Ignition coil unit.</li> <li>5. Defective magneto stator coil.</li> <li>6. Float-chamber fuel level too low.</li> <li>7. Clogged air cleaner element.</li> <li>8. Clogged fuel hose, resulting in inadequate fuel supply to carburetor.</li> <li>9. Clogged fuel cock vacuum pipe.</li> </ol>	<p>Replace. Replace. Adjust. Replace.</p> <p>Replace. Adjust or replace. Clean Clean, and prime. Clean.</p>
<b>Dirty or heavy exhaust smoke.</b>	<ol style="list-style-type: none"> <li>1. Too much engine oil to the engine.</li> <li>2. Use of incorrect engine oil.</li> </ol>	<p>Check oil pump. Change.</p>
<b>Engine lacks power.</b>	<ol style="list-style-type: none"> <li>1. Excessively worn cylinder or piston rings.</li> <li>2. Stiff piston ring in place.</li> <li>3. Gas leaks from crankshaft oil seal.</li> <li>4. Spark plug gaps incorrect.</li> <li>5. Clogged jets in carburetor.</li> <li>6. Float-chamber fuel level out of adjustment.</li> <li>7. Clogged air cleaner element.</li> <li>8. Fouled spark plug.</li> <li>9. Sucking air from intake pipe.</li> <li>10. Slipping or worn V-belt.</li> <li>11. Damaged/worn rollers in the movable drive face.</li> <li>12. Weakened movable driven face spring.</li> <li>13. Too rich fuel/air mixture due to defective starter system.</li> </ol>	<p>Replace. Replace. Replace. Adjust or replace. Clean. Adjust or replace. Clean. Clean or replace. Retighten or replace. Replace. Replace. Replace. Replace.</p>
<b>Engine overheats.</b>	<ol style="list-style-type: none"> <li>1. Heavy carbon deposit on piston crown.</li> <li>2. Defective oil pump or clogged oil circuit.</li> <li>3. Fuel level too low in float chamber.</li> <li>4. Air leakage from intake pipe.</li> <li>5. Use of incorrect engine oil.</li> <li>6. Use of improper spark plug.</li> <li>7. Clogged exhaust pipe/muffler.</li> </ol>	<p>Clean. Replace or clean. Adjust or replace. Retighten or replace. Change. Change. Clean or replace.</p>

## CARBURETOR

Complaint	Symptom and possible causes	Remedy
<b>Trouble with starting.</b>	<ol style="list-style-type: none"> <li>1. Starter jet is clogged.</li> <li>2. Air leaking from a joint between starter body and carburetor.</li> <li>3. Air leaking from carburetor's joint or vacuum hose joint.</li> <li>4. Starter plunger is not operating properly.</li> </ol>	<p>Clean. Check starter body and carburetor for tightness, and replace gasket. Check and replace. Check and replace.</p>
<b>Idling or low-speed trouble.</b>	<ol style="list-style-type: none"> <li>1. Pilot jet, pilot air jet are clogged or loose.</li> <li>2. Air leaking from carburetor's joint, vacuum pipe joint, or starter.</li> <li>3. Pilot outlet is clogged.</li> <li>4. Starter plunger is not fully closed.</li> </ol>	<p>Check and clean. Clean and replace. Check and clean. Check and replace.</p>
<b>Medium or high-speed trouble.</b>	<ol style="list-style-type: none"> <li>1. Main jet or main air jet is clogged.</li> <li>2. Needle jet is clogged.</li> <li>3. Fuel level is improperly set.</li> <li>4. Throttle valve is not operating properly.</li> <li>5. Fuel filter is clogged.</li> </ol>	<p>Check and clean. Check and clean. Check and replace. Check throttle valve for operation. Check and clean.</p>
<b>Overflow and fuel level fluctuations.</b>	<ol style="list-style-type: none"> <li>1. Needle valve is worn or damaged.</li> <li>2. Spring in deedle valve is broken.</li> <li>3. Float is not working properly.</li> <li>4. Foreign matter has adhered to needle valve.</li> <li>5. Fuel level is too high or low.</li> </ol>	<p>Replace. Replace. Check and adjust. Clean. Adjust or replace.</p>

## 7-13 SERVICING INFORMATION

### ELECTRICAL

Complaint	Symptom and possible causes	Remedy
No sparking or poor sparking.	<ol style="list-style-type: none"> <li>1. Defective CDI &amp; Ignition coil unit.</li> <li>2. Defective spark plug.</li> <li>3. Defective magneto stator coil.</li> <li>4. Loose connection of lead wire.</li> </ol>	Replace. Replace. Replace. Connect/tighten.
Spark plug soon becomes fouled with carbon.	<ol style="list-style-type: none"> <li>1. Mixture too rich.</li> <li>2. Idling speed set too high.</li> <li>3. Incorrect gasoline.</li> <li>4. Dirty element in air cleaner.</li> <li>5. Spark plug too cold.</li> <li>6. Incorrect engine oil.</li> </ol>	Adjust carburetor. Adjust carburetor. Change. Clean. Replace by hot type plug. Replace.
Spark plug electrodes overheat or burn.	<ol style="list-style-type: none"> <li>1. Spark plug too hot.</li> <li>2. The engine overheats.</li> <li>3. Spark plug loose.</li> <li>4. Mixture too lean.</li> <li>5. Not enough engine oil.</li> </ol>	Replace by hot type plug. Turn up. Retighten. Adjust carburetor. Check oil pump.
Magneto does not charge.	<ol style="list-style-type: none"> <li>1. Open or short in lead wires, or loose lead connections.</li> <li>2. Shorted, grounded or open magneto coil.</li> <li>3. Shorted or open regulator/rectifier.</li> </ol>	Repair, replace or retighten. Replace. Replace.
Magneto charge, but charging rate is below the specifications.	<ol style="list-style-type: none"> <li>1. Lead wires tend to get shorted or open-circuited or loosely connected at terminal.</li> <li>2. Grounded or open-circuited stator coils of magneto.</li> <li>3. Defective regulator/rectifier.</li> <li>4. Defective cell plates in the battery.</li> </ol>	Repair, or retighten.  Replace. Replace. Replace the battery.
Magneto overcharges	<ol style="list-style-type: none"> <li>1. Internal short-circuit in the battery.</li> <li>2. Resistor element in the regulator/rectifier damaged or defective.</li> <li>3. Regulator/rectifier unit poorly grounded.</li> </ol>	Replace the battery. Replace. Clean and tighten ground connection.
Unstable charging.	<ol style="list-style-type: none"> <li>1. Lead wire insulation frayed due to vibration, resulting in intermittent shorting.</li> <li>2. Magneto coil internally shorted.</li> <li>3. Defective regulator/rectifier.</li> </ol>	Repair or replace.  Replace. Replace.
Starter button is not effective.	<ol style="list-style-type: none"> <li>1. Battery run down.</li> <li>2. Defective switch contacts.</li> <li>3. Brushes not seating properly on commutator in starter motor.</li> <li>4. Defective starter relay.</li> <li>5. Defective starter pinion gears.</li> <li>6. Defective front or rear brake light switch circuit.</li> </ol>	Recharge or replace. Replace. Repair or replace. Replace. Replace. Replace or repair.

### BATTERY

Complaint	Symptom and possible causes	Remedy
Battery runs down quickly.	<ol style="list-style-type: none"> <li>1. The charging method is not correct.</li> <li>2. Cell plates have lost much of their active material as a result of over-charging.</li> <li>3. A short-circuit condition exists within the battery due to excessive accumulation of sediments caused by the incorrect electrolyte.</li> <li>4. Battery is too old.</li> </ol>	Check the magneto and regulator/rectifier circuit connections, and make necessary adjustments to obtain specified charging operation. Replace the battery, and correct the charging system. Replace the battery.  Replace the battery.
Reversed battery polarity.	<ol style="list-style-type: none"> <li>1. The battery has been connected the wrong way round in the system, so that it is being charged in the reverse direction.</li> </ol>	Replace the battery and be sure to connect the battery properly.
Battery discharges too rapidly.	<ol style="list-style-type: none"> <li>1. Dirty container top and sides.</li> <li>2. Battery is too old.</li> </ol>	Clean. Replace.

**CHASSIS**

Complaint	Symptom and possible causes	Remedy
Handling feels too heavy.	<ol style="list-style-type: none"> <li>1. Steering stem nut overtightened.</li> <li>2. Broken bearing/race in steering stem.</li> <li>3. Distorted steering stem.</li> <li>4. Not enough pressure in tires.</li> </ol>	Adjust. Replace. Replace. Adjust.
Wobbly handle.	<ol style="list-style-type: none"> <li>1. Loss of balance between right and left front suspension.</li> <li>2. Distorted front axle or crooked tire.</li> </ol>	Replace. Replace.
Wobbly front wheel.	<ol style="list-style-type: none"> <li>1. Distorted wheel rim.</li> <li>2. Worn front wheel bearings.</li> <li>3. Defective or incorrect tire.</li> <li>4. Loose nut on axle.</li> <li>5. Loose nuts on the rear shock.</li> <li>6. Worn engine mounting bushing.</li> <li>7. Loose nuts or bolts for engine mounting.</li> </ol>	Replace. Replace. Replace. Retighten. Retighten. Replace. Tighten.
Front suspension too soft.	<ol style="list-style-type: none"> <li>1. Weakened springs.</li> <li>2. Oil leakage of shock absorber.</li> </ol>	Replace. Replace.
Front suspension too stiff.	<ol style="list-style-type: none"> <li>1. Not enough grease.</li> <li>2. Worn suspension arm spacer.</li> </ol>	Refill. Replace.
Noisy front suspension.	<ol style="list-style-type: none"> <li>1. Not enough grease.</li> <li>2. Loose nuts on suspension.</li> </ol>	Refill. Retighten.
Wobbly rear wheel.	<ol style="list-style-type: none"> <li>1. Distorted wheel rim.</li> <li>2. Defective or incorrect tire.</li> <li>3. Loose nuts on the rear shock absorber.</li> <li>4. Worn engine mounting bushing.</li> <li>5. Loose nuts or bolts for engine mounting.</li> </ol>	Replace. Replace. Replace. Replace. Retighten.
Rear suspension too soft.	<ol style="list-style-type: none"> <li>1. Weakened spring.</li> <li>2. Oil leakage of rear shock absorber.</li> </ol>	Replace. Replace.
Noisy rear suspension.	<ol style="list-style-type: none"> <li>1. Loosen nuts on shock absorber.</li> <li>2. Worn engine mounting bushing.</li> </ol>	Retighten. Replace.

**BRAKES**

Complaint	Symptom and possible causes	Remedy
Insufficient brake power.	<ol style="list-style-type: none"> <li>1. Leakage of brake fluid from hydraulic system.</li> <li>2. Worn pad.</li> <li>3. Oil adhesion on engaging surface of pad.</li> <li>4. Worn disc.</li> <li>5. Air entered into hydraulic system.</li> <li>6. Worn shoe.</li> <li>7. Friction surfaces of shoes are dirty with oil.</li> <li>8. Excessively worn drum.</li> <li>9. Too much brake lever play.</li> </ol>	Repair or replace. Replace. Clean disc and pads. Replace. Bleed air. Replace. Replace. Replace. Adjust.
Brake squeaking.	<ol style="list-style-type: none"> <li>1. Carbon adhesion on pad surface.</li> <li>2. Tilted pad.</li> <li>3. Damaged wheel bearing.</li> <li>4. Worn pad.</li> <li>5. Foreign substance entered into brake fluid.</li> <li>6. Clogged return ports of master cylinder.</li> <li>7. Brake shoe surface glazed.</li> <li>8. Loose front-wheel axle or rear-wheel axle nut.</li> <li>9. Worn shoe.</li> </ol>	Repair surface with sandpaper. Modify and fitting. Replace. Replace. Replace brake fluid. Disassemble and clean master cylinder. Repair surface with sandpaper. Tighten to specified torque. Replace.

## 7-15 SERVICING INFORMATION

---

Complaint	Symptom and possible causes	Remedy
<b>Excessive brake lever stroke.</b>	<ol style="list-style-type: none"><li>1. Air entered into hydraulic system.</li><li>2. Insufficient brake fluid.</li><li>3. Improper quality of brake fluid.</li><li>4. Worn brake cam lever.</li><li>5. Excessively worn shoes and/or drum.</li></ol>	Bleed air. Replenish fluid to normal level; bleed air. Replace with correct fluid. Replace. Replace.
<b>Leakage of brake fluid.</b>	<ol style="list-style-type: none"><li>1. Insufficient tightening of connection joints.</li><li>2. Cracked hose.</li><li>3. Worn piston seal.</li></ol>	Tighten to specified torque. Replace. Replace.
<b>Brake drags.</b>	<ol style="list-style-type: none"><li>1. Rusty moving parts.</li></ol>	Clean and lubricate.



Prepared by

**HYOSUNG MOTORS & MACHINERY INC.**

Overseas Service

2nd Ed. APR. 1999

Manual No. 99000-91201

Printed in Korea