



**Ninja 650R
ER-6f
ER-6f ABS**



Motorcycle Service Manual

Quick Reference Guide

General Information	1
Periodic Maintenance	2
Fuel System (DFI)	3
Cooling System	4
Engine Top End	5
Clutch	6
Engine Lubrication System	7
Engine Removal/Installation	8
Crankshaft/Transmission	9
Wheels/Tires	10
Final Drive	11
Brakes	12
Suspension	13
Steering	14
Frame	15
Electrical System	16
Appendix	17

This quick reference guide will assist you in locating a desired topic or procedure.

- Bend the pages back to match the black tab of the desired chapter number with the black tab on the edge at each table of contents page.
- Refer to the sectional table of contents for the exact pages to locate the specific topic required.



Ninja 650R
ER-6f
ER-6f ABS

Motorcycle Service Manual

All rights reserved. No parts of this publication may be reproduced, stored in a retrieval system, or transmitted in any form or by any means, electronic mechanical photocopying, recording or otherwise, without the prior written permission of Quality Assurance Division/Consumer Products & Machinery Company/Kawasaki Heavy Industries, Ltd., Japan.

No liability can be accepted for any inaccuracies or omissions in this publication, although every possible care has been taken to make it as complete and accurate as possible.

The right is reserved to make changes at any time without prior notice and without incurring an obligation to make such changes to products manufactured previously. See your Motorcycle dealer for the latest information on product improvements incorporated after this publication.

All information contained in this publication is based on the latest product information available at the time of publication. Illustrations and photographs in this publication are intended for reference use only and may not depict actual model component parts.

LIST OF ABBREVIATIONS

A	ampere(s)	lb	pound(s)
ABDC	after bottom dead center	m	meter(s)
AC	alternating current	min	minute(s)
ATDC	after top dead center	N	newton(s)
BBDC	before bottom dead center	Pa	pascal(s)
BDC	bottom dead center	PS	horsepower
BTDC	before top dead center	psi	pound(s) per square inch
°C	degree(s) Celsius	r	revolution
DC	direct current	rpm	revolution(s) per minute
F	farad(s)	TDC	top dead center
°F	degree(s) Fahrenheit	TIR	total indicator reading
ft	foot, feet	V	volt(s)
g	gram(s)	W	watt(s)
h	hour(s)	Ω	ohm(s)
L	liter(s)		

COUNTRY AND AREA CODES

AT	Austria	GB	United Kingdom
AU	Australia	MY	Malaysia
CA	Canada	SEA	South East Asia
CAL	California	US	United States
CH	Switzerland	WVTA (FULL H)	WVTA Model with Honeycomb Catalytic Converter (Full Power)
DE	Germany	GB WVTA (FULL H)	WVTA Model with Honeycomb Catalytic Converter (Left Side Traffic, Full Power)
EUR	Europe		

EMISSION CONTROL INFORMATION

To protect the environment in which we all live, Kawasaki has incorporated crankcase emission (1) and exhaust emission (2) control systems in compliance with applicable regulations of the United States Environmental Protection Agency and California Air Resources Board. Additionally, Kawasaki has incorporated an evaporative emission control system (3) in compliance with applicable regulations of the California Air Resources Board on vehicles sold in California only.

1. Crankcase Emission Control System

This system eliminates the release of crankcase vapors into the atmosphere. Instead, the vapors are routed through an oil separator to the inlet side of the engine. While the engine is operating, the vapors are drawn into combustion chamber, where they are burned along with the fuel and air supplied by the fuel injection system.

2. Exhaust Emission Control System

This system reduces the amount of pollutants discharged into the atmosphere by the exhaust of this motorcycle. The fuel, ignition, and exhaust systems of this motorcycle have been carefully designed and constructed to ensure an efficient engine with low exhaust pollutant levels.

The exhaust system of this model motorcycle manufactured primarily for sale in California includes a catalytic converter system.

3. Evaporative Emission Control System

Vapors caused by fuel evaporation in the fuel system are not vented into the atmosphere. Instead, fuel vapors are routed into the running engine to be burned, or stored in a canister when the engine is stopped. Liquid fuel is caught by a vapor separator and returned to the fuel tank.

The Clean Air Act, which is the Federal law covering motor vehicle pollution, contains what is commonly referred to as the Act's "tampering provisions".

"Sec. 203(a) The following acts and the causing thereof are prohibited.

(3)(A) for any person to remove or render inoperative any device or element of design installed on or in a motor vehicle or motor vehicle engine in compliance with regulations under this title prior to its sale and delivery to the ultimate purchaser, or for any manufacturer or dealer knowingly to remove or render inoperative any such device or element of design after such sale and delivery to the ultimate purchaser.

(3)(B) for any person engaged in the business of repairing, servicing, selling, leasing, or trading motor vehicles or motor vehicle engines, or who operates a fleet of motor vehicles knowingly to remove or render inoperative any device or element of design installed on or in a motor vehicle or motor vehicle engine in compliance with regulations under this title following its sale and delivery to the ultimate purchaser..."

NOTE

○ *The phrase "remove or render inoperative any device or element of design" has been generally interpreted as follows.*

1. *Tampering does not include the temporary removal or rendering inoperative of devices or elements of design in order to perform maintenance.*

2. *Tampering could include.*

a. *Maladjustment of vehicle components such that the emission standards are exceeded.*

b. *Use of replacement parts or accessories which adversely affect the performance or durability of the motorcycle.*

c. *Addition of components or accessories that result in the vehicle exceeding the standards.*

d. *Permanently removing, disconnecting, or rendering inoperative any component or element of design of the emission control systems.*

WE RECOMMEND THAT ALL DEALERS OBSERVE THESE PROVISIONS OF FEDERAL LAW, THE VIOLATION OF WHICH IS PUNISHABLE BY CIVIL PENALTIES NOT EXCEEDING \$10 000 PER VIOLATION.

TAMPERING WITH NOISE CONTROL SYSTEM PROHIBITED

Federal law prohibits the following acts or the causing thereof. (1) The removal or rendering inoperative by any person other than for purposes of maintenance, repair, or replacement, of any device or element of design incorporated into any new vehicle for the purpose of noise control prior to its sale or delivery to the ultimate purchaser or while it is in use, or (2) the use of the vehicle after such device or element of design has been removed or rendered inoperative by any person.

Among those acts presumed to constitute tampering are the acts listed below.

- Replacement of the original exhaust system or muffler with a component not in compliance with Federal regulations.
- Removal of the muffler(s) or any internal portion of the muffler(s).
- Removal of the air box or air box cover.
- Modifications to the muffler(s) or air inlet system by cutting, drilling, or other means if such modifications result in increased noise levels.

Foreword

This manual is designed primarily for use by trained mechanics in a properly equipped shop. However, it contains enough detail and basic information to make it useful to the owner who desires to perform his own basic maintenance and repair work. A basic knowledge of mechanics, the proper use of tools, and workshop procedures must be understood in order to carry out maintenance and repair satisfactorily. Whenever the owner has insufficient experience or doubts his ability to do the work, all adjustments, maintenance, and repair should be carried out only by qualified mechanics.

In order to perform the work efficiently and to avoid costly mistakes, read the text, thoroughly familiarize yourself with the procedures before starting work, and then do the work carefully in a clean area. Whenever special tools or equipment are specified, do not use makeshift tools or equipment. Precision measurements can only be made if the proper instruments are used, and the use of substitute tools may adversely affect safe operation.

For the duration of the warranty period, we recommend that all repairs and scheduled maintenance be performed in accordance with this service manual. Any owner maintenance or repair procedure not performed in accordance with this manual may void the warranty.

To get the longest life out of your vehicle.

- Follow the Periodic Maintenance Chart in the Service Manual.
- Be alert for problems and non-scheduled maintenance.
- Use proper tools and genuine Kawasaki Motorcycle parts. Special tools, gauges, and testers that are necessary when servicing Kawasaki motorcycles are introduced by the Service Manual. Genuine parts provided as spare parts are listed in the Parts Catalog.
- Follow the procedures in this manual carefully. Don't take shortcuts.
- Remember to keep complete records of maintenance and repair with dates and any new parts installed.

How to Use This Manual

In this manual, the product is divided into its major systems and these systems make up the manual's chapters. The Quick Reference

Guide shows you all of the product's system and assists in locating their chapters. Each chapter in turn has its own comprehensive Table of Contents.

For example, if you want ignition coil information, use the Quick Reference Guide to locate the Electrical System chapter. Then, use the Table of Contents on the first page of the chapter to find the Ignition Coil section.

Whenever you see these WARNING and CAUTION symbols, heed their instructions! Always follow safe operating and maintenance practices.

WARNING

This warning symbol identifies special instructions or procedures which, if not correctly followed, could result in personal injury, or loss of life.

CAUTION

This caution symbol identifies special instructions or procedures which, if not strictly observed, could result in damage to or destruction of equipment.

This manual contains four more symbols (in addition to WARNING and CAUTION) which will help you distinguish different types of information.

NOTE

○ *This note symbol indicates points of particular interest for more efficient and convenient operation.*

- Indicates a procedural step or work to be done.
- Indicates a procedural sub-step or how to do the work of the procedural step it follows. It also precedes the text of a NOTE.
- ★ Indicates a conditional step or what action to take based on the results of the test or inspection in the procedural step or sub-step it follows.

In most chapters an exploded view illustration of the system components follows the Table of Contents. In these illustrations you will find the instructions indicating which parts require specified tightening torque, oil, grease or a locking agent during assembly.

General Information

Table of Contents

Before Servicing	1-2
Model Identification.....	1-7
General Specifications.....	1-10
Unit Conversion Table	1-13



1-2 GENERAL INFORMATION

Before Servicing

Before starting to perform an inspection service or carry out a disassembly and reassembly operation on a motorcycle, read the precautions given below. To facilitate actual operations, notes, illustrations, photographs, cautions, and detailed descriptions have been included in each chapter wherever necessary. This section explains the items that require particular attention during the removal and reinstallation or disassembly and reassembly of general parts.

Especially note the following:

Battery Ground

Before completing any service on the motorcycle, disconnect the battery cables from the battery to prevent the engine from accidentally turning over. Disconnect the ground (-) first and then the positive (+). When completed with the service, first connect the positive (+) cable to the positive (+) terminal of the battery then the negative (-) cable to the negative terminal.

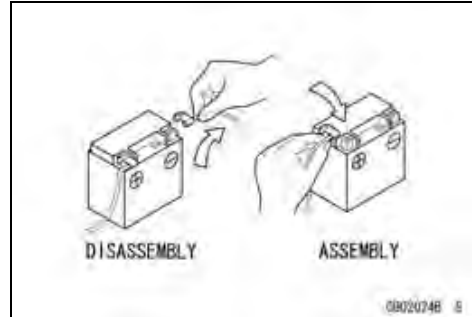

Edges of Parts

Lift large or heavy parts wearing gloves to prevent injury from possible sharp edges on the parts.



Solvent

Use a high-flash point solvent when cleaning parts. High-flash point solvent should be used according to directions of the solvent manufacturer.



Cleaning Vehicle before Disassembly

Clean the vehicle thoroughly before disassembly. Dirt or other foreign materials entering into sealed areas during vehicle disassembly can cause excessive wear and decrease performance of the vehicle.

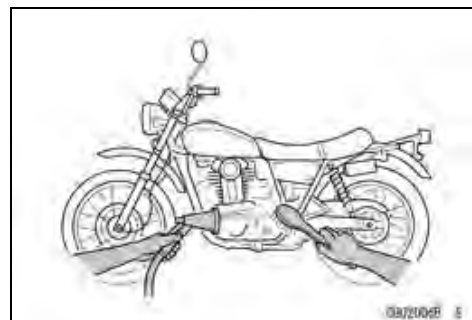

Before Servicing

Arrangement and Cleaning of Removed Parts

Disassembled parts are easy to confuse. Arrange the parts according to the order the parts were disassembled and clean the parts in order prior to assembly.

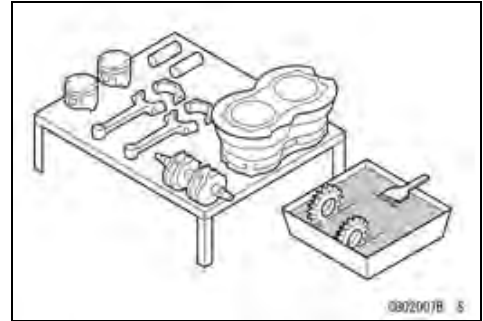

Storage of Removed Parts

After all the parts including subassembly parts have been cleaned, store the parts in a clean area. Put a clean cloth or plastic sheet over the parts to protect from any foreign materials that may collect before re-assembly.

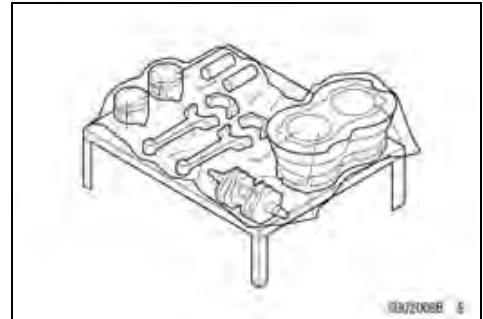

Inspection

Reuse of worn or damaged parts may lead to serious accident. Visually inspect removed parts for corrosion, discoloration, or other damage. Refer to the appropriate sections of this manual for service limits on individual parts. Replace the parts if any damage has been found or if the part is beyond its service limit.

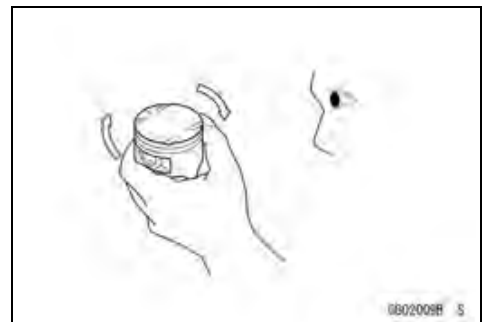

Replacement Parts

Replacement parts must be KAWASAKI genuine or recommended by KAWASAKI. Gaskets, O-rings, oil seals, grease seals, circlips or cotter pins must be replaced with new ones whenever disassembled.



Assembly Order

In most cases assembly order is the reverse of disassembly, however, if assembly order is provided in this Service Manual, follow the procedures given.

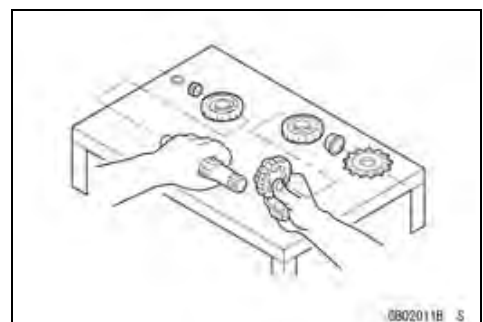

1-4 GENERAL INFORMATION

Before Servicing

Tightening Sequence

Generally, when installing a part with several bolts, nuts, or screws, start them all in their holes and tighten them to a snug fit. Then tighten them according to the specified sequence to prevent case warpage or deformation which can lead to malfunction. Conversely when loosening the bolts, nuts, or screws, first loosen all of them by about a quarter turn and then remove them. If the specified tightening sequence is not indicated, tighten the fasteners alternating diagonally.

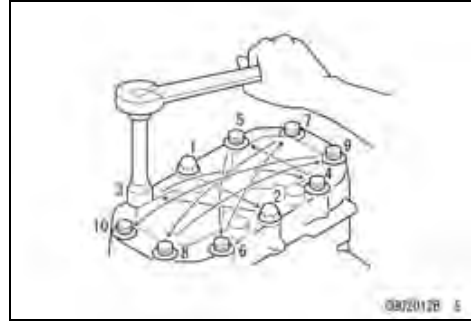

Tightening Torque

Incorrect torque applied to a bolt, nut, or screw may lead to serious damage. Tighten fasteners to the specified torque using a good quality torque wrench. Often, the tightening sequence is followed twice-initial tightening and final tightening with torque wrench.

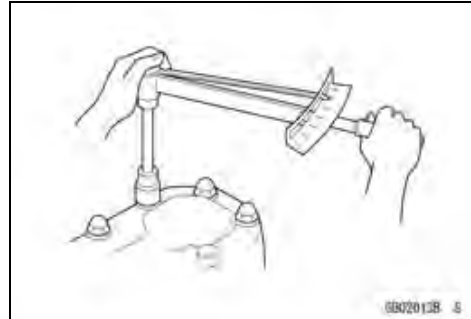

Force

Use common sense during disassembly and assembly, excessive force can cause expensive or hard to repair damage. When necessary, remove screws that have a non-permanent locking agent applied using an impact driver. Use a plastic-faced mallet whenever tapping is necessary.

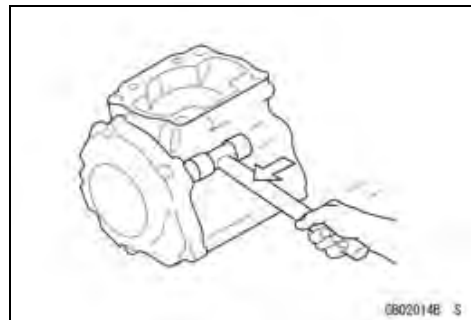

Gasket, O-ring

Hardening, shrinkage, or damage of both gaskets and O-rings after disassembly can reduce sealing performance. Remove old gaskets and clean the sealing surfaces thoroughly so that no gasket material or other material remains. Install new gaskets and replace used O-rings when re-assembling.



Liquid Gasket, Non-permanent Locking Agent

For applications that require Liquid Gasket or a Non-permanent Locking Agent, clean the surfaces so that no oil residue remains before applying liquid gasket or non-permanent locking agent. Do not apply them excessively. Excessive application can clog oil passages and cause serious damage.



Before Servicing

Press

For items such as bearings or oil seals that must be pressed into place, apply small amount of oil to the contact area. Be sure to maintain proper alignment and use smooth movements when installing.

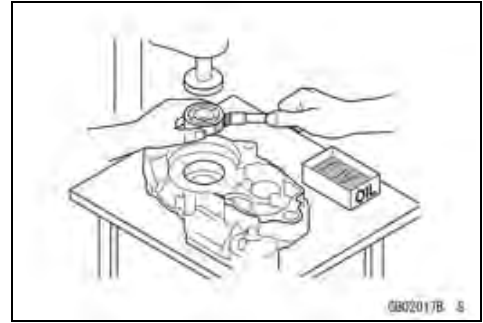

Ball Bearing and Needle Bearing

Do not remove pressed ball or needle unless removal is absolutely necessary. Replace with new ones whenever removed. Press bearings with the manufacturer and size marks facing out. Press the bearing into place by putting pressure on the correct bearing race as shown.

Pressing the incorrect race can cause pressure between the inner and outer race and result in bearing damage.

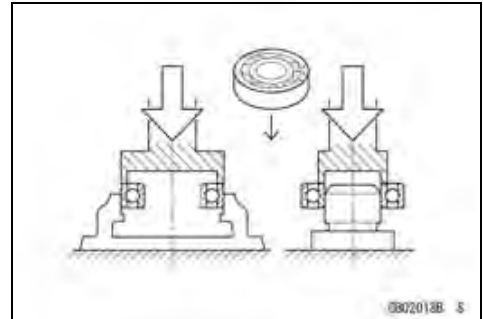

Oil Seal, Grease Seal

Do not remove pressed oil or grease seals unless removal is necessary. Replace with new ones whenever removed. Press new oil seals with manufacture and size marks facing out. Make sure the seal is aligned properly when installing.

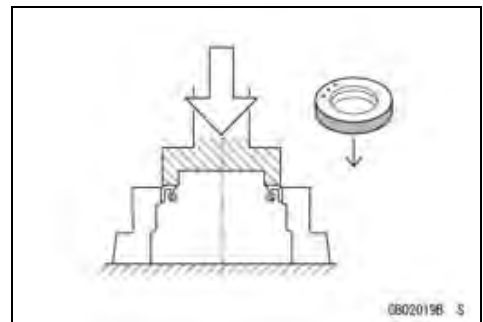

Apply specified grease to the lip of seal before installing the seal.

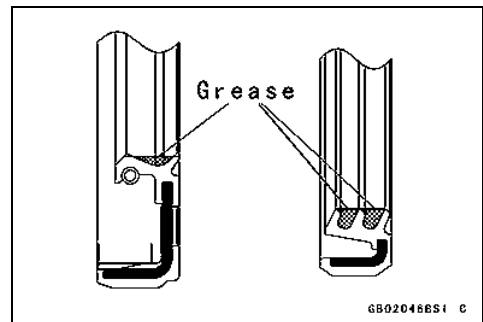

Circlips, Cotter Pins

Replace circlips or cotter pins that were removed with new ones. Take care not to open the clip excessively when installing to prevent deformation.

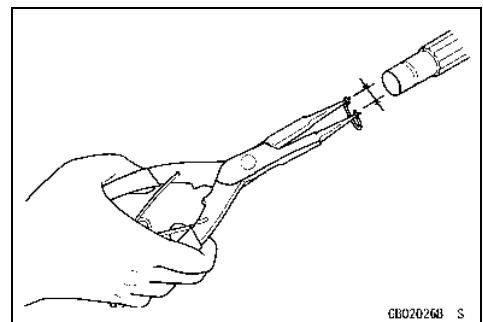

1-6 GENERAL INFORMATION

Before Servicing

Lubrication

It is important to lubricate rotating or sliding parts during assembly to minimize wear during initial operation. Lubrication points are called out throughout this manual, apply the specific oil or grease as specified.

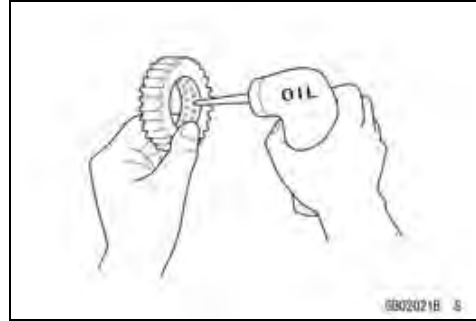

Direction of Engine Rotation

When rotating the crankshaft by hand, the free play amount of rotating direction will affect the adjustment. Rotate the crankshaft to positive direction (clockwise viewed from output side).

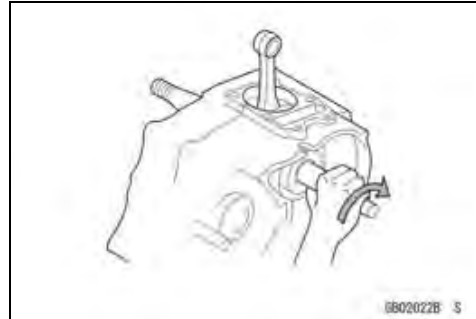

Electrical Leads

A two-color lead is identified first by the primary color and then the stripe color. Unless instructed otherwise, electrical leads must be connected to those of the same color.

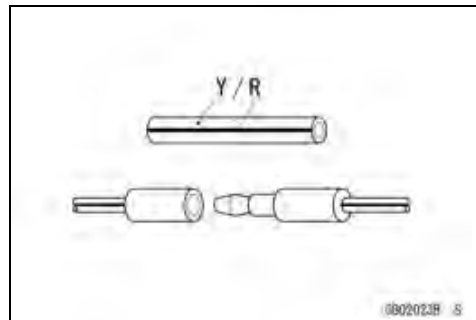

Instrument

Use a meter that has enough accuracy for an accurate measurement. Read the manufacturer's instructions thoroughly before using the meter. Incorrect values may lead to improper adjustments.

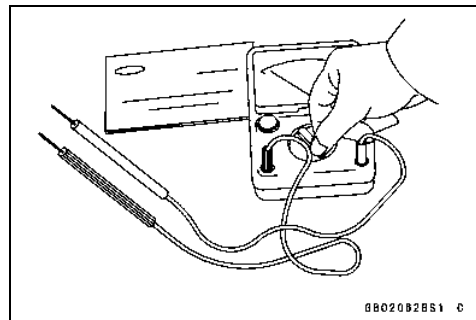

Model Identification

EX650C9F (EUR Models) Left Side View



EX650C9F (EUR Models) Right Side View



1-8 GENERAL INFORMATION

Model Identification

EX650C9F (US, CA Models) Left Side View



EX650C9F (US, CA Models) Right Side View



Model Identification

EX650D9F Left Side View



EX650D9F Right Side View



Frame Number



Engine Number



1-10 GENERAL INFORMATION

General Specifications

Items	EX650C9F, EX650D9F
Dimensions	
Overall Length	2 100 mm (82.68 in.)
Overall Width	760 mm (29.9 in.)
Overall Height	1 200 mm (47.24 in.)
Wheelbase	1 410 mm (55.51 in.)
Road Clearance	145 mm (5.71 in.)
Seat Height	790 mm (31.1 in.)
Curb Mass:	
EX650C Models:	204 kg (450 lb)
Front	104 kg (229 lb)
Rear	100 kg (221 lb)
EX650D Models:	208 kg (459 lb)
Front	105 kg (232 lb)
Rear	103 kg (227 lb)
Fuel Tank Capacity	15.5 L (4.10 US gal.)
Performance	
Minimum Turning Radius	2.7 m (8.9 ft)
Engine	
Type	4-stroke, DOHC, 2-cylinder
Cooling System	Liquid-cooled
Bore and Stroke	83.0 × 60.0 mm (3.27 × 2.36 in.)
Displacement	649 cm ³ (39.6 cu in.)
Compression Ratio	11.3 : 1
Maximum Horsepower	53 kW (72 PS) @8 500 r/min (rpm) (MY) 52 kW (71 PS) @8 000 r/min (rpm) (US, CA, CAL) – – –
Maximum Torque	66 N·m (6.7 kgf·m, 49 ft·lb) @7 000 r/min (rpm) (US, CA, CAL) – – –
Carburetion System	FI (Fuel Injection), KEIHIN TTK38 × 2
Starting System	Electric starter
Ignition System	Battery and coil (transistorized)
Timing Advance	Electronically advanced (IC igniter in ECU)
Ignition Timing	From 10° BTDC @1 300 r/min (rpm) To 34° BTDC @5 000 r/min (rpm)
Spark Plug	NGK CR9EIA-9
Cylinder Numbering Method	Left to right, 1-2
Firing Order	1-2
Valve Timing:	
Inlet:	
Open	31° BTDC
Close	61° ABDC
Duration	272°

General Specifications

Items	EX650C9F, EX650D9F
Exhaust: Open Close Duration Lubrication System Engine Oil: Grade Viscosity Capacity	50° BBDC 30° ATDC 260° Forced lubrication (semi-dry sump) API SE, SF or SG API SH, SJ, SL or SM with JASO MA, MA1 or MA2 SAE 10W-40 2.4 L (2.5 US qt)
Drive Train Primary Reduction System: Type Reduction Ratio Clutch Type Transmission: Type Gear Ratios: 1st 2nd 3rd 4th 5th 6th Final Drive System: Type Reduction Ratio Overall Drive Ratio	Gear 2.095 (88/42) Wet multi disc 6-speed, constant mesh, return shift 2.438 (39/16) 1.714 (36/21) 1.333 (32/24) 1.111 (30/27) 0.966 (28/29) 0.852 (23/27) Chain drive 3.067 (46/15) 5.473 @Top gear
Frame Type Caster (Rake Angle) Trail Front Tire: Type Size Rim Size Rear Tire: Type Size Rim Size Front Suspension: Type Wheel Travel	Tubular, diamond 25° 106 mm (4.17 in.) Tubeless 120/70 ZR17 M/C (58W) 17 x 3.50 Tubeless 160/60 ZR17 M/C (69W) 17 x 4.50 Telescopic fork 120 mm (4.72 in.)

1-12 GENERAL INFORMATION

General Specifications

Items	EX650C9F, EX650D9F
Rear Suspension: Type Wheel Travel Brake Type: Front Rear	Swingarm 125 mm (4.92 in.) Dual discs Single disc
Electrical Equipment Battery Headlight: Type Bulb: High Low Tail/Brake Light Alternator: Type Rated Output	12 V 10 Ah Semi-sealed beam 12 V 55 W + 55 W (quartz-halogen) 12 V 55 W (quartz-halogen) LED Three-phase AC 24 A/14 V @5 000 r/min (rpm)

Specifications are subject to change without notice, and may not apply to every country.

Unit Conversion Table

Prefixes for Units:

Prefix	Symbol	Power
mega	M	× 1 000 000
kilo	k	× 1 000
centi	c	× 0.01
milli	m	× 0.001
micro	μ	× 0.000001

Units of Mass:

kg	×	2.205	=	lb
g	×	0.03527	=	oz

Units of Volume:

L	×	0.2642	=	gal (US)
L	×	0.2200	=	gal (imp)
L	×	1.057	=	qt (US)
L	×	0.8799	=	qt (imp)
L	×	2.113	=	pint (US)
L	×	1.816	=	pint (imp)
mL	×	0.03381	=	oz (US)
mL	×	0.02816	=	oz (imp)
mL	×	0.06102	=	cu in

Units of Force:

N	×	0.1020	=	kg
N	×	0.2248	=	lb
kg	×	9.807	=	N
kg	×	2.205	=	lb

Units of Length:

km	×	0.6214	=	mile
m	×	3.281	=	ft
mm	×	0.03937	=	in

Units of Torque:

N·m	×	0.1020	=	kgf·m
N·m	×	0.7376	=	ft·lb
N·m	×	8.851	=	in·lb
kgf·m	×	9.807	=	N·m
kgf·m	×	7.233	=	ft·lb
kgf·m	×	86.80	=	in·lb

Units of Pressure:

kPa	×	0.01020	=	kgf/cm ²
kPa	×	0.1450	=	psi
kPa	×	0.7501	=	cmHg
kgf/cm ²	×	98.07	=	kPa
kgf/cm ²	×	14.22	=	psi
cmHg	×	1.333	=	kPa

Units of Speed:

km/h	×	0.6214	=	mph
------	---	--------	---	-----

Units of Power:

kW	×	1.360	=	PS
kW	×	1.341	=	HP
PS	×	0.7355	=	kW
PS	×	0.9863	=	HP

Units of Temperature:

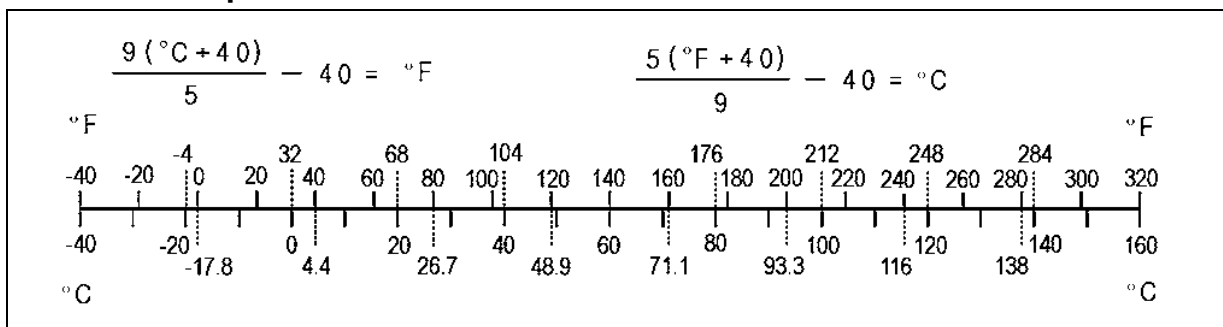

Periodic Maintenance

Table of Contents

Periodic Maintenance Chart	2-2	Brake Hose and Pipe Damage and Installation Condition	
Torque and Locking Agent.....	2-5	Inspection.....	2-31
Specifications	2-11	Brake Fluid Level Inspection.....	2-32
Special Tools	2-13	Brake Pad Wear Inspection	2-33
Periodic Maintenance Procedures.....	2-14	Brake Operation Inspection	2-33
Fuel System (DFI).....	2-14	Brake Light Switch Operation	
Air Cleaner Element Cleaning.....	2-14	Inspection.....	2-33
Throttle Control System		Suspensions	2-34
Inspection.....	2-15	Front Forks/Rear Shock Absorber	
Engine Vacuum Synchronization		Operation Inspection.....	2-34
Inspection.....	2-15	Front Fork Oil Leak Inspection.....	2-34
Idle Speed Inspection	2-17	Rear Shock Absorber Oil Leak	
Idle Speed Adjustment.....	2-18	Inspection.....	2-35
Fuel Hose Inspection (fuel leak, damage, installation condition)..	2-18	Steering System	2-35
Evaporative Emission Control		Steering Play Inspection	2-35
System Inspection (CAL and		Steering Play Adjustment.....	2-35
SEA Models)	2-18	Steering Stem Bearing	
Cooling System.....	2-19	Lubrication.....	2-36
Coolant Level Inspection.....	2-19	Electrical System	2-37
Water Hose Damage and		Lights and Switches Operation	
Installation Condition		Inspection.....	2-37
Inspection.....	2-20	Headlight Aiming Inspection	2-39
Engine Top End	2-20	Sidestand Switch Operation	
Valve Clearance Inspection	2-20	Inspection.....	2-40
Valve Clearance Adjustment.....	2-21	Engine Stop Switch Operation	
Air Suction System Damage		Inspection.....	2-41
Inspection.....	2-24	Others	2-42
Clutch.....	2-24	Chassis Parts Lubrication	2-42
Clutch Operation Inspection.....	2-24	Bolts, Nuts and Fasteners	
Wheels/Tires.....	2-25	Tightness Inspection	2-43
Air Pressure Inspection.....	2-25	Replacement Parts	2-44
Wheel/Tire Damage Inspection....	2-25	Air Cleaner Element	
Tire Tread Wear, Abnormal Wear		Replacement.....	2-44
Inspection.....	2-26	Fuel Hose Replacement	2-44
Wheel Bearing Damage		Coolant Change.....	2-45
Inspection.....	2-26	Radiator Hose and O-ring	
Final Drive.....	2-27	Replacement.....	2-47
Drive Chain Lubrication Condition		Engine Oil Change.....	2-47
Inspection.....	2-27	Oil Filter Replacement	2-48
Drive Chain Slack Inspection	2-28	Brake Hose and Pipe	
Drive Chain Slack Adjustment	2-28	Replacement.....	2-49
Wheel Alignment Inspection	2-29	Brake Fluid Change	2-50
Drive Chain Wear Inspection	2-30	Master Cylinder Rubber Parts	
Chain Guide Inspection.....	2-30	Replacement.....	2-51
Brake System	2-31	Caliper Rubber Parts	
Brake Fluid Leak (Brake Hose		Replacement.....	2-52
and Pipe) Inspection	2-31	Spark Plug Replacement	2-55

2-2 PERIODIC MAINTENANCE

Periodic Maintenance Chart

The scheduled maintenance must be done in accordance with this chart to keep the motorcycle in good running condition. **The initial maintenance is vitally important and must not be neglected.**

Periodic Inspection

ITEM	FREQUENCY	* ODOMETER READING x 1 000 km (x 1 000 mile)							See Page
	Whichever comes first → ↓ Every	1 (0.6)	6 (3.75)	12 (7.5)	18 (11.25)	24 (15)	30 (18.75)	36 (22.5)	
Fuel System									
Air cleaner element - clean				●		●		●	2-14
Throttle control system (play, smooth return, no drag) - inspect	year	●		●		●		●	2-15
Engine vacuum synchronization - inspect				●		●		●	2-15
Idle speed - inspect		●		●		●		●	2-17
Fuel leak (fuel hose and pipe) - inspect	year	●		●		●		●	2-18
Fuel hose and pipe damage - inspect	year	●		●		●		●	2-18
Fuel hose and pipe installation condition - inspect	year	●		●		●		●	2-18
Evaporative emission control system function (CAL, SEA Models) - inspection		●	●	●	●	●	●	●	2-18
Cooling System									
Coolant level - inspect		●		●		●		●	2-19
Coolant leak (water hose and pipe) - inspect	year	●		●		●		●	2-20
Water hose damage - inspect	year	●		●		●		●	2-20
Water hose installation condition - inspect	year	●		●		●		●	2-20
Engine Top End									
Valve clearance - inspect	US, CA, CAL Models					●			2-20
	Other than US, CA, CAL Models	Every 42 000 km (26 250 mile)							
Air suction system damage - inspect				●		●		●	2-24
Clutch									
Clutch operation (play, disengagement, engagement) - inspect		●		●		●		●	2-24
Wheels and Tires									
Tire air pressure - inspect	year			●		●		●	2-25
Wheel/tire damage - inspect				●		●		●	2-25
Tire tread wear, abnormal wear - inspect				●		●		●	2-26
Wheel bearing damage - inspect	year			●		●		●	2-26

PERIODIC MAINTENANCE 2-3

Periodic Maintenance Chart

ITEM	FREQUENCY	* ODOMETER READING × 1 000 km (× 1 000 mile)							See Page
		Whichever comes first →							
	↓ Every	1 (0.6)	6 (3.75)	12 (7.5)	18 (11.25)	24 (15)	30 (18.75)	36 (22.5)	
Final Drive									
Drive chain lubrication condition - inspect #		Every 600 km (400 mile)							2-27
Drive chain slack - inspect #		Every 1 000 km (600 mile)							2-28
Drive chain wear - inspect #				●		●		●	2-30
Chain guide wear - inspect				●		●		●	2-30
Brakes									
Brake fluid leak (brake hose and pipe) - inspect	year	●	●	●	●	●	●	●	2-31
Brake hose and pipe damage - inspect	year	●	●	●	●	●	●	●	2-31
Brake hose and pipe installation condition - inspect	year	●	●	●	●	●	●	●	2-31
Brake fluid level - inspect	6 months	●	●	●	●	●	●	●	2-32
Brake pad wear - inspect #			●	●	●	●	●	●	2-33
Brake operation (effectiveness, play, no drag) - inspect	year	●	●	●	●	●	●	●	2-33
Brake light switch operation - inspect		●	●	●	●	●	●	●	2-33
Suspension									
Front forks/rear shock absorber operation (damping and smooth stroke) - inspect				●		●		●	2-34
Front forks/rear shock absorber oil leak - inspect	year			●		●		●	2-34
Steering									
Steering play - inspect	year	●		●		●		●	2-35
Steering stem bearings - lubricate	2 years					●			2-36
Electrical System									
Lights and switches operation - inspect	year			●		●		●	2-37
Headlight aiming - inspect	year			●		●		●	2-39
Sidestand switch operation - inspect	year			●		●		●	2-40
Engine stop switch operation - inspect	year			●		●		●	2-41
Others									
Chassis parts - lubricate	year			●		●		●	2-42
Bolts and nuts tightness - inspect		●		●		●		●	2-43

#: Service more frequently when operating in severe conditions; dusty, wet, muddy, high speed or frequent starting/stopping.

*: For higher odometer readings, repeat at the frequency interval established here.

2-4 PERIODIC MAINTENANCE

Periodic Maintenance Chart

Periodic Replacement Parts

ITEM	FREQUENCY ↓ Every	* ODOMETER READING × 1 000 km (× 1 000 mile)					See Page
		1 (0.6)	12 (7.5)	24 (15)	36 (22.5)	48 (30)	
Air cleaner element # - replace	2 years						2-44
Fuel hose - replace	4 years					●	2-44
Coolant - change	3 years				●		2-45
Radiator hose and O-ring - replace	3 years				●		2-47
Engine oil # - change	year	●	●	●	●	●	2-47
Oil filter - replace	year	●	●	●	●	●	2-48
Brake hose and pipe - replace	4 years					●	2-49
Brake fluid - change	2 years			●		●	2-50
Rubber parts of master cylinder and caliper - replace	4 years					●	2-51
Spark plug - replace			●	●	●	●	2-55

#: Service more frequently when operating in severe conditions; dusty, wet, muddy, high speed or frequent starting/stopping.

*: For higher odometer readings, repeat at the frequency interval established here.

Torque and Locking Agent

The following tables list the tightening torque for the major fasteners requiring use of a non-permanent locking agent or silicone sealant etc.

Letters used in the "Remarks" column mean:

AL: Tighten the two clamp bolts alternately two times to ensure even tightening torque.

EO: Apply engine oil.

L: Apply a non-permanent locking agent to the threads.

Lh: Left-hand Threads

MO: Apply molybdenum disulfide oil solution.

(mixture of the engine oil and molybdenum disulfide grease in a weight ratio 10 : 1)

R: Replacement Parts

S: Follow the specified tightening sequence.

Si: Apply silicone grease (ex. PBC grease).

SS: Apply silicone sealant.

Fastener	Torque			Remarks
	N-m	kgf-m	ft-lb	
Fuel System (DFI)				
Crankshaft Sensor Bolts	6.0	0.61	53 in-lb	
Fuel Level Sensor Bolts	6.9	0.70	61 in-lb	L
Fuel Pump Bolts	9.8	1.0	87 in-lb	L, S
Oxygen Sensor (Equipped Models)	44	4.5	32	
Speed Sensor Bolt	7.8	0.80	69 in-lb	L
Speed Sensor Bracket Bolts	9.8	1.0	87 in-lb	
Switch Housing Screws	3.5	0.36	31 in-lb	
Timing Rotor Bolt	40	4.1	30	
Water Temperature Sensor	12	1.2	106 in-lb	
Cooling System				
Baffle Plate Bolts	5.9	0.60	52 in-lb	
Radiator Bolt	15	1.5	11	
Water Hose Clamp Screws	2.0	0.20	18 in-lb	
Thermostat Housing Bolts	9.8	1.0	87 in-lb	
Water Pump Cover Bolts	9.8	1.0	87 in-lb	
Water Pump Drain Bolt	9.8	1.0	87 in-lb	
Water Pump Impeller Bolt	9.8	1.0	87 in-lb	
Water Temperature Sensor	12	1.2	106 in-lb	
Engine Top End				
Air Suction Valve Cover Bolts	9.8	1.0	87 in-lb	
Baffle Plate Bolts	5.9	0.60	52 in-lb	
Camshaft Cap Bolts	12	1.2	106 in-lb	S
Camshaft Chain Tensioner Cap Bolt	20	2.0	15	
Camshaft Chain Tensioner Mounting Bolts	9.8	1.0	87 in-lb	
Camshaft Sprocket Bolts	15	1.5	11	L
Cylinder Head Bolts (M10)	56	5.7	41	MO, S
Cylinder Head Bolts (M6)	12	1.2	106 in-lb	S
Cylinder Head Cover Bolts	9.8	1.0	87 in-lb	
Rear Camshaft Chain Guide Bolts	20	2.0	15	L
Spark Plugs	15	1.5	11	

2-6 PERIODIC MAINTENANCE

Torque and Locking Agent

Fastener	Torque			Remarks
	N-m	kgf-m	ft-lb	
Throttle Body Assy Holder Bolts	12	1.2	106 in-lb	
Cylinder Bolt (M8)	27.5	2.8	20	MO, S
Cylinder Nut	49	5.0	36	MO, S
Cylinder Bolts (M6)	12	1.2	106 in-lb	S
Exhaust Pipe Manifold Holder Nuts	17	1.7	13	
Muffler Body Mounting Bolt (Front)	20	2.0	15	
Muffler Body Mounting Bolt (Rear)	20	2.0	15	
Clutch				
Clutch Cable Clamp Bracket Bolt	9.8	1.0	87 in-lb	
Clutch Cable Holder Bolts	9.8	1.0	87 in-lb	L
Clutch Cover Bolts	9.8	1.0	87 in-lb	
Clutch Hub Nut	130	13.3	96	R
Clutch Lever Clamp Bolts	7.8	0.80	69 in-lb	S
Clutch Spring Bolts	9.8	1.0	87 in-lb	
Timing Rotor Bolt Cap	4.9	0.50	43 in-lb	
Oil Filler Plug	–	–	–	Hand-tighten
Oil Pump Chain Guide Bolts	12	1.2	106 in-lb	L (1)
Oil Pump Sprocket Bolt	12	1.2	106 in-lb	L, Lh
Timing Inspection Cap	3.9	0.40	35 in-lb	
Engine Lubrication System				
Engine Oil Drain Plug	30	3.1	22	
Filter Plate Bolts	9.8	1.0	87 in-lb	L
Holder Mounting Bolt	25	2.5	18	L
Lower Fairing Bracket Bolts	12	1.2	106 in-lb	L
Oil Filter	17.5	1.8	13	EO, R
Oil Pan Bolts	12	1.2	106 in-lb	S
Oil Passage Plug	20	2.0	15	L
Oil Passage Plug (M6)	3.9	0.40	35 in-lb	
Oil Pipe Plate Bolt	9.8	1.0	87 in-lb	L
Oil Plate Bolts	9.8	1.0	87 in-lb	L
Oil Pressure Relief Valve	15	1.5	11	L
Oil Pressure Switch	15	1.5	11	SS
Oil Pump Chain Guide Bolts	12	1.2	106 in-lb	L (1)
Oil Pump Cover Bolts	9.8	1.0	87 in-lb	L
Oil Pump Sprocket Bolt	12	1.2	106 in-lb	L, Lh
Engine Removal/Installation				
Engine Bracket Bolts (Left)	25	2.5	18	S
Engine Bracket Bolts (Right)	25	2.5	18	S
Engine Mounting Nut (Lower)	44	4.5	32	S
Engine Mounting Nut (Rear)	44	4.5	32	S
Engine Mounting Bolt (Left)	44	4.5	32	S
Engine Mounting Bolt (Right)	44	4.5	32	S

Torque and Locking Agent

Fastener	Torque			Remarks
	N-m	kgf-m	ft-lb	
Crankshaft/Transmission				
Breather Plate Bolts	9.8	1.0	87 in-lb	L
Race Holder Screw	4.9	0.50	43 in-lb	L
Connecting Rod Big End Nuts	see Text	←	←	MO
Crankcase Bolt (M8, L = 110 mm)	27.5	2.8	20	S
Crankcase Bolt (M6, L = 32 mm)	19.6	2.0	14	S
Crankcase Bolts (M6, L = 38 mm)	19.6	2.0	14	S
Crankcase Bolts (M6, L = 45 mm)	19.6	2.0	14	S
Crankcase Bolt (M8, L = 50 mm)	27.5	2.8	20	S
Crankcase Bolts (M8, L = 60 mm)	35	3.6	26	MO, S
Crankcase Bolt (M8, L = 60 mm)	27.5	2.8	20	S
Crankcase Bolts (M8, L = 73 mm)	35	3.6	26	MO, S
Crankcase Bolts (M9, L = 113 mm)	44	4.5	32	MO, S
Crankcase Bolts (M9, L = 83 mm)	44	4.5	32	MO, S
Upper Crankcase Bolt (M8, L = 120 mm)	27.5	2.8	20	S
Upper Crankcase Bolts (M8, L = 110 mm)	27.5	2.8	20	S
Oil Pipe Bolts	9.8	1.0	87 in-lb	L
Oil Plate Bolts	9.8	1.0	87 in-lb	L
Shift Shaft Return Spring Pin	29	3.0	21	L
Timing Rotor Bolt	40	4.1	30	
Drive Shaft Bearing Holder Screw	4.9	0.50	43 in-lb	L
Gear Positioning Lever Bolt	12	1.2	106 in-lb	L
Neutral Switch	15	1.5	11	
Neutral Switch Holder Screw	4.9	0.50	43 in-lb	L
Transmission Case Oil Nozzle	2.9	0.30	26 in-lb	L
Shift Drum Bearing Holder Screws	4.9	0.50	43 in-lb	L
Shift Drum Cam Bolt	12	1.2	106 in-lb	L
Shift Pedal Bolt	12	1.2	106 in-lb	
Shift Rod Plate Bolt	9.8	1.0	87 in-lb	L
Shift Shaft Cover Bolts	9.8	1.0	87 in-lb	L (3)
Shift Shaft Cover Screw	4.9	0.50	43 in-lb	L, S
Transmission Case Bolts	20	2.0	15	
Wheels/Tires				
Front Axle	108	11.0	80	
Front Axle Clamp Bolt	34	3.5	25	
Rear Axle Nut	108	11.0	80	
Final Drive				
Engine Sprocket Nut	125	12.7	92	MO
Rear Axle Nut	108	11.0	80	
Rear Sprocket Nuts	59	6.0	44	
Speed Sensor Bolt	7.8	0.80	69 in-lb	L
Speed Sensor Bracket Bolts	9.8	1.0	87 in-lb	

2-8 PERIODIC MAINTENANCE

Torque and Locking Agent

Fastener	Torque			Remarks
	N-m	kgf-m	ft-lb	
Brakes				
Caliper Bleed Valve	7.8	0.80	69 in-lb	
Brake Hose Banjo Bolts	25	2.5	18	
Brake Lever Pivot Bolt	1.0	0.10	9 in-lb	Si
Brake Lever Pivot Bolt Locknut	5.9	0.60	52 in-lb	
Brake Disc Mounting Bolts	27	2.8	20	L
Front Brake Light Switch Screw	1.2	0.12	11 in-lb	
Front Brake Reservoir Cap Screws	1.5	0.15	13 in-lb	
Front Caliper Mounting Bolts	34	3.5	25	
Front Master Cylinder Clamp Bolts	11	1.1	97 in-lb	S
Brake Pedal Bolt	8.8	0.90	78 in-lb	
Rear Caliper Mounting Bolts	25	2.5	18	
Rear Master Cylinder Mounting Bolts	25	2.5	18	
Rear Master Cylinder Push Rod Locknut	17	1.7	13	
Brake Pipe Joint Nuts (EX650D Models)	18	1.8	13	
Wheel Rotation Sensor Bolts (EX650D Models)	20	2.0	15	
Suspension				
Front Axle Clamp Bolt	34	3.5	25	
Front Fork Bottom Allen Bolts	30	3.1	22	L
Front Fork Clamp Bolts (Lower)	21	2.1	15	AL
Front Fork Clamp Bolts (Upper)	20	2.0	15	
Front Fork Top Plugs	25	2.5	18	
Rear Shock Absorber Bolts	59	6.0	44	
Swingarm Pivot Shaft Nut	108	11.0	80	
Steering				
Front Fork Clamp Bolts (Lower)	21	2.1	15	AL
Front Fork Clamp Bolts (Upper)	20	2.0	15	
Handlebar Holder Bolts	25	2.5	18	S
Handlebar Holder Mounting Nuts	34	3.5	25	
Switch Housing Screws	3.5	0.36	31 in-lb	
Steering Stem Head Bolt	108	11.0	80	
Steering Stem Nut	20	2.0	15	
Frame				
Footpeg Stay Bolts	25	2.5	18	S
Front Fender Mounting Bolts	8.8	0.90	78 in-lb	
Front Turn Signal Light Mounting Screws	1.2	0.12	11 in-lb	
Grab Rail Mounting Bolts	25	2.5	18	
Lower Fairing Bracket Bolts	12	1.2	106 in-lb	L
Lower Fairing Mounting Bolts	8.8	0.90	78 in-lb	
Seat Lock Mounting Screws	1.2	0.12	11 in-lb	
Sidestand Bolt	44	4.5	32	
Sidestand Switch Bolt	8.8	0.90	78 in-lb	L

Torque and Locking Agent

Fastener	Torque			Remarks
	N-m	kgf-m	ft-lb	
Electrical System				
Tail/Brake Light Mounting Bolts	8.8	0.90	78 in-lb	
License Plate Light Mounting Screws	1.2	0.12	11 in-lb	
Alternator Cover Bolts	9.8	1.0	87 in-lb	
Alternator Lead Holding Plate Bolt	9.8	1.0	87 in-lb	L
Alternator Rotor Bolt	155	15.8	114	MO
Engine Ground Lead Terminal Bolt	9.8	1.0	87 in-lb	
Front Brake Light Switch Screw	1.2	0.12	11 in-lb	
Front Turn Signal Light Mounting Screws	1.2	0.12	11 in-lb	
Fuel Pump Bolts	9.8	1.0	87 in-lb	L, S
Meter Cover Screws	1.2	0.12	11 in-lb	
Regulator/Rectifier Bolts	8.8	0.90	78 in-lb	
Switch Housing Screws	3.5	0.36	31 in-lb	
Sidestand Switch Bolt	8.8	0.90	78 in-lb	L
Starter Motor Terminal Nut	6.0	0.61	53 in-lb	
Starter Motor Clutch Bolts	34	3.5	25	L
Starter Motor Mounting Bolts	9.8	1.0	87 in-lb	L
Starter Motor Terminal Locknut	11	1.1	97 in-lb	
Starter Motor Through Bolts	5.0	0.51	44 in-lb	
Stator Coil Bolts	12	1.2	106 in-lb	L
Crankshaft Sensor Bolts	6.0	0.61	53 in-lb	
Neutral Switch	15	1.5	11	
Oil Pressure Switch	15	1.5	11	SS
Oxygen Sensor (Equipped Models)	44	4.5	32	
Spark Plugs	15	1.5	11	
Speed Sensor Bolt	7.8	0.80	69 in-lb	L
Timing Rotor Bolt	40	4.1	30	
Water Temperature Sensor	12	1.2	106 in-lb	
Fuel Level Sensor Bolts	6.9	0.70	61 in-lb	L

2-10 PERIODIC MAINTENANCE

Torque and Locking Agent

The table below, relating tightening torque to thread diameter, lists the basic torque for the bolts and nuts. Use this table for only the bolts and nuts which do not require a specific torque value. All of the values are for use with dry solvent-cleaned threads.

Basic Torque for General Fasteners

Threads Diameter (mm)	Torque		
	N·m	kgf·m	ft·lb
5	3.4 ~ 4.9	0.35 ~ 0.50	30 ~ 43 in·lb
6	5.9 ~ 7.8	0.60 ~ 0.80	52 ~ 69 in·lb
8	14 ~ 19	1.4 ~ 1.9	10.0 ~ 13.5
10	25 ~ 34	2.6 ~ 3.5	19.0 ~ 25
12	44 ~ 61	4.5 ~ 6.2	33 ~ 45
14	73 ~ 98	7.4 ~ 10.0	54 ~ 72
16	115 ~ 155	11.5 ~ 16.0	83 ~ 115
18	165 ~ 225	17.0 ~ 23.0	125 ~ 165
20	225 ~ 325	23.0 ~ 33.0	165 ~ 240

Specifications

Item	Standard	Service Limit
Fuel System (DFI)		
Throttle Grip Free Play	2 ~ 3 mm (0.08 ~ 0.12 in.)	---
Idle Speed	1 300 ±50 r/min (rpm)	---
Bypass Screws (Turn out)	0 ~ 2 1/2 (for reference)	---
Engine Vacuum	35.3 ±1.3 kPa (265 ±10 mmHg)	---
Air Cleaner Element	Polyurethane Foam	---
Cooling System		
Coolant:		
Type (recommended)	Permanent type of antifreeze	---
Color	Green	---
Mixed Ratio	Soft water 50%, Coolant 50%	---
Freezing Point	-35°C (-31°F)	---
Total Amount	1.2 L (1.3 US qt)	---
Engine Top End		
Valve Clearance:		
Exhaust	0.22 ~ 0.31 mm (0.0087 ~ 0.0122 in.)	---
Inlet	0.15 ~ 0.21 mm (0.0059 ~ 0.0083 in.)	---
Clutch		
Clutch Lever Free Play	2 ~ 3 mm (0.08 ~ 0.12 in.)	---
Engine Lubrication System		
Engine Oil:		
Type	API SE, SF or SG API SH, SJ, SL or SM with JASO MA, MA1 or MA2	---
Viscosity	SAE 10W-40	---
Capacity	1.7 L (1.8 US qt) (when filter is not removed) 1.9 L (2.0 US qt) (when filter is removed) 2.4 L (2.5 US qt) (when engine is completely dry)	---
Level	Between upper and lower level lines (after idling or running)	---
Wheels/Tires		
Tread Depth:		
Front	4.8 mm (0.19 in.)	1 mm (0.04 in.), (AT, CH, DE) 1.6 mm (0.06 in.)
Rear	6.2 mm (0.24 in.)	Up to 130 km/h (80 mph): 2 mm (0.08 in.), Over 130 km/h (80 mph): 3 mm (0.12 in.)
Air Pressure (when Cold):		
Front	Up to 180 kg (397 lb) load: 225 kPa (2.25 kgf/cm ² , 32 psi)	---

2-12 PERIODIC MAINTENANCE

Specifications

Item	Standard	Service Limit
Rear	Up to 180 kg (397 lb) load: 250 kPa (2.50 kgf/cm ² , 36 psi)	---
Final Drive		
Drive Chain Slack	25 ~ 35 mm (1.0 ~ 1.4 in.)	---
Chain 20-link Length	317.5 ~ 318.2 mm (12.50 ~ 12.53 in.)	323 mm (12.7 in.)
Standard Chain:		
Make	DAIDO	---
Type	DID 520VP2-T	---
Link	114 links	---
Brakes		
Brake Fluid:		
Grade	DOT4	---
Brake Pad Lining Thickness:		
Front	4.5 mm (0.18 in.)	1 mm (0.04 in.)
Rear	5.0 mm (0.20 in.)	1 mm (0.04 in.)
Brake Light Timing:		
Front	Pulled ON	---
Rear	ON after about 10 mm (0.39 in.) of pedal travel	---
Electrical System		
Spark Plug:		
Type	NGK CR9EIA-9	---
Gap	0.8 ~ 0.9 mm (0.031 ~ 0.035 in.)	---

Special Tools

Inside Circlip Pliers:
57001-143

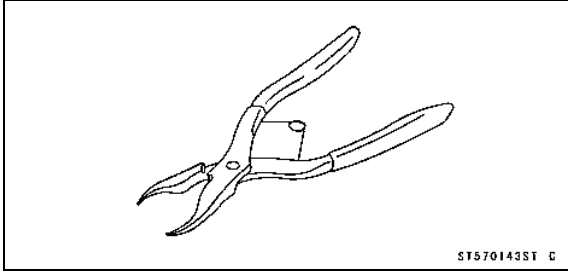

Throttle Sensor Setting Adapter:
57001-1538

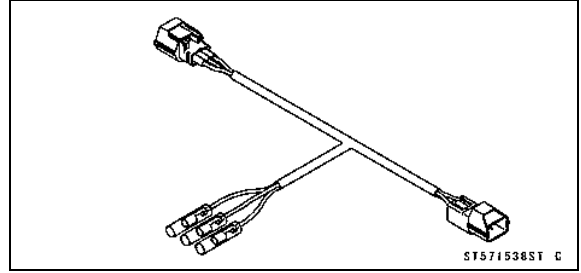

Steering Stem Nut Wrench:
57001-1100

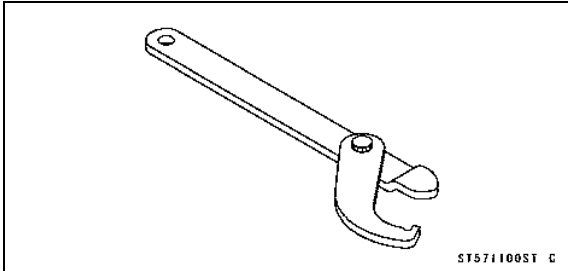

Extension Tube:
57001-1578

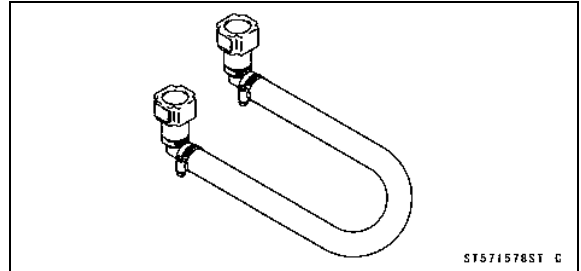

Oil Filter Wrench:
57001-1249

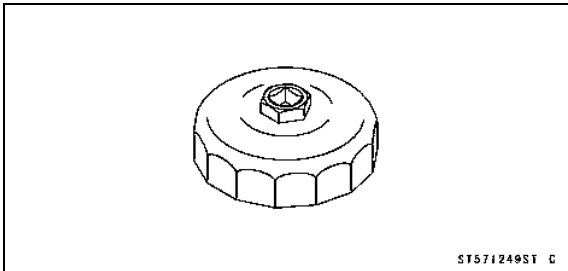

Pilot Screw Adjuster, E:
57001-1603

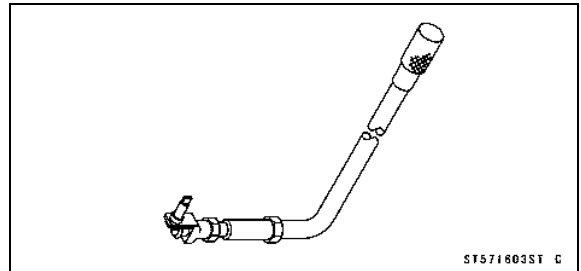

Vacuum Gauge:
57001-1369

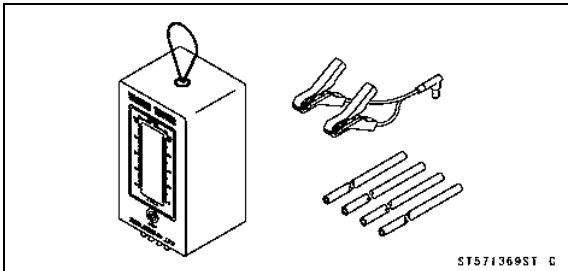

2-14 PERIODIC MAINTENANCE

Periodic Maintenance Procedures

Fuel System (DFI)

Air Cleaner Element Cleaning

NOTE

- In dusty areas, the element should be cleaned more frequently than the recommended interval.
- After riding through rain or on muddy roads, the element should be cleaned immediately.

⚠ WARNING

If dirt or dust is allowed to pass through into the throttle body assy, the throttle may become stuck, possibly causing accident.

CAUTION

If dirt gets through into the engine, excessive engine wear and possibly engine damage will occur.

- Remove:
 - Fuel Tank (see Fuel Tank Removal in the Fuel System (DFI) chapter)
 - Air Switching Valve Hose [A]
 - Air Cleaner Element Screw [B]
 - Air Cleaner Element [C]

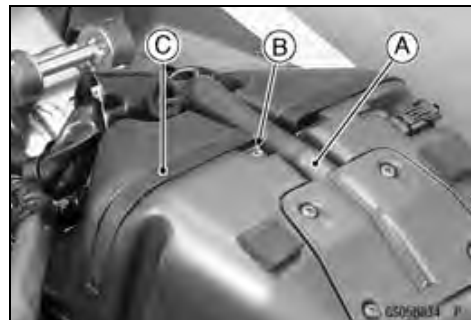

- Remove:
 - Plastic Holder [A]
 - Element [B]

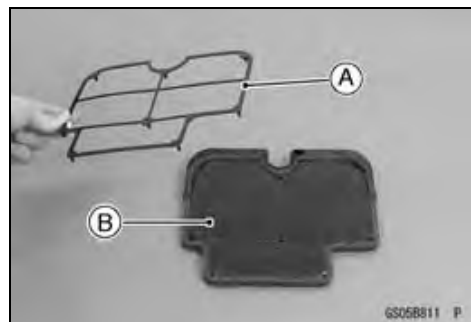

⚠ WARNING

Clean the element in a well-ventilated area, and make sure that there are no sparks or flame anywhere near the working area. Because of the danger of highly flammable liquids, do not use gasoline or a low-flash point solvent to clean the element.

- Clean the element [A] in a bath of high-flash point solvent, and then dry it with compressed air or by shaking it.
- After cleaning, saturate a clean, lint-free towel with SE, SF, or SG class SAE 30 oil and apply the oil to the element by tapping the element outside with the towel.
- Visually inspect the element for tears or breaks.
- If the element has any tears or breaks, replace the element with a new one.
- Install the element.

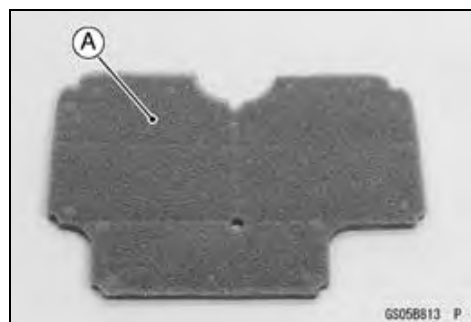

Periodic Maintenance Procedures

Throttle Control System Inspection

- Check that the throttle grip [A] moves smoothly from full open to close, and the throttle closes quickly and completely by the return spring in all steering positions.
- ★ If the throttle grip does not return properly, check the throttle cable routing, grip free play, and cable damage. Then lubricate the throttle cable.
- Check the throttle grip free play [B].

Throttle Grip Free Play

Standard: 2 ~ 3 mm (0.08 ~ 0.12 in.)

- ★ If the free play is incorrect, adjust the throttle cable as follows.
- Loosen the locknut [A] at the upper end of the accelerator cable.
- Turn the adjuster [B] in completely so as to give the throttle grip plenty of play.

- Remove the right upper fairing cover (see Upper Fairing Cover Removal in the Frame chapter).
- Loosen the locknut [A] at the middle of the decelerator cable.
- Turn the adjuster [B] until there is no play when the throttle grip is completely closed.
- Tighten the locknut.
- Turn the accelerator cable adjuster until the proper amount of throttle grip free play is obtained.
- Tighten the locknut.

Engine Vacuum Synchronization Inspection

NOTE

○ These procedures are explained on the assumption that the inlet and exhaust systems of the engine are in good condition.

- Situate the motorcycle so that it is vertical.
- Remove the left upper fairing cover (see Upper Fairing Cover Removal in the Frame chapter).
- Disconnect the inlet air pressure sensor hose temporary.
- Pull off the rubber caps [A] from the fitting of each throttle body.
- Connect the inlet air pressure sensor hose on the left fitting of the throttle body.

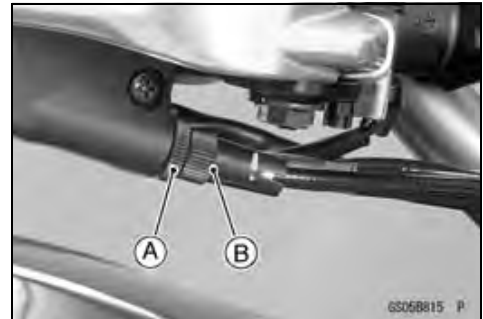
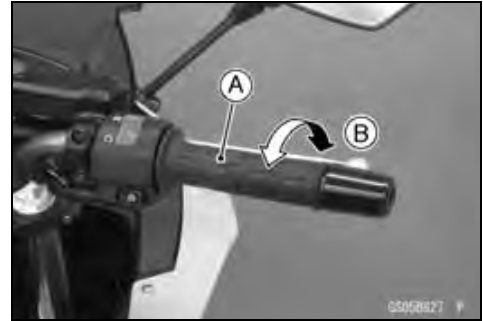

2-16 PERIODIC MAINTENANCE

Periodic Maintenance Procedures

- Connect a vacuum gauge (special tool) and hoses [A] to the fittings of the throttle body as shown in the figure.

Special Tool - Vacuum Gauge: 57001-1369

- Connect a highly accurate tachometer to one of the stick coil primary leads.

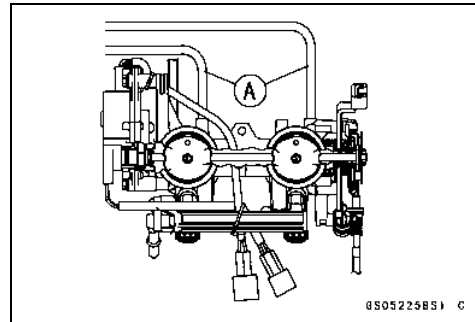

- Start the engine and warm it up thoroughly.
- Check the idle speed, using a highly accurate tachometer.
- Open and close the throttle.
- ★ If the idle speed is out of the specified range, adjust it.

CAUTION

Do not measure the idle speed by the tachometer of the meter unit.

- While idling the engine, inspect the engine vacuum, using the vacuum gauge.

Special Tool - Vacuum Gauge: 57001-1369

Engine Vacuum

**Standard: 35.3 ± 1.3 kPa (265 ± 10 mmHg) at Idle Speed
1 300 ± 50 r/min (rpm)**

- ★ If any one vacuum is not within the specification, turn in the bypass screws until it seats fully but not tightly.

Special Tool - Pilot Screw Adjuster, E [A]: 57001-1603

CAUTION

Do not over tighten them. They could be damaged, requiring replacement.



- Turn out the bypass screw of the higher vacuum between #1 [A] and #2 [B] to the lower vacuum.
- Open and close the throttle valves after each measurement and adjust the idle speed as necessary.
- Inspect the vacuums as before.
- ★ If both vacuums are within the specification, finish the engine vacuum synchronization.
- ★ If any vacuum can not be adjusted within the specification, remove the bypass screws #1, #2 and clean them.

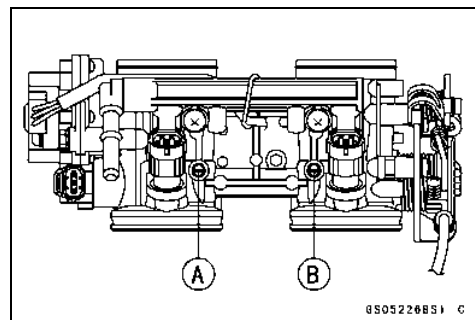

Periodic Maintenance Procedures

- Remove the bypass screw [A], spring [B], washer [C] and O-ring [D].
- Check the bypass screw and its hole for carbon deposits.
- ★ If any carbon accumulates, wipe the carbon off from the bypass screw and the hole, using a cotton pad penetrated with a high-flash point solvent.
- Replace the O-ring with a new one.
- Check the tapered portion [E] of the bypass screw for wear or damage.
- ★ If the bypass screw is worn or damaged, replace it.
- Turn in the bypass screw until it seats fully but not tightly.

- Repeat the same procedure for other bypass screws.
- Repeat the synchronization.
- ★ If the vacuums are correct, check the output voltage of the main throttle sensor (see Main Throttle Sensor Output Voltage Inspection in the Fuel System (DFI) chapter).

Special Tool - Throttle Sensor Setting Adapter: 57001-1538

Main Throttle Sensor Output Voltage Connections to Adapter:

- Meter (+) → R (Sensor Y/W) lead
- Meter (-) → W (Sensor BR/BK) lead

Standard: DC 1.005 ~ 1.035 V at idle throttle opening

- ★ If the output voltage is out of the range, check the main throttle sensor input voltage (see Main Throttle Sensor Input Voltage Inspection in the Fuel System (DFI) chapter).
- Remove the vacuum gauge hoses and install the rubber caps onto the original positions.

Idle Speed Inspection

- Start the engine and warm it up thoroughly.
- With the engine idling, turn [A] the handlebar to both sides.
- ★ If handlebar movement changes the idle speed, the throttle cables may be improperly adjusted or incorrectly routed or damaged. Be sure to correct any of these conditions before riding (see Throttle Control System Inspection and Cable, Wire, and Hose Routing section in the Appendix chapter).

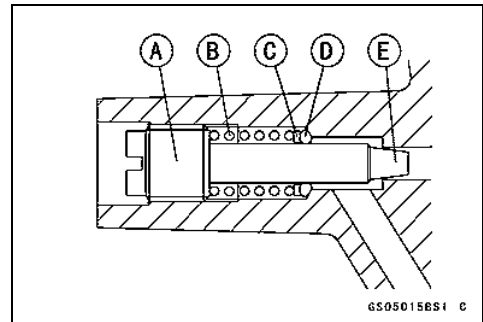

⚠ WARNING

Operation with improperly adjusted, incorrectly routed or damaged cables could result in an unsafe riding condition.

- Check idle speed.
- ★ If the idle speed is out of the specified range, adjust it.

Idle Speed

Standard: 1 300 ±50 r/min (rpm)

2-18 PERIODIC MAINTENANCE

Periodic Maintenance Procedures

Idle Speed Adjustment

- Start the engine and warm it up thoroughly.
- Turn the adjusting screw [A] until the idle speed is correct.
- Open and close the throttle a few times to make sure that the idle speed is within the specified range. Readjust if necessary.



Fuel Hose Inspection (fuel leak, damage, installation condition)

○ If the motorcycle is not properly handled, the high pressure inside the fuel line can cause fuel to leak [A] or the hose to burst. Remove the fuel tank (see Fuel Tank Removal in the Fuel System (DFI) chapter) and check the fuel hose.

- ★ Replace the fuel hose if any fraying, cracks [B] or bulges [C] are noticed.

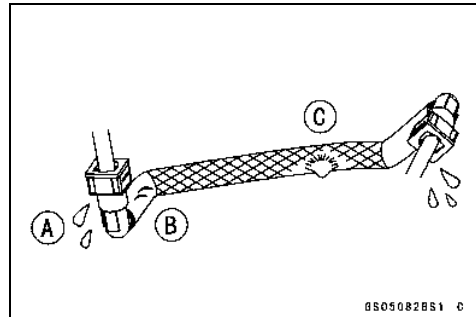

- Check that the hoses are routed according to Cable, Wire, and Hose Routing section in the Appendix chapter.
- ★ Replace the hose if it has been sharply bent or kinked (see Fuel Hose Replacement).

Hose Joints [A]

Fuel Hose [B]

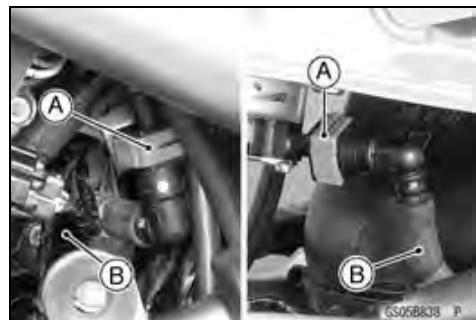

- Check that the hose joints are securely connected.
- Push and pull [A] the hose joints [B] back and forth more than two times, and make sure it is locked.
- ★ If it does not lock, reinstall the hose joint.

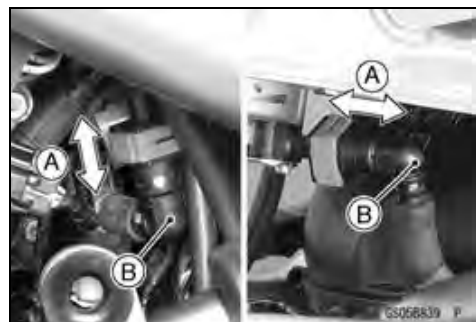

⚠ WARNING

Make sure the hose joint is installed correctly on the delivery pipe by sliding the joint, or the fuel could leak.

Evaporative Emission Control System Inspection (CAL and SEA Models)

- Inspect the canister as follows.
- Remove the upper fairing (see Upper Fairing Removal in the Frame chapter).
- Remove the canister [A], and disconnect the hoses from the canister.
- Visually inspect the canister for cracks or other damage.
- ★ If the canister has any cracks or bad damage, replace it with a new one.

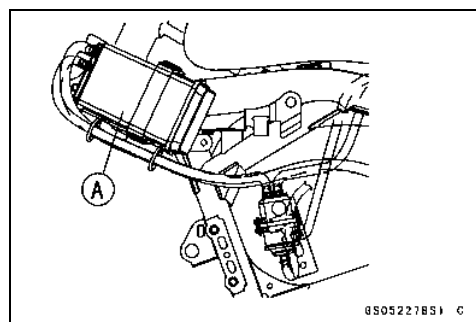

NOTE

- The canister is designed to work well through the motorcycle's life without any maintenance if it is used under normal conditions.

Periodic Maintenance Procedures

- Check the liquid/vapor separator as follows.
 - Remove the canister cover on the left side of the frame.
 - Disconnect the hoses from the separator, and remove the separator [A].
 - Visually inspect the separator for cracks and other damage.
 - ★ If the separator has any cracks or damage, replace it with a new one.
 - To prevent the gasoline from flowing into or out of the canister, hold the separator perpendicular to the ground.
- Check the hoses of the evaporative emission control system as follows.
 - Check that the hoses are securely connected and clips are in position.
 - Replace any kinked, deteriorated or damaged hoses.
 - Route the hoses according to Cable, Wire, and Hose Routing section in the Appendix chapter.
 - When installing the hoses, avoid sharp bending, kinking, flattening or twisting, and route the hoses with a minimum of bending so that the emission flow will not be obstructed.

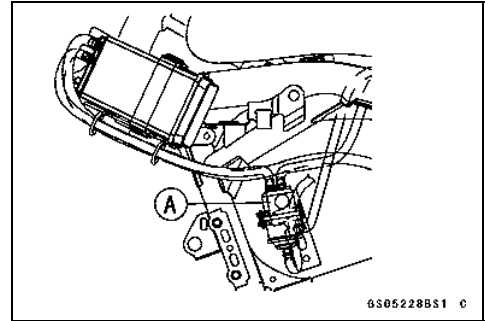

Cooling System

Coolant Level Inspection

NOTE

- Check the level when the engine is cold (room or ambient temperature).
 - Check the coolant level in the reserve tank [A] with the motorcycle held perpendicular (do not use the sidestand).
 - ★ If the coolant level is lower than the "L" level line [B], remove the upper fairing (see Upper Fairing Removal in the Frame chapter) and unscrew the reserve tank cap, and add coolant to the "F" level line [C].
- "L": Low
"F": Full

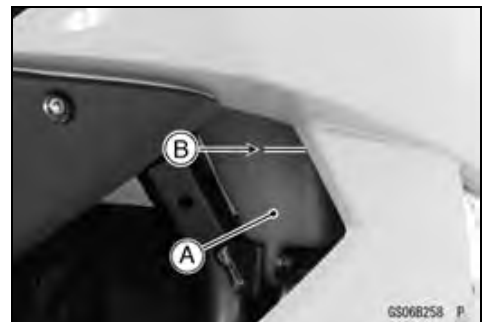

CAUTION

For refilling, add the specified mixture of coolant and soft water. Adding water alone dilutes the coolant and degrades its anticorrosion properties. The diluted coolant can attack the aluminum engine parts. In an emergency, soft water alone can be added. But the diluted coolant must be returned to the correct mixture ratio within a few days. If coolant must be added often or the reservoir tank has run completely dry, there is probably leakage in the cooling system. Check the system for leaks. Coolant ruins painted surfaces. Immediately wash away any coolant that spills on the frame, engine, wheels or other painted parts.

2-20 PERIODIC MAINTENANCE

Periodic Maintenance Procedures

Water Hose Damage and Installation Condition Inspection

- The high pressure inside the water hose can cause coolant to leak [A] or the hose to burst if the line is not properly maintained.
- Visually inspect the hoses for signs of deterioration. Squeeze the hoses. A hose should not be hard and brittle, nor should it be soft or swollen.
- ★ Replace the hose if any fraying, cracks [B] or bulges [C] are noticed.
- Check that the hoses are securely connected and clamps are tightened correctly.

Torque - Water Hose Clamp Screws: 2.0 N-m (0.20 kgf-m, 18 in-lb)

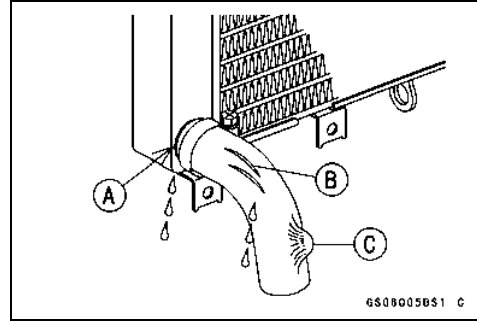

Engine Top End

Valve Clearance Inspection

NOTE

○ Valve clearance must be checked and adjusted when the engine is cold (room temperature).

- Remove:
 - Cylinder Head Cover (see Cylinder Head Cover Removal in the Engine Top End chapter)
 - Lower Fairing (see Lower Fairing Removal in the Frame chapter)
 - Timing Inspection Cap [A]
 - Timing Rotor Bolt Cap [B]
- Check the valve clearance when the pistons are at TDC.
- The pistons are numbered beginning with the engine left side.
- Using a wrench on the timing rotor bolt, turn the crankshaft clockwise until the 1/T mark line [A] on the timing rotor is aligned with the notch [B] in the edge of the timing inspection hole [C] in the clutch cover for #1 piston and 2/T mark line [D] for #2 piston.

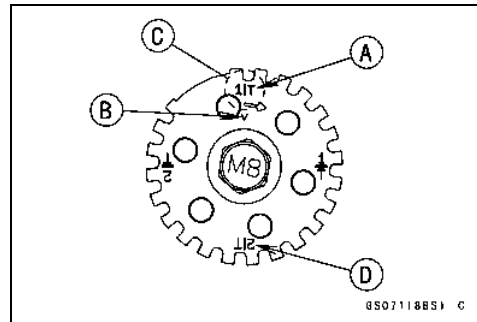
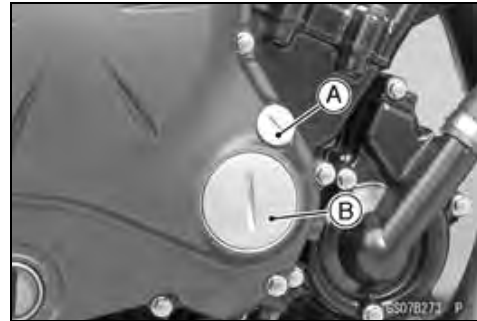

- Measure the valve clearance of the valves for which the cams [A] are turned away from each other.

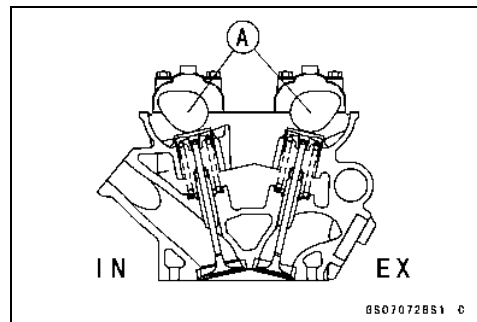

Periodic Maintenance Procedures

- Using the thickness gauge [A], measure the valve clearance between cam and valve lifter.

Valve Clearance

Standard:

Exhaust 0.22 ~ 0.31 mm (0.0087 ~ 0.0122 in.)

Inlet 0.15 ~ 0.21 mm (0.0059 ~ 0.0083 in.)

- Each piston has two inlet and two exhaust valves. Measure these two inlet or exhaust valves at the same crankshaft position.



NOTE

- Check the valve clearance using this method only. Checking the clearance at any other cam position may result in improper valve clearance.

Valve Clearance Measuring Position

#1 Piston TDC at End of Compression Stroke:

Inlet valve clearances of #1 piston, and

Exhaust valve clearances of #1 piston

#2 Piston TDC at End of Compression Stroke:

Inlet valve clearances of #2 piston, and

Exhaust valve clearances of #2 piston

- ★ If the valve clearance is not within the specified range, first record the clearance, and then adjust it.

Valve Clearance Adjustment

- To change the valve clearance, remove the camshaft chain tensioner, camshafts and valve lifters. Replace the shim with one of a different thickness.

NOTE

- Mark and record the locations of the valve lifters and shims so that they can be reinstalled in their original positions.
- If there is no valve clearance, use a shim that is a few sizes smaller, and remeasure the valve clearance.

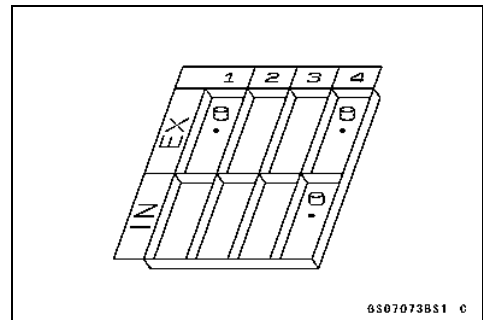

- To select a new shim which brings the valve clearance within the specified range, refer to the Valve Clearance Adjustment Charts.
- Apply a thin coat of molybdenum disulfide grease to the valve lifters.
- Install the camshafts. Be sure to time the camshafts properly (see Camshaft Installation in the Engine Top End chapter).
- Remeasure any valve clearance that was adjusted. Readjust if necessary.

CAUTION

Do not put shim stock under the shim. This may cause the shim to pop out at high rpm, causing extensive engine damage.
Do not grind the shim. This may cause it to fracture, causing extensive engine damage.

2-22 PERIODIC MAINTENANCE

Periodic Maintenance Procedures

VALVE CLEARANCE ADJUSTMENT CHART INLET VALVE

		PRESENT SHIM															Example							
PART No. (92180-)		1014	1016	1018	1020	1022	1024	1026	1028	1030	1032	1034	1036	1038	1040	1042	1044	1046	1048	1050	1052	1054		
MARK		50	55	60	65	70	75	80	85	90	95	00	05	10	15	20	25	30	35	40	45	50		
THICKNESS (mm)		2.50	2.55	2.60	2.65	2.70	2.75	2.80	2.85	2.90	2.95	3.00	3.05	3.10	3.15	3.20	3.25	3.30	3.35	3.40	3.45	3.50		
VALVE CLEARANCE MEASUREMENT	Example	0.00~0.01	-	-	-	-	2.50	2.55	2.60	2.65	2.70	2.75	2.80	2.85	2.90	2.95	3.00	3.05	3.10	3.15	3.20	3.25	3.30	
		0.02~0.06	-	-	-	2.50	2.55	2.60	2.65	2.70	2.75	2.80	2.85	2.90	2.95	3.00	3.05	3.10	3.15	3.20	3.25	3.30	3.35	
		0.07~0.11	-	-	2.50	2.55	2.60	2.65	2.70	2.75	2.80	2.85	2.90	2.95	3.00	3.05	3.10	3.15	3.20	3.25	3.30	3.35	3.40	
		0.12~0.14	-	2.50	2.55	2.60	2.65	2.70	2.75	2.80	2.85	2.90	2.95	3.00	3.05	3.10	3.15	3.20	3.25	3.30	3.35	3.40	3.45	3.50
		0.15~0.21	SPECIFIED CLEARANCE/NO CHANGE REQUIRED																					
		0.22~0.24	2.55	2.60	2.65	2.70	2.75	2.80	2.85	2.90	2.95	3.00	3.05	3.10	3.15	3.20	3.25	3.30	3.35	3.40	3.45	3.50		
		0.25~0.29	2.60	2.65	2.70	2.75	2.80	2.85	2.90	2.95	3.00	3.05	3.10	3.15	3.20	3.25	3.30	3.35	3.40	3.45	3.50			
		0.30~0.34	2.65	2.70	2.75	2.80	2.85	2.90	2.95	3.00	3.05	3.10	3.15	3.20	3.25	3.30	3.35	3.40	3.45	3.50				
		0.35~0.39	2.70	2.75	2.80	2.85	2.90	2.95	3.00	3.05	3.10	3.15	3.20	3.25	3.30	3.35	3.40	3.45	3.50					
		0.40~0.44	2.75	2.80	2.85	2.90	2.95	3.00	3.05	3.10	3.15	3.20	3.25	3.30	3.35	3.40	3.45	3.50						
		0.45~0.49	2.80	2.85	2.90	2.95	3.00	3.05	3.10	3.15	3.20	3.25	3.30	3.35	3.40	3.45	3.50							
		0.50~0.54	2.85	2.90	2.95	3.00	3.05	3.10	3.15	3.20	3.25	3.30	3.35	3.40	3.45	3.50								
		0.55~0.59	2.90	2.95	3.00	3.05	3.10	3.15	3.20	3.25	3.30	3.35	3.40	3.45	3.50									
		0.60~0.64	2.95	3.00	3.05	3.10	3.15	3.20	3.25	3.30	3.35	3.40	3.45	3.50										
		0.65~0.69	3.00	3.05	3.10	3.15	3.20	3.25	3.30	3.35	3.40	3.45	3.50											
		0.70~0.74	3.05	3.10	3.15	3.20	3.25	3.30	3.35	3.40	3.45	3.50												
		0.75~0.79	3.10	3.15	3.20	3.25	3.30	3.35	3.40	3.45	3.50													
		0.80~0.84	3.15	3.20	3.25	3.30	3.35	3.40	3.45	3.50														
		0.85~0.89	3.20	3.25	3.30	3.35	3.40	3.45	3.50															
0.90~0.94	3.25	3.30	3.35	3.40	3.45	3.50																		
0.95~0.99	3.30	3.35	3.40	3.45	3.50																			
1.00~1.04	3.35	3.40	3.45	3.50																				
1.05~1.09	3.40	3.45	3.50																					
1.10~1.14	3.45	3.50																						
1.15~1.19	3.50																							

INSTALL THE SHIM OF THIS THICKNESS (mm)

65071198#3 C

1. Measure the clearance (when engine is cold).
2. Check present shim size.
3. Match clearance in vertical column with present shim size in horizontal column.
4. Install the shim specified where the lines intersect. This shim will give the proper clearance.

Example: Present shim is **2.95 mm**.
 Measured clearance is **0.42 mm**.
 Replace **2.95 mm** shim with **3.20 mm** shim.

5. Remeasure the valve clearance and readjust if necessary.

Periodic Maintenance Procedures

VALVE CLEARANCE ADJUSTMENT CHART EXHAUST VALVE

		PRESENT SHIM														Example													
PART No. (92180-)		1014	1016	1018	1020	1022	1024	1026	1028	1030	1032	1034	1036	1038	1040	1042	1044	1046	1048	1050	1052	1054							
MARK		50	55	60	65	70	75	80	85	90	95	00	05	10	15	20	25	30	35	40	45	50							
THICKNESS (mm)		2.50	2.55	2.60	2.65	2.70	2.75	2.80	2.85	2.90	2.95	3.00	3.05	3.10	3.15	3.20	3.25	3.30	3.35	3.40	3.45	3.50							
VALVE CLEARANCE MEASUREMENT	Example	0.00~0.04	-	-	-	-	-	2.50	2.55	2.60	2.65	2.70	2.75	2.80	2.85	2.90	2.95	3.00	3.05	3.10	3.15	3.20	3.25						
		0.05~0.09	-	-	-	-	2.50	2.55	2.60	2.65	2.70	2.75	2.80	2.85	2.90	2.95	3.00	3.05	3.10	3.15	3.20	3.25	3.30						
		0.10~0.14	-	-	-	2.50	2.55	2.60	2.65	2.70	2.75	2.80	2.85	2.90	2.95	3.00	3.05	3.10	3.15	3.20	3.25	3.30	3.35						
		0.15~0.19	-	-	2.50	2.55	2.60	2.65	2.70	2.75	2.80	2.85	2.90	2.95	3.00	3.05	3.10	3.15	3.20	3.25	3.30	3.35	3.40						
		0.20~0.21	-	2.50	2.55	2.60	2.65	2.70	2.75	2.80	2.85	2.90	2.95	3.00	3.05	3.10	3.15	3.20	3.25	3.30	3.35	3.40	3.45						
		0.22~0.31	SPECIFIED CLEARANCE/NO CHANGE REQUIRED																										
		0.32~0.34	2.55	2.60	2.65	2.70	2.75	2.80	2.85	2.90	2.95	3.00	3.05	3.10	3.15	3.20	3.25	3.30	3.35	3.40	3.45	3.50							
		0.35~0.39	2.60	2.65	2.70	2.75	2.80	2.85	2.90	2.95	3.00	3.05	3.10	3.15	3.20	3.25	3.30	3.35	3.40	3.45	3.50								
		0.40~0.44	2.65	2.70	2.75	2.80	2.85	2.90	2.95	3.00	3.05	3.10	3.15	3.20	3.25	3.30	3.35	3.40	3.45	3.50									
		0.45~0.49	2.70	2.75	2.80	2.85	2.90	2.95	3.00	3.05	3.10	3.15	3.20	3.25	3.30	3.35	3.40	3.45	3.50										
		0.50~0.54	2.75	2.80	2.85	2.90	2.95	3.00	3.05	3.10	3.15	3.20	3.25	3.30	3.35	3.40	3.45	3.50											
		0.55~0.59	2.80	2.85	2.90	2.95	3.00	3.05	3.10	3.15	3.20	3.25	3.30	3.35	3.40	3.45	3.50												
		0.60~0.64	2.85	2.90	2.95	3.00	3.05	3.10	3.15	3.20	3.25	3.30	3.35	3.40	3.45	3.50													
		0.65~0.69	2.90	2.95	3.00	3.05	3.10	3.15	3.20	3.25	3.30	3.35	3.40	3.45	3.50														
		0.70~0.74	2.95	3.00	3.05	3.10	3.15	3.20	3.25	3.30	3.35	3.40	3.45	3.50															
		0.75~0.79	3.00	3.05	3.10	3.15	3.20	3.25	3.30	3.35	3.40	3.45	3.50																
		0.80~0.84	3.05	3.10	3.15	3.20	3.25	3.30	3.35	3.40	3.45	3.50																	
		0.85~0.89	3.10	3.15	3.20	3.25	3.30	3.35	3.40	3.45	3.50																		
		0.90~0.94	3.15	3.20	3.25	3.30	3.35	3.40	3.45	3.50																			
		0.95~0.99	3.20	3.25	3.30	3.35	3.40	3.45	3.50																				
1.00~1.04	3.25	3.30	3.35	3.40	3.45	3.50																							
1.05~1.09	3.30	3.35	3.40	3.45	3.50																								
1.10~1.14	3.35	3.40	3.45	3.50																									
1.15~1.19	3.40	3.45	3.50																										
1.20~1.24	3.45	3.50																											
1.25~1.29	3.50																												

INSTALL THE SHIM OF THIS THICKNESS (mm)

65071208#3 C

1. Measure the clearance (when engine is cold).
2. Check present shim size.
3. Match clearance in vertical column with present shim size in horizontal row.
4. Install the shim specified where the lines intersect. This shim will give the proper clearance.

Example: Present shim is **2.95 mm**.
 Measured clearance is **0.47 mm**.
 Replace **2.95 mm** shim with **3.15 mm** shim.

5. Remeasure the valve clearance and readjust if necessary.

2-24 PERIODIC MAINTENANCE

Periodic Maintenance Procedures

Air Suction System Damage Inspection

- Remove:
 - Fuel Tank (see Fuel Tank Removal in the Fuel System (DFI) chapter)
 - Fuel Hose (see Fuel Hose Replacement)
- Connect the following parts temporary.
 - Fuel Pump Lead Connector [A]
 - Fuel Level Sensor Lead Connector [B]
 - Extension Tube [C]

Special Tool - Extension Tube: 57001-1578

- Pull the air switching valve hose [D] out of the air cleaner housing.
- Start the engine and run it at idle speed.
- Plug [A] the air switching valve hose end with your finger and feel vacuum pulsing in the hose.
- ★ If there is no vacuum pulsation, check the hose line for leak. If there is no leak, check the air switching valve (see Air Switching Valve Unit Test in the Electrical System chapter) or air suction valve (see Air Suction Valve Inspection in the Engine Top End chapter).

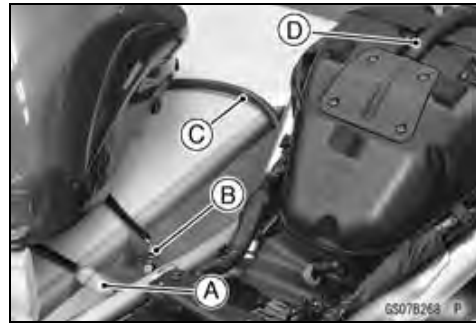

Clutch

Clutch Operation Inspection

- Pull the clutch lever just enough to take up the free play [A].
- Measure the gap between the lever and the lever holder.
- ★ If the gap is too wide, the clutch may not release fully. If the gap is too narrow, the clutch may not engage fully. In either case, adjust it.

Clutch Lever Free Play

Standard: 2 ~ 3 mm (0.08 ~ 0.12 in.)

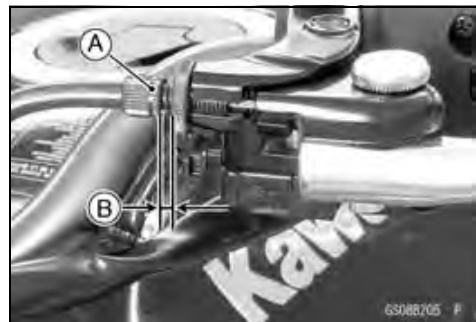

⚠ WARNING

To avoid a serious burn, never touch the engine or exhaust pipe during clutch adjustment.

- Turn the adjuster [A] so that 5 ~ 6 mm (0.20 ~ 0.24 in.) [B] of threads are visible.

Periodic Maintenance Procedures

- Remove the right upper fairing cover (see Upper Fairing Cover Removal in the Frame chapter).
- Open the clamp [A].
- Slide the dust cover [B] out of place.
- Loosen the locknut [C].
- Turn the adjusting nut [D] until the free play is correct.

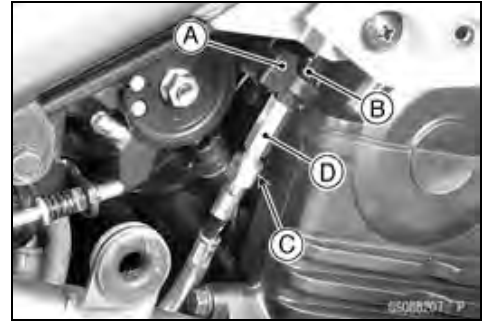

⚠ WARNING

Be sure that the outer cable end at the clutch lever is fully seated in the adjuster at the clutch lever, or it could slip into place later, creating enough cable play to prevent clutch disengagement.

- Tighten the locknut, and slip the dust cover back onto place.
- After the adjustment, start the engine and check that the clutch does not slip and that it releases properly.

Wheels/Tires

Air Pressure Inspection

- Remove the air valve cap.
- Measure the tire air pressure with an air pressure gauge [A] when the tires are cold (that is, when the motorcycle has not been ridden more than a mile during the past 3 hours).
- Install the air valve cap.
- ★ Adjust the tire air pressure according to the specifications if necessary.

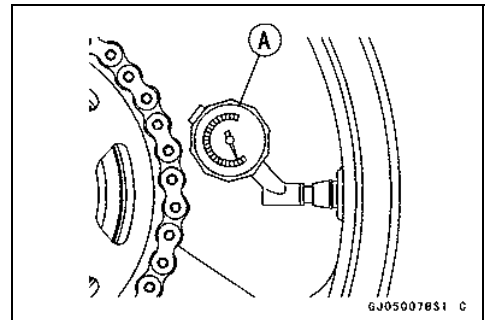

Air Pressure (when Cold)

- Front: Up to 180 kg (397 lb)
225 kPa (2.25 kgf/cm², 32 psi)
- Rear: Up to 180 kg (397 lb)
250 kPa (2.50 kgf/cm², 36 psi)

Wheel/Tire Damage Inspection

- Remove any imbedded stones [A] or other foreign particles [B] from tread.
- Visually inspect the tire for cracks and cuts, and replace the tire if necessary. Swelling or high spots indicate internal damage, requiring tire replacement.
- Visually inspect the wheel for cracks, cuts and dents damage.
- ★ If any damage is found, replace the the wheel if necessary.

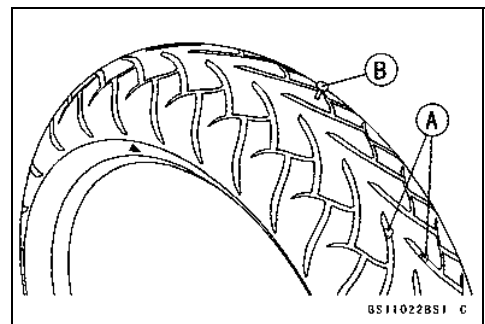

2-26 PERIODIC MAINTENANCE

Periodic Maintenance Procedures

Tire Tread Wear, Abnormal Wear Inspection

As the tire tread wears down, the tire becomes more susceptible to puncture and failure. An accepted estimate is that 90% of all tire failures occur during the last 10% of tread life (90% worn). So it is false economy and unsafe to use the tires until they are bald.

- Measure the tread depth at the center of the tread with a depth gauge [A]. Since the tire may wear unevenly, take measurement at several places.
- ★ If any measurement is less than the service limit, replace the tire (see Tire Removal/Installation in the Wheels/Tires chapter).

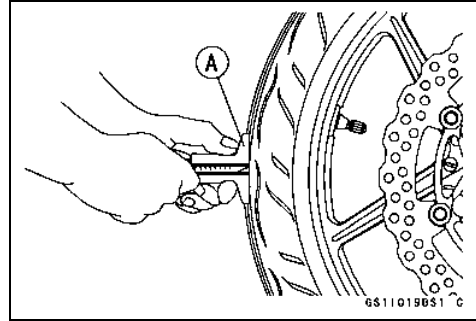

Tread Depth

Standard:

Front	4.8 mm (0.19 in.)
Rear	6.2 mm (0.24 in.)

Service Limit:

Front	1 mm (0.04 in.) (AT, CH, DE) 1.6 mm (0.06 in.)
Rear	2 mm (0.08 in.) (Up to 130 km/h (80 mph)) 3 mm (0.12 in.) (Over 130 km/h (80 mph))

⚠ WARNING

To ensure safe handling and stability, use only the recommended standard tires for replacement, inflated to the standard pressure.

NOTE

- Most countries may have their own regulations a minimum tire tread depth: be sure to follow them.
- Check and balance the wheel when a tire is replaced with a new one.

Wheel Bearing Damage Inspection

- Raise the front wheel off the ground with the jack (see Front Wheel Removal in the Wheels/Tires chapter).
- Turn the handlebar all the way to the right or left.
- Inspect the roughness of the front wheel bearing by pushing and pulling [A] the wheel.
- Spin [B] the front wheel lightly, and check for smoothly turn, roughness, binding or noise.
- ★ If roughness, binding or noise is found, remove the front wheel and inspect the wheel bearing (see Front Wheel Removal, Hub Bearing Inspection in the Wheels/Tires chapter).



Periodic Maintenance Procedures

- Raise the rear wheel off the ground with the stand (see Rear Wheel Removal in the Wheels/Tires chapter).
- Inspect the roughness of the rear wheel bearing by pushing and pulling [A] the wheel.
- Spin [B] the rear wheel lightly, and check for smoothly turn, roughness, binding or noise.
- ★ If roughness, binding or noise is found, remove the rear wheel and inspect the wheel bearing (see Rear Wheel Removal, Hub Bearing Inspection in the Wheels/Tires chapter) and coupling (see Coupling Bearing Inspection in the Final Drive chapter).



Final Drive

Drive Chain Lubrication Condition Inspection

- If a special lubricant is not available, a heavy oil such as SAE 90 is preferred to a lighter oil because it will stay on the chain longer and provide better lubrication.
- If the chain appears especially dirty, clean it before lubrication.

CAUTION

The O-rings between the side plates seal in the lubricant between the pin and the bushing. To avoid damaging the O-rings and resultant loss of lubricant, observe the following rules.
 Use only kerosene or diesel oil for cleaning an O-ring of the drive chain. Any other cleaning solution such as gasoline will cause deterioration and swelling of the O-ring. Immediately blow the chain dry with compressed air after cleaning. Complete cleaning and drying the chain within 10 minutes.

- Apply oil to the sides of the rollers so that oil will penetrate to the rollers and bushings. Apply the oil to the O-rings so that the O-rings will be coated with oil.
- Wipe off any excess oil.
 - Oil Applied Areas [A]
 - O-rings [B]

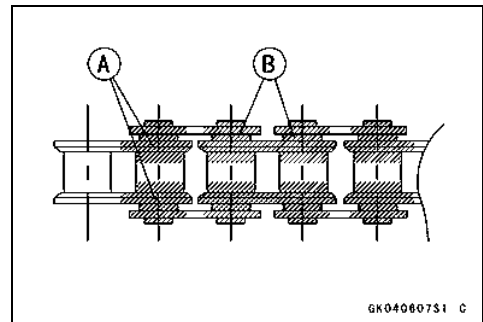

GK040607S1 C

2-28 PERIODIC MAINTENANCE

Periodic Maintenance Procedures

Drive Chain Slack Inspection

NOTE

- Check the slack with the motorcycle setting on its side-stand.
- Clean the chain if it is dirty, and lubricate it if it appears dry.
- Check the wheel alignment (see Wheel Alignment Inspection).
- Rotate the rear wheel to find the position where the chain is tightest.
- Measure the vertical movement (chain slack) [A] midway between the sprockets.
- ★ If the chain slack exceeds the standard, adjust it.

Chain Slack

Standard: 25 ~ 35 mm (1.0 ~ 1.4 in.)

Drive Chain Slack Adjustment

- Raise the rear wheel off the ground with the stand.
- Remove the cotter pin [A], and loosen the axle nut [B].
- Loosen the both chain adjuster locknuts [C].
- ★ If the chain is too loose, turn out the right and left chain adjusters [D] evenly.
- ★ If the chain is too tight, turn in the right and left chain adjusters evenly, and kick the wheel forward.
- Turn both chain adjusters evenly until the drive chain has the correct amount of slack. To keep the chain and wheel properly aligned, the edge [E] of the left wheel alignment indicator [F] should align with the same swingarm mark or position [G] that the right indicator notch aligns with.

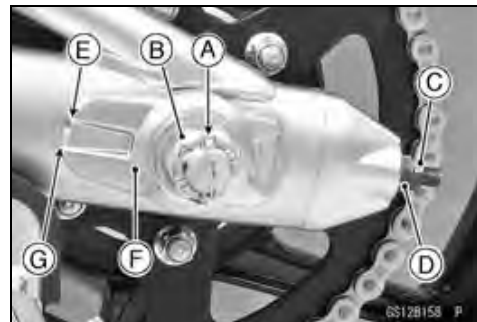
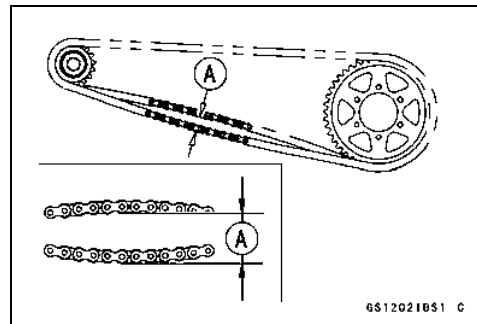

⚠ WARNING

Misalignment of the wheel will result in abnormal wear and may result in an unsafe riding condition.

- Tighten both chain adjuster locknuts securely.
- Tighten the axle nut.
- Torque - Rear Axle Nut: 108 N·m (11.0 kgf·m, 80 ft·lb)**
- Turn the wheel, measure the chain slack again at the tightest position, and readjust if necessary.
- Insert a new cotter pin [A].

NOTE

- When inserting the cotter pin, if the slots in the nut do not align with the cotter pin hole in the axle, tighten the nut clockwise [B] up to next alignment.
- It should be within 30°.
- Loosen once and tighten again when the slot goes past the nearest hole.

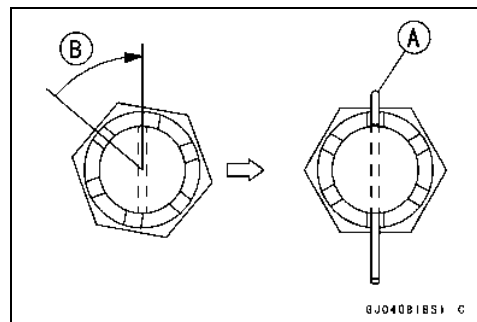

Periodic Maintenance Procedures

- Bend the cotter pin [A] over the nut.

⚠ WARNING

If the rear axle nut is not securely tightened or the cotter pin is not installed, an unsafe riding condition may result.

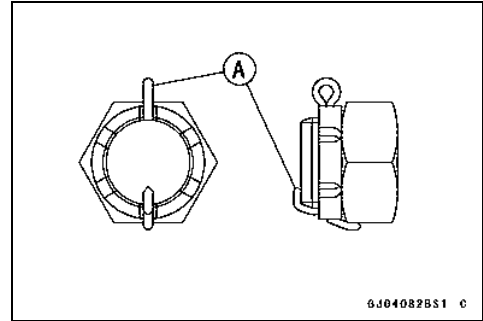

Wheel Alignment Inspection

- Check that the edge [A] on the left wheel alignment indicator [B] aligns with the same swingarm mark or position [C] that the right wheel alignment indicator edge aligns with.
- ★ If they do not, adjust the chain slack and align the wheel alignment (see Drive Chain Slack Adjustment).

NOTE

○ Wheel alignment can be also checked using the straightedge or string method.

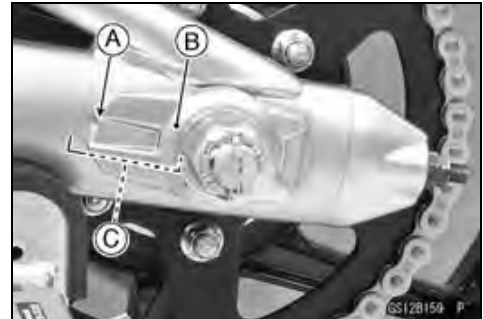

⚠ WARNING

Misalignment of the wheel will result in abnormal wear, and may result in an unsafe riding condition.

2-30 PERIODIC MAINTENANCE

Periodic Maintenance Procedures

Drive Chain Wear Inspection

- Remove the chain cover (see Swingarm Removal in the Suspension chapter).
- Rotate the rear wheel to inspect the drive chain for damaged rollers, and loose pins and links.
- ★ If there is any irregularity, replace the drive chain.
- ★ Lubricate the drive chain if it appears dry.
- Stretch the chain taut by hanging a 98 N (10 kg, 20 lb) weight [A] on the chain.
- Measure the length of 20 links [B] on the straight part [C] of the chain from the pin center of the 1st pin to the pin center of the 21st pin. Since the chain may wear unevenly, take measurements at several places.
- ★ If any measurements exceed the service limit, replace the chain. Also, replace the front and rear sprockets when the drive chain is replaced.

Drive Chain 20-link Length

Standard: 317.5 ~ 318.2 mm (12.50 ~ 12.53 in.)

Service Limit: 323 mm (12.7 in.)

⚠ WARNING

If the drive chain wear exceeds the service limit, replace the chain or an unsafe riding condition may result. A chain that breaks or jumps off the sprockets could snag on the engine sprocket or lock the rear wheel, severely damaging the motorcycle and causing it to go out of control. For safety, use only the standard chain. It is an endless type and should not be cut for installation.

Standard Chain

Make: DAIDO

Type: DID 520VP2-T

Link: 114 links

Chain Guide Inspection

- Remove the swingarm (see Swingarm Removal in the Suspension chapter).
- Visually inspect the chain guide [A].
- ★ Replace the chain guide if it shows any signs of abnormal wear or damage.

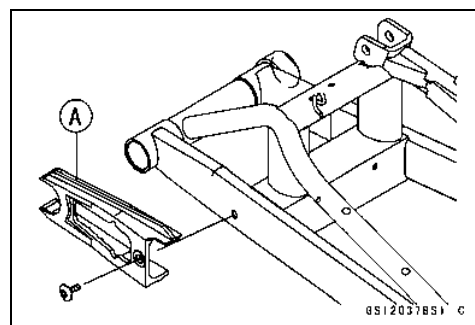
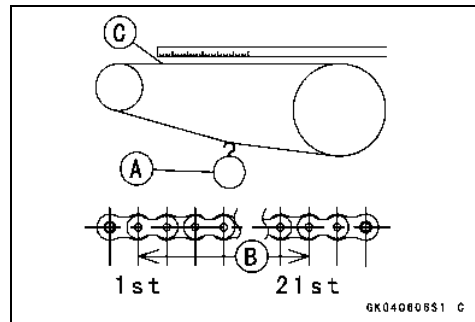

Periodic Maintenance Procedures

Brake System

Brake Fluid Leak (Brake Hose and Pipe) Inspection

- For models equipped with an ABS, remove the battery case (see Battery Case Removal in the Frame chapter).
- Apply the brake lever or pedal, and inspect the brake fluid leak from the brake hoses [A], pipes (ABS equipped models) [B] and fittings [C].
- ★ If the brake fluid leaked from any position, inspect or replace the problem part.

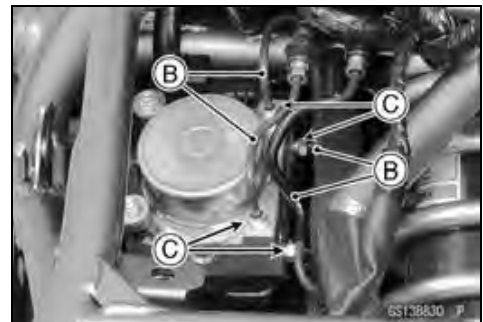
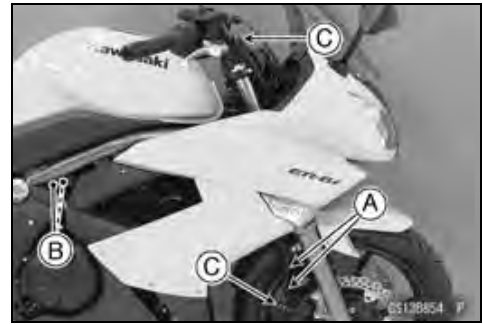

Brake Hose and Pipe Damage and Installation Condition Inspection

- For models equipped with an ABS, remove the battery case (see Battery Case Removal in the Frame chapter).
- Inspect the brake hoses, fittings and pipes (ABS equipped models) for deterioration, cracks and signs of leakage.
- The high pressure inside the brake line can cause fluid to leak [A] or the hose, pipes (ABS equipped models) to burst if the line is not properly maintained. Bend and twist the rubber hose while examining it.
- ★ Replace the hose and pipe (ABS equipped models) if any crack [B], bulge [C] or leakage is noticed.
- ★ Tighten any brake hose banjo bolts and brake pipe joint nuts.

Torque - Brake Hose Banjo Bolts: 25 N·m (2.5 kgf·m, 18 ft·lb)

**Brake Pipe Joint Nuts: 18 N·m (1.8 kgf·m, 13 ft·lb)
(EX650D Models)**

- Inspect the brake hose routing.
- ★ If any brake hose and pipe (ABS equipped models) routing is incorrect, run the brake hose according to Cable, Wire, and Hose Routing section in the Appendix chapter.

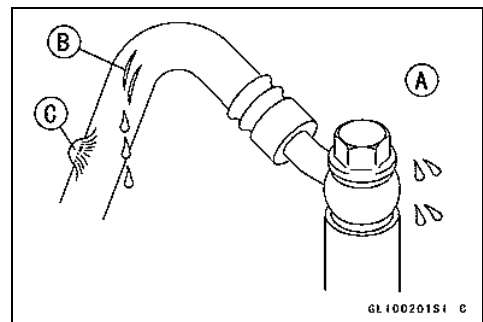

2-32 PERIODIC MAINTENANCE

Periodic Maintenance Procedures

Brake Fluid Level Inspection

- Check that the brake fluid level in the front brake reservoir [A] is above the lower level line [B].

NOTE

○ Hold the reservoir horizontal by turning the handlebar when checking brake fluid level.

- ★ If the fluid level is lower than the lower level line, fill the reservoir to the upper level line [C] in the reservoir.

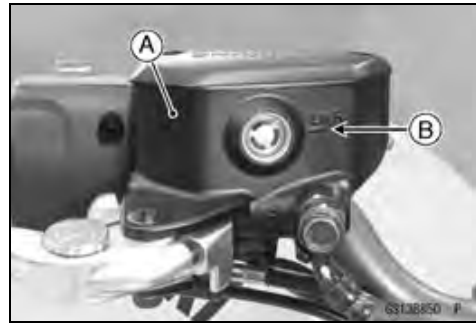

- Remove the seat (see Seat Removal in the Frame chapter).
- Check that the brake fluid level in the rear brake reservoir [A] is above the lower level line [B].
- ★ If the fluid level is lower than the lower level line, fill the reservoir to the upper level line [C].

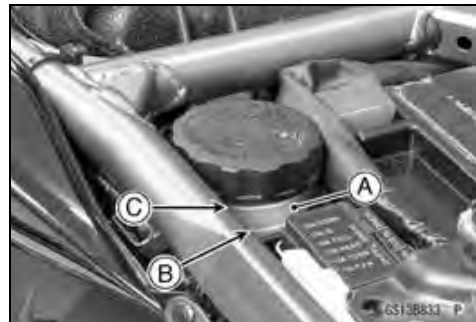

⚠ WARNING

Change the brake fluid in the brake line completely if the brake fluid must be refilled but the type and brand of the brake fluid that is already in the reservoir are unidentified. After changing the fluid, use only the same type and brand of fluid thereafter.

Recommended Disc Brake Fluid

Grade: DOT4

- Follow the procedure below to install the rear brake fluid reservoir cap correctly.
- First, tighten the rear brake fluid reservoir cap [B] clockwise [C] by hand until slight resistance is felt indicating that the cap is seated on the reservoir body, then tighten the cap an additional 1/6 turn [D] while holding the brake fluid reservoir body [A].

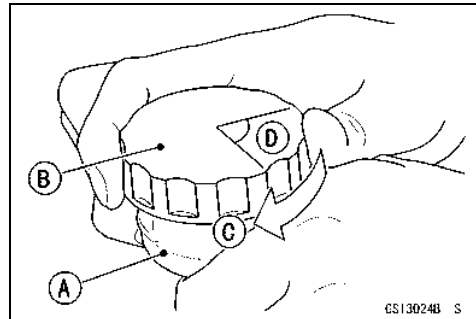

Periodic Maintenance Procedures

Brake Pad Wear Inspection

- Check the lining thickness [A] of the pads in each caliper.
- ★ If the lining thickness of either pad is less than the service limit [B], replace both pads in the caliper as a set.

Pad Lining Thickness

Standard:

Front [C] 4.5 mm (0.18 in.)

Rear [D] 5.0 mm (0.20 in.)

Service Limit: 1 mm (0.04 in.)

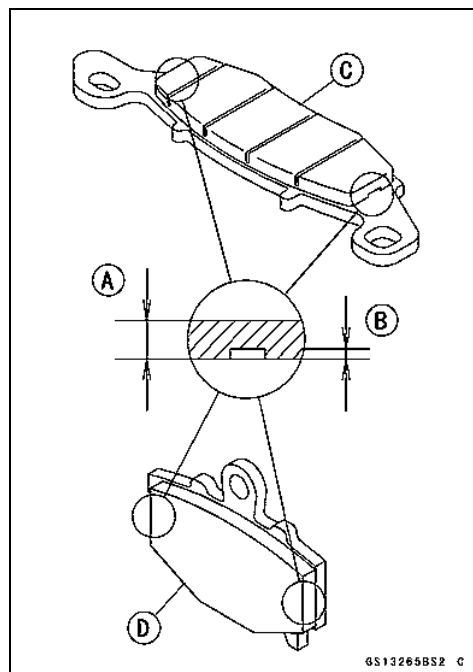

Brake Operation Inspection

- Inspect the operation of the front and rear brake by running the vehicle on the dry road.
- ★ If the brake operation is insufficiency, inspect the brake system.

⚠ WARNING

When inspecting by running the vehicle, note a surrounding traffic situation enough in the place of safety.

Brake Light Switch Operation Inspection

- Turn the ignition switch ON.
- The brake light [A] should go on when the brake lever is applied or after the brake pedal is depressed about 10 mm (0.39 in.).



- ★ If it does not, adjust the brake light switch.
- Remove the right footpeg stay (see Footpeg Stay Removal in the Frame chapter).
- While holding the switch body, turn the adjusting nut to adjust the switch.
 - Switch Body [A]
 - Adjusting Nut [B]
 - Light sooner as the body rises [C]
 - Light later as the body lowers [D]

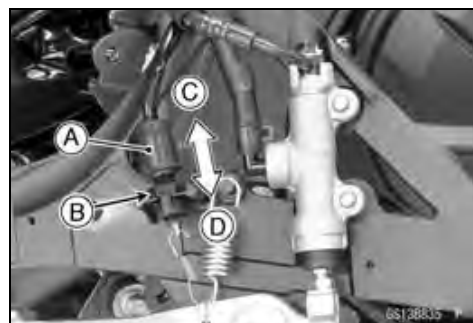

CAUTION

To avoid damaging the electrical connections inside the switch, be sure that the switch body does not turn during adjustment.

2-34 PERIODIC MAINTENANCE

Periodic Maintenance Procedures

- ★ If it does not go on, inspect or replace the following items.
 - Battery (see Charging Condition Inspection in the Electrical System chapter)
 - Brake Light (LED) (see Tail/Brake Light (LED) Removal in the Electrical System chapter)
 - Main Fuse 30 A and Taillight Fuse 10 A (see Fuse Inspection in the Electrical System chapter)
 - Front Brake Light Switch [A] (see Switch Inspection in the Electrical System chapter)
 - Rear Brake Light Switch (see Switch Inspection in the Electrical System chapter)
 - Harness (see Wiring Inspection in the Electrical System chapter)



Suspensions

Front Forks/Rear Shock Absorber Operation Inspection

- Pump the forks down and up [A] 4 or 5 times, and inspect the smooth stroke.
 - ★ If the forks do not smoothly or noise is found, inspect the fork oil level or fork clamps (see Front Fork Oil Change in the Suspension chapter).
-
- Pump the seat down and up [A] 4 or 5 times, and inspect the smooth stroke.
 - ★ If the shock absorber does not smoothly stroke or noise is found, inspect the oil leak (see Rear Shock Absorber Oil Leak Inspection).



Front Fork Oil Leak Inspection

- Visually inspect the front forks [A] for oil leakage.
- ★ Replace or repair any defective parts, if necessary.



Periodic Maintenance Procedures

Rear Shock Absorber Oil Leak Inspection

- Visually inspect the shock absorber [A] for oil leakage.
- ★ If the oil leakage is found on it, replace the shock absorber with a new one.



Steering System

Steering Play Inspection

- Raise the front wheel off the ground using the jack (see Front Wheel Removal in the Wheels/Tires chapter).
- With the front wheel pointing straight ahead, alternately tap each end of the handlebar. The front wheel should swing fully left and right from the force of gravity until the fork hits the stop.
- ★ If the wheel binds or catches before the stop, the steering is too tight.
- Feel for steering looseness by pushing and pulling [A] the forks.
- ★ If you feel looseness, the steering is too loose.



NOTE

- The cables and wiring will have some effect on the motion of the fork which must be taken into account.
- Be sure the leads and cables are properly routed.
- The bearings must be in good condition and properly lubricated in order for any test to be valid.

Steering Play Adjustment

- Remove the steering stem head (see Stem, Stem Bearing Removal in the Steering chapter).
- Bend the claws [A] of the claw washer straighten.
- Remove the steering stem locknut [B] and claw washer.

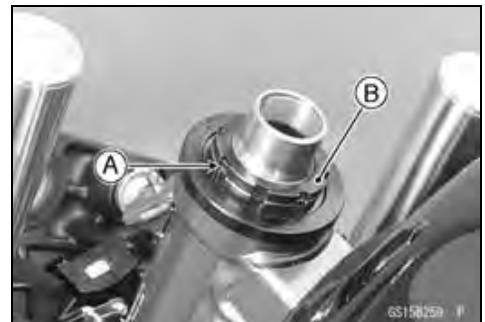

- Adjust the steering.

Special Tool - Steering Stem Nut Wrench [A]: 57001-1100

- ★ If the steering is too tight, loosen the stem nut [B] a fraction of a turn.
- ★ If the steering is too loose, tighten the stem nut a fraction of a turn.

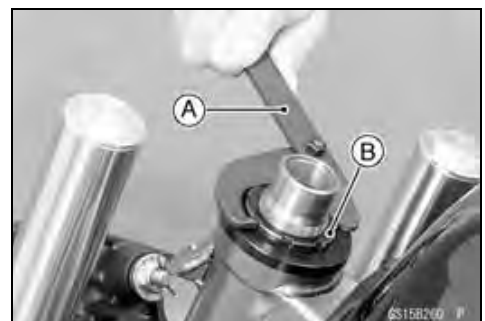

NOTE

- Turn the stem nut 1/8 turn at time maximum.

2-36 PERIODIC MAINTENANCE

Periodic Maintenance Procedures

- Install the claw washer [A] so that its bent side [B] faces upward, and engage the bent claws with the grooves of stem locknut [C].
- Hand tighten the stem locknut until it touches the claw washer.
- Tighten the stem locknut clockwise until the claws are aligned with the grooves (ranging from 2nd to 4th) of stem nut [D], and bend the 2 claws downward [E].
- Install the steering stem head.
- Install the washer.
- Tighten:

Torque - Steering Stem Head Bolt: 108 N·m (11.0 kgf·m, 80 ft·lb)

Front Fork Clamp Bolts (Upper): 20 N·m (2.0 kgf·m, 15 ft·lb)

- Check the steering again.
- ★ If the steering is still too tight or too loose, repeat the adjustment.

Steering Stem Bearing Lubrication

- Remove the steering stem (see Stem, Stem Bearing Removal in the Steering chapter).
- Using a high-flash point solvent, wash the upper and lower ball bearings [A] in the cages, and wipe the upper and lower outer races, which are press-fitted into the frame head pipe, clean off grease and dirt.
- Visually check the outer races and the ball bearings.
- ★ Replace them if they show wear or damage.
- Pack the upper and lower ball bearings in the cages with grease, and apply a light coat of grease to the upper and lower outer races.
- Install the steering stem (see Stem, Stem Bearing Installation in the Steering chapter).
- Adjust the steering (see Steering Play Adjustment).

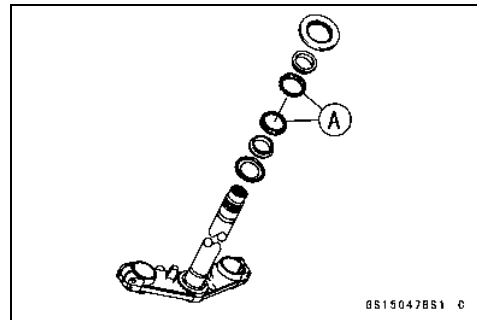
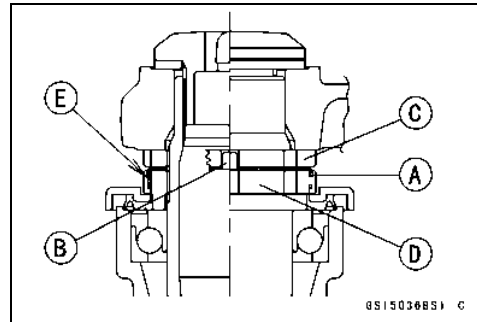

Periodic Maintenance Procedures

Electrical System

Lights and Switches Operation Inspection

First Step

- Set the gear position in the neutral position.
- Turn the ignition switch ON.
- The following lights should go on according to below table.

City Lights [A]	goes on
Taillight (LED) [B]	goes on
License Plate Light [C]	goes on
Meter Panel LCD [D]	goes on
Neutral Indicator Light (LED) [E]	goes on
Oil Pressure Warning Indicator Light (LED) [F]	goes on
FI Indicator Light (LED) [G]	goes on (about 2 seconds)
Water Temperature Warning Indicator Light (LED) [H]	goes on (about 3 seconds)

EX650D Models

ABS Indicator Light (LED) [I]	goes on
-------------------------------	---------

- ★If the light does not go on, inspect or replace the following item.

Battery (see Charging Condition Inspection in the Electrical System chapter)

Main Fuse 30 A and Taillight Fuse 10 A (see Fuse Inspection in the Electrical System chapter)

Applicable Bulb (see Wiring Diagram in the Electrical System chapter)

Meter Unit for Meter Panel LCD (see Meter Unit Inspection in the Electrical System chapter)

Meter Unit for Neutral Indicator Light (LED) (see Meter Unit Inspection in the Electrical System chapter)

Meter Unit for Oil Pressure Warning Indicator Light (LED) (see Meter Unit Inspection in the Electrical System chapter)

Meter Unit for FI Indicator Light (LED) (see Meter Unit Inspection in the Electrical System chapter)

Meter Unit for Water Temperature Warning Indicator Light (LED) (see Meter Unit Inspection in the Electrical System chapter)

ECU (see ECU Power Supply Inspection in the Fuel System (DFI) chapter)

Ignition Switch (see Switch Inspection in the Electrical System chapter)

Neutral Switch (see Switch Inspection in the Electrical System chapter)

Harness (see Wiring Inspection in the Electrical System chapter)

Meter Unit for ABS Indicator Light (LED) (EX650D Models, see ABS Indicator Light (LED) Inspection in the Brakes chapter)

- Turn off the ignition switch.
- The all lights should go off.
- ★If the light does not go off, replace the ignition switch.

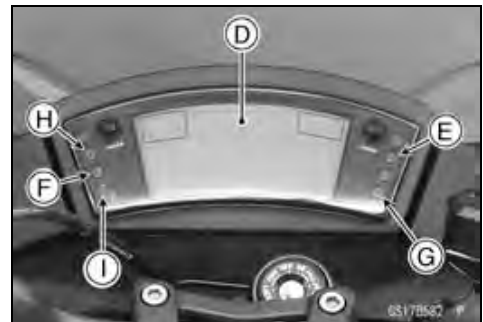
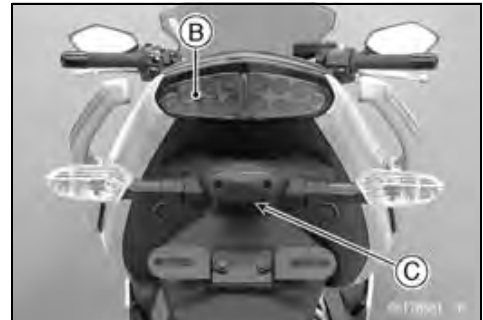

2-38 PERIODIC MAINTENANCE

Periodic Maintenance Procedures

Second Step

- Turn the ignition switch to P (Park) position.
- The city light, taillight (LED) and license plate light should go on.
- ★ If the light does not go on, inspect or replace the following item.
 - Ignition Switch (see Switch Inspection in the Electrical System chapter)

Third Step

- Turn on the turn signal switch [A] (left or right position).
- The left or right turn signal lights [B] (front and rear) according to the switch position should flash.
- The turn signal indicator light (LED) [C] in the meter unit should flash.
- ★ If the each light does not flash, inspect or replace the following item.
 - Turn Signal Light Bulb (see Turn Signal Light Bulb Replacement in the Electrical System chapter)
 - Meter Unit for Turn Signal Indicator Light (LED) (see Meter Unit Inspection in the Electrical System chapter)
 - Turn Signal Relay Fuse 10 A (see Fuse Inspection in the Electrical System chapter)
 - Turn Signal Switch (see Switch Inspection in the Electrical System chapter)
 - Turn Signal Relay (see Turn Signal Relay Inspection in the Electrical System chapter)
 - Harness (see Wiring Inspection in the Electrical System chapter)
- Push the turn signal switch.
- The turn signal lights and indicator light (LED) should go off.
- ★ If the light does not go off, inspect or replace the following item.
 - Turn Signal Switch (see Switch Inspection in the Electrical System chapter)
 - Turn Signal Relay (see Turn Signal Relay Inspection in the Electrical System chapter)



Fourth Step

- Set the dimmer switch [A] to low beam position.
- Start the engine.
- The low beam headlight should go on.
- ★ If the low beam headlight does not go on, inspect or replace the following item.
 - Headlight Low Beam Bulb (see Headlight Bulb Replacement in the Electrical System chapter)
 - Headlight Fuse 10 A (see Fuse Inspection in the Electrical System chapter)
 - Dimmer Switch (see Switch Inspection in the Electrical System chapter)
 - Headlight Relay in Relay Box (see Relay Circuit Inspection in the Electrical System chapter)
 - Harness (see Wiring Inspection in the Electrical System chapter)

Periodic Maintenance Procedures

- Set the dimmer switch to high beam position.
- The low beam [A] and high beam [B] headlights should go on.
- The high beam indicator light (LED) [C] should go on.
- ★ If the high beam headlight and/or high beam indicator light (LED) does not go on, inspect or replace the following item.
 - Headlight High Beam Bulb (see Headlight Bulb Replacement in the Electrical System chapter)
 - Dimmer Switch (see Switch Inspection in the Electrical System chapter)
- Turn off the engine stop switch.
- The low beam and high beam headlights should stay going on.
- ★ If the headlights and high beam indicator light (LED) does go off, inspect or replace the following item.
 - Headlight Relay in Relay Box (see Relay Circuit Inspection in the Electrical System chapter)
- Turn off the ignition switch.
- The headlights and high beam indicator light (LED) should go off.



Headlight Aiming Inspection

- Inspect the headlight beam for aiming.
- ★ If the headlight beam points to one side rather than straight ahead, adjust the horizontal beam.

Headlight Beam Horizontal Adjustment

- Turn the horizontal adjuster [A] on the headlight in or out until the beam points straight ahead.
- ★ If the headlight beam points too low or high, adjust the vertical beam.



Headlight Beam Vertical Adjustment

- Turn the vertical adjuster [A] on the headlight in or out to adjust the headlight vertically.

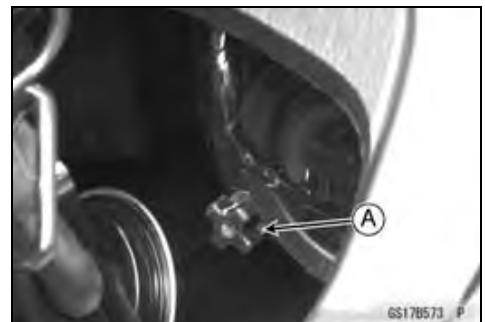

NOTE

- ON high beam, the brightest points should be slightly below horizontal with the motorcycle on its wheels and the rider seated. Adjust the headlight to the proper angle according to local regulations.

2-40 PERIODIC MAINTENANCE

Periodic Maintenance Procedures

NOTE

○ For the United States model, the proper angle is 0.4 degrees below horizontal. This is 50 mm (2.0 in.) drop at 7.6 m (25 ft) measured from the center of the headlight with the motorcycle on its wheels and the rider seated.

50 mm (2.0 in.) [A]

Center of Brightest Spot [B]

7.6 m (25 ft) [C]

Height of Headlight Center [D]

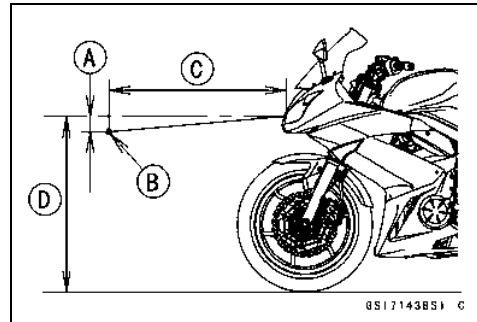

Sidestand Switch Operation Inspection

● Inspect the sidestand switch [A] operation accordance to below table.

Sidestand Switch Operation

Sidestand	Gear Position	Clutch Lever	Engine Start	Engine Run
Up	Neutral	Released	Starts	Continue running
Up	Neutral	Pulled in	Starts	Continue running
Up	In Gear	Released	Does not start	Continue running
Up	In Gear	Pulled in	Starts	Continue running
Down	Neutral	Released	Starts	Continue running
Down	Neutral	Pulled in	Starts	Continue running
Down	In Gear	Released	Does not start	Stops
Down	In Gear	Pulled in	Does not start	Stops



Periodic Maintenance Procedures

- ★If the sidestand switch operation does not work, inspect or replace the following item.
 - Battery (see Charging Condition Inspection in the Electrical System chapter)
 - Main Fuse 30 A (see Fuse Inspection in the Electrical System chapter)
 - Ignition Fuse 10 A (see Fuse Inspection in the Electrical System chapter)
 - Ignition Switch (see Switch Inspection in the Electrical System chapter)
 - Sidestand Switch (see Switch Inspection in the Electrical System chapter)
 - Engine Stop Switch (see Switch Inspection in the Electrical System chapter)
 - Starter Button (see Switch Inspection in the Electrical System chapter)
 - Neutral Switch (see Switch Inspection in the Electrical System chapter)
 - Starter Relay (see Starter Relay Inspection in the Electrical System chapter)
 - Relay Box (see Relay Circuit Inspection in the Electrical System chapter)
 - Starter Circuit Relay (see Relay Circuit Inspection in the Electrical System chapter)
 - Harness (see Wiring Inspection in the Electrical System chapter)
- ★If the all parts are good condition, replace the ECU (see ECU Removal/Installation in the Fuel System (DFI) chapter).

Engine Stop Switch Operation Inspection

First Step

- Turn on the ignition switch.
- Set the neutral position.
- Turn the engine stop switch to stop position [A].
- Push the starter button.
- The engine does not start.
- ★If the engine starts, inspect or replace the following item.
 - Engine Stop Switch (see Switch Inspection in the Electrical System chapter)

Second Step

- Turn on the ignition switch.
- Set the neutral position.
- Turn the engine stop switch to run position [A].
- Push the starter button and run the engine.
- Turn the engine stop switch to stop position.
- Immediately the engine should be stop.
- ★If the engine does not stop, inspect or replace the following item.
 - Engine Stop Switch (see Switch Inspection in the Electrical System chapter)
- ★If the engine stop switch is good condition, replace the ECU (see ECU Removal/Installation in the Fuel System (DFI) chapter).



2-42 PERIODIC MAINTENANCE

Periodic Maintenance Procedures

Others

Chassis Parts Lubrication

- Before lubricating each part, clean off any rusty spots with rust remover and wipe off any grease, oil, dirt, or grime.
- Lubricate the points listed below with indicated lubricant.

NOTE

○ Whenever the vehicle has been operated under wet or rainy conditions, or especially after using a high-pressure water spray, perform the general lubrication.

Pivots: Lubricate with Grease.

Brake Lever
Brake Pedal
Clutch Lever
Rear Brake Joint Pin
Sidestand

Points: Lubricate with Grease.

Clutch Inner Cable Upper and Lower Ends [A]
Throttle Inner Cable Upper and Lower Ends

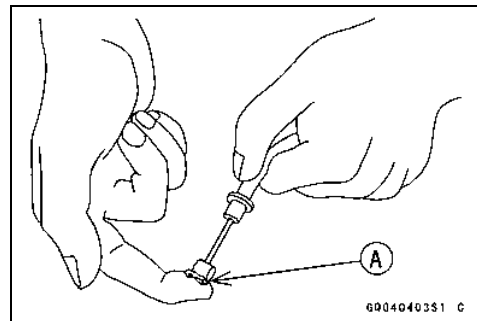

Cables: Lubricate with Rust Inhibitor.

Clutch Cable
Throttle Cables

- Lubricate the cables by seeping the oil between the cable and housing.
- The cable may be lubricated by using a commercially available pressure cable lubricator with an aerosol cable lubricant.

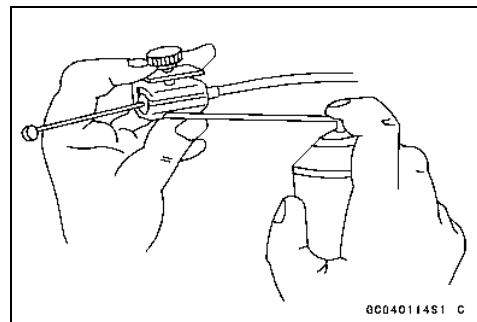

- With the cable disconnected at both ends, the inner cable should move freely [A] within the cable housing.
- ★ If cable movement is not free after lubricating, if the cable is frayed [B], or if the cable housing is kinked [C], replace the cable.

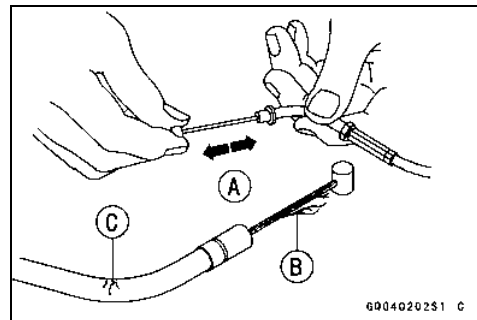

Periodic Maintenance Procedures

Bolts, Nuts and Fasteners Tightness Inspection

- Check the tightness of the bolts and nuts listed here. Also, check to see that each cotter pin is in place and in good condition.

NOTE

○ *For the engine fasteners, check the tightness of them when the engine is cold (at room temperature).*

- ★ If there are loose fasteners, retighten them to the specified torque following the specified tightening sequence. Refer to the appropriate chapter for torque specifications. If torque specifications are not in the appropriate chapter, see the Standard Torque Table. For each fastener, first loosen it by 1/2 turn, then tighten it.
- ★ If cotter pins are damaged, replace them with new ones.

Bolt, Nut and Fastener to be checked

Engine:

Clutch Lever Pivot Bolt Locknut
 Engine Bracket Bolts
 Engine Mounting Bolts and Nuts
 Exhaust Pipe Manifold Holder Nuts
 Muffler Body Mounting Bolts

Wheels:

Front Axle
 Front Axle Clamp Bolt
 Rear Axle Nut
 Rear Axle Nut Cotter Pin

Brakes:

Brake Lever Pivot Nut
 Brake Pedal Bolt
 Caliper Mounting Bolts
 Front Master Cylinder Clamp Bolts
 Rear Master Cylinder Mounting Bolts
 Rear Master Cylinder Push Rod Joint Cotter Pin

Suspension:

Front Fork Clamp Bolts
 Rear Shock Absorber Bolt and Nut
 Swingarm Pivot Shaft Nut

Steering:

Steering Stem Head Bolt
 Handlebar Holder Bolts

Others:

Footpeg Stay Bolts
 Front Fender Mounting Bolts
 Sidestand Bolt

2-44 PERIODIC MAINTENANCE

Periodic Maintenance Procedures

Replacement Parts

Air Cleaner Element Replacement

- Refer to the Air Cleaner Element Cleaning.

Fuel Hose Replacement

CAUTION

When removing and installing the fuel hose joint, do not apply strong force to the outlet pipe on the fuel pump and delivery pipe on the throttle body assy. The pipes made from resin could be damaged.

- Remove:
 - Fuel Tank (see Fuel Tank Removal in the Fuel System (DFI) chapter)
 - Left Upper Fairing Cover (see Upper Fairing Cover Removal in the Frame chapter)
- Be sure to place a piece of cloth [A] around the fuel hose joint.
- Insert a minus screwdriver [B] into the slit [C] on the joint lock.
- Turn [A] the driver to unlock the joint lock [B].
- Pull [C] the fuel hose joint [D] out of the delivery pipe.

⚠ WARNING

Be prepared for fuel spillage; any spilled fuel must be completely wiped up immediately. When the fuel hose is disconnected, fuel spills out from the hose and the pipe. Cover the hose connection with a clean shop towel to prevent fuel spillage.

- Install the new fuel hose so that the white mark [A] side faces throttle body assy.
- Insert [B] the fuel hose joint [C] straight onto the delivery pipe until the hose joint clicks.
- Push [D] the joint lock [E].

- Push and pull [A] the fuel hose joint [B] back and forth more than two times and make sure it is locked and does not come off.

⚠ WARNING

Make sure the fuel hose joint is installed correctly on the delivery pipe or the fuel could leak.

- ★ If it comes off, reinstall the hose joint.
- Run the fuel hose correctly (see Cable, Wire, and Hose Routing section in the Appendix chapter).
- Install the removed parts (see appropriate chapters).
- Start the engine and check the fuel hose for leaks.

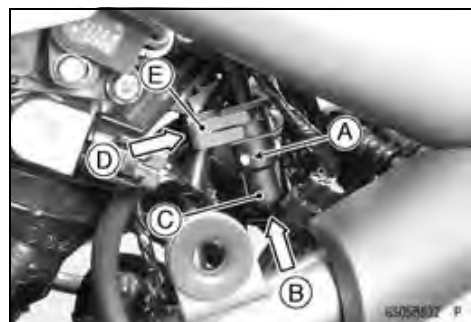
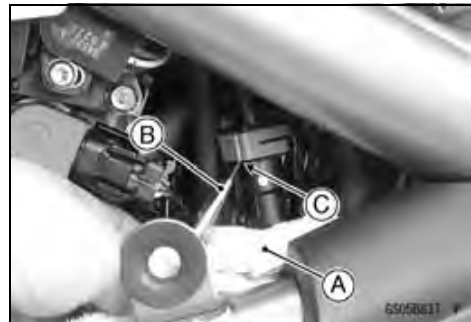

Periodic Maintenance Procedures

Coolant Change

⚠ WARNING

To avoid burns, do not remove the radiator cap or try to change the coolant when the engine is still hot. Wait until it cools down. Coolant on tires will make them slippery and can cause an accident and injury. Immediately wipe up or wash away any coolant that spills on the frame, engine, or other painted parts.

Since coolant is harmful to the human body, do not use for drinking.

- Remove:
 - Upper Fairing (see Upper Fairing Removal in the Frame chapter)
 - Reserve Tank Bolts [A]
 - Reserve Tank [B]
 - Reserve Tank Over Flow Hose [C]

- Hook the projection [A] of the reserve tank into the hole [B] of the frame.

- Place a container under the water pump drain bolt [A], then remove the drain bolt.

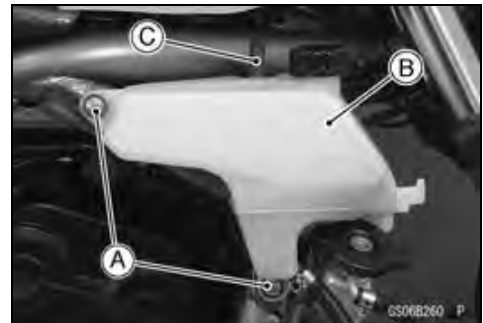

2-46 PERIODIC MAINTENANCE

Periodic Maintenance Procedures

- Remove the radiator cap [A] in two steps. First turn the cap counterclockwise to the first stop. Then push and turn it further in the same direction and remove the cap.
- The coolant will drain from the radiator and engine.

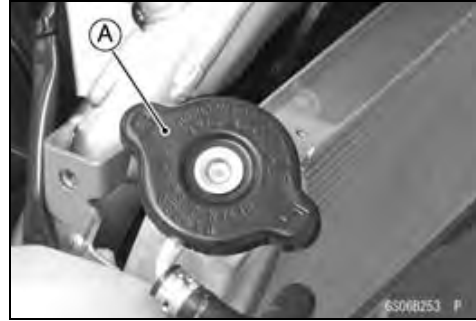

- Take off the reserve tank from the frame.
- Remove the reserve tank cap, and pour the coolant into a suitable container.
- Hook the reserve tank to the frame again.
- Tighten the drain bolt with the gasket.
- Replace the drain bolt gasket with a new one.

Torque - Water Pump Drain Bolt: 9.8 N·m (1.0 kgf·m, 87 in·lb)

- When filling the coolant, choose a suitable mixture ratio by referring to the coolant manufacturer's directions.

CAUTION

Soft or distilled water must be used with the antifreeze in the cooling system. If hard water is used in the system, it causes scales accumulation in the water passages, and considerably reduces the efficiency of the cooling system.

Water and Coolant Mixture Ratio (Recommended)

Soft Water:	50%
Coolant:	50%
Freezing Point:	-35°C (-31°F)
Total Amount:	1.2 L (1.3 US qt)

- Fill the radiator up to the filler neck [A] with coolant.

NOTE

○ Pour in the coolant slowly so that it can expel the air from the engine and radiator.

- Check the cooling system for leaks.
- Tap the radiator hoses to force any air bubbles caught inside.
- Fill the radiator up to the filler neck with coolant, and install the radiator cap.



Periodic Maintenance Procedures

- Install the reserve tank.
- Fill the reserve tank up to the “F” (full) level line [A] with coolant and install the cap [B].
- Start the engine, warm it up thoroughly until the radiator fan turns on and then stop the engine.
- Check the coolant level in the reserve tank after the engine cools down.
- ★ If the coolant level is lower than the “L” (low) level line, add coolant to the “F” level line.

CAUTION

Do not add more coolant above the “F” level line.



Radiator Hose and O-ring Replacement

- Drain the coolant (see Coolant Change).
- Remove:
 - Thermostat Housing [A] (see Thermostat Removal in the Cooling System chapter)
 - Water Pump Cover [B] (see Water Pump Removal in the Cooling System chapter)
 - Hoses [C]
 - O-rings [D]
- Apply grease to the new O-rings and install them.
- Install the new hoses and tighten the clamps securely.
- Fill the coolant (see Coolant Change).
- Check the cooling system for leaks.

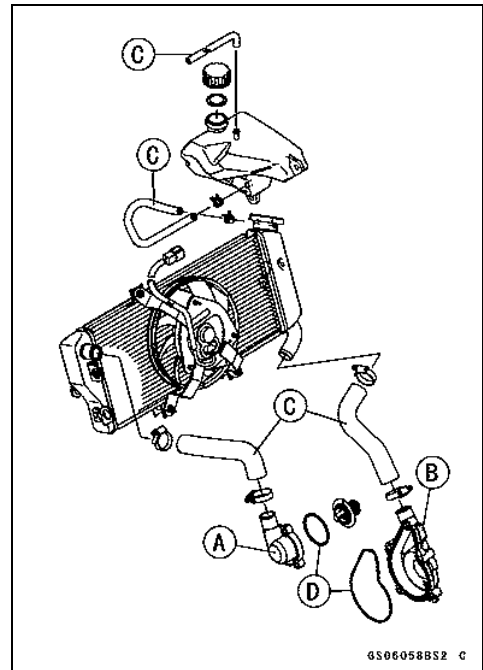

Engine Oil Change

- Situate the motorcycle so that it is vertical after warming up the engine.
- Unscrew the oil filler plug [A].
- Place an oil pan beneath the engine.



2-48 PERIODIC MAINTENANCE

Periodic Maintenance Procedures

- Remove the engine oil drain bolt [A] to drain the oil.
- The oil in the oil filter can be drained by removing the filter (see Oil Filter Replacement).
- ★ Replace the drain bolt gasket [B] with a new one.
- Tighten the drain bolt.

Torque - Engine Oil Drain Plug: 30 N·m (3.1 kgf·m, 22 ft·lb)

- Pour in the specified type and amount of oil.

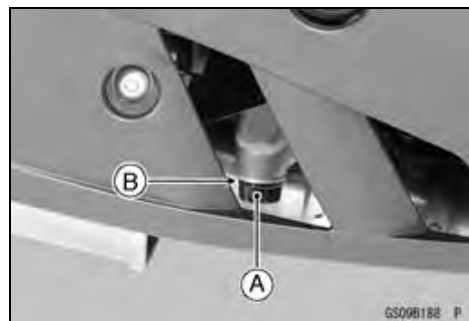

Recommended Engine Oil

Type: API SE, SF or SG

API SH, SJ, SL or SM with JASO MA, MA1 or MA2

Viscosity: SAE 10W-40

Capacity: 1.7 L (1.8 US qt) (when filter is not removed)

1.9 L (2.0 US qt) (when filter is removed)

2.4 L (2.5 US qt) (when engine is completely dry)

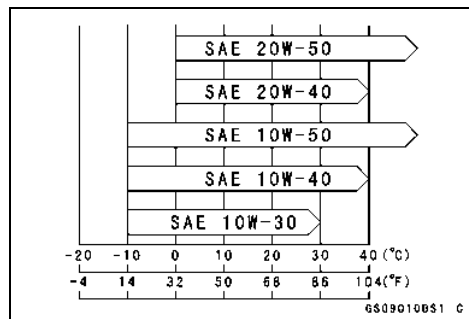

NOTE

- Do not add any chemical additive to the oil. Oils fulfilling the above requirements are fully formulated and provide adequate lubrication for both the engine and the clutch.
- Although 10W-40 engine oil is the recommended oil for most conditions, the oil viscosity may need to be changed to accommodate atmospheric conditions in your riding area.
- Check the oil level (see Oil Level Inspection in the Engine Lubrication System chapter).

Oil Filter Replacement

- Drain the engine oil (see Engine Oil Change).
- Remove the lower fairing (see Lower Fairing Removal in the Frame chapter).
- Remove the oil filter [A] with the oil filter wrench [B].

Special Tool - Oil Filter Wrench: 57001-1249



- Replace the filter with a new one.
- Apply grease to the O-ring [A] before installation.
- Tighten the filter with the oil filter wrench.

Torque - Oil Filter: 17.5 N·m (1.8 kgf·m, 13 ft·lb)

NOTE

- Hand tightening of the oil filter can not be allowed since it does not reach to this tightening torque.
- Pour in the specified type and amount of oil (see Engine Oil Change).

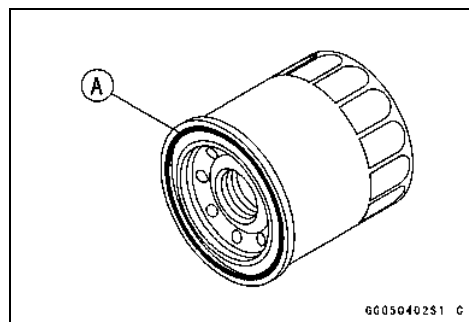

Periodic Maintenance Procedures

Brake Hose and Pipe Replacement

CAUTION

Brake fluid quickly ruins painted plastic surfaces; any spilled fluid should be completely washed away immediately.

- Remove the brake hose banjo bolts [A].
- Remove the brake hoses [B] as note the following.
 - Take care not to spill the brake fluid on the painted or plastic parts.
 - Temporary secure the end of the brake hose to some high place to keep fluid loss to a minimum.

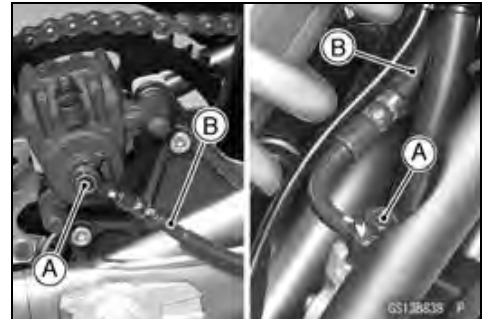
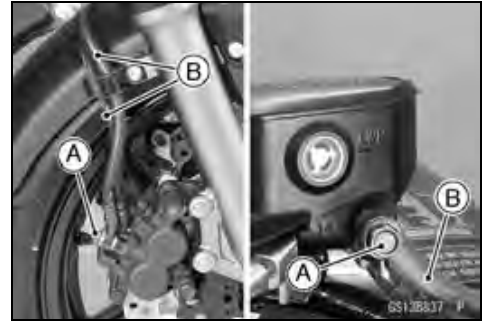

- For models equipped with an ABS, note the following.
- Remove:
 - Air Cleaner Housing (see Air Cleaner Housing Removal in the Fuel System (DFI) chapter)
 - Battery Case (see Battery Case Removal in the Frame chapter)
 - Upper Fairing (see Upper Fairing Removal in the Frame chapter)
- Remove the brake pipe joint nuts [C].
- Remove the bracket bolts [D] and the brackets [E].

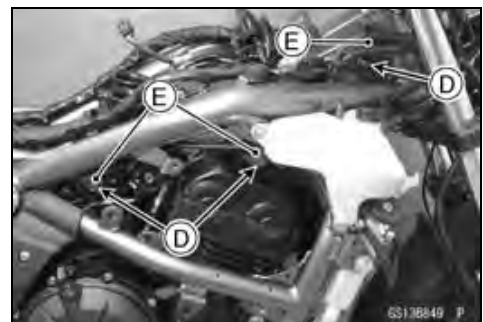
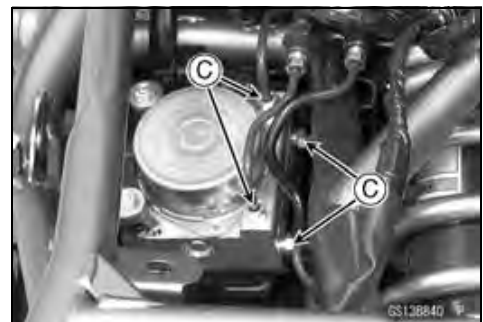

2-50 PERIODIC MAINTENANCE

Periodic Maintenance Procedures

- Install the brake hose as note the following.
- Replace the washers [A] that are on each side of hose fitting [B] with new ones.
- Avoid sharp bending, kinking, flattening or twisting, and route the hoses according to Cable, Wire, and Hose Routing section in the Appendix chapter.
- Tighten:
 - Torque - Brake Hose Banjo Bolts: 25 N·m (2.5 kgf·m, 18 ft·lb)**
 - Brake Pipe Joint Nuts (EX650D Models): 18 N·m (1.8 kgf·m, 13 ft·lb)**
- Fill the brake line (see Brake Fluid Change).

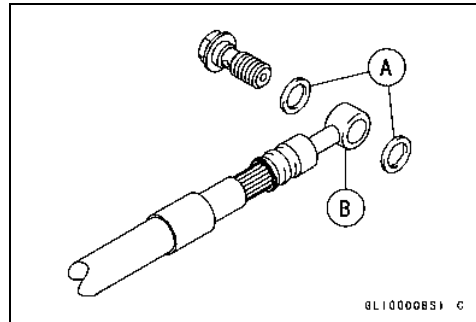

Brake Fluid Change

NOTE

- The procedure to change the front brake fluid is as follows. Changing the rear brake fluid is the same as for the front brake.

- Level the brake fluid reservoir.
- Remove the reservoir cap and diaphragm.
- Remove the rubber cap from the bleed valve [A] on the caliper.
- Attach a clear plastic hose [B] to the bleed valve, and run the other end of the hose into a container.
- Fill the reservoir with fresh specified brake fluid.

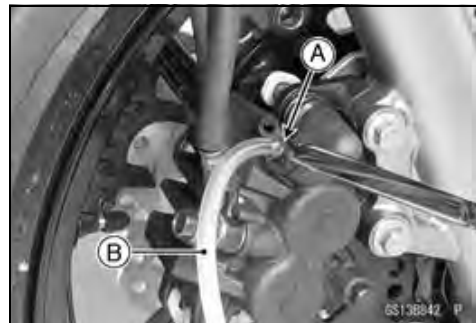

- Change the brake fluid.
- Repeat this operation until fresh brake fluid comes out from the plastic hose or the color of the fluid changes.
 1. Open the bleed valve [A].
 2. Apply the brake and hold it [B].
 3. Close the bleed valve [C].
 4. Release the brake [D].

NOTE

- The fluid level must be checked often during the changing operation and replenished with fresh brake fluid. If the fluid in the reservoir runs out any time during the changing operation, the brakes will need to be bled since air will have entered the brake line.
- Front Brake: Repeat the above steps for the other caliper.

- Remove the clear plastic hose.
- Install the diaphragm and reservoir cap.
- Tighten:

Torque - Front Brake Reservoir Cap Screws: 1.5 N·m (0.15 kgf·m, 13 in·lb)

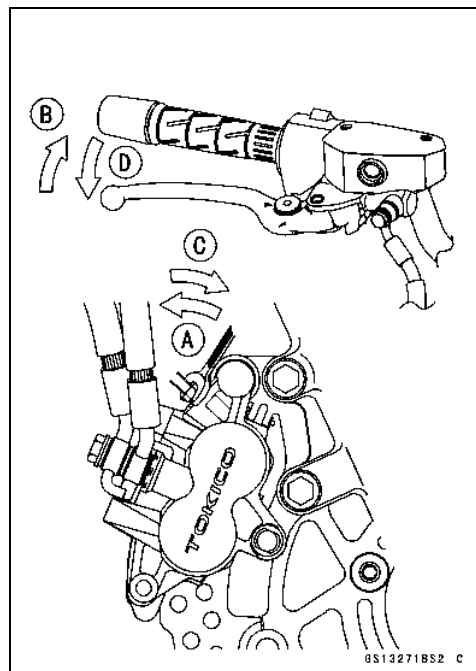

Periodic Maintenance Procedures

- Follow the procedure below to install the rear brake fluid reservoir cap correctly.
- First, tighten the rear brake fluid reservoir cap [B] clockwise [C] by hand until slight resistance is felt indicating that the cap is seated on the reservoir body, then tighten the cap an additional 1/6 turn [D] while holding the brake fluid reservoir body [A].

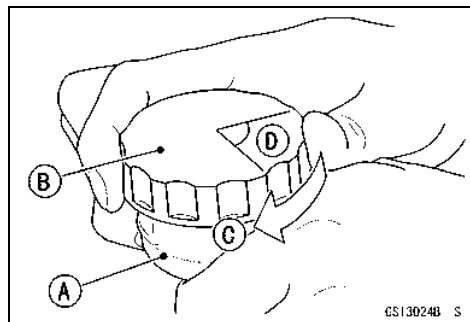

- Tighten the bleed valve, and install the rubber cap.
- Torque - Caliper Bleed Valve: 7.8 N-m (0.80 kgf-m, 69 in-lb)**
- After changing the fluid, check the brake for good braking power, no brake drag, and no fluid leakage.
- ★ If necessary, bleed the air from the lines.

**Master Cylinder Rubber Parts Replacement
Front Master Cylinder Disassembly**

- Remove the front master cylinder (see Front Master Cylinder Removal in the Brakes chapter).
- Remove the reservoir cap and diaphragm, and pour the brake fluid into a container.
- Unscrew the locknut and pivot bolt, and remove the brake lever.
- Pull the dust cover [A] out of place, and remove the circlip [B].
- Special Tool - Inside Circlip Pliers: 57001-143**
- Pull out the piston [C], secondary cup [D], primary cup [E], and return spring [F].

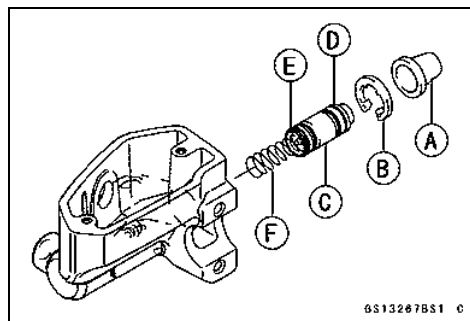

CAUTION

Do not remove the secondary cup from the piston since removal will damage it.

Rear Master Cylinder Disassembly

NOTE

○ Do not remove the push rod clevis for master cylinder disassembly since removal requires brake position adjustment.

- Remove the rear master cylinder (see Rear Master Cylinder Removal in the Brakes chapter).
- Remove the circlip [A].
- Special Tool - Inside Circlip Pliers: 57001-143**
- Pull out the push rod with the piston stop.
- Take off the piston [B], secondary cup [C], primary cup [D] and return spring [E].
- Remove the circlip [F] and pull out the brake hose connector [G] and O-ring [H].
- Special Tool - Inside Circlip Pliers: 57001-143**

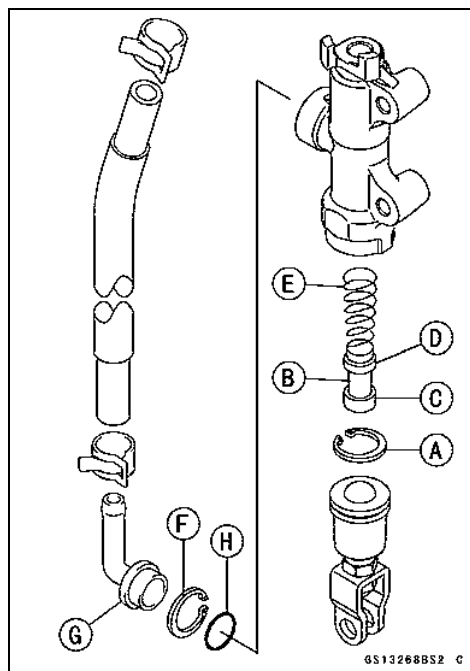

CAUTION

Do not remove the secondary cup from the piston since removal will damage it.

2-52 PERIODIC MAINTENANCE

Periodic Maintenance Procedures

Master Cylinder Assembly

- Before assembly, clean all parts including the master cylinder with brake fluid or alcohol.

CAUTION

Except for the disc pads and disc, use only disc brake fluid, isopropyl alcohol, or ethyl alcohol for cleaning brake parts. Do not use any other fluid for cleaning these parts. Gasoline, engine oil, or any other petroleum distillate will cause deterioration of the rubber parts. Oil spilled on any part will be difficult to wash off completely, and will eventually deteriorate the rubber used in the disc brake.

- Apply brake fluid to the new parts and to the inner wall of the cylinder.
- Take care not to scratch the piston or the inner wall of the cylinder.
- Apply silicone grease to the brake lever pivot bolt and the push rod.
- Tighten:

Torque - Brake Lever Pivot Bolt: 1.0 N·m (0.10 kgf·m, 9 in·lb)

Brake Lever Pivot Bolt Locknut: 5.9 N·m (0.60 kgf·m, 52 in·lb)

Caliper Rubber Parts Replacement

Front Caliper Disassembly

- Remove:
 - Front Caliper (see Front Caliper Removal in the Brakes chapter)
 - Brake Pads (see Front Brake Pad Removal in the Brakes chapter)
 - Pad Spring
- Using compressed air, remove the pistons.
 - Cover the piston area with a clean, thick cloth [A].
 - Blow compressed air [B] into the hole for the banjo bolt to remove the piston.

⚠ WARNING

To avoid serious injury, never place your fingers or palm in front of the piston. If you apply compressed air into the caliper, the piston may crush your hand or fingers.

- Pull out the pistons by hand.
- Remove:
 - Caliper Holder
 - Dust Seals
 - Fluid Seals
 - Bleed Valve
 - Rubber Cap

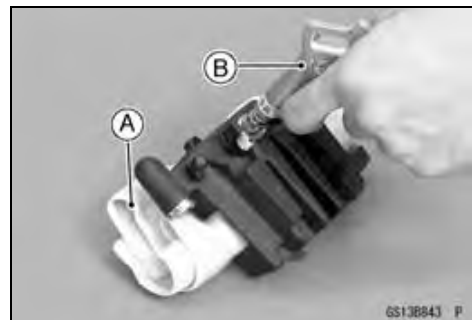

Periodic Maintenance Procedures

NOTE

- If compressed air is not available, do as follows with the brake hose connected to the caliper.
- Prepare a container for brake fluid, and perform the work above it.
- Remove the brake pads (see Front Brake Pad Removal in the Brakes chapter).
- Pump the brake lever until the pistons come out of the cylinders, and then disassemble the caliper.

Front Caliper Assembly

- Clean the caliper parts except for the pads.

CAUTION
For cleaning the parts, use only disc brake fluid, isopropyl alcohol, or ethyl alcohol.

- Install the bleed valve and rubber cap.
- Torque - Caliper Bleed Valve: 7.8 N·m (0.80 kgf·m, 69 in·lb)**

- Replace the fluid seals [A] with new ones.
- Apply brake fluid to the fluid seals, and install them into the cylinders by hand.
- Replace the dust seals [B] with new ones if they are damaged.
- Apply brake fluid to the dust seals, and install them into the cylinders by hand.

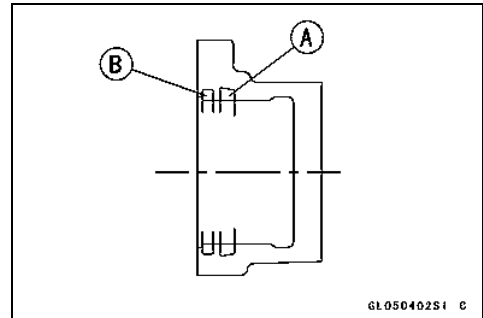

- Apply brake fluid to the outside of the pistons, and push them into each cylinder by hand.
- Check the friction boot [A] and the dust cover [B] replace them with new ones if they are damaged.
- Apply a thin coat of PBC (Poly Butyl Cuprysil) grease to the caliper holder shafts [C] (PBC is a special high-temperature, water-resistance grease).

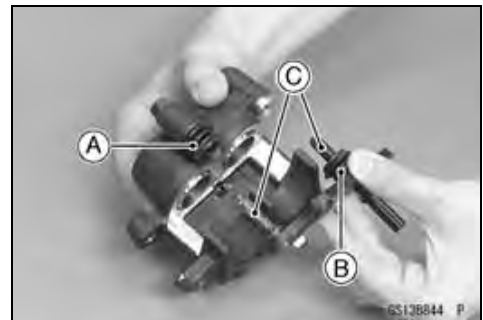

- Install the pad spring [A].
- Install the pads (see Front Brake Pad Installation in the Brakes chapter).
- Wipe up any spilled brake fluid on the caliper with wet cloth.

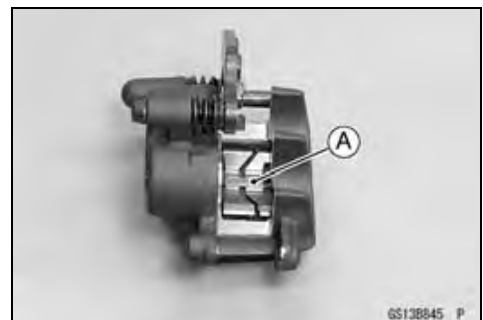

2-54 PERIODIC MAINTENANCE

Periodic Maintenance Procedures

Rear Caliper Disassembly

- Remove:
 - Rear Caliper (see Rear Caliper Removal in the Brakes chapter)
 - Brake Pads (see Rear Brake Pad Removal in the Brakes chapter)
 - Pad Spring
- Using compressed air, remove the piston.
 - Cover the piston area with a clean, thick cloth [A].
 - Blow compressed air [B] into the hole for the banjo bolt to remove the piston.

⚠ WARNING

To avoid serious injury, never place your fingers or palm in front of the piston. If you apply compressed air into the caliper, the piston may crush your hand or fingers.

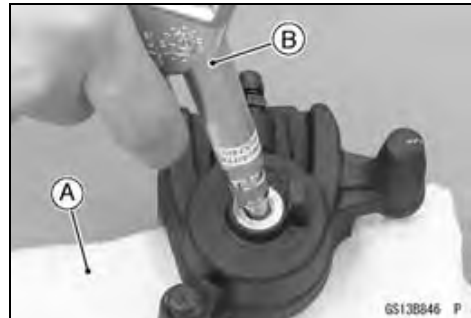

- Pull out the pistons by hand.
- Remove:
 - Caliper Holder
 - Dust Seal
 - Fluid Seal
 - Bleed Valve
 - Rubber Cap

NOTE

- If compressed air is not available, do as follows with the brake hose connected to the caliper.
- Prepare a container for brake fluid, and perform the work above it.
- Remove the brake pads (see Rear Brake Pad Removal in the Brakes chapter).
- Pump the brake pedal until the piston come out of the cylinder, and then disassemble the caliper.

Rear Caliper Assembly

- Clean the caliper parts except for the pads.

CAUTION

For cleaning of the parts, use only disc brake fluid, isopropyl alcohol, or ethyl alcohol.

- Install the bleed valve and rubber cap.
 - Torque - Caliper Bleed Valve: 7.8 N·m (0.80 kgf·m, 69 in·lb)**

Periodic Maintenance Procedures

- Replace the fluid seal [A] with a new one.
- Apply brake fluid to the fluid seal, and install it into the cylinder by hand.
- Replace the dust seal [B] with a new one if it is damaged.
- Apply brake fluid to the dust seal, and install it into the cylinder by hand.

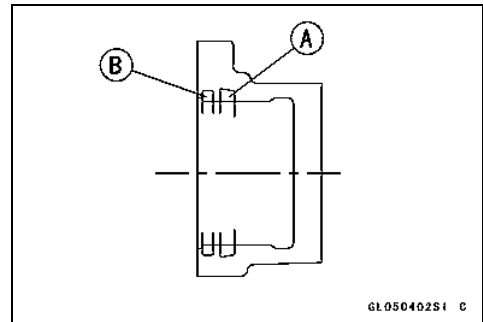

- Apply brake fluid to the outside of the piston, and push it into the cylinder by hand.
- Check the friction boot [A] and dust cover [B] replace them with new ones if they are damaged.
- Apply a thin coat of PBC (Poly Butyl Cuprysil) grease to the caliper holder shafts [C] (PBC is a special high-temperature, water-resistance grease).

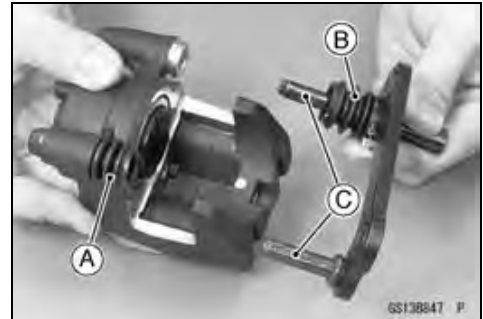

- Install the pad spring [A] in the caliper as shown.
- Install the pads (see Rear Brake Pad Installation in the Brakes chapter).
- Wipe up any spilled brake fluid on the caliper with wet cloth.



Spark Plug Replacement

- Remove:
 - Stick Coils (see Stick Coil Removal in the Electrical System chapter)
- Remove the spark plugs using the 16 mm (0.63 in.) plug wrench [A] vertically.



2-56 PERIODIC MAINTENANCE

Periodic Maintenance Procedures

- Replace the spark plug with a new one.

Standard Spark Plug

Type: **NGK CR9EIA-9**

- Insert the spark plug [A] into the plug wrench [B].
- Install the spark plug into the plug hole, and hand-tighten it first.

CAUTION

The insulator of the spark plug may break if when the wrench is inclined during tightening.

- Tighten:
Torque - Spark Plugs: 15 N·m (1.5 kgf·m, 11 ft·lb)
- Install the stick coils securely.
- Pull the stick coils lightly to check the installation condition.

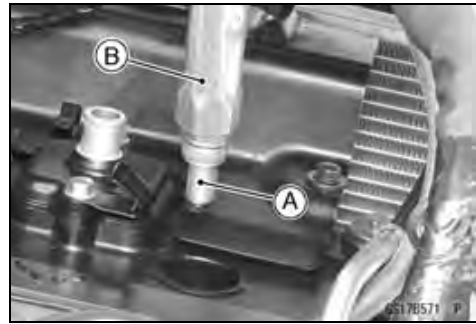

Fuel System (DFI)

Table of Contents

Exploded View.....	3-4
DFI System.....	3-10
DFI Parts Location.....	3-15
Specifications	3-18
Special Tools and Sealant	3-20
DFI Servicing Precautions.....	3-22
DFI Servicing Precautions	3-22
Troubleshooting the DFI System.....	3-24
Outline.....	3-24
Inquiries to Rider.....	3-27
DFI System Troubleshooting Guide	3-30
Self-Diagnosis	3-35
Self-diagnosis Outline.....	3-35
Self-diagnosis Procedures.....	3-35
Service Code Clearing Procedures.....	3-36
How to Read Service Codes.....	3-38
How to Erase Service Codes.....	3-38
Service Code Table.....	3-39
Backups	3-40
Main Throttle Sensor (Service Code 11)	3-42
Main Throttle Sensor Removal/Adjustment	3-42
Main Throttle Sensor Input Voltage Inspection	3-42
Main Throttle Sensor Output Voltage Inspection	3-43
Main Throttle Sensor Resistance Inspection	3-44
Inlet Air Pressure Sensor (Service Code 12).....	3-45
Inlet Air Pressure Sensor Removal.....	3-45
Inlet Air Pressure Sensor Installation.....	3-45
Inlet Air Pressure Sensor Input Voltage Inspection.....	3-45
Inlet Air Pressure Sensor Output Voltage Inspection.....	3-46
Inlet Air Temperature Sensor (Service Code 13).....	3-51
Inlet Air Temperature Sensor Removal/Installation.....	3-51
Inlet Air Temperature Sensor Output Voltage Inspection.....	3-51
Inlet Air Temperature Sensor Resistance Inspection	3-52
Water Temperature Sensor (Service Code 14)	3-54
Water Temperature Sensor Removal/Installation	3-54
Water Temperature Sensor Output Voltage Inspection.....	3-54
Water Temperature Sensor Resistance Inspection.....	3-55
Crankshaft Sensor (Service Code 21).....	3-56
Crankshaft Sensor Removal/Installation.....	3-56
Crankshaft Sensor Resistance Inspection	3-56
Crankshaft Sensor Peak Voltage Inspection.....	3-56
Speed Sensor (Service Code 24, 25).....	3-58
Speed Sensor Removal/Installation.....	3-58
Speed Sensor Inspection.....	3-58
Speed Sensor Input Voltage Inspection.....	3-58
Speed Sensor Output Voltage Inspection	3-59
Vehicle-down Sensor (Service Code 31).....	3-61
Vehicle-down Sensor Removal	3-61
Vehicle-down Sensor Installation	3-61
Vehicle-down Sensor Inspection.....	3-61

3-2 FUEL SYSTEM (DFI)

Subthrottle Sensor (Service Code 32).....	3-64
Subthrottle Sensor Removal/Adjustment.....	3-64
Subthrottle Sensor Input Voltage Inspection.....	3-64
Subthrottle Sensor Output Voltage Inspection.....	3-65
Subthrottle Sensor Resistance Inspection.....	3-66
Oxygen Sensor-not activated (Service Code 33) (Equipped Models).....	3-67
Oxygen Sensor Removal/Installation.....	3-67
Oxygen Sensor Inspection.....	3-67
Stick Coils #1, #2: (Service Code 51, 52).....	3-69
Stick Coil Removal/Installation.....	3-69
Stick Coil Primary Winding Resistance Inspection.....	3-69
Stick Coil Input Voltage Inspection.....	3-69
Radiator Fan Relay (Service Code 56).....	3-71
Radiator Fan Relay Removal/Installation.....	3-71
Radiator Fan Relay Inspection.....	3-71
Subthrottle Valve Actuator (Service Code 62).....	3-72
Subthrottle Valve Actuator Removal.....	3-72
Subthrottle Valve Actuator Inspection.....	3-72
Subthrottle Valve Actuator Resistance Inspection.....	3-72
Subthrottle Valve Actuator Input Voltage Inspection.....	3-73
Air Switching Valve (Service Code 64).....	3-75
Air Switching Valve Removal/Installation.....	3-75
Air Switching Valve Inspection.....	3-75
Oxygen Sensor Heater (Service Code 67) (Equipped Models).....	3-76
Oxygen Sensor Heater Removal/Installation.....	3-76
Oxygen Sensor Heater Inspection.....	3-76
Oxygen Sensor Heater Power Source Voltage Inspection.....	3-76
Oxygen Sensor-Incorrect Output Voltage (Service Code 94) (Equipped Models).....	3-78
Oxygen Sensor Removal/Installation.....	3-78
Oxygen Sensor Inspection.....	3-78
FI Indicator Light (LED).....	3-80
FI Indicator Light (LED) Inspection.....	3-80
ECU.....	3-81
ECU Removal.....	3-81
ECU Installation.....	3-81
ECU Power Supply Inspection.....	3-82
DFI Power Source.....	3-85
ECU Fuse Removal.....	3-85
ECU Fuse Installation.....	3-85
ECU Fuse Inspection.....	3-85
ECU Main Relay Removal/Installation.....	3-85
ECU Main Relay Inspection.....	3-85
Fuel Line.....	3-86
Fuel Pressure Inspection.....	3-86
Fuel Flow Rate Inspection.....	3-87
Fuel Pump.....	3-89
Fuel Pump Removal.....	3-89
Fuel Pump Installation.....	3-89
Fuel Pump Operation Inspection.....	3-90
Fuel Pump Operating Voltage Inspection.....	3-91
Pressure Regulator Removal.....	3-92
Pump Screen, Fuel Filter Cleaning.....	3-92
Fuel Injectors.....	3-94
Fuel Injector Removal/Installation.....	3-94
Fuel Injector Audible Inspection.....	3-94
Fuel Injector Resistance Inspection.....	3-94
Fuel Injector Power Source Voltage Inspection.....	3-95

Fuel Injector Output Voltage Inspection	3-96
Fuel Injector Fuel Line Inspection	3-97
Throttle Grip and Cables	3-99
Throttle Grip Free Play Inspection	3-99
Throttle Grip Free Play Adjustment.....	3-99
Throttle Cable Installation	3-99
Throttle Cable Lubrication.....	3-99
Throttle Body Assy	3-100
Idle Speed Inspection/Adjustment	3-100
Synchronization Inspection/Adjustment.....	3-100
Throttle Body Assy Removal.....	3-100
Throttle Body Assy Installation.....	3-102
Throttle Body Assy Disassembly	3-103
Throttle Body Assy Assembly	3-103
Air Cleaner.....	3-104
Air Cleaner Element Removal/Installation	3-104
Air Cleaner Element Inspection	3-104
Air Cleaner Oil Draining	3-104
Air Cleaner Housing Removal.....	3-104
Air Cleaner Housing Installation.....	3-105
Fuel Tank.....	3-106
Fuel Tank Removal	3-106
Fuel Tank Installation	3-108
Fuel Tank and Cap Inspection	3-109
Fuel Tank Cleaning	3-109
Evaporative Emission Control System (CAL and SEA Models)	3-110
Parts Removal/Installation	3-110
Hose Inspection	3-110
Separator Inspection.....	3-110
Separator Operation Test.....	3-111
Canister Inspection	3-111

3-4 FUEL SYSTEM (DFI)

Exploded View

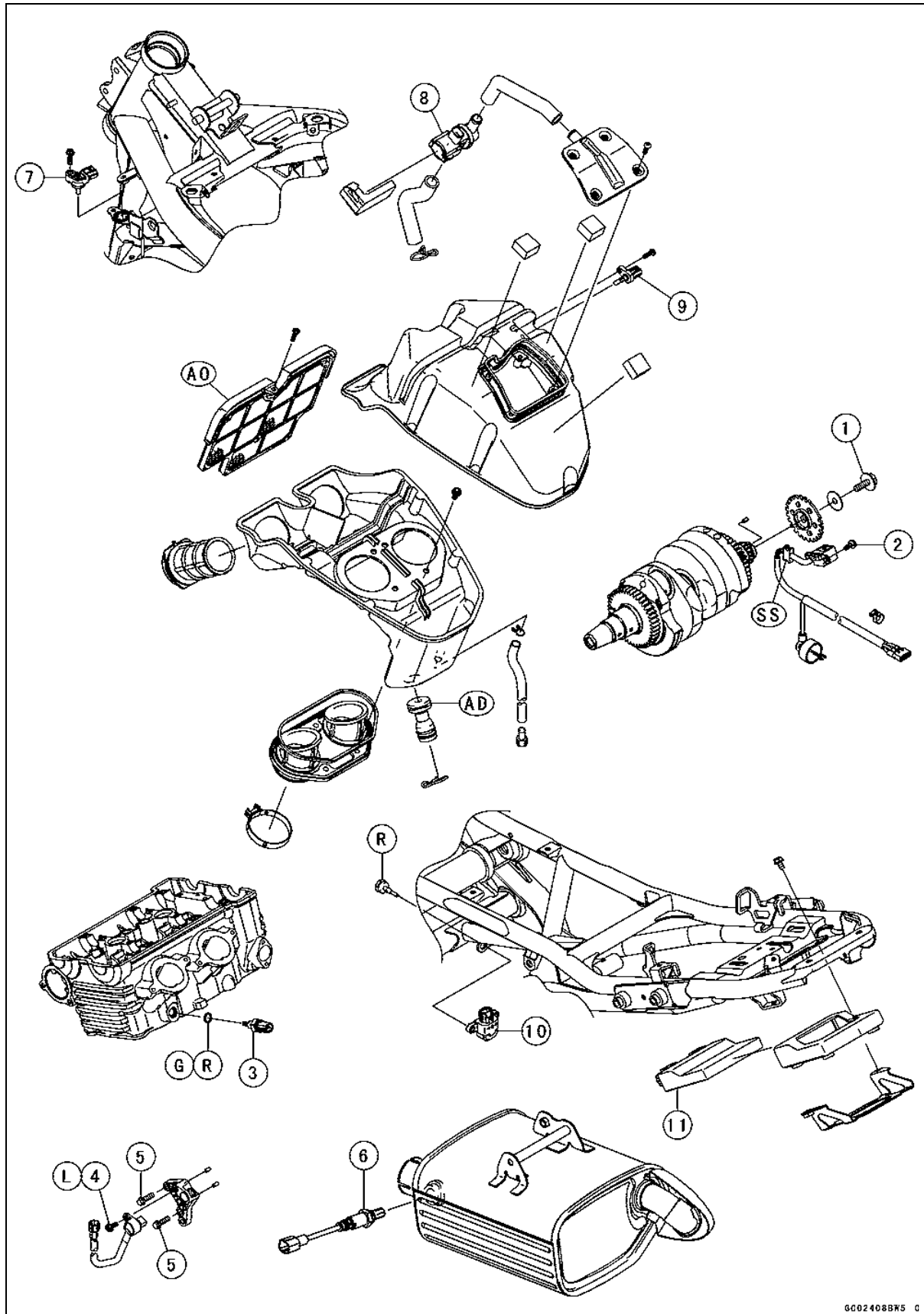

GG02408BK5 C

Exploded View

No.	Fastener	Torque			Remarks
		N-m	kgf-m	ft-lb	
1	Timing Rotor Bolt	40	4.1	30	
2	Crankshaft Sensor Bolts	6.0	0.61	53 in-lb	
3	Water Temperature Sensor	12	1.2	106 in-lb	
4	Speed Sensor Bolt	7.8	0.80	69 in-lb	L
5	Speed Sensor Bracket Bolts	9.8	1.0	87 in-lb	
6	Oxygen Sensor (Equipped Models)	44	4.5	32	

- 7. Inlet Air Pressure Sensor
 - 8. Air Switching Valve
 - 9. Inlet Air Temperature Sensor
 - 10. Vehicle-down Sensor
 - 11. ECU (Electronic Control Unit)
- AD: Apply adhesive.
 AO: Apply high-quality-foam-air-filter oil.
 G: Apply grease.
 L: Apply a non-permanent locking agent.
 R: Replacement Parts
 SS: Apply silicone sealant.

3-6 FUEL SYSTEM (DFI)

Exploded View

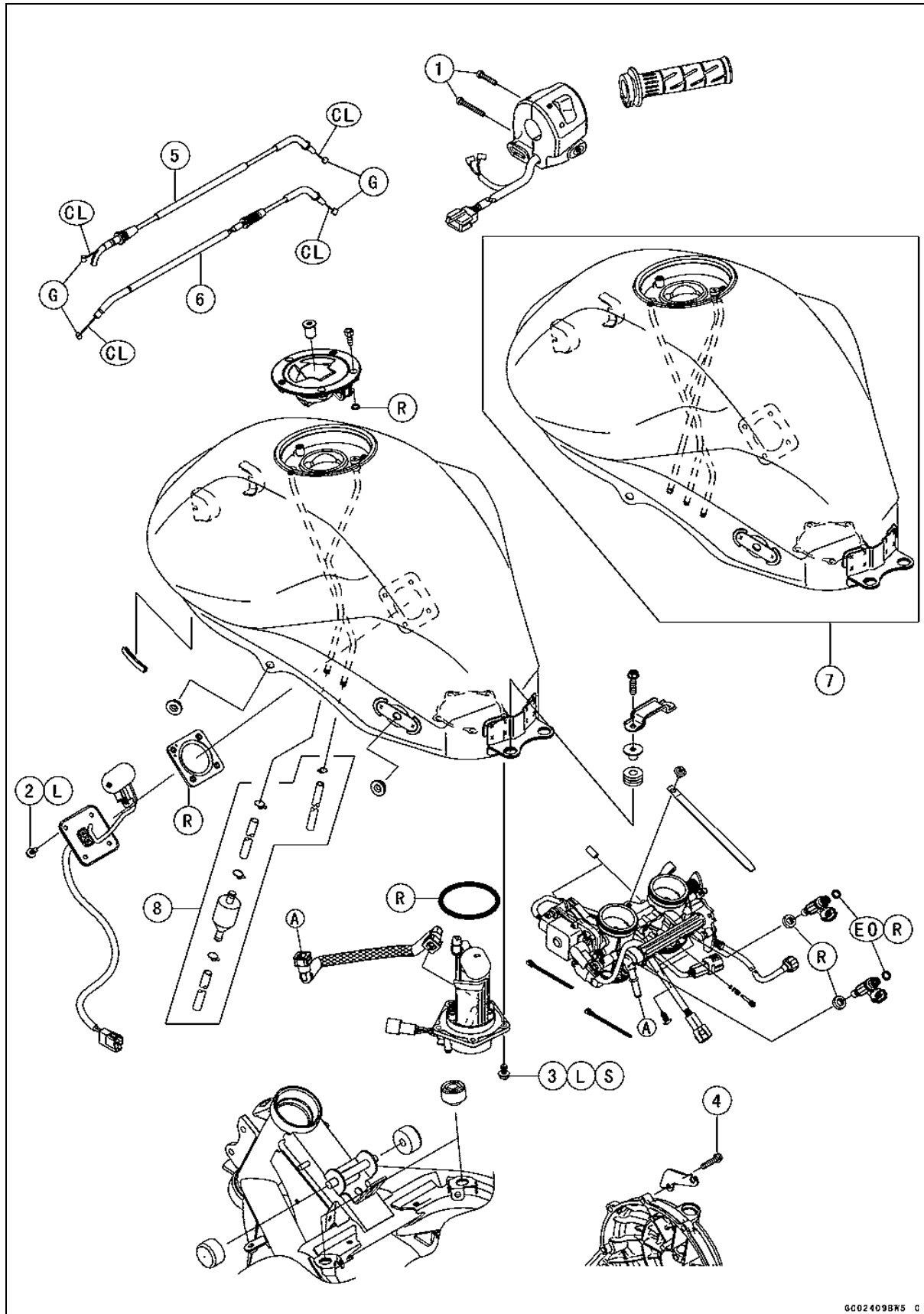

GG02409BK5 C

Exploded View

No.	Fastener	Torque			Remarks
		N·m	kgf·m	ft·lb	
1	Switch Housing Screws	3.5	0.36	31 in·lb	
2	Fuel Level Sensor Bolts	6.9	0.70	61	L
3	Fuel Pump Bolts	9.8	1.0	87 in·lb	L, S
4	Clutch Cover Bolt	9.8	1.0	87 in·lb	

5. Throttle Cable (Accelerator)

6. Throttle Cable (Decelerator)

7. CAL and SEA Models

8. Other than CAL and SEA Models

CL: Apply cable lubricant.

EO: Apply engine oil.

G: Apply grease.

L: Apply a non-permanent locking agent.

R: Replacement Parts

S: Follow the specified tightening sequence.

3-8 FUEL SYSTEM (DFI)

Exploded View

CAL and SEA Models

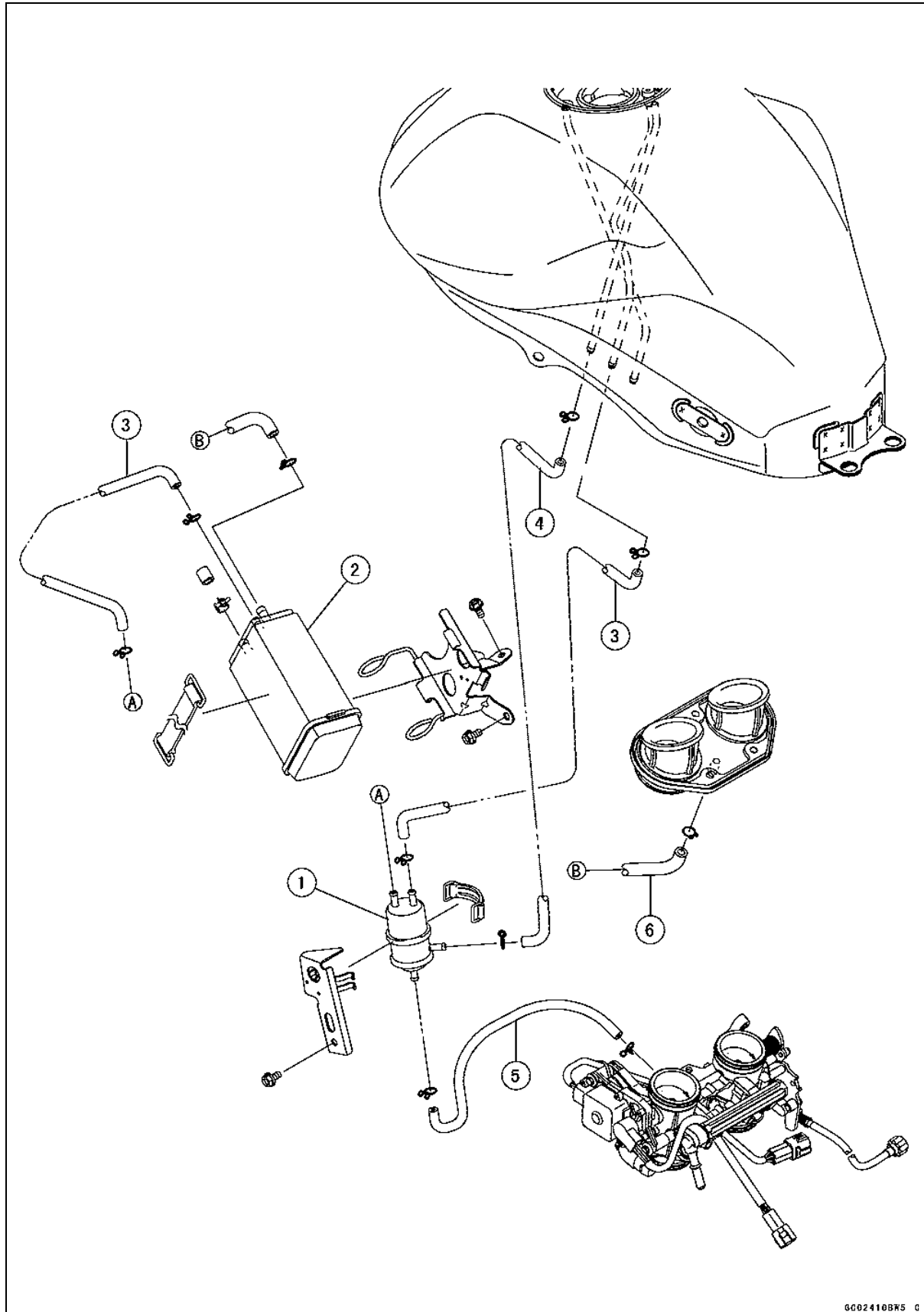

Exploded View

1. Separator
2. Canister
3. Tube (Blue)
4. Tube (Red)
5. Tube (White)
6. Tube (Green)

3-10 FUEL SYSTEM (DFI)

DFI System

DFI System

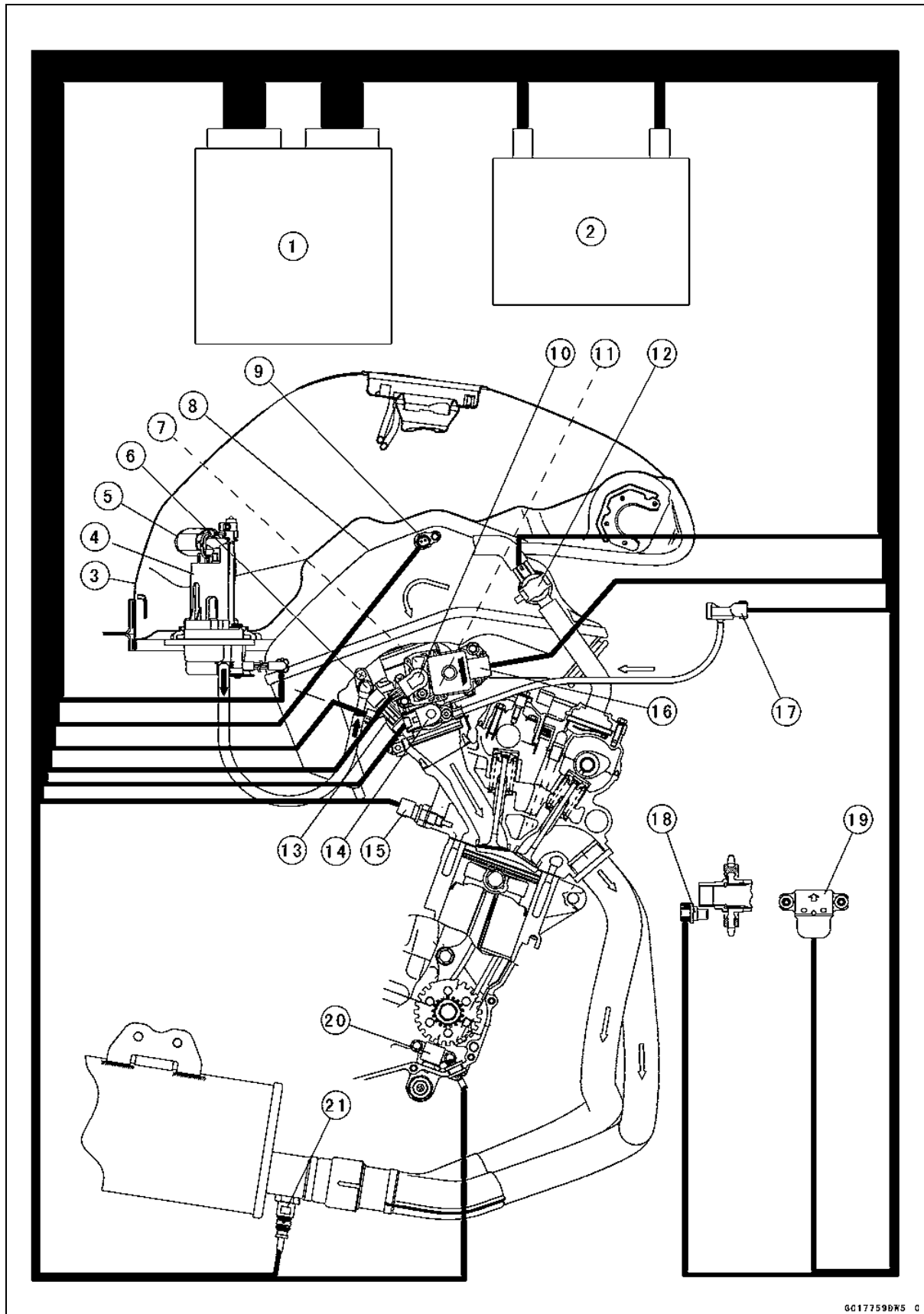

GC177590R5 C

DFI System

1. ECU (Electronic Control Unit)
2. Battery
3. Fuel Tank
4. Fuel Pump
5. Pressure Regulator
6. Delivery Pipe
7. Subthrottle Valve
8. Air Cleaner Housing
9. Inlet Air Temperature Sensor
10. Subthrottle Sensor
11. Main Throttle Valve
12. Air Switching Valve
13. Injectors
14. Main Throttle Sensor
15. Water Temperature Sensor
16. Subthrottle Valve Actuator
17. Inlet Air Pressure Sensor
18. Speed Sensor
19. Vehicle-down Sensor
20. Crankshaft Sensor
21. Oxygen Sensor (Equipped Models)

3-12 FUEL SYSTEM (DFI)

DFI System

DFI System Wiring Diagram

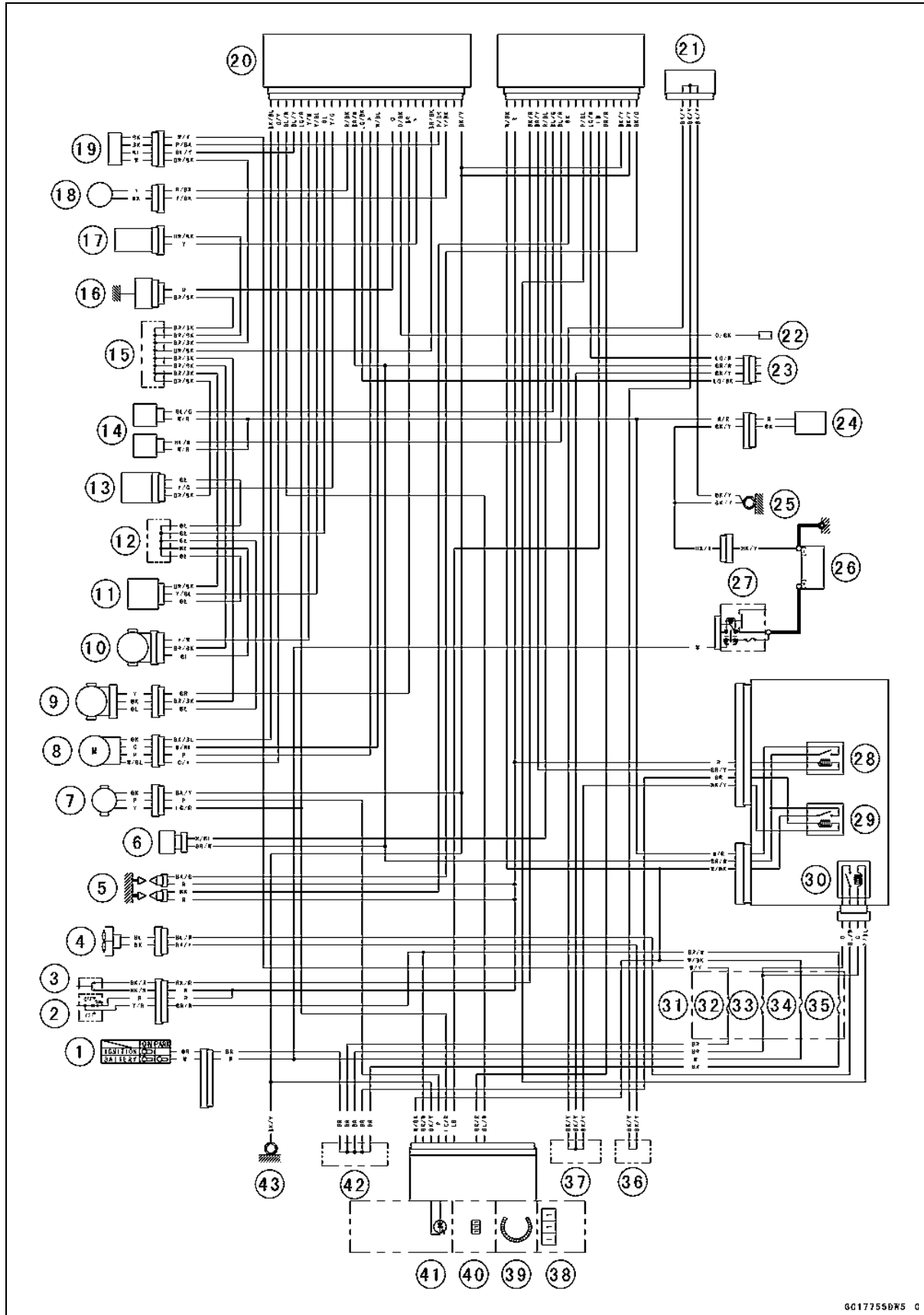

DFI System

Part Name

1. Ignition Switch
2. Engine Stop Switch
3. Starter Button
4. Fan Motor
5. Stick Coils
6. Air Switching Valve
7. Speed Sensor
8. Subthrottle Valve Actuator
9. Subthrottle Sensor
10. Main Throttle Sensor
11. Inlet Air Pressure Sensor
12. Water-proof Joint D
13. Vehicle-down Sensor
14. Injectors
15. Water-proof Joint E
16. Water Temperature Sensor
17. Inlet Air Temperature Sensor
18. Crankshaft Sensor
19. Oxygen Sensor (Equipped Models)
20. ECU (Electronic Control Unit)
21. Joint Connector
22. Self-diagnosis Terminal
23. Kawasaki Diagnostic System Connector
24. Fuel Pump
25. Frame Ground
26. Battery 12 V 10 Ah
27. Main Fuse 30 A
28. Fuel Pump Relay
29. ECU Main Relay
30. Radiator Fan Relay
31. Fuse Box
32. Oxygen Sensor Heater Fuse 10 A
33. Radiator Fan Fuse 15 A
34. ECU Fuse 15 A
35. Ignition Fuse 10 A
36. Water-proof Joint A
37. Water-proof Joint B
38. Speedometer
39. Tachometer
40. Water Temperature Warning Indicator Light (LED)
41. FI Indicator Light (LED)
42. Water-proof Joint C
43. Frame Ground

○Lead Color Codes:

BK: Black	G: Green	P: Pink
BL: Blue	GY: Gray	PU: Purple
BR: Brown	LB: Light Blue	R: Red
CH: Chocolate	LG: Light Green	W: White
DG: Dark Green	O: Orange	Y: Yellow

3-14 FUEL SYSTEM (DFI)

DFI System

Terminal Numbers of ECU Connectors

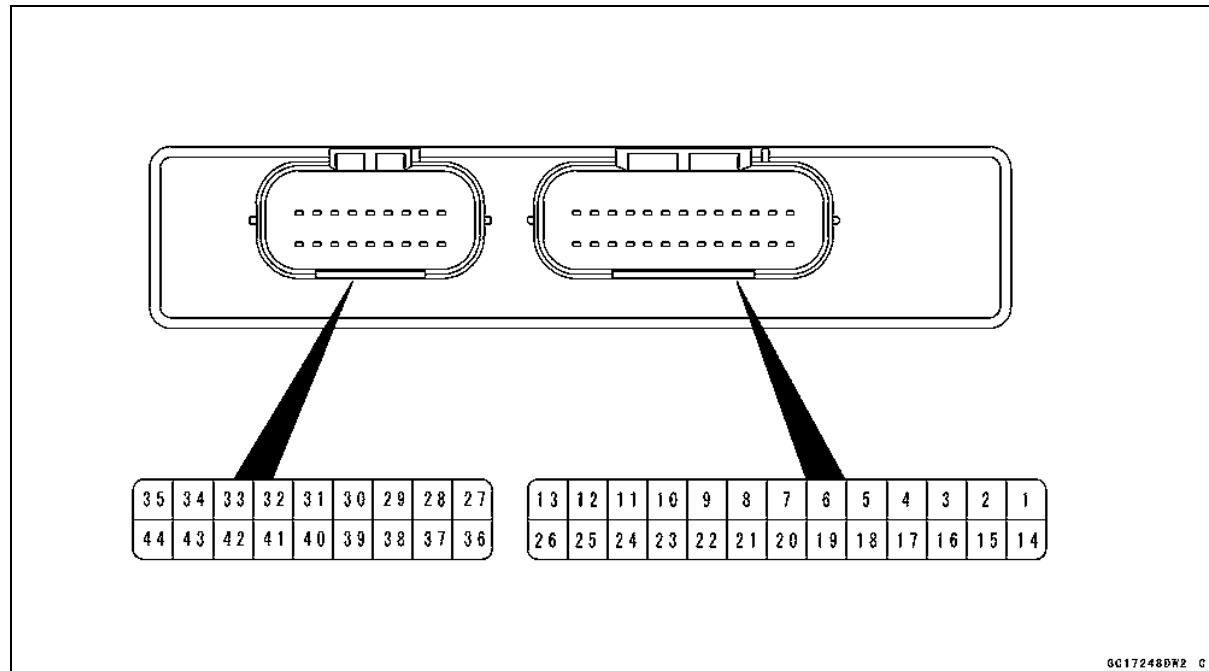

Terminal Names

1. Subthrottle Valve Actuator: BK/BL
2. Subthrottle Valve Actuator: G/Y
3. Water Temperature Warning Indicator Light: BL/W
4. Oxygen Sensor: BL/Y
5. Speed Sensor: LG/R
6. Main Throttle Sensor: Y/W
7. Inlet Air Pressure Sensor: Y/BL
8. Power Supply to Sensors: BL
9. Vehicle-down Sensor: Y/G
10. Neutral Switch: LG
11. Crankshaft Sensor (+): R/BK
12. Power Supply to ECU (from ECU Main Relay): BR/W
13. External Communication Line: LG/BK
14. Subthrottle Valve Actuator: P
15. Subthrottle Valve Actuator: W/BL
16. Unused
17. Water Temperature Sensor: O
18. Self-diagnosis Terminal: O/BK
19. Subthrottle Sensor: BR
20. Inlet Air Temperature Sensor: Y
21. Unused
22. Ground for Sensors: BR/BK
23. Oxygen Sensor Heater: P/BK
24. Crankshaft Sensor (-): Y/BK
25. Unused
26. Ground for ECU: BK/Y
27. Power Supply to ECU (from Battery): W/BK
28. Engine Stop Switch: R
29. Starter Lockout Switch: R/G
30. Starter Button: BK/R
31. Fuel Pump Relay: BR/Y
32. Air Switching Valve: R/BL
33. Injector #2: BL/G
34. Injector #1: BL/R
35. Stick Coil #1: BK
36. Sidestand Switch: G/BK
37. Fan Relay: P/BL
38. External Communication Line: LG/W
39. Meter Unit (Tachometer): LB
40. FI Indicator Light: BR/R
41. -
42. Ground for Fuel System: BK/Y
43. Ground for Ignition System: BK/Y
44. Stick Coil #2: BK/G

DFI Parts Location

Ignition Switch [A]
FI Indicator Light (LED) [B]

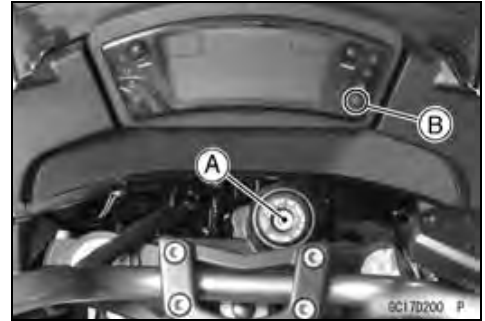

Main Throttle Sensor [A]
Subthrottle Sensor [B]
Subthrottle Valve Actuator [C]
Fuel Injectors #1, #2 [D]

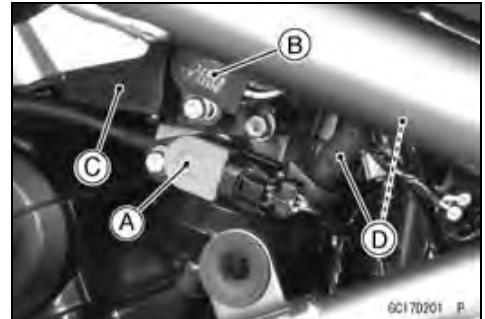

Water Temperature Sensor [A]



Air Switching Valve [A]
Inlet Air Temperature Sensor [B]
Inlet Air Pressure Sensor [C]



Fuel Pump [A]



3-16 FUEL SYSTEM (DFI)

DFI Parts Location

Relay Box (ECU Main Relay, Fan Relay, Fuel Pump Relay) [A]
Battery 12V 10Ah [B]
Fuse Box (Oxygen Sensor Heater Fuse 10A, Fan Fuse 15A, ECU Fuse 15A, Ignition Fuse 10A) [C]

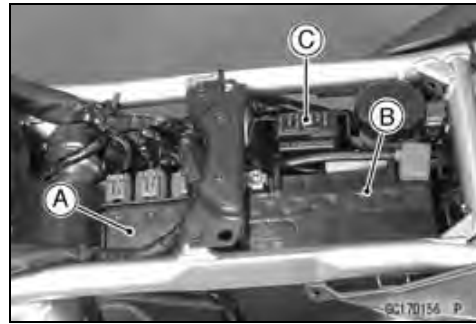

ECU [A]
Kawasaki Diagnostic System Connector [B]
Self-diagnosis Terminal [C]

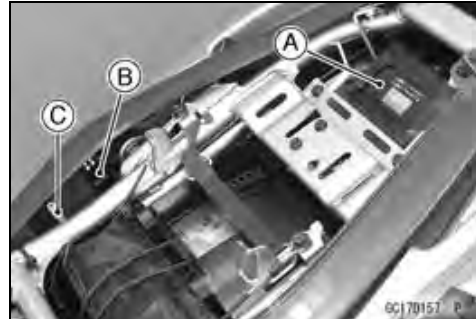

Crankshaft Sensor [A]



Vehicle-down Sensor [A]



Speed Sensor [A]
Neutral Switch [B]

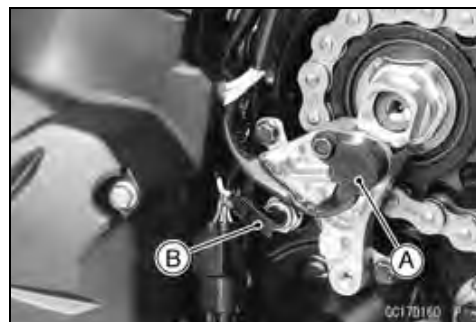

DFI Parts Location

Oxygen Sensor (Equipped Models) [A]



3-18 FUEL SYSTEM (DFI)

Specifications

Item	Standard
Digital Fuel Injection System	
Idle Speed	1 300 ±50 r/min (rpm)
Throttle Body Assy:	
Type	Two barrel type
Bore	φ38 mm (1.5 in.)
Bypass Screws (Turn out)	0 ~ 2 1/2 (for reference)
ECU (Electronic Control Unit):	
Make	DENSO
Type	Digital memory type, with built in IC igniter, sealed with resin
Usable Engine Speed	100 ~ 11 180 r/min (rpm)
Fuel Pressure (High Pressure Line):	
With Engine Idling	294 kPa (3.0 kgf/cm ² , 43 psi) with fuel pump running
Fuel Pump:	
Type	In-tank friction pump
Discharge	60 mL (2.0 US oz.) or more for 3 seconds
Fuel Injectors:	
Type	INP-287
Nozzle Type	One spray type with 12 holes
Resistance	About 11.7 ~ 12.3 Ω at 20°C (68°F)
Main Throttle Sensor:	Non-adjustable and non-removable
Input Voltage	DC 4.75 ~ 5.25 V
Output Voltage	DC 1.005 ~ 1.035 V at Idle Throttle Opening DC 4.2 ~ 4.4 V at Full Throttle Opening
Resistance	4 ~ 6 kΩ
Inlet Air Pressure Sensor:	
Input Voltage	DC 4.75 ~ 5.25 V
Output Voltage	DC 3.80 ~ 4.20 V at standard atmospheric pressure (see this text for details)
Inlet Air Temperature Sensor:	
Resistance	5.4 ~ 6.6 kΩ at 0°C (32°F) 0.29 ~ 0.39 kΩ at 80°C (176°F)
Output Voltage	About 2.25 ~ 2.50 V at 20°C (68°F)
Water Temperature Sensor:	
Resistance	see Electrical System chapter
Output Voltage	About 2.80 ~ 2.97 V at 20°C (68°F)
Speed Sensor:	
Input Voltage	About DC 9 ~ 11 V at Ignition Switch ON
Output Voltage	About DC 0.05 ~ 0.07 V or DC 4.5 ~ 4.9 V at Ignition Switch ON and 0 km/h (0 mph)
Vehicle-down Sensor:	
Detection Method	Magnetic flux detection method
Detection Angle	more than 60 ~ 70° for each bank
Input Voltage	DC 4.75 ~ 5.25 V

Specifications

Item	Standard
Output Voltage	with the sensor tilted 60 ~ 70° or more: 0.65 ~ 1.35 V
Subthrottle Sensor:	with the sensor arrow mark pointed up: 3.55 ~ 4.45 V
Input Voltage	Non-adjustable and non-removable
Output Voltage	DC 4.75 ~ 5.25 V
Resistance	DC 0.4 ~ 0.6 V at Idle Throttle Opening
Subthrottle Valve Actuator:	DC 3.825 ~ 3.975 V at Full Throttle Opening
Input Voltage	4 ~ 6 kΩ
Resistance	About DC 8.5 ~ 10.5 V
Subthrottle Valve Actuator:	About 5.5 ~ 7.5 Ω
Input Voltage	About DC 8.5 ~ 10.5 V
Resistance	About 5.5 ~ 7.5 Ω
Oxygen Sensor (Equipped Models):	
Output Voltage (Rich)	DC 0.7 V or more
Output Voltage (Lean)	DC 0.2 V or less
Heater Resistance	11.7 ~ 14.5 Ω at 20°C (68°F)
Throttle Grip and Cables	
Throttle Grip Free Play	2 ~ 3 mm (0.08 ~ 0.12 in.)

3-20 FUEL SYSTEM (DFI)

Special Tools and Sealant

Oil Pressure Gauge, 5 kgf/cm²:
57001-125

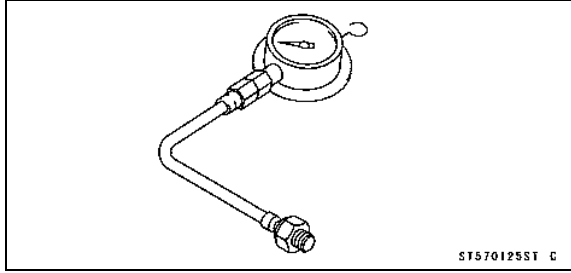

Peak Voltage Adapter:
57001-1415

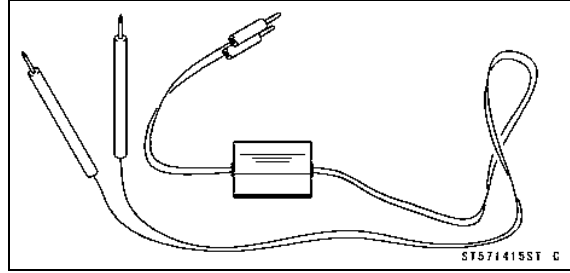

Fork Oil Level Gauge:
57001-1290

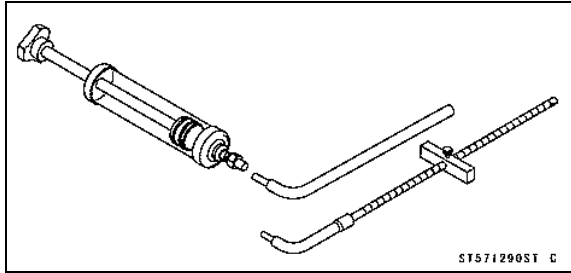

Needle Adapter Set:
57001-1457

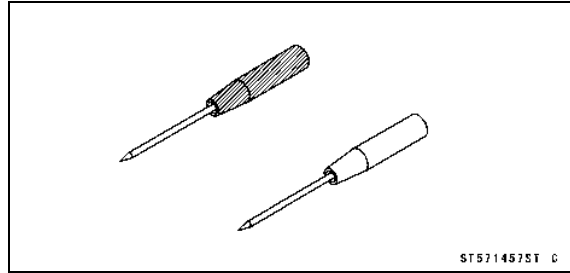

Vacuum Gauge:
57001-1369

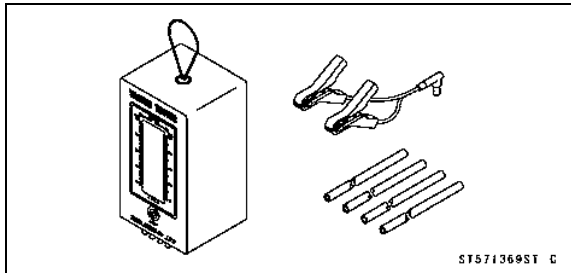

Throttle Sensor Setting Adapter:
57001-1538

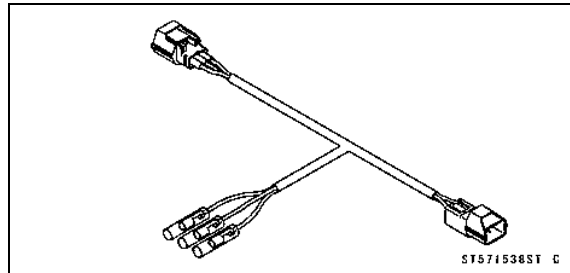

Hand Tester:
57001-1394

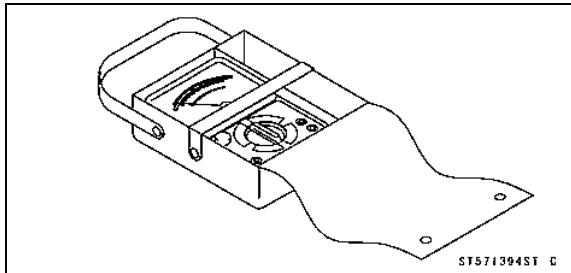

Fuel Pressure Gauge Adapter:
57001-1593

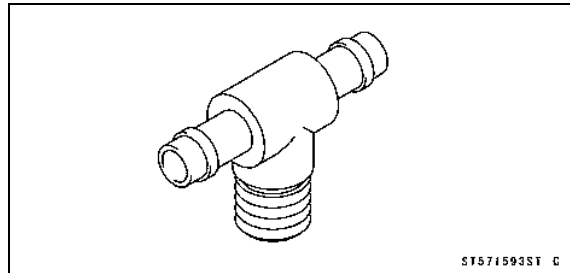

Throttle Sensor Setting Adapter #1:
57001-1400

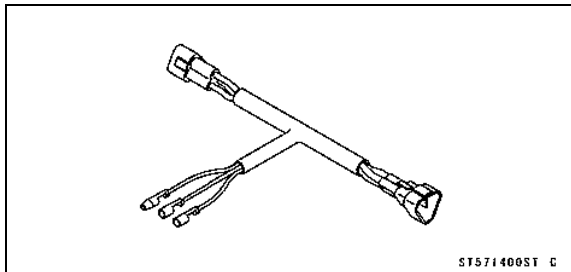

Fuel Hose:
57001-1607

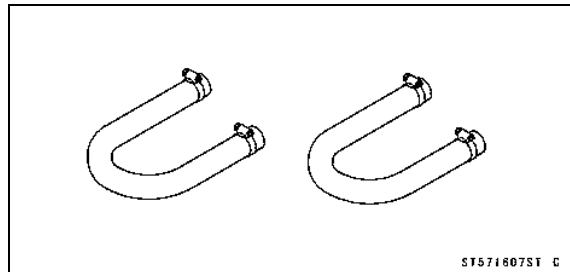

Special Tools and Sealant

Oxygen Sensor Measuring Adapter:
57001-1682

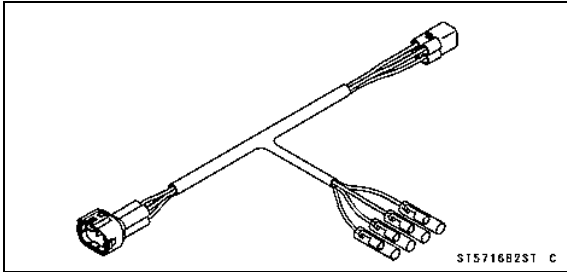

Kawasaki Bond (Silicone Sealant):
56019-120

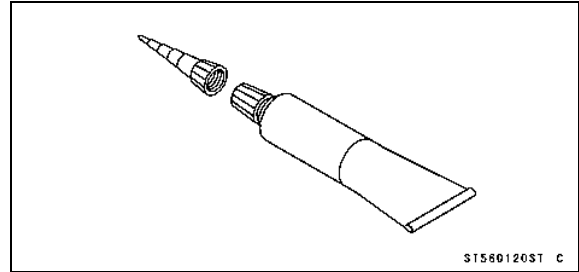

Measuring Adapter:
57001-1700

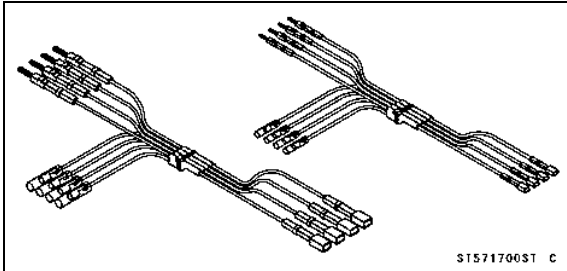

3-22 FUEL SYSTEM (DFI)

DFI Servicing Precautions

DFI Servicing Precautions

There are a number of important precautions that should be followed servicing the DFI system.

- This DFI system is designed to be used with a 12 V sealed battery as its power source. Do not use any other battery except for a 12 V sealed battery as a power source.
- Do not reverse the battery cable connections. This will damage the ECU.
- To prevent damage to the DFI parts, do not disconnect the battery cables or any other electrical connections when the ignition switch is on or while the engine is running.
- Take care not to short the cables that are directly connected to the battery positive (+) terminal to the chassis ground.
- When charging, remove the battery from the motorcycle. This is to prevent ECU damage by excessive voltage.
- Whenever the DFI electrical connections are to be disconnected, first turn off the ignition switch, and disconnect the battery (-) terminal. Do not pull the lead, only the connector. Conversely, make sure that all the DFI electrical connections are firmly reconnected before starting the engine.
- Connect these connectors until they click [A].

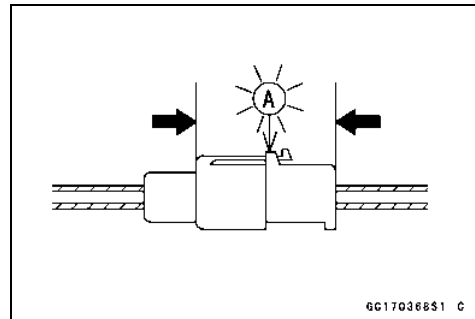

- Do not turn the ignition switch ON while any of the DFI electrical connectors are disconnected. The ECU memorizes service codes.
- Do not spray water on the electrical parts, DFI parts, connectors, leads, and wiring.
- If a transceiver is installed on the motorcycle, make sure that the operation of the DFI system is not influenced by electric wave radiated from the antenna. Check operation of the system with the engine at idle. Locate the antenna as far as possible away from the ECU.
- When any fuel hose is disconnected, fuel may spout out by residual pressure in the fuel line. Cover the hose joint with a piece of clean cloth to prevent fuel spillage.
- When any fuel hose is disconnected, do not turn on the ignition switch. Otherwise, the fuel pump will operate and fuel will spout from the fuel hose.
- Do not operate the fuel pump if the pump is completely dry. This is to prevent pump seizure.
- Before removing the fuel system parts, blow the outer surfaces of these parts clean with compressed air.
- To prevent corrosion and deposits in the fuel system, do not add to fuel any fuel antifreeze chemicals.

DFI Servicing Precautions

○If the motorcycle is not properly handled, the high pressure inside the fuel line can cause fuel to leak or the hose to burst. Remove the fuel tank (see Fuel Tank Removal) and check the fuel hose [A].

★Replace the fuel hose if any fraying, cracks or bulges are noticed.

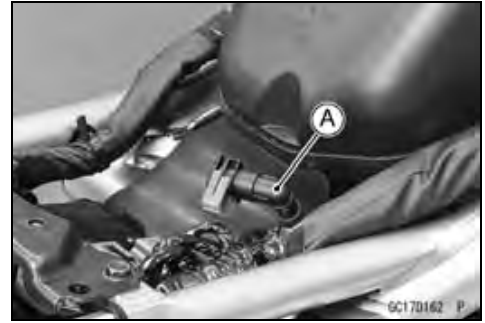

○To maintain the correct fuel/air mixture (F/A), there must be no inlet air leaks in the DFI system. Be sure to install the oil filler plug [A] after filling the engine oil.

Torque - Oil Filler Plug: Hand-tighten

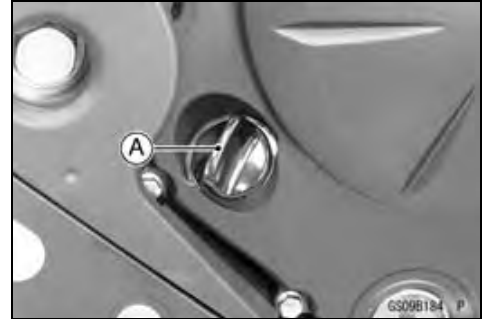

3-24 FUEL SYSTEM (DFI)

Troubleshooting the DFI System

Outline

When an abnormality in the DFI system occurs, the FI indicator light (LED) goes on to alert the rider on the meter panel. In addition, the condition of the problem is stored in the memory of the ECU (electronic control unit). With the engine stopped and turned in the self-diagnosis mode, the service code [A] is indicated by the number of times the FI indicator light (LED) blinks.

When due to a malfunction, the FI indicator light (LED) remains lit, ask the rider about the conditions [B] under which the problem occurred and try to determine the cause [C].

First, conduct a self-diagnosis inspection and then a non-self-diagnosis inspection. The non-self-diagnosis items are not indicated by the FI indicator light (LED). Don't rely solely on the DFI self-diagnosis function, use common sense.

Even when the DFI system is operating normally, the FI indicator light (LED) [A] may light up under strong electrical interference. No repair needed. Turn the ignition switch OFF to stop the indicator light.

When the FI indicator light (LED) goes on and the motorcycle is brought in for repair, check the service codes.

When the repair has been done, the light (LED) does not go on. But the service codes stored in memory are not erased to preserve the problem history, and the light (LED) can display the codes in the self-diagnosis mode. The problem history is referred when solving unstable problems.

When the motorcycle is down, the vehicle-down sensor is turned OFF and the ECU shuts off the fuel injectors and ignition system. The FI indicator light (LED) blinks but the service code cannot be displayed. The ignition switch is left ON. If the starter button is pushed, the electric starter turns but the engine does not start. To start the engine again, raise the motorcycle, turn the ignition switch OFF, and then ON. The vehicle-down sensor is turned ON and the light (LED) goes OFF.

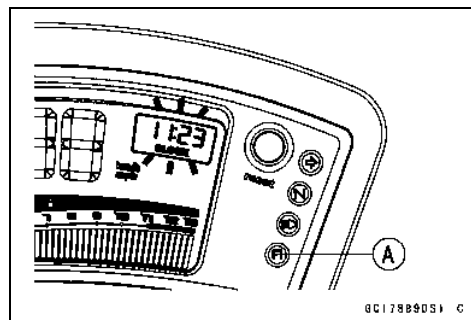
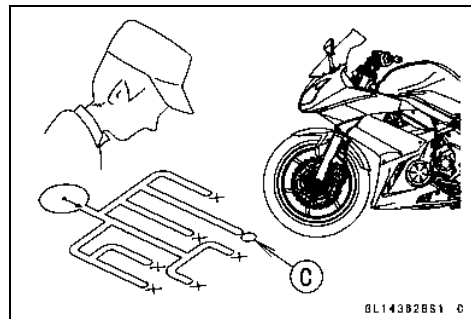
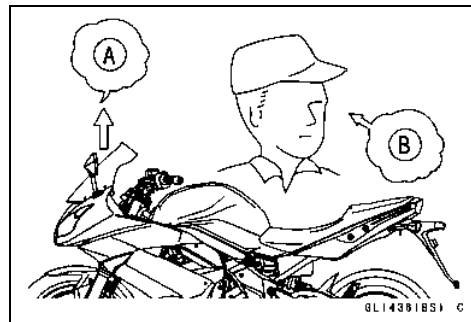

Troubleshooting the DFI System

- The DFI part connectors [A] have seals [B], including the ECU.
- Join the connector and insert the needle adapters [C] inside the seals [B] from behind the connector until the adapter reaches the terminal.

Special Tool - Needle Adapter Set: 57001-1457

CAUTION

Insert the needle adapter straight along the terminal in the connector to prevent short-circuit between terminals.

- Make sure that measuring points are correct in the connector, noting the position of the lock [D] and the lead color before measurement. Do not reverse connections of the hand tester or a digital meter.
- Be careful not to short-circuit the leads of the DFI or electrical system parts by contact between adapters.
- Turn the ignition switch ON and measure the voltage with the connector joined.

CAUTION

Incorrect, reverse connection or short circuit by needle adapters could damage the DFI or electrical system parts.

- After measurement, remove the needle adapters and apply silicone sealant to the seals [A] of the connector [B] for waterproofing.

Sealant - Kawasaki Bond (Silicone Sealant): 56019-120

- Always check battery condition before replacing the DFI parts. A fully charged battery is a must for conducting accurate tests of the DFI system.

- Trouble may involve one or in some cases all items. Never replace a defective part without determining what CAUSED the problem. If the problem was caused by some other item or items, they too must be repaired or replaced, or the new replacement part will soon fail again.
- Measure coil winding resistance when the DFI part is cold (at room temperature).
- Make sure all connectors in the circuit are clean and tight, and examine leads for signs of burning, fraying, short, etc. Deteriorated leads and bad connections can cause reappearance of problems and unstable operation of the DFI system.
- ★ If any wiring is deteriorated, replace the wiring.

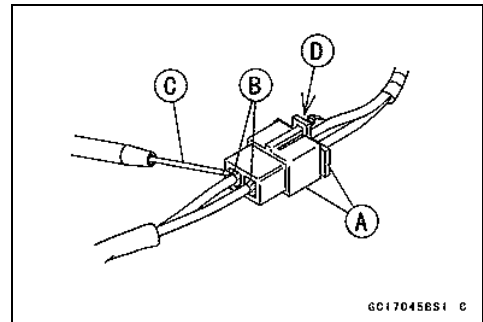

GC170456S1 C

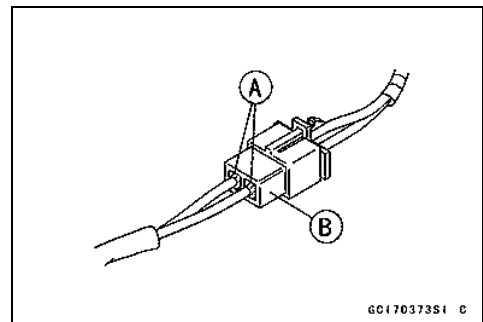

GC170373S1 C

3-26 FUEL SYSTEM (DFI)

Troubleshooting the DFI System

- Pull each connector [A] apart and inspect it for corrosion, dirt, and damage.
- ★ If the connector is corroded or dirty, clean it carefully. If it is damaged, replace it. Connect the connectors securely.
- Check the wiring for continuity.
- Use the wiring diagram to find the ends of the lead which is suspected of being a problem.
- Connect the hand tester between the ends of the leads.
- Set the tester to the $\times 1 \Omega$ range, and read the tester.
- ★ If the tester does not read 0Ω , the lead is defective. Replace the lead or the main harness [B] or the sub harness.

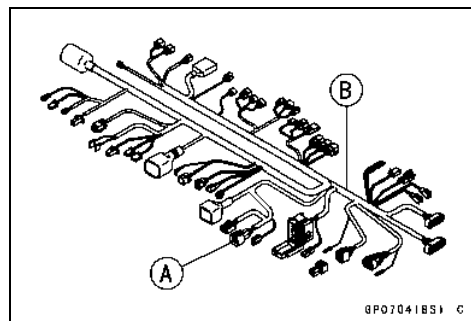

- If both ends of a harness [A] are far apart, ground [B] the one end [C], using a jumper lead [D] and check the continuity between the end [E] and the ground [F]. This enables to check a long harness for continuity. If the harness is open, repair or replace the harness.

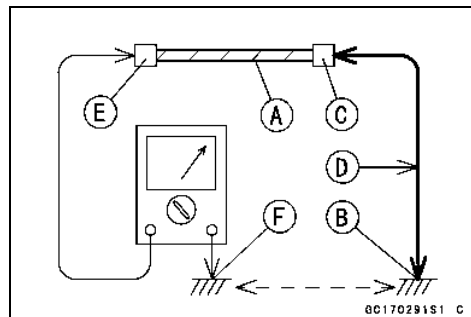

- When checking a harness [A] for short circuit, open one end [B] and check the continuity between the other end [C] and ground [D]. If there is continuity, the harness has a short circuit to ground, and it must be repaired or replaced.

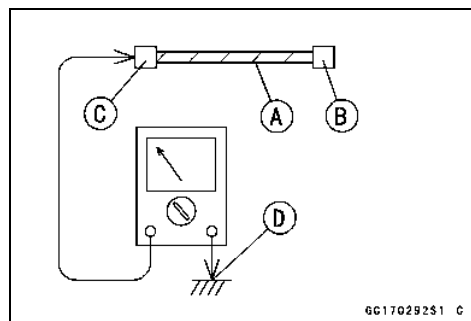

- Narrow down suspicious locations by repeating the continuity tests from the ECU connectors.
- ★ If no abnormality is found in the wiring or connectors, the DFI parts are the next likely suspects. Check the part, starting with input and output voltages. However, there is no way to check the ECU itself.
- ★ If an abnormality is found, replace the affected DFI part.
- ★ If no abnormality is found in the wiring, connectors, and DFI parts, replace the ECU.

Troubleshooting the DFI System

DFI Diagnosis Flow Chart

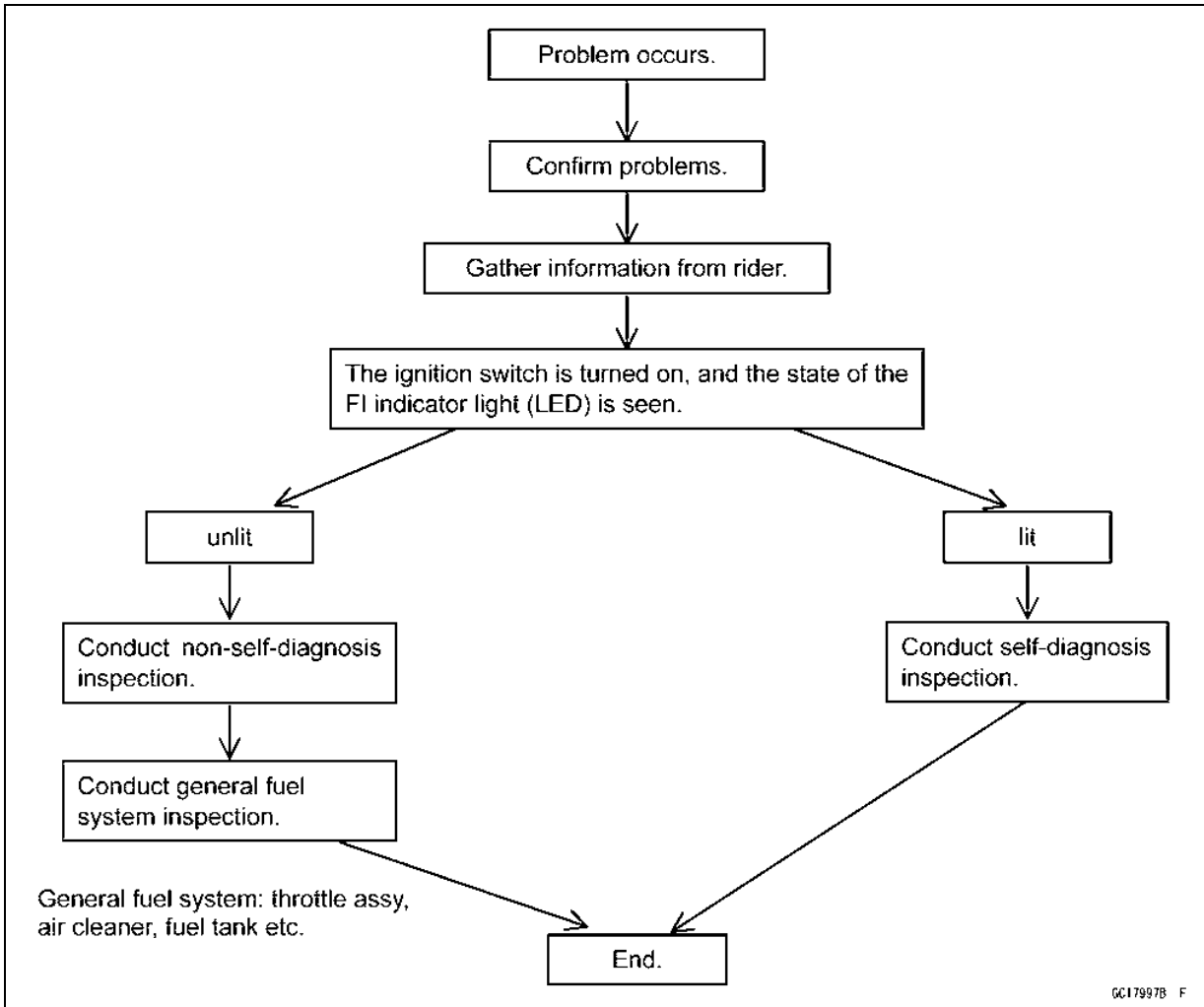

Inquiries to Rider

- Each rider reacts to problems in different ways, so it is important to confirm what kind of symptoms the rider has encountered.
- Try to find out exactly what problem occurred under exactly what conditions by asking the rider; knowing this information may help you reproduce the problem.
- The following sample diagnosis sheet will help prevent you from overlooking any areas, and will help you decide if it is a DFI system problem, or a general engine problem.

3-28 FUEL SYSTEM (DFI)

Troubleshooting the DFI System

Sample Diagnosis Sheet

Rider name:		Registration No. (license plate No.):	
Year of initial registration:		Model:	
Engine No.:		Frame No.:	
Date problem occurred:		Mileage:	
Environment when problem occurred.			
Weather	<input type="checkbox"/> fine, <input type="checkbox"/> cloudy, <input type="checkbox"/> rain, <input type="checkbox"/> snow, <input type="checkbox"/> always, <input type="checkbox"/> other:		
Temperature	<input type="checkbox"/> hot, <input type="checkbox"/> warm, <input type="checkbox"/> cold, <input type="checkbox"/> very cold, <input type="checkbox"/> always, <input type="checkbox"/> other:		
Problem frequency	<input type="checkbox"/> chronic, <input type="checkbox"/> often, <input type="checkbox"/> once		
Road	<input type="checkbox"/> street, <input type="checkbox"/> highway, <input type="checkbox"/> mountain road (<input type="checkbox"/> uphill, <input type="checkbox"/> downhill), <input type="checkbox"/> bumpy, <input type="checkbox"/> pebble		
Altitude	<input type="checkbox"/> normal, <input type="checkbox"/> high (about 1 000 m or more)		
Motorcycle conditions when problem occurred.			
FI indicator light (LED)	<input type="checkbox"/> light up immediately after ignition switch ON, and goes off after 1 ~ 2 seconds (normal)		
	<input type="checkbox"/> lights blinks immediately after ignition switch ON, and stays on (DFI problem)		
	<input type="checkbox"/> lights up immediately after ignition switch ON, but goes off after about 10 seconds (DFI problem)		
	<input type="checkbox"/> unlights (light (LED), ECU or its wiring fault)		
	<input type="checkbox"/> sometimes lights up (probably wiring fault)		
Starting difficulty	<input type="checkbox"/> starter motor not rotating		
	<input type="checkbox"/> starter motor rotating but engine doesn't turn over		
	<input type="checkbox"/> starter motor and engine don't turn over		
	<input type="checkbox"/> no fuel flow (<input type="checkbox"/> no fuel in tank, <input type="checkbox"/> no fuel pump sound)		
	<input type="checkbox"/> engine flooded (do not crank engine with throttle opened, which promotes engine flooding)		
	<input type="checkbox"/> no spark		
	<input type="checkbox"/> other		
Engine stops	<input type="checkbox"/> right after starting		
	<input type="checkbox"/> when opening throttle grip		
	<input type="checkbox"/> when closing throttle grip		
	<input type="checkbox"/> when moving off		
	<input type="checkbox"/> when stopping the motorcycle		
	<input type="checkbox"/> when cruising		
	<input type="checkbox"/> other		
Poor running at low speed	<input type="checkbox"/> very low idle speed, <input type="checkbox"/> very high idle speed, <input type="checkbox"/> rough idle speed		
	<input type="checkbox"/> battery voltage is low (charge the battery)		
	<input type="checkbox"/> spark plug loose (tighten it)		
	<input type="checkbox"/> spark plug dirty, broken, or gap maladjusted (remedy it)		
	<input type="checkbox"/> backfiring		
	<input type="checkbox"/> afterfiring		
	<input type="checkbox"/> hesitation when acceleration		
	<input type="checkbox"/> engine oil viscosity too high		
	<input type="checkbox"/> brake dragging		
	<input type="checkbox"/> engine overheating		
<input type="checkbox"/> clutch slipping			

Troubleshooting the DFI System

	<input type="checkbox"/> other
Poor running or no power at high speed	<input type="checkbox"/> spark plug loose (tighten it)
	<input type="checkbox"/> spark plug dirty, broken, or gap maladjusted (remedy it)
	<input type="checkbox"/> spark plug incorrect (replace it)
	<input type="checkbox"/> knocking (fuel poor quality or incorrect, → use high-octane gasoline)
	<input type="checkbox"/> brake dragging
	<input type="checkbox"/> clutch slipping
	<input type="checkbox"/> engine overheating
	<input type="checkbox"/> engine oil level too high
	<input type="checkbox"/> engine oil viscosity too high
	<input type="checkbox"/> other

3-30 FUEL SYSTEM (DFI)

DFI System Troubleshooting Guide

NOTE

- This is not an exhaustive list, giving every possible cause for each problem listed. It is meant simply as a rough guide to assist the troubleshooting for some of the more common difficulties in DFI system.
- The ECU may be involved in the DFI electrical and ignition system troubles. If these parts and circuits are checked out good, be sure to check the ECU for ground and power supply. If the ground and power supply are checked good, replace the ECU.

Engine Won't Turn Over

Symptoms or Possible Causes	Actions
Neutral, starter lockout or sidestand switch trouble	Inspect each switch (see chapter 16).
Vehicle-down sensor operated	Turn ignition switch OFF (see chapter 3).
Vehicle-down sensor trouble	Inspect (see chapter 3).
Crankshaft sensor trouble	Inspect (see chapter 16).
Stick coil shorted or not in good contact	Inspect or Reinstall (see chapter 16).
Stick coil trouble	Inspect (see chapter 16).
Spark plug dirty, broken or gap maladjusted	Inspect and replace (see chapter 2).
Spark plug incorrect	Replace it with the correct plug (see chapter 2).
ECU ground and power supply trouble	Inspect (see chapter 3).
ECU trouble	Inspect (see chapter 3).
No or little fuel in tank	Supply fuel (see Owner's Manual).
Fuel injector trouble	Inspect and replace (see chapter 3).
Fuel pump not operating	Inspect (see chapter 3).
Fuel pump relay trouble	Inspect and replace (see chapter 3).
Fuel filter or pump screen clogged	Inspect and replace fuel pump (see chapter 3).
Fuel pressure regulator trouble	Inspect fuel pressure and replace fuel pump (see chapter 3).
Fuel line clogged	Inspect and repair (see chapter 3).

Poor Running at Low Speed

Symptoms or Possible Causes	Actions
Spark weak:	
Stick coil shorted or not in good contact	Inspect or Reinstall (see chapter 16).
Stick coil trouble	Inspect (see chapter 16).
Spark plug dirty, broken or gap maladjusted	Inspect and replace (see chapter 2).
Spark plug incorrect	Replace it with the correct plug (see chapter 2).
ECU trouble	Inspect (see chapter 3).
Fuel/air mixture incorrect:	
Little fuel in tank	Supply fuel (see Owner's Manual).
Air cleaner clogged, poorly sealed, or missing	Clean element or inspect sealing (see chapter 2).
Air duct loose	Reinstall (see chapter 3).
Throttle body assy holder loose	Reinstall (see chapter 3).
Throttle body assy dust seal damage	Replace (see chapter 3).
Fuel injector O-ring damage	Replace (see chapter 3).
Fuel filter or pump screen clogged	Inspect and replace fuel pump (see chapter 3).

DFI System Troubleshooting Guide

Symptoms or Possible Causes	Actions
Fuel pressure regulator trouble	Inspect fuel pressure and replace fuel pump (see chapter 3).
Fuel line clogged	Inspect and repair (see chapter 3).
Inlet air pressure sensor trouble	Inspect (see chapter 3).
Water temperature sensor trouble	Inspect (see chapter 3).
Inlet air temperature sensor trouble	Inspect (see chapter 3).
Main throttle sensor trouble	Inspect (see chapter 3).
Subthrottle sensor trouble	Inspect (see chapter 3).
Subthrottle valve actuator trouble	Inspect (see chapter 3).
Unstable (rough) idling:	
Fuel pressure too low or too high	Inspect (see chapter 3).
Fuel injector trouble	Inspect (see chapter 3).
Main throttle sensor trouble	Inspect (see chapter 3).
Subthrottle sensor trouble	Inspect (see chapter 3).
Subthrottle valve actuator trouble	Inspect (see chapter 3).
Engine vacuum not synchronizing	Inspect and adjust (see chapter 2).
Inlet air pressure sensor trouble	Inspect (see chapter 3).
Water temperature sensor trouble	Inspect (see chapter 3).
Inlet air temperature sensor trouble	Inspect (see chapter 3).
Engine stalls easily:	
Spark plug dirty, broken or gap maladjusted	Inspect and replace (see chapter 2).
Stick coil trouble	Inspect (see chapter 16).
Main throttle sensor trouble	Inspect (see chapter 3).
Subthrottle sensor trouble	Inspect (see chapter 3).
Subthrottle valve actuator trouble	Inspect (see chapter 3).
Inlet air pressure sensor trouble	Inspect (see chapter 3).
Water temperature sensor trouble	Inspect (see chapter 3).
Inlet air temperature sensor trouble	Inspect (see chapter 3).
Fuel pump trouble	Inspect (see chapter 3).
Fuel injector trouble	Inspect (see chapter 3).
Fuel pressure too low or too high	Inspect (see chapter 3).
Fuel pressure regulator trouble	Inspect fuel pressure and replace fuel pump (see chapter 3).
Fuel line clogged	Inspect and repair (see chapter 3).
Poor acceleration:	
Fuel pressure too low	Inspect (see chapter 3).
Water or foreign matter in fuel	Change fuel. Inspect and clean fuel system (see chapter 3).
Fuel filter or pump screen clogged	Inspect and replace fuel pump (see chapter 3).
Fuel pump trouble	Inspect (see chapter 3).
Fuel injector trouble	Inspect (see chapter 3).
Main throttle sensor trouble	Inspect (see chapter 3).
Subthrottle sensor trouble	Inspect (see chapter 3).
Subthrottle valve actuator trouble	Inspect (see chapter 3).
Inlet air pressure sensor trouble	Inspect (see chapter 3).

3-32 FUEL SYSTEM (DFI)

DFI System Troubleshooting Guide

Symptoms or Possible Causes	Actions
Water temperature sensor trouble	Inspect (see chapter 3).
Inlet air temperature sensor trouble	Inspect (see chapter 3).
Spark plug dirty, broken or gap maladjusted	Inspect and replace (see chapter 2).
Stick coil trouble	Inspect (see chapter 16).
Stumble:	
Fuel pressure too low	Inspect (see chapter 3).
Fuel injector trouble	Inspect (see chapter 3).
Main throttle sensor trouble	Inspect (see chapter 3).
Subthrottle sensor trouble	Inspect (see chapter 3).
Subthrottle valve actuator trouble	Inspect (see chapter 3).
Inlet air pressure sensor trouble	Inspect (see chapter 3).
Water temperature sensor trouble	Inspect (see chapter 3).
Inlet air temperature sensor trouble	Inspect (see chapter 3).
Surge:	
Unstable fuel pressure	Fuel pressure regulator trouble (Inspect and replace fuel pump) or kinked fuel line (Inspect and replace fuel pump) (see chapter 3).
Fuel injector trouble	Inspect (see chapter 3).
Water temperature sensor trouble	Inspect (see chapter 3).
Backfiring when deceleration:	
Spark plug dirty, broken or gap maladjusted	Inspect and replace (see chapter 2).
Fuel pressure too low	Inspect (see chapter 3).
Fuel pump trouble	Inspect (see chapter 3).
Main throttle sensor trouble	Inspect (see chapter 3).
Subthrottle sensor trouble	Inspect (see chapter 3).
Subthrottle valve actuator trouble	Inspect (see chapter 3).
Inlet air pressure sensor trouble	Inspect (see chapter 3).
Water temperature sensor trouble	Inspect (see chapter 3).
Inlet air temperature sensor trouble	Inspect (see chapter 3).
Air switching valve trouble	Inspect and replace (see chapter 16).
Air suction valve trouble	Inspect and replace (see chapter 5).
After fire:	
Spark plug burned or gap maladjusted	Replace (see chapter 2).
Fuel injector trouble	Inspect (see chapter 3).
Inlet air pressure sensor trouble	Inspect (see chapter 3).
Water temperature sensor trouble	Inspect (see chapter 3).
Inlet air temperature sensor trouble	Inspect (see chapter 3).
Other:	
Intermittent any DFI fault and its recovery	Check that DFI connectors are clean and tight, and examine leads for signs of burning or fraying (see chapter 3).

DFI System Troubleshooting Guide

Poor Running or No Power at High Speed

Symptoms or Possible Causes	Actions
Firing incorrect:	
Stick coil shorted or not in good contact	Inspect or Reinstall (see chapter 16).
Stick coil trouble	Inspect (see chapter 16).
Spark plug dirty, broken or gap maladjusted	Inspect and replace (see chapter 2).
Spark plug incorrect	Replace it with the correct plug (see chapter 2).
ECU trouble	Inspect (see chapter 3).
Fuel/air mixture incorrect:	
Air cleaner clogged, poorly sealed, or missing	Clean element or inspect sealing (see chapter 2).
Air duct loose	Reinstall (see chapter 3).
Throttle body assy holder loose	Reinstall (see chapter 3).
Throttle body assy dust seal damage	Replace (see chapter 3).
Water or foreign matter in fuel	Change fuel. Inspect and clean fuel system (see chapter 3).
Fuel injector O-ring damage	Replace (see chapter 3).
Fuel injector clogged	Inspect and repair (see chapter 3).
Fuel line clogged	Inspect and repair (see chapter 3).
Fuel pump operates intermittently and often DFI fuse blows.	Fuel pump bearings may wear. Replace the fuel pump (see chapter 3).
Fuel pump trouble	Inspect (see chapter 3).
Inlet air pressure sensor trouble	Inspect (see chapter 3).
Cracked or obstructed inlet air pressure sensor vacuum hose	Inspect and repair or replace (see chapter 3).
Water temperature sensor trouble	Inspect (see chapter 3).
Inlet air temperature sensor trouble	Inspect (see chapter 3).
Main throttle sensor trouble	Inspect (see chapter 3).
Subthrottle sensor trouble	Inspect (see chapter 3).
Subthrottle valve actuator trouble	Inspect (see chapter 3).
Knocking:	
Fuel poor quality or incorrect	Fuel change (Use the gasoline recommended in the Owner's Manual).
Spark plug incorrect	Replace it with the correct plug (see chapter 2).
Stick coil trouble	Inspect (see chapter 16).
ECU trouble	Inspect (see chapter 3).
Engine vacuum not synchronizing	Inspect and adjust (see chapter 2).
Inlet air pressure sensor trouble	Inspect (see chapter 3).
Water temperature sensor trouble	Inspect (see chapter 3).
Inlet air temperature sensor trouble	Inspect (see chapter 3).
Miscellaneous:	
Subthrottle sensor trouble	Inspect (see chapter 3).
Subthrottle valve actuator trouble	Inspect (see chapter 3).
Speed sensor trouble	Inspect (see chapter 3).
Throttle valves will not fully open	Inspect throttle cables and lever linkage (see chapter 3).

3-34 FUEL SYSTEM (DFI)

DFI System Troubleshooting Guide

Symptoms or Possible Causes	Actions
Engine overheating - Water temperature sensor, crankshaft sensor or speed sensor trouble	(see Overheating of Troubleshooting Guide in chapter 17)
Air switching valve trouble	Inspect and replace (see chapter 16).
Air suction valve trouble	Inspect and replace (see chapter 5).
Exhaust Smokes Excessively:	
(Black smoke)	
Air cleaner element clogged	Clean element (see chapter 2).
Fuel pressure too high	Inspect (see chapter 3).
Fuel injector trouble	Inspect (see chapter 3).
Water temperature sensor trouble	Inspect (see chapter 3).
Inlet air temperature sensor trouble	Inspect (see chapter 3).
(Brown smoke)	
Air duct loose	Reinstall (see chapter 3).
Fuel pressure too low	Inspect (see chapter 3).
Water temperature sensor trouble	Inspect (see chapter 3).
Inlet air temperature sensor trouble	Inspect (see chapter 3).

Self-Diagnosis

Self-diagnosis Outline

The self-diagnosis system has three modes and can be switched to another mode by grounding the self-diagnosis terminal.

User Mode

The ECU notifies the rider of troubles in DFI system and ignition system by lighting the FI indicator when DFI system and ignition system parts are faulty, and initiates fail-safe function. In case of serious troubles, the ECU stops the injection/ignition/starter motor operation.

Dealer Mode 1

The FI indicator light (LED) emits service code(s) to show the problem(s) which the DFI system, and ignition system has at the moment of diagnosis.

Dealer Mode 2

The FI indicator light (LED) emits service code(s) to show the problem(s) which the DFI system, and ignition system had in the past.

Self-diagnosis Procedures

○When a problem occurs with the DFI system and ignition system, the FI indicator light (LED) [A] goes on.

NOTE

- Use a fully charged battery when conducting self-diagnosis. Otherwise, the light (LED) blinks very slowly or does not blink.
- Keep the self-diagnosis terminal grounded during self-diagnosis, with an auxiliary lead.

- Remove the seat (see Seat Removal in the Frame chapter).
- Ground the self-diagnosis terminal [A] (Orange/Black lead) to the battery (-) terminal or battery (-) cable connector, using a wire.

- Turn on the ignition switch.
- Connect an auxiliary lead [A] to the self-diagnosis terminal [B] for grounding.
- To enter the self-diagnosis dealer mode 1, ground [C] the self-diagnosis indicator terminal to the battery (-) terminal for more than 2 seconds [D], and then keep it grounded continuously [E].
- Count the blinks of the light (LED) to read the service code. Keep the auxiliary lead ground until you finish reading the service code.

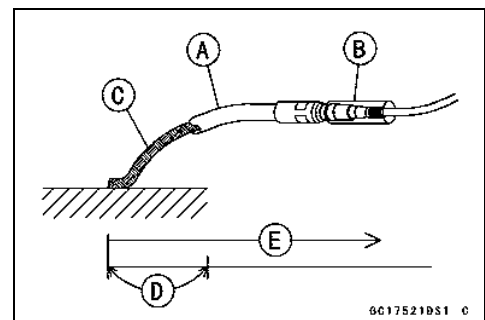
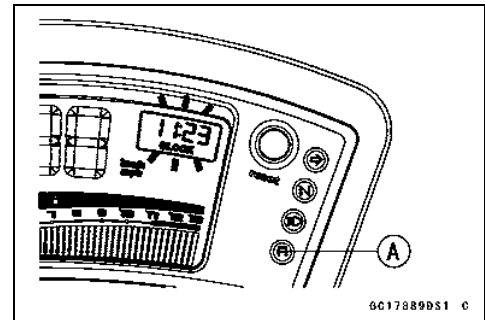

3-36 FUEL SYSTEM (DFI)

Self-Diagnosis

- To enter the self-diagnosis dealer mode 2, open [A] and ground [B] the lead more than five times [C] within 2 seconds [D] after the lead is first grounded, and then keep it grounded continuously [E] for more than 2 seconds.
- Count the blinks of the light (LED) to read the service code. Keep the auxiliary lead ground until you finish reading the service code.
 - Auxiliary Lead [F]
 - Self-diagnosis Terminal [G]

NOTE

- To enter the dealer mode 2 from the dealer mode 1, turn off the ignition switch once.

Service Code Clearing Procedures

- Enter the self-diagnosis dealer mode 2 (see Self-diagnosis Procedures).

NOTE

- Make sure to keep the grounding until the following opening and grounding starts.
- Pull the clutch lever in more than 5 seconds, and then release it.
- Repeat opening [A] and grounding [B] the lead (self-diagnosis terminal) more than five times [C] within 2 seconds [D] after the lead is grounded, and then keep it grounded continuously [E] for more than 2 seconds.
 - Auxiliary Lead [F]
 - Self-diagnosis Terminal [G]

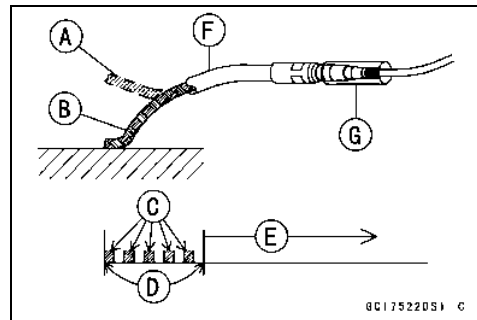
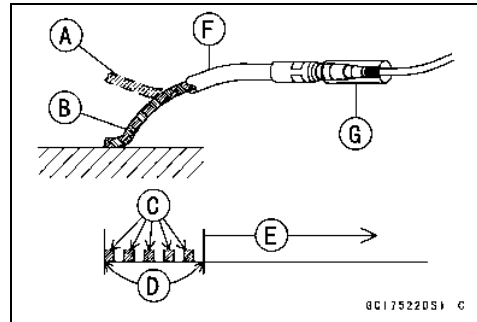

Self-Diagnosis

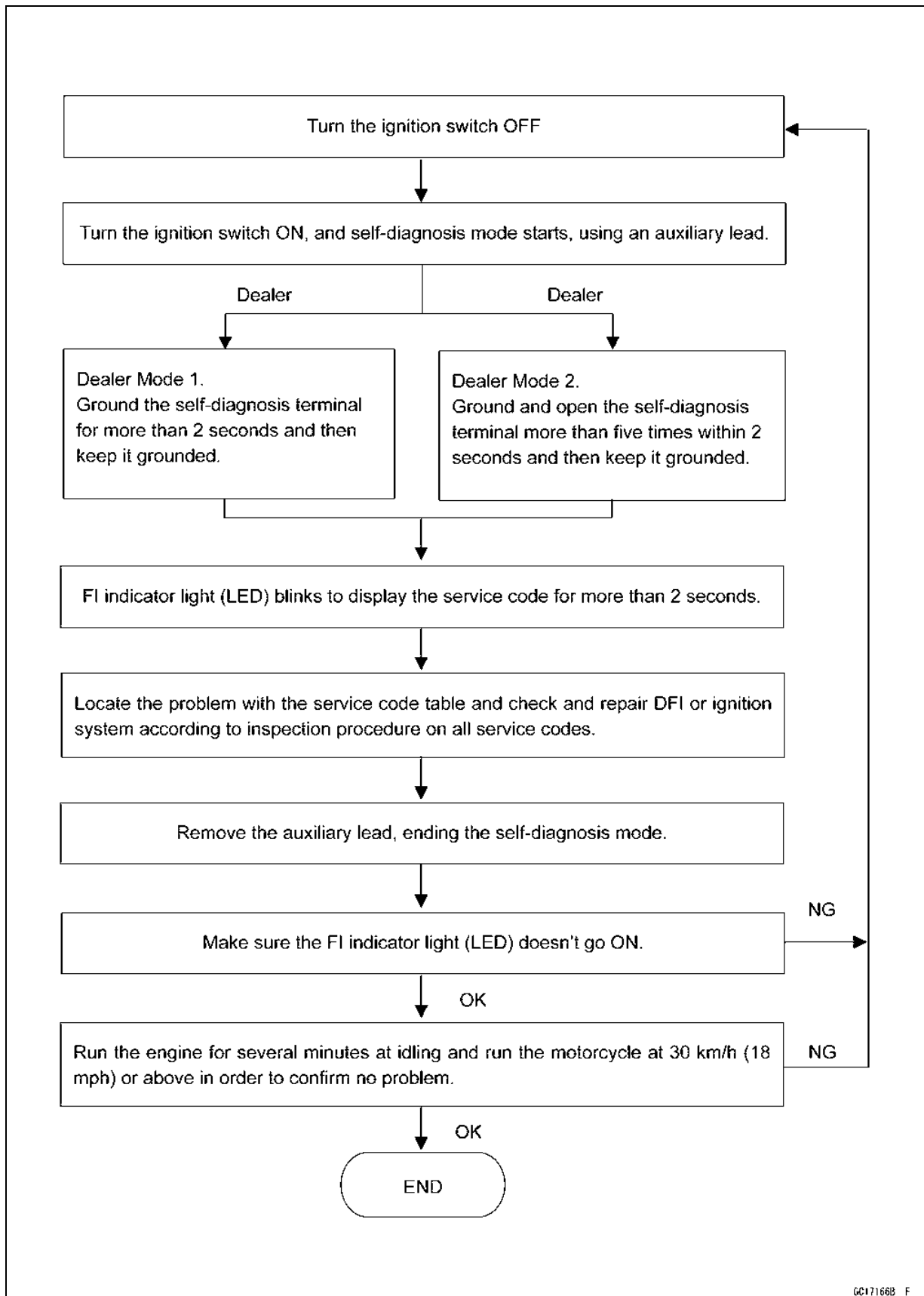

3-38 FUEL SYSTEM (DFI)

Self-Diagnosis

How to Read Service Codes

- Service codes are shown by a series of long and short blinks of the FI indicator light (LED) as shown below.
- Read 10th digit and unit digit as the FI indicator light (LED) blinks.
- When there are a number of problems, all the service codes can be stored and the display will begin starting from the lowest number service code in the numerical order. Then after completing all codes, the display is repeated until the self-diagnosis indicator terminal is open.
- If there is no problem, no code and unlight.
- For example, if two problems occurred in the order of 21, 12, the service codes are displayed from the lowest number in the order listed.
(12 → 21) → (12 → 21) → . . . (repeated)

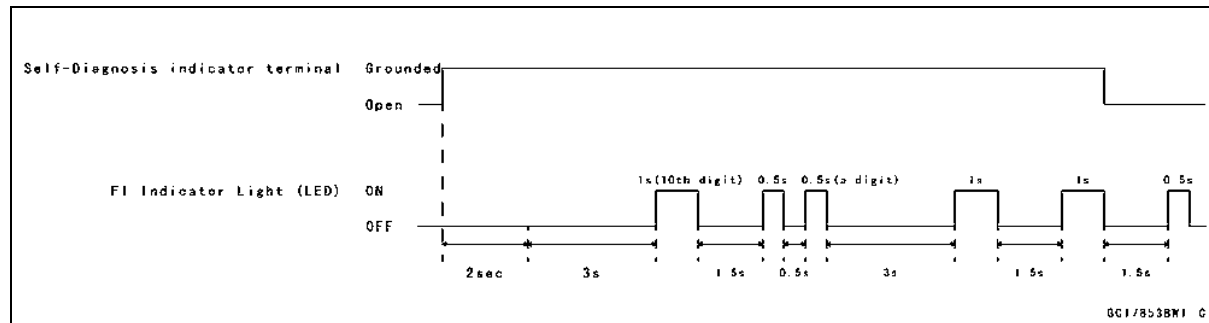

- If the problem is with the following parts, the ECU cannot memorize these problems, the FI indicator light (LED) does not go on, and no service codes can be displayed.











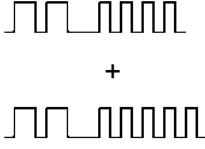

FI Indicator Light (LED)
Fuel Pump
Fuel Pump Relay
ECU Main Relay
ECU Power Source Wiring and Ground Wiring (see ECU Inspection)
Fuel Injectors

How to Erase Service Codes

- Even if the ignition switch is turned OFF, the battery or the ECU are disconnected or the problem is solved, all service codes remain in the ECU.
- Refer to the Service Code Clearing Procedure for the service code erasure.

Self-Diagnosis

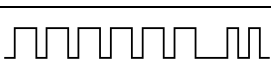
Service Code Table

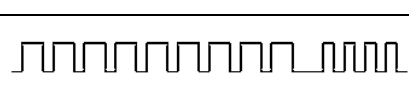
Service Code	FI Indicator Light (LED)	Problems
11	 ON OFF	Main throttle sensor malfunction, wiring open or short
12		Inlet air pressure sensor malfunction, wiring open or short
13		Inlet air temperature sensor malfunction, wiring open or short
14		Water temperature sensor malfunction, wiring open or short
21		Crankshaft sensor malfunction, wiring open or short
24 and 25		Speed sensor malfunction, wiring open or short First 24 is displayed and then 25, repeatedly
31		Vehicle-down sensor, malfunction, wiring open or short
32		Subthrottle sensor malfunction, wiring open or short
33		Oxygen sensor inactivation, wiring open or short (Equipped Models)
51		Stick (Ignition) coil #1 malfunction, wiring open or short
52		Stick (Ignition) coil #2 malfunction, wiring open or short
56		Radiator fan relay malfunction, wiring open or short
62		Subthrottle valve actuator malfunction, wiring open or short
64		Air switching valve malfunction, wiring open or short
67		Oxygen sensor heater malfunction, wiring open or short (Equipped Models)
94		Oxygen sensor malfunction, wiring open or short (Equipped Models)

Notes:

- The ECU may be involved in these problems. If all the parts and circuits checked out good, be sure to check the ECU for ground and power supply. If the ground and power supply are checked good, replace the ECU.
- When no service code is displayed, the electrical parts of the DFI system has no fault, and the mechanical parts of the DFI system and the engine are suspect.

3-40 FUEL SYSTEM (DFI)

Self-Diagnosis

Backups

○The ECU takes the following measures to prevent engine damage when the DFI or the ignition system parts have troubles.

Service Codes	Parts	Output Signal Usable Range or Criteria	Backups by ECU
11	Main Throttle Sensor	Main Throttle Sensor Output Voltage 0.2 ~ 4.8 V	If the main throttle sensor system fails (the output voltage is out of the usable range, wiring short or open), the ECU locks ignition timing into the ignition timing at closed throttle position and sets the DFI in the D-J method. Also, the main throttle sensor system and inlet air pressure fails, the ECU locks ignition timing into the ignition timing at closed throttle position and sets the DFI in the α -N method.
12	Inlet Air Pressure Sensor	Inlet Air Pressure (absolute) $P_v = 150 \sim 800$ mmHg	If the inlet air pressure sensor system fails (the signal is out of the usable range, wiring short or open), the ECU sets the DFI in the α - N method.
13	Inlet Air Temperature Sensor	Inlet Air Temperature $T_a = -30^{\circ}\text{C} \sim +120^{\circ}\text{C}$	If the inlet air temperature sensor fails (the signal is out of the usable range, wiring short or open), the ECU sets T_a at 40°C .
14	Water Temperature Sensor	Water Temperature $T_w = -30^{\circ}\text{C} \sim +120^{\circ}\text{C}$	If the water temperature sensor system fails (the signal is out of the usable range, wiring short or open), the ECU sets T_w at 80°C .
21	Crankshaft Sensor	Crankshaft sensor must send 22 signals to the ECU at the one cranking.	If crankshaft sensor generates other than 22 signals, the engine stops by itself.
24 and 25	Speed Sensor	Speed sensor must send 4 signals to the ECU at the one rotation of the engine sprocket. The gear position is decided by the signal of the speed sensor.	If the speed sensor system fails (no signal, wiring short or open), the speedometer shows 0, and the ECU sets the top (6) gear position.
31	Vehicle-down Sensor	Output Voltage (signal) $V_d = 0.65 \sim 4.45$ V	If the vehicle-down sensor system has failures (the output voltage V_d is more than usable range, wiring open), the ECU shuts off the fuel pump, the fuel injectors and the ignition system.
32	Subthrottle Sensor	Output Voltage 0.15 ~ 4.85 V	If the subthrottle sensor system fails (the signal is out of the usable range, wiring short or open), the ECU drive the subthrottle valve to the full closed position, and it stops the current to the actuator.
33	Oxygen Sensor (Equipped Models)	The oxygen sensor is active and sensor must send signals (output voltage) continuously to the ECU.	If the oxygen sensor is not activated, the ECU stops oxygen sensor feedback mode.

Self-Diagnosis

Service Codes	Parts	Output Signal Usable Range or Criteria	Backups by ECU
51	Stick Coil #1*	The stick coil primary winding must send signals continuously to the ECU.	If the stick coil #1 primary winding has failures (no signal, wiring short or open), the ECU shuts off the injector #1 to stop fuel to the cylinder #1, though the engine keeps running.
52	Stick Coil #2*	The stick coil primary winding must send signals continuously to the ECU.	If the stick coil #2 primary winding has failures (no signal, wiring short or open), the ECU shuts off the injector #2 to stop fuel to the cylinder #2, though the engine keeps running.
62	Subthrottle Valve Actuator	The actuator operates open and close of the subthrottle valve by the pulse signal from the ECU.	If the subthrottle valve actuator fails (the signal is out of the usable range, wiring short or open), the ECU stops the current to the actuator.
67	Oxygen Sensor (Equipped Models)	The oxygen sensor heater raise temperature of the sensor for its earlier activation. 12V-6.6W, 0.55A	If the oxygen sensor heater fails (wiring short or open), the ECU stops the current to the heater.
94	Oxygen Sensor (Equipped Models)	The oxygen sensor must send signals (output voltage) continuously to the ECU	If the oxygen sensor output voltage is incorrect, the ECU stops oxygen sensor feed back mode.

Note:

(1) D-J Method and α - N Method: When the engine load is light like at idling or low speed, the ECU determines the injection quantity by calculating from the throttle vacuum (inlet air pressure sensor output voltage) and engine speed (crankshaft sensor output voltage). This method is called D-J method (low-speed mode). As the engine speed increases, and the engine load turns middle to heavy, the ECU determines the injection quantity by calculating from the throttle opening (throttle sensor output voltage) and the engine speed. This method is called α - N method (high-speed mode).

(*) This depends on the number of stopped cylinders.

3-42 FUEL SYSTEM (DFI)

Main Throttle Sensor (Service Code 11)

Main Throttle Sensor Removal/Adjustment

CAUTION

Do not remove or adjust the main throttle sensor [A] since it has been adjusted and set with precision at the factory.

Never drop the throttle body assy, especially on a hard surface. Such a shock to the sensor can damage it.



Main Throttle Sensor Input Voltage Inspection

NOTE

○Be sure the battery is fully charged.

- Turn the ignition switch OFF.
- Remove the left upper fairing cover (see Upper Fairing Cover Removal in the Frame chapter).
- Disconnect the main throttle sensor connector and connect the harness adapter [A] between these connectors.

Special Tool - Throttle Sensor Setting Adapter: 57001-1538

- Connect a digital meter to the harness adapter leads.

Main Throttle Sensor Input Voltage

Connections to Adapter:

Digital Meter (+) → BK (sensor BL) lead

Digital Meter (-) → W (sensor BR/BK) lead

- Measure the input voltage with the engine stopped and with the connector joined.
- Turn the ignition switch ON.

Input Voltage

Standard: DC 4.75 ~ 5.25 V

- Turn the ignition switch OFF.
- ★ If the input voltage is normal, check the output voltage.
- If the input voltage is less than the standard, remove the ECU and check the wiring between these connectors.
- Disconnect the ECU and sensor connectors.

Wiring Continuity Inspection

ECU Connector [A] ↔

Main Throttle Sensor Connector [B]

BL lead (ECU terminal 8) [C]

BR/BK lead (ECU terminal 22) [D]

- ★ If the wiring is good, check the ECU for its ground and power supply (see ECU Power Supply Inspection).
- ★ If the ground and power supply are good, replace the ECU (see ECU Removal/Installation).

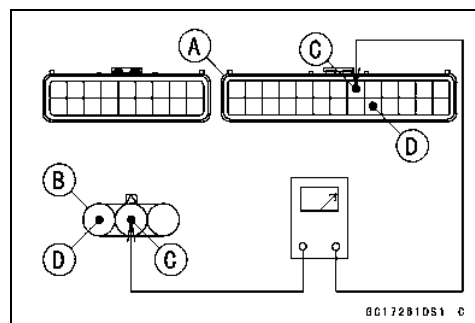

Main Throttle Sensor (Service Code 11)

Main Throttle Sensor Output Voltage Inspection

- Measure the output voltage at the main throttle sensor in the same way as input voltage inspection, Note the following.

- Disconnect the main throttle sensor connector and connect the harness adapter [A] between these connectors.

Special Tool - Throttle Sensor Setting Adapter: 57001-1538

Main Throttle Sensor Output Voltage

Connections to Adapter:

Digital Meter (+) → R (sensor Y/W) lead

Digital Meter (-) → W (sensor BR/BK) lead

- Start the engine and warm it up thoroughly.
- Check idle speed to ensure the throttle opening is correct.

Idle Speed

Standard: 1 300 ±50 r/min (rpm)

- ★ If the idle speed is out of the specified range, adjust it (see Idle Speed Inspection in the Periodic Maintenance chapter).

- Turn the ignition switch OFF.
- Measure the output voltage with the engine stopped, and with the connector joined.
- Turn the ignition switch ON.

Output Voltage

Standard: DC 1.005 ~ 1.035 V at idle throttle opening

DC 4.2 ~ 4.4 V at full throttle opening

(for reference)

NOTE

- Open the throttle, confirm the output voltage will be raise.
- The standard voltage refers to the value when the voltage reading at the Input Voltage Inspection shows 5 V exactly.
- When the input voltage reading shows other than 5 V, derive a voltage range as follows.

Example:

In the case of a input voltage of 4.75 V.

$$1.005 \times 4.75 \div 5.00 = 0.955 \text{ V}$$

$$1.035 \times 4.75 \div 5.00 = 0.983 \text{ V}$$

Thus, the valid range is 0.955 ~ 0.983 V

- Turn the ignition switch OFF.
- ★ If the output voltage is out of the standard, inspect the main throttle sensor resistance (see Main Throttle Sensor Resistance Inspection).



3-44 FUEL SYSTEM (DFI)

Main Throttle Sensor (Service Code 11)

- ★ If the output voltage is normal, check the wiring for continuity.
- Disconnect the ECU and sensor connectors.

Wiring Continuity Inspection

ECU Connector [A] ↔

Main Throttle Sensor Connector [B]

Y/W lead (ECU terminal 6) [C]

BR/BK lead (ECU terminal 22) [D]

- ★ If the wiring is good, check the ECU for its ground and power supply (see ECU Power Supply Inspection).
- ★ If the ground and power supply are good, replace the ECU (see ECU Removal/Installation).

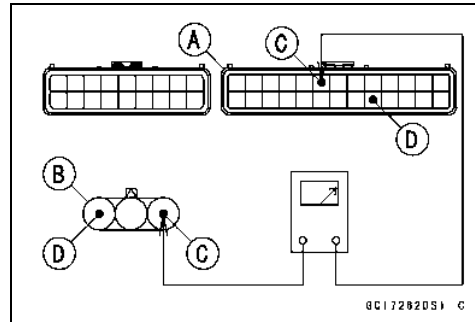

Main Throttle Sensor Resistance Inspection

- Turn the ignition switch OFF.
- Remove the left upper fairing cover (see Upper Fairing Cover Removal in the Frame chapter).
- Disconnect the main throttle sensor connector.
- Connect a digital meter [A] to the main throttle sensor connector [B].
- Measure the main throttle sensor resistance.

Main Throttle Sensor Resistance

Connections: BL lead [C] ↔ BR/BK lead [D]

Standard: 4 ~ 6 kΩ

- ★ If the reading is out of the range, replace the throttle body assy.
- ★ If the reading is within the range, but the problem still exists, replace the ECU (see ECU Removal/Installation).

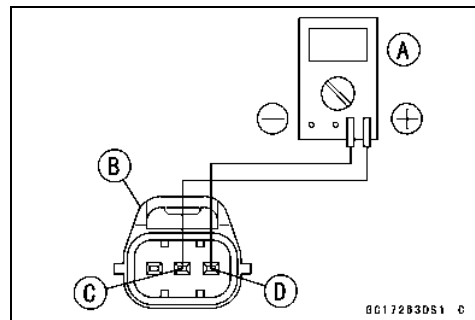

Main Throttle Sensor Circuit

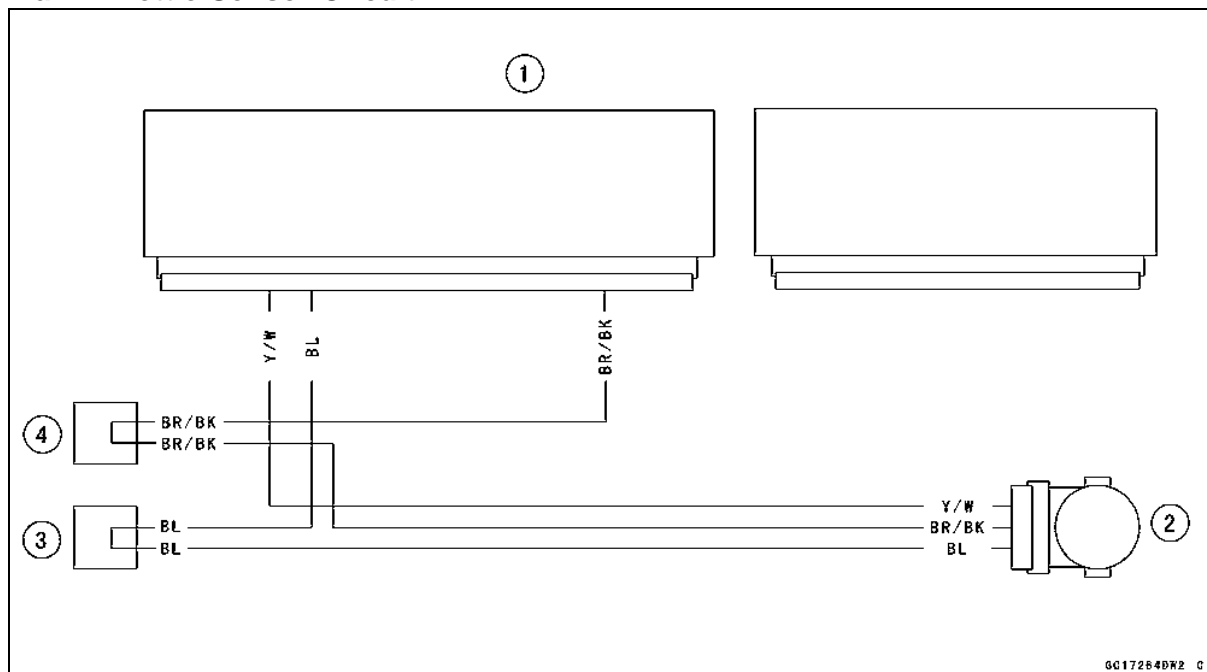

1. ECU
2. Main Throttle Sensor
3. Water-proof Joint D
4. Water-proof Joint E

Inlet Air Pressure Sensor (Service Code 12)

CAUTION

Never drop the sensor, especially on a hard surface. Such a shock to the part can damage it.

Inlet Air Pressure Sensor Removal

- Remove the upper fairing (see Upper Fairing Removal in the Frame chapter).
- Disconnect the inlet air pressure sensor connector [A] and the vacuum hose [B].
- Remove the bolt [C], and take off the inlet air pressure sensor [D].

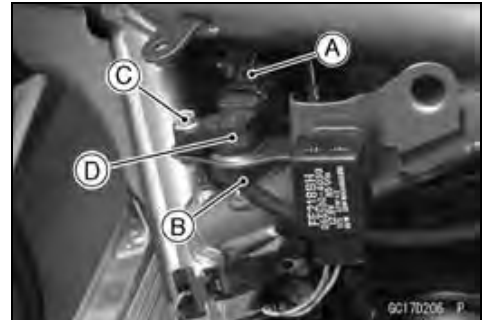

Inlet Air Pressure Sensor Installation

- Installation is the reverse of removal.

Inlet Air Pressure Sensor Input Voltage Inspection

NOTE

○ *Be sure the battery is fully charged.*

- Turn the ignition switch OFF.
- Remove the upper fairing (see Upper Fairing Removal in the Frame chapter).
- Disconnect the inlet air pressure sensor connector and connect the harness adapter [A] between these connectors.

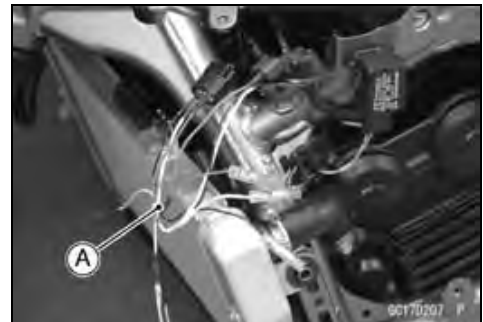

Special Tool - Measuring Adapter: 57001-1700

- Connect a digital meter to the harness adapter leads.

Inlet Air Pressure Sensor Input Voltage

Connections to Adapter:

Digital Meter (+) → R (sensor BL) lead

Digital Meter (-) → BK (sensor BR/BK) lead

- Measure the input voltage with the engine stopped and with the connector joined.
- Turn the ignition switch ON.

Input Voltage

Standard: DC 4.75 ~ 5.25 V

- Turn the ignition switch OFF.
- ★ If the reading is within the standard, check the output voltage (see Inlet Air Pressure Sensor Output Voltage Inspection).

3-46 FUEL SYSTEM (DFI)

Inlet Air Pressure Sensor (Service Code 12)

★If the reading is out of the standard, remove the ECU and check the wiring for continuity between main harness connectors.

Special Tool - Hand Tester: 57001-1394

○Disconnect the ECU and sensor connectors.

Wiring Continuity Inspection

ECU Connector [A] ←→

Inlet Air Pressure Sensor Connector [B]

BL lead (ECU terminal 8) [C]

BR/BK lead (ECU terminal 22) [D]

★If the wiring is good, check the ECU for its ground and power supply (see ECU Power Supply Inspection).

★If the ground and power supply are good, replace the ECU (see ECU Removal/Installation).

Inlet Air Pressure Sensor Output Voltage Inspection

● Measure the output voltage at the inlet air pressure sensor in the same way as input voltage inspection, note the following.

○ Disconnect the inlet air pressure sensor connector and connect the harness adapter [A] between these connectors.

Special Tool - Measuring Adapter: 57001-1700

Inlet Air Pressure Sensor Output Voltage

Connections to Adapter:

Digital Meter (+) → W (sensor Y/BL) lead

Digital Meter (-) → BK (sensor BR/BK) lead

● Measure the output voltage with the engine stopped and with the connector joined.

● Turn the ignition switch ON.

Output Voltage

Usable Range: DC 3.80 ~ 4.20 V at standard atmospheric pressure (101.32 kPa, 76 cmHg)

NOTE

○ The output voltage changes according to local atmospheric pressure.

● Turn the ignition switch OFF.

★ If the reading is out of the usable range, replace the sensor.

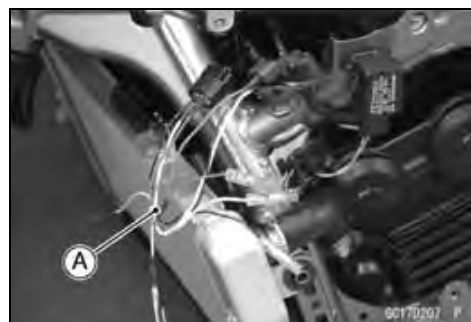
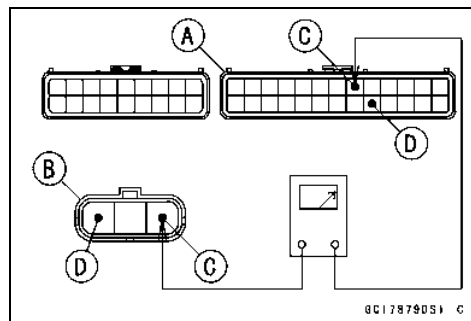

Inlet Air Pressure Sensor (Service Code 12)

★ If the reading is within the usable range, remove the ECU and check the wiring for continuity between main harness connector.

Special Tool - Hand Tester: 57001-1394

○ Disconnect the ECU and sensor connectors.

Wiring Continuity Inspection

ECU Connector [A] ←→

Inlet Air Pressure Sensor Connector [B]

Y/BL lead (ECU terminal 7) [C]

BR/BK lead (ECU terminal 22) [D]

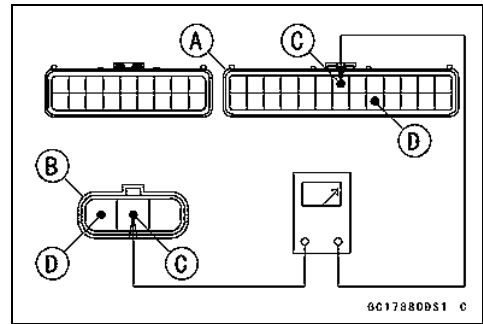

- ★ If the wiring is good, check the sensor for various vacuum.
- Remove the inlet air pressure sensor [A] and disconnect the vacuum hose from the sensor.
- Connect an auxiliary hose [B] to the inlet air pressure sensor.
- Temporarily install the inlet air pressure sensor.
- Connect a digital meter [C], vacuum gauge [D], the fork oil level gauge [E] and the harness adapter to the inlet air pressure sensor.

Special Tools - Fork Oil Level Gauge: 57001-1290

Vacuum Gauge: 57001-1369

Measuring Adapter: 57001-1700

Inlet Air Pressure Sensor Output Voltage

Connections to Adapter:

Digital Meter (+) → W (sensor Y/BL) lead

Digital Meter (-) → BK (sensor BR/BK) lead

- Turn the ignition switch ON.
- Measure the inlet air pressure sensor output voltage from various vacuum readings, while pulling the handle of the fork oil level gauge.
- Check the inlet air pressure sensor output voltage, using the following formula and chart.

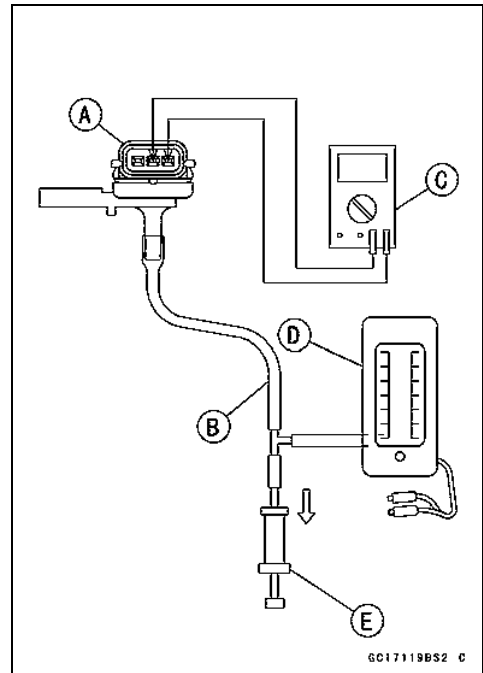

3-48 FUEL SYSTEM (DFI)

Inlet Air Pressure Sensor (Service Code 12)

Suppose:

Pg: Vacuum Pressure (Gauge) to Sensor

PI: Local Atmospheric Pressure (Absolute) measured by a barometer

Pv: Vacuum Pressure (Absolute) to Sensor

Vv: Sensor Output Voltage (V)

then

$$Pv = PI - Pg$$

For example, suppose the following data is obtained:

Pg = 8 cmHg (Vacuum Gauge Reading)

PI = 70 cmHg (Varometer Reading)

Vv = 3.2 V (Digital Meter Reading)

then

$$Pv = 70 - 8 = 62 \text{ cmHg (Absolute)}$$

Plot this Pv (62 cmHg) at a point [1] on the chart and draw a vertical line through the point. Then, you can get the usable range [2] of the sensor output voltage.

$$\text{Usable range} = 3.04 \sim 3.49 \text{ V}$$

Plot Vv (3.2 V) on the vertical line. → Point [3].

Results: In the chart, Vv is within the usable range and the sensor is normal.

Pv = 24 ~ 55 cmHg

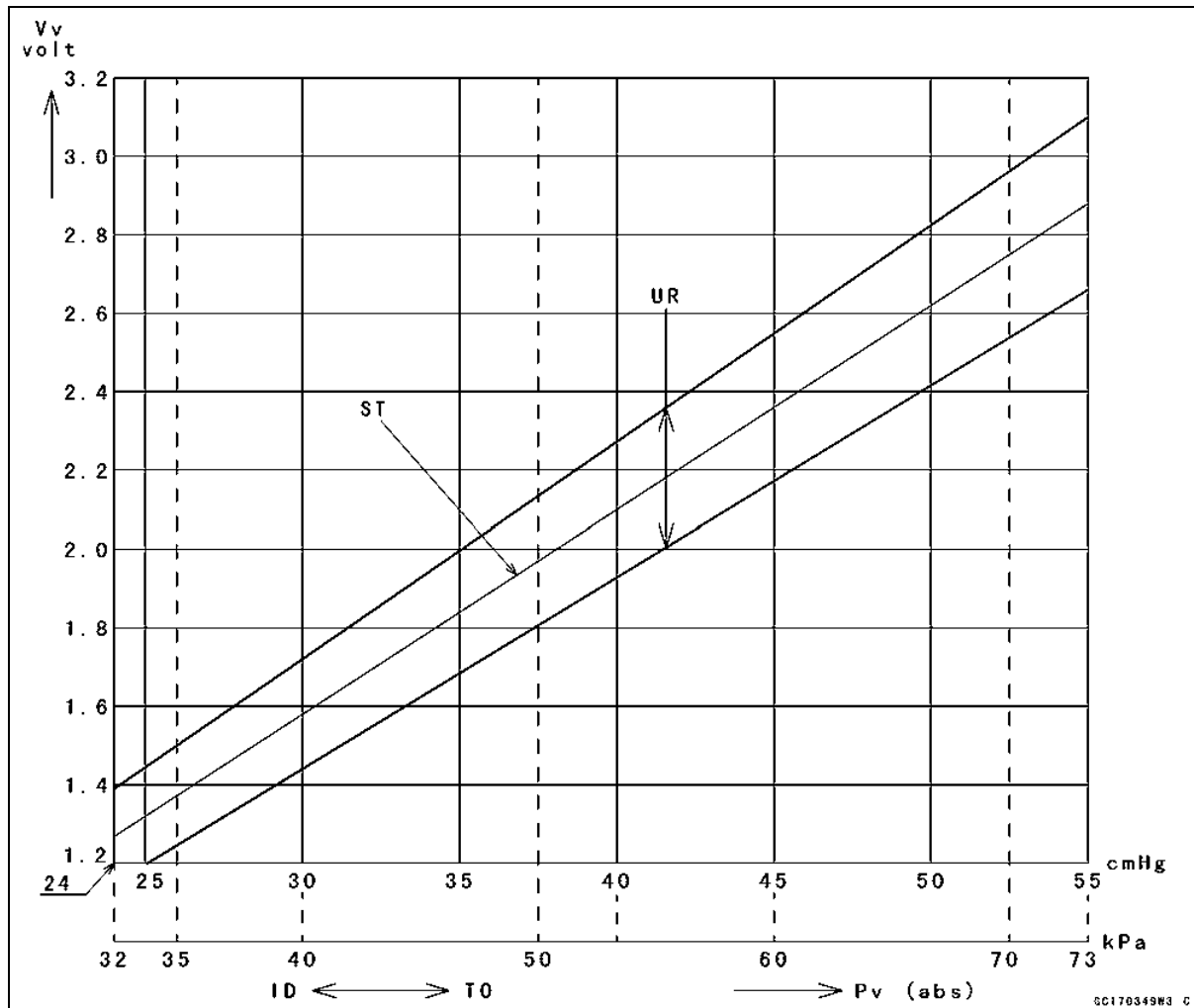

GC170349M3 C

Inlet Air Pressure Sensor (Service Code 12)

Pv = 55 ~ 86 cmHg

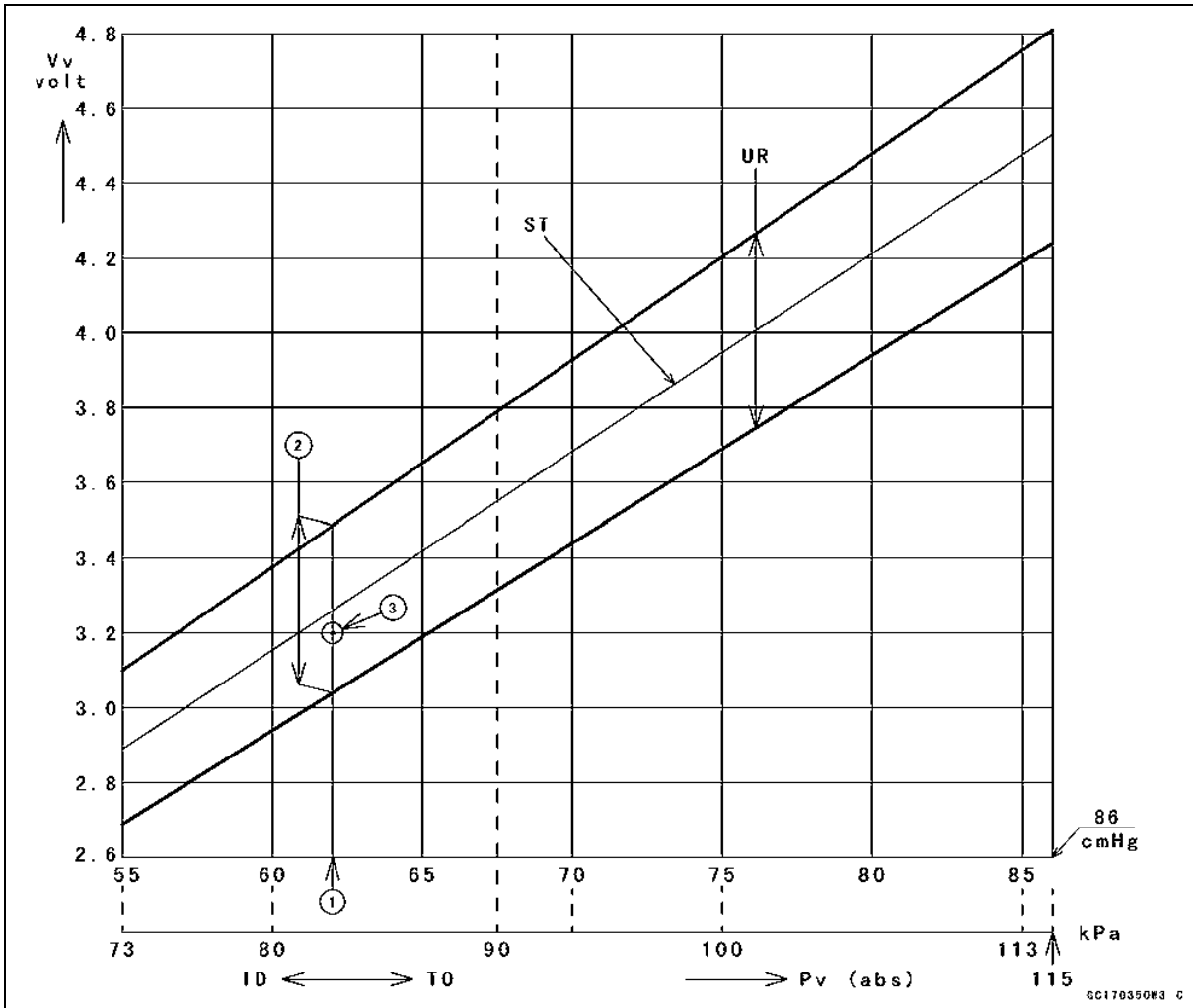

ID: Idling

Ps: Standard Atmospheric Pressure (Absolute)

Pv: Throttle Vacuum Pressure (Absolute)

ST: Standard of Sensor Output Voltage (V)

TO: Throttle Full Open

UR: Usable Range of Sensor Output Voltage (V)

Vv: Inlet Air Pressure Sensor Output Voltage (V) (Digital Meter Reading)

GC170350W3 C

3-50 FUEL SYSTEM (DFI)

Inlet Air Pressure Sensor (Service Code 12)

Inlet Air Pressure Sensor Circuit

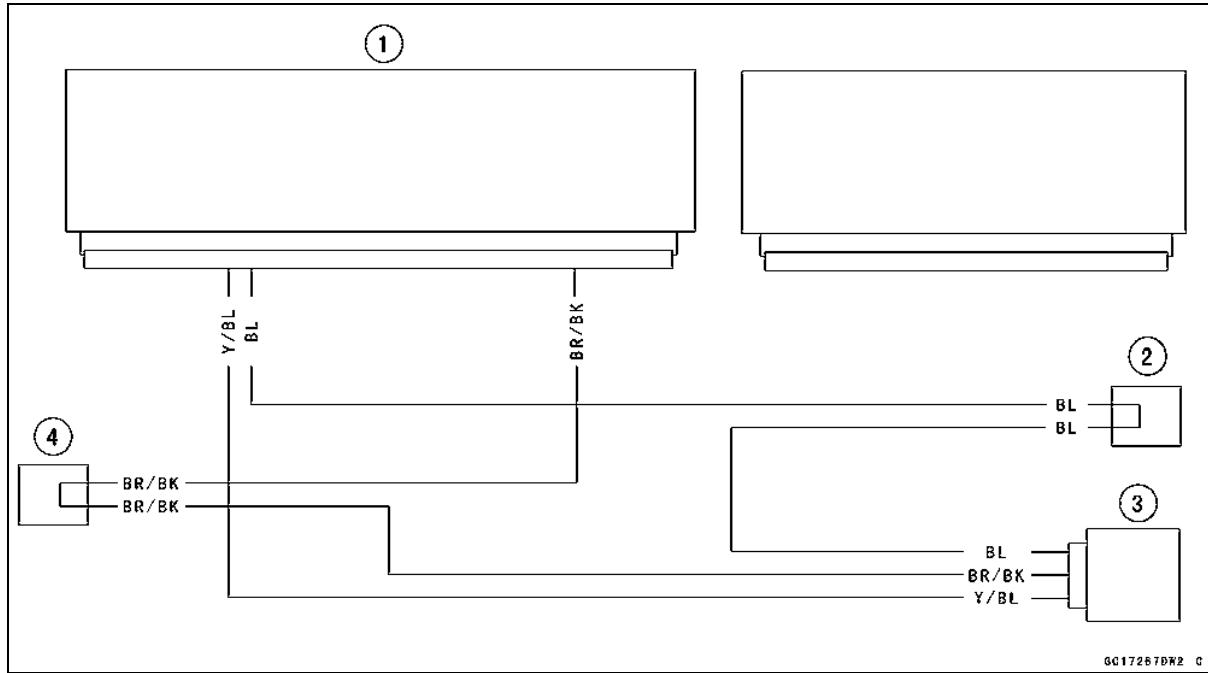

1. ECU
2. Water-proof Joint D
3. Inlet Air Pressure Sensor
4. Water-proof Joint E

Inlet Air Temperature Sensor (Service Code 13)

Inlet Air Temperature Sensor Removal/Installation

CAUTION
Never drop the sensor, especially on a hard surface. Such a shock to the sensor can damage it.

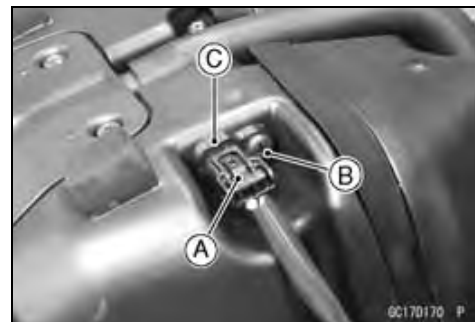

- Remove the fuel tank (see Fuel Tank Removal).
- Disconnect the connector [A].
- Remove the screw [B].
- Pull out the inlet air temperature sensor [C].
- Put the inlet air temperature sensor into the air cleaner housing.
- Tighten the screw securely.

Inlet Air Temperature Sensor Output Voltage Inspection

NOTE

○ Be sure the battery is fully charged.

- Turn the ignition switch OFF.
- Remove the fuel tank (see Fuel Tank Removal).
- Disconnect the inlet air temperature sensor connector and connect the harness adapter [A] between these connectors as shown in the figure.



Main Harness [B]
Inlet Air Temperature Sensor [C]

Special Tool - Measuring Adapter: 57001-1700

- Connect a digital meter [D] to the harness adapter leads.

Inlet Air Temperature Sensor Output Voltage Connections to Adapter:

Digital Meter (+) → R (sensor Y) lead
Digital Meter (-) → BK (sensor BR/BK) lead

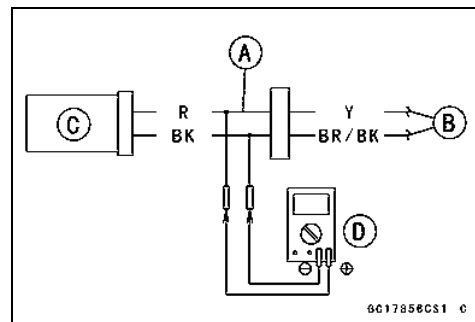

- Measure the output voltage with the engine stopped and the connector joined.
- Turn the ignition switch ON.

Output Voltage

Standard: About DC 2.25 ~ 2.50 V at inlet air temperature 20°C (68°F)

NOTE

○ The output voltage changes according to the inlet air temperature.

- Turn the ignition switch OFF.
- ★ If the reading is within the standard, check the ECU for its ground and power supply (see ECU Power Supply Inspection).
- ★ If the ground and power supply are good, replace the ECU (see ECU Removal/Installation).

3-52 FUEL SYSTEM (DFI)

Inlet Air Temperature Sensor (Service Code 13)

★ If the reading is out of the standard, remove the ECU and check the wiring for continuity between main harness side connectors.

Special Tool - Hand Tester: 57001-1394

○ Disconnect the ECU and sensor connectors.

Wiring Continuity Inspection

ECU Connector [A] ←→

Inlet Air Temperature Sensor Connector [B]

Y lead (ECU terminal 20) [C]

BR/BK lead (ECU terminal 22) [D]

★ If the wiring is good, check the inlet air temperature sensor resistance (see Inlet Air Temperature Sensor Resistance Inspection).

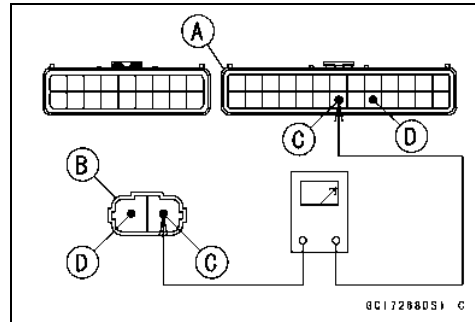

Inlet Air Temperature Sensor Resistance Inspection

- Remove the inlet air temperature sensor (see Inlet Air Temperature Sensor Removal/Installation).
- Suspend the sensor [A] in a container of machine oil so that the heat-sensitive portion is submerged.
- Suspend a thermometer [B] with the heat-sensitive portion [C] located in almost the same depth with the sensor.

NOTE

○ The sensor and thermometer must not touch the container side or bottom.

- Place the container over a source of heat and gradually raise the temperature of the oil while stirring the oil gently for even temperature.
- Using a digital meter, measure the internal resistance of the sensor across the terminals at the temperatures shown in the following.

Inlet Air Temperature Sensor Resistance

Standard: 5.4 ~ 6.6 k Ω at 0°C (32°F)

0.29 ~ 0.39 k Ω at 80°C (176°F)

- ★ If the reading is out of the standard, replace the sensor.
- ★ If the reading is within the standard, but the problem still exists, replace the ECU (see ECU Removal/Installation).

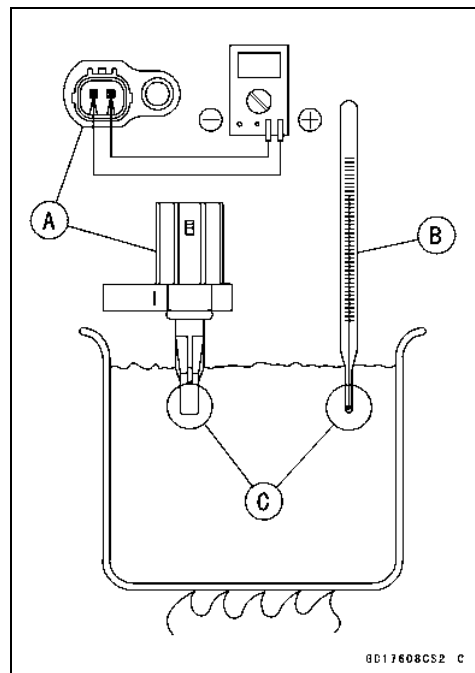

Inlet Air Temperature Sensor (Service Code 13)

Inlet Air Temperature Sensor Circuit

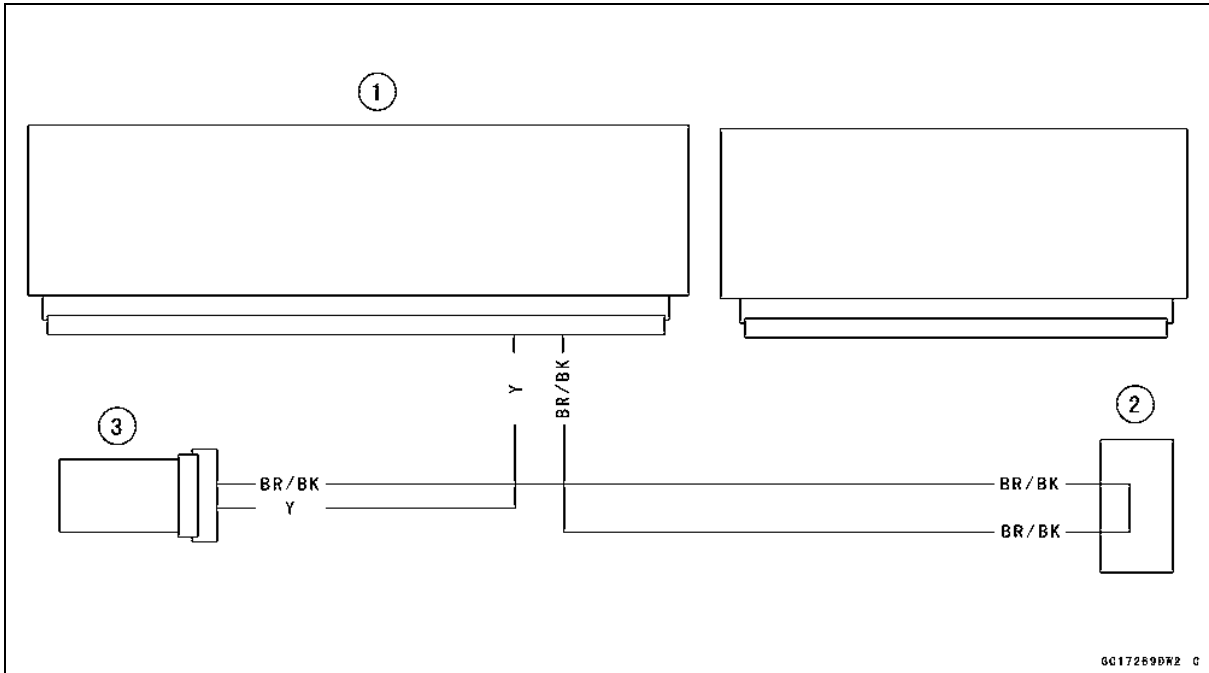

- 1. ECU
- 2. Water-proof Joint E
- 3. Inlet Air Temperature Sensor

3-54 FUEL SYSTEM (DFI)

Water Temperature Sensor (Service Code 14)

Water Temperature Sensor Removal/Installation

CAUTION

Never drop the sensor, especially on a hard surface. Such a shock to the sensor can damage it.

- Drain the coolant (see Coolant Change in the Periodic Maintenance chapter).
- Disconnect the sensor connector [A], and unscrew the water temperature sensor [B].
- Apply grease to the new O-ring on the water temperature sensor.
- Tighten:
Torque - Water Temperature Sensor: 12 N·m (1.2 kgf·m, 106 in·lb)
- Fill the engine with coolant and bleed the air from the cooling system (see Coolant Change in the Periodic Maintenance chapter).

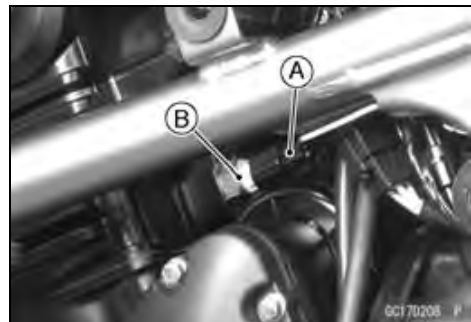

Water Temperature Sensor Output Voltage Inspection

NOTE

○ Be sure the battery is fully charged.

- Turn the ignition switch OFF.
- Remove the left upper fairing cover (see Upper Fairing Cover Removal in the Frame chapter).
- Disconnect the water temperature sensor connector and connect the harness adapter [A] between these connectors as shown in the figure.

Main Harness [B]

Water Temperature Sensor [C]

Special Tool - Measuring Adapter: 57001-1700

- Connect a digital meter [D] to the harness adapter leads.

Water Temperature Sensor Output Voltage

Connections to Adapter:

Digital Meter (+) → R (sensor O) lead

Digital Meter (-) → BK (sensor BR/BK) lead

- Measure the output voltage with the engine stopped and with the connector joined.
- Turn the ignition switch ON.

Output Voltage

Standard: About DC 2.80 ~ 2.97 V at 20°C (68°F)

NOTE

○ The output voltage changes according to the coolant temperature in the engine.

- Turn the ignition switch OFF.
- ★ If the reading is within the standard, check the ECU for its ground and power supply (see ECU Power Supply Inspection).
- ★ If the ground and power supply are good, replace the ECU (see ECU Removal/Installation).

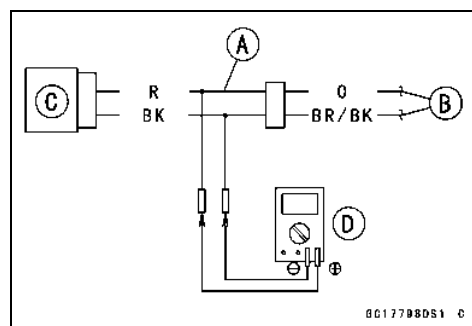

Water Temperature Sensor (Service Code 14)

★If the reading is out of the standard, remove the ECU and check the wiring for continuity between main harness connectors.

Special Tool - Hand Tester: 57001-1394

○Disconnect the ECU and sensor connectors.

Wiring Continuity Inspection

ECU Connector [A] ←→

Water Temperature Sensor Connector [B]

O lead (ECU terminal 17) [C]

BR/BK lead (ECU terminal 22) [D]

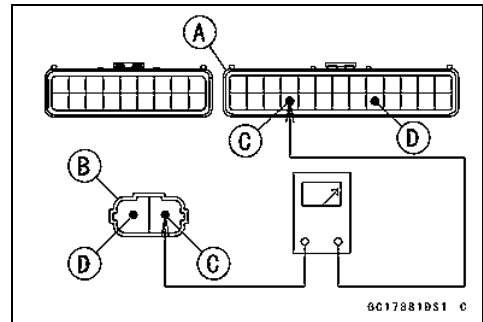

★If the wiring is good, check the water temperature sensor resistance (see Water Temperature Sensor Resistance Inspection).

Water Temperature Sensor Resistance Inspection

●Refer to the Water Temperature Sensor Inspection in the Electrical System chapter.

★If the reading is within the standard, but the problem still exists, replace the ECU (see ECU Removal/Installation).

Water Temperature Sensor Circuit

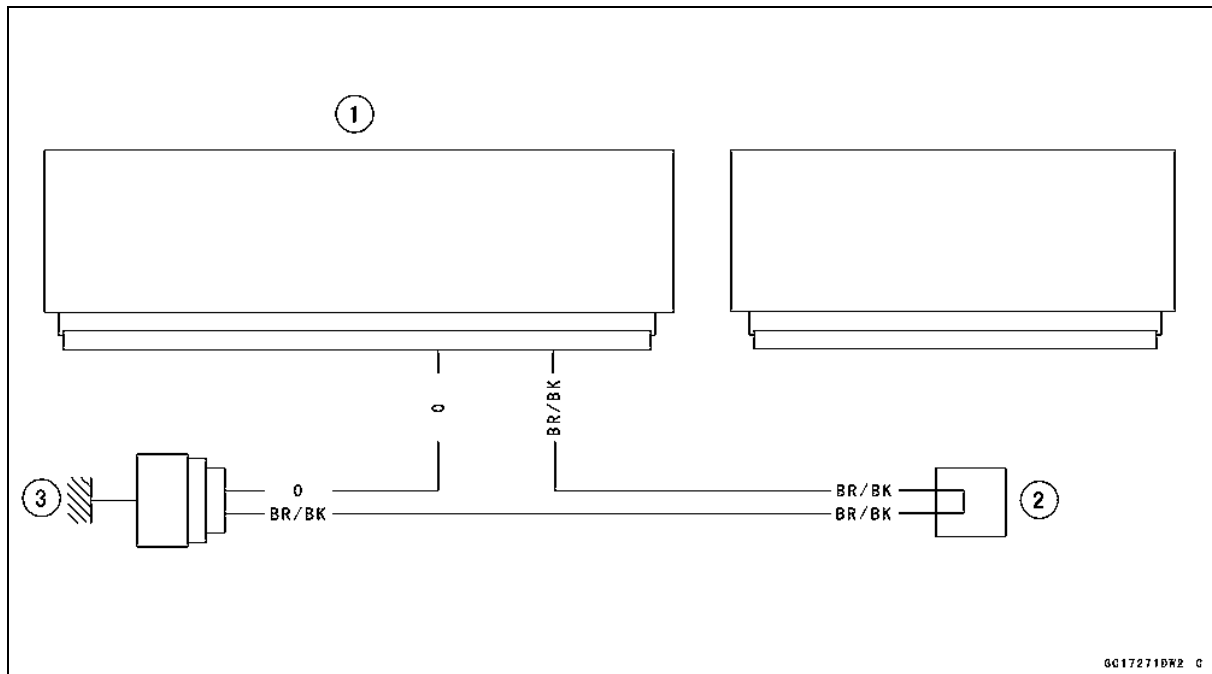

- 1. ECU
- 2. Water-proof Joint E
- 3. Water Temperature Sensor

3-56 FUEL SYSTEM (DFI)

Crankshaft Sensor (Service Code 21)

Start the engine and switch the diagnosis mode to Dealer 1 mode to know all the problem that the DFI system has at the time of self-diagnosis. If the engine cannot be started, the self-diagnosis system does not detect dynamic condition of the crankshaft sensor. In this case, turn off the ignition switch and turn it on again to enter the Dealer 2 mode. In this mode, the system tells all the troubles which the DFI system had in both static and dynamic conditions.

Crankshaft Sensor Removal/Installation

- Refer to the Crankshaft Sensor Removal/Installation in the Electrical System chapter.

Crankshaft Sensor Resistance Inspection

- Refer to the Crankshaft Sensor Inspection in the Electrical System chapter.
- ★ If the reading is within the standard, check the peak voltage (see Crankshaft Sensor Peak Voltage Inspection).

Crankshaft Sensor Peak Voltage Inspection

- Refer to the Crankshaft Sensor Peak Voltage Inspection in the Electrical System chapter.
- ★ If the reading is within the standard, remove the ECU and check the wiring for continuity between main harness connectors.

Special Tool - Hand Tester: 57001-1394

- Disconnect the ECU and sensor connectors.

Wiring Continuity Inspection

ECU Connector [A] ↔

Crankshaft Sensor Connector [B]

R/BK lead (ECU terminal 11) [C]

Y/BK lead (ECU terminal 24) [D]

- ★ If the wiring is good, check the ECU for its ground and power supply (see ECU Power Supply Inspection).
- ★ If the ground and power supply are good, replace the ECU (see ECU Removal/Installation).

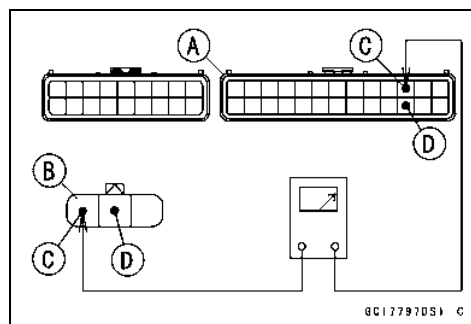

Crankshaft Sensor (Service Code 21)

Crankshaft Sensor Circuit

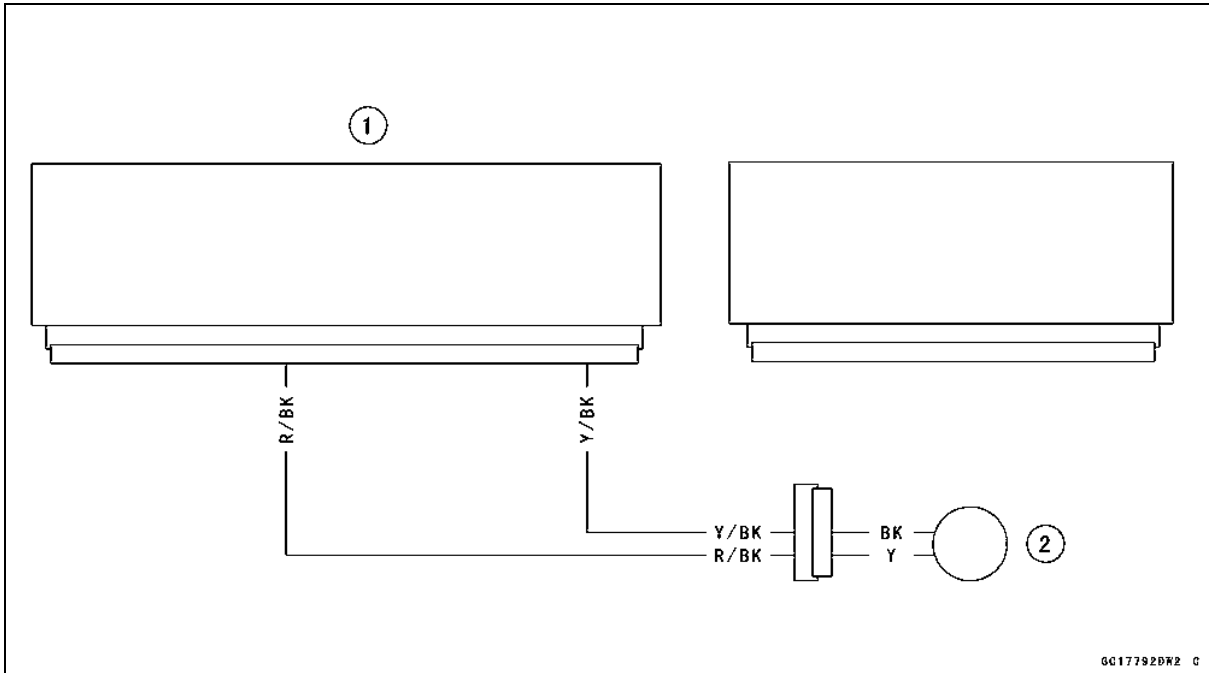

- 1. ECU
- 2. Crankshaft Sensor

3-58 FUEL SYSTEM (DFI)

Speed Sensor (Service Code 24, 25)

Speed Sensor Removal/Installation

- Refer to the Speed Sensor Removal/Installation in the Electrical System chapter.

Speed Sensor Inspection

- Refer to the Speed Sensor Inspection in the Electrical System chapter.

Speed Sensor Input Voltage Inspection

NOTE

○ Be sure the battery is fully charged.

- Turn the ignition switch OFF.
- Remove the left upper fairing cover (see Upper Fairing Cover Removal in the Frame chapter).
- Disconnect the speed sensor connector [A] and connect the harness adapter [B] between the harness connector and speed sensor connector.

Special Tool - Throttle Sensor Setting Adapter #1: 57001-1400

- Connect a digital meter to the harness adapter leads.

Speed Sensor Input Voltage Connections to Adapter:

Digital Meter (+) → BL (sensor P) lead [C]

Digital Meter (-) → BK/BL (sensor BK) lead [D]

- Measure the input voltage with the engine stopped, and with the connector joined.
- Turn the ignition switch ON.

Input Voltage

Standard: About DC 9 ~ 11 V at Ignition Switch ON

- Turn the ignition switch OFF.
- ★ If the reading is out of the range, check the wiring (see wiring diagram in this section), and meter unit (see Meter Unit Inspection in the Electrical System chapter).
- ★ If the reading is good, check the output voltage.

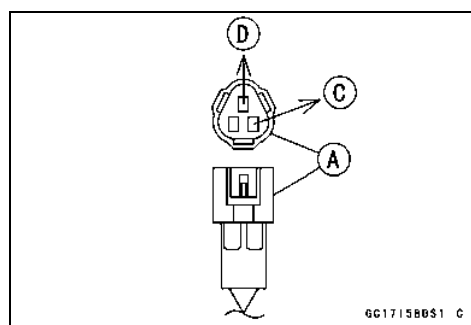

Speed Sensor (Service Code 24, 25)

Speed Sensor Output Voltage Inspection

- Before this inspection, inspect the input voltage (see Speed Sensor Input Voltage Inspection).

NOTE

○ Be sure the battery is fully charged.

- Turn the ignition switch OFF.
- Remove the left upper fairing cover (see Upper Fairing Cover Removal in the Frame chapter).
- Disconnect the speed sensor connector [A] and connect the harness adapter [B] between the harness connector and speed sensor connector.

Special Tool - Throttle Sensor Setting Adapter #1: 57001-1400

- Connect a digital meter to the harness adapter leads.

Speed Sensor Output Voltage

Connections to Adapter:

Digital Meter (+) → Y/W (sensor Y) lead [C]

Digital Meter (-) → BK/BL (sensor BK) lead [D]

- Measure the output voltage with the engine stopped, and with the connector joined.
- Turn the ignition switch ON.

Output Voltage

Standard: About DC 0.05 ~ 0.07 V or DC 4.5 ~ 4.9 V

NOTE

○ Rotate the rear wheel by hand, confirm the output voltage will be raise or lower.

- Turn the ignition switch OFF.
- ★ If the reading is out of the range, check the speed sensor (see Speed Sensor Inspection in the Electrical System chapter) and the wiring to ECU (see wiring diagram in this section).
- ★ If the reading, speed sensor and wiring are good, check the ECU for its ground, and power supply (see ECU Power Supply Inspection).
- ★ If the ground and power supply are good, replace the ECU (see ECU Removal/Installation).

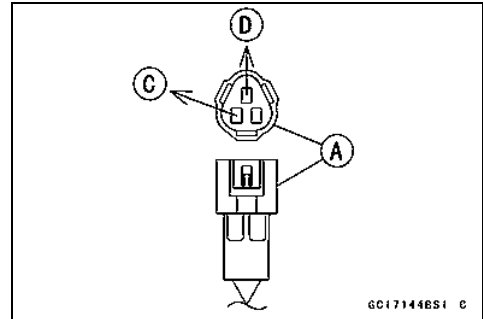

3-60 FUEL SYSTEM (DFI)

Speed Sensor (Service Code 24, 25)

Speed Sensor Circuit

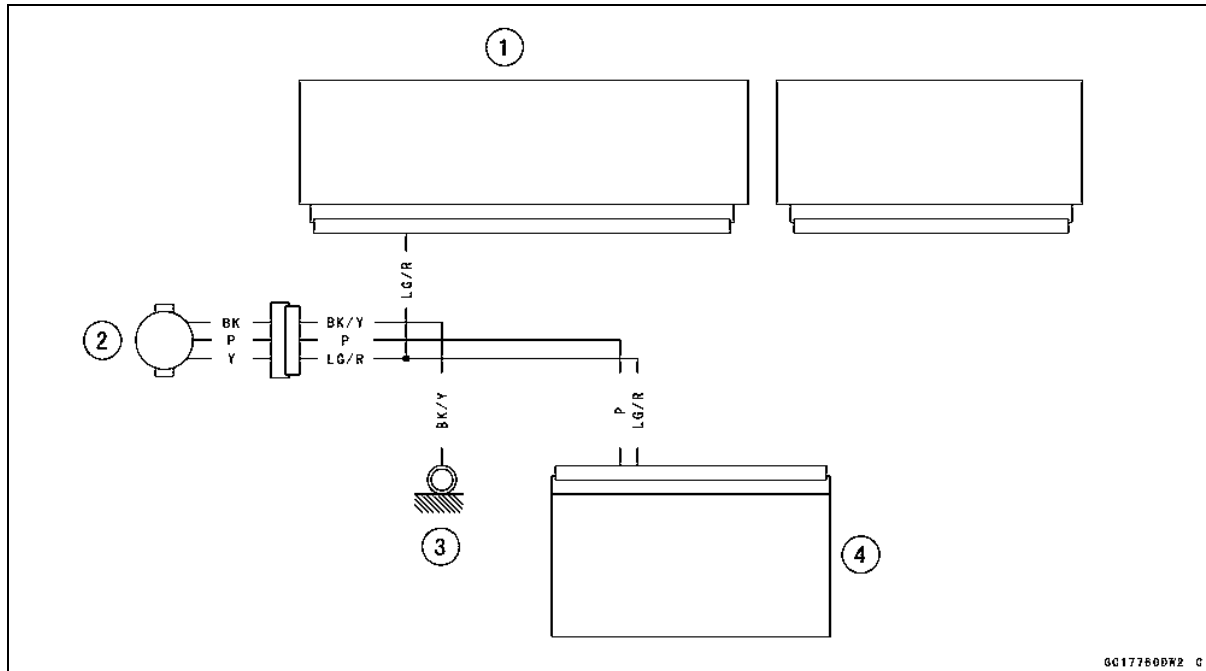

1. ECU
2. Speed Sensor
3. Frame Ground
4. Meter Unit

Vehicle-down Sensor (Service Code 31)

Vehicle-down Sensor Removal

CAUTION

Never drop the vehicle-down sensor, especially on a hard surface. Such a shock to the sensor can damage it.

- Remove:
 - Right Frame Cover (see Frame Cover Removal in the Frame chapter)
 - Connector [A]
 - Vehicle-down Sensor [B] and Dampers [C]

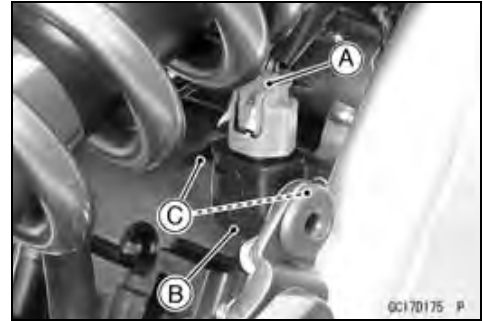

Vehicle-down Sensor Installation

- Replace the mounting dampers with new ones.
- The UP mark [A] of the sensor should face upward.

⚠ WARNING

Incorrect installation of the vehicle-down sensor could cause sudden loss of engine power. The rider could lose balance during certain riding situations like leaning over in a turn with the potential for an accident resulting in injury or death. Ensure that the vehicle-down sensor is held in place by the sensor brackets.

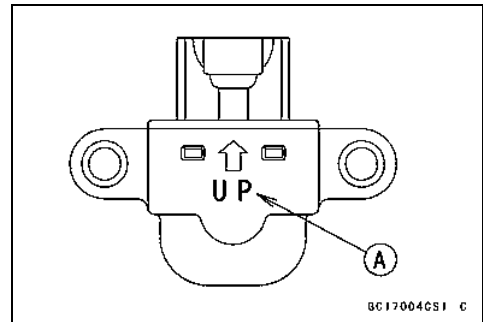

Vehicle-down Sensor Inspection

NOTE

○ Be sure the battery is fully charged.

- Connect a digital meter [A] to the connector [B] of the vehicle-down sensor [C] with the needle adapter set [D].

Special Tool - Needle Adapter Set: 57001-1457

Vehicle-down Sensor Power Source Voltage

Connections to Sensor Connector:

Meter (+) → BL lead [E]

Meter (-) → BR/BK lead [F]

- Turn the ignition switch ON, and measure the power source voltage with the connector joined.

Input Voltage

Standard: DC 4.75 ~ 5.25 V

- Turn the ignition switch OFF.
- ★ If the reading of input voltage is less than the standard, check the ECU for its ground, power supply and wiring.
- ★ If the power source is normal, check the output voltage.

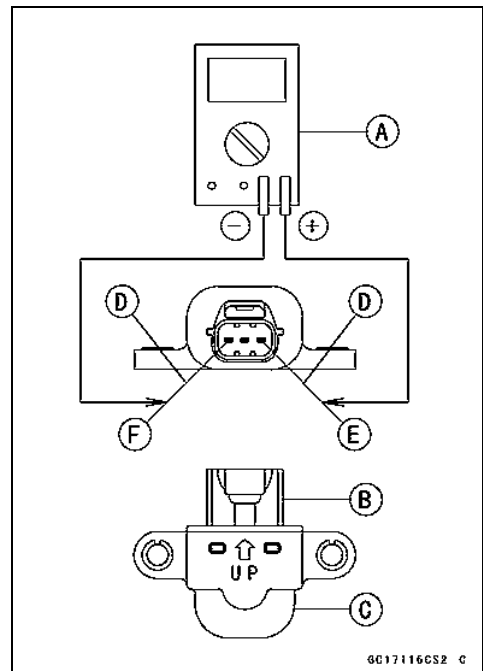

3-62 FUEL SYSTEM (DFI)

Vehicle-down Sensor (Service Code 31)

- Remove the vehicle-down sensor (see Vehicle-down Sensor Removal).
- Do not disconnect the sensor connector.
- Connect a digital meter [A] to the connector with needle adapter set [B].

Special Tool - Needle Adapter Set: 57001-1457

Vehicle-down Sensor Output Voltage

Connections to Sensor Connector:

Meter (+) → Y/G lead [E]

Meter (-) → BR/BK lead [F]

- Hold the sensor vertically.
- Turn the ignition switch ON, and measure the output voltage with the connector joined.
- Tilt the sensor 60 ~ 70° or more [C] right or left, then hold the sensor almost vertical with the arrow mark pointed up [D], and measure the output voltage.

Output Voltage

Standard: with sensor tilted 60 ~ 70° or more right or left: 0.65 ~ 1.35 V

with sensor arrow mark pointed up: 3.55 ~ 4.45 V

NOTE

○ If you need to test again, turn the ignition switch OFF, and then ON.

- Turn the ignition switch OFF.
- ★ If the output voltage is normal, check the wiring.
- ★ If the wiring is good, check the ECU for its ground and power supply (see ECU Power Supply Inspection).
- ★ If the ground and power supply are good, replace the ECU (see ECU Removal/Installation).
- ★ If the output voltage is out of the specified, replace the vehicle-down sensor.

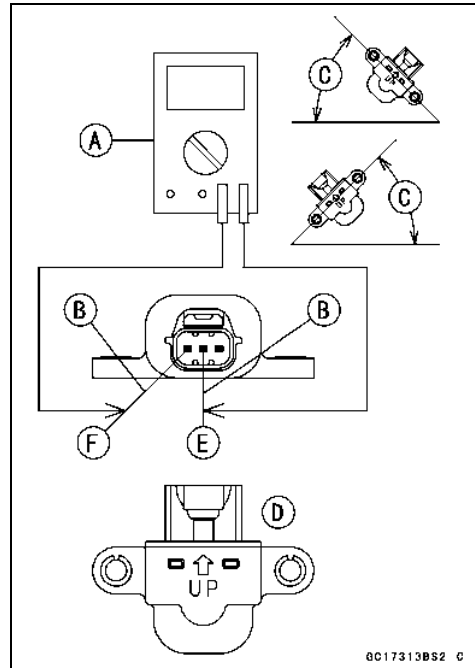

Vehicle-down Sensor (Service Code 31)

Vehicle-down Sensor Circuit

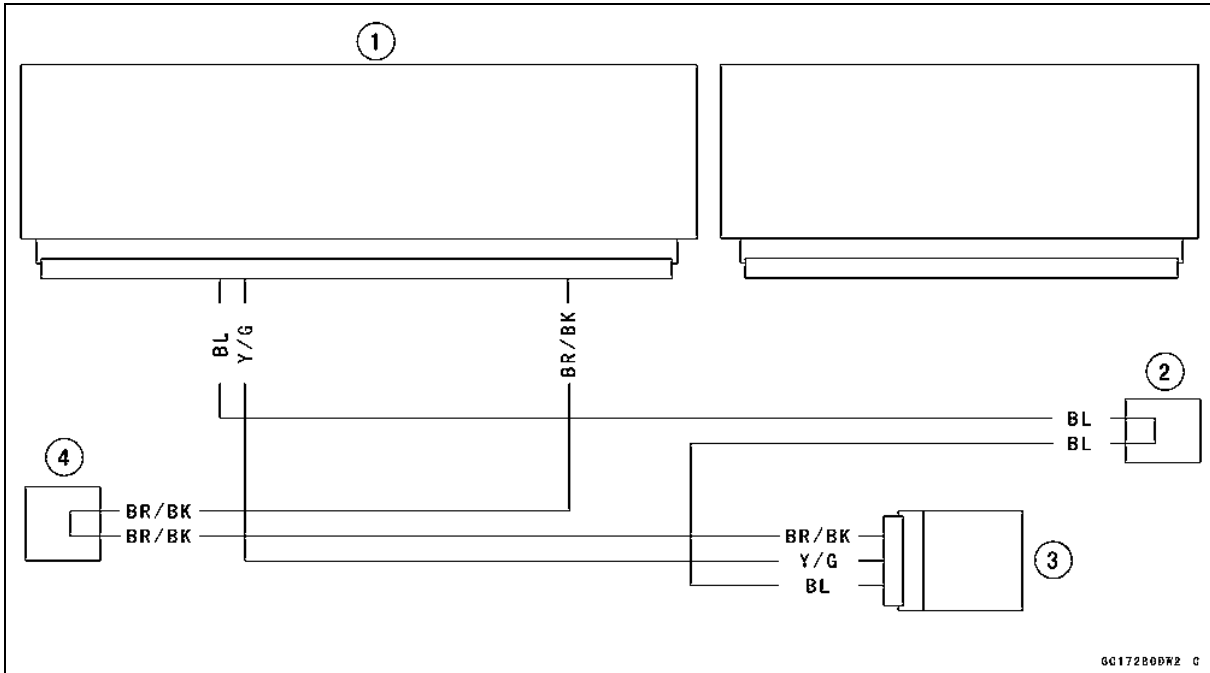

GC172B0DR2 C

- 1. ECU
- 2. Water-proof Joint D
- 3. Vehicle-down Sensor
- 4. Water-proof Joint E

3-64 FUEL SYSTEM (DFI)

Subthrottle Sensor (Service Code 32)

Subthrottle Sensor Removal/Adjustment

CAUTION

Do not remove or adjust the subthrottle sensor [A] since it has been adjusted and set with precision at the factory.

Never drop the throttle body assy, especially on a hard surface. Such a shock to the sensor can damage it.



Subthrottle Sensor Input Voltage Inspection

NOTE

○Be sure the battery is fully charged.

- Remove the air cleaner housing (see Air Cleaner Housing Removal).
- Turn the ignition switch OFF.
- Disconnect the subthrottle sensor connector and connect the harness adapter [A] between these connectors.

Special Tool - Throttle Sensor Setting Adapter #1: 57001-1400

- Connect a digital meter to the harness adapter leads.

Subthrottle Sensor Input Voltage

Connections to Adapter:

Digital Meter (+) → BL (sensor BL) lead

Digital Meter (-) → BK/BL (sensor BK) lead

- Measure the input voltage with the engine stopped and with the connector joined.
- Turn the ignition switch ON.

Input Voltage

Standard: DC 4.75 ~ 5.25 V

- Turn the ignition switch OFF.
- ★ If the reading is within the standard, check the output voltage (see Subthrottle Sensor Output Voltage Inspection).
- ★ If the reading is out of the standard, remove the ECU and check the wiring for continuity between main harness connectors.

Special Tool - Hand Tester: 57001-1394

- Disconnect the ECU and sensor connectors.

Wiring Continuity Inspection

ECU Connector [A] ↔

Subthrottle Sensor Connector [B]

BL lead (ECU terminal 8) [C]

BR/BK lead (ECU terminal 22) [D]

- ★ If the wiring is good, check the ECU for its ground and power supply (see ECU Power Supply Inspection).
- ★ If the ground and power supply are good, replace the ECU (see ECU Removal/Installation).

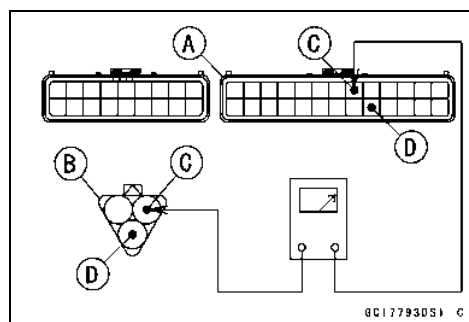

Subthrottle Sensor (Service Code 32)

Subthrottle Sensor Output Voltage Inspection

- Remove the air cleaner housing (see Air Cleaner Housing Removal).
- Measure the output voltage at the subthrottle sensor in the same way as input voltage inspection. Note the following.
- Disconnect the subthrottle sensor connector and connect the harness adapter [A] between these connectors.

Special Tool - Throttle Sensor Setting Adapter #1: 57001-1400



Subthrottle Sensor Output Voltage

Connections to Adapter:

Digital Meter (+) → Y/W (sensor Y) lead

Digital Meter (-) → BK/BL (sensor BK) lead

- Turn the ignition switch ON.
- Measure the output voltage when the subthrottle valve is fully opened or completely closed by hand.

Output Voltage

Standard: DC 0.4 ~ 0.6 V (at idle throttle opening)

DC 3.825 ~ 3.975 V (at full throttle opening)

NOTE

- Turn the lever counterclockwise, confirm the output voltage will be raise.
- The standard voltage refers to the value when the voltage reading at the Input Voltage Inspection shows 5 V exactly.
- When the input voltage reading shows other than 5 V, derive a voltage range as follows.

Example:

In the case of a input voltage of 4.75 V.

$$0.4 \times 4.75 \div 5.00 = 0.38 \text{ V}$$

$$0.6 \times 4.75 \div 5.00 = 0.57 \text{ V}$$

Thus, the valid range is 0.38 ~ 0.57 V

- Turn the ignition switch OFF.
- ★ If the output voltage is out of the standard, inspect the subthrottle sensor resistance.
- ★ If the reading is within the standard, remove the ECU and check the wiring for continuity between main harness connectors.

Special Tool - Hand Tester: 57001-1394

- Disconnect the ECU and sensor connectors.

Wiring Continuity Inspection

ECU Connector [A] ↔

Subthrottle Sensor Connector [B]

BR lead (ECU terminal 19) [C]

BR/BK lead (ECU terminal 22) [D]

- ★ If the wiring is good, check the ECU for its ground and power supply (see ECU Power Supply Inspection).
- ★ If the ground and power supply are good, replace the ECU (see ECU Removal/Installation).

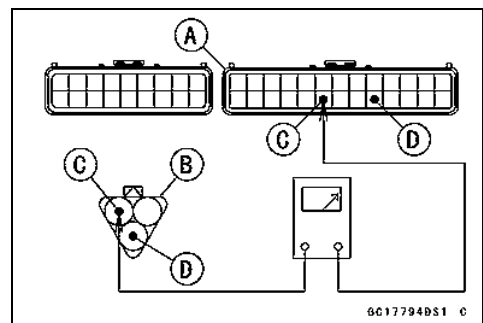

3-66 FUEL SYSTEM (DFI)

Subthrottle Sensor (Service Code 32)

Subthrottle Sensor Resistance Inspection

- Turn the ignition switch OFF.
- Disconnect the subthrottle sensor connector.
- Connect a digital meter [A] to the subthrottle sensor connector [B].
- Measure the subthrottle sensor resistance.

Throttle Sensor Resistance

Connections: BL lead [C] ↔ BK lead [D]

Standard: 4 ~ 6 kΩ

- ★ If the reading is out of the range, replace the throttle body assy (see Throttle Body Assy Removal/Installation).
- ★ If the reading is within the range, but the problem still exists, replace the ECU (see ECU Removal/Installation).

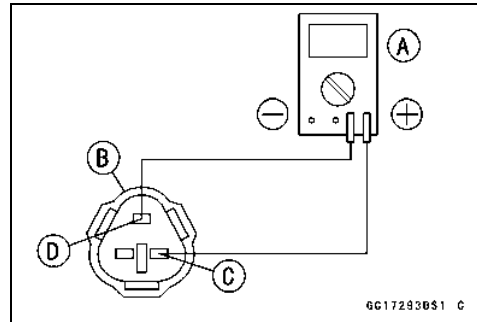

Subthrottle Sensor Circuit

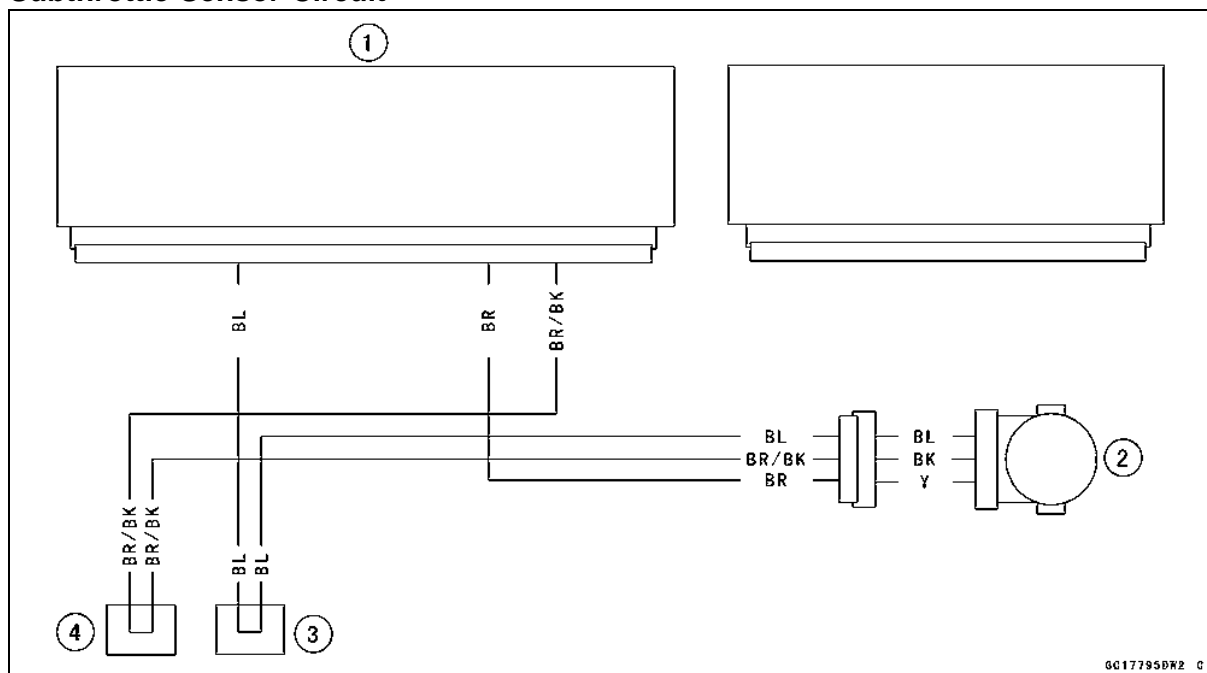

1. ECU
2. Subthrottle Sensor
3. Water-proof Joint D
4. Water-proof Joint E

Oxygen Sensor-not activated (Service Code 33) (Equipped Models)

Oxygen Sensor Removal/Installation

- Refer to the Oxygen Sensor Removal/Installation in the Electrical System chapter.

Oxygen Sensor Inspection

- Warm up the engine thoroughly until the radiator fan starts.
- Turn the ignition switch OFF.
- Disconnect the oxygen sensor connector and connect the harness adapter [A] between these connectors.

Special Tool - Oxygen Sensor Measuring Adapter: 57001-1682

- Connect a digital meter to the harness adapter leads.

Oxygen Sensor Output Voltage

Connections to Adapter:

Digital Meter (+) → BL (sensor BL) lead

Digital Meter (-) → BR (sensor W) lead

- Remove the air switching valve hose from the fitting.
- Install the suitable plug [A] on the fitting [B] and shut off the secondary air.

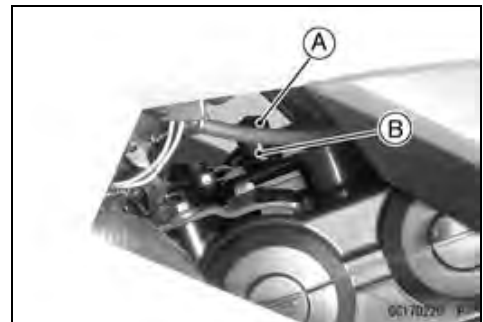

- Turn the ignition switch ON.
- Start the engine, and let it idle.
- Measure the output voltage with the connector joined.

Output Voltage (with Plug)

Standard: DC 0.7 V or more

- Next, remove the plug from the fitting [A] with idling.
- Measure the output voltage with the connector joined.

Output Voltage (without Plug)

Standard: DC 0.2 V or less

- Turn the ignition switch OFF.



3-68 FUEL SYSTEM (DFI)

Oxygen Sensor-not activated (Service Code 33) (Equipped Models)

★If the reading is out of the standard (with plug: DC 0.7 V or more, without plug: DC 0.2 V or less), remove the ECU and check the wiring for continuity between main harness connectors.

Special Tool - Hand Tester: 57001-1394

○Disconnect the ECU and sensor connectors.

Wiring Continuity Inspection

ECU Connector [A] ←→

Oxygen Sensor Connector [B]

BL/Y lead (ECU terminal 4) [C]

BR/BK lead (ECU terminal 22) [D]

- ★If the wiring is good, replace the sensor.
- ★If the reading is within the standard (with plug: DC 0.7 V or more, without plugs: DC 0.2 V or less), check the ECU for its ground and power supply (see ECU Power Supply Inspection).
- ★If the ground and power supply are good, replace the ECU (see ECU Removal/Installation).

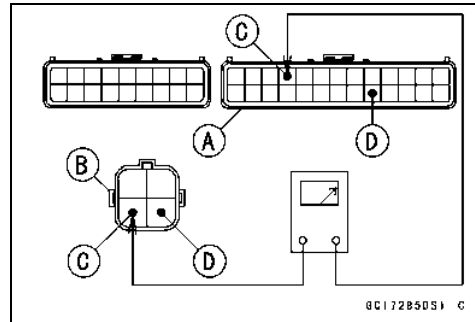

Oxygen Sensor Circuit

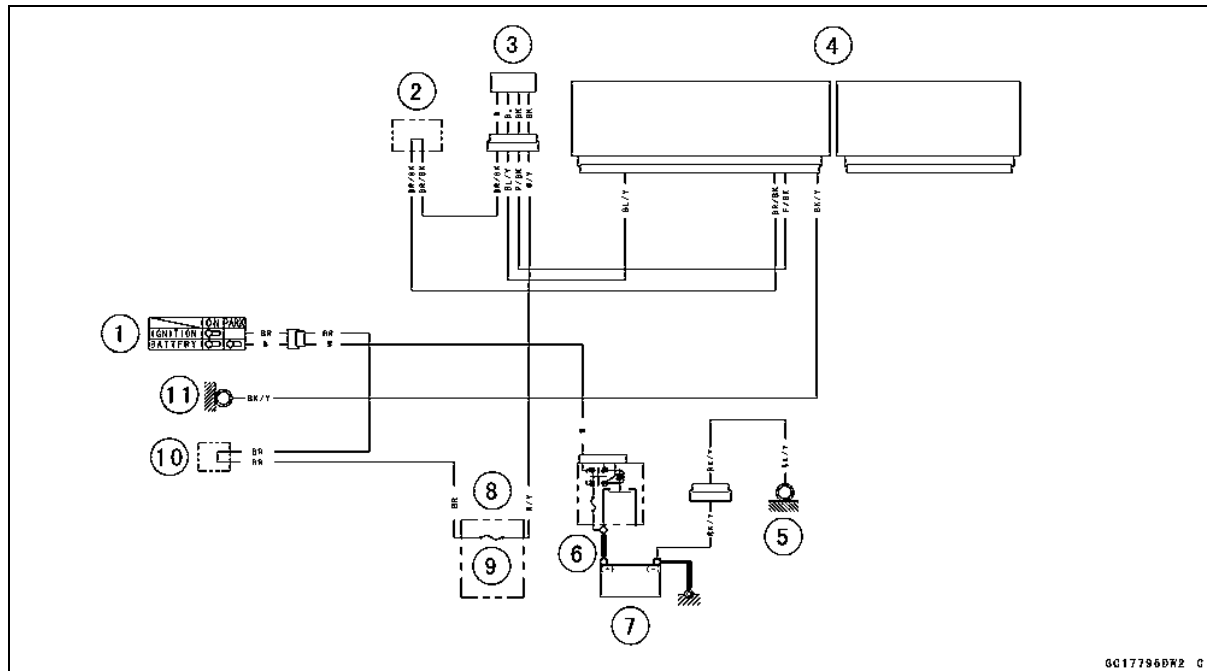

1. Ignition Switch
2. Water-proof Joint E
3. Oxygen Sensor
4. ECU
5. Frame Ground
6. Main Fuse 30 A
7. Battery 12 V 10 Ah
8. Fuse Box
9. Oxygen Sensor Heater Fuse 10 A
10. Water-proof Joint C
11. Frame Ground

Stick Coils #1, #2: (Service Code 51, 52)

Stick Coil #1: Service Code 51

Stick Coil #2: Service Code 52

Stick Coil Removal/Installation

- Refer to the Stick Coil Removal/Installation in the Electrical System chapter.

Stick Coil Primary Winding Resistance Inspection

- Refer to the Stick Coil Inspection in the Electrical System chapter.
- ★ If the reading is within the standard, check the input voltage (see Stick Coil Input Voltage Inspection).

Stick Coil Input Voltage Inspection

NOTE

○ Be sure the battery is fully charged.

- Turn the ignition switch OFF.
- Remove the ECU (see ECU Removal).
- Do not disconnect the ECU connectors.
- Connect a digital meter [A] to the connector [B] with the needle adapter set.

Special Tool - Needle Adapter Set: 57001-1457

Stick Coil Input Voltage

Connections to ECU Connector:

For Stick Coil #1

Digital Meter (+) → BK lead (terminal 35)

Digital Meter (-) → BK/Y lead (terminal 43)

For Stick Coil #2

Digital Meter (+) → BK/G lead (terminal 44)

Digital Meter (-) → BK/Y lead (terminal 43)

- Measure the input voltage to each primary winding of the stick coils with the engine stopped and with the connectors joined.
- Turn the engine stop switch to run position.
- Turn the ignition switch ON.

Input Voltage

Standard: Battery Voltage

- Turn the ignition switch OFF.
- ★ If the input voltage is out of the standard, check the wiring for continuity (see wiring diagram in this section).
- ★ If the wiring is good, check the ECU for its ground and power supply (see ECU Power Supply Inspection).
- ★ If the ground and power supply are good, replace the ECU (see ECU Removal/Installation).
- ★ If the input voltage is within the standard, check the ECU for its ground and power supply (see ECU Power Supply Inspection).
- ★ If the ground and power supply are good, replace the ECU (see ECU Removal/Installation).

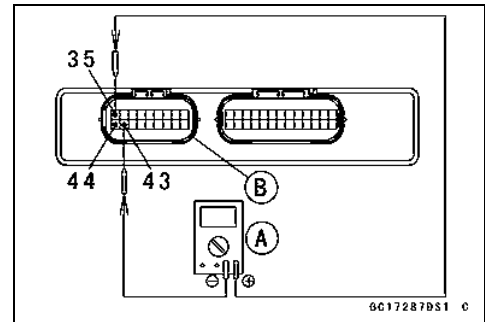

3-70 FUEL SYSTEM (DFI)

Stick Coils #1, #2: (Service Code 51, 52)

Stick Coil Circuit

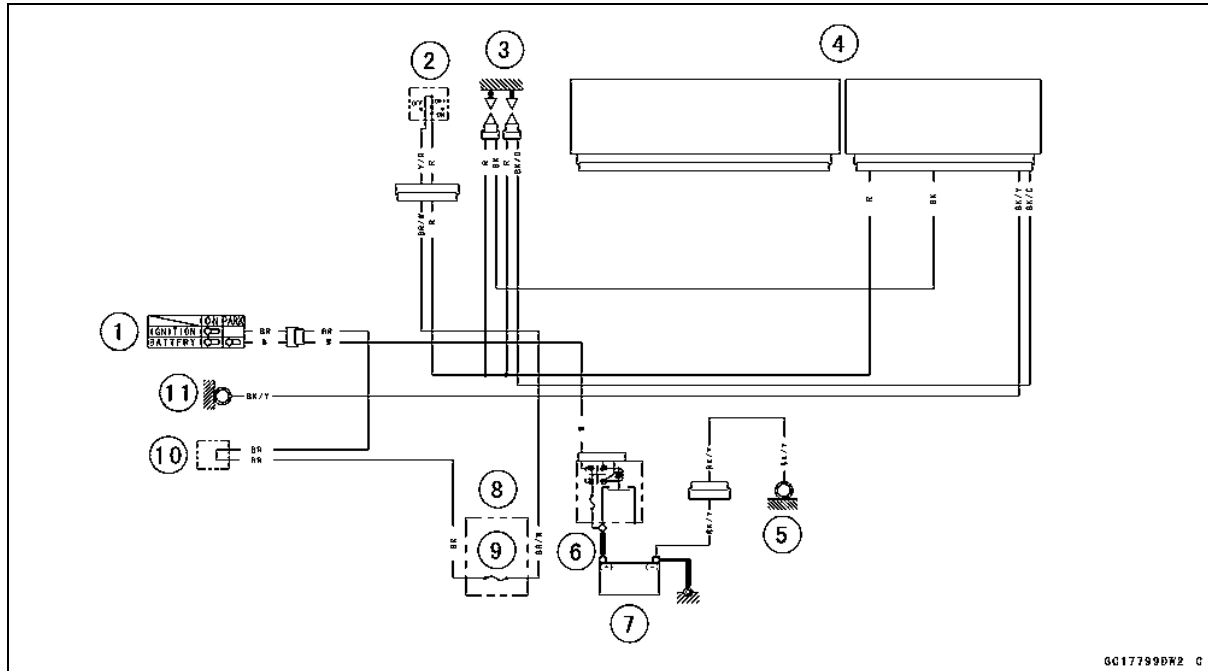

1. Ignition Switch
2. Engine Stop Switch
3. Stick Coils
4. ECU
5. Frame Ground
6. Main Fuse 30 A
7. Battery 12 V 10 Ah
8. Fuse Box
9. Ignition Fuse 10 A
10. Water-proof Joint C
11. Frame Ground

GC17799DR2 C

Radiator Fan Relay (Service Code 56)

Radiator Fan Relay Removal/Installation

- The radiator fan relay is built in the relay box [A].
- Refer to the Relay Box Removal in the Electrical System chapter.



Radiator Fan Relay Inspection

- Refer to the Relay Circuit Inspection in the Electrical System chapter.
- ★If the radiator fan relay is normal, check the wiring for continuity (see wiring diagram in this section).
- ★If the wiring is good, check the ECU for its ground and power supply (see ECU Power Supply Inspection).
- ★If the ground and power supply are good, replace the ECU (see ECU Removal/Installation).

Radiator Fan Relay Circuit

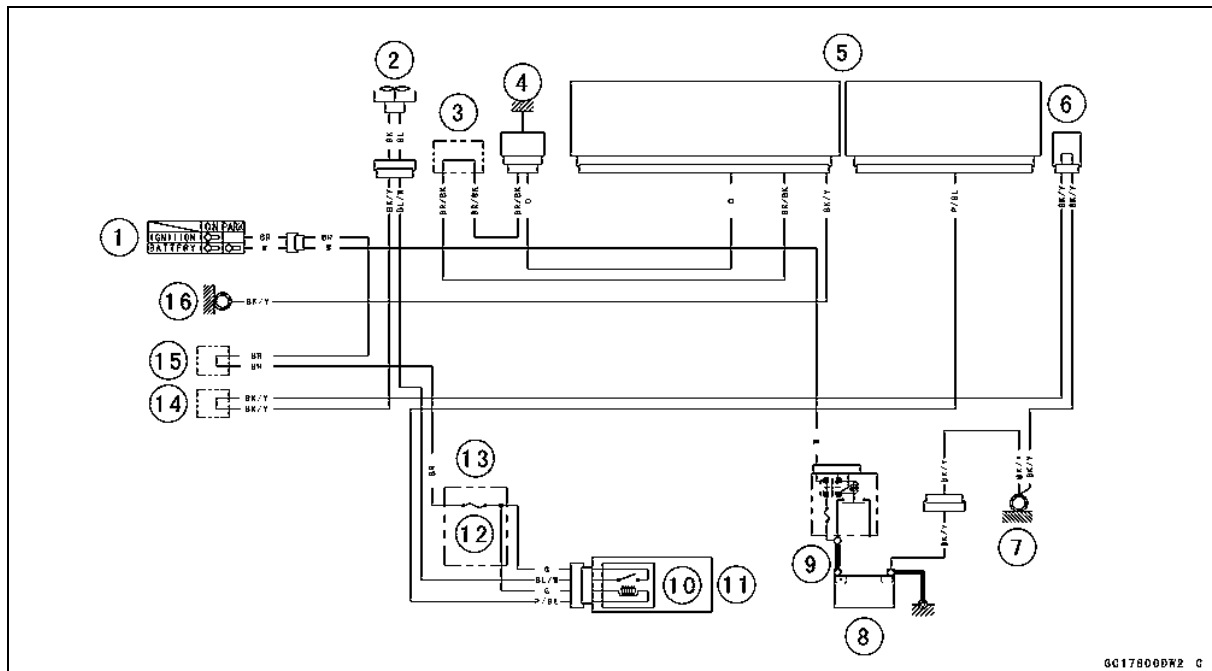

- | | |
|-----------------------------|----------------------------|
| 1. Ignition Switch | 9. Main Fuse 30 A |
| 2. Fan Motor | 10. Radiator Fan Relay |
| 3. Water-proof Joint E | 11. Relay Box |
| 4. Water Temperature Sensor | 12. Radiator Fan Fuse 15 A |
| 5. ECU | 13. Fuse Box |
| 6. Joint Connector | 14. Water-proof Joint A |
| 7. Frame Ground | 15. Water-proof Joint C |
| 8. Battery 12 V 10 Ah | 16. Frame Ground |

GC17806DR2 C

3-72 FUEL SYSTEM (DFI)

Subthrottle Valve Actuator (Service Code 62)

Subthrottle Valve Actuator Removal

CAUTION

Do not remove the subthrottle valve actuator [A] since it has been adjusted and set with precision at the factory.

Never drop the throttle body assy, especially on a hard surface. Such a shock to the actuator can damage it.



Subthrottle Valve Actuator Inspection

NOTE

○Be sure the battery is fully charged.

- Remove the air cleaner housing (see Air Cleaner Housing Removal).
- Turn the ignition switch ON.
- Check to see that all the subthrottle valves [A] open and close smoothly.
- ★ If the subthrottle valves do not operate, check the subthrottle valve actuator resistance (see Subthrottle Valve Actuator Resistance Inspection).



Subthrottle Valve Actuator Resistance Inspection

- Turn the ignition switch OFF.
- Remove the air cleaner housing (see Air Cleaner Housing Removal).
- Disconnect the subthrottle valve actuator connector [A].



- Connect a digital meter to the subthrottle valve actuator connector [A].
- Measure the subthrottle valve actuator resistance.

Subthrottle Valve Actuator Resistance

Connections: BK lead [1] ↔ P lead [2]

G lead [3] ↔ W/BL lead [4]

Standard: About 5.5 ~ 7.5 Ω

- ★ If the reading is out of the standard, replace the throttle body assy (see Throttle Body Assy Removal/Installation).
- ★ If the reading is within the range, check the input voltage (see Subthrottle Valve Actuator Input Voltage Inspection).

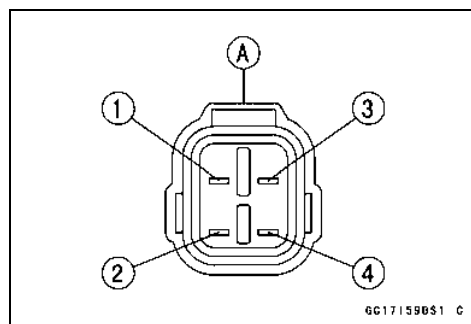

Subthrottle Valve Actuator (Service Code 62)

Subthrottle Valve Actuator Input Voltage Inspection

NOTE

○Be sure the battery is fully charged.

- Turn the ignition switch OFF.
- Disconnect the subthrottle valve actuator connector and connect the harness adapter [A] between these connectors as shown in the figure.

Main Harness [B]

Subthrottle Valve Actuator [C]

Special Tool - Measuring Adapter: 57001-1700

- Connect the peak voltage adapter [D] and a digital meter [E] to the harness adapter leads.

Special Tool - Peak Voltage Adapter: 57001-1415

Type: KEK-54-9-B

Subthrottle Valve Actuator Input Voltage Connections to Adapter:

- (I) Digital Meter (+) → R (harness P) lead
Digital Meter (-) → BK (harness BK/BL) lead
- (II) Digital Meter (+) → W (harness W/BL) lead
Digital Meter (-) → Y (harness G/Y) lead

- Measure the actuator input voltage with the engine stopped and with the connector joined.
- Turn the ignition switch ON.

Input Voltage

Standard: About DC 8.5 ~ 10.5 V

- Turn the ignition switch OFF.
- ★ If the reading is in specification, but the actuator does not operate, replace the throttle body assy (see Throttle Body Assy Removal/Installation).

- ★ If the reading is out of the specification, remove the ECU and check the wiring for continuity between main harness connectors.

Special Tool - Hand Tester: 57001-1394

○Disconnect the ECU and actuator connectors.

Wiring Continuity Inspection

ECU Connector [A] ↔

Subthrottle Valve Actuator Connector [B]

BK/BL lead (ECU terminal 1) [C]

G/Y lead (ECU terminal 2) [D]

P lead (ECU terminal 14) [E]

W/BL lead (ECU terminal 15) [F]

- ★ If the wiring is good, check the ECU for its ground and power supply (see ECU Power Supply Inspection).
- ★ If the ground and power supply are good, replace the ECU (see ECU Removal/Installation).

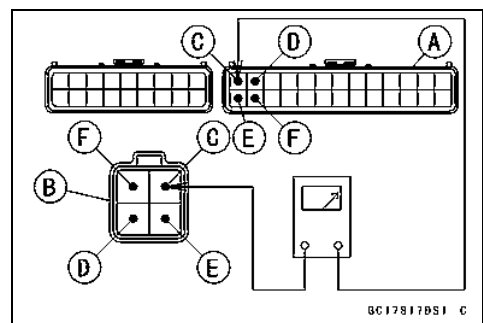
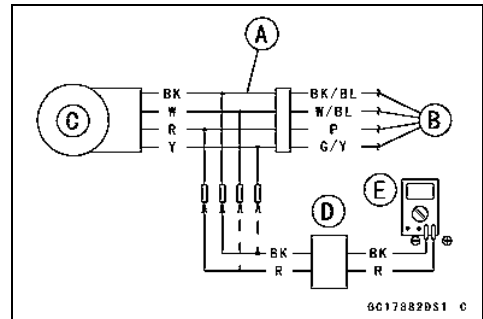

3-74 FUEL SYSTEM (DFI)

Subthrottle Valve Actuator (Service Code 62)

Subthrottle Valve Actuator Circuit

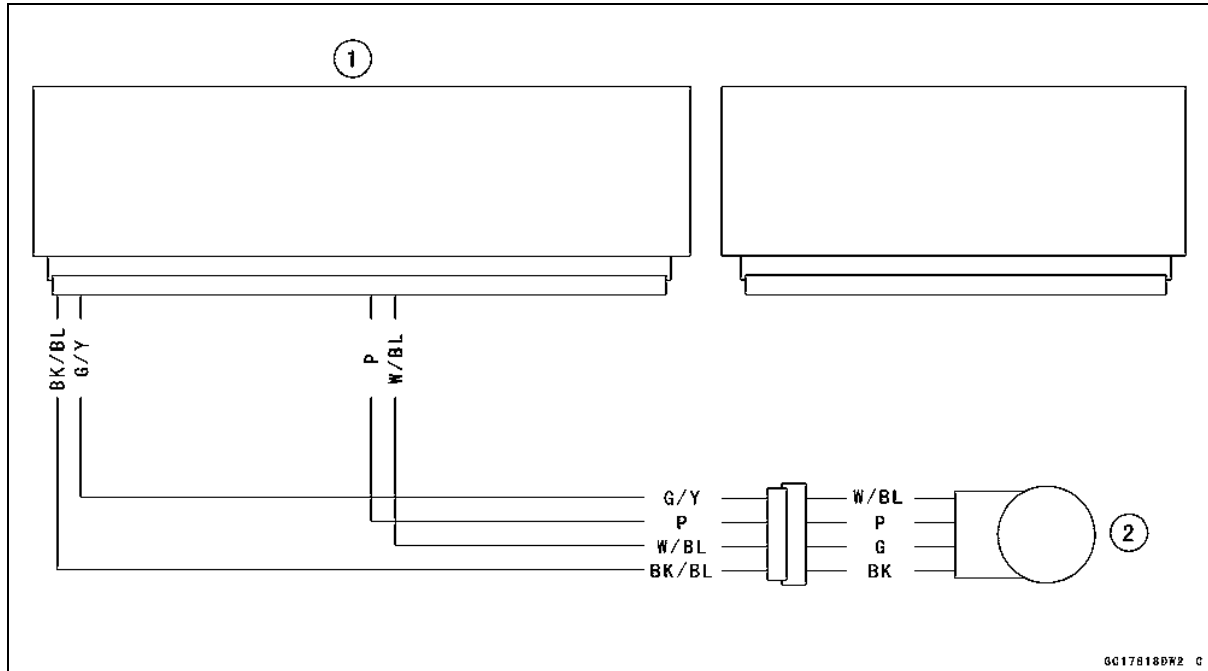

1. ECU
2. Subthrottle Valve Actuator

Air Switching Valve (Service Code 64)

Air Switching Valve Removal/Installation

- Refer to the Air Switching Valve Removal/Installation in the Engine Top End chapter.

Air Switching Valve Inspection

- Refer to the Air Switching Valve Operation Test/Unit Test in the Electrical System chapter.
- Remove the fuel tank (see Fuel Tank Removal) and check the wiring continuity, using the following diagram.

Air Switching Valve Circuit

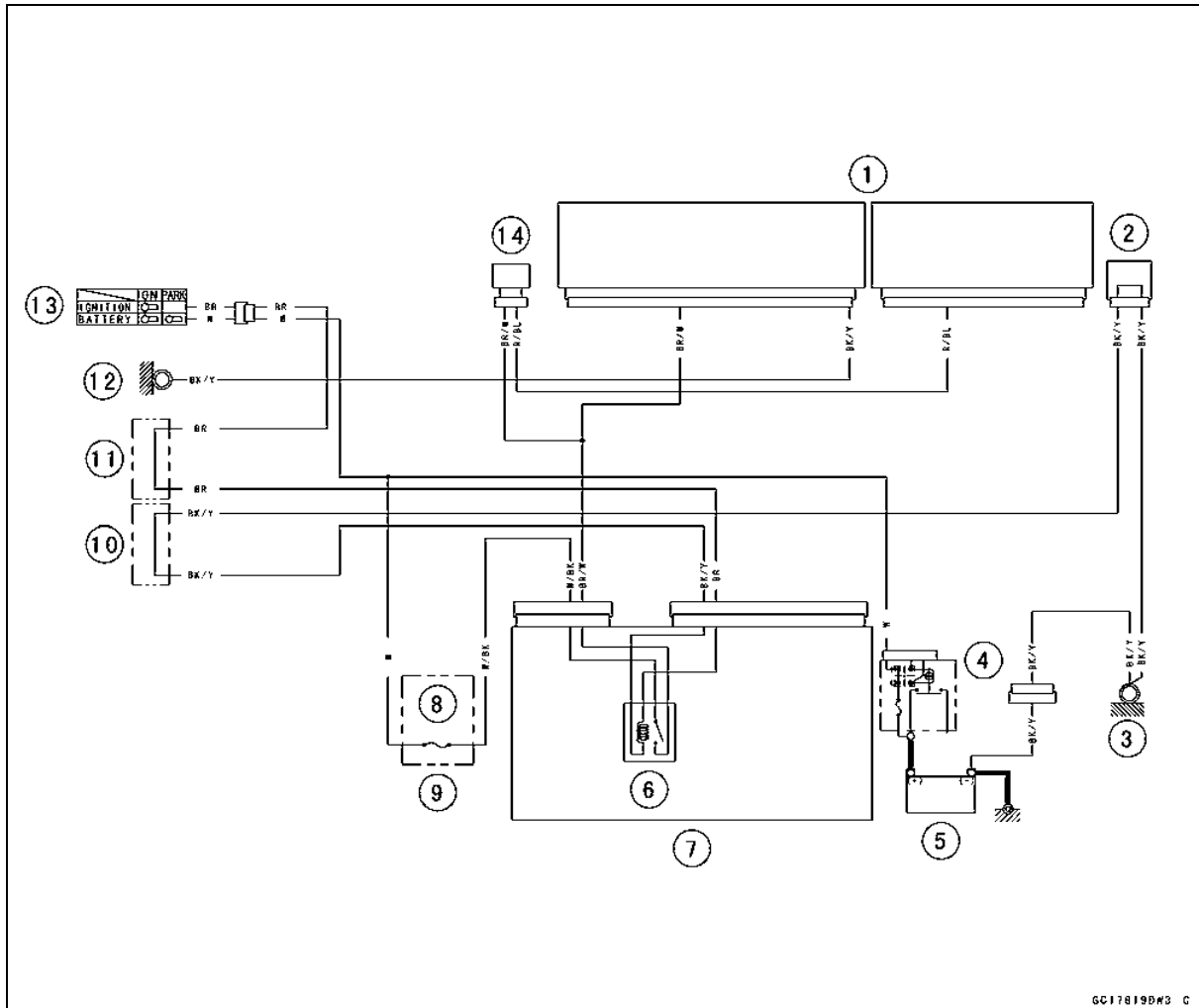

1. ECU
2. Joint Connector
3. Frame Ground
4. Main Fuse 30 A
5. Battery 12V 10Ah
6. ECU Main Relay
7. Relay Box
8. ECU Fuse 15 A
9. Fuse Box
10. Water-proof Joint B
11. Water-proof Joint C
12. Frame Ground
13. Ignition Switch
14. Air Switching Valve

GC17819D#3 C

3-76 FUEL SYSTEM (DFI)

Oxygen Sensor Heater (Service Code 67) (Equipped Models)

Oxygen Sensor Heater Removal/Installation

The oxygen sensor heater is built in the oxygen sensor. So, the heater itself can not be removed. Remove the oxygen sensor (see Oxygen Sensor Removal in the Electrical System chapter).

Oxygen Sensor Heater Inspection

- Turn the ignition switch off.
- Disconnect the oxygen sensor lead connector [A].



- Connect a digital meter [A] to the oxygen sensor lead connector [B].
- Measure the oxygen sensor heater resistance.

Oxygen Sensor Heater Resistance

Connections: BK lead [C] ↔ BK lead [D]

Standard: 11.7 ~ 14.5 Ω at 20°C (68°F)

- ★ If the reading is out of the standard, replace the sensor.
- ★ If the reading is within the standard, check the power source voltage (see Oxygen Sensor Heater Power Source Voltage Inspection).

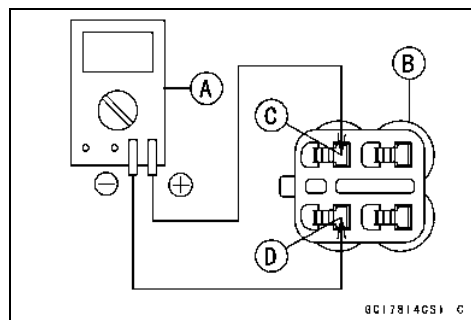

Oxygen Sensor Heater Power Source Voltage Inspection

NOTE

○ Be sure the battery is fully charged.

- Turn the ignition switch OFF.
- Disconnect the oxygen sensor lead connector and connect the harness adapter [A] between these connectors.

Special Tool - Oxygen Sensor Measuring Adapter: 57001-1682

- Connect a digital meter to the harness adapter lead.

Oxygen Sensor Power Source Voltage

Connections to Adapter:

Digital Meter (+) → W (sensor BK) lead

Digital Meter (-) → Battery (-) terminal

- Measure the power source voltage with the engine stopped and with the connector joined.
- Turn the ignition switch ON.

Power Source Voltage

Standard: Battery Voltage

- Turn the ignition switch OFF.
- ★ If the reading is in specification, but the problem still exists, replace the ECU (see ECU Removal/Installation).
- ★ If the reading is out of the standard, check the following.
 - Oxygen Sensor Heater Fuse 10 A (see Fuse Inspection in the Electrical System chapter)
 - Power Source Wiring (see wiring diagram in this section)



Oxygen Sensor Heater (Service Code 67) (Equipped Models)

★If the fuse and wiring are good, remove the ECU and check the wiring for continuity between main harness connectors.

Special Tool - Hand Tester: 57001-1394

○Disconnect the ECU and sensor connectors.

Wiring Continuity Inspection

ECU Connector [A] ←→

Oxygen Sensor Connector [B]

P/BK lead (ECU terminal 23) [C]

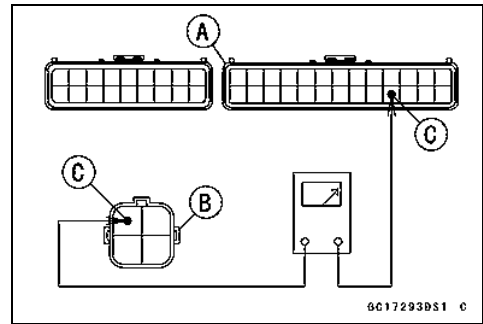

★If the wiring is good, check the ECU for its ground and power supply (see ECU Power Supply Inspection).

★If the ground and power supply are good, replace the ECU (see ECU Removal/Installation).

Oxygen Sensor Circuit

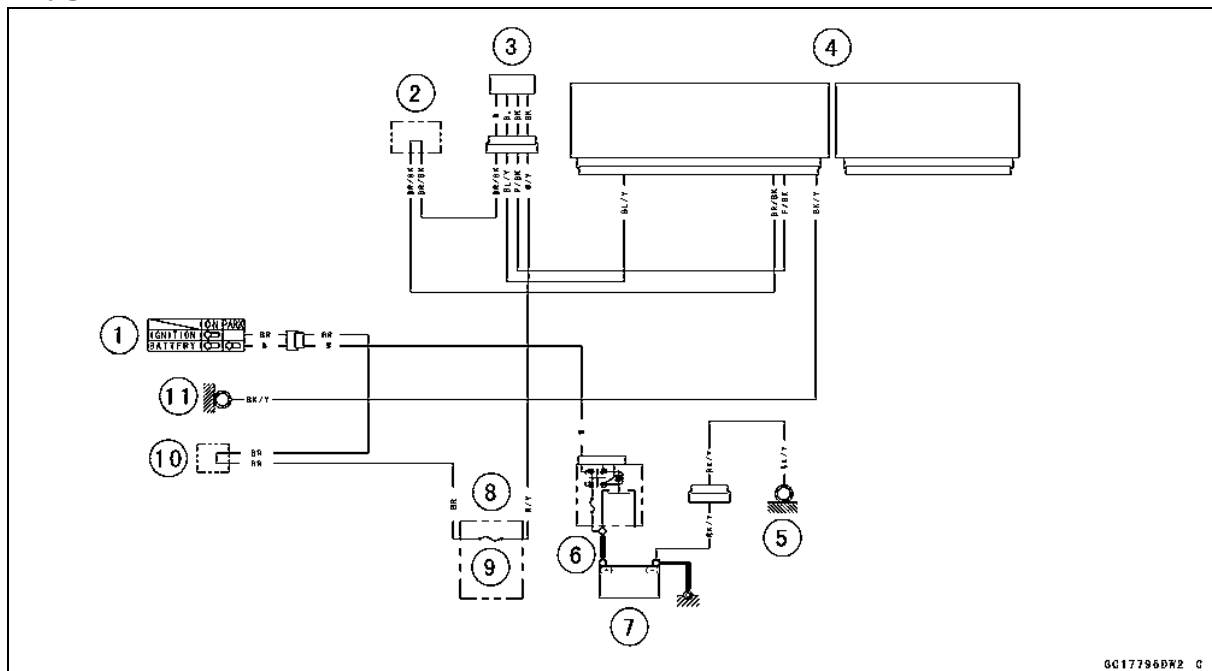

1. Ignition Switch
2. Water-proof Joint E
3. Oxygen Sensor
4. ECU
5. Frame Ground
6. Main Fuse 30 A
7. Battery
8. Fuse Box
9. Oxygen Sensor Heater Fuse 10 A
10. Water-proof Joint C
11. Frame Ground

3-78 FUEL SYSTEM (DFI)

Oxygen Sensor-Incorrect Output Voltage (Service Code 94) (Equipped Models)

Oxygen Sensor Removal/Installation

- Refer to the Oxygen Sensor Removal/Installation in the Electrical System chapter.

Oxygen Sensor Inspection

- Warm up the engine thoroughly until the radiator fan starts.
- Turn the ignition switch OFF.
- Disconnect the oxygen sensor connector and connect the harness adapter [A] between these connectors.

Special Tool - Oxygen Sensor Measuring Adapter: 57001-1682

- Connect a digital meter to the harness adapter lead.

Oxygen Sensor Output Voltage

Connections to Adapter:

Meter (+) → BL (sensor BL) lead

Meter (-) → BR (sensor W) lead

- Remove the air switching valve hose from the fitting.
- Install the suitable plug [A] on the fitting [B] and shut off the secondary air.

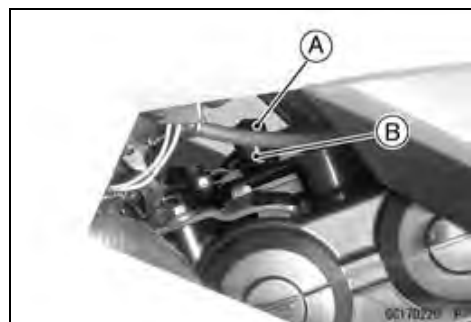

- Turn the ignition switch ON.
- Start the engine, and let it idle.
- Measure the output voltage with the connector joined.

Output Voltage (with Plug)

Standard: DC 0.7 V or more

- Next, remove the plug from the fitting [A] with idling.
- Measure the output voltage with the connector joined.

Output Voltage (without Plug)

Standard: DC 0.2 V or less

- Turn the ignition switch OFF.
- ★ If the reading is out of the standard (with plug: DC 0.7 V or more, without plug: DC 0.2 V or less), check the following.
 - Fuel Pressure (see Fuel Pressure Inspection)
 - Fuel Injector (see Fuel Injectors section)
- ★ If the fuel pressure and fuel injectors are good, replace the sensor.
- ★ If the reading is within the standard (with plug: DC 0.7 V or more, without plug: DC 0.2 V or less), check the ECU for its ground and power supply (see ECU Power Supply Inspection).
- ★ If the ground and power supply are good, replace the ECU (see ECU Removal/Installation).



Oxygen Sensor-Incorrect Output Voltage (Service Code 94) (Equipped Models)

Oxygen Sensor Circuit

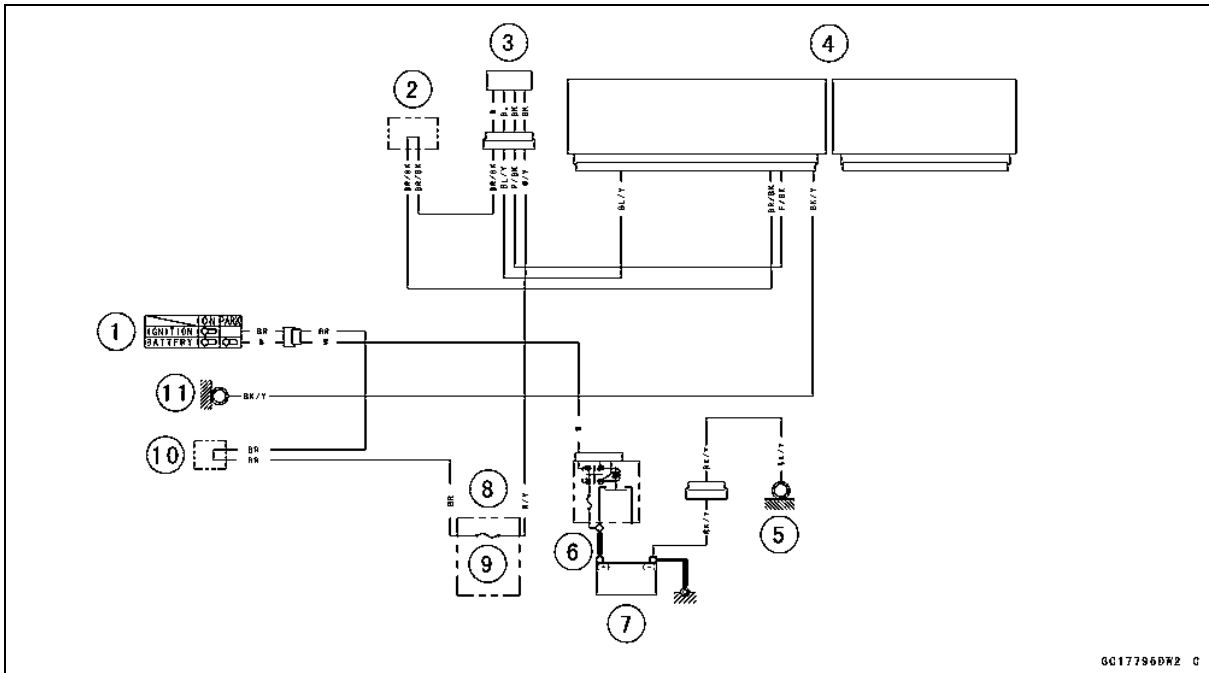

1. Ignition Switch
2. Water-proof Joint E
3. Oxygen Sensor
4. ECU
5. Frame Ground
6. Main Fuse 30 A
7. Battery 12 V 10 Ah
8. Fuse Box
9. Oxygen Sensor Heater Fuse 10 A
10. Water-proof Joint C
11. Frame Ground

GC17796072 C

3-80 FUEL SYSTEM (DFI)

FI Indicator Light (LED)

FI Indicator Light (LED) Inspection

- Refer to the Electronic Combination Meter Unit Inspection in the Electrical System chapter.

FI Indicator Light (LED) Circuit

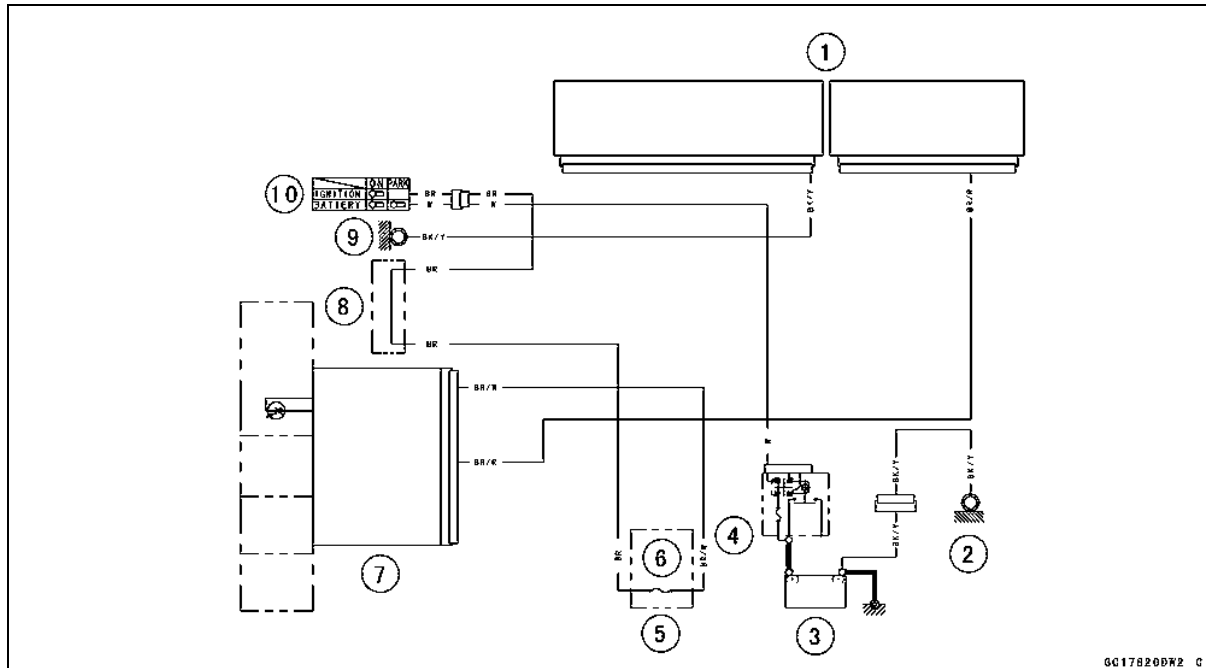

1. ECU
2. Frame Ground
3. Battery 12V 10 Ah
4. Main Fuse 30 A
5. Fuse Box
6. Ignition Fuse 10 A
7. Meter Unit
8. Water-proof Joint C
9. Frame Ground
10. Ignition Switch

ECU

CAUTION

Never drop the ECU, especially on a hard surface. Such a shock to the ECU can damage it.

ECU Removal

- Remove:
 - Seat Covers (see Seat Cover Removal in the Frame chapter)
- Remove the nuts [A] and washers to lower the rear fender.

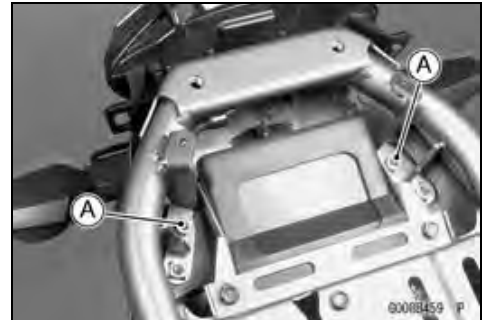

- Remove the bolts [A].



- Disconnect the ECU connectors [A]
- Take off the ECU [B] and the bracket [C].

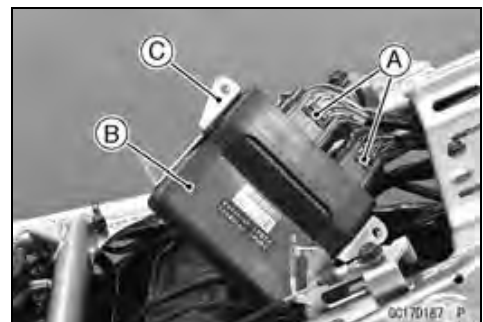

ECU Installation

- Installation is the reverse of removal.
- Fit [A] the bracket on the ECU as shown in the figure.

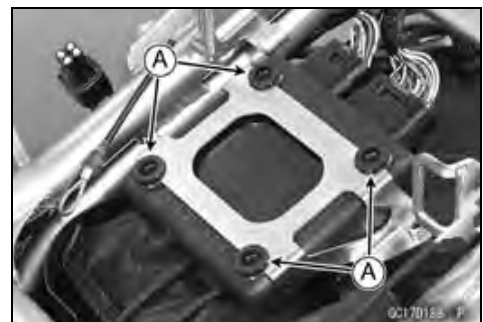

3-82 FUEL SYSTEM (DFI)

ECU

ECU Power Supply Inspection

- Remove the seat (see Seat Removal in the Frame chapter).
 - Visually inspect the ECU connectors.
 - ★ If the connector is clogged with mud or dust, blow it off with compressed air.
 - Remove the ECU (see ECU Removal).
 - Visually inspect the terminals [A] of the ECU connectors.
 - ★ If the terminals of the main harness connectors are damaged, replace the main harness.
 - ★ If the terminals of the ECU connectors are damaged, replace the ECU.
-
- Turn the ignition switch OFF.
 - Disconnect the ECU connectors [A].
 - Set the hand tester [B] to the $\times 1 \Omega$ range and check the following wiring for continuity.

Special Tool - Hand Tester: 57001-1394

ECU Grounding Continuity Inspection

Connections:

- (I) BK/Y leads (ECU terminal 26, 42 or 43) \longleftrightarrow Battery (-) Terminal
- (II) Engine Ground \longleftrightarrow Battery (-) Terminal

Criteria:

Both: 0Ω

- ★ If no continuity, check the connectors, the engine ground lead, or main harness, and repair or replace them if necessary.

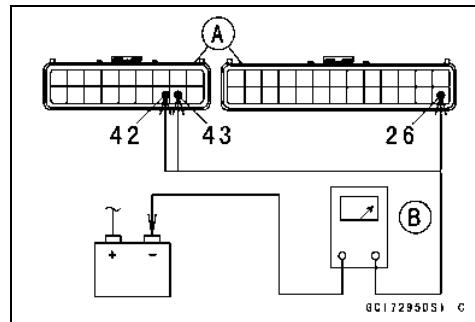
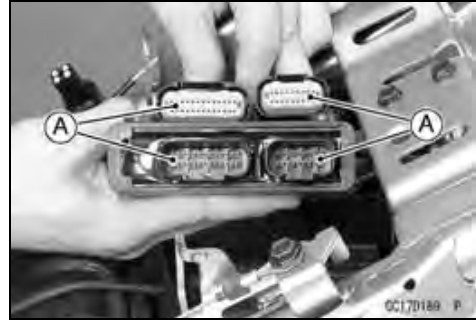

ECU

★If the wiring is good, check the power source voltage of the ECU.

NOTE

○Be sure the battery is fully charged.

- Connect the ECU connectors.
- Connect a digital meter [A] to the connector [B] with the needle adapter set.

Special Tool - Needle Adapter Set: 57001-1457

ECU Power Supply Inspection

Connections:

- (I) **Digital Meter (+)** → **Terminal 12 (BR/W)**
Digital Meter (-) → **Battery (-) terminal**
- (II) **Digital Meter (+)** → **Terminal 27 (W/BK)**
Digital Meter (-) → **Battery (-) terminal**

Ignition Switch OFF:

- Terminal 12 (BR/W): 0 V**
- Terminal 27 (W/BK): Battery Voltage**

Ignition Switch ON:

- Both: Battery Voltage**

★If the reading is out of the specification, check the following.

- Main Fuse 30 A (see Fuse Inspection in the Electrical System chapter)
- ECU Fuse 15 A (see Fuse Inspection in the Electrical System chapter)
- ECU Main Relay (see Relay Circuit Inspection in the Electrical System chapter)
- Power Source Wiring (see wiring diagram in this section)

★If the fuse, wiring and relay are good, replace the ECU (see ECU Removal/Installation).

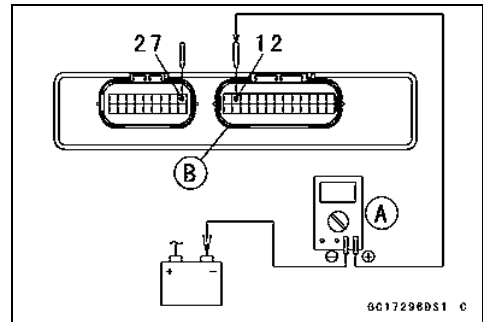

6C17296DS1 C

3-84 FUEL SYSTEM (DFI)

ECU

ECU Power Source Circuit

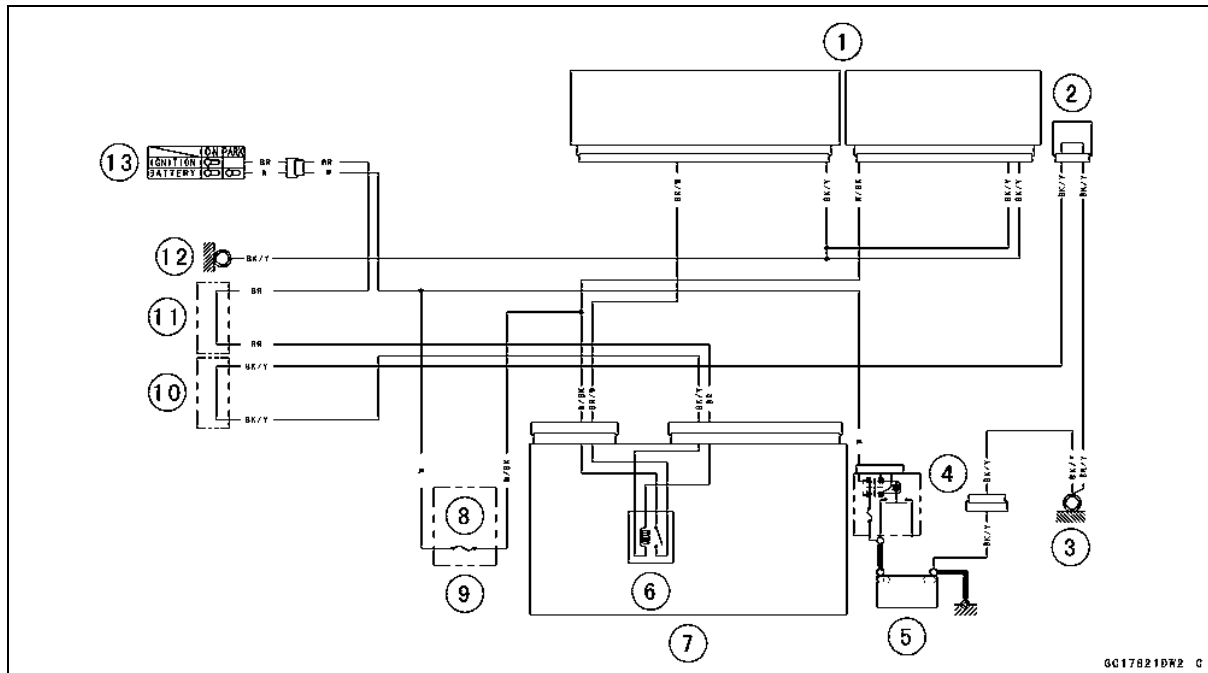

1. ECU
2. Joint Connector
3. Frame Ground
4. Main Fuse 30 A
5. Battery 12 V 10Ah
6. ECU Main Relay
7. Relay Box
8. ECU Main Fuse 15 A
9. Fuse Box
10. Water-proof Joint B
11. Water-proof Joint C
12. Frame Ground
13. Ignition Switch

DFI Power Source

ECU Fuse Removal

- Refer to the 15 A ECU Fuse Removal in the Electrical System chapter.

ECU Fuse Installation

- ★ If a fuse fails during operation, inspect the DFI system to determine the cause, and then replace it with a new fuse of proper amperage.
- Refer to the Fuse Installation in the Electrical System chapter.

ECU Fuse Inspection

- Refer to the Fuse Inspection in the Electrical System chapter.

ECU Main Relay Removal/Installation

- The ECU main relay is built in the relay box [A].
- Refer to the Relay Box Removal in the Electrical System chapter.



ECU Main Relay Inspection

- Refer to the Relay Circuit Inspection in the Electrical System chapter.

3-86 FUEL SYSTEM (DFI)

Fuel Line

Fuel Pressure Inspection

NOTE

○ Be sure the battery is fully charged.

- Remove:
 - Fuel Tank (see Fuel Tank Removal)
 - Fuel Hose (see Fuel Hose Replacement in the Periodic Maintenance chapter)
- Be sure to place a piece of cloth around the fuel supply pipes of the fuel pump and the throttle body assy.

⚠ WARNING

Be prepared for fuel spillage; any spilled fuel must be completely wiped up immediately. When the fuel hose is disconnected, fuel spills out from the hose and the pipe because of residual pressure. Cover the hose connection with a piece of clean cloth to prevent fuel spillage.

- Install the fuel pressure gauge adapter [A] and fuel hoses (Special Tool: 57001-1607) [B] between the fuel supply pipes of the fuel pump and throttle body assy.
- Secure the fuel hoses with the clamps.
- Connect the pressure gauge [C] to the fuel pressure gauge adapter.

Special Tools - Oil Pressure Gauge, 5 kgf/cm²: 57001-125
Fuel Pressure Gauge Adapter: 57001-1593
Fuel Hose: 57001-1607

⚠ WARNING

Do not try to start the engine with the fuel hoses disconnected.

- Connect the fuel pump lead connector.
- Turn the engine stop switch run position.
- Turn the ignition switch ON. The fuel pump will turn 3 seconds, and then stop.

NOTE

○ Turn the ignition switch ON and inspect the fuel line leakage after installing the special tools.

CAUTION

Do not drive the fuel pump 3 seconds or more without the fuel in the fuel tank. If the fuel pump is driven without the fuel, it may be damaged.

- Start the engine, and let it idle.
- Measure the fuel pressure with the engine idling.

Fuel Pressure (with Engine Idling)

Standard: 294 kPa (3.0 kgf/cm², 43 psi)

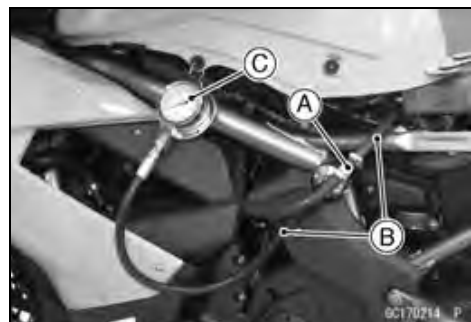

Fuel Line

NOTE

○The gauge needle will fluctuate. Read the pressure at the average of the maximum and minimum indications.

- Turn the ignition switch OFF.
- ★ If the fuel pressure is much higher than specified, the fuel pressure regulator in the fuel pump have been clogged or stuck. Replace the fuel pump (see Fuel Pump section).
- ★ If the fuel pressure is much lower than specified, check the following.
 - Fuel Line Leakage (see Fuel Injector Fuel Line Inspection)
 - Amount of Fuel Flow (see Fuel Flow Rate Inspection)
- After above checks, measure the fuel pressure again.
- Remove the fuel pressure gauge, hoses and adapter.
- Install:
 - Fuel Hose (see Fuel Hose Replacement in the Periodic Maintenance chapter)
 - Fuel Tank (see Fuel Tank Installation)
- Start the engine and check for fuel leakage.

Fuel Flow Rate Inspection

▲ WARNING

Gasoline is extremely flammable and can be explosive under certain conditions. Make sure the area is well-ventilated and free from any source of flame or sparks; this includes any appliance with a pilot light. Do not smoke. Turn the ignition switch OFF. Be prepared for fuel spillage; any spilled fuel must be completely wiped up immediately.

NOTE

○Be sure the battery is fully charged.

- Turn the ignition switch OFF.
- Wait until the engine cools down.
- Prepare a fuel hose (Special Tool: 57001-1607) and a measuring cylinder.

Special Tool - Fuel Hose: 57001-1607

- Remove:
 - Side Covers (see Side Cover Removal in the Frame chapter)
 - Fuel Tank Bolts (see Fuel Tank Removal)
- Open the fuel tank cap [A] to lower the pressure in the tank.
- Remove the fuel hose from the fuel pump (see Fuel Tank Removal).
- Be sure to place a piece of cloth around the fuel supply pipe of the fuel pump.

▲ WARNING

Be prepared for fuel spillage; any spilled fuel must be completely wiped up immediately. When the fuel hose is disconnected, fuel spills out from the hose and the pipe because of residual pressure. Cover the hose connection with a piece of clean cloth to prevent fuel spillage.



3-88 FUEL SYSTEM (DFI)

Fuel Line

- Connect the prepared fuel hose [A] to the fuel supply pipe of the fuel pump.
- Secure the fuel hose with a clamp.
- Insert the fuel hose into the measuring cylinder [B].

⚠ WARNING

Wipe off spilled out fuel immediately. Be sure to hold the measuring cylinder vertical.

- Close the fuel tank cap.
- Turn the engine stop switch to run position.
- Turn the ignition switch ON.
- The fuel pump should operate for 3 seconds, and then should stop.

CAUTION

Do not drive the fuel pump 3 seconds or more without the fuel in the fuel tank. If the fuel pump is driven without the fuel, it may be damaged.

- Measure the discharge for 3 seconds.
- Repeat this operation several times.

Amount of Fuel Flow

Standard: 60 mL (2.0 US oz.) or more for 3 seconds

- Turn the ignition switch OFF.
- ★ If the fuel flow is much less than the specified, replace the fuel pump (see Fuel Pump Removal/Installation).
- Install the fuel tank (see Fuel Tank Installation).
- Start the engine and check for fuel leakage.



Fuel Pump

Fuel Pump Removal

⚠ WARNING

Gasoline is extremely flammable and can be explosive under certain conditions. Make sure the area is well-ventilated and free from any source of flame or sparks; this includes any appliance with a pilot light. Do not smoke. Turn the ignition switch OFF. Disconnect the battery (-) terminal.

To make fuel spillage minimum, draw the fuel out from the fuel tank when the engine is cold. Be prepared for fuel spillage; any spilled fuel must be completely wiped up immediately.

CAUTION

Never drop the fuel pump, especially on a hard surface. Such a shock to the pump can damage it.

- Draw the fuel out from the fuel tank with a commercially available electric pump.
- Remove the fuel tank (see Fuel Tank Removal).
- Be careful of fuel spillage from the fuel tank since fuel still remains in the fuel tank and fuel pump. Plug the fuel supply pipe of the fuel pump.
- Turn the fuel tank upside down.
- Remove:
 - Fuel Pump Bolts [A]
 - Fuel Pump [B] and gasket
- Discard the fuel pump gasket.

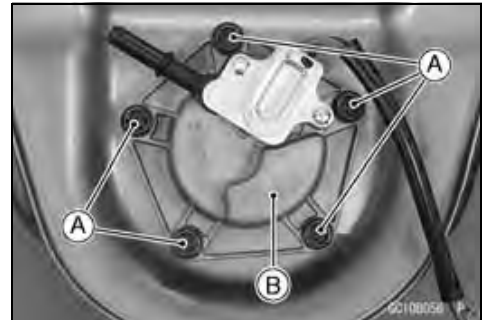

CAUTION

Do not pull the lead of the fuel pump. If they are pulled, the lead terminals may be damaged.

Fuel Pump Installation

- Remove dirt or dust from the fuel pump [A] by lightly applying compressed air.



3-90 FUEL SYSTEM (DFI)

Fuel Pump

- Replace the fuel pump gasket [A] with a new one.

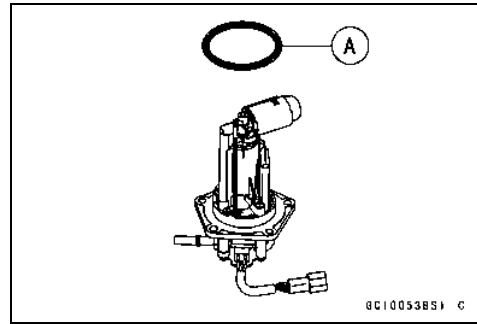

- Apply a non-permanent locking agent to the threads of the fuel pump bolts.
- Tighten the fuel pump bolts to a snug fit following the tightening sequence shown.

Front [A]

- Following the tightening sequence, tighten the fuel pump bolts to the specified torque.

Torque - Fuel Pump Bolts: 9.8 N·m (1.0 kgf·m, 87 in·lb)

- Tighten the fuel pump bolts again to check the tightness in the order shown.

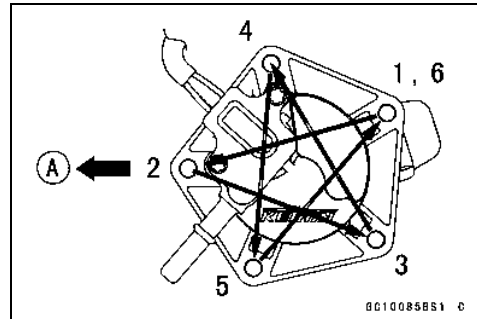

Fuel Pump Operation Inspection

NOTE

○ Be sure the battery is fully charged.

- Turn the engine stop switch to run position.
- Turn the ignition switch ON and make sure that the fuel pump operates (make light sounds) for 3 seconds, and then stops.
- Turn the ignition switch OFF.
- ★ If the pump does not operate as described above, inspect the operating voltage (see Fuel Pump Operating Voltage Inspection).

Fuel Pump

Fuel Pump Operating Voltage Inspection

NOTE

○ Be sure the battery is fully charged.

- Turn the ignition switch OFF.
- Remove the left side cover (see Side Cover Removal in the Frame chapter).
- Disconnect the fuel pump lead connector and connect the harness adapter [A] between these connectors as shown in the figure.

Main Harness [B]
Fuel Pump [C]

Special Tool - Measuring Adapter: 57001-1700

- Connect a digital meter [D] to the harness adapter leads.

Fuel Pump Operating Voltage

Connections to Adapter:

Digital Meter (+) → R (pump R) lead

Digital Meter (-) → BK (pump BK) lead

- Measure the operating voltage with engine stopped and with the connector joined.
- Turn the engine stop switch run position.
- Turn the ignition switch ON.

Operating Voltage

Standard: Battery Voltage for 3 seconds, and then 0 V

- Turn the ignition switch OFF.
- ★ If the reading stays on battery voltage and never shows 0 V, check the fuel pump relay (see Relay Circuit Inspection in the Electrical System chapter).
- ★ If the pump relay is normal, check the ECU for its ground and power supply (see ECU Power Supply Inspection).
- ★ If the ground and power supply are good, replace the ECU (see ECU Removal/Installation).
- ★ If there is still no battery voltage, check the ECU main relay and fuel pump relay (see Relay Circuit Inspection in the Electrical System chapter).
- ★ If the main relay and pump relay are normal, check the wiring for continuity (see wiring diagram in this section).
- ★ If the wiring is good, check the ECU for its ground and power supply (see ECU Power Supply Inspection).
- ★ If the ground and power supply are good, replace the ECU (see ECU Removal/Installation).
- ★ If the reading is in specification, but the pump does not operate, replace the fuel pump (see Fuel Pump Removal/Installation).

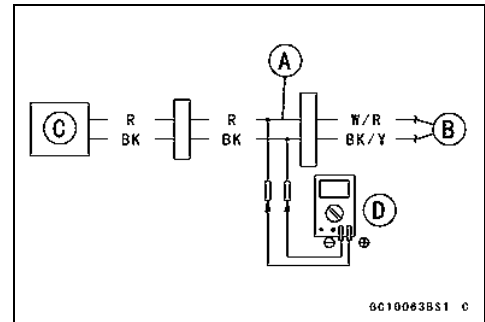

3-92 FUEL SYSTEM (DFI)

Fuel Pump

Pressure Regulator Removal

○The pressure regulator [A] is built into the fuel pump [B] and cannot be removed.

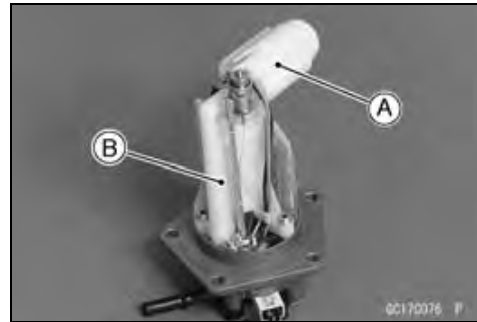

Pump Screen, Fuel Filter Cleaning

○The pump screen [A] and fuel filter [B] are built into the pump and cannot be cleaned or checked.

★If the pump screen or fuel filter is suspected of clogging or being damaged, replace it with the fuel pump as a set.

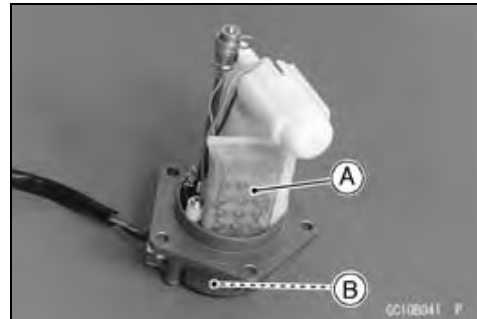

Fuel Pump

Fuel Pump Circuit

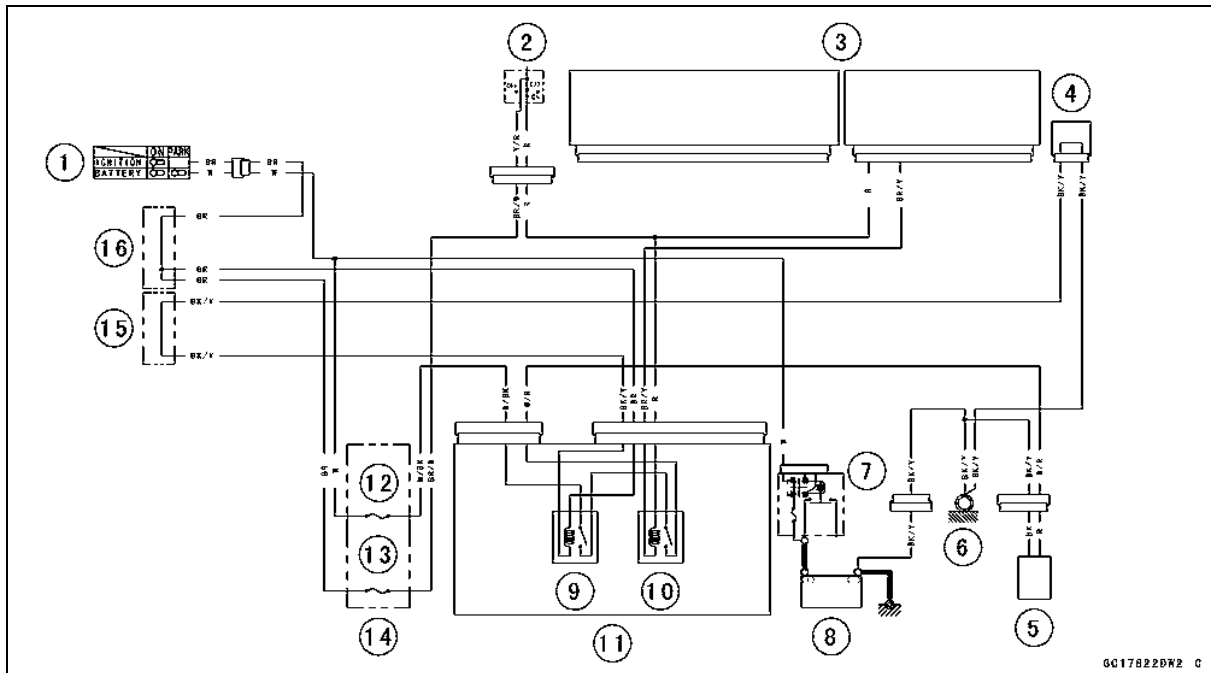

1. Ignition Switch
2. Engine Stop Switch
3. ECU
4. Joint Connector
5. Fuel Pump
6. Frame Ground
7. Main Fuse 30 A
8. Battery 12 V10 Ah
9. ECU Main Relay
10. Fuel Pump Relay
11. Relay Box
12. ECU Fuse 15 A
13. Ignition Fuse 10 A
14. Fuse Box
15. Water-proof Joint B
16. Water-proof Joint C

3-94 FUEL SYSTEM (DFI)

Fuel Injectors

Fuel Injector Removal/Installation

- Refer to the Throttle Body Assy Disassembly/Assembly.

Fuel Injector Audible Inspection

- Start the engine, and let it to idle.
- Apply the tip of a screwdriver [A] to the fuel injector [B]. Put the grip end onto your ear, and listen whether the fuel injector is clicking or not.
- A sound scope [C] can also be used.
- The click interval becomes shorter as the engine speed rises.
- Do the same for the other fuel injector.
- ★ If all the injectors click at a regular intervals, the injectors are normal.
- Turn the ignition switch OFF.
- ★ If any fuel injector does not click, check the fuel injector resistance (see Fuel Injector Resistance Inspection).

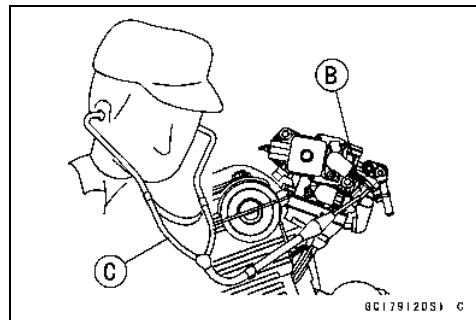
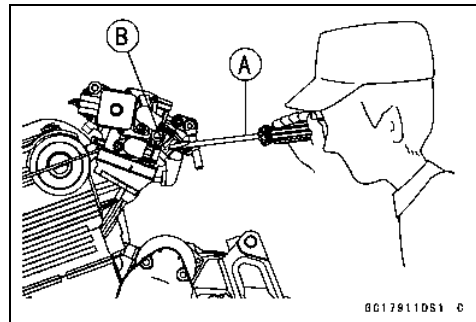

Fuel Injector Resistance Inspection

- Remove:
 - Air Cleaner Housing (see Air Cleaner Housing Removal)
- Disconnect the injector connector [A].
- Connect a digital meter [B] to the injector terminal.
- Measure the fuel injector resistance.

Fuel Injector Resistance

Connections:

For Fuel Injector #1

W/R ↔ BL/R Terminal

For Fuel Injector #2

W/R ↔ BL/G Terminal

Standard: About 11.7 ~ 12.3 Ω at 20°C (68°F)

- ★ If the reading is out of the standard, replace the injector.
- ★ If the reading is within the standard, check the power source voltage (see Fuel Injector Power Source Voltage Inspection).

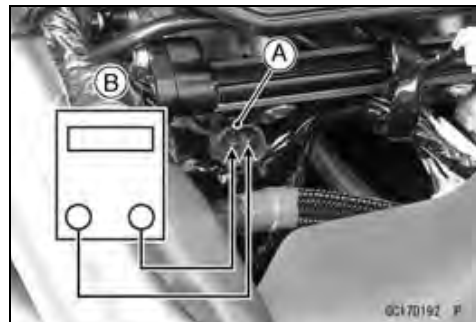

Fuel Injectors

Fuel Injector Power Source Voltage Inspection

NOTE

○ Be sure the battery is fully charged.

- Turn the ignition switch OFF.
- Disconnect the injector connector and connect the harness adapter [A] between these connectors as shown in the figure.

Main Harness [B]

Fuel Injector #1 [C]

Special Tool - Measuring Adapter: 57001-1700

- Connect a digital meter [D] to the harness adapter leads.

Fuel Injector Power Source Voltage

Connections to Adapter:

For Fuel Injector #1, #2

Digital Meter (+) → R (injector W/R) lead

Digital Meter (-) → Battery (-) terminal

- Measure the power source voltage with the engine stopped.
- Turn the engine stop switch to run position.
- Turn the ignition switch ON.

Power Source Voltage

Standard: Battery Voltage for 3 seconds, and then 0 V

- Turn the ignition switch OFF.
- ★ If the reading stays on battery voltage and never shows 0 V, check the fuel pump relay (see Relay Circuit Inspection in the Electrical System chapter).
- ★ If the pump relay is normal, check the ECU for its ground and power supply (see ECU Power Supply Inspection).
- ★ If the ground and power supply are good, replace the ECU (see ECU Removal/Installation).
- ★ If there is still no battery voltage, check the ECU main relay and pump relay (see Relay Circuit Inspection in the Electrical System chapter).
- ★ If the main relay and pump relay are normal, check the power source wiring (see wiring diagram in this section).
- ★ If the wiring is good, check the ECU for its ground and power supply (see ECU Power Supply Inspection).
- ★ If the ground and power supply are good, replace the ECU (see ECU Removal/Installation).
- ★ If the reading is in specification, check the output voltage (see Fuel Injector Output Voltage Inspection).

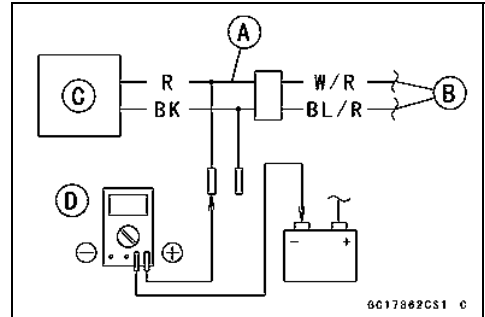

3-96 FUEL SYSTEM (DFI)

Fuel Injectors

Fuel Injector Output Voltage Inspection

NOTE

○ Be sure the battery is fully charged.

- Turn the ignition switch OFF.
- Remove the ECU (see ECU Removal).
- Do not disconnect the ECU connector.
- Connect a digital meter [A] to the connector [B] with the needle adapter set.

Special Tool - Needle Adapter Set: 57001-1457

Fuel Injector Output Voltage

Connections to ECU Connector:

For Fuel Injector #1

Digital Meter (+) → BL/R lead (ECU terminal 34)

Digital Meter (-) → Battery (-) terminal

For Fuel Injector #2

Digital Meter (+) → BL/G lead (ECU terminal 33)

Digital Meter (-) → Battery (-) terminal

- Measure the output voltage with the engine stopped and with the connector joined.
- Turn the engine stop switch to run position.
- Turn the ignition switch ON.

Output Voltage

Standard: Battery Voltage for 3 seconds, and then 0 V

- Turn the ignition switch OFF.
- ★ If the reading is in specification, check the ECU for its ground and power supply (see ECU Power Supply Inspection).
- ★ If the ground and power supply are good, replace the ECU (see ECU Removal/Installation).
- ★ If the reading is out of the specification, remove the ECU and check the wiring for continuity between main harness connectors.

Special Tool - Hand Tester: 57001-1394

- Disconnect the ECU and injector connectors.

Wiring Continuity Inspection

ECU Connector [A] ↔ Fuel Injector Connector [B]

For Fuel Injector #1 [C]

BL/R lead (ECU terminal 34) [D]

For Fuel Injector #2

BL/G lead (ECU terminal 33)

- ★ If the wiring is good, check the ECU for its ground and power supply (see ECU Power Supply Inspection).
- ★ If the ground and power supply are good, replace the ECU (see ECU Removal/Installation).

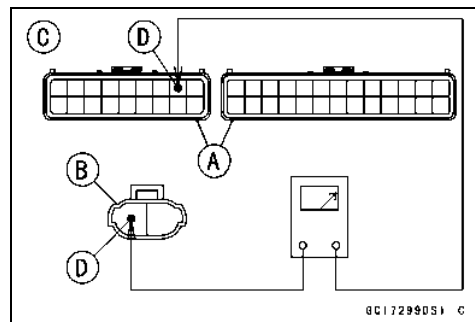
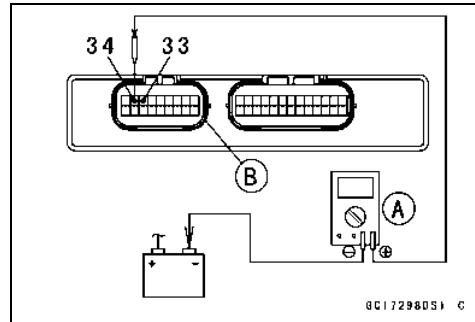

Fuel Injectors

Fuel Injector Fuel Line Inspection

- Remove:
 - Fuel Tank (see Fuel Tank Removal)
 - Fuel Hose (see Fuel Hose Replacement in the Periodic Maintenance chapter)
- Be sure to place a piece of cloth around the fuel supply pipes of the fuel pump and the throttle body assy.

▲ WARNING

Be prepared for fuel spillage; any spilled fuel must be completely wiped up immediately. When the fuel hose is disconnected, fuel spills out from the hose and the pipe because of residual pressure. Cover the hose connection with a piece of clean cloth to prevent fuel spillage.

- Check the injector fuel line for leakage as follows.
- Connect a commercially available vacuum/pressure pump [A] to the nipple of the delivery pipe [B] with a high-pressure fuel hose [C] (both ends connected with the clamps [D]) as shown.

Torque - Fuel Hose Clamp Screws: 1.5 N·m (0.15 kgf·m, 13 in·lb)

- Apply soap and water solution to the areas [E] as shown.
- Watching the pressure gauge, squeeze the pump lever [F], and build up the pressure until the pressure reaches the maximum pressure.

Injector Fuel Line Maximum Pressure
Standard: 294 kPa (3.0 kgf/cm², 43 psi)

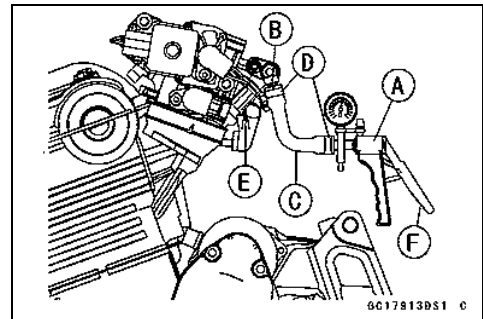

CAUTION

During pressure testing, do not exceed the maximum pressure for which the system is designed.

- Watch the gauge for at least 6 seconds.
- ★ If the pressure holds steady, the fuel line is good.
- ★ If the pressure drops at once or if bubbles are found in the area, the fuel line is leaking. Replace the fuel supply pipe assy, injectors and related parts.
- Repeat the leak test, and check the fuel line for no leakage.
- Install:
 - Fuel Hose (see Fuel Hose Replacement in the Periodic Maintenance chapter)
 - Fuel Tank (see Fuel Tank Installation)
- Start the engine and check for fuel leakage.

3-98 FUEL SYSTEM (DFI)

Fuel Injectors

Fuel Injector Circuit

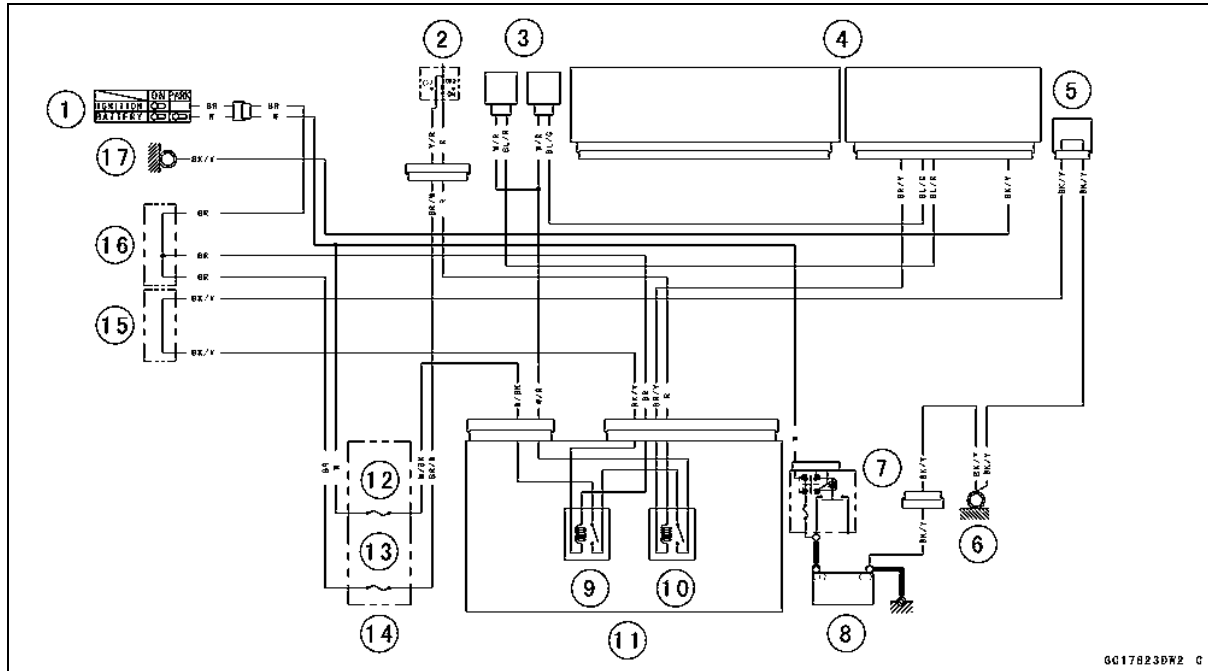

1. Ignition Switch
2. Engine Stop Switch
3. Fuel Injectors
4. ECU
5. Joint Connector
6. Frame Ground
7. Main Fuse 30 A
8. Battery 12 V10 Ah
9. ECU Main Relay
10. Fuel Pump Relay
11. Relay Box
12. ECU Fuse 15 A
13. Ignition Fuse 10 A
14. Fuse Box
15. Water-proof Joint B
16. Water-proof Joint C
17. Frame Ground

GC17823DW2 C

Throttle Grip and Cables

Throttle Grip Free Play Inspection

- Refer to the Throttle Control System Inspection in the Periodic Maintenance chapter.

Throttle Grip Free Play Adjustment

- Refer to the Throttle Control System Inspection in the Periodic Maintenance chapter.

Throttle Cable Installation

- Install the throttle cables in accordance with the Cable, Wire, and Hose Routing section in the Appendix chapter.
- Install the upper ends of the throttle cables in the grip after installing the lower ends of the throttle cables in the throttle pulley on the throttle body assy.
- After installation, adjust each cable properly (see Throttle Control System Inspection in the Periodic Maintenance chapter).

⚠ WARNING

Operation with incorrectly routed or improperly adjusted cables could result in an unsafe riding condition.

Throttle Cable Lubrication

- Refer to the Chassis Parts Lubrication in the Periodic Maintenance chapter.

3-100 FUEL SYSTEM (DFI)

Throttle Body Assy

Idle Speed Inspection/Adjustment

- Refer to the Idle Speed Inspection/Adjustment in the Periodic Maintenance chapter.

Synchronization Inspection/Adjustment

- Refer to the Engine Vacuum Synchronization Inspection in the Periodic Maintenance chapter.

Throttle Body Assy Removal

⚠ WARNING

Gasoline is extremely flammable and can be explosive under certain conditions. Turn the ignition switch OFF. Disconnect the battery (-) cable terminal. Do not smoke. Make sure the area is well-ventilated and free from any source of flame or sparks; this includes any appliance with a pilot light.

Be prepared for fuel spillage: any spilled fuel must be completely wiped up immediately.

CAUTION

Never drop the throttle body assy especially on a hard surface. Such a shock to the body assy can damage it.

- Remove:
 - Air Cleaner Housing (see Air Cleaner Housing Removal)
 - Fuel Hose (see Fuel Hose Replacement in the Periodic Maintenance chapter)
- Open the clamps [A].
- Disconnect the connectors [B].

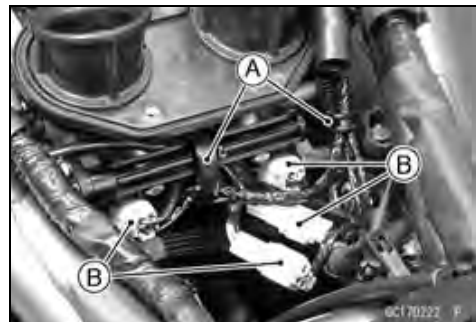

- Remove:
 - Left Upper Fairing Cover (see Upper Fairing Cover Removal in the Frame chapter)
 - Main Throttle Sensor Connector [A]
 - Vacuum Hose [B]



Throttle Body Assy

- Loosen the throttle body assy holder clamp bolts [A] on both sides.



- Remove the throttle case [A] to make a throttle cable slack.



- Free the idle adjusting screw [A] from the bracket.

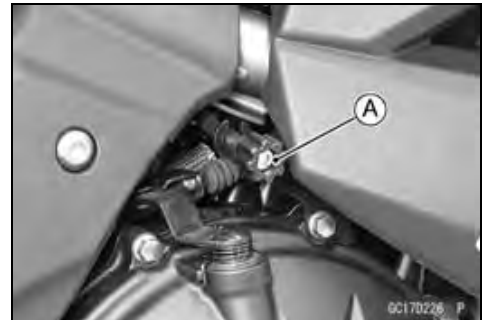

- Remove the right upper fairing cover (see Upper Fairing Cover Removal in the Frame chapter).
- Remove the throttle cable lower ends [A] from the throttle pulley.
- Pull off the throttle body assy from the holder.
- After removing the throttle body assy, stuff pieces of lint-free, clean cloths into the throttle body assy holders.



CAUTION

If dirt gets into the engine, excessive engine wear and possible engine damage will occur.

- ★ If the throttle body assy is to be disassembled, loosen the air cleaner duct clamp screws [A], and remove the air cleaner duct [B].

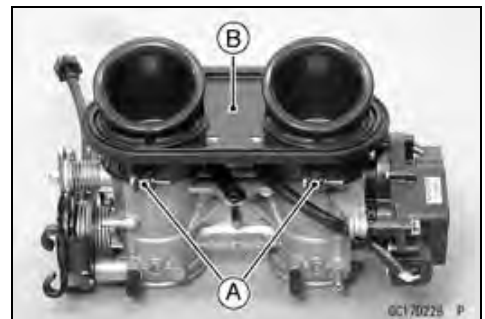

3-102 FUEL SYSTEM (DFI)

Throttle Body Assy

Throttle Body Assy Installation

- ★ If the air cleaner duct [A] was removed, install it.
- Install the duct clamp screws [B] in the direction as shown.
Bolt Heads [C]

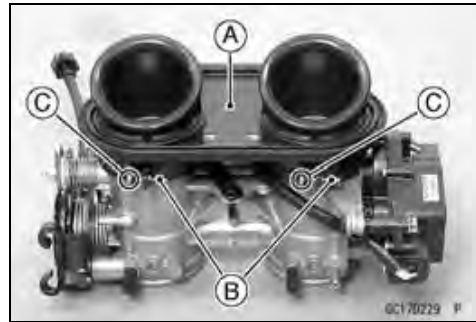

- Install the throttle body assy holder clamp bolts [A] in the direction as shown.
Bolt Heads [B]
- Route the leads and hoses according to Cable, Wire, and Hose Routing section in the Appendix chapter.

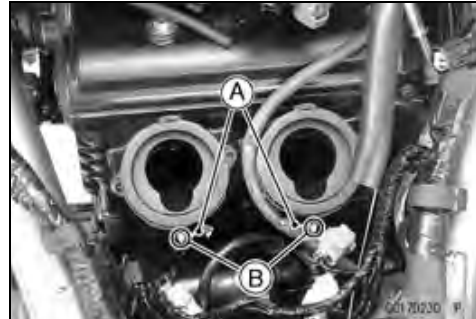

- Fit the accelerator cable end [A] and the decelerator cable end [B] into the throttle pulley.
- Check fuel leakage from the throttle body assy.

▲ WARNING

Fuel spilled from the throttle body assy is hazardous.

- Install the idle adjusting screw to the bracket.
- Install the right upper fairing cover (see Upper Fairing Cover Installation in the Frame chapter).
- Apply a thin coating of grease to the throttle cable upper ends.
- Install the upper ends [A] of the throttle cables in the grip.
- Fit the projection [B] of the right switch housing into the hole [C] of the handlebar.
- Turn the throttle grip and make sure that the throttle valves move smoothly and return by spring force.
- Check the throttle grip free play (see Throttle Control System Inspection in the Periodic Maintenance chapter).

▲ WARNING

Operation with an incorrectly routed cable could result in an unsafe riding condition.

- Adjust:
Throttle Grip Free Play (see Throttle Control System Inspection in the Periodic Maintenance chapter)
Idle Speed (see Idle Speed Adjustment in the Periodic Maintenance chapter)

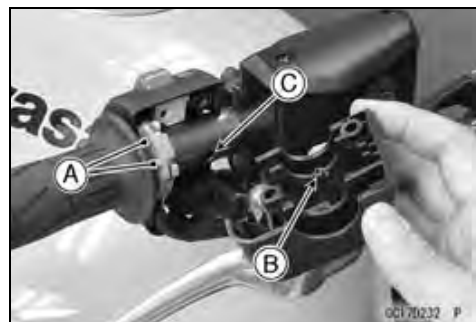

Throttle Body Assy

Throttle Body Assy Disassembly

CAUTION

Do not remove, disassemble or adjust the main throttle sensor [A], subthrottle sensor [B], subthrottle valve actuator [C], throttle link mechanism [D] and throttle body assy [E], because they are adjusted or set at the manufacturer. Adjustment of these parts could result in poor performance, requiring replacement of the throttle body assy.

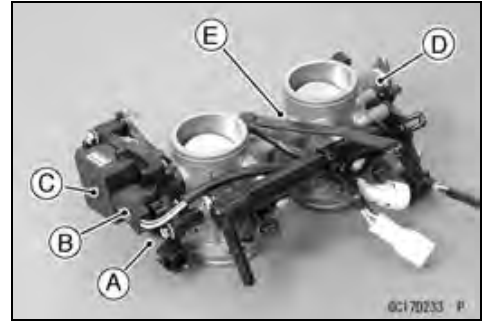

CAUTION

Never drop the throttle body assy, especially on a hard surface. Such a shock to the body assy can damage it.

- Remove:
 - Throttle Body Assy (see Throttle Body Assy Removal)
 - Screws [A]
 - Delivery Pipe [B]
 - Fuel Injectors [C]

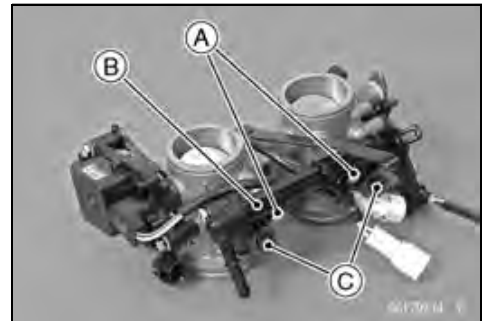

Throttle Body Assy Assembly

- Replace the O-rings [A] and seals [B] with the new ones.
- Before assembling, blow away dirt or dust from the throttle body and delivery pipe by applying compressed air.
- Apply engine oil to the new O-rings of each injector [C], insert them into the delivery pipe and confirm whether the injectors turn smoothly or not.
- Install the injectors along with the delivery pipe assy into the throttle bodies.
- Install the throttle body assy (see Throttle Body Assy Installation).



3-104 FUEL SYSTEM (DFI)

Air Cleaner

Air Cleaner Element Removal/Installation

- Refer to the Air Cleaner Element Replacement in the Periodic Maintenance chapter.

Air Cleaner Element Inspection

- Remove the air cleaner element (see Air Cleaner Element Replacement in the Periodic Maintenance chapter).
- Visually inspect the element [A] for tears or breaks.
- ★ If the element has any tears or breaks, replace the element with a new one.



Air Cleaner Oil Draining

A drain hose is connected to the bottom of the air cleaner to drain water or oil accumulated in the cleaner part.

- Visually inspect the drain hose [A] for accumulation of water or oil.
- ★ If any water or oil accumulates in the hose, remove the plug [B] from the drain hose and drain it.

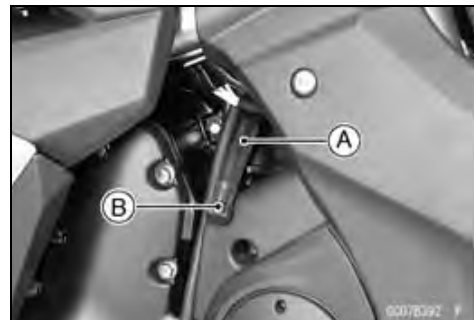

⚠ WARNING

Be sure to reinstall the plug in the drain hose after draining. Oil on tires will make them slippery and can cause an accident and injury.

Air Cleaner Housing Removal

- Remove:
 - Air Switching Valve (see Air Switching Valve Removal in the Engine Top End chapter)
 - Inlet Air Temperature Sensor Connector [A]
 - Screws [B]
 - Cover [C]
- Remove the left upper fairing cover (see Upper Fairing Cover Removal in the Frame chapter).
- Disconnect the breather hose [A] on the upper crankcase.

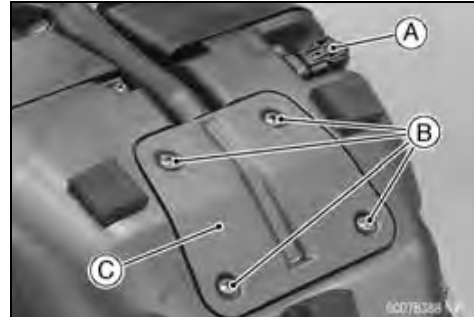

Air Cleaner

- Unscrew the bolts [A] and remove the air cleaner housing [B].

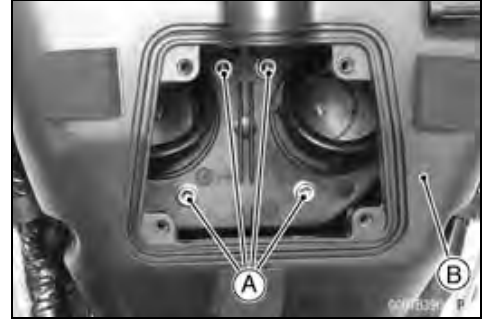

Air Cleaner Housing Installation

- Install the clamp on the breather hose [A] as shown in the figure.
 Pinch Heads [B]
 Viewed from Top [C]
 Front [D]

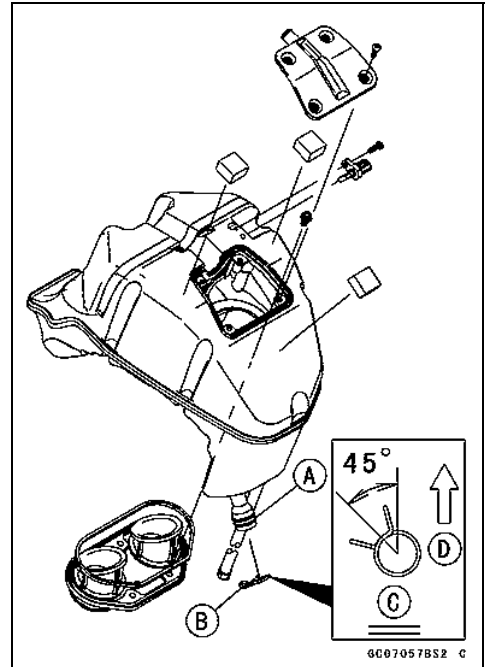

- Insert the breather hose [A] into the crankcase as shown in the figure.
 0 ~ 5 mm (0.0 ~ 0.2 in.) [B]



3-106 FUEL SYSTEM (DFI)

Fuel Tank

Fuel Tank Removal

⚠ WARNING

Gasoline is extremely flammable and can be explosive under certain conditions. Make sure the area is well-ventilated and free from any source of flame or sparks; this includes any appliance with a pilot light. Do not smoke. Turn the ignition switch OFF and disconnect the battery (-) terminal.

To avoid fire, do not remove the fuel tank when the engine is still hot. Wait until it cools down.

To make fuel spillage minimum, draw the fuel out from the fuel tank when the engine is cold.

Be prepared for fuel spillage; any spilled fuel must be completely wiped up immediately.

- Turn the ignition switch and engine stop switch OFF.
- Wait until the engine cools down.
- Open the fuel tank cap [A] to lower the pressure in the tank.
- During tank removal, keep the tank cap open to release pressure in the tank. This makes fuel spillage less.



- Remove:
 - Side Covers (see Side Cover Removal in the Frame chapter)
 - Fuel Tank Bolts [A]



- Draw the fuel out from the fuel tank with a commercially available pump [A].
 - Use a soft plastic hose [B] as a pump inlet hose in order to insert the hose smoothly.
 - Put the hose through the fill opening [C] into the tank and draw the fuel out.
- Front [D]

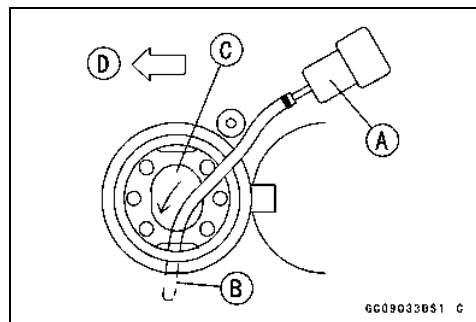

⚠ WARNING

The fuel could not be removed completely from the fuel tank. Be careful for remained fuel spillage.

Fuel Tank

- Disconnect:
 - Fuel Pump Lead Connector [A]
 - Fuel Level Sensor Lead Connector [B]
- Remove the fuel tank breather hose and the fuel drain hose from the fuel tank.

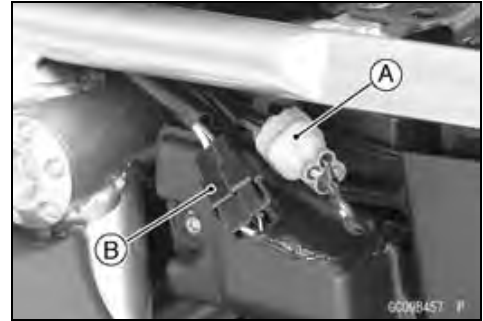

- Be sure to place a piece of cloth around the fuel hose joint.
- Insert a minus screwdriver [A] into the slit [B] on the joint lock.

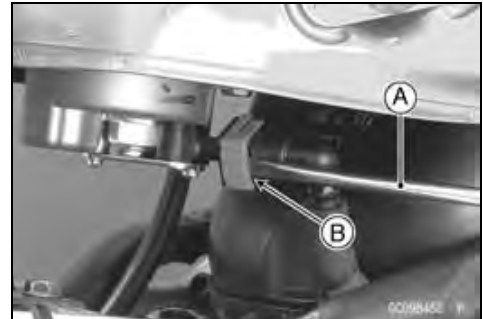

- Turn the driver [A] to disconnect the joint lock [B].
- Pull [C] the fuel hose joint [D] out of the outlet pipe.

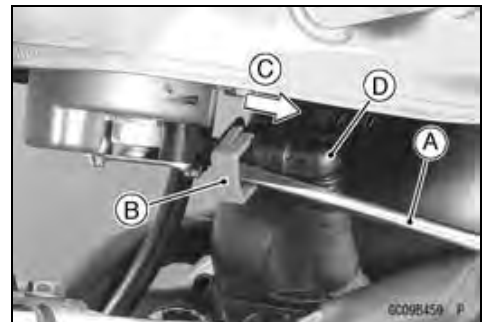

CAUTION
<p>When removing the fuel hose joint, do not apply strong force to the outlet pipe on the fuel pump. The pipe made from resin could be damaged.</p>

⚠ WARNING
<p>Be prepared for fuel spillage; any spilled fuel must be completely wiped up immediately. When the fuel hose is disconnected, fuel spills out from the hose and the pipe because of residual pressure. Cover the hose connection with a piece of clean cloth to prevent fuel spillage.</p>

- Close the fuel tank cap.
- Remove the fuel tank [A], and place it on planks [B].
- Do not apply the load to the fuel pump outlet portion [C] especially the outlet pipe made from resin.



3-108 FUEL SYSTEM (DFI)

Fuel Tank

Fuel Tank Installation

- Note the WARNING on the previous page (see Fuel Tank Removal).
- Route the hoses correctly (see Cable, Wire, and Hose Routing section in the Appendix chapter).
- Check that the rubber dampers [A] are on the frame and the fuel tank.
- ★ If the dampers are damaged or deteriorated, replace them.

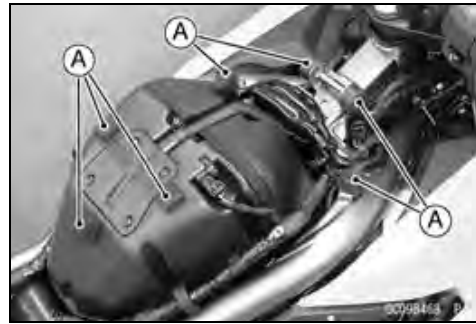

- Install the trim [A] on the fuel tank.
- Align the trim end [A] with the hollow [B] of the fuel tank as shown in the figure.

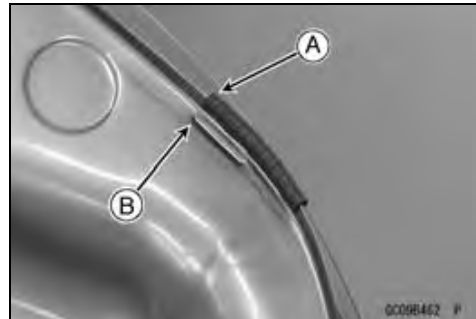

- Insert [A] the fuel hose joint [B] straight onto the delivery pipe until the hose joint clicks.

CAUTION

When installing the fuel hose joint, do not apply strong force to the outlet pipe on the fuel pump. The pipe made from resin could be damaged.

- Push the joint lock [C] until it clicks.
- Push and pull [A] the hose joint [B] back and forth more than two times and make sure it is locked and does not come off.

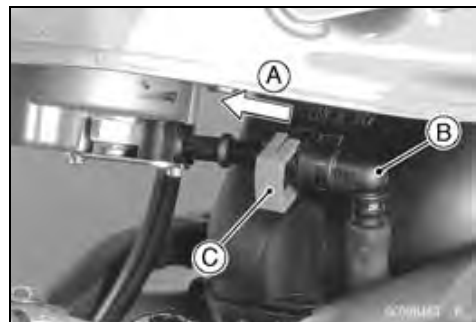

⚠ WARNING

Make sure the hose joint is installed correctly on the delivery pipe by sliding the joint, or the fuel could leak.

- ★ If it comes off, reinstall the hose joint.
- Connect the fuel pump lead, the fuel level sensor lead connectors and the battery (-) cable terminal.

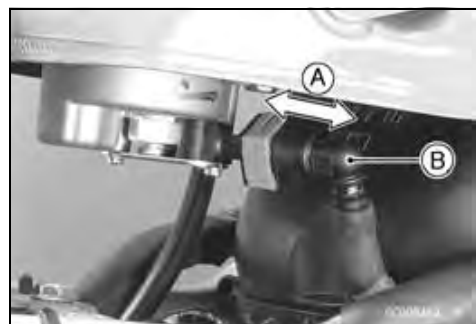

Fuel Tank

Fuel Tank and Cap Inspection

- Visually inspect the gasket [A] on the tank cap for any damage.
- ★ Replace the gasket if it is damaged.
- Check to see if the water drain pipe [B] and fuel breather pipe [C] in the tank is not clogged. Check the tank cap breather also.
- ★ If they are clogged, remove the tank and drain it, and then blow the breather free with compressed air.



CAUTION

Do not apply compressed air to the air vent holes [D] in the tank cap. This could cause damage and clogging of the labyrinth in the cap.

Fuel Tank Cleaning

⚠ WARNING

Clean the tank in a well-ventilated area, and take care that there are no sparks or flame anywhere near the working area. Because of the danger or highly flammable liquids, do not use gasoline or low-flash point solvents to clean the tank.

- Remove:
 - Fuel Pump (see Fuel Pump Removal)
- Pour some high-flash point solvent into the fuel tank and shake the tank to remove dirt and fuel deposits.
- Draw the solvent out of the fuel tank.
- Dry the tank with compressed air.
- Install:
 - Fuel Pump (see Fuel Pump Installation)
 - Fuel Tank (see Fuel Tank Installation)

3-110 FUEL SYSTEM (DFI)

Evaporative Emission Control System (CAL and SEA Models)

The Evaporative Emission Control System routes fuel vapors from the fuel system into the running engine or stores the vapors in a canister when the engine is stopped. Although no adjustments are required, a thorough visual inspection must be made at the intervals specified by the Periodic Maintenance Chart.

Parts Removal/Installation

⚠ WARNING

Gasoline is extremely flammable and can be explosive under certain conditions. Make sure the area is well-ventilated and free from any source of flame or sparks; this includes any appliance with a pilot light. Do not smoke. Turn the ignition switch OFF.

CAUTION

If gasoline, solvent, water or any other liquid enters the canister, the canister's vapor absorbing capacity is greatly reduced. If the canister does become contaminated, replace it with a new one.

- To prevent the gasoline from flowing into or out of the canister, hold the separator perpendicular to the ground.
- Connect the hoses according to the diagram of the system (see Cable, Wire, and Hose Routing section in the Appendix chapter). Make sure they do not get pinched or kinked.

Hose Inspection

- Refer to the Evaporative Emission Control System Inspection in the Periodic Maintenance chapter.

Separator Inspection

- Refer to the Evaporative Emission Control System Inspection in the Periodic Maintenance chapter.

Evaporative Emission Control System (CAL and SEA Models)

Separator Operation Test**⚠ WARNING**

Gasoline is extremely flammable and can be explosive under certain conditions. Do not smoke. Turn the ignition switch OFF. Make sure the area is well-ventilated and free from any source of flame or sparks; this includes any appliance with a pilot light.

- Connect the hoses to the separator, and install the separator on the motorcycle.
- Disconnect the breather hose from the separator, and inject about 20 mL (0.68 US oz.) of gasoline [A] into the separator [B] through the hose fitting.
- Disconnect the fuel return hose [C] from the fuel tank [D].
- Run the open end of the return hose into the container and hold it level with the tank top [E].
- Start the engine, and let it idle.
- ★ If the gasoline in the separator comes out of the hose, the separator works well. If it does not, replace the separator with a new one.

Canister Inspection

- Refer to the Evaporative Emission Control System Inspection in the Periodic Maintenance chapter.

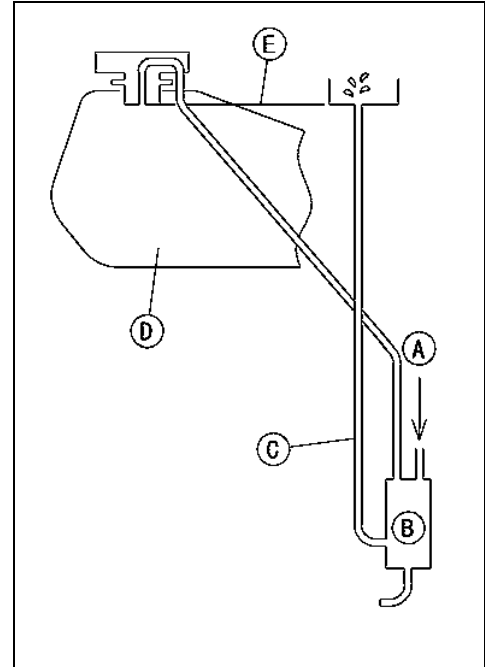

Cooling System

Table of Contents

Exploded View.....	4-2
Coolant Flow Chart.....	4-4
Specifications	4-6
Special Tools	4-7
Coolant	4-8
Coolant Deterioration Inspection.....	4-8
Coolant Level Inspection.....	4-8
Coolant Draining	4-8
Coolant Filling	4-8
Pressure Testing	4-8
Cooling System Flushing	4-9
Coolant Reserve Tank Removal/Installation	4-9
Water Pump.....	4-10
Water Pump Removal.....	4-10
Water Pump Installation.....	4-10
Mechanical Seal Inspection	4-11
Water Pump Housing Disassembly	4-11
Water Pump Housing Assembly	4-12
Impeller Assembly.....	4-12
Pump Impeller Inspection	4-12
Radiator.....	4-13
Radiator and Radiator Fan Removal	4-13
Radiator and Radiator Fan Installation	4-14
Radiator Inspection	4-15
Radiator Cap Inspection	4-15
Radiator Filler Neck Inspection	4-16
Thermostat	4-17
Thermostat Removal.....	4-17
Thermostat Installation.....	4-17
Thermostat Inspection	4-18
Hose and Pipes	4-19
Hose Installation	4-19
Hose Inspection	4-19
Water Temperature Sensor	4-20
Water Temperature Sensor Removal/Installation	4-20
Water Temperature Sensor Inspection	4-20

4-2 COOLING SYSTEM

Exploded View

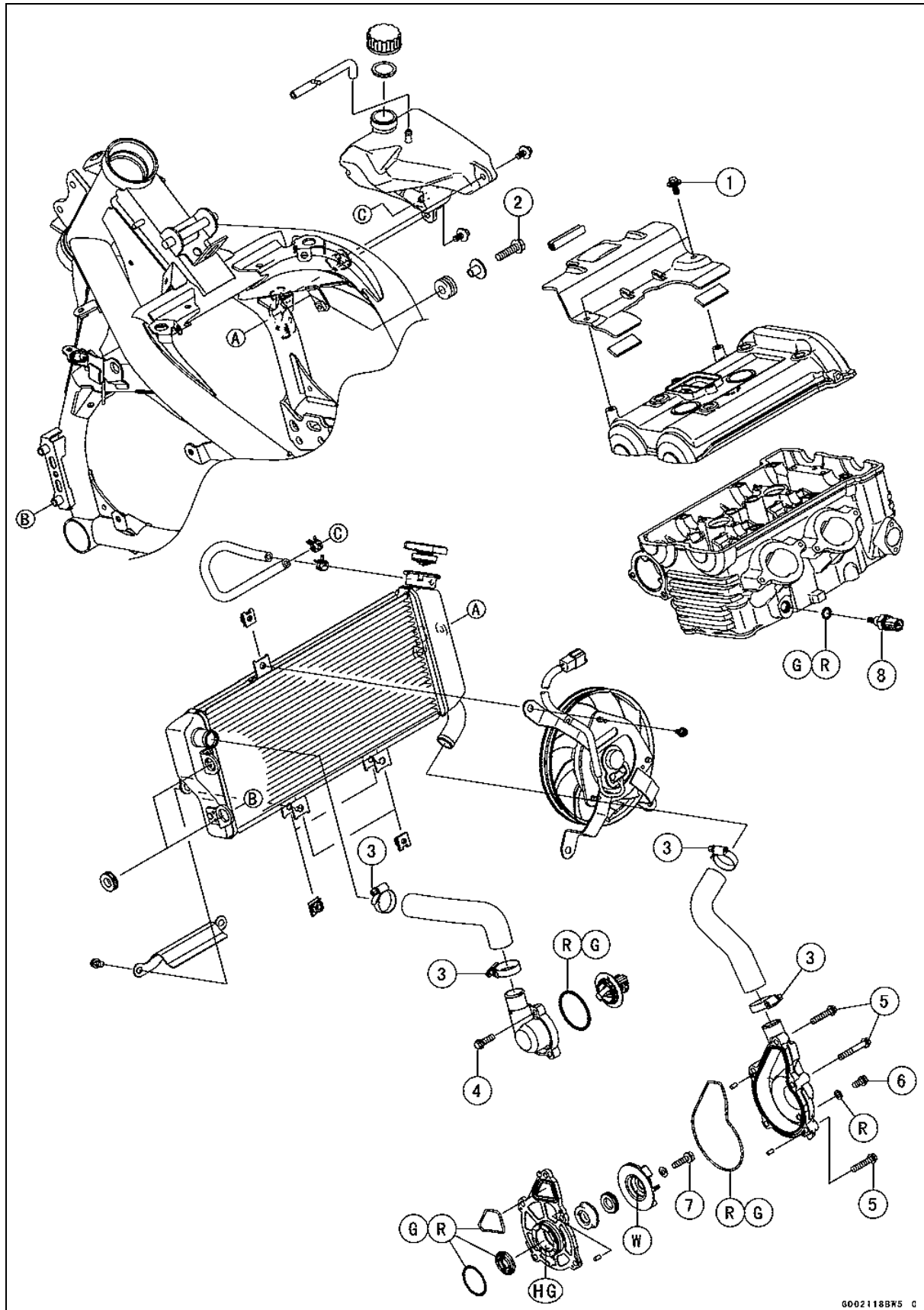

Exploded View

No.	Fastener	Torque			Remarks
		N·m	kgf·m	ft·lb	
1	Baffle Plate Bolts	5.9	0.60	52 in·lb	
2	Radiator Bolt	15	1.5	11	
3	Water Hose Clamp Screws	2.0	0.20	18 in·lb	
4	Thermostat Housing Bolts	9.8	1.0	87 in·lb	
5	Water Pump Cover Bolts	9.8	1.0	87 in·lb	
6	Water Pump Drain Bolt	9.8	1.0	87 in·lb	
7	Water Pump Impeller Bolt	9.8	1.0	87 in·lb	
8	Water Temperature Sensor	12	1.2	106 in·lb	

G: Apply grease.

HG: Apply high-temperature grease.

R: Replacement Parts

W: Apply water.

4-4 COOLING SYSTEM

Coolant Flow Chart

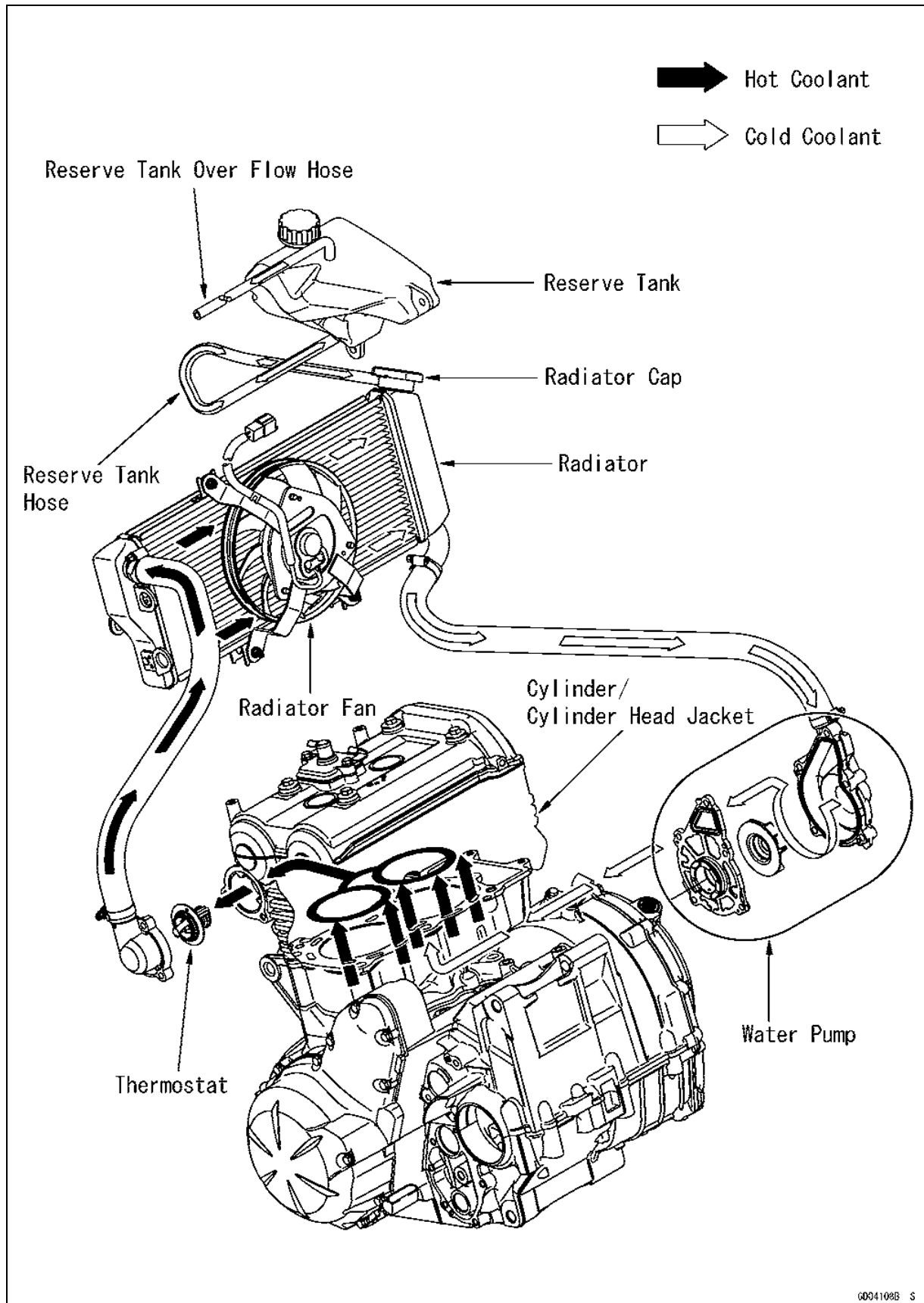

Coolant Flow Chart

Permanent type antifreeze is used as a coolant to protect the cooling system from rust and corrosion. When the engine starts, the water pump turns and the coolant circulates.

The thermostat is a wax pellet type which opens or closes with coolant temperature changes. The thermostat continuously changes its valve opening to keep the coolant temperature at the proper level. When coolant temperature is below 80.5 ~ 83.5°C (177 ~ 182°F), the thermostat closes so that the coolant flow is restricted through the air bleeder hole, causing the engine to warm up more quickly. When coolant temperature is more than 80.5 ~ 83.5°C, the thermostat opens and the coolant flows.

When the coolant temperature goes up beyond 104°C (219°F), the radiator fan relay conducts to operate the radiator fan. The radiator fan draws air through the radiator core when there is not sufficient air flow such as at low speeds. This increases up the cooling action of the radiator. When the temperature is below 99°C (210°F), the fan relay opens and the radiator fan stops.

In this way, this system controls the engine temperature within narrow limits where the engine operates most efficiently even if the engine load varies.

The system is pressurized by the radiator cap to suppress boiling and the resultant air bubbles which can cause engine overheating. As the engine warms up, the coolant in the radiator and the water jacket expands. The excess coolant flows through the radiator cap and hose to the reserve tank to be stored there temporarily. Conversely, as the engine cools down, the coolant in the radiator and the water jacket contracts, and the stored coolant flows back to the radiator from the reserve tank.

The radiator cap has two valves. One is a pressure valve which holds the pressure in the system when the engine is running. When the pressure exceeds 112.3 ~ 141.7 kPa (1.15 ~ 1.45 kgf/cm², 16.3 ~ 20.5 psi), the pressure valve opens and releases the pressure to the reserve tank. As soon as pressure escapes, the valve closes, and keeps the pressure at 112.3 ~ 141.7 kPa (1.15 ~ 1.45 kgf/cm², 16.3 ~ 20.5 psi). When the engine cools down, another small valve (vacuum valve) in the cap opens. As the coolant cools, the coolant contracts to form a vacuum in the system. The vacuum valve opens and allows the coolant from the reserve tank to enter the radiator.

4-6 COOLING SYSTEM

Specifications

Item	Standard
Coolant Provided when Shipping Type (Recommended) Color Mixed Ratio Freezing Point Total Amount	Permanent type of antifreeze (soft water and ethylene glycol plus corrosion and rust inhibitor chemicals for aluminum engines and radiators) Green Soft water 50%, coolant 50% -35°C (-31°F) 1.2 L (1.3 US qt) (reserve tank full level, including radiator and engine)
Radiator Cap Relief Pressure	112.3 ~ 141.7 kPa (1.15 ~ 1.45 kgf/cm ² , 16.3 ~ 20.5 psi)
Thermostat Valve Opening Temperature Valve Full Opening Lift	80.5 ~ 83.5°C (177 ~ 182°F) 8 mm (0.31 in.) or more at 95°C (203°F)

Special Tools

**Bearing Driver Set:
57001-1129**

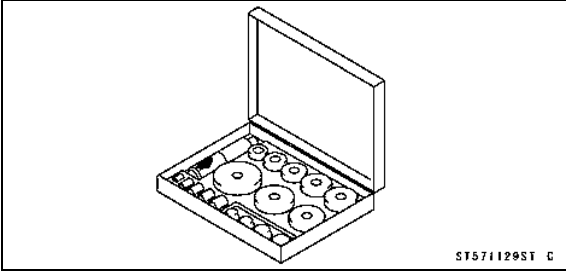

**Oil Seal Driver:
57001-1660**

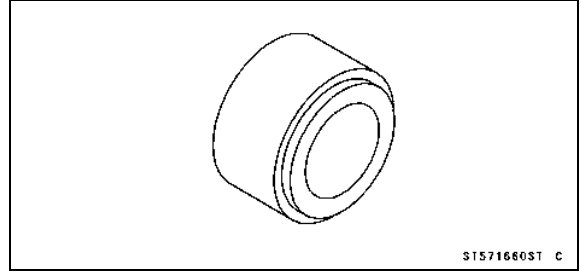

4-8 COOLING SYSTEM

Coolant

Coolant Deterioration Inspection

- Remove the upper fairing (see Upper Fairing Removal in the Frame chapter).
- Visually inspect the coolant [A] in the reserve tank.
- ★ If whitish cotton-like wafts are observed, aluminum parts in the cooling system are corroded. If the coolant is brown, iron or steel parts are rusting. In either case, flush the cooling system.
- ★ If the coolant gives off an abnormal smell, check for a cooling system leak. It may be caused by exhaust gas leaking into the cooling system.

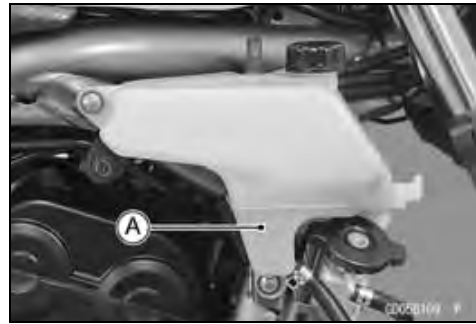

Coolant Level Inspection

- Refer to the Coolant Level Inspection in the Periodic Maintenance chapter.

Coolant Draining

- Refer to the Coolant Change in the Periodic Maintenance chapter.

Coolant Filling

- Refer to the Coolant Change in the Periodic Maintenance chapter.

Pressure Testing

- Remove the radiator cap (see Coolant Change in the Periodic Maintenance chapter), and install a cooling system pressure tester [A] on the filler neck [B].

NOTE

○ Wet the cap sealing surfaces with water or coolant to prevent pressure leaks.

- Build up pressure in the system carefully until the pressure reaches 141.7 kPa (1.45 kgf/cm², 20.5 psi).

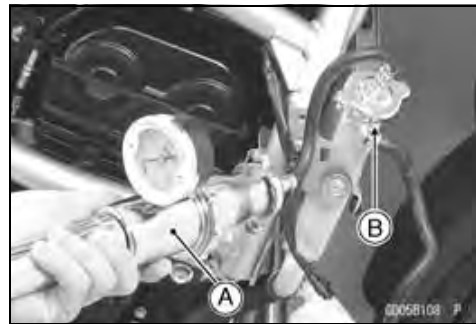

CAUTION

During pressure testing, do not exceed the pressure for which the system is designed. The maximum pressure is 141.7 kPa (1.45 kgf/cm², 20.5 psi).

- Watch the gauge for at least 6 seconds.
- ★ If the pressure holds steady, the system is all right.
- ★ If the pressure drops and no external source is found, check for internal leaks. Droplets in the engine oil indicate internal leakage. Check the cylinder head gasket and the water pump.
- Remove the pressure tester, replenish the coolant, and install the radiator cap.

Coolant

Cooling System Flushing

Over a period of time, the cooling system accumulates rust, scale, and lime in the water jacket and radiator. When this accumulation is suspected or observed, flush the cooling system. If this accumulation is not removed, it will clog up the water passage and considerably reduce the efficiency of the cooling system.

- Drain the cooling system (see Coolant Change in the Periodic Maintenance chapter).
- Fill the cooling system with fresh water mixed with a flushing compound.

CAUTION
<p>Do not use a flushing compound which is harmful to the aluminum engine and radiator. Carefully follow the instructions supplied by the manufacturer of the cleaning product.</p>

- Warm up the engine, and run it at normal operating temperature for about ten minutes.
- Stop the engine, and drain the cooling system.
- Fill the system with fresh water.
- Warm up the engine and drain the system.
- Repeat the previous two steps once more.
- Fill the system with a permanent type coolant and bleed the air from the system (see Coolant Change in the Periodic Maintenance chapter).

Coolant Reserve Tank Removal/Installation

- The coolant reserve tank is removed and installed during coolant change (see Coolant Change in the Periodic Maintenance chapter).

4-10 COOLING SYSTEM

Water Pump

Water Pump Removal

- Drain the coolant (see Coolant Change in the Periodic Maintenance chapter).
- Remove:
 - Water Hose [A]
 - Water Pump Cover Bolts [B]
 - Water Pump Cover [C]

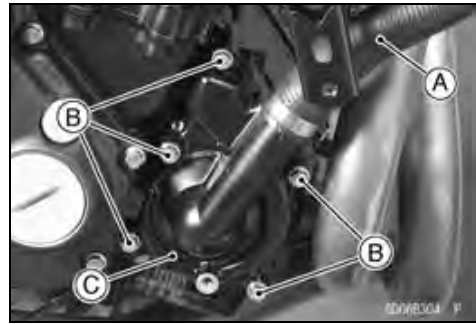

- Shift the transmission into 1st gear.
- While applying the rear brake, remove the water pump impeller bolt [A].
- Remove:
 - Impeller [B]
 - Water Pump Housing [C]



Water Pump Installation

- Replace the water pump housing oil seal with a new one.
 - Press in the oil seal until it is bottomed.
 - Apply high-temperature grease to the outer circumference of the oil seal.
- Replace the O-rings [A] on the water pump housing with new ones.
- Apply grease to the O-rings and the lips of the oil seal [B].

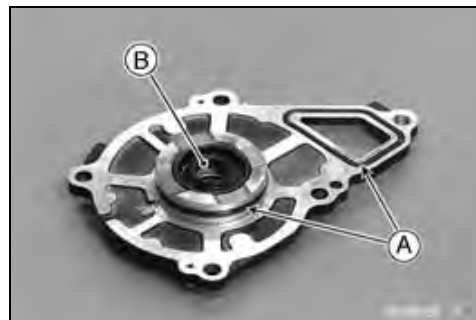

- Be sure that the dowel pin [A] is in position.
- Install the water pump housing.
- Install the impeller.
 - Apply water to the inside of the mechanical seal.
- When installing the water pump impeller bolt, shift the transmission into 1st gear and apply the rear brake.
- Tighten:
 - Torque - Water Pump Impeller Bolt: 9.8 N·m (1.0 kgf·m, 87 in·lb)**



- Replace the O-ring [A] on the water pump cover with a new one and apply grease to it.



Water Pump

- Install the two dowel pins [A].
- Install the water pump cover.
- Tighten:
 - Torque - Water Pump Cover Bolts: 9.8 N·m (1.0 kgf·m, 87 in·lb)**



- Align the line [A] of the water pump cover and the white paint mark [B] of the water hose.
- Install the water hose clamp [C] so that the screw head faces the front.
- Tighten:
 - Torque - Water Hose Clamp Screws: 2.0 N·m (0.20 kgf·m, 18 in·lb)**
- Fill the radiator with the coolant (see Coolant Change in the Periodic Maintenance chapter).



Mechanical Seal Inspection

- Remove the impeller (see Water Pump Removal).
- Visually inspect the mechanical seal.
- ★ If any one of the parts is damaged, replace the mechanical seal as a unit.
- The sealing seat and rubber seal may be removed easily by hand.
 - Impeller Sealing Seat Surface [A]
 - Rubber Seal [B]
 - Mechanical Seal Diaphragm [C]

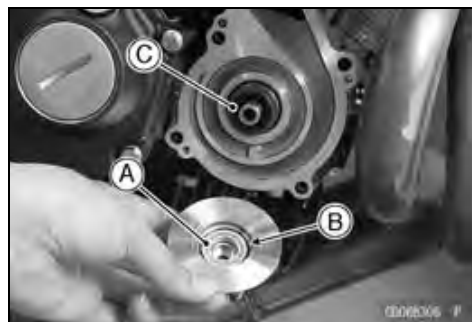

Water Pump Housing Disassembly

CAUTION
Be careful not to damage the sealing surface of the mechanical seal.

- Remove the water pump housing (see Water Pump Removal).
- Take the oil seal [A] out of the housing [B] with a hook [C].

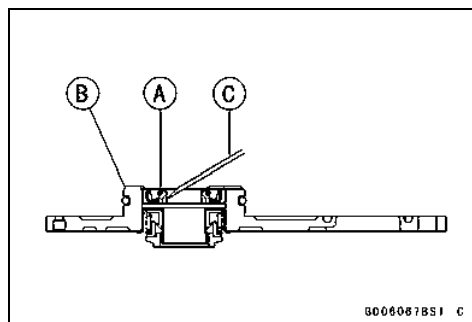

- Press the mechanical seal [A] out of the housing with a bearing driver [B].
- Special Tool - Bearing Driver Set: 57001-1129**

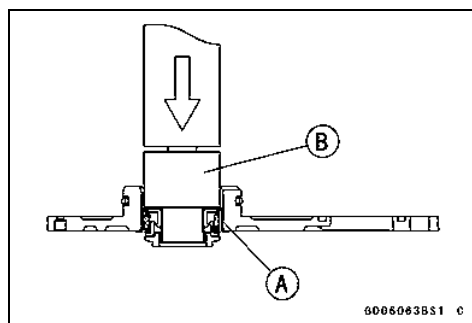

4-12 COOLING SYSTEM

Water Pump

Water Pump Housing Assembly

- Apply grease [A] to the new oil seal [B].
- Press the oil seal into the housing with a bearing driver so that the seal surface is flush [C] with the end of the hole.
- Apply high-temperature grease to the outer circumference [D] of the oil seal so that it will go into place smoothly.
- Press the new mechanical seal into the housing with the oil seal driver [E] until its flange [F] touches the surface [G] of the housing.

Special Tool - Oil Seal Driver: 57001-1660

Impeller Assembly

- Clean the sliding surface of the mechanical seal with a high-flash point solvent, and apply a little coolant to the sliding surface to give the mechanical seal initial lubrication.
- Apply coolant to the surfaces of the rubber seal [A] and sealing seat [B], and install the rubber seal and sealing seat into the impeller by pressing them by hand until the seat stops at the bottom of the hole.

Pump Impeller Inspection

- Remove the water pump cover (see Water Pump Removal).
- Visually check the impeller [A].
- ★ If the surface is corroded, or if the blades are damaged, replace the impeller (see Water Pump Removal).

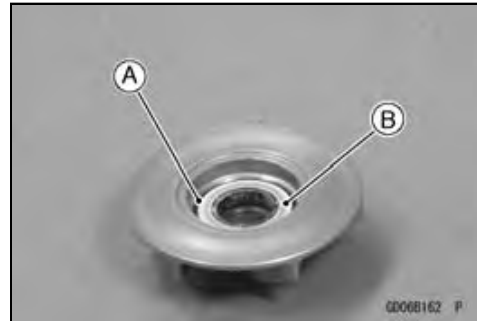
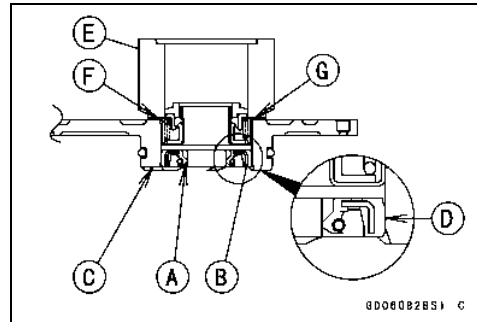

Radiator

Radiator and Radiator Fan Removal

- Drain the coolant (see Coolant Change in the Periodic Maintenance chapter).
- Open the clamp [A].
- Disconnect the radiator fan lead connector [B].
- Remove the water hose [C].

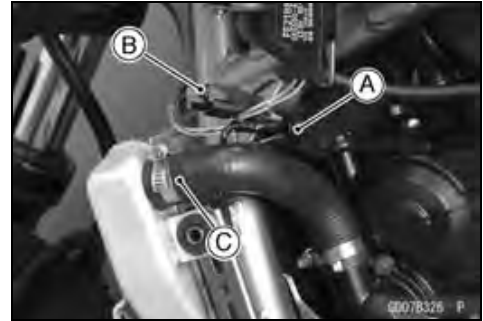

- Remove:
 - Water Hose [A]
 - Reserve Tank Hose [B]
 - Radiator Bolt [C]



- Pull [A] the radiator [B] toward the left, noting the baffle plate [C] on the cylinder head cover.

CAUTION

Do not touch the radiator core. This could damage the radiator fins, resulting in loss of cooling efficiency.

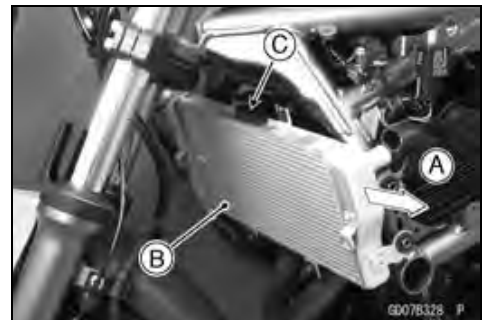

- Remove:
 - Radiator Fan Mounting Bolts [A]
 - Radiator Fan [B]

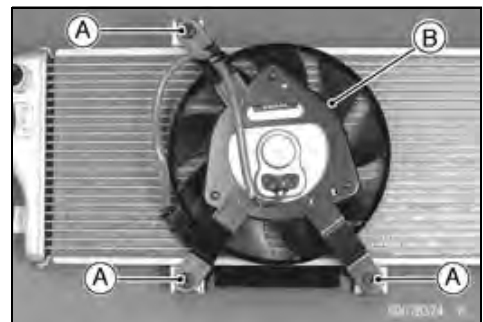

- Remove the bolts [A] and radiator guard [B] as necessary.

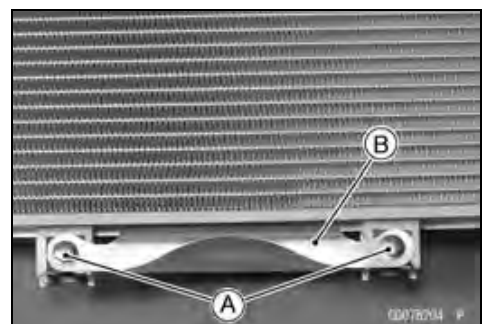

4-14 COOLING SYSTEM

Radiator

Radiator and Radiator Fan Installation

- ★ If the radiator guard [A] was removed, install it.
- Install the radiator fan [B].
- Install the rubber dampers [C] and collar [D] to the radiator and frame.
- Align the projections [E] on the frame with the holes [F] on the dampers.
- Note the baffle plate on the cylinder head cover when installing the radiator.
- Tighten:
 - Torque - Radiator Bolt [G]: 15 N·m (1.5 kgf·m, 11 ft·lb)**
- Position the reserve tank hose clamp [H] so that its pinch heads faces downward.
- Install the water hose clamps [I] as shown in the figure.
 - Torque - Water Hose Clamp Screws: 2.0 N·m (0.20 kgf·m, 18 in·lb)**
- Fill the radiator with the coolant (see Coolant Change in the Periodic Maintenance chapter).

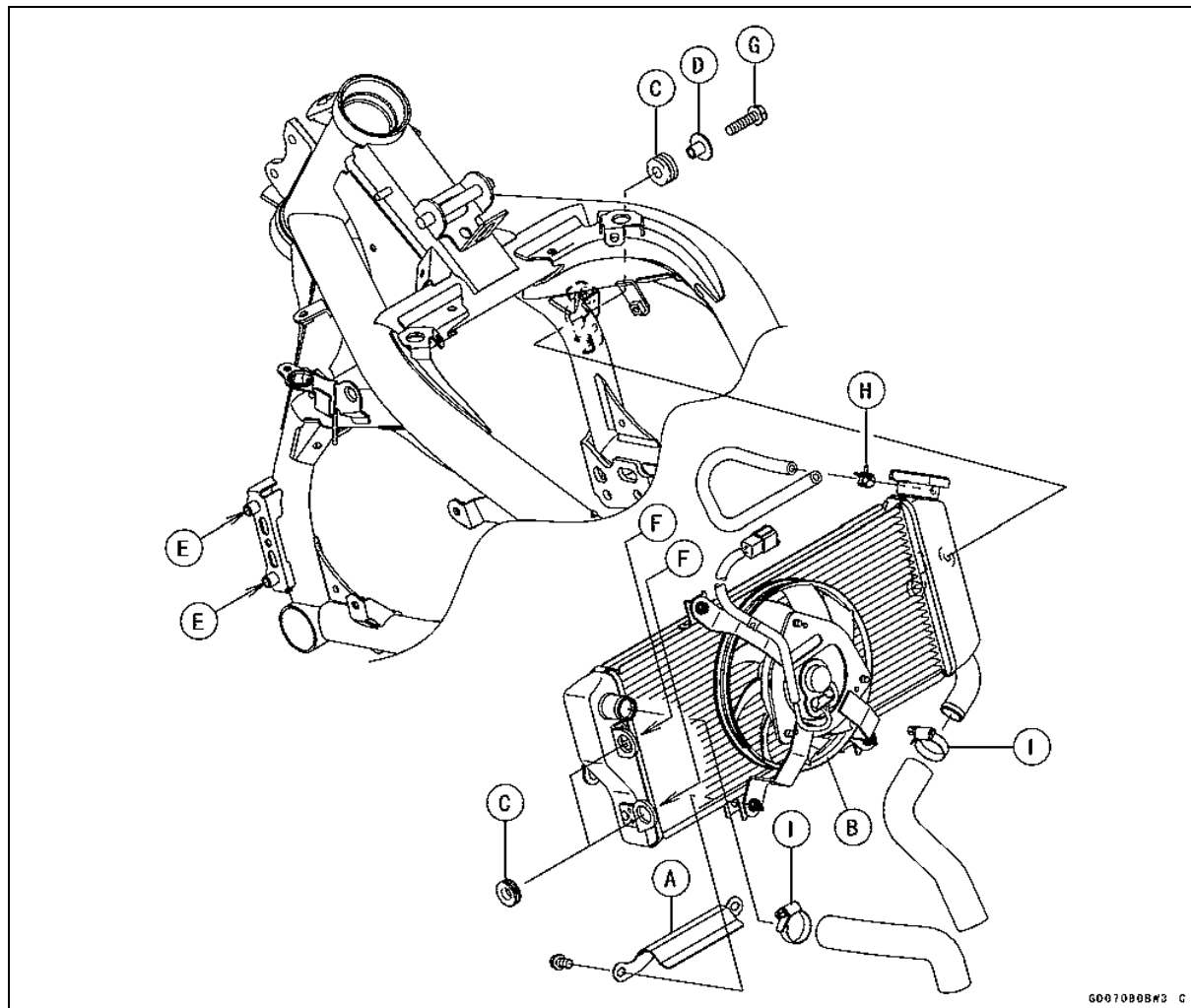

Radiator

Radiator Inspection

- Remove the radiator (see Radiator and Radiator Fan Removal).
- Check the radiator core.
- ★ If there are obstructions to air flow, remove them.
- ★ If the corrugated fins [A] are deformed, carefully straighten them.
- ★ If the air passages of the radiator core are blocked more than 20% by unremovable obstructions or irreparably deformed fins, replace the radiator with a new one.

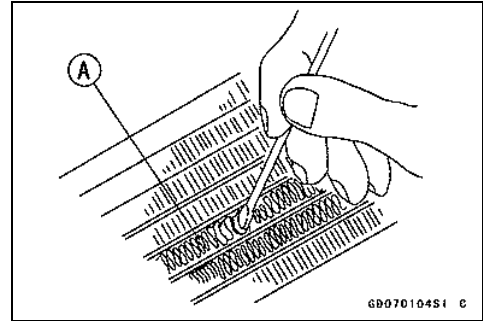

CAUTION

When cleaning the radiator with steam cleaner, be careful of the following to prevent radiator damage: Keep the steam gun [A] away more than 0.5 m (1.6 ft) [B] from the radiator core. Hold the steam gun perpendicular [C] (not oblique [D]) to the core surface. Run the steam gun, following the core fin direction.

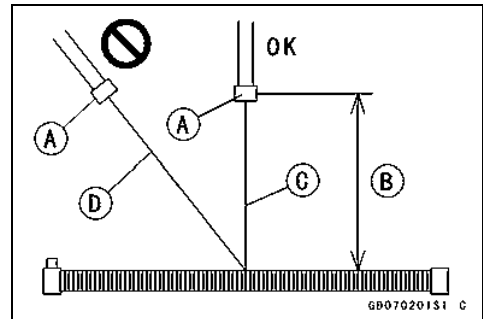

Radiator Cap Inspection

- Remove the radiator cap (see Coolant Change in the Periodic Maintenance chapter).
- Check the condition of the bottom [A] and top [B] valve seals and valve spring [C].
- ★ If any one of them shows visible damage, replace the cap with a new one.

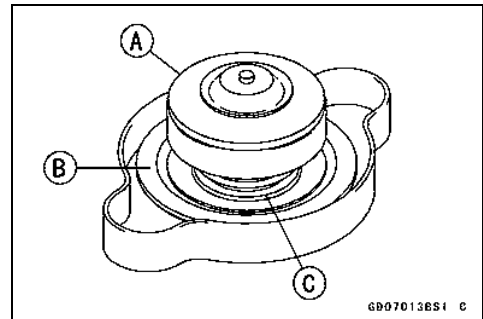

- Install the cap [A] on a cooling system pressure tester [B].

NOTE

○ Wet the cap sealing surfaces with water or coolant to prevent pressure leaks.

- Watching the pressure gauge, pump the pressure tester to build up the pressure until the relief valve opens: the gauge needle flicks downward. Stop pumping and measure leak time at once. The relief valve must open within the specified range in the table below and the gauge hand must remain within the same range at least 6 seconds.

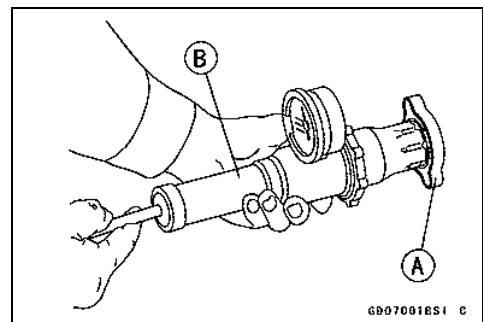

Radiator Cap Relief Pressure

Standard: 112.3 ~ 141.7 kPa (1.15 ~ 1.45 kgf/cm², 16.3 ~ 20.5 psi)

- ★ If the cap can not hold the specified pressure or if it holds too much pressure, replace it with a new one.

4-16 COOLING SYSTEM

Radiator

Radiator Filler Neck Inspection

- Remove the radiator cap (see Coolant Change in the Periodic Maintenance chapter).
- Check the radiator filler neck for signs of damage.
- Check the condition of the top and bottom sealing seats [A] in the filler neck. They must be smooth and clean for the radiator cap to function properly.

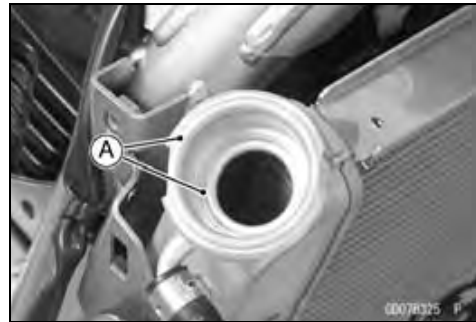

Thermostat

Thermostat Removal

- Drain the coolant (see Coolant Change in the Periodic Maintenance chapter).
- Remove:
 - Water Hose [A]
 - Thermostat Housing Bolts [B]
 - Thermostat Housing [C]

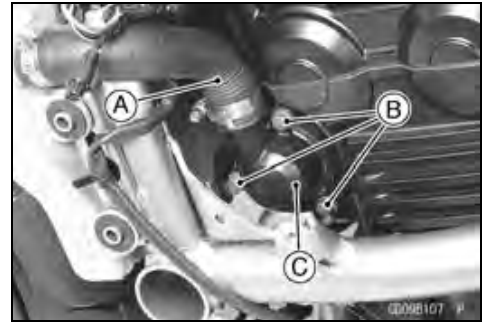

- Pull the thermostat [A] out of the cylinder head.



Thermostat Installation

- Install the thermostat [A] in the cylinder head so that the air bleeder hole [B] is on top.

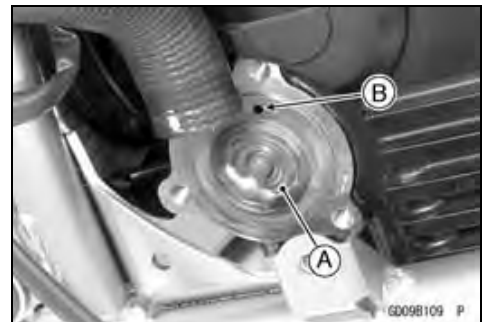

- Install a new O-ring [A] into the housing and apply grease to it.
- Tighten:
 - Torque - Thermostat Housing Bolts: 9.8 N·m (1.0 kgf·m, 87 in·lb)**



4-18 COOLING SYSTEM

Thermostat

- Align the line [A] of the thermostat housing and the white paint mark [B] of the water hose [C].
- Install the water hose clamp [D] as shown.
- Tighten:
Torque - Water Hose Clamp Screws: 2.0 N·m (0.20 kgf·m, 18 in·lb)
- Fill the radiator with coolant (see Coolant Change in the Periodic Maintenance chapter).

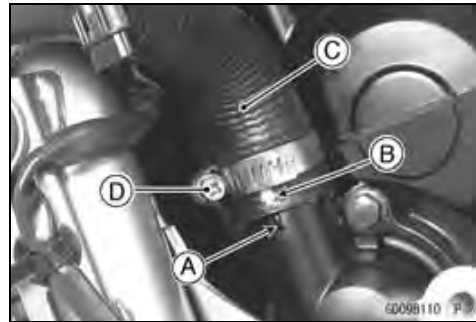

Thermostat Inspection

- Remove the thermostat (see Thermostat Removal), and inspect the thermostat valve [A] at room temperature.
- ★ If the valve is open, replace the thermostat with a new one.



- To check valve opening temperature, suspend the thermostat [A] in a container of water and raise the temperature of the water.
- The thermostat must be completely submerged and must not touch the container sides or bottom. Suspend an accurate thermometer [B] in the water so that the heat sensitive portions [C] are located in almost the same depth. It must not touch the container, either.
- ★ If the measurement is out of the specified range, replace the thermostat with a new one.

Thermostat Valve Opening Temperature
80.5 ~ 83.5°C (177 ~ 182°F)

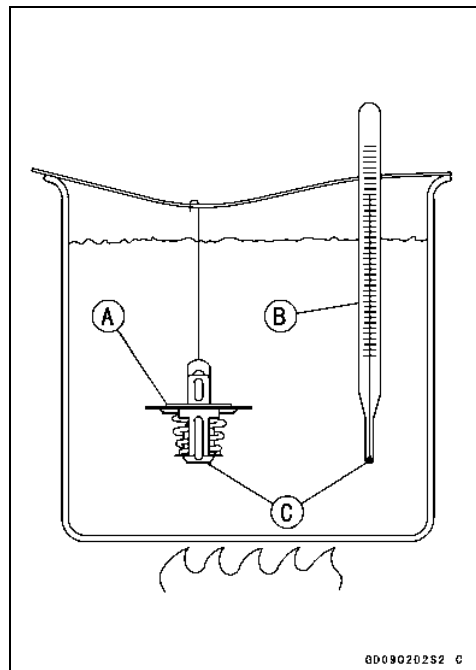

Hose and Pipes

Hose Installation

- Install the hoses and pipes, being careful to follow bending direction. Avoid sharp bending, kinking, flattening or twisting.
- Run the hoses (see Cable, Wire, and Hose Routing section in the Appendix chapter).
- Install the clamp [A] as near as possible to the hose end to clear the raised rib of the fitting. This will prevent the hoses from working loose.
- The clamp screws should be positioned correctly to prevent the clamps from contacting the other parts.

Torque - Water Hose Clamp Screws: 2.0 N·m (0.20 kgf·m, 18 in·lb)

Hose Inspection

- Refer to the Water Hose Damage and Installation Condition Inspection in the Periodic Maintenance chapter.

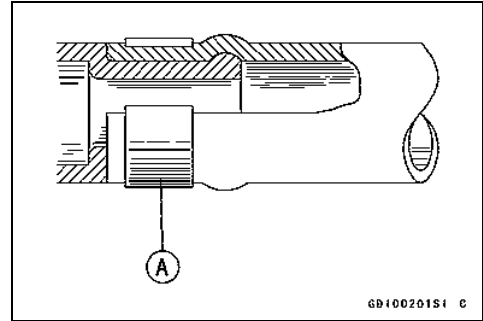

4-20 COOLING SYSTEM

Water Temperature Sensor

CAUTION
<p>The water temperature sensor should never be allowed to fall on a hard surface. Such a shock to the water temperature sensor can damage it.</p>

Water Temperature Sensor Removal/Installation

- Refer to the Water Temperature Sensor Removal/Installation in the Fuel System (DFI) chapter.

Water Temperature Sensor Inspection

- Refer to the Water Temperature Sensor Inspection in the Electrical System chapter.

Engine Top End

Table of Contents

Exploded View.....	5-2	Valves.....	5-29
Exhaust System Identification.....	5-6	Valve Clearance Inspection.....	5-29
Specifications.....	5-7	Valve Clearance Adjustment.....	5-29
Special Tools and Sealant.....	5-9	Valve Removal.....	5-29
Clean Air System.....	5-11	Valve Installation.....	5-29
Air Suction Valve Removal.....	5-11	Valve Guide Removal.....	5-29
Air Suction Valve Installation.....	5-11	Valve Guide Installation.....	5-30
Air Suction Valve Inspection.....	5-12	Valve-to-Guide Clearance	
Air Switching Valve Removal.....	5-12	Measurement (Wobble	
Air Switching Valve Installation....	5-12	Method).....	5-30
Air Switching Valve Operation		Valve Seat Inspection.....	5-31
Test.....	5-12	Valve Seat Repair.....	5-31
Air Switching Valve Unit Test.....	5-13	Cylinder, Pistons.....	5-36
Clean Air System Hose		Cylinder Removal.....	5-36
Inspection.....	5-13	Cylinder Installation.....	5-36
Cylinder Head Cover.....	5-14	Piston Removal.....	5-36
Cylinder Head Cover Removal....	5-14	Piston Installation.....	5-37
Cylinder Head Cover Installation..	5-14	Cylinder Wear Inspection.....	5-38
Camshaft Chain Tensioner.....	5-16	Piston Wear Inspection.....	5-38
Camshaft Chain Tensioner		Piston Ring, Piston Ring Groove	
Removal.....	5-16	Wear Inspection.....	5-39
Camshaft Chain Tensioner		Piston Ring Groove Width	
Installation.....	5-16	Inspection.....	5-39
Camshaft, Camshaft Chain.....	5-18	Piston Ring Thickness Inspection	5-39
Camshaft Removal.....	5-18	Piston Ring End Gap Inspection..	5-40
Camshaft Installation.....	5-20	Throttle Body Assy Holder.....	5-41
Camshaft, Camshaft Cap Wear...	5-23	Throttle Body Assy Holder	
Camshaft Runout.....	5-23	Removal.....	5-41
Cam Wear Inspection.....	5-23	Throttle Body Assy Holder	
Camshaft Chain Removal.....	5-24	Installation.....	5-41
Cylinder Head.....	5-25	Muffler.....	5-42
Cylinder Compression		Muffler Body Removal.....	5-42
Measurement.....	5-25	Exhaust Pipe Removal.....	5-42
Cylinder Head Removal.....	5-26	Muffler Body and Exhaust Pipe	
Cylinder Head Installation.....	5-26	Installation.....	5-44
Cylinder Head Warp Inspection...	5-28		

5-2 ENGINE TOP END

Exploded View

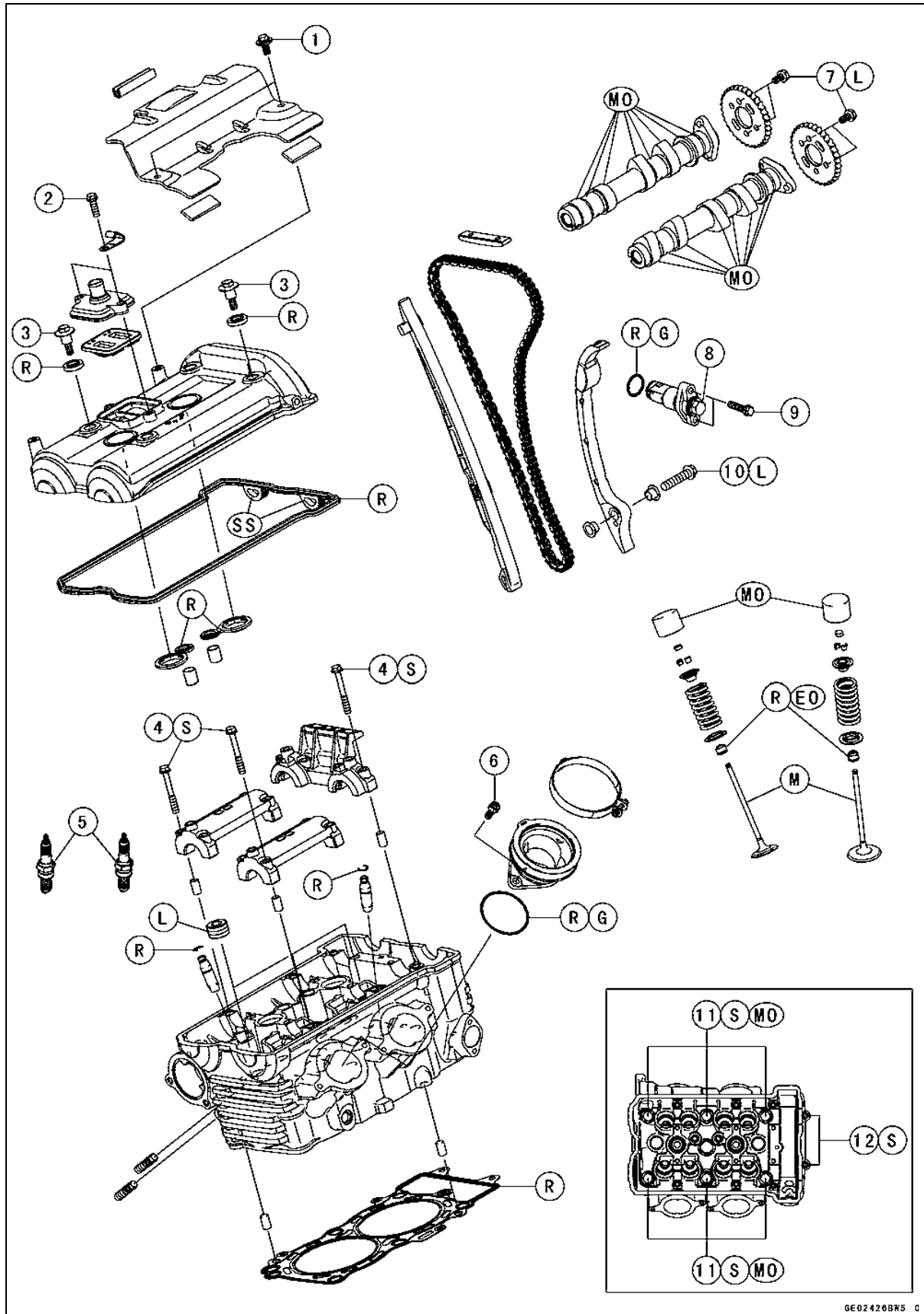

GE02426BK5 C

Exploded View

No.	Fastener	Torque			Remarks
		N-m	kgf-m	ft-lb	
1	Baffle Plate Bolts	5.9	0.60	52 in-lb	
2	Air Suction Valve Cover Bolts	9.8	1.0	87 in-lb	
3	Cylinder Head Cover Bolts	9.8	1.0	87 in-lb	
4	Camshaft Cap Bolts	12	1.2	106 in-lb	S
5	Spark Plugs	15	1.5	11	
6	Throttle Body Assy Holder Bolts	12	1.2	106 in-lb	
7	Camshaft Sprocket Bolts	15	1.5	11	L
8	Camshaft Chain Tensioner Cap Bolt	20	2.0	15	
9	Camshaft Chain Tensioner Mounting Bolts	9.8	1.0	87 in-lb	
10	Rear Camshaft Chain Guide Bolt	20	2.0	15	L
11	Cylinder Head Bolts (M10)	56	5.7	41	MO, S
12	Cylinder Head Bolts (M6)	12	1.2	106 in-lb	S

EO: Apply engine oil.

G: Apply grease.

L: Apply a non-permanent locking agent.

M: Apply molybdenum disulfide grease.

MO: Apply molybdenum disulfide oil solution.

(mixture of the engine oil and molybdenum disulfide grease in a weight ratio 10 : 1)

R: Replacement Parts

S: Follow the specified tightening sequence.

SS: Apply silicone sealant.

5-4 ENGINE TOP END

Exploded View

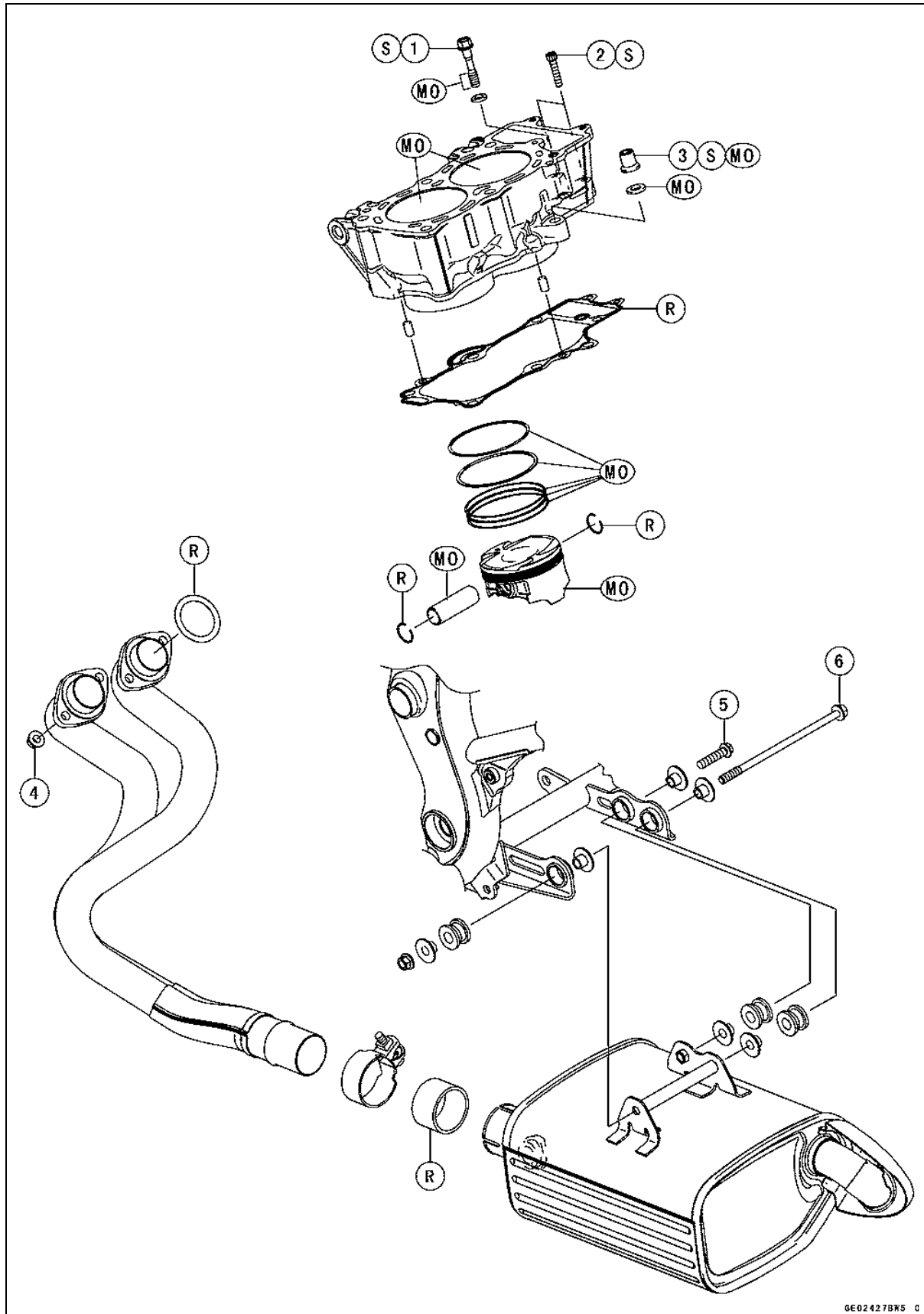

GE02427BK5 C

Exploded View

No.	Fastener	Torque			Remarks
		N·m	kgf·m	ft·lb	
1	Cylinder Bolt (M8)	27.5	2.8	20	MO,S
2	Cylinder Bolts (M6)	12	1.2	106 in·lb	S
3	Cylinder Nut	49	5.0	36	MO, S
4	Exhaust Pipe Manifold Holder Nuts	17	1.7	13	
5	Muffler Body Mounting Bolt (Front)	20	2.0	15	
6	Muffler Body Mounting Bolt (Rear)	20	2.0	15	

MO: Apply molybdenum disulfide oil solution.

(mixture of the engine oil and molybdenum disulfide grease in a weight ratio 10 : 1)

R: Replacement Parts

S: Follow the specified tightening sequence.

5-6 ENGINE TOP END

Exhaust System Identification

Exhaust System

MANIFOLD	MUFFLER BODY	SPECIFICATION	MODEL
Non-Catalyst <hr/> P/No. 39178-0074 Mark: KHI M 101	Honeycomb Type Catalyst With Oxygen Sensor <hr/> P/No. 18091-0502 Mark: KHI K 597	WVTA (FULL H)	EX650C9F
		GB WVTA (FULL H)	EX650C9F
		AU	EX650C9F
		SEA	EX650C9F
		MY	EX650C9F
	Honeycomb Type Catalyst Without Oxygen Sensor <hr/> P/No. 18091-0525 Mark: - EPA Noise Emission Control Information	WVTA (FULL H)	EX650D9F
		GB WVTA (FULL H)	EX650D9F
		US	EX650C9F
		CA	EX650C9F
		CAL	EX650C9FL

GE243688 F

Manifold Mark Position [A]

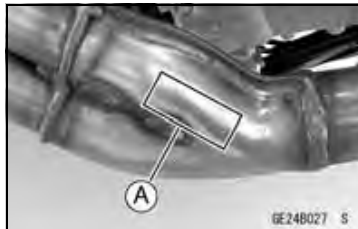

Muffler Body Mark Position [B]

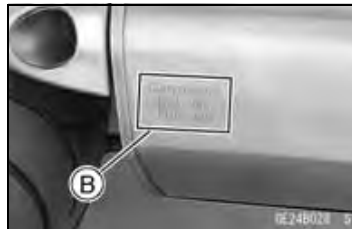

Honeycomb Type Catalyst Position [C]

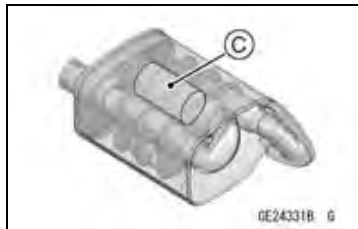

Muffler Body with Hole [D] for Oxygen Sensor [E]

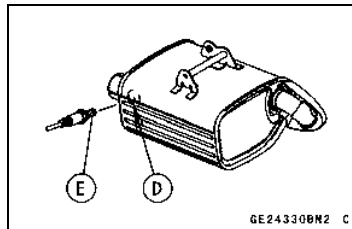

Specifications

Item	Standard	Service Limit
Camshafts		
Cam Height:		
Exhaust	35.843 ~ 35.957 mm (1.4111 ~ 1.4156 in.)	35.74 mm (1.407 in.)
Inlet	36.543 ~ 36.657 mm (1.4387 ~ 1.4432 in.)	36.44 mm (1.435 in.)
Camshaft Journal, Camshaft Cap Clearance	0.028 ~ 0.071 mm (0.0011 ~ 0.0028 in.)	0.16 mm (0.0063 in.)
Camshaft Journal Diameter	23.950 ~ 23.972 mm (0.9429 ~ 0.9438 in.)	23.92 mm (0.9417 in.)
Camshaft Bearing Inside Diameter	24.000 ~ 24.021 mm (0.9449 ~ 0.9457 in.)	24.08 mm (0.9480 in.)
Camshaft Runout	TIR 0.02 mm (0.0008 in.) or less	TIR 0.1 mm (0.004 in.)
Cylinder Head		
Cylinder Compression	(Usable Range) 1 295 ~ 1 948 kPa (13.2 ~ 19.9 kgf/cm ² , 188 ~ 282 psi) at 570 r/min (rpm)	— — —
Cylinder Head Warp	— — —	0.05 mm (0.002 in.)
Valves		
Valve Clearance:		
Exhaust	0.22 ~ 0.31 mm (0.0087 ~ 0.0122 in.)	— — —
Inlet	0.15 ~ 0.21 mm (0.0059 ~ 0.0083 in.)	— — —
Valve Head Thickness:		
Exhaust	0.8 mm (0.031 in.)	0.5 mm (0.020 in.)
Inlet	0.5 mm (0.020 in.)	0.25 mm (0.0098 in.)
Valve Stem Bend	TIR 0.01 mm (0.0004 in.) or less	TIR 0.05 mm (0.002 in.)
Valve Stem Diameter:		
Exhaust	4.455 ~ 4.470 mm (0.1754 ~ 0.1760 in.)	4.44 mm (0.175 in.)
Inlet	4.475 ~ 4.490 mm (0.1762 ~ 0.1768 in.)	4.46 mm (0.176 in.)
Valve Guide Inside Diameter:		
Exhaust	4.500 ~ 4.512 mm (0.1772 ~ 0.1776 in.)	4.58 mm (0.180 in.)
Inlet	4.500 ~ 4.512 mm (0.1772 ~ 0.1776 in.)	4.58 mm (0.180 in.)
Valve/Valve Guide Clearance (Wobble Method):		
Exhaust	0.08 ~ 0.16 mm (0.0032 ~ 0.0063 in.)	0.35 mm (0.014 in.)
Inlet	0.03 ~ 0.10 mm (0.0012 ~ 0.0039 in.)	0.29 mm (0.011 in.)
Valve Seat Cutting Angle	32°, 45°, 55°, 60°	— — —
Valve Seating Surface:		
Width:		
Exhaust	0.5 ~ 1.0 mm (0.02 ~ 0.04 in.)	— — —
Inlet	0.5 ~ 1.0 mm (0.02 ~ 0.04 in.)	— — —
Outside Diameter:		
Exhaust	27.6 ~ 27.8 mm (1.087 ~ 1.094 in.)	— — —
Inlet	32.6 ~ 32.8 mm (1.283 ~ 1.291 in.)	— — —

5-8 ENGINE TOP END

Specifications

Item	Standard	Service Limit
Valve Spring Free Length:		
Exhaust	41.91 mm (1.650 in.)	40.5 mm (1.59 in.)
Inlet	41.91 mm (1.650 in.)	40.5 mm (1.59 in.)
Cylinder, Pistons		
Cylinder Inside Diameter	82.994 ~ 83.006 mm (3.2675 ~ 3.2679 in.)	83.09 mm (3.271 in.)
Piston Diameter	82.969 ~ 82.984 mm (3.2665 ~ 3.2671 in.)	82.82 mm (3.261 in.)
Piston/Cylinder Clearance	0.010 ~ 0.037 mm (0.0004 ~ 0.0015 in.)	— — —
Piston Ring/Groove Clearance:		
Top	0.03 ~ 0.07 mm (0.001 ~ 0.003 in.)	0.17 mm (0.0067 in.)
Second	0.02 ~ 0.06 mm (0.001 ~ 0.002 in.)	0.16 mm (0.0063 in.)
Piston Ring Groove Width:		
Top	0.92 ~ 0.94 mm (0.0362 ~ 0.0370 in.)	1.02 mm (0.0402 in.)
Second	1.01 ~ 1.03 mm (0.0398 ~ 0.0406 in.)	1.11 mm (0.0437 in.)
Piston Ring Thickness:		
Top	0.87 ~ 0.89 mm (0.0343 ~ 0.0350 in.)	0.80 mm (0.031 in.)
Second	0.97 ~ 0.99 mm (0.0382 ~ 0.0390 in.)	0.90 mm (0.035 in.)
Piston Ring End Gap:		
Top	0.25 ~ 0.40 mm (0.0098 ~ 0.0157 in.)	0.7 mm (0.028 in.)
Second	0.40 ~ 0.55 mm (0.0157 ~ 0.0217 in.)	0.9 mm (0.035 in.)

Special Tools and Sealant

Compression Gauge, 20 kgf/cm²:
57001-221

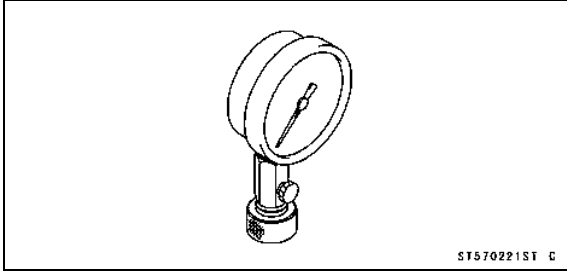

ST570221ST C

Valve Seat Cutter, 60° - ϕ 30:
57001-1123

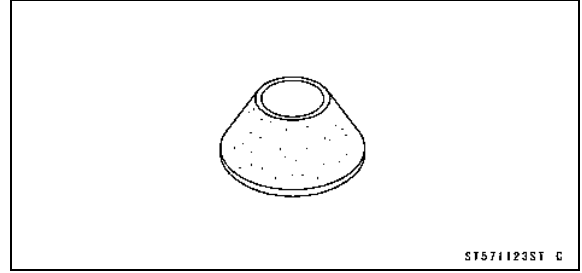

ST571123ST C

Valve Spring Compressor Assembly:
57001-241

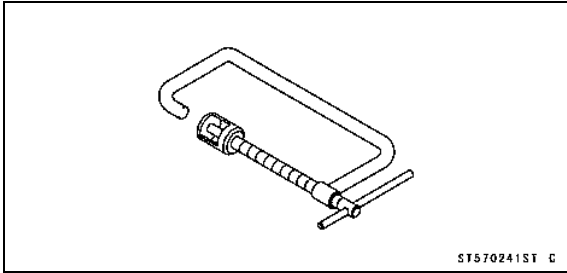

ST570241ST C

Valve Seat Cutter Holder Bar:
57001-1128

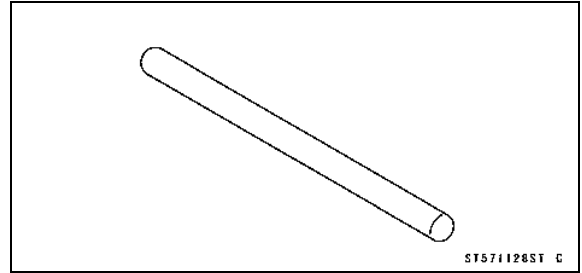

ST571128ST C

Valve Seat Cutter, 45° - ϕ 35:
57001-1116

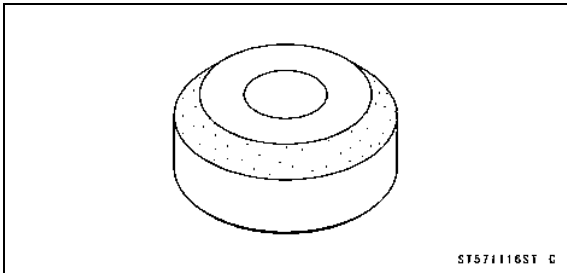

ST571116ST C

Valve Seat Cutter, 45° - ϕ 30:
57001-1187

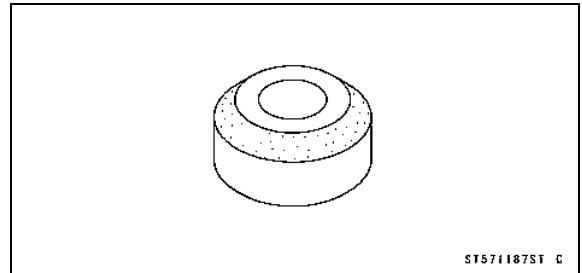

ST571187ST C

Valve Seat Cutter, 32° - ϕ 30:
57001-1120

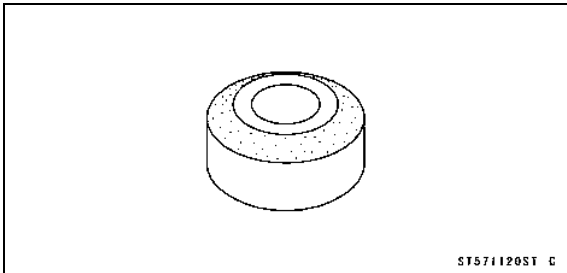

ST571120ST C

Valve Seat Cutter, 55° - ϕ 35:
57001-1247

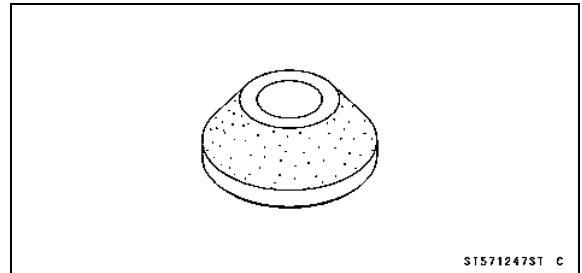

ST571247ST C

Valve Seat Cutter, 32° - ϕ 35:
57001-1121

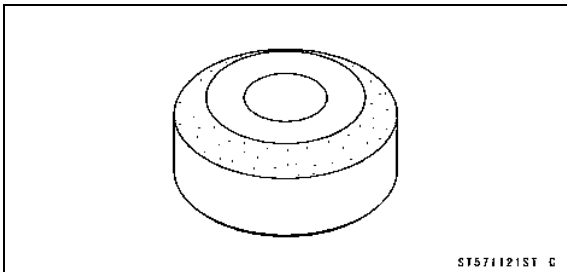

ST571121ST C

Valve Spring Compressor Adapter, ϕ 21:
57001-1272

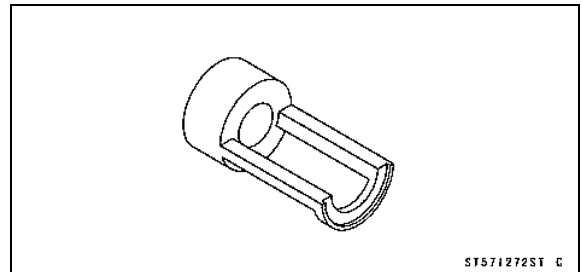

ST571272ST C

5-10 ENGINE TOP END

Special Tools and Sealant

Compression Gauge Adapter, M10 × 1.0:
57001-1317

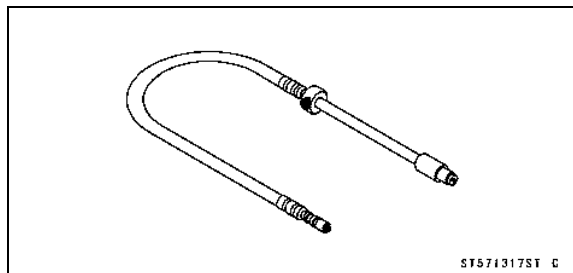

Piston Pin Puller:
57001-1568

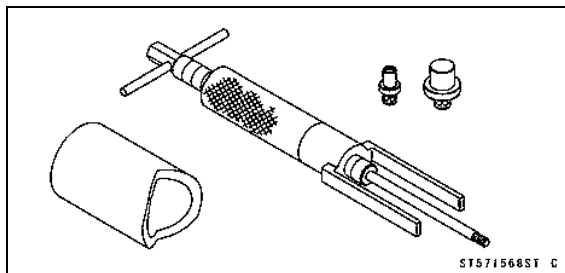

Valve Seat Cutter Holder, ϕ 4.5:
57001-1330

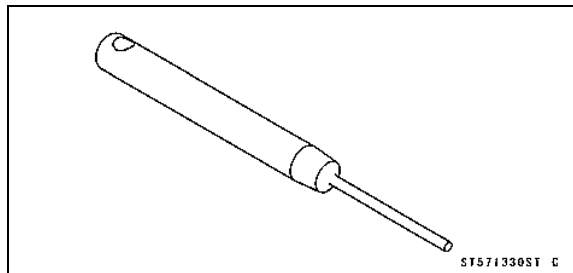

Piston Pin Puller Adapter, ϕ 12:
57001-1657

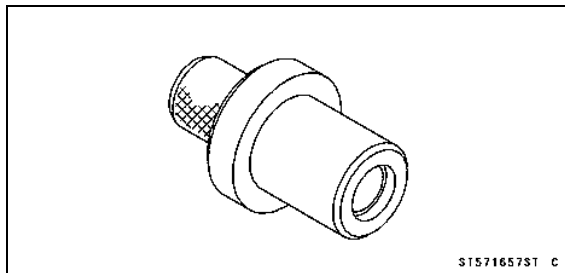

Valve Guide Arbor, ϕ 4.5:
57001-1331

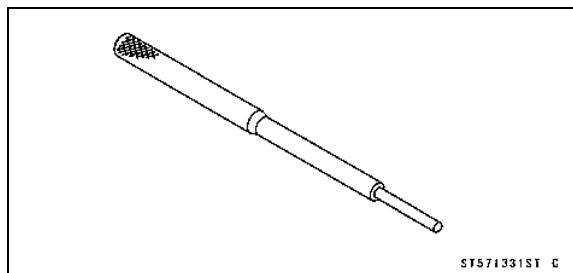

Kawasaki Bond (Silicone Sealant):
92104-0004

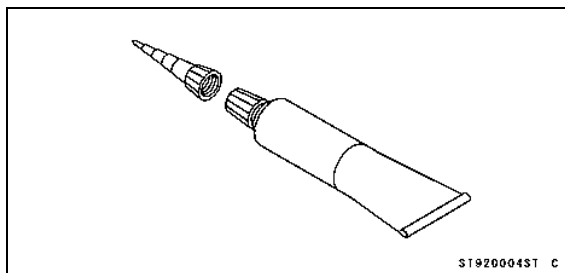

Valve Guide Reamer, ϕ 4.5:
57001-1333

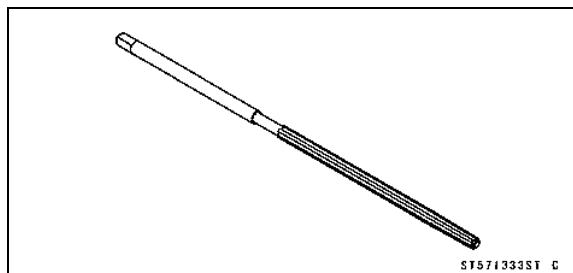

Clean Air System

Air Suction Valve Removal

- Remove:
 - Air Switching Valve (see Air Switching Valve Removal)
 - Air Suction Valve Cover Bolts [A]
 - Clamp [B]
 - Air Suction Valve Cover [C]



- Remove the air suction valve [A].



Air Suction Valve Installation

- Install the air suction valve [A] so that its side where stopper is fixed with the screws [B] faces the front [C].

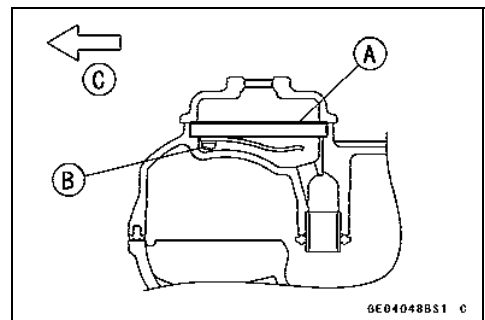

- Install the clamp [A] as shown.
- Tighten:
 - Torque - Air Suction Valve Cover Bolts: 9.8 N·m (1.0 kgf·m, 87 in·lb)**

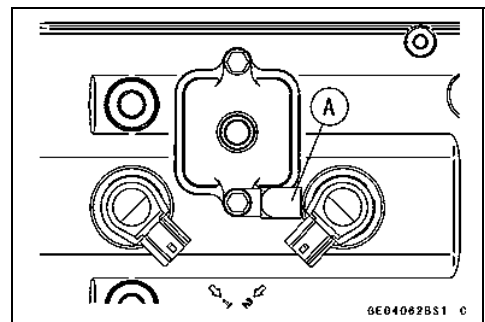

5-12 ENGINE TOP END

Clean Air System

Air Suction Valve Inspection

- Remove the air suction valve (see Air Suction Valve Removal).
- Visually inspect the reeds [A] for cracks, folds, warps, heat damage or other damage.
- ★ If there is any doubt as to the condition of the reeds, replace the air suction valve as an assembly.
- Check the reed contact areas [B] of the valve holder for grooves, scratches, any signs of separation from the holder or heat damage.
- If there is any doubt as to the condition of the reed contact areas, replace the air suction valve as an assembly.
- If any carbon or other foreign particles have accumulated between the reed and the reed contact area, wash the valve assembly clean with a high-flash point solvent.

CAUTION

Do not scrape off the deposits with a scraper as this could damage the rubber, requiring replacement of the suction valve assembly.

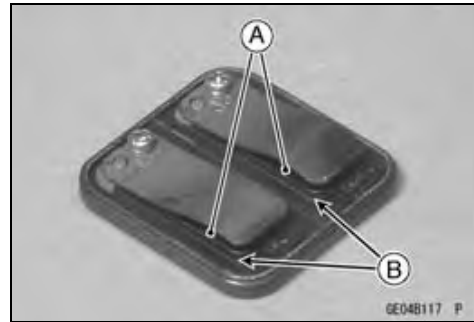

Air Switching Valve Removal

- Remove:
 - Fuel Tank (see Fuel Tank Removal in the Fuel System (DFI) chapter)
 - Left Upper Fairing Cover (see Upper Fairing Cover Removal in the Frame chapter)
- Separate the air switching valve hose [A] from the air suction valve cover.
- Disconnect the connector [A].
- Separate the air switching valve hose [B] from the air cleaner housing, and remove the air switching valve [C].

CAUTION

Never drop the air switching valve, especially on a hard surface. Such a shock to the valve can damage it.

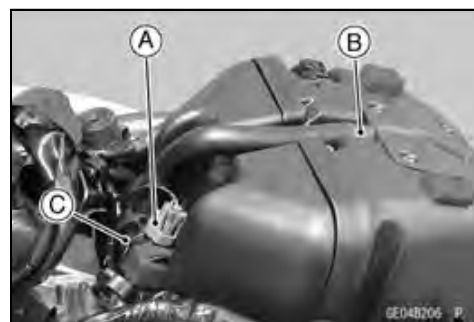

Air Switching Valve Installation

- Install the air switching valve [A] with hoses [B] as shown.
- Install the clamp [C] so that its pinch heads face the right.
- Connect the air switching valve lead connector.

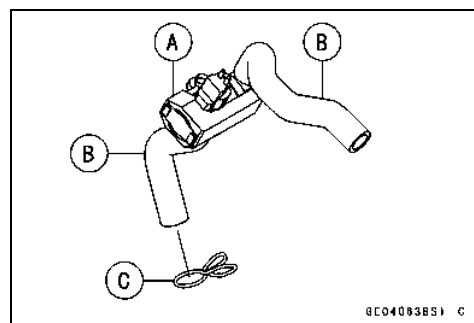

Air Switching Valve Operation Test

- Refer to the Air Suction System Damage Inspection in the Periodic Maintenance chapter.

Clean Air System

Air Switching Valve Unit Test

- Refer to the Air Switching Valve Unit Test in the Electrical System chapter.

Clean Air System Hose Inspection

- Be certain that all the hoses are routed without being flattened or kinked, and are connected correctly to the air cleaner housing, air switching valve and air suction valve cover.
- ★ If they are not, correct them. Replace them if they are damaged.

5-14 ENGINE TOP END

Cylinder Head Cover

Cylinder Head Cover Removal

- Remove:
 - Air Suction Valve (see Air Suction Valve Removal)
 - Stick Coils (see Stick Coil Removal in the Electrical System chapter).
 - Throttle Cables (see Throttle Body Assy Removal in the Fuel System (DFI) chapter)
 - Inlet Air Pressure Sensor Hose [A]
 - Baffle Plate Bolts [B]
 - Baffle Plate [C]
 - Cylinder Head Cover Bolts [D]
 - Clamp [E]

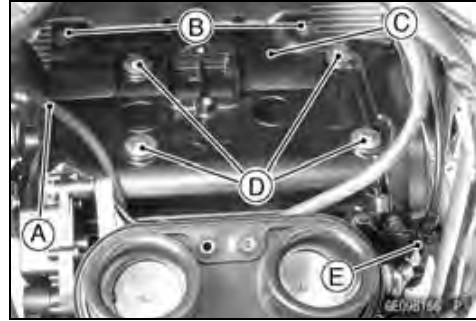

EX650D Models

- Remove:
 - Upper Fairing (see Upper Fairing Removal in the Frame chapter)
 - Bolt [A]
 - Damper [B]

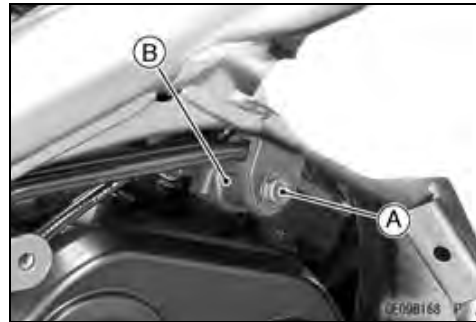

- Remove the cylinder head cover.

Cylinder Head Cover Installation

- Replace the head cover gasket [A] with a new one.
- Apply silicone sealant [B] to the cylinder head as shown in the figure.

Sealant - Kawasaki Bond (Silicone Sealant): 92104-0004

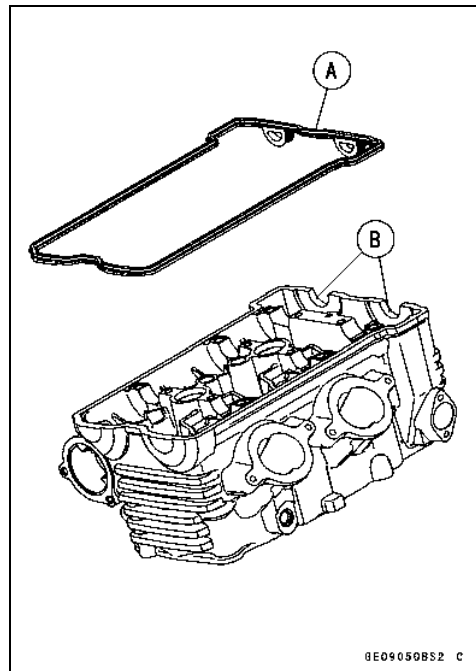

Cylinder Head Cover

- Replace the plug hole gaskets [A] with new ones.
- Be sure to install the following parts.
 - Dowel Pins [B]
 - Plug Hole Gaskets

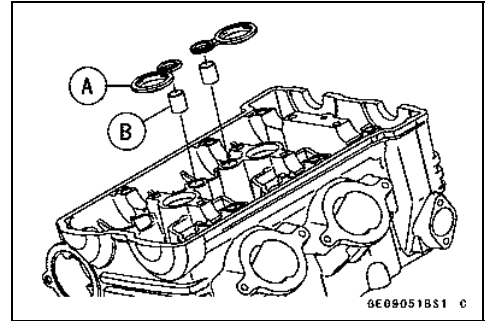

- Install the rubber washers [A] with metal side faces upward.
- Tighten:
 - Torque - Cylinder Head Cover Bolts: 9.8 N·m (1.0 kgf·m, 87 in·lb)**

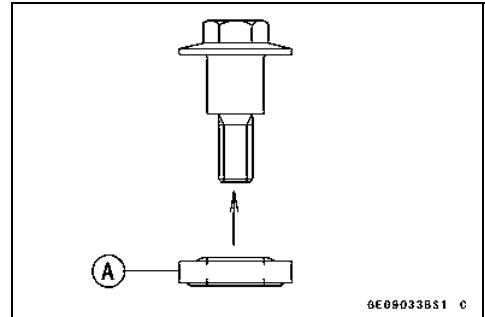

- Be sure that the dampers [A] of the baffle plate is in position.
- Tighten:
 - Torque - Baffle Plate Bolts: 5.9 N·m (0.60 kgf·m, 52 in·lb)**

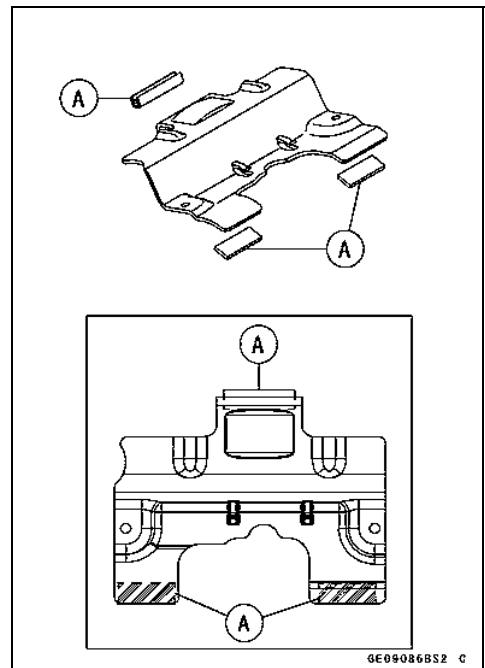

5-16 ENGINE TOP END

Camshaft Chain Tensioner

Camshaft Chain Tensioner Removal

CAUTION

This is a non-return type camshaft chain tensioner. The push rod does not return to its original position once it moves out to take up camshaft chain slack. Observe all the rules listed below:

When removing the tensioner, do not take out the mounting bolts only halfway. Retightening the mounting bolts from this position could damage the tensioner and the camshaft chain. Once the bolts are loosened, the tensioner must be removed and reset as described in "Camshaft Chain Tensioner Installation."

Do not turn over the crankshaft while the tensioner is removed. This could upset the camshaft chain timing, and damage the valves.

- Remove:
 - Right Upper Fairing Cover (see Upper Fairing Cover Removal in the Frame chapter)
 - Cap Bolt [A] and Washer

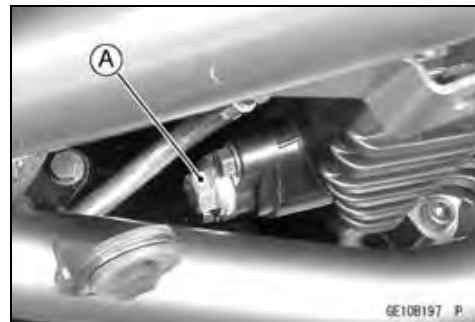

- Remove the spring [A].
- Remove the mounting bolts [B], and take off the camshaft chain tensioner body [C].

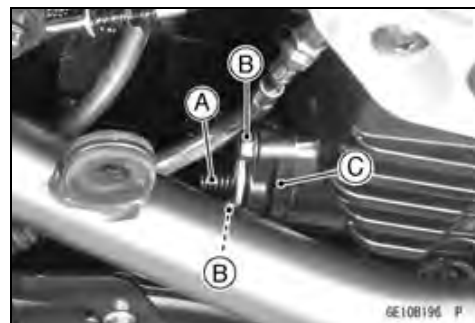

Camshaft Chain Tensioner Installation

- Replace the O-ring [A] with a new one.
- Apply grease to the new O-ring.
- Release the stopper [B] and push the push rod [C] into the tensioner body [D].

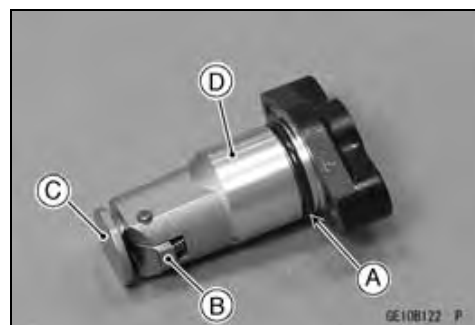

Camshaft Chain Tensioner

- Install the tensioner body so that the stopper [A] faces upward.
- Tighten the tensioner mounting bolts.

Torque - Camshaft Chain Tensioner Mounting Bolts: 9.8 N·m (1.0 kgf·m, 87 in·lb)



- Install:
 - Spring [A]
 - Washer [B]

- Tighten:

Torque - Camshaft Chain Tensioner Cap Bolt [C]: 20 N·m (2.0 kgf·m, 15 ft·lb)

- Turn the crankshaft 2 turns clockwise to allow the tensioner to expand and recheck the camshaft chain timing.

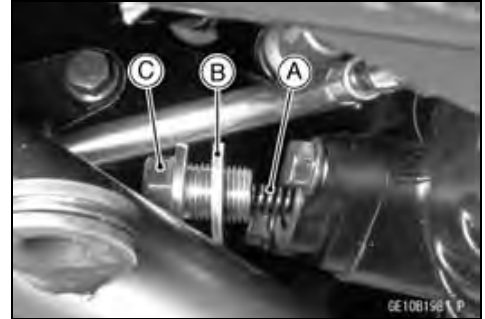

5-18 ENGINE TOP END

Camshaft, Camshaft Chain

Camshaft Removal

- Remove:
 - Cylinder Head Cover (see Cylinder Head Cover Removal)
 - Lower Fairing (see Lower Fairing Removal in the Frame chapter)
 - Timing Inspection Cap [A]
 - Timing Rotor Bolt Cap [B]

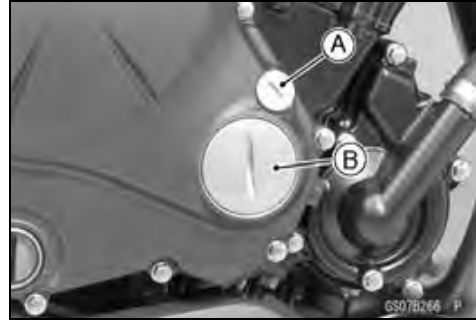

- Using a wrench on the timing rotor bolt, turn the crankshaft clockwise until the 2/T mark line [A] on the timing rotor is aligned with the notch [B] in the edge of the timing inspection hole [C] in the clutch cover.

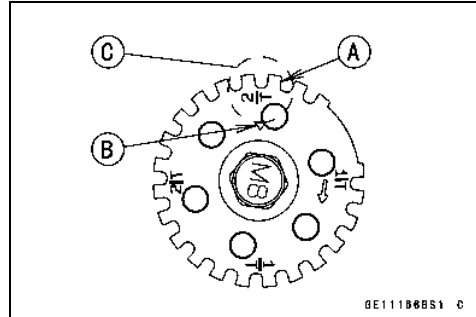

- ★ If the clutch cover is removed, perform the next procedure.
- Using a wrench on the timing rotor bolt, turn the crankshaft clockwise until the 1/T mark line [A] on the timing rotor is aligned with the mating surface [B] of the crankcase front side.

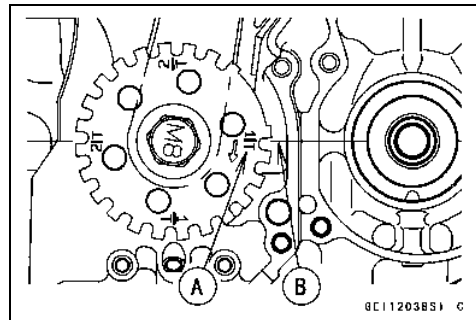

Camshaft, Camshaft Chain

- Remove the camshaft chain tensioner (see Camshaft Chain Tensioner Removal).
- Loosen the camshaft cap bolts as shown sequence [1 ~ 12] in the figure, and remove them.
- Remove:
 - Camshaft Caps [A]
 - Camshafts [B]

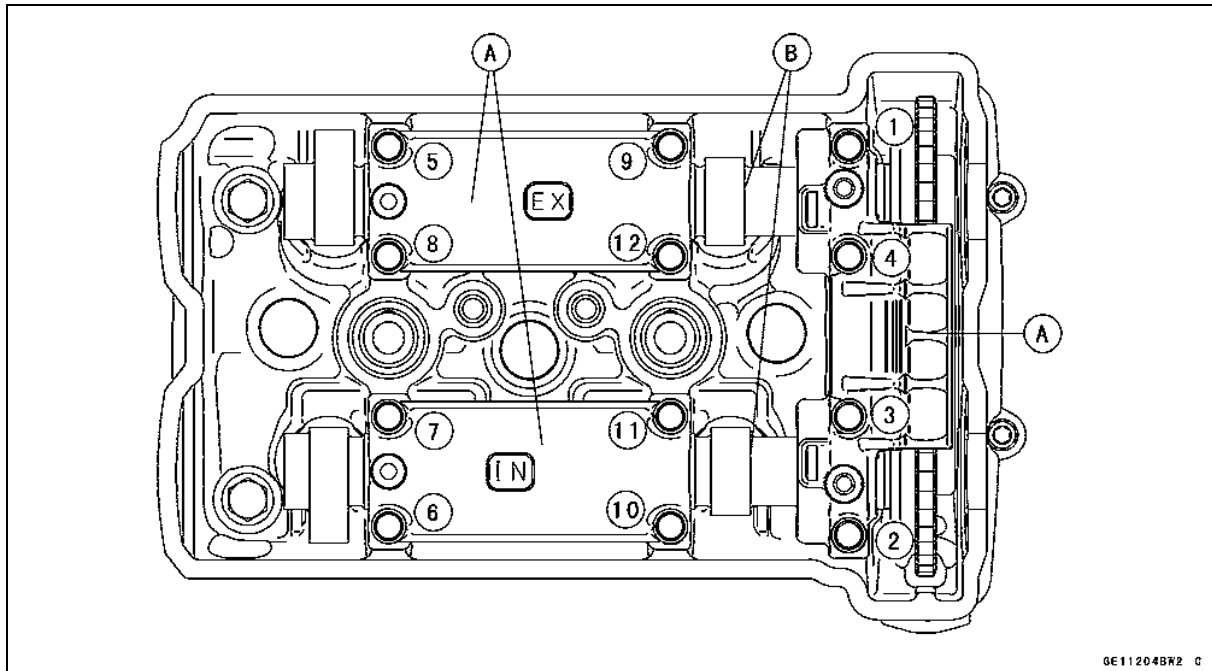

CAUTION

The crankshaft may be turned while the camshafts are removed. Always pull the chain taut while turning the crankshaft. This avoids kinking the chain on the lower (crankshaft) sprocket. A kinked chain could damage both the chain and the sprocket.

- Stuff a clean cloth into the chain tunnel to keep any parts from dropping into the crankcase.
- Remove the cam sprocket mounting bolts [A].
- Remove the cam sprocket.

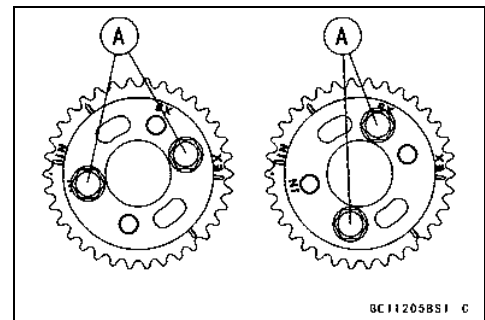

5-20 ENGINE TOP END

Camshaft, Camshaft Chain

Camshaft Installation

- Replace the plug hole gaskets [A] with new ones.
- Be sure to install the following parts.
 - Plug Hole Gaskets
 - Dowel Pins [B]

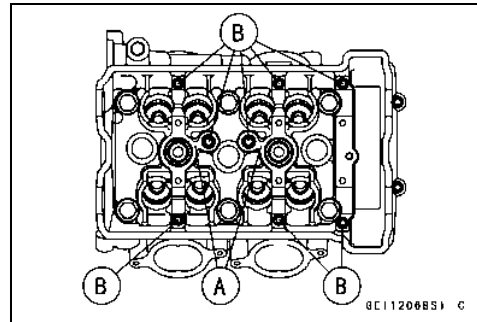

- Install the cam sprockets so that the marked ("IN" and "EX") side faces to the outward.
- The inlet [A] and exhaust [B] cam sprockets are identical.

CAUTION

Inlet cam sprocket must use "IN" marked bolt holes [C]. Exhaust cam sprocket must use "EX" marked bolt holes [D].

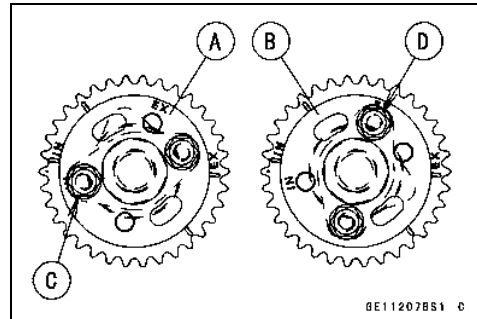

- Apply a non-permanent locking agent to the camshaft sprocket bolts and tighten them.

Torque - Camshaft Sprocket Bolts: 15 N·m (1.5 kgf·m, 11 ft·lb)

- Apply molybdenum disulfide oil solution to all cams [A], journals [B] and thrust blocks [C] with × marks.
- ★ If a new camshaft is to be used, apply a thin coat of molybdenum disulfide grease to the cam surfaces.

NOTE

- The exhaust camshaft has a 2412 EX mark [D] and the inlet camshaft has a 2412 IN mark [E]. Be careful not to mix up these shafts.

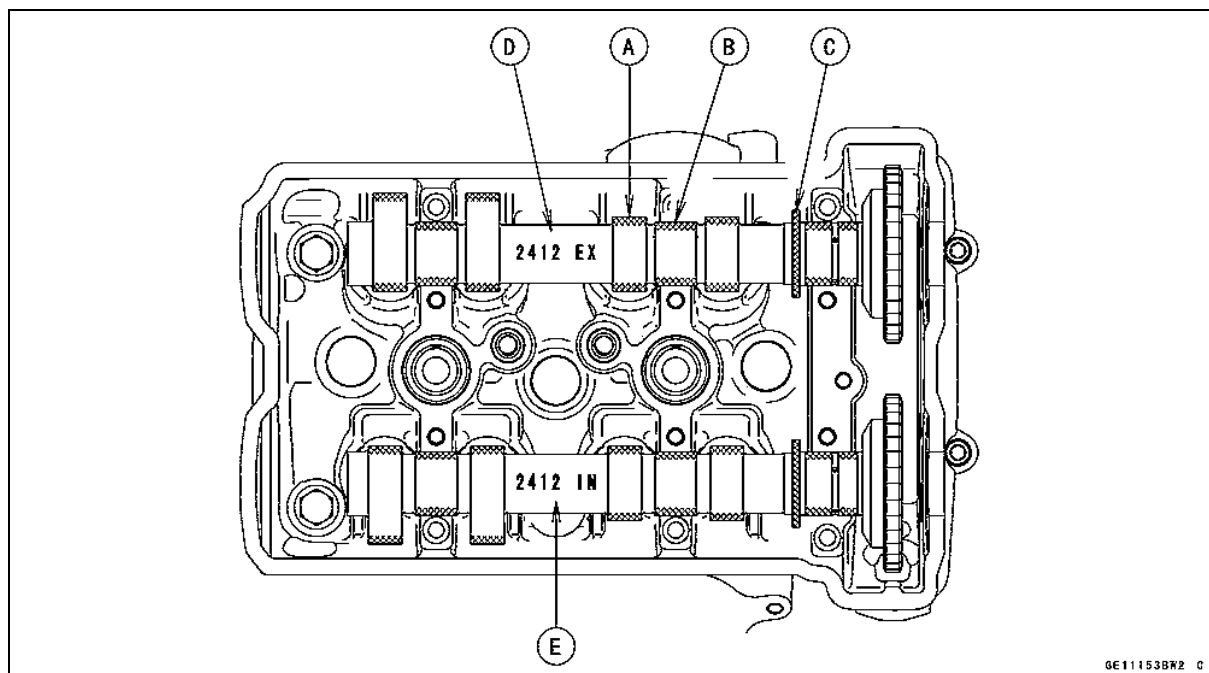

Camshaft, Camshaft Chain

- Using a wrench on the timing rotor bolt, turn the crankshaft clockwise until the 2/T mark line [A] on the timing rotor is aligned with the notch [B] in the edge of the timing inspection hole [C] in the clutch cover.

CAUTION

The crankshaft may be turned while the camshafts are removed. Always pull the chain taut while turning the crankshaft. This avoids kinking the chain on the lower (crankshaft) sprocket. A kinked chain could damage both the chain and the sprocket.

- ★ If the clutch cover is removed, perform the next procedure.
- Using a wrench on the bolt, turn the crankshaft clockwise until the 1/T mark line [A] on the timing rotor is aligned with the mating surface [B] of the crankcase front side.

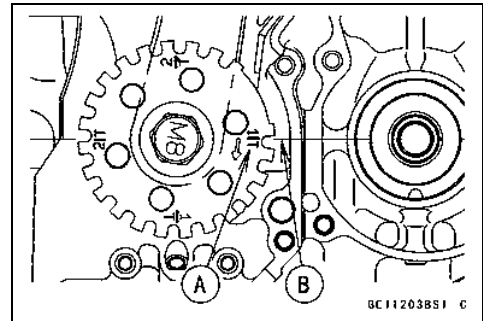
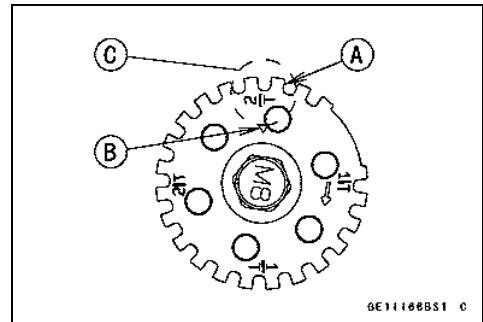

- Pull the tension side (exhaust side) [A] of the chain taut to install the chain.
- Engage the camshaft chain with the camshaft sprockets so that the timing marks on the sprockets are positioned as shown in the figure.
- The timing marks must be aligned with the cylinder head upper surface [B].
 - EX Mark [C] (Between #1 Pin and #2 Pin)
 - IN Mark [D] (Between #31 Pin and #32 Pin)
 - #1 Pin [E]
 - #2 Pin [F]
 - #31 Pin [G]
 - #32 Pin [H]

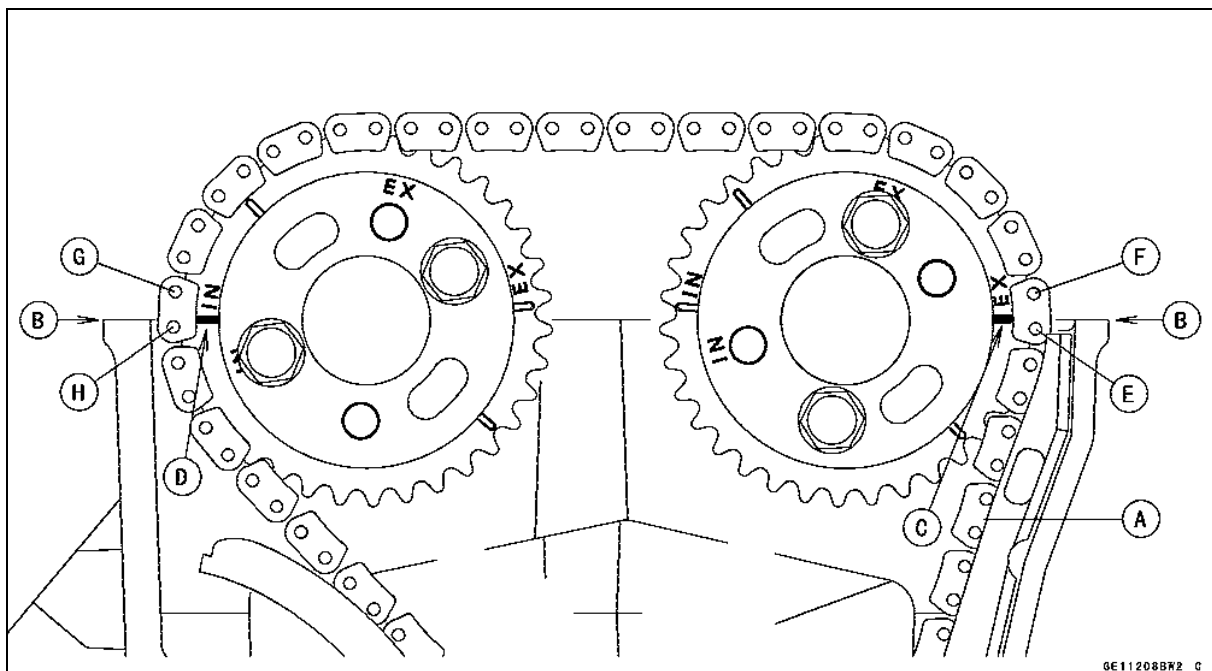

5-22 ENGINE TOP END

Camshaft, Camshaft Chain

- Before installing the camshaft caps, install the camshaft chain tensioner body temporarily (see Camshaft Chain Tensioner Installation).
- Install the camshaft caps as shown.

NOTE

○ The exhaust cap has a "EX" mark [A] and the inlet cap has a "IN" mark [B]. Be careful not to mix up these caps.

- First tighten the camshaft cap bolts [9 ~ 12] evenly to seat the camshaft in place, then tighten all bolts following the specified tightening sequence.

Torque - Camshaft Cap Bolts (1 ~ 12): 12 N·m (1.2 kgf·m, 106 in·lb)

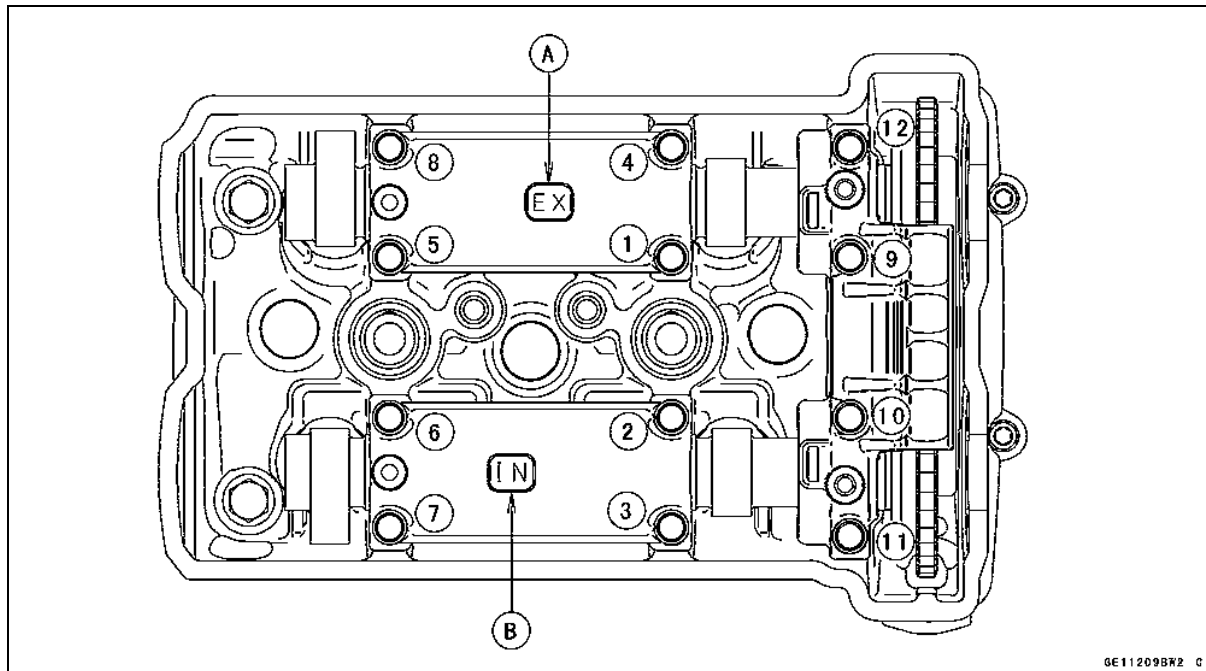

- Install the camshaft chain tensioner (see Camshaft Chain Tensioner Installation).
- Turn the crankshaft 2 turns clockwise to allow the tensioner to expand and recheck the camshaft chain timing.
- Replace the O-ring of the timing inspection cap and timing rotor bolt cap with new ones.
- Apply grease to the new O-rings.
- Install the timing inspection cap and timing rotor bolt cap.

Torque - Timing Inspection Cap: 3.9 N·m (0.40 kgf·m, 35 in·lb)

Timing Rotor Bolt Cap: 4.9 N·m (0.50 kgf·m, 43 in·lb)

- Install the cylinder head cover (see Cylinder Head Cover Installation).

GE11209BK2 C

Camshaft, Camshaft Chain

Camshaft, Camshaft Cap Wear

- Remove the camshaft caps (see Camshaft Removal).
- Cut strips of plastigage (press gauge) to journal width. Place a strip on each journal parallel to the camshaft installed in the correct position.
- Tighten the camshaft cap bolts to the specified torque (see Camshaft Installation).

NOTE

○ Do not turn the camshaft when the plastigage is between the journal and camshaft cap.

- Remove the camshaft cap again, measure each clearance between the camshaft journal and the camshaft cap using plastigage [A].

Camshaft Journal, Camshaft Cap Clearance

Standard: 0.028 ~ 0.071 mm (0.0011 ~ 0.0028 in.)

Service Limit: 0.16 mm (0.0063 in.)

- ★ If any clearance exceeds the service limit, measure the diameter of each camshaft journal with a micrometer.

Camshaft Journal Diameter

Standard: 23.950 ~ 23.972 mm (0.9429 ~ 0.9438 in.)

Service Limit: 23.92 mm (0.9417 in.)

- ★ If the camshaft journal diameter is less than the service limit, replace the camshaft with a new one and measure the clearance again.
- ★ If the clearance still remains out of the limit, replace the cylinder head unit.

Camshaft Runout

- Remove the camshaft (see Camshaft Removal).
- Set the camshaft in a camshaft alignment jig or on V blocks.
- Measure runout with a dial gauge at the specified place as shown in the figure.
- ★ If the runout exceeds the service limit, replace the shaft.

Camshaft Runout

Standard: TIR 0.02 mm (0.0008 in.) or less

Service Limit: TIR 0.1 mm (0.004 in.)

Cam Wear Inspection

- Remove the camshaft (see Camshaft Removal).
- Measure the height [A] of each cam with a micrometer.
- ★ If the cams are worn down past the service limit, replace the camshaft.

Cam Height

Standard:

Exhaust 35.843 ~ 35.957 mm (1.4111 ~ 1.4156 in.)

Inlet 36.543 ~ 36.657 mm (1.4387 ~ 1.4432 in.)

Service Limit:

Exhaust 35.74 mm (1.407 in.)

Inlet 36.44 mm (1.435 in.)

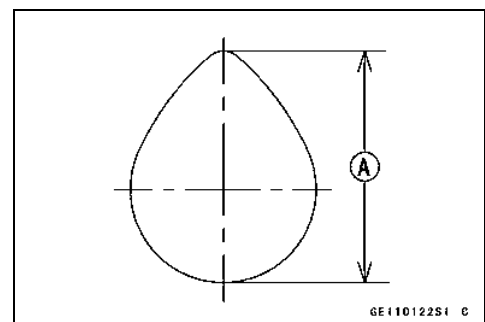
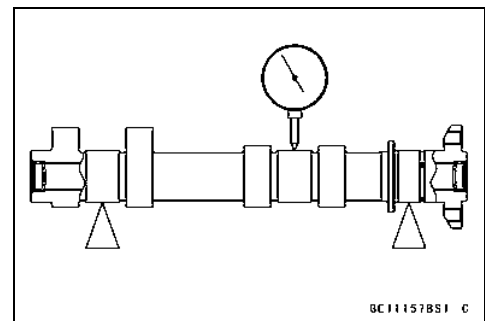
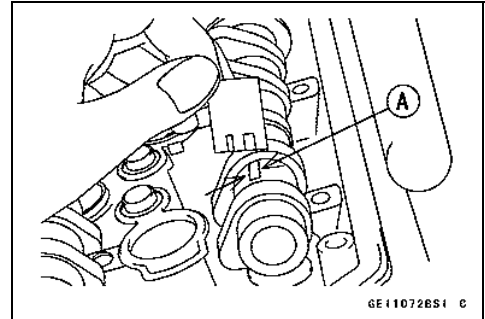

5-24 ENGINE TOP END

Camshaft, Camshaft Chain

Camshaft Chain Removal

- Split the crankcase (see Crankcase Splitting in the Crankshaft/Transmission chapter).
- Remove the camshaft chain [A] from the crankshaft sprocket.



Cylinder Head

Cylinder Compression Measurement

NOTE

○ Use the battery which is fully charged.

- Warm up the engine thoroughly.
- Stop the engine.
- Remove:
 - Spark Plugs (see Spark Plug Replacement in the Periodic Maintenance chapter)
- Attach the compression gauge [A] and adapter [B] firmly into the spark plug hole.
- Using the starter motor, turn the engine over with the throttle fully open until the compression gauge stops rising; the compression is the highest reading obtainable.

Special Tools - Compression Gauge, 20 kgf/cm²: 57001-221
Compression Gauge Adapter, M10 × 1.0: 57001-1317

Cylinder Compression

Usable Range: 1 295 ~ 1 948 kPa (13.2 ~ 19.9 kgf/cm², 188 ~ 282 psi) at 570 r/min (rpm)

- Repeat the measurement for the other cylinder.
- Install the spark plugs (see Spark Plug Replacement in the Periodic Maintenance chapter).

○ The following table should be consulted if the obtainable compression reading is not within the usable range.



Problem	Diagnosis	Remedy (Action)
Cylinder compression is higher than usable range	Carbon accumulation on piston and in combustion chamber possibly due to damaged valve stem oil seal and/or damaged piston oil rings (This may be indicated by white exhaust smoke).	Remove the carbon deposits and replace damaged parts if necessary.
	Incorrect cylinder head gasket thickness	Replace the gasket with a standard part.
Cylinder compression is lower than usable range	Gas leakage around cylinder head	Replace damaged gasket and check cylinder head warp.
	Bad condition of valve seating	Repair if necessary.
	Incorrect valve clearance	Adjust the valve clearance.
	Incorrect piston/cylinder clearance	Replace the piston and/or cylinder.
	Piston seizure	Inspect the cylinder and replace/repair the cylinder and/or piston as necessary.
	Bad condition of piston ring and/or piston ring grooves	Replace the piston and/or the piston rings.

5-26 ENGINE TOP END

Cylinder Head

Cylinder Head Removal

- Drain the coolant (see Coolant Change in the Periodic Maintenance chapter).
- Remove:
 - Exhaust Pipes (see Exhaust Pipe Removal)
 - Camshafts (see Camshaft Removal)
 - Throttle Body Assy Holders (see Throttle Body Assy Holder Removal)
 - Water Hose [A]
 - Front Camshaft Chain Guide [B]
 - Water Temperature Sensor Connector [C]
- Remove the cylinder head and cylinder bolts, following the specified sequence.
- Firstly remove the M6 cylinder head bolts and M6 cylinder bolts [A].

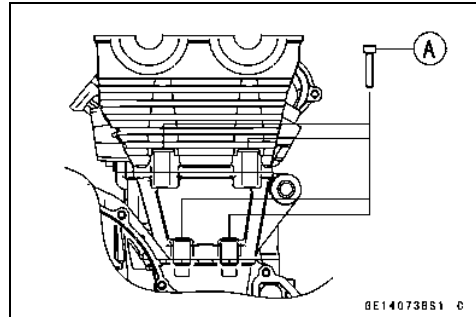
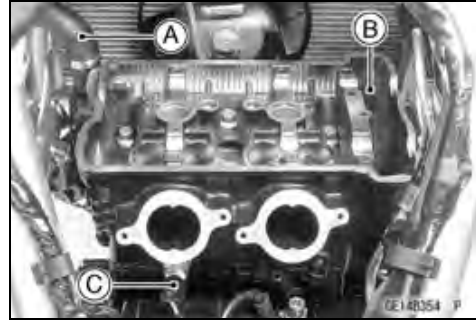

- Secondly, loosen the M8 cylinder bolt [B].
- Thirdly, loosen the M10 cylinder nut [C].
- Lastly, remove the M10 cylinder head bolts [D].

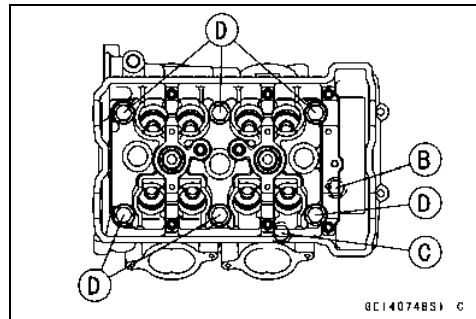

- Take off the cylinder head.

Cylinder Head Installation

NOTE

- The camshaft cap is machined with the cylinder head, so if a new cylinder head is installed, use the cap that is supplied with the new head.
- Install a new cylinder head gasket [A] and dowel pins [B].

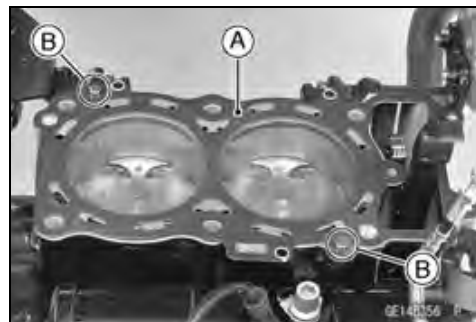

Cylinder Head

- Apply molybdenum disulfide oil solution [A] to both sides of washers and the threads of bolts and nut.
M10 Cylinder Head Bolts [B]
M10 Cylinder Nut [C]
M8 Cylinder Bolt [D]
- Tighten the all bolts and nut following the tightening sequence [1 ~ 8].

Torque - Cylinder Head Bolts (M10):

First: 25 N·m (2.5 kgf·m, 18 ft·lb)

Final: 56 N·m (5.7 kgf·m, 41 ft·lb)

Cylinder Nut (M10): 49 N·m (5.0 kgf·m, 36 ft·lb)

Cylinder Bolt (M8): 27.5 N·m (2.8 kgf·m, 20 ft·lb)

NOTE

- The tightening sequence No.1 ~ No.5 are the cylinder head bolts that are tightened between the cylinder head with the crankcase.
- The No.6 is the cylinder head bolt that is tightened between the cylinder head with the cylinder.
- The No.7 and No.8 are the cylinder nut and cylinder bolt that are tightened between the cylinder and the crankcase.

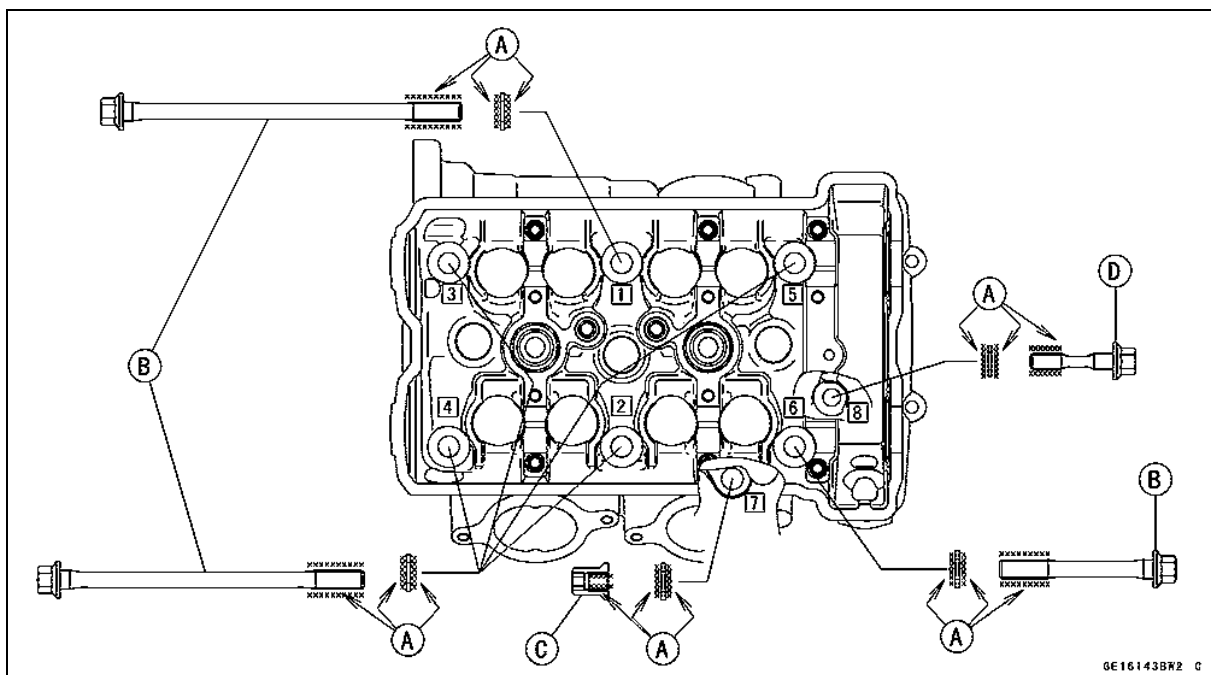

6E16143BR2 C

- Tighten the M6 cylinder head bolts and M6 cylinder bolts [A].

Torque - Cylinder Head Bolts (M6): 12 N·m (1.2 kgf·m, 106 in·lb)

Cylinder Bolts (M6): 12 N·m (1.2 kgf·m, 106 in·lb)

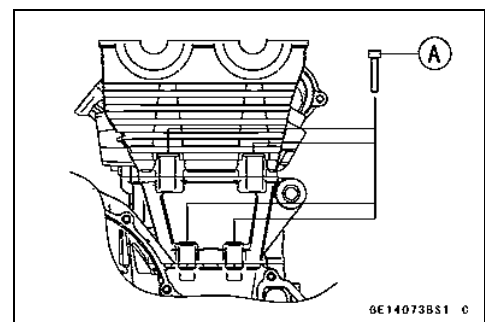

6E14073BS1 C

5-28 ENGINE TOP END

Cylinder Head

- Install the front camshaft chain guide [A].
- Insert the end [B] of front camshaft chain guide into the hollow on the lower crankcase half.
- Install the removed parts (see appropriate chapters).

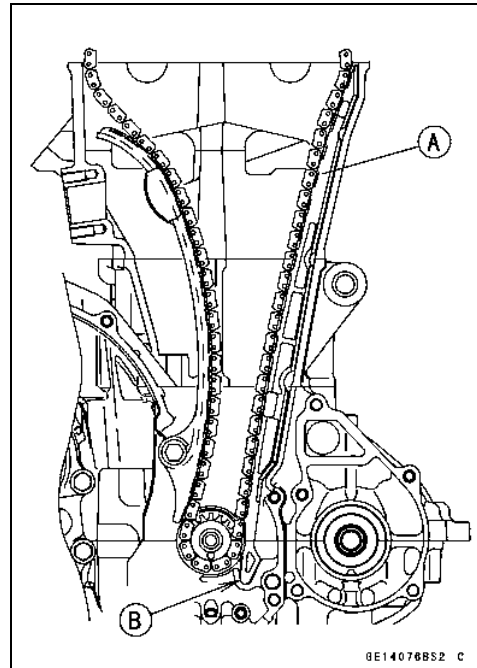

Cylinder Head Warp Inspection

- Clean the cylinder head.
- Lay a straightedge across the lower surface of the cylinder head at several positions.
- Use a thickness gauge [A] to measure the space between the straightedge [B] and the head.

Cylinder Head Warp

Standard: ---

Service Limit: 0.05 mm (0.002 in.)

- ★ If the cylinder head is warped more than the service limit, replace it.
- ★ If the cylinder head is warped less than the service limit, repair the head by rubbing the lower surface on emery paper secured to a surface plate (first No. 200, then No. 400).

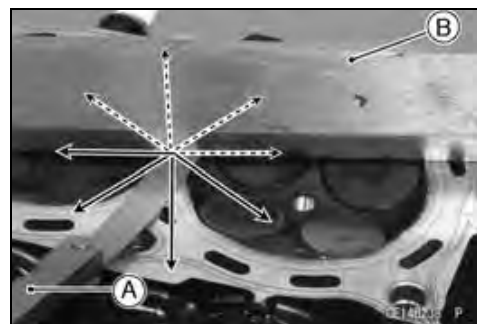

Valves

Valve Clearance Inspection

- Refer to the Valve Clearance Inspection in the Periodic Maintenance chapter.

Valve Clearance Adjustment

- Refer to the Valve Clearance Adjustment in the Periodic Maintenance chapter.

Valve Removal

- Remove cylinder head (see Cylinder Head Removal).
- Remove the valve lifter and shim.
- Mark and record the valve lifter and shim locations so they can be installed in their original positions.
- Using the valve spring compressor assembly, remove the valve.

Special Tools - Valve Spring Compressor Assembly [A]:
57001-241

Valve Spring Compressor Adapter, $\phi 21$ [B]:
57001-1272

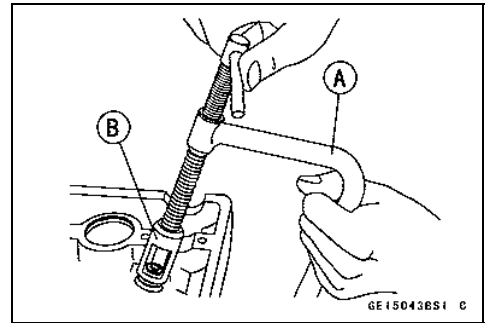

Valve Installation

- Replace the oil seal with a new one.
- Apply engine oil to the oil seal lip.
- Apply a thin coat of molybdenum disulfide grease to the valve stem before valve installation.
- Install the springs so that the closed coil end faces downwards (the side painted in green faces upwards).

Valve Stem [A]

Oil Seal [B]

Spring Seat [C]

Closed Coil End [D]

Valve Spring [E]

Side Painted in Red [F]

Retainer [G]

Split Keepers [H]

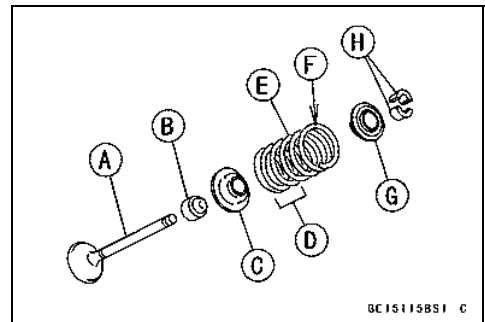

Valve Guide Removal

- Remove:
 - Valve (see Valve Removal)
 - Oil Seal
 - Spring Seat
- Heat the area around the valve guide to 120 ~ 150°C (248 ~ 302°F), and hammer lightly on the valve guide arbor [A] to remove the guide from the top of the head.

CAUTION

Do not heat the cylinder head with a torch. This will warp the cylinder head. Soak the cylinder head in oil and heat the oil.

Special Tool - Valve Guide Arbor, $\phi 4.5$: 57001-1331

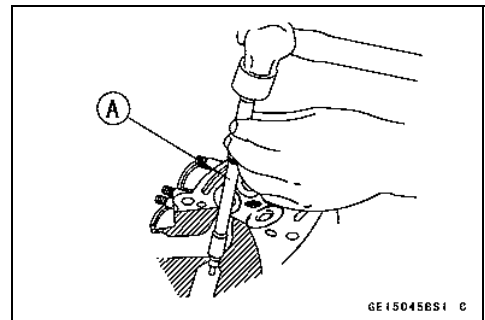

5-30 ENGINE TOP END

Valves

Valve Guide Installation

- Apply engine oil to the valve guide outer surface before installation.
- Heat the area around the valve guide hole to about 120 ~ 150°C (248 ~ 302°F).
- Drive the valve guide in from the top of the head using the valve guide arbor. The flange stops the guide from going in too far.

Special Tool - Valve Guide Arbor, ϕ 4.5: 57001-1331

- Wait until the cylinder head cools down and then ream the valve guide with the valve guide reamer [A] even if the old guide is reused.
- Turn the reamer in a clockwise direction until the reamer turns freely in the guide. Never turn the reamer counter-clockwise or it will be dulled.
- Once the guides are reamed they must be cleaned thoroughly.

Special Tool - Valve Guide Reamer, ϕ 4.5: 57001-1333

Valve-to-Guide Clearance Measurement (Wobble Method)

If a small bore gauge is not available, inspect the valve guide wear by measuring the valve to valve guide clearance with the wobble method as indicated below.

- Insert a new valve [A] into the guide [B] and set a dial gauge against the stem perpendicular to it as close as possible to the cylinder head mating surface.
- Move the stem back and forth [C] to measure valve/valve guide clearance.
- Repeat the measurement in a direction at a right angle to the first.
- ★ If the reading exceeds the service limit, replace the guide.

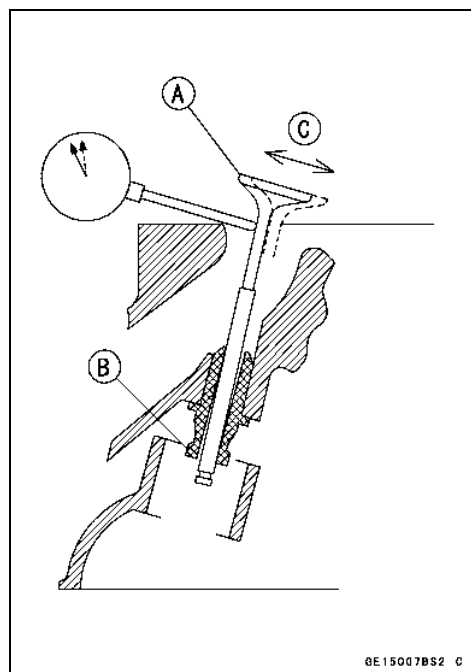
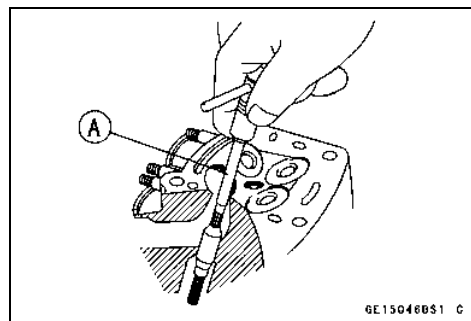

NOTE

- The reading is not actual valve/valve guide clearance because the measuring point is above the guide.

Valve/Valve Guide Clearance (Wobble Method)

Standard:

Exhaust	0.08 ~ 0.16 mm (0.0032 ~ 0.0063 in.)
Inlet	0.03 ~ 0.10 mm (0.0012 ~ 0.0039 in.)

Service Limit:

Exhaust	0.35 mm (0.014 in.)
Inlet	0.29 mm (0.011 in.)

Valves

Valve Seat Inspection

- Remove the valve (see Valve Removal).
- Check the valve seating surface [A] between the valve [B] and valve seat [C].
- Measure the outside diameter [D] of the seating pattern on the valve seat.
- ★ If the outside diameter is too large or too small, repair the seat (see Valve Seat Repair).

Valve Seating Surface Outside Diameter

Standard:

Exhaust	27.6 ~ 27.8 mm (1.087 ~ 1.094 in.)
Inlet	32.6 ~ 32.8 mm (1.283 ~ 1.291 in.)

- Measure the seat width [E] of the portion where there is no build-up carbon (white portion) of the valve seat with a vernier caliper.

Good [F]

- ★ If the width is too wide [G], too narrow [H] or uneven [J], repair the seat (see Valve Seat Repair).

Valve Seating Surface Width

Standard:

Exhaust	0.5 ~ 1.0 mm (0.02 ~ 0.04 in.)
Inlet	0.5 ~ 1.0 mm (0.02 ~ 0.04 in.)

Valve Seat Repair

- Repair the valve seat with the valve seat cutters [A].

Special Tools - Valve Seat Cutter Holder Bar [C]: 57001-1128

Valve Seat Cutter Holder, ϕ 4.5 [B]: 57001-1330

For Exhaust Valve Seat

Valve Seat Cutter, 45° - ϕ 30: 57001-1187

Valve Seat Cutter, 32° - ϕ 30: 57001-1120

Valve Seat Cutter, 60° - ϕ 30: 57001-1123

For Inlet Valve Seat

Valve Seat Cutter, 45° - ϕ 35: 57001-1116

Valve Seat Cutter, 32° - ϕ 35: 57001-1121

Valve Seat Cutter, 55° - ϕ 35: 57001-1247

- ★ If the manufacturer's instructions are not available, use the following procedure.

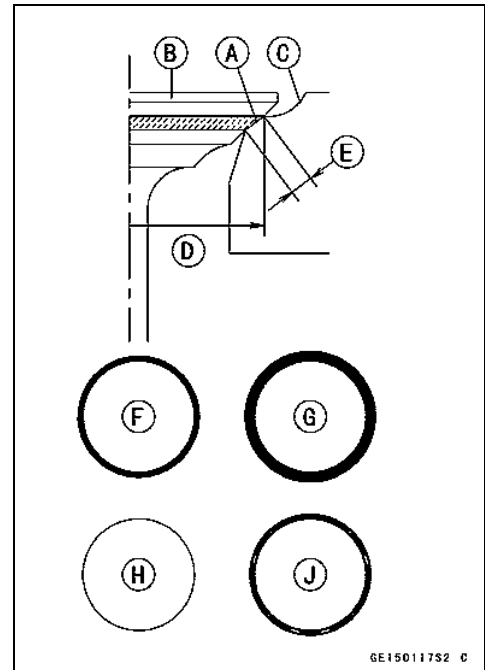

GE150117S2 C

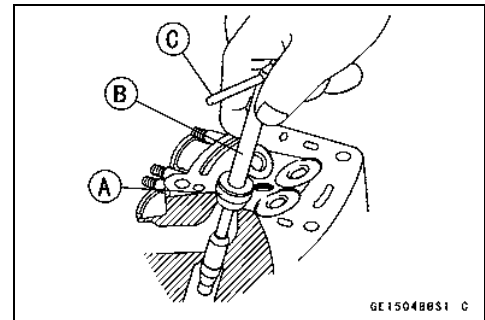

GE150488S1 C

5-32 ENGINE TOP END

Valves

Seat Cutter Operation Care

1. This valve seat cutter is developed to grind the valve for repair. Therefore the cutter must not be used for other purposes than seat repair.
2. Do not drop or shock the valve seat cutter, or the diamond particles may fall off.
3. Do not fail to apply engine oil to the valve seat cutter before grinding the seat surface. Also wash off ground particles sticking to the cutter with washing oil.

NOTE

○Do not use a wire brush to remove the metal particles from the cutter. It will take off the diamond particles.

4. Setting the valve seat cutter holder in position, operate the cutter in one hand. Do not apply too much force to the diamond portion.

NOTE

○Prior to grinding, apply engine oil to the cutter and during the operation, wash off any ground particles sticking to the cutter with washing oil.

5. After use, wash it with washing oil and apply thin layer of engine oil before storing.

Marks Stamped on the Cutter

The marks stamped on the back of the cutter [A] represent the following.

- 60° Cutter angle [B]
φ37.5 Outer diameter of cutter [C]

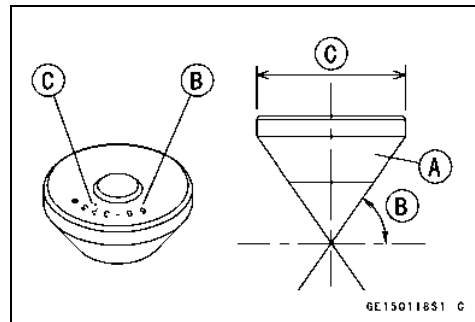

Operating Procedures

- Clean the seat area carefully.
- Coat the seat with machinist's dye.
- Fit a 45° cutter into the holder and slide it into the valve guide.
- Press down lightly on the handle and turn it right or left. Grind the seating surface only until it is smooth.

CAUTION

Do not grind the seat too much. Overgrinding will reduce valve clearance by sinking the valve into the head. If the valve sinks too far into the head, it will be impossible to adjust the clearance, and the cylinder head must be replaced.

Valves

- Measure the outside diameter of the seating surface with a vernier caliper.
- ★ If the outside diameter of the seating surface is too small, repeat the 45° grind until the diameter is within the specified range.
 - Widened Width [A] of engagement by machining with 45° cutter
 - Ground Volume [B] by 32° cutter
 - 32° [C]
 - Correct Width [D]
 - Ground Volume [E] by 60° or 55° cutter
 - 60° or 55° [F]

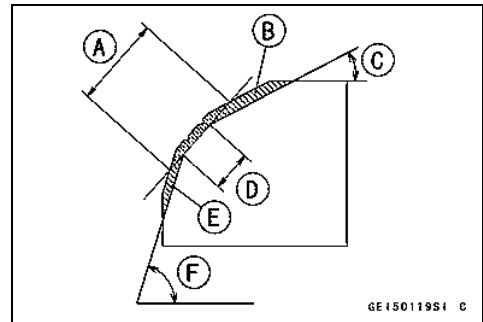

- Measure the outside diameter of the seating surface with a vernier caliper.
- ★ If the outside diameter of the seating surface is too small, repeat the 45° grind [A] until the diameter is within the specified range.
 - Original Seating Surface [B]

NOTE

- Remove all pittings of flaws from 45° ground surface.
 - After grinding with 45° cutter, apply thin coat of machinist's dye to seating surface. This makes seating surface distinct and 32° and 60° (or 55°) grinding operation easier.
 - When the valve guide is replaced, be sure to grind with 45° cutter for centering and good contact.
- ★ If the outside diameter [A] of the seating surface is too large, make the 32° grind described below.
 - ★ If the outside diameter of the seating surface is within the specified range, measure the seat width as described below.
 - Grind the seat at a 32° angle [B] until the seat outside diameter is within the specified range.
 - To make the 32° grind, fit a 32° cutter into the holder, and slide it into the valve guide.
 - Turn the holder one turn at a time while pressing down very lightly. Check the seat after each turn.

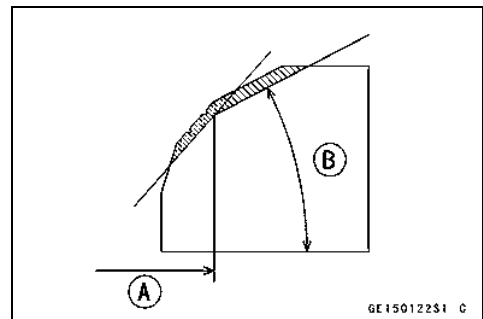
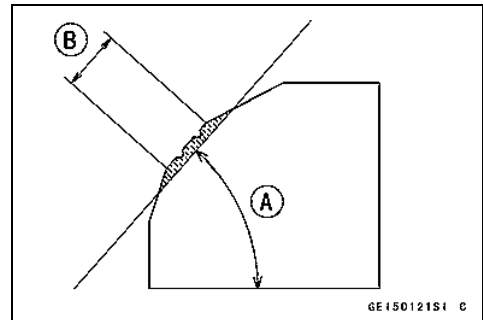

CAUTION

The 32° cutter removes material very quickly. Check the seat outside diameter frequently to prevent overgrinding.

- After making the 32° grind, return to the seat outside diameter measurement step above.
- To measure the seat width, use a vernier caliper to measure the width of the 45° angle portion of the seat at several places around the seat.
- ★ If the seat width is too narrow, repeat the 45° grind until the seat is slightly too wide, and then return to the seat outside diameter measurement step above.

5-34 ENGINE TOP END

Valves

- ★ If the seat width is too wide, make the 60° or 55° [A] grind described below.
- ★ If the seat width is within the specified range, lap the valve to the seat as described below.
- Grind the seat at a 60° or 55° angle until the seat width is within the specified range.
- To make the 60° or 55° grind, fit 60° or 55° cutter into the holder, and slide it into the valve guide.
- Turn the holder, while pressing down lightly.
- After making the 60° or 55° grind, return to the seat width measurement step above.
Correct Width [B]

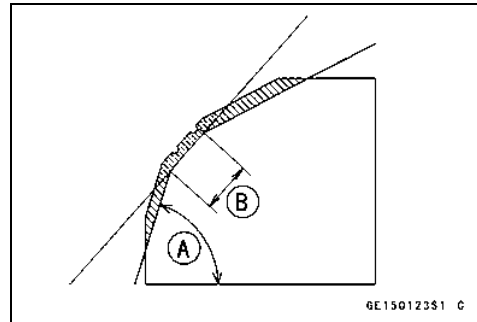

- Lap the valve to the seat, once the seat width and outside diameter are within the ranges specified above.
- Put a little coarse grinding compound on the face of the valve in a number of places around the valve head.
- Spin the valve against the seat until the grinding compound produces a smooth, matched surface on both the seat and the valve.
- Repeat the process with a fine grinding compound.
Lapper [A]
Valve Seat [B]
Valve [C]
- The seating area should be marked about in the middle of the valve face.
- ★ If the seat area is not in the right place on the valve, check to be sure the valve is the correct part. If it is, it may have been refaced too much; replace it.
- Be sure to remove all grinding compound before assembly.
- When the engine is assembled, be sure to adjust the valve clearance (see Valve Clearance Adjustment in the Periodic Maintenance chapter).

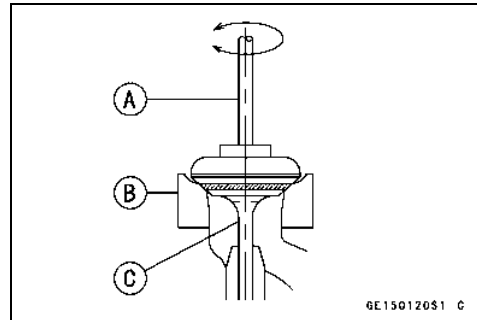

Valves

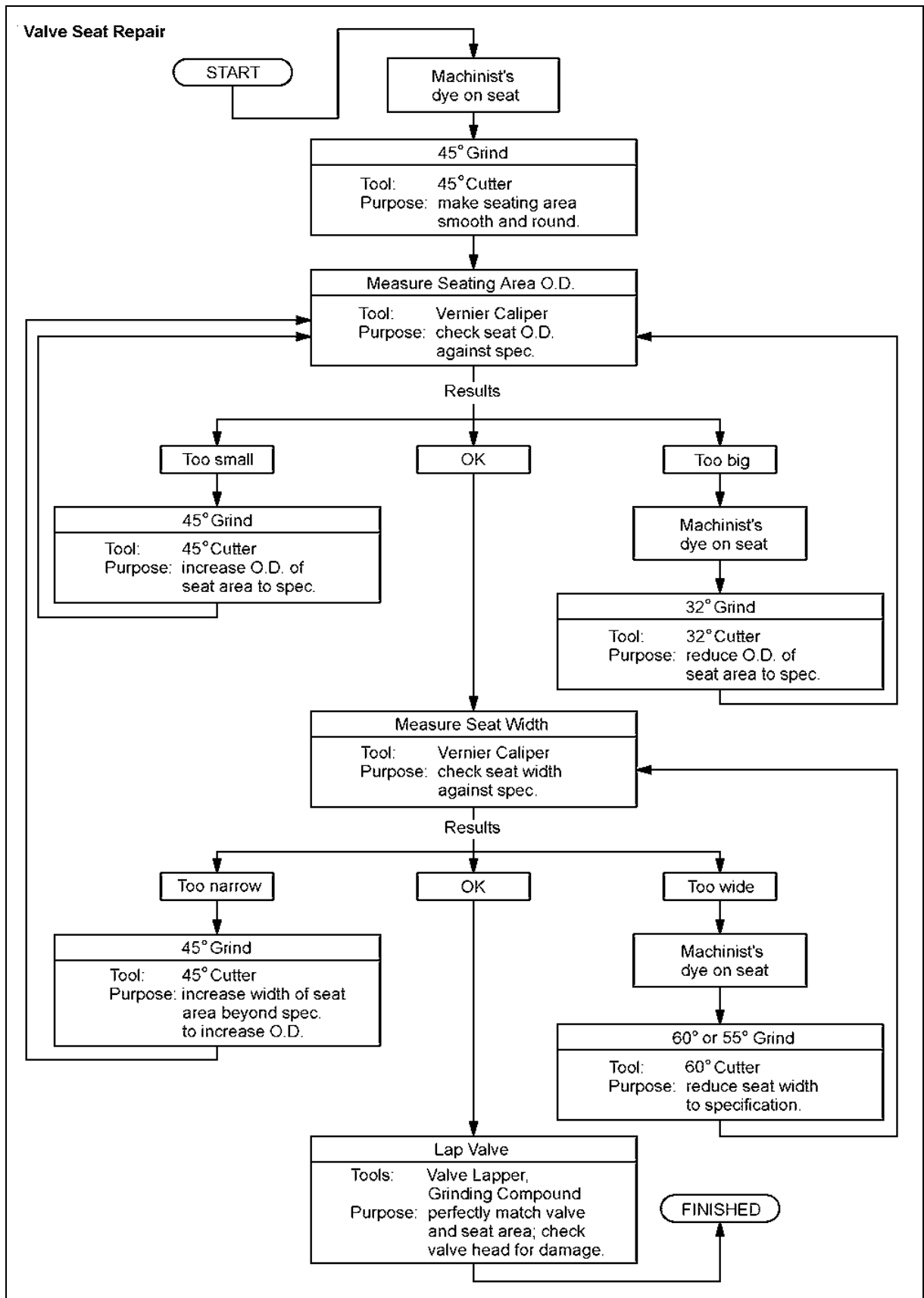

5-36 ENGINE TOP END

Cylinder, Pistons

Cylinder Removal

- Remove:
 - Cylinder Head (see Cylinder Head Removal)
 - Engine Mounting Bolts (Left and Right) [A] (see Engine Removal in the Engine Removal/Installation chapter)
 - Engine Brackets (Left and Right) [B] (see Engine Removal in the Engine Removal/Installation chapter)
 - Cylinder [C]

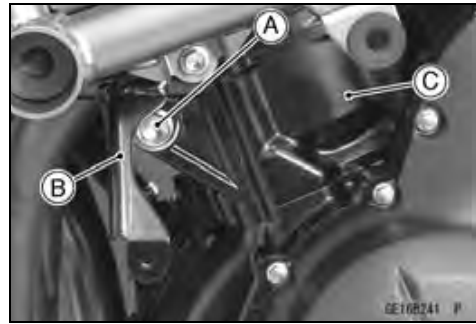

Cylinder Installation

NOTE

○ If a new cylinder is used, use new piston ring.

- Install the dowel pins [A] and new cylinder gasket [B].

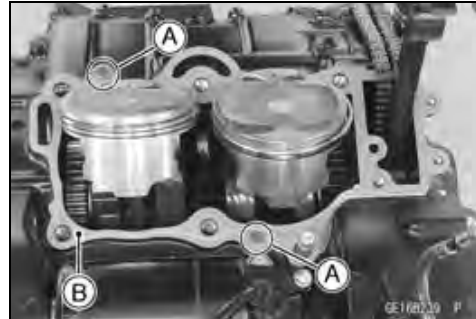

- The piston ring openings must be positioned as shown in the figure. The openings of the oil ring steel rails must be about 30 ~ 40° of angle from the opening of the top ring.

Top Ring [A]
Second Ring [B]
Oil Ring Steel Rails [C]
Oil Ring Expander [D]
Hollow [E]
30 ~ 40° [F]

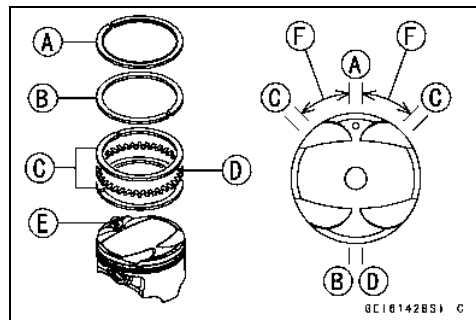

- Apply molybdenum disulfide oil solution to the cylinder bore, piston rings and piston skirt.
- Prepare two auxiliary head bolts with their head cut.
- Install the two bolts [A] diagonally in the crankcase.
- Position the crankshaft so that all the piston heads are almost level.
- Install the cylinder block.
- Insert the piston rings with your thumbs.

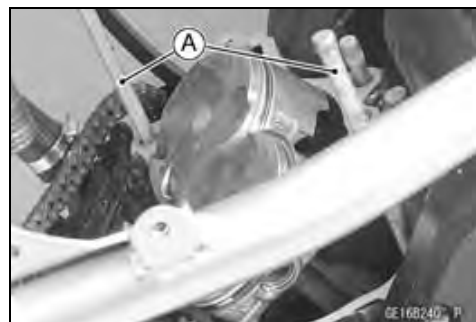

Piston Removal

- Remove the cylinder (see Cylinder Removal).
- Place a clean cloth under the pistons and remove the piston pin snap ring [A] from the outside of each piston.



Cylinder, Pistons

- Remove the piston pins.

Special Tools - Piston Pin Puller [A]: 57001-1568

Piston Pin Puller Adapter, ϕ 12 [D]: 57001-1657

Center Bolt [B]

Shell of Piston [C]

- Remove the pistons.

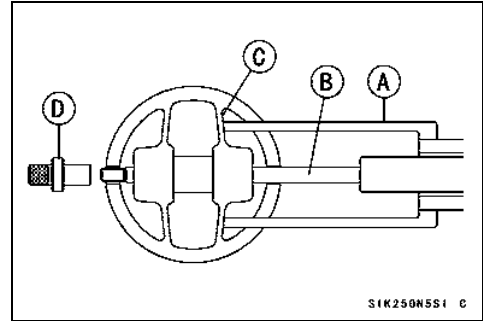

- Carefully spread the ring opening with your thumbs and then push up on the opposite side of the ring [A] to remove it.
- Remove the 3-piece oil ring with your thumbs in the same manner.

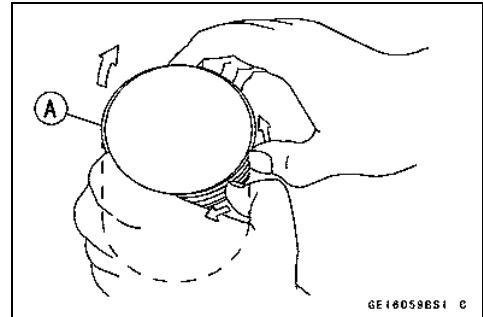

Piston Installation

- Apply molybdenum disulfide oil solution to the oil ring expander, install the oil ring expander [A] in the bottom piston ring groove so the ends [B] butt together.
- Apply molybdenum disulfide oil solution to the oil ring steel rails, and install the oil ring steel rails, one above the expander and one below it.
- Spread the rail with your thumbs, but only enough to fit the rail over the piston.
- Release the rail into the bottom piston ring groove.

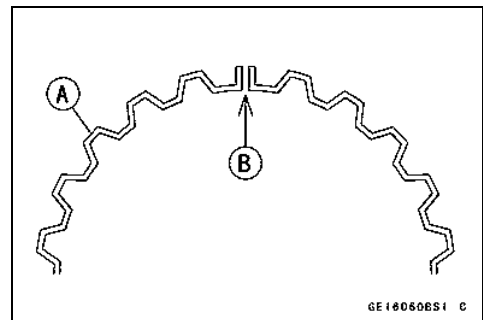

NOTE

○ The oil ring rails have no "top" or "bottom".

- Apply molybdenum disulfide oil solution to the top and second rings.
- Do not mix up the top and second ring.
- Install the top ring [A] so that the "R" mark [B] faces up.
- Install the second ring [C] so that the "RN" mark [D] faces up.

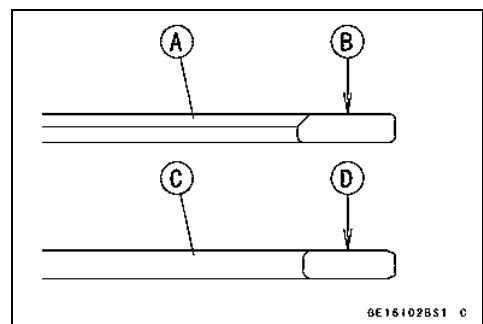

5-38 ENGINE TOP END

Cylinder, Pistons

NOTE

○ If a new piston is used, use new piston ring.

- Install the piston with its marking hollow [A] facing forward.

- Fit a new piston pin snap ring into the side of the piston so that the ring opening [A] does not coincide with the slit [B] of the piston pin hole.
- Apply molybdenum disulfide oil solution to the piston pins and piston skirt.
- When installing the piston pin snap ring, compress it only enough to install it and no more.

CAUTION

Do not reuse snap rings, as removal weakens and deforms them. They could fall out and score the cylinder wall.

- Install the cylinder (see Cylinder Installation).

Cylinder Wear Inspection

- Since there is a difference in cylinder wear in different directions, take a side-to-side and a front-to-back measurement at each of the two locations (total of four measurements) shown in the figure.
- ★ If any of the cylinder inside diameter measurements exceeds the service limit, replace the cylinder.
 - 10 mm (0.39 in.) [A]
 - 60 mm (2.36 in.) [B]

Cylinder Inside Diameter

Standard: 82.994 ~ 83.006 mm (3.2675 ~ 3.2679 in.)

Service Limit: 83.09 mm (3.271 in.)

Piston Wear Inspection

- Measure the outside diameter [A] of each piston 18 mm (0.7087 in.) [B] up from the bottom of the piston at a right angle to the direction of the piston pin.
- ★ If the measurement is under service limit, replace the piston.

Piston Diameter

Standard: 82.969 ~ 82.984 mm (3.2665 ~ 3.2671 in.)

Service Limit: 82.82 mm (3.261 in.)

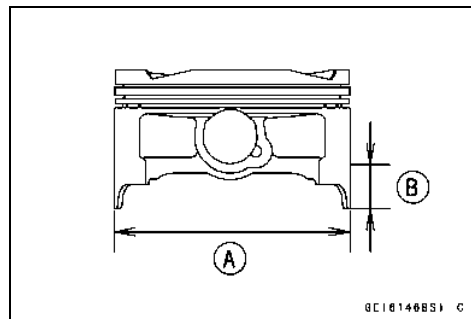
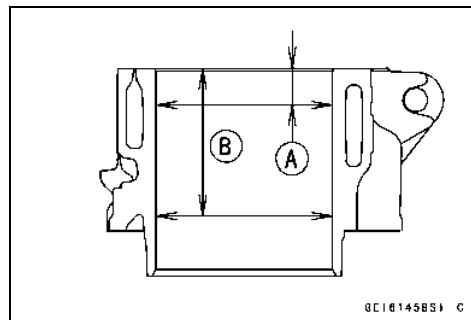
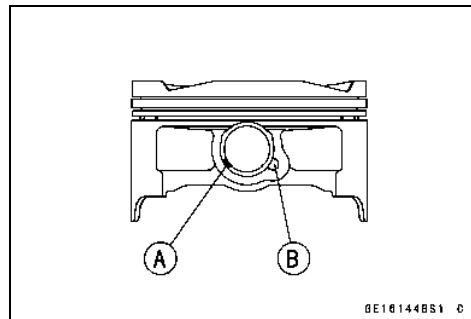
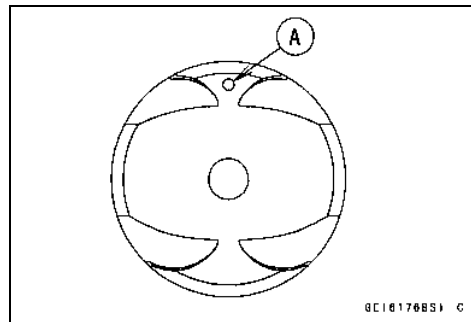

Cylinder, Pistons

Piston Ring, Piston Ring Groove Wear Inspection

- Check for uneven groove wear by inspecting the ring seating.
- ★ The rings should fit perfectly parallel to groove surfaces. If not, replace the piston and all the piston rings.
- With the piston rings in their grooves, make several measurements with a thickness gauge [A] to determine piston ring/groove clearance.

Piston Ring/Groove Clearance

Top

- Standard:** 0.03 ~ 0.07 mm (0.001 ~ 0.003 in.)
- Service Limit:** 0.17 mm (0.0067 in.)

Second

- Standard:** 0.02 ~ 0.06 mm (0.001 ~ 0.002 in.)
- Service Limit:** 0.16 mm (0.0063 in.)

Piston Ring Groove Width Inspection

- Measure the piston ring groove width.
- Use a vernier caliper at several points around the piston.

Piston Ring Groove Width

Top [A]

- Standard:** 0.92 ~ 0.94 mm (0.0362 ~ 0.0370 in.)
- Service Limit:** 1.02 mm (0.0402 in.)

Second [B]

- Standard:** 1.01 ~ 1.03 mm (0.0398 ~ 0.0406 in.)
- Service Limit:** 1.11 mm (0.0437 in.)

- ★ If the width of any of the two grooves is wider than the service limit at any point, replace the piston.

Piston Ring Thickness Inspection

- Measure the piston ring thickness.
- Use the micrometer to measure at several points around the ring.

Piston Ring Thickness

Top [A]

- Standard:** 0.87 ~ 0.89 mm (0.0343 ~ 0.0350 in.)
- Service Limit:** 0.80 mm (0.031 in.)

Second [B]

- Standard:** 0.97 ~ 0.99 mm (0.0382 ~ 0.0390 in.)
- Service Limit:** 0.90 mm (0.035 in.)

- ★ If any of the measurements is less than the service limit on either of the rings, replace all the rings.

NOTE

- When using new rings in a used piston, check for uneven groove wear. The rings should fit perfectly parallel to the groove sides. If not, replace the piston.

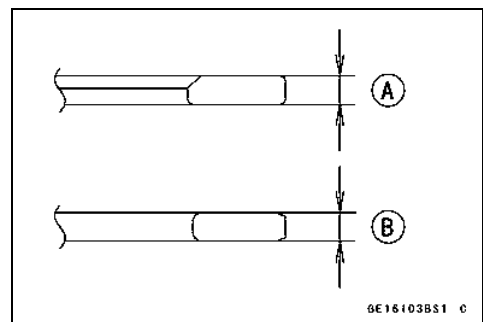
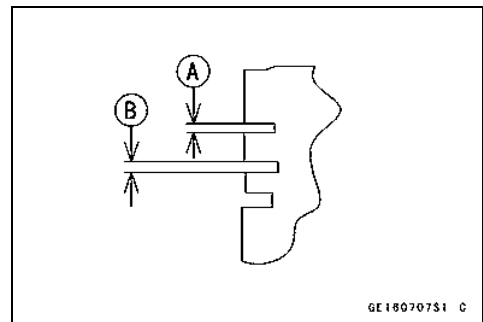
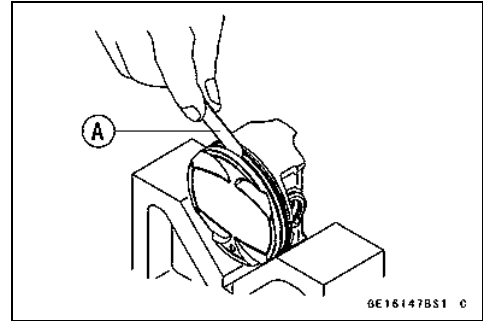

5-40 ENGINE TOP END

Cylinder, Pistons

Piston Ring End Gap Inspection

- Place the piston ring [A] inside the cylinder, using the piston to locate the ring squarely in place. Set it close to the bottom of the cylinder, where cylinder wear is low.
- Measure the gap [B] between the ends of the ring with a thickness gauge.

Piston Ring End Gap

Top

Standard: 0.25 ~ 0.40 mm (0.0098 ~ 0.0157 in.)

Service Limit: 0.7 mm (0.028 in.)

Second

Standard: 0.40 ~ 0.55 mm (0.0157 ~ 0.0217 in.)

Service Limit: 0.9 mm (0.035 in.)

- ★ If the end gap of either ring is greater than the service limit, replace all the rings.

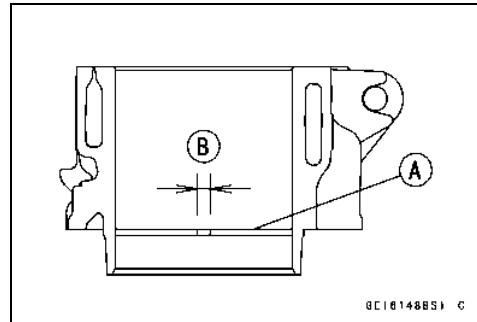

Throttle Body Assy Holder

Throttle Body Assy Holder Removal

- Remove:
 - Throttle Body Assy (see Throttle Body Assy Removal in the Fuel System (DFI) chapter)
 - Clamps [A]
 - Bolts [B]
 - Throttle Body Assy Holders [C]



Throttle Body Assy Holder Installation

- Be sure to install the new O-rings [A].
- Apply grease to the new O-rings.
- Tighten:
 - Torque - Throttle Body Assy Holder Bolts: 12 N·m (1.2 kgf·m, 106 in·lb)**
- Install the clamps [B] so that their projections [C] fit on the holes of the holders.
- Be sure that the clamp bolt heads [D] face outward.
 - Upside View [E]

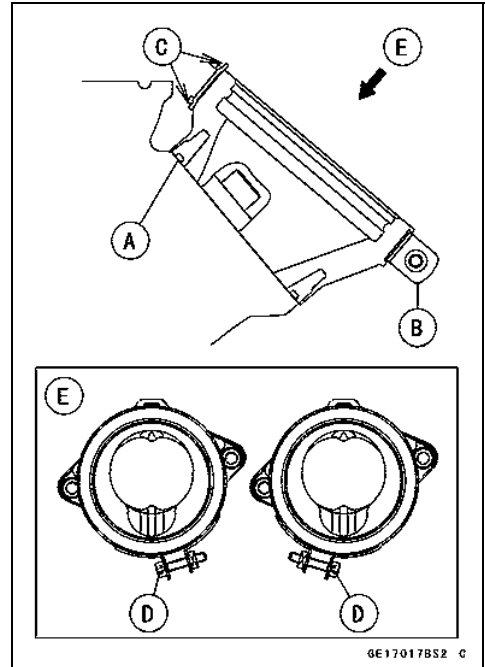

5-42 ENGINE TOP END

Muffler

Muffler Body Removal

⚠ WARNING

To avoid a serious burn, do not remove the muffler when the engine is still hot. Wait until the muffler cool down.

- Remove:
 - Right Footpeg Stay (see Footpeg Stay Removal in the Frame chapter)
 - Lower Fairing Brackets (see Lower Fairing Bracket Removal in the Frame chapter)
 - Oxygen Sensor Lead Connector [A] (Equipped Models)



- Loosen the exhaust pipe manifold holder nuts [A].



- Loosen the muffler body clamp bolt [A].
- Remove the muffler body mounting bolts [B] and nut, and pull the muffler body [C] to backward.

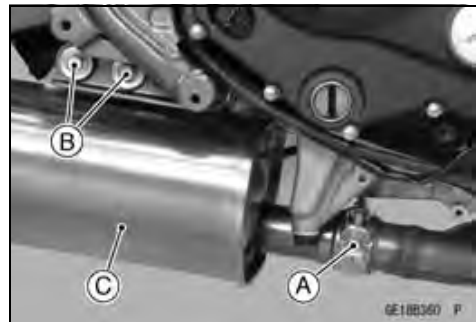

Exhaust Pipe Removal

- Remove:
 - Lower Fairing (see Lower Fairing Removal in the Frame chapter)
 - Exhaust Pipe Manifold Holder Nuts [A]



Muffler

- Loosen the muffler body clamp bolt [A].
- Remove the exhaust pipe to forward.



5-44 ENGINE TOP END

Muffler

Muffler Body and Exhaust Pipe Installation

- Replace the exhaust pipe gaskets [A] and muffler body gasket [B] with new ones and install them.
- Install the muffler body gasket until it is bottomed so that the chamfer side [C] faces exhaust pipe [D].
- Install:
 - Muffler Body [E]
 - Exhaust Pipe
- Tighten:
 - Torque - Exhaust Pipe Manifold Holder Nuts [F]: 17 N·m (1.7 kgf·m, 13 ft·lb)**
 - Muffler Body Mounting Bolts (Front and Rear) [G]: 20 N·m (2.0 kgf·m, 15 ft·lb)**
- Install the muffler body clamp bolt [H] as shown in the figure.
- Tighten the muffler body clamp bolt.

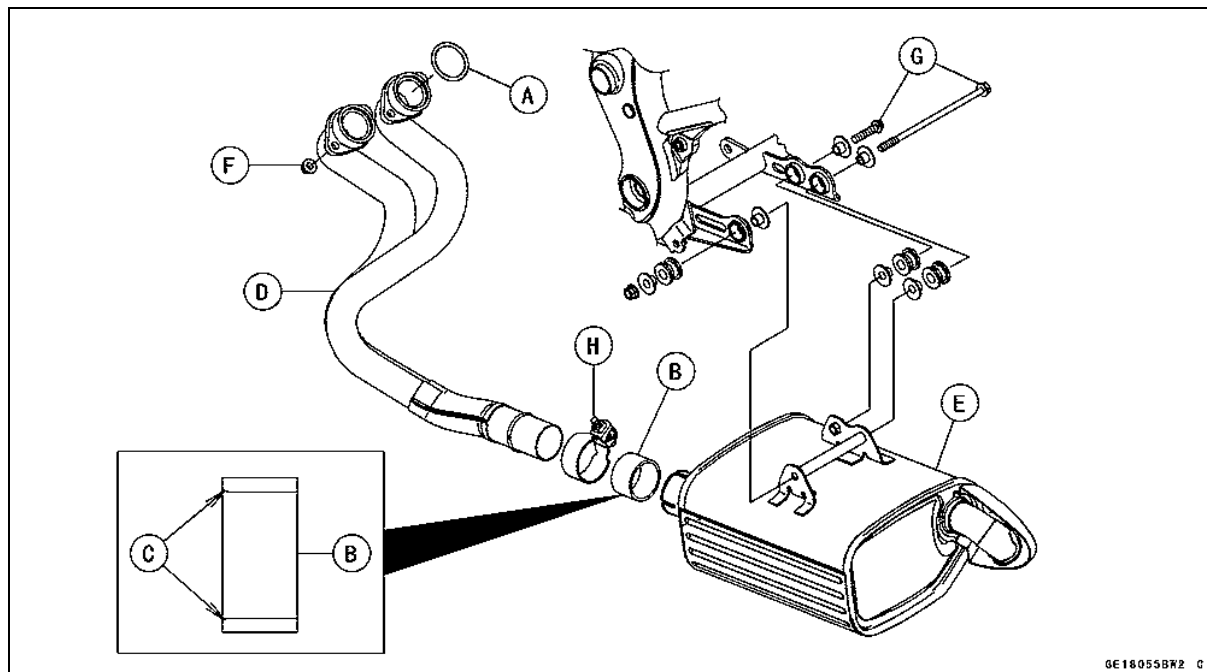

- Install the right footpeg stay (see Footpeg Stay Installation in the Frame chapter).
- For the oxygen sensor equipped Models, route its lead correctly (see Cable, Wire, and Hose Routing section in the Appendix chapter).

CAUTION

Do not pull strongly, twist, or bend the oxygen sensor lead. This may cause the wiring open.

- Thoroughly warm up the engine, wait until the engine cools down, and retighten all the bolts and nuts.

Clutch

Table of Contents

Exploded View	6-2
Specifications	6-4
Special Tool and Sealant	6-5
Clutch Lever and Cable	6-6
Clutch Lever Free Play Inspection	6-6
Clutch Lever Free Play Adjustment	6-6
Clutch Cable Removal	6-6
Clutch Cable Installation	6-6
Clutch Cable Lubrication	6-7
Clutch Lever Installation	6-7
Clutch Lever Adjustment	6-7
Clutch Cover	6-8
Clutch Cover Removal	6-8
Clutch Cover Installation	6-8
Release Shaft Removal	6-8
Release Shaft Installation	6-9
Clutch Cover Disassembly	6-9
Clutch Cover Assembly	6-9
Clutch	6-11
Clutch Removal	6-11
Clutch Installation	6-12
Clutch Plate, Wear, Damage Inspection	6-14
Clutch Plate Warp Inspection	6-14
Clutch Spring Free Length Measurement	6-14
Clutch Housing Finger Inspection	6-15
Clutch Housing Spline Inspection	6-15

6-2 CLUTCH

Exploded View

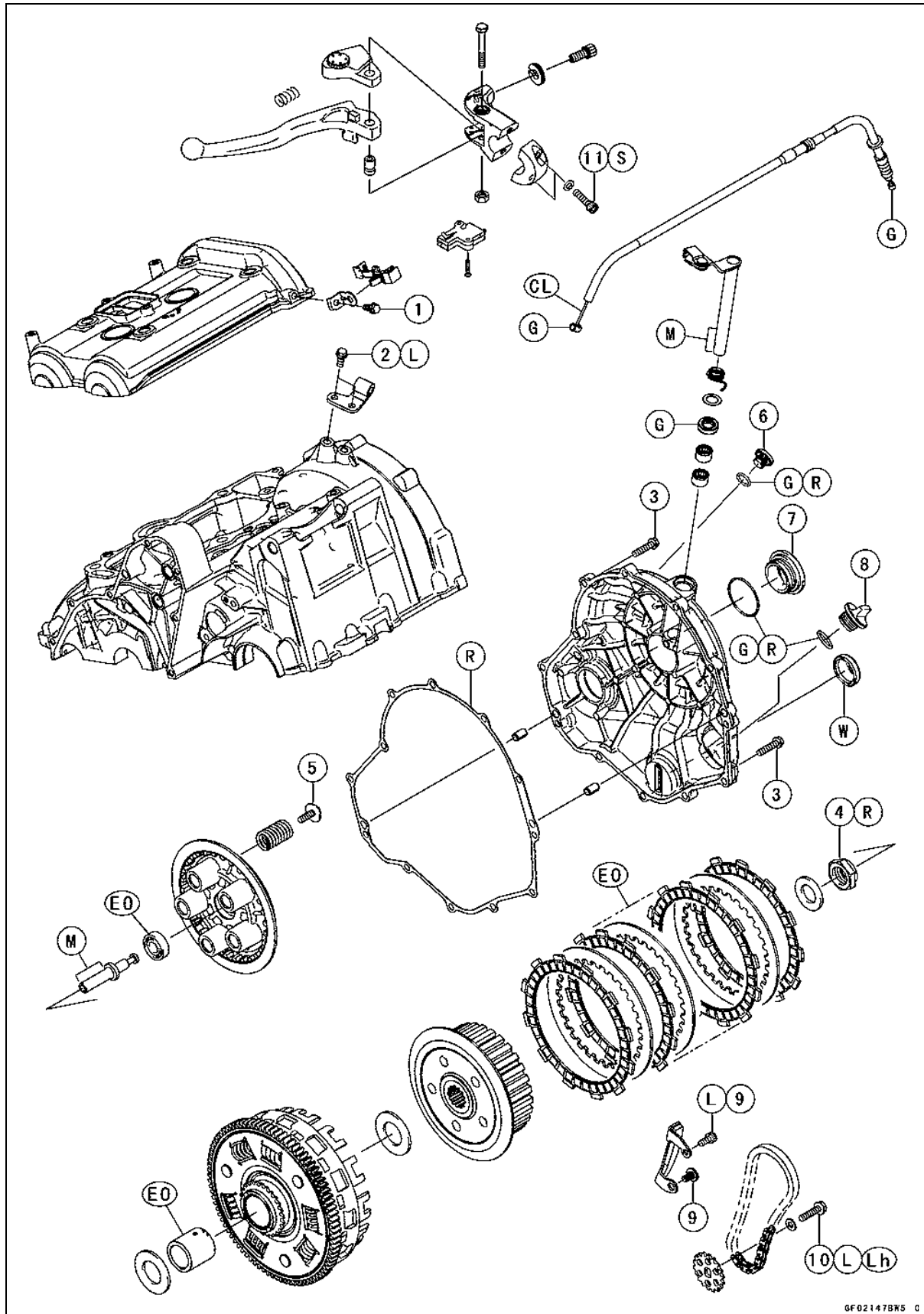

GF02147BK5 C

Exploded View

No.	Fastener	Torque			Remarks
		N·m	kgf·m	ft·lb	
1	Clutch Cable Clamp Bracket Bolt	9.8	1.0	87 in·lb	
2	Clutch Cable Holder Bolts	9.8	1.0	87 in·lb	L
3	Clutch Cover Bolts	9.8	1.0	87 in·lb	
4	Clutch Hub Nut	130	13.3	96	R
5	Clutch Spring Bolts	9.8	1.0	87 in·lb	
6	Timing Inspection Cap	3.9	0.40	35 in·lb	
7	Timing Rotor Bolt Cap	4.9	0.50	43 in·lb	
8	Oil Filler Plug	–	–	–	Hand-tighten
9	Oil Pump Chain Guide Bolts	12	1.2	106 in·lb	L (1)
10	Oil Pump Sprocket Bolt	12	1.2	106 in·lb	L, Lh
11	Clutch Lever Clamp Bolts	7.8	0.80	69 in·lb	S

CL: Apply cable lubricant.

EO: Apply engine oil.

G: Apply grease.

L: Apply a non-permanent locking agent.

Lh: Left-hand Threads

M: Apply molybdenum disulfide grease.

R: Replacement Parts

S: Follow the specified tightening sequence.

W: Apply water.

6-4 CLUTCH

Specifications

Item	Standard	Service Limit
Clutch Lever Free Play	2 ~ 3 mm (0.08 ~ 0.12 in.)	— — —
Clutch		
Friction Plate Thickness	2.92 ~ 3.08 mm (0.115 ~ 0.121 in.)	2.8 mm (0.110 in.)
Friction Plate Warp	0.15 mm (0.0059 in.) or less	0.3 mm (0.012 in.)
Steel Plate Warp	0.2 mm (0.008 in.) or less	0.3 mm (0.012 in.)
Clutch Spring Free Length	33.60 mm (1.323 in.)	32.6 mm (1.28 in.)

Special Tool and Sealant

**Clutch Holder:
57001-1243**

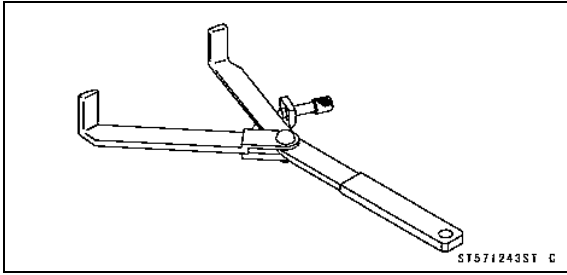

**Kawasaki Bond (Silicone Sealant):
92104-0004**

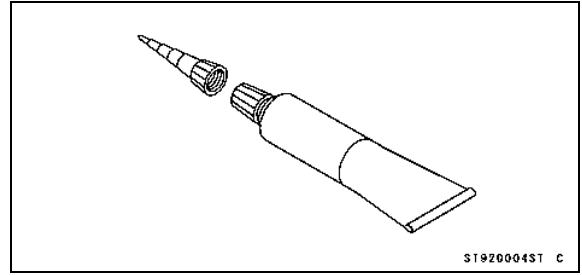

6-6 CLUTCH

Clutch Lever and Cable

Clutch Lever Free Play Inspection

- Refer to the Clutch Operation Inspection in the Periodic Maintenance chapter.

Clutch Lever Free Play Adjustment

- Refer to the Clutch Operation Inspection in the Periodic Maintenance chapter.

Clutch Cable Removal

- Remove the right upper fairing cover (see Upper Fairing Cover Removal in the Frame chapter).
- Open the clamp [A].
- Slide the dust cover [B] out of place.
- Loosen the locknut [C], and turn the adjusting nut [D] to give the cable plenty of play.

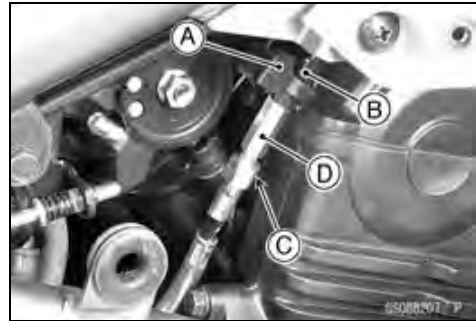

- Screw in the adjuster.
- Line up the slots [A] in the clutch lever [B] and adjuster [C], and then free the cable from the lever.

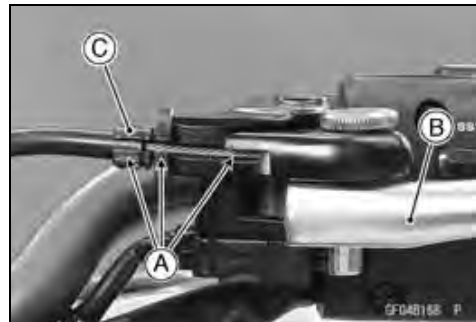

- Free the idle adjusting screw [A] from the bracket [B].
- Remove the bolt [C] to take off the bracket.

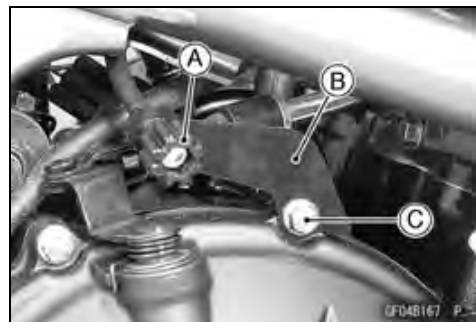

- Slide the dust cover [A] at the clutch cable lower end, and pull the clutch cable out of the clutch cable holder [B].
- Free the clutch inner cable tip [C] from the clutch release lever [D].
- Push the release lever toward the front of the motorcycle and tape the release lever to the clutch cover to prevent the release shaft from falling out.
- Pull the clutch cable out of the frame.

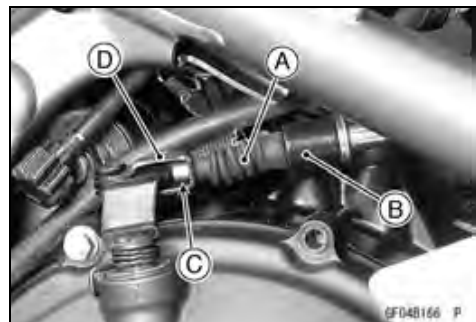

Clutch Cable Installation

- Run the clutch cable correctly (see Cable, Wire, and Hose Routing section in the Appendix chapter).
- Adjust the clutch cable (see Clutch Operation Inspection in the Periodic Maintenance chapter).

Clutch Lever and Cable

Clutch Cable Lubrication

- Refer to the Chassis Parts Lubrication in the Periodic Maintenance chapter.

Clutch Lever Installation

- Install the clutch lever so that the mating surface [A] of the clutch lever clamp is aligned with the punch mark [B].
- Tighten the upper clamp bolt first, and then the lower clamp bolt.
- There will be a gap at the lower part of the clamp after tightening.

Torque - Clutch Lever Clamp Bolts: 7.8 N·m (0.80 kgf·m, 69 in·lb)

Clutch Lever Adjustment

The adjuster has 5 positions so that the clutch lever position can be adjusted to suit the operator's hand.

- Push the lever forward and turn the adjuster [A] to align the number with the arrow mark [B] on the lever holder.
- The distance from the grip to the lever is minimum at number 5 and maximum at number 1.

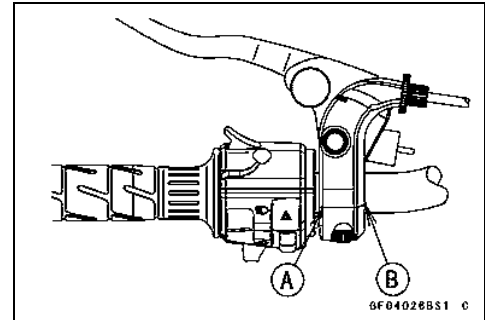

6-8 CLUTCH

Clutch Cover

Clutch Cover Removal

- Drain the engine oil (see Engine Oil Change in the Periodic Maintenance chapter).
- Remove:
 - Right Frame Cover (see Frame Cover Removal in the Frame chapter)
 - Lower Fairing (see Lower Fairing Removal in the Frame chapter)
 - Clutch Cable Lower End [A] (see Clutch Cable Removal)
 - Clutch Cover Mounting Bolts [B]
- Turn the release lever [A] toward the rear as shown, and remove the clutch cover [B].
 - About 90° [C]

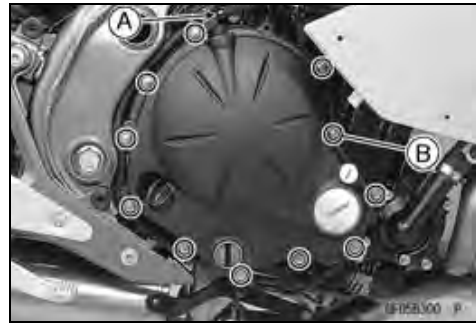

Clutch Cover Installation

- Apply silicone sealant to the following areas [A].
 - Crankcase Halves Mating Surface
 - Crankshaft Sensor Lead Grommet
 - Sealant - Kawasaki Bond (Silicone Sealant): 92104-0004
 - Install the dowel pins [B].
 - Replace the clutch cover gasket with a new one.
 - Install the clutch cover.
- Torque - Clutch Cover Bolts: 9.8 N·m (1.0 kgf·m, 87 in·lb)**
- Tighten with Bracket [A]

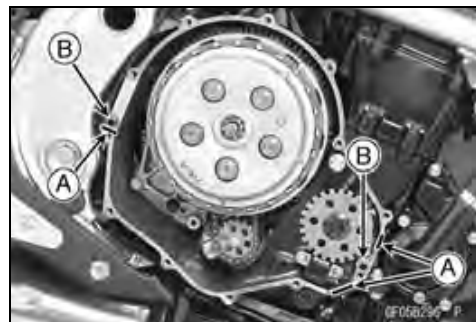

Release Shaft Removal

CAUTION

Do not remove the clutch release lever and shaft assembly unless it is absolutely necessary. If removed, the oil seal replacement may be required.

- Remove the clutch cover (see Clutch Cover Removal).
- Pull the lever and shaft assembly [A] straight out of the clutch cover.



Clutch Cover

Release Shaft Installation

- Apply grease to the oil seal lips on the upper ridge of the clutch cover.
- Apply molybdenum disulfide grease to the pusher-holding portion [A] on the release shaft.
- Install the washer [B] and spring [C].
- Insert the release shaft straight into the upper hole of the clutch cover.

CAUTION

When inserting the release shaft, be careful not to remove the spring of the oil seal.

- Fit the spring ends [A] as shown in the figure.
Release Shaft [B]
Clutch Cover [C]

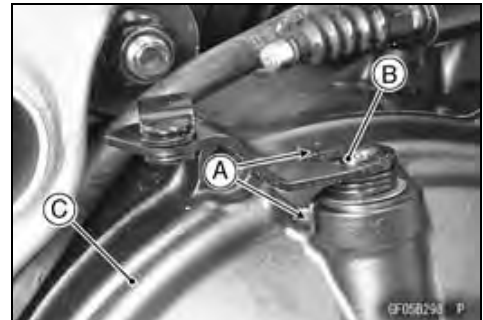
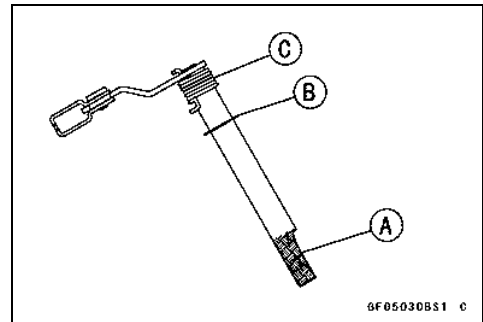

Clutch Cover Disassembly

- Remove:
Clutch Cover (see Clutch Cover Removal)
Release Lever and Shaft Assembly (see Release Shaft Removal)
Oil Seal [A]
Needle Bearings [B]

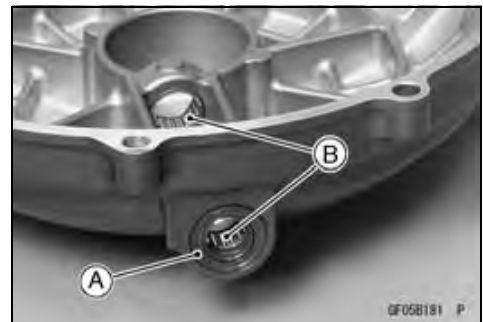

- Remove:
Oil Level Gauge [A]
Timing Inspection Cap [B]
Timing Rotor Bolt Cap [C]
Oil Filler Plug [D]



Clutch Cover Assembly

- Replace the needle bearings and oil seal with new ones.

NOTE

- Install the needle bearings so that the manufacture's mark face out.
- Install the needle bearings [A] and oil seal [B] position as shown.
- Press [C] the bearing so that the bearing surface [D] is flush with the housing end of clutch cover [E].

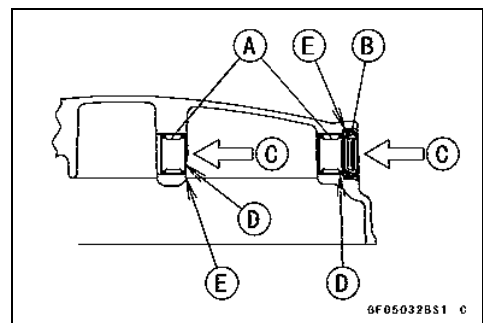

6-10 CLUTCH

Clutch Cover

- Apply water to the rubber of the oil gauge [A] and press [B] it so that the ring [C] face outside.
- Replace the O-rings of the following parts.
 - Timing Inspection Cap
 - Timing Rotor Bolt Cap
 - Oil Filler Plug
- Apply grease to the new O-rings.
- Tighten:
 - Torque - Timing Inspection Cap: 3.9 N·m (0.40 kgf·m, 35 in·lb)**
 - Timing Rotor Bolt Cap: 4.9 N·m (0.50 kgf·m, 43 in·lb)**
 - Oil Filler Plug: Hand-tighten**

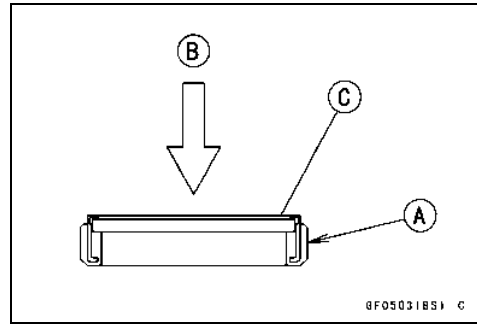

Clutch

Clutch Removal

- Remove:
 - Clutch Cover (see Clutch Cover Removal)
 - Clutch Spring Bolts [A]
 - Clutch Springs
 - Clutch Spring Plate [B] (with bearing)
 - Pusher [C]

- Remove:
 - Friction Plates
 - Steel Plates
- Hold the clutch hub [A] steady with the clutch holder [B], and remove the clutch hub nut [C] and washer [D].

Special Tool - Clutch Holder: 57001-1243

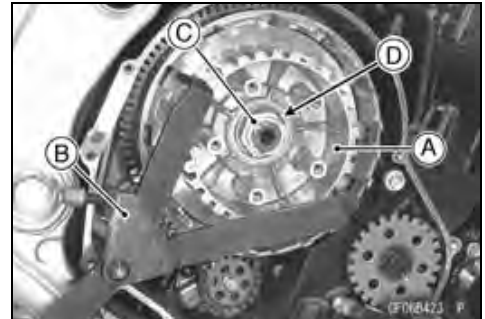
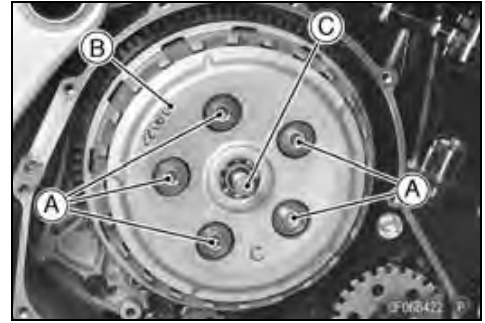

- Remove:
 - Clutch Hub [A]
 - Spacer [B]

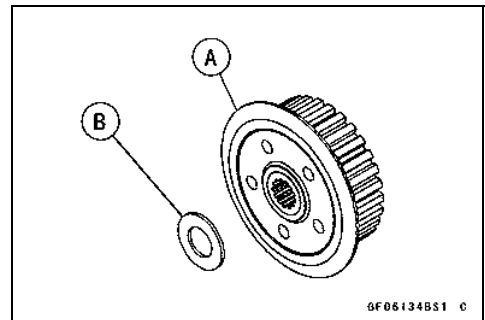

- Remove the oil pump sprocket bolt [A].

NOTE

○ *The oil pump sprocket bolt has a left-hand threads.*
- Using the holes [B], pull out the sleeve [C].
- Remove the following as a set.
 - Clutch Housing [D]
 - Oil Pump Chain [E]
 - Oil Pump Sprocket [F]



- Remove:
 - Spacer [A]
 - Bolts [B]
 - Oil Pump Chain Guide [C]

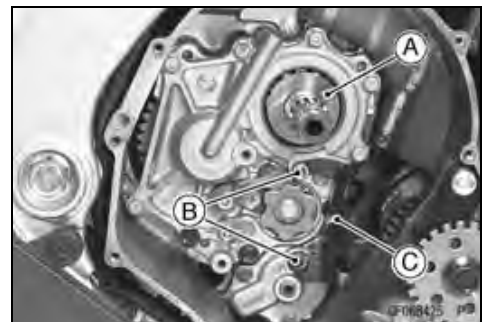

6-12 CLUTCH

Clutch

Clutch Installation

- Install the oil pump chain guide [A].
 - Apply a non-permanent locking agent to the upper chain guide bolt [B].
 - Torque - Oil Pump Chain Guide Bolts: 12 N·m (1.2 kgf·m, 106 in·lb)**
 - Install the spacer [C] onto the drive shaft.
-
- Put the oil pump chain [A] on the clutch housing gear [B] and the oil pump sprocket [C].

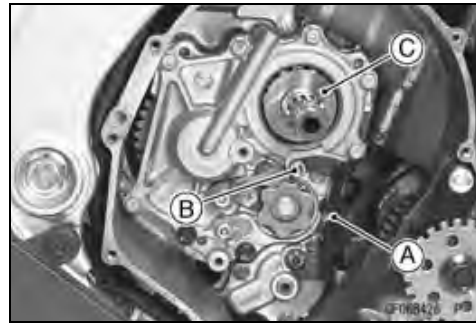

- Install the following on the drive shaft as a set.
 - Clutch Housing [A]
 - Oil Pump Chain [B]
 - Oil Pump Sprocket [C]
- Install the sleeve [D] so that the holes [E] faces outward.
- Apply engine oil to the sleeve.
- ★ If you feel a catch as the sleeve installs, replace it with a new one.
- Align the hole on the oil pump sprocket with the oil pump shaft.
- Apply a non-permanent locking agent to the oil pump sprocket bolt [F] and install the washer.
- Tighten:
 - Torque - Oil Pump Sprocket Bolt: 12 N·m (1.2 kgf·m, 106 in·lb)**

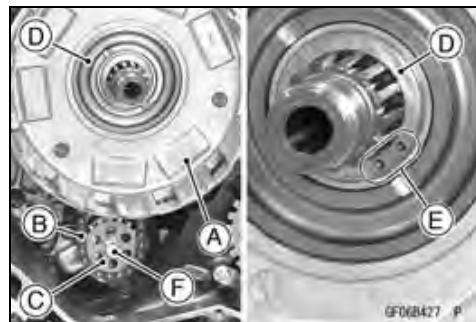

NOTE

○ The oil pump sprocket bolt has a left-hand threads.

- Install the following parts onto the drive shaft.
 - Spacer [A]
 - Clutch Hub [B]

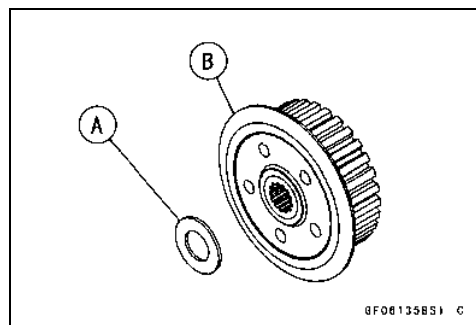

Clutch

- Install the washer so that the OUT SIDE mark [A] faces outward.



- Replace the clutch hub nut [A] with a new one.
- Hold the clutch hub [B] steady with the clutch holder [C], and tighten the clutch hub nut.

Special Tool - Clutch Holder: 57001-1243

Torque - Clutch Hub Nut: 130 N·m (13.3 kgf·m, 96 ft·lb)



- Install the friction plates and steel plates, starting with a friction plate and alternating them.

CAUTION

If new dry friction plates and steel plates are installed, apply engine oil to the surfaces of each plate to avoid clutch plate seizure.

- Install the last friction plate [A] fitting the tangs in the grooves in the housing as shown in the figure.



- Apply molybdenum disulfide grease to the pusher end [A].
- Install the pusher [B] into the drive shaft direction as shown in the figure.

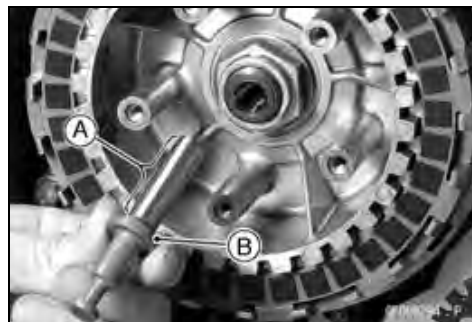

6-14 CLUTCH

Clutch

- Apply engine oil to the sliding surfaces of the bearing [A].
- Install the spring plate [B] on the clutch hub [C].
- Install the clutch springs, and tighten the clutch spring bolts.

Torque - Clutch Spring Bolts: 9.8 N·m (1.0 kgf·m, 87 in·lb)

- Install the clutch cover (see Clutch Cover Installation).

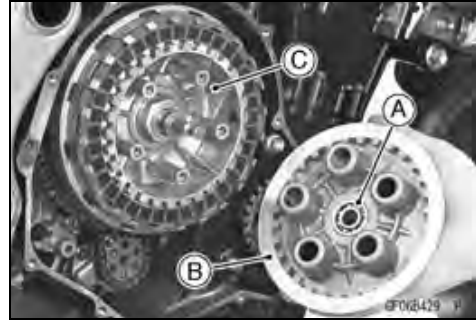

Clutch Plate, Wear, Damage Inspection

- Visually inspect the friction and steel plates for signs of seizure, overheating (discoloration), or uneven wear.
- Measure the thickness of each friction plate [A] at several points.
- ★ If any plates show signs of damage, or if they have worn past the service limit, replace them with new ones.

Friction Plate Thickness

Standard: 2.92 ~ 3.08 mm (0.115 ~ 0.121 in.)

Service Limit: 2.8 mm (0.110 in.)

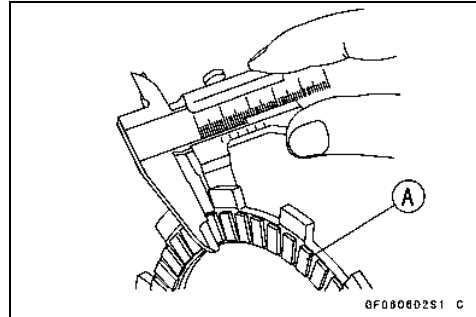

Clutch Plate Warp Inspection

- Place each friction plate or steel plate on a surface plate and measure the gap between the surface plate [A] and each friction plate or steel plate [B] with a thickness gauge [C]. The gap is the amount of friction or steel plate warp.
- ★ If any plate is warped over the service limit, replace it with a new one.

Friction Plate Warp

Standard: 0.15 mm (0.0059 in.) or less

Service Limit: 0.3 mm (0.012 in.)

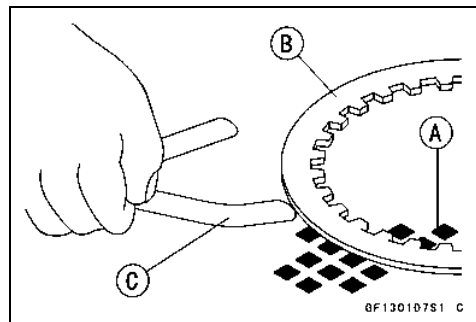

Steel Plate Warp

Standard: 0.2 mm (0.008 in.) or less

Service Limit: 0.3 mm (0.012 in.)

Clutch Spring Free Length Measurement

- Measure the free length of the clutch springs [A].
- ★ If any spring is shorter than the service limit, it must be replaced.

Clutch Spring Free Length

Standard: 33.60 mm (1.323 in.)

Service Limit: 32.6 mm (1.28 in.)

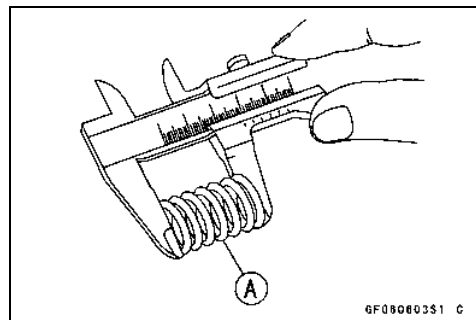

Clutch

Clutch Housing Finger Inspection

- Visually inspect the clutch housing fingers [A] where the friction plate tangs [B] hit them.
- ★ If they are badly worn or if there are groove cuts where the tangs hit, replace the housing. Also, replace the friction plates if their tangs are damaged.

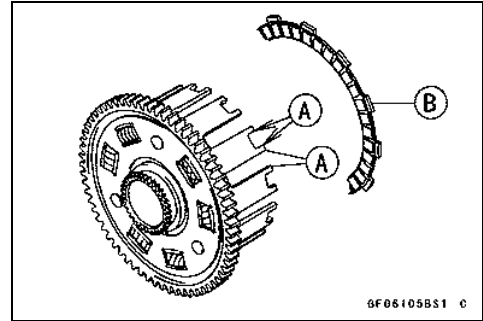

Clutch Housing Spline Inspection

- Visually inspect where the teeth [A] on the steel plates wear against the clutch hub splines [B].
- ★ If there are notches worn into the splines, replace the clutch hub. Also, replace the steel plates if their teeth are damaged.

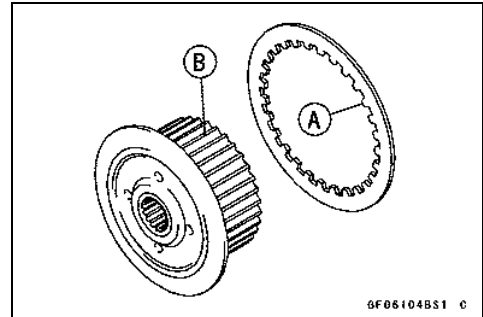

Engine Lubrication System

Table of Contents

Exploded View.....	7-2
Engine Oil Flow Chart.....	7-4
Specifications	7-6
Special Tools and Sealant	7-7
Engine Oil and Oil Filter.....	7-8
Oil Level Inspection.....	7-8
Engine Oil Change.....	7-8
Oil Filter Replacement	7-8
Oil Pan.....	7-9
Oil Pan Removal	7-9
Oil Pan Installation	7-10
Oil Pressure Relief Valve.....	7-11
Oil Pressure Relief Valve Removal	7-11
Oil Pressure Relief Valve Installation	7-11
Oil Pressure Relief Valve Inspection	7-11
Oil Pump.....	7-12
Oil Pump Removal	7-12
Oil Pump Installation	7-13
Oil Pressure Measurement.....	7-15
Oil Pressure Measurement	7-15
Oil Pressure Switch	7-16
Oil Pressure Switch Removal	7-16
Oil Pressure Switch Installation	7-16

7-2 ENGINE LUBRICATION SYSTEM

Exploded View

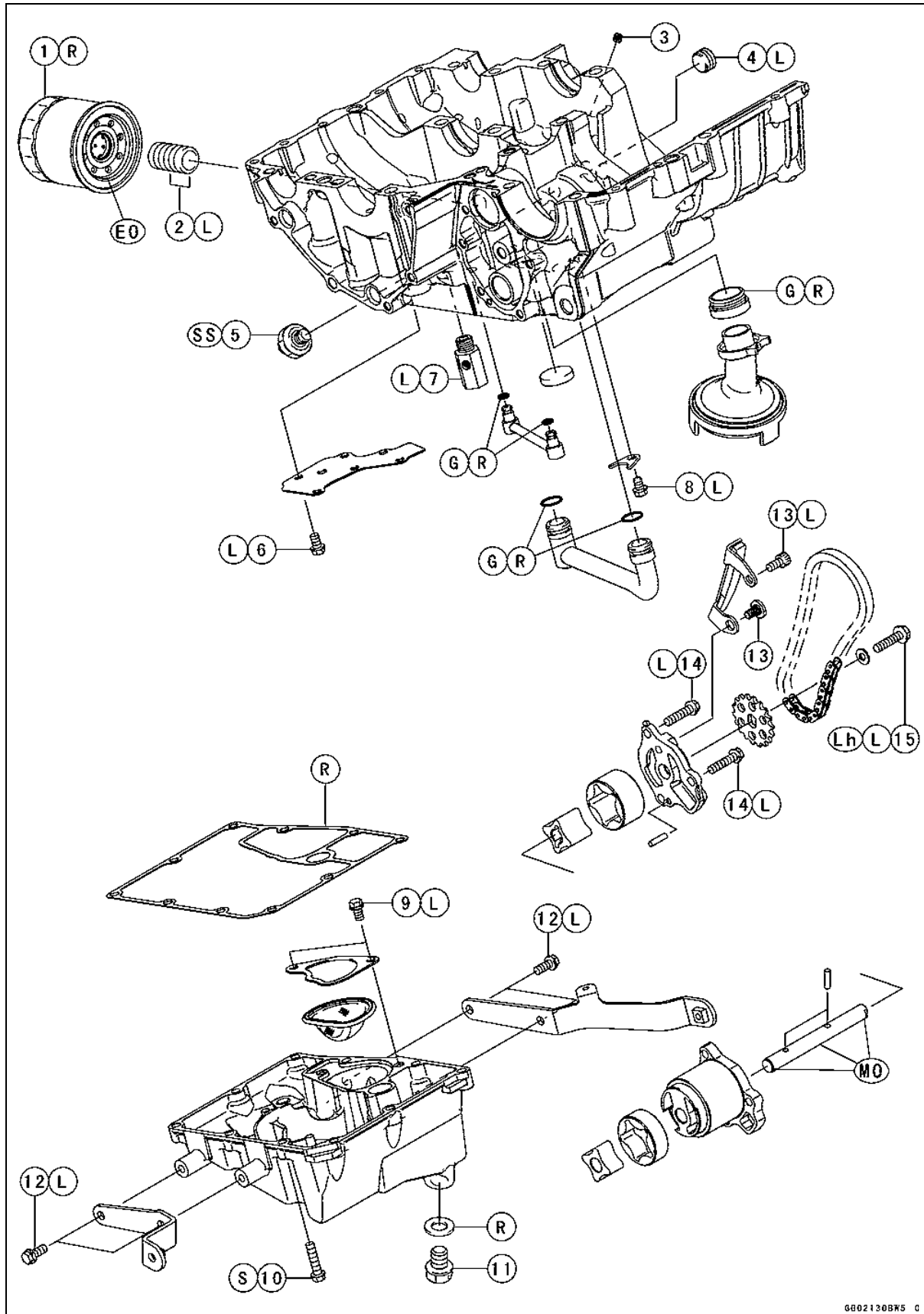

GG02130BK5 C

ENGINE LUBRICATION SYSTEM 7-3

Exploded View

No.	Fastener	Torque			Remarks
		N·m	kgf·m	ft·lb	
1	Oil Filter	17.5	1.8	13	EO, R
2	Holder Mounting Bolt	25	2.5	18	L
3	Oil Passage Plug (M6)	3.9	0.40	35 in·lb	
4	Oil Passage Plug	20	2.0	15	L
5	Oil Pressure Switch	15	1.5	11	SS
6	Oil Plate Bolts	9.8	1.0	87 in·lb	L
7	Oil Pressure Relief Valve	15	1.5	11	L
8	Oil Pipe Plate Bolt	9.8	1.0	87 in·lb	L
9	Filter Plate Bolts	9.8	1.0	87 in·lb	L
10	Oil Pan Bolts	12	1.2	106 in·lb	S
11	Engine Oil Drain Plug	30	3.1	22	
12	Lower Fairing Bracket Bolts	12	1.2	106 in·lb	L
13	Oil Pump Chain Guide Bolts	12	1.2	106 in·lb	L (1)
14	Oil Pump Cover Bolts	9.8	1.0	87 in·lb	L
15	Oil Pump Sprocket Bolt	12	1.2	106 in·lb	L, Lh

EO: Apply engine oil.

G: Apply grease.

L: Apply a non-permanent locking agent.

Lh: Left-hand Threads

MO: Apply molybdenum disulfide oil solution.

(mixture of the engine oil and molybdenum disulfide grease in a weight ratio 10 : 1)

R: Replacement Parts

S: Follow the specified tightening sequence.

SS: Apply silicone sealant.

7-4 ENGINE LUBRICATION SYSTEM

Engine Oil Flow Chart

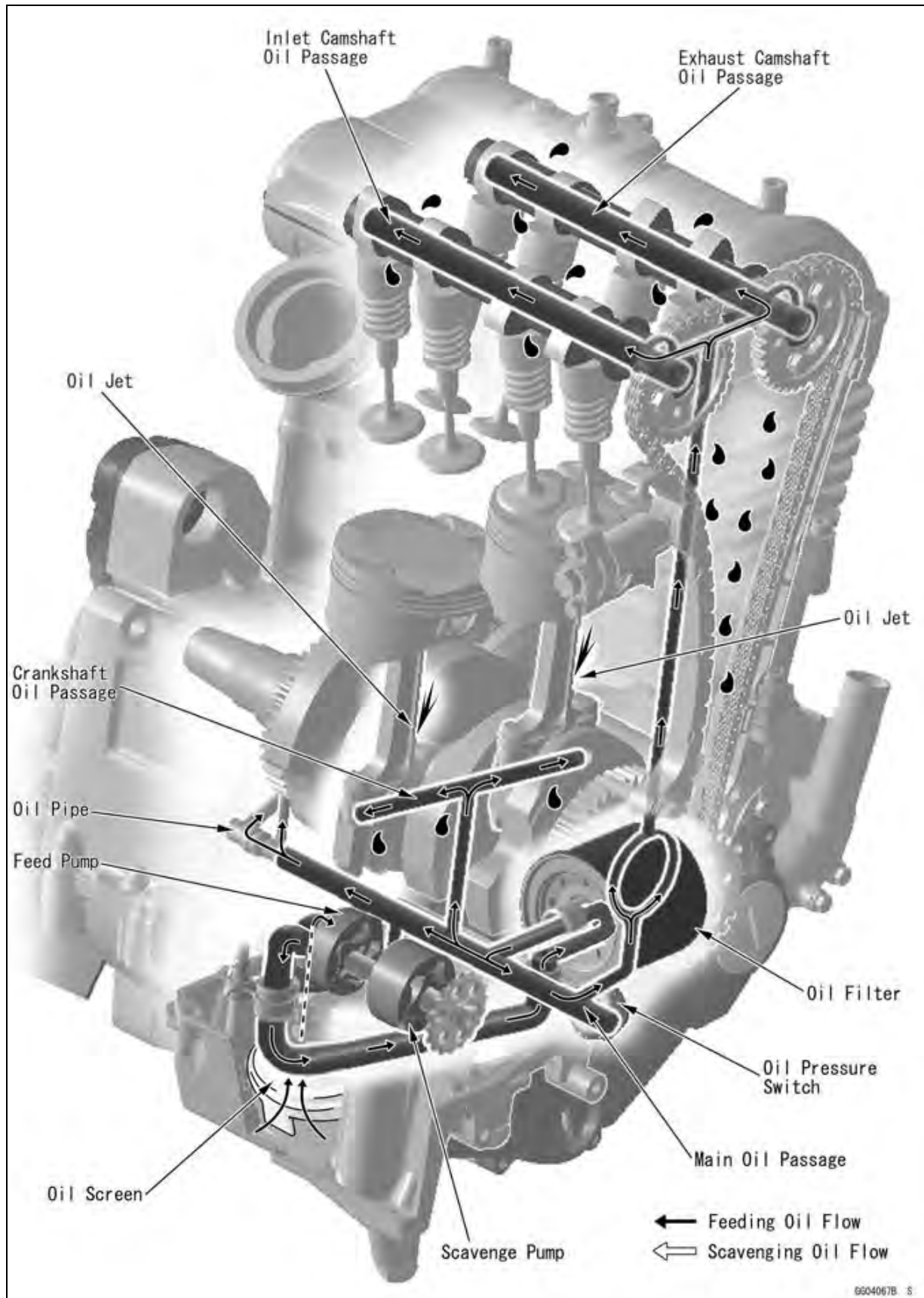

Engine Oil Flow Chart

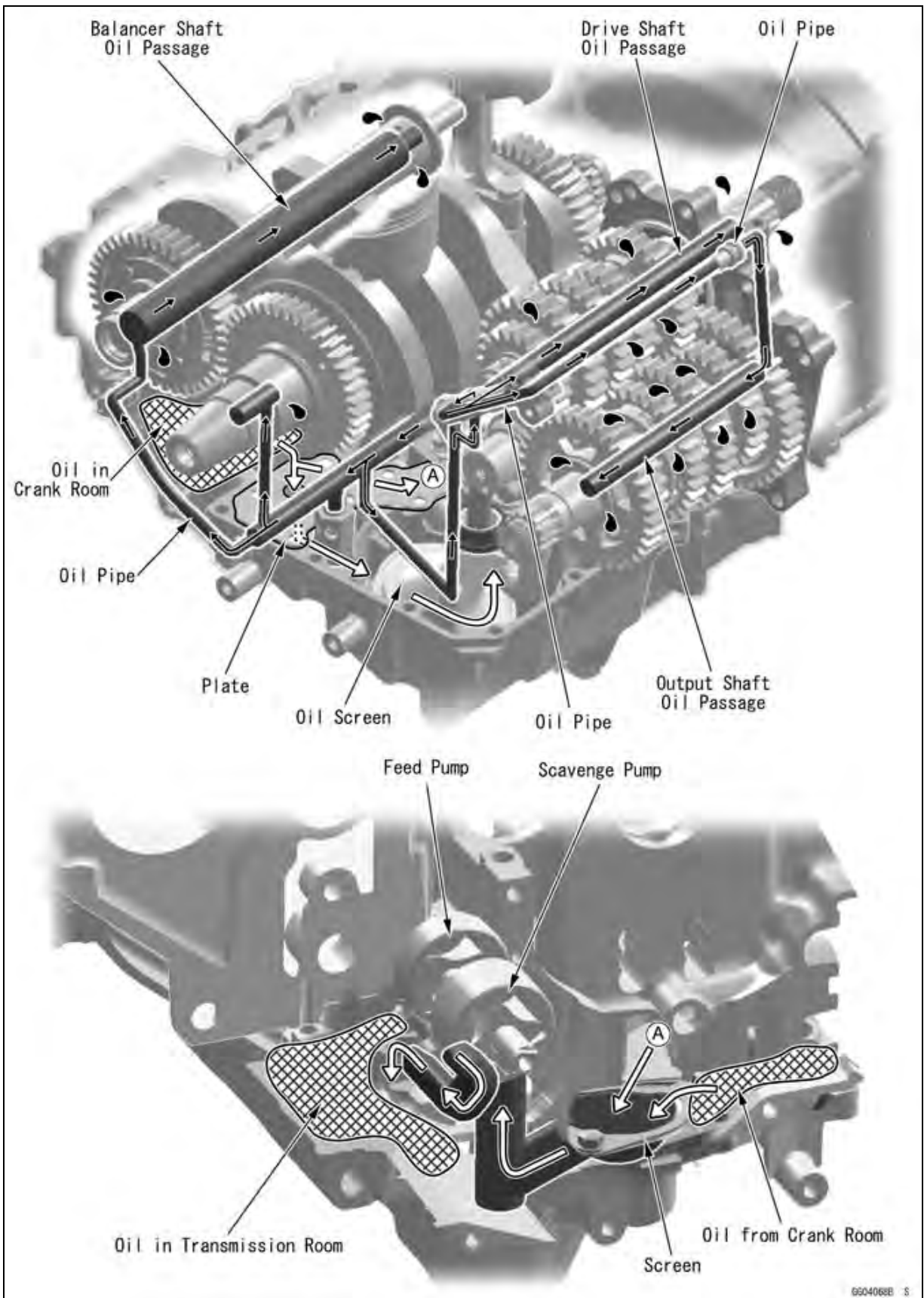

6504068B S

7-6 ENGINE LUBRICATION SYSTEM

Specifications

Item	Standard
Engine Oil Type Viscosity Capacity: Level	API SE, SF or SG API SH, SJ, SL or SM with JASO MA, MA1 or MA2 SAE 10W-40 1.7 L (1.8 US qt) (when filter is not removed) 1.9 L (2.0 US qt) (when filter is removed) 2.4 L (2.5 US qt) (when engine is completely dry) Between upper and lower level lines
Oil Pressure Measurement Oil Pressure	216 ~ 294 kPa (2.2 ~ 3.0 kgf/cm ² , 31 ~ 43 psi) at 4 000 r/min (rpm), Oil Temperature 90°C (194°F)

Special Tools and Sealant

Oil Pressure Gauge, 10 kgf/cm²:
57001-164

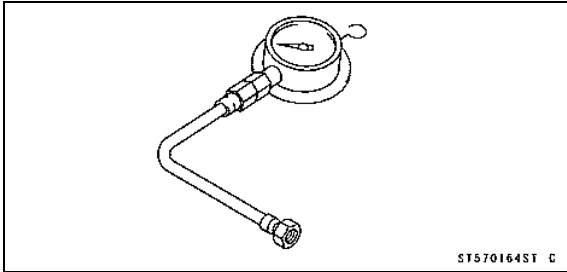

Kawasaki Bond (Silicone Sealant):
56019-120

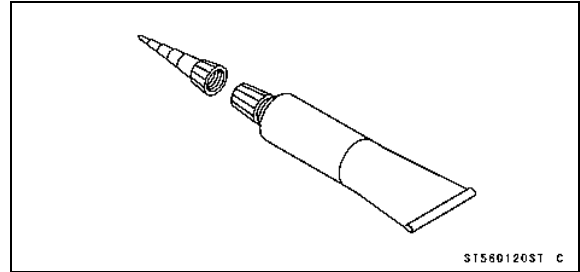

Oil Pressure Gauge Adapter, PT3/8:
57001-1233

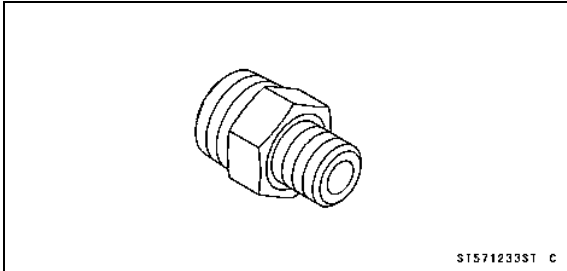

7-8 ENGINE LUBRICATION SYSTEM

Engine Oil and Oil Filter

⚠ WARNING

Motorcycle operation with insufficient, deteriorated, or contaminated engine oil will cause accelerated wear and may result in engine or transmission seizure, accident, and injury.

Oil Level Inspection

- Check that the engine oil level is between the upper [A] and lower [B] levels in the gauge.

NOTE

- Situate the motorcycle so that it is perpendicular to the ground.
- If the motorcycle has just been used, wait several minutes for all the oil to drain down.
- If the oil has just been changed, start the engine and run it for several minutes at idle speed. This fills the oil filter with oil. Stop the engine, then wait several minutes until the oil settles.



CAUTION

Racing the engine before the oil reaches every part can cause engine seizure.

If the engine oil gets extremely low or if the oil pump or oil passages clog up or otherwise do not function properly, the oil pressure warning indicator light (LED) will blink. If this blink stays on when the engine is running above idle speed, stop the engine immediately and find the cause.

- ★ If the oil level is too high, remove the excess oil, using a syringe or some other suitable device.
- ★ If the oil level is too low, add the correct amount of oil through the oil filter opening. Use the same type and make of oil that is already in the engine.

NOTE

- If the engine oil type and make are unknown, use any brand of the specified oil to top off the level in preference to running the engine with the oil level low. Then at your earliest convenience, change the oil completely.

Engine Oil Change

- Refer to the Engine Oil Change in the Periodic Maintenance chapter.

Oil Filter Replacement

- Refer to the Oil Filter Replacement in the Periodic Maintenance chapter.

Oil Pan

Oil Pan Removal

- Drain the engine oil (see Engine Oil Change in the Periodic Maintenance chapter).
- Remove:
 - Lower Fairing Brackets (see Lower Fairing Bracket Removal in the Frame chapter)
 - Exhaust Pipe (see Exhaust Pipe Removal in the Engine Top End chapter)
 - Muffler Body (see Muffler Body Removal in the Engine Top End chapter)
- Remove:
 - Oil Pan Bolts [A]
 - Oil Pan [B]

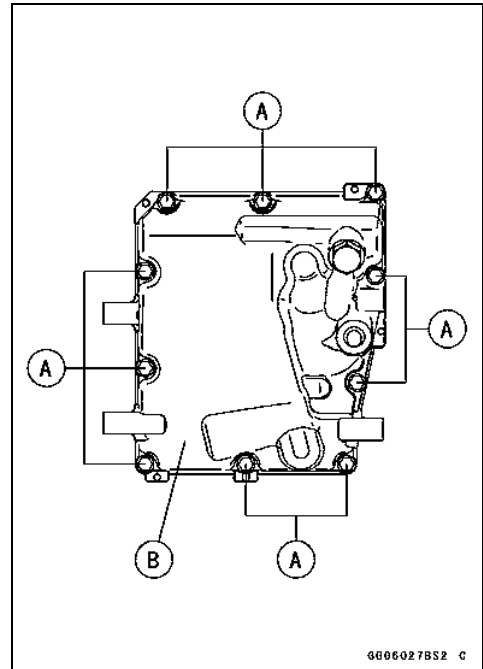

- Remove the following from the oil pan as necessary.
 - Filter Plate Bolts [A]
 - Filter Plate [B]
 - Filter [C]

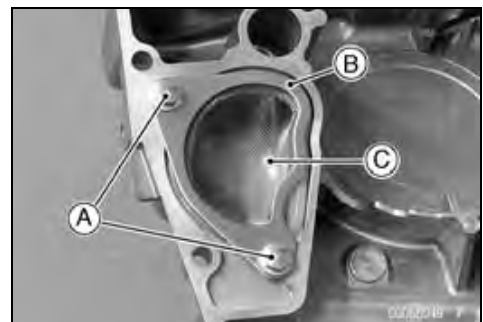

- Remove the following from the lower crankcase half as necessary.
 - Oil Screen [A]
 - Oil Pipe Plate Bolt [B]
 - Oil Pipe Plate [C]
 - Oil Pipes [D]
 - Dampers [E]

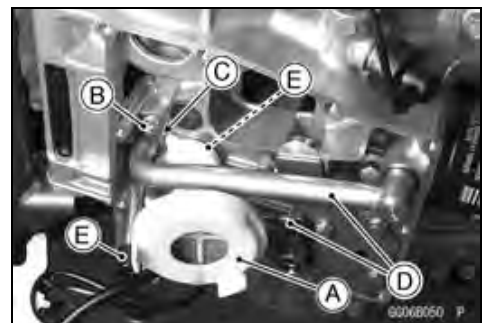

7-10 ENGINE LUBRICATION SYSTEM

Oil Pan

Oil Pan Installation

- Replace the O-rings with new ones.
- Apply grease to the O-rings on the oil pipes [A].
- Install the oil pipe plate [B] so that its guide portion fits the oil pipe as shown in the figure.
- Apply a non-permanent locking agent to the oil pipe plate bolt.

Torque - Oil Pipe Plate Bolt [C]: 9.8 N·m (1.0 kgf·m, 87 in·lb)

- Install the damper [D] to the end of the breather pipe.
- Apply grease to the damper.
- Apply grease to the damper [A] on the oil screen [B], and install it on the lower crankcase half as shown in the figure.
- Install the oil screen so that its guide portion [C] fits the crankcase rib [D].

- Apply non-permanent locking agent to the filter plate bolts and tighten them.

Torque - Filter Plate Bolts: 9.8 N·m (1.0 kgf·m, 87 in·lb)

- Replace the oil pan gasket with a new one.
- When installing the oil pan, align [A] the damper [B] on the breather pipe with the hollow [C] of the oil pan.

- Tighten the oil pan bolts following the specified tightening sequence.

Torque - Oil Pan Bolts: 12 N·m (1.2 kgf·m, 106 in·lb)

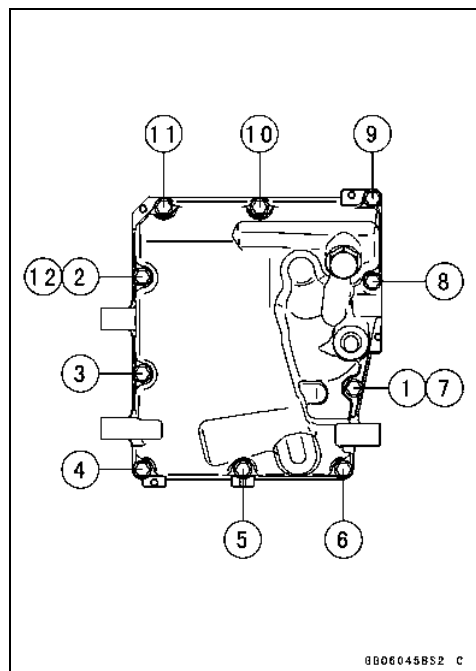
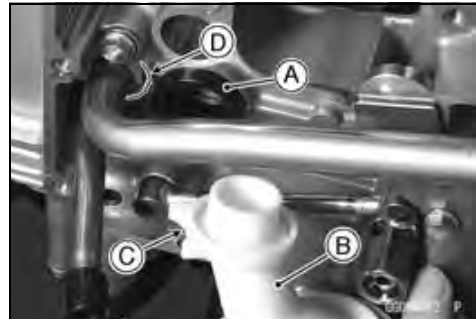
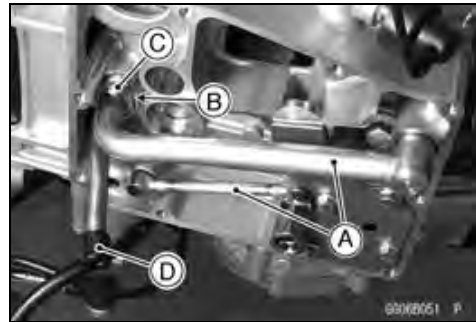

Oil Pressure Relief Valve

Oil Pressure Relief Valve Removal

- Remove:
 - Oil Pan (see Oil Pan Removal)
 - Oil Pressure Relief Valve [A]



Oil Pressure Relief Valve Installation

- Apply a non-permanent locking agent to the threads of the oil pressure relief valve, and tighten it.

CAUTION

Do not apply too much non-permanent locking agent to the threads. This may block the oil passage.

Torque - Oil Pressure Relief Valve: 15 N·m (1.5 kgf·m, 11 ft·lb)

- Install the oil pan (see Oil Pan Installation).

Oil Pressure Relief Valve Inspection

- Remove the oil pressure relief valve (see Oil Pressure Relief Valve Removal).
- Check to see if the valve [A] slides smoothly when pushing it in with a wooden or other soft rod, and see if it comes back to its seat by spring [B] pressure.

NOTE

○ Inspect the valve in its assembled state. Disassembly and assembly may change the valve performance.

- ★ If any rough spots are found during above inspection, wash the valve clean with a high-flash point solvent and blow out any foreign particles that may be in the valve with compressed air.

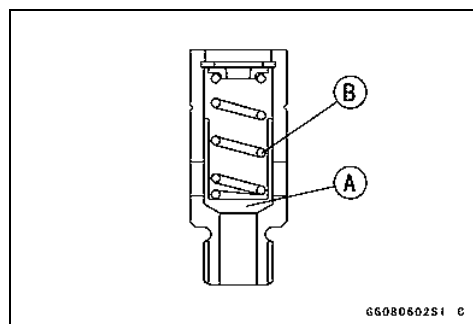

⚠ WARNING

Clean the oil pressure relief valve in a well-ventilated area, and take care that there is no spark or flame anywhere near the working area. Because of the danger of highly flammable liquids, do not use gasoline or low-flash point solvent.

- ★ If cleaning does not solve the problem, replace the oil pressure relief valve as an assembly. The oil pressure relief valve is precision made with no allowance for replacement of individual parts.

7-12 ENGINE LUBRICATION SYSTEM

Oil Pump

Oil Pump Removal

- Remove:
 - Clutch (see Clutch Removal in the Clutch chapter)
 - Oil Pump Cover Bolts [A]



- Temporarily install the oil pump sprocket bolt [A].

NOTE

○ The oil pump sprocket bolt has a left-hand threads.



- Using the oil pump sprocket bolt [A], pull out the oil pump [B] as an assembly.



- Remove the outer rotor [A] for feed pump.



- Remove the oil pump cover [A].



Oil Pump

- Remove:
Inner Rotor [A] for Scavenge Pump
Outer Rotor [B] for Scavenge Pump



- Remove the pin [A].



- Remove:
Pin [A]
Inner Rotor for Feed Pump [B]
Oil Pump Shaft [C]

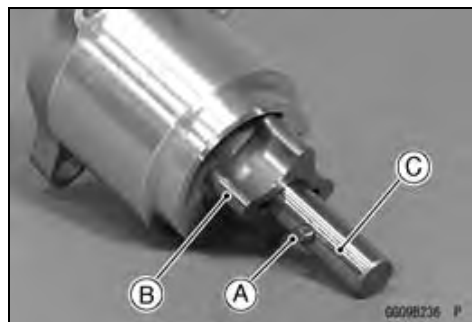

Oil Pump Installation

- Apply molybdenum disulfide oil solution to the portion [A] of the oil pump shaft as shown in the figure.
- Assemble the following parts.
Oil Pump Shaft [B]
Pin [C]
Inner Rotor for Feed Pump [D]
Oil Pump Body [E]
Pin [F]
Inner Rotor [G] for Scavenge Pump
Outer Rotor [H] for Scavenge Pump

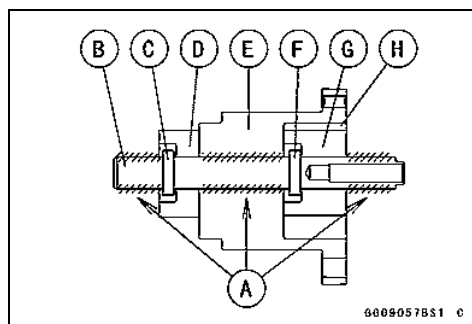

NOTE

- The scavenge pump rotors are wider than the feed pump rotors.

7-14 ENGINE LUBRICATION SYSTEM

Oil Pump

- Install:
 - Dowel Pin [A]
 - Outer Rotor [B] for Feed Pump
 - Fit the pin of the crankcase into the hole [C] in the oil pump body.
 - Turn the oil pump shaft so that the inner rotor [D] fits into the outer rotor.
-
- Fit the pin [A] into the hole [B] on the oil pump cover [C].
 - Apply a non-permanent locking agent to the oil pump cover bolts and tighten them.
- Torque - Oil Pump Cover Bolts: 9.8 N·m (1.0 kgf·m, 87 in-lb)**
- Check whether the oil pump turns smoothly.

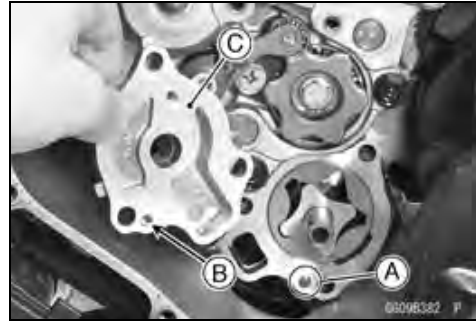
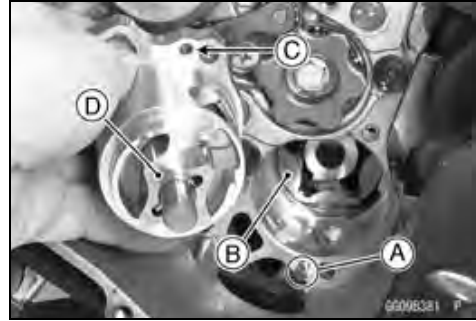

Oil Pressure Measurement

Oil Pressure Measurement

- Remove:
 - Right Lower Fairing Bracket (see Lower Fairing Bracket Removal in the Frame chapter)
 - Oil Passage Plug [A]



- Attach the adapter [A] and gauge [B] to the plug hole.
 - Special Tools - Oil Pressure Gauge, 10 kgf/cm²: 57001-164**
 - Oil Pressure Gauge Adapter, PT3/8: 57001-1233**



- Start the engine and warm up the engine.
- Run the engine at the specified speed, and read the oil pressure gauge.
- ★ If the oil pressure is much lower than the standard, check the oil pump, relief valve, and/or crankshaft bearing insert wear immediately.
- ★ If the reading is much higher than the standard, check the oil passages for clogging.

Oil Pressure

Standard: 216 ~ 294 kPa (2.2 ~ 3.0 kgf/cm², 31 ~ 43 psi) at 4 000 r/min (rpm), oil temperature 90°C (194°F)

- Stop the engine.
- Remove the oil pressure gauge and adapter.

⚠ WARNING

Take care against burns from hot engine oil that will drain through the oil passage when the gauge adapter is removed.

- Apply a non-permanent locking agent to the oil passage plug, and install it.
 - Torque - Oil Passage Plug: 20 N·m (2.0 kgf·m, 15 ft·lb)**

7-16 ENGINE LUBRICATION SYSTEM

Oil Pressure Switch

Oil Pressure Switch Removal

- Drain the engine oil (see Engine Oil Change in the Periodic Maintenance chapter).
- Remove:
 - Lower Fairing (see Lower Fairing Removal in the Frame chapter)
 - Switch Cover [A]
 - Switch Terminal Bolt [B]
 - Oil Pressure Switch [C]

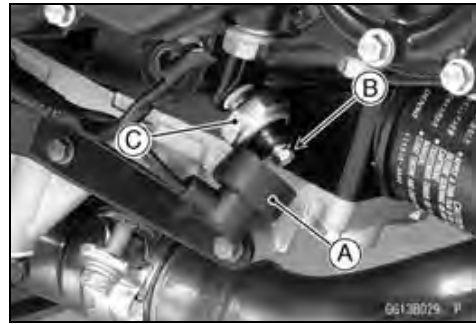

Oil Pressure Switch Installation

- Apply silicone sealant to the threads of the oil pressure switch [A] and tighten it.
- Sealant - Kawasaki Bond (Silicone Sealant): 56019-120**
- Torque - Oil Pressure Switch: 15 N·m (1.5 kgf·m, 11 ft·lb)**- Install the switch lead [B] direction downward.
- Apply grease to the terminal [C], and tighten the terminal bolt securely.
- Front [D]

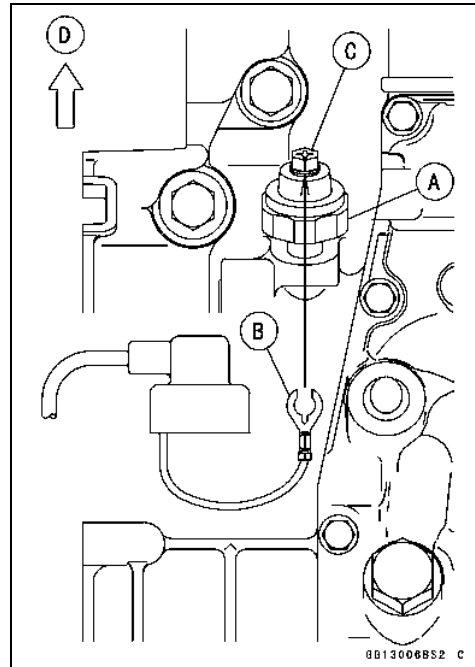

NOTE

- Apply a small amount grease to the terminal so that grease should not close two breather holes [A] for switch diaphragm.

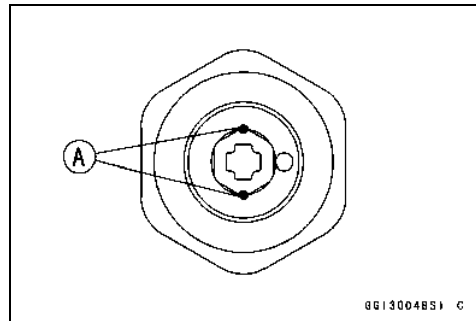

Engine Removal/Installation

Table of Contents

Exploded View.....	8-2
Engine Removal/Installation.....	8-4
Engine Removal.....	8-4
Engine Installation.....	8-6

8-2 ENGINE REMOVAL/INSTALLATION

Exploded View

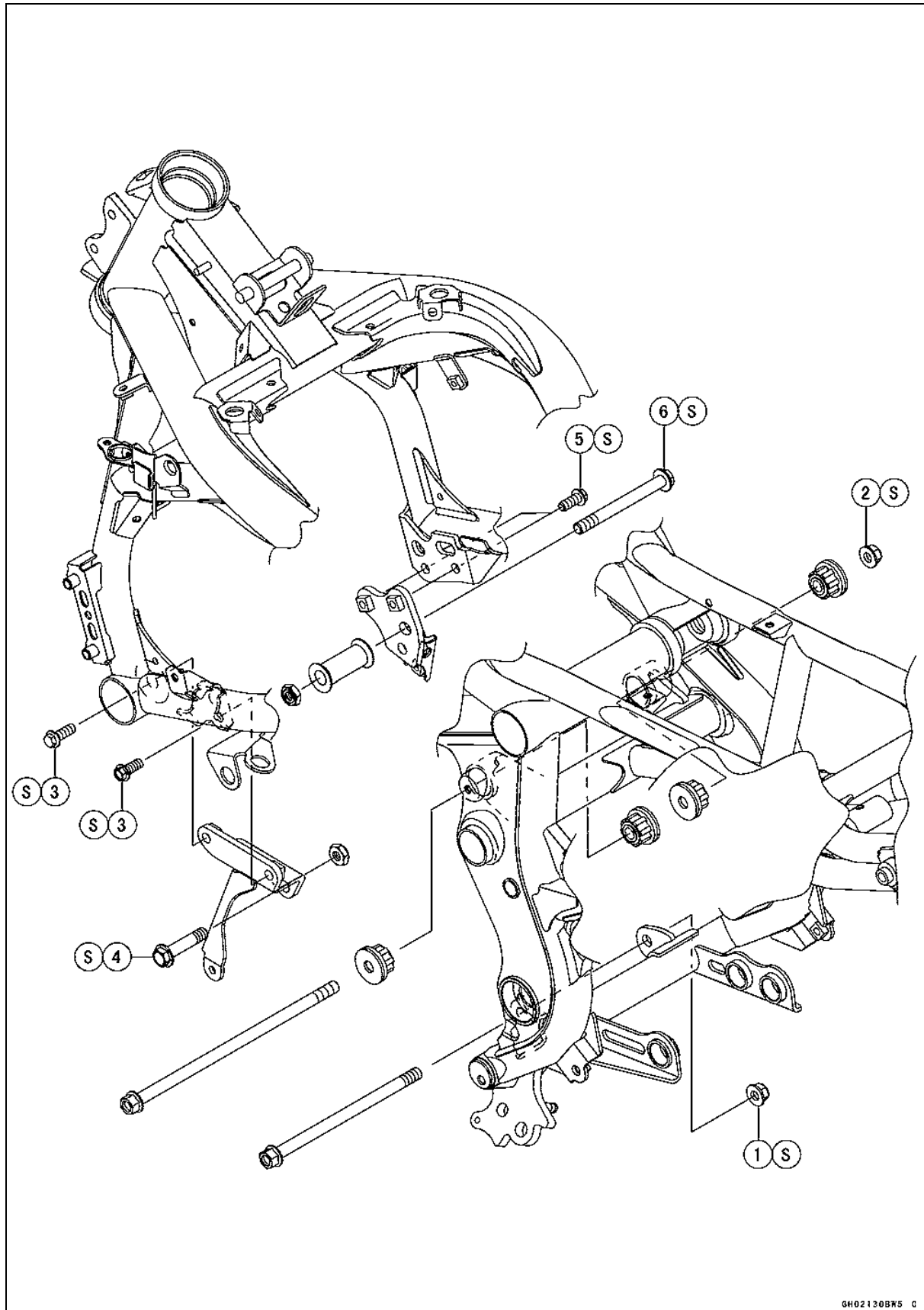

GH02130BK5 C

ENGINE REMOVAL/INSTALLATION 8-3

Exploded View

No.	Fastener	Torque			Remarks
		N·m	kgf·m	ft·lb	
1	Engine Mounting Nut (Lower)	44	4.5	32	S
2	Engine Mounting Nut (Rear)	44	4.5	32	S
3	Engine Bracket Bolts (Left)	25	2.5	18	S
4	Engine Mounting Bolt (Left)	44	4.5	32	S
5	Engine Bracket Bolts (Right)	25	2.5	18	S
6	Engine Mounting Bolt (Right)	44	4.5	32	S

S: Follow the specified tightening sequence.

8-4 ENGINE REMOVAL/INSTALLATION

Engine Removal/Installation

Engine Removal

- Support the rear part of the swingarm with a stand.
- Squeeze the brake lever slowly and hold it with a band [A].

▲ WARNING

Be sure to hold the front brake when removing the engine, or the motorcycle may fall over. It could cause an accident and injury.



CAUTION

Be sure to hold the front brake when removing the engine, or the motorcycle may fall over. The engine or the motorcycle could be damaged.

- Drain:
 - Engine Oil (see Engine Oil Change in the Periodic Maintenance chapter)
 - Coolant (see Coolant Change in the Periodic Maintenance chapter)
- Remove:
 - Air Switching Valve and Hose (see Air Switching Valve Removal in the Engine Top End chapter)
 - Throttle Body Assy (see Throttle Body Assy Removal in the Fuel System (DFI) chapter)
 - Radiator and Water Hoses (see Radiator and Radiator Fan Removal in the Cooling System chapter)
 - Frame Covers (see Frame Cover Removal in the Frame chapter)
 - Lower Fairing Brackets (see Lower Fairing Bracket Removal in the Frame chapter)
 - Exhaust Pipe (see Exhaust Pipe Removal in the Engine Top End chapter)
 - Muffler Body (see Muffler Body Removal in the Engine Top End chapter)
 - Clutch Cable (see Clutch Cable Removal in the Clutch chapter)
 - Stick Coils (see Stick Coil Removal in the Electrical System chapter)
 - Shift Pedal (see Shift Pedal Removal in the Crankshaft/Transmission chapter)
 - Engine Sprocket (see Engine Sprocket Removal in the Final Drive chapter)

Engine Removal/Installation

- Remove the baffle plate bolts [A], and take off the baffle plate [B].

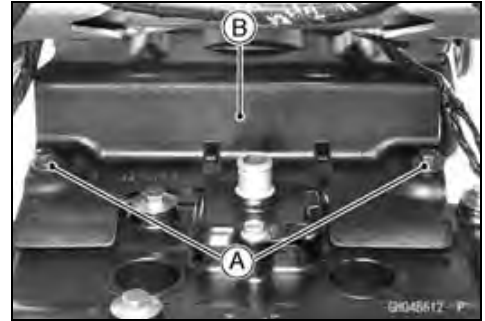

- Slide out the rubber cap [A].
- Disconnect the oil pressure switch lead terminal [B].

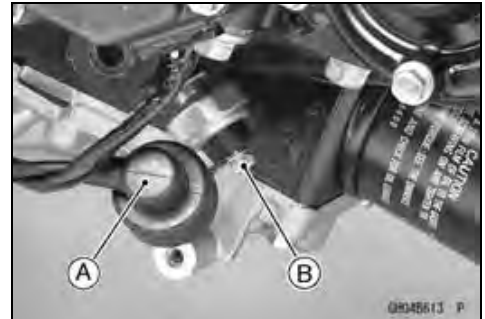

- Disconnect:
 - Crankshaft Sensor Lead Connector [A]
 - Starter Motor Cable Terminal [B]
 - Engine Ground Lead Terminal [C]

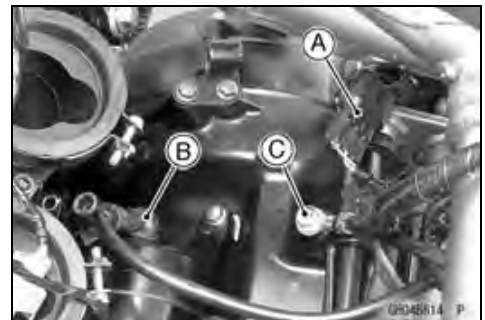

- Disconnect:
 - Alternator Lead Connector [A]
 - Sidestand Switch Lead Connector [B]
 - Speed Sensor Lead Connector [C]
 - Water Temperature Sensor Lead Connector [D]

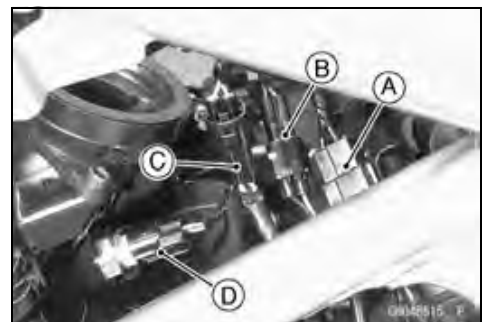

- Disconnect the neutral switch lead terminal [A].

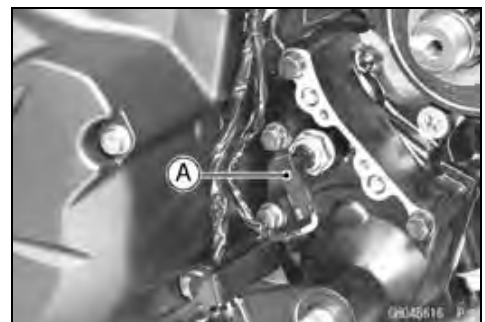

8-6 ENGINE REMOVAL/INSTALLATION

Engine Removal/Installation

- Support the engine using a suitable stand or jack [A].
- Put planks [B] to balance the engine.

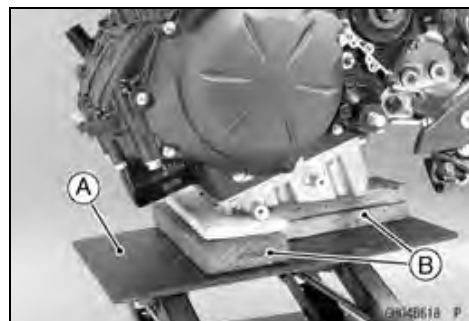

- Remove the engine mounting bolt [A] on both sides.
- Remove the bracket bolts [B] on both sides.
- Remove the engine mounting bolts [C], and take off the engine.



Engine Installation

- Support the engine using a suitable stand or jack.
- Put planks to balance the engine.

- Install the dampers [A].
- Install the engine to the frame.
- Insert the lower and rear engine mounting bolts.

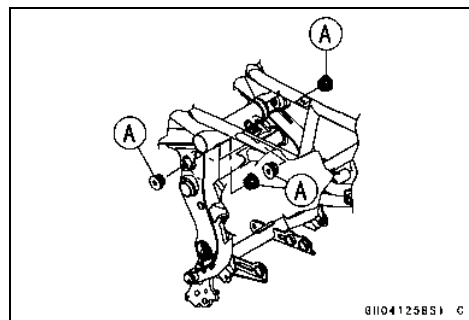

- Install the left engine bracket [A] temporary.
- Install the right engine bracket [B] temporary.
- Place the collar [C] as shown in the figure.

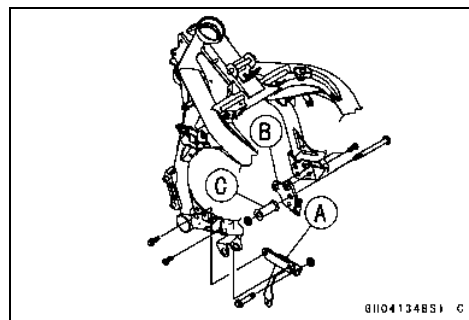

Engine Removal/Installation

- By the following specified sequence, tighten the engine mounting bolts and nuts.

○ Tighten:

Torque - Engine Mounting Nut (Lower) [A]: 44 N·m (4.5 kgf·m, 32 ft·lb)

○ Tighten:

Torque - Engine Mounting Nut (Rear) [B]: 44 N·m (4.5 kgf·m, 32 ft·lb)

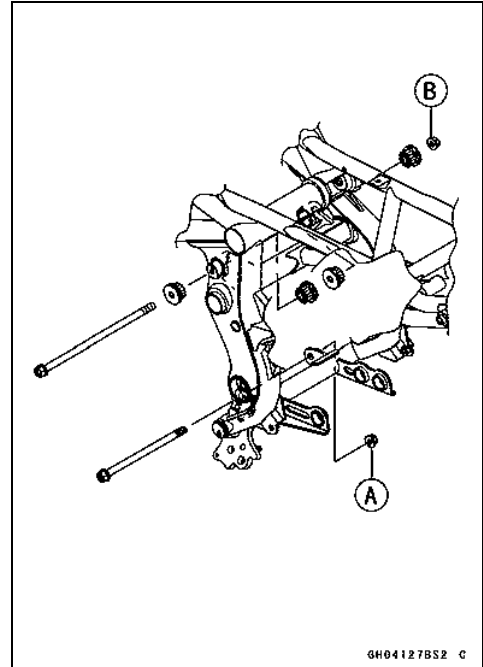

○ Tighten:

Torque - Engine Bracket Bolts (Left) [C]: 25 N·m (2.5 kgf·m, 18 ft·lb)

○ Tighten:

Torque - Engine Mounting Bolt (Left) [D]: 44 N·m (4.5 kgf·m, 32 ft·lb)

○ Tighten:

Torque - Engine Bracket Bolts (Right) [E]: 25 N·m (2.5 kgf·m, 18 ft·lb)

○ Tighten:

Torque - Engine Mounting Bolt (Right) [F]: 44 N·m (4.5 kgf·m, 32 ft·lb)

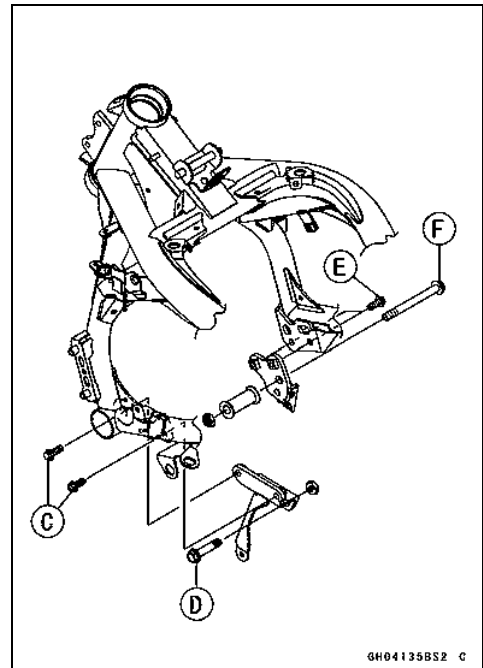

8-8 ENGINE REMOVAL/INSTALLATION

Engine Removal/Installation

- Run the leads, cables, and hoses correctly (see Cable, Wire, and Hose Routing section in the Appendix chapter).
- Tighten:
 - Torque - Engine Ground Lead Terminal Bolt: 9.8 N·m (1.0 kgf·m, 87 in·lb)**
- Install the removed parts (see appropriate chapters).
- Adjust:
 - Throttle Cables (see Throttle Control System Inspection in the Periodic Maintenance chapter)
 - Clutch Cable (see Clutch Operation Inspection in the Periodic Maintenance chapter)
 - Drive Chain (see Drive Chain Slack Adjustment in the Periodic Maintenance chapter)
- Fill the engine with engine oil (see Engine Oil Change in the Periodic Maintenance chapter).
- Fill the engine with coolant and bleed the air from the cooling system (see Coolant Change in the Periodic Maintenance chapter).
- Adjust the idling (see Idle Speed Adjustment in the Periodic Maintenance chapter).

Crankshaft/Transmission

Table of Contents

Exploded View	9-2
Specifications	9-6
Special Tools and Sealants	9-9
Crankcase Splitting	9-10
Crankcase Splitting	9-10
Crankcase Assembly	9-12
Crankshaft and Connecting Rods	9-18
Crankshaft Removal	9-18
Crankshaft Installation	9-18
Connecting Rod Removal	9-18
Connecting Rod Installation	9-19
Crankshaft/Connecting Rod Cleaning	9-22
Connecting Rod Bend	9-22
Connecting Rod Twist	9-23
Connecting Rod Big End Side Clearance	9-23
Connecting Rod Big End Bearing Insert/Crankpin Wear	9-23
Crankshaft Side Clearance	9-25
Crankshaft Runout	9-25
Crankshaft Main Bearing Insert/Journal Wear	9-26
Balancer	9-28
Balancer Removal	9-28
Balancer Installation	9-28
Balancer Shaft Bearing Insert/Journal Clearance	9-28
External Shift Mechanism	9-31
Shift Pedal Removal	9-31
Shift Pedal Installation	9-31
External Shift Mechanism Removal	9-31
External Shift Mechanism Installation	9-32
External Shift Mechanism Inspection	9-33
Transmission	9-34
Transmission Assy Removal	9-34
Transmission Assy Installation	9-34
Transmission Assy Disassembly	9-35
Transmission Assy Assembly	9-36
Transmission Shaft Removal	9-37
Transmission Shaft Installation	9-37
Transmission Shaft Disassembly	9-38
Transmission Shaft Assembly	9-38
Shift Drum and Fork Removal	9-41
Shift Drum and Fork Installation	9-41
Shift Drum Disassembly	9-41
Shift Drum Assembly	9-41
Shift Fork Bending	9-41
Shift Fork/Gear Groove Wear	9-41
Shift Fork Guide Pin/Drum Groove Wear	9-41
Gear Dog and Gear Dog Hole Damage	9-42
Ball Bearing, Needle Bearing, and Oil Seal	9-43
Ball and Needle Bearing Replacement	9-43
Ball and Needle Bearing Wear	9-43
Oil Seal Inspection	9-43

9-2 CRANKSHAFT/TRANSMISSION

Exploded View

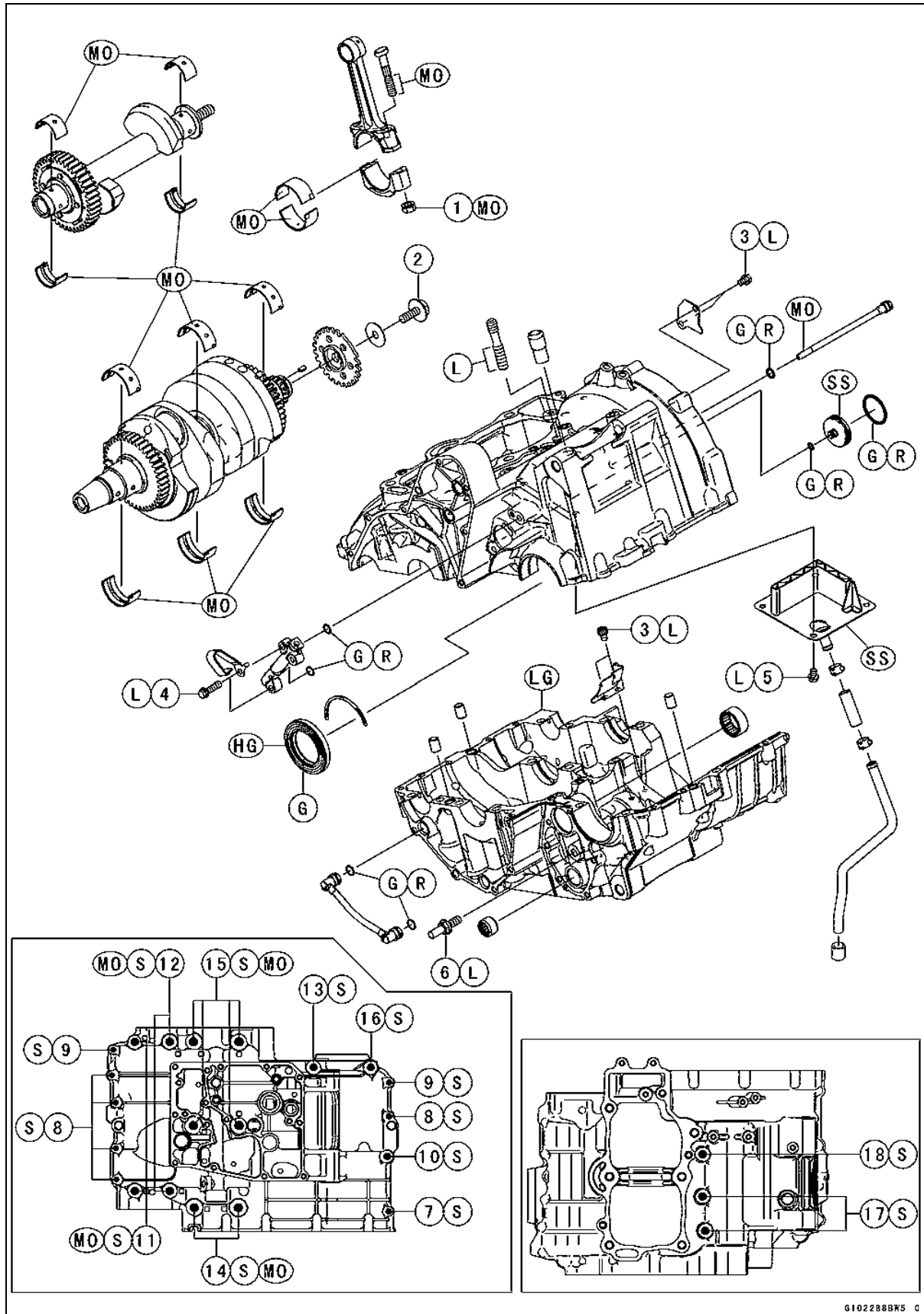

G102288K5 C

CRANKSHAFT/TRANSMISSION 9-3

Exploded View

No.	Fastener	Torque			Remarks
		N·m	kgf·m	ft·lb	
1	Connecting Rod Big End Nuts	see Text	←	←	MO
2	Timing Rotor Bolt	40	4.1	30	
3	Oil Plate Bolts	9.8	1.0	87 in·lb	L
4	Oil Pipe Bolts	9.8	1.0	87 in·lb	L
5	Breather Plate Bolts	9.8	1.0	87 in·lb	L
6	Shift Shaft Return Spring Pin	29	3.0	21	L
7	Crankcase Bolt (M6, L = 32 mm)	19.6	2.0	14	S
8	Crankcase Bolts (M6, L = 38 mm)	19.6	2.0	14	S
9	Crankcase Bolts (M6, L = 45 mm)	19.6	2.0	14	S
10	Crankcase Bolt (M8, L = 50 mm)	27.5	2.8	20	S
11	Crankcase Bolts (M8, L = 60 mm)	35	3.6	26	MO, S
12	Crankcase Bolts (M8, L = 73 mm)	35	3.6	26	MO, S
13	Crankcase Bolt (M8, L = 110 mm)	27.5	2.8	20	S
14	Crankcase Bolts (M9, L = 83 mm)	44	4.5	32	MO, S
15	Crankcase Bolts (M9, L = 113 mm)	44	4.5	32	MO, S
16	Crankcase Bolt (M8, L = 60 mm)	27.5	2.8	20	S
17	Upper Crankcase Bolts (M8, L = 110 mm)	27.5	2.8	20	S
18	Upper Crankcase Bolt (M8, L = 120 mm)	27.5	2.8	20	S

G: Apply grease.

HG: Apply high-temperature grease.

L: Apply a non-permanent locking agent.

LG: Apply liquid gasket.

MO: Apply molybdenum disulfide oil solution.

(mixture of the engine oil and molybdenum disulfide grease in a weight ratio 10 : 1)

R: Replacement Parts

S: Follow the specified tightening sequence.

SS: Apply silicone sealant.

9-4 CRANKSHAFT/TRANSMISSION

Exploded View

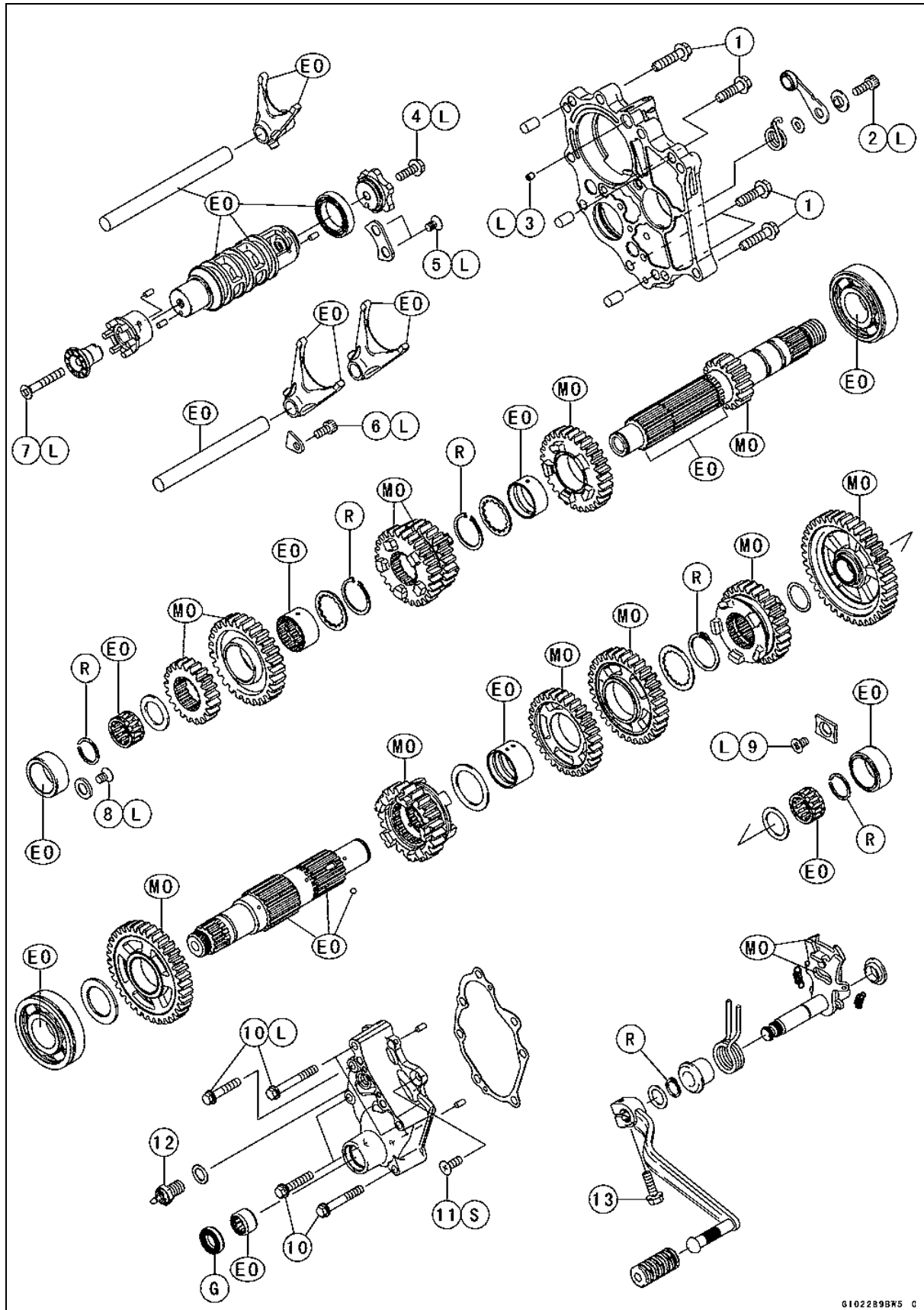

G102289BK5 C

CRANKSHAFT/TRANSMISSION 9-5

Exploded View

No.	Fastener	Torque			Remarks
		N-m	kgf-m	ft-lb	
1	Transmission Case Bolts	20	2.0	15	
2	Gear Positioning Lever Bolt	12	1.2	106 in-lb	L
3	Transmission Case Oil Nozzle	2.9	0.30	26 in-lb	L
4	Shift Drum Cam Bolt	12	1.2	106 in-lb	L
5	Shift Drum Bearing Holder Screws	4.9	0.50	43 in-lb	L
6	Shift Rod Plate Bolt	9.8	1.0	87 in-lb	L
7	Neutral Switch Holder Screw	4.9	0.50	43 in-lb	L
8	Race Holder Screw	4.9	0.50	43 in-lb	L
9	Drive Shaft Bearing Holder Screw	4.9	0.50	43 in-lb	L
10	Shift Shaft Cover Bolts	9.8	1.0	87 in-lb	L (3)
11	Shift Shaft Cover Screw	4.9	0.50	43 in-lb	L, S
12	Neutral Switch	15	1.5	11	
13	Shift Pedal Bolt	12	1.2	106 in-lb	

EO: Apply engine oil.

G: Apply grease.

L: Apply a non-permanent locking agent.

MO: Apply molybdenum disulfide oil solution.

(mixture of the engine oil and molybdenum disulfide grease in a weight ratio 10 : 1)

R: Replacement Parts

9-6 CRANKSHAFT/TRANSMISSION

Specifications

Item	Standard	Service Limit																					
Crankshaft, Connecting Rods																							
Connecting Rod Bend	— — —	TIR 0.2/100 mm (0.008/3.94 in.)																					
Connecting Rod Twist	— — —	TIR 0.2/100 mm (0.008/3.94 in.)																					
Connecting Rod Big End Side Clearance	0.13 ~ 0.38 mm (0.0051 ~ 0.0150 in.)	0.58 mm (0.023 in.)																					
Connecting Rod Big End Bearing Insert/Crankpin Clearance	0.017 ~ 0.041 mm (0.0007 ~ 0.0016 in.)	0.08 mm (0.003 in.)																					
Crankpin Diameter:	37.984 ~ 38.000 mm (1.4954 ~ 1.4961 in.)	37.97 mm (1.4949 in.)																					
Marking:																							
None	37.984 ~ 37.992 mm (1.4954 ~ 1.4957 in.)	— — —																					
○	37.993 ~ 38.000 mm (1.4958 ~ 1.4961 in.)	— — —																					
Connecting Rod Big End Inside Diameter:	41.000 ~ 41.016 mm (1.6142 ~ 1.6148 in.)	— — —																					
Marking:																							
None	41.000 ~ 41.008 mm (1.6142 ~ 1.6145 in.)	— — —																					
○	41.009 ~ 41.016 mm (1.6145 ~ 1.6148 in.)	— — —																					
Connecting Rod Big End Bearing Insert Thickness:																							
Brown	1.475 ~ 1.480 mm (0.05807 ~ 0.05827 in.)	— — —																					
Black	1.480 ~ 1.485 mm (0.05827 ~ 0.05846 in.)	— — —																					
Blue	1.485 ~ 1.490 mm (0.05846 ~ 0.05866 in.)	— — —																					
Connecting Rod Big End Bearing Insert Selection:																							
<table border="1"> <thead> <tr> <th rowspan="2">Connecting Rod Big End Inside Diameter Marking</th> <th rowspan="2">Crankpin Diameter Marking</th> <th colspan="2">Bearing Insert</th> </tr> <tr> <th>Size Color</th> <th>Part Number</th> </tr> </thead> <tbody> <tr> <td>None</td> <td>○</td> <td>Brown</td> <td>92139-0116</td> </tr> <tr> <td>None</td> <td>None</td> <td rowspan="2">Black</td> <td rowspan="2">92139-0115</td> </tr> <tr> <td>○</td> <td>○</td> </tr> <tr> <td>○</td> <td>None</td> <td>Blue</td> <td>92139-0114</td> </tr> </tbody> </table>				Connecting Rod Big End Inside Diameter Marking	Crankpin Diameter Marking	Bearing Insert		Size Color	Part Number	None	○	Brown	92139-0116	None	None	Black	92139-0115	○	○	○	None	Blue	92139-0114
Connecting Rod Big End Inside Diameter Marking	Crankpin Diameter Marking	Bearing Insert																					
		Size Color	Part Number																				
None	○	Brown	92139-0116																				
None	None	Black	92139-0115																				
○	○																						
○	None	Blue	92139-0114																				
Connecting Rod Bolt Stretch:	(Usable Range)																						
New Connecting Rod	0.24 ~ 0.36 mm (0.0094 ~ 0.0142 in.)	— — —																					
Used Connecting Rod	0.20 ~ 0.32 mm (0.0079 ~ 0.0126 in.)	— — —																					
Crankshaft Side Clearance	0.05 ~ 0.20 mm (0.0020 ~ 0.0079 in.)	0.40 mm (0.016 in.)																					

CRANKSHAFT/TRANSMISSION 9-7

Specifications

Item	Standard	Service Limit																					
Crankshaft Runout	TIR 0.02 mm (0.0008 in.) or less	TIR 0.05 mm (0.002 in.)																					
Crankshaft Main Bearing Insert/Journal Clearance	0.012 ~ 0.036 mm (0.0005 ~ 0.0014 in.)	0.07 mm (0.003 in.)																					
Crankshaft Main Journal Diameter:	37.984 ~ 38.000 mm (1.4954 ~ 1.4961 in.)	37.96 mm (1.4945 in.)																					
Marking:																							
None	37.984 ~ 37.992 mm (1.4954 ~ 1.4957 in.)	---																					
1	37.993 ~ 38.000 mm (1.4958 ~ 1.4961 in.)	---																					
Crankcase Main Bearing Inside Diameter:	41.000 ~ 41.016 mm (1.6142 ~ 1.6148 in.)	---																					
Marking:																							
○	41.000 ~ 41.008 mm (1.6142 ~ 1.6145 in.)	---																					
None	41.009 ~ 41.016 mm (1.6145 ~ 1.6148 in.)	---																					
Crankshaft Main Bearing Insert Thickness:																							
Brown	1.490 ~ 1.494 mm (0.05866 ~ 0.05882 in.)	---																					
Black	1.494 ~ 1.498 mm (0.05882 ~ 0.05898 in.)	---																					
Blue	1.498 ~ 1.502 mm (0.05898 ~ 0.05913 in.)	---																					
Crankshaft Main Bearing Insert Selection:																							
<table border="1" style="width: 100%; border-collapse: collapse;"> <thead> <tr> <th rowspan="2" style="text-align: center;">Crankcase Main Bearing Inside Diameter Marking</th> <th rowspan="2" style="text-align: center;">Crankshaft Main Journal Diameter Marking</th> <th colspan="2" style="text-align: center;">Bearing Insert*</th> </tr> <tr> <th style="text-align: center;">Size Color</th> <th style="text-align: center;">Part Number</th> </tr> </thead> <tbody> <tr> <td style="text-align: center;">○</td> <td style="text-align: center;">1</td> <td style="text-align: center;">Brown</td> <td style="text-align: center;">92028-1905</td> </tr> <tr> <td style="text-align: center;">None</td> <td style="text-align: center;">1</td> <td rowspan="2" style="text-align: center;">Black</td> <td rowspan="2" style="text-align: center;">92028-1904</td> </tr> <tr> <td style="text-align: center;">○</td> <td style="text-align: center;">None</td> </tr> <tr> <td style="text-align: center;">None</td> <td style="text-align: center;">None</td> <td style="text-align: center;">Blue</td> <td style="text-align: center;">92028-1903</td> </tr> </tbody> </table>				Crankcase Main Bearing Inside Diameter Marking	Crankshaft Main Journal Diameter Marking	Bearing Insert*		Size Color	Part Number	○	1	Brown	92028-1905	None	1	Black	92028-1904	○	None	None	None	Blue	92028-1903
Crankcase Main Bearing Inside Diameter Marking	Crankshaft Main Journal Diameter Marking	Bearing Insert*																					
		Size Color	Part Number																				
○	1	Brown	92028-1905																				
None	1	Black	92028-1904																				
○	None																						
None	None	Blue	92028-1903																				
*The bearing inserts for Nos. 1, 2 and 3 journals have oil grooves.																							
Balancer Shaft																							
Balancer Shaft Bearing Insert/Journal Clearance	0.011 ~ 0.033 mm (0.0004 ~ 0.0013 in.)	0.08 mm (0.003 in.)																					
Balancer Shaft Journal Diameter:	27.987 ~ 28.000 mm (1.1019 ~ 1.1024 in.)	27.96 mm (1.1008 in.)																					
Marking:																							
None	27.987 ~ 27.993 mm (1.1019 ~ 1.1021 in.)	---																					
○	27.994 ~ 28.000 mm (1.1021 ~ 1.1024 in.)	---																					

9-8 CRANKSHAFT/TRANSMISSION

Specifications

Item	Standard	Service Limit																					
Crankcase Bearing Bore Diameter:	31.000 ~ 31.016 mm (1.2205 ~ 1.2211 in.)	---																					
Marking:																							
○	31.000 ~ 31.008 mm (1.2205 ~ 1.2208 in.)	---																					
None	31.009 ~ 31.016 mm (1.2208 ~ 1.2211 in.)	---																					
Balancer Shaft Bearing Insert Thickness:																							
Brown	1.490 ~ 1.494 mm (0.05866 ~ 0.05882 in.)	---																					
Black	1.494 ~ 1.498 mm (0.05882 ~ 0.05898 in.)	---																					
Blue	1.498 ~ 1.502 mm (0.05898 ~ 0.05913 in.)	---																					
Balancer Shaft Bearing Insert Selection:																							
		<table border="1"> <thead> <tr> <th rowspan="2">Crankcase Bearing Inside Diameter Marking</th> <th rowspan="2">Balancer Shaft Journal Diameter Marking</th> <th colspan="2">Bearing Insert*</th> </tr> <tr> <th>Size Color</th> <th>Part Number</th> </tr> </thead> <tbody> <tr> <td>○</td> <td>○</td> <td>Brown</td> <td>92139-0119</td> </tr> <tr> <td>○</td> <td>None</td> <td rowspan="2">Black</td> <td rowspan="2">92139-0118</td> </tr> <tr> <td>None</td> <td>○</td> </tr> <tr> <td>None</td> <td>None</td> <td>Blue</td> <td>92139-0117</td> </tr> </tbody> </table>		Crankcase Bearing Inside Diameter Marking	Balancer Shaft Journal Diameter Marking	Bearing Insert*		Size Color	Part Number	○	○	Brown	92139-0119	○	None	Black	92139-0118	None	○	None	None	Blue	92139-0117
Crankcase Bearing Inside Diameter Marking	Balancer Shaft Journal Diameter Marking	Bearing Insert*																					
		Size Color	Part Number																				
○	○	Brown	92139-0119																				
○	None	Black	92139-0118																				
None	○																						
None	None	Blue	92139-0117																				
*The bearing inserts for Nos. 1 and 2 journals have oil grooves.																							
Transmission																							
Shift Fork Ear Thickness	5.9 ~ 6.0 mm (0.232 ~ 0.236 in.)	5.8 mm (0.23 in.)																					
Gear Groove Width	6.05 ~ 6.15 mm (0.238 ~ 0.242 in.)	6.3 mm (0.25 in.)																					
Shift Fork Guide Pin Diameter	6.9 ~ 7.0 mm (0.272 ~ 0.276 in.)	6.8 mm (0.27 in.)																					
Shift Drum Groove Width	7.05 ~ 7.20 mm (0.278 ~ 0.283 in.)	7.3 mm (0.29 in.)																					

Special Tools and Sealants

Outside Circlip Pliers:
57001-144

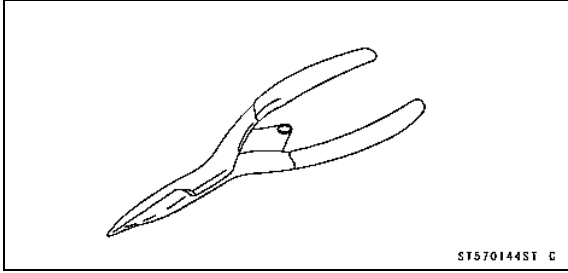

Kawasaki Bond (Silicone Sealant):
92104-0004

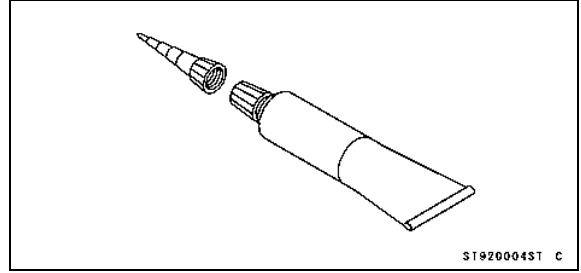

Bearing Driver Set:
57001-1129

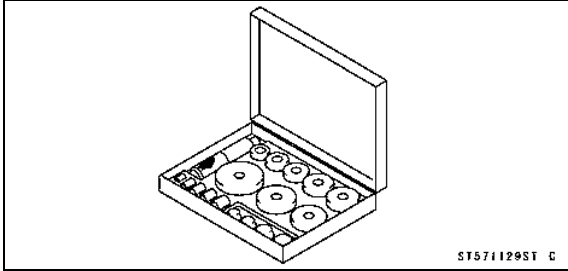

Kawasaki Bond (Liquid Gasket - Black):
92104-1064

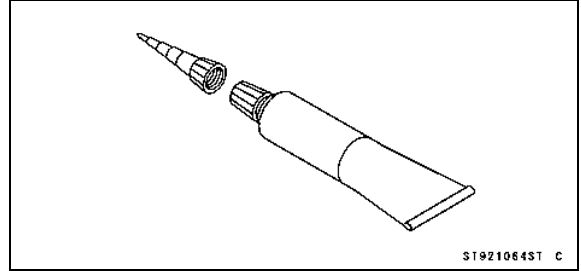

9-10 CRANKSHAFT/TRANSMISSION

Crankcase Splitting

Crankcase Splitting

- Remove the engine (see Engine Removal in the Engine Removal/Installation chapter)
- Set the engine on a clean surface and hold the engine steady while parts are being removed.
- Remove:
 - Pistons (see Piston Removal in the Engine Top End chapter)
 - Alternator Rotor (see Alternator Rotor Removal in the Electrical System chapter)
 - Starter Motor (see Starter Motor Removal in the Electrical System chapter)
 - Timing Rotor (see Timing Rotor Removal in the Electrical System chapter)
 - Clutch (see Clutch Removal in the Clutch chapter)
 - Oil Pump (see Oil Pump Removal in the Engine Lubrication System chapter)
 - Water Pump (see Water Pump Removal in the Cooling System chapter)
 - Transmission Assy (see Transmission Assy Removal)
- Remove the upper crankcase bolts [A] and the washers.

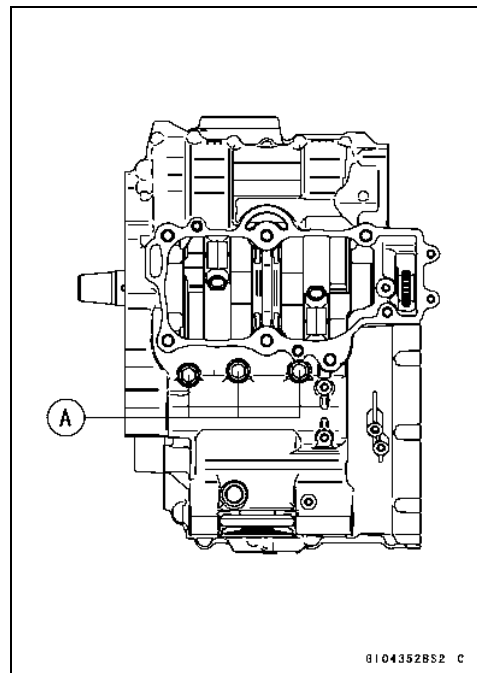

Crankcase Splitting

- Remove the oil pan, oil screen and oil pipes (see Oil Pan Removal in the Engine Lubrication System chapter).
- Remove the lower crankcase bolts, following the specified sequence.
 - Firstly, loosen the M6 bolts [A].
 - Secondly, loosen the M8 bolts [B].
 - Lastly, loosen the M9 bolts [C].
- Tap lightly around the crankcase mating surface with a plastic mallet, and split the crankcase. Take care not to damage the crankcase.

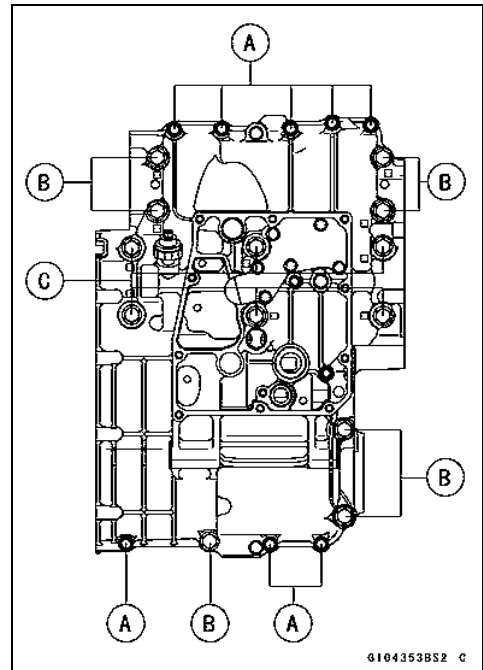

- ★ If the oil pipe is to be removed, follow the next procedure.
 - Unscrew the bolts [A] and remove the oil pipe [B].

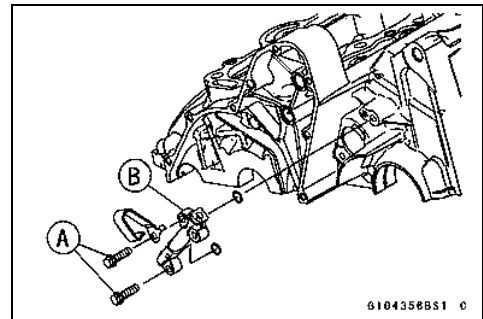

- Prepare a $\phi 5$ mm rod [A], and insert it to the hole of the upper crankcase half.
- Remove the oil pipe [B], tapping [C] the rod as shown.

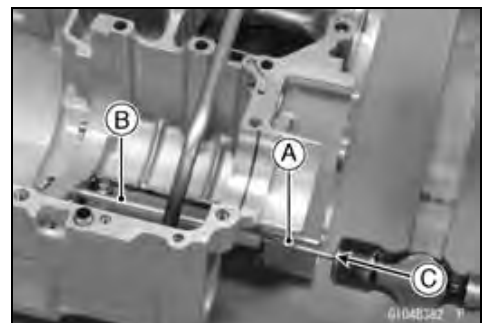

- ★ If the breather plate [A] is to be removed, follow the next procedure.
 - Remove the oil pipe (see above).
 - Cut the gasket around the plate [B].
 - Remove:
 - Breather Plate Bolts [C]
 - Breather Plate with Pipe [D]

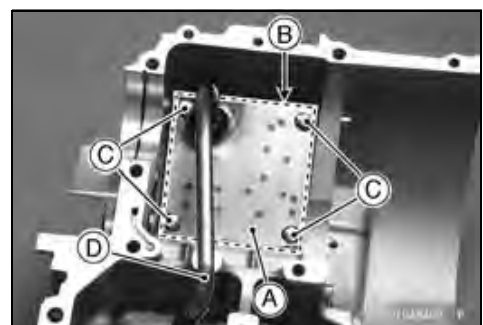

9-12 CRANKSHAFT/TRANSMISSION

Crankcase Splitting

Crankcase Assembly

CAUTION

The upper and lower crankcase halves are machined at the factory in the assembled state, so the crankcase halves must be replaced as a set.

- With a high-flash point solvent, clean off the mating surfaces of the crankcases halves and wipe dry.
- Using compressed air, blow out the oil passages in the crankcase halves.

★ If the oil plate [A] on the upper crankcase half was removed, install it as shown.

- Apply a non-permanent locking agent to the oil plate bolts and tighten them.

Torque - Oil Plate Bolts [B]: 9.8 N·m (1.0 N·m, 87 in·lb)

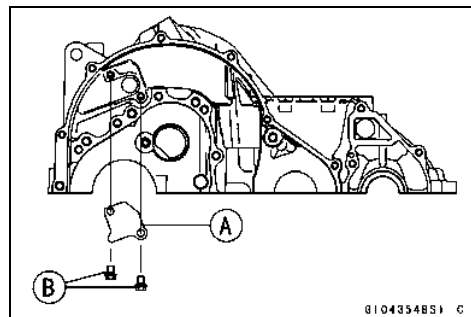

- When the new needle bearing [A] for the shift drum is installed in the lower crankcase half [B], press and insert [C] the new needle bearing until it is bottomed.

Special Tool - Bearing Driver Set: 57001-1129

- When the new needle bearing [D] for the shift shaft is installed in the lower crankcase half, press and insert [E] the new needle bearing so that the bearing surface is flush with the end of hole.
- The marked side of the needle bearing faces outside of the crankcase.

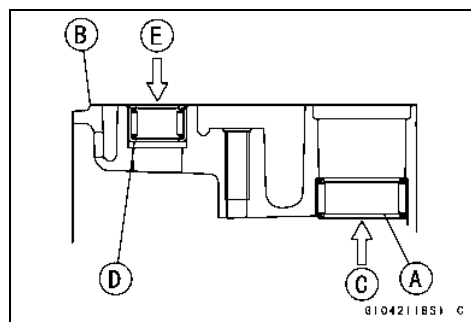

Special Tool - Bearing Driver Set: 57001-1129

- When the new oil plug [A] and new race [B] for drive shaft is installed in the upper crankcase half [C], install them using the following steps.

- Apply grease to the new O-rings [D].
- Apply silicone sealant to the portions [E] on the upper crankcase half, and insert [F] the new oil plug until it is bottomed.

Sealant - Kawasaki Bond (Silicone Sealant): 92104-0004

- Press and insert the new race until it is bottomed.

Special Tool - Bearing Driver Set: 57001-1129

NOTE

- Install the new race so that the stepped side [G] faces inside of the crankcase.
- Do not apply silicone sealant to the O-ring and the oil line.

- Install the race holder [H] direction as shown.

- Apply a non-permanent locking agent to the threads of the race holder screw [I] and tighten it.

Torque - Race Holder Screw: 4.9 N·m (0.50 kgf·m, 43 in·lb)

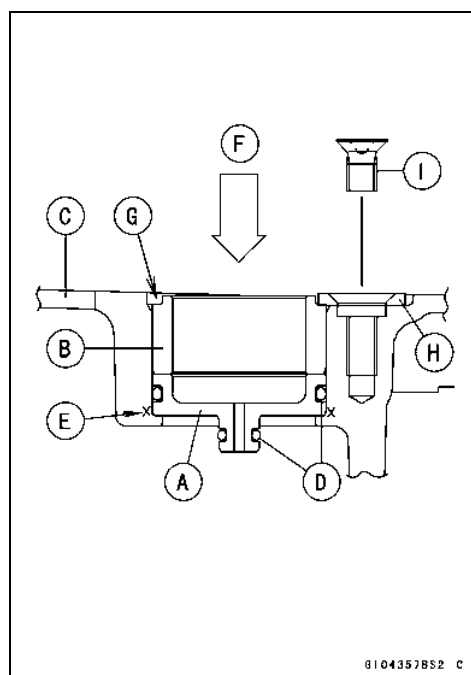

Crankcase Splitting

- Apply silicone sealant to the breather plate mating surface [A] 1 mm (0.04 in.) or more thick, and then install the breather plate.

Sealant - Three Bond: TB1207B

NOTE

- Make the application finish within 7 minutes when the liquid gasket to the mating surface of the breather plate is applied.
- Moreover fit the plate and tighten the bolts just after application of the liquid gasket.

- Apply a non-permanent locking agent to the threads and tighten the bolts [A].

Torque - Breather Plate Bolts: 9.8 N·m (1.0 kgf·m, 87 in·lb)

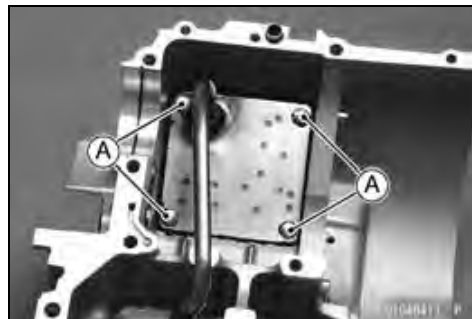
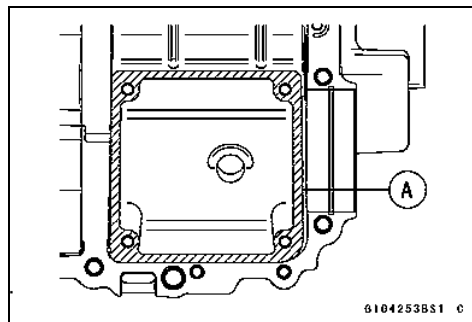

- Install the breather pipe [A].
- Align the white mark [B] on the pipe with the white mark [C] on the breather fitting.
- Install the clamps [D] so that the pinch heads [E] face the white marks.

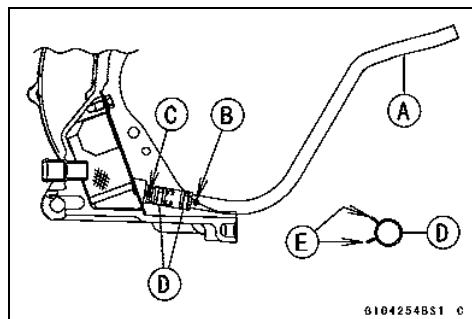

- Apply molybdenum disulfide oil solution to the edge of the oil pipe [E].
- Install the oil pipe [A] so that its flange [B] touches to the surface [C] of the upper crankcase half.
- Apply grease to the new O-ring [D] on the oil pipe.

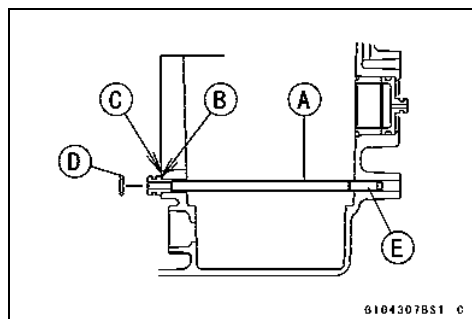

- Replace the O-rings [A] with new ones.
- Apply grease to the new O-rings.
- Apply a non-permanent locking agent to the threads of the oil pipe bolts and tighten them.
- Install the clamp with the upper oil pipe bolt.

Torque - Oil Pipe Bolts: 9.8 N·m (1.0 kgf·m, 87 in·lb)

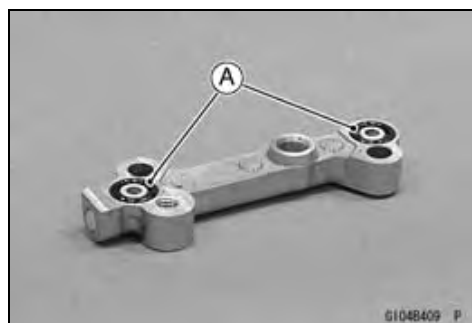

9-14 CRANKSHAFT/TRANSMISSION

Crankcase Splitting

- Install the crankshaft and the balancer shaft on the upper crankcase half.
- Apply molybdenum disulfide oil solution to the following items.
 - Crankshaft Main Bearing Insert
 - Balancer Shaft Bearing Insert
- Align [A] the timing mark on the balancer gear [B] with the timing mark on the balancer drive gear [C] of the crankshaft.

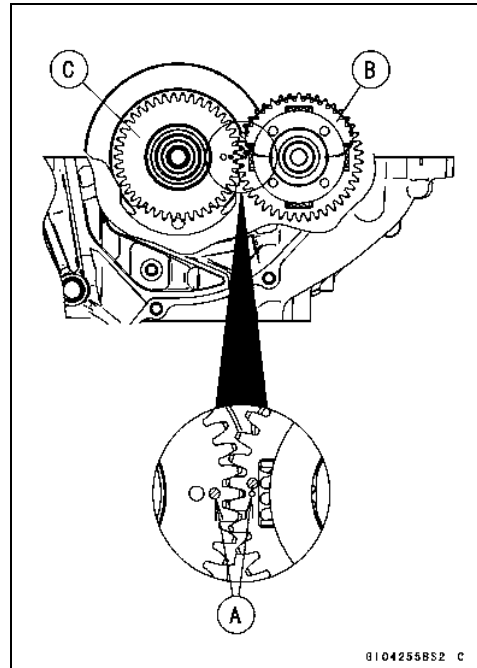

- Be sure to hang the camshaft chain [A] on the crankshaft.



- Be sure that the dowel pins [A] are in position.

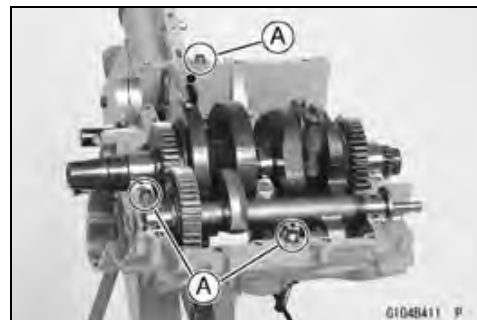

- Set the bearing groove [A] on the positioning ring [B] as shown.

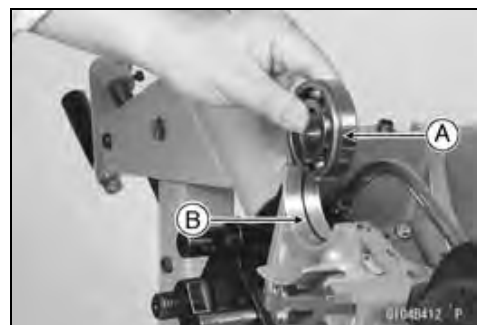

Crankcase Splitting

- Apply liquid gasket [A] to the mating surface of the lower crankcase half.

Sealant - Kawasaki Bond (Liquid Gasket-Black): 92104
-1064

NOTE

- Especially, apply a liquid gasket carefully so that it shall be filled up on the grooves.

CAUTION

Do not apply liquid gasket around the crankshaft main bearing inserts, and oil passage holes.

- Do not apply liquid gasket to the oil passage [B].

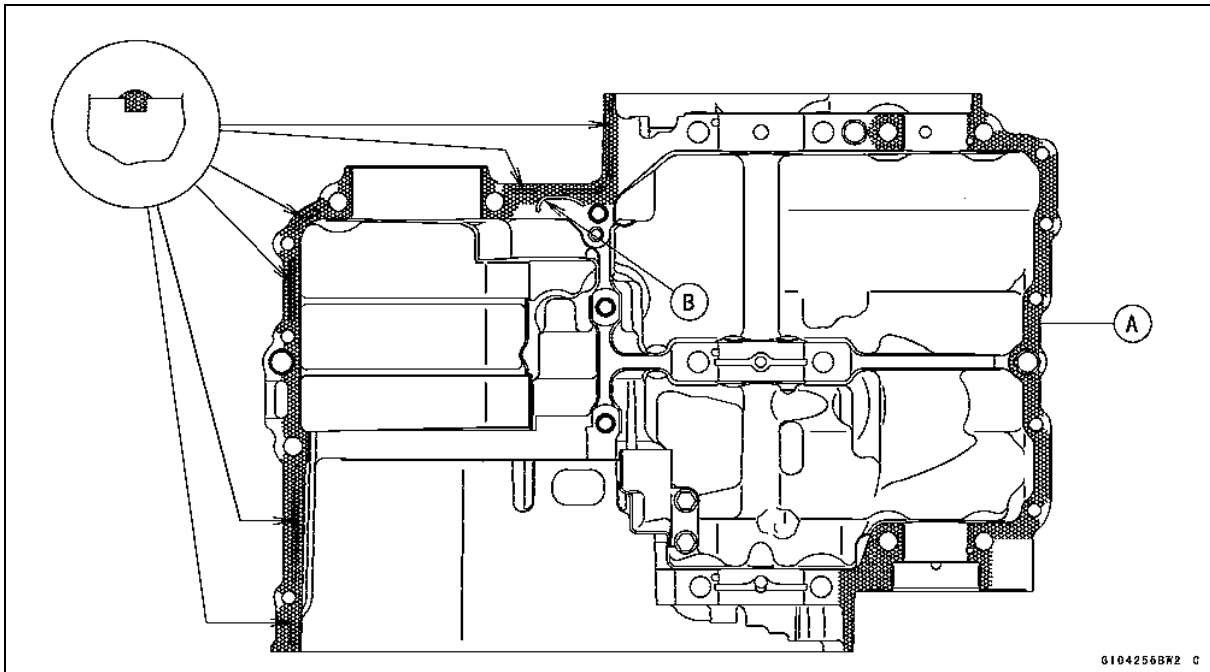

9-16 CRANKSHAFT/TRANSMISSION

Crankcase Splitting

- Fit the lower crankcase half to the upper crankcase half.
- Insert [A] the breather pipe [B] on the upper crankcase half through the hole [C] on the lower crankcase half.

NOTE

- Make the application finish within 20 minutes when the liquid gasket to the mating surface of the lower crankcase half is applied.
- Moreover fit the case and tighten the case bolts just after finishing the application of the liquid gasket.

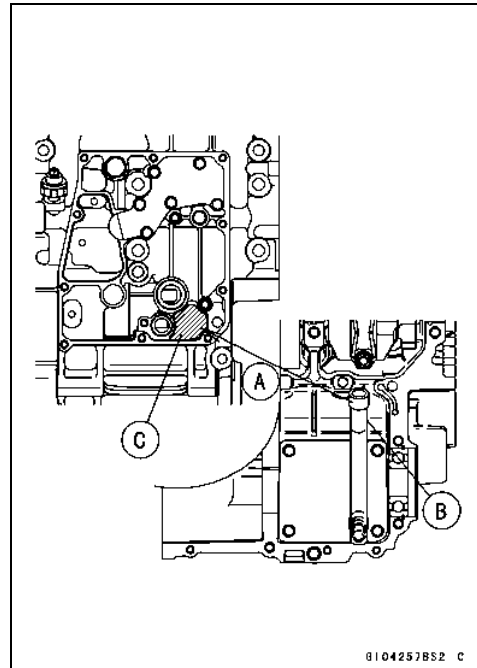

- The M9 bolts [1 ~ 6] (see the next figure) have copper plated washers, replace them with new ones.
- Apply molybdenum disulfide oil solution to both sides [A] of the M9 bolts washers and the threads [B] of the M9 bolts.

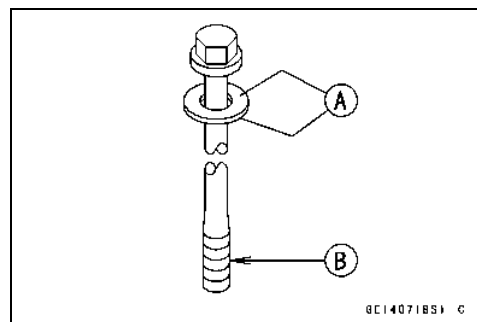

- Apply molybdenum disulfide oil solution to flange [A] and the threads [B] of the M8 bolts which is tightening order is [7 ~ 10] only (see the next figure).

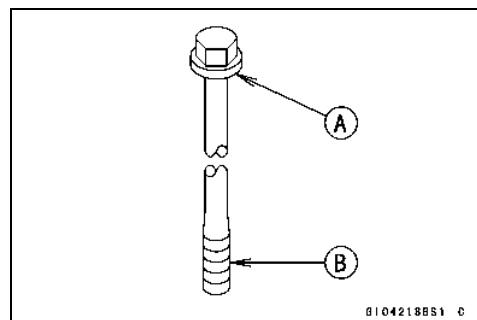

Crankcase Splitting

- Tighten the lower crankcase bolts using the following steps.

- Following the sequence numbers on the lower crankcase half, tighten the M9 bolts [1, 2] L= 113 mm (4.45 in.) with washers.

Torque - Crankcase Bolts (M9): 44 N·m (4.5 kgf·m, 32 ft·lb)

- Tighten the M9 bolts [3, 4] L= 83 mm (3.27 in.) with washers.

Torque - Crankcase Bolts (M9): 44 N·m (4.5 kgf·m, 32 ft·lb)

- Tighten the M9 bolts [5, 6] L= 113 mm (4.45 in.) with washers.

Torque - Crankcase Bolts (M9): 44 N·m (4.5 kgf·m, 32 ft·lb)

- Tighten the M8 bolts [7 ~ 10].

Torque - Crankcase Bolts (M8): 35 N·m (3.6 kgf·m, 26 ft·lb)

- Tighten the M8 bolts [A] (do not apply molybdenum disulfide oil solution).

Torque - Crankcase Bolts (M8): 27.5 N·m (2.8 kgf·m, 20 ft·lb)

- Tighten the M6 bolts [B].

Torque - Crankcase Bolts (M6): 19.6 N·m (2.0 kgf·m, 14 ft·lb)

- The upper crankcase bolts have copper plated washers, replace them with new ones.
- Tighten the upper crankcase bolts with washers.

Torque - Upper Crankcase Bolts [A]: 27.5 N·m (2.8 kgf·m, 20 ft·lb)

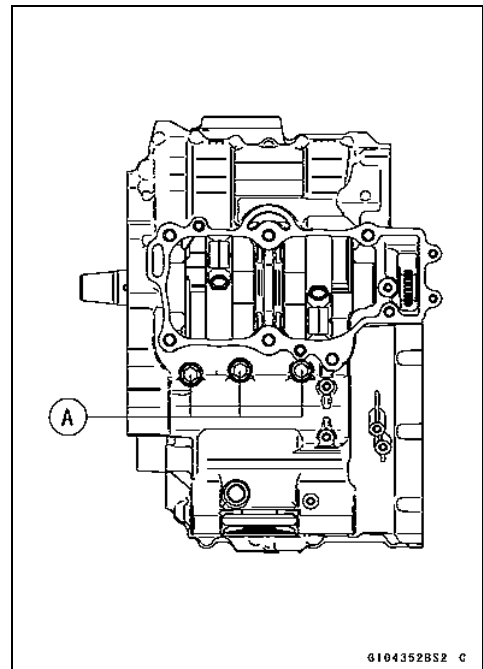
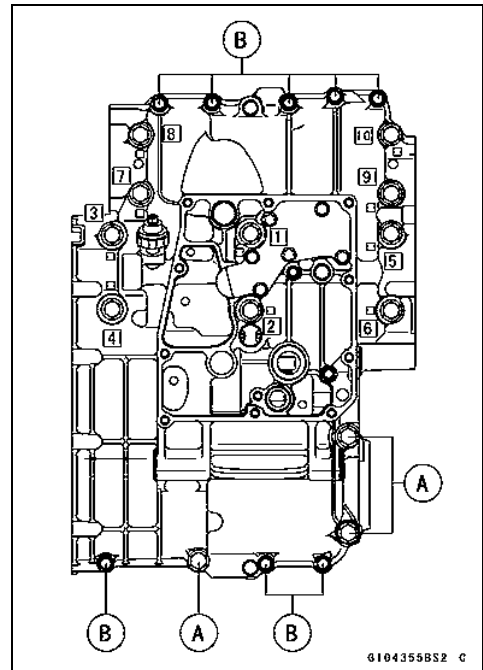

- After tightening all crankcase bolts, check the following items.

- Wipe up the liquid gasket that seeps out around the crankcase mating surface.
- Crankshaft and balancer shaft turn freely.

9-18 CRANKSHAFT/TRANSMISSION

Crankshaft and Connecting Rods

Crankshaft Removal

- Split the crankcase (see Crankcase Splitting).
- Remove:
 - Camshaft Chain [A]
 - Crankshaft [B]

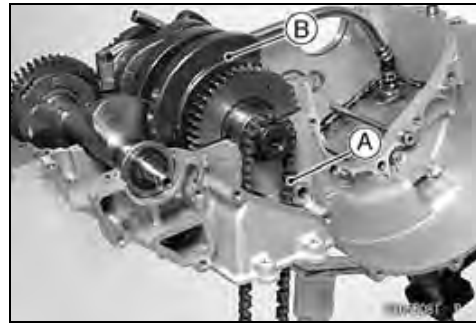

Crankshaft Installation

NOTE

○ If the crankshaft is replaced with a new one, refer to the Connecting Rod Big End Bearing/Crankshaft Main Bearing Insert Selection in the Specifications.

CAUTION

If the crankshaft, bearing inserts, or crankcase halves are replaced with new ones, select the bearing inserts and check clearance with a plastigage (press gauge) before assembling engine to be sure the correct bearing inserts are installed.

- Apply molybdenum disulfide oil solution to the crankshaft main bearing inserts.
- Align [A] the timing mark on the balancer gear [B] with the timing mark on the balancer drive gear [C] of the crankshaft.
- Install the crankshaft with the camshaft chain [A] hanging on it.

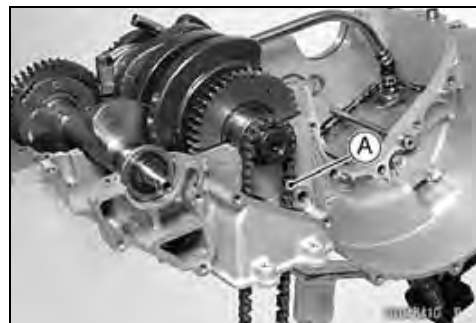
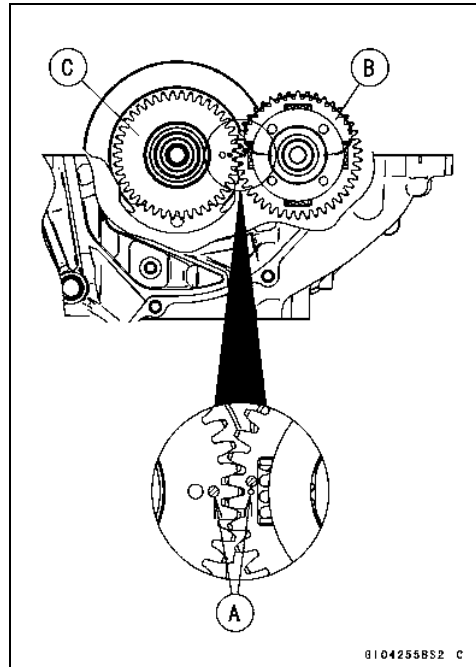

Connecting Rod Removal

- Split the crankcase (see Crankcase Splitting).
- Remove the connecting rod nuts [A].
- Remove the crankshaft (see Crankshaft Removal).

NOTE

○ Mark and record the locations of the connecting rods and their big end caps so that they can be reassembled in their original positions.

- Remove the connecting rods from the crankshaft.

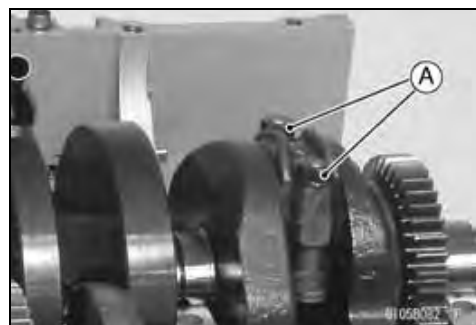

CAUTION

Discard the connecting rod bolts. To prevent damage to the crankpin surfaces, do not allow the connecting rod bolts to bump against the crankpins.

Crankshaft and Connecting Rods

Connecting Rod Installation

CAUTION

To minimize vibration, the connecting rods should have the same weight mark.

- Big End Cap [A]
- Connecting Rod [B]
- Weight Mark, Alphabet [C]
- Diameter Mark [D]: "O" or no mark

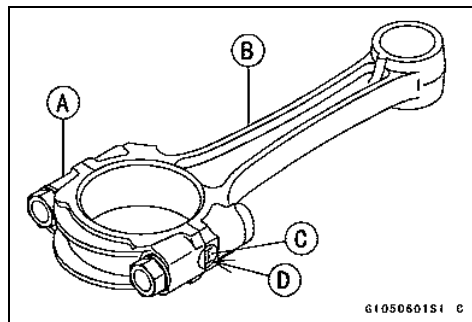

CAUTION

If the connecting rods, big end bearing inserts, or crankshaft are replaced with new ones, select the bearing insert and check clearance with a plasti-gage (press gauge) before assembling engine to be sure the correct bearing inserts are installed.

- Apply molybdenum disulfide oil solution [A] to the inner surfaces of upper and lower bearing inserts.
- Do not apply any grease or oil [B] to the cap inside and cap insert outside.
- Install the inserts so that their nails [C] are on the same side and fit them into the recess of the connecting rod and cap.

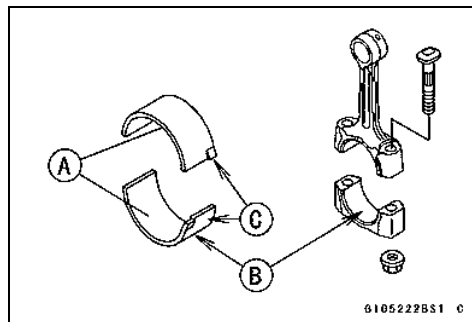

CAUTION

Wrong application of oil and grease could cause bearing damage.

- When installing the inserts [A], be careful not to damage the insert surface with the edge of the connecting rod [B] or the cap [C]. One way to install inserts is as follows.
 - Installation [D] to Cap
 - Installation [E] to Connecting Rod
 - Push [F]
 - Spare Dowel Pin [G]
 - Connecting Rod Bolts [H]

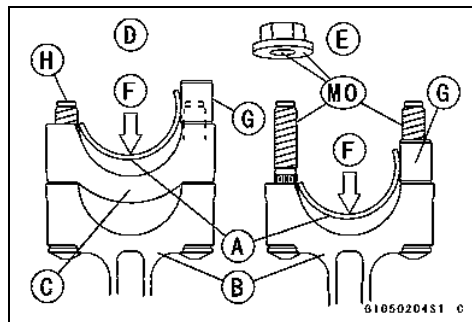

- Remove debris and clean the surface of inserts.
- Apply molybdenum disulfide oil solution [MO] to the threads and seating surfaces of the big end nuts and bolts.

- Install the crankshaft (see Crankshaft Installation).
- Install each connecting rod on its original crankpin.

NOTE

- Install each connecting rod so that its oil jet [A] faces the exhaust side (the front [B]) (see Engine Oil Flow Chart in the Engine Lubrication System chapter).
- Install the cap on the connecting rod, aligning the weight and diameter marks.

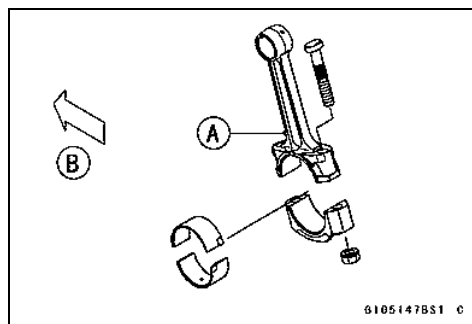

9-20 CRANKSHAFT/TRANSMISSION

Crankshaft and Connecting Rods

- The connecting rod big end is bolted using the “plastic region fastening method”.
- This method precisely achieves the needed clamping force without exceeding it unnecessarily, allowing the use of thinner, lighter bolts further decreasing connecting rod weight.
- There are two types of the plastic region fastening. One is a bolt length measurement method and other is a rotation angle method. Observe one of the following two, but the bolt length measurement method is preferable because this is a more reliable way to tighten the big end nuts.

CAUTION

The connecting rod bolts are designed to stretch when tightened. Never reuse the connecting rod bolts. See the table below for correct bolt and nut usage.

CAUTION

Be careful not to overtighten the nuts. The bolts must be positioned on the seating surface correctly to prevent the bolt heads from hitting the crankcase.

(1) Bolt Length Measurement Method

- Be sure to clean the bolts, nuts, and connecting rods thoroughly with a high-flash point solvent, because the new connecting rods, bolts, and nuts are treated with an anti-rust solution.

⚠ WARNING

Clean the bolts, nuts, and connecting rods in a well-ventilated area, and take care that there is no spark or flame anywhere near the working area. This includes any appliance with a pilot light. Because of the danger of highly flammable liquids, do not use gasoline or low-flash point solvents to clean them.

CAUTION

Immediately dry the bolts and nuts with compressed air after cleaning. Clean and dry the bolts and nuts completely.

- Apply a small amount of molybdenum disulfide oil solution to the following.
 - Threads [A] of Nuts and Bolts
 - Seating Surfaces [B] of Nuts and Connecting Rods

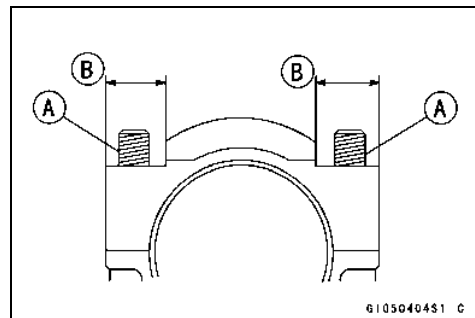

Crankshaft and Connecting Rods

- Install new bolts in reused connecting rods.
- Dent both bolt head and bolt tip with a punch as shown.
- Before tightening, use a point micrometer to measure the length of new connecting rod bolts and record the values to find the bolt stretch.

Connecting Rod [A]
 Mark here with a punch [B].
 Nuts [C]
 Fit micrometer pins into punch marks [D].

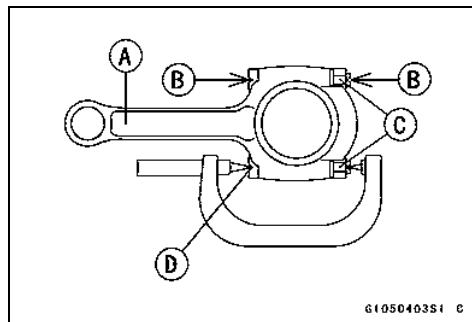

- Tighten the big end nuts until the bolt elongation reaches the length specified in the table.
- Check the length of the connecting rod bolts.
- ★ If the stretch is more than the usable range, the bolt has stretched too much. An overelongated bolt may break in use.

$$\text{Bolt Length after tightening} - \text{Bolt Length before tightening} = \text{Bolt Stretch}$$

Connecting Rod Assy	Bolt	Nut	Usable Range of Connecting Rod Bolt Stretch
New	Use the bolts attached to new connecting rod.	Attached to new connecting rod	0.24 ~ 0.36 mm (0.0094 ~ 0.0142 in.)
		New	
Used	Replace the bolts with new ones.	Used	0.20 ~ 0.32 mm (0.0079 ~ 0.0126 in.)
		New	

(2) Rotation Angle Method

- ★ If you don't have a point micrometer, you may tighten the nuts using the "Rotation Angle Method".
- Be sure to clean the bolts and nuts thoroughly with a high-flash point solvent, because the new bolts and nuts are treated with an anti-rust solution.

⚠ WARNING

Clean the bolts and nuts in a well-ventilated area, and take care that there is no spark or flame anywhere near the working area. This includes any appliance with a pilot light. Because of the danger or highly flammable liquids, do not use gasoline or low-flash point solvents to clean them.

CAUTION

Immediately dry the bolts and nuts with compressed air after cleaning. Clean and dry the bolts and nuts completely.

9-22 CRANKSHAFT/TRANSMISSION

Crankshaft and Connecting Rods

- Install new bolts in reused connecting rods.
- Apply a small amount of molybdenum disulfide oil solution to the following.
 - Threads [A] of Nuts and Bolts
 - Seating Surfaces [B] of Nuts and Connecting Rods

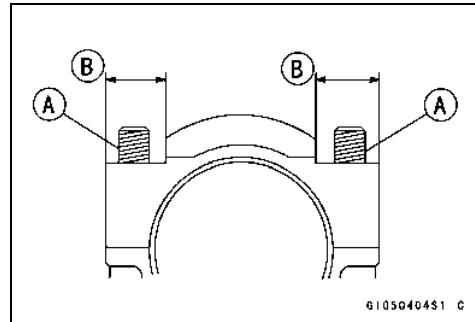

- First, tighten the nuts to the specified torque. See the table below.
- Next, tighten the nuts $120^\circ \pm 5^\circ$.
- Mark [A] the connecting rod big end caps and nuts so that nuts can be turned 120° [B] properly.

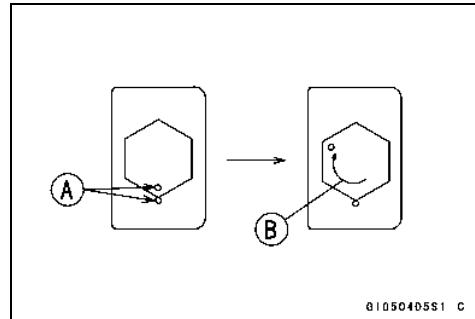

Connecting Rod Assy	Bolt	Nut	Torque + Angle N·m (kgf·m, ft·lb)
New	Use the bolts attached to new connecting rod.	Attached to new connecting rod	18 (1.8, 13.0) + 120°
		New	20 (2.0, 15) + 120°
Used	Replace the bolts with new ones.	Used	24 (2.4, 17.4) + 120°
		New	25 (2.6, 18.8) + 120°

Crankshaft/Connecting Rod Cleaning

- After removing the connecting rods from the crankshaft, clean them with a high-flash point solvent.
- Blow the crankshaft oil passages with compressed air to remove any foreign particles or residue that may have accumulated in the passages.

Connecting Rod Bend

- Remove the connecting rod big end bearing inserts, and reinstall the connecting rod big end cap.
- Select an arbor [A] of the same diameter as the connecting rod big end, and insert the arbor through the connecting rod big end.
- Select an arbor of the same diameter as the piston pin and at least 100 mm (3.94 in.) long, and insert the arbor [B] through the connecting rod small end.
- On a surface plate, set the big-end arbor on V block [C].
- With the connecting rod held vertically, use a height gauge to measure the difference in the height of the arbor above the surface plate over a 100 mm (3.94 in.) length to determine the amount of connecting rod bend.
- ★ If connecting rod bend exceeds the service limit, the connecting rod must be replaced.

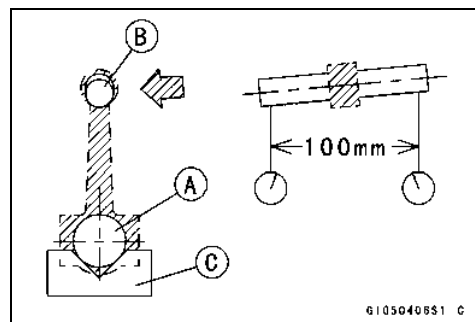

Connecting Rod Bend

Service Limit: TIR 0.2/100 mm (0.008/3.94 in.)

Crankshaft and Connecting Rods

Connecting Rod Twist

- With the big-end arbor [A] still on V block [C], hold the connecting rod horizontally and measure the amount that the arbor [B] varies from being paralleled with the surface plate over a 100 mm (3.94 in.) length of the arbor to determine the amount of connecting rod twist.
- ★ If connecting rod twist exceeds the service limit, the connecting rod must be replaced.

Connecting Rod Twist

Service Limit: TIR 0.2/100 mm (0.008/3.94 in.)

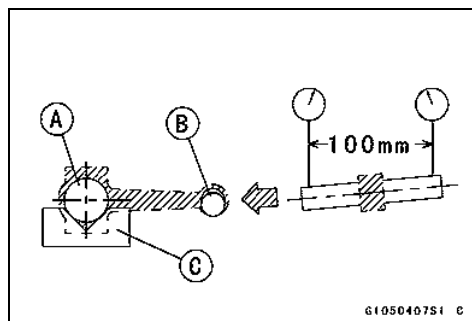

Connecting Rod Big End Side Clearance

- Measure connecting rod big end side clearance.
- Insert a thickness gauge [A] between the big end and either crank web to determine clearance.

Connecting Rod Big End Side Clearance

Standard: 0.13 ~ 0.38 mm (0.0051 ~ 0.0150 in.)

Service Limit: 0.58 mm (0.023 in.)

- ★ If the clearance exceeds the service limit, replace the connecting rod with new one and then check clearance again. If the clearance is too large after connecting rod replacement, the crankshaft also must be replaced.

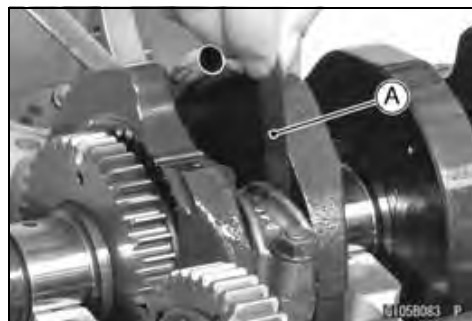

Connecting Rod Big End Bearing Insert/Crankpin Wear

- Measure the bearing insert/crankpin [A] clearance with plastigage [B].
- Tighten the big end nuts to the specified torque (see Connecting Rod Installation).

NOTE

- Do not move the connecting rod and crankshaft during clearance measurement.

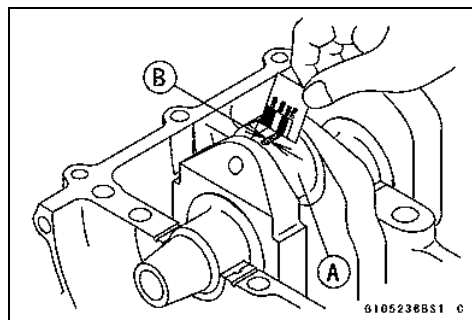

CAUTION

After measurement, replace the connecting rod bolts and nuts.

Connecting Rod Big End Bearing Insert/Crankpin Clearance

Standard: 0.017 ~ 0.041 mm (0.0007 ~ 0.0016 in.)

Service Limit: 0.08 mm (0.003 in.)

9-24 CRANKSHAFT/TRANSMISSION

Crankshaft and Connecting Rods

- ★ If the clearance is within the standard, no bearing replacement is required.
- ★ If the clearance is between 0.042 mm (0.00165 in.) and the service limit (0.08 mm, 0.003 in.), replace the bearing inserts [A] with inserts painted blue [B]. Check insert/crankpin clearance with the plastigage. The clearance may exceed the standard slightly, but it must not be less than the minimum in order to avoid bearing seizure.
- ★ If the clearance exceeds the service limit, measure the diameter of the crankpins.

Crankpin Diameter

Standard: 37.984 ~ 38.000 mm (1.4954 ~ 1.4961 in.)

Service Limit: 37.97 mm (1.4949 in.)

- ★ If any crankpin has worn past the service limit, replace the crankshaft with a new one.
- ★ If the measured crankpin diameters are not less than the service limit, but do not coincide with the original diameter markings on the crankshaft, make new marks on it.

Crankpin Diameter Marks

None 37.984 ~ 37.992 mm (1.4954 ~ 1.4957 in.)

○ 37.993 ~ 38.000 mm (1.4958 ~ 1.4961 in.)

△: Crankpin Diameter Marks, "○" or no mark.

- Measure the connecting rod big end inside diameter, and mark each connecting rod big end in accordance with the inside diameter.
- Tighten the connecting rod big end nuts to the specified torque (see Connecting Rod Installation).

NOTE

○ The mark already on the big end should almost coincide with the measurement.

Connecting Rod Big End Inside Diameter Marks

None 41.000 ~ 41.008 mm (1.6142 ~ 1.6145 in.)

○ 41.009 ~ 41.016 mm (1.6145 ~ 1.6148 in.)

Big End Cap [A]

Connecting Rod [B]

Weight Mark, Alphabet [C]

Diameter Mark (Around Weight Mark) [D]: "○" or no mark

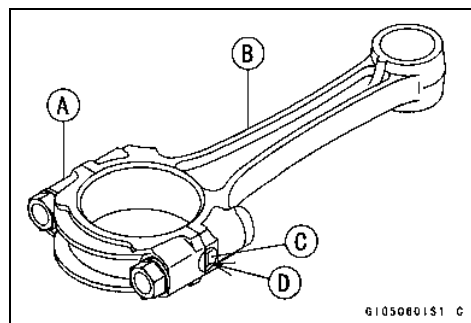
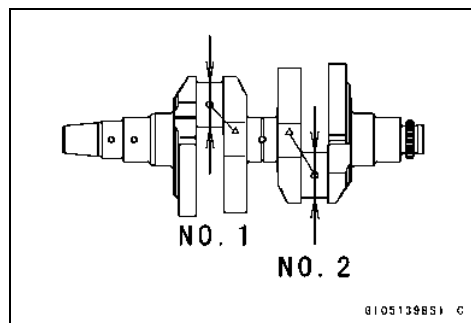
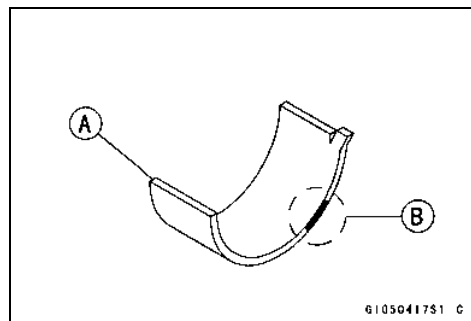

Crankshaft and Connecting Rods

- Select the proper bearing insert [A] in accordance with the combination of the connecting rod and crankshaft coding. Size Color [B]

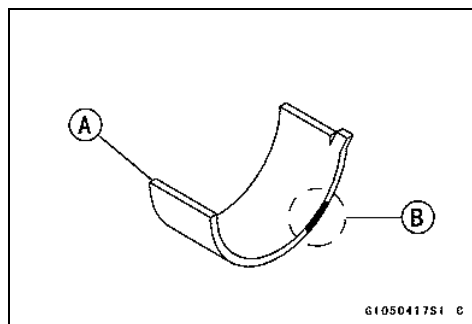

Connecting Rod Big End Inside Diameter Marking	Crankpin Diameter Marking	Bearing Insert	
		Size Color	Part Number
None	○	Brown	92139-0116
None	None	Black	92139-0115
○	○		
○	None	Blue	92139-0114

- Install the new inserts in the connecting rod and check insert/crankpin clearance with the plastigage.

Crankshaft Side Clearance

- Insert a thickness gauge [A] between the crankcase main bearing and the crank web at the No. 2 journal [B] to determine clearance.
- ★ If the clearance exceeds the service limit, replace the crankcase halves as a set.

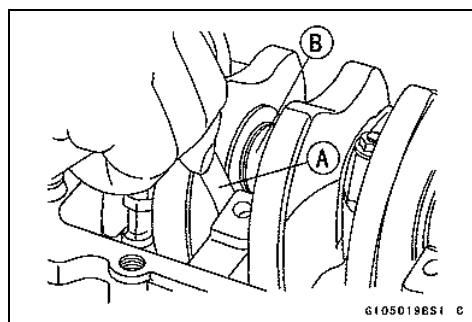

NOTE

○ The upper and lower crankcase halves are machined at the factory in the assembled state, so the crankcase halves must be replaced as a set.

Crankshaft Side Clearance

Standard: 0.05 ~ 0.20 mm (0.0020 ~ 0.0079 in.)
 Service Limit: 0.40 mm (0.016 in.)

Crankshaft Runout

- Measure the crankshaft runout.
- ★ If the measurement exceeds the service limit, replace the crankshaft.

Crankshaft Runout

Standard: TIR 0.02 mm (0.0008 in.) or less
 Service Limit: TIR 0.05 mm (0.002 in.)

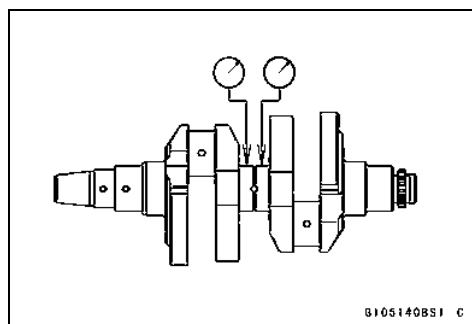

9-26 CRANKSHAFT/TRANSMISSION

Crankshaft and Connecting Rods

Crankshaft Main Bearing Insert/Journal Wear

- Using a plastigage (press gauge) [A], measure the bearing insert/journal [B] clearance.

NOTE

- Tighten the crankcase bolts to the specified torque (see Crankcase Assembly).
- Do not turn the crankshaft during clearance measurement.
- Journal clearance less than 0.025 mm (0.00098 in.) can not be measured by plastigage, however, using genuine parts maintains the minimum standard clearance.

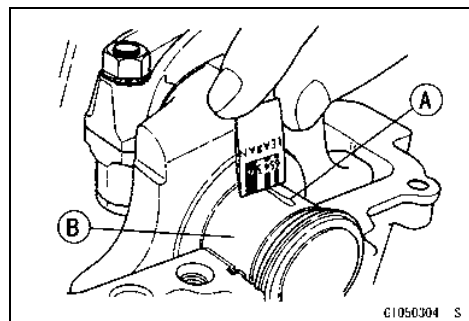

Crankshaft Main Bearing Insert/Journal Clearance

Standard: 0.012 ~ 0.036 mm (0.0005 ~ 0.0014 in.)

Service Limit: 0.07 mm (0.003 in.)

- ★ If the clearance is within the standard, no bearing replacement is required.
- ★ If the clearance is between 0.037 mm (0.0015 in.) and the service limit (0.07 mm, 0.003 in.), replace the bearing inserts [A] with inserts painted blue [B]. Check insert/journal clearance with the plastigage. The clearance may exceed the standard slightly, but it must not be less than the minimum in order to avoid bearing seizure.
- ★ If the clearance exceeds the service limit, measure the diameter of the crankshaft main journal.

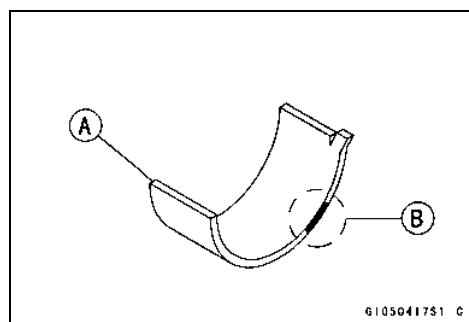

Crankshaft Main Journal Diameter

Standard: 37.984 ~ 38.000 mm (1.4954 ~ 1.4961 in.)

Service Limit: 37.96 mm (1.4945 in.)

- ★ If any journal has worn past the service limit, replace the crankshaft with a new one.
- ★ If the measured journal diameters are not less than the service limit, but do not coincide with the original diameter markings on the crankshaft, make new marks on it.

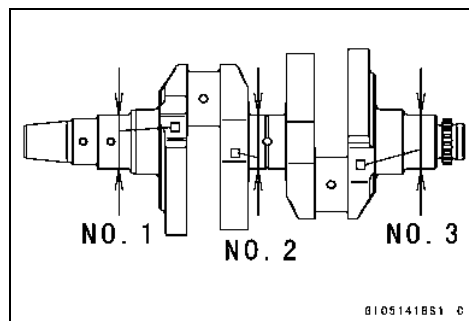

Crankshaft Main Journal Diameter Marks

None 37.984 ~ 37.992 mm (1.4954 ~ 1.4957 in.)

1 37.993 ~ 38.000 mm (1.4958 ~ 1.4961 in.)

- : Crankshaft Main Journal Diameter Marks, "1" or no mark.

Crankshaft and Connecting Rods

- Measure the main bearing inside diameter, and mark the upper crankcase half in accordance with the inside diameter.
Crankcase Main Bearing Inside Diameter Marks: “○” or no mark.
- Tighten the crankcase bolts to the specified torque (see Crankcase Assembly).

NOTE

○ The mark already on the upper crankcase half should almost coincide with the measurement.

Crankcase Main Bearing Inside Diameter Marks

○ 41.000 ~ 41.008 mm (1.6142 ~ 1.6145 in.)

None 41.009 ~ 41.016 mm (1.6145 ~ 1.6148 in.)

□□□: Crankcase Main Bearing Inside Diameter Marks, “○” mark or no mark

No.1 Journal [A]

No.2 Journal [B]

No.3 Journal [C]

- Select the proper bearing insert [A] in accordance with the combination of the crankcase and crankshaft coding.
Size Color [B]

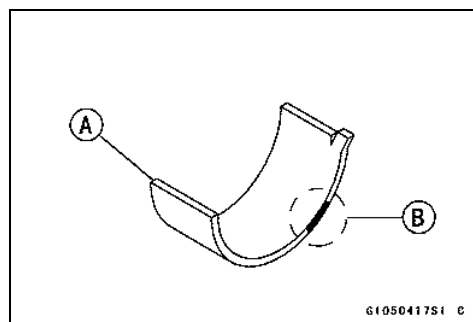
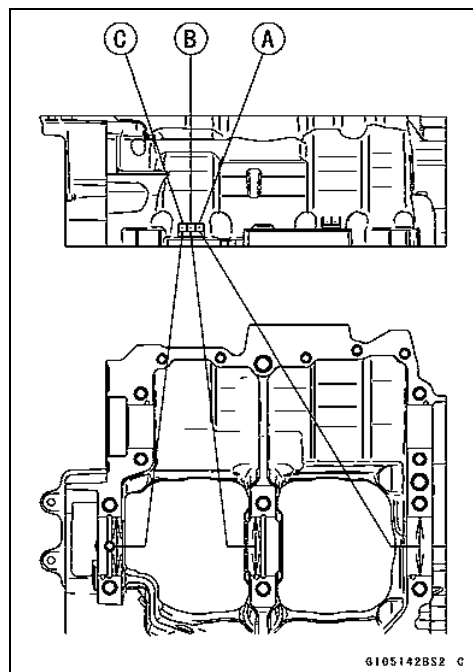

Crankcase Main Bearing Inside Diameter Marking	Crankshaft Main Journal Diameter Marking	Bearing Insert*	
		Size Color	Part Number
○	1	Brown	92028-1905
None	1	Black	92028-1904
○	None		
None	None	Blue	92028-1903

* The bearing inserts for Nos. 1, 2 and 3 journals have oil groove.

- Install the new inserts in the crankcase halves and check insert/journal clearance with the plastigage.

9-28 CRANKSHAFT/TRANSMISSION

Balancer

Balancer Removal

- Split the crankcase (see Crankcase Splitting).
- Pull the balancer shaft [A] with the balancer gear out of the crankcase.



Balancer Installation

- Apply molybdenum disulfide oil solution to the inside of the balancer shaft bearing insert.
- Align [A] the timing mark on the balancer gear [B] with the timing mark on the balancer drive gear [C] of the crankshaft.
- Assemble the crankcase (see Crankcase Assembly).

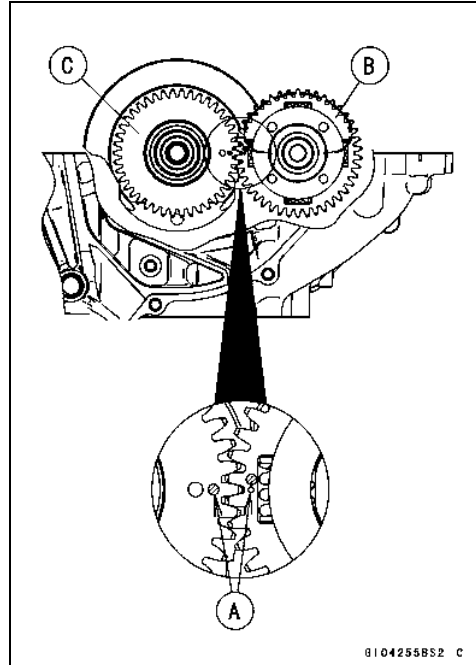

Balancer Shaft Bearing Insert/Journal Clearance

- Measure the bearing insert/journal clearance using a plastigage.
- Split the crankcase and wipe each bearing insert and journal surface clean of oil.
- Cut strips of plastigage to bearing insert width, and place a strip on each journal parallel to the balancer shaft so that the plastigage will be compressed between the journal and the bearing insert.
- Install the lower crankcase half, and tighten the case bolts to the specified torque (see Crankcase Assembly).

Balancer

NOTE

- Do not turn the balancer shaft during clearance measurement.
- Remove the lower crankcase half and measure the plastigage width [A] to determine the bearing insert/journal [B] clearance.

Balancer Shaft Bearing Insert/Journal Clearance
Standard: 0.011 ~ 0.033 mm (0.0004 ~ 0.0013 in.)
Service Limit: 0.08 mm (0.003 in.)

- ★ If the clearance is within the standard, no bearing insert replacement is required.
- ★ If the clearance is between 0.034 mm (0.00134 in.) and the service limit (0.08 mm (0.003 in.)), replace the bearing inserts [A] with inserts painted blue [B]. Check insert/journal clearance with a plastigage. The clearance may exceed the standard slightly, but it must not be less than the minimum in order to avoid bearing seizure.
- ★ If the clearance exceeds the service limit, measure the diameter of the balancer shaft journal.

Balancer Shaft Journal Diameter
Standard: 27.987 ~ 28.000 mm (1.1019 ~ 1.1024 in.)
Service Limit: 27.96 mm (1.1008 in.)

- ★ If either journal has worn past the service limit, replace the balancer shaft with a new one.
- ★ If the measured journal diameters are not less than the service limit, but do not coincide with the original diameter markings on the balancer shaft, write new marks on it.

Balancer Shaft Diameter Marks
None 27.987 ~ 27.993 mm (1.1019 ~ 1.1021 in.)
 ○ 27.994 ~ 28.000 mm (1.1021 ~ 1.1024 in.)

△: Balancer Shaft Journal Diameter Marks, “○” mark or no mark.

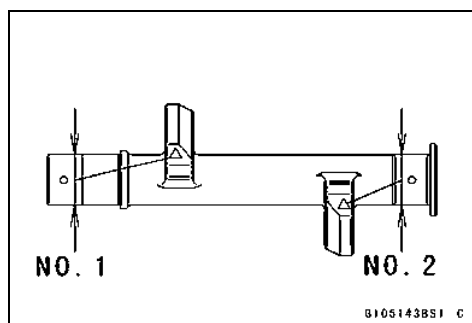
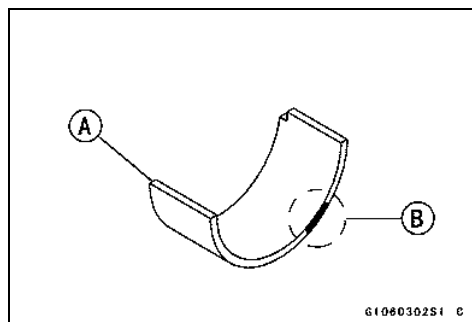
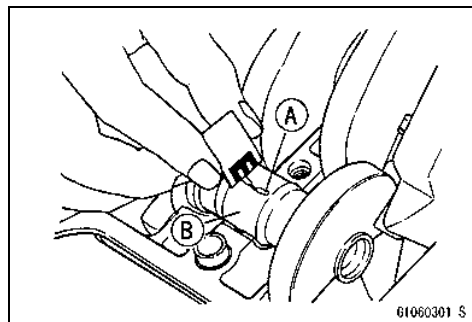

9-30 CRANKSHAFT/TRANSMISSION

Balancer

- Put the lower crankcase half on the upper crankcase half without bearing inserts, and tighten the case bolts to the specified torque and sequence (see Crankcase Assembly).
- Measure the crankcase bearing bore diameter for the balancer shaft, and mark the upper crankcase half in accordance with the bore diameter.

NOTE

- The mark already on the upper crankcase half should almost coincide with the measurement.

Crankcase Bearing Bore Diameter Marks

○ 31.000 ~ 31.008 mm (1.2205 ~ 1.2208 in.)

None 31.009 ~ 31.016 mm (1.2208 ~ 1.2211 in.)

- □: Crankcase Bearing Bore Diameter Marks, “○” mark or no mark.

No.1 Journal [A]

No.2 Journal [B]

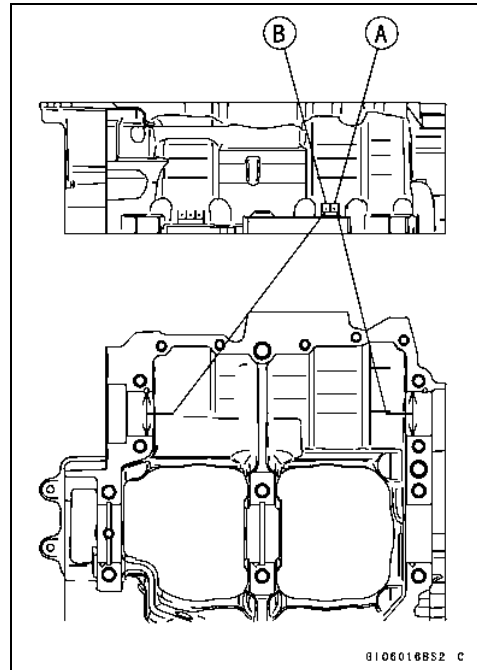

- Select the proper bearing insert in accordance with the combination of the crankcase and the balancer shaft coding.
- Install the new inserts in the crankcase and check insert/journal clearance with a plastigage.

Crankcase Bearing Inside Diameter Marking	Balancer Shaft Journal Diameter Marking	Bearing Insert*	
		Size Color	Part Number
○	○	Brown	92139-0119
○	None	Black	92139-0118
None	○		
None	None	Blue	92139-0117

*The bearing insert for Nos. 1 and 2 journals have oil grooves.

External Shift Mechanism

Shift Pedal Removal

- Remove:
 - Shift Pedal Bolt [A]
 - Shift Pedal [B]

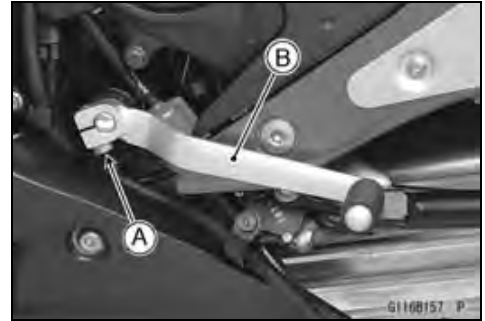

Shift Pedal Installation

- Align the punch mark [A] on the shift shaft with the punch mark [B] on the shift pedal.
 - Tighten the shift pedal bolt securely.
- Torque - Shift Pedal Bolt: 12 N·m (1.2 kgf·m, 106 in·lb)**

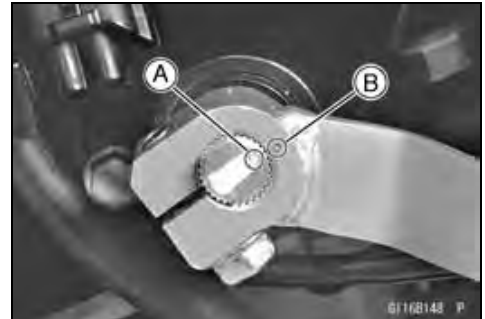

- Be sure the shift pedal position is as shown in the figure.
 - Shift Pedal [A]
 - Bolt [B] of Left Footpeg Stay

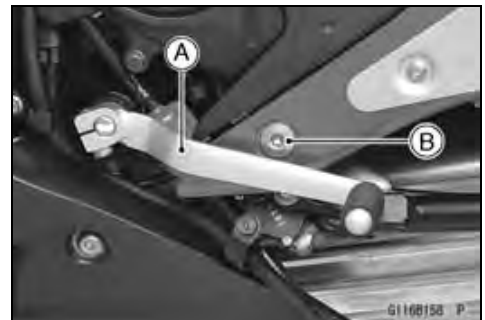

External Shift Mechanism Removal

- Drain the engine oil (see Engine Oil Change in the Periodic Maintenance chapter).
- Remove:
 - Engine Sprocket (see Engine Sprocket Removal in the Final Drive chapter)
 - Shift Pedal (see Shift Pedal Removal)
 - Neutral Switch Lead Connector [A]
 - Shift Shaft Cover Bolts [B]
 - Shift Shaft Cover Screw [C]
 - Shift Shaft Cover [D]

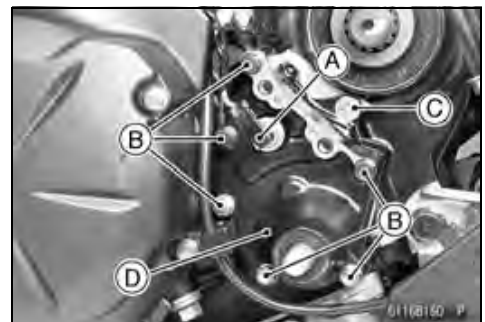

- Remove the shift shaft assembly [A].

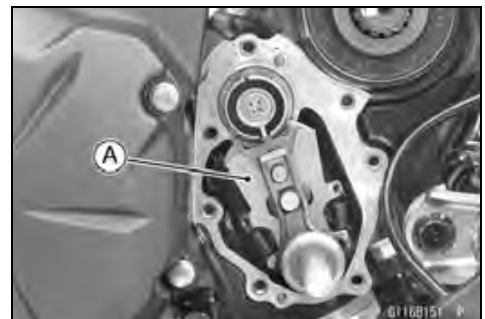

9-32 CRANKSHAFT/TRANSMISSION

External Shift Mechanism

- Remove:
 - Clutch (see Clutch Removal in the Clutch chapter)
 - Gear Positioning Lever Bolt [A]
 - Spacer [B]
 - Gear Positioning Lever [C]
 - Washer and Spring

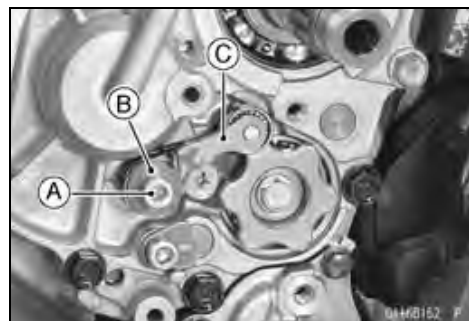

External Shift Mechanism Installation

- Install the gear positioning lever [A] as shown in the figure.
 - Spring [B]
 - Washer [C]
 - Spacer [D]
 - Bolt [E]
- Hook the spring at gear positioning lever, pushing up [F] the hook portion, as shown in the figure.
- Apply a non-permanent locking agent to the gear positioning lever bolt and tighten it.

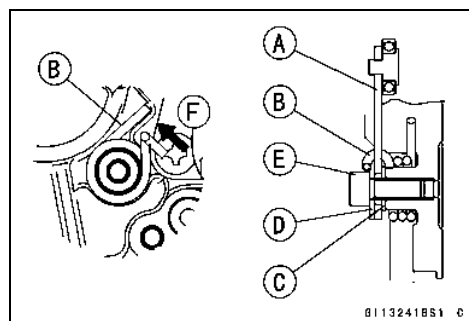

Torque - Gear Positioning Lever Bolt: 12 N-m (1.2 kgf-m, 106 in-lb)

- Apply molybdenum disulfide oil solution to the rubbing surface [A] between the lever [B] and pawl [C], and move them two or three times up and down to lubricate them.
- Be sure that the collar [D] is on the shaft.
- Be sure that the spring hook portions [E] are as shown.

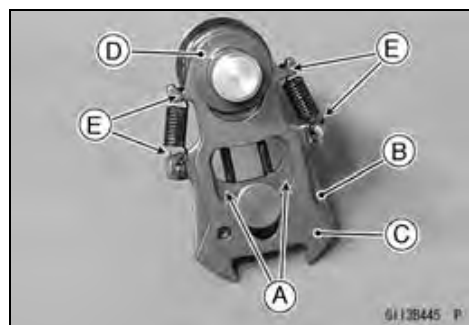

- Install the shift shaft assembly [A].
- Be sure that the washer [B] is on the shaft.
- Be sure that the dowel pins [C] are in position.

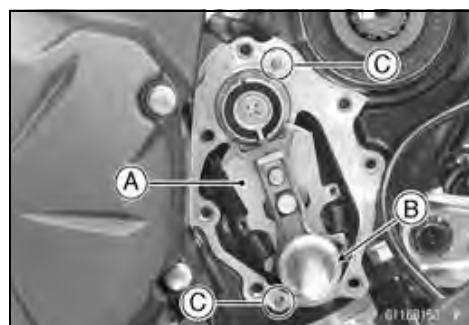

- When the new needle bearing [A] is installed in the shift shaft cover [B], press and insert the new needle bearing until it is bottomed.

Special Tool - Bearing Driver Set: 57001-1129

- When the new oil seal [C] is installed in the shift cover, press and insert the new oil seal so that its surface is flush with the end of the hole.

Special Tool - Bearing Driver Set: 57001-1129

- Apply engine oil to the needle bearing.
- Apply grease to the oil seal lips.

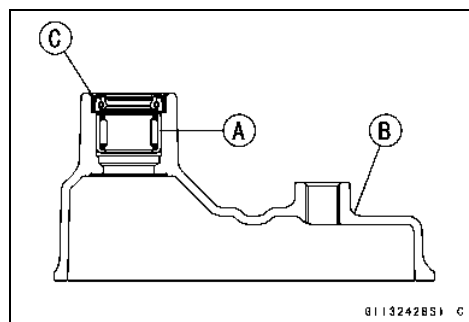

External Shift Mechanism

- Replace the shift shaft cover gasket with a new one.
 - Install the shift shaft cover.
 - Apply a non-permanent locking agent to the shift shaft cover screw [A] and bolts [B, C].
 - Do not apply a non-permanent locking agent to the shift shaft cover bolts [D, E].
 - First tighten the cover bolts, then tighten the cover screw.
- Torque - Shift Shaft Cover Bolts: 9.8 N·m (1.0 kgf·m, 87 in·lb)**
- Shift Shaft Cover Screw: 4.9 N·m (0.50 kgf·m, 43 in·lb)**

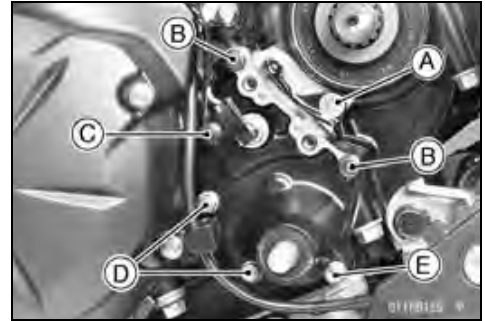

External Shift Mechanism Inspection

- Examine the shift shaft [A] for any damage.
- ★ If the shaft is bent, straighten or replace it.
- ★ If the serration [B] are damaged, replace the shaft.
- ★ If the springs [C] are damaged in any way, replace them.
- ★ If the shift mechanism arm [D] is damaged in any way, replace the shaft.

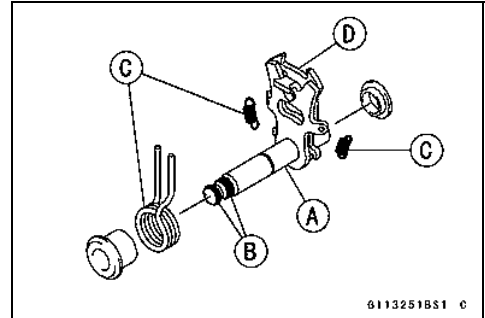

- Check the return spring pin [A] is not loose.
 - ★ If it is loose, unscrew it, apply a non-permanent locking agent to the threads, and tighten it.
- Torque - Shift Shaft Return Spring Pin: 29 N·m (3.0 kgf·m, 21 ft·lb)**



- Check the gear positioning lever [A] and its spring for breaks or distortion.
- ★ If the lever or spring are damaged in any way, replace them.
- Visually inspect the shift drum cam [B].
- ★ If they are badly worn or if they show any damage, replace it.



9-34 CRANKSHAFT/TRANSMISSION

Transmission

Transmission Assy Removal

- Remove:
 - Shift Shaft Assembly (see External Shift Mechanism Removal)
 - Neutral Switch Holder Screw [A]
 - Neutral Switch Holder [B] and Pin
 - Shift Drum Holder [C] and Pin

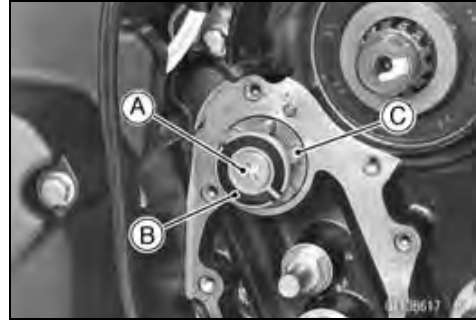

- Remove the collar [A] and the O-ring [B] from the output shaft [C].

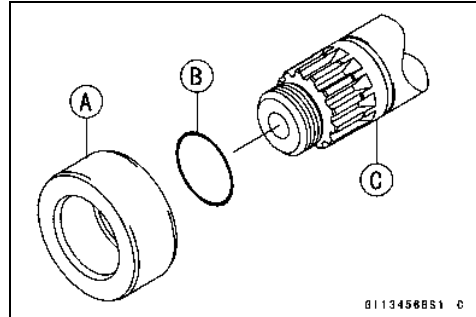

- Remove:
 - Clutch (see Clutch Removal in the Clutch chapter)
 - Transmission Case Bolts [A]
- ★ If the transmission assy is to be disassembled, remove the following.
 - Shift Rod Plate Bolt and Plate [B]
 - Gear Positioning Lever [C] (see External Shift Mechanism Removal)

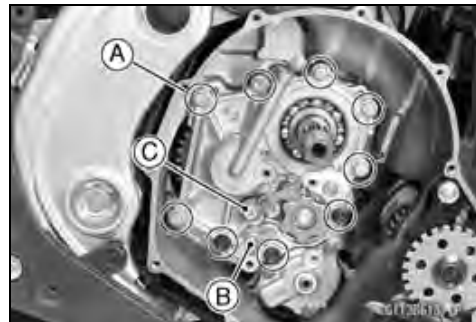

- Pull the transmission assy out of the crankcase.

Transmission Assy Installation

- Be sure that the dowel pins [A] are in position.
- Apply grease to the new O-ring [B] on the oil pipe [C].
- Install the transmission assy on the crankcase.
- Tighten:
 - Torque - Transmission Case Bolts: 20 N·m (2.0 kgf·m, 15 ft·lb)**

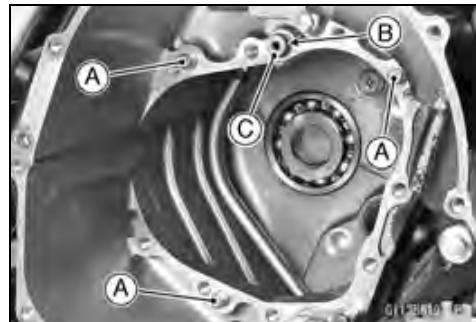

Transmission

- ★ If the gear positioning lever [A] was removed, install it (see External Shift Mechanism Installation).
- ★ If the shift rod plate [B] was removed, install it.
- Apply a non-permanent locking agent to the shift rod plate bolt, and tighten it.

Torque - Shift Rod Plate Bolt [C]: 9.8 N·m (1.0 kgf·m, 87 in·lb)

- Set the gear positioning lever to the neutral position [D].
- Check that the drive and output shaft turn freely.

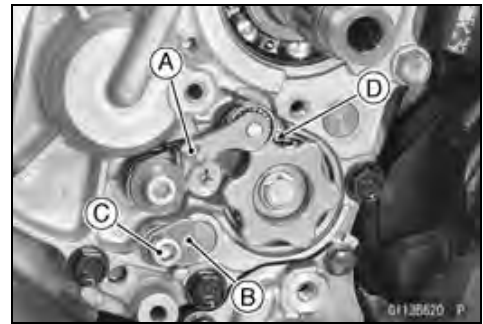

- Install:
 - Pin [A]
 - Shift Drum Holder [B]
 - Pin [C]
 - Neutral Switch Holder [D]
- Apply a non-permanent locking agent to the neutral switch holder screw [E] and tighten it.

Torque - Neutral Switch Holder Screw: 4.9 N·m (0.50 kgf·m, 43 in·lb)

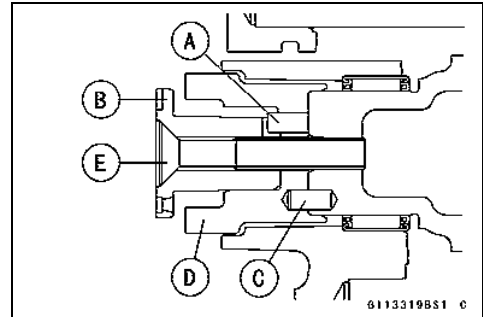

- Apply grease to the new O-ring [A], and install its position on the output shaft.
- Apply grease to the oil seal lips.
- Install the collar [B].
- When the new oil seal [C] is installed, press in it onto the collar so that the surface of the oil seal is flush with the surface [D] of the crankcase.
- Apply high-temperature grease to the outer circumference [E] of the oil seal so that it will go into place smoothly.

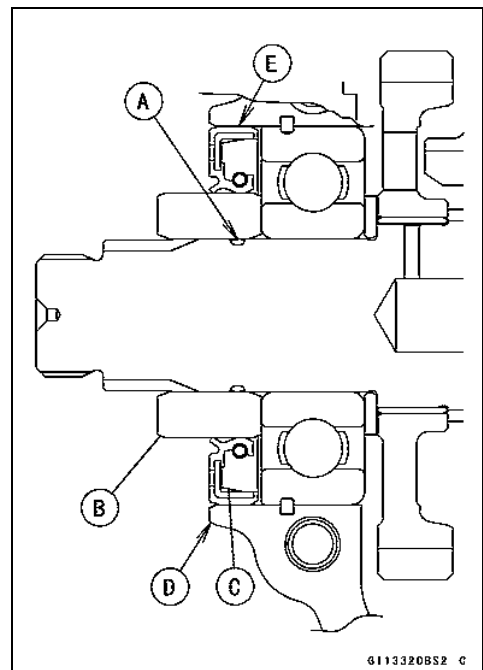

Transmission Assy Disassembly

- Remove the transmission assy (see Transmission Assy Removal).
- Remove the following from the transmission case [A].
 - Shift Rods [B]
 - Shift Forks [C]
 - Drive Shaft [D]
 - Output Shaft [E]

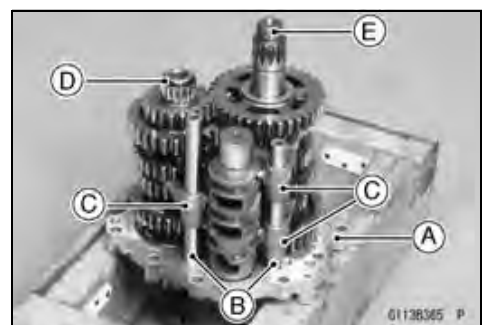

9-36 CRANKSHAFT/TRANSMISSION

Transmission

- Remove:
 - Shift Drum Cam Bolt [A]
 - Shift Drum [B] and Pin
 - Shift Drum [C]

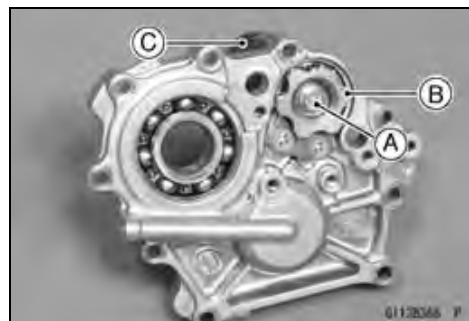

Transmission Assy Assembly

- When the new ball bearing [A] and new race [B] are installed in the transmission case [C], press and insert them until they are bottomed.

Special Tool - Bearing Driver Set: 57001-1129

NOTE

○ Install the new ball bearing and new race so that the stepped side [D] faces inside of the transmission case.

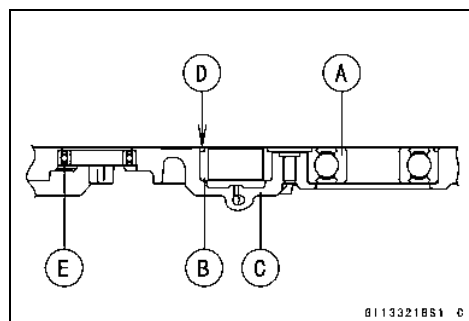

- When the ball bearing [E] for shift drum is installed in the transmission case, insert the ball bearing until it is bottomed.

- Install the shift drum bearing holder [A].
- Apply a non-permanent locking agent to the threads of the shift drum bearing holder screws [B], and tighten them.

Torque - Shift Drum Bearing Holder Screws: 4.9 N·m (0.50 kgf·m, 43 in·lb)

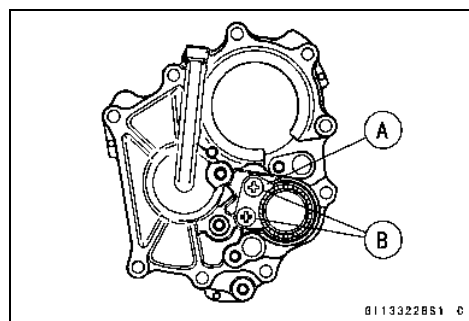

- Install the drive shaft bearing holder [A].
- Apply a non-permanent locking agent to the threads of the drive shaft bearing holder screw [B] and tighten it.

Torque - Drive Shaft Bearing Holder Screw: 4.9 N·m (0.50 kgf·m, 43 in·lb)

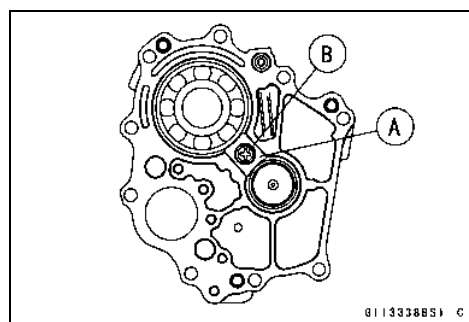

Transmission

- Install the following on the transmission case [A].
 - Shift Drum [B]
 - Pin [C]
 - Shift Drum Cam [D]
- Align the pin with the hole on the shift drum cam.
- Apply a non-permanent locking agent to the shift drum cam bolt [E] and tighten it.
- Torque - Shift Drum Cam Bolt: 12 N·m (1.2 kgf·m, 106 in·lb)**
- Install the following as a set.
 - Drive Shaft [F]
 - Output Shaft [G]
- Install the forks as shown in the figure.
- Position the one [H] with shortest ears on the drive shaft and place the pin in the center groove in the shift drum.
- The two forks [J] on the output shaft are identical.
- Install the shift rods.
- The rod [K] length of the output shaft side is shorter than the rod [L] length of the drive shaft side.
- Apply molybdenum disulfide oil solution to the transmission gears shown with X marks [M].
- Be sure that the spacer [N] is on the output shaft.
- Install the transmission assy (see Transmission Assy Installation).

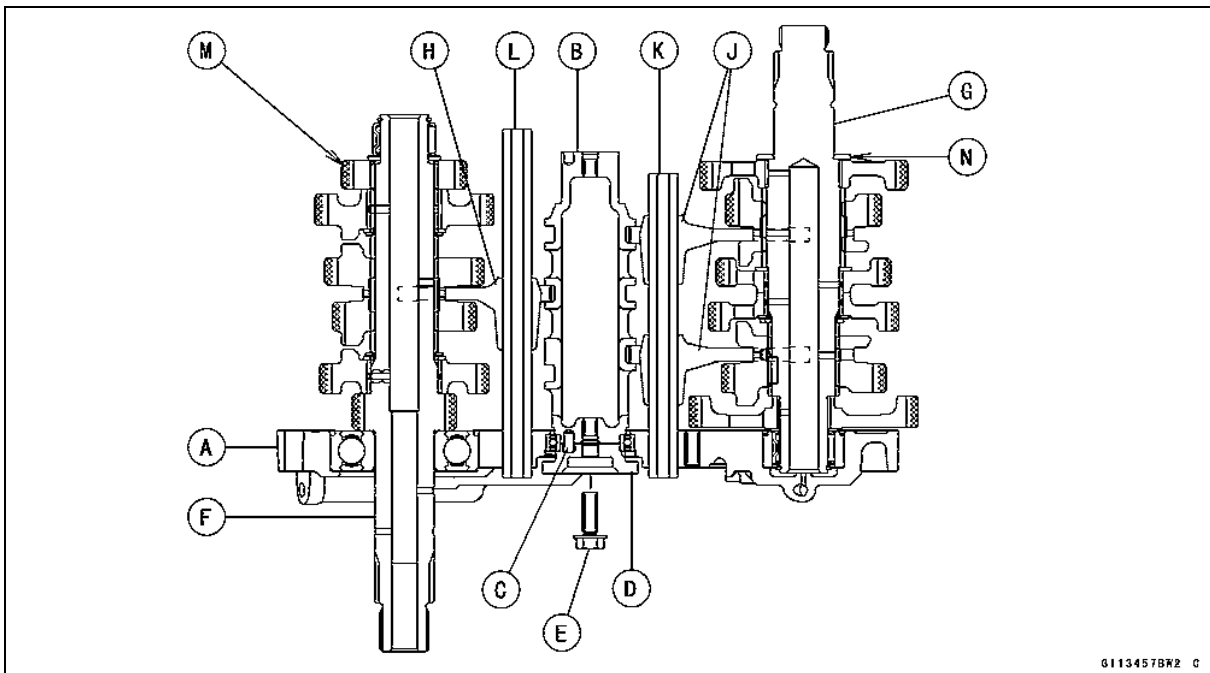

Transmission Shaft Removal

- Refer to the Transmission Assy Disassembly.

Transmission Shaft Installation

- Refer to the Transmission Assy Assembly.

9-38 CRANKSHAFT/TRANSMISSION

Transmission

Transmission Shaft Disassembly

- Remove the transmission shafts (see Transmission Assy Disassembly).
- Remove the circlips, disassemble the transmission shafts.

Special Tool - Outside Circlip Pliers: 57001-144

- The 5th gear [A] on the output shaft has three steel balls assembled into it for the positive neutral finder mechanism. Remove the 5th gear.
- Set the output shaft in a vertical position holding the 3rd gear [B].
- Spin the 5th gear quickly [C] and pull it off upward.

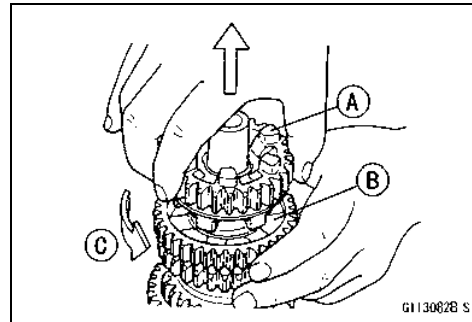

Transmission Shaft Assembly

- Apply engine oil to the bushings, needle bearings and shafts.
- Install the gear bushings [A] on the shaft with their holes [B] aligned.

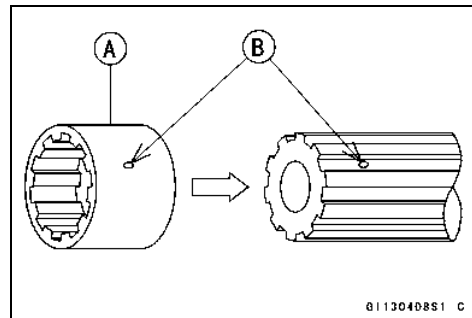

- Replace any circlips removed with new ones.
- Install the circlips [A] so that the opening [B] is aligned with a spline groove [C].

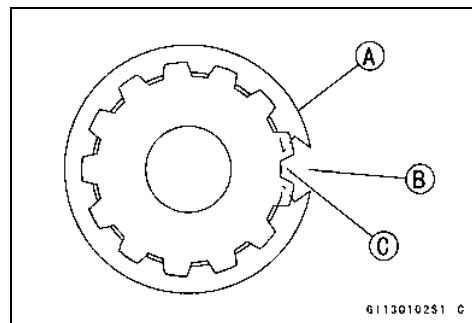

- The drive shaft gears can be recognized by size: the gear with the smallest diameter is 1st gear, and the largest one is 6th gear. Be sure that all parts are put back in the correct sequence and all circlips and washers are properly in place.
- Install the 3rd/4th gear onto the drive shaft with their oil holes aligned.
- Install the 6th gear bushing onto the drive shaft with their oil holes aligned.
- The output shaft gears can be recognized by size: the gear with the largest diameter is 1st gear, and the smallest one is 6th gear. Be sure that all parts are put back in the correct sequence and all circlips and washers are properly in place.
- Install the 5th and 6th gears onto the output shaft with their oil holes aligned.
- Install the 3rd/4th gear bushings onto the output shaft with their oil holes aligned.

Transmission

- Fit the steel balls into the 5th gear holes in the output shaft, aligning oil hole as shown in the figure.
 - 5th Gear [A]
 - Output Shaft [B]
 - Steel Balls [C]
 - Oil Holes [D]

CAUTION

Do not apply grease to the balls to hold them in place. This will cause the positive neutral finder mechanism to malfunction.

- After assembling the 5th gear with steel balls in place on the output shaft, check the ball-locking effect that the 5th gear doesn't come out of the output shaft when moving it up and down by hand.
- Check that each gear spins or slides freely on the transmission shafts without binding after assembly.

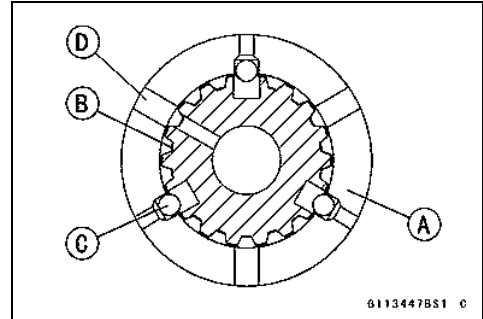

9-40 CRANKSHAFT/TRANSMISSION

Transmission

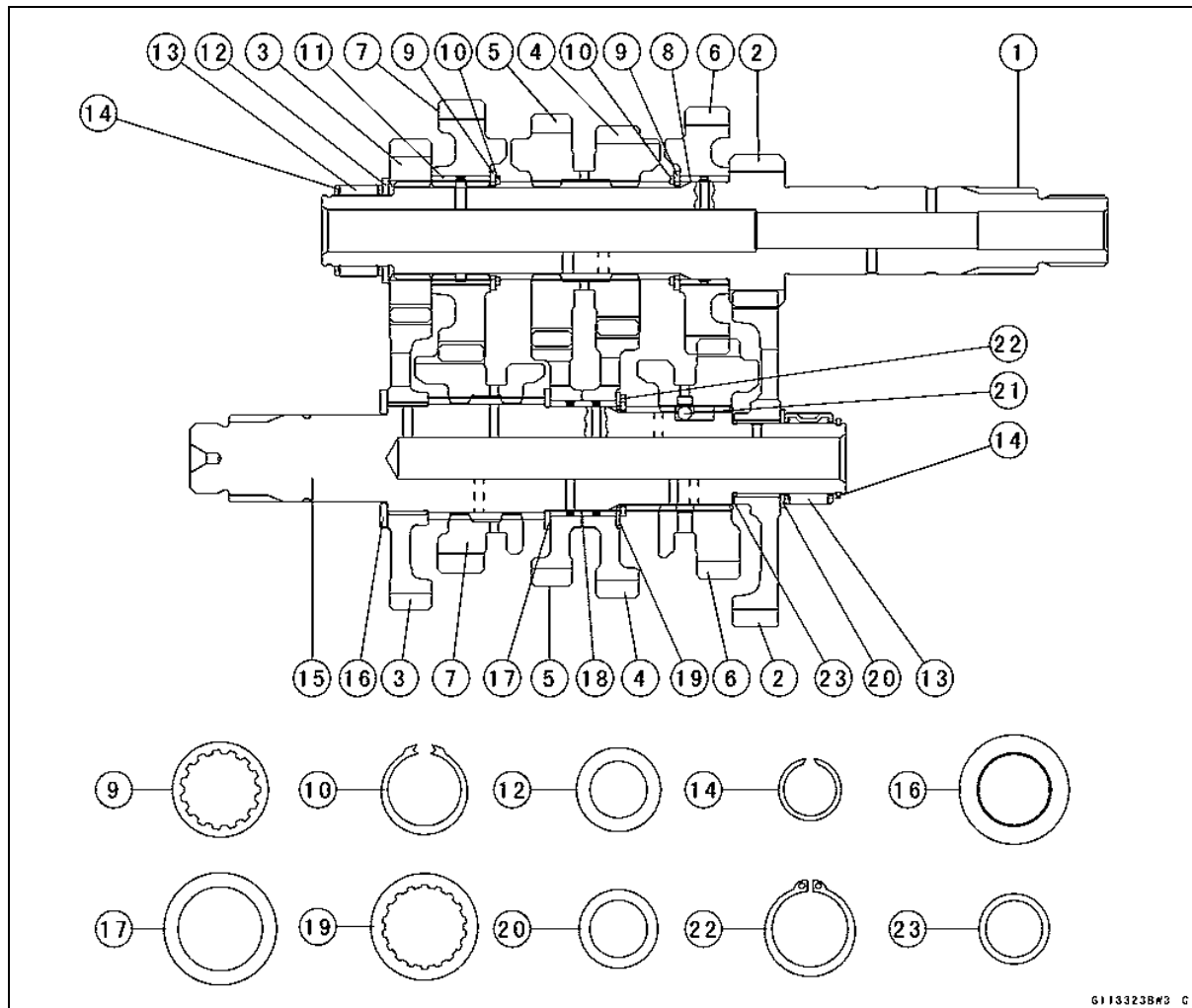

1. Drive Shaft
2. 1st Gear
3. 2nd Gear
4. 3rd Gear
5. 4th Gear
6. 5th Gear
7. 6th (Top) Gear
8. Bushing
9. Toothed Washer, $\phi 34$ mm (1.34 in.)
10. Circlip
11. Bushing
12. Thrust Washer, $\phi 30$ mm (1.18 in.)
13. Needle Bearing
14. Circlip
15. Output Shaft
16. Spacer, $\phi 39$ mm (1.54 in.)
17. Washer, $\phi 40$ mm (1.57 in.)
18. Bushing
19. Toothed Washer, $\phi 38$ mm (1.50 in.)
20. Shim, $\phi 28$ mm (1.10 in.)
21. Steel Ball
22. Circlip, $\phi 32.2$ mm (1.268 in.)
23. Thrust Washer, $\phi 25$ mm (0.98 in.)

G113323B*3 C

Transmission

Shift Drum and Fork Removal

- Refer to the Transmission Assy Disassembly.

Shift Drum and Fork Installation

- Refer to the Transmission Assy Assembly.

Shift Drum Disassembly

- Refer to the Transmission Assy Disassembly.

Shift Drum Assembly

- Refer to the Transmission Assy Assembly.

Shift Fork Bending

- Visually inspect the shift forks, and replace any fork that is bent. A bent fork could cause difficulty in shifting, or allow the transmission to jump out of gear when under power. 90° [A]

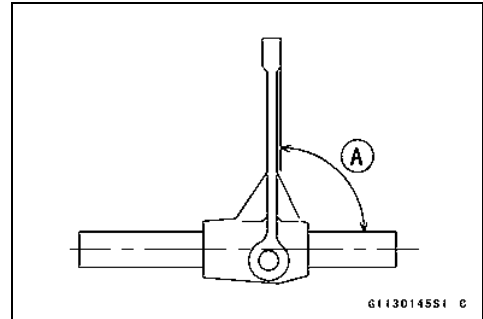

Shift Fork/Gear Groove Wear

- Measure the thickness of the shift fork ears [A], and measure the width [B] of the gear grooves.
- ★ If the thickness of a shift fork ear is less than the service limit, the shift fork must be replaced.

Shift Fork Ear Thickness

Standard: 5.9 ~ 6.0 mm (0.232 ~ 0.236 in.)

Service Limit: 5.8 mm (0.23 in.)

- ★ If the gear groove is worn over the service limit, the gear must be replaced.

Gear Groove Width

Standard: 6.05 ~ 6.15 mm (0.238 ~ 0.242 in.)

Service Limit: 6.3 mm (0.25 in.)

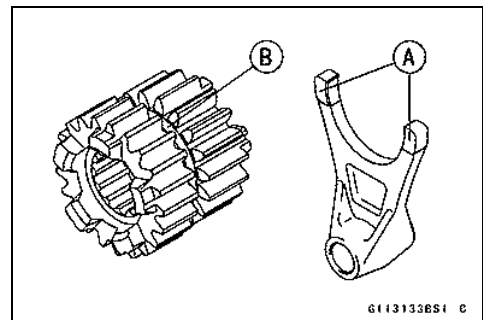

Shift Fork Guide Pin/Drum Groove Wear

- Measure the diameter of each shift fork guide pin [A], and measure the width [B] of each shift drum groove.
- ★ If the guide pin on any shift fork is less than the service limit, the fork must be replaced.

Shift Fork Guide Pin Diameter

Standard: 6.9 ~ 7.0 mm (0.272 ~ 0.276 in.)

Service Limit: 6.8 mm (0.27 in.)

- ★ If any shift drum groove is worn over the service limit, the drum must be replaced.

Shift Drum Groove Width

Standard: 7.05 ~ 7.20 mm (0.278 ~ 0.283 in.)

Service Limit: 7.3 mm (0.29 in.)

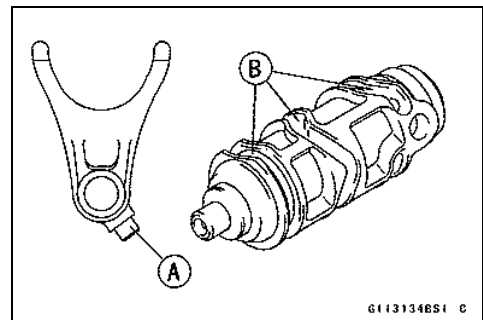

9-42 CRANKSHAFT/TRANSMISSION

Transmission

Gear Dog and Gear Dog Hole Damage

- Visually inspect the gear dogs [A] and gear dog holes [B].
- ★ Replace any damaged gears or gears with excessively worn dogs or dog holes.

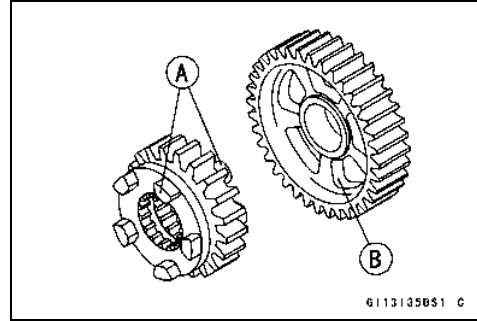

Ball Bearing, Needle Bearing, and Oil Seal

Ball and Needle Bearing Replacement

CAUTION
Do not remove the ball or needle bearings unless it is necessary. Removal may damage them.

- Using a press or puller, remove the ball bearing and/or needle bearings.

NOTE

○ *In the absence of the above mentioned tools, satisfactory results may be obtained by heating the case to approximately 93°C (200°F) max., and tapping the bearing in or out.*

CAUTION
Do not heat the case with a torch. This will warp the case. Soak the case in oil and heat the oil.

- Using a press and the bearing driver set [A], install the new ball bearing until it stops at the bottom of its housing.
- The new needle bearings must be pressed into the crankcase so that the end is flush with the end of the hole.

Special Tool - Bearing Driver Set: 57001-1129

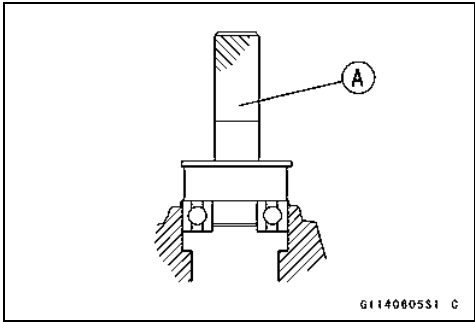

Ball and Needle Bearing Wear

CAUTION
Do not remove the bearings for inspection. Removal may damage them.

- Check the ball bearings.
- Since the ball bearings are made to extremely close tolerances, the wear must be judged by feel rather than measurement. Clean each bearing in a high-flash point solvent, dry it (do not spin the bearing while it is dry), and oil it with engine oil.

- Spin [A] the bearing by hand to check its condition.
- ★ If the bearing is noisy, does not spin smoothly, or has any rough spots, replace it.
- Check the needle bearings.
- The rollers in a needle bearing normally wear very little, and wear is difficult to measure. Instead of measuring, inspect the bearing for abrasion, color change, or other damage.
- ★ If there is any doubt as to the condition of a needle bearing, replace it.

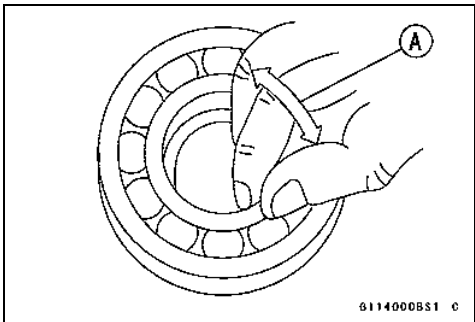

Oil Seal Inspection

- Inspect the oil seals.
- ★ Replace it if the lips are misshapen, discolored (indicating that the rubber has deteriorated), hardened or otherwise damaged.

Wheels/Tires

Table of Contents

Exploded View	10-2
Specifications	10-4
Special Tools	10-5
Wheels (Rims)	10-6
Front Wheel Removal	10-6
Front Wheel Installation	10-6
Rear Wheel Removal	10-7
Rear Wheel Installation	10-8
Wheel Inspection	10-9
Axle Inspection	10-10
Balance Inspection	10-10
Balance Adjustment	10-10
Balance Weight Removal	10-11
Balance Weight Installation	10-11
Tires	10-13
Air Pressure Inspection/Adjustment	10-13
Tire Inspection	10-13
Tire Removal	10-13
Tire Installation	10-13
Tire Repair	10-15
Hub Bearing	10-16
Hub Bearing Removal	10-16
Hub Bearing Installation	10-16
Hub Bearing Inspection	10-16
Hub Bearing Lubrication	10-17

10-2 WHEELS/TIRES

Exploded View

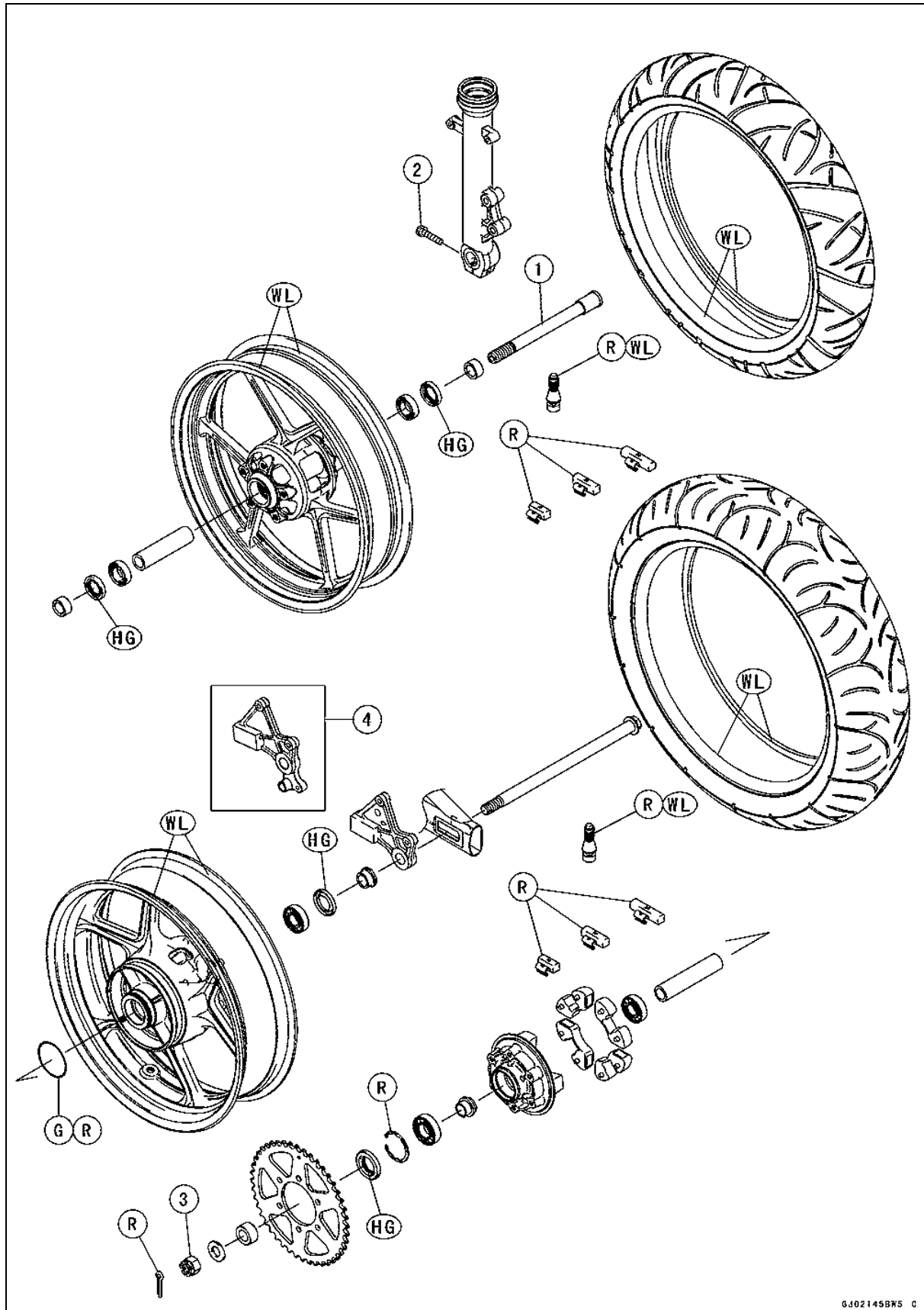

GJ02145BK5 C

Exploded View

No.	Fastener	Torque			Remarks
		N-m	kgf-m	ft-lb	
1	Front Axle	108	11.0	80	
2	Front Axle Clamp Bolt	34	3.5	25	
3	Rear Axle Nut	108	11.0	80	

4. EX650D Models

G: Apply grease.

HG: Apply high-temperature grease.

R: Replacement Parts

WL: Apply soap and water solution or rubber lubricant.

10-4 WHEELS/TIRES

Specifications

Item	Standard	Service Limit
Wheels (Rims)		
Rim Runout:		
Axial	TIR 0.5 mm (0.02 in.) or less	TIR 1.0 mm (0.04 in.)
Radial	TIR 0.8 mm (0.03 in.) or less	TIR 1.0 mm (0.04 in.)
Axle Runout/100 mm (3.94 in.)	TIR 0.03 mm (0.001 in.) or less	TIR 0.2 mm (0.008 in.)
Wheel Balance	10 g (0.35 oz.) or less	— — —
Balance Weights	10 g (0.35 oz.) 20 g (0.71 oz.) 30 g (1.06 oz.)	— — —
Rim Size:		
Front	17 × 3.50	— — —
Rear	17 × 4.50	— — —
Tires		
Air Pressure (when Cold):		
Front	Up to 180 kg (397 lb) load: 225 kPa (2.25 kgf/cm ² , 32 psi)	— — —
Rear	Up to 180 kg (397 lb) load: 250 kPa (2.50 kgf/cm ² , 36 psi)	— — —
Tread Depth:		
Front	4.8 mm (0.19 in.)	1 mm (0.04 in.) (AT, CH, DE) 1.6 mm (0.06 in.)
Rear	6.2 mm (0.24 in.)	Up to 130 km/h (80 mph): 2 mm (0.08 in.) Over 130 km/h (80 mph): 3 mm (0.12 in.)
Standard Tires:	Make, Type	Size
Front	BRIDGESTONE, BATTLAX BT021F J	120/70 ZR17 M/C (58 W)
Rear	BRIDGESTONE, BATTLAX BT021R J	160/60 ZR17 M/C (69 W)

WARNING

Use the same manufacturer's tires on both front and rear wheels.

Special Tools

**Bearing Driver Set:
57001-1129**

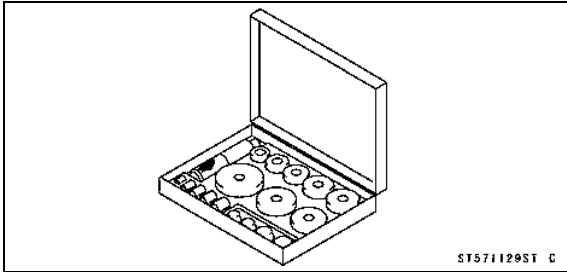

**Bearing Remover Shaft, $\phi 13$:
57001-1377**

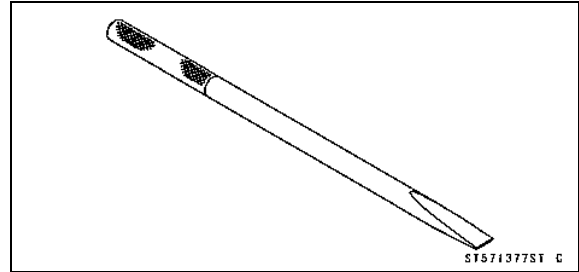

**Jack:
57001-1238**

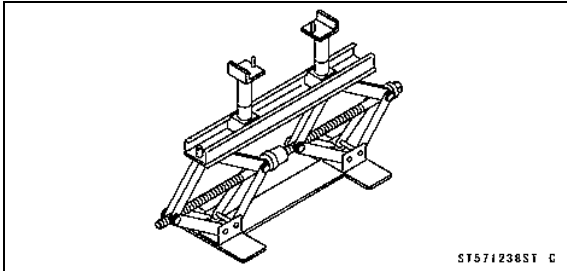

**Jack Attachment:
57001-1608**

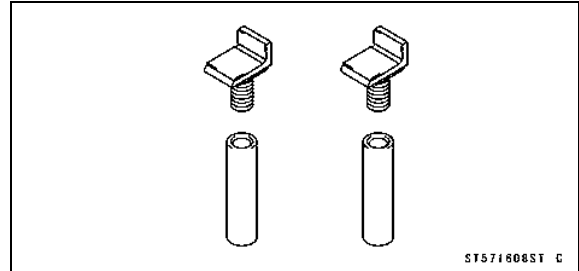

**Bearing Remover Head, $\phi 20 \times \phi 22$:
57001-1293**

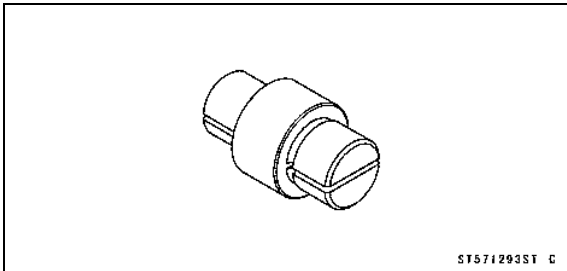

10-6 WHEELS/TIRES

Wheels (Rims)

Front Wheel Removal

- Remove:
 - Front Caliper Mounting Bolts [A] (Both Sides)
 - Front Caliper [B] (Both Sides)

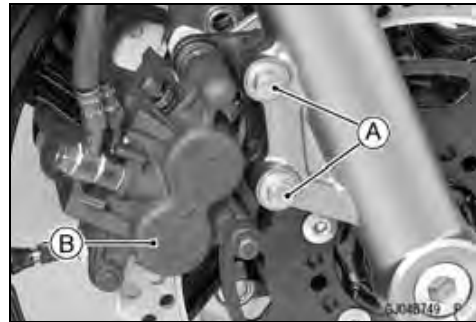

- Loosen:
 - Front Axle Clamp Bolt [A]
 - Front Axle [B]



- Remove:
 - Lower Fairing (see Lower Fairing Removal in the Frame chapter)
 - Lower Fairing Brackets (see Lower Fairing Bracket Removal in the Frame chapter)
- Raise the front wheel off the ground.
 - Special Tools - Jack: 57001-1238**
 - Jack Attachment: 57001-1608**
- Pull out the axle to the right and drop the front wheel out of the forks.

CAUTION

Do not lay the wheel down on one of the discs. This can damage or warp the disc. Place blocks under the wheel so that the disc does not touch the ground.

Front Wheel Installation

NOTE

- The direction of the wheel rotation [A] is shown by an arrow [B] on the wheel spoke.
- Check the wheel rotation mark on the front wheel and install it.

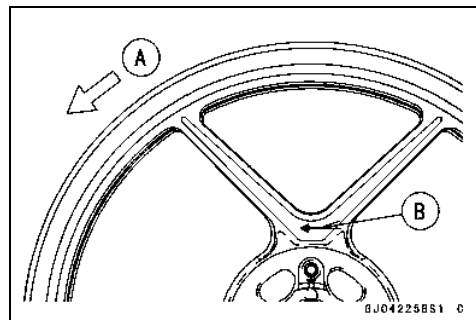

Wheels (Rims)

- Apply high-temperature grease to the grease seal lips.
- Fit the collars [A] on the both sides of the hub.
- The collars are identical.
- Insert the front axle.
- Remove the jack and the jack attachment.
- Tighten:

Torque - Front Axle: 108 N·m (11.0 kgf·m, 80 ft·lb)

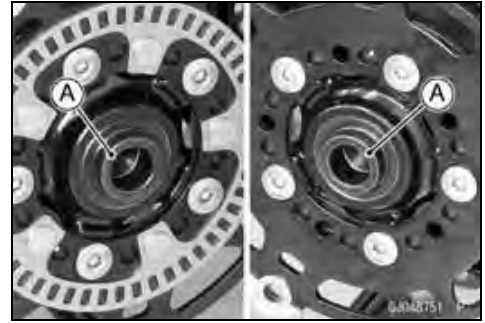

- Before tightening the axle clamp bolt [A] on the right front fork leg, pump the front fork up and down 4 or 5 times to allow the right front fork leg to seat on the front axle.

NOTE

○ Put a block in front of the front wheel to stop moving.

- Tighten:

Torque - Front Axle Clamp Bolt: 34 N·m (3.5 kgf·m, 25 ft·lb)

- Install the removed parts (see appropriate chapters).
- Check the front brake effectiveness (see Brake Operation Inspection in the Periodic Maintenance chapter).



⚠ WARNING

Do not attempt to drive the motorcycle until a full brake lever is obtained by pumping the brake lever until the pads are against the disc. The brake will not function on the first application of the lever if this is not done.

Rear Wheel Removal

- Raise the rear wheel off the ground using the stand [A].



- For models equipped with an ABS, remove the rear wheel rotation sensor from the caliper bracket (see Rear Wheel Rotation Sensor Removal in the Brakes chapter).

- Remove:

Rear Caliper Mounting Bolts [A]

Rear Caliper [B]

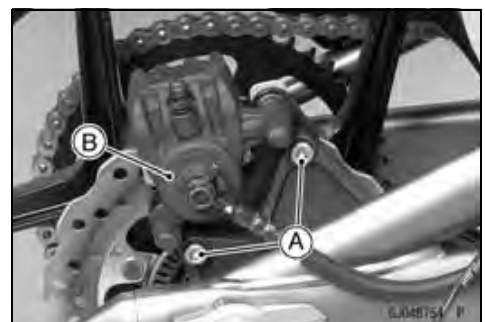

10-8 WHEELS/TIRES

Wheels (Rims)

- Remove:
 - Cotter Pin [A]
 - Rear Axle Nut [B]
 - Washer [C]
 - Rear Axle [D]

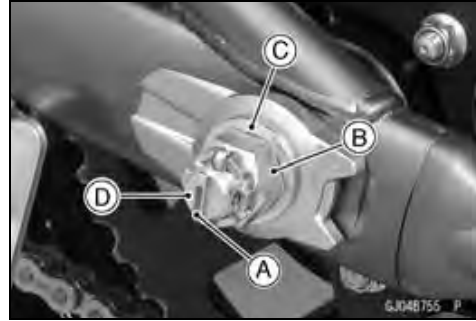

- Remove the drive chain [A] from the rear sprocket toward the left.
- Move the rear wheel back and remove it.

CAUTION

Do not lay the wheel on the ground with the disc facing down. This can damage or warp the disc. Place blocks under the wheel so that the disc does not touch the ground.



Rear Wheel Installation

- Apply high-temperature grease to the grease seal lips.
- Fit the collars on the both sides of the hub.
 - Left Side Collar [A]
 - Right Side Collar [B] (with Flange)

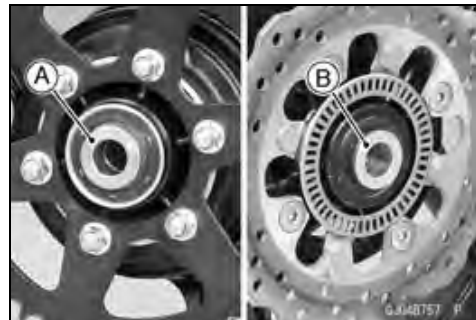

- Engage the drive chain with the rear sprocket.
- Install the caliper bracket [A] onto the stopper [B] of the swingarm.
- Insert the axle from the right side of the wheel.
- Install the washer and axle nut.
- Adjust the drive chain slack before tightening the axle nut (see Drive Chain Slack Inspection in the Periodic Maintenance chapter).
- Tighten:



Torque - Rear Axle Nut: 108 N·m (11.0 kgf·m, 80 ft·lb)

- Insert a new cotter pin [A].

NOTE

- When inserting the cotter pin, if the slots in the nut do not align with the cotter pin hole in the axle, tighten the nut clockwise [B] up to next alignment.
- It should be within 30°.
- Loosen once and tighten again when the slot goes past the nearest hole.

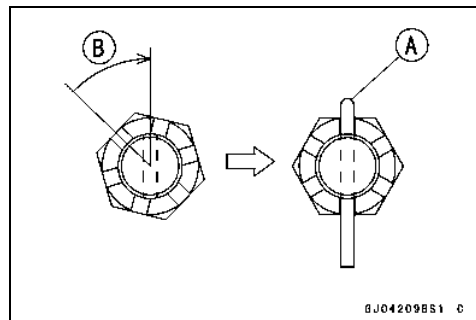

6J04209BS1 ©

Wheels (Rims)

- Bend the cotter pin [A] over the nut [B].

⚠ WARNING

If the rear axle nut is not securely tightened or the cotter pin is not installed, an unsafe riding condition may result.

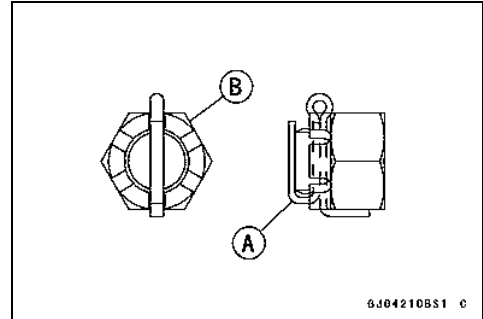

- Install the rear caliper (see Caliper Installation in the Brakes chapter).
- For models equipped with an ABS, install the rear wheel rotation sensor (see Rear Wheel Rotation Sensor Installation in the Brakes chapter).
- Check the rear brake effectiveness (see Brake Operation Inspection in the Periodic Maintenance chapter).

⚠ WARNING

Do not attempt to drive the motorcycle until a full brake pedal is obtained by pumping the brake pedal until the pads are against the disc. The brake will not function on the first application of the pedal if this is not done.

Wheel Inspection

- Raise the front/rear wheel off the ground.
 - Special Tools - Jack: 57001-1238
 - Jack Attachment: 57001-1608
- Spin the wheel lightly, and check for roughness or binding.
- ★ If roughness or binding is found, replace the hub bearings (see Hub Bearing Removal/Installation).
- Inspect the wheel for small cracks, dents, bending, or warp.
- ★ If there is any damage to the wheel, replace the wheel.
- Remove the wheel, and support it with the tire by the axle.
- Measure the rim runout, axial [A] and radial [B], with a dial gauge.
- ★ If rim runout exceeds the service limit, check the hub bearings (see Hub Bearing Inspection).
- ★ If the problem is not due to the bearings, replace the wheel.

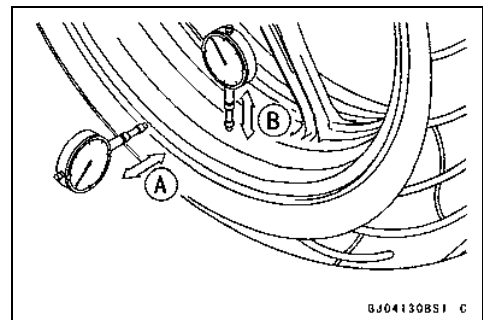

Rim Runout (with tire installed)

Standard:

Axial	TIR 0.5 mm (0.02 in.) or less
Radial	TIR 0.8 mm (0.03 in.) or less

Service Limit:

Axial	TIR 1.0 mm (0.04 in.)
Radial	TIR 1.0 mm (0.04 in.)

⚠ WARNING

Never attempt to repair a damaged wheel. If there is any damage besides wheel bearings, the wheel must be replaced to insure safe operational condition.

10-10 WHEELS/TIRES

Wheels (Rims)

Axle Inspection

- Remove the front and rear axles (see Front/Rear Wheel Removal).
- Visually inspect the front and rear axles for damages.
- ★ If the axle is damaged or bent, replace it.
- Measure the axle runout.
 - Place the axle in V blocks that are 100 mm (3.94 in.) [A] apart.
 - Set a dial gauge [B] on the axle at a point halfway between the blocks.
 - Turn [C] the axle.
 - The difference between the highest and lowest dial readings is the amount of runout.
- ★ If axle runout exceeds the service limit, replace the axle.

Axle Runout/100 mm (3.94 in.)

Standard: TIR 0.03 mm (0.001 in.) or less

Service Limit: TIR 0.2 mm (0.008 in.)

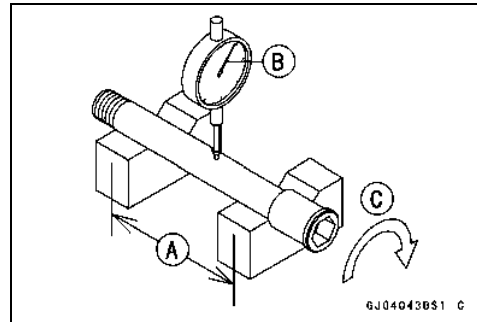

Balance Inspection

- Remove the front and rear wheels (see Front/Rear Wheel Removal).
- Support the wheel so that it can be spun freely.
- Spin the wheel lightly, and mark [A] the wheel at the top when the wheel stops.
- Repeat this procedure several times. If the wheel stops of its own accord in various positions, it is well balanced.
- ★ If the wheel always stops in one position, adjust the wheel balance (see Balance Adjustment).

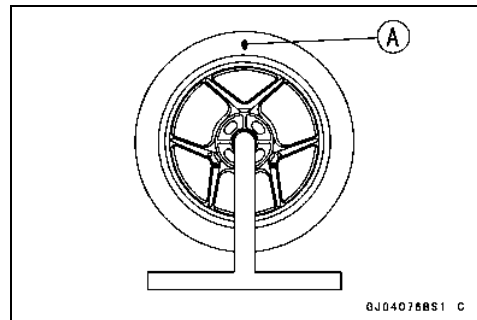

Balance Adjustment

- If the wheel always stops in one position, provisionally attach a balance weight [A] on the rim at the marking using adhesive tape.
- Rotate the wheel 1/4 turn [B], and see whether or not the wheel stops in this position. If it does, the correct balance weight is being used.
- ★ If the wheel rotates and the weight goes up, replace the weight with the next heavier size. If the wheel rotates and the weight goes down, replace the weight with the next lighter size. Repeat these steps until the wheel remains at rest after being rotated 1/4 turn.
- Rotate the wheel another 1/4 turn and then another 1/4 turn to see if the wheel is correctly balanced.
- Repeat the entire procedure as many times as necessary to achieve correct wheel balance.
- Permanently install the balance weight.

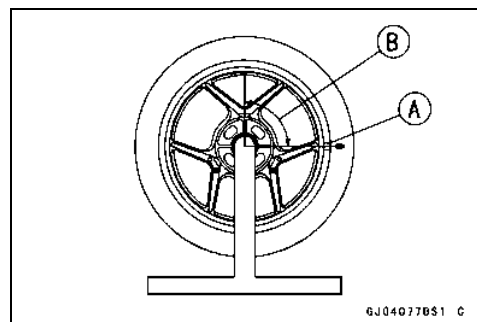

Wheels (Rims)

Balance Weight Removal

- Insert a regular tip screwdrivers [A] [B] between the rib [C] and the weight [D] as shown in the figure.
- Pry the balance weight with two screwdrivers and remove the balance weight.
- Discard the used balance weight.

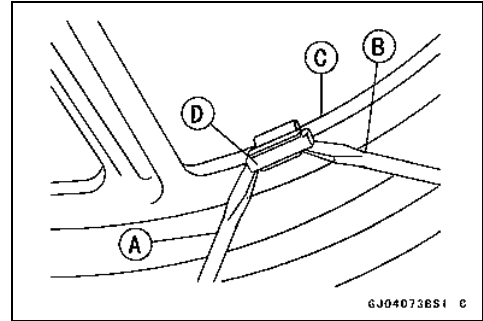

CAUTION

Do not tap the screwdrivers. The rim could be damaged.

Balance Weight Installation

- Check if the weight portion has any play on the blade [A] and clip [B].
- ★ If it does, discard it.

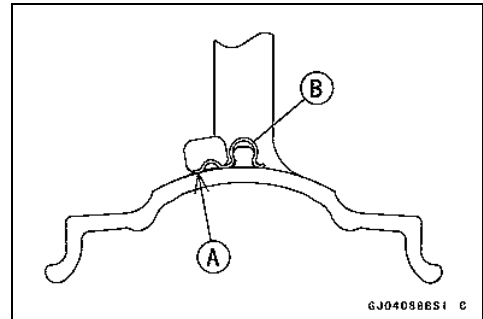

⚠ WARNING

If the balance weight has any play on the rib of the rim, the blade and/or clip have been stretched. Replace the loose balance weight. Do not reuse used balance weight. Unbalanced wheels can create an unsafe riding condition.

Balance Weight

Part Number	Weight
41075-0007	10 g (0.35 oz.)
41075-0008	20 g (0.71 oz.)
41075-0009	30 g (1.06 oz.)

NOTE

- Balance weights are available from Kawasaki dealers in 10, 20 and 30 grams (0.35, 0.71 and 1.06 oz.) sizes. An imbalance of less than 10 grams (0.35 oz.) will not usually affect running stability.
 - Do not use four or more balance weight (more than 90 gram, 3.2 oz.). If the wheel requires an excess balance weight, disassemble the wheel to find the cause.
- Slip the balance weight [A] onto the rib [B] by pushing or lightly hammering [C] the clip [D].
 - Left Side [E]
 - Right Side [F]

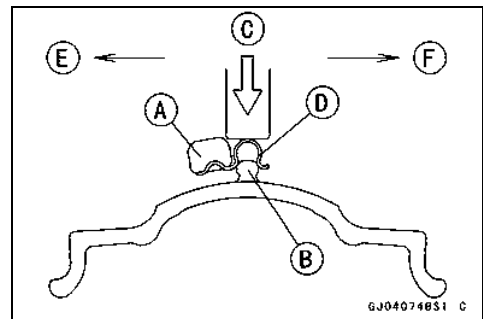

10-12 WHEELS/TIRES

Wheels (Rims)

- Be sure to install the balance weight.
- Check that the blade [A] and clip [B] are fully seated on the rim [C] and that the clip is hooked over the rib [D].
 - Left Side [E]
 - Right Side [F]

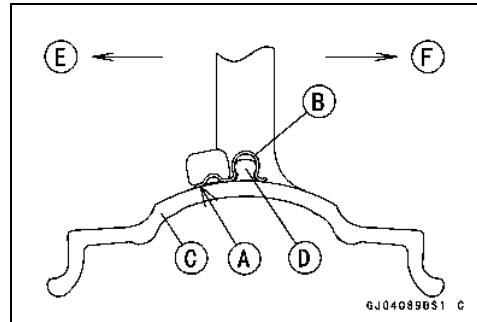

Tires

Air Pressure Inspection/Adjustment

- Refer to the Air Pressure Inspection in the Periodic Maintenance chapter.

Tire Inspection

- Refer to the Wheel/Tire Damage Inspection in the Periodic Maintenance chapter.

Tire Removal

- Remove:
 - Wheels (see Front/Rear Wheel Removal)
 - Valve Core (Let out the air)
- To maintain wheel balance, mark the valve stem position on the tire with chalk so that the tire can be reinstalled in the same position.
 - Chalk Mark or Yellow Mark [A]
 - Air Valve [B]
 - Align [C]
- Lubricate the tire beads and rim flanges on both sides with a soap and water solution or rubber lubricant. This helps the tire beads slip off the rim flanges.

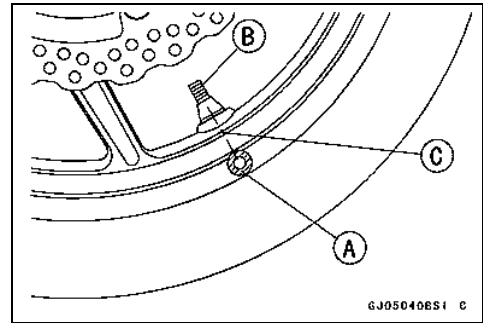

CAUTION
Never lubricate with engine oil or petroleum distillates because they will deteriorate the tire.

- Remove the tire from the rim using a suitable commercially available tire changer.

NOTE

- *The tires cannot be removed with hand tools because they fit the rims too tightly.*

Tire Installation

⚠ WARNING
Use the same manufacturer's tires on both front and rear wheels.

- Inspect the rim and tire, and replace them if necessary.
- Clean the sealing surfaces of the rim and tire, and smooth the sealing surfaces of the rim with a fine emery cloth if necessary.
- Remove the air valve and discard it.

CAUTION
Replace the air valve whenever the tire is replaced. Do not reuse the air valve.

10-14 WHEELS/TIRES

Tires

- Install a new valve in the rim.
- Remove the valve cap, lubricate the stem seal [A] with a soap and water solution or rubber lubricant, and pull [B] the valve stem through the rim from the inside out until it snaps into place.

CAUTION

Do not use engine oil or petroleum distillates to lubricate the stem because they will deteriorate the rubber.

- The air valve is shown in the figure.

Valve Cap [A]
Valve Core [B]
Stem Seal [C]
Valve Stem [D]
Valve Seat [E]
Valve Opened [F]

- Check the tire rotation mark on the front and rear tires and install them on the rim accordingly.

Tire Rotation Mark [A]
Rotating Direction [B]

- Position the tire on the rim so that the air valve [A] align with the tire balance mark [B] (the chalk mark made during removal, or the yellow paint mark on a new tire).
- Install the tire bead over the rim flange using a suitable commercially available tire changer.
- Lubricate the tire beads and rim flanges with a soap and water solution or rubber lubricant to help seat the tire beads in the sealing surfaces of the rim while inflating the tire.
- Center the rim in the tire beads, and inflate the tire with compressed air until the tire beads seat in the sealing surfaces.

⚠ WARNING

Be sure to install the valve core whenever inflating the tire, and do not inflate the tire to more than 400 kPa (4.0 kgf/cm², 57 psi). Overinflation can explode the tire with possibility of injury and loss of life.

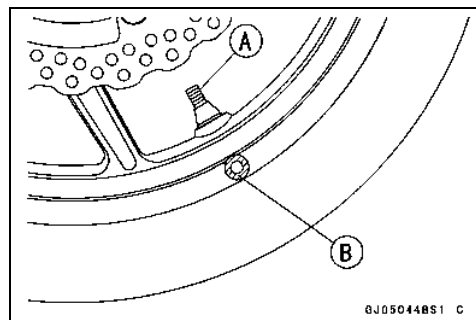
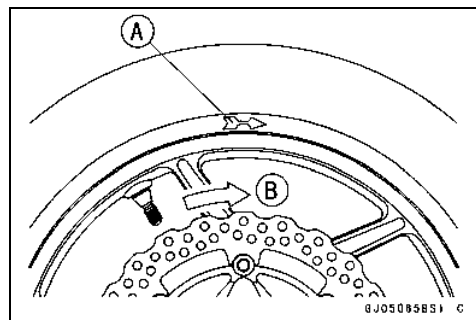
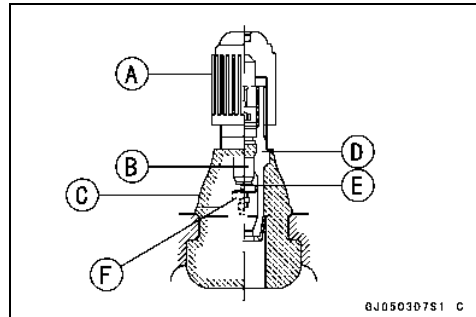
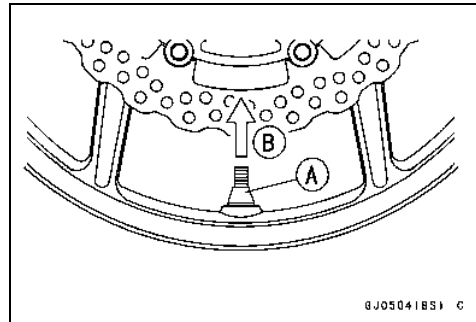

Tires

- Check to see that the rim lines [A] on both sides of the tire sidewalls are parallel with the rim flanges.
- ★ If the rim flanges and tire sidewall rim lines are not parallel, remove the valve core.
- Lubricate the rim flanges and tire beads.
- Install the valve core and inflate the tire again.
- After the tire beads seat in the rim flanges, check for air leakage.
- Inflate the tire slightly above standard inflation.
- Use a soap and water solution or submerge the tire, and check for bubbles that would indicate leakage.
- Adjust the air pressure to the specified pressure (see Air Pressure Inspection in the Periodic Maintenance chapter).
- Install the air valve cap.
- Adjust the wheel balance (see Balance Adjustment).

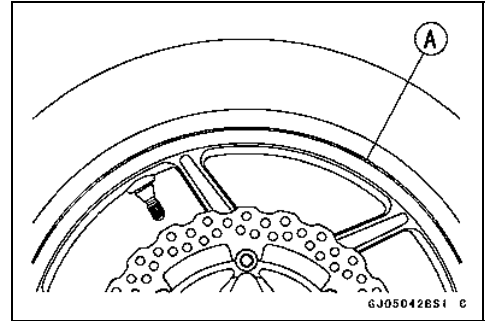

Tire Repair

Currently two types of repair for tubeless tires have come into wide use. One type is called a temporary (external) repair which can be carried out without removing the tire from the rim, and the other type is called permanent (internal) repair which requires tire removal. It is generally understood that higher running durability is obtained by permanent (internal) repairs than by temporary (external) ones. Also, permanent (internal) repairs have the advantage of permitting a thorough examination for secondary damage not visible from external inspection of the tire. For these reasons, Kawasaki does not recommend temporary (external) repair. Only appropriate permanent (internal) repairs are recommended. Repair methods may vary slightly from make to make. Follow the repair methods indicated by the manufacturer of the repair tools and materials so that safe results can be obtained.

10-16 WHEELS/TIRES

Hub Bearing

Hub Bearing Removal

- Remove the wheels (see Front/Rear Wheel Removal), and take out the following.
 - Collars
 - Coupling (Out of rear hub)
 - Grease Seals
- Use the bearing remover to remove the hub bearings [A].

CAUTION

Do not lay the wheel on the ground with the disc facing down. This can damage or warp the disc. Place wooden blocks under the wheel so that the disc does not touch the ground.

- Special Tools - Bearing Remover Head, $\phi 20 \times \phi 22$ [B]: 57001-1293**
Bearing Remover Shaft, $\phi 13$ [C]: 57001-1377

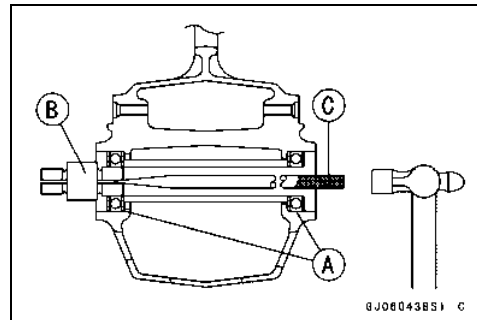

Hub Bearing Installation

- Before installing the hub bearings, blow any dirt or foreign particles out of the hub with compressed air to prevent contamination of the bearings.
- Replace the bearings with new ones.

NOTE

○ Install the bearings so that the marked side faces out.

- Install the bearings by using the bearing driver set which does not contact the bearing inner race.
- Press in each bearing [A] right until they are bottomed.

Special Tool - Bearing Driver Set [B]: 57001-1129

- Replace the grease seals with new ones.
- Press in the grease seals [A] so that the seal surface is flush [B] with the end of the hole.
- Apply high-temperature grease to the grease seal lips.

Special Tool - Bearing Driver Set [C]: 57001-1129

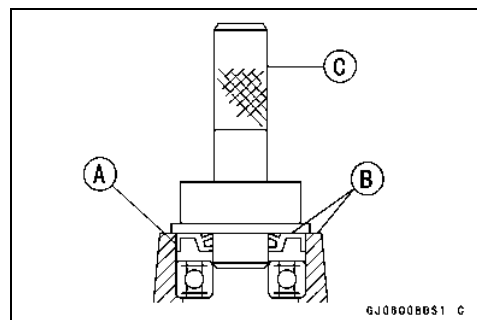
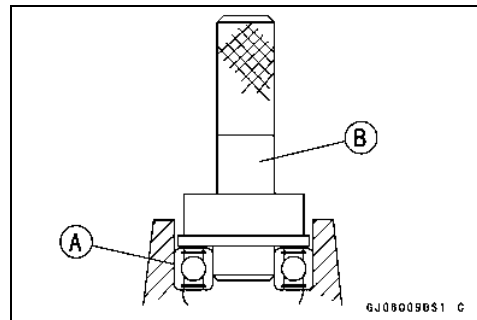

Hub Bearing Inspection

Since the hub bearings are made to extremely close tolerances, the clearance can not normally be measured.

NOTE

○ Do not remove any bearings for inspection. If any bearings are removed, they will need to be replaced with new ones.

- Turn each bearing in the hub back and forth [A] while checking for plays, roughness, or binding.
- ★ If bearing play, roughness or binding is found, replace the bearing.
- Examine the bearing seal [B] for tears or leakage.
- ★ If the seal is torn or is leaking, replace the bearing.

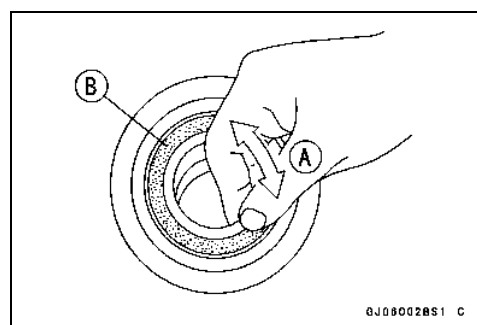

Hub Bearing

Hub Bearing Lubrication

NOTE

- *Since the hub bearings are packed with grease and sealed, lubrication is not required.*

Final Drive

Table of Contents

Exploded View	11-2
Specifications	11-4
Special Tools	11-5
Drive Chain	11-6
Drive Chain Slack Inspection	11-6
Drive Chain Slack Adjustment	11-6
Wheel Alignment Inspection/Adjustment	11-6
Drive Chain Wear Inspection	11-6
Drive Chain Lubrication.....	11-6
Drive Chain Removal	11-6
Drive Chain Installation	11-7
Sprocket, Coupling	11-10
Engine Sprocket Removal	11-10
Engine Sprocket Installation	11-11
Rear Sprocket Removal.....	11-11
Rear Sprocket Installation.....	11-11
Coupling Installation.....	11-12
Coupling Bearing Removal	11-12
Coupling Bearing Installation	11-12
Coupling Bearing Inspection	11-13
Coupling Bearing Lubrication.....	11-13
Coupling Damper Inspection.....	11-13
Sprocket Wear Inspection.....	11-13
Rear Sprocket Warp Inspection	11-14

11-2 FINAL DRIVE

Exploded View

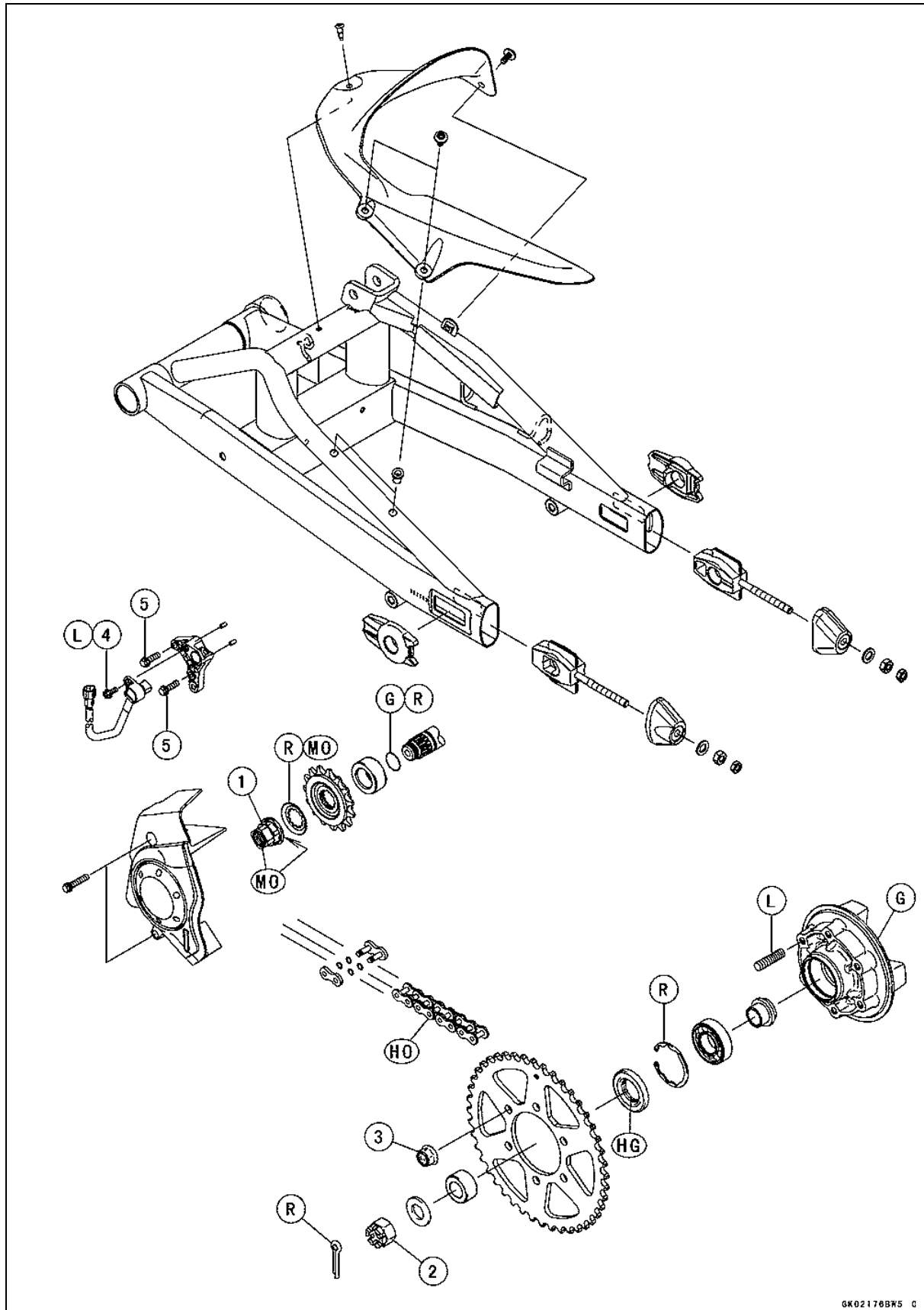

GK02176BK5 C

Exploded View

No.	Fastener	Torque			Remarks
		N·m	kgf·m	ft·lb	
1	Engine Sprocket Nut	125	12.7	92	MO
2	Rear Axle Nut	108	11.0	80	
3	Rear Sprocket Nuts	59	6.0	44	
4	Speed Sensor Bolt	7.8	0.80	69 in·lb	L
5	Speed Sensor Bracket Bolts	9.8	1.0	87 in·lb	

G: Apply grease.

HG: Apply high-temperature grease.

HO: Apply heavy oil.

L: Apply a non-permanent locking agent.

MO: Apply molybdenum disulfide oil solution.

(mixture of the engine oil and molybdenum disulfide grease in a weight ratio 10 : 1)

R: Replacement Parts

11-4 FINAL DRIVE

Specifications

Item	Standard	Service Limit
Drive Chain		
Drive Chain Slack	25 ~ 35 mm (1.0 ~ 1.4 in.)	---
Drive Chain Wear (20-link Length)	317.5 ~ 318.2 mm (12.50 ~ 12.53 in.)	323 mm (12.7 in.)
Standard Chain:		
Make	DAIDO	---
Type	DID 520VP2-T	---
Link	114 Links	---
Sprockets		
Rear Sprocket Warp	TIR 0.4 mm (0.016 in.) or less	TIR 0.5 mm (0.020 in.)

Special Tools

Inside Circlip Pliers:
57001-143

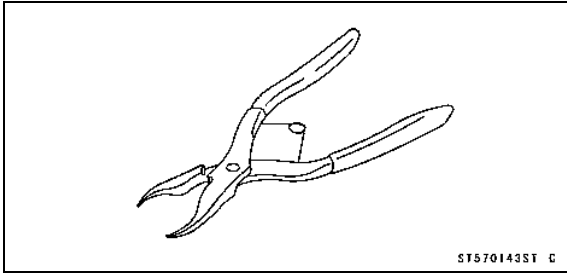

Bearing Driver Set:
57001-1129

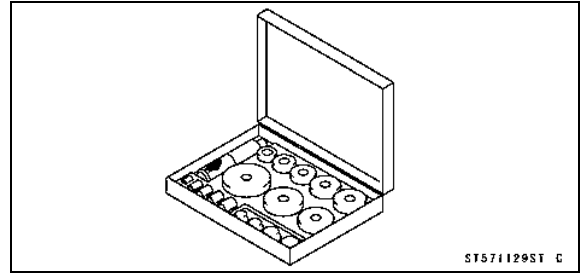

11-6 FINAL DRIVE

Drive Chain

Drive Chain Slack Inspection

- Refer to the Drive Chain Slack Inspection in the Periodic Maintenance chapter.

Drive Chain Slack Adjustment

- Refer to the Drive Chain Slack Adjustment in the Periodic Maintenance chapter.

Wheel Alignment Inspection/Adjustment

- Refer to the Wheel Alignment Inspection in the Periodic Maintenance chapter.

Drive Chain Wear Inspection

- Refer to the Drive Chain Wear Inspection in the Periodic Maintenance chapter.

Drive Chain Lubrication

- Refer to the Drive Chain Lubrication Condition Inspection in the Periodic Maintenance chapter.

Drive Chain Removal

NOTE

○ Since the drive chain is installed through the swingarm, the chain cannot be removed other than by cutting it. Prepare the new link pin, link plate, grease seals, and tools for rejoining the chain.

- Remove the muffler body (see Muffler Body Removal in the Engine Top End chapter).
- Using a suitable tool, replace the drive chain.

**Recommended Tool - DID Chain Joint "ZJ"
Make DAIDO KOGYO**

CAUTION

Read the Tool Manual before replacing the chain.

- Remove:
 - Body [A]
 - Pin Holder [B]
 - Positioning Pin [C]
 - "U" Holder [D]
 - Plate Holder [E]
 - Cutting and Riveting Pin [F]
 - Part for Riveting [G]
 - Part for Cutting [H]

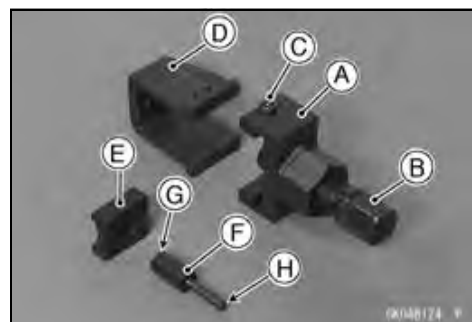

Drive Chain

- Grind [A] the heads of the link pin to make it flat.
- Set the cutting and riveting pin [C] in the pin holder [B] as shown in the figure.

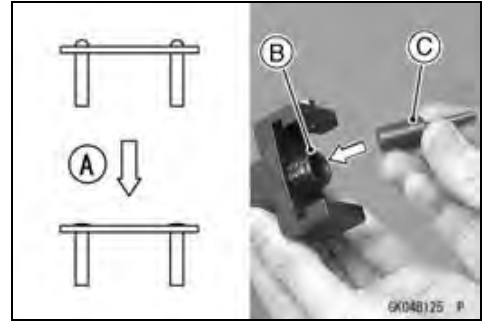

- Set the “U” holder and body, align the positioning pin [A] with the “A mark” [B].
- Tighten the pin holder by hand until the cutting and riveting pin touches the link pin.
- Be sure that the cutting and riveting pin hits center of the link pin.

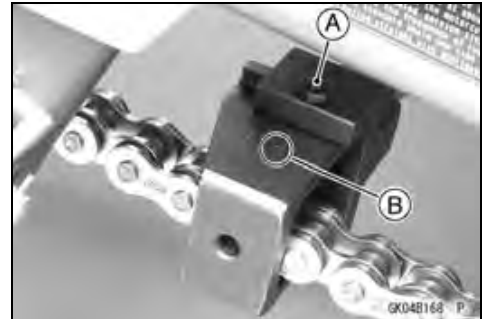

- Hold the body with a wrench [A].
- Turn the pin holder clockwise [B] with another wrench, and remove the link pin.
- Do the same procedure for removal of the other link pin.

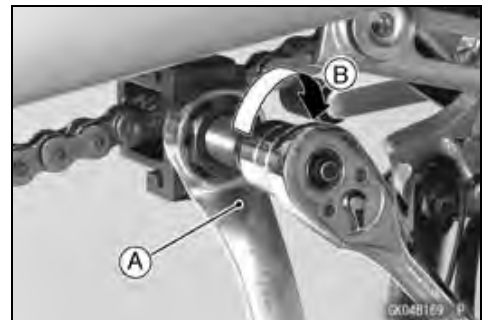

Drive Chain Installation

- Engage the new drive chain to the old drive chain, and change the position of the chains by pulling the old chain.
- Remove the old drive chain from the new drive chain.
- Replace the link pin [A], link plate and grease seals [B] [C] with new ones.
- Apply grease to the link pin and grease seals.
- Install the grease seals on the link pin and insert it in the ends of the drive chain.
- Install the link plate so that the mark [D] faces out.

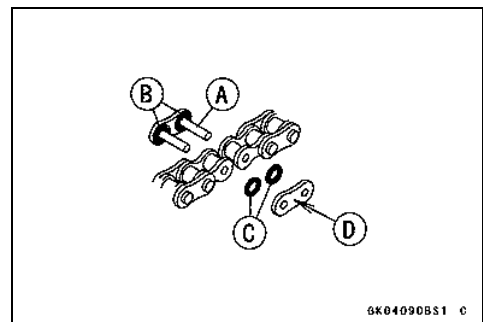

- Set the cutting and riveting pin [B] and plate holder [C] on the pin holder [A] as shown in the figure.

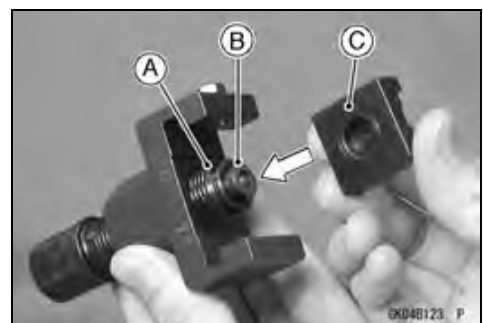

11-8 FINAL DRIVE

Drive Chain

- Set the “U” holder and body, align the positioning pin [A] with the “A mark” [B].
- Hold the body with a wrench [C].
- Turn the pin holder clockwise [D] with another wrench and press in the link plate on the link pin.
- Remove the “U” holder and body.

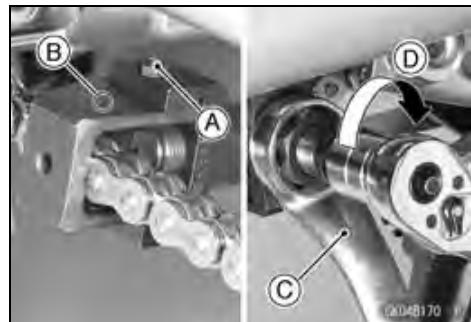

- Set the cutting and riveting pin [B] in the pin holder [A] as shown in the figure.

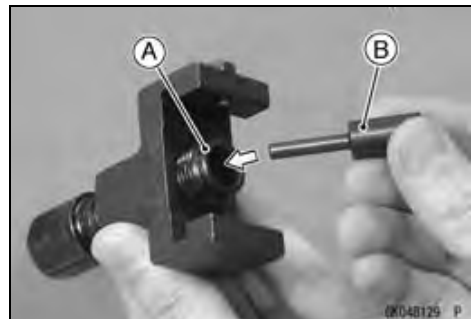

- Set the “U” holder and body, align the positioning pin [A] with the “B mark” [B].
- Tighten the pin holder by hand until the cutting and riveting pin touches the link pin.

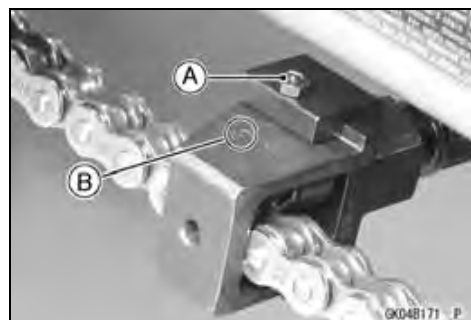

- Hold the body with a wrench [A].
- Turn the pin holder clockwise [B] with another wrench until the cutting and riveting pin touches the link plate.
- Do the same procedure for removal of the other link pin.

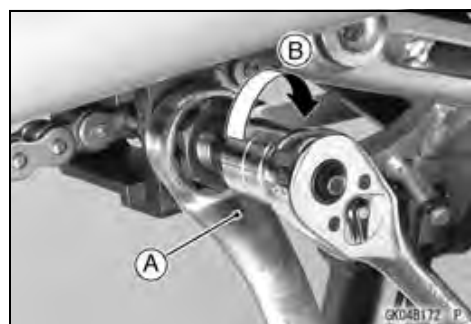

Drive Chain

- After riveting, check the ends of the riveted pins for cracks.
- Measure the outside diameter [A] of the link pin and width [B] of the link plates.

Link Pin Outside Diameter

Standard: 5.7 ~ 6.0 mm (0.22 ~ 0.24 in.)

Link Plate Outside Width

Standard: 17.25 ~ 17.55 mm (0.679 ~ 0.691 in.)

- ★ If the reading is not the specified length, cut and rejoin the chain again.
- Check that the rollers move smoothly.
- Adjust the drive chain slack after installing the chain (see Drive Chain Slack Adjustment in the Periodic Maintenance chapter).

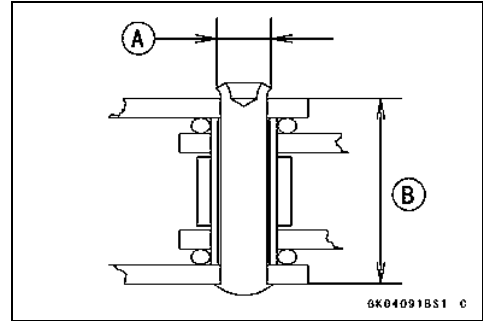

11-10 FINAL DRIVE

Sprocket, Coupling

Engine Sprocket Removal

- Remove:
 - Left Frame Cover (see Frame Cover Removal in the Frame chapter)
 - Engine Sprocket Cover Bolts [A]
 - Engine Sprocket Cover [B]

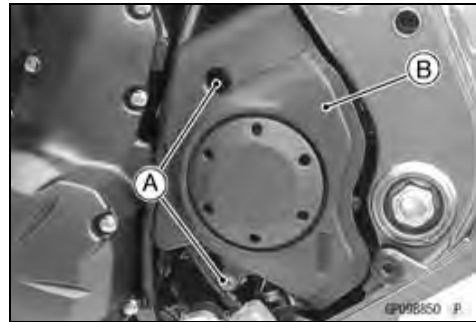

- Remove:
 - Speed Sensor Bracket Bolts [A]
 - Speed Sensor Bracket [B]

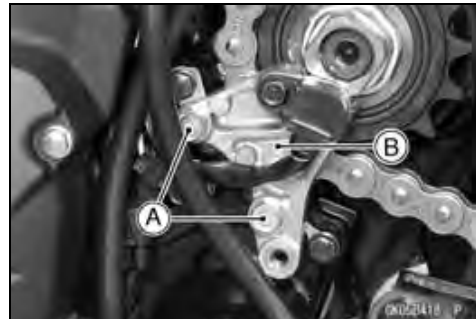

- Flatten out the bended washer [A].
- Remove the engine sprocket nut [B] and washer.

NOTE

○ When loosening the engine sprocket nut, hold the rear brake on.

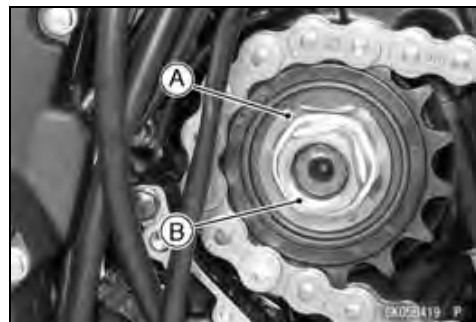

- Loosen the drive chain (see Drive Chain Slack Adjustment in the Periodic Maintenance chapter).
- Remove the drive chain from the rear sprocket toward the right.
- Pull the engine sprocket [A] with drive chain [B] off the output shaft [C].
- Disengage the drive chain from the engine sprocket.

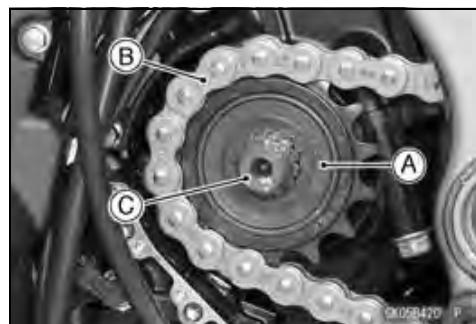

Sprocket, Coupling

Engine Sprocket Installation

- Replace the sprocket washer with a new one.
- Install the engine sprocket [A] so that "OUTSIDE" letters face outward.
- Apply molybdenum disulfide oil solution to the threads of the output shaft and seating surface of the engine sprocket nut.
- After torquing the engine sprocket nut, bend the one side of the washer [B] over the nut.

NOTE

- Tighten the engine sprocket nut while applying the rear brake.

- Tighten:

Torque - Engine Sprocket Nut: 125 N-m (12.7 kgf-m, 92 ft-lb)
Speed Sensor Bracket Bolts: 9.8 N-m (1.0 kgf-m, 87 in-lb)

- Install the engine sprocket cover, and tighten the bolts.
- Adjust the drive chain slack after installing the sprocket (see Drive Chain Slack Adjustment in the Periodic Maintenance chapter).
- Bend the end of axle cotter pin surely after tightening the axle nut (see Rear Wheel Installation in the Wheels/Tires chapter).

Rear Sprocket Removal

- Remove the rear wheel (see Rear Wheel Removal in the Wheels/Tires chapter).

CAUTION

Do not lay the wheel on the ground with the disc facing down. This can damage or warp the disc. Place blocks to under the wheel so that the disc does not touch the ground.

- Remove the rear sprocket nuts [A].
- Remove the rear sprocket [B].

Rear Sprocket Installation

- Install the sprocket facing the tooth number marking [A] outward.
- Tighten:
 - Torque - Rear Sprocket Nuts: 59 N-m (6.0 kgf-m, 44 ft-lb)**
- Install the rear wheel (see Rear Wheel Installation in the Wheels/Tires chapter).

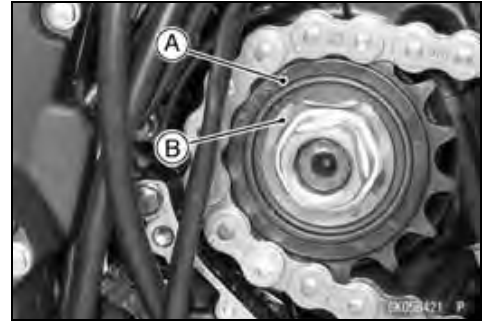

11-12 FINAL DRIVE

Sprocket, Coupling

Coupling Installation

- Apply high-temperature grease to the coupling grease seal lips [A].
- Apply grease to the coupling internal surface [B].

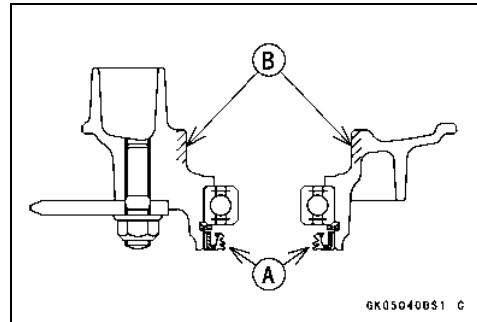

- Apply grease to the following.
 - Wheel Flange Portion [A]
 - O-ring [B]
- Install the collar [C].

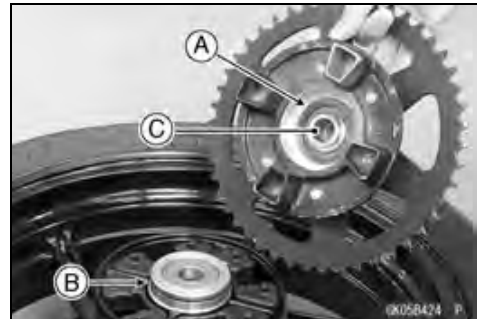

Coupling Bearing Removal

- Remove:
 - Coupling
 - Grease Seal
 - Circlip [A]

Special Tool - Inside Circlip Pliers: 57001-143

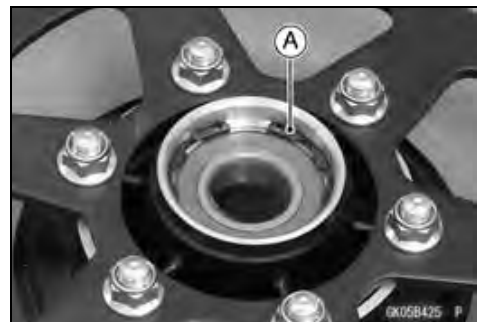

- Remove the bearing [A] by tapping from the wheel side.

Special Tool - Bearing Driver Set [B]: 57001-1129

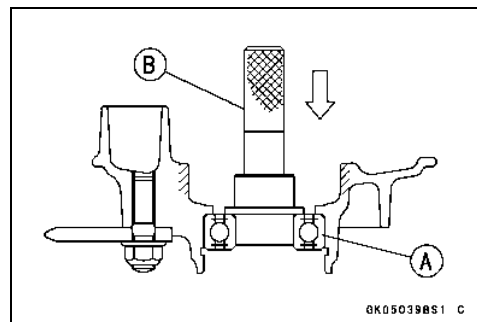

Coupling Bearing Installation

- Replace the bearing with a new one.
 - Press in the bearing [A] until it is bottomed.
- Special Tool - Bearing Driver Set [B]: 57001-1129**
- Replace the circlip with a new one.

Special Tool - Inside Circlip Pliers: 57001-143

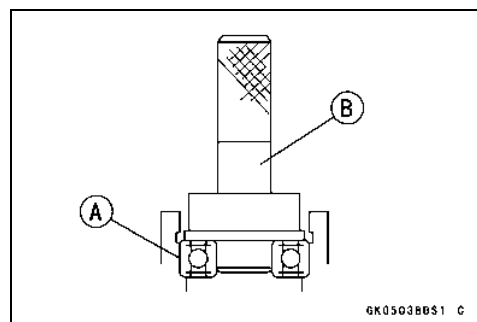

Sprocket, Coupling

- Replace the grease seal with a new one.
- Press in the grease seal so that the seal surface is flush with the end of the hole.
- Apply high-temperature grease to the grease seal lips.

Special Tool - Bearing Driver Set: 57001-1129

Coupling Bearing Inspection

Since the coupling bearing is made to extremely close tolerances, the clearance can not normally be measured.

NOTE

○ *It is not necessary to remove the coupling bearing for inspection. If the bearing is removed, it will need to be replaced with a new one.*

- Turn the bearing in the coupling back and forth [A] while checking for plays, roughness or binding.
- ★ If the bearing play, roughness or binding is found, replace the bearing.
- Examine the bearing seal [B] for tears or leakage.
- ★ If the seal is torn or is leaking, replace the bearing.

Coupling Bearing Lubrication

NOTE

○ *Since the coupling bearing is packed with grease and sealed, lubrication is not required.*

Coupling Damper Inspection

- Remove the rear wheel coupling, and inspect the rubber dampers [A].
- Replace the damper if it appears damaged or deteriorated.

Sprocket Wear Inspection

- Visually inspect the engine and rear sprocket teeth for wear and damage.
- ★ If the teeth are worn as illustrated, replace the sprocket, and inspect the drive chain wear (see Drive Chain Wear Inspection in the Periodic Maintenance chapter).
 - Worn Tooth (Engine Sprocket) [A]
 - Worn Tooth (Rear Sprocket) [B]
 - Direction of Rotation [C]

NOTE

○ *If a sprocket requires replacement, the chain is probably worn also. When replacing a sprocket, inspect the chain.*

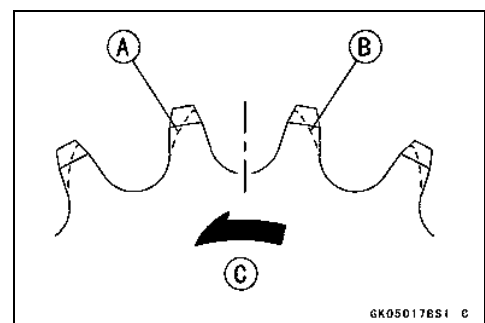
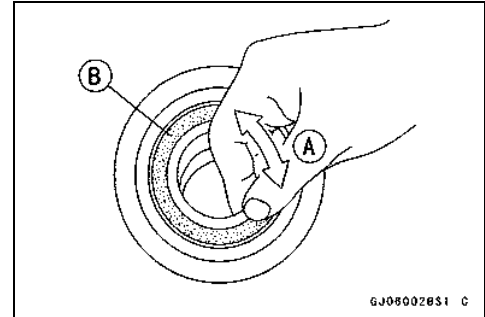

11-14 FINAL DRIVE

Sprocket, Coupling

Rear Sprocket Warp Inspection

- Raise the rear wheel off the ground with stand so that it will turn freely.
- Set a dial gauge [A] against the rear sprocket [B] near the teeth as shown, and rotate [C] the rear wheel to measure the sprocket runout (warp). The difference between the highest and lowest dial gauge readings is the amount of runout (warp).
- ★ If the runout exceeds the service limit, replace the rear sprocket.

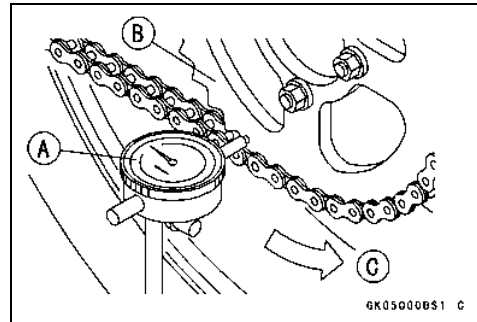

Rear Sprocket Warp

Standard: TIR 0.4 mm (0.016 in.) or less

Service Limit: TIR 0.5 mm (0.020 in.)

Brakes

Table of Contents

Exploded View	12-4
Specifications	12-12
Special Tools	12-13
Brake Lever, Brake Pedal.....	12-14
Brake Lever Position Adjustment.....	12-14
Brake Pedal Position Inspection	12-14
Brake Pedal Position Adjustment.....	12-14
Brake Pedal Removal	12-14
Brake Pedal Installation	12-15
Calipers	12-16
Caliper Removal	12-16
Caliper Installation	12-16
Front Caliper Disassembly.....	12-17
Front Caliper Assembly.....	12-17
Rear Caliper Disassembly	12-17
Rear Caliper Assembly	12-17
Caliper Fluid Seal Damage Inspection.....	12-17
Caliper Dust Seal Damage Inspection	12-18
Caliper Dust Boot and Friction Boot Damage Inspection.....	12-18
Caliper Piston and Cylinder Damage Inspection	12-19
Caliper Holder Shaft Wear Inspection.....	12-19
Brake Pads.....	12-20
Front Brake Pad Removal.....	12-20
Front Brake Pad Installation.....	12-20
Rear Brake Pad Removal	12-20
Rear Brake Pad Installation	12-20
Brake Pad Wear Inspection	12-20
Master Cylinder	12-21
Front Master Cylinder Removal	12-21
Front Master Cylinder Installation	12-21
Rear Master Cylinder Removal.....	12-22
Rear Master Cylinder Installation.....	12-22
Front Master Cylinder Disassembly	12-22
Rear Master Cylinder Disassembly.....	12-22
Master Cylinder Assembly	12-22
Master Cylinder Inspection	12-23
Brake Disc	12-24
Brake Disc Removal	12-24
Brake Disc Installation	12-24
Brake Disc Wear Inspection.....	12-24
Brake Disc Warp	12-24
Brake Fluid	12-25
Brake Fluid Level Inspection.....	12-25
Brake Fluid Change	12-25
Brake Line Bleeding.....	12-25
Brake Hose.....	12-28
Brake Hose Removal/Installation.....	12-28
Brake Hose Inspection.....	12-28
Anti-Lock Brake System (Equipped Models)	12-29
Parts Location	12-29

12-2 BRAKES

ABS Servicing Precautions	12-33
ABS Troubleshooting Outline	12-35
Inquiries to Rider	12-38
Self-diagnosis Outline	12-40
Self-diagnosis Procedures	12-40
Service Code Clearing Procedures	12-41
How to Read Service Codes	12-43
How to Erase Service Codes	12-43
ABS Indicator Light (LED) Inspection	12-45
Solenoid Valve Inspection (Service Code 13,14,17,18)	12-45
ABS Solenoid Valve Relay Inspection (Service Code 19)	12-45
Front, Rear Wheel Rotation Difference Abnormal (Service Code 25)	12-47
ABS Motor Relay Inspection (Service Code 35)	12-47
Front Wheel Rotation Sensor Signal Abnormal (Service Code 42)	12-48
Front Wheel Rotation Sensor Wiring Inspection (Service Code 43)	12-49
Rear Wheel Rotation Sensor Signal Abnormal (Service Code 44)	12-50
Rear Wheel Rotation Sensor Wiring Inspection (Service Code 45)	12-51
Power Supply Voltage Abnormal (Under-Voltage) (Service Code 52)	12-51
Power Supply Voltage Abnormal (Over-Voltage) (Service Code 53)	12-52
ECU Inspection (Service Code 55)	12-53
ABS Hydraulic Unit Removal	12-54
ABS Hydraulic Unit Installation	12-55
ABS Hydraulic Unit Inspection	12-56
Front Wheel Rotation Sensor Removal	12-56
Front Wheel Rotation Sensor Installation	12-57
Rear Wheel Rotation Sensor Removal	12-57
Rear Wheel Rotation Sensor Installation	12-58
Wheel Rotation Sensor Inspection	12-58
Wheel Rotation Sensor Air Gap Inspection	12-58
Wheel Rotation Sensor Rotor Inspection	12-59
Brake Hose and Pipe Removal/Installation	12-59
Brake Hose and Pipe Inspection	12-59
ABS Solenoid Valve Relay Fuse 25 A Removal	12-59
ABS Motor Relay Fuse 30 A Removal	12-59
Fuse Installation	12-59
Fuse Inspection	12-60

Dummy Page

12-4 BRAKES

Exploded View

EX650C Models

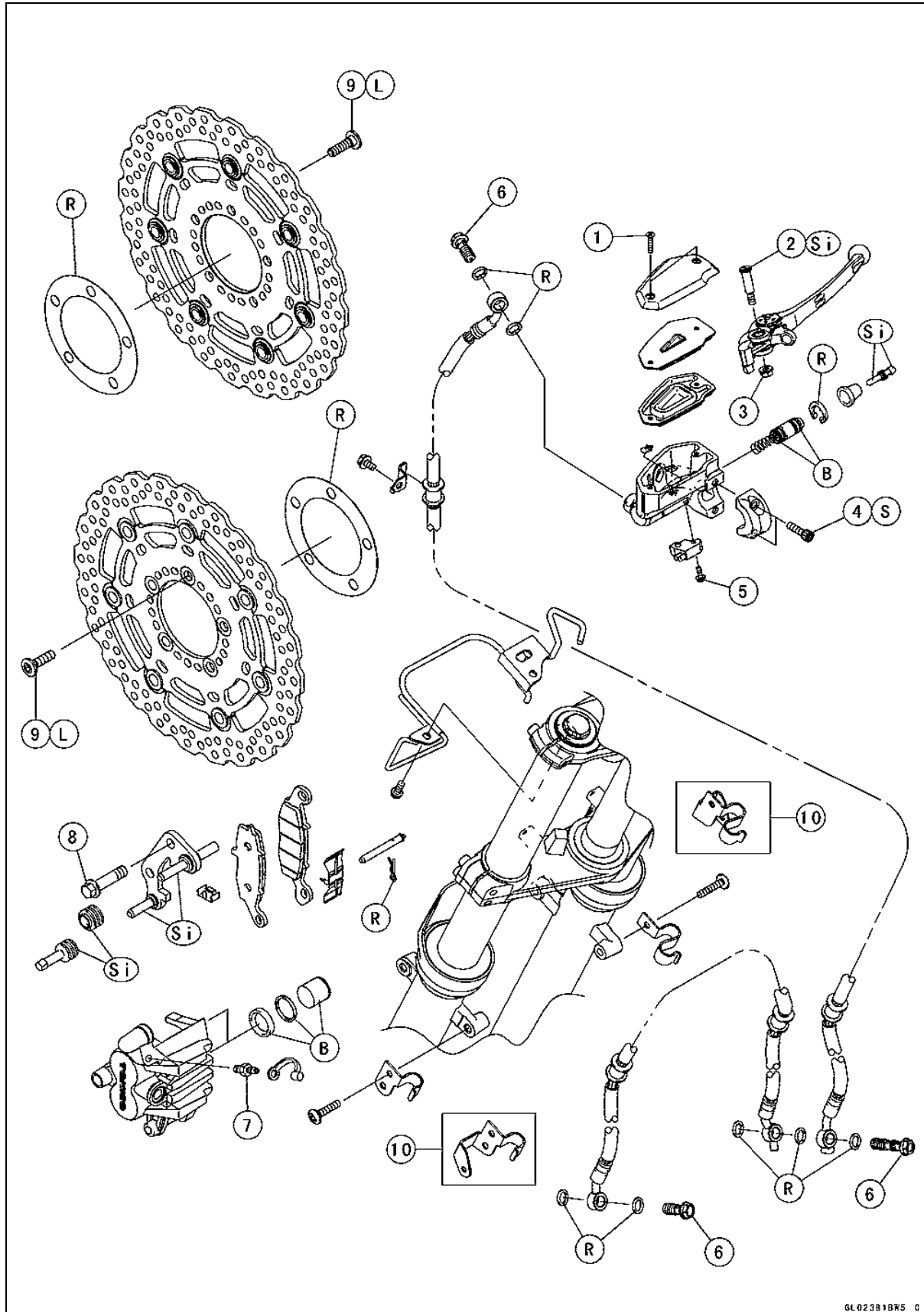

GL02381BK5 C

Exploded View

No.	Fastener	Torque			Remarks
		N·m	kgf·m	ft·lb	
1	Front Brake Reservoir Cap Screws	1.5	0.15	13 in·lb	
2	Brake Lever Pivot Bolt	1.0	0.10	9 in·lb	Si
3	Brake Lever Pivot Bolt Locknut	5.9	0.60	52 in·lb	
4	Front Master Cylinder Clamp Bolts	11	1.1	97 in·lb	S
5	Front Brake Light Switch Screw	1.2	0.12	11 in·lb	
6	Brake Hose Banjo Bolts	25	2.5	18	
7	Caliper Bleed Valve	7.8	0.80	69 in·lb	
8	Front Caliper Mounting Bolts	34	3.5	25	
9	Brake Disc Mounting Bolts	27	2.8	20	L

10. Other than EUR and MY Models

B: Apply brake fluid.

L: Apply a non-permanent locking agent.

R: Replacement Parts

S: Follow the specified tightening sequence.

Si: Apply silicone grease (ex. PBC grease).

12-6 BRAKES

Exploded View

EX650C Models

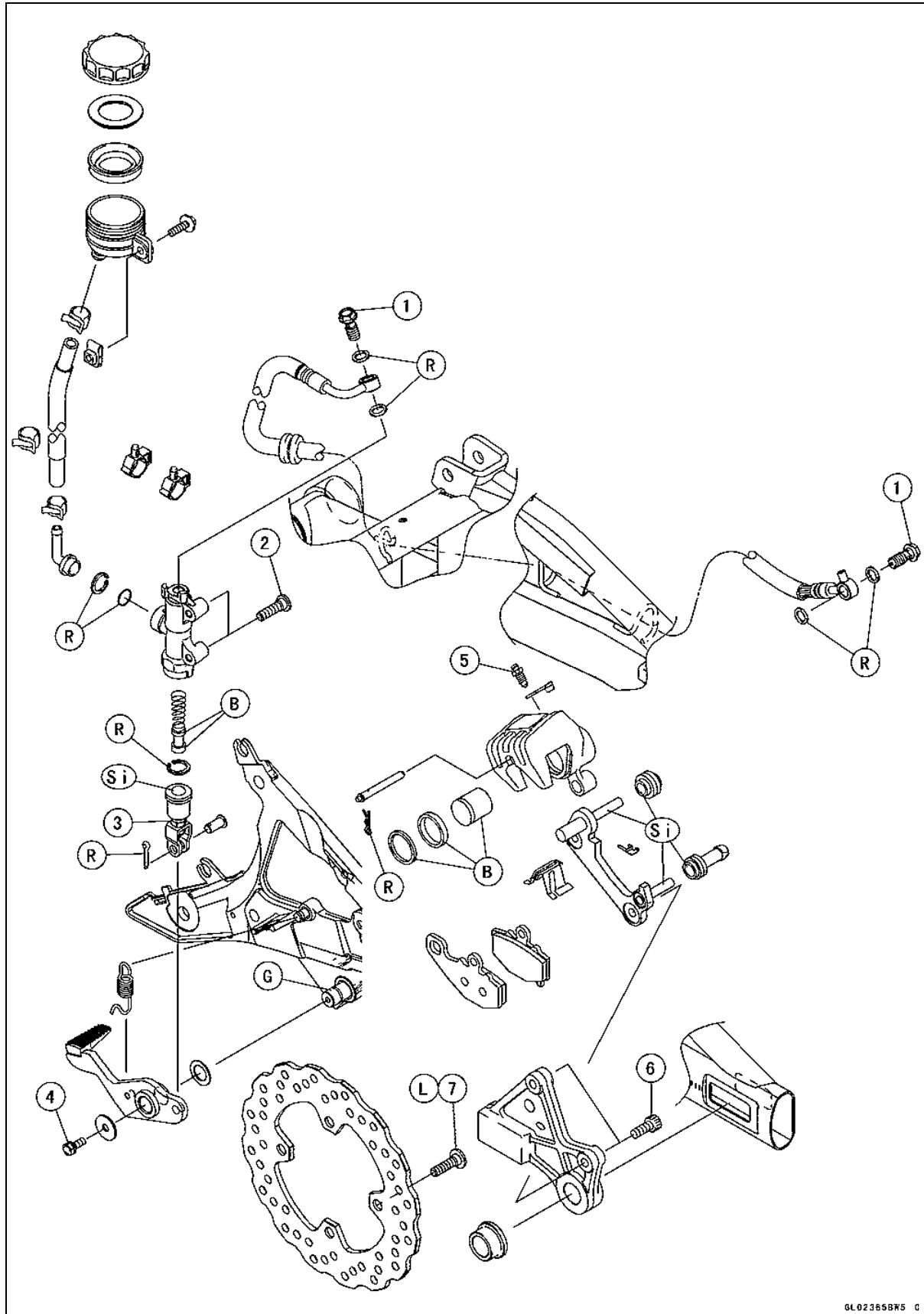

GL02365BK5 C

Exploded View

No.	Fastener	Torque			Remarks
		N·m	kgf·m	ft·lb	
1	Brake Hose Banjo Bolts	25	2.5	18	
2	Rear Master Cylinder Mounting Bolts	25	2.5	18	
3	Rear Master Cylinder Push Rod Locknut	17	1.7	13	
4	Brake Pedal Bolt	8.8	0.90	78 in·lb	
5	Caliper Bleed Valve	7.8	0.80	69 in·lb	
6	Rear Caliper Mounting Bolts	25	2.5	18	
7	Brake Disc Mounting Bolts	27	2.8	20	L

B: Apply brake fluid.

G: Apply grease.

L: Apply a non-permanent locking agent.

R: Replacement Parts

Si: Apply silicone grease (ex. PBC grease).

12-8 BRAKES

Exploded View

EX650D Models

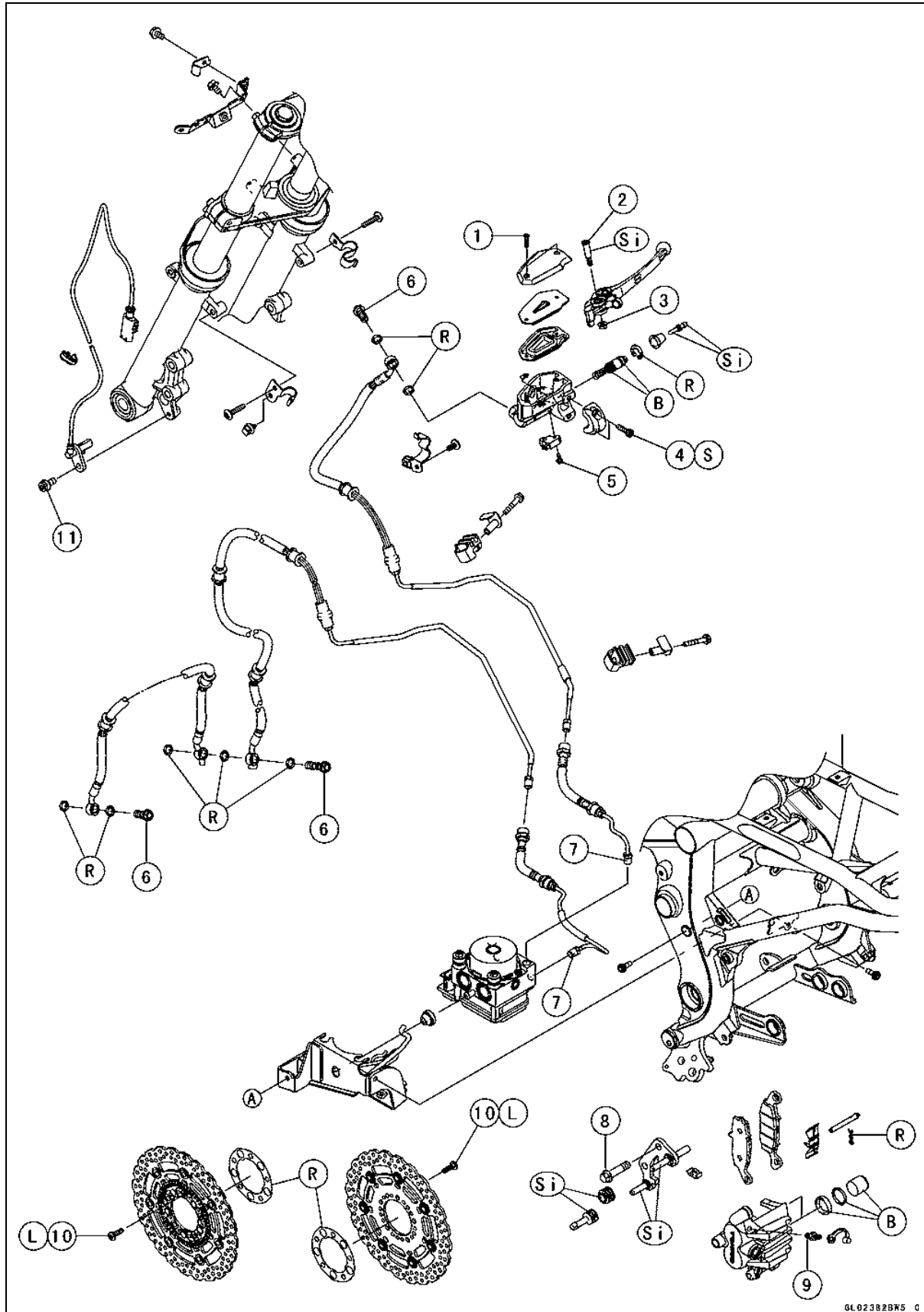

GL02382BK5 C

Exploded View

No.	Fastener	Torque			Remarks
		N·m	kgf·m	ft·lb	
1	Front Brake Reservoir Cap Screws	1.5	0.15	13 in·lb	
2	Brake Lever Pivot Bolt	1.0	0.10	9 in·lb	Si
3	Brake Lever Pivot Bolt Locknut	5.9	0.60	52 in·lb	
4	Front Master Cylinder Clamp Bolts	11	1.1	97 in·lb	S
5	Front Brake Light Switch Screw	1.2	0.12	11 in·lb	
6	Brake Hose Banjo Bolts	25	2.5	18	
7	Brake Pipe Joint Nuts	18	1.8	13	
8	Front Caliper Mounting Bolts	34	3.5	25	
9	Caliper Bleed Valve	7.8	0.80	69 in·lb	
10	Brake Disc Mounting Bolts	27	2.8	20	L
11	Front Wheel Rotation Sensor Bolt	20	2.0	15	

B: Apply brake fluid.

L: Apply a non-permanent locking agent.

R: Replacement Parts

S: Follow the specified tightening sequence.

Si: Apply silicone grease (ex. PBC grease).

12-10 BRAKES

Exploded View

EX650D Models

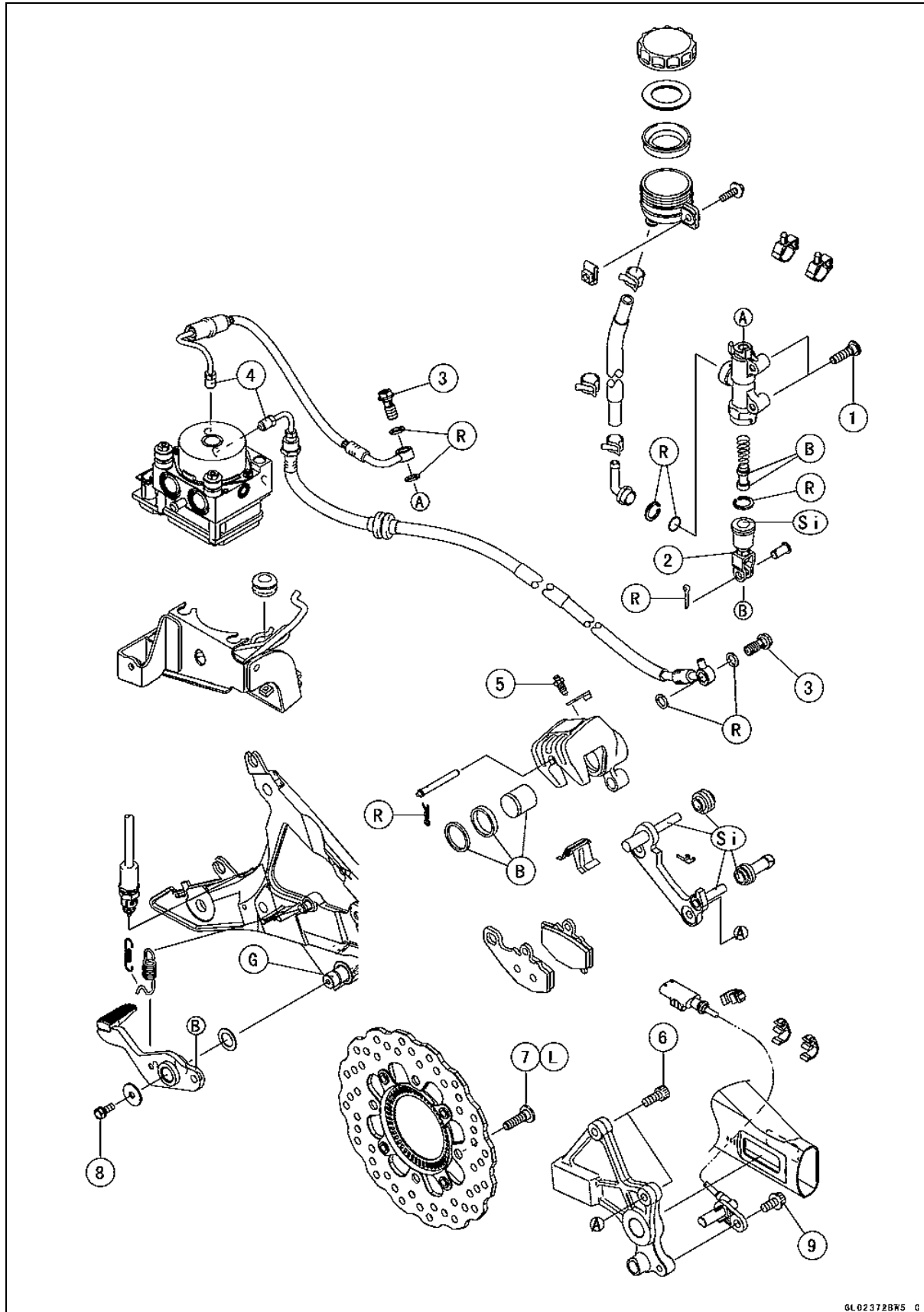

GL02372BK5 C

Exploded View

No.	Fastener	Torque			Remarks
		N·m	kgf·m	ft·lb	
1	Rear Master Cylinder Mounting Bolts	25	2.5	18	
2	Rear Master Cylinder Push Rod Locknut	17	1.7	13	
3	Brake Hose Banjo Bolts	25	2.5	18	
4	Brake Pipe Joint Nuts	18	1.8	13	
5	Caliper Bleed Valve	7.8	0.80	69 in·lb	
6	Rear Caliper Mounting Bolts	25	2.5	18	
7	Brake Disc Mounting Bolts	27	2.8	20	L
8	Brake Pedal Bolt	8.8	0.90	78 in·lb	
9	Rear Wheel Rotation Sensor Bolt	20	2.0	15	

B: Apply brake fluid.

G: Apply grease.

L: Apply a non-permanent locking agent.

R: Replacement Parts

Si: Apply silicone grease (ex. PBC grease).

12-12 BRAKES

Specifications

Item	Standard	Service Limit
Brake Lever, Brake Pedal		
Lever Position	5-way adjustable (to suit rider)	---
Lever Free Play	Non-adjustable	---
Pedal Position	About 40 mm (1.6 in.) below top of footpeg	---
Pedal Free Play	Non-adjustable	---
Brake Pads		
Lining Thickness:		
Front	4.5 mm (0.18 in.)	1 mm (0.04 in.)
Rear	5.0 mm (0.20 in.)	1 mm (0.04 in.)
Brake Discs		
Thickness:		
Front	4.8 ~ 5.2 mm (0.19 ~ 0.20 in.)	4.5 mm (0.18 in.)
Rear	4.8 ~ 5.2 mm (0.19 ~ 0.20 in.)	4.5 mm (0.18 in.)
Runout	TIR 0.15 mm (0.0059 in.) or less	TIR 0.3 mm (0.01 in.)
Brake Fluid		
Grade	DOT4	---

Special Tools

**Jack:
57001-1238**

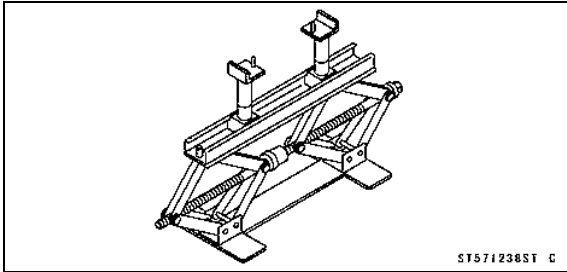

**Jack Attachment:
57001-1608**

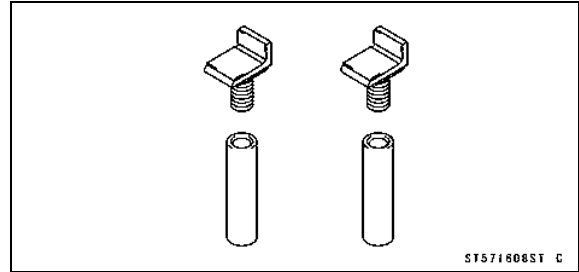

**Hand Tester:
57001-1394**

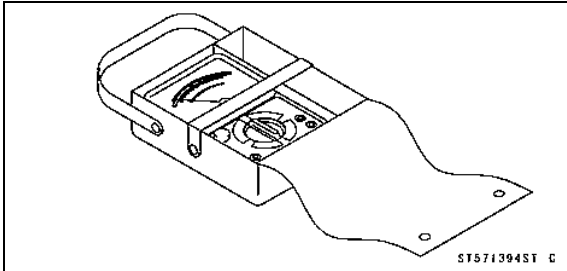

12-14 BRAKES

Brake Lever, Brake Pedal

Brake Lever Position Adjustment

The brake lever adjuster has 5 positions so that the brake lever position can be adjusted to suit the operator's hand.

- Push the lever forward and turn the adjuster [A] to align the number with the arrow mark [B] on the lever holder.
- The distance from the grip to the lever is minimum at number 5 and maximum at number 1.

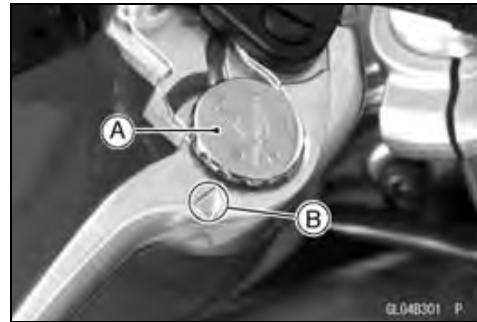

Brake Pedal Position Inspection

- Measure the brake pedal position [A].

Pedal Position

Standard: About 40 mm (1.6 in.) below top of footpeg [B]

- ★ If it is incorrect, adjust the brake pedal position.



Brake Pedal Position Adjustment

NOTE

○ Usually it is not necessary to adjust the pedal position, but always adjust it when the push rod locknut has been loosened.

- Remove:
 - Right Footpeg Stay (see Footpeg Stay Removal in the Frame chapter)
- Loosen the locknut [A] and turn the push rod with the hex head [B] to achieve the correct pedal position.
- ★ If the length [C] shown is 70 ± 1 mm (2.76 ± 0.04 in.), the pedal position will be within the standard range.
- Tighten:
 - Torque - Rear Master Cylinder Push Rod Locknut: 17 N·m (1.7 kgf·m, 13 ft·lb)**
- Install the right footpeg stay (see Footpeg Stay Installation in the Frame chapter).
- Check the brake light switch operation (see Brake Light Switch Operation Inspection in the Periodic Maintenance chapter).

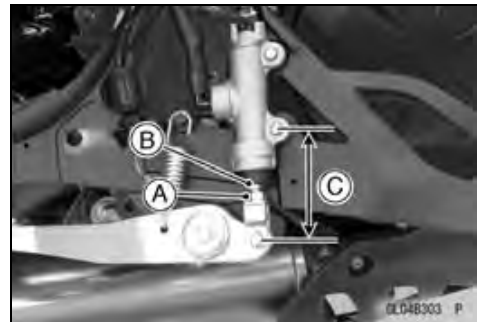

Brake Pedal Removal

- Remove:
 - Right Footpeg Stay (see Footpeg Stay Removal in the Frame chapter)
 - Cotter Pin [A]
 - Joint Pin [B]
 - Rear Brake Light Switch Spring [C]
 - Return Spring [D]
- Remove the mounting bolt [E] and take out the brake pedal.

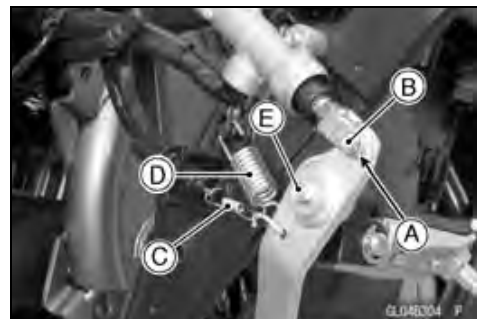

Brake Lever, Brake Pedal

Brake Pedal Installation

- Apply grease to the pivot shaft [A].
- Install:
 - Washer [B]
 - Brake Pedal [C]
 - Washer [D]
- Tighten:
 - Torque - Brake Pedal Bolt [E]: 8.8 N·m (0.90 kgf·m, 78 in·lb)**

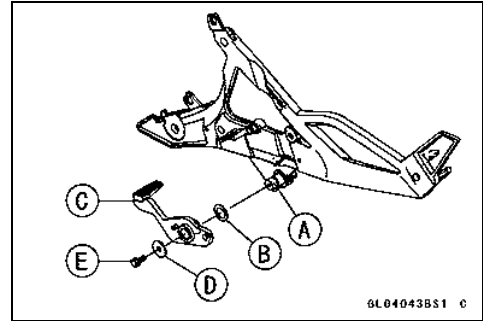

- Install the following parts as shown in the figure.
 - Return Spring [A]
 - Rear Brake Light Switch Spring [B]

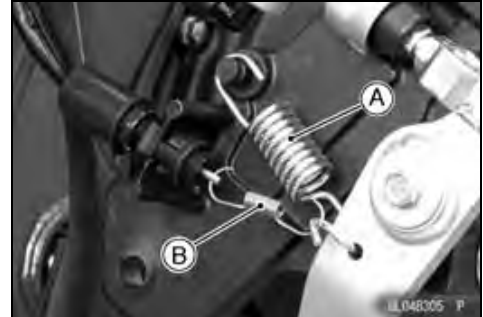

- Install the joint pin [A].
- Replace the cotter pin with a new one.
- Insert the cotter pin [B] and bend the pin ends as shown.

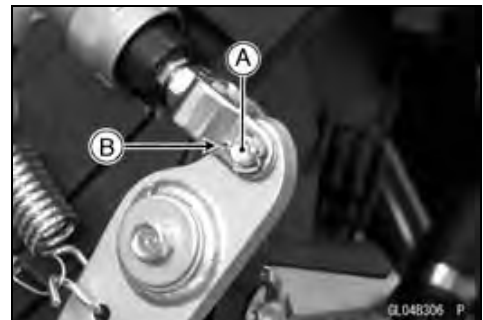

- Install the right footpeg stay (see Footpeg Stay Installation in the Frame chapter).
- Check the brake pedal position (see Brake Pedal Position Inspection).

12-16 BRAKES

Calipers

Caliper Removal

CAUTION

Immediately wipe up any brake fluid that spilled.

NOTE

○ If the caliper is to be disassembled after removal and compressed air is not available, disassemble the caliper before brake hose removal (see *Caliper Rubber Parts Replacement in the Periodic Maintenance chapter*).

Front Brake

- Loosen the banjo bolt [A] so as not to spill brake fluid.
- Remove the caliper mounting bolts [B].
- Remove the banjo bolt and take off the brake hoses from the caliper.

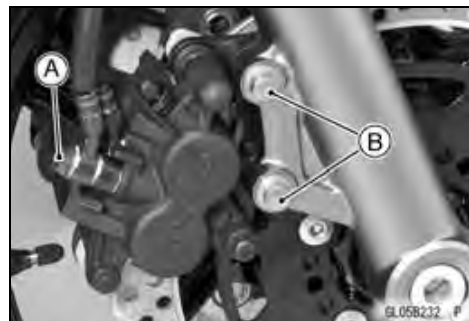

Rear Brake

- Loosen the banjo bolt [A] so as not to spill brake fluid.
- Remove the caliper mounting bolts [B].
- Remove the banjo bolt and take off the brake hose from the caliper.

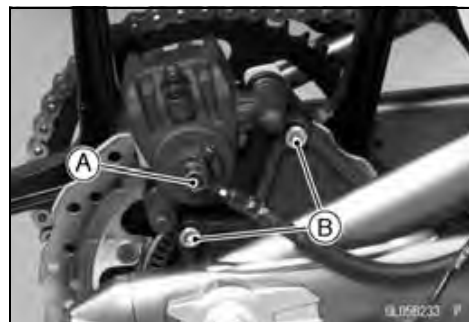

Caliper Installation

- Install the caliper(s), and tighten the bolts.
 - Torque - Front Caliper Mounting Bolts: 34 N·m (3.5 kgf·m, 25 ft·lb)
 - Rear Caliper Mounting Bolts: 25 N·m (2.5 kgf·m, 18 ft·lb)
- Install the brake hose lower end.
- Replace the washers [A] on each side of hose fitting [B] with new ones.
- Tighten:
 - Torque - Brake Hose Banjo Bolts: 25 N·m (2.5 kgf·m, 18 ft·lb)

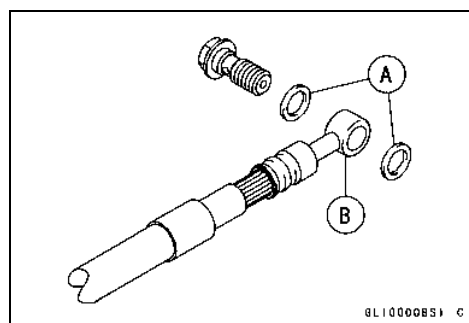

Calipers

- Check the fluid level in the brake reservoirs (see Brake Fluid Level Inspection in the Periodic Maintenance chapter).
- Bleed the brake line (see Brake Line Bleeding).
- Check the brake for good braking power, no brake drag, and no fluid leakage.

⚠ WARNING

Do not attempt to drive the motorcycle until a full brake lever or pedal is obtained by pumping the brake lever or pedal and the pads are against the disc. The brakes will not function on the first application of the lever or pedal if this is not done.

Front Caliper Disassembly

- Refer to the Caliper Rubber Parts Replacement in the Periodic Maintenance chapter.

Front Caliper Assembly

- Refer to the Caliper Rubber Parts Replacement in the Periodic Maintenance chapter.

Rear Caliper Disassembly

- Refer to the Caliper Rubber Parts Replacement in the Periodic Maintenance chapter.

Rear Caliper Assembly

- Refer to the Caliper Rubber Parts Replacement in the Periodic Maintenance chapter.

Caliper Fluid Seal Damage Inspection

The fluid seal (piston seal) [A] is placed around the piston to maintain clearance between the pad and the disc. If the seal is in a poor condition, it could lead the pad to wear excessively or the brake to drag, which may cause the temperature of the discs or the brake fluid to increase.

- Replace the fluid seal(s) if it exhibits any of the conditions listed below.
 - Brake fluid leakage around the pad.
 - Brakes overheat.
 - Considerable difference in inner and outer pad wear.
 - Seal and piston are stuck together.
- ★ If the fluid seal is replaced, replace the dust seal(s) [B] as well. Also, replace all seals every other time the pads are changed.

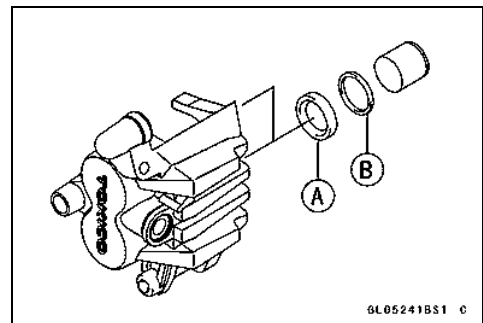

6L05241BS1 C

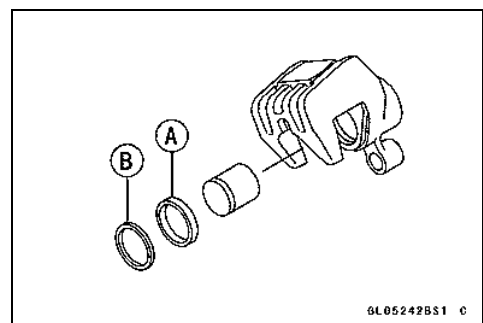

6L05242BS1 C

12-18 BRAKES

Calipers

Caliper Dust Seal Damage Inspection

- Check that the dust seal(s) [A] are not cracked, worn, swollen, or otherwise damaged.
- ★ If they show any damage, replace the dust seals with new ones.
 - Piston(s) [B]
 - Fluid Seal(s) [C]

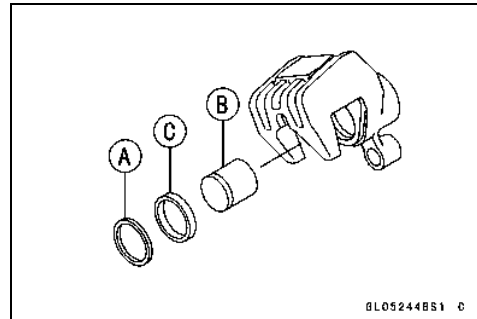
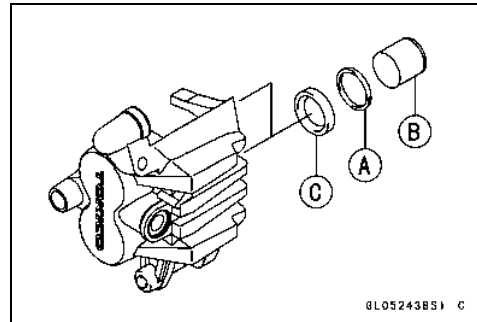

Caliper Dust Boot and Friction Boot Damage Inspection

- Check that the dust boot [A] and friction boot [B] are not cracked, worn, swollen, or otherwise damaged.
- ★ If they show any damage, replace it.

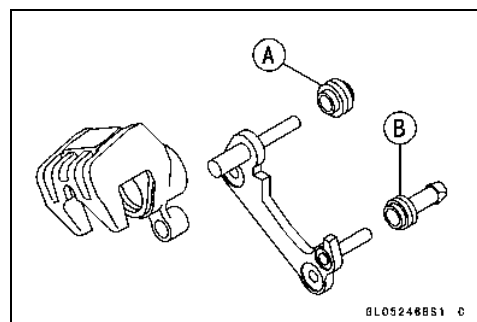
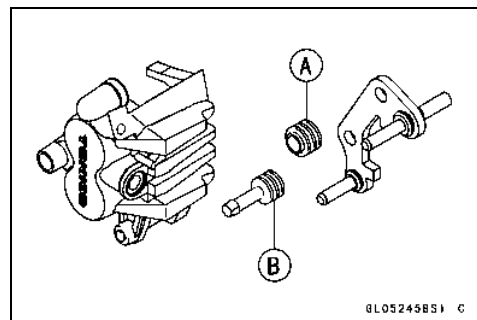

Calipers

Caliper Piston and Cylinder Damage Inspection

- Visually inspect the piston(s) [A] and cylinder surface(s) [B].
- ★ Replace the caliper if the cylinder and piston are badly scored or rusty.

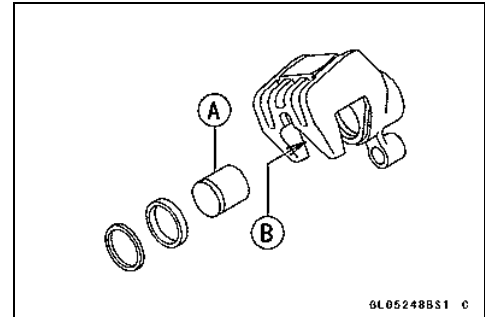
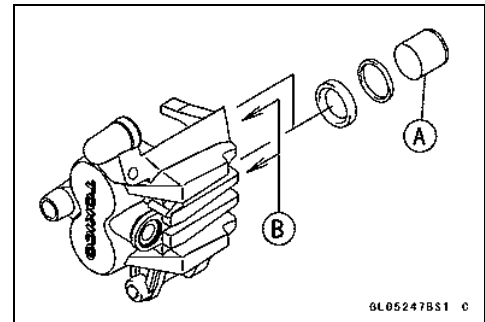

Caliper Holder Shaft Wear Inspection

The caliper body must slide smoothly on the caliper holder shaft [A]. If the body does not slide smoothly, one pad will wear more than the other, pad wear will increase, and constant drag on the disc will raise brake and brake fluid temperature.

- Check to see that the caliper holder shaft is not badly worn or stepped, and that the friction boot [B] is not damaged.
- ★ If the friction boot is damaged, replace the friction boot. To replace the friction boot, remove the pads and the caliper holder.
- ★ If the caliper holder shaft is damage, replace the caliper holder.

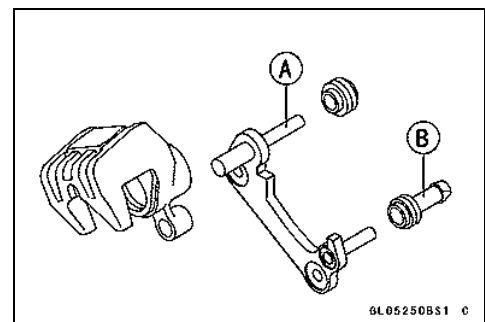
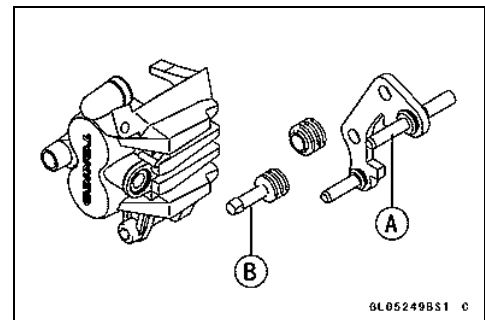

12-20 BRAKES

Brake Pads

Front Brake Pad Removal

- Remove the front caliper with the hose installed (see Caliper Removal).
- Draw out the holder shaft pin [A], and take off the holder shaft [B].
- Remove the pad [C] from the holder shaft [D].
- Remove the other side pad [E].

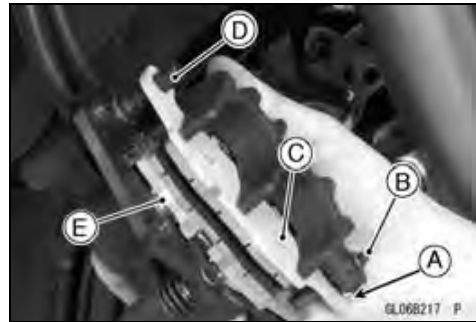

Front Brake Pad Installation

- Push the caliper pistons in by hand as far as they will go.
- Install the pad spring in its correct position.
- Install the pad on the piston side first, then install the other pad on the holder.
- Install the front caliper (see Caliper Installation).

⚠ WARNING

Do not attempt to drive the motorcycle until a full brake lever is obtained by pumping the brake lever until the pads are against the disc. The brake will not function on the first application of the lever if this is not done.

Rear Brake Pad Removal

- Remove the rear caliper with the hose installed (see Caliper Removal).
- Draw out the holder shaft pin [A], and take off the holder shaft [B].
- Remove the pad [C] from the holder shaft [D].
- Remove the other side pad [E].

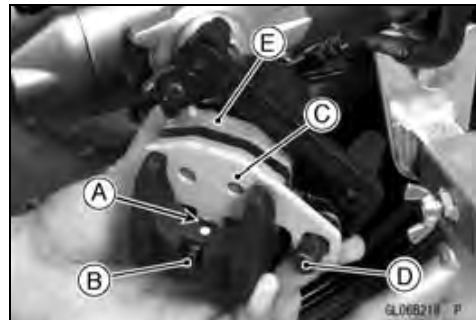

Rear Brake Pad Installation

- Push the caliper piston in by hand as far as it will go.
- Install the pad spring in its correct position.
- Install the pad on the piston side first, then install the other pad on the holder.
- Install the rear caliper (see Caliper Installation).

⚠ WARNING

Do not attempt to drive the motorcycle until a full brake pedal is obtained by pumping the brake pedal and the pads are against the disc. The brake will not function on the first application of the pedal if this is not done.

Brake Pad Wear Inspection

- Refer to the Brake Pad Wear Inspection in the Periodic Maintenance chapter.

Master Cylinder

Front Master Cylinder Removal

- Remove the banjo bolt [A] to disconnect the brake hose from the master cylinder [B].



- Disconnect the front brake light switch connectors [A].
- Unscrew the clamp bolts [B], and take off the master cylinder as an assembly with the reservoir, brake lever and brake switch installed.

CAUTION

Immediately wipe up any brake fluid that spilled.



- Remove:
 - Brake Lever Pivot Bolt [A] and Locknut [B]
 - Brake Lever [C]
 - Front Brake Light Switch [D]

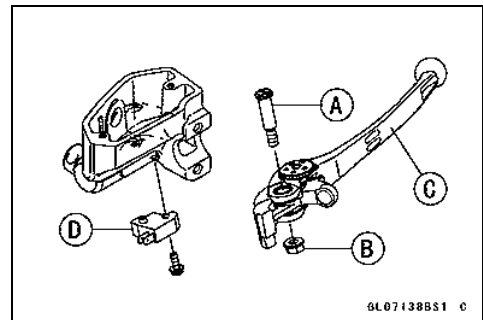

Front Master Cylinder Installation

- Install the front master cylinder.
- Align the punch mark [A] of the handlebar with the mating surface [B] of the master cylinder clamp.

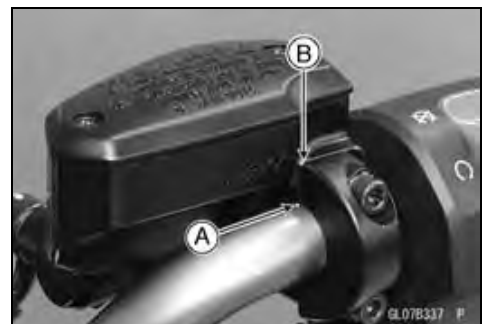

- Tighten the upper clamp bolt [A] first, and then the lower clamp bolt [B]. There will be a gap at the lower part of the clamp after tightening.

Torque - Front Master Cylinder Clamp Bolts: 11 N·m (1.1 kgf·m, 97 in·lb)

- Connect the front brake light switch connectors [C].
- Replace the washers on each side of the hose fitting with new ones.
- Tighten:

Torque - Brake Hose Banjo Bolt: 25 N·m (2.5 kgf·m, 18 ft·lb)

- Bleed the brake line (see Brake Line Bleeding).
- Check the brake for good braking power, no brake drag, and no fluid leakage.



12-22 BRAKES

Master Cylinder

Rear Master Cylinder Removal

- Unscrew the brake hose banjo bolt [A] on the master cylinder.



- Unscrew the master cylinder mounting bolts [A].
- Remove the cotter pin [B].
- Pull off the joint pin [C] while pressing down the brake pedal.
- Pull off the reservoir hose lower end [D], and drain the brake fluid into a container.
- Remove the master cylinder.

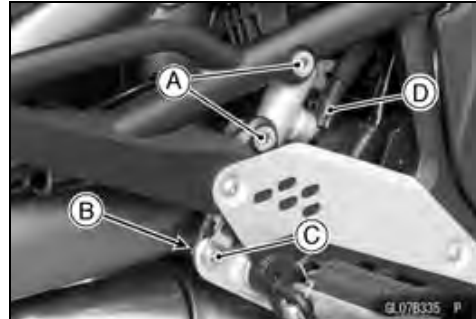

Rear Master Cylinder Installation

- Install the joint pin.
- Replace the cotter pin with a new one.
- Insert the cotter pin, and bend the pin ends.
- Replace the washers on each side of hose fitting with new ones.
- Tighten:

Torque - Rear Master Cylinder Mounting Bolts: 25 N·m (2.5 kgf·m, 18 ft·lb)

Brake Hose Banjo Bolt: 25 N·m (2.5 kgf·m, 18 ft·lb)

- Bleed the brake line (see Brake Line Bleeding).
- Check the brake for good braking power, no brake drag, and no fluid leakage.

Front Master Cylinder Disassembly

- Refer to the Master Cylinder Rubber Parts Replacement in the Periodic Maintenance chapter.

Rear Master Cylinder Disassembly

- Refer to the Master Cylinder Rubber Parts Replacement in the Periodic Maintenance chapter.

Master Cylinder Assembly

- Refer to the Master Cylinder Rubber Parts Replacement in the Periodic Maintenance chapter.

Master Cylinder

Master Cylinder Inspection

- Remove the master cylinders (see Front/Rear Master Cylinder Removal).
- Disassemble the front and rear master cylinders.
- Check that there are no scratches, rust or pitting on the inner wall [A] of each master cylinder and on the outside of each piston [B].
- ★ If a master cylinder or piston shows any damage, replace them.
- Inspect the primary cup [C] and secondary cup [D].
- ★ If a cup is worn, damaged softened (rotted), or swollen, the piston assembly should be replaced to renew the cups.
- ★ If fluid leakage is noted at the brake lever, the piston assembly should be replaced to renew the cups.
- Check the dust covers [E] for damage.
- ★ If they are damaged, replace them.
- Check the piston return springs [F] for any damage.
- ★ If the springs are damaged, replace them.
- Check that relief port [G] and supply port [H] are not plugged.
- ★ If the relief port becomes plugged, the brake pads will drag on the disc. Blow the ports clean with compressed air.

Front Master Cylinder [J]

Rear Master Cylinder [K]

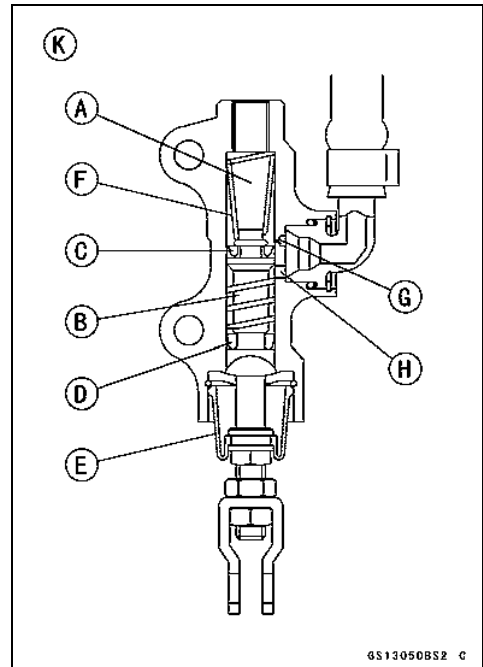
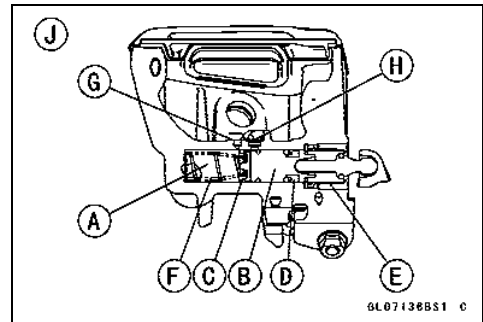

12-24 BRAKES

Brake Disc

Brake Disc Removal

- Remove the wheel (see Front/Rear Wheel Removal in the Wheels/Tires chapter).
- Unscrew the mounting bolts [A], and take off the disc.
- For front brake disc, remove the gaskets.

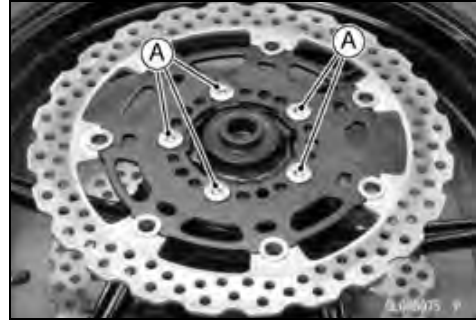

Brake Disc Installation

- For front brake disc, replace the gaskets with new ones.
- Install the brake disc on the wheel so that the marked side [A] faces out.
- Apply a non-permanent locking agent to the threads of the front and rear brake disc mounting bolts.
- Tighten:

Torque - Brake Disc Mounting Bolts: 27 N·m (2.8 kgf·m, 20 ft·lb)



Brake Disc Wear Inspection

- Measure the thickness of each disc at the point where it has worn the most.
 - ★ If the disc has worn past the service limit, replace it.
- Measuring Area [A]

Disc Thickness

Standard:

Front	4.8 ~ 5.2 mm (0.19 ~ 0.20 in.)
Rear	4.8 ~ 5.2 mm (0.19 ~ 0.20 in.)

Service Limit:

Front	4.5 mm (0.18 in.)
Rear	4.5 mm (0.18 in.)

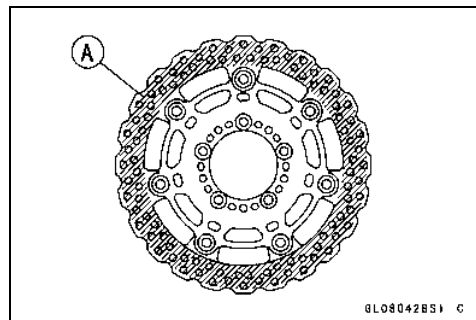

Brake Disc Warp

- Raise the wheel off the ground (see Front/Rear Wheel Removal in the Wheels/Tires chapter).
- For front disc inspection, turn the handlebar fully to one side.
- Set up a dial gauge against the disc [A] as shown and measure disc runout, while turning [B] the wheel by hand.
- ★ If runout exceeds the service limit, replace the disc.

Disc Runout

Standard:	TIR 0.15 mm (0.0059 in.) or less
Service Limit:	TIR 0.3 mm (0.01 in.)

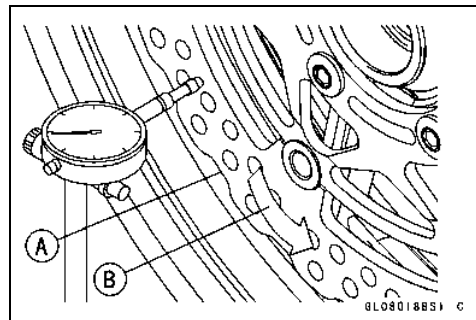

Brake Fluid

Brake Fluid Level Inspection

- Refer to the Brake Fluid Level Inspection in the Periodic Maintenance chapter.

Brake Fluid Change

- Refer to the Brake Fluid Change in the Periodic Maintenance chapter.

Brake Line Bleeding

The brake fluid has a very low compression coefficient so that almost all the movement of the brake lever or pedal is transmitted directly to the caliper for braking action. Air, however, is easily compressed. When air enters the brake lines, brake lever or pedal movement will be partially used in compressing the air. This will make the lever or pedal feel spongy, and there will be a loss in braking power.

▲ WARNING

Be sure to bleed the air from the brake line whenever brake lever or pedal action feels soft or spongy after the brake fluid is changed, or whenever a brake line fitting has been loosened for any reason.

NOTE

- *The procedure to bleed the front brake line is as follows. Bleeding the rear brake line is the same as for the front brake.*

- Remove the reservoir cap and diaphragm.
- Fill the reservoir with fresh brake fluid to the upper level line [A].
- Slowly pump the brake lever several times until no air bubbles can be seen rising up through the fluid from the holes at the bottom of the reservoir.
- Bleed the air completely from the master cylinder by this operation.

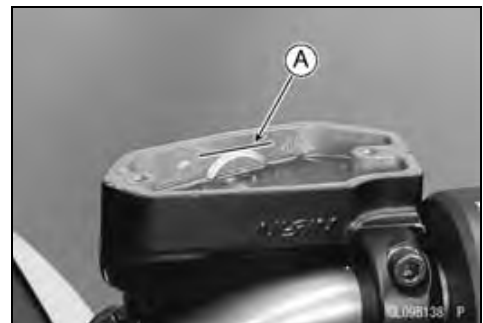

- Remove the rubber cap [A] on the caliper.
- Attach a clear plastic hose [B] to the bleed valve [C], and run the other end of the hose into a container.

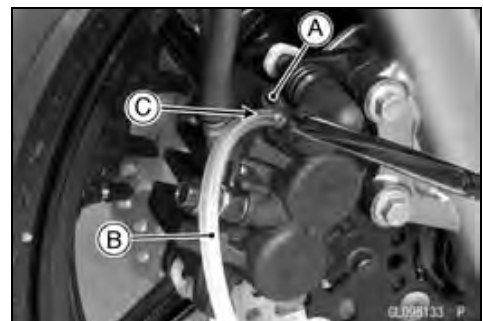

12-26 BRAKES

Brake Fluid

- Bleed the brake line and the caliper.
- Repeat this operation until no more air can be seen coming out into the plastic hose.
 1. Pump the brake lever until it becomes hard, and apply the brake and hold it [A].
 2. Quickly open and close [B] the bleed valve while holding the brake applied.
 3. Release the brake [C].

NOTE

- The fluid level must be checked often during the bleeding operation and replenished with fresh brake fluid as necessary. If the fluid in the reservoir runs completely out any time during bleeding, the bleeding operation must be done over again from the beginning since air will have entered the line.
 - Tap the brake hose lightly from the caliper to the reservoir for more complete bleeding.
 - Front Brake: First bleeding the right caliper then repeat the above steps for the left caliper.
- Remove the clear plastic hose.
 - Install the diaphragm and reservoir cap.
 - Tighten:

Torque - Front Brake Reservoir Cap Screws: 1.5 N·m (0.15 kgf·m, 13in·lb)

- For rear brake, follow the procedure below to install the rear reservoir cap correctly.
- First, tighten the rear brake fluid reservoir cap [B] clockwise [C] by hand until slight resistance is felt indicating that the cap is seated on the reservoir body, then tighten the cap an additional 1/6 turn [D] while holding the brake fluid reservoir body [A].

- Tighten the bleed valve, and install the rubber cap.
- Torque - Caliper Bleed Valve: 7.8 N·m (0.80 kgf·m, 69 in·lb)**
- Check the fluid level (see Brake Fluid Level Inspection in the Periodic Maintenance chapter).
- After bleeding is done, check the brake for good braking power, no brake drag, and no fluid leakage.

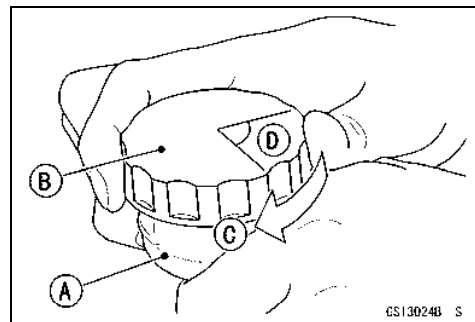
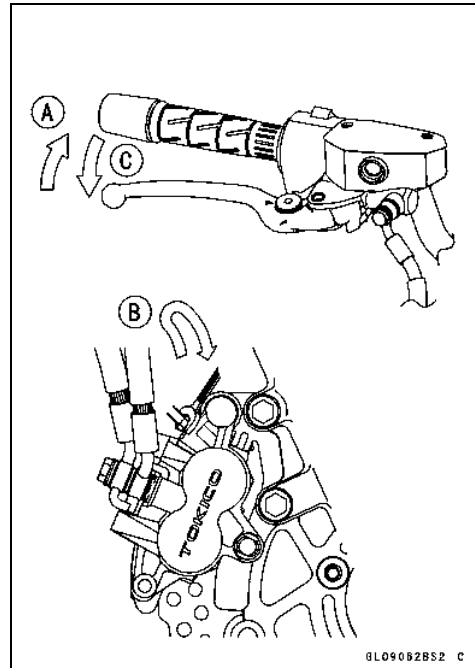

Brake Fluid

WARNING

When working with the disc brake, observe the precautions listed below.

1. Never reuse old brake fluid.
2. Do not use fluid from a container that has been left unsealed or that has been open for a long time.
3. Do not mix two types and brands of fluid for use in the brake. This lowers the brake fluid boiling point and could cause the brake to be ineffective. It may also cause the rubber brake parts to deteriorate.
4. Don't leave the reservoir cap off for any length of time to avoid moisture contamination of the fluid.
5. Don't change the fluid in the rain or when a strong wind is blowing.
6. Except for the disc pads and disc, use only disc brake fluid, isopropyl alcohol, or ethyl alcohol for cleaning of the brake parts. Do not use any other fluid for cleaning these parts. Gasoline, engine oil, or any other petroleum distillate will cause deterioration of the rubber parts. Oil spilled on any part will be difficult to wash off completely and will eventually deteriorate the rubber used in the disc brake.
7. When handling the disc pads or disc, be careful that no disc brake fluid or any oil gets on them. Clean off any fluid or oil that inadvertently gets on the pads or disc with a high-flash point solvent. Do not use one which will leave an oily residue. Replace the pads with new ones if they cannot be cleaned satisfactorily.
8. Brake fluid quickly ruins painted surfaces; any spilled fluid should be completely wiped up immediately.
9. If any of the brake line fittings or the bleed valve is opened at any time, the **AIR MUST BE BLED FROM THE BRAKE LINE.**

12-28 BRAKES

Brake Hose

Brake Hose Removal/Installation

- Refer to the Brake Hose and Pipe Replacement in the Periodic Maintenance chapter.

Brake Hose Inspection

- Refer to the Brake Hose Damage and Installation Condition Inspection in the Periodic Maintenance chapter.

Anti-Lock Brake System (Equipped Models)

Parts Location

Front Wheel Rotation Sensor [A]
 Front Wheel Rotation Sensor Rotor [B]



Rear Wheel Rotation Sensor [A]
 Rear Wheel Rotation Sensor Rotor [B]

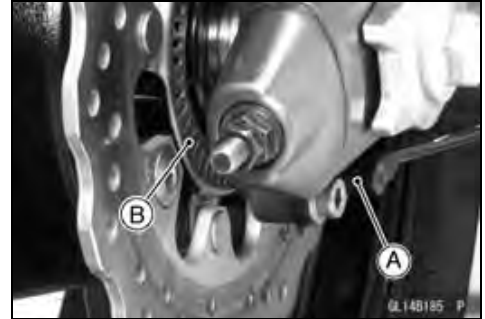

ABS Indicator Light [A]



ABS Hydraulic Unit [A]



ABS Solenoid Valve Relay Fuse 25A [A]
 ABS Motor Relay Fuse 30A [B]

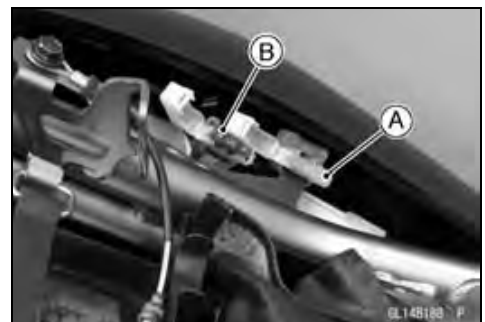

12-30 BRAKES

Anti-Lock Brake System (Equipped Models)

ABS Kawasaki Diagnostic System Connector [A]
ABS Self-diagnosis Terminal [B]

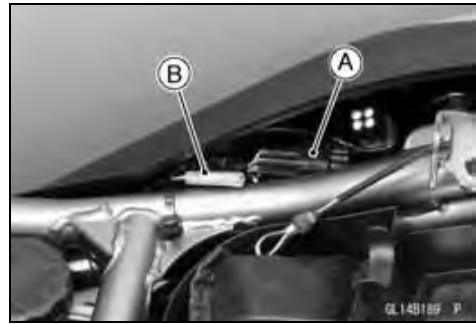

Anti-Lock Brake System (Equipped Models)

ABS System Wiring Diagram

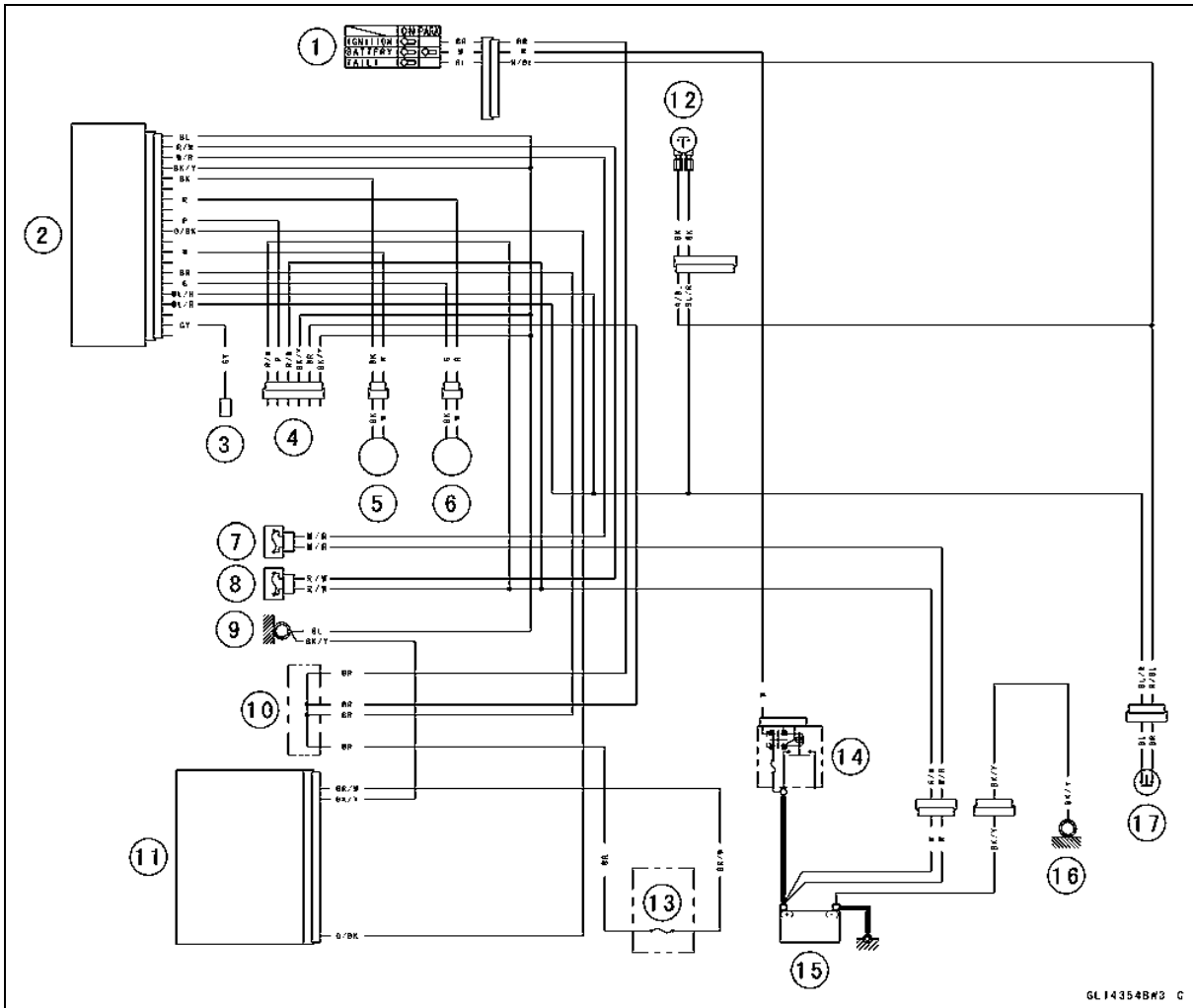

- | | |
|---|------------------------------|
| 1. Ignition Switch | 9. Frame Ground |
| 2. ABS Hydraulic Unit | 10. Water-proof Joint C |
| 3. ABS Self-diagnosis Terminal | 11. Meter Unit |
| 4. ABS Kawasaki Diagnostic System Connector | 12. Front Brake Light Switch |
| 5. Front Wheel Rotation Sensor | 13. Ignition Fuse 10 A |
| 6. Rear Wheel Rotation Sensor | 14. Main Fuse 30 A |
| 7. ABS Solenoid Valve Relay Fuse 25 A | 15. Battery 12 V 10 Ah |
| 8. ABS Motor Relay Fuse 30 A | 16. Frame Ground |
| | 17. Rear Brake Light Switch |

○Color Codes:

- | | | |
|-----------|-----------|-----------|
| BK: Black | GY: Gray | R: Red |
| BL: Blue | O: Orange | W: White |
| BR: Brown | P: Pink | Y: Yellow |
| G: Green | | |

GL 14354B#3 C

12-32 BRAKES

Anti-Lock Brake System (Equipped Models)

Terminal Names

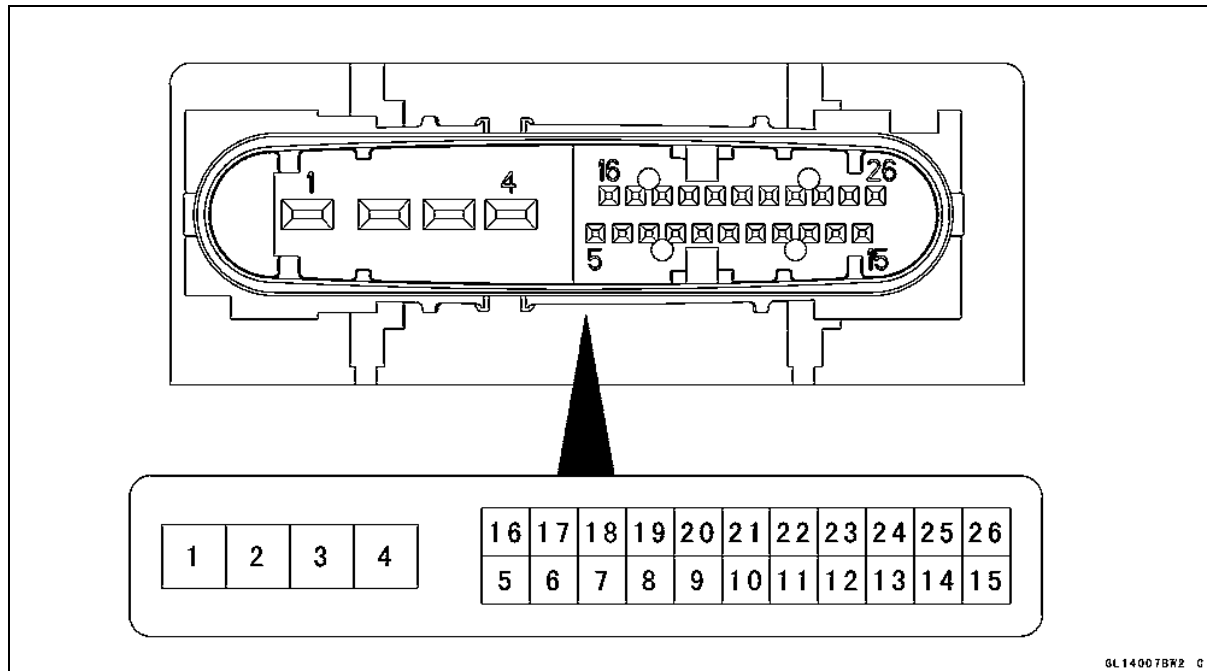

GL14007BR2 C

1. Ground to Motor
2. Power Supply to ABS Motor Relay
3. Power Supply to ABS Solenoid Valve Relay
4. Ground
5. Front Wheel Rotation Sensor Signal
6. Unused
7. Power Supply to Rear Wheel Rotation Sensor
8. Unused
9. Unused
10. Unused
11. ABS Kawasaki Diagnostic System Terminal
12. ABS Indicator Light (LED)
13. Unused
14. Unused
15. Unused
16. Power Supply to Front Wheel Rotation Sensor
17. Unused
18. Power Supply
19. Rear Wheel Rotation Sensor Signal
20. Front Brake Light Switch
21. Rear Brake Light Switch
22. Unused
23. Unused
24. Unused
25. ABS Self-diagnosis Terminal
26. Unused

Anti-Lock Brake System (Equipped Models)

ABS Servicing Precautions

There are a number of important precautions that should be followed servicing the ABS system.

- This ABS system is designed to be used with a 12 V sealed battery as its power source. Do not use any other battery except for a 12 V sealed battery as a power source.
- Do not reverse the battery cable connections. This will damage the ABS hydraulic unit.
- To prevent damage to the ABS parts, do not disconnect the battery cables or any other electrical connections when the ignition switch is ON or while the engine is running.
- Take care not to short the leads that are directly connected to the battery positive (+) terminal to the chassis ground.
- Do not turn the ignition switch ON while any of the ABS electrical connectors are disconnected. The ABS hydraulic unit memorizes service codes.
- Do not spray water on the electrical parts, ABS parts, connectors, leads and wiring.
- If a transceiver is installed on the motorcycle, make sure that the operation of the ABS system is not influenced by electric wave radiated from the antenna. Locate the antenna as far as possible away from the ABS hydraulic unit.
- Whenever the ABS electrical connections are to be disconnected, first turn off the ignition switch.
- The ABS parts should never be struck sharply, as with a hammer, or allowed to fall on a hard surface. Such a shock to the parts can damage them.
- The ABS parts cannot be disassembled. Even if a fault is found, do not try to disassemble and repair the ABS parts, replace it.
- The ABS has many brake lines, pipes, and leads. And the ABS cannot detect problems with the conventional braking system (brake disc wear, unevenly worn brake pad, and other mechanical faults). To prevent trouble, check the brake lines and pipes for correct routing and connection, the wiring for correct routing, and the brakes for proper braking power. Be sure to check for fluid leakage, and bleed the brake line thoroughly.

⚠ WARNING

If any of the brake line fittings, including the ABS hydraulic unit joint nuts, or the bleed valve is opened at any time, the air must be bled completely from the brake line.

CAUTION

Do not ride the motorcycle with air in the brake line, or the ABS could malfunction.

12-34 BRAKES

Anti-Lock Brake System (Equipped Models)

- The ABS indicator light (LED) [A] may light if the tire pressure is incorrect, a non-recommended tire is installed, or the wheel is deformed. If the indicator light lights, remedy the problem and clear the service code.

▲ WARNING

Use of non-recommended tires may cause malfunctioning of ABS and can lead to extended braking distance. The rider could have an accident as a result. Always use recommended standard tires for this motorcycle.

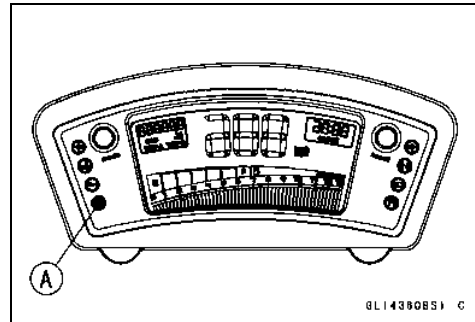

- The ABS indicator light (LED) may come on if the engine is run with the motorcycle on its stand and the transmission in gear. If the indicator light comes on, just turn the ignition switch OFF, then clear service code 42, which indicates a "Faulty front wheel rotation sensor".
- When the ABS operates, the ABS makes noise and the rider feels the reaction force on the brake lever and brake pedal. This is a normal condition. It informs the rider that the ABS is operating normally.
- Service codes detected once by the ABS hydraulic unit will be memorized in the ABS hydraulic unit. Therefore, after maintenance work is finished, be sure to erase the service codes. Do not erase the service codes during troubleshooting. Wait until all the checks and repair work are finished to prevent duplication of previous service codes and unnecessary maintenance work.
- Before delivering the motorcycle to the customer, be sure to erase any service codes which might be stored in the ABS hydraulic unit. Using the self-diagnosis feature, make sure that only start code 12 is shown. A fully charged battery is a must for conducting reliable self-diagnosis. Test run the motorcycle at a speed of more than 20 km/h (12 mph) to see that the ABS indicator light (LED) does not come on. Finally, test run the motorcycle at a speed of more than 30 km/h (20 mph) and brake suddenly to see that the motorcycle stops without loss of steering control and the ABS operates normally (The reaction force generated is felt in the brake lever and pedal.). This completes the final inspection.

Anti-Lock Brake System (Equipped Models)

ABS Troubleshooting Outline

When an abnormality in the system occurs, the ABS indicator light (LED) lights up to alert the rider. In addition, the nature of the fault is stored in the memory of the ABS hydraulic unit and when in the self-diagnosis mode, the service code [A] is indicated by the number of times the ABS indicator light (LED) blinks. The service codes stored in memory are not erased until the mode has been changed to the fault erase mode after the fault has been corrected. Therefore, after correcting the problem, always erase the service codes and then run the self-diagnosis program to confirm normal signal output. When, due to a malfunction, the ABS indicator light (LED) remains lit, get a thorough understanding of the background before starting the repair work. Ask the rider about the conditions [B] under which the problem occurred and try to determine the cause [C]. Do not rely solely on the ABS self-diagnosis function, use common sense; check the brakes for proper braking power, and brake fluid level, search for leaks, etc.

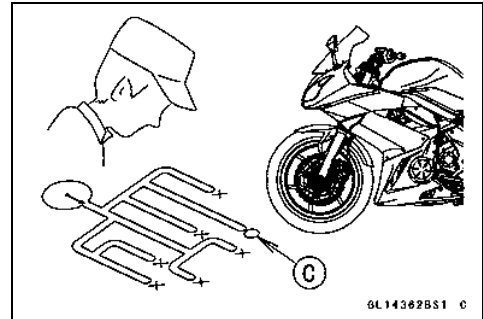
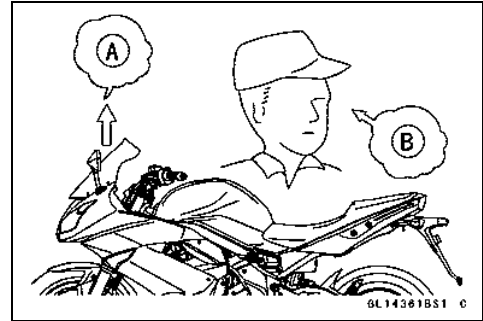

Even when the ABS is operating normally, the ABS indicator light (LED) may light up under the conditions listed below. Turn the ignition switch OFF to stop the indicator light. If the motorcycle runs without erasing the service code, the light may light up again.

- After continuous riding on a rough road.
- When the engine is started with the stand raised and the transmission engaged, and the rear wheel turns.
- When accelerating so abruptly that the front wheel leaves the ground.
- When the ABS has been subjected to strong electrical interference.
- When tire pressure is abnormal. Adjust tire pressure.
- When a tire different in size from the standard size is being used. Replace with standard size.
- When the wheel is deformed. Replace the wheel.

Much of the ABS troubleshooting work consists of confirming continuity of the wiring. The ABS parts are assembled and adjusted by the manufacturer, so there is no need to disassemble or repair them. Replace the ABS hydraulic unit.

The basic troubleshooting procedures are listed below.

- Carry out pre-diagnosis inspections as a preliminary inspection.
- Determine the fault using the self-diagnosis function.
- Check wiring and connections from the ABS hydraulic unit connector to the suspected faulty ABS part, using the hand tester.

Special Tool - Hand Tester: 57001-1394

12-36 BRAKES

Anti-Lock Brake System (Equipped Models)

- Visually inspect the wiring for signs of burning or fraying.
- ★ If any wiring is poor, replace the damaged wiring.
- Pull each connector [A] apart and inspect it for corrosion, dirt and damage.
- ★ If the connector is corroded or dirty, clean it carefully. If it is damaged, replace it.
- Check the wiring for continuity.
- Use the wiring diagram to find the ends of the lead which is suspected of being a problem.
- Connect the hand tester between the ends of the leads.

Special Tool - Hand Tester: 57001-1394

- Set the tester to the $\times 1 \Omega$ range, and read the tester.
- ★ If the tester does not read 0Ω , the lead is defective. Replace the main harness [B] if necessary.
- Narrow down suspicious parts and close in on the faulty ABS part by repeating the continuity tests.
- ★ If no abnormality is found in the wiring or connectors, the ABS parts are the next likely suspects. Check each part one by one.
- ★ If an abnormality is found, replace the affected ABS part.

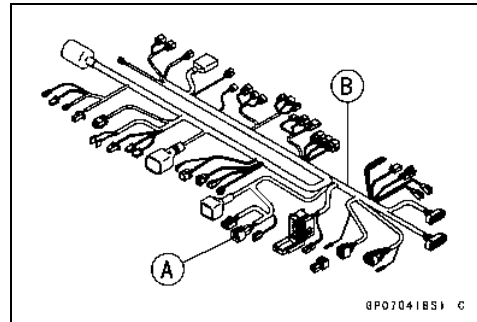

Anti-Lock Brake System (Equipped Models)

ABS Diagnosis Flow Chart

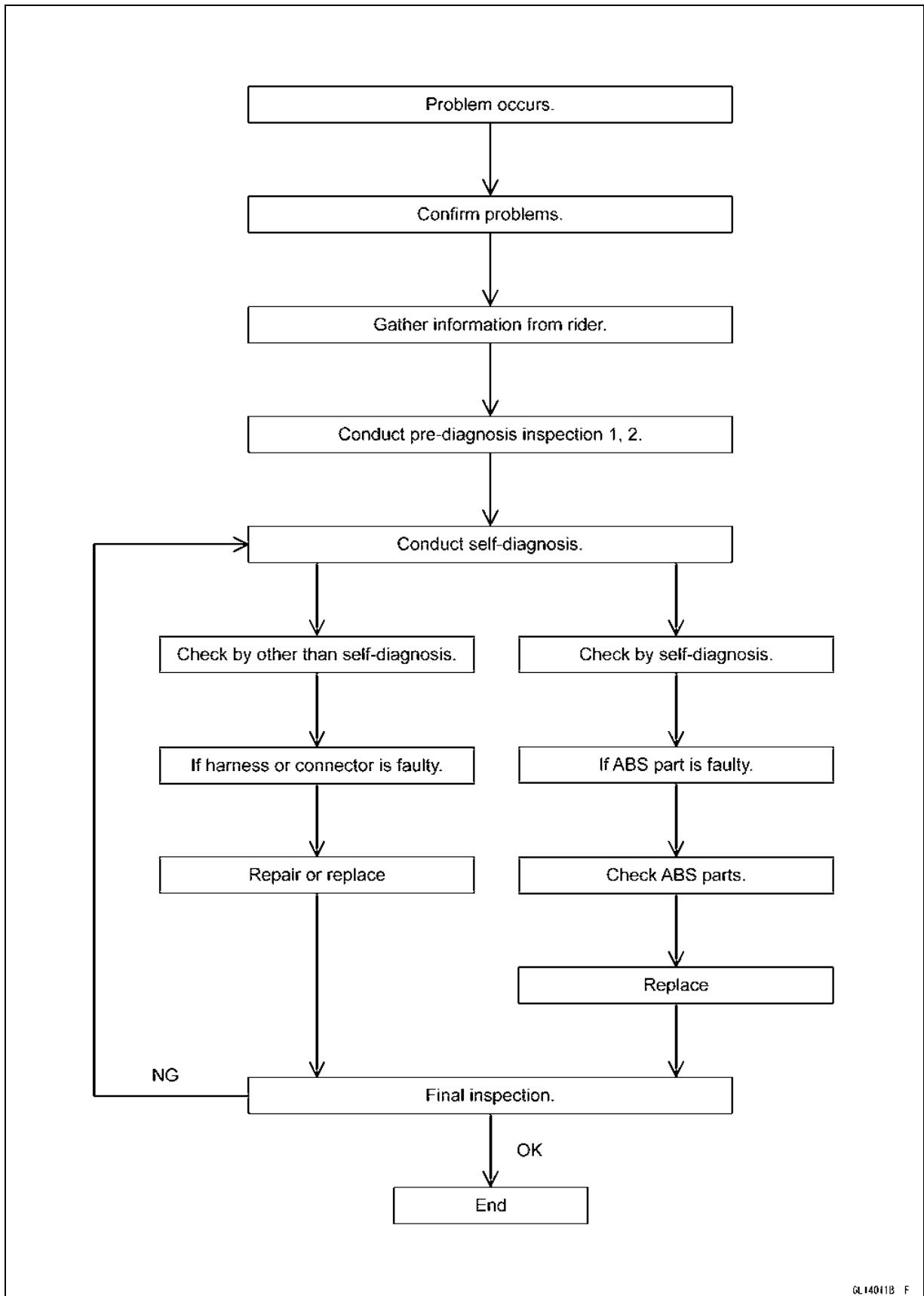

GL14011B F

12-38 BRAKES

Anti-Lock Brake System (Equipped Models)

Inquiries to Rider

- Each rider reacts to problems in different ways, so it is important to confirm what kind of condition the rider is dissatisfied with.
- Try to find out exactly what problem occurs under exactly what conditions by asking the rider; knowing this information may help you reproduce the problem in the shop.
- The diagnosis sheet will help prevent you from overlooking any keys, so always use it.

Sample Diagnosis Sheet

Rider name:				Registration No. (license plate No.):			
Year of initial registration:				Model:			
Engine No.:				Frame No.:			
Date problem occurred:				Frequency:			
Weather:				Mileage:			
Phenomenon	<input type="checkbox"/> Brake lever vibration or noise	<input type="checkbox"/> Indicator light blinks	<input type="checkbox"/> Braking distance too long	<input type="checkbox"/> Abnormal brake lever movement	<input type="checkbox"/> ABS not working	<input type="checkbox"/> ABS works but indicator light doesn't light up	<input type="checkbox"/> ABS operating too frequently
	<input type="checkbox"/> Pedal vibration or noise	<input type="checkbox"/> Indicator light remains lit up		<input type="checkbox"/> Abnormal pedal movement			
Engine conditions at problem	<input type="checkbox"/> At start-up		<input type="checkbox"/> After starting		<input type="checkbox"/> At 5 000 r/min (rpm) or more		
Road conditions	<input type="checkbox"/> Slippery road (<input type="checkbox"/> snow, <input type="checkbox"/> gravel, <input type="checkbox"/> other) <input type="checkbox"/> Rough surface <input type="checkbox"/> Other						
Driving conditions	<input type="checkbox"/> High-speed cornering <input type="checkbox"/> Driving 10 km/h (6 mph) or above <input type="checkbox"/> Driving below 10 km/h (6 mph) <input type="checkbox"/> When stopping <input type="checkbox"/> When turning						
Brake application	<input type="checkbox"/> Gradual <input type="checkbox"/> Abrupt						
Other conditions	<input type="checkbox"/> Large brake lever stroke <input type="checkbox"/> Large pedal stroke						

Anti-Lock Brake System (Equipped Models)

Pre-Diagnosis Inspection 1

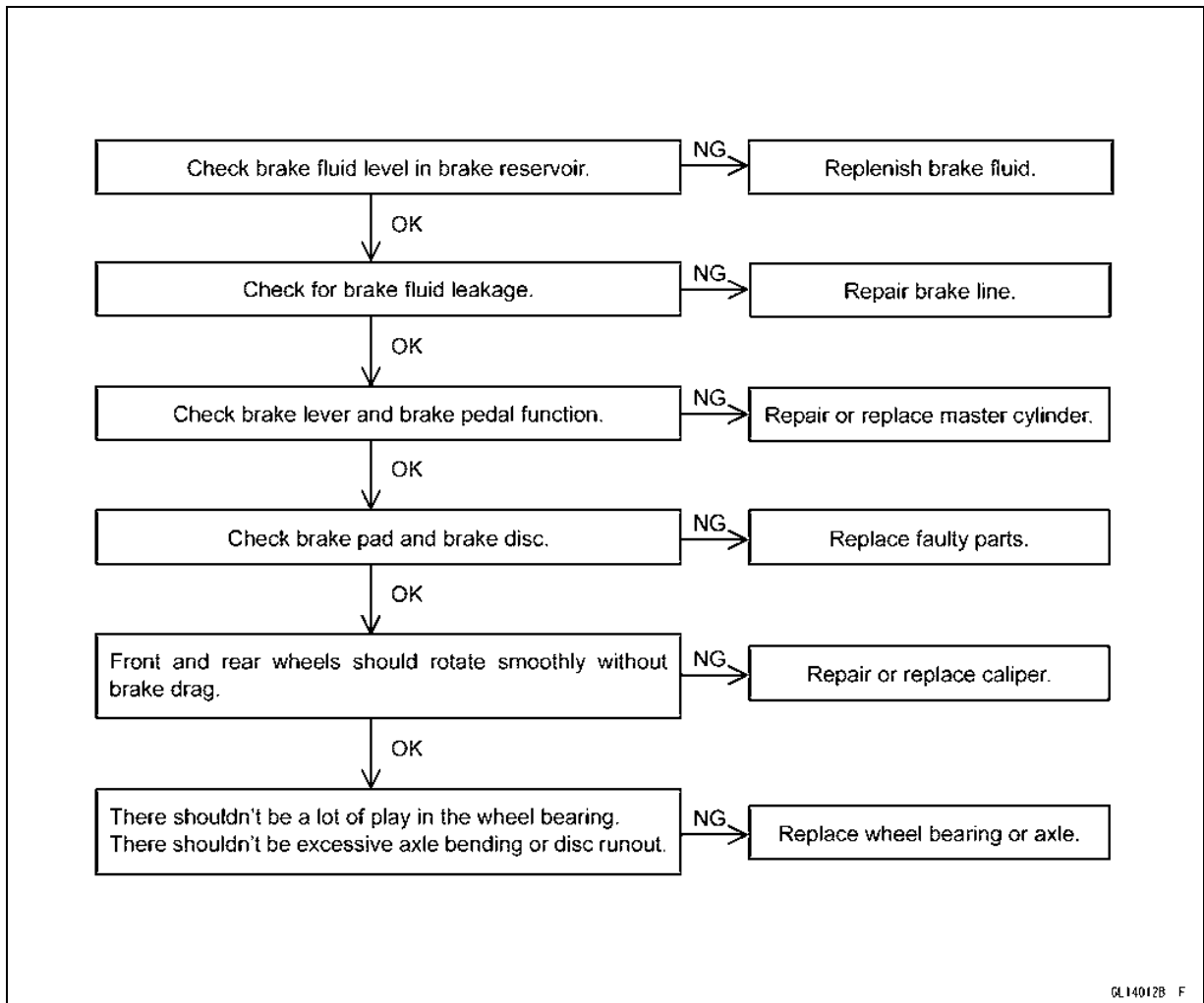

12-40 BRAKES

Anti-Lock Brake System (Equipped Models)

Pre-Diagnosis Inspection 2

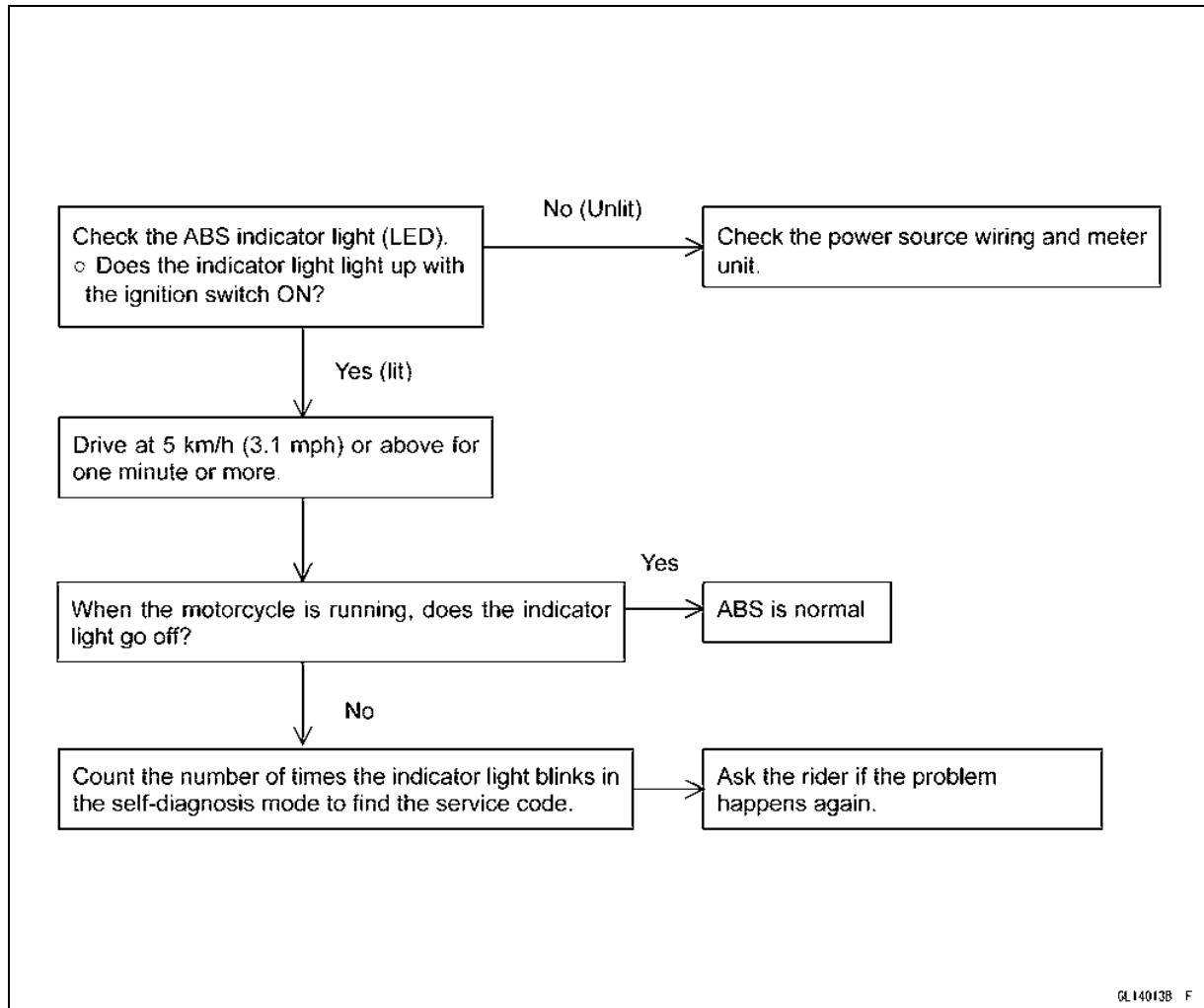

Self-diagnosis Outline

When the indicator light has blinked or come on, the ABS hydraulic unit memorizes and stores the service code (15 codes including "Normal Code") for the service person to troubleshoot easily. The service code memory is powered directly by the battery and cannot be canceled by the ignition switch.

The ABS hydraulic unit can memorize up to six service codes. Further service codes are memorized after erasing the preceding six service codes. If there is no fault, only the start code 12 is shown, indicating that "The ABS is normal".

Self-diagnosis Procedures

○When a problem occurs with the ABS system, the ABS indicator light (LED) [A] lights.

NOTE

- Use a fully charged battery when conducting self-diagnosis. Otherwise, the light blinks very slowly or does not blink.
- The motorcycle is stopped.
- Keep the self-diagnosis terminal grounded during self-diagnosis, with an auxiliary lead.

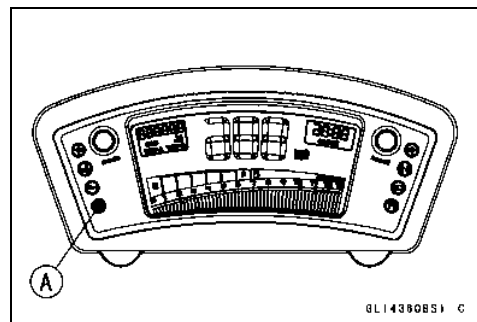

Anti-Lock Brake System (Equipped Models)

- Remove the seat (see Seat Removal in the Frame chapter).
- Ground the self-diagnosis terminal [A] (Gray) to the battery (-) terminal or battery (-) cable connector, using a lead [B].
- Turn on the ignition switch.
- Count the blinks of the light to read the service code. Keep the auxiliary lead ground until you finish reading the service code.

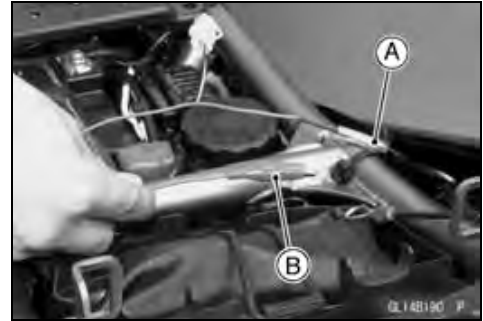

Service Code Clearing Procedures

- Start the service code erase mode with the following procedure.
 - The erase mode starts when the ABS self-diagnosis terminal is disconnected from the ground terminal after starting the self-diagnosis mode.
 - The service code can be erased by grounding and ungrounding (each time for at least one second) the ABS self-diagnosis terminal three times or more within about 12.5 seconds after starting the erase mode.
 - The ABS indicator light (LED) remains lit during the erase mode and after erasing.
 - Once erasing is finished, enter the self-diagnosis mode again to confirm that the service codes have been erased. If the ABS has been reset and all codes have been erased, only start code 12 will be shown.

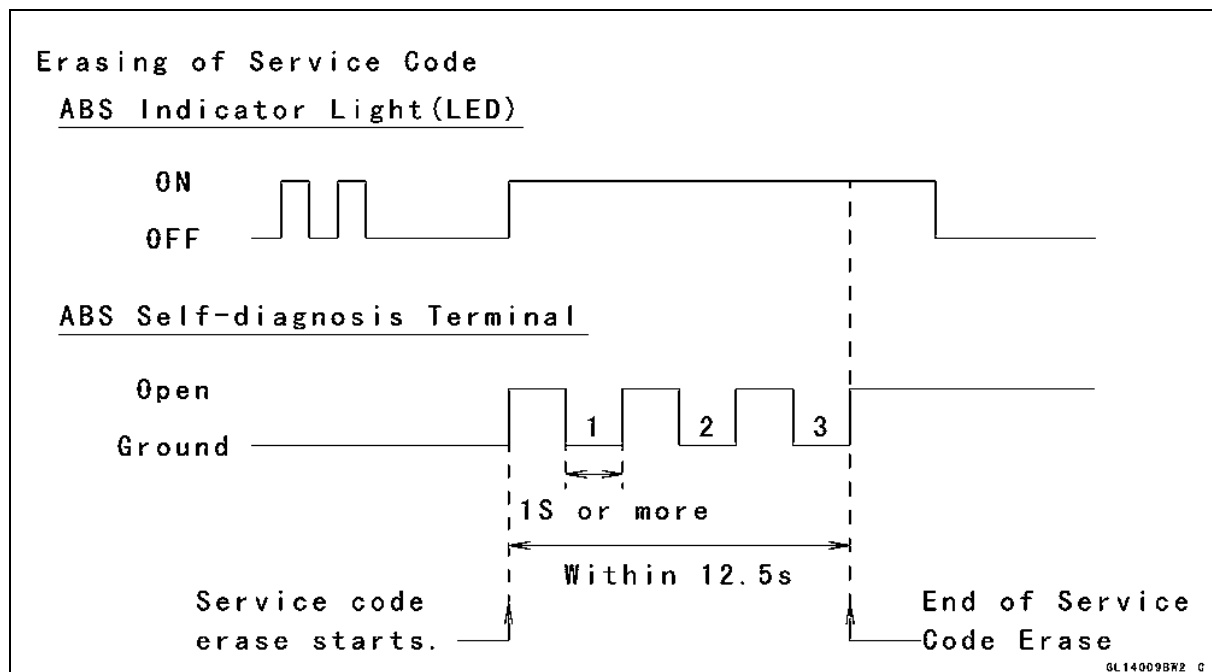

12-42 BRAKES

Anti-Lock Brake System (Equipped Models)

Self-diagnosis Flow Chart

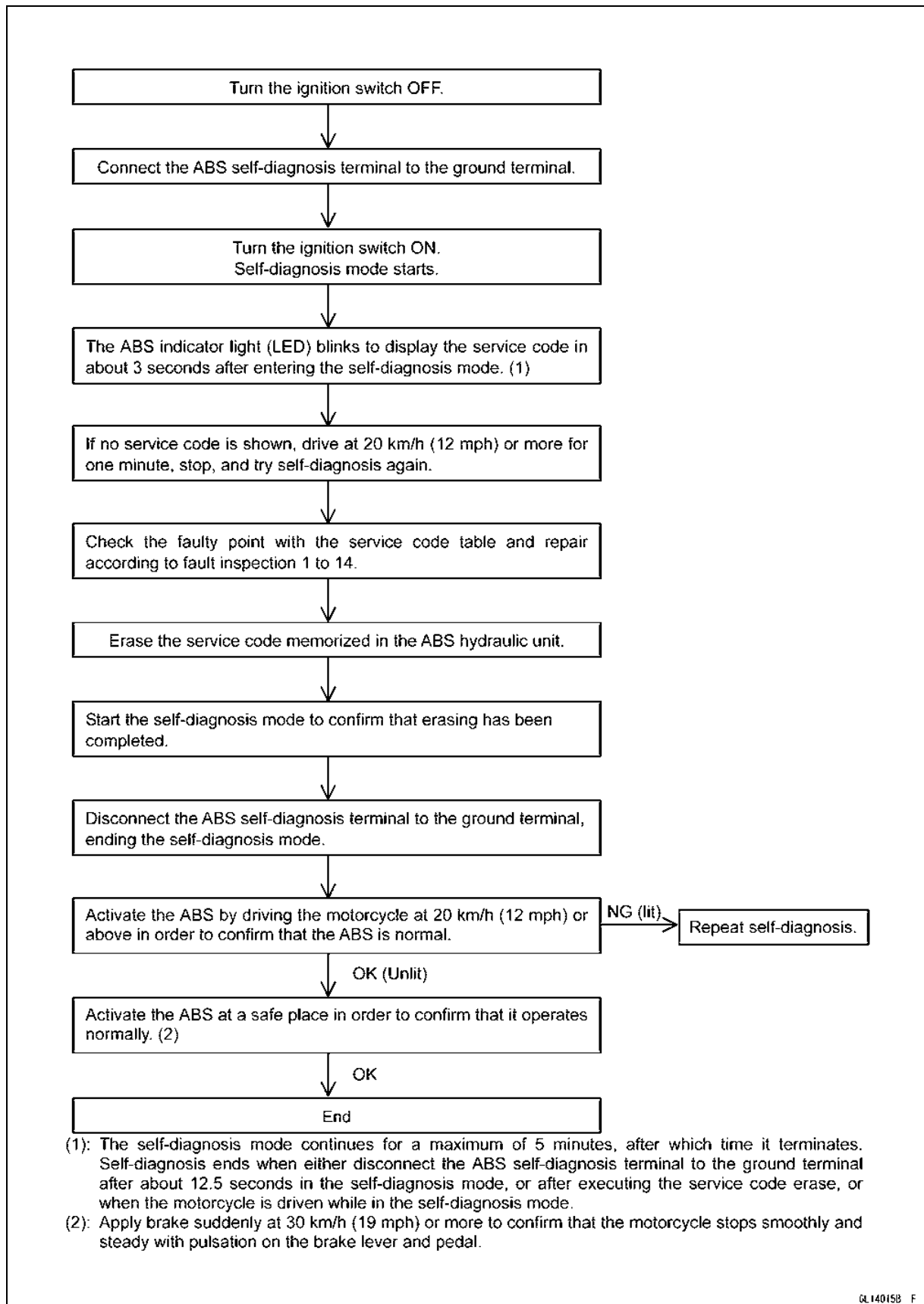

Anti-Lock Brake System (Equipped Models)

How to Read Service Codes

- Service codes are shown by a series of long and short blinks of the ABS indicator light (LED) as shown below.
- Read 10th digit and unit digit as the ABS indicator light (LED) blinks.
- When there are a number of faults, a maximum of six service codes can be stored and the display will begin starting from the last service code entered.
- For the display pattern, first, start code 12 is shown, next up to six service codes starting with the last one stored, then the display is repeated from the start code once again.

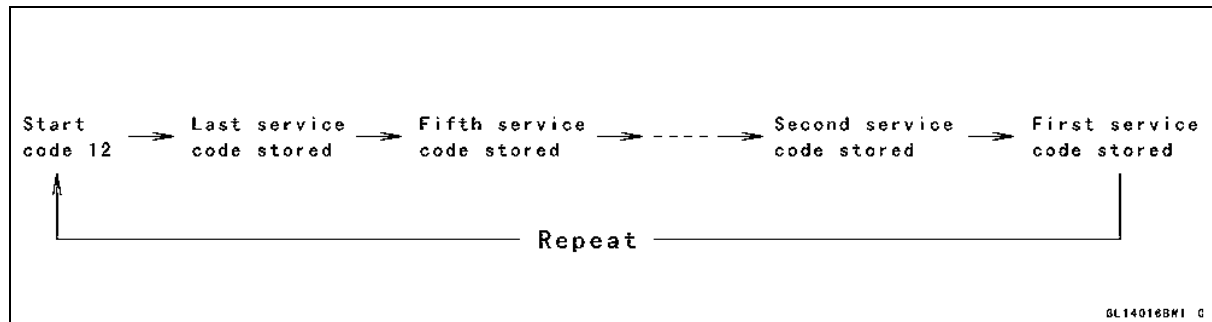

- If there is no fault, only the start code is shown.

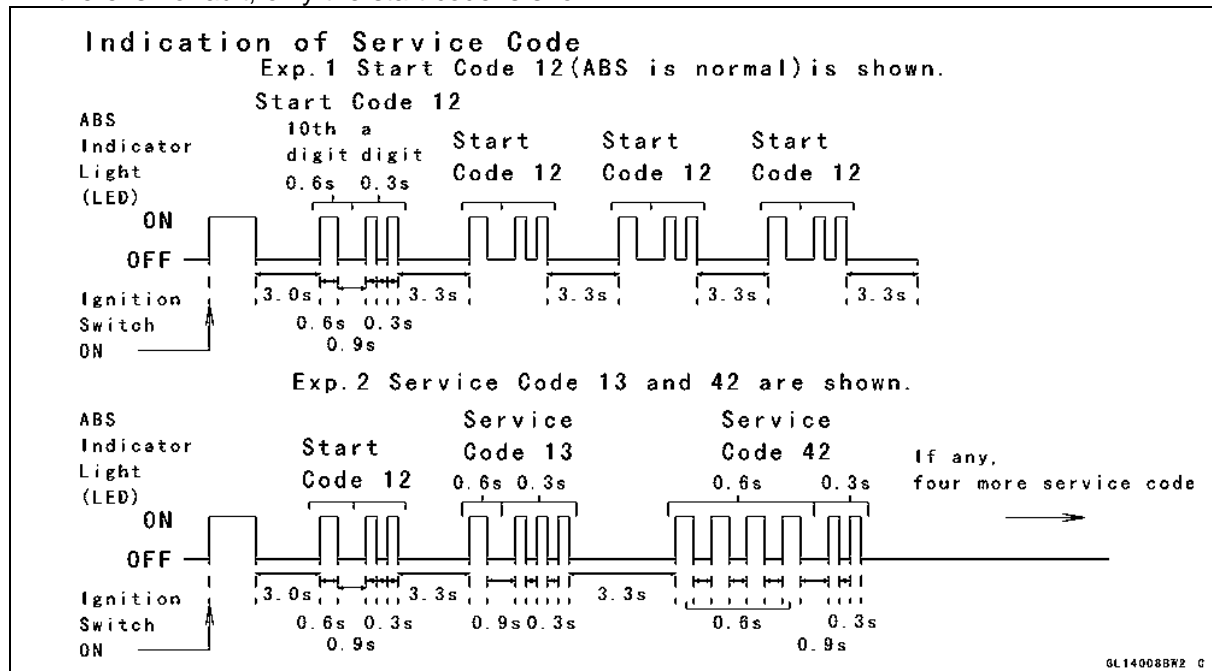







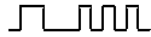

How to Erase Service Codes

- Even if the ignition switch is turned OFF, the battery or the ABS hydraulic unit are disconnected, all service codes remain in the ABS hydraulic unit.
- Refer to the Service Code Clearing Procedure for the service code erasure.

12-44 BRAKES

Anti-Lock Brake System (Equipped Models)

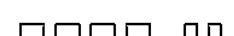
Service Code Table

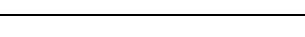
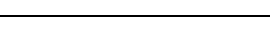
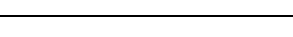
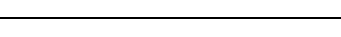
Service Code	ABS Indicator Light (LED)	Problems	Light State
12	 ON OFF	Start code (not fault)	After starts, turn off
13		Rear inlet solenoid valve trouble (open, temperature abnormal)	ON
14		Rear outlet solenoid valve trouble (open, temperature abnormal)	ON
17		Front inlet solenoid valve trouble (open, temperature abnormal)	ON
18		Front outlet solenoid valve trouble (open, temperature abnormal)	ON
19		ABS solenoid valve relay trouble (wiring shorted or open, stuck relay (ON or OFF) or dropout)	ON
25		Front, rear wheel rotation difference abnormal (substandard tire, sensor rotor teeth number wrong)	ON
35		ABS motor relay trouble (wiring shorted or open, stuck relay (ON or OFF))	ON
42		Front wheel rotation sensor signal abnormal (sensor or rotor missing, too large clearance, rotor tooth worn or missing)	ON
43		Front wheel rotation sensor wiring (wiring shorted or open, connector bad connection)	ON
44		Rear wheel rotation sensor signal abnormal (sensor or rotor missing, too large clearance, rotor tooth worn or missing)	ON
45		Rear wheel rotation sensor wiring (wiring shorted or open, connector bad connection)	ON
52		Power supply voltage abnormal (under-voltage)	ON
53		Power supply voltage abnormal (over-voltage)	ON
55		ECU trouble (ECU operation abnormal)	ON

Anti-Lock Brake System (Equipped Models)

ABS Indicator Light (LED) Inspection

- Turn the ignition switch ON.
- ★ If the ABS indicator light (LED) [A] lights, it is normal.
- ★ If the ABS indicator light (LED) does not light, check the meter unit (see Electronic Combination Meter Unit Inspection in the Electrical System chapter).
- ★ If the meter unit is normal, proceed to the 2nd step.

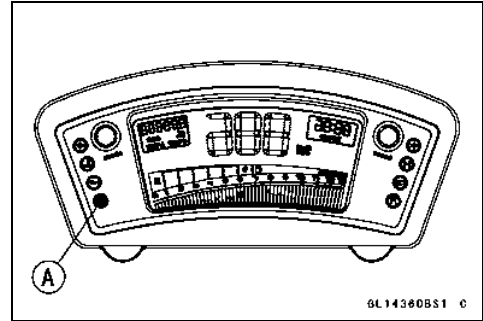

- Do the 2nd step test.
- Check for continuity between the orange/black lead terminal of the main harness side connector [A] and ground.

Special Tool - Hand Tester: 57001-1394

- ★ If there is the continuity in the lead, replace or repair the main harness.
- ★ If there is not the continuity in the lead, proceed to the 3rd step.

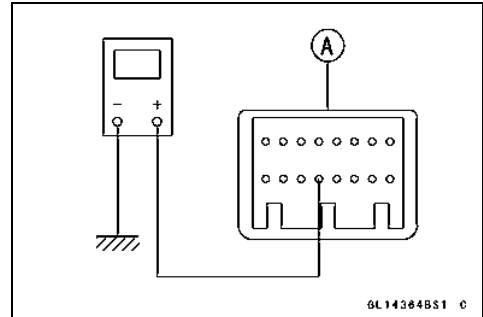

- Do the 3rd step test.
- Disconnect the ABS hydraulic unit connector and meter connector.
- Check for continuity between the orange/black lead terminal of the main harness side connector [A] and orange/black lead terminal of the main harness side connector [B].
- ★ If there is the continuity in the lead, replace the ABS hydraulic unit.
- ★ If there is not the continuity in the lead, replace or repair the main harness.

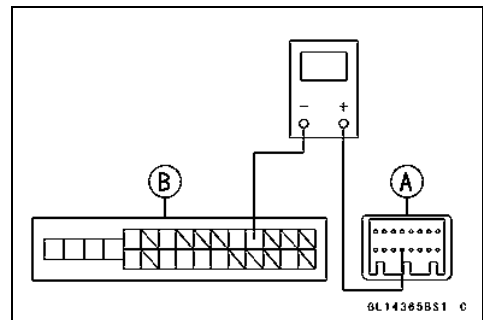

Solenoid Valve Inspection (Service Code 13,14,17,18)

- Do the 1st step test.
- Recheck the service code indication; erase the service code, perform the pre-diagnosis inspection 1 and 2, and retrieve the service code.
- ★ If the ABS indicator light (LED) [A] lit, faulty solenoid valve in the ABS hydraulic unit. Replace the ABS hydraulic unit.
- ★ If the ABS indicator light (LED) unlit, ABS system is normal (service code is not stored; temporary failure.).

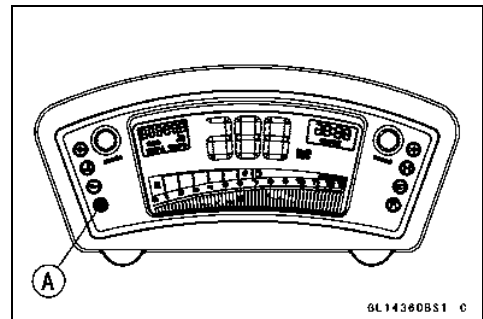

ABS Solenoid Valve Relay Inspection (Service Code 19)

- Do the 1st step test.
- Check the ABS solenoid valve relay fuse [A].
- ★ If the fuse blown, 2nd step.
- ★ If the fuse correct, 4th step.



12-46 BRAKES

Anti-Lock Brake System (Equipped Models)

- Do the 2nd step test.
- Disconnect the ABS hydraulic unit connector [A].
- Check for continuity between the white/red and black/yellow lead terminals of the ABS hydraulic unit connector.
- ★ If there is the continuity in the lead, replace the ABS hydraulic unit.
- ★ If there is not the continuity in the lead, 3rd step.

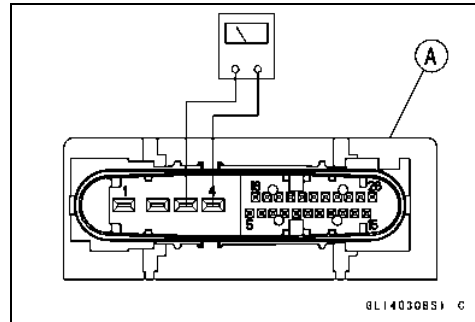

- Do the 3rd step test.
- Check for continuity between the white/red lead terminal of the main harness side connector [A] and white/red lead terminal of the fuse box [B].
- ★ If there is the continuity in the lead, replace the fuse.
- ★ If there is not the continuity in the lead, replace or repair the main harness.

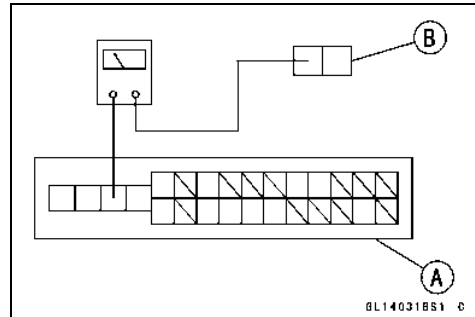

- Do the 4th step test.
- Check the battery terminal voltage between the white/red lead terminal of the fuse box [A] and ground.

Special Tool - Hand Tester: 57001-1394

Battery Terminal Voltage

Standard: Battery Voltage

- ★ If the battery terminal voltage is not within the specification, 5th step.
- ★ If the battery terminal voltage correct, 6th step.

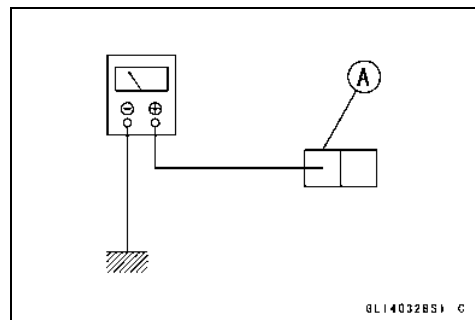

- Do the 5th step test.
- Check for continuity between the positive (+) cable [A] of the battery and white/red lead terminal of the main harness side connector [B].
- ★ If there is the continuity in the lead, 4th step.
- ★ If there is not the continuity in the lead, replace or repair the main harness.

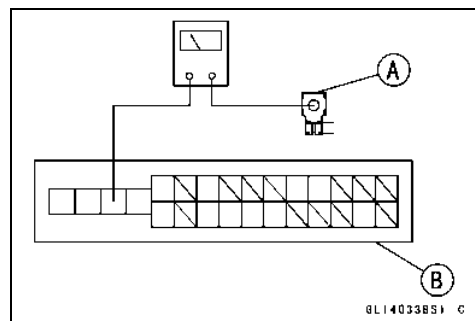

- Do the 6th step test.
- Recheck the service code indication; erase the service code, perform the pre-diagnosis inspection 1 and 2, and retrieve the service code.
- ★ If the ABS indicator light (LED) [A] lit, faulty ABS solenoid valve relay in the ABS hydraulic unit. Replace the ABS hydraulic unit.
- ★ If the ABS indicator light (LED) unlit, ABS system is normal (service code is not stored; temporary failure.).

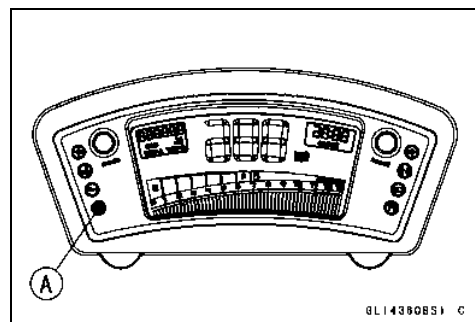

Anti-Lock Brake System (Equipped Models)

Front, Rear Wheel Rotation Difference Abnormal (Service Code 25)

- Do the 1st step test.
- Check the following and correct the faulty part.
 - Incorrect the tire pressure.
 - Tires not recommended for the motorcycle were installed (incorrect tire size).
 - Deformation of the wheel or tire.
 - Sensor rotor for missing teeth and clogging with foreign matter.
- ★ If the all parts correct, 2nd step.
- Do the 2nd step test.
- Recheck the service code indication; erase the service code, perform the pre-diagnosis inspection 1 and 2, and retrieve the service code.
- ★ If the ABS indicator light (LED) [A] lit, faulty ECU in the ABS hydraulic unit. Replace the ABS hydraulic unit.
- ★ If the ABS indicator light (LED) unlit, ABS system is normal (service code is not stored; temporary failure.).

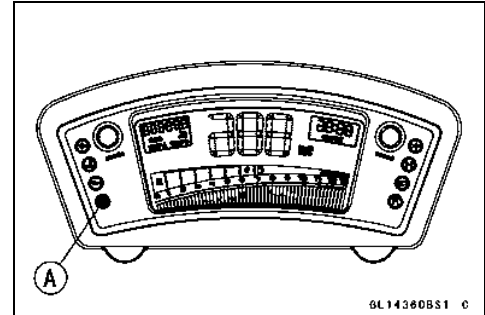

ABS Motor Relay Inspection (Service Code 35)

- Do the 1st step test.
- Check the ABS motor relay fuse [A].
- ★ If the fuse blown, 2nd step.
- ★ If the fuse correct, 4th step.



- Do the 2nd step test.
- Disconnect the ABS hydraulic unit connector.
- Check for continuity between the red/white and black/yellow lead terminals of the ABS hydraulic unit connector [A].
- ★ If there is the continuity in the lead, replace the ABS hydraulic unit.
- ★ If there is not the continuity in the lead, 3rd step.

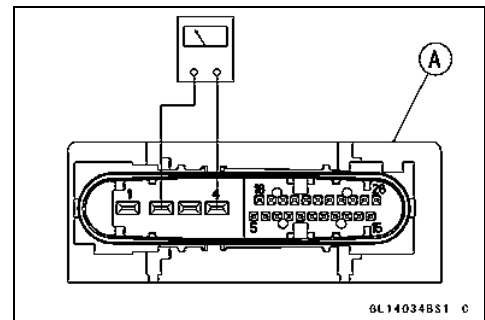

- Do the 3rd step test.
- Check for continuity between the red/white lead terminal of the main harness side connector [A] and red/white lead terminal of the fuse box [B].
- ★ If there is the continuity in the lead, replace the fuse.
- ★ If there is not the continuity in the lead, replace or repair the main harness.

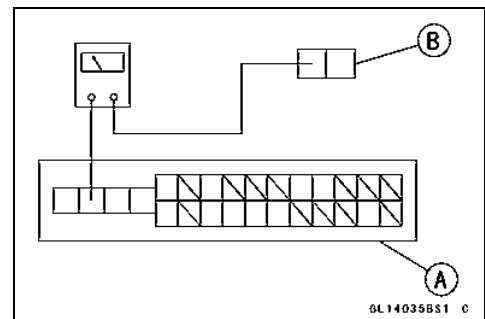

12-48 BRAKES

Anti-Lock Brake System (Equipped Models)

- Do the 4th step test.
- Check the battery terminal voltage between the red/white lead terminal of the fuse box [A] and ground.

Special Tool - Hand Tester: 57001-1394

Battery Terminal Voltage

Standard: Battery Voltage

- ★ If the battery terminal voltage is not within the specification, 5th step.
- ★ If the battery terminal voltage correct, 6th step.

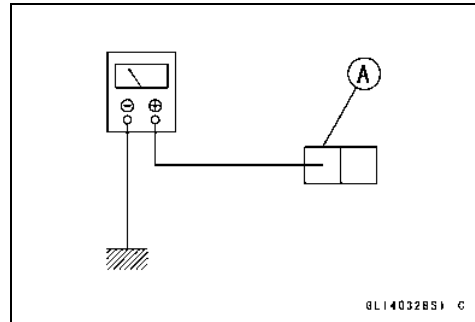

- Do the 5th step test.
- Check for continuity between the positive (+) cable [A] of the battery and red/white lead terminal of the main harness side connector [B].
- ★ If there is the continuity in the lead, 4th step.
- ★ If there is not the continuity in the lead, replace or repair the main harness.

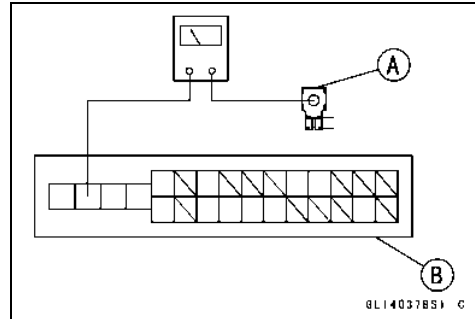

- Do the 6th step test.
- Recheck the service code indication; erase the service code, perform the pre-diagnosis inspection 1 and 2, and retrieve the service code.
- ★ If the ABS indicator light (LED) [A] lit, faulty ABS motor relay in the ABS hydraulic unit. Replace the ABS hydraulic unit.
- ★ If the ABS indicator light (LED) unlit, ABS system is normal (service code is not stored; temporary failure.).

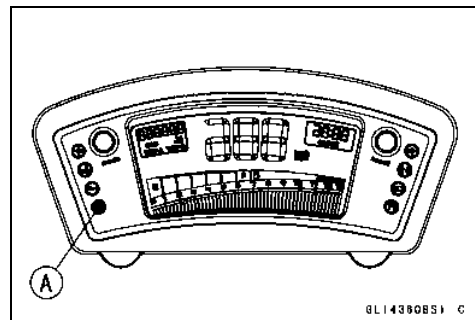

Front Wheel Rotation Sensor Signal Abnormal (Service Code 42)

- Do the 1st step test.
- Measure the air gap between the front wheel rotation sensor and sensor rotor.
Thickness Gauge [A]

Air Gap

Standard: 1 mm (0.04 in.)

- ★ If the measurement is over standard, check each part for deformation and looseness and correct accordingly. Recheck the air gap.
- ★ If the measurement is correct, 2nd step.

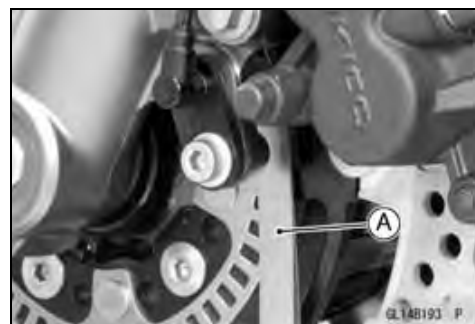

Anti-Lock Brake System (Equipped Models)

- Do the 2nd step test.
 - Check that there is iron or other magnetic deposits between the sensor [A] and sensor rotor [B], and the sensor rotor slots for obstructions.
 - Check the installation condition of the sensor for looseness.
 - Check the sensor and sensor rotor tip for deformation or damage (e.g., chipped sensor rotor teeth).
 - ★ If the sensor and sensor rotor in bad condition, remove the any deposits. Install the properly or replace faulty part.
 - ★ If the all correct, 3rd step.
-
- Do the 3rd step test.
 - Recheck the service code indication; erase the service code, perform the pre-diagnosis inspection 1 and 2, and retrieve the service code.
 - ★ If the ABS indicator light (LED) [A] lit, faulty ECU in the ABS hydraulic unit. Replace the ABS hydraulic unit.
 - ★ If the ABS indicator light (LED) unlit, ABS system is normal (service code is not stored; temporary failure.).

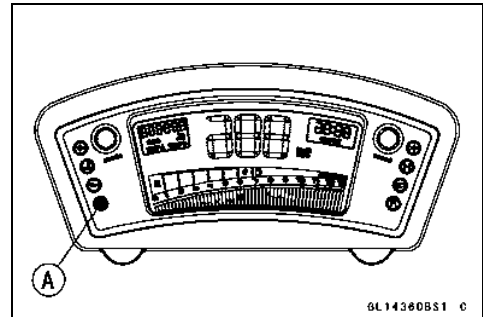

Front Wheel Rotation Sensor Wiring Inspection (Service Code 43)

- Do the 1st step test.
 - Disconnect the ABS hydraulic connector and front wheel rotation sensor connector.
 - Short the white and black lead terminals of the main harness side connector [A] with a jumper lead, and check for continuity between the white and black lead terminals of the main harness side connector [B].
 - ★ If there is the continuity in the lead, 2nd step.
 - ★ If there is not the continuity in the lead, replace or repair the main harness.
-
- Do the 2nd step test.
 - Check for continuity between the white lead terminal of the sensor connector [A] and ground, and black lead terminal of the sensor connector and ground.
 - ★ If there is the continuity in the lead, replace the front wheel rotation sensor.
 - ★ If there is not the continuity in the lead, 3rd step.

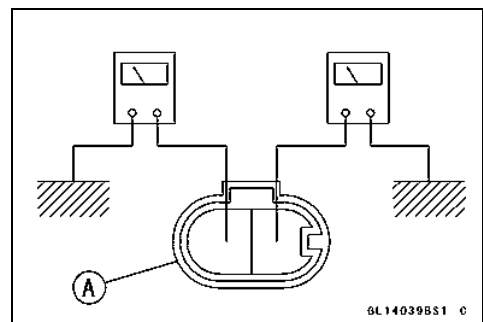
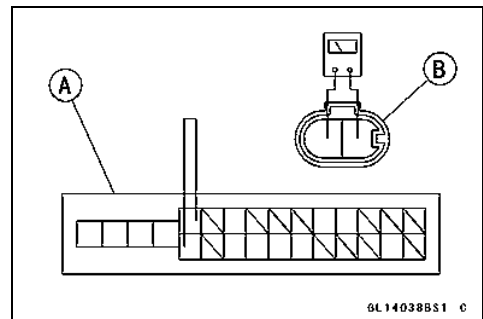

12-50 BRAKES

Anti-Lock Brake System (Equipped Models)

- Do the 3rd step test.
- Recheck the service code indication; erase the service code, perform the pre-diagnosis inspection 1 and 2, and retrieve the service code.
- ★ If the ABS indicator light (LED) [A] lit, faulty ECU in the ABS hydraulic unit. Replace the ABS hydraulic unit.
- ★ If the ABS indicator light (LED) unlit, ABS system is normal (service code is not stored; temporary failure.).

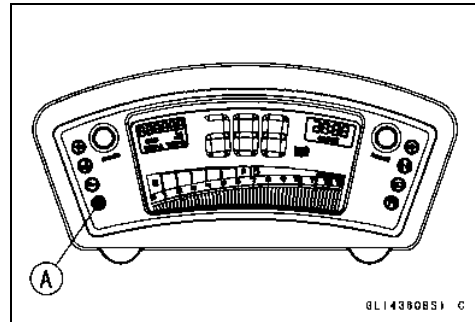

Rear Wheel Rotation Sensor Signal Abnormal (Service Code 44)

- Do the 1st step test.
- Measure the air gap between the rear wheel rotation sensor and sensor rotor.
Thickness Gauge [A]

Air Gap

Standard: 1 mm (0.04 in.)

- ★ If the measurement is over standard, check each part for deformation and looseness and correct accordingly. Recheck the air gap.
- ★ If the measurement is correct, 2nd step.



- Do the 2nd step test.
- Check that there is iron or other magnetic deposits between the sensor [A] and sensor rotor [B], and the sensor rotor slots for obstructions.
- Check the installation condition of the sensor for looseness.
- Check the sensor and sensor rotor tip for deformation or damage (e.g., chipped sensor rotor teeth).
- ★ If the sensor and sensor rotor in bad condition, remove the any deposits. Install the properly or replace faulty part.
- ★ If the all correct, 3rd step.

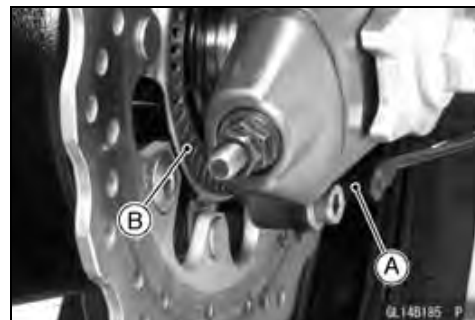

- Do the 3rd step test.
- Recheck the service code indication; erase the service code, perform the pre-diagnosis inspection 1 and 2, and retrieve the service code.
- ★ If the ABS indicator light (LED) [A] lit, faulty ECU in the ABS hydraulic unit. Replace the ABS hydraulic unit.
- ★ If the ABS indicator light (LED) unlit, ABS system is normal (service code is not stored; temporary failure.).

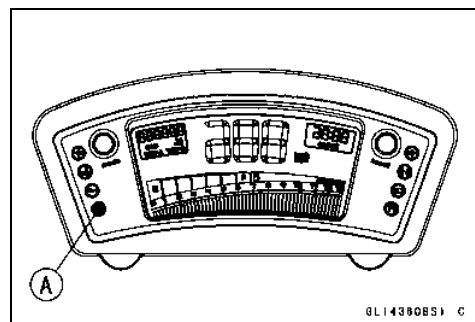

Anti-Lock Brake System (Equipped Models)

Rear Wheel Rotation Sensor Wiring Inspection (Service Code 45)

- Do the 1st step test.
 - Disconnect the ABS hydraulic unit connector and rear wheel rotation sensor connector.
 - Short the red and green lead terminals of the main harness side connector [A] with a jumper lead, and check for continuity between the red and green lead terminals of the main harness side connector [B].
 - ★ If there is the continuity in the lead, 2nd step.
 - ★ If there is not the continuity in the lead, replace or repair the main harness.

- Do the 2nd step test.
 - Check for continuity between the white lead terminal of the sensor connector [A] and ground, and black lead terminal of the sensor connector and ground.
 - ★ If there is the continuity in the lead, replace the rear wheel rotation sensor.
 - ★ If there is not the continuity in the lead, 3rd step.

- Do the 3rd step test.
 - Recheck the service code indication; erase the service code, perform the pre-diagnosis inspection 1 and 2, and retrieve the service code.
 - ★ If the ABS indicator light (LED) [A] lit, faulty ECU in the ABS hydraulic unit. Replace the ABS hydraulic unit.
 - ★ If the ABS indicator light (LED) unlit, ABS system is normal (service code is not stored; temporary failure.).

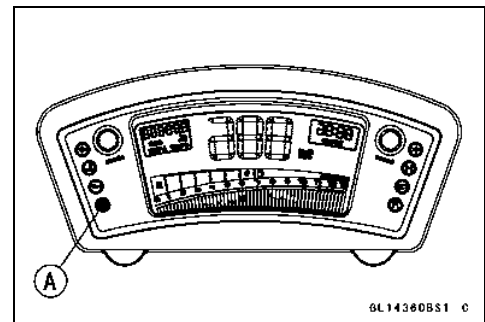
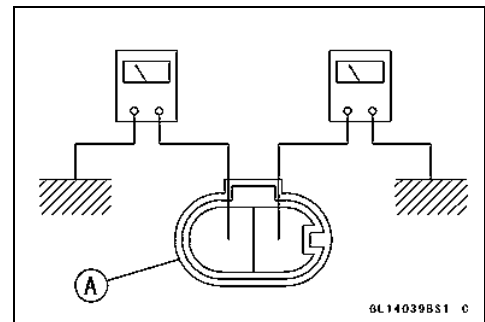
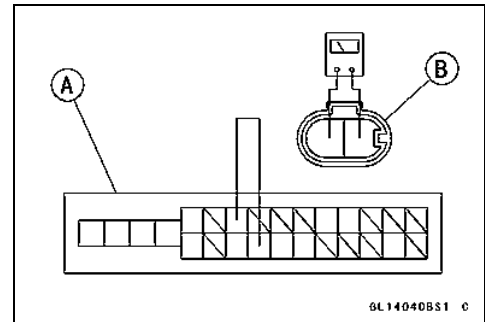

Power Supply Voltage Abnormal (Under-Voltage) (Service Code 52)

- Do the 1st step test.
 - Disconnect the ABS Kawasaki diagnostic system connector and ABS hydraulic unit connector.
 - Check for continuity between the brown lead terminal of the main harness side connector [A] and brown lead terminal of the main harness side [B].
 - ★ If there is the continuity in the lead, 2nd step.
 - ★ If there is not the continuity in the lead, replace or repair the main harness.

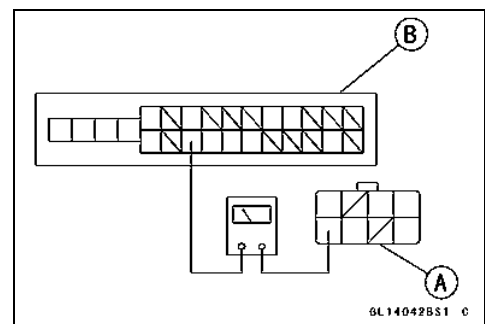

12-52 BRAKES

Anti-Lock Brake System (Equipped Models)

- Do the 2nd step test.
- Connect the ABS Kawasaki diagnostic system connector and ABS hydraulic unit connector.
- Check the battery terminal voltage, connect the hand tester to the brown terminal of ABS Kawasaki diagnostic system connector [A] and ground.

Special Tool - Hand Tester: 57001-1394

- Turn the ignition switch ON.

Battery Terminal Voltage

Standard: 9.6 V or more

- ★ If the battery terminal voltage is not within the specification, 3rd step.
- ★ If the battery terminal voltage correct, 4th step.

- Do the 3rd step test.

- Inspect the following parts.

Battery (see Charging Condition Inspection in the Electrical System chapter)

Ignition Switch (see Switch Inspection in the Electrical System chapter)

Main Harness (see Wiring Inspection in the Electrical System chapter)

Main Fuse 30 A (see Fuse Inspection in the Electrical System chapter)

- Do the 4th step test.

- Recheck the service code indication; erase the service code, perform the pre-diagnosis inspection 1 and 2, and retrieve the service code.

★ If the ABS indicator light (LED) [A] lit, faulty ECU in the ABS hydraulic unit. Replace the ABS hydraulic unit.

★ If the ABS indicator light (LED) unlit, ABS system is normal (service code is not stored; temporary failure.).

Power Supply Voltage Abnormal (Over-Voltage) (Service Code 53)

- Do the 1st step test.

- Disconnect the ABS Kawasaki diagnostic system connector and ABS hydraulic unit connector.

- Check for continuity between the brown lead terminal of the main harness side connector [A] and brown lead terminal of the main harness side [B].

★ If there is the continuity in the lead, 2nd step.

★ If there is not the continuity in the lead, replace or repair the main harness.

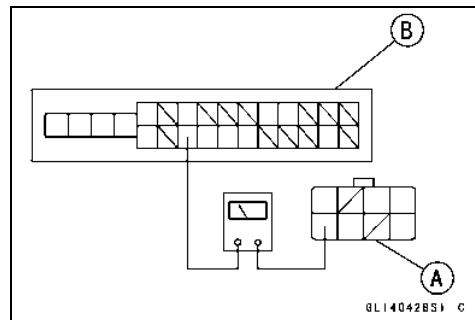
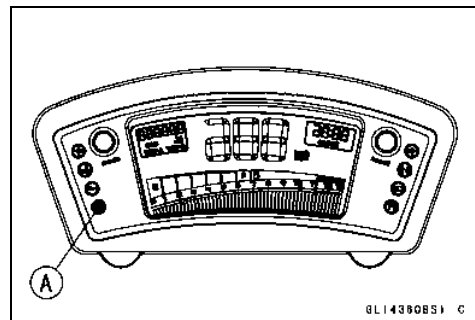
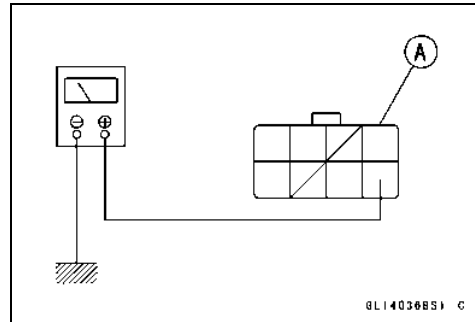

Anti-Lock Brake System (Equipped Models)

- Do the 2nd step test.
- Connect the ABS Kawasaki diagnostic system connector and ABS hydraulic unit connector.
- Check the battery terminal voltage, connect the hand tester to the brown terminal of ABS Kawasaki diagnostic system connector [A] and ground.

Special Tool - Hand Tester: 57001-1394

- Turn the ignition switch ON.

Battery Terminal Voltage

Standard: 16.6 V or less

- ★ If the battery terminal voltage is not within the specification, 3rd step.
- ★ If the battery terminal voltage correct, 4th step.

- Do the 3rd step test.
- Check the battery condition and regulator/rectifier (see Charging Condition Inspection, Regulator/Rectifier Inspection in the Electrical System chapter).

- Do the 4th step test.
- Recheck the service code indication; erase the service code, perform the pre-diagnosis inspection 1 and 2, and retrieve the service code.
- ★ If the ABS indicator light (LED) [A] lit, faulty ECU in the ABS hydraulic unit. Replace the ABS hydraulic unit.
- ★ If the ABS indicator light (LED) unlit, ABS system is normal (service code is not stored; temporary failure.).

ECU Inspection (Service Code 55)

- Do the 1st step test.
- Recheck the service code indication; erase the service code, perform the pre-diagnosis inspection 1 and 2, and retrieve the service code.
- ★ If the ABS indicator light (LED) [A] lit, faulty ECU in the ABS hydraulic unit. Replace the ABS hydraulic unit.
- ★ If the ABS indicator light (LED) unlit, ABS system is normal (service code is not stored; temporary failure.).

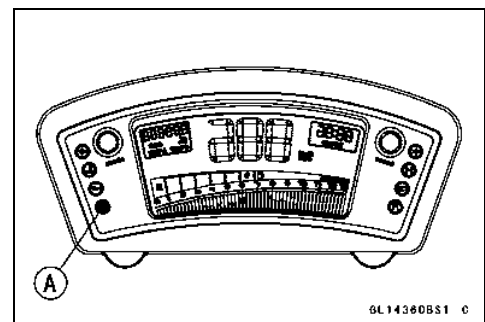
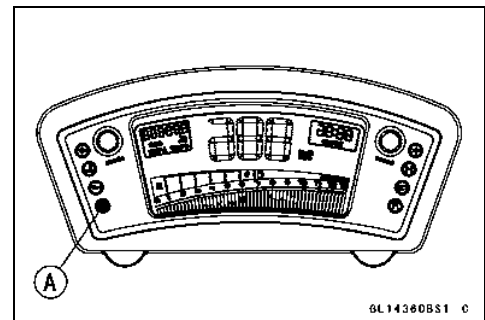
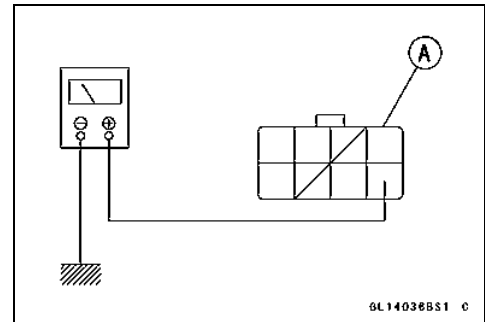

12-54 BRAKES

Anti-Lock Brake System (Equipped Models)

ABS Hydraulic Unit Removal

CAUTION

The ABS hydraulic unit [A] has been adjusted and set with precision at the factory. Therefore, it should be handled carefully, never struck sharply, as with a hammer, or allowed to fall on a hard surface.

Be careful not to get water or mud on the ABS hydraulic unit.



- Drain the brake fluid from the front and rear brake lines.
- Drain the brake fluid through the bleed valve by pumping the brake lever and pedal.
- Remove:
 - Battery Case (see Battery Case Removal in the Frame chapter)
 - Muffler Body (see Muffler Body Removal in the Engine Top End chapter)
 - Regulator/Rectifier (see Regulator/Rectifier Removal in the Electrical System chapter)
- Raise the rear wheel off the ground using the jack.

Special Tools - Jack: 57001-1238

Jack Attachment: 57001-1608

- Put a block in front of the front wheel to stop moving.
- Remove the rear shock absorber bolt and nut (lower), and lower the swingarm.
- Clean the ABS hydraulic unit.

CAUTION

Clean all fittings on the ABS hydraulic unit and the rear master cylinder because dirt around the banjo bolts could contaminate the brake fluid in the line during removal/installation.

Spread out a shop towel around the ABS hydraulic unit before removing the brake line so that brake fluid does not leak on the parts.

- Remove the bolts [A].



Anti-Lock Brake System (Equipped Models)

- Remove the brake pipe joint nuts [A].
- Tape the brake line opening to prevent brake fluid leakage or contamination by foreign matter.

CAUTION

Brake fluid quickly ruins painted plastic surfaces; any spilled fluid should be completely washed away immediately.

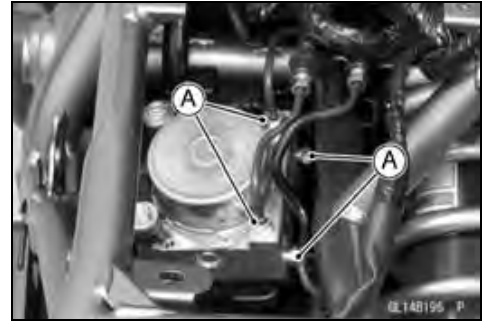

- Disconnect the connector [A].
- Pull the lever [B] as shown.
- Remove the ABS hydraulic unit with its bracket.

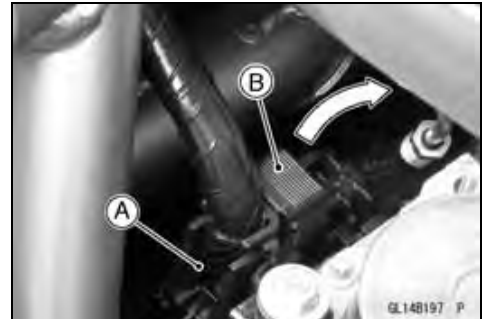

- Remove:
Nuts [A] and Bracket [B]

CAUTION

The ABS hydraulic unit has been adjusted and set with precision at the factory. Do not try to disassemble and repair the ABS hydraulic unit.

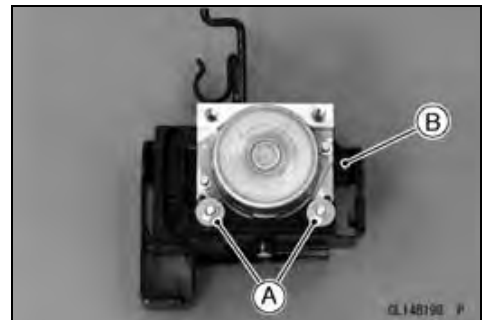

ABS Hydraulic Unit Installation

- Install the bracket to the ABS hydraulic unit.

CAUTION

Brake fluid quickly ruins painted plastic surfaces; any spilled fluid should be completely washed away immediately.

- Route the lead correctly, and join the connector securely.
- Route the brake pipes correctly (see Cable, Wire, and Hose Routing section in the Appendix chapter).
- Install the brake pipes.
 - To Rear Master Cylinder [A]
 - To Rear Caliper [B]
 - To Front Master Cylinder [C]
 - To Front Calipers [D]
- Tighten:
 - Torque - Brake Pipe Joint Nuts: 18 N·m (1.8 kgf·m, 13 ft·lb)**
- Install the ABS hydraulic unit to the frame.



12-56 BRAKES

Anti-Lock Brake System (Equipped Models)

ABS Hydraulic Unit Inspection

- Remove the ABS hydraulic unit (see ABS Hydraulic Unit Removal).
- Visually inspect the ABS hydraulic unit.
- ★ Replace the ABS hydraulic unit if any of them are cracked, or otherwise damaged.
- Visually inspect the connector terminals [A].
- ★ Replace the ABS hydraulic unit or main harness if either of the terminals are cracked, bent, or otherwise damaged.
- ★ If the ABS hydraulic unit connector is clogged with mud or dust, blow it off with compressed air.



Front Wheel Rotation Sensor Removal

CAUTION

The wheel rotation sensor should be handled carefully, never struck sharply, as with a hammer, or allowed to fall on a hard surface since the wheel rotation sensor is precision made. Be careful not to get water or mud on the wheel rotation sensor. Do not try to disassemble or repair the wheel rotation sensor.

- Remove:
 - Fuel Tank (see Fuel Tank Removal in the Fuel System (DFI) chapter)
 - Nut [A] and Clamp



- Free the sensor lead from the clamp [A].

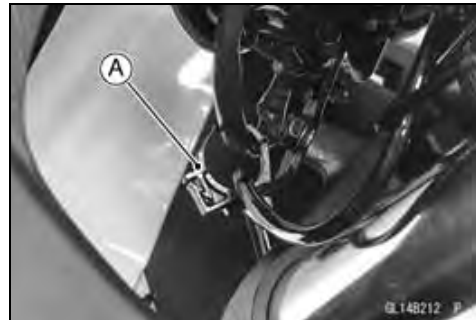

Anti-Lock Brake System (Equipped Models)

- Disconnect the connector [A].



- Remove:
 - Bolt [A]
 - Front Wheel Rotation Sensor [B]
- Free the sensor lead from the clamps.

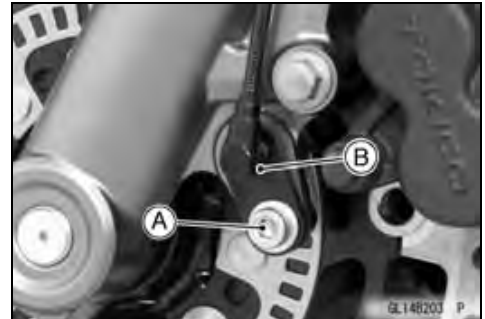

Front Wheel Rotation Sensor Installation

- Installation is the reverse of removal.
- Route the lead correctly (see Cable, Wire, and Hose Routing section in the Appendix chapter).
- Torque - Front Wheel Rotation Sensor: 20 N·m (2.0 kgf·m, 15 ft·lb)

Rear Wheel Rotation Sensor Removal

CAUTION

The wheel rotation sensor should be handled carefully, never struck sharply, as with a hammer, or allowed to fall on a hard surface since the wheel rotation sensor is precision made. Be careful not to get water or mud on the wheel rotation sensor. Do not try to disassemble or repair the wheel rotation sensor.

- Remove:
 - Right Frame Cover (see Frame Cover Removal in the Frame chapter)
- Disconnect the connector [A].



12-58 BRAKES

Anti-Lock Brake System (Equipped Models)

- Remove:
 - Bolt [A]
 - Rear Wheel Rotation Sensor [B]
- Free the sensor lead from the clamps.

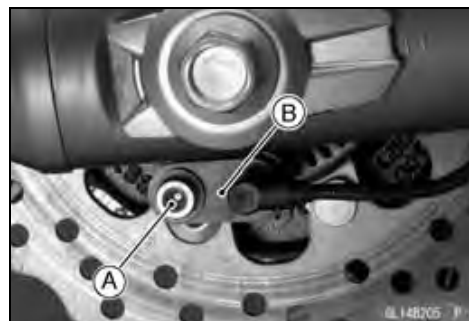

Rear Wheel Rotation Sensor Installation

- Installation is the reverse of removal.
- Route the lead correctly (see Cable, Wire, and Hose Routing section in the Appendix chapter).

Torque - Rear Wheel Rotation Sensor: 20 N·m (2.0 kgf·m, 15 ft·lb)

Wheel Rotation Sensor Inspection

- Remove the front wheel rotation sensor [A] from the front fork.
- Remove the rear wheel rotation sensor [B] from the caliper bracket.
- Visually inspect the wheel rotation sensors.
- ★ Replace the wheel rotation sensor if it is cracked, bent, or otherwise damaged.

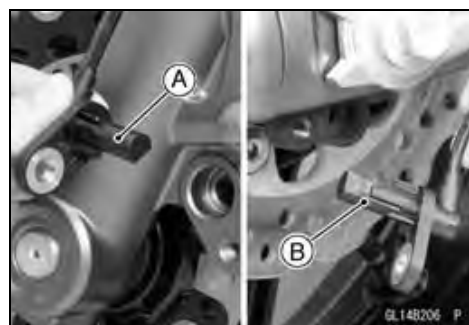

Wheel Rotation Sensor Air Gap Inspection

- Raise the front/rear wheel off the ground (see Front/Rear Wheel Removal in the Wheels/Tires chapter).
- Measure the air gap between the sensor and sensor rotor at several points by turning the wheel slowly. Thickness Gauge [A]

Air Gap

Standard:

Front	1 mm (0.04 in.)
Rear	1 mm (0.04 in.)



NOTE

- The sensor air gap cannot be adjusted.
- ★ If the air gap is not within the specification, inspect the hub bearing (see Hub Bearing Inspection in the Wheels/Tires chapter), sensor installation condition and sensor (see Wheel Rotation Sensor Inspection).

Anti-Lock Brake System (Equipped Models)

Wheel Rotation Sensor Rotor Inspection

- Remove the front/rear brake discs (see Brake Disc Removal).
- Visually inspect the wheel rotation sensor rotor.
- ★ If the rotor is deformed or damaged (chipped teeth [A]), replace the sensor rotor with the brake disc.
- ★ If there is iron or other magnetic deposits [B], remove the deposits.

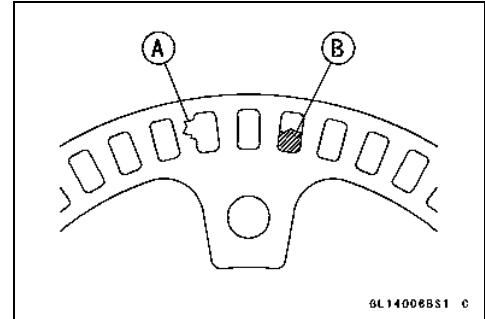

Brake Hose and Pipe Removal/Installation

- Refer to the Brake Hose and Pipe Replacement in the Periodic Maintenance chapter.

Brake Hose and Pipe Inspection

- Refer to the Brake Hose and Pipe Damage and Installation Condition Inspection in the Periodic Maintenance chapter.

ABS Solenoid Valve Relay Fuse 25 A Removal

- Remove the seat (see Seat Removal in the Frame chapter).
- Unlock the hook, and open the lid [A].
- Pull out the relay fuse [B] from the fuse box with needle nose pliers.

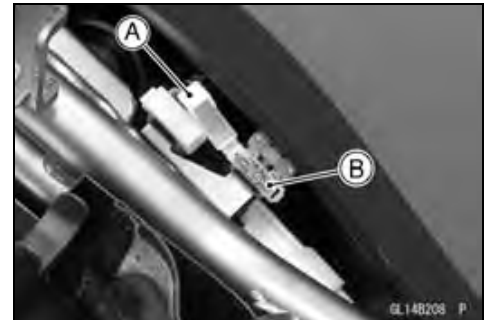

ABS Motor Relay Fuse 30 A Removal

- Remove the seat (see Seat Removal in the Frame chapter).
- Unlock the hook, and open the lid [A].
- Pull out the relay fuse [B] from the fuse box with needle nose pliers.

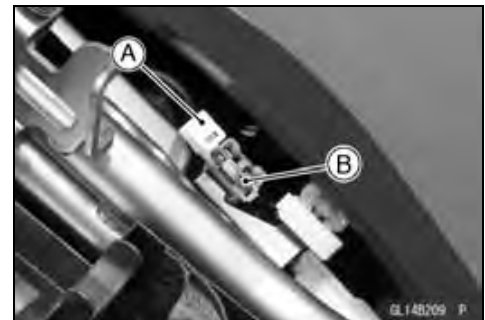

Fuse Installation

- If a fuse fails during operation, inspect the electrical system to determine the cause, and then replace it with a new fuse of proper amperage.

12-60 BRAKES

Anti-Lock Brake System (Equipped Models)

Fuse Inspection

- Remove the fuse (see ABS Solenoid Valve Relay Fuse 25 A/ABS Motor Relay Fuse 30 A Removal).
- Inspect the fuse element.
- ★ If it is blown out, replace the fuse. Before replacing a blown fuse, always check the amperage in the affected circuit. If the amperage is equal to or greater than the fuse rating, check the wiring and related components for a short circuit.

Housing [A]

Fuse Element [B]

Terminals [C]

Blown Element [D]

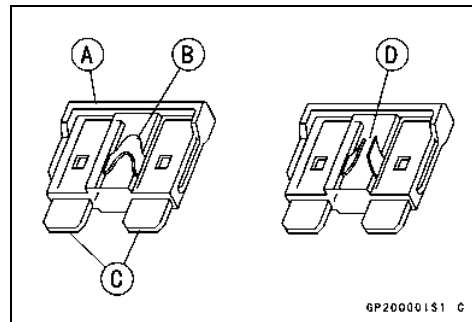

CAUTION

When replacing a fuse, be sure the new fuse matches the specified fuse rating for that circuit. Installation of a fuse with a higher rating may cause damage to wiring and components.

Suspension

Table of Contents

Exploded View	13-2
Specifications	13-6
Special Tools	13-7
Front Fork	13-9
Front Fork Removal	13-9
Front Fork Installation	13-9
Front Fork Oil Change	13-9
Front Fork Disassembly	13-11
Front Fork Assembly	13-12
Inner Tube, Outer Tube Inspection	13-14
Dust Seal Inspection	13-14
Spring Tension Inspection	13-14
Rear Shock Absorber	13-15
Spring Preload Adjustment	13-15
Rear Shock Absorber Removal	13-15
Rear Shock Absorber Installation	13-16
Rear Shock Absorber Inspection	13-16
Swingarm.....	13-17
Swingarm Removal.....	13-17
Swingarm Installation.....	13-18
Swingarm Bearing Removal	13-18
Swingarm Bearing Installation	13-18
Swingarm Bearing, Sleeve Inspection	13-19
Swingarm Bearing Lubrication	13-20
Chain Guide Inspection.....	13-20

13-2 SUSPENSION

Exploded View

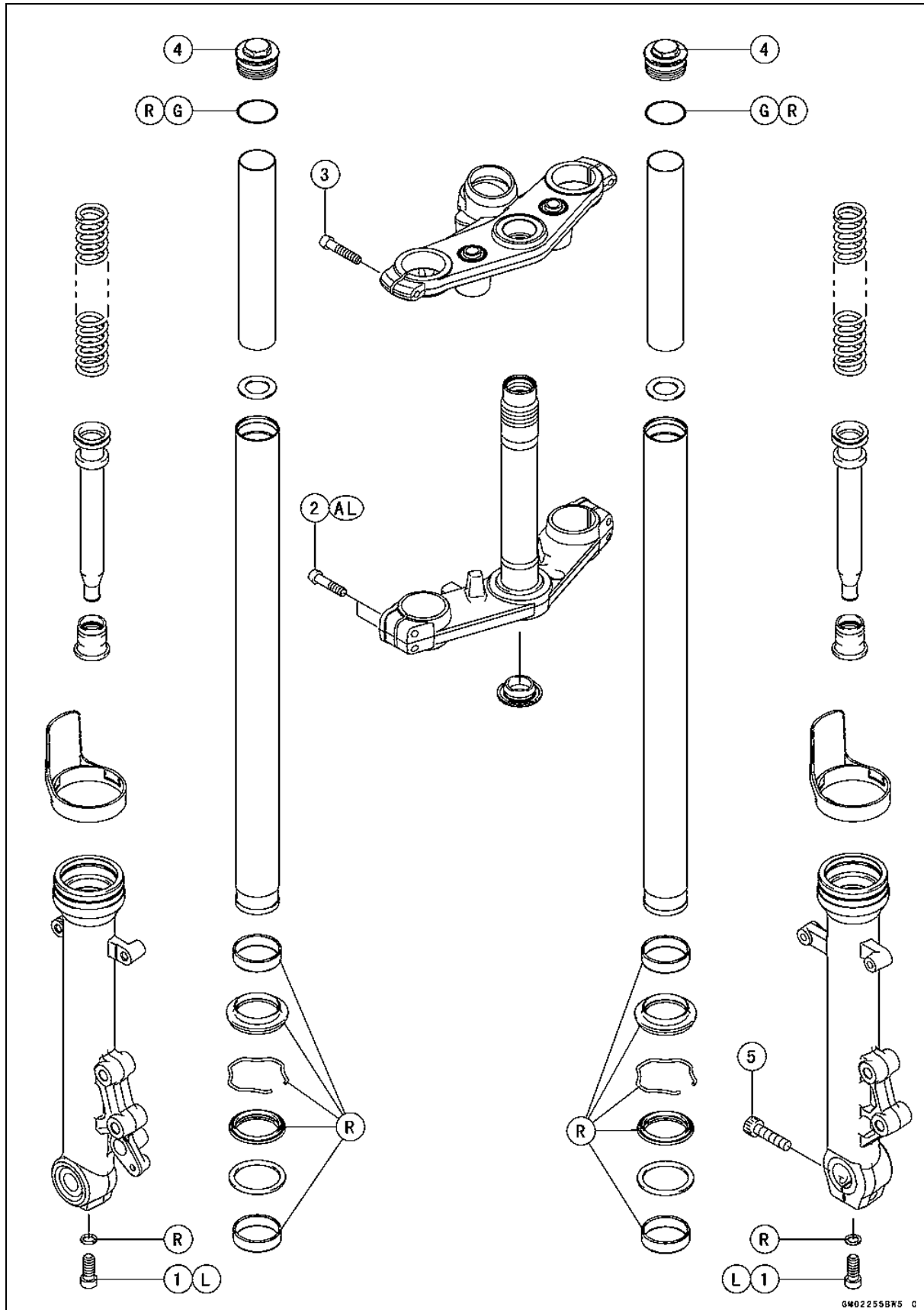

Exploded View

No.	Fastener	Torque			Remarks
		N·m	kgf·m	ft·lb	
1	Front Fork Bottom Allen Bolts	30	3.1	22	L
2	Front Fork Clamp Bolts (Lower)	21	2.1	15	AL
3	Front Fork Clamp Bolts (Upper)	20	2.0	15	
4	Front Fork Top Plugs	25	2.5	18	
5	Front Axle Clamp Bolt	34	3.5	25	

AL: Tighten the two clamp bolts alternately two times to ensure even tightening torque.

G: Apply grease.

L: Apply a non-permanent locking agent.

R: Replacement Parts

13-4 SUSPENSION

Exploded View

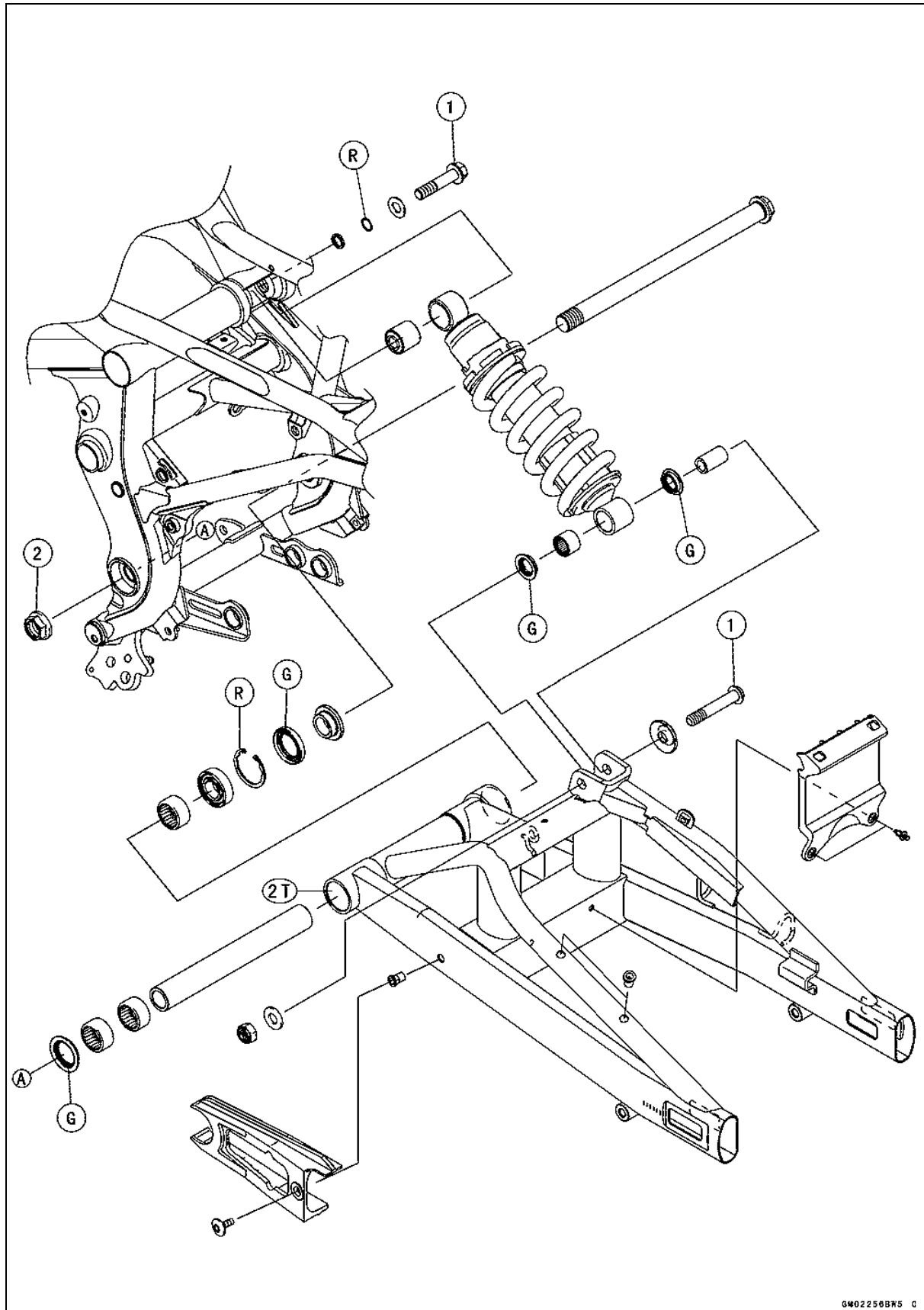

6W02256BK5 C

Exploded View

No.	Fastener	Torque			Remarks
		N-m	kgf-m	ft-lb	
1	Rear Shock Absorber Bolts	59	6.0	44	
2	Swingarm Pivot Shaft Nut	108	11.0	80	

G: Apply grease.

R: Replacement Parts

2T: Apply 2-stroke oil.

13-6 SUSPENSION

Specifications

Item	Standard
Front Fork (Per One Unit)	
Fork Inner Tube Outside Diameter	41 mm (1.6 in.)
Air Pressure	Atmospheric pressure (Non-adjustable)
Fork Spring Setting	Non-adjustable
Damper Setting	Non-adjustable
Fork Oil:	
Viscosity	KAYABA KHL34-G10 or equivalent
Amount:	
EX650C Models	approx. 400 mL (13.5 US oz.) (when changing oil) 469 ±4 mL (15.9 ±0.14 US oz.) (after disassembly and completely dry)
EX650D Models	approx. 405 mL (13.7 US oz.) (when changing oil) 478 ±4 mL (16.2 ±0.14 US oz.) (after disassembly and completely dry)
Fork Oil Level:	
EX650C Models	114 ±2 mm (4.49 ±0.08 in.) (below from inner tube top with fully compressed, without fork spring)
EX650D Models	105 ±2 mm (4.13 ±0.08 in.) (below from inner tube top with fully compressed, without fork spring)
Fork Spring Free Length	
EX650C Models	294.7 mm (11.60 in.) (Service limit 289 mm (11.38 in.))
EX650D Models	296.2 mm (11.66 in.) (Service limit 290 mm (11.42 in.))
Rear Shock Absorber	
Spring Preload	4th position (Adjustable Range: 1st ~ 7th position)
Gas Pressure	980 kPa (10 kgf/cm ² , 142 psi, Non-adjustable)

Special Tools

Inside Circlip Pliers:
57001-143

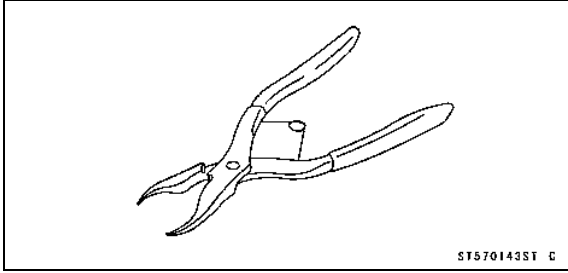

ST570143ST C

Jack:
57001-1238

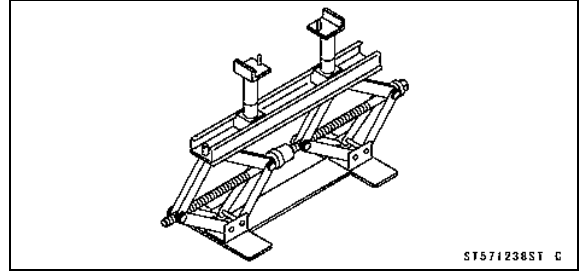

ST571238ST C

Fork Cylinder Holder Handle:
57001-183

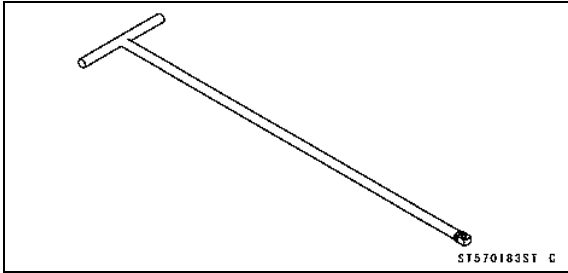

ST570183ST C

Front Fork Oil Seal Driver:
57001-1219

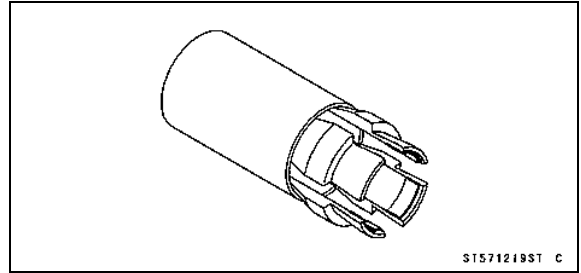

ST571219ST C

Fork Cylinder Holder Adapter:
57001-1057

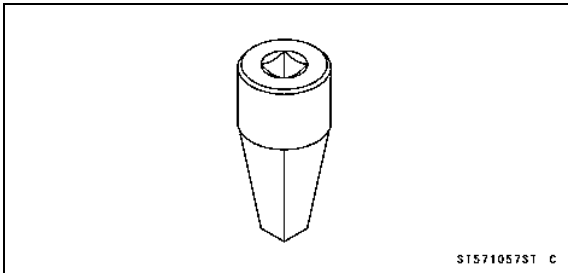

ST571057ST C

Fork Oil Level Gauge:
57001-1290

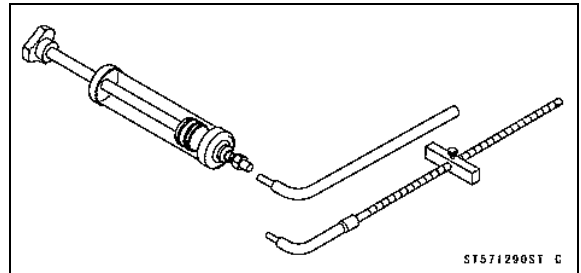

ST571290ST C

Oil Seal & Bearing Remover:
57001-1058

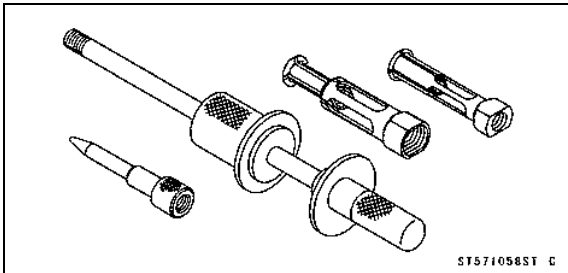

ST571058ST C

Jack Attachment:
57001-1608

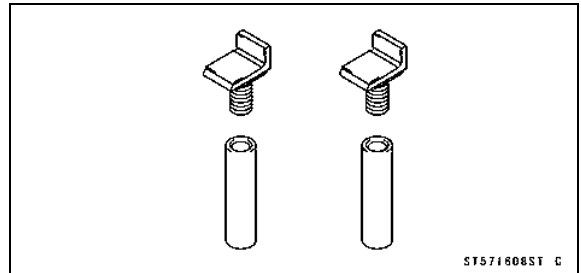

ST571608ST C

Bearing Driver Set:
57001-1129

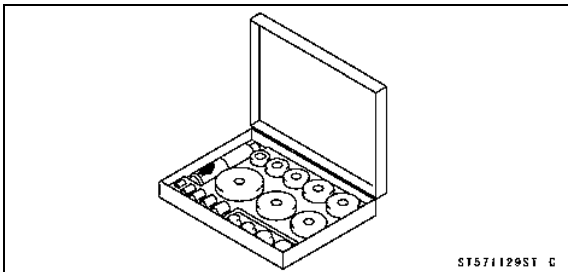

ST571129ST C

Needle Bearing Driver, $\phi 28$:
57001-1610

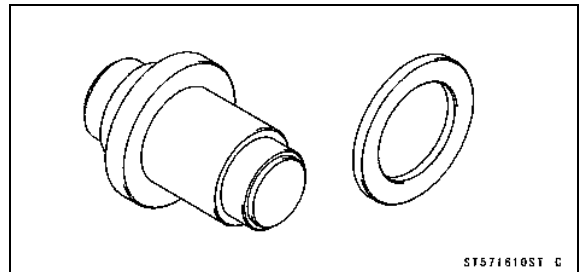

ST571610ST C

13-8 SUSPENSION

Special Tools

Spacer, $\phi 28$:
57001-1663

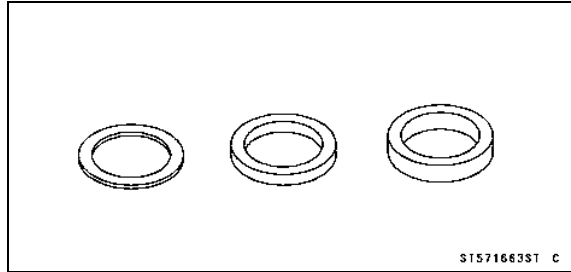

Front Fork

Front Fork Removal

- Remove:
 - Upper Fairing (see Upper Fairing Removal in the Frame chapter)
 - Front Wheel (see Front Wheel Removal in the Wheels/Tires chapter)
 - Front Fender (see Front Fender Removal in the Frame chapter)
 - Front Wheel Rotation Sensor (ABS equipped models, see Front Wheel Rotation Sensor Removal in the Brakes chapter)

- ★ Loosen the upper front fork clamp bolt [A] and front fork top plug [B] beforehand if the fork leg is to be disassembled.

NOTE

- Loosen the top plug after loosening the upper front fork clamp bolt.

- Loosen the upper front fork clamp bolt and lower front fork clamp bolts [C].
- With a twisting motion, work the fork leg down and out.

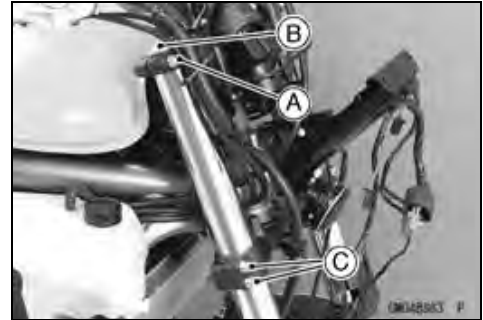

Front Fork Installation

- Install the fork with the upper end of the inner tube flush [A] against the top surface of the stem head [B].

- Tighten:

Torque - Front Fork Clamp Bolts (Lower): 21 N·m (2.1 kgf·m, 15 ft·lb)

Front Fork Top Plugs: 25 N·m (2.5 kgf·m, 18 ft·lb)

NOTE

- Tighten the top plug before tightening the upper front fork clamp bolt.
- Tighten the two clamp bolts alternately two times to ensure even tightening torque.

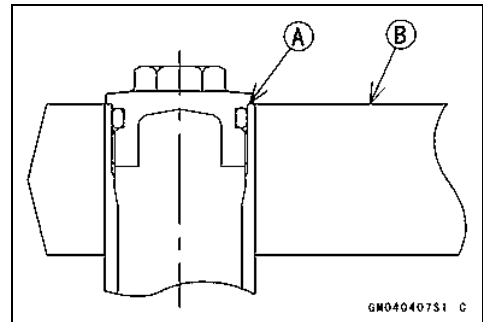

- Tighten:

Torque - Front Fork Clamp Bolts (Upper): 20 N·m (2.0 kgf·m, 15 ft·lb)

- Install the removed parts (see appropriate chapters).

Front Fork Oil Change

- Remove the front fork (see Front Fork Removal).

- Remove:

- Top Plug [A] with O-ring
- Spacer [B]
- Fork Spring Seat [C]
- Fork Spring [D]

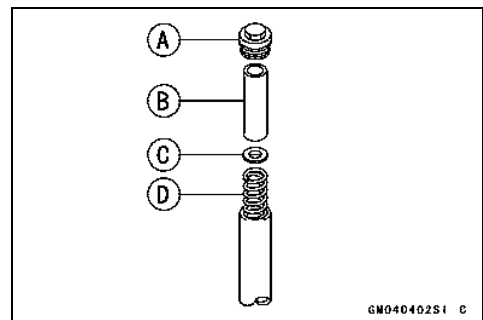

13-10 SUSPENSION

Front Fork

- Compress [A] the fork [B] upside down to draw out the oil into the suitable container [C].

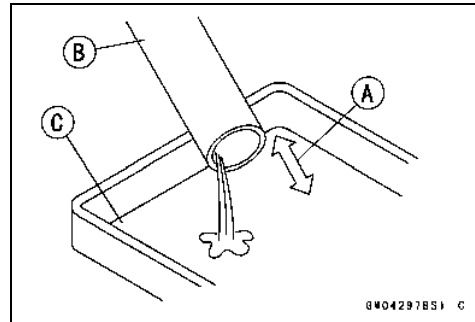

- Hold the fork tube upright, pour in the type and amount of fork oil specified.

Fork Oil

Viscosity:

KAYABA KHL34-G10 or equivalent

Amount (Per Side):

When changing oil:

EX650C Models approx. 400 mL (13.5 US oz.)

EX650D Models approx. 405 mL (13.7 US oz.)

After disassembly and completely dry:

EX650C Models 469 ±4 mL (15.9 ±0.14 US oz.)

EX650D Models 478 ±4 mL (16.2 ±0.14 US oz.)

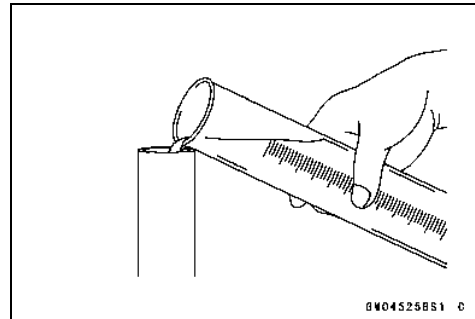

NOTE

- Move the outer tube up and down a few times to remove the air that is trapped in the fork oil in order to stabilize the oil level.

- Hold the outer tube vertically in a vise and compress the fork completely.
- Wait until the oil level stabilizes.
- Use the fork oil level gauge [A] to measure the distance between the top of the inner tube to the oil level.

Special Tool - Fork Oil Level Gauge: 57001-1290

- Set the oil level gauge stopper [B] so that the distance [C] from the bottom of the stopper to the lower end of the pipe is the standard oil level distance.
- A correct measurement can not be obtained unless the level gauge pipe is placed in the center of the inner tube.

Oil Level (fully compressed, without spring)

Standard:

EX650C Models 114 ±2 mm (4.49 ±0.08 in.)

EX650D Models 105 ±2 mm (4.13 ±0.08 in.)

- Place the stopper of the level gauge at the top [D] of the inner tube [E] and pull the handle slowly to draw out the excess oil from fork into the gauge, thus attaining the standard level.

- ★ If not oil is drawn out, there is not enough oil in the fork. Pour in some more oil and measure again.

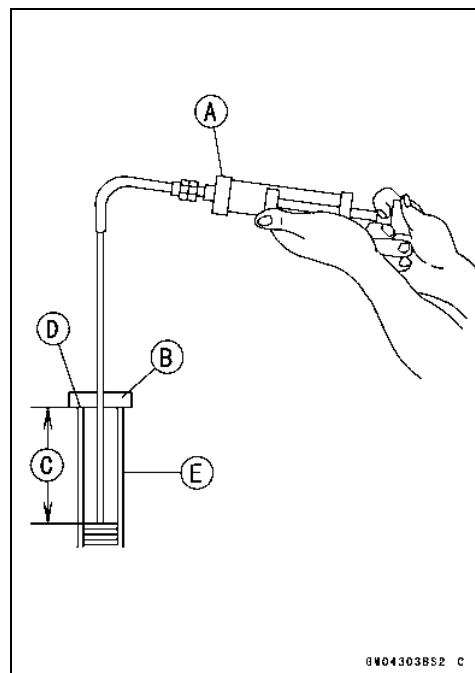

Front Fork

- Repeat the same procedure for adjusting the other fork.
- Install:
 - Fork Spring [A]
 - Fork Spring Seat [B]
 - Spacer [C]
- Replace the top plug O-ring with a new one.
- Install:
 - Top Plug
 - Front Fork (see Front Fork Installation)

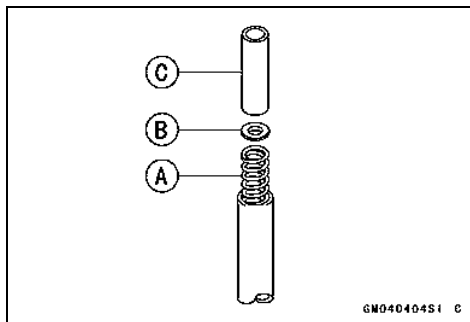

Front Fork Disassembly

- Remove the front fork (see Front Fork Removal).
- Remove:
 - Top Plug [A] with O-ring
 - Spacer [B]
 - Fork Spring Seat [C]
 - Fork Spring [D]
- Drain the fork oil (see Front Fork Oil Change).

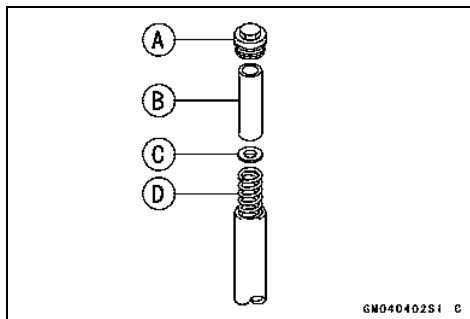

- Remove the Allen bolt [A] from the bottom of the fork.
 - Special Tools - Fork Cylinder Holder Handle [B]: 57001-183**
 - Fork Cylinder Holder Adapter [C]: 57001-1057**

NOTE

○ Hold the outer tube in a vise [D], stop the cylinder unit [E] from turning by using the special tools, and unscrew the Allen bolt.

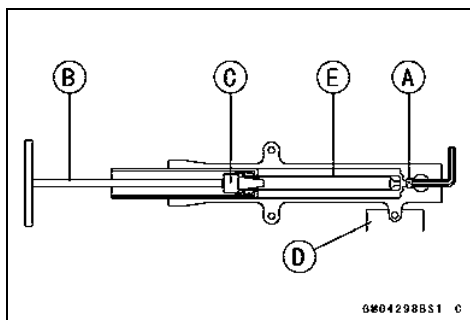

- Remove the cylinder unit [A], washer, and the spring [B] from the inner tube.

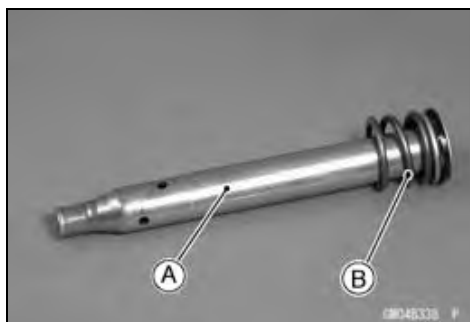

- Remove the following from the top of the outer tube.
 - Dust Seal [A]
 - Retaining Ring [B]



13-12 SUSPENSION

Front Fork

- Separate the inner tube [A] from the outer tube [B].

NOTE

○ From the compressed state, firmly pull down the outer tube a few times towards the direction of elongation.

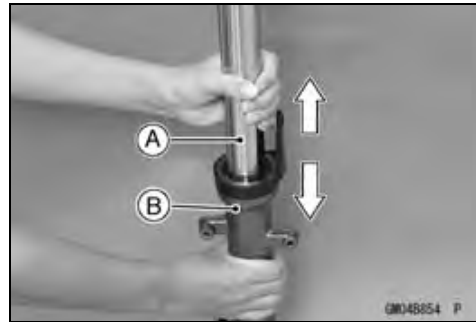

- Remove the following from the inner tube.

Inner Guide Bushing [A]
Outer Guide Bushing [B]
Washer [C]
Oil Seal [D]

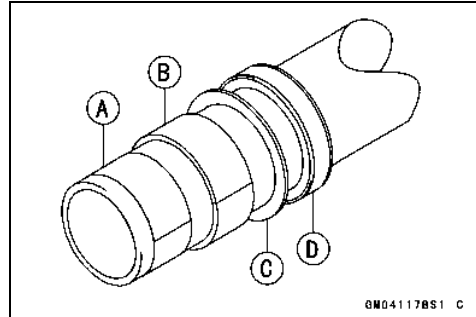

- Remove the cylinder base [A] from the bottom of the outer tube.

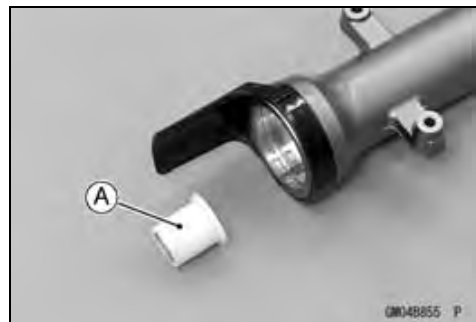

Front Fork Assembly

- Check the top plug O-ring and replace it with a new one.
- Replace the following parts with new ones.
 - Retaining Ring [A]
 - Dust Seal [B]
 - Oil Seal [C]
 - Inner Guide Bushing [D]
 - Outer Guide Bushing [E]
 - Fork Bottom Allen Bolt Gasket [F]

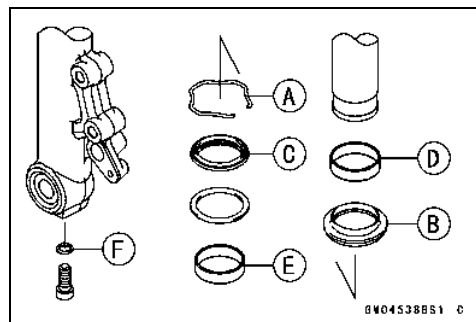

- Install the guide bushing on the end of the inner tube.
- Insert the cylinder unit and the spring into the inner tube, and install the cylinder base [A] onto the cylinder end [B] that protrudes from the bottom.
- Install the cylinder base starting with its stepped end.
- Be sure that the spring [C] is in position.
- Insert the inner tube, cylinder unit, washer, spring, and cylinder base as a set into the outer tube.

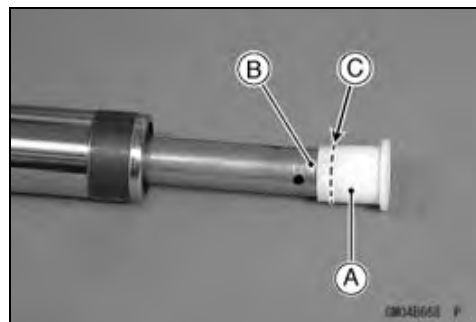

Front Fork

- Install the new guide bushing [A] with a use one [B] on it by tapping the use one with the fork oil seal driver [C].
- The split [D] of the bushing should face toward the side of the motorcycle.

Special Tool - Front Fork Oil Seal Driver: 57001-1219

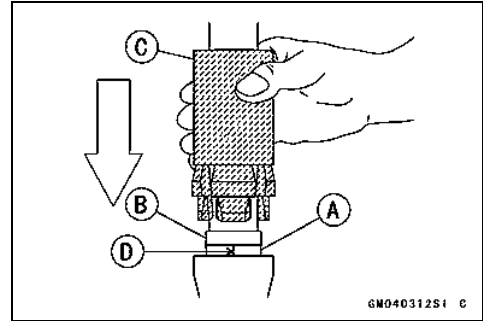

- Install the washer and the oil seal [A] into the outer tube.

Special Tool - Front Fork Oil Seal Driver [B]: 57001-1219

- Install the retaining ring on the outer tube.

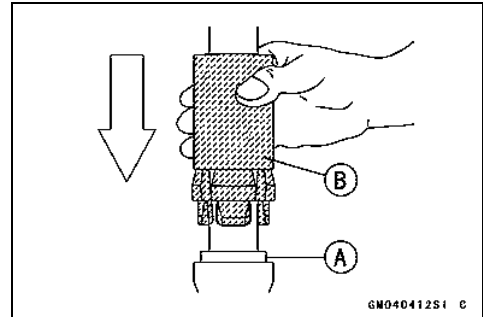

- Apply non-permanent locking agent to the threads of the bottom Allen bolt [A].
- Hold the front fork horizontally in a vise [B].
- Hold the cylinder unit [C] with the special tools and tighten the bottom Allen bolt to secure the cylinder in place.

**Special Tools - Fork Cylinder Holder Handle [D]: 57001-183
Fork Cylinder Holder Adapter [E]: 57001-1057**

**Torque - Front Fork Bottom Allen Bolt: 30 N·m (3.1 kgf·m,
22 ft·lb)**

- Pour in the specified type of oil (see Front Fork Oil Change).

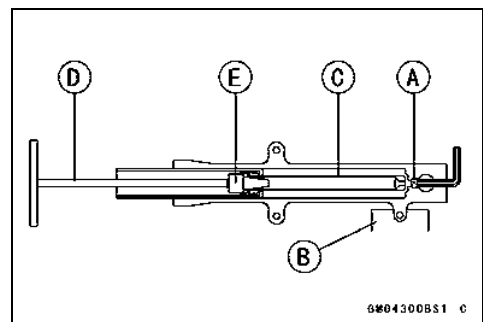

13-14 SUSPENSION

Front Fork

Inner Tube, Outer Tube Inspection

- Visually inspect the inner tube [A], and repair any damage.
- Nicks or rust damage can sometimes be repaired by using a wet-stone to remove sharp edges or raised areas which cause seal damage.
- ★ If the damage is not repairable, replace the inner tube. Since damage to the inner tube damages the oil seal, replace the oil seal whenever the inner tube is repaired or replaced.

CAUTION

If the inner tube is badly bent or creased, replace it. Excessive bending, followed by subsequent straightening, can weaken the inner tube.

- Temporarily assemble the inner and outer tubes, and pump them back and forth manually to check for smooth operation.
- ★ If you feel binding or catching, the inner and outer tubes must be replaced.

⚠ WARNING

A straightened inner or outer fork tube may fall in use, possibly causing an accident. Replace a badly bent or damaged inner or outer tube and inspect the other tube carefully before reusing it.

Dust Seal Inspection

- Inspect the dust seal [A] for any signs of deterioration or damage.
- ★ Replace it if necessary.

Spring Tension Inspection

- Since a spring becomes shorter as it weakens, check its free length [A] to determine its condition.
- ★ If the spring of either fork leg is shorter than the service limit, it must be replaced. If the length of a replacement spring and that of the remaining spring vary greatly, the remaining spring should also be replaced in order to keep the fork legs balanced for motorcycle stability.

Spring Free Length

Standard:

EX650C Models	294.7 mm (11.60 in.)
EX650D Models	296.2 mm (11.66 in.)

Service Limit:

EX650C Models	289 mm (11.38 in.)
EX650D Models	290 mm (11.42 in.)

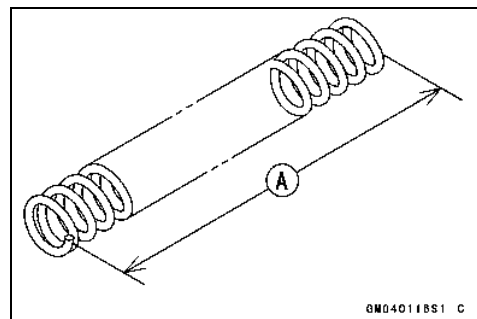
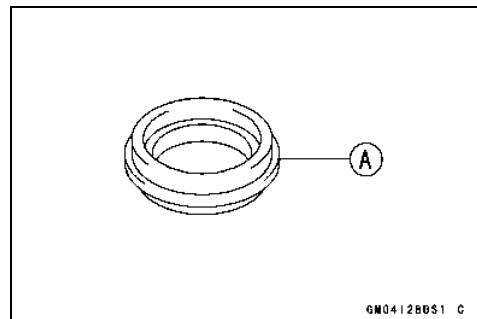
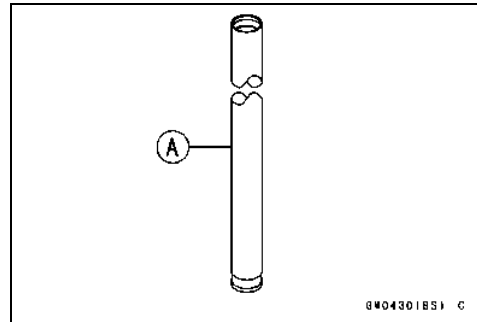

Rear Shock Absorber

Spring Preload Adjustment

- Using the hook wrench [A], turn the adjusting nut [B] to adjust the spring preload.
- The standard adjuster setting for average-build rider of 68 kg (150 lb) with no passenger and no accessories is 4th position.

Spring Preload Setting

Standard Position: 4th position

Adjustable Range: 1st to 7th position

- If the compression of the spring is not suited to the operating conditions, adjust it to an appropriate position by referring to the table below.

Spring Preload Adjustment

Adjuster Position	Damping Force	Shock Absorber Hardness	Load	Road Conditions	Driving Speed
1st	Weak	Soft	Light	Good	Low
↑	↑	↑	↑	↑	↑
↓	↓	↓	↓	↓	↓
7th	Strong	Hard	Heavy	Bad	Highway

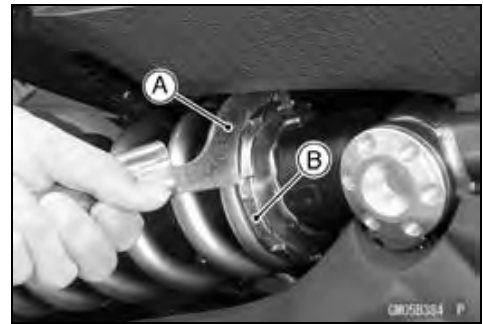

Rear Shock Absorber Removal

- Remove:
 - Muffler Body (see Muffler Body Removal in the Engine Top End chapter)
- Raise the rear wheel off the ground using the jack.

Special Tools - Jack: 57001-1238

Jack Attachment: 57001-1608

- Squeeze the brake lever slowly and hold it with a band [A].

⚠ WARNING

Be sure to hold the front brake when removing the shock absorber, or the motorcycle may fall over. It could cause an accident and injury.



- Remove:
 - Right Stay Cover [A]



13-16 SUSPENSION

Rear Shock Absorber

- Remove:
 - Rear Shock Absorber Bolt (Upper) [A]
 - Rear Shock Absorber Bolt (Lower) [B], Nut and Washer
- Remove the shock absorber [C] backward.

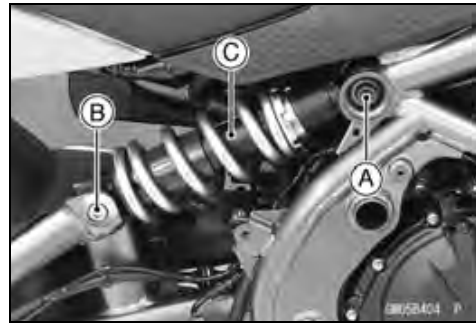

Rear Shock Absorber Installation

- Installation is the reverse of removal.
- Replace the O-ring of the rear shock absorber bolt (upper) with a new one.
- Apply grease to the lip of oil seals.
- Be sure to install the oil seals to the shock absorber.
- Fit the O-ring and washer, and then install them.

NOTE

- Check that the O-ring is securely installed.
- Install the rear shock absorber so that the label side faces to inside.
- Tighten:
 - Torque - Rear Shock Absorber Bolts: 59 N·m (6.0 kgf·m, 44 ft·lb)**
- Install the removed parts (see appropriate chapters).

Rear Shock Absorber Inspection

- Remove the rear shock absorber (see Rear Shock Absorber Removal).
- Visually inspect the following items.
 - Smooth Stroke
 - Oil Leakage
 - Crack or Dent
- ★ If there is any damage to the rear shock absorber, replace it.
- Visually inspect the rubber bushing.
- ★ If it show any signs of damage, replace it.

Swingarm

Swingarm Removal

- Remove:
 - Chain Cover Bolts [A]
 - Quick Rivet [B]
 - Chain Cover [C]

- Free the brake hose [A] from the clamps [B].
- For models equipped with an ABS, remove the rear wheel rotation sensor (see Rear Wheel Rotation Sensor Removal in the Brakes chapter).
- Remove:
 - Muffler Body (see Muffler Body Removal in the Engine Top End chapter)
 - Rear Caliper (see Rear Caliper Removal in the Brakes chapter)
- Raise the rear wheel off the ground using the jack.
 - Special Tools - Jack: 57001-1238**
 - Jack Attachment: 57001-1608**
- Remove:
 - Rear Wheel (see Rear Wheel Removal in the Wheels/Tires chapter)
 - Drive Chain (see Drive Chain Removal in the Final Drive chapter)
- Remove the lower rear shock absorber nut and bolt [A].

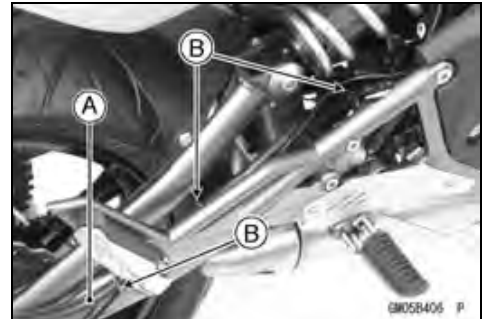
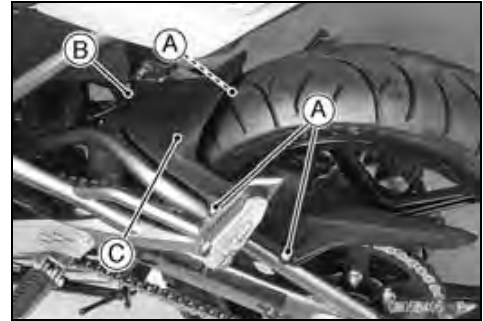

- Unscrew the swingarm pivot shaft nut [A].
- Pull off the pivot shaft [B], and remove the swingarm.

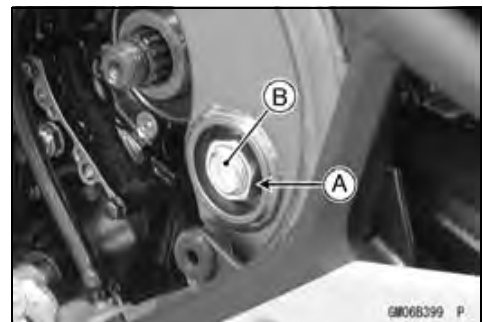

13-18 SUSPENSION

Swingarm

Swingarm Installation

- Installation is the reverse of removal.
- Apply grease to the lip of the oil seals.
- Be sure to install the oil seal and collar to the swingarm.
- Tighten the pivot shaft nut.

Torque - Swingarm Pivot Shaft Nut: 108 N·m (11.0 kgf·m, 80 ft·lb)

- Install the removed parts (see appropriate chapters).

Swingarm Bearing Removal

- Remove:
 - Swingarm (see Swingarm Removal)
 - Collar [A]
 - Oil Seals [B]
 - Sleeve [C]
 - Circlip [D]

Special Tool - Inside Circlip Pliers: 57001-143

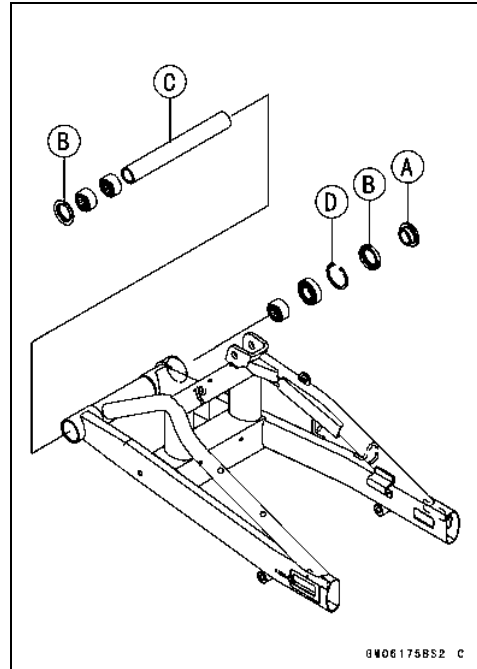

- Remove the ball bearing and needle bearings.

Special Tool - Oil Seal & Bearing Remover [A]: 57001-1058

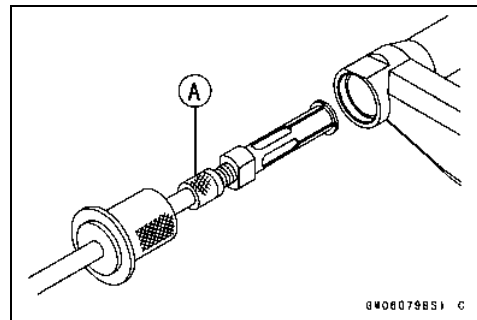

Swingarm Bearing Installation

- Apply 2 stroke oil to the inner surface of the swingarm.
- Replace the ball and needle bearings [A] with new ones.
- Install the ball and needle bearings so that the manufacturer's marks face out.

Special Tools - Bearing Driver Set: 57001-1129

Needle Bearing Driver, $\phi 28$ [B]: 57001-1610

Spacer, $\phi 28$: 57001-1663

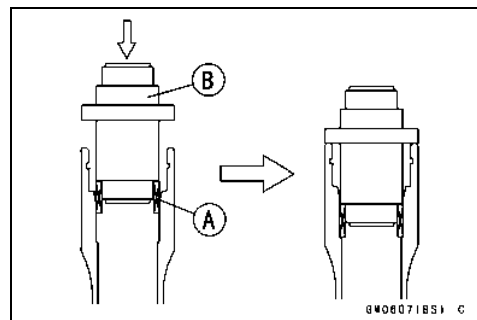

Swingarm

- Install the needle bearings [A], ball bearing [B] and oil seals [C] position as shown.

Circlip [D]

25 mm (0.98 in.) [E]

17 mm (0.67 in.) [F]

1 mm (0.04 in.) [G]

1 mm (0.04 in.) [H]

1 mm (0.04 in.) [I]

23.5 mm (0.93 in.) [J]

5.5 mm (0.22 in.) [K]

Left Side [L]

Right Side [M]

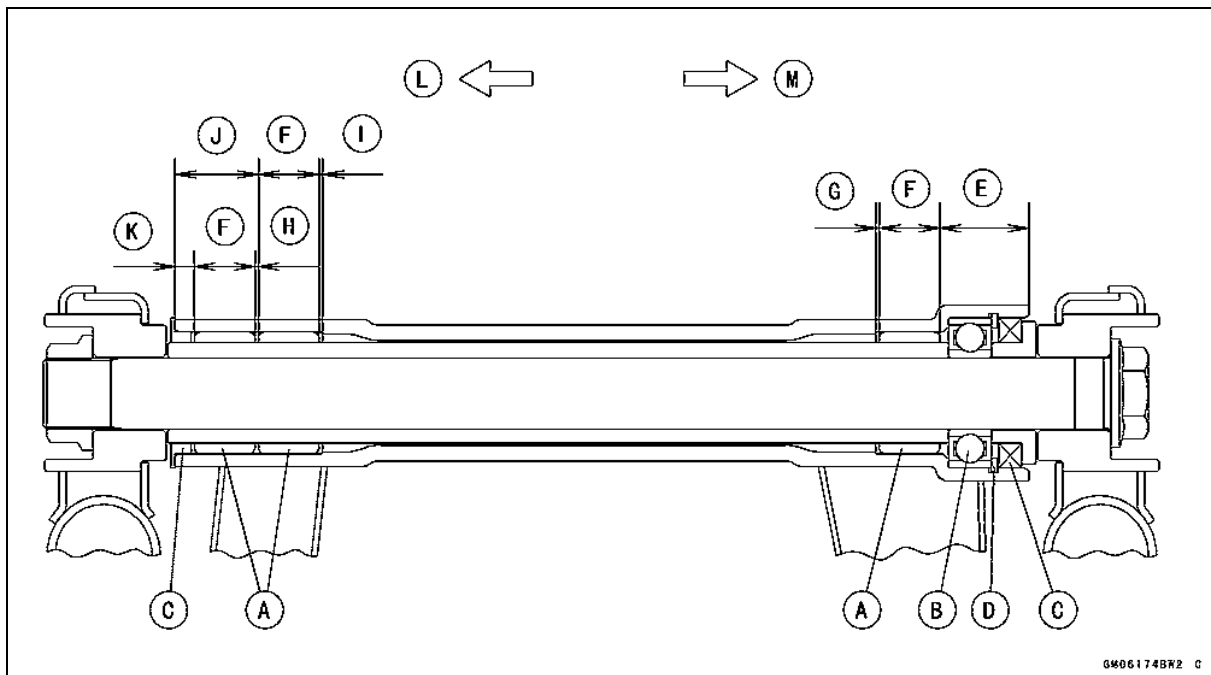

GM06174BR2 C

Swingarm Bearing, Sleeve Inspection

CAUTION

Do not remove the bearings for inspection. Removal may damage them.

- Inspect the needle bearings [A] and ball bearing installed in the swingarm.
- The rollers and ball in a bearing normally wear very little, and wear is difficult to measure. Instead of measuring, visually inspect the bearing for abrasion, discoloration, or other damage.
- ★ If the needle bearing and sleeve [B] show any signs of abnormal wear, discoloration, or damage, replace them as a set.

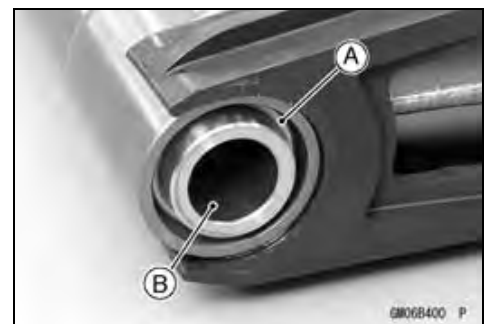

GM06400 P

13-20 SUSPENSION

Swingarm

- Turn the bearing in the swingarm back and forth [A] while checking for plays, roughness, or binding.
- ★ If bearing play, roughness, or binding is found, replace the bearing.
- Examine the bearing seal [B] for tears or leakage.
- ★ If the seal is torn or is leaking, replace the bearing.

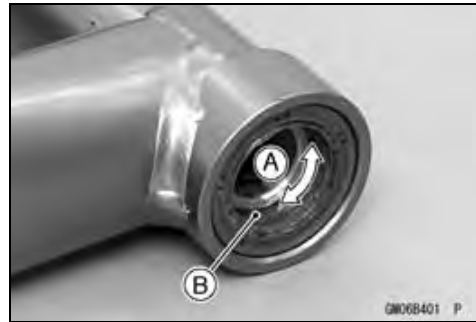

Swingarm Bearing Lubrication

NOTE

- *Since the bearings are packed with grease and sealed, lubrication is not required.*

Chain Guide Inspection

- Refer to the Chain Guide Wear Inspection in the Periodic Maintenance chapter.

Steering

Table of Contents

Exploded View	14-2
Special Tools	14-4
Steering	14-5
Steering Inspection	14-5
Steering Adjustment.....	14-5
Steering Stem.....	14-6
Stem, Stem Bearing Removal.....	14-6
Stem, Stem Bearing Installation.....	14-7
Steering Stem Bearing Lubrication	14-9
Steering Stem Warp Inspection	14-9
Stem Cap Deterioration, Damage Inspection	14-9
Handlebar	14-10
Handlebar Removal	14-10
Handlebar Installation	14-10

14-2 STEERING

Exploded View

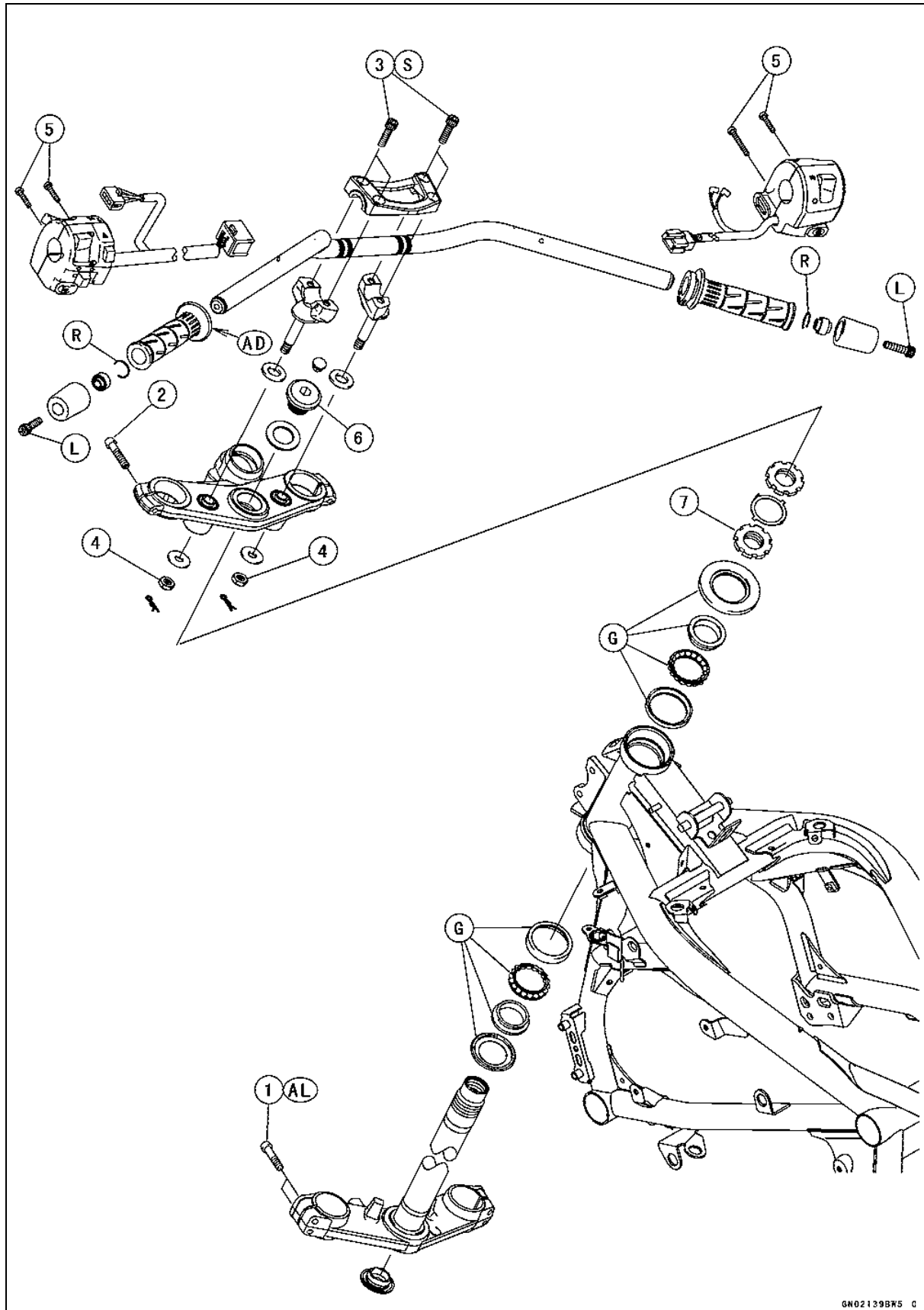

Exploded View

No.	Fastener	Torque			Remarks
		N-m	kgf-m	ft-lb	
1	Front Fork Clamp Bolts (Lower)	21	2.1	15	AL
2	Front Fork Clamp Bolts (Upper)	20	2.0	15	
3	Handlebar Holder Bolts	25	2.5	18	S
4	Handlebar Holder Mounting Nuts	34	3.5	25	
5	Switch Housing Screws	3.5	0.36	31 in-lb	
6	Steering Stem Head Bolt	108	11.0	80	
7	Steering Stem Nut	20	2.0	15	

AD: Apply adhesive.

AL: Tighten the two clamp bolts alternately two times to ensure even tighten torque.

G: Apply grease.

L: Apply a non-permanent locking agent.

R: Replacement Parts

S: Follow the specified tightening sequence.

14-4 STEERING

Special Tools

Head Pipe Outer Race Press Shaft:
57001-1075

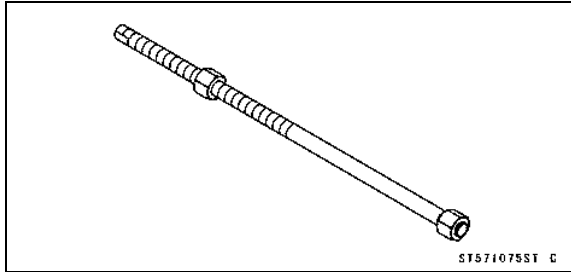

Steering Stem Bearing Driver, $\phi 42.5$:
57001-1344

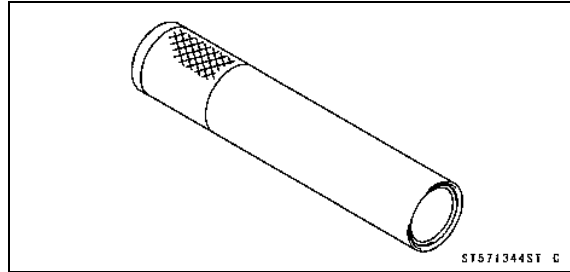

Steering Stem Nut Wrench:
57001-1100

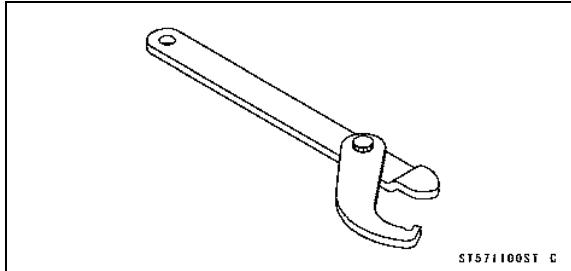

Steering Stem Bearing Driver Adapter, $\phi 41.5$:
57001-1345

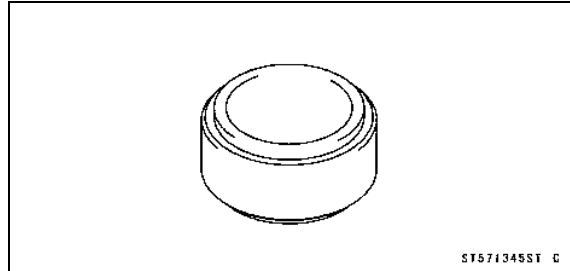

Bearing Driver Set:
57001-1129

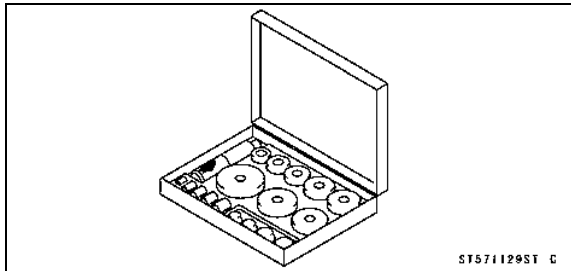

Head Pipe Outer Race Driver, $\phi 55$:
57001-1446

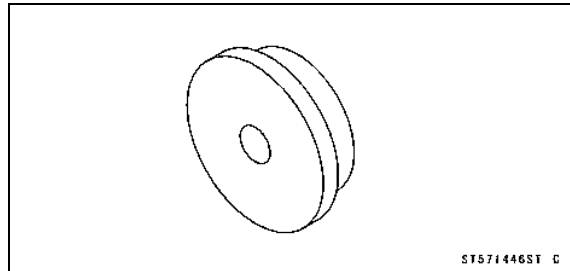

Steering

Steering Inspection

- Refer to the Steering Play Inspection in the Periodic Maintenance chapter.

Steering Adjustment

- Refer to the Steering Play Adjustment in the Periodic Maintenance chapter.

14-6 STEERING

Steering Stem

Stem, Stem Bearing Removal

- Remove:
 - Upper Fairing (see Upper Fairing Removal in the Frame chapter)
 - Front Fender (see Front Fender Removal in the Frame chapter)
 - Front Wheel (see Front Wheel Removal in the Wheels/Tires chapter)
 - Handlebar (see Handlebar Removal)
 - Under Bracket (see Under Bracket Removal in the Frame chapter)
 - Front Forks (see Front Fork Removal in the Suspension chapter)
 - Steering Stem Head (see Steering Play Adjustment in the Periodic Maintenance chapter)

- Bend the claws [A] of claw washer straighten.
- Remove the steering stem locknut [B].

Special Tool - Steering Stem Nut Wrench: 57001-1100

- Remove the claw washer.



- Pushing up the stem base, and remove the steering stem nut [A] with stem cap [B].

Special Tool - Steering Stem Nut Wrench [C]: 57001-1100

- Remove:
 - Steering Stem [D]
 - Upper Ball Bearing Inner Race and Ball Bearing



- To remove the ball bearing outer races [A] pressed into the head pipe [B], insert a bar [C] into the recesses of head pipe, and applying it to both recess alternately hammer it to drive the race out.

NOTE

○ If either steering stem bearing is damaged, it is recommended that both the upper and lower bearings (including outer races) should be replaced with new ones.

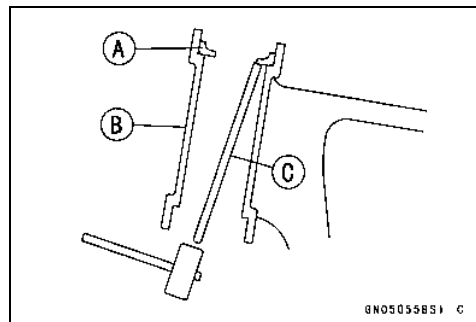

Steering Stem

- Remove the lower ball bearing inner race (with its oil seal) [A] which is pressed onto the steering stem with a suitable commercially available chisel [B].

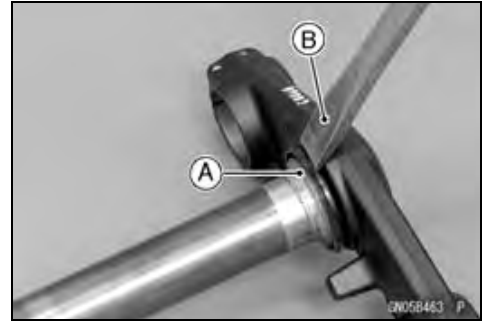

Stem, Stem Bearing Installation

- Replace the bearing outer races with new ones.
- Apply grease to the outer races.
- Drive them into the head pipe at the same time.

Special Tools - Head Pipe Outer Race Press Shaft [A]:
 57001-1075
Bearing Driver Set: 57001-1129
Head Pipe Outer Race Driver, $\phi 55$ [B]: 57001-1446

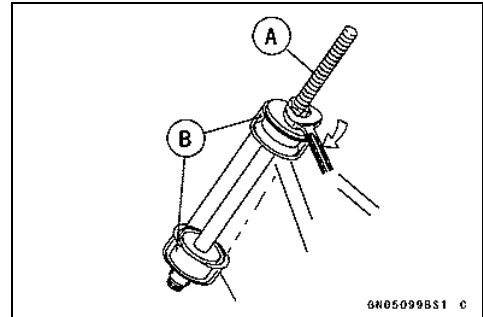

- Replace the bearing inner races and oil seal with new ones.
- Apply grease to the oil seal.
- Install the oil seal [A] on the steering stem, and drive the lower ball bearing inner race [B] applied the grease onto the stem.

Special Tools - Steering Stem Bearing Driver, $\phi 42.5$ [C]:
 57001-1344
Steering Stem Bearing Driver Adapter, $\phi 41.5$ [D]: 57001-1345

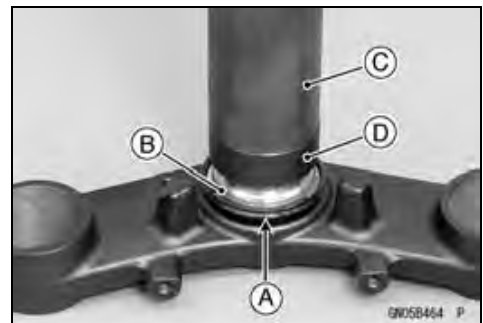

- Install the lower ball bearing [A] onto the stem.
- Grease the following.
 - Inner and Outer Races
 - Lower and Upper Ball Bearings
- The lower and upper ball bearings are identical.

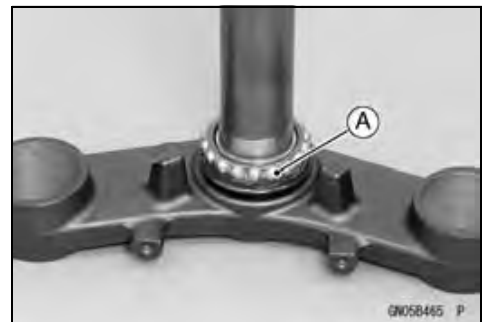

14-8 STEERING

Steering Stem

- Install the steering stem [A] through the head pipe, and install the ball bearing [B] and inner race [C] on it.
- Apply grease to the stem cap [D].
- Install:
 - Stem Cap
 - Steering Stem Nut [E]

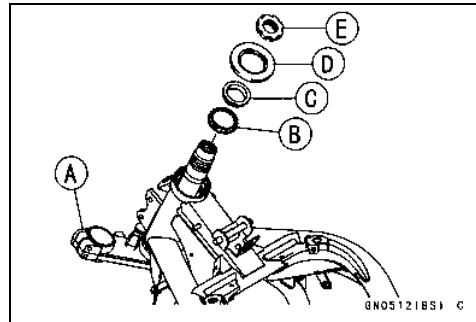

- Settle the bearings in place as follows.
- Tighten the steering stem nut with **55 N·m (5.6 kgf·m, 41 ft·lb)** of torque first, and loosen it a fraction of a turn until it turns lightly. Afterward tighten it again with specified torque using a steering stem nut wrench [A].
- Check that there is no play and the steering stem turns smoothly without rattles. If not, the steering stem bearings may be damaged.

Special Tool - Steering Stem Nut Wrench: 57001-1100

Torque - Steering Stem Nut: 20 N·m (2.0 kgf·m, 15 ft·lb)

- Install the claw washer [A] so that its bent side [B] faces upward, and engage the bent claws with the grooves of stem locknut [C].
- Hand tighten the stem locknut until it touches the claw washer.
- Tighten the stem locknut clockwise until the claws are aligned with the grooves (ranging from 2nd to 4th) of stem nut [D], and bend the 2 claws downward [E].
- Install the stem head.
- Install the washer, and temporary tighten the steering stem head bolt.
- Install the front forks (see Front Fork Installation in the Suspension chapter).

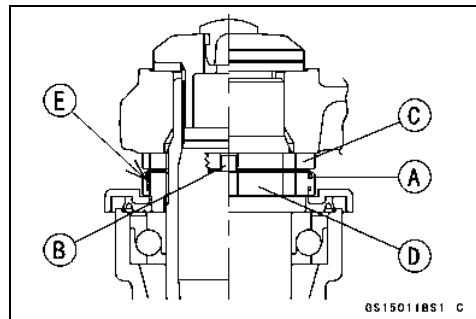
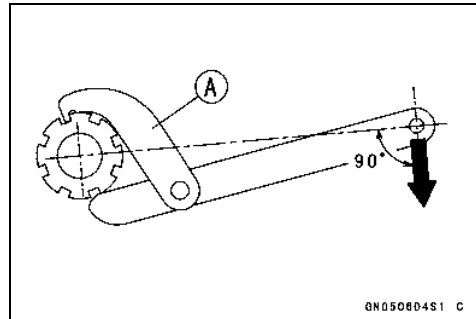

NOTE

- Tighten the upper front fork clamp bolts first, next the stem head bolt, last the lower front fork clamp bolts.
- Tighten the two lower front fork clamp bolts alternately two times to ensure even tightening torque.

Torque - Front Fork Clamp Bolts (Upper): 20 N·m (2.0 kgf·m, 15 ft·lb)

Steering Stem Head Bolt: 108 N·m (11.0 kgf·m, 80 ft·lb)

Front Fork Clamp Bolts (Lower): 21 N·m (2.1 kgf·m, 15 ft·lb)

▲ WARNING

Do not impede the handlebar turning by routing the cables, harnesses and hoses improperly (see Cable, Wire, and Hose Routing section in the Appendix chapter).

- Install the removed parts (see appropriate chapters).

Steering Stem

Steering Stem Bearing Lubrication

- Refer to the Steering Stem Bearing Lubrication in the Periodic Maintenance chapter.

Steering Stem Warp Inspection

- Whenever the steering stem is removed, or if the steering can not be adjusted for smooth action, check the steering stem for straightness.
- ★ If the steering stem [A] is bent, replace the steering stem.

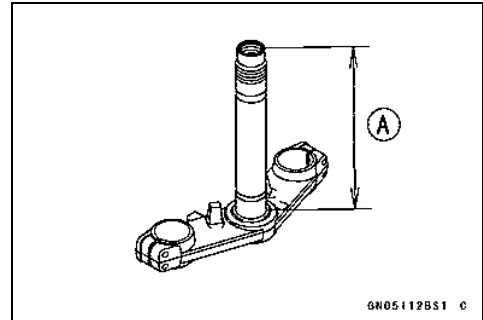

Stem Cap Deterioration, Damage Inspection

- ★ Replace the stem cap if its oil seal [A] shows damage.



14-10 STEERING

Handlebar

Handlebar Removal

- Remove:
 - Clutch Lever Clamp Bolts [A]
 - Clutch Lever Assembly [B]
 - Left Switch Housing [C]
 - Handlebar Weight [D]
 - Handlebar Grip [E]

- Remove:
 - Front Master Cylinder [A] (see Front Master Cylinder Removal in the Brakes chapter)
 - Right Switch Housing [B]
 - Handlebar Weight [C]
 - Throttle Grip [D]

- Remove:
 - Handlebar Holder Bolts [A]
 - Handlebar Holder [B]
 - Handlebar [C]

- Remove:
 - Cotter Pins [A]
 - Handlebar Holder Mounting Nuts [B]
 - Washers
 - Lower Handlebar Holders [C]

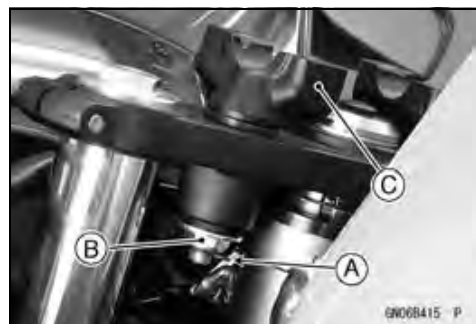
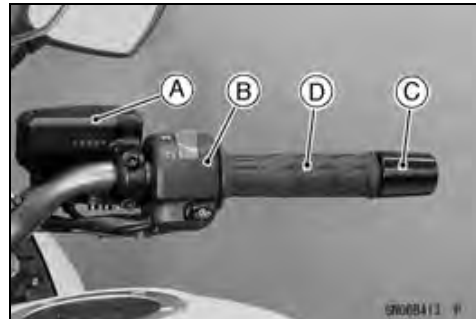
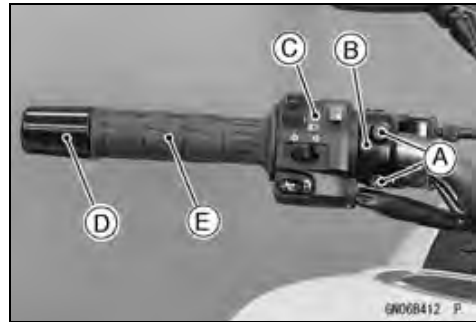

Handlebar Installation

- Install the lower handlebar holders [A], noting the letters "L" [B] and "R" [C].
- Install the washers.
- Tighten:
 - Torque - Handlebar Holder Mounting Nuts: 34 N-m (3.5 kgf-m, 25 ft-lb)**
- Install the cotter pins.

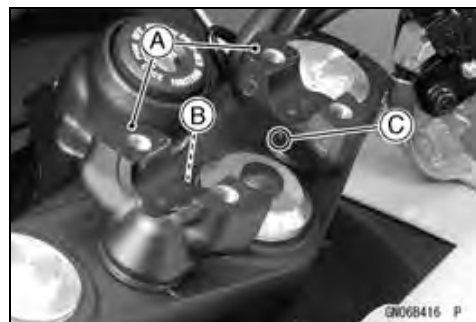

Handlebar

- Align the punch mark [A] on the handlebar and the corner edge [B] on the lower handlebar holder.

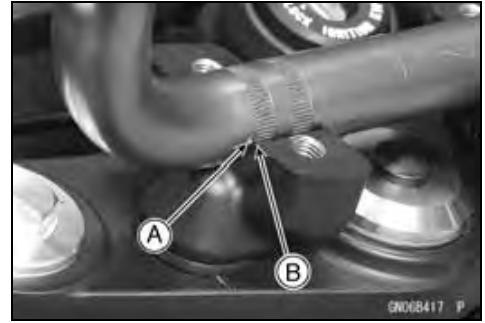

- Tighten the front holder bolts first, and then the rear holder bolts. There will be a gap [A] at the rear part of the holder after tightening.

Torque - Handlebar Holder Bolts: 25 N·m (2.5 kgf·m, 18 ft·lb)



- Install:
 - Throttle Grip
 - Throttle Cable Tips [A]
 - Right Switch Housing
- Fit the projection [B] into a hole [C] in the handlebar.

- Tighten:

Torque - Switch Housing Screws: 3.5 N·m (0.36 kgf·m, 31 in·lb)

- Apply a non-permanent locking agent to the right handlebar weight bolt.
- Install the front brake master cylinder (see Front Master Cylinder Installation in the Brakes chapter).

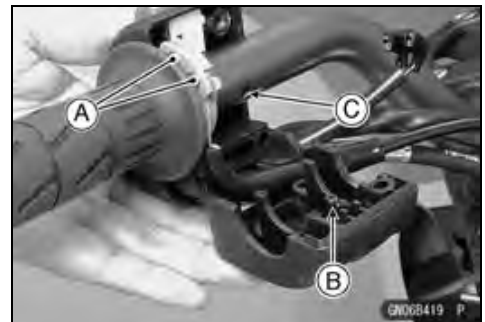

- Apply adhesive cement to the inside of the left handlebar grip.
- Apply a non-permanent locking agent to the left handlebar weight bolt.
- Install the left switch housing.
- Fit the projection [A] into a hole [B] in the handlebar.

- Tighten:

Torque - Switch Housing Screws: 3.5 N·m (0.36 kgf·m, 31 in·lb)

- Install the clutch lever (see Clutch Lever Installation in the Clutch chapter).



Frame

Table of Contents

Exploded View.....	15-2	Seat Cover Installation.....	15-17
Seat	15-8	Fenders	15-19
Seat Removal	15-8	Front Fender Removal.....	15-19
Seat Installation	15-8	Front Fender Installation.....	15-19
Fairings.....	15-9	Flap Removal.....	15-19
Lower Fairing Removal.....	15-9	Flap Installation.....	15-19
Lower Fairing Installation.....	15-9	Rear Fender Removal.....	15-20
Lower Fairing Bracket Removal...	15-9	Rear Fender Installation.....	15-20
Lower Fairing Bracket Installation	15-10	Frame	15-21
Upper Fairing Cover Removal	15-10	Frame Inspection	15-21
Upper Fairing Cover Installation ..	15-10	Battery Case.....	15-22
Upper Fairing Removal.....	15-10	Battery Case Removal.....	15-22
Upper Fairing Installation.....	15-11	Battery Case Installation	15-23
Upper Fairing Disassembly.....	15-11	Footpeg Stay	15-24
Upper Fairing Assembly.....	15-12	Footpeg Stay Removal	15-24
Upper Inner Fairing Removal.....	15-13	Footpeg Stay Installation	15-24
Upper Inner Fairing Installation....	15-13	Windshield.....	15-25
Upper Fairing Bracket Removal...	15-13	Windshield Removal	15-25
Upper Fairing Bracket Installation	15-14	Windshield Installation	15-25
Under Bracket Removal.....	15-14	Sidestand.....	15-26
Under Bracket Installation.....	15-14	Sidestand Removal.....	15-26
Inner Fairing Removal.....	15-14	Sidestand Installation.....	15-26
Inner Fairing Installation.....	15-15	Frame Cover.....	15-27
Side Covers	15-16	Frame Cover Removal.....	15-27
Side Cover Removal	15-16	Frame Cover Installation.....	15-27
Side Cover Installation	15-16	Rear View Mirrors.....	15-28
Seat Covers.....	15-17	Rear View Mirror Removal	15-28
Seat Cover Removal.....	15-17	Rear View Mirror Installation.....	15-28

15-2 FRAME

Exploded View

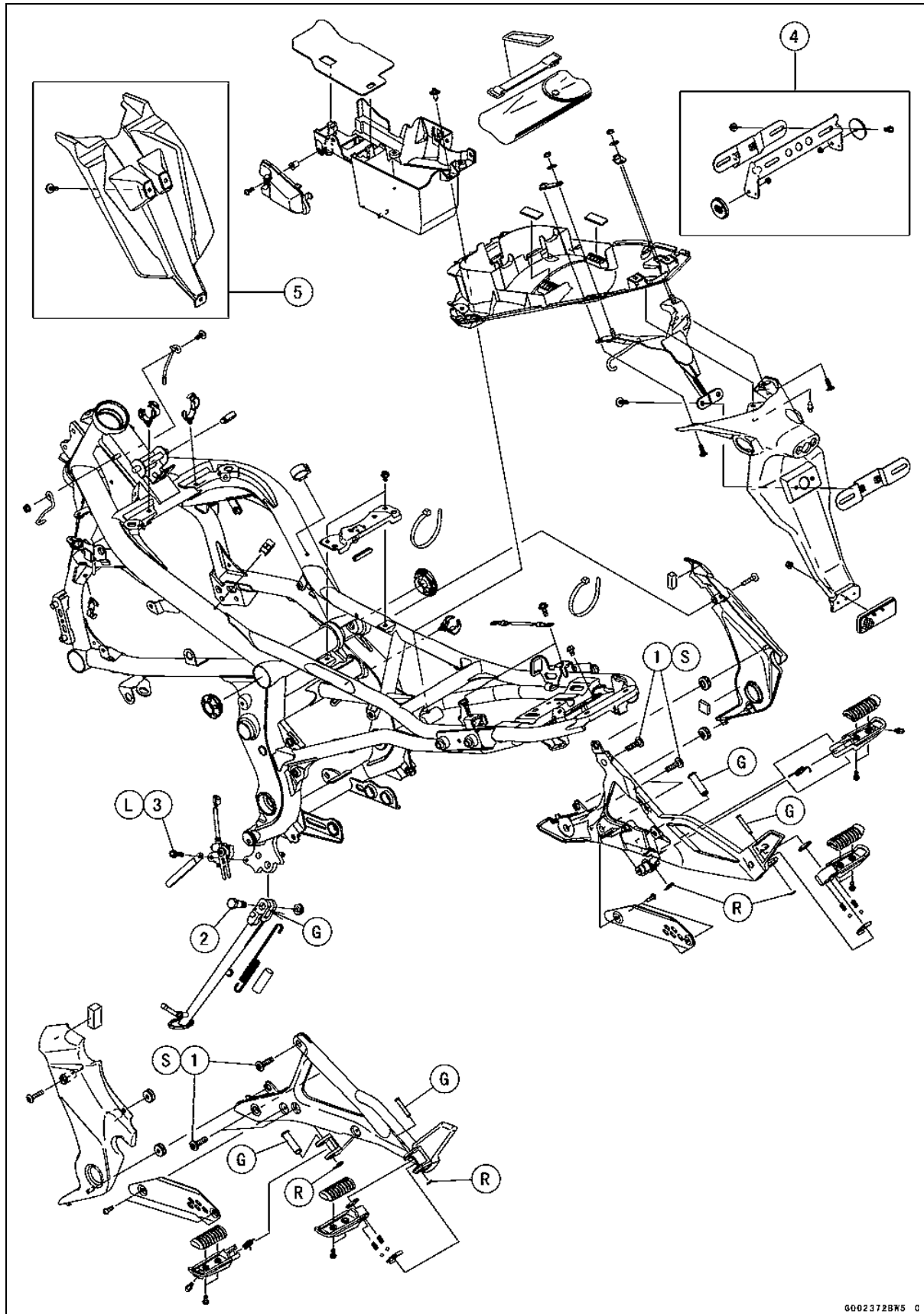

Exploded View

No.	Fastener	Torque			Remarks
		N·m	kgf·m	ft·lb	
1	Footpeg Stay Bolts	25	2.5	18	S
2	Sidestand Bolt	44	4.5	32	
3	Sidestand Switch Bolt	8.8	0.90	78 in·lb	L

4. US, CA, CAL and SEA Models

5. AU Model

G: Apply grease.

L: Apply a non-permanent locking agent.

R: Replacement Parts

S: Follow the specified tightening sequence.

15-4 FRAME

Exploded View

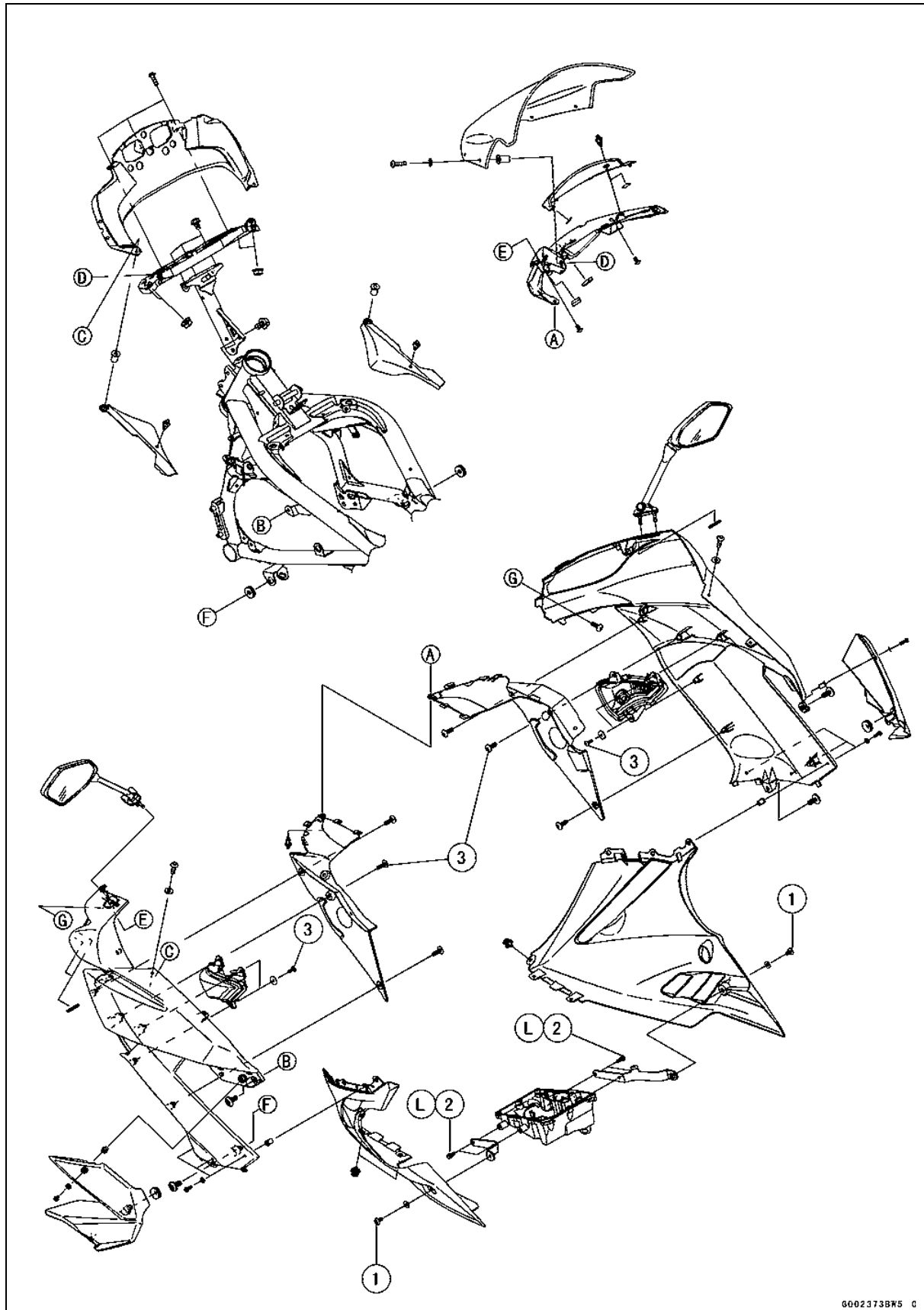

0002373BK5 C

Exploded View

No.	Fastener	Torque			Remarks
		N-m	kgf-m	ft-lb	
1	Lower Fairing Mounting Bolts	8.8	0.90	78 in-lb	
2	Lower Fairing Bracket Bolts	12	1.2	106 in-lb	L
3	Front Turn Signal Light Mounting Screws	1.2	0.12	11 in-lb	

L: Apply a non-permanent locking agent.

15-6 FRAME

Exploded View

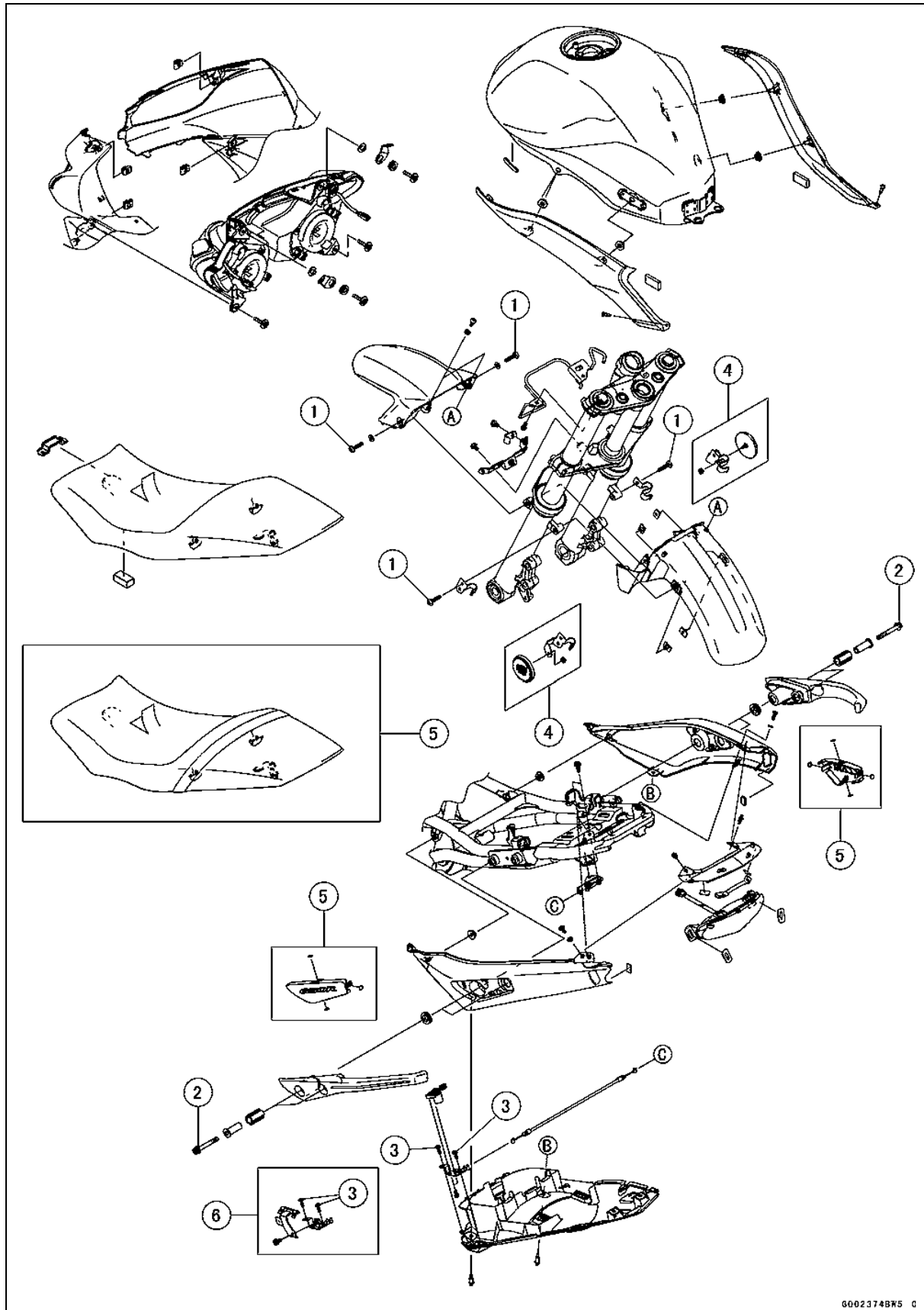

G002374BK5 C

Exploded View

No.	Fastener	Torque			Remarks
		N-m	kgf-m	ft-lb	
1	Front Fender Mounting Bolts	8.8	0.90	78 in-lb	
2	Grab Rail Mounting Bolts	25	2.5	18	
3	Seat Lock Mounting Screws	1.2	0.12	11 in-lb	

4. US, CA, CAL, AU and SEA Models

5. US, CA, CAL and AU Models

6. ABS Equipped Models

15-8 FRAME

Seat

Seat Removal

- Insert the ignition switch key [A] into the seat lock.
- Turn the key clockwise, and pull up on the rear of the seat [B].
- Remove the seat backward.

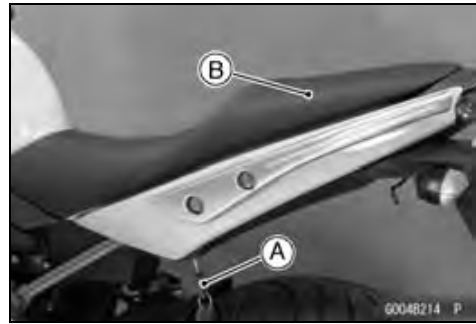

Seat Installation

- Slip the seat hook [A] to under the brace [B] of the fuel tank.
- Insert the seat hooks [C] into the hook holes [D].
- Push down the rear part of the seat until the lock clicks.

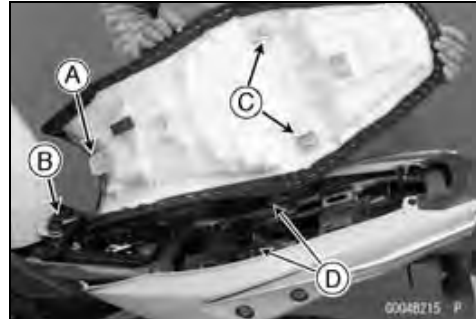

Fairings

Lower Fairing Removal

- Remove the quick rivets [A].

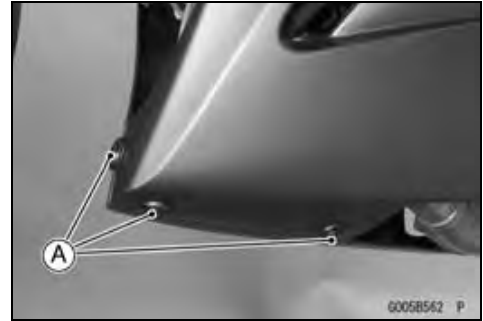

- Remove the bolts [A] and washers.
- Pull the upper fairing outward to clear the stopper [B] and take off the lower fairing [C].

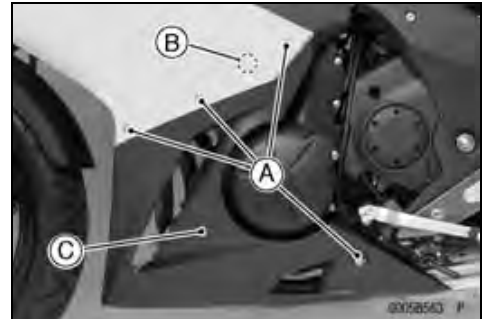

Lower Fairing Installation

- Installation is the reverse of removal; note the following.
- Insert the tabs [A] into the slots [B].

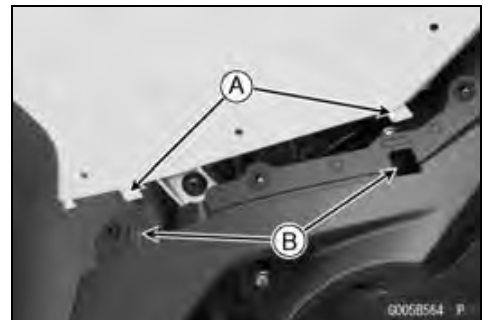

- Tighten:

Torque - Lower Fairing Mounting Bolt [A] (Both Sides): 8.8 N·m (0.90 kgf·m, 78 in·lb)

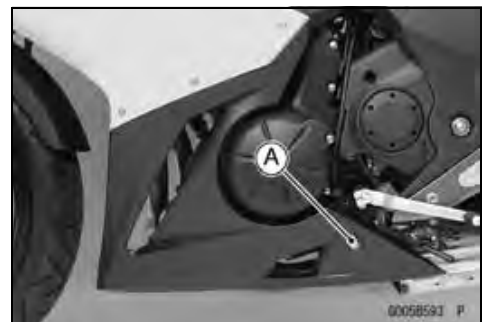

Lower Fairing Bracket Removal

- Remove:
 - Lower Fairing (see Lower Fairing Removal)
 - Lower Fairing Bracket Bolts [A]
- For right side, clear the lead from the clamp [B].

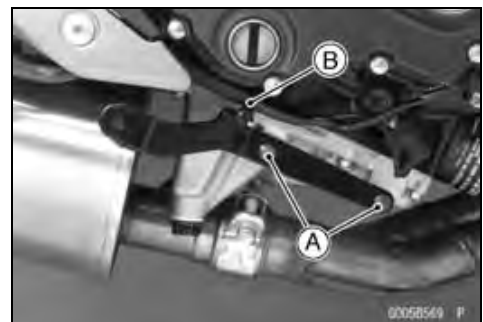

15-10 FRAME

Fairings

Lower Fairing Bracket Installation

- For right side, hold the lead with the clamp.
- Apply a non-permanent locking agent to the threads of the lower fairing bracket bolts.
- Tighten:

Torque - Lower Fairing Bracket Bolts: 12 N·m (1.2 kgf·m, 106 in·lb)

Upper Fairing Cover Removal

- Remove the mounting bolt [A] and washer.
- Pull the upper fairing cover [B] outward to clear the stopper, and then take it off.

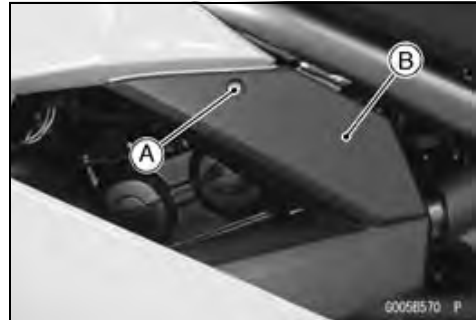

Upper Fairing Cover Installation

- Insert the tabs [A] into the slots [B].
- Insert the projections [C] into the grommets [D].
- Install the mounting bolt and washer.

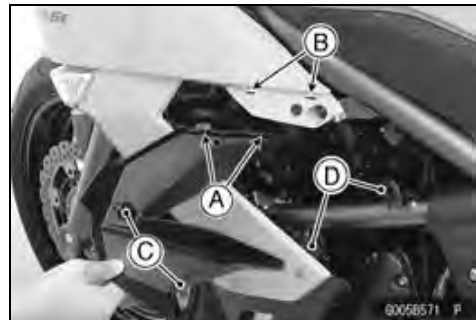

Upper Fairing Removal

- Remove:
 - Lower Fairing (see Lower Fairing Removal)
 - Upper Fairing Covers (see Upper Fairing Cover Removal)
 - Bolts [A] (Both sides)

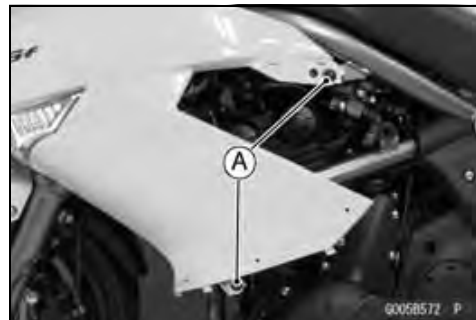

- Free the turn signal leads from the clamps on both sides.
- Disconnect:
 - City Light Lead Connector [A] (Both Sides)
 - Head Light Connector [B] (Both Sides)
 - Turn Signal Lead Connector [C] (Both Sides)

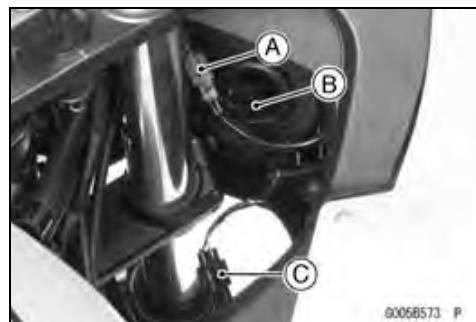

Fairings

- Remove:
 - Windshield (see Windshield Removal)
 - Quick Rivets [A]
 - Meter Cover [B]

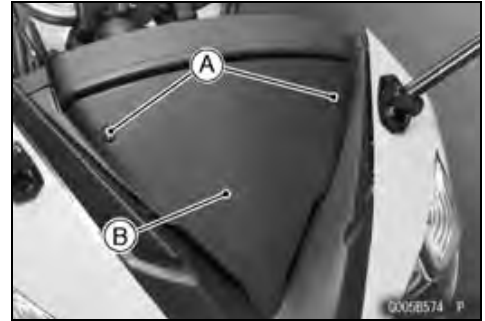

- Slide the dust cover [A] and disconnect the meter unit connector [B].
- Remove the bolts [C].

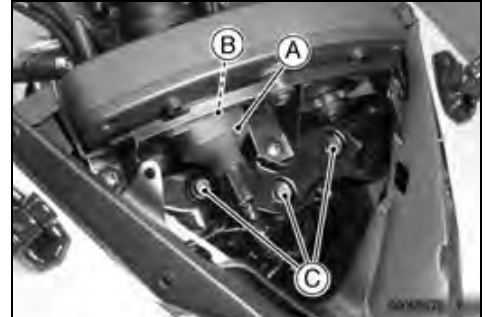

- Pull the upper fairing [A] outward to clear the stoppers [B] on both sides.
- Remove the upper fairing forward [C].



Upper Fairing Installation

- Installation is the reverse of removal; note the following.
 - Run the leads correctly (see Cable, Wire, and Hose Routing section in the Appendix chapter).

Upper Fairing Disassembly

- Remove:
 - Headlight (see Headlight Removal in the Electrical System chapter)
 - Nuts [A] and Rear View Mirrors
- Pull out the grommets [B] and remove the bracket [C].
- Remove the screws [D].

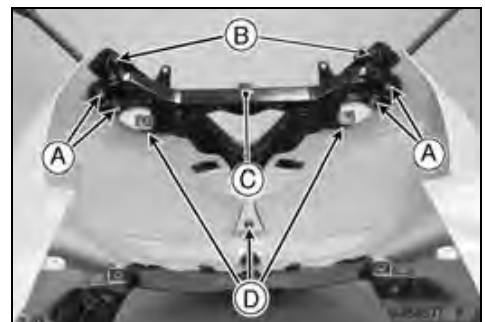

15-12 FRAME

Fairings

- Remove the quick rivet [A].
- Separate the upper center fairing [B], upper fairings [C] and inner fairings [D].

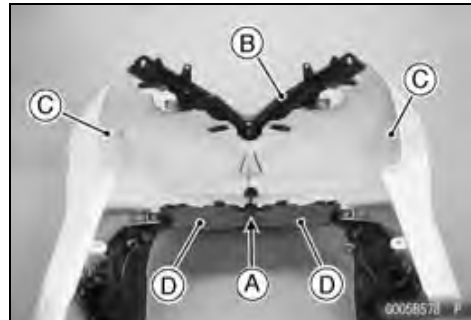

- Remove the inner fairings (see Inner Fairing Removal).
- Remove the front turn signal light mounting screws [A] and washers, and then take off the turn signal light [B].

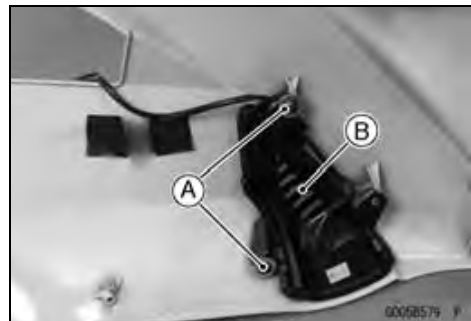

Upper Fairing Assembly

- Installation is the reverse of removal; note the following.
- Tighten:

**Torque - Front Turn Signal Light Mounting Screws: 1.2 N·m
(0.12 kgf·m, 11 in·lb)**

- Fit the ribs [A] to inside of the upper fairing [B].

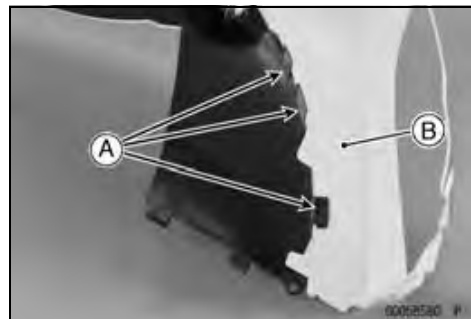

- Fit the ribs [A] to assemble the left and right inner fairings as shown in the figure.



Fairings

○ Insert the tabs [A] to the slots and fit the projections [B] to the holes as shown in the figure.



○ Install the grommets [A] to the holes [B] on both sides of the upper center fairing and bracket after rear view mirrors installation.



Upper Inner Fairing Removal

- Remove:
 - Quick Rivet [A]
 - Bolt [B] and washer
 - Upper Inner Fairing [C]



Upper Inner Fairing Installation

○ Installation is the reverse of removal.

Upper Fairing Bracket Removal

- Remove the upper fairing (see Upper Fairing Removal).
- Free the leads from the clamps [A].

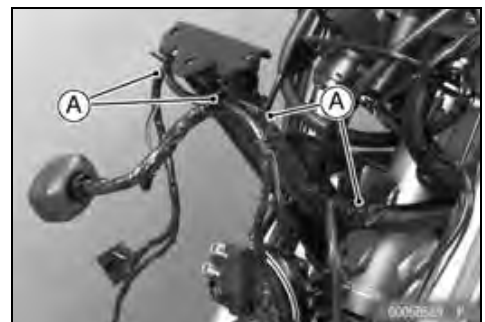

15-14 FRAME

Fairings

- Remove the bolts [A], and take off the upper fairing bracket [B].

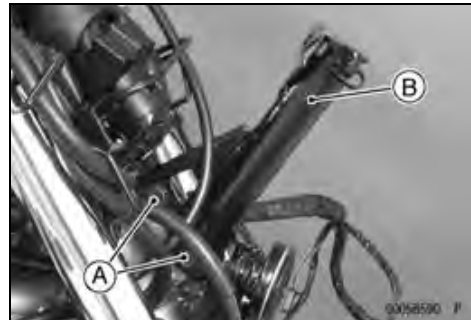

Upper Fairing Bracket Installation

- Installation is the reverse of removal.
- Run the leads correctly (see Cable, Wire, and Hose Routing section in the Appendix chapter).

Under Bracket Removal

- Remove the upper fairing (see Upper Fairing Removal).
- Free the leads from the clamp [A].
- Remove:
 - Bolt [B] with Clamp [C]
 - Bolts [D]

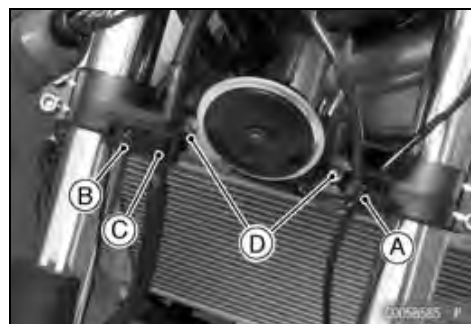

Under Bracket Installation

- Installation is the reverse of removal; note the following.
- Run the leads correctly (see Cable, Wire, and Hose Routing section in the Appendix chapter).

Inner Fairing Removal

- Remove:
 - Headlight (see Headlight Removal in the Electrical System chapter).
 - Quick Rivet [A]
- Separate the left and right inner fairings [B].

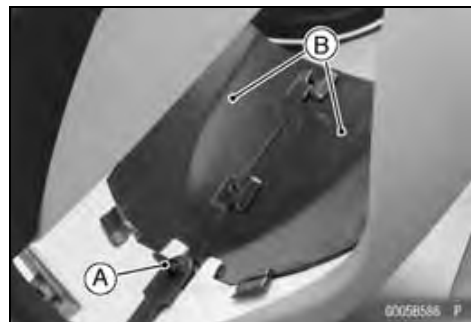

- Free the lead from the clamp [A].
- Remove:
 - Screws [B]
 - Inner Fairing [C]

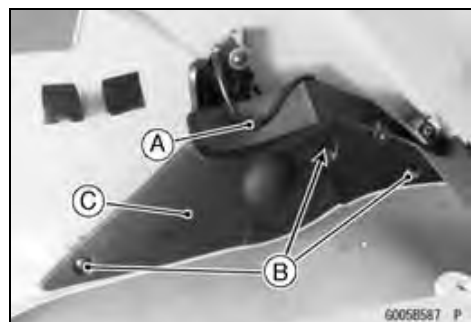

Fairings

Inner Fairing Installation

● Installation is the reverse of removal; note the following.

○ Tighten:

Torque - Front Turn Signal Light Mounting Screw [A]: 1.2 N·m (0.12 kgf·m, 11 in·lb)

○ Fit the ribs [A] to inside of the upper fairing [B].

○ Fit the ribs [C] to assemble the left and right inner fairings as shown in the figure.

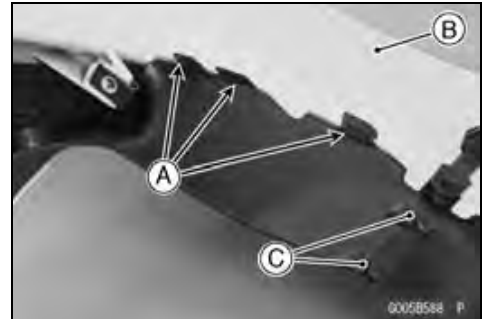

15-16 FRAME

Side Covers

Side Cover Removal

- Remove the seat (see Seat Removal).
- Remove the quick rivet [A].
- Pull the side cover [B] evenly outward to clear the stoppers.

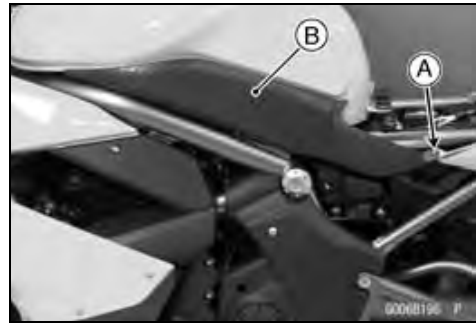

Side Cover Installation

- Install the trim [A] securely.
- Install the side cover.
- Fit the rib [B] to inside of the trim.
- Insert the projections [C] into the grommets [D].
- Install the quick rivet.

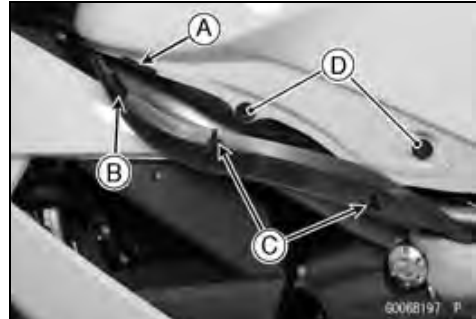

Seat Covers

Seat Cover Removal

- Remove:
 - Seat (see Seat Removal)
 - Quick Rivets [A]
 - Center Seat Cover [B]

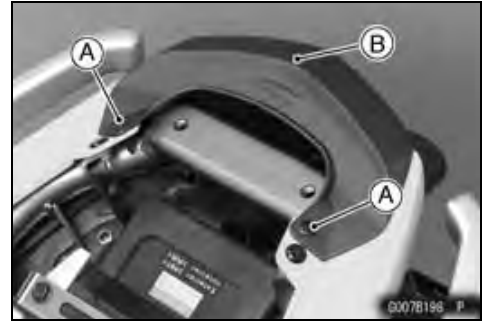

- Remove:
 - Bolts [A]
 - Grab Rail [B] (Equipped Models)

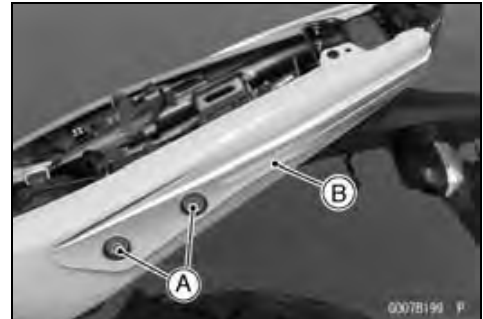

- Remove:
 - Screw [A] and washer



- Remove:
 - Quick Rivets [A]
 - Seat Cover [B]

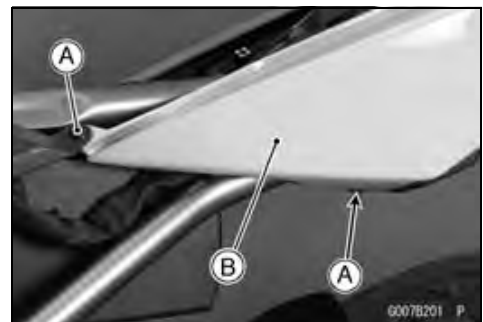

Seat Cover Installation

- Install the damper [A] to the seat cover [B] so that the arrow mark [C] faces upward.

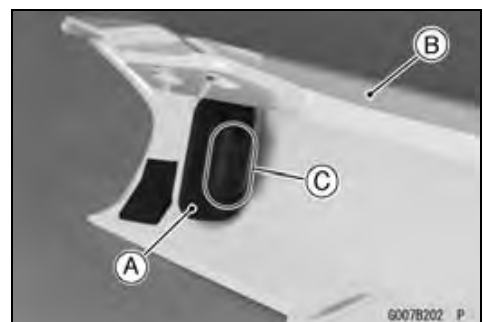

15-18 FRAME

Seat Covers

- Install the seat cover.
- Fit the projection [A] into the grommet [B].
- Insert the ribs [C] into the inside of the rear fender.

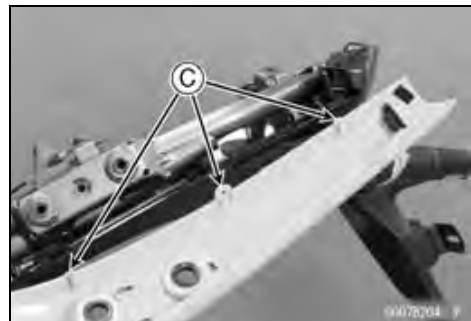

- Install:
 - Screw
 - Quick Rivets
 - Grab Rail (Equipped Models)
- Tighten:
 - Torque - Grab Rail Mounting Bolts: 25 N·m (2.5 kgf·m, 18 ft·lb)**

- Install the center seat cover [A].
- Fit the projections [B] into the seat cover slits [C].
- Install the quick rivets.

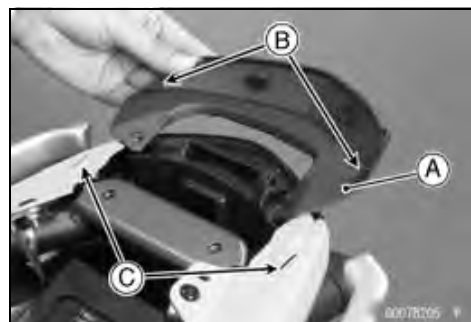

Fenders

Front Fender Removal

- Remove:
 - Front Fender Bolts [A] (Both Sides)
 - Front Fender [B]

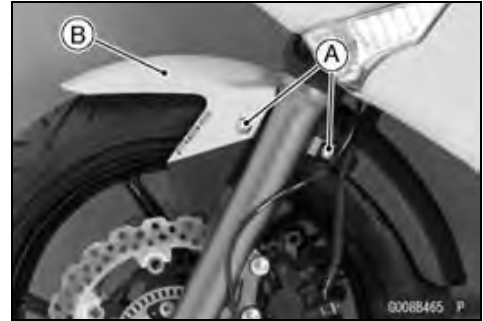

Front Fender Installation

- Install the front fender [A] together with the brake hose clamp [B] on both sides.
- Tighten
 - Torque - Front Fender Mounting Bolts [C]: 8.8 N·m (0.90 kgf·m, 78 in·lb)



Flap Removal

- Remove:
 - Seat (see Seat Removal)
 - Seat Covers (see Seat Cover Removal)
 - Rear Right Turn Signal Light Lead Connector [A]
 - Rear Left Turn Signal Light Lead Connector [B]
 - License Plate Light Lead Connector [C]

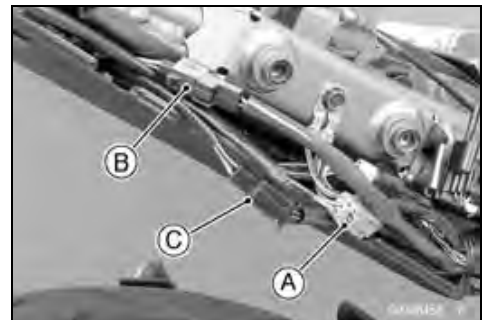

- Remove:
 - Bolts [A]
 - Nuts [B] and Washers

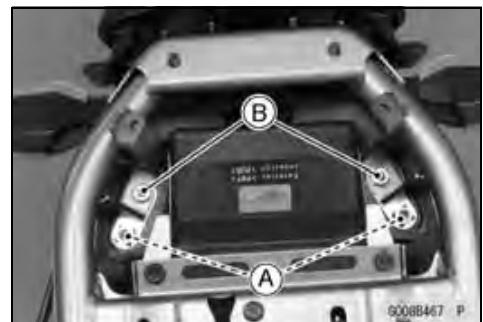

- Clear the leads from the clamp [A].
- Remove the quick rivet [B], and take off the flap [C].

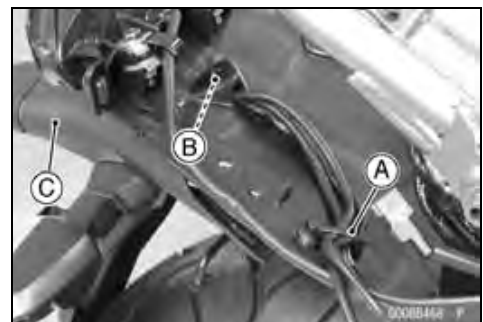

Flap Installation

- Installation is the reverse of removal.

15-20 FRAME

Fenders

Rear Fender Removal

- Remove:
 - Seat Cover (see Seat Cover Removal)
 - Rear Right Turn Signal Light Lead Connector [A]
 - Rear Left Turn Signal Light Lead Connector [B]
 - License Plate Light Lead Connector [C]
 - Tail/Brake Light Lead Connector [D]
- Clear the harness and leads from the clamp [E].

- For models equipped with an ABS, remove the fuse holder bolt [A].

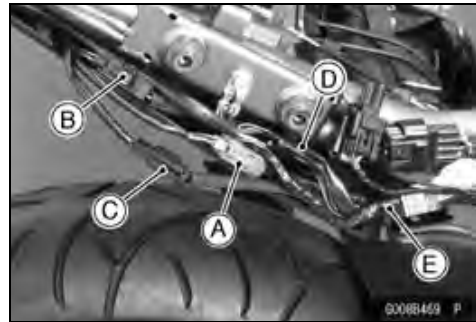

- Free the seat lock cable end [A].
- Remove the quick rivet [B].



- Remove the nuts [A] and washers.

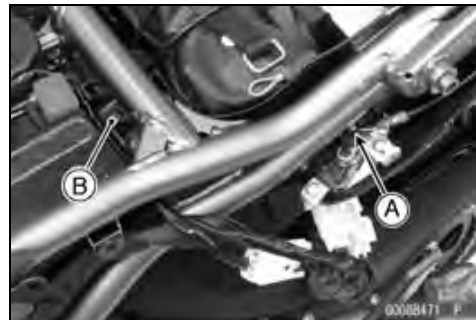

- Clear the leads from the clamp [A], and take off the rear fender.

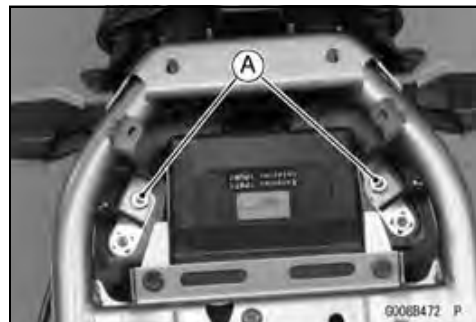

Rear Fender Installation

- Installation is the reverse of removal.



Frame

Frame Inspection

- Visually inspect the frame for cracks, dents, bending or warp.
- If there is any damage to the frame, replace it.

⚠ WARNING

A repaired frame may fail in use, possibly causing an accident. If the frame is bent, dented, cracked, or warped, replace it.

15-22 FRAME

Battery Case

Battery Case Removal

- Remove:
 - Seat Cover (see Seat Cover Removal)
 - Battery (see Battery Removal in the Electrical System chapter)
 - Fuel Tank (see Fuel Tank Removal in the Fuel System (DFI) chapter)
- Free the harness from the clamp [A].
- Remove the bolts [B] and remove the fuel tank bracket [C].

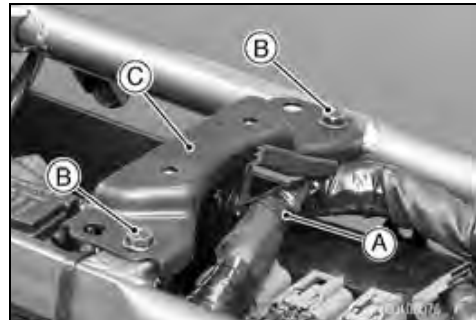

- Free the harness from the clamp [A].



- Remove the bolt [A], and lower the rear brake reservoir [B].

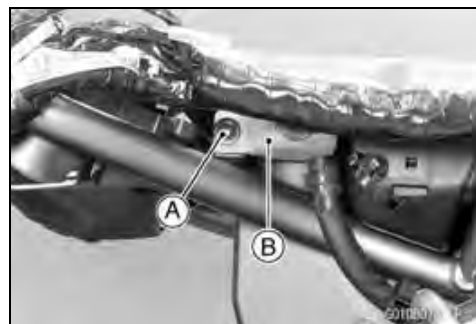

- Remove the bolt [A] and remove the starter relay cover [B].
- Pull the starter relay from the battery case.

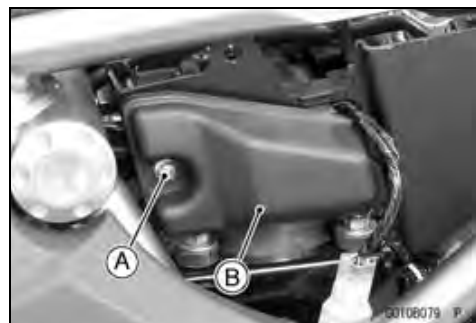

Battery Case

- Remove:
 - Clamp [A]
 - Fuse Box [B]
 - Quick Rivet [C]

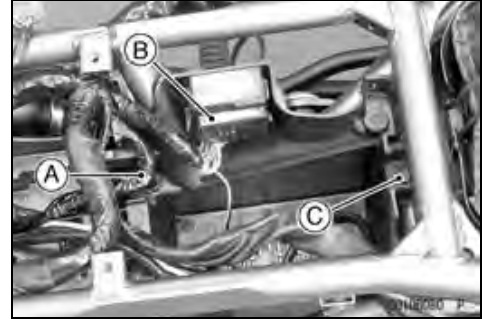

- Remove the battery case [A].

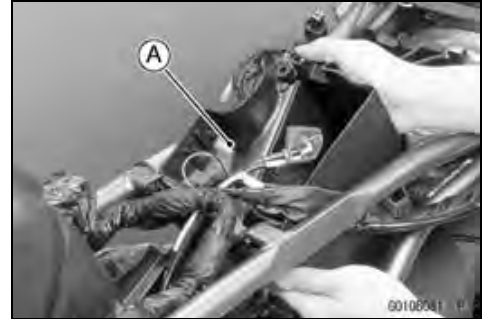

Battery Case Installation

- Installation is the reverse of removal.
- Run the cables and harness correctly (see Cable, Wire, and Hose Routing section in the Appendix chapter).

15-24 FRAME

Footpeg Stay

Footpeg Stay Removal

- Remove:
 - Frame Cover (see Frame Cover Removal)
 - Bolts [A]
 - Footpeg Stay Guard [B]

- Remove:
 - Footpeg Stay Bolts [A]
 - Footpeg Stay [B]
 - Rear Master Cylinder (Right Side, see Rear Master Cylinder Removal in the Brakes chapter)
 - Brake Pedal (Right Side, see Brake Pedal Removal in the Brakes chapter)
 - Rear Brake Light Switch Lead Connector (Right Side)

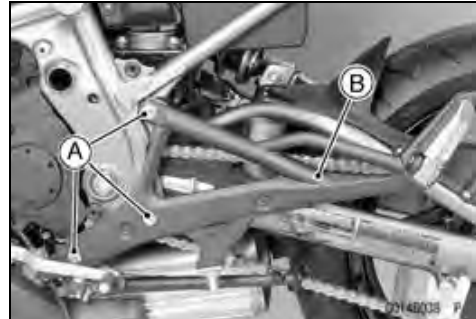
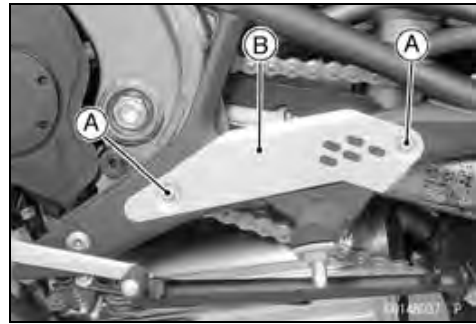

Footpeg Stay Installation

- Install:
 - Rear Master Cylinder (Right Side, see Rear Master Cylinder Installation in the Brakes chapter)
 - Brake Pedal (Right Side, see Brake Pedal Installation in the Brakes chapter)
 - Rear Brake Light Switch Lead Connector (Right Side)

- Install the footpeg stay temporary.
- Tighten the footpeg stay bolts loosely following the specified tightening sequence [1 ~ 3].
- Tighten the footpeg stay bolts following the specified tightening sequence [1 ~ 3].
 - Torque - Footpeg Stay Bolts: 25 N·m (2.5 kgf·m, 18 ft·lb)**
- Install:
 - Footpeg Stay Guard
 - Bolts



Windshield

Windshield Removal

- Remove:
 - Bolts [A] and Washers
 - Windshield [B]

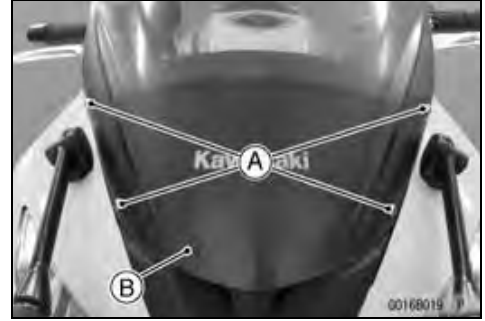

Windshield Installation

- Installation is the reverse of removal.

15-26 FRAME

Sidestand

Sidestand Removal

- Raise the rear wheel off the ground using a stand [A].
- Remove:
 - Left Frame Cover (see Frame Cover Removal)
 - Left Footpeg Stay (see Footpeg Stay Removal)



- Remove:
 - Sidestand Switch Bolt [A] with Clamp [B]
 - Sidestand Switch [C]

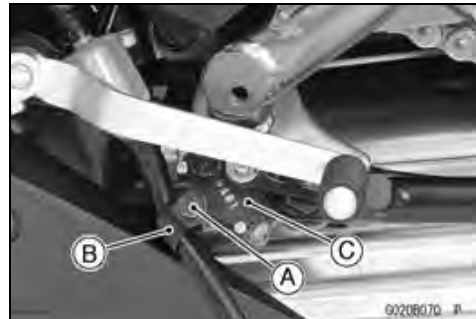

- Remove:
 - Spring [A]
 - Sidestand Nut [B]
 - Sidestand Bolt [C]
 - Sidestand [D]

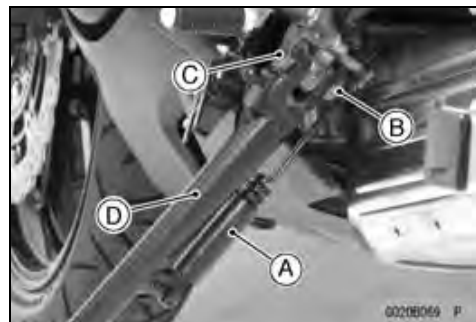

Sidestand Installation

- Apply grease to the sliding area [A] of the sidestand [B].
- Tighten the sidestand bolt and lock them with the nut.
 - Torque - Sidestand Bolt: 44 N·m (4.5 kgf·m, 32 ft·lb)**
- Hook the spring as shown in the figure.
- Install the sidestand switch and clamp.
- Apply a non-permanent locking agent to the thread of the sidestand switch bolt.
- Tighten:
 - Torque - Sidestand Switch Bolt: 8.8 N·m (0.90 kgf·m, 78 in·lb)**
- Install the footpeg stay (see footpeg Stay Installation).

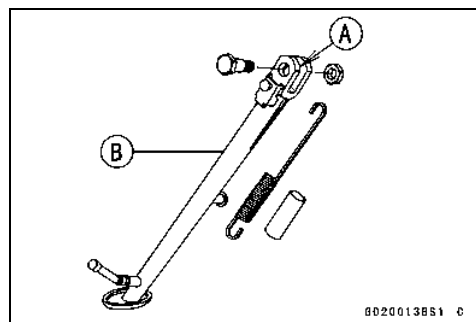

Frame Cover

Frame Cover Removal

- Remove the bolt [A].
- Pull the frame cover [B] outward to clear the stoppers.

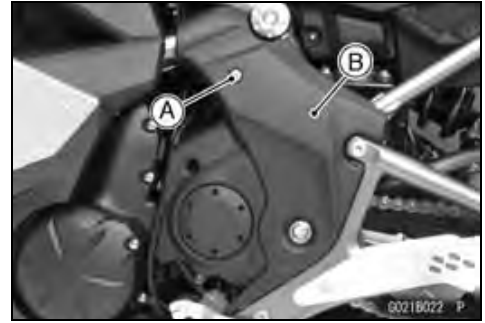

Frame Cover Installation

- Fit the rib [A] to the inside of the footpeg stay.
- Insert the projections [B] into the grommets [C].
- Tighten the bolt.

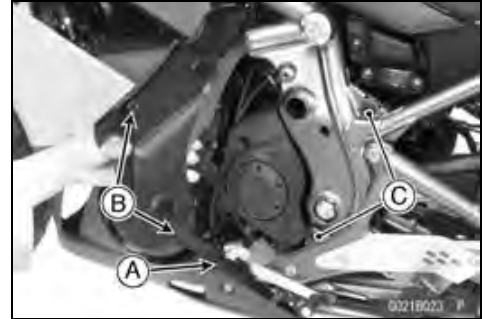

15-28 FRAME

Rear View Mirrors

Rear View Mirror Removal

- Remove:
 - Center Inner Fairing together with Meter Unit (see Meter Unit Removal in the Electrical System chapter)
 - Nuts [A]
 - Rear View Mirror [B]



Rear View Mirror Installation

- Installation is the reverse of removal.

Electrical System

Table of Contents

Exploded View.....	16-4
Specifications	16-10
Special Tools and Sealant	16-11
Parts Location.....	16-12
Wiring Diagram (Other than US, CA and CAL Models).....	16-14
Wiring Diagram (US, CA and CAL Models).....	16-16
Wiring Diagram (EX650D Models)	16-18
Precautions.....	16-20
Electrical Wiring.....	16-21
Wiring Inspection	16-21
Battery	16-22
Battery Removal	16-22
Battery Installation	16-22
Battery Activation	16-22
Precautions.....	16-25
Interchange.....	16-25
Charging Condition Inspection.....	16-26
Refreshing Charge	16-26
Charging System.....	16-28
Alternator Cover Removal.....	16-28
Alternator Cover Installation.....	16-28
Stator Coil Removal.....	16-29
Stator Coil Installation.....	16-29
Alternator Rotor Removal	16-29
Alternator Rotor Installation	16-30
Alternator Inspection.....	16-31
Regulator/Rectifier Inspection.....	16-32
Charging Voltage Inspection.....	16-35
Starter Motor Clutch	16-37
Starter Motor Clutch Removal/Installation	16-37
Starter Motor Clutch Inspection	16-37
Starter Motor Clutch Disassembly	16-37
Starter Motor Clutch Assembly	16-37
Ignition System.....	16-38
Crankshaft Sensor Removal.....	16-38
Crankshaft Sensor Installation.....	16-39
Crankshaft Sensor Inspection.....	16-39
Crankshaft Sensor Peak Voltage Inspection.....	16-39
Timing Rotor Removal	16-40
Timing Rotor Installation	16-40
Stick Coil Removal.....	16-40
Stick Coil Installation.....	16-40
Stick Coil Inspection.....	16-41
Stick Coil Primary Peak Voltage Inspection	16-41
Spark Plug Removal	16-42
Spark Plug Installation	16-42
Spark Plug Condition Inspection.....	16-42
Interlock Operation Inspection	16-43
IC Igniter Inspection	16-44
Electric Starter System.....	16-47

16-2 ELECTRICAL SYSTEM

Starter Motor Removal.....	16-47
Starter Motor Installation.....	16-47
Starter Motor Disassembly.....	16-48
Starter Motor Assembly	16-48
Brush Inspection	16-50
Commutator Cleaning and Inspection.....	16-50
Armature Inspection.....	16-51
Brush Lead Inspection	16-51
Right-hand End Cover Inspection	16-51
Starter Relay Inspection.....	16-51
Lighting System.....	16-54
Headlight Beam Horizontal Adjustment.....	16-54
Headlight Beam Vertical Adjustment.....	16-54
Headlight Bulb Replacement	16-54
City Light Bulb Replacement.....	16-55
Headlight Removal.....	16-55
Headlight Installation.....	16-55
Tail/Brake Light (LED) Removal.....	16-56
Tail/Brake Light (LED) Installation.....	16-56
License Plate Light Bulb Replacement	16-56
Turn Signal Light Bulb Replacement	16-58
Turn Signal Relay Inspection	16-58
Air Switching Valve	16-61
Air Switching Valve Operation Test.....	16-61
Air Switching Valve Unit Test	16-61
Radiator Fan System.....	16-63
Fan Motor Inspection	16-63
Meter, Gauge, Indicator Unit.....	16-64
Meter Unit Removal/Installation	16-64
Meter, Gauge Disassembly.....	16-65
Electronic Combination Meter Unit Inspection	16-65
Switches and Sensors	16-74
Brake Light Timing Inspection.....	16-74
Brake Light Timing Adjustment	16-74
Switch Inspection	16-74
Water Temperature Sensor Inspection	16-75
Speed Sensor Removal.....	16-75
Speed Sensor Installation	16-75
Speed Sensor Inspection.....	16-76
Fuel Level Sensor Inspection.....	16-76
Oxygen Sensor Removal (Equipped Models).....	16-77
Oxygen Sensor Installation (Equipped Models).....	16-77
Oxygen Sensor Inspection (Equipped Models).....	16-77
Fuel Reserve Switch Inspection.....	16-78
Relay Box	16-79
Relay Box Removal	16-79
Relay Circuit Inspection	16-79
Diode Circuit Inspection.....	16-80
Fuse.....	16-82
30 A Main Fuse Removal.....	16-82
Fuse Box Fuse Removal.....	16-82
15 A ECU Fuse Removal.....	16-82
Fuse Installation.....	16-83
Fuse Inspection.....	16-83

Dummy Page

16-4 ELECTRICAL SYSTEM

Exploded View

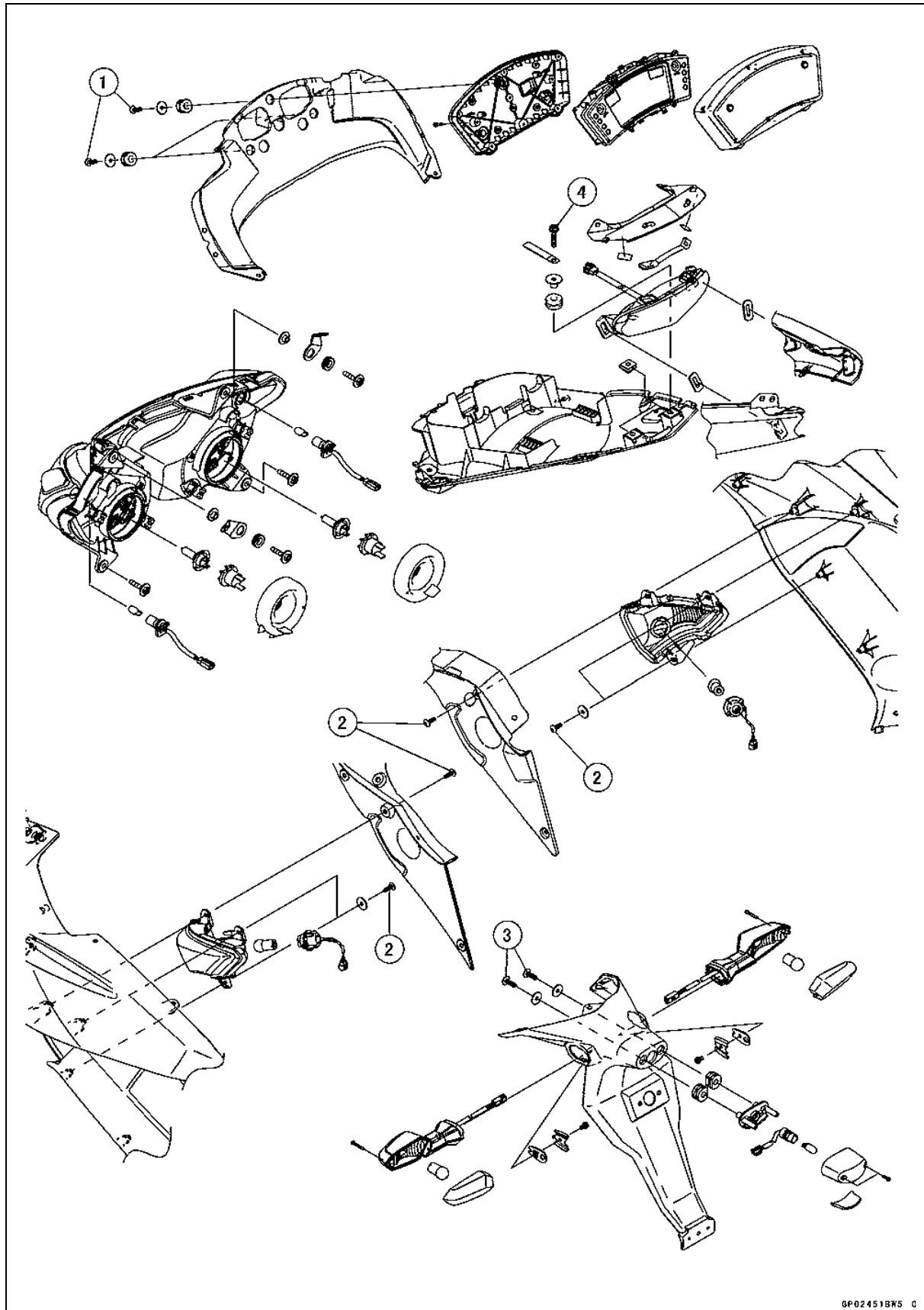

GP02451BK5 C

Exploded View

No.	Fastener	Torque			Remarks
		N·m	kgf·m	ft·lb	
1	Meter Cover Screws	1.2	0.12	11 in·lb	
2	Front Turn Signal Light Mounting Screws	1.2	0.12	11 in·lb	
3	License Plate Light Mounting Screws	1.2	0.12	11 in·lb	
4	Tail/Brake Light Mounting Bolts	8.8	0.90	78 in·lb	

16-6 ELECTRICAL SYSTEM

Exploded View

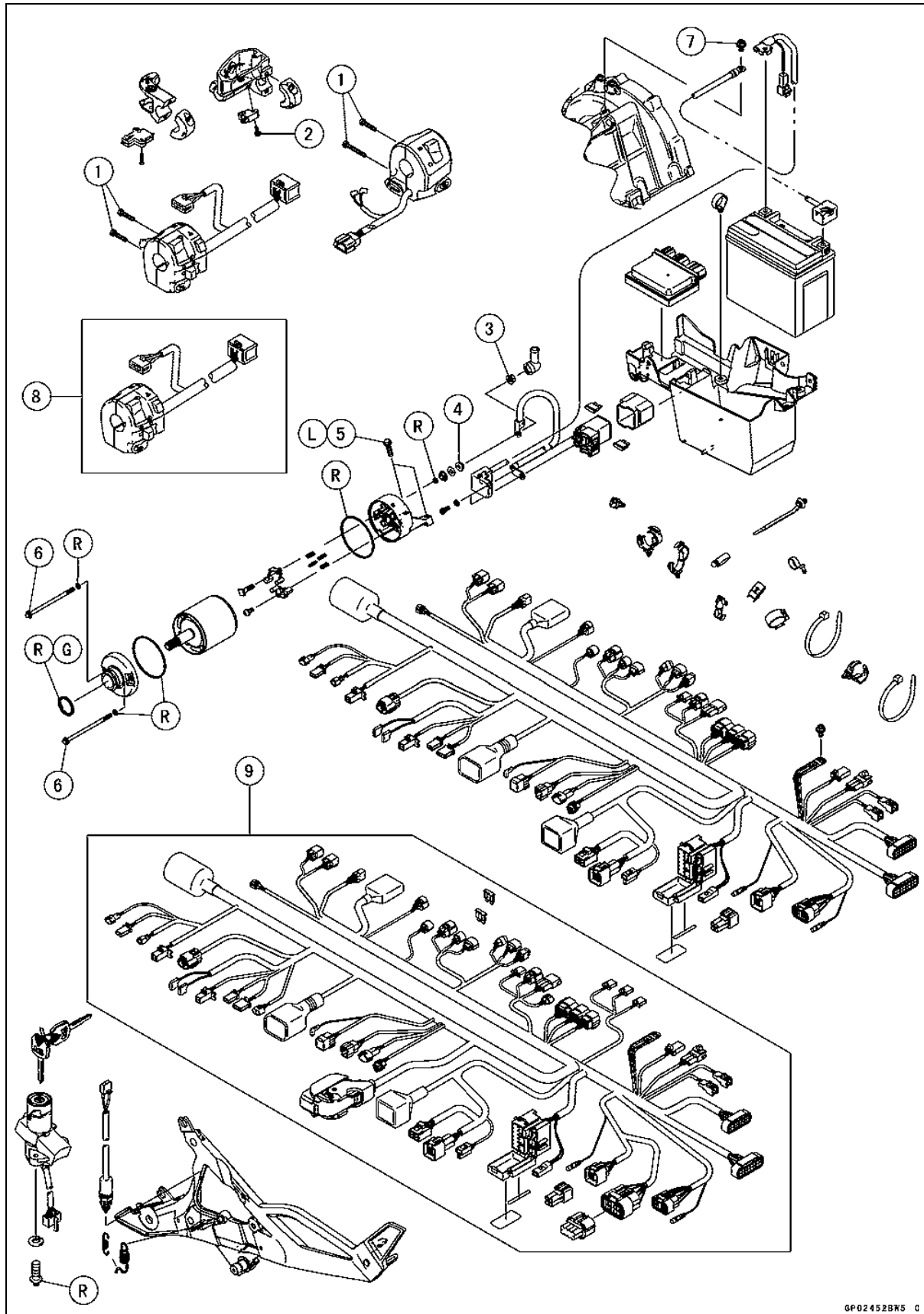

GP02452BK5 C

Exploded View

No.	Fastener	Torque			Remarks
		N·m	kgf·m	ft·lb	
1	Switch Housing Screws	3.5	0.36	31 in·lb	
2	Front Brake Light Switch Screw	1.2	0.12	11 in·lb	
3	Starter Motor Terminal Nut	6.0	0.61	53 in·lb	
4	Starter Motor Terminal Locknut	11	1.1	97 in·lb	
5	Starter Motor Mounting Bolts	9.8	1.0	87 in·lb	L
6	Starter Motor Through Bolts	5.0	0.51	44 in·lb	
7	Engine Ground Lead Terminal Bolt	9.8	1.0	87 in·lb	

8. US, CA and CAL Models

9. EX650D Models

G: Apply grease.

L: Apply a non-permanent locking agent.

R: Replacement Parts

16-8 ELECTRICAL SYSTEM

Exploded View

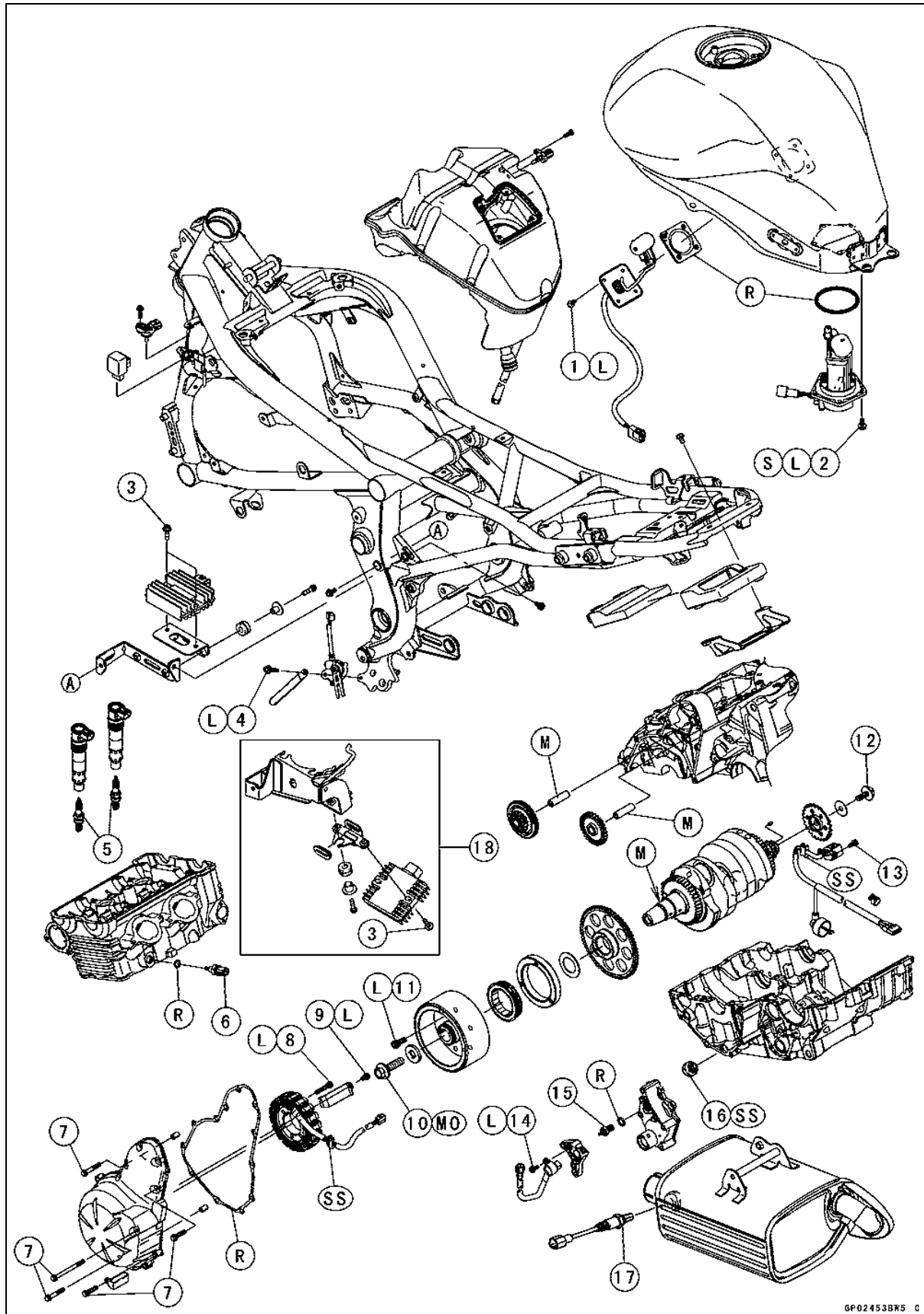

GP02453BK5 C

Exploded View

No.	Fastener	Torque			Remarks
		N-m	kgf-m	ft-lb	
1	Fuel Level Sensor Bolts	6.9	0.70	61 in-lb	L
2	Fuel Pump Bolts	9.8	1.0	87 in-lb	L, S
3	Regulator/Rectifier Bolts	8.8	0.90	78 in-lb	
4	Sidestand Switch Bolt	8.8	0.90	78 in-lb	L
5	Spark Plugs	15	1.5	11	
6	Water Temperature Sensor	12	1.2	106 in-lb	
7	Alternator Cover Bolts	9.8	1.0	87 in-lb	
8	Stator Coil Bolts	12	1.2	106 in-lb	L
9	Alternator Lead Holding Plate Bolt	9.8	1.0	87 in-lb	L
10	Alternator Rotor Bolt	155	15.8	114	MO
11	Starter Motor Clutch Bolts	34	3.5	25	L
12	Timing Rotor Bolt	40	4.1	30	
13	Crankshaft Sensor Bolts	6.0	0.61	53 in-lb	
14	Speed Sensor Bolt	7.8	0.80	69 in-lb	L
15	Neutral Switch	15	1.5	11	
16	Oil Pressure Switch	15	1.5	11	SS
17	Oxygen Sensor (Equipped Models)	44	4.5	32	

18. EX650D Models

L: Apply a non-permanent locking agent.

M: Apply molybdenum disulfide grease.

MO: Apply molybdenum disulfide oil solution.

(Mixture of the engine oil and molybdenum disulfide grease in a weight ratio 10 : 1)

R: Replacement Parts

SS: Apply silicone sealant.

16-10 ELECTRICAL SYSTEM

Specifications

Item	Standard
Battery	
Type	Sealed Battery
Model Name	FTX12-BS
Capacity	12 V 10 Ah
Voltage	12.6 V or more
Charging System	
Type	Three-phase AC
Alternator Output Voltage	42 V or more at 4 000 r/min (rpm)
Stator Coil Resistance	0.18 ~ 0.27 Ω
Charging Voltage (Regulator/Rectifier Output Voltage)	14.2 ~ 15.2 V
Ignition System	
Crankshaft Sensor:	
Resistance	376 ~ 564 Ω
Peak Voltage	2.0 V or more
Stick Coil:	
Primary Winding Resistance	1.1 ~ 1.5 Ω at 20 °C (68 °F)
Secondary Winding Resistance	10.8 ~ 16.2 k Ω at 20 °C (68 °F)
Primary Peak Voltage	117 V or more
Spark Plug:	
Type	NGK CR9EIA-9
Gap	0.8 ~ 0.9 mm (0.031 ~ 0.035 in.)
Electric Starter System	
Starter Motor:	
Brush Length	12 mm (0.47 in.) (Service limit: 6.5 mm, 0.26 in.)
Commutator Diameter	28 mm (1.10 in.) (Service limit: 27 mm, 1.06 in.)
Air Switching Valve	
Resistance	18 ~ 22 Ω at 20°C (68°F)
Switch and Sensor	
Rear Brake Light Switch Timing	ON after about 10 mm (0.39 in.) pedal travel
Fuel Level Sensor Resistance:	5 ~ 7 Ω at Full Position 204 ~ 210 Ω at Empty Position
Engine Oil Pressure Switch Connections	When engine is stopped: ON When engine is running: OFF
Water Temperature Sensor Resistance	in the text

Special Tools and Sealant

Hand Tester:
57001-1394

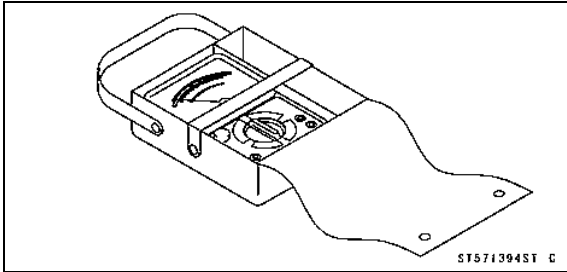

Grip:
57001-1591

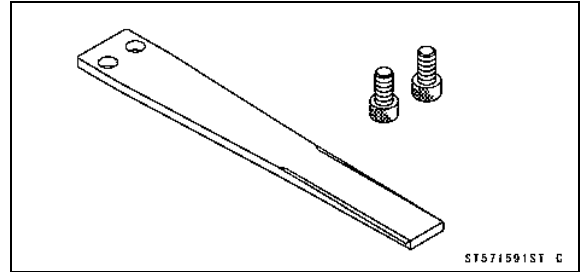

Flywheel Puller Assembly, M38 x 1.5/M35 x 1.5:
57001-1405

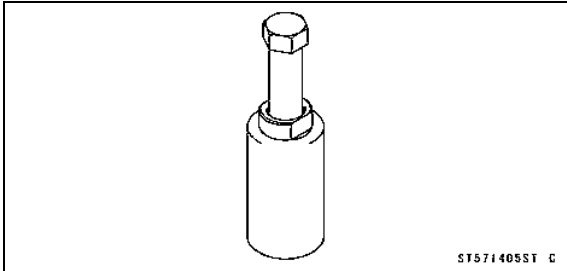

Rotor Holder:
57001-1567

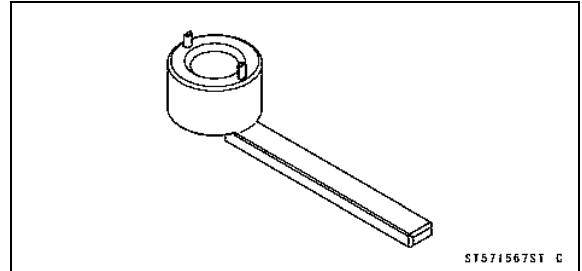

Peak Voltage Adapter:
57001-1415

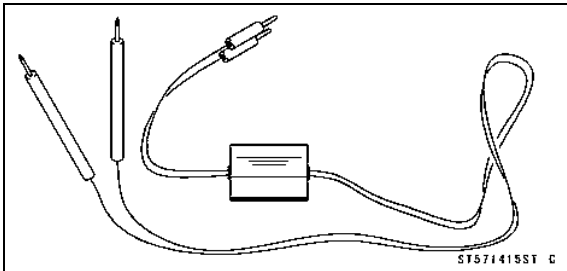

Rotor Holder:
57001-1658

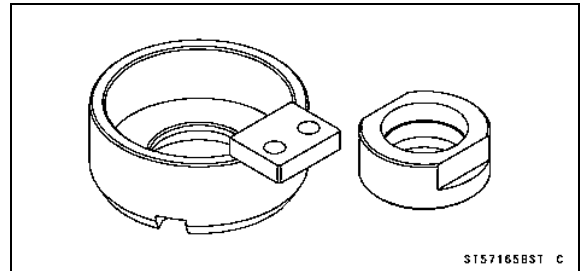

Lead Wire - Peak Voltage Adapter:
57001-1449

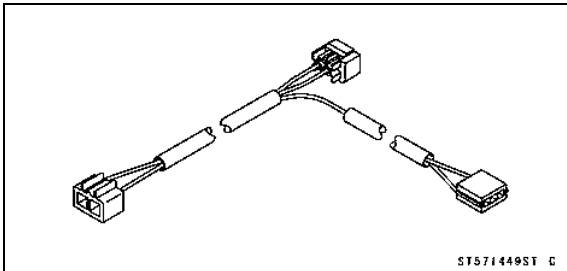

Kawasaki Bond (Silicone Sealant):
92104-0004

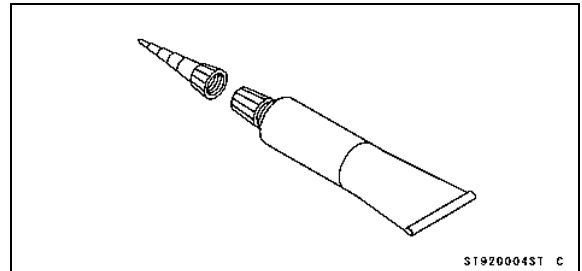

16-12 ELECTRICAL SYSTEM

Parts Location

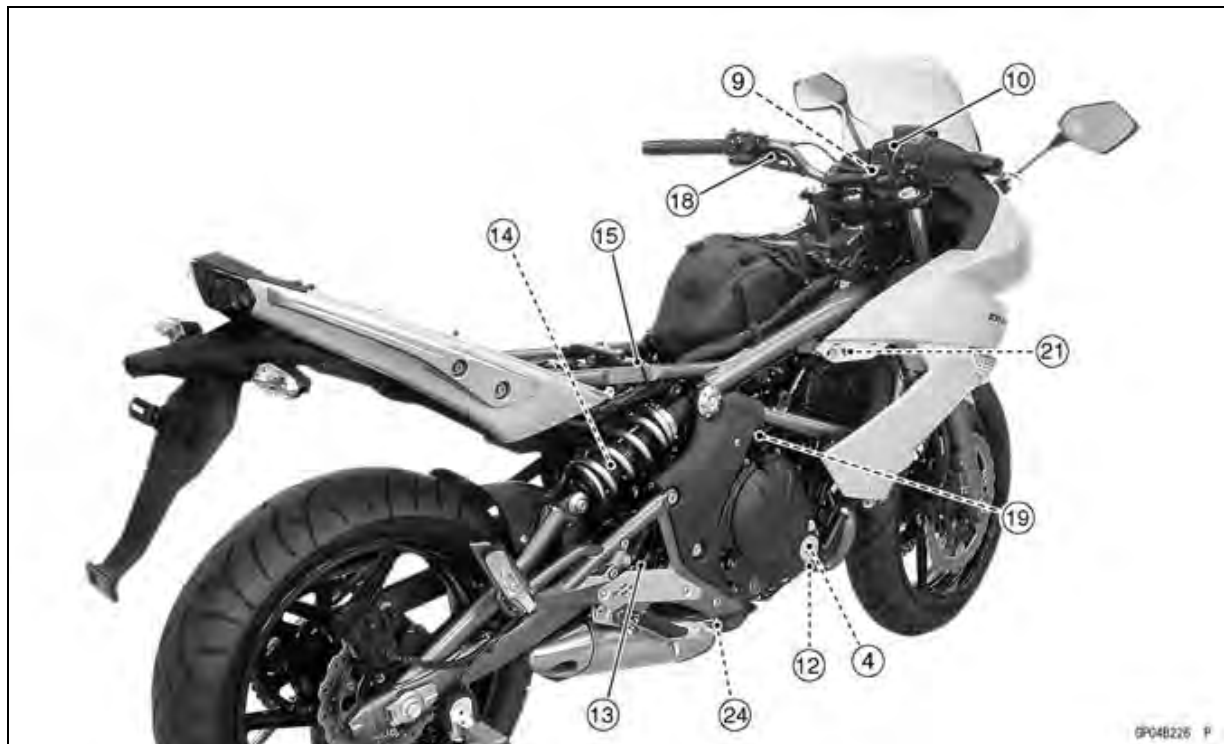

Parts Location

1. Air Switching Valve
2. Alternator
3. Battery 12 V 10 Ah
4. Crankshaft Sensor
5. ECU
6. Radiator Fan Motor
7. Front Brake Light Switch
8. Fuse Box with ECU Main Fuse
9. Ignition Switch
10. Meter Unit
11. Neutral Switch
12. Oil Pressure Switch
13. Rear Brake Light Switch
14. Regulator/Rectifier
15. Relay Box
16. Sidestand Switch
17. Speed Sensor
18. Starter Lockout Switch
19. Starter Motor
20. Starter Relay with Main Fuse
21. Stick Coils
22. Turn Signal Relay
23. Water Temperature Sensor
24. Oxygen Sensor (Equipped Models)

16-14 ELECTRICAL SYSTEM

Wiring Diagram (Other than US, CA and CAL Models)

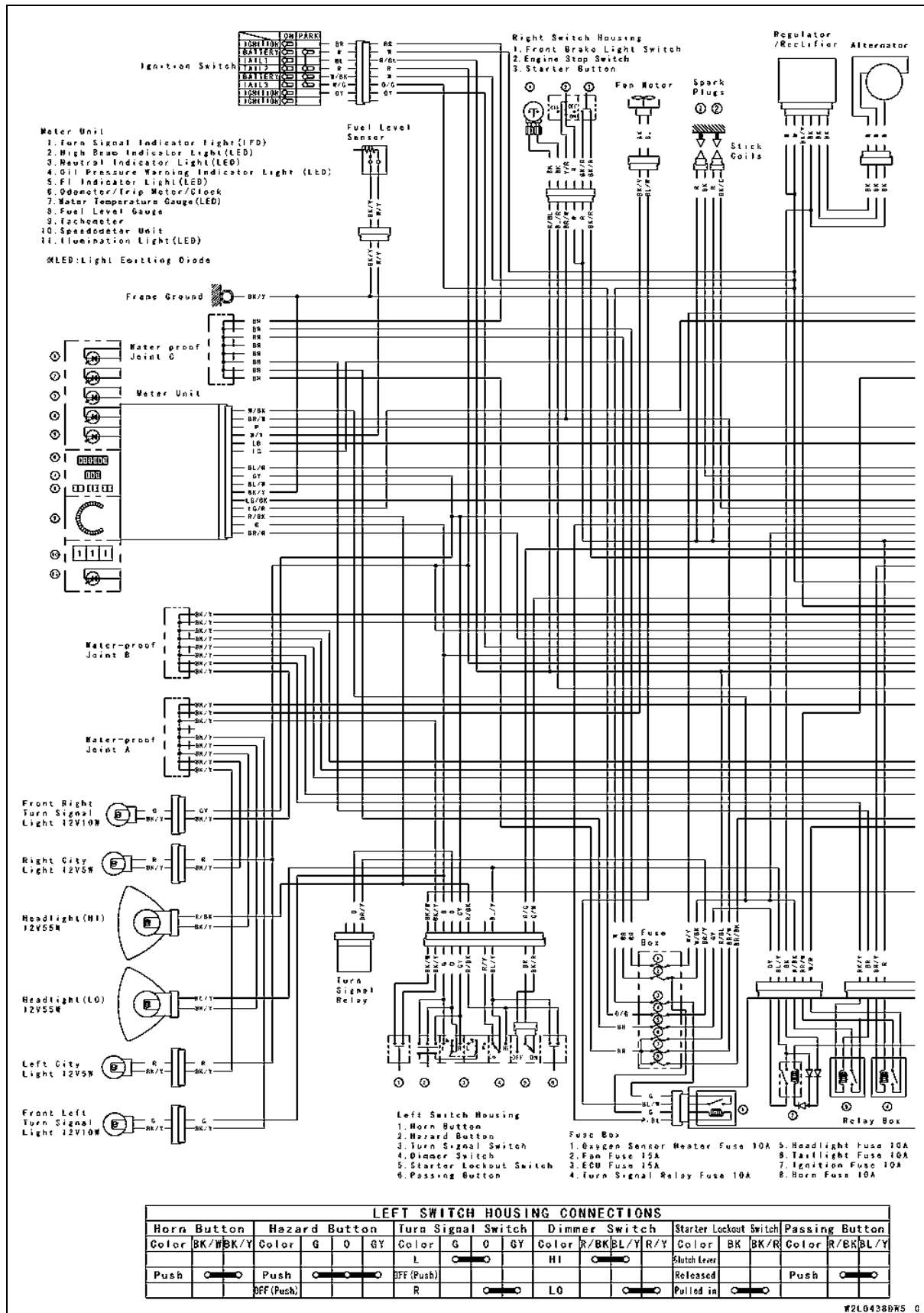

Wiring Diagram (Other than US, CA and CAL Models)

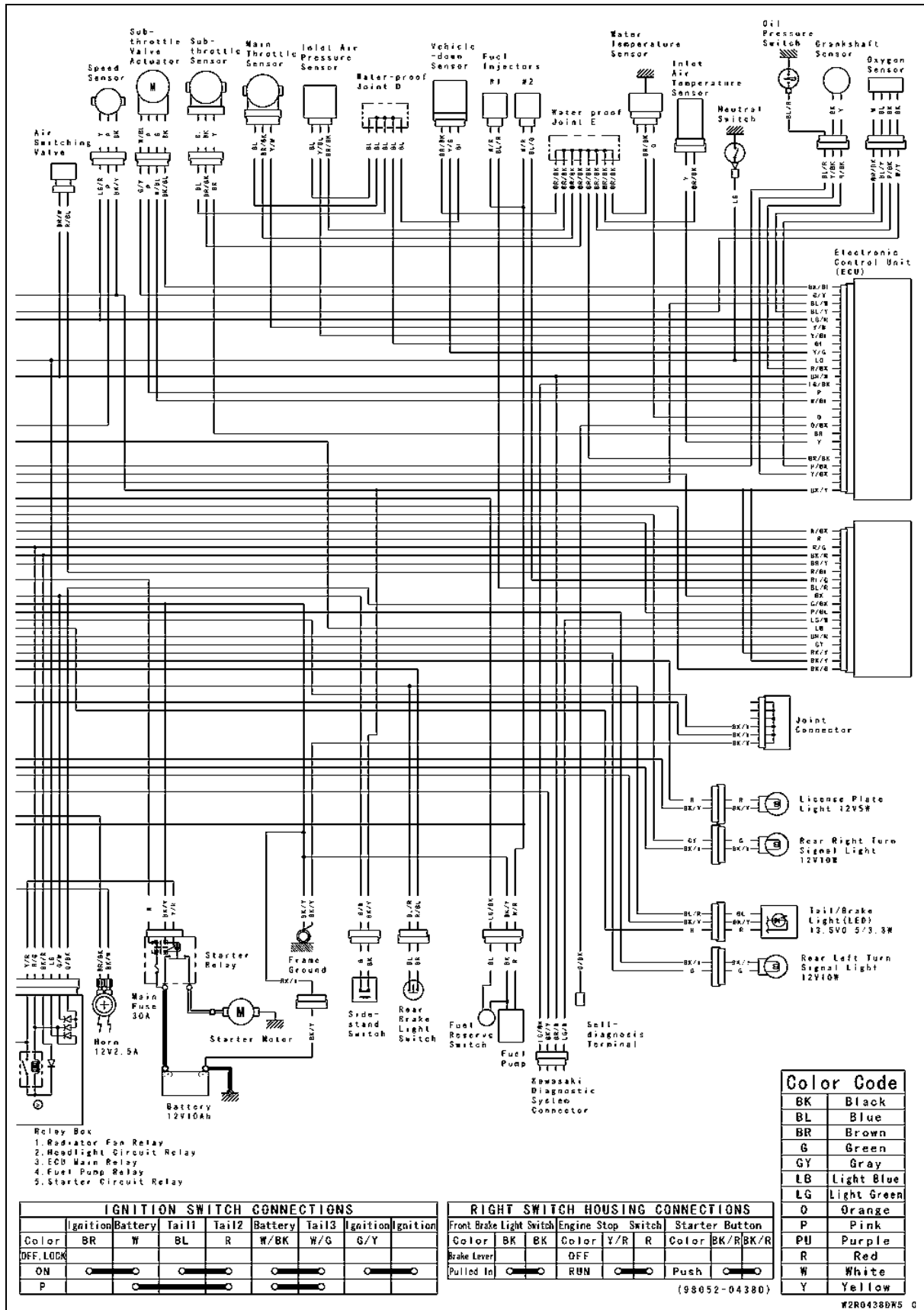

16-16 ELECTRICAL SYSTEM

Wiring Diagram (US, CA and CAL Models)

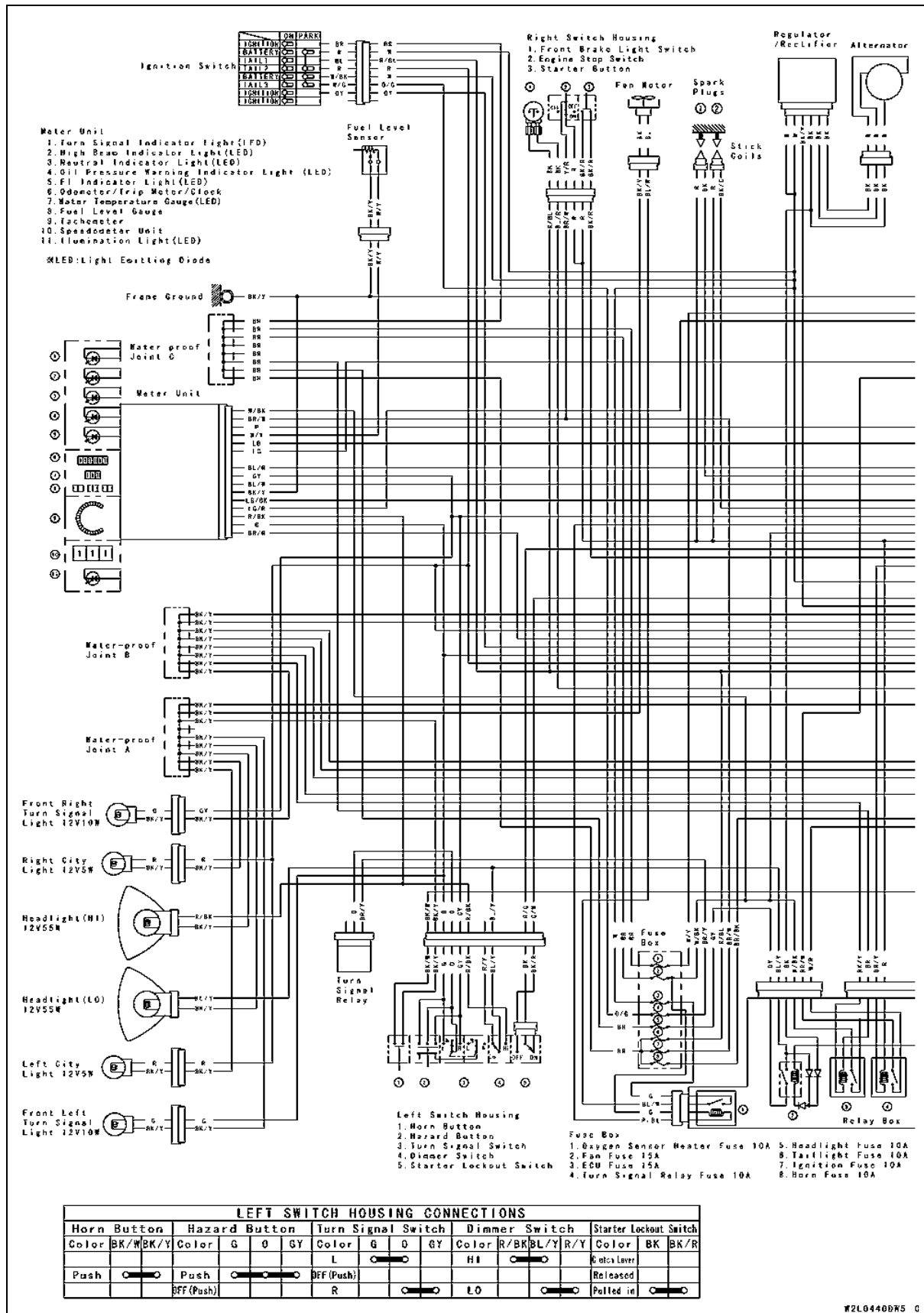

Wiring Diagram (US, CA and CAL Models)

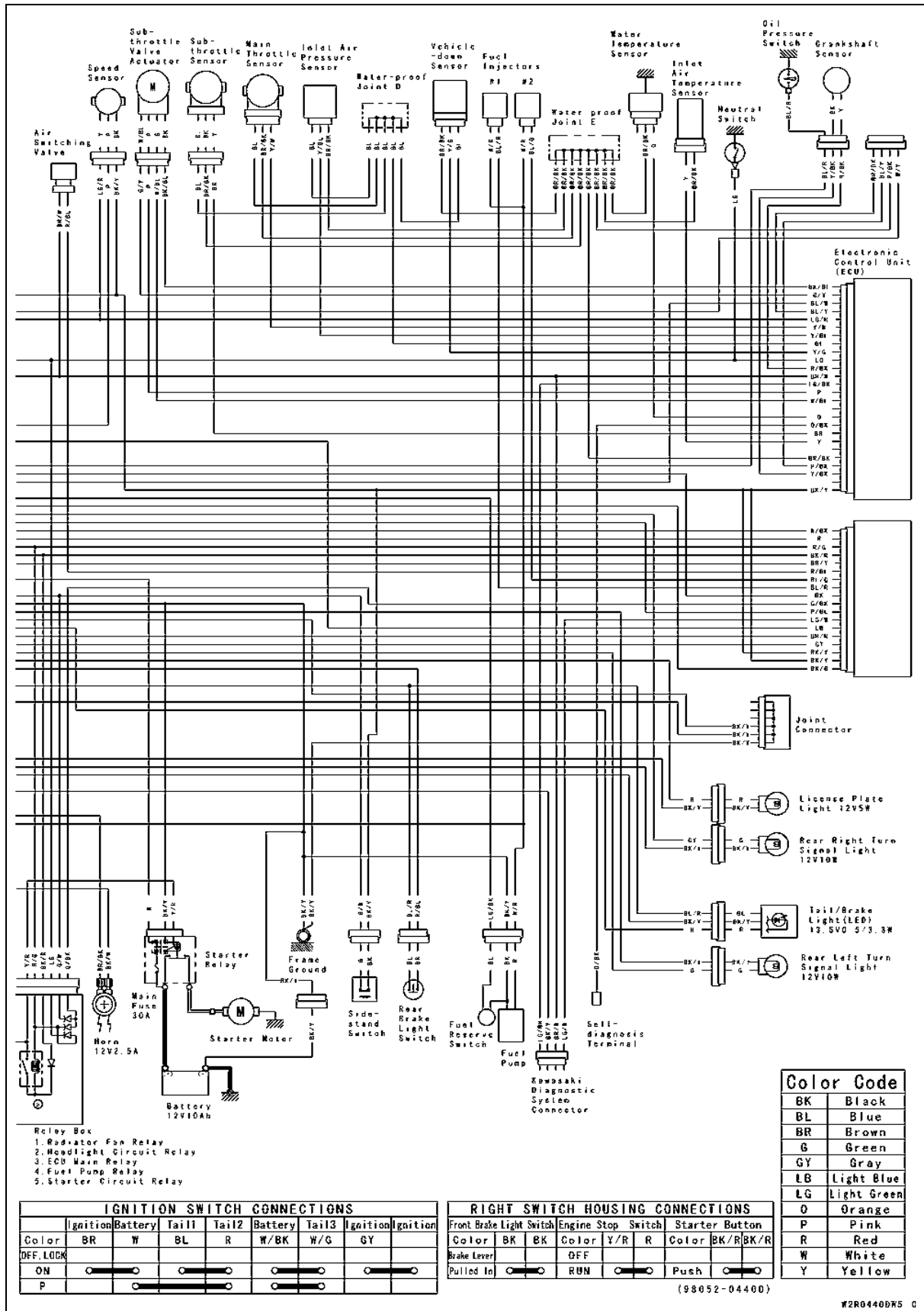

16-18 ELECTRICAL SYSTEM

Wiring Diagram (EX650D Models)

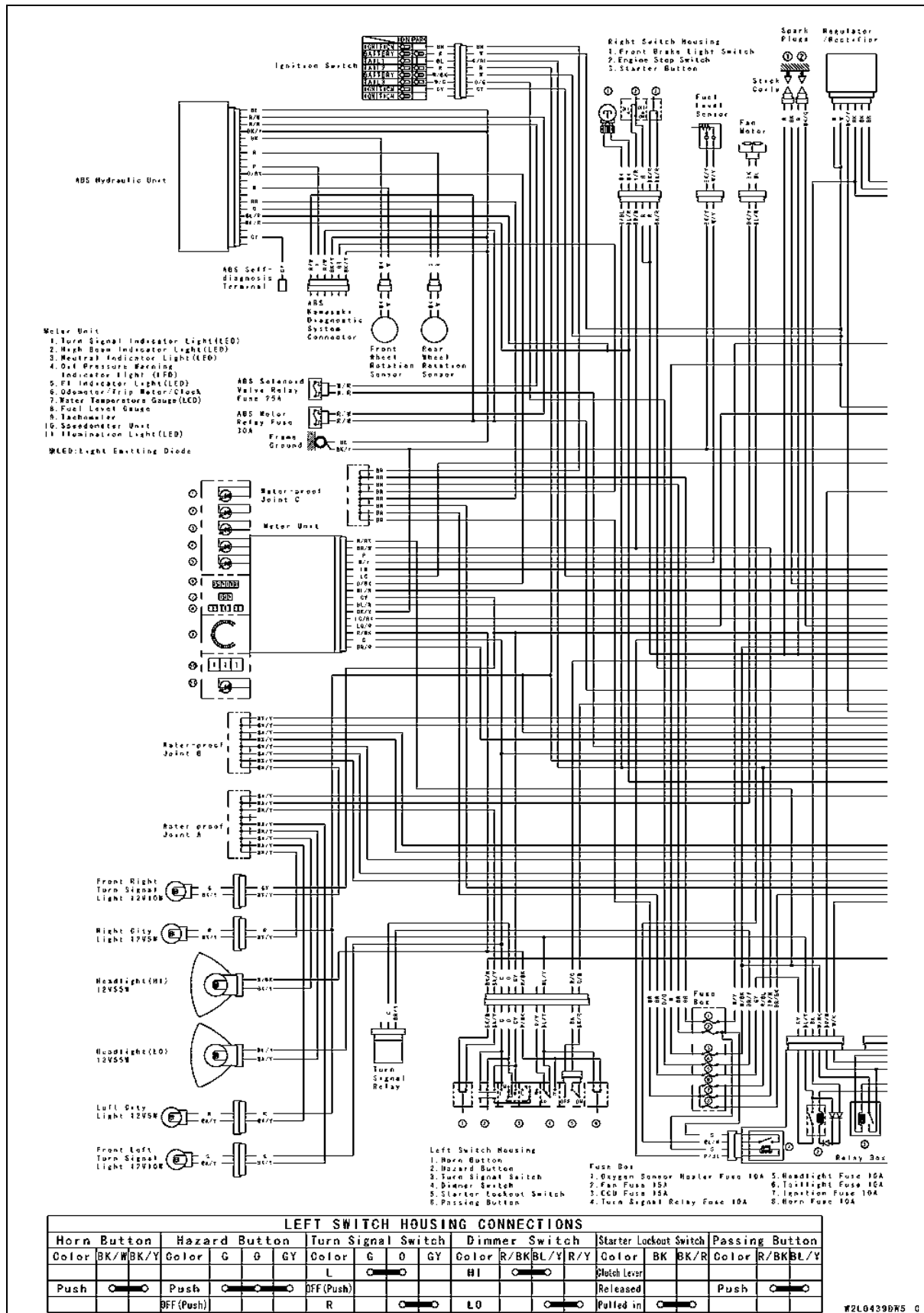

Wiring Diagram (EX650D Models)

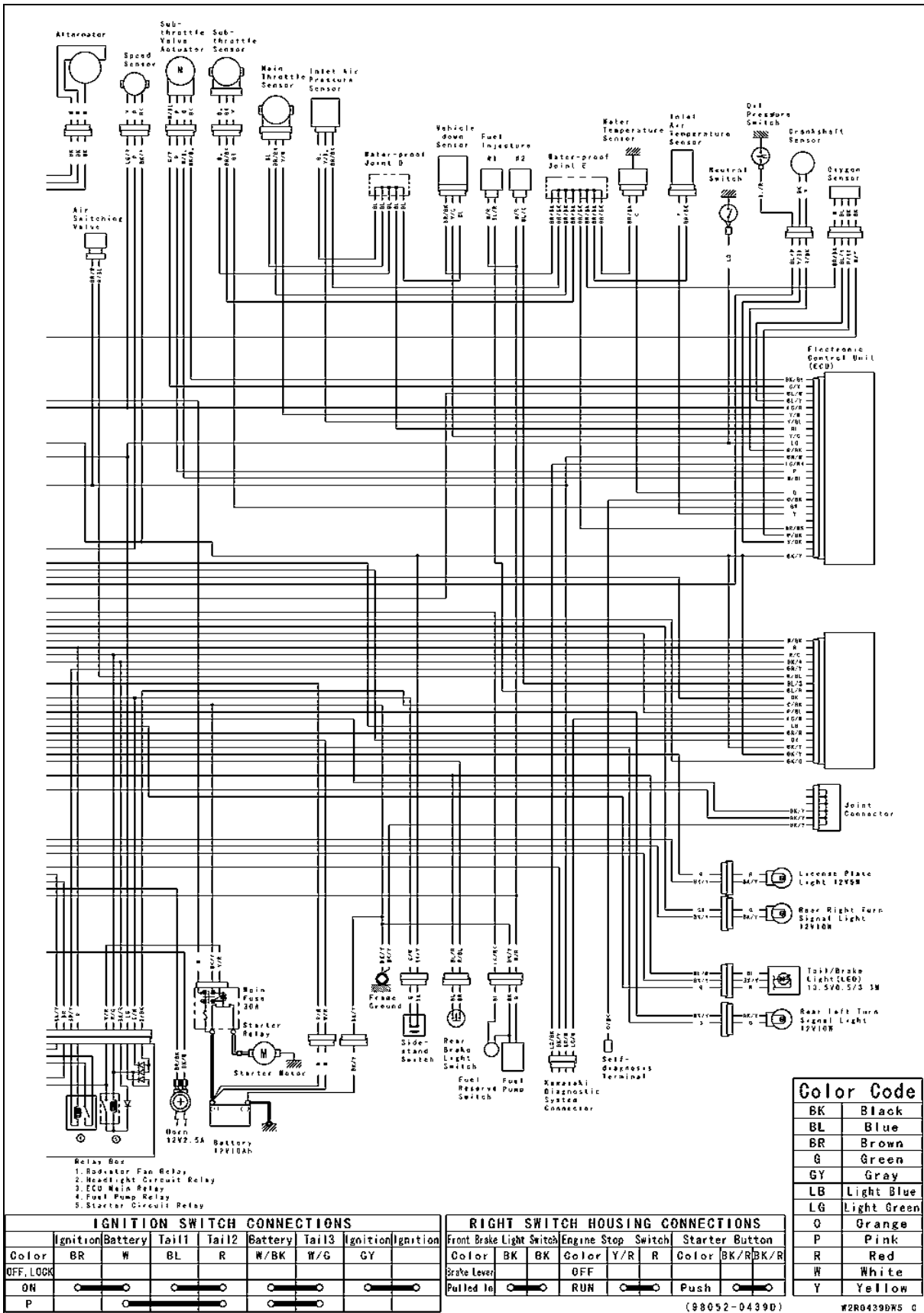

16-20 ELECTRICAL SYSTEM

Precautions

There are a number of important precautions that are musts when servicing electrical systems. Learn and observe all the rules below.

- Do not reverse the battery cable connections. This will burn out the diodes on the electrical parts.
- Always check battery condition before condemning other parts of an electrical system. A fully charged battery is a must for conducting accurate electrical system tests.
- The electrical parts should never be struck sharply, as with a hammer, or allowed to fall on a hard surface. Such a shock to the parts can damage them.
- To prevent damage to electrical parts, do not disconnect the battery cables or any other electrical connections when the ignition switch is on, or while the engine is running.
- Because of the large amount of current, never keep the starter button pushed when the starter motor will not turn over, or the current may burn out the starter motor windings.
- Take care not to short the cables that are directly connected to the battery positive (+) terminal to the chassis ground.
- Troubles may involve one or in some cases all items. Never replace a defective part without determining what CAUSED the failure. If the failure was caused by some other item or items, they must be repaired or replaced, or the new replacement will soon fail again.
- Make sure all connectors in the circuit are clean and tight, and examine wires for signs of burning, fraying, etc. Poor wires and bad connections will affect electrical system operation.
- Measure coil and winding resistance when the part is cold (at room temperature).

Electrical Wiring

Wiring Inspection

- Visually inspect the wiring for signs of burning, fraying, etc.
- ★ If any wiring is poor, replace the damaged wiring.
- Pull each connector [A] apart and inspect it for corrosion, dirt, and damage.
- ★ If the connector is corroded or dirty, clean it carefully. If it is damaged, replace it.
- Check the wiring for continuity.
- Use the wiring diagram to find the ends of the lead which is suspected of being a problem.
- Connect the hand tester between the ends of the leads.

Special Tool - Hand Tester: 57001-1394

- Set the tester to the $\times 1 \Omega$ range, and read the tester.
- ★ If the tester does not read 0Ω , the lead is defective. Replace the lead or the wiring harness [B] if necessary.

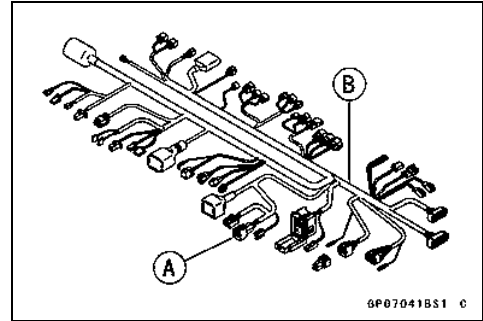

16-22 ELECTRICAL SYSTEM

Battery

Battery Removal

- Turn off the ignition switch.
- Remove the seat (see Seat Removal in the Frame chapter).
- Disconnect the negative (-) cable [A].

CAUTION

Be sure to disconnect the negative (-) cable first.

- Slide out the positive (+) terminal cap [B] and then disconnect the positive (+) cable.
- Remove the battery [A].

NOTE

- Run the suitable band [B] into the positive (+) terminal.
- Pull up the battery with both hands.



Battery Installation

- Turn off the ignition switch.
- Put the battery into the battery case.
- Install the positive (+) cable first.
- Install the negative (-) cable [A].
- Apply a little grease on the terminals to prevent corrosion.
- Cover the positive (+) terminal with the cap [B].

Battery Activation

Electrolyte Filling

- Make sure that the model name [A] of the electrolyte container matches the model name [B] of the battery. These names must be the same.

Battery Model Name for EX650C/D: FTX12-BS

CAUTION

Be sure to use the electrolyte container with the same model name as the battery since the electrolyte volume and specific gravity vary with the battery type. This is to prevent overfilling of the electrolyte, shorting the battery life, and deterioration of the battery performance.

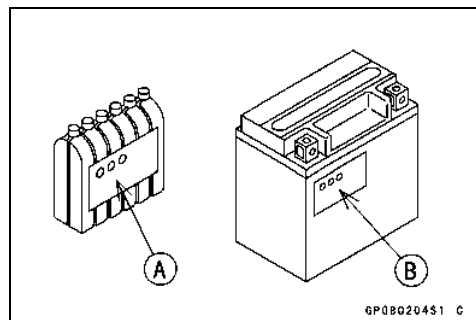

Battery

CAUTION

Do not remove the aluminum sealing sheet [A] from the filler ports [B] until just prior to use. Be sure to use the dedicated electrolyte container for correct electrolyte volume.

- Place the battery on a level surface.
- Check to see that the sealing sheet has no peeling, tears, or holes in it.
- Remove the sealing sheet.

NOTE

○ The battery is vacuum sealed. If the sealing sheet has leaked air into the battery, it may require a longer initial charge.

- Remove the electrolyte container from the vinyl bag.
- Detach the strip of caps [A] from the container and set aside, these will be used later to seal the battery.

NOTE

○ Do not pierce or otherwise open the sealed cells [B] of the electrolyte container. Do not attempt to separate individual cells.

- Place the electrolyte container upside down with the six sealed cells into the filler ports of the battery. Hold the container level, push down to break the seals of all six cells. You will see air bubbles rising into each cell as the ports fill.

NOTE

○ Do not tilt the electrolyte container

- Check the electrolyte flow.
- ★ If no air bubbles [A] are coming up from the filler ports, or if the container cells have not emptied completely, tap the container [B] a few times.
- Keep the container in place for **20** minutes or more. Don't remove the container from the battery until it's empty, the battery requires all the electrolyte from the container for proper operation.

CAUTION

Removal of the container before it is completely empty can shorten the service life of the battery. Do not remove the electrolyte container until it is completely empty and 20 minutes have elapsed.

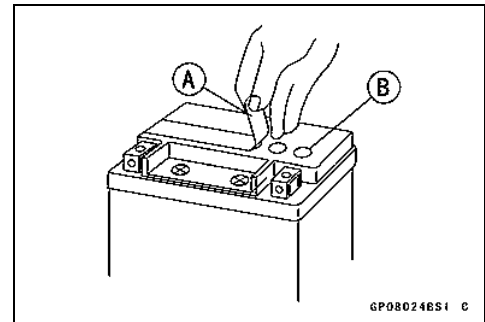

GP080246S1 C

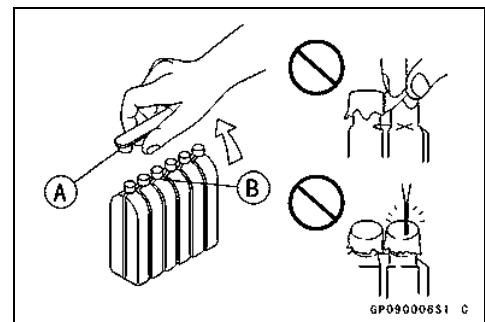

GP090006S1 C

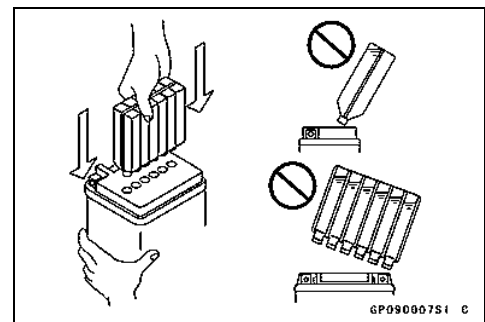

GP090007S1 C

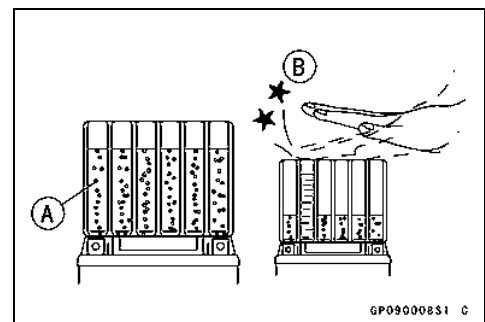

GP090008S1 C

16-24 ELECTRICAL SYSTEM

Battery

- Gently remove the container from the battery.
- Let the battery sit for **30** minutes prior to charging to allow the electrolyte to permeate into the plates for optimum performance.

NOTE

○ *Charging the battery immediately after filling can shorten service life. Let the battery sit for at least 30 minutes after filling.*

Initial Charge

- Place the strip [A] of caps loosely over the filler ports.
- Newly activated sealed batteries require an initial charge.

Standard Charge: 1.2 A × 5 ~ 10 hours

- ★ If using a recommended battery charger, follow the charger's instructions for newly activated sealed battery.

Kawasaki-recommended chargers

Optimate III

Yuasa 1.5 Amp Automatic Charger

Battery Mate 150-9

- ★ If the above chargers are not available, use equivalent one.

NOTE

○ *Charging rates will vary depending on how long the battery has been stored, temperature, and the type of charger used. Let battery sit 30 minutes after initial charge, then check voltage using a voltmeter. If it is not at least 12.6 V, repeat charging cycle.*

- After charging is completed, press down firmly with both hands to seat the strip of caps [A] into the battery (don't pound or hammer.). When properly installed, the strip of the caps will be level with the top of the battery.

CAUTION

Once the strip of the caps is installed onto the battery, never remove the caps, nor add water or electrolyte to the battery.

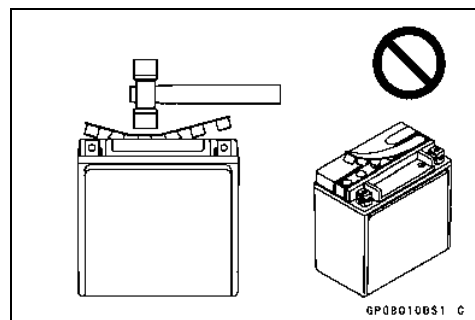
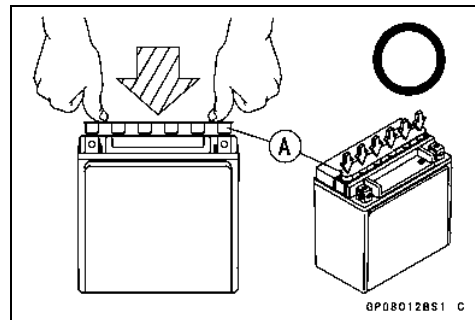
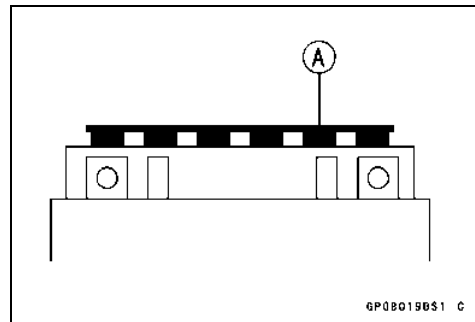

Battery

NOTE

- To ensure maximum battery life and customer satisfaction, it is recommended the battery be load tested at three times its amp-hour rating for 15 seconds. Re-check voltage and if less than 12.6 V repeat the charging cycle and load test. If still below 12.6 V the battery is defective.

Precautions

- 1) No need of topping-up
No topping-up is necessary in this battery until it ends its life under normal use. Forcibly prying off the seal cap to add water is very dangerous. Never do that.
- 2) Refreshing charge
If an engine will not start, a horn sounds weak, or lamps are dim, it indicates the battery has been discharged. Give refresh charge for 5 to 10 hours with charge current shown in the specification (see Specifications).
When a fast charge is inevitably required, do it following precisely the maximum charge current and time conditions indicated on the battery.

CAUTION

This battery is designed to sustain no unusual deterioration if refresh-charged according to the method specified above. However, the battery's performance may be reduced noticeably if charged under conditions other than given above. Never remove the seal cap during refresh charge.

If by chance an excessive amount of gas is generated due to overcharging, the relief valve releases the gas to keep the battery normal.

- 3) When you do not use the motorcycle for months.
Give a refresh charge before you store the motorcycle and store it with the negative cable removed. Give a refresh charge **once a month** during storage.
- 4) Battery life
If the battery will not start the engine even after several refresh charges, the battery has exceeded its useful life. Replace it (Provided, however, the vehicle's starting system has no problem).

⚠ WARNING

Keep the battery away from sparks and open flames during charging, since the battery gives off an explosive gas mixture of hydrogen and oxygen. When using a battery charger, connect the battery to the charger before turning on the charger.

This procedure prevents sparks at the battery terminals which could ignite any battery gases.

No fire should be drawn near the battery, or no terminals should have the tightening loosened.

The electrolyte contains sulfuric acid. Be careful not to have it touch your skin or eyes. If touched, wash it off with liberal amount of water. Get medical attention if severe.

Interchange

A sealed battery can fully display its performance only when combined with a proper vehicle electric system. Therefore, replace a sealed battery only on a motorcycle which was originally equipped with a sealed battery.

Be careful, if a sealed battery is installed on a motorcycle which had an ordinary battery as original equipment, the sealed battery's life will be shortened.

16-26 ELECTRICAL SYSTEM

Battery

Charging Condition Inspection

Battery charging condition can be checked by measuring battery terminal voltage with a digital voltmeter [A].

- Remove the battery (see Battery Removal).

CAUTION

Be sure to disconnect the negative (-) lead first.

- Measure the battery terminal voltage.

NOTE

○ Measure with a digital voltmeter which can be read to one decimal place voltage.

- ★ If the reading is 12.6 V or more, no refresh charge is required, however, if the reading is below the specified, refresh charge is required.

Battery Terminal Voltage

Standard: 12.6 V or more

Terminal Voltage (V) [A]

Battery Charge Rate (%) [B]

Refresh charge is required [C]

Good [D]

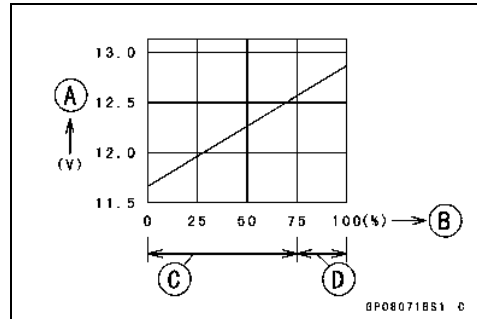
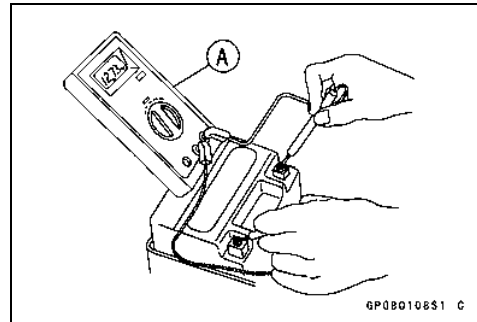

Refreshing Charge

- Remove the battery [A] (see Battery Removal).
- Refresh-charge by following method according to the battery terminal voltage.

⚠ WARNING

This battery is sealed type. Never remove seal sheet [B] even at charging. Never add water. Charge with current and time as stated below.

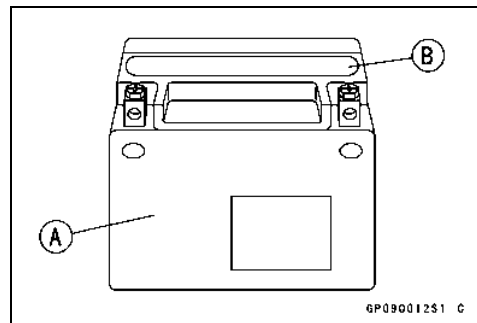

Terminal Voltage: 11.5 ~ less than 12.6 V

Standard Charge

1.2 A × 5 ~ 10 h (see following chart)

Quick Charge

5.0 A × 1 h

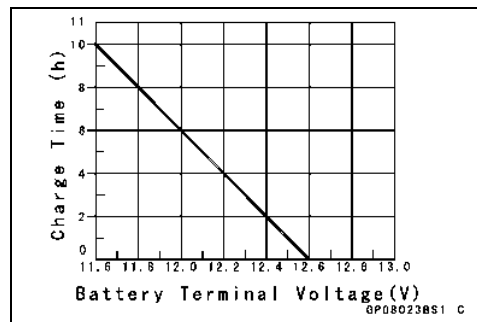

CAUTION

If possible, do not quick charge. If the quick charge is done unavoidably, do the standard charge later on.

Terminal Voltage: less than 11.5 V

Charging Method: 1.2 A × 20 h

Battery

NOTE

- Increase the charging voltage to a maximum voltage of 25 V if the battery will not accept current initially. Charge for no more than 5 minutes at the increased voltage then check if the battery is drawing current. If the battery will accept current decrease the voltage and charge by the standard charging method described on the battery case. If the battery will not accept current after 5 minutes, replace the battery.

Battery [A]
 Battery Charger [B]
 Standard Value [C]
 Current starts to flow [D]

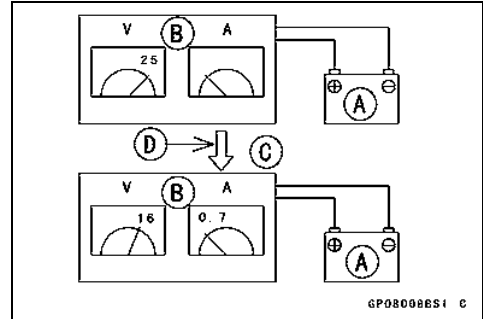

- Determine battery condition after refreshing charge.
- Determine the condition of the battery 30 minutes after completion of the charge by measuring the terminal voltage according to the table below.

Criteria	Judgement
12.6 V or higher	Good
12.0 ~ lower than 12.6 V	Charge insufficient → Recharge
lower than 12.0 V	Unserviceable → Replace

16-28 ELECTRICAL SYSTEM

Charging System

Alternator Cover Removal

- Remove:
 - Lower Fairing (see Lower Fairing Removal in the Frame chapter)
 - Frame Cover (see Frame Cover Removal in the Frame chapter)
 - Engine Oil (Drain, see Engine Oil Change in the Periodic Maintenance chapter)
 - Bolts [A]
 - Engine Sprocket Cover [B]
- Disconnect the alternator lead connector [A].

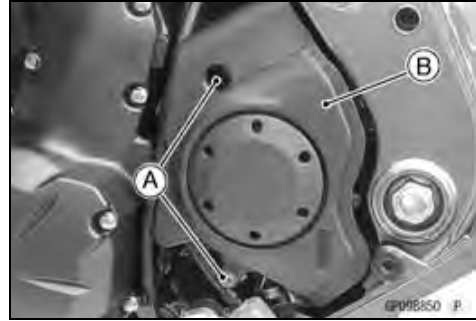

- Remove:
 - Left Upper Fairing Cover (see Upper Fairing Cover Removal in the Frame chapter)
 - Alternator Cover Bolts [A]
 - Alternator Cover [B]

NOTE

○ Place a suitable container under the alternator cover.

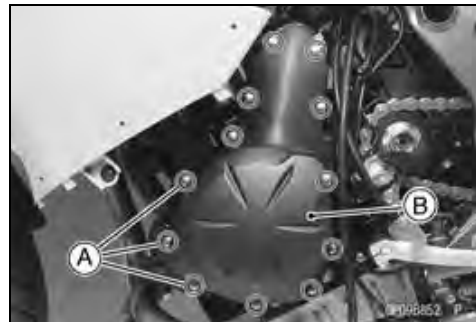

Alternator Cover Installation

- Apply silicone sealant to the alternator lead grommet and crankcase halves mating surface [A].
 - Sealant - Kawasaki Bond (Silicone Sealant): 92104-0004**
- Install the dowel pins [B].
- Replace the alternator cover gasket with a new one.
- Install the alternator cover.
 - Torque - Alternator Cover Bolts: 9.8 N·m (1.0 kgf·m, 87 in·lb)**

70 mm (2.8 in.) Bolt [A]
35 mm (1.4 in.) Bolts [B]
Tighten with Clamp [C]

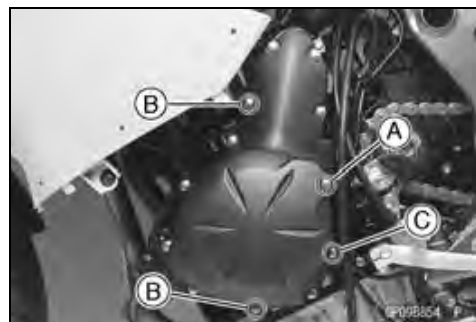
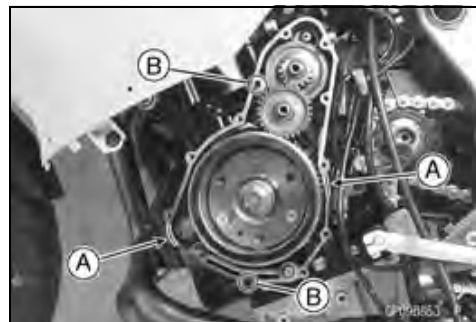

Charging System

Stator Coil Removal

- Remove:
 - Alternator Cover (see Alternator Cover Removal)
 - Holding Plate Bolt [A] and Plate
 - Alternator Lead Grommet [B]
 - Stator Coil Bolts [C]
- Take off the stator coil [D] from the alternator cover.

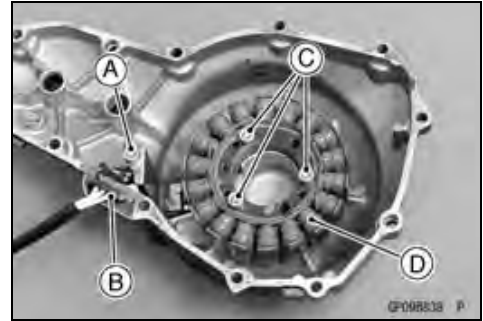

Stator Coil Installation

- Apply a non-permanent locking agent to the threads of the stator coil bolts and the holding plate bolt.
- Clamp the alternator lead with a holding plate.
- Install the stator coil.

Torque - Stator Coil Bolts: 12 N·m (1.2 kgf·m, 106 in·lb)
Alternator Lead Holding Plate Bolt: 9.8 N·m (1.0 kgf·m, 87 in·lb)

- Apply silicone sealant to the circumference of the alternator lead grommet, and fit the grommet into the notch of the cover.

Sealant - Kawasaki Bond (Silicone Sealant): 92104-0004

Alternator Rotor Removal

- Remove:
 - Alternator Cover (see Alternator Cover Removal)
 - Starter Idle Gear [A] and Shaft
 - Torque Limiter [B] and Shaft

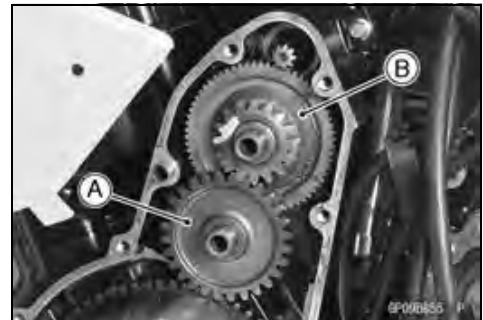

- Wipe oil off the circumference of the rotor.
- Hold the alternator rotor steady with the rotor holder [A].

Special Tools - Grip [B]: 57001-1591
Rotor Holder: 57001-1658

- Remove the rotor bolt [C] and the washer.



16-30 ELECTRICAL SYSTEM

Charging System

- Using the flywheel puller [A], remove the alternator rotor from the crankshaft.

Special Tool - Flywheel Puller Assembly, M38 x 1.5/M35 x 1.5: 57001-1405

CAUTION

Do not attempt to strike the alternator rotor itself. Striking the rotor can cause the magnets to lose their magnetism.



Alternator Rotor Installation

- Using a cleaning fluid, clean off any oil or dirt on the following portions and dry them with a clean cloth.
 - Crankshaft Tapered Portion [A]
 - Alternator Rotor Tapered Portion [B]
- Apply a thin coat of molybdenum disulfide grease to the crankshaft [C].

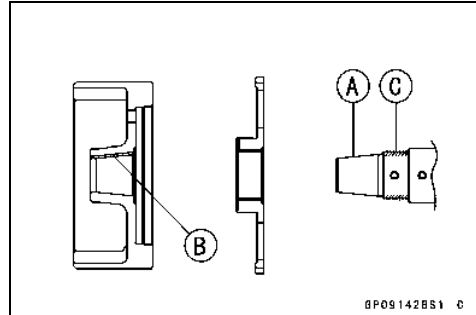

- Install the starter clutch gear [A] and washer [B].
- Again, clean the crankshaft tapered portion [C] and dry there.
- Install the alternator rotor while turning the starter clutch gear clockwise.

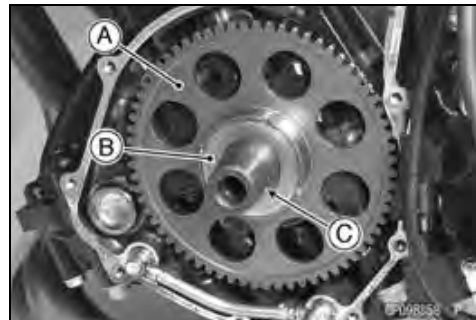

- Install the washer [A].

NOTE

○ Confirm the alternator rotor fit or not to the crankshaft before tightening it with specified torque.

- Apply molybdenum disulfide oil solution to the threads and seating surface of the rotor bolt.
- Install the rotor bolt [B] and tighten it with 70 N·m (7.0 kgf·m, 52 ft·lb) of torque.
- Remove the rotor bolt and washer.
- Check the tightening torque with flywheel puller.
- ★ If the rotor is not pulled out with 20 N·m (2.0 kgf·m, 15 ft·lb) of drawing torque, it is installed correctly.
- ★ If the rotor is pulled out with under 20 N·m (2.0 kgf·m, 15 ft·lb) of drawing torque, clean off any oil dirt or flaw of the crankshaft and rotor tapered portion, and dry them with a clean cloth. Then, confirm that it is not pulled out with above torque.
- Tighten the alternator rotor bolt while holding the alternator rotor steady with the rotor holder.

Special Tools - Grip: 57001-1591

Rotor Holder: 57001-1658

Torque - Alternator Rotor Bolt: 155 N·m (15.8 kgf·m, 114 ft·lb)



Charging System

- Apply a thin coat of molybdenum disulfide grease to the shafts [A], and install them.
- Install the torque limiter [B] and starter idle gear [C].
- Install the alternator cover (see Alternator Cover Installation).

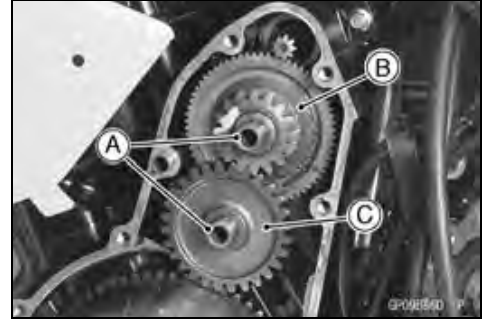

Alternator Inspection

There are three types of alternator failures: short, open (wire burned out), or loss in rotor magnetism. A short or open in one of the coil wires will result in either a low output, or no output at all. A loss in rotor magnetism, which may be caused by dropping or hitting the alternator, by leaving it near an electromagnetic field, or just by aging, will result in low output.

- To check the alternator output voltage, do the following procedures.
 - Turn off the ignition switch.
 - Remove the left frame cover (see Frame Cover Removal in the Frame chapter).
 - Disconnect the alternator lead connector [A].
 - Connect the hand tester as shown in the table 1.

Special Tool - Hand Tester: 57001-1394

- Start the engine.
- Run it at the rpm given in the table 1.
- Note the voltage readings (total 3 measurements).

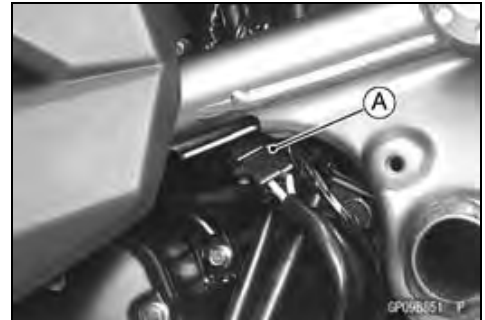

Table 1: Alternator Output Voltage

Tester Range	Connections		Reading at 4 000 rpm
	Tester (+) to	Tester (-) to	
250 V AC	One White lead	Another White lead	42 V or more

- ★ If the output voltage shows the value in the table, the alternator operates properly.
- ★ If the output voltage shows a much lower than the value in the table, the alternator is defective.
- Check the stator coil resistance as follows.
 - Stop the engine.
 - Connect the hand tester as shown in the table 2.
 - Note the readings (total 3 measurement).

Table 2: Stator Coil Resistance

Tester Range	Connections		Reading
	Tester (+) to	Tester (-) to	
× 1 Ω	One White lead	Another White lead	0.18 ~ 0.27 Ω

16-32 ELECTRICAL SYSTEM

Charging System

- ★ If there is more resistance than shown in the table, or no hand tester reading (infinity) for any two leads, the stator has an open lead and must be replaced. Much less than this resistance means the stator is shorted, and must be replaced.
- Using the highest resistance range of the hand tester, measure the resistance between each of the white leads and chassis ground.
- ★ Any hand tester reading less than infinity (∞) indicates a short, necessitating stator replacement.
- ★ If the stator coils have normal resistance, but the voltage check showed the alternator to be defective; then the rotor magnets have probably weakened, and the rotor must be replaced.

Regulator/Rectifier Inspection

- Remove:
 - Bolts [A]

- Slide out the dust cover, and disconnect the connector [A].
- Remove the regulator/rectifier [B] with the bracket.

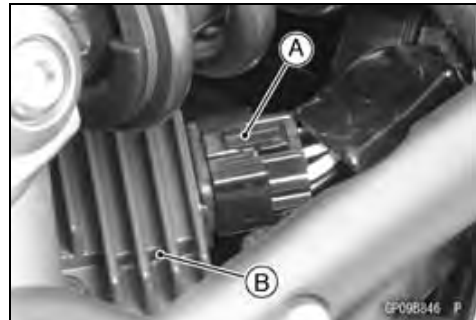
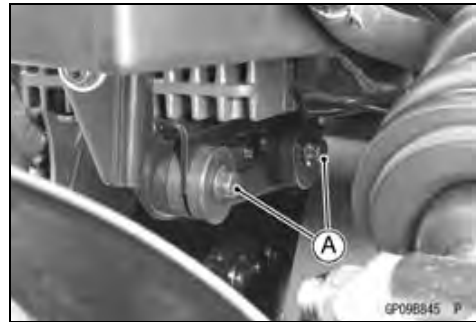

EX650D Models

- Remove the muffler body (see Muffler Body Removal in the Engine Top End chapter).
- Slide out the dust cover [A], and disconnect the connector.
- Remove the bolts [B], and take off the regulator/rectifier [C].

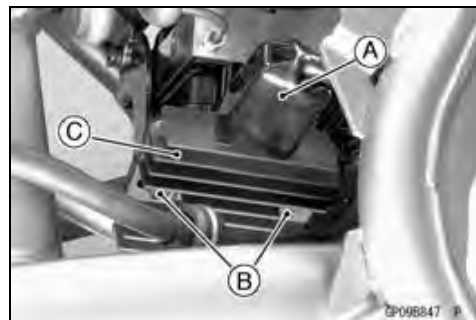

Charging System

Rectifier Circuit Check

- Check conductivity of the following pair of terminals.

Rectifier Circuit Inspection

Tester connection	W1-BK1,	W1-BK2,	W1-BK3
	BK/Y-BK1,	BK/Y-BK2,	BK/Y-BK3

- ★ The resistance should be low in one direction and more than ten times as much in the other direction. If any two leads are low or high in both directions, the rectifier is defective and the regulator/rectifier must be replaced.

NOTE

- The actual meter reading varies with the meter used and the individual rectifier, but, generally speaking the lower reading should be from zero to one half the scale.

Regulator Circuit Check

To test the regulator out of circuit, use three 12 V batteries and a test light (12 V 3 ~ 6 W bulb in a socket with leads).

CAUTION

The test light works as an indicator and also a current limiter to protect the regulator/rectifier from excessive current. Do not use an ammeter instead of a test light.

- Check to be sure the rectifier circuit is normal before continuing.
- Do the 1st step regulator circuit test.
 - Connect the test light and the 12 V battery to the regulator/rectifier as shown.
 - Check the BK1, BK2 and BK3 terminal respectively.
 - ★ If the test light turns on, the regulator/rectifier is defective. Replace it.
 - ★ If the test light does not turn on, continue the test.
- Do the 2nd step regulator circuit test.
 - Connect the test light and the 12 V battery in the same manner as specified in the "Regulator Circuit Test-1st Step".
 - Apply 12 V to the voltage W2 terminal.
 - Check the BK1, BK2 and BK3 terminal respectively.
 - ★ If the test light turns on, the regulator/rectifier is defective. Replace it.
 - ★ If the test light does not turn on, continue the test.

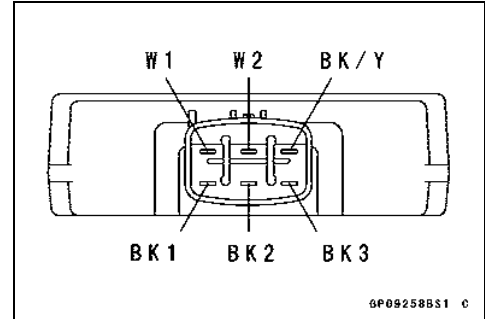

GP09258B51 C

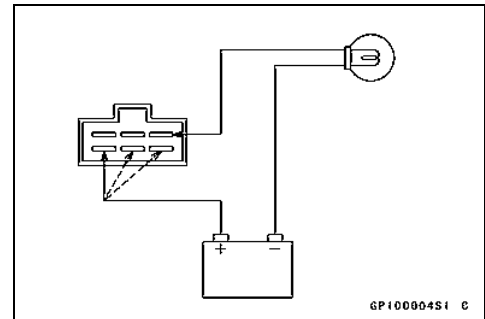

GP10000451 C

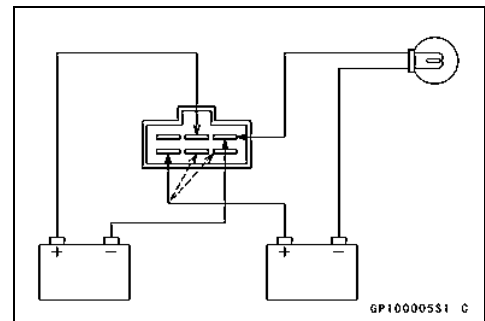

GP10000551 C

16-34 ELECTRICAL SYSTEM

Charging System

- Do the 3rd step regulator circuit test.
- Connect the test light and the 12 V battery in the same manner as specified in the "Regulator Circuit Test-1st Step".
- Momentarily apply 24 V to the voltage W2 terminal by adding a 12 V battery.
- Check the BK1, BK2 and BK3 terminals respectively.

CAUTION

Do not apply more than 24 V. If more than 24 V is applied, the regulator/rectifier may be damaged. Do not apply 24 V more than a few seconds. If 24 V is applied for more than a few seconds, the regulator/rectifier may be damaged.

- ★ If the test light did not light when the 24 V was applied momentarily to the voltage monitoring terminal, the regulator/rectifier is defective. Replace it.
- ★ If the regulator/rectifier passes all of the tests described, it may still be defective. If the charging system still does not work properly after checking all of the components and the battery, test the regulator/rectifier by replacing it with a known good unit.

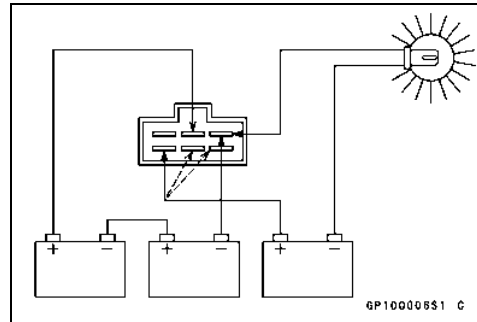

Charging System

Charging Voltage Inspection

- Check the battery condition (see Charging Condition Inspection).
- Warm up the engine to obtain actual alternator operating conditions.
- Remove the seat (see Seat Removal in the Frame chapter).
- Check that the ignition switch is turned off, and connect the hand tester [A] to the battery terminals [B].

Special Tool - Hand Tester: 57001-1394

- Start the engine, and note the voltage readings at various engine speeds with the headlight turned on and then turned off (To turn off the headlight, disconnect the headlight connector on the headlight unit.). The readings should show nearly battery voltage when the engine speed is low, and, as the engine speed rises, the readings should also rise. But they must be kept under the specified voltage.

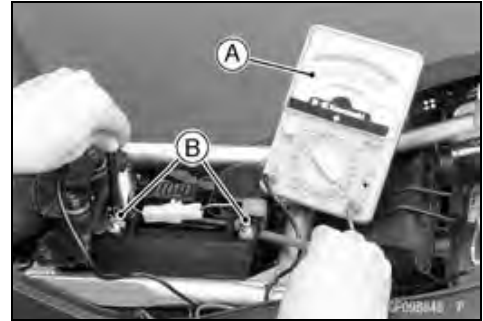

Charging Voltage

Tester Range	Connections		Reading
	Tester (+) to	Tester (-) to	
25 V DC	Battery (+)	Battery (-)	14.2 ~ 15.2 V

- Turn off the ignition switch to stop the engine, and disconnect the hand tester.
- ★ If the charging voltage is kept between the values given in the table, the charging system is considered to be working normally.
- ★ If the charging voltage is much higher than the values specified in the table, the regulator/rectifier is defective or the regulator/rectifier leads are loose or open.
- ★ If the charging voltage does not rise as the engine speed increases, then the regulator/rectifier is defective or the alternator output is insufficient for the loads. Check the alternator and regulator/rectifier to determine which part is defective.

16-36 ELECTRICAL SYSTEM

Charging System

Charging System Circuit

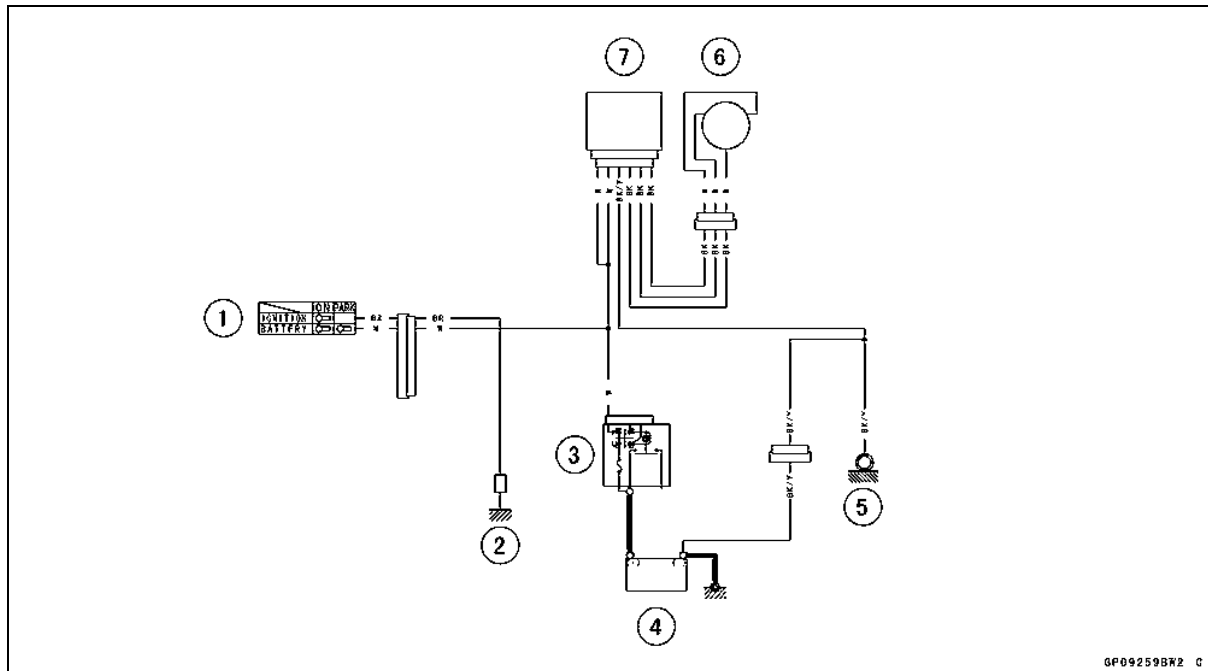

1. Ignition Switch
2. Load
3. Main Fuse 30 A
4. Battery 12 V 10 Ah
5. Frame Ground
6. Alternator
7. Regulator/Rectifier

Starter Motor Clutch

Starter Motor Clutch Removal/Installation

- Refer to the Alternator Rotor Removal/Installation.

Starter Motor Clutch Inspection

- Remove:
 - Alternator Cover (see Alternator Cover Removal)
 - Starter Idle Gear and Torque Limiter Shafts
- Turn the starter motor clutch gear [A] by hand. The starter motor clutch gear should turn clockwise [B] freely, but should not turn counterclockwise [C].
- ★ If the starter motor clutch does not operate as it should or if it makes noise, go to the next step.
- Disassemble the starter motor clutch, and visually inspect the clutch parts.
- ★ If there is any worn or damaged part, replace it.

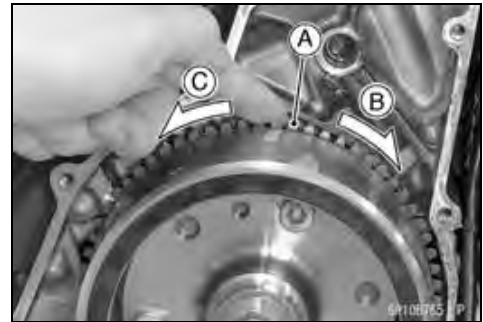

NOTE

- Examine the starter motor clutch gear as well. Replace it if it worn or damaged.

Starter Motor Clutch Disassembly

- Remove:
 - Alternator Rotor (see Alternator Rotor Removal)
 - Starter Motor Clutch Bolts [A]



- Remove:
 - Starter Motor Clutch [A]



Starter Motor Clutch Assembly

- Apply a non-permanent locking agent to the threads of the starter motor clutch bolts, and tighten them.
- Torque - Starter Motor Clutch Bolts: 34 N·m (3.5 kgf·m, 25 ft·lb)**

16-38 ELECTRICAL SYSTEM

Ignition System

⚠ WARNING

The ignition system produces extremely high voltage. Do not touch the spark plugs or stick coils while the engine is running, or you could receive a severe electrical shock.

CAUTION

Do not disconnect the battery cables or any other electrical connections when the ignition switch is on, or while the engine is running. This is to prevent ECU (Electronic Control Unit) damage.
Do not install the battery backwards. The negative side is grounded. This is to prevent damage to the ECU.

Crankshaft Sensor Removal

- Remove:
 - Lower Fairing (see Lower Fairing Removal in the Frame chapter)
 - Right Frame Cover (see Frame Cover Removal in the Frame chapter)
 - Crankshaft Sensor Lead Connector [A]

- Remove:
 - Rubber Cap [A] (Slide Out)
 - Oil Pressure Switch Lead Terminal [B]
 - Clutch Cover (see Clutch Cover Removal in the Clutch chapter)

- Remove:
 - Bolts [A]
 - Crankshaft Sensor [B]
- Pull out the grommet [C].

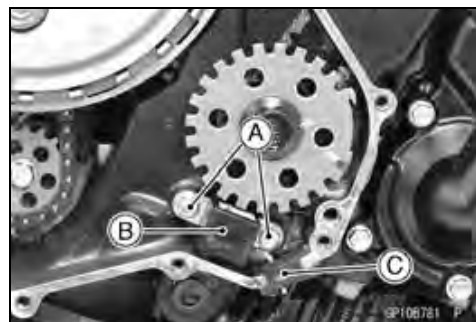

Ignition System

Crankshaft Sensor Installation

- Route the crankshaft sensor lead correctly (see Cable, Wire, and Hose Routing section in the Appendix chapter).
- Tighten:
 - Torque - Crankshaft Sensor Bolts [A]: 6.0 N·m (0.61 kgf·m, 53 in·lb)**
- Apply silicone sealant to the circumference of the crankshaft sensor lead grommet [B].
 - Sealant - Kawasaki Bond (Silicone Sealant): 92104-0004**
- Install the grommet to the crankcase, and connect the crankshaft sensor lead connector.

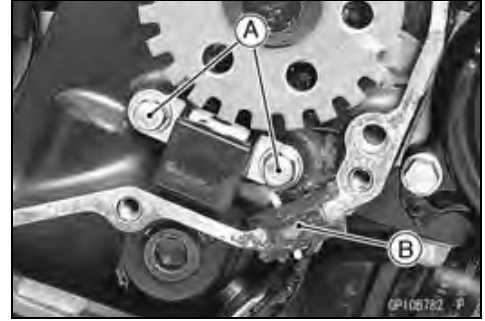

Crankshaft Sensor Inspection

- Remove:
 - Right Frame Cover (see Frame Cover Removal in the Frame chapter)
 - Crankshaft Sensor Lead Connector [A]
- Set the hand tester to the $\times 100 \Omega$ range and connect (+) lead to the black lead and (-) lead to the yellow lead in the connector.
- Special Tool - Hand Tester: 57001-1394**



Crankshaft Sensor Resistance:

Standard: 376 ~ 564 Ω

- ★ If there is more resistance than the specified value, the coil has an open lead and must be replaced. Much less than this resistance means the coil is shorted, and must be replaced.
- Using the highest resistance range of the tester, measure the resistance between the crankshaft sensor leads and chassis ground.
- ★ Any tester reading less than infinity (∞) indicates a short, necessitating replacement of the crankshaft sensor assembly.

Crankshaft Sensor Peak Voltage Inspection

NOTE

- Be sure the battery is fully charged.
- Using the peak voltage adapter [A] is a more reliable way to determine the condition of the crankshaft sensor than crankshaft sensor internal resistance measurements.
- Remove:
 - Crankshaft Sensor Lead Connector (see Crankshaft Sensor Removal)
- Set the hand tester [B] to the \times DC 10 V range, and connect it peak voltage adapter.
- Connect the black lead of the adapter to yellow lead and red lead to black lead in the crankshaft sensor connector.
- Turn the ignition switch and engine stop switch ON.

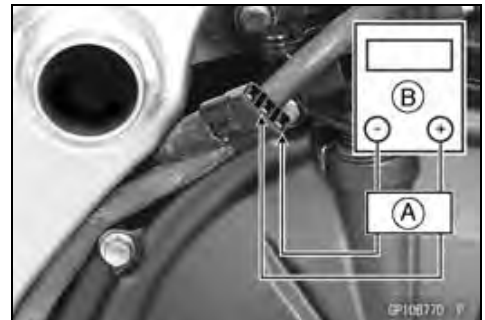

16-40 ELECTRICAL SYSTEM

Ignition System

- Pushing the starter button, turn the engine 4 ~ 5 seconds with the transmission gear in neutral to measure the crankshaft sensor peak voltage.
- Repeat the measurement 5 or more times.

Crankshaft Sensor Peak Voltage

Standard: 2.0 V or more

Special Tools - Hand Tester: 57001-1394

Peak Voltage Adapter: 57001-1415

Type: KEK-54-9-B

- ★ If the tester reading is not specified one, check the crankshaft sensor.

Timing Rotor Removal

- Remove:
 - Clutch Cover (see Clutch Cover Removal in the Clutch chapter)
 - Crankshaft Sensor (see Crankshaft Sensor Removal)
- Remove the timing rotor [A].
- Holding the timing rotor with the rotor holder [B] and unscrew the rotor bolt [C].

Special Tool - Rotor Holder: 57001-1567

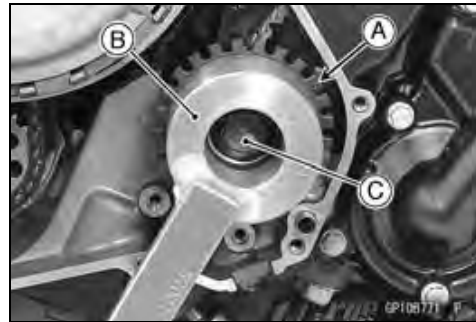

Timing Rotor Installation

- Fit the rotor to the crankshaft.
- Tighten the rotor bolt.
- Torque - Timing Rotor Bolt: 40 N·m (4.1 kgf·m, 30 ft·lb)
- Install the removed parts (see appropriate chapters).

Stick Coil Removal

- Remove the air cleaner housing (see Air Cleaner Housing Removal in the Fuel System (DFI) chapter).
- Disconnect the stick coil connectors [A].
- Pull the stick coils [B] off the spark plugs.

CAUTION

Do not pry the connector part of the coil while removing the coil.

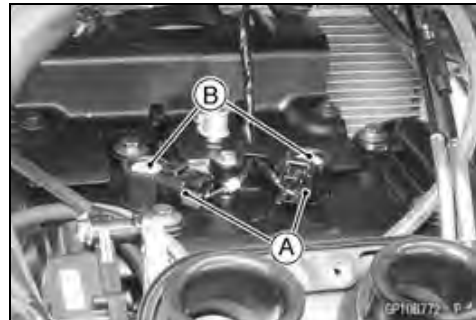

Stick Coil Installation

- Insert the coil as shown being careful of the coil heads [A] direction.

CAUTION

Do not tap the coil head while installing the coil.

- Pull the stick coils lightly to check the installation condition.
- Connect the connectors.
- Run the hoses and harness correctly (see Cable, Wire, and Hose Routing section in the Appendix chapter).
- Install the removed parts (see appropriate chapters).

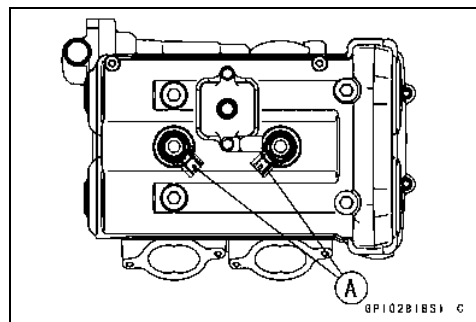

Ignition System

Stick Coil Inspection

- Remove the stick coils (see Stick Coil Removal).
- Measure the primary winding resistance [A] as follows.
 - Connect the hand tester between the coil terminals.
 - Set the tester to the $\times 1 \Omega$ range, and read the tester.
- Measure the secondary winding resistance [B] as follows.
 - Connect the tester between the plug terminal and (-) coil terminal.
 - Set the tester to the $\times 1 \text{ k}\Omega$ range and read the tester.

Stick Coil Winding Resistance

Primary Windings:	1.1 ~ 1.5 Ω
Secondary Windings:	10.8 ~ 16.2 $\text{k}\Omega$

- ★ If the tester does not read as specified, replace the coil.

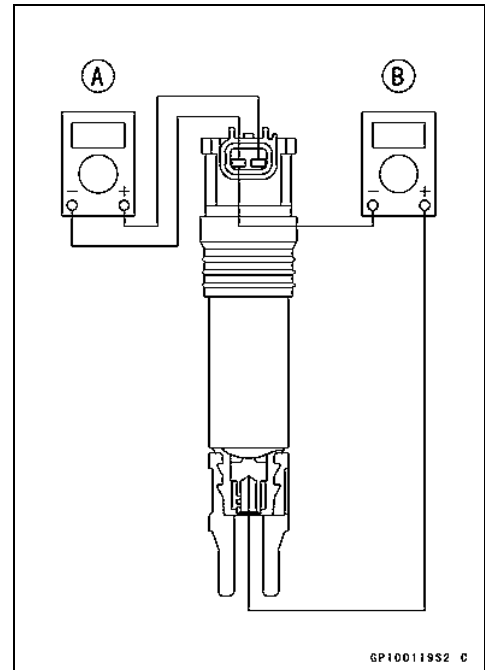

Stick Coil Primary Peak Voltage Inspection

NOTE

- Be sure the battery is fully charged.

- Remove the stick coils (see Stick Coil Removal), but do not remove the spark plugs.
- Measure the primary peak voltage as follows.
 - Install the new spark plug [A] into each stick coil [B], and ground them onto the engine.
 - Connect the peak voltage adapter [C] into the hand tester [D] which is set to the $\times \text{DC } 250 \text{ V}$ range.
 - Connect the adapter to the lead wire-peak voltage adapter [E] which is connected between the stick coil connector and stick coil.

ECU [F]
Battery [G]

- Special Tools - Hand Tester: 57001-1394**
Peak Voltage Adapter: 57001-1415
Type: KEK-54-9-B
Lead Wire-Peak Voltage Adapter: 57001-1449

Primary Lead Connection

- Adapter (R, +) to lead wire-peak voltage adapter (R)
- Adapter (BK, -) to lead wire-peak voltage adapter (W)

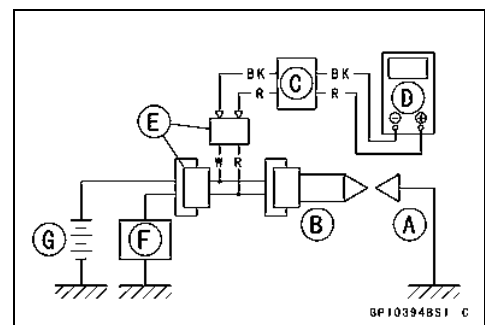
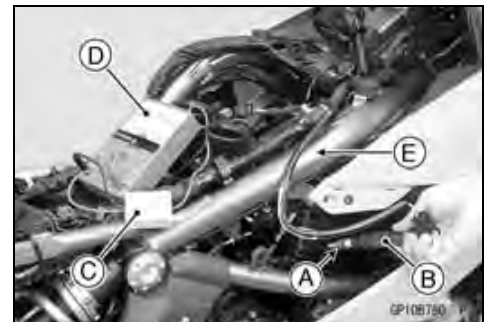

16-42 ELECTRICAL SYSTEM

Ignition System

⚠ WARNING

To avoid extremely high voltage shocks, do not touch the spark plugs or tester connections.

- Turn the ignition switch and the engine stop switch ON.
- Pushing the starter button, turn the engine 4 ~ 5 seconds with the transmission in neutral to measure the primary peak voltage.
- Repeat the measurements 5 times for one stick coil.

Stick Coil Primary Peak Voltage

Standard: 117 V or more

- Repeat the test for the other stick coil.
- ★ If the reading is less than the specified value, check the following.
 - Stick Coils (see Stick Coil Inspection)
 - Crankshaft Sensor (see Crankshaft Sensor Inspection)
 - ECU (see ECU Power Supply Inspection in the Fuel System (DFI) chapter)

Spark Plug Removal

- Refer to the Spark Plug Replacement in the Periodic Maintenance chapter.

Spark Plug Installation

- Refer to the Spark Plug Replacement in the Periodic Maintenance chapter.

Spark Plug Condition Inspection

- Remove the spark plugs (see Spark Plug Replacement in the Periodic Maintenance chapter).
- Visually inspect the spark plugs.
- ★ If the spark plug center electrode [A] and/or side electrode [B] are corroded or damaged, or if the insulator [C] is cracked, replace the plug.
- ★ If the spark plug is dirtied or the carbon is accumulated, replace the spark plug.
- Measure the gap [D] with a wire-type thickness gauge.

Spark Plug Gap: 0.8 ~ 0.9 mm (0.031 ~ 0.035 in.)

- ★ If the gap is incorrect, replace the spark plug.
- Use the standard spark plug or its equivalent.

Spark Plug: NGK CR9EIA-9

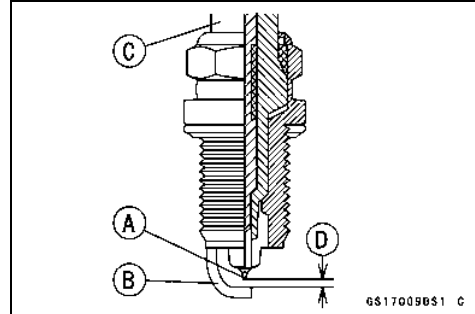

Ignition System

Interlock Operation Inspection

- Raise the rear wheel off the ground with a stand.

1st Check

- Start the engine to the following conditions.

Condition

Transmission Gear → 1st Position

Clutch Lever → Release

Sidestand → Down or Up

- Turn the ignition switch ON and push the starter button.
- Then the starter motor should not turn when the starter system circuit is normality.
- ★ If the engine is start, inspect the starter lockout switch, neutral switch and relay box.
- ★ If their parts are normality, replace the ECU.

2nd Check

- Start the engine to the following conditions.

Condition

Transmission Gear → 1st Position

Clutch Lever → Pulled in

Sidestand → Up

- Turn the ignition switch ON and push the starter button.
- Then the starter motor should turn when the starter system circuit is normality.
- ★ If the starter motor is not turn, inspect the starter lockout switch, neutral switch and relay box.
- ★ If their parts are normality, replace the ECU.

3rd Check

- Inspect the engine for its secure stop after the following operations are completed.
- Run the engine to the following conditions.

Condition

Transmission Gear → 1st Position

Clutch Lever → Pulled in

Sidestand → Up

- Set the sidestand on the ground, then the engine will stop.
- ★ If whichever may not be stopped, inspect the neutral switch, starter lockout switch, sidestand switch and relay box.
- ★ If their parts are normality, replace the ECU.

16-44 ELECTRICAL SYSTEM

Ignition System

IC Igniter Inspection

- The IC igniter is built in the ECU [A].
- Refer to the Interlock Operation Inspection, Ignition System Troubleshooting chart and Fuel System (DFI) chapter for ECU Power Supply Inspection.



Ignition System

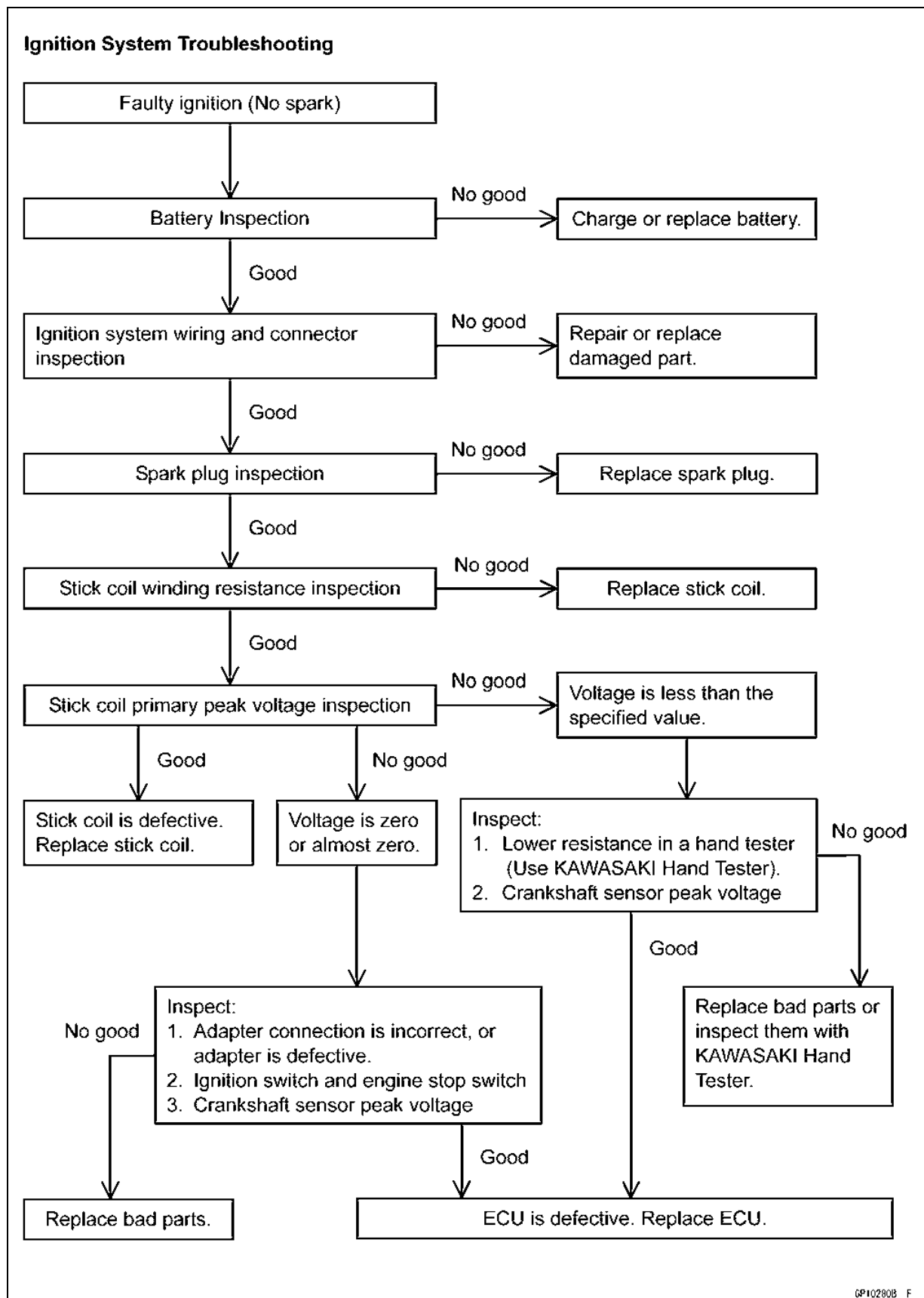

GP10280B F

16-46 ELECTRICAL SYSTEM

Ignition System

Ignition System Circuit

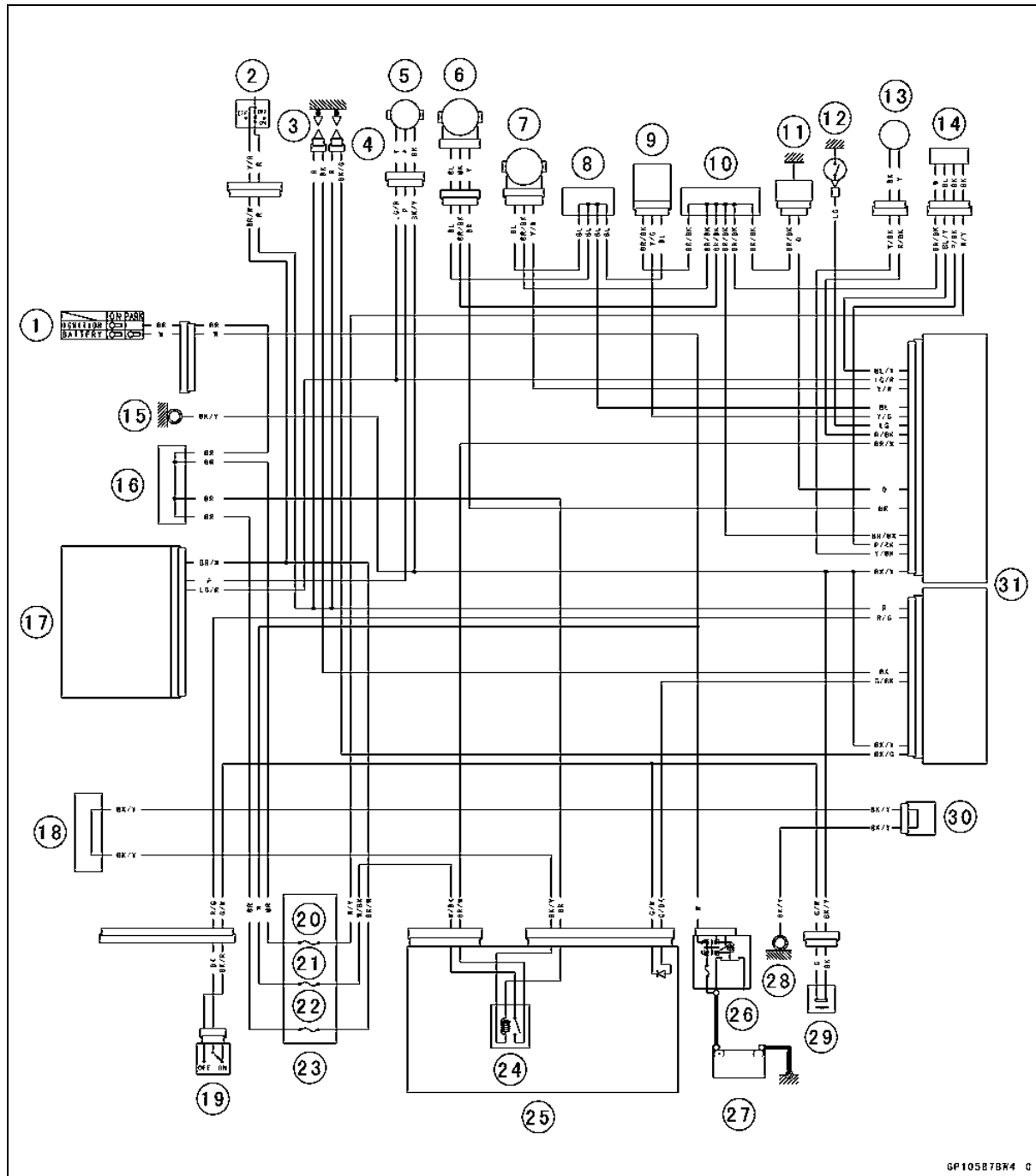

- | | | |
|------------------------------|-------------------------------------|------------------------|
| 1. Ignition Switch | 12. Neutral Switch | 21. ECU Fuse 15 A |
| 2. Engine Stop Switch | 13. Crankshaft Sensor | 22. Ignition Fuse 10 A |
| 3. Spark Plugs | 14. Oxygen Sensor (Equipped Models) | 23. Fuse Box |
| 4. Stick Coils | | 24. ECU Main Relay |
| 5. Speed Sensor | 15. Frame Ground | 25. Relay Box |
| 6. Subthrottle Sensor | 16. Water-proof Joint C | 26. Main Fuse 30 A |
| 7. Main Throttle Sensor | 17. Meter Unit | 27. Battery 12 V 10 Ah |
| 8. Water-proof Joint D | 18. Water-proof Joint B | 28. Frame Ground |
| 9. Vehicle-down Sensor | 19. Starter Lockout Switch | 29. Sidestand Switch |
| 10. Water-proof Joint E | 20. Oxygen Sensor Heater Fuse 10 A | 30. Joint Connector |
| 11. Water Temperature Sensor | | 31. ECU |

SF105B7BR4 C

Electric Starter System

Starter Motor Removal

CAUTION

Do not tap the starter motor shaft or body. Tapping the shaft or body could damage the motor.

- Remove:
 - Air Cleaner Housing (see Air Cleaner Housing Removal in the Fuel System (DFI) chapter)
- Slide out the rubber cap [A].
- Remove the starter motor cable terminal nut [B].
- Remove the mounting bolts [C].
- Pull out the starter motor [D].

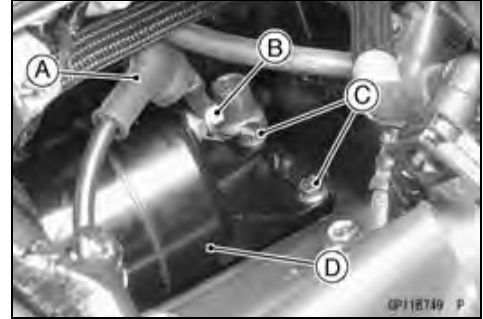

Starter Motor Installation

CAUTION

Do not tap the starter motor shaft or body. Tapping the shaft or body could damage the motor.

- When installing the starter motor, clean the starter motor legs [A] and crankcase [B] where the starter motor is grounded.
 - Replace the O-ring [A] with a new one.
 - Apply grease to the O-ring.
 - Apply a non-permanent locking agent to the threads of the bolts and tighten the bolts.
- Torque - Starter Motor Mounting Bolts: 9.8 N·m (1.0 kgf·m, 87 in·lb)**

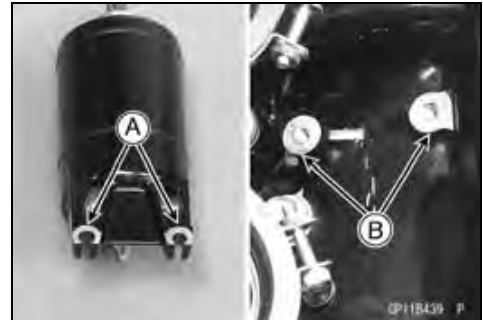

- Install the starter motor cable [A] as shown.
 - About 20° [B]
 - Front [C]
- Tighten:
 - Torque - Starter Motor Terminal Nut: 6.0 N·m (0.61 kgf·m, 53 in·lb)**
- Slide back the rubber cap to the original position.

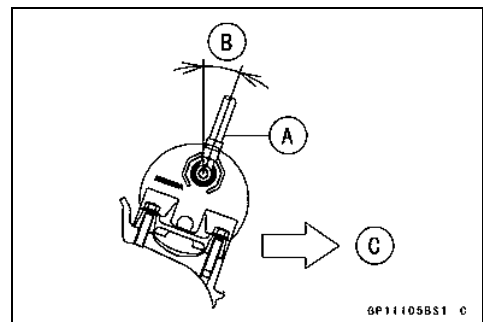

16-48 ELECTRICAL SYSTEM

Electric Starter System

Starter Motor Disassembly

- Remove the starter motor (see Starter Motor Removal).
- Take off the starter motor through bolts [A] and remove the both end covers [B].

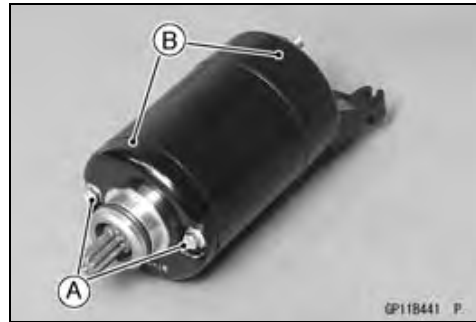

- Pull out the armature [A] out of the yoke [B].

NOTE

○ Do not remove the circlip [C] from the shaft.

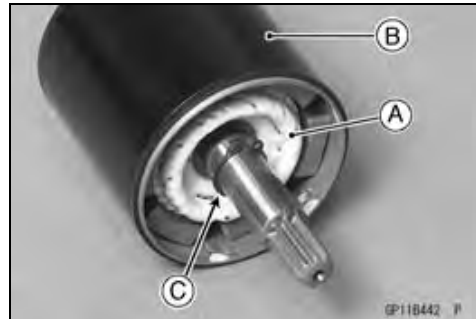

- Remove the starter motor terminal locknut [A].



- Pull out the brushes from the brush holder [A].
- Remove:
 - Brush Springs [B]
 - Starter Motor Terminal [C]
 - Positive Brush Assembly [D]
 - Screw [E]
 - Negative Brush Assembly [F]
 - Brush Holder

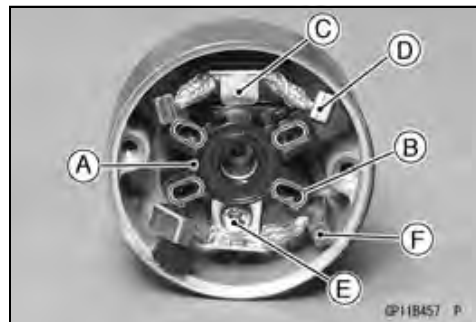

Starter Motor Assembly

- Be sure that the stopper [A] is in position.
- Align the hole [B] of the brush holder [C] to the boss [D] of the right-hand end cover [E].

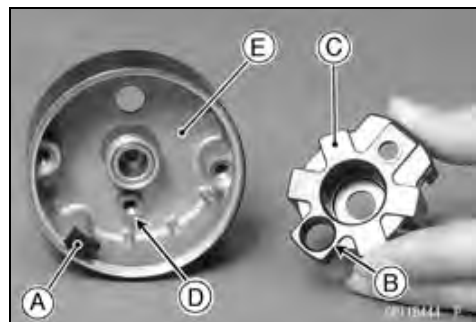

Electric Starter System

- Align the stoppers [A] of the negative brush assembly [B] to the grooves [C] of the brush holder [D].
- Tighten the screw securely.

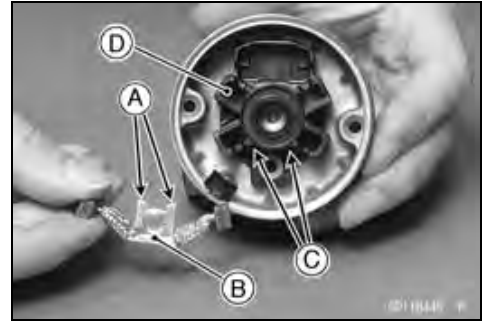

- Align the stoppers [A] of the positive brush assembly [B] to the grooves [C] of the brush holder [D].
- Install the starter motor terminal.

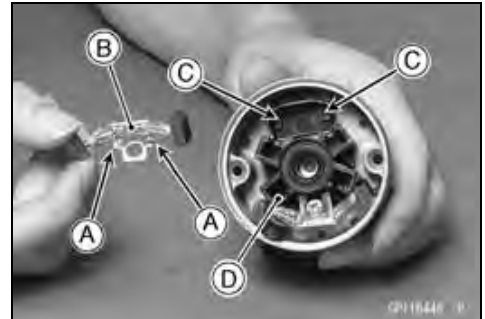

- Replace the O-ring [A] with a new one.
- Install the following parts to the starter motor terminal [B].
 - New O-ring
 - Collar [C]
 - Washer [D]
 - Starter Motor Terminal Locknut [E]
- Install the collar so that stepped side faces outward.
- Tighten:
 - Torque - Starter Motor Terminal Locknut: 11 N·m (1.1 kgf·m, 97 in·lb)**

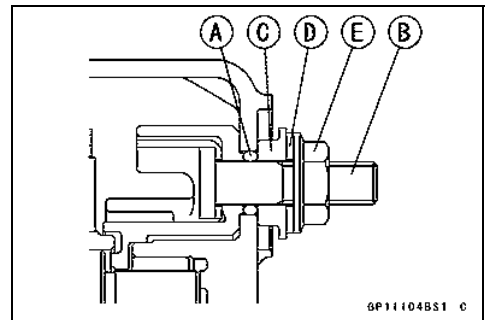

- Install the brush springs [A] and insert the brushes [B].

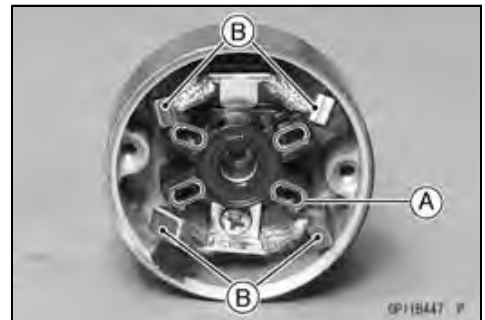

- Apply thin coat of grease to the oil seal [A].

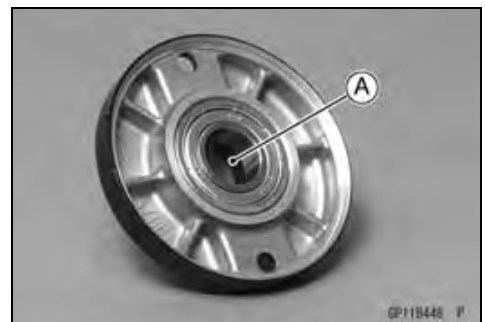

16-50 ELECTRICAL SYSTEM

Electric Starter System

- Replace the O-rings [A] with new ones.
- Insert the armature [B] so that commutator side [C] faces hollow side [D] of the yoke [E].

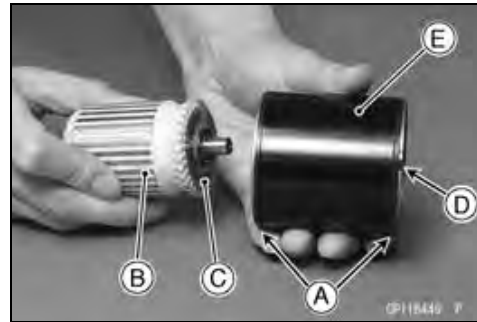

- Align the marks [A] to assembly the yoke and the end covers [B].

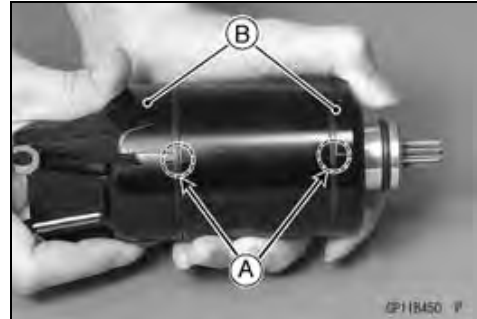

- Replace the O-rings [A] with new ones.
 - Tighten the through bolts [B].
- Torque - Starter Motor Through Bolts: 5.0 N-m (0.51 kgf-m, 44 in-lb)**

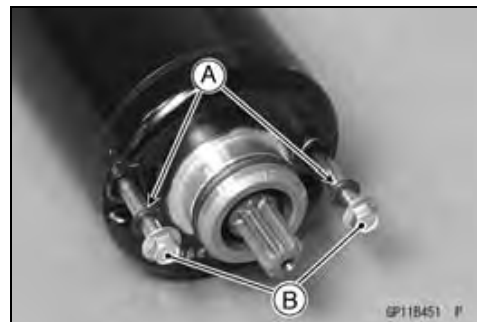

Brush Inspection

- Measure the length of each brush [A].
- ★ If any is worn down to the service limit, replace the brush assembly.

Starter Motor Brush Length

Standard: 12 mm (0.47 in.)

Service Limit: 6.5 mm (0.26 in.)

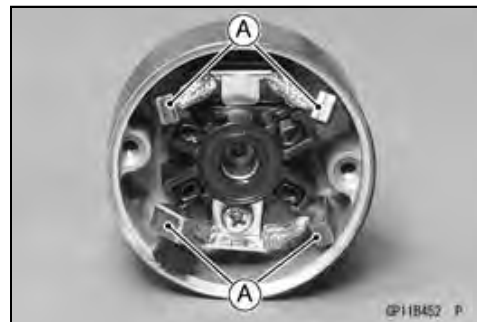

Commutator Cleaning and Inspection

- Clean the metallic debris off the between commutator segments [A].

NOTE

○ Do not use emery or sand paper on the commutator.

- Check the commutator for damage or abnormal wear.
- ★ Replace the starter motor with a new one if there is any damage or wear.
- Visually inspect the commutator segments for discoloration.
- ★ Replace the starter motor with a new one if discoloration is noticed.

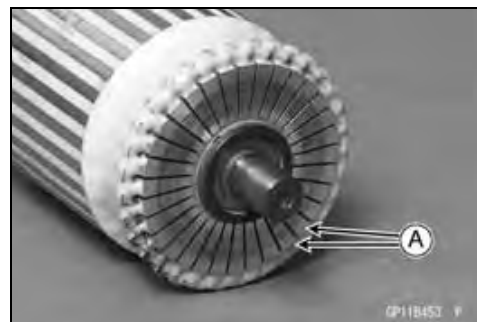

Electric Starter System

Armature Inspection

- Using the $\times 1 \Omega$ hand tester range, measure the resistance between any two commutator segments [A].

Special Tool - Hand Tester: 57001-1394

- ★ If there is a high resistance or no reading (∞) between any two segments, a winding is open and the starter motor must be replaced.
- Using the highest hand tester range, measure the resistance between the segments and the shaft [B].
- ★ If there is any reading at all, the armature has a short and the starter motor must be replaced.

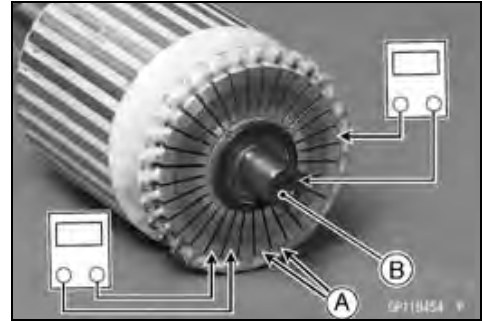

NOTE

○ Even if the foregoing checks show the armature to be good, it may be defective in some manner not readily detectable with the hand tester. If all other starter motor and starter motor circuit components check good, but the starter motor still does not turn over or only turns over weakly, replace the starter motor with a new one.

Brush Lead Inspection

- Using the $\times 1 \Omega$ hand tester range, measure the resistance as shown.

Terminal Bolt and Positive Brushes [A]

Right-hand End Cover and Negative Brushes [B]

Special Tool - Hand Tester: 57001-1394

- ★ If there is not close to zero ohms, the brush lead has an open. Replace the brush assembly.

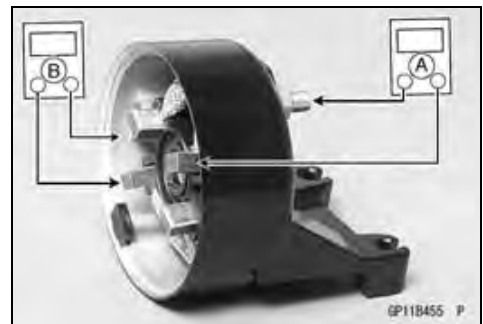

Right-hand End Cover Inspection

- Using the highest tester range, measure the resistance as shown.

Terminal Bolt and Right-hand End Cover [A]

Terminal Bolt and Negative Brushes [B]

Special Tool - Hand Tester: 57001-1394

- ★ If there is any reading, the brush assy and/or terminal bolt assy have a short. Replace the starter motor.

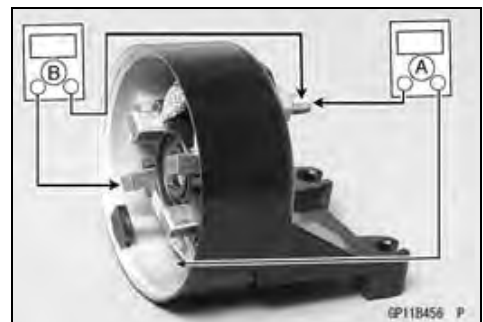

Starter Relay Inspection

- Remove:
 - Battery Negative (-) Cable (see Battery Removal)
 - Bolt [A]
 - Cover [B]

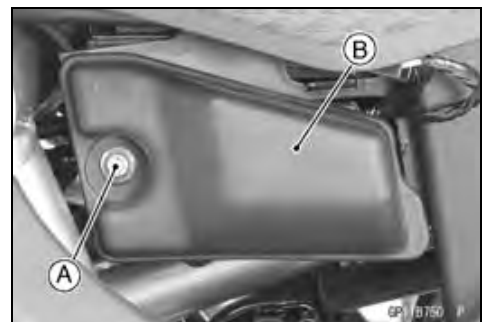

16-52 ELECTRICAL SYSTEM

Electric Starter System

- Disconnect:
 - Connector [A]
 - Starter Motor Cable [B]
 - Battery Positive (+) Cable [C]
- Remove the starter relay.

CAUTION

The battery positive (+) cable with the rubber cap is connected directly to the battery positive (+) terminal even when the ignition switch off, so take care not to short the removed cable to chassis ground.

- Connect the hand tester [A] and 12 V battery [B] to the starter relay [C] as shown.

Special Tool - Hand Tester: 57001-1394

- ★ If the relay does not work as specified, the relay is defective. Replace the relay.

Testing Relay

Tester Range: × 1 Ω range

Criteria: When battery is connected → 0 Ω

When battery is disconnected → ∞ Ω

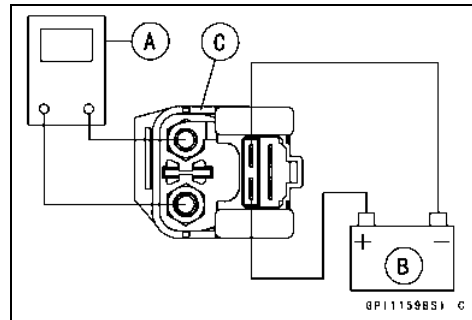
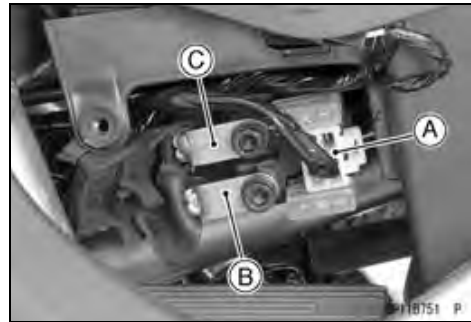

Electric Starter System

Electric Starter Circuit

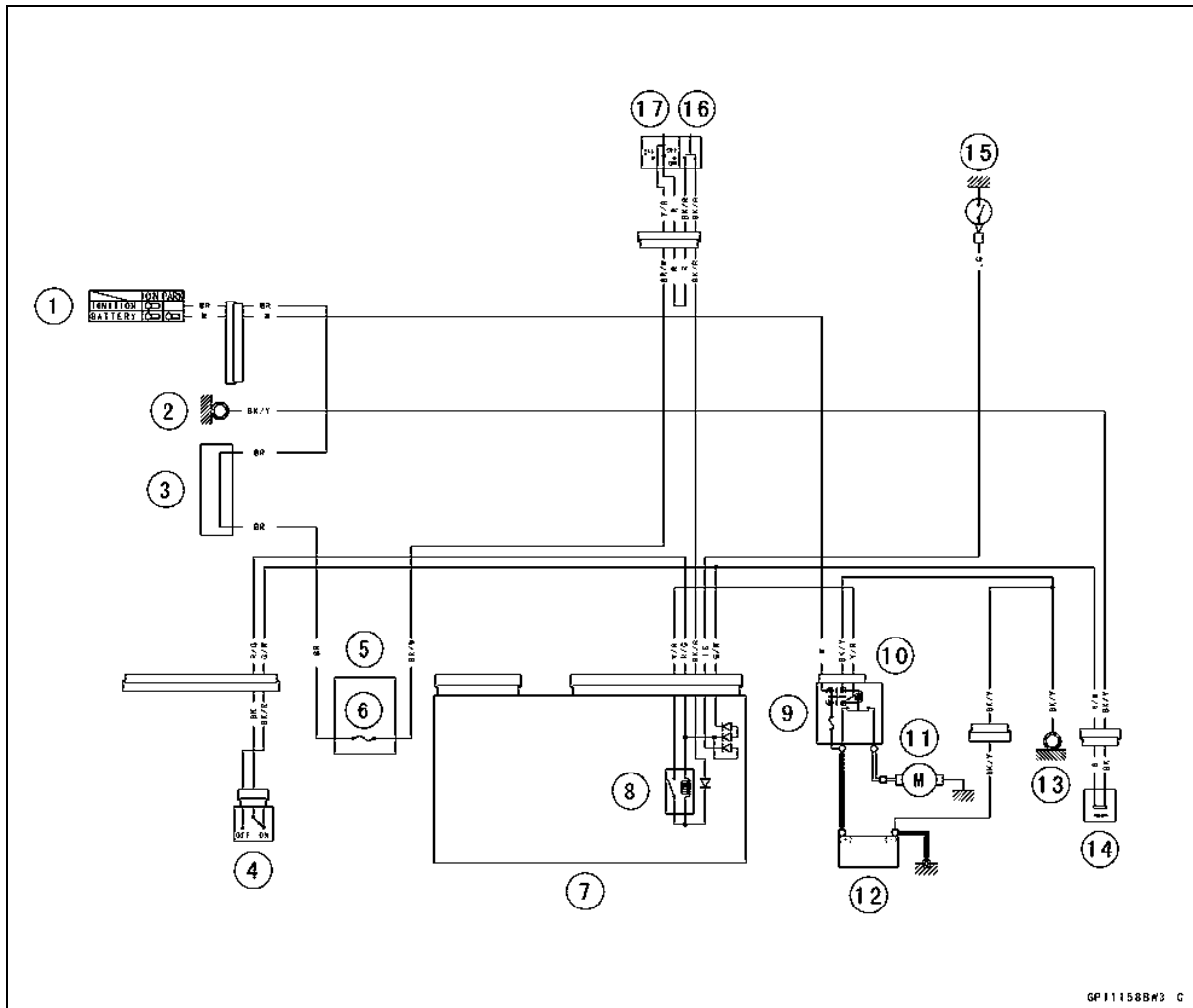

1. Ignition Switch
2. Frame Ground
3. Water-proof Joint C
4. Starter Lockout Switch
5. Fuse Box
6. Ignition Fuse 10 A
7. Relay Box
8. Starter Circuit Relay
9. Main Fuse 30 A
10. Starter Relay
11. Starter Motor
12. Battery 12 V 10 Ah
13. Frame Ground
14. Sidestand Switch
15. Neutral Switch
16. Starter Button
17. Engine Stop Switch

16-54 ELECTRICAL SYSTEM

Lighting System

This motorcycle adopt the daylight system and have a headlight relay in the relay box. The headlight does not go on when the ignition switch and the engine stop switch are first turned on. The headlight comes on after the starter button is released and stays on until the ignition switch is turned off. The headlight will go out momentarily whenever the starter button is pressed and come back on when the button is released.

Headlight Beam Horizontal Adjustment

- Refer to the Headlight Aiming Inspection in the Periodic Maintenance chapter.

Headlight Beam Vertical Adjustment

- Refer to the Headlight Aiming Inspection in the Periodic Maintenance chapter.

Headlight Bulb Replacement

- Remove:
 - Headlight Connector [A]
 - Headlight Bulb Dust Cover [B]

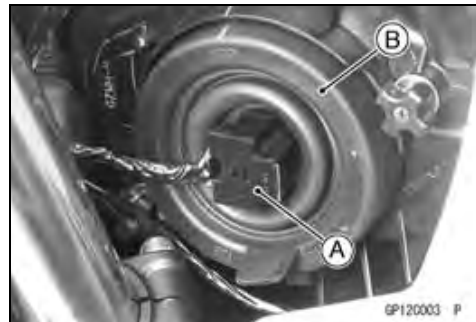

- Release the hook [A], and pull out the headlight bulb [B].

CAUTION
When handling the quartz-halogen bulb, never touch the glass portion with bare hands. Always use a clean cloth. Oil contamination from hands or dirty rags can reduce bulb life or cause the bulb to explode.

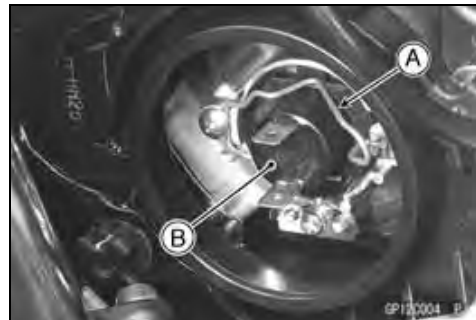

NOTE

- Clean off any contamination that inadvertently gets on the bulb with alcohol or soap and water solution.

- Replace the headlight bulb with a new one.
- Fit the projection [A] of the bulb in the hollow [B] of the headlight.
- Install the hook [C].

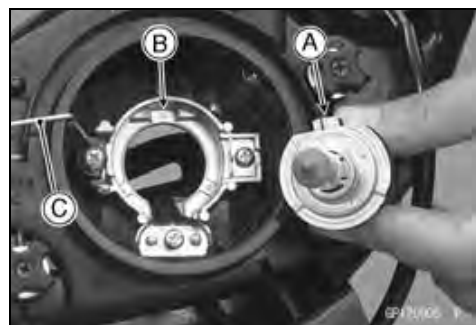

Lighting System

- Fit the dust cover [A] firmly onto the bulb so that the TOP mark [B] is aligned with the arrow mark [C] on the headlight.
- After installation, adjust the headlight aim (see Headlight Aiming Inspection in the Periodic Maintenance chapter).

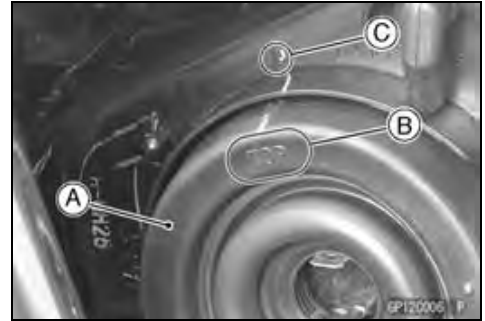

City Light Bulb Replacement

- Pull out the socket [A] together with the bulb.

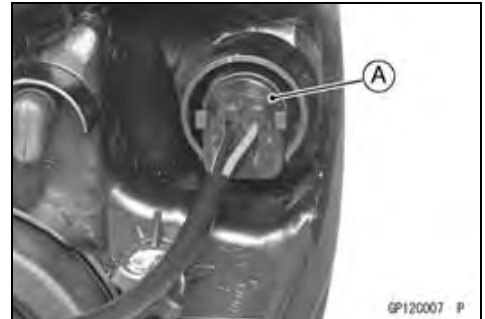

- Pull the bulb [A] out of the socket [B].

CAUTION
Do not turn the bulb. Pull the bulb out to prevent damage to the bulb. Do not use bulb rated for greater wattage than the specified bulb.

- Replace the bulb with a new one.

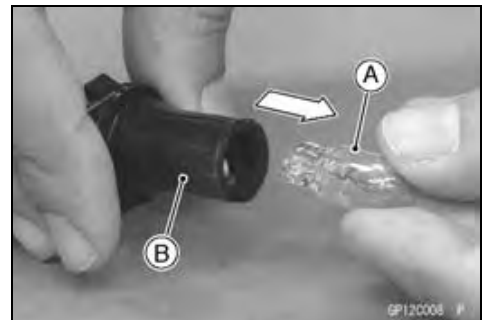

Headlight Removal

- Remove:
 - Upper Fairing (see Upper Fairing Removal in the Frame chapter)
 - Bolts [A]
 - Headlight [B]

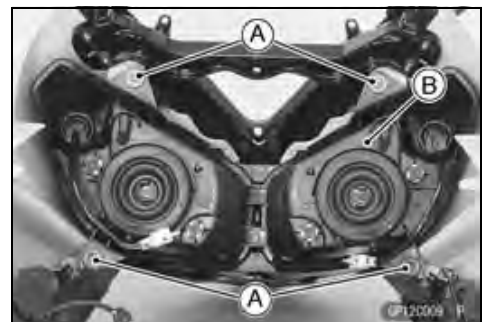

Headlight Installation

- Installation is the reverse of removal.

16-56 ELECTRICAL SYSTEM

Lighting System

Tail/Brake Light (LED) Removal

- Remove:
 - Seat Cover (see Seat Cover Removal in the Frame chapter)
- Disconnect the tail/brake light lead connector [A]



- Remove the nuts [A] and washers.

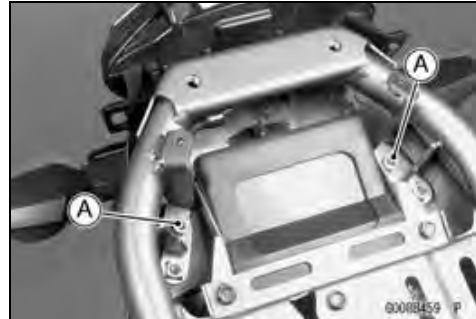

- Remove the tail/brake light mounting bolts [A], and take off the tail/brake light unit [B].

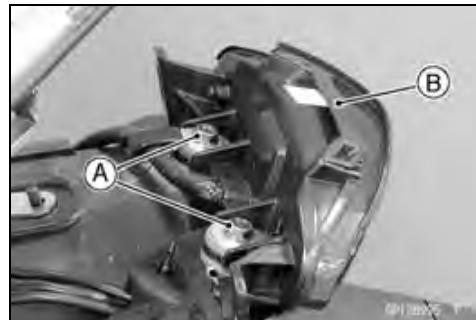

Tail/Brake Light (LED) Installation

- Installation is the reverse of removal; note the following.
- Tighten:
 - Clamp [A]
 - Torque - Tail/Brake Light Mounting Bolts [B]: 8.8 N·m (0.90 kgf·m, 78 in·lb)

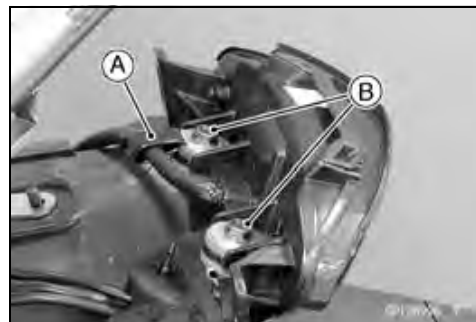

License Plate Light Bulb Replacement

- Remove:
 - Screws [A]
 - License Plate Light Cover [B]

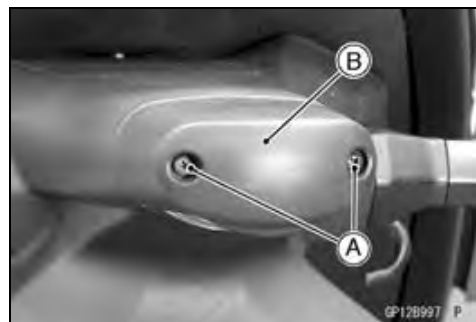

Lighting System

- Pull the bulb [A] out of the socket [B].

CAUTION

Do not turn the bulb. Pull the bulb out to prevent damage to the bulb. Do not use bulb rated for greater wattage than the specified valve.

- Replace the bulb with a new one.
- Install the license plate light cover.

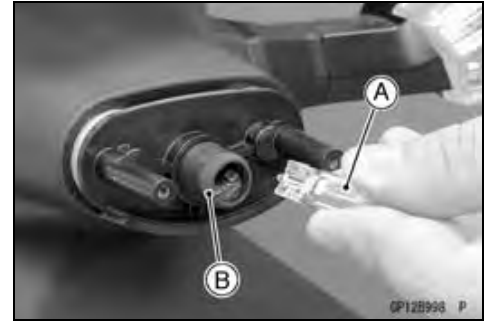

Headlight/Tail Light Circuit

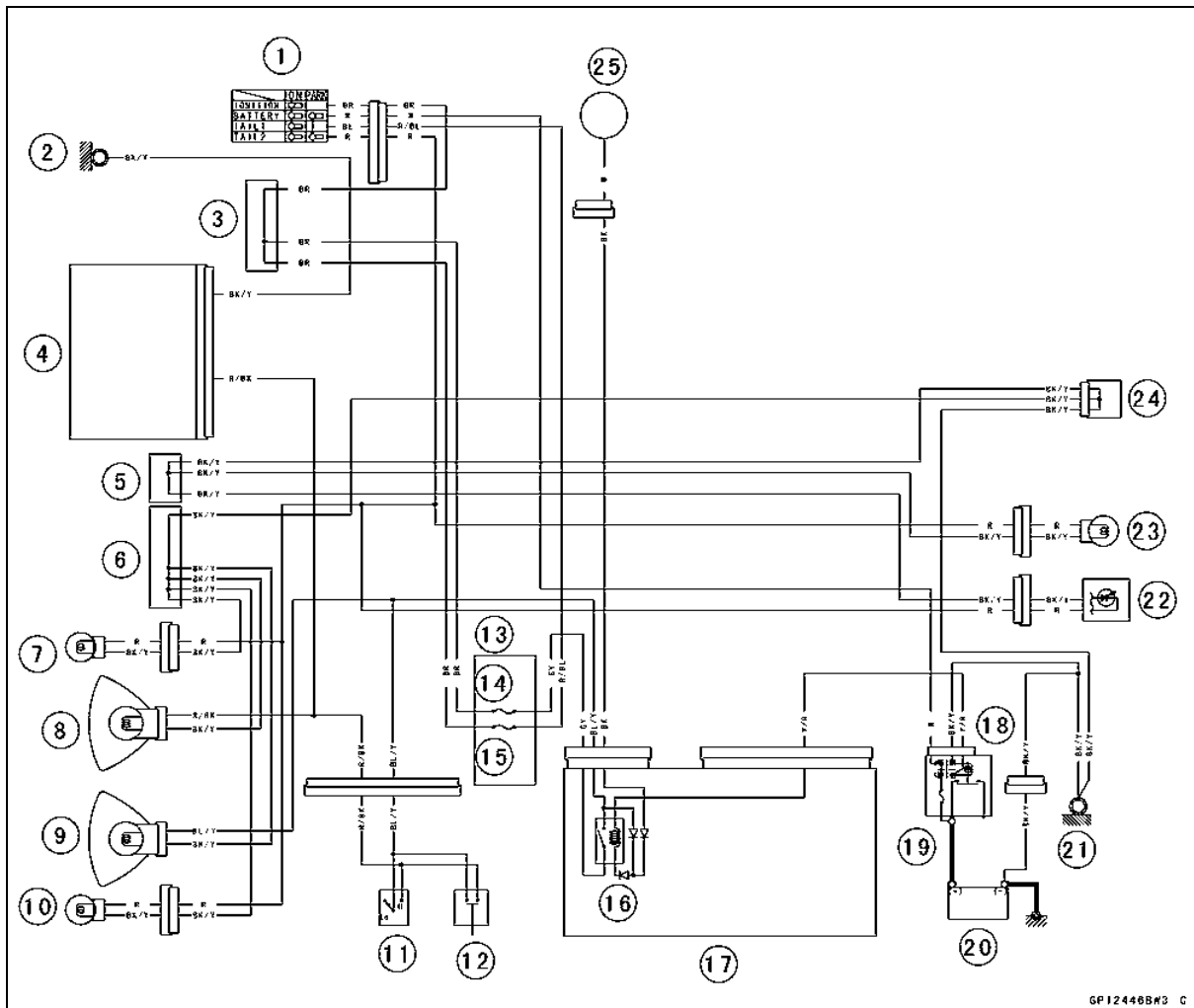

- | | |
|--------------------------------------|-----------------------------|
| 1. Ignition Switch | 14. Headlight Fuse 10 A |
| 2. Frame Ground | 15. Tail Light Fuse 10 A |
| 3. Water-proof Joint C | 16. Headlight Circuit Relay |
| 4. Meter Unit | 17. Relay Box |
| 5. Water-proof Joint B | 18. Starter Relay |
| 6. Water-proof Joint A | 19. Main Fuse 30 A |
| 7. Right City Light | 20. Battery 12 V 10 Ah |
| 8. Headlight (High Beam) | 21. Frame Ground |
| 9. Headlight (Low Beam) | 22. Tail/Brake Light (LED) |
| 10. Left City Light | 23. License Plate Light |
| 11. Dimmer Switch | 24. Joint Connector |
| 12. Passing Button (Equipped Models) | 25. Alternator |
| 13. Fuse Box | |

GP12446B#3 C

16-58 ELECTRICAL SYSTEM

Lighting System

Turn Signal Light Bulb Replacement

- Unscrew the screw [A] and remove the lens [B].

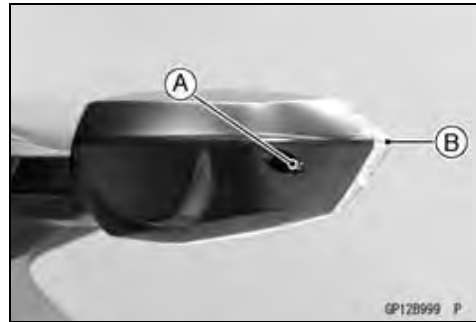

- Remove the bulb [A].
 - Push and turn counterclockwise the bulb.



- Insert the new bulb [A] by aligning its pins [B] with the grooves [C] in the socket, and turn the bulb clockwise.
- Install the lens.

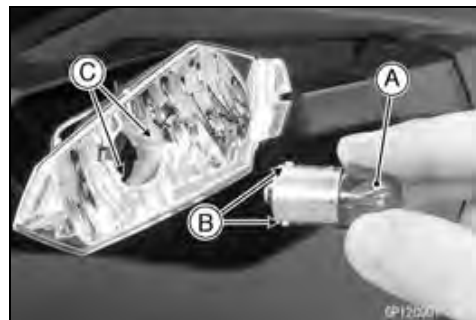

Turn Signal Relay Inspection

- Remove:
 - Upper Fairing (see Upper Fairing Removal in the Frame chapter)
 - Turn Signal Relay [A]



Lighting System

- Connect one 12 V battery and turn signal lights as indicated in the figure, and count how many times the lights flash for one minute.

Turn Signal Relay [A]

Turn Signal Lights [B]

12 V Battery [C]

- ★ If the lights do not flash as specified, replace the turn signal relay.

Testing Turn Signal Relay

Load		Flashing Times (c/m*)
The Number of Turn Signal Lights	Wattage (W)	
1**	10	140 ~ 250
2	20	75 ~ 95

(*): Cycle(s) per minute

(**): Corrected to "one light burned out".

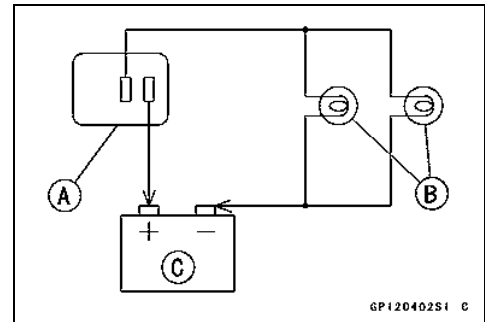

16-60 ELECTRICAL SYSTEM

Lighting System

Turn Signal Light Circuit

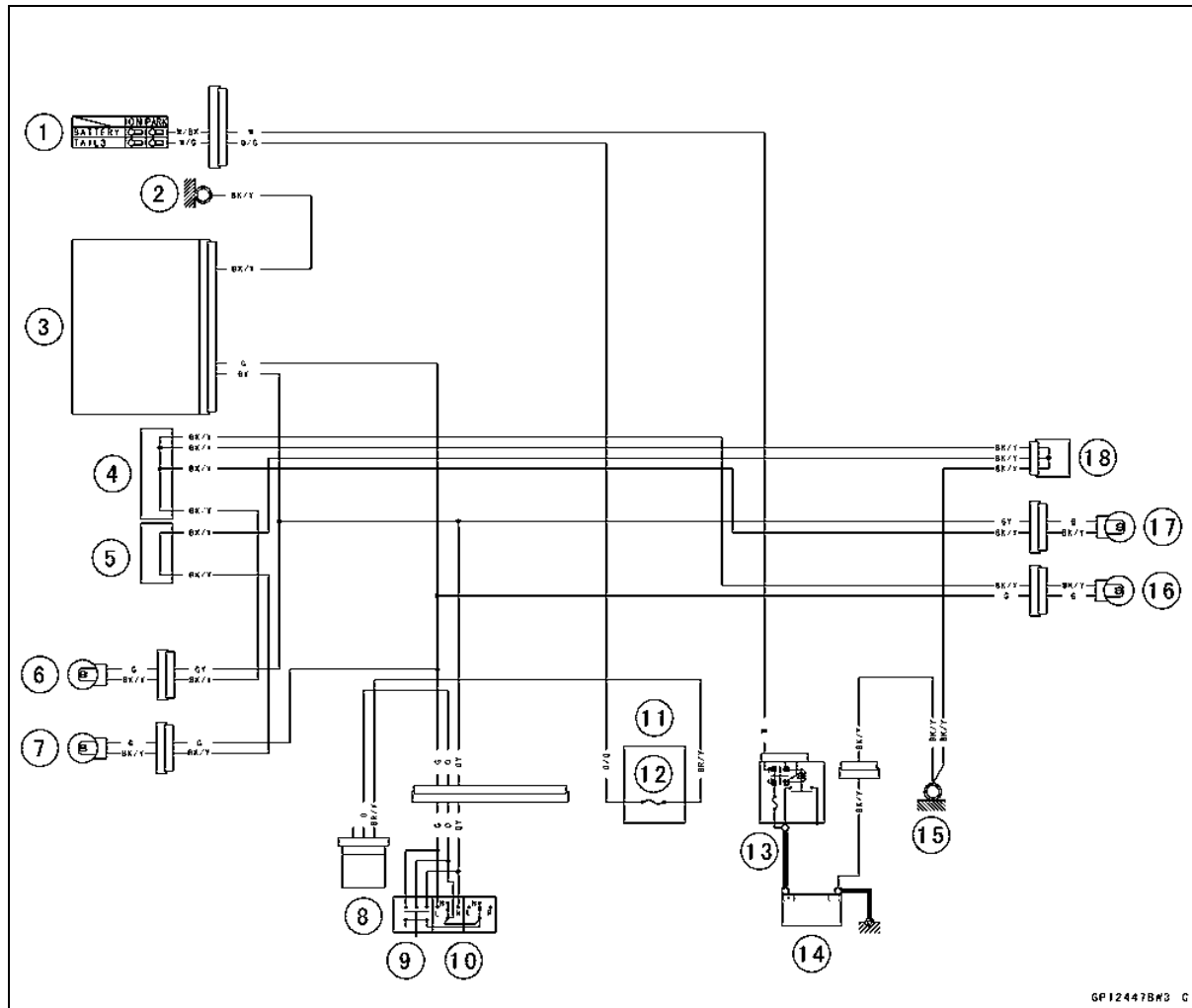

1. Ignition Switch
2. Frame Ground
3. Meter Unit
4. Water-proof Joint B
5. Water-proof Joint A
6. Front Right Turn Signal Light
7. Front Left Turn Signal Light
8. Turn Signal Relay
9. Hazard Button
10. Turn Signal Switch
11. Fuse Box
12. Turn Signal Relay Fuse 10 A
13. Main Fuse 30 A
14. Battery 12 V 10 Ah
15. Frame Ground
16. Rear Left Turn Signal Light
17. Rear Right Turn Signal Light
18. Joint Connector

GP12447BR2 C

Air Switching Valve

Air Switching Valve Operation Test

- Remove the fuel tank (see Fuel Tank Removal in the Fuel System (DFI) chapter).
- Pull the air switching valve hose [A] out of the air cleaner base.



- Take the air switching valve hose end outside of the frame.
- Reinstall the fuel tank (see Fuel Tank Installation in the Fuel System (DFI) chapter).
- Start the engine and run it at idle speed.
- Plug the air switching valve hose end [A] with your finger and feel vacuum pulsing in the hose.
- ★ If there is no vacuum pulsation, check the hose line for leak. If there is no leak, check the air switching valve (see Air Switching Valve Unit Test).
- Apply a soap and water solution or rubber lubricant to the end of the air switching valve hose and install the hose on the fitting.



Air Switching Valve Unit Test

- Remove the air switching valve (see Air Switching Valve Removal in the Engine Top End chapter).
- Set the hand tester [A] to the $\times \Omega$ range and connect it to the air switching valve terminals as shown.

Special Tool - Hand Tester: 57001-1394

Air Switching Valve Resistance

Standard: 18 ~ 22 Ω at 20°C (68°F)

- ★ If the resistance reading is except the specified value, replace it with a new one.
- Connect the 12 V battery [A] to the air switching valve terminals as shown.

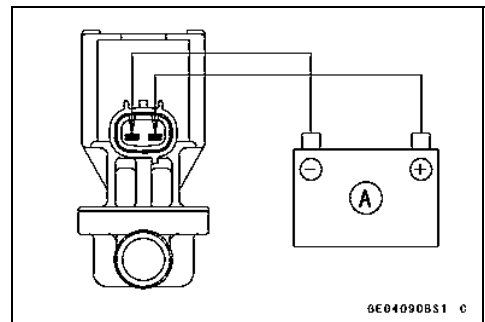
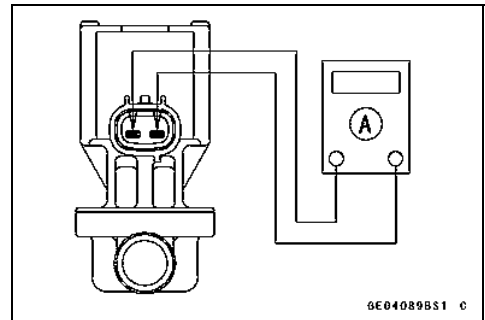

16-62 ELECTRICAL SYSTEM

Air Switching Valve

- Blow the air to the inlet air duct [A], and make sure does not flow the blown air from the outlet air duct [B].

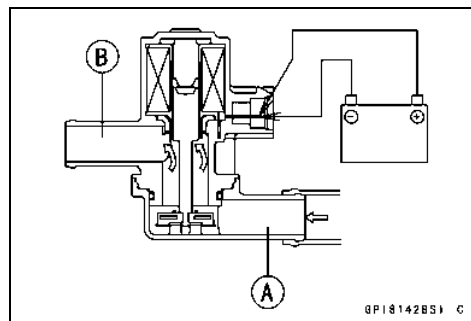

- Disconnect the 12 V battery.
- Blow the air to the inlet air duct [A] again, and make sure flow the blown air from the outlet air duct [B].
- ★ If the air switching valve does not operate as described, replace it with a new one.

NOTE

- To check air flow through the air switching valve, just blow through the air cleaner hose [C].

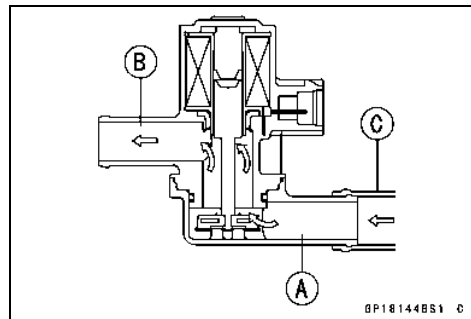

Radiator Fan System

Fan Motor Inspection

- Disconnect the connector [A].
- Using an auxiliary leads, supply battery power to the fan motor.
- ★ If the fan does not rotate, the fan motor is defective and must be replaced.



Radiator Fan Circuit

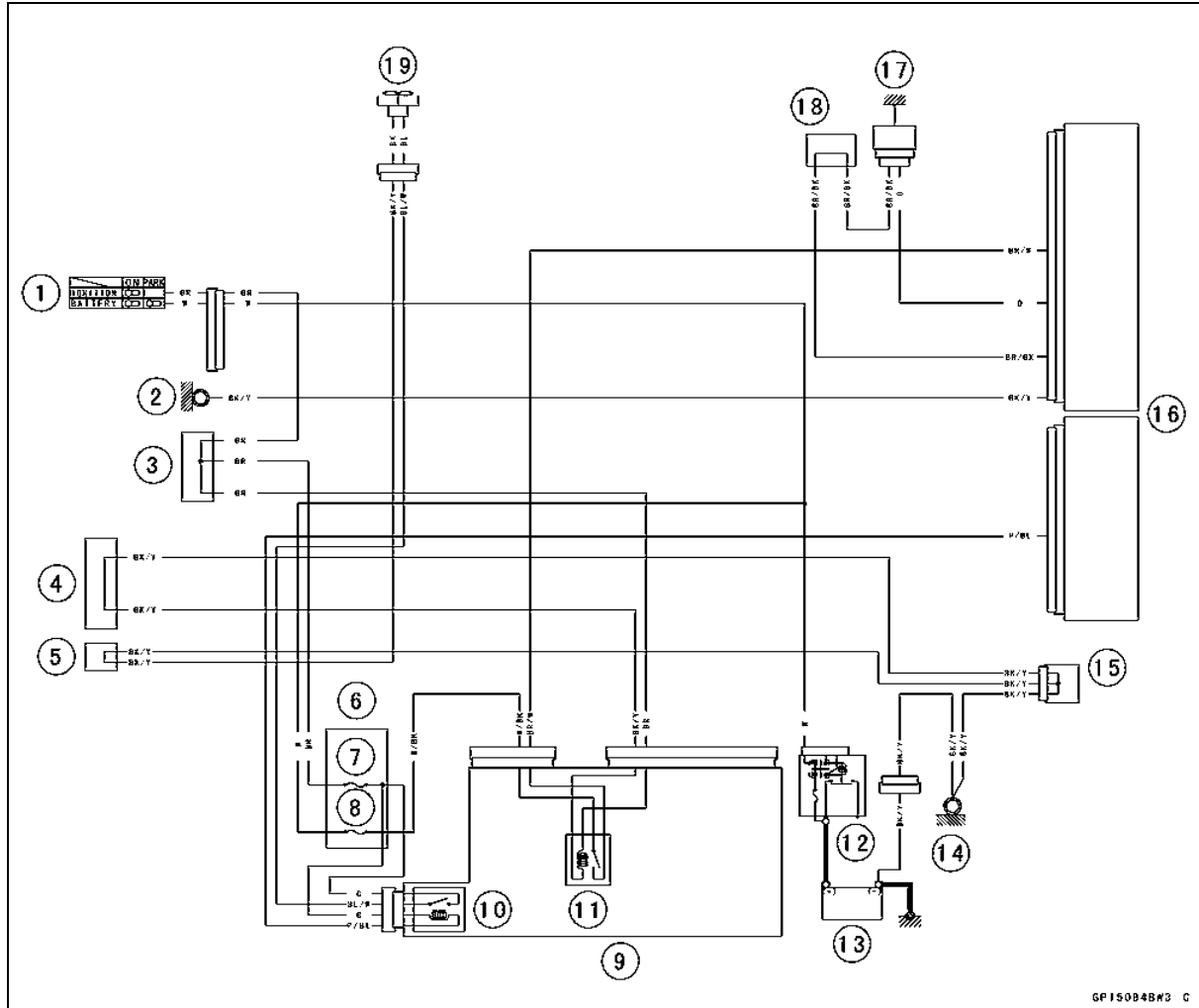

- | | |
|------------------------|------------------------------|
| 1. Ignition Switch | 11. ECU Main Relay |
| 2. Frame Ground | 12. Main Fuse 30 A |
| 3. Water-proof Joint C | 13. Battery 12 V 10 Ah |
| 4. Water-proof Joint B | 14. Frame Ground |
| 5. Water-proof Joint A | 15. Joint Connector |
| 6. Fuse Box | 16. ECU |
| 7. Fan Fuse 15 A | 17. Water Temperature Sensor |
| 8. ECU Fuse 15 A | 18. Water-proof Joint E |
| 9. Relay Box | 19. Radiator Fan |
| 10. Radiator Fan Relay | |

GF150B4B#3 C

16-64 ELECTRICAL SYSTEM

Meter, Gauge, Indicator Unit

Meter Unit Removal/Installation

- Remove:
 - Lower Fairing (see Lower Fairing Removal in the Frame chapter)
 - Upper Fairing Covers (see Upper Fairing Cover Removal in the Frame chapter)
 - Bolt [A] (Both Sides)



- Remove:
 - Windshield (see Windshield Removal in the Frame chapter)
 - Quick Rivets [A]
 - Meter Cover [B]

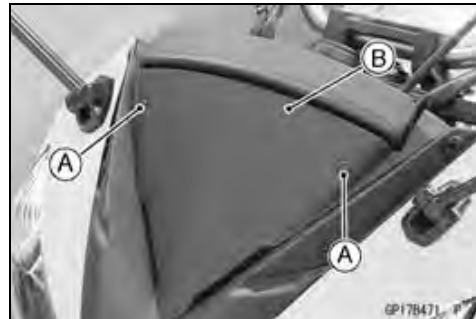

- Slide out the dust cover [A], and disconnect the connector.
- Remove the screws [B], and take off the center inner fairing together with the meter unit.

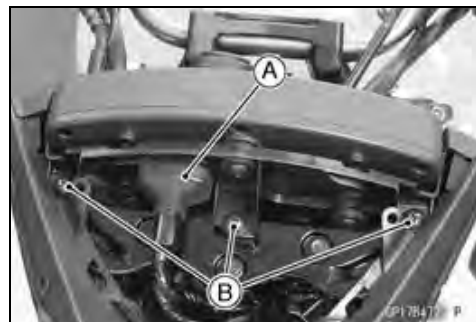

- Remove the screws [A] and washers, and separate the meter unit [B] and the center inner fairing [C].

CAUTION

Place the meter unit so that the face is up. If a meter unit is left upside down or sideways for any length of time, it will malfunction.

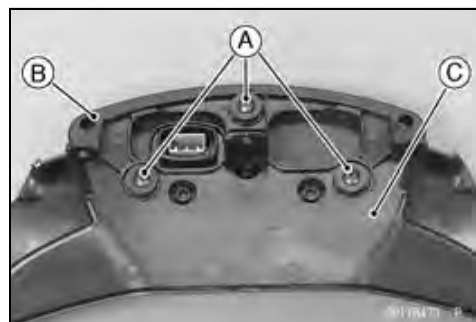

- Installation is the reverse of removal.
- Tighten:
 - Torque - Meter Cover Screws: 1.2 N·m (0.12 kgf·m, 11 in·lb)

Meter, Gauge, Indicator Unit

Meter, Gauge Disassembly

- Remove:
 - Meter Unit (see Meter Unit Removal)
 - Screws [A]
 - Lower Meter Cover [B]

- Separate the meter assembly [A] and upper meter cover [B].

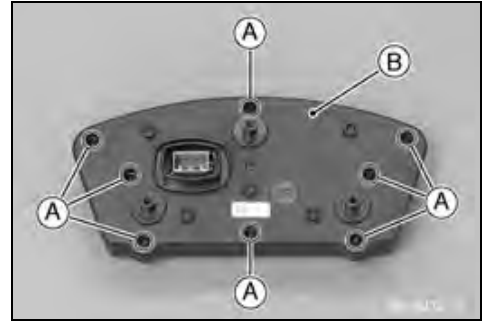

Electronic Combination Meter Unit Inspection

- Remove the meter unit [A] (see Meter Unit Removal).
 - [1] High Beam Indicator Light (LED) (+)
 - [2] FI Indicator Light (LED) (-)
 - [3] Speed Sensor Signal
 - [4] Tachometer Signal
 - [5] ABS Indicator Light (LED) (EX650D Models)
 - [6] Oil Pressure Warning Indicator Light (LED) (-)
 - [7] Battery (+)
 - [8] Ground (-)
 - [9] Neutral Indicator Light (LED) (-)
 - [10] Right Turn Signal Indicator Light (LED) (+)
 - [11] Fuel Level Gauge
 - [12] Fuel Reserve Switch
 - [13] Left Turn Signal Indicator Light (LED) (+)
 - [14] Water Temperature Sensor
 - [15] Speed Sensor Supply Voltage
 - [16] Ignition

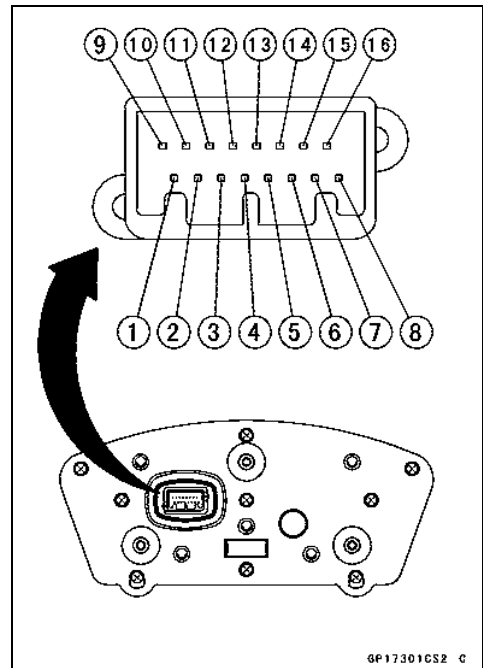

CAUTION

Do not drop the meter unit. Place the meter unit so that it faces upward. If the meter unit is left upside down or sideways for a long time or dropped, it will malfunction. Do not short each terminals.

6P17301CS2 C

16-66 ELECTRICAL SYSTEM

Meter, Gauge, Indicator Unit

Liquid Crystal Display (LCD) Segments Check

- Using the auxiliary leads, connect the 12 V battery to the meter unit connector as follows.
- Connect the battery positive terminal to the terminal [7].
- Connect the battery negative terminal to the terminal [8].
- Anything does not happen, it is normal.

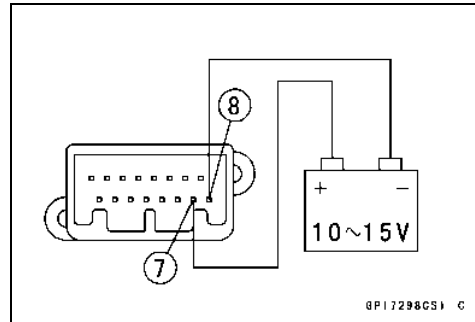

- Connect the terminal [16] to the terminal [7].

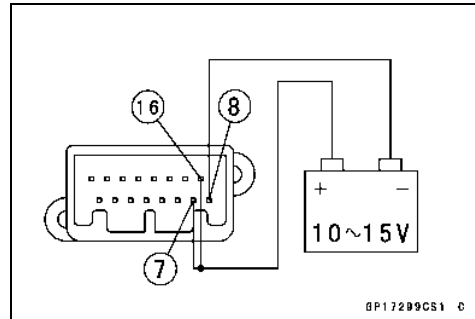

- When the terminals are connected, all the LCD segments [A] and water temperature warning indicator light [B] appear for 3 seconds.
- For models equipped with an ABS, the ABS indicator light [C] appears.
- ★ If the LCD segments and water temperature warning indicator light will not appear, replace the meter assembly.
- Disconnect the terminal [16].
- All the LCD segments disappear.
- ★ If the segments do not disappear, replace the meter assembly.

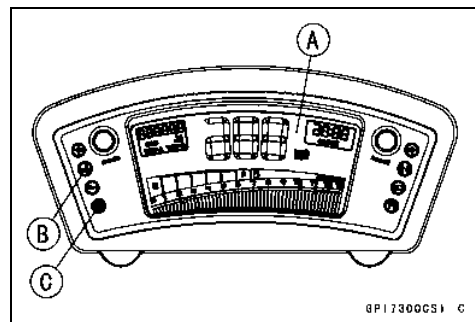

Meter, Gauge, Indicator Unit

MODE AND RESET BUTTON Operation Check

- Connect the 12 V battery and terminals in the same manner as specified in the "Liquid Crystal Display (LCD) Segments Check".
- Check that the display change to the ODO, TRIP A and TRIP B displays each time the MODE button [A] is pressed.
- If the fuel level gauge flashed, display change to FUEL, ODO, TRIP A and TRIP B.
- ★ If the display function does not work, replace the meter assembly.

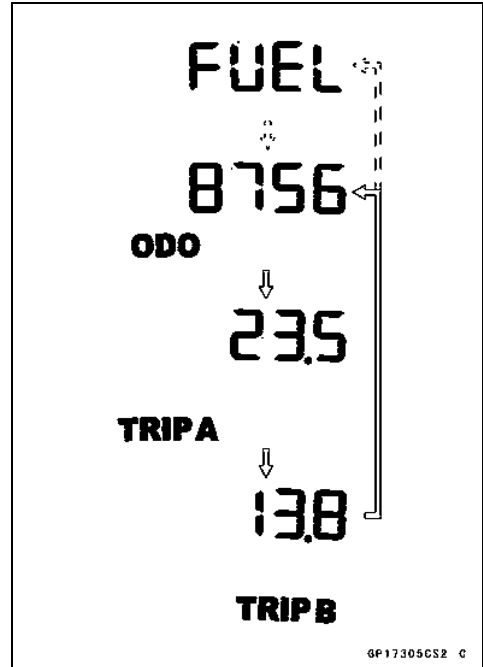
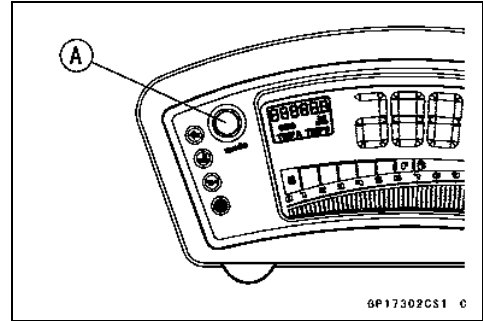

- Indicate the ODO mode.
- Check that when the RESET button [A] in ODO mode is pushed for more than two seconds, the meter display turns to the clock set mode.
- Both the hour and minute display start flashing.

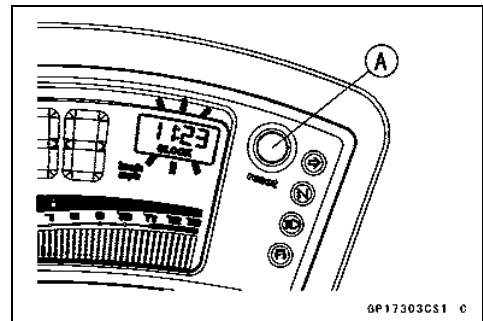

- In the HOUR/MINUTE setting mode, press the RESET button again to effect the HOUR setting mode.
- The hour display flashes on the display.
- Press the MODE button to set the hour.

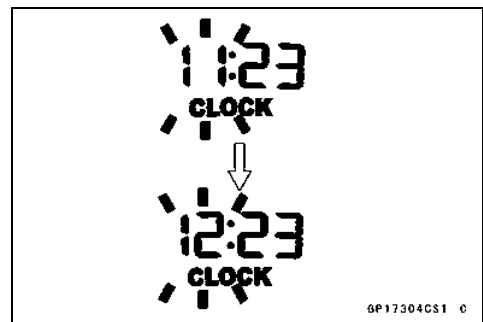

16-68 ELECTRICAL SYSTEM

Meter, Gauge, Indicator Unit

- In the HOUR setting mode, press the RESET button to effect the MINUTE setting mode.
- The minute display flashes on the display.
- Press the MODE button to set the minute.

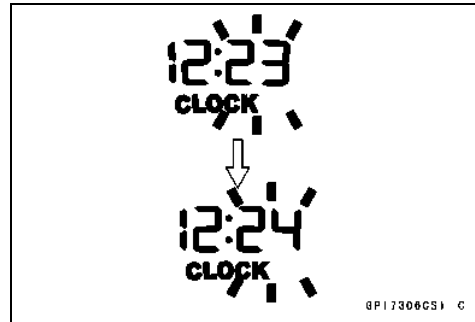

- In the MINUTE setting mode, press the RESET button to return to the HOUR/MINUTE setting mode.
- Press the MODE button to complete the time setting process.
- The clock starts counting the seconds as soon as the MODE button is pressed.

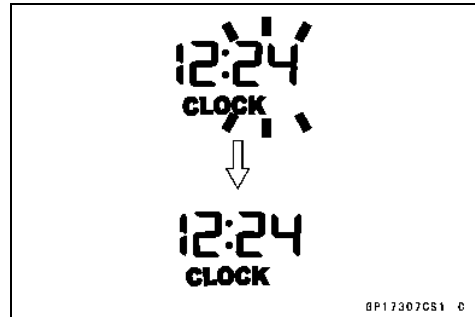

- Indicate the ODO mode.
- Check that the display [A] change to the mile and km display each time by pushing the RESET button while MODE button pushed in.

NOTE

- Mile/Km display can alternate between English and metric modes (mile and km) in the digital meter. Make sure that km or mile according to local regulations is correctly displayed before riding.

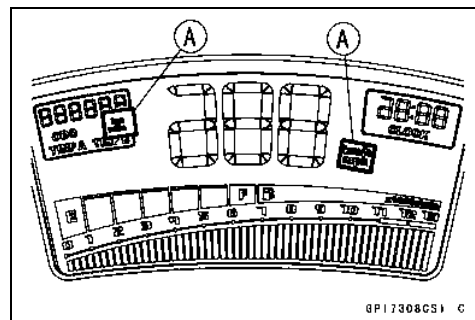

- ★ If the display function does not work and adjust, replace the meter assembly.

Speedometer Check

- Connect the 12 V battery and terminals in the same manner as specified in the "Liquid Crystal Display (LCD) Segments Check".
- The speed equivalent to the input frequency is indicated in the oscillator [A], if the square wave (illustrated as shown) would be input into the terminal [3].
- Indicates approximately 60 mph in case the input frequency would be approximately 172.6 Hz.
- Indicates approximately 60 km/h in case the input frequency would be approximately 107.9 Hz.

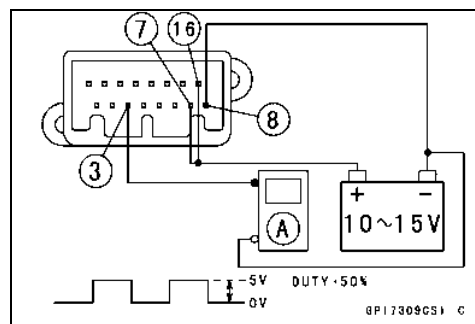

- If the oscillator is not available, the speedometer can be checked as follows.
- Install the meter unit.
- Raise the rear wheel off the ground with stand.
- Turn on the ignition switch.
- Rotate the rear wheel by hand.
- Check that the speedometer shows the speed.
- ★ If the speedometer does not work, check the speed sensor electric source voltage and speed sensor.
- ★ If the electric source voltage and speed sensor are normal, replace the meter assembly.

Meter, Gauge, Indicator Unit

Speed Sensor Electric Source Check

- Connect the 12 V battery and terminals in the same manner as specified in the "Liquid Crystal Display (LCD) Segments Check".
- Set the hand tester to the DC 25 V range and connect it to the terminals [15] and [8].

Special Tool - Hand Tester: 57001-1394

- ★ If the voltage is less than 9 V, replace the meter assembly.

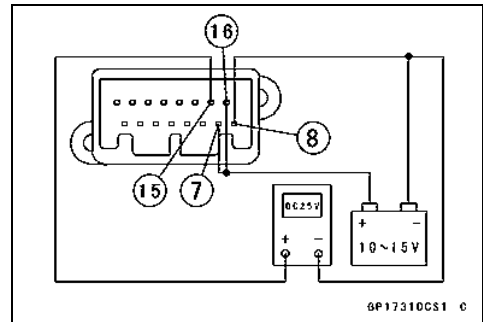

Odometer Check

- Check the odometer with the speedometer in the same way.
- ★ If value indicated in the odometer is not added, replace the meter assembly.

NOTE

- The data is maintained even if the battery is disconnected.
- When the figures come to 999999, they are stopped and locked.

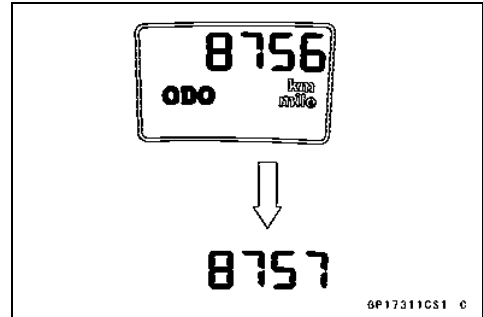

Trip A/B Meter Check

- Check the trip A or B meters with the speedometer in the same way.
- ★ If value indicated in the trip A/B meters is not added, replace the meter assembly.
- Check that when the RESET button is pushed for more than two seconds, the figure display turns to 0.0.
- ★ If the figure display does not indicate 0.0, replace the meter assembly.

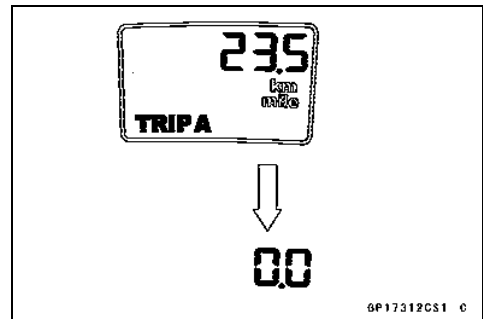

Tachometer Check

- Connect the 12 V battery and terminals in the same manner as specified in the "Liquid Crystal Display (LCD) Segments Check".
- The revolutions per minute (rpm) equivalent to the input frequency is indicated in the oscillator [A] if the square wave (illustrated as shown) would be input into the terminal [4].
- Indicates approximately 4 000 rpm in case the input frequency would be approximately 133.3 Hz.

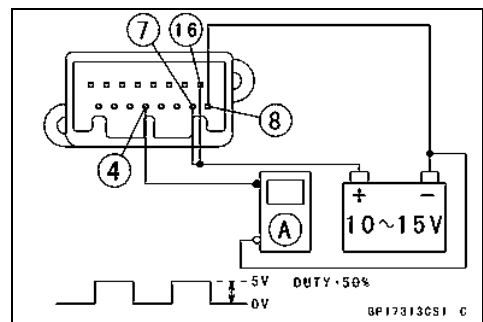

16-70 ELECTRICAL SYSTEM

Meter, Gauge, Indicator Unit

- If the oscillator is not available, the tachometer can be checked as follows.
- Connect the 12 V battery and terminals in the same manner as specified in the "Liquid Crystal Display (LCD) Segments Check".
- When the terminals are connected, the tachometer goes and disappears from minimum to the maximum reading momentarily. It goes again, and then the tachometer disappears.
- ★ If the tachometer segments function does not work, replace the meter assembly.
- Using the insulated auxiliary lead, quickly open and connect the terminal [16] to the terminal [4] repeatedly.
- Then the tachometer segments [A] should flick [B].
- ★ If the hand does not flick, replace the meter assembly.

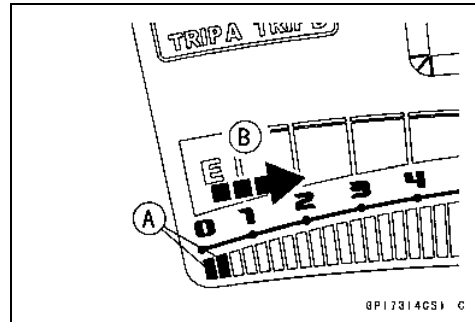

Fuel Level Gauge Check

- Connect the 12 V battery and terminals in the same manner way as specified in the "Liquid Crystal Display (LCD) Segments Check".
- Connect the variable rheostat [A] to the terminal [11] as shown.

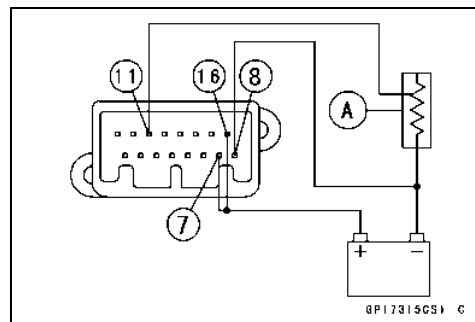

- Check that the number of segments [A] matches the resistance value of the variable rheostat.
- When the terminal [11] is connected, one segment in the fuel level gauge should appear about every 15 seconds.

Variable Rheostat Resistance (Ω)	Display Segments
10	6
110	3
200	1

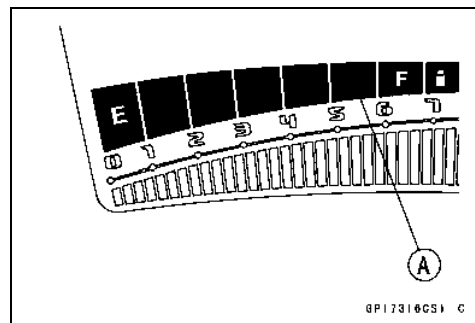

- ★ If the display function does not work, replace the meter assembly.

Fuel Level Warning Check

- Connect the 12 V battery and terminals in the same manner way as specified in the "Liquid Crystal Display (LCD) Segments Check".
- Connect the variable rheostat [A] to the terminal [12] as shown.
- Adjust the resistance value to the approximately 100 Ω .

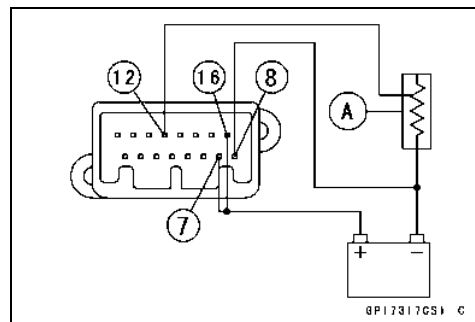

Meter, Gauge, Indicator Unit

- Check that one segment [A] in the fuel gauge starts flashing.
- Check that the FUEL segments [B] flashes in the LCD.
- ★ If the display function does not work, replace the meter assembly.

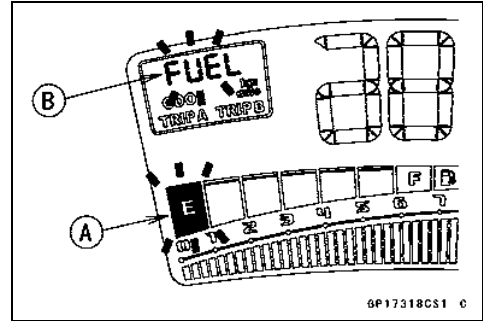

Indicator Lights Inspection

- Connect the 12 V battery and terminals in the same manner as specified in the "Liquid Crystal Display (LCD) Segments Check".

- Left Turn Signal Indicator Light (LED) [A]
- Right Turn Signal Indicator Light (LED) [B]
- Neutral Indicator Light (LED) [C]
- High Beam Indicator Light (LED) [D]
- ABS Indicator Light (LED) (EX650D Models) [E]
- Oil Pressure Warning Indicator Light (LED) [F]
- FI Indicator Light (LED) [G]
- Water Temperature Warning Indicator Light (LED) [H]

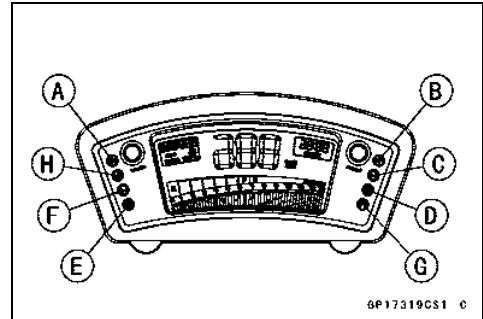

- Using the auxiliary leads, connect a 12 V battery to the meter unit connector as follows.

- Water Temperature Warning Indicator Light (LED)**
Battery Negative (-) Terminal to Terminal [14]

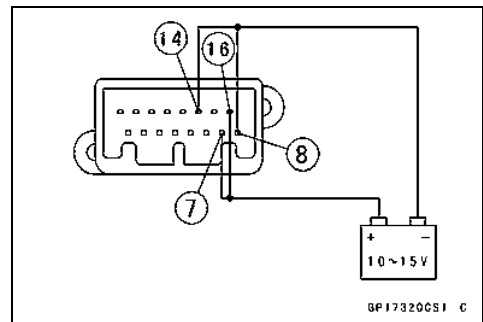

- Oil Pressure Warning Indicator Light (LED)**
Battery Negative (-) Terminal to Terminal [6]

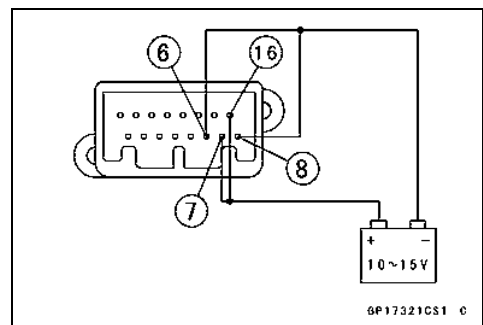

16-72 ELECTRICAL SYSTEM

Meter, Gauge, Indicator Unit

High Beam Indicator Light (LED)

Battery Positive (+) Terminal to Terminal [1]

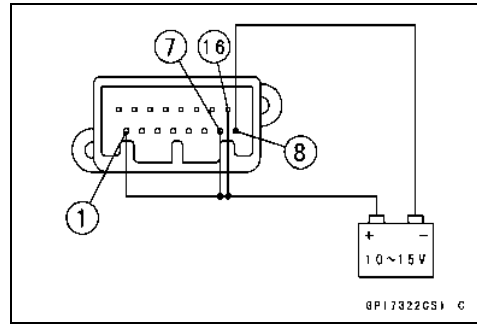

Neutral Indicator Light (LED)

Battery Negative (-) Terminal to Terminal [9]

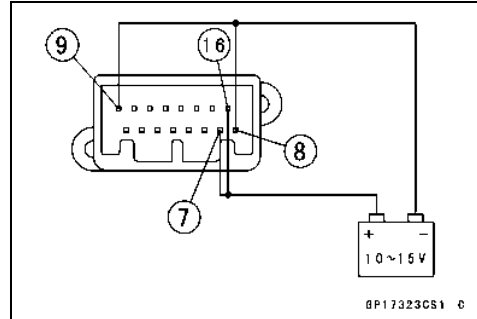

Right and Left Turn Signal Indicator Light (LED)

For Right Turn Signal Indicator Light (LED)
Battery Positive (+) Terminal to Terminal [10]

For Left Turn Signal Indicator Light (LED)
Battery Positive (+) Terminal to Terminal [13]

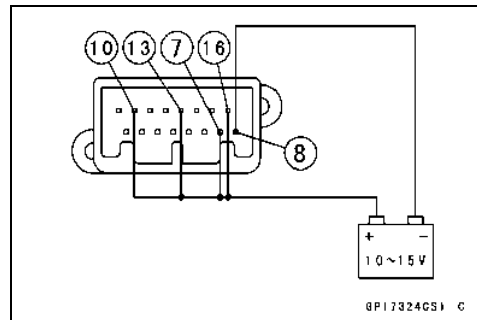

FI Indicator Light (LED)

Battery Negative (-) Terminal to Terminal [2]

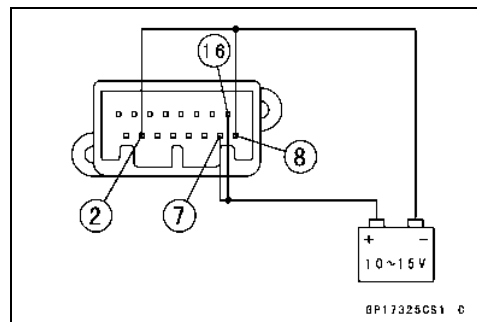

★If each lights (LED) does not go on, replace the meter assembly.

Meter, Gauge, Indicator Unit

EX650D Models

ABS Indicator Light (LED)

Battery Negative (-) Terminal to Terminal [5]

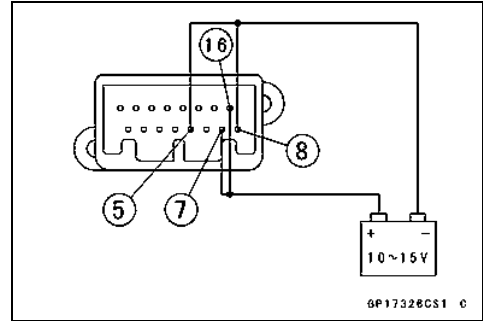

★If the light (LED) keeps going on, replace the meter assembly.

Meter Circuit

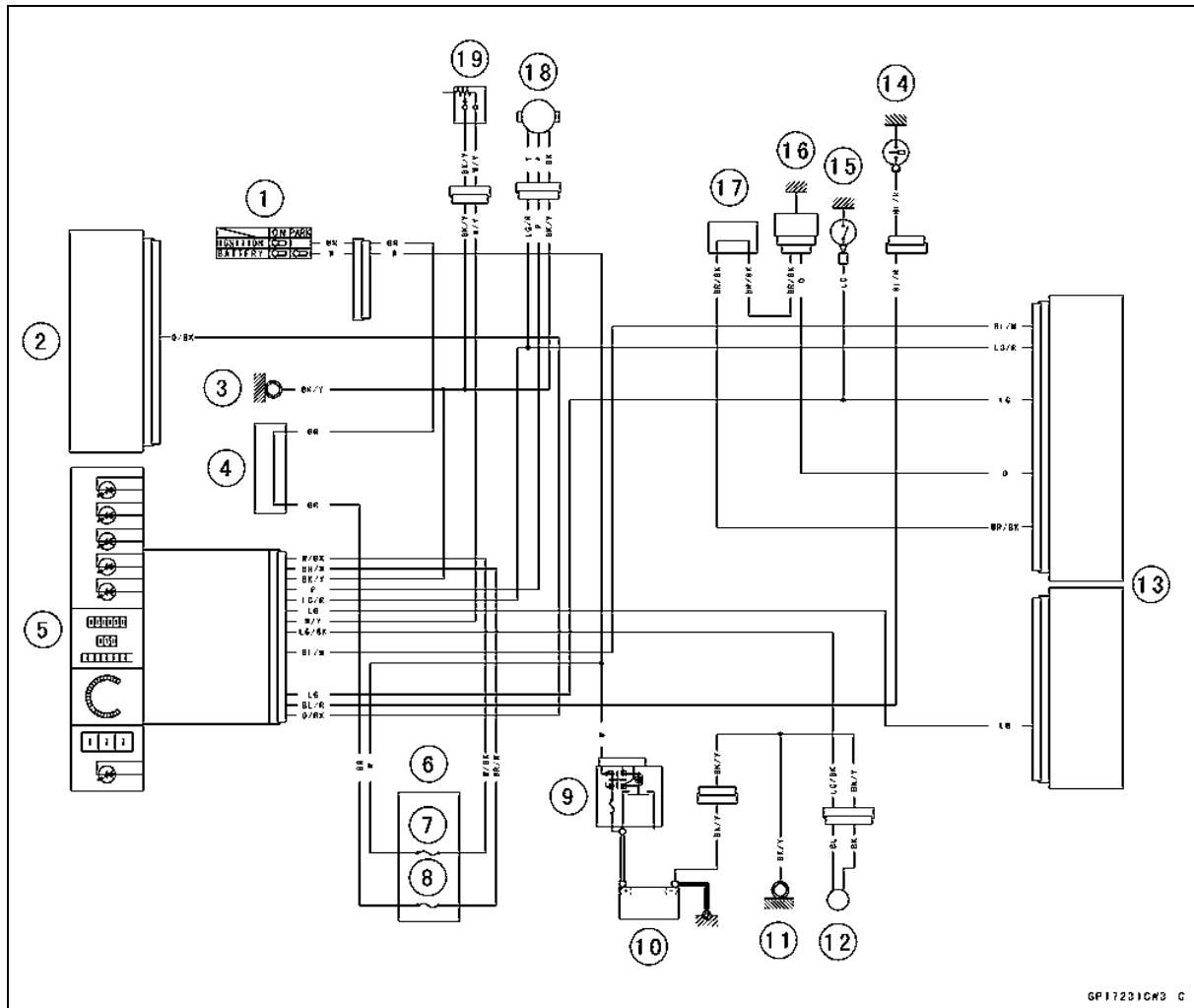

- | | |
|---|------------------------------|
| 1. Ignition Switch | 11. Frame Ground |
| 2. ABS Hydraulic Unit (ABS Equipped Models) | 12. Fuel Reserve Switch |
| 3. Frame Ground | 13. ECU |
| 4. Water-proof Joint C | 14. Oil Pressure Switch |
| 5. Meter Unit | 15. Neutral Switch |
| 6. Fuse Box | 16. Water Temperature Sensor |
| 7. ECU Fuse 15 A | 17. Water-proof Joint E |
| 8. Ignition Fuse 10 A | 18. Speed Sensor |
| 9. Main Fuse 30 A | 19. Fuel Level Sensor |
| 10. Battery 12 V 10 Ah | |

16-74 ELECTRICAL SYSTEM

Switches and Sensors

Brake Light Timing Inspection

- Refer to the Brake Light Switch Operation Inspection in the Periodic Maintenance chapter.

Brake Light Timing Adjustment

- Refer to the Brake Light Switch Operation Inspection in the Periodic Maintenance chapter.

Switch Inspection

- Using a hand tester, check to see that only the connections shown in the table have continuity (about zero ohms).
- For the switch housings and the ignition switch, refer to the tables in the Wiring Diagram.
- ★ If the switch has an open or short, repair it or replace it with a new one.

Special Tool - Hand Tester: 57001-1394

Rear Brake Light Switch Connections

Rear Brake Light Switch Connections		
Color	BR	BL
When brake pedal is pushed down	○—	—○
When brake pedal is released		

Sidestand Switch Connections

Sidestand Switch Connections		
Color	BK	G
When sidestand is down		
When sidestand is up	○—	—○

Neutral Switch Connections

Neutral Switch Connections		
Color	SW. Terminal	Ground
When transmission is in neutral	○—	—○
When transmission is not in neutral		

Oil Pressure Switch Connections*

Oil Pressure Switch Connections *		
Color	SW. Terminal	Ground
When engine is stopped	○—	—○
When engine is running		

*: Engine lubrication system is in good condition.

Switches and Sensors

Water Temperature Sensor Inspection

- Remove the water temperature sensor (see Water Temperature Sensor Removal/Installation in the Fuel System (DFI) chapter).
- Suspend the sensor [A] in a container of coolant so that the temperature-sensing projection [C] is submerged.
- Suspend an accurate thermometer [B] with temperature-sensing projection [C] located in almost the same depth with the sensor.

NOTE

- The sensor and thermometer must not touch the container side or bottom.
- Place the container over a source of heat and gradually raise the temperature of the coolant while stirring the coolant gently.
- Using the hand tester, measure the internal resistance of the sensor.
- ★ If the hand tester does not show the specified values, replace the sensor.

Water Temperature Sensor Resistance

Temperature	Resistance (kΩ)
-20°C (-4°F)	*18.80 ±2.37
0°C (32°F)	*(about 6.544)
40°C (104°F)	1.136 ±0.095
100°C (212°F)	0.1553 ±0.0070

*: Reference Information

Speed Sensor Removal

CAUTION

Never drop the sensor especially on a hard surface. Such a shock to the sensor can damage it.

- Remove the engine sprocket cover (see Engine Sprocket Removal in the Final Drive chapter).
- Disconnect the speed sensor lead connector [A].
- Remove:
Bolt [A]
Speed Sensor [B]

Speed Sensor Installation

- Installation is the reverse of removal.
- Apply a non-permanent locking agent to the sensor bolt, and tighten it.

Torque - Speed Sensor Bolt: 7.8 N·m (0.80 kgf·m, 69 in·lb)

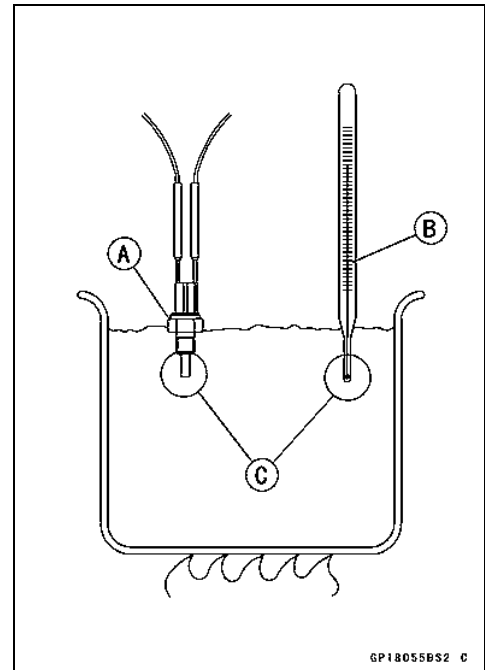

GP18055BS2 C



GP18B448 P



GP18B448 P

16-76 ELECTRICAL SYSTEM

Switches and Sensors

Speed Sensor Inspection

- Remove the speed sensor (see Speed Sensor Removal).
- Connect the speed sensor connector [A] with the battery [B], 10 k Ω resistor [C] and hand tester [D] as shown.
- Set the tester to the DC 25 V range.

Special Tool - Hand Tester: 57001-1394

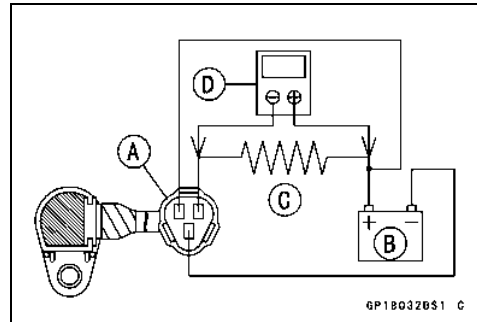

- Trace [A] each side of the speed sensor surface with the screw driver.
- Then the tester indicator should flick [B].
- ★ If the tester indicator does not flick, replace the speed sensor.

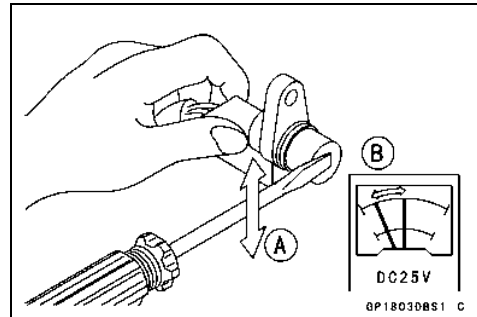

Fuel Level Sensor Inspection

- Remove the fuel tank (see Fuel Tank Removal in the Fuel System (DFI) chapter).
- Remove:
 - Bolts [A]
 - Fuel Level Sensor [B]

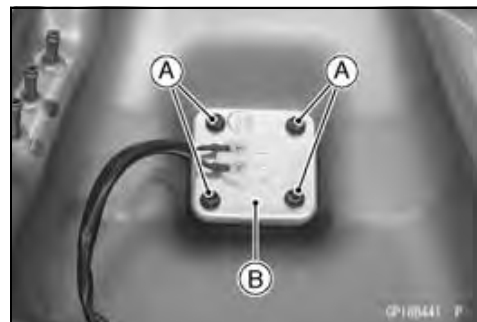

- Check that the float moves up and down smoothly without binding. It should go down under its own weight.
- ★ If the float does not move smoothly, replace the sensor.
 - Float in Full Position [A]
 - Float in Empty Position [B]

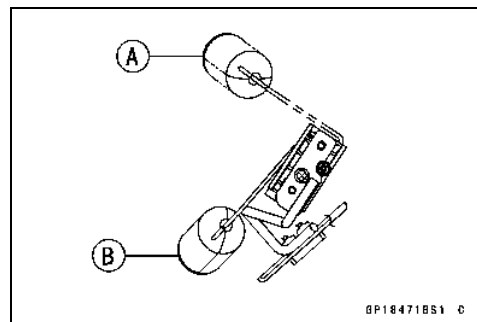

- Using the hand tester [A], measure the resistance across the terminals in the fuel level sensor lead connector [B].

Special Tools - Hand Tester: 57001-1394

- ★ If the tester readings are not as specified, or do not change smoothly according as the float moves up and down, replace the sensor.

Fuel Level Sensor Resistance

Standard: Full position: 5 ~ 7 Ω

Empty position [C]: 204 ~ 210 Ω

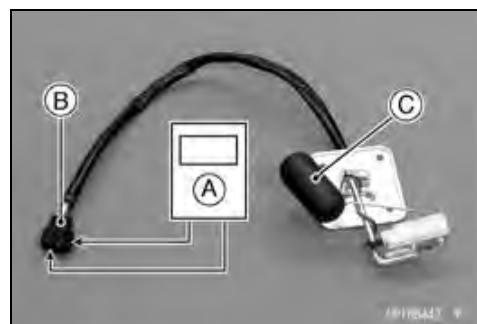

Switches and Sensors

- Install a new gasket [A] on the fuel level sensor as shown. Hollows [B]
 - Apply a non-permanent locking agent to the threads of the level sensor bolts and tighten it.
- Torque - Fuel Level Sensor Bolts: 6.9 N·m (0.70 kgf·m, 61 in·lb)**

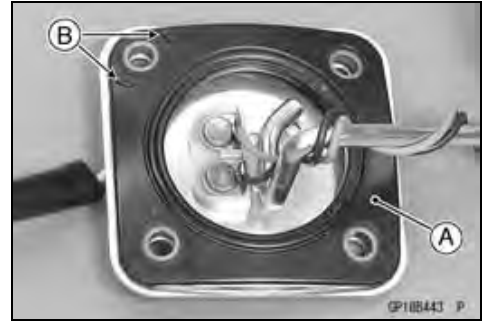

Oxygen Sensor Removal (Equipped Models)

CAUTION

Never drop the sensor especially on a hard surface. Such a shock to the sensor can damage it.

- Remove:
Lower Fairing (see Lower Fairing Removal in the Frame chapter)
- Disconnect the oxygen sensor lead connector [A].
- Remove the oxygen sensor [A].



Oxygen Sensor Installation (Equipped Models)

CAUTION

Never drop the oxygen sensor [A], especially on a hard surface. Such a shock to the unit can damage it. Do not touch the sensing part [B] and filter holes [C] of the sensor to prevent oil contact. Oil contamination from hands can reduce sensor performance.

- Tighten:
Torque - Oxygen Sensor: 44 N·m (4.5 kgf·m, 32 ft·lb)
- Run the oxygen sensor lead correctly (see Cable, Wire, and Hose Routing section in the Appendix chapter).

Oxygen Sensor Inspection (Equipped Models)

- Refer to the Oxygen Sensor Inspection in the Fuel System (DFI) chapter.

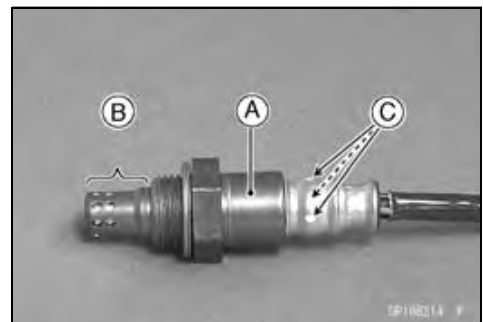

16-78 ELECTRICAL SYSTEM

Switches and Sensors

Fuel Reserve Switch Inspection

- Fill the fuel tank with fuel.
- Close the fuel tank cap surely.
- Remove the fuel tank (see Fuel Tank Removal in the Fuel System (DFI) chapter).
- Connect the test light [A] (12 V 3.4 W bulb a socket with leads) and the 12 V battery [B] to the fuel pump connector [C].

Connections:

Battery (+) → 12 V 3.4 W Bulb (One Side)

12 V 3.4 W Bulb (Other Side) → BL Lead Terminal

Battery (-) → BK Lead Terminal

- ★ If the test light turn on, the reserve switch is defective. Replace the fuel pump.

- Remove the fuel pump (see Fuel Pump Removal in the Fuel System (DFI) chapter).
- Connect the test light (12 V 3.4 W bulb in a socket with leads) and the 12 V battery to the fuel pump connector as shown.

12 V Battery [A]

Test Light [B]

Fuel Pump Connector [C]

Fuel Reserve Switch [D]

- ★ If the test light does not light, replace the fuel pump.

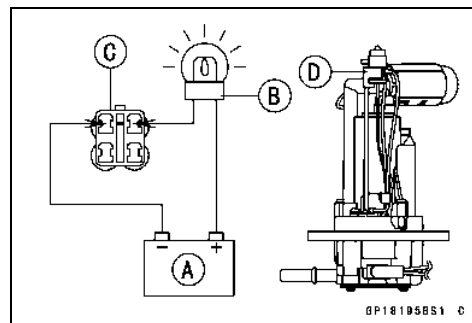
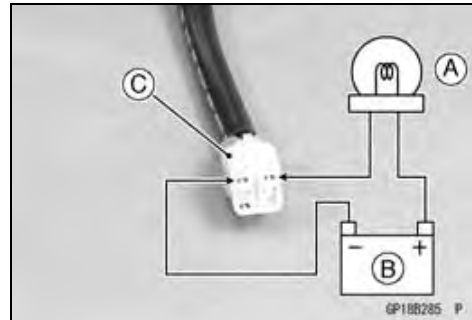

NOTE

- It may take a long time to turn on the test light in case that the fuel reserve switch is inspected just after the fuel pump is removed. Leave the fuel reserve switch with leads for inspection connected for few minutes.

Relay Box

The relay box [A] has relays and diodes. The relays and diodes can not be removed.



Relay Box Removal

- Remove:
 - Fuel Tank (see Fuel Tank Removal in the Fuel System (DFI) chapter)
- Take out the relay box [A] and disconnect the connectors [B].

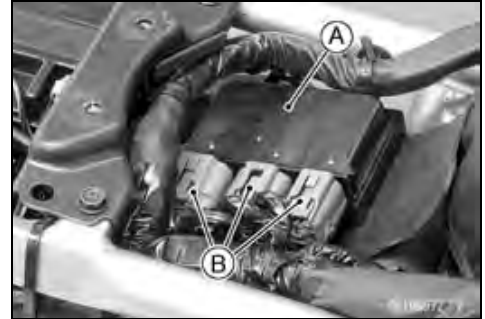

Relay Circuit Inspection

- Remove the relay box (see Relay Box Removal).
- Check conductivity of the following numbered terminals by connecting the hand tester and one 12 V battery to the relay box as shown (see Relay Box Internal Circuit in this section).
- ★ If the tester does not read as specified, replace the relay box.

Relay Circuit Inspection (with the battery disconnected)

	Tester Connection	Tester Reading (Ω)
Headlight Relay	1-3	∞
ECU Main Relay	7-6	∞
	4-5	Not ∞^*
Fuel Pump Relay	7-8	∞
	9-10	Not ∞^*
Starter Circuit Relay	11-16	∞
	11-12	∞
Fan Relay	17-20	∞
	18-19	Not ∞^*

*: The actual reading varies with the hand tester used.

16-80 ELECTRICAL SYSTEM

Relay Box

Relay Circuit Inspection (with the battery connected)

	Battery Connection		Tester Connection	Tester Reading (Ω)
	(+)	(-)		
ECU Main Relay	2-11		1-3	0
	4-5		7-6	0
Fuel Pump Relay	9-10		7-8	0
Fan Relay	18-19		17-20	0

	Battery Connection		Tester Connection DC 25 V Range	Tester Reading (V)
	(+)	(-)		
Starter Circuit Relay	16-12		11-12	Battery Voltage

(+): Apply positive lead.

(-): Apply negative lead.

Diode Circuit Inspection

- Remove the relay box (see Relay Box Removal).
- Check conductivity of the following pairs of terminals (see Relay Box Internal Circuit in this section).

Diode Circuit Inspection

Tester Connection	1-11, 2-11, 12-13, 12-15, 12-16, 13-14, 13-15
-------------------	---

- ★ The resistance should be low in one direction and more than ten times as much in the other direction. If any diode shows low or high in both directions, the diode is defective and the relay box must be replaced.

NOTE

- The actual meter reading varies with the meter or tester used and the individual diodes, but generally speaking, the lower reading should be from zero to one half the scale.

Relay Box

Relay Box Internal Circuit

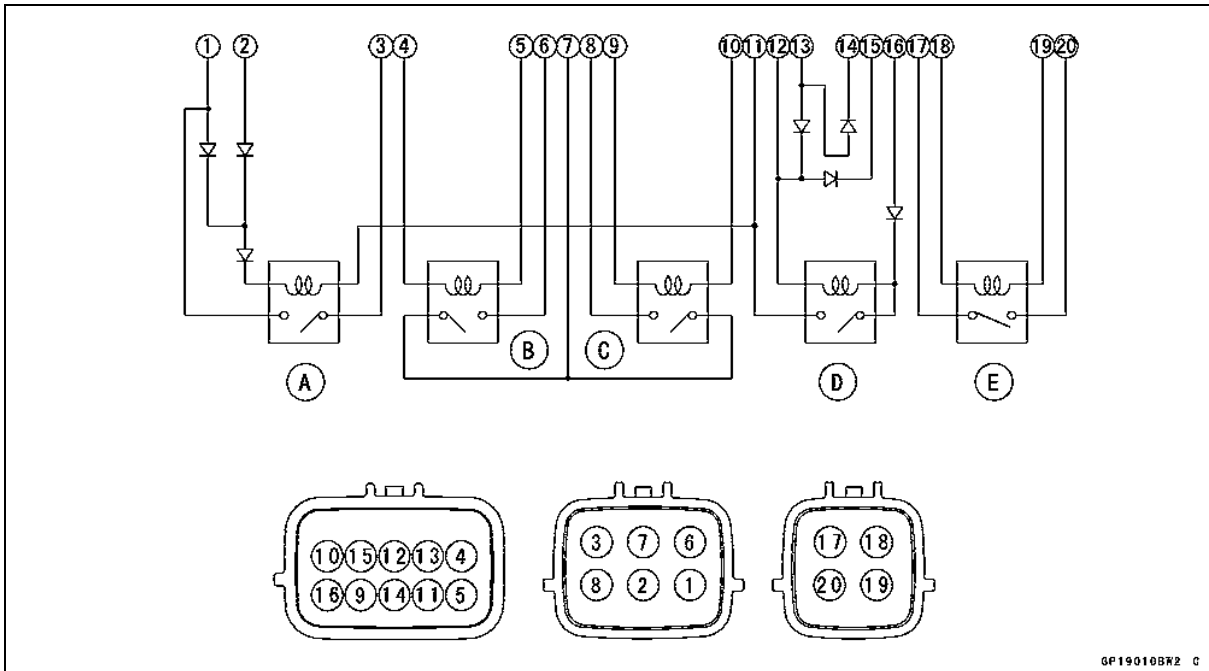

GF190108R2 C

- A: Headlight Relay
- B: ECU Main Relay
- C: Fuel Pump Relay
- D: Starter Circuit Relay
- E: Fan Relay

16-82 ELECTRICAL SYSTEM

Fuse

30 A Main Fuse Removal

- Remove:
 - Bolt [A]
 - Cover [B]
- Take off the starter relay from the battery case.
- Remove the cover [A], and pull out the main fuse [B] with needle nose pliers.

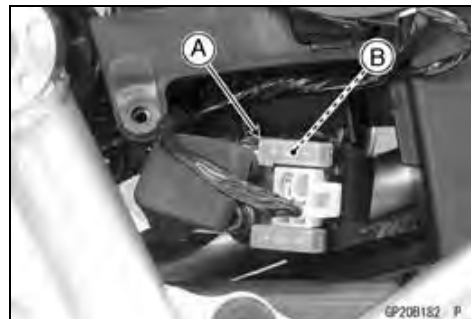
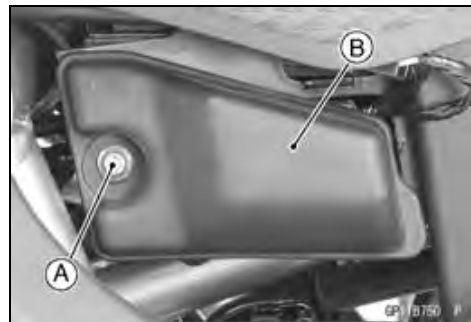

Fuse Box Fuse Removal

- Remove:
 - Seat (see Seat Removal in the Frame chapter)
- Open the lid [A].
- Pull the fuses [A] straight out of the fuse box with needle nose pliers.

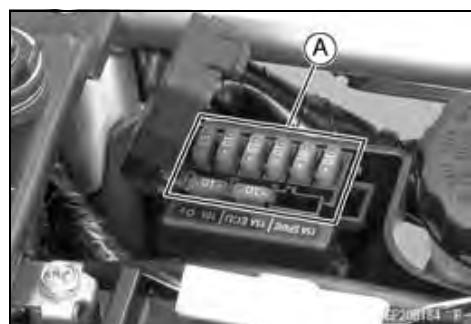

15 A ECU Fuse Removal

- Remove:
 - Seat (see Seat Removal in the Frame chapter)
- Open the lid [A].



Fuse

- Pull the ECU fuse [A] straight out of the fuse box with needle nose pliers.



Fuse Installation

- If a fuse fails during operation, inspect the electrical system to determine the cause, and then replace it with a new fuse of proper amperage.
- Install the fuse box fuses on the original position as specified on the lid.

Fuse Inspection

- Remove the fuse (see 30 A Main/Fuse Box /15 A ECU Fuse Removal).
- Inspect the fuse element.
- ★ If it is blown out, replace the fuse. Before replacing a blown fuse, always check the amperage in the affected circuit. If the amperage is equal to or greater than the fuse rating, check the wiring and related components for a short circuit.

Housing [A]

Fuse Element [B]

Terminals [C]

Blown Element [D]

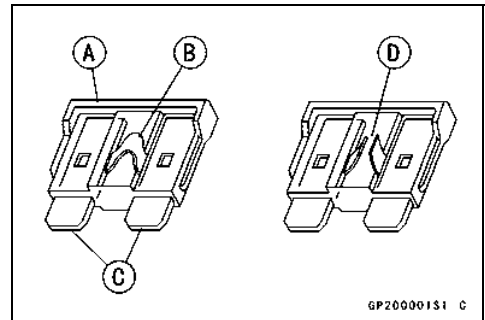

CAUTION

When replacing a fuse, be sure the new fuse matches the specified fuse rating for that circuit. Installation of a fuse with a higher rating may cause damage to wiring and components.

Appendix

Table of Contents

Cable, Wire, and Hose Routing	17-2
Troubleshooting Guide	17-42

17-2 APPENDIX

Cable, Wire, and Hose Routing

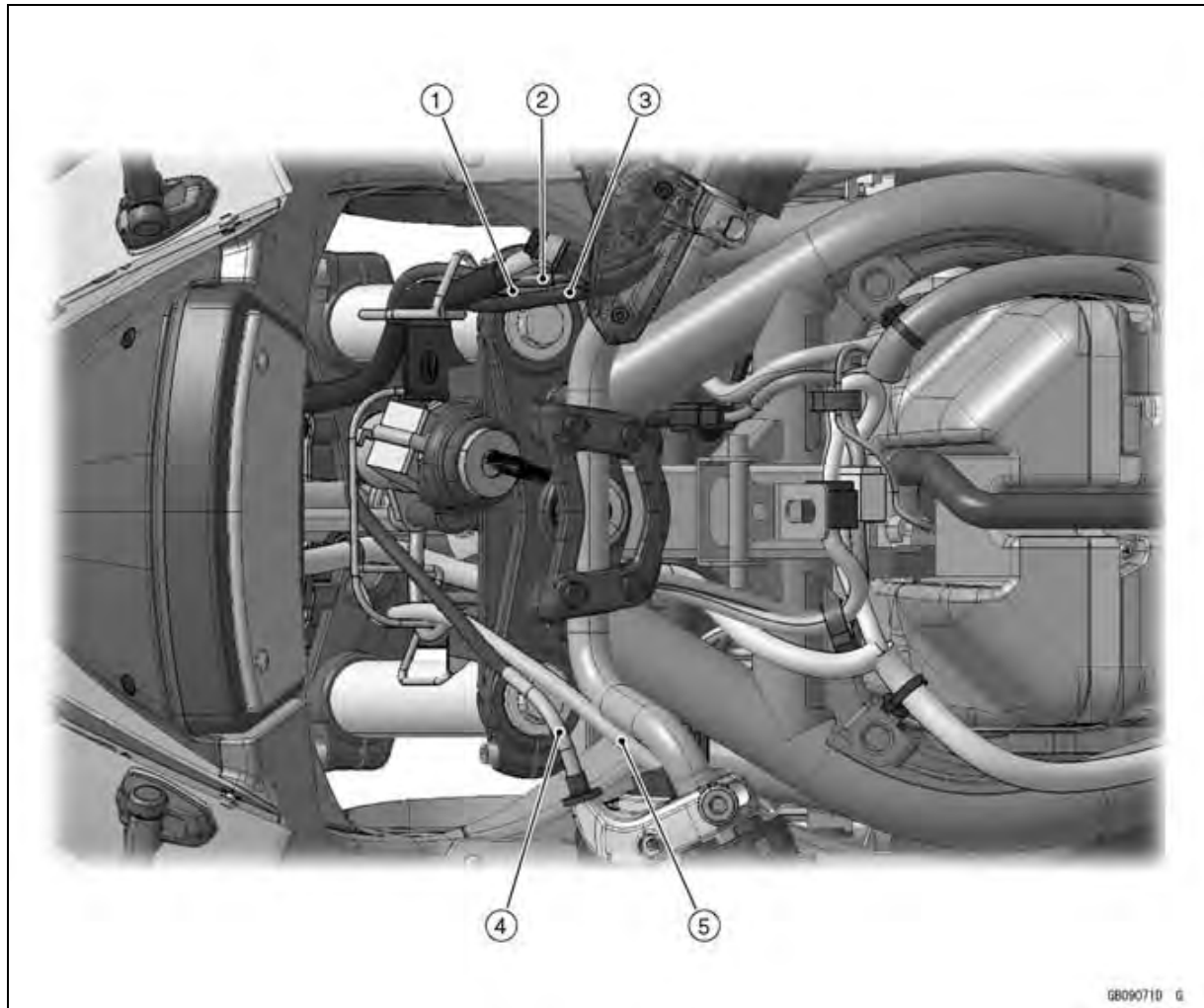

Cable, Wire, and Hose Routing

1. Throttle Cable (Decelerator)
2. Throttle Cable (Accelerator)
3. Right Switch Housing Lead
4. Clutch Cable
5. Left Switch Housing Lead

17-4 APPENDIX

Cable, Wire, and Hose Routing

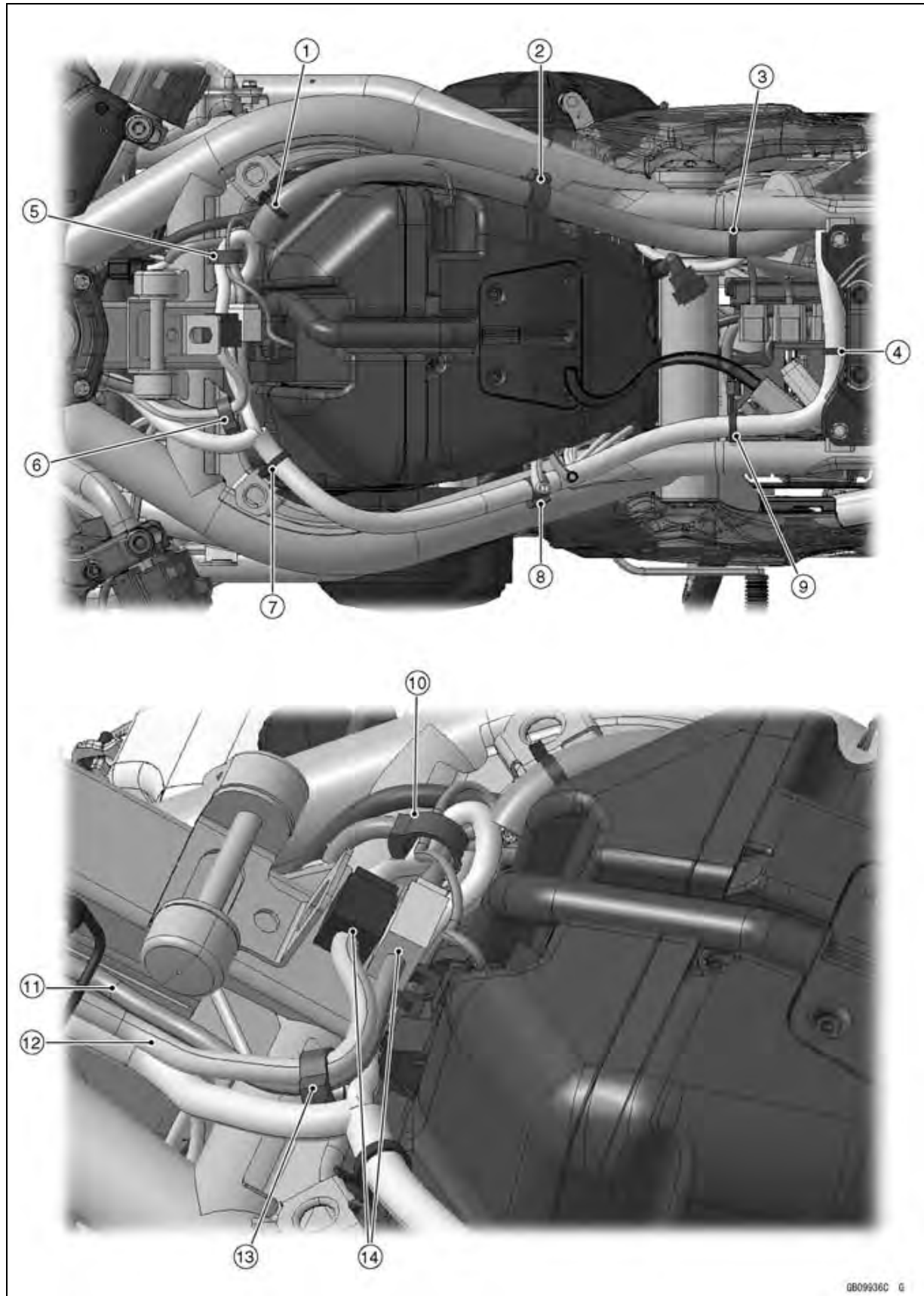

GB09936C G

Cable, Wire, and Hose Routing

1. Insert the clamp into the frame from the air cleaner side.
2. Clamp
3. Insert the clamp into the frame.
4. Insert the clamp into the fuel tank bracket.
5. Clamp (Faces the stopper forward.)
6. Clamp (Faces the stopper outward.)
7. Insert the clamp into the frame from the air cleaner side.
8. Clamp
9. Insert the clamp into the frame.
10. Clamp (Run the air switching valve lead, left switch housing lead (main harness side) and ignition switch lead (main harness side) in turn from upper side.)
11. Ignition Switch Lead
12. Left Switch Housing Lead
13. Clamp (Run the left switch housing lead and ignition switch lead in turn from upper side.)
14. Cover the connectors with the caps securely, and place the left switch housing lead connector in front of the ignition switch lead connector.

17-6 APPENDIX

Cable, Wire, and Hose Routing

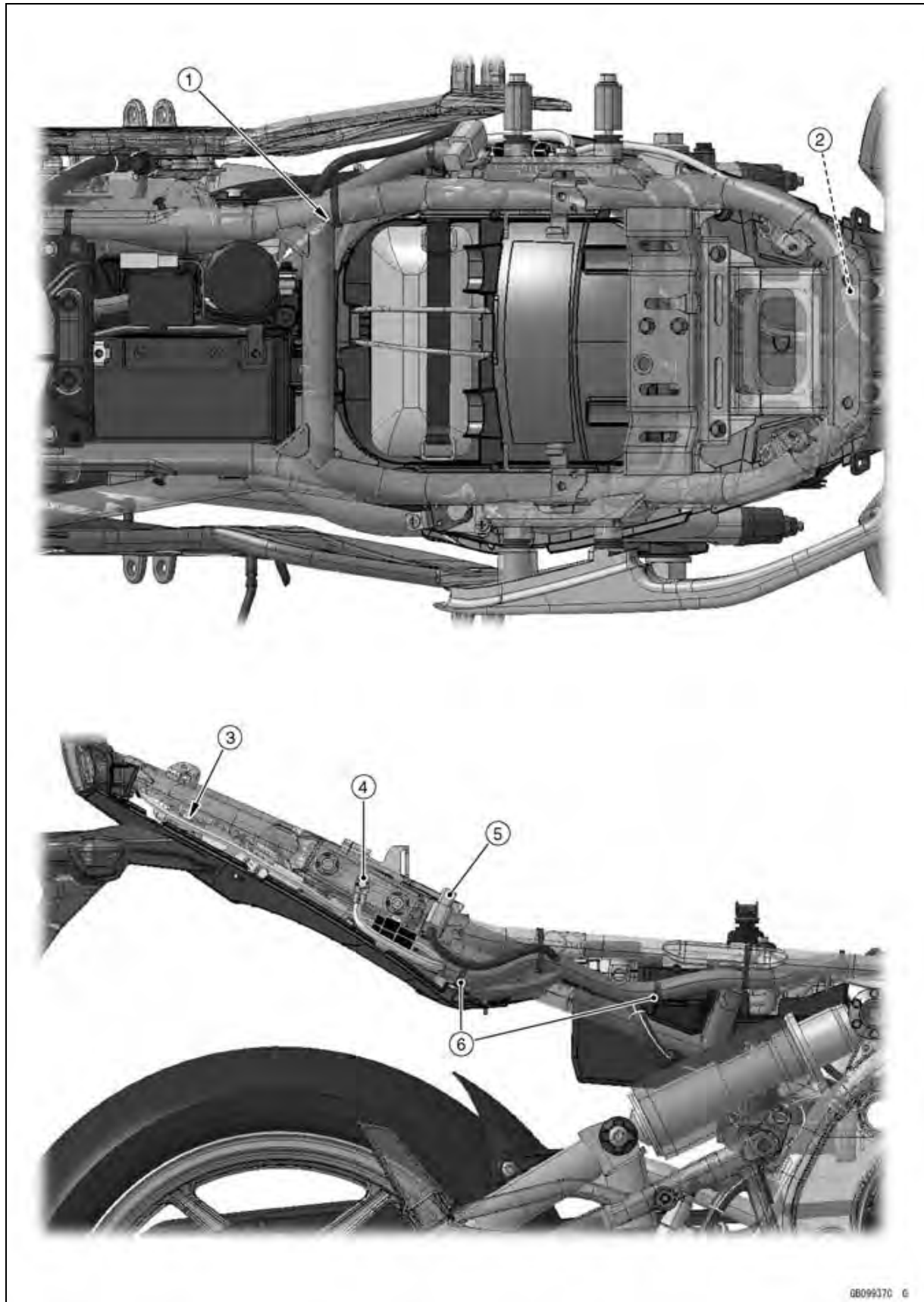

Cable, Wire, and Hose Routing

1. Run the band into the space of the frame gusset.
2. Clamp
3. Run the tail/brake light lead to outside of the rear fender mounting bracket.
4. Frame Ground
5. Insert the Kawasaki diagnostic system connector to the bracket.
6. Clamps

17-8 APPENDIX

Cable, Wire, and Hose Routing

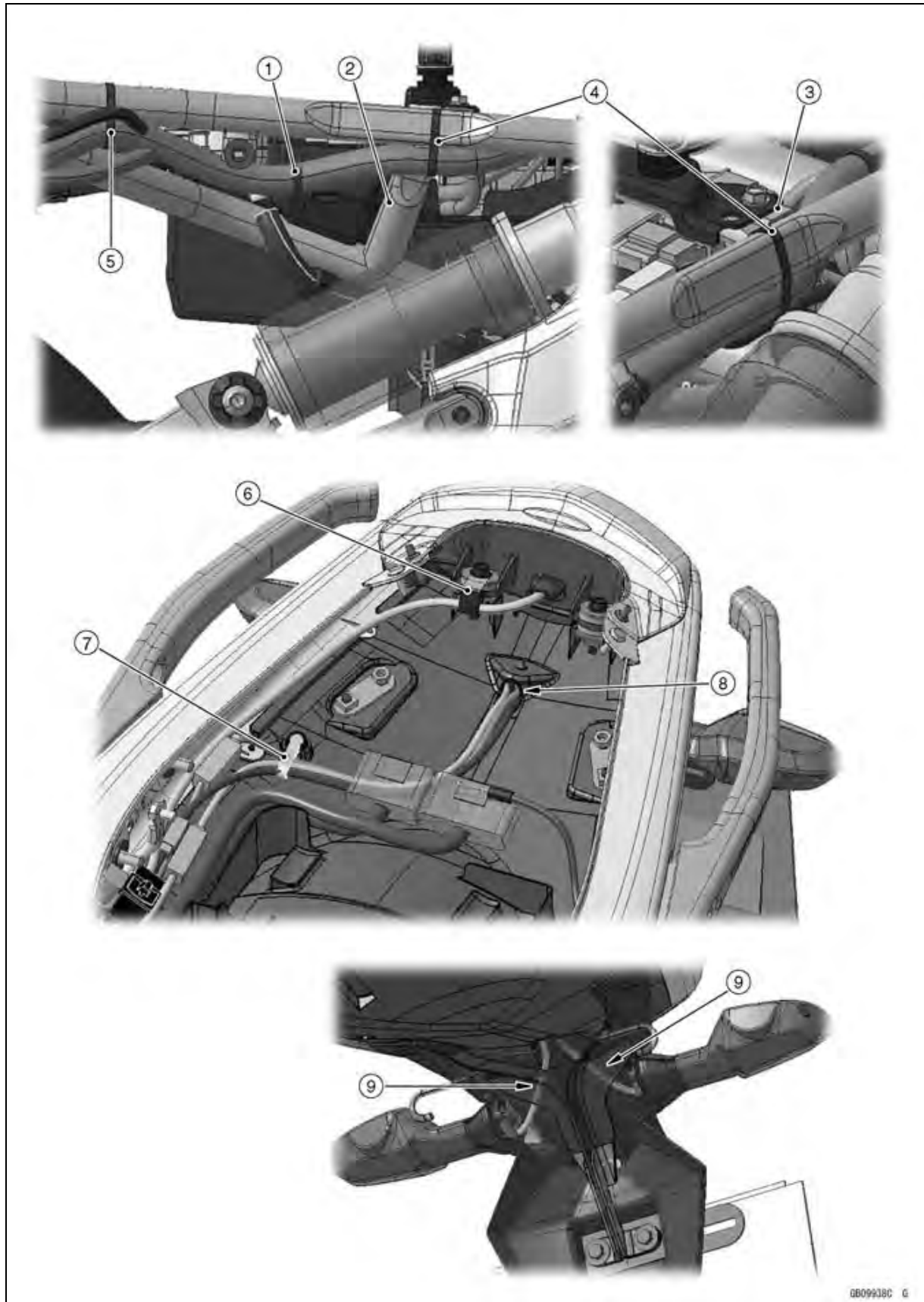

Cable, Wire, and Hose Routing

1. Clamp
2. Frame Pipe
3. Fuel Tank Bracket
4. Bands (Hold the main harness between the frame pipe and fuel tank bracket.)
5. Band (Hold the main harness in rear of the frame cross pipe.)
6. Clamp (Tighten with the tail/brake light mounting bolt. Bend the clamp downward.)
7. Clamp (Hold the turn signal light leads and license plate light lead. Faces the clamp forward.)
8. Run the turn signal light leads and license plate light lead into the hole of the rear fender.
9. Run the turn signal light leads over the flap bracket.

17-10 APPENDIX

Cable, Wire, and Hose Routing

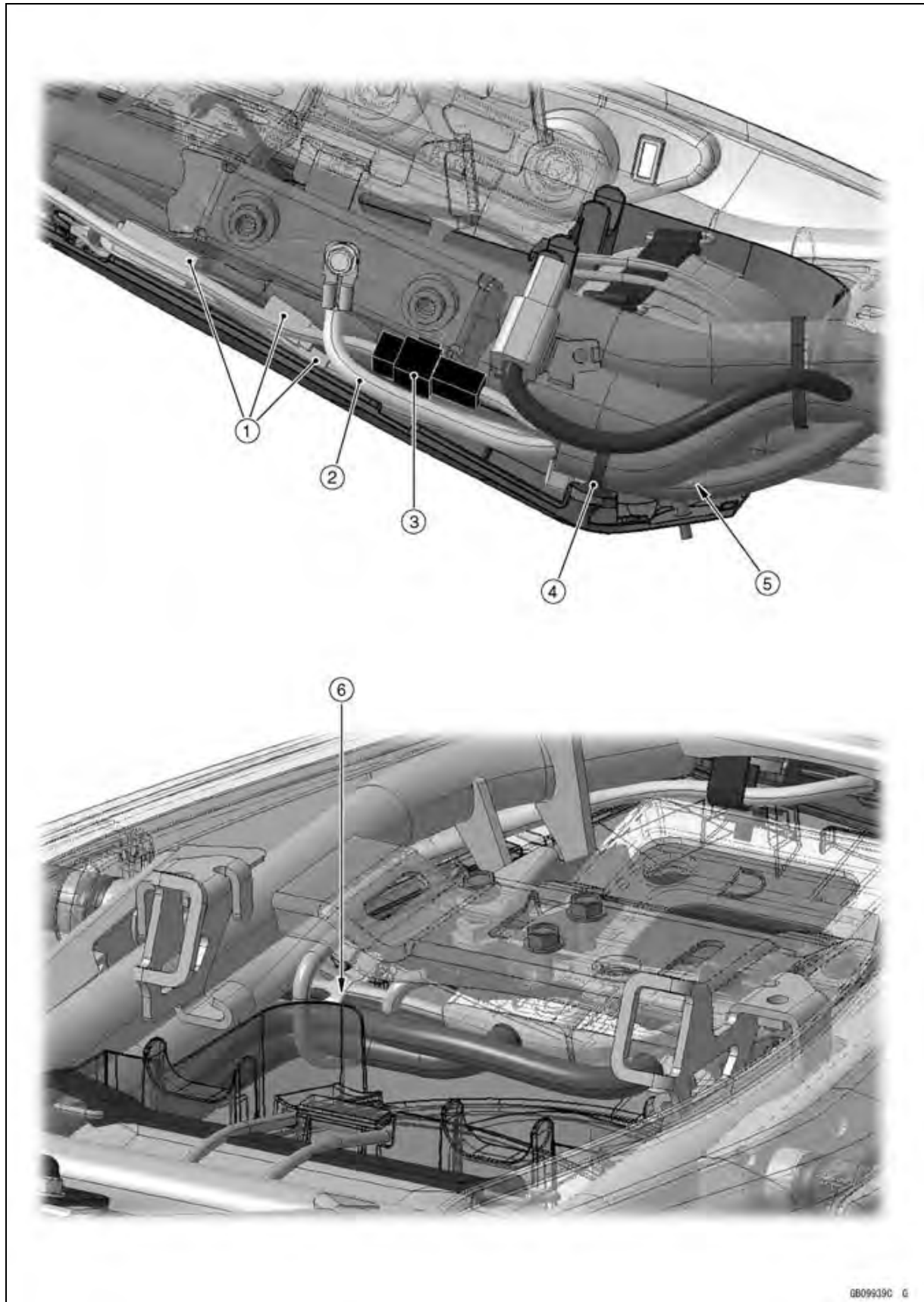

GB099390 G

Cable, Wire, and Hose Routing

1. Place the turn signal light lead connectors and license plate light lead connector between the frame and rear fender.
2. Run the frame ground lead to outside of the other leads.
3. Insert the tail/brake light lead connector into the grab rail bracket.
4. Clamp (Insert the clamp into the rear fender.)
5. Run the joint connector and water-proof joint to inside of the clamp.
6. Run the ECU leads into the frame hook.

17-12 APPENDIX

Cable, Wire, and Hose Routing

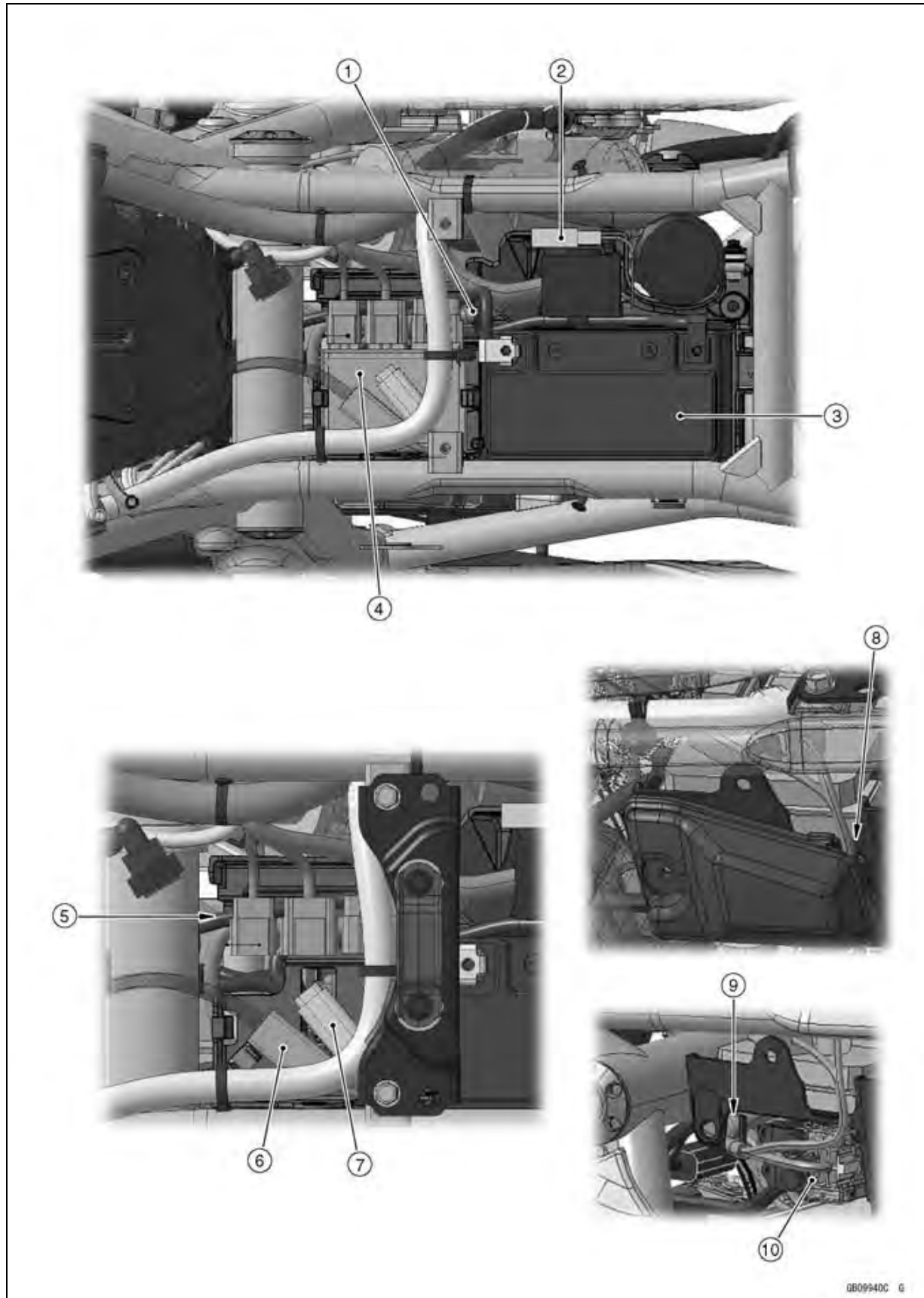

Cable, Wire, and Hose Routing

1. Clamp (Hold the main harness, and insert the clamp into the battery case.)
2. Battery Negative (-) Lead Connector
3. Battery 12V 10Ah
4. Relay Box
5. Run the battery positive (+) cable, main harness and battery negative (-) cable in turn from left side.
6. Fuel Level Sensor Lead Connector
7. Fuel Pump Lead Connector
8. Run the fuel level sensor lead and fuel pump lead into the slit of the starter motor relay cover.
9. Run the starter relay lead on the hook of the battery case. (Strain the lead between its hook and the starter relay.)
10. Starter Relay

17-14 APPENDIX

Cable, Wire, and Hose Routing

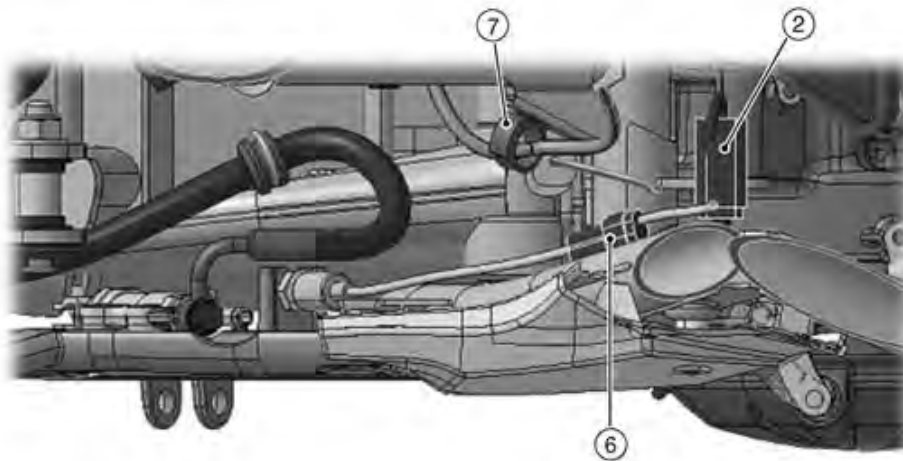
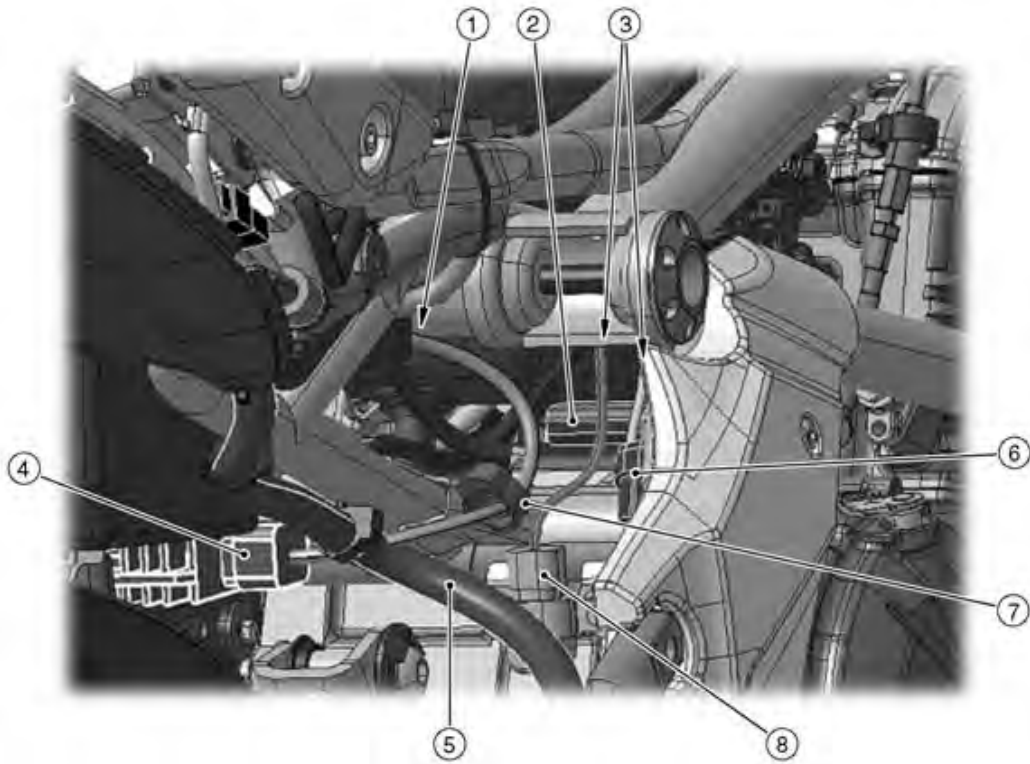

Cable, Wire, and Hose Routing

1. Run the regulator/rectifier lead into the battery case opening.
2. Crankshaft Sensor Lead Connector
3. Run the vehicle-down sensor lead and rear brake light switch lead in front of the frame cross pipe.
4. Regulator/Rectifier Lead Connector
5. Rear Brake Reservoir Hose
6. Rear Brake Light Switch Lead Connector
7. Clamp (Hold the regulator/rectifier lead. Insert the clamp into the frame.)
8. Vehicle-down Sensor Lead Connector

17-16 APPENDIX

Cable, Wire, and Hose Routing

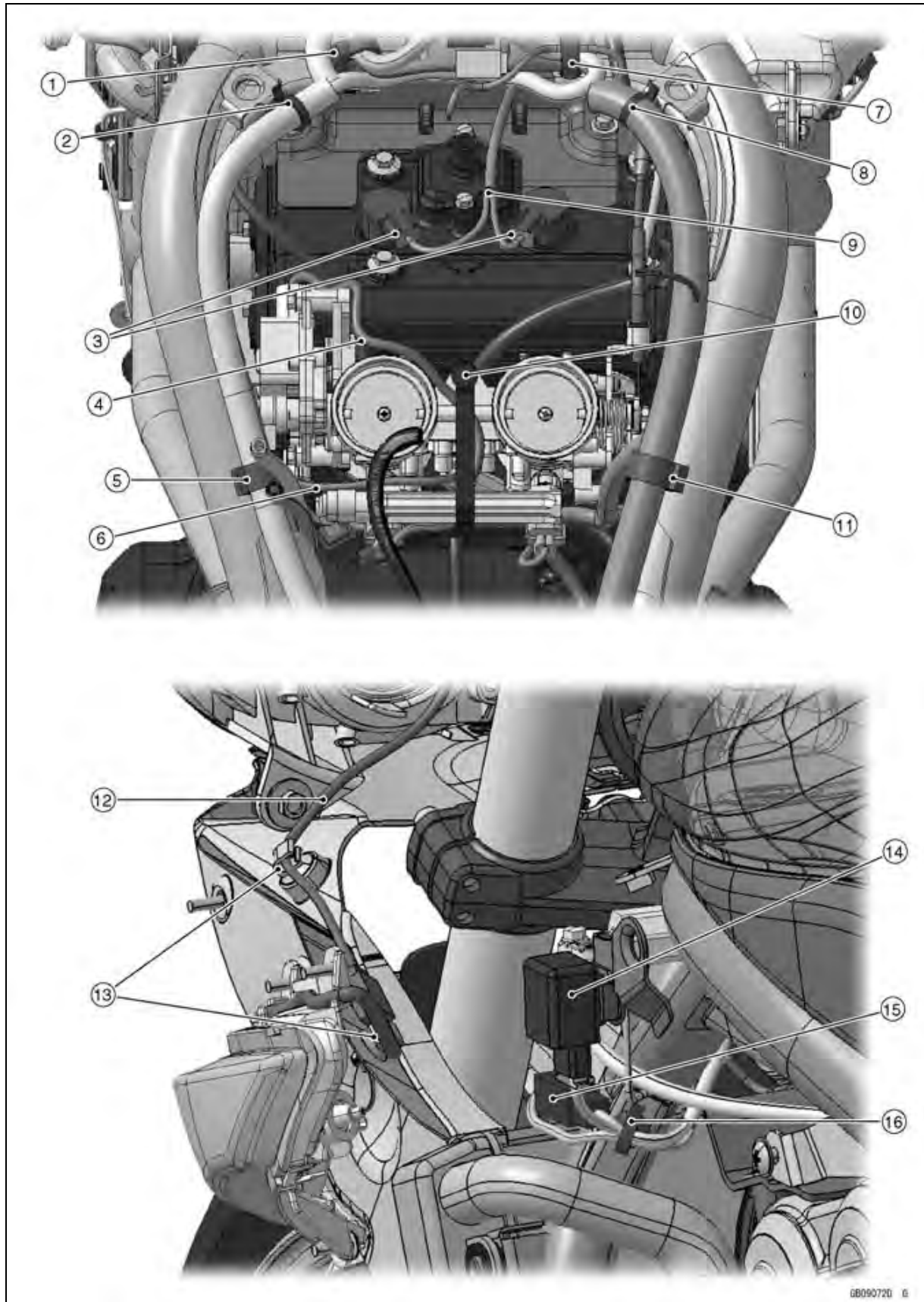

Cable, Wire, and Hose Routing

1. Clamp
2. Clamp
3. Stick Coil Lead Connectors
4. Subthrottle Valve Actuator Lead
5. Clamp
6. Subthrottle Sensor Lead
7. Clamp
8. Clamp
9. Clamp (Hold the stick coil leads.)
10. Clamp (Install the clamp with the quick rivet onto the throttle body assy. Hold the subthrottle valve actuator lead. Bend the clamp downward along the delivery pipe so that the subthrottle sensor lead and the subthrottle valve actuator lead places under the delivery pipe.)
11. Clamp (Insert the clamp into the frame. Hold the main harness.)
12. Front Left Turn Signal Light Lead
13. Clamps (Insert clamp into the upper fairing. Hold the front left turn signal light lead.)
14. Turn Signal Relay
15. Radiator Fan Lead Connector
16. Clamp (Insert clamp into the frame. Hold the turn signal relay lead and radiator fan lead.)

17-18 APPENDIX

Cable, Wire, and Hose Routing

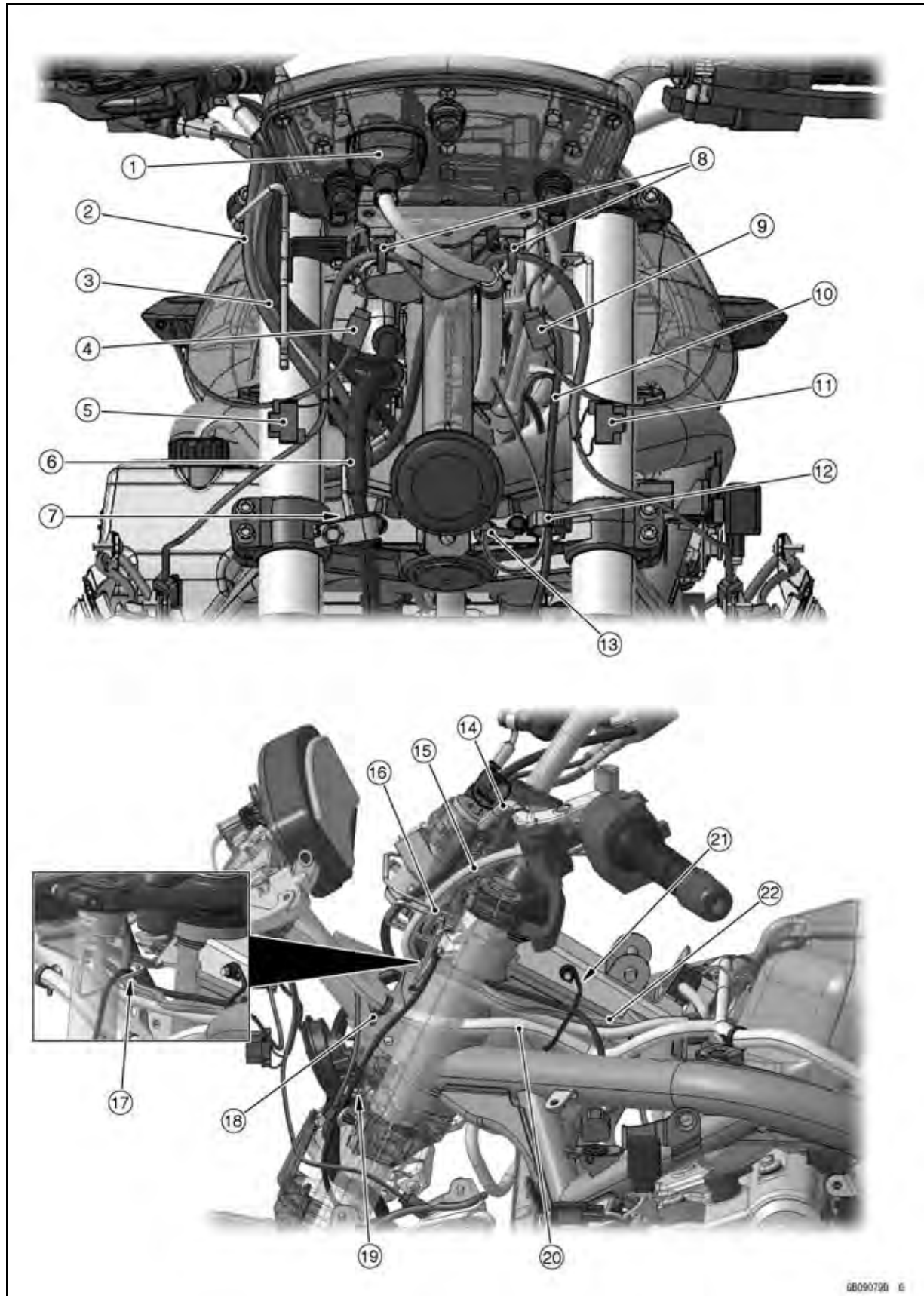

Cable, Wire, and Hose Routing

1. Meter Unit Connector (Cover the connector with the cap securely.)
2. Throttle Cable (Accelerator)
3. Throttle Cable (Decelerator)
4. Right City Light Lead Connector
5. Headlight (Lo) Lead Connector
6. Front Brake Hose
7. Clamp (Hold the front brake hose lead.)
8. Insert clamps into the upper fairing bracket.
9. Left City Light Lead Connector
10. Front Wheel Rotation Sensor Lead (EX650D model)
11. Headlight (Hi) Lead Connector
12. Clamp (Insert clamp into the under bracket. Hold the horn lead and front wheel rotation sensor lead (EX650D model).)
13. Insert clamp into the under bracket.
14. Clutch Cable
15. Left Switch Housing Lead
16. Hang the ignition switch lead on the guide.
17. Run the front wheel rotation sensor lead into the guide as shown in the figure. (EX650D model)
18. Clamp (Insert clamp into the stay of the upper fairing bracket. Hold the main harness.)
19. Insert the connector of horn from the underside.
20. Main Harness
21. Clamp (Hold the ignition switch lead, left switch housing lead and main harness in turn from upper side.)
22. Ignition Switch Lead

17-20 APPENDIX

Cable, Wire, and Hose Routing

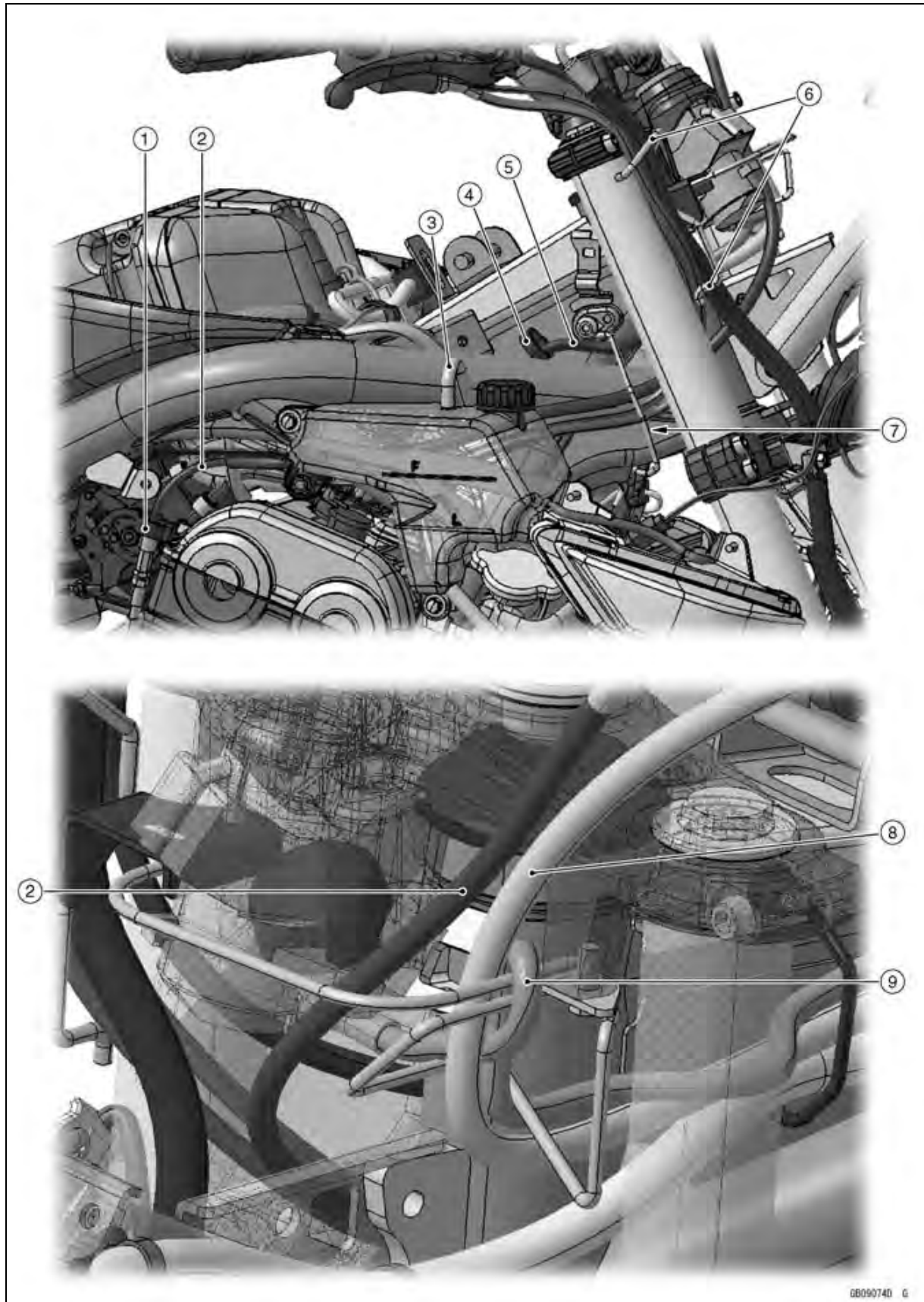

Cable, Wire, and Hose Routing

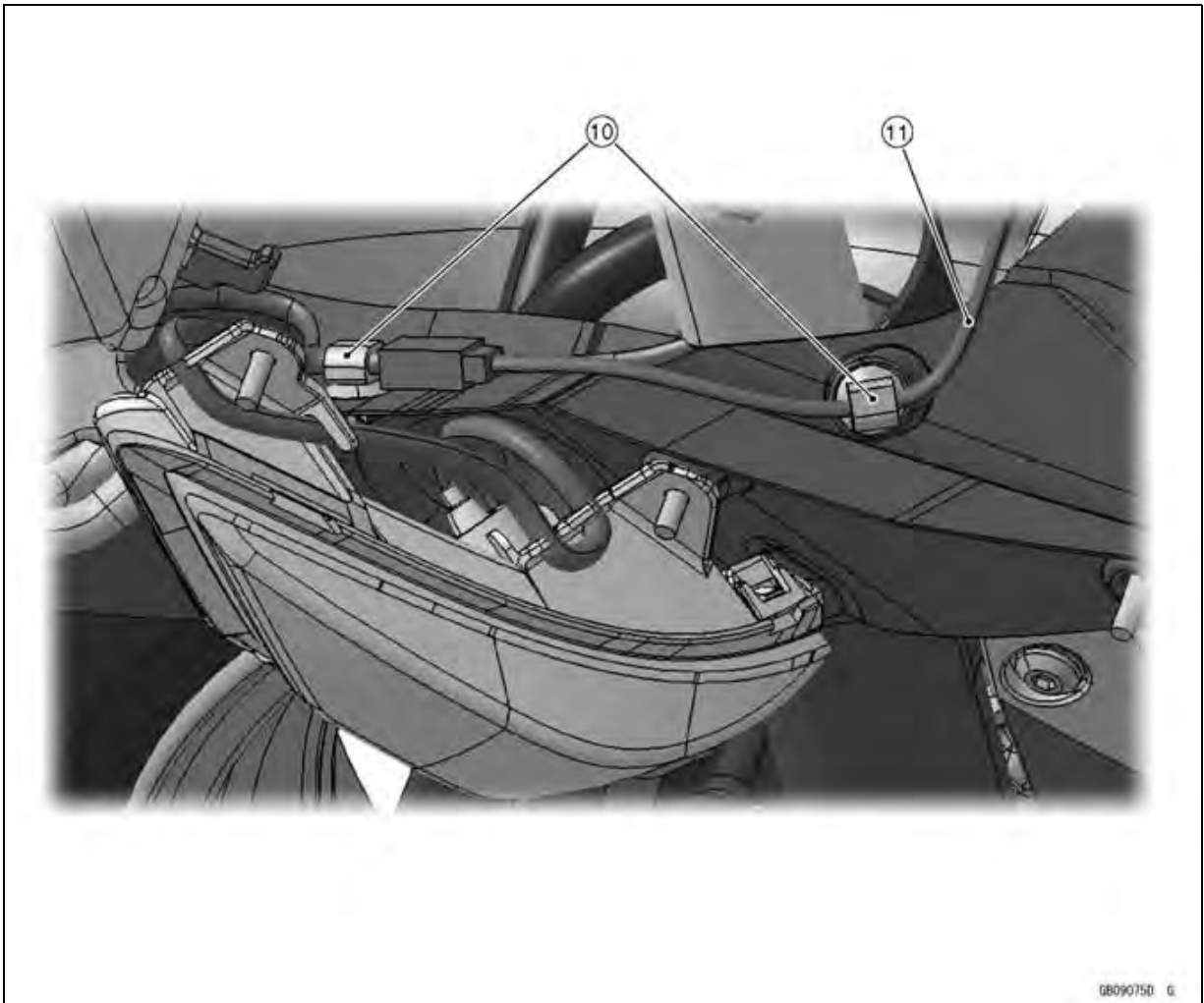

GB090750 G

1. Clamp (Hold the clutch cable.)
2. Clutch Cable
3. Reserve Tank Over Flow Hose
4. Clamp (Insert clamp into the frame. Hold the right switch housing lead.)
5. Right Switch Housing Lead
6. Clamps (Hold the right switch housing lead, front brake hose, throttle cable (decelerator) and throttle cable (accelerator) in turn from inside.)
7. Run the right switch housing lead, clutch cable, throttle cable (decelerator) and throttle cable (accelerator) in turn from upper side. (Hold the cables so that they lift up.)
8. Left Switch Housing Lead
9. Ignition Switch Lead
10. Clamps (Insert clamp into the upper fairing. Hold the front right turn signal light lead.)
11. Front Right Turn Signal Light Lead

17-22 APPENDIX

Cable, Wire, and Hose Routing

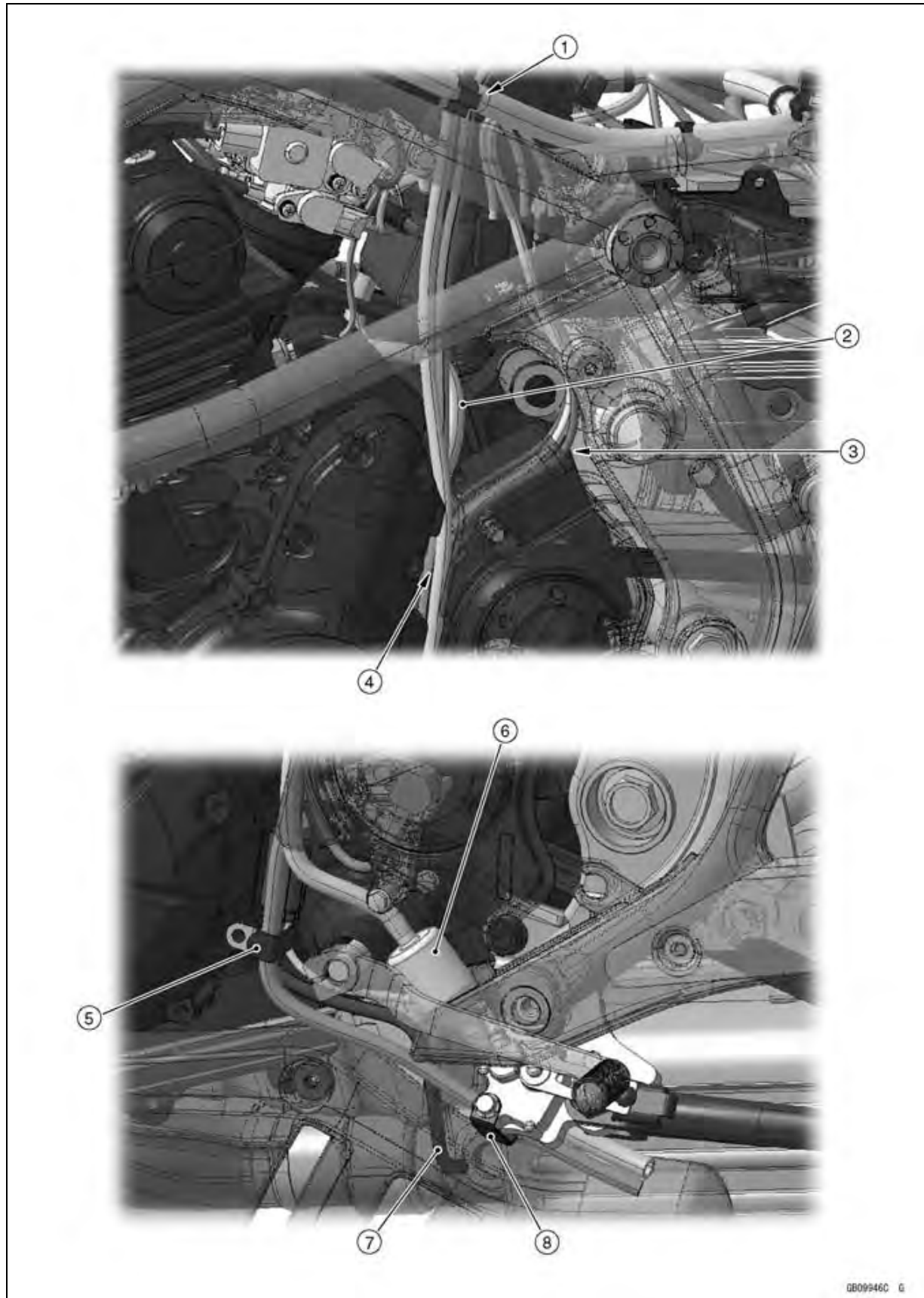

QB09946C 6

Cable, Wire, and Hose Routing

1. Run the fuel tank breather tube and fuel tank drain tube between the main harness and air cleaner housing.
2. Air Cleaner Drain Hose
3. Run the electrical leads into the upper space of the engine sprocket cover.
4. Run the fuel tank breather tube, fuel tank drain tube, electrical leads and air cleaner drain hose in turn from outside between the engine and engine sprocket cover.
5. Clamp (Hold the fuel tank drain tube, oxygen sensor lead and sidestand switch lead in turn from outside.)
6. Fuel Tank Breather (Other than CAL and SEA Models)
7. Oxygen Sensor Lead (Equipped Models)
8. Clamp (Hold the sidestand switch lead and fuel tank drain tube.)

17-24 APPENDIX

Cable, Wire, and Hose Routing

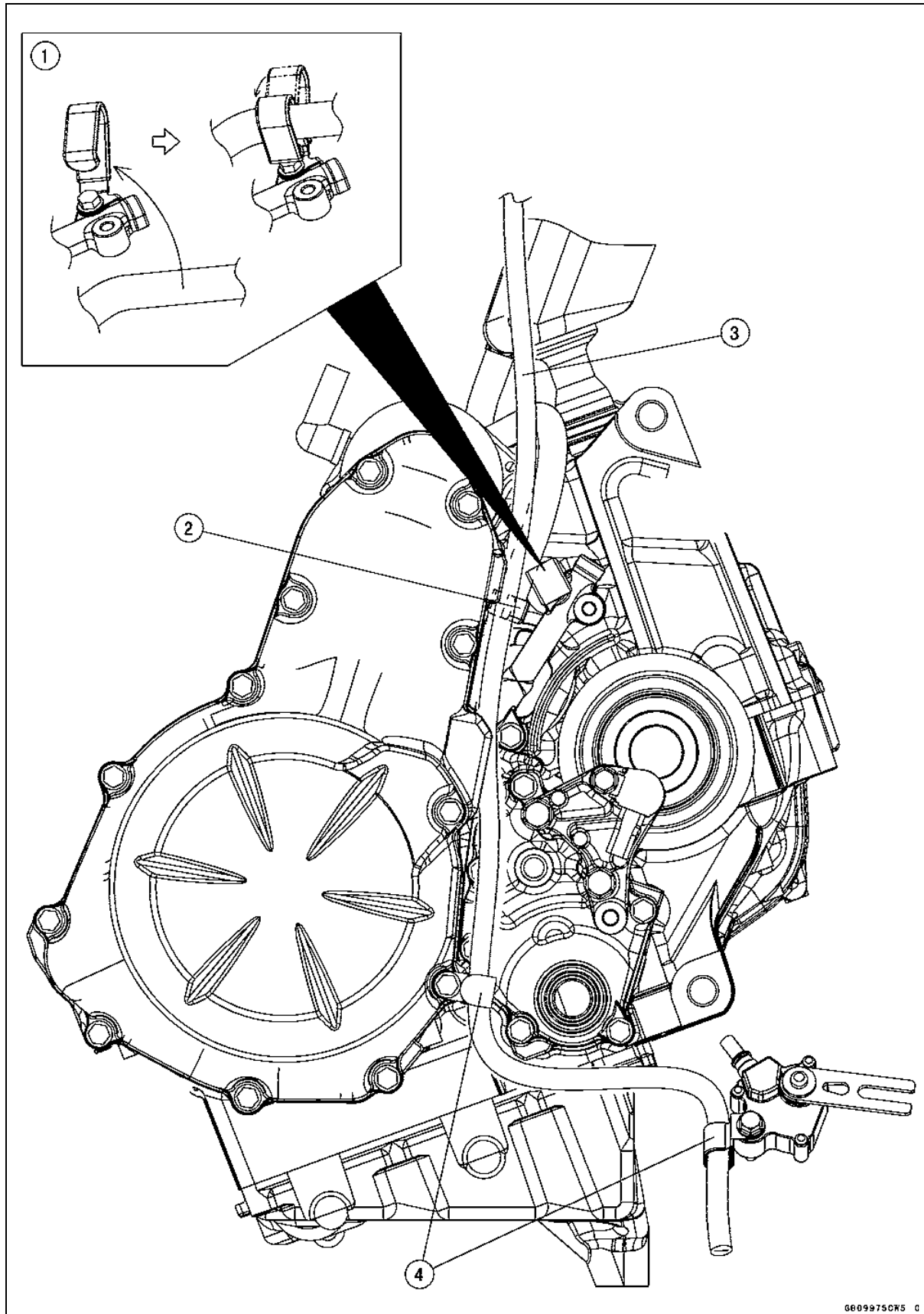

0609975CR5 C

Cable, Wire, and Hose Routing

1. Run the harness into the clamp, and then bend the clamp.
2. Place the air cleaner drain hose end as shown in the figure.
3. Fuel Tank Drain Tube
4. Clamps

17-26 APPENDIX

Cable, Wire, and Hose Routing

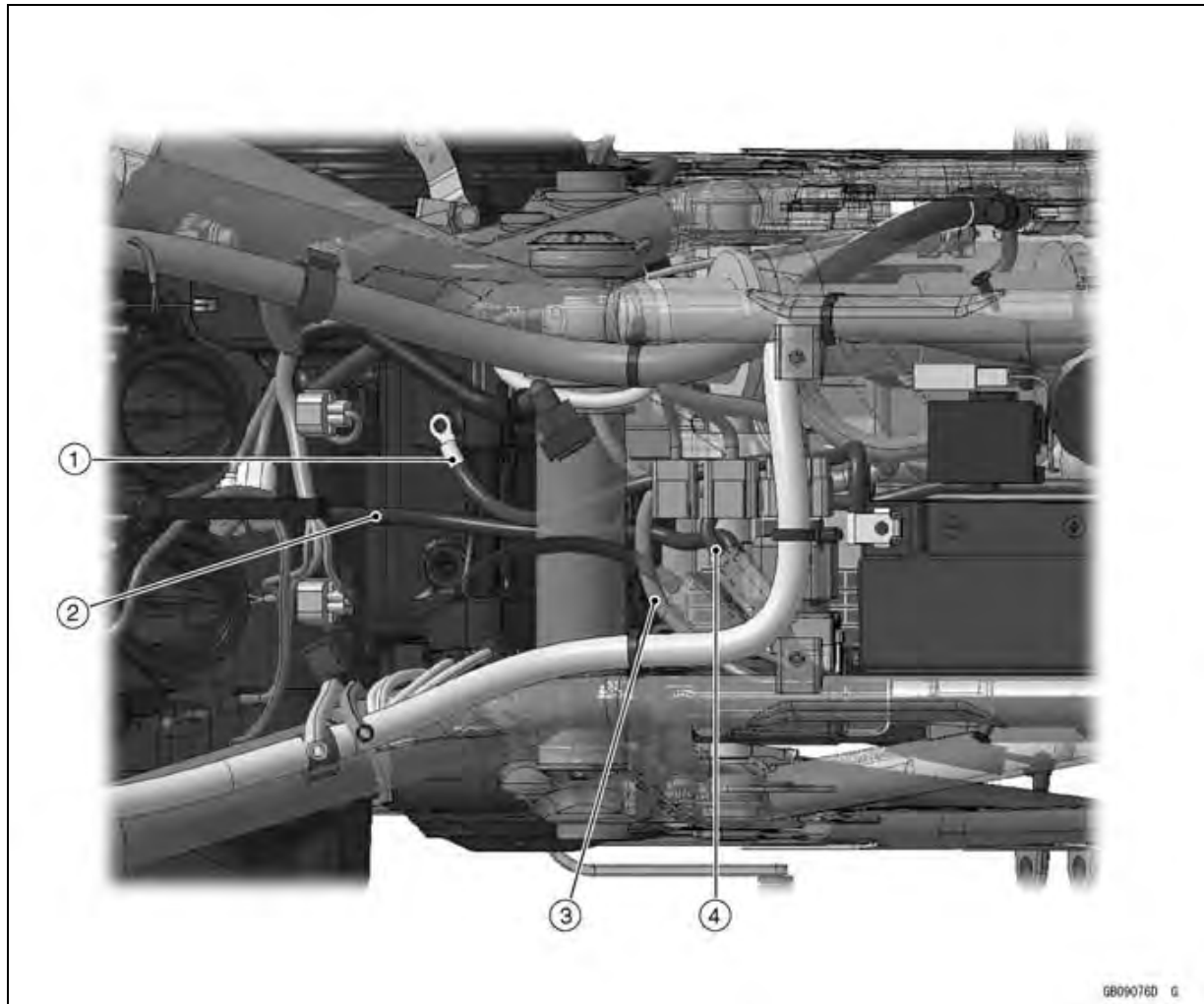

Cable, Wire, and Hose Routing

1. Engine Ground Lead
2. Starter Motor Cable
3. Starter Relay Lead
4. Battery Positive (+) Cable

17-28 APPENDIX

Cable, Wire, and Hose Routing

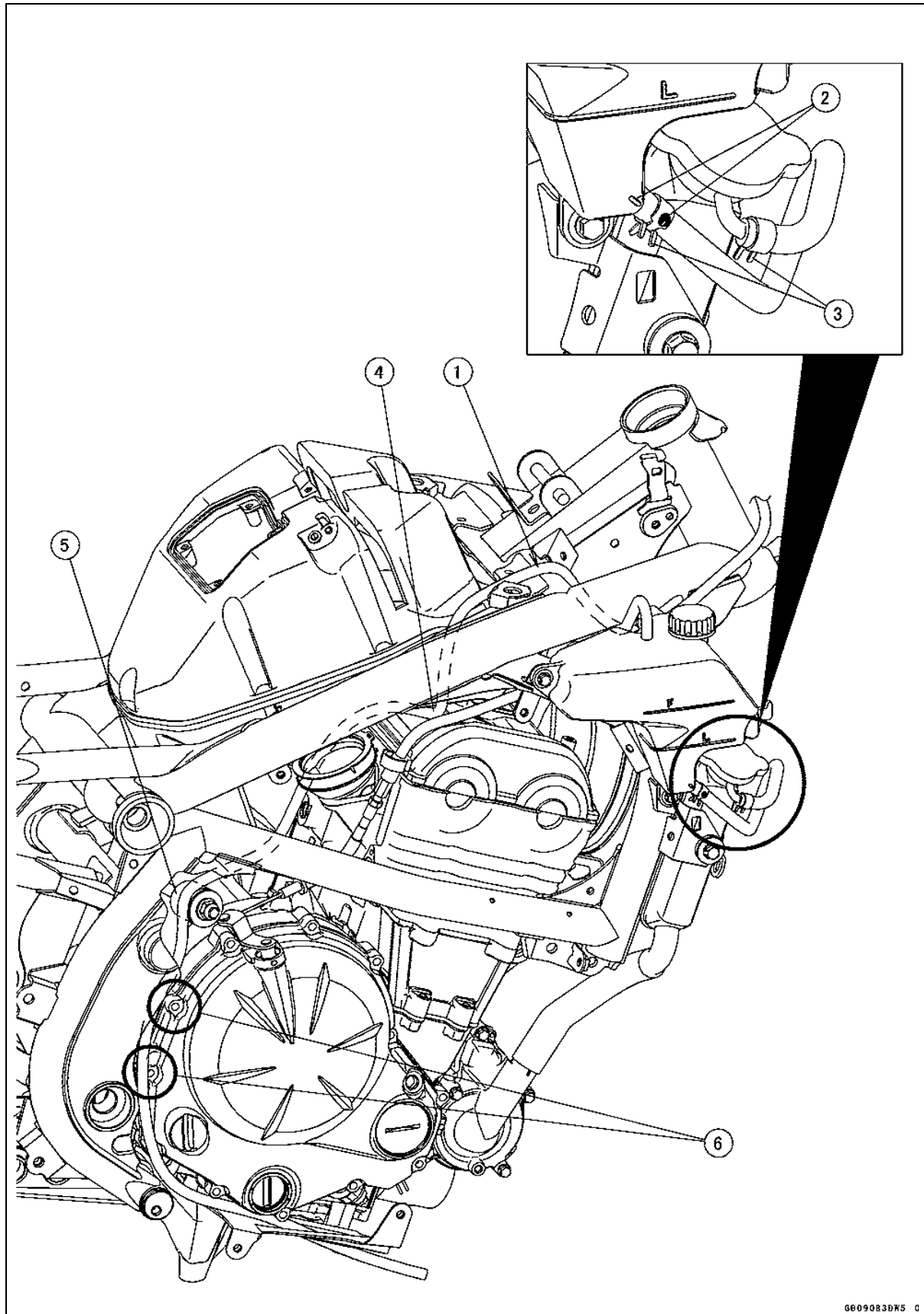

06090830X5 C

Cable, Wire, and Hose Routing

1. Align the white paint of the reserve tank over flow hose with the welding bead.
2. Align the paint of the reserve tank hose with the reserve tank projection.
3. Clamps (Faces the clamp knobs downward.)
4. Run the reserve tank over flow hose under the throttle cables.
5. Run the reserve tank over flow hose in rear of the engine mounting bolt.
6. Run the reserve tank over flow hose between these bosses.

17-30 APPENDIX

Cable, Wire, and Hose Routing

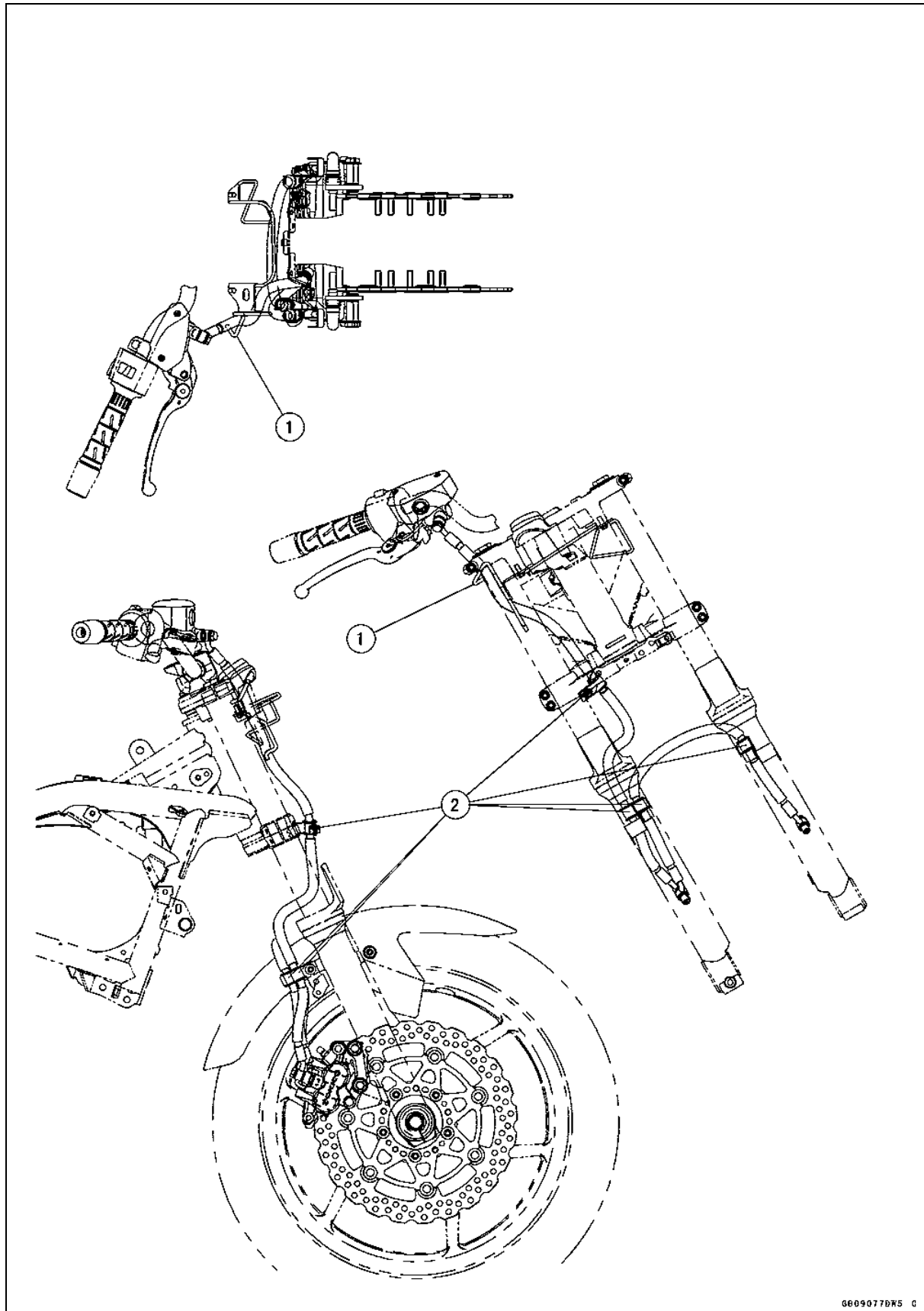

060907DK5 C

Cable, Wire, and Hose Routing

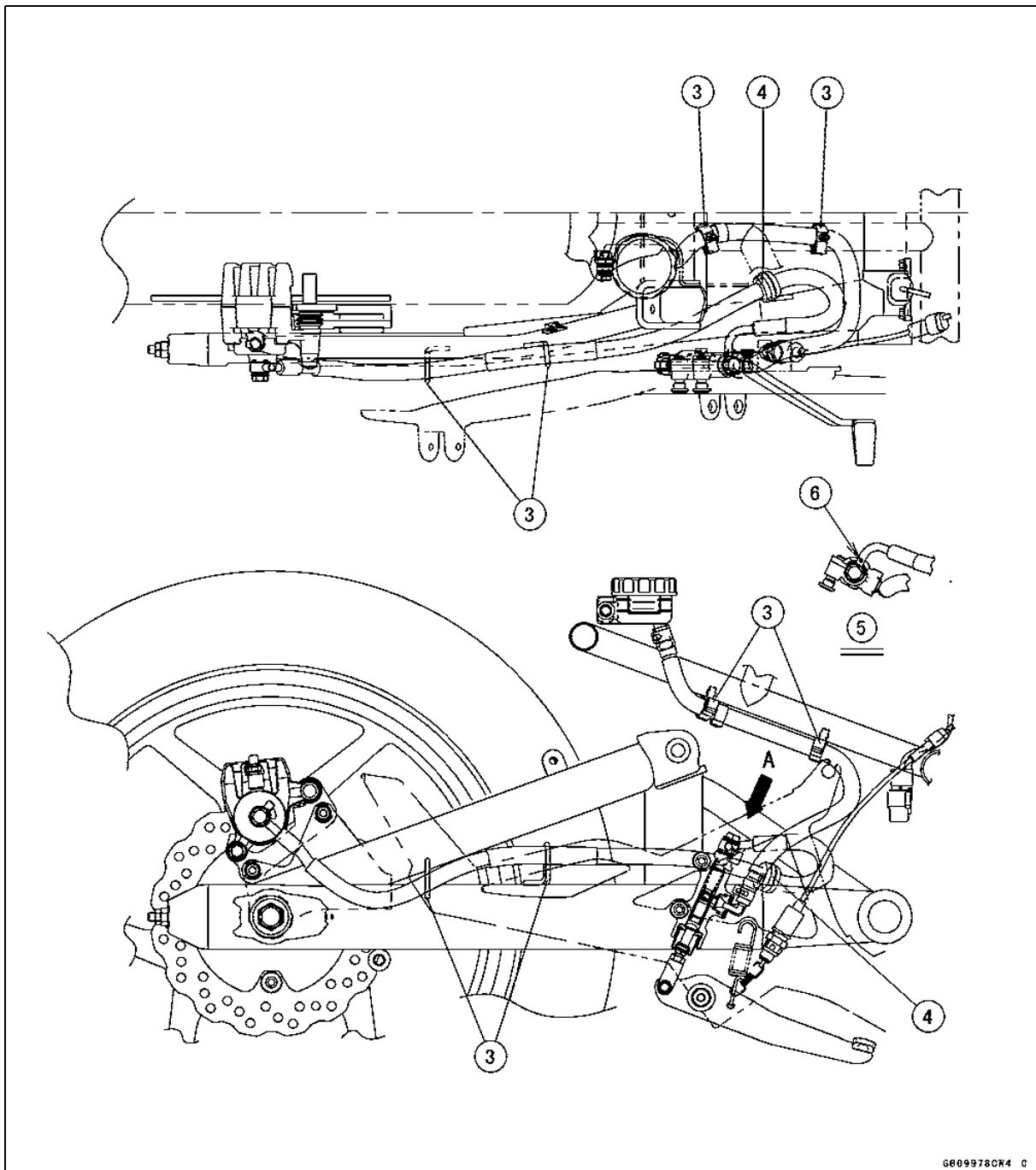

1. Run the brake hose into the guide.
2. Clamps
3. Clamps
4. Clamp with Damper
5. Viewed A
6. Faces the white paint upward.

6809978074 C

17-32 APPENDIX

Cable, Wire, and Hose Routing

EX650D Models

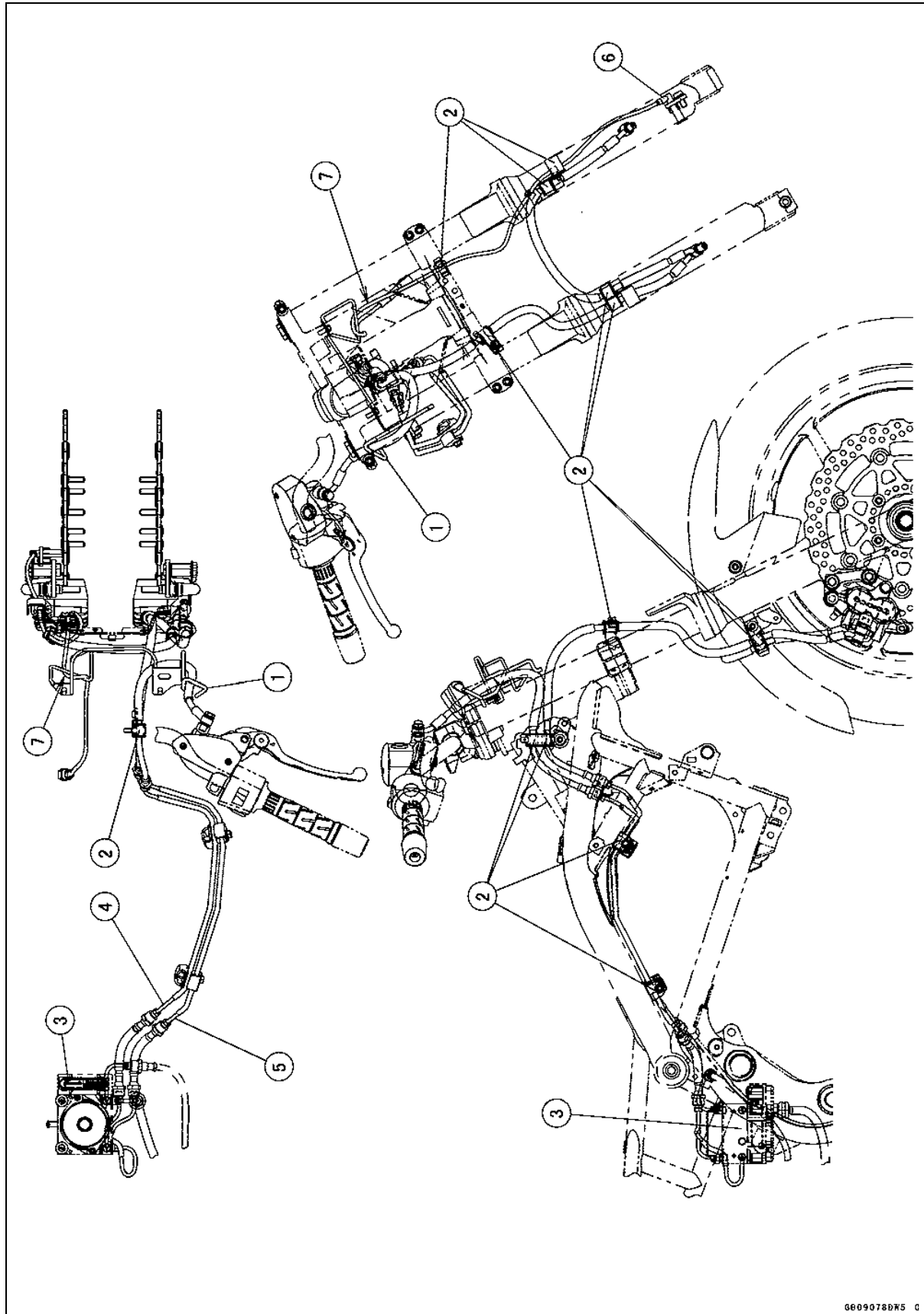

Cable, Wire, and Hose Routing

EX650D Models

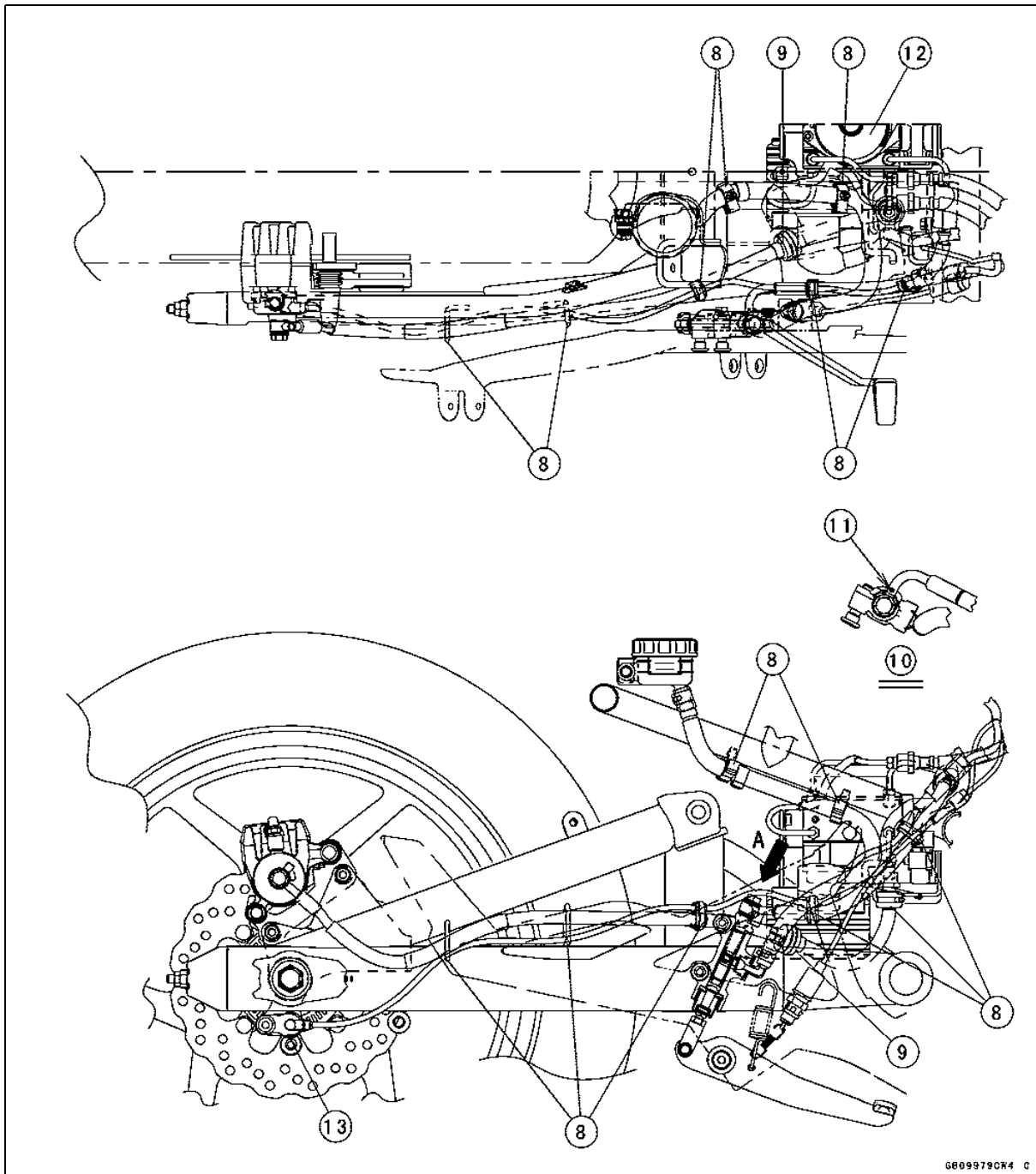

1. Run the brake hose into the guide.
2. Clamps
3. ABS Hydraulic Unit
4. Brake Pipe (from Front Master Cylinder)
5. Brake Pipe (to Front Calipers)
6. Front Wheel Rotation Sensor
7. Run the front wheel rotation sensor lead into the guide.
8. Clamps
9. Clamp with Damper
10. Viewed A
11. Faces the white paint upward.
12. ABS Hydraulic Unit
13. Rear Wheel Rotation Sensor

6E09979C74 C

17-34 APPENDIX

Cable, Wire, and Hose Routing

EX650D Models

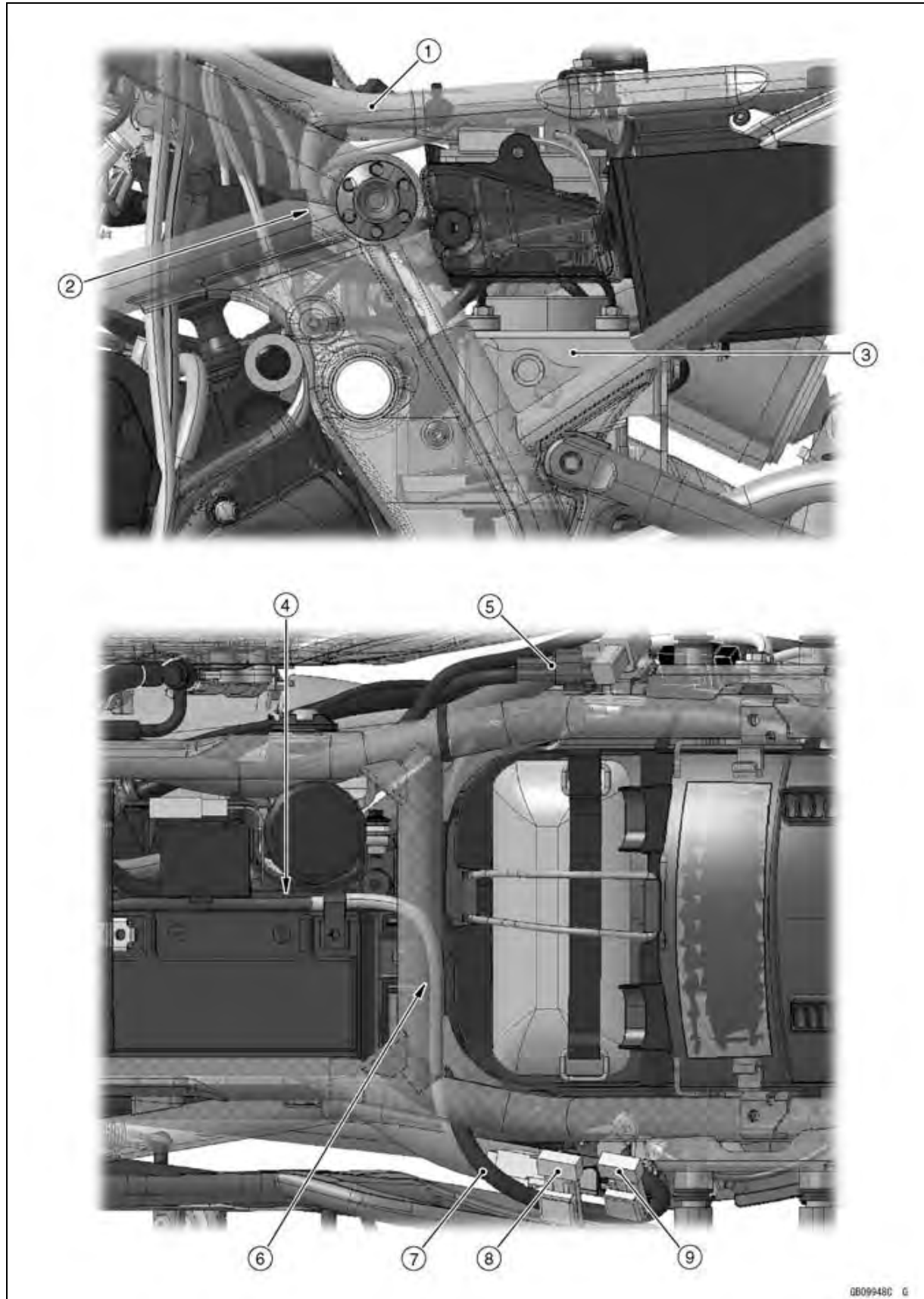

QB099480 6

Cable, Wire, and Hose Routing

1. Main Harness
2. Run the ABS hydraulic unit lead in front of the frame cross pipe.
3. ABS Hydraulic Unit
4. Run the battery positive (+) cable and ABS fuse lead in turn from upper side.
5. ABS Kawasaki Diagnostic System Connector (Insert the connector into the bracket.)
6. Run the battery positive (+) cable in front of the ABS fuse lead. (Place the leads to the rear of the frame cross pipe.)
7. Run the ABS fuse lead to outside of the bracket.
8. ABS Motor Relay Fuse 30A
9. ABS Solenoid Valve Relay Fuse 25A

17-36 APPENDIX

Cable, Wire, and Hose Routing

EX650D Models

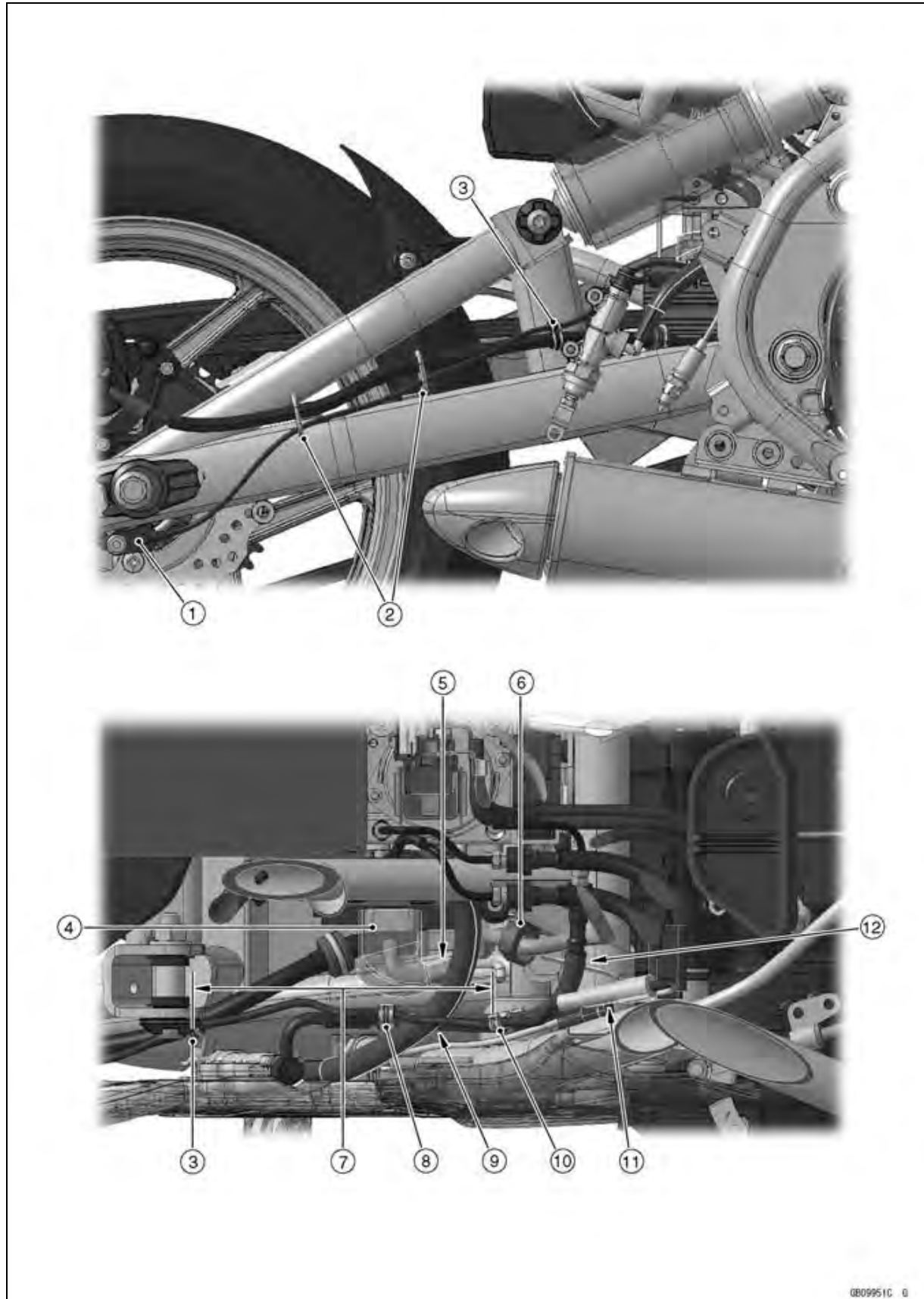

QB0995 1C 0

Cable, Wire, and Hose Routing

1. Rear Wheel Rotation Sensor
2. Run the rear wheel rotation sensor lead into the clamps.
3. Clamp (hold the rear wheel rotation sensor lead with the brake hose under the rear shock absorber lower end.)
4. Cover the connector with the cap securely.
5. Run the regulator/rectifier lead under the rear reservoir hose.
6. Clamp (Hold the regulator/rectifier lead. Insert the clamp into the frame.)
7. Strain the rear wheel rotation sensor lead in this area.
8. Clamp (hold the rear wheel rotation sensor lead with the brake hose by the brake hose fitting end.)
9. Run the rear wheel rotation sensor lead over the rear reservoir hose.
10. Clamp (hold the rear wheel rotation sensor lead with the brake hose.)
11. Run the rear wheel rotation sensor lead over the rear brake light switch lead.
12. Run the vehicle-down sensor lead under the brake hose.

17-38 APPENDIX

Cable, Wire, and Hose Routing

EX650D Models

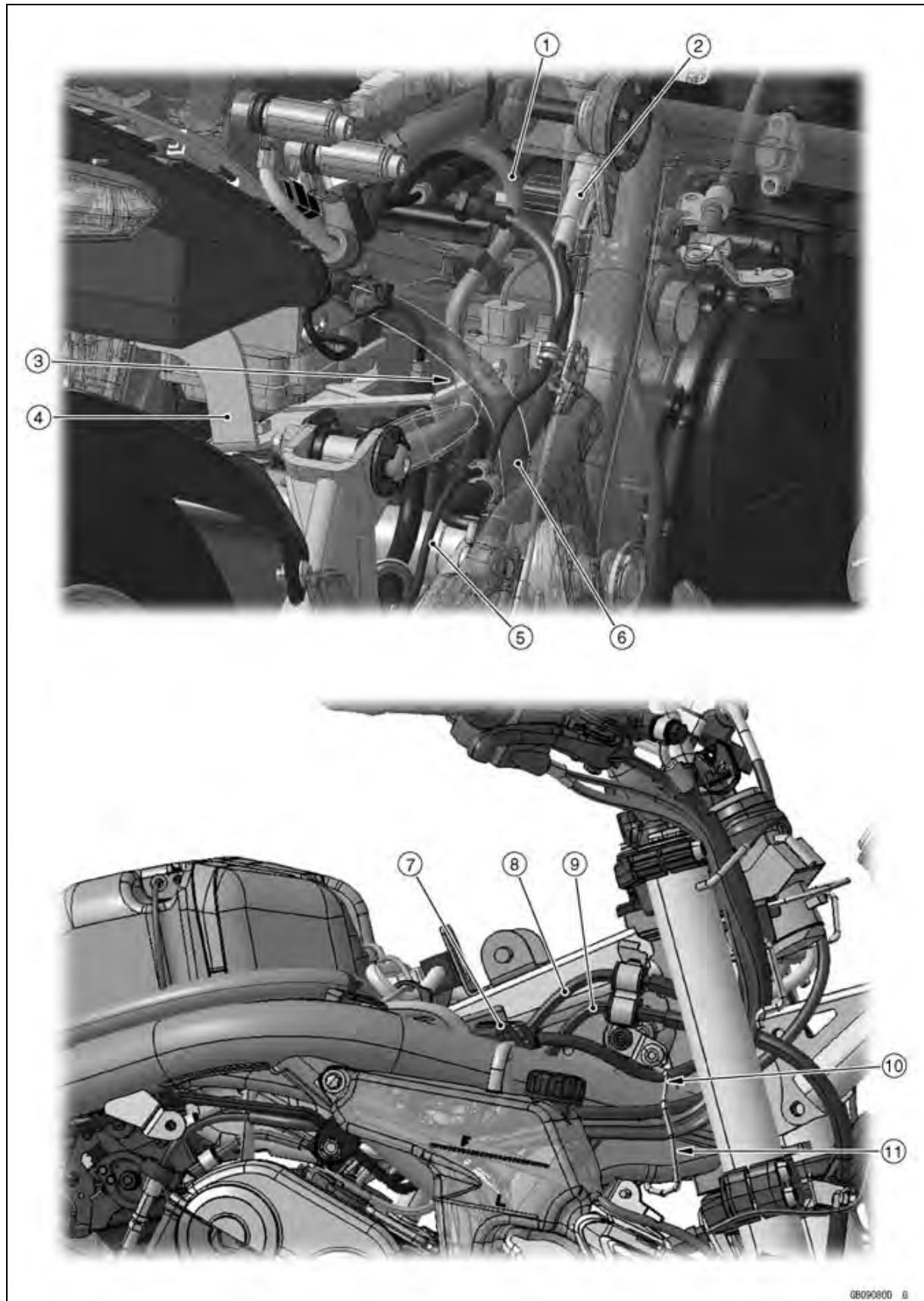

Cable, Wire, and Hose Routing

1. Regulator/Rectifier Lead
2. Place the rear rotation sensor connector over the frame cross pipe.
3. Run the regulator/rectifier lead in front of the ABS hydraulic unit bracket.
4. ABS Hydraulic Unit Bracket
5. Rear Wheel Rotation Sensor Lead
6. Rear Reservoir Hose
7. Clamp (Insert the clamp into the frame. Hold the right switch housing lead.)
8. Brake Hose (from Front Master Cylinder)
9. Brake Hose (to Front Calipers)
10. Run the right switch housing lead into the clamp.
11. Clamp (Hold the clutch cable, throttle cable (decelerator) and throttle cable (accelerator) in turn from upper side.)

17-40 APPENDIX

Cable, Wire, and Hose Routing

CAL and SEA Models

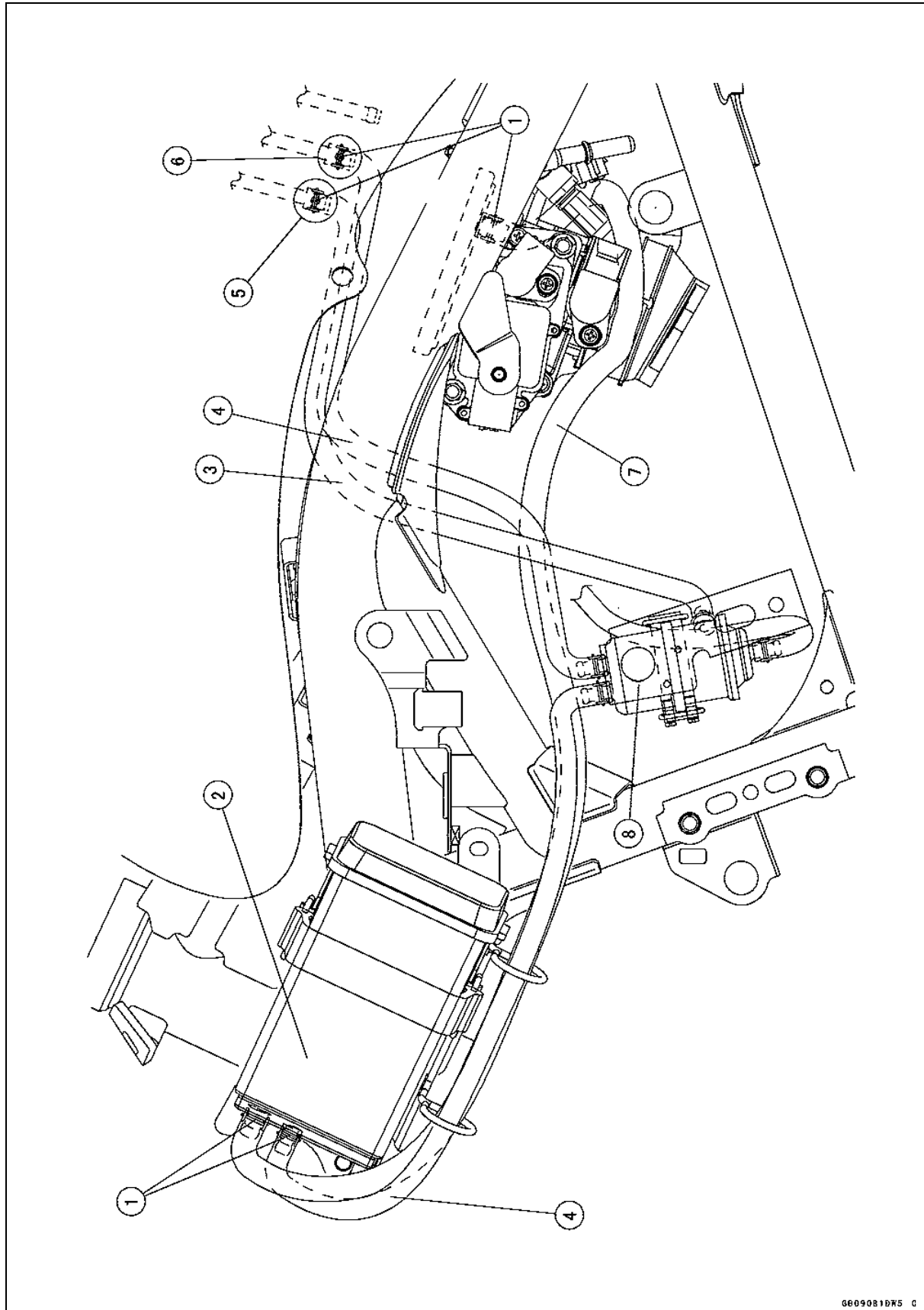

Cable, Wire, and Hose Routing

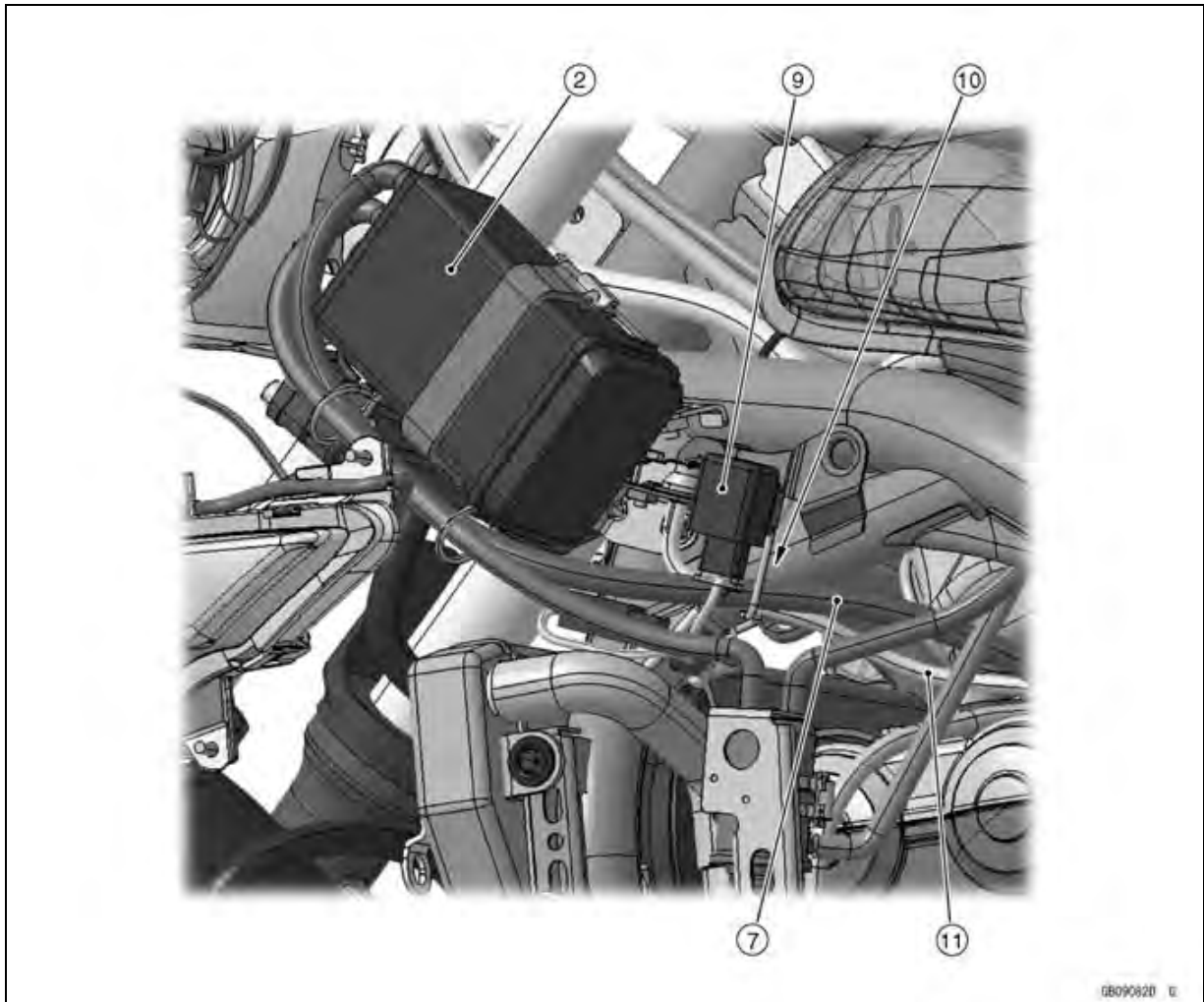

GB090620 U

1. Clamps
2. Canister
3. Tube (Red)
4. Tube (Blue)
5. Align the clamp knob with the red paint as shown in the figure.
6. Align the clamp knob with the blue paint as shown in the figure.
7. Tube (Green)
8. Separator
9. Turn Signal Relay
10. Clamp (Hold the tube (green), and fix the turn signal relay to the frame.)
11. Vacuum Hose

Troubleshooting Guide

NOTE

- Refer to the Fuel System chapter for most of DFI trouble shooting guide.
- This is not an exhaustive list, giving every possible cause for each problem listed. It is meant simply as a rough guide to assist the troubleshooting for some of the more common difficulties.

Engine Doesn't Start, Starting Difficulty:

Starter motor not rotating:

- Starter lockout switch or neutral switch trouble
- Starter motor trouble
- Battery voltage low
- Starter relay not contacting or operating
- Starter button not contacting
- Wiring open or shorted
- Ignition switch trouble
- Engine stop switch trouble
- Fuse blown

Starter motor rotating but engine doesn't turn over:

- Starter clutch trouble
- Vehicle-down sensor (DFI) coming off

Engine won't turn over:

- Valve seizure
- Valve lifter seizure
- Cylinder, piston seizure
- Crankshaft seizure
- Connecting rod small end seizure
- Connecting rod big end seizure
- Transmission gear or bearing seizure
- Camshaft seizure
- Starter idle gear seizure

No fuel flow:

- No fuel in tank
- Fuel pump trouble
- Fuel tank air vent obstructed
- Fuel filter clogged
- Fuel line clogged

Engine flooded:

- Clean spark plug and adjust plug gap
- Starting technique faulty
(When flooded, do not crank the engine with the throttle fully opened. This promotes engine flood because more fuel is supplied automatically by DFI.)

No spark; spark weak:

- Vehicle-down sensor (DFI) coming off
- Ignition switch not ON
- Engine stop switch turned OFF
- Clutch lever not pulled in or gear not in neutral
- Battery voltage low

- Spark plug dirty, broken, or gap maladjusted
- Stick coil shorted or not in good contact
- Stick coil trouble
- Spark plug incorrect
- ECU trouble
- Neutral, starter lockout, or side stand switch trouble
- Crankshaft sensor trouble
- Ignition switch or engine stop switch shorted
- Wiring shorted or open
- Fuse blown

Fuel/air mixture incorrect:

- Bypass screw and/or idle adjusting screw maladjusted
- Air passage clogged
- Air cleaner clogged, poorly sealed, or missing

Compression Low:

- Spark plug loose
- Cylinder head not sufficiently tightened down
- No valve clearance
- Cylinder, piston worn
- Piston ring bad (worn, weak, broken, or sticking)
- Piston ring/groove clearance excessive
- Cylinder head gasket damaged
- Cylinder head warped
- Valve spring broken or weak
- Valve not seating properly (valve bent, worn, or carbon accumulation on the seating surface)

Poor Running at Low Speed:

Spark weak:

- Battery voltage low
- Spark plug dirty, broken, or maladjusted
- Stick coil wiring trouble
- Stick coil not in good contact
- Spark plug incorrect
- ECU trouble
- Crankshaft sensor trouble
- Stick coil trouble

Fuel/air mixture incorrect:

- Bypass screw maladjusted
- Air passage clogged
- Air bleed pipe bleed holes clogged
- Pilot passage clogged
- Air cleaner clogged, poorly sealed, or missing
- Fuel tank air vent obstructed
- Fuel pump trouble
- Throttle body assy holder loose
- Air cleaner duct loose

Troubleshooting Guide

Compression low:

- Spark plug loose
- Cylinder head not sufficiently tightened down
- No valve clearance
- Cylinder, piston worn
- Piston ring bad (worn, weak, broken, or sticking)
- Piston ring/groove clearance excessive
- Cylinder head warped
- Cylinder head gasket damaged
- Valve spring broken or weak
- Valve not seating properly (valve bent, worn, or carbon accumulation on the seating surface)

Other:

- ECU trouble
- Throttle body assy not synchronizing
- Engine oil viscosity too high
- Drive train trouble
- Brake dragging
- Air suction valve trouble
- Air switching valve trouble
- Engine overheating
- Clutch slipping

Poor Running or No Power at High Speed:

Firing incorrect:

- Spark plug dirty, broken, or maladjusted
- Stick coil wiring trouble
- Stick coil not in good contact
- Spark plug incorrect
- Camshaft position trouble
- ECU trouble
- Crankshaft sensor trouble
- Stick coil trouble

Fuel/air mixture incorrect:

- Air cleaner clogged, poorly sealed, or missing
- Air cleaner O-ring damaged
- Air cleaner duct loose
- Water or foreign matter in fuel
- Throttle body assy holder loose
- Fuel to injector insufficient (DFI)
- Fuel tank air vent obstructed
- Fuel line clogged
- Fuel pump trouble

Compression low:

- Spark plug loose
- Cylinder head not sufficiently tightened down
- No valve clearance
- Cylinder, piston worn
- Piston ring bad (worn, weak, broken, or sticking)
- Piston ring/groove clearance excessive

- Cylinder head gasket damaged
- Cylinder head warped
- Valve spring broken or weak
- Valve not seating properly (valve bent, worn, or carbon accumulation on the seating surface)

Knocking:

- Carbon built up in combustion chamber
- Fuel poor quality or incorrect
- Spark plug incorrect
- ECU trouble
- Crankshaft sensor trouble

Miscellaneous:

- Throttle valve won't fully open
- Brake dragging
- Clutch slipping
- Engine overheating
- Engine oil level too high
- Engine oil viscosity too high
- Drive train trouble
- Air suction valve trouble
- Air switching valve trouble
- Catalytic converter melt down due to muffler overheating (KLEEN)

Overheating:

Firing incorrect:

- Spark plug dirty, broken, or maladjusted
- Spark plug incorrect
- ECU trouble

Muffler overheating:

- For KLEEN, do not run the engine even if with only one cylinder misfiring or poor running (Request the nearest service facility to correct it)
- For KLEEN, do not push-start with a dead battery (Connect another full-charged battery with jumper cables, and start the engine using the electric starter)
- For KLEEN, do not start the engine under misfire due to spark plug fouling or poor connection of the stick coil
- For KLEEN, do not coast the motorcycle with the ignition switch off (Turn the ignition switch ON and run the engine)
- ECU trouble

Fuel/air mixture incorrect:

- Throttle body assy holder loose
- Air cleaner duct loose
- Air cleaner poorly sealed, or missing
- Air cleaner O-ring damaged
- Air cleaner clogged

Compression high:

- Carbon built up in combustion chamber

Engine load faulty:

- Clutch slipping
- Engine oil level too high

17-44 APPENDIX

Troubleshooting Guide

- Engine oil viscosity too high
- Drive train trouble
- Brake dragging

Lubrication inadequate:

- Engine oil level too low
- Engine oil poor quality or incorrect

Gauge incorrect:

- Water temperature gauge broken
- Water temperature sensor broken

Coolant incorrect:

- Coolant level too low
- Coolant deteriorated
- Wrong coolant mixed ratio

Cooling system component incorrect:

- Radiator fin damaged
- Radiator clogged
- Thermostat trouble
- Radiator cap trouble
- Radiator fan relay trouble
- Fan motor broken
- Fan blade damaged
- Water pump not turning
- Water pump impeller damaged

Over Cooling:**Gauge incorrect:**

- Water temperature gauge broken
- Water temperature sensor broken

Cooling system component incorrect:

- Radiator fan relay trouble
- Thermostat trouble

Clutch Operation Faulty:**Clutch slipping:**

- Friction plate worn or warped
- Steel plate worn or warped
- Clutch spring broken or weak
- Clutch hub or housing unevenly worn
- No clutch lever play
- Clutch inner cable trouble
- Clutch release mechanism trouble

Clutch not disengaging properly:

- Clutch plate warped or too rough
- Clutch spring compression uneven
- Engine oil deteriorated
- Engine oil viscosity too high
- Engine oil level too high
- Clutch housing frozen on drive shaft
- Clutch hub nut loose
- Clutch hub spline damaged
- Clutch friction plate installed wrong
- Clutch lever play excessive
- Clutch release mechanism trouble

Gear Shifting Faulty:**Doesn't go into gear; shift pedal doesn't return:**

- Clutch not disengaging
- Shift fork bent or seized
- Gear stuck on the shaft
- Gear positioning lever binding
- Shift return spring weak or broken
- Shift return spring pin loose
- Shift mechanism arm spring broken
- Shift mechanism arm broken
- Shift pawl broken

Jumps out of gear:

- Shift fork ear worn, bent
- Gear groove worn
- Gear dogs and/or dog holes worn
- Shift drum groove worn
- Gear positioning lever spring weak or broken
- Shift fork guide pin worn
- Drive shaft, output shaft, and/or gear splines worn

Overshifts:

- Gear positioning lever spring weak or broken
- Shift mechanism arm spring broken

Abnormal Engine Noise:**Knocking:**

- ECU trouble
- Carbon built up in combustion chamber
- Fuel poor quality or incorrect
- Spark plug incorrect
- Overheating

Piston slap:

- Cylinder/piston clearance excessive
- Cylinder, piston worn
- Connecting rod bent
- Piston pin, piston pin hole worn

Valve noise:

- Valve clearance incorrect
- Valve spring broken or weak
- Camshaft bearing worn
- Valve lifter worn

Other noise:

- Connecting rod small end clearance excessive
- Connecting rod big end clearance excessive
- Piston ring/groove clearance excessive
- Piston ring worn, broken, or stuck
- Piston ring groove worn
- Piston seizure, damage
- Cylinder head gasket leaking
- Exhaust pipe leaking at cylinder head connection
- Crankshaft runout excessive

Troubleshooting Guide

Engine mount loose
 Crankshaft bearing worn
 Primary gear worn or chipped
 Camshaft chain tensioner trouble
 Camshaft chain, sprocket, guide worn
 Air suction valve damaged
 Air switching valve damaged
 Alternator rotor loose
 Catalytic converter melt down due to muffler overheating (KLEEN)

Abnormal Drive Train Noise:

Clutch noise:

Clutch housing/friction plate clearance excessive
 Clutch housing gear worn
 Wrong installation of outside friction plate

Transmission noise:

Bearings worn
 Transmission gear worn or chipped
 Metal chips jammed in gear teeth
 Engine oil insufficient

Drive line noise:

Drive chain adjusted improperly
 Drive chain worn
 Rear and/or engine sprocket worn
 Chain lubrication insufficient
 Rear wheel misaligned

Abnormal Frame Noise:

Front fork noise:

Oil insufficient or too thin
 Spring weak or broken

Rear shock absorber noise:

Shock absorber damaged

Disc brake noise:

Pad installed incorrectly
 Pad surface glazed
 Disc warped
 Caliper trouble

Other noise:

Bracket, nut, bolt, etc. not properly mounted or tightened

Oil Pressure Warning Light Goes On:

Engine oil pump damaged
 Engine oil screen clogged
 Engine oil filter clogged
 Engine oil level too low
 Engine oil viscosity too low
 Camshaft bearing worn
 Crankshaft bearing worn
 Oil pressure switch damaged
 Wiring faulty
 Relief valve stuck open

O-ring at the oil passage in the crankcase damaged

Exhaust Smokes Excessively:

White smoke:

Piston oil ring worn
 Cylinder worn
 Valve oil seal damaged
 Valve guide worn
 Engine oil level too high

Black smoke:

Air cleaner clogged

Brown smoke:

Air cleaner duct loose
 Air cleaner O-ring damaged
 Air cleaner poorly sealed or missing

Handling and/or Stability Unsatisfactory:

Handlebar hard to turn:

Cable routing incorrect
 Hose routing incorrect
 Wiring routing incorrect
 Steering stem nut too tight
 Steering stem bearing damaged
 Steering stem bearing lubrication inadequate
 Steering stem bent
 Tire air pressure too low

Handlebar shakes or excessively vibrates:

Tire worn
 Swingarm pivot bearing worn
 Rim warped, or not balanced
 Wheel bearing worn
 Handlebar holder bolt loose
 Steering stem nut loose
 Front, rear axle runout excessive
 Engine mounting bolt loose

Handlebar pulls to one side:

Frame bent
 Wheel misalignment
 Swingarm bent or twisted
 Swingarm pivot shaft runout excessive
 Steering maladjusted
 Front fork bent
 Right and left front fork oil level uneven

Shock absorption unsatisfactory:

(Too hard)
 Front fork oil excessive
 Front fork oil viscosity too high
 Rear shock absorber adjustment too hard
 Tire air pressure too high
 Front fork bent
 (Too soft)
 Tire air pressure too low
 Front fork oil insufficient and/or leaking
 Front fork oil viscosity too low

17-46 APPENDIX

Troubleshooting Guide

Rear shock adjustment too soft
Front fork, rear shock absorber spring weak
Rear shock absorber oil leaking

Brake Doesn't Hold:

Air in the brake line
Pad or disc worn
Brake fluid leakage
Disc warped
Contaminated pad
Brake fluid deteriorated
Primary or secondary cup damaged in master cylinder
Master cylinder scratched inside

Battery Trouble:

Battery discharged:

Charge insufficient
Battery faulty (too low terminal voltage)
Battery cable making poor contact
Load excessive (e.g., bulb of excessive wattage)
Ignition switch trouble
Alternator trouble
Wiring faulty
Regulator/rectifier trouble

Battery overcharged:

Alternator trouble
Regulator/rectifier trouble
Battery faulty

MODEL APPLICATION

Year	Model	Beginning Frame No.
2009	EX650C9F	JKAEXEC1□9DA19833 JKAEX650CCDA19835
2009	EX650D9F	JKAEX650CDDA23433

□:This digit in the frame number changes from one machine to another.



KAWASAKI HEAVY INDUSTRIES, LTD.
Consumer Products & Machinery Company

Part No.99924-1419-01

Printed in Japan