

Kawasaki

Ninja ZX-10R

2006 Ninja ZX-10R Racing Kit Manual

This manual contains only the information of the racing kit parts. Refer to the base manual listed below for information of the original model.

Base Manual	Part Number
Ninja ZX-10R Motorcycle Service Manual	99924-1365-01

Congratulation on your purchase of racing kit parts for the 2006 Ninja ZX-10R.

IMPORTANT

This manual provides how to install racing kit parts for the 2006 Ninja ZX-10R and how to tune up basically.

As for the basic knowledge, refer to the base Service Manual for the Ninja ZX-10R (P/No. 99924-1365-01).

When you participate in a race, it is necessary to modify the machine for the regulation. So we want you to ask for the tuning up shop.

⚠ WARNING

AFTER ANY MODIFICATION TO TUNE THE VEHICLE TO A COMPETITION MACHINE, IT SHOULD NOT BE USED ON PUBLIC STREETS, ROADS OR HIGHWAYS. THE USE OF THIS VEHICLE SHOULD BE LIMITED TO PARTICIPATION IN SANCTIONED COMPETITION EVENTS UPON A CLOSED COURSE.

CAUTION

When operating the engine, be careful not to trouble persons with noise. Do not turn the engine with loud engine and exhaust noise.

DISCLAIMER OF WARRANTY

ON OPTIONAL TUNING PARTS FOR RACING ARE NO WARRANTIES EXPRESSED OR IMPLIED.

BASIC WORKS IN INSTALLING KIT PARTS

We are going to make up the original Ninja ZX-10R for the racing machine. We recommend that the rider himself should do the basic works, removing parts or installing parts etc., given advices by the tuning shop. In a race, although trouble will be apt to happen, if you participate in basic works, you can discriminate cause of trouble, so you can return the race soon.

But concerning difficult technical works, you should ask to tuning shop.

Table of Contents

General Specifications	3
Racing Kit Service Data	5
Periodic Maintenance Chart.....	5
Engine Parts Installation	7
Air Intake Parts	7
Camshaft Chain Tensioner.....	8
Camshafts, Sprockets.....	9
Cylinder Head	11
Cylinder Compression	12
Pistons.....	13
Crankshaft Main Journal Bushings	15
Connecting Rod Bolts	17
Connecting Rod Big End Bushings.....	19
Clutch Adjustment (Back-Torque Limiter Setting)	20
Transmission	26
Alternator	28
Water Temperature Sensor	32
Radiator (Kit)	32
Oil Catch Tank (Kit).....	36
Cover Gaskets (Kit)	38
ECU (Kit)	38
Frame Parts Installation	39
Throttle Parts (Kit Parts)	39
Final Drive Parts (Kit Parts)	40
Brake Pads (Kit Parts)	40
Seat Height Adjustment	41
Front Fork Springs (Kit Parts)	43
Electrical System	45
Battery	45
Main Harness and Sub Harness (Kit Part).....	45
Wiring Diagram (with Original Meter).....	54
Wiring Diagram (with Kit Meter).....	56

General Specifications

Item	2006 Ninja ZX-10R Racing
Engine: Ignition timing Fuel (Recommended) Engine oil (Recommended): Level	10°BTDC @1 100 r/min (rpm) Racing gasoline Racing oil Between upper and lower levels of oil level gauge.
Drive Train: Primary drive reduction ratio	1.611 (87/54)

Transmission Gear Table

		STD (Type A)	Type B	Type C	Type D
1st	In	13127-0020	13127-0030	13127-0031	13127-0032
	Out	13262-0170	13262-0267	13262-0275	13262-0281
	Teeth (Out/In)	38/15	31/13	34/14	37/16
	Gear Ratio	2.533	2.385	2.429	2.313
2nd	In	13262-0185	-	-	13262-0279
	Out	13262-0152	-	-	13262-0282
	Teeth (Out/In)	39/19	-	-	36/18
	Gear Ratio	2.053	-	-	2.000
3rd	In	See Gear Selection	See Gear Selection	See Gear Selection	-
	Out	13262-0182	13262-0268	13262-0276	-
	Teeth (Out/In)	33/19	34/19	28/16	-
	Gear Ratio	1.737	1.789	1.750	-
4th	In	See Gear Selection	See Gear Selection	-	-
	Out	13262-0166	13262-0269	-	-
	Teeth (Out/In)	32/21	31/20	-	-
	Gear Ratio	1.525	1.550	-	-
5th	In	13262-0135	13262-0265	13262-0273	13262-0135 (STD)
	Out	13262-0183	13262-0270	13262-0277	13262-0351
	Teeth (Out/In)	29/21	29/20	28/20	30/21
	Gear Ratio	1.381	1.450	1.400	1.429
6th	In	13262-0136	13262-0266	13262-0274	13262-0280
	Out	13262-0171	13262-0271	13262-0278	13262-0283
	Teeth (Out/In)	30/23	29/21	28/21	28/22
	Gear Ratio	1.304	1.381	1.333	1.273

Input 3rd/4th Gear Selection Table

		4th Gear	
		A (=C)	B
3rd Gear	A	13262-0134 (19/21)	13262-0286 (19/20)
	B	13262-0284 (19/21)	13262-0264 (19/20)
	C	13262-0272 (16/21)	13262-0285 (16/20)

Gear Identification Slit Number Table

		Standard (Type A)	Type B	Type C	Type D
1 st	Input	0	2	3	4
	Output	1	2	3	4
2 nd	Input	1	-	-	2
	Output	1	-	-	2
3 rd	Input	1	2	0	-
	Output	0	2	3	-
4 th	Input	0	1	-	-
	Output	2	1	-	-
5 th	Input	2	0	3	-
	Output	1	0	3	2
6 th	Input	1	2	3	4
	Output	0	2	3	4

Engine Sprocket

13144-0021 #520-16T

13144-0022 #520-17T

Racing Kit Service Data

Item	Standard
Cylinder Head, Valves:	
Valve timing:	
Duration:	
Intake	300°
Exhaust	292°
Camshaft timing (cam lift center):	
Intake	104° (ATDC)
Exhaust	102° (BTDC)
Valve clearance:	
Intake	0.22 mm
Exhaust	0.20 mm
Squish	0.85 mm
Valve to piston clearance:	
Intake	1.45 mm @10°ATDC
Exhaust	1.80 mm @10°BTDC
Ignition System:	
Spark plugs	NGK CR9EIA-9 (STD), R0045Q-10 or R0373A-10
Spark plug tightening torque	13 N·m (1.3 kgf·m, 113 in·lb)

These values show the specifications when standard cylinder head and gasket are used.

Periodic Maintenance Chart

The scheduled maintenance must be done in accordance with this chart to keep the motorcycle in good running condition.

OPERATION	FREQUENCY	Each	Every	Every	Every	Every	As
		Race	2 races	3 races	5 races	10 races	Required
Engine							
Clutch plate - - check*		•					
Throttle grip play - - check*		•					
Spark plug - - clean/gap*		•					
Engine oil - - change		•					
Oil filter - - replace		•					
Valve lapping					•		
Cylinder head/valve - - decarbonization					•		
Cylinder - - check*					•		
Piston/cylinder clearance - - check*					•		
Piston ring, piston, and piston pin - - replace (When pistons 13001-0077 are used)				•			
Piston ring, piston, and piston pin - - replace (When pistons 13001-0078 are used)			•				
Crankshaft main bearing - - check*						•	

	FREQUENCY	Each Race	Every 2 races	Every 3 races	Every 5 races	Every 10 races	As Required
Connecting rod big end bearing - - check*						•	
Transmission gear, bearing - - check*						•	
Engine sprocket - - check*		•					
Coolant - - change							•
Radiator hoses, connections - - check*		•					
Frame							
Brake operation - - check*		•					
Brake pad wear - - check*		•					
Brake fluid level - - check*		•					
Brake fluid - - change*							year
Brake master cylinder cup and dust seal - - replace							year
Brake caliper piston seal and dust seal - - replace							year
Brake hose - - replace							2 years
Drive chain - - adjust		•					
Drive chain - - lubricate		•					
Drive chain wear - - check*		•					
Drive chain guide - - replace		If damaged					
Front fork - - clean/check*		•					
Front fork oil - - change		First change after 2 races, then every 5 races					
Nut, bolt, and fastener tightness - - check*		•					
Fuel system - - clean		•					
Fuel hose, fuel filter - - replace							•
Steering play - - check*		•					
Steering stem bearing - - grease					•		
Rear sprocket - - replace							•
General lubrication of chassis - - perform		•					
Wheel bearing (rear) - - grease						•	
Swingarm pivot, uni-track linkage - - grease					•		
Swingarm pivot, uni-track linkage - - check*					•		

*: Replace, add, adjust, clean, or torque if necessary.

Engine Parts Installation

Air Intake Parts

- Remove the air cleaner element or cut the cleaner element off remaining the wire net to reduce the air flow resistance.

When removing the air cleaner element, remove the element and relational parts as shown below.

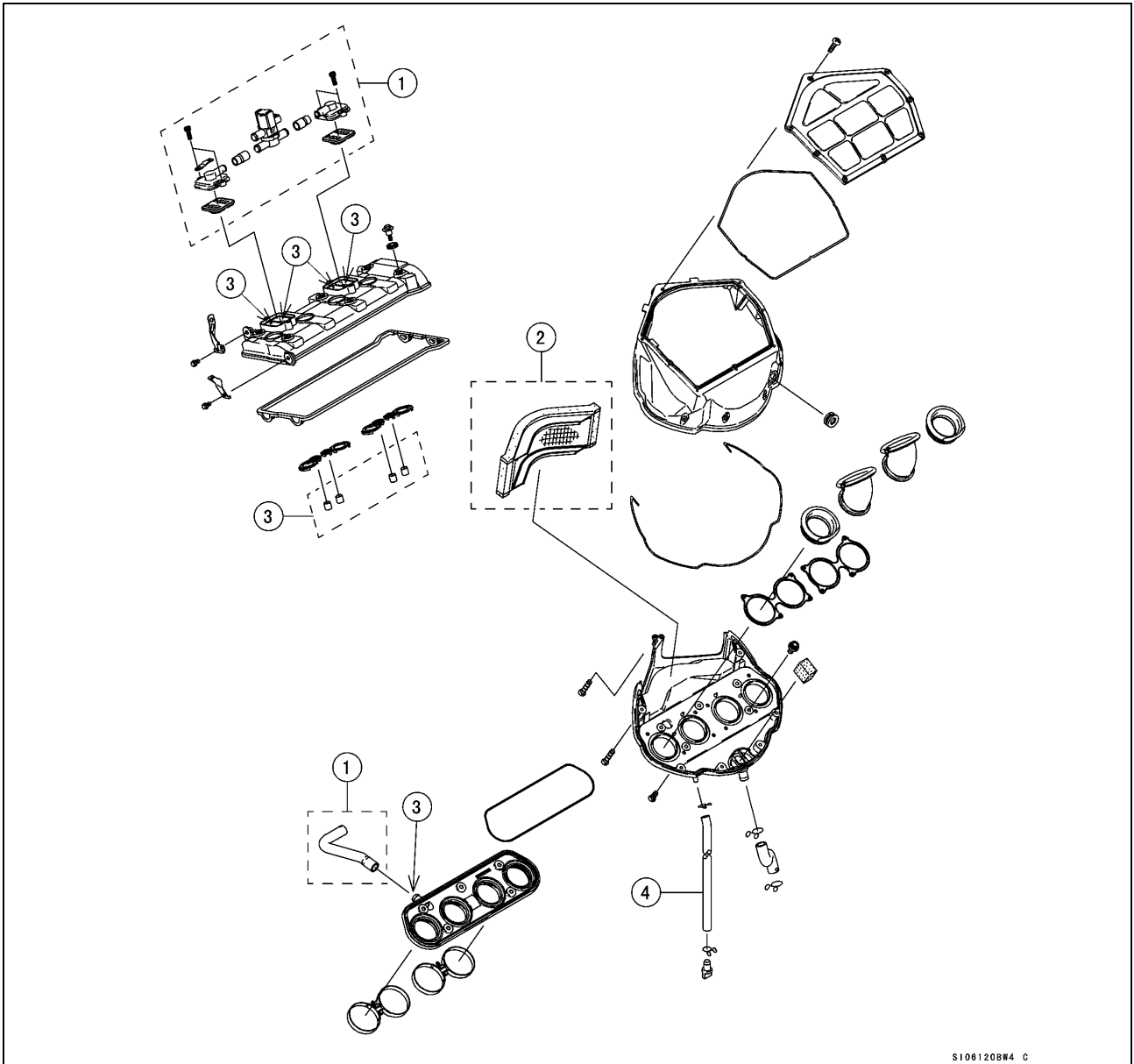

1. Relational Parts of Secondary Air: Remove the Parts.
2. Remove the parts or cut the cleaner element off remaining the wire net.
3. Secondary Air Passages on Cylinder Head: Plug the holes, or press-fit the plugs (92066-1005) instead of the original pins.
Output of Secondary Air on Air Cleaner: Plug the hole
4. Air Cleaner Drain Tube: Use it cutting it in suitable length.

Camshaft Chain Tensioner

- Replace the cam chain tensioner with the kit to decrease the flutter of tensioner.
- Apply the engine oil to the tensioner rod, O-ring and tensioner body, insert them into the tensioner body.

Check to see that the tensioner rod turns freely in the body, if not, polish the tensioner rod or fine the female threads in the body with a tap (Diameter × Pitch = 6 mm × 1.0 mm).

- Install the tensioner on the cylinder block with the tensioner rod is fully pushed back.
- Turn the tensioner rod in with a screwdriver until it becomes hard to turn.
- Turn the crankshaft clockwise forcing lightly to the tensioner rod with twisting force to take up any gap and tighten the locknut.
- After adjusting the tensioner rod, if the tensioner rod does not stick out from the tensioner body, use the kit long tensioner rod (13116-1166).

NOTE

Never forward the tensioner rod forcibly, this will increase mechanical loss of the tensioner and may damage to the chain guide.

The cam chain tensioner must be adjusted at every race.

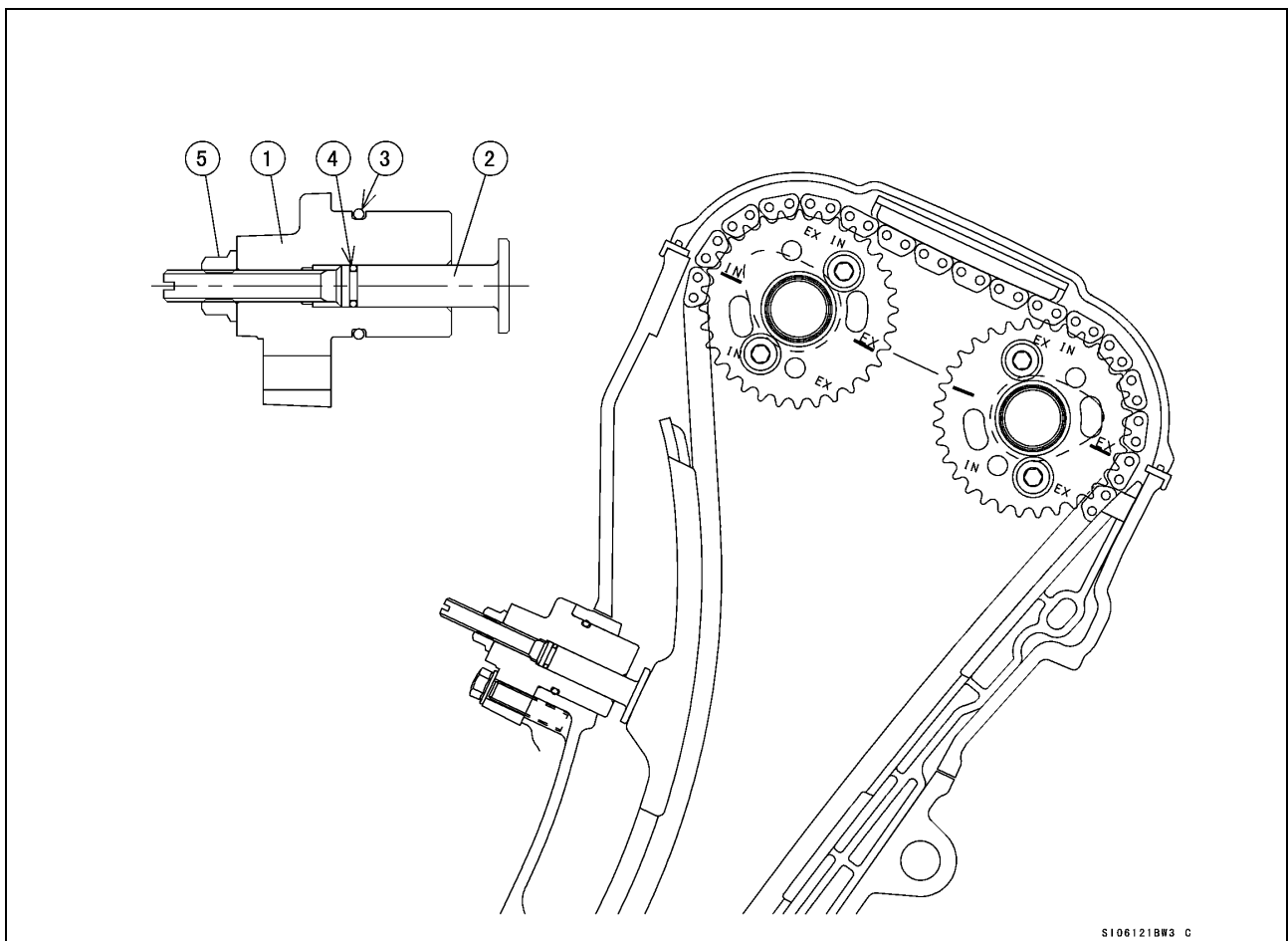

1. Tensioner Body
2. Tensioner Rod: 13116-1166 (Kit)
3. O-ring

4. O-ring
5. Locknut

Camshafts, Sprockets

Camshafts, Sprockets:

Camshaft	Duration	Lift
49118-0008 (STD) (Intake)	300°	9.1 mm
49118-0045 (STD) (Exhaust)	292°	8.5 mm
49118-0034 (Kit) (Intake)	310°	9.7 mm
49118-0077 (Kit) (Exhaust)	280°	8.0 mm

- Use the kit valve springs (49078-0049) when the kit exhaust camshaft (49118-0077) is used.
Install the kit valve springs facing the rough coiled side (pink paint end) to the retainer.
- Adjust the valve clearance within the specified value. Intake: 0.15 ~ 0.24 mm, Exhaust: 0.17 ~ 0.22 mm
- More performance is expected when adjusted from middle value to upper limit between adjustable range.
- If you can not adjust the valve timing for racing, install the camshaft sprocket to the camshaft using the round bolt holes and adjust the cam chain timing according to the Ninja ZX-10R Service Manual. If you adjust the valve timing, install the sprocket to the camshaft between the adjustable range of the long bolt holes.
- Tighten the camshaft sprocket bolts to 15 N·m (1.5 kgf·m, 11 ft·lb) of torque.

Valve Timing

Timing (cam lift center)	Intake	Exhaust
When the round bolt holes are used (Original)	104° (Original camshaft)	102° (Original or Kit camshaft)
When the long bolt holes are used	108° (Kit camshaft)	102° (Original or Kit camshaft)

When grinding the cylinder head bottom surface, grinding the cylinder top surface or using thinner gaskets, be sure the valve to piston clearance especially.

When using the sprocket long bolt holes and adjusting the valve timing to be different from the standard timing, check the valve to piston clearance of all cylinders after adjusting the valve clearance correctly.

Valve to Piston Clearance (Min.)

Intake	0.7 mm
Exhaust	1.2 mm

If the valve to piston clearance is less than the minimum value, do not start the engine because the valves will touch the piston and the engine may be damaged.

Adjust the valve timing again to keep the valve to piston clearance more than the minimum value.

- Method of measuring clearance of valve and piston –1.
Holding the crankshaft at 10° ATDC (intake) and 10° BTDC (exhaust) of crankshaft timing, measure the amount of the tappet movement until the valve comes in contact with the piston pushing the tappet.

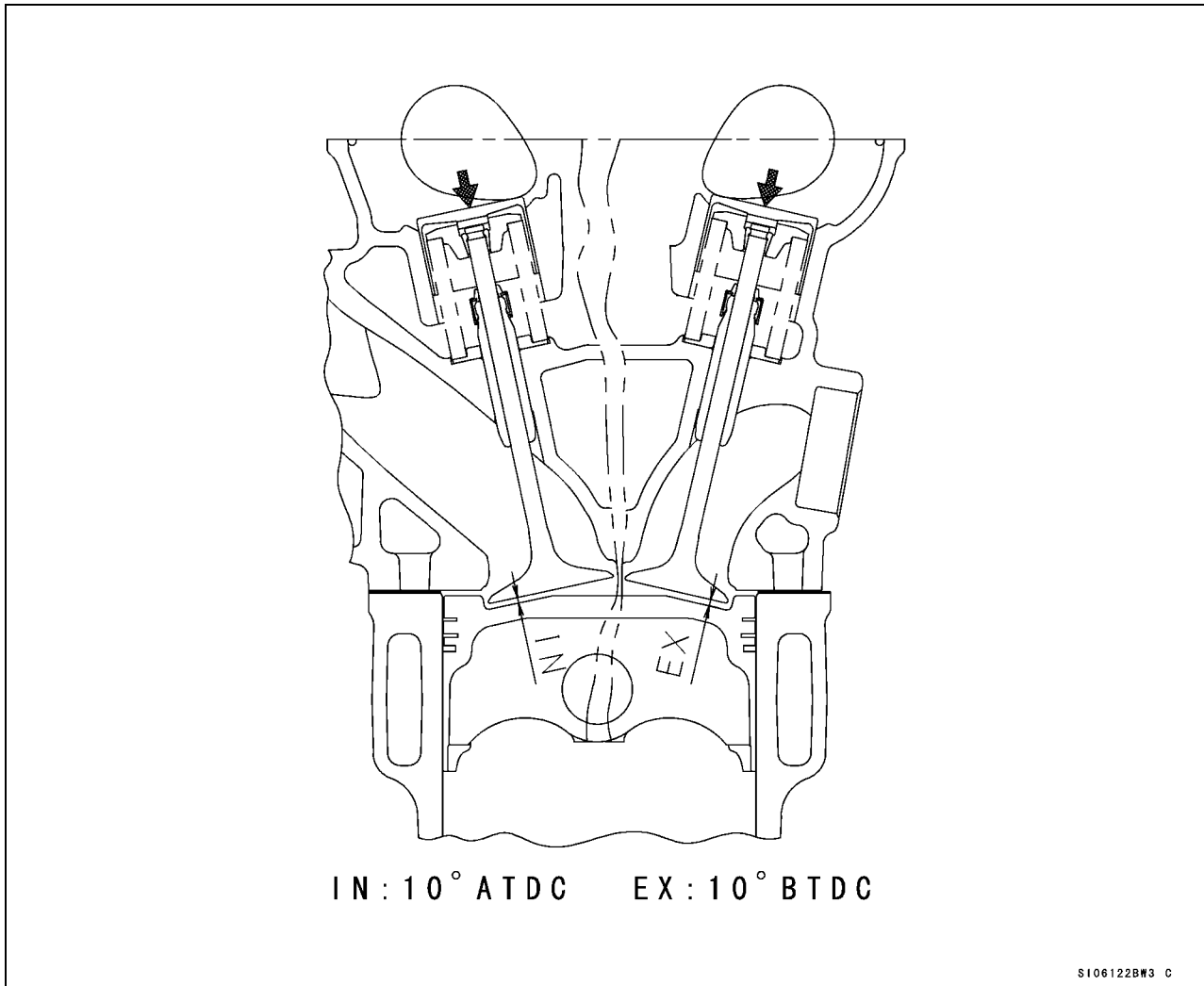

- Method of measuring clearance of valve and piston –2.
 - Adjust the valve clearance and valve timing.
 - Remove the cylinder head, and put a small piece of modeling clay on the hollow of piston to prevent valve from coming in contact.
 - Install the cylinder head and adjust the camshaft chain timing.
 - Turn the crankshaft by two rotations or more.
 - Remove the cylinder head and measure the thickness of the clay. The thickness of the collapsed clay is a clearance of the valve and the piston.

Cylinder Head

- Before reassemble the cylinder head grind off the stepped portions of the port and smooth the inside of ports to make intake/exhaust gas flow smooth.
Grind off the stepped portions only at the mating surface between the carburetor holder and the intake port.
When using the kit camshaft (49118-0034), grind off the inside of the intake port to extent 1mm from the original port diameter for improve the performance.
Mark the carburetor holders so that they can be installed in their original positions.
Grind off and smooth the stepped portions at the mating surface between the valve seat and the port.
Smooth the inside of the intake port and exhaust port.
- Chamfer the machining edge of the cylinder head where the valve seat installed, also smooth the dome of the combustion chamber with the valves installed. Excessive smoothing may reduce the cylinder compression.
- Use the hand grinder.
Use #200 oil stone for eliminating any stepped portion and #300 oil stone for finishing.

NOTE

These procedures make air resistance less and intake/exhaust gas flow more smooth. However, much more effect can not be expected by excessive grinding and smoothing. It may be done to the extent of getting rid of uneven surfaces.

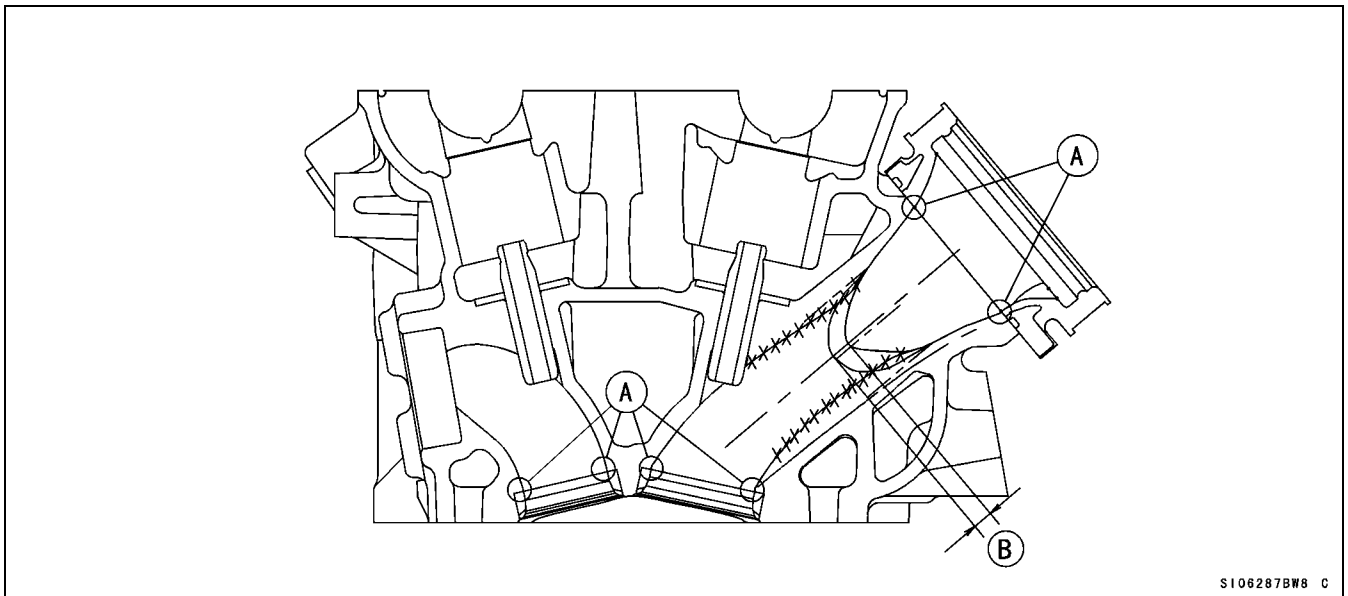

S106287B#8 C

A: Stepped Portions

B: Grind off the rib to 5 mm

X: Grind Area (All around port)

- The combustion chambers are modified by cutting work but the edges shown must be hand finished for smooth corners.

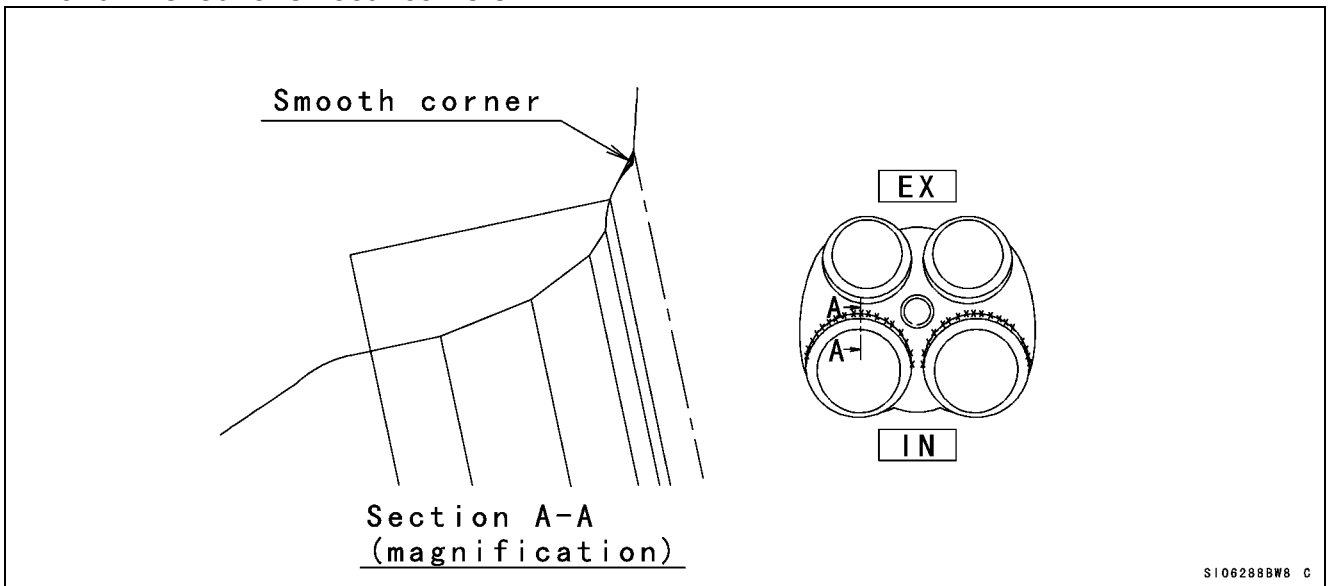

NOTE

When grinding the cylinder head surface or using thinner gasket, adjust the valve timing to keep that the valve to piston clearance is not less than the minimum value (IN: 0.7 mm, EX: 1.2 mm).

Cylinder Compression

- To adjust the cylinder compression, adjust the thickness of the cylinder head gasket or smooth the cylinder head under surface or cylinder top surface to make the piston squish 0.65 mm. Keep the piston squish more than 0.65 mm.

Grind off the cylinder head under surface to 0.4 mm. Do not grind the cylinder upper surface. This can raise the compression ratio while keeping the clearance of the piston and valve, and one of the squish. Although, as the engine machining is uneven, determine the cutting dimension after keeping the recess and the squish before machining.

Position the piston at Top Dead Center, and put a small piece of modeling clay on the shoulder of the piston. Install the cylinder head gasket and cylinder head, and tighten the head bolts to the specified torque.

Remove the cylinder head and measure the thickness of the clay. The thickness of the collapsed clay is the size of the squish.

The most preferable squish measurement is 0.65 mm.

Select proper cylinder head gasket.

Cylinder Head Gasket

Part No.	Tightening thickness	Remarks
11004-0026	0.65 mm (STD)	KIT
11004-0052	0.60 mm	KIT
11004-0022	0.55 mm	KIT
11004-0034	0.50 mm	KIT
11004-0023	0.45 mm	KIT

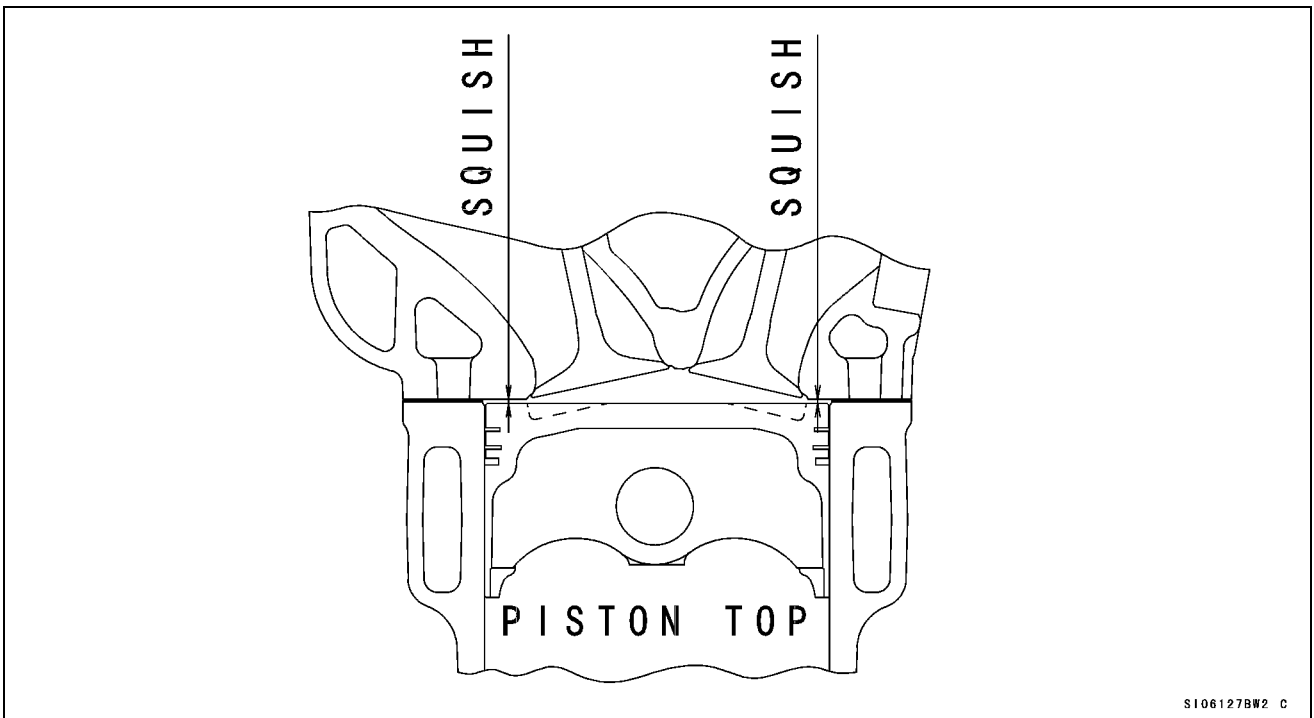

Pistons

Kit Piston: SB

(1) 13001-0077

- Kit pistons are exclusive the two piston rings for reduce the compression height (between the center of piston pin hole and the shoulder of the piston) and the mechanical friction loss.
- Kit piston has more reduced the weight compared the original piston.
- To adjust the cylinder compression to 14.3, use the kit pistons and grind off the cylinder head under surface to 0.4 mm.
Always use the higher octane rating gasoline for prevent the knocking.
- Use the kit piston rings and kit piston pins.
- When replacing the kit pistons with the original pistons, inspect the squish (refer to the Cylinder Compression section).

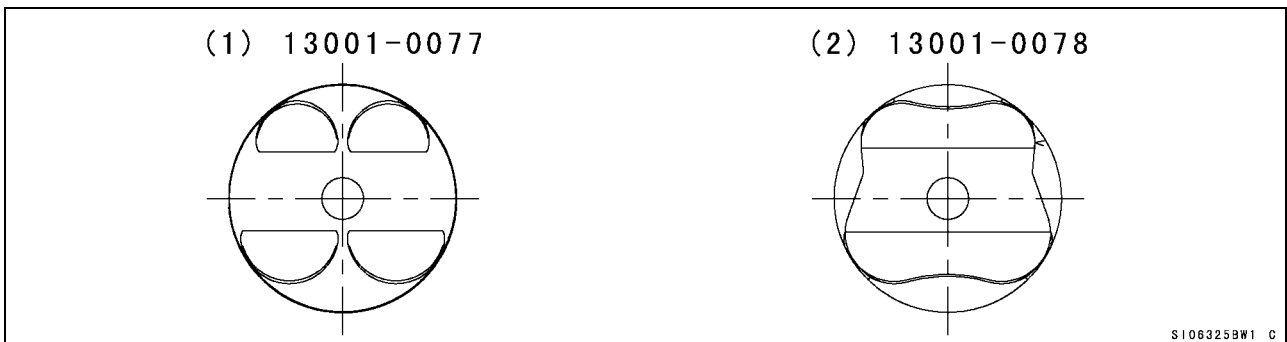

(2) 13001-0078

- Kit pistons are exclusive the two piston rings for reduce the compression height (dimension between the center of piston pin hole to shoulder of the piston) and the mechanical friction loss.
- Kit piston has more reduced the weight compared the original piston.
- To adjust the cylinder compression to 14.5, use the kit pistons and remodel the original cylinder head.
- Use the kit piston rings and kit piston pins.
- When replacing the kit pistons with the original pistons, inspect the squish (refer to the Cylinder Compression section).
- Remodel the cylinder head according to the following figure.
- The specified squish is 0.60 to 0.65 mm: front and rear, and 0.60 to 0.67 mm: left and right side.
- Replace the cylinder head gasket with the thinner or thicker one or grind the side squish portions of the combustion chamber and the piston head with the emery cloth if the squish is without the specified range.

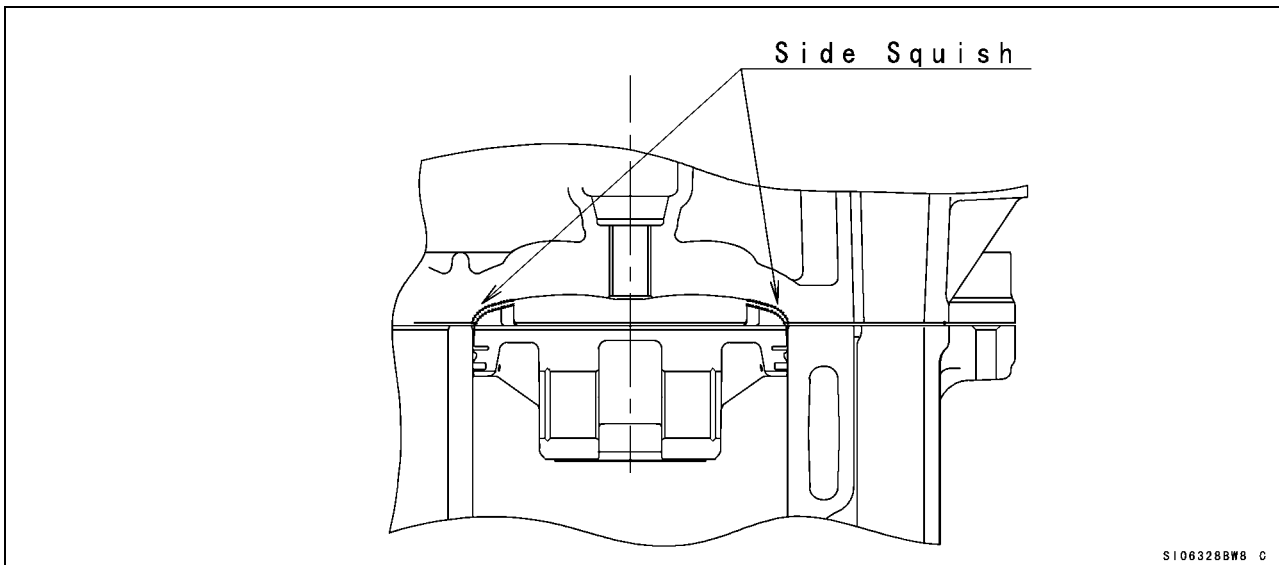

Note: Remodel the cylinder head following below.

Grind the around the valve seats in the combustion chamber until taking up the edges and smoothing, and then polish the combustion chamber lightly. Do not polish too much because the cylinder compression decreases.

At this time, do so as not to damage the valve seat with the valve installed.

Do not damage the 90° valve seating surface during the cylinder head modification.

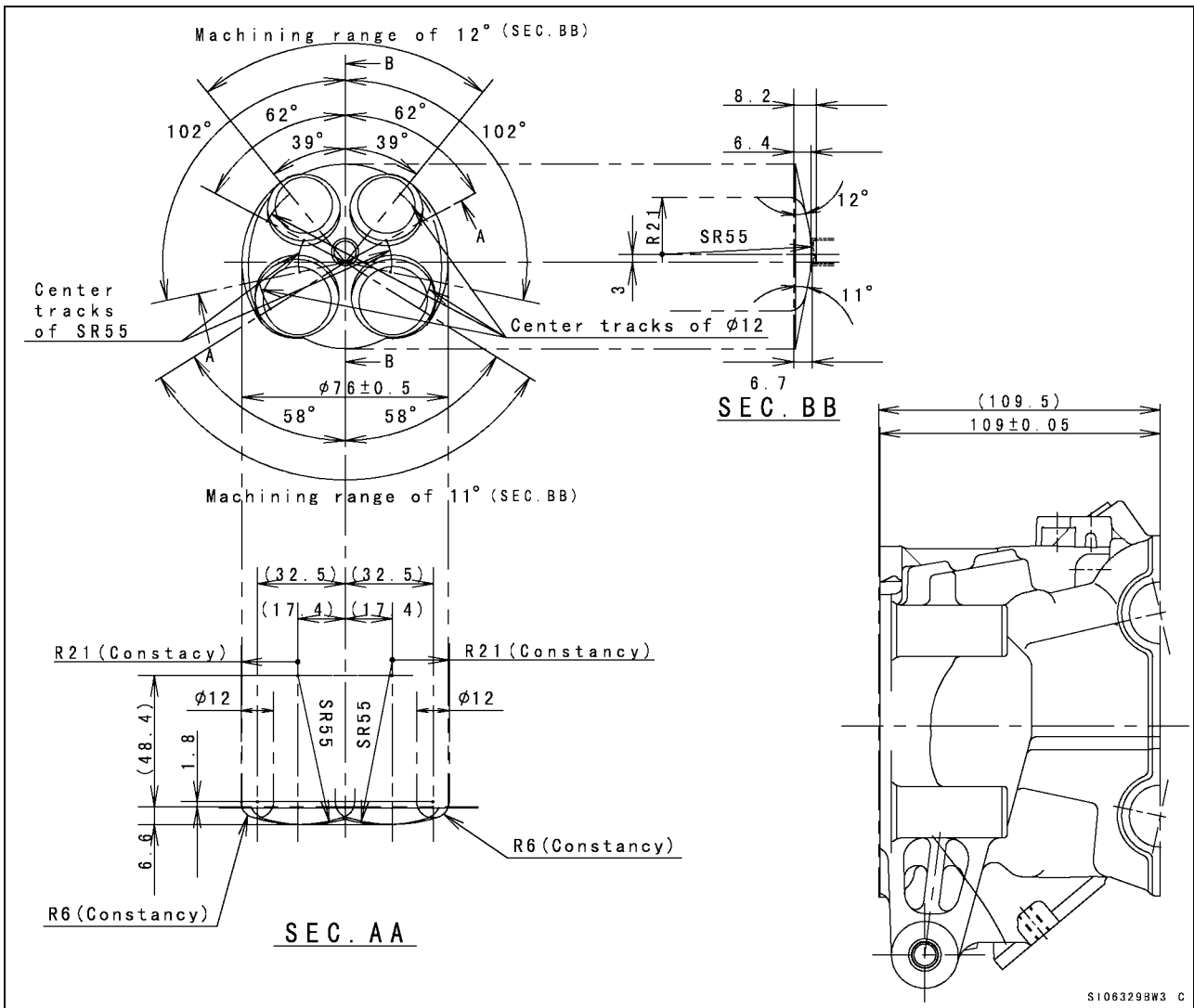

Note: Use the kit pistons (13001-0077, -0078) following below.

Use the kit connecting rod assemblies (13251-0015).

Use the kit piston rings (13008-0019).

There are the machining edges for the valve relief portions of the piston heads. Must be hand finished for smooth corners. (Round the corner to R1)

Crankshaft Main Journal Bushings

The kit bushings are improved in anti-seizuring characteristics as well as in wear-resistance as compared with the standard bushings.

Crankshaft Main Journal Clearance

※ When adjust the clearance by measurement in case aiming the clearance 0.035 mm.

Crankshaft Main Journal Diameter Marks

None: 34.984~34.992 mm
 "1" Mark: 34.993~35.000 mm

None [C]
 1: [D]

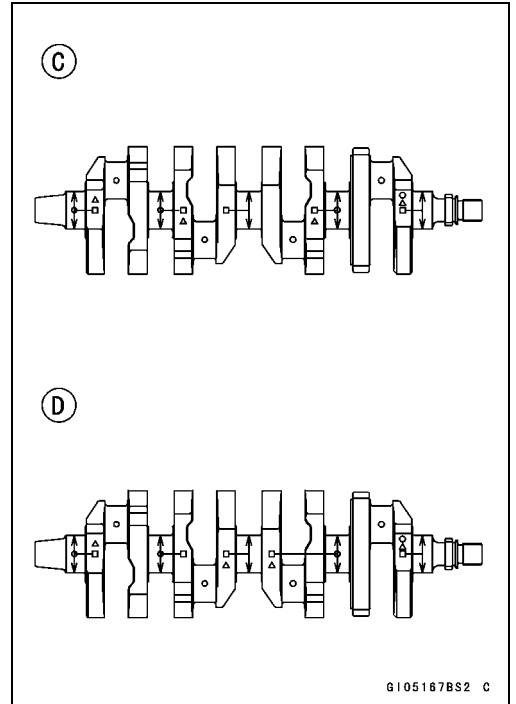

Crankcase Main Bearing Inside Diameter Marks

○: 38.000~38.008 mm
 None: 38.009~38.016 mm

Mark portion: # 1~5

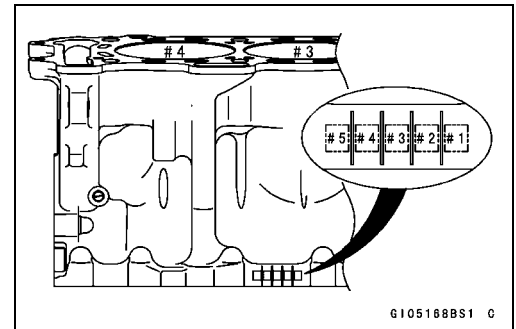

Crankshaft Main Journal Bushings

Color	Kit Bushing #1.5	Kit Bushing #2,3,4	Standard Bushing #1.5	Standard Bushing #2,3,4	Thickness
Blue	92139-0146	92139-0149	92139-0029	92139-0032	1.503~1.499 mm
Black	92139-0147	92139-0150	92139-0030	92139-0033	1.499~1.495 mm
Brown	92139-0148	92139-0151	92139-0031	92139-0034	1.495~1.483 mm

[A]: Color Mark

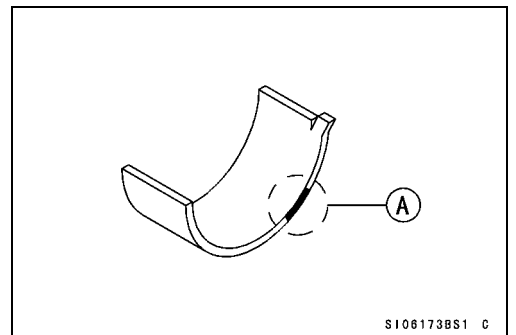

Crankshaft Main Journal Bushing Selection

Crankshaft	1	1	None	None
Crankcase	○	None	○	None
Crankshaft Main Journal Bushing	Brown	Black		Blue
Clearance (recommend)	10 ~ 34 μm	10 ~ 34 μm	10 ~ 34 μm	

NOTE

Make the clearances between the crankshaft main journals within the prescribed allowances. Excessive clearances will cause the oil pressure at the crankshaft main journals to drop and lead to the damage of the bearing.

Connecting Rod Bolts

1. Original Connecting Rod

Use the original connecting bolts and nuts.

Make recesses at both ends of the original connecting rod bolt to measure its length and determine the bolt stretch.

Connecting Rod : 13251 – 0019

Bolt : 92153 – 0491

92153 – 0809 (Spare Part : Attached Recess)

Nut : 92015 - 1311

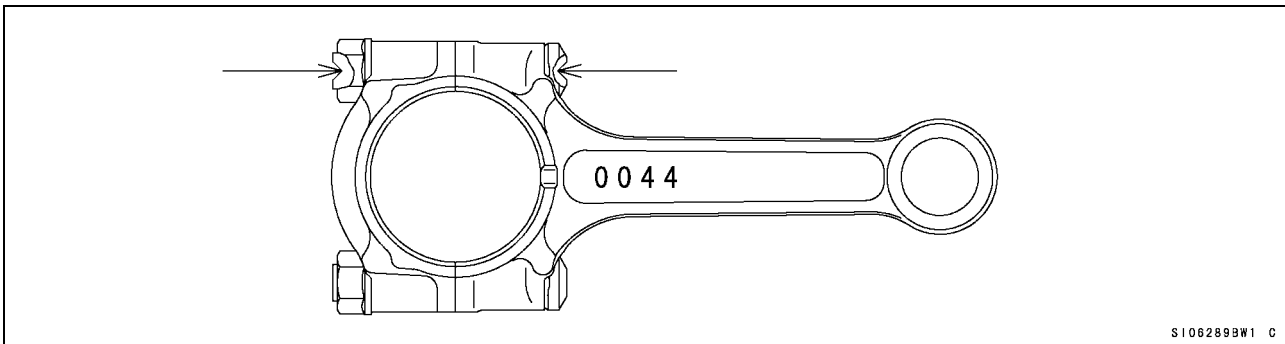

- Install the original bolts into the connecting rod.
- Before every tightening, use a point micrometer to measure the length of the bolts and record the values to find the bolt stretch.
- Apply a small amount of molybdenum disulfide grease to the threads and seating surfaces of nuts and bolts.
- Tighten the big end nuts at the torque (reference torque) of 20 N·m (2.0 kgf·m, 14.5 ft·lb).
- Check the length of the bolts and find the bolt stretch.

Bolt Length after tightening – Bolt Length before tightening = Stretch

Bolt Stretch

Usable Range: 0.32 mm (0.0126 in.) target

- Turn the big end nuts more until the bolt stretch reaches the usable range.

NOTE

Replace the original bolts with new ones if they have already been tightened up to usable range 2 times.

Replace the bolts with new ones if they are used for the engine with a not clear feature.

2. Kit Connecting Rod

Connecting Rod Bolt

Use the kit connecting rod bolts (with the original connecting rod bolts) and nuts.

The kit connecting rod can use the original connecting rod bolt (92153-0491).

When using the original connecting rod bolts, make recesses at both ends of the original connecting rod bolt to measure its length and determine the bolt stretch.

Connecting rod : 13251 – 0015

Bolt : 92153 – 0809 (Attached Recess)

Nut: 92015 - 1311

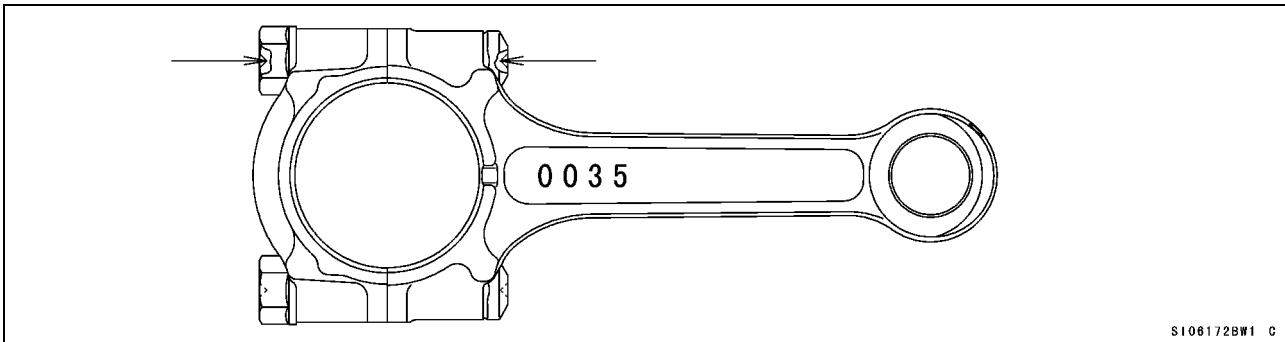

※Installation of the kit connecting rod bolt is same as installation of the original connecting rod bolt in the 1. original connecting rod section. Refer to the 1. original connecting rod section.

Connecting Rod Big End Bushings

The connecting rod bushing in the kit has improved its anti-seizure feature than standard one.

Connecting Rod Big End Bushing/Crankpin Clearance

※When adjust the clearance by measurement in case aiming the clearance 0.050 mm.

Crankpin Diameter Marks

○: 34.493~34.500 mm

None: 34.484~34.492 mm

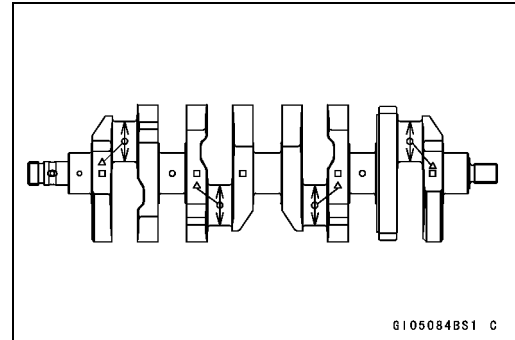

Connecting Rod Big End Bore Diameter Marks

○: 37.509~37.516 mm

None: 37.500~37.508 mm

[A]. Diameter Mark (○ or no mark)

[B]. Weight Mark (Alphabet, E, F et)

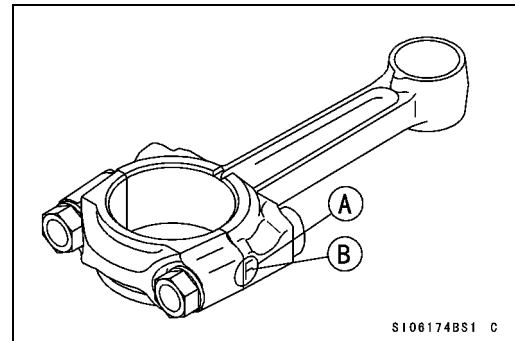

Connecting Rod Big End Bushings

Color	Kit Bushing Part Number	Thickness
Blue	92139-0109	1.488 ~ 1.493 mm
Black	92139-0110	1.483 ~ 1.488 mm
Brown	92139-0111	1.478 ~ 1.483 mm
Pink	92139-0156	1.473 ~ 1.478 mm

[A]. Color Mark

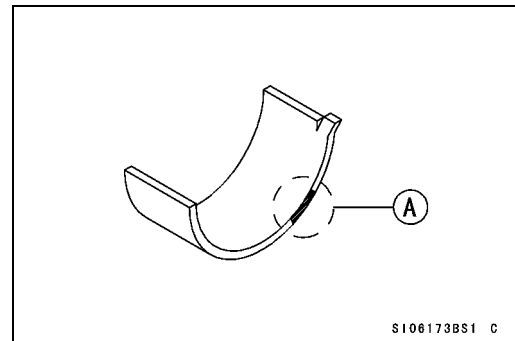

Big End Bushing Selection

Crankshaft	○	○	None	None
Connecting Rod	None	○	None	○
Bushing	Brown	Black		Blue
Clearance (recommend)	34 ~ 60 μm	32 ~ 58 μm		30 ~ 56 μm

※ Use the pink bushings when the clearances cannot adjusted within the prescribed allowances even if the brown bushings are used.

NOTE

Make the clearances between the connecting rod big ends within the prescribed allowances. Excessive clearances will cause the oil pressure at the connecting rod big end to drop and lead to the damage of the bearing.

Clutch Adjustment (Back-Torque Limiter Setting)

The Ninja ZX-10R engine is equipped with the Kawasaki back-torque limiter mechanism in the clutch. The back-torque limiter works to reduce the chance of rear wheel hop caused by engine braking during hard braking and down shifting. The back-torque limiter operating condition can be changed by changing the total thickness of clutch plates and changing the number of leaf springs. Try different settings and select the best.

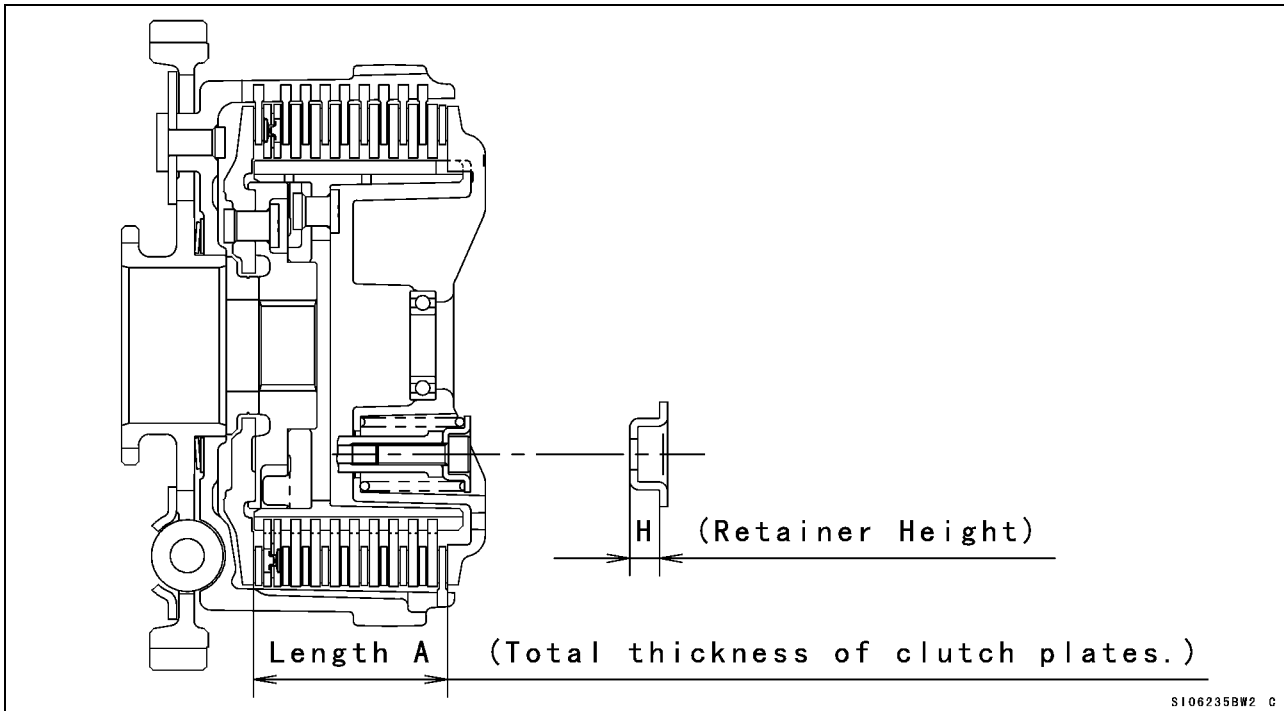

- The standard setting of length [A], total thickness of clutch plates shown below, becomes about 53.5 mm (t 2.9 × 7 pcs. + t 2.6 × 2 pcs.). For this setting the effective stroke of clutch spring plate during the back-torque limiter operation is adjusted between 0.45 and 0.75 mm.

By increasing the effective stroke the back-torque limiter causes more slip. The effective stroke increases by decreasing the length [A]. The length [A] between 51.9 and 53.5 mm is available by changing the combination of the steel plates. Replace one steel plate with a thinner one and try the setting. If the operation of the back-torque limiter is not enough replace other steel plates one by one.

Thickness (mm)	Part Number
1.6	13089-0005
2.3	13089-0008 (STD)
2.6	13089-0009 (STD)
2.9	13089-1093 (STD)

※ The steel plate (t 1.6 13089-0005) is the standard part for ZX-6RR.

When decreasing the length [A], total thickness of clutch plates, use the kit spring retainers (provided as optional production parts) to keep the preload of clutch springs according to the table below.

Length [A]	Part Number	Height [H]
53.0 ~ 53.5 mm	13091-1840	8 mm
52.5 ~ 52.9 mm	13091-1041 + Washer (92022-304)	7 mm (6 mm + 1 mm)
51.9 ~ 52.4 mm	13091-1041	6 mm

※ Washer (92022-304) = Outside Dia. 11 mm
 Inside Dia. 6.2 mm
 Thickness 1.0 mm

- ※ If you have clutch slip during acceleration use shorter spring retainers by one size to increase preload of clutch springs.
- The original springs and retainers can be used if the length [A] is between 51.9 ~ 53.5 mm.
- For precise setting the measurement of the effective stroke of clutch spring plate is recommended.
 - Remove oil from clutch plates.
 - Hold an extra drive shaft in a vise and install the following clutch parts on the shaft.

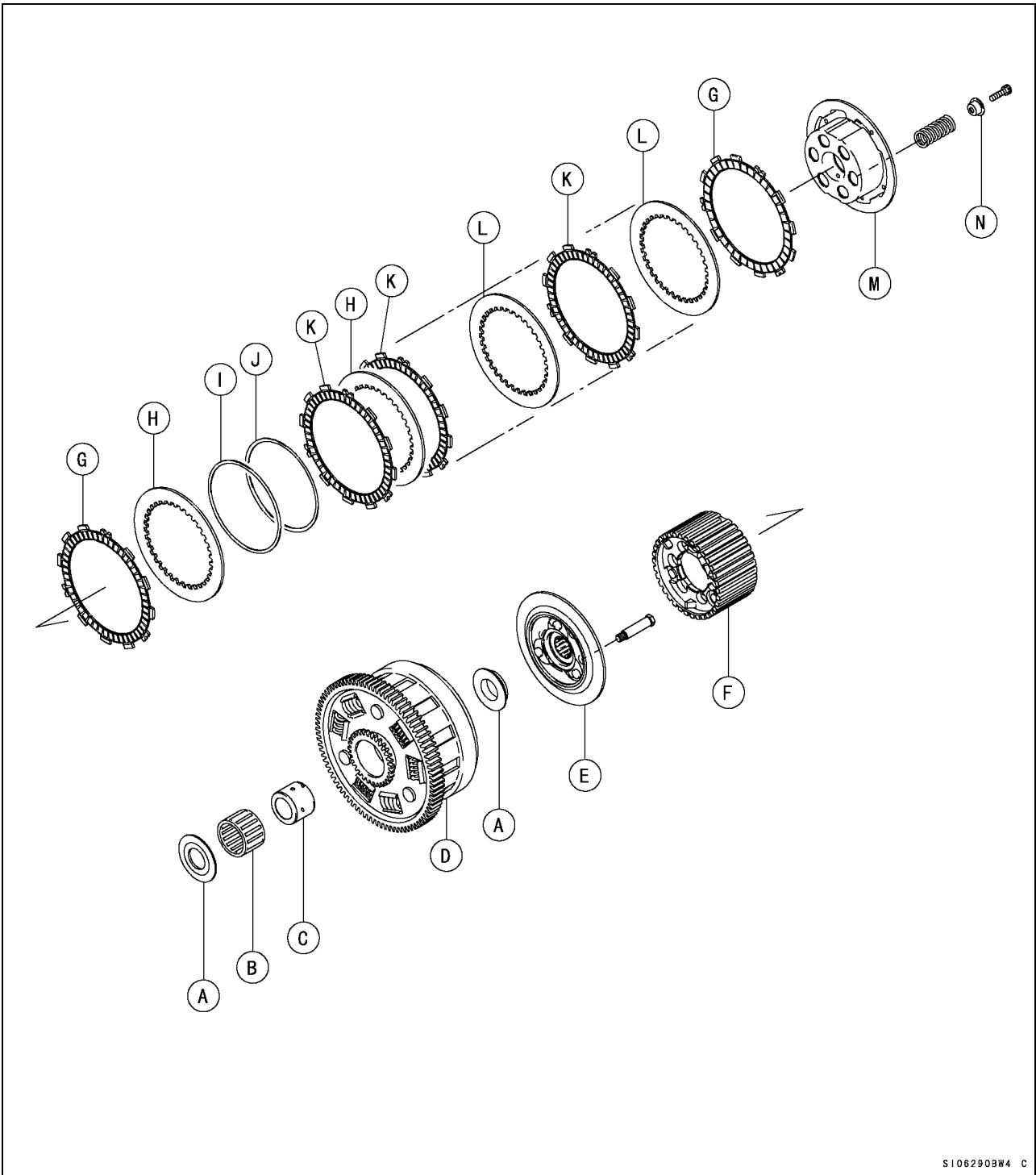

S1062903W4 C

- | | |
|--------------------|--------------------------------|
| [A] Spacers | [G] Friction Plates (48 Slots) |
| [B] Needle Bearing | [H] Steel Plates (t 2.6 mm) |
| [C] Bushing | [I] Washer |
| [D] Clutch Housing | [J] Spring |
| [E] Clutch Hub | [K] Friction Plates (36 Slots) |
| [F] Sub Clutch Hub | [L] Steel Plates (t 2.9 mm) |
| | [M] Spring Plate |
| | [N] Spring Retainer |

- Engage the cam followers (Clutch Hub) with the cams (Sub Clutch Hub).
 - To measure the effective stroke of clutch spring plate, set a dial gauge [A] against the raised center [B] of the clutch spring plate.
 - Move the clutch housing gear back and forth [C]. The difference between the highest and lowest gauge readings is the amount of the effective stroke of clutch spring plate.
- [D] Drive Shaft

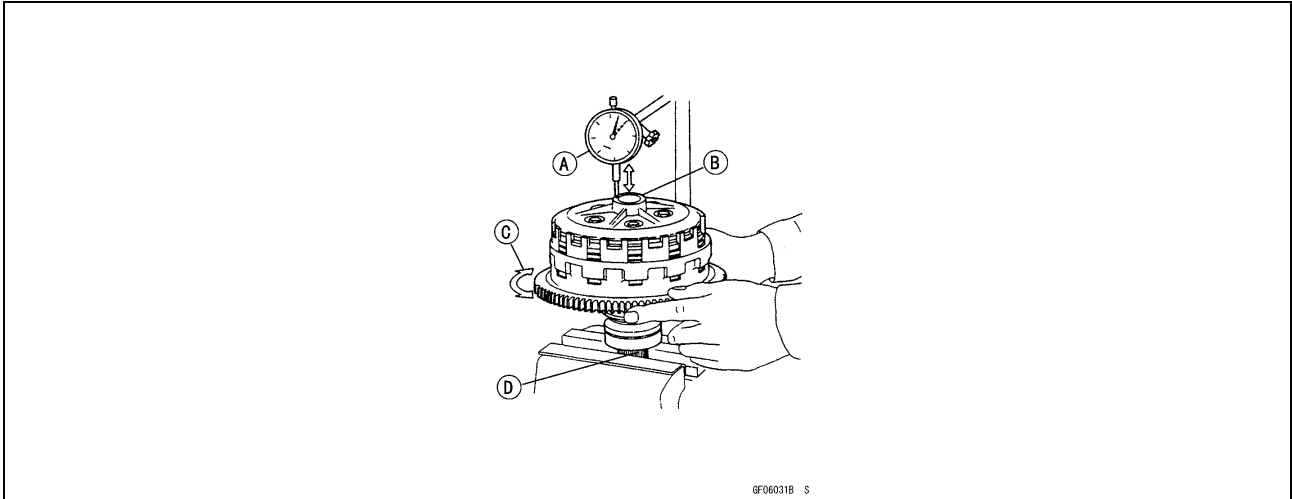

- After installing the clutch to the engine, measure and record the depth [B] shown below, the length from the clutch spring plate to the top surface of the sub clutch hub, using a caliper or a depth gauge. Manage the depth [B] to adjust the effective stroke after that, because the friction disks would be worn and the length [A] would change. The decrease of the depth [B] from the initial setting shows the increase of the effective stroke of clutch spring plate from the value initially measured.

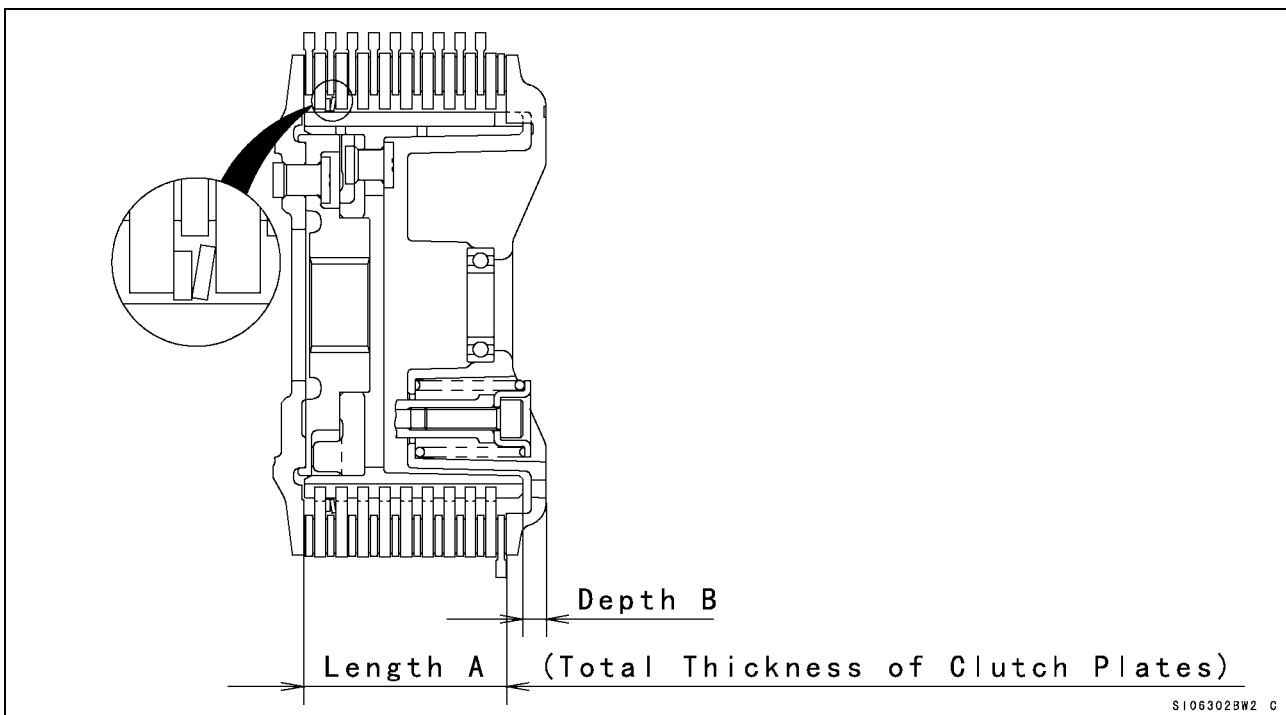

Spring Plate Assembly

The spring plate assembly are available for increase the spring constant. When outbreak the starting judder, use the spring plate assembly of the kit parts. Whenever the plate thickness is difference for adjusting the clutch plate, take care the length [A].

Part Number	Spring Constant	ID Color
13089-0003	2004 ~ 2005 ZX-10R (Standard)	None
13089-0011	40 % up comparison standard	White
13089-0012	60 % up comparison standard	Blue

※Identification Color: The ID marks are on the springs between the steel plates.

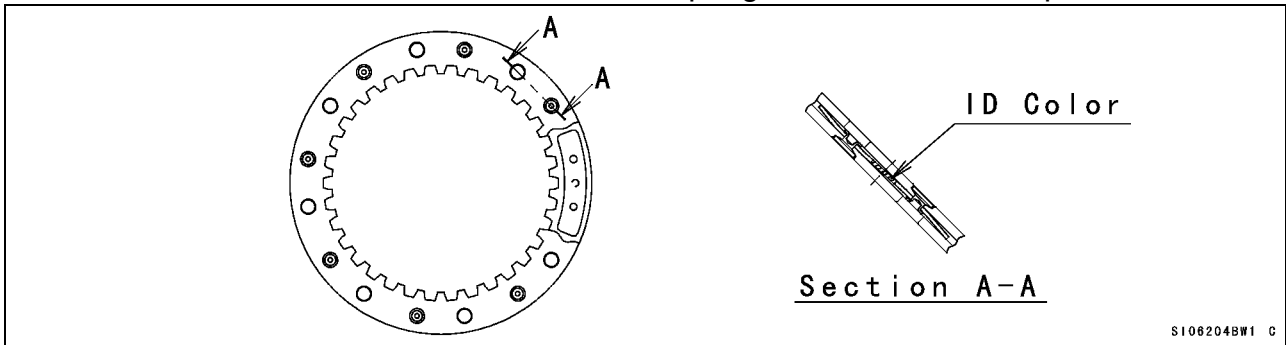

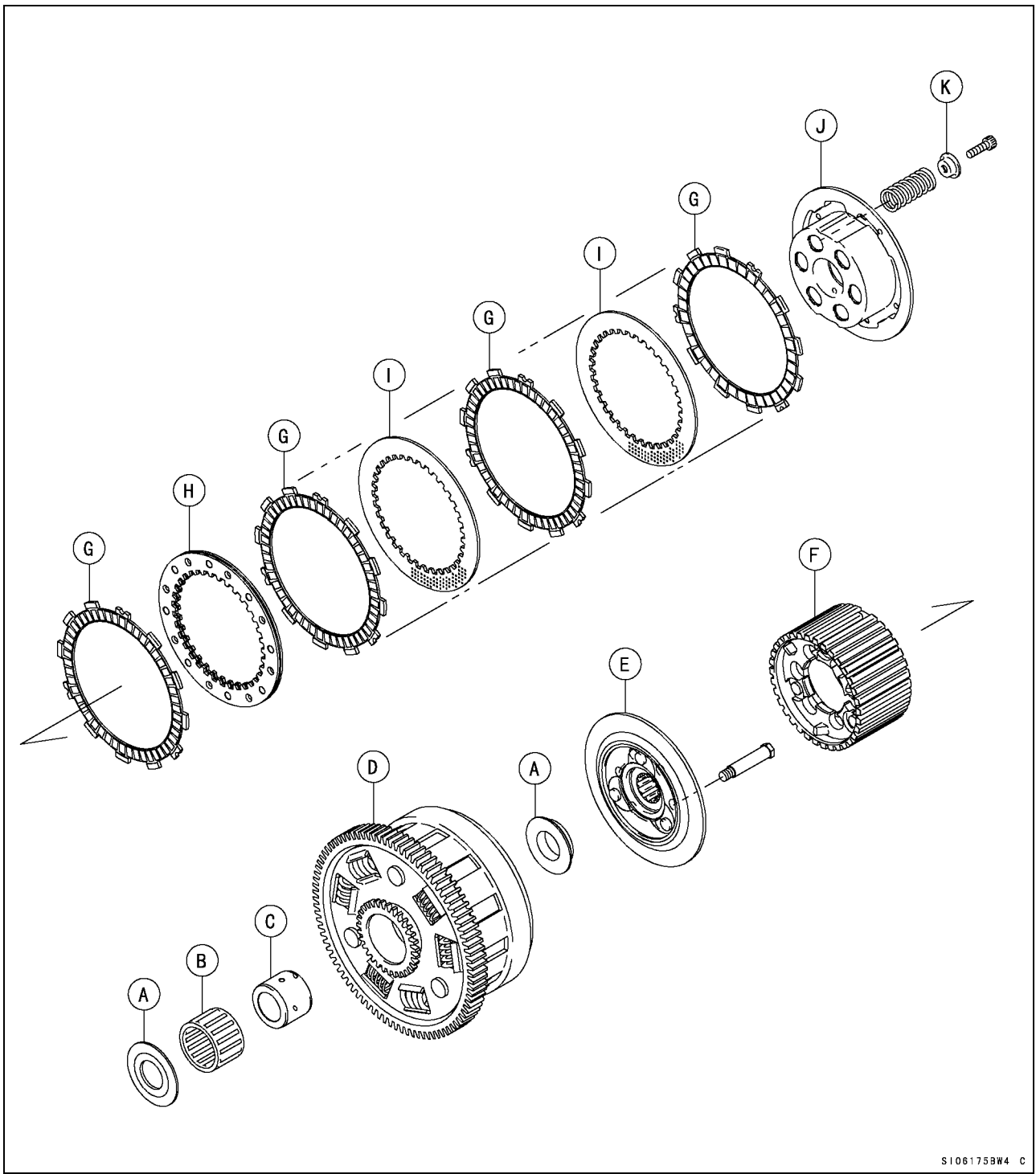

S1061759W4 C

- [A] Spacers
- [B] Needle Bearing
- [C] Bushing
- [D] Clutch Housing
- [E] Clutch Hub
- [F] Sub Clutch Hub

- [G] Friction Plates
- [H] Spring Plate Assembly
- [I] Steel Plates
- [J] Spring Plate
- [K] Spring Retainer

Transmission

- Type B ~ D of the kit gears are available of the 2006 model ZX-10R. To change the gear ratios with combination the gears.
- Remove the three steel balls (600A0500) from the output shaft assembly. This is done to start easily the engine with the second gear.
- Replace the circlips with new ones if they were removed.

Transmission Shimming

By using washers with various thickness, keep the axial clearance between 0.3 mm and 0.4 mm, to prevent the inclination of gears and to keep smooth gear-shifting.

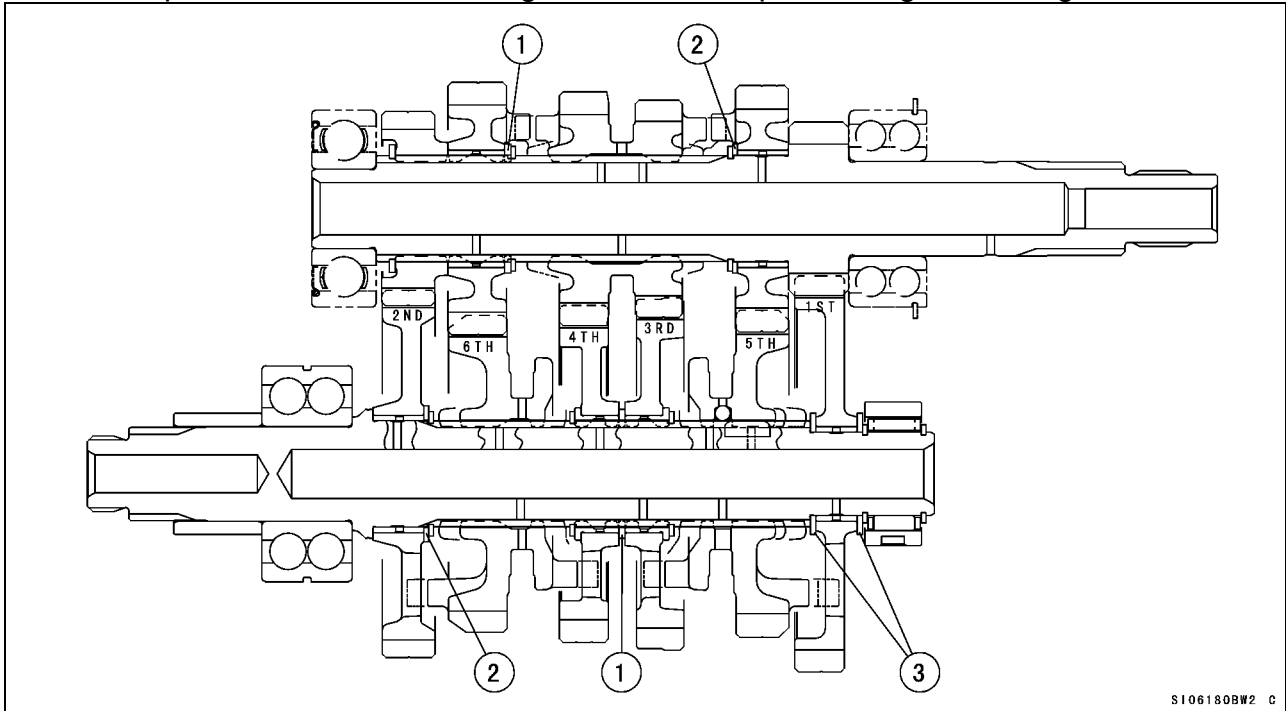

	Thickness (mm)	Part No.	Remarks
① Spline washer	1.2	92200-0229	Kit
	1.4	92200-0230	Kit
	1.6	92200-0050	Original
	1.8	92200-0231	Kit
	2.0	92200-0232	Kit
② Plane washer A	0.8	92200-0225	Kit
	1.0	92200-0226	Kit
	1.2	92200-0051	Original
	1.4	92200-0227	Kit
	1.6	92200-0228	Kit
③ Plane washer B	1.4	92200-0138	Original

Use the type B ~ D input shafts with the shim adjustment since their sizes are, different from the standard shaft, designed taking the shim adjustment into account in order to make the dog lengths of the 3rd – 5th & 2nd – 6th gear dogs equal. Adjust the dog length of each gears to smooth gear-shifting.

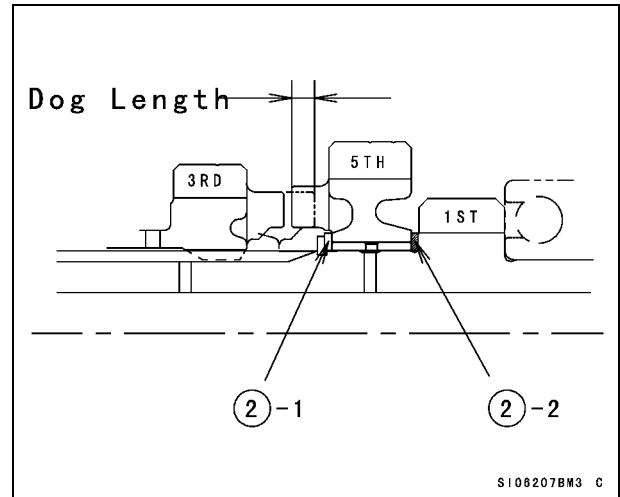
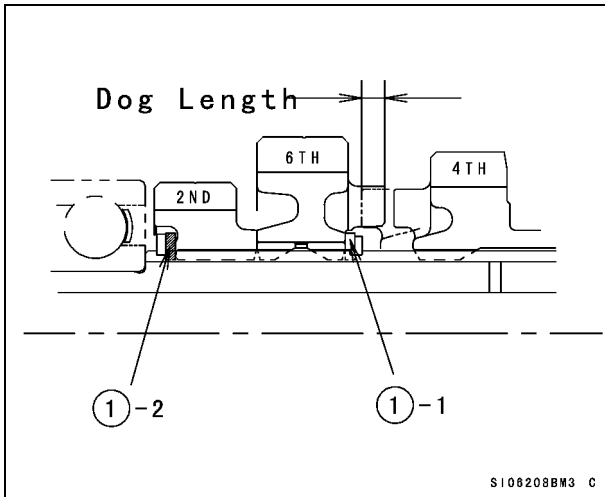

Standard Adjusting

- ①-2 Use the standard spline washer t1.6 mm (92200-0050)
- ②-2 Use the standard spline washer t1.2 mm (92200-0051)

When thin the washer of ①-1 (②-1) from the standard washer and thickly the washer of ①-2 (②-2) from the standard washer to increase the dog length of gears also reverse the combination to reduced the dog length of gear.

Alternator

Racing kit of the 2006 model ZX-10R are available the alternator. To quicken response by reducing the flywheel mass and to reduce the weight, use the kit alternator. Also use the kit alternator improve the engine ability

Kit Alternator Rated Output

10 A @ 8 000 rpm (original: 30 A @ 5 000 rpm)

※ Effective current 7~8 A for running the race method vehicle.

- Select and use the kit alternator or original alternator for racing conditions.

1. Kit Alternator Installation

When using the kit alternator, remove the related parts of the original alternator, and changing the around parts of the starter from original parts to kit parts. Install the kit alternator as shown in the illustration.

Used Parts Table

	Part Name	Part No.	Remark
1	Cover	14031-0063	Kit
2	Rotor	21007-0083	21001-0042
3	Stator	21003-0044	
4	Washer	92200-0306	Kit
5	Bolt	92153-0386	Kit
6	Bolt	92151-1546	Kit
7	Bolt	92150-1717	Original

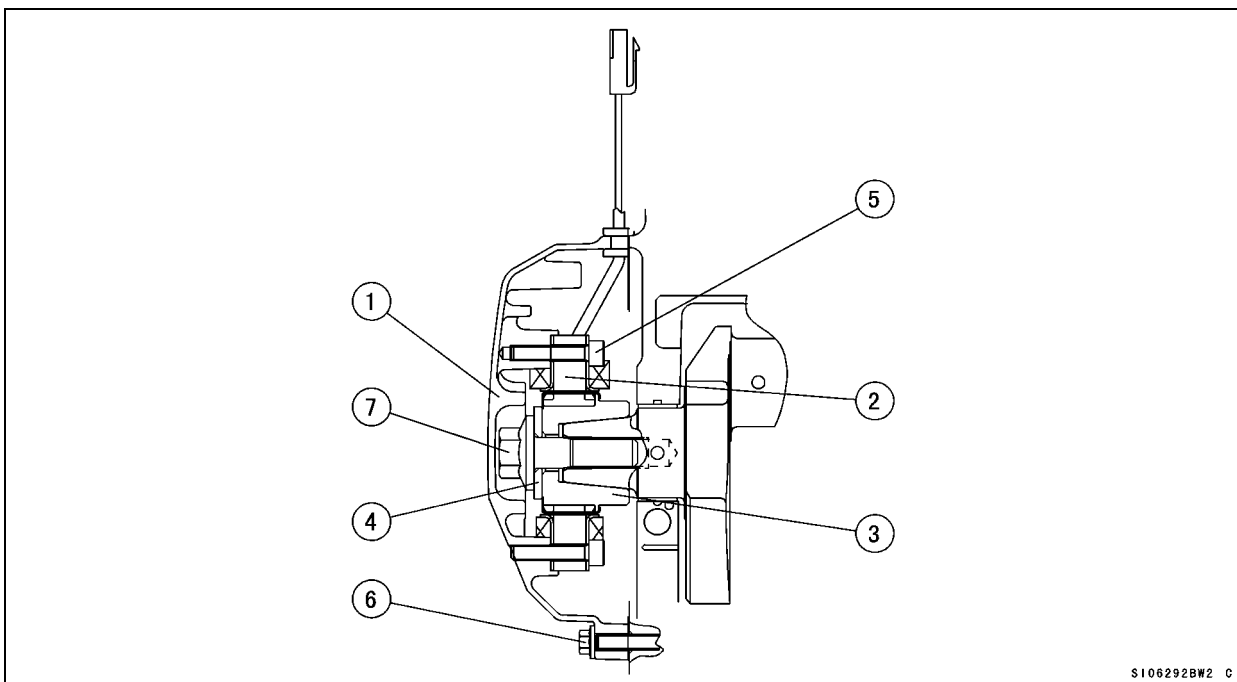

S106292BW2 C

Stator Installation

The stator is fixed to the cover (14031-0063) by the bolts.

Run the alternator lead from the inside of the cover as shown in the illustration.

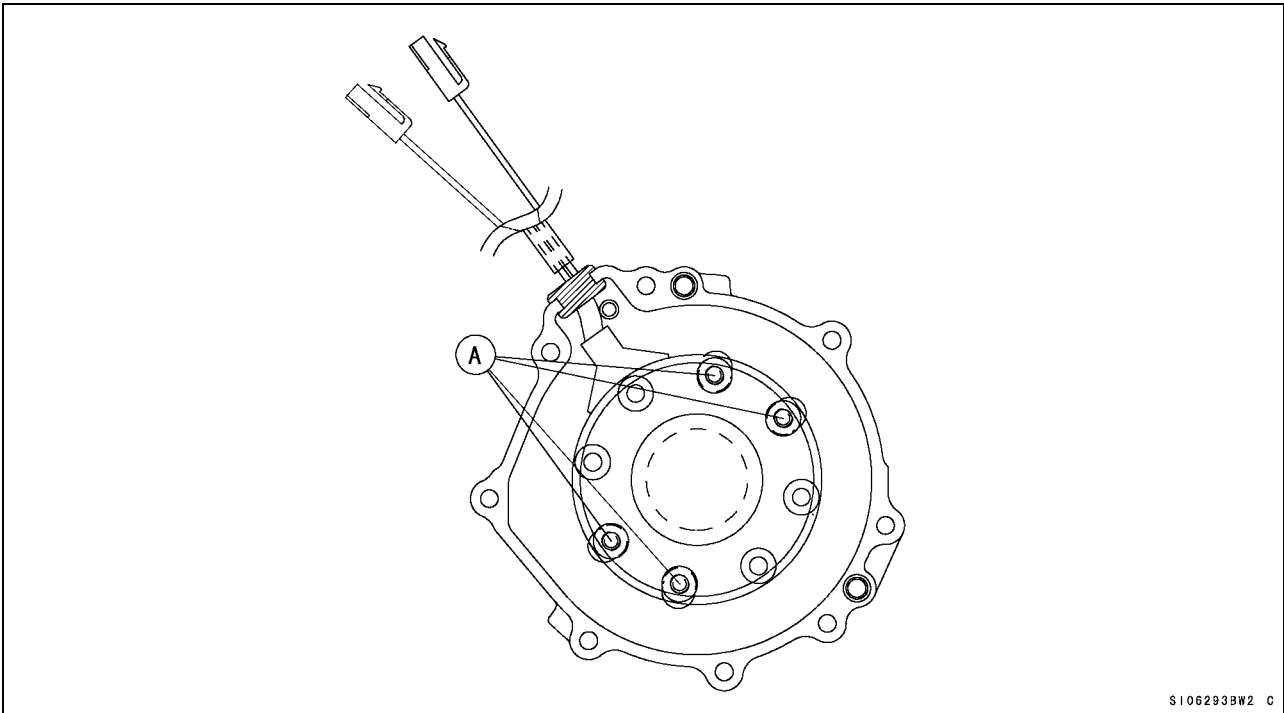

S106293BW2 C

A. Fix the stator to the cover by the bolts.

Regulator Installation

Use the kit alternator and the kit regulator (21066-0010) as a set. Install the kit regulator same position of the original regulator. Connect the kit sub harness (26031-0323) between the kit regulator and the kit alternator.

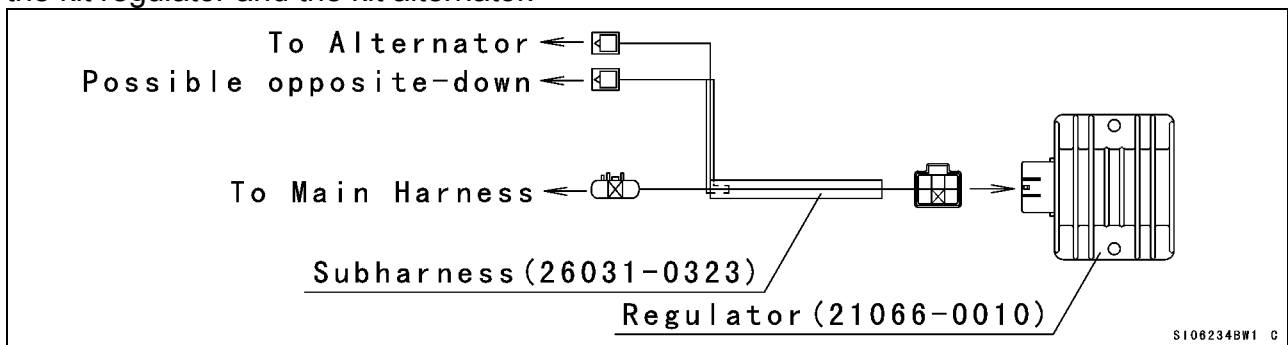

S106234BW1 C

2. In case of without Starter Motor

※ Refer to the illustration of 1. Kit Alternator Installation.

Remove the related parts of the starter motor and insert the plugs to the hole of the starter motor inserted as shown in the illustration.

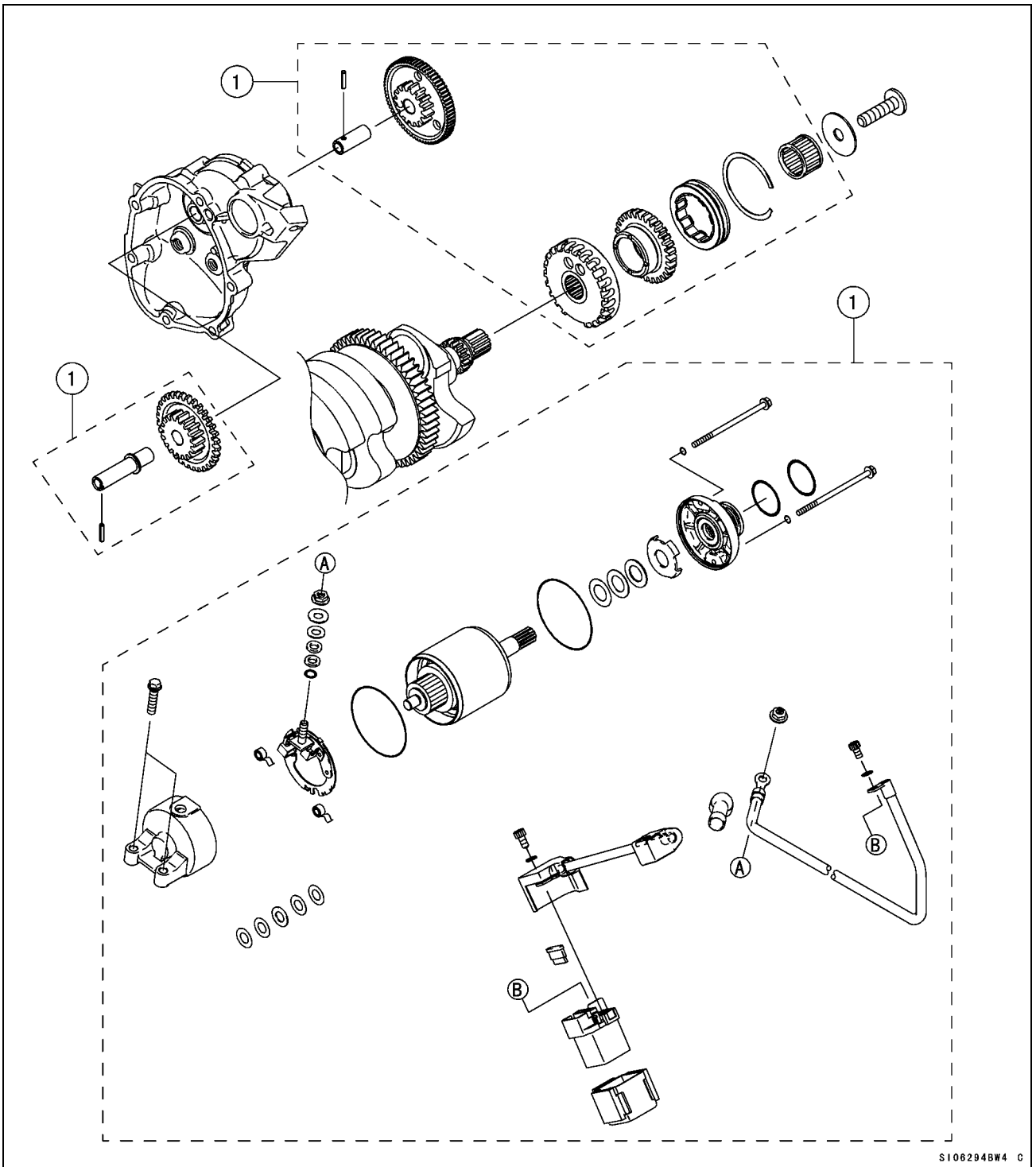

S106294BW4 C

1. Remove the parts.

	Part Name	Part No.	Remark
1	Plug	92066-1332	Kit
2	Plug	92066-1333	Kit
3	O-ring	92055-1262	Kit
4	Bolt	130G0625	Kit
5	Nut	312B0600	Kit

- Calk the bolt for unplug the plug.
- Insert the plug into the hole of the starter motor and tighten the nut.
- Apply liquid gasket.

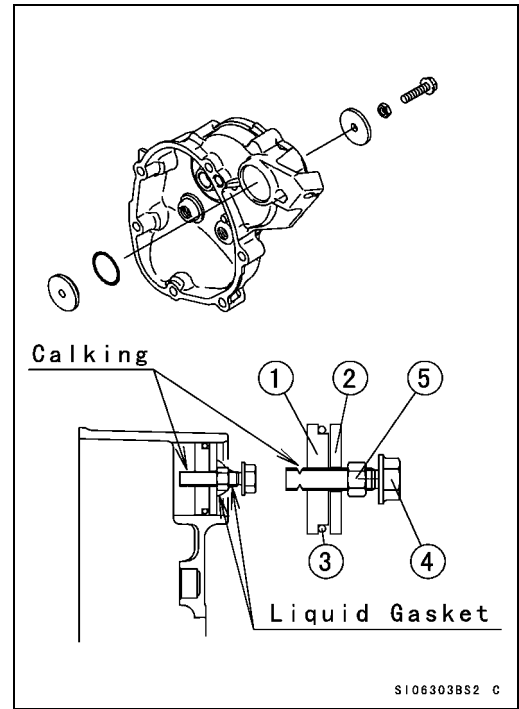

- Replace the pulsing rotor with the kit rotor (21007-0085).
 1. Rotor: 21007-0085 (Kit)
 2. Collar: 92143-1291 (Kit)
 3. Washer: 92200-0238 (Original)
 4. Bolt: 92153-1521 (Original)

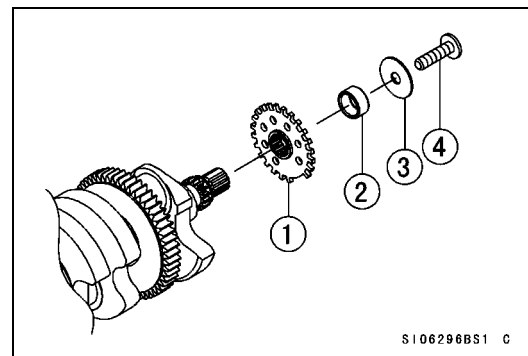

Water Temperature Sensor

The original water temperature sensor installed in the cylinder head must remain and connected to the main harness because the electronic control unit (E.C.U.) needs the output signal from the original water temperature sensor.

Radiator (Kit)

2006 model ZX-10R racing kit provides the sub radiator (39060-0030) to improved the cooling function.

Radiator Installation

Sub Radiator

- Cut the brackets at the bottom of the main radiator.

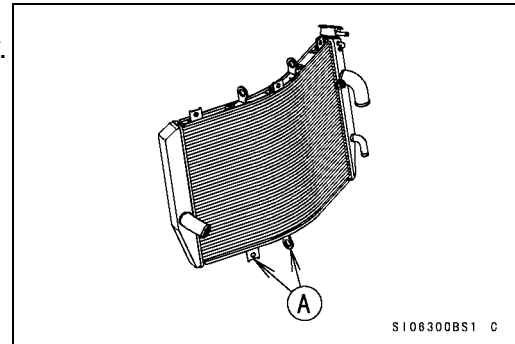

A. Cut the brackets.

- Install the sub radiator stays as shown in the illustration.
 - Fix the center kit stay (35063-0316) on the crankcase by the bolt.
 - Fix the right side kit stay (35063-0317) on the starter cover [A] by the bolt.
 - Fix the left side kit stay (35063-0318) on the alternator cover [B] by the bolts.
- ※ If the stay contacts to the around parts, grind the stay to prevent the contact.
- ※ As some stays may not be able to install according to the applied muffler, remodel the stay or make suitable one by your owe.

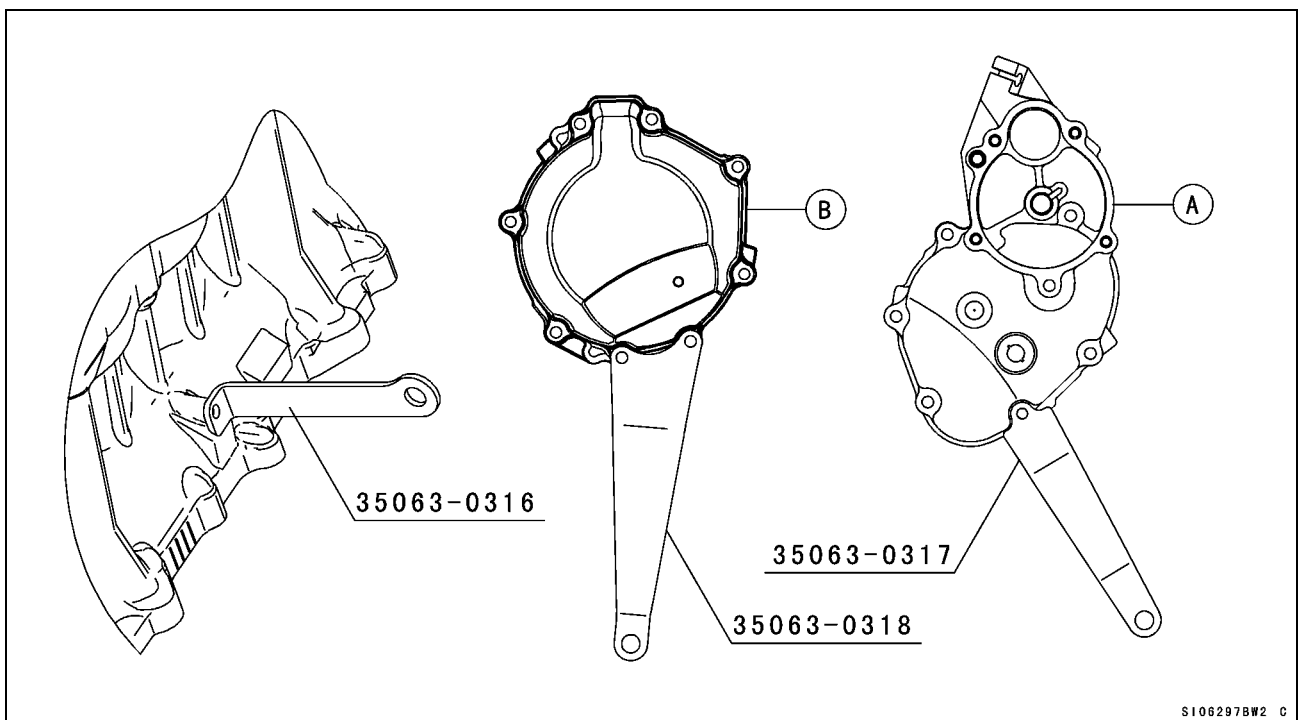

- Connect the main radiator and sub radiator with the brackets (11054-0459).
Fix the brackets (11054-0459) on the sub radiator by the bolts (130L0612).

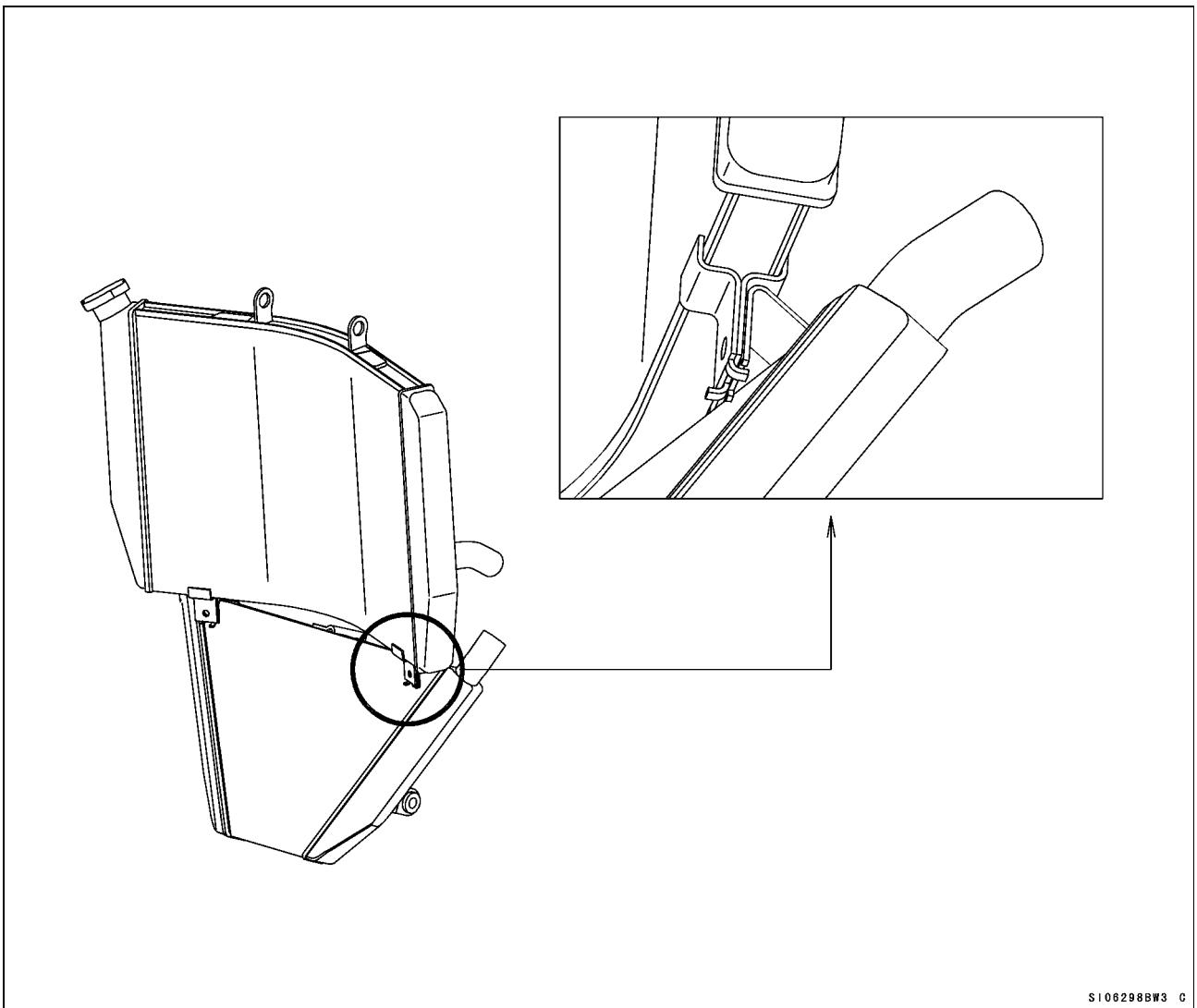

- Fix a wire netting in front of sub radiator for prevent the fin damages due to the stepping stone.
- Machine the original cowl to meet the outline of radiator.
- Fill the space between the cowl and the sides of radiator by fixing a sponge or the like.

NOTE

After radiator's installation, be sure to check that there is no interference between the radiator and the manifold, tire and the front fork full bottomed.

Water Pipe Installation

Use the main radiator only.

- Divide the original water hose (39062-0109) between the cylinder head and the radiator and insert the water pipe (39192-0011).
- Install the kit water temperature sensor (for water temperature gauge of kit meter, 21176-1099) to the kit water pipe.
- Pinch the terminal of the kit water temperature sensor ground lead (26011-0071) between the water hose and the kit water pipe and clamp it on the hose as shown in the illustration. Install the other side terminal of the ground lead with the crankshaft sensor cover by the bolt.

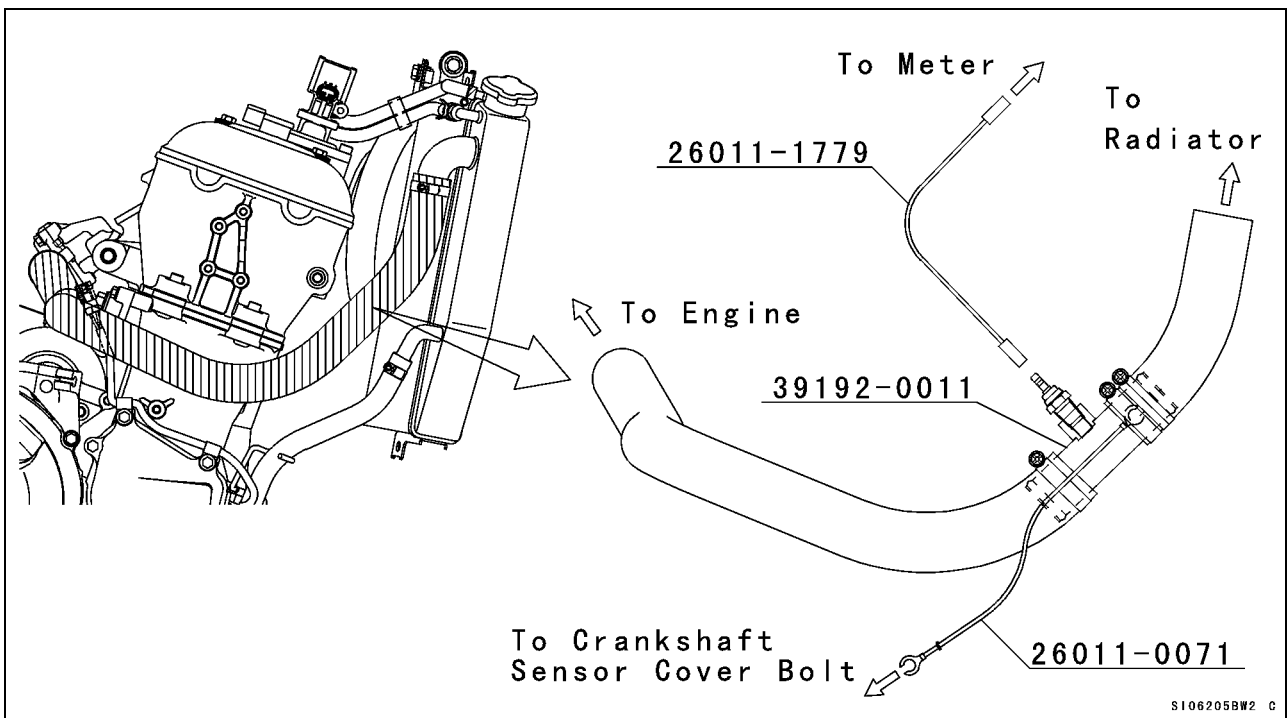

Water Outlet of Radiator Body

Same situation of the original radiator.

Use the kit sub radiator with the main radiator.

Water Inlet of Radiator Body

- Divide the original water hose (39062-0109) between the cylinder head and the radiator and insert the water pipe (39192-0039).
- Install the kit water temperature sensor (for water temperature gauge of kit meter, 21176-1099) to the kit water pipe.
- Pinch the terminal of the kit water temperature sensor ground lead (26011-0071) between the water hose and the kit water pipe and clamp it on the hose as shown in the illustration. Install the other side terminal of the ground lead with the crankshaft sensor cover.

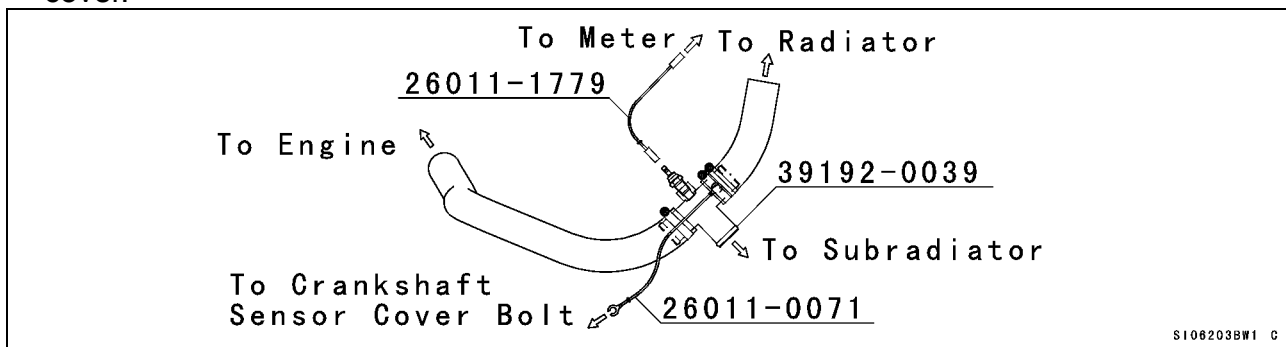

Water Outlet of Main Radiator

Remove the original water pipe (39192-0029) and install the kit water pipe (39192-0038). Install the kit water hose (39062-1072) between the water pipe and the kit sub radiator.

Reserve tank Installation

When using the radiator (Kit), the original reserve tank cannot be used. Prepare a suitable substitute reserve tank.

Reserve Tank should be equipped with a band so as not to affect the running and the handling.

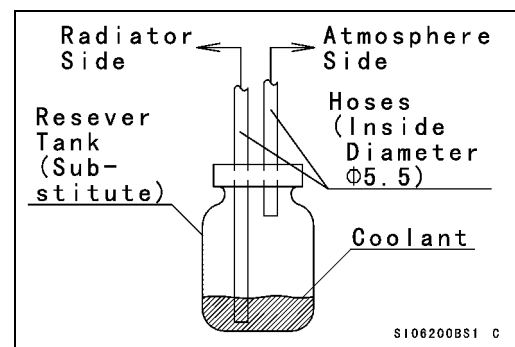

NOTE

Capacity of a reserve tank should be more than 200 cc.

Position of the hose to a reserve tank.

* End of the hose to the radiator should be always in the coolant.

* End of the hose to atmosphere should be always beyond the coolant surface.

Oil Catch Tank (Kit)

Use the oil catch tank for the engine blowby gas.

Oil Catch Tank: 52001-0002

Tank Capacity: Approximately 570 cc

Oil Catch Tank Installation

- Install the mounting bracket (11054-0455) with regulator under the cross pipe of the frame by the bolts (use the original regulator mounting bolts).
- Install the oil catch tank to the bracket as shown in the illustration.
Used Bolts: 132L0608 (x2)
- After installing the oil catch tank, make sure not to interface with the drive chain, swingarm (suspension at fully bottomed).
- Close the boss of oil drain of the oil catch tank with M6 bolt and washer (92022-304), add the wiring not to be missing.

Oil Catch Tank Hose Installation

1	92192-0226	Crankcase to oil catch tank
2	92192-0227	Oil catch tank to air cleaner

- Remove the original breather hose (92192-0237).
- Install the hose clamps so that the kit clamps (92171-0338) are catch tank side and the original clamps (92171-0391) are other side on the hoses.
- Run the hoses as shown in the illustration.

NOTE

Protect the hose and check the no blockade at the its curved part when the hose is afraid of interfering with edge part on the way of the hose routing. Specially, about the hose toward the crankcase, check the no blockage by the fuel pump.

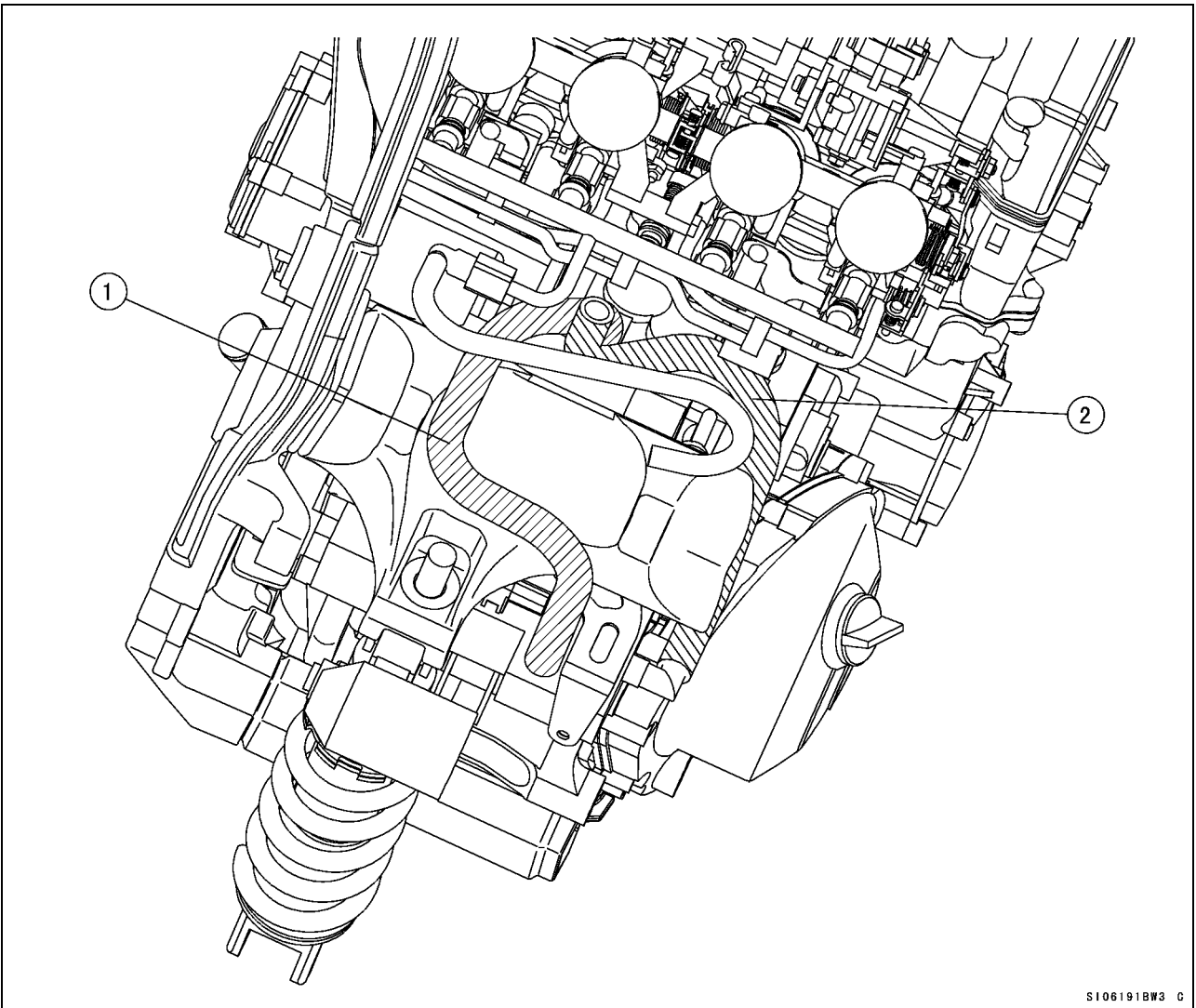
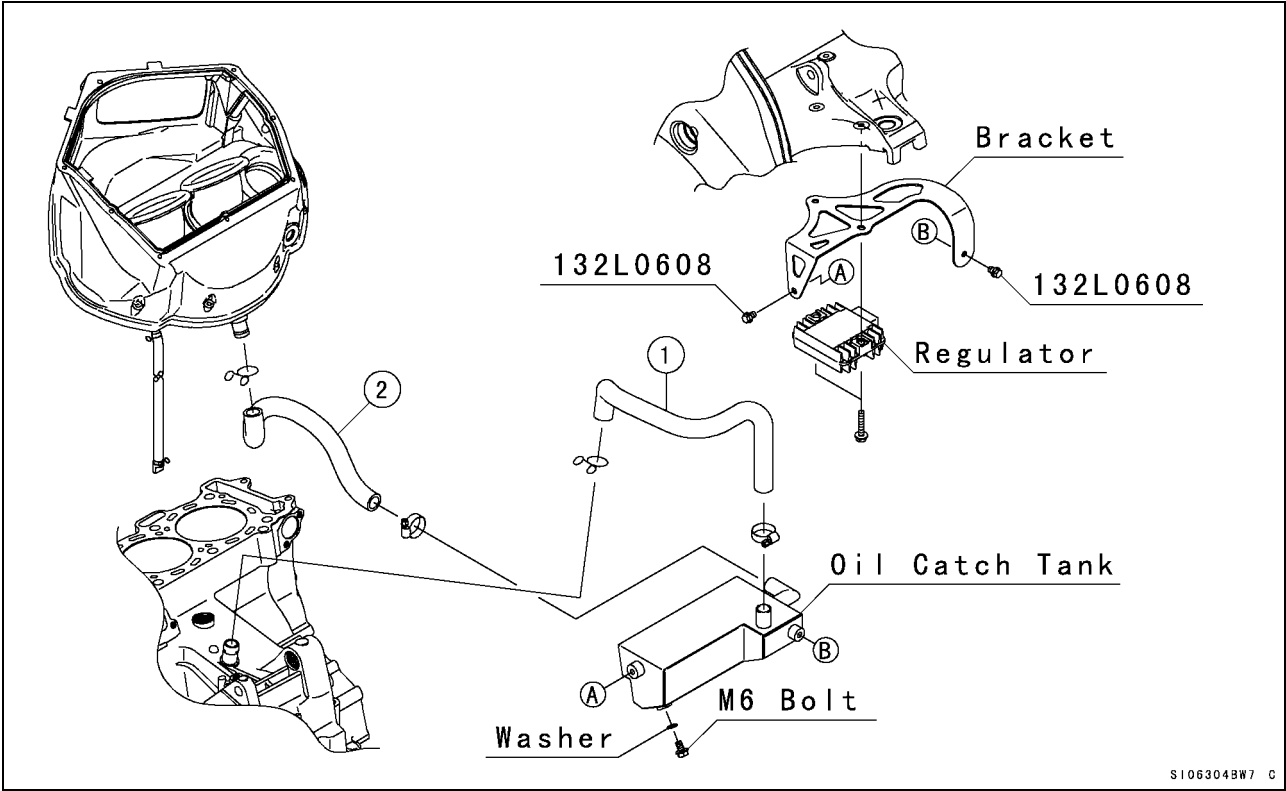

Cover Gaskets (Kit)

The kit cover gasket are available of the 2006 model ZX-10R.

They are made from “metal-foam” and made easy to separate.

Starter Clutch Cover:	11061-0230
Idle Gear Cover:	11061-0229
Clutch Cover:	11061-0232
Oil Pan:	11061-0233
Alternator Cover:	11061-0231

ECU (Kit)

The 2006 model ZX-10R kit ECU has following functions. Refer to the **Kawasaki FI Calibration Tool Instruction manual** for the ECU function set up method.

1. Auto Shift Functions

Be sure use the point type sensor.

Recommended: **Dynojet** mode or **Battle Factory** mode

Part installation is refer to the Electrical Part Installation section in this Manual.

2. Pit Road Engine Revolution Limit Functions

ON/Off Changing Switch Part Number: 27010-0040 (use the kit meter)

Part installation is refer to the Electrical Part Installation section in this Manual.

3. Shift Indicator Functions

Part installation is refer to the Electrical Part Installation section in this Manual.

NOTE

When using the original meter, lit the shift up indicator light so that the shift up indicator lamp of the kit does not used.

Use the shift up indicator lamp of the kit together with the kit meter but do not function as the FI indicator light.

Frame Parts Installation

Throttle Parts (Kit Parts)

The following throttle cases, grip and reels are available as kit parts. These kit parts quicken throttle response to the twist grip.

1) Throttle Case

Parts	P/No.
Throttle Case, Upper	32099-0004
Throttle Case, Lower	32099-0005
Bolts (2)	120S0625
Grip, Right	46075-1143

2) Throttle Reels

Two types are available.

P/No.	I.D. Mark	Twist Grip Turn Angle to Full Throttle
59101-0001	R21.5	60°
59101-0002	R20.0	65°

Throttle Reel Travel Angle.....Effective angle excluding throttle cable free play.

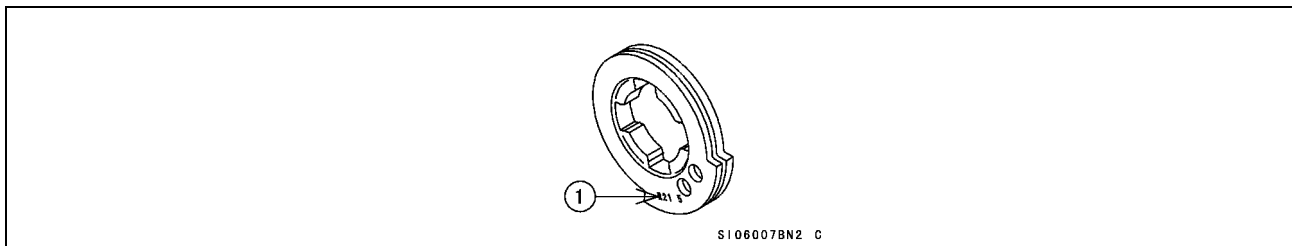

1. Identification Mark

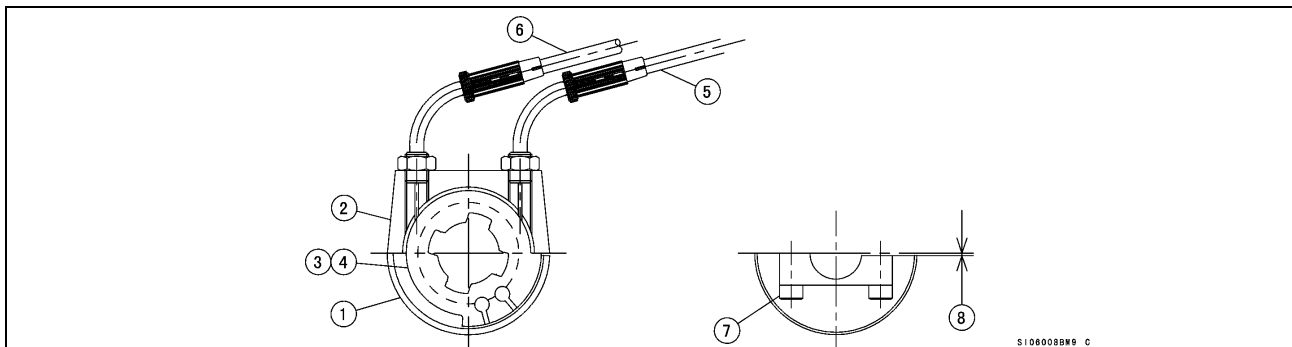

1. Upper Case: 32099-0004
2. Lower Case: 32099-0005
3. Reel, 60°: 59101-0001
4. Reel, 65°: 59101-0002
5. Throttle Cable, Acceleration: 54012-0185
6. Throttle Cable, Deceleration: 54012-0186
7. Bolt: 120S0625
8. Install the upper case and lower case which mating clearance backward.

Final Drive Parts (Kit Parts)

1) Drive Chain

#520 Joint endless drive chain is available as an kit parts.

2) Chain Guard

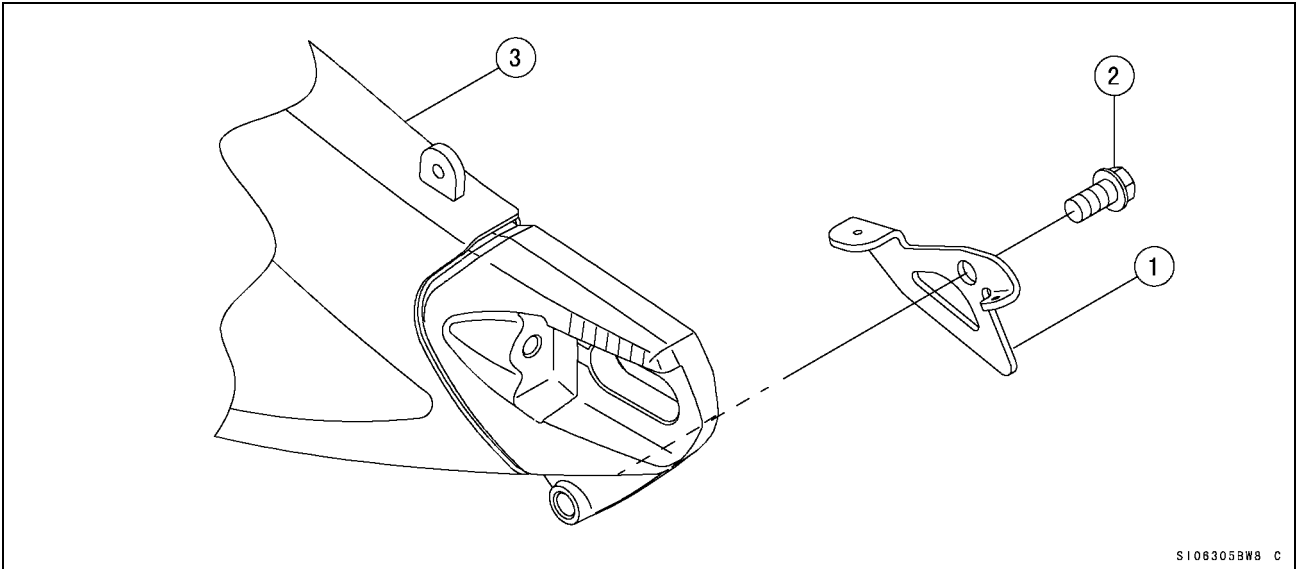

1. Guard: 55020-0236
2. Bolt: 130J1020
3. Swingarm (Left Side)

Brake Pads (Kit Parts)

The front and rear brake pads for racing use are available. The front pads are for higher braking force, and the rear pads are for higher braking force.

Front Brake Pads

P/No.	Mark	Braking Force
43082-0005	F9633	High
Original	C93YT	↕
43082-1293 (ZX-6RR Original)	C93ZM	Low

NOTE

Removing the plate (13271-0365) from original front brake pads of ZX-10R is permissible.

Rear Brake Pads

P/No.	Mark	Braking Force
Original	FO GG	High
43082-1220	C93G	↕
43082-1192	C93	Low

Seat Height Adjustment

- Loosen the nut (1) and insert the spacer (2) as required.
- Tighten the nut (1) to 59 N·m (6.0 kgf·m, 43 ft·lb) of torque.
- When changing the seat height, adjust the spring preload of the rear shock absorber.
As the rear suspension tends to be softer when raising the seat height with the adjusting spacer of the seat height applied, adjust the spring preload of the rear shock absorber as required.
One turn of the spring adjusting nut changes the spring length by 1.5 mm.

Seat Height Adjustment

Spacer Set: 92026-0057

- 1. Nut
- 2. Spacer
- 3. Collar
- 4. Bracket

P/No.	Quantity	Thickness
92026-1582	1	1.0 mm
92026-1583	1	2.0 mm
92026-1584	1	3.2 mm
92026-1585	2	4.5 mm
11053-1276	1	—

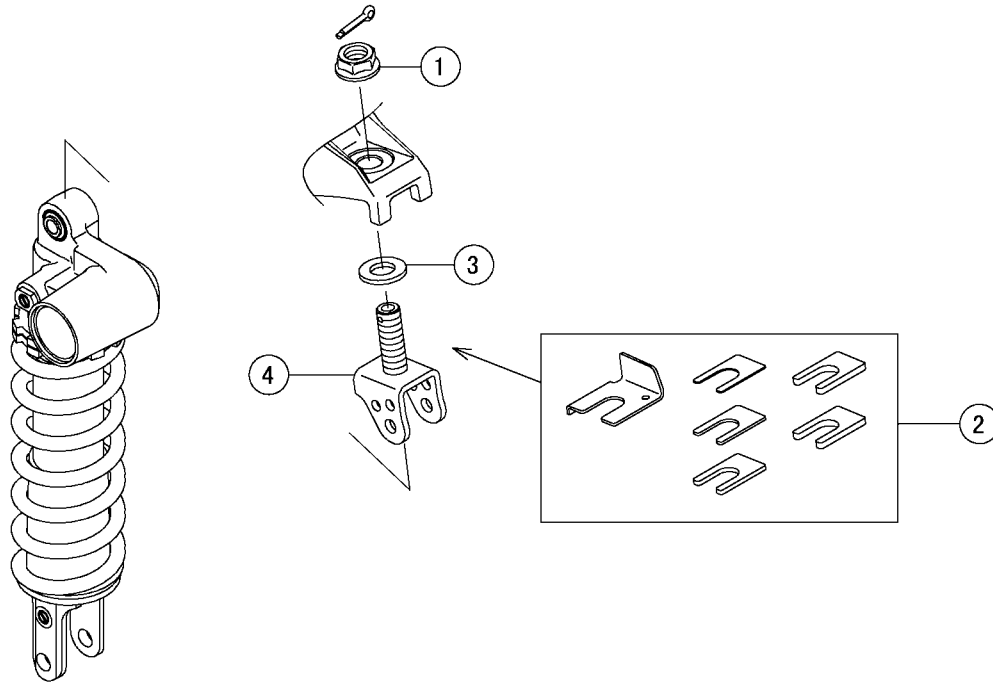

Spacer for seat height adjust
insert between collar and bracket.

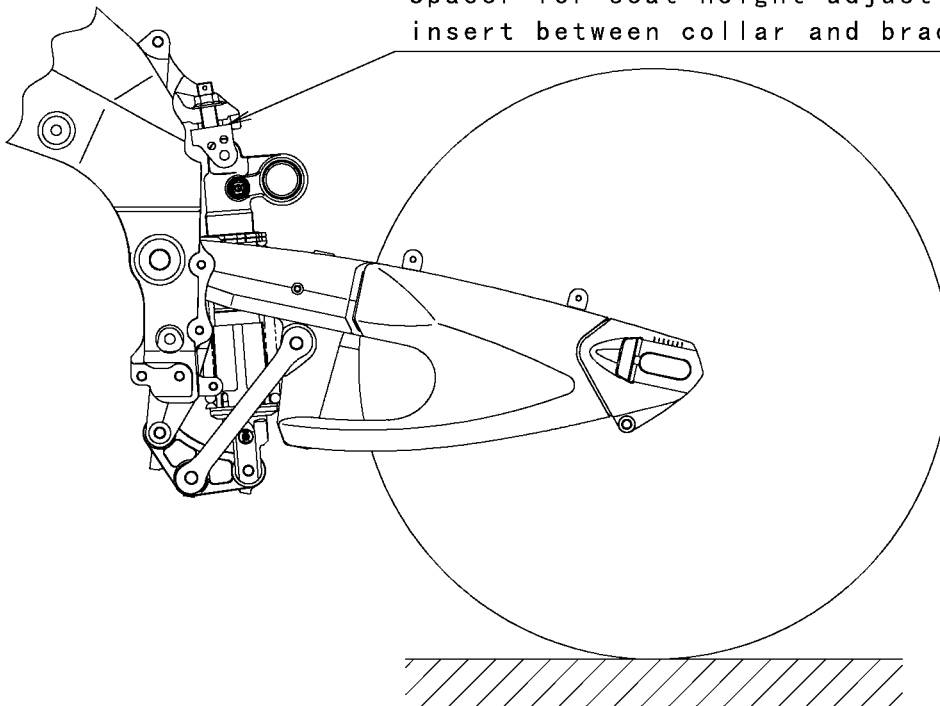

S1063148W5 C

Front Fork Springs (Kit Parts)

The kit front fork springs are available for racing.

1) Front Fork Specifications

Items	Original
Rebounded damping setting (Upper)	9th (0 ~ -11)
Compression damping setting (Lower)	7th (0 ~ -13)
Fork oil	KAYABA KHL 15-10
Fork oil level	111 mm
Oil lock	Oil lock piece
Oil seal	---
Spring length	230.1 mm (mount), 232.1 mm (free)
Spring constant	8.8 N/mm
Spacer length	101 mm
Sub spring stroke	20.5 mm

2) Front Fork Spring

P/No.	A × B × C (mm)	Number of Wiring	Spring Constant
Original	4.7 × 28.7 × 232.1	14.6	K = 9.25 N/mm
44026-0091	4.8 × 28.5 × 232.1	14.8	K = 9.5 N/mm
44026-0092	4.8 × 28.5 × 232.1	14.1	K = 10.0 N/mm
44026-0093	4.9 × 28.3 × 232.1	14.7	K = 10.5 N/mm

A: Coil Diameter

B: Spring Inside Diameter

C: Spring Free Length

3) Front Fork Spring Replacement

Replace the main spring referring to the Fork Oil Change section of the base Service Manual.

Identification Mark

The following ID marks are on the springs.

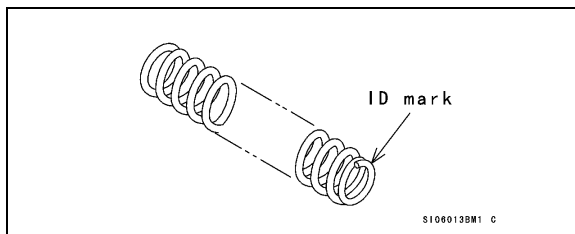

Spring	ID Mark (Smaller diameter end side)
44026-0091 (K = 9.5)	One slit
44026-0092 (K = 10.0)	Two slit
44026-0093 (K = 10.5)	Three slit

Fork Spring Installation

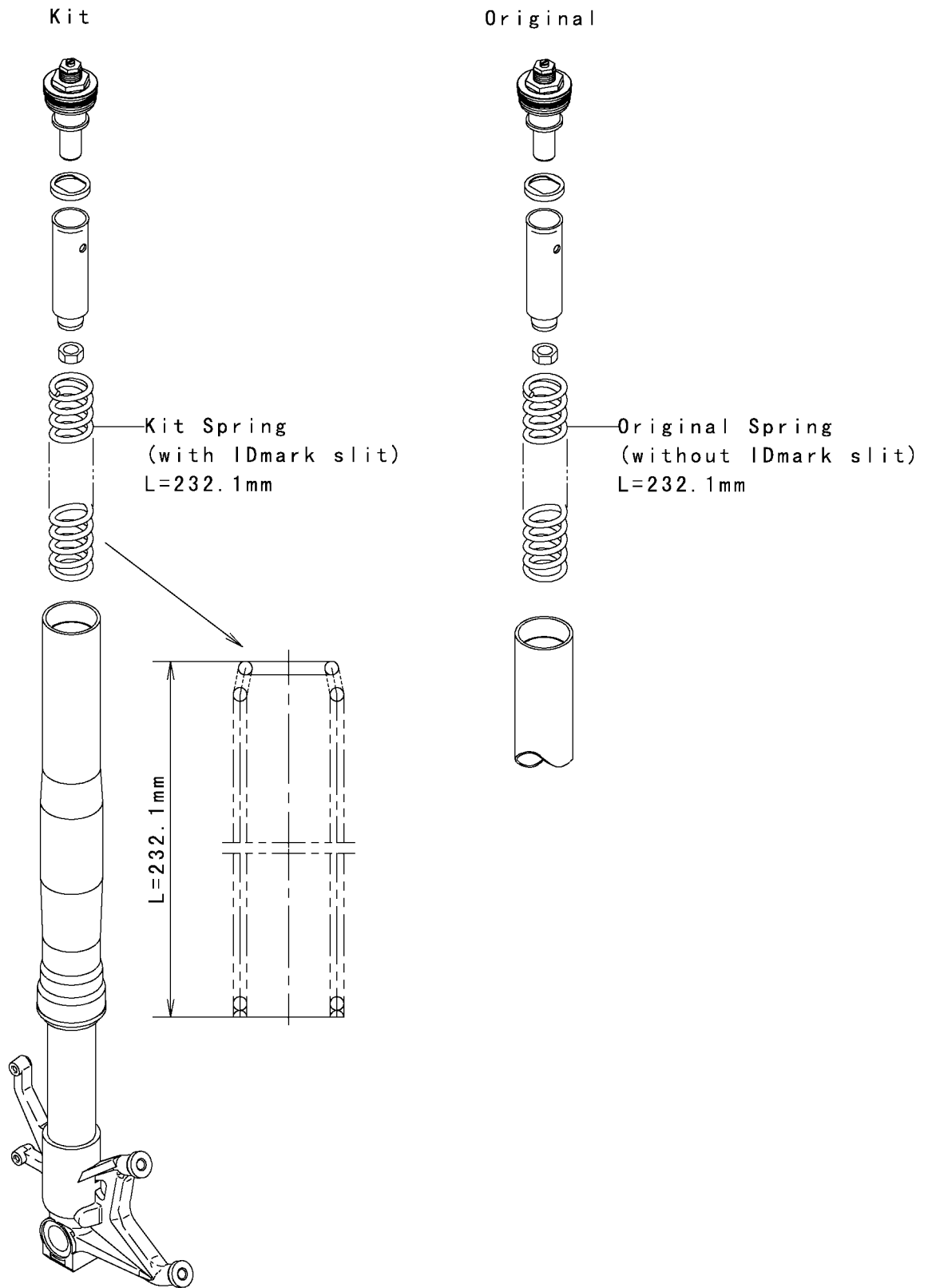

S106315BWS C

Electrical System

Battery

Use the original battery with 12 V 10 Ah or more capacity.

Main Harness and Sub Harness (Kit Part)

Main harness and sub harness are available for racing use as kit parts. Select one of them in accordance with your race regulation.

Main Harness (with Original Meter and Kit Meter): 26031-0328

Sub Harness (with Original Meter): 26031-0425

Sub Harness (with Kit Meter): 26031-0426

Meter (Kit Parts) Installation

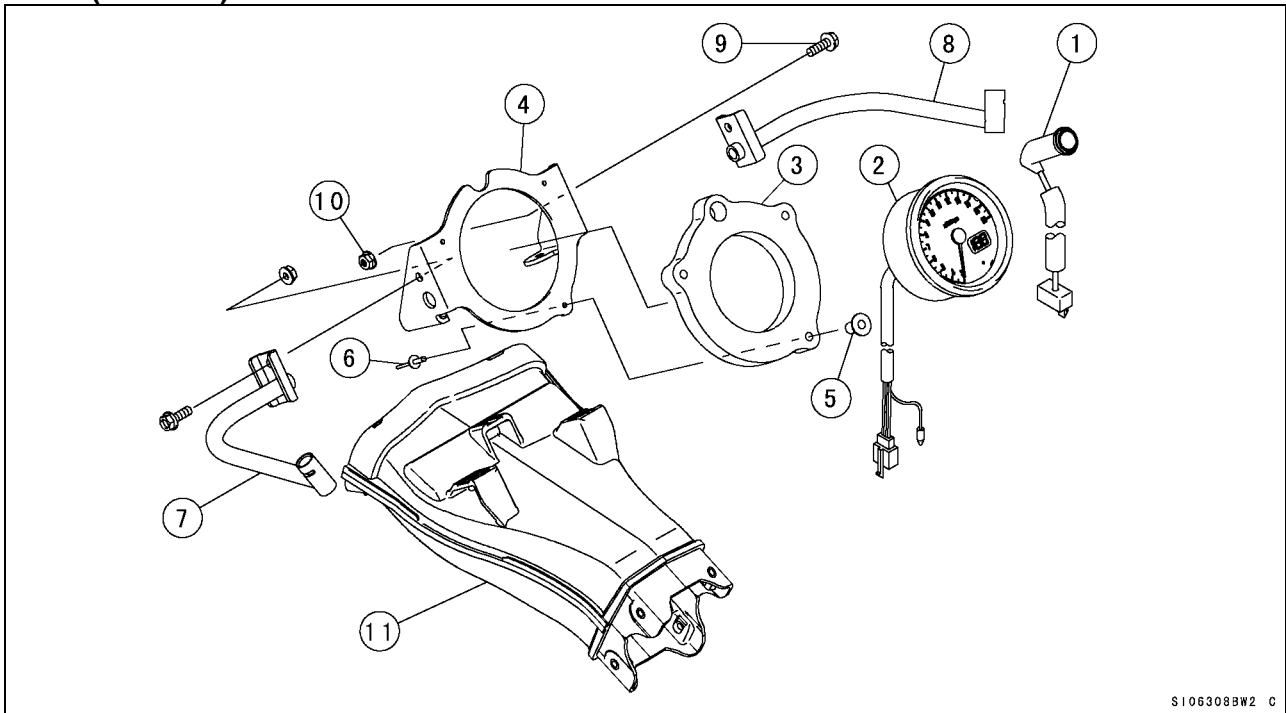

S1063088W2 C

1. Shift Up Indicator Lamp (Kit): 23016-0006
2. Tachometer with Water Temperature Gauge (Kit): 25031-1142
3. Damper (Kit): 39156-0098
4. Meter Bracket (Kit): 11053-1673
5. Collar (Kit): 92152-0058
6. Rivet (Kit): 92039-1106
7. Bracket (Kit): 11053-0423
8. Bracket (Kit): 11053-0424
9. Bolt (Kit): 130J0618
10. Nut (Kit): 92015-1233
11. Ram Air Duct (Original): 39045-0015

- Insert the three collars [5] into the damper [3].
- Insert the rivet [6] from the backside of the meter bracket [4] and fix them.
- Install the bracket [4] to the original air duct [11].

Main Harness Combination Parts Table

Use the kit main harness or sub harness with the following parts as a set.

Parts	Main Harness (26031-0426)	Main Harness (26031-0425)	Sub Harness (26031-0427)
Meter Assembly (Original)	○	×	○
Tachometer with Water temperature Gauge (Kit)	×	○	×
Water Temperature Gauge Lead (Kit)	×	○	×
Water temperature sensor (Kit)	×	○	×
Relay Box (Kit)	○	○	×

NOTE

When using the main harness (26031-0425, 0426), relay box (27002-1062) required.

When using the sub harness (26031-0427) no kit parts required.

Removal Parts

When using the kit main harness (kit meter: 26031-0425), the following original parts are not required.

Original Main Harness

Meter Assembly

Bracket (Rear View Mirror & Meter Assembly)

Ignition Switch

Left Switch Housing

Rear Brake Light Switch

Side Stand Switch

Relay Box

Turn Signal Relay

Head Light, Tail/ Brake Light

License Plate Light

Front Right Turn Signal Light

Front Left Turn Signal Light

Rear Right Turn Signal Light

Rear Left Turn Signal Light

Horn

When using the kit main harness (Original meter: 26031-0426), the following original parts are not required.

Original Main Harness

Ignition Switch

Rear Brake Light Switch

Side Stand Switch

Relay Box

Turn Signal Relay

Head Light, Tail/ Brake Light

License Plate Light

Front Right Turn Signal Light

Front Left Turn Signal Light

Rear Right Turn Signal Light

Rear Left Turn Signal Light

Horn

Kit Meter

When using the kit tachometer with water temperature gauge, the following kit parts, kit main harness (26031-0425) are required.

Tachometer with Water Temperature Gauge (Kit): 25031-1142

Water Temperature Gauge Lead (Kit): 26011-1779

Water Temperature Gauge Ground Lead (Kit): 26011-0071

Water Temperature Sensor (Kit): 21176-1099

Kit Main Harness Installation

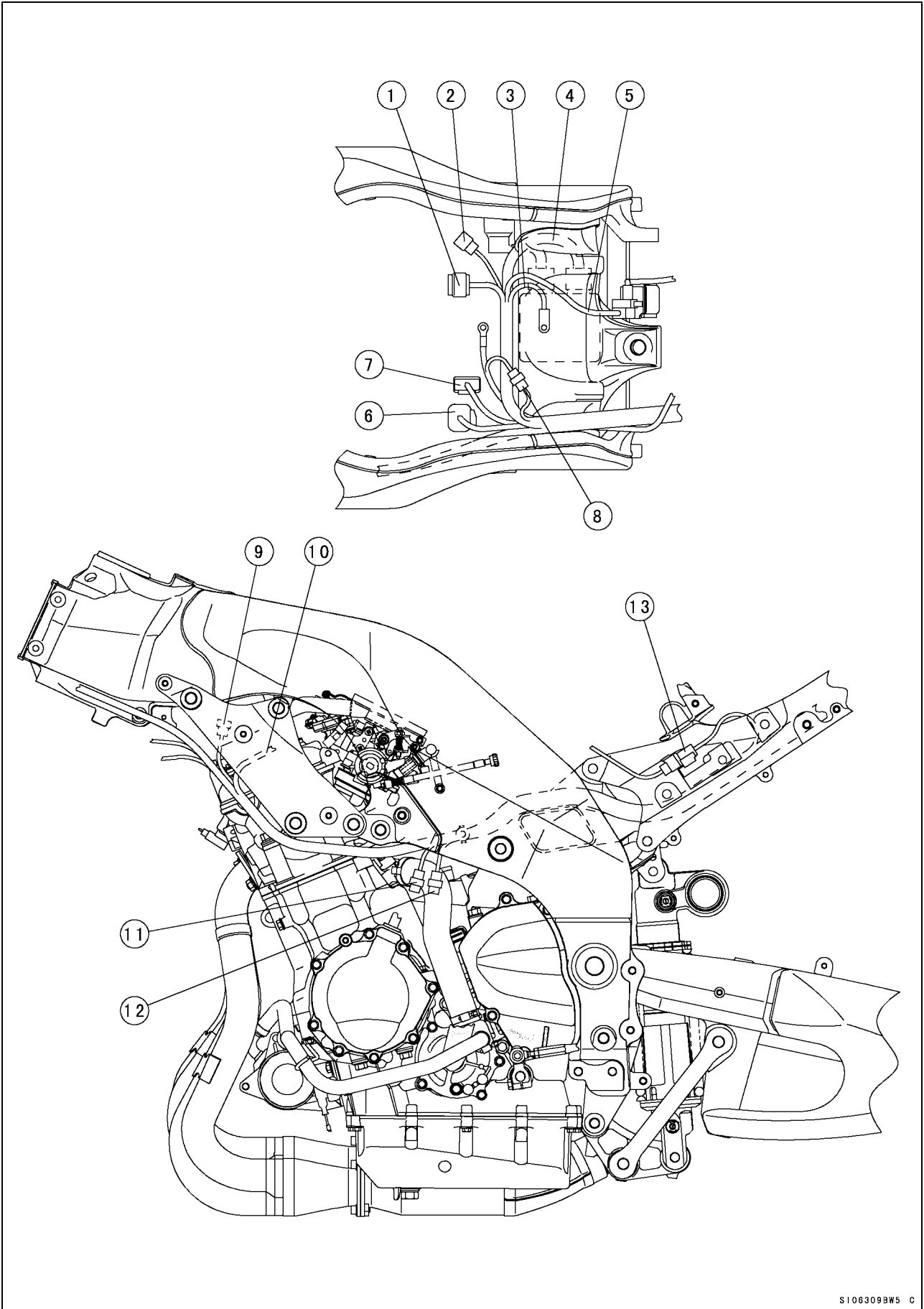

S1063098W5 C

1. To throttle bodies connector (Brown).
2. Intake Air Temperature Sensor (Black)
3. Frame Ground
4. Regulator
5. Starter Relay
6. To front sub harness connector (26031-0307 or 26031-0308).
7. Camshaft Position Sensor (Gray)
8. Ignition Coils (Gray)
9. Camshaft Position Sensor
10. Connect to the ignition coil (with tape from #1 to #4)
11. Auto Shifter (Blue)
12. White Connector (do not use)
13. Fuel Pump (Black)

- Remove the original main harness from the frame.
- Install the kit main harness (26031-0425, 0426) as shown in the illustration.
- Use the original part for the [8] battery ground cable.
- Connect the [9] camshaft position sensor connector to the camshaft position sensor at the cylinder head front side.
- When using the recommended auto shifter to connect the [11] auto shifter connector.

NOTE

When using the kit tachometer, always connect the water temperature sensor connector at the cylinder head rear side.

For recommended auto shifter, refer to the Kawasaki FI Calibration Tool Instruction Manual of another sheet.

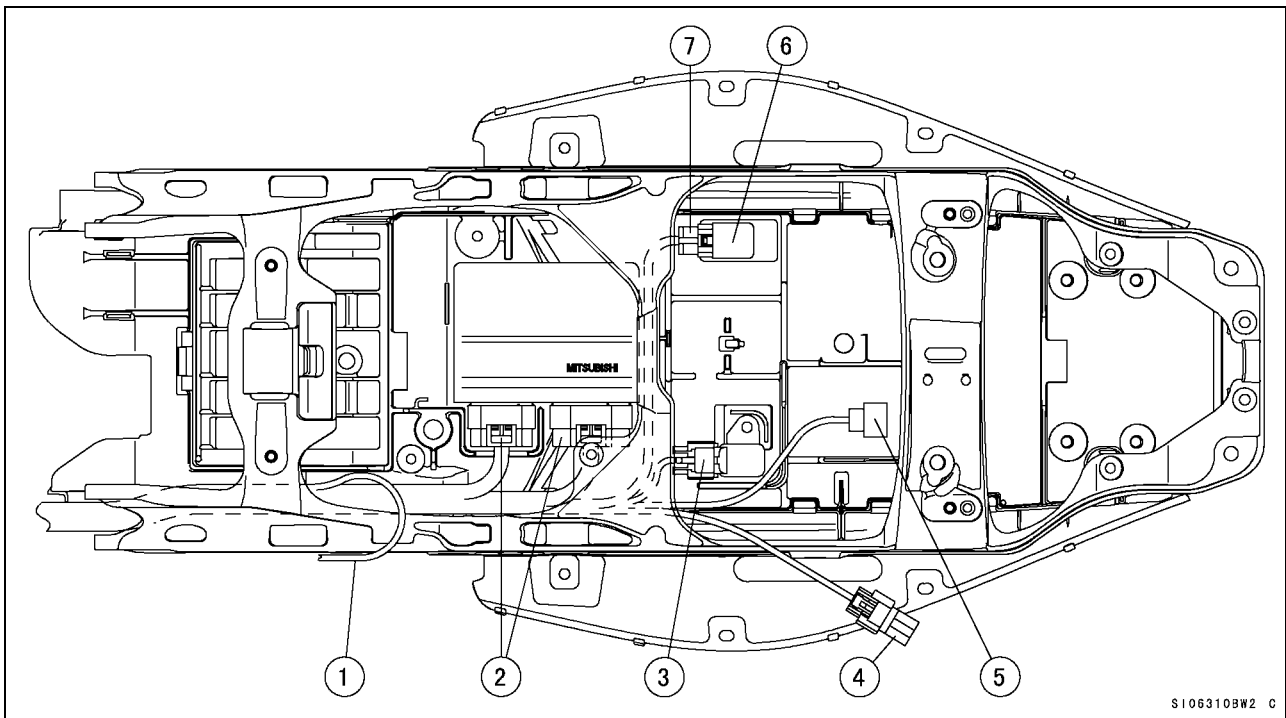

1. To connect the Fuel Pump.
2. To connect the E.C.U (Black).
3. To connect the atmospheric pressure sensor (Black).
4. To connect the inter face box (Black).
5. To connect the vehicle down sensor (Gray).
6. Relay Box (27002-1062)
7. To connect the relay box (Black).

- Remove the original relay box and original turn signal relay.
- Install the [6] relay (27002-1062) to the position removed the turn signal relay (Original).
Be careful to the interference with surrounding parts when install to the other position.

Sub Harness (Original Meter) Installation

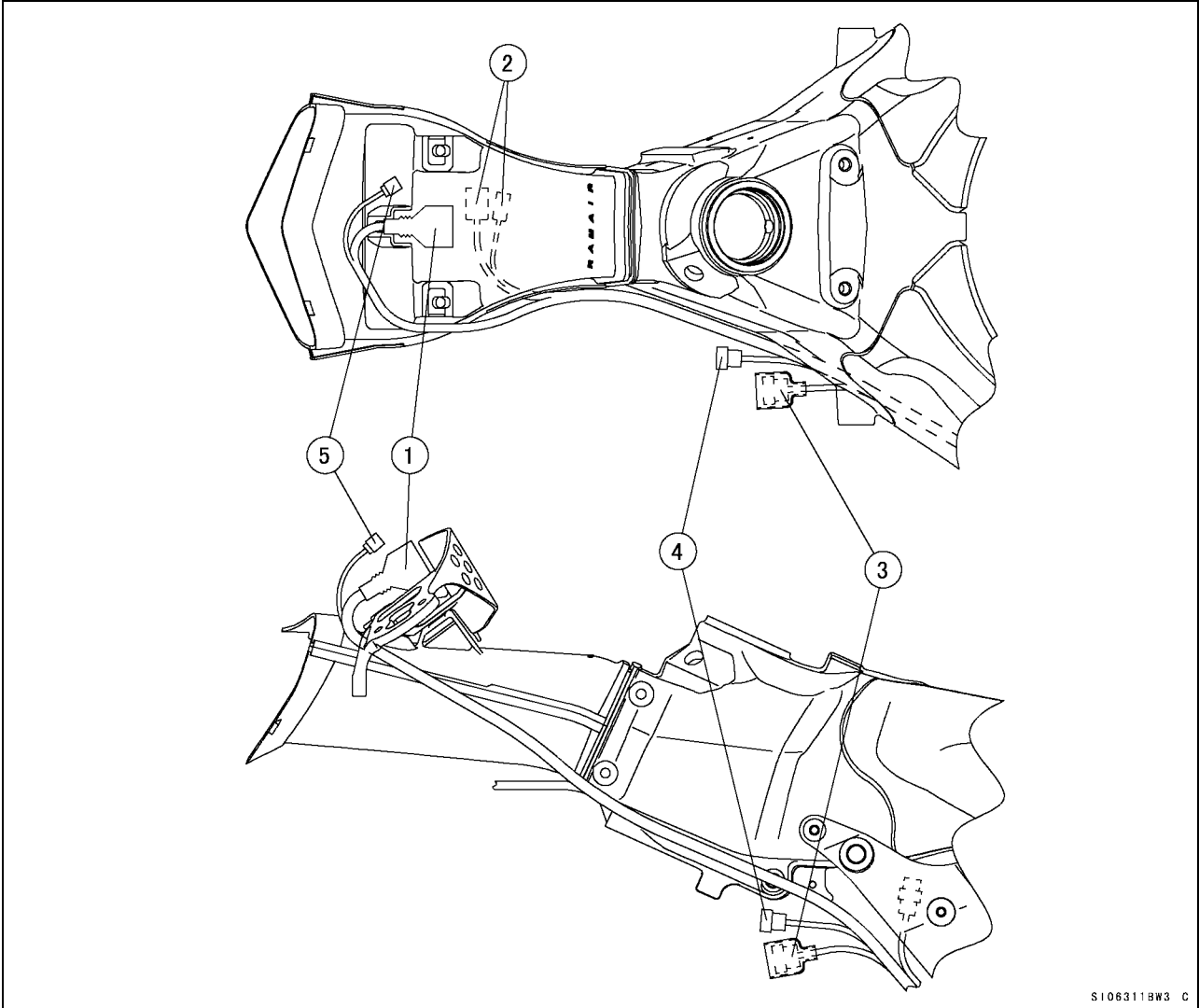

1. To connect the original meter (Black).
2. To connect the right switch housing (Black).
3. To connect the left switch housing (Black).
4. Semitransparent connector (not use)
5. To connect the shift up indicator (Green).

- Install the harness (26031-0426) for the original meter as shown in the illustration.
- When using the original meter, use the left and right original switch housings.

NOTE

When using the original meter, function the head light dimmer switch or/and passing button for the speed control switch function.

Hold the stop watch function of the stop watch switch.

In case of difficulty confirming the shift up indicator lamp in the original meter, connect to the [5] optional shift up indicator lamp.

Sub Harness (Kit Meter) Installation

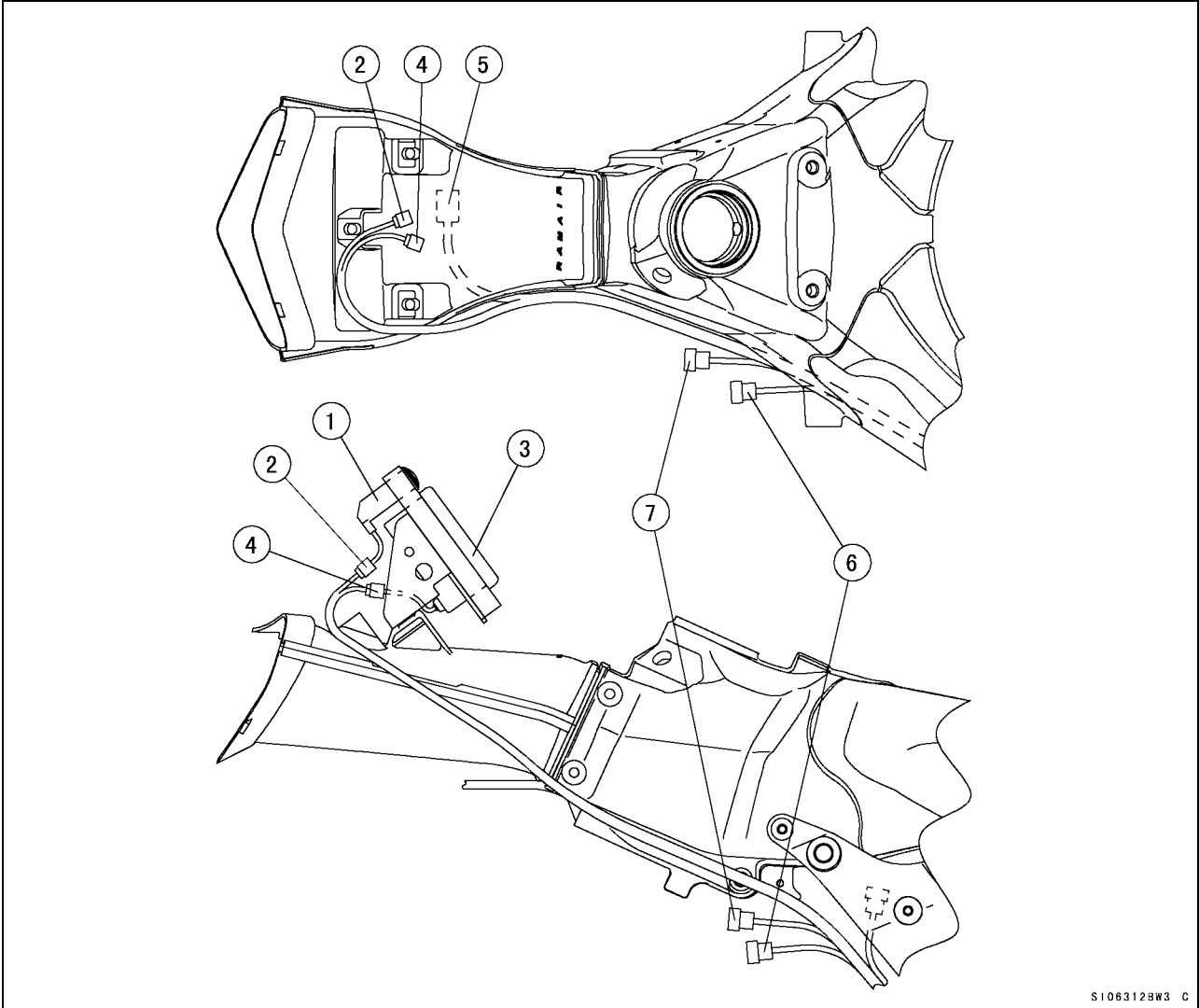

1. Shift up Indicator Lamp (23016-0006)
2. To connect the shift up indicator lamp (Green).
3. Tachometer with Water Temperature Gauge (25031-1142)
4. To connect the tachometer with water temperature gauge (Black).
5. To connect the right switch housing (Black).
6. To connect the speed control switch (27010-0040) (Black).
7. Semitransparent connector (not use)

- Install the harness for the kit meter (26031-0425) as shown in the illustration.

NOTE

The right switch housing is usable both the original (46094-0040) and the kit (46091-1809) one.

Kit Sub Harness (26031-0427) Installation

- Install the kit sub harness (26031-0244) as shown in the illustration.

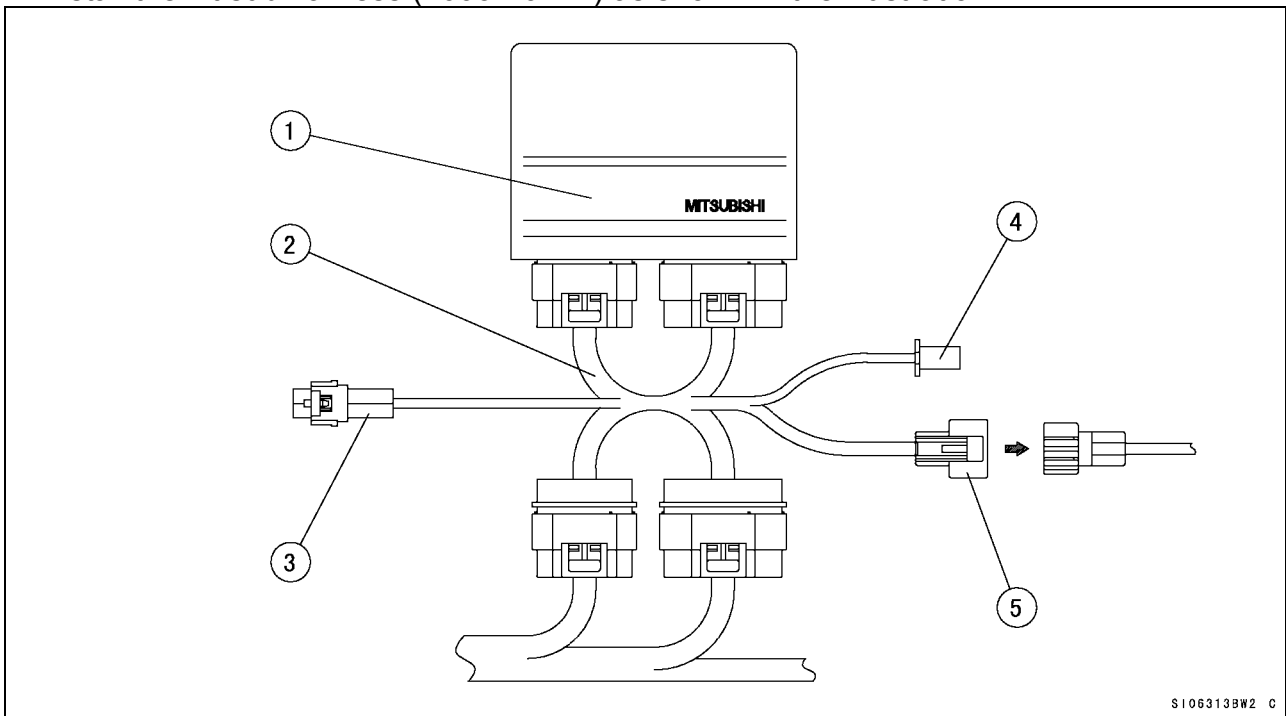

1. E.C.U.
2. Sub Harness (26031-0427)
3. To connect the auto-shifter (Blue).
4. To connect the speed limit switch (Black).
5. To connect the inter face box (Black).

- Connect the [3] auto shifter and the [4] speed limit switch, extending the lead as required.

Wiring Diagram (with Original Meter)

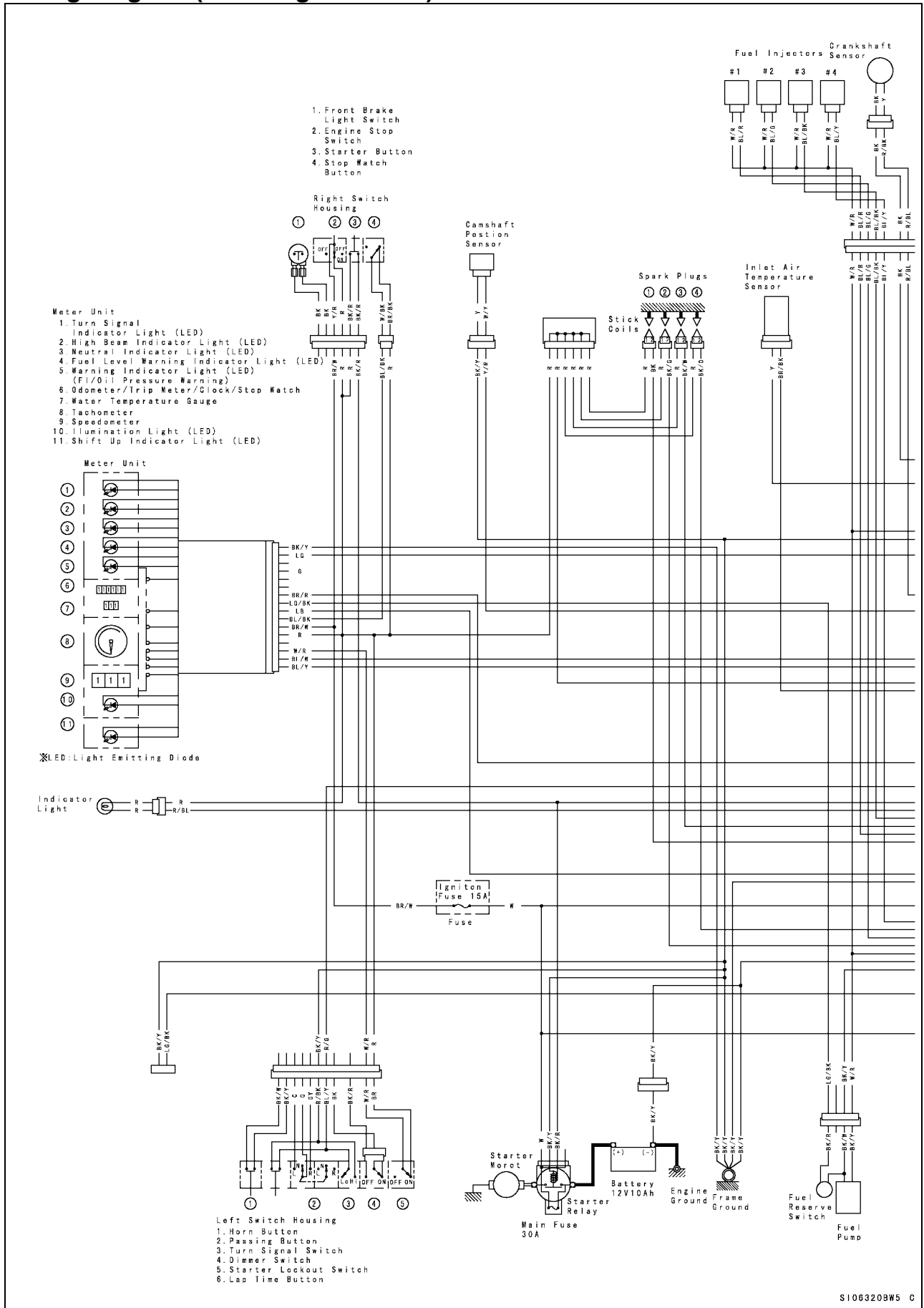

S106320BW5 C

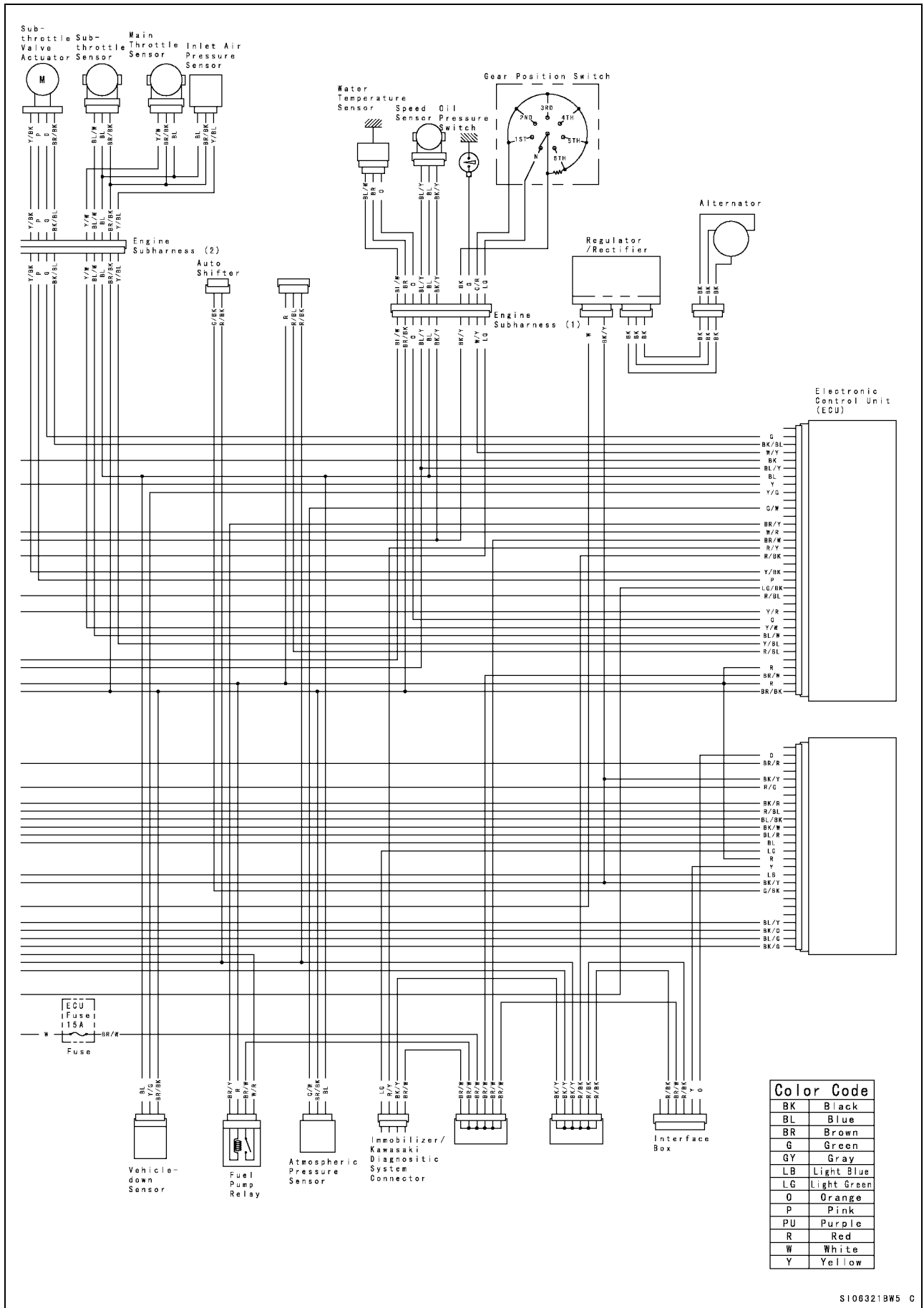

Color Code	
BK	Black
BL	Blue
BR	Brown
G	Green
GY	Gray
LB	Light Blue
LG	Light Green
O	Orange
P	Pink
PU	Purple
R	Red
W	White
Y	Yellow

S1063219W5 C

Wiring Diagram (with Kit Meter)

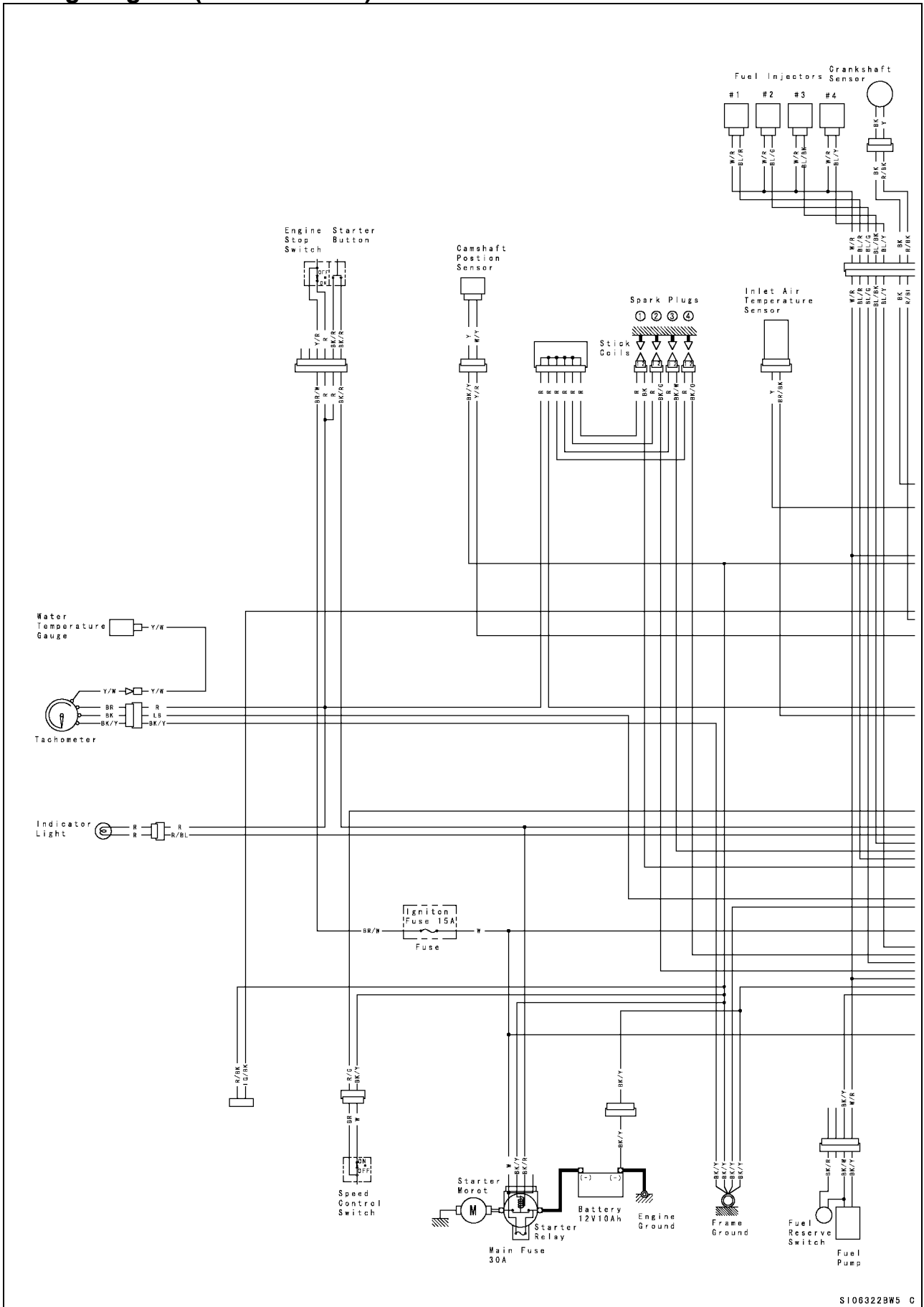

S1063229W5 C

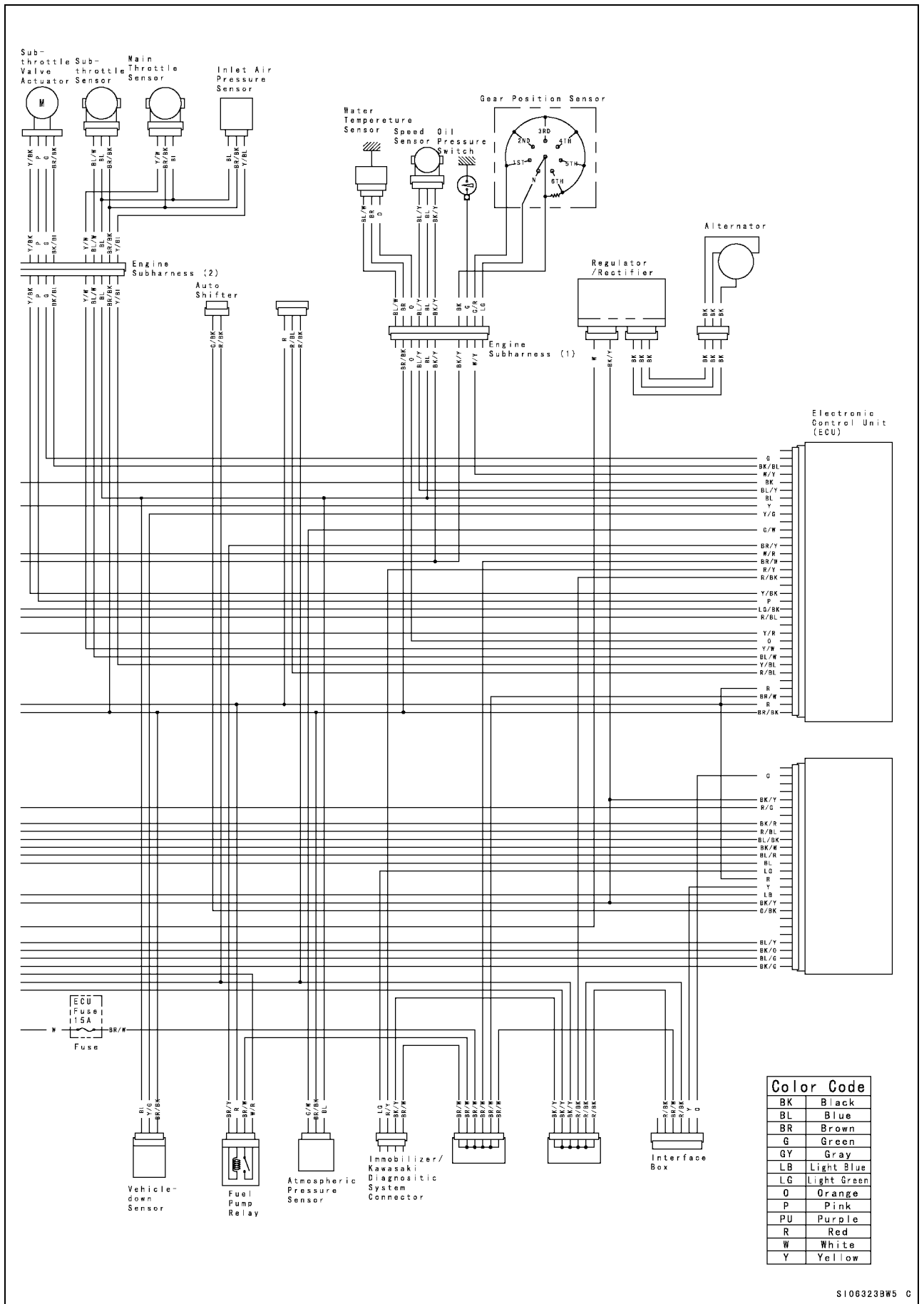

S1063238W5 C

Racing Kit Parts List

This catalog covers:
'06 ZX1000DR6F Engine

GRID NO. **B-3** This grid covers:
Valve(s)

E1210



Ref. No.	Part No.	Description	Spec Code	Quantity-ZX1000			
				'06			
49078	49078-0049 (OPTION)	SPRING-ENGINE VALVE,EXHAUST					8

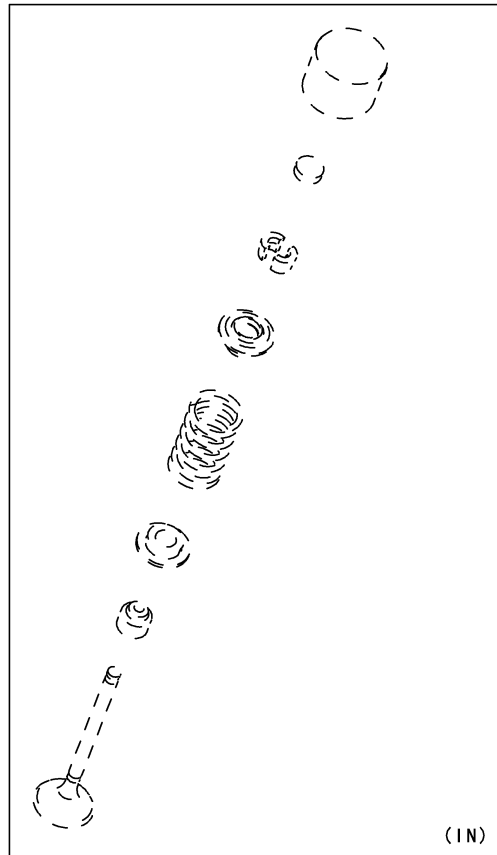
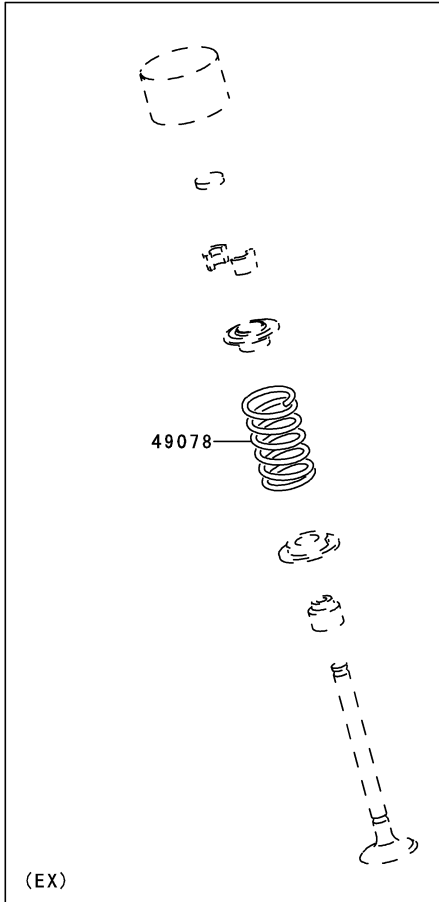

E1230

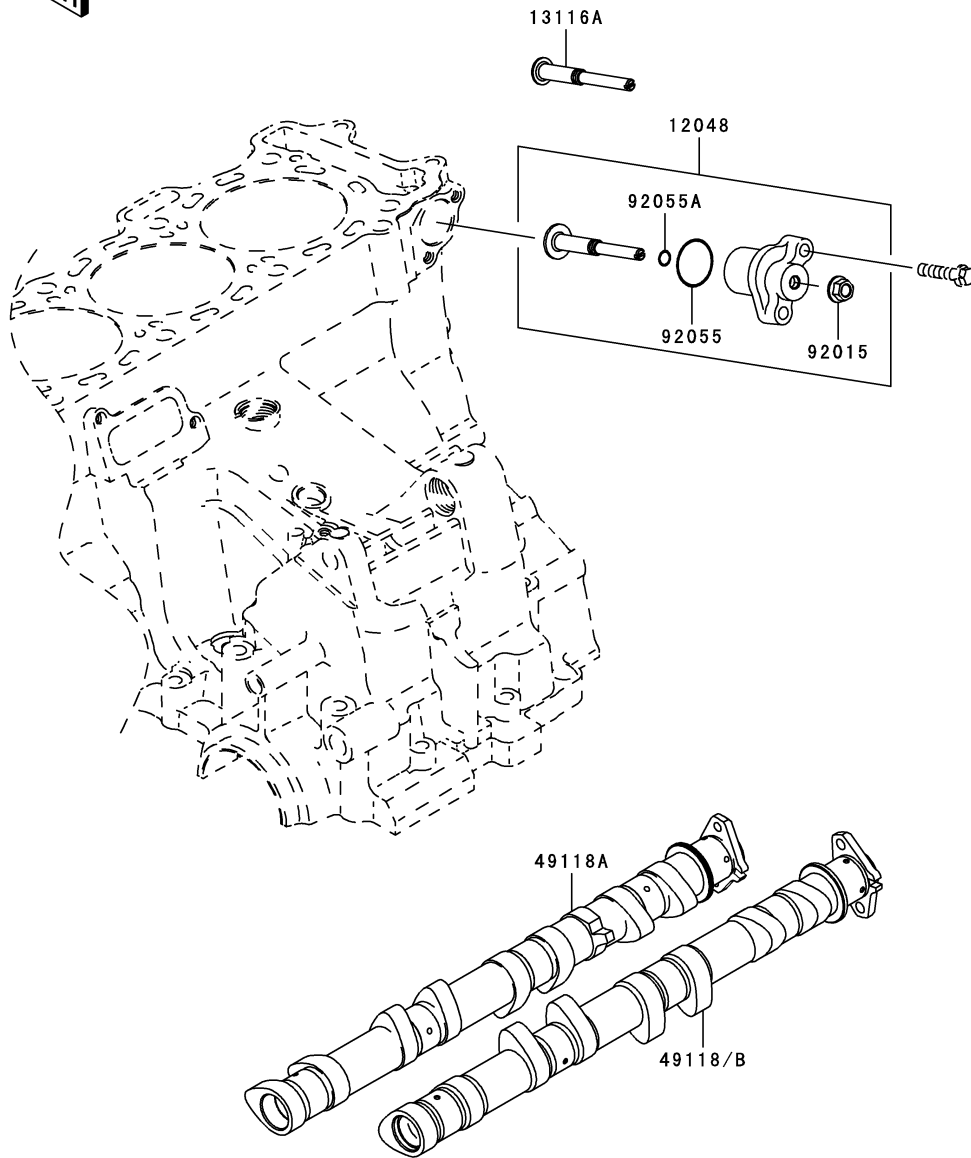

Ref. No.	Part No.	Description	Spec Code	Quantity-ZX1000	
				'06	DR6F
12048	12048-0028 (OPTION)	TENSIONER-ASSY			1
13116	13116-1166 (OPTION)	ROD-PUSH			AR
49118	49118-0034 (OPTION)	CAMSHAFT-COMP,INTAKE			1
49118A	49118-0077 (OPTION)	CAMSHAFT-COMP,EXHAUST			1
49118B	49118-0078 (OPTION)	CAMSHAFT-COMP,INTAKE			1
92015	92015-1078 (OPTION)	NUT,FLANGED,6MM			1
92055	92055-0053 (OPTION)	RING-O,20.8X1.9			1
92055A	92055-011 (OPTION)	RING-O,5MM			1

This catalog covers:
'06 ZX1000DR6F Engine

GRID NO. **B-5** This grid covers:
Crankshaft/Piston(s)

E1320

Ref. No.	Part No.	Description	Spec Code	Quantity-ZX1000			
				'06			
13001	13001-0077 (OPTION)	PISTON-ENGINE,SB		4			
13001A	13001-0078 (OPTION)	PISTON-ENGINE		4			
13002	13002-0013 (OPTION)	PIN-PISTON		4			
13008	13008-0019 (OPTION)	RING-SET-PISTON		4			
13251	13251-0015 (OPTION)	ROD-ASSY-CONNECTING,L=110.45		4			
92015	92015-1311 (OPTION)	NUT,FLANGED,8MM		8			
92033	92033-1161 (OPTION)	RING-SNAP,PISTON PIN		8			
92139	92139-0109 (OPTION)	BUSHING,SB CONROD,BLUE		AR			
92139A	92139-0110 (OPTION)	BUSHING,SB CONROD,BLACK		8			
92139B	92139-0111 (OPTION)	BUSHING,SB CONROD,BROWN		AR			
92139C	92139-0146 (OPTION)	BUSHING,CRANK #1,BLUE		AR			
92139D	92139-0147 (OPTION)	BUSHING,CRANK #1,BLACK		4			
92139E	92139-0148 (OPTION)	BUSHING,CRANK #1,BROWN		AR			
92139F	92139-0149 (OPTION)	BUSHING,CRANK #2,BLUE		AR			
92139G	92139-0150 (OPTION)	BUSHING,CRANK #2,BLACK		6			
92139H	92139-0151 (OPTION)	BUSHING,CRANK #2,BROWN		AR			
92139I	92139-0156 (OPTION)	BUSHING,CON-ROD,PINK		AR			
92153	92153-0809 (OPTION)	BOLT,CON-ROD,M8X45.5		8			

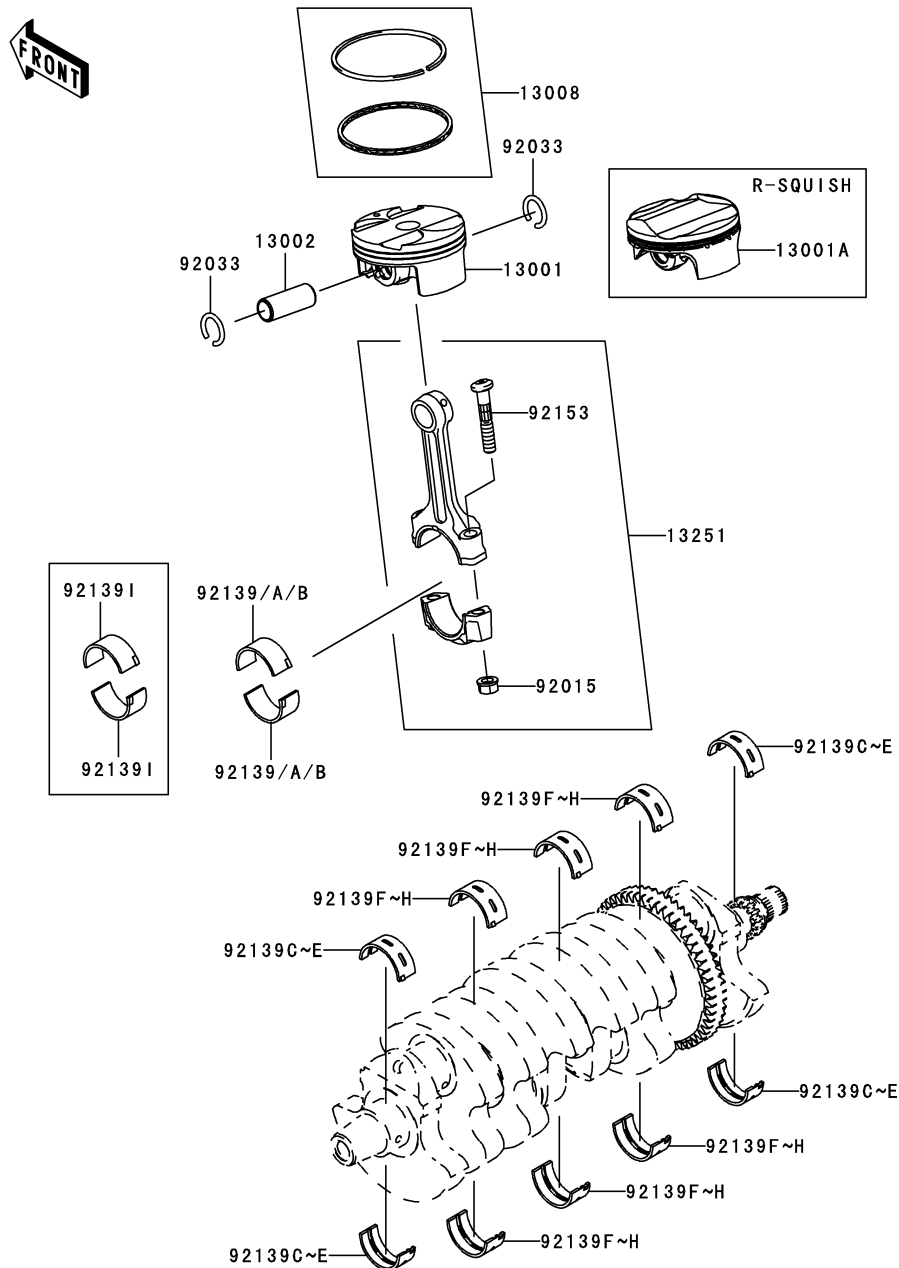

This catalog covers:
'06 ZX1000DR6F Engine

GRID NO. This grid covers:
B-6 Clutch



E1350

Ref. No.	Part No.	Description	Spec Code	Quantity-ZX1000			
				'06			
13089	13089-0011 (OPTION)	PLATE-CLUTCH,STD +40%		1			
13089A	13089-0012 (OPTION)	PLATE-CLUTCH,STD +60%		1			

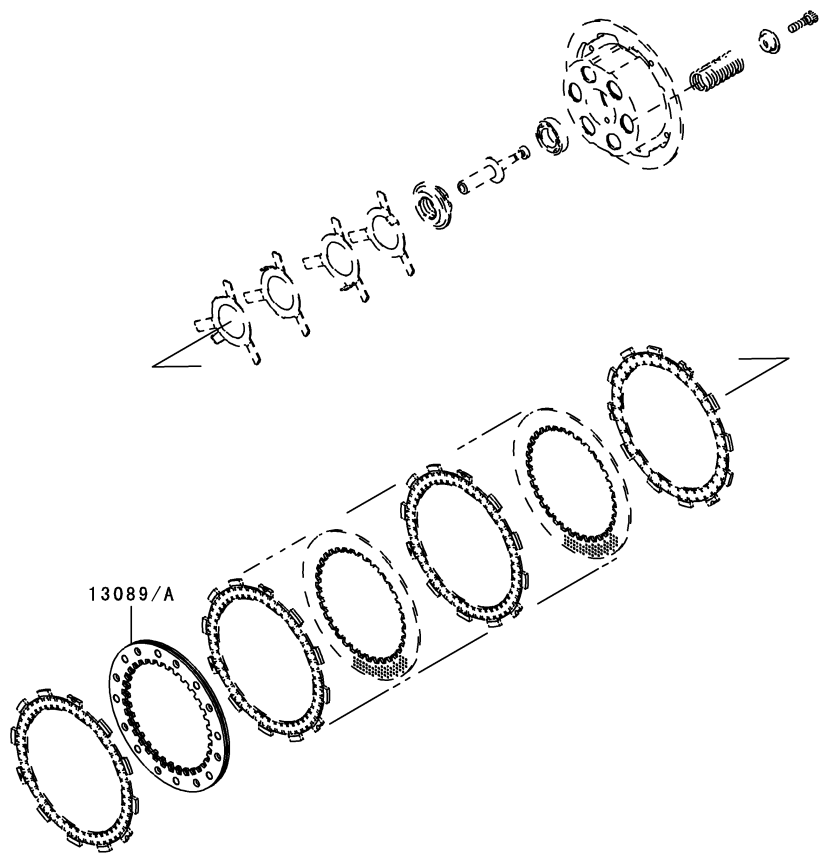

E1361

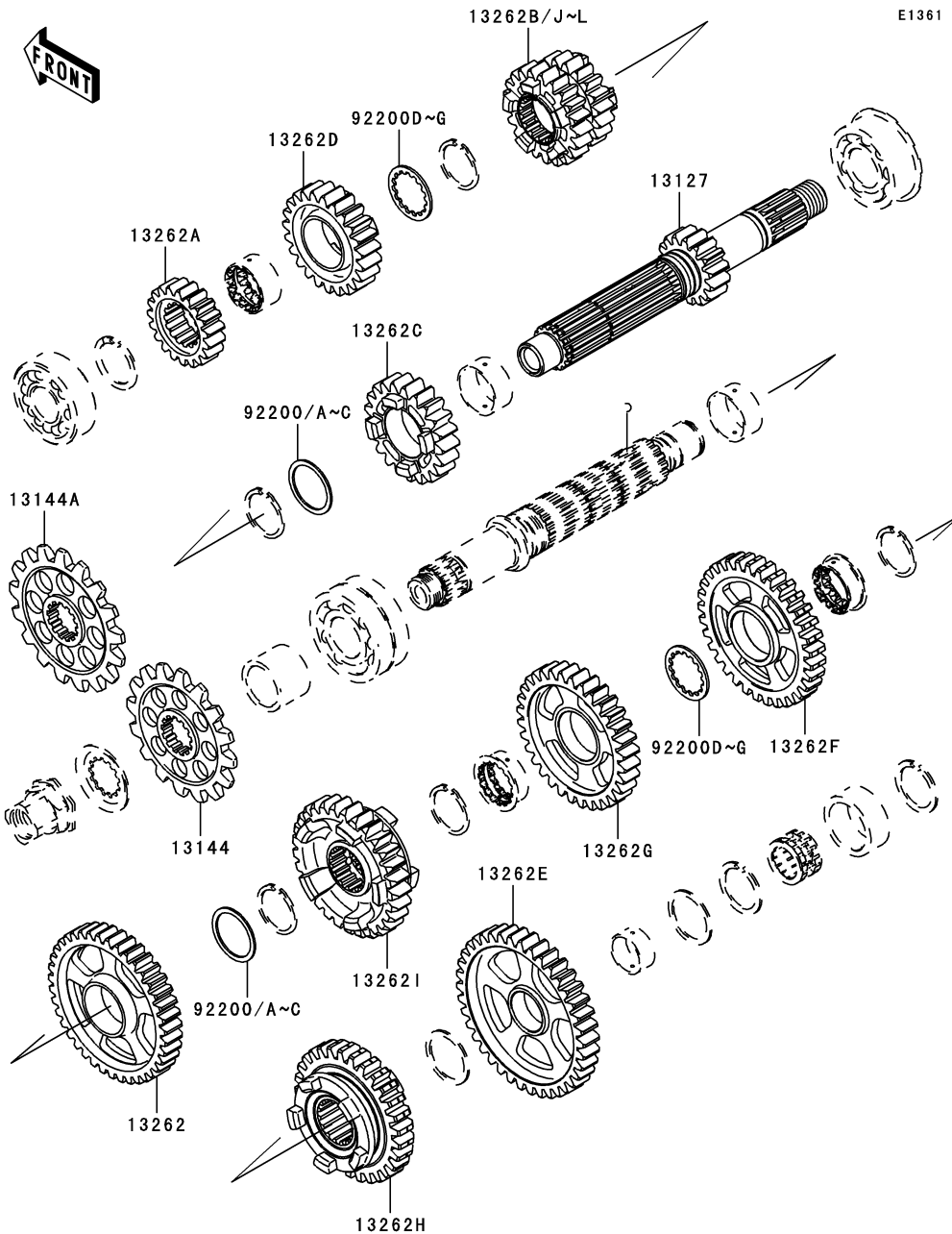

Ref. No.	Part No.	Description	Spec Code	Quantity-ZX1000			
				'06			
13127	13127-0041 (OPTION)	SHAFT-TRANSMISSION INPUT,13T		1			
13144	13144-0021 (OPTION)	SPROCKET-OUTPUT,16T,#520		1			
13144A	13144-0022 (OPTION)	SPROCKET-OUTPUT,17T,#520		1			
13262	13262-0152 (OPTION)	GEAR,OUTPUT 2ND,39T		1			
13262A	13262-0185 (OPTION)	GEAR,INPUT 2ND,19T		1			
13262B	13262-0264 (OPTION)	GEAR,INPUT 3RD&4TH,19T&20T		1			
13262C	13262-0265 (OPTION)	GEAR,INPUT 5TH,20T		1			
13262D	13262-0266 (OPTION)	GEAR,INPUT 6TH,21T		1			
13262E	13262-0267 (OPTION)	GEAR,OUTPUT LOW,31T		1			
13262F	13262-0268 (OPTION)	GEAR,OUTPUT 3RD,34T		1			
13262G	13262-0269 (OPTION)	GEAR,OUTPUT 4TH,31T		1			
13262H	13262-0270 (OPTION)	GEAR,OUTPUT 5TH,29T		1			
13262I	13262-0271 (OPTION)	GEAR,OUTPUT 6TH,29T		1			
13262J	13262-0284 (OPTION)	GEAR,INPUT 3RD&4TH,19T&21T		1			
13262K	13262-0285 (OPTION)	GEAR,INPUT 3RD&4TH,16T&20T		1			
13262L	13262-0286 (OPTION)	GEAR,INPUT 3RD&4TH,19T&20T		1			
92200	92200-0225 (OPTION)	WASHER,28.1X34.0X0.8		AR			
92200A	92200-0226 (OPTION)	WASHER,28.1X34.0X1.0		AR			
92200B	92200-0227 (OPTION)	WASHER,28.1X34.0X1.4		AR			
92200C	92200-0228 (OPTION)	WASHER,28.1X34.0X1.6		AR			
92200D	92200-0229 (OPTION)	WASHER,28.3X34.0X1.2		AR			

This catalog covers:
'06 ZX1000DR6F Engine

GRID NO. **B-8** This grid covers:
Transmission(2/2)(TYPE-B)

E1361

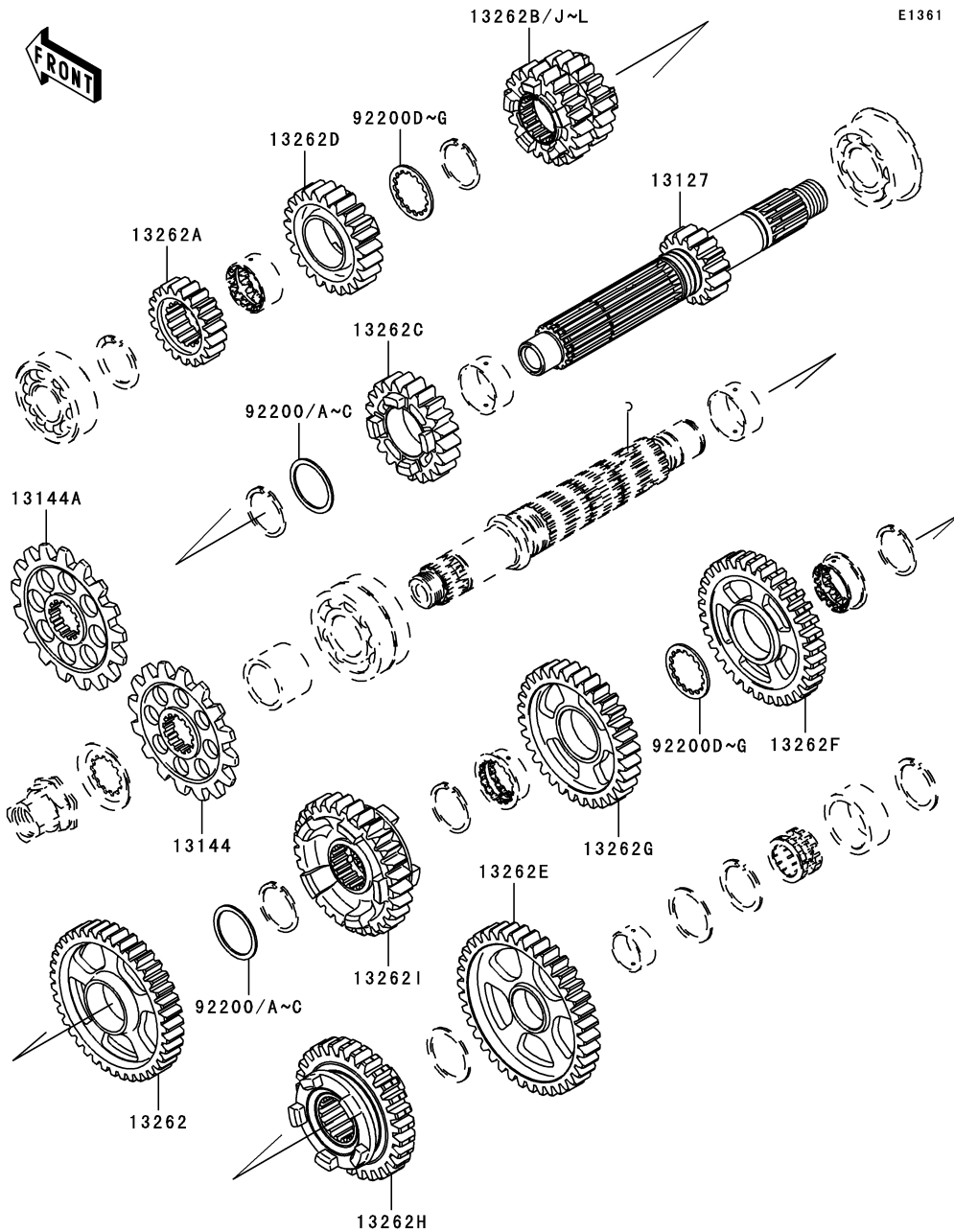

Ref. No.	Part No.	Description	Spec Code	Quantity-ZX1000			
				'06			
92200E	92200-0230 (OPTION)	WASHER,28.3X34.0X1.4	AR				
92200F	92200-0231 (OPTION)	WASHER,28.3X34.0X1.8	AR				
92200G	92200-0232 (OPTION)	WASHER,28.3X34.0X2.0	AR				

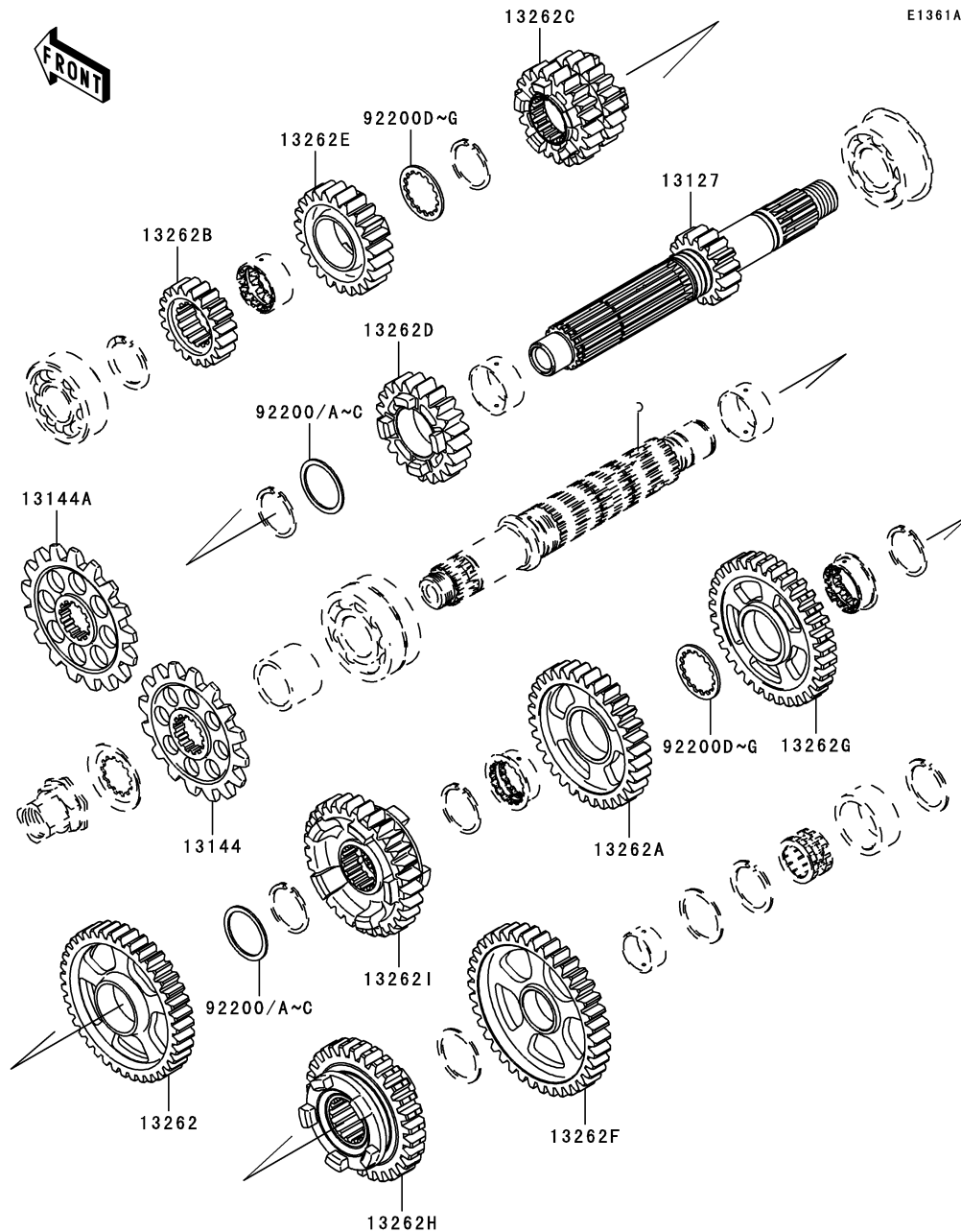

E1361A

Ref. No.	Part No.	Description	Spec Code	Quantity-ZX1000			
				'06			
13127	13127-0042 (OPTION)	SHAFT-TRANSMISSION INPUT,14T		1			
13144	13144-0021 (OPTION)	SPROCKET-OUTPUT,16T,#520		1			
13144A	13144-0022 (OPTION)	SPROCKET-OUTPUT,17T,#520		1			
13262	13262-0152 (OPTION)	GEAR,OUTPUT 2ND,39T		1			
13262A	13262-0166 (OPTION)	GEAR,OUTPUT 4TH,32T		1			
13262B	13262-0185 (OPTION)	GEAR,INPUT 2ND,19T		1			
13262C	13262-0272 (OPTION)	GEAR,INPUT 3RD&4TH,16T&21T		1			
13262D	13262-0273 (OPTION)	GEAR,INPUT 5TH,20T		1			
13262E	13262-0274 (OPTION)	GEAR,INPUT 6TH,21T		1			
13262F	13262-0275 (OPTION)	GEAR,OUTPUT LOW,34T		1			
13262G	13262-0276 (OPTION)	GEAR,OUTPUT 3RD,28T		1			
13262H	13262-0277 (OPTION)	GEAR,OUTPUT 5TH,28T		1			
13262I	13262-0278 (OPTION)	GEAR,OUTPUT 6TH,28T		1			
92200	92200-0225 (OPTION)	WASHER,28.1X34.0X0.8		AR			
92200A	92200-0226 (OPTION)	WASHER,28.1X34.0X1.0		AR			
92200B	92200-0227 (OPTION)	WASHER,28.1X34.0X1.4		AR			
92200C	92200-0228 (OPTION)	WASHER,28.1X34.0X1.6		AR			
92200D	92200-0229 (OPTION)	WASHER,28.3X34.0X1.2		AR			

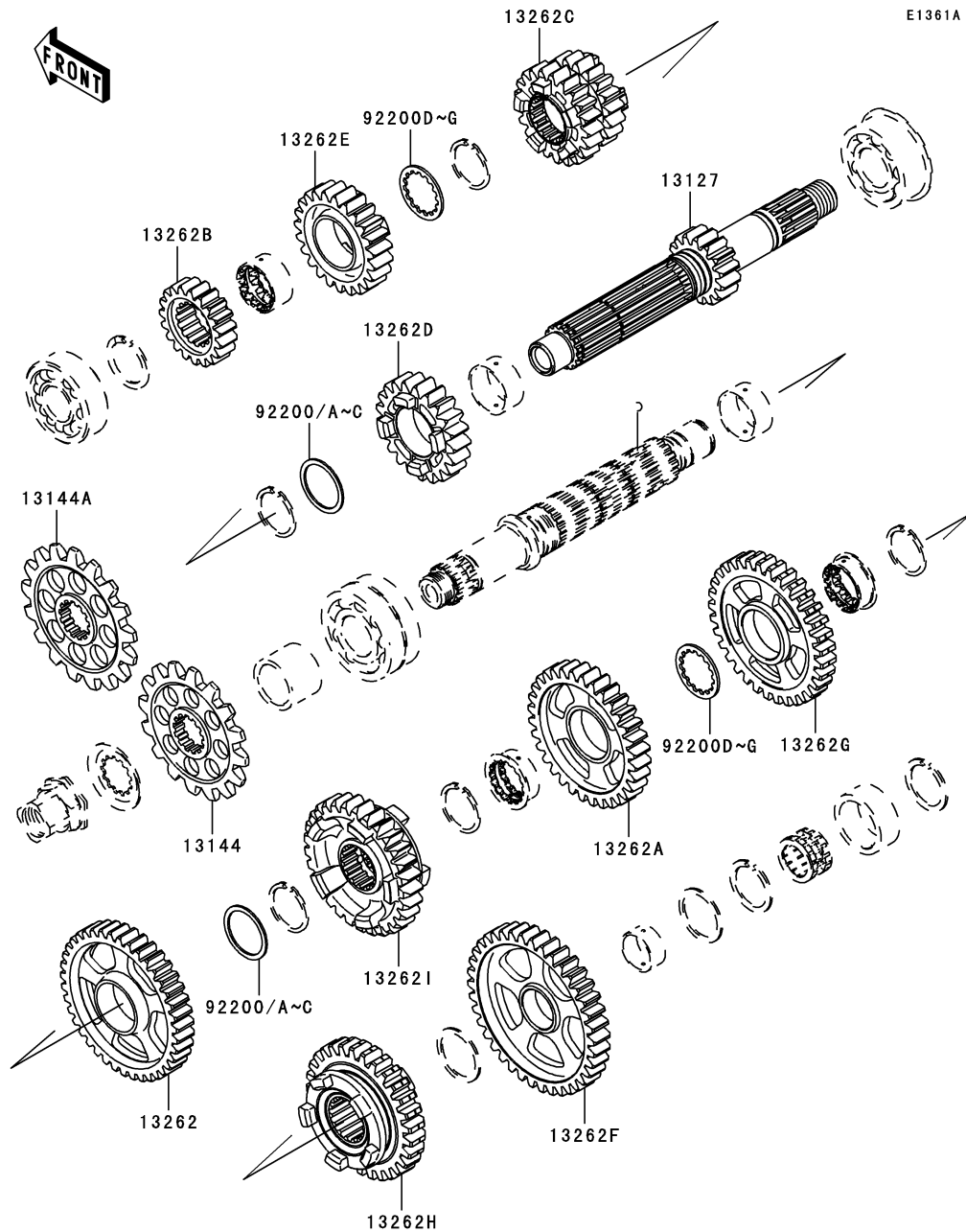

Ref. No.	Part No.	Description	Spec Code	Quantity-ZX1000			
				'06			
92200E	92200-0230 (OPTION)	WASHER,28.3X34.0X1.4	AR				
92200F	92200-0231 (OPTION)	WASHER,28.3X34.0X1.8	AR				
92200G	92200-0232 (OPTION)	WASHER,28.3X34.0X2.0	AR				

E1361B

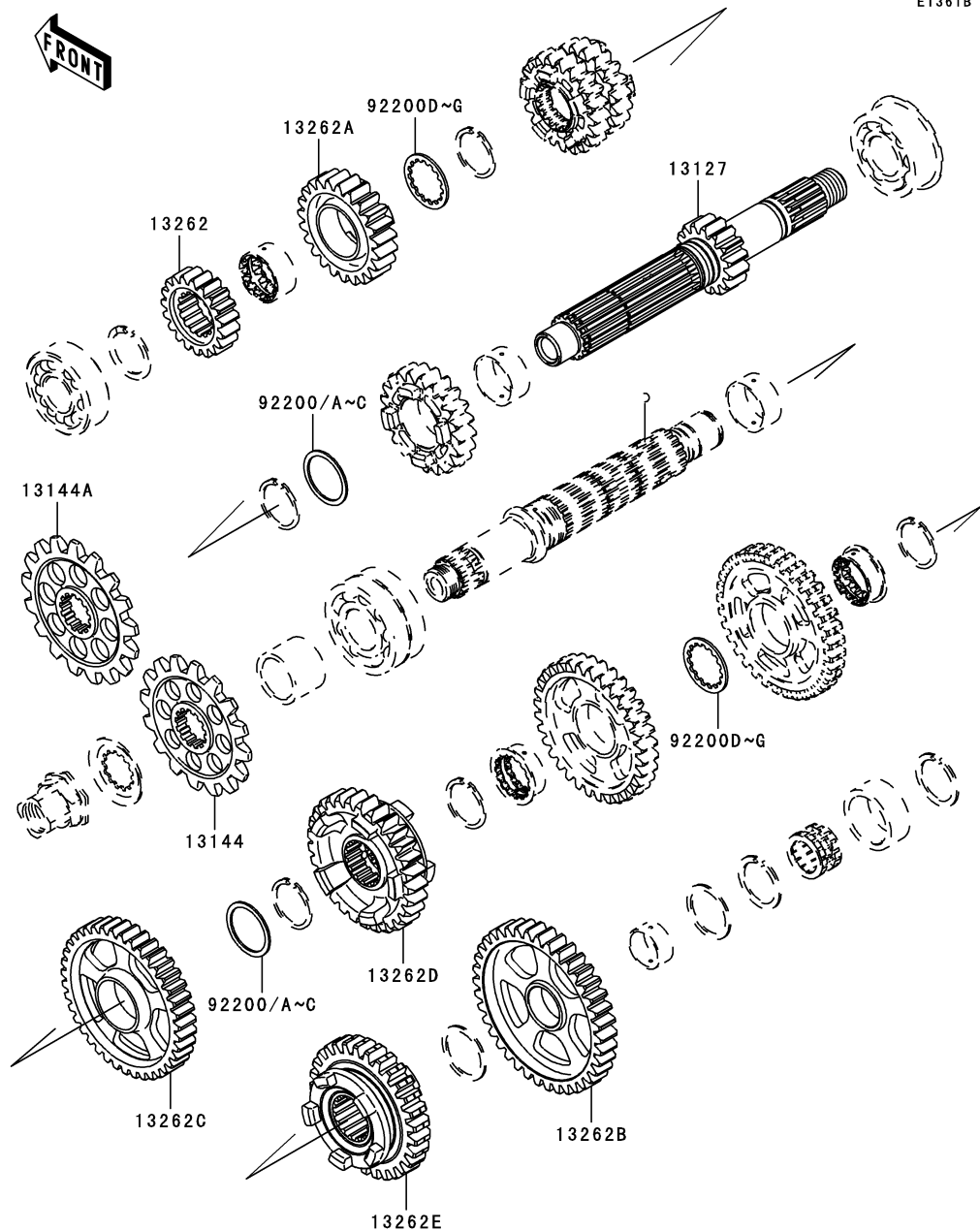

Ref. No.	Part No.	Description	Spec Code	Quantity-ZX1000			
				'06			
13127	13127-0043 (OPTION)	SHAFT-TRANSMISSION INPUT,16T				1	
13144	13144-0021 (OPTION)	SPROCKET-OUTPUT,16T,#520				1	
13144A	13144-0022 (OPTION)	SPROCKET-OUTPUT,17T,#520				1	
13262	13262-0279 (OPTION)	GEAR,INPUT 2ND,18T				1	
13262A	13262-0280 (OPTION)	GEAR,INPUT 6TH,22T				1	
13262B	13262-0281 (OPTION)	GEAR,OUTPUT LOW,37T				1	
13262C	13262-0282 (OPTION)	GEAR,OUTPUT 2ND,36T				1	
13262D	13262-0283 (OPTION)	GEAR,OUTPUT 6TH,28T				1	
13262E	13262-0351 (OPTION)	GEAR,OUTPUT 5TH,30T				1	
92200	92200-0225 (OPTION)	WASHER,28.1X34.0X0.8				AR	
92200A	92200-0226 (OPTION)	WASHER,28.1X34.0X1.0				AR	
92200B	92200-0227 (OPTION)	WASHER,28.1X34.0X1.4				AR	
92200C	92200-0228 (OPTION)	WASHER,28.1X34.0X1.6				AR	
92200D	92200-0229 (OPTION)	WASHER,28.3X34.0X1.2				AR	

This catalog covers:
'06 ZX1000DR6F Engine

GRID NO. **B-12** This grid covers:
Transmission(2/2)(TYPE-D)

E1361B

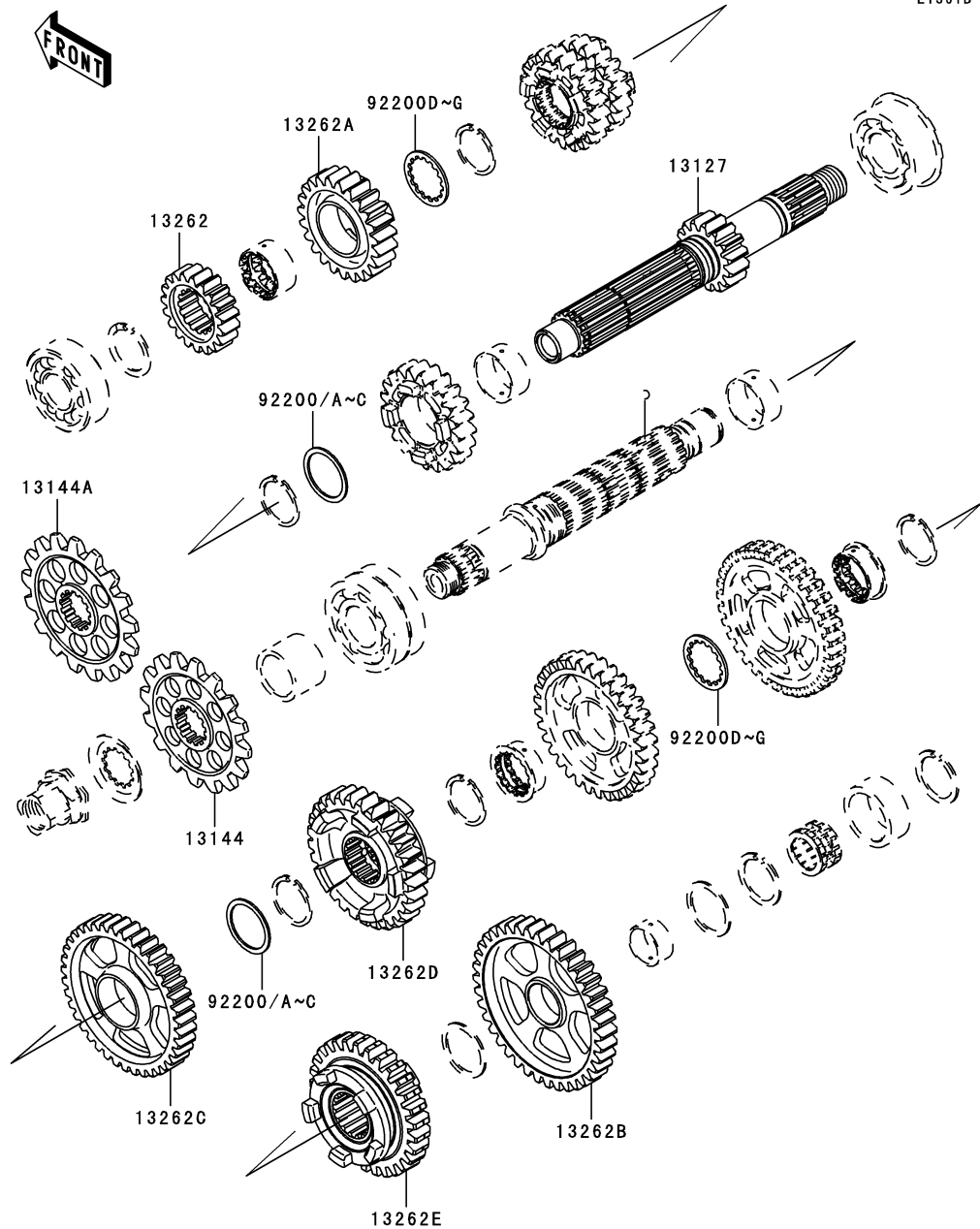

Ref. No.	Part No.	Description	Spec Code	Quantity-ZX1000			
				'06			
92200E	92200-0230 (OPTION)	WASHER,28.3X34.0X1.4	AR				
92200F	92200-0231 (OPTION)	WASHER,28.3X34.0X1.8	AR				
92200G	92200-0232 (OPTION)	WASHER,28.3X34.0X2.0	AR				

This catalog covers:

'06 ZX1000DR6F Engine

GRID NO.

B-13

This grid covers:

Gear Change Drum/Shift Fork(s)

E1362

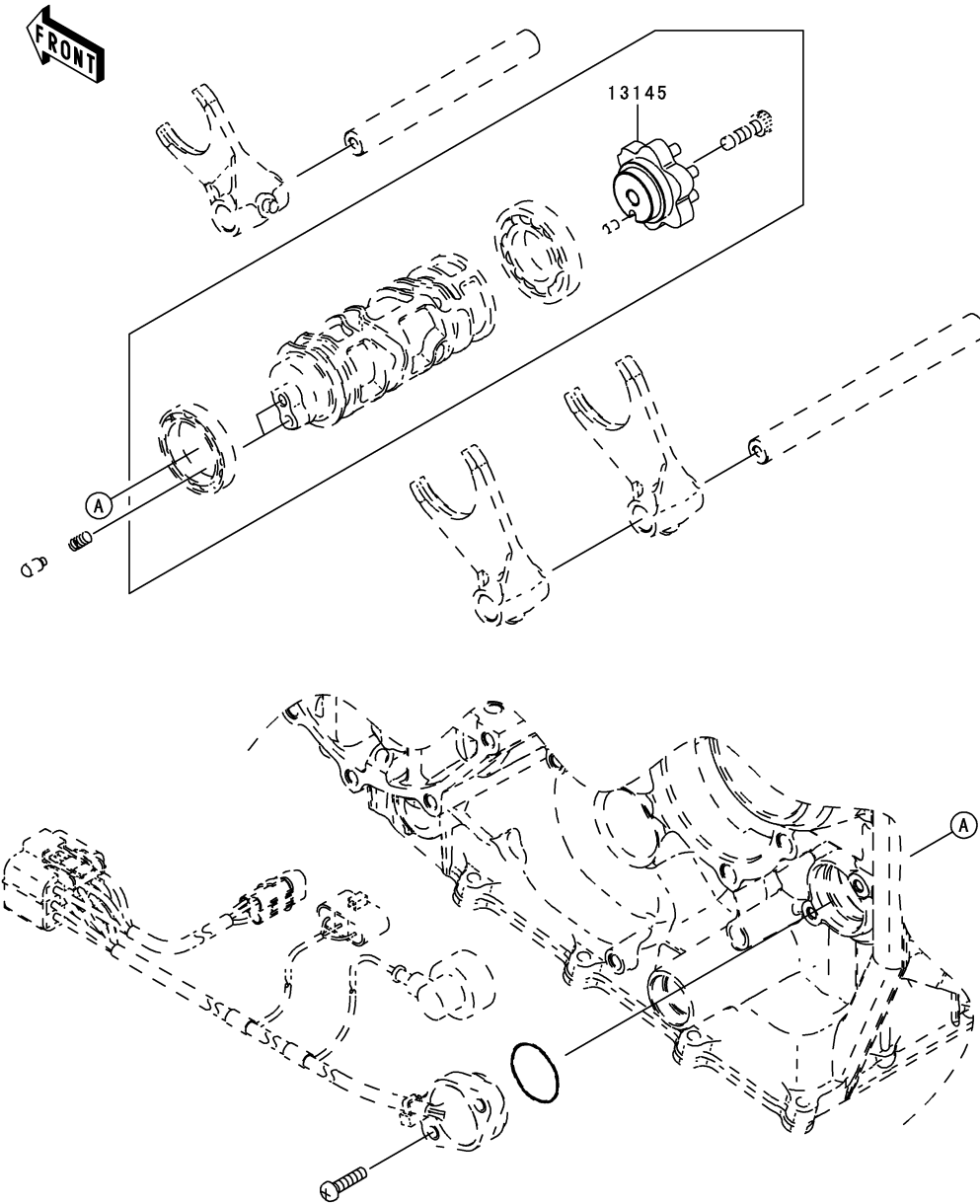

Ref. No.	Part No.	Description	Spec Code	Quantity-ZX1000			
				'06			
13145	13145-0021 (OPTION)	CAM-CHANGE DRUM					1

This catalog covers:

'06 ZX1000DR6F Engine

GRID NO.

B-14

This grid covers:

Gear Change Mechanism

E1370

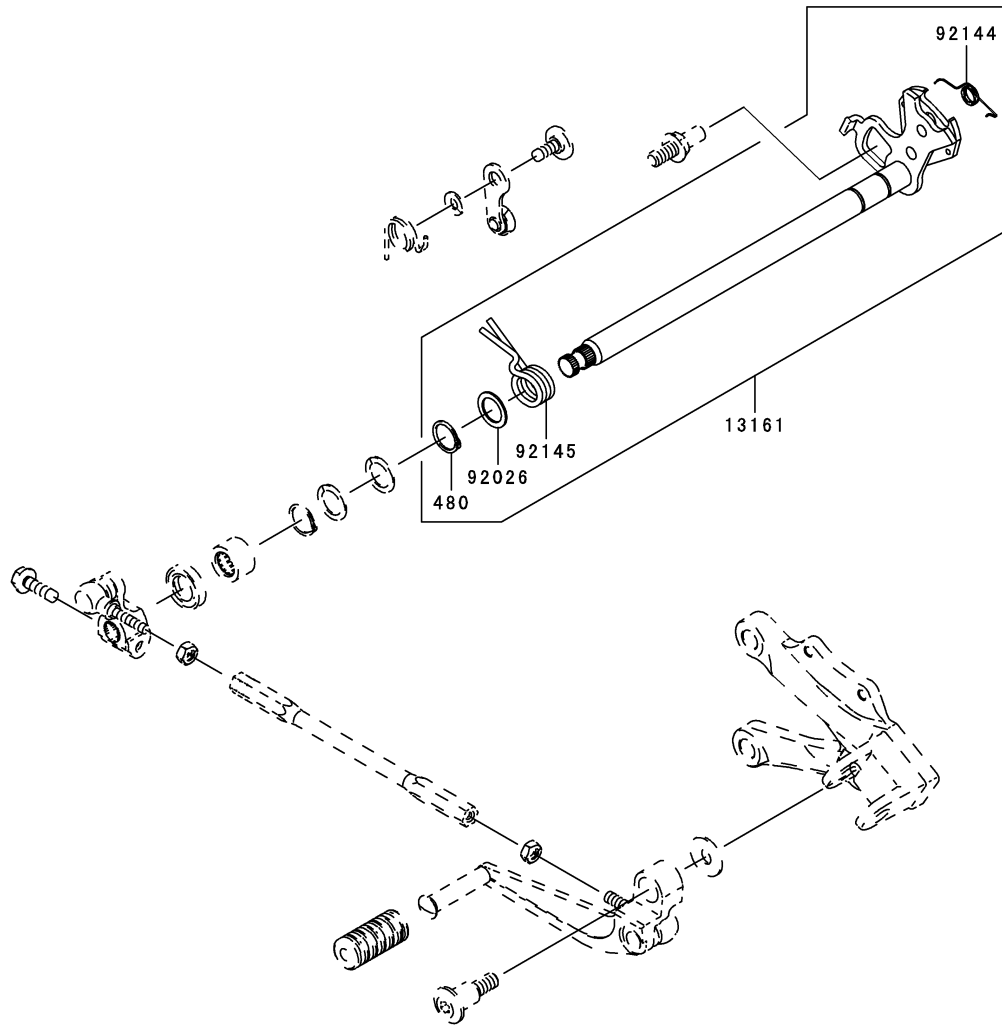

Ref. No.	Part No.	Description	Spec Code	Quantity-ZX1000			
				'06			
13161	13161-0042 (OPTION)	LEVER-COMP-CHANGE SHAFT		1			
92026	92026-1534 (OPTION)	SPACER,14X20X1.0		1			
92144	92144-1029 (OPTION)	SPRING		1			
92145	92145-0287 (OPTION)	SPRING		1			
480	480J1400 (OPTION)	CIRCLIP-TYPE-C,14MM		1			

E1431

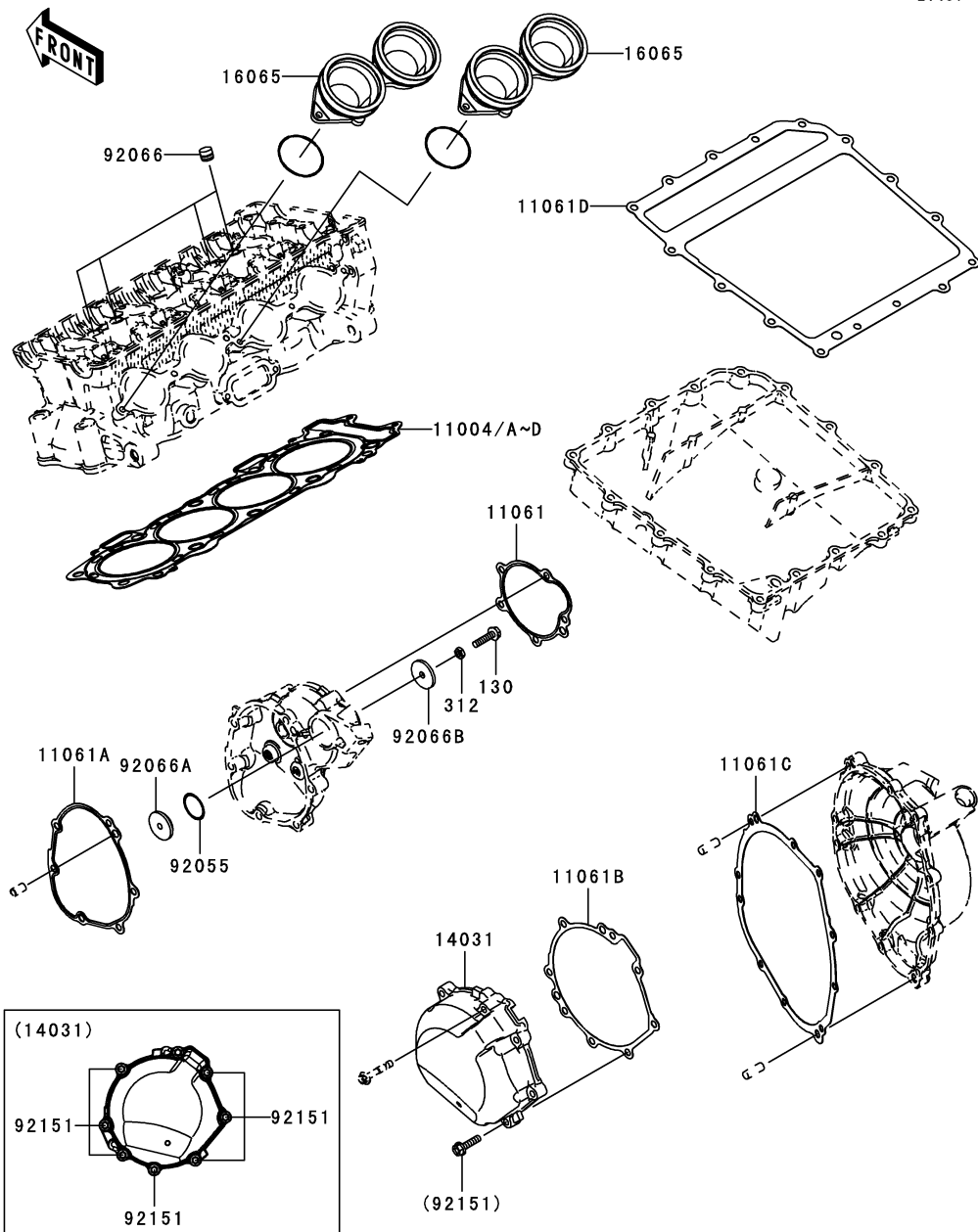

Ref. No.	Part No.	Description	Spec Code	Quantity-ZX1000		
				'06		
11004	11004-0022 (OPTION)	GASKET-HEAD,T=0.55				1
11004A	11004-0023 (OPTION)	GASKET-HEAD,T=0.45				1
11004B	11004-0026 (OPTION)	GASKET-HEAD,T=0.65				1
11004C	11004-0034 (OPTION)	GASKET-HEAD,T=0.50				1
11004D	11004-0052 (OPTION)	GASKET-HEAD,T=0.60				1
11061	11061-0229 (OPTION)	GASKET,IDLE GEAR COVER				1
11061A	11061-0230 (OPTION)	GASKET,STARTER COVER				1
11061B	11061-0231 (OPTION)	GASKET,GENERATOR COVER				1
11061C	11061-0232 (OPTION)	GASKET,CLUTCH COVER				1
11061D	11061-0233 (OPTION)	GASKET,OIL PAN				1
14031	14031-0063 (OPTION)	COVER-GENERATOR				1
16065	16065-0033 (OPTION)	HOLDER-CARBURETOR				2
92055	92055-1262 (OPTION)	RING-O,24.4X3.1				1
92066	92066-1005 (OPTION)	PLUG				4
92066A	92066-1332 (OPTION)	PLUG,STARTER HOLE				1
92066B	92066-1333 (OPTION)	PLUG,STARTER HOLE				1
92151	92151-1546 (OPTION)	BOLT,FLANGED,6X25				7
130	130G0625 (OPTION)	BOLT-FLANGED,6X25				1
312	312B0600 (OPTION)	NUT-HEX,6MM				1

This catalog covers:
'06 ZX1000DR6F Engine

GRID NO.

C-4

This grid covers:
Fuel Injection

E1530

Ref. No.	Part No.	Description	Spec Code	Quantity-ZX1000			
				'06			
				DR6F			
21175	21175-0096 (OPTION)	CONTROL UNIT-ELECTRONIC		1			
21176	21176-1099 (OPTION)	SENSOR,TEMP		1			
26011	26011-0071 (OPTION)	WIRE-LEAD,TEMP SENSOR EARTH		1			
26011A	26011-1779 (OPTION)	WIRE-LEAD,METER-TEMP SENSOR		1			
26031	26031-0240 (OPTION)	HARNES,INTERFACE BOX		1			
26031A	26031-0425 (OPTION)	HARNES,KIT METER		1			
26031B	26031-0426 (OPTION)	HARNES,STD METER		1			
26031C	26031-0427 (OPTION)	HARNES,STD		1			
27002	27002-1062 (OPTION)	RELAY-ASSY		1			

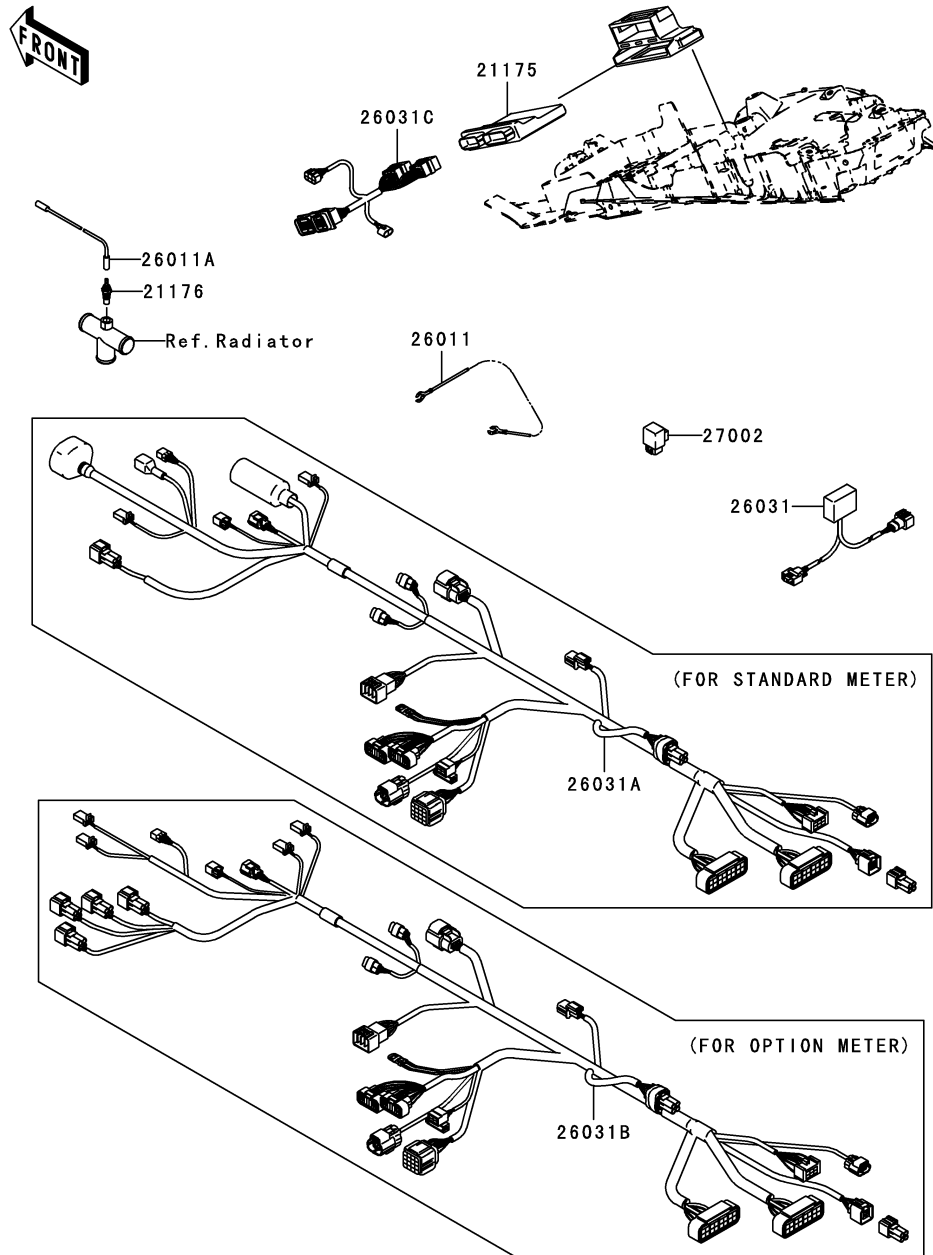

E1710

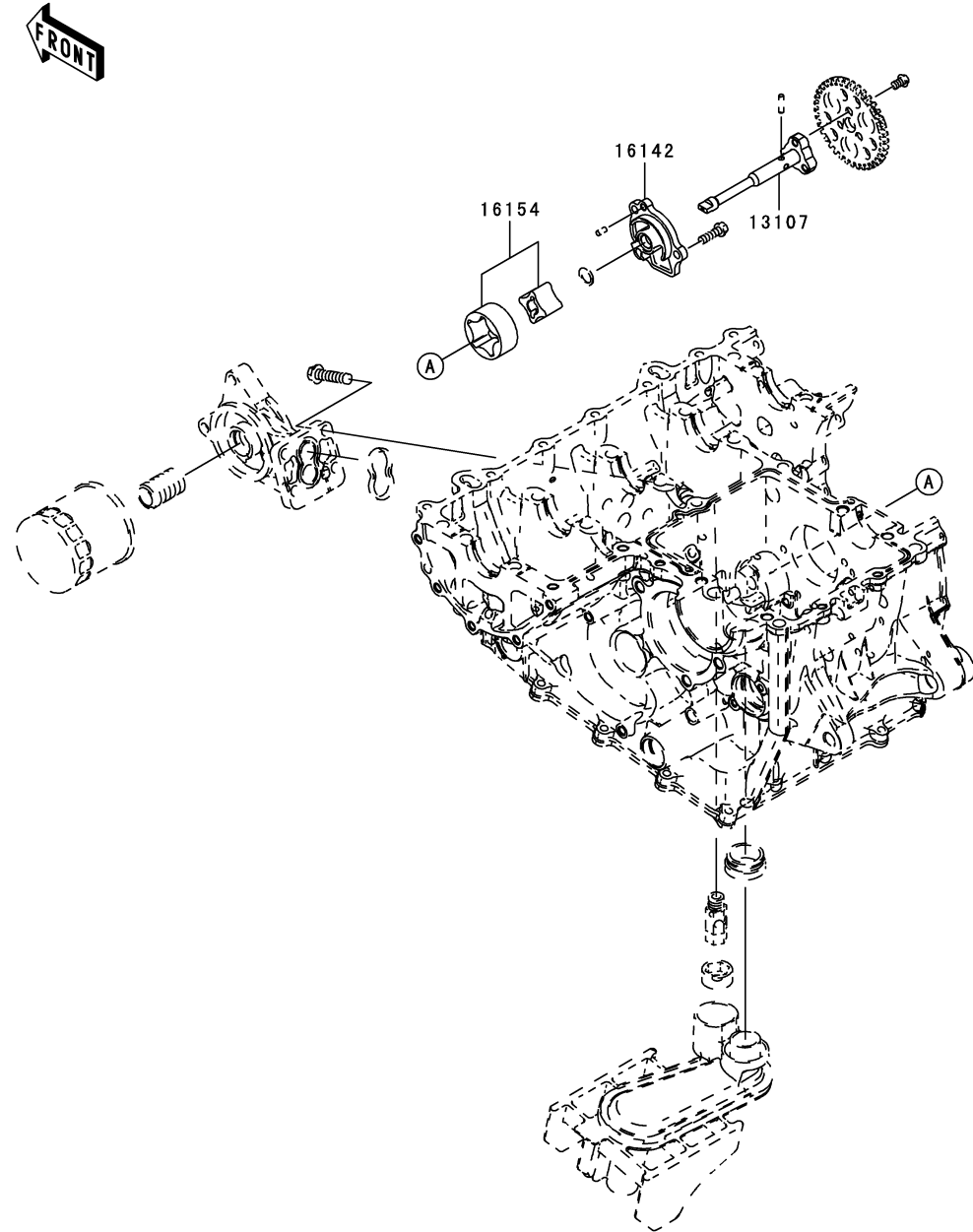

Ref. No.	Part No.	Description	Spec Code	Quantity-ZX1000			
				'06			
13107	13107-0127 (OPTION)	SHAFT					1
16142	16142-0036 (OPTION)	COVER-PUMP					1
16154	16154-0060 (OPTION)	ROTOR-PUMP					1

E1810

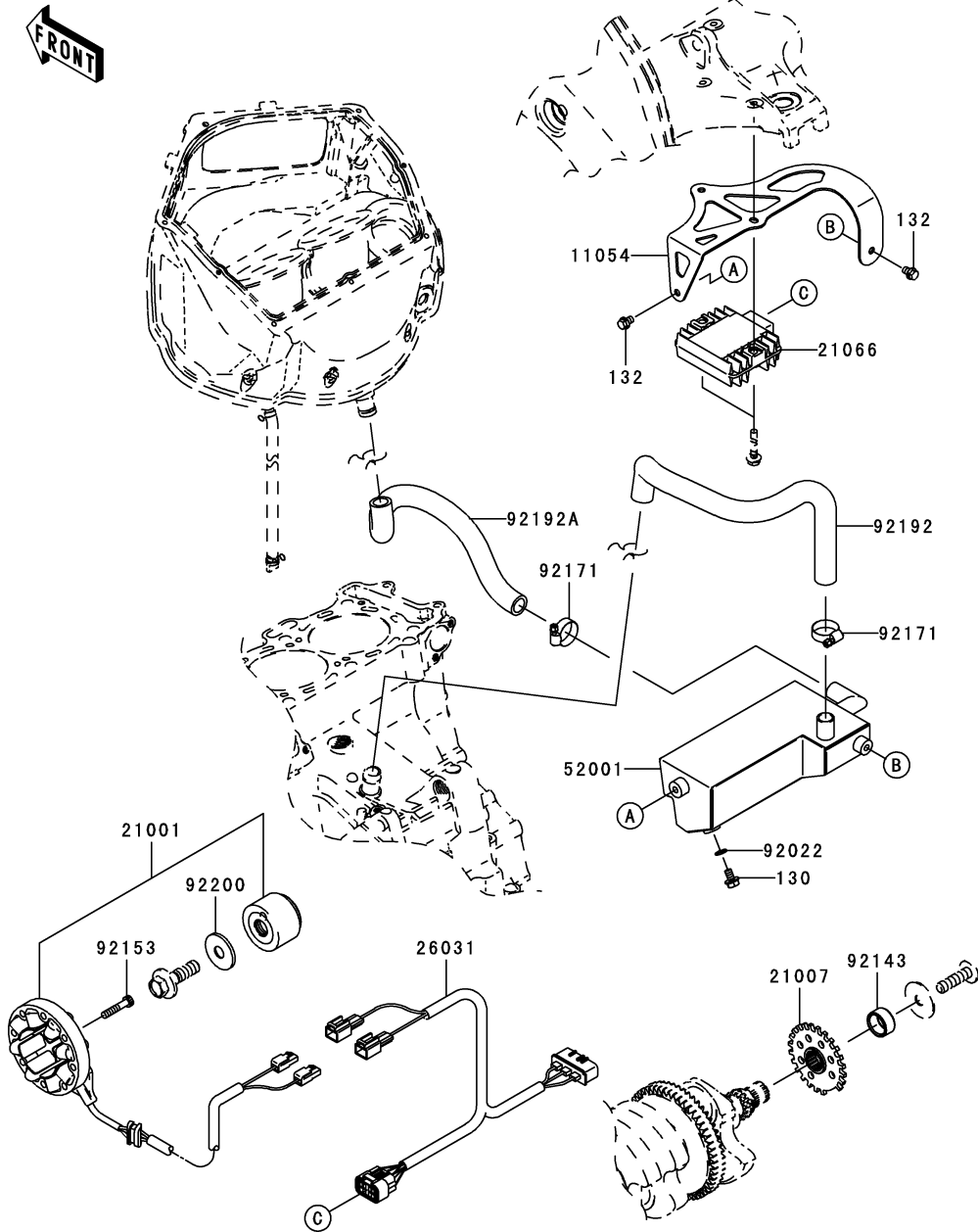

Ref. No.	Part No.	Description	Spec Code	Quantity-ZX1000			
				'06			
11054	11054-0455	BRACKET,OIL TANK				1	
21001	21001-0042	GENERATOR				1	
	(OPTION)						
21007	21007-0085	ROTOR				1	
	(OPTION)						
21066	21066-0010	REGULATOR-VOLTAGE				1	
	(OPTION)						
26031	26031-0323	HARNES				1	
	(OPTION)						
52001	52001-0002	TANK-OIL				1	
92022	92022-304	WASHER,6.2X11X1				1	
92143	92143-1291	COLLAR,SPROCKET				1	
	(OPTION)						
92153	92153-0386	BOLT,TORX,M6X28				4	
	(OPTION)						
92171	92171-0338	CLAMP				2	
92192	92192-0226	TUBE,CASE-TANK				1	
92192A	92192-0227	TUBE,TANK-AIR CLEANER				1	
92200	92200-0306	WASHER,12X36X3.2				1	
	(OPTION)						
130	130Y0610	BOLT-FLANGED,6X10				1	
132	132L0608	BOLT-FLANGED-SMALL,6X8				2	

E3032

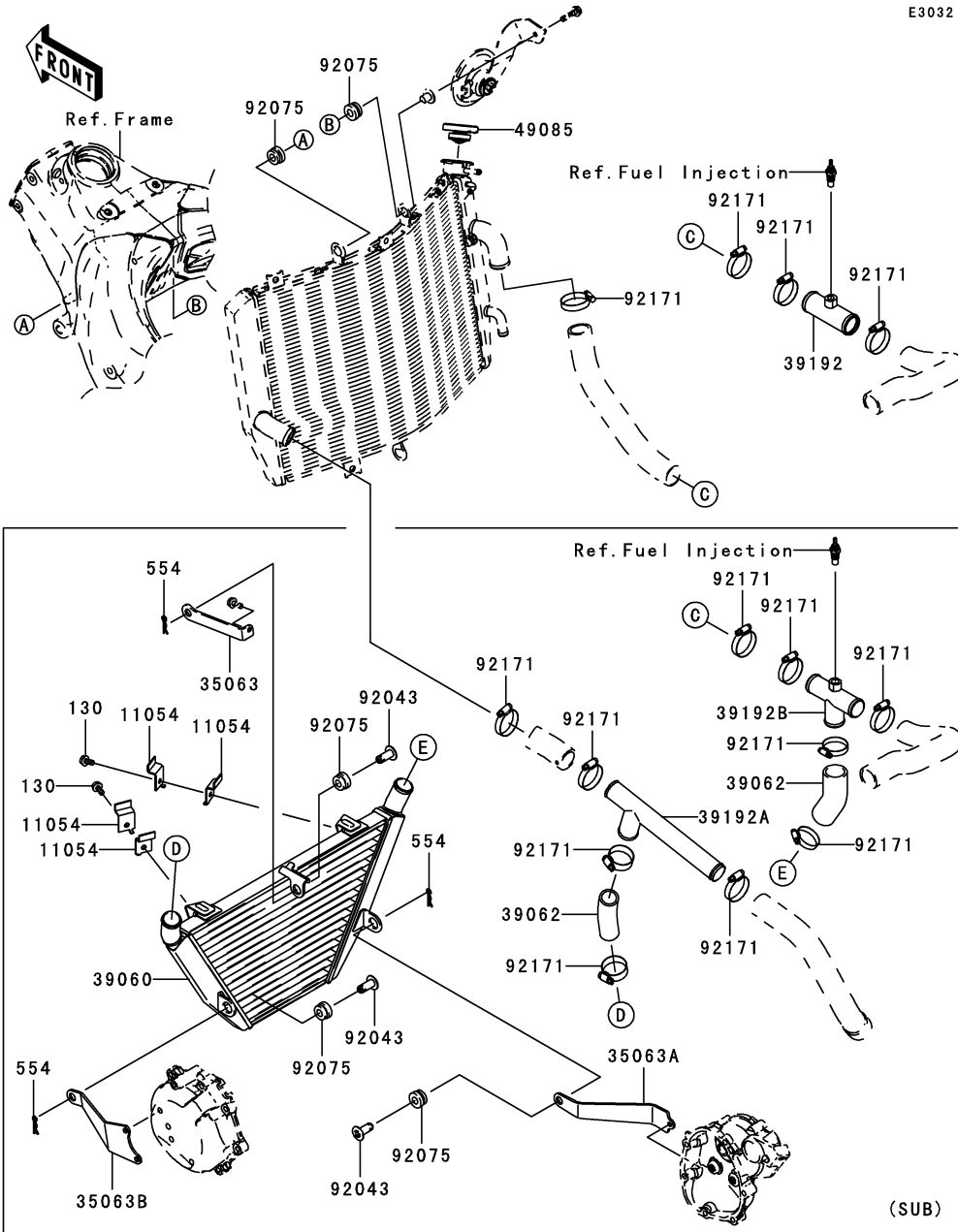

Ref. No.	Part No.	Description	Spec Code	Quantity-ZX1000	
				'06	DR6F
11054	11054-0459 (OPTION)	BRACKET		4	
35063	35063-0316 (OPTION)	STAY,MAIN		1	
35063A	35063-0317 (OPTION)	STAY,RH,SUB RAD		1	
35063B	35063-0318 (OPTION)	STAY,LH,SUB RAD		1	
39060	39060-0030 (OPTION)	RADIATOR,SUB		1	
39062	39062-1072 (OPTION)	HOSE-COOLING		2	
39192	39192-0011 (OPTION)	PIPE-WATER		1	
39192A	39192-0038 (OPTION)	PIPE-WATER,LH,SUB RAD		1	
39192B	39192-0039 (OPTION)	PIPE-WATER,RH,SUB RAD		1	
49085	49085-1078 (OPTION)	CAP-ASSY-PRESSURE		1	
92043	92043-1436 (OPTION)	PIN		3	
92075	92075-1123 (OPTION)	DAMPER,RUBBER		3	
92171	92171-0179 (OPTION)	CLAMP		7	
130	130L0612 (OPTION)	BOLT-FLANGED,6X12		2	
554	554A1000 (OPTION)	PIN-SNAP,10MM		3	

This catalog covers:

'06 ZX1000DR6F Chassis

GRID NO.

D-3

This grid covers:

Rear Hub

F2240

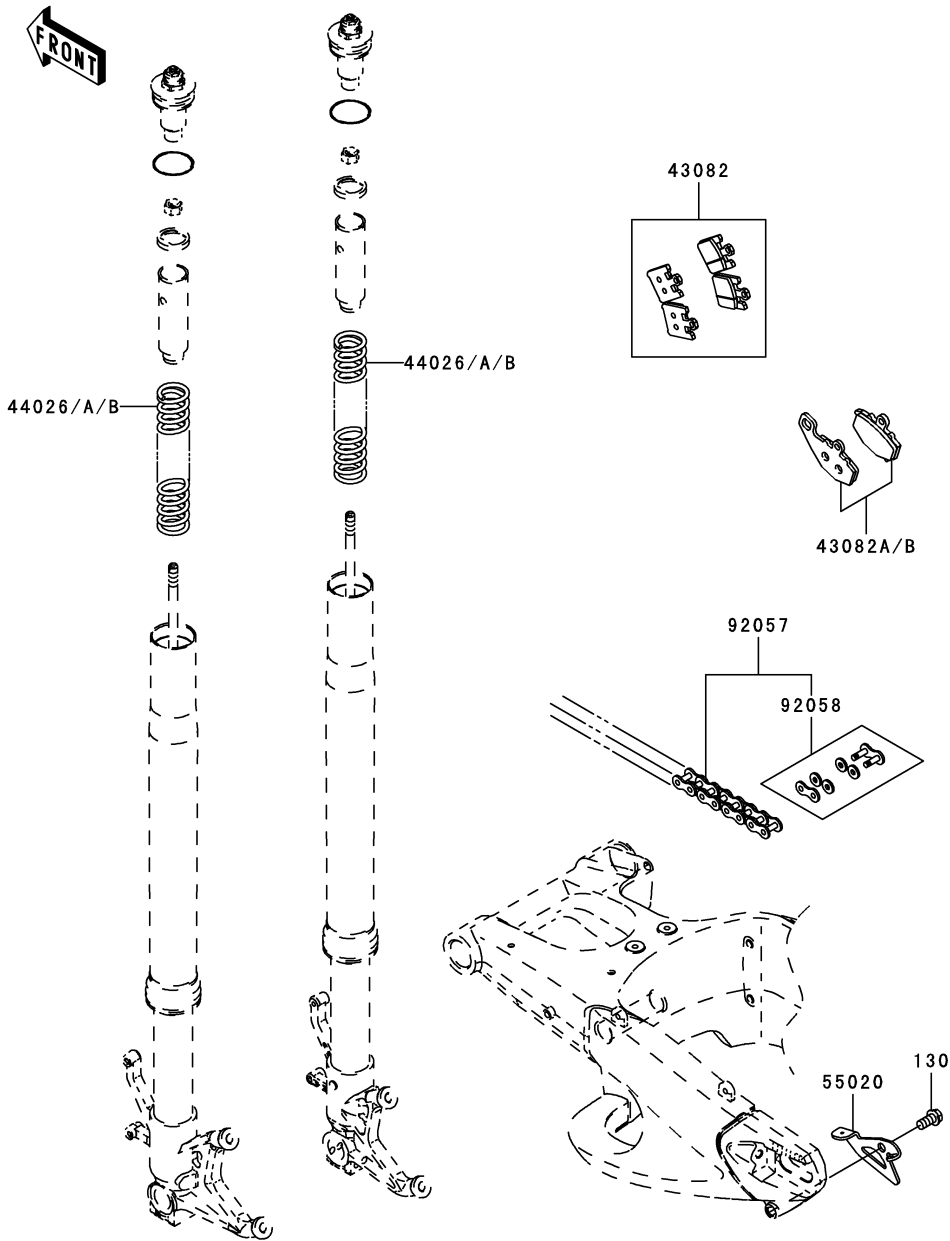

Ref. No.	Part No.	Description	Spec Code	Quantity-ZX1000			
				'06			
				DR6F			
43082	43082-0005 (OPTION)	PAD-ASSY-BRAKE,FR,F9633				2	
43082A	43082-1192 (OPTION)	PAD-ASSY-BRAKE,RR,C93				1	
43082B	43082-1220 (OPTION)	PAD-ASSY-BRAKE,RR,C93G				1	
44026	44026-0091 (OPTION)	SPRING-FRONT FORK,K=9.5N/MM				2	
44026A	44026-0092 (OPTION)	SPRING-FRONT FORK,K=10.0N/MM				2	
44026B	44026-0093 (OPTION)	SPRING-FRONT FORK,K=10.5N/MM				2	
55020	55020-0236 (OPTION)	GUARD,CHAIN				1	
92057	92057-1529 (OPTION)	CHAIN,DRIVE,120L(#520)				1	
92058	92058-1090 (OPTION)	JOINT-CHAIN,DRIVE(#520)				1	
130	130J1020 (OPTION)	BOLT-FLANGED,10X20				1	

This catalog covers:

'06 ZX1000DR6F Chassis

GRID NO.

D-4

This grid covers:

Handlebar

F2310

Ref. No.	Part No.	Description	Spec Code	Quantity-ZX1000			
				'06			
				DR6F			
27010	27010-0040 (OPTION)	SWITCH,SPEED CONTROL					1
31064	31064-1151 (OPTION)	PIPE-COMP,GRIP					1
32099	32099-0004 (OPTION)	CASE,UPP					1
32099A	32099-0005 (OPTION)	CASE,LWR					1
46075	46075-1143 (OPTION)	GRIP,THROTTLE					1
46091	46091-1809 (OPTION)	HOUSING-ASSY-CONTROL,RH					1
54012	54012-0185 (OPTION)	CABLE-THROTTLE,OPENING					1
54012A	54012-0186 (OPTION)	CABLE-THROTTLE,CLOSING					1
59101	59101-0001 (OPTION)	REEL,R21.5,60DEG					1
59101A	59101-0002 (OPTION)	REEL,R20.0,65DEG					1
92160	92160-1625 (OPTION)	DAMPER,KILL SWITCH					1
120	120S0625 (OPTION)	BOLT-SOCKET,6X25					2
220	220C0522	SCREW-PAN-CROS,5X22					2

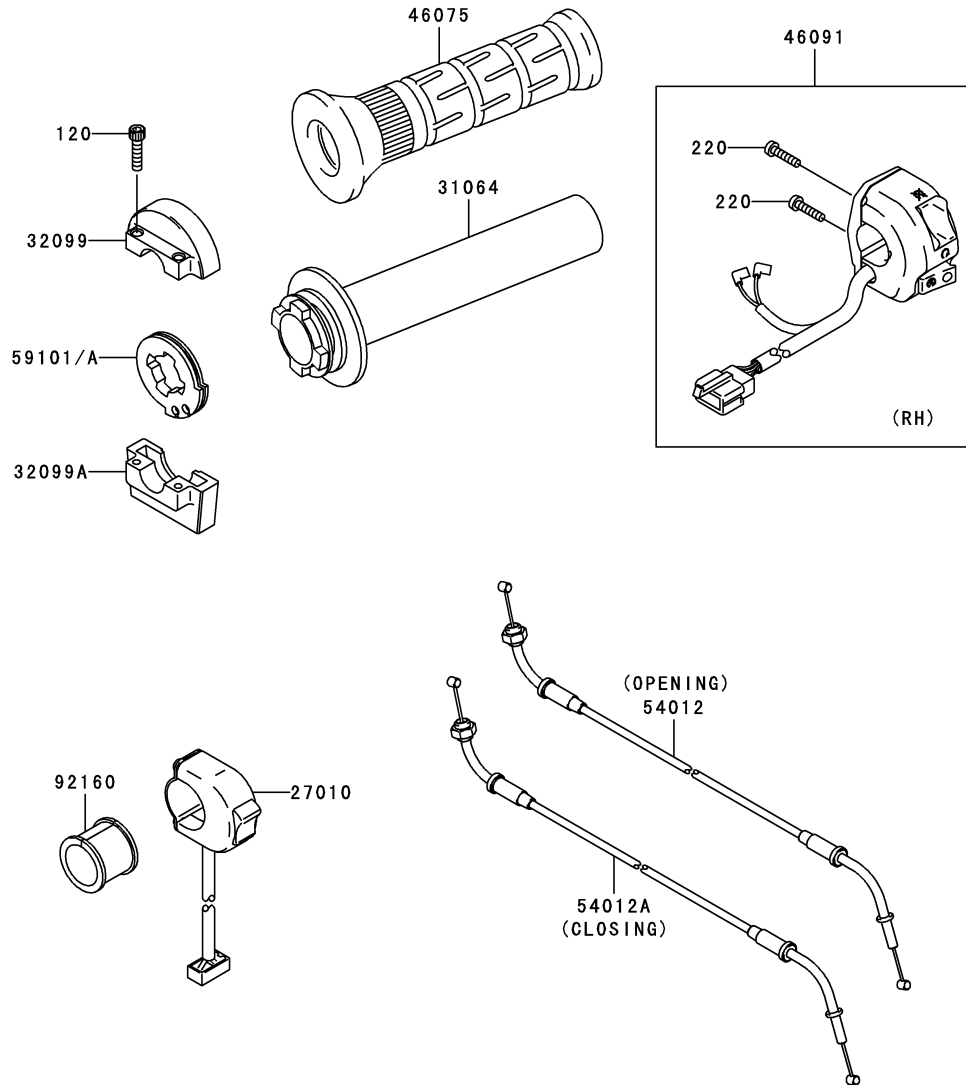

F2530



Ref. No.	Part No.	Description	Spec Code	Quantity-ZX1000			
				'06			
				DR6F			
11053	11053-1673 (OPTION)	BRACKET,KIT METER					1
11054	11054-0423 (OPTION)	BRACKET,COWLING STAY,LH					1
11054A	11054-0424 (OPTION)	BRACKET,COWLING STAY,RH					1
13061	13061-0124 (OPTION)	BOSS					2
23016	23016-0006 (OPTION)	LAMP-ASSY,INDICATOR					1
25031	25031-1142 (OPTION)	METER-ASSY					1
39156	39156-0098 (OPTION)	PAD,KIT METER					1
92015	92015-1233 (OPTION)	NUT,FLANGED,6MM,BLACK					2
92039	92039-1106 (OPTION)	RIVET					3
92152	92152-0058 (OPTION)	COLLAR					3
92153	92153-1275 (OPTION)	BOLT,SOCKET,6X12					2
130	130J0618 (OPTION)	BOLT-FLANGED,6X18					2
554	554A1200 (OPTION)	PIN-SNAP					2
670	670E2014 (OPTION)	O RING,14MM					2

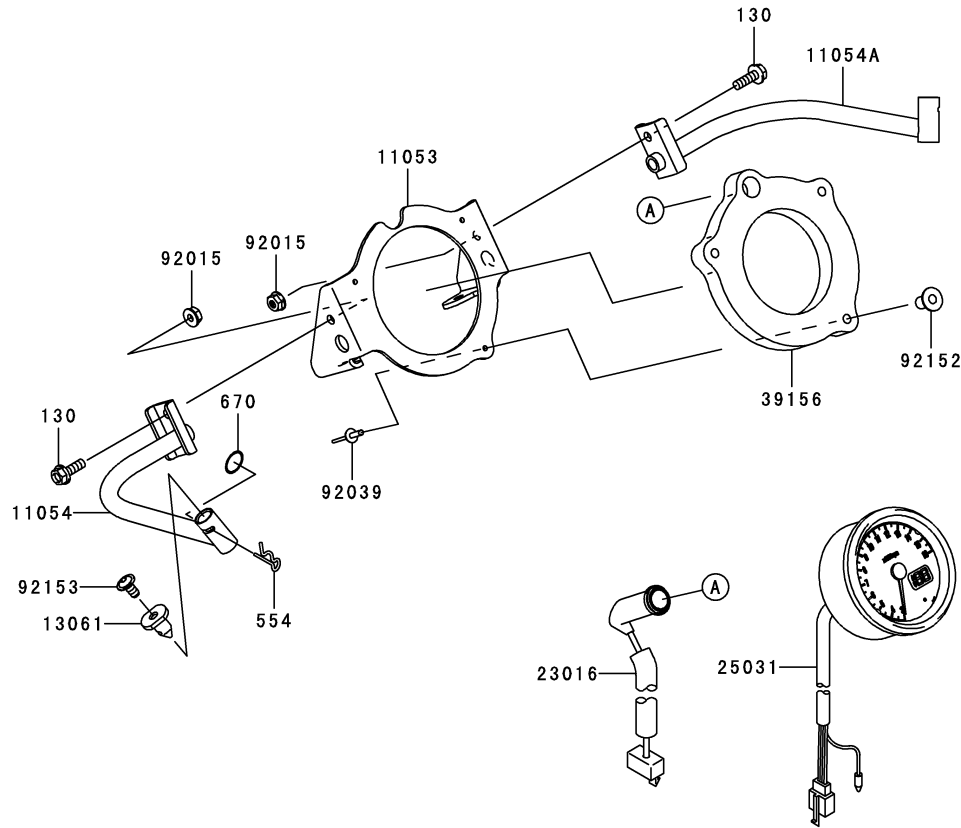



KAWASAKI HEAVY INDUSTRIES, LTD.
Consumer Products & Machinery Company

Doc No. 99929-0011-01