



---

# WORKSHOP MANUAL

---

633212

---



## MSS Fly 50 4T

---



# **WORKSHOP MANUAL**

## **MSS Fly 50 4T**

The descriptions and illustrations given in this publication are not binding. While the basic specifications as described and illustrated in this booklet remain unchanged, PIAGGIO-GILERA reserves the right, at any time and without being required to update this publication beforehand, to make any changes to components, parts or accessories, which it considers necessary to improve the product or which are required for manufacturing or construction reasons.

Not all versions shown in this publication are available in all countries. The availability of single models should be checked at the official Piaggio sales network.

"© Copyright 2007 - PIAGGIO & C. S.p.A. Pontedera. All rights reserved. Reproduction of this publication in whole or in part is prohibited."

PIAGGIO & C. S.p.A. - After sales

V.le Rinaldo Piaggio, 23 - 56025 PONTEDERA (Pi)

---

# WORKSHOP MANUAL

## MSS Fly 50 4T

This workshop manual has been drawn up by Piaggio & C. Spa to be used by the workshops of Piaggio-Gilera dealers. This manual is addressed to Piaggio service mechanics who are supposed to have a basic knowledge of mechanics principles and of vehicle fixing techniques and procedures. Any important changes made to the vehicles or to specific fixing operations will be promptly reported by updates to this manual. Nevertheless, no fixing work can be satisfactory if the necessary equipment and tools are unavailable. It is therefore advisable to read the sections of this manual relating to specific tools, along with the specific tool catalogue.

**N.B.** Provides key information to make the procedure easier to understand and carry out.

**CAUTION** Refers to specific procedures to carry out for preventing damages to the vehicle.

**WARNING** Refers to specific procedures to carry out to prevent injuries to the repairer.



**Personal safety** Failure to completely observe these instructions will result in serious risk of personal injury.



**Safeguarding the environment** Sections marked with this symbol indicate the correct use of the vehicle to prevent damaging the environment.



**Vehicle intactness** The incomplete or non-observance of these regulations leads to the risk of serious damage to the vehicle and sometimes even the invalidity of the guarantee.



## INDEX OF TOPICS

CHARACTERISTICS

CHAR

TOOLING

TOOL

MAINTENANCE

MAIN

TROUBLESHOOTING

TROUBL

ELECTRICAL SYSTEM

ELE SYS

ENGINE FROM VEHICLE

ENG VE

ENGINE

ENG

SUSPENSIONS

SUSP

BRAKING SYSTEM

BRAK SYS

CHASSIS

CHAS

PRE-DELIVERY

PRE DE

TIME

TIME

## INDEX OF TOPICS

**C**HARACTERISTICS

**CHAR**

---

**Rules**

This section describes general safety rules for any maintenance operations performed on the vehicle.

---

**Safety rules**

- If work can only be done on the vehicle with the engine running, make sure that the premises are well-ventilated, using special extractors if necessary; never let the engine run in an enclosed area. Exhaust fumes are toxic.
  - The battery electrolyte contains sulphuric acid. Protect your eyes, clothes and skin. Sulphuric acid is highly corrosive; in the event of contact with your eyes or skin, rinse thoroughly with abundant water and seek immediate medical attention.
  - The battery produces hydrogen, a gas that can be highly explosive. Do not smoke and avoid sparks or flames near the battery, especially when charging it.
  - Fuel is highly flammable and it can be explosive given some conditions. Do not smoke in the working area, and avoid open flames or sparks.
  - Clean the brake pads in a well-ventilated area, directing the jet of compressed air in such a way that you do not breathe in the dust produced by the wear of the friction material. Even though the latter contains no asbestos, inhaling dust is harmful.
- 

**Maintenance rules**

- Use original PIAGGIO spare parts and lubricants recommended by the Manufacturer. Non-original or non-conforming spares may damage the vehicle.
  - Use only the appropriate tools designed for this vehicle.
  - Always use new gaskets, sealing rings and split pins upon refitting.
  - After removal, clean the components using non-flammable or low flash-point solvents. Lubricate all the work surfaces, except tapered couplings, before refitting these parts.
  - After refitting, make sure that all the components have been installed correctly and work properly.
  - For removal, overhaul and refit operations use only tools with metric measures. Metric bolts, nuts and screws are not interchangeable with coupling members with English measurement. Using unsuitable coupling members and tools may damage the vehicle.
  - When carrying out maintenance operations on the vehicle that involve the electrical system, make sure the electric connections have been made properly, particularly the ground and battery connections.
-

## Vehicle identification

### VEHICLE IDENTIFICATION

Specification	Desc./Quantity
Engine prefix	C442M ÷ 1001
Chassis prefix	ZAPM44200 ÷ 1001



## Dimensions and mass

### WEIGHT AND DIMENSIONS

Specification	Desc./Quantity
Length	1,880
Maximum height	1150 mm
Seat height	785
Width	735
Wheelbase	1,340
Kerb weight	105 kg



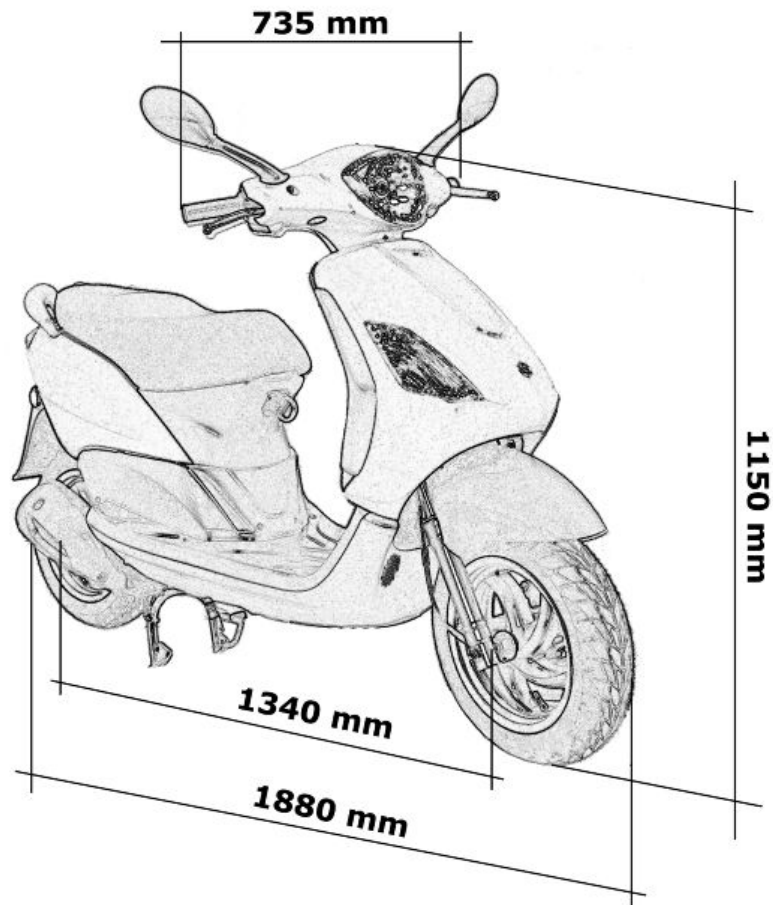

**Engine**

**ENGINE**

Specification	Desc./Quantity
Engine type	Single cylinder 4-stroke Piaggio Hi-PER4
Bore x stroke	39 X 41.8 mm
Cubic capacity	49.93 cm <sup>3</sup>
Compression ratio	11.5 :1
Timing system	single overhead camshaft, driven by a chain to the left side.
Depression carburettor	KEIHN CVK 18
CO adjustment	3,2% ± 0,5
Engine idle	1900 ÷ 2000 rpm.
Air filter	Sponge, soaked in a mixture (50% SELENIA Air Filter Oil and 50% unleaded petrol).
Starting system	electric starter/kick-starter
Lubrication	Engine lubrication with lobe pump (inside the crankcase), chain-driven, and double filter: mesh and centrifugal.
Fuel supply	Gravity feed, with unleaded petrol (with a minimum octane rating of 95) with carburettor.
Max. power (crankshaft)	2,5 KW (3,4 CV) at 6500 rpm.
Cooling system	forced coolant circulation system
Valve clearance	intake: 0.10 mm discharge: 0.15 mm

## Transmission

### TRANSMISSION

Specification	Desc./Quantity
Transmission	With automatic expandable pulley variator, torque server, V-belt, automatic clutch, gear reduction unit.

## Capacities

### CAPACITY

Specification	Desc./Quantity
Rear hub oil	Quantity: approx. 85 cc
Engine oil	Capacity: approx. 850 cm <sup>3</sup>
Fuel tank capacity	approx. 7.2 litres (of which 1.5 l is reserve)

## Electrical system

### IMPIANTO ELETTRICO

Specification	Desc./Quantity
Type of ignition	Capacitive discharge type electronic ignition, with incorporated high voltage coil
Ignition advance variable, with microprocessor (before T.D.C.)	10° at 1800-2000 rpm 26° at 5000-6000 rpm
Spark plug	Champion RG 4 PHP Champion RG 4 HC
Alternative spark plug	DENSO U24ESR-NB
Battery	12V-9Ah
Fuse	10A
Generator	single-phase alternating current

## Frame and suspensions

### FRAME AND SUSPENSION

Specification	Desc./Quantity
Type of chassis	Welded tubular steel chassis with stamped sheet reinforcements.
Front suspension	Telescopic mechanical fork, 76-mm travel.
Rear suspension	Single hydraulic shock absorber, 72.5-mm travel

## Brakes

### BRAKES

Specification	Desc./Quantity
Front brake	Disc brake (Ø 200 mm) with hydraulic control (lever on the right end of the handlebar) and floating calliper.
Rear brake	drum brake (Ø 140 mm) with mechanical linkage.(l.h. brake lever).

## Wheels and tyres

### WHEELS AND TYRES

Specification	Desc./Quantity
Front wheel rim	Die-cast aluminium alloy 3.50 x 12"
Front tyre	Tubeless, 120/70-12"
Rear wheel rim	Die-cast aluminium alloy: 3.00"x12"
Rear tyre	Tubeless, 120/70 - 12"
Front tyre pressure	1.8 bar
Rear tyre pressure	2 bar
Rear wheel pressure (rider and passenger):	2.3 bar

N.B.

**CHECK AND ADJUST TYRE PRESSURE WITH TYRES AT AMBIENT TEMPERATURE. ADJUST PRESSURE ACCORDING TO THE WEIGHT OF RIDER AND ACCESSORIES.**

## Secondary air

- The SAS (Secondary air housing) operating principle for 50 4T engines is similar to that for 50 2T engines; the only difference lies in how air is sucked in the external and the external side of the transmission compartment.
- Air is taken in along tube «A» (to the cylinder side) and, after been cleaned through the filter «B», gets into the reed valve «C» to be directed towards the head through a flexible pipe and then a rigid one «D» flanged to the head. In this way, the air reaches the discharge pipe to increase the amount of oxygen in the unburned gases before the catalytic converter, thus helping a better reaction of this device.

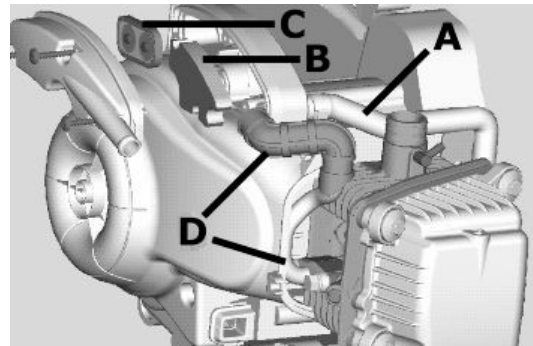

## Carburettor

### 50cc Version

## Kehin

### KEHIN CARBURETTOR

Specification	Desc./Quantity
Type	CVK 18
Throttle valve diameter:	Ø 18,5
Choke diameter	Ø 17
Marking on body:	Z61B
Maximum thrust	75
Maximum air thrust (on body)	Ø1,1
Marking on conical needle:	NGBA
Throttle spring:	100 ÷ 159 gr
Minimum thrust	35
Idle air jet (on body):	Ø 1,4
Initial opening - idle mixture screw:	1 3/4
Starter jet	40
Starter air nozzle (on the body):	Ø 1.5
Choke needle travel:	11,5 mm

## Tightening Torques

### FRONT BRAKE

Name	Torque in Nm
Brake fluid pump - hose fitting	16 ÷ 20 Nm
Brake fluid pipe-calliper fitting	19 ÷ 24
Calliper tightening screw	24 ÷ 27
Disc tightening screw	8 ÷ 10
Oil bleed screw	7 ÷ 10

### FRONT SUSPENSION

Name	Torque in Nm
Lower fork fixing screw	15 ÷ 20
Front wheel axle nut	45 - 50

### STEERING ASSEMBLY

Name	Torque in Nm
Upper steering ring nut	35 ÷ 40
Steering lower ring nut	8 ÷ 10
Handlebar fixing screw	50 ÷ 55

### CHASSIS

Name	Torque in Nm
Swinging arm - engine pin*	33 ÷ 41
Frame/swing-arm bolt (*)	64÷72
Shock absorber - chassis nut (**)	20 to 25 Nm
shock absorber - engine pin (*)	33 to 41 N-m
Rear wheel axle (*)	104÷126 N-m
Centre-stand mounting bracket bolt	25÷30 N-m
Centre-stand mounting bracket screw	20÷25 N-m
Side stand fixing screw	12 ÷ 20
Side stand bracket fixing screw	15 ÷ 20

## Overhaul data

## Assembly clearances

## Cylinder - piston assy.

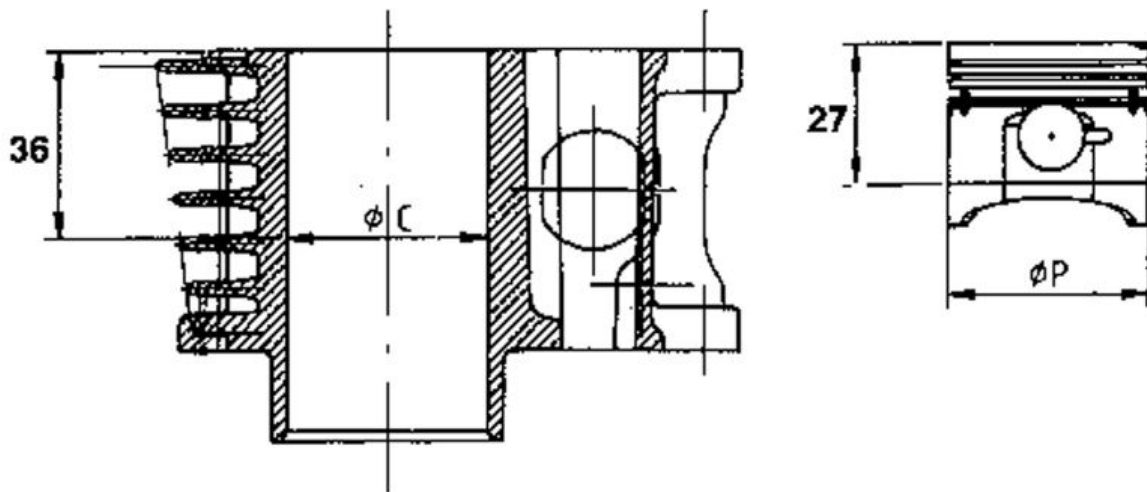
**CONNECTION PISTON AND CYLINDER**

Name	Initials	Cylinder	Piston	Play on fitting
Cylinder (with asso piston/right way)	A	38,993 ÷ 39,000	38,954 ÷ 38,961	0.032 ÷ 0.046
Cylinder (with shiram piston)	A	38,993 ÷ 39,000	38,949 ÷ 38,956	0.037 ÷ 0.051
Cylinder (with asso piston/right way)	B	39,000 ÷ 39,007	38,961 ÷ 38,968	0.032 ÷ 0.046
Cylinder (with shiram piston)	B	39,000 ÷ 39,007	38,956 ÷ 38,966	0.037 ÷ 0.051
Asso piston/right way (with asso cylinder/right way)	C	39,007 ÷ 39,014	38,968 ÷ 38,975	0,032 ÷ 0,046
Asso piston/right way (with shiram cylinder)	C	39,007 ÷ 39,014	38,963 ÷ 38,970	0,037 ÷ 0,051
Shiram piston (with asso cylinder/right way)	D	39,014 ÷ 39,021	38,975 ÷ 38,982	0,032 ÷ 0,046
Shiram piston (with shiram cylinder)	D	39,014 ÷ 39,021	38,970 ÷ 38,977	0,037 ÷ 0,051
Cylinder 1st oversize	A1	39.193 ÷ 39.200	39.154 ÷ 39.161	0.032 ÷ 0.046
Cylinder 1st oversize	B1	39.200 ÷ 39.207	39.161 ÷ 39.168	0.032 ÷ 0.046
Piston 1st oversize	C1	39.207 ÷ 39.214	39.168 ÷ 39.175	0.032 ÷ 0.046
Piston 1st oversize	D1	39.214 ÷ 39.221	39.175 ÷ 39.182	0.032 ÷ 0.046
Cylinder 2nd oversize	A2	39.393 ÷ 39.400	39.354 ÷ 39.361	0.032 ÷ 0.046
Cylinder 2nd oversize	B2	39.400 ÷ 39.407	39.361 ÷ 39.368	0.032 ÷ 0.046
Piston 2nd oversize	C2	39.407 ÷ 39.414	39.368 ÷ 39.375	0.032 ÷ 0.046
Piston 2nd oversize	D2	39.414 ÷ 39.421	39.375 ÷ 39.382	0.032 ÷ 0.046
Cylinder 3rd oversize	A3	39.593 ÷ 39.600	39.554 ÷ 39.561	0.032 ÷ 0.046
Cylinder 3rd oversize	B3	39.600 ÷ 39.607	39.561 ÷ 39.568	0.032 ÷ 0.046
Piston 3rd oversize	C3	39.607 ÷ 39.614	39.568 ÷ 39.575	0.032 ÷ 0.046
Piston 3rd oversize	D3	39.614 ÷ 39.621	39.575 ÷ 39.582	0.032 ÷ 0.046

**Piston rings**

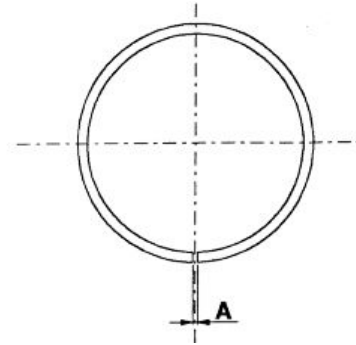

**SEAL RINGS**

Name	Description	Dimensions	Initials	Quantity
1st Compression ring		39 x 1	A	0.08 ÷ 0.20
2nd Compression ring		39 x 1	A	0.05 ÷ 0.20
Oil scraper ring		39 x 2	A	0.20 ÷ 0.70
1st Compression ring 1st Oversize		39.2 x 1	A	0.08 ÷ 0.20
2nd Compression ring 1st Oversize		39.2 x 1	A	0.05 ÷ 0.20
Oil scraper ring 1st Oversize		39.2 x 2	A	0.20 ÷ 0.70
1st Compression ring 2nd Oversize		39.4 x 1	A	0.08 ÷ 0.20
2nd Compression ring 2nd Oversize		39.4 x 1	A	0.05 ÷ 0.20
Oil scraper ring 2nd Oversize		39.4 x 2	A	0.20 ÷ 0.70
1st Compression ring 3rd Oversize		39.6 x 1	A	0.08 ÷ 0.20
2nd Compression ring 3rd Oversize		39.6 x 1	A	0.05 ÷ 0.20
Oil scraper ring 3rd Oversize		39.6 x 2	A	0.20 ÷ 0.70

**Crankcase - crankshaft - connecting rod**

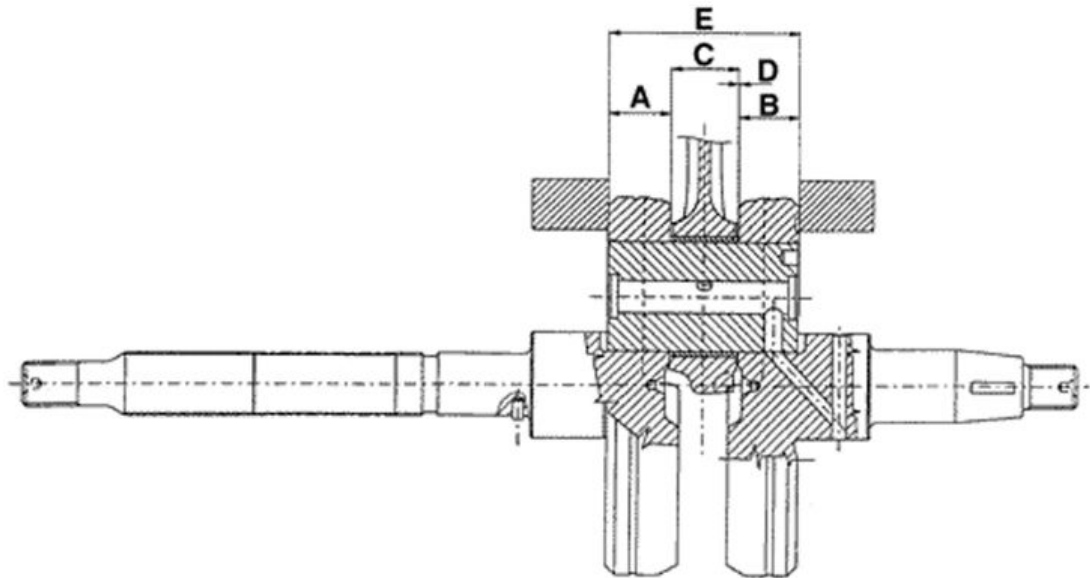

**END PLAY BETWEEN DRIVING SHAFT AND CONNECTING ROD**

Name	Description	Dimensions	Initials	Quantity
Half-shaft, transmission side		14 +0 -0.005	A	
Flywheel-side half-shaft		16 +0 -0.005	B	
Connecting rod		14.8 +0.05 -0	C	
Spacer tool		45.00 / Fits and clearances D = 0.15 ÷ 0.30	E	

**Slot packing system**

N.B.

MEASUREMENT "A" TO BE TAKEN IS A VALUE OF PISTON RE-ENTRY, IT INDICATES BY HOW MUCH THE PLANE FORMED BY THE PISTON CROWN FALLS BELOW THE PLANE FORMED BY THE TOP OF THE CYLINDER. THE FURTHER THE PISTON GETS INSIDE THE CYLINDER, THE THINNER THE HEAD GASKET TO BE APPLIED SHOULD BE (TO RECOVER THE COMPRESSION RATIO) AND VICE VERSA.

**Characteristic**

Shimming system to control the compression ratio

CR: 11.1 ÷ 12.9

**PISTON PROTRUSION CHECK**

Name	Measure A	Thickness
shimming_1	0.05 ÷ 0.25	0.35
shimming_2	0.25 ÷ 0.40	0.25

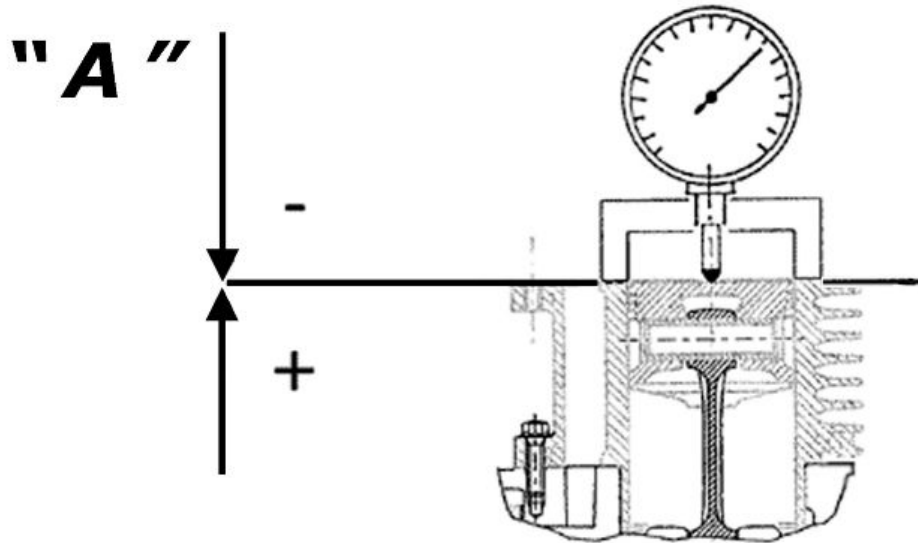

**Products**

**TABLE OF RECOMMENDED PRODUCTS**

Product	Description	Specifications
AGIP ROTRA 80W-90	rear hub oil	SAE 80W/90 Oil that exceeds the requirements of API GL3 specifications
AGIP CITY HI TEC 4T	Oil to lubricate flexible transmissions (brakes, throttle control and odometer)	Oil for 4-stroke engines
AGIP FILTER OIL	Oil for air filter sponge	Mineral oil with specific additives for increased adhesiveness
AGIP GP 330	Grease (brake control levers, throttle grip)	Calcium complex soap-based grease with NLGI 2; ISO-L-XBCIB2
AGIP CITY HI TEC 4T	Engine oil	SAE 5W-40, API SL, ACEA A3, JASO MA Synthetic oil
AGIP BRAKE 4	Brake fluid	FMVSS DOT 4 Synthetic fluid
MONTBLANC MOLYBDENUM GREASE	Grease for driven pulley shaft adjusting ring and movable driven pulley housing	Grease with Molybdenum disulphide
AGIP GREASE PV2	Grease for the steering bearings, pin seats and swinging arm	White anhydrous-calcium based grease to protect roller bearings; temperature range between -20 C and +120 C; NLGI 2; ISO-L-XBCIB2.
AGIP GREASE SM 2	Grease for odometer transmission gear case	Lithium grease with NLGI 2 molybdenum disulphide; ISO-L-XBCHB2, DIN KF2K-20







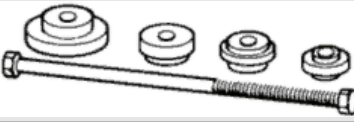

## INDEX OF TOPICS

TOOLING

TOOL

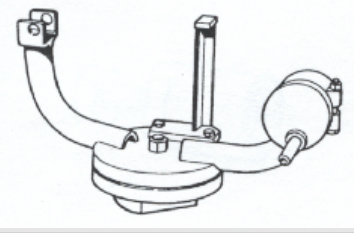
**TOOLS**

Stores code	Description	
001330Y	Tool for fitting steering seats	
001467Y008	Pliers to extract 17 mm ø bearings	
001467Y009	Driver for OD 42-mm bearings	
004499Y	Camshaft bearing extractor	
005095Y	Engine support	
008119Y009	Tube to assemble shafts and axles	

Stores code	Description	
020004Y	Punch for removing fifth wheels from headstock	
020055Y	Wrench for steering tube ring nut	
020150Y	Air heater support	
020151Y	Air heater	
020162Y	Flywheel extractor	
020171Y	Punch for Ø 17 mm roller case	

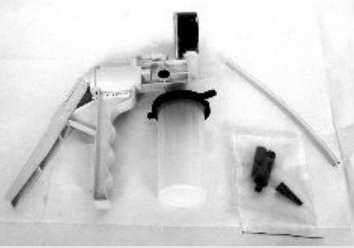

Stores code	Description	
020265Y	Bearing fitting base	
020288Y	Fork to assemble piston on cylinder	
020291Y	Valve fitting/ removal tool	
020306Y	Punch for assembling valve sealing rings	
020329Y	MityVac vacuum-operated pump	
020330Y	Stroboscopic light to check timing	



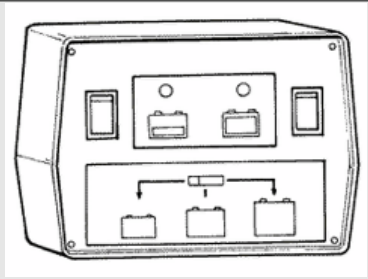



Stores code	Description	
020331Y	Digital multimeter	

020332Y	Digital rev counter	
---------	---------------------	---

020333Y	Single battery charger	
---------	------------------------	--

020334Y	Multiple battery charger	
---------	--------------------------	---

Stores code	Description	
020335Y	Magnetic support for dial gauge	
020340Y	Flywheel and transmission oil seals fitting punch	
020358Y	37x40-mm Adaptor	
020359Y	42x47-mm Adaptor	
020360Y	52x55-mm Adaptor	
020362Y	12 mm guide	

Stores code	Description	
020363Y	20 mm guide	
020364Y	25-mm guide	
020376Y	Adaptor handle	
020431Y	Valve oil seal extractor	
020432Y	Tool to fit the start-up sector spring	
020439Y	17 mm guide	

Stores code	Description	
020448Y	Pin lock fitting tool	
020449Y	Piston position check support	
020450Y	Camshaft fitting/removal tool	
020452Y	Tube for removing and refitting the driven pulley shaft	
020456Y	Ø 24 mm adaptor	
020565Y	Flywheel lock calliper spanner	



---

Stores code	Description	
494929Y	Exhaust fumes analyser	

---

# INDEX OF TOPICS

**MAINTENANCE**

**MAIN**

## Maintenance chart

### AFTER 1,000 KM OR 4 MONTHS

90'

Action
Hub oil - change
Valve clearance - check
Idle speed (*) - adjustment
Throttle lever - adjustment
Steering - adjustment
Brake control levers - greasing
Brake pads - check condition and wear
Brake fluid level - check
Safety locks - check
Electrical system and battery - check
Tyre pressure - check
Vehicle and brake test - road test

(\*) See instructions in «Idle speed adjustment» section

### AT 6000 KM OR 12 MONTHS, 18000, 30000, 42000, 54000 AND 66000 KM

60'

Action
Engine oil - replacement
Hub oil level - check
Spark plug / electrode gap - check
Oil filter (net filter) - clean
Variable speed rollers - check or replacement
Brake pads - check condition and wear
Brake fluid level - check
Electrical system and battery - check
Tyre inflation and wear - Check
Vehicle and brake test - road test

### EVERY 12000 OR 24 MONTHS AND AT 60000 KM

Action
Engine oil - replacement
Hub oil level - check
Spark plug / electrode gap - check / replacement
Air filter - clean
Oil filter (net filter) - clean
Idle speed (*) - adjustment
Throttle lever - adjustment
Variable speed rollers - check or replacement
Driving belt - replacement
Odometer gear - greasing
Steering - adjustment
Brake control levers - greasing
Brake pads - check condition and wear
Brake fluid level - check
Transmission elements - lubrication
Emergency blockings (°) - Check
Suspensions - check
Electrical system and battery - check
Headlight - adjustment
Tyres condition and wear - Check
Tyre pressure - check
Vehicle and brake test - road test

(\*) Refer to rules (Check to CO)

(°) Refer to predelivery operations

**EVERY 24000 KM OR 48000 KM****Action**

Engine oil - replacement
Hub oil level - check
Spark plug / electrode gap - check / replacement
Air filter - clean
Oil filter (net filter) - clean
Valve clearance - check
Idle speed (*) - adjustment
Throttle lever - adjustment
Variable speed rollers - check or replacement
Driving belt - replacement
Cylinder ventilation system - check
Odometer gear - greasing
Steering - adjustment
Brake control levers - greasing
Brake pads - check condition and wear
Brake fluid level - check
Transmission elements - lubrication
Emergency blockings (°) - Check
Suspensions - check
Electrical system and battery - check
Headlight - adjustment
Tyres condition and wear - Check
Tyre pressure - check
Vehicle and brake test - road test

(\*)Refer to rules (Check to CO)

(°) Refer to predelivery operations.

**EVERY 36000****Action**

Engine oil - replacement
Hub oil level - check
Spark plug / electrode gap - check / replacement
Air filter - clean
Oil filter (net filter) - clean
Idle speed (*) - adjustment
Throttle lever - adjustment
Variable speed rollers - check or replacement
Driving belt - replacement
Odometer gear - greasing
Steering - adjustment
Brake control levers - greasing
Brake pads - check condition and wear
Brake fluid hoses - replacement
Brake fluid level - check
Transmission elements - lubrication
Emergency blockings (°) - Check
Suspensions - check
Electrical system and battery - check
Headlight - adjustment
Tyres condition and wear - Check
Tyre pressure - check
Vehicle and brake test - road test

(\*)Refer to rules (Check to CO)

(°) Refer to predelivery operations.

**EVERY 72000****Action**

Engine oil - replacement
Hub oil level - check
Spark plug / electrode gap - check / replacement
Air filter - clean
Oil filter (net filter) - clean

**Action**

Valve clearance - check
Idle speed (*) - adjustment
Throttle lever - adjustment
Variable speed rollers - check or replacement
Driving belt - replacement
Cylinder ventilation system - check
Odometer gear - greasing
Steering - adjustment
Brake control levers - greasing
Brake pads - check condition and wear
Brake fluid hoses - replacement
Brake fluid level - check
Transmission elements - lubrication
Emergency blockings (°) - Check
Suspensions - check
Electrical system and battery - check
Headlight - adjustment
Tyres condition and wear - Check
Tyre pressure - check
Vehicle and brake test - road test

(\*)Refer to rules (Check to CO)  
 (°) Refer to predelivery operations.

**EVERY 2 YEARS**

**Action**

Brake fluid - change
----------------------

**EVERY 3,000 KM**

10'

**Action**

Engine oil - level check/ top-up
----------------------------------

**Carburettor**

- Disassemble the carburettor in its parts, wash all of them with solvent, dry all body grooves with compressed air to ensure adequate cleaning.
- Check carefully that the parts are in good condition.
- The **throttle valve** should move freely in the chamber. Replace valve in case of wear due to excessive clearance.
- If there are wear marks in the chamber causing inadequate tightness or a free valve slide (even if it is new), replace the carburettor.
- It is advisable to replace the gaskets at every refit.

**WARNING**

**PETROL IS HIGHLY EXPLOSIVE ALWAYS REPLACE THE GASKETS TO AVOID PETROL LEAKS**

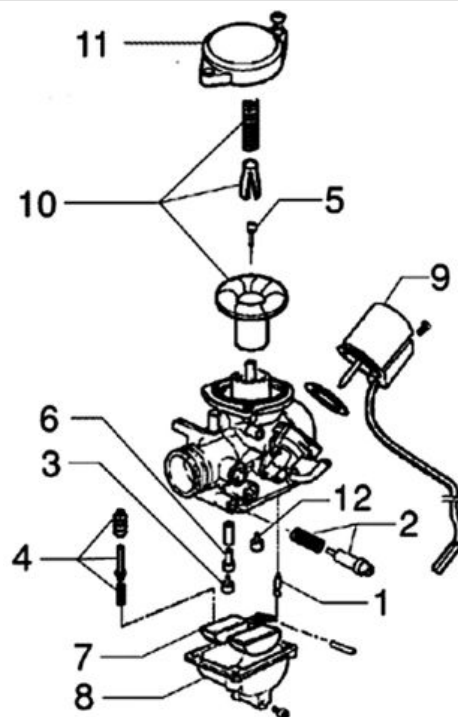

1. Needle valve - 2. Idle speed adjustment screw - 3. Max jet - 4. Accelerating pump - 5. Tapered pin - 6. Jet holder - 7. Float - 8. Chamber - 9. Starter device - 10. Vacuum valve - 11. Cover - 12. Minimum jet.

## Checking the spark advance

The vehicle is provided with a variable spark advance electronic device. Two reference marks for the timing can be found on the flywheel cover as to find out with more precision the reference mark on the fan. To check, use a stroboscopic gun Tecnotest 130/P or similar type. Start the engine and let it run at 1900 revs/min, act on the phase shifter to align the reference mark on the flywheel fan in between the two reference marks on the casing; at the same time, read the spark advance value on the stroboscopic gun display. The value should be 10°.

Repeat the above operation with engine running at 5000-6000 revs/min, spark advance should be 26°.

### CAUTION

**SHOULD THE FLASH INDICATIONS BE UNSTABLE AND THE RPM INDICATION DOES NOT CORRESPOND WITH THE TRUE ENGINE SPEED VARIATION (FOR EXAMPLE, VALUES SHOWN ARE HALVED), INSTALL A 10 ÷ 15 KΩ RESISTIVE CABLE CONNECTED IN SERIES TO AN HV CABLE. IF THE IRREGULAR READING CONTINUES AFTER THIS OPERATION, CHECK THE COMPONENTS OF THE IGNITION SYSTEM.**

### N.B.

**WHEN THE INDUCTION CLAMP READS THE SIGNAL CORRECTLY, A READING CAN BE CARRIED OUT AT OVER 6000 RPM.**

## RPM LIMITER

Specification	Desc./Quantity
1 spark out of 7	8200 Revs/min
1 spark out of 3	8300 Revs/min
Suppression of all sparks	8500 Revs/min

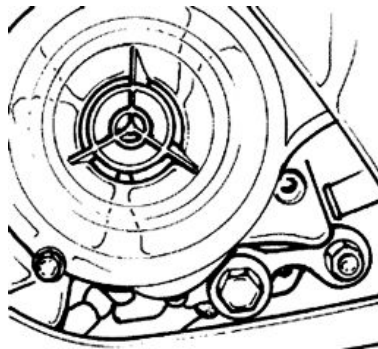

CURVA DI VARIAZIONE ANTICIPO ACCENSIONE

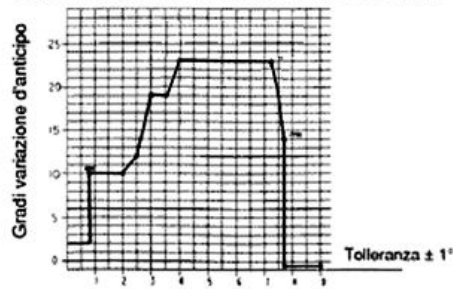

## Spark plug

Detach the spark plug cap and then remove the spark plug.

- Carefully examine the spark plug, and replace it if the insulator is damaged or chipped.
- With the aid of a feeler gauge, measure the spark gap and, if necessary, adjust by bending outer electrode with care.
- Ensure the sealing washer is in good conditions.
- Refit the spark plug by engaging the thread manually and then tightening it to the prescribed torque using the box-spanner provided.

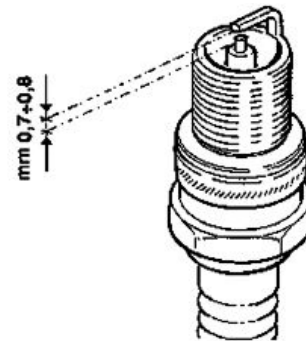

### Characteristic

#### Electrode gap

0.7 ÷ 0.8 mm

#### Spark plug

NGK CR 8EB

#### Alternative spark plug

DENSO U24ESR-NB

### Locking torques (N\*m)

Spark plug 10 ÷ 15 Nm

The central electrode of the above spark plug is treated with silicone oil that acts as an antioxidant agent. If the silicone oil is in excess, crystals tend to form and, by causing hot fire points to preignition phenomena, tend to reduce the spark plug performance. This results in difficulties for vehicles to reach the maximum speed and anomalous noises.

If the above situation should occur, replace the spark plug before performing any other intervention. Before installing the new spark plug, blow with air to remove the silicone oil in excess.

Direct the jet of compressed air into the round groove between the threaded metal part and the ceramic part of the inner electrode while turning the spark plug to allow removal of the oil in excess.

## Hub oil

### Check

Rest the vehicle on its centre stand on an even surface.

- Unscrew the oil dipstick "A", dry it with a clean cloth and reinsert it, **screwing it in thoroughly**.
- Pull out the dipstick and check that the oil level is above the "middle" notch (dipstick with 3 notches). For dipsticks with 2 notches, the oil level must remain in the lower half of the dipstick.
- Screw up the oil dipstick again and make sure it is locked properly into place.

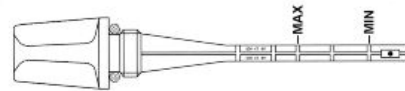
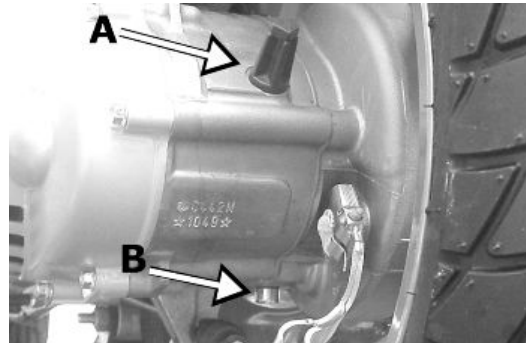

### Recommended products

#### AGIP ROTRA 80W-90 rear hub oil

SAE 80W/90 Oil that exceeds the requirements of API GL3 specifications

### Replacement

Remove the oil filler cap/dipstick "A".

- Unscrew the oil drainage plug "B" shown in the figure and drain out all the oil.
- Screw the drainage plug back and fill up the hub with the required oil (about 100 cm<sup>3</sup>)

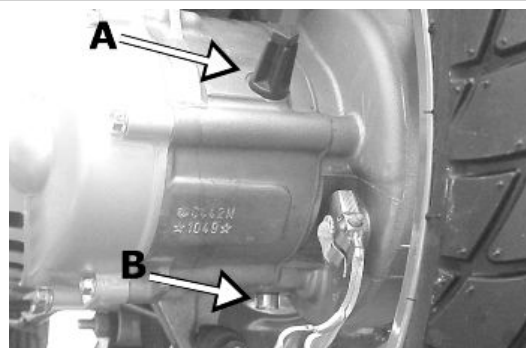



## Air filter

- Remove the l.h.s. fairing.
- Remove the air-box cover after removing the 6 fixing screws shown in the figure, and then extract the filtering element.

### Cleaning:

- Clean with water and neuter soap;
- Dry with a clean cloth, without squeezing, and with light jets of air;
- Immerge in a 50% oil-petrol mixture;
- Let it drip and then compress it with your hands, without squeezing.
- Refit all components in the reverse order.

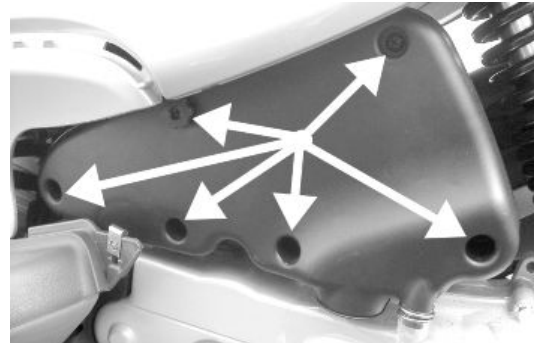

### CAUTION

IF THE VEHICLE IS MOSTLY USED ON DUSTY ROADS, THE AIR FILTER NEEDS TO BE CLEANED AT SHORTER INTERVALS THAN INDICATED IN THE SCHEDULED MAINTENANCE TABLE.  
DO NOT RUN THE ENGINE WITH THE AIR FILTER DISASSEMBLED OR EXCESS WEAR OF CYLINDER AND PISTON WILL RESULT.

### Recommended products

#### AGIP FILTER OIL Oil for air filter sponge

Mineral oil with specific additives for increased adhesiveness

## Engine oil

- The oil decanting system is a labyrinth type so it does not require servicing.

### N.B.

IN THE EVENT OF LONG ROUTES OR LACK OF SERVICING, ADEQUATELY CLEAN THE LABYRINTH BY REMOVING THE FOUR SCREWS AND SHEET METAL COVER.

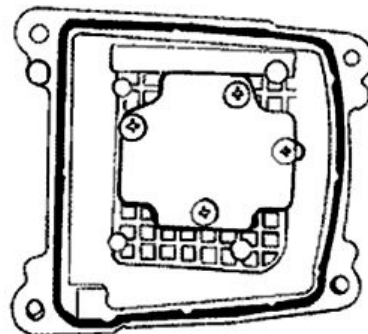

## Replacement

Loosen the oil filler plug.

- Unscrew the gauze strainer drain plug on the flywheel side and allow the oil to drain completely.
- Retighten the drain plug and pour in approximately 600-650 cc of oil.

- Start the engine, let it idle for about a minute and then switch it off.
- Wait for at least ten minutes and then top up by adding oil to the «MAX» level.

## Check

Check oil level every time the vehicle is used, with the engine cold. The level should be between the MAX and MIN marks on the oil level dipstick shown in figure; the stand should be firm on an even surface during the check.

If the check is carried out after the vehicle has been used, i.e. the engine is hot, the level line will be very low; for an adequate check, wait at least 10 minutes after the engine stops in order to have the correct level.

Check by pushing the dipstick all the way into the hole.

### CAUTION



**USING THE ENGINE WITH INSUFFICIENT LUBRICATION OR WITH THE WRONG LUBRICANTS MAY INCREASE WEAR AND TEAR ON THE MOVING PARTS AND MAY CAUSE SERIOUS DAMAGE.**

### Characteristic

#### Engine oil

Capacity: ~ 850 cc



## Engine oil filter

- Change oil when the engine is hot.
- Place a container under the oil sump and remove the oil drainage cap.
- After draining the oil, clean the mesh filter with a specific solvent and then blow it with compressed air.
- The filter can be reached after removing cap "A" (see figure).
- After this operation, refit the filter and screw the oil cap at the prescribed torque using a new O-Ring

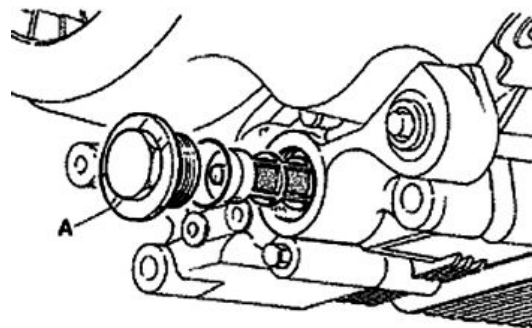

- Refill the engine with oil through the oil filling hole located in the oil sump.
- Engine oil capacity: ~ 850 cc.
- Lock the cap manually.

**N.B.**

Run the engine for a couple of minutes and check the oil level when the engine is cold. The level should always be below the MAX mark

**N.B.**

For the first top-up or when servicing, add 850 cm<sup>3</sup> of engine oil; for any other case, add 650 cm<sup>3</sup> and top-up, if required.

**Recommended products****AGIP CITY HI TEC 4T Engine oil**

SAE 5W-40 Synthetic oil that exceed the requirements of API SL, ACEA A3, JASO MA specifications

**Locking torques (N\*m)**

**Engine oil pre-filter cover 25 ÷ 28 Nm**

**Checking the ignition timing**

- Turn the flywheel clockwise until its 2nd notch coincides with the Pick-up reference mark as shown in the figure.

Make sure that the reference point on the camshaft command crown is aligned with the reference point on the head as shown in the second figure.

If the reference is opposite the indicator on the head, turn the crankshaft once more as the piston must be at the TDC of the bursting phase.

**N.B.**

**TIME THE TIMING SYSTEM UNIT AS DESCRIBED IN CHAPTER 6 IF IT IS NOT IN PHASE**

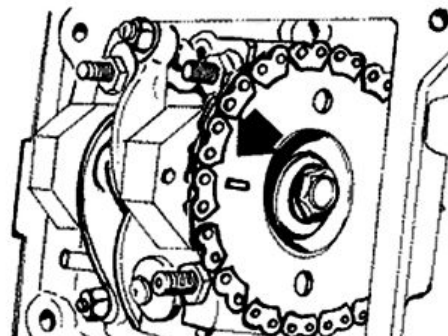
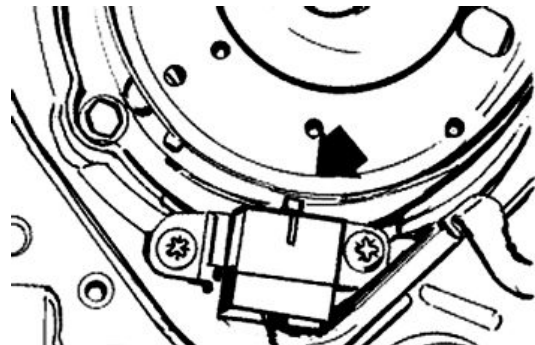

## Checking the valve clearance

- Remove the spark plug access cover, undo the 4 fixing screws indicated in the figure and remove the tappet cover.

- To check valve clearance, centre the reference marks of the timing system point as described above.

- Use an adequate thickness gauge to check that the clearance between the valve and the register corresponds with the indicated values.

Should the valve clearance values, intake and drainage respectively, be different from the ones indicated below, adjust them by loosening the lock nut and operate on the register with a screwdriver as shown in the figure.

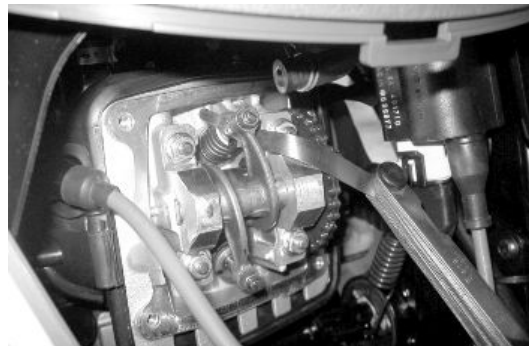
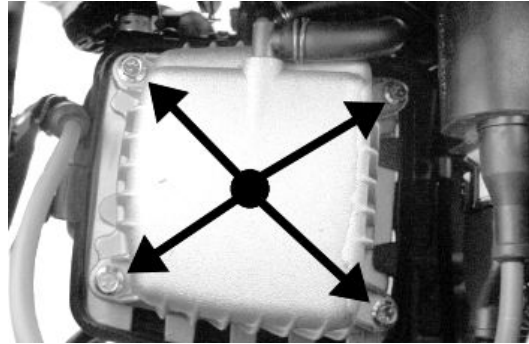

### Characteristic

#### Inlet (with cold engine)

0.10 mm

#### Outlet (with cold engine)

0.15 mm

## Headlight adjustment

Proceed as follows:

1. Place the vehicle, in running order and with the tyres inflated to the prescribed pressure, on a flat surface 10-m away from a white screen situated in a shaded area, making sure that the longitudinal axis of the scooter is perpendicular to the screen;
2. Turn on the headlight and check that the borderline of the projected light beam on the screen is not lower than  $\frac{9}{10}$  of the distance from the ground to the centre of vehicle headlamp and higher than  $\frac{7}{10}$ ;
3. If otherwise, adjust the right headlight with screw «A».

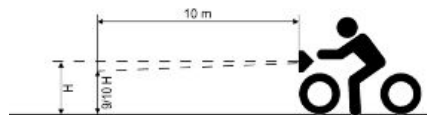
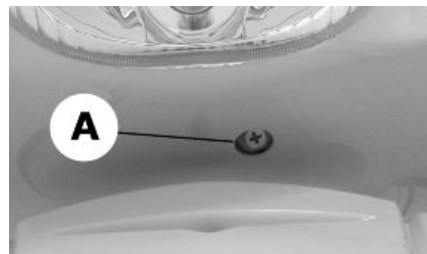

**N.B.**

**THE ABOVE PROCEDURE COMPLIES WITH THE EUROPEAN STANDARDS REGARDING MAXIMUM AND MINI-**

**MUM HEIGHT OF LIGHT BEAMS. REFER TO THE STATUTORY REGULATIONS IN FORCE IN EVERY COUNTRY WHERE THE VEHICLE IS USED.**

## CO check

The check may be necessary in the event of irregularities in the engine performances, or when adjusting the engine idle speed.

- The test must be carried out only after having carefully cleaned all carburettor components with the air filter clean and the spark plug in good conditions.

- 1) Warm up the engine by riding the vehicle for about 5-10 minutes, as this is the time required for the choke device to disengage.
- 2) Shut down the engine only for the time required to carry out operations 3) and 4).
- 3) Remove the RH side fairing and the SAS box cover by loosening the 3 screws shown in the figure. Interpose a plastic sheet between the secondary air one-way valve and its housing on the cover. Ensure the valve gasket seals properly. Re-fit the SAS box cover.
- 4) Fit the special tool for the collection of exhaust gases as shown in the picture. Pay attention in ensuring the seal between the exhaust pipe and the collection tube. Insert the gas analyser and the exhaust tube.
- 5) Insert the multimeter thermometer inside the sump, through the oil filler hole.
- 6) Start up the engine and, before adjusting the idle speed, ensure the oil temperature is between 70 and 80 °C.
- 7) Wait for a few minutes to let the temperature stabilise.
- 8) **Without ever activating the throttle** and through the idle screw, bring the engine speed to  $1,950 \pm 50$  rpm.

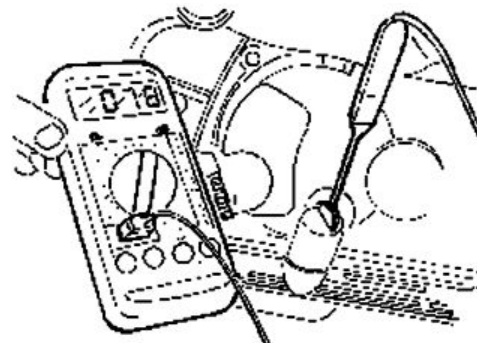
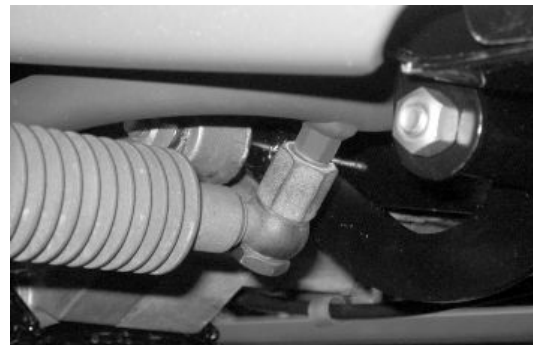
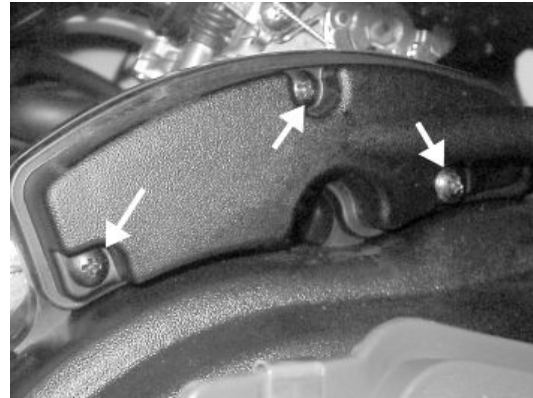



9) Adjust the flow screw so to obtain a "CO" reading of  $3.2 \% \pm 0.5 \%$ .

10) **Slowly** twist the throttle handgrip, bringing the engine up to a speed of 4,000 rpm and then release it; check the idle speed is the same as before, otherwise repeat the operations starting from point (3).

### Specific tooling

**020332Y Digital rev counter**

**494929Y Exhaust fumes analyser**

**020331Y Digital multimeter**

## SAS filters inspection and cleaning

After taking out the plug spark cover, unscrew the three screws «**A**» and remove the right fairing. Unscrew the three screws «**B**» and remove the housing cover of the secondary air system. Detach the housing cover and remove the filtering element «**C**» made of sponge. Wash the sponge with water and neutral soap, then dry with a clean cloth and short blasts of compressed air. While cleaning the filter, check the condition of the reed valve «**D**», and mount it back in place on the housing. Before closing the cover of the SAS housing, check the good condition of the sealing O-ring; replace it if damaged or deformed.

**N.B.**

The reed valve can be inserted in only one direction on the SAS housing

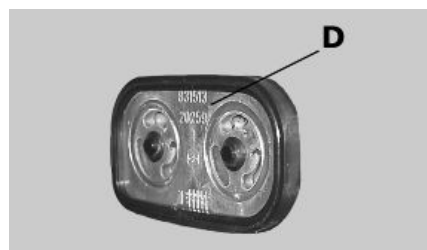
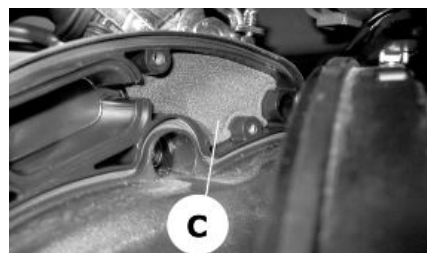
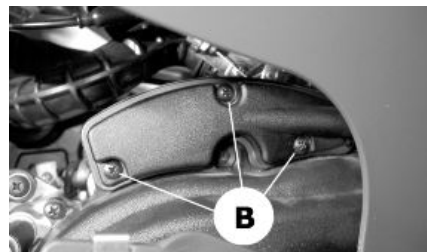
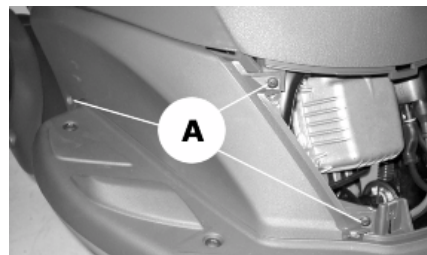



# INDEX OF TOPICS

**TROUBLESHOOTING**

**TROUBL**



This section makes it possible to find the solutions to use in troubleshooting.

For each breakdown, a list of the possible causes and respective interventions is given.

## Engine

### Poor performance

#### POOR PERFORMANCE

Possible Cause	Operation
The carburettor is dirty; vacuum operated cock failure	Dismantle, wash with solvent and dry with compressed air or replace
Excess of encrustations in the combustion chamber	Descale the cylinder, the piston, the head and the valves
Incorrect timing or worn timing system elements	Time the system again or replace the worn parts
Muffler obstructed	Replace
Automatic starter failure	Check: mechanical movement, electric connection and fuel supply, replace if required.
Oil level exceeds maximum	Check for causes and fill to reach the correct level
Lack of compression: parts, cylinder and valves worn	Replace the worn parts
Transmission belt worn	Replace
Inefficient automatic transmission	Check the rollers and the pulley movement, replace the damaged parts and lubricate the driven pulley moveable guide with Montblanc Molybdenum Grease
Clutch slipping	Check the clutch system and/or the bell and replace if necessary
Overheated valves	Remove the head and the valves, grind or replace the valves
Wrong valve adjustment	Adjust the valve clearance properly
Valve seat distorted	Replace the head assembly
Air filter blocked or dirty.	Dismantle the sponge, wash with water and shampoo, then soak it in a mixture of 50% petrol and 50% of specific oil (Selenia Air Filter Oil), then hand dry without squeezing, allow to drip dry and then reassemble.
Defective floating valve	Check the proper sliding of the float and the functioning of the valve

### Rear wheel spins at idle

#### REAR WHEEL

Possible Cause	Operation
Idling rpm too high	Check the idling speed and, if necessary, adjust the C.O.
Clutch fault	Check the spring/friction mass and the clutch bell
Air filter housing not sealed	Correctly refit the filter housing and replace it if it is damaged
Purifier-carburettor fitting damaged	Replace

### Starting difficulties

#### STARTING PROBLEMS

Possible Cause	Operation
Altered fuel characteristics	Drain off the fuel no longer up to standard; then, refill
Rpm too low at start-up or engine and start-up system damaged	Check the starter motor and the system.
Incorrect valve sealing or valve adjustment - Engine flooded.	Inspect the head and/or restore the correct clearance Try starting-up with the throttle fully open. If the engine fails to start, remove the spark plug, dry it and before refitting, make the motor turn so as to expel the fuel excess taking care to connect the cap to the spark plug, and this in turn to the ground. If the fuel tank is empty, refuel and start up.

Possible Cause	Operation
Automatic starter failure	Check: mechanical movement, electric connection and fuel supply, replace if required.
Air filter blocked or dirty.	Dismantle the sponge, wash with water and shampoo, then soak it in a mixture of 50% petrol and 50% of specific oil (Selenia Air Filter Oil), then hand dry without squeezing, allow to drip dry and then reassemble.
Faulty spark plug or incorrect ignition advance	Replace the spark plug or check the ignition circuit components
The carburettor is dirty; vacuum operated cock failure	Dismantle, wash with solvent and dry with compressed air or replace
Battery flat	Check the charge of the battery, if there are any sulphur marks, replace and use the new battery following the instructions shown in the chapter
Intake coupling cracked or clamps incorrectly tightened	Replace the intake coupling and check the clamps are tightened
Defective floating valve	Check the proper sliding of the float and the functioning of the valve
Carburettor nozzles clogged	Dismantle, wash with solvent and dry with compressed air

## Excessive oil consumption/Exhaust smoke

### EXCESSIVE OIL CONSUMPTION / EXHAUST SMOKE

Possible Cause	Operation
Worn valve oil guard	Replace the valve oil guard
Oil leaks from the couplings or from the gaskets	Check and replace the gaskets or restore the coupling seal
Worn or broken piston rings or piston rings that have not been fitted properly	Replace the piston cylinder unit or just the piston rings
Worn valve seat	Check and if necessary replace head assembly

## Insufficient lubrication pressure

### POOR LUBRICATION PRESSURE

Possible Cause	Operation
By-Pass remains open	Check the By-Pass and replace if required. Carefully clean the By-Pass area.
Oil pump with excessive clearance	Perform the dimensional checks on the oil pump components
Oil filter too dirty	Replace the cartridge filter
Oil level too low	Restore the level using the recommended oil type (Selenia HI Scooter 4 Tech)

## Engine tends to cut-off at full throttle

### ENGINE TENDS TO CUT OUT AT FULL THROTTLE

Possible Cause	Operation
DEFECTIVE CIRCUIT OF FEEDING	Check and possibly replace the automatic vacuum tap, check the vacuum intake and the conduit seal
Incorrect float level	Restore the level in the tank by bending on the float the thrusting reed of the petrol inlet rod so as to have the float parallel to the tank level with the carburettor inverted.
Water in the carburettor	Empty the tank through the appropriate bleed nipple.
Maximum nozzle dirty - lean mixture	Wash the nozzle with solvent and dry with compressed air

## Engine tends to cut-off at idle

### ENGINE TENDS TO CUT-OFF AT IDLE

Possible Cause	Operation
Incorrect timing	Time the system and check the timing system components

Possible Cause	Operation
Incorrect idle adjustment	Adjust using the rpm indicator
Pressure too low at the end of compression	Check the thermal group seals and replace worn components
Faulty spark plug or incorrect ignition advance	Replace the spark plug or check the ignition circuit components
The starter remains on	Check: electric wiring, circuit not interrupted, mechanical movement and power supply; replace if necessary
Minimum nozzle dirty	Wash the nozzle with solvent and dry with compressed air

## Excessive exhaust noise

### EXCESSIVE EXHAUST NOISE

Possible Cause	Operation
Depression intake pipe of the secondary air device disconnected or dented	Replace the pipe
Reed valve of the secondary air device does not close correctly and wears out the rubber coupling between the device and the head pipe	Replace the device and the coupling

## High fuel consumption

### HIGH FUEL CONSUMPTION

Possible Cause	Operation
Float level	Restore the level in the tank by bending on the float the thrusting reed of the petrol inlet rod so as to have the float parallel to the tank level with the carburettor inverted.
Loose nozzles	Check the maximum and minimum nozzles are adequately fixed in their fittings
Starter inefficient	Check: electric wiring, circuit continuity, mechanical sliding and power supply
Air filter blocked or dirty.	Dismantle the sponge, wash with water and shampoo, then soak it in a mixture of 50% petrol and 50% of specific oil (Selenia Air Filter Oil), then hand dry without squeezing, allow to drip dry and then reassemble.

## SAS malfunctions

### ANOMALIES IN THE SECONDARY AIR DEVICE

Possible Cause	Operation
Depression intake pipe of the secondary air device disconnected or dented	Replace the pipe
Reed valve of the secondary air device does not close correctly and wears out the rubber coupling between the device and the head pipe	Replace the device and the coupling

## Transmission and brakes

## Clutch grabbing or performing inadequately

### IRREGULAR CLUTCH PERFORMANCE OR SLIPPAGE

Possible Cause	Operation
Faulty clutch	Check that there is no grease on the masses. Check that the clutch mass contact surface with the casing is mainly in the centre with equivalent characteristics on the three masses. Check that the clutch casing is not scored or worn in an anomalous way

## Insufficient braking

### INSUFFICIENT BRAKING

Possible Cause	Operation
Inefficient braking system	Check the pad wear (1.5 min). Check that the brake discs are not worn, scored or warped. Check the correct level of fluid in the pumps and change brake fluid if necessary. Check there is no air in the circuits; if necessary, bleed the air. Check that the front brake calliper moves in axis with the disc.
Fluid leakage in hydraulic braking system	Failing elastic fittings, plunger or brake pump seals, replace

## Brakes overheating

### BRAKES OVERHEATING

Possible Cause	Operation
Rubber gaskets swollen or stuck	Replace gaskets.
Compensation holes on the pump clogged	Clean carefully and blast with compressed air
Brake disc slack or distorted	Check the brake disc screws are locked; use a dial gauge and a wheel mounted on the vehicle to measure the axial shift of the disc.
Defective piston sliding	Check calliper and replace any damaged part.

## Electrical system

### Battery

#### BATTERY

Possible Cause	Operation
Battery	This is the device in the system that requires the most frequent attention and the most thorough maintenance. If the vehicle is not used for some time (1 month or more) the battery needs to be recharged periodically. The battery runs down completely in the course of 3 months. If the battery is fitted on a motorcycle, be careful not to invert the connections, keeping in mind that the black ground wire is connected to the negative terminal while the red wire is connected to the terminal marked+.

## Turn signal lights malfunction

### TURN INDICATOR NOT WORKING

Possible Cause	Operation
Electronic ignition device failure	With the key switch set to "ON" jump the contacts 1 (Blue - Black) and 3 (White) on the voltage regulator connector. If by operating the turn indicator control the lights are not steadily on, replace the control unit; otherwise, check the cable harness and the switch.

## Steering and suspensions

## Rear wheel

### **REAR WHEEL ROTATES WITH ENGINE AT IDLE**

Possible Cause	Operation
Idling rpms too high	Adjust the engine idle speed and the CO%, if necessary.
Clutch fault	Check the springs / clutch masses

## Controls

### **STEERING CONTROLS AND SUSPENSIONS**

Possible Cause	Operation
Torque not conforming	Check the tightening of the top and bottom ring nuts. If irregularities continue in turning the steering even after making the above adjustments, check the seats in which the ball bearings rotate: if they are recessed or if the balls are squashed, replace them.
Steering hardening	Check the tightening of the top and bottom ring nuts. If irregularities continue in turning the steering even after making the above adjustments, check the seats in which the ball bearings rotate: if they are recessed or if the balls are squashed, replace them.
Malfunctions in the suspension system	If the front suspension is noisy, check: the efficiency of the front shock absorber; the condition of the ball bearings and relevant lock-nuts, the limit switch rubber buffers; and the movement bushings. In conclusion, check the tightening torque of the wheel hub, the brake calliper, the shock absorber disc in the attachment to the hub and the steering tube.
Seal fault or breakage	Replace the shock absorber Check the condition of wear of the steering covers and the adjustments.

# INDEX OF TOPICS

ELECTRICAL SYSTEM

ELE SYS

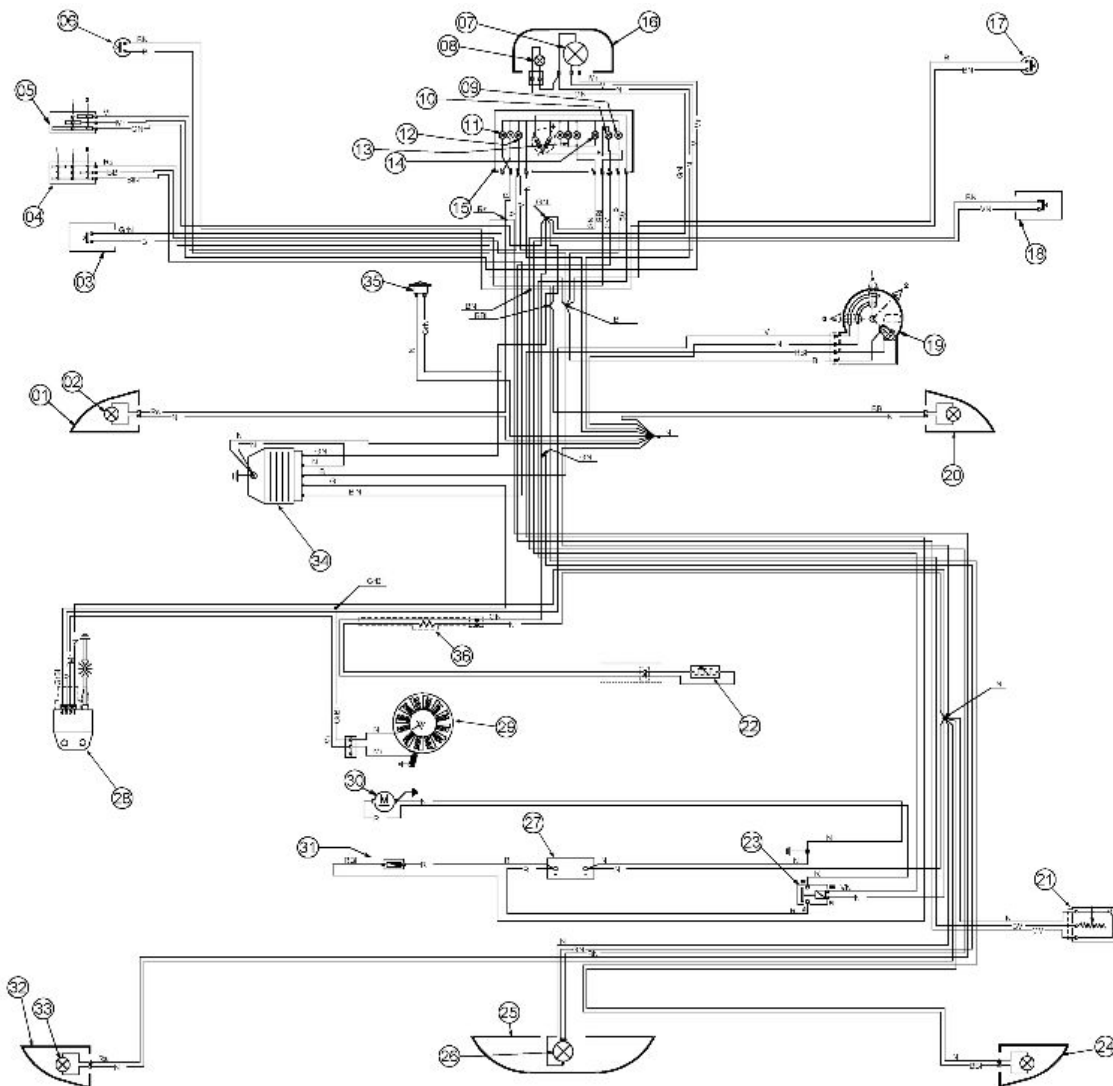

**ELECTRICAL SYSTEM**

Specification	Desc./Quantity	
1	Front left turn indicator	
2	Front turn indicator bulbs	Front turn indicator bulbs 12V-10W x 2
3	Horn button	
4	Indicators switch	
5	Light switch	
6	Rear stop switch	
7	Headlight bulb	12V-35/35W
8	Front tail light bulb	<b>Type:</b> All glass <b>Power:</b> 12V 5W <b>Quantity:</b> 1
9	Right turn indicator warning light	12V - 2W
10	Low fuel warning light	12V - 1.2W
11	Left turn indicator warning light	12V - 2W
12	High-beam warning light	12V - 1.2W
13	Instrument panel light bulbs	<b>Type:</b> All glass <b>Power:</b> 12V 1.2W <b>Quantity:</b> 2
14	Headlight warning light	12V 1.2W
15	Odometer with warning lights and level indicator	
16	Front headlight	

	Specification	Desc./Quantity
17	Front brake stop button	
18	Starter button	
19	Key switch	
20	front right turn indicator	
21	Fuel level transmitter	
22	Automatic starter	
23	Starter remote control	
24	rear right turn indicator	
25	Rear light assembly	
26	Stop and tail light bulb	<b>Type:</b> Spherical <b>Power:</b> 12V 21/5W <b>Quantity:</b> 1
27	Battery	12V - 9Ah
28	Electronic ignition device	
29	Magneto flywheel	
30	Starter motor	
31	Fuse carrier	(N° 1 fuse to 10 A)
32	rear left turn indicator	
33	Rear turn indicator bulbs	Two, 12V-10W, spherical
34	Voltage regulator	
35	Claxon in c.c.	
36	Resistance	6,8 Ohm - 10W

**Colours of the electrical cables:**

**B** = White, **Bl** = Blue, **G** = Yellow, **Mr** = Brown, **N** = Black, **Gr** = Grey,  
**Rs** = Pink, **R** = Red, **Vi** = Purple, **V** = Green

**Conceptual diagrams**

**Ignition**

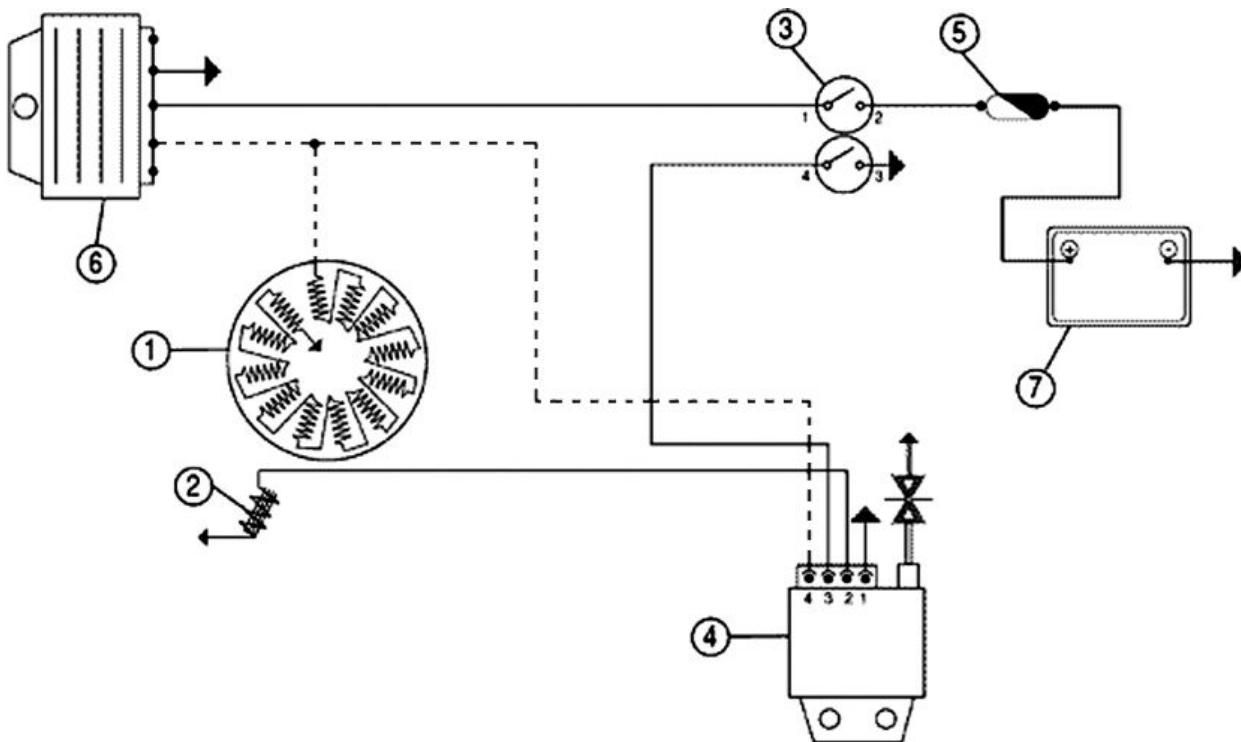



**IGNITION**

	Specification	Desc./Quantity
1	Magneto flywheel	
2	Pick - up	
3	Key switch contacts	
4	Electronic ignition device	
5	Fuse	10 A
6	Voltage regulator	
7	Battery	12V-9Ah

**Headlights and automatic starter section**

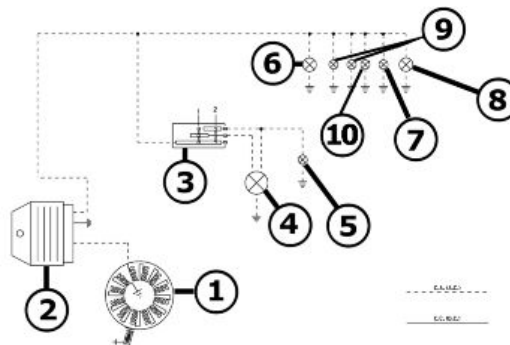

**HEADLIGHTS**

	Specification	Desc./Quantity
1	Magneto flywheel	
2	Voltage regulator	
3	Light switch	
4	Headlight bulb	12V-35/35W
5	High-beam warning light	12V - 1.2W
6	Rear light bulb	12V - 5W
7	Headlight warning light	12V - 1.2W
8	Front position light filament	12V - 5W
9	Instrument panel light bulbs	<b>Type:</b> All glass <b>Power:</b> 12V 1.2W <b>Quantity:</b> 2
10	Instrument panel lighting bulbs	12V - 2W

**Battery recharge and starting**

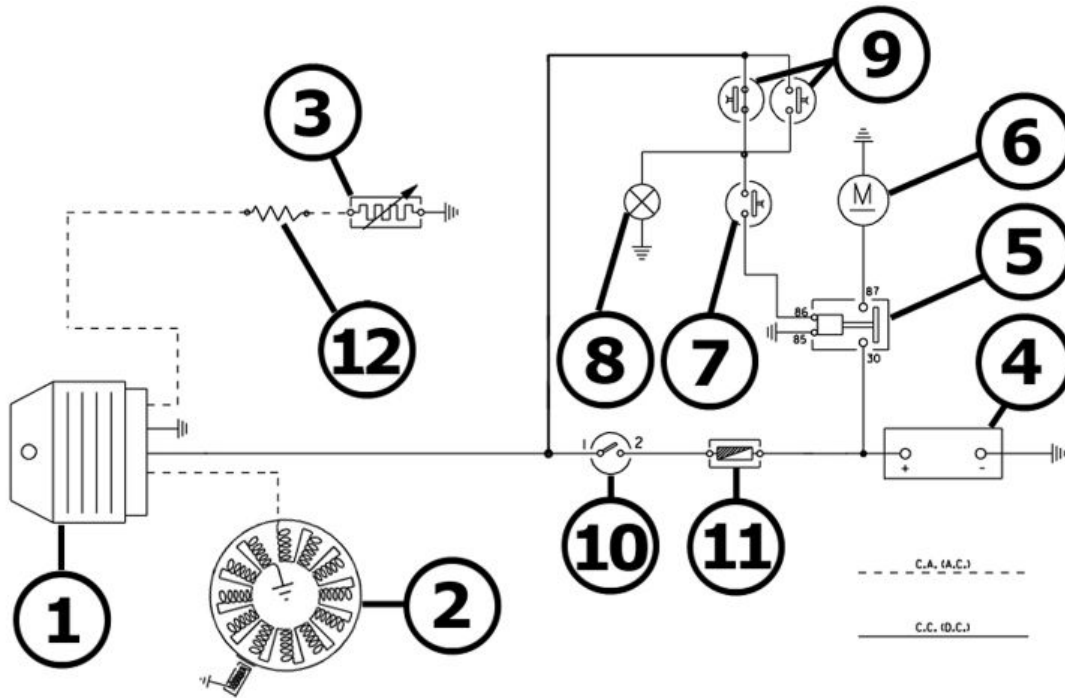

**BATTERY RECHARGE AND START-UP SECTION**

	Specification	Desc./Quantity
1	Voltage regulator	
2	Magneto flywheel	
3	Automatic starter	
4	Battery	12V-9Ah
5	Remote starter switch	
6	Starter motor	
7	Start up button	
8	Brake light filament	12V-21W
9	Front and rear brake light button	
10	Key switch	
11	Main fuse	10A
12	Resistance	6,8 Ohm - 10W

Level indicators and enable signals section

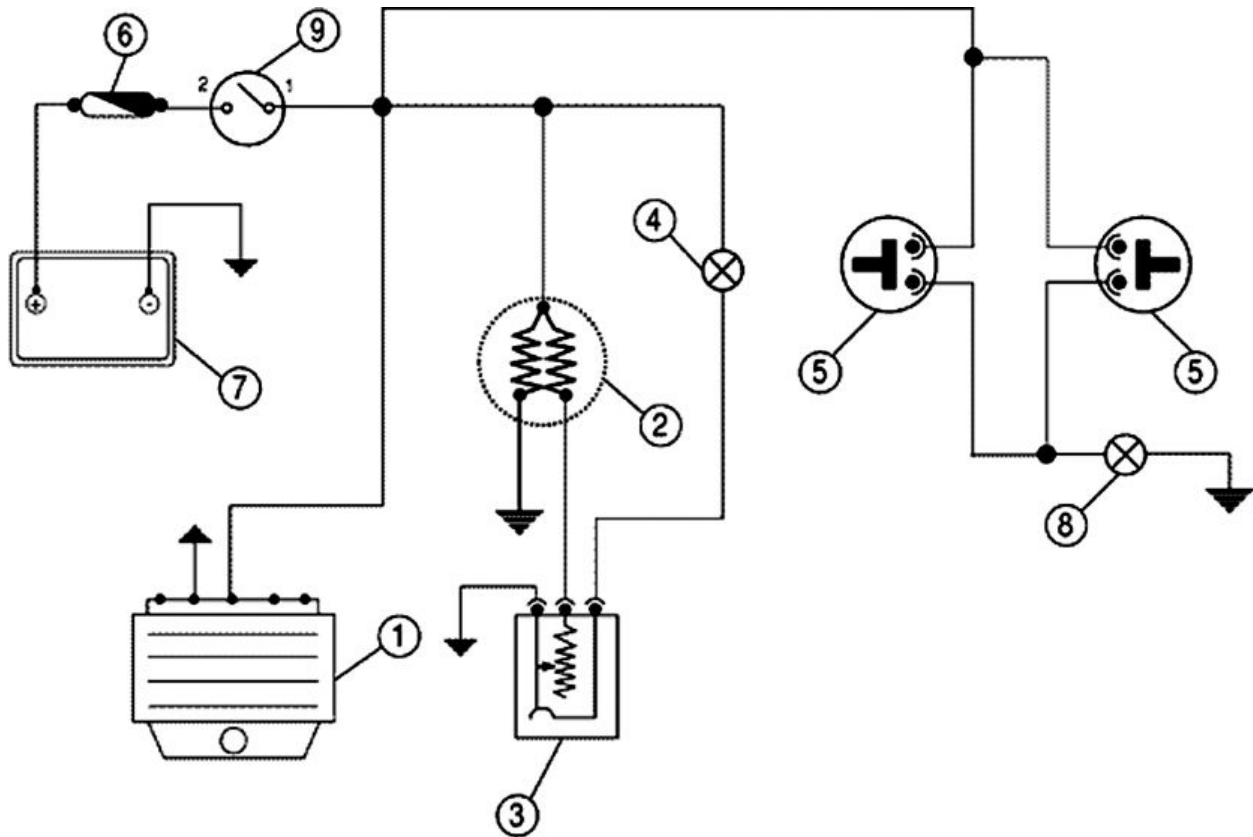

**START PERMISSIVE BUTTONS AND LEVEL INDICATORS**

	Specification	Desc./Quantity
1	Voltage regulator	
2	Fuel gauge	
3	Fuel level sender	
4	Low fuel warning light	12V - 1.2W
5	Front and rear brake light button	
6	Fuse	10 A
7	Battery	12V-9Ah
8	Brake light filament	12V-21W
9	Key switch contacts	

**Turn signal lights**

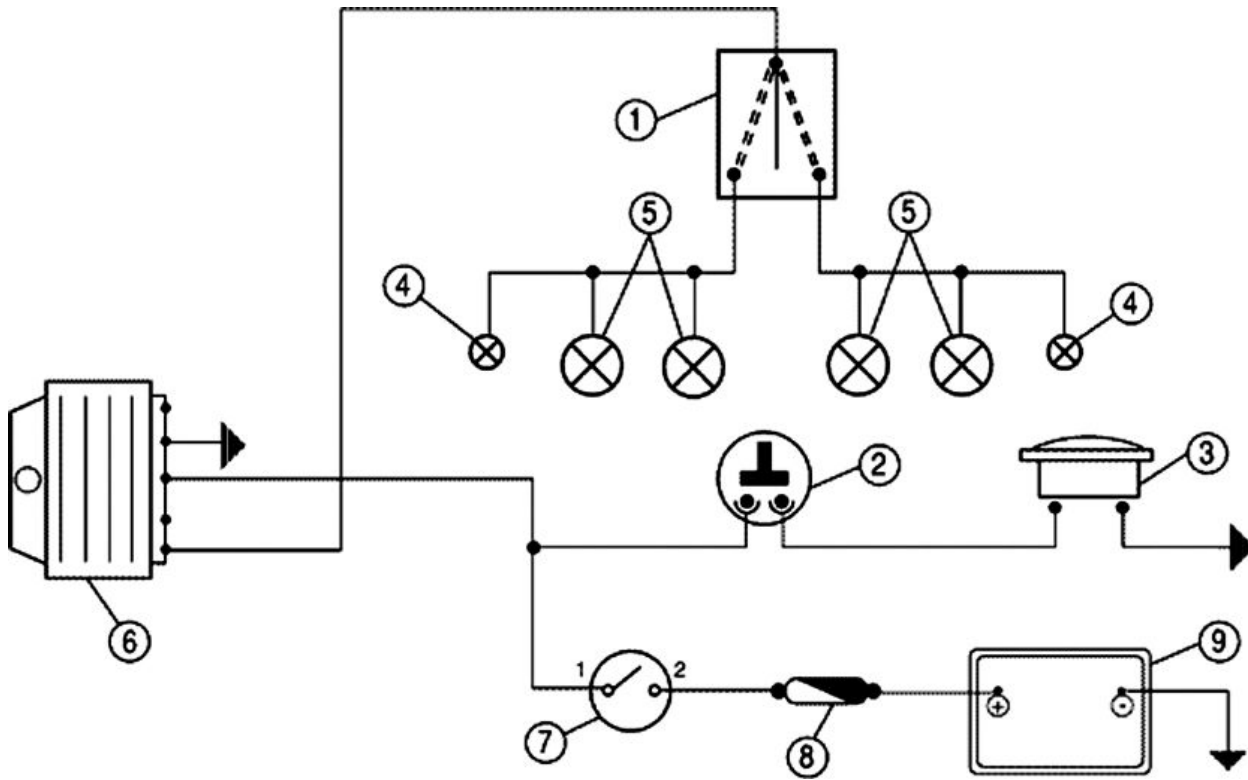

**TURN INDICATORS AND HORN**

	Specification	Desc./Quantity
1	Indicators switch	
2	Horn button	
3	Horn	
4	Two (2) turn signal warning light bulbs	12V - 2W
5	4 Turn indicator bulbs	12V-10W
6	Voltage regulator	
7	Key switch contacts	
8	Fuse	10 A
9	Battery	12V-9Ah

**Checks and inspections**

In case the cause of ignition failure or malfunction cannot be easily identified at sight, first of all replace the control unit by another one in operating conditions.

Remember that the engine must be off to disconnect and replace the control unit.

If after replacement the vehicle starts properly, the control unit is failing and must be replaced.

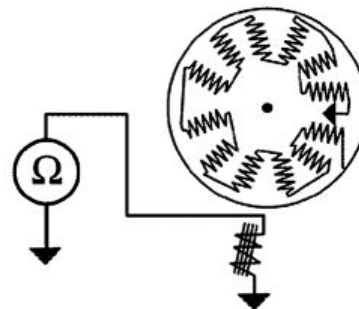

If the failure persists, check the generator and the stator components as follows:

After visually checking the electrical connections, use a specific tester to measurement the stator winding and the pickup (see table).

If any failure is found after checking the loading coil and the pick-up, **replace the stator and the damaged parts.**

Disconnect the connector on the flywheel cover and measure the resistance between either contact and the earthing.

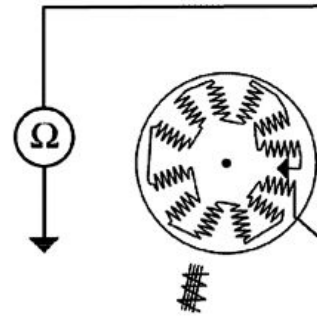

**Specific tooling**

020331Y Digital multimeter

**PICK-UP CHECK**

	Specification	Desc./Quantity
1	1) Brown cable and earth	~ 170 Ω

**STATOR WINDING CHECK**

	Specification	Desc./Quantity
1	1) Black cable and earth	~ 1 Ω

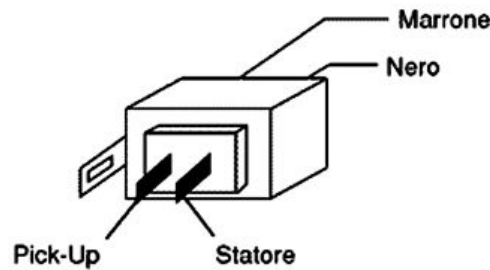

**Ignition circuit**

All the control operations of the system that require the disconnection of cables (checks of the connections and the devices making up the ignition circuit) must be done with the engine off: if this is not done, the controls might be irretrievably damaged.

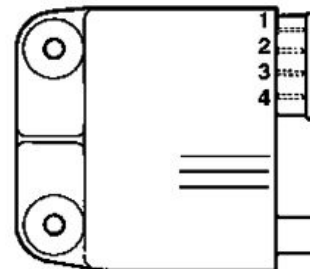

## Stator check

- Using a tester, check the resistance between the brown-earth and black-earth terminal.

### N.B.

VALUES ARE STATED AT AMBIENT TEMPERATURE. A CHECK WITH THE STATOR AT OPERATING TEMPERATURE LEADS TO VALUES HIGHER THAN THOSE STATED.

### Electric characteristic

#### Stator : Brown-earth

approx. 170  $\Omega$  (Pick-Up)

#### Stator : Black-earth

~ 1  $\Omega$  (Stator)

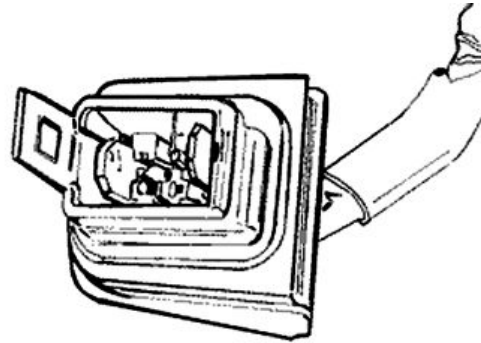

## Voltage regulator check

A malfunction in the voltage regulator might cause the following problems depending on the type of fault:

- 1) Bulbs burned out (regulator in short circuit).
- 2) Malfunction of the lighting system and the electric starter (regulator interrupted).
- 3) Battery not recharging.
- 4) Turn indicators not working.

The regulator is earthed through the electrical system, so the regulator body does not earth the circuits inside the regulator.

There must be insulation between each regulator terminal and the regulator body (use the tester to check electric resistance).

### 1) BURSTING LIGHT BULBS

Replace the voltage regulator as this is definitely faulty.

### 2) HEADLIGHTS AND CHOKE NOT-OPERATIONAL

In order to leave the AC free from absorptions, so to carry out voltage checks, please proceed as follows. Remove the handlebar covers. Detach the connections from the headlight and the 5 PIN connector from the dashboard. Remove the taillight bulb. Remove the automatic choke connector from the system.

Access the voltage regulator, start the engine and let it run at idle.

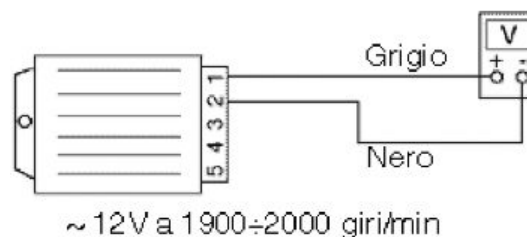
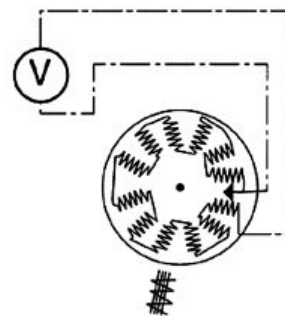

Insert the positive terminal from the tester (setting the tester on AC mode) on terminal no. 1 (yellow-black wire) and the negative terminal on terminal no. 2 (black wire); check for voltage (see figure). If voltage is present, check the wiring from the headlight to the voltage regulator, and the operation of the light switch.

If no voltage is found, put the negative terminal to earth; if this provides voltage readings, check the earth wire (terminal no. 2) on the regulator (black wire); otherwise, replace the regulator as certainly faulty.

As a last test it is possible to check the output voltage from the stator:

-Detach the regulator connector and interpose the tester in AC mode, between the Gray-Blue wire (4) and earth (see figure).

-The voltage output at 2,000 rpm must be approx. 25 - 35V

If this test also gives no voltage, replace the regulator as certainly faulty.

#### N.B.

TO MEASURE THE ABOVE VOLTAGE USE AN ANALOGUE TESTER THAT CAN MEASURE ALTERNATING VOLTAGES AND KEEP THE ENGINE AT IDLE TO HAVE AN ALTERNATING VOLTAGE OF A FREQUENCY AS CLOSE AS POSSIBLE TO 50HZ SO AS TO DETECT THE EFFICIENT VOLTAGE VALUE SUPPLIED BY THE REGULATOR (ABOUT 12V).

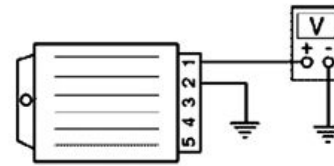

~ 12V a 1900÷2000 giri/min.

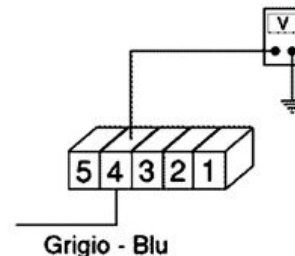

~ 25÷35V a 1900÷2000 giri/min.

## Recharge system voltage check

### 3) BATTERY DOES NOT RECHARGE

The fault in the DC section of the voltage regulator may cause, depending on the type of failure, the following faults:

- a) Bursting of protection fuse due to excessively high voltage (regulator short-circuited) and resulting in the battery not recharging.**
- b) Battery not recharging (regulator circuit interrupted).**

#### Interventions

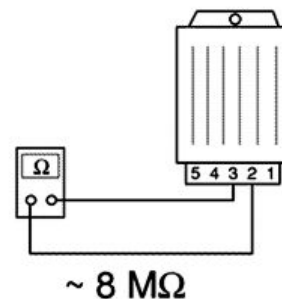

~ 8 MΩ

a) Bursting of protection fuse (regulator short-circuited).

Check the wiring running from the fuse to the ignition key-switch is not damaged, as this may create a short-circuit with earth (thus excluding possible regulator failures); if the protection fuse bursts only after the ignition key-switch is turned to "ON", and with the regulator connector detached, it is then necessary to check the wirings and systems downstream the key-switch are not short-circuited with earth.

Proceed by measuring the resistance between contacts 3 (White) and 2 (Black) from the voltage regulator (with the connector detached).

If the reading differs excessively from the figures shown, replace the regulator as short-circuited.

b) Battery not recharging (regulator circuit interrupted).

To check for the presence of faults on the recharging section of the voltage regulator, it is necessary to initially operate on the battery, using two testers (one for voltages and one for currents), as shown in the second figure, and follow the operations given below:

Start the engine (connecting, temporarily, the red wire to the positive terminal of the battery, so to avoid damaging the instrument measuring the current).

Check the voltage at idle is at least 13V (charged battery) and the recharge current is 1.5 - 2A with the lighting system and the choke device excluded, as described in the chapter "CHECKING THE VOLTAGE REGULATOR".

As the engine speed increases, so do the recharge current and voltage, and at speeds above 4,000 rpm, a recharging current of approx. 4.5A must be observed; reactivating the lighting system and choke device, and operating the stop light and

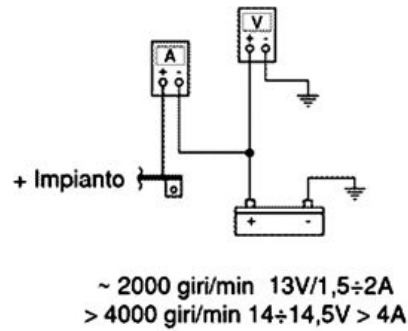



horn, current values of  $\geq 5A$  may be found, with voltage readings of 14 - 14.5V (regulator threshold voltage).

**If the readings do not match the above figures, replace the regulator; otherwise check wiring and connections.**

### Electric characteristic

#### Voltage regulator resistance

~ 8 M $\Omega$

## Sealed battery

INSTRUCTIONS FOR REFRESHING THE STOCK CHARGE OF AN OPEN CIRCUIT

### 1) Voltage check

Before installing the battery on the vehicle, check the open circuit voltage with a normal tester.

- If the voltage exceeds 12.60 V, the battery may be installed without any renewal recharge.
- If voltage is below 12.60 V, a renewal recharge is required as explained in 2).

### 2) Constant voltage battery charge mode

- Constant voltage equal to 14.40÷14.70V
- Initial charge voltage equal to 0.3÷0.5 for nominal capacity
- Duration of the charge: 10 to 12 h recommended
- Minimum 6 h
- Maximum 24 h

### 3) Constant current battery charge mode

- Charge current equal to 1/10 of the nominal capacity of the battery
- Duration of the charge: 5 h

#### WARNING

**-WHEN THE BATTERY IS REALLY FLAT (WELL BELOW 12.6V) IT MIGHT BE THAT 5 HOURS OF RECHARGING ARE NOT ENOUGH TO ACHIEVE OPTIMAL PERFORMANCE. IN THESE CONDITIONS IT IS HOWEVER ESSENTIAL NOT TO EXCEED EIGHT HOURS OF CONTINUOUS RECHARGING SO AS NOT TO DAMAGE THE BATTERY ITSELF.**

1 Hold the vertical tube

2 Look at the level

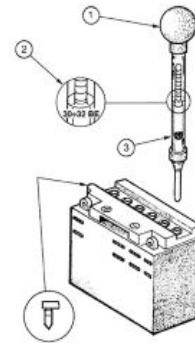

---

3 The float must be freed

---

## Dry-charge battery

The battery is an electrical device which requires careful monitoring and diligent maintenance. The maintenance rules are:

### 1) Check the level of the electrolyte

The electrolyte level must be checked frequently and must reach the upper level. Only use distilled water, to restore this level.

If it is necessary to add water too frequently, check the vehicle's electrical system: the battery works overcharged and is subject to quick wear.

### 2) Load status check

After restoring the electrolyte level, check its density using an appropriate densitometer (see the figure). When the battery is charged, you should detect a density of 30 to 32 Bé corresponding to a specific weight of 1.26 to 1.28 at a temperature of no lower than 15° C.

A density reading of less than 20° Bé indicates that the battery is completely flat and it must therefore be recharged.

After charging the battery, check each element electrolyte level and density. If the scooter is not used for a given time (1 month or more) it will be necessary to periodically recharge the battery.

The battery runs down completely in the course of three months.

If it is necessary to refit the battery in the vehicle, be careful not to reverse the connections, remembering that the earth wire (**black**) marked (-) must be connected to the - **negative** terminal while the other two **red** wires marked (+) must be connected to the terminal marked with the + **positive** sign.

Regular bench charging must be carried out with the specific battery charger, (single) or (multiple), setting the battery charger selector to the type of battery to be recharged. Connections to the power supply source must be implemented by connecting the corresponding poles (+ to+ and - to -).

### 4) Cleaning the battery

The battery should always be kept clean, especially on its top side, and the terminals should be coated with Vaseline.

#### WARNING

- Before recharging the battery, remove the plugs of each cell. Keep the battery away from naked flames or sparks when charging.

Remove the battery from the vehicle removing the negative clamp first.

#### CAUTION

**NEVER USE FUSES WITH A CAPACITY HIGHER THAN THAT RECOMMENDED.  
USING A FUSE OF UNSUITABLE RATING MAY SERIOUSLY DAMAGE THE VEHICLE OR EVEN CAUSE A FIRE.**

#### CAUTION

**DRINKING WATER CONTAINS MINERALS THAT CAN BE EXTREMELY HARMFUL TO THE BATTERY: USE DISTILLED WATER ONLY.**

#### CAUTION

**TO ENSURE MAXIMUM PERFORMANCE THE BATTERY MUST BE CHARGED BEFORE USE.**

---

**INADEQUATE CHARGING OF THE BATTERY WITH A LOW ELECTROLYTE LEVEL BEFORE IT IS FIRST USED SHORTENS THE LIFE OF THE BATTERY.**

#### **Specific tooling**

**020333Y Single battery charger**

**020334Y Multiple battery charger**

---

#### **WARNING**

- Battery electrolyte is toxic and it may cause serious burns. It contains sulphuric acid. Avoid contact with eyes, skin and clothing. In case of contact with eyes or skin, flush abundantly with water for about 15 minutes and seek immediate medical attention.

In the event of accidental ingestion of the fluid, immediately drink large quantities of water or milk. Follow with milk of magnesia, beaten egg or vegetable oil. Seek immediate medical attention

Batteries produce explosive gases; keep clear of free flames, sparks or cigarettes; ventilate the area when recharging the battery indoors.

Always protect your eyes when working close to batteries.

**Keep out of the reach of children.**

---

1)- Remove the short closed tube and the caps, then pour sulphuric acid into the cells using the type specified for batteries, with a specific gravity of 1.26, corresponding to 30° Bé, at a minimum temperature of 15°C until the upper level is reached.

2) - Leave to rest for at least 2 hours; then, restore the level with sulphuric acid.

3)- Within the following 24 hours, recharge with the specific battery charger (single) or (multiple) at a density of about 1/10 of the battery nominal capacity and until the acid density is about 1.27, corresponding to 31° Bé, and these values are stabilised.

4) - Once the charge is over, level the acid (by adding **distilled water**). Close and clean carefully.

5)- Once the above operations have been performed, install the battery in the vehicle ensuring the connections between the wiring and the battery terminals are correct.

#### **WARNING**

**- ONCE THE BATTERY HAS BEEN INSTALLED IN THE VEHICLE IT IS NECESSARY TO REPLACE THE SHORT TUBE (WITH CLOSED END) NEAR THE + POSITIVE TERMINAL WITH THE CORRESPONDING LONG TUBE (WITH OPEN END), THAT YOU FIND FITTED TO THE VEHICLE, TO ENSURE THAT THE GASES THAT FORM CAN ESCAPE PROPERLY.**

#### **Specific tooling**

**020333Y Single battery charger**

**020334Y Multiple battery charger**

---

# INDEX OF TOPICS

ENGINE FROM VEHICLE

ENG VE

---

## Exhaust assy. Removal

---

- Remove the 2 fixing nuts from the manifold to the head



- Undo the 2 screws fixing the muffler to the housing; then remove the whole muffler paying attention to the interference between its supporting bracket and the cooling cover.

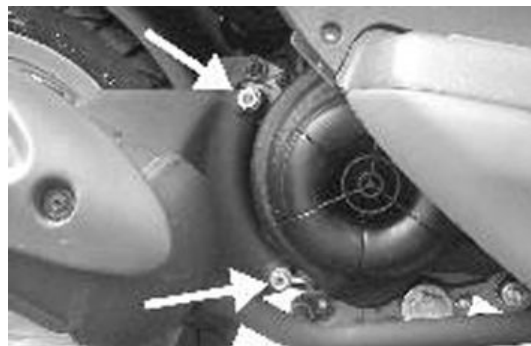

---

## Removal of the engine from the vehicle

### Removing the engine from the frame

---

- Disconnect the battery.
- Remove the muffler assembly.
- Remove the rear wheel.
- Remove the rear brake mechanical transmission.
- Disconnect the electric terminals.
- Remove the throttle grip transmission.
- Disconnect the tubing (petrol-vacuum operated cock control).
- Disconnect the swinging arm on the engine side
- Disconnect the rear shock absorber lower clamping

**WARNING**

Be very careful when handling fuel.

**CAUTION**

When installing the battery, first attach the positive cable and then the negative cable.

**WARNING**

Wear safety goggles when using hitting tools.

---

# INDEX OF TOPICS

ENGINE

ENG

---

## Automatic transmission

---

### Transmission cover

---

- Remove the 12 fixing screws.
- Remove the oil filling cap and then slide out the cover.

If this operation is carried out directly on the vehicle, it is necessary to remove the transmission cooling coupling and the air filter housing retainers.

**N.B.**

**USE A MALLET ON THE APPROPRIATE COUPLINGS TO REMOVE THE COVER.**

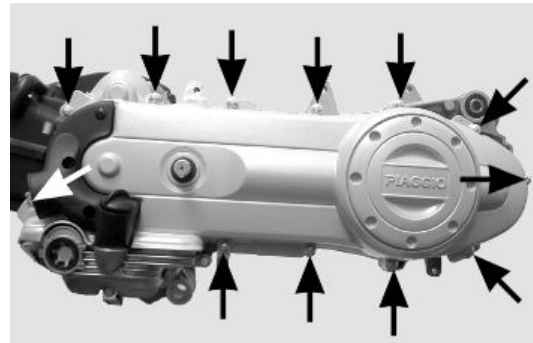

---

### Kickstart

---

- To remove the start up pinion push the starter lever to facilitate extracting the pinion.
- Remove the kick-start screw and lever.
- Remove the Seeger ring and the washer indicated in the figure.
- Pull out the toothed sector.

**WARNING**

**THE SECTOR KEEPS THE SPRING SET, BE CAREFUL SO AS NOT TO CAUSE ANY ACCIDENTS**



---

### Air duct

---

- To remove the intake throat on the transmission cover, just remove the three fixing screws indicated in the figure.

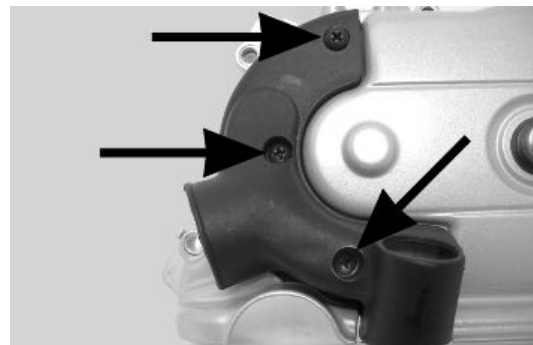

---

## Removing the driven pulley shaft bearing

- Slightly heat the crankshaft from the inside side to avoid damaging the coated surface and use the driven pulley shaft or a pin of the same diameter to remove the bearing.

**N.B.**

**IN CASE OF DIFFICULTY A STANDARD 8MM-INSIDE DIAMETER EXTRACTOR CAN BE USED.**

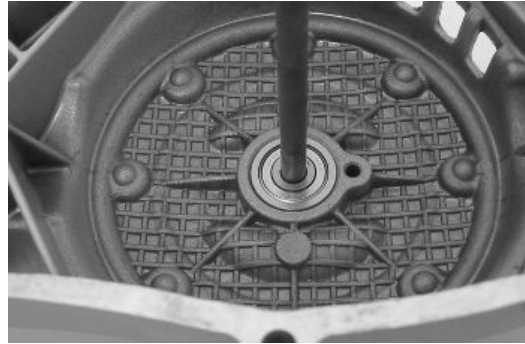

---

## Refitting the driven pulley shaft bearing

Refit the bearing with the aid of a bushing with the same diameter as the external plate of the bearing after slightly heating the crankcase from the inside.

**N.B.**

**WHEN REFITTING, ALWAYS REPLACE THE BEARING WITH A NEW ONE.**

**CAUTION**

**WHEN REMOVING/REFITTING THE BEARING, TAKE CARE NOT TO DAMAGE THE COVER PAINTED SURFACE.**

---

## Removing the driven pulley

- Lock the clutch bell housing with the specific tool.
- Remove the nut, the clutch bell housing and the whole of the driven pulley assembly.

**N.B.**

**THE UNIT CAN ALSO BE REMOVED WITH THE DRIVING PULLEY MOUNTED.**

### Specific tooling

**020565Y Flywheel lock calliper spanner**





## Inspecting the clutch drum

- Check that the clutch bell is not worn or damaged.
- Measure the inner diameter of the clutch bell.

### Characteristic

#### Clutch bell diameter/standard value

Ø 107+0.2 +0 mm

#### Clutch bell diameter/max. value allowed after use

Ø 107.5 mm

#### Eccentricity measured /max.

0.20 mm



## Removing the clutch

- Equip the tool with long pins screwed into position «A» from the outside, insert the entire driven pulley in the tool and have the central screw make contact.

### CAUTION

THE TOOL WILL BE DEFORMED IF THE CENTRAL SCREW IS TIGHTENED UP TOO FAR.

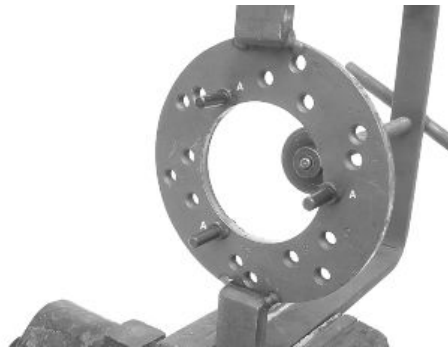

- Using a 34 mm socket wrench remove the clutch locking nut.
- Loosen the central screw by undoing spring of the driven pulley unit
- Separate the components.

### Specific tooling

**020444Y Tool for fitting/ removing the driven pulley clutch**



---

## Inspecting the clutch

- Check the thickness of the clutch mass friction material.
- The masses must not show traces of lubricants; otherwise, check the driven pulley unit seals.

**N.B.**

**UPON RUNNING-IN, THE MASSES MUST EXHIBIT A CENTRAL FAYING SURFACE AND MUST NOT BE DIFFERENT FROM ONE ANOTHER. VARIOUS CONDITIONS CAN CAUSE THE CLUTCH TO TEAR.**

**CAUTION**

**DO NOT OPEN THE MASSES USING TOOLS TO PREVENT A VARIATION IN THE RETURN SPRING LOAD.**

**Characteristic****Check minimum thickness**

1 mm



---

## Pin retaining collar

- Remove the collar with the aid of 2 screwdrivers.



- Remove the three guide pins and the mobile half pulley.



## Removing the driven half-pulley bearing

- Remove the roller bearing with the special extractor inserted from the bottom of the fixed half-pulley.

### CAUTION

POSITION THE HOLDING EDGE OF THE EXTRACTION PLIERS BETWEEN THE END OF THE BEARING AND THE BUILT IN SEALING RING.

### Specific tooling

001467Y029 Bell for bearings, O.D. 38 mm



- Remove the ball bearing retention snap ring.
- Expel the ball bearing from the side of the clutch housing by means of the special tool.

### N.B.

PROPERLY SUPPORT THE HALF-PULLEY SO AS NOT TO DEFORM THE SLIDING SURFACE OF THE DRIVING BELT

### Specific tooling

020376Y Adaptor handle

020363Y 20 mm guide



## Inspecting the driven fixed half-pulley

- Check that there are no signs of wear on the work surface of the belt. If there are, replace the half-pulley..
- Make sure the bearings do not show signs of unusual wear.
- Measure the external diameter of the pulley bushing.

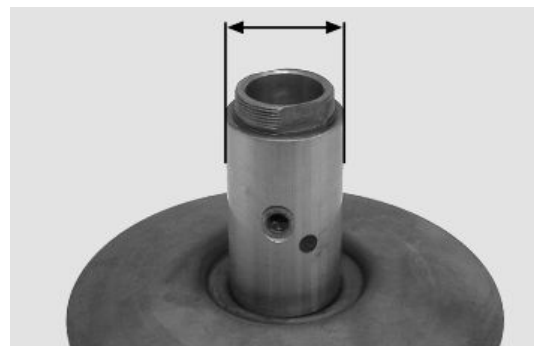

### Characteristic

**Stationary driven half-pulley/Standard diameter**

Ø 33.965 to 33.985 mm

**Stationary driven half-pulley / Minimum diameter admitted after use**

Ø 33.96 mm

## Inspecting the driven sliding half-pulley

- Remove the 2 inner sealing rings and the two O-rings.
- Measure the inside diameter of the mobile half-pulley bushing.

### Characteristic

#### Mobile driven half-pulley/ Maximum diameter allowed

Ø 34.08 mm

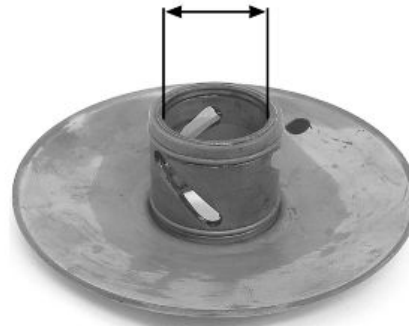

- Check the belt contact surfaces.
- Insert the new oil seal and O-rings on the mobile half-pulley.
- Fitting the half-pulley on the bushing.

### Recommended products

#### AGIP GREASE SM 2 Grease for the tone wheel revolving ring

Soap-based lithium grease containing NLGI 2 Molybdenum disulphide; ISO-L-XBCHB2, DIN KF2K-20



- Make sure the pins and collar are not worn, reassemble the pins and collar.
- Use a greaser with a curved spout to lubricate the driven pulley unit with around 6 g of grease. This operation must be done through one of the holes inside the bushing until grease comes out of the opposite hole. This procedure is necessary to prevent the presence of grease beyond the O-ring.

### Recommended products

#### AGIP GREASE SM 2 Grease for the tone wheel revolving ring

Soap-based lithium grease containing NLGI 2 Molybdenum disulphide; ISO-L-XBCHB2, DIN KF2K-20

## Refitting the driven half-pulley bearing

- Fit a new ball bearing with the specific tool.
- Fit the ball bearing retention snap ring.
- Fit the new roller bearing with the wording visible from the outside.

### CAUTION

PROPERLY SUPPORT THE HALF-PULLEY TO PREVENT DAMAGE TO THE THREADED END WHILE THE BEARINGS ARE BEING FITTED.

### Specific tooling

020376Y Adaptor handle



020456Y Ø 24 mm adaptor

020362Y 12 mm guide

020171Y Punch for Ø 17 mm roller case

## Inspecting the clutch spring

- Check that the contrast spring of the driven pulley does not show signs of deformation
- Measure the free length of the spring

### Characteristic

#### Standard length

118 mm

#### Minimum length allowed after use

XXXX



- Check the thickness of the clutch mass friction material.
- The masses must not show traces of lubricants; otherwise, check the driven pulley unit.

### N.B.

UPON RUNNING-IN, THE MASSES MUST EXHIBIT A CENTRAL CONTACT SURFACE AND MUST NOT BE DIFFERENT FROM ONE ANOTHER. VARIOUS CONDITIONS CAN CAUSE THE CLUTCH TO TEAR.

### CAUTION

DO NOT OPEN THE MASSES USING TOOLS SO AS TO PREVENT A VARIATION IN THE RETURN SPRING LOAD.



### Characteristic

#### Minimum thickness permitted:

1 mm

## Refitting the clutch

- Preassemble the driven pulley group with spring, sheath and clutch.
- Position the spring with the sheath
- Insert the components in the tool and preload the spring being careful not to damage the plastic sheath and the end of the threaded bar.



- Reassemble the nut securing the clutch and tighten to the prescribed torque.

**CAUTION**

SO AS NOT TO DAMAGE THE CLUTCH NUT USE A SOCKET WRENCH WITH SMALL CHAMFER.

**CAUTION**

POSITION THE NON-CHAMFERED SURFACES OF THE NUT IN CONTACT WITH THE CLUTCH

**Locking torques (N\*m)**

Nut locking clutch unit on pulley  $55 \div 60$  Nm

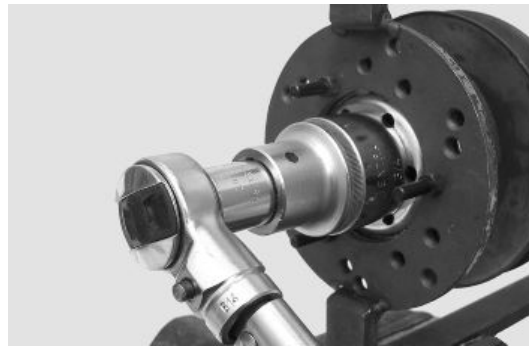
**Refitting the driven pulley**

- Refit the driven pulley assembly, the clutch bell and the nut, using the specific tool.

**Specific tooling**

020565Y Flywheel lock calliper spanner

**Locking torques (N\*m)**

Driven pulley shaft nut 40 to 44 Nm

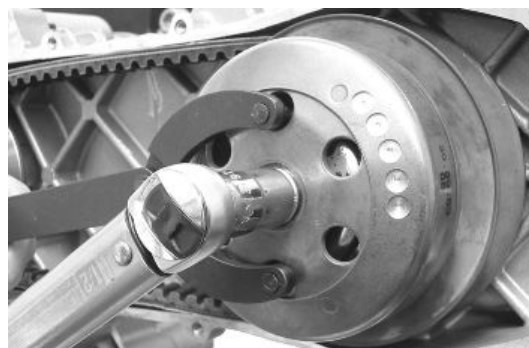
**Drive-belt**

- Make sure the driving belt is not damaged and does not have cracks in the toothed grooves.
- Check the width of the belt.

**Characteristic**

Transmission belt/Minimum width

17.5 mm



## Removing the driving pulley

- Lock the driving pulley using the appropriate tool.
- Remove the central nut with the related washer, then remove the drive and the plastic fan.
- Remove the stationary half-pulley.

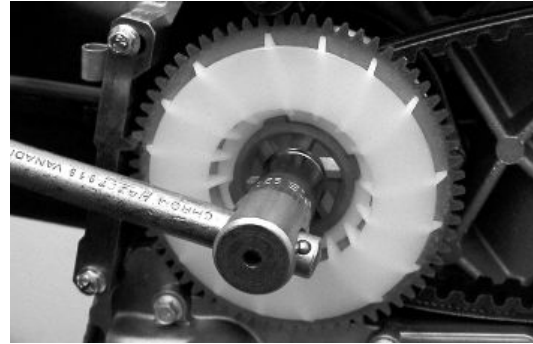

- Remove the belt, washer and remove the mobile half-pulley with its bushing, being careful that the rollers and contrast plate fitted loosely on it do not come off.

### Specific tooling

020451Y Starting ring gear lock

## Inspecting the rollers case

- 1) Check that the bushing and the sliding rings of the mobile pulley do not show signs of scoring or deformation.
- 2) Check the roller running tracks on the contact pulley; there must not be signs of wear and check the condition of the contact surface of the belt on the half-pulleys (mobile and stationary).
- 3) Check that the rollers do not show signs of marked facetting on the sliding surface and that the metallic insert does not come out of the plastic shell borders.
- 4) Check the integrity of the sliding blocks of the contact plate.

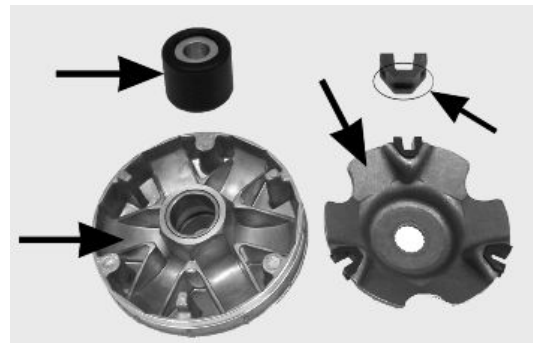

- Check that the internal bushing shown in the figure is not abnormally worn and measure inside diameter «A».
- Measure outside diameter «B» of the pulley sliding bushing shown in the figure.

### CAUTION

DO NOT LUBRICATE OR CLEAN THE BUSHING.

### Characteristic

Driving pulley / Maximum diameter:

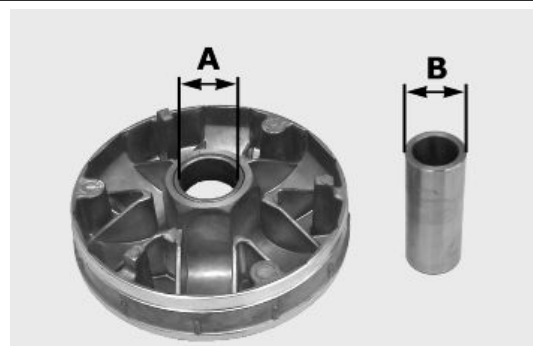



20.12 mm

**Driving pulley/ Standard diameter:**

20.021 mm

**Driving pulley bushing/ Diameter maximum:**

XXX mm

**Driving pulley bushing/ Standard diameter:**

20 -0.020/-0.041mm

## Refitting the driving pulley

- Manually move the movable driven half-pulley away by pulling it towards the clutch unit and insert the belt observing the direction of rotation of the first fitting.

**N.B.**

**IT IS GOOD PRACTICE ALWAYS TO FIT THE BELT SO THAT THE WORDS CAN BE READ IN CASE IT DOES NOT SHOW A FITTING SIDE.**



- Refit the components of the assembly (roller container assembly with bushing, limiting washer, stationary half-pulley, cooling fan belt with drive, washer and nut).

- With the specific tool, tighten the lock nut to 20 Nm and then perform a final 90° locking in order to prevent the rotation of the driving pulley.

**N.B.**

**REPLACE THE NUT WITH A NEW ONE AT EVERY REFIT CAUTION**

**UPON FITTING THE DRIVING PULLEY UNIT IT IS OF UTMOST IMPORTANCE THAT THE BELT IS FREE INSIDE IN ORDER TO AVOID WRONG TIGHTENING AND CONSEQUENTLY DAMAGING THE CRANKSHAFT KNURLING.**



### Specific tooling

**020451Y Starting ring gear lock**

**Locking torques (N\*m)**

**Crankshaft pulley nut 18 to 20 + 90° Nm**



## Refitting the transmission cover

- Check the following for wear: toothed section, toothed section shaft, cover seat bushing, pinion shaft and its seating in the crankcase and the return spring.
- Remove the damaged components.
- Grease the spring.
- Remove the toothed sector and load the spring with an appropriate tool.
- Refit the washer, the Seeger and the Kick-start lever.

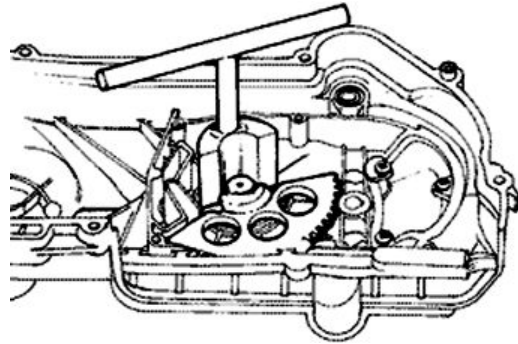

### Recommended products

#### AGIP GREASE MU3 Grease for odometer transmission gear case

Soap-based lithium grease with NLGI 3; ISO-L-XBCHA3, DIN K3K-20

- Insert the pinion in its seating by pushing the starter lever.
- Fit the intake throat and tighten the 3 screws.

- Make sure the oil sump presents centring dowels and sealing gaskets.
- Replace the cover tightening the 12 screws to the prescribed torque.
- Refit the oil filling cap.

### Locking torques (N\*m)

Transmission cover screws 11 ÷ 13 Nm

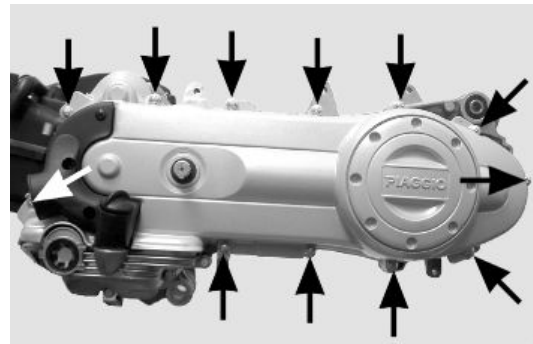

## End gear

## Removing the hub cover

- Drain the rear hub oil
- Remove driven pulley
- Remove the rear brake shoes
- Remove the 5 screws fixing the cover to the crankcase
- Remove the cover with the wheel axle and pull it out
- Remove the intermediate gear with the appropriate shim washers

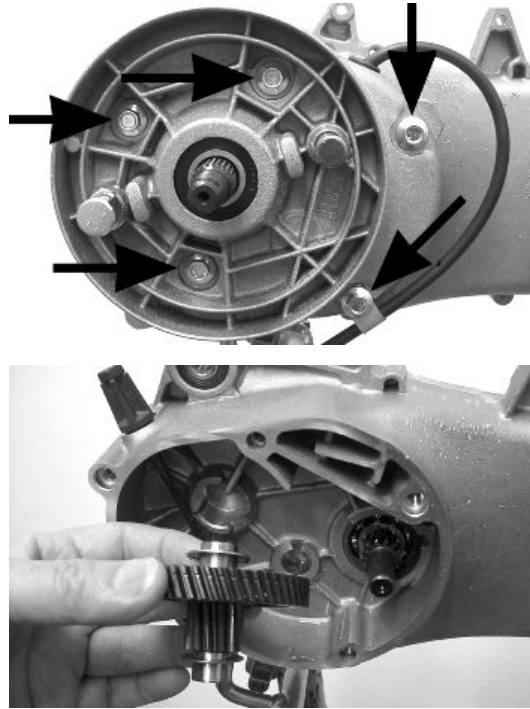

## Removing the wheel axle bearings

- Remove the oil seal and the seeger ring.
- Fix the hub cover properly to avoid damaging the sealing surface with the housing
- Remove the wheel axle bearing using the specific tool

### Specific tooling

**020363Y 20 mm guide**

**020376Y Adaptor handle**

**020477Y Adaptor 37 mm**

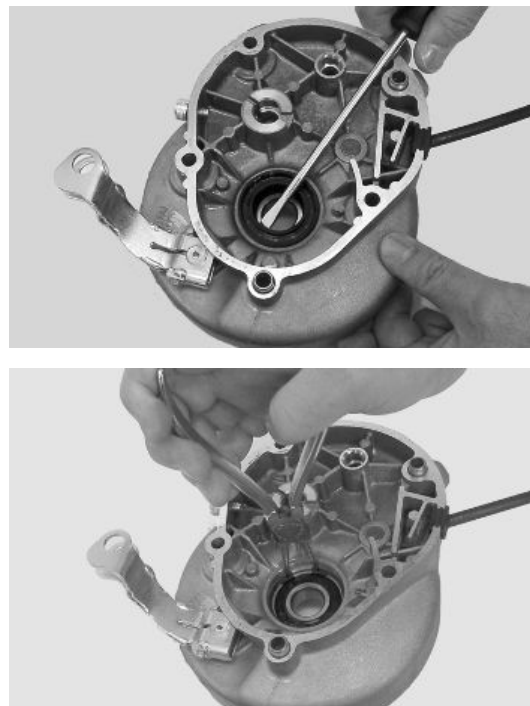



### Removing the driven pulley shaft bearing

- Remove the seeger ring
- Heat the engine crankcase but do not direct the hot air towards the bearing
- Extract the driven pulley shaft together with the bearing with a few mallet blows



- Remove the bearing off the driven pulley shaft using the specific tool and a press

**N.B.**

**USE THE SPECIFIC TOOL ON THE SIDE WITH THE SMALLER INTERNAL DIAMETER**

#### Specific tooling

**020452Y Tube for removing and refitting the driven pulley shaft**



## Inspecting the hub shaft

- Check the three shafts for wear or distortion of the toothed surfaces, the bearing housings, and the oil seal housings.
- In case of anomalies, replace the damaged components.
- Check capacity ( A ) of the transmission gear (wear, deformations, etc.)
- Check the pulley shaft seating: Superficial wear ( B ) may indicate irregularities in the crankcase seatings or in the pulley shaft capacities

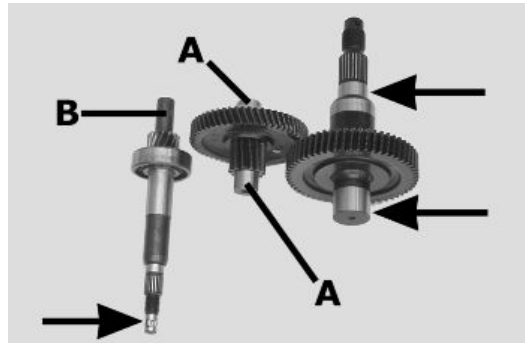

## Inspecting the hub cover

- Check that the fitting surface is not dented or distorted.
- If faults are found, replace the hub cover.

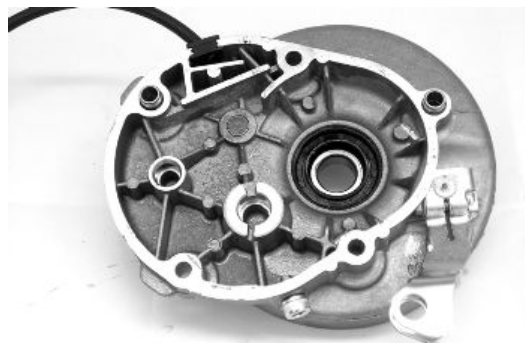

## Refitting the wheel axle bearing

- Support the hub cover on a wooden surface
- Heat up the hub cover using the thermal gun.
- Preassemble the bearing on the specific punch using grease and then insert the bearing in its seating
- Refit the seeger ring and the oil seal using the 42 x 47 mm adaptor

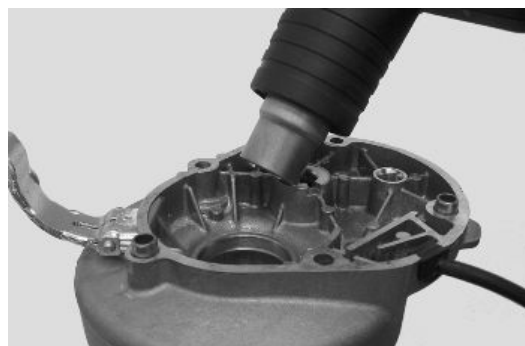

**N.B.**

**POSITION THE OIL SEAL WITH THE SEALING LIP FACING THE HUB INTERNAL SIDE**

### Specific tooling

**020150Y Air heater support**

**020151Y Air heater**

**020376Y Adaptor handle**

020363Y 20 mm guide

020359Y 42x47-mm Adaptor

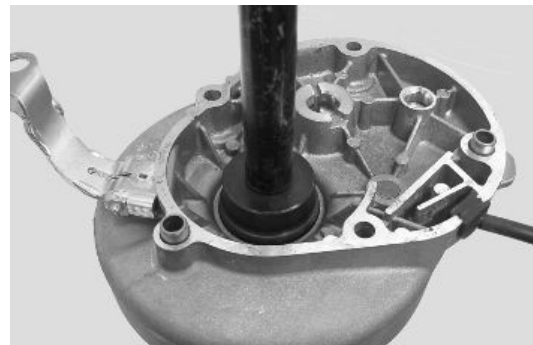
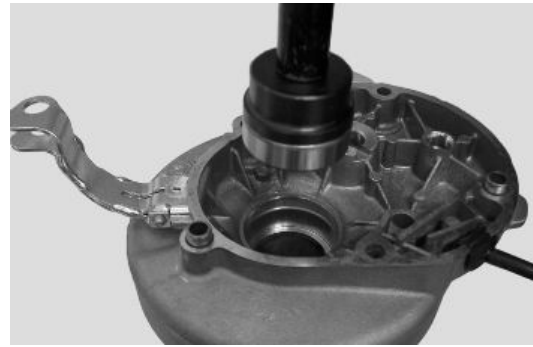

### Refitting the hub bearings

- Remove the wheel axle on the cover and pay attention not to damage the sealing lip of the oil seal
- Apply a thin layer of grease on the two shim washers of the intermediate gear and fit one on the cap so that it does not interfere with the wheel axle gear when placing the transmission shaft



### Refitting the hub cover

- Apply product recommended for surfaces on the hub cap and refit cap on the crankcase
- Fit the 5 screws and tighten them to the specified torque.

**N.B.**

**CLEAN THE CONTACT SURFACES OF THE HUB COVER AND THE HALF CRANKCASE OF RESIDUE FROM PREVIOUS GASKETS BEFORE APPLYING A NEW ONE.**

#### Recommended products

**Loctite 510 Liquid sealant**





Gasket

### Locking torques (N\*m)

hub cap screws 24 - 26

## Flywheel cover

### Cooling hood

- Remove the manifold and the carburettor undoing the 2 fixing screws on the head
- Remove the fastening clamp of the secondary air pipe and disconnect it
- Remove the 4 front coupling screws (1 of them is a knob) and the side fixing screw at the crankcase base.
- Remove the 4 side screws
- Extract the 3 covers - Remove the cover sealing gaskets on the head
- For refitting, repeat the removal steps but in reverse order

#### CAUTION

TAKE CARE TO CORRECTLY POSITION THE FLYWHEEL CONNECTOR.

#### N.B.

WHEN REFITTING THE COVER, TAKE CARE NOT TO DAMAGE THE STATOR WIRING.

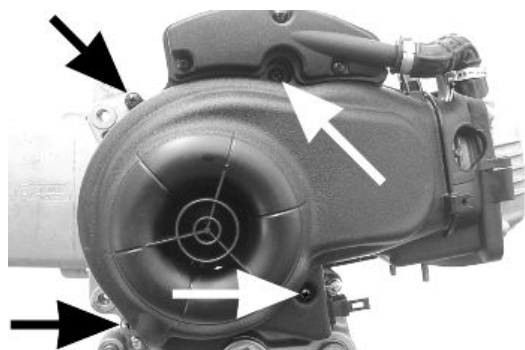
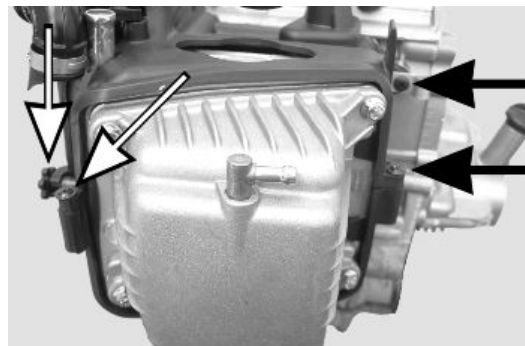
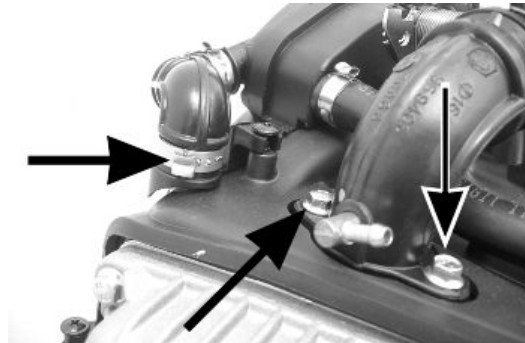

## Cooling fan

- Remove the cooling fan by undoing the 3 screws fixing it to the rotor
- When refitting the fan, pay attention that the screw holes in the fan and the rotor coincide, then tighten screws at the specified torque.

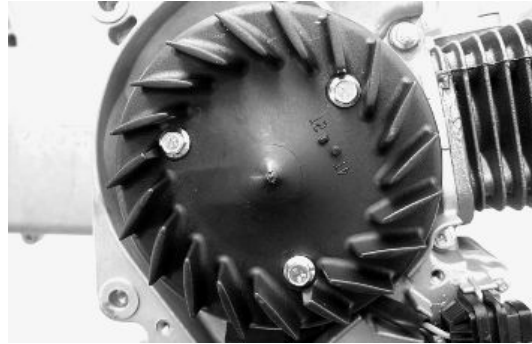

## Removing the stator

- Remove the 2 Pick-Up screws and the 2 stator fixing screws indicated in the figure.
- Remove the stator and its wiring.

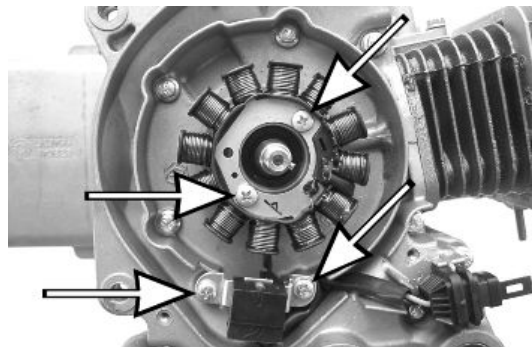

## Refitting the stator

- Refit the stator and flywheel carrying out the removal procedure in reverse, tightening the retainers to the specified torque.

### N.B.

THE PICK-UP CABLE MUST BE POSITIONED ADHERING TO THE FUSION TONGUE ON THE CRANKSHAFT IN SUCH A WAY AS TO AVOID BEING CRUSHED BY THE FAN COVER ASSEMBLY.

### Locking torques (N\*m)

Pick-up screws 3 ÷ 4 Stator screws 3 ÷ 4

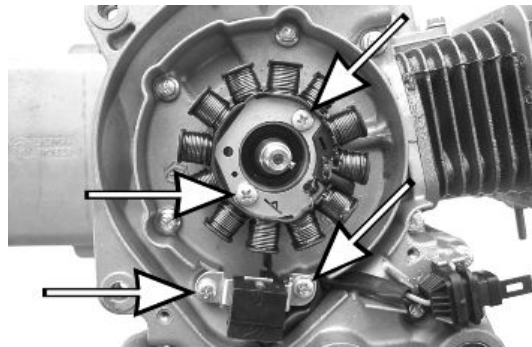

## Flywheel and starting

---

## Removing the starter motor

- Undo the screw on the power positive contact and disconnect the cable
- Undo the 2 screws fixing the starter motor to the crankcase and recover the power wiring.

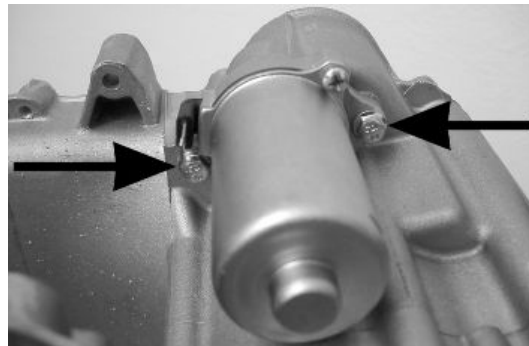
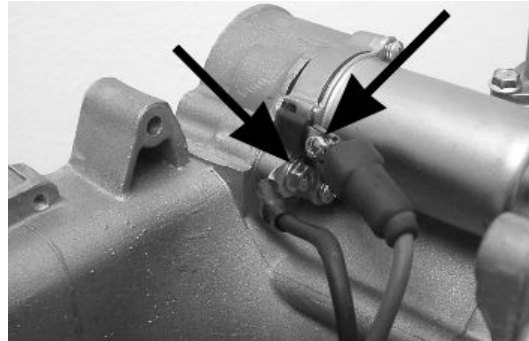

---

## Removing the flywheel magneto

- Lock the rotation of the flywheel using the calliper spanner.
- Remove the nut.

**CAUTION**

THE USE OF A CALLIPER SPANNER OTHER THAN THE ONE SUPPLIED COULD DAMAGE THE STATOR COILS



- Extract the flywheel with the extractor.

**Specific tooling**

**020565Y** Flywheel lock calliper spanner

**020162Y** Flywheel extractor





---

## Inspecting the flywheel components

- Check that the flywheel internal magnets are in good conditions.
- Check that the flywheel splines exhibit no loosening.
- Check there are no deformations that may cause rubbing on the stator and the Pick-Up.
- Check that the stator winding, its ferromagnetic support and the pick-up are in good conditions.



---

## Starter gear rim

- Check the tothing is level and in good conditions



---

## Intermediate gear

- Check that the keying tothing on the crown and the starter motor are in good conditions.
- Check that the Bendix opens and returns adequately.



## Refitting the flywheel magneto

- Refit the stator and the pick-up being careful to pass the wiring through the appropriate crankcase couplings.
- Refit the flywheel to the crankshaft being careful to respect the keying, then lock rotation with the specific tool and tighten the nut to the prescribed torque.

### N.B.

A VARIATION OF THE AIR GAP DISTANCE CAN LEAD TO A VARIATION IN THE IGNITION ADVANCE SUCH AS TO CAUSE PINGING, KNOCKING ETC.

### Specific tooling

020565Y Flywheel lock calliper spanner

### Locking torques (N\*m)

Flywheel nut 52 ÷ 58

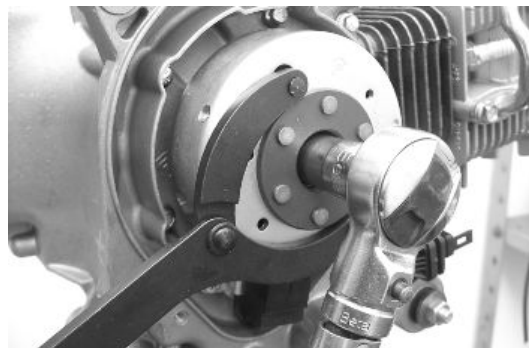
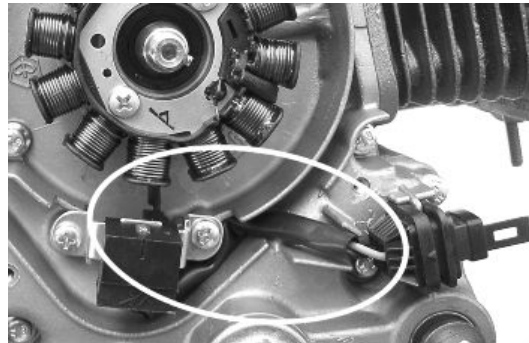

## Refitting the starter motor

- Install the starter motor in its seating in the crankcase.
- Tighten the screw on the head side but do not lock it, screw the second screw inserting the earth cable (black), then tighten the 2 screws at the prescribed torque.
- Tighten the locking screw of the positive cable (red) on the side contact.

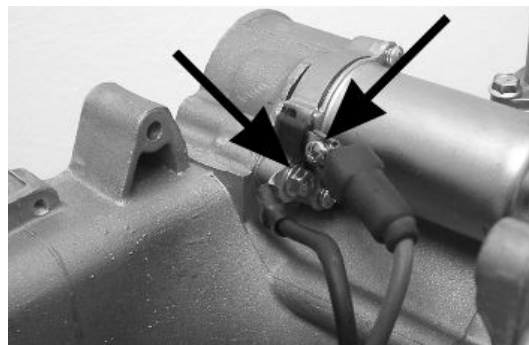

### N.B.

REFIT THE REMAINING PARTS AS DESCRIBED IN THE CYLINDER HEAD, TIMING, LUBRICATION, FLYWHEEL AND TRANSMISSION CHAPTERS.

### Locking torques (N\*m)

Starter motor screws 11 ÷ 13

## Cylinder assy. and timing system

## Removing the rocker-arms cover

- Remove the cooling covers
- Remove the 4 retainers of the tappet cover
- Remove the cover and the O-ring
- Remove the 4 screws and then remove the Blow-by cover
- Clean the nozzle labyrinth and the membrane (replace it, if necessary), then remove the cover unit.

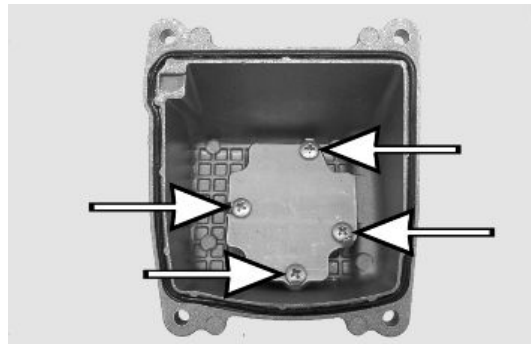
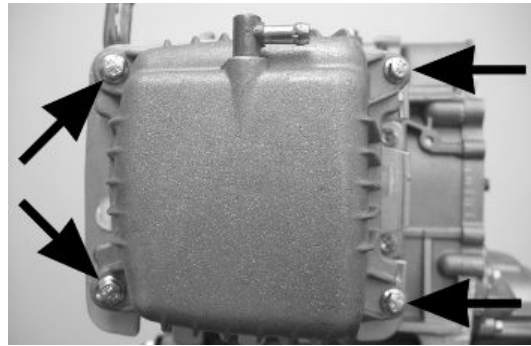

### See also

[Cooling hood](#)

## Removing the timing system drive

- Temporarily loosen the tensioner central screw and remove it together with the spring.
- Unscrew the 2 retainers indicated in the figure and remove the chain tightener support being careful to recover the sealing gasket.

### N.B.

**SHOULD THE GASKET NOT BE IN GOOD CONDITIONS, REPLACE IT AFTER CAREFULLY CLEANING THE FAYING SURFACE IN ORDER TO AVOID ENGINE OIL LEAKS**

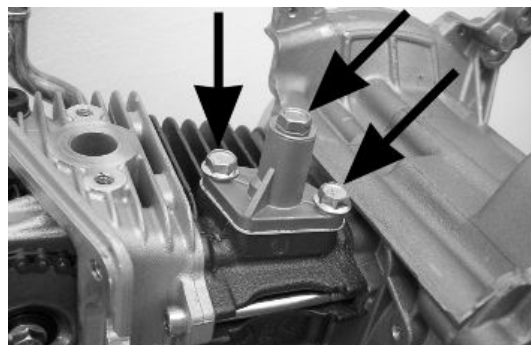

- Remove the driving pulley
- Remove the oil pump chain
- Remove the tappet cover
- Remove the central screw and the belleville washer indicated in the figure and lock the camshaft crown with the specific tool.

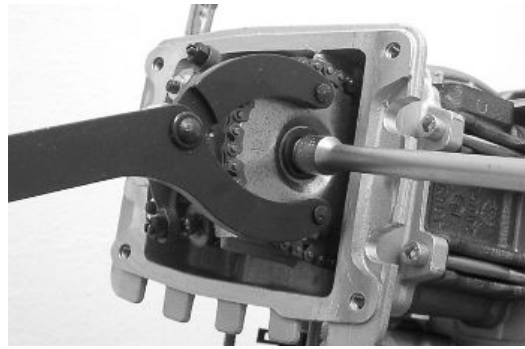

**N.B.**

**TO FACILITATE REMOVING THE HEAD COMPONENTS, SET THE CRANKSHAFT TO THE TIMING POINT (TDC OF THE COMPRESSION END).**

### Specific tooling

#### 020565Y Flywheel lock calliper spanner

- Remove the camshaft control pulley and the washer below.
- Remove the pinion of the crankshaft timing control
- To remove the chain lower guiding pad, remove the head by pulling it upwards

**N.B.**

**IT IS ADVISABLE TO MARK THE CHAIN IN ORDER TO ENSURE THAT THE DIRECTION OF ROTATION IS MAINTAINED.**

### See also

[Removing the rocker-arms cover](#)

[Removing the driving pulley](#)

[Removal](#)

## Removing the cam shaft

- Remove the bearing clamping screw indicated in the figure.

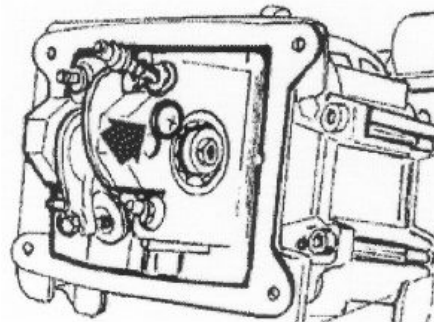

- Remove the entire camshaft with bearing using the specific tool shown in the figure.
- Take out the camshaft bearing with the aid of the specific tool, being careful to mount a screw on the camshaft in order to protect its thread.

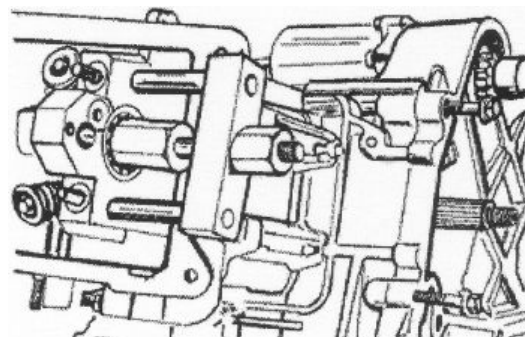

**N.B.**

**IF A BEARING SEPARATES FROM THE CAMSHAFT, IT IS ESSENTIAL TO FIT A NEW BEAR.**

### Specific tooling

**020450Y Camshaft fitting/removal tool**

**004499Y Camshaft bearing extractor**

**004499Y001 Bearing extractor bell**

**004499Y002 Bearing extractor screw**

**004499Y006 Bearing extractor ring**

**004499Y027 Bearing extractor part**

- Pull out the rocking lever bolt operating on the flywheel hole and remove the rocking levers at the same time.

**N.B.**

**MARK THE ASSEMBLY POSITION OF THE ROCKING LEVERS IN ORDER TO AVOID MISPLACING THE INTAKE AND DISCHARGE ENDS.**

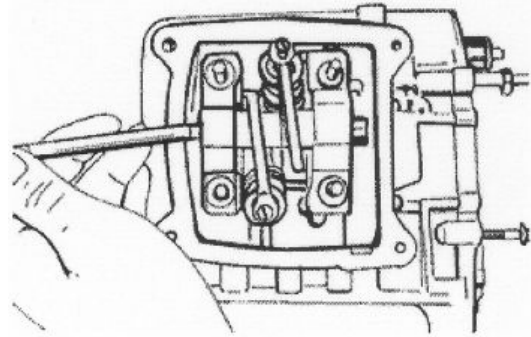

## Removing the cylinder head

- Remove the cooling covers, the timing control, the camshaft and the rocking levers.

- Remove the spark plug.

- Remove the 2 side fixings shown in the figure.

- Loosen the 4 head-cylinder fastening nuts in two or three stages and in criss-cross fashion.

- Remove the head, the two centring dowels and the gasket.

**N.B.**

**IF NEEDED, THE HEAD MAY BE REMOVED WITH THE CAMSHAFT, PINS AND ROCKING LEVERS WITHOUT REMOVING THE DRIVING PULLEY UNIT. REMEMBER TO HOLD THE TIMING CHAIN WITH A PIECE OF METAL CABLE AND TO ADJUST THE CHAIN TIGHTENER UPON RE-FITTING.**

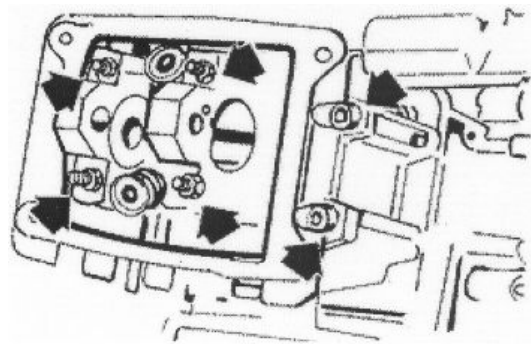



## Removing the valves

- Using the specific tool fitted with the element shown in the figure, remove the cotters, the plates and the spring between the valves.

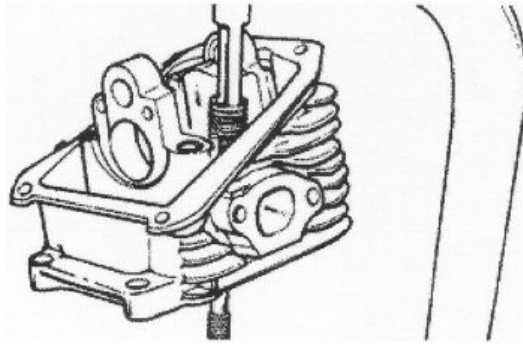

- Remove the oil seals with the appropriate tool.
- Remove the lower spring supports.

### Specific tooling

020431Y Valve oil seal extractor

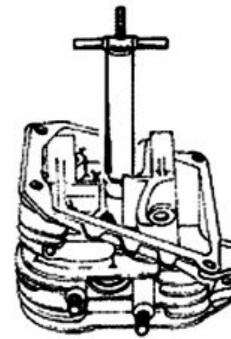

## Removing the cylinder - piston assy.

- Remove the cylinder paying attention to the 2 cylinder centring dowels in the housing.
- Remove the cylinder base gasket.

To avoid damaging the piston, keep it fixed while removing the cylinder.

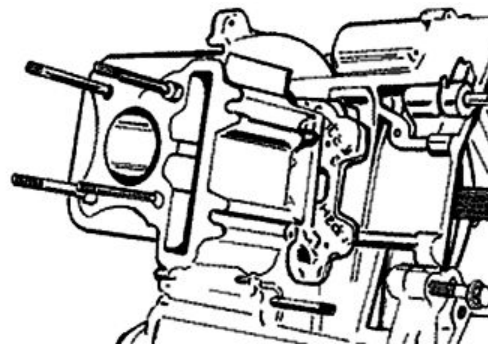

- Remove the two stop rings, the wrist pin and the piston.

- Remove the 3 piston rings.

**N.B.**

**BE CAREFUL NOT TO DAMAGE THE PISTON RINGS DURING REMOVAL.**

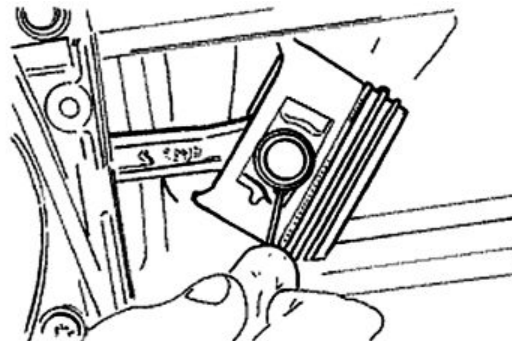

## Inspecting the small end

- Measure the internal diameter of the small end using an internal micrometer.

### N.B.

IF THE DIAMETER OF THE ROD SMALL END EXCEEDS THE MAXIMUM DIAMETER ALLOWED, SHOWS SIGNS OF WEAR OR OVERHEATING REPLACE THE CRANKSHAFT AS DESCRIBED IN THE "CRANKCASE AND CRANKSHAFT" CHAPTER".

### Characteristic

**Max. diameter admitted: check the small end**

13.030 mm

**Standard diameter: check the small end**

13 +0.025+0.015mm

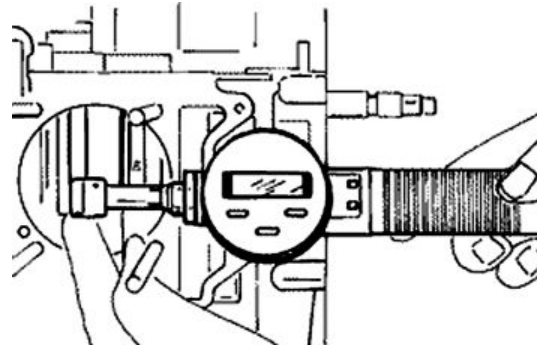

## Inspecting the wrist pin

- Measure the outer diameter of the gudgeon pin.

### Characteristic

**Standard diameter: gudgeon pin**

13 -0-0.004mm

**Minimum admissible diameter gudgeon pin**

12.990 mm

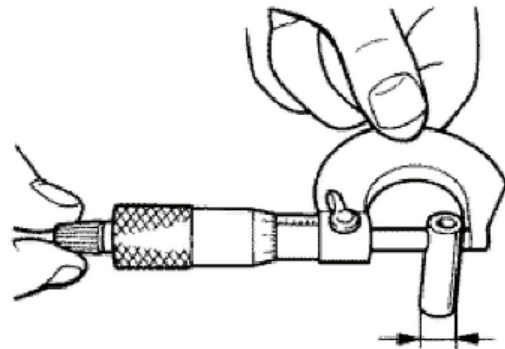

## Inspecting the piston

- Calculate the piston pin coupling clearance.

### Fitting clearance

**Pin coupling clearance**  $13 +0.010+0.005\text{mm}$   $0.005 \div 0.014$  mm



- Measure the outside diameter of the piston, perpendicular to the gudgeon pin axis.
- Carry out the measurement at 27 from the piston crown as shown in the figure.

- Carefully clean the sealing rings housings with the aid of an old piston ring.

- Measure the coupling clearance between the sealing rings and the piston grooves using a thickness gauge, as shown in the figure.
- If the clearances detected exceed the limits specified in the table, the piston and the piston rings should be replaced.

**PISTON**

Name	Description	Dimensions	Initials	Quantity
Top piston ring		0.030 ÷ 0.065 mm		0.080 mm
Middle piston ring		0.020 ÷ 0.055 mm		0.070 mm
oil scraper		0.040 ÷ 0.160 mm		0.20 mm

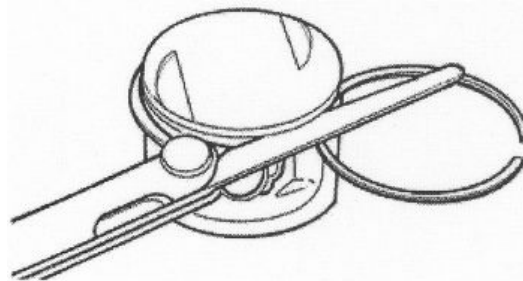

**Inspecting the cylinder**

- Using a bore meter, measure the inner cylinder diameter at three different points according to the directions shown in the figure.
- Check that the coupling surface with the head is not worn or misshapen.
- Pistons and cylinders are classified into categories based on their diameter. The coupling is carried out in pairs (A-A, B-B, C-C, D-D).

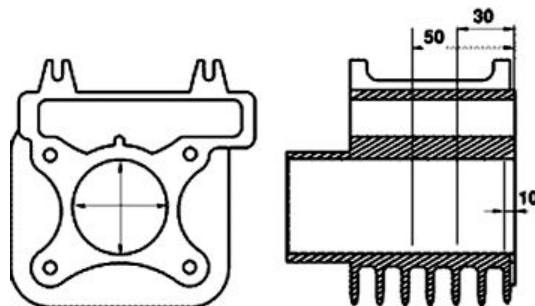

**Characteristic**

**Maximum allowable run-out:**

0.05 mm

- The cylinder rectifying operation should be carried out with a surfacing that respects the original angle. at 120° crossed.
- The cylinder surface roughness should be of R.A.= 0.30 ÷ 0.50.
- This is indispensable for a good seating of the sealing rings, which in turn minimises oil consumption and guarantees optimum performance.

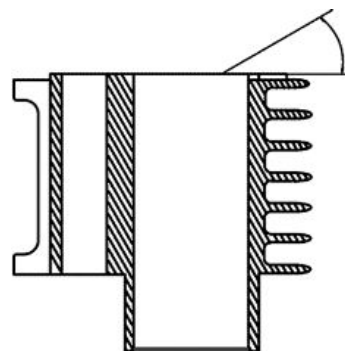



- The pistons are oversized due to cylinder rectification and are subdivided into two categories 1st and 2nd with 0.2-0.4mm oversize. They are also classified into 4 categories A-A, B-B, C-C, D-D.

## Inspecting the piston rings

- Alternately insert the three sealing rings into the cylinder, in the area where it retains its original diameter. Using the piston, insert the rings perpendicularly to the cylinder axis.
- Measure the opening, see figure, of the sealing rings using a thickness gauge.
- If any measurements are greater than specified, replace the piston rings.

**N.B.**

**BEFORE REPLACING ONLY THE PISTON RINGS, ENSURE THAT THE CLEARANCE BETWEEN THE PISTON RINGS AND THE PISTON RING GROOVES, AND BETWEEN THE PISTON AND THE CYLINDER, IS AS SPECIFIED. IN ANY CASE, NEW PISTON RINGS USED IN COMBINATION WITH A USED CYLINDER MAY HAVE DIFFERENT BEDDING CONDITIONS THAN THE STANDARD.**

### SEALING RINGS

Name	Description	Dimensions	Initials	Quantity
Top piston ring		0.08 ÷ 0.20 mm		0.35 mm
Middle piston ring		0.05 ÷ 0.20 mm		0.30 mm
oil scraper		0.20 ÷ 0.70 mm		0.80 mm

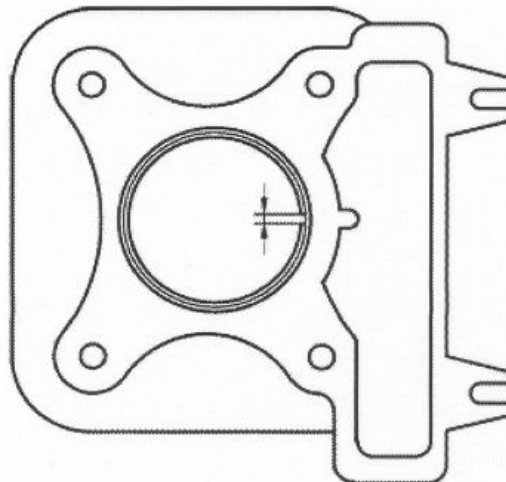

## Removing the piston

- Install piston and wrist pin onto the connecting rod, aligning the piston arrow the arrow facing towards the exhaust.
- Fit the pin stop ring onto the appropriate tool.

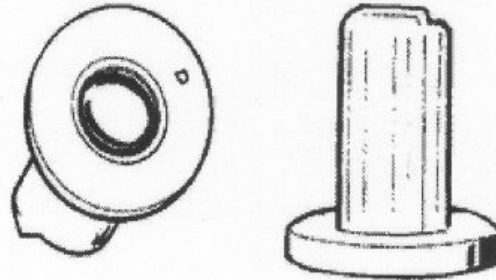

### Specific tooling

**020448Y Pin lock fitting tool**

- With the opening in the position indicated on the tool, set the lock ring into position in the tool with the punch.
- Rest the tool on the piston paying attention that the 90° chamfered side faces upwards as indicated in the figure.
- Fit the gudgeon pin stop using the plug.

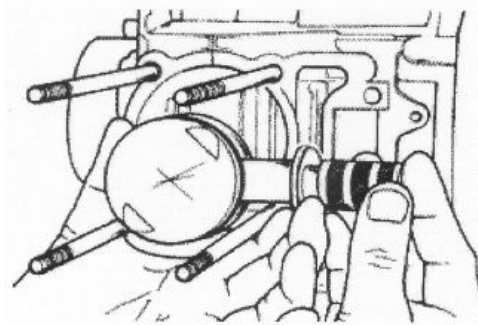

### CAUTION

USING A HAMMER TO POSITION THE RINGS CAN DAMAGE THE LOCKING HOUSING.

## Choosing the gasket

N.B.

MEASUREMENT "A" TO BE TAKEN IS A VALUE OF PISTON RE-ENTRY, IT INDICATES BY HOW MUCH THE PLANE FORMED BY THE PISTON CROWN FALLS BELOW THE PLANE FORMED BY THE TOP OF THE CYLINDER. THE FURTHER THE PISTON GETS INSIDE THE CYLINDER, THE THINNER THE HEAD GASKET TO BE APPLIED SHOULD BE (TO RECOVER THE COMPRESSION RATIO) AND VICE VERSA.

### Characteristic

Shimming system to control the compression ratio

CR: 11.1 ÷ 12.9

### PISTON PROTRUSION CHECK

Name	Measure A	Thickness
shimming_1	0.05 ÷ 0.25	0.35
shimming_2	0.25 ÷ 0.40	0.25

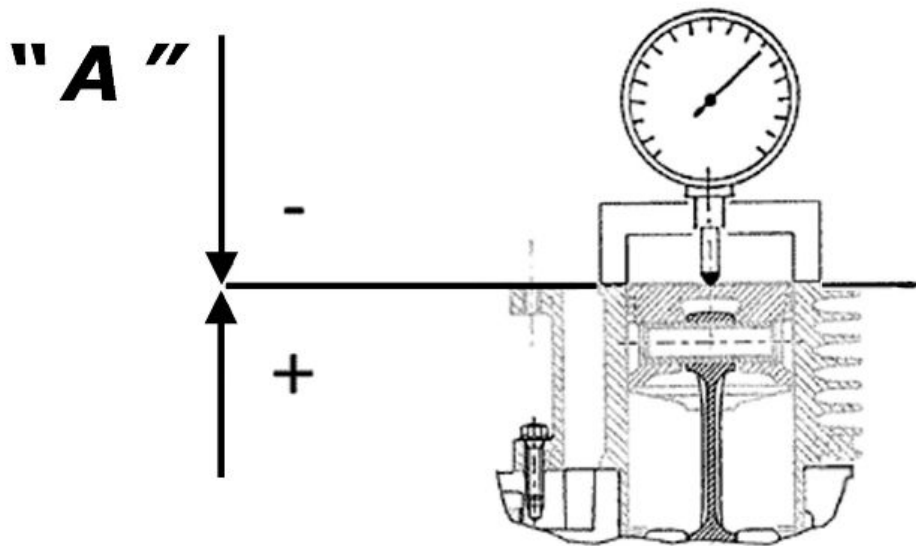

- Provisionally fit the piston into the cylinder, without any base gasket.
- Fit a dial gauge on the specific tool, then rest both on a stop surface.
- Zero set the dial gauge on the stop surface. Keeping the zero position, assemble the tool on the cylinder and lock it with 2 nuts as shown in the figure.
- Rotate the crankshaft until TDC (the inverted point of the dial gauge rotation)
- Measure piston protrusion compared with the head plane and determine the gasket thickness to be used according to the table below. By correctly identifying the cylinder base gasket thickness, an adequate compression ratio is maintained.
- Remove the specific tool and the cylinder.

### Characteristic

#### Standard compression ratio

C.R.  $11.5 \div 12 \div 1$

#### CYLINDER BASE GASKET THICKNESS

Specification	Desc./Quantity
Cylinder height	$56.45 \pm 0.05$
Head gasket thickness (fibre)	$0.95 \pm 0.06$
Measure detected	$0.9 \pm 0.05$
Base gasket thickness	0.4
Measure detected	$1 \pm 0.05$
Base gasket thickness	0.5

**CYLINDER BASE GASKET THICKNESS**

Specification	Desc./Quantity
Cylinder height	57.15 ± 0.05
Head gasket thickness (steel)	0.3 ± 0.05
Measure detected	0.20 ± 0.05
Base gasket thickness	0.4
Measure detected	0.30 ± 0.05
Base gasket thickness	0.5

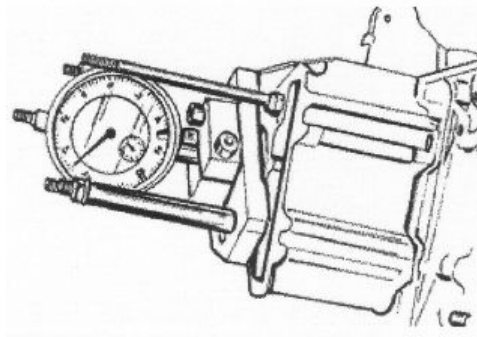

This engine is manufactured with two different head gasket solutions:

- Fibre gasket drw. 969244 0.95 mm thick.
- Steel gasket drw. 969393 0.3 mm thick.

In order to guarantee an adequate compression ratio, the gaskets match cylinders with different heights:

- **Fibre gaskets with cylinder 56.45 mm high**
- **Fibre gaskets with cylinder 57.15 mm high**

In order to carry out the revision both gaskets should be present on the spare parts.

All pin-piston-cylinder units supplied with the spare parts present cylinders 57.15 mm high

## Refitting the piston rings

- Fit the oil scraper ring starting from the spring, taking care that the spring ends do not superimpose. Fit the two piston rings so that their gaps and that of the oil scraper ring are never aligned.
- Fit the 2nd sealing ring with the identifying letter «T» facing towards the piston crown.
- Fit the 1st sealing ring with the reference letter «T» facing towards the piston crown.
- Misalign the lining openings at 120° as shown in the figure.
- Lubricate the components with engine oil.

### N.B.

IN ORDER TO OBTAIN A GOOD BEDDING, THE 2 SEALING PISTON RINGS ARE MADE OF CONE SHAPED CONTACT SECTION TO THE CYLINDER. AS A RESULT IT IS IMPORTANT TO RESPECT THE FITTING INSTRUCTION TO ASSEMBLY THE RINGS WITH THE "T" MARK FACING UPWARDS.

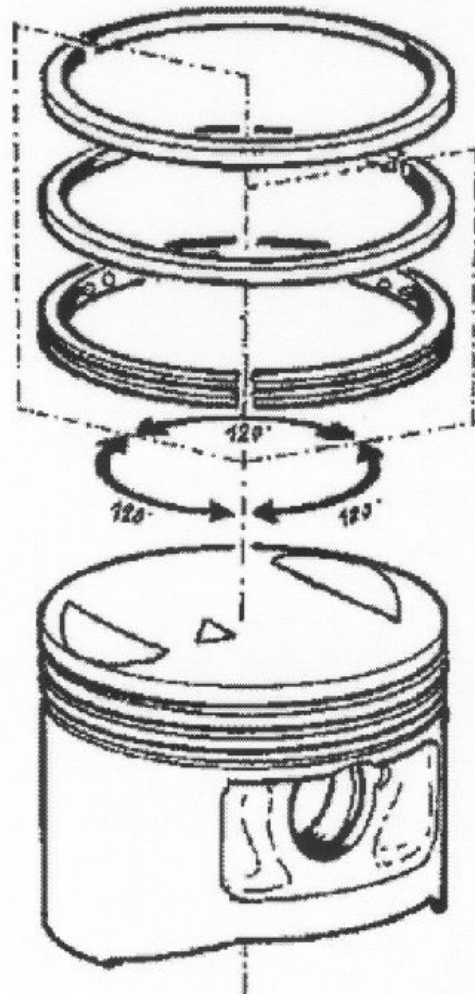

- Alternately insert the three sealing rings into the cylinder, in the area where it retains its original diameter. Using the piston, insert the rings perpendicularly to the cylinder axis.
- Measure the opening, see figure, of the sealing rings using a thickness gauge.
- If any measurements are greater than specified, replace the piston rings.

### N.B.

**BEFORE REPLACING ONLY THE PISTON RINGS, ENSURE THAT THE CLEARANCE BETWEEN THE PISTON RINGS AND THE PISTON RING GROOVES, AND BETWEEN THE PISTON AND THE CYLINDER, IS AS SPECIFIED. IN ANY CASE, NEW PISTON RINGS USED IN COMBI-**

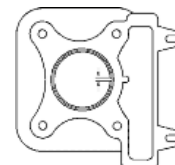

**NATION WITH A USED CYLINDER MAY HAVE DIFFERENT BEDDING CONDITIONS THAN THE STANDARD.**

### **SEALING RINGS**

Name	Description	Dimensions	Initials	Quantity
Top piston ring		0.08 ÷ 0.20 mm		0.35 mm
Middle piston ring		0.05 ÷ 0.20 mm		0.30 mm
oil scraper		0.20 ÷ 0.70 mm		0.80 mm

## **Refitting the cylinder**

If the four cylinder stud bolts should be replaced in this kind of engine, it is necessary to tighten the head nuts strictly following the procedure below.

The procedure is different from that indicated in the vehicle manuals:

Head nuts tightening (only for stud bolts replacement)  $6 \div 7 \text{ N}^* \text{m} + 90^\circ + 90^\circ + 90^\circ$

The  $45^\circ$  rotation reduction of the key is necessary to avoid stud bolt stretching.

- Fit the base gasket of the chosen thickness, previously determined.
- Fit the cylinder as shown in the figure
- The piston can be kept out of the housing plane using the appropriate tool.

**N.B.**

**BEFORE FITTING THE CYLINDER, CAREFULLY BLOW OUT THE LUBRICATION DUCT AND OIL THE CYLINDER BARREL.**

### **Specific tooling**

**020288Y Fork to assemble piston on cylinder**

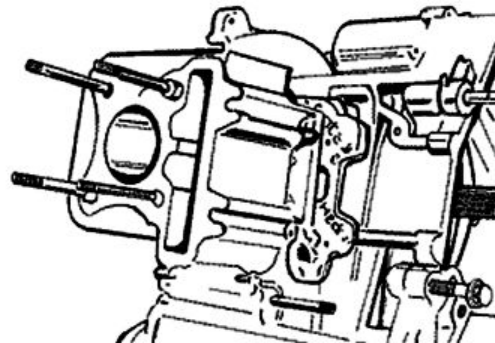

## **Inspecting the cylinder head**

- Using a trued bar check that the cylinder head surface is not worn or distorted.
- Check that the camshaft and rocking lever pin bearings show no signs of wear.
- Check that the cylinder head cover surface, the intake manifold and the exhaust manifold are not worn.

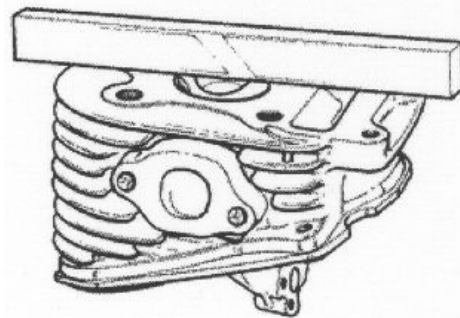

### **Characteristic**

**Maximum admitted unevenness: Head check**

0.05 mm

**HEAD CHECK**

Specification	Desc./Quantity
Standard diameter (mm) A	Ø 32.015 ÷ 32.025 mm
Standard diameter (mm) B	Ø 16.0 ÷ 16.018
Standard diameter (mm) C	Ø 11.0 ÷ 11.018

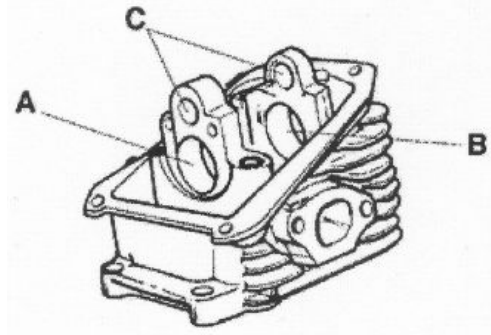

**Inspecting the timing system components**

- Check that the guide shoe and the tensioner shoe are not worn out.
- Ensure that the camshaft drive pulley, the chain assembly and the sprocket wheel are not worn.
- If sings of wear are found, replace the parts. if the chain, pinion or pulley are worn, replace the whole assembly.

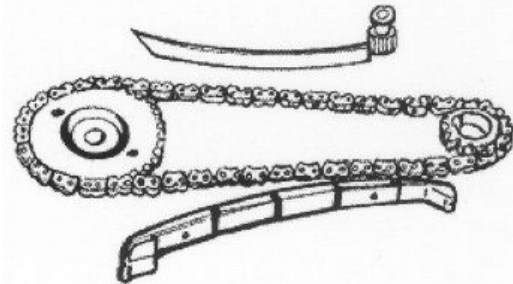

- Remove the central screw and the tensioner spring. Check that the one-way mechanism is not worn.
- Check the condition of the tensioner spring.
- If examples of wear are found, replace the whole assembly.

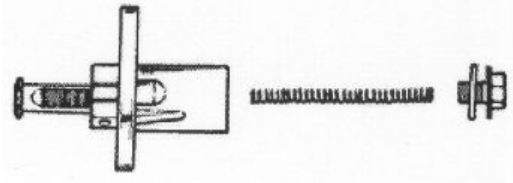

**Inspecting the valve sealings**

- Measure the width of the sealing surface on the valve seats.

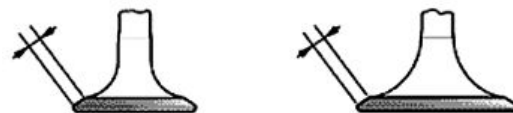

**Characteristic**

**Sealing surface width: Intake**

1.5 mm

**Sealing surface width: Drainage**



1.6 mm

- Insert the valves into the cylinder head.
- Test the 2 valves alternatively.
- The test is carried out by filling the manifold with petrol and checking that the head does not ooze through the valves when these are just pressed with the fingers.

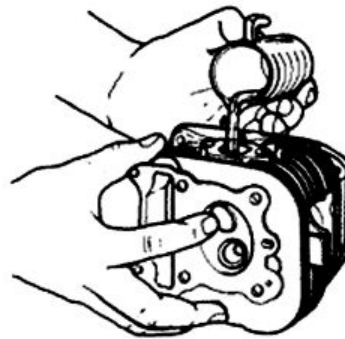

### Inspecting the valve housings

- Remove any carbon formation from the valve guides.
- Measure the inside diameter of each valve guide.
- Take the measurement at three different heights in the rocker arm push direction.

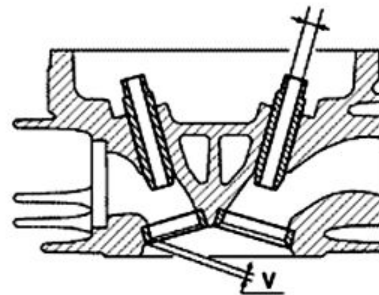

#### Characteristic

**Discharge guide: Standard diameter**

5 +0+0.012mm

**Discharge guide: Wear limit**

5.022 mm

**Intake guide: Standard diameter**

5 +0+0.012mm

**Intake guide: Wear limit**

5.022 mm

- If the width of the impression on the valve seat or the diameter of the valve guide exceed the specified limits, replace the cylinder head.
- Check width of the impression on the valve seat «V»

#### Characteristic

**Wear limits:**

Max. 1.6 mm.



## Inspecting the valves

- Measure the diameter of the valve stems in the three positions indicated in the diagram.
- Calculate the clearance between the valve and the valve guide.

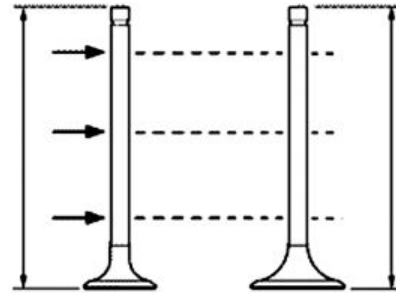

### Characteristic

#### Minimum diameter allowed: Intake

4.970 mm

#### Minimum admissible diameter drainage

4.960 mm

### Fitting clearance

**Standard clearance: Intake** 0.015 ÷ 0.042 mm

**Standard clearance: drainage** 0.025 ÷ 0.052 mm

- Check that there are no signs of wear on the contact surface with the articulated register terminal.
- If the sealing surface on the valves is wider than the specified limit, damaged in one or more points or curved, replace the valve with a new one.

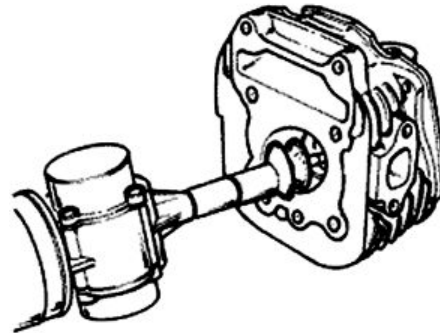

### Characteristic

#### Valve standard length: Intake

70.1 mm

#### Valve standard length: drainage

69.2 mm

### Fitting clearance

**Max. clearance allowed: Intake** 0.052 mm **Max.**

**clearance allowed: drainage** 0.062 mm

- If the checks above give no failures, you can use the same valves. For best sealing results, it is advisable to grind the valves. Grind the valves gently with a fine-grained lapping compound. During grinding, keep the cylinder head in a horizontal position. This will prevent the lapping compound residues from penetrating between the valve stem/guide coupling.

### CAUTION

**TO AVOID SCORING THE CONTACT SURFACE, DO NOT KEEP ROTATING THE VALVE WHEN NO LAPPING COMPOUND IS LEFT. CAREFULLY WASH THE CYLINDER HEAD AND THE VALVES WITH A SUITABLE PRODUCT FOR THE TYPE OF LAPPING COMPOUND BEING USED.**

## Inspecting the springs and half-cones

- Check that the upper spring caps and the cotter halves show no signs of abnormal wear.

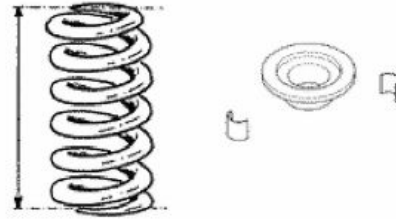

## Refitting the valves

- Lubricate the valve guides with graphite grease.
- Place the lower plates of the valve spring on the head.
- Use the punch to fit the 2 sealing rings one at a time.

### Specific tooling

#### 020306Y Punch for assembling valve sealing rings

- Fit the valves, the springs and the upper caps.
- Using the appropriate tool, compress the springs and insert the cotters in their seats.

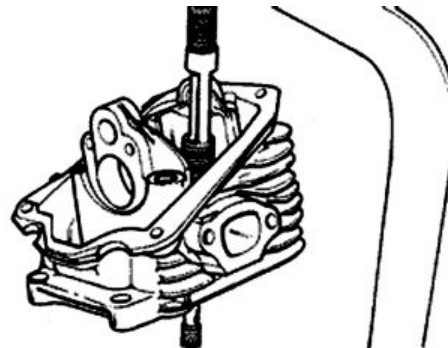
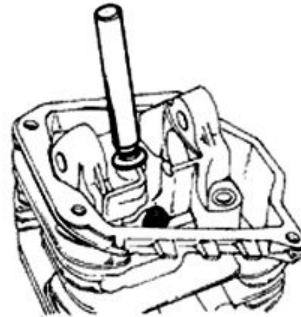

## Inspecting the cam shaft

- Inspect the cam shaft for signs of abnormal wear on the cams.

### Characteristic

#### Standard diameter - Bearing A:

Ø 12 +0.002 +0.010

#### mm Standard diameter - Bearing B:

Ø 16-0.015 -0.023 mm

#### Minimum diameter allowed - Bearing A:

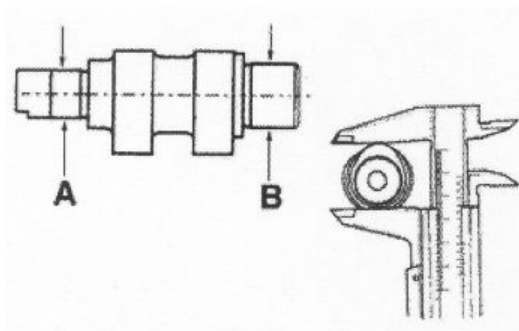

Ø 11.98 mm

**Minimum diameter allowed - Bearing B:**

Ø 15.96 mm

- If any of the above dimensions are outside the specified limits, or there are signs of excessive wear, replace the defective components with new ones.

**N.B.**

A BALL BEARING IS FITTED ON BEARING «A»; CONSEQUENTLY, BEARING «B» IS THE MOST IMPORTANT AS IT WORKS DIRECTLY ON THE HEAD ALUMINIUM

**Characteristic**

**Standard height - Intake:**

25.935 mm

**Standard height - Discharge:**

25.935 mm

**Fitting clearance**

**Maximum admissible axial clearance:** 0.5 mm

- Check there are no signs of scoring or wear on the rocking lever bolt.
- Measure the diameter «A».
- Measure the internal diameter of each rocking lever. level «B».

Check there are no signs of wear on the pad from contact with the cam and on the jointed adjustment plate.

- In case of anomalies, replace the damaged components.

**Characteristic**

**Minimum admissible diameter**

Ø 10.970 mm

**Maximum diameter allowed:**

Ø 11.030 mm

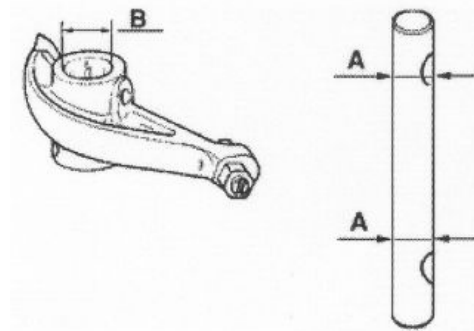
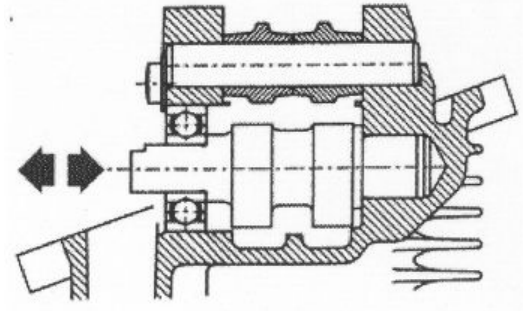

## Refitting the head and timing system components

- Fix the head on a workbench.
- Screw the tool to fit the camshaft fully down on the bearing's inner track.
- Fit the camshaft fully into its seating together with the bearing with the aid of a mallet.
- Remove the tool.
- Fit the head gasket after cleaning the faying surface carefully.
- Insert the head in the cylinder stud bolts and tighten the 4 fixing nuts to the prescribed torque.

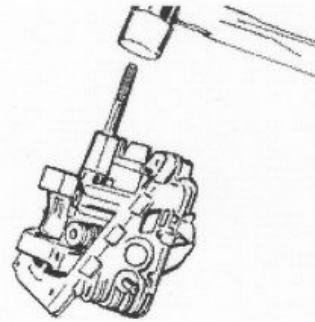

### Specific tooling

#### 020450Y Camshaft fitting/removal tool

#### Locking torques (N\*m)

**Head-cylinder stud bolt nuts:** 6 ÷ 7 +135° +90° Nm  
first fitting, upon refitting tighten again at 6 ÷ 7 90° +90° Nm

- Loosen the rocking lever registers.
- Fit the pin, the intake rocking lever and the discharge rocking lever.
- Lubricate the 2 rocking levers through the holes.

**N.B.**

**IF A BEARING SEPARATES FROM THE CAMSHAFT, IT IS ESSENTIAL TO FIT A NEW BEARING.**

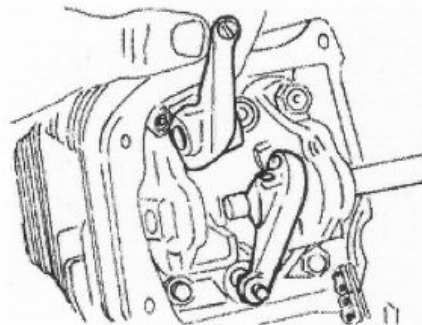

- Screw the limit screw for the pin and the camshaft with the washer indicated in the figure and tighten it to the prescribed torque.

#### Locking torques (N\*m)

**Rocking lever axle and camshaft bearing screw** 3 ÷ 4 Nm

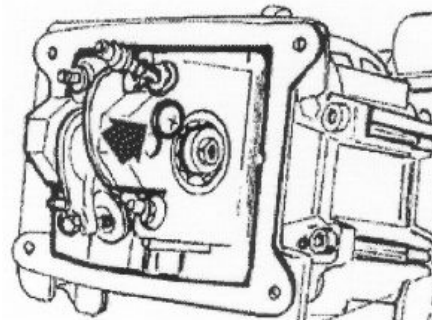

- Finish the head tightening following the procedure below: screw the four head nuts to an initial torque at two crossed passes. Afterwards tighten the nuts with 2 turns of 90° each to be done at two crossed passes.

-Finish the tightening of the head to the crankcase with the 2 side screws.

**N.B.**

**SHOULD THE CRANKCASE OR THE CYLINDER STUD BOLTS BE REPLACED, IT IS NECESSARY TO CARRY OUT AN INITIAL TIGHTENING PLUS OTHER 3 TURNS OF 90° EACH AT 3 CROSSED PASSES**

### Locking torques (N\*m)

**Head-cylinder stud bolt nuts:**  $6 \div 7 +135^\circ +90^\circ$  Nm  
 first fitting, upon refitting tighten again at  $6 \div 7 90^\circ +90^\circ$   
**Nm Head cover screws**  $8 \div 10$  Nm

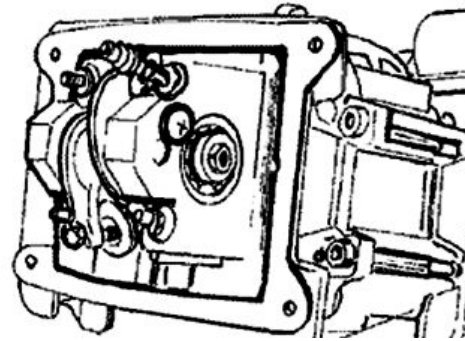

## Refitting the timing chain

- Insert the timing chain pads in their corresponding seatings, the screw and the spacer as indicated in the figure.

- Tighten to the prescribed torque and check the tensioner pad moves adequately.

- Insert the timing pinion in driving shaft with the chamfered side facing the insertion (towards the main bearing).

- Loop the timing chain around the sprocket on the crankshaft.

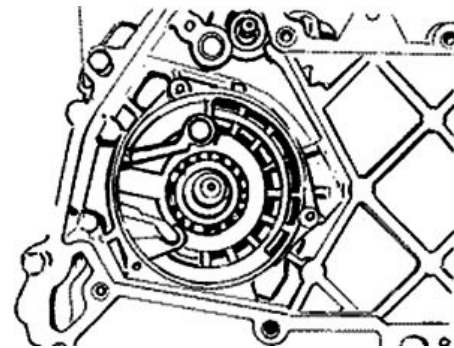

### Locking torques (N\*m)

**Chain tensioner pad screw**  $5 \div 7$  Nm

- Refit the spacer on the cam shaft.

- Rotate the engine so that the piston is at top dead centre, using the reference marks on the flywheel and the crankcase.

- With this operation, insert the chain on the camshaft control pulley and make the reference notch coincide with the point on the head.

- Fit the pulley onto the camshaft.

- Fit the belleville washer so that the outer rim touches the pulley.

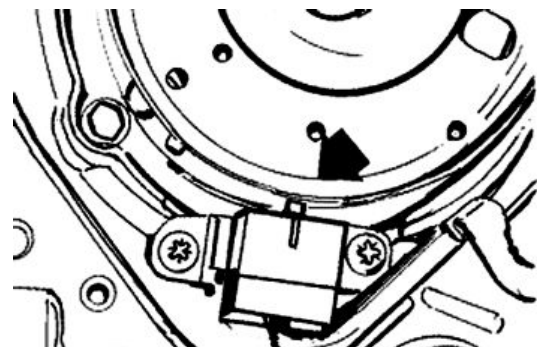

- Bring the screw closer but without reaching its final locking point.

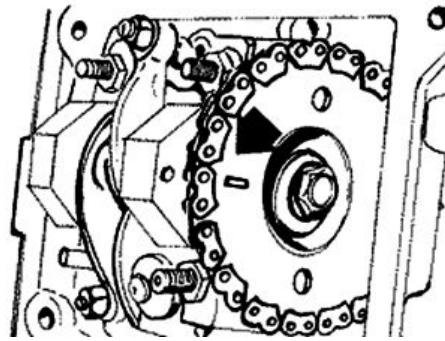

- Push the tensioner pad lightly so as to check the correct timing.
- Use the specific tool to lock the camshaft crown gear and tighten the screw.
- Adjust valve clearance.
- Replace the O-Ring on the tappet cover.
- Fit the tappet cover and lock it with the 4 fixing screws indicated in the figure.

### Specific tooling

**020565Y Flywheel lock calliper spanner**

### Locking torques (N\*m)

**Camshaft pulley screw 12 ÷ 14 Head cover screw 8 ÷ 10 Nm**

- Predisporre il cursore del tenditore nella posizione di riposo.
- Montare il tenditore sul cilindro utilizzando una nuova guarnizione, bloccare le 2 viti alla coppia prescritta.
- Inserire la molla con la vite centrale e bloccarla alla coppia prescritta.
- Montare la candela.

### Characteristic

#### Recommended spark plug

NGK CR 9EB - CHAMPION RG 4HC

#### Alternative spark plug

DENSO U24ESR-NB

### Electric characteristic

#### Electrode gap

0.7 ÷ 0.8 mm

### Locking torques (N\*m)

**Timing chain tensioner screw 8 ÷ 10 Nm Timing chain tensioner central screw 5 - 6 Ignition spark plug 10 ÷ 15 Nm**



## Refitting the rocker-arms cover

- Carry out the removal procedure but in reverse order and tighten the four fixing screws to the specified torque.

**N.B.**

FIT A NEW O-RING ON THE TAPPET COVER.

**Locking torques (N\*m)**

Timing chain tensioner screws 8 ÷ 10 Nm

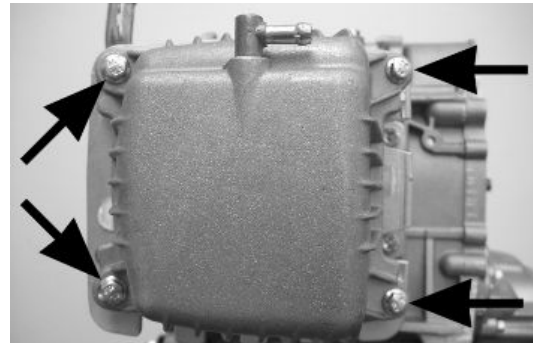

## Refitting the intake manifold

- Fit the cover sealing gaskets on the head.
- Fit the 2 covers.
- Fit the inlet manifold and do up the 2 screws to the specified torque.
- Fit the carburettor on the inlet manifold and lock the clamp.
- Fit the secondary air pipe and fix it with the appropriate clamp.

**N.B.**

FIT THE CARBURETTOR THROUGH THE SUPPLEMENT ON THE MANIFOLD.

**Locking torques (N\*m)**

Inlet manifold screw 7 ÷ 9 Nm

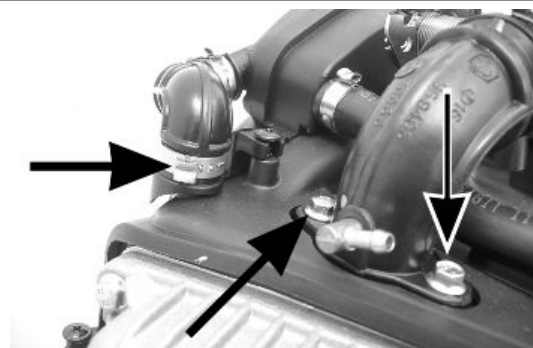

## Crankcase - crankshaft

- First remove the following units:

Driving pulley Driven pulley

Final reduction greasing

Oil pump Flywheel with stator

Cylinder-piston-head unit

Starter motor with cables.

**See also**

[Removal](#)

[Removing the starter motor](#)

[Removing the cylinder - piston assy.](#)

[Removing the driven pulley](#)

[Removing the stator](#)

[Removing the driving pulley](#)

## Splitting the crankcase halves

- Remove the ten crankshaft coupling screws.
- Separate the crankcase halves keeping the half casing driving shaft engaged on the transmission side.
- Remove the crankshaft.

### CAUTION

IF YOU FAIL TO DO THIS, THE CRANKSHAFT MIGHT ACCIDENTALLY FALL.

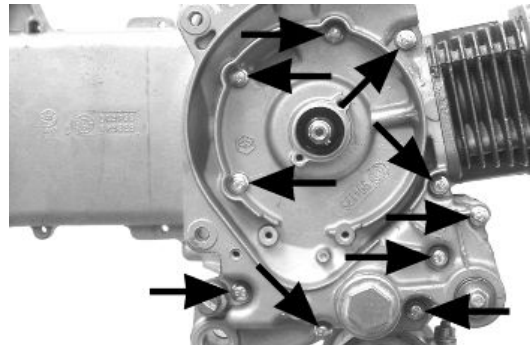

- Remove the oil guard on the flywheel side.

### CAUTION

THE CENTRIFUGAL OIL FILTER IS IN THE FLYWHEEL AXLE SHAFT. CONSEQUENTLY, DO NOT WASH WITH SOLVENTS OR BLOW COMPRESSED AIR SO THAT NO IMPURITIES LEAK OUT. A CENTRIFUGAL OIL FILTER'S LIFE IS THE SAME AS THE ENGINE'S AND IS MAINTENANCE FREE.

- Check the axial clearance on the connecting rod.

### Fitting clearance

Standard connecting rod axial clearance  $0.15 \div 0.30$  mm Max. connecting rod clearance 0.5 mm

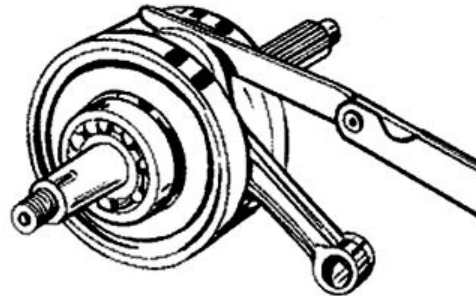

- Check the correct radial clearance of the connecting rod by holding the driving shaft with your hands and, with a dial gauge fitted to the rod small end, measuring the clearance, move the connecting rod vertically as shown in the figure.

### Fitting clearance

Connecting rod radial - standard clearance  $0.006 \div 0.018$  mm Connecting rod max. - radial clearance 0.25 mm

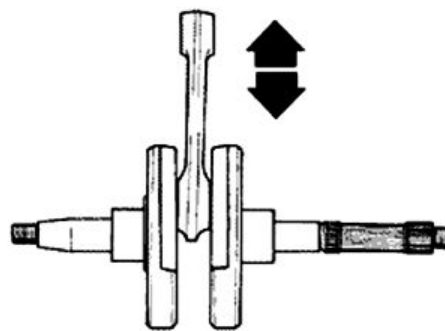



- Check that the half shaft surfaces are not scored and with the aid of a gauge check the driving shaft width as indicated in the figure.

### Characteristic

#### Standard measure

45 mm

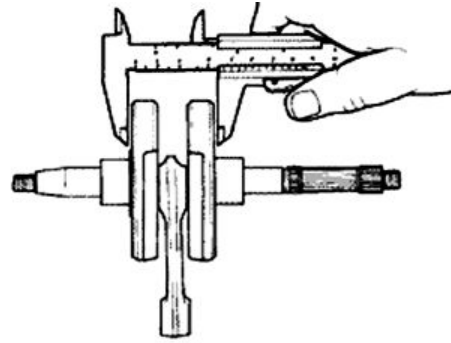

## Removing the crankshaft bearings

- Remove the flywheel bearing fitted on the driving shaft using the specific tool.

### Specific tooling

004499Y Camshaft bearing extractor

004499Y001 Bearing extractor bell

004499Y002 Bearing extractor screw

004499Y006 Bearing extractor ring

004499Y034 Bearing extractor part

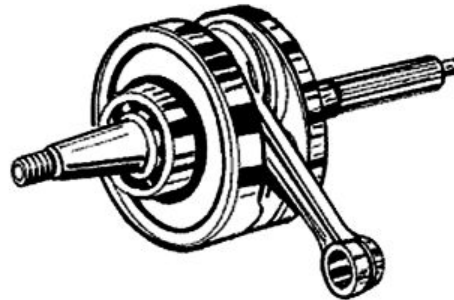

## Refitting the crankshaft bearings

- Heat a new main bearing in an oil bath at 120°.
- Place the driving shaft on the support base and insert the bearing with the aid of an adequate piece of tube if necessary.

### N.B.

USE A NEW BEARING WHEN REFITTING

### WARNING

THE CENTRIFUGAL OIL FILTER IS IN THE FLYWHEEL AXLE SHAFT. DO NOT WASH WITH SOLVENTS OR BLOW COMPRESSED AIR SO THAT NO IMPURITIES LEAK OUT.

### Specific tooling

020265Y Bearing fitting base

008119Y009 Tube to assemble shafts and axles

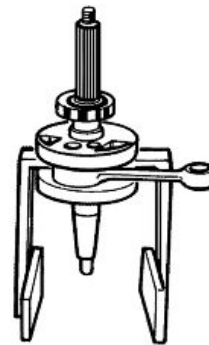

- Support the crankcase on a surface and place it with the driving shaft axle in a vertical position.
- Warm the crankcase at ~ 120° C with a thermal gun (and support).
- Fit the punch with guide and adaptor, place the bearing on the punch using grease (to keep it from falling).
- Insert the bearing in the crankcase; if needed, use a mallet but do so with extreme care so as not to damage the engine crankcase limit stop.

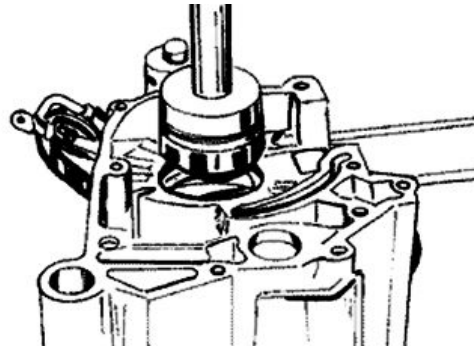

### Specific tooling

**020359Y 42x47-mm Adaptor**

**020364Y 25-mm guide**

**020376Y Adaptor handle**

**020360Y 52x55-mm Adaptor**

## Inspecting the crankshaft alignment

- Install the crankshaft on the support and measure the displacement at the 4 points shown in the figure.

**N.B.**

IF VALUES OTHER THAN THOSE ALLOWED ARE DETECTED, TRY STRAIGHTENING THE CRANKSHAFT BY INSERTING A WOODEN WEDGE BETWEEN THE HALF SHAFTS OR BY CLOSING THEM WITH A VICE AS NEEDED. IF EVEN AFTER THIS OPERATION THE VALUES ARE NOT THOSE ADMITTED, REPLACE THE CRANKSHAFT.

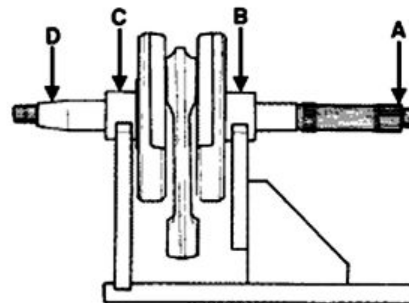

### Characteristic

**Off-line maximum admitted - A**

0.15 mm

**Off-line maximum admitted - B**

0.02 mm

**Off-line maximum admitted - C**

0.02 mm

**Off-line maximum admitted - D**

0.10 mm

- Check that the driving shaft cone, the tab seat, the oil seal capacity, the toothed gear and the threaded tangs are in good working order.
- In case of failures, replace the crankshaft.

### Specific tooling

---

**020074Y Support base for checking crankshaft alignment**

---

**Refitting the crankcase halves**

---

- Be careful to place the two centring dowels preferably on the flywheel side half casing.
- Insert the crankshaft on the half casing on the transmission side.

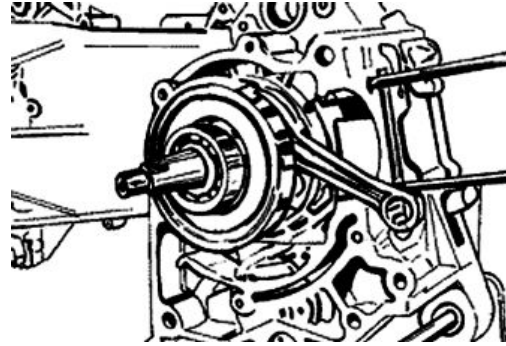

- Fit the gasket recommended for surfaces on the half casing on the transmission side after greasing the two faying surfaces carefully.
- Insert the flywheel half casing.
- Fit the 10 screws and tighten them to the prescribed torque.

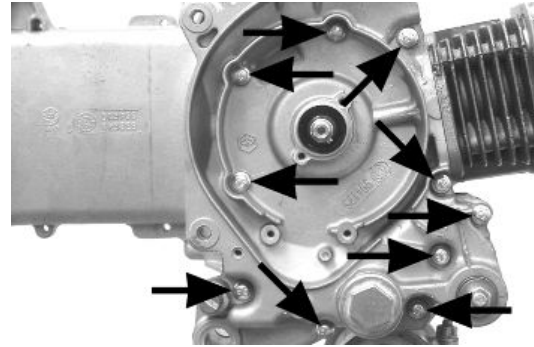

**N.B.**

**WHEN FITTING THE HALF CASING AND THE CRANKSHAFT, TAKE CARE NOT TO DAMAGE THE SHAFT THREADED TANGS.**

**Recommended products**

**Loctite 510 Liquid sealant**

Gasket

**Locking torques (N\*m)**

**Half casing joint bolts: 8 ÷ 10 Nm**

- Fit a new O-Ring on the mesh oil filter and on the filling cap; lubricate the rings.
- Insert the filter on the engine and lock the cap to the prescribed torque.

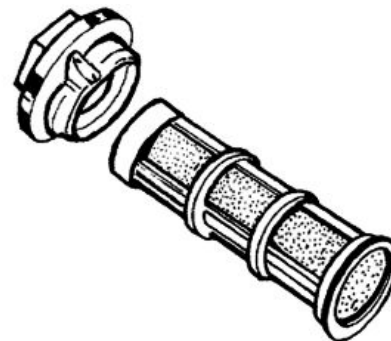
**Locking torques (N\*m)**

**Engine oil pre-filter cover: 25 ÷ 28 Nm**

---

**Lubrication**

---

---

## Crankshaft oil seals

---

### Removal

---

- Check that the chain contrast pad is not worn.
- Otherwise, replace the pad or fit it inverted to make it work on the other side.
- Any operation on the chain cover oil seal should be carried out placing the cover on the workbench on the covering plate side of the oil pump chain.
- Remove the oil seal with a tube section of 30 mm in diameter ( $\varnothing$  32 mm Max).

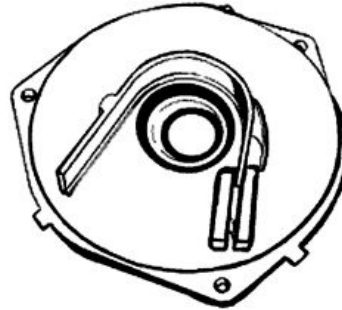

- 
- Extract the flywheel oil seal from the crankcase being careful not to damage or score the crankcase.

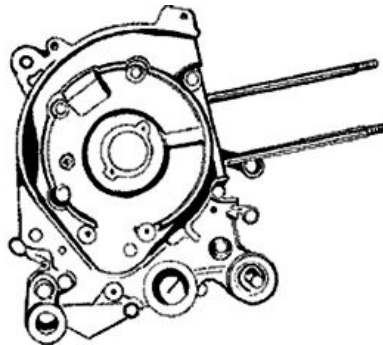

---

### Refitting

---

- Apply engine oil on the oil seal and it seating on the crankcase.
- From the outside and using the specific punch, place the oil seal fully down until it reaches the bottom of the seating in the crankcase.

**N.B.**

**FAILURE TO USE THE SPECIFIC TOOL CAN RESULT IN AN INCORRECT DEPTH POSITION AND AS A CONSEQUENCE IN INADEQUATE OIL SEALING.**

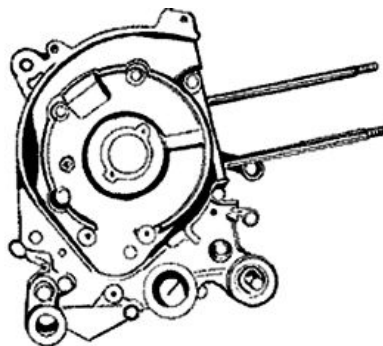

- Fit a new oil seal on the outer rim with the help of the specific tools below.
- Fit a new O-ring and lubricate it with grease.
- Install the cover on the engine crankcase, insert the three screws and place the cover in its position.
- Tighten the 3 screws to the prescribed torque.

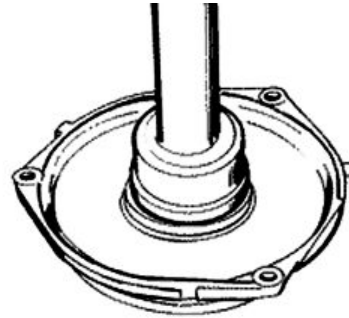

### Specific tooling

**020376Y Adaptor handle**

**020358Y 37x40-mm Adaptor**

### Locking torques (N\*m)

**Timing chain/oil pump compartment cover screws 4 ÷ 5 Nm**

## Oil pump

### Removal

- Remove the chain compartment cover undoing the 3 fixing screws indicated in the figure.
- Take out the cover using the appropriate fusion couplings on the cover with a pair of pliers

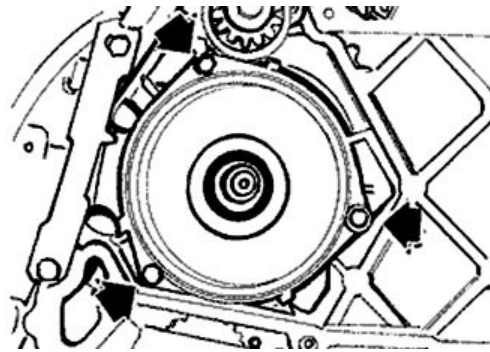

- Undo the 2 clamping screws in the figure and remove the cover over the pump control crown gear.
- Block the rotation of the oil pump control gear with a screwdriver inserted through one of its pump holes.

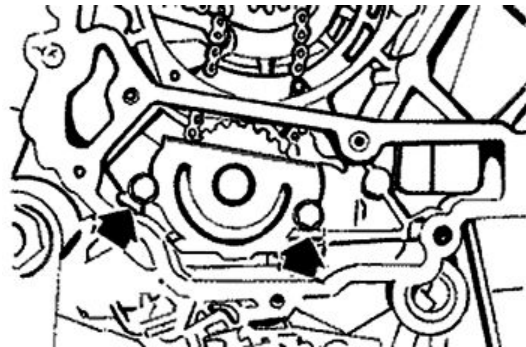

- Remove the central screw and the belleville washer
- Remove the chain with the crown gear.
- Remove the crankshaft control pinion.
- Remove the oil pump by undoing the 2 screws indicated in the figure.
- Remove the oil pump seal.

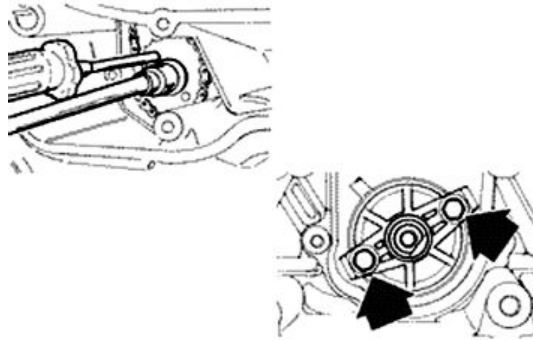

**IT IS ADVISABLE TO MARK THE CHAIN IN ORDER TO ENSURE THAT THE INITIAL DIRECTION OF ROTATION IS MAINTAINED.**

## Inspection

- Remove the two screws and the oil pump cover.
- Remove the clip retaining the innermost rotor.
- Remove and wash the rotors thoroughly with a degreasing solvent and compressed air.
- Reassemble the rotors in the pump body, keeping the two reference marks visible. Replace the clip.



- Measure distance between rotors (inner rotor/ outer rotor) with a thickness gauge in the position shown in the picture.

### Characteristic

#### Admissible maximum clearance 1

0.15 mm

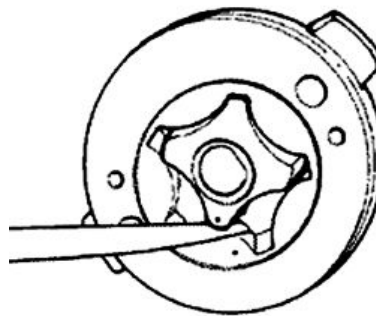

- Measure the distance between the outer rotor and the pump body (see figure).

### Characteristic

#### Admissible maximum clearance 2

0.20 mm

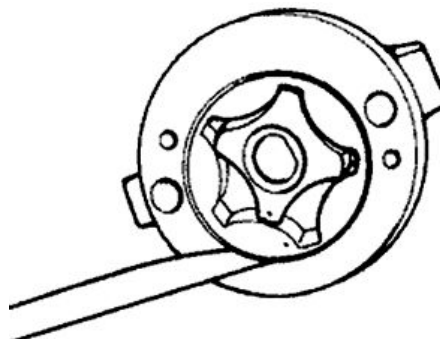



- Check the axial clearance of the rotors using a trued bar as reference as shown in the figure.

**N.B.**

**MAKE SURE THE TRUED BAR IS POSITIONED PROPERLY ON THE TWO POINTS ON THE PUMP BODY.**

### Characteristic

**Admissible maximum clearance 3**

0.09 mm

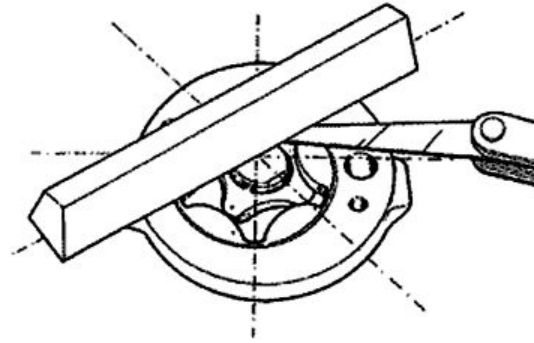

## Refitting

- Check there are no signs of wear on the oil pump shaft or body.
- Check there are no signs of scoring or wear on the oil pump cover.
- If you detect non-conforming measurements or scoring, replace the faulty parts or the assembly.
- Fit the cover on the pump being careful to align the holes (2 on the cover and 2 on the pump body) fixing the oil pump on the crankcase.
- Fit the oil pump on the crankcase by tightening the two screws to the prescribed torque.
- Fit the pulley on the pump, the central screw to the specified torque and the belleville washer.
- Check that there is no seizing and/or friction during the pulley rotation.

**N.B.**

**FIT THE BELLEVILLE WASHER SO THAT ITS OUTER (CURVED) RIM TOUCHES THE PULLEY.**

### Locking torques (N\*m)

**Central screw 12 ÷ 14 Nm Cover screws 0.7 ÷ 0.9 Nm Oil pump screws 5 - 6**



## Removing the oil sump

- Remove the oil filling cap, the transmission cover, the complete driving pulley assembly with belt and pinion.
- Unscrew the oil drainage plug «A» shown in the figure and drain out all the oil from the sump.
- Remove the 6 screws indicated in the figure.

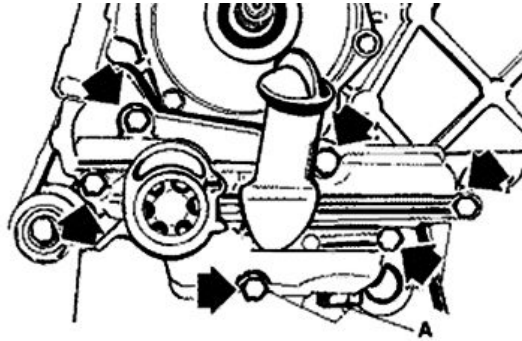

## Refitting the oil sump

- Clean and grease the faying surfaces.
- Apply LOCTITE 510 on the sump surface and tighten the 6 fixing screws to the specified torque.
- Refit the driving pulley assembly, the belt, the pinion and the transmission cover.

**WHEN TESTING THE LUBRICATION SYSTEM, REFER TO THE "CRANKCASE AND CRANKSHAFT" CHAPTER, REGARDING LUBRICATION OF THE CRANKSHAFT AND CONNECTING ROD**

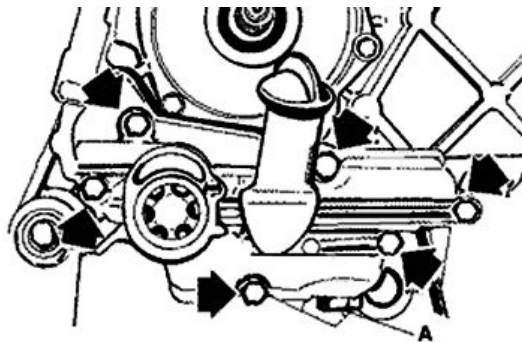

### Locking torques (N\*m)

**Oil sump screws 8 ÷ 10 Nm**

## Fuel supply

- Disconnect the fuel supply and the suction taking pipe from the carburettor.
- Check that there are no fuel leaks between the two tubes.
- Close the fuel outlet pipe.
- By means of the MITYVAC pump apply 0.1 bar of suction to the tap.
- Make sure that the suction is kept stable and that there are no fuel leaks.
- Reconnect the suction pipe to the manifold.
- Position the fuel pipe with the outlet at the point of the tap.
- Turn the engine by using the starter for five seconds with the carburettor at minimum.

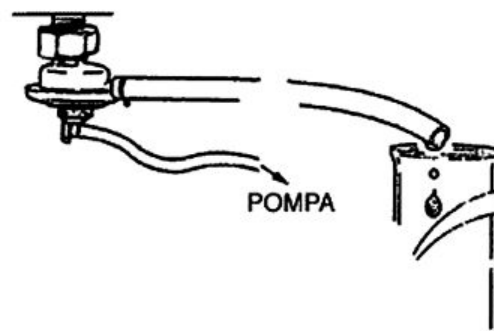



- Take up the fuel by means of a graded burette.

**N.B.**

THE MEASUREMENT MAY BE FALSIFIED BY THE INCORRECT NUMBER OF REVS OR BY THE WRONG POSITION OF THE TUBE. IN THIS CASE, THE TENDENCY IS TO OBTAIN A REDUCED FUEL FLOW RATE. THE SUCTION OUTLET ON THE MANIFOLD HAS A SECTION INTENTIONALLY REDUCED FOR THE PURPOSE OF ENHANCING THE SUCTION PULSATION AND THEREBY GUARANTEE A CONSTANT TAP FLOW RATE.

**Specific tooling****020329Y MityVac vacuum-operated pump****Characteristic****Minimum flow rate**

20 cc

- Completely empty the fuel tank.
- Remove the petrol delivery pipe and the low-pressure pipe.
- Loosen the clip and remove the cock.
- Clean the tank and the filter of the cock with a specific solvent.
- Refit the cock making sure that there is an O-Ring.
- Turn the cock to the direction it had before it was removed and block the clip.

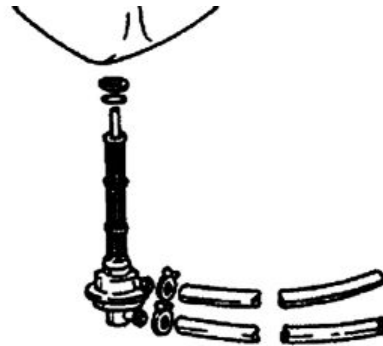
**N.B.**

THE FILTER CAN BE UNSCREWED FROM THE COCK TO FACILITATE CLEANING.

**Removing the carburettor**

- To detach the carburettor from the engine, remove the two clamps anchoring the carburettor to the inlet manifold and the air intake coupling to the filter.
- Remove the fuel supply pipe.
- Disconnect the starter connection.
- Detach the accelerator cable with the sheath that connects the plate and the support.
- Remove the carburettor.

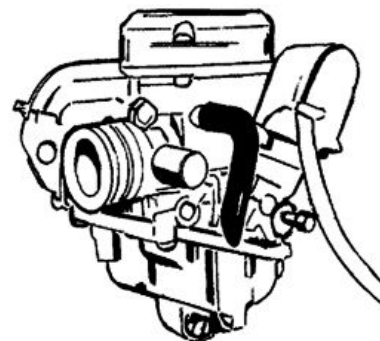

- Remove the protection, the bracket and the starter undoing the screw shown in the figure.

**CAUTION**

THE CARBURETTOR FEATURES AN ANTI-VIBRATION RUBBER BUFFER FITTED ON THE LOWER SUPPLEMENT OF THE ACCELERATING PUMP BODY. UPON REFITTING THE CARBURETTOR ON THE ENGINE, MAKE SURE THIS BUFFER IS PRESENT SO THAT THE PETROL IN THE TANK DOES NOT EMULSIFY.

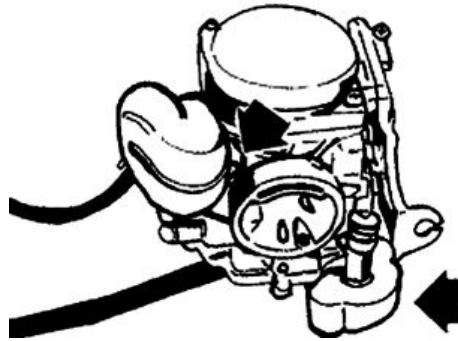

- Remove the 2 fixing screws indicated in the figure, the vacuum chamber cover and the spring.
- Remove the vacuum valve together with the diaphragm; the pin, the spring and its plastic guide.

**WARNING**

DURING THE REMOVAL OF THE COVER TAKE SPECIAL CARE NOT TO RELEASE THE SPRING ACCIDENTALLY.

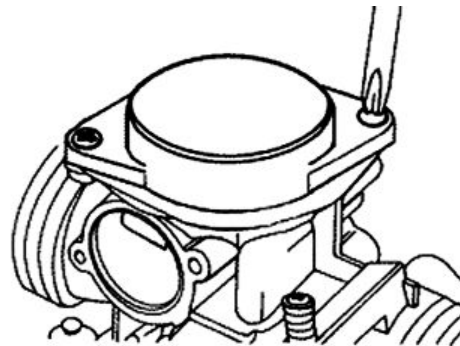

- Remove the 3 fixing screws and the chamber with the gasket.

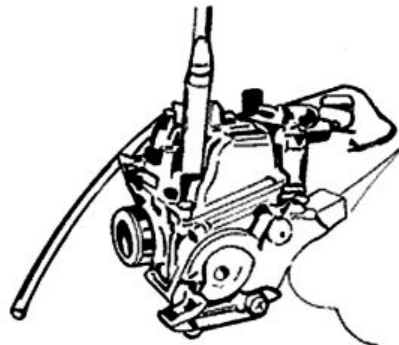

- Remove the chamber components following the procedure below.
- Undo the 2 screws fixing the intake pump diaphragm cover.

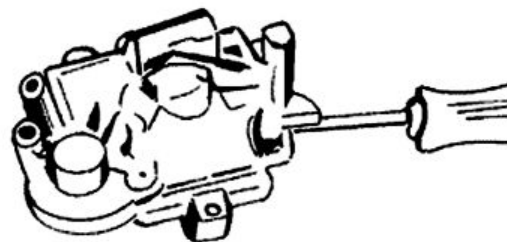

- 
- Remove the cover being careful with the spring below, then remove the spring, take out the rubber protection and the diaphragm together with the pipe O-Ring.

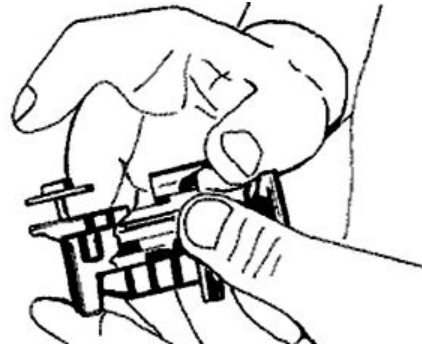

- 
- Remove the accelerating pump jet together with the ball spring.

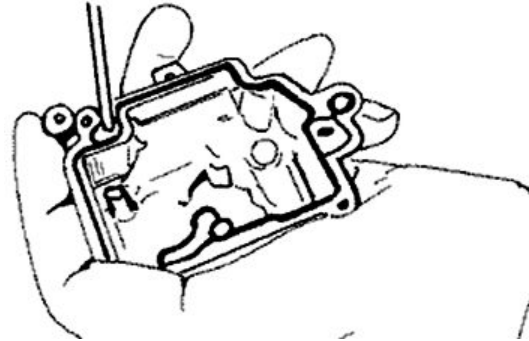

- 
- Remove the screw indicated in the figure fixing the float pin.
  - Remove the float and the plunger.



- 
- Remove the maximum nozzle.
  - Remove diffuser.

- 
- Remove the minimum nozzle.

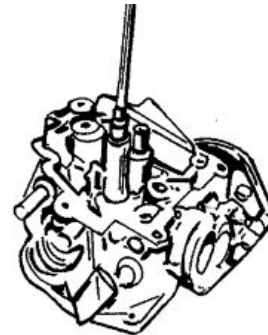



- Remove the sprayer tilting the carburettor body.

**N.B.**

**THIS OPERATION IS NECESSARY TO AVOID LOSING SPRAYER PARTS WHEN CLEANING THE CARBURETTOR BODY. IF THE SPRAYER IS FORCED IN ITS HOUSING DO NOT ATTEMPT TO REMOVE IT AS THIS WILL ONLY DAMAGE IT.**

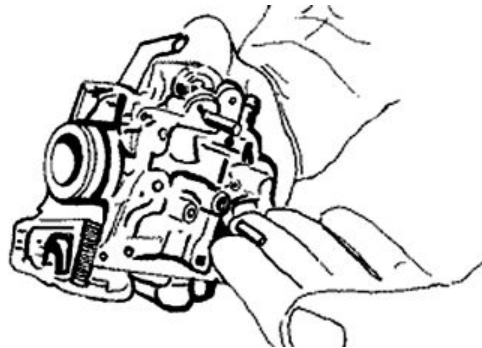

- Remove the idle flow screw with the O-ring and the spring.

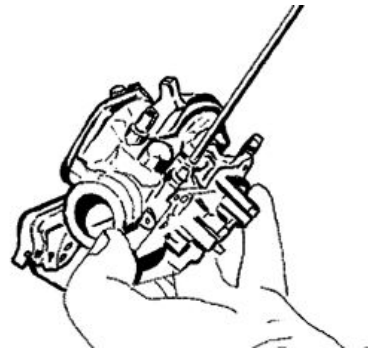

**CAUTION**

**DO NOT ATTEMPT REMOVING PARTS EMBEDDED IN THE CARBURETTOR BODY SUCH AS: FUEL SUPPLY PIPE, PIN SEATING, STARTER NOZZLE, THROTTLE VALVE CONTROL VALVE SHAFT. DO NOT REMOVE THROTTLE-SHAFT CONNECTION SCREWS. THE FIXING SCREWS ARE CAULKED AFTER THE ASSEMBLY AND THEIR REMOVAL DAMAGES THE SHAFT.**

## Refitting the carburettor

- Before refitting, wash the carburettor body accurately with a degreasing solvent and compressed air.
- Pay special attention to the fuel supply pipe and the plunger seat.

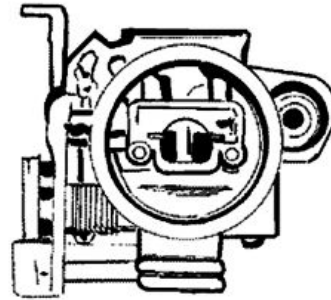

- For the minimum circuit, make sure the following points are properly cleaned: air gauging, outlet section controlled by flow screw, progression holes near the throttle valve.

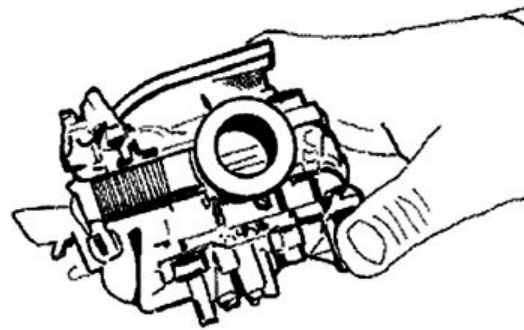

- For the starter circuit, blow the connection pipe properly with the jet. This is necessary because the nozzle support hides other inaccessible internal calibrations.
  - Blow the intake nozzle properly.
- The acceleration nozzle outlet is extremely small and is oriented to the throttle valve.

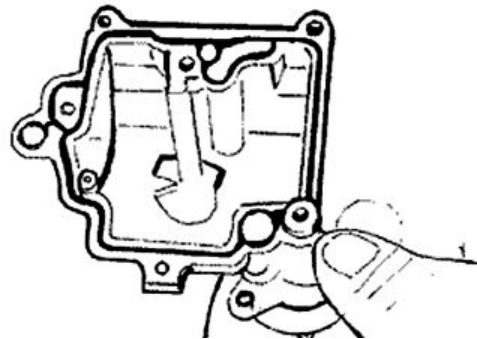

- Check that the carburettor body has the closing ball for the idle circuit pipe.
- Check that the coupling surfaces, the chamber and the diaphragm are not dented.
- Check that the depression valve housing pipe is not scratched.
- Check that the throttle valve and the shaft do not show abnormal wear.
- Check that the plunger seat does not show abnormal wear.
- Replace the carburettor in case of irregularities.

**N.B.**

**TO AVOID DAMAGES, DO NOT INTRODUCE METAL OBJECTS IN THE ADJUSTED SECTIONS.**

- Wash and blow the minimum nozzle properly and reassemble it.

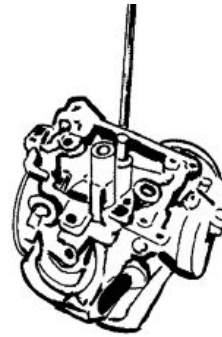

- Accurately wash and blow the components of the maximum circuit, the sprayer, the diffuser and the nozzle.
- Introduce the sprayer in the carburettor body with the bigger cylindric part directed to the diffuser.
- Fit the diffuser.
- Assemble the maximum nozzle.

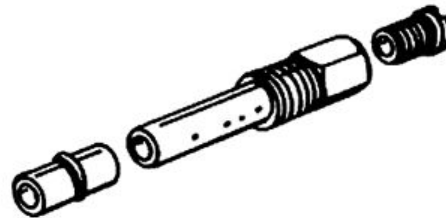

- Check that the tapered pin does not show signs of wear on the sealing surfaces of the shock absorber pin and the return clamp.
- Replace the rod if worn out.
- Check that the float is not worn on the pin housing or on the contact plate with the rod and that there are no fuel infiltrations.
- Replace it in case of anomalies.
- Fit the float together with the pin and rod in its position and lock it with its screw.

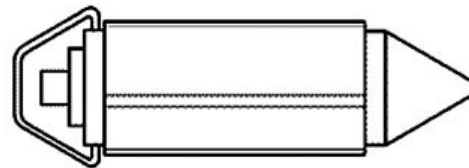

**N.B.**

**INTRODUCE THE RETURN SPRING ON THE FLOAT PLATE ADEQUATELY**

- Insert the ball in the corresponding accelerating pump.
- Fit the spring.
- Fit the accelerating pump nozzle.

**WARNING**

**WHEN REFITTING, PAY SPECIAL ATTENTION TO THE COMPONENTS AS THEY ARE SMALL.**

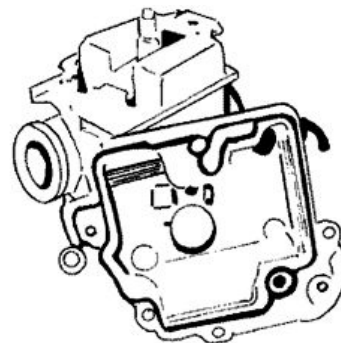



- Check the diaphragm is in good conditions and remove the remaining components of the accelerating pump following these steps:

- Insert the O-Ring in the pipe.
- Insert the diaphragm together with the pin and its spring.

**N.B.**

**REPLACE THE DIAPHRAGM IF THERE ARE SIGNS OF UNDULATIONS, CRACKS OR HARDENING.**

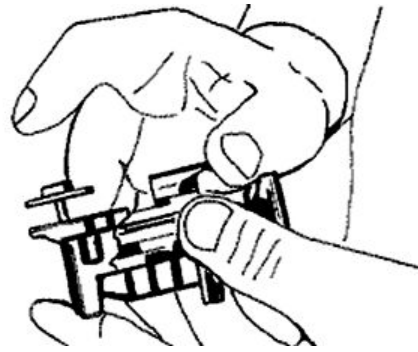

- Fit the accelerating pump diaphragm cover and tighten the 2 fixing screws making sure the spring below is correctly positioned.

- Fit the rubber bellows protecting the pin in the upper part of the accelerating pump.

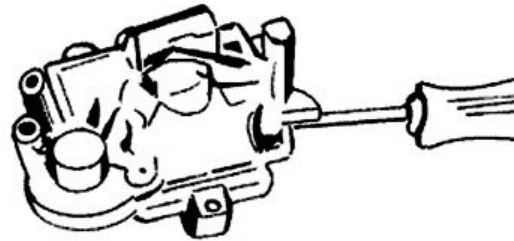

## Level check

- Tilt the carburettor so that the needle valve at the fuel supply is closed and the float weight does not affect it.

- Check that the diaphragm closing line and the float central line are parallel as shown in the figure.

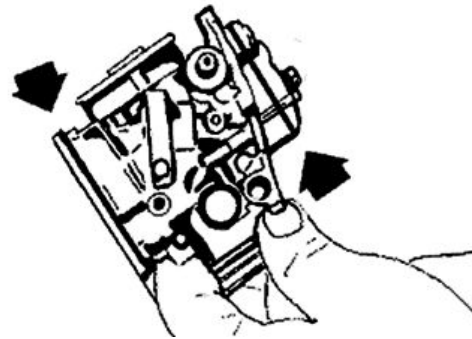

- Blow air in to the tank and then assembly it and its gasket on the carburettor body with the 3 fixing screws.

**N.B.**

**-ALWAYS USE NEW RINGS AND GASKETS FOR REFITTING.**

**WARNING**

**THE SCREW IN THE TANK BOTTOM IS A BLEEDING ONE AND CONSEQUENTLY IT ONLY REQUIRES CLEANING.**

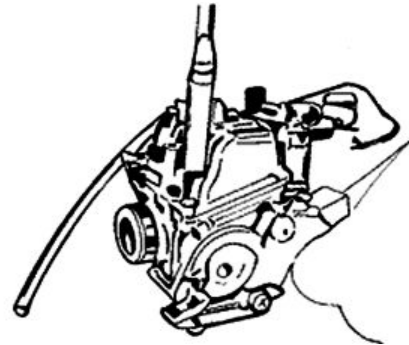

- Insert the diaphragm into the throttle valve.
- Insert the tapered pin together with the plastic support and the contrast spring into the throttle valve.

**N.B.**

**PLACE THE SPRING PLASTIC SUPPORT WITH ITS TEETH FACING THE INNER SIDE OF THE MEMBRANE TO BE ABLE TO FIT THE LOWER END OF THE THROTTLE VALVE SPRING.**

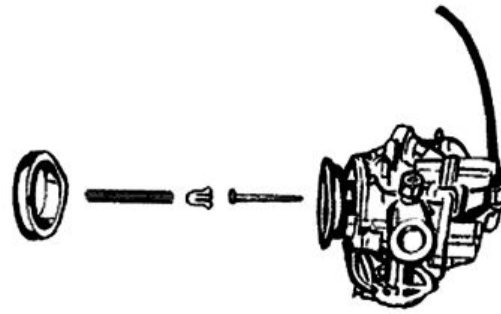

- Fit the vacuum chamber cover with the 2 fixing screws paying special attention to the spring.

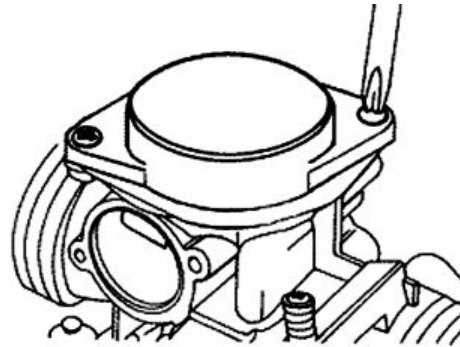

## Inspecting the automatic choke device

- Check that the automatic starter piston is not deformed or rusty.
- Check that the piston slides freely in its seating.
- Check that the piston sealing O-Ring is not deformed.
- The starter must be more or less functional depending on the ambient temperature.
- Measure the protrusion of the piston as shown in the figure and check its corresponding value.
- Make sure that the starter is adjusted for the ambient temperature.

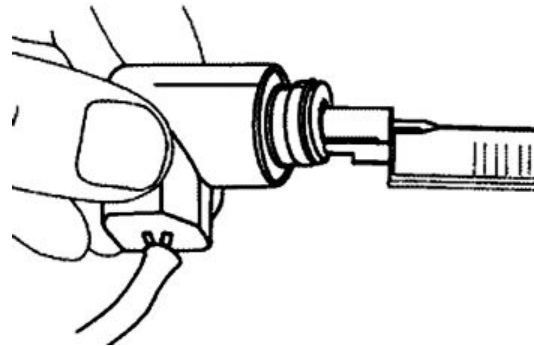
**Characteristic****Protrusion value**

11 mm

**ambient temperature**

24° C



- The starter should disconnect progressively by means of electrical heating.
- Check the starter resistance when adjusted to the ambient temperature.

**Characteristic  
ambient temperature**

24° C

**Electric characteristic  
Automatic starter resistance**

6  $\Omega$   $\pm$  5 %

- Use battery to power the automatic starter and check that piston protrudes as much as possible.
- The correct warm up time depends on the ambient temperature.
- If protrusion, resistance or timing values are different from the ones prescribed, replace the starter.

**Characteristic  
Battery**

12V-9Ah

**max. protrusion**

15 mm

**max. time**

15 min

- Fit the starter, the support bracket and the protection with the screw indicated in the figure.

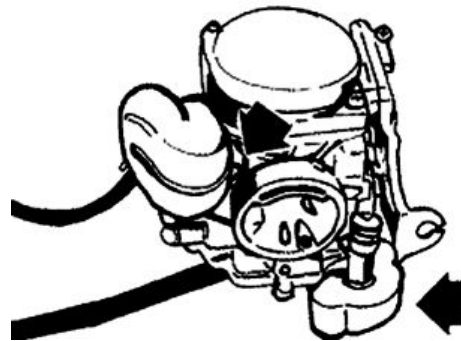
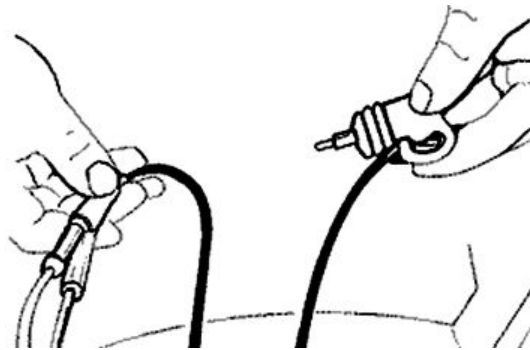
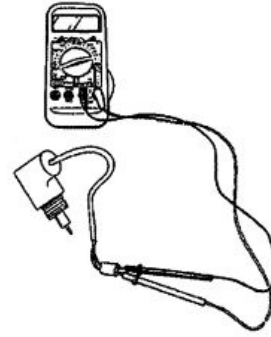

- Insert rubber pipes for chamber ventilation.
- Insert the O-Ring, the washer, the spring and the idle flow screw in their seatings.

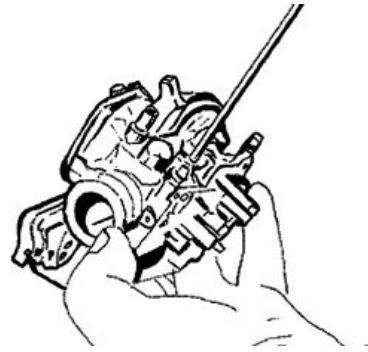

- Refit the carburettor on the engine and connect again the accelerator cable with the sheath and the support plate and the electrical connection of the starter.
- Reconnect the fuel supply pipe and tighten the 2 clamping screw fixing the carburettor to the inlet manifold and the air inlet coupling to the filter.

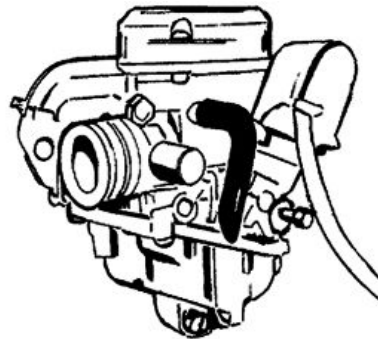

## Adjusting the idle

- The engine does not require frequent idle speed adjustments, but it is essential to strictly follow certain rules when adjusting the idle speed.
- Before adjusting the carburettor make sure to respect requirements on lubrication, valve clearance, and complying timing; spark plug should be in optimum conditions, air filter clean and sealed, and the exhaust system tight.

- Warm up the engine by running it at least 10 minutes at a speed as close as possible to the maximum one.
- Connect the vehicle to the exhaust fumes analyser inserting the probe into a sealed extension pipe placed at the muffler exit end.

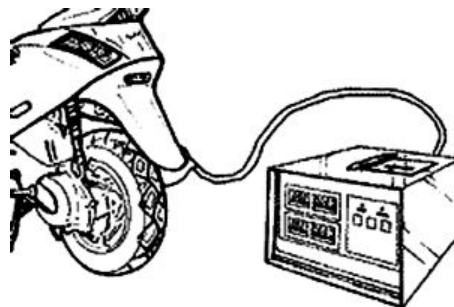

### N.B.

THE EXTENSION TUBE IS INDISPENSABLE SO AS NOT TO SEND POLLUTED EXHAUST FUMES TO THE AMBIENT OXYGEN. IT IS ESSENTIAL TO USE AN EXHAUST FUMES ANALYSER PREVIOUSLY HEATED AND PREPARED TO GUARANTEE THE RESET OF THE READING OF GASES AND THE CORRECT GAS CAPACITY. FAILURE TO RESPECT THESE REGULATIONS RESULTS IN INACCURATE READINGS.

### Characteristic

#### Pipe ideal length

40 ÷ 50 cm

- Connect the tester thermometer to the sump, using a cover with oil expressly prepared for probes.
- Start the engine and before adjusting the idle speed, make sure that the oil temperature is between 70÷80 °C.

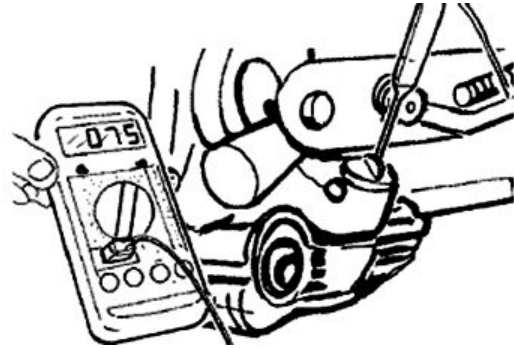

### Specific tooling

**020331Y Digital multimeter**

- Using the rpm indicator in the analyser or a separate one, adjust the idle screw.

**N.B.**

THE WASTED SPARK IGNITION SYSTEM OFFERS REMARKABLE POWER. READINGS MAY NOT BE ACCURATE IF INADEQUATE RPM INDICATORS ARE USED.

### Specific tooling

**020332Y Digital rev counter**

### Characteristic

#### Idle speed

about 1900/2000 rpm

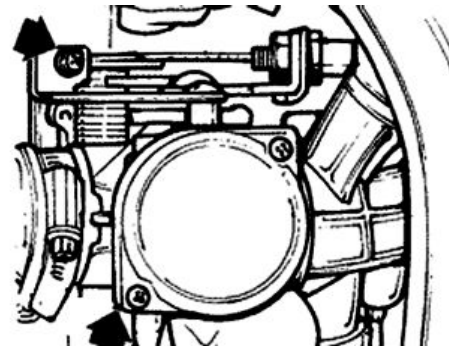

- Adjust the flow screw until a percentage of carbon monoxide (CO) is obtained. When the screw is loosened the CO value rises (rich mix). Tightening the screw decreases the CO (lean mix).
- If the adjustment of the flow screw causes a rpm increase readjust the revs again and if necessary, the flow screw to reach stable values.

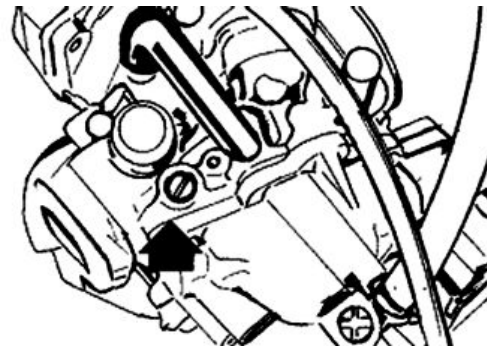

### Characteristic

#### CO adjustment

3,2% ± 0,5

- When the oil temperature, the numbers of revs and the percentage of carbon monoxide are respected the idle carburetion is considered correct.
- Further information can be drawn from the analyser:
  - carbon dioxide percentages (CO<sub>2</sub>), the percentage of carbon dioxide has an inverted course compared to the percentage of (CO), values over 13% are considered correct.
  - Non complying values indicate lack of tightness in the exhaust system.
  - Unburned hydrocarbons (HC) are measured in parts per million (PPM). The HC value decreases while the rpm increases; with the engine at idle it is normal to obtain 200 ÷ 400 PPM, these emission values are deemed normal for an engine with a diagram of timing for motorcycles. Higher values can cause

loss of engine blows as the mixture is too lean (low CO), ignition failure or, incorrect timing or a clogged or unsealed exhaust valve.

If it is difficult to adjust CO values, check accurately:

- That the automatic starter is efficient.
  - That the tapered pin-housing is efficient
  - Tank level adjustments
-

# INDEX OF TOPICS

**SUSPENSIONS**

**SUSP**

---

## Sospensioni anteriore

---

This section is devoted to operations that can be carried out on the suspension.

---

## Front

---

### Removing the front wheel

---

- Remove the wheel axle lock nut.
- Remove the wheel axle and the wheel.
- Upon removal take care not to damage the sensor that detects movement in the odometer.

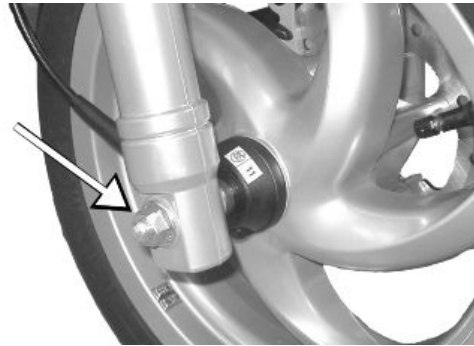

---

### Front wheel hub overhaul

#### Wheel hub ball bearings

---

- Remove the front wheel
- Keep the wheel level by means of two wooden wedges
- With the appropriate pliers and tool remove the wheel bearing on the side the rpm indicator detects movement, as shown in the photograph



- Remove the internal spacer
- Use appropriate handle, adaptor and guide and hit with a mallet to extract the bearing and the spacer bushing on the brake disc side; insert handle on the side the rpm indicator detects movement, as shown in the photo



- Check that the bearings do not show flaws or jamming. Otherwise, replace them.
- Check that the internal spacer does not show abnormal wear. Otherwise, replace it.
- With a hot air gun heat the seat of the bearing on the brake calliper side
- With an appropriate tool remove the bearing on the brake disc side
- Insert the spacer bushing on the brake disc side



- With a hot air gun heat the seat of the bearing on the side the rpm indicator detects movement
- Insert the internal spacer with the centring ring facing to the brake disc side, as shown in the photo
- Use an appropriate tool to insert the bearing on the side the rpm indicator detects movement



### Specific tooling

**001467Y009 Driver for OD 42-mm bearings**

**001467Y014 Pliers to extract Ø 15-mm bearings**

**020357Y 32x35-mm Adaptor**

**020376Y Adaptor handle**

**020412Y 15 mm guide**

**020456Y Ø 24 mm adaptor**

## Refitting the front wheel

- Follow the same procedure as per removal but in reverse order, tighten to the specified torque, remember to offset the odometer movement sensor by 90° compared with its own seating on the wheel so as to avoid damages.

### Locking torques (N\*m)

**Front wheel axle nut 45 - 50**

## Handlebar

### Removal

Smontaggio manubrio

Remove the handlebar cover before carrying out this operation,.

- After removing the transmissions and disconnecting the electrical terminals, remove the terminal fixing the handlebar to the steering.
- Check all components and replace faulty parts.



#### N.B.

**IF THE HANDLEBAR IS BEING REMOVED TO REMOVE THE STEERING, TILT THE HANDLEBAR FORWARD TO AVOIDING DAMAGING THE TRANSMISSIONS.**

### Refitting

Carry out the removal operations but in the reverse order, observing the prescribed tightening torque.

#### Locking torques (N\*m)

Handlebar fixing screw  $50 \div 55$

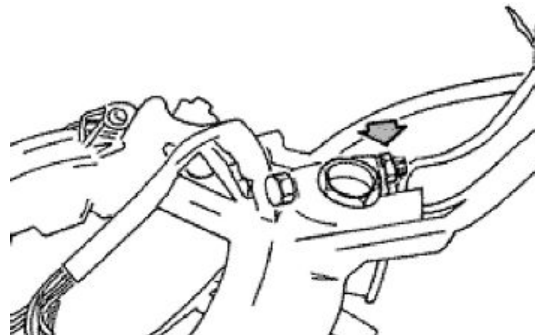

## Front fork

### Overhaul

#### Replacing the dust ring and removing the stanchion

- Remove the wheel axle.
- Remove the lower screw (1).
- Discharge the oil in the suspension.
- Remove the stem.
- Replace the sealing rings (3-4) with new ones.
- Insert the new sealing rings only after lubricating their seatings.
- Refit the stem and the lower screw (1).

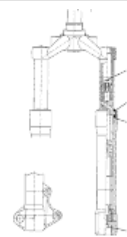



- Remove the upper screw (2).
- Add 30 cc  $\pm$ 1 "Fork PG" oil (SAE 20W oil for forks).
- Refit all components.

**Locking torques (N\*m)**

**Upper screw tightening torque 20 to 25 Nm Lower screw tightening torque: 20 to 25 Nm**

**Refitting**

When fitting the fork, lubricate with the steering bearing tracks with the recommended grease. Tighten the lower ring nut "A" and the upper ring nut "B" to the specified torque

**Recommended products**

**AGIP GREASE PV2 Grease for the steering bearings, pin seats and swinging arm**

White anhydrous-calcium based grease to protect roller bearings; temperature range between -20 C and +120 C; NLGI 2; ISO-L-XBCIB2.

**Locking torques (N\*m)**

**Steering lower ring nut 8  $\div$  10 Upper steering ring nut 35  $\div$  40**

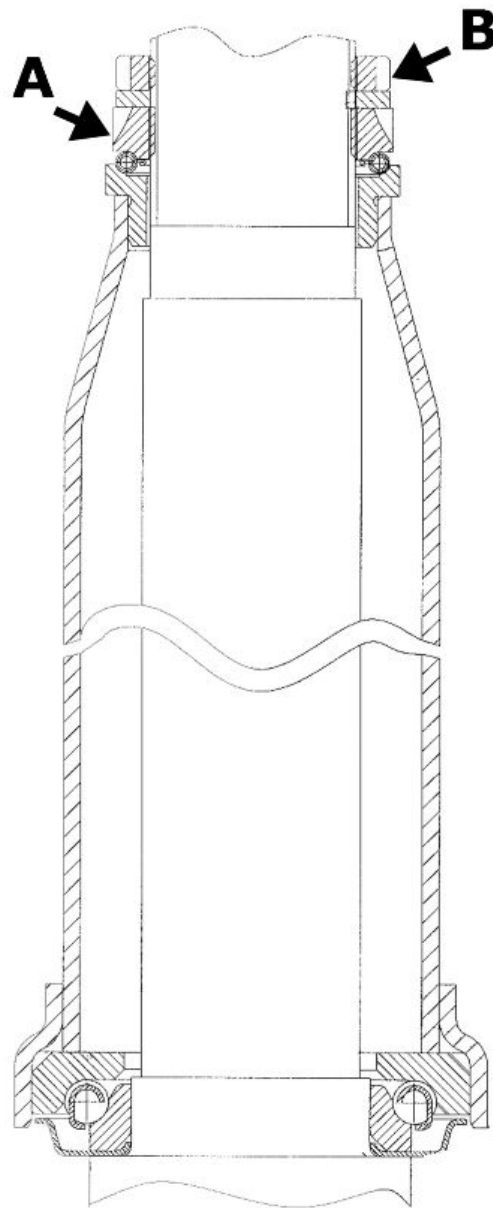

## Steering column

### Refitting

Lower and upper bearing races to frame

Lower and upper seating on the chassis

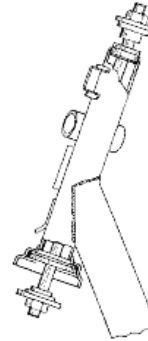

### Removal

Rondella e sede superiore cuscinetto superiore

After removing the upper seating, tilt the vehicle to a side and take out the steering tube making sure mudflaps have been removed and the calliper disconnected.



Sede inferiore e superiore dal telaio

To remove the bearing seats from the chassis, use the appropriate tool as shown in the figure.

**N.B.**

To remove the lower seating of the lower bearing just use a screwdriver as a lever between the seating and the shell.



**LOWER AND UPPER SEATING FROM THE CHASSIS**

Titolo	Durata/Valore	Testo Breve (< 4000 car.)	Indirizzo Immagine
Lower and upper seating from the chassis			

### Rear

## Removing the rear wheel

- Use a screwdriver as a lever between the drum and the cover.
- Straighten the split pin and remove the cap.
- Remove the wheel acting on the central fixing point.

### WARNING

- ALWAYS USE NEW SPLIT PINS FOR REFITTING.

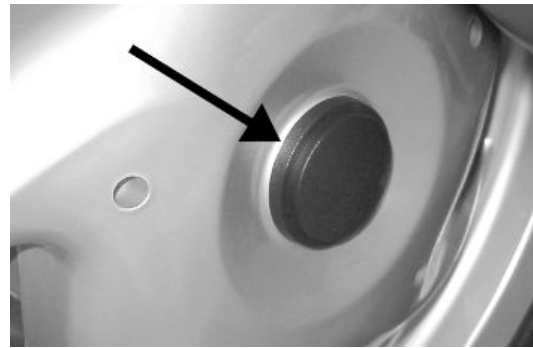
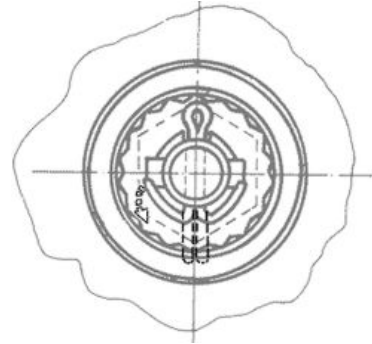

## Refitting the rear wheel

- Refit the parts in the reverse order as for removal, lock the wheel nut to the specified torque.

### WARNING

- FOLD THE EDGES OF THE SPLIT PIN AS SHOWN IN ORDER TO AVOID BACKSLASH BETWEEN THE CAP AND THE WHEEL AXLE.

### Locking torques (N\*m)

Rear wheel axle 104 ÷ 126

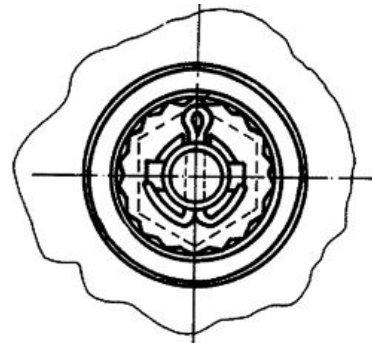

## Shock absorbers

### Removal

#### Shock-absorber

- To replace the shock absorber remove the rear cover and battery access flap to get and remove the shock absorber/ chassis anchoring nut. Then remove the shock absorber/engine anchorage nut.

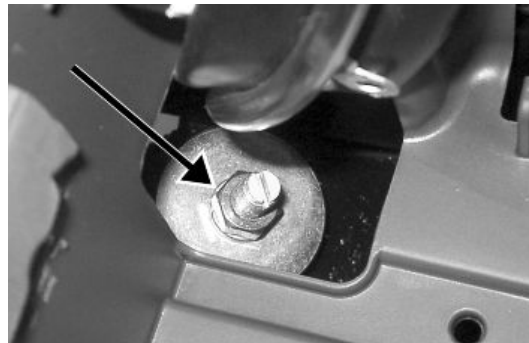
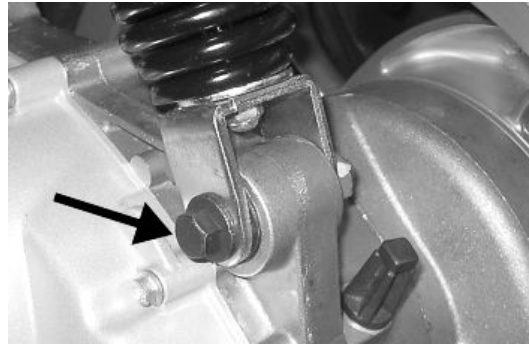

## Refitting

- When refitting, tighten the shock absorber/chassis anchoring nut and the shock absorber/engine pin to the prescribed torque.

### Locking torques (N\*m)

Shock absorber/engine pin torque 33 to 41 N-m Shock absorber/frame nut torque 20 to 25 Nm

## Centre-stand

### Sostituzione cavalletto completo

- Undo the screw marked in the figure.
- When refitting, secure to the prescribed torque.

### Locking torques (N\*m)

Centre stand screw 32 ÷ 40

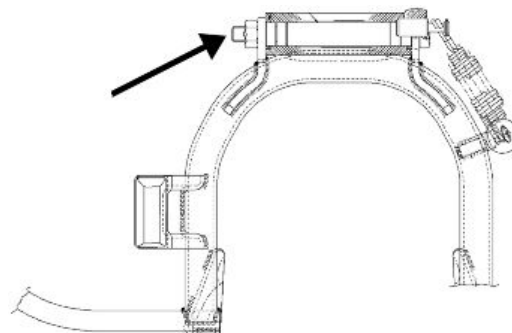

## INDEX OF TOPICS

**B**RAKING SYSTEM

**BRAK SYS**

## Front brake calliper

### Removal

- Inspect the condition of the hoses, packing and joint. In the event of fluid leaks from the calliper, this must be replaced.
- Detach the oil brake pipe from the calliper; pour the fluid inside a container.
- Remove the clamps shown in the figure.



### Overhaul

Proceed as follows:

- 1) remove the two male hexagonal screws (1) and take out the two pads (10);
- 2) remove the two male hexagonal screws (2) and remove the reaction plate (3);
- 3) take out the fixed plate (4) from the guide;
- 4) remove the internal elements from the floating body (5) with the help of short blows of compressed air through the brake fluid pipe in order to facilitate the expulsion of pistons (6).

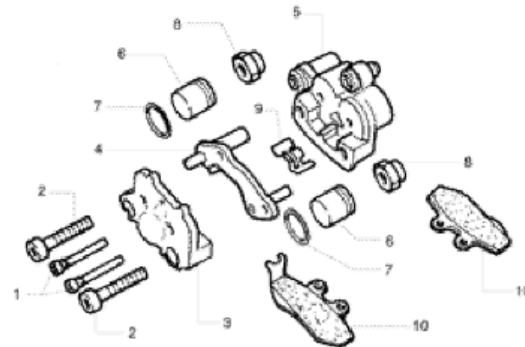

5) Check:

- that the plates and the body are whole and in good condition;
- that the cylinder and the floating body of the calliper do not show signs of scratches or erosion, otherwise replace the entire calliper;
- that the guides of the fixed plate are not scratched or eroded, otherwise replace the entire plate;
- that the brake pad check spring works properly.

### Reassembly

- 1) insert the pistons (6) and the sealing rings (7) in the body;

2) place the guide rubbers (8) and refit the fixed plate (4);

3) assemble the reaction plate (3) tightening the screws (2), insert the brake pad check spring (9) and then the pads, fixing them with the corresponding screws (1);

5) place the calliper on the disc and lock it to the strut by tightening the fixing screws;

6) fix the pipe joint on the calliper at the prescribed torque.

### **Functioning**

This is a floating type calliper.

It takes advantage of the action and reaction principle to obtain the thrust for both pads.

The body and the reaction plate body work integrally and can move axially with respect of the fixed plate that is integral to the strut.

The pistons, forced by pressure to push the pad to the disk, cause the reaction plate to push in turn the other pad towards the disc.

### **The brake pad lock spring**

1. Pad fixing screws
2. Reaction plate fixing screws
3. Reaction plate
4. Fixed plate
5. Floating body
6. Piston
7. Piston sealing rings
8. Guide protection rubbers
9. Brake pad check spring
10. Pads

### **CAUTION**

**ALL THE SEALS AND GASKETS MUST BE REPLACED EVERY TIME THE CALLIPER IS SERVICED.**

### **Locking torques (N\*m)**

**Calliper tightening screw 24 ÷ 27 Brake fluid  
pipe-calliper fitting 19 ÷ 24**

---

## Refitting



- When refitting, tighten the nuts to the prescribed torque.
- Bleed the system.

**N.B.**

**WHILE REFITTING, REPLACE THE COPPER GASKETS ON THEIR FITTINGS.**

### Locking torques (N\*m)

Oil bleed screw 7 ÷ 10 Calliper tightening screw 24 ÷ 27 Brake fluid pipe-calliper fitting 19 ÷ 24

See also

[Front](#)

## Front brake disc

### Removal

- Remove the front wheel undoing the axle clamping.
- Undo the five disc clamps.

### Locking torques (N\*m)

Disc tightening screw 8 ÷ 10

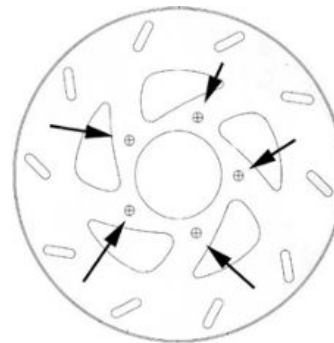

### Refitting

- When refitting, position the disc correctly making sure that it rotates in the right direction.

### Locking torques (N\*m)

Disc tightening screw 8 - 12



## Disc Inspection

- Remove the wheel and check for unevenness of the disc.

Maximum permissible out of true is 0.1 mm. If the value measured is greater, fit a new disc and repeat the check.

- If the problem persists, check and replace the wheel rim if necessary.

### Specific tooling

**020335Y Magnetic support for dial gauge**



## Front brake pads

### Removal

Proceed as follows:

- Remove the front calliper.
- Loosen the two pins shown in the figure that lock the two pads.
- Remove the pads, being careful with the pad spring clamp.
- Check the thickness of the pads.



### Characteristic

#### Minimum value

1.5 mm

### See also

[Front](#)  
brake calliper

## Refitting

To fit, proceed as follows:

- Insert the two pads in the callipers.
- Screw the two pad lock pins to the correct torque, and apply the recommended product.
- Fit the calliper on its support, tightening the two screws to the prescribed torque.

**N.B.**

**IF IT IS NOT POSSIBLE TO CORRECTLY POSITION THE CALLIPER ON THE DISC DURING FITTING, GENTLY EXPAND THE PADS.**

### Recommended products

**Loctite 243 Medium-strength threadlock**

Loctite 243 medium-strength threadlock

### Locking torques (N\*m)

Screw tightening calliper to the support 20 ÷ 25 Pad fastening pin 19.6 ÷ 24.5

## Fill

### Front

-Once the bleed valve is closed, fill the system with brake liquid to the maximum level.

-Undo the bleed screw.

-Apply the tube of the special tool to the bleed screws.

When bleeding it is necessary to fill the oil tank in continuation while working with a MITYVAC pump on the bleed screws until no more air comes out of the system.

The operation is finished when just oil comes out of the bleed screws.

-Do up the bleed screw.

-When the operation is over, tighten up the oil bleed screw to the prescribed torque.

#### N.B.

IF AIR CONTINUES TO COME OUT DURING PURGING, EXAMINE ALL THE FITTINGS: IF SAID FITTINGS DO NOT SHOW SIGNS OF BEING FAULTY, LOOK FOR THE AIR INPUT AMONG THE VARIOUS SEALS ON THE PUMP AND CALLIPER PISTONS.

#### CAUTION

- DURING THE OPERATIONS, THE VEHICLE MUST BE ON THE STAND AND LEVEL.

#### N.B.

DURING PURGING FREQUENTLY CHECK THE LEVEL TO PREVENT AIR GETTING INTO THE SYSTEM THROUGH THE PUMP.

#### WARNING

- BRAKING CIRCUIT FLUID IS HYGROSCOPIC. IT ABSORBS HUMIDITY FROM THE SURROUNDING AIR. IF THE LEVEL OF HUMIDITY IN THE BRAKING FLUID EXCEEDS A GIVEN VALUE, BRAKING EFFICIENCY WILL BE REDUCED. THEREFORE, ALWAYS USE FLUID FROM SEALED CONTAINERS. UNDER NORMAL DRIVING AND CLIMATIC CONDITIONS YOU SHOULD CHANGE THIS LIQUID EVERY TWO YEARS. IF THE BRAKES ARE USED INTENSELY AND/OR IN HARSH CONDITIONS, CHANGE THE FLUID MORE FREQUENTLY.

#### CAUTION

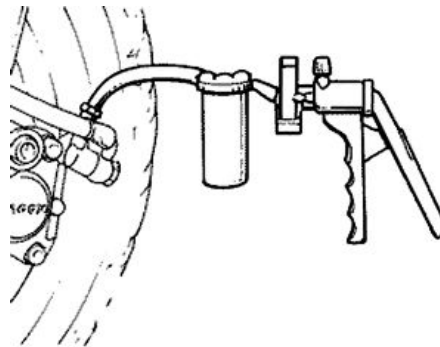
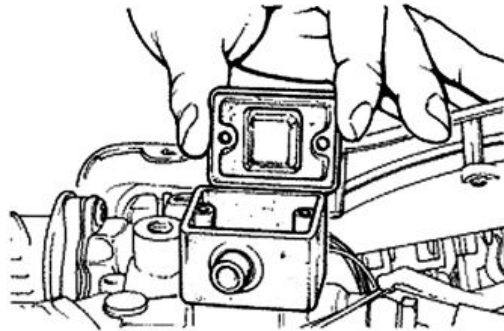

WHEN CARRYING OUT THE OPERATION, BRAKE FLUID MAY LEAK FROM BETWEEN THE BLEED SCREW AND ITS SEAT ON THE CALLIPER.  
CAREFULLY DRY THE CALLIPER AND DEGREASE THE DISC SHOULD THERE BE OIL ON IT.

### Specific tooling

020329Y MityVac vacuum-operated pump

### Recommended products

AGIP BRAKE 4 Brake fluid

FMVSS DOT 4 Synthetic fluid

### Locking torques (N\*m)

Oil bleed screw  $7 \div 10$

## Front brake pump

-After removing the front and rear handlebar covers, act on the two stand fixing points (see the figure).

- Disconnect the tube, collecting the brake oil in a container.

- On refitting, perform the operation in reverse.

- Tighten the hydraulic line to the prescribed torque and bleed the system.

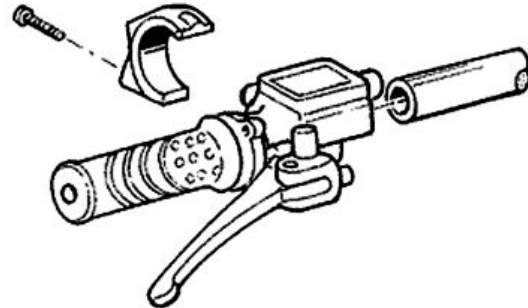

### Locking torques (N\*m)

Brake fluid pump - hose fitting  $16 \div 20$  Nm

## Removal

- Bleed the circuit and drain the brake fluid through the bleeding screw located on the calliper and actuate the brake lever until no more fluid flows out.

-Remove the oil pump from the handlebar; remove the brake lever and then remove the wheel cylinder.

1 - Tank cap screw.

2. Tank cover.

3. Diaphragm.

4. Bellows.

5. Sealing ring.

6. Piston.

7. Gasket.

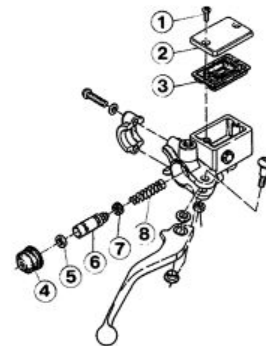

## 8 - Spring

**CAUTION**

- THE PRESENCE OF BRAKE FLUID ON THE DISC OR BRAKE PADS REDUCES THE BRAKING EFFICIENCY. IN THIS CASE, REPLACE THE PADS AND CLEAN THE DISC WITH A HIGH-QUALITY SOLVENT. CONTACT WITH BRAKE FLUID WILL DAMAGE PAINTED SURFACES.  
 RUBBER PARTS SHOULD NEVER BE LEFT IN ALCOHOL FOR LONGER THAN 20 SECONDS.  
 AFTER WASHING, THE PIECES MUST BE DRIED WITH A BLAST OF COMPRESSED AIR AND A CLEAN CLOTH.  
 THE SEALING RINGS MUST BE IMMERSSED IN THE OPERATING LIQUID.

**Refitting**

Before fitting, the parts must be perfectly clean and free of traces of oil, diesel fuel, grease, etc.. They should be washed thoroughly in denatured alcohol before proceeding.

- Reinstall the individual parts in the reverse order to the removal, paying attention to the correct positioning of the rubber parts in order to ensure leak tightness.

- 1 - Tank cap screw.
2. Tank cover.
3. Diaphragm.
4. Bellows.
5. Sealing ring.
6. Piston.
7. Gasket.
8. Spring.

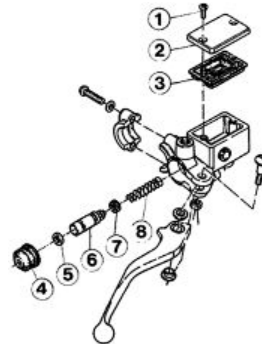
**Rear drum brake**

Once the muffler and the wheel have been removed, follow these steps:

1. Remove the shoe spring using the specific spanner.
2. Remove the shoe with the aid of a lever.
3. Refit the new shoes giving a few taps with the mallet.
4. Attach the spring using the specific pliers.

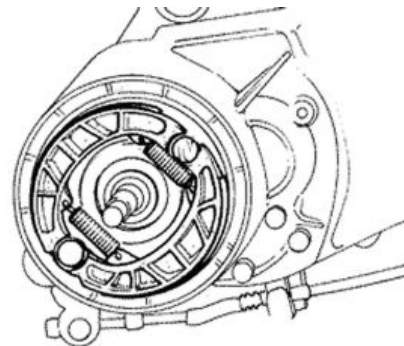

**Specific tooling**

**020325Y Pliers for brake-shoe springs**

---

# INDEX OF TOPICS

**CHASSIS**

**CHAS**

QUESTA SEZIONE È IN LAVORAZIONE

### Removing the ignition key-switch when on \*off\*

- Remove the shield back plate
- Push the lock body until the stop spring does not show grooves.
- Keep the lock body blocked with a screwdriver and remove the spring with a pair of pliers.
- Take out the lock block.



### Removing the ignition key-switch when on \*lock\*

Remove the shield.

- Remove the switch of the key switch.
- Make a hole on the block using a drill as shown in the figure.
- Insert the wheel cylinder with the key and with the anchoring tab facing down halfway on the lock body taking care that the insertion phase of the key is oriented matching "ON" (the only position that enables the cylinder to get into the lock body); now turn the key leftwards to "OFF" and at the same time press until the cylinder is completely in.

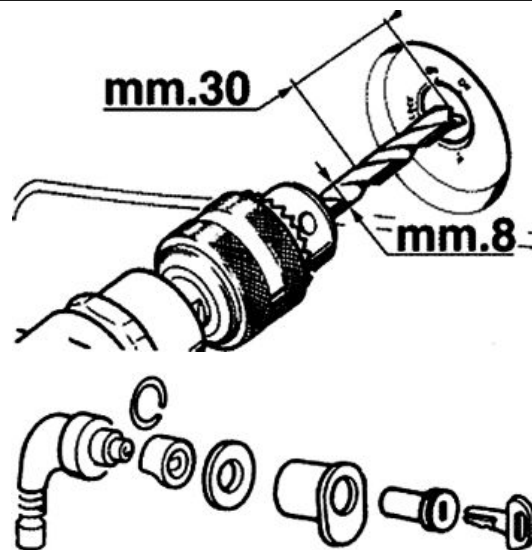

### Footrest

- Remove the side fairings
- Remove the shield back plate
- Remove the 6 screws shown in the photograph

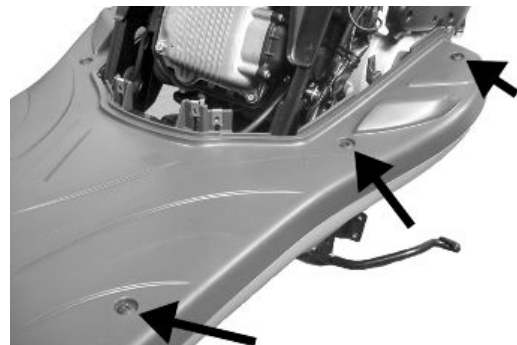

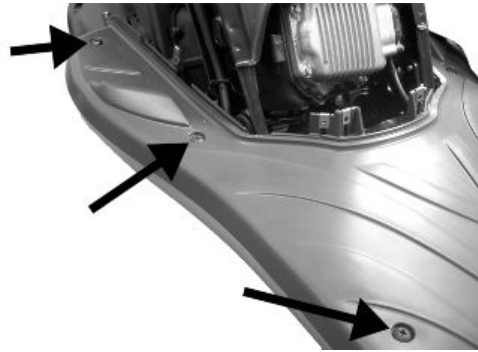

## Air filter

- Unscrew the 7 cover screws and remove the cover to reach the filter sponge.
- To disassemble the filter housing, unscrew the 2 bottom screws and disconnect the manifold connections, the carburettor and the external air intake.

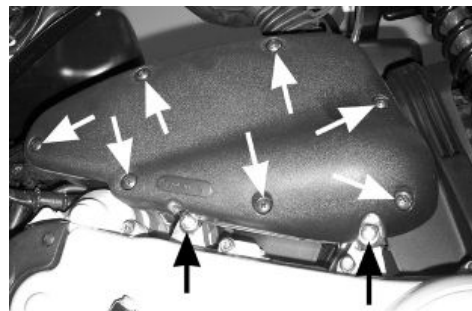

## Rear mudguard

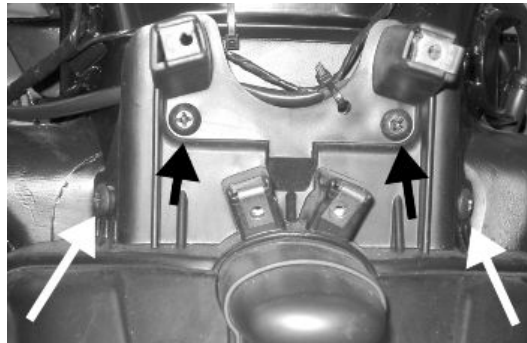

- Remove the side fairings
- Remove the 4 screws shown in the photograph



---

### Helmet bay

- Remove the side fairings
- Remove the helmet compartment by undoing the 4 screws indicated in the figure

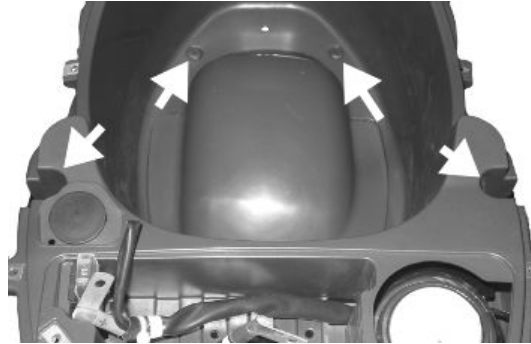

---

### Fuel tank

- Remove the side fairings
- Remove the rear mudguard
- Remove the crews shown in the photograph
- Remove the shock absorber upper clamping in order to create the necessary space to take out the tank.

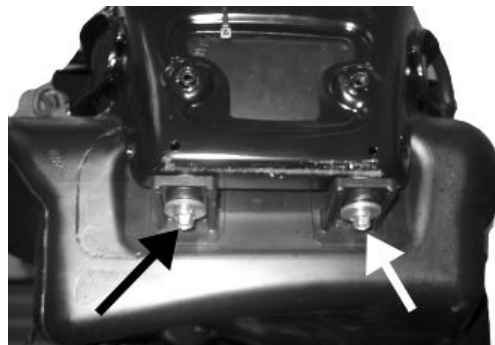

# INDEX OF TOPICS

**P**RE-DELIVERY

**P**RE DE

---

**Aesthetic inspection****Appearance check:**

- Paintwork
  - Fitting plastic parts
  - Scratches
  - Dirt
- 

**Tightening torques inspection****Lock check**

- Safety locks
- clamping screws

**Safety locks**

---

Rear shock absorber upper fixing

---

Rear shock absorber lower fixing

---

Front wheel axle nut

---

Wheel hub nut

---

Frame - swinging arm bolt \*

---

Swinging arm bolt - Engine

---

Engine arm pin - Frame arm

---

Handlebar lock nut

---

Steering lower ring nut

---

Upper steering ring nut

---

**Electrical system**

## Electrical system:

- Main switch
  - Headlamps: high-beam lights, low-beam lights, tail and parking lights and their warning lights
  - Adjusting the headlights according to the regulations currently in force
  - Rear light, parking light, stop light
  - Front and rear stop light switches
  - Turn indicators and their warning lights
  - Instrument panel lights
  - Instrument panel: fuel gauge
  - Instrument panel warning lights
  - Horn
  - Starter
-

**CAUTION**

**TO ENSURE MAXIMUM PERFORMANCE, THE BATTERY MUST BE CHARGED BEFORE USE. INADEQUATE CHARGING OF THE BATTERY WITH A LOW LEVEL OF ELECTROLYTE BEFORE IT IS FIRST USED SHORTENS THE LIFE OF THE BATTERY.**

**WARNING**

**BEFORE RECHARGING THE BATTERY, REMOVE THE CAPS OF EACH CELL. KEEP THE BATTERY AWAY FROM NAKED FLAMES OR SPARKS WHILE IT IS CHARGED. REMOVE THE BATTERY FROM THE SCOOTER, DISCONNECTING THE NEGATIVE TERMINAL FIRST.**

**CAUTION**

**WHEN INSTALLING THE BATTERY, ATTACH THE POSITIVE LEAD FIRST AND THEN THE NEGATIVE ONE.**

**WARNING**

**BATTERY ELECTROLYTE IS TOXIC AND IT MAY CAUSE SERIOUS BURNS. IT CONTAINS SULPHURIC ACID. AVOID CONTACT WITH EYES, SKIN AND CLOTHING.**

**IN CASE OF CONTACT WITH EYES OR SKIN, RINSE WITH ABUNDANT WATER FOR ABOUT 15 MINUTES AND SEEK MEDICAL ATTENTION AT ONCE.**

**IF IT IS SWALLOWED, IMMEDIATELY DRINK LARGE QUANTITIES OF WATER OR VEGETABLE OIL. SEEK IMMEDIATE MEDICAL ATTENTION.**

**BATTERIES PRODUCE EXPLOSIVE GAS; KEEP THEM AWAY FROM NAKED FLAMES, SPARKS AND CIGARETTES. IF THE BATTERY IS CHARGED IN A CLOSED PLACE, TAKE CARE TO ENSURE ADEQUATE VENTILATION. ALWAYS PROTECT YOUR EYES WHEN WORKING CLOSE TO BATTERIES.**

**KEEP OUT OF THE REACH OF CHILDREN**

**CAUTION**

**NEVER USE FUSES WITH A CAPACITY HIGHER THAN THE RECOMMENDED CAPACITY. USING A FUSE OF UNSUITABLE RATING MAY SERIOUSLY DAMAGE THE VEHICLE OR EVEN CAUSE A FIRE.**

---

## Levels check

Level check:

- Hydraulic brake system fluid level.
  - Rear hub oil level
  - Engine oil level
- 

## Road test

**Test ride**

- Cold start
  - Instrument operations
  - Response to the throttle control
  - Stability on acceleration and braking
  - Rear and front brake efficiency
  - Rear and front suspension efficiency
  - Abnormal noise
-

**Static test**

Static control after the test ride:

- Starting when warm
- Starter operation
- Minimum hold (turning the handlebar)
- Uniform turning of the steering
- Possible leaks

**CAUTION**

**CHECK AND ADJUST TYRE PRESSURE WITH TYRES AT AMBIENT TEMPERATURE.**

**CAUTION**

**NEVER EXCEED THE RECOMMENDED INFLATION PRESSURES OR TYRES MAY BURST.**

---

**Functional inspection**

Functional check up:

Braking system (hydraulic)

- Lever travel

Braking system (mechanical)

- Lever travel

Clutch

- Proper functioning check

Engine

- Throttle travel check

Others

- Check documentation
  - Check the frame and engine numbers
  - Tool kit
  - License plate fitting
  - Check locks
  - Check tyre pressures
  - Installation of mirrors and any accessories
-

# INDEX OF TOPICS

TIME

TIME

This section is devoted to the time necessary to carry out repairs.

The description and code for each operation is indicated.



**Engine**

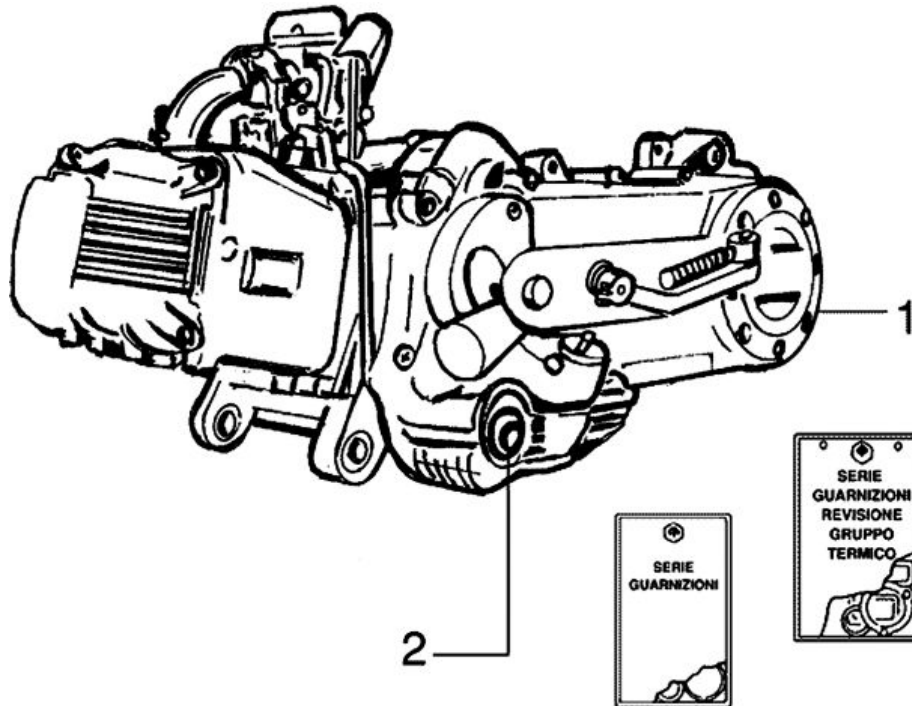

**ENGINE**

	Code	Action	Duration
1	001001	Engine from frame - Removal and re-fit.	
2	003064	Engine oil - Change	

**Crankcase**

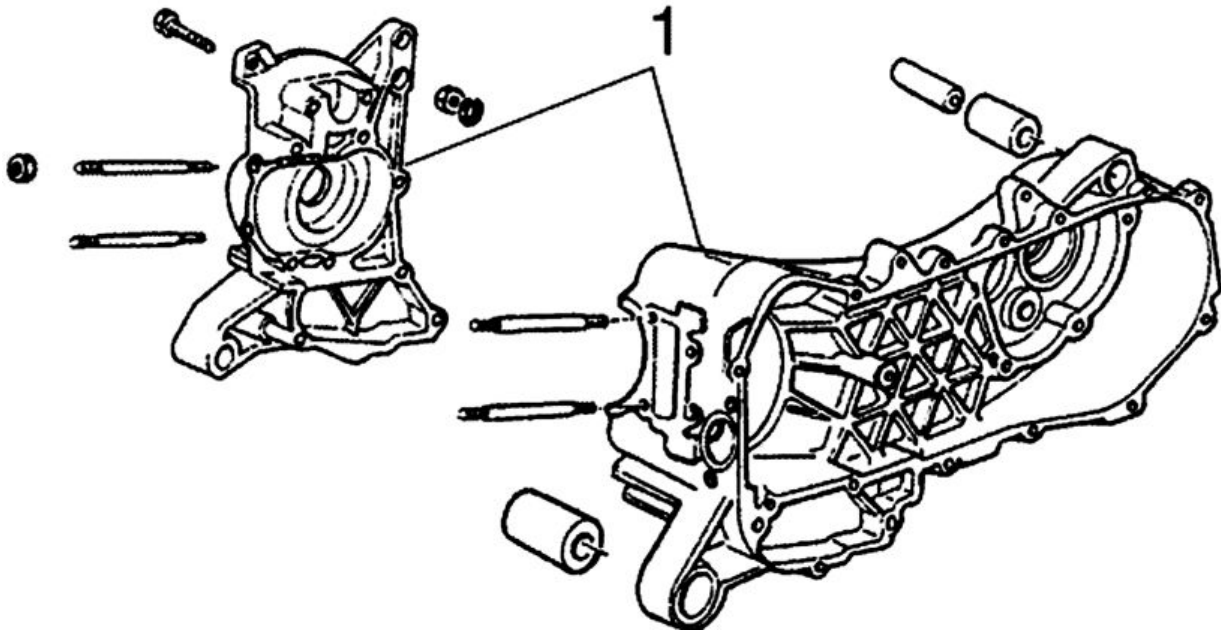

**CRANKCASE**

	Code	Action	Duration
1	001133	Engine crankcase - Replacement	

**Crankshaft**

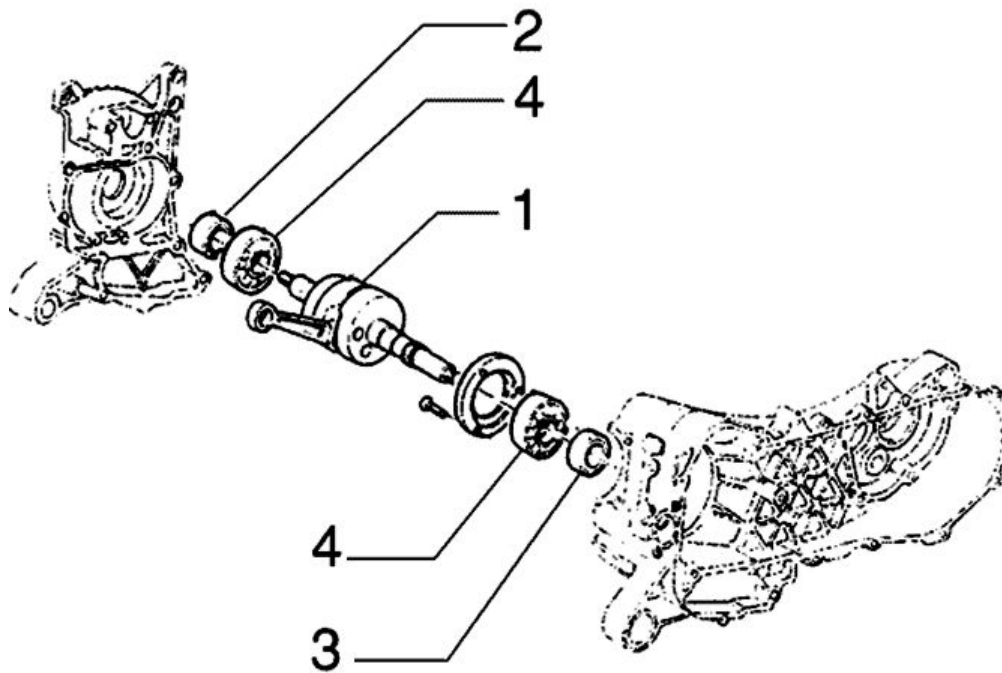



**CRANKSHAFT**

	Code	Action	Duration
1	001117	Crankshaft - Replacement	
2	001099	Oil seal, flywheel side - Replacement	
3	001100	Oil seal, clutch side - Replacement	
4	001118	Main bearings - Replacement	

**Cylinder assy.**

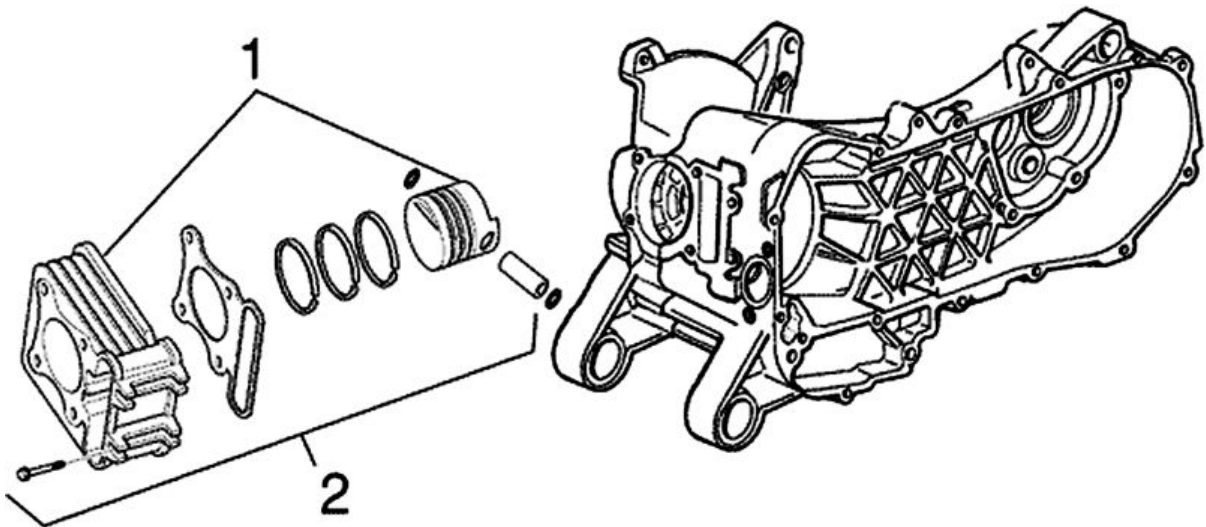

**CYLINDER- PISTON**

	Code	Action	Duration
1	001002	Cylinder Piston - Replacement	
2	001107	Cylinder Piston - Inspection /Cleaning	

## Cylinder head assy.

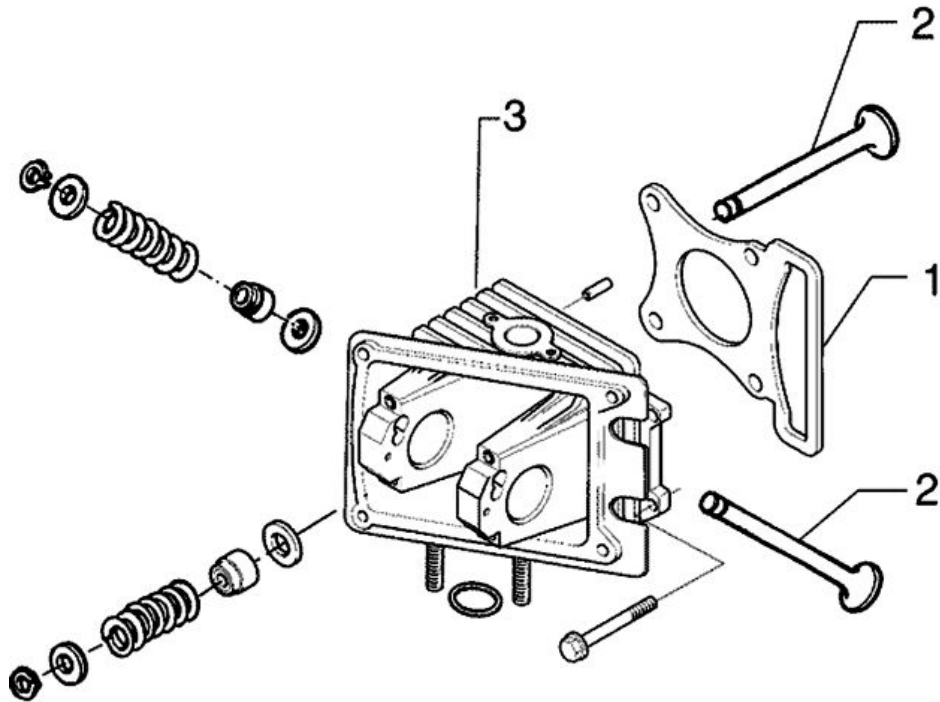
**HEAD**

	Code	Action	Duration
1	001056	Head gasket - Replacement	
2	001045	Valves - Replacement	
3	001126	Head - Replacement	

Rocker arms support assy.

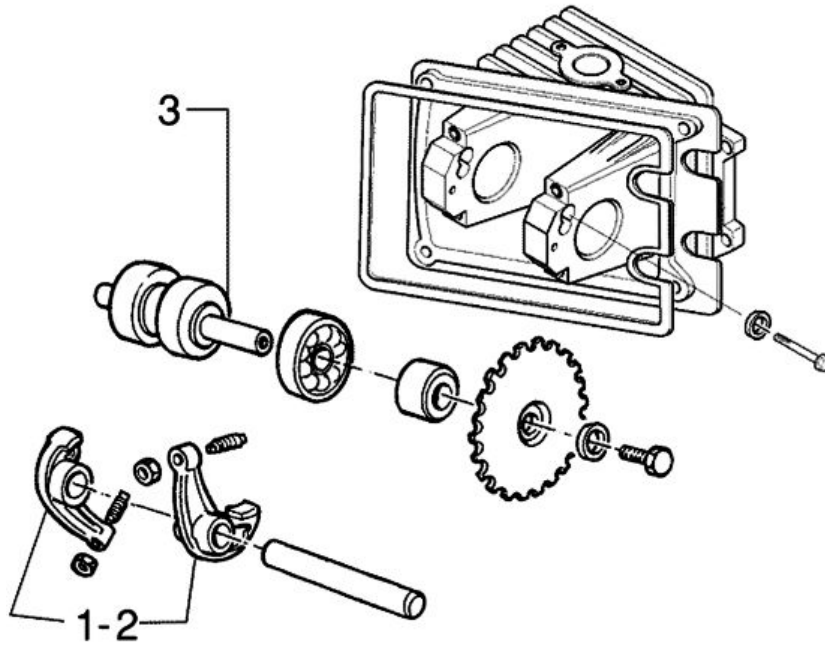

**CAMSHAFT SUPPORT**

	Code	Action	Duration
1	001049	Valve clearance - Adjustment	
2	001148	Valve rocking levers - Replacement	
3	001044	Camshaft - Replacement	

## Cylinder head cover

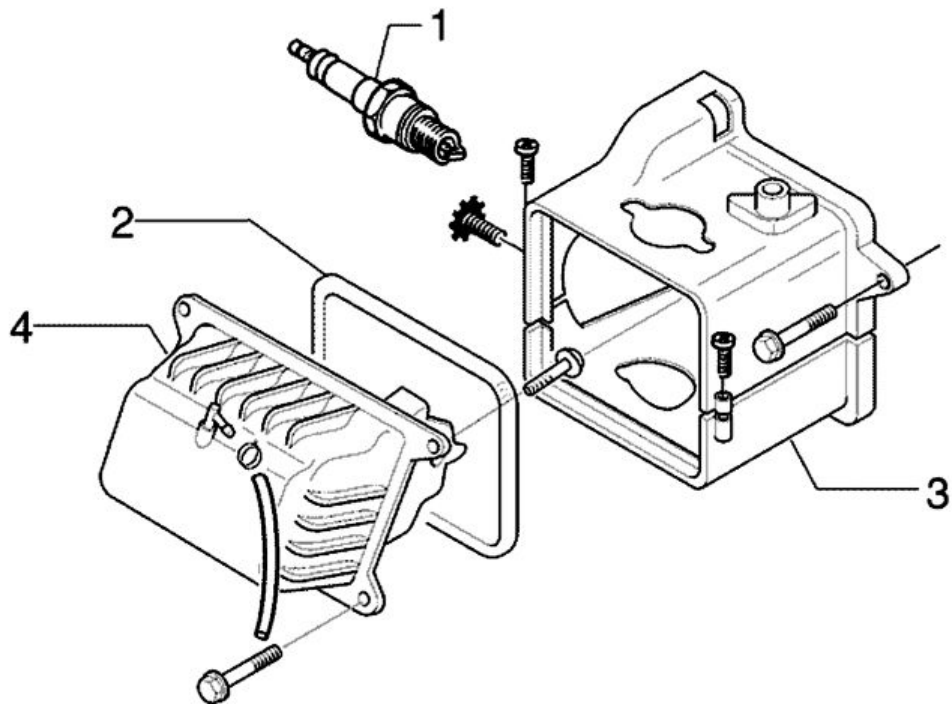

### HEAD COVER

	Code	Action	Duration
1	001093	Spark plug - Replacement	
2	001088	Head cover gasket - Replacement	
3	001097	Cooling hood - Replacement	
4	001089	Head cover - Replacement	

Driven pulley

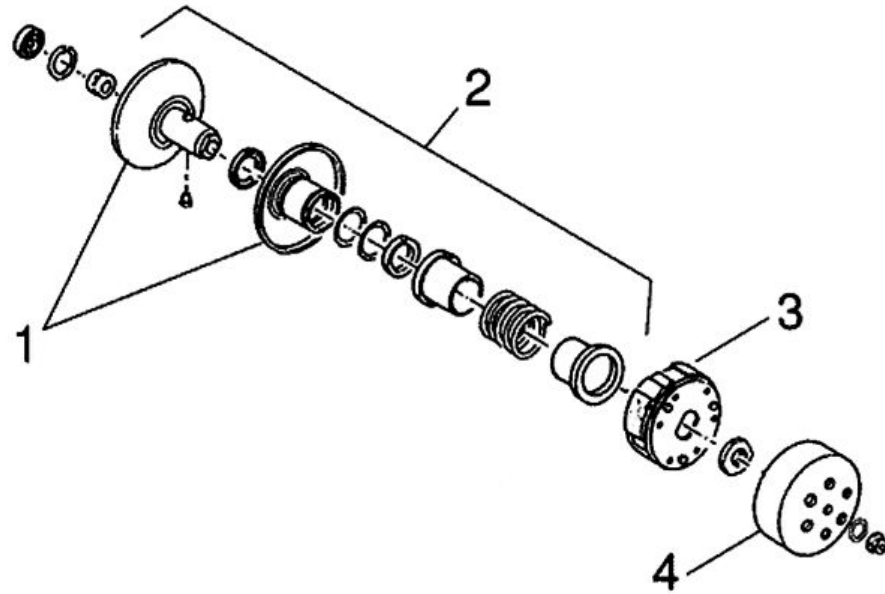

**DRIVEN PULLEY - CLUTCH**

	Code	Action	Duration
1	001110	Driven pulley - Replacement	
2	001012	Driven pulley - Overhaul	
3	001022	Clutch - Replacement	
4	001155	Clutch bell housing - Replacement	

## Oil pump

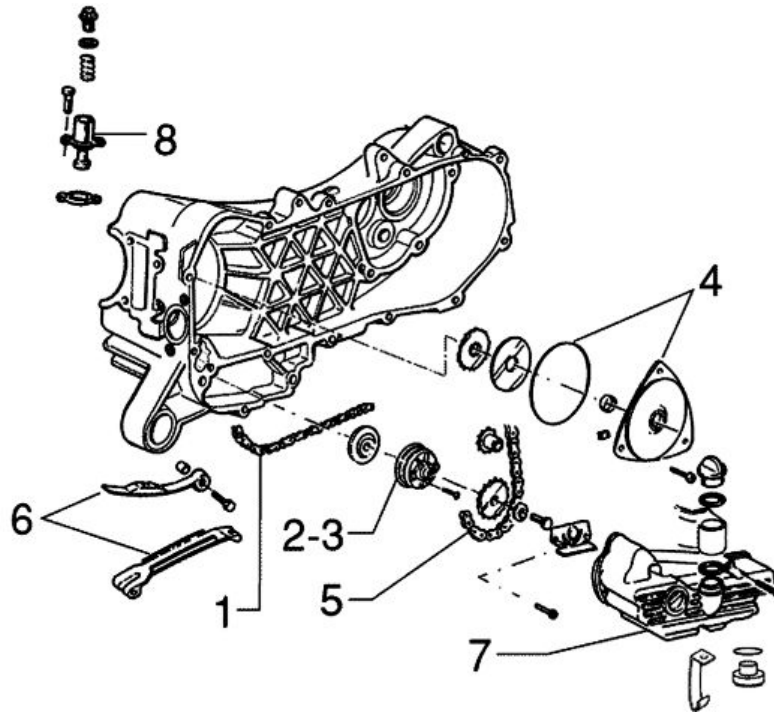

### OIL PUMP

	Code	Action	Duration
1	001051	Belt/Timing chain - Change	
2	001112	Oil pump - change	
3	001042	Oil pump - Service	
4	001121	Chain cover oil seal - Replacement	
5	001122	Oil pump chain - Replacement	
6	001125	Chain guide pads - Replacement	
7	001130	Oil sump - Replacement	
8	001129	Chain tightener - Overhaul and replacement	

Driving pulley

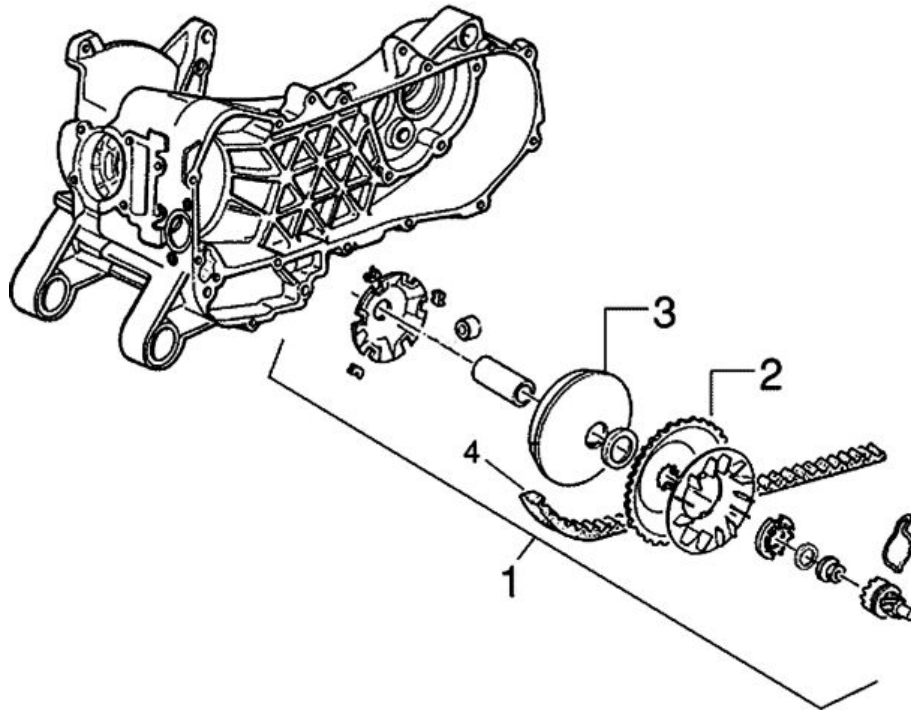

**REAR-VIEW PULLEY**

	Code	Action	Duration
1	001177	Variator rollers / shoes - Replacement	
2	001086	rear-view half-pulley - Replacement	
3	001066	Driving pulley - Removal and refitting	
4	001011	Driving belt - Replacement	

## Transmission cover

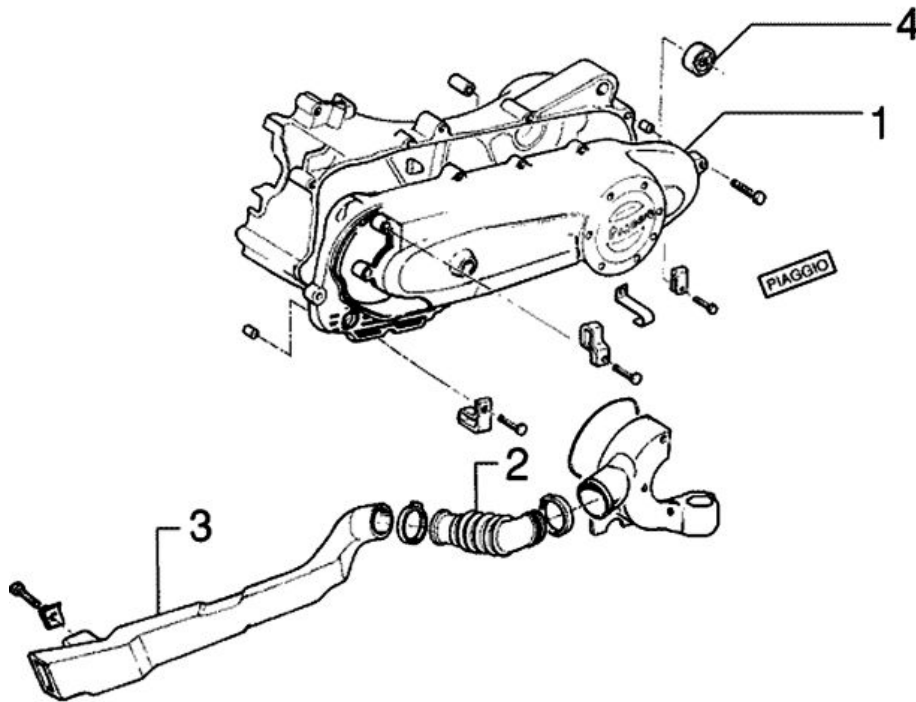

### TRANSMISSION COVER

	Code	Action	Duration
1	001096	Transmission crankcase cover - replace	
2	001132	Transmission air inlet pipe - Replacement	
3	001131	Transmission air intake - Replacement	
4	001135	Transmission cover bearing - Replacement	



**Starter motor**

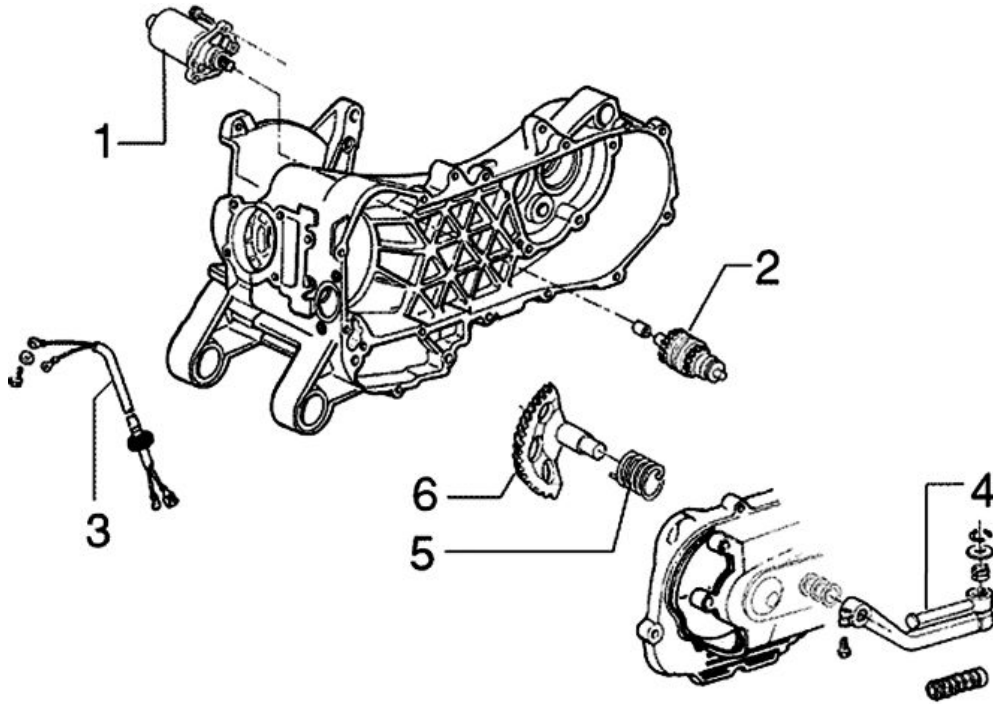

**STARTER MOTOR - START UP LEVER**

	Code	Action	Duration
1	001020	Starter motor - change	
2	001017	Starter sprocket wheel - replace	
3	005045	Starter motor with cables unit - Re-plac.	
4	001084	Starter lever - Replacement	
5	008008	Starter spring pack - Replacement	
6	001021	Kick starter - Inspection	

**Flywheel magneto**

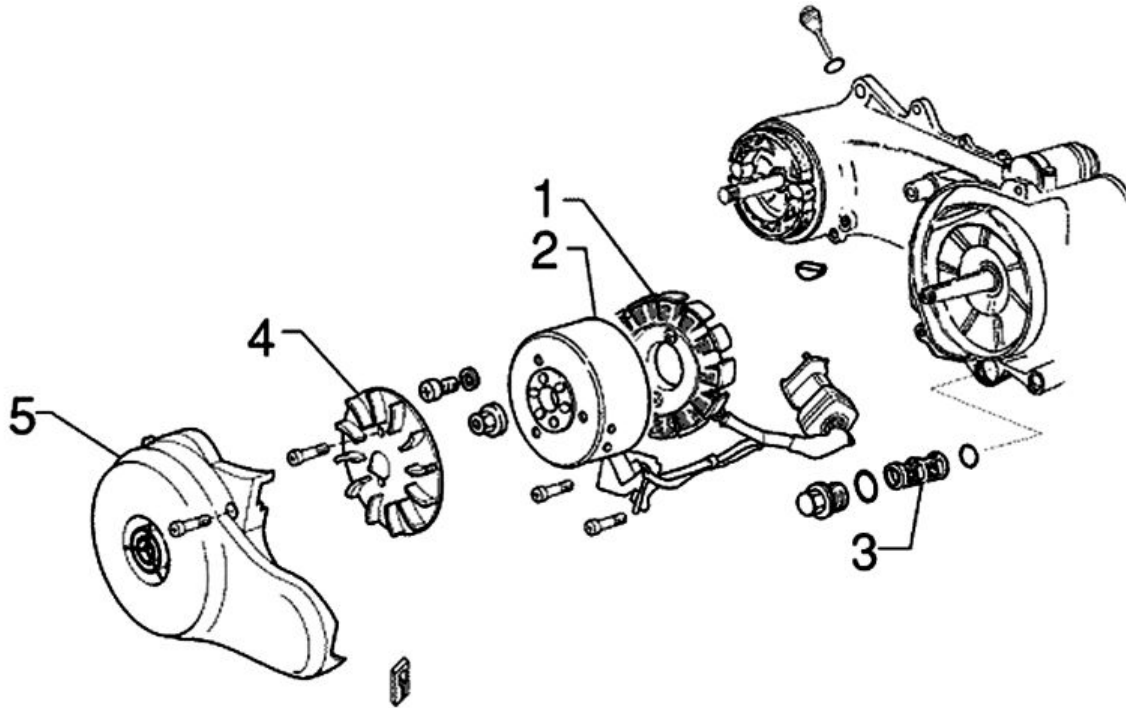

**FLYWHEEL FAN**

	Code	Action	Duration
1	001067	Stator - Fitting and Refitting	
2	001058	Flywheel - Replacement	
3	001102	Net oil filter - Replacement / Cleaning	
4	001109	Cooling fan - Replacement	
5	001087	Flywheel cover - Replacement	

**Carburettor**

**CARBURETTOR**

	Code	Action	Duration
1	001013	Intake manifold - change	
2	004122	Air cleaner carburettor fitting - Replacement	
3	001081	Automatic choke - Replacement	
4	001008	Carburettor - Inspection	
5	001063	Carburettor - Replacement	

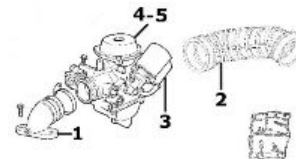

Exhaust pipe

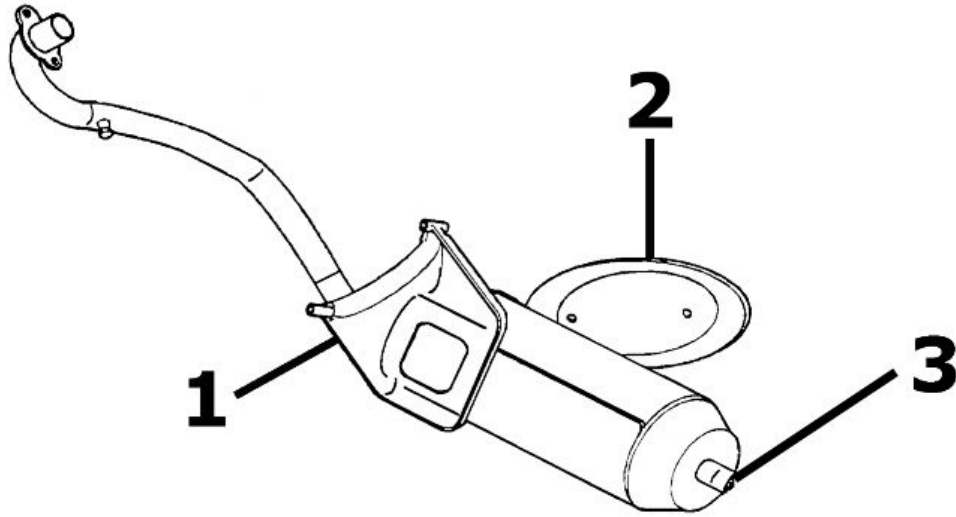

**MUFFLER**

	Code	Action	Duration
1	001009	Muffler - Replacement	
2	001095	Muffler guard - Replacement	
3	001136	Exhaust emissions - Adjustment	

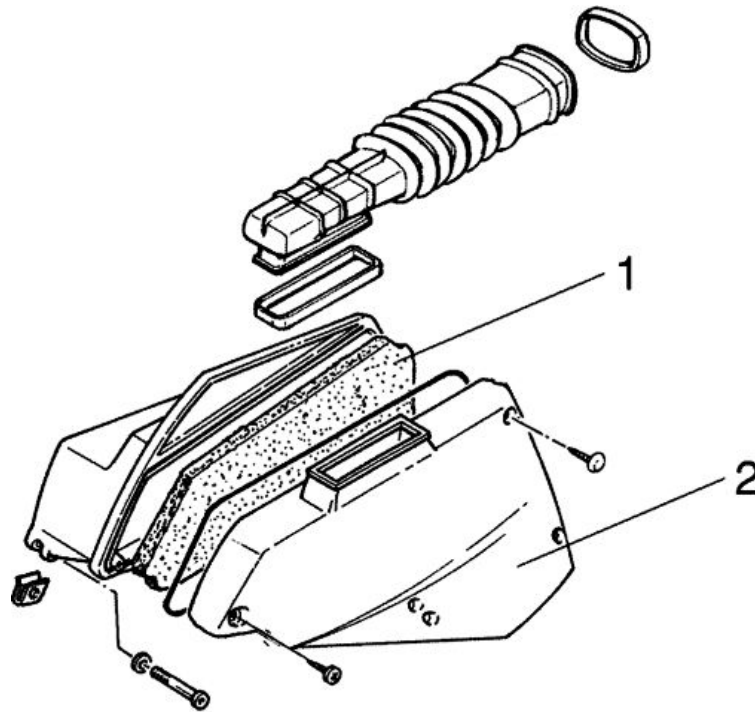
**Air cleaner****AIR FILTER**

	<b>Code</b>	<b>Action</b>	<b>Duration</b>
1	001014	Air filter - Replacement /Cleaning	
2	001015	Air filter box - Replacement	

Frame

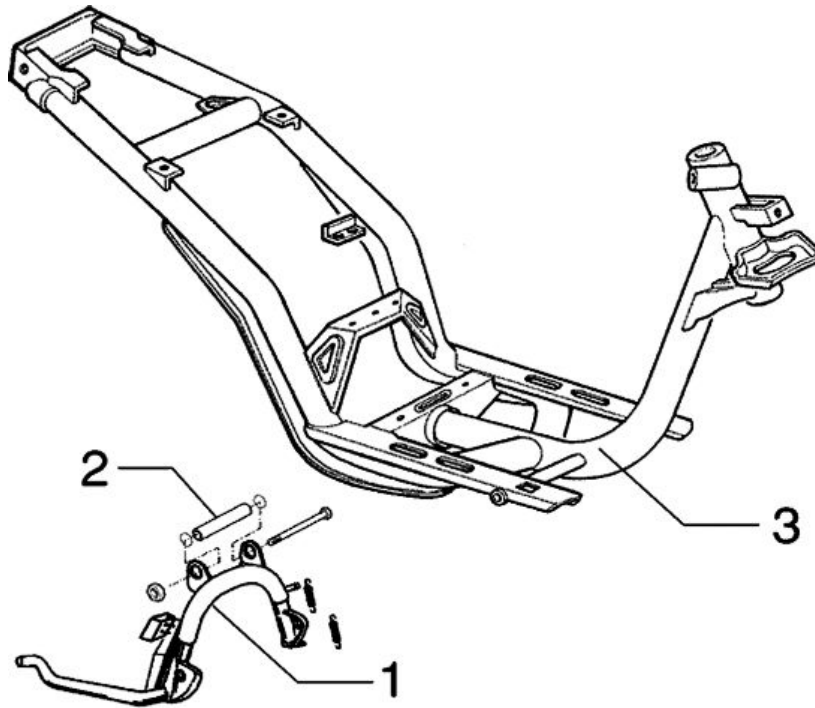

**FRAME**

	Code	Action	Duration
1	004004	Stand - Replacement	
2	001053	Stand bolt - Replacement	
3	004001	Frame - replace	

## Legshield spoiler

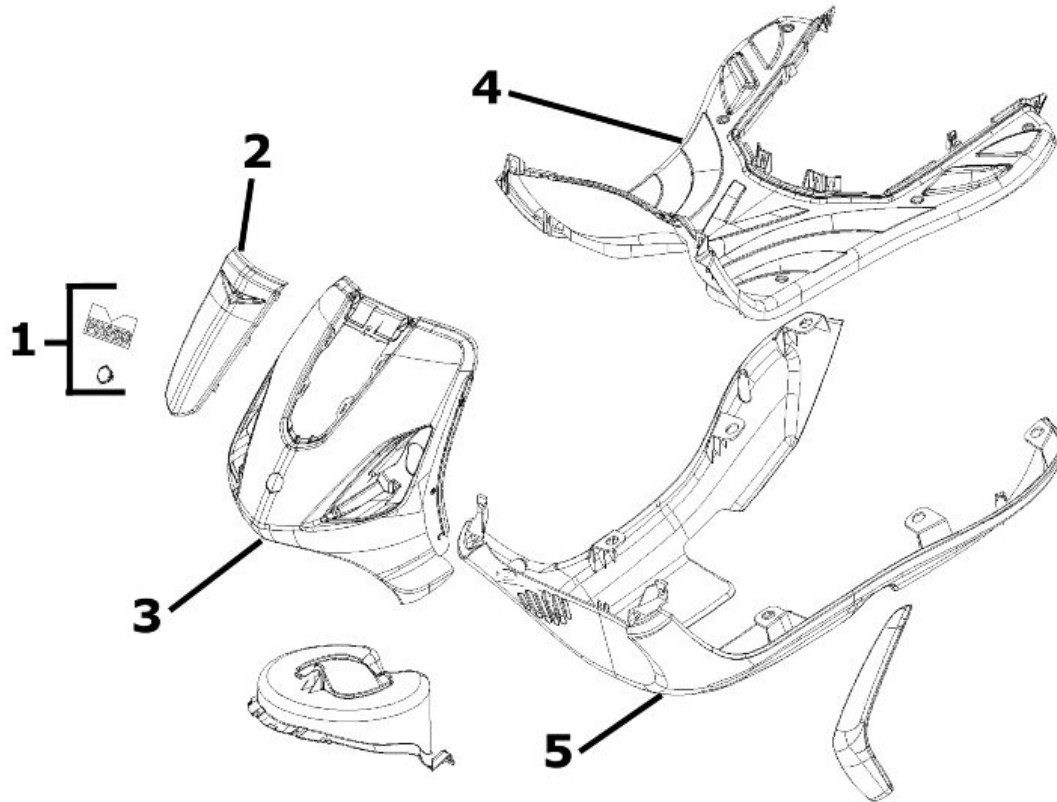
**FRONT SHIELD SPOILER**

	<b>Code</b>	<b>Action</b>	<b>Duration</b>
1	004159	Plates / Stickers - Replacement	
2	004149	Shield central cover - Replacement	
3	004064	Front shield, front part - Removal and refitting	
4	004015	Footrest - Removal and Refitting	
5	004053	Spoiler - Replacement	

Rear cover

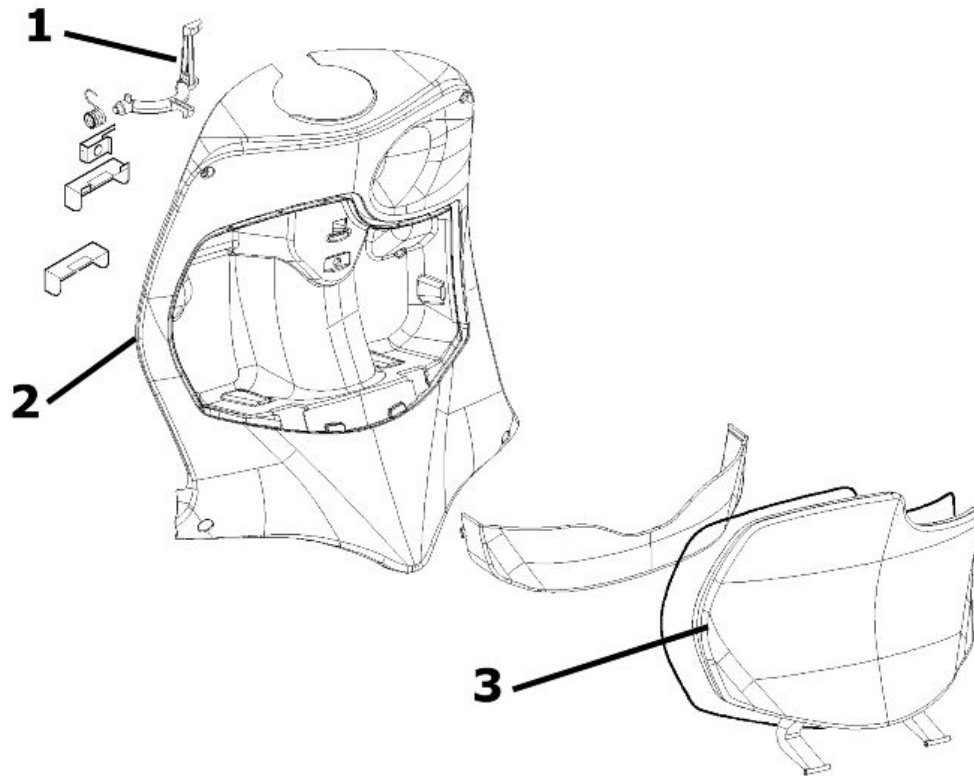

**REAR SHIELD**

	Code	Action	Duration
1	004174	Trunk levers - Replacement	
2	004065	Front shield, rear part - Removal and refitting	
3	004081	Glove box door - Replacement	

## Central cover

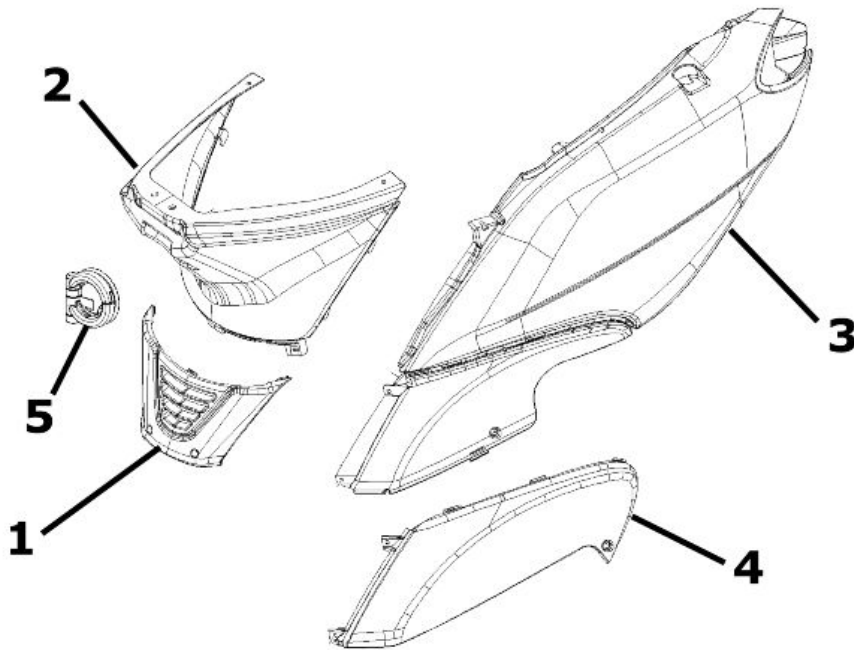

### CENTRAL COVER

	Code	Action	Duration
1	004059	Spark plug inspection flap - Replacement	
2	004106	Under-saddle band - Replacement	
3	004085	Fairing (1) - Replacement	
4	004105	Right side clamp - Replacement	
5	004131	Luggage rack support - Replacement	



Mudguard

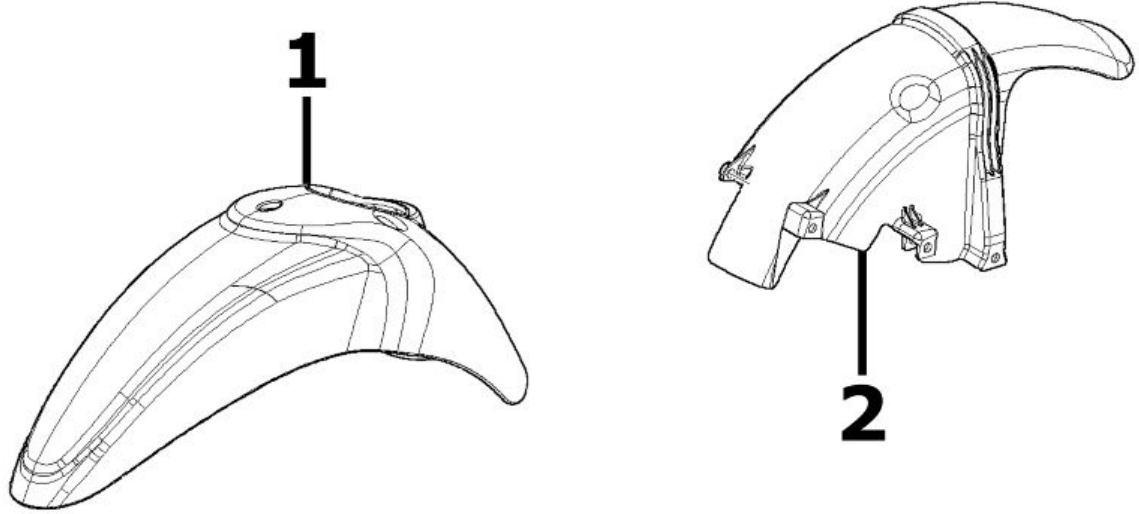

**MUDGUARDS**

	<b>Code</b>	<b>Action</b>	<b>Duration</b>
1	004002	Front mudguard - Replacement	
2	004009	Rear mudguard - Replacement	

## Fuel tank

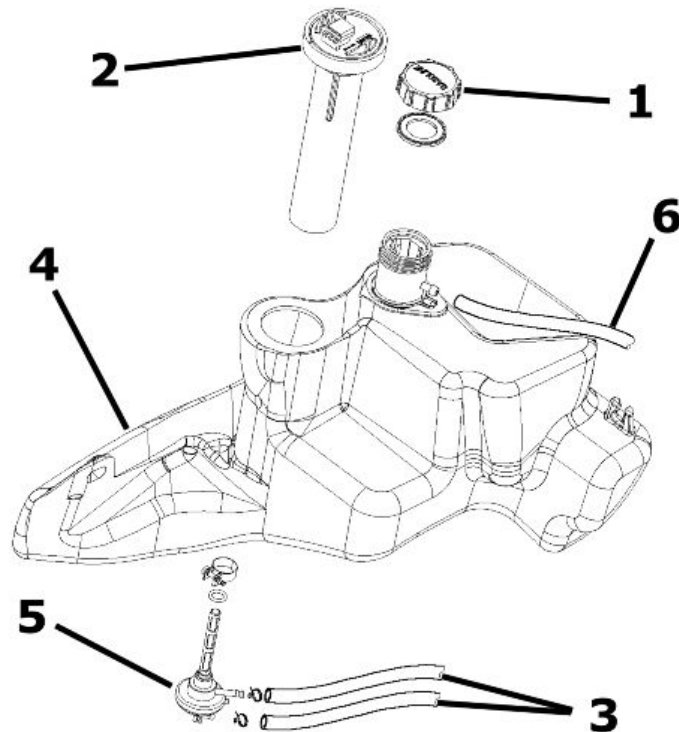
**FUEL TANK**

	<b>Code</b>	<b>Action</b>	<b>Duration</b>
1	004168	Fuel tank cap - Replacement	
2	005010	Tank float - Replacement	
3	004112	Cock-carburettor hose - Replacement	
4	004005	Fuel tank - Replacement	
5	004007	Fuel valve - Replacement	
6	004109	Fuel tank breather - change	

Rear shock-absorber

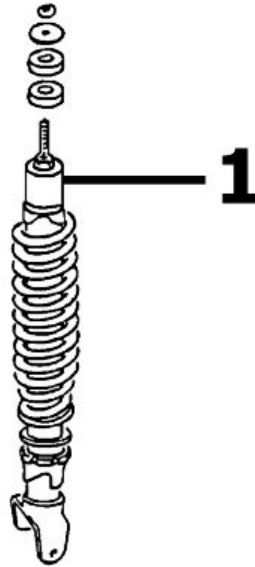

**REAR SHOCK ABSORBER**

	<b>Code</b>	<b>Action</b>	<b>Duration</b>
1	003007	Rear shock absorber - Removal and Refitting	

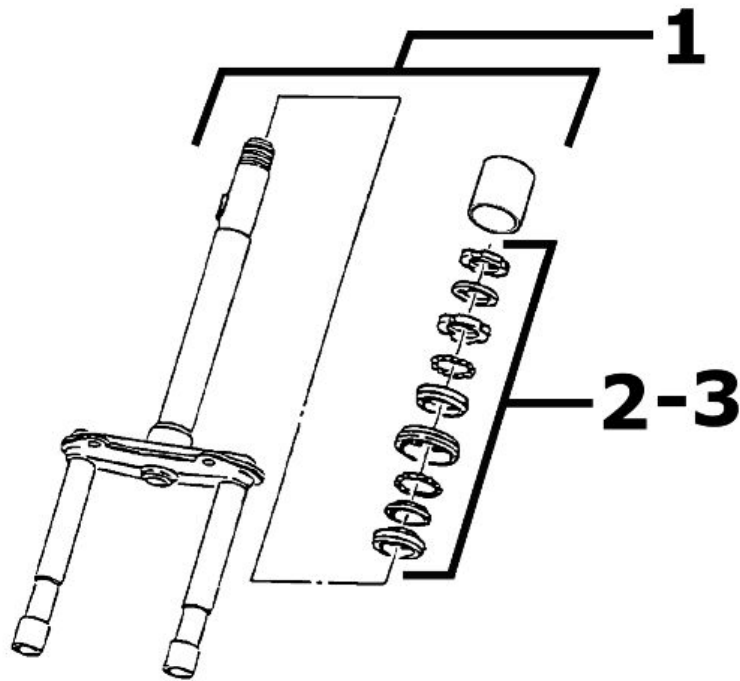
**Steering column bearings****STEERING FIFTH WHEELS**

	<b>Code</b>	<b>Action</b>	<b>Duration</b>
1	003051	Complete fork - replace	
2	003002	Steering fifth wheel - Replacement	
3	003073	Steering clearance - Adjustment	

**Handlebar covers**

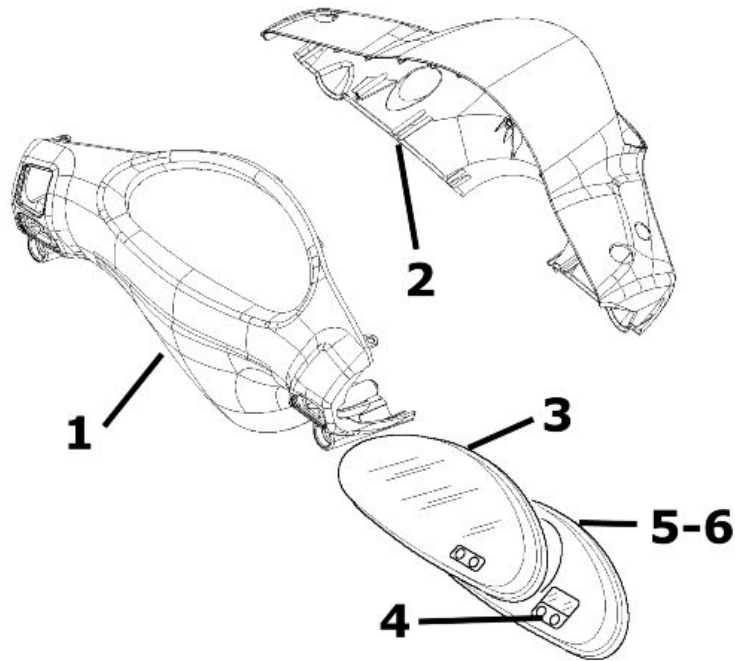

**HANDLEBAR COVERS**

	<b>Code</b>	<b>Action</b>	<b>Duration</b>
1	004019	Handlebar rear section - Replacement	
2	004018	Handlebar front section - Replacement	
3	005078	Odometer glass - Replacement	
4	005076	Clock / Cell - Replacement	
5	005014	Odometer - Replacement	
6	005038	Instrument panel warning light bulbs - Replacement	

## Handlebar components

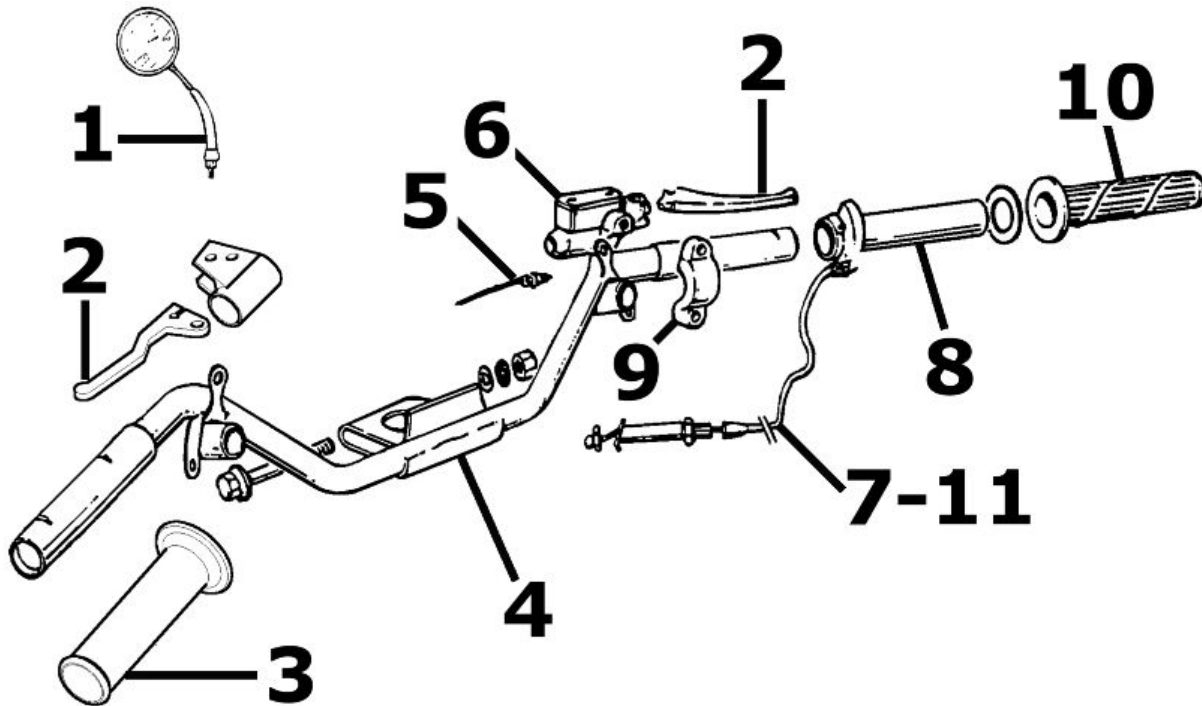

### HANDLEBAR COMPONENTS

	Code	Action	Duration
1	004066	Driving mirror - Replacement	
2	002037	Brake or clutch lever - Replacement	
3	002071	Left hand grip - Replacement	
4	003001	Handlebar - Replacement	
5	005017	Stop switch - Replacement	
6	002024	Front brake pump - Removal and Re-fitting	
7	002063	Throttle control transmission - Replacement	
8	002060	Complete throttle control - Replacement	
9	004162	Mirror support and/or brake pump fitting U-bolt - Replacement	
10	002059	Right hand grip - Replacement	
11	003061	Accelerator transmission - adjust	

Swing-arm

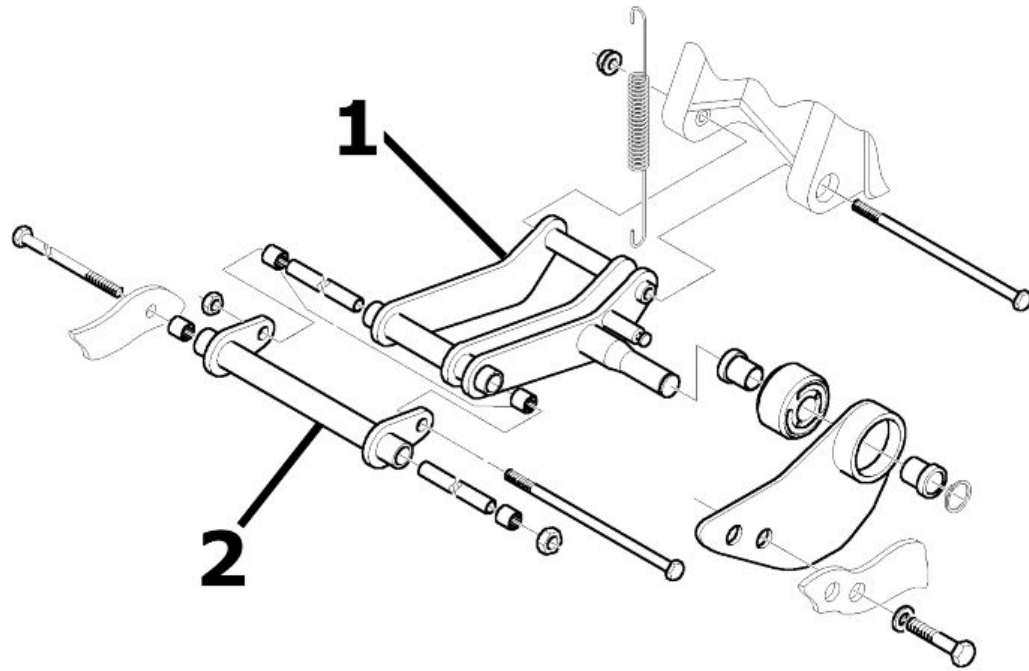

**SWINGING ARM**

	Code	Action	Duration
1	001072	Engine / frame swinging arm fitting - Replacement	
2	003080	Swinging arm on frame - Replacement	

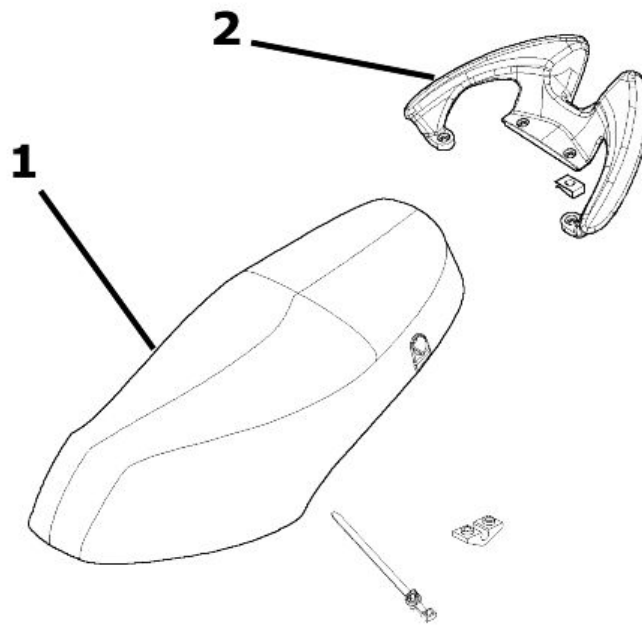
**Seat****SADDLE**

	<b>Code</b>	<b>Action</b>	<b>Duration</b>
1	004003	Saddle - Replacement	
2	004068	Passenger handgrip - Replacement	

---



Turn signal lights

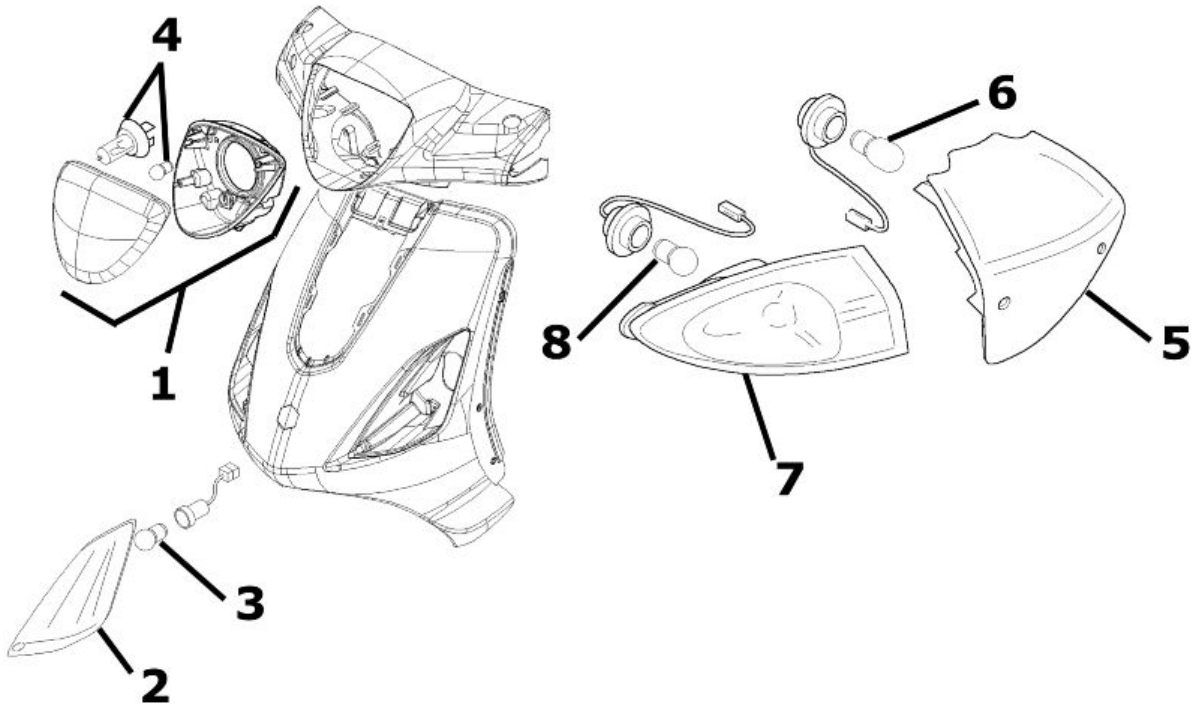

**TURN INDICATOR LIGHTS**

	Code	Action	Duration
1	005002	Front headlamp - change	
2	005012	Front turn indicator - Replacement	
3	005067	Front turn indicator bulb - Replacement	
4	005008	Front headlamp bulbs - Replacement	
5	005005	Taillight - Replacement	
6	005066	Rear light bulbs - Replacement	
7	005022	Rear turn indicators - Replacement	
8	005068	Rear turn indicator bulb - Replacement	

## Front wheel

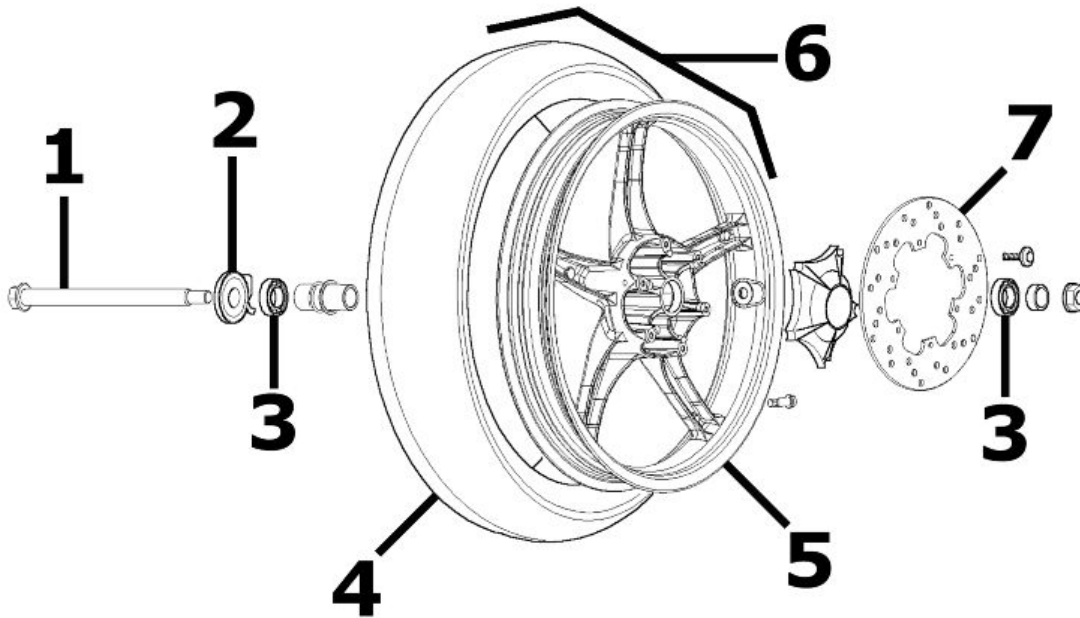

### FRONT WHEEL

	Code	Action	Duration
1	003038	Front wheel axle - Remov. and refitt.	
2	002011	Odometer movement sensor - Replacement	
3	003040	Front wheel bearings - Replacement	
4	003047	Front tyre - Replacement	
5	003037	Front wheel rim - Removal and Refitting	
6	004123	Front wheel - Replacement	
7	002041	Front brake disc - Replacement	

#### Grease tone wheel or drive

Please take note that the code has been introduced:

900001 - Tone wheel / drive greasing - 15'.

Never mistake the codes 002011 (movement sensor replacement) and 005089 (tone wheel replacement) in the event of noise of the indicated components. The grease recommended is TUTELA MRM 2 (soap-based lithium grease with Molybdenum disulphide).

In the following points we indicate with an arrow the area to be greased (1 - Drive, 2 - Tone wheel)

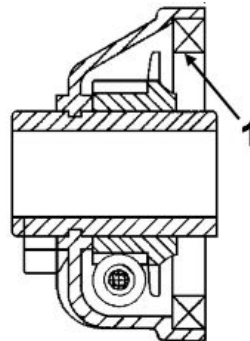

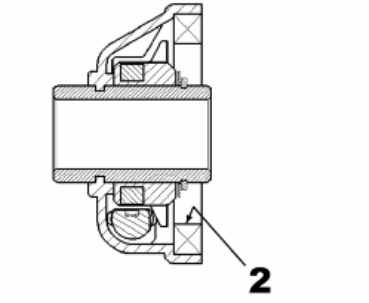

Rear wheel

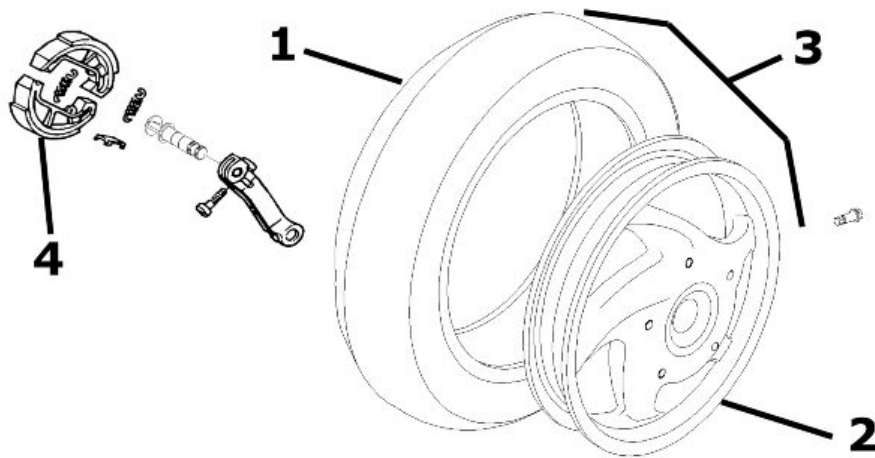

**REAR WHEEL**

	Code	Action	Duration
1	004126	Rear wheel tyre - Replacement	
2	001071	Rear wheel rim - Removal and Refitting	
3	001016	Rear wheel - Replacement	
4	002002	Rear brake pads/shoes - Repl.	

## Electric devices

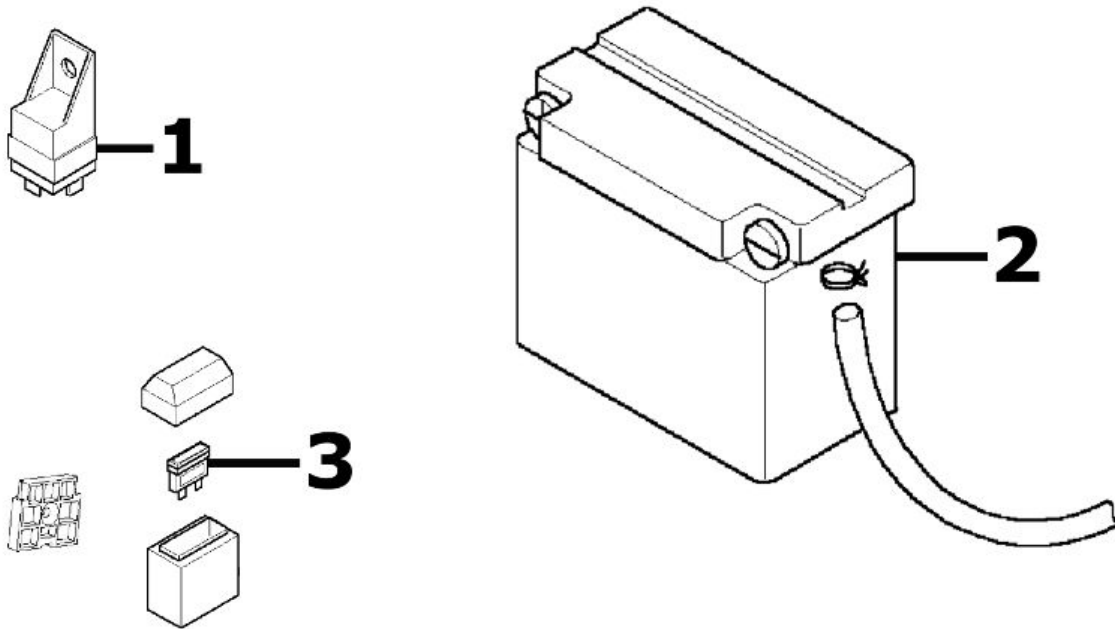

### ELECTRICAL DEVICES

	Code	Action	Duration
1	005011	Start-up remote control switch - Replacement	
2	005007	Battery - change	
3	005052	Fuse (1) - Replacement	

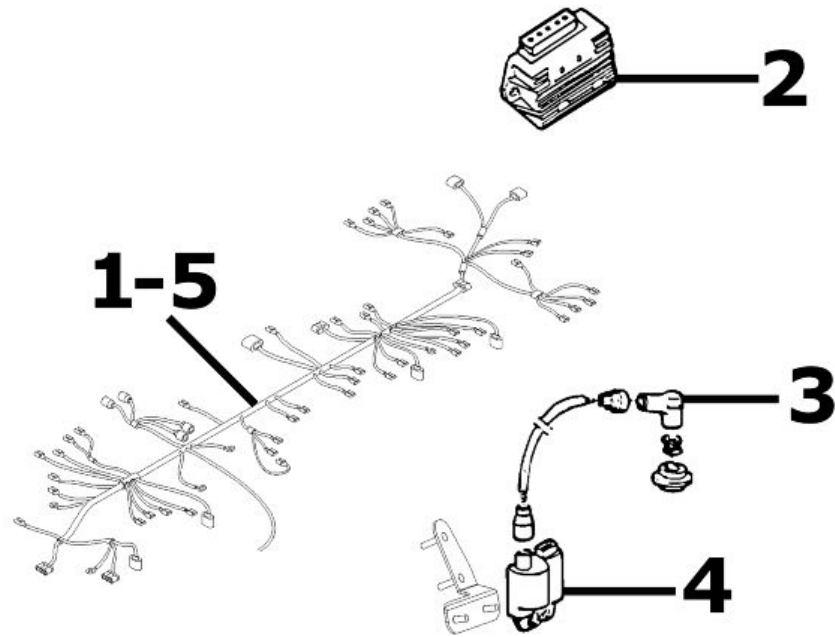

**ELECTRICAL DEVICES**

	<b>Code</b>	<b>Action</b>	<b>Duration</b>
1	005001	Electrical system - Replacement	
2	005009	Voltage regulator - Replacement	
3	001094	Spark plug cap - Replacement	
4	001023	Control unit - Replacement	
5	005114	Electrical system - Service	

## Electronic controls

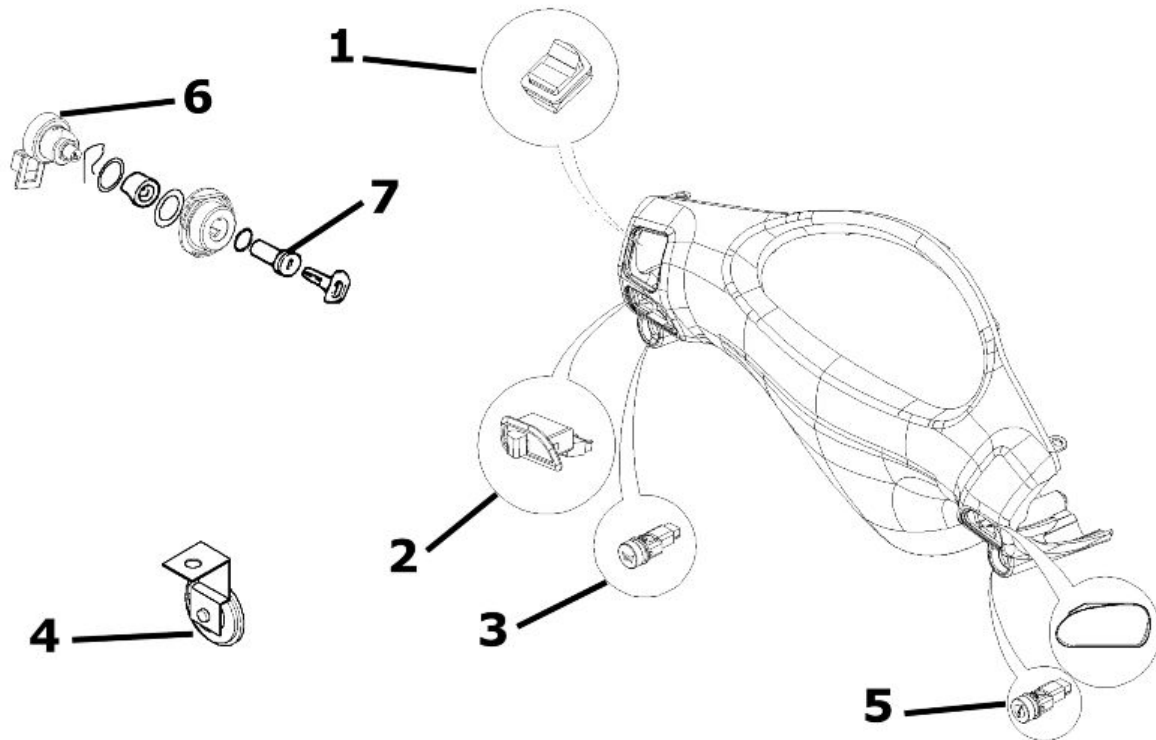

### ELECTRIC CONTROLS

	Code	Action	Duration
1	005039	Headlight switch - Replacement	
2	005006	Light switch or turn indicators - Replacement	
3	005040	Horn button - Replacement	
4	005003	Horn - Replacement	
5	005041	Starter button - Replacement	
6	005016	Key switch - Replacement	
7	004096	Lock series - Replacement	

**Transmissions**

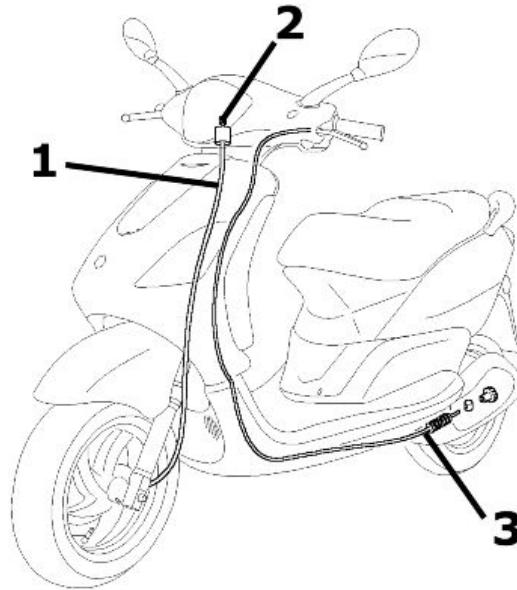

**TRANSMISSIONS**

	<b>Code</b>	<b>Action</b>	<b>Duration</b>
1	002051	Odometer transmission assembly - Replacement	
2	002049	Odometer cable - Replacement	
3	002053	Rear brake transmission complete - replacement	

## Brake callipers

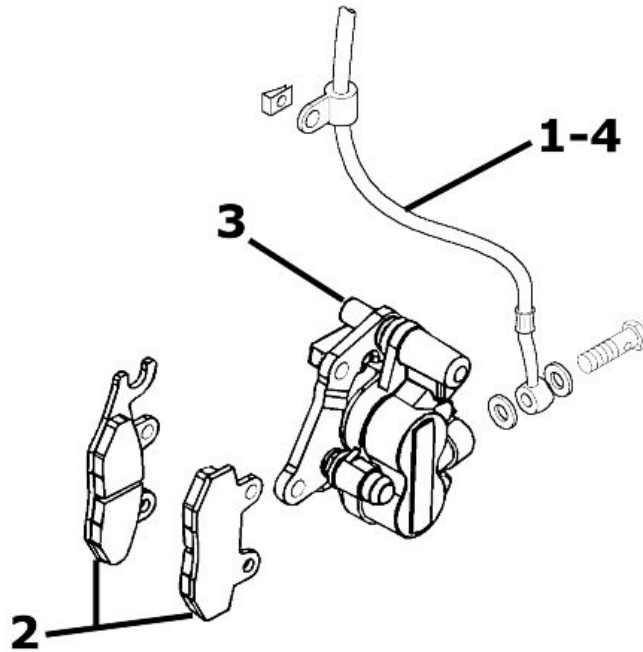

### CALLIPER

	Code	Action	Duration
1	002021	Front brake hose - Remov. and Refitt.	
2	002007	Front brake shoes/pads - Remov. and Refitt	
3	002039	Front brake calliper - Removal and Refitting	
4	002047	Front brake fluid and air bleed system - Replacement	



Steering column

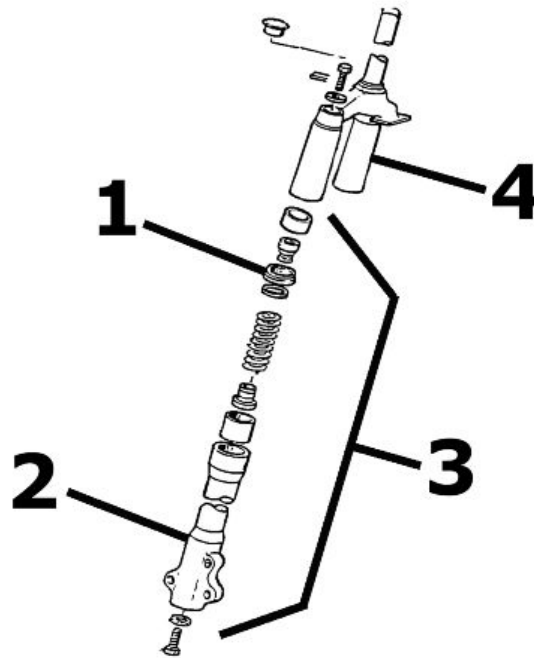

**STEERING**

	Code	Action	Duration
1	003048	Fork oil seal - Replacement	
2	003076	Fork sheath - Replacement	
3	003079	Fork stem - Replacement	
4	003010	Front suspension - Service	

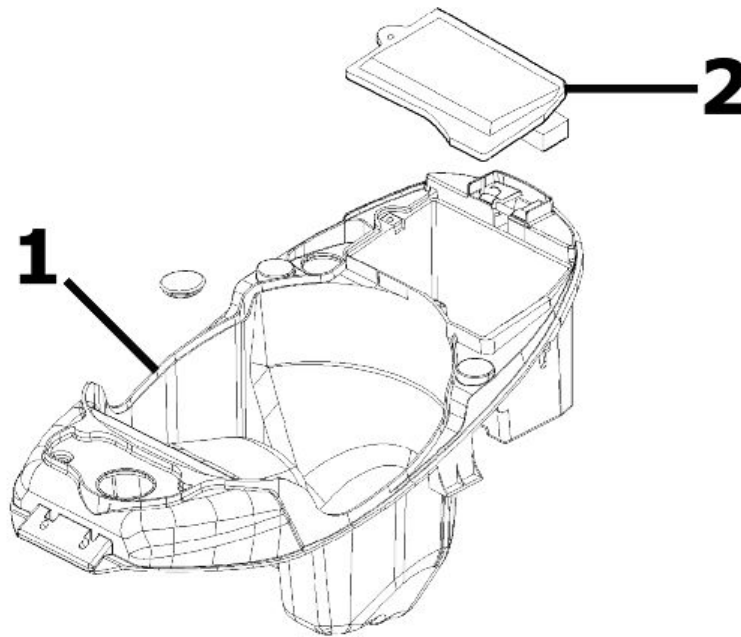
**Helmet bay****HELMET COMPARTMENT**

	<b>Code</b>	<b>Action</b>	<b>Duration</b>
1	004016	Helmet compartment - Removal and Refitting	
2	005046	Battery cover - Replacement	

Rear wheel axle

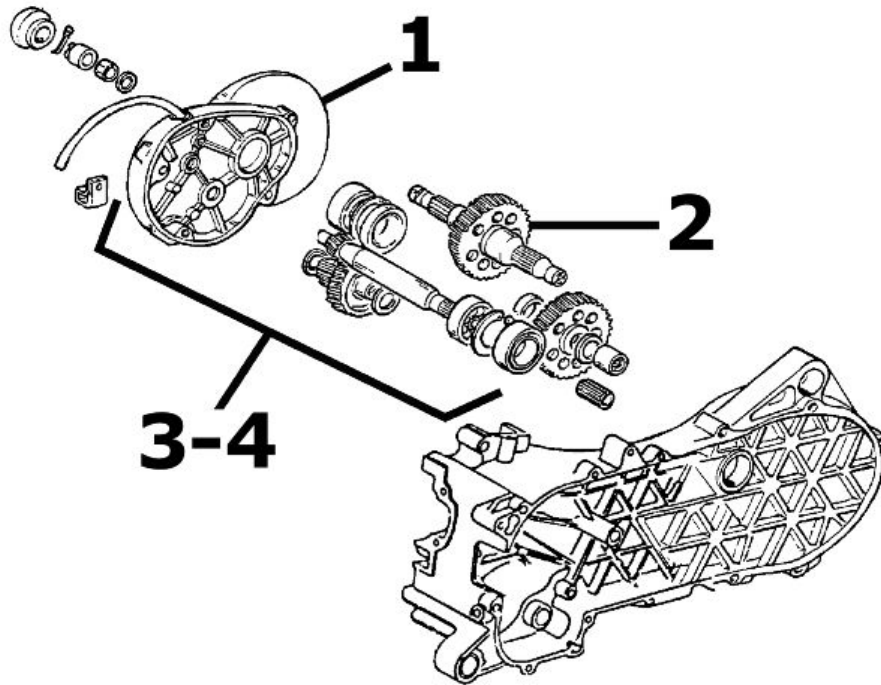

**REAR WHEEL AXLE**

	<b>Code</b>	<b>Action</b>	<b>Duration</b>
1	001156	Gear reduction unit cover - Replacement	
2	004125	Rear wheel axle - Replacement	
3	001010	Geared reduction unit - Service	
4	003065	Gear box oil - Replacement	

## Secondary air box

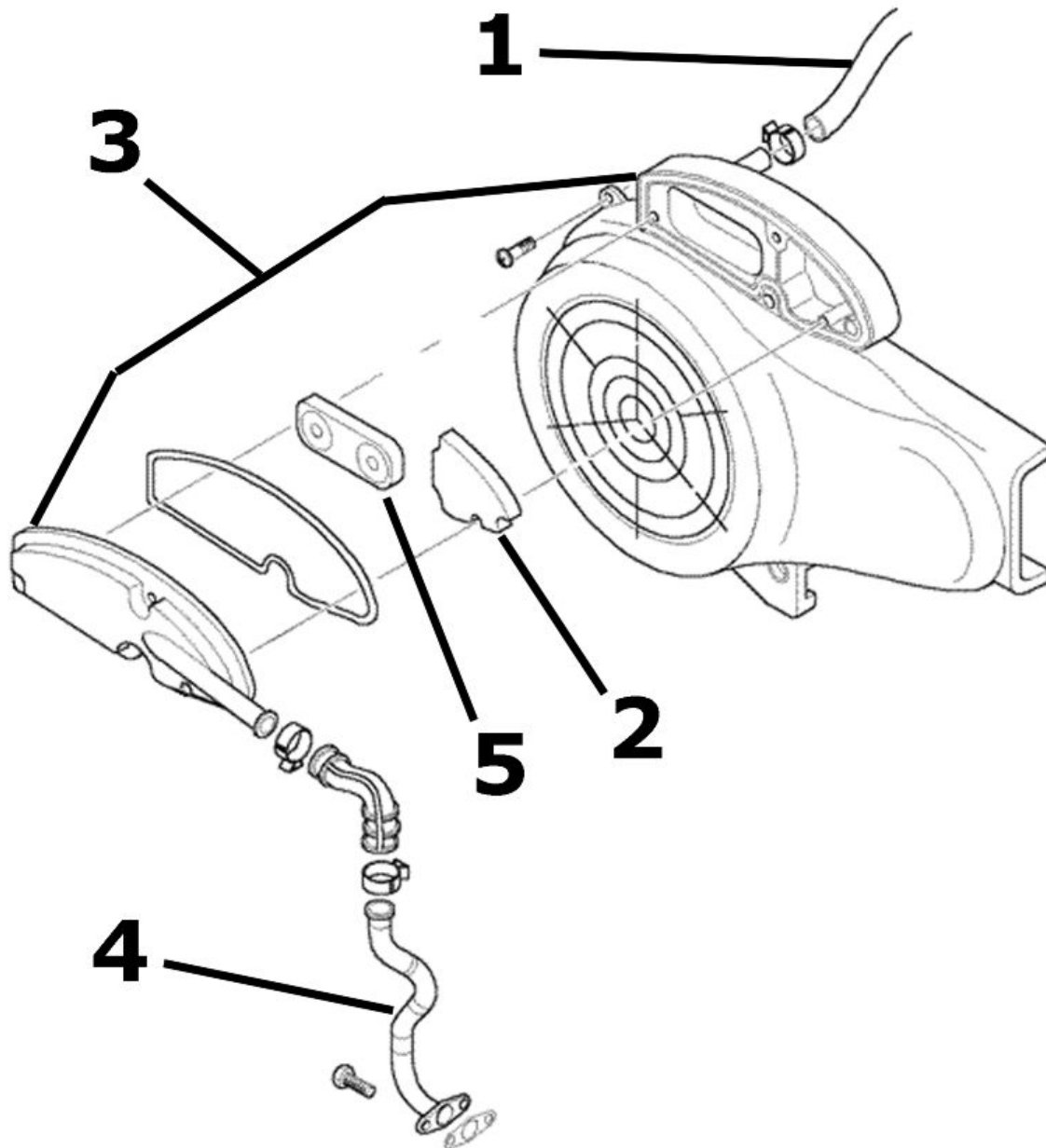

### SECONDARY AIR HOUSING

	Code	Action	Duration
1	001164	Crankcase secondary air connection - Replacement	
2	001161	Secondary air filter - Replacement / Cleaning	
3	001162	Secondary air housing - Replacement	
4	001163	Muffler secondary air connection - Replacement	
5	001165	Secondary air reed - Replacement	

## **A**

Air filter: 33, 144

## **B**

Battery: 44, 50, 57, 58

Brake: 134, 136, 137, 139, 140, 184

## **C**

Carburettor: 11, 29, 113, 117, 162

## **E**

Engine oil: 33

## **F**

Fuel: 43, 112, 145, 170

## **H**

Headlight: 36

Horn:

Hub oil: 32

## **I**

Identification: 8

## **M**

Maintenance: 7, 27

## **O**

Oil filter: 34

## **S**

Saddle:

Shock absorbers: 131

Spark plug: 31

Start-up:

## **T**

Tank: 145, 170

Transmission: 10, 43, 63, 73, 160

Turn indicators:

Tyres: 11