

SUZUKI

GS500/F

SUPPLEMENTARY SERVICE MANUAL

USE THIS MANUAL WITH:
GS500E SERVICE MANUAL (99500-34091-01E)



GS500K4/FK4 ('04-MODEL)

FOREWORD

This manual describes service data, service specifications and servicing procedures which differ from those of the GS500K3 ('03-MODEL).

NOTE:

* Any differences between the GS500K3 ('03-model) and GS500K4/FK4 ('04-model) in specifications and service data are indicated with an asterisk mark (*).

* Please refer to the GS500K3 Service Manual for details which are not given in this manual.

CONTENTS

SPECIFICATIONS	3
SERVICE DATA	5
TIGHTENING TORQUE.....	13
ENGINE	13
CHASSIS.....	14
PERIODIC MAINTENANCE CHART.....	15
LOWER CRANKCASE.....	16
COWLING (For GS500F)	17
FRONT FORK.....	18
REMOVAL	18
DISASSEMBLY	19
INSPECTION	20
REASSEMBLY	21
INSTALLATION.....	23
WIRING DIAGRAM.....	24
GS500K4/UK4 (P-02, 09, 19, 54).....	24
GS500FK4/FUK4 (P-02, 19, 54).....	24
GS500K4 (P-24, 28).....	25
GS500FK4 (P-03, 24, 28, 33).....	26
WIRING HARNESS AND HOSE ROUTING.....	27
WIRING HARNESS ROUTING	27
WIRING HARNESS ROUTING (For GS500F).....	29
OIL COOLER HOSE ROUTING (For GS500F).....	30
CARBURETOR AND AIR CLEANER HOSE ROUTING	31
PAIR (AIR SUPPLY) SYSTEM HOSE ROUTING.....	32
FRONT BRAKE HOSE ROUTING (For GS500F)	33
FRONT TURN SIGNAL LIGHT INSTALLATION (For GS500F).....	34

COUNTRY AND AREA CODES

The following codes stand for the applicable country (-ies) and area (-s).

CODE	COUNTRY or AREA
P-02	UK
P-03	USA (Except for California)
P-09	Colombia
P-19	EU
P-24	Australia
P-28	Canada
P-33	California (USA)
P-54	Spain

SPECIFICATIONS

DIMENSIONS AND DRY MASS

Overall length	2 080 mm (81.9 in)
Overall width	800 mm (31.5 in)
Overall height	1 060 mm (41.7 in) GS500/U
	* 1 150 mm (45.3 in) GS500F/FU
Wheelbase	1 405 mm (55.3 in)
Ground clearance.....	150 mm (5.9 in) GS500/U
	* 120 mm (4.7 in) GS500F/FU
Seat height	790 mm (31.1 in)
Dry mass	174 kg (383 lbs)..... GS500/U
	* 180 kg (396 lbs)..... GS500F/FU

ENGINE

Type	Four-stroke, air-cooled, DOHC
Number of cylinders	2
Bore.....	74.0 mm (2.913 in)
Stroke.....	56.6 mm (2.228 in)
Displacement	487 cm ³ (29.7 cu. in)
Compression ratio	9.0 : 1
Carburetor	BSR34, twin
Air cleaner	Non-woven fabric element
Starter system	Electric
Lubrication system	Wet sump
Idle speed.....	1 200 ± 100 r/min

DRIVE TRAIN

Clutch	Wet multi-plate type
Transmission.....	6-speed constant mesh
Gearshift pattern	1-down, 5-up
Primary reduction ratio	2.714 (76/28)
Gear ratios, Low	2.461 (32/13)
2nd.....	1.777 (32/18)
3rd.....	1.380 (29/21)
4th.....	1.125 (27/24)
5th.....	0.961 (25/26)
Top.....	0.851 (23/27)
Final reduction ratio.....	2.437 (39/16)
Drive chain	D.I.D. 520VM, 110 links

CHASSIS

Front suspension	Telescopic, coil spring, oil damped
Rear suspension	Link type, coil spring, oil damped
Front suspension stroke.....	120 mm (4.7 in)
Rear wheel travel	115 mm (4.5 in)
Caster	25° 05'
Trail	97 mm (3.82 in)
Steering angle.....	35°
Turning radius.....	2.7 m (8.9 ft)
Front brake.....	Disc brake
Rear brake	Disc brake
Front tire size	110/70-17M/C 54H, tubeless
Rear tire size	130/70-17M/C 62H, tubeless

ELECTRICAL

Ignition type.....	Electronic ignition (transistorized)
Ignition timing.....	* 5° B.T.D.C. at 1 200 r/min P-03, 28, 33 12° B.T.D.C. at 1 200 r/min Others
Spark plug.....	NGK DPR8EA-9 or DENSO X24EPR-U9
Battery.....	12 V 39.6 kC (11 Ah)/10 HR
Generator.....	Three-phase A.C. generator
Fuse	20 A
Headlight.....	12 V 60/55 W
Position light.....	12 V 4 W.....GS500/U * 12 V 5 W.....GS500F/FU
Turn signal light.....	12 V 21 W
Brake light/Taillight.....	12 V 32/3 cp (× 2 pcs.)..... P-03, 28, 33 12 V 21/5 W (× 2 pcs.) Others
Speedometer light.....	12 V 1.7 W
Tachometer light	12 V 1.7 W
Neutral indicator light	12 V 1.7 W
High beam indicator light	12 V 1.7 W
Turn signal indicator light	12 V 1.7 W
Oil pressure indicator light	12 V 1.7 W

CAPACITIES

Fuel tank, including reserve	19 L (5.0/4.2 US/Imp gal) E-33 20 L (5.3/4.4 US/Imp gal) Others
reserve.....	4.3 L (1.1/0.9 US/Imp gal)
Engine oil, oil change	2 600 ml (2.7/2.3 US/Imp qt)
with filter change	2 900 ml (3.1/2.6 US/Imp qt)
overhaul.....	3 200 ml (3.4/2.8 US/Imp qt)
Front fork oil (each leg).....	* 380 ml (12.7/13.4 US/Imp oz)

These specifications are subject to change without notice.

SERVICE DATA**VALVE + GUIDE**

Unit: mm (in)

ITEM	STANDARD		LIMIT
Valve diam.	IN.	39 (1.5)	—
	EX.	32 (1.3)	—
Valve lift	IN.	8.5 (0.33)	—
	EX.	8.0 (0.31)	—
Tappet clearance (when cold)	IN. & EX.	0.03 – 0.08 (0.001 – 0.003)	—
Valve guide to valve stem clearance	IN.	0.025 – 0.055 (0.0010 – 0.0022)	—
	EX.	0.040 – 0.070 (0.0016 – 0.0028)	—
Valve stem deflection	IN. & EX.	—	0.35 (0.014)
Valve guide I.D.	IN. & EX.	7.000 – 7.015 (0.2756 – 0.2762)	—
Valve stem O.D.	IN.	6.960 – 6.975 (0.2740 – 0.2746)	—
	EX.	6.945 – 6.960 (0.2734 – 0.2740)	—
Valve stem runout	IN. & EX.	—	0.05 (0.002)
Valve head thickness	IN. & EX.	—	0.5 (0.02)
Valve seat width	IN. & EX.	1.0 – 1.2 (0.04 – 0.05)	—
Valve head radial runout	IN. & EX.	—	0.03 (0.001)
Valve spring free length (IN. & EX.)	INNER	—	35.6 (1.40)
	OUTER	—	40.6 (1.60)
Valve spring tension (IN. & EX.)	INNER	10.9 – 12.5 kgf (24.0 – 27.6 lbs) at length 31.0 mm (1.22 in)	—
	OUTER	20.3 – 23.3 kgf (44.8 – 51.4 lbs) at length 35.0 mm (1.38 in)	—

CAMSHAFT + CYLINDER HEAD

Unit: mm (in)

ITEM	STANDARD		LIMIT
Cam height	IN.	36.090 – 36.130 (1.4208 – 1.4224)	35.80 (1.409)
	EX.	36.090 – 36.130 (1.4208 – 1.4224)	35.80 (1.409)
Camshaft journal oil clearance	IN. & EX.	0.032 – 0.066 (0.0013 – 0.0026)	0.150 (0.0060)
Camshaft journal holder I.D.	IN. & EX.	22.012 – 22.025 (0.8666 – 0.8671)	—
Camshaft journal O.D.	IN. & EX.	21.959 – 21.980 (0.8645 – 0.8654)	—
Camshaft runout	IN. & EX.	—	0.10 (0.004)
Cam chain pin (at arrow "3")	18th pin		—
Cylinder head distortion	—		0.10 (0.004)

CYLINDER + PISTON + PISTON RING

Unit: mm (in)

ITEM	STANDARD		LIMIT
Compression pressure	1 000 – 1 400 kPa (10 – 14 kgf/cm ² , 142 – 199 psi)		800 kPa (8 kgf/cm ² , 144 psi)
Compression pressure difference	—		200 kPa (2 kgf/cm ² , 28 psi)
Piston to cylinder clearance	0.050 – 0.060 (0.0020 – 0.0024)		0.120 (0.0047)
Cylinder bore	74.000 – 74.015 (2.9134 – 2.9140)		74.080 (2.9165)
Piston diam.	73.945 – 73.960 (2.9112 – 2.9118) Measure at 15 mm (0.6 in) from the skirt end.		73.880 (2.9087)
Cylinder distortion	—		0.10 (0.004)
Piston ring free end gap	1st	N	Approx. 7.0 (0.28)
	2nd	N	Approx. 11.0 (0.43)
Piston ring end gap	1st	0.10 – 0.25 (0.004 – 0.010)	
	2nd	0.10 – 0.25 (0.004 – 0.010)	
Piston ring to groove clearance	1st	—	
	2nd	—	

ITEM	STANDARD		LIMIT
Piston ring groove width	1st	1.21 – 1.23 (0.047 – 0.048)	—
	2nd	1.21 – 1.23 (0.047 – 0.048)	—
	Oil	2.51 – 2.53 (0.099 – 0.100)	—
Piston ring thickness	1st	1.17 – 1.19 (0.046 – 0.047)	—
	2nd	1.17 – 1.19 (0.046 – 0.047)	—
Piston pin bore	18.002 – 18.008 (0.7087 – 0.7090)		18.030 (0.7098)
Piston pin O.D.	17.995 – 18.000 (0.7085 – 0.7087)		17.980 (0.7079)

CONROD + CRANKSHAFT + BALANCER

Unit: mm (in)

ITEM	STANDARD	LIMIT
Conrod small end I.D.	18.006 – 18.014 (0.7089 – 0.7092)	18.040 (0.7102)
Conrod big end side clearance	0.1 – 0.2 (0.004 – 0.008)	0.3 (0.012)
Conrod big end width	22.95 – 23.00 (0.904 – 0.906)	—
Crank pin width	23.10 – 23.15 (0.909 – 0.911)	—
Conrod big end oil clearance	0.024 – 0.048 (0.0009 – 0.0019)	0.080 (0.0031)
Crank pin O.D.	33.976 – 34.000 (1.3376 – 1.3386)	—
Crankshaft journal oil clearance	0.020 – 0.044 (0.0008 – 0.0017)	0.080 (0.0031)
Crankshaft journal O.D.	31.976 – 32.000 (1.2589 – 1.2598)	—
Crankshaft thrust bearing thickness	2.950 – 2.975 (0.1161 – 0.1171)	2.850 (0.1122)
Crankshaft runout	—	0.05 (0.002)
Balancer journal oil clearance	0.020 – 0.044 (0.0008 – 0.0017)	0.080 (0.0031)
Balancer journal O.D.	31.984 – 32.000 (1.2592 – 1.2598)	—
Balancer spring free length	—	14.9 (0.59)

OIL PUMP

ITEM	STANDARD	LIMIT
Oil pump reduction ratio	1.879 (76/28 × 27/39)	—
Oil pressure (at 60 °C, 140 °F)	Above 200 kPa (2.0 kgf/cm ² , 28 psi) Below 500 kPa (5.0 kgf/cm ² , 71 psi) at 3 000 r/min	—

CLUTCH

Unit: mm (in)

ITEM	STANDARD	LIMIT
Clutch lever play	10 – 15 (0.4 – 0.6)	—
Clutch release screw	1/4 – 1/2 turn back	—
Drive plate thickness	2.92 – 3.08 (0.115 – 0.121)	2.62 (0.103)
Drive plate claw width	15.8 – 16.0 (0.62 – 0.63)	15.0 (0.59)
Driven plate distortion	—	0.10 (0.004)
Clutch spring free length	—	60.8 (2.39)

TRANSMISSION + DRIVE CHAIN

Unit: mm (in) Except ratio

ITEM	STANDARD	LIMIT	
Primary reduction ratio	2.714 (76/28)	—	
Final reduction ratio	2.437 (39/16)	—	
Gear ratios	Low	2.461 (32/13)	
	2nd	1.777 (32/18)	
	3rd	1.380 (29/21)	
	4th	1.125 (27/24)	
	5th	0.961 (25/26)	
	Top	0.851 (23/27)	
Shift fork to groove clearance	0.1 – 0.3 (0.004 – 0.012)	0.5 (0.020)	
Shift fork groove width	No.1, No.2 & No.3	5.5 – 5.6 (0.217 – 0.220)	—
Shift fork thickness	No.1, No.2 & No.3	5.3 – 5.4 (0.209 – 0.213)	—
Countershaft length (Low to 2nd)	114.7 $\begin{smallmatrix} +0.1 \\ -0 \end{smallmatrix}$ (4.516 $\begin{smallmatrix} +0.004 \\ -0 \end{smallmatrix}$)	—	
Drive chain	Type	D.I.D.: DID520VM	—
	Links	110	—
	20-pitch length	—	319.4 (12.57)
Drive chain slack	20 – 30 (0.8 – 1.2)	—	

CARBURETOR

ITEM	SPECIFICATION	
	GS500 P-02, 19, 24, 54 GS500F P-02, 19, 24, 54	GS500U P-19 GS500FU P-19
Carburetor type	MIKUNI BSR34	←
Bore size	34 mm	←
I.D. No.	* 01DN	* 01DP
Idle r/min	1 200 ± 100 r/min	←
Float height	13.0 ± 1.0 mm	←
Main jet (M.J.)	* #130	* #135
Jet needle (J.N.)	5DH57-3rd	←
Needle jet (N.J.)	P-5M	←
Throttle valve (Th.V.)	#105	←
Pilot jet (P.J.)	#17.5	←
Pilot screw (P.S.)	* 3 turns back	* ←
Throttle cable play	2.0 – 4.0 mm (0.08 – 0.16 in)	←

CARBURETOR

ITEM	SPECIFICATION	
	GS500 P-09, 28 GS500F P-03, 28	GS500F P-33
Carburetor type	MIKUNI BSR34	←
Bore size	34 mm	←
I.D. No.	* 01DS	* 01DU
Idle r/min	1 200 ± 100 r/min	←
Float height	13.0 ± 1.0 mm	←
Main jet (M.J.)	* # 130	* ←
Jet needle (J.N.)	5DH91	5DH60
Needle jet (N.J.)	P-5M	←
Throttle valve (Th.V.)	#105	←
Pilot jet (P.J.)	#17.5	←
Pilot screw (P.S.)	* PRE-SET (3 turns back)	* ←
Throttle cable play	2.0 – 4.0 mm (0.08 – 0.16 in)	←

ELECTRICAL

Unit: mm (in)

ITEM		SPECIFICATION		NOTE
Ignition timing		* 5° B.T.D.C. at 1 200 r/min		P-03, 28, 33
		12° B.T.D.C. at 1 200 r/min		Others
Firing order		L-R		
Spark plug		Type	DENSO: X24EPR-U9 NGK: DPR8EA-9	
		Gap	0.8 – 0.9 (0.031 – 0.035)	
Spark performance		Over 8 (0.3) at 1 atm.		
Signal generator resistance		250 – 420 Ω		
Ignition coil resistance		Primary	3 – 6 Ω	Terminal – Terminal
		Secondary	18 – 30 kΩ	Plug cap – Terminal
Signal generator peak voltage		1.8 V and more		⊕ Probe: Br ⊖ Probe: B/BI
Ignition coil primary peak voltage		100 V and more		⊕ Probe: W or B/Y ⊖ Probe: Ground
Generator Max. output		Approx. 200 W at 5 000 r/min		
Generator no-load voltage		More than 75 V (AC) at 5 000 r/min		
Regulated voltage		13.5 – 15.5 V at 5 000 r/min		
Starter relay resistance		3 – 5 Ω		
Battery		Type designation	* CB10L-B2	
		Capacity	12 V 39.6 kC (11 Ah)/10 HR	
		Standard electrolyte S.G.	1.28 at 20 °C (68 °F)	
Fuse size		20 A		

WATTAGE

Unit: W

ITEM		SPECIFICATION		
		GS500/U P-02, 09, 19, 24, 54	GS500F/FU P-02, 19, 24, 54	P-03, 28, 33
Headlight	HI	60	←	←
	LO	55	←	←
Position light		4	* 5	* ←
Brake light/Taillight		21/5	←	32/3 cp
Turn signal light		21	←	←
Tachometer light		1.7	←	←
Speedometer light		1.7	←	←
Turn signal indicator light		1.7	←	←
High beam indicator light		1.7	←	←
Neutral indicator light		1.7	←	←
Oil pressure indicator light		1.7	←	←

BRAKE + WHEEL

Unit: mm (in)

ITEM	STANDARD		LIMIT
Rear brake pedal height	55 (2.2)		—
Brake disc thickness	Front	4.5 ± 0.2 (0.177 ± 0.008)	4.0 (0.16)
	Rear	6.0 ± 0.2 (0.236 ± 0.008)	5.5 (0.22)
Brake disc runout	—		0.30 (0.012)
Master cylinder bore	Front	12.700 – 12.725 (0.5000 – 0.5010)	—
	Rear	12.700 – 12.743 (0.5000 – 0.5017)	—
Master cylinder piston diam.	Front	12.630 – 12.670 (0.4972 – 0.4988)	—
	Rear	12.657 – 12.684 (0.4983 – 0.4994)	—
Brake caliper cylinder bore	Front	30.230 – 30.306 (1.1902 – 1.1931)	—
	Rear	38.180 – 38.256 (1.5031 – 1.5061)	—
Brake caliper piston diam.	Front	30.150 – 30.200 (1.1870 – 1.1890)	—
	Rear	38.098 – 38.148 (1.4999 – 1.5019)	—
Wheel rim runout	Axial	—	2.0 (0.08)
	Radial	—	2.0 (0.08)
Wheel axle runout	Front	—	0.25 (0.010)
	Rear	—	0.25 (0.010)
Wheel rim size	Front	17 × MT3.00, 17M/C × MT3.00	—
	Rear	17 × MT3.50, 17M/C × MT3.50	—
Tire size	Front	110/70-17M/C 54H	—
	Rear	130/70-17M/C 62H	—
Tire tread depth	Front	—	1.6 (0.06)
	Rear	—	2.0 (0.08)

SUSPENSION

Unit: mm (in)

ITEM	STANDARD	LIMIT
Front fork stroke	120 (4.7)	—
Front fork spring free length	* 343 (13.5)	* 336 (13.2)
Front fork oil level	* 110 (4.3)	—
Front fork oil type	SUZUKI FORK OIL #10 or equivalent fork oil	—
Front fork oil capacity (each leg)	* 380 ml (12.8/13.4 US/lmp oz)	—
Front fork inner tube O.D.	* 36.9 (1.45)	—
Rear shock absorber spring adjuster	4th position among 7	—
Rear wheel travel	115 (4.5)	—
Swingarm pivot shaft runout	—	0.3 (0.01)

TIRE PRESSURE

COLD INFLATION TIRE PRESSURE	SOLO RIDING			DUAL RIDING		
	kPa	kgf/cm ²	psi	kPa	kgf/cm ²	psi
FRONT	225	2.25	33	225	2.25	33
REAR	250	2.50	36	280	2.80	41

FUEL + OIL

ITEM	SPECIFICATION	NOTE
Fuel type	Use only unleaded gasoline of at least 87 pump octane (R/2 + M/2) or 91 octane or higher rated by the research method. Gasoline containing MTBE (Methyl Tertiary Butyl Ether), less than 10% ethanol, or less than 5% methanol with appropriate cosolvents and corrosion inhibitor is permissible.	P-03, 28, 33
	Gasoline used should be graded 91 octane or higher. An unleaded gasoline is recommended.	Others
Fuel tank including reserve	19 L (5.0/4.2 US/lmp gal)	P-33
	20 L (5.3/4.4 US/lmp gal)	Others
reserve	4.3 L (1.1/0.9 US/lmp gal)	
Engine oil type	SAE 10W-40, API SF or SG	
Engine oil capacity	Change	2 600 ml (2.7/2.3 US/lmp qt)
	Filter change	2 900 ml (3.1/2.6 US/lmp qt)
	Overhaul	3 200 ml (3.4/2.8 US/lmp qt)
Brake fluid type	DOT 4	

TIGHTENING TORQUE ENGINE

ITEM	N-m	kgf-m	lb-ft
Cylinder head cover bolt	14	1.4	10.0
Cylinder head nut	38	3.8	27.5
Cylinder head bolt	10	1.0	7.0
Cylinder stud bolt	15	1.5	11.0
Camshaft journal holder bolt	10	1.0	7.0
Cam sprocket bolt	18	1.8	13.0
Cam chain tensioner mounting bolt	10	1.0	7.0
Conrod bearing cap nut	32	3.2	23.0
Generator mounting rotor bolt	120	12.0	87.0
Starter clutch bolt	18	1.8	13.0
Signal generator bolt	20	2.0	14.5
Crankcase bolt (6 mm)	11	1.1	8.0
(8 mm)	22	2.2	16.0
Counter-balancer shaft setting bolt	40	4.0	29.0
Oil pump mounting screw	10	1.0	7.0
Oil pressure regulator	19	1.9	13.5
Oil drain plug	23	2.3	16.5
Oil pan bolt	14	1.4	10.0
Clutch sleeve hub nut	50	5.0	36.0
Clutch spring set bolt	5	0.5	3.5
Oil cooler hose bolt (crankcase side) (For GS500F)	* 26	* 2.6	* 19.0
Exhaust pipe bolt	10	1.0	7.0
Muffler mounting bolt	23	2.3	16.5
Engine mounting bolt	66	6.6	47.5

CHASSIS

ITEM		N·m	kgf-m	lb-ft
Steering stem head nut		45	4.5	32.5
Front fork upper clamp bolt		23	2.3	16.5
Front fork lower clamp bolt		30	3.0	21.5
Front fork cap bolt		* 25	* 2.5	* 18.0
Front fork damper rod bolt		* 28	* 2.8	* 20.0
Front axle nut	Normal nut with cotter pin	44	4.4	32.0
	Self-lock nut	49	4.9	35.5
Front axle pinch bolt		23	2.3	16.5
Handlebar set bolt		23	2.3	16.5
Handlebar holder set nut		60	6.0	43.5
Front brake master cylinder mounting bolt		10	1.0	7.0
Front brake caliper mounting bolt		43	4.3	31.0
Front footrest bolt		23	2.3	16.5
Brake hose union bolt		23	2.3	16.5
Air bleeder valve		8	0.8	6.0
Front and rear disc bolt		23	2.3	16.5
Swingarm pivot nut		72	7.2	52.0
Rear shock absorber upper and lower mounting nut		60	6.0	43.5
Rear cushion lever rod mounting nut		85	8.5	61.5
Rear cushion lever mounting nut (Front & Center)		85	8.5	61.5
Rear brake caliper mounting bolt		26	2.6	19.0
Rear brake caliper housing bolt		33	3.3	24.0
Rear brake master cylinder rod lock nut		18	1.8	13.0
Rear brake pedal bolt		10	1.0	7.0
Torque link nut (Front & Rear)		35	3.5	25.5
Rear brake master cylinder mounting bolt		10	1.0	7.0
Rear axle nut	Normal nut with cotter pin	65	6.5	47.0
	Self-lock nut	78	7.8	56.5

PERIODIC MAINTENANCE CHART

Interval: This interval should be judged by odometer reading or months, whichever comes first.

Item	Interval	km	1 000	6 000	12 000	18 000	24 000
		miles	600	4 000	7 500	11 000	14 500
		months	2	12	24	36	48
Battery (Specific gravity of electrolyte)		—	I	I	I	I	I
Air cleaner element		Clean every 3 000 km (2 000 miles) and replace every 12 000 km (7 500 miles).					
Exhaust pipe bolts and muffler bolts		T	T	T	T	T	T
Tappet clearance		I	I	I	I	I	I
Spark plugs		—	I	R	I	R	R
Fuel line		I	I	I	I	I	I
		Replace every 4 years.					
Engine oil and filter		R	R	R	R	R	R
Idle speed		I	I	I	I	I	I
Throttle cable play		I	I	I	I	I	I
Throttle valve synchronization		I (C.A. only)	—	I	—	I	I
Evaporative emission system (California model only)		—	—	I	—	I	I
		Replace vapor hose every 4 years.					
PAIR (air supply) system		—	—	I	—	I	I
Clutch cable play		I	I	I	I	I	I
Drive chain		I	I	I	I	I	I
		Clean and lubricate every 1 000 km (600 miles).					
Brakes		I	I	I	I	I	I
Brake hose		I	I	I	I	I	I
		Replace every 4 years.					
Brake fluid		—	I	I	I	I	I
		Replace every 2 years.					
Tires		I	I	I	I	I	I
Steering		I	I	I	I	I	I
Front forks		I	—	I	—	I	I
Rear suspension		I	—	I	—	I	I
Chassis bolts and nuts		T	T	T	T	T	T

NOTE:

I=Inspect and clean, adjust, replace or lubricate as necessary

R=Replace

T=Tighten

NOTE:

(California model only) and (C.A. only) means that the item or the maintenance interval to be applied for the California model.

LOWER CRANKCASE

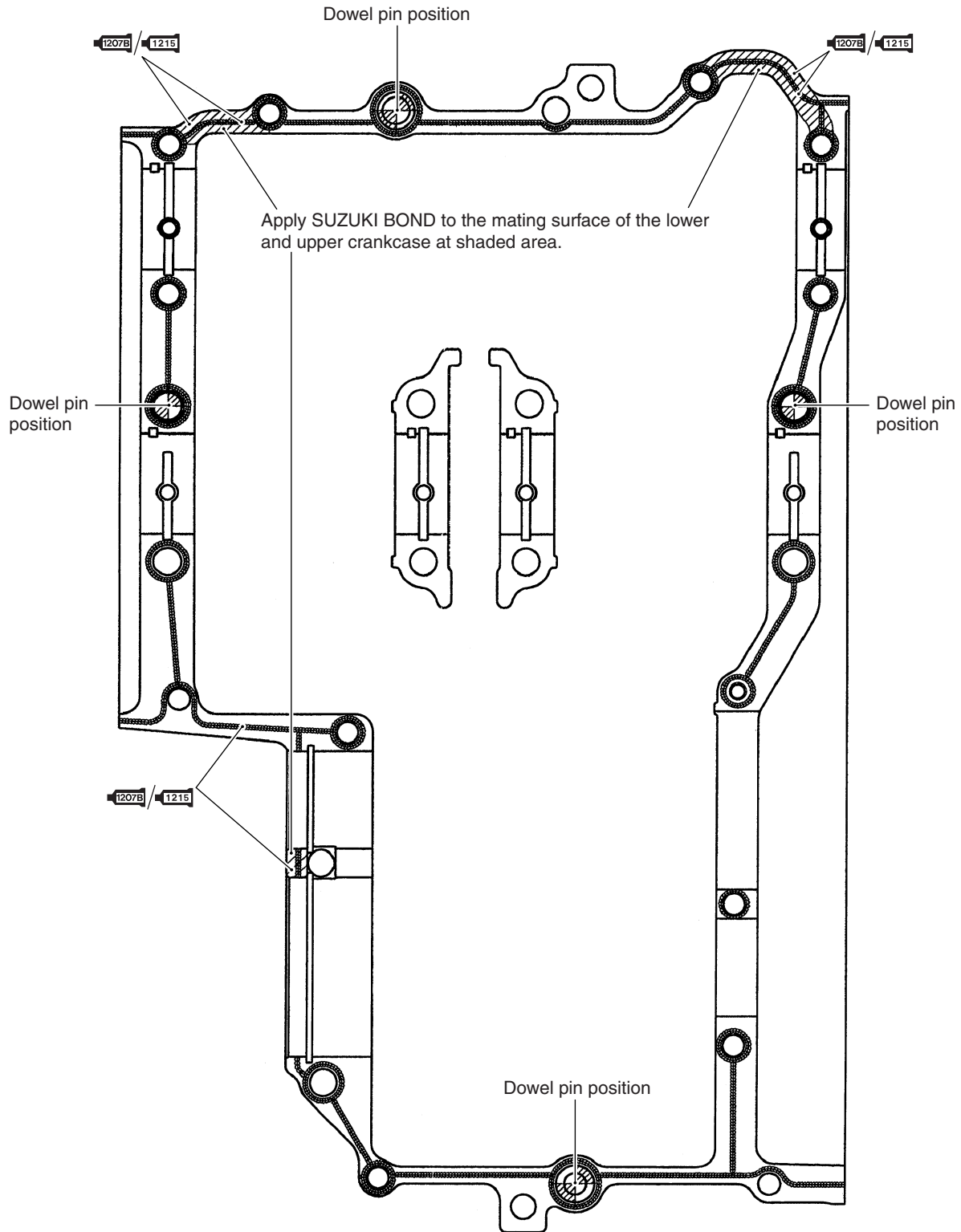

1207B 99104-31140: SUZUKI BOND "1207B" (USA)

1215 99000-31110: SUZUKI BOND "1215" (Others)

COWLING (For GS500F)

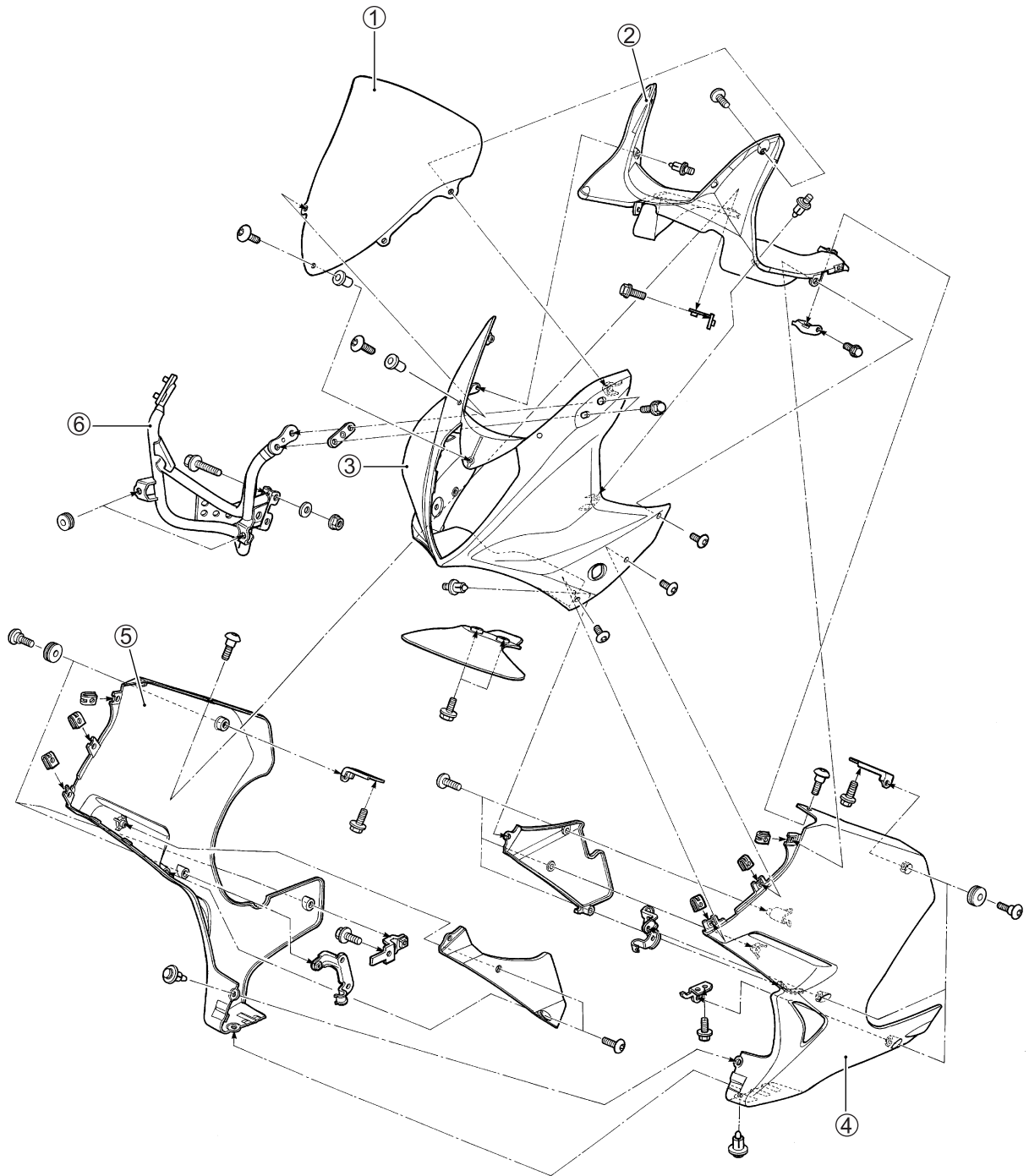

①	Screen
②	Front cowling cover (Center)
③	Front cowling
④	Front cowling cover (LH)
⑤	Front cowling cover (RH)
⑥	Cowling brace

FRONT FORK

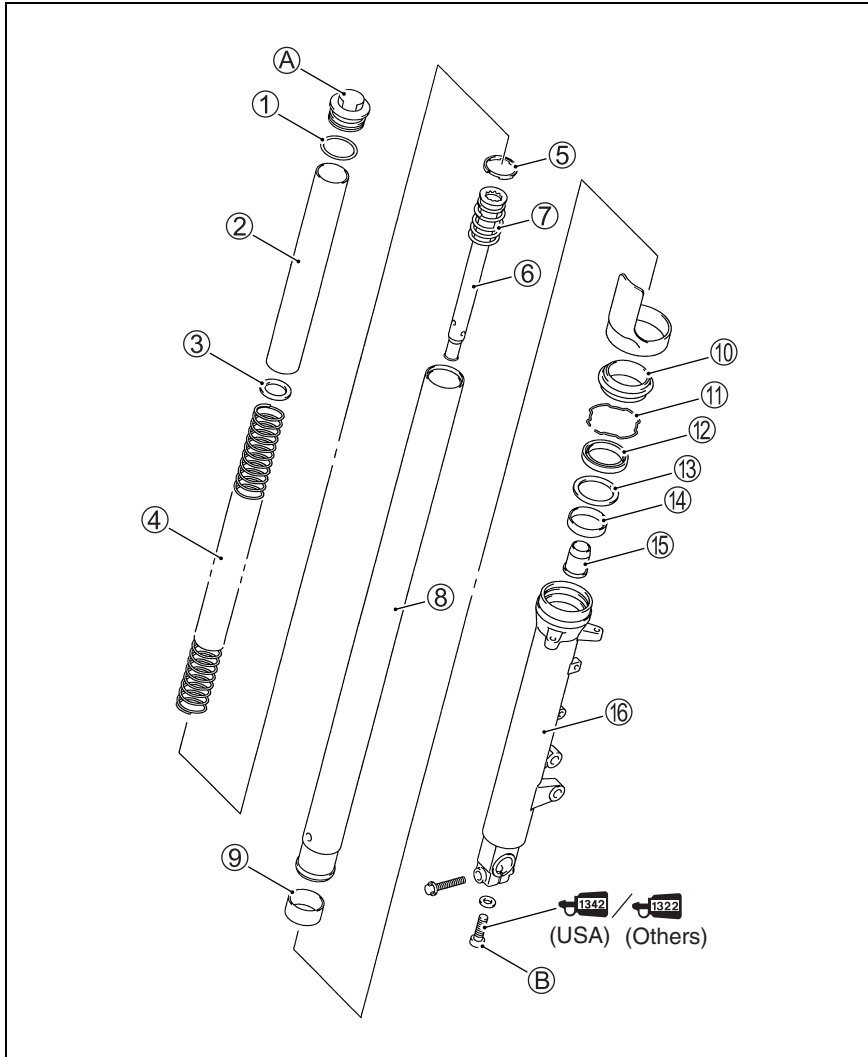

①	O-ring
②	Spacer
③	Spring retainer
④	Front fork spring
⑤	Damper rod ring
⑥	Damper rod
⑦	Rebound spring
⑧	Inner tube
⑨	Anti-friction metal (Inner)
⑩	Dust seal
⑪	Oil seal stopper ring
⑫	Oil seal
⑬	Oil seal retainer
⑭	Anti-friction metal (Outer)
⑮	Oil lock piece
⑯	Outer tube
A	Front fork cap bolt
B	Damper rod bolt



ITEM	N·m	kgf·m	lb·ft
A	25	2.5	18.0
B	28	2.8	20.0

REMOVAL

- Remove the front wheel.
- Remove the front fender and fender brace.

⚠ WARNING

Make sure that the motorcycle is supported securely.

- Slightly loosen the front fork cap bolt ① to facilitate later disassembly before loosening the front fork clamp bolts.
- Loosen the front fork upper clamp bolt ②.

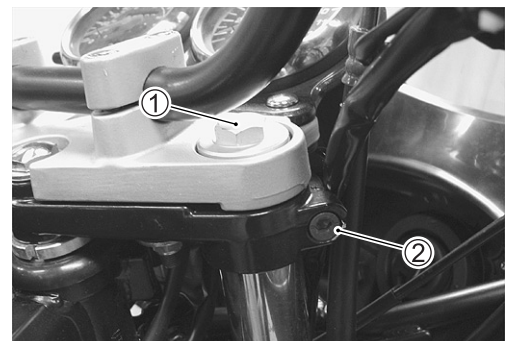

- Loosen the front fork lower clamp bolt ③ and remove the front fork.

NOTE:

Hold the front fork by the hand to prevent sliding out of the steering stem.

CAUTION

Do not operate the brake lever while the caliper is removed.

DISASSEMBLY

- Remove the front fork cap bolt.
- Remove the spacer ①, spring retainer ② and spring ③.

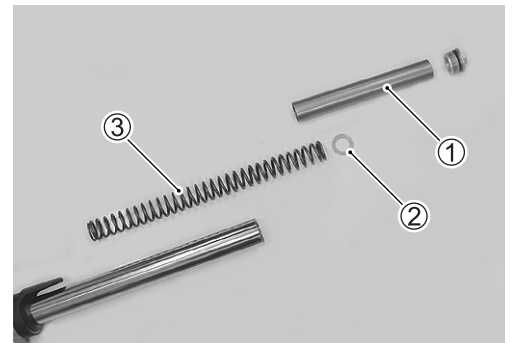
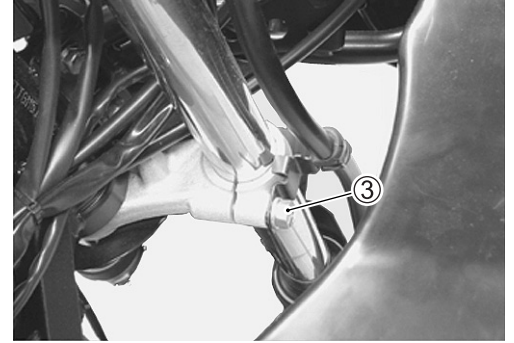

- Invert the front fork and stroke it several times to drain out the fork oil.
- Hold the fork inverted for a few minutes.

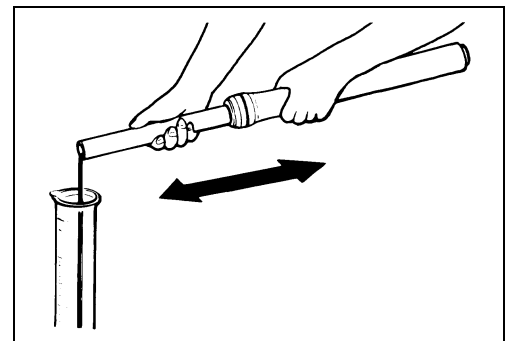

- Remove the damper rod bolt using the special tools and 7 mm hexagon wrench.

TOOL 09940-34520: "T" handle
09940-34531: Attachment "A"

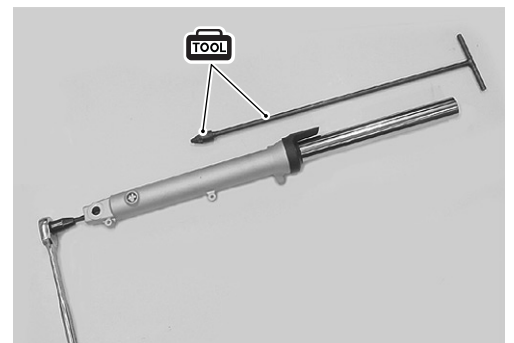

- Remove the damper rod ④ and rebound spring ⑤.

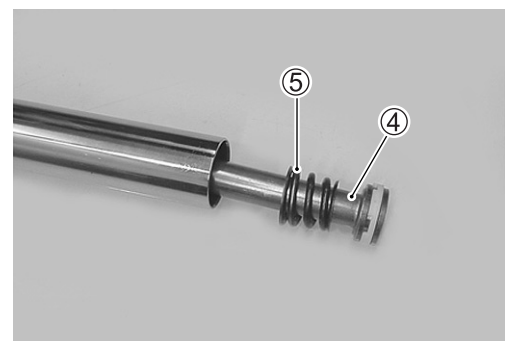

- Remove the dust seal ⑥ and oil seal stopper ring ⑦.

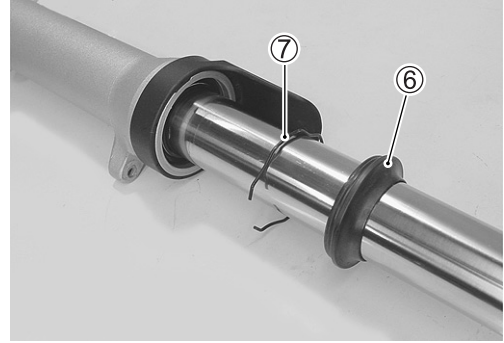

- Separate the inner tube out of the outer tube.

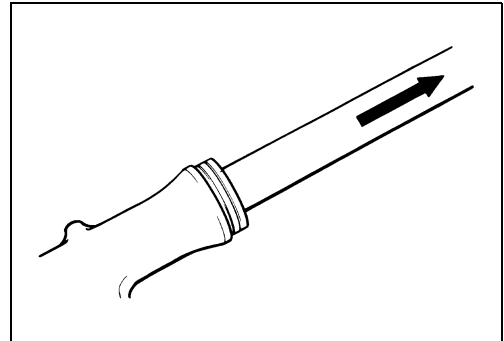

- Remove the following parts.

- Ⓐ Oil seal
- Ⓑ Oil seal retainer
- Ⓒ Anti-friction metal (Outer)
- Ⓓ Anti-friction metal (Inner)
- Ⓔ Oil lock piece

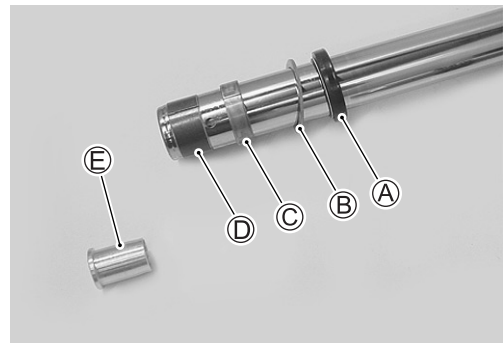

INSPECTION DAMPER ROD RING

Inspect the damper rod ring for wear or damage. If damper rod ring is worn or damaged, replace it with a new one.



INNER AND OUTER TUBES

Inspect the inner and outer tube sliding surfaces for scratches or damage. Replace the tube(s) if necessary.

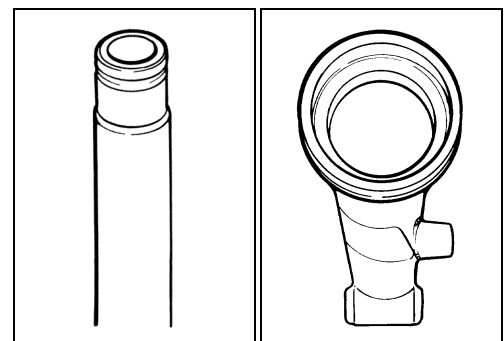

FORK SPRING

Measure the fork spring free length. If the fork spring free length is shorter than the service limit, replace the fork spring with a new one.

DATA Front fork spring free length
Service limit: 336 mm (13.2 in)

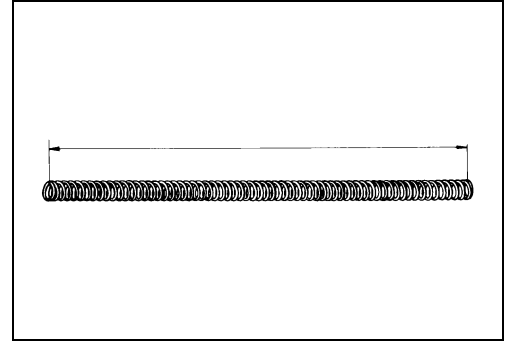

INNER AND OUTER ANTI-FRICTION METALS

- Inspect the teflon coated surface of the anti-friction metals for wear and damage. Replace the metal(s) if necessary.

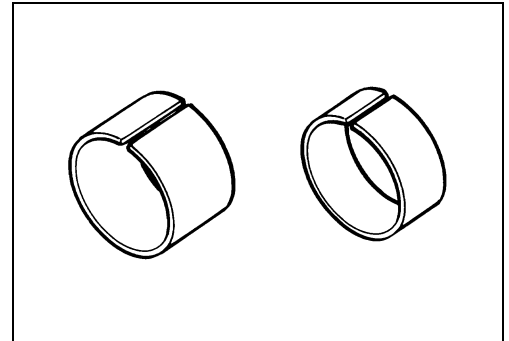

REASSEMBLY

Reassembly is in the reverse order of disassembly. Pay attention to the following points.

ANTI-FRICTION METALS

- Clean the inner tube metal groove.
- Hold the inner tube vertically and install the anti-friction metals by hand.

CAUTION

Use special care to prevent damaging the teflon coated surface of the anti-friction metals when installing them.

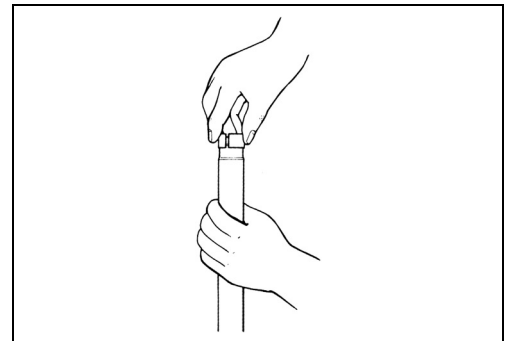

OIL SEAL

- Apply fork oil lightly to the lip of a new oil seal and install it.

FORK 99000-99044-10G:
SUZUKI FORK OIL #10 or equivalent fork oil



- Insert the inner tube into the outer tube and fit a new oil seal using the special tools.

TOOL 09940-52861: Front fork oil seal installer set

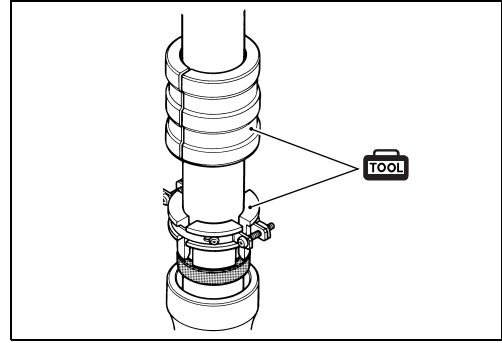

- Install the oil seal stopper ring and a new dust seal.

- ① Anti-friction metal (Outer)
- ② Oil seal retainer
- ③ Oil seal
- ④ Oil seal stopper ring
- ⑤ Dust seal

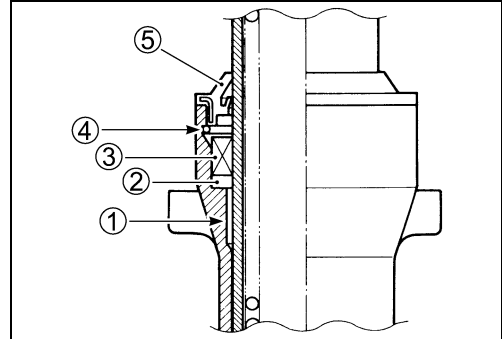

CAUTION

Make sure that the oil seal stopper ring ④ is fit securely.

DAMPER ROD

- Install a new gasket ①.
- Apply THREAD LOCK to the damper rod bolt and tighten it to the specified torque.

1342 99000-32050: THREAD LOCK "1342" (USA)

1322 99000-32110: THREAD LOCK "1322" (Others)

W Damper rod bolt: 28 N·m (2.8 kgf·m, 20.0 lb·ft)

TOOL 09940-34520: "T" handle

09940-34531: Attachment "A"

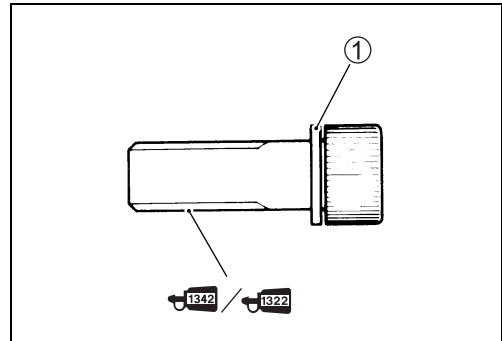

FORK OIL

- Pour specified fork oil into the inner tube.

DATA Front fork oil capacity (each leg):

380 ml (12.8/13.4 US/Imp oz)

FORK 99000-99044-10G:

SUZUKI FORK OIL #10 or equivalent fork oil

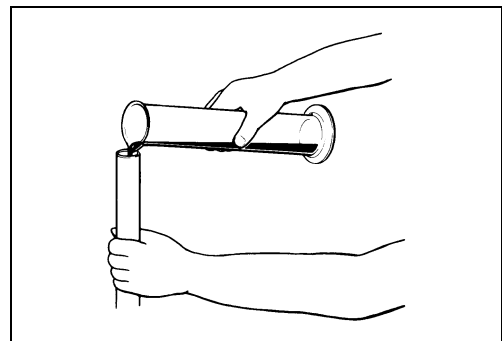

- Hold the front fork vertically and adjust the fork oil level with the special tool.

DATA Front fork oil level: 110 mm (4.3 in)

TOOL 09943-74111: Front fork oil level gauge

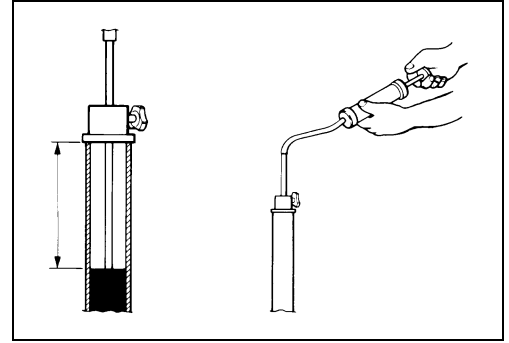

- Apply fork oil lightly to a new O-ring and install it to the front fork cap bolt.

FORK 99000-99044-10G:
SUZUKI FORK OIL #10 or equivalent fork oil

- Temporarily tighten the cap bolt.

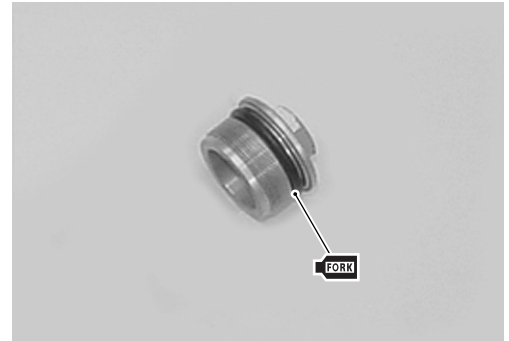

INSTALLATION

Installation is in the reverse order of removal. Pay attention to the following points.

- When installing the front fork assembly, align the upper surface **A** of the inner tube with the surface **B** of the steering upper bracket.
- Tighten the front fork upper clamp bolt **①** to the specified torque.

U Front fork upper clamp bolt: 23 N·m (2.3 kgf-m, 16.5 lb-ft)

- Tighten the front fork lower clamp bolt **②** to the specified torque.

U Front fork lower clamp bolt: 30 N·m (3.0 kgf-m, 21.5 lb-ft)

- Tighten the front fork cap bolt to the specified torque.

U Front fork cap bolt: 25 N·m (2.5 kgf-m, 18.0 lb-ft)

- Recheck that the surface **A** is flush with the surface **B**.
- Install the front fender and front wheel.

NOTE:

Before tightening the front fender brace mounting screws, move the front forks up and down several times.

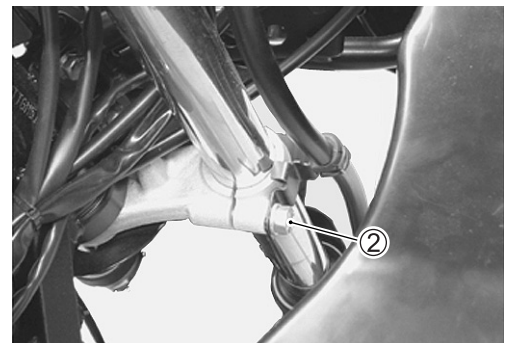
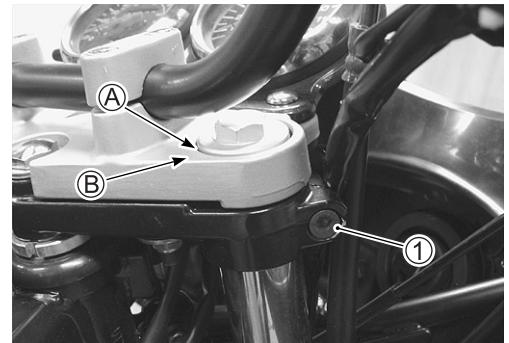

WIRING DIAGRAM

GS500K4/UK4 (P-02, 09, 19, 54)

GS500FK4/FUK4 (P-02, 19, 54)

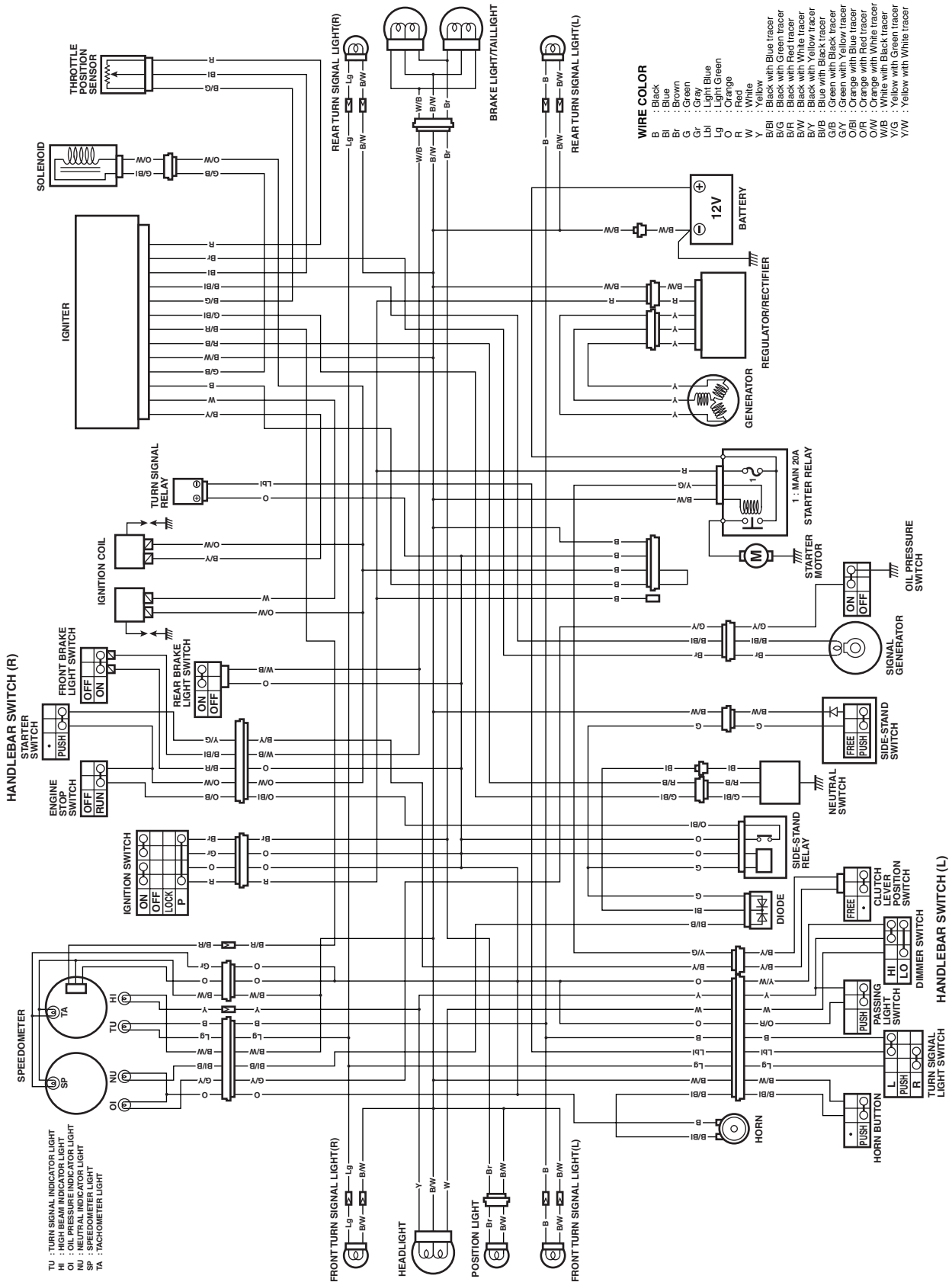

GS500K4 (P-24, 28)

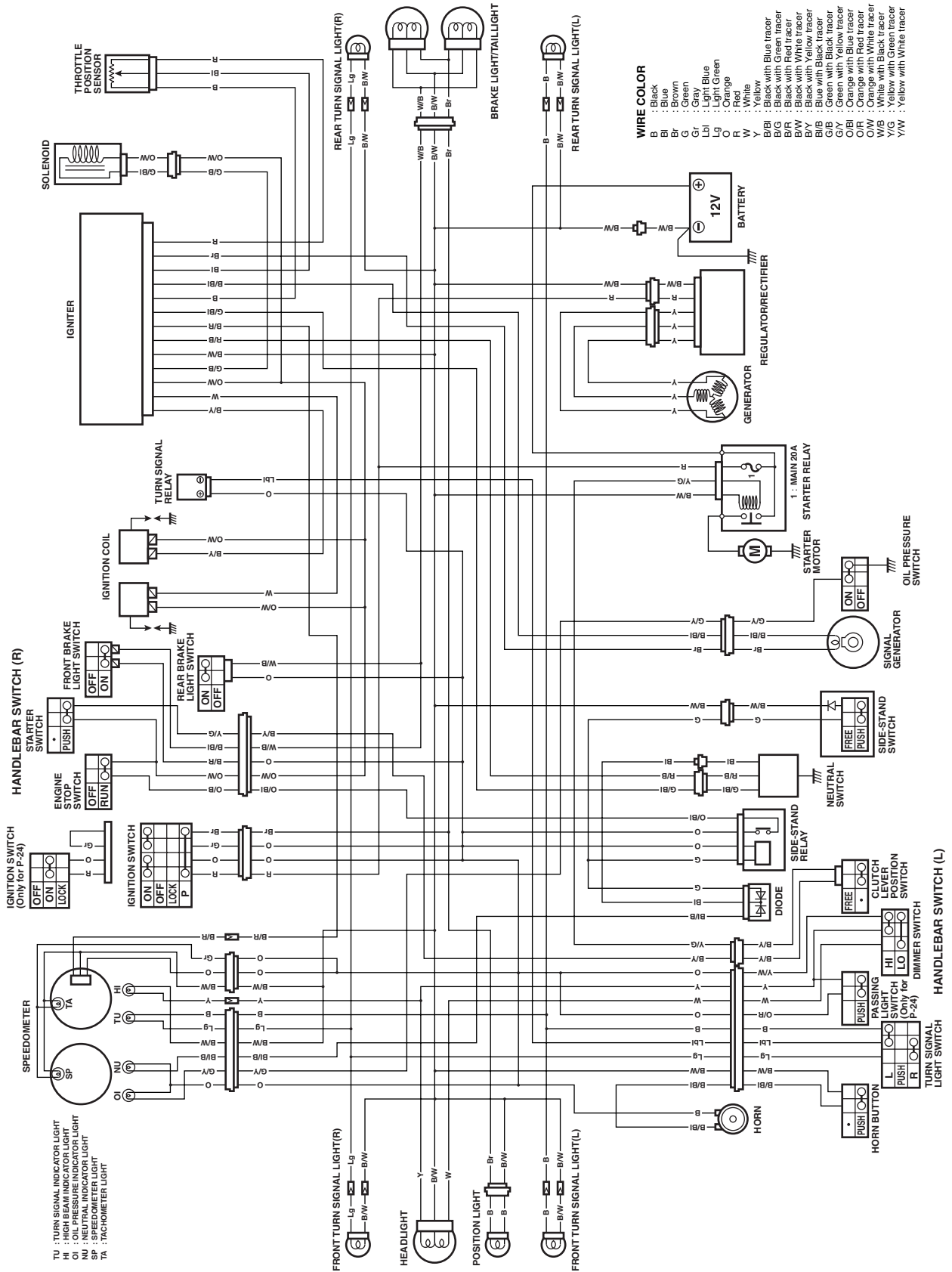

GS500FK4 (P-03, 24, 28, 33)

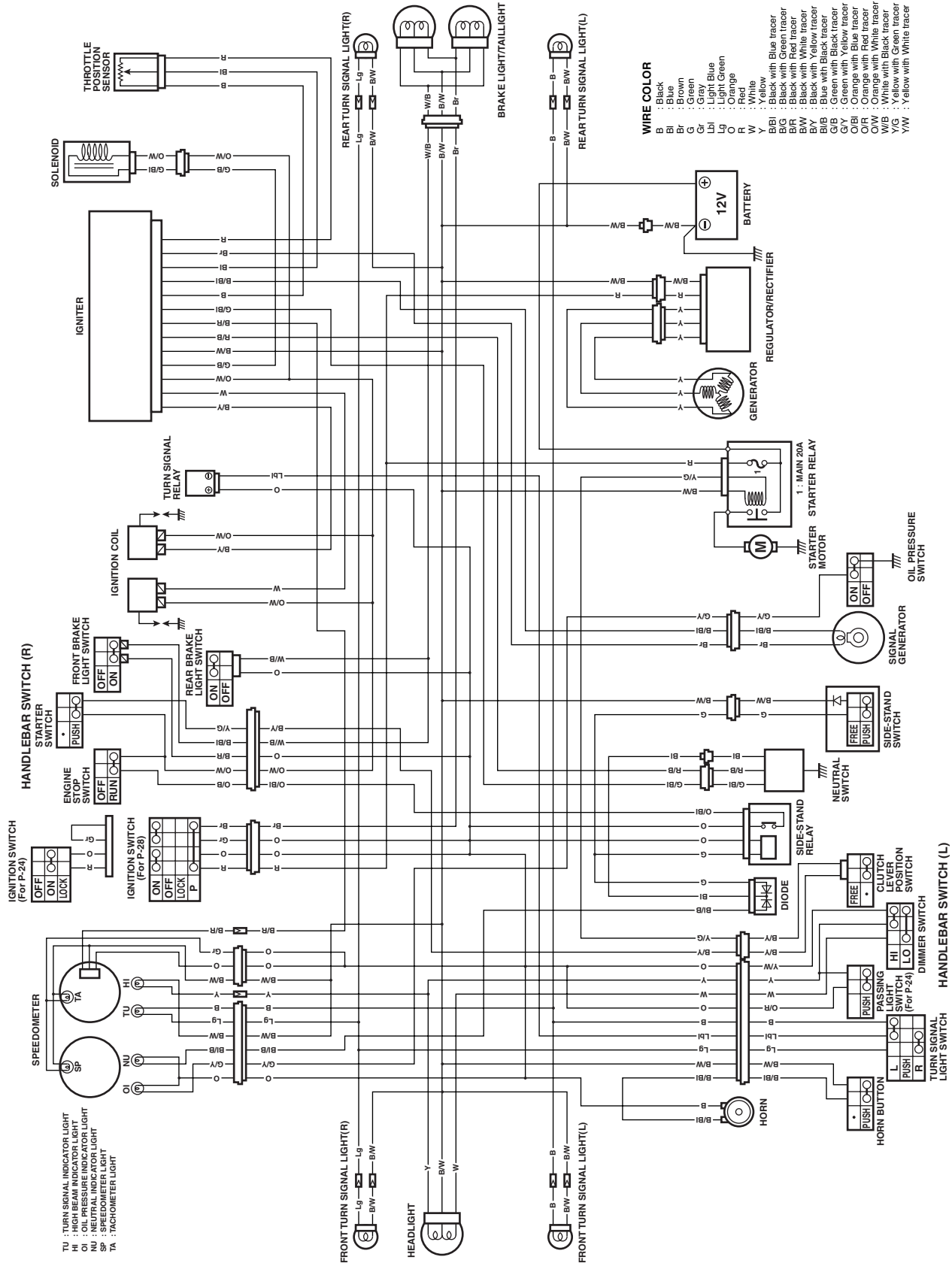

WIRING HARNESS AND HOSE ROUTING

WIRING HARNESS ROUTING

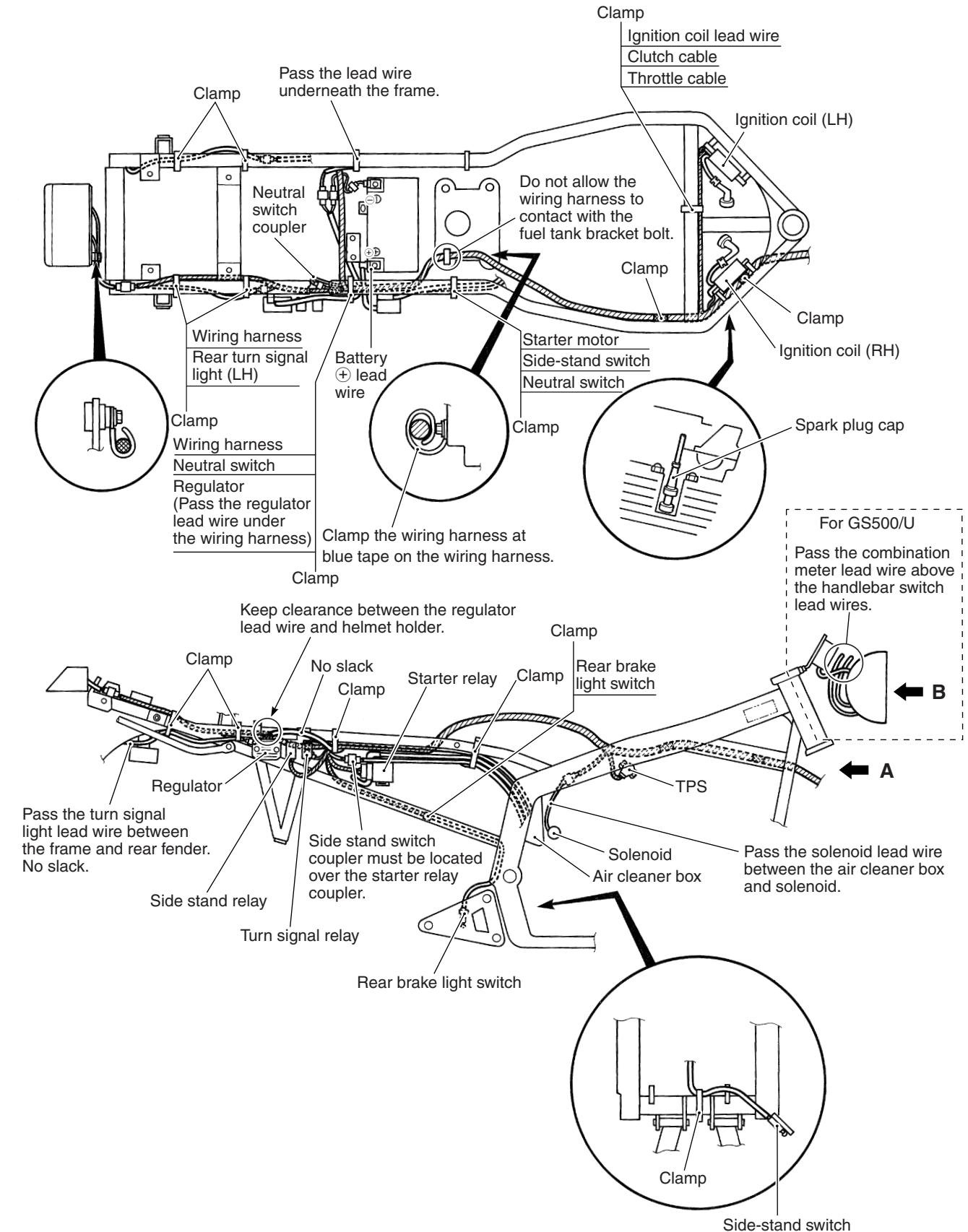

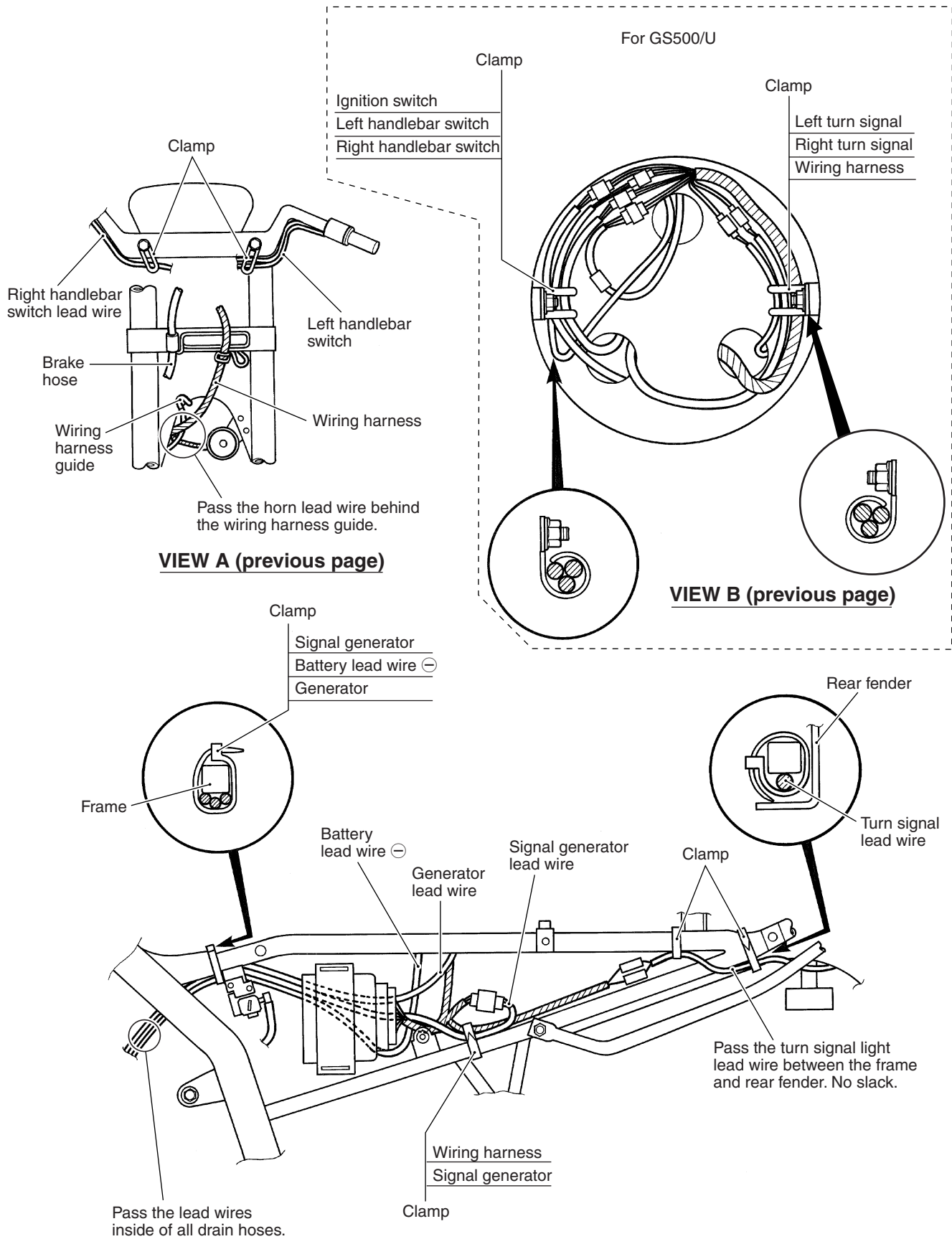

WIRING HARNESS ROUTING (For GS500F)

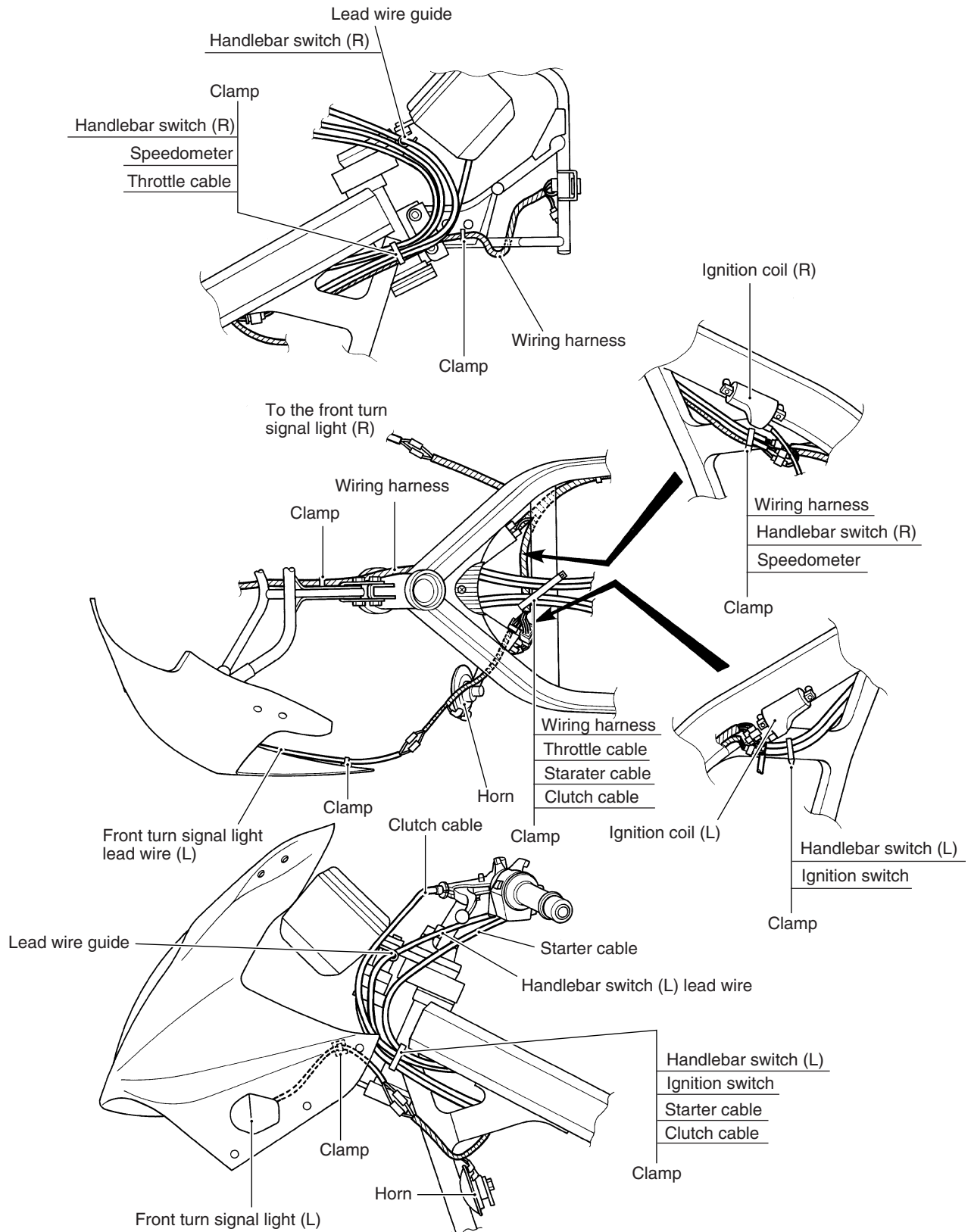

OIL COOLER HOSE ROUTING (For GS500F)

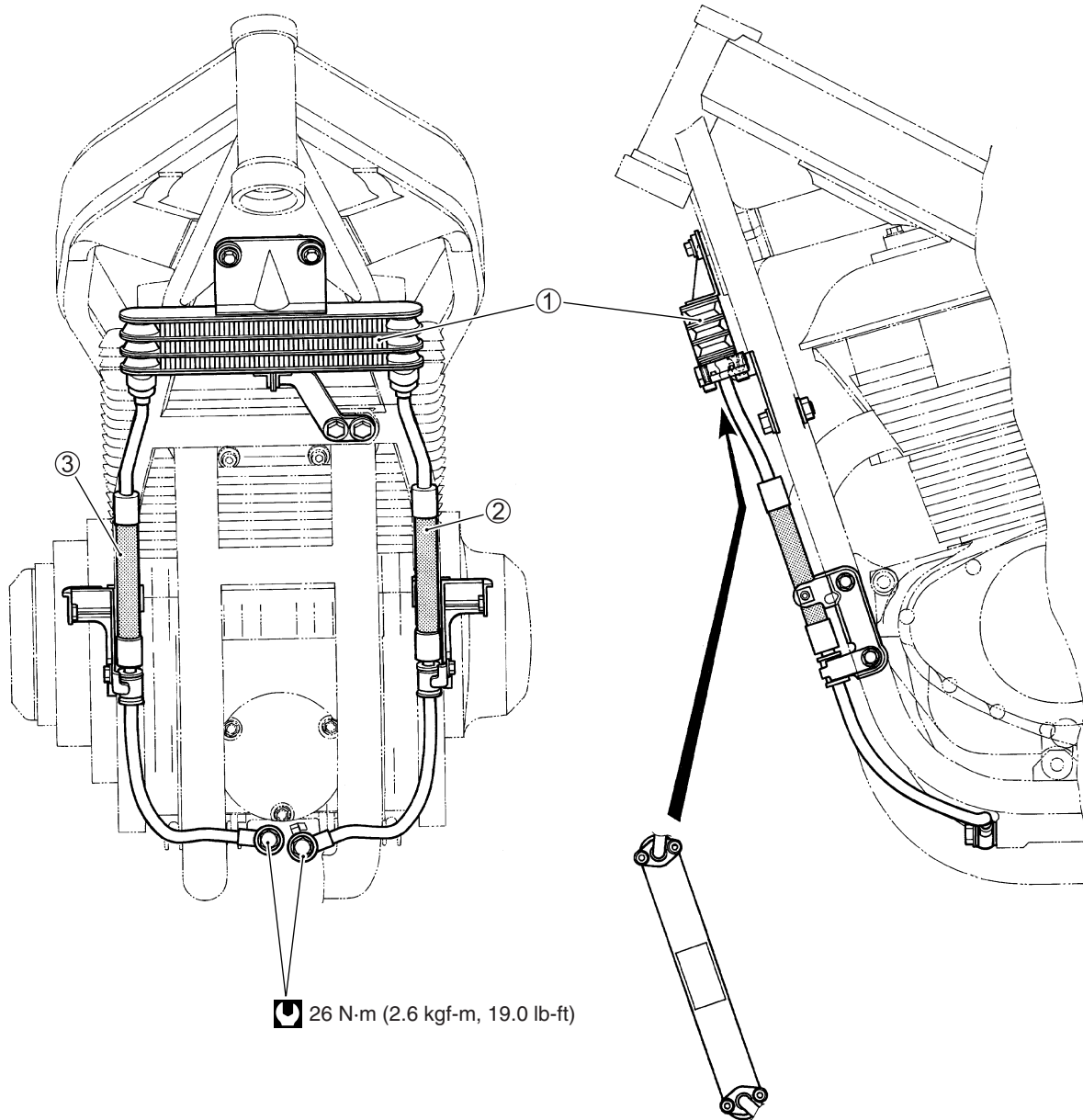

①	Oil cooler
②	Oil cooler hose (LH)
③	Oil cooler hose (RH)

CARBURETOR AND AIR CLEANER HOSE ROUTING

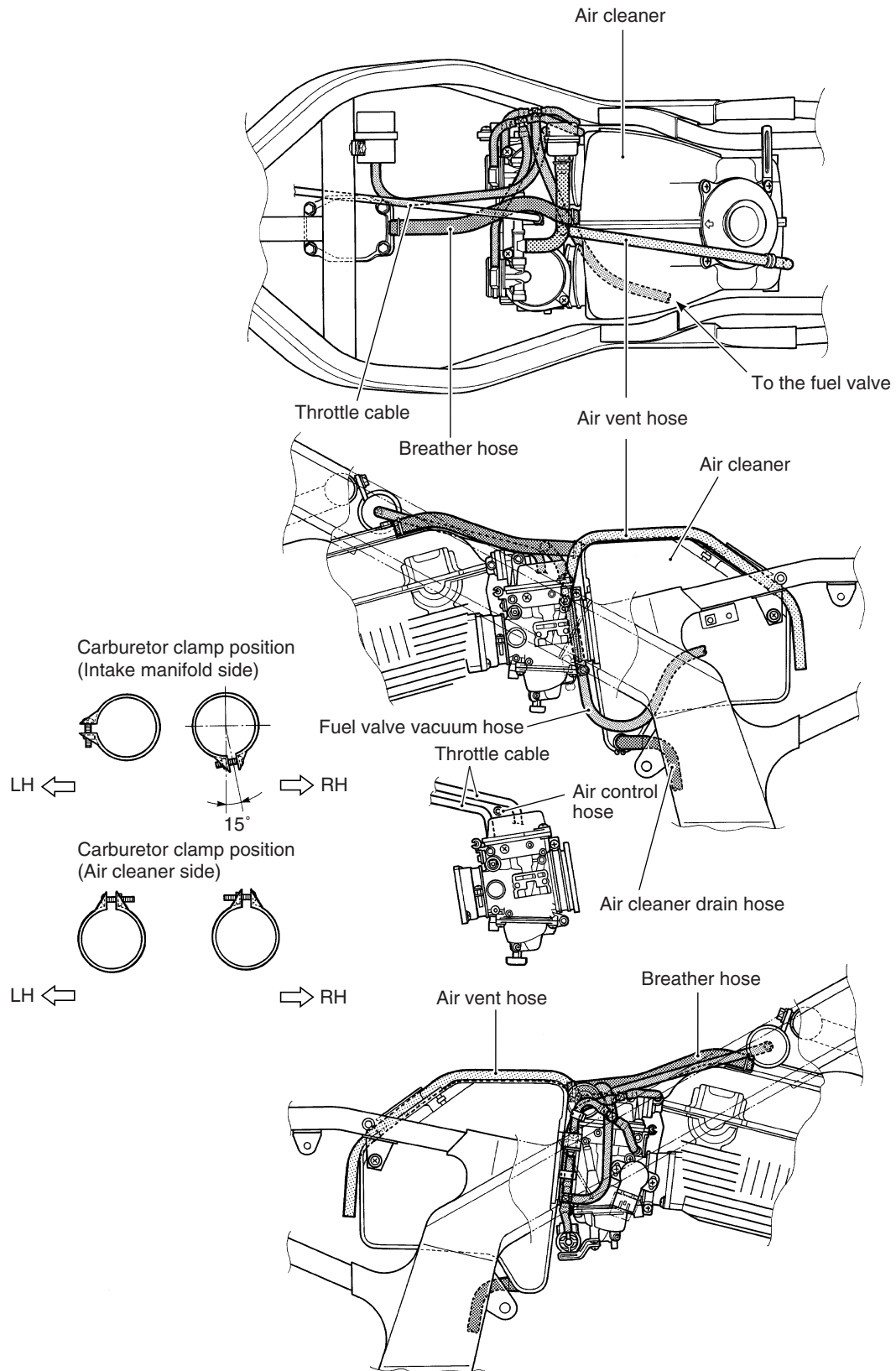

PAIR (AIR SUPPLY) SYSTEM HOSE ROUTING

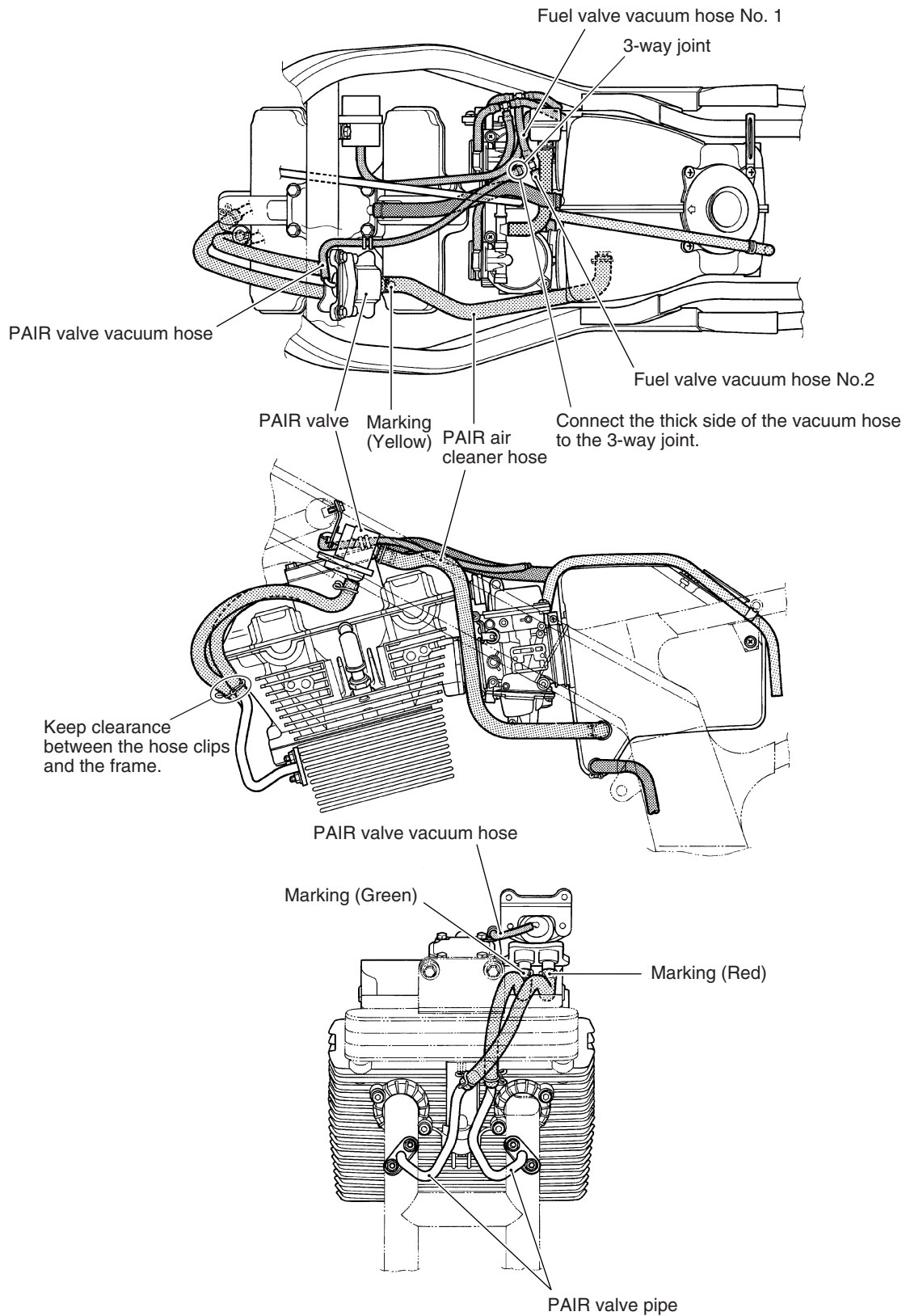

FRONT BRAKE HOSE ROUTING (For GS500F)

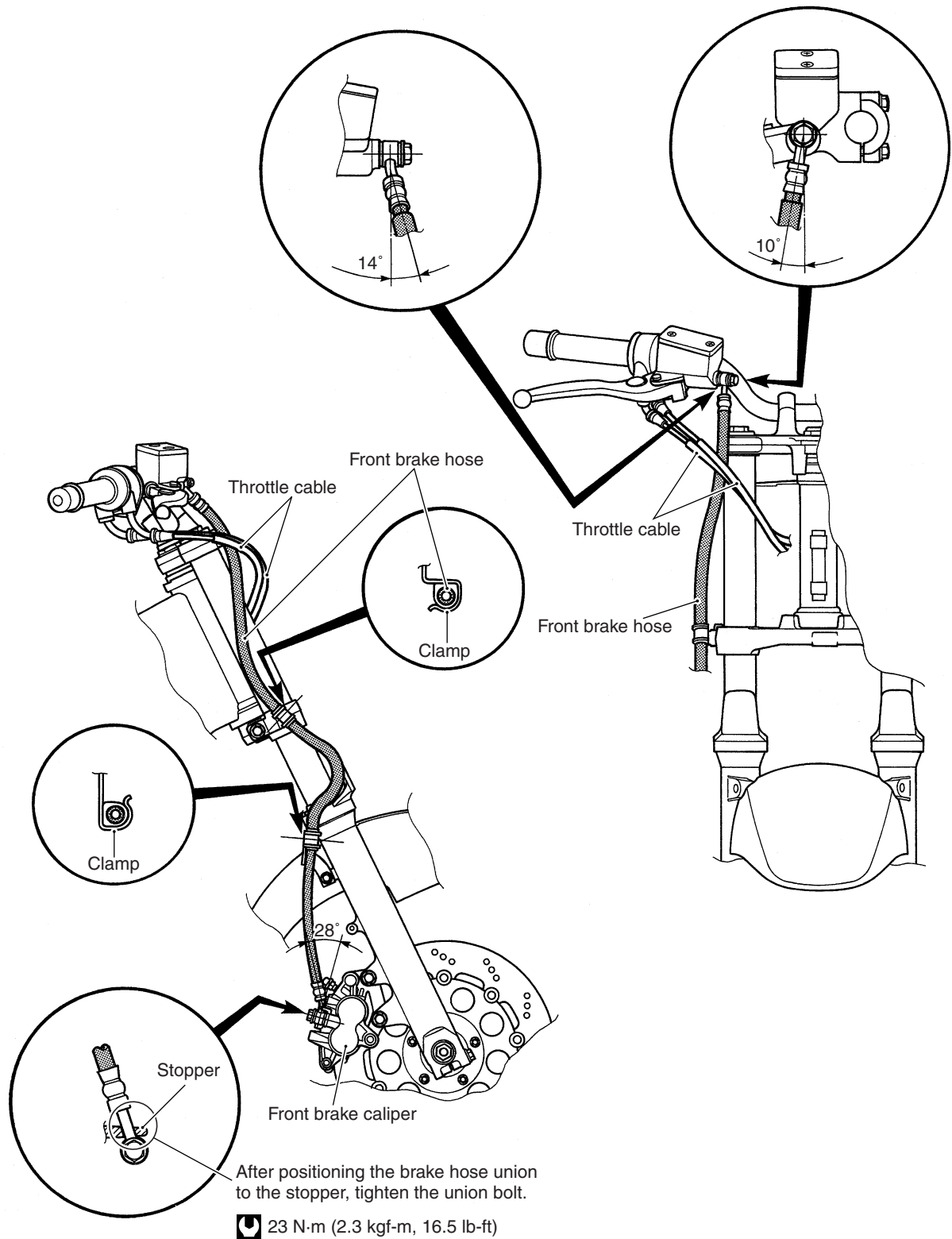

FRONT TURN SIGNAL LIGHT INSTALLATION (For GS500F)

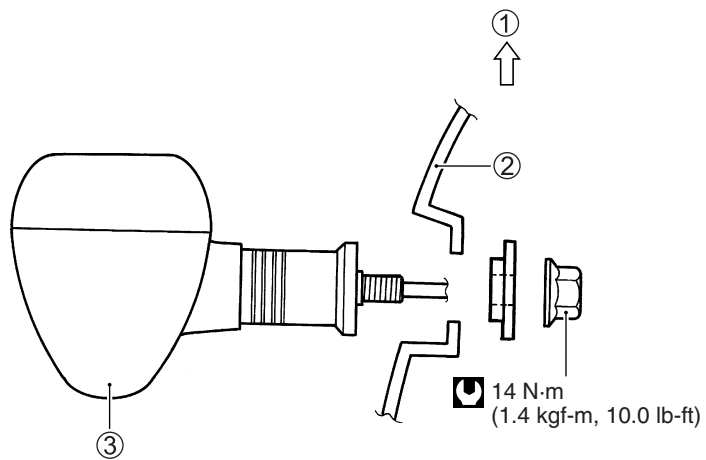

①	Forward
②	Cowling
③	Front turn signal light

Prepared by

SUZUKI MOTOR CORPORATION

January, 2004

Part No. 99501-34150-03E

Printed in Japan

SUZUKI MOTOR CORPORATION
