

TRIUMPH

Daytona 675 Motorcycle Race Kit Manual



FOR CLOSED-CIRCUIT USE ONLY

Contents

Introduction	4
General Information	5
Engine Parts	7
Head Gasket	
0.65 mm - A9618072	7
0.60 mm - A9618073	7
Cams, Valve Spring & Sprocket Kits	9
Cam - Inlet Kit - A9618055	9
Cam - Exhaust Kit - A9618056	9
Valve Spring Kit - A9618086	9
Camshaft Sprocket Kit - A9618057	9
Cam Chain Kit - A9618059	11
Cam Chain Tensioner Kit (manually adjustable) - A9618060	12
Inlet & Exhaust Valve Kit - A9618061	14
Conrod Bearing Shell	
1.476 mm to 1.482 mm White - A110411	15
1.482 mm to 1.488 mm Red - A110412	15
Main Bearing Shell	
1.491 mm to 1.495 mm White - A1161301	16
1.495 mm to 1.499 mm Red - A1161302	16
1.499 mm to 1.503 mm Blue - A1161303	16
1.503 mm to 1.507 mm Green - A1161304	16
Air Funnel Kit - A9618063	17
Exhaust System, Stage 2 (Arrow) - A9600197	19
Air Filter Kit - A9618075	23
Slipper Clutch Kit - A9610014	23
Slipper Clutch Tool - A3880037	23
Transmission Kits	24
1st Gear pair & Housing Kit - A9618066	24
Shaft, Input Kit - A9618064 (spares only)	25
Gear, Output Kit - A9618065 (spares only)	25
Wheel Detent Kit - A9618068 (spares only)	25
Alternator Kit - A9618069	27
Alternator Puller Tool Kit - A3880206	27
Manual Idle Speed Adjuster Kit - A9618076	29
Race ECU Kit - A9618070	30
Race Harness Kit - A9618071	32

Motorcycle Accessories	33
Engine Protector Kits	33
Clutch Cover, Carbon Fibre Kit - A9728028	33
Crank Cover, Carbon Fibre Kit - A9728029	33
Standard Alternator Cover, Carbon Fibre Kit - A9728031	33
Race Alternator Cover, Carbon Fibre Kit - A9728032	33



Introduction

Daytona 675 Race Parts

Triumph's ground-breaking Daytona 675 has not only received global recognition for its performance on the road, but also for its outstanding ability on the race track. To further support this exceptional track ability, Triumph have launched a Racing Support Programme, which is now further complemented by the launch of a range of Triumph Genuine Race Parts.

Factory developed in collaboration with Paul Young Racing, these parts have been designed to give significant improvements in engine performance for race purposes. This results in the class-leading Daytona 675 being competitive on the racetrack at the highest level.

Triumph Genuine Race Parts are sold individually and a number of the parts need to be used in conjunction with each other to ensure the best performance gains are realised and also to prevent premature wear on associated components. Please ensure you read the user manual in full to understand this detail prior to fitting or using any of the Triumph Genuine Race Parts.

General Information

Please note:

- The Race Kit parts detailed in this publication are made in accordance with FIM technical regulations and are NOT street legal.
- The Race Kit parts covered in this publication are intended for racing purposes only and any Triumph motorcycle fitted with such kits MUST NOT be used on public roads.
- The Race Kit parts detailed in this publication may only be used on a closed-circuit in the hands of experienced riders.
- Before fitting any Race Kit parts, customers should check the technical regulations of their race class to ensure conformity.
- The information provided in this publication should always be used together with the official Triumph Daytona 675 service manual.
- Completely read all the instructions before commencing the installation and set up of the race kit in order to become thoroughly familiar with the kits' features and the installation process.
- When removing components which incorporate a gasket ALWAYS ensure a new gasket is fitted on re-assembly.
- The race kit parts detailed in this publication are not covered by any warranty.
- Prices and specifications are subject to change without notice.
- The information contained in this publication is accurate at the time of final approval, however, Triumph Motorcycles reserves the right to amend the information at any time without notice.

Warnings, Cautions and Notes.

Throughout this publication particularly important information is presented in the following form:

Warning

This warning symbol identifies special instructions or procedures, which if not correctly followed could result in personal injury, or loss of life.

Caution

This caution symbol identifies special instructions or procedures, which if not strictly observed, could result in damage to, or destruction of, equipment.

NOTE

- **This note symbol indicates points of particular interest for more efficient and convenient operation.**

Warning

These accessory kits are for racing only. They are for use solely during closed-course racing. A motorcycle fitted with these kits must not be used on public roads. It is illegal to use a motorcycle fitted with these kits on public roads. A motorcycle fitted with these kits does not comply with local laws and regulations. If you use a motorcycle fitted with these kits on public roads, you may be prosecuted.

Warning

These accessory kits are designed for use on Triumph Daytona 675 motorcycles only and should not be fitted to any other Triumph model or to any other manufacturer's motorcycle. Fitting these accessory kits to any other Triumph model, or to any other manufacturer's motorcycle, will affect the performance, stability and handling of the motorcycle. This may affect the riders ability to control the motorcycle and could cause an accident.

Warning

Always have Triumph approved parts, accessories and conversions fitted by a trained technician of an authorised Triumph dealer. The fitment of parts, accessories and conversions by a technician who is not of an authorised Triumph dealer may affect the handling, stability or other aspects of the motorcycles operation which may result in loss of motorcycle control and an accident.

Warning

Throughout this operation, ensure that the motorcycle is stabilised and adequately supported on a paddock stand to prevent risk of injury from the motorcycle falling.

Warning

A torque wrench of known accurate calibration must be used when fitting this accessory kit. Failure to tighten any of the fasteners to the correct torque specification may affect motorcycle performance, handling and stability. This may result in loss of motorcycle control and an accident.

Warning

If the engine has recently been running, the exhaust system will be hot. Before working on or near the exhaust system, allow sufficient time for the system to cool, as touching any part of a hot exhaust could cause burn injuries.

Caution

The use of some of these kits will require changes to the fuelling settings. To alter the fuelling settings a third party programmable control unit will be required.

Head Gasket

⚠ Caution

The use of the following race kit cylinder head gaskets will require changes to the fuelling settings. To alter fuelling settings a third party programmable control unit will be required.

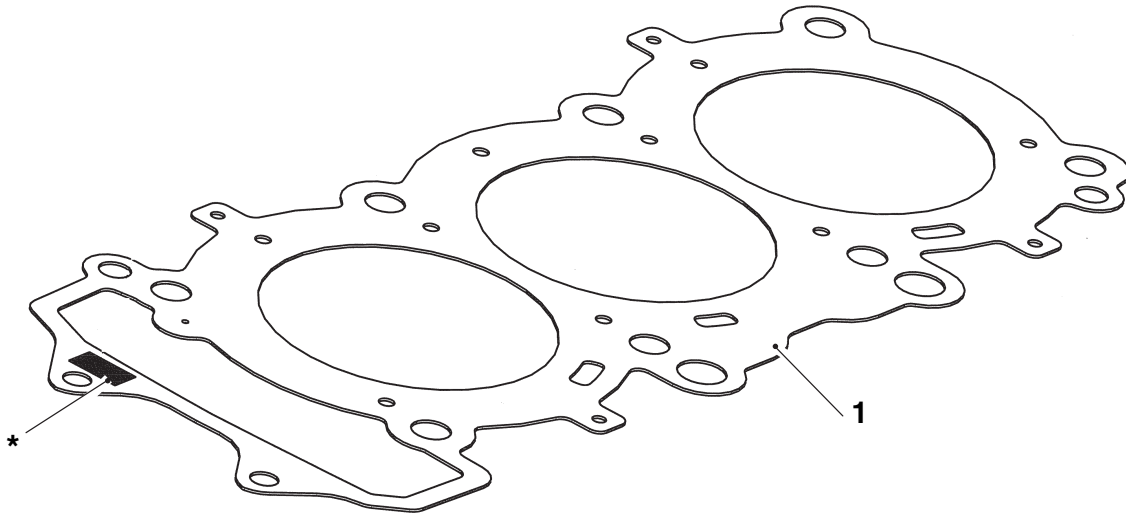

* Thickness "t" marking location

Parts Supplied - A9618072 (0.65 mm) or A9618073 (0.60 mm)

Item	Description	Qty
1	Head gasket (t = 0.65 mm)	1
1	Head gasket (t = 0.60 mm)	1

- The thickness of the standard cylinder head gasket is 0.7 mm. The Race Kit gaskets are available in 0.60 mm and 0.65 mm thicknesses. The thickness (t) of the gasket is clearly marked on the gasket in the position (*) shown above.

NOTE

- Due to variation in production tolerances, the race kit cylinder head gaskets may not be suitable for all engines. Use the appropriate gasket to adjust the squish height (the squish height is the gap between the flat portion of the piston and the cylinder head). Always ensure that the chosen gasket provides a minimum squish height of 0.65 mm.

⚠ Warning

Running the engine at less than the minimum recommended squish height can lead to the pistons contacting the cylinder head, causing major engine damage.

1. Remove the existing cylinder head gasket in line with the procedures detailed in the Daytona 675 service manual.
2. Position a piece of solder (with a diameter approximately 1.3 mm) on the four squish surfaces of each piston. Position the solder in line with the corresponding squish surfaces on the cylinder head and hold in place with a small amount of grease.
3. Refit the cylinder head with the head gasket.
4. Slowly turn the engine over, by hand, to compress the solder to the same height as the squish clearance.
5. Remove the cylinder head and head gasket.
6. Measure the compressed thickness of the solder. The squish clearance must be a minimum of 0.65 mm. If the thickness of the solder is less than 0.65 mm repeat steps 2 to 6 with a thicker head gasket until the squish clearance is at an acceptable level. Note, a race gasket is not always suitable for use.
7. Fit the chosen cylinder head gasket following the procedures detailed in the Daytona 675 service manual.

Camshaft, Valve Spring & Sprocket Kits

Warning

The race kit must be fitted as a complete set. If it is not fitted as a complete set a failure may result which could cause loss of motorcycle control and an accident.

Caution

The use of the camshaft, valve spring & sprocket race kits detailed below will require changes to the fuelling settings. To alter fuelling settings a third party programmable control unit will be required.

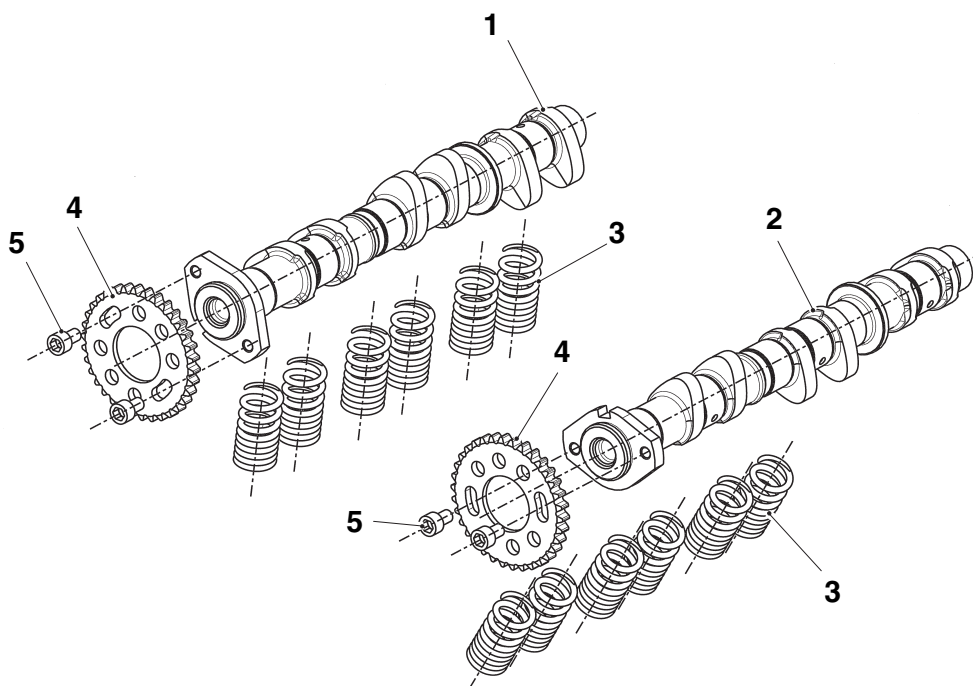

Parts Supplied

Camshaft Inlet Kit - A9618055

Item	Description	Qty
1	Cam assy, inlet, race	1

Valve Spring Kit - A9618086

Item	Description	Qty
3	Valve spring, 14.4 id, race	12

Camshaft Exhaust Kit - A9618056

Item	Description	Qty
2	Cam assy, exhaust, race	1

Camshaft Sprocket Kit - A9618057

Item	Description	Qty
4	Sprocket, camshaft, 34T	2
5	Socket head cap screw, encapsulated, M6 x 10	4

NOTE

- **The standard inlet cam is 9.25 mm max lift and 258.50° duration. The race kit inlet cam is 9.25 mm max lift and 268.74° duration.**
 - **The standard exhaust cam is 8.5 mm max lift and 246° duration. The race kit exhaust cam is 8.5 mm max lift and 262.21° duration.**
 - **The race kit valve spring must be used in conjunction with the standard spring platforms and retainers. The fitted length of the race springs is the same as the standard spring.**
1. The race kit valve springs should be assembled in the same manner as the standard valve springs. Follow the procedure detailed in section 3 of the Daytona 675 service manual. Ensure the springs are installed with the close wound, colour coded end of the springs facing downwards, towards the piston.
 2. The race kit camshafts should be assembled in the same manner as the standard camshafts. Follow the procedure detailed in section 3 of the Daytona 675 service manual.
 3. The race kit cam sprockets should be mounted and secured to the camshafts using the slotted holes in the sprocket. The slotted holes allow adjustment of the valve timing. The circular holes in the sprockets are for Triumph service tool T3880102 and should not be used to mount the sprockets to the camshafts.
 5. Always check the inlet and exhaust piston to valve clearance for the timing selected to use, before running the engine. You must ensure both clearances are adequate. As a guide, the standard nominal piston to valve clearance is 1.3 mm inlet & 1.5 mm exhaust.
 6. When the desired timing has been set the new socket retaining screws provided should be tightened to **15 Nm**. Note, if the screws are released for any reason, apply ThreeBond 1305 to the threads before re-tightening.

NOTE

- **No timing marks are included on the race sprockets. Race engines will typically have different depths skimmed off the cylinder head and, therefore require specific individual timing.**
4. The camshafts should be timed using cam degreering equipment which typically consists of a degree wheel, pointer, dial indicator and piston stop. Optimum cam timing will depend on the exact specification of the engine, but a recommended starting point is 104° IMOP (Inlet Maximum Opening Point) and 104° EMOP (Exhaust Maximum Opening Point).

Cam Chain Kit

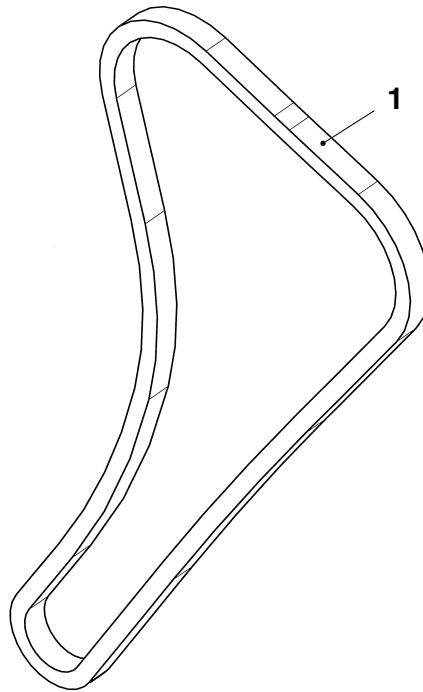

Parts supplied - A9618059

Item	Description	Qty
1	Cam chain	1

1. Remove the existing cam chain following the procedures detailed in section 3 of the Daytona 675 service manual.
2. Fit the race cam chain following the procedures detailed in section 3 of the Daytona 675 service manual.

Manually Adjustable Cam Chain Tensioner Kit

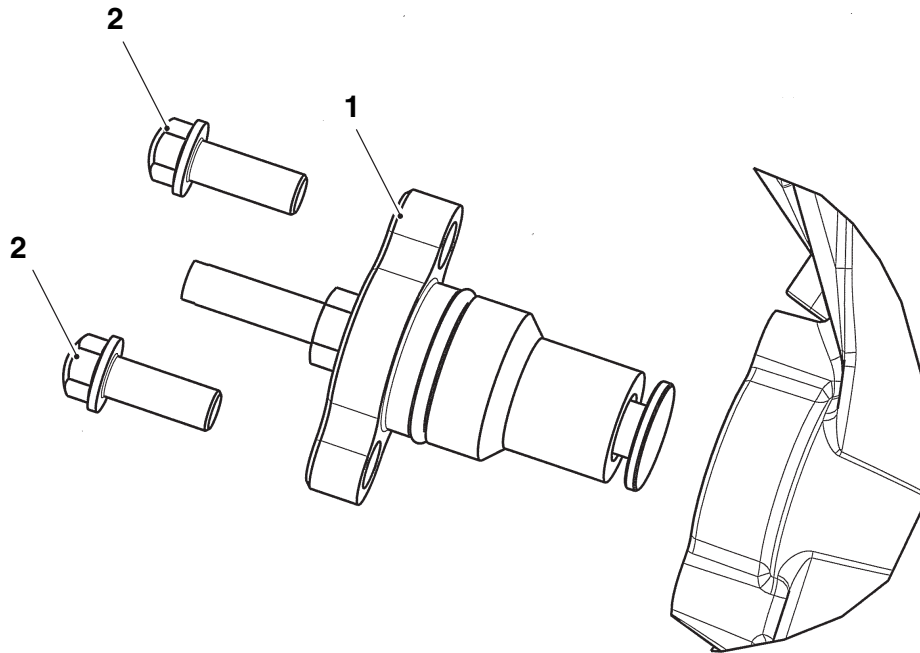

Parts supplied - A9618060

Item	Description	Qty
1	Tensioner, camchain, manual, assembly	1
2	Bolt, reduced hex head flange, S/less, M6 X 16, encapsulated	2

- Remove the standard tensioner following the procedure detailed in the Daytona 675 service manual.
- Back off the plunger locknut on the new tensioner assembly before installation.

NOTE

- Do not start the motorcycle engine with the tensioner removed.**
- Thoroughly clean the tensioner mounting surface on the cylinder head.
 - Remove the crank cover to gain access to the crankshaft.

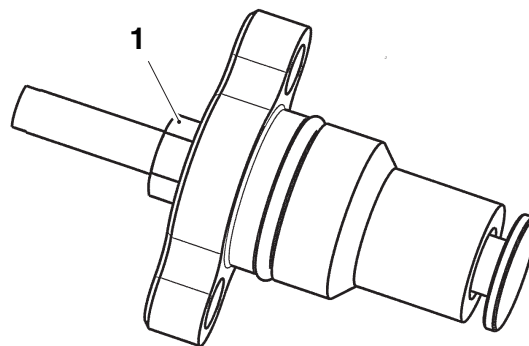

1. Plunger locknut

5. Lightly coat the large O-ring with oil, install the new tensioner assembly and secure with the new fixings provided.
6. Tighten the tensioner fixings to a torque value of **9 Nm**.
7. Finger tighten the plunger on the new tensioner while turning the crankshaft by hand. At certain points during engine rotation you will feel the plunger tighten as it takes up the slack in the cam chain. **DO NOT** force the plunger, continue steady finger tightening only to take up the slack in the chain as you rotate the crankshaft.
8. When the slack in the cam chain has been completely taken up, back off the plunger by 1/4 turn.
9. While holding the plunger in position, tighten the plunger locknut to a torque value of **9 Nm**. Ensure the plunger is not allowed to turn while tightening the locknut.

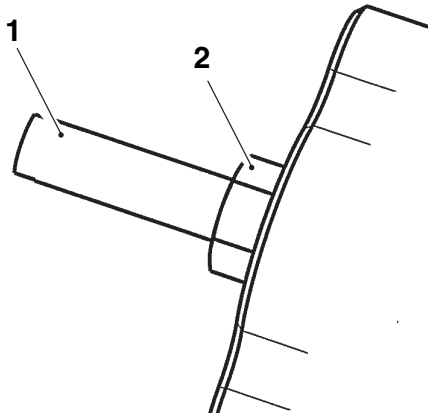

1. Plunger
2. Plunger locknut

Inlet & Exhaust Valve Kit

⚠ Caution

The use of the following race kit inlet & exhaust valves will require changes to the fuelling settings. To alter fuelling settings a third party programmable control unit will be required.

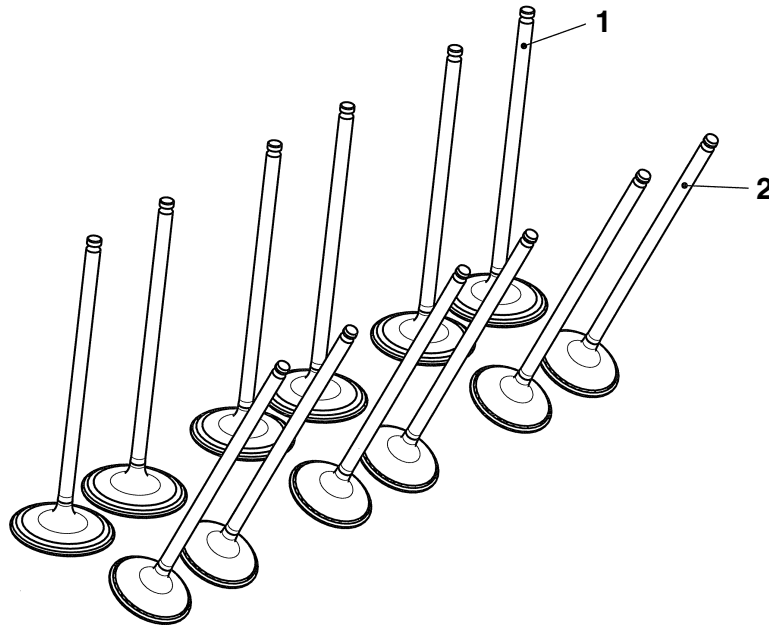

Parts supplied - A9618061

Item	Description	Qty
1	Inlet valve, 29.65 dia	6
2	Exhaust valve, 24.85 dia	6

- **The valves supplied in the race kit are used to increase compression ratio, by having a flat face on the combustion chamber side. They are made from the same material and have the same mass as the standard valves.**

1. Remove the existing inlet and exhaust valves following the procedure detailed in section 3 of the Daytona 675 service manual.
2. The valve seat widths on the race kit valves are narrower than the standard valves, therefore the bottom angle (120°) of the cylinder head valve seats must be modified to ensure the seat on the head matches the seat on the valve.
3. Check the head seat and valve seat are matched correctly by applying engineers blue to the cylinder head seat (90°) and then assembling a valve.
4. When the correct match of head seat and valve seat have been confirmed assemble the race inlet and exhaust valves, following the procedure detailed in section 3 of the Daytona 675 service manual.

Conrod Bearing Shell

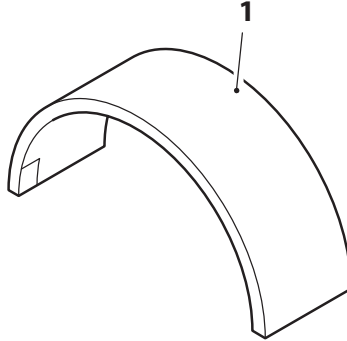

Parts supplied - A1110411

Item	Description	Thickness	Colour	Qty
1	Conrod bearing shell, race	1.476 mm to <1.482 mm	White	1

Parts supplied - A1110412

Item	Description	Thickness	Colour	Qty
1	Conrod bearing shell, race	1.482 mm to <1.488 mm	Red	1

- The race conrod bearing shells should be assembled in the same manner as the standard conrod bearing shells.
- Follow the procedure detailed in section 5 of the Daytona 675 service manual to remove the connecting rods, select the correct bearing shells for each connecting rod and refit the connecting rods.

Main Bearing Shell

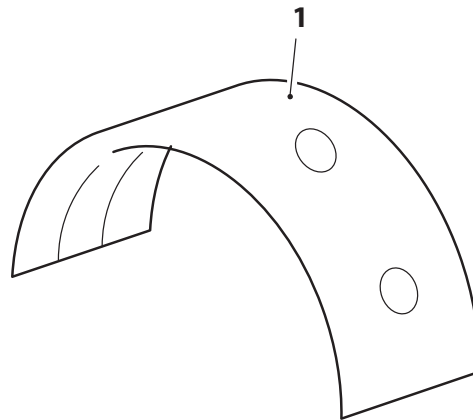

Parts supplied - A1161301

Item	Description	Thickness	Colour	Qty
1	Main bearing shell, race	1.491 mm to <1.495 mm	White	1

Parts supplied - A1161302

Item	Description	Thickness	Colour	Qty
1	Main bearing shell, race	1.495 mm to <1.499 mm	Red	1

Parts supplied - A1161303

Item	Description	Thickness	Colour	Qty
1	Main bearing shell, race	1.499 mm to <1.503 mm	Blue	1

Parts supplied - A1161304

Item	Description	Thickness	Colour	Qty
1	Main bearing shell, race	1.503 mm to <1.507 mm	Green	1

- The race main bearing shells should be assembled in the same manner as the standard main bearing shells.
- Follow the procedure detailed in section 5 of the Daytona 675 service manual to remove the standard bearing shells and select the correct bearing shells required.

Air Funnel Kit

⚠ Caution

The use of the following race air funnel kit will require changes to the fuelling settings. To alter fuelling settings a third party programmable control unit will be required.

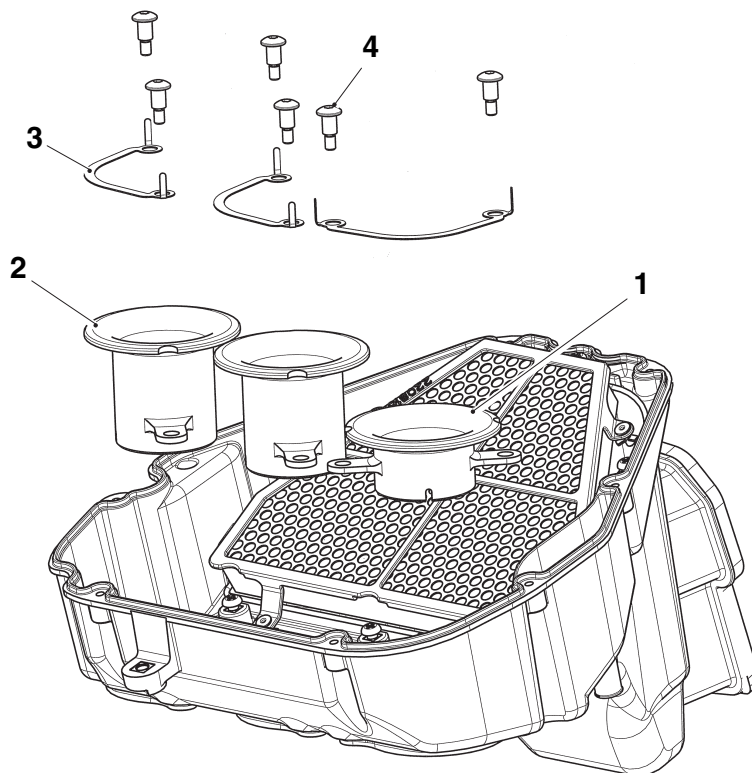

Parts supplied - A9618063

Item	Description	Qty
1	Air funnel short, race	1
2	Air funnel long, race	2
3	Fixing retainer	3

NOTE

- It is essential that the race ECU kit - A9618070 is used with the air funnel race kit to allow correct offset for fuelling cylinder 3 (short air funnel).
- The parts supplied in the race kit are designed to replace the standard intake air funnels located in the airbox.
- Item 4 (6 off) is the standard fixing supplied with the standard air funnel. It is not supplied in the race kit.

1. Remove the airbox lid.
2. Remove the standard intake air funnels. Retain the fixings (2 per air funnel) for reuse.
3. Fit the 2 long race kit air funnels to cylinders 1 & 2 and the short air funnel to cylinder 3.
5. Fold the retention tabs, on the fixing retainers, over the 6 fixings as shown below.

NOTE

- **The cylinders are numbered 1 to 3 from left to right of the engine.**
4. Fit one of the fixing retainers provided to each air funnel and retain with the original fixings. Apply ThreeBond 1364 locking compound to the threads only and tighten the fixings to a torque value of **6 Nm**.

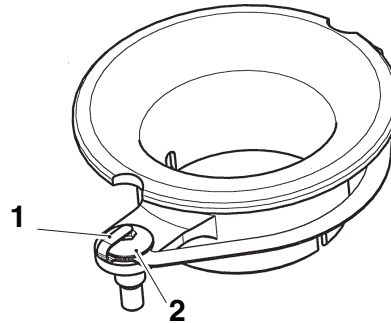

1. Retention tab
2. Fixing

Exhaust System, Stage 2 (Arrow)

⚠ Caution

The use of the Arrow stage 2 exhaust system will require changes to the fuelling settings. To alter fuelling settings a third party programmable control unit will be required.

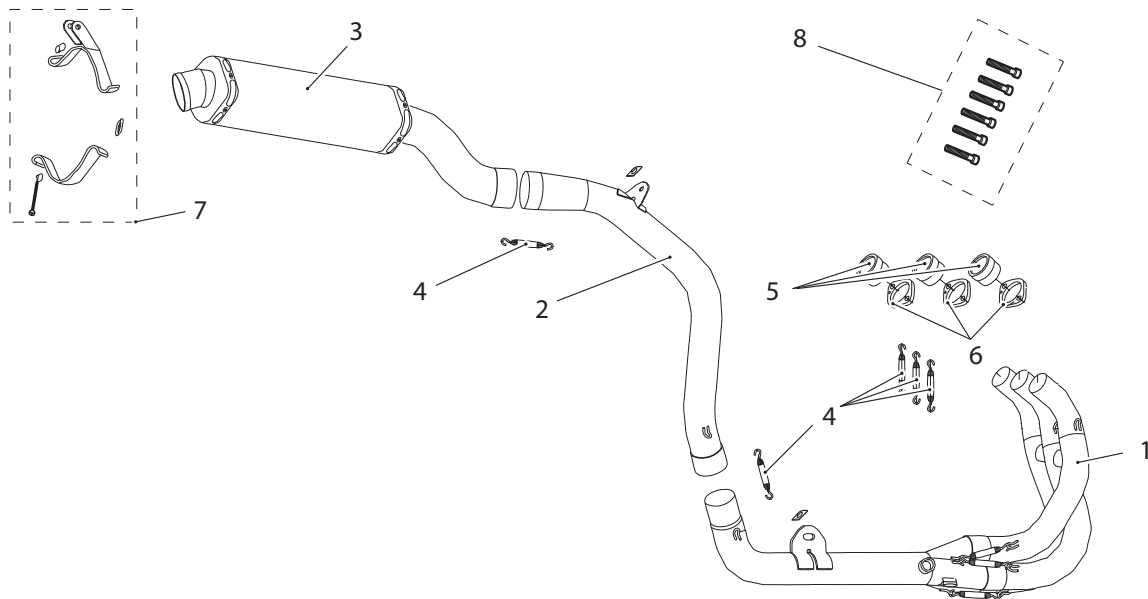

Parts supplied - A9600197

Item	Description	Qty
1	Downpipe collector assy	1
2	Intermediate pipe	1
3	Silencer	1
4	Spring	5
5	Primary header bushing	3
6	Primary header flange	3
7	Silencer bracket assembly	1
8	Capscrew, M8	6

1. Remove the seat, battery, rear bodywork, lower fairings, radiator, radiator fan, rear light, pillion foot rest hangers and exhaust system following the procedures detailed in the Daytona 675 service manual.
2. Remove the exhaust valve actuator from its actuator cables.
3. Remove and discard the exhaust gaskets and M8 studs from the cylinder head.
4. Apply silicone sealant to the mating surface of the primary header bush which contacts the cylinder head, the recommended sealant is Dow Corning Firestop 700 white silicone.
5. Fit the three primary header bushes to the cylinder head and secure in the orientation shown below using the primary header flanges and M8 cap screws provided.

NOTE

- The flat on the primary header bush should be aligned with the flat in the exhaust port such that none of the exhaust port is obscured by the primary header bush.

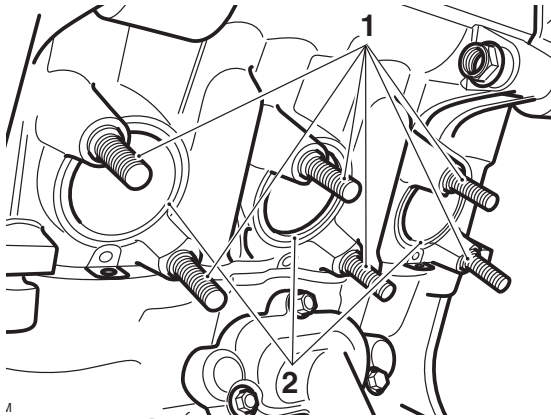

1. M8 Stud
2. Gasket

NOTE

- To obtain maximum performance the exhaust port should be machined, removing material from the area shown in red. The exhaust port shape should match the inside surface of the primary header bush.

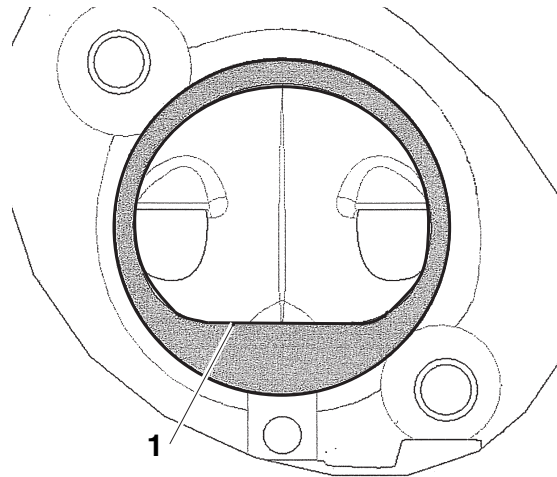

1. Flat - primary header bush

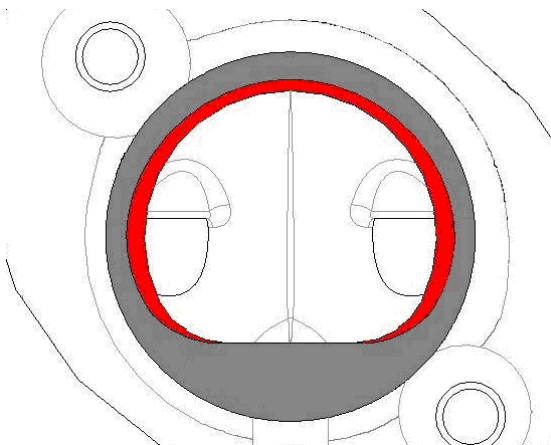

6. Position the downpipe collector assembly to the underside of the engine and insert the downpipe ends fully into the primary header bushes. Secure with the three springs provided. Ensure the spring mounting holes are positioned as shown below for all three flanges.

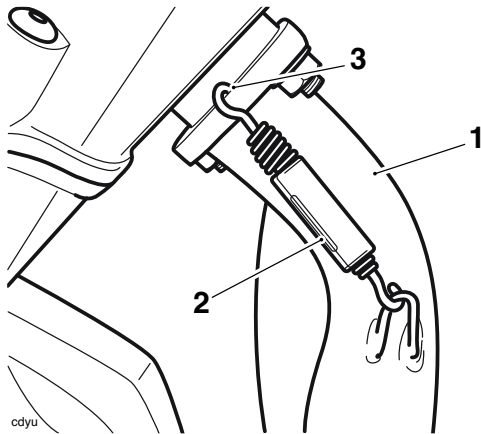

- 1. Down pipe
- 2. Spring
- 3. Spring mounting hole position

7. Loosely secure the assembly to the original exhaust mounting point using the original fixings.

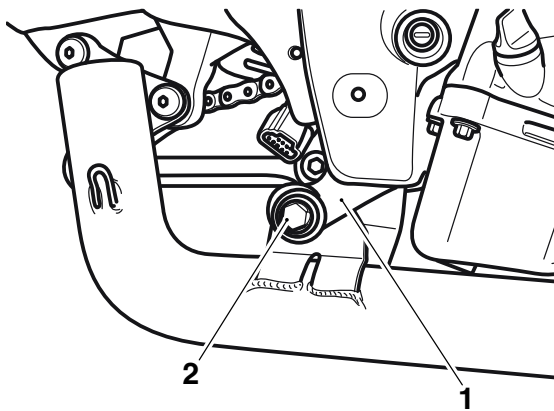

- 1. Exhaust mounting point
- 2. Original fixings

8. Insert the end of the intermediate pipe into the collector pipe in the orientation shown below. Secure with the spring provided.

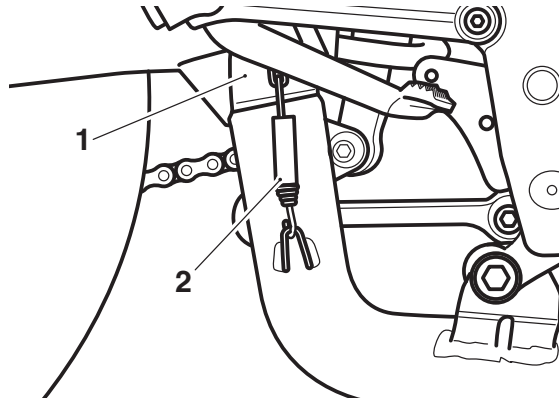

- 1. Intermediate pipe
- 2. Spring

9. Loosely secure the intermediate pipe to the exhaust mounting point using the original fixing as shown.

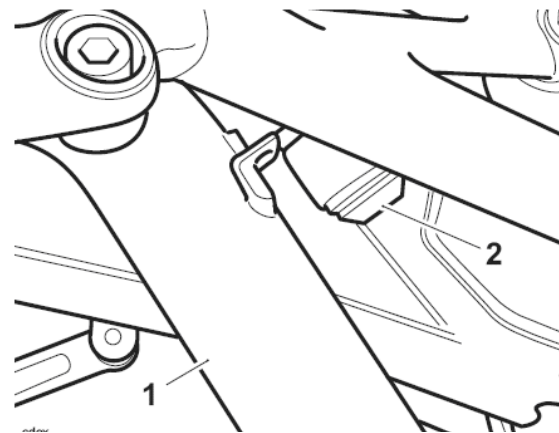

- 1. Intermediate pipe
- 2. Original fixing

10. Assemble the silencer clamp/bracket and loosely fit to the silencer in the orientation shown below.

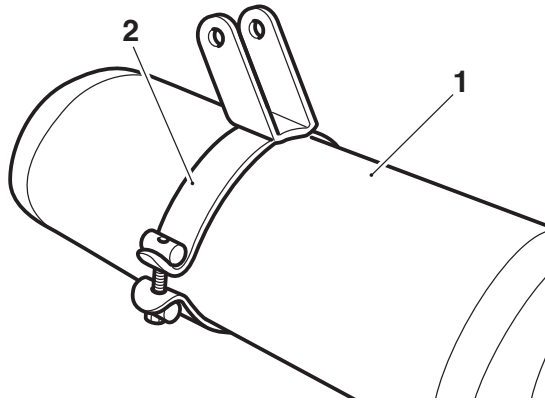

- 1. Silencer**
2. Silencer clamp/bracket

11. Fit the silencer to the intermediate pipe and secure with the spring provided. Loosely secure the silencer bracket/clamp to the silencer mounting point using the original fixings.

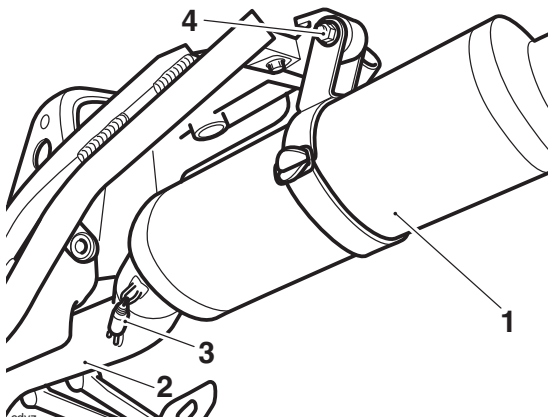

- 1. Silencer**
2. Intermediate pipe
3. Spring
4. Silencer mounting point

12. Check the exhaust system is correctly aligned with the rear frame and tighten the fixings to the following torque values; Rear exhaust mounting point **27 Nm**. Silencer bracket fixing **9 Nm**. Intermediate pipe mounting point fixing **22 Nm**. Collector pipe front mounting point fixings **15 Nm**. Primary header flanges, M8 cap screws **19 Nm**.

13. If fitting the oxygen sensor use the adaptor provided and tighten the sensor to a torque value of **25 Nm**.

14. Fit the correct specification spark plugs as recommended below.

NOTE

- **Triumph recommends two options of spark plug. Choose the correct option depending on the engine compression ratio. For a standard compression ratio use NGK CR10EIX. For high compression ratio engines use NGK R0373A. Always ensure there is sufficient clearance between spark plug and piston, before attempting to start the engine.**

15. Refit the radiator, rear bodywork, lower fairings, battery and seat as described in the Daytona 675 service manual.

NOTE

- **The radiator fan, rear light and pillion foot rest hangers are NOT refitted.**

Air Filter Kit

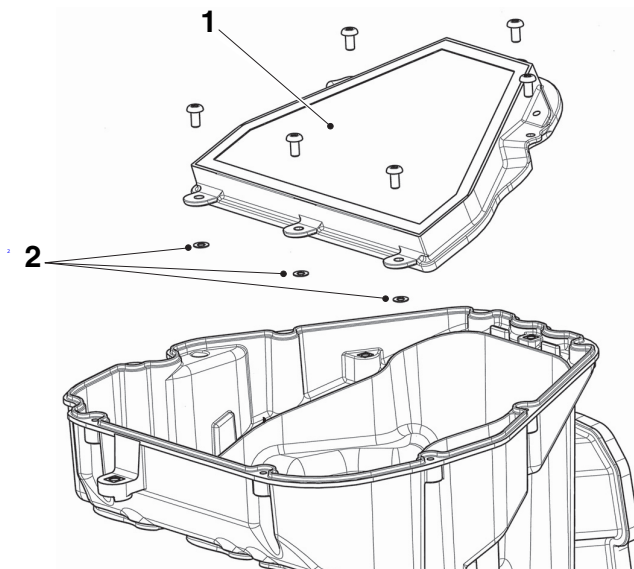

Parts supplied - A9618075

Item	Description	Qty
1	Air filter	1
2	Retaining washer	3

NOTE

- This kit is supplied by BMC Air Filters. For fitment details refer to the instruction contained in the kit.
- If you have any queries with regard to the air filter kit, in the first instance contact BMC. For contact details see; www.bmcairfilters.com.
- Loctite or similar should NOT be applied to the fixings as described in the supplied instructions as this could strip the insert out of the plastic moulding when removing the filter. The kit is supplied with 3 plastic retaining washers to retain the fixings. The 3 plastic retaining washers should be fitted to the 3 rear fixings as shown above. Tighten the fixings to a torque value of 4 Nm.

Slipper clutch Kit - A9610014

- The slipper clutch kit is supplied by STM Trading s.r.l. For fitment details refer to the instruction contained in the kit.
- If you have any queries with regard to the slipper clutch kit, in the first instance contact STM. For contact details see; www.slipperclutch.com.

Slipper clutch Tool - A3880037

- It is recommended to use the slipper clutch tool when fitting the slipper clutch.

Transmission Kit

Warning

The race kit must be fitted as a complete set. If it is not fitted as a complete set a failure may result which could cause loss of motorcycle control and an accident.

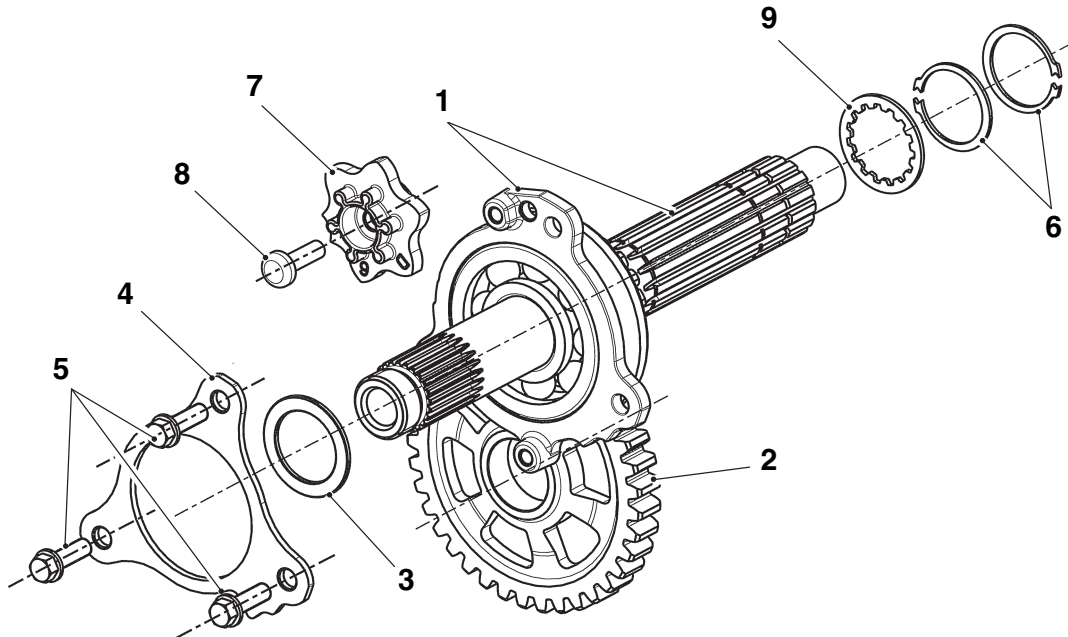

Parts supplied

1st gear pair & housing kit - A9618066

Item	Description	Qty
1	Input shaft assembly	1
2	Output gear	1
3	Spacer, clutch	1
4	Bearing retainer plate	1
5	Bolt, reduced hex head flange, M6 x 20, black, encapsulated	3
6	Circlip, 28 mm	2
7	Wheel detent	1
8	Screw, Torx head, M6 x 20, black	1
9	Washer, splined, 28 x 34 x 1.5	1

NOTE

- The standard first gear ratio is 34/13 (2.615).
- The race kit first gear ratio is 37/16 (2.313).

A9618066 - 1st gear pair & housing

1. Remove the existing output shaft assembly from the engine following the procedures detailed in section 7 of the Daytona 675 service manual.
2. Remove the output shaft bearing and plain thrust washer from the existing output shaft assembly.
3. Replace the existing 1st gear with the race kit 1st gear (2) supplied. Ensure the orientation of the race kit 1st gear is the same as the standard 1st gear. Lubricate the 1st gear and 1st gear bush with clean engine oil during assembly.
4. Re-assemble the plain thrust washer and output shaft bearing onto the output shaft.
5. Remove the existing selector drum assembly from the engine following the procedures detailed in section 7 of the Daytona 675 service manual.
6. Remove the existing detent wheel and fixing from the selector drum assembly. Note how the detent wheel is timed relative to the selector drum by way of a dowel.
7. Assemble the race kit detent wheel (7) to the selector drum assembly, ensuring it is timed to the drum in the same way as the original detent wheel.
8. Fit the M6 Torx head screw (8) to the selector drum assembly and tighten to a torque value of **12 Nm**. Ensure the detent wheel (7) is fully inserted into the bearing, up to its shoulder.
9. Remove the existing input shaft from the engine following the procedures detailed in section 7 of the Daytona 675 service manual.
10. Remove all gears, circlips, bushes and washers from the original input shaft, taking care to note the orientation of components in line with the recommendations in section 7 of the Daytona 675 service manual. Discard the two small circlips and splined washer, which sits adjacent to the 5th input gear on the shaft.
11. Re-assemble all gears, bushes and washers from the original input shaft onto the race kit input shaft assembly following the procedures detailed in section 7 of the Daytona 675 service manual. Ensure the new circlips (6) and splined washer (9) from the race kit are used.
12. Re-assemble the input shaft assembly into the upper crankcase in line with the recommendations in section 7 of the Daytona 675 service manual.
13. Fit the new bearing retainer plate (4) and secure with the new fixings (5) provided. Tighten the fixings to a torque value of **12 Nm**.

NOTE

- **The race kit splined washer (9) replaces the standard splined washer adjacent to the 5th input gear. The standard splined washer in this location cannot be used in conjunction with the race kit and must be discarded.**

14. Fit the new race kit clutch spacer (3) onto the input shaft adjacent to the bearing.

NOTE

- **The race kit clutch spacer replaces the standard clutch spacer. The standard clutch spacer cannot be used in conjunction with the race kit and must be discarded.**

15. Fit the selector drum assembly into the crankcase following the procedures detailed in section 7 of the Daytona 675 service manual.

16. Fit the output assembly into the crankcase following the procedures detailed in section 7 of the Daytona 675 service manual.

Shaft, Input Kit - A9618064

(Spares kit only - Must not be fitted in isolation to a standard engine.)

Item	Description	Qty
1	Input shaft assembly, race	1
5	Bolt, reduced hex head flange, M6 x 20, black, encapsulated	3
6	Circlip, 28 mm shaft	2

Gear, Output Kit - A9618065

(Spares kit only - Must not be fitted in isolation to a standard engine.)

Item	Description	Qty
2	Gear, output 1st, 37T, race	1

Wheel Detent Kit - A9618068

(Spares kit only - Must not be fitted in isolation to a standard engine.)

Item	Description	Qty
7	Wheel, detent, race	1
8	Screw, Torx, pan head, M6 x 1.0 x 20, black	1

Alternator Kit

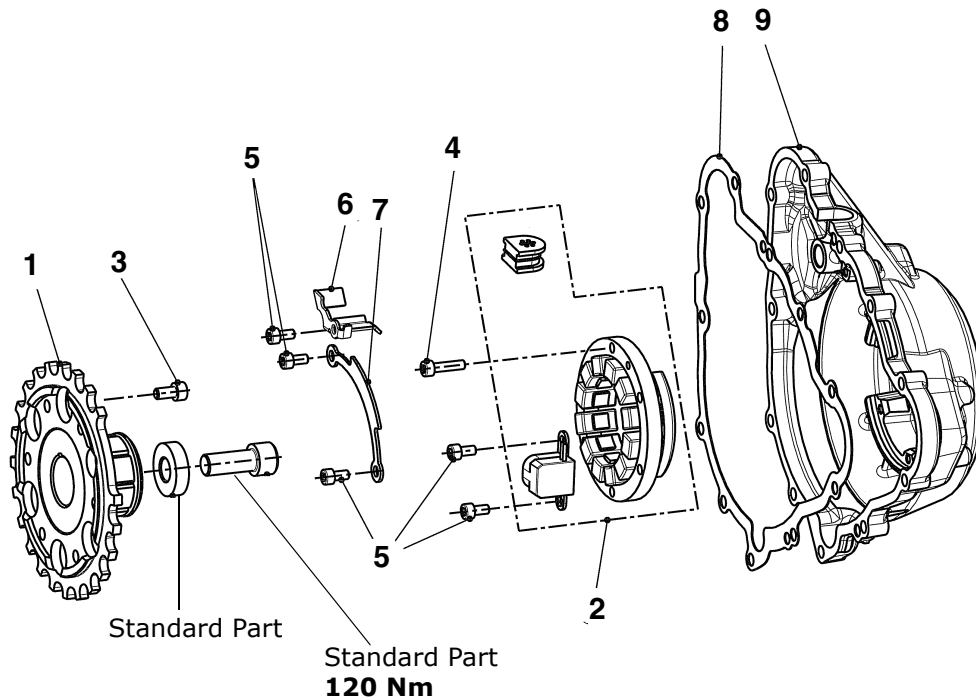

Parts supplied - A9618069

Item	Description	Qty
1	Rotor, race ACG	1
2	Stator, race ACG (includes crank sensor)	1
3	Screw, caphead, M6 x 1 x 12, ENC (to retain sprag clutch housing)	6
4	Screw, skt hd cap, M5 x 0.8 x 20	6
5	Screw, skt hd cap, M5 x 0.8 x 10	5
6	Plate, wire retainer	1
7	Plate, wire retainer	1
8	Gasket, alternator cover (standard part)	1
9	Cover, alternator (unpainted sand casting)	1

Alternator Puller Tool Kit - A3880206

Item	Description	Qty
1	Puller tool, alternator	1

1. Remove all grease and oil from the taper surfaces on both the crankshaft and rotor before assembly.
2. Apply silicone sealant to the cable grommet (ThreeBond 1215 is recommended).
3. If removed, the fixings (3), (4) & (5) should be replaced with new items, or a thread locking compound must be applied (ThreeBond 1305 is recommended).
4. Tighten the fixings to the following torque values; Item (3) **16 Nm**, Items (4) & (5) **6 Nm**.
5. If removal of the race rotor is required, Triumph service tool T3880206 should be used and follow the procedure detailed below.

Rotor removal - Race ACG

Caution

Do not use tools of any kind to tighten the service tool T3880375. Tighten the tool by hand only. Over-tightening of the service tool will lead to damage of the alternator rotor.

1. Clean the alternator rotor removing all traces of oil.
2. Fit the service tool T3880375 to the outside diameter of the rotor. Retain the tool to prevent the crankshaft from rotating and remove the centre bolt from the crankshaft.
3. With the crankshaft bolt removed, locate the spigot of the thrust pad supplied with service tool A3880206 into the end of the crankshaft.
4. Assemble the threaded portion of service tool A3880206 into the threaded portion of the rotor. Ensure the thrust pad does not fall out during assembly of the service tool.
5. Hold the service tool T3880375 to prevent rotation of the rotor, then tighten service tool A3880206 to release the taper seating of the rotor from the crankshaft.
6. Withdraw the rotor and service tools as an assembly and then separate the tools from the rotor. Collect the woodruff key and the service tool thrust pad from the crankshaft.

Manual Idle Speed Adjuster Kit

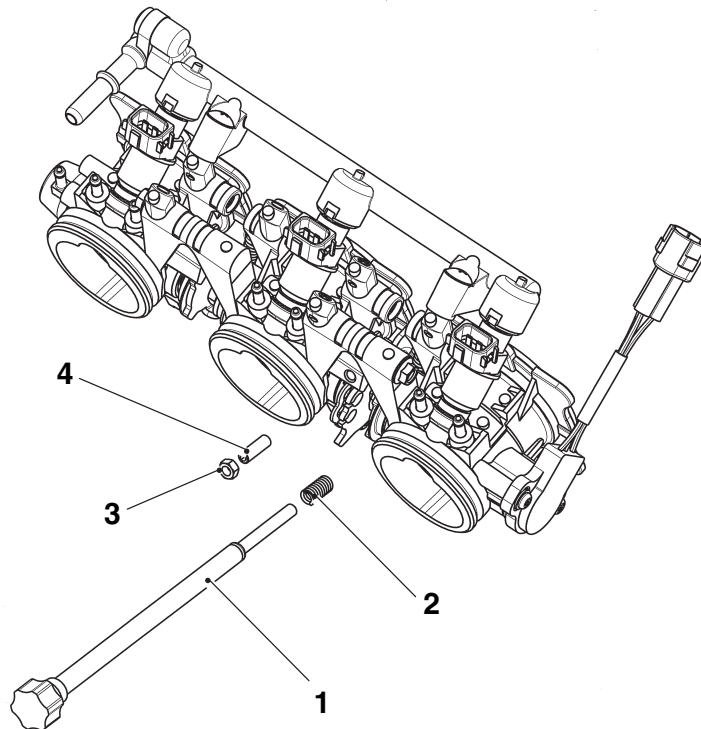

Parts supplied - A9618076

Item	Description	Qty
1	Screw, manual adjuster	1
2	Spring, compression coil	1

1. Remove the throttle body assembly following the procedure detailed in the Daytona 675 service manual.
2. Remove items 3 & 4 shown above from the assembly.
3. Fit the manual adjuster screw and compression spring supplied (items 1 & 2).
4. Refit the throttle body assembly following the procedure detailed in the Daytona 675 service manual.
5. Adjust the idle speed using the manual adjuster screw (item 1) as required.

Race ECU Kit - A9618070

Warning

The race ECU **MUST** be used with the following race kits; A9618055 camshaft - inlet, A9618056 camshaft - exhaust, A9618057 camshaft sprocket, A9618058 valve spring, A9618063 air funnel and A9618071 race harness.

NOTE

- The race ECU will only work with the race harness A9618071, and production instruments fitted.
- The race ECU is pre-programmed for use with the following set of race kits; inlet & exhaust camshafts (set to IMOP 104° / EMOP 104° with vernier sprockets), valves, air filter, air funnels and Arrow stage 2 exhaust system. The tune has been developed to suit a compression ratio of 14:1 with enlarged and polished inlet ports and the exhaust ports modified as recommended on page 20. However, due to variation between race prepared engines fuelling adjustments will be required.
- The tune is for a rubber fuel hose only, Triumph Part No. 1240177, it is NOT suitable for a plastic fuel hose.
- The air & fuel ratio should be checked and any adjustments to the fuelling setting should be made using a third party programmable control unit.
- The rev limit on the race ECU has been increased by 1000 rpm over standard.
- The indicated speed shown on the instruments is calibrated for the first gear pair and housing race kit (A9618066). If the standard gearbox is used, or the final drive ratio is changed, the indicated speed will be incorrect.
- Idle speed should be set to between 1,500 and 1,800 rpm.

ECU Malfunction indicator light

- This will flash a sequence of error codes if any faults are present.
- Flash codes have a long flash for the first digit and a short flash for the second digit. For example; fault code "32" would be: *long, long, long, short, short.*
- When a fault has been identified and rectified, the ECU can be cleared by the following sequence: full throttle, ignition ON; flick the kill switch off/on/off/on/off.

Caution

No ECU faults should be present during motorcycle operation. If the motorcycle is used with ECU faults present it will be operating in default "limp home" mode only which will produce inconsistent operation.



Fault Code Table

Flash Code	Problem
02	Crank sensor
33	#1 injector
34	#2 injector
35	#3 injector
37	#1 ignition coil
38	#2 ignition coil
39	#3 ignition coil
06	Throttle position sensor
09	MAP sensor
68	MAP sensor pipe disconnected
12	Coolant sensor
13	Air temperature sensor
14	Atmospheric air pressure sensor
41	Fuel pump
65	EEPROM error
26	5v sensor supply problem
15	Roll over sensor
22	Gear position sensor
24	Ignition switch circuit problem
25	Battery voltage supply problem
43	Cooling fan relay
44	Airflap solenoid
66	Instrument communication error
70	Vehicle speed sensor
67	Main relay
Continuous Short Flash	Harness or instruments

Race Harness Kit

Parts supplied - A9618071

Item	Description	Qty
1	Main harness, race	1
2	Connector, quick shift	1

NOTE

- **The race harness will not work without the Race ECU A9618070.**
- The relay and fuse box position has changed on the race harness for ease of access and maintenance. They are now located alongside the battery, under the seat. Ensure they are secured in position so they do not suffer from vibration problems.
- The race harness does not support all of the OE equipment, therefore, the following components can be removed from the motorcycle; oxygen sensor, exhaust valve, idle speed control, secondary air injection (SAI), purge control (California only), lights and air intake flap solenoid. The SAI ports must be blocked off if the system is removed. The throttle body purge ports must be blocked of before use (California only).
- The race harness still supports the cooling fan and incorporates a relay for the fan. You may remove the cooling fan but must leave the relay in place.
- The race harness does not support the idle speed control motor and therefore, this may be removed from the throttle body. It is recommended to use the manual idle speed adjuster A9618076 to replace the throttle stop screw when using the race harness. Throttle body balance should be checked if the ISC cam is removed from the throttle body assembly.
- The race harness is suitable for use with both the standard and race kit alternator. It is recommended to always run an alternator, without it the battery will discharge in a very short period of time.
- The combination of the race ECU and race harness allows the ability to have ignition cut for "quick shift". To use this feature connect a suitable 5V 2mA switch to the supplied connector and mount the switch in a convenient position. When the switch is pressed the ignition will cut for 40ms.
- If the quick shift function is not going to be used, leave the harness connector blanked off to avoid possible short circuits.



Motorcycle Accessories

Engine Protector Kits

Parts supplied

Clutch cover, carbon fibre Kit - A9728028

Item	Description	Qty
1	Clutch cover, carbon fibre	1

Crank cover, carbon fibre Kit - A9728029

Item	Description	Qty
1	Crank cover, carbon fibre	1

Standard alternator cover, carbon fibre Kit - A9728031

Item	Description	Qty
1	Standard alternator cover, carbon fibre	1

Race Alternator cover, carbon fibre Kit - A9728032

Item	Description	Qty
1	Race alternator cover, carbon fibre	1

1. Apply silicone sealant to the mating surfaces of the carbon fibre cover and corresponding engine cover. The recommended sealant is "Impact Adhesive 5255" (or direct equivalent) which is a high temperature, chemical and environmental resistant sealant.

NO WARRANTIES ARE PROVIDED FOR THIS RACING KIT. TRIUMPH MOTORCYCLES DOES NOT PROVIDE ANY WARRANTIES FOR THIS RACING KIT OR FOR ANY OF THE PARTS IN THIS RACING KIT. ALL WARRANTIES, EXPRESS OR IMPLIED, ARE SPECIFICALLY DISCLAIMED. TRIUMPH MOTORCYCLES DOES NOT PROVIDE ANY WARRANTIES OF MERCHANTABILITY OR FITNESS FOR A PARTICULAR PURPOSE. IN NO EVENT SHALL TRIUMPH MOTORCYCLES, ITS RELATED COMPANIES OR UNITED STATES REPRESENTATIVES BE LIABLE FOR ANY ALLEGED BREACH OF WARRANTIES INCLUDING WARRANTIES OF MERCHANTABILITY OR WARRANTIES OF FITNESS FOR A PARTICULAR PURPOSE. TRIUMPH MOTORCYCLES LTD, ITS RELATED COMPANIES AND ITS REPRESENTATIVES IN THE UNITED STATES, SPECIFICALLY DISCLAIM ALL LIABILITY ARISING OUT OF THE USE OF THIS RACING KIT. IN NO EVENT SHALL TRIUMPH MOTORCYCLES LTD, ITS RELATED COMPANIES OR ITS UNITED STATES REPRESENTATIVES BE LIABLE FOR ANY DAMAGES ARISING OUT OF THE USE OF THIS RACING KIT. THIS MEANS THAT, IN NO EVENT, SHALL TRIUMPH MOTORCYCLES LTD, ITS RELATED COMPANIES OR ITS UNITED STATES REPRESENTATIVES BE LIABLE FOR ANY GENERAL, INDIRECT OR CONSEQUENTIAL DAMAGES ARISING OUT OF THE USE OF THIS RACING KIT.