



FZS600

2000

5DM1-AE2

**SUPPLEMENTARY
SERVICE MANUAL**

FOREWORD

This Supplementary Service Manual has been prepared to introduce new service and data for the FZS600 2000. For complete service information procedures it is necessary to use this Supplementary Service Manual together with the following manual.

FZS600 SERVICE MANUAL: 5DM1-AE1

**FZS600 2000
SUPPLEMENTARY
SERVICE MANUAL**

©1999 by Yamaha Motor Co., Ltd.

First Edition, June 1999

**Any reproduction or unauthorized use
without the written permission of
Yamaha Motor Co., Ltd. is expressly
prohibited.**

NOTICE

This manual was produced by the Yamaha Motor Company primarily for use by Yamaha dealers and their qualified mechanics. It is not possible to include all the knowledge of a mechanic in one manual, so it is assumed that anyone who uses this book to perform maintenance and repairs on Yamaha scooter has a basic understanding of the mechanical ideas and the procedures of scooter repair. Repairs attempted by anyone without this knowledge are likely to render the scooter unfit for use.

Yamaha Motor Company, Ltd. is continually striving to improve all its models. Modifications and significant changes in specifications or procedures will be forwarded to all authorized Yamaha dealers and will appear in future editions of this manual where applicable.

NOTE: _____

Designs and specifications are subject to change without notice.

IMPORTANT INFORMATION

Particularly important information is distinguished in this manual by the following.



The Safety Alert Symbol means ATTENTION! BECOME ALERT! YOUR SAFETY IS INVOLVED!



Failure to follow WARNING instructions could result in severe injury or death to the motorcycle operator, a bystander or a person inspecting or repairing the motorcycle.

CAUTION:

A CAUTION indicates special precautions that must be taken to avoid damage to the motorcycle.

NOTE:

A NOTE provides key information to make procedures easier or clearer.

HOW TO USE THIS MANUAL

This manual is intended as a handy, easy-to-read reference book for the mechanic. Comprehensive explanations of all installation, removal, disassembly, assembly, repair and inspection procedures are laid out with the individual steps in sequential order.

- ① The manual is divided into chapters. An abbreviation and symbol in the upper right corner of each page indicate the current chapter. Refer to "SYMBOLS" on the following page.
- ② Each chapter is divided into sections. The current section title is shown at the top of each page, except in Chapter 3 ("Periodic Inspections and Adjustments"), where the sub-section title (-s) appear. (In Chapter 3, "Periodic Inspections and Adjustments", the sub-section title appears at the top of each page, instead of the section title.)
- ③ Sub-section titles appear in smaller print than the section title.
- ④ To help identify parts and clarify procedure steps, there are exploded diagrams at the start of each removal and disassembly section.
- ⑤ Numbers are given in the order of the jobs in the exploded diagram. A circled number indicates a disassembly step.
- ⑥ Symbols indicate parts to be lubricated or replaced (see "SYMBOLS").
- ⑦ A job instruction chart accompanies the exploded diagram, providing the order of jobs, names of parts, notes in jobs, etc.
- ⑧ Jobs requiring more information (such as special tools and technical data) are described sequentially.

CLUTCH ENG

CLUTCH

Order	Job name/Part name	Q'ty	Remarks
Removing the clutch			
1	Compression spring	6	Remove the parts in the order listed.
2	Pressure plate	1	
3	Short clutch push rod	1	
4	O-ring	1	
5	Ball	1	
6	Long clutch push rod	1	Refer to "INSTALLING THE CLUTCH" section.
7	Friction plate	8	
8	Clutch plate	8	
9	Friction plate (large)	1	
10	Clutch spring plate	1	Refer to "REMOVING/INSTALLING THE CLUTCH" section.
11	Nut	1	

CLUTCH ENG

REMOVING THE CLUTCH

- Straighten the lock washer tab.
- Loosen:
 - clutch boss nut ①

NOTE:
While holding the clutch boss ② with the universal clutch holder ③, loosen the clutch boss nut.

Universal clutch holder ③
90890-04086

- Remove:
 - spacer ④
 - bearing ⑤

NOTE:
Insert two M6-mm bolts ⑥ into the spacer and then remove the spacer by pulling on the bolts.

CHECKING THE FRICTION PLATES

The following procedure applies to all of the friction plates.

- Check:
 - friction plate
Damage/wear → Replace the friction plates as a set.
- Measure:
 - friction plate thickness
Out of specification → Replace the friction plates as a set.

NOTE:
Measure the friction plate at four places.

Friction plate thickness
2.94 - 3.06 mm
<Limit>: 2.8 mm

CHECKING THE CLUTCH PLATES

























The following procedure applies to all of the clutch plates.

- Check:
 - clutch plate
Damage → Replace the clutch plates as a set.
- Measure:
 - clutch plate warpage
(with a surface plate and thickness gauge ①)
 - Out of specification → Replace the clutch plates as a set.

Clutch plate warpage limit
Less than 0.1 mm

4-32

4-34

① GEN INFO 	② SPEC 	
③ CHK ADJ 	④ ENG 	
⑤ COOL 	⑥ CARB 	
⑦ CHAS 	⑧ ELEC 	
⑨ TRBL SHTG 	⑩ 	
⑪ 	⑫ 	
⑬ 	⑭ 	
⑮ 	⑯ 	⑰ 
⑱ 	⑲ 	⑳ 
㉑ 	㉒ 	㉓ 
㉔ 	㉕ New	

EB003000

SYMBOLS

The following symbols are not relevant to every vehicle.

Symbols ① to ⑨ indicate the subject of each chapter.

- ① General information
- ② Specifications
- ③ Periodic inspection and adjustment
- ④ Engine
- ⑤ Cooling system
- ⑥ Carburetor(-s)
- ⑦ Chassis
- ⑧ Electrical system
- ⑨ Troubleshooting

Symbols ⑩ to ⑰ indicate the following.

- ⑩ Serviceable with engine mounted
- ⑪ Filling fluid
- ⑫ Lubricant
- ⑬ Special tool
- ⑭ Tightening torque
- ⑮ Wear limit, clearance
- ⑯ Engine speed
- ⑰ Electrical data

Symbols ⑱ to ㉓ in the exploded diagrams indicate the types of lubricants and lubrication points.

- ⑱ Apply engine oil
- ⑲ Apply gear oil
- ⑳ Apply molybdenum disulfide oil
- ㉑ Apply wheel bearing grease
- ㉒ Apply lightweight lithium-soap base grease
- ㉓ Apply molybdenum disulfide grease

Symbols ㉔ to ㉕ in the exploded diagrams indicate the following:

- ㉔ Apply locking agent (LOCTITE®)
- ㉕ Use new one

CONTENTS

GENERAL INFORMATION

FEATURES	1
SPEEDOMETER	1

SPECIFICATIONS

GENERAL SPECIFICATIONS	2
MAINTENANCE SPECIFICATIONS	3
ENGINE	3
CHASSIS	4
CABLE ROUTING	7

PERIODIC INSPECTIONS AND ADJUSTMENTS

PERIODIC MAINTENANCE/LUBRICATION INTERVALS	19
CHASSIS	21
ADJUSTING THE FRONT FORK LEGS	21

CHASSIS

FRONT FORK	22
CHECKING THE FRONT FORK LEGS	23
ASSEMBLING THE FRONT FORK LEGS	23

ELECTRICAL

SIGNAL SYSTEM	26
CIRCUIT DIAGRAM	26
SIGNAL SYSTEM CHECK	28
CLOCK	31

FZS600 2000 WIRING DIAGRAM



GENERAL INFORMATION

FEATURES SPEEDOMETER

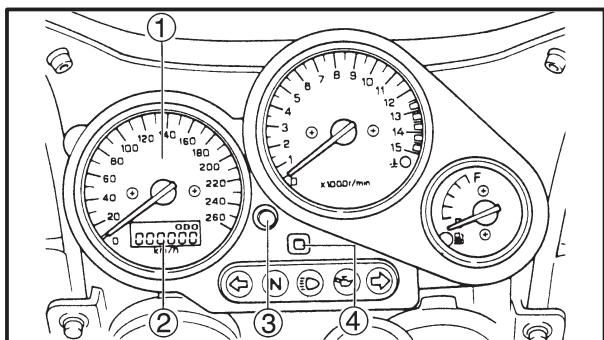

- ① Speedometer
- ② Odometer/Tripmeter/Clock
- ③ "SELECT" button
- ④ "RESET" button

This speedometer is equipped with:

- an odometer
- two tripmeters
- a clock

Odometer and tripmeter modes

When set to "ODO", the motorcycle's total mileage is indicated.

When set to "TRIP 1" or "TRIP 2", the motorcycle's mileage since the tripmeter was last reset is indicated. Use the tripmeters to estimate how far you can ride on a tank of fuel. This information will enable you to plan fuel stops in the future.

Selecting a mode

Push the "SELECT" button ③ to change between the odometer mode "ODO", the tripmeter modes "TRIP 1" and "TRIP 2", and the clock mode in the following order:

"ODO" → "TRIP 1" → "TRIP 2" → Clock → "ODO"

Resetting a meter

To reset either tripmeter 1 or 2 to 0.0, select either by pushing the "SELECT" button ③ and push the "RESET" button ④ for at least one second.

Clock mode

To change the display to the clock mode, push the "SELECT" button ③.

To change the display back to the odometer mode, push the "SELECT" button ③.

To set the clock

1. Push both the "SELECT" button ③ and "RESET" button ④ for at least two seconds.
2. When the hour digits start flashing, push the "RESET" button ④ to set the hours.
3. Push the "SELECT" button ③ to change the minutes.
4. When the minute digits start flashing, push the "RESET" button ④ to set the minutes.
5. Push the "SELECT" button ③ to start the clock.

NOTE:

After setting the clock, be sure to push the "SELECT" button before turning the main switch to "OFF", otherwise the clock will not be set.



SPECIFICATIONS

GENERAL SPECIFICATIONS

Model	FZS600
Model code:	5DM7 5DM8 5DM9
Fuel: Type Fuel tank capacity Fuel reserve amount	Regular unleaded gasoline 20 L 3.5 L
Tire pressure: Maximum load-except motorcycle Loading condition A* front rear Loading condition B* front rear High-speed riding front rear	187 kg 0 ~ 90 kg 225 kPa (2.25 kg/cm ² , 2.25 bar) 250 kPa (2.5 kg/cm ² , 2.5 bar) 90 ~ 187 kg 225 kPa (2.25 kg/cm ² , 2.25 bar) 290 kPa (2.9 kg/cm ² , 2.9 bar) 225 kPa (2.25 kg/cm ² , 2.25 bar) 290 kPa (2.9 kg/cm ² , 2.9 bar)
Bulb voltage, wattage × quantity: Headlight Marker light Brake/tail light Front turn signal light Rear turn signal light Meter light Indicator light Neutral indicator light High beam indicator light Oil level warning light Turn indicator light Fuel level warning light Engine temperature warning light	12 V 60 W/55 W × 1 12 V 5 W × 1 12 V 21 W/5 W × 2 12 V 21 W × 2 12 V 21 W × 2 12 V 2 W × 3 14 V 1.4 W × 1 14 V 1.4 W × 1 14 V 1.4 W × 1 14 V 1.4 W × 2 12 V 2 W × 1 LED

*Load is the total weight of cargo, rider, passenger and accessories.



MAINTENANCE SPECIFICATIONS

ENGINE

Item	Standard	Limit
Valve spring:		
Free length IN/EX	40.09 mm	37.5 mm
Set length (valve closed) IN/EX	34.5 mm	•••
Compressed pressure IN/EX	131.4 ~ 153.0 N (13.4 ~ 15.6 kg)	•••
Tilt limit IN/EX	•••	2.5°/1.8 mm
Direction of winding IN/EX	Clockwise	•••
Carburetor:		
I.D. mark	5DM1 01 (GB) (N) (SF) (DK) (D) (NL) (B) (F) (E) (P) (IRL) (GR)	•••
	5DM2 11 (D) (F)	•••
Main jet (M.J)	#115	•••
Main air jet (M.A.J)	#80	•••
Jet needle (J.N)	5D86-3/5 (GB) (N) (SF) (DK) (D) (NL) (B) (F) (E) (P) (IRL) (GR)	•••
	5D92-3/5 (D) (F)	•••
Needle jet (N.J)	P-0	•••
Pilot air jet (P.A.J.1)	#130	•••
Pilot outlet (P.O)	0.95	•••
Pilot jet (P.J)	#12.5	•••
Bypass 1 (B.P.1)	0.9	•••
Bypass 2 (B.P.2)	0.8	•••
Bypass 3 (B.P.3)	0.8	•••
Pilot screw (P.S)	2	•••
Valve seat size (V.S)	1.0	•••
Starter jet (G.S.1)	0.6	•••
Starter jet (G.S.2)	0.8	•••
Throttle valve size (TH.V)	#110	•••
Fuel level (F.L) (with special tool)	3.5 mm	•••
Engine idle speed	1,150 ~ 1,250 r/min	•••
Intake vacuum	30.7 ~ 33.3 kPa (230 ~ 250 mmHg)	•••

MAINTENANCE SPECIFICATIONS

SPEC

CHASSIS

Item	Standard	Limit
Front suspension:		
Front fork travel	120 mm	•••
Fork spring free length	316.8 mm	319 mm
Fitting length	309.8 mm	•••
Collar length	183 mm	•••
Spring Rate (K1)	7.35 N/mm (0.75 kg/mm)	•••
(K2)	13.72 N/mm (1.4 kg/mm)	•••
Stroke (K1)	0 ~ 70 mm	•••
(K2)	70 ~ 120 mm	•••
Optional spring	No	•••
Oil capacity	465 cm ³	•••
Oil level	132 mm	•••
Oil grade	Fork oil 10W or equivalent	•••
Drive chain:		
Type/manufacturer	50VA7/DAIDO	•••
No. of links	110	•••
Chain free play	30 ~ 45 mm	•••

TIGHTENING TORQUES

CHASSIS

Part to be tightened	Thread size	Tightening torque		Remarks
		Nm	m•kg	
Holder, clutch lever 1	M6 × 1.0	11	1.1	

MAINTENANCE SPECIFICATIONS

SPEC

ELECTRICAL

Item	Standard	Limit
Ignition system: Ignition timing (B.T.D.C.) Advanced timing (B.T.D.C.) Advance type	10°/1,250 r/min 50°/4,500 r/min Digital type
T.C.I.: Pickup coil resistance T.C.I. unit model/manufacture	189 ~ 231 Ω Y-L J4T095/MITSUBISHI
Charging system: Type Model/manufacture Standard output Stator coil resistance	A.C. magneto F4T359/MITSUBISHI 14 V 18 A at 5,000 r/min 0.36 ~ 0.44 Ω at 20°C/W-W
Starter motor: Model/manufacture I.D. number Output Armature coil resistance Brush overall length Brush spring pressure Commutator dia. Mica undercut (depth) Mica undercut (width)	SM-13/MITSUBA SM-13 0.7 kW 0.0015 ~ 0.0025 Ω at 20°C 10 mm 7.64 ~ 10.00 N (779 ~ 1,020 gf) 28 mm 0.7 mm 0.8 mm 4 mm ... 27 mm
Starter relay: Model/manufacture Amperage rating Coil winding resistance	MS5F-631/JIDECO 180 A 4.18 ~ 4.62 Ω at 20°C
Horn: Type Quantity Model/manufacture Maximum amperage Performance Coil winding resistance	Plane type 1 pcs YF-12/NIKKO 3.0 A 105 ~ 113 db/2 m 1.15 ~ 1.25 Ω at 20°C
Flasher/hazard relay: Type Model/manufacture Self cancelling device Hazard flasher device Flasher frequency Wattage	Full transistor type FE246BH/DENSO No Yes 75 ~ 95 cyl/min 21 W × 2 + 3.4 W
Thermostat switch: Model/manufacture	4BA/DENSO	...

MAINTENANCE SPECIFICATIONS

SPEC



Item	Standard	limit
Starting circuit cut-off relay:		
Model/manufacture	G8R-30Y-B/OMRON	...
Coil winding resistance	202.5 ~ 247.5 Ω at 20°C	...
Fuel pump relay:		
Model/manufacture	G8R-30Y-B/OMRON	...
Coil winding resistance	202.5 ~ 247.5 Ω at 20°C	...
Amperage for individual circuit:		
Main	30 A	...
Headlight	20 A	...
Signal	20 A	...
Ignition	20 A	...
Fan	10 A	...
Parking/Hazard	10 A	...
Back up	5 A	...
Reserve	30 A	...
	20 A	...
	10 A	...
	5 A	...

EB205000

CABLE ROUTING

- ① Throttle cable
- ② Clutch cable
- ③ Handlebar switch (left)
- ④ Starter cable
- ⑤ Main switch
- ⑥ Main switch lead
- ⑦ Brake hose
- ⑧ Speed sensor lead
- ⑨ Headlight lead
- ⑩ Handlebar switch (right)

- A Use a plastic band to fasten together the handlebar switch lead (L) and the handlebar.
- B Use a plastic clamp to fasten together the handlebar switch lead (left), clutch cable and starter cable
- C Pass the speed sensor lead inside of the clamp code.
- D Pass the brake hose outside of the speed sensor lead, then use a plastic clamp to fasten them.

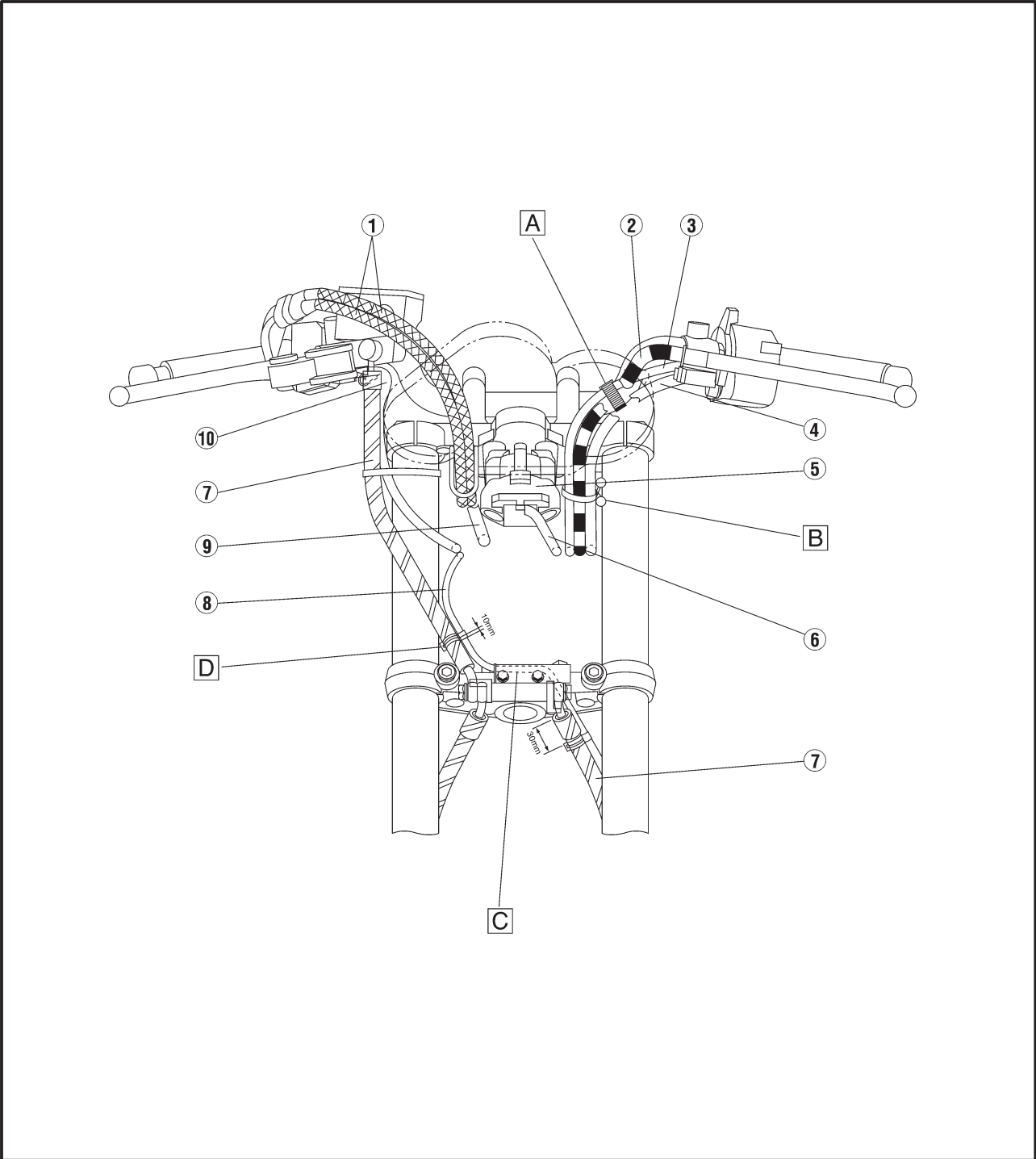

CABLE ROUTING

SPEC



- | | | |
|--------------------------------|-----------------------------|----------------------------|
| ① Main switch lead | ⑫ Flasher lery | ⑳ Sidestand switch lead |
| ② Handlebar switch lead (left) | ⑬ Battery | ㉑ Neutral switch lead |
| ③ Clutch cable | ⑭ Starter relay | ㉒ Oil level switch lead |
| ④ Starter cable | ⑮ Battery positive (+) lead | ㉓ Radiator |
| ⑤ Rectifier/regulator | ⑯ Seat lock cable | ㉔ Rectifier/regulator lead |
| ⑥ Horn lead | ⑰ Seat lock stay | ㉕ Horn |
| ⑦ Box | ⑱ Cross tube | ㉖ Speed sensor lead |
| ⑧ Air guide plate | ⑲ AC magneto lead | ㉗ Brake hose |
| ⑨ Fan motor lead | ⑳ Starter motor lead | ㉘ Horn lead |
| ⑩ High tension code | ㉑ Air filter drain hose | ㉙ Horn bracket |
| ⑪ Relay assembly | ㉒ Neutral switch | ㉚ Rear fender |

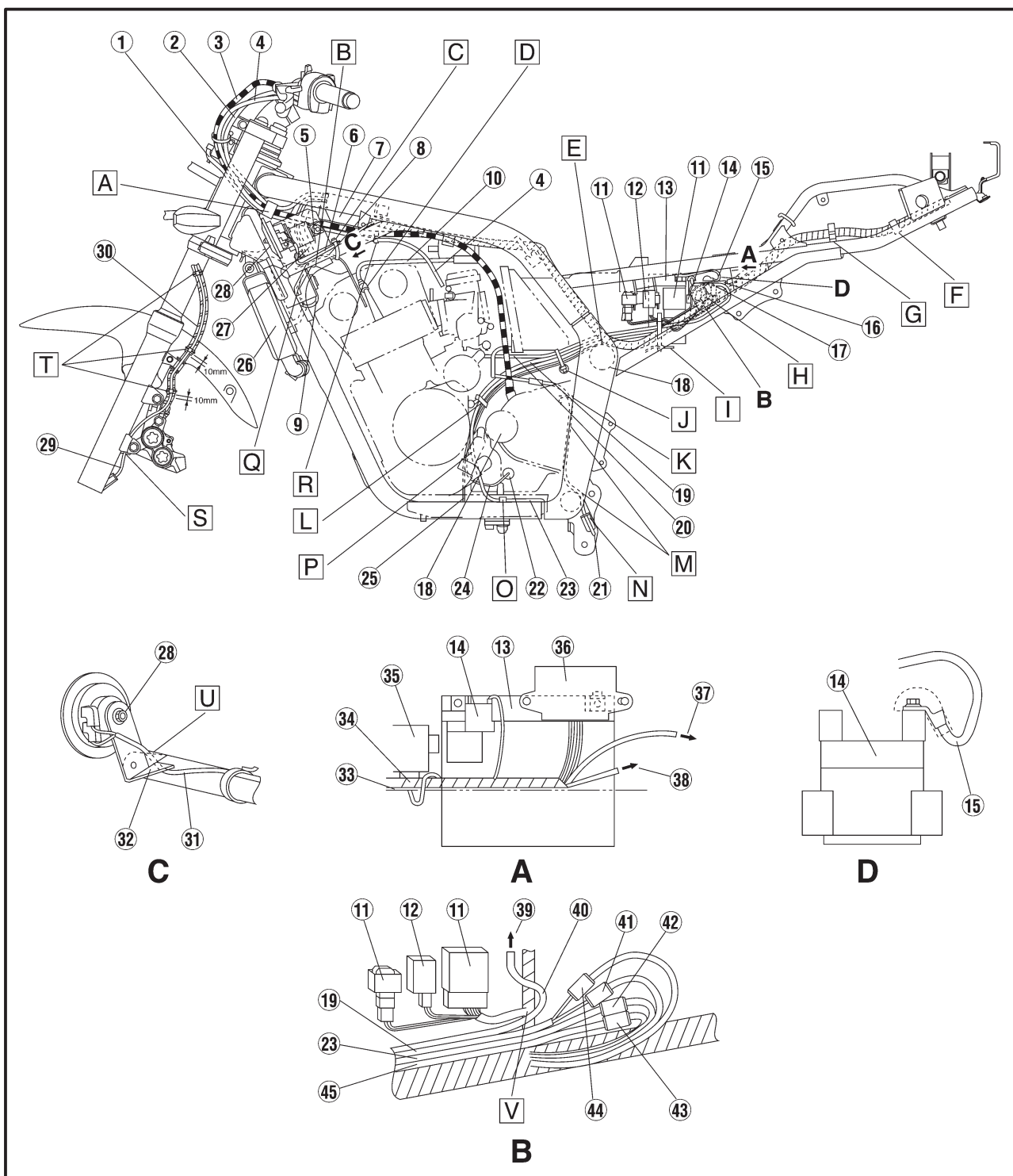

CABLE ROUTING



- ③4 Wire harness
- ③5 Relay
- ③6 Fuse box
- ③7 To front brake switch
- ③8 To battery negative (-) lead
- ③9 To starter relay
- ④0 Starter motor lead
- ④1 Pickup coupler
- ④2 Sidestand switch coupler
- ④3 Oil level/neutral switch coupler
- ④4 AC magneto coupler

- ④5 Oil level/neutral switch lead
- A Use a plastic clamp to fasten the handlebar switch lead (left), main switch lead, clutch cable and starter cable to the frame.
- B Pass the fan motor lead through the guide gear, then into the box.
- C Use a plastic clamp to fasten the horn lead and air guide plate to the frame.

- D When installing the plug cap, the high tension code should be facing the inside of the body.
- E Pass the wire harness, starter motor lead, AC magneto lead, sidestand switch lead and oil/neutral switch lead over the cross tube.
- F Use a plastic clamp to fasten together the wire harness and the frame.

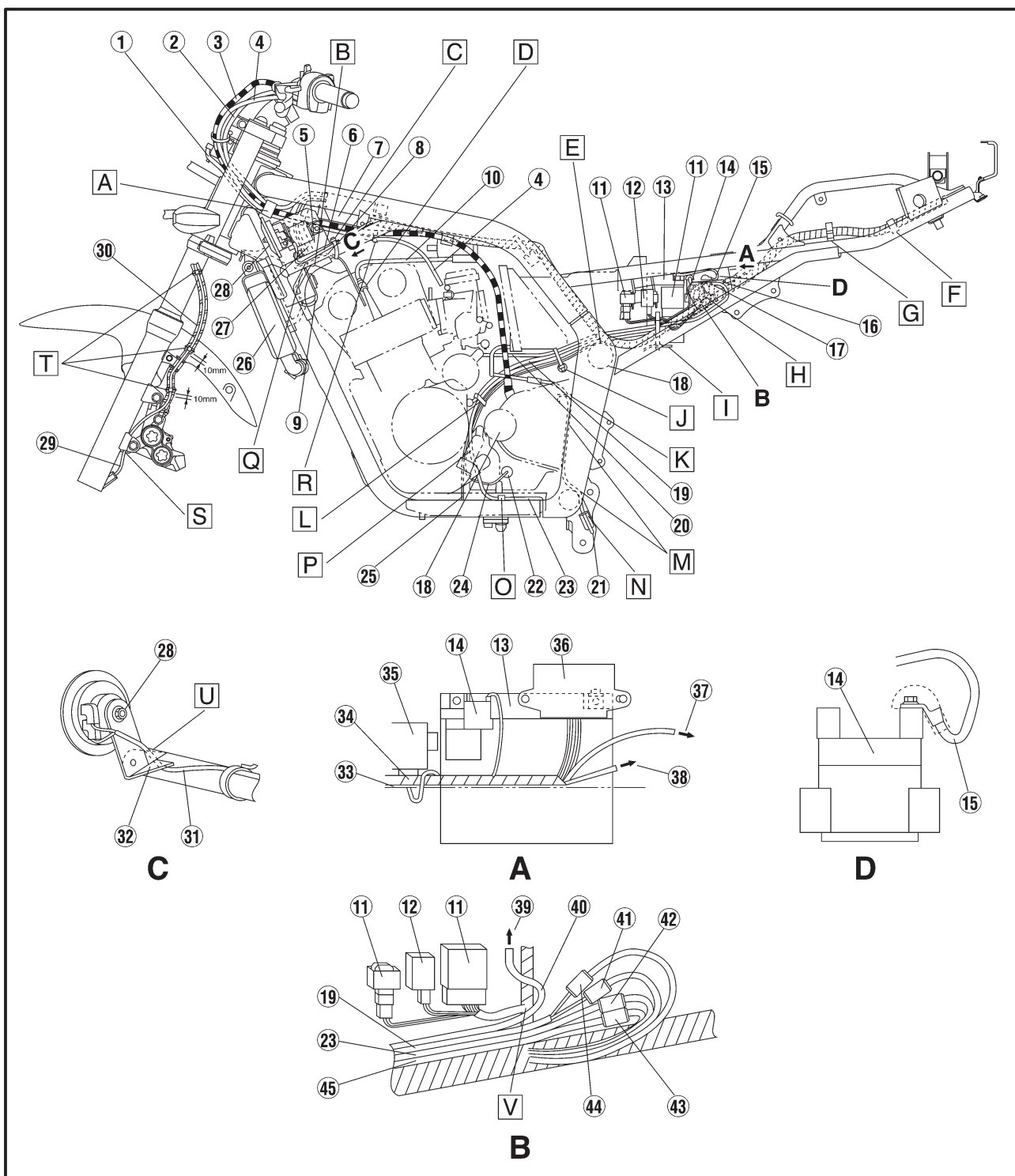

CABLE ROUTING



- G** Use a plastic clamp to fasten together the wire harness and the frame.
- H** Push couplers into the lock stay of the frame after connecting wires.
- I** Use a plastic band to fasten together wireharness, starter motor lead, AC magneto lead, sidestand switch lead and oil level/neutral switch lead, then hold the clamp to the frame bracket. Position the band end to out side of chassis.
- J** Use a plastic locking tie to fasten the starter motor lead, AC magneto lead, sidestand switch lead and oil level/neutral switch lead to the frame bracket. Cut off the excess end of the tie.
- K** Pass the air cleaner drain hose through the engine clamp.
- L** Use a steel holder to fasten together the AC magneto lead, sidestand lead and oil level/neutral switch lead.
- M** Pass the air cleaner drain hose in front of the rear arm pivot shaft and back of the cross tube.
- N** Pass the air cleaner drain hose through the pipe holder of rear shock absorber bracket, then draw it out to the left side of the body.

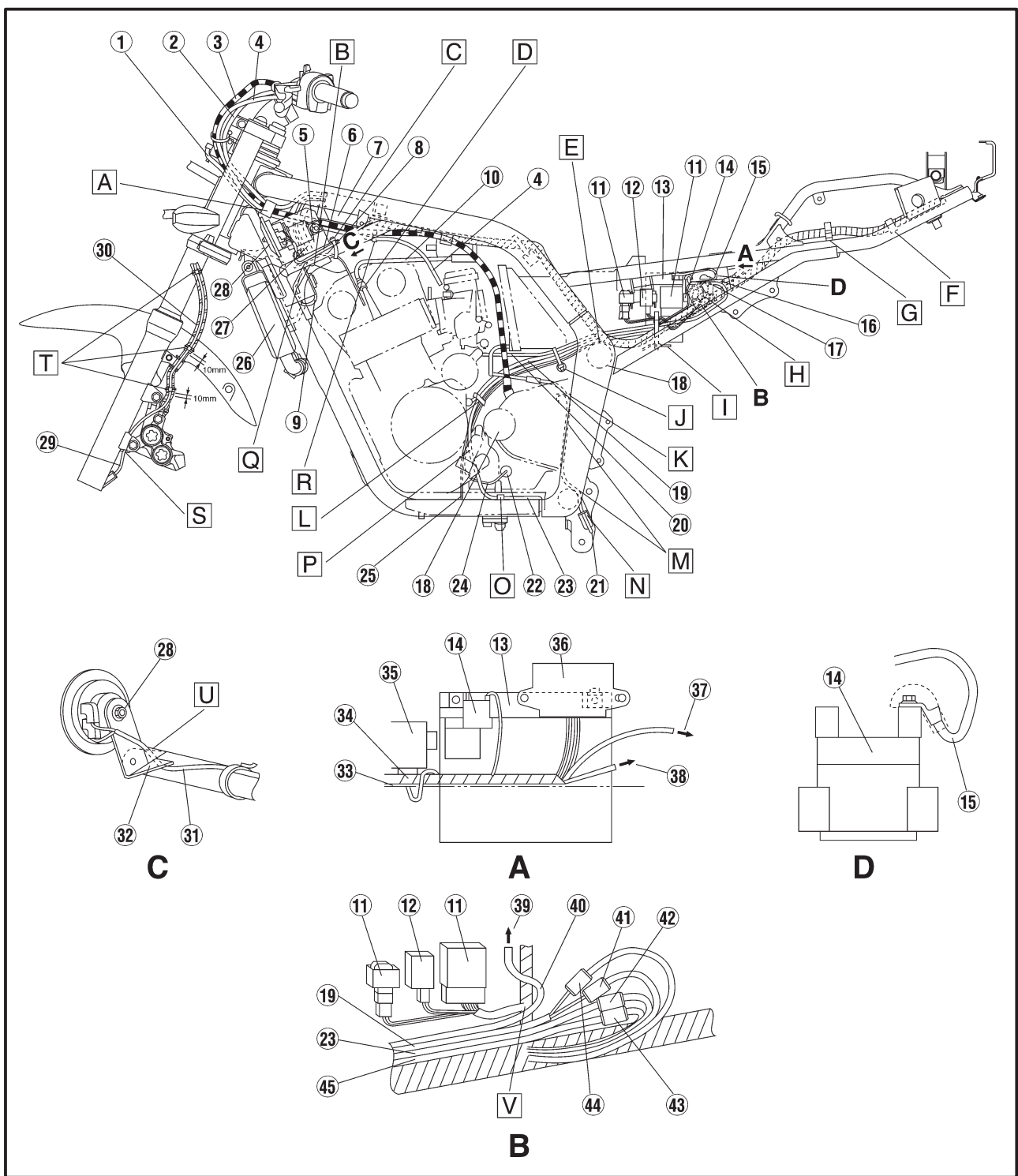

CABLE ROUTING



- Q** Use a plastic clamp to fasten together the sidestand switch lead and the frame.
- P** Pass the sidestand switch lead through the bottom of the coolant pipe.
- Q** Do not loosen the fan motor lead here.
- R** Pass the clutch cable and starter cable outside of high tension code#1.
- S** Use a steel holder to fasten together the speed sensor lead and outer tube.
- T** Use a plastic clamp to fix the speed sensor lead at 3 points after running the lead along the outside of the brake hose. First. Fasten the bottom end of the speed sensor lead without loosening. Second. Fasten the lead several times from the bottom end by running along the brake hose.
- U** Pass the horn lead under the horn bracket, then connect it at the back of the horn.
- V** Pass only the starter lead through the bottom of the joint of wire harness.

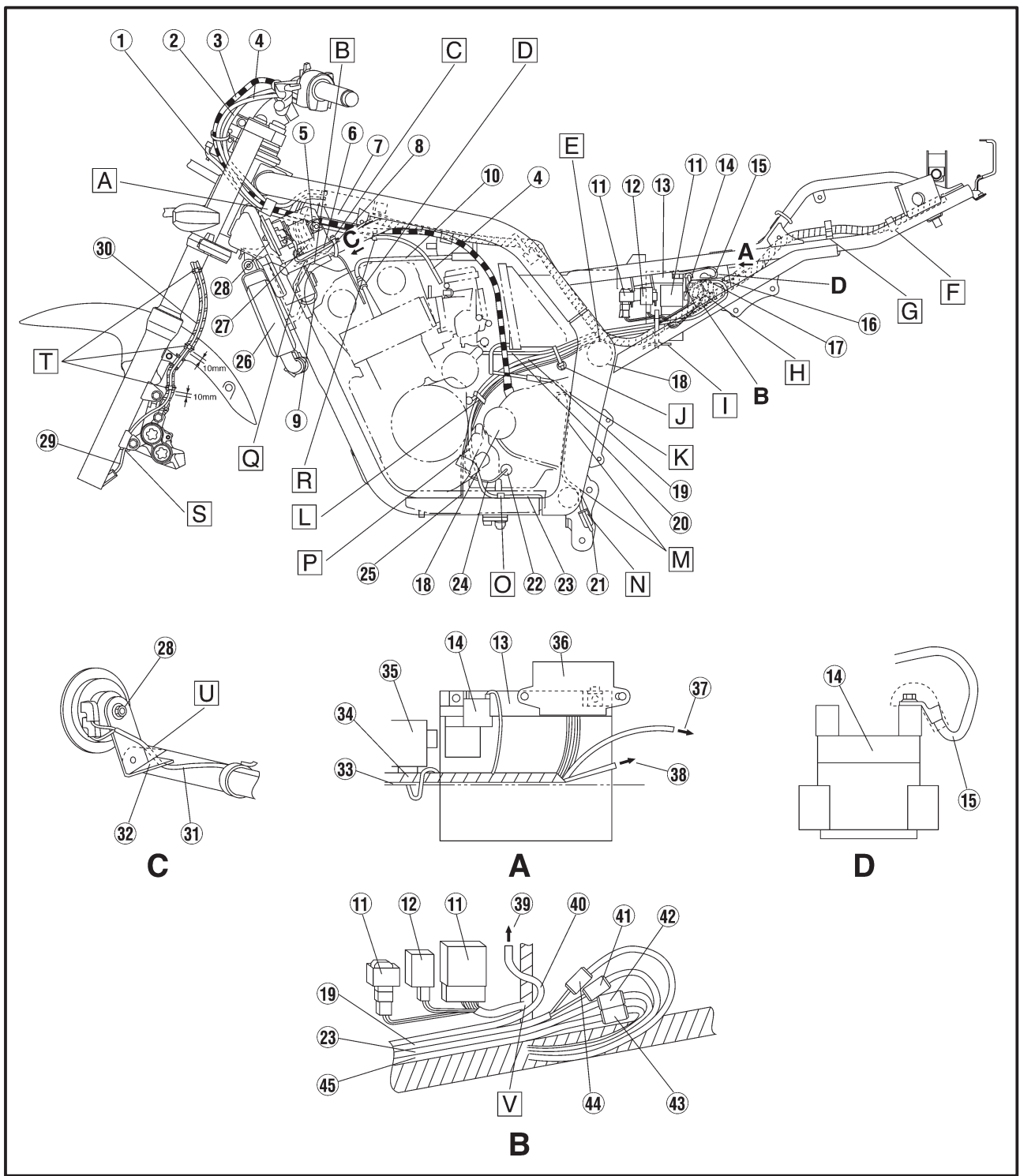

CABLE ROUTING



- ① Rear brake switch lead
- ② Battery
- ③ Reservoir tank over flow hose
- ④ Cross tube
- ⑤ Battery negative (-) lead
- ⑥ Reservoir tank hose
- ⑦ Air filter
- ⑧ To fuel tank
- ⑨ Fuel tank breather hose
- ⑩ Fuel tank drain hose
- ⑪ T.P.S. lead
- ⑫ Box
- ⑬ Speed sensor lead
- ⑭ Handlebar switch lead (right)
- ⑮ Throttle cable
- ⑯ Brake hose
- ⑰ Guide wire
- ⑱ Headlight lead
- ⑲ Main switch lead
- ⑳ Reservoir tank
- ㉑ Air filter box bracket
- ㉒ Swingarm bracket
- ㉓ Engine bracket

- A** Pass the fuel tank drain hose, fuel tank breather hose and reservoir tank over flow pipe between the rear arm and the engine crankcase.
- B** Pass the fuel tank drain hose and fuel tank breather hose between air filter joint #3 and #4. After installing the fuel tank, pull it down toward the air filter joint so that there will be no bend of loosening between them.

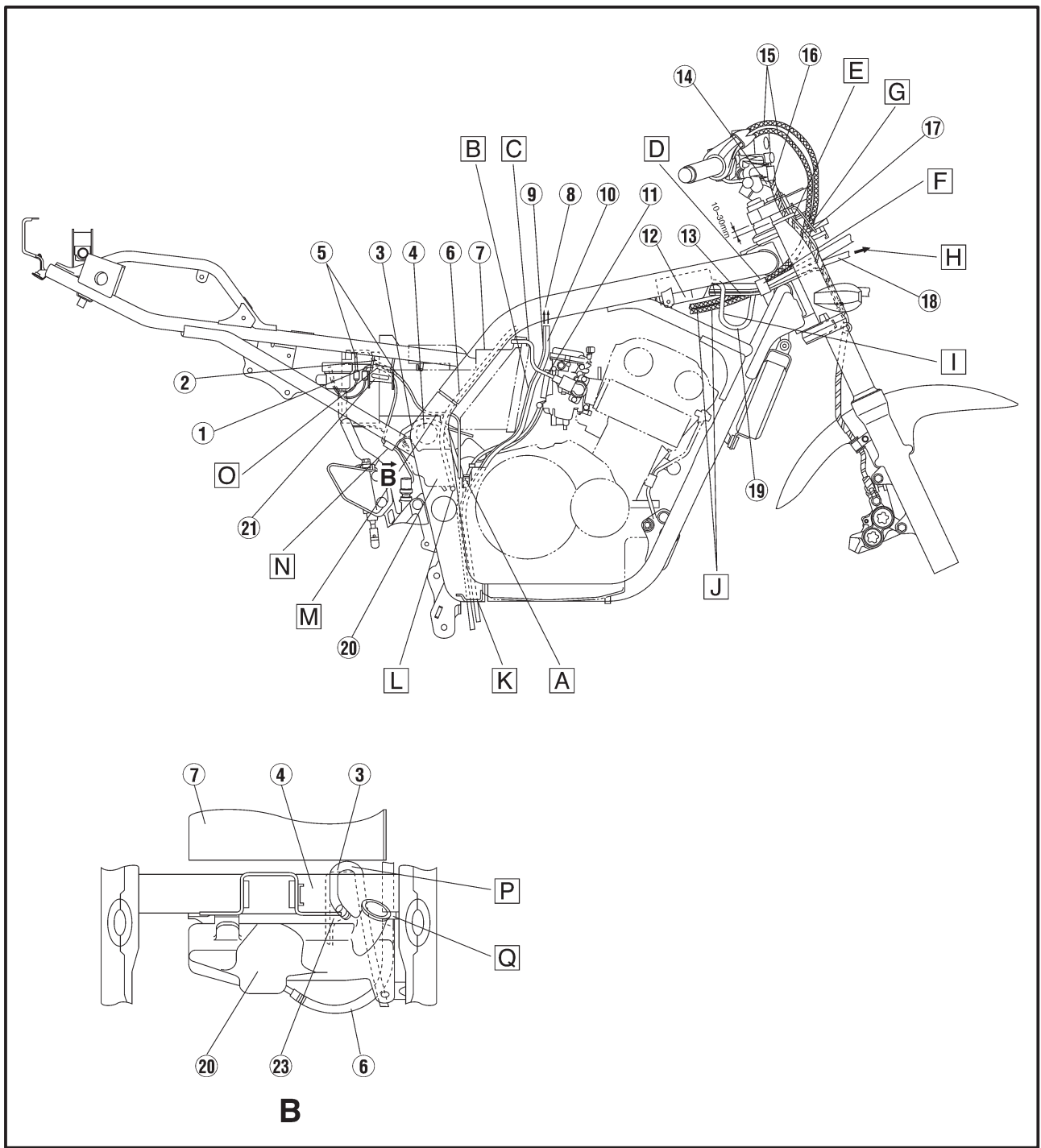

CABLE ROUTING

SPEC



- C** Pass the T.P.S lead as shown, then install cover to the air filter case.
- D** Use a plastic clamp to fasten together the throttle cables, headlight lead, handlebar switch (right) and speed sensor lead.
- E** Use a plastic locking tie to fasten the handlebar switch (right) and brake hose to the right front fork inner tube.
- F** Pass the throttle cable, with the pull side up, through the center of the clamp.
- G** Pass the throttle cable through the guide wire installed to the handle crown.
- H** To front cowling.
- I** Pass the main switch lead under the throttle cables, headlight lead, handlebar switch lead (right) and speed sensor lead, then insert it right side of the box.
- J** Pass the throttle cable under the box.
- K** Pass the reservoir tank over flow hose and fuel tank drain hose through the cable holder.
- L** To coolant reservoir tank.
- M** Pass the battery negative (-) lead inside of the reservoir hose.
- N** Use the plastic clamp to fasten together the rear brake switch lead and the frame. The latch of the clamp must face the outside of the body.

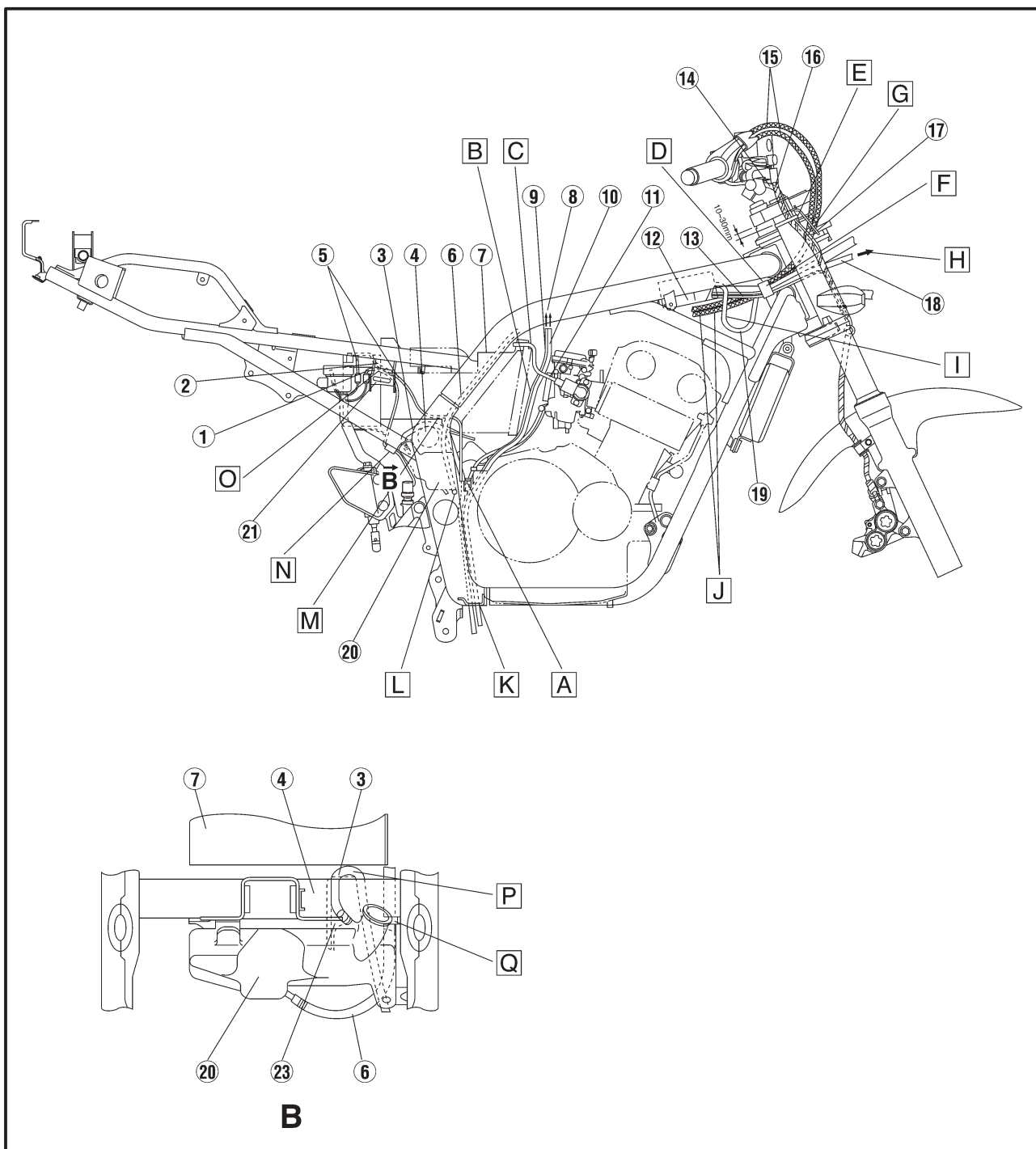

- Pass the battery negative lead and rear brake switch lead inside the air filter bracket of the frame.
- Pass the reservoir tank over flow pipe between the air filter case and cross tube, and then outside of engine bracket.
- Use a clamp to fasten together the coolant reservoir hose and the bracket rear arm.

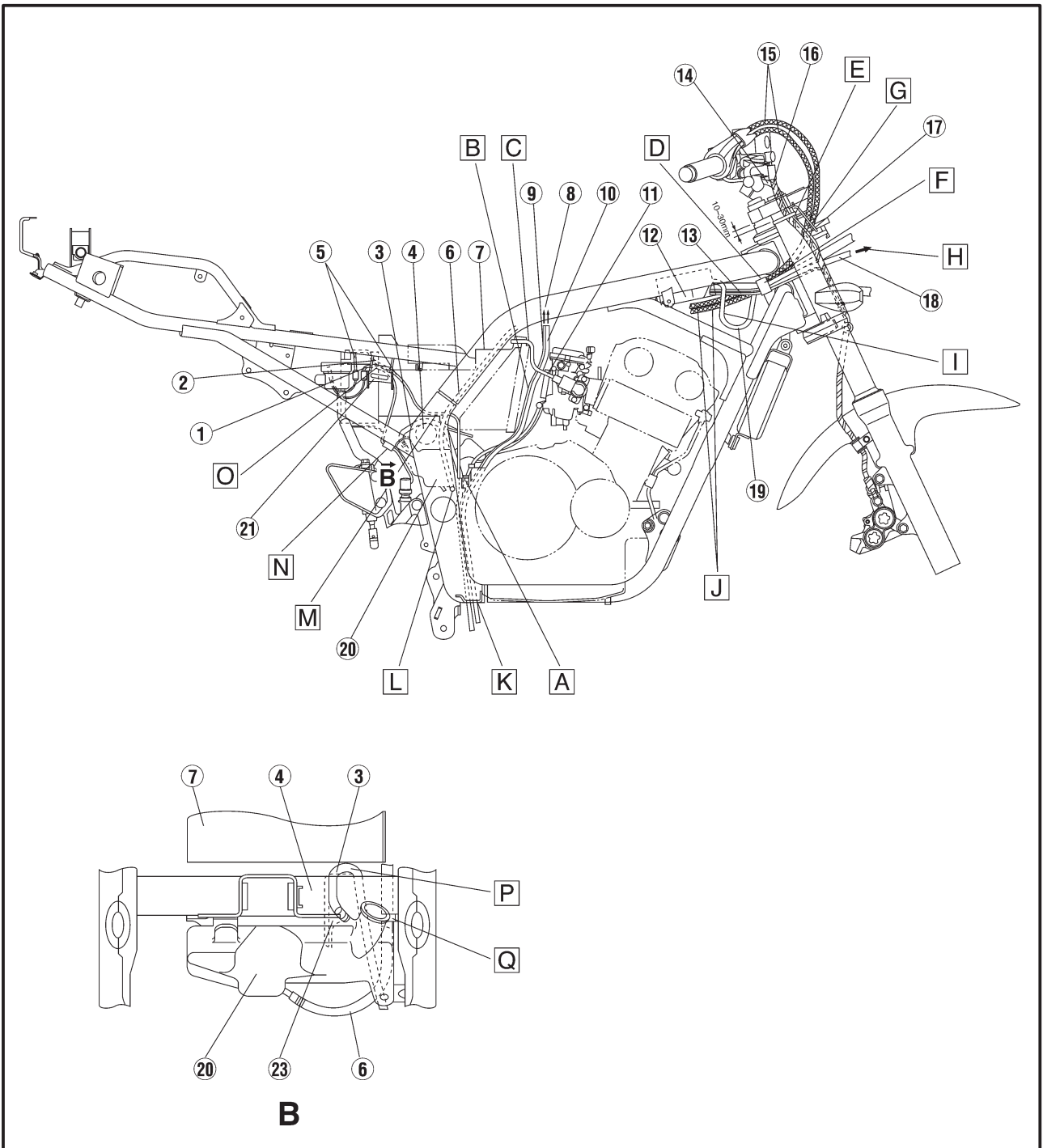

CABLE ROUTING

SPEC



- | | | |
|---------------------------------|-----------------------------|---------------------------------------|
| ① Throttle cable | ⑬ Pipe | ⑳ Ignitor |
| ② Speed sensor lead | ⑭ Fuel hose | ㉑ Rear turn signal light lead (right) |
| ③ Handlebar switch lead (right) | ⑮ T.P.S lead | ㉒ Taillight lead |
| ④ Headlight lead | ⑯ Fuel pipe | ㉓ Rear turn signal light lead (left) |
| ⑤ Thermostat housing | ⑰ Fuel sender, coupler | ㉔ Taillight bracket |
| ⑥ Carburetor heater hose | ⑱ Battery negative (-) lead | ㉕ Starter motor lead |
| ⑦ Reservoir tank hose | ⑲ Battery | ㉖ Starter relay |
| ⑧ Throttle cable | ㉑ Rear brake hose | ㉗ Relay |
| ⑨ Fuel pump | ㉒ Rear brake reservoir tank | ㉘ Relay assembly |
| ⑩ Fuel filter | ㉓ Rear brake switch lead | ㉙ Wire harness |
| ⑪ Fuel tank breather hose | ㉔ Fuse box | ㉚ Fuel pump lead coupler |
| ⑫ Fuel tank drain hose | ㉕ Seat lock cable | ㉛ Ignition coil |

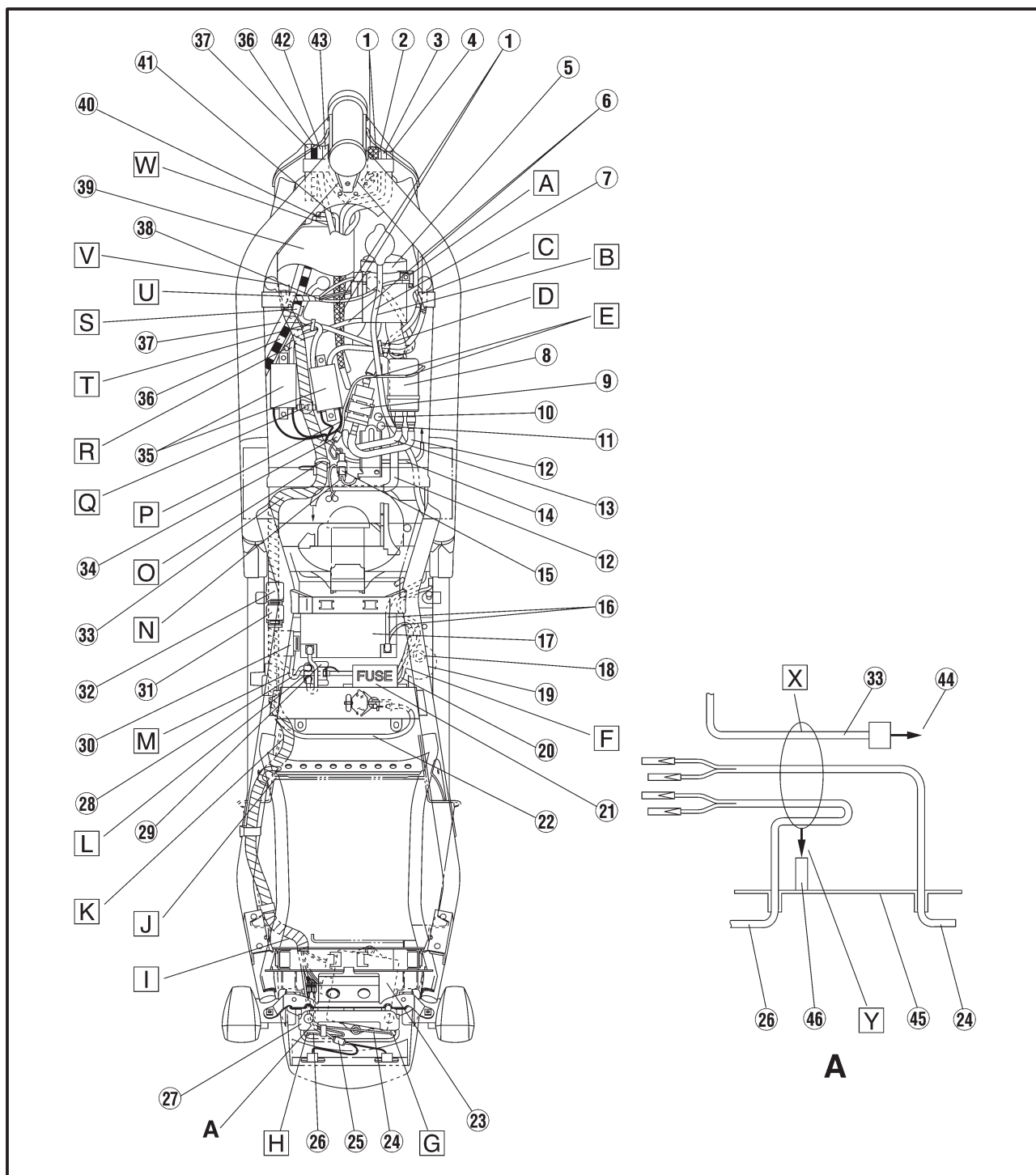

CABLE ROUTING



- ③7 Clutch cable
- ③8 Starter cable
- ③9 Ground lead
- ④0 Box
- ④1 Fan motor lead
- ④2 Rectifier/regulator lead.
- ④3 Handlebar switch lead (left)
- ④4 Main switch lead
- ④5 Wire harness
- ④6 To taillight
- ④7 Rear fender
- ④8 Clamp

- A Tighten the ground lead and the thermostat housing together with a bolt.
- B Pass the reservoir hose left side of thermo stat housing.
- C Do not fasten the high tension cord #4 with locking tie.
- D Use a plastic band to fasten the high tension cord #3, #4.
- E Fuel pump lead comes over.
- F Pass the rear brake switch lead and battery negative lead under

- the coolant reservoir tank, between the reservoir hose and the battery, then are connected at the right side of the battery.
- G Pass the rear flasher lead (R) through the rear fender.
- H Pass the rear flasher lead (L) through the rear fender.
- I Pass the wire harness through the groove of the rear fender.
- J Wire harness shouldn't come top of the rear fender rib.

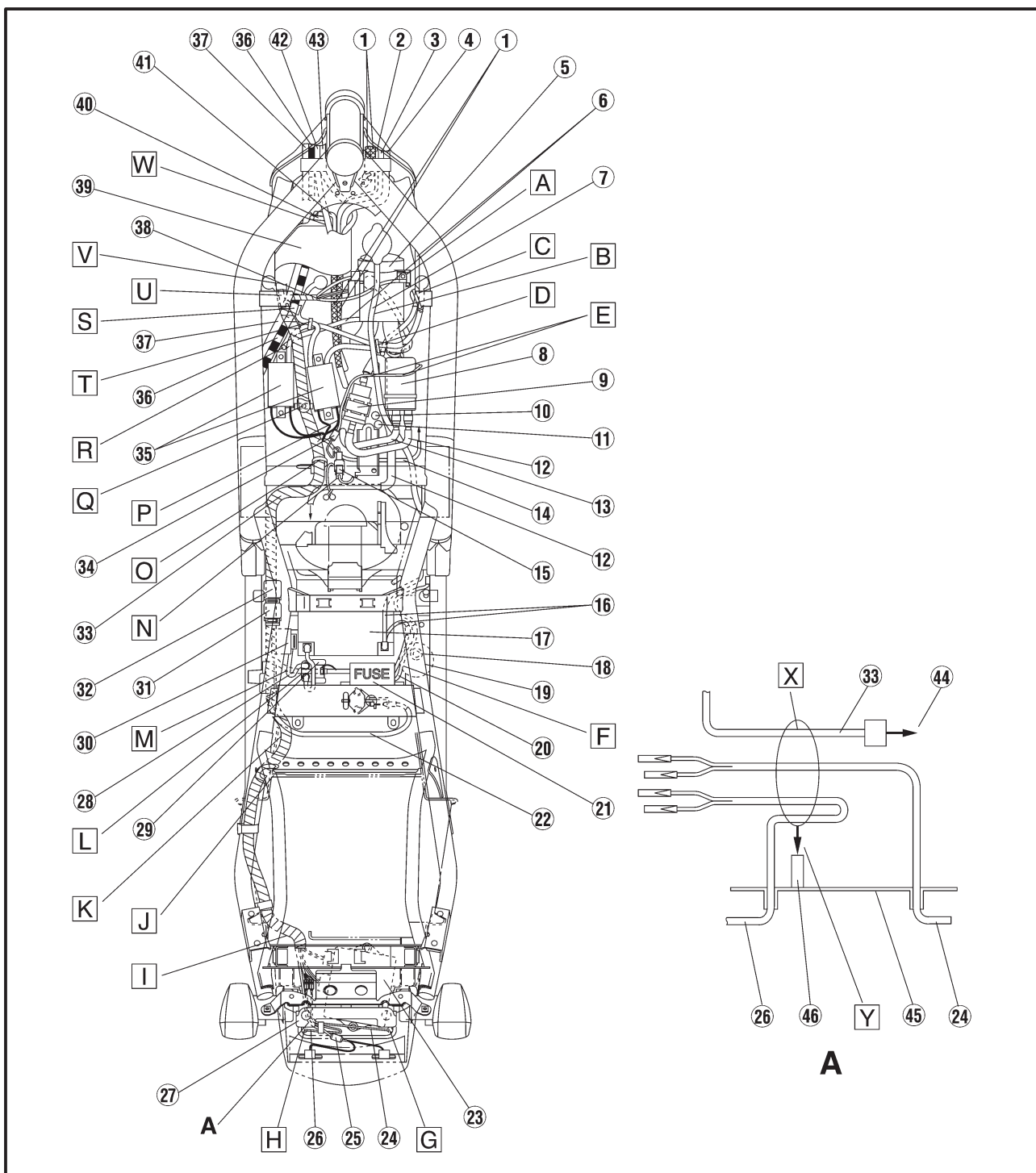

CABLE ROUTING



- K** Pass the wire harness inside of the rear fender rib.
- L** Pass the wireharness under the starter relay.
- M** Pass the starter motor lead under the joint of the harness, then pull upward.
- N** Set the fuel sender coupler in the cross pipe of the frame.
- O** Use a plastic clamp to fasten together the wire harness and cross pipe of the frame.
- P** Pass the fuel pump lead between the ignition coil and fuel filter, then push under.
- Q** Use a plastic clamp to fasten together the wire harness and stay.
- R** Pass the carburetor inlet hose under the high tension cord #2, #4.
- S** Use a clamp to fasten the clutch cable and starter cable.
- T** Use a plastic clamp to fasten high tension code #2, and #4.
- U** Set the clamp, which is fixed to the wire harness, in T-stud of the frame.
- V** Put the wire harness into the box through the groove at the back, then connect it in the box.

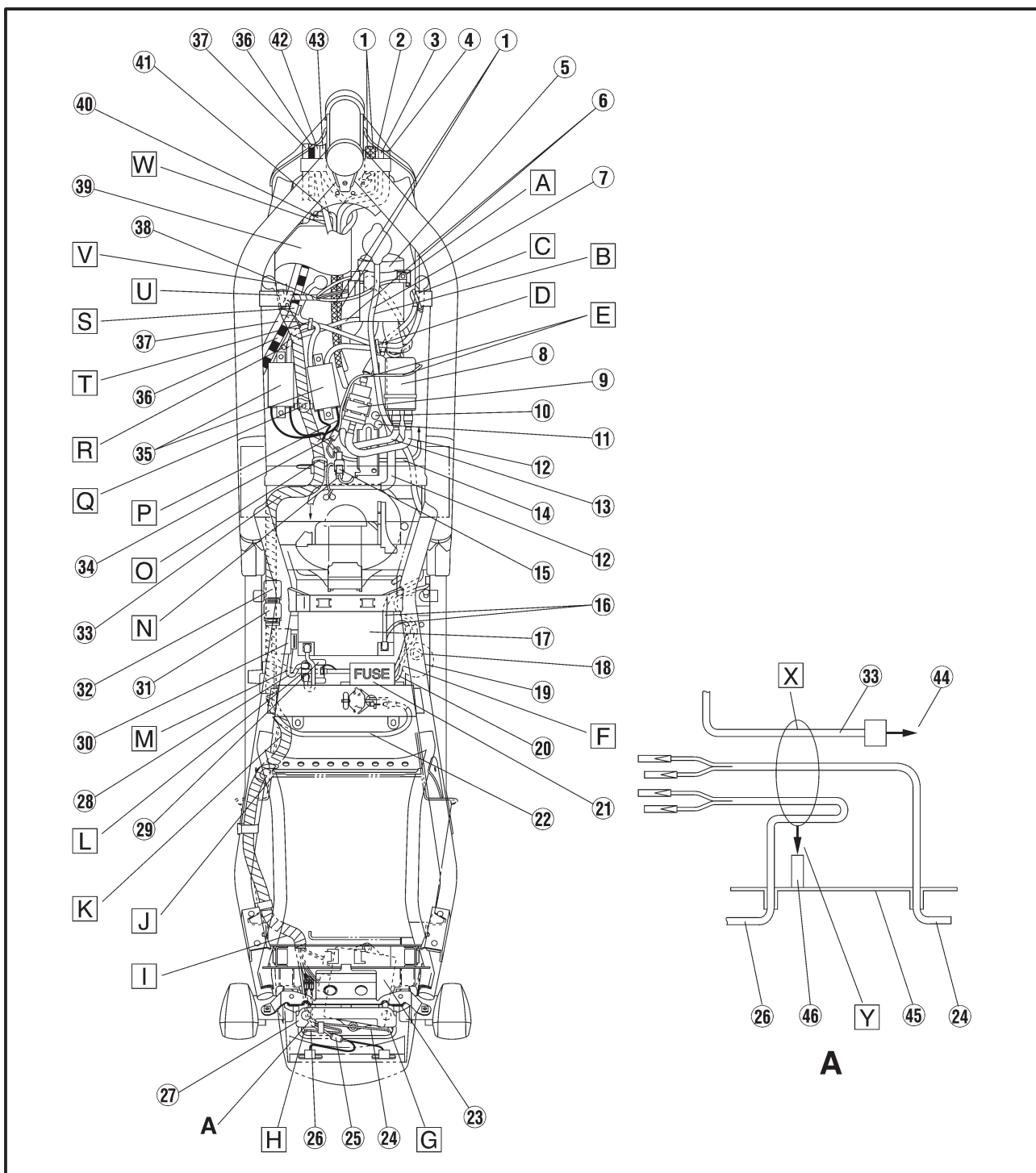



- W Pass the rectifier/regulator lead, fan motor lead, handlebar switch lead (left), main switch lead, headlight lead, handlebar switch lead (right) and speed sensor lead through front side of the box, then connect each coupler in the box.
- Y Align the connector position of rear turn signal light leads (left and right), then bend the rear
- X Use a plastic clamp to fasten the wire harness after passing always under the taillight bracket.

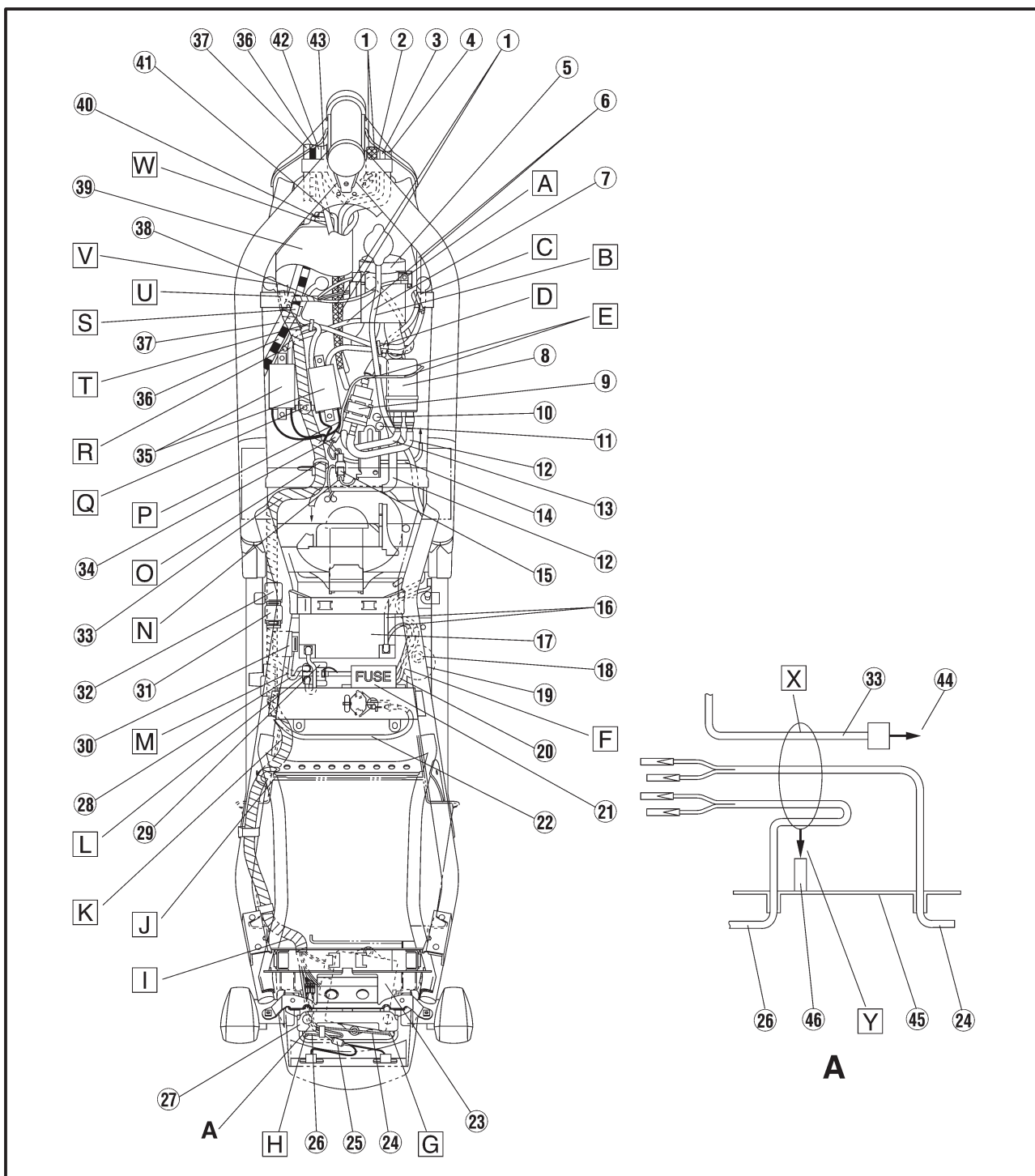

PERIODIC MAINTENANCE/LUBRICATION INTERVALS

**CHK
ADJ**



EB3000000

PERIODIC INSPECTIONS AND ADJUSTMENTS PERIODIC MAINTENANCE/LUBRICATION INTERVALS

NO.	ITEM	CHECKS AND MAINTENANCE JOBS	INITIAL (1,000 km)	EVERY	
				6,000 km or 6 months (whichever comes first)	12,000 km or 12 months (whichever comes first)
1	* Fuel line	<ul style="list-style-type: none"> • Check fuel hoses for cracks or damage. • Replace if necessary. 		√	√
2	* Fuel filter	<ul style="list-style-type: none"> • Check condition. • Replace if necessary. 			√
3	Spark plugs	<ul style="list-style-type: none"> • Check condition. • Clean, regap or replace if necessary. 	√	√	√
4	* Valves	<ul style="list-style-type: none"> • Check valve clearance. • Adjust if necessary. 	Every 42,000 km or 42 months (whichever comes first)		
5	Air filter	<ul style="list-style-type: none"> • Clean or replace if necessary. 		√	√
6	Clutch	<ul style="list-style-type: none"> • Check operation. • Adjust or replace cable. 	√	√	√
7	* Front brake	<ul style="list-style-type: none"> • Check operation, fluid level and vehicle for fluid leakage. (See NOTE) • Correct accordingly. • Replace brake pads if necessary. 	√	√	√
8	* Rear brake	<ul style="list-style-type: none"> • Check operation, fluid level and vehicle for fluid leakage. (See NOTE) • Correct accordingly. • Replace brake pads if necessary. 	√	√	√
9	* Wheels	<ul style="list-style-type: none"> • Check balance, runout and for damage. • Rebalance or replace if necessary. 		√	√
10	* Tires	<ul style="list-style-type: none"> • Check tread depth and for damage. • Replace if necessary. • Check air pressure. • Correct if necessary. 		√	√
11	* Wheel bearings	<ul style="list-style-type: none"> • Check bearing for looseness or damage. • Replace if necessary. 		√	√
12	* Swingarm	<ul style="list-style-type: none"> • Check swingarm pivoting point for play. • Correct if necessary. • Lubricate with molybdenum disulfide grease every 24,000 km or 24 months (whichever comes first). 		√	√
13	Drive chain	<ul style="list-style-type: none"> • Check chain slack. • Adjust if necessary. Make sure that the rear wheel is properly aligned. • Clean and lubricate. 	Every 1,000 km and after washing the motorcycle or riding in the rain		
14	* Steering bearings	<ul style="list-style-type: none"> • Check bearing play and steering for roughness. • Correct accordingly. • Lubricate with lithium soap base grease every 24,000 km or 24 months (whichever comes first). 		√	√
15	* Chassis fasteners	<ul style="list-style-type: none"> • Make sure that all nuts, bolts and screws are properly tightened. • Tighten if necessary. 		√	√

PERIODIC MAINTENANCE/LUBRICATION INTERVALS



NO.	ITEM	CHECKS AND MAINTENANCE JOBS	INITIAL (1,000 km)	EVERY	
				6,000 km or 6 months (whichever comes first)	12,000 km or 12 months (whichever comes first)
16	Sidestand/centerstand	<ul style="list-style-type: none"> • Check operation. • Lubricate and repair if necessary. 		√	√
17	* Sidestand switch	<ul style="list-style-type: none"> • Check operation. • Replace if necessary. 	√	√	√
18	* Front fork	<ul style="list-style-type: none"> • Check operation and for oil leakage. • Correct accordingly. 		√	√
19	* Rear shock absorber assembly	<ul style="list-style-type: none"> • Check operation and shock absorber for oil leakage. • Replace shock absorber assembly if necessary. 		√	√
20	* Rear suspension relay arm and connecting arm pivoting points	<ul style="list-style-type: none"> • Check operation. • Lubricate with molybdenum disulfide grease every 24,000 km or 24 months (whichever comes first). 		√	√
21	* Carburetors	<ul style="list-style-type: none"> • Check engine idling speed, synchronization and starter operation. • Adjust if necessary. 	√	√	√
22	Engine oil	<ul style="list-style-type: none"> • Check oil level and vehicle for oil leakage. • Correct if necessary. • Change. (Warm engine before draining.) 	√	√	√
23	Engine oil filter cartridge	<ul style="list-style-type: none"> • Replace. 	√		√
24	* Cooling system	<ul style="list-style-type: none"> • Check coolant level and vehicle for coolant leakage. • Correct if necessary. • Change coolant every 24,000 km or 24 months (whichever comes first). 		√	√

* Since these items require special tools, data and technical skills, they should be serviced by a Yamaha dealer.

NOTE: _____

- The air filter needs more frequent service if you are riding in unusually wet or dusty areas.
- Hydraulic brake system
 - When disassembling the master cylinder or caliper, always replace the brake fluid. Check the brake fluid level regularly and fill as required.
 - Replace the oil seals on the inner parts of the master cylinder and caliper every two years.
 - Replace the brake hoses every four years or if cracked or damaged.

CHASSIS

FRONT FORK

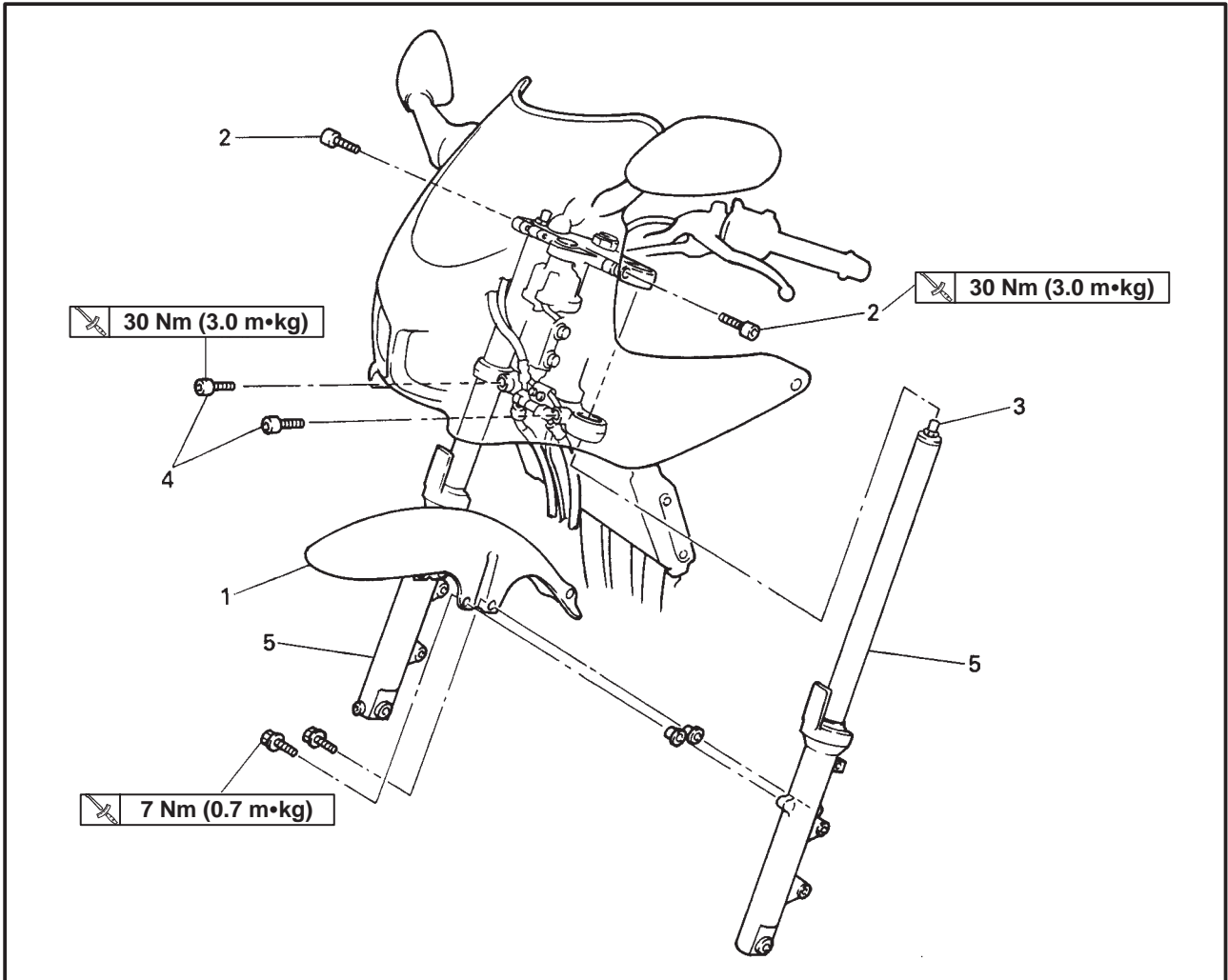

Order	Job name/Part name	Q'ty	Remarks
	Removing the front fork		
	Front wheel		Remove the parts in the order listed. Refer to "FRONT WHEEL AND BRAKE DISCS" section.
	Front brake calipers		Refer to "FRONT AND REAR BRAKES" section.
1	Front fender	1	
2	Bolt (upper bracket)	2	Loosen } Refer to "REMOVING/ INSTALLING THE FRONT FORK LEGS" section.
3	Cap bolt	2	
4	Bolt (lower bracket)	2	
5	Front fork assembly (left/right)	1/1	Refer to "REMOVING/INSTALLING THE FRONT FORK LEGS" section. For installation, reverse the removal procedure.

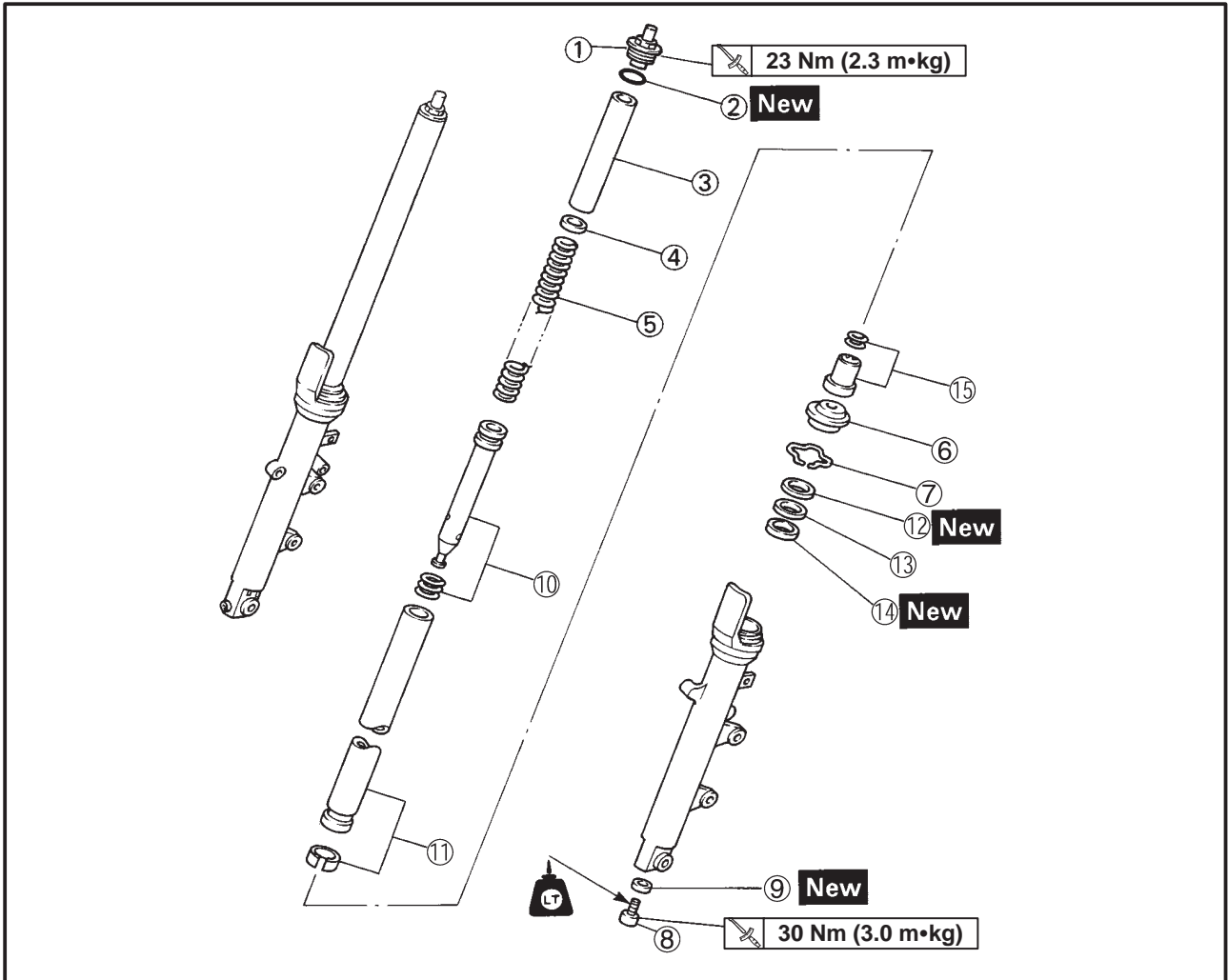

Order	Job name/Part name	Q'ty	Remarks
	Disassembling the front fork		Disassembly the parts in the order listed.
①	Cap bolt	1	Refer to "ASSEMBLING THE FRONT FORK LEGS" section.
②	O-ring	1	
③	Spacer	1	
④	Washer	1	
⑤	Front fork spring	1	
⑥	Dust seal	1	
⑦	Oil seal clip	1	
⑧	Bolt	1	
⑨	Gasket	1	
⑩	Damper rod/rebound spring	1/1	
⑪	Inner tube/Inner tube bushing	1	
⑫	Oil seal	1	
⑬	Washer	1	
			Refer to "DISASSEMBLING / ASSEMBLING THE FRONT FORK LEGS" section.

FRONT FORK

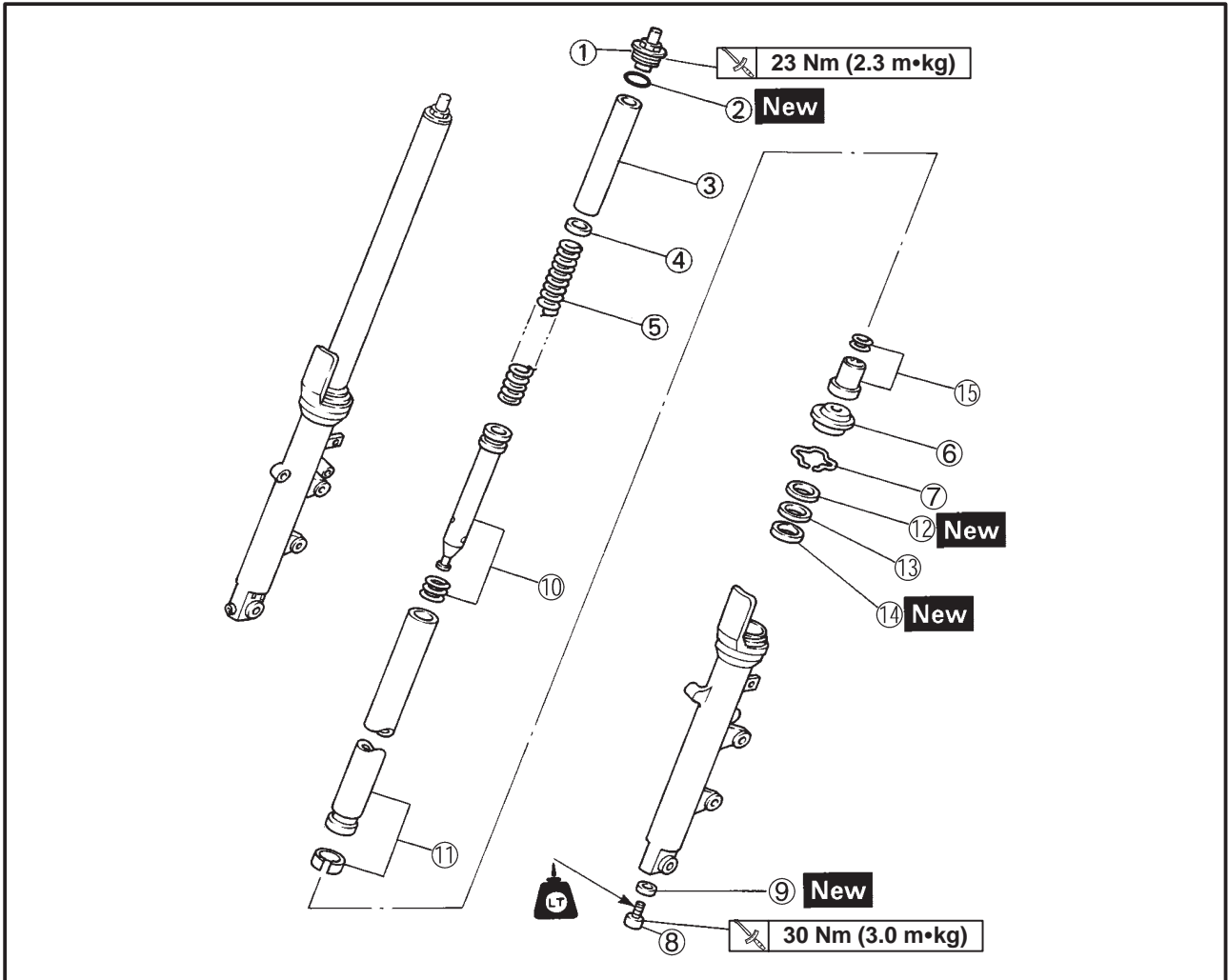

Order	Job name/Part name	Q'ty	Remarks
⑭	Outer tube bushing	1	Refer to "ASSEMBLING THE FRONT FORK LEGS" section. For assembly, reverse the disassembly procedure.
⑮	Oil flow stopper	1/1	

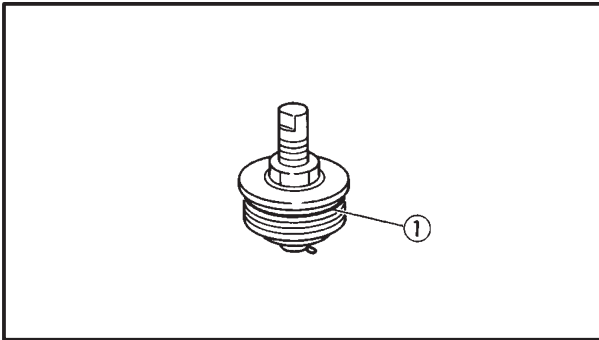
**CHECKING THE FRONT FORK LEGS**

1. Check:

- cap bolt O-ring ①
Damage/wear → Replace.

EB703700

ASSEMBLING THE FRONT FORK LEGS

1. Fill:

- front fork leg
(with the specified amount of the recommended fork oil)



Quantity (each front fork leg)
0.465 L



Yamaha fork and shock oil
10 W or equivalent.

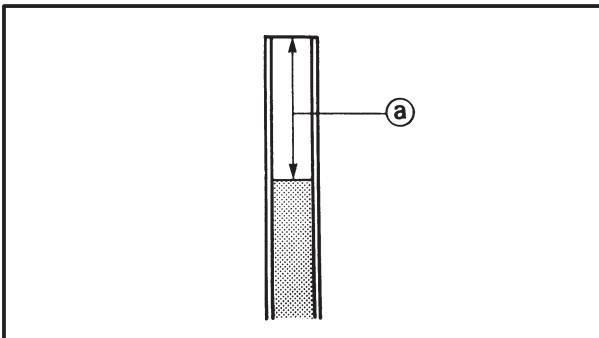

Front fork leg oil level ① (from the top of the inner tube, with the inner tube fully compressed and without the fork spring)
132 mm

**NOTE:**

- While filling the front fork leg, keep it upright.
- After filling, slowly pump the front fork leg up and down to distribute the fork oil.

SIGNAL SYSTEM

ELEC

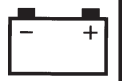

- ③ Main switch
- ④ Battery
- ⑥ Fuse (main)
- ③⑤ Flasher relay
- ④⑩ Turn switch
- ④① Hazard switch
- ④② Front turn signal light
- ④③ Rear turn signal light
- ⑤② Fuse (signal)
- ⑥⑩ Relay 2

SIGNAL SYSTEM CHECK

EB806023

1. If the turn signal light and/or turn indicator light fails to blink:

1. Bulb and bulb socket

- Check the bulb and bulb socket for continuity.

CONTINUITY

NO CONTINUITY

Replace the bulb and/or bulb socket.

2. Turn switch

- Disconnect the left handlebar switch couplers from the wire harness.
- Set the hazard switch "OFF"
- Check for continuity as follows:
Brown/White ① – Chocolate ②
Brown/White ① – Dark green ③

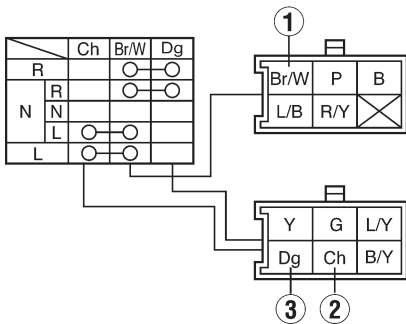

CONTINUITY

NO CONTINUITY

Replace the left handlebar switch.

3. Hazard switch

- Disconnect the left handlebar switch couplers from the wire harness.
- Set the turn switch "Neutral position"
- Check for continuity as follows:
Brown/White ① – Chocolate ②
Brown/White ① – Dark green ③
Chocolate ② – Dark green ③

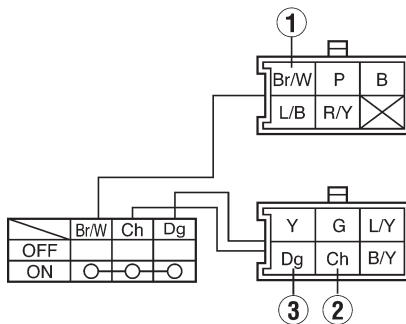

CONTINUITY

*

NO CONTINUITY

Replace the left handlebar switch.

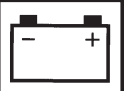

4. Voltage

- Connect the pocket tester (DC 20 V) to the flasher relay coupler.

Tester (+) lead → Brown terminal ①
Tester (-) lead → Frame ground

- Turn the main switch to “ON”.
- Check the voltage (12 V) of the “Brown” ① lead at the flasher relay terminal.



5. Voltage

- Connect the pocket tester (DC 20 V) to the flasher relay coupler.

Tester (+) lead → Brown/White terminal ①
Tester (-) lead → Frame ground

- Turn the main switch to “ON”.
- Turn the turn switch to “L”/“R” or push the hazard switch.
- Check the voltage (12 V) on the “Brown/White” ① lead at the flasher relay terminal.

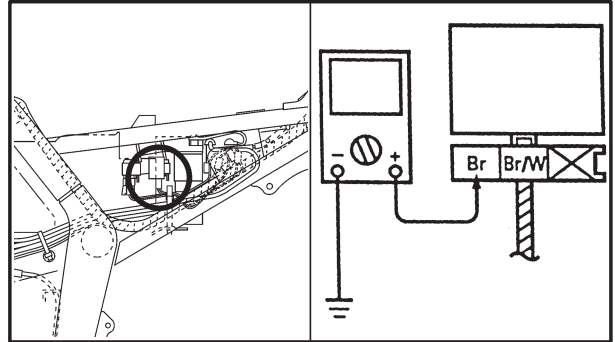
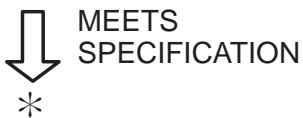

OUT OF SPECIFICATION

The wiring circuit from the main switch to the flasher relay connector is faulty, repair it.

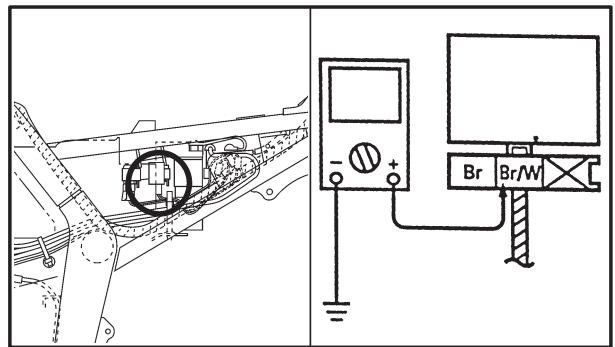

OUT OF SPECIFICATION

The flasher relay is faulty, replace it.



6. Voltage

- Connect the pocket tester (DC 20 V) to the bulb socket connector.

A Flasher light
B Turn indicator light

At the flasher light (left):
 Tester (+) lead → Chocolate lead ①
 Tester (-) lead → Frame ground

At the flasher light (right):
 Tester (+) lead → Dark green lead ②
 Tester (-) lead → Frame ground

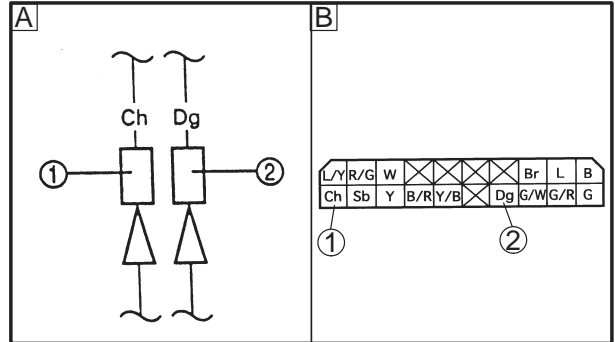

- Turn the main switch to “ON”.
- Turn the turn switch to “L”/“R” or push the hazard switch.
- Check the voltage (12 V) of the “Chocolate” lead or “Dark green” lead on the bulb socket connector.

 MEETS SPECIFICATION

This circuit is not faulty.

OUT OF SPECIFICATION



The wiring circuit from the left handlebar switch to the bulb socket connector is faulty, repair it.

CLOCK

EAS00805

The clock fails to come on.

1. Voltage

- Connect the pocket tester (DC 20 V) to the clock coupler.

Tester (+) read → Brow ①
Tester (-) read → Frame ground

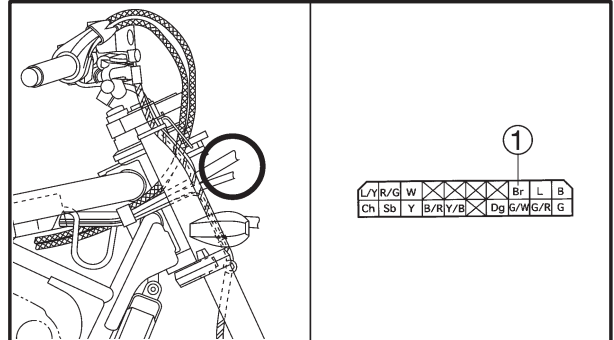

- Turn the main switch to “ON”.
- Check the voltage (12 V) on the “Brown” ① lead at the clock terminal.

↓ MEETS SPECIFICATION

2. Clock

- Check that the clock is operating properly.
- When setting the clock after its power source has been disconnected (e.g., when the battery is removed), first set the clock to 1:00 AM and then to the correct time.

↓ MEETS SPECIFICATION

This circuit is not faulty.

OUT OF SPECIFICATION

The wiring circuit from the main switch to the clock coupler is faulty, repair it.

OUT OF SPECIFICATION

The clock is faulty, replace it.

FZS600 2000 WIRING DIAGRAM

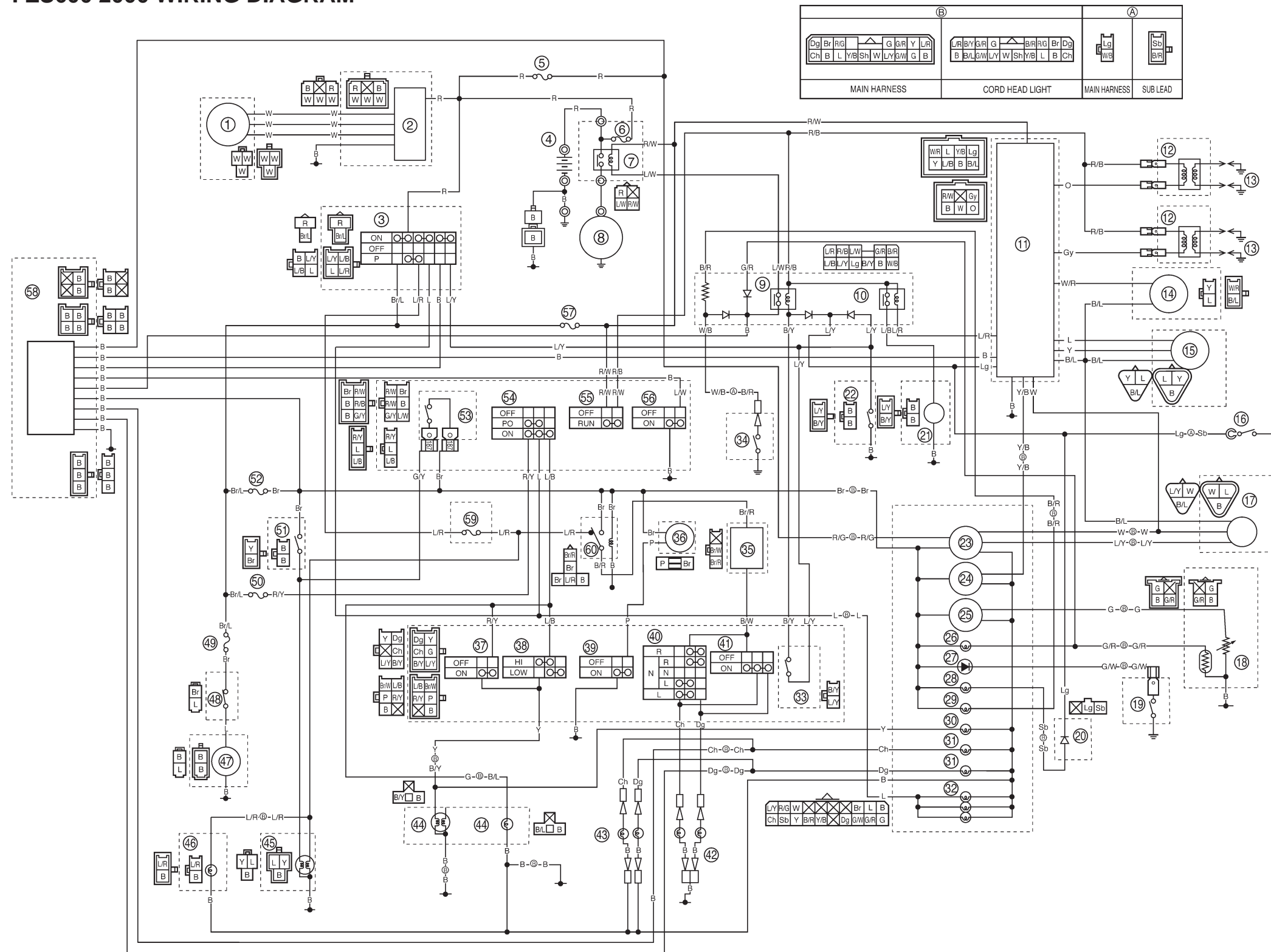

- ① A.C. magneto
- ② Rectifier/regulator
- ③ Main switch
- ④ Battery
- ⑤ Fuse (back up)
- ⑥ Fuse (main)
- ⑦ Starter relay
- ⑧ Starter motor
- ⑨ Starting circuit cut-off relay
- ⑩ Fuel pump relay
- ⑪ Ignitor unit
- ⑫ Ignition coil
- ⑬ Spark plug
- ⑭ Pick up coil
- ⑮ Throttle position sensor
- ⑯ Neutral switch
- ⑰ Speed sensor
- ⑱ Fuel sender
- ⑲ Thermo switch (engine temperature)
- ⑳ Diode
- ㉑ Fuel pump
- ㉒ Sidestand switch
- ㉓ Speedometer
- ㉔ Tachometer
- ㉕ Fuel meter
- ㉖ Fuel level warning light
- ㉗ Engine temperature warning light
- ㉘ Neutral indicator light
- ㉙ Oil level warning light
- ㉚ High beam indicator light
- ㉛ Turn indicator light
- ㉜ Meter light
- ㉝ Clutch switch
- ㉞ Oil level switch
- ㉟ Flasher relay
- ㊱ Horn
- ㊲ Pass switch
- ㊳ Dimmer switch
- ㊴ Horn switch
- ㊵ Turn switch
- ㊶ Hazard switch
- ㊷ Front turn signal light
- ㊸ Rear turn signal light
- ㊹ Headlight
- ㊺ Tail/Brake light
- ㊻ Auxiliary light
- ㊼ Fan motor
- ㊽ Thermo switch (fan motor)
- ㊾ Fuse (fan motor)
- ㊿ Fuse (head light)
- 1 Rear brake switch
- 2 Fuse (signal)
- 3 Front brake switch
- 4 Light switch
- 5 Engine stop switch
- 6 Starter switch
- 7 Fuse
- 8 Alarm
- 9 Fuse (parking)
- 0 Relay 2

COLOR CODE

B Black	P Pink	B/L Black/Blue	G/W Green/White	R/W Red/White
Br Brown	Lg Light green	B/R Black/Red	G/Y Green/Yellow	R/Y Red/Yellow
Ch Chocolate	O Orange	B/W Black/White	L/B Blue/Black	W/B White/Black
Dg Dark green	R Red	B/Y Black/Yellow	L/R Blue/Red	W/G White/Green
G Green	Sb Sky blue	Br/L Brown/Blue	L/W Blue/White	W/R White/Red
Gy Gray	W White	Br/W Brown/White	L/Y Blue/Yellow	Y/B Yellow/Black
L Blue	Y Yellow	G/R Green/Red	R/B Red/Black	Y/R Yellow/Red