



YW50AP

SERVICE MANUAL

EB000000

YW50AP
SERVICE MANUAL
©2001 by Yamaha Motor Corporation U.S.A.
First edition, November 2001
All rights reserved.
Any reprinting or unauthorized use
without the written permission of
Yamaha Motor Corporation U.S.A.
is expressly prohibited.
P/N LIT-11616-15-39

NOTICE

This manual was produced by the Yamaha Motor Company, Ltd. primarily for use by Yamaha dealers and their qualified mechanics. It is not possible to include all the knowledge of a mechanic in one manual. Therefore, anyone who uses this book to perform maintenance and repairs on Yamaha vehicles should have a basic understanding of mechanics and the techniques to repair these types of vehicles. Repair and maintenance work attempted by anyone without this knowledge is likely to render the vehicle unsafe and unfit for use.

Yamaha Motor Company, Ltd. is continually striving to improve all of its models. Modifications and significant changes in specifications or procedures will be forwarded to all authorized Yamaha dealers and will appear in future editions of this manual where applicable.

NOTE:

Designs and specifications are subject to change without notice.

IMPORTANT MANUAL INFORMATION

Particularly important information is distinguished in this manual by the following.



The Safety Alert Symbol means ATTENTION! BECOME ALERT! YOUR SAFETY IS INVOLVED!

WARNING

Failure to follow WARNING instructions could result in severe injury or death to the scooter operator, a bystander or a person checking or repairing the scooter.

CAUTION:

A CAUTION indicates special precautions that must be taken to avoid damage to the scooter.

NOTE:

A NOTE provides key information to make procedures easier or clearer.

HOW TO USE THIS MANUAL

This manual is intended as a handy, easy-to-read reference book for the mechanic. Comprehensive explanations of all installation, removal, disassembly, assembly, repair and check procedures are laid out with the individual steps in sequential order.

- ① The manual is divided into chapters. An abbreviation and symbol in the upper right corner of each page indicate the current chapter. Refer to "SYMBOLS".
- ② Each chapter is divided into sections. The current section title is shown at the top of each page, except in Chapter 3 ("PERIODIC CHECKS AND ADJUSTMENTS"), where the sub-section title(s) appears.
- ③ Sub-section titles appear in smaller print than the section title.
- ④ To help identify parts and clarify procedure steps, there are exploded diagrams at the start of each removal and disassembly section.
- ⑤ Numbers are given in the order of the jobs in the exploded diagram. A circled number indicates a disassembly step.
- ⑥ Symbols indicate parts to be lubricated or replaced. Refer to "SYMBOLS".
- ⑦ A job instruction chart accompanies the exploded diagram, providing the order of jobs, names of parts, notes in jobs, etc.
- ⑧ Jobs requiring more information (such as special tools and technical data) are described sequentially.

CYLINDER HEAD, CYLINDER AND PISTON ENG

CYLINDER HEAD, CYLINDER AND PISTON

CYLINDER HEAD, CYLINDER AND PISTON

Order	Job name/Part name	Q'ty	Remarks
	Cylinder head, Cylinder and piston removal		Remove the parts in the order.
	Engine		Refer to the "ENGINE REMOVAL" section
1	Muffler/Gasket	1/1	
2	Air shroud (cylinder head)	1	
3	Spark plug	1	
4	Cylinder head/Cylinder head gasket	1/1	
5	Cylinder	1	
6	Piston pin clip	2	
7	Piston pin/ Bearing	1/1	
8	Piston	1	
9	Piston ring set	1	
10	Cylinder gasket	1	
			Reverse the removal procedure for installation.

4-3

CYLINDER HEAD, CYLINDER, PISTON ENG

PISTON PIN AND PISTON REMOVAL

1. Remove:
● Piston pin clip ①

NOTE:
Before removing the piston pin clip, cover the crankcase with a clean rag so you will not accidentally drop the clip into the crankcase.

2. Remove:
● Piston pin ①
● Piston ②
● Piston pin bearing ③

CAUTION:
Do not use a hammer to drive the piston pin out.

CYLINDER HEAD INSPECTION

1. Eliminate:
● Carbon deposits
Use a rounded scraper ①.



















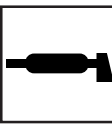

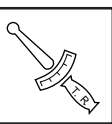
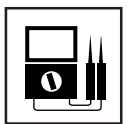
2. Inspect:
● Cylinder head warpage
Out of specification→Re-surface.
.....
Warpage measurement and re-surfacing steps:
● Attach a straight edge ① and a thickness gauge ② on the cylinder head.
● Measure the warpage limit.

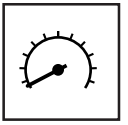
Warpage limit:
0.02 mm

● If the warpage is out of specification, reface the cylinder head.

NOTE:
Rotate the head several times to avoid removing too much material from one side.

4-4

① GEN INFO 	② SPEC 	
③ INSP ADJ 	④ ENG 	
⑤ CARB 	⑥ CHAS 	
⑦ ELEC 	⑧ TRBL SHTG ?	
⑨ 	⑩ 	
⑪ 	⑫ 	
⑬ 	⑭ 	
⑮ 	⑯ 	
⑰ 	⑱ 	⑲ 
⑳ 	㉑ 	㉒ 
㉓ 	㉔ New	

EAS00009

SYMBOLS

The following symbols are not relevant to every vehicle.

Symbols ① to ⑧ are designed as thumb tabs to indicate the chapter's number and content.

- ① General information
- ② Specifications
- ③ Periodic inspection and adjustment
- ④ Engine
- ⑤ Carburetor(s)
- ⑥ Chassis
- ⑦ Electrical system
- ⑧ Troubleshooting

Symbols ⑨ to ⑯ indicate the following.

- ⑨ Serviceable with engine mounted
- ⑩ Filling fluid
- ⑪ Lubricant
- ⑫ Special tool
- ⑬ Tightening torque
- ⑭ Wear limit, clearance
- ⑮ Engine speed
- ⑯ Electrical data







Symbols ⑰ to ㉒ in the exploded diagrams indicate the types of lubricants and lubrication points.

- ⑰ Engine oil
- ⑱ Gear oil
- ⑲ Molybdenum disulfide oil
- ㉑ Wheel bearing grease
- ㉒ Lithium soap base grease
- ㉓ Molybdenum disulfide grease

Symbols ㉔ to ㉕ in the exploded diagrams indicate the following.

- ㉔ Apply locking agent (LOCTITE®)
- ㉕ Replace the part

INDEX

GENERAL INFORMATION	
	1
SPECIFICATIONS	
	2
PERIODIC INSPECTION AND ADJUSTMENT	
	3
ENGINE OVERHAUL	
	4
CARBURETION	
	5
CHASSIS	
	6
ELECTRICAL	
	7
TROUBLESHOOTING	?
	8

CHAPTER 1. GENERAL INFORMATION

SCOOTER IDENTIFICATION	1-1
VEHICLE IDENTIFICATION NUMBER	1-1
MODEL CODE	1-1
IMPORTANT INFORMATION	1-2
PREPARATION FOR REMOVAL AND DISASSEMBLY	1-2
REPLACEMENT PARTS	1-2
GASKETS, OIL SEALS AND O-RINGS	1-2
LOCK WASHERS/PLATES AND COTTER PINS	1-2
BEARINGS AND OIL SEALS	1-3
CIRCLIPS	1-3
CHECKING OF CONNECTIONS	1-4
HOW TO USE THE CONVERSION TABLE	1-5
CONVERSION TABLE	1-5
SPECIAL TOOLS	1-6

CHAPTER 2. SPECIFICATIONS

GENERAL SPECIFICATION	2-1
MAINTENANCE SPECIFICATION	2-4
ENGINE	2-4
TIGHTENING TORQUES	2-6
ENGINE	2-6
MAINTENANCE SPECIFICATION	2-7
CHASSIS	2-7
TIGHTENING TORQUES	2-8
CHASSIS	2-8
MAINTENANCE SPECIFICATION	2-9
ELECTRICAL	2-9
GENERAL TORQUE SPECIFICATIONS	2-11
LUBRICATION POINTS AND LUBRICATION TYPE	2-12
ENGINE	2-12
CHASSIS	2-13
CABLE ROUTING	2-14

CHAPTER 3. PERIODIC INSPECTION AND ADJUSTMENTS

INTRODUCTION	3-1
PERIODIC MAINTENANCE/LUBRICATION INTERVALS	3-1
COVER AND PANEL	3-3
SIDECOVER AND SEAT	3-3
LOWER COWLING, UPPER COVER, LEG SHIELD 1, 2 AND FOOTREST BOARD	3-4
HANDLEBAR COVER(FRONT AND REAR)	3-5
ENGINE	3-6
IDLE SPEED ADJUSTMENT	3-6
THROTTLE CABLE FREE ADJUSTMENT	3-7
AUTOLUBE PUMP AIR BLEEDING	3-8
SPARK PLUG INSPECTION	3-9
ENGINE OIL LEVEL INSPECTION	3-10
TRANSMISSION OIL REPLACEMENT	3-11
AIR FILTER ELEMENT CLEANING	3-12
V-BELT INSPECTION	3-14
CHASSIS	3-15
FRONT BRAKE LEVER FREE PLAY CHECK	3-15
REAR BRAKE LEVER FREE PLAY CHECK.....	3-15
BRAKE PAD INSPECTION	3-15
BRAKE SHOE INSPECTION	3-16
BRAKE FLUID LEVEL INSPECTION	3-16
AIR BLEEDING (HYDRAULIC BRAKE SYSTEM)	3-17
STEERING ADJUSTMENT	3-18
TIRE INSPECTION.....	3-19
WHEEL INSPECTION	3-22
FRONT FORK INSPECTION.....	3-22
REAR SHOCK ABSORBER INSPECTION.....	3-22
SEAT LOCK CABLE ADJUSTMENT	3-22
CABLE CHECKING AND LUBRICATING	3-23
LEVERS LUBRICATING	3-23
CENTERSTAND LUBRICATING	3-23
ELECTRICAL	3-24
BATTERY INSPECTION	3-24
FUSE INSPECTION	3-29
HEADLIGHT BEAM ADJUSTMENT	3-30
HEADLIGHT BULB REPLACEMENT.....	3-30
TURN SIGNAL AND TAILLIGHT BULB REPLACEMENT	3-31
TAILLIGHT BULB REPLACEMENT.....	3-32
LICENSE LIGHT BULB REPLACEMENT.....	3-32

CHAPTER 4. ENGINE

ENGINE OVERHAUL	4-1
WIREHARNES AND CABLES	4-1
CYLINDER HEAD, CYLINDER AND PISTON	4-3
CYLINDER HEAD, CYLINDER AND PISTON	4-3
PISTON PIN AND PISTON REMOVAL	4-4
CYLINDER HEAD INSPECTION	4-4
CYLINDER AND PISTON INSPECTION	4-5
PISTON RINGS INSPECTION	4-7
PISTON PIN AND PISTON PIN BEARING	4-7
PISTON PIN AND PISTON INSTALLATION	4-8
CYLINDER AND CYLINDER HEAD	4-9
V-BELT, CLUTCH AND SECONDARY/PRIMARY SHEAVE	4-11
KICK STARTER AND CRANKCASE COVER(LEFT)	4-11
KICK STARTER	4-12
KICK STARTER INSTALLATION	4-13
V-BELT, CLUTCH AND SECONDARY/PRIMARY SHEAVE	4-14
SECONDARY SHEAVE	4-15
PRIMARY SHEAVE REMOVAL	4-16
SECONDARY SHEAVE REMOVAL	4-16
CLUTCH INSPECTION	4-17
V-BELT INSPECTION	4-18
PRIMARY SHEAVE INSPECTION	4-19
SECONDARY SHEAVE	4-20
SECONDARY SHEAVE INSTALLATION	4-21
PRIMARY SHEAVE	4-22
STARTER CLUTCH AND STARTER MOTOR	4-24
STARTER CLUTCH AND STARTER MOTOR	4-24
STARTER CLUTCH AND GEARS INSPECTION	4-26
C.D.I. MAGNET	4-27
C.D.I. MAGNETO	4-27
C.D.I. MAGNETO REMOVAL	4-28
C.D.I. MAGNETO INSTALLATION	4-28
AUTOLUBE PUMP	4-29
AUTOLUBE PUMP	4-29
AUTOLUBE PUMP INSTALLATION	4-30
TRANSMISSION	4-31
TRANSMISSION	4-31
CRANKCASE AND REED VALVE	4-33
CRANKCASE AND REED VALVE	4-33
CRANKCASE(RIGHT) REMOVAL	4-35
CHECKING THE CRANKCASE	4-35
CHECKING THE BEARINGS AND OIL SEALS	4-35
REED VALVE INSPECTION	4-36
CRANKCASE (RIGHT) INSTALLATION	4-36
CRANKSHAFT	4-38
CRANKSHAFT	4-38
CRANKSHAFT REMOVAL	4-39
CRANKSHAFT INSPECTION	4-39
CRANKSHAFT INSTALLATION	4-40

CHAPTER 5 CARBURETION

CARBURETION	5-1
CARBURETOR	5-1
CABURETOR DISASSEMBLY	5-2
CABURETOR INSPECTION	5-3
CARBURETOR ASSEMBLY	5-5
FUEL LEVEL ADJUSTMENT	5-6
AUTO CHOKE INSPECTION	5-7
FUEL COCK INSPECTION	5-8

CHAPTER 6 CHASSIS

FRONT WHEEL AND BRAKE DISC	6-1
FRONT WHEEL AND BRAKE DISC	6-1
FRONT WHEEL DISASSEMBLY	6-2
FRONT WHEEL DISASSEMBLY	6-3
FRONT WHEEL INSPECTION	6-3
BRAKE DISC INSPECTION	6-4
FRONT WHEEL ASSEMBLY	6-4
FRONT WHEEL INSTALLATION	6-5
WHEEL STATIC BALANCE ADJUSTMENT	6-6
FRONT BRAKE	6-8
BRAKE PAD	6-8
BRAKE PAD REPLACEMENT	6-9
MASTER CYLINDER	6-12
MASTER CYLINDER DISASSEMBLY	6-13
MASTER CYLINDER INSPECTION	6-14
MASTER CYLINDER ASSEMBLY	6-14
MASTER CYLINDER INSTALLATION	6-15
CALIPER	6-17
CALIPER DISASSEMBLY	6-18
BRAKE CALIPER DISASSEMBLY	6-19
CALIPER INSPECTION	6-19
BRAKE CALIPER ASSEMBLY	6-20
BRAKE CALIPER INSTALLATION	6-20
REAR WHEEL AND REAR BRAKE	6-21
REAR WHEEL	6-21
REAR BRAKE	6-22
REAR WHEEL INSPECTION	6-23
REAR BRAKE INSPECTION	6-23
REAR BRAKE INSTALLATION	6-24
HANDLEBAR	6-25
HANDLEBAR	6-25
HANDLEBAR INSTALLATION	6-27
STEERING	6-29
STEERING	6-29
STEERING REMOVAL	6-30
STEERING INSPECTION	6-31
STEERING INSTALLATION	6-31
FRONT FORK	6-34
FRONT FORK	6-34
FRONT FORK DISASSEMBLY	6-35
FRONT FORK REMOVAL	6-36
FRONT FORK DISASSEMBLY	6-36
FRONT FORK INSPECTION	6-37
FRONT FORK ASSEMBLY	6-37
FRONT FORK INSTALLATION	6-39

CHAPTER 7 ELECTRICAL

ELECTRICAL COMPONENTS	7-1
ELECTRICAL COMPONENTS	7-1
CIRCUIT DIAGRAM	7-2
CHECKING SWITCHES	7-4
CHECKING STEPS	7-4
SWITCH CONNECTION AS SHOWN IN THIS MANUAL	7-4
SWITCH POSITION AND TERMINAL CONNECTION	7-5
CHECKING THE BLUBS AND BULB SOCKETS	7-5
CHECKING THE BULBS AND BULB SOCKETS	7-6
TYPES OF BULBS	7-6
CHECKING THE CONDITION OF THE BULBS	7-7
CHECKING THE CONDITION OF THE BULB SOCKETS	7-8
IGNITION SYSTEM	7-9
CIRCUIT DIAGRAM	7-9
TROUBLESHOOTING	7-10
CHARGING SYSTEM	7-14
CIRCUIT DIAGRAM	7-14
TROUBLESHOOTING	7-15
ELECTRIC STARTING SYSTEM	7-18
CIRCUIT DIAGRAM	7-18
TROUBLESHOOTING	7-19
STARTER MOTOR	7-22
STARTER MOTOR DISASSEMBLY	7-23
INSPECTION AND REPAIR	7-24
LIGHTING SYSTEM	7-26
CIRCUIT DIAGRAM	7-26
TROUBLESHOOTING	7-27
LIGHTING SYSTEM CHECK	7-29
SIGNAL SYSTEM	7-33
CIRCUIT DIAGRAM	7-33
TROUBLESHOOTING	7-34
SIGNAL SYSTEM CHECK	7-36
AUTO CHOKE SYSTEM	7-42
CIRCUIT DIAGRAM	7-42
TROUBLESHOOTING	7-43

CHAPTER 8 TROUBLESHOOTING

STARTING FAILURE/HARD STARTING	8-1
FUEL SYSTEM	8-1
IGNITION SYSTEM	8-2
COMPRESSION SYSTEM	8-2
POOR IDLE SPEED PERFORMANCE	8-3
POOR IDLE SPEED PERFORMANCE	8-3
POOR MEDIUM AND HIGH SPEED PERFORMANCE	8-3
POOR MEDIUM AND HIGH SPEED PERFORMANCE	8-3
FULTY AUTOMATIC(V-BELT TYPE)	8-4
SCOOTER DOES NOT MOVE WHILE ENGINE IS OPERATING	8-4
CLUTCH OUT FAILURE	8-4
POOR STANDING START(LOW CLIMBING ABILITY)	8-4
POOR ACCELERATION(POOR HIGH SPEED)	8-4
OVER HEAT	8-5
OVERHEAT	8-5
POOR SPEED	8-5
POOR SPEED	8-5
IMPROPER KICKING	8-6
SLIPPING	8-6
HARD KICKING	8-6
KICK CRANK NOT RETURNING	8-6
FAULTY BRAKE	8-7
POOR BRAKING EFFECT	8-7
MALFUNCTION	8-7
INSTABLE HANDLING	8-8
INSTABLE HANDLING	8-8
FAULTY SIGNAL AND LIGHTING SYSTEM	8-9
HEADLIGHT DARK	8-9
BULB BURNT OUT	8-9
FLASHER DOES NOT BLINK	8-9
FLASHER KEEPS ON	8-9
FLASHER BLINKS SLOWER	8-10
FLASHER BLINKS QUICKER	8-10
HORN DOES NOT SOUND	8-10

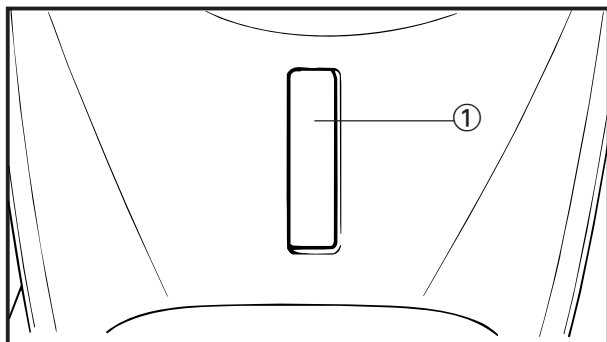

EAS00015

GENERAL INFORMATION SCOOTER IDENTIFICATION

EAS00017

VEHICLE IDENTIFICATION NUMBER

The vehicle identification number ① is stamped into the frame.

EAS00018

MODEL CODE

The model code label ① is affixed to the location shown in the figure. Record the information on this label in the space provided. This information will be needed to order spare parts.

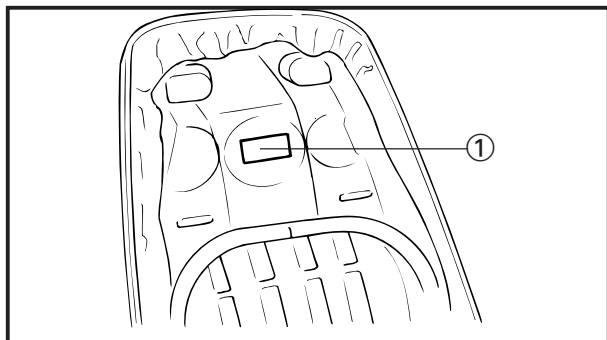

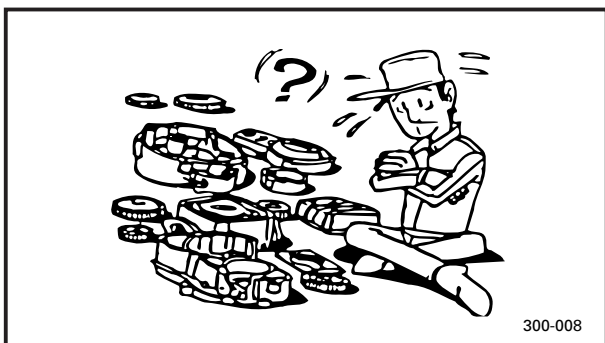
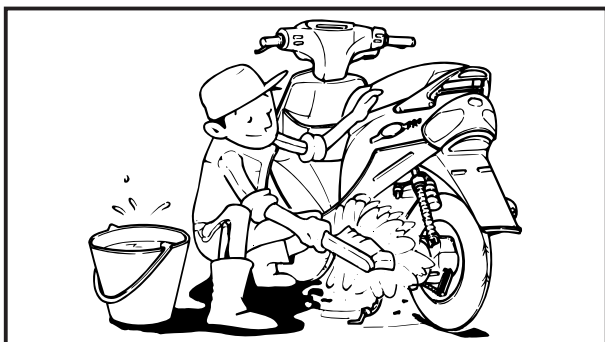

300-008

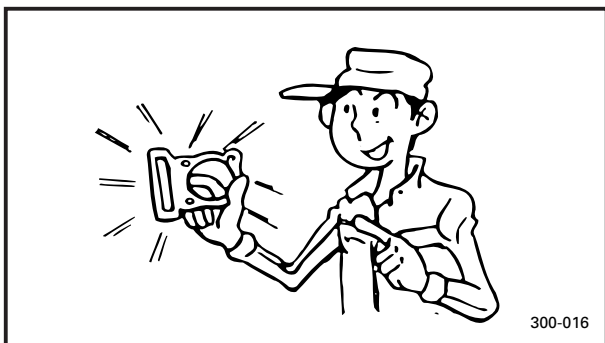

300-016

EAS00020

IMPORTANT INFORMATION PREPARATION FOR REMOVAL AND DISASSEMBLY

1. Before removal and disassembly, remove all dirt, mud, dust and foreign material.
2. Use only the proper tools and cleaning equipment.
Refer to "SPECIAL TOOLS".
3. When disassembling, always keep mated parts together. This includes gears, cylinders, pistons and other parts that have been "mated" through normal wear. Mated parts must always be reused or replaced as an assembly.
4. During disassembly, clean all of the parts and place them in trays in the order of disassembly. This will speed up assembly and allow for the correct installation of all parts.
5. Keep all parts away from any source of fire.

EAS00021

REPLACEMENT PARTS

Use only genuine Yamaha parts for all replacements. Use oil and grease recommended by Yamaha for all lubrication jobs.

Other brands may be similar in function and appearance, but inferior in quality.

EAS00022

GASKETS, OIL SEALS AND O-RINGS

1. When overhauling the engine, replace all gaskets, seals and O-rings. All gasket surfaces, oil seal lips and O-rings must be cleaned.
2. During reassembly, properly oil all mating parts and bearings and lubricate the oil seal lips with grease.

EAS00023

LOCK WASHERS/PLATES AND COTTER PINS

After removal, replace all lock washers/plates ① and cotter pins. After the bolt or nut has been tightened to specification, bend the lock tabs along a flat of the bolt or nut.

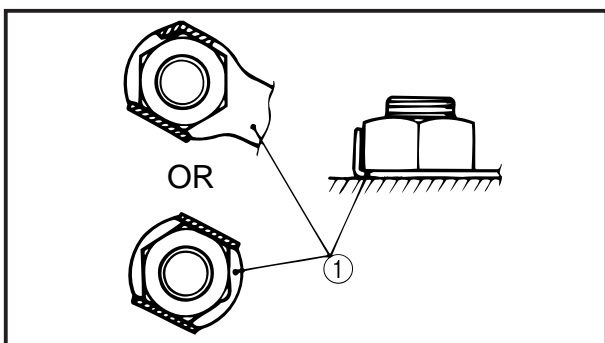

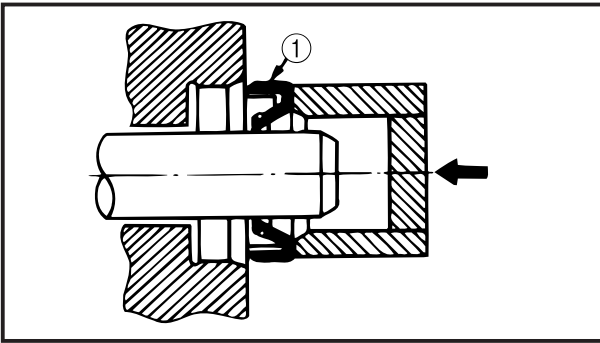

EAS00024

BEARINGS AND OIL SEALS

Install bearings and oil seals so that the manufacturer's marks or numbers are visible. When installing oil seals, lubricate the oil seal lips with a light coat of lithium soap base grease.

Oil bearings liberally when installing, if appropriate.

① Oil seal

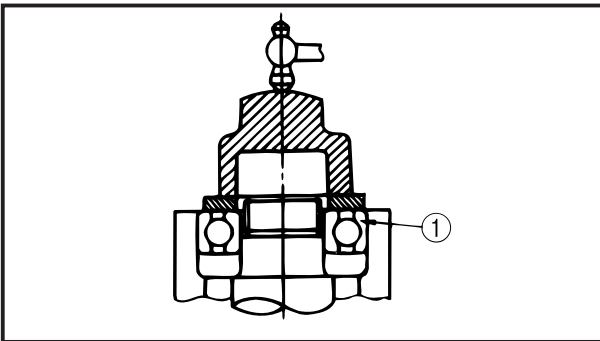

CAUTION: _____

Do not spin the bearing with compressed air because this will damage the bearing surfaces.

① Bearing

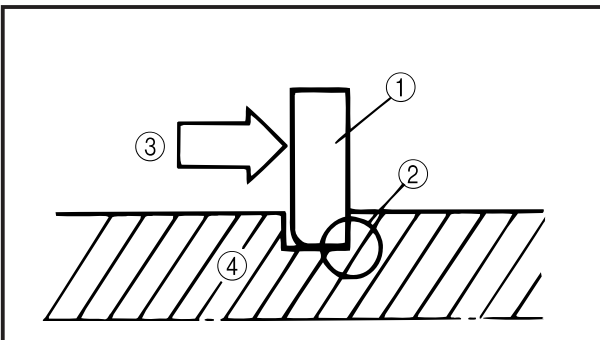

EAS00025

CIRCLIPS

Before reassembly, check all circlips carefully and replace damaged or distorted circlips.

Always replace piston pin clips after one use.

When installing a circlip ①, make sure the sharp-edged corner ② is positioned opposite the thrust ③ that the circlip receives.

④ Shaft

EB801000

CHECKING OF CONNECTIONS

Dealing with stains, rust, moisture, etc. on the connector.

1. Disconnect:
 - Connector
2. Dry each terminal with an air blower.
3. Connect and disconnect the connector two or three.
4. Pull the read to check that it will not come off.
5. If the terminal comes off, bend up the pin ① and reinsert the terminal into the connector.

6. Connect:
 - Connector

NOTE: _____

The two connectors "click" together.

7. Check for continuity with a tester.

NOTE: _____

- If there is no continuity, clean the terminals.
- Be sure to perform the steps 1 to 7 listed above when checking the wireharness.
- For a field remedy, use a contact revitalizer available on the market.
- Use the tester on the connector as shown.

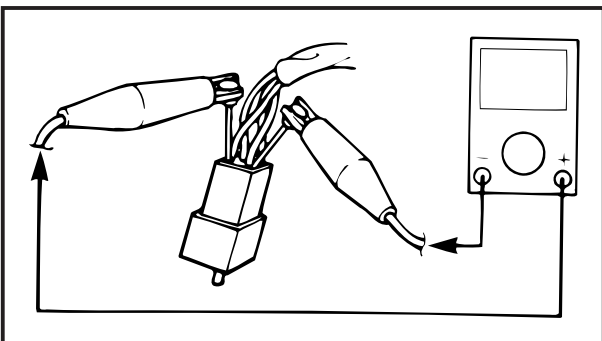
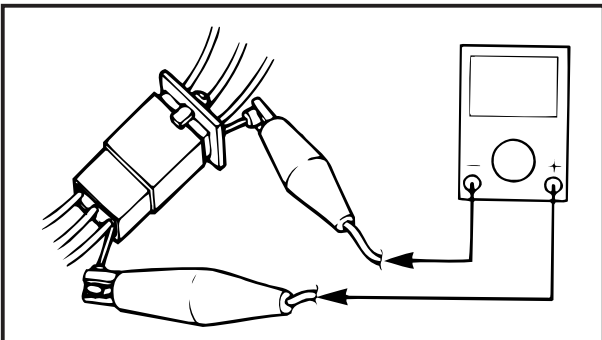
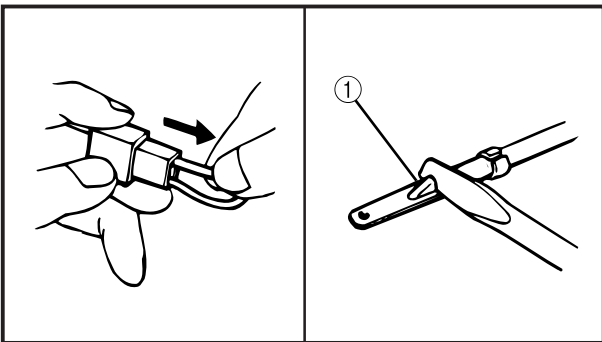
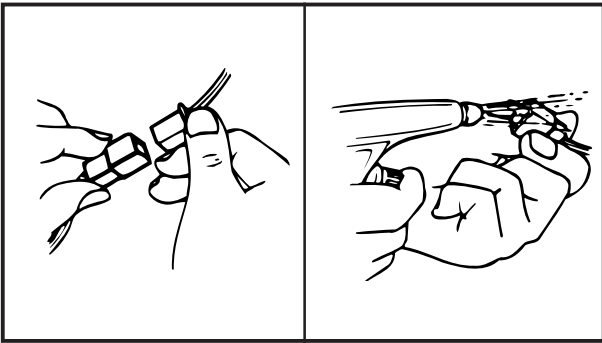

HOW TO USE THE CONVERSION TABLE



EB201000

HOW TO USE THE CONVERSION TABLE

All specification data in this manual are listed in SI and METRIC UNITS.

Use this table to convert METRIC unit data to IMPERIAL unit data.

Ex.

METRIC		MULTIPLIER	=	IMP
** mm	×	0.03937	=	** in
2 mm	×	0.03937	=	0.083 in

CONVERSION TABLE

METRIC TO IMP			
	Known	Multiplier	Result
Torque	m.kg	7.233	ft.lb
	m.kg	86.794	in.lb
	cm.kg	0.0723	ft.lb
	cm.kg	0.8679	in.lb
Weight	kg	2.205	lb
	g	0.03527	oz
Distance	km/h	0.6214	mph
	km	0.6214	mi
	m	3.281	ft
	m	1.094	yd
	cm	0.3937	in
	mm	0.03937	in
Volume/ Capacity	cc(cm ³)	0.03527	oz (IMP liq.)
	cc(cm ³)	0.06102	cu.in
	lit(liter)	0.8799	qt(IMP liq.)
	lit(liter)	0.2199	gal(IMP liq.)
Miscellaneous	kg/mm	55.997	lb/in
	kg/cm ²	14.2234	psi(lb/in ²)
	Centigrade	9/5(°C)+32	Fahrenheit (°F)



EE102000

SPECIAL TOOLS

The following special tools are necessary for complete and accurate tune-up and assembly. Use only the appropriate special tools; this Will help prevent damage caused by the use of inappropriate tools or improvised techniques.

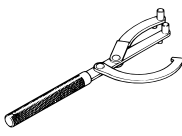
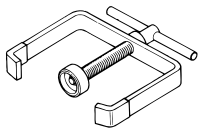
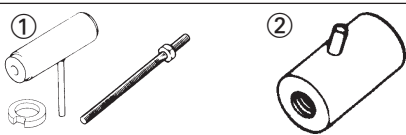
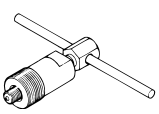
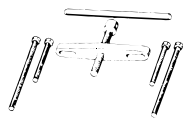
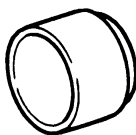
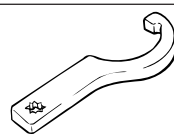
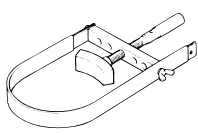
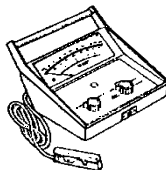
When placing an order, refer to the list provided below to avoid any mistakes.

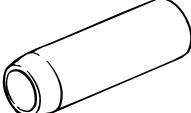
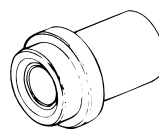
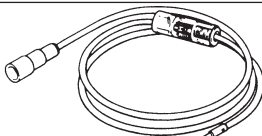
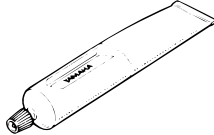
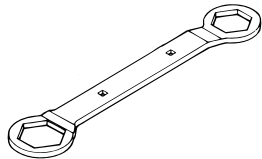
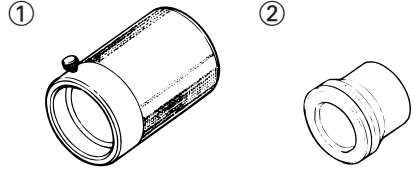
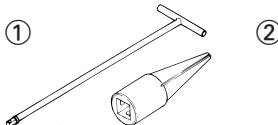
Tool No.	Tool name / Function	Illustration
YU-01235	Rotor holding tool This tool is used to hold the generator rotor when removing or installing the generator rotor bolt.	
YS-28891	Clutch spring holder This tool is used to disassembly and assembly the secondary pulley.	
YU -90050 -90062	Crankshaft Installation set ① Adapter ② These tools are used to install the crankshaft.	
YU-01189	Flywheel puller This tool is used for removing the rotor.	
YU- 01135-A	Crankcase Separating tool This tool is used to remove the crankshaft or separate the crankcase.	
YM-33299	Oil seal guide This tool is used for protecting the oil seal lip when installing the secondary sliding sheave.	
YU-33975	Steering nut wrench This tool is used to loosen or tighten the steering stem ring nut.	
YU-01701	Sheave holder This tool is used to hold the clutch housing when removing or installing the clutch housing nut.	
YU-8036-A	Inductive tachometer This tool is used to check engine speed.	

Tool No.	Tool name / Function	Illustration
YU-03112	<p>Pocket tester</p> <p>This tool is used to check the electrical system.</p>	
YM-1409	<p>Oil seal guide</p> <p>This tool is used to install the left side crankcase oil seal.</p>	
YM-1410	<p>Oil seal driver</p> <p>This tool is used to install the left side crankcase oil seal.</p>	
YM-34487	<p>Dynamic spark tester</p> <p>This instrument is necessary for checking the ignition system components.</p>	
ACC-1100-15-01	<p>Quick Gasket ®</p> <p>This sealant is used to seal to mating surfaces (e.g., crankcase mating surfaces).</p>	
90890-01348	<p>Locknut wrench</p> <p>This tool is used to loosen and tighten the clutch carrier locknut of the secondary sheave.</p>	
<p>YU-33963 ① -1400 ②</p>	<p>Front fork seal driver Weight ① Adapter ②</p> <p>These tools are used when installing the fork seal.</p>	
<p>T-handle ① YM-01326 Holder YM-01300-1 ②</p>	<p>T-handle ① / Damper rod holder ②</p> <p>These tools are needed to loosen and tighten the damper rod holding bolt.</p>	
YM-01312-A	<p>Fuel level gauge</p> <p>This gauge is used to measure the fuel level in the float chamber.</p>	



SPECIFICATION

GENERAL SPECIFICATION

Model	YW50AP
Model code:	5PJ1
Dimensions: Overall length Overall width Overall height Seat height Wheelbase Minimum ground clearance Minimum turning radius	1,890 mm(74.4 in) 705 mm(27.8 in) 1,110 mm(43.7 in) 765 mm(30.1 in) 1,275 mm(50.2 in) 120 mm(4.7 in) 2,000 mm(78.7 in)
Basic weight: With oil and full fuel tank	94 kg(207 lb)
Engine: Engine type Cylinder arrangement Displacement Bore × stroke Compression ratio Starting system Lubrication system:	Air cooled 2 stroke, gasoline torque induction Forward- inclined single cylinder 49cm ³ (2.99 cu.in) 40.0 × 39.2 mm(1.57 × 1.54 in) 7.2:1 Electric and kick starter Separate lubrication
Oil Type or Grade: Engine Oil	For YAMAHA brand: Yamalube 2 or Air cooled 2-stroke engine oil (ISO EG-C, EG-D grade)
Transmission Oil Oil Capacity: Oil Tank (Engine Oil) Transmission Oil: Periodic Oil Change Total Amount	Yamalube 4 SAE 10W/30 SE or GL gear oil 1.4 L (1.23 Imp•qt, 1.48 US qt) 0.11 L(0.096 Imp.qt, 0.12 US qt) 0.13 L(0.11 Imp.qt, 0.13 US qt)
Air Filter:	Wet type element
Fuel: Type Tank Capacity	Regular unleaded gasoline 5.7 L (1.25 Imp.gal, 1.5 US gal)
Carburetor: Type / Manufacturer	Y14P/1/ TEIKEI

GENERAL SPECIFICATION

SPEC



Model	YW50A
Spark Plug: Type/Manufacturer Gap	BPR7HS/NGK 0.6 ~ 0.7 mm(0.02 ~ 0.03 in)
Clutch Type	Dry, Centrifugal automatic
Transmission: Primary Reduction System Primary Reduction Ratio Secondary Reduction System Secondary Reduction Ratio Transmission Type Operation	Helical gear 4.000 Supur gear 3.666 V-belt Automatic
Chassis: Frame type Caster angle Trail	Steel tube underbone 26.5° 93mm(3.7 in)
Tire: Type Size Manufacturer Type	Tubeless 120/90-10 130/90-10 CHENG SHIN CHENG SHIN 56J 59J
Maximum load* Cold tire Pressure: Up to 90 kg Front Rear 90 kg load~Maximum load* Front Rear	143 kg(315 lb) 200kpa(2.0 kg/cm ² , 29 psi) 200kpa(2.0 kg/cm ² , 29 psi) 200kpa(2.0 kg/cm ² , 29 psi) 200kpa(2.0 kg/cm ² , 29 psi)
Brake: Front brake type operation Rear brake type operation	Single disc brake Right hand operation Drum brake Left hand operation
Suspension: Front suspension Rear suspension	Telescopic fork Unit swing
Shock absorber: Front shock absorber Rear shock absorber	Coil spring/oil damper Coil spring/oil damper
Wheel travel: Front wheel travel Rear wheel travel	65 mm(2.56 in) 60 mm(2.36 in)
Electrical: Ignition system Generator system Battery type Battery capacity	C.D.I Flywheel Magneto YTX5L-BS 12V 4AH

GENERAL SPECIFICATION

SPEC



Model	YW50A
Headlight type:	Bulb
Bulb wattage x quantity:	
Headlight	12V 35W/35W×2
Tail/brake light	12 V 5W/21W×1
Flasher light	10W×4
Licence plate light	5W×1
Meter light	3.4W×1/1.7W×1
High beam indicator light	1.7W×1
Oil indicator light	1.7W×1
Turn indicator light	1.7W×1

**MAINTENANCE SPECIFICATION
ENGINE**

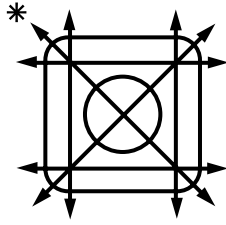
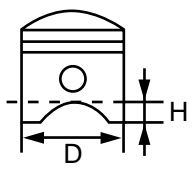
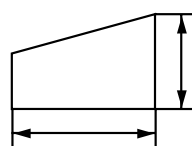
Item	Standard	Limit
<p>Cylinder head: Warp limit</p>  <p>*Lines indicate straightedge measurement</p>	<p>...</p>	<p>0.03 mm (0.0012 in)</p>
<p>Cylinder: Bore size</p> <p>Taper limit</p> <p>Out of round limit</p>	<p>40.000~40.014mm (1.5748~1.5754 in)</p> <p>...</p> <p>...</p>	<p>40.10 mm (1.5787 in)</p> <p>0.05 mm (0.0020 in)</p> <p>0.03 mm (0.0012 in)</p>
<p>Piston: Piston to cylinder clearance</p> <p>Piston size "D"</p> <p>Measuring point "H"</p> <p>Piston pin bore inside diameter</p> <p>Piston pin outside diameter</p> 	<p>0.035~0.040 mm (0.0014~0.0016 in)</p> <p>39.958~39.972 mm (1.5731~1.5737 in)</p> <p>5 mm(0.2 in)</p> <p>10.004~10.015 mm (0.3939~0.3943 in)</p> <p>9.996~10.000 mm (0.3935~0.3937 in)</p>	<p>0.10 mm (0.0039 in)</p> <p>...</p> <p>...</p> <p>10.045 mm (0.4 in)</p> <p>9.975 mm (0.39 in)</p>
<p>Piston Ring: Sectional Sketch (B × T)/Type</p> <p>Top Ring</p> <p>2nd Ring</p> <p>End Gap (Installed):</p> <p>Top Ring</p> <p>2nd Ring</p> <p>Side Clearance (Installed):</p> <p>Top Ring</p> <p>2nd Ring</p> 	<p>1.2 × 1.6 mm/ keystone (0.05 × 0.06 in)</p> <p>1.2 × 1.6 mm/ keystone (0.05 × 0.06 in)</p> <p>0.15~0.35 mm (0.005~0.01 in)</p> <p>0.15~0.35 mm (0.005~0.01 in)</p> <p>0.03~0.05 mm (0.0012~0.0020 in)</p> <p>0.03~0.05 mm (0.0012~0.0020 in)</p>	<p>...</p> <p>...</p> <p>0.6 mm(0.02 in)</p> <p>0.6 mm(0.02 in)</p> <p>0.1 mm(0.0039 in)</p> <p>0.1 mm(0.0039 in)</p>

MAINTENANCE SPECIFICATION



SPEC



Item	Standard	Limit
<p>Crankshaft:</p> <div style="text-align: center;"> </div> <p>Crank Width "A" Run Out Limit "C" Connecting Rod Big End Side Clearance "D" Small End Free Play "F"</p>	<p>37.90~37.95 mm(1.49~1.49 in) 0.03 mm(0.0012 in) 0.2~0.5 mm (0.0029~0.020 in) 0.4~0.8 mm (0.016~0.031 in)</p>	<p>... ... 1.0 mm(0.04 in) ...</p>
<p>Automatic centrifugal clutch:</p> <p>Clutch shoe thickness Clutch housing inside diameter</p> <p>Clutch shoe spring free length Clutch - in revolution Clutch - stall revolution</p>	<p>4.0 mm(0.16 in) 105 mm (4.13 in) 94 mm(3.7 in) 3,300~3,700 r/min 5,500~6,500 r/min</p>	<p>2.5 mm(0.1 in) 105.5 mm (4.15 in) 91 mm(3.58 in)</p>
<p>V-belt:</p> <p>V-belt width</p>	<p>16.6 mm(0.65 in)</p>	<p>14.6 mm(0.57 in)</p>
<p>Kick Starter:</p> <p>Type Kick Clip Tension</p>	<p>Ratchet type 1.5~2.5 N (0.15~0.25 kgf) (0.34~0.56 lb)</p>	
<p>Carburetor:</p> <p>I.D. Mark Main Jet (M.J.) Needle jet (NJ) Jet Needle-clip Position (J.N.) Main Air Jet (M.A.J.) Cutaway (C.A.) Pilot Jet (P.J.) Bypass Valve Seat Size (V.S.) Starter Jet (G.S.) Float Height Fuel level height Engine Idling Speed</p>	<p>5DA-01 #80 2.085 3N24-3/5 2.0 3.5 #44 0.8 1.8 #48 15 ~ 17 mm(0.59 ~ 0.67 in) 3.0~4.0 mm(0.12 ~ 0.16 in) 1,750~1,850 r/min</p>	
<p>Reed Valve:</p> <p>Thickness Valve Stopper Height Valve bending limit</p>	<p>0.150~0.154 mm(0.059~0.0060 in) 6.0~6.4 mm(0.24~0.25 in) 0.2 mm (0.0078)</p>	



**TIGHTENING TORQUES
ENGINE**

Part to be tightened	Part name	Thread size	Q'ty	Tightening torque			Remarks
				Nm	m•kg	ft•lb	
Spark plug	—	M 14	1	20	2.0	14	
Cylinder head and cylinder	Nut	M 7	4	14	1.4	10	
Cylinder	Stud bolt	M 7	4	10	1.0	7	
Air shroud 1	Screw	M 6	3	7	0.7	5.1	
Air shroud 1×2	Screw	6.0	1	2	0.2	1.4	
Fan	Screw	M 6	3	7	0.7	5.1	
Autolube pump	Screw	M 5	2	4	0.4	2.8	
Reed valve	Bolt	M 6	4	11	1.1	8.0	
Air filter	Screw	M 6	2	9	0.9	6.5	
Carburetor cap	Screw	M 4	2	2	0.2	1.4	
Exhaust pipe	Screw	M 6	2	9	0.9	6.5	
Muffler	Bolt	M 8	2	26	2.6	18.2	
Exhaust protector	Bolt	M 6	3	11	1.1	8.0	
Protector	Screw	M 6	1	9	0.9	6.5	
Crankcase 1×2	Bolt	M 6	6	12	1.2	8.4	
Transmission case cover	Bolt	M 6	6	12	1.2	8.4	
Crankcase cover 1(left)	Bolt	M 6	12	12	1.2	8.4	
Bolt(case2)	Screw	M 6	1	7	0.7	5.1	
Crankcase cover2(left)	Bolt	M 6	3	7	0.7	5.1	
Drain bolt	Bolt	M 8	1	18	1.8	13	
Oil plug	Plug	M 14	1	3	0.3	22	
Idle gear plate	Screw	M 6	2	8	0.8	5.8	
Kick crank	Bolt	M 6	1	9	0.9	6.5	
Starter motor	Bolt	M 6	2	13	1.3	9.4	
Clutch housing	Nut	M 10	1	40	4.0	29	
Clutch weight	Nut	M 10	1	30	3.0	22	
Magnet base	Screw	M 6	2	8	0.8	5.8	
C.D.I. rotor	Nut	M 10	1	38	3.8	27	



CHASSIS

Item	Standard	Limit
Steering system: Steering bearing type No /size of steel balls: Upper Lower	Ball and race bearing 22 pcs 19 pcs
Front suspension: Front fork travel Fork spring free length Fork length (Installed) Spring rate (K1) (K2) Inner tube vend limit	70 mm(2.8 in) 236.6 mm(9.31 in) 212.1 mm(8.35 in) 15.68 Nm/mm(1.6 kg/mm,90lb/in) 23.5 Nm/mm(2.43 kg/mm,136lb/in) 233.6 mm 0.2 mm (0.008 in)
Rear suspension: Shock absorber stroke Shock absorber free length (Installed) Spring free length (Installed) Spring rate (K1)	55 mm(2.2 in) 281.8 mm(11.1 in) 159.8 mm(6.29 in) 71.15 N/mm(7.26 kg/mm,407lb/in)
Front wheel: Type Rim size Rim material Rim runout limit radial lateral	Cast wheel MT3.50×10 Aluminum 1 mm(0.04 in) 1 mm(0.04 in)
Rear wheel: Type Rim size Rim material Rim runout limit radial lateral	Cast wheel MT3.50×10 Aluminum 1 mm(0.04 in) 1 mm(0.04 in)
Front disc brake: Type Disc outside diameter × thickness Pad thickness Master cylinder inside diameter Caliper cylinder outside diameter Brake fluid type	Single 180×4.0mm (7.1×0.16 in) 6 mm(0.24 in) 11 mm(0.4 in) 34.93 mm(1.38 in) DOT #4(or DOT #3)	... 180×3.5 mm (7.1×0.14in) 0.8 mm(0.03 in)
Rear drum brake: Type Drum inside diameter Shoe thickness	Leading, trailing 130 mm(5.12 in) 4 mm(0.16 in)	... 131 mm(5.16 in) 2 mm(0.08 in)
Brake lever: Brake lever free play (front at lever side) Brake lever free play (rear) Throttle cable free play	2~5 mm(0.08~0.20 in) 10~20 mm(0.39~0.79 in) 3~5 mm(0.12~0.20 in)



**TIGHTENING TORQUES
CHASSIS**

Part to be tightened	Thread size	Tightening torque			Remarks	
		Nm	m•kg	ft•lb		
Frame and engine bracket	M 12	84	8.4	61	See "page3-18"	
Engine bracket, compression rod and engine	M 10	45	4.5	31		
Rear carrier	M 6	13	1.3	9.4		
Rear shock absorber and frame	M 10	30	3.0	22		
Rear shock absorber and engine	M 8	16	1.6	12		
Steering ring nut	M 25	22	2.2	16		
Handle holder and steering shaft	M 10	43	4.3	37		
Brake hose and master cylinder	M 8	20	2.0	14		
Fuel tank	M 6	10	1.0	7		
Fuel cock	M 6	7	0.7	5.1		
Fuel sender	M 5	4	0.4	2.9		
Box	M 6	7	0.7	5.1		
Seat lock assembly	M 6	7	0.7	5.1		
Plastic parts & cover	M 5	2	0.2	1.4		
Footrest board	M 6	7	0.7	5.1		
Front wheel axle and nut	M 10	70	7.0	51		
Rear wheel axle and nut	M 14	120	12.0	87		
Rear brake cam lever	M 6	10	1.0	7.2		
Front brake caliper and front fork	M 8	23	2.3	16.6		
Brake disc and hub	M10	20	2.0	14.5		
Brake hose and caliper	M 8	23	2.3	16.6		
Brake caliper and bleed screw	M 5	6	0.6	4.3		



ELECTRICAL

Item	Standard	limit
Ignition timing: Ignition timing (B.T.D.C.) Advanced type	14° at 5,000 r/min Fixed
C.D.I.:		
Pickup coil resistance/color	248 ~ 372Ω at 20°C (68°F) (W/R-W/L)
Source coil resistance/color	640 ~ 960 Ω at 20°C (68°F) (B/ R-G/W)
C.D.I. unit model/manufacturer	5PJ/TIIC	...
Ignition coil:		
Model/manufacturer	4WX/TIIC	...
Minimum spark gap	6 mm (0.24 in)	...
Primary winding resistance	0.32~0.48 Ω at 20°C (68°F)	...
Secondary winding resistance	5.68~8.52kΩ at 20°C (68°F)	...
Spark plug cap:		
Type	Resin	...
Resistance	5 kΩ	...
Charging System/Type:	Flywheel magneto	...
C.D.I. Magneto:		
Model/Manufacturer	5PJ/TIIC	...
Nominal output	12V 85W/5,000 rpm	...
Charging current	0.6A at 3,000r/min 1.2A at 8,000r/min
Charging voltage	13~14V at 4,000 rpm	...
Charging Coil Resistance (Color)	0.48~0.72 Ω (White-Black)	...
Lighting Coil Resistance (Color)	0.4~0.6 Ω (Yellow/Red- Black)	...
Lighting Voltage	12~15V (3,000~8,000 rpm)	...
Rectifier:		...
Model/Manufacturer	3GF/Taichung	...
Capacity	8A	...
Withstand voltage	18V	...
Battery:		
Specific gravity	1.320	...
Electric starter system:		
Type	Constant mesh type	...
Starter motor:		
Model/manufacturer/ID number	4WX/shulin	...
Output	0.14 kw	...
Armature coil resistance	0.0648 ~ 0.0792 Ω at 20°C (68°F)	...
Brush overall length	6.5 mm (0.26 in)	3 mm (0.12 in)
Spring force	5.49 ~ 8.24 N (360~540 g) (12.69~19.04 oz)	400g
Commutator diameter	16.1 mm (0.63 in)	15.1 mm (0.59 in)
Mica undercut (depth)	1.05 mm (0.04 in)	...
Starter relay:		
Model/manufacturer	4WX/Shulin	...
Amperage rating	20A	...
Coil resistance	54~66 Ω	...

MAINTENANCE SPECIFICATION

SPEC



Item	Standard	limit
Horn: Model/manufacturer Maximum amperage	4KP/Asian 1.5A
Flasher relay: Type Flasher frequency	Capacitor 60~120 Cycle/min
Fuel gage: Model/manufacturer Sender unit resistance - full - empty	4VP/San Chu 4~10 Ω 90~100 Ω
Oil level gauge: Model/manufacturer	4VP/Lun Ping	...
Circuit breaker: Type MAIN	Fuse 7Ax1pc.



GENERAL TORQUE SPECIFICATIONS

This chart specifies torque for standard fasteners with standard I.S.O. pitch threads. Torque specifications for special components or assemblies are included in the applicable sections of this book. To avoid warpage, tighten multi-fastener assemblies in a crisscross fashion, in progressive stages, until full torque is reached. Unless otherwise specified, torque specifications call for clean, dry threads. Components should be at room temperature.

A (Nut)	B (Bolt)	General torque specifications		
		Nm	m•kg	ft•lb
10 mm	6 mm	6	0.6	4.3
12 mm	8 mm	15	1.5	11
14 mm	10 mm	30	3.0	22
17 mm	12 mm	55	5.5	40
19 mm	14 mm	85	8.5	61
22 mm	16 mm	130	13.0	94

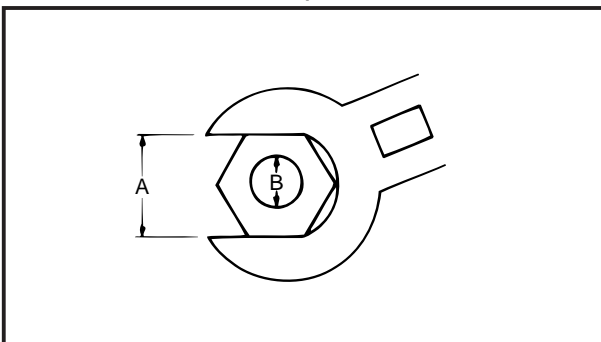

A: Distance across flats

B: Outside thread diameter



LUBRICATION POINTS AND LUBRICATION TYPE

ENGINE

Lubrication Point	Lubricant Type
Oil seal lips	
O-rings	
Bearings	
Piston surface	
Piston pin	
Cylinder	
Transmission case (bearing)	
Autolube pump	
Starter wheel gear	
Idle gear plate	
Secondary drive gear	
Kickstarter pinion gear	
Drive axle	
Pump drive gear	
Main axle	
Main axle (bearing)	

LUBRICATION POINTS AND LUBRICATION TYPE

SPEC



CHASSIS

Lubrication Point	Lubricant Type
Oil seal lips	
O-rings	
Bearings	
Speedometer drive gear	
Front brake camshaft	
Front brake cable	
Throttle cable	
Tube guide (throttle grip) inner surface	
Upper steering stem ring nut	
Upper bearing outer race	
Lower bearing outer race	
Rear brake camshaft	
Centerstand	



CABLE ROUTING

- ① Horn
- ② Rectifier regulator
- ③ Main switch
- ④ Headlight leads
- ⑤ Speedometer cable
- ⑥ Ignition coil
- ⑦ Throttle cable 1
- ⑧ Throttle cable 3
- ⑨ Battery negative(-)
- ⑩ Wire brake
- ⑪ Fuel sender lead
- ⑫ Seat lock cable
- ⑬ Oil tank hose
- ⑭ C.D.I. unit
- ⑮ Wire harness brand.
- [A] Pass the speedometer cable through the right hole of front fender, then through the guide.
- [B] Pass the wire harness through the inside of ignition coil.
- [C] Secure the ground lead and the ignition coil base to the ignition coil stay.
- [D] Pass the wire harness through the inside of oil tank.
- [E] Pass the seat cable through the inside of frame.
- [F] Align the clip with the white brand.
- [G] Clamp the wire harness.
- [H] Insert the seat cable through the frame tube.
- [I] Clamp wireharness, rear brake cable throttle cable 1,3.
- [J] Position the cylinder between the supporter and main switch.

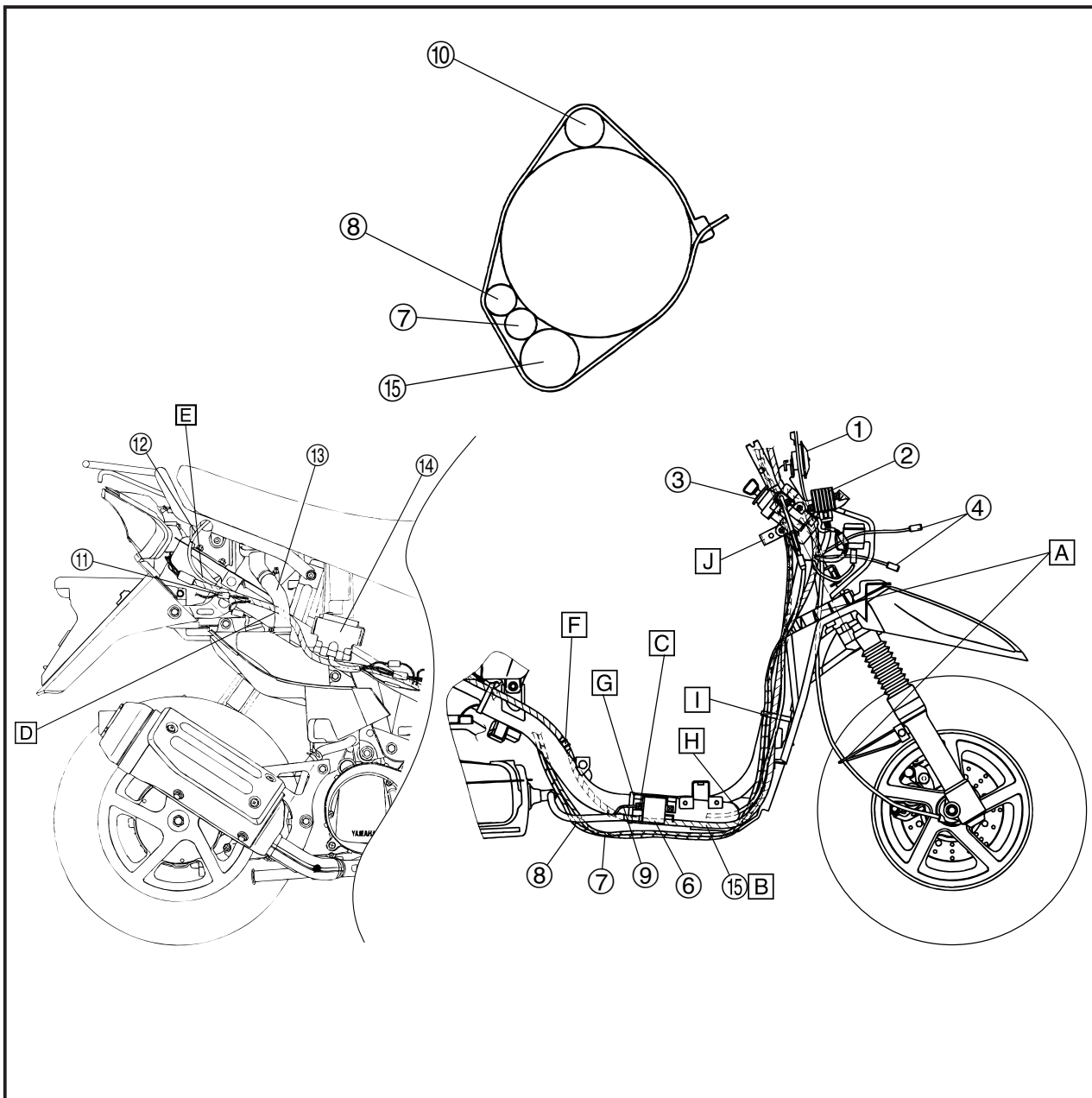



- ① Brake cable
- ② Speedometer cable
- ③ Fuel tank overflow hose
- ④ Brake cable holder
- ⑤ Brake hose
- ⑥ Brake hose holder
- ⑦ License bracket
- ⑧ Flasher relay
- ⑨ Fuel tank breather hose
- ⑩ Fuel hose
- ⑪ Breather hose

- A Pass the brake hose through the holder.
- B Insert the fuel overflow hose bottom.
- C Pass the fuel overflow hose through the rear fender hole.
- D Pass the fuel overflow hose through the holder.
- E Hold the fuel overflow hose with a clamp.
- F Pass the brake cable through the holder.

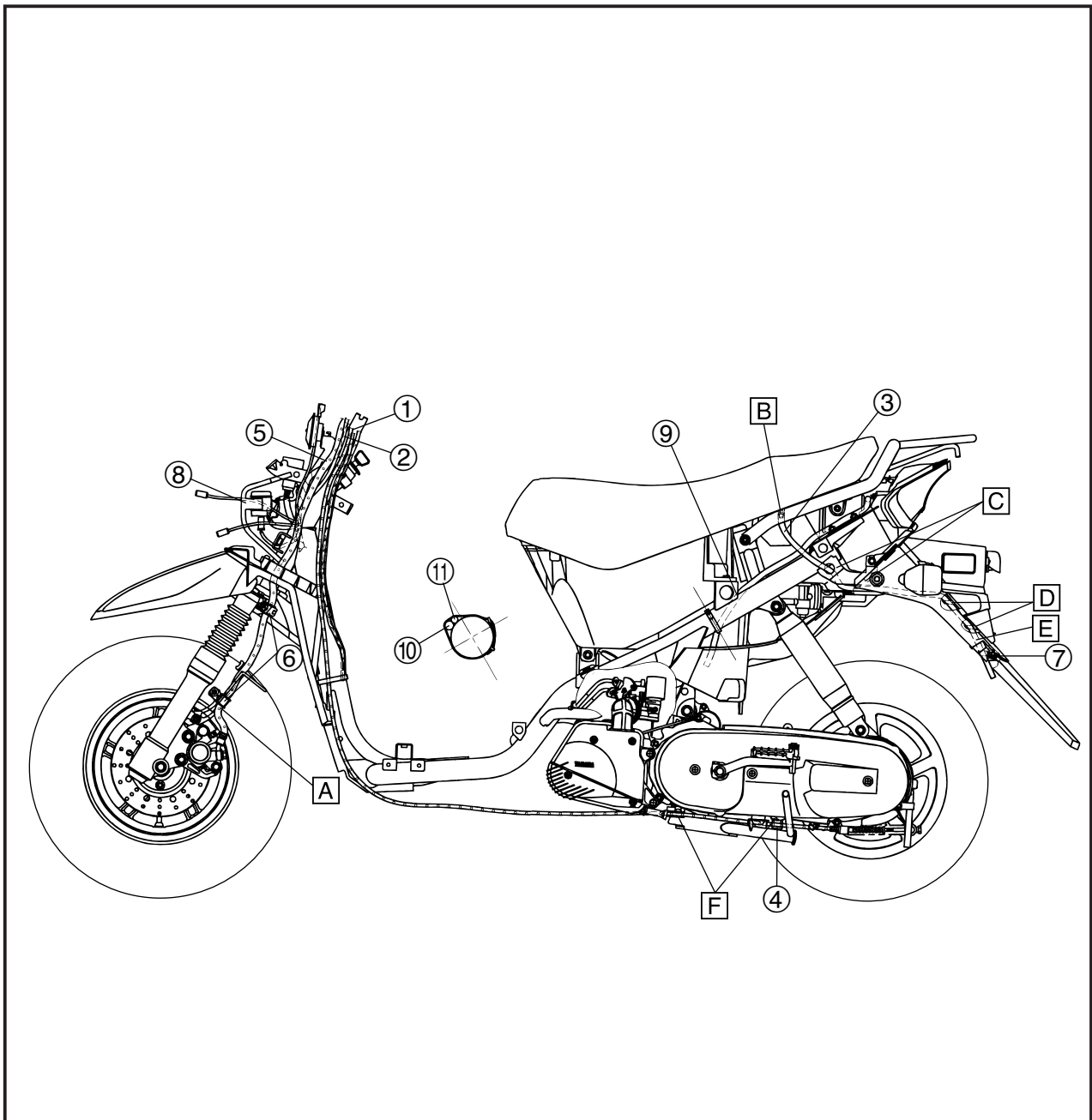



- ① Brake hose
- ② Front fender
- ③ Front fork assembly
- ④ Nut
- ⑤ Plate washer
- ⑥ Brake hose holder
- ⑦ Flange bolt
- ⑧ Bolt
- ⑨ Brake hose holder
- ⑩ Flange bolt

[A] Pass the brake hose through the holder.

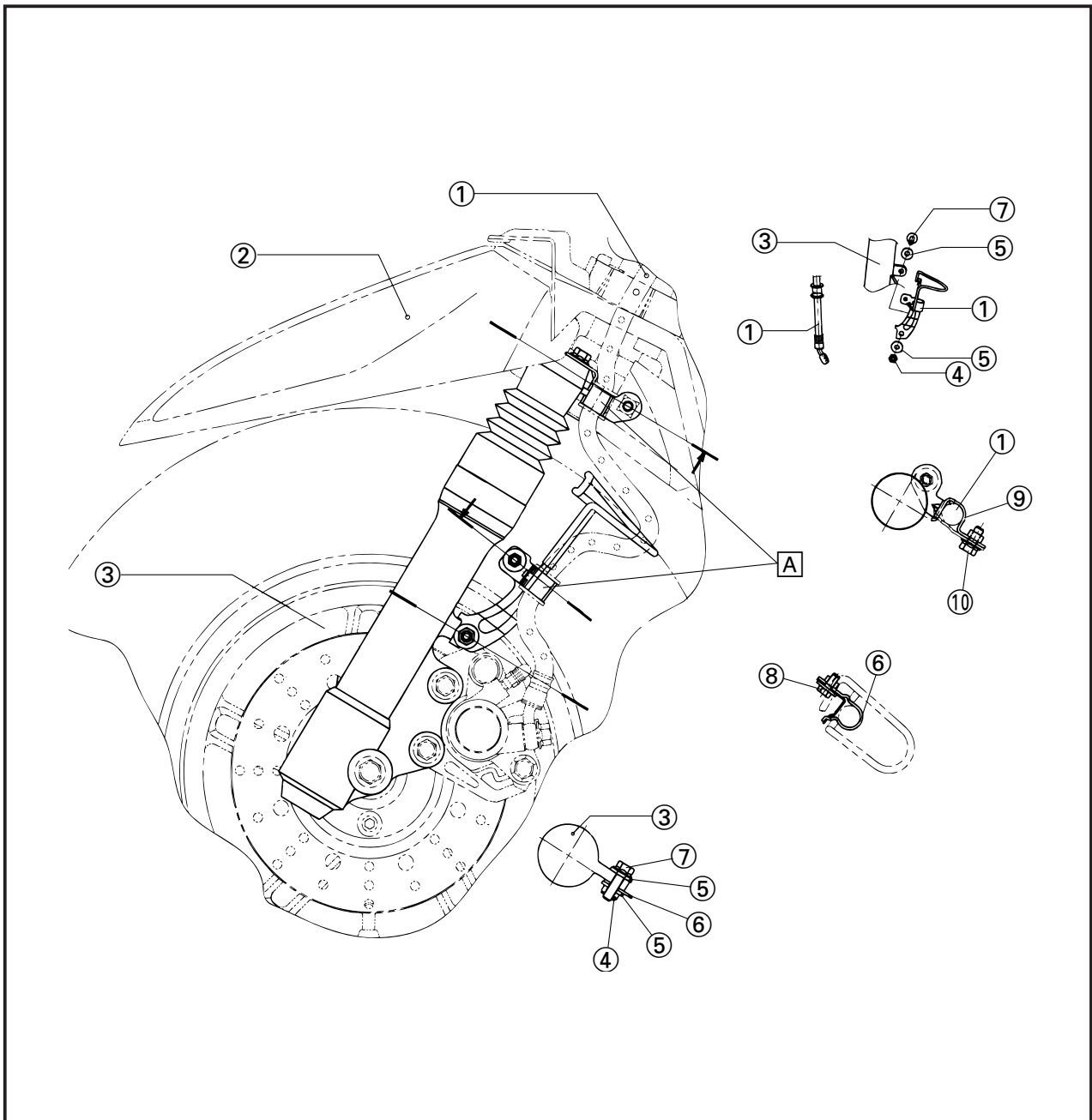



- | | | |
|---------------------------|--|--|
| ① Ignition coil | ⑭ Battery(+)-lead | and autolube hose on to carburetor throttle cable. |
| ② Spark plug lead | Ⓐ Pass battery leads through the slot of footrestboard. | Ⓔ Pass the battery leads over frame member. |
| ③ Starter relay leads | Ⓑ Cover them after securing starter relay leads. | Ⓜ Put fuse box on to footrest board holder. |
| ④ Auto choke leads | Ⓒ Pass the seat lock cable through the hole of bracket. | Ⓨ Pass throttle cable, 1,3 wireharness, autolube pump cable, brake cable through the outside of battery box. |
| ⑤ Starter relay | Ⓓ Pass the fuel tank breather hose over seat lock cable. | |
| ⑥ Bind | Ⓔ Clamp carburetor vacuum hose, fuel hose and fuel cock vacuum hose. | |
| ⑦ C.D.I. unit | Ⓕ Clamp autochoke leads | |
| ⑧ Autolube hose | | |
| ⑨ Seat lock cable | | |
| ⑩ Bracket | | |
| ⑪ Fuel tank breather hose | | |
| ⑫ Bind 2 | | |
| ⑬ Battery(-)-lead | | |

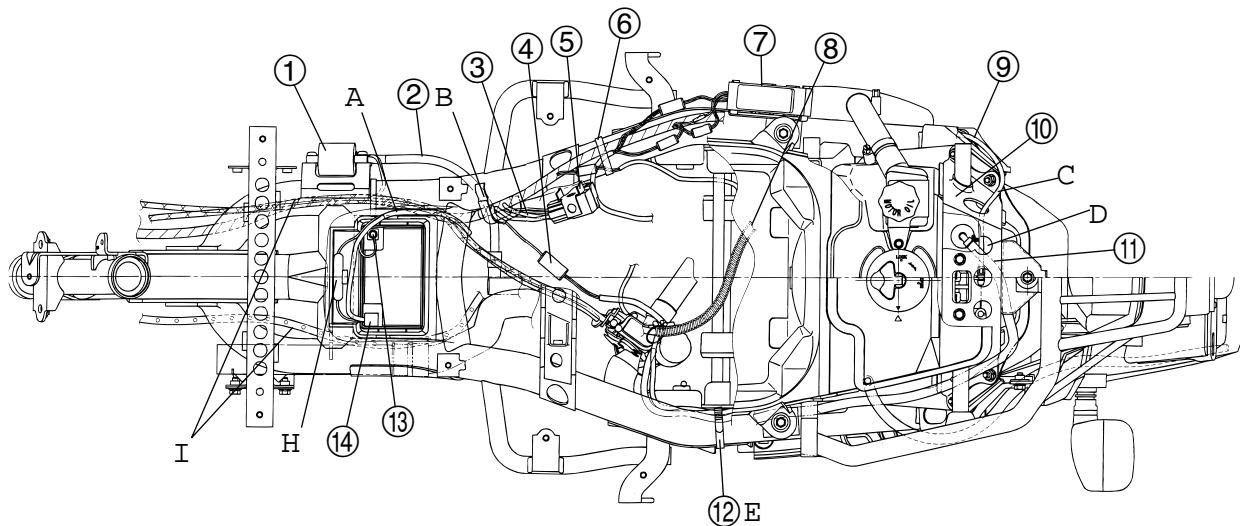



- ① Handlebar switch(right)
- ② Speedometer
- ③ Wire brake
- ④ Handlebar switch(left)
- ⑤ Wire harness
- ⑥ Brake hose
- ⑦ Speedometer cable
- ⑧ Throttle cable1
- ⑨ Throttle cable 3
- ⑩ Front flasher leads

- A Pass brake cable through the slot of bracket.
- B Avoid clamping front flasher leads when installing handlebar covers.
- C Pass throttle cable1,3 through between handlebar and wireharness.
- D Hang the wireharness bind on to the bracket.

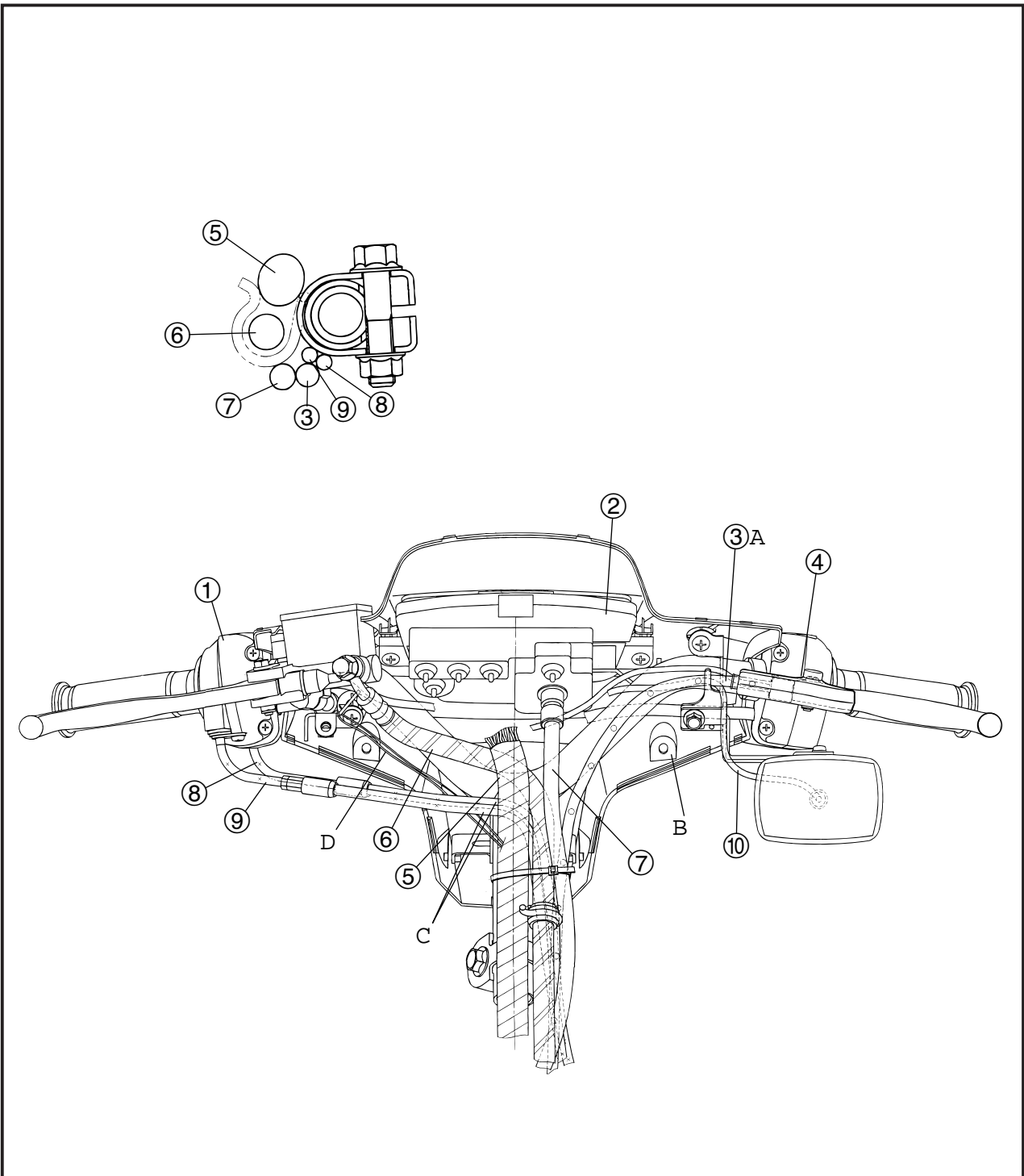

EB300000

PERIODIC INSPECTIONS AND ADJUSTMENTS

INTRODUCTION

This chapter includes all information necessary to perform recommended inspections and adjustments. These preventive maintenance procedures, if followed, will ensure more reliable vehicle operation and a longer service life. The need for costly overhaul work will be greatly reduced. This information applies to vehicles already in service as well as to new vehicles that are being prepared for sale. All service technicians should be familiar with this entire chapter.

YP301000

PERIODIC MAINTENANCE/LUBRICATION INTERVALS

NO.	ITEM	ROUTINE	TYPE	BREAK-IN	EVERY	
				INITIAL 1,000 km (600 mi)	3,000 km (2,000 mi) or 6 months (whichever comes first)	6,000 km (4,000 mi) or 12 months (whichever comes first)
1 *	Fuel line	<ul style="list-style-type: none"> • Check fuel hoses and vacuum hose for cracks or damage. • Replace if necessary. 	—		○	○
2	Spark plug	<ul style="list-style-type: none"> • Check condition. • Clean, regap or replace if necessary. 	Refer to SPARK PLUG INSPECTION	○	○	○
3	Air filter element	<ul style="list-style-type: none"> • Clean or replace if necessary. 	Same as engine oil		○	○
4 *	Front brake	<ul style="list-style-type: none"> • Check operation, fluid level and vehicle for fluid leakage. 	Brake fluid DOT 4 (or DOT 3)	○	○	○
		<ul style="list-style-type: none"> • Replace brake pads. 		Whenever worn to the limit.		
5 *	Rear brake	<ul style="list-style-type: none"> • Check operation. • Adjust brake lever free play. 	—	○	○	○
		<ul style="list-style-type: none"> • Replace brake shoes. 		Whenever worn to the limit.		
6 *	Wheels	<ul style="list-style-type: none"> • Check balance, runout and for damage. • Replace if necessary. 	—		○	○
7 *	Tires	<ul style="list-style-type: none"> • Check tread depth and for damage. • Replace if necessary. • Check air pressure. • Correct if necessary. 	—	○	○	○
8 *	Wheel bearings	<ul style="list-style-type: none"> • Check Bearing for looseness or damage. • Replace if necessary. 	—		○	○
9 *	Steering bearings	<ul style="list-style-type: none"> • Check bearing play and steering for roughness. 		○	○	○
		<ul style="list-style-type: none"> • Lubricate with lithium soap base grease. 	—	Every 12,000 km(8,000 mi) or 24 months(whichever occurs first).		
10 *	Chassis fasteners	<ul style="list-style-type: none"> • Make sure that all nuts, bolts and screws are properly tightened. 	—		○	○

PERIODIC INSPECTION AND ADJUSTMENTS



NO.	ITEM	ROUTINE	TYPE	BREAK-IN	EVERY	
				INITIAL 1,000 km (600 mi)	3,000 km (2,000 mi) or 6 months (whichever comes first)	6,000 km (4,000 mi) or 12 months (whichever comes first)
11	Centerstand	<ul style="list-style-type: none"> • Check operation. • Lubricate with lithium soap base grease (all purpose grease). 	Same as engine oil		○	○
12	* Front fork	<ul style="list-style-type: none"> • Check operation and for oil leakage. 	-		○	○
13	* Rear shock absorber assembly	<ul style="list-style-type: none"> • Check operation and shock absorber for oil leakage. • Replace shock absorber assembly if necessary. 	-		○	○
14	* Carburetor	<ul style="list-style-type: none"> • Check engine idling speed. • Adjust if necessary. 	-	○	○	○
15	* Autolube pump	<ul style="list-style-type: none"> • Check operation. • Correct if necessary. • Bleed if necessary. 	-	○	○	○
16	* Final transmission oil	<ul style="list-style-type: none"> • Check oil level and vehicle for oil leakage. 	-	○	○	○
		<ul style="list-style-type: none"> • Replace. 	Yamalube 4 SAE 10W 30 SE or GL gear oil	○	Every 12,000 km (8,000 mi) or 24 months (whichever occurs first).	
17	* V-belt	<ul style="list-style-type: none"> • Replace. 	-		Every 9,000 km (6,000 mi)	

Items marked with an asterisk (*) require special tools, data and technical skills for servicing. Take the scooter to a Yamaha dealer.

NOTE: _____

- The air filter needs more frequent service if you are riding in unusually wet or dusty areas.
- Brake fluid replacement:
 1. Replace the brake fluid after disassembling the master cylinder or caliper cylinder. Check the brake fluid level and add fluid as required.
 2. Replace the master cylinder and caliper cylinder oil seals every two years.
 3. Replace the brake hoses every four years, or if cracked or damaged.

NOTE: _____

From 6,000 mi (9,000 km)-or 18 months, repeat the maintenance intervals starting 2,000 mi (3,000 mi) or 6 months.

COVER AND PANEL
SIDECOVER AND SEAT

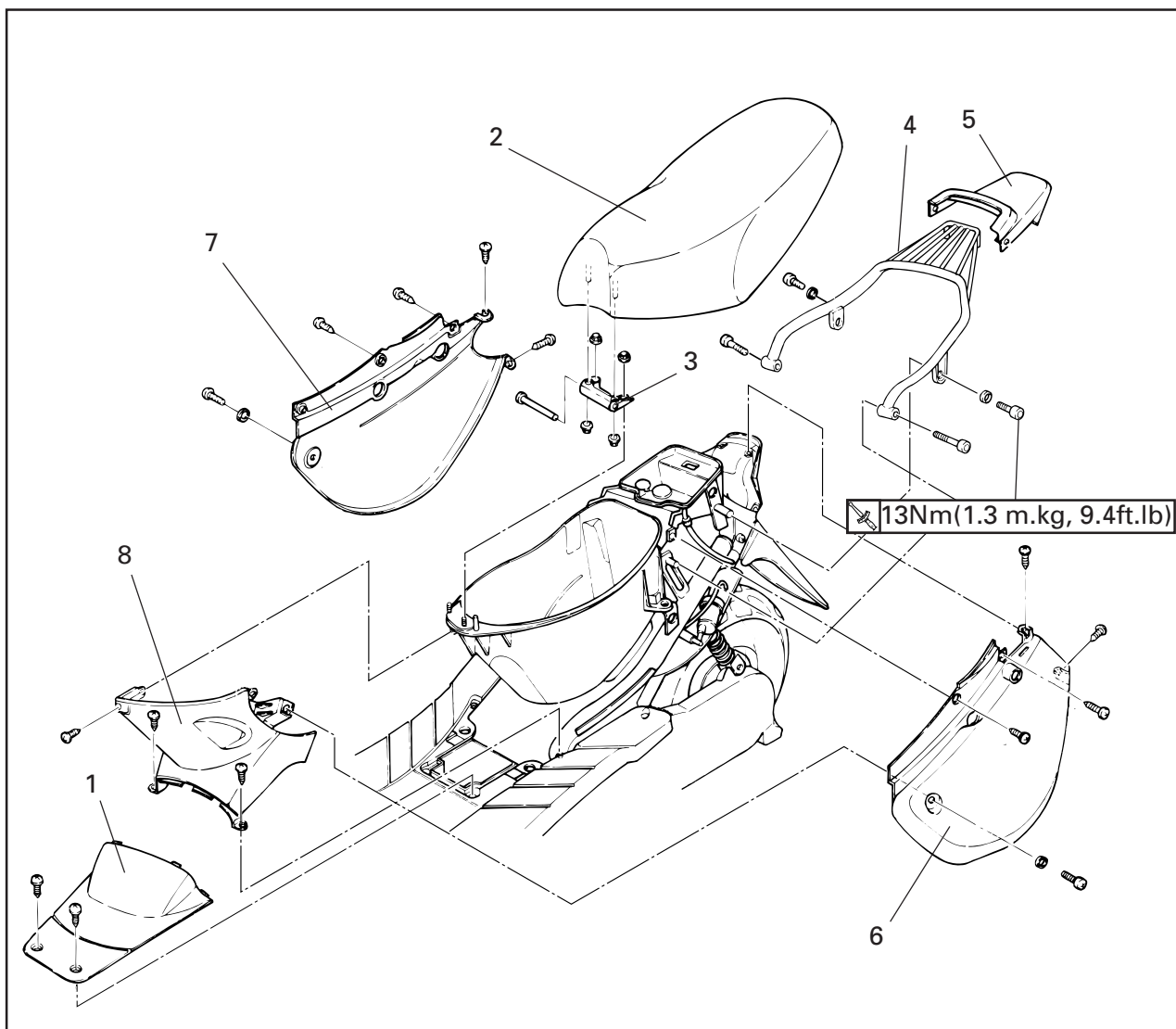

Order	Job name/Part name	Q'ty	Remarks
1.	Sidecover and seat removal Battery box cover	1	Remove the parts in order. NOTE: _____ Insert the (-) screwdriver into the slot of battery cover and pickup then remove. _____
2.	Seat	1	
3.	Seat hange	1	
4.	Rear carrier	1	
5.	Rear cover	1	
6.	Left side cover	1	
7.	Right side cover	1	
8.	Center cover	1	Reverse the removal procedure for instal- lation.

LOWER COWLING, UPPER COVER, LEG SHIELD 1, 2 AND FOOTREST BOARD

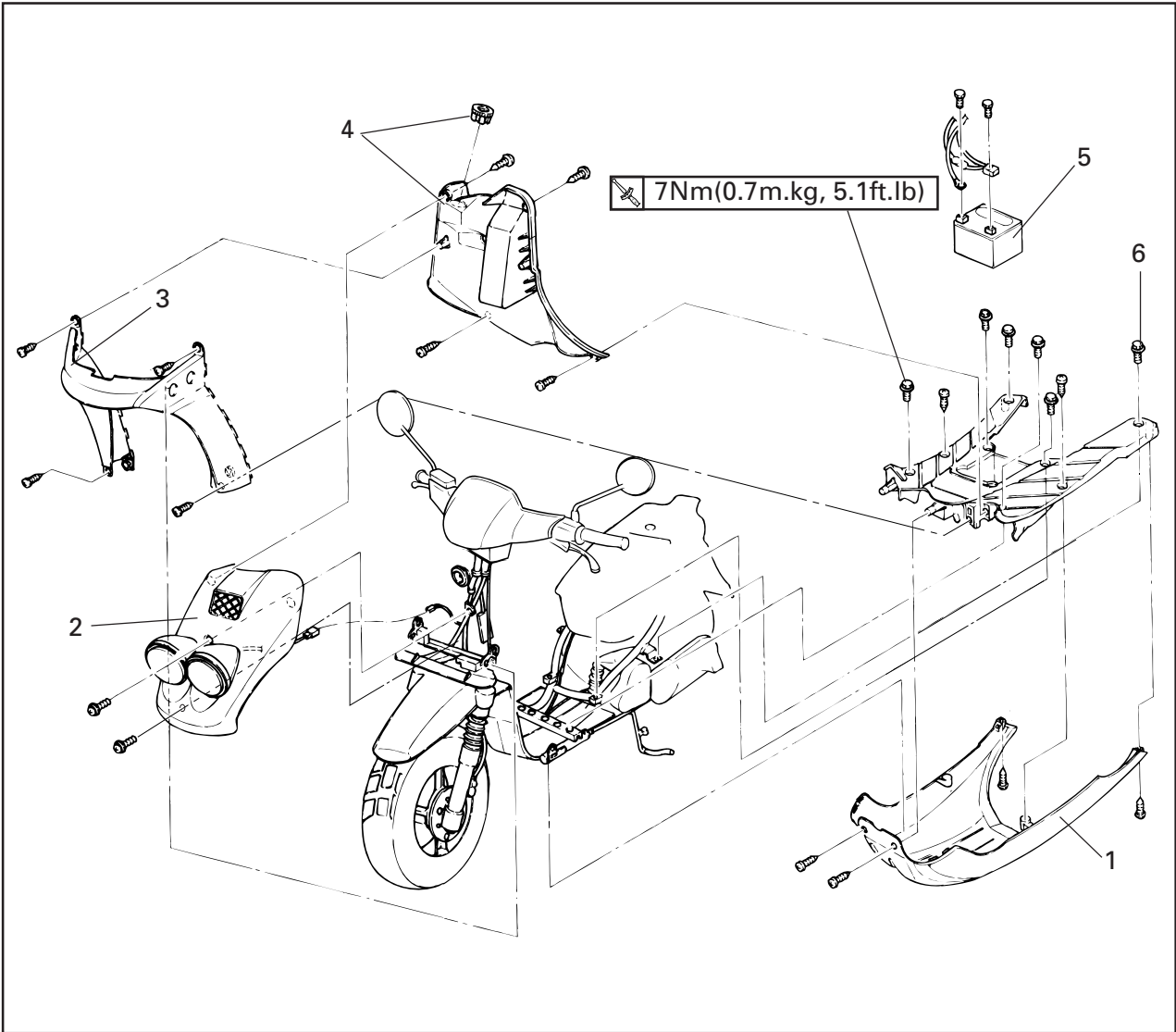

Order	Job name/ part name	Q'ty	Remarks
	Lower cowl, upper cover, leg shield 1,2 and footrest board removal		Remove the parts in order.
1.	Lower cowl	1	
2.	Upper cover	1	
3.	Leg shield 1	1	
4.	Main switch cover/ leg shield 2	1/1	
5.	Battery	1	
6.	Footrest board	1	
			Reverse the removal procedure for installation.

HANDLEBAR COVER(FRONT AND REAR)

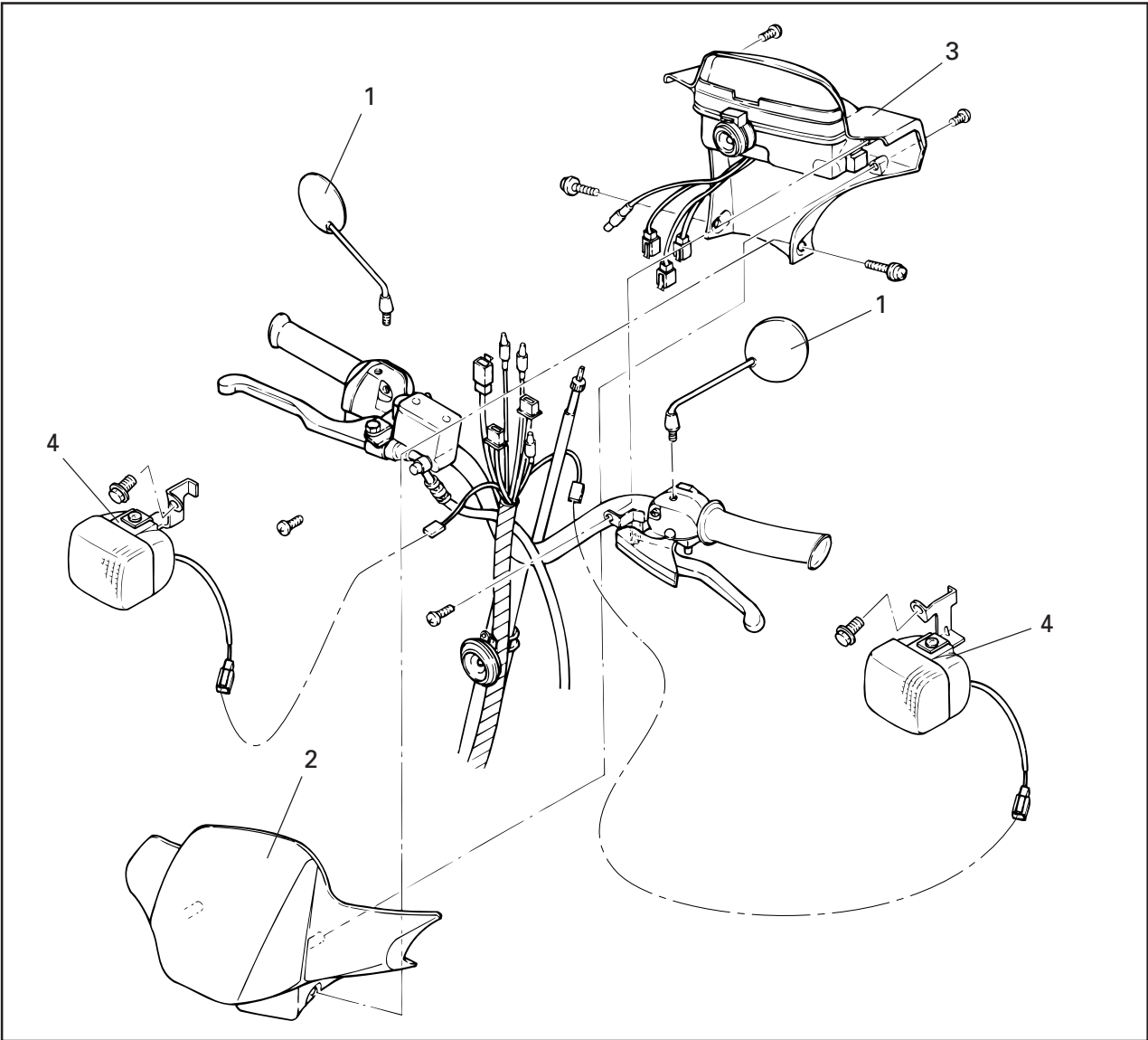

Order	Job name / Part name	Q'ty	Remarks
	Handlebar cover(Front and Rear) removal.		Remove the part in order.
1.	Mirrors	2	
2.	Front handlebar cover	1	
3.	Rear handlebar cover	1	
4.	Flasher light(Left/Right)	1/1	
			Reverse the removal procedure for installation.

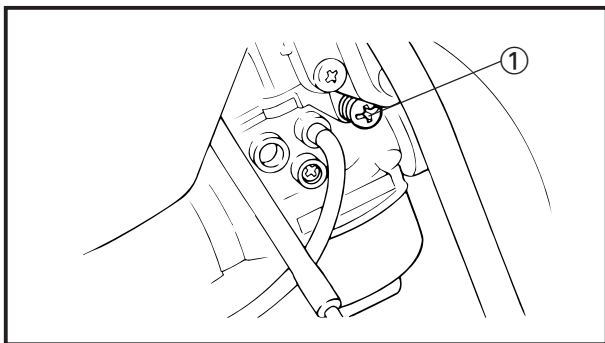
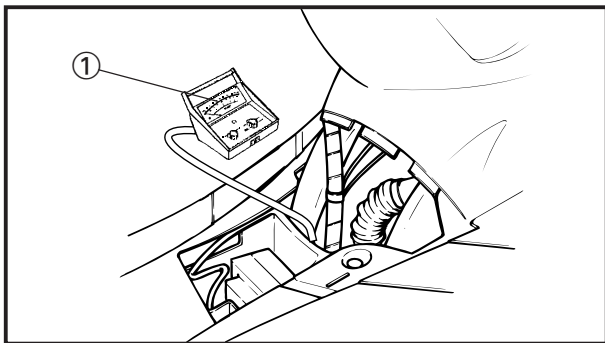
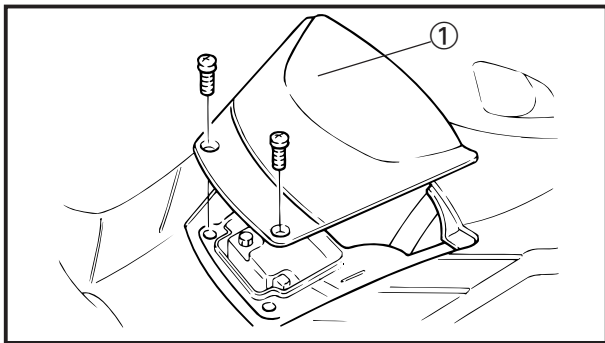

ENGINE IDLE SPEED ADJUSTMENT

- Remove
 - Battery box cover ①

- Start the engine and let it warm up.

⚠ WARNING

Before starting the engine, be sure to use the centerstand for safety.

- Attach:
 - Inductive tachometer ①
To the spark plug lead

	Inductive tachometer: YU-8036-A
--	------------------------------------

- Check:
 - Engine idle speed
Out of specification → Adjust.

	Engine idle speed: 1,750~1,850 r/min
---	---

- Adjust:
 - Engine idle speed

Adjustment steps.

- Turn the throttle stop screw ① in or out until specified idle speed is obtained.

Turn in	Idle speed becomes higher.
Turn out	Idle speed becomes lower.

THROTTLE CABLE FREE ADJUSTMENT

INSP
ADJ

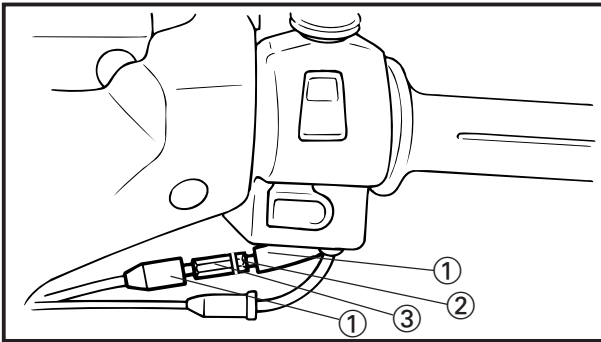
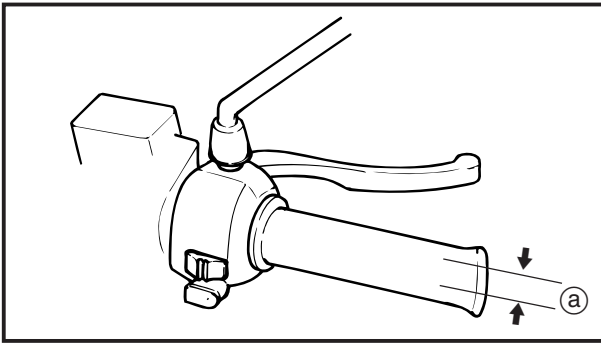

THROTTLE CABLE FREE ADJUSTMENT

1. Check:
 - Throttle cable free play ①Out of specification → Adjust.



Free play:
3 ~ 5 mm (0.12 ~ 0.20 in)

Throttle cable free play adjustment steps;

NOTE:

Before adjusting the throttle cable free play, the engine idle speed should be adjusted.

- Remove the adjuster cover ①
- Loosen the locknut ② on the throttle cable.
- Turn the adjuster ③ in or out until the specified free play is obtained.

Turning in → Free play is increased.

Turning out → Free play is decreased.

- Tighten the locknuts.
- Install the adjuster cover

⚠ WARNING

After adjusting the throttle cable free play, start the engine and turn the handlebar to the right and to the left to ensure that this does not cause the engine idling speed to change.

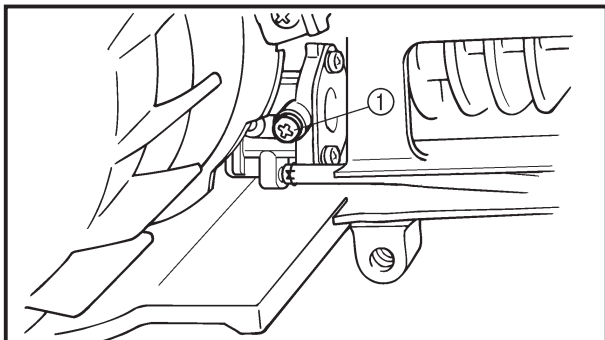
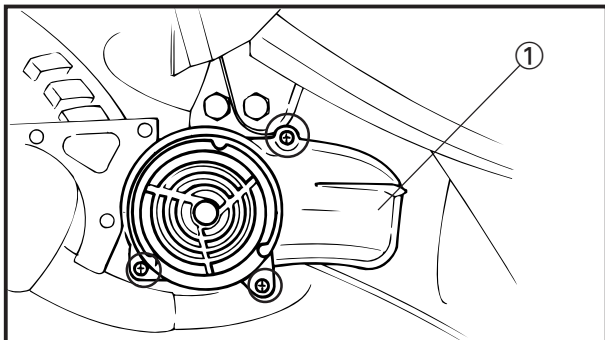

AUTOLUBE PUMP AIR BLEEDING

1. Remove
 - Lower cowling
 - Air shroud 1 ①
2. Air bleeding:
 - Pump case and / or oil hose.

Air bleeding steps:

- Place a rag under the autolube pump to catch the oil.
- Remove the bleed screw ①.
- Keep the oil running out until air bubbles disappear.
- When air bubbles are expelled completely, tighten the bleed screw.

NOTE: _____

Check the bleed screw gasket. If damaged, replace with a new one.

Place a oil pan under the autolube pump to catch oil.

3. Air bleeding:
 - Pump distributor and/or delivery hose

Air bleeding steps:

- Start the engine.
- Run the engine for 2-3 minutes at 2000 r/ min. This will completely remove autolube pump system of air.

SPARK PLUG INSPECTION

1. Remove:
 - Battery box cover
2. Inspect:
 - Spark plug type
Incorrect → Replace.

Standard spark plug:
BPR7HS/NGK

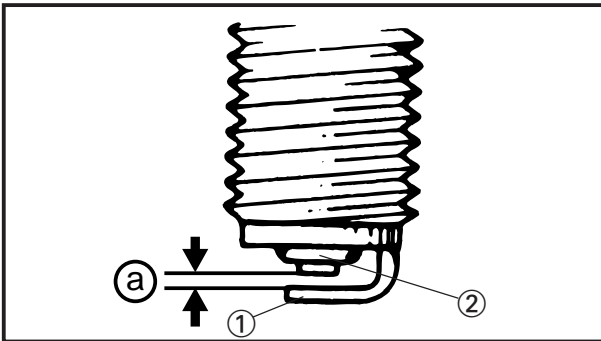

3. Inspect:
 - Electrode ①
Wear/Damage → Replace.
 - Insulator ②
Abnormal color → Replace.
Normal color is a medium-to-light tan color.
4. Clean the spark plug with a spark plug cleaner or wire brush.
5. Measure:
 - Plug gap ③
Use a wire gauge or feeler gauge.
Out of specification → Regap.



Spark plug gap:
0.6 ~ 0.7 mm (0.02 ~ 0.03 in)

6. Tighten:
 - Spark plug  20 Nm (2.0 m.kg, 14 ft.lb)
7. Install:
 - Battery box cover.

ENGINE OIL LEVEL INSPECTION

INSP
ADJ

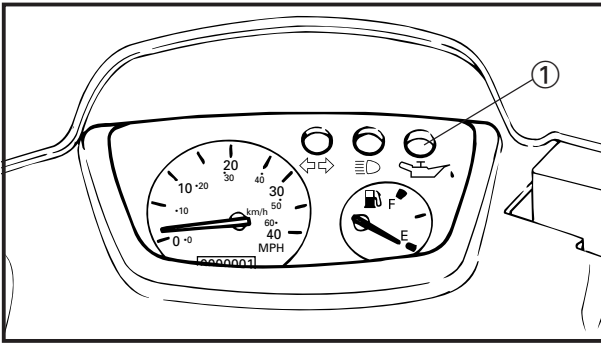

ENGINE OIL LEVEL INSPECTION

1. Inspect:
 - Engine oil level Oil level low → Add sufficient oil by the following inspection steps.

① "OIL" indicator light

Engine oil level visual inspection steps:

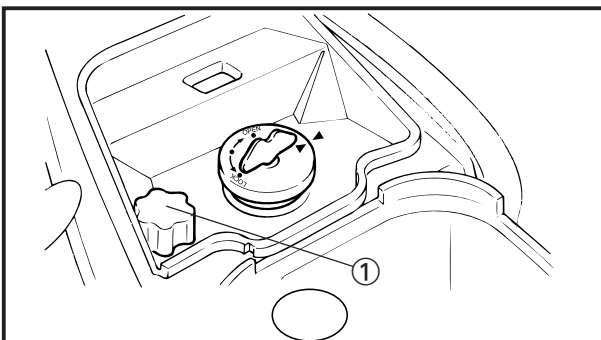
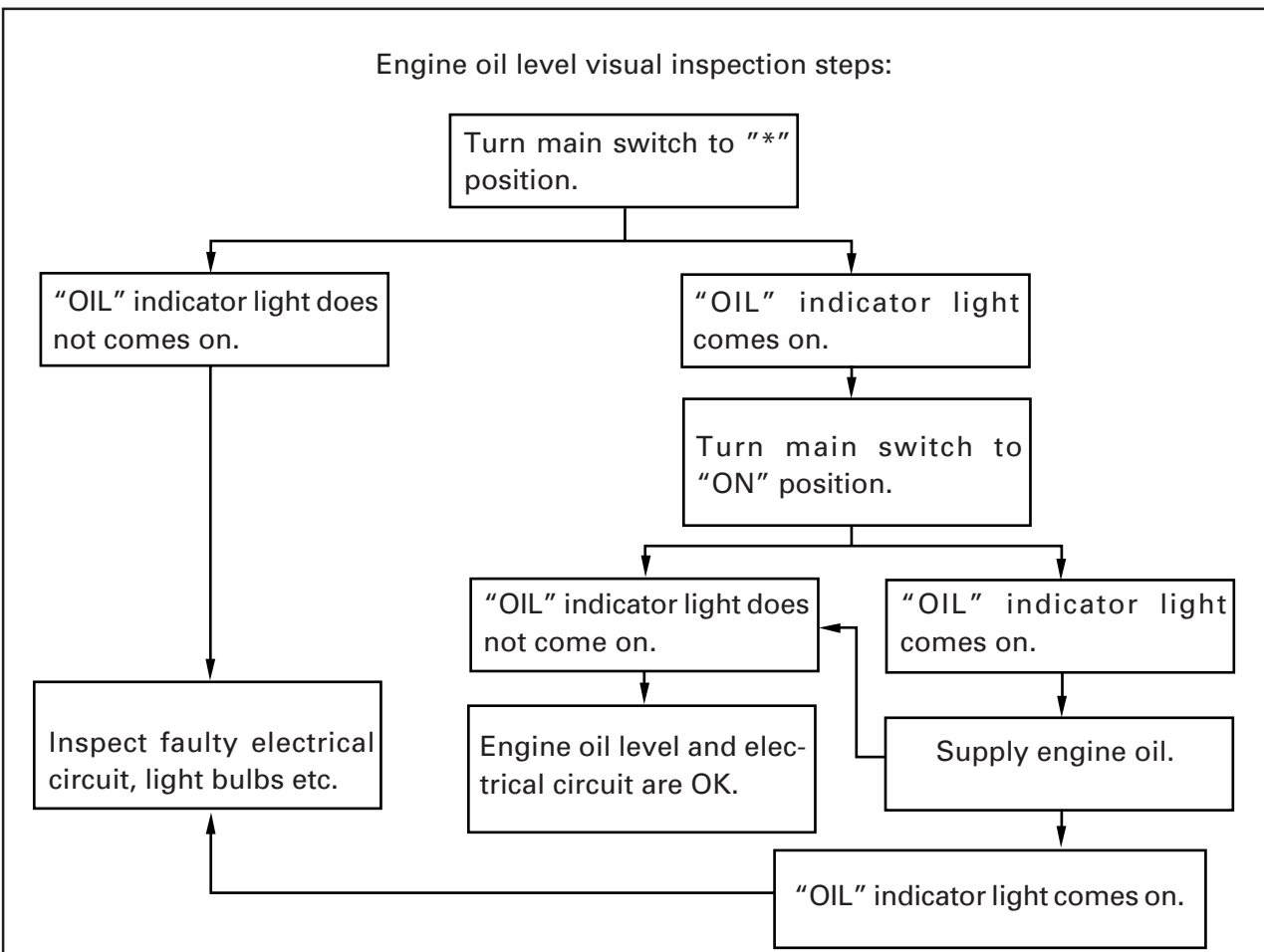

Recommended oil:

For Yamaha:

Yamalube 2 or 2-stroke engine oil
(ISO EG-C, EG-D grade)

Total:

1.4L(1.23 Imp.qt, 1.48 US.qt)

NOTE:

Install the oil tank filler cap ① and push it fully into the filler.

TRANSMISSION OIL REPLACEMENT

INSP
ADJ

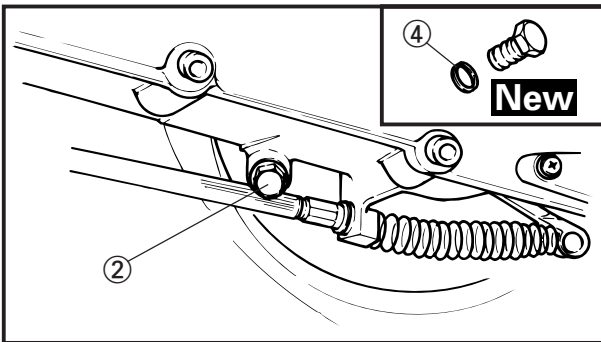
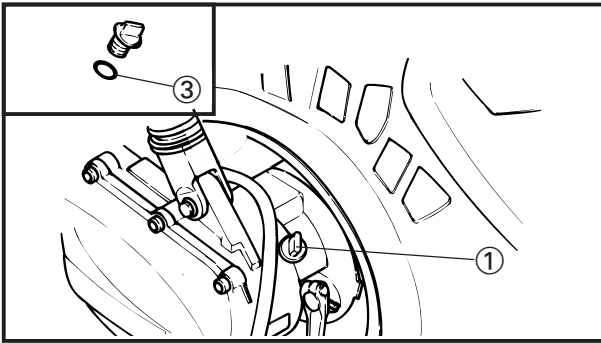

TRANSMISSION OIL REPLACEMENT

1. Warm up the engine for several minutes, then stop the engine.
2. Place a container under the drain hole.
3. Remove:
 - Oil filler plug ①
 - Drain bolt (with gasket) ②

NOTE:

Drain the transmission oil completely. While draining, slightly tilt the scooter to the right and to the left.

4. Inspect:
 - Gasket (drain bolt) ④ **New**
 - O-ring (oil filler plug) ③
Damage → Replace.

5. Install:

- Drain bolt

18 Nm (1.8 m.kg, 13 ft.lb)

6. Fill:

- Transmission case



Recommended oil:

Yamalube 4 SAE 10W 30SE or GL gear oil

Oil capacity:

Total amount

0.13 L (0.11 Imp.qt, 0.13 US.qt)

Periodic oil change

0.11 L (0.096 Imp.qt, 0.12 US qt)

CAUTION:

- Always use the same type of oil; mixing oils may result in a harmful chemical reaction and lead to poor performance.
- Do not allow foreign material to enter the transmission case.

7. Install:

- Oil filler plug (with O-ring)

8. Inspect:

- Oil leaks
- Oil level

NOTE:

Wipe off any oil spilt on the transmission, tire or wheel.

AIR FILTER ELEMENT CLEANING

INSP
ADJ

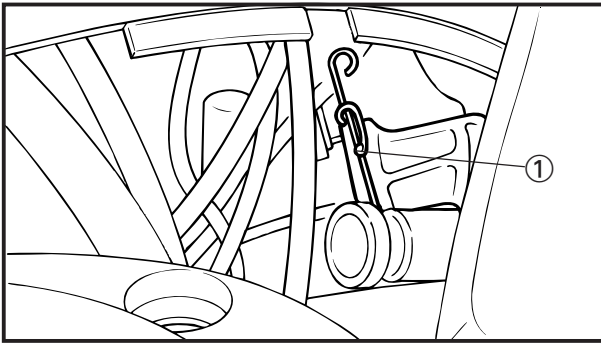

AIR FILTER ELEMENT CLEANING

1. Remove:
 - Battery box cover
2. Remove:
 - Carburetor joint clamp ①

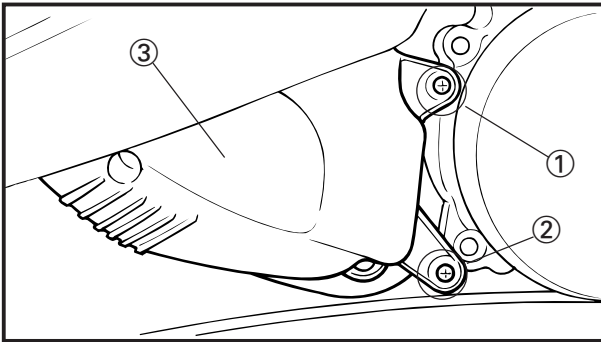

3. Remove:
 - Screw ①②
 - Air filter ③

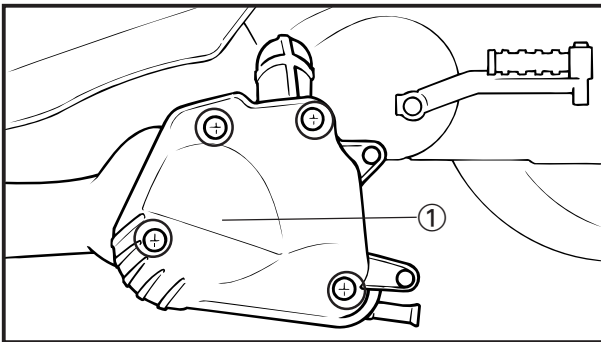

4. Remove:
 - Air filter case ①
 - Air filter element

CAUTION:

Never operate the engine with the air filter element removed. This will allow unfiltered air to enter, causing rapid wear and possible engine damage. Additionally, operation without the cleaner element will affect carburetor jetting with subsequent poor performance and possible engine overheating.

Be careful not to have rags or the like blocking the intake area of the air filter.

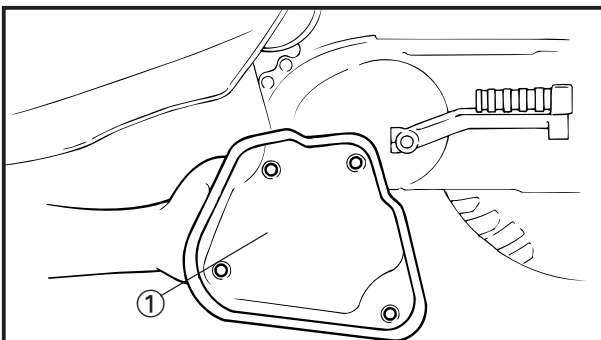

5. Inspect:
 - Element ①
 - Damage → Replace.
6. Clean:
 - Air filter element

Air filter element cleaning steps:

- Wash the element gently, but thoroughly in solvent.

AIR FILTER ELEMENT CLEANING

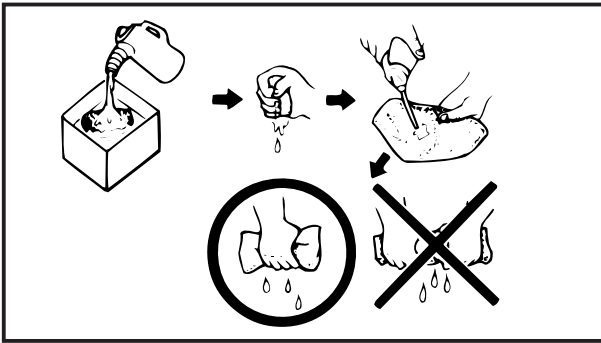

⚠ WARNING

Never use low flash point solvents such as gasoline to clean the element. Such solvent may lead to a fire or explosion.

- Squeeze the excess solvent out of the element and let dry.

CAUTION:

Do not twist the element when squeezing the element.

- Apply the foam -air filter oil or engine oil .
- Squeeze out the excess oil.

NOTE:

The element should be wet but not dripping.

7. Install:

- Air filter
- Battery box cover

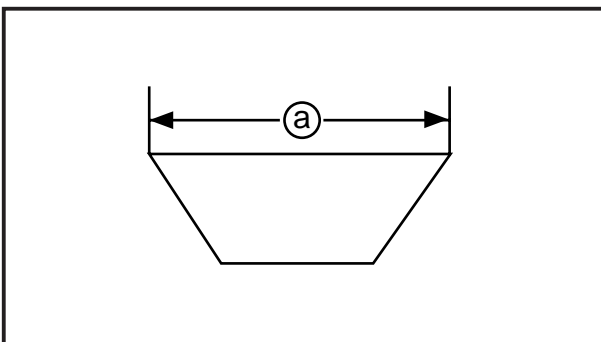
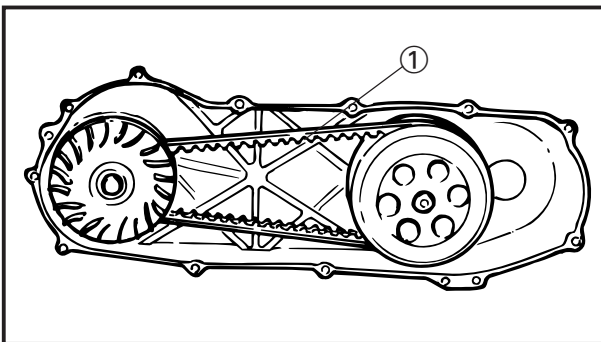
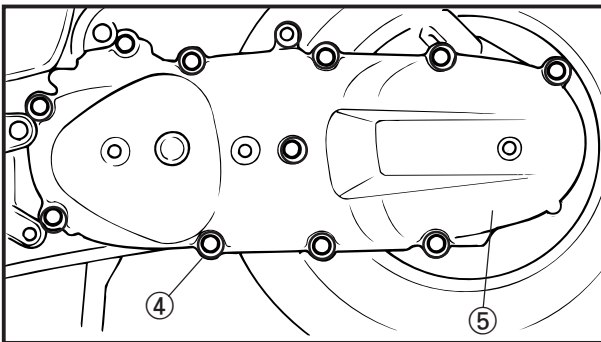
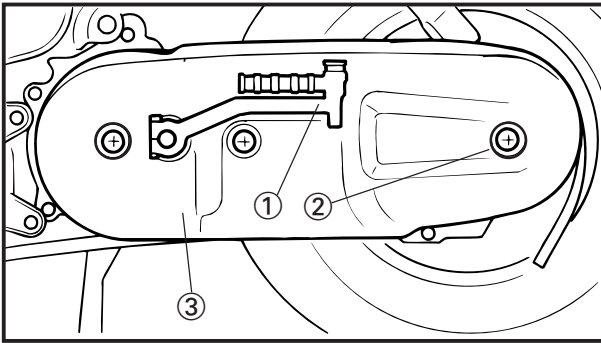

V-BELT INSPECTION

1. Remove:

- Kick crank ①
- Screws ②
- Crankcase cover 2(left) ③
- Screws(Air cleaner and left crankcase cover) ④
- Crankcase cover 1(left) ⑤

2. Inspect

- V-belt ①
Cracks/Wear/Damage→Replace.
Oil or grease adhere to the V-belt→Check the primary and secondary sheaves.
Refer to "ENGINE OVERHAUL - INSPECTION AND REPAIR" section in the CHAPTER 4.

3. Measure:

- V-belt width ①
Out of specification→Replace.
Refer to "ENGINE OVERHAUL" section in the CHAPTER 4.



V-belt width:
16.6 mm (0.65 in)
<Limit> 14.6 mm (0.57 in)

NOTE:

Measure the V-belt width on several points.

4. Install:

- Crankcase cover 1 (left)

	12Nm(1.2m.kg, 8.4 ft.lb)
--	--------------------------

- Air cleaner

	9Nm(0.9m.kg, 6.5 ft.lb)
--	-------------------------

- Crankcase cover 2 (left)

	7Nm(0.7m.kg, 5.1 ft.lb)
--	-------------------------

- Kick crank

	9Nm(0.9m.kg, 6.5 ft.lb)
--	-------------------------

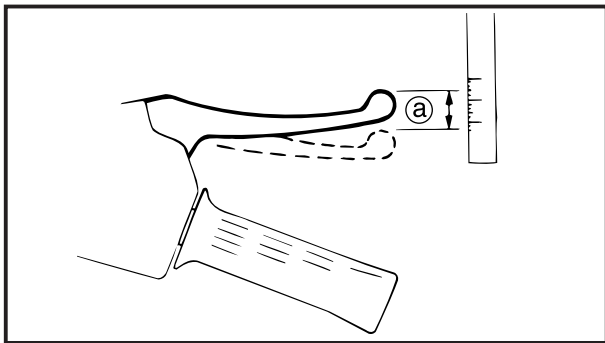

CHASSIS

FRONT BRAKE LEVER FREE PLAY CHECK

1. Check:
 - Front brake lever free play

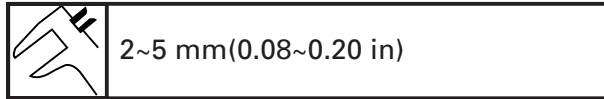

⚠ WARNING

A soft or spongy feeling in the brake lever can indicate the presence of air in the brake system. This air must be removed by bleeding the brake system before the motorcycle is operated. Air in the system will cause greatly diminished braking capability and can result in loss of control and an accident. Inspect and bleed the system if necessary.

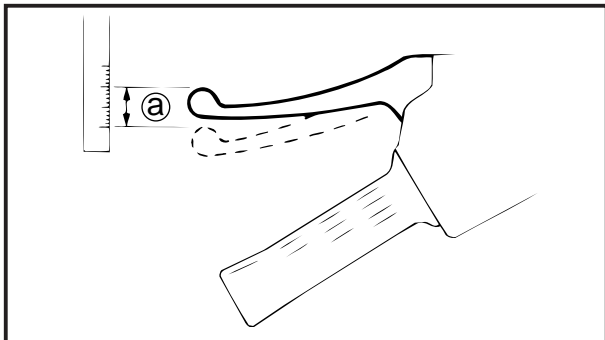

REAR BRAKE LEVER FREE PLAY CHECK

1. Check:
 - Rear brake lever free play ①
 Out of specification → Adjust.

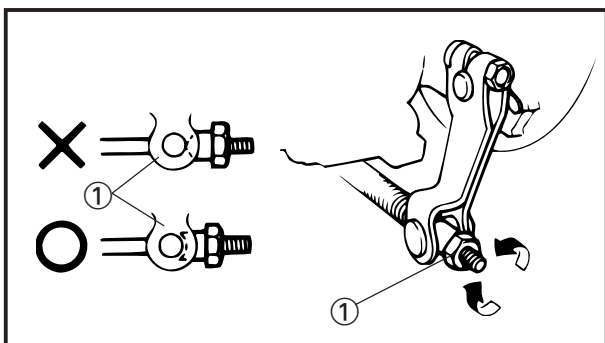
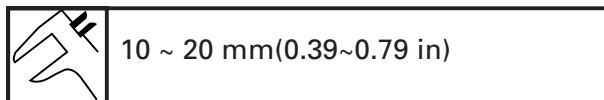

Rear brake lever free play adjustment steps:

- Turn the adjuster ① in or out until the correct free play is obtained.

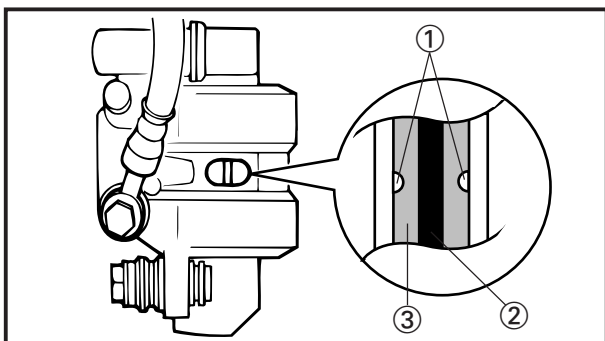

BRAKE PAD INSPECTION

1. Activate the brake lever.
2. Inspect:
 - Brake pad
Wear indicator ① nearly contacting brake disc → Replace brake pads as a set. Refer to the "BRAKE PAD REPLACEMENT" section in the CHAPTER 6.
 - ② Brake disc
 - ③ Brake pads

BRAKE SHOE INSPECTION/ BRAKE FLUID LEVEL INSPECTION

INSP
ADJ

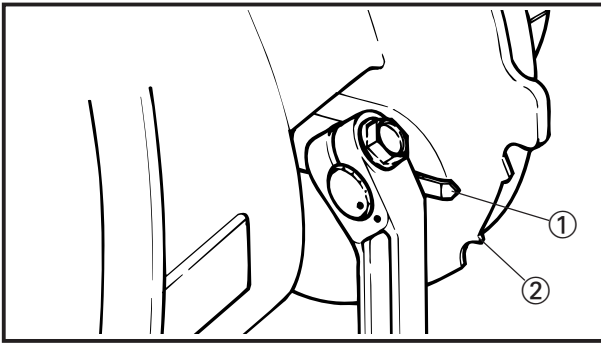

BRAKE SHOE INSPECTION

1. Activate the brake lever.
2. Inspect:
 - Wear indicator ①Indicator at wear limit line ② → Replace brake shoes.

BRAKE FLUID LEVEL INSPECTION

NOTE:

Position the scooter straight up when inspecting the fluid level.

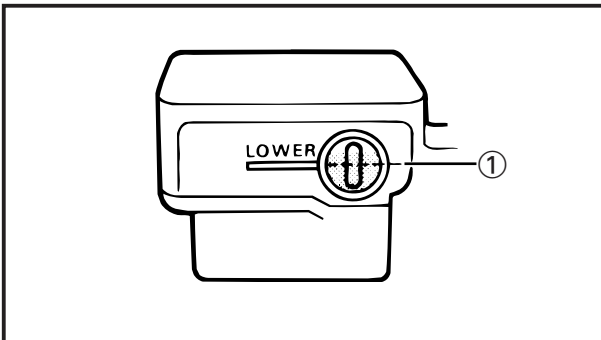

1. Inspect:

- Fluid level is under "LOWER" level line ① → Fill to proper level.



Recommended fluid:
DOT#4(or DOT#3)

CAUTION:

The fluid may corrode painted surfaces or plastic parts. Always clean up spilled fluid immediately.

⚠ WARNING

- Use only the designated quality fluid. Otherwise, the rubber seals may deteriorate causing leakage and poor brake performance.
- Refill with the same type of fluid. Mixing fluids may result in a harmful chemical reaction leading to poor brake performance.
- Be careful that water does not enter the master cylinder when refilling. Water will significantly lower the boiling point of the fluid and may result in vapor lock.

AIR BLEEDING (HYDRAULIC BRAKE SYSTEM)

1. Bleed:

- Brake fluid

Air bleeding steps:

- Add proper brake fluid to the reservoir.
- Install the diaphragm. Be careful not to spill any fluid or allow the reservoir to overflow.
- Connect the clear plastic tube ① tightly to the caliper bleed screw.
- Place the other end of the tube into a container.
- Slowly apply the brake lever several times.
- Pull the lever in. Hold the lever in position.
- Loosen the bleed screw and allow the lever to travel towards its limit.
- Tighten the bleed screw when the limit has been reached, then release the lever.
- Repeat steps (e) to (h) until the air bubbles have been removed from the system.
- Add brake fluid to proper level.

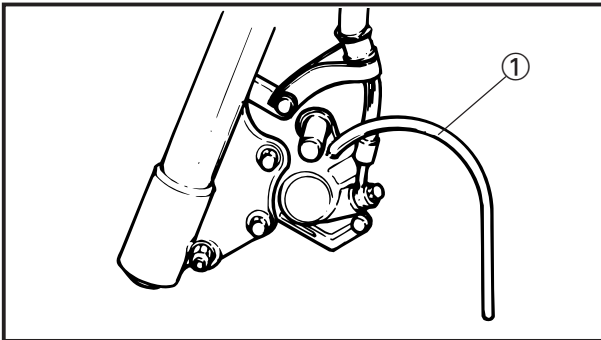

⚠ WARNING

Check the operation of the brake after bleeding the brake system.

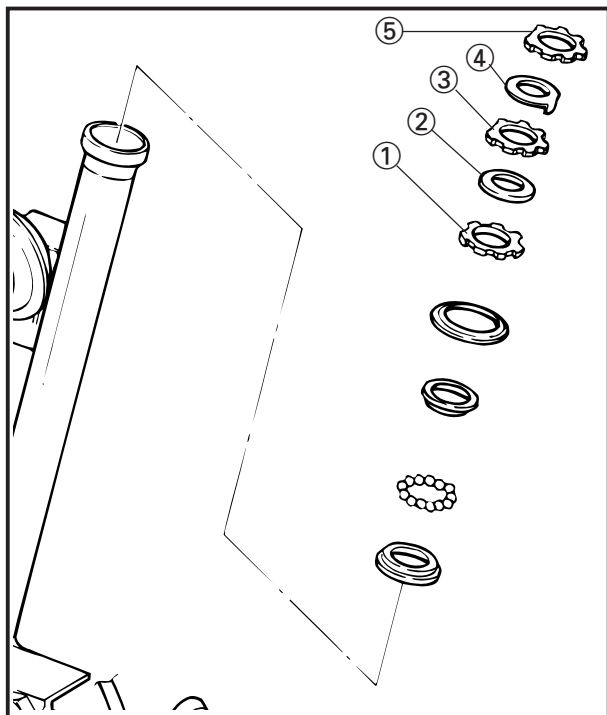

STEERING ADJUSTMENT

1. Check:

- Steering assembly bearings
Gap the bottom of the forks and gently rock the fork assembly back and forth.
Loosen→Adjust.

Adjustment steps:

- Remove upper cover, lower cowling, leg shield 1,2. refer to "COVER AND PANEL" section.
- Remove all ringnuts using ringnut wrench.



Ring nut wrench:
YU-33975

- Tighten the ring nut 3 ① using nut wrench.

 22 Nm(2.2 m.kg, 16 ft.lb)

NOTE:

Set the torque wrench to the ring nut wrench so that they form a right angle.

- Loosen the ring nut 3 ① 1/4 turn.
- Install rubber ring ② and ring nut 2 ③, then tighten the ring nut 2 until it contacts with rubber ring.

CAUTION:

Aligning the slot of ring nut 2 with the slot of ring nut 3. If not, slightly tighten ring nut 2 until the slots alignment.

- Install special washer ④

NOTE:

Insert the projections of special washer into the slots of ring nut 3, 2

- Install ring nut 1 ⑤  66Nm(6.6 m.kg, 47.8 ft.lb)

- Move the handlebar up and down, and/or back and forth. If handlebar play is excess, remove the front fork assembly and check the balls/ball races. Refer to chapter 6.

FRONT

Manufacturec	Size	Type
CHENG SHIN	120/90-10	56J

REAR

Manufacturec	Size	Type
CHENG SHIN	130/90-10	59J

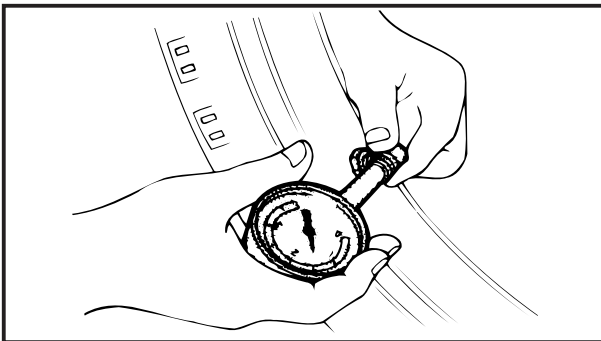

TIRE INSPECTION

⚠ WARNING

- The tire pressure should only be checked and regulated when the tire temperature equals the ambient air temperature.
- The tire pressure must be adjusted according to the total weight (including cargo, rider passenger and accessories) and the anticipated riding speed.
- Operation of an overloaded scooter could cause tire damage, an accident or an injury. **NEVER OVERLOAD THE SCOOTER.**

Basic weight (with oil and a full fuel tank)	94 kg (207 lb)	
Maximum load*	143 kg (315 lb)	
Cold tire pressure	Front	Rear
	200 kpa (2.0 kgf/cm ² , 29 psi)	200 kpa (2.0 kgf/cm ² , 29 psi)

* Total of cargo, rider, passenger and accessories.

⚠ WARNING

It is dangerous to ride with a worn-out tire. When the tire tread reaches the wear limit, replace the tire immediately.

2. Inspect:

- Tire surfaces
Wear/Damage → Replace.

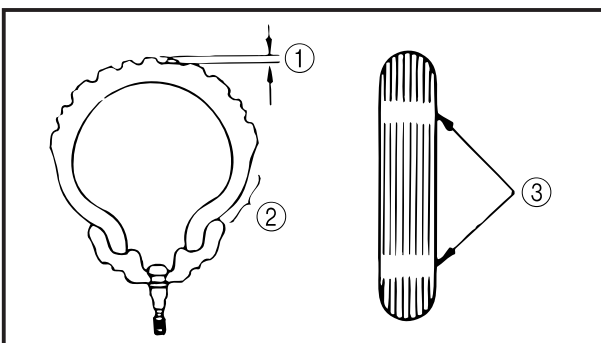

	Minimum tire tread depth ① (front and rear): 1.6 mm (0.06 in)
---	---

- ① Tread depth
- ② Side wall
- ③ Wear indicator

⚠ WARNING

- Do not use a tubeless tire on a wheel designed only for tube tires to avoid tire failure and personal injury from sudden deflation.
- When using tube tires, be sure to install the correct tube.
- Always replace a new tube tire and a new tube as a set.
- To avoid pinching the tube, make sure the wheel rim band and tube are centered in the wheel groove.
- Patching a punctured tube is not recommended. If it is absolutely necessary to do so, use great care and replace the tube as soon as possible with a good quality replacement.

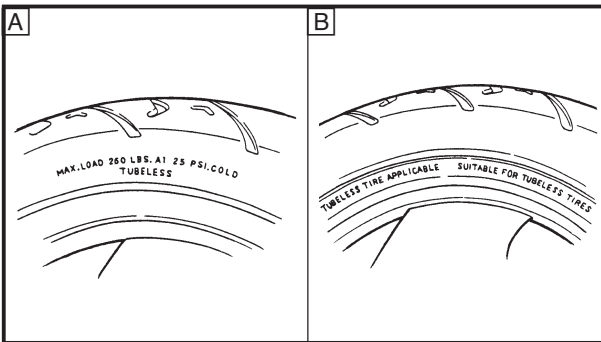

- A Tire
- B Wheel

Tube wheel	Tube tire only
Tubeless wheel	Tube or tubeless tire

- After extensive tests, the tires listed below have been approved by Yamaha Motor Co., Ltd. for this model. The front and rear tires should always be by the same manufacturer and of the same design. No guarantee concerning handling characteristics can be given if a tire combination other than one approved by Yamaha is used on this scooter.

⚠ WARNING

New tires have a relatively low grip on the road surface until they have been slightly worn. Therefore, approximately 100 km should be traveled at normal speed before any high-speed riding is done.

NOTE:

For tires with a direction of rotation mark ①:

- Install the tire with the mark pointing in the direction of wheel rotation.
- Align the mark ② with the valve installation point.

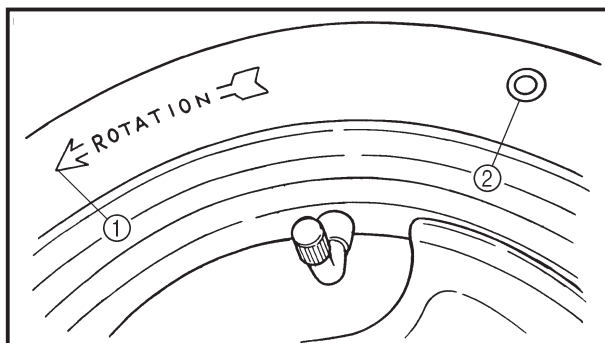

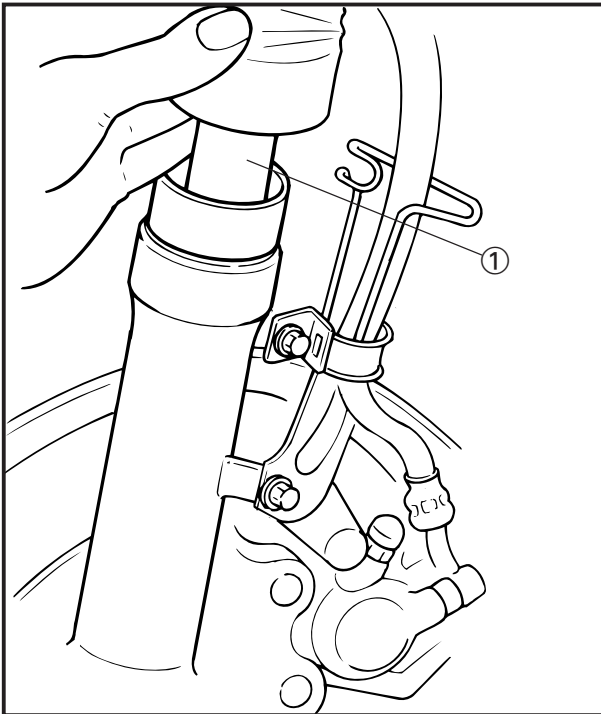

WHEEL INSPECTION

1. Inspect:
 - wheels
 - Damage/Bends→Replace.

⚠ WARNING

Never attempt to make any repairs to the wheel.

NOTE:

After a tire or wheel has been changed or replaced, always balance the wheel.

FRONT FORK INSPECTION

1. Inspect:
 - Front fork①
 - Bends/Damage→Replace inner tube comp, fork ass’y.
 - Grease leakage→Replace inner tube comp. fork ass’y.
 - Unsmooth operation→Replace fork ass’y.

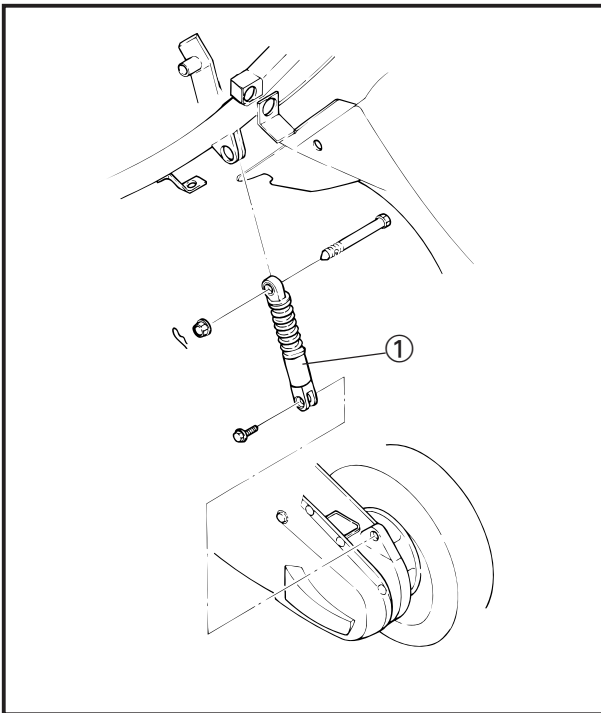

REAR SHOCK ABSORBER INSPECTION

1. Inspection:
 - Rear shock absorber①
 - Oil leaks/Damage→Replace.
2. Check
 - Tightening torque

	Upper(nut)	30Nm (3.0 m.kg, 22ft.lb)
	Lower (bolt)	16 Nm(1.6 m.kg, 12ft.lb)

SEAT LOCK CABLE ADJUSTMENT

1. Remove:
 - Upper cover
 - Refer to “COVER AND PANEL” section.
2. Adjust:
 - Seat cable

Seat cable adjustment steps:

- Loosen lock nut ①
- Turn adjuster ② in or out to adjust the seat lock cable.
- Tighten the lock nut.

3. Install:
 - Upper cover

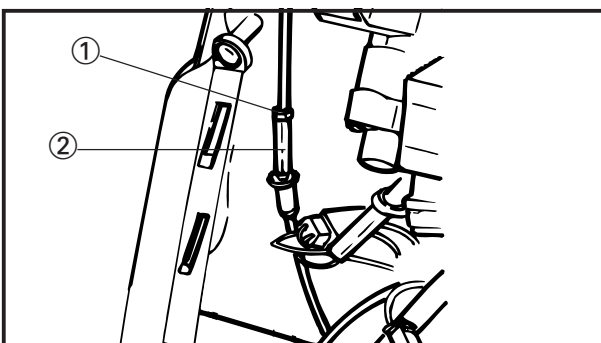



EAS00170

CABLE CHECKING AND LUBRICATING

The following procedure applies to all of the cable sheaths and cables.

WARNING

Damaged cable sheaths may cause the cable to corrode and interfere with its movement. Replace damaged cable sheaths and cables as soon as possible.

1. Check:
 - cable sheath
Damage → Replace.
2. Check:
 - cable operation
Rough movement → Lubricate.

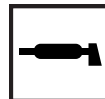

Recommended lubricant
Engine oil or a suitable cable lubricant

NOTE:

Hold the cable end upright and pour a few drops of lubricant into the cable sheath or use a suitable lubricating device.

EAS00171

LEVERS LUBRICATING

Lubricate the pivoting point and metal-to-metal moving parts of the levers.



Recommended lubricant
Lithium soap base grease

EAS00173

CENTERSTAND LUBRICATING

Lubricate the pivoting point and metal-to-metal moving parts of the centerstand.

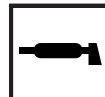

Recommended lubricant
Lithium soap base grease

ELECTRICAL

BATTERY INSPECTION

NOTE:

Since the MF battery is of a sealed-type construction, it is impossible to measure the specific gravity of the electrolyte in order to check the state of charge in the battery. Therefore, to check the state of charge in the battery, voltage must be measured at the battery terminals.

CAUTION:

CHARGING METHOD

- This battery is sealed type. Never remove sealing caps even when charging. With the sealing cap removed, this balancing will not be maintained, and battery performance will lower gradually.
- Never add water. If distilled water is added, chemical reaction in the battery will not proceed in the normal way, thus making it impossible for the battery to operate regularly.
- The charging time, charging current and charging voltage for the MF battery is different than general type batteries.

The MF battery should be charged as instructed in the "Charging method". Should the battery be overcharged, the electrolyte level will lower extremely. Therefore, use special care when charging the battery.

- Avoid using any electrolyte other than specified. The specific gravity of the MF battery electrolyte is 1.32 at 20°C (68°F). (The specific gravity of the general type battery electrolyte is 1.28.) If the electrolyte whose specific gravity is less than 1.32, the sulfuric acid will decrease and thus low battery performance will result.

Should any electrolyte, whose specific gravity is 1.32 or more, be used, the battery plates will corrode and battery life will shorten.

1. Remove:
 - Battery box cover
Refer to "COVER AND PANEL" section.
2. Remove:
 - Battery

NOTE:

Remove the (-) lead first.

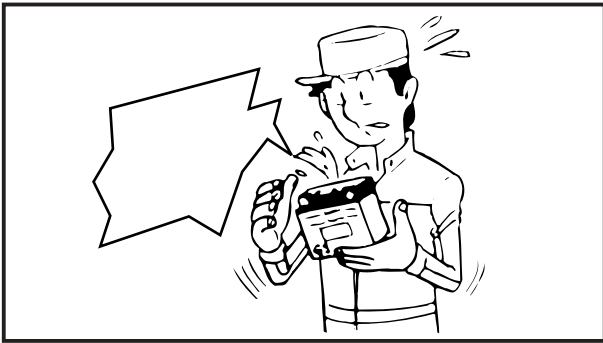

⚠ WARNING

Batteries generate explosive hydrogen gas and contain electrolyte which is made of poisonous and highly caustic sulfuric acid.

Therefore, always follow these preventive measures:

- Wear protective eye gear when handling or working near batteries.
- Charge batteries in a well-ventilated area.
- Keep batteries away from fire, sparks or open flames (e.g., welding equipment, lighted cigarettes).
- DO NOT SMOKE when charging or handling batteries.
- KEEP BATTERIES AND ELECTROLYTE OUT OF REACH OF CHILDREN.
- Avoid bodily contact with electrolyte as it can cause severe burns or permanent eye injury.

FIRST AID IN CASE OF BODILY CONTACT:

EXTERNAL

- Skin — Wash with water.
- Eyes — Flush with water for 15 minutes and get immediate medical attention.

INTERNAL

- Drink large quantities of water or milk followed with milk of magnesia, beaten egg or vegetable oil. Get immediate medical attention.

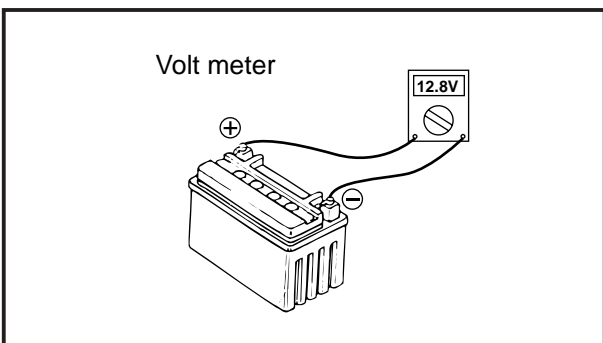

3. Check:

- Battery condition

Battery condition checking steps:

- Connect a digital volt meter to the battery terminals.

Tester (+) lead Battery (+) terminal.
Tester (-) lead Battery (-) terminal.

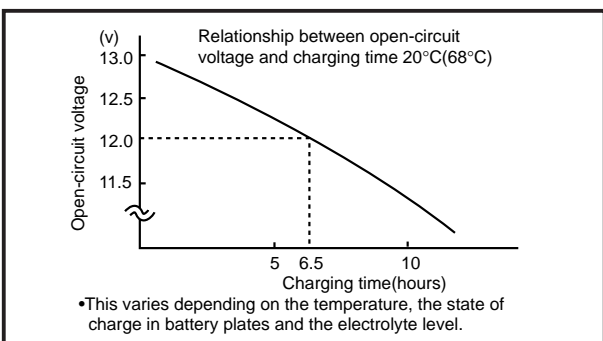

NOTE:

The state of a discharged MF battery can be checked by measuring open circuit voltage (the voltage measured with the positive terminals being disconnected).

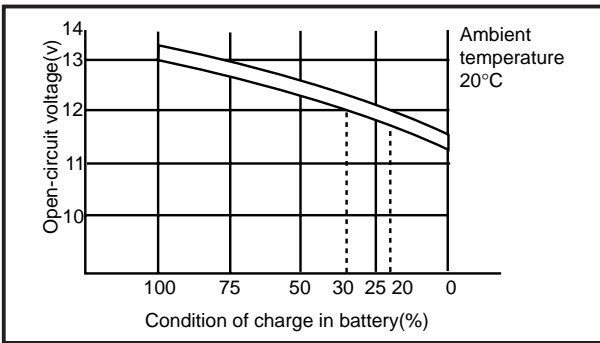

Open circuit voltage	Charging time
12.8 v or more	No charging is necessary.

● Check the battery condition using figures.

EXAMPLE:

Open circuit voltage = 12.0v

Charging time = 6.5 hours

Condition of charge in battery = 20 ~ 30%

2. Charging method of MF battery

CAUTION:

- If it is impossible to set the standard charging current, be careful not to overcharge.
- When charging the battery, be sure to remove it from the motorcycle. (If charging has to be done with the battery mounted on the motorcycle for some reason, be sure to disconnect the wire at the negative terminal.)
- Never remove the sealing plug from the MF battery.
- Use special care so that charging clips are in a full contact with the terminal and that they are not shorted. (A corroded clip of the charger may cause the battery to generate heat at the contact area. A weak clip spring may cause sparks.)
- Before removing the clips from the battery terminals, be sure to turn off the power switch of the charger.
- Change in the open-circuit voltage of the MF battery after being charged is shown below. As shown in the figure, the open circuit voltage is stabilized 30 minutes after charging has been completed. Therefore, to check the condition of the battery, measure the open-circuit voltage 30 minutes after has been completed.

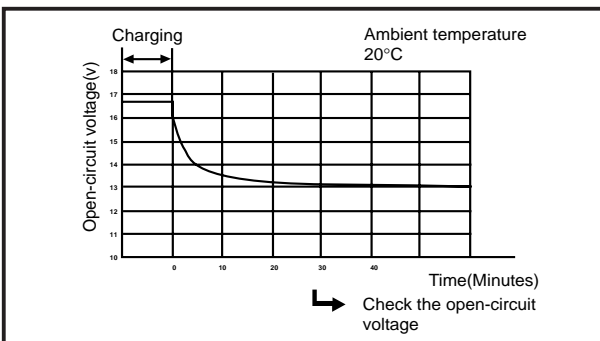

Charging method using a variable-current (voltage) type charger

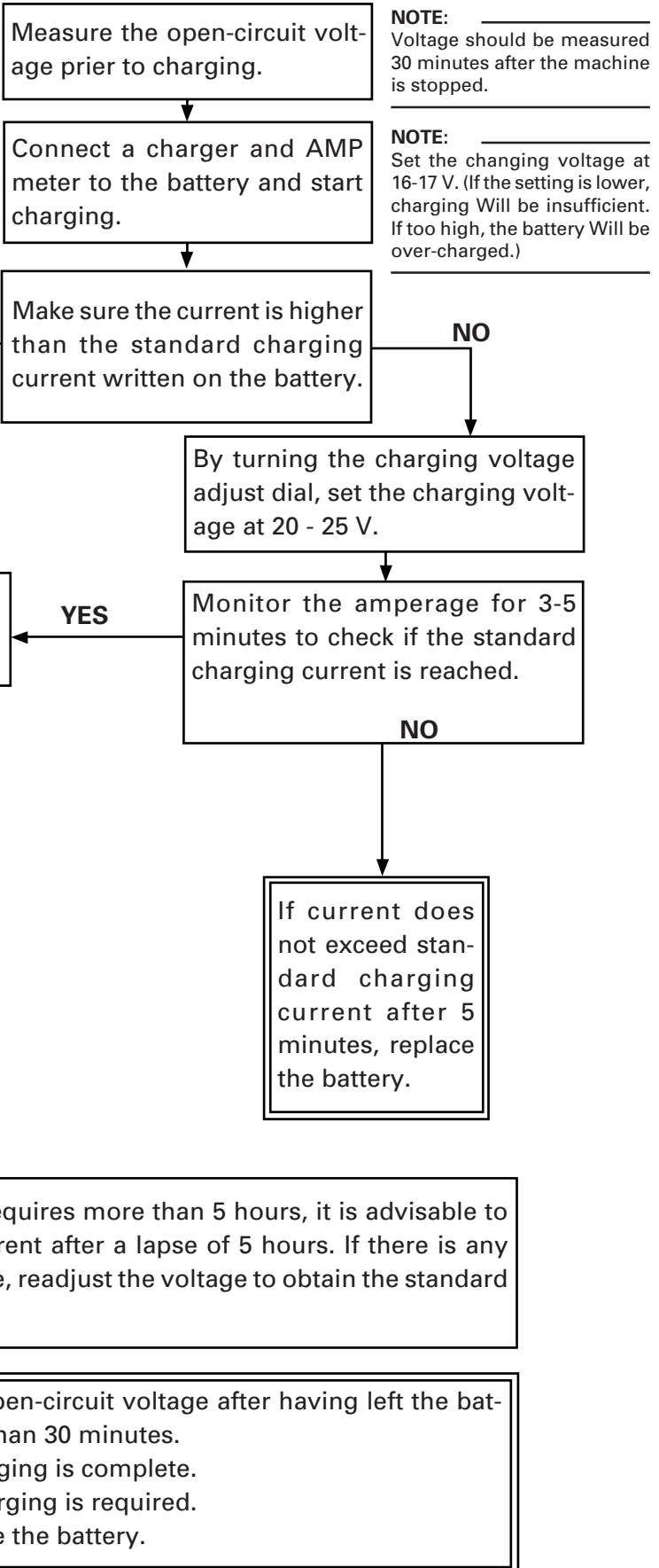
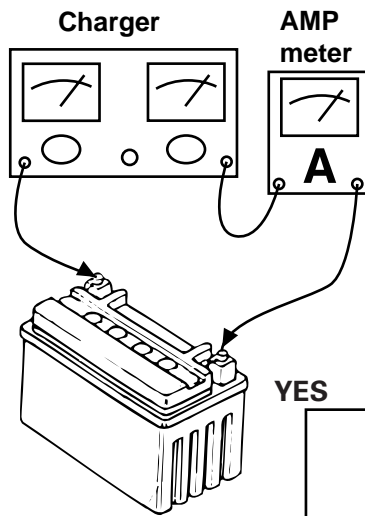

Charging method using a constant-voltage type charger

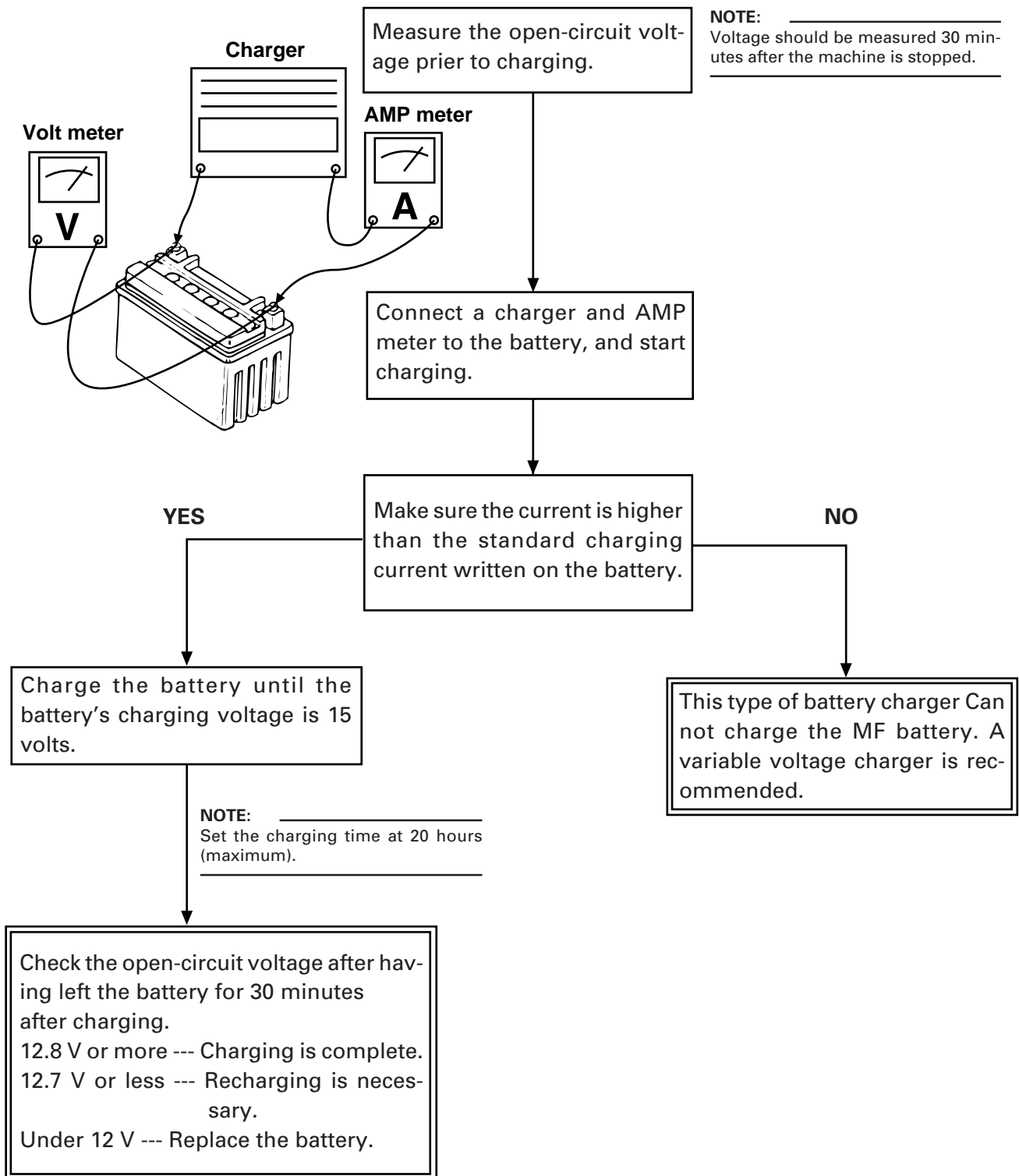

Charging method using a constant current type charger

This type of battery charger Can not charge the MF battery.

4. Inspect:
 - Battery terminal
Dirty terminal→Clean with wire brush.
Poor connection→Correct.

NOTE: _____

After cleaning terminals, apply _____ lightly to the terminals.

5. Install
 - Battery
 - Battery box cover

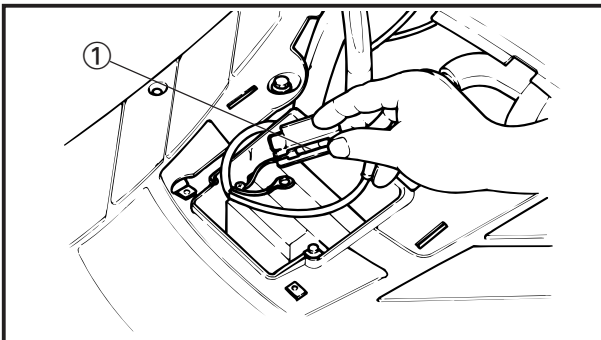

FUSE INSPECTION

1. Remove:
 - Battery box cover
Refer to "COVER AND PANEL" section.
2. Remove:
 - Fuse ①
3. Inspect:
 - Fuse ①
defective→Replace

Blown fuse procedure steps:

- Turn off ignition and the circuit.
- Install a new fuse of proper amperage.
- Turn on switches to verify operation of electrical device.
- If fuse blows immediately again, check circuit in question.

⚠ WARNING _____

Never use a fuse with an amperage rating other than that specified. Improvising or using a fuse with the wrong amperage rating may cause extensive damage to the electrical system, cause the lighting and ignition systems to malfunction and could possibly cause a fire.

Description	Amperage	Quantity
Main	7A	1

4. Install:
 - Fuse
 - Battery box cover

HEADLIGHT BEAM ADJUSTMENT /HEADLIGHT BULB REPLACEMENT

INSP
ADJ

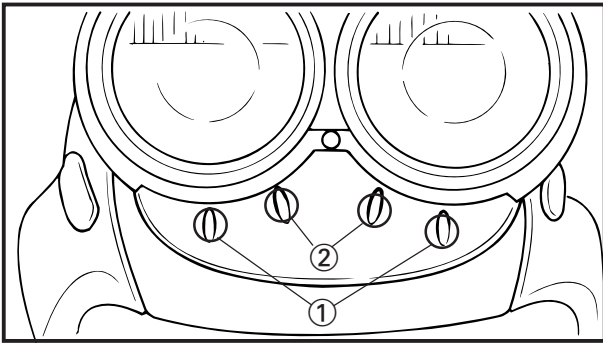

HEAD LIGHT BEAM ADJUSTMENT

1. Adjust:
 - Head light (vertically)
Turn the adjusting screw ① in or out to adjust headlight beam.
 - Head light (Horizontal)
Turn the adjusting screw ② in or out to adjust headlight beam.

HEADLIGHT BULB REPLACEMENT

1. Remove:
 - Upper cover
Refer to "COVER AND PANEL" section.

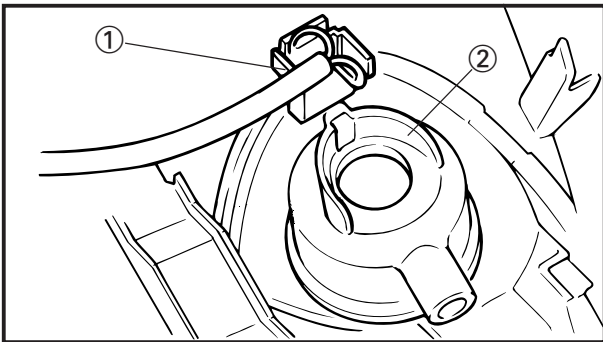

2. Disconnect:
 - Headlight coupler ①
3. Remove:
 - Bulb holder cover ②

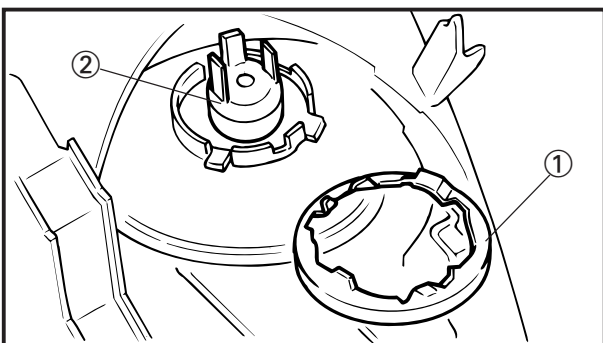

4. Remove:
 - Headlight bulb holder ①
Turn the bulb holder counterclockwise to remove it.
5. Remove:
 - Bulb(defective) ②

⚠ WARNING

Since the headlight bulb gets extremely hot, keep flammable products and your hands away from the bulb until it has cooled down.

6. Install:
 - Bulb(new)

CAUTION: _____

Avoid touching the glass part of the head-light bulb to keep it free from oil, otherwise the transparency of the glass, the life of the bulb and the luminous flux will be adversely affected. If the headlight bulb gets soiled, thoroughly clean it with a cloth moistened with alcohol or lacquer thinner.

7. Install:
 - Bulb holder
 - Turn the bulb holder clockwise to install it.
8. Install:
 - Bulb holder cover
9. Connect:
 - Headlight coupler
10. Install:
 - Upper cover
11. Adjust:
 - Headlight beam

Refer to "HEADLIGHT BEAM ADJUSTMENT" section

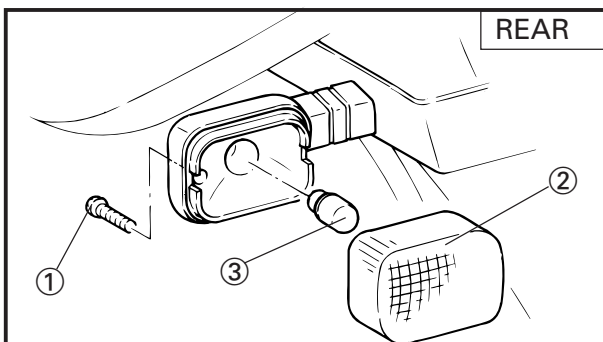
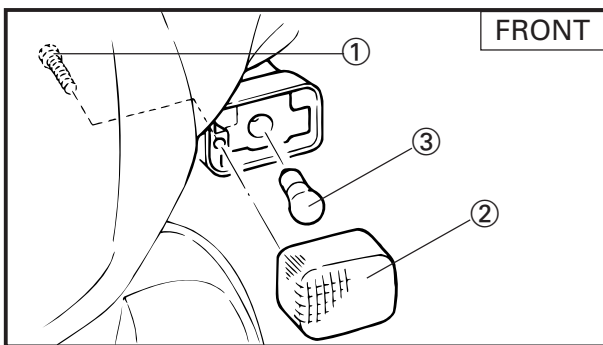

TURN SIGNAL BULB REPLACEMENT

1. Remove:
 - Screw ①
 - Lens ②
2. Replace:
 - Bulb (defective)③
3. Install:
 - Lens ②
 - Screw ①

CAUTION: _____

Do not over-tighten the screws as the lens may break.

CAUTION:

Avoid touching the glass part of the head-light bulb to keep it free from oil, otherwise the transparency of the glass, the life of the bulb and the luminous flux will be adversely affected. If the headlight bulb gets soiled, thoroughly clean it with a cloth moistened with alcohol or lacquer thinner.

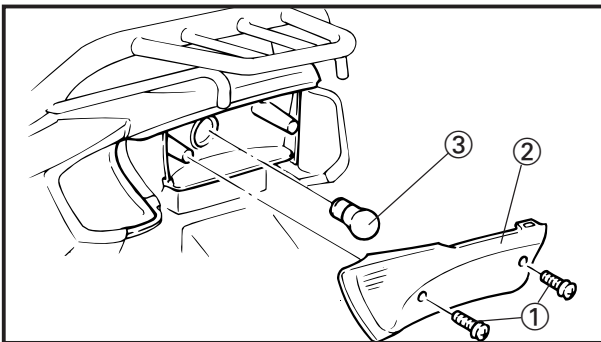

TAILLIGHT BULB REPLACEMENT

1. Remove:
 - Screws ①
 - Lens ②
2. Replace:
 - Bulb (defective) ③
3. Install:
 - Lens ②
 - Screws ①

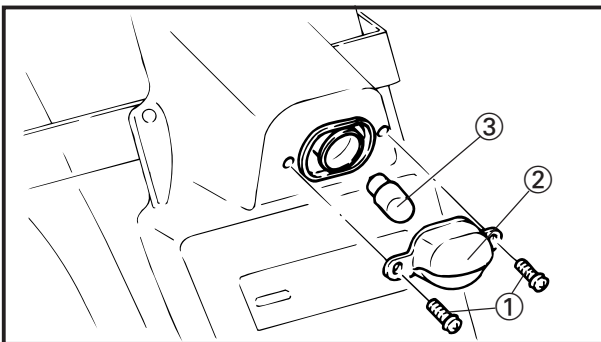

LICENSE LIGHT BULB REPLACEMENT

1. Remove:
 - Screws ①
 - Lens ②
2. Replace:
 - Bulb (defective) ③
3. Install:
 - Lens ②
 - Screws ①



EB400000

ENGINE OVERHAUL

ENGINE REMOVAL

WIREHARNESS AND CABLES

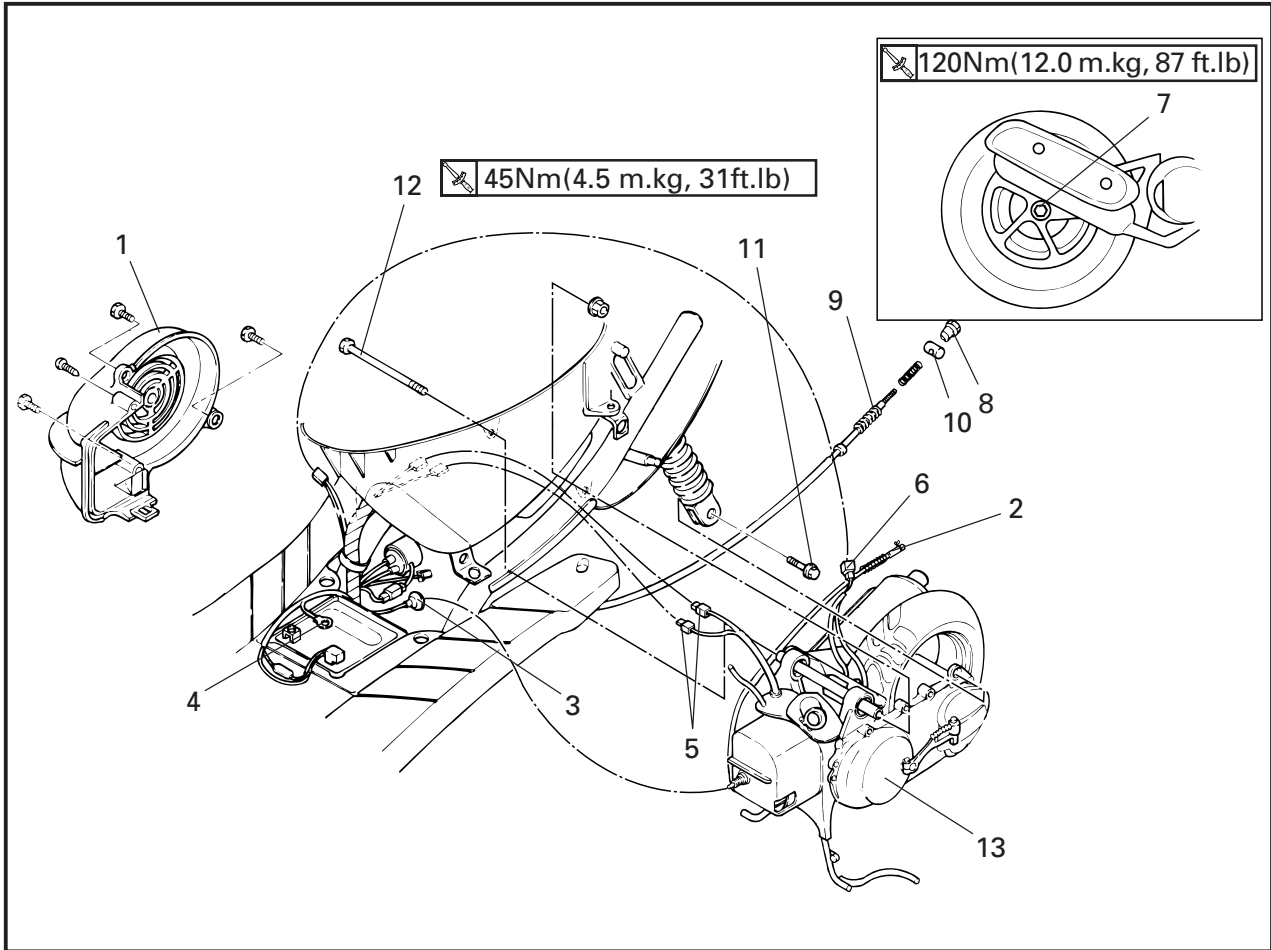

Order	Job name/Part name	Q'ty	Remarks
	Wireharness and cables removal		Remove the parts in order.
	Rear carrier		Refer to "COVER AND PANEL" section in CHAPTER 3.
	Tail cover		
	Left side panel		
	Right side panel		
	Battery box cover		
	Center cowling		
	Air filter case		
	Carburetor		
1	Air shroud 1	1	
2	Autolube delivery hose	1	

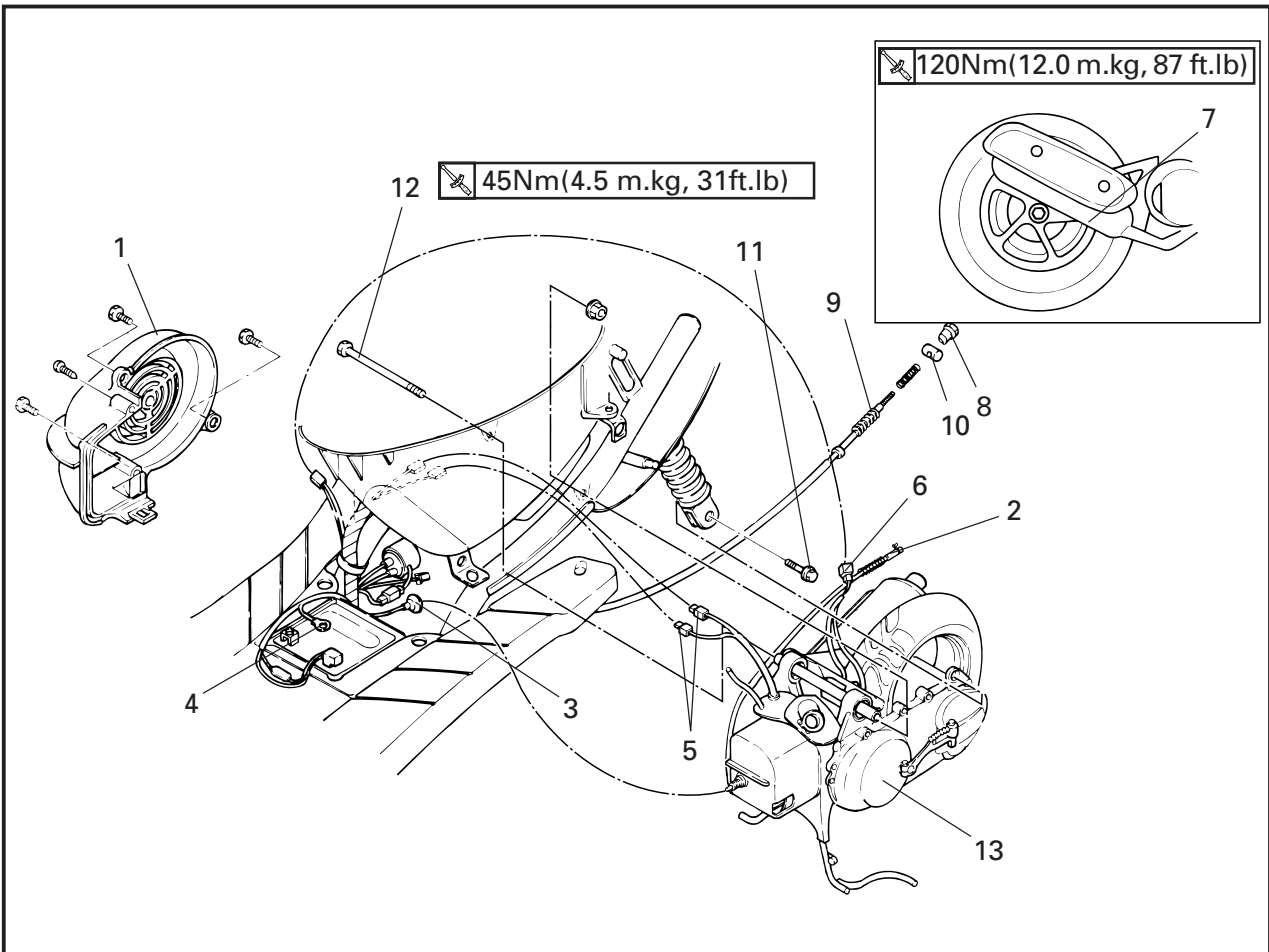

Order	Job name/Part name	Q'ty	Remarks
3	Spark plug cap	1	
4	Battery (-) lead	1	
5	C.D.I magneto leads coupler	1	
6	Starter motor leads coupler	1	
7	Rear wheel nut	1	NOTE: Loosen the rear wheel nut.
8	Rear brake adjuster	1	
9	Rear brake cable	1	
10	Pin	1	
11	Bolt	1	
12	Engine mount bolt	1	
13	Engine	1	Reverse the removal procedure for installation.



CYLINDER HEAD, CYLINDER AND PISTON

CYLINDER HEAD, CYLINDER AND PISTON

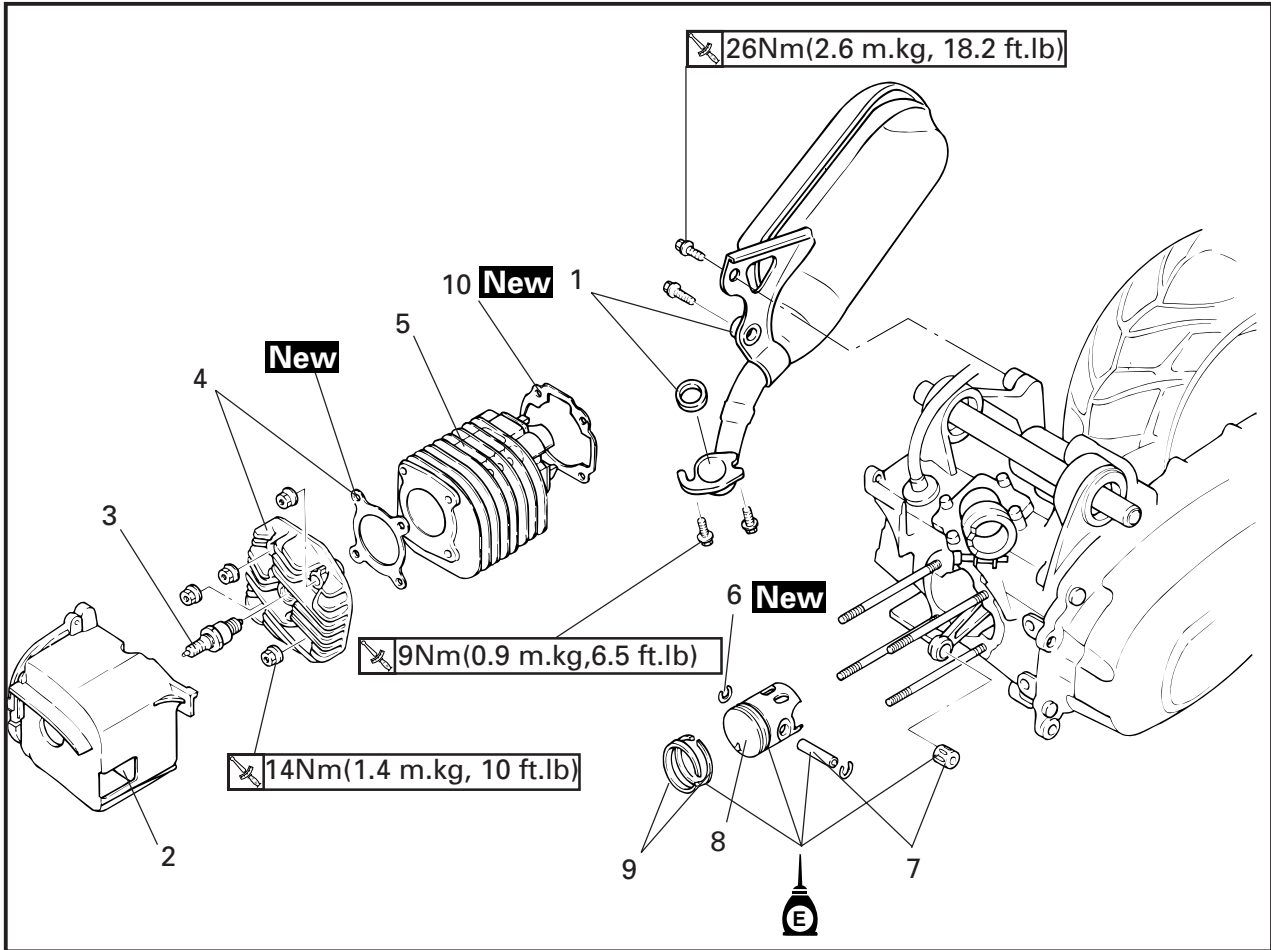

Order	Job name/Part name	Q'ty	Remarks
	Cylinder head, Cylinder and piston removal		Remove the parts in the order.
	Engine		Refer to the "ENGINE REMOVAL" section
1	Muffler/Gasket	1/1	
2	Air shroud 2	1	
3	Spark plug	1	
4	Cylinder head/Cylinder head gasket	1/1	
5	Cylinder	1	
6	Piston pin clip	2	
7	Piston pin/ Bearing	1/1	
8	Piston	1	
9	Piston ring set	1	
10	Cylinder gasket	1	
			Reverse the removal procedure for installation.

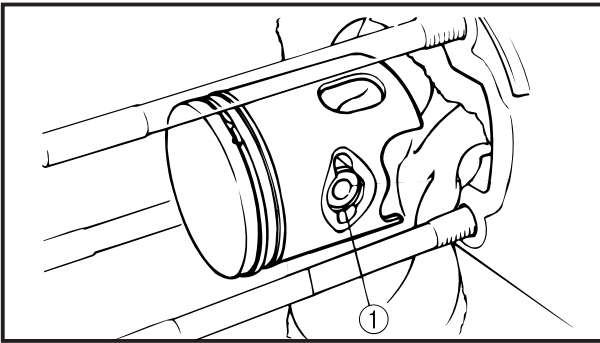

PISTON PIN AND PISTON REMOVAL

1. Remove:
 - Piston pin clip ①

NOTE: _____

Before removing the piston pin clip, cover the crankcase with a clean rag so you will not accidentally drop the clip into the crankcase.

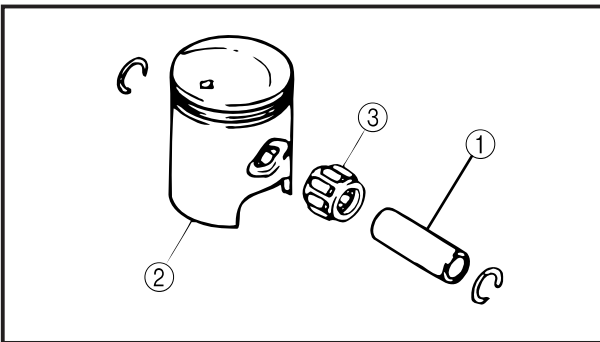

2. Remove:
 - Piston pin ①
 - Piston ②
 - Piston pin bearing ③

CAUTION: _____

Do not use a hammer to drive the piston pin out.

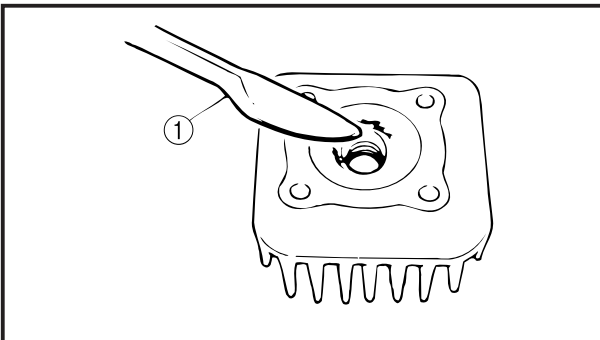

CYLINDER HEAD INSPECTION

1. Eliminate:
 - Carbon deposits
 Use a rounded scraper ①.

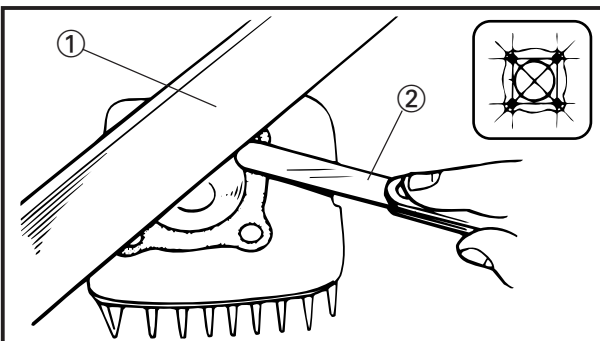

2. Inspect:
 - Cylinder head warpage
 Out of specification → Re-surface.

Warpage measurement and re-surfacement steps:

- Attach a straight edge ① and a thickness gauge ② on the cylinder head.
- Measure the warpage limit.

	Warpage limit: 0.03 mm(0.0012 in)
--	--------------------------------------

- If the warpage is out of specification, reface the cylinder head.

NOTE: _____

Rotate the head several times to avoid removing too much material from one side.

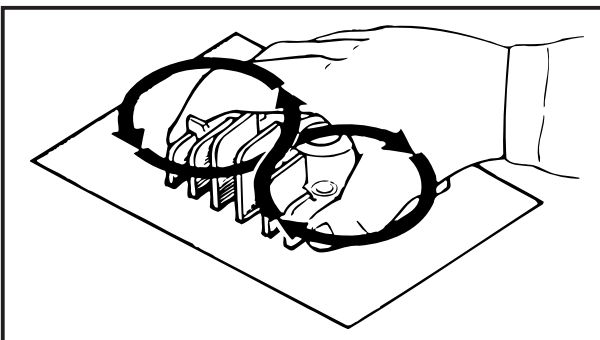

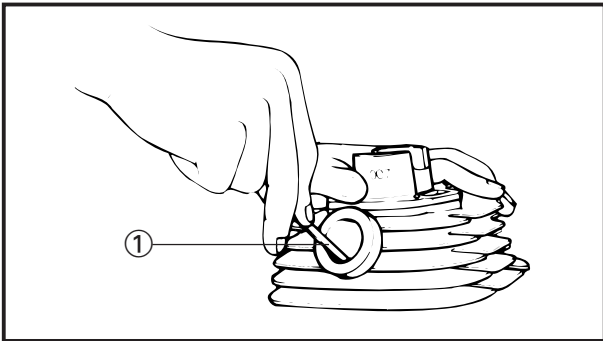

CYLINDER AND PISTON INSPECTION

1. Eliminate:
 - Carbon deposits
Use a rounded scraper ①.
2. Inspect:
 - Cylinder wall
Wear/Scratches→Rebore or replace.

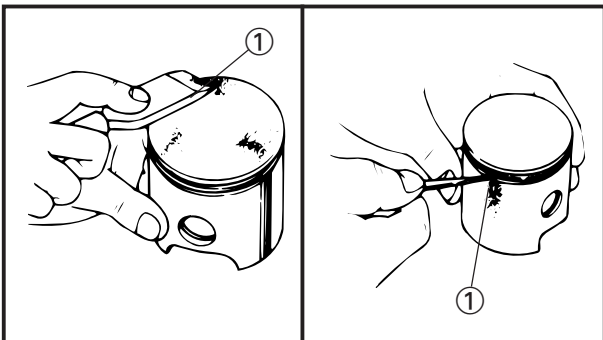

3. Eliminate:
 - Carbon deposits ①
From the piston crown and ring grooves.

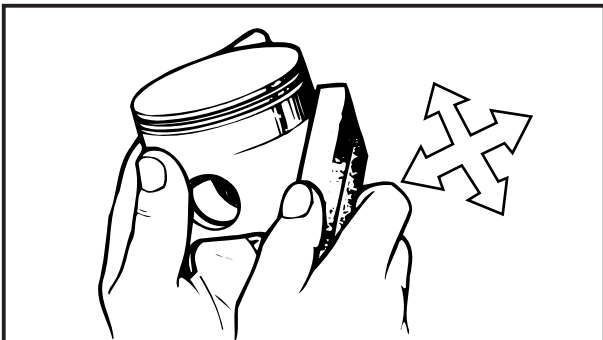

4. Remove:
 - Score marks and lacquer deposits
From the sides of piston.
5. Inspect:
 - Piston wall
Wear/Scratches/Damage→Replace.

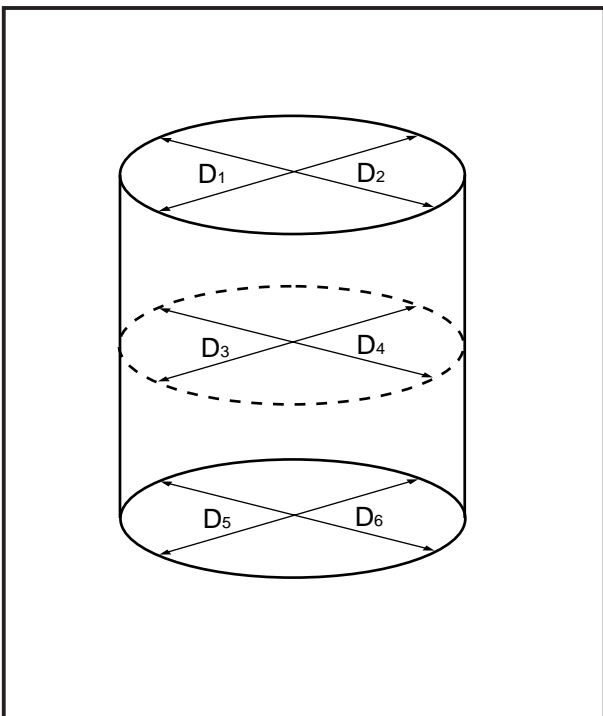

6. Measure:
 - Piston-to cylinder clearance

Piston to cylinder clearance measurement steps: First step:

- Measure the cylinder bore "C" with a cylinder bore gauge.

NOTE: _____

Measure the cylinder bore "C" in parallel to and at right angles to the crankshaft. Then, find the average of the measurements.





	Standard	Wear limit
Cylinder bore "C"	40.000~40.014mm (1.5748~1.5754 in)	40.10 mm (1.5787 in)
Taper "T"	-	0.05 mm (0.0020 in)
Out of round "R"	-	0.03 mm (0.0012 in)
C = Maximum D T=(Maximum D1 or D2) - (Maximum D5 or D6) R=(Maximum D1 D3 or D5) - (Maximum D2 D4 or D6)		

- If out of specification, rebore or replace cylinder, and replace piston and piston rings as a set.

2nd step:

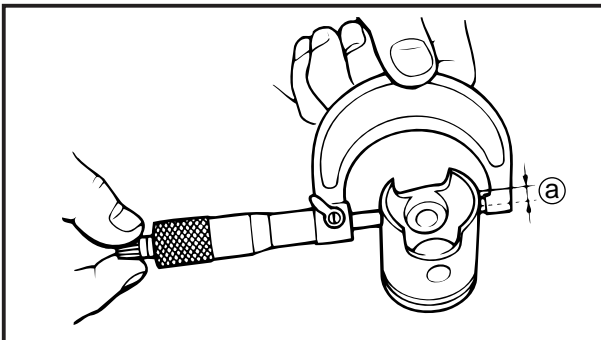
- Measure the piston skirt diameter "p" with a micrometer.
 Ⓐ 10 mm from the piston bottom edge.



	Piston size P 39.958~39.972 mm(1.5731~1.5737 in)
---	---

- If out of specification, replace piston and piston rings as a set.

3rd step:

- Calculate the piston-to cylinder clearance with following formula:

$$\text{Piston-to cylinder clearance} = \text{Cylinder bore "C"} - \text{Piston skirt diameter "p"}$$

- If out of specification, rebore or replace cylinder, and replace piston and piston rings as a set.

$$\begin{aligned} \text{Piston-to cylinder clearance:} \\ &0.035 \sim 0.040\text{mm} (0.014 \sim 0.0016 \text{ in}) \\ \text{Limit : } &0.10 \text{ mm} (0.0039 \text{ in}) \end{aligned}$$

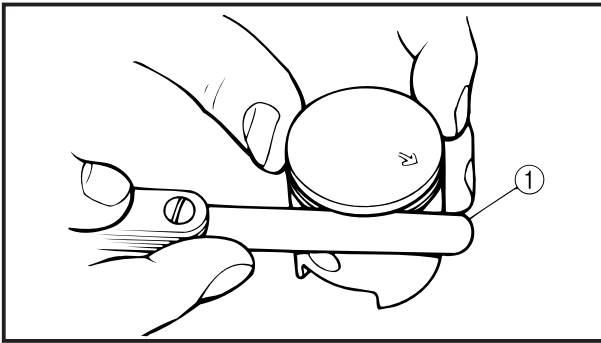

PISTON RINGS INSPECTION

1. Measure:

- Side clearance
Out of specification → Replace piston and/or rings.
Use a feeler gauge ①

	Standard	Limit
Top ring	0.03 ~ 0.05 mm (0.0012 ~ 0.002 in)	0.1 mm (0.0039 in)
2nd ring	0.03 ~ 0.05 mm (0.0012 ~ 0.002 in)	0.1 mm (0.0039 in)

2. Install:

- Piston ring
Into the cylinder
Push the ring with the piston crown.

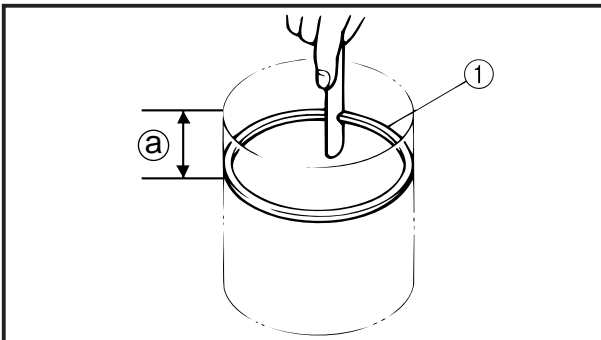

3. Measure:

- End gap
Out of specification → Replace rings as a set.
Use a feeler gauge ①.

	Standard	Limit
Top ring	0.15 ~ 0.35 mm (0.005 ~ 0.01 in)	0.6 mm (0.02 in)
2nd ring	0.15 ~ 0.35 mm (0.005 ~ 0.01 in)	0.6 mm (0.02 in)

① Measuring Point 20 mm (0.79 in)

PISTON PIN AND PISTON PIN BEARING

1. Inspect:

- Piston pin
Blue discoloration/Groove → Replace, then inspect lubrication system.

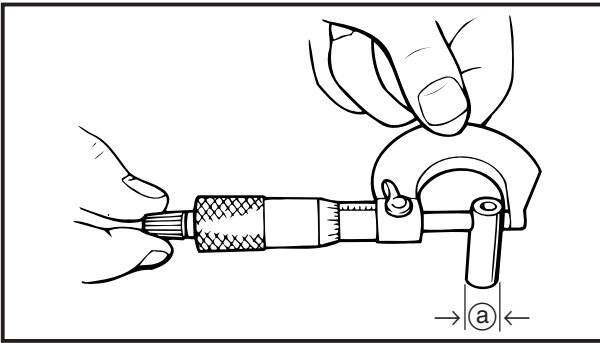

2. Measure:

- Outside diameter (a) (piston pin)
Out of specification → Replace.



Out side diameter (piston pin):
9.996~10.000 mm(0.3935~0.3937in)

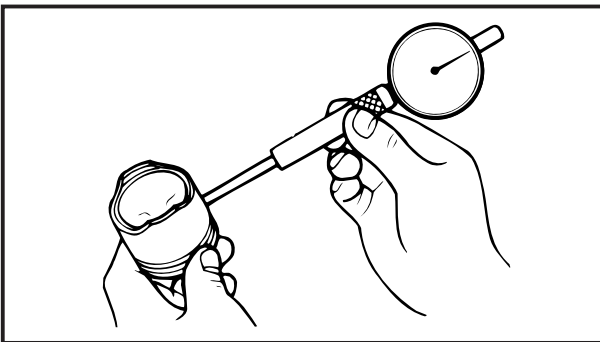

3. Measure:

- Piston pin-to-piston clearance
Out of specification → Replace piston.

Piston pin-to-piston clearance =
Bore size (piston pin)
Outside diameter (piston pin)



Piston pin-to-piston clearance:
0.004~0.019 mm(0.0016~0.00075 in)
<Limit: 0.07 mm>(0.003 in)

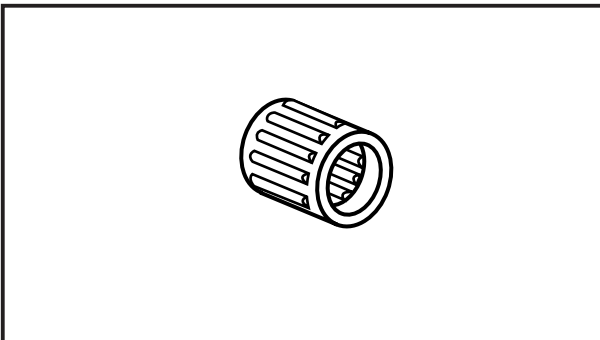

4. Inspect:

- Bearing(piston pin)
Pitting/Damage → Replace.

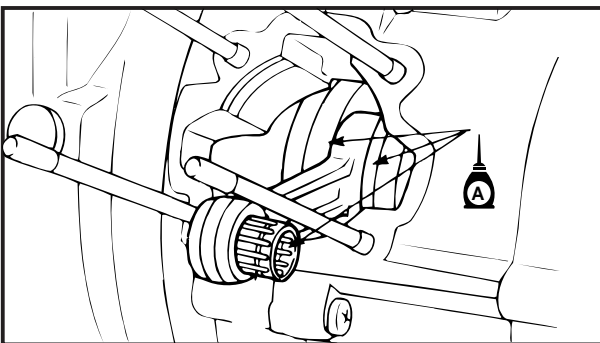

PISTON PIN AND PISTON INSTALLATION

1. Apply:

- Engine oil
(to the crankshaft bearing, connecting rod big end bearing, small end bearing, piston pin, piston ring grooves and piston skirt areas.)

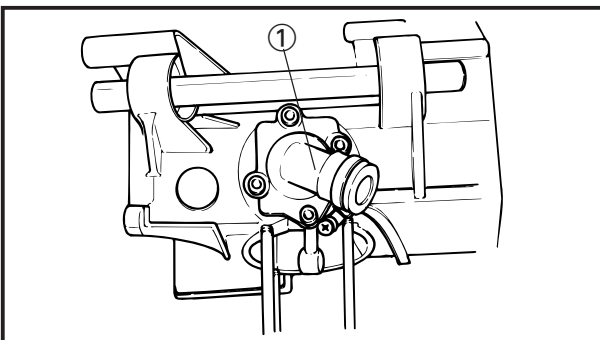

2. Install:

- Reed valve gasket
- Reed valve
- Carburetor joint ①  11Nm(1.1 m.kg, 8ft.lb)

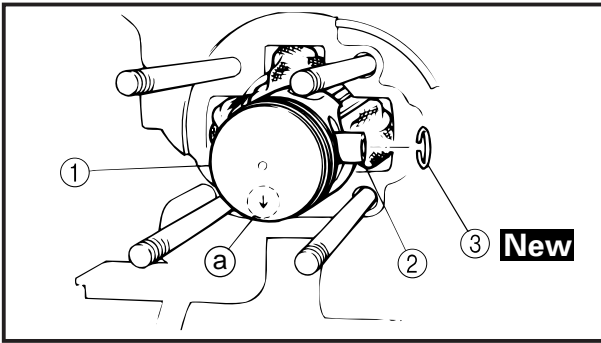

3. Install:
 - Small end bearing
 - Piston ①
 - Piston pin ②
 - Piston pin clip ③ **New**

NOTE: _____

- The arrow ③ on the piston to the exhaust side.
- Before installing the piston pin clip, cover the crankcase with a clean towel or rag so you will not accidentally drop the pin clip material into the crankcase.
- Always use a new piston pin clip.

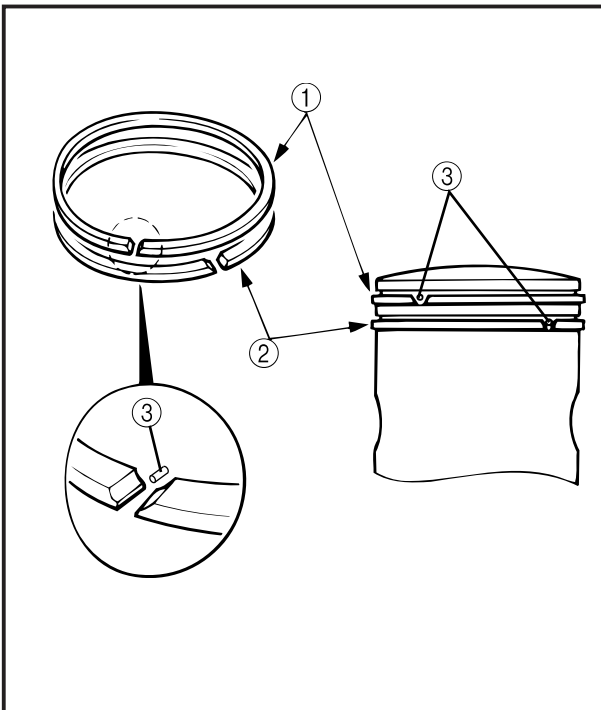

CYLINDER AND CYLINDER HEAD

1. Install:
 - Cylinder gasket (new gasket)
2. Check:
 - Piston rings

- ① 1st ring
- ② 2nd ring

NOTE: _____

Make sure the ring ends ① are properly fitted around the ring locating pins ③ in the piston grooves.

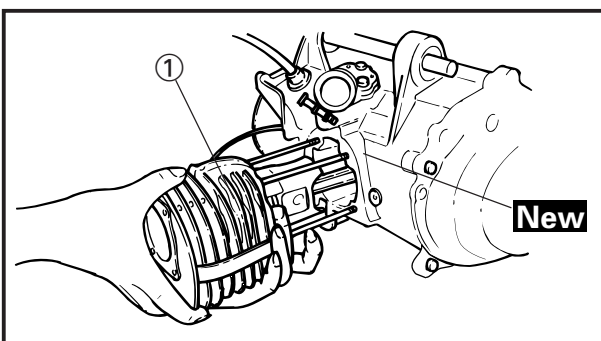

3. Install:
 - Cylinder ①

NOTE: _____

Install the cylinder with one hand while compressing the piston rings with the other hand.

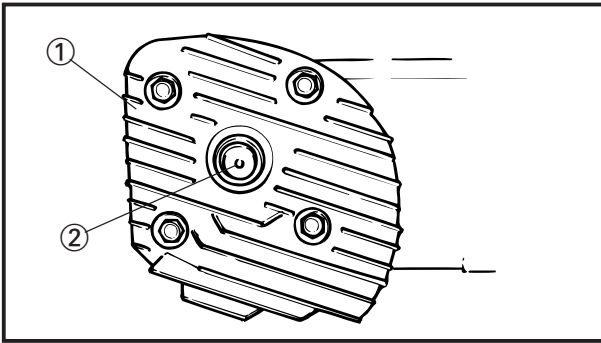

4. Install:
- Cylinder head gasket (new gasket)

5. Install:

- Cylinder head ①

	14Nm(1.4m.kg,10ft.lb)
--	-----------------------
- Spark plug ②

	20Nm(2.0m.kg,14ft.lb)
--	-----------------------
- Air shroud

NOTE: _____

Tighten the cylinder head holding nuts in stage, using a crisscross pattern.

V-BELT, CLUTCH AND SECONDARY/PRIMARY SHEAVE

ENG



V-BELT, CLUTCH AND SECONDARY/PRIMARY SHEAVE KICK STARTER AND CRANKCASE COVER (LEFT)

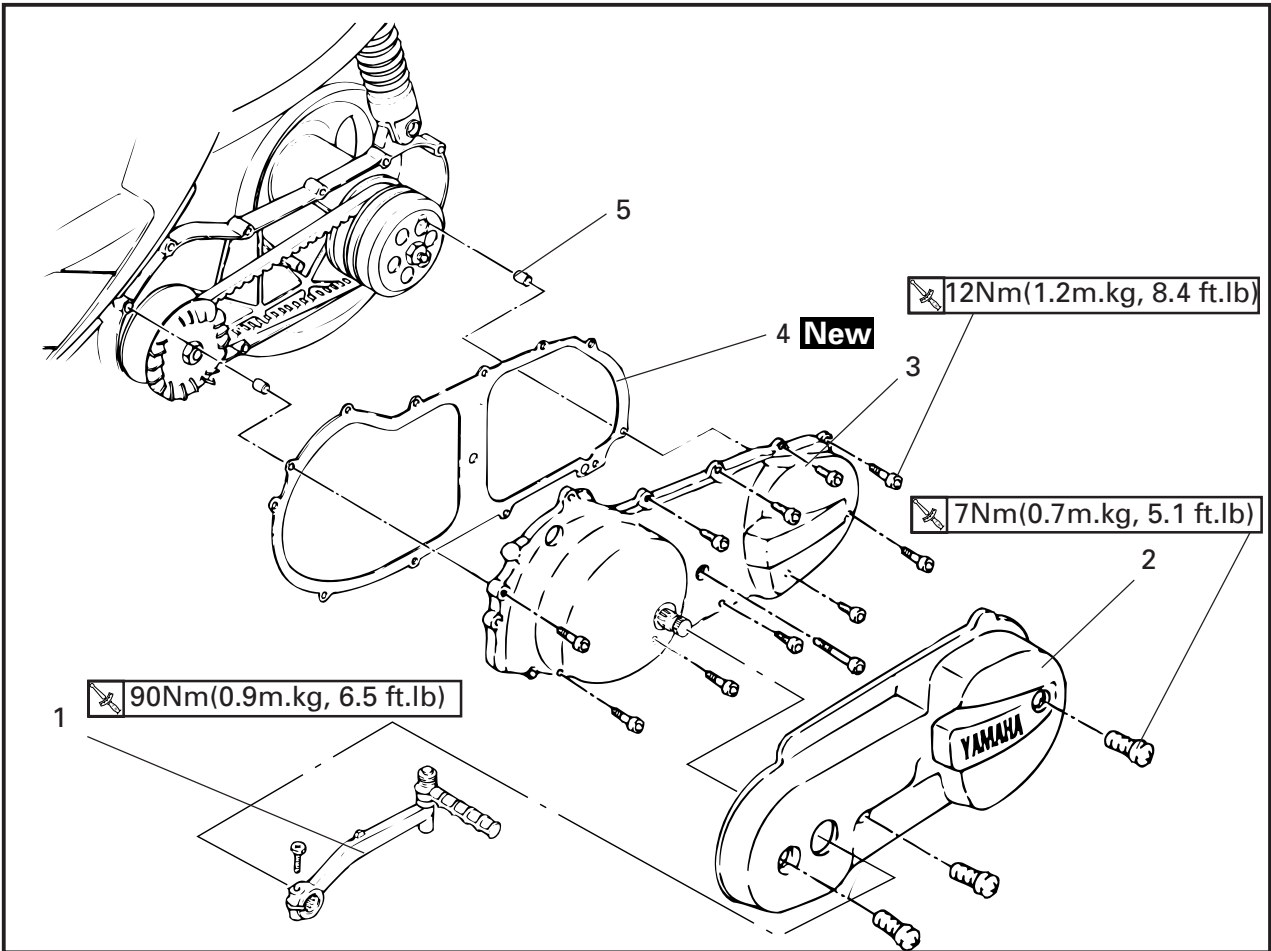

Order	Job name/Part name	Q'ty	Remarks
	Kick starter and crankcase cover (left) removal		Remove the parts in order.
1	Kick starter	1	
2	Crankcase cover 2 (left)	1	
3	Crankcase cover 1 (left)	1	
4	Gasket	1	
5	Pin	1	
		2	Reverse the removal procedure for installation.

V-BELT, CLUTCH AND SECONDARY/PRIMARY SHEAVE

ENG



V-BELT, CLUTCH AND SECONDARY/PRIMARY SHEAVE KICK STARTER

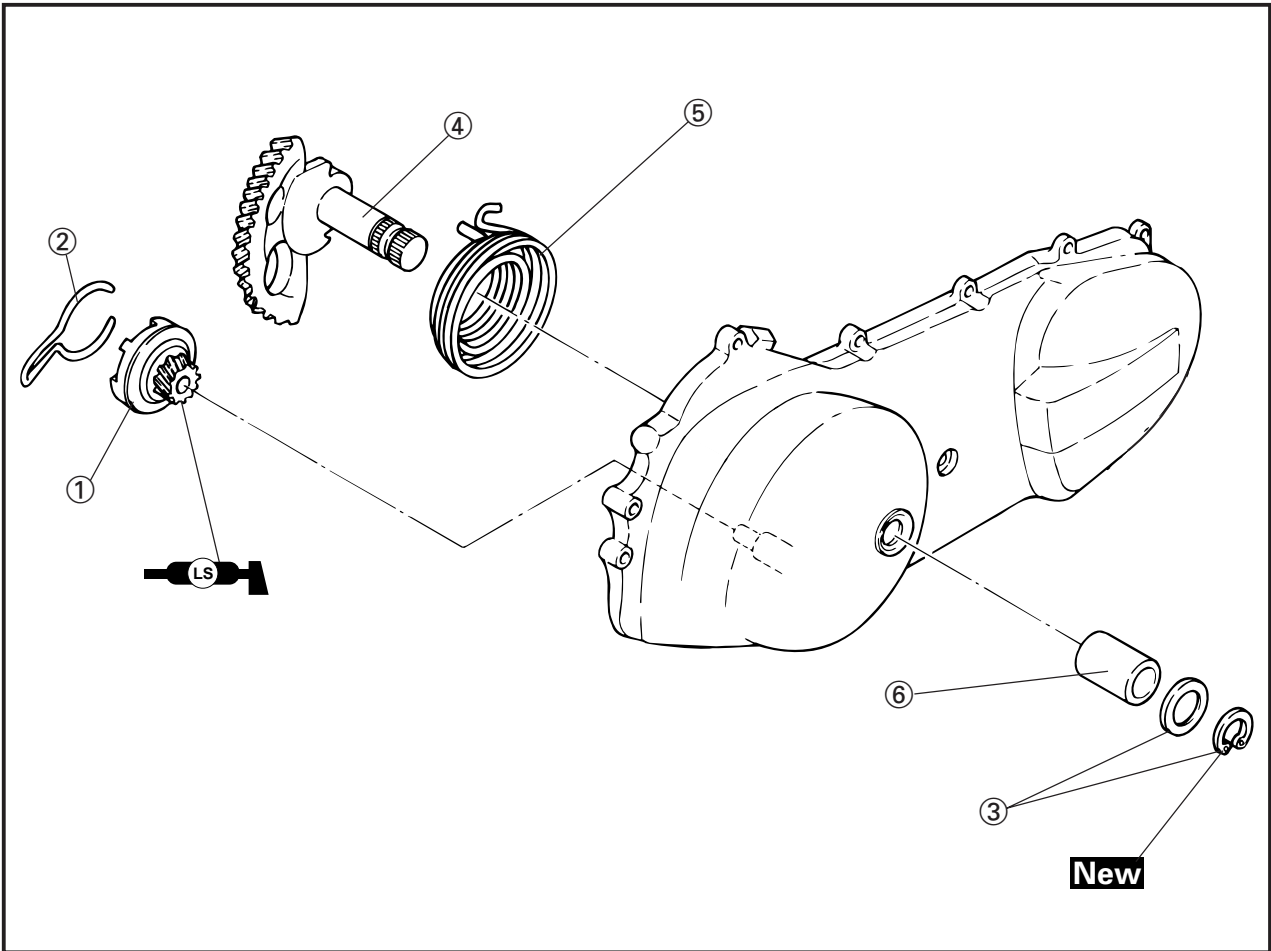

Order	Job name/Part name	Q'ty	Remarks
	Kick starter removal		Remove the parts in order.
	Crankcase cover 1 (left) removal		
①	Kickstarter pinion gear	1	
②	Kickstarter pinion gear clip	1	
③	Circlip/Plain washer	1/1	
④	Kickstarter segment gear	1	
⑤	Return spring	1	
⑥	Collar	1	
			Reverse the removal procedure for installation.

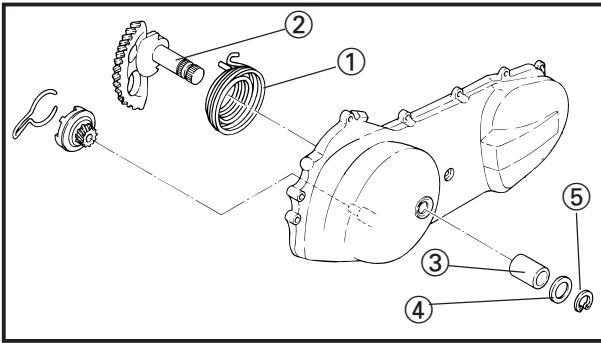

KICK STARTER INSTALLATION

1. Install:
 - Return spring ①
 - Kickstarter segment gear ②
 - Collar ③
 - Plain washer ④
 - Circlip ⑤

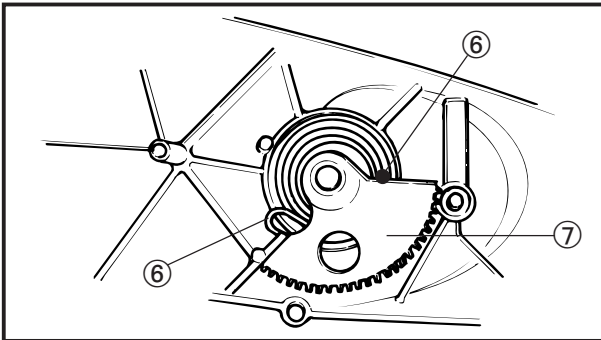

Installation steps:

- a. Install return spring ⑥ and segment gear ⑦ as shown.
- b. Install clip ⑤.
- c. Hook the spring onto the crankcase projection ⑧.
- d. Install the kick starter pinion gear ⑨ and the kick starter.

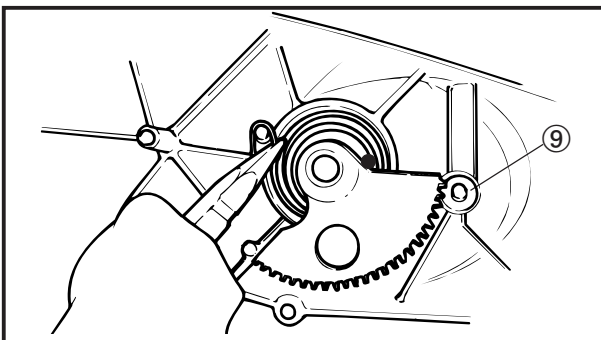
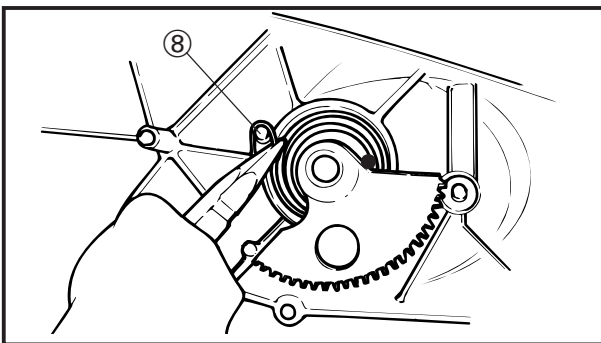
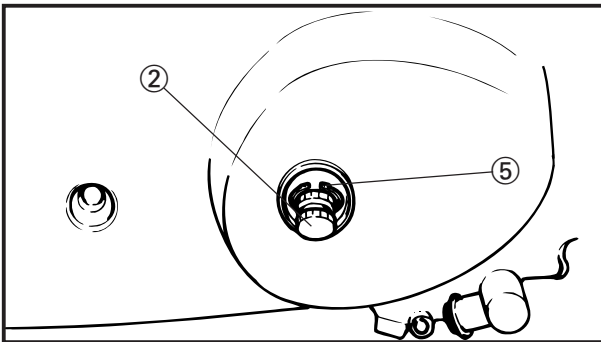

V-BELT, CLUTCH AND SECONDARY/PRIMARY SHEAVE



V-BELT, CLUTCH AND SECONDARY/PRIMARY SHEAVE

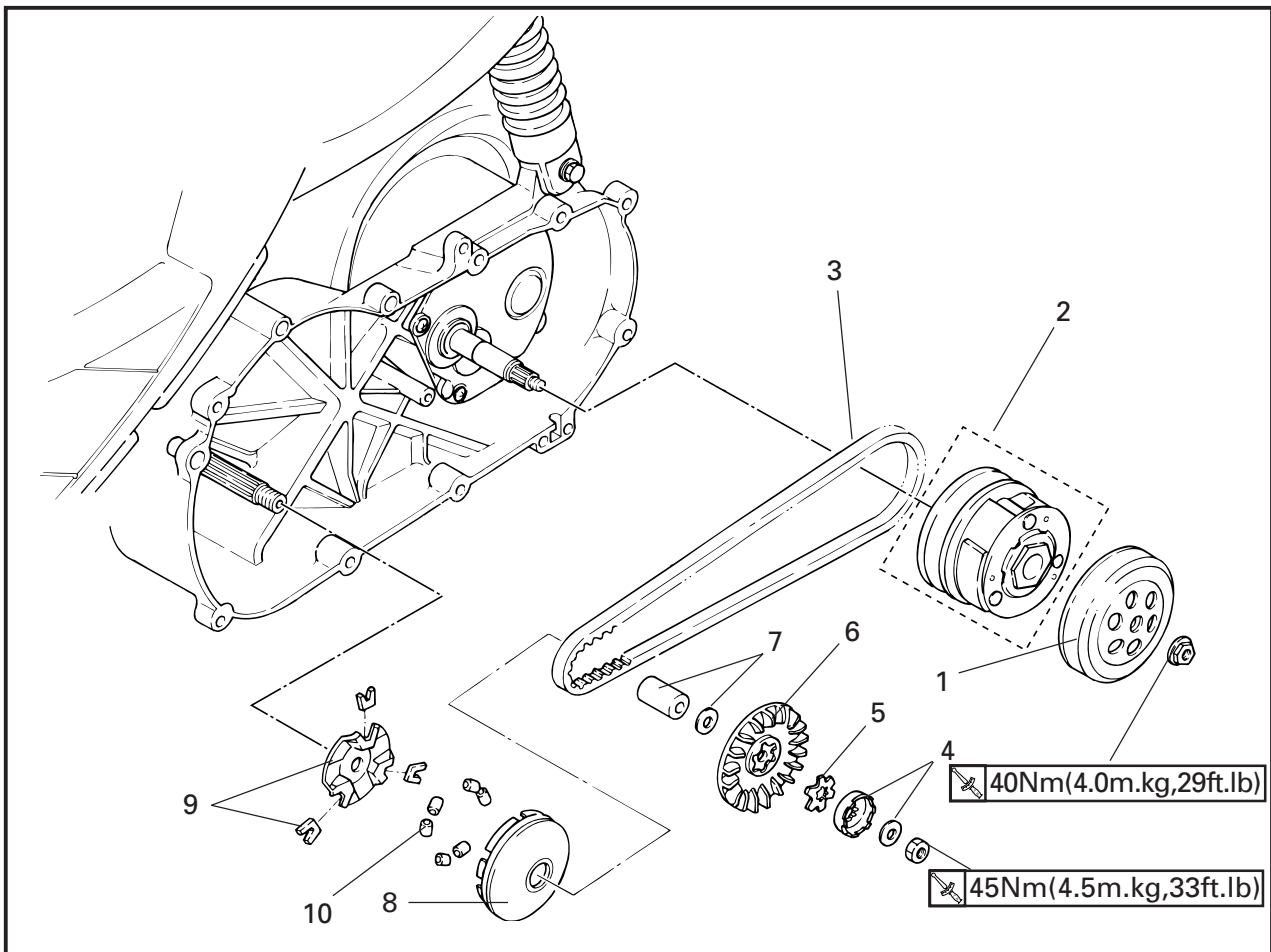

Order	Job name/Part name	Q'ty	Remarks
	V-belt, clutch and secondary/primary sheave removal		Remove the parts in order.
	Lower cowling		Refer to "COVER AND PANEL" section in chapter 3.
	Air shroud 3		
	Crankcase cover (left)		
1	Clutch housing	1	Refer to "ENGINE REMOVAL" section.
2	Secondary sheave assembly	1	
3	V-belt	1	Refer to "SECONDARY SHEAVE AND V-BELT REMOVAL" section.
4	Conical washer/One-way clutch	1/1	
5	Crow washer	1	Refer to "PRIMARY SHEAVE REMOVAL ASSEMBLY" section.
6	Primary fixed sheave	1	
7	Collar/Washer	1/1	
8	Primary sliding sheave	1	
9	Cam/ Slider	1/3	
10	Weight	6	
			Reverse the removal procedure for installation

V-BELT, CLUTCH AND SECONDARY/PRIMARY SHEAVE

ENG



SECONDARY SHEAVE

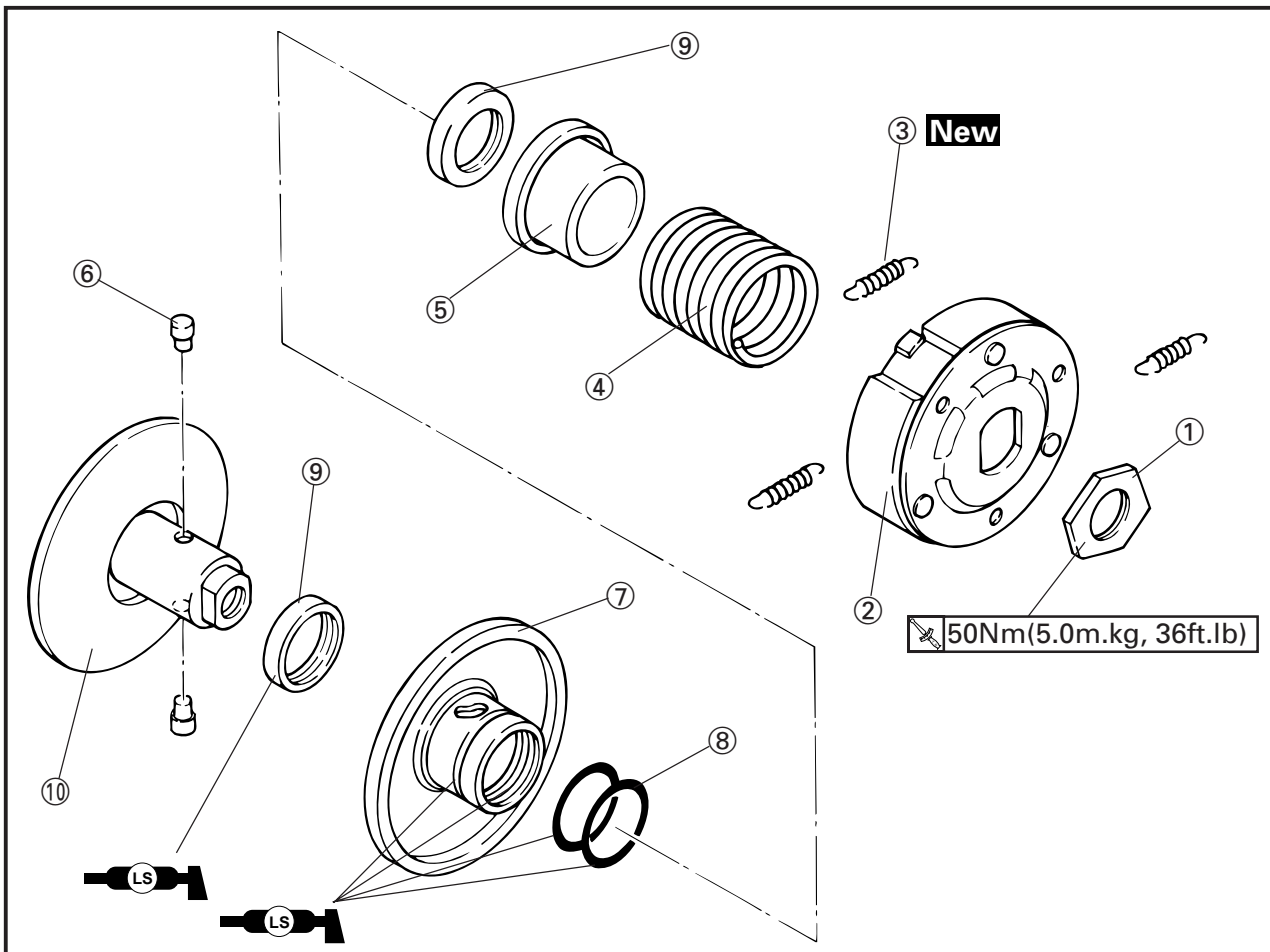

Order	Job name/Part name	Q'ty	Remarks
	Secondary sheave disassembly		Disassemble the parts in order.
①	Nut	1	Refer to "SECONDARY SHEAVE DISASSEMBLY" section.
②	Clutch carrier	1	
③	Clutch shoe spring	2	
④	Compression spring	1	
⑤	Spring seat	1	
⑥	Guide pin	2	
⑦	Secondary sliding sheave	1	
⑧	O-ring	2	
⑨	Oil seal	2	
⑩	Secondary fixed sheave	1	
			Reverse the disassembly procedure for assembly.

V-BELT, CLUTCH AND SECONDARY/PRIMARY SHEAVE

ENG

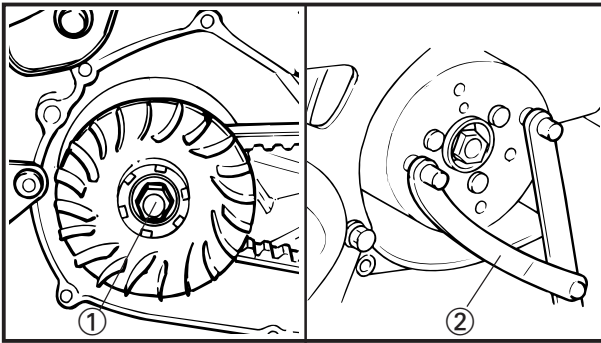

PRIMARY SHEAVE REMOVAL

1. Remove:
 - Fan
2. Remove:
 - Nut ① (primary sheave)

NOTE:

When loosening the nut (primary sheave), hold the C.D.I. magneto using flywheel holding tool ②.

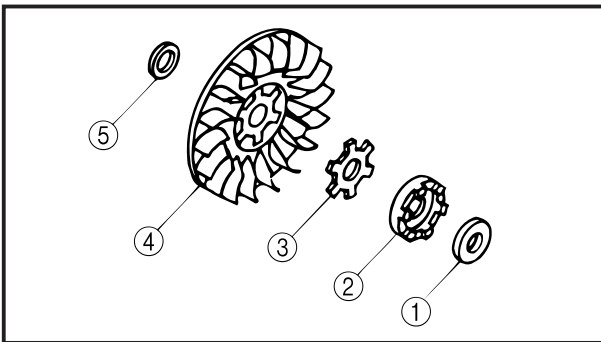

Rotor holding tool:
YU-01235

3. Remove:
 - Conical spring washer ①
 - One-way clutch ②
 - Washer ③
 - Primary fixed sheave ④
 - Shim ⑤
 - V-Belt
4. Remove:
 - Collar ①
 - Primary sheave assembly ②

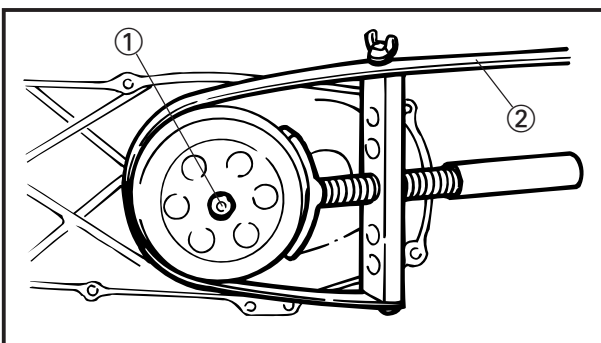
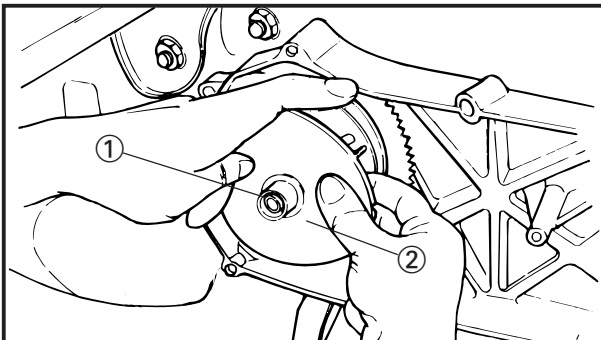

SECONDARY SHEAVE REMOVAL

1. Remove:
 - Nut ① (secondary sheave)

NOTE:

Hold the secondary sheave using sheave holder ②.



Sheave holder:
YU-01701

2. Remove:
 - Clutch housing
 - Secondary sheave assembly
 - Dowel pins

V-BELT, CLUTCH AND SECONDARY/PRIMARY SHEAVE

ENG

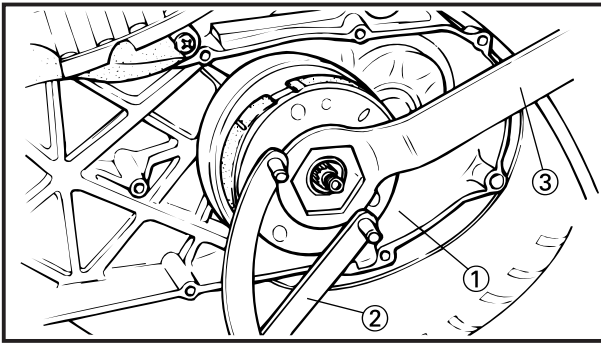

3. Loosen:
 - Nut(Clutch carrier)①

NOTE: _____

Install the secondary sheave to primary drive shaft as shown, and hold the secondary sheave by Universal Roter Holder ② to loosen the nut ①.



Roter holding tool:
YU-01235

CAUTION: _____

Do not remove the clutch securing nut yet. If the nut is removed without compressing the secondary sheave. It jumps and causes injury.

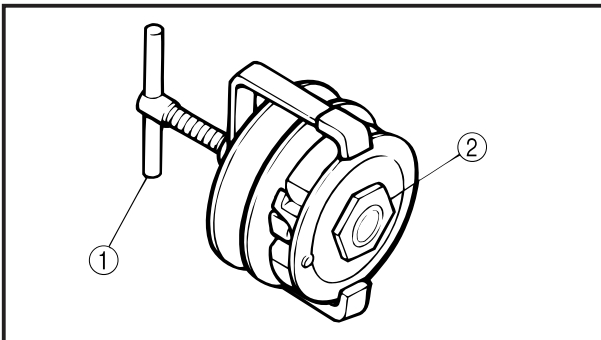

4. Attach:
 - Clutch spring holder ①



Clutch spring holder:
YS-28891

5. Remove:
 - Clutch securing nut ②

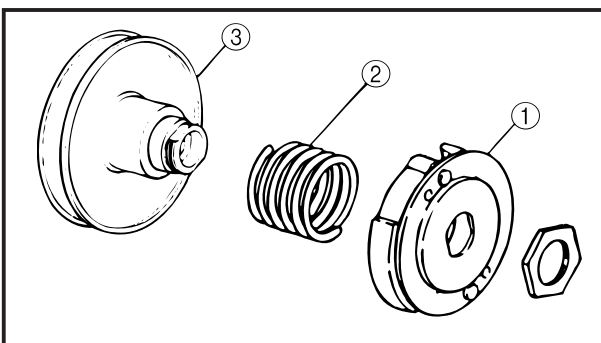

6. Remove:
 - Clutch assembly ①
 - Clutch spring ②
 - Spring seat ③
 - Guide pins
 - Secondary sliding sheave

CLUTCH INSPECTION

1. Inspect:
 - Clutch shoes

Glazed parts→Sand with coarse sand-paper.

NOTE: _____

After using the sand paper, clean of the polished particles with cloth.

V-BELT, CLUTCH AND SECONDARY/PRIMARY SHEAVE

ENG

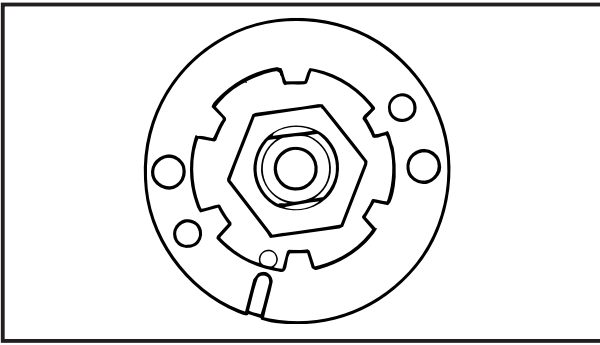

2. Measure:

- Clutch shoe thickness (a)
Out of specification → Replace.



Clutch shoe thickness:
4 mm (0.16 in)
<Wear limit>:
2.5 mm (0.1 in)

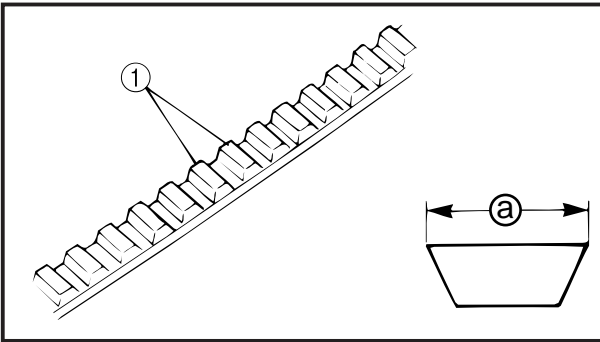

V-BELT INSPECTION

1. Inspect:

- V-belt (1)
Crack → Replace.

NOTE: _____

Replace the V-belt smeared with a lot of oil or grease.

2. Measure:

- V-belt width (a)
Out of specification → Replace.



V-belt width:
16.6 mm (0.65 in)
<Wear limit>:
14.6 mm (0.57 in)

V-BELT, CLUTCH AND SECONDARY/PRIMARY SHEAVE

ENG

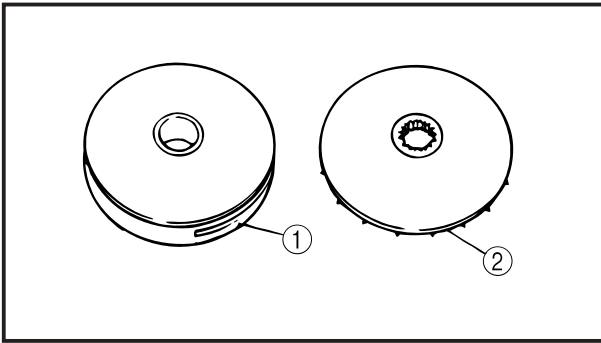

PRIMARY SHEAVE INSPECTION

1. Inspect:

- Primary sliding sheave ①
 - Primary fixed sheave ②
- Wear/Cracks/Scratch/Damage
→Replace.

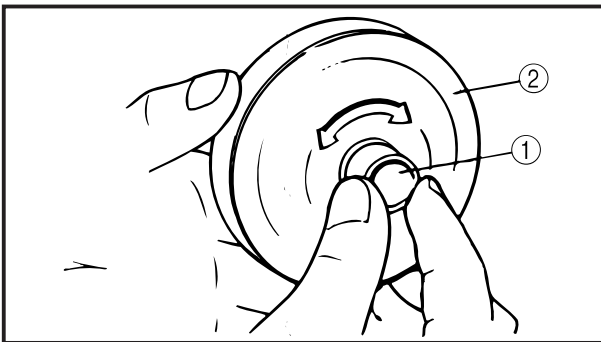

2. Check:

- Free movement
- Insert the collar ① into the primary sliding sheave ②, and check for free movement.
Stick or excessive play → Replace the sheave or collar.

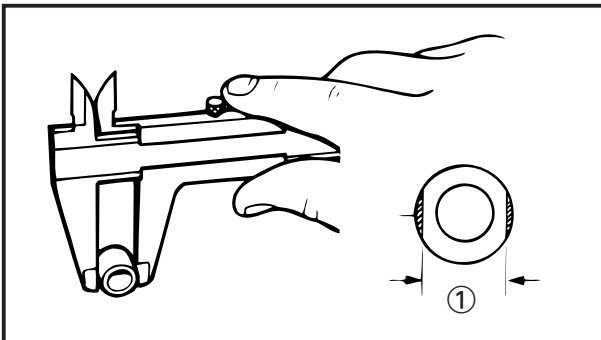

3. Measure:

- Out side diameter ① (weight)
- Out of specification → Replace.



Out side diameter (weight)
15.0 mm(0.59 in)
<Limit 14.5 mm>(0.57 in)

V-BELT, CLUTCH AND SECONDARY/PRIMARY SHEAVE

ENG

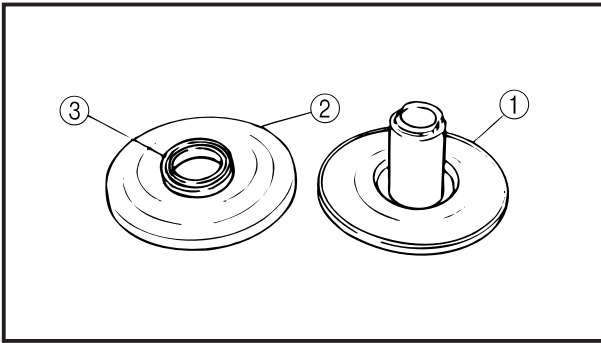

SECONDARY SHEAVE

1. Inspect:

- Secondary fixed sheave ①
- Secondary sliding sheave ②
Scratch/Crack/Damage→Replace as a set.
- Oil seal ③
Damage→Replace

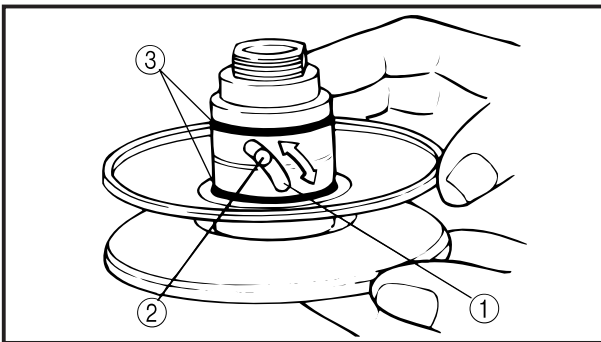

2. Inspect:

- Torque cam groove ①
Wear/Damage→Replace as a set.
- Guide pin ②
- O-rings ③
Damage→Replace.

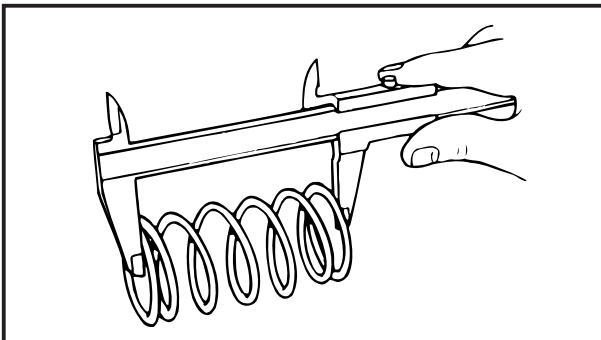

3. Measure:

- Clutch spring free length
Out of specification→Replace.



Clutch spring free length:
94 mm(3.7 in)
<Limit>:
91 mm(3.58 in)

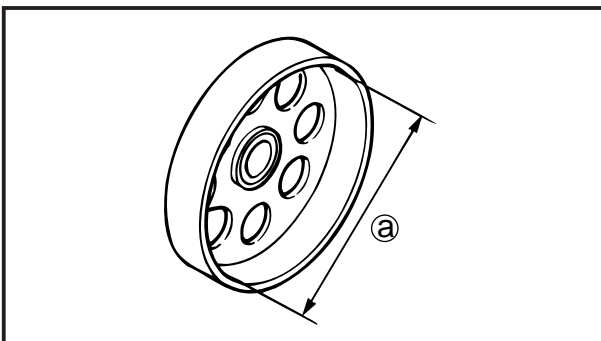

4. Inspect:

- Clutch housing inner surface
Oil/Scratches→Remove.

Oil	Use a rag soaked in lacquer thinner or solvent.
Scratches	Use an emery cloth (lightly and evenly polishing).

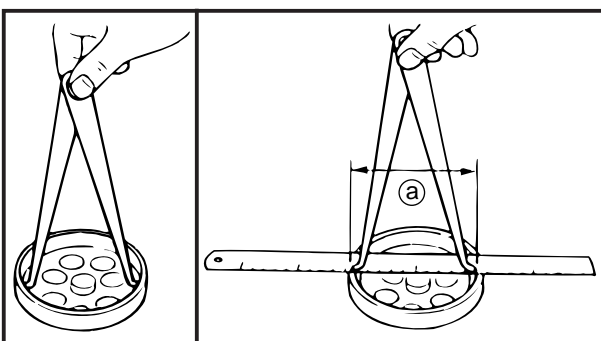

5. Measure:

- Clutch housing inside diameter ①
Out of specification→Replace.



Clutch housing inside diameter:
105 mm(4.13 in)
<Wear limit>:
105.5 mm(4.15 in)

V-BELT, CLUTCH AND SECONDARY/PRIMARY SHEAVE

ENG

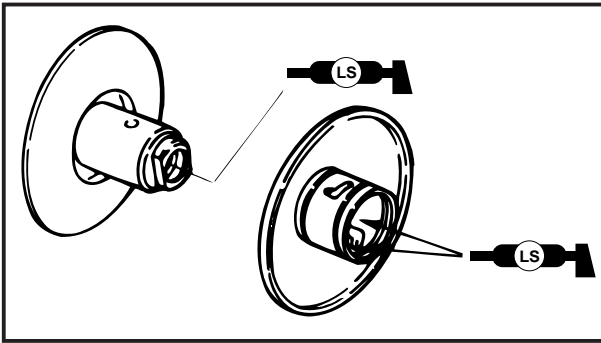

SECONDARY SHEAVE INSTALLATION

When assembling the secondary sheave, reverse the disassembly procedure. Note the following points.

1. Apply:
 - Lithium soap base grease (to the inside of the sliding/fixed sheave)

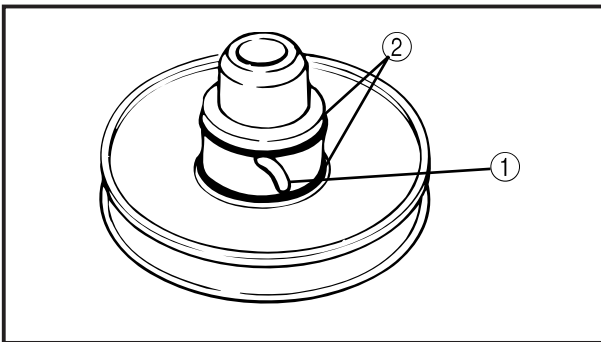

2. Install:
 - Sliding sheave ①

NOTE:

Be careful so that the oil seal ② lips are not turned over when installing the sheave.

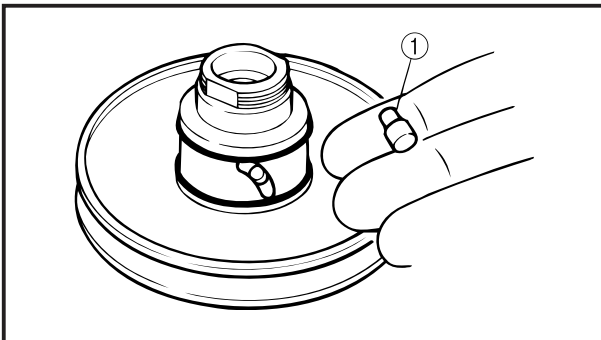

3. Apply:
 - Lithium soap base grease (to the torque cam grooves and O-rings)

4. Install:
 - Guide pin ①

5. Check:
 - Sliding sheave
Unsmooth operation → Repair.

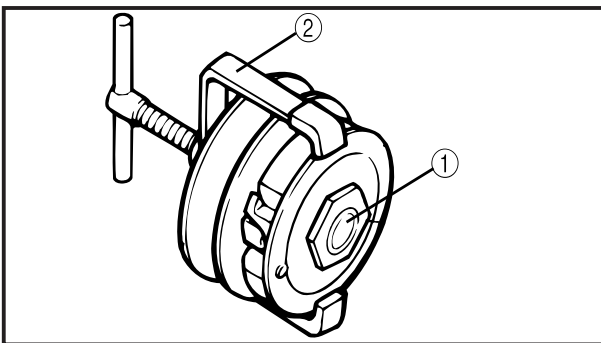

6. Install:
 - Clutch securing nut ①
Use clutch spring holder ②



Clutch spring holder:
YS-28891

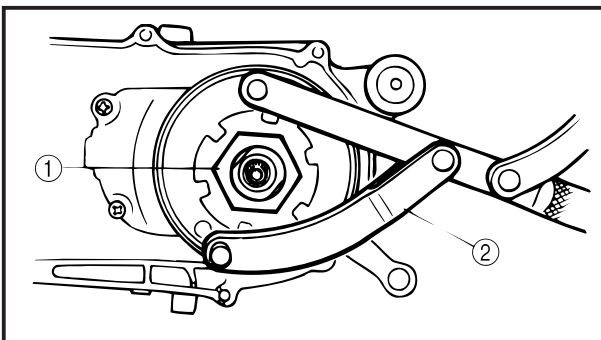

7. Tighten:
 - Clutch securing nut ①

 50 Nm (5.0 m.kg, 36 ft.lb)

Use Flywheel holding tool ②



Rotor holding tool
YU-01235

V-BELT, CLUTCH AND SECONDARY/PRIMARY SHEAVE

ENG

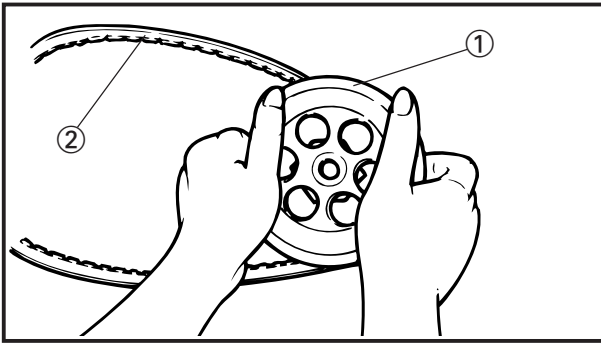

8. Install:
- Secondary sheave assembly
 - Clutch housing ①
 - V-belt ②

NOTE:

The V-belt must be installed with the arrow forward.

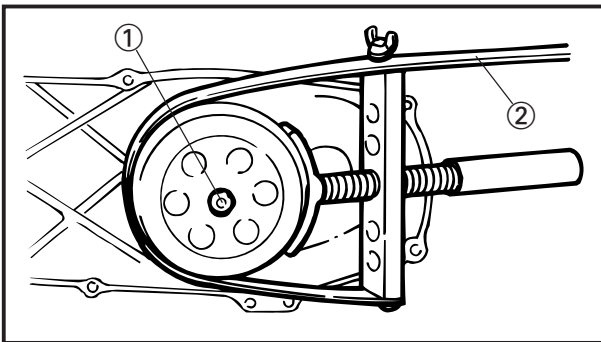

9. Tighten:
- Nut ① (secondary sheave)

40 Nm(4.0 m.kg, 29 ft.lb)

Use sheaveholder ②



Sheave holder:
YU-01701

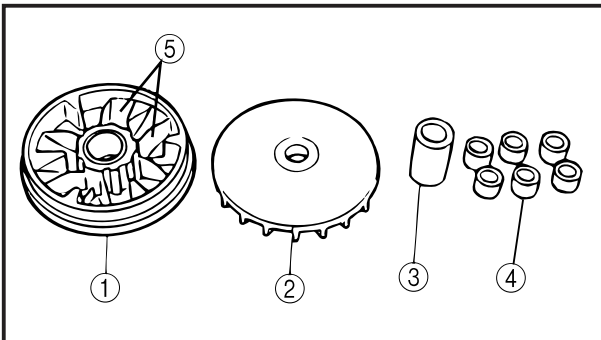

PRIMARY SHEAVE

1. Clean:
- Primary sliding sheave face ①
 - Primary fixed sheave face ②
 - Collar ③
 - Weight ④
 - Primary sliding sheave cam surface ⑤

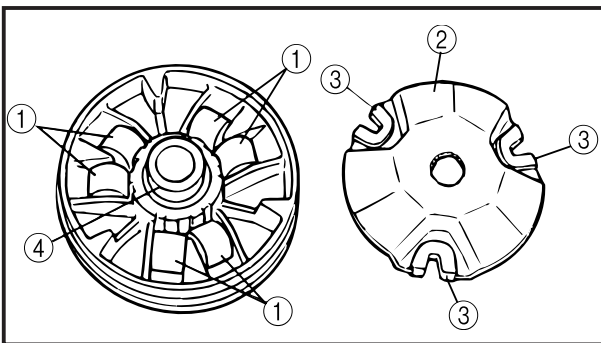

2. Install:
- Weight ①
 - Cam ②
 - Slider ③
 - Collar ④

3. Check:
- Cam operation
 - Not smooth → Repair.

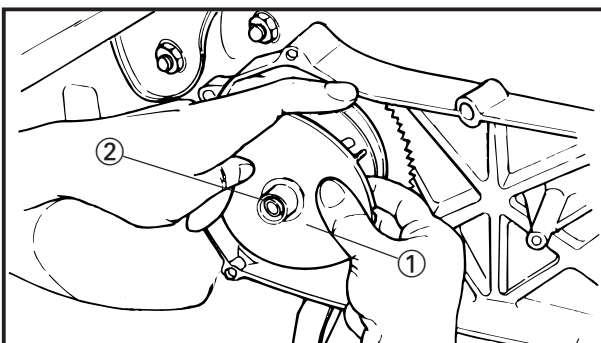

4. Install:
- Primary sheave assembly ①
 - Collar ②

5. Install:
- V-belt

V-BELT, CLUTCH AND SECONDARY/PRIMARY SHEAVE

ENG

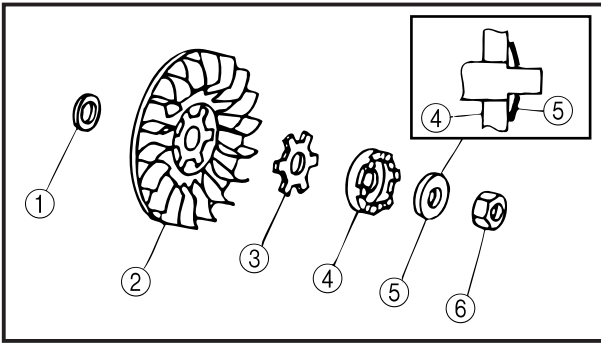

6. Install:

- Shim ①
- Primary fixed sheave ②
- Washer ③
- One-way clutch ④
- Conical spring washer ⑤
- Nut ⑥

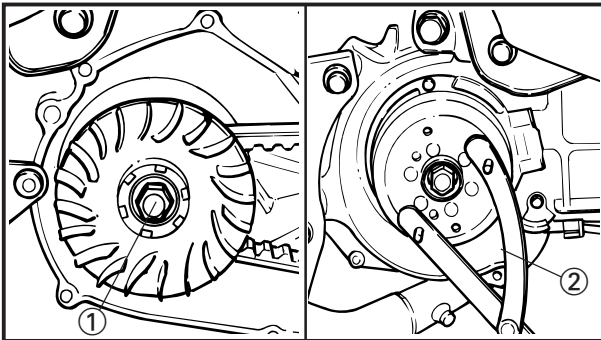

7. Tighten:

- Nut ① (primary sheave)

 45 Nm (4.5 m.kg, 31ft.lb)

NOTE:

When tightening the nut (primary sheave), hold the C.D.I. magneto using Flywheel Holding Tool ②.



Rotor holding tool:
YU-01235

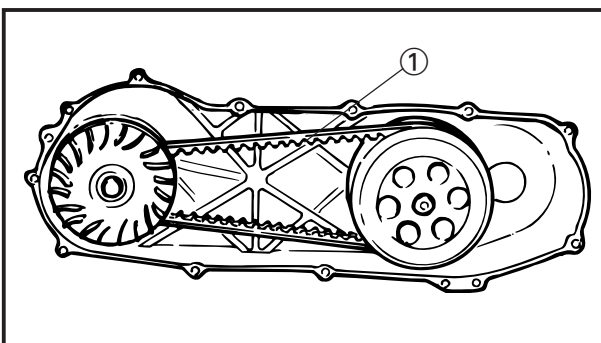

8. Adjust:

- V-belt ①

Tense the V-belt by turning the primary sheave several times.

9. Install:

- Fan

 7 Nm (0.7 m.kg, 5.1 ft.lb)

STARTER CLUTCH AND STARTER MOTOR



STARTER CLUTCH AND STARTER MOTOR



STARTER CLUTCH AND STARTER MOTOR

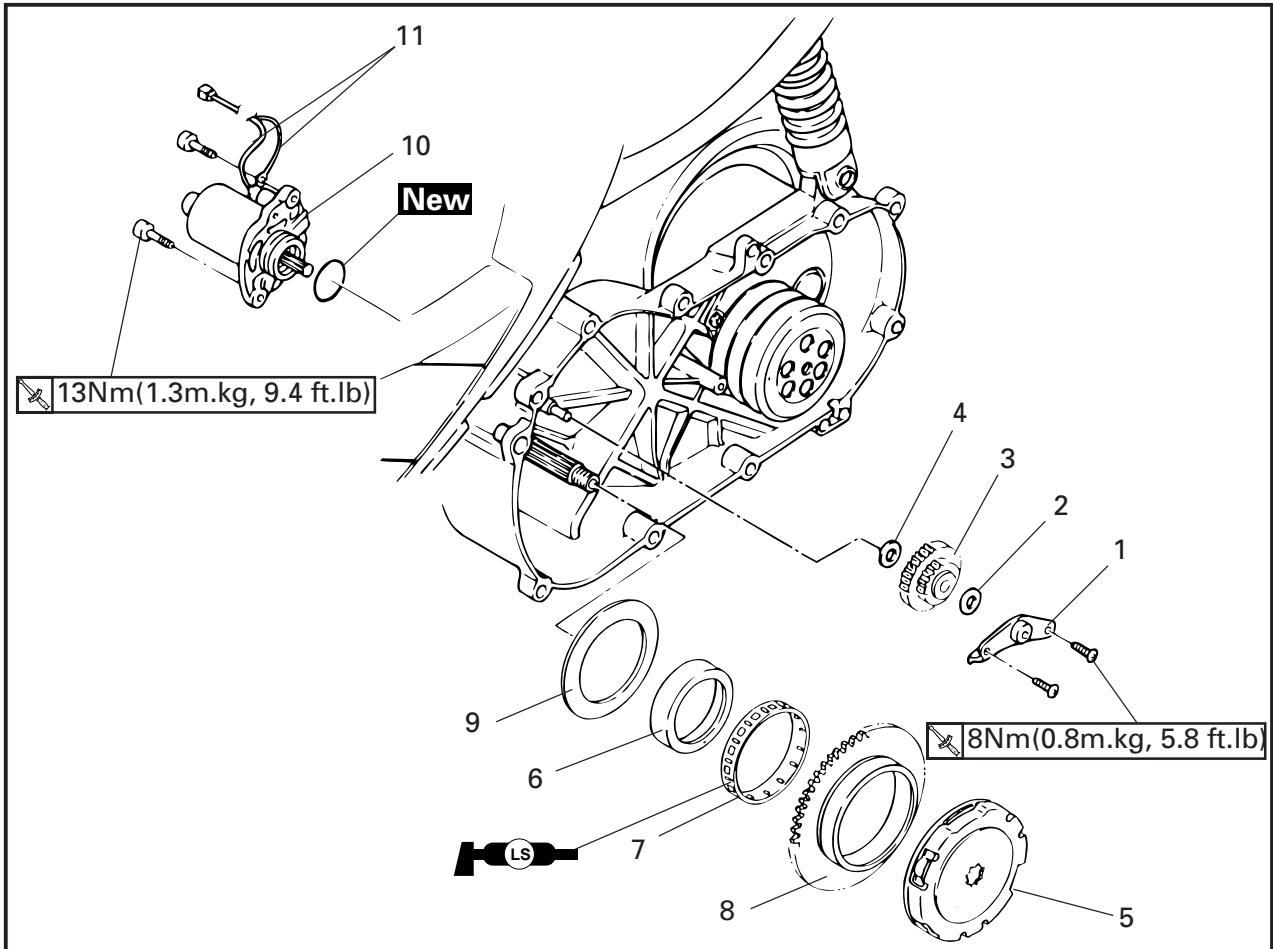

Order	Job name/Part name	Q'ty	Remarks
	Starter clutch and starter motor removal		Remove the parts in order.
	Left/Right side cover		Refer to "COVERS AND PANEL" section in chapter 3.
	Center cover		
	Lower cowling		Refer to "C.D.I. MAGNETO" section
	Air shroud 3		
	Cooling fan		Refer to "REAR WHEEL" section in chapter 6.
	Rear wheel		
	Crankcase cover (left) 1,2		Refer to "KICKER STARTER" section.
	Primary sheave		Refer to "V-BELT, PRIMARY SHEAVE" section.
1	Plate	1	
2	Plain washer	1	
3	Idle gear	1	
4	Plain washer	2	
5	Starter clutch	1	

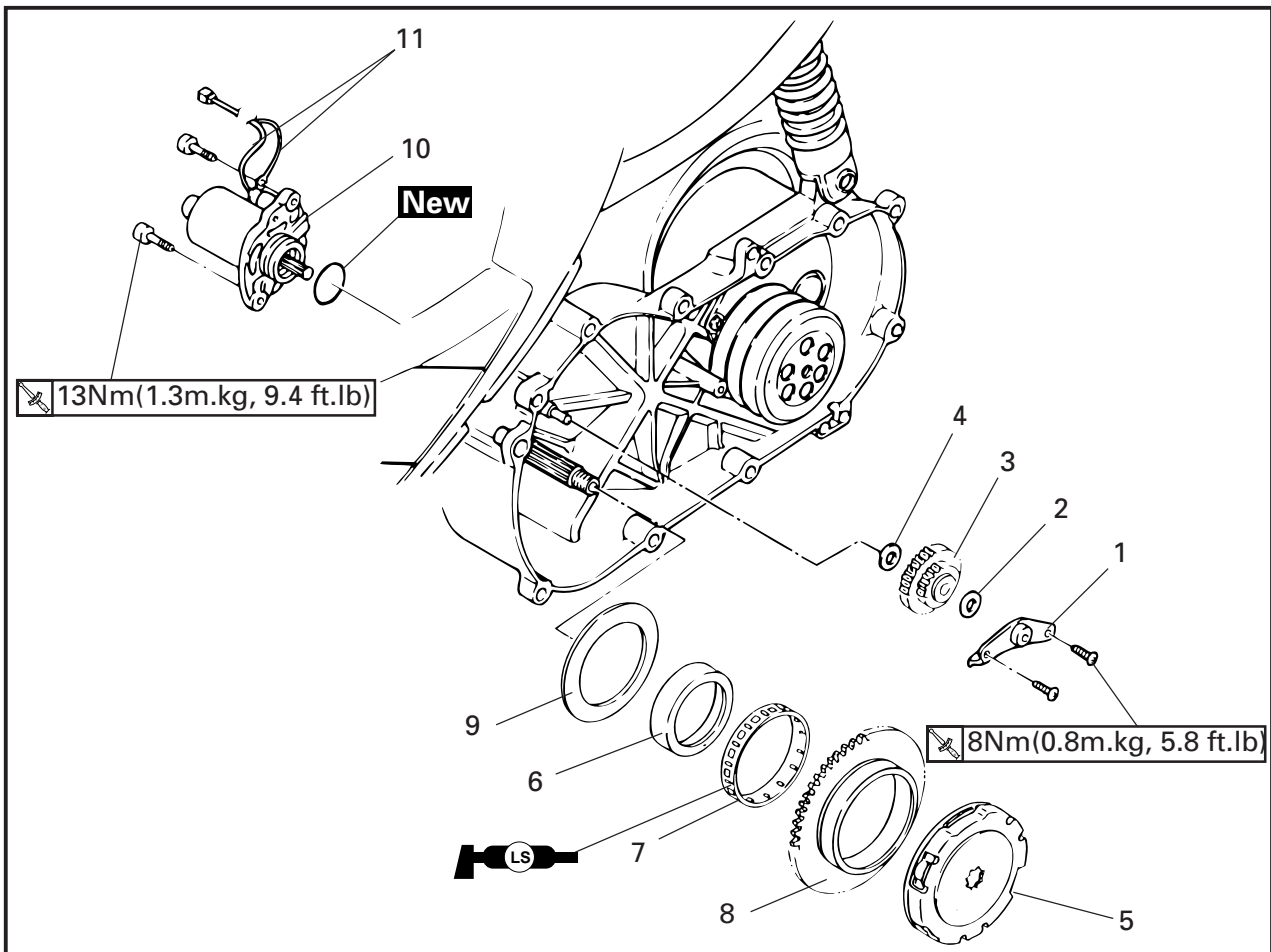

Order	Job name/Part name	Q'ty	Remarks
6	Gear boss	1	Reverse the removal procedure for installation
7	Bearing	1	
8	Starter wheel gear	1	
9	Plate washer	1	
10	Starter motor	1	
11	Starter motor coupler	2	

STARTER CLUTCH AND GEARS INSPECTION

1. Inspect:

- Starter clutch
 - Push the dowel pin to arrow direction.
 - Unsmooth operation → Replace starter clutch assembly.

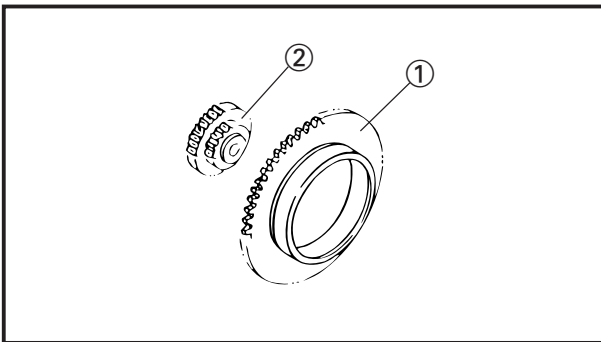

2. Inspect:

- Starter wheel gear teeth ①
- Idle gear teeth ②
- Burrs/Chips/Roughness/Wear → Replace.

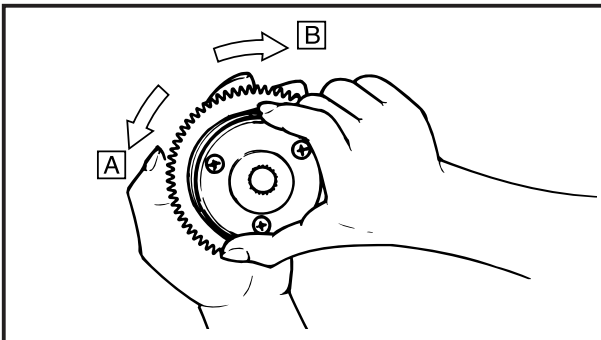

3. Inspect:

- Starter clutch operation

Clutch operation checking steps:

- Install the starter wheel gear to the starter clutch, and hold the starter clutch.
- When turning the wheel gear clockwise **A** the starter clutch and the wheel gear should be engaged.

If not the starter clutch is faulty. Replace it.

- When turning the wheel gear counter clockwise **B**, the wheel gear should turn freely. If not, the starter clutch is faulty. Replace it.



C.D.I. MAGNETO



C.D.I. MAGNETO

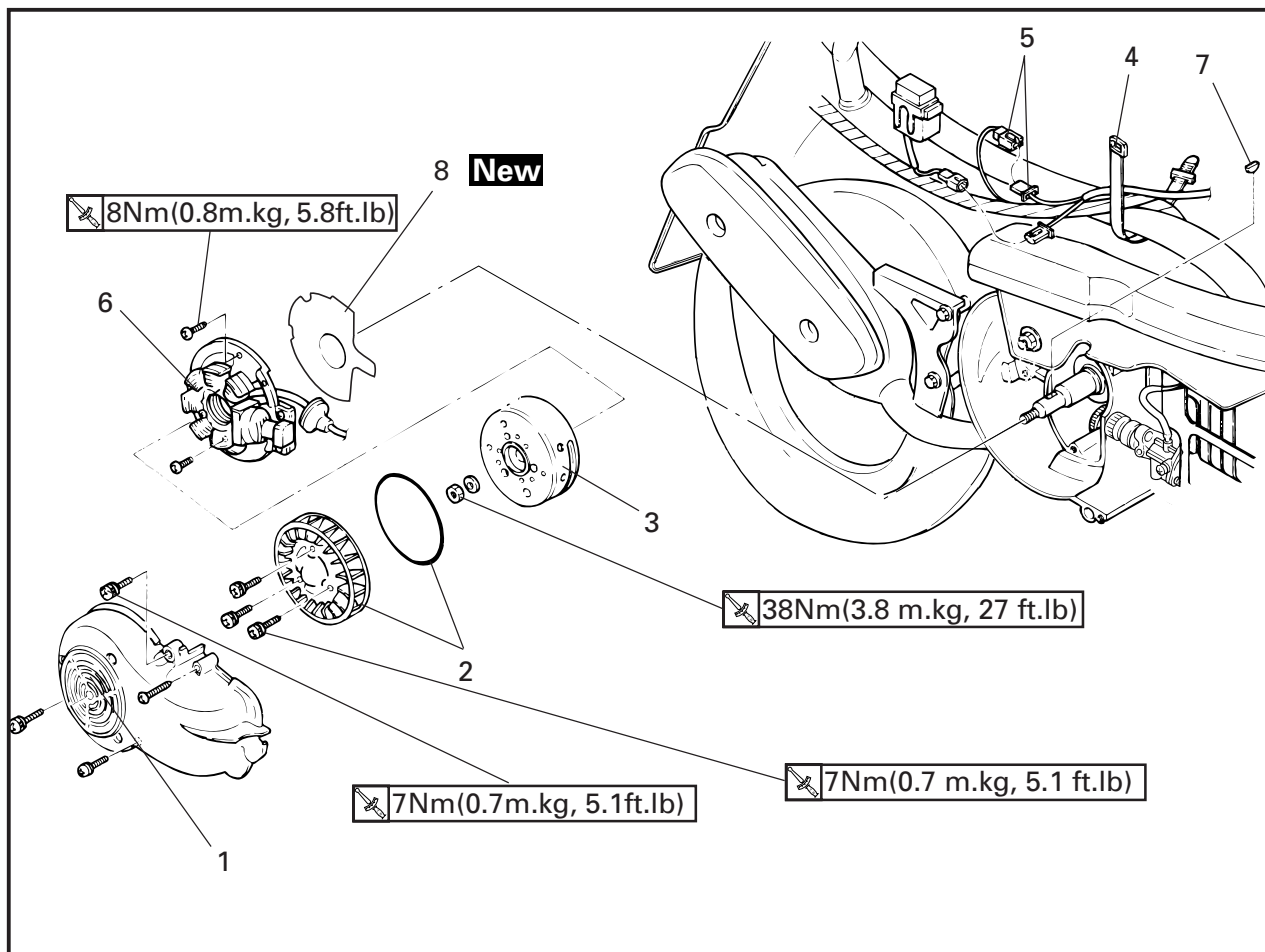

Order	Job name/Part name	Q'ty	Remarks
	C.D.I. magneto removal		Remove the parts in order.
	Rear carrier		Refer to "COVER AND PANEL" section in chapter 3.
	Tail cover		
	Left side cover		
	Right side cover		
	Center cover		
	Lower cowling		
1	Air shroud 1	1	
2	Fan /O-ring	1/1	
3	Magneto rotor	1	
4	Bind	1	
5	Couplers (magneto leads)	1	
6	Stator coil	1	
7	Woodruff key	1	
8	Gasket (Magneto cover)	1	
			Reverse the removal procedure for installation.

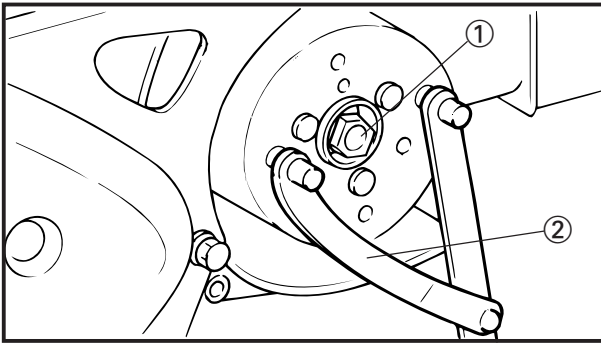
**C.D.I. MAGNETO REMOVAL**

- Remove:
 - Nut ①(rotor)
 - Plain washer

NOTE:

Hold the rotor to loosen the nut by the flywheel holding tool ②.



Rotor holding tool:
YU-01235

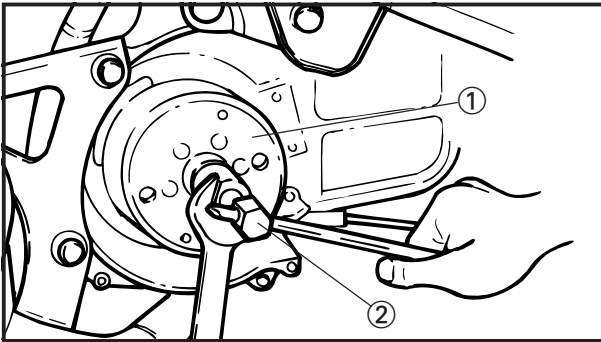



- Remove:
 - Rotor ①
 - Woodruff key
 Use the flywheel magneto puller ②.

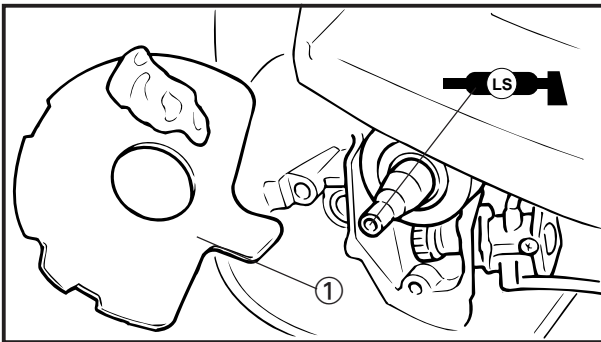

Flywheel puller:
YU-01189

- Stator assembly
- Gasket

**C.D.I. MAGNETO INSTALLATION**

- Install:
 - Gasket ①
- Apply:
 - Lithium soap base grease (to oil seal)
- Pass the C.D.I. magneto lead through the crankcase hole.
- Install:
 - Stator assembly  8 Nm(0.8 m.kg, 5.8 ft.lb)
- Install:
 - Woodruff key
 - C.D.I. magneto Rotor ②
 - Plain washer
 - Nut  38Nm(3.8 m.kg, 31.1ft.lb)

NOTE:

- Clean the tapered portion of the crankshaft and the magneto rotor hub.
- When installing the magneto rotor, make sure the woodruff key is properly seated in the keyway of the crankshaft.
- Do not allow the rotor holding tool to touch the projection on the magneto rotor.

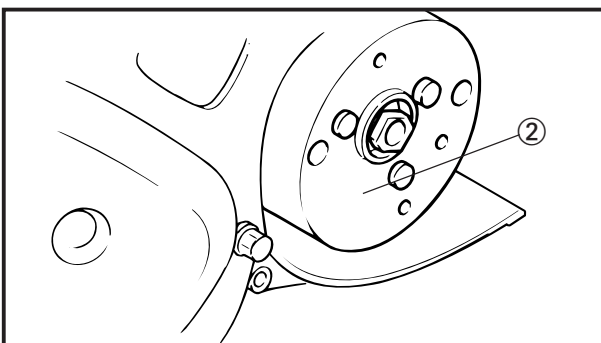



AUTOLUBE PUMP



AUTOLUBE PUMP

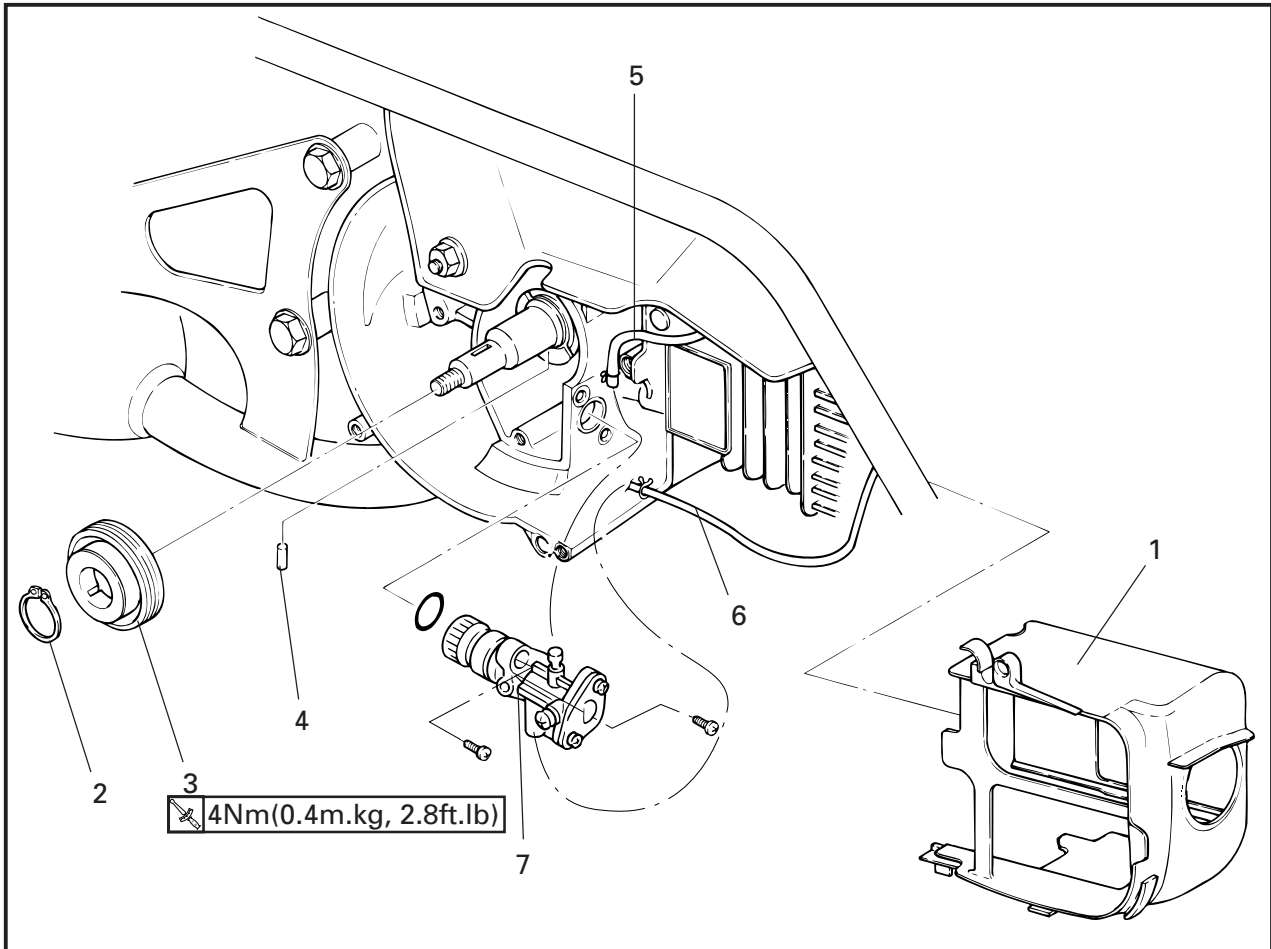

Order	Job name/Part name	Q'ty	Remarks
	Autolube pump removal		Remove the parts in order.
	C.D.I. magneto		Refer to "C.D.I. magneto" section.
1	Air shroud 2.	1	
2	Circlip	1	
3	Pump drive gear	1	
4	Pin	1	
5	Oil hose	1	
6	Oil delivery hose	1	
7	Autolube pump ass'y	1	Refer to "Autolube pump installation" section
			Reverse the removal procedure for installation.

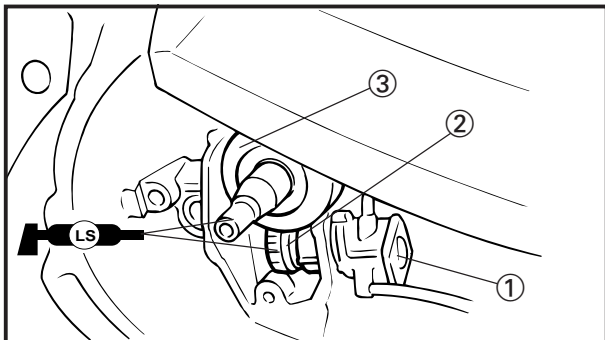
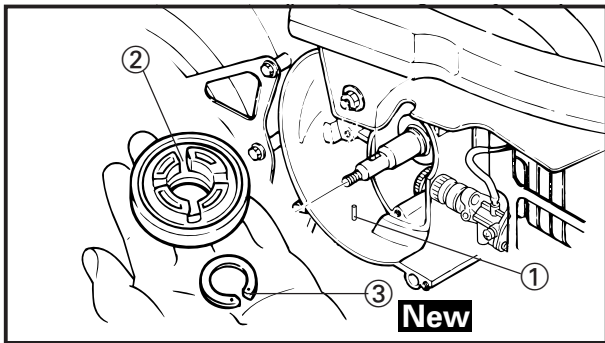

AUTOLUBE PUMP INSTALLATION

CAUTION:

After installing autolube pump, it must be bled.

1. Install
 - Pin ①
 - Pump drive gear ②
 - Circlip ③ **New**
2. Apply:
 - Lithium soap base grease (to O-ring)
3. Install:
 - Autolube pump ① 4 Nm(0.4m.kg, 2.8ft.lb)
4. Apply:
 - Lithium soap base grease (to autolube pump gear ②,③)

	15 cc (0.92 cu • in)
---	----------------------



TRANSMISSION



TRANSMISSION

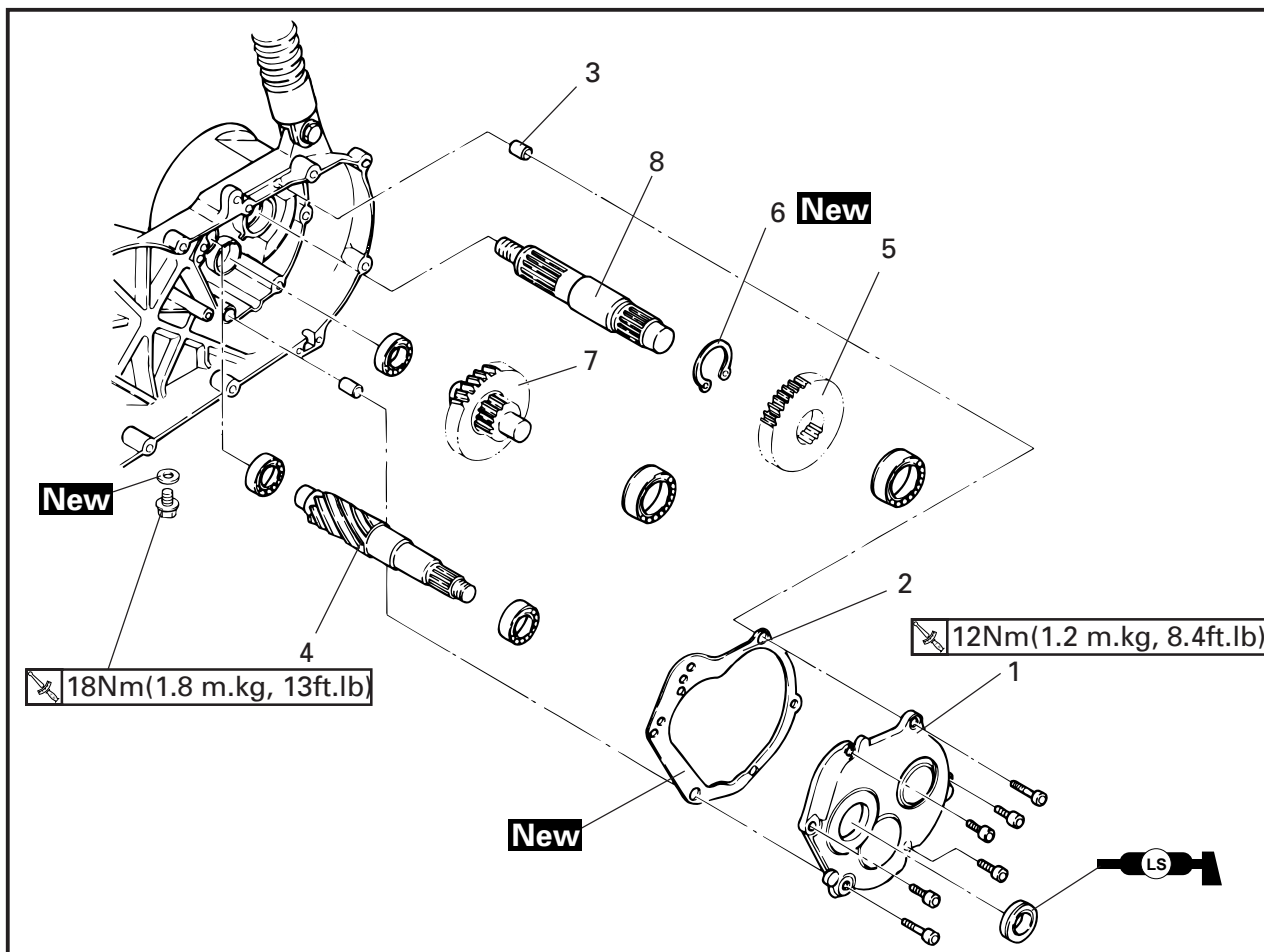

Order	Job name/Part name	Q'ty	Remarks
	Transmission removal		Remove the parts in order. Refer to "REAR WHEEL/REAR BRAKE " section in chapter 7.
	Rear wheel		
	Secondary sheave		
	Drain the transmission oil.		Refer to "V-BELT, CLUTCH, SECONDARY/ PRIMARY SHEAVE" section
	Drain the transmission oil.		Refer to "TRANSMISSION OIL REPLACEMENT " section in chapter 3.
1	Transmission case cover	1	
2	Gasket (transmission case cover)	1	
3	Dowel pin	2	
4	Primary drive gear	1	
5	Drive gear	1	
6	Circlip	1	
7	Main axle	1	

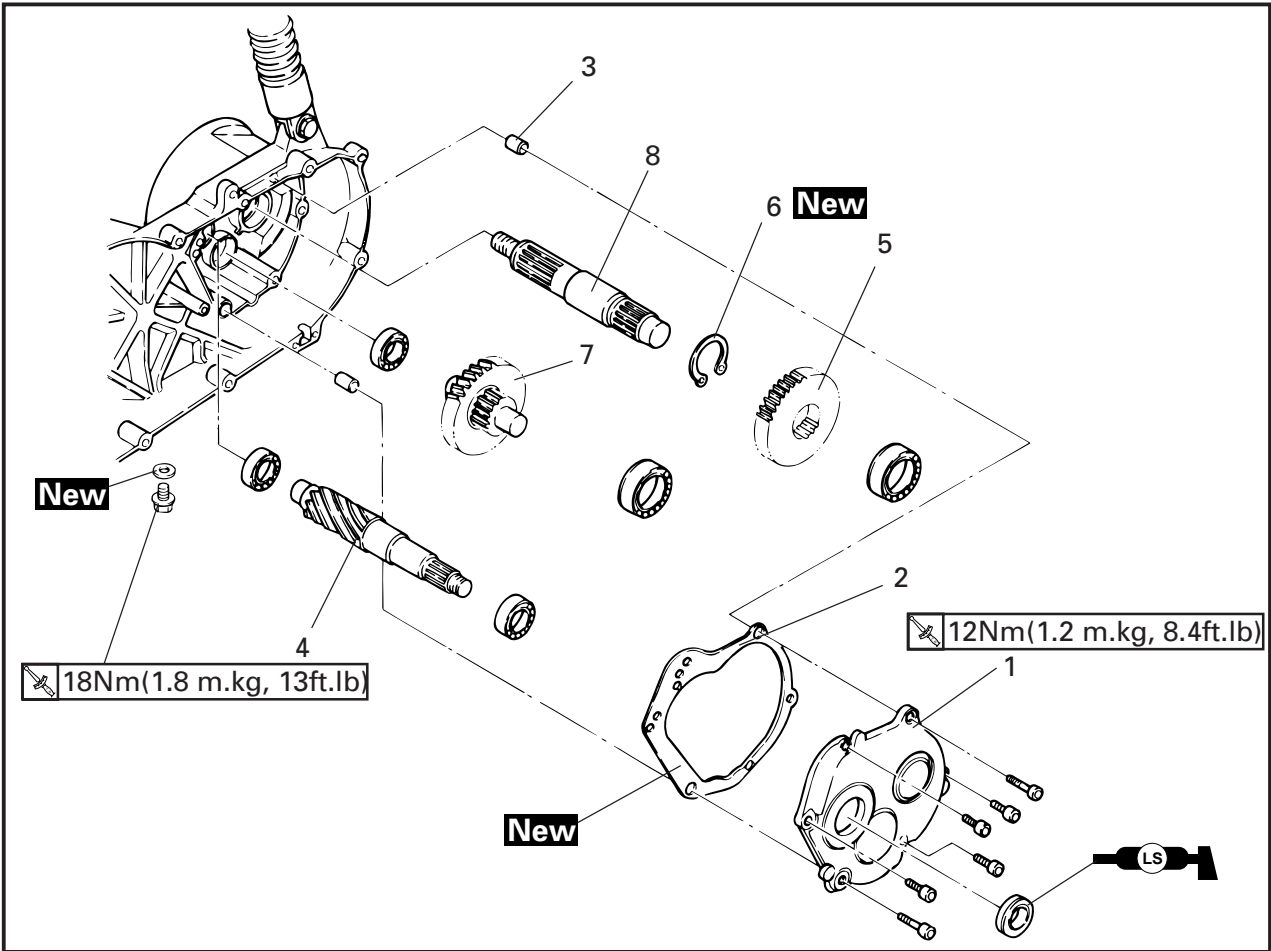

Order	Job name/Part name	Q'ty	Remarks
8	Drive axle	1	Reverse the removal procedure for installation.

CRANKCASE AND REED VALVE

CRANKCASE AND REED VALVE

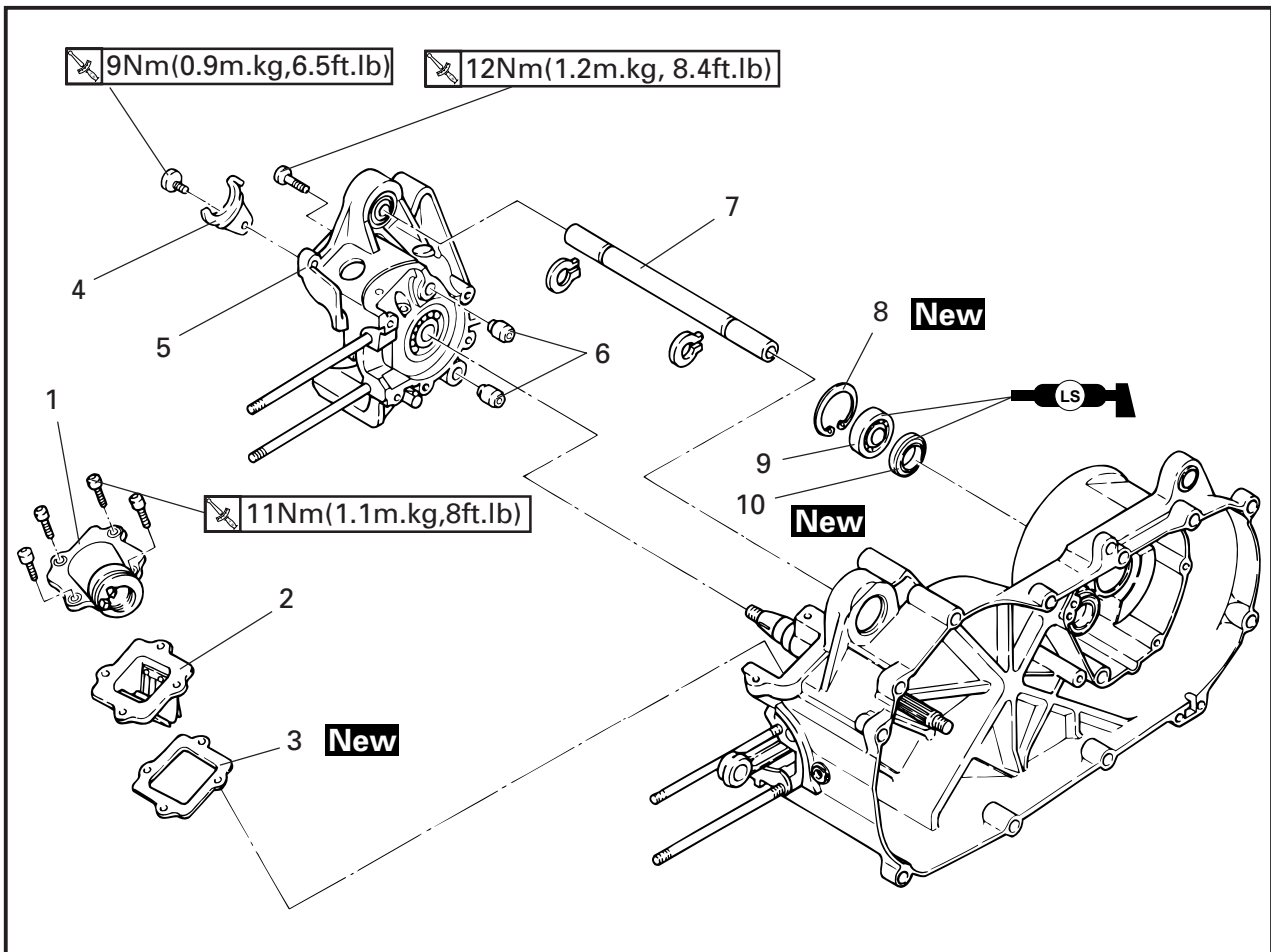

Order	Job name/Part name	Q'ty	Remarks
	Crankcase and Reed valve removal		Remove the parts in order.
	Engine removal		Refer to "ENGINE REMOVAL" section.
	Cylinder head, cylinder, piston		Refer to "CYLINDER HEAD CYLINDER AND PISTON" section.
	Crankcase cover (left)		Refer to "KICK STARTER AND CRANKCASE COVER (LEFT) " section.
	V-belt, clutch, secondary/primary sheave		Refer to "V-BELT, CLUTCH AND SECONDARY/PRIMARY SHEAVE " section.
	C.D.I . magneto		Refer to "C.D.I. MAGNETO" section.
	Starter clutch, starter motor		Refer to "STARTOR CLUTCH AND STARTOR MOTOR" section.
	Autolube pump		Refer to "AUTOLUBE PUMP" section.
	Rear wheel		Refer to "REAR WHEEL AND REAR BRAKE" section in chapter 6.
	Transmission		Refer to "TRANSMISSION" section.

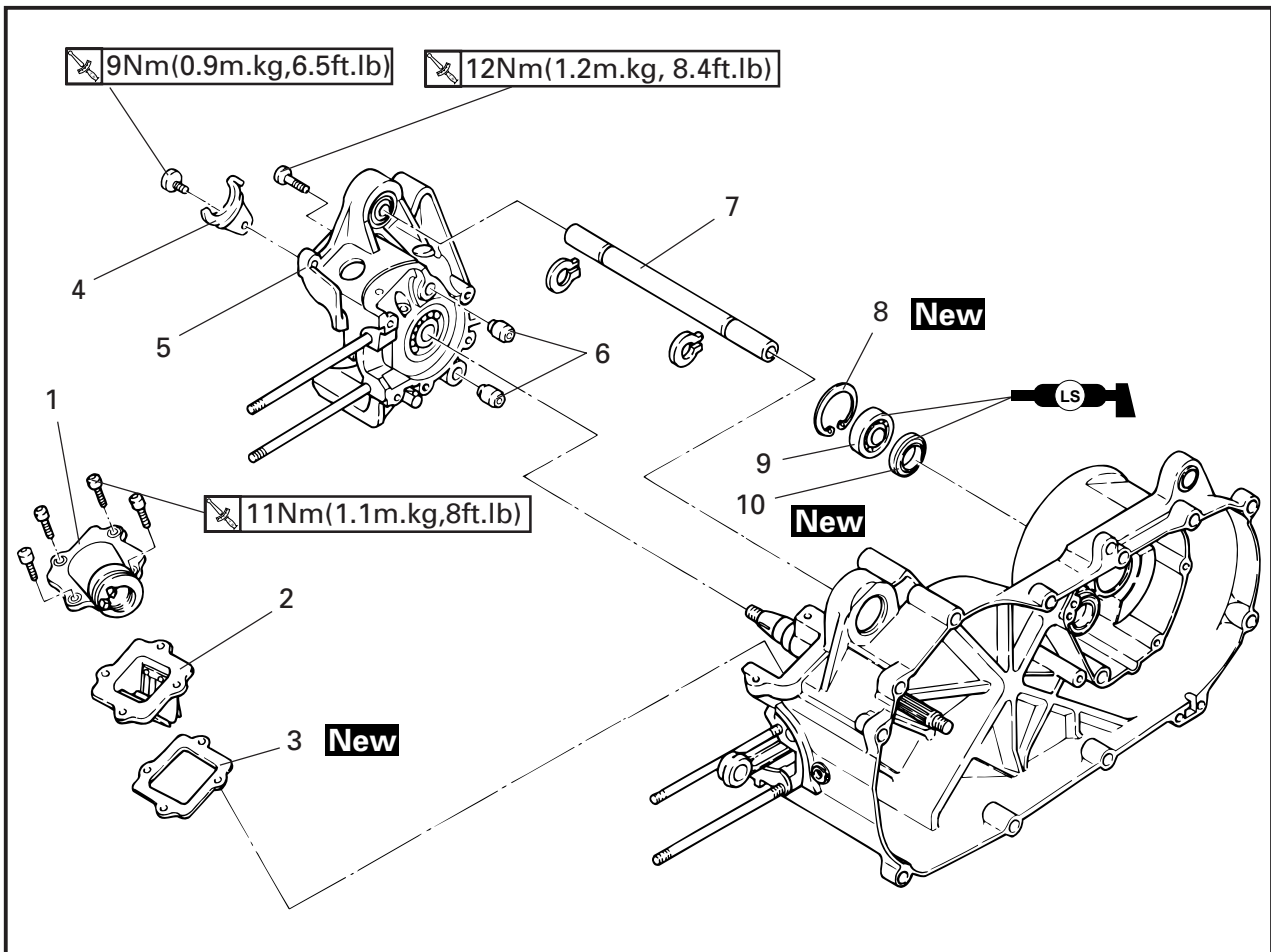

Order	Job name/Part name	Q'ty	Remarks
1	Intake manifold	1	Reverse the removal procedure for installation.
2	Reed valve	1	
3	Valve seat gasket	1	
4	Stopper	1	
5	Crankcase 2	1	
6	Dowel pin	2	
7	Engine mount spacer	1	
8	Circlip	1	
9	Bearing	1	
10	Oil seal	1	

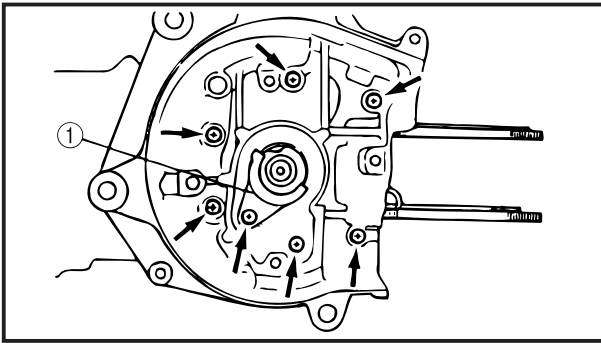

CRANKCASE(RIGHT) REMOVAL

1. Remove:

- Oil seal stopper ①
- Screws (crankcase)  9Nm(0.9 m.kg,6.5ft.lb)

NOTE: _____

Loosen each screw 1/4 turn, and remove them after all are loosened.

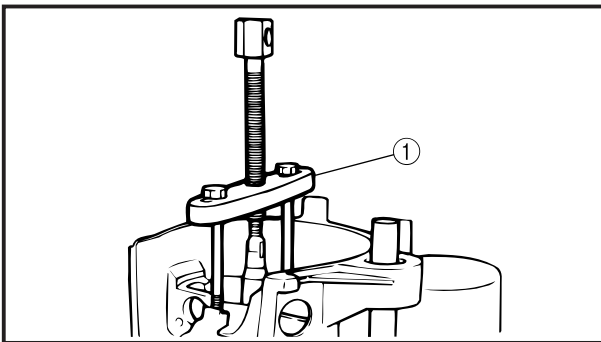

2. Attach:

- Crankcase separating tool ①



Crankcase separating tool:
YU-01135

NOTE: _____

Fully tighten the tool holding bolts, but make sure the tool body is parallel with the case. If necessary, one screw may be backed out slightly to level tool body.

3. Remove

- Crankcase (right)
As pressure is applied, alternately tap on the engine mounting bosses.

CHECKING THE CRANKCASE

1. Thoroughly wash the crankcase halves in a mild solvent.
2. Thoroughly clean all the gasket surfaces and crankcase mating surfaces.
3. Check:
 - crankcase
Cracks/damage → Replace.
 - oil delivery passages
Obstruction → Blow out with compressed air.

CHECKING THE BEARINGS AND OIL SEALS

1. Check:
 - bearings
Clean and lubricate the bearings, then rotate the inner race with your finger.
Rough movement → Replace.
2. Check:
 - oil seals
Damage/wear → Replace.

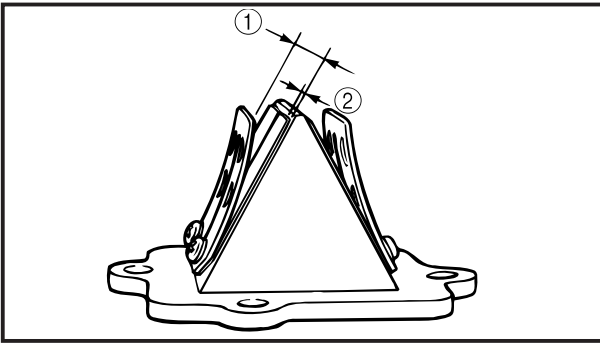

REED VALVE INSPECTION

1. Measure:

- Valve stopper height ①
Out of specification → Adjust stopper/Replace valve stopper.



Valve stopper height ①
6.0~6.4 mm (0.24~0.25 in)

2. Measure:

- Reed valve clearance ②
Out of specification → Replace reed valve.



Reed valve clearance ②
Less than 0.2 mm (0.0079 in)

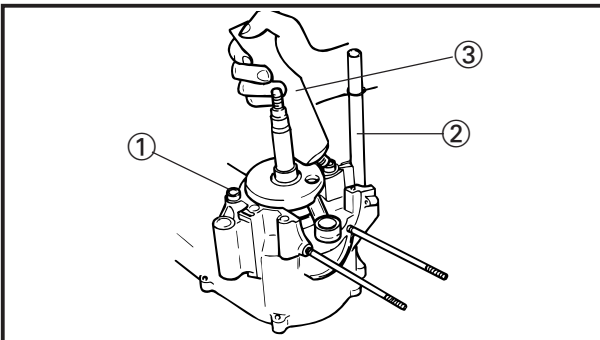

CRANKCASE (RIGHT) INSTALLATION

1. Install:

- Dowel pins ①
- Engine mount spacer ②

2. Apply:

- Sealant ③
To the mating surfaces of both case halves.



Quick gasket®:
ACC-1100-15-01

NOTE:

Do not allow any sealant to come into contact with the oil galley.

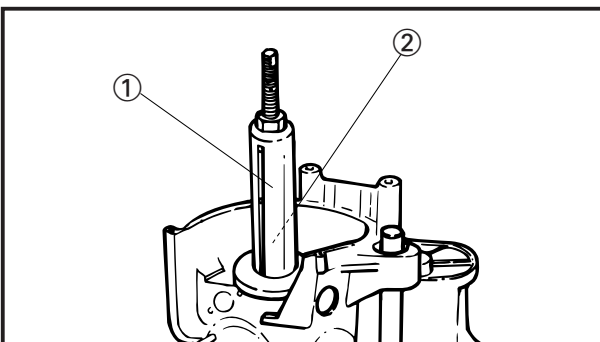

3. Attach:

- Crankshaft installing tool ①, ②



Crankshaft installation set ①
YU-90050
Crankshaft installer adapter
(M10) ②
YU-90062

CRANKCASE AND REED VALVE

ENG

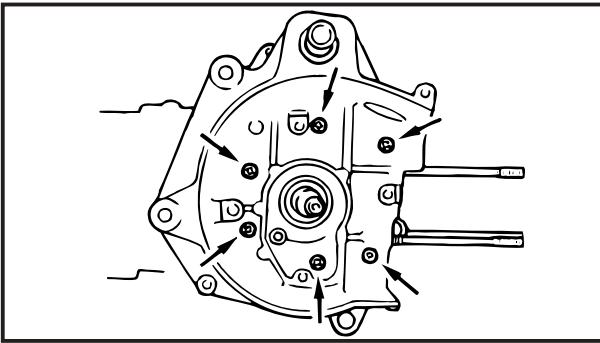

4. Tighten:
- Crankcase holding screws

 12 Nm(1.2 m.kg, 8.4 ft.lb)

NOTE: _____

Tighten the crankcase holding screws in stage, using a crisscross pattern.

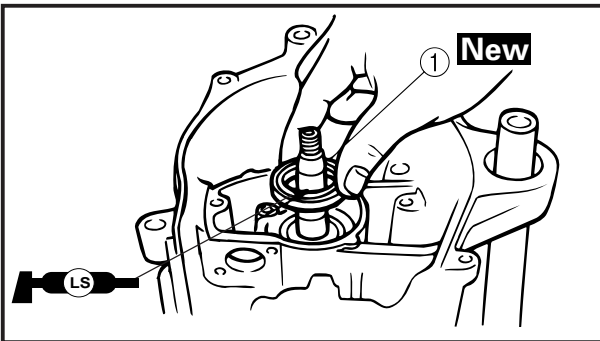

5. Check:
- Crankshaft operation
 - Unsmooth operation Repair.

6. Install:

- Oil seal (right crank case) ① **New**
- Apply grease on to oil seal lip.

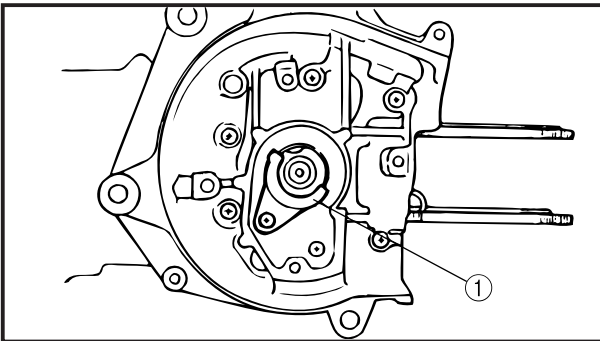

7. Install:

- Oil seal stopper plate ①

 9 Nm(0.9 m.kg, 6.5 ft.lb)

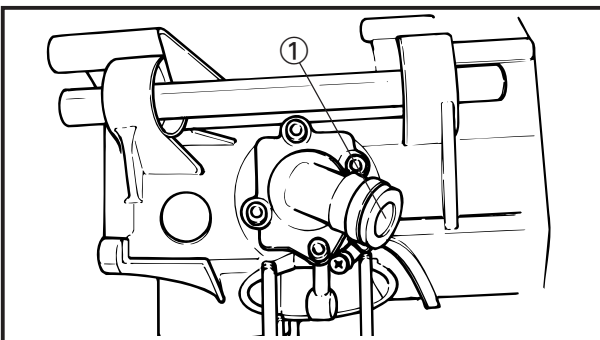

8. Install:

- Gasket
- Reed valve
- Intake manifold ①  11 Nm(1.1 m.kg, 8 ft.lb)



CRANKSHAFT

CRANKSHAFT

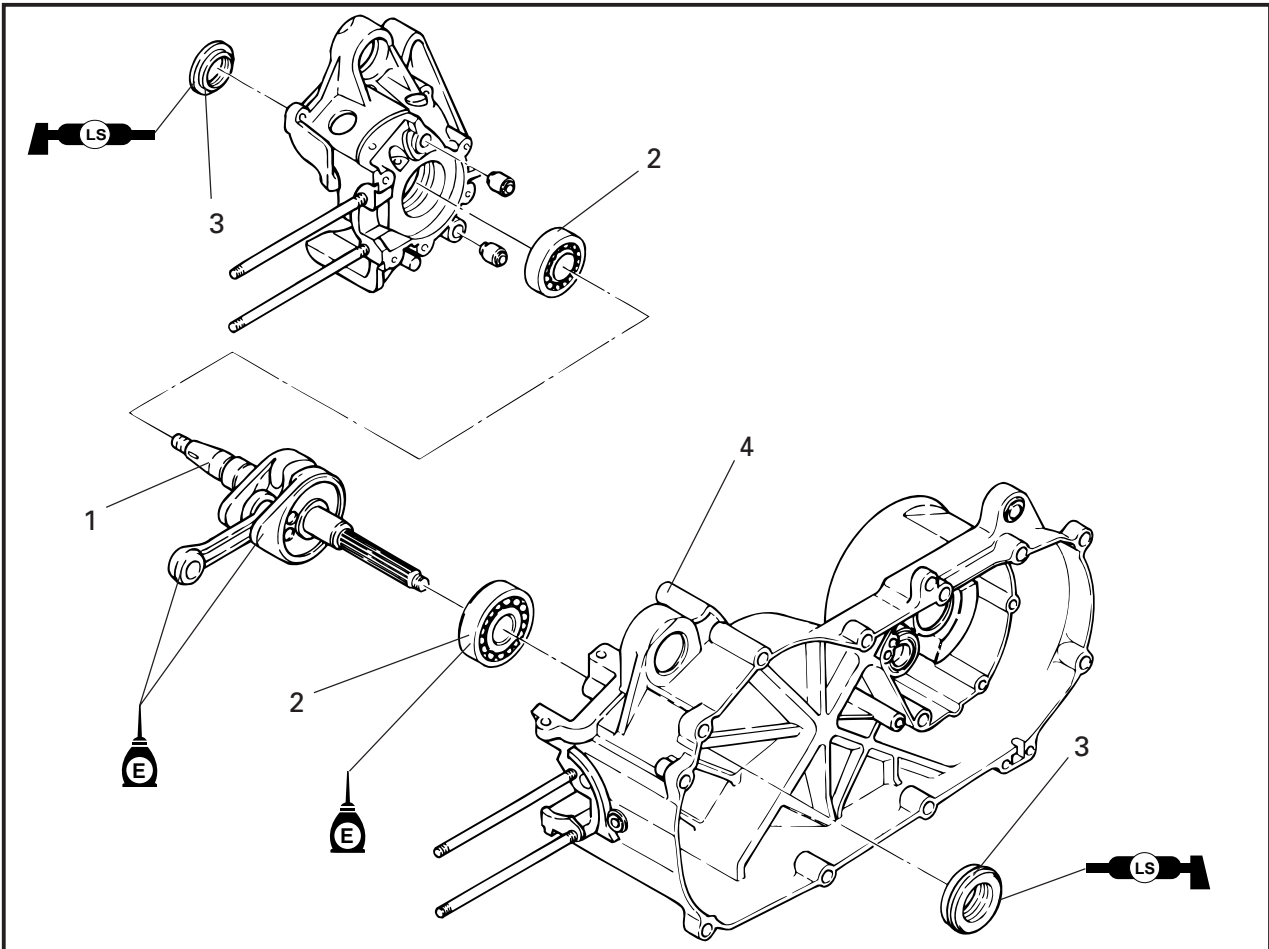

Order	Job name/Part name	Q'ty	Remarks
	Crankshaft removal Right crankcase removal		Remove the parts in order. Refer to "CRANK CASE AND REED VALVE" section.
1	Crankshaft	1	
2	Bearing	2	
3	Oil seal	2	
4	Crankcase cover (left)	1	Reverse the removal procedure for installation.

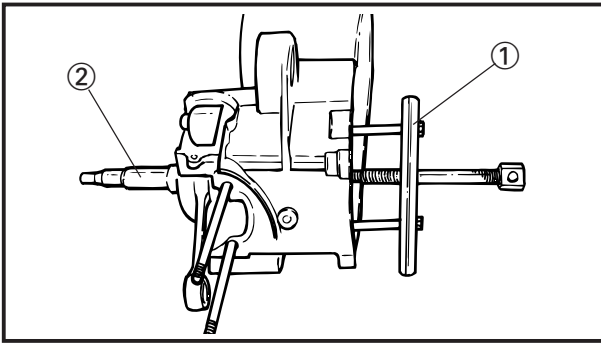

CRANKSHAFT REMOVAL

1. Attach:
 - Crankcase separating tool ①



Crankcase separating tool:
YU-01135-A

2. Remove:
 - Crankshaft ②

NOTE:

Make sure the crankcase separating tool is centered over the crankshaft assembly.

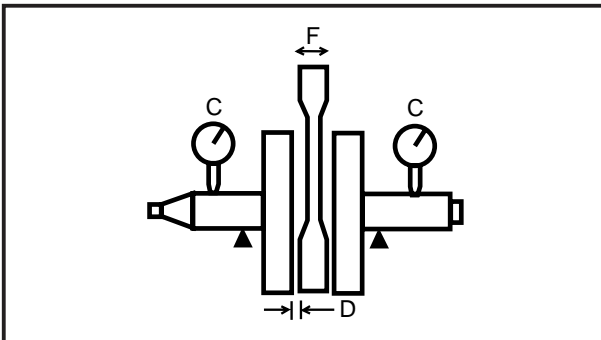

CRANKSHAFT INSPECTION

1. Measure:
 - Runout limit "C"
 - Connecting rod big end side clearance "D"
 - Small end free play limit "F"
Out of specification → Replace.
Use V-blocks, dial gauge and thickness gauge.



Runout limit "C":
0.03 mm (0.0012 in)
Connecting rod big end side clearance "D":
0.2 ~ 0.5 mm (0.0079 ~ 0.020 in)
Small end free play "F":
0.4 ~ 0.8 mm (0.016 ~ 0.031 in)

2. Inspect:
 - Bearings (crankshaft)
Spin the bearing inner race.
Excessive play/Roughness → Replace.
Pitting/Damage → Replace.

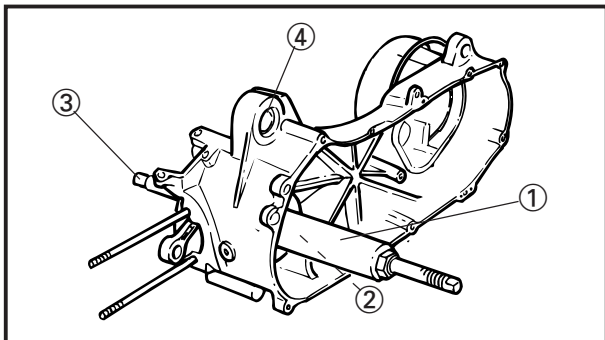

CRANKSHAFT INSTALLATION

1. Attach:
 - Crankshaft Installing Tool

	Crankshaft installation set ①
	YU-90050
	Crankshaft installer adapter (M10) ②
	YU-90062

2. Install:
 - Crankshaft ③
(to the crankcase ④)

CAUTION: _____

To avoid scratching the crankshaft and to ease the installation procedure, lubricate the oil seal lips with grease and each bearing with engine oil.

NOTE: _____

Hold the connecting rod at top dead center (TDC) with one hand while turning the nut of the crankshaft installing tool with the other. Turn the crankshaft installing tool until the crankshaft assembly bottoms against the bearing.

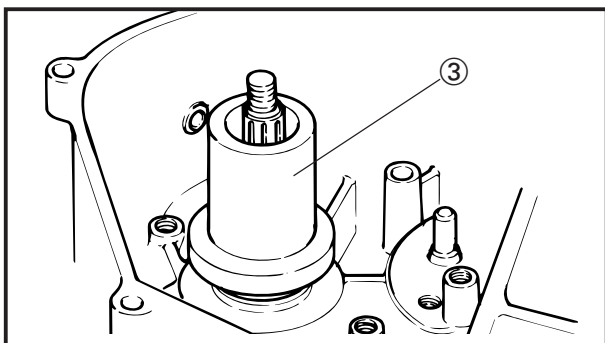
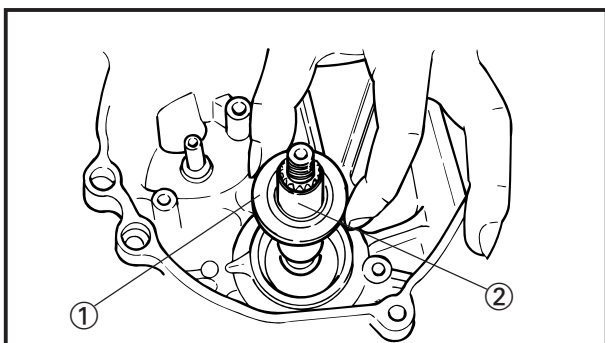

3. Install:
 - Oil seal ① **New**
 - Apply lithium soap base grease onto the oil seal lip.
 - Use the guide ② and seal driver ③ to install the oil seal

	Oil seal driver
	YM-1410
	Oil seal guide
	YM-1409



CARBURETION
CARBURETOR

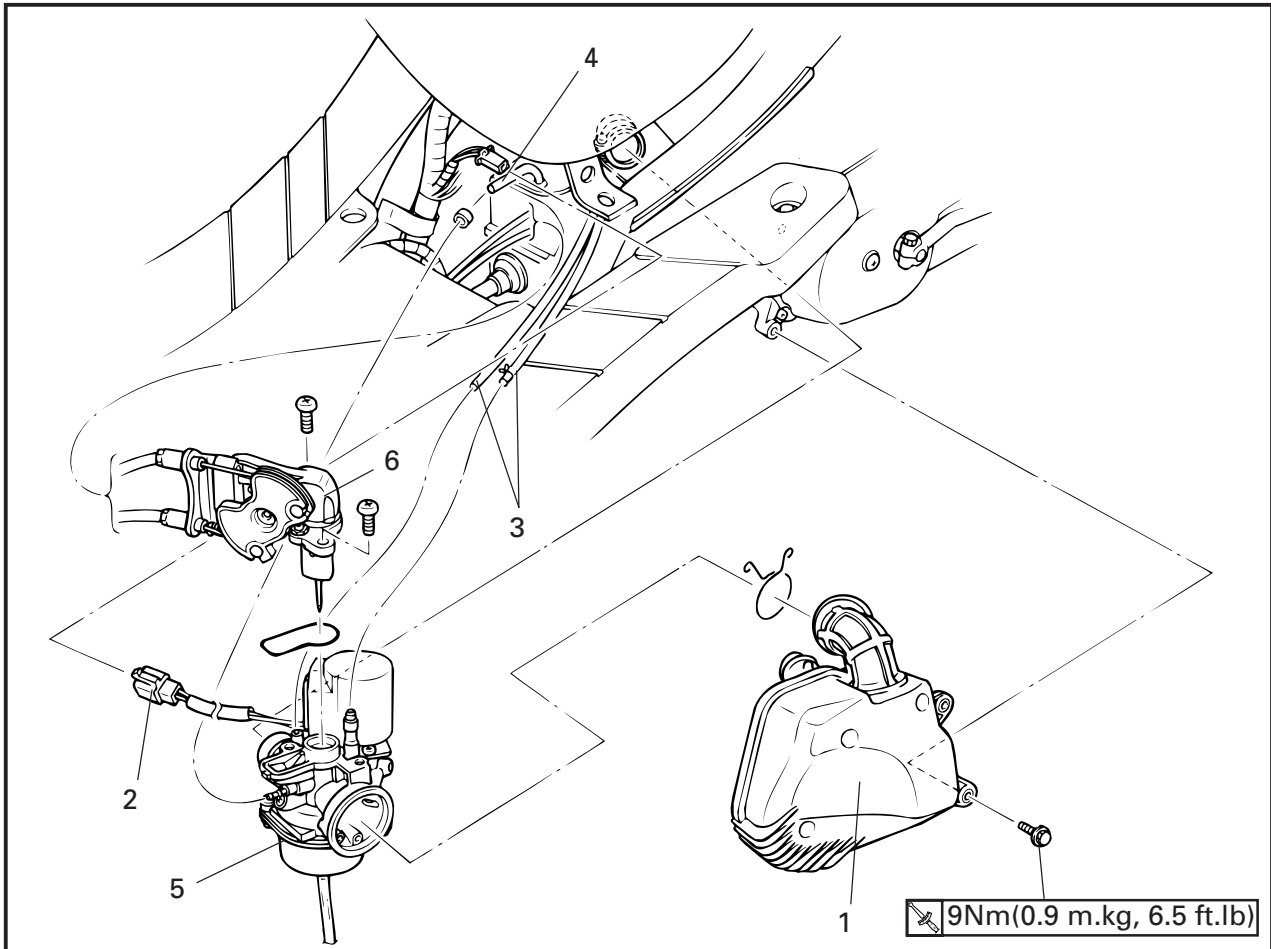

Order	Job name/Part name	Q'ty	Remarks
	Carburetor removal		Remove the parts in order.
	Battery box cover		Refer to "COVER AND PANEL" section in CHAPTER 3.
	Grip		
	End cover		
	Left/Right cover		
	Center cover		
1	Air cleaner case assembly	1	
2	Auto choke lead coupler	1	
3	Fuel hose/vacuum hose	1	
4	Oil delivery pipe assembly	1	
5	Carburetor	1	
6	Throttle cable	1	
			Reverse the removal procedure for installation.



CABURETOR DISASSEMBLY

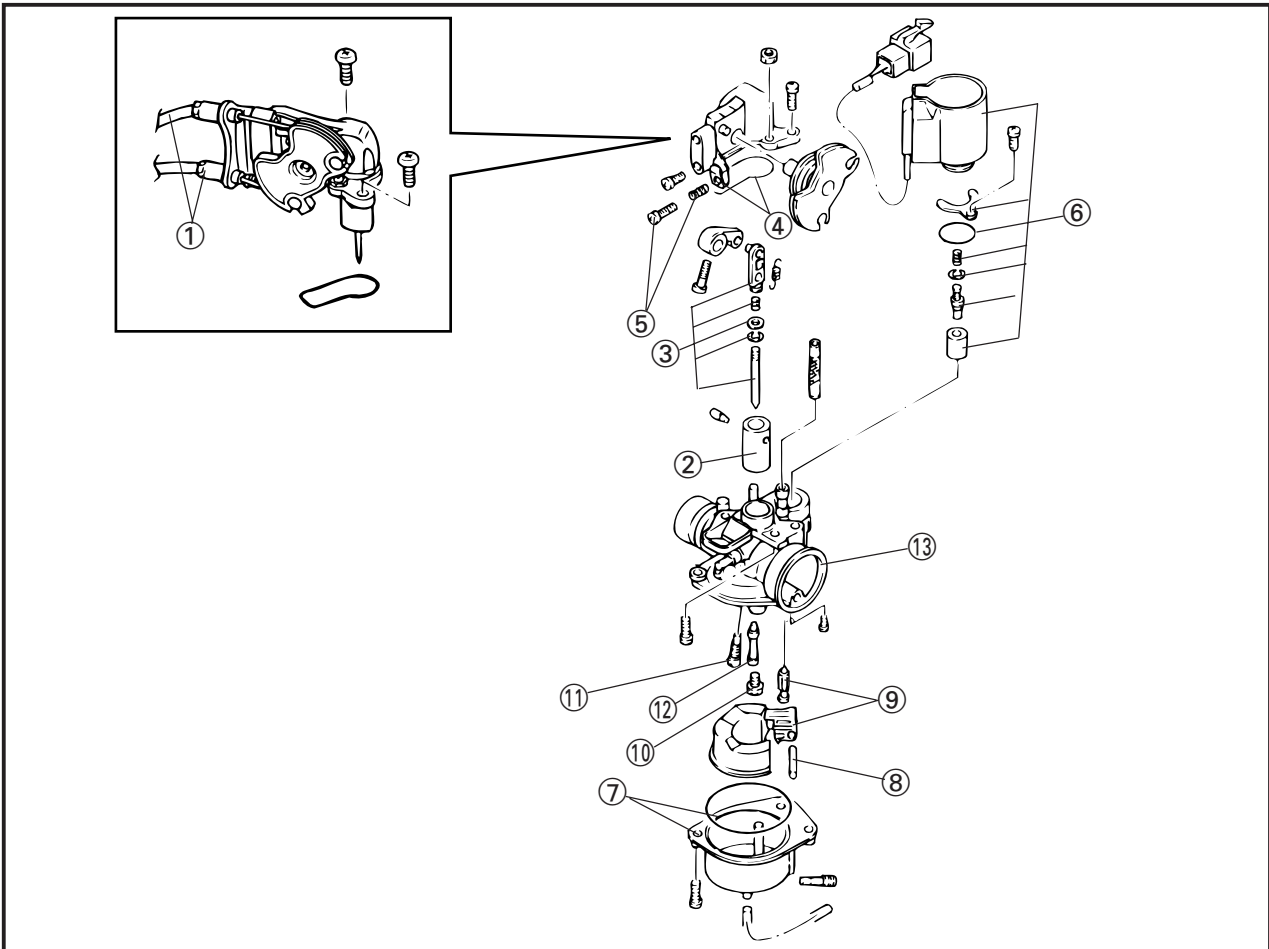

Order	Job name/Part name	Q'ty	Remarks
	Carburetor disassembly		Disassemble the parts in order.
①	Throttle cable	1	
②	Throttle valve	1	
③	Needle set	1	
④	Carburetor top cover/o-ring	1	
⑤	Throttle stop screw	1	
⑥	Auto choke unit assembly	1	
⑦	Float chamber/Seal ring	1/1	
⑧	Float pin	1	
⑨	Float/Needle valve	1	
⑩	Main jet	1	
⑪	Pilot jet	1	
⑫	Main nozzle	1	
⑬	Carburetor body	1	
			Reverse the removal procedure for installation.



CABURETOR INSPECTION

1. Check:
 - Carburetor body
 - Float chamber
 - Jet housing
 - Cracks/damage → Replace.

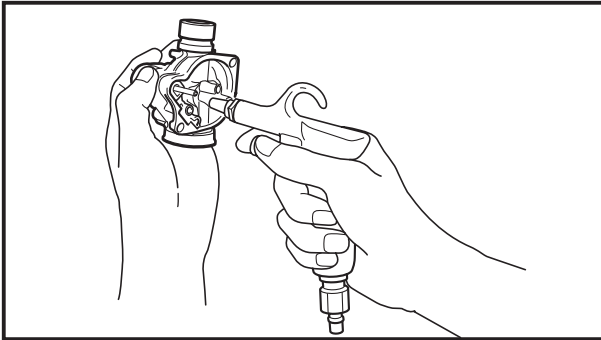

2. Check:
 - Fuel passages
 - Obstruction → Clean.

- a. Wash the carburetor in a petroleum-based solvent. Do not use any caustic carburetor cleaning solution.
- b. Blow out all of the passages and jets with compressed air.

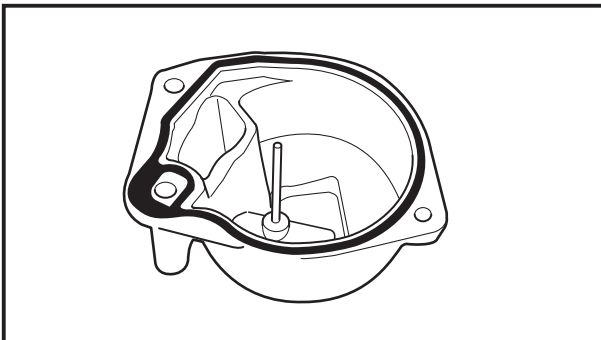

3. Check:
 - Float chamber body
 - Dirt → Clean.
4. Check:
 - Float chamber rubber gasket
 - Cracks/damage/wear → Replace.
5. Check:
 - Float
 - Damage → Replace.

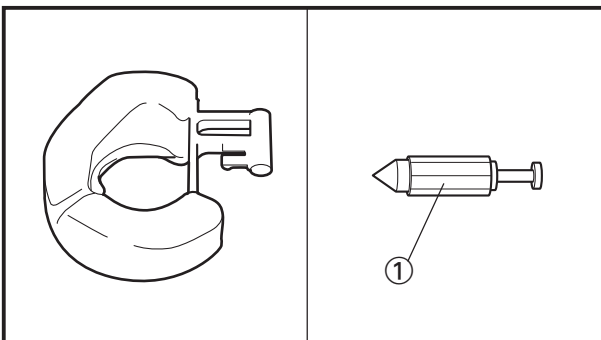

6. Check:
 - Needle valve ①
 - Damage/obstruction/wear → Replace the needle valve.

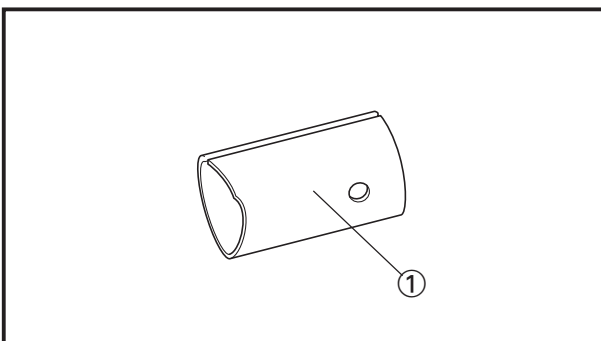

7. Check:
 - Throttle valve ①
 - Damage/scratches/wear → Replace.

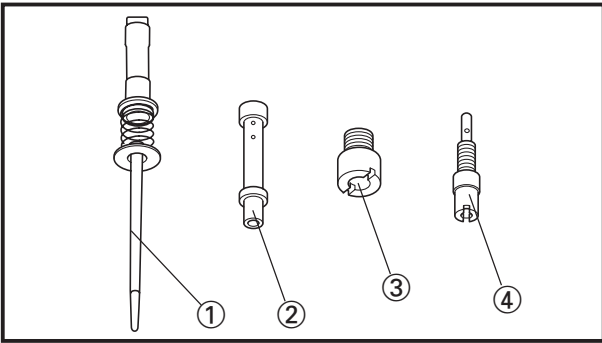

8. Check:

- Jet needle kit ①
- Main nozzle ②
- Main jet ③
- Pilot jet ④

Bends/damage/wear → Replace.

Obstruction → Clean.

Blow out the jets with compressed air.

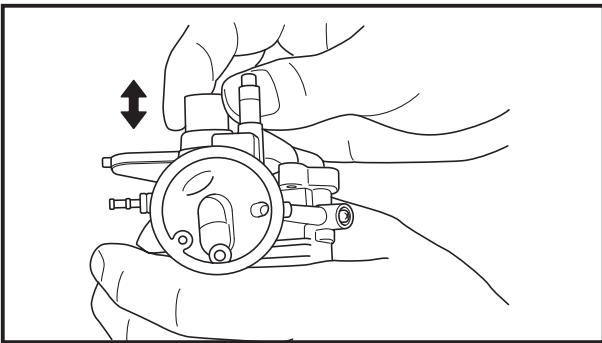

9. Check:

- Throttle valve movement
Insert the throttle valve into the carburetor
Body and move it up and down.
Tightness → Replace the piston valve.

10. Check:

- Vacuum hose
- Fuel hose
Cracks/damage/wear → Replace.
Obstruction → Clean.
Blow out the hoses with compressed air.

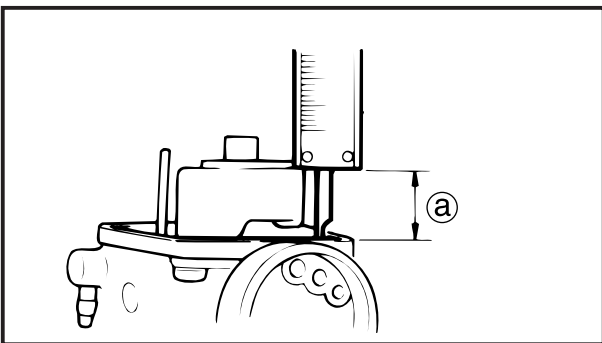

11. Measure:

- Float height ①
Out of specification → Inspect needle valve, float and valve seat.

	<p>Float height: 15 ~ 17 mm (0.59 ~ 0.67 in)</p>
--	--

Float height measurement steps:

- Install the needle valve, float and float pin to the carburetor body.
- Hold the carburetor in an upside down position.
- Measure the distance between the mating surface of the float chamber (gasket removed) and top of the float using a gauge.



NOTE: _____

The float arm should be resting on the needle valve, but not compressing the needle valve.

- If the float height is not within specification, inspect the needle valve, float and valve seat.
- If it is worn, replace it.

NOTE: _____

The float height is properly adjusted at the Yamaha factory. Never attempt to adjust it.

CARBURETOR ASSEMBLY

To assemble the carburetor, reverse the disassembly procedures.

Note the following points.

CAUTION: _____

- **Before reassembling, wash all parts in clean gasoline.**
 - **Always use a new gasket.**
-

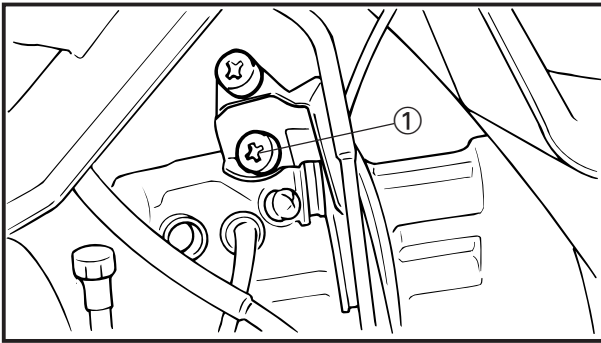

1. Install:
 - Throttle cable ①

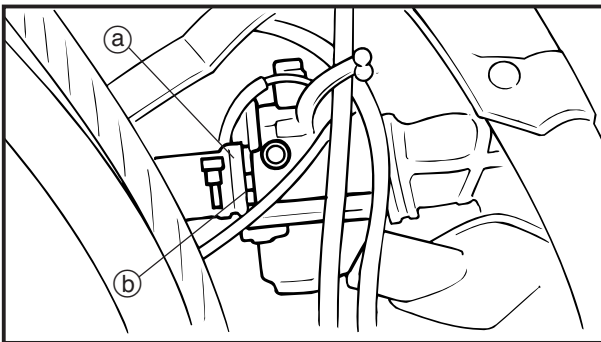

2. Install:
 - Carburetor assembly

NOTE: _____
Align the projection (a) with the projections (b).

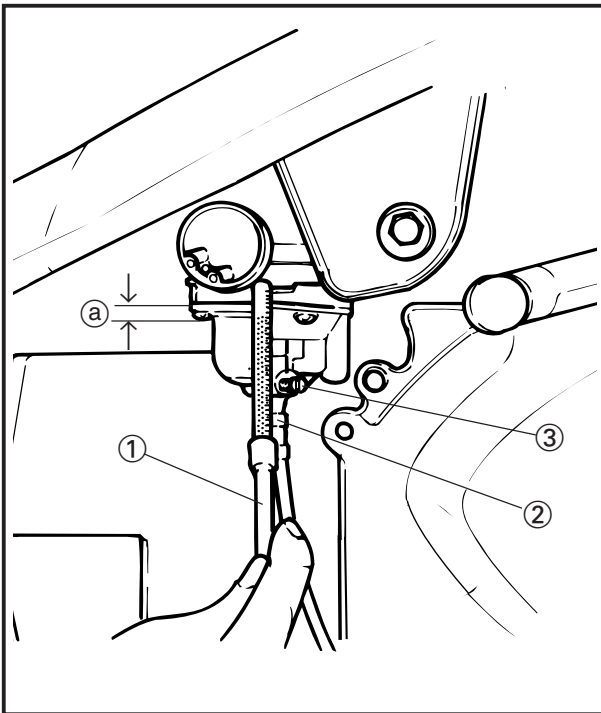

FUEL LEVEL ADJUSTMENT

1. Measure:
 - Fuel level (a)
 Out of specifications → Adjust.

	Fuel level (a): 3.0~4.0 mm (0.12~0.16 in) (Below the float chamber line)
--	--

Measurement steps:

- Place the scooter on a level surface.
- Use a garage jack under the engine to ensure that the carburetor is positioned vertically.
- Connect the fuel level gauge ① to the drain pipe ②.

	Fuel level gauge: YM-01312-A
--	---------------------------------

- Loosen the drain screw ③.
- Measure the fuel level (a) with the gauge.
- If the fuel level is incorrect, adjust the fuel level:
- Remove the float chamber float and the needle valve.
- Inspect the needle valve.
- If it is worn, replace it.

- Install the carburetor.
- Recheck the fuel level.

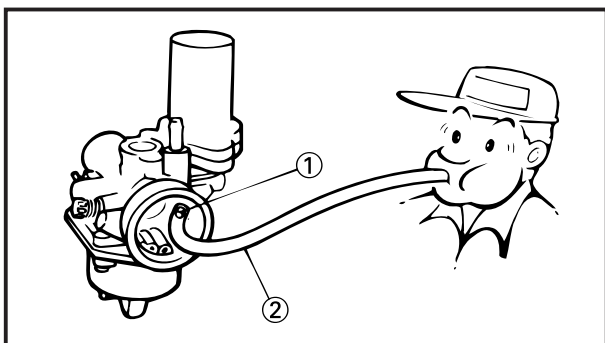

AUTO CHOKE INSPECTION
(Ambient temperature lower than 45°C)

1. Remove:
 - Carburetor
2. Inspect:
 - Autochoke unit

Connect a suitable hose ② to the starter ①, and blow it with the mouth etc.
Possible→Good condition.
Impossible→Replace auto choke unit.

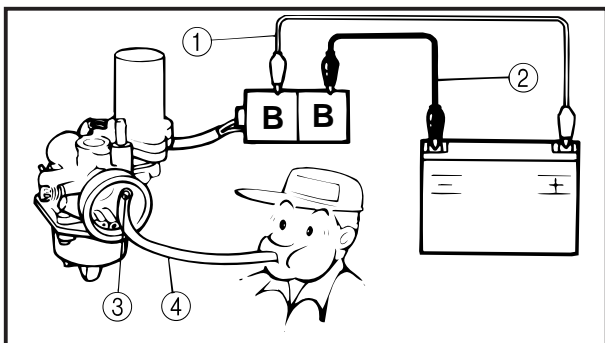

3. Inspect:
 - Auto choke unit (with battery)

Inspection and adjustment steps:

- Connect auto choke unit leads to the 12 V battery for 5 minutes.
Black terminal→12 V battery (+) ①
Black terminal→12 V battery (-) ②
- Connect a suitable hose ④ to the starter ③, and blow it with the mouth etc.
Possible→Replace auto choke unit.
Impossible→Good condition.



FUEL COCK INSPECTION

1. Stop the engine.
2. Remove:
 - Rear carrier
 - Tail cover
 - Left side cover
 - Battery box cover
 Refer to "COVER AND PANEL" section in chapter 3.
3. Inspect:
 - Fuel cock

Fuel cock inspection steps:

- Disconnect the fuel hose ①.
- Place the receptacle under the fuel hose end.
- If fuel stops flowing out in a few seconds, the fuel cock is in good condition. If not, clean or replace the fuel cock.
- Disconnect the vacuum hose ② and breathe in the vacuum hose with the mouth etc. for vacuum .
- If fuel flows out of the fuel hose under vacuum and stops under non-vacuum, the fuel cock is in good condition. If not, clean or replace the vacuum hose, fuel hose and fuel cock.

4. Install:
 - Battery box cover
 - Left side cover
 - Tail cover
 - Rear carrier

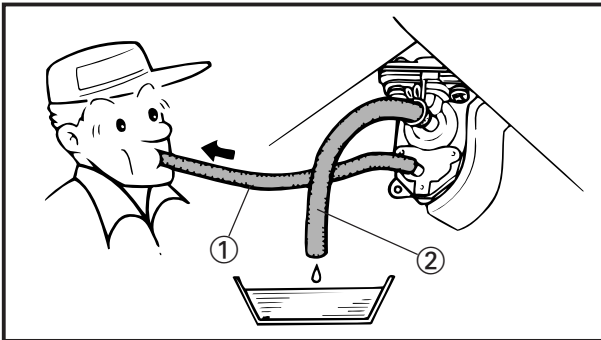

CHASSIS
FRONT WHEEL AND BRAKE DISC

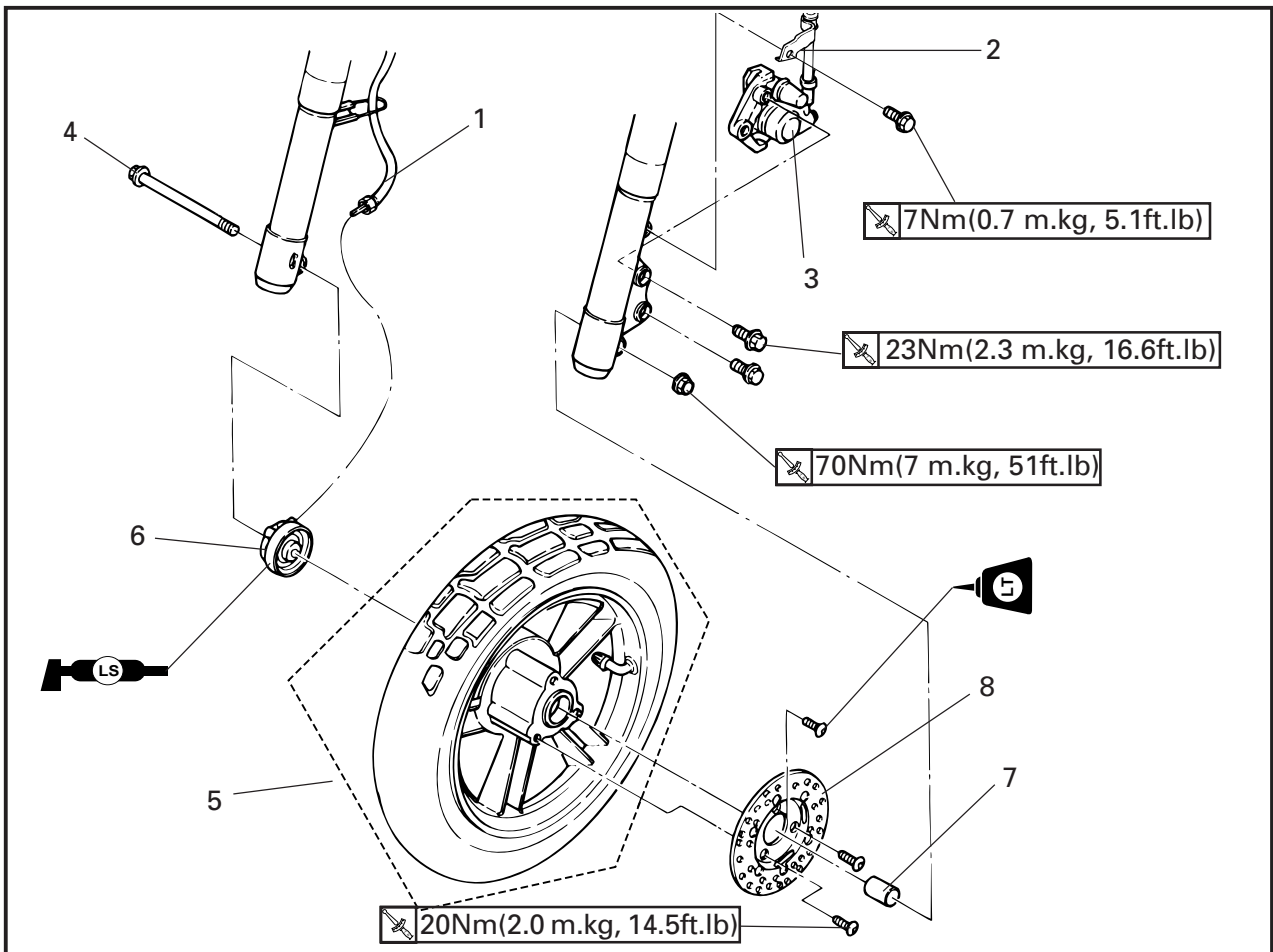

Order	Job name/Part name	Q'ty	Remarks
	Front wheel and brake disc removal		Remove the parts in order. ⚠ WARNING Securely support the scooter so there is no danger of it falling over.
1	Speedometer cable	1	Refer to "FRONT WHEEL INSTALLATION" section.
2	Front brake hose holder	1	
3	Brake caliper	1	
4	Wheel axle	1	
5	Front wheel assembly	1	
6	Gear unit assembly	1	
7	Collar	1	Refer to "FRONT WHEEL ASSEMBLY" section.
8	Brake disc	1	Reverse the removal procedure for installation.

FRONT WHEEL DISASSEMBLY

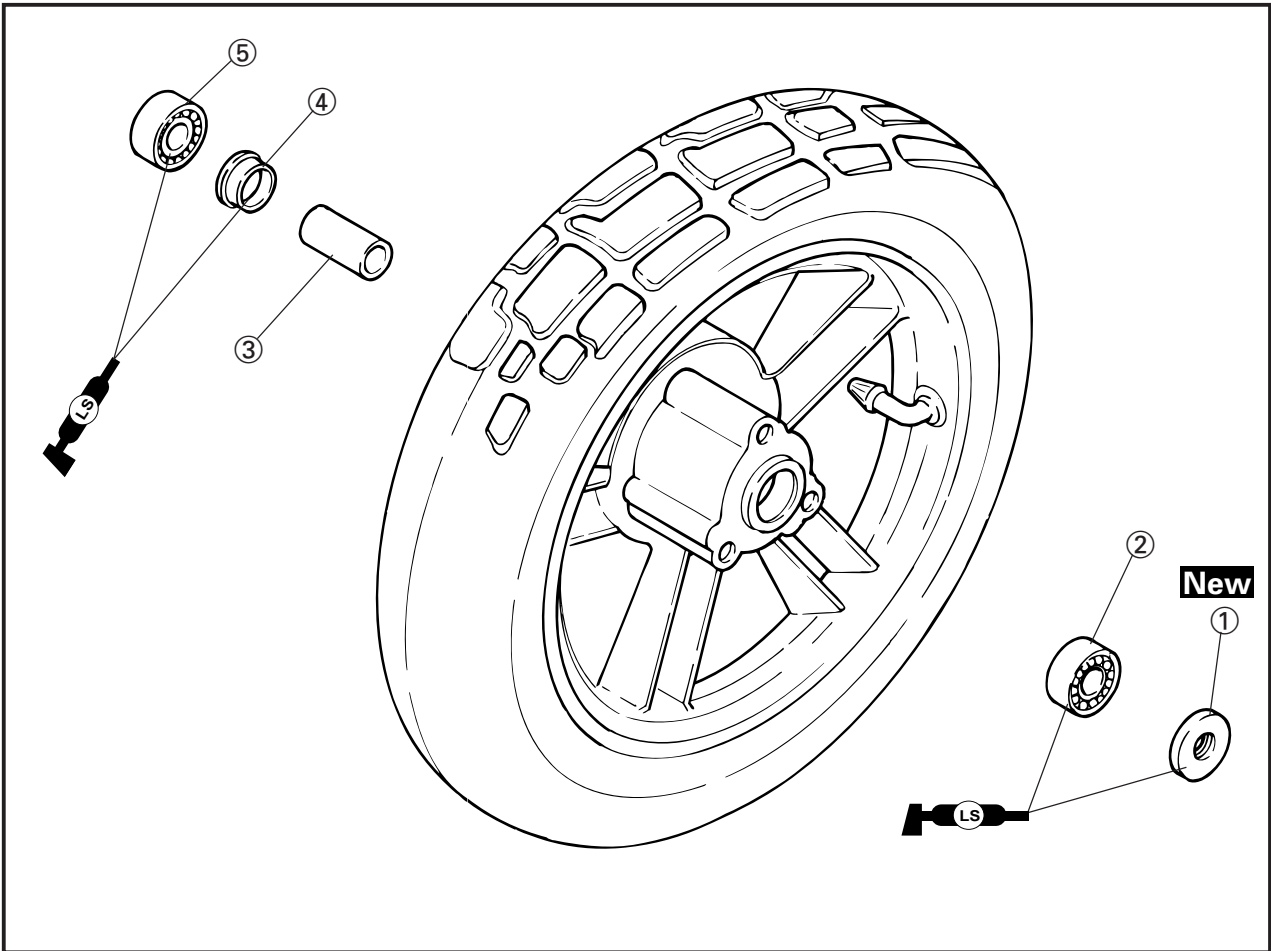

Order	Job name/Part name	Q'ty	Remarks
	Front wheel disassembly		Remove the parts in order.
①	Oil seal	1	Refer to "FRONT WHEEL DISASSEMBLY/ASSEMBLY" section.
②	Bearing	1	
③	Collar	1	
④	Spacer	1	
⑤	Bearing	1	
			Reverse the removal procedure for installation.

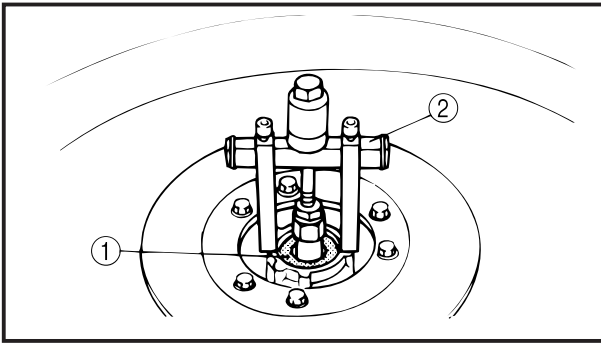

YP

FRONT WHEEL DISASSEMBLY

1. Remove:

- Bearing ①
- Spacer

Remove the bearing using a general bearing puller ②.

CAUTION:

Handle the wheel with care not to damage the brake disc. If the brake disc is damaged, replace.

YP700020

FRONT WHEEL INSPECTION

1. Inspect:

- Front wheel axle
(by rolling it on a flat surface)
Bends → Replace.

WARNING

Do not attempt to straighten a bent wheel axle.

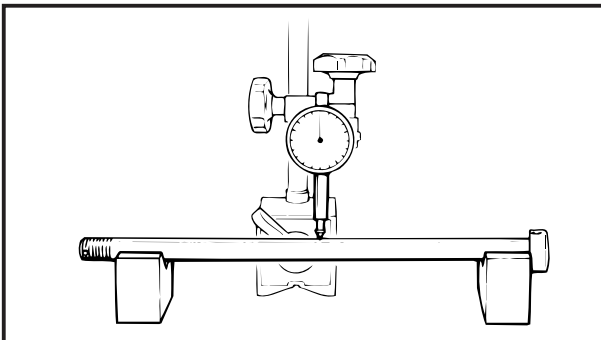

Wheel axle bending limit:
0.25 mm (0.0098 in)

2. Inspect:

- Front tire
Wear/damage → Replace.
Refer to "TIRE INSPECTION" in CHAPTER 3.
- Front wheel
Refer to "WHEEL INSPECTION" in CHAPTER 3.

3. Measure:

- Front wheel runout
Over the specified limits → Replace.



Front wheel runout limits:
Radial ①: 1.0 mm (0.04 in)
Lateral ②: 1.0 mm (0.04 in)

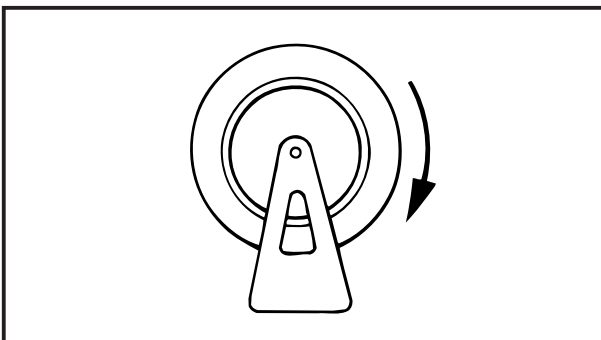
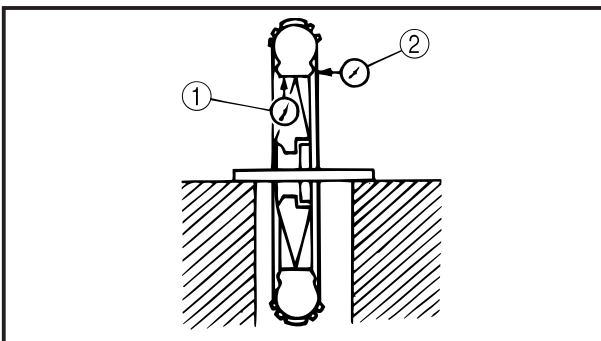

4. Inspect:

- Front wheel bearings
Bearings allow free play in the wheel hub or the wheel does not turn smoothly → Replace.
- Oil seals
Wear / damage → Replace.

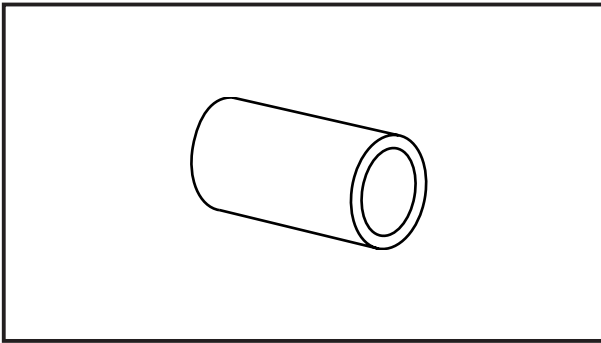

4. Inspect:
 - Collar

Grooved wear→Replace the collar and the oil seal as a set.

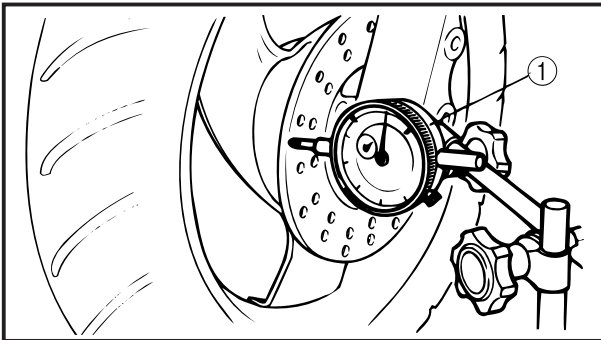

YP....

BRAKE DISC INSPECTION

1. Measure:
 - Brake disc deflection①

	Maximum deflection: 0.15 mm (0.0059 in)
---	--

Out of specification→Replace.

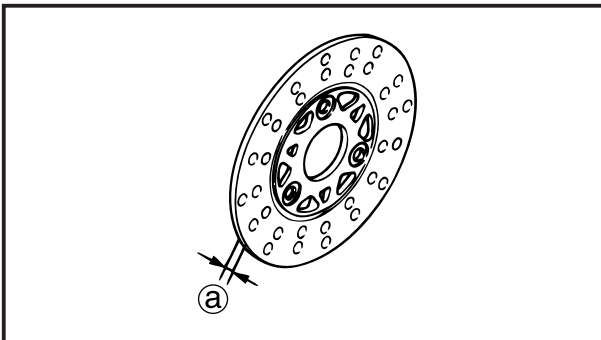

2. Measure:
 - Brake disc thickness②

	Brake disc thickness: 4.0 mm (0.16 in)
	Minimum thickness: 3.5 mm(0.14 in)

Out of specification→Replace.

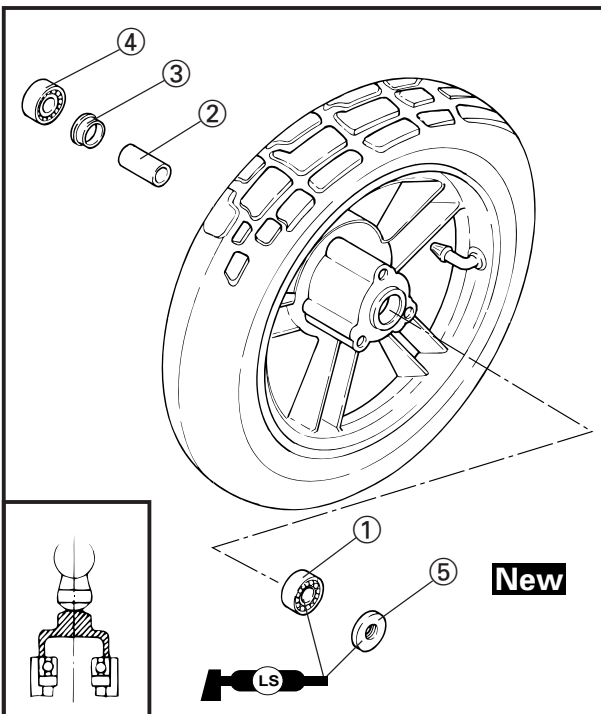

YP....

FRONT WHEEL ASSEMBLY

1. Install:
 - Bearing ①
 - Collar ②
 - Spacer ③
 - Bearing ④
 - Oil seal ⑤

NOTE:

- Apply the lithium soap base grease on the bearing and oil seal lip when installing.
- Use a socket that matches the outside diameter of the race of the bearing.
- Always use a new oil seal.
- Install the oil seal with its manufacturer's marks or numbers facing outward.

CAUTION:

Do not strike the inner race of balls of the bearing. Contact should be made only with the outer race.

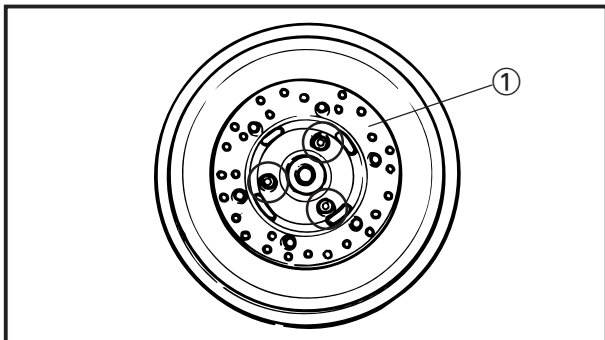

2. Install:
- Brake disc ①  20 Nm(2.0 m.kg, 14 ft.lb)

NOTE: _____
Tighten the bolts (brake disc) in stage using a crisscross pattern.

EB700030

FRONT WHEEL INSTALLATION

Reverse the "REMOVAL" procedure.
Note the following points.

1. Lubricate:
- Front wheel axle
 - Bearings
 - Oil seal (lips)
 - Drive/driven gear (speedometer)

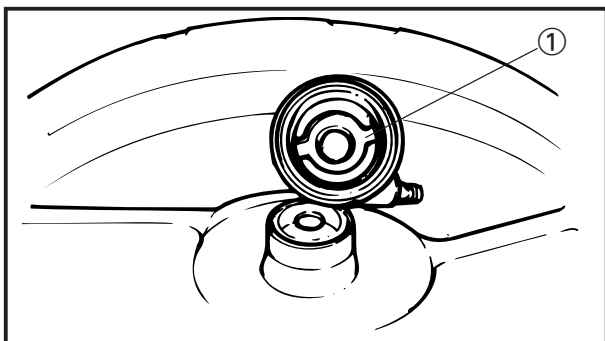

 Recommended lubricant:
Lithium soap base grease

2. Install:
- Speedometer gear unit ①

NOTE: _____
Make sure that the wheel hub and the speedometer gear unit are installed with the three projections meshed into the two slots.

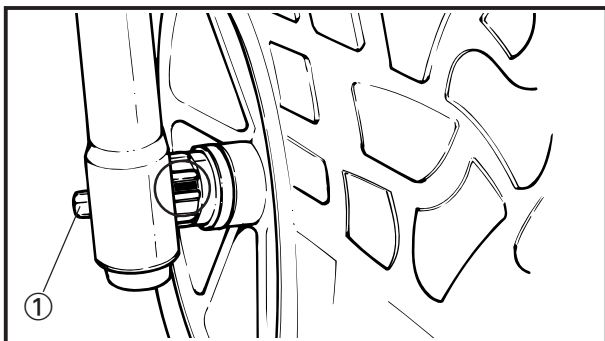

3. Install:
- Front wheel

NOTE: _____
Make sure that the slot in the speedometer gear unit fits over the stopper on the front fork outer tube.

4. Tighten:
- Front wheel axle ①
 - Axle nut (front wheel axle)  70 Nm(7.0 m.kg, 51 ft.lb)

CAUTION: _____
Before tightening the axle nut, stroke the front fork several times to check for proper fork operation.

WARNING _____
Make sure that the brake hose is routed properly.

YP700040

WHEEL STATIC BALANCE ADJUSTMENT

NOTE: _____

- After replacing the tire and/or rim, the wheel static balance should be adjusted.
- Adjust the front wheel static balance with the brake disc installed.

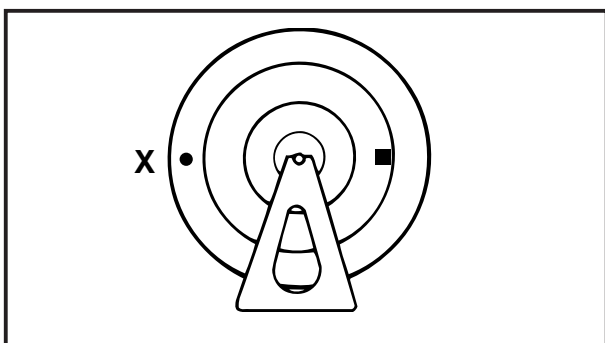
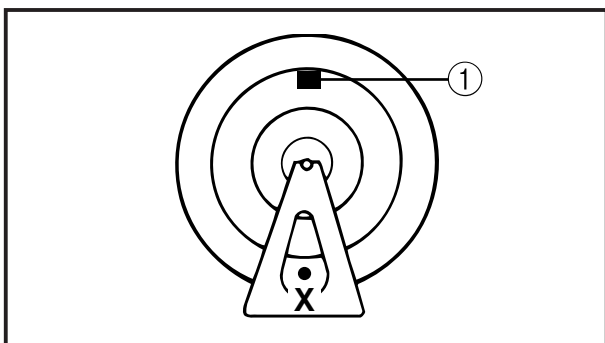
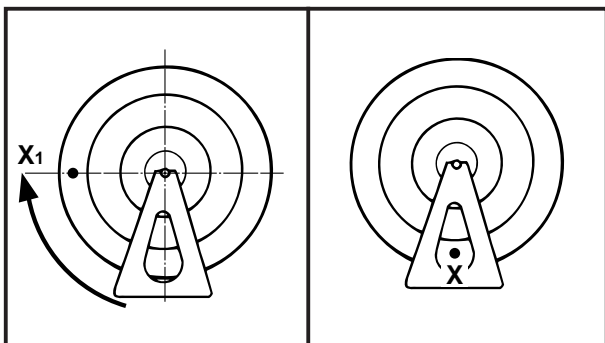
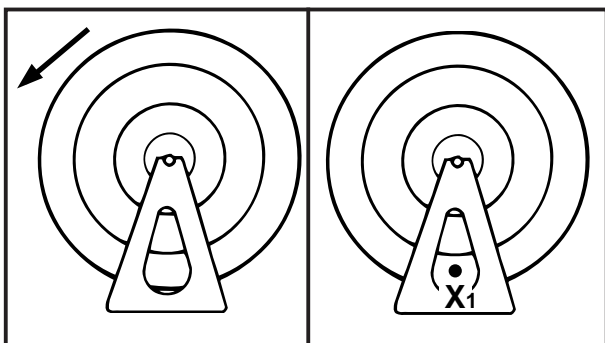

1. Remove:
 - Balancing weight
2. Set:
 - Wheel
(on a suitable stand)
3. Find:
 - Heavy spot

Procedure:

- a. Spin the wheel and wait for it to rest.
- b. Put an "X1" mark on the wheel's bottom spot.
- c. Turn the wheel so that the "X1" mark is 90° up.
- d. Release the wheel and wait for it to rest. Put an "X2" mark on the wheel's bottom spot.
- e. Repeat the above b., c., and d. several times until all marks come to the same spot.
- f. This spot is the wheel's heavy spot "X".

4. Adjust:
 - Wheel static balance

Adjusting steps:

- Install a balancing weight ① on the rim exactly opposite to the heavy spot "X".

NOTE: _____

Start with the smallest weight.

- Turn the wheel so that the heavy spot is 90° up.
- Check that the heavy spot is at rest there. If not, try another weight until the wheel is balanced.

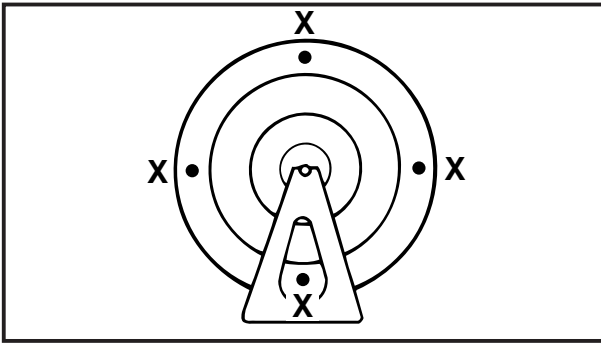

5. Check:

- Wheel static balance

Checking steps:

- Turn the wheel so that it comes to each point as shown.
 - Check that the wheel is at rest at each point.
- If not, readjust the front wheel static balance.

FRONT BRAKE
BRAKE PAD

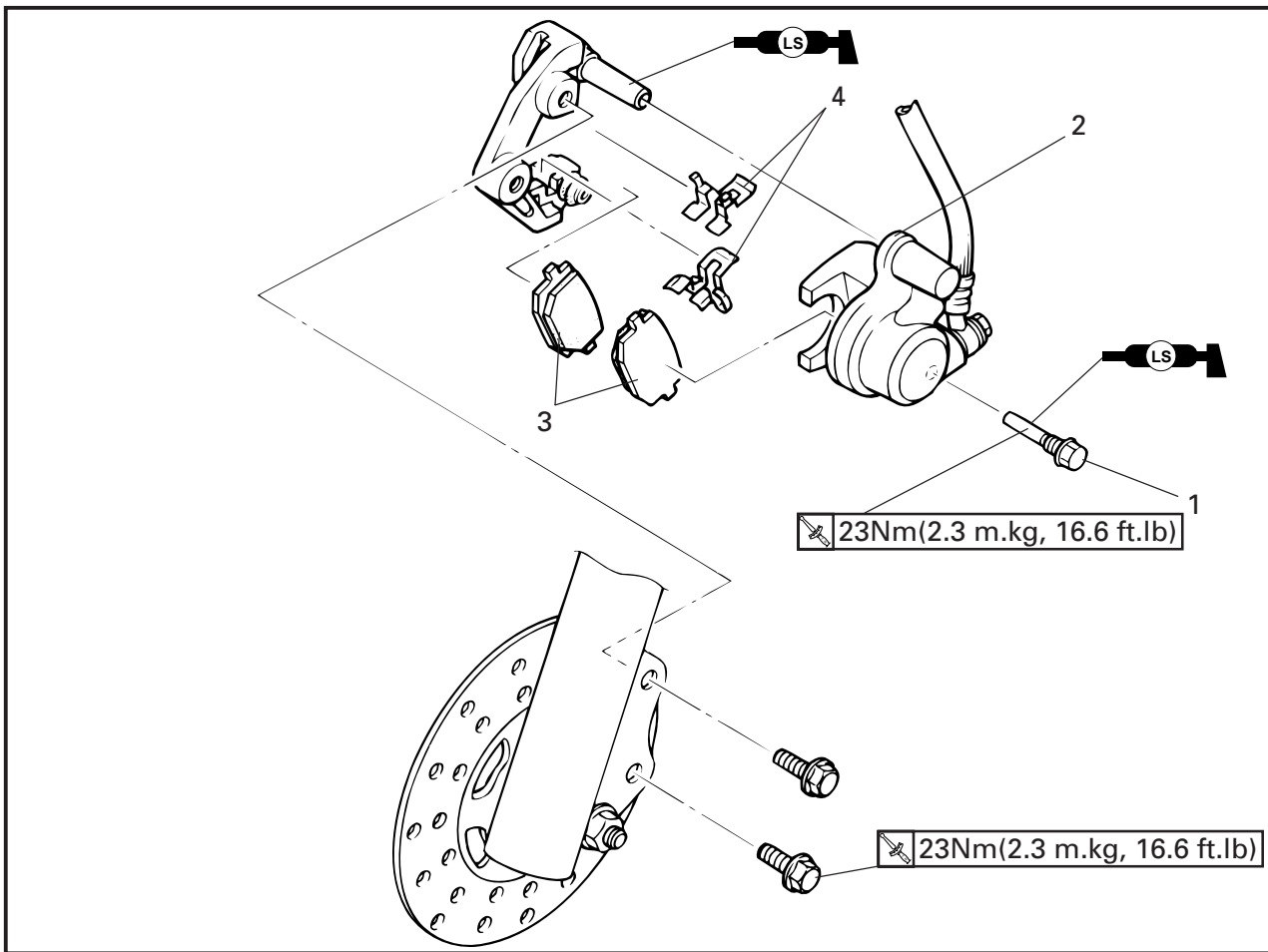

Order	Job name/Part name	Q'ty	Remarks
	Brake pad removal		Remove the parts in order.
1	Caliper support bolt	1	Refer to " BRAKE PAD REPLACEMENT " section .
2	Caliper	1	
3	Brake pad	2	
4	Pad spring	2	
			Reverse the removal procedure for installation.

**CAUTION:**

Disc brake components rarely require disassembly. **DO NOT:**

- Disassembly components unless absolutely necessary.
- Use solvents in internal brake component.
- Use contaminated brake fluid for cleaning.
- Use only clean fluid.
- Allow brake fluid to come in contact with the eyes otherwise eye injury may occur.
- Allow brake fluid to contact painted surfaces or plastic parts otherwise damage may occur.
- Disconnect any hydraulic connection otherwise the entire system must be disassembled, drained, cleaned, and then properly filled and bled after reassembly.

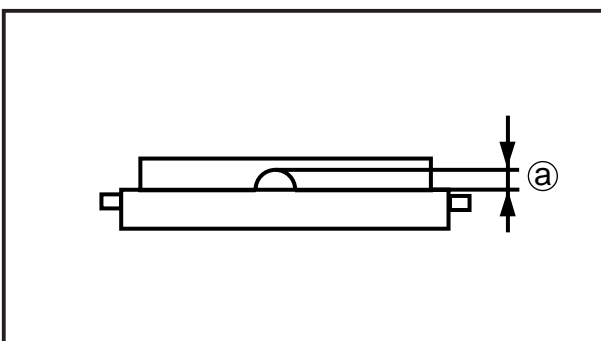
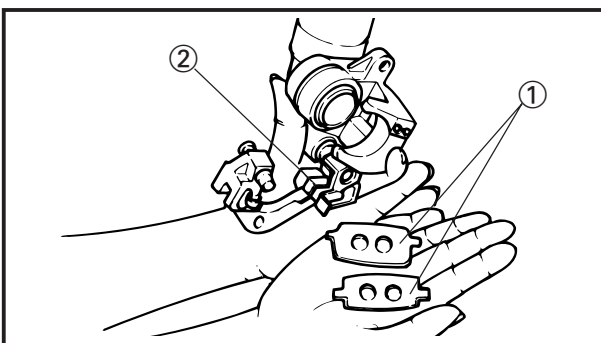
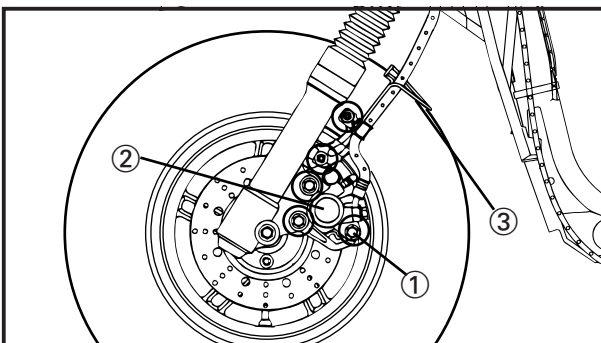
**BRAKE PAD REPLACEMENT****NOTE:**

It is not necessary to disassemble the brake caliper and brake hose to replace the brake pads.

1. Loosen:
 - Retaining bolt ①
2. Remove:
 - Brake caliper ②
 - Holder (brake hose) ③
3. Remove:
 - Retaining bolt
 - Pads ①
 - Pad spring ②

NOTE:

- Replace the pad spring if the pad replacement is required.
- Replace the pads as a set if either is found to be worn to the wear limit.





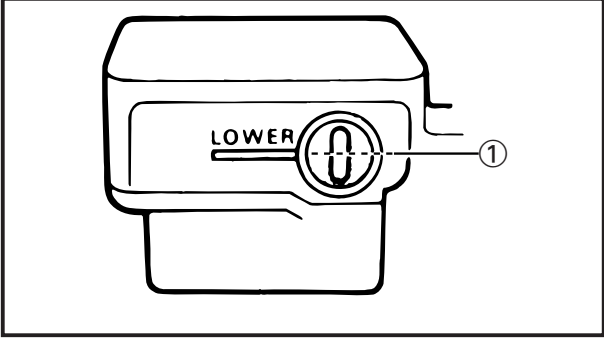
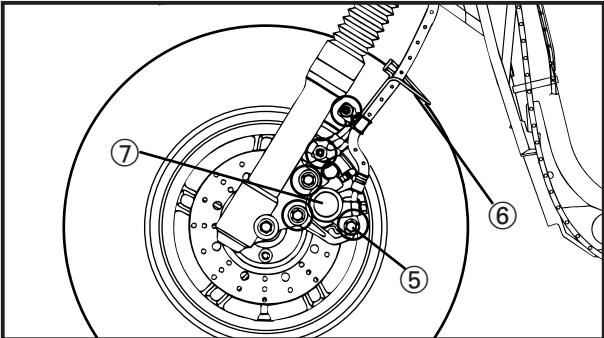
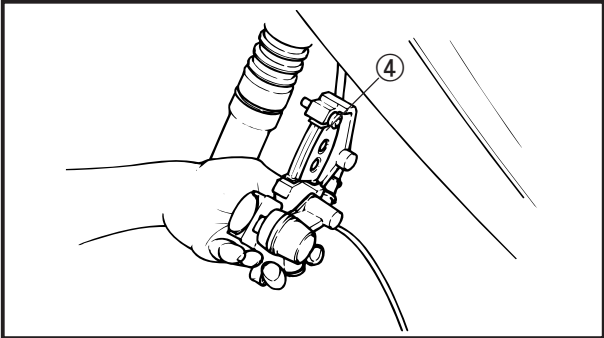
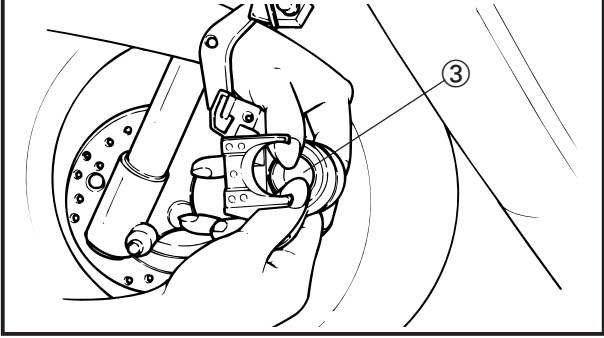
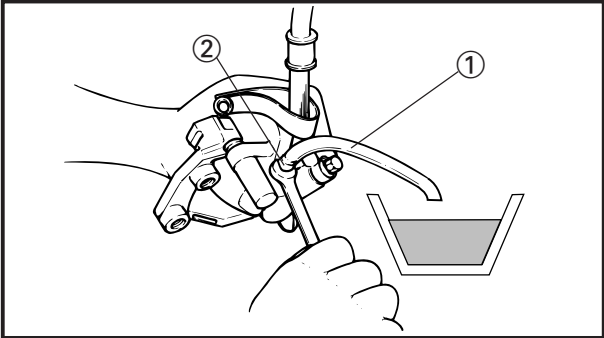

Wear limit (a):
0.8 mm (0.03 in)



4. Install:
- Pad springs
 - Brake pads (new)

Installation steps:

- Connect a suitable hose (1) tightly to the caliper bleed screw (2). Then, place the other end of this hose into an open container.
- Loosen the caliper bleed screw and push the piston (3) into the caliper by your finger.
- Tighten the caliper bleed screw.
 -  6 Nm (0.6 m.kg, 4.3 ft.lb)
- Install the pad spring (new) and brake pad (new) (4)
- Tighten retaining bolt (5)
 -  23 Nm (2.3 m.kg, 16.6 ft.lb)
- Install brake hose holder (6)
 -  7 Nm (0.7 m.kg, 5.15 ft.lb)
- Install caliper (7)
 -  23 Nm (2.3 m.kg, 16.6 ft.lb)

5. Inspect:
- Brake fluid level
Refer to the "BRAKE FLUID INSPECTION" section in the CHAPTER 3.
 - ① "LOWER" level line



6. Check:
 - Brake lever operation
A softy or spongy feeling Bleed→brake system.
Refer to “ AIR BLEEDING ” section in the CHAPTER 3.

MASTER CYLINDER

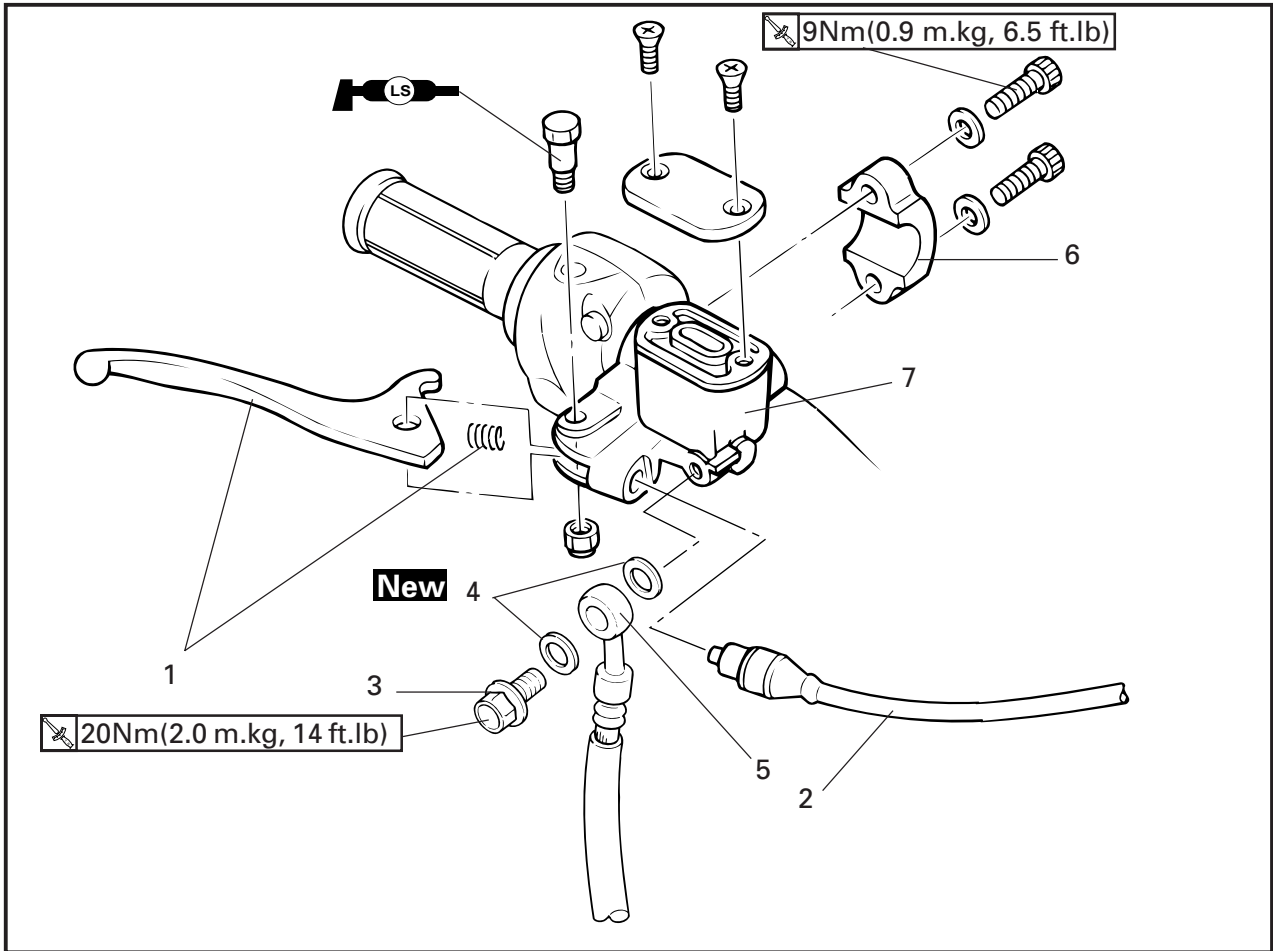

Order	Job name/Part name	Q'ty	Remarks
	Master cylinder removal Drain the brake fluid		Remove the parts in order. Refer to "BRAKE FLUID REPLACEMENT" section in CHAPTER 3.
1	Brake lever/compression spring	1/1	Refer to "MASTER CYLINDER INSTALLATION" section.
2	Brake switch	1	
3	Union bolt	1	
4	Copper washer	2	
5	Brake hose	1	
6	Master cylinder bracket	1	
7	Master cylinder	1	
			Reverse the removal procedure for installation.

MASTER CYLINDER DISASSEMBLY

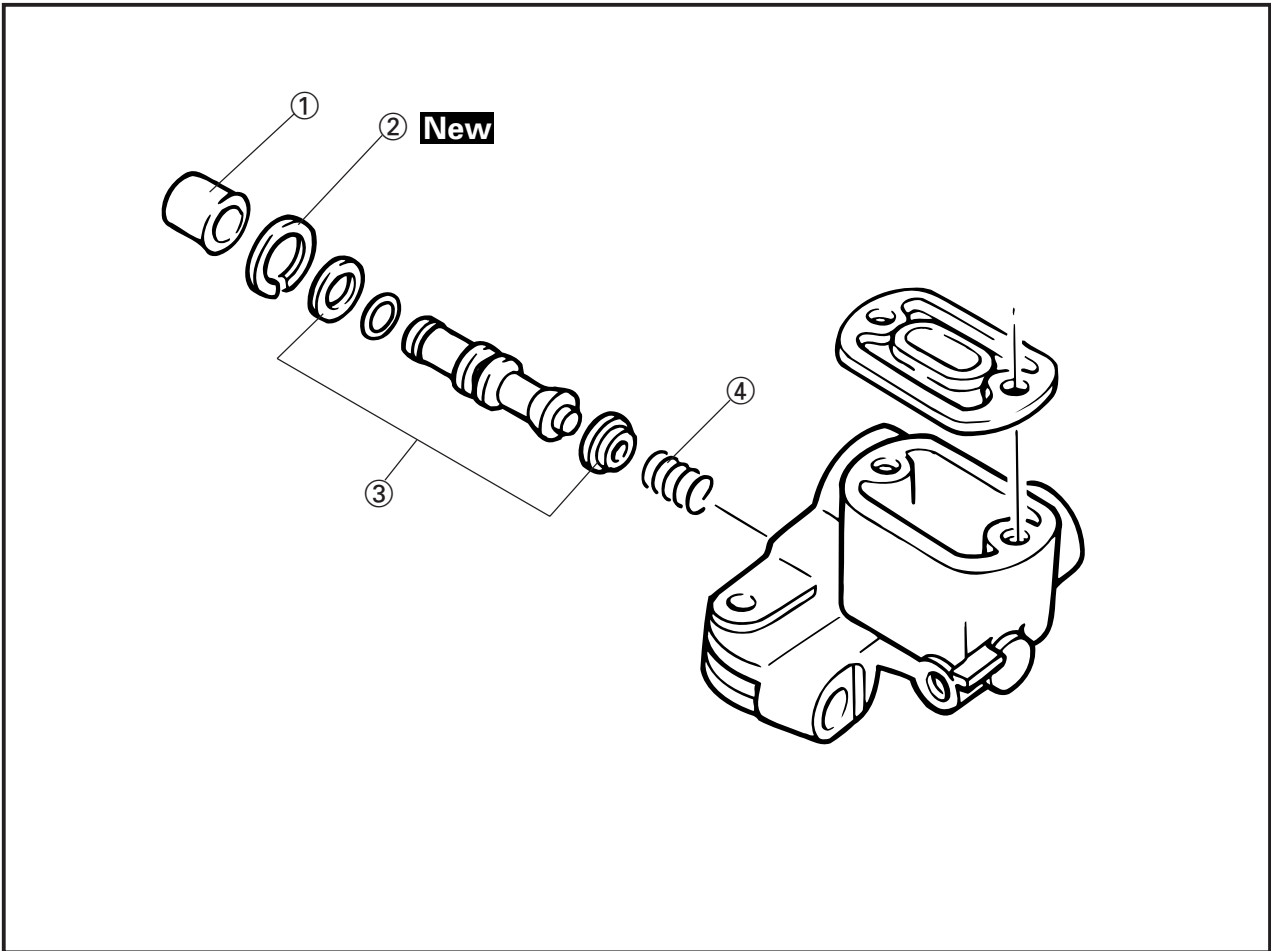

Order	Job name/Part name	Q'ty	Remarks
	Master cylinder disassembly		Remove the parts in order.
①	Master cylinder boot	1	Refer to "MASTER CYLINDER ASSEMBLY" section.
②	Circlip	1	
③	Master cylinder kit	1	
④	Spring	1	
			Reverse the disassembly procedure for assembly.

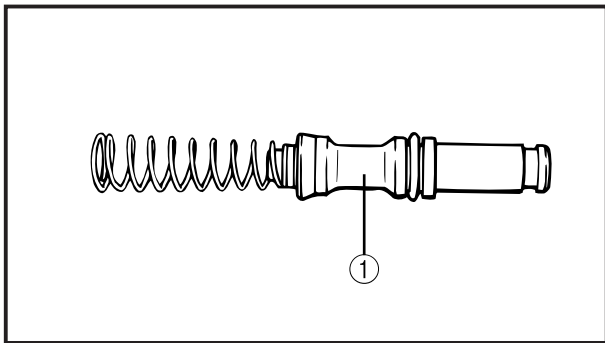

YP702040

MASTER CYLINDER INSPECTION

1. Inspect:
 - Master cylinder kit ①
Wear/scratches→Replace the master cylinder assembly.
 - Master cylinder boot
Cracks/damage→Replace.

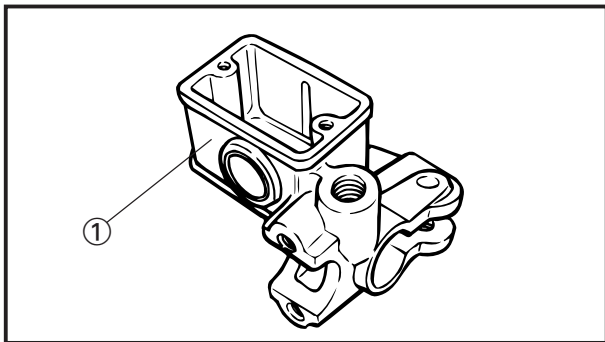

2. Inspect:
 - Master cylinder ①
 - Scratches/wear/damage→Replace the master cylinder assembly.

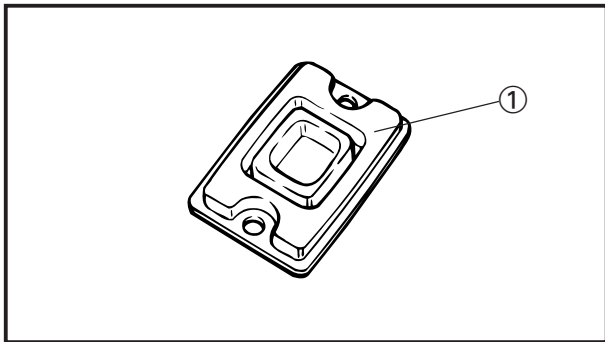

3. Inspect:
 - Diaphragm ①
Wear/damage→Replace.

YP.....

MASTER CYLINDER ASSEMBLY

⚠ WARNING

- All internal brake components should be cleaned and lubricated with new brake fluid only before installation.



Recommended brake fluid:
DOT #4(or DOT #3)

- Replace the piston seals and dust seals whenever a master cylinder is disassembled.

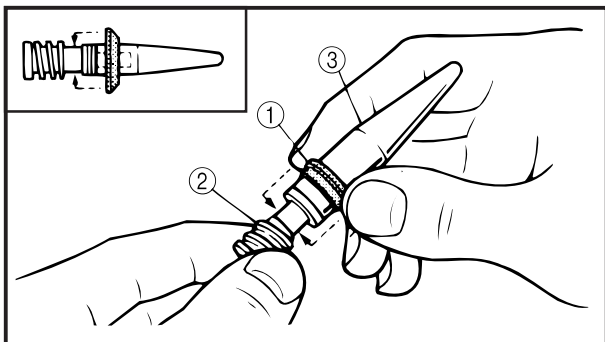

1. Install:
 - Cylinder cup ①
 - Master cylinder piston ②
Install cylinder cup ① by using cylinder cup installer ③.



Cylinder cup installer set:
90890-01996

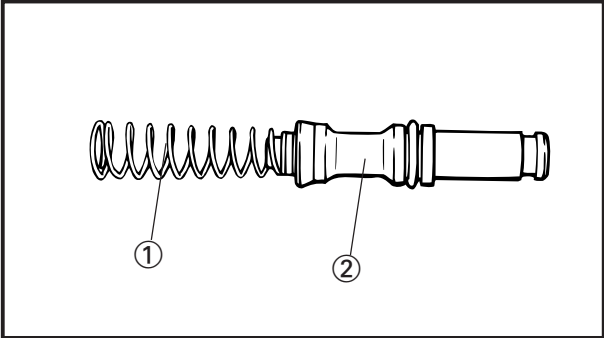

2. Install:
 - Spring ①
Install the spring with its smaller diameter to the master cylinder piston.
 - Master cylinder kit ②

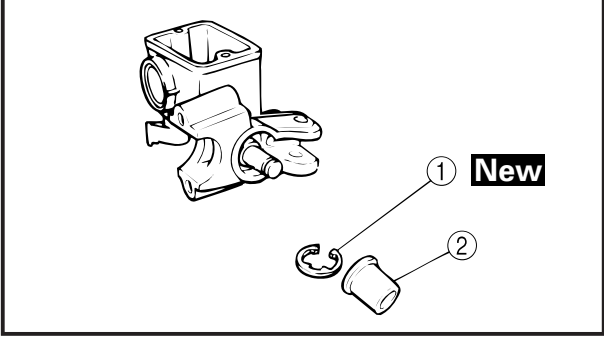

3. Install:
 - Circlip ① **New**
Install the circlip securely into the master cylinder groove.
 - Master cylinder boot ②

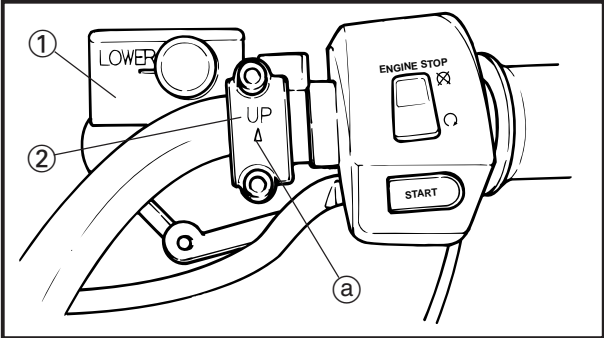

YP....

MASTER CYLINDER INSTALLATION

1. Install:
 - Master cylinder ①
 - Master cylinder bracket ②

 9 Nm (0.9 m.kg, 6.5 ft.lb)

CAUTION: _____

- Install the master cylinder bracket ② with the "UP" mark (a) facing upward.
 - Align the end of the holder with the punch mark b on the handle bar.
- _____

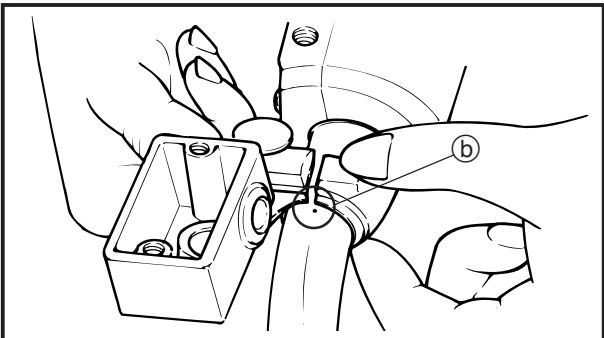



2. Air bleed:

- Brake system

Refer to "AIR BLEEDING" section in CHAPTER 3.

⚠ WARNING

- **Use only designated quality brake fluid:**
Otherwise, the rubber seals may deteriorate, causing leakage and poor brake performance.
- **Refill with the same type of brake fluid:**
Mixing fluids may result in a harmful chemical reaction and lead to poor performance.
- **Be careful that water does not enter the significantly lower the boiling point of the fluid may result in vapor lock.**

3. Inspect:

- Brake operation

CALIPER

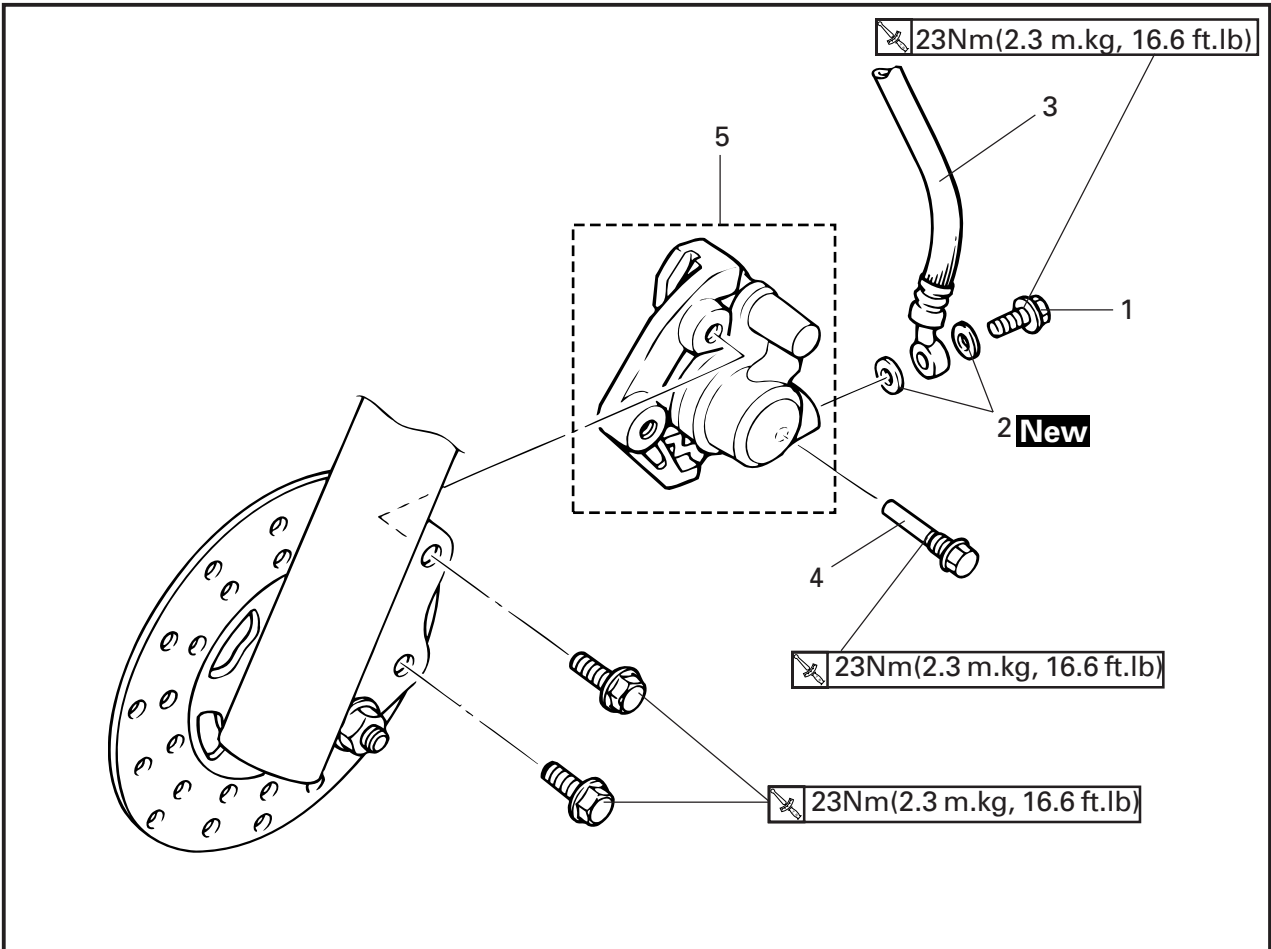

Order	Job name/Part name	Q'ty	Remarks
	Caliper removal Drain the brake fluid		Remove the parts in order. Refer to "BRAKE FLUID REPLACE- MENT" section in CHAPTER 3.
1	Union bolt	1	Refer to "CALIPER INSTALLATION" sec- tion.
2	Copper washer	2	
3	Brake hose	1	
4	Caliper support bolt	1	
5	Caliper assembly	1	
			Reverse the removal procedure for in- stallation.

CALIPER DISASSEMBLY

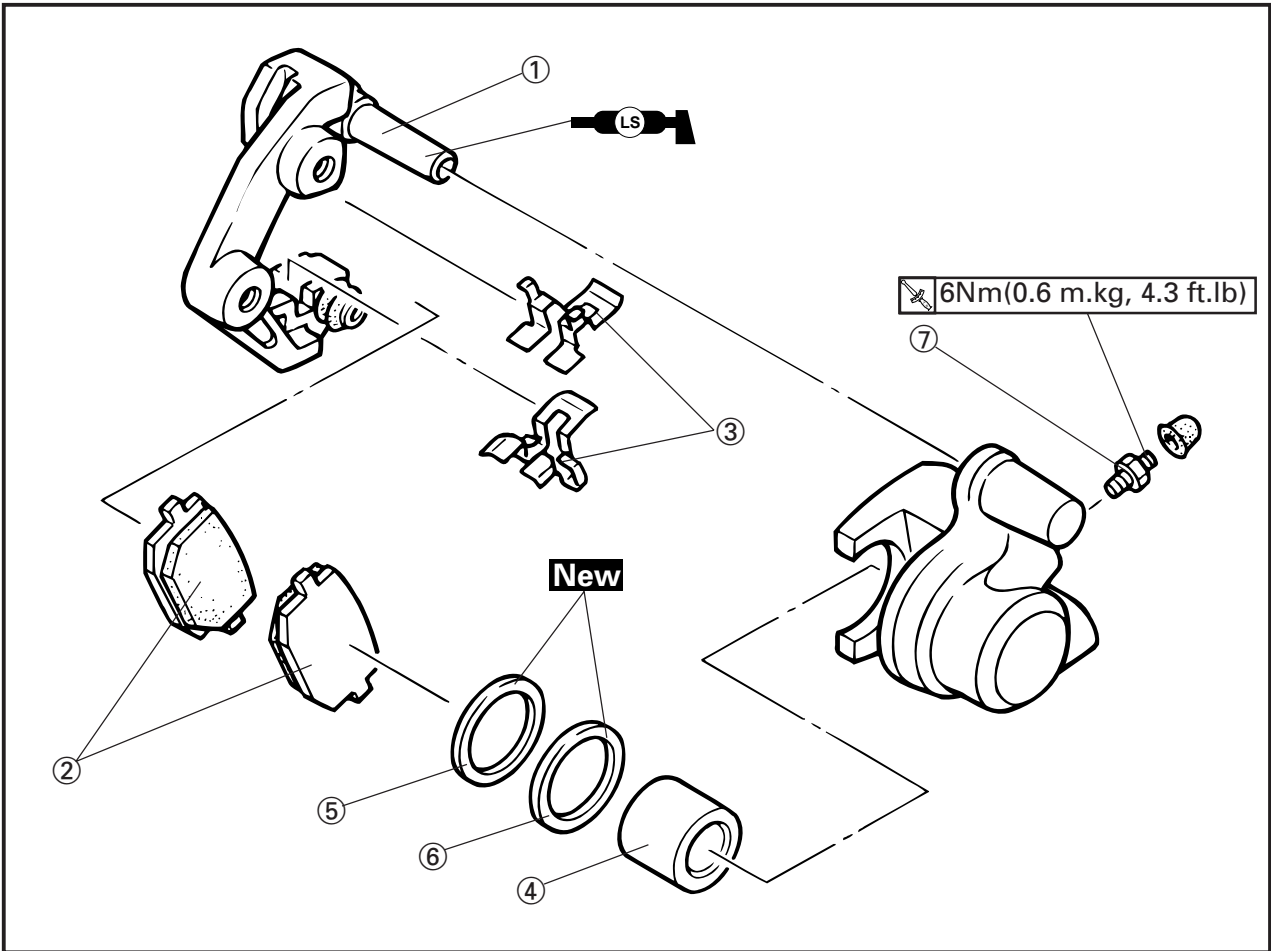

Order	Job name/Part name	Q'ty	Remarks
	Caliper disassembly		Remove the parts in order.
①	Caliper bracket	1	Refer to "BRAKE CALIPER DISASSEMBLY/ASSEMBLY" section.
②	Brake pad	2	
③	Pad spring	2	
④	Caliper piston	1	
⑤	Dust seal	1	
⑥	Piston seal	1	
⑦	Bleed screw	1	
			Reverse the disassembly procedure for assembly.

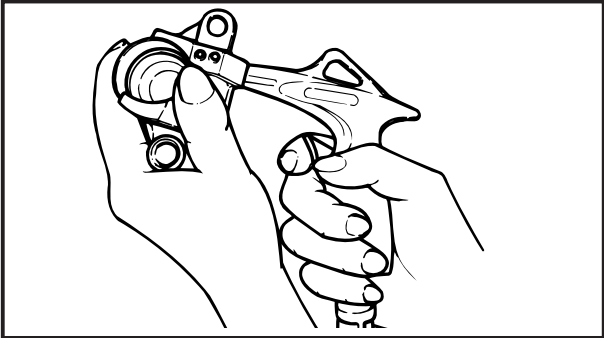

YP702020

BRAKE CALIPER DISASSEMBLY

NOTE: _____

Before disassembling either brake caliper, drain the brake fluid from the brake hose, master cylinder, brake caliper and reservoir tank.

1. Remove:

- Brake caliper piston

Removal steps:

- Blow compressed air into the hose joint opening to force out the caliper piston from the brake caliper body.

WARNING _____

- Never try to pry out the caliper piston.
- Cover the caliper piston with a rag. Be careful not to get injured when the piston is expelled from the master cylinder.

CAUTION: _____

Carefully remove the caliper piston to prevent damage.

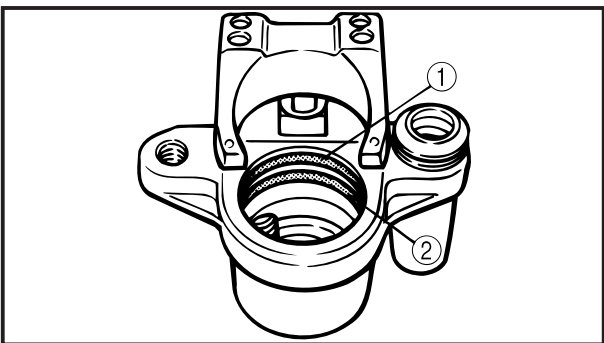

2. Remove:

- Dust seal ①
- Piston seal ②

When removing, push the seals by your finger.

CAUTION: _____

- Do not use a sharp instrument. Remove seals by your finger.
- Do not re-use removed parts.

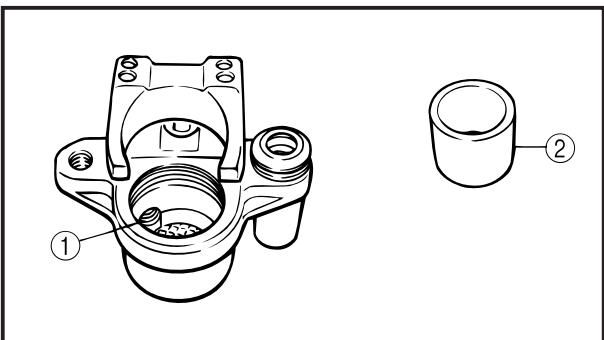

YP...

CALIPER INSPECTION

1. Inspect:

- Caliper cylinder ①
- Caliper piston ②

Scratches, wear→Replace caliper assembly.

EB702050

BRAKE CALIPER ASSEMBLY

⚠ WARNING

- All internal brake components should be cleaned and lubricated with new brake fluid only before installation.

	Recommended brake fluid: DOT #4(or DOT #3)
---	---

- Replace the caliper piston seals whenever a brake caliper is disassembled.

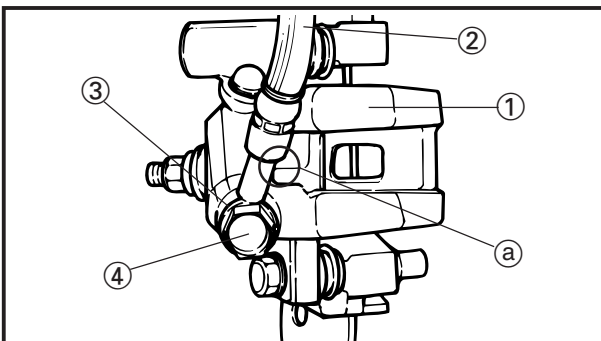
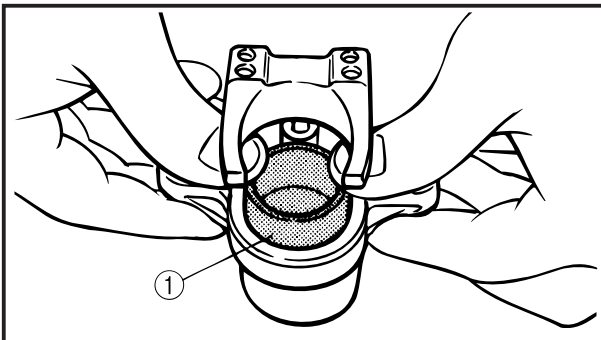
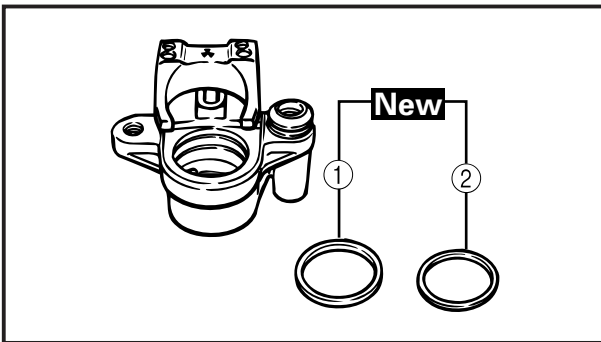

1. Install:

- Piston seal ① **New**
- Dust seal ② **New**

2. Install:

- Caliper piston ①
Apply brake fluid to the outer surface and install.

CAUTION:

- Do not force.
- Use care to prevent damage on caliper piston.

YP.....

BRAKE CALIPER INSTALLATION

1. Install:

- Caliper ①
- Caliper support bolt

 23Nm(2.3m.kg, 16.6ft.lb)

- Brake hose ②
- Copper washer ③ **New**
- Union bolt ④

 25Nm(2.5 m.kg,18ft.lb)

CAUTION:

When installing the brake hose to the caliper, lightly touch the brake hose with the stopper ① on the caliper.

REAR WHEEL AND REAR BRAKE

REAR WHEEL

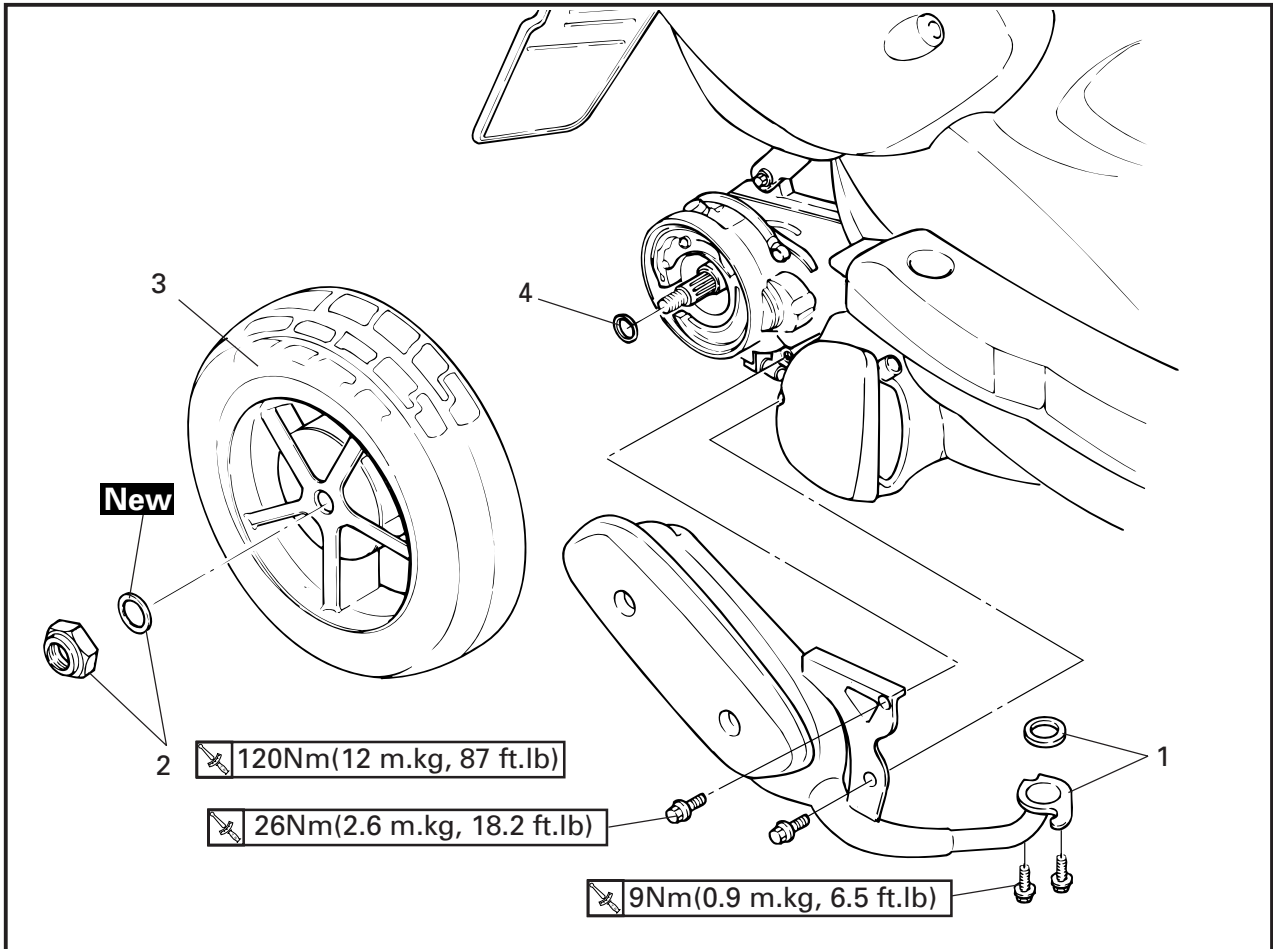

Order	Job name/Part name	Q'ty	Remarks
	Rear wheel and rear brake removal		Remove the parts in order. NOTE: Place the scooter on a suitable atand so that the rear wheel is elevated.
1	Muffler assembly/Gasket	1/1	
2	Nut/Plain washer	1	
3	Rear wheel assembly	1	
4	Plain washer	1	
			Reverse the disassembly procedure for installation.

REAR BRAKE

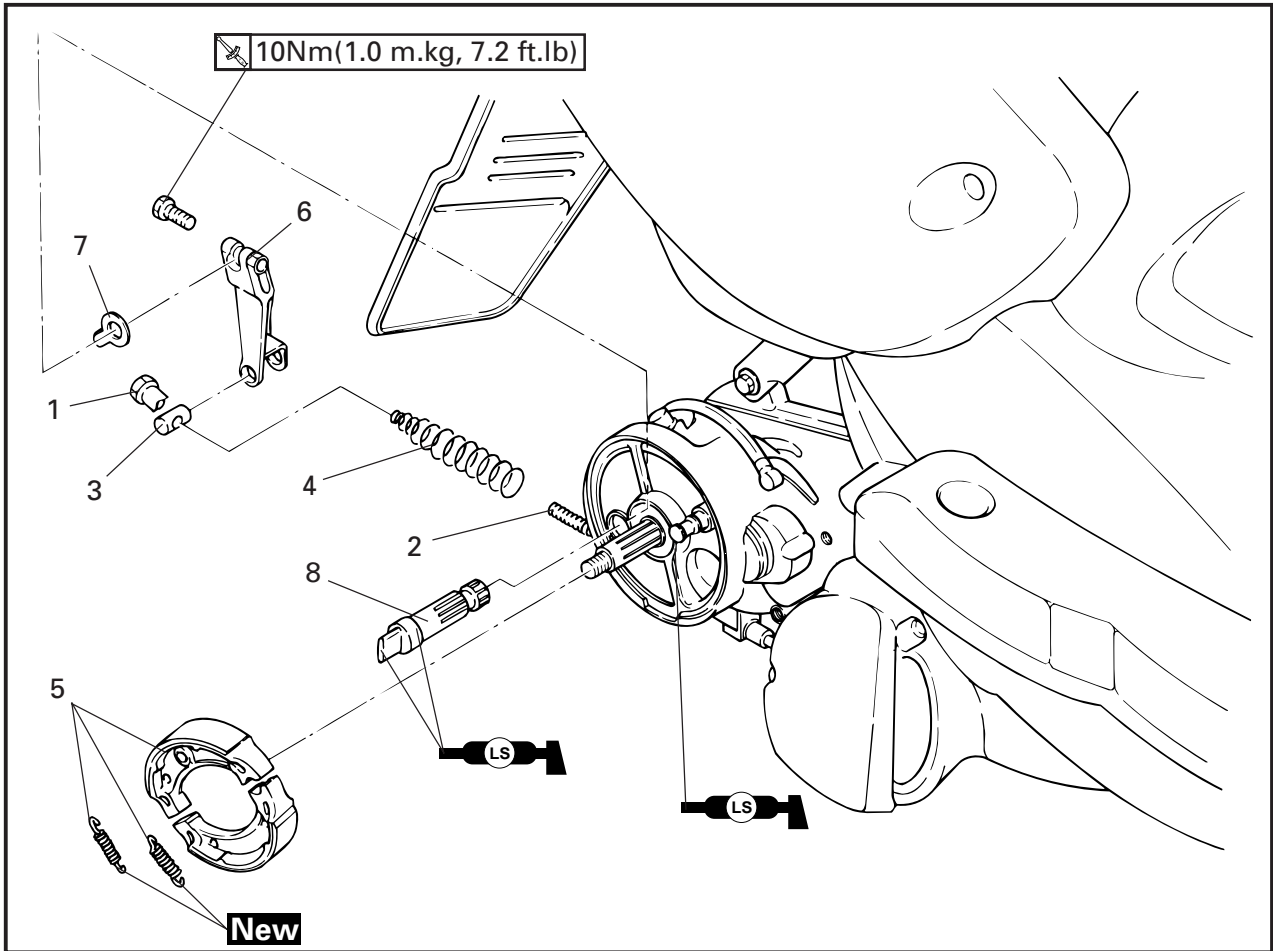

Order	Job name/Part name	Q'ty	Remarks
1	Adjuster	1	Reverse the removal procedure for installation.
2	Brake cable	1	
3	Pin	1	
4	Return spring	1	
5	Brake shoe	1	
6	Camshaft lever	1	
7	Wear indicator	1	
8	Brake camshaft	1	

EB701020

REAR WHEEL INSPECTION

1. Inspect:
 - Rear wheel axle
 - Rear wheel
 - Rear wheel bearings
 - Oil seals
 Refer to "FRONT WHEEL".
2. Measure:
 - Rear wheel runout
 Refer to "FRONT WHEEL".

EB701021

REAR BRAKE INSPECTION

1. Inspect:
 - Brake lining surface
 Glazed areas → Polish.
 Use coarse sand paper.

NOTE:

After polishing, wipe the polished particles with a cloth.

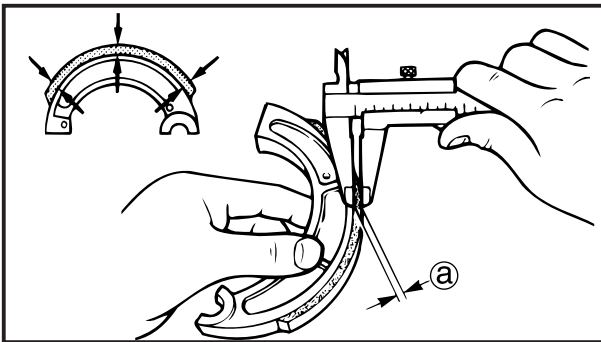

2. Measure:
 - Brake lining thickness (a)



Brake lining thickness (a) :
 Standard:
 4 mm (0.16 in)
 Limit:
 2 mm (0.08 in)

Out of specification → Replace.
 Measuring points " ↑ "

NOTE:

Replace the brake shoes as a set, if either is worn to the wear limit.

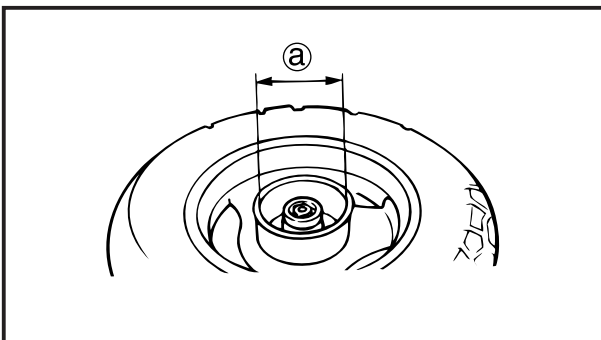

3. Measure:
 - Brake drum inside diameter (a)
 Out of specification → Replace the wheel.



Brake drum inside diameter:
 Standard:
 130 mm (5.12 in)
 Limit:
 131 mm (5.16 in)

4. Inspect:
 - Brake drum inner surface
 - Oil/scratches→Repair.
 - Oil
 - Use a rag soaked in lacquer thinner or solvent.
 - Scratches
 - Use an emery cloth (lightly and evenly polishing)
5. Inspect:
 - Cam shaft face.
 - Wear→Replace.

⚠ WARNING

When inspecting the brake lining, do not spill oil or grease on the brake lining.

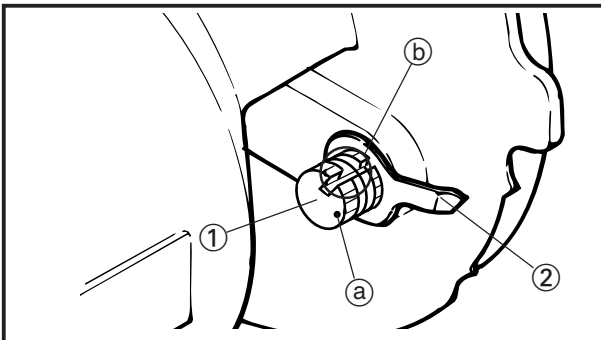

YP....

REAR BRAKE INSTALLATION

1. Install:
 - Camshaft ①
 - Indicator plate ②

Installation steps:

- Set the camshaft with its punched mark (a) facing the direction as shown.
- Align the projection (b) on the indicator plate with the camshaft notch and install.
- Check the proper position of the brake shoe.

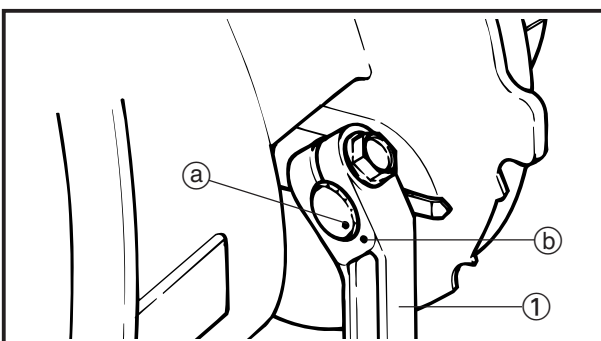

2. Install:
 - Camshaft lever ①  10Nm(1.0 m.kg, 7.2ft.lb)

NOTE:

Set the camshaft with its punched mark (a) facing the direction on the cam shaft lever (b).

HANDLEBAR
HANDLEBAR

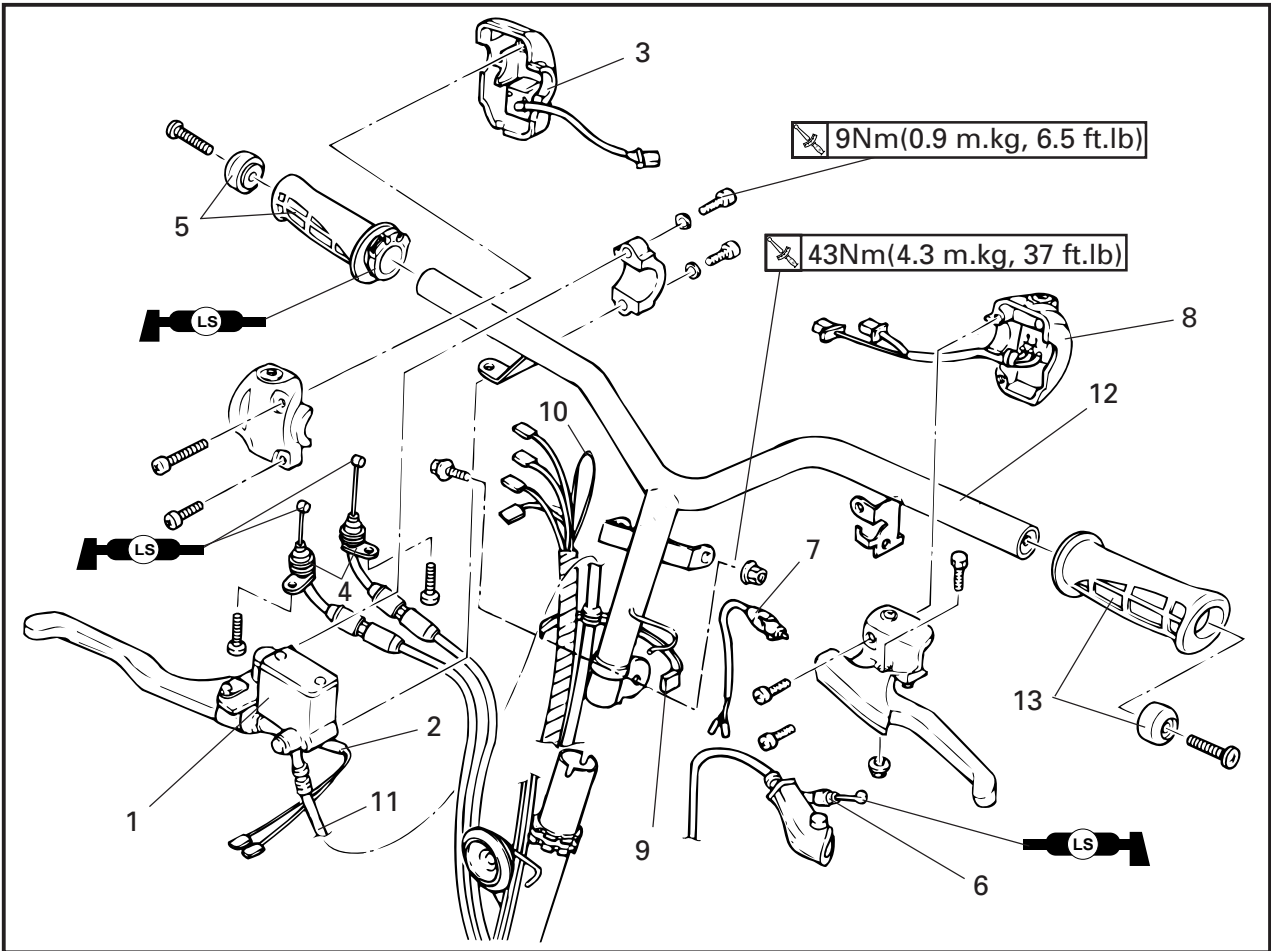

Order	Job name/Part name	Q'ty	Remarks
	Handlebar removal		Remove the parts in order.
	Left/Right bake mirror		Refer to "COVERS AND PANEL" IN CHAPTER 3.
	Front protector bar		
	Upper cover		
	Front/Rear handlebar cover		
	Left/Right flasher		
1	Brake master cylinder	1	
2	Front brake switch	1	
3	Handlebar switch (Right)	1	
4	Throttle cable	1	
5	Right grip	1/1	
6	Brake cable	1	
7	Rear brake switch	1	
8	Handlebar switch (Left)	1	
9	Bind	1	

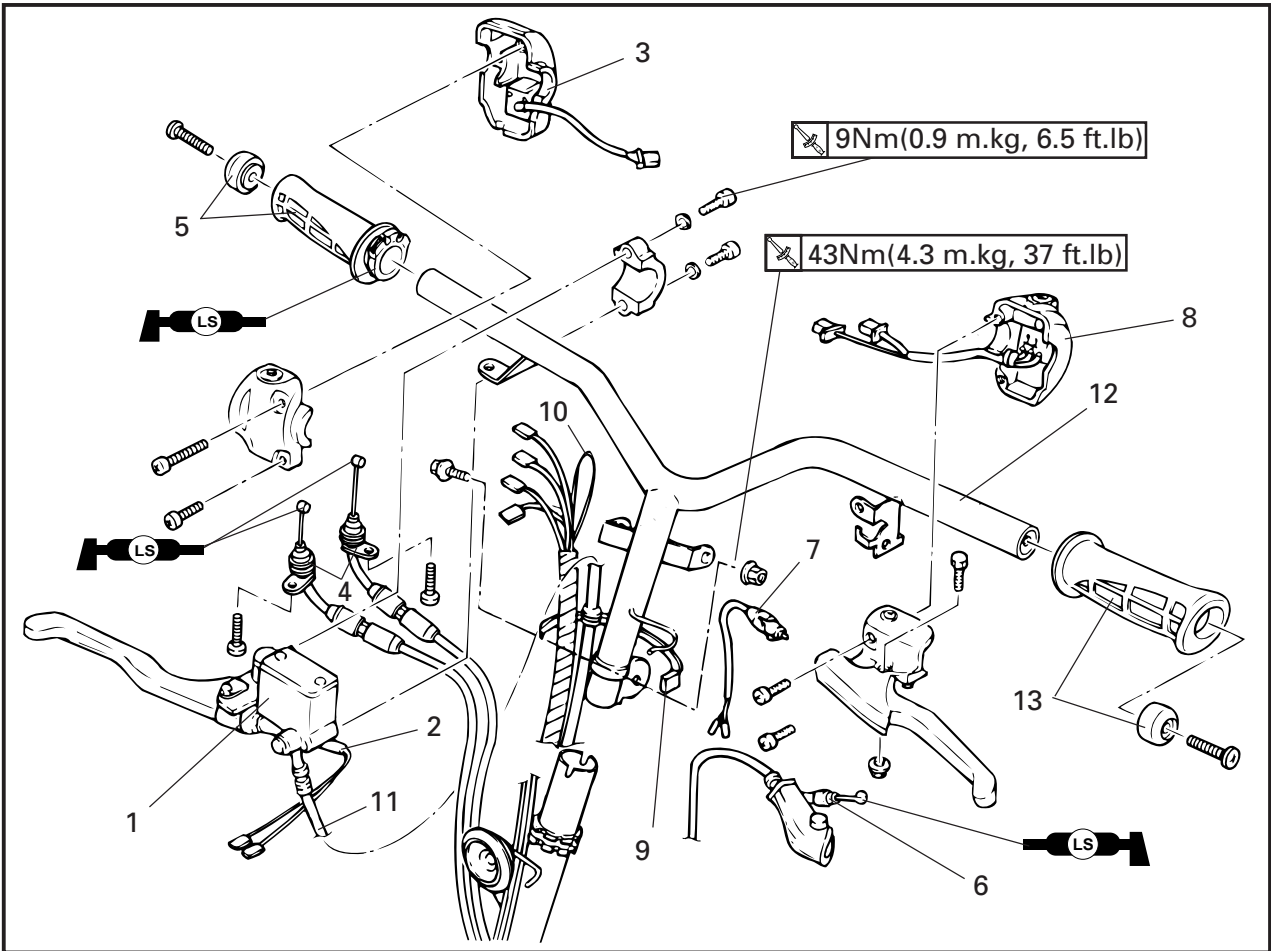

Order	Job name/Part name	Q'ty	Remarks
10	Wire harness strap	1	Reverse the removal procedure for installation.
11	Brake hose	1	
12	Handlebar comp.	1	
13	Left grip	1/1	

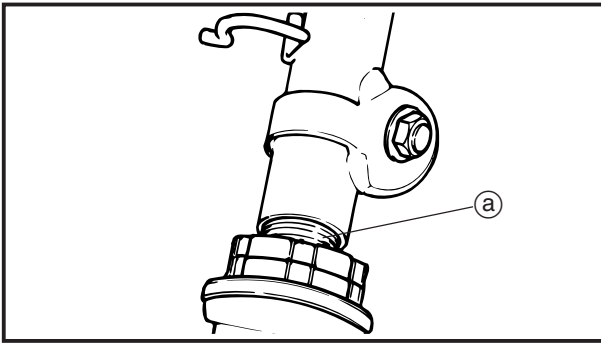

HANDLEBAR INSTALLATION

- Clean:
 - Steering shaft (a)

⚠ WARNING

Proper cables and leads routing is essential to issue safe scooter operation.

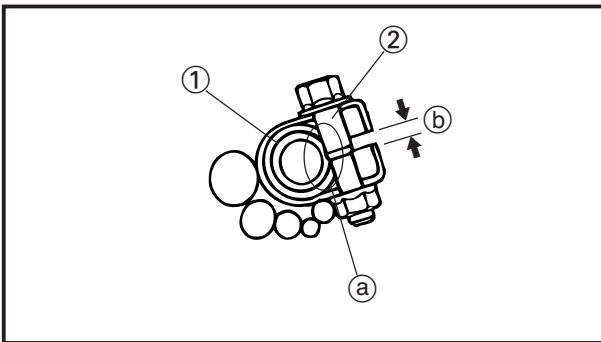

- Install:
 - Handlebar (1)
 - Bolt (2)
 - Nut

 43Nm(4.3 m.kg, 37ft.lb)

NOTE:

Match the bolt (2) on to the steering column dent (a).

CAUTION:

There must be a space b after tightening bolt (2).

- Install:
 - Band

NOTE:

Clamp the wire harness.

- Apply:
 - Lithium soap base grease (to throttle cable end and handlebar right end).

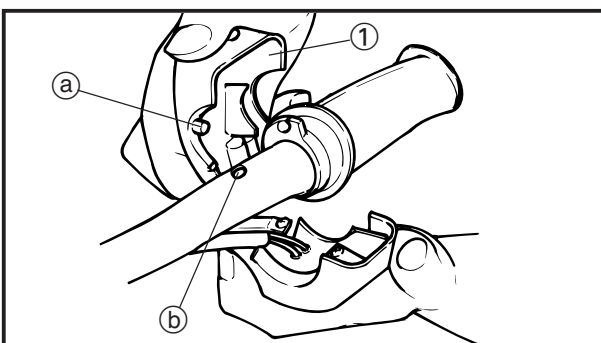

- Install:
 - Handlebar switch (right) (1)

NOTE:

Insert the projection (a) into the hole (b) on the handlebar comp.

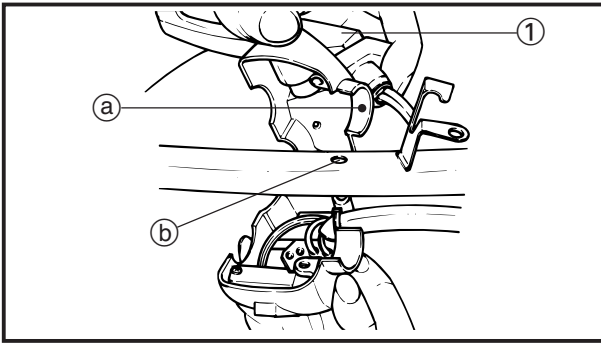

6. Install:

- Handlebar switch (left) ①

NOTE: _____

Insert the projection (a) into the hole (b) on the handlebar comp.

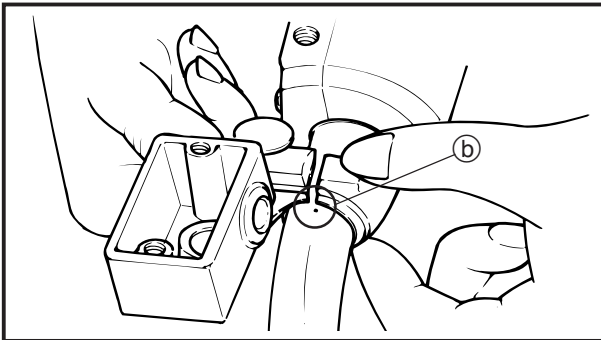

7. Install:

- Master cylinder

NOTE: _____

Match the slot with the punched mark (b) on the handlebar comp.

STEERING

STEERING

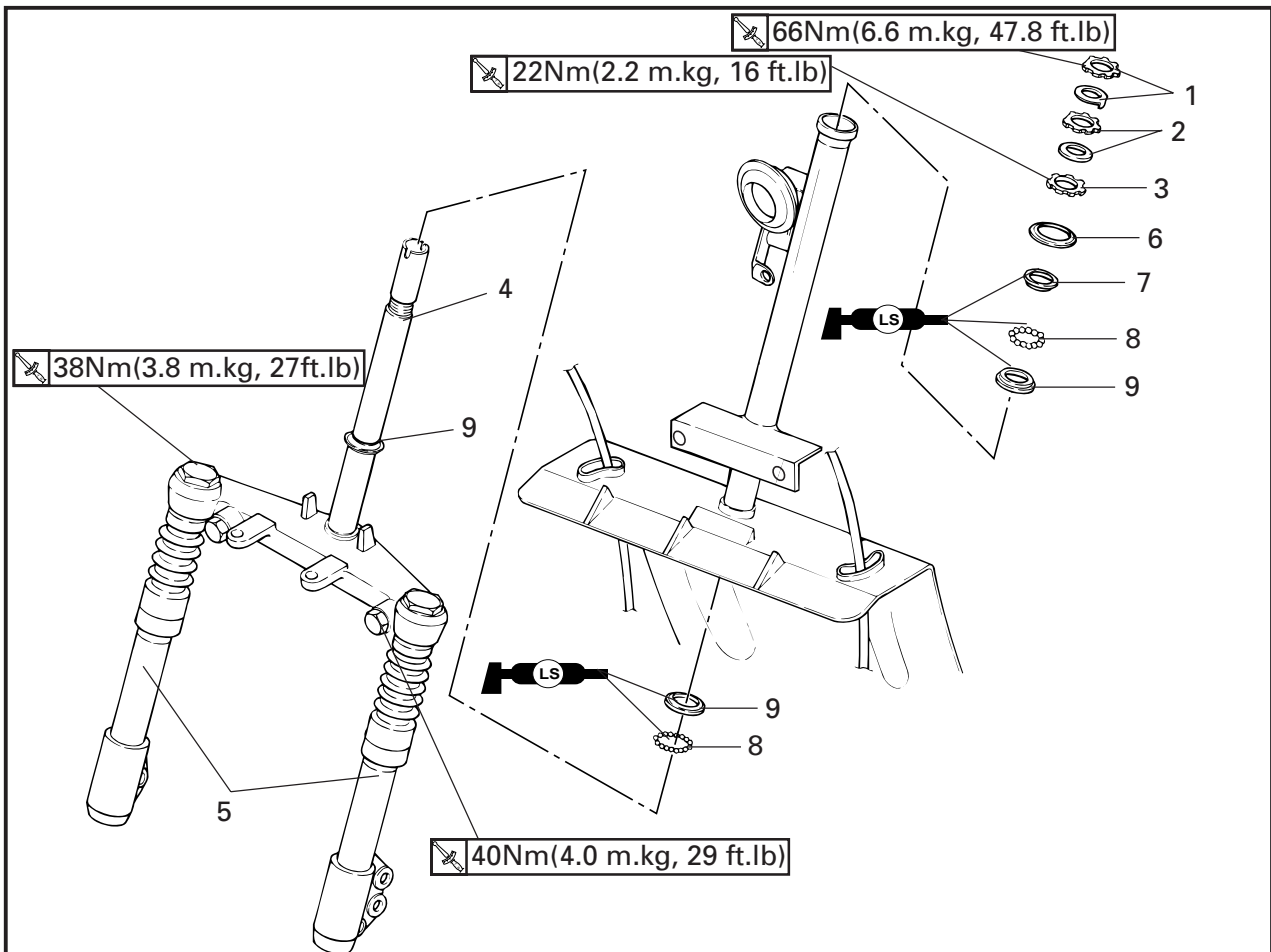

Order	Job name/Part name	Q'ty	Remarks
	Steering removal		Remove the parts in order Refer to "HANDLEBAR" section. Refer to "FRONT WHEEL AND BRAKE DISC" section
	Handlebar		
	Front wheel		
1	Ring nut 1/ Special washer	1/1	Refer to "STEERING REMOVAL/INSTALLATION" section.
2	Ring nut 2/ Rubber washer	1/1	
3	Ring nut 3	1	
4	Under bracket	1	
5	Front fork (Left/Right)	1/1	
6	Bearing cover	1	
7	Ball race	1	
8	Ball (Upper/Lower)	22/19	
9	Ball race	3	
			Reverse the removal procedure for installation.

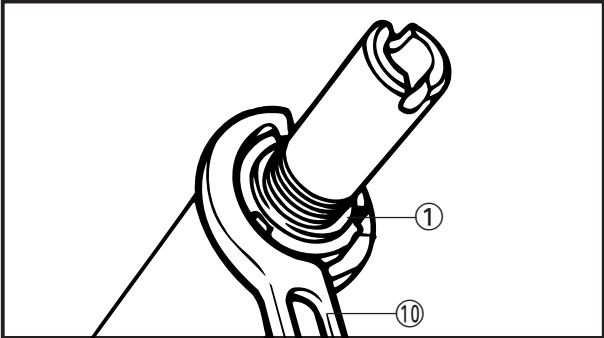

STEERING REMOVAL

⚠ WARNING

- Securely support the scooter so that there is no danger of it falling over.
- Stand the scooter on a level surface.

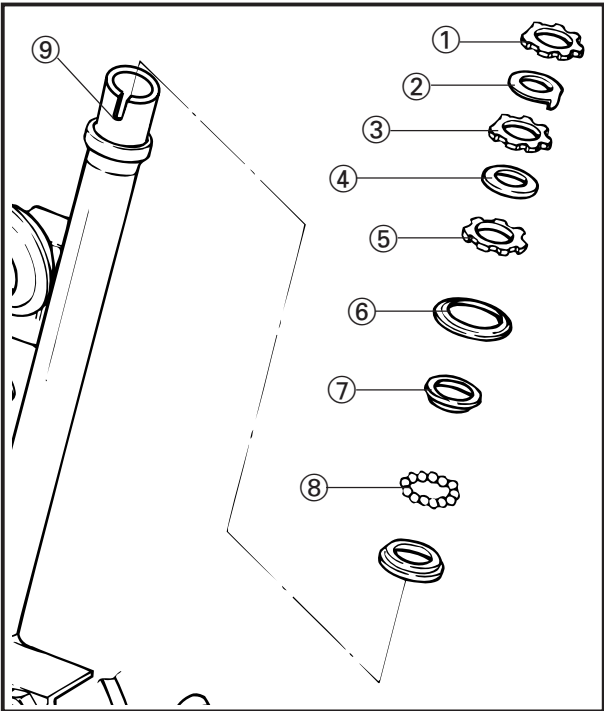

1. Removal:
 - Ring nut 1 ①
 - Special washer ②
 - Ring nut 2 ③
 - Rubber washer ④
 - Ring nut 3 ⑤
 - Bearing cover ⑥
 - Ball race ⑦
 - Ball ⑧
 - Front fork assembly ⑨

NOTE:

- Remove the ring nuts by steering nut wrench.

	Steering nut wrench ⑩ YU-33975
--	-----------------------------------

- Hold the lower bracket by hand, then remove by using the steering nut wrench ⑩.
- Do not loss the balls (Upper: 22 pcs, Lower: 19 pcs).

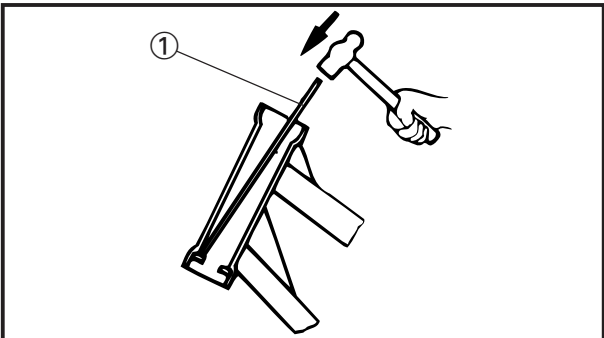

2. Remove
 - Front fork assembly
Refer to "FRONT FORK" section.
3. Remove
 - Ball race

Ball race replacement steps:

- Remove the ball races on the head pipe using long rod ① and the hammer as shown.
- Remove the ball races on the under bracket using the floor chisel ② and the hammer as shown.

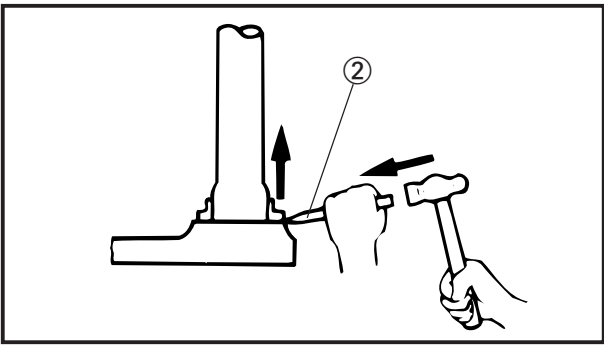

STEERING INSPECTION

1. Wash the bearing races with a solvent.
2. Inspect:
 - Ball race
 - Ball
 Pitting/Damage→Replace.

NOTE: _____

Always replace bearings and races as set.

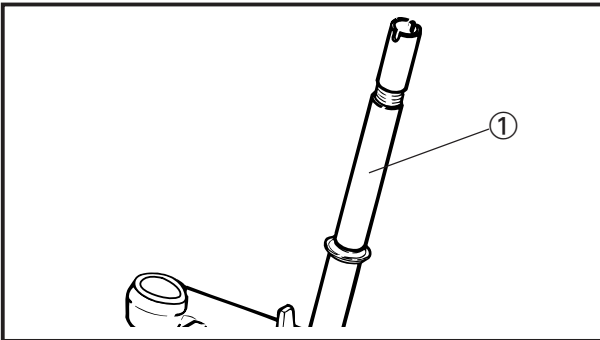

3. Inspect:
 - Under bracket ①
 Crack/Bend/Damage→Replace.

⚠ WARNING _____

Do not attempt to straighten a bent under bracket as this may dangerously weaken the under bracket.

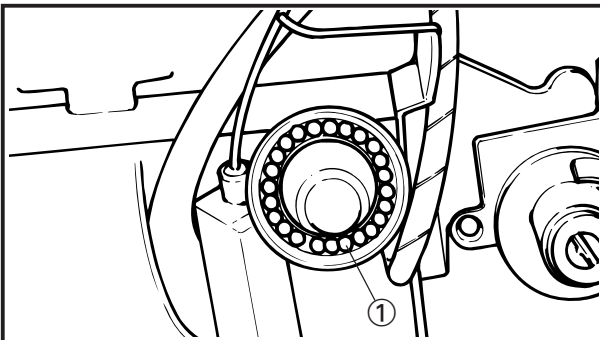

STEERING INSTALLATION

1. Install:
 - Ball ①

NOTE: _____

Upper.....22 pcs
 Lower..... 19 pcs

2. Lubricate
 - Ball
 - Ball race

	Lithium soap base grease
---	--------------------------

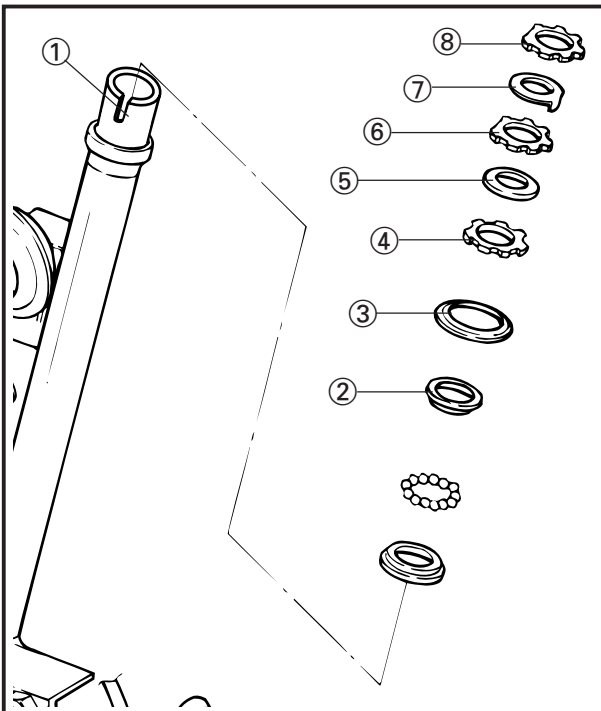

3. Install:
- Front fork assembly ①
 - Ball race (Upper) ②
 - Bearing cover ③
 - Ring nut 3 ④
 - Rubber washer ⑤
 - Ring nut 2 ⑥
 - Special washer ⑦
 - Ring nut 1 ⑧

NOTE: _____
 Securely support the steering shaft so that there is no danger of it falling down.

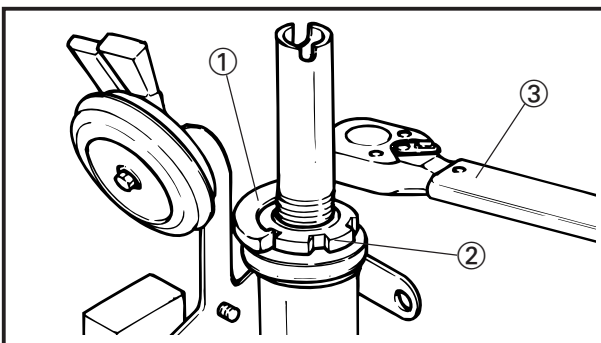

4. Tighten:
- Ring nuts
- *****
- Tighten steps:
- Tighten the ring nut 3 ② using the ring nut wrench ①

 22 Nm (2.2 m.kg, 16 ft.lb)

 Steering nut wrench:
YU-33975

NOTE: _____
 Set the torque wrench ③ to ring nut wrench ① so that they form right angle.

⚠ WARNING _____

Do not over-tightening.

- Loosen the ring nut 3 ② 1/4 turn.
- Check the front fork by turning it lock to lock. If there is any binding, remove the front fork assembly and inspect the steering ball bearings and ball races.
- Install rubber washer ④ and ring nut 2 ⑤, then turn the ring nut 2 until it contacts with rubber washer.

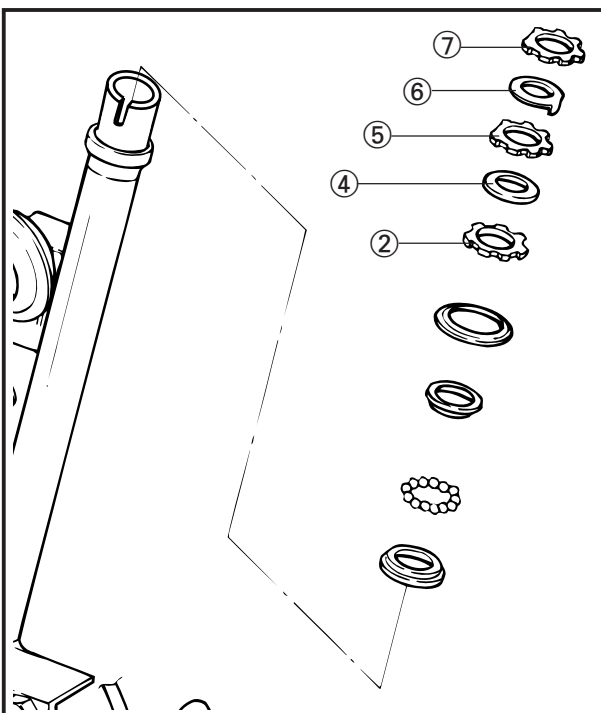

CAUTION: _____

Slots on the ring nut 2 and ring nut 3 should be align. If not, turn the ring nut 2 towards tighten direction until slots alignment.

- Install special washer ⑥

NOTE: _____

Insert the projections of the special washer into the slots.

- Install ring nut 1 ⑦ and tighten.

 66Nm(6.6 m.kg, 47.8 ft.lb)

FRONT FORK
FRONT FORK

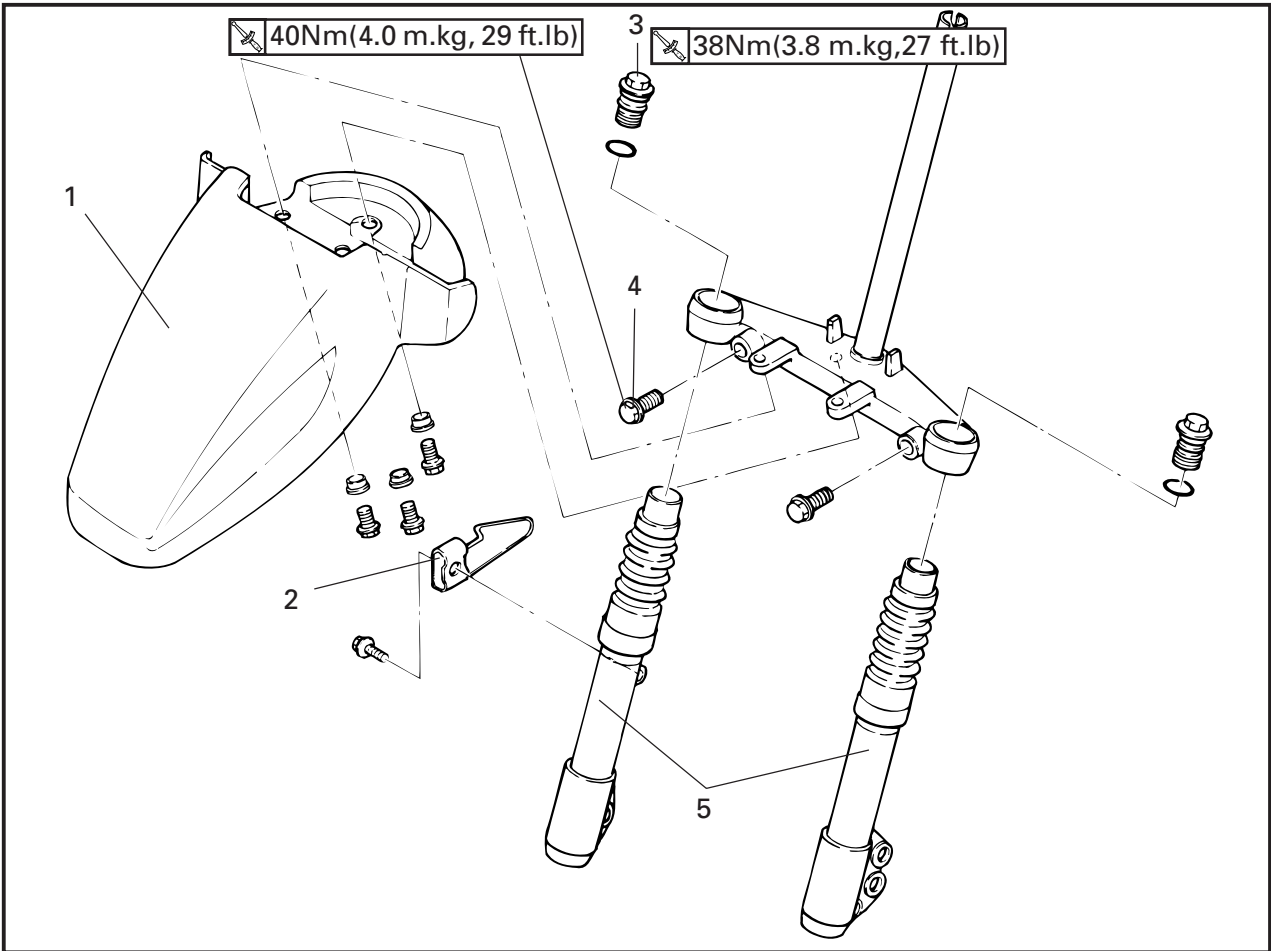

Order	Job name/Part name	Q'ty	Remarks
	Front fork removal		Remove the parts in order.
	Steering		Refer to "Steering" section.
1	Under fender	1	
2	Speedometer cable holder	1	
3	Cap bolt	2	
4	Pinch bolt	2	Refer to "FRONT FORK REMOVAL/INSTALLATION" section.
5	Front fork	2	Reverse the removal procedure for installation.

FRONT FORK DISASSEMBLY

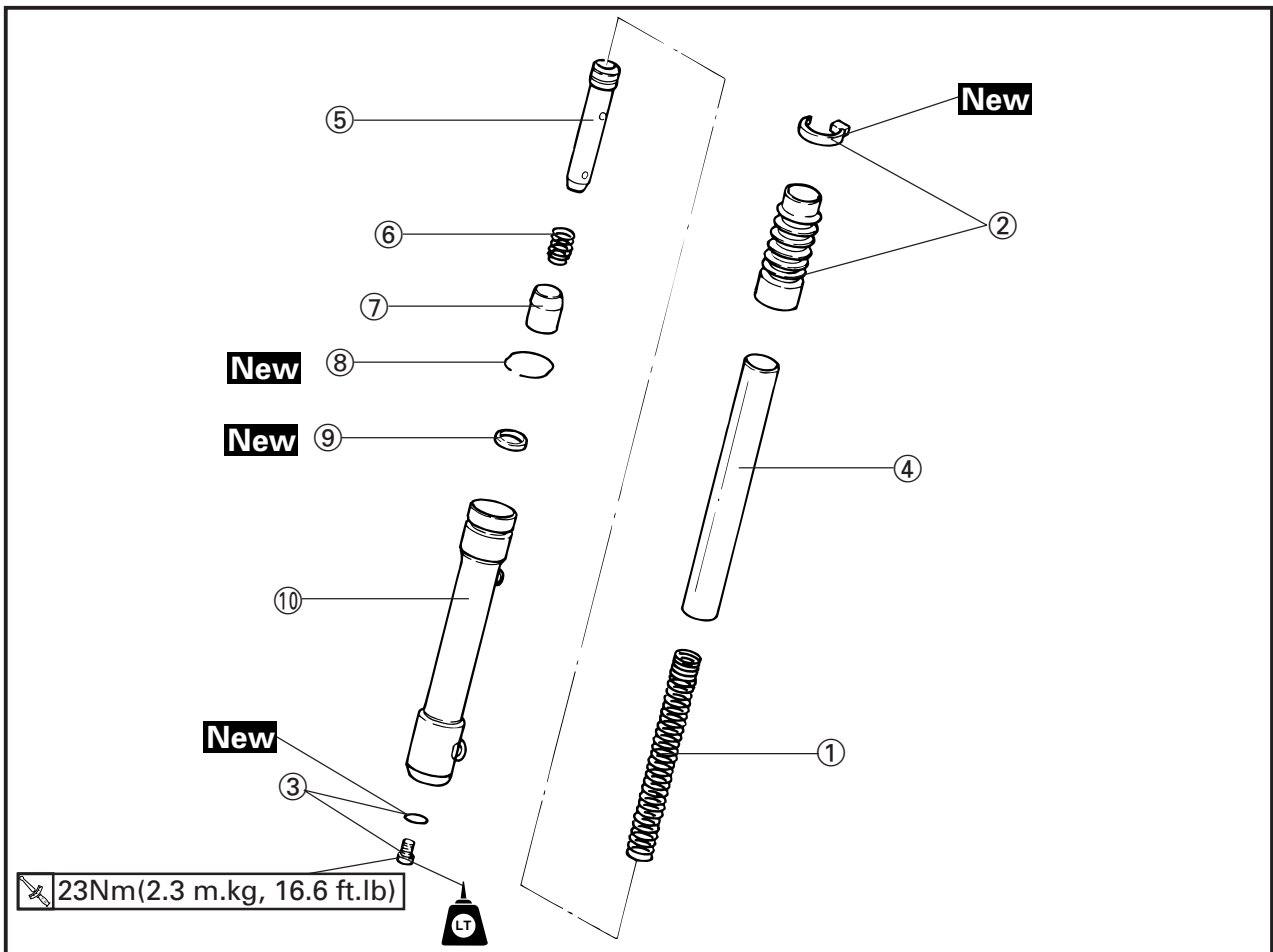

Order	Job name/Part name	Q'ty	Remarks
①	Front fork disassembly Fork spring	1	Remove the parts in order. Refer to "FRONT FORK REMOVAL/INSTALLATION" section.
②	Band/Front fork boot	1	
③	Bolt/Copper washer	1/1	Refer to "FRONT FORK DISASSEMBLY/ASSEMBLY" section.
④	Inner tube	1	
⑤	Damper rod	1/1	
⑥	Rebound spring	1	
⑦	Oil lock piece	1/1	
⑧	Oil seal clip	1	
⑨	Oil seal	1	
⑩	Outer tube	1	Reverse the disassembly procedure for assembly.

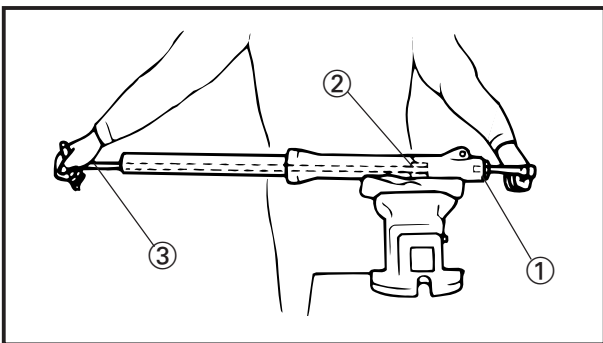
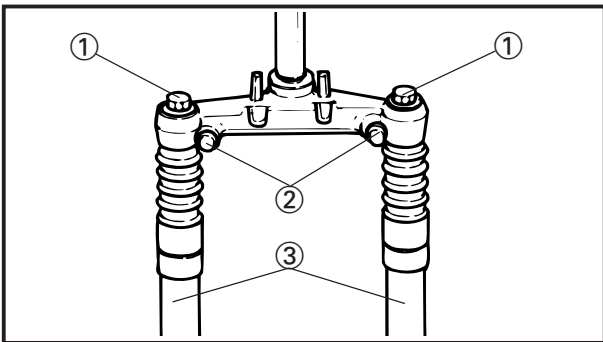
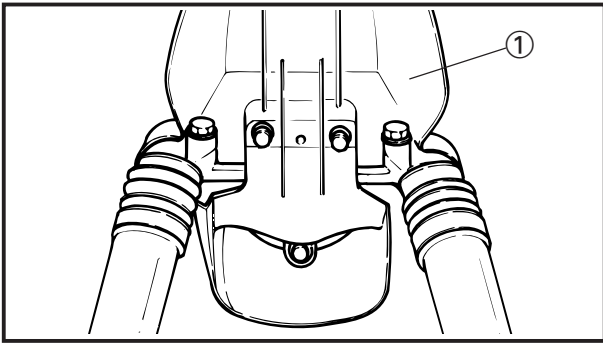

YP....

FRONT FORK REMOVAL

⚠ WARNING

- Securely support the scooter so there is no danger of it falling over.
- Stand the scooter on a level surface.
- Stand the scooter on its centerstand.

1. Remove:
 - Under fender ①

2. Remove:
 - Cap bolt ①
 - Pinch bolt ②

⚠ WARNING

Fork spring will jump out after removing cap bolt.

3. Remove:
 - Front fork (Left/Right) ③

YP703020

FRONT FORK DISASSEMBLY

1. Remove:
 - Bolt (damper rod) ①
 Loosen the bolt (damper rod) ① while holding the damper rod with T-handle ③ and holder ②.

	T-handle
	YM-1326
	Holder
	YM-01300-1

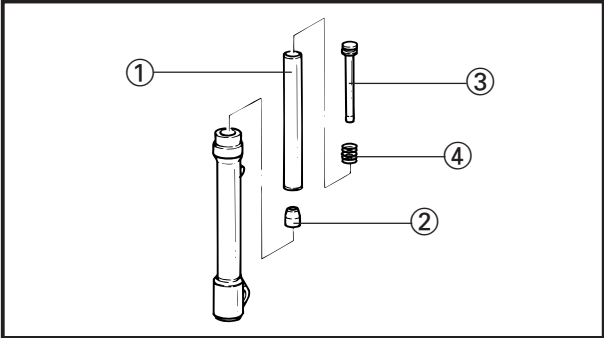

2. Remove:
- Inner tube ①
 - Oil lock piece ②
 - Damper rod ③
 - Rebound spring ④

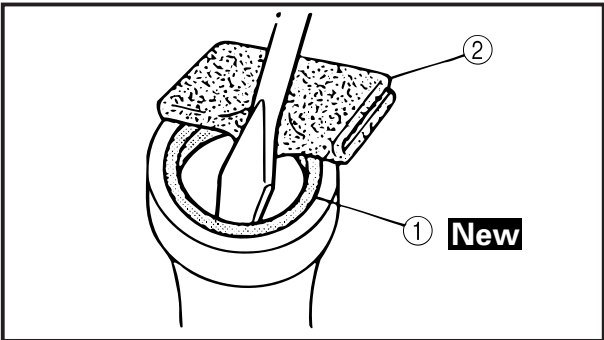

3. Remove:
- Oil seal ① **New**

CAUTION: _____

Never reuse the oil seal.

② Rag

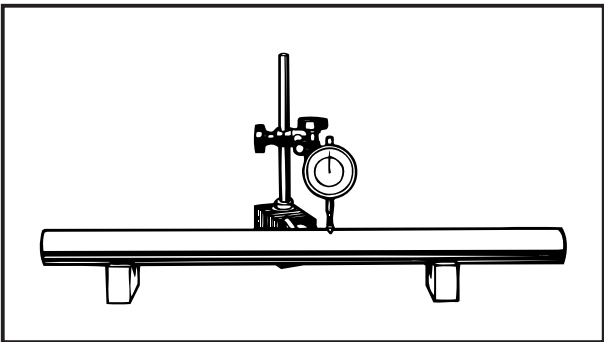

YP703030

FRONT FORK INSPECTION

1. Inspect:
- Inner tube bending

	Inner tube bending limit: 0.2 mm(0.008 in)
---	---

Scratches/bends/damage→Replace.

⚠ WARNING _____

Do not attempt to straighten a bent inner tube as this may dangerously weaken the tube.

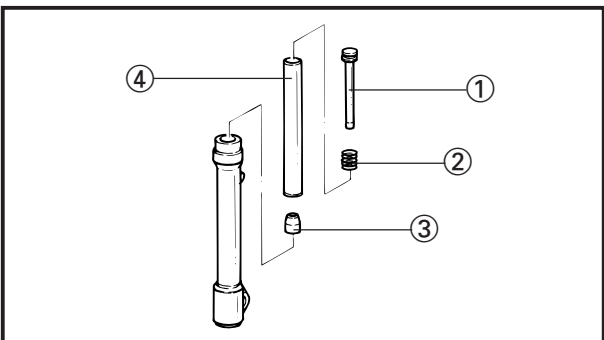

YP....

FRONT FORK ASSEMBLY

Reverse the "DISASSEMBLY" procedure.
Note the following points.

1. Install:
- Damper rod ①
 - Rebound spring ②
 - Oil lock piece ③
 - Inner tube ④

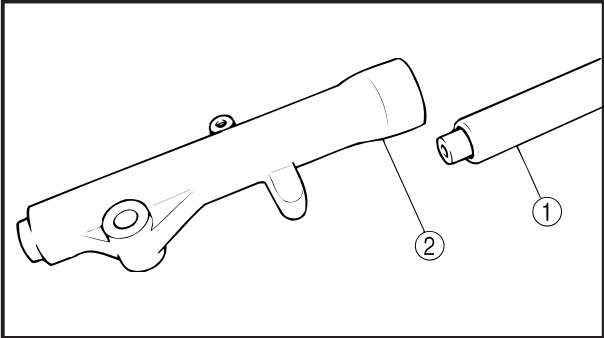

2. Install:
- Inner tube ①
 - Into outer tube ②.

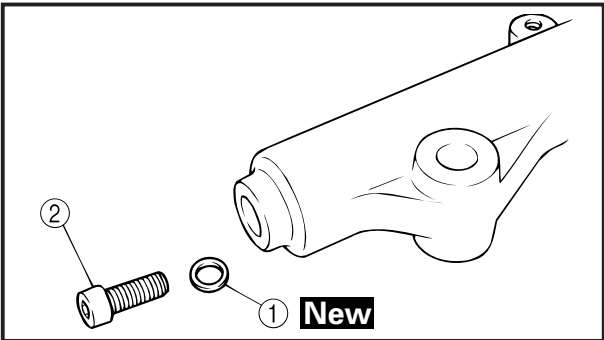

3. Install:
- Plain washer ① **New**
 - Bolt (damper rod) ②

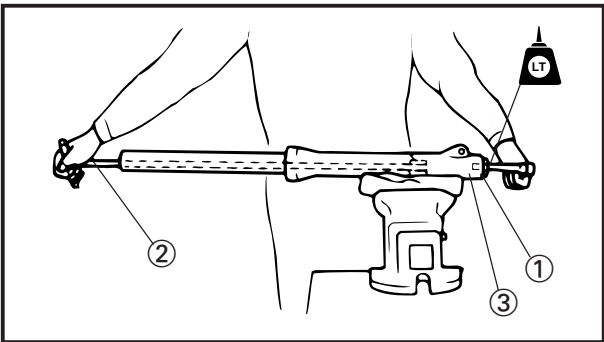

4. Tighten:
- Bolt (damper rod) ①

 23Nm(2.3 m.kg, 16.6ft.lb)

NOTE:

Tighten the damper rod bolt ① while holding the damper rod with a T-handle ② and holder ③.

	T-handle YM-01326-A
	Holder YM-01300-1

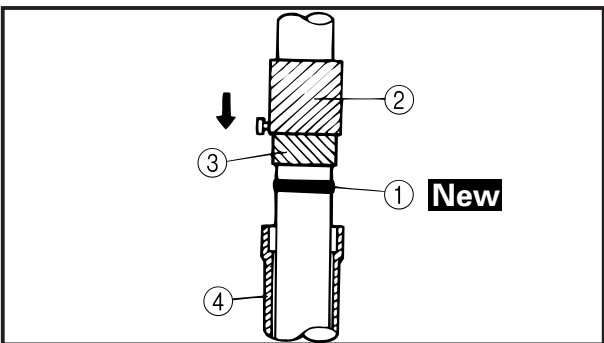

5. Install:
- Oil seal ① **New**
 - Retaining clip
 - Use the fork seal driver weight ② and the attachment ③.

NOTE:

- Before installing the oil seal ①, apply lithium soap base grease onto the oil seal lips.
- Adjust the retaining clip so that it fits into the outer tube groove.

CAUTION:

Make sure that the oil seal numbered side faces upward.

	Fork seal driver weight: YM-33963
	Attachment: YM-01400

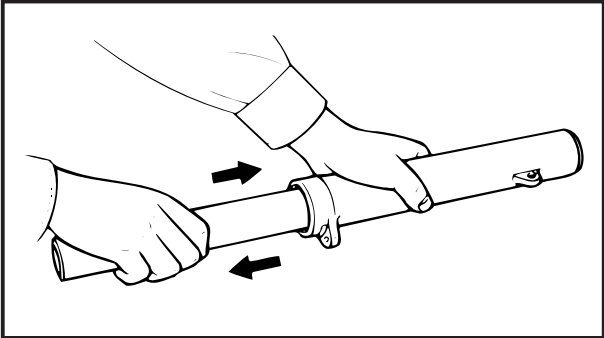

6. Inspect:
- Inner tube operation
- Unsmooth operation → Disassembly and recheck.

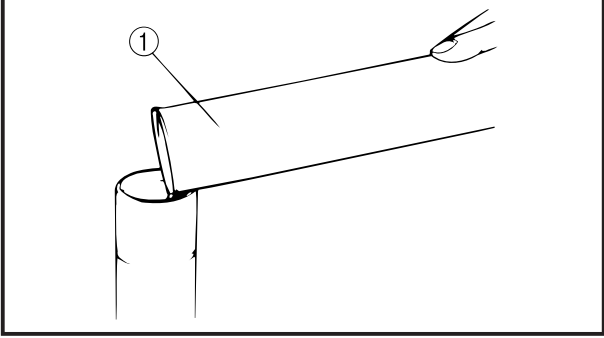

7. Fill:
- Fork oil ①

	Oil quantity:
	88 cc
	Recommended oil:
	Fork oil 10 W or equivalent

8. After filling up, slowly pump the fork up and down to distribute the fork oil.

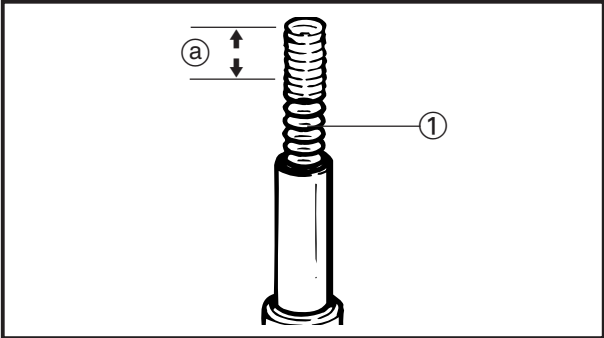

9. Install:
- Front fork spring ①

NOTE: _____

- Install the fork spring with its smaller pitch@a upward .
- Before installing the cap bolt, apply grease to the O-ring.
- Temporarily tighten the cap bolt.

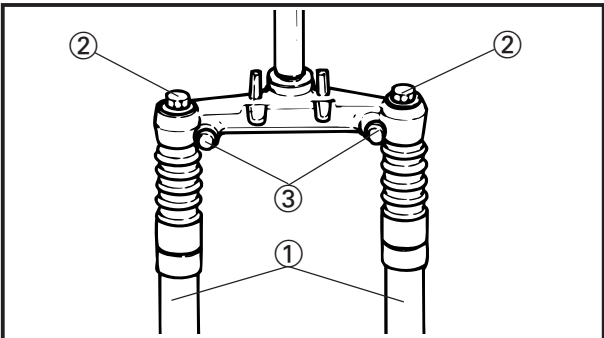

EB703050

FRONT FORK INSTALLATION

Reverse the "REMOVAL" procedure.



Note the following points.

1. Install:
- Front fork ①

NOTE: _____

Apply grease onto cap bolt O-ring before installing cap bolt.

2. Tighten:
- Cap bolts ②
 - Pinch bolts ③

	38Nm(3.8 m.kg, 27 ft.lb)
	40Nm(4.0 m.kg, 29 ft.lb)

ELECTRICAL

ELECTRICAL COMPONENTS

- ① Main switch
- ② Flasher relay
- ③ Oil level gauge
- ④ C.D.I. UNIT
- ⑤ Fuel level gauge
- ⑥ Starter relay
- ⑦ Fuse
- ⑧ Battery
- ⑨ Ignition coil
- ⑩ Rectifier/Regulator
- ⑪ Horn

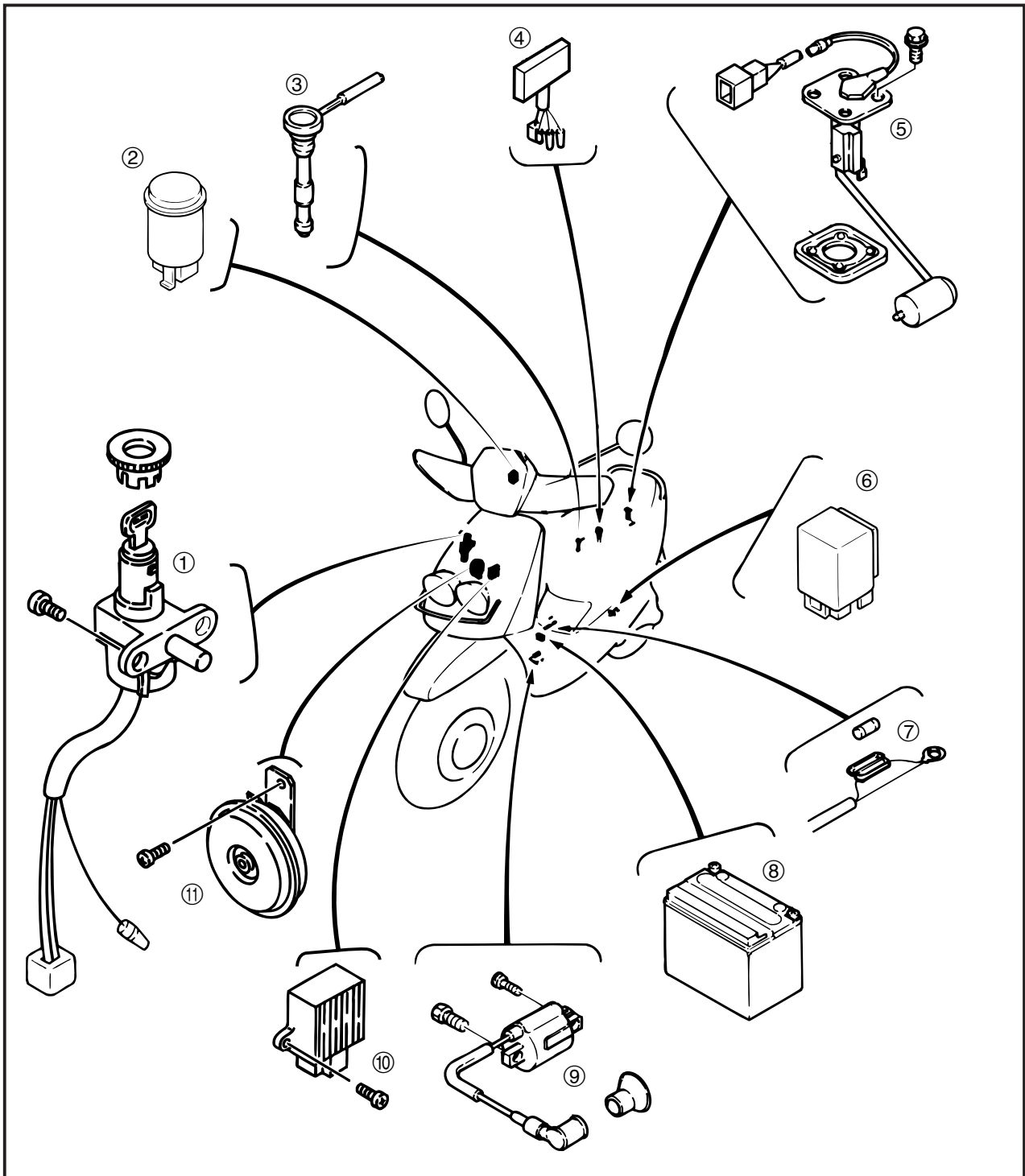

CIRCUIT DIAGRAM

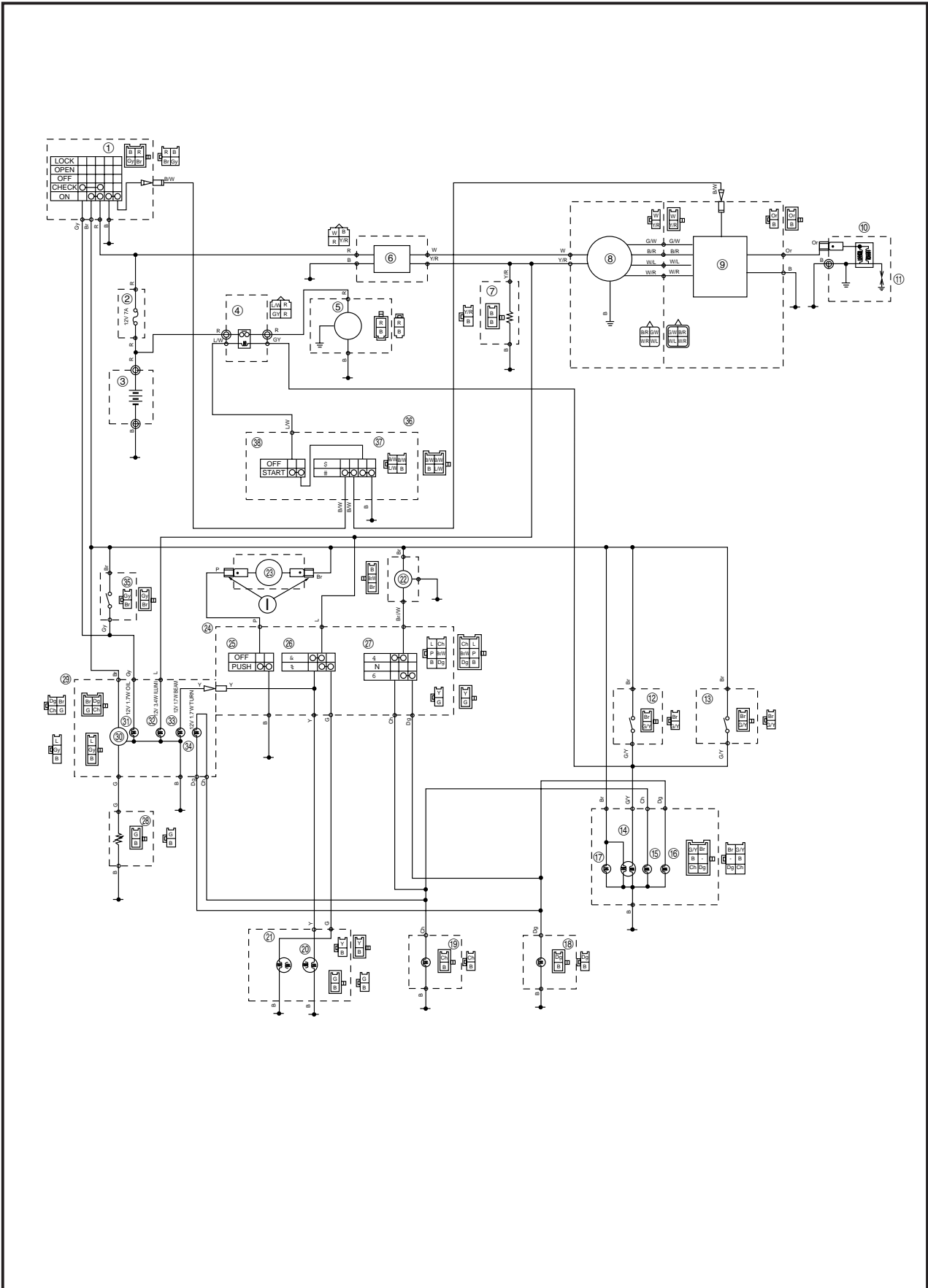

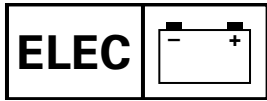

- ① Main switch
- ② Main fuse
- ③ Battery
- ④ Starter relay
- ⑤ Starter motor
- ⑥ Rectifier regulator
- ⑦ Auto choke
- ⑧ C.D.I. magneto
- ⑨ C.D.I. unit
- ⑩ Ignition coil
- ⑪ Spark plug
- ⑫ Rear brake switch
- ⑬ Front brake switch
- ⑭ Tail/Brake light
- ⑮ Rear flasher light(left)
- ⑯ Rear flasher light(right)
- ⑰ Licence light
- ⑱ Front flasher light(right)
- ⑲ Front flasher light(left)
- ⑳ Head light(for high beam)
- ㉑ Head light(for low beam)
- ㉒ Flasher relay
- ㉓ Horn
- ㉔ Handlebar switch (left)
- ㉕ Horn switch
- ㉖ Dimmer switch
- ㉗ Turn switch
- ㉘ Fuel sender
- ㉙ Meter
- ㉚ Fuel gauge
- ㉛ Oil indicator light
- ㉜ Meter light
- ㉝ High beam indicator light
- ㉞ Turn indicator light
- ㉟ Oil level gauge
- ㊱ Handlebar switch (right)
- ㊲ Starter switch
- ㊳ Engine stop switch

COLOR CODE

B	Black	Gy	Gray	L/R	Blue/ Red
Br	Brown	Y	Yellow	R/B	Red/Black
Ch	Chocolate	W	White	R/Y	Red/Yellow
Dg	Dark Green	B/R	Black/Red	R/W	Red/white
G	Green	Br/W	Brown/White	Y/R	Yellow/White
L	Blue	G/R	Green/Red	W/G	White/Green
Or	Orange	G/Y	Green/Yellow	G/W	Green/White
Sb	Sky blue	L/B	Blue/Black	W/R	White/Red
P	Pink	L/Y	Blue/Yellow	L/G	Blue/Green
R	Red	L/W	Blue/White		

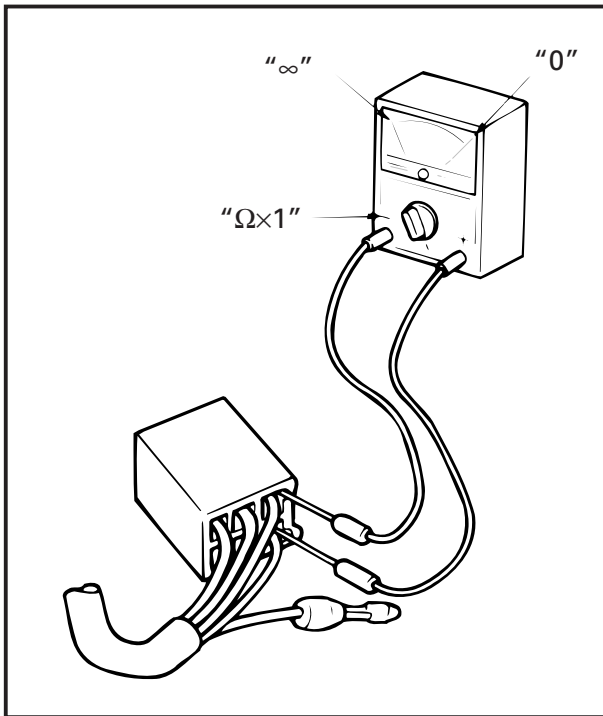
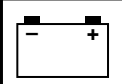

YP-N

CHECKING SWITCHES

CHECKING STEPS

Using pocket tester, check switches for continuity between their terminals to determine whether they are correctly connected.

Replace the switch component if any of the combinations does not produce the correct reading.



Pocket tester:
YU-03112

NOTE:

- Turn the switch to the "ON", "OFF" positions several times.
- Adjust the pocket tester to correct "0" position before checking switches.
- Set the pocket tester selector to "×1"Ω.

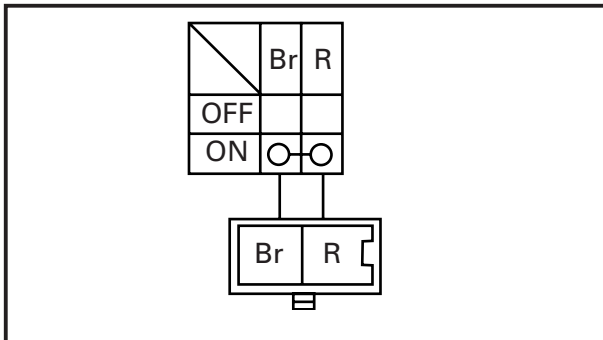

SWITCH CONNECTION AS SHOWN IN THIS MANUAL

This manual contains connection charts, like the one shown on the left, showing the terminal connections of switches (e.g. the main switch, handlebar switch, brake switch, lighting switch etc.)

The column on the extreme left indicates the different switch positions, the top line indicates the colors of the leads connected to the terminals on the switch.

"○—○" indicates terminals between which there is continuity, i.e. a closed circuit, in the given switch position.

In this chart:

"Br and R" have continuity with the switch in the "ON" position.

SWITCH POSITION AND TERMINAL CONNECTION

Before checking a switch refer to the checking switches as shown in the left page and check for the correct terminal connections (closed circuit) according to the color combinations shown in the chart.

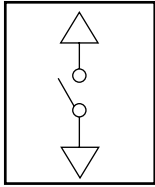

Poor connection, fault → Repair or replace.

Rear brake switch



Main switch

	Gy	Br	R	B	B/W
LOCK					
OPEN					
OFF					
*	○		○		
ON		○	○	○	○

Front brake switch



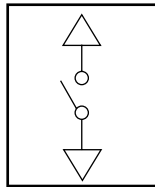

Horn switch

	P	B
Release		
Push in	○	○

Ch	L
Br/W	P
Dg	B

Dimmer switch

	G	L	Y
		○	○
	○	○	

Y
G

Turn switch

	Ch	Br/W	Dg
←	○	○	
-			
→		○	○

Start switch

	L/W	L/G
Release		
Push in	○	○

B/W	B/W
B	L/W

Engine stop switch

	B/W	B/W	L/G	B
OFF				
RUN	○	○	○	○

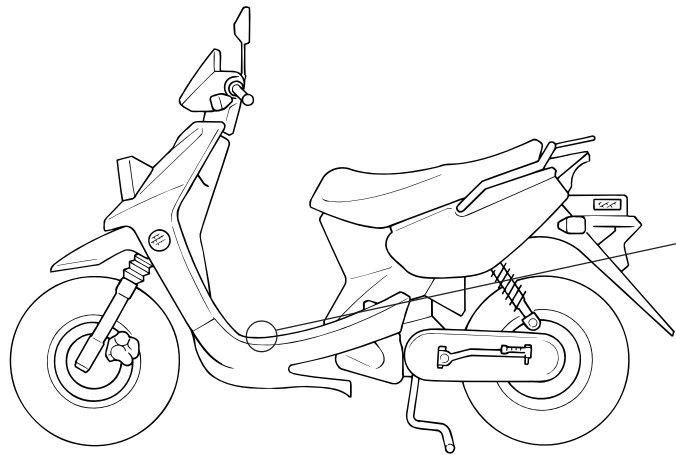

Fuse

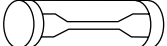

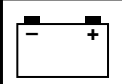

EAS00733

CHECKING THE BULBS AND BULB SOCKETS

Check each bulb and bulb socket for damage or wear, proper connections, and also for continuity between the terminals.

Damage/wear → Repair or replace the bulb, bulb socket or both.

Improperly connected → Properly connect.

No continuity → Repair or replace the bulb, bulb socket or both.

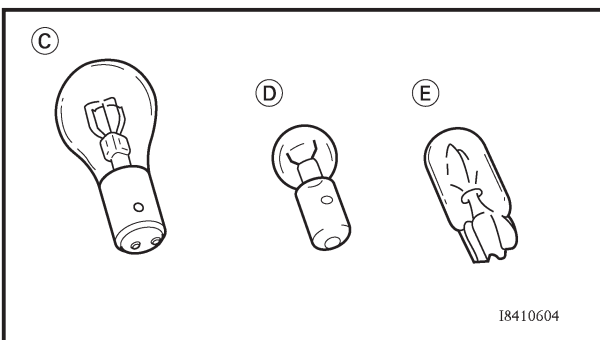
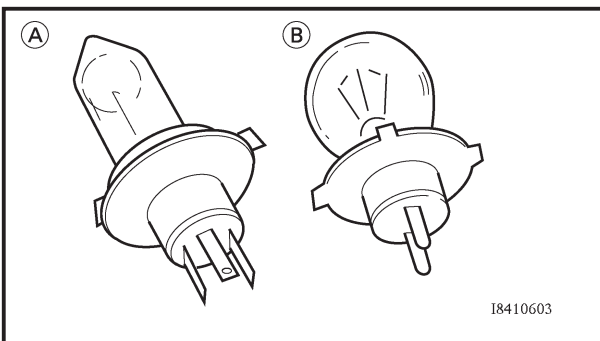

TYPES OF BULBS

The bulbs used on this scooter are shown in the illustration on the left.

- Bulbs **A** and **B** are used for the headlights and usually use a bulb holder that must be detached before removing the bulb. The majority of these types of bulbs can be removed from their respective socket by turning them counterclockwise.
- Bulbs **C** are used for turn signal and tail/brake lights and can be removed from the socket by pushing and turning the bulb counterclockwise.
- Bulbs **D** and **E** are used for meter and indicator lights and can be removed from their respective socket by carefully pulling them out.

CHECKING THE CONDITION OF THE BULBS
 The following procedure applies to all of the bulbs.

1. Remove:
 - bulb

⚠ WARNING

Since the headlight bulb gets extremely hot, keep flammable products and your hands away from the bulb until it has cooled down.

CAUTION:

- Be sure to hold the socket firmly when removing the bulb. Never pull the lead, otherwise it may be pulled out of the terminal in the coupler.
- Avoid touching the glass part of the headlight bulb to keep it free from oil, otherwise the transparency of the glass, the life of the bulb, and the luminous flux will be adversely affected. If the headlight bulb gets soiled, thoroughly clean it with a cloth moistened with alcohol or lacquer thinner.

2. Check:
 - bulb (for continuity)
 (with the pocket tester)
 No continuity → Replace.

	Pocket tester YU-03112
---	---------------------------

NOTE:

Before checking for continuity, set the pocket tester to "0" and to the " $\Omega \times 1$ " range.

- a. Connect the positive tester probe to terminal ① and the negative tester probe to terminal ②, and check the continuity.
- b. Connect the positive tester probe to terminal 1 and the negative tester probe to terminal ③, and check the continuity.
- c. If either of the readings indicate no continuity, replace the bulb.

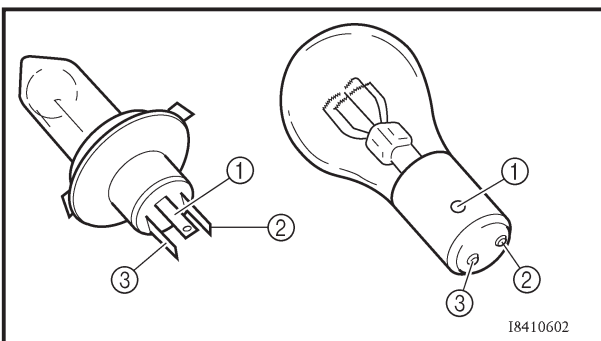

CHECKING THE CONDITION OF THE BULB SOCKETS

The following procedure applies to all of the bulb sockets.

1. Check:
 - bulb socket (for continuity)
(with the pocket tester)
No continuity → Replace.



NOTE: _____

Check each bulb socket for continuity in the same manner as described in the bulb section; however, note the following.

- a. Install a good bulb into the bulb socket.
- b. Connect the pocket tester probes to the respective leads of the bulb socket.
- c. Check the bulb socket for continuity. If any of the readings indicate no continuity, replace the bulb socket.

IGNITION SYSTEM CIRCUIT DIAGRAM

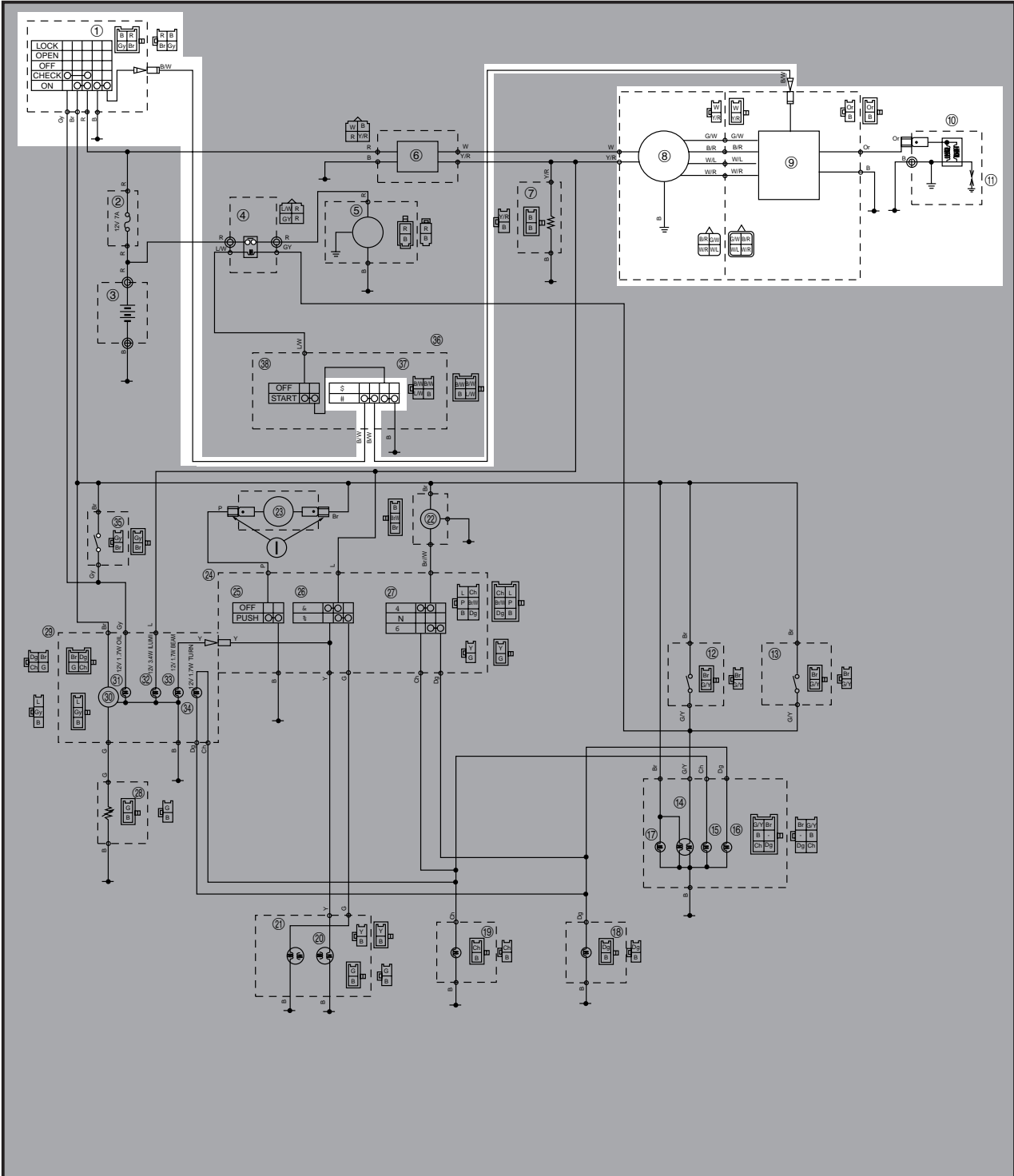

- ① Main switch
- ⑧ C.D.I. magneto
- ⑨ C.D.I. unit
- ⑩ Ignition coil
- ⑪ Spark plug
- ⑳ Engine stop switch

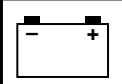

TROUBLESHOOTING

IF IGNITION SYSTEM SHOULD BECOME INOPERATIVE (NO SPARK OR INTERMITTENT SPARK)

NOTE:

- Remove the following parts before troubleshooting.
 - Battery box cover
 - Center cowling
 - Rear carrier
 - Tail cover
 - Side cover (right)
 - Handlebar cover (front)
- Use the following special tools in this troubleshooting.

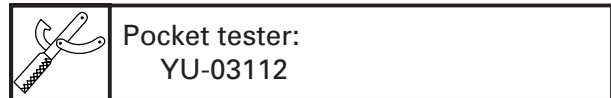
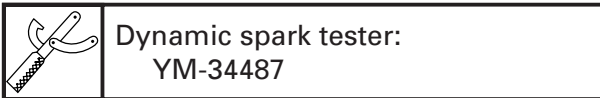

1. Spark plug

- Check the spark plug condition.
- Check the spark plug type.
- Check the spark plug gap. Refer to the "SPARK PLUG INSPECTION" section in the CHAPTER 3.

Standard spark plug:
BPR7HS (NGK)

Spark plug gap:
0.6~0.7 mm(0.02~0.03 in)

INCORRECT

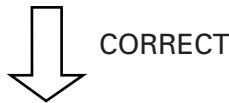

Spark plug is faulty, replace it or repair plug gap.

2. Ignition spark gap

- Disconnect the spark plug cap from spark plug.
- Connect the dynamic spark tester ① as shown.
- ② Spark plug cap
- Check the ignition spark gap ③.
- Start engine, and increase spark gap until misfire occurs.

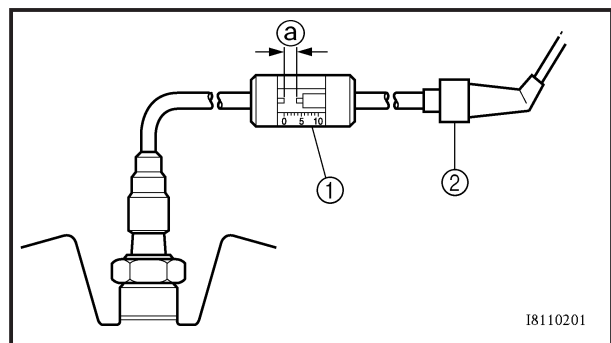

MEETS SPECIFICATION

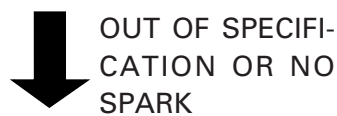

*

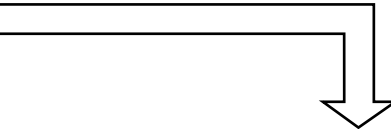

Ignition system is good.

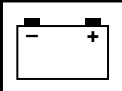

3. Spark plug cap resistance

- Remove the spark plug cap.
- Connect the pocket tester ($\Omega \times 1k$) to the spark plug cap.
- Check the spark plug cap for specified resistance.

Spark plug cap resistance:
5k Ω at 20°C (68°F)

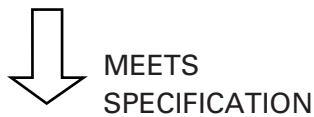
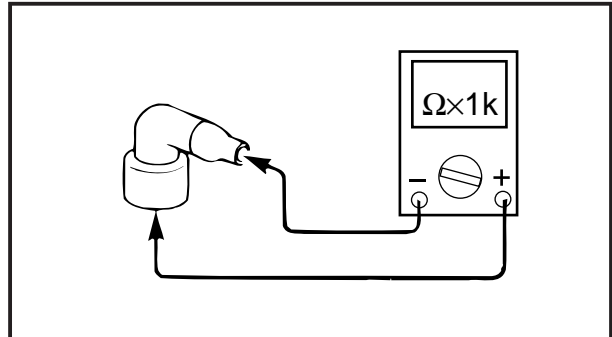

OUT OF SPECIFICATION

4. Ignition coil resistance

- Disconnect the ignition coil leads from the ignition coil.
- Connect the pocket tester ($\Omega \times 1$) to the ignition coil.

Ignition coil:
Tester (+) lead → Terminal ①
Tester (-) lead → Coil base ②

- Check the primary coil for specification resistance.

Primary coil resistance:
0.32~0.48 Ω at 20°C (68°F)

- Connect the pocket tester ($\Omega \times 1 k$) to the ignition coil.

Tester (+) lead → Spark plug lead ①
Tester (-) lead → Coil base ②

- Check the secondary coil for specified resistance.

Secondary coil resistance:
5.68 ~ 8.52 k Ω at 20°C (68°F)
(Spark plug lead - Coil base)

Replace spark plug cap.

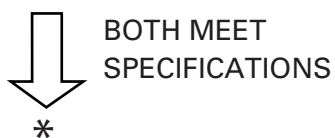
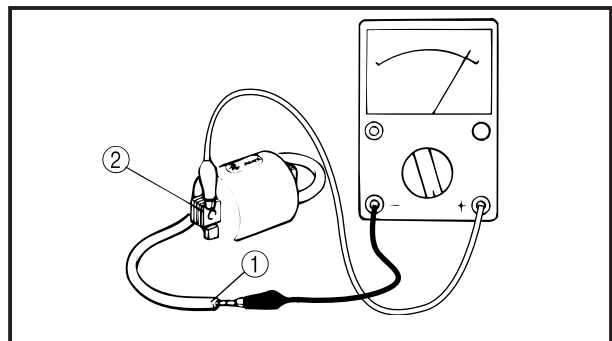
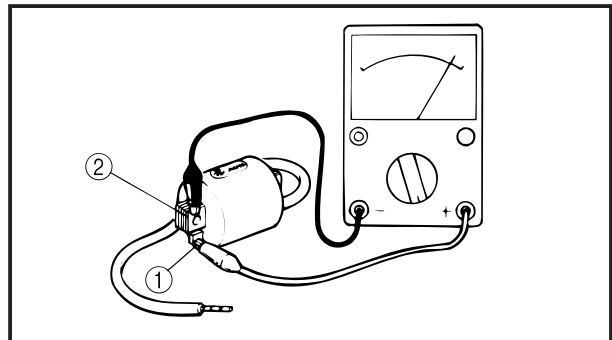

OUT OF SPECIFICATION

Ignition coil is faulty, replace it.

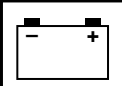

5. Pickup coil resistance

- Disconnect the pickup coil coupler from the wireharness.
- Connect the pocket tester ($\Omega \times 100$) to the pickup coil terminal.

Tester (+) lead → White/Red lead ①
 Tester (-) lead → White/Blue ②

- Check the pickup coil for specified resistance.

 Pickup coil resistance:
 248 ~ 372 Ω at 20°C (68°F)
 (White/Red-White/Blue)

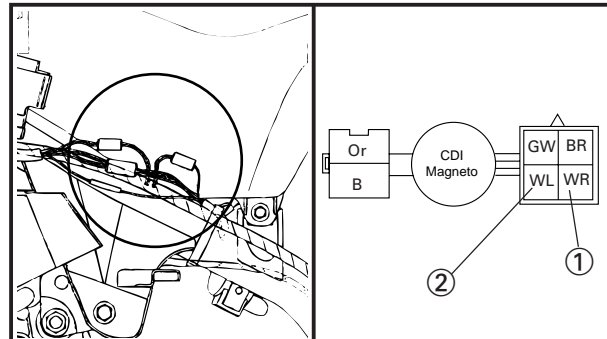

OUT OF SPECIFICATION

Pickup coil is faulty, replace it.

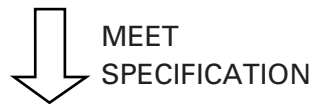

6. Source resistance

- Disconnect the source coil coupler from the wireharness.
- Connect the pocket tester ($\Omega \times 100$) to the source coil terminal.

Tester (+) lead → Black/Red lead ①
 Tester (-) lead → Green/White ②

- Check the source coil for specified resistance.

 Source coil resistance:
 640 ~ 960 Ω at 20°C (68°F)
 (Black/Red - Green/White)

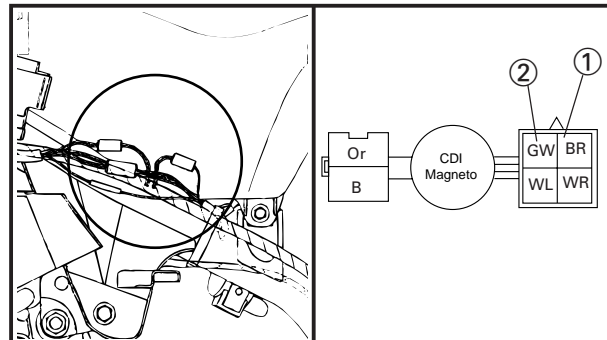

OUT OF SPECIFICATION

Source coil is faulty, replace it.

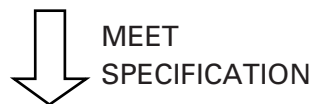

7. Main switch
 Refer to "CHECKING SWITCHES" section.

NO CONTINUITY

Main switch is faulty, replace it.



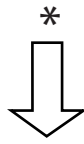
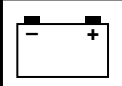

8. Engine stop switch
Refer to "CHECKING SWITCHES" section.

NO CONTINUITY

Engine stop switch is faulty, replace it.

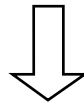

CONTINUITY

9. Wiring connection
Check the entire ignition system for connections.
Refer to the "WIRING DIAGRAM" section.

POOR CONNECTION

Correct.

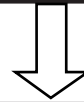

CORRECT

Replace CDI unit.

CHARGING SYSTEM
CIRCUIT DIAGRAM

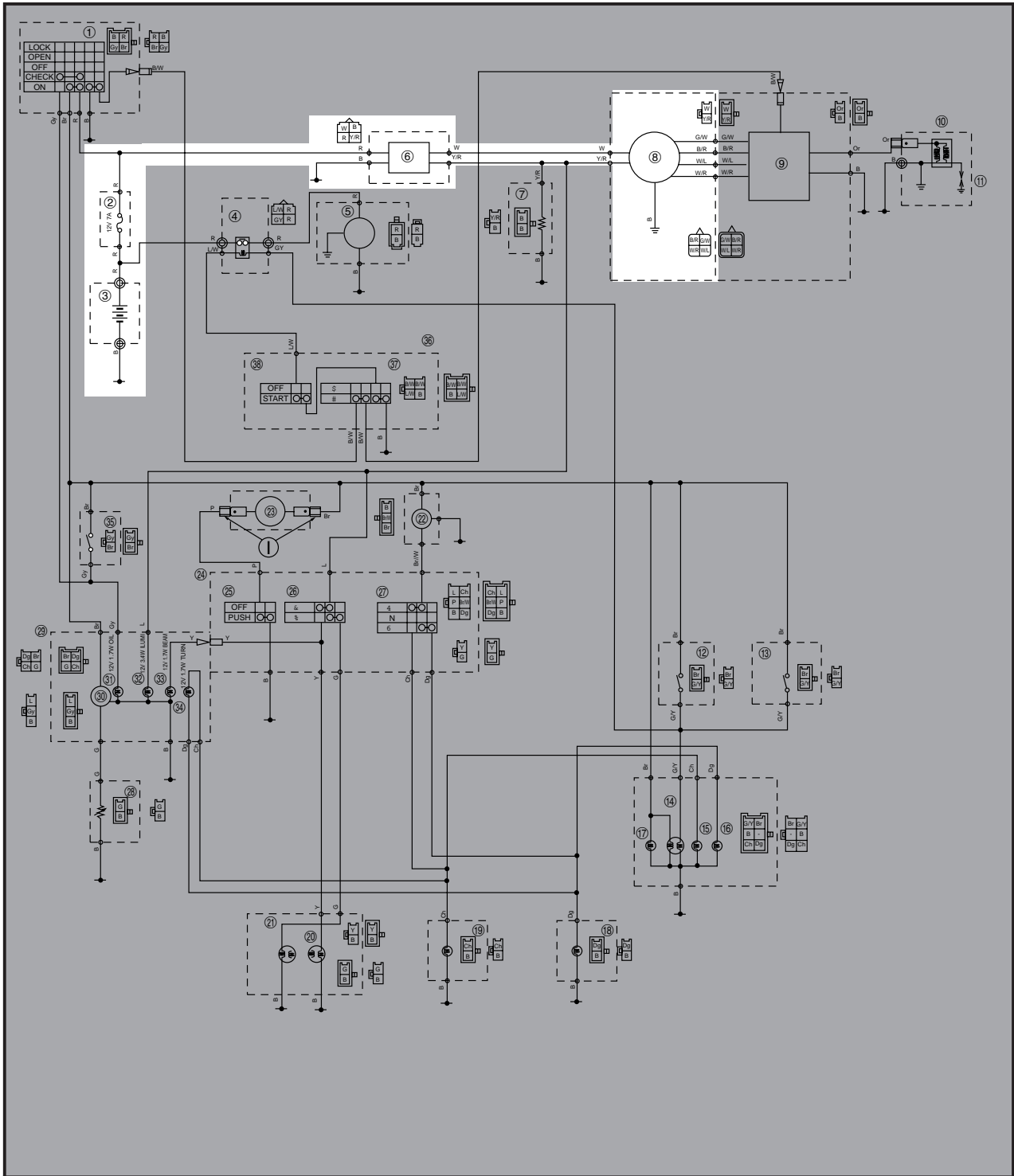

- ② Main fuse
- ③ Battery
- ⑥ Rectifier Regulator
- ⑧ CDI magnet

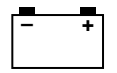

TROUBLESHOOTING

THE BATTERY IS NOT CHARGED.

NOTE:

- Remove the following parts before troubleshooting.
 - 1) Front protector bar
 - 2) Upper cover
 - 3) Rear carrier
 - 4) Tail cover
 - 5) Right side cover
- Use the following special tool (s) in this troubleshooting.



Inductive tachometer:
YU-8036-A



Pocket tester:
YU-03112

1. Fuse (main)

- Remove the fuse.
- Connect the pocket tester ($\Omega \times 1$) to the fuse.
- Check the fuse for continuity.

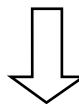

CONTINUITY

NO CONTINUITY



Fuse is faulty, replace it.

2. Battery

- Check the battery condition
Refer to the "BATTERY INSPECTION" section in the CHAPTER 3.



Open circuit voltage:
12.8V or more at 20°C (68°F)

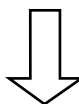

CORRECT

INCORRECT



- Clean battery terminals.
- Recharge or replace battery.

*

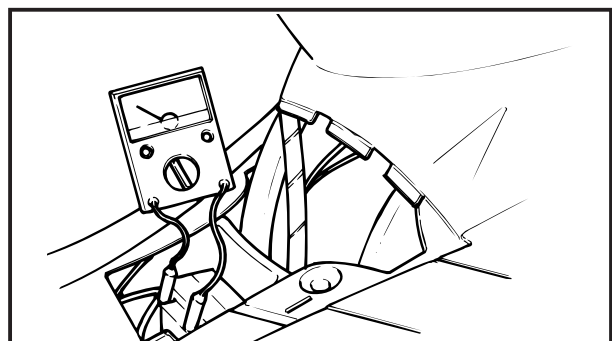

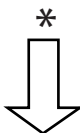

3. Charging voltage

- Connect the inductive tachometer to the spark plug lead.
- Connect the pocket tester (DC20V) to the battery.

Tester (+) lead → Battery (+) terminal
Tester (-) lead → Battery (-) terminal

- Start the engine and accelerate to about 5,000 r/min.
- Check charging voltage.

 Charging voltage:
13 ~ 14 V at 4,000 r/min

NOTE: _____
Use a full charged battery.

MEETS SPECIFICATION

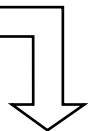

Charging circuit is good.

OUT OF SPECIFICATION

4. Charging coil and lighting coil resistance

- Disconnect the charging coil coupler from the wireharness.
- Connect the pocket tester " $\Omega \times 1$ " to the charging coils.
- Measure the charging coil and lighting coil resistance.

Charging coil resistance:
Tester (+) lead → White lead ①
Tester (-) lead → Earth

Lighting coil resistance:
Tester (+) lead → Yellow/Red ②
Tester (-) lead → Earth

 Charging coil resistance:
0.48~0.72 Ω at 20°C (68°F)
Lighting coil resistance:
0.4~0.6 Ω at 20°C (68°F)

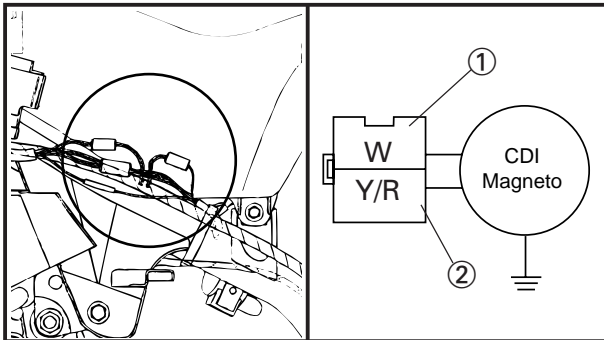

OUT OF SPECIFICATION



Charging coil is faulty, replace it.

MEET SPECIFICATION

*

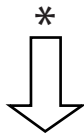
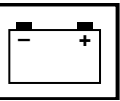

5. Wiring connection
Check the entire ignition system for connections.
Refer to the "WIRING DIAGRAM" section.

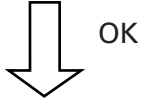

Replace rectifier regulator.

POOR CONNECTION



Correct.

**ELECTRIC STARTING SYSTEM
CIRCUIT DIAGRAM**

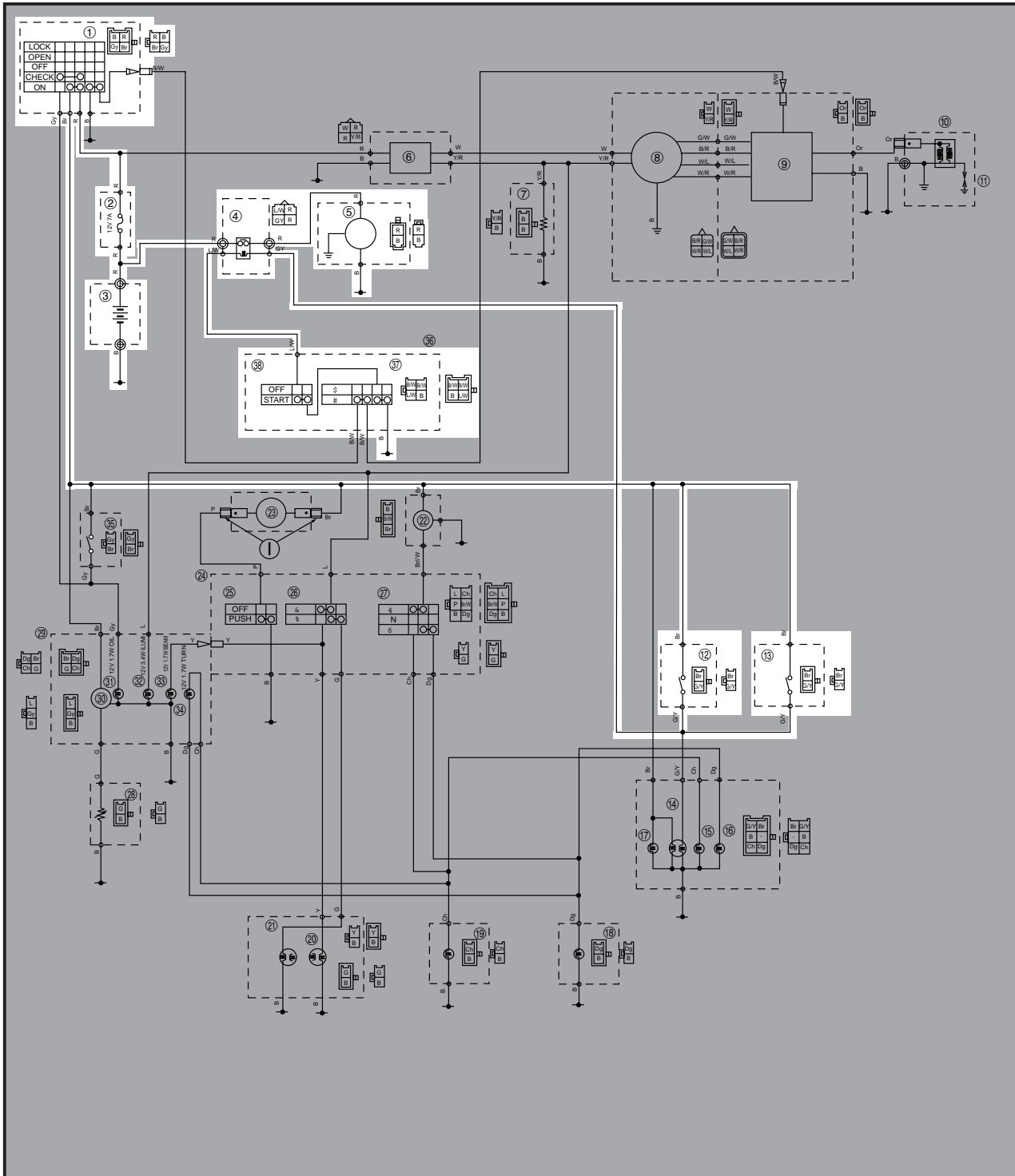

- ① Main switch
- ② Main fuse
- ③ Battery
- ④ Starter relay
- ⑤ Starter motor
- ⑫ Rear brake switch
- ⑬ Front brake switch
- ⑰ Engine stop switch
- ⑱ Starter switch

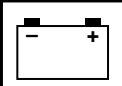

TROUBLESHOOTING

STARTER MOTOR DOES NOT OPERATE.

NOTE:

- Remove the following parts before troubleshooting.

1) Battery box cover	4) Side covers (left and right)
2) Rear carrier	5) Trunk
3) Tail cover	6) Handlebar cover (front)
- Use the following special tool in this troubleshooting.



Pocket tester:
YU-03112

1. Fuse

- Remove the fuse.
- Connect the pocket tester ($\Omega \times 1$) to the fuse.
- Check the fuse for continuity.

NO CONTINUITY

Fuse is faulty, replace it.

CONTINUITY

2. Battery

- Check the battery condition. Refer to the "BATTERY INSPECTION" section in the CHAPTER 3.

Open circuit voltage:
12.8 V or more at 20°C (68°F)

INCORRECT

- Clean battery terminals.
- Recharge or replace battery.

CORRECT

3. Starter motor

- Connect the battery ① positive terminal and starter motor cable ② using a jumper lead ③ *.

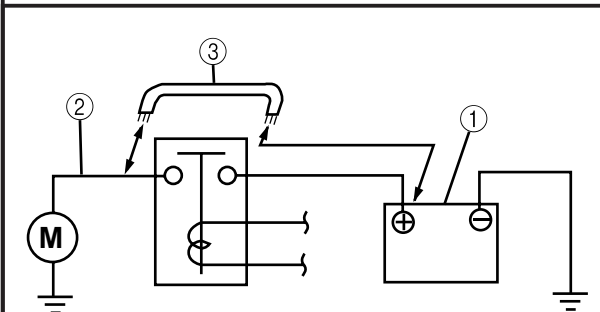

- Check the starter motor for operation.

⚠ WARNING

- A wire for the jumper lead must have the equivalent capacity as that of the battery lead or more, otherwise it may cause the jumper lead to be burned.
- This check is likely to produce sparks, so be sure that no flammable gas or fluid is in the vicinity.

DOES NOT MOVE

Starter motor is faulty, repair or replace it.

MOVES

*

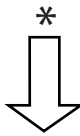
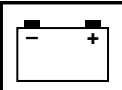

<p>4. Starter relay</p> <ul style="list-style-type: none"> • Disconnect the relay unit coupler from the wire harness. • Connect the pocket tester ($\Omega \times 1$) and battery (12V) to the relay unit coupler terminals.
<p>Battery (+) lead → Blue/White terminal ①</p> <p>Battery (-) lead → Green/Yellow terminal ②</p>
<ul style="list-style-type: none"> • Check the starter relay for continuity.
<p>Tester (+) lead → ③ terminal</p> <p>Tester (-) lead → ④ terminal</p>

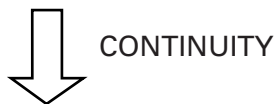
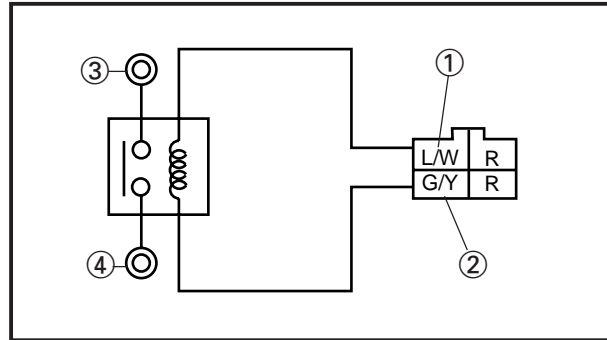

<p>5. Main switch</p> <p>Refer to "CHECKING SWITCHES" section.</p>



<p>6. "START" switch</p> <p>Refer to "CHECKING SWITCHES" section.</p>
--



<p>7. Engine stop switch</p> <p>Refer to "CHECKING SWITCHES" section.</p>
--



NO CONTINUITY

Replace the starter relay.

NO CONTINUITY

Main switch is faulty, replace it.

NO CONTINUITY

"START" switch is faulty, replace handlebar switch (right).

Engine stop switch is faulty, replace it.



8. Brake switches (front and rear)

- Disconnect the brake switch leads from the wire harness.
- Connect the pocket tester ($\Omega \times 1$) to the brake switch leads.

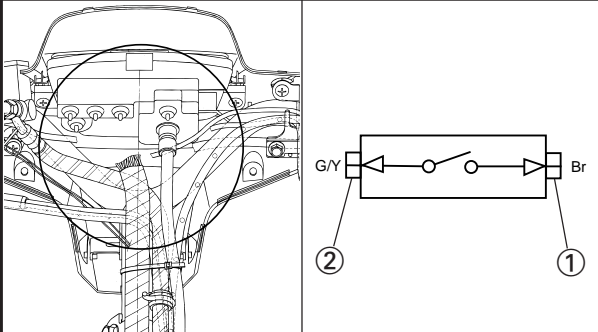

- Check the brake switch for continuity

Switch Position	Good condition			Bad condition	
Brake is applied	○	×	×	○	○
Brake is not applied	×	○	×	○	○

○:Continuity ×:No continuity



9. Wiring connection

- Check the entire electrical starting system for connections. Refer to "WIRING DIAGRAM" section.

BAD CONDITION

Replace brake switch(es).

POOR CONNECTION

Correct.

STARTER MOTOR

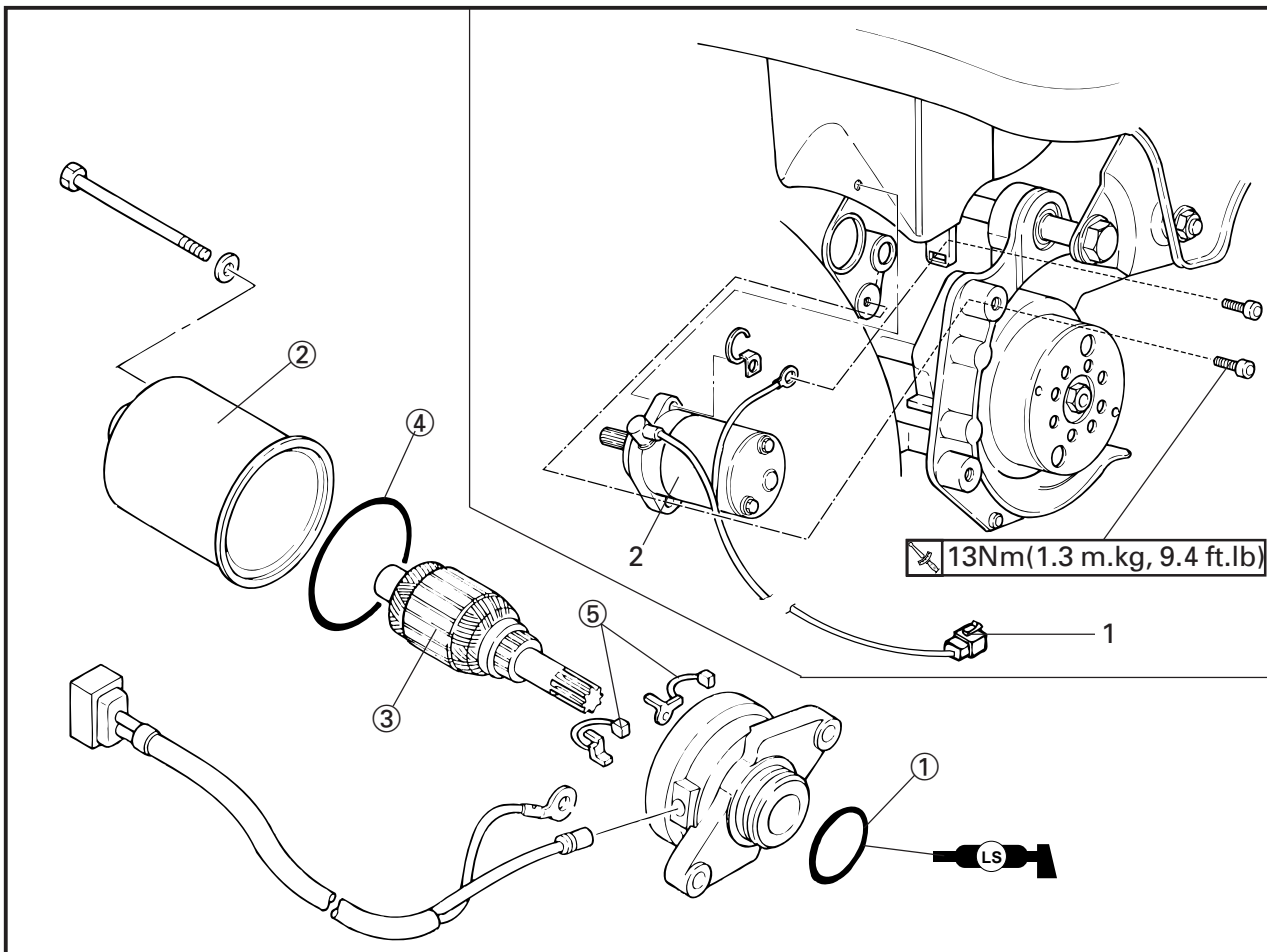

Order	Job name/Part name	Q'ty	Remarks
	Starter motor removal		Remove the parts in order.
	Rear carrier		Refer to "COVER PANEL" section in CHAPTER 3. Refer to "REAR WHEEL AND REAR BRAKE" section in CHAPTER 6. Refer to "ENGINE REMOVAL" section chapter 4.
	Tail cover		
	Battery box cover		
	Left/Right side cover		
	Center cowling		
	Muffler		
	Rear wheel		
	Air shroud 3		
1	Starter motor coupler	2	
2	Starter motor	1	Reverse the removal procedure for installation.



STARTER MOTOR DISASSEMBLY

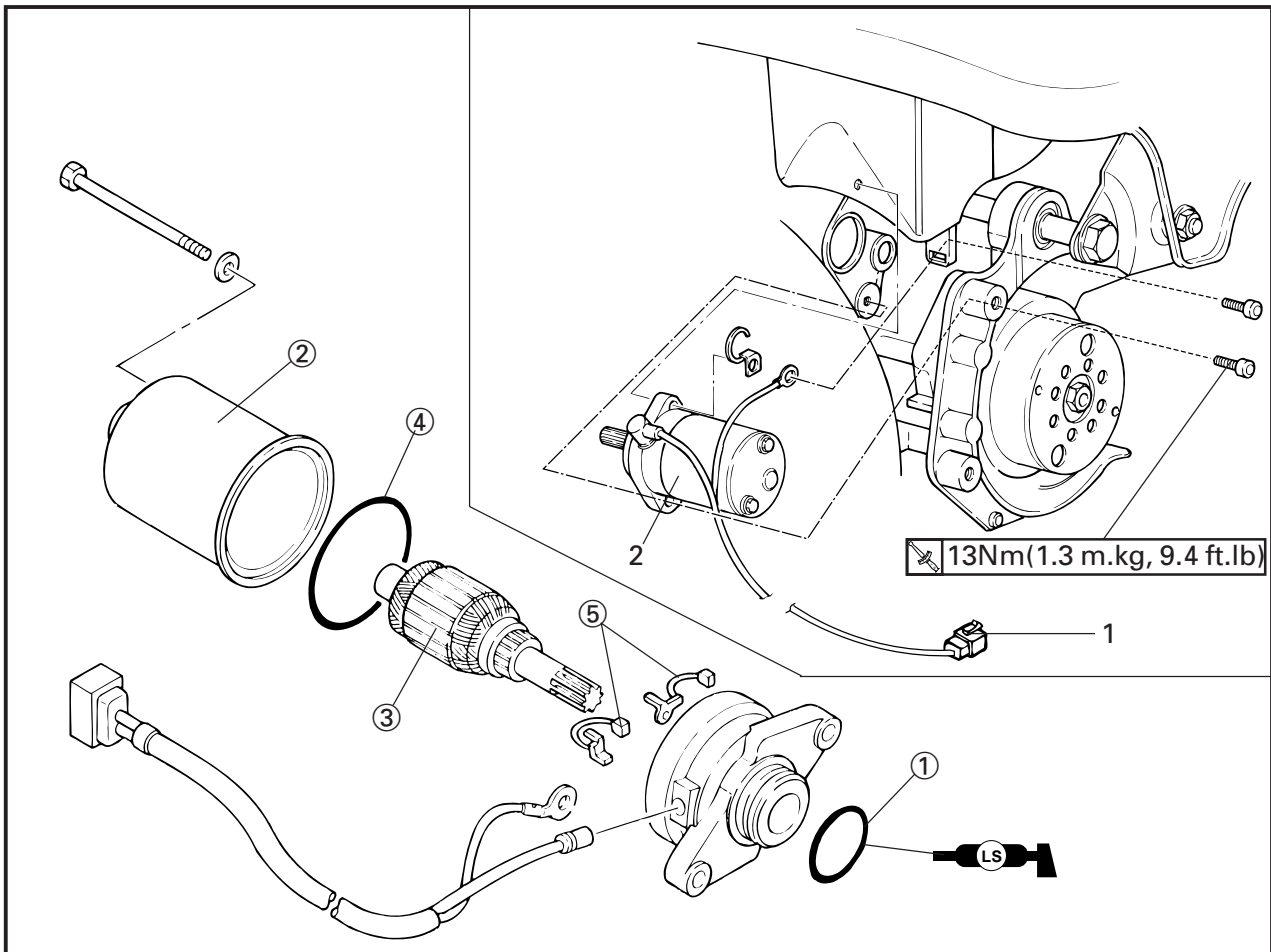

Order	Job name/Part name	Q'ty	Remarks
	Starter motor disassembly		Disassembly the parts in order.
①	O-ring	1	Refer to "Starter motor assembly"
②	Rear bracket	1	
③	Armature ass'y	1	
④	Ring	1	
⑤	Brush holder set	1	
			Reverse the disassembly procedure for assembly.

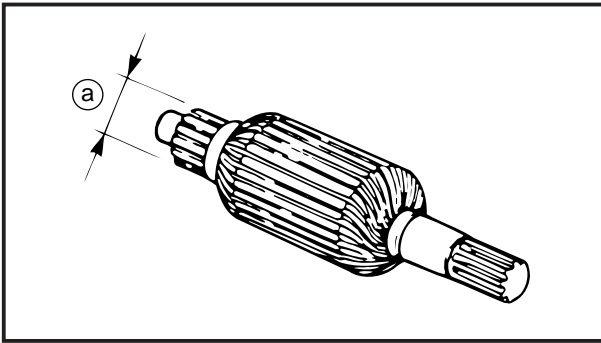
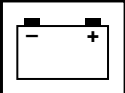

YP803034

INSPECTION AND REPAIR

1. Inspect:
 - Commutator
 - Dirt→Clean it with #600 grit sandpaper.
2. Measure:
 - Commutator diameter (a)



Commutator wear limit:
15.1 mm (0.59 in)

Out of specification→Replace the starter motor

3. Measure:
 - Mica undercut (a)



Mica undercut:
1.05 mm (0.04 in)

Out of specification→Scrape the mica to the proper value (a hacksaw blade can be ground to fit).

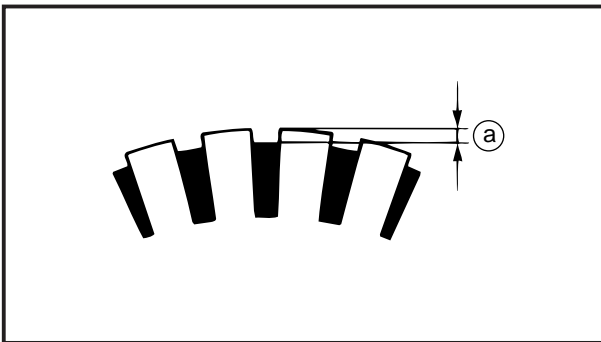

NOTE:

The mica insulation of the commutator must be undercut to ensure proper operation of commutator.

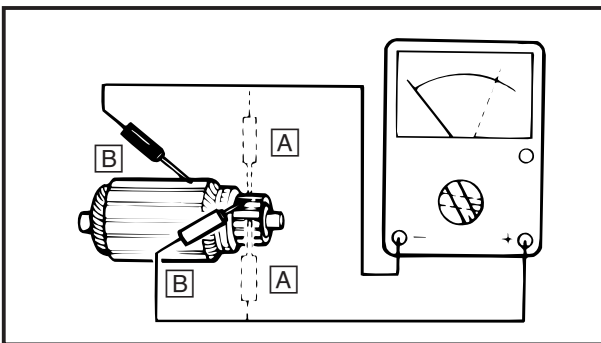

4. Inspect:
 - Armature coil resistances (installation/continuity)
 - Defects→Replace the starter motor.
 - If commutator is dirty, clean it with sandpaper.

	Good condition	Bad condition		
A	○	○	×	×
B	×	○	×	○

O: Continuity
x: No continuity
Bad condition→Replace.

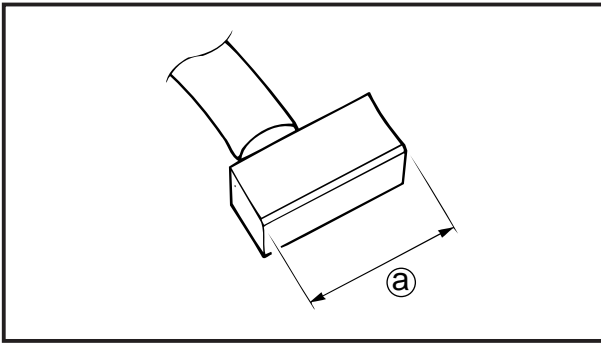
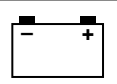

5. Measure:

- Brush length (a)

Out of specification → Replace.



Brush length wear limit
3.0 mm (0.012 in)

6. Measure:

- Brush spring force

Fatigue/out of specification → Replace as a set.

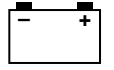

LIGHTING SYSTEM
CIRCUIT DIAGRAM

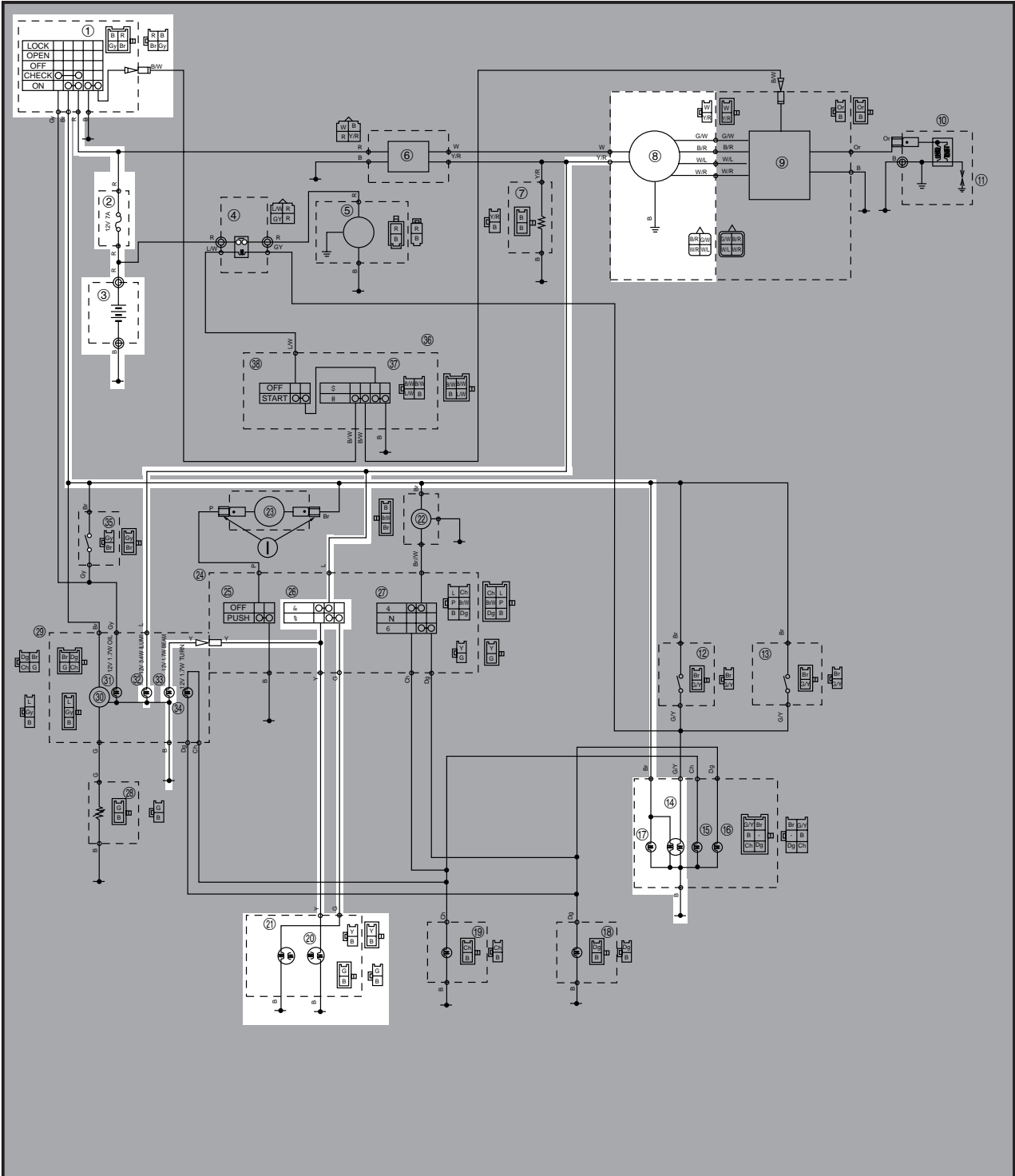

- | | |
|------------------|-----------------------------|
| ① Main switch | ⑳ Head light(for high beam) |
| ② Fuse | ㉑ Head light(for low beam) |
| ③ Battery | ㉒ Light dimmer switch |
| ⑧ C.D.I. magneto | ㉓ Meter light |
| ⑭ Tail light | ㉔ High beam indicator light |
| ⑰ Licence light | |

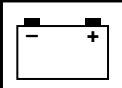

YP805010

TROUBLESHOOTING

IF THE HEADLIGHT, HIGH BEAM INDICATOR LIGHT, TAILLIGHT AND/OR METER LIGHT FAIL TO COME ON.

Procedure

Check:

1. Lights switch
2. Dimmer switch
3. Wiring connection (entire lighting system)

NOTE:

- Remove the following parts before troubleshooting.
 - 1) Front handlebar cover
 - 2) Rear carrier
 - 3) Right side cover
- Use the special tools specified in the troubleshooting section.

	Pocket tester: YU-03112
--	----------------------------

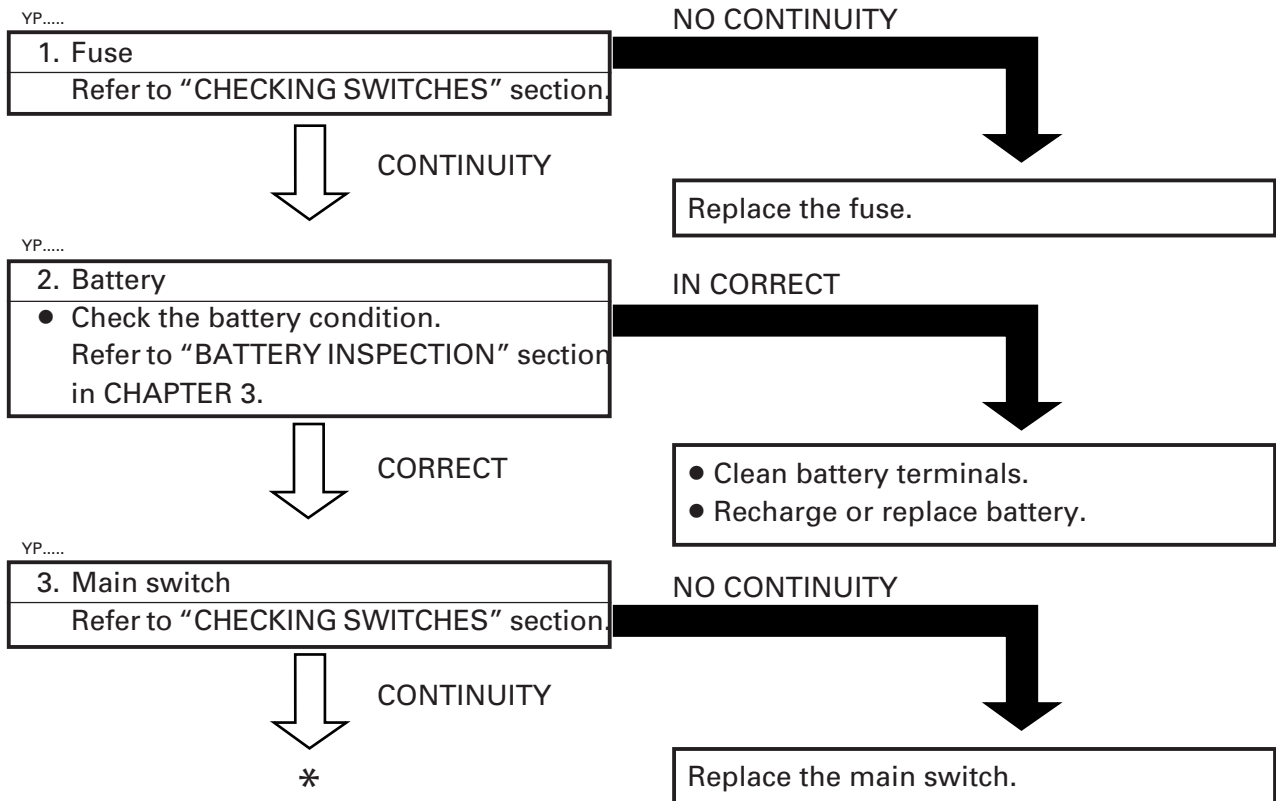

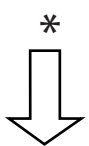

YP

4. Dimmer switch
Refer to "CHECKING SWITCHES" section.

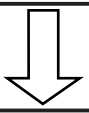

CONTINUITY

5. Lighting coil resistance

- Disconnect the lighting coil coupler from the wireharness.
- Connect the pocket tester " $\Omega \times 1$ " to the lighting coils.
- Measure the lighting coil resistances.

Tester (+) lead → Yellow/Red lead ①
Tester (-) lead → Earth



Lighting coil resistance:
0.4 ~ 0.6 Ω at 20°C (68°F)

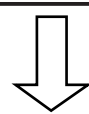

MEET SPECIFICATION

*

NO CONTINUITY

Replace the left handlebar switch.

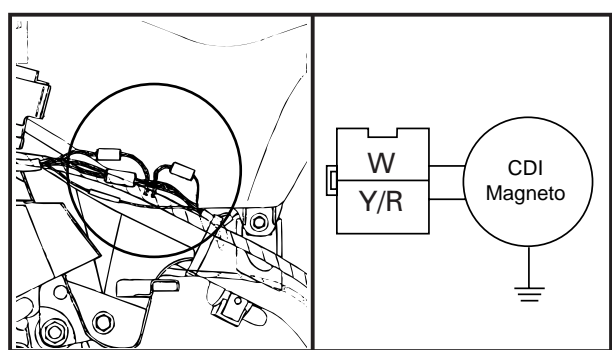

OUT OF SPECIFICATION

Lighting coil is faulty, replace it.

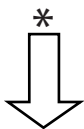

YP.....

6. Wiring connection
 • Check the connections of the entire lighting system.
 Refer to "WIRING DIAGRAM".

POOR CONNECTIONS



Correct.

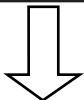

Check the condition of each of the lighting system's circuits.
 Refer to "LIGHTING SYSTEM CHECK"

YP805020

LIGHTING SYSTEM CHECK

1. If the headlight and the high beam indicator light fail to come on.

1. Bulb and bulb socket
 Refer to "CHECKING SWITCHES" section.

NO CONTINUITY

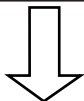

2. Voltage
 • Connect the pocket tester (DC20V) to the headlight and high beam indicator light couplers.

Replace the bulb and/or bulb socket.

- [A] When the dimmer switch is on low beam.
- [B] When dimmer switch is on high beam.

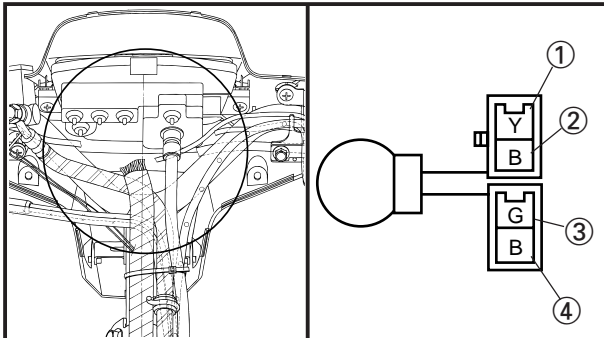

Headlight(low beam):
 Tester (+) lead→Green ① lead
 Tester (-) lead→Black ② lead
Headlight(high beam):
 Tester (+) lead→Yellow ③ lead
 Tester (-) lead→Black ④ lead

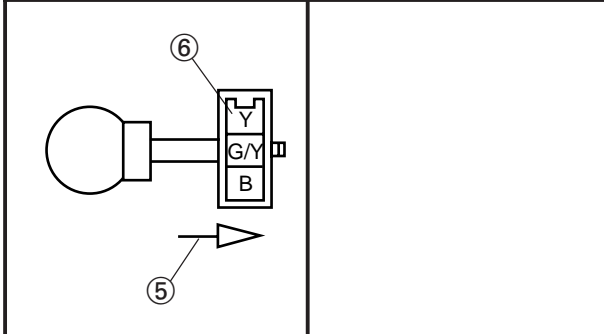

High beam indicator light:
 Tester (+) lead→Yellow ⑤ lead
 Tester (-) lead→Black ⑥ lead

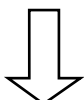

*

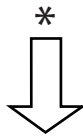
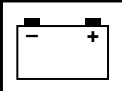

- Turn the main switch to on.
- Start the engine.
- Turn the dimmer switch to low beam or high beam.
- Check for voltage (12V) on the lead at bulb socket connectors.

OUT OF SPECIFICATION

The wiring circuit from the main switch to bulb socket connector is faulty. Repair.

MEETS SPECIFICATION

This circuit is not faulty.

YP805021

2. If the meter light fails to come on.

1. Bulb and bulb socket
Refer to "CHECKING SWITCHES" section.

NO CONTINUITY

Replace the bulb and/or bulb socket.

CONTINUITY

2. Voltage
- Connect the pocket tester (DC20V) to the bulb socket coupler.

Tester (+) lead →
Blue terminal ①

Tester (-) lead →
Black terminal ②

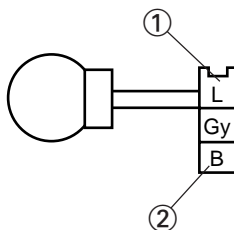
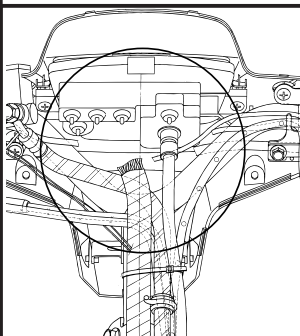

- Turn the main switch to on.
- Start the engine.
- Check the voltage (12V) of the leads on the bulb socket connector.

OUT OF SPECIFICATION

The wiring circuit from main switch to bulb socket is faulty. Repair.

MEETS SPECIFICATION

This circuit is not faulty.

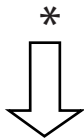
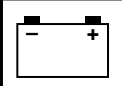

3. Licence light does not come on.

1. Bulb and bulb socket

- Check the bulb and bulb socket for continuity

NO CONTINUITY

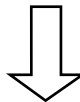

CONTINUITY

Bulb and/or bulb socket are faulty, replace.

2. Voltage

- Connect the pocket tester (DC20V) to the bulb socket connector.

Tester (+) lead → Brown ① lead.
 Tester (-) lead → Black ② lead.

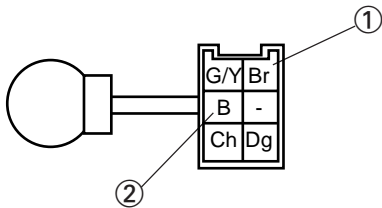

OUT OF SPECIFICATION

- Turn the main switch to on.
- Check the voltage (12V) on the "Brown" lead at the bulb socket connector.

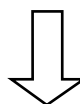

MEETS SPECIFICATION (12V)

Wiring circuit from main switch to bulb socket connector is faulty. Repair.

This circuit is not faulty.

YP805022

3. The taillight fails to come on.

1. Bulb and bulb socket
Refer to "CHECKING SWITCHES" section.

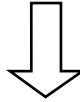

CONTINUITY

NO CONTINUITY



Replace the bulb and/or bulb socket.

2. Voltage
 • Connect the pocket tester (DC20V) to the bulb socket connector.

Tester (+) lead →
Brown terminal ①
 Tester (-) lead →
Black terminal ②

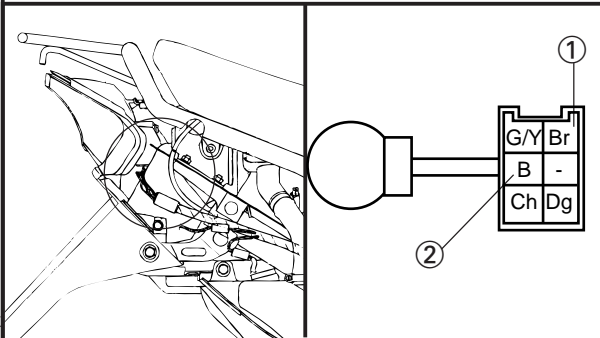

• Turn the main switch to on.
 • Check the voltage (12V) on the bulb socket connector.

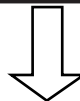

MEETS SPECIFICATION

OUT OF SPECIFICATION



The wiring circuit from main switch to bulb connector is faulty. Repair.

This circuit is not faulty.

**SIGNAL SYSTEM
CIRCUIT DIAGRAM**

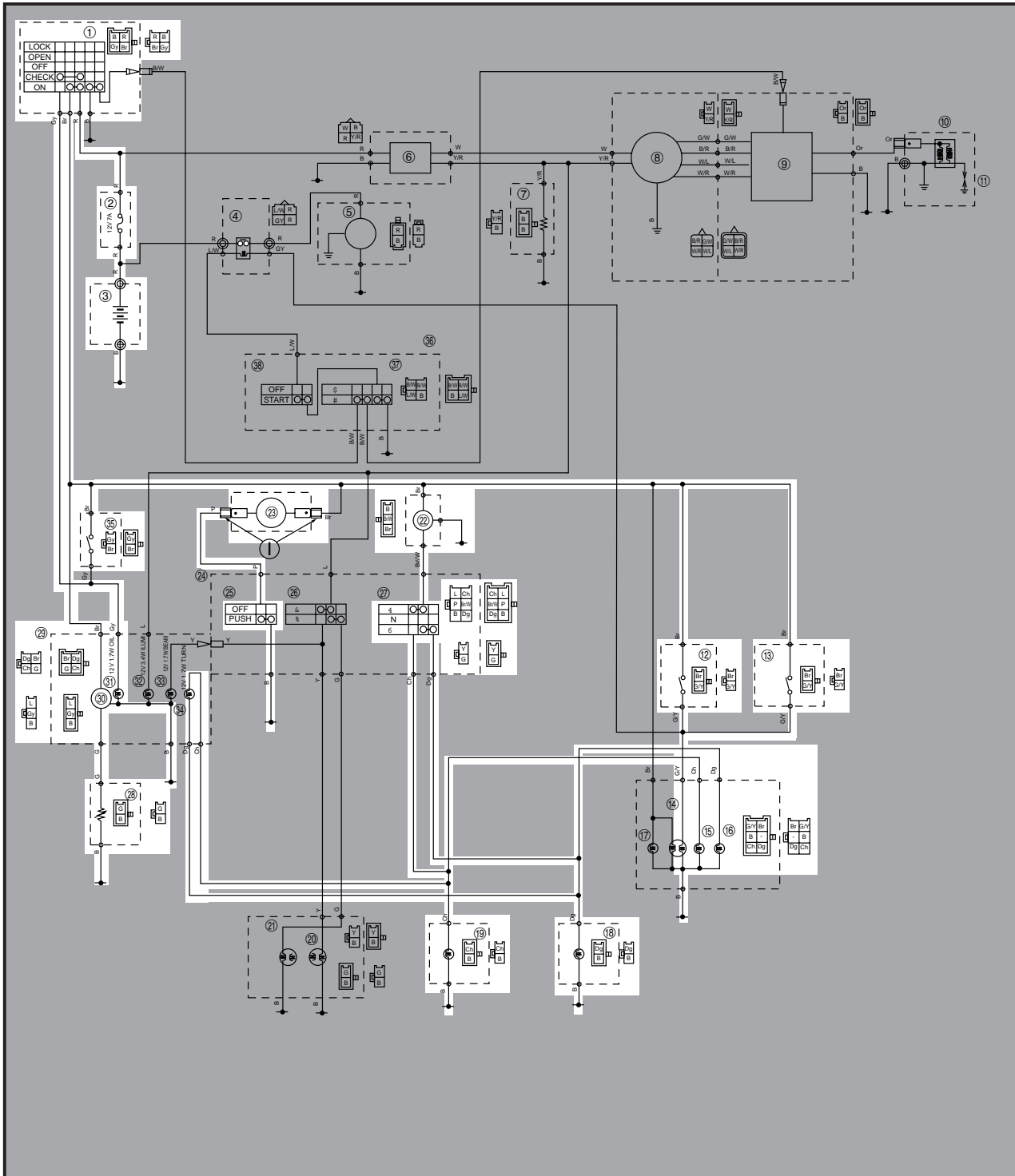

- | | | |
|-----------------------------|------------------------------|------------------------|
| ① Main switch | ⑬ Front flasher light(right) | ⑲ Turn switch |
| ② Main fuse | ⑭ Front flasher light(left) | ⑳ Fuel sender |
| ③ Battery | ⑮ Rear flasher light(right) | ㉑ Fuel meter |
| ⑫ Rear brake switch | ⑯ Rear flasher light(left) | ㉒ Oil indicator light |
| ⑬ Front brake switch | ⑰ Flasher relay | ㉓ Turn indicator light |
| ⑭ Brake light | ⑱ Horn | ㉔ Oil level gauge |
| ⑮ Rear flasher light(right) | ㉒ Handlebar switch (Left) | |
| | ㉓ Horn switch | |

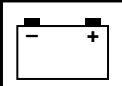

YP806010

TROUBLESHOOTING

IF THE FLASHER LIGHT, BRAKE LIGHT AND/OR INDICATOR LIGHT FAIL TO COME ON. IF THE HORN FAILS TO SOUND.

Procedure

Check:

- | | |
|----------------|---|
| 1. Fuse (Main) | 3. Main switch |
| 2. Battery | 4. Wiring connection (entire signal system) |

NOTE:

- Remove the following parts before troubleshooting.

1) Battery box cover	5) Tail cover
2) Front protector bar	6) Side covers(Left/Right)
3) Upper cover	7) Center cover
4) Rear carrier	
- Use the special tools in the troubleshooting section .

	Pocket tester: YU-03112
--	----------------------------

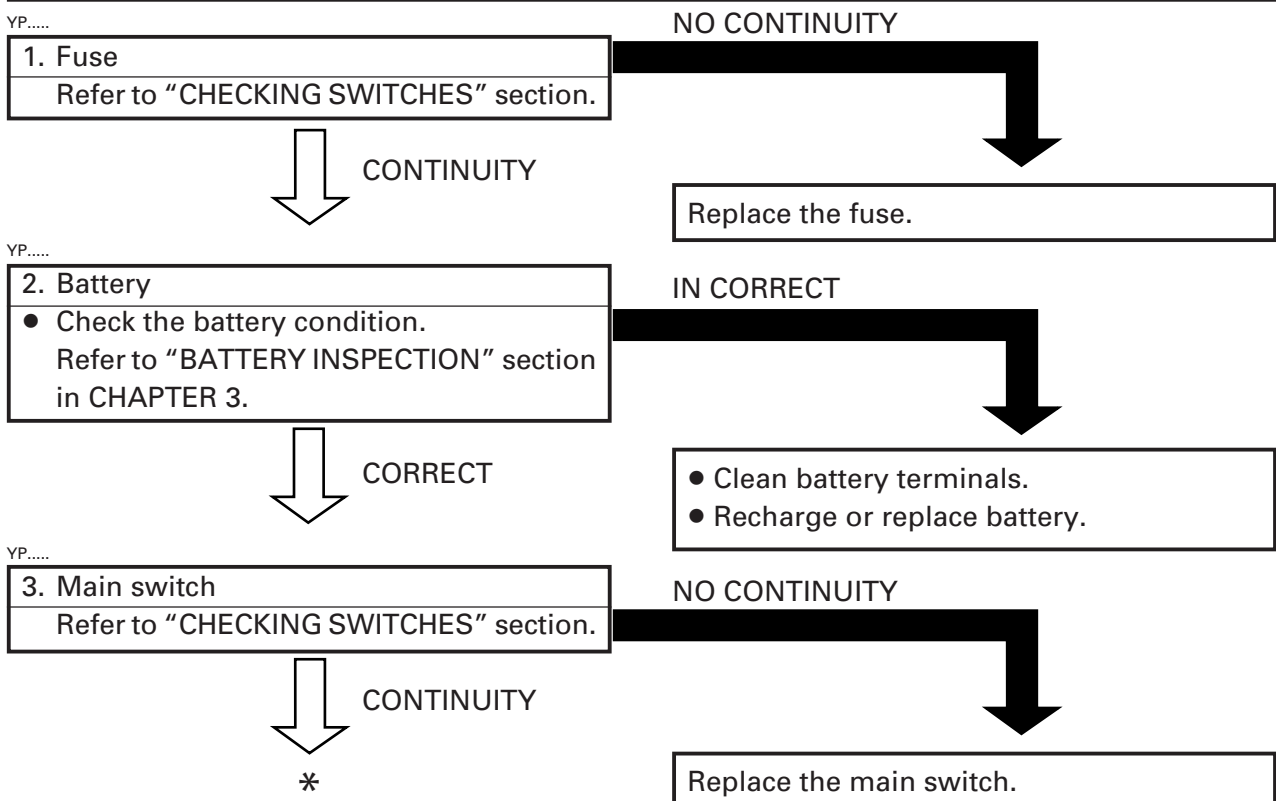

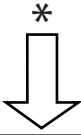

YP.....

4. Wireharness
• Check the connections of the entire signal system.
Refer to "CIRCUIT SYSTEM WIRING DIAGRAM" section.

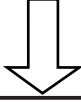

CONTINUITY

Check condition of each of the signal system's circuits.
Refer to "SIGNAL SYSTEM CHECK" section.

POOR CONNECTION



Correct.

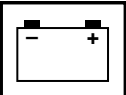

YP806020

SIGNAL SYSTEM CHECK

1. If the horn fails to sound.

1. HORN switch
Refer to "CHECKING SWITCHES" section.

NO CONTINUITY

CONTINUITY

Replace the left handlebar switch.

2. Voltage

- Connect the pocket tester (DC20V) to the horn lead.

Tester (+) lead → Brown terminal ①.
Tester (-) lead → Frame ground

- Turn the main switch to on.
- Check for voltage (12V) on the "Brown" lead at the horn terminal.

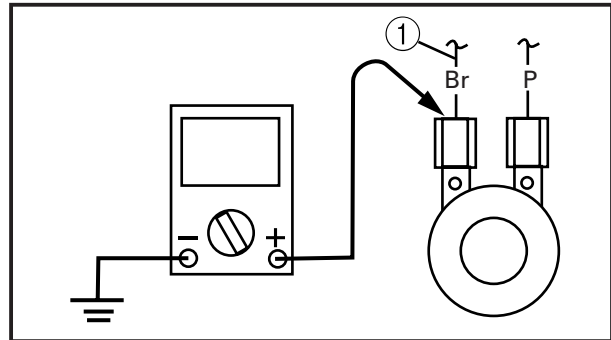

OUT OF SPECIFICATION

MEETS SPECIFICATION

The wiring circuit from the main switch to the horn is faulty. Repair.

3. Horn

- Connect the pocket tester (DC20V) to the horn at the "Pink" terminal.

Tester (+) lead → Pink ① terminal.
Tester (-) lead → Frame ground

- Turn the main switch to on.
- Check for voltage on the "Pink" lead at the horn terminal.

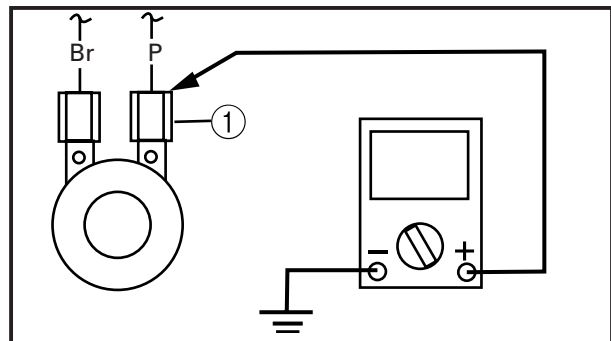

NO CONTINUITY

CONTINUITY

Adjust or replace horn.

Replace the horn.

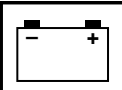

YP806022

2. If the brake light fails to come on:

1. Bulb and bulb socket
Refer to "CHECKING SWITCHES" section.



NO CONTINUITY

Replace the bulb and/or bulb socket.

2. Brake switch (Front/Rear)
Refer to "CHECKING SWITCHES" section.



NO CONTINUITY

Replace brake switch.

3. Voltage
 • Connect the pocket tester (DC20V) to the bulb socket connector.
 Tester (+) lead ⇒ Green/Yellow terminal ①
 Tester (-) lead ⇒ Black terminal ②

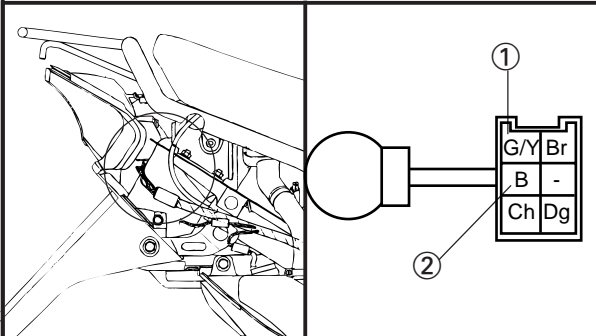

• Turn the main switch to on.
 • The brake lever is pulled in.
 • Check for voltage (12V) of the "Green/Yellow" lead on the bulb socket connector.

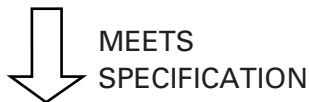

OUT OF SPECIFICATION

This circuit is not faulty.

4. Wiring connection

• Wiring circuit from the main switch to the bulb socket connector is faulty. Repair. Refer to "SIGNAL SYSTEM WIRING DIAGRAM" .

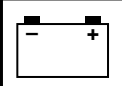

YP806023

3. If the flasher light and/or turn indicator light fails to blink.

1. Bulb and bulb socket
Refer to "CHECKING SWITCHES" section.

NO CONTINUITY

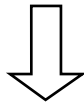

CONTINUITY

Replace the bulb and/or bulb socket.

2. Turn switch
Refer to "CHECKING SWITCHES" section.

NO CONTINUITY

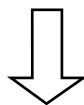

CONTINUITY

Replace the left handlebar switch.

3. Voltage

- Connect the pocket tester (DC20V) to the flasher relay coupler.

Tester (+) lead → Brown lead ①.
Tester (-) lead → Black lead ②

- Turn the main switch to on.
- Check for voltage (12V) of the "Brown" lead at the flasher relay terminal.

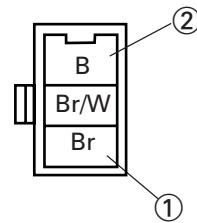

OUT OF SPECIFICATION

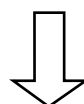

MEETS SPECIFICATION

The wiring circuit from main switch to flasher relay connector is faulty. Repair.

4. Voltage

- Connect the pocket tester (DC20V) to the flasher relay coupler.

Tester (+) lead → Brown/White lead ①.
Tester (-) lead → Black lead ②

- Turn the main switch to on.
- Check for voltage (12V) on the "Brown/White" lead at the flasher relay terminal.

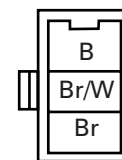

OUT OF SPECIFICATION

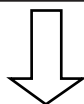

MEETS SPECIFICATION

The flasher relay is faulty. Replace.

*

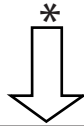
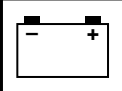

5. Voltage

- Connect the pocket tester (DC20V) to the bulb socket connector.

At flasher light (left)
 Tester (+) lead → Chocolate lead ①
 Tester (-) lead → Black terminal ③

At flasher light (right)
 Tester (+) lead → Dark green lead ②
 Tester (-) lead → Black terminal ③

- Turn the main switch to on.
- Turn the turn switch to left or right.
- Check for voltage (12V) on the "Chocolate" lead and "Dark green" at the flasher light terminal.

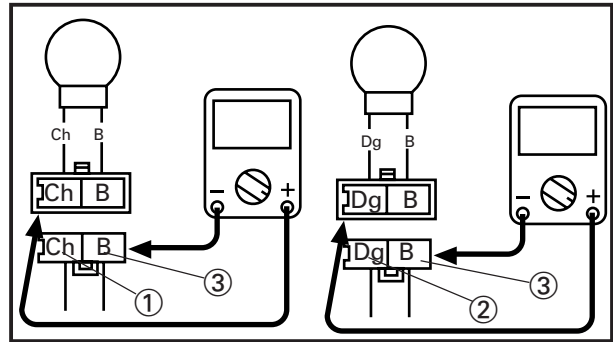

OUT OF SPECIFICATION

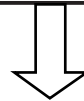

MEETS SPECIFICATION

This circuit is not faulty.

6. Wiring connection

- Wiring circuit from the turn switch to bulb socket connector is fault. Repair. Refer to "CIRCUIT DIAGRAM".

4. "OIL" indicator light does not come on.

1. Bulb and bulb socket

- Check the bulb and bulb socket for continuity.

NO CONTINUITY

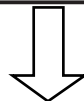

CONTINUITY

Replace bulb and/or bulb socket.

2. Oil level switch

- Remove the oil level switch from the oil tank.
- Connect the Pocket Tester ($\Omega \times 1$) to the oil level switch.

Tester (+) Lead → Brown ①
 Tester (-) Lead → Gray ②

- Check the oil level gauge for continuity.

Switch position	Good condition	Bad condition		
A Upright position	×	○	×	○
B Upside down position	○	×	×	○

○: Continuity ×: No continuity

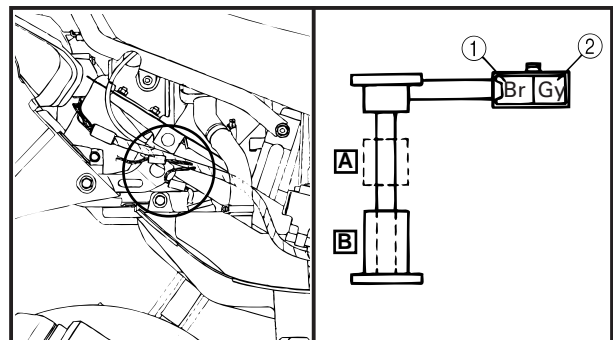

BAD CONDITION

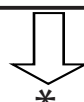

GOOD CONDITION

Replace oil level switch.

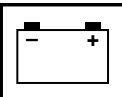

3. Voltage

- Connect the Pocket Tester (DC20V) to the bulb socket connector.

Tester (+) Lead → Gray lead ①

Tester (-) Lead → Black lead ②

- Turn the main switch to “*”
- Check for voltage (12V) on the “Gray” lead at bulb socket connector.

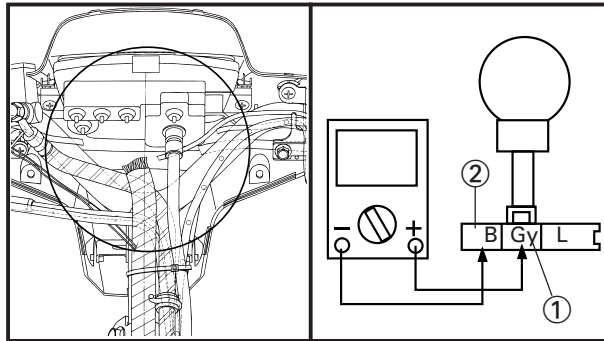

MEETS SPECIFICATION (12V)

OUT OF SPECIFICATION

This circuit is good.

4. Wiring connection

- Check the entire signal system for connections. Refer to the “WIRING DIAGRAM” section.

YP806027

5. If the fuel gauge fails to operate.

1. Fuel sender

- Remove the fuel sender from the fuel tank.
- Disconnect the fuel sender coupler from the wireharness. Connect the pocket tester ($\Omega \times 10$) to the fuel sender coupler lead.

Tester (+) lead → Green terminal ①

Tester (-) lead → Black terminal ②

- Check the fuel sender for specified resistance.

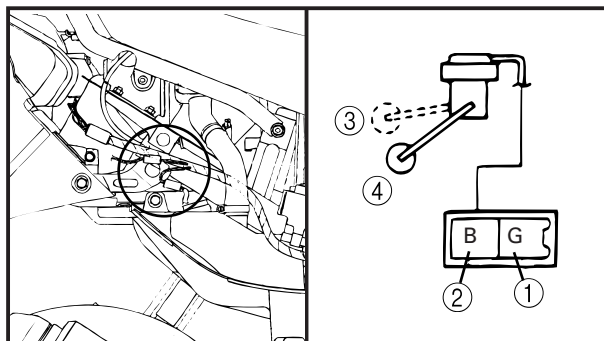

	Float position	Specified resistance
	UP ③	4~10Ω
	DOWN ④	90~100Ω

BOTH MEET SPECIFICATION

OUT OF SPECIFICATION

Replace the fuel sender.

2. Voltage

- Connect the pocket tester (DC20V) to the fuel gauge coupler.

Tester (+) lead → Brown terminal ①
 Tester (-) lead → Frame ground

- Turn the main switch to "ON".
- Check for voltage (12V) of the "Brown" lead on the fuel sender lead.

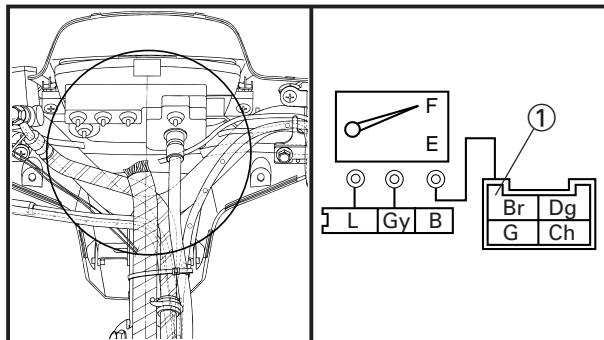

OUT OF SPECIFICATION

MEETS SPECIFICATION

3. Fuel gauge

- Connect the fuel sender to wireharness.
- Move the float to "UP" ① or "DOWN" ②.

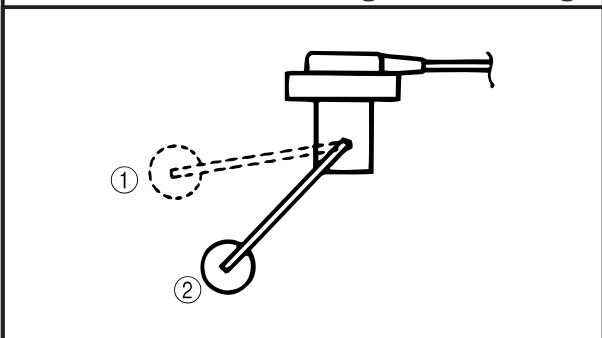

- Turn the main switch to "ON".
- Check the fuel gauge needle moves "F" or "E".

Float position	Needle moves
Float "UP" ①	"F"
Float "DOWN" ②	"E"

MOVES

This circuit is not faulty.

Check the connection of the entire signal system .
 Refer to "CHECKING OF CONNECTIONS".
 Refer to "CIRCUIT DIAGRAM".

NOTE: _____
 Before reading the meter, stay put the float for more than three minutes respectively at "UP" or "DOWN".

DOES NOT MOVE

Replace the fuel gauge.

**AUTO CHOKE SYSTEM
CIRCUIT DIAGRAM**

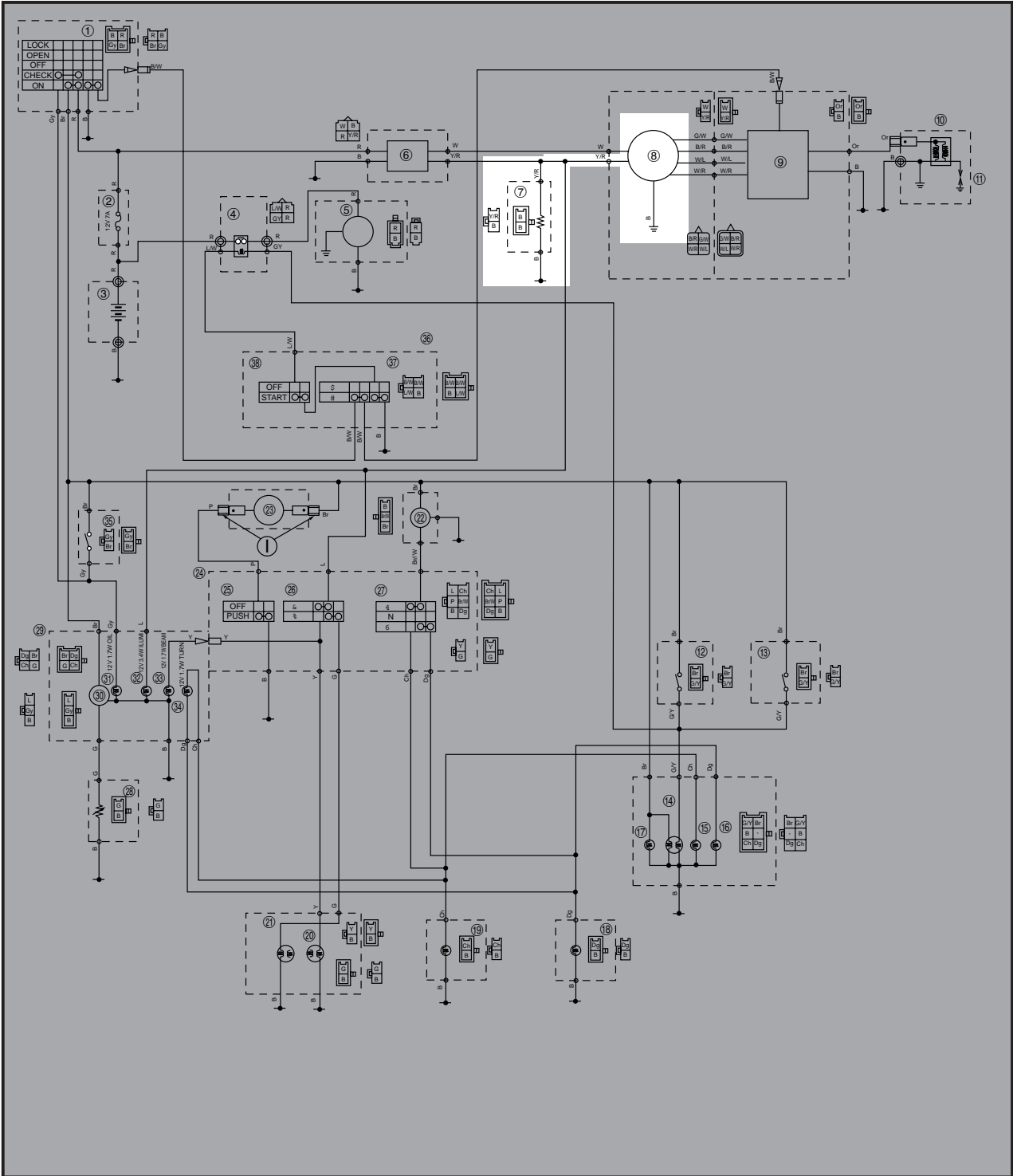

- ⑦ Auto choke
- ⑧ C.D.I. magneto

YP.....

TROUBLESHOOTING

IF THE AUTO CHOKE FAILS TO OPERATE.

Procedure

Check:

1. Lighting coil resistance
2. Auto choke unit resistance
3. Wiring connection (entire auto choke system)

NOTE: _____

- Remove the following parts before troubleshooting.
 1. Battery box cover
 2. Rear carrier
 3. Tail cover
 4. Right side cover
- Use the special tools specified in the troubleshooting section.

Pocket tester:
YU-03112

1. Lighting coil resistance

- Disconnect the CDI magneto couple from wire harness.
- Connect the pocket tester ($\Omega \times 1$) to the lighting coil coupler

Tester (+) Lead → Yellow/Red ① terminal
Tester (-) Lead → Frame earth

② C.D.I. magneto

- Check the lighting coil for specified resistance

Lighting coil resistance
0.4~0.6 Ω 20°C (68°F)

OUT OF SPECIFICATION

Replace the lighting coil

↓
MEETS
SPECIFICATION
*

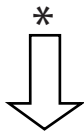
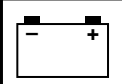

YP...

2. Auto choke unit resistance

- Disconnect the auto choke unit coupler from the wireharness.
- Connect the pocket tester ($\Omega \times 1$) to the auto choke unit coupler lead.

Tester (+) lead → Black terminal ①

Tester (-) lead → Black terminal ②



Auto choke unit resistance:
8~12 Ω at 20°C (68°F)

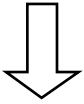

MEETS
SPECIFICATION

3. Wiring connection

- Check the connection of the entire auto choke system.
Refer to "CIRCUIT DIAGRAM" section.

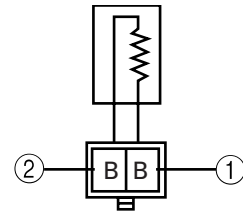
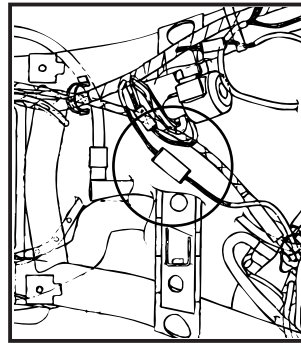

OUT OF SPECIFICATION

Replace the auto choke unit.

POOR CONNECTION

Correct.

TROUBLESHOOTING

NOTE:

The following troubleshooting does not cover all the possible causes of trouble. It should be helpful, however, as a guide to troubleshooting. Refer to the relative procedure in this manual for inspection, adjustment and replacement of parts.

STARTING FAILURE/HARD STARTING

FUEL SYSTEM

PROBABLE CAUSE

Fuel tank	<ul style="list-style-type: none"> ● Empty ● Clogged fuel filter ● Deteriorated fuel or fuel containing water or foreign material ● Clogged fuel tank cap 	<ul style="list-style-type: none"> ● Empty ● Clogged fuel filter ● Deteriorated fuel or fuel containing water or foreign material ● Clogged fuel tank cap
Fuel cock	<ul style="list-style-type: none"> ● Clogged fuel hose ● Clogged fuel cock ● Faulty fuel cock operation ● Broken or disconnected fuel cock 	<ul style="list-style-type: none"> ● Clogged fuel hose ● Clogged fuel cock ● Faulty fuel cock operation ● Broken or disconnected fuel cock
Carburetor	<ul style="list-style-type: none"> ● Deteriorated fuel, fuel containing water or foreign material ● Clogged pilot jet ● Clogged pilot air passage ● Sucked-in air ● Deformed float ● Groove-worn needle valve ● Improperly sealed valve seat ● Improperly adjusted fuel level ● Improperly set pilot jet ● Clogged starter jet 	<ul style="list-style-type: none"> ● Deteriorated fuel, fuel containing water or foreign material ● Clogged pilot jet ● Clogged pilot air passage ● Sucked-in air ● Deformed float ● Groove-worn needle valve ● Improperly sealed valve seat ● Improperly adjusted fuel level ● Improperly set pilot jet ● Clogged starter jet
Auto choke	<ul style="list-style-type: none"> ● Starter plunger malfunction ● Wax malfunction ● Faulty thermister 	<ul style="list-style-type: none"> ● Starter plunger malfunction ● Wax malfunction ● Faulty thermister
Air cleaner	<ul style="list-style-type: none"> ● Clogged air filter 	<ul style="list-style-type: none"> ● Clogged air filter

STARTING FAILURE/HARD STARTING



IGNITION SYSTEM

PROBABLE CAUSE

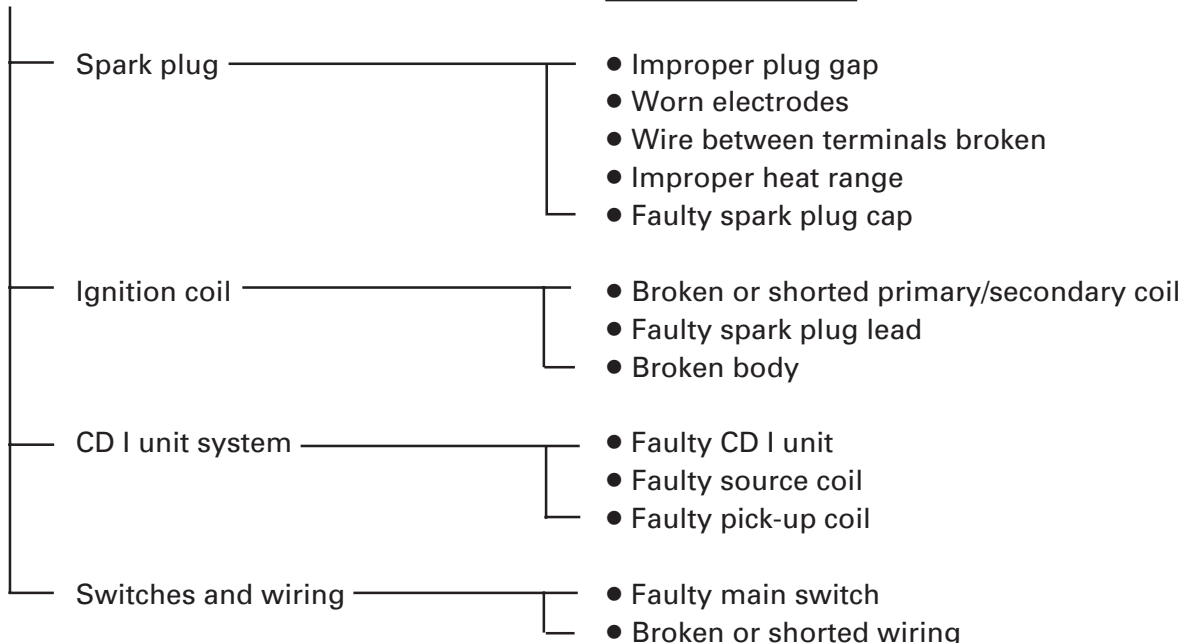

COMPRESSION SYSTEM

PROBABLE CAUSE

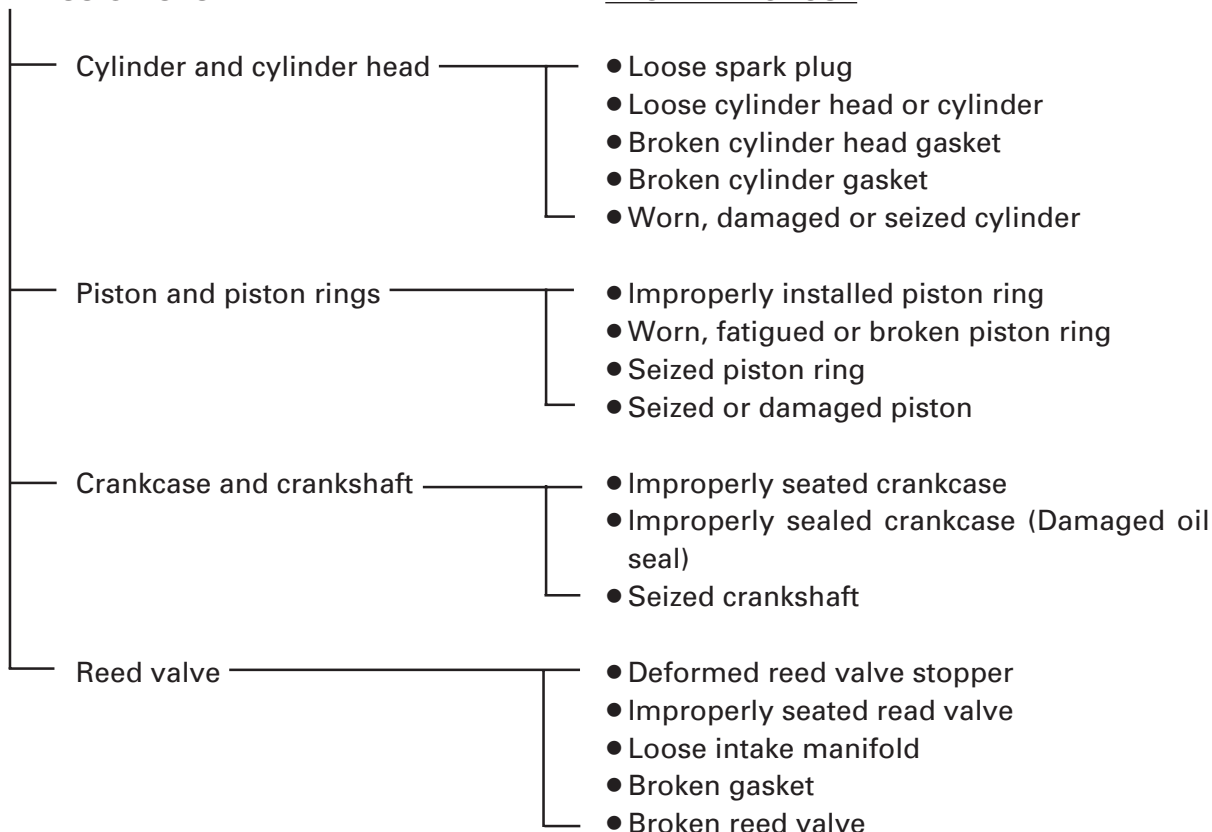

**POOR IDLE SPEED PERFORMANCE
POOR MEDIUM AND HIGH SPEED PERFORMANCE**

**TRBL
SHTG**



POOR IDLE SPEED PERFORMANCE

POOR IDLE SPEED PERFORMANCE

PROBABLE CAUSE

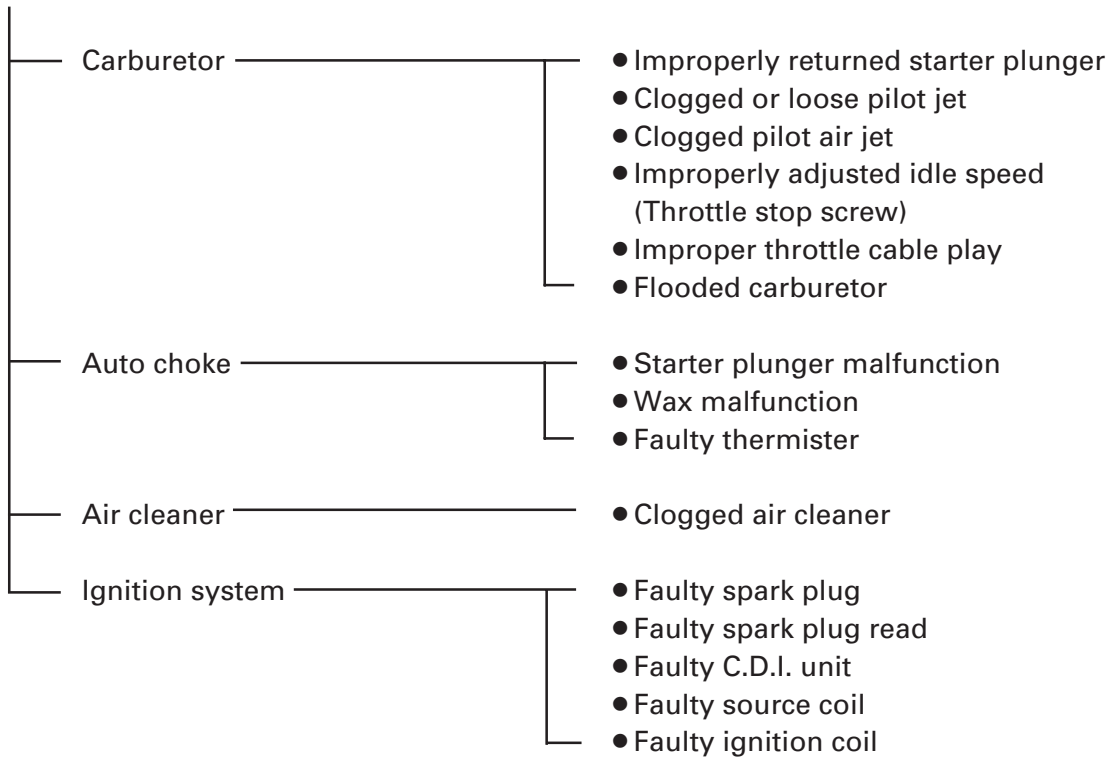

POOR MEDIUM AND HIGH SPEED PERFORMANCE

POOR MEDIUM AND HIGH SPEED PERFORMANCE

PROBABLE CAUSE

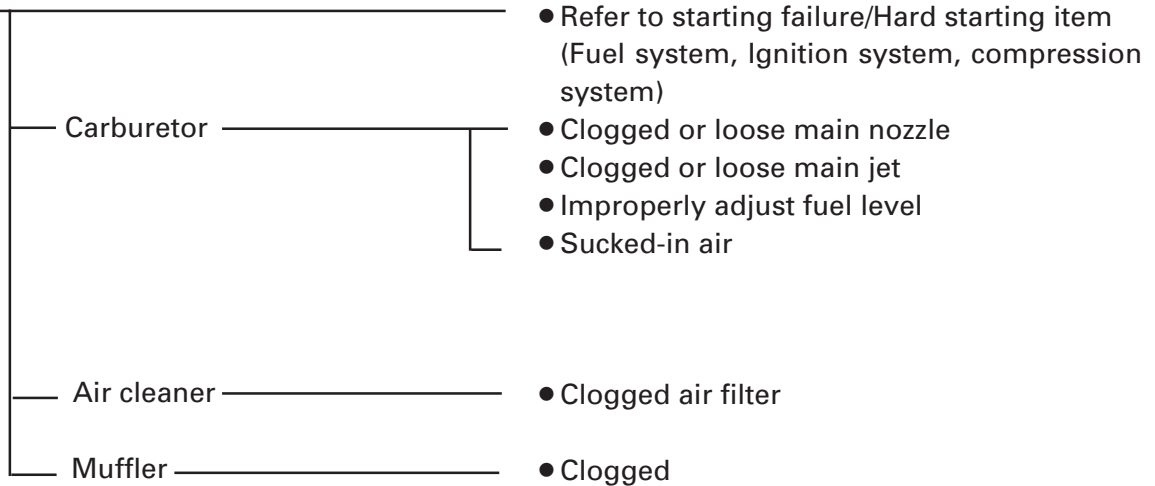

FAULTY AUTOMATIC(V-BELT TYPE)

SCOOTER DOES NOT MOVE WHILE ENGINE IS OPERATING

PROBABLE CAUSE

- V-belt ————— ● Worn, damaged or slipped V-belt
- Cam, slider ————— ● Worn, damaged
- Compression spring ————— ● Damaged
- Transmission ————— ● Damaged

CLUTCH OUT FAILURE

- Clutch weight spring ————— ● Damaged
- Clutch shoe ————— ● Pealed lining
- Primary sheave ————— ● Seized primary sliding sheave and collar

POOR STANDING START(LOW CLIMBING ABILITY)

PROBABLE CAUSE

- V-belt ————— ● Worn or slipped V-belt
- Primary sheave ————— ● Improper operation
● Damaged
- Compression spring ————— ● Damaged
- Secondary sheave ————— ● Improper operation
● Worn guide pin
- Clutch shoe ————— ● Plealed lining

POOR ACCELERATION(POOR HIGH SPEED)

PROBABLE CAUSE

- V-belt ————— ● Worn
● Greasy
- Weight ————— ● Worn
● Improper operation
- Primary/ Secondary seave ————— ● Worn

OVERHEAT

OVER HEAT

PROBABLE CAUSE

<p>Ignition system</p>	<ul style="list-style-type: none"> ● Improper plug gap ● Improper spark plug heat range ● Faulty C.D.I. unit
<p>Fuel system</p>	<ul style="list-style-type: none"> ● Improper carburetor setting ● Clogged air filter
<p>Compression system</p>	<ul style="list-style-type: none"> ● Carbon accumulation of cylinder head
<p>Muffler, Exhaust pipe</p>	<ul style="list-style-type: none"> ● Clogged
<p>Oil pimp</p>	<ul style="list-style-type: none"> ● Faulty oil pump ● Faulty oil quality
<p>Brake</p>	<ul style="list-style-type: none"> ● Drag
<p>Cooling system</p>	<ul style="list-style-type: none"> ● Fan damaged

POOR SPEED

POOR SPEED

PROBABLE CAUSE

<p>Ignition system</p>	<ul style="list-style-type: none"> ● Faulty spark plug ● Improper spark plug heat range ● Faulty C.D.I. unit ● Faulty source coil
<p>Fuel system</p>	<ul style="list-style-type: none"> ● Clogged fuel tank cap ● Clogged air filter ● Clogged carburetor
<p>Compression system</p>	<ul style="list-style-type: none"> ● Worn cylinder ● Worn, fatigued or broken piston ring ● Broken cylinder head gasket ● Broken cylinder gasket ● Carbon accumulation of cylinder head
<p>Muffler, Exhaust pipe</p>	<ul style="list-style-type: none"> ● Clogged
<p>Clutch</p>	<ul style="list-style-type: none"> ● Refer to "FAULTY AUTOMATIC"
<p>Brake</p>	<ul style="list-style-type: none"> ● Drag

IMPROPER KICKING

SLIPPING

PROBABLE CAUSE

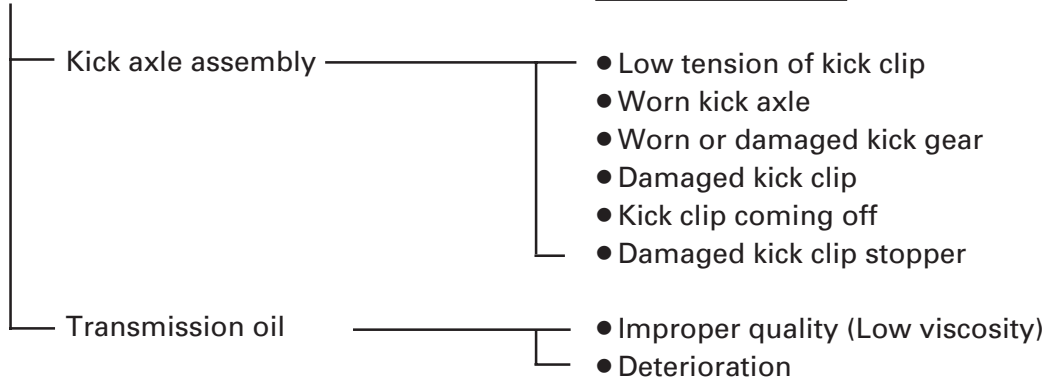

HARD KICKING

PROBABLE CAUSE

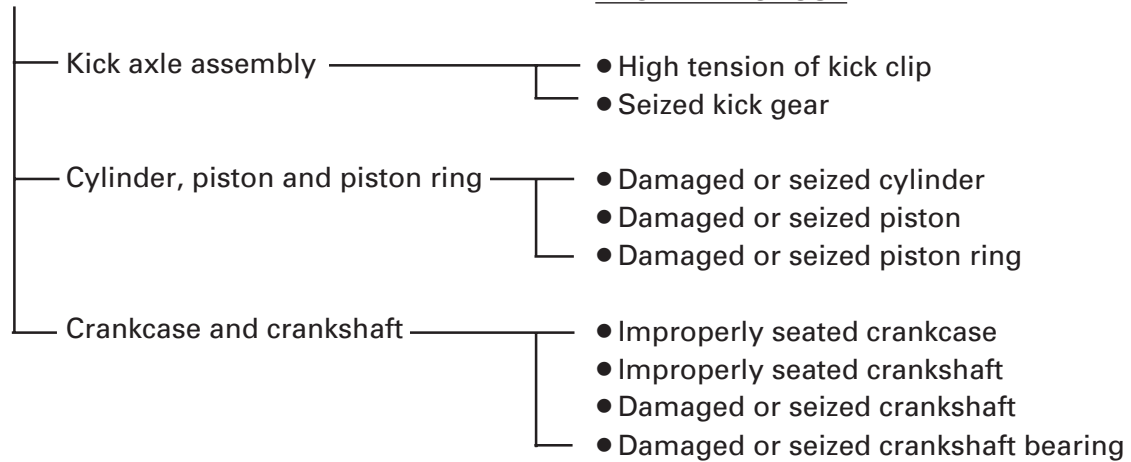

KICK CRANK NOT RETURNING

PROBABLE CAUSE

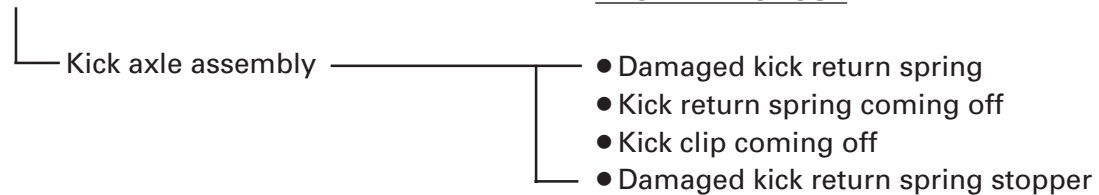

FAULTY BRAKE

POOR BRAKING EFFECT

PROBABLE CAUSE

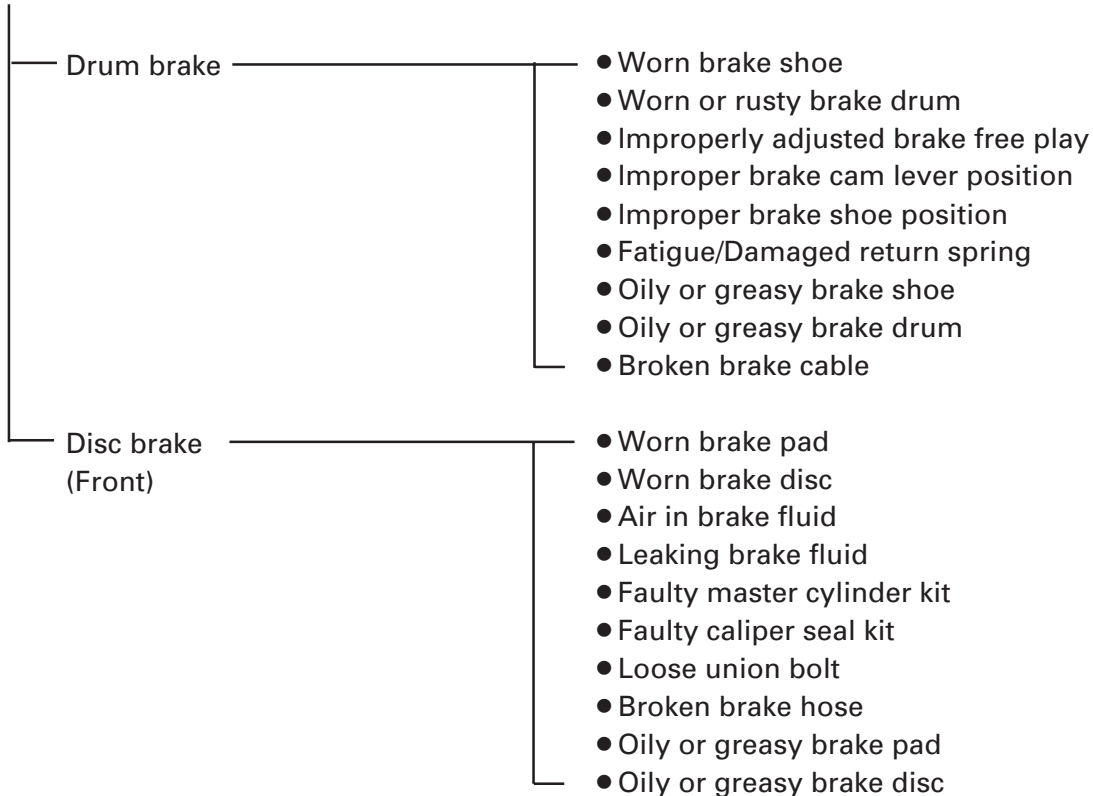

MALFUNCTION

PROBABLE CAUSE

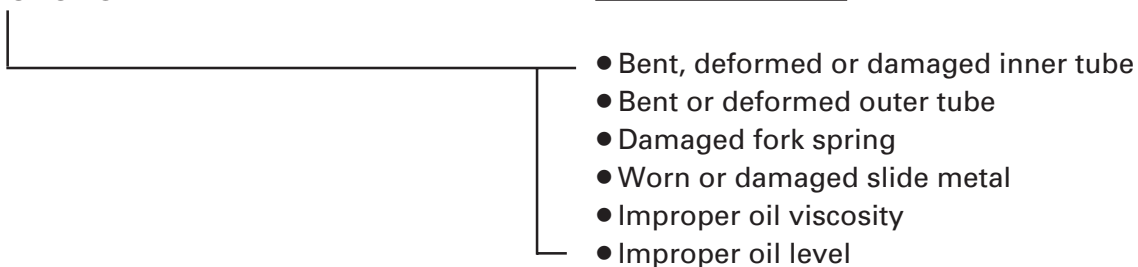

UNSTABLE HANDLING

INSTABLE HANDLING

PROBABLE CAUSE

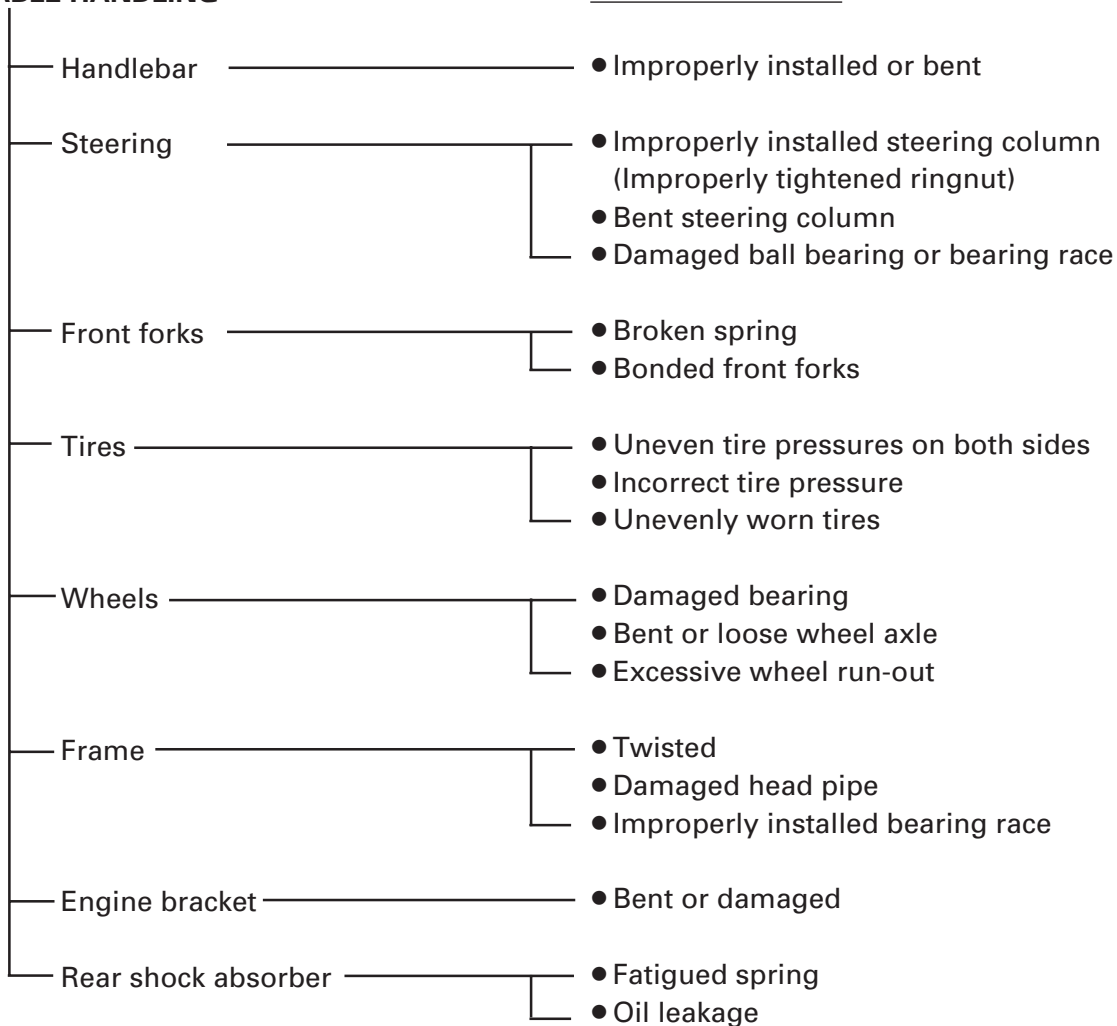

FAULTY SIGNAL AND LIGHTING SYSTEM

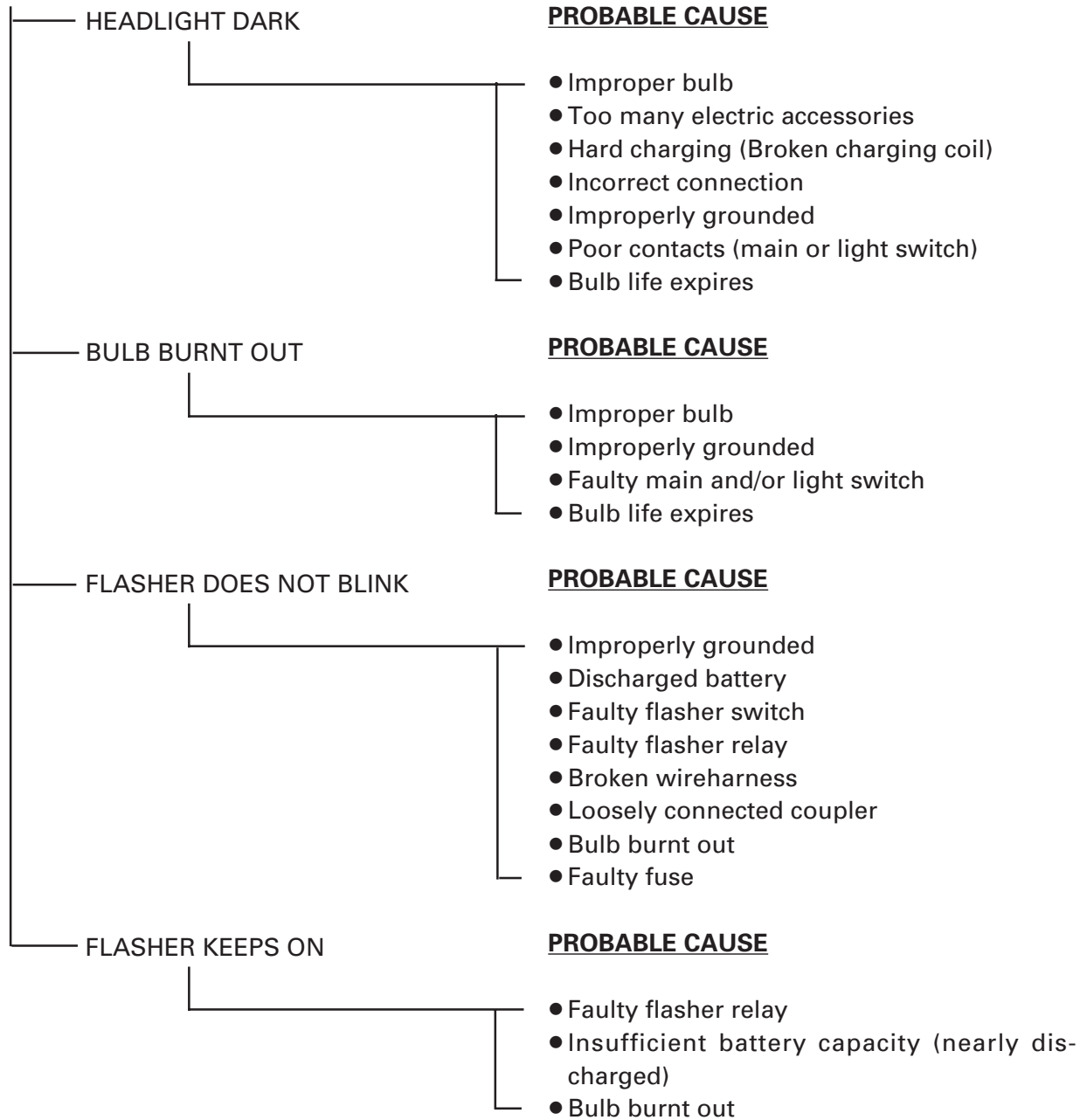

FAULTY SIGNAL AND LIGHTING SYSTEM

TRBL
SHTG

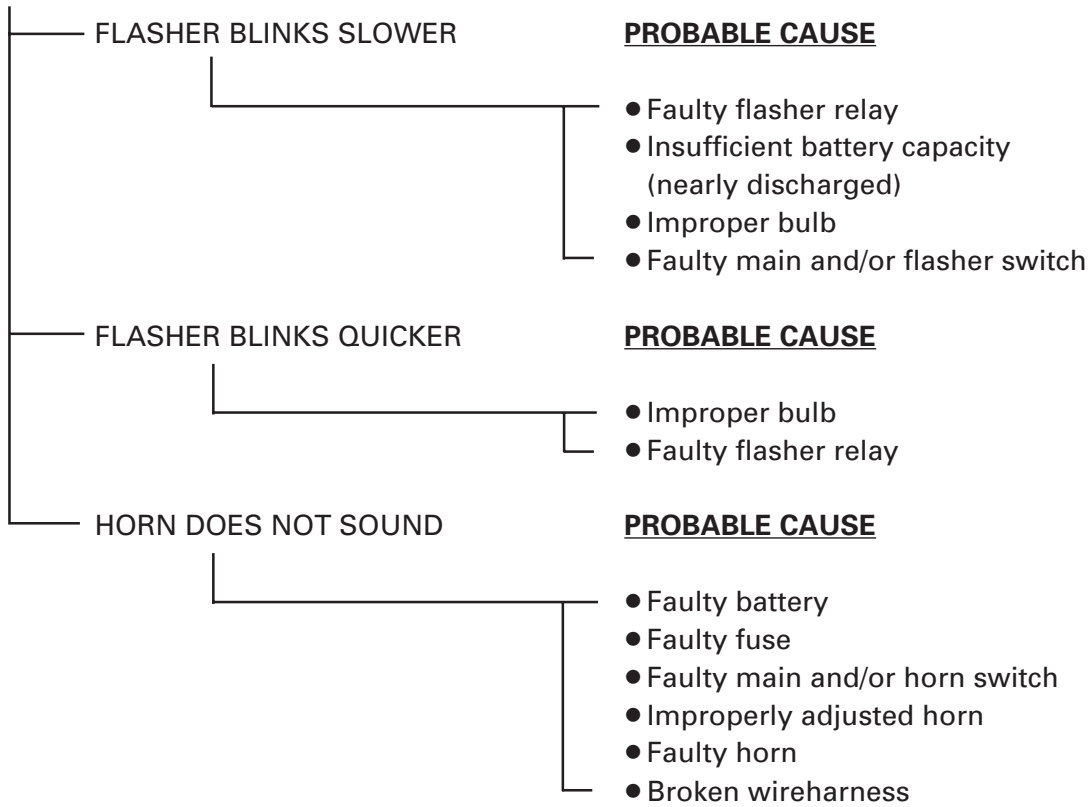

WIRING DIAGRAM

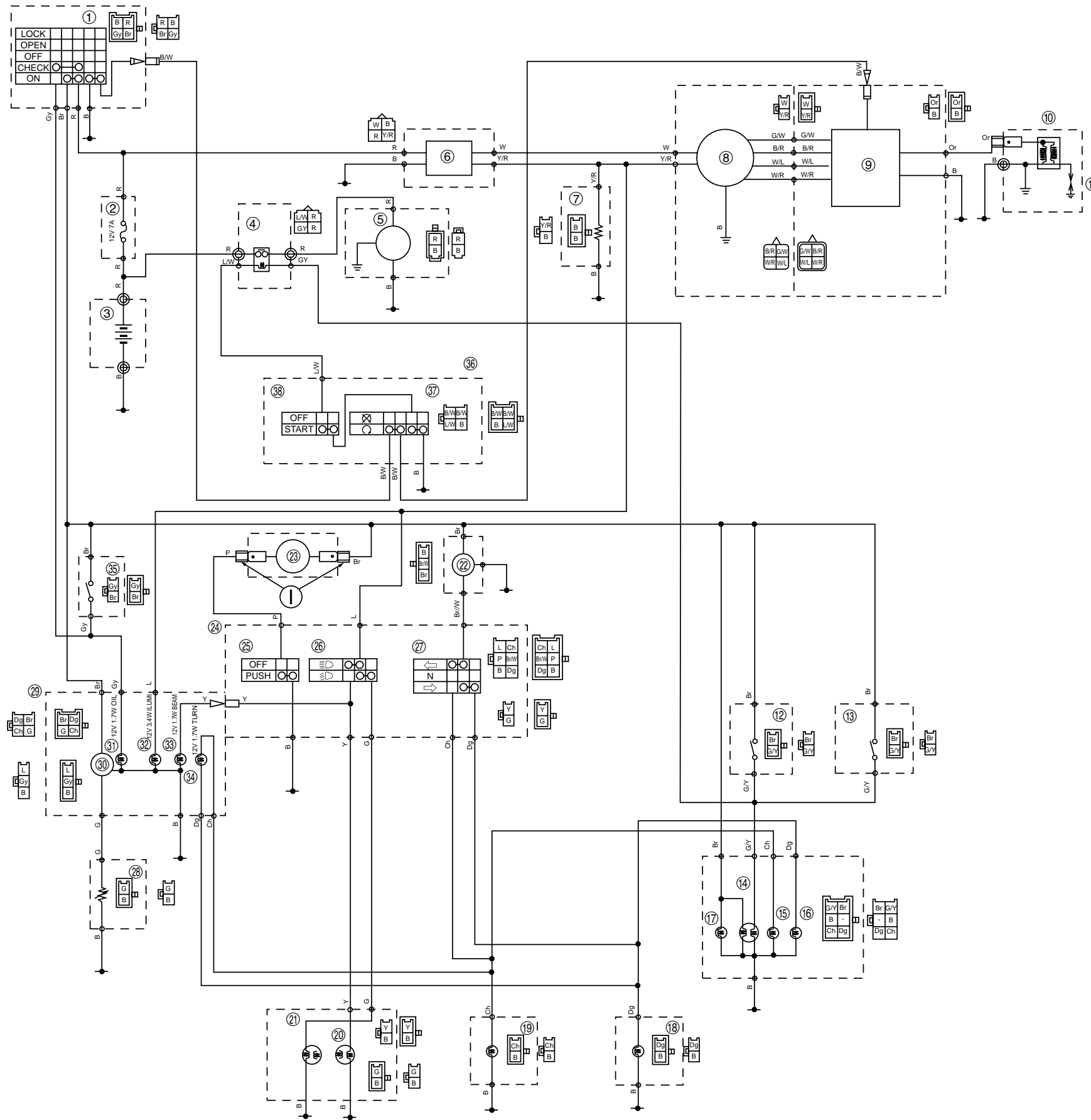

①	Main switch
②	Main fuse
③	Battery
④	Starter relay
⑤	Starter motor
⑥	Rectifier regulator
⑦	Auto choke
⑧	C.D.I. magneto
⑨	C.D.I. unit
⑩	Ignition
⑪	Spark plug
⑫	Front brake switch
⑬	Rear brake switch
⑭	Tail/Brake light
⑮	Front flasher light(right)
⑯	Front flasher light(left)
⑰	Head light
⑱	Flasher relay
⑲	Horn
⑳	Handlebar switch (left)
㉑	Horn switch
㉒	Dimmer switch
㉓	Turn switch
㉔	Fuel sender
㉕	Meter
㉖	Fuel gauge
㉗	Oil indicator light
㉘	Meter light
㉙	High beam indicator light
㉚	Turn indicator light
㉛	Oil level gauge
㉜	Handlebar switch (right)
㉝	Starter switch
㉞	Engine stop switch

B	Black
Br	Brown
Ch	Chocolate
Dg	Dark Green
G	Green
L	Blue
Or	Orange
Sb	Sky blue
P	Pink
R	Red
Gy	Gray
Y	Yellow
W	White
B/R	Black/Red
Br/w	Brown/White
G/R	Green/Red
G/Y	Green/Yellow
L/B	Blue/Black
L/Y	Blue/Yellow
L/W	Blue/White
L/R	Blue/ Red
R/B	Red/Black
R/Y	Red/Yellow
R/W	Red/white
Y/R	Yellow/White
W/G	White/Green
G/W	Green/White
W/R	White/Red
L/G	Blue/Green

