

DRIVING & ADJUSTMENT INSTRUCTIONS

1939 A.J.S. MOTOR CYCLES.

Model.	Bore and Stroke.				c.c.	Description.
39-12	62.5	m.m.	x	80	m.m.	246 c.c. Standard (coil ignition)
39-12M	62.5	m.m.	x	80	m.m.	246 c.c. Standard (magneto ,,)
39-22	62.5	m.m.	x	80	m.m.	246 c.c. De Luxe (two port)
39-22SS	62.5	m.m.	x	80	m.m.	246 c.c. " 250 Silver Streak "
39-22T	62.5	m.m.	x	80	m.m.	246 c.c. Competition 250
39-16	69	m.m.	x	93	m.m.	347 c.c. Standard (coil ignition)
39-16M	69	m.m.	x	93	m.m.	347 c.c. Standard (magneto ,,)
39-26	69	m.m.	x	93	m.m.	347 c.c. De Luxe (two port)
39-26SS	69	m.m.	x	93	m.m.	347 c.c. " 350 Silver Streak "
39-26T	69	m.m.	x	93	m.m.	347 c.c. Competition 350
39-8	82.5	m.m.	x	93	m.m.	498 c.c. De Luxe (two port)
39-18	82.5	m.m.	x	93	m.m.	498 c.c. De Luxe (single port)
39-18SS	82.5	m.m.	x	93	m.m.	498 c.c. " 500 Silver Streak "
39-18T	82.5	m.m.	x	93	m.m.	498 c.c. Competition 500
39-9	82.5	m.m.	x	93	m.m.	498 c.c. De Luxe (side valve)
39-2	85.5	m.m.	x	85.5	m.m.	990 c.c. Big Twin (English Mdl)
39-2A	85.5	m.m.	x	85.5	m.m.	990 c.c. Big Twin (Export ,,)

All Models, except 39-9, 39-2 and 39-2A, have overhead valves.

ISSUED BY THE MANUFACTURERS

A.J.S. MOTOR CYCLES

(Proprietors: ASSOCIATED MOTOR CYCLES LIMITED)

Registered Offices:

Plumstead Road, London,
S.E.18 - - England

Nearest Station :

WOOLWICH ARSENAL,
SOUTHERN RAILWAY.

Factories :

BURRAGE GROVE and MAXEY ROAD,
PLUMSTEAD, S.E.18.

Telegrams and Cables: " Icanhopit- Wol-London."

PREFACE.

Motorcycling is one of the most economical and pleasurable modes of transport. It is our sincere wish that every "A.J.S." owner should obtain, from his mount, the service, comfort and innumerable miles of low-cost travel that we have earnestly endeavoured to build into it.

However, it must be remembered, a motor cycle is a highly specialised piece of engineering, and must be treated with reasonable care and consideration. While it does not call for great skill in driving, the exercise of a little mechanical sense, and the occasional use of a spanner, cleaning cloth, etc., is very necessary if the maximum service is to be obtained with the requisite degree of satisfaction.

In the following pages we give, in simple and straightforward language, comprehensive instructions concerning the lubrication and adjustment of those parts likely to require attention. Neglect to make necessary adjustments, or only casual attention to the lubrication of important parts, will soon neutralise the best efforts of the designers, and may bring needless trouble to the owner.

We are always pleased to give "A.J.S." owners the full benefit of our wide experience in matters relating to motor cycles of our manufacture. Enquiries of a technical nature should be addressed to the "Service Department" and must necessarily include full particulars of the motor cycle concerned—i.e., engine number, in full (stamped on the driving side of the crankcase, immediately under the cylinder base), frame number and full details of the enquiry.

Messrs. A.J.S. MOTOR CYCLES.

SPARES LIST.

A very comprehensive priced catalogue of spare parts for all 1939 "A.J.S." Motor Cycles is available. It costs one shilling, post paid, and we strongly recommend all owners of 1939 "A.J.S." Machines to obtain a copy.

CORRESPONDENCE.

Our routine is organised into different departments, therefore delay cannot be avoided if matters relating to more than one department are contained in one letter.

Consequently it is desirable, when communicating with more than one department, to do so on separate sheets, each of which should bear your name and address. In particular, requests for technical advice should not be on the same sheets as orders for spare parts.

CLAIMS UNDER GUARANTEE.

If it is necessary to make a claim under the guarantee, full particulars regarding the procedure to be adopted is detailed in paragraph 173.

DRIVING.

(1). **CONTROLS.** (All Models except 2A.)

The following controls are provided :—

CARBURETTER	Throttle	Quick action twist grip on the right handlebar. Twist inwards to open throttle.
	Air ...	Small lever on right handlebar. Pull inwards to open air valve.
IGNITION	Advance/Retard	Small lever on left handlebar. Pull inwards to advance ignition.
IGNITION SWITCH	...	Combined with main lighting switch in panel on top of petrol tank, on Models 12 and 16 only.
VALVE LIFTER	...	Short lower lever on left handlebar
CLUTCH	Large upper lever on left handlebar.
FRONT BRAKE	Large lever on right handlebar.
REAR BRAKE	Foot pedal on left-hand side of machine.
GEARS	The forward pedal on the right-hand side of the gear box. (See paragraph 4 for gear positions.)
HORN	Switch on right handlebar.
LIGHTS	... Main Switch	... Located in the bottom centre of the panel mounted on the top of the petrol tank. (See paragraphs 141 and 142 for switch positions.)
	Dip Switch	... Two-way switch on the left handlebar. This controls the normal and dipped beams.
STEERING DAMPER	...	Knurled ebonite knob on top of steering column. Turn in clockwise direction to increase damping action.
FORK DAMPER	Knurled ebonite knob on left side of front fork lower front spindle. Turn in clockwise direction to increase the damping action,

The following controls are provided on Model 2A. (Export Big Twin.)

IGNITION	Advance/Retard		Small lever on left handlebar. Push forward to advance ignition. (Or, alternatively, twist grip on left handlebar. Twist inwards to advance ignition.)
VALVE LIFTER	Large lever on left handlebar.
CLUTCH	Foot lever on left side of machine.
REAR BRAKE	Foot pedal on right side of machine.
GEARS	Hand lever, working in gate fixed to left of petrol tank. Gear positions are marked on gate.
	Four Speed Box	...	First (lowest gear). Most forward position in gate. Neutral. Between first and second gears. Second. Third. Top. Position nearest to driver.
	Three Speed Box	...	Reverse. Most forward position. Neutral. First. (Lowest gear.) Second. Top. Position nearest to driver.

(Carburetter, front brake, lights, horn and dampers as Page 3.)

(2). **FUEL.**

For machines fitted with standard pistons we recommend all makes of No. 1 quality Petrol. For machines fitted with high compression pistons use a fuel composed of half No. 1 quality Petrol and half pure Benzol. If an ultra high compression piston is used it is essential to use an Alcohol fuel.

The tap that controls the main fuel feed is of the "push" type. The tap push slide has two knobs. One of these is hexagon in shape, and this should be pushed in order to allow fuel to pass from the tank to the carburetter. The other knob is round in shape and has a knurled edge. Push this end in order to turn "off" the fuel. This variety in the two ends enables the tap to be used, with certainty, in the dark. The two knobs are marked "ON " and "OFF."

(3). **A SUGGESTION.**

Before attempting to start the engine or to use the machine on the road, a new owner is advised, first of all, to place the machine on the rear stand, sit on the saddle, and become familiar with the position and operation of the various controls. Particular attention should be devoted to the various gear positions as detailed in paragraph 4.

(4). **GEAR POSITIONS. (All Models except 2A.)**

Before starting the engine, make sure the gear is in the neutral, or free, position. Make a habit of always placing the gear in neutral after a run on the machine.

Neutral is indicated by the pointer on the foot change pedal being in line with the pointer that is bolted to the kickstarter case cover.

Every time the gear foot change pedal is fully depressed a gear is engaged and every time the pedal is raised to the limit of its movement a gear is also engaged. The downward movement is best made with the toe and the upward by the instep.

Three models of Burman gear boxes are used on 1939 "A.J.S." Motor Cycles.

The H.P. Box is fitted to Models 12, 12M, 22, 22SS.

The C.P. Box is fitted to Models 16, 16M, 22T, 26, 26SS, 26T, 8, 9, 18, 18SS and 18T.

The B.A.P. Box is fitted to Models 2 and 2A.

On all gear boxes the neutral position is between the first (lowest) and the second gears. There are four gear ratios and the fourth is called "TOP."

On the MODEL H.P. GEAR BOX the gear foot change pedal is pressed downwards, from the neutral position, to engage the first (lowest) gear. Then, to engage all the higher gears, the pedal must be raised, step by step, till, after three movements, the top gear is engaged. The next lower gear can always be engaged by a downward movement and the next higher gear engaged by an upward movement.

On MODEL C.P. and B.A.P. GEAR BOXES the gear foot change pedal is raised upward, from the neutral position, to engage first (lowest) gear. Then, to engage all the higher gears, the pedal must be pressed downwards, step by step, till, after three movements, the top gear is engaged. The next lower gear can always be engaged by an upward movement and the next higher gear engaged by a downward movement.

Gear positions on Model 2A.

Two patterns of B.A.P. Gear Boxes are fitted to Model 2A. One provides four forward gears and the other three forward and one reverse gear.

On both boxes the gear changes are made by a hand controlled lever working in a gate mounted on the left hand side of the petrol tank.

On the four speed box the positions in the gate are:—

First (or lowest) gear. Most forward notch in the gate.

Neutral.

Second gear.

Third gear.

Fourth (or top) gear. Most rearward notch in the gate.

On the three speed and reverse gear box the positions in the gate are :—

Reverse. Most forward notch in the gate.

Neutral.

First (or lowest) gear.

Second gear.

Third (or top) gear. Most rearward notch in the gate.

(5).STARTING THE ENGINE.

- (a) Make sure there is enough fuel in the petrol tank.
- (b) Inspect the level of the oil in the oil tank (see paragraph 22).
- (c) Make sure the gear is in the neutral position.
- (d) Turn " ON " the fuel supply tap.
- (e) Place the air control lever in the closed position.
- (f) Fully advance the ignition control lever and then slightly slack it back so that the ignition is slightly retarded from the fully advanced position.
- (g) Slightly open the throttle by twisting the twist grip inwards not more than one-sixth of its total movement.
- (h) Flood the carburetter by depressing the spring plunger in the top, or cap, of the float chamber and holding it down till fuel is seen emerging from the small holes bored in the knurled edge of the cap.
- (i) Raise the exhaust valve by lifting the small lower lever on the left handlebar and, while this is kept raised, turn over the engine by depressing the kickstarter crank two or three times.
- (j) Switch on Ignition (on Models 12 and 16 only).
- (k) Then give the kickstarter crank a vigorous downward kick and, when it is almost at the bottom of its movement, release the handlebar exhaust lifter lever, when the engine should commence to fire.

After the engine has started, let it run for a second or two and then open the air lever, a trifle at a time, till it runs evenly. Then, by flicking open the twist grip two or three times, allow the engine speed to increase and decrease in order to clear the combustion chamber and the silencing system of all condensed moisture, which otherwise has a heavy corrosive action on the silencer interior.

Do not let the engine race, neither let it just tick over, but set the twist grip so that it is running at a moderate speed in order to get "warmed up." While it is doing this take the opportunity of checking the oil circulation as detailed in paragraph 18.

One or two minutes is ample time for starting, warming up and checking the oil circulation. The machine can then be taken on the road.

(6). STOPPING THE ENGINE.

To stop the engine, close the throttle, raise the small lower lever on the left handlebar (exhaust lifter lever) and keep it raised till the engine has ceased to revolve. (Also, on Models 12 and 16, switch off the ignition).

(7). ON THE ROAD.

With the engine running, sit astride the machine, free the clutch by pulling up the large lever on the left handlebar, gently move the machine forward till the rear stand is released, and then engage the lowest gear. (See paragraph 4).

If, at first, the lowest gear will not engage after the clutch has been freed, release the clutch lever and, after a second or so, make another attempt. This condition may exist in the case of a new machine but it tends to completely disappear after some little use.

Next, slowly release the clutch handlebar lever, when the machine will commence to move forward. Guard against having the engine speed too high when first engaging the clutch and regulate the speed, as required, by moving the twist grip.

When well under way, disengage the clutch, slightly close the throttle, engage second gear, release the clutch lever and open up the throttle to increase the speed. Repeat these operations in order to engage third and top gears, respectively.

Immediately the machine is well under way the ignition should be fully advanced and it should be left in that position unless it is necessary to retard it to ease the engine. Never run for any considerable distance with the ignition retarded.

Always endeavour to make the movements of hand (on the clutch) and foot (on the gear pedal) as simultaneous as possible, but remember in all gear changes, a steady pressure of the foot is desirable, and this pressure should be maintained until the clutch lever is fully released. It is not sufficient to just jab the foot pedal and then release the clutch lever.

When actually in motion, it will be found sufficient to merely free the clutch a trifle to ease the drive when changing gear, and, with reasonable care, changes of gear can be made without a sound.

Avoid letting the engine race when changing gear. Normally, the movements of the clutch lever and the foot pedal are too quick to permit any appreciable rise in engine revolutions, but, until this stage of efficiency is reached, the beginner is advised to slightly close the throttle when making a change, because by suddenly engaging the clutch while the engine is racing an enormous load is imposed on both gears and chains.

When, by reason of travelling slowly in top gear, such as may be caused by traffic conditions, or by reason of travelling up a hill, the engine commences to labour, it is necessary to change to a lower gear in order to lessen the strain on the engine and transmission. A good driver is able to sense such conditions and will make the change before the engine has reached the stage of distress. Remember the gear box is provided to be used, and full use should be made of the lower gears in order to obtain effortless running and hill climbing.

Avoid slipping the clutch to control the speed.

It must be remembered that on Model 2A the clutch is controlled by a foot pedal which is mounted on the left hand side of the machine. Therefore all references in the above paragraphs to the clutch handlebar lever should apply to the foot clutch pedal in the case of Model 2A.

(8) STOPPING.

To stop the machine, close the throttle, declutch by lifting the large lever on the left handlebar, and gently apply both brakes, increasing the pressure on them as the speed of the machine decreases.

Place the gear foot change pedal in the neutral position before releasing the clutch lever.

Stop the engine (see paragraph 6), and before leaving the machine turn off the fuel supply, because, should the carburettor flood while the machine is stationary, there is a possibility of neat petrol entering the cylinder via the inlet port.

When this occurs there is risk of fire and a real danger of the oil thinning with the consequent risk of engine seizure.

(9) RUNNING IN.

Driving on full throttle should be avoided for the first five hundred miles. A speed of thirty miles per hour should not be exceeded during this period, the engine should not be allowed to labour (so use the gear box) and it should not be allowed to attain a high rate of revolutions on the lower gears or in neutral.

After this initial "running in," short speed bursts are permissible, but it is recommended not to indulge in extended high speeds until at least a thousand miles have been covered. At the conclusion of the first one hundred, and five hundred, miles, the adjustment of tappets, chains, brakes, contact breaker, wheel bearings, fork spindles and steering head bearings should be checked, and corrected if necessary. After the initial settling-down process, attention to such details will only be necessary at very infrequent intervals.

(10) " **DON'TS.**"

DO NOT race the engine unnecessarily or let in the clutch sufficiently suddenly to cause the rear wheel to spin. Take a pride in making a silent, smooth get-a-way.

DO NOT use the brakes with violence. Brake early and drive on the throttle instead of the brakes.

DO NOT allow the engine to labour on a high gear on a steep gradient. Remember that an easier, faster and better ascent can be made on the next lower gear.

DO NOT force the engine, or drive above a maximum speed of 30 m.p.h. for the first 500 miles. Mention is made of this because of the natural desire of an owner to ascertain his new mount's maximum capabilities. Therefore, until all the bearings are well "run in," it is advisable to refrain from speed bursts with the accompanying possibility of seized bearings, piston rings, etc. The first 500 miles of an engine's existence is far more important than the next 5,000.

DO NOT race the engine in neutral gear position, accelerate violently from a standstill, or drive at full speed on open throttle when in a residential district. Any motor vehicle, when driven in such a manner, creates abnormal noise. In the interests of all motorists we earnestly implore every "A.J.S." owner to studiously refrain from any of the practices enumerated, or any calculated to cause annoyance to the public in general. Recollect that the degree of silence of your motor cycle is not judged by the actual noise it is making, but by comparison with other noises present. For example, in a busy street your motor cycle might be inaudible, while in a quiet narrow street of high buildings it might be heard for several hundred yards, although, in each case, being driven in exactly the same manner.

LUBRICATION.

(11). LUBRICATION.

Efficient lubrication is of vital importance, and it is **false** economy to use cheap oils and greases. The cost of exclusively using the best and most suitable lubricant will be repaid many times by long wear and good service.

We recommend the following oils and greases for use in " A.J.S." Motor Cycles:

ENGINE LUBRICATION.

In Summer : Patent Castrol " XXL."
Golden Shell " Extra Heavy."
Mobiloil " D."
Essolube " Racer."
Motorine "B de Luxe."

In Winter : Patent Castrol " XXL."
Golden Shell " Extra Heavy."
Mobiloil " BB."
Essolube "Racer."
Motorine " B de Luxe."

The oils mentioned above flow freely when cold and, at the same time, have good heat resisting properties.

GEAR BOX LUBRICATION AND ALL FRAME PARTS USING GREASE.

Castrollease "Medium."
Shell " Retinax " Grease.
Mobilgrease " No. 2."
Esso Grease.
Belmoline " D."

When buying oils and greases it is advisable to specify the brand as well as the grade, and, as an additional precaution, to **only** buy in sealed containers or from branded cabinets.

(12). **ENGINE LUBRICATION SYSTEM.**

The engine is lubricated by the DRY SUMP system, the main bulk of oil is carried in a tank, and the pump forces the oil through to the various parts requiring lubrication. The oil then drains into the crankcase sump, from which it is extracted and returned to the oil tank by the pump. This process is continuous while the engine is revolving, and, because the oil pump is capable of exhausting a greater amount of oil than it is capable of injecting into the engine, the crankcase sump is kept free of excess oil.

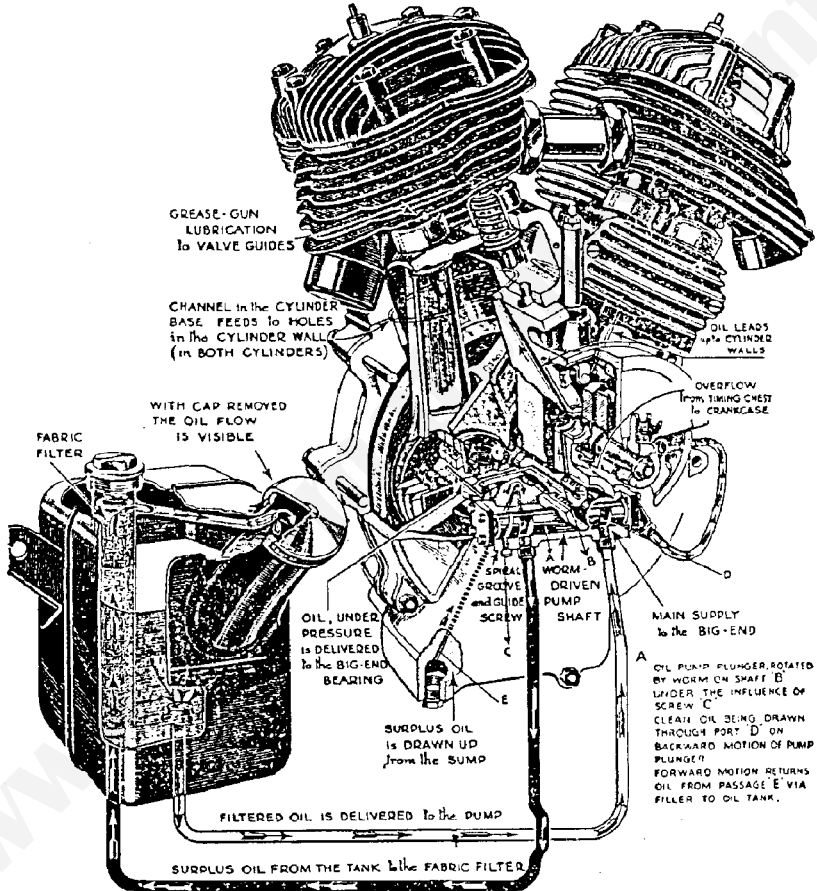

Illustration 1.

This shows the oiling system on Models 2 and 2A. The same system is used on all other models but, in the case of the overhead models there is an additional external oil feed from the engine pump to the overhead rocker box.

(13). **ENGINE OIL CIRCULATION.**

As already mentioned, oil is fed to the oil pump by gravity. The oil pump has only one moving part. This is the plunger, which rotates and also has a reciprocating motion. The plunger is rotated by the timing side flywheel axle, and, while rotating, moves forwards and backwards because of the influence of the small guide screw which engages in the profiled groove cut in the rear end of the plunger.

As the plunger moves in its housing in one direction, the large end draws oil from the crankcase sump, while, at the same time, the smaller end is delivering oil to the various channels provided. Upon the reverse movement of the plunger, the large end returns to the tank the oil it has already drawn from the sump, while the smaller end takes in a fresh charge of oil from the tank in readiness for delivery to the engine on the following movement of the plunger. This action goes on all the time the engine is revolving.

In the oil tank is a filter in the form of a felt cartridge, through which the returning oil is compelled to pass before emerging through the spout immediately underneath the oil tank filler cap, from which it rejoins the main supply of oil in the tank. The felt filter effectively removes all dirt and other foreign matter that the oil may have collected during its passage through the engine.

Reference to illustration 1, of the oiling system shows that the oil pump forces oil through :—

- (a) A channel to the timing side flywheel axle bearing, and then through a drilled passage in the flywheel, to the big-end bearing, the splash from which passes into the interior of the cylinder.
- (b) A channel, controlled by a ball valve, direct to the cylinder so that this, the most vital part of the engine, receives an adequate supply of oil, particularly at high engine speeds.
- (c) A channel to the timing gear case, in which the oil is allowed to " build up " to a pre-determined level, after which all surplus oil drains back into the crankcase sump via a hole cut between the timing gear case and the flywheel chamber.
- (d) On Overhead Valve Models only, a pipe fixed to the oil pump housing front cap and leading to the rocker box, by which all the overhead rocker mechanism and valves are positively lubricated, by an ingenious arrangement of oil jets that pass a pre-determined quantity of oil, which eventually passes down the push rod cover tubes and through grooves machined in the tappet guides into the timing gear case, and from there it drains back into the crankcase sump, as detailed in paragraph (c).

(14). **THE OIL TANK.**

Oil for engine lubrication is carried in the tank situated immediately under the saddle. In use, the level of the oil in the tank should never be allowed to fall below the half-way mark that is indicated on the outside of the tank.

At periods, not greater than every 5,000 miles, the oil tank should be drained, thoroughly washed out with petrol, and then refilled with fresh, clean oil. A drain plug is provided in the bottom of the tank to facilitate this process.

The felt cartridge oil filter is located in the oil tank and on each occasion the engine is decarbonised, or not less frequently than every 1,500 miles, this filter should be removed and thoroughly washed in petrol.

The filter is situated under the hexagon headed cap in the top of the tank. By unscrewing this cap and lifting away the spring and dished washer, which will be found under it, access to the filter is possible in order to withdraw it from the tube in which it fits.

On all single cylinder machines, access to the filter is facilitated by removing the two nuts retaining the saddle springs to the saddle frame, which will enable the saddle to be raised. The filter can then be easily withdrawn in the direction towards the rear wheel.

(15). **OILING ADJUSTMENT.**

The correct delivery of oil to each part of the engine is arranged internally by suitably dimensioned passages, and no provision is made for external adjustment of the oil supply except for the oil feed to the inlet valve stem on all Overhead Valve Models.

The adjuster for the inlet valve stem oil feed, on Overhead Valve Models, consists of a needle pointed screw that can be locked in position by a thin lock nut. This screw is located in the cylinder head. Once the adjuster is set it requires little, or no, adjustment. The approximate correct setting is half a complete turn from the fully closed position, and, unless troubled with valve squeak or excess oil we advise the adjustment to be left as set by our testers during the road tests of the machine.

Valve squeak generally indicates this valve is not passing enough oil, in which case the needle valve should be unscrewed a trifle. Excessive oil consumption, an oily exhaust, or an oiled plug, in the case of a new machine, usually indicates this needle valve is passing too much oil, in which case it should be screwed home, a trifle at a time, till the symptoms disappear.

(16). **OVERHEAD EXHAUST VALVE STEM LUBRICATION.**

On all Overhead Valve Models there is an oil channel cast in the cylinder head to lead oil direct to the exhaust valve stem. No adjustment is provided for this oil feed because, in use, the oil passage allows oil to flow against the stem and oil not immediately used by the stem is then by-passed back to the crankcase sump by the method detailed in paragraph 13. This constant flow of oil against the stem, followed by the instant removal of the surplus, prevents the oil passage becoming choked with burnt oil. This feature, coupled with the means of lubricating the inlet valve stem, is a definite advancement in engine lubrication design.

(17). **VALVE STEM LUBRICATION ON SIDE VALVE MODELS.**

On all side valve models each valve guide is furnished with a grease nipple in order to directly lubricate each valve stem by means of a grease gun. Only a small quantity of graphite grease or one of the recommended grades of grease should be injected through each nipple at intervals not more frequently than every 500 miles.

(18). **CHECKING OIL CIRCULATION.**

Provision is made to observe the oil in circulation, and it is advisable to do this before each run.

If the filler cap is removed, the returning oil can be seen running from the small spout just inside the filler cap orifice. This check should be made immediately after starting the engine from cold. This is because, while the engine is stationary, oil from all parts of the interior of the engine drains back into the crankcase sump, so that until this surplus is cleared, the return flow is very positive and continuous. Therefore, if the oil circulation is deranged, the fact is apparent at once, by the lack of a steady return flow.

It should be remembered that normally the return flow is somewhat spasmodic and mixed with air bubbles. This is partly due to the fact the return portion of the oil pump plunger has greater pumping capacity than that delivering fresh oil, and partly due to the variations in the amount of oil in suspension in the crankcase according to the engine speed. For example, upon a sudden acceleration, the return flow may completely cease for a time, only, of course, to resume at a greater rate than normal upon deceleration.

(19). **REMOVING THE OIL PUMP PLUNGER.**

To remove the oil pump plunger, it is necessary to proceed as follows :—

Drain the oil tank.

Remove the four bolts holding the oil pump housing rear cap to the crankcase and take away the cap.

Unscrew the guide screw for the oil pump plunger. (This is the screw, having a hexagon head, that screws into the oil pump housing portion of the crankcase. It is located in the under side of the housing, just in front of the rear cap. This screw is at right angles to the plunger and its reduced end engages in the profiled groove cut in the rear end of the pump plunger).

Then the pump plunger can be extracted from its housing.

(20). **WARNING.**

If, for any reason, the engine is dismantled, the oil pump plunger **MUST** be removed before the two halves of the crankcase are separated.

(21). **REPLACING THE OIL PUMP PLUNGER.**

To replace the oil pump plunger, it is necessary to proceed as follows:—

See that the interior and exterior of the oil pump plunger and its housing are free from dirt. Then smear the plunger with clean engine oil.

Insert the narrow end of the plunger in the rear end of the plunger housing and gently push it into place.

Next, introduce the guide screw into its hole and while gently screwing this, slightly move the plunger in a to and fro motion until the narrow end of the guide screw is felt to engage in the profiled groove cut in the end of the plunger. Once the guide screw has engaged in the groove it should be screwed right home.

If the screw does not engage in the groove, and it is tightly screwed against the body of the plunger, the plunger will be prevented from rotating, so that, when the engine is turned for starting, the teeth on the plunger and on the timing side flywheel axle will be stripped. Therefore great care must be taken to prevent this occurring.

There now only remains to replace the end cap. It will be noticed there is a paper washer under each end cap, and if either, or both, are damaged, it is necessary to replace with

new. (Paper washer, for oil pump end cap. Part number STD 582, price each 1d., postage 1½d. extra.)

It is most essential that both of the end caps are an air tight fit on the pump housing, and consequently it is advisable to smear one side of each washer with a small quantity of liquid jointing compound, and to place that side in contact with the end cap.

Note that the cap on the front end of the housing is retained by four screws having cheese heads, and the cap on the rear end is retained by four small bolts having hexagon heads. (Except on S.V. Models, when bolts are used for both caps).

(22). **POINTS TO REMEMBER.**

Clean the oil filter felt cartridge, as detailed in paragraph 14, and, if necessary, replace with new. (All models, except 2 and 2A, oil filter cartridge, for oil tank, part number STD 796, price each 2s. 9d., postage 3d. Models 2 and 2A, part number D5T571, price each 2s. 9d., postage 3d.). A dirty or choked filter will inevitably cause heavy oil consumption.

Make sure the oil tank has an ample supply of oil. The level should not be less than the half-way mark indicated on the outside of the oil tank, nor more than within one inch from the top of the filling orifice.

Make sure both end caps on the oil pump plunger housing are air tight.

Before each run check the operation of the oil in circulation, by inspection through the oil tank filling orifice.

(23). **GEAR BOX LUBRICATION.**

All mechanism inside the gear box is lubricated with grease. A grease nipple is provided on the top edge of the kickstarter case cover, and this is the only point requiring grease gun application.

If desired, instead of using the grease nipple, grease may be inserted through the round screwed plug mounted in the top edge of the kickstarter case cover, in the case of Models 8, 9, 16, 16M, 18, 18SS, 18T, 22T, 26, 26SS, 26T and 2, and through a rectangular aperture in the top of the gear box shell, in the case of Models 12, 12M, 22, 22SS and 2A. This aperture is covered by a slotted plate that is retained by two studs and nuts, and, upon slackening both nuts the rear end of the plate may be swung aside in order to uncover the aperture.

The gear box must not be entirely filled with grease, and, under normal conditions, the addition of about two ounces of grease every 1000 miles will be sufficient.

In no circumstances must heavy grease be used for gear box lubrication.

(24). **CHAIN LUBRICATION.**

Both the primary and dynamo chains run in an oil bath case. The inspection cap orifice in the chain case determines the correct oil level, and it is imperative that the level is not allowed to fall lower than about 3/16in, below the height of the bottom edge of this orifice. Add engine oil to maintain this level. It is advisable to check the oil level each week because failure to maintain it will result in rapid chain wear with the possibility of total destruction.

The inspection cap has a screw passing through its centre, and this screw engages in a plate (situated inside the chain case) that bridges the orifice. Between the back of the inspection cap and the outside of the chain case is a cork washer. It is advisable to secure the cork washer to the inspection cap with liquid jointing compound.

To remove the inspection cap, the central screw must be undone about four complete turns. This will enable the cap to be slid sideways out of position, and then, by tilting the cap assembly, the back plate can be slipped through the orifice and the complete assembly removed. It can be replaced in the reverse manner, taking care to centralise the cork washer before screwing home the central screw.

The rear chain should be removed every 1,500 to 2,000 miles in Summer, and every 1,000 miles in Winter, and thoroughly washed in paraffin. After removing the paraffin by draining and wiping with a rag, it should be immersed, for several minutes, in a bath of molten tallow, or, as a poorer substitute, ordinary engine oil. If the latter is used, the chain should be laid in soak overnight in order to ensure penetration to all joints. If treated in this manner the maximum miles of satisfactory service will be obtained.

On every model equipped with magneto ignition the case covering the magneto driving chain is packed with grease during assembly, and a grease nipple is fitted to the case cover. A small quantity of grease should be added every 1,000 miles.

It must be remembered that on Models 2 and 2A there is not a separate dynamo and therefore there is not a dynamo chain running in the front chaincases of those models.

(25). **HUB LUBRICATION.**

The hubs are packed with grease when first assembled. This prevents the entry of mud and water as well as lubricating the bearings. A small quantity of grease should be injected through the angular grease nipple in the centre of each hub shell every 500 miles.

It should be remembered that if too great a quantity of grease is injected there will be a tendency for some of the surplus to work into the brake drum, and the brake efficiency will be considerably reduced.'

- (26). **FORK SPINDLE LUBRICATION.**
To maintain an efficient front fork action, it is essential the fork spindles receive adequate lubrication. Two grease nipples are fitted in the fork girder, two are fitted in the fork crown, and one is fitted in the top lug, in front, on the steering stem. Grease should be injected through these nipples every 500 miles, until it is seen to exude from both ends of each bearing. This surplus should then be wiped off.
- (27). **STEERING HEAD BEARING LUBRICATION.**
A grease nipple is fitted in the head lug of the main frame to lubricate the bottom steering head bearing, and another nipple is fitted to the head clip, at the top of the steering stem, to lubricate the top bearing. These bearings require very little grease, and only a small quantity should be injected every 1,000 miles.
- (28). **BRAKE CAM LUBRICATION.**
A grease nipple is fitted to each brake cam expander bush, and a very small quantity of grease should be injected every 1,000 miles. Excessive quantities of grease may get on the brake linings; (See warning in paragraph 25.)
- (29). **BRAKE ROD JOINT LUBRICATION.**
About every 1,000 miles (more frequently in bad weather), place a drop or two of engine oil on each brake rod joint and on the threaded end of the brake rod.
- (30). **SPEEDOMETER LUBRICATION.**
The speedometer driving gear box screws into the front brake cover plate, and on its end is a sunk grease nipple. A small quantity of grease should be injected every 500 miles. No other part of the speedometer requires lubrication,
- (31). **CONTROL LEVER LUBRICATION.**
A drop or two of engine oil should be placed on all the moving parts of the various control levers every 1,000 miles.
- (32). **BRAKE PEDAL LUBRICATION.**
A grease nipple is provided in the heel of the foot brake pedal to lubricate the bolt and bush on which the pedal is hinged. A small quantity of grease should be injected every 1,000 miles. On Model 2A the grease nipple for the brake pedal is located in the pedal spindle bush which is situated between the two front engine plates. It is close to the right hand engine plate.
- (33). **CLUTCH CONTROL LUBRICATION. (Model 2A.)**
A grease nipple is provided in the foot operated clutch pedal and another to lubricate the coupling shaft, which is situated between the two rear engine plates.
A small quantity of grease should be injected in these two points every 500 miles.

(34). **CONTROL CABLE LUBRICATION.**

Control cables are very susceptible to the influence of dryness and rust, and they should be kept flooded out with lubricant. The effect of efficiently lubricating a dry control cable has to be tried to believe the immense difference it causes. In order to do this, we fit in a convenient position, a small metal clip to each control cable. These clips cover small bared patches on the outer casings through which lubricant can be injected by means of a specially constructed oil gun. (Special oil gun, for control cables. Part number B.G.G., price each 5s. 9d., postage 4d. extra.) This gun is not supplied with the standard tool kit. The operation of flooding a control cable only takes a few minutes. It is necessary to slide the clip along the casing to enable the gun to be damped to the casing so that the bared patch occupies a central position on the rubber pad that is on the nozzle of the gun. The clamping pressure is provided by the large, milled-edge disc just under the rubber pad. The screwed plunger of the gun is then given a few turns (in a clockwise direction), which action forces oil through the metal spiral of the outer casing, and floods the entire length of the cable with lubricant.

Avoid oiling the ignition control cable to excess, because, if this is done, there is a danger of oil collecting inside the contact breaker cover and thereby causing misfiring.

To fill the oil gun, unscrew the barrel from the end cap nearest to the nozzle. Unscrew the operating handle as far as it will go and then pour the lubricant into the barrel. (Engine oil or a very light grease may be used). Then replace the end cap and nozzle assembly and the gun is ready for use.

(35). **MAGNETO LUBRICATION. (All Models except 12 and 16.)**

The magneto bearings are packed with grease during assembly, and at least once every 10,000 miles the magneto should be dismantled for cleaning, adjustment and repacking the bearings with grease. This is preferably carried out at a Lucas Service Station.

(36). **DYNAMO LUBRICATION. (Miller Separate Dynamo.)**

On Models 12 and 16 (which are fitted with coil ignition), oil and grease are used as lubricants for the dynamo. There is an oil lubricator on the driving end of the dynamo, and a few drops of thin oil should be inserted through this every 500 miles.

In the centre of the commutator end of the dynamo is a round beaded screw. Once every 1,000 miles this should be removed and a small quantity of grease should be pressed into the hole in which the screw fits. Avoid using too much grease, or too great a pressure, otherwise grease may be forced right through the bearing and get on to the commutator and cause trouble.

- (37). **DYNAMO LUBRICATION. (Lucas Separate Dynamo.)**
All single cylinder models equipped with magneto ignition are fitted with Lucas Dynamos.
The dynamo bearings are packed with grease during assembly, and at least once every 10,000 miles, the dynamo should be dismantled for cleaning, adjustment and repacking the bearings with grease. This is preferably carried out at a Lucas Service Station.
- (33). **DYNAMO LUBRICATION. (Lucas Magdyno.)**
Models 2 and 2A are equipped with Lucas Magdynos. The bearings are packed with grease during assembly, and at least once every 10,000 miles, the dynamo and magneto units of the magdyno should be dismantled for cleaning, adjustment and repacking with grease. This is preferably carried out at a Lucas Service Station.
In addition, a lubricator is provided in the end of the brush gear cover, in which a drop or two of thin oil should be inserted every 500 miles.
- (39). **FILLING THE GREASE GUN.**
The standard grease gun consists of a barrel having a spring loaded end cap, to which is fixed a centre steel piston in the shape of a long rod. This piston fits into a small cylinder made in one with the screwed top cap, on the end of which is the cupped nozzle that fits over the grease nipples. In the barrel of the gun, and sliding on the central piston rod, is a cork piston.
The grease must be filled on the TOP of this cork piston. The gun may be filled with grease by inserting the grease in the barrel of the gun by means of a lath or similar "spoon." However, it is better to obtain the grease packed in the special containers that are supplied, having loose collars in which are holes so that, by placing the barrel of the gun over the hole in the central floating plate and pressing downwards, the gun is instantly charged with grease. Twisting the gun, and, at the same time, taking it away from the floating plate, leaves the top of the gun barrel flush with grease, and then all that remains to be done is to replace the screwed top cap.
- (40). **SPECIAL.**
In addition to the parts mentioned in the preceding paragraphs, there are several parts of a motor cycle that have a very small moving motion which can, with benefit, be lubricated. Among these are the bolts on which the front and rear stands hinge. It is advised to occasionally remove these bolts and lightly smear them with grease before refitting.
Because grease prevents the entry of water, it is advisable, during the wet season, to smear grease round the contact breaker cover and the high tension pick-up on the magneto (or coil).

MAINTENANCE.

(41). **TO REMOVE AND REPLACE THE PETROL TANK.**

(Models 16, 16M, 26, 26SS, 8, 18, 18SS.)

The petrol tank, and its fittings, is designed so that it may be easily removed in order to provide ready access to the engine.

To remove the petrol tank, proceed as follows :—

Remove the positive wire from the battery.

Remove the petrol pipe, drain the petrol from the tank, remove the tank connection pipe and the four tank fixing bolts with their rubber pads and metal washers.

Remove the inspection lamp from the instrument panel and also remove the three screws that fix the panel to the top of the tank.

Then, lift away the tank, and, while doing so, pass the instrument panel through the slot between the two halves of the tank.

The tank can be taken right away from the machine and the panel can be hung over the front forks, out of the way, and it will be noted there is no need to disconnect any of the electric cables.

To replace the petrol tank and instrument panel, reverse the procedure described above.

(Models 22T, 26T, 1ST, 9, 2, 2A.)

To remove the tanks on these models it is only necessary to remove the petrol pipe, drain the tank, remove the tank connection pipe, and the four fixing bolts and the tank can be taken away. In addition, on Models 9, 2, 2A, it is also necessary to remove the three screws fixing the instrument panel, lift up the panel and disconnect the electric cables from the fittings mounted in the panel, before the tank can be taken right away from the machine.

(42). **TO RAISE THE PETROL TANK. (Models 12, 12M, 22, 22SS.)**

On these models the instrument panel cannot be passed through the tank.

To raise the petrol tank in order to provide sufficient room for access to the engine to dismantle parts of it, proceed as follows :—

Remove the petrol pipe, drain the petrol from the tank, remove the tank connection pipe and the four tank fixing bolts with their rubber pads and metal washers.

Slide the tank backwards until its rear end is resting on the nose of the saddle and insert a wooden block, or other suitable packing under the forward end of the tank so as to support the tank at a height sufficient to permit access to the rocker box fixing bolts.

If it is desired to take the tank right away from the machine it is additionally necessary to:—

Remove the positive wire from the battery, remove the instrument panel from the top of the tank by removing the three fixing screws, disconnect the electric cables from the fittings mounted in the panel and then lift the tank away from the machine.

To replace the petrol tank, reverse the procedure described above.

(43). TO REMOVE AND REPLACE THE ROCKER BOX. (All O.H.V. Models.)

Before attempting to remove, or replace, the rocker box, it is essential the valves are closed. In that position, the piston is at the extreme top of its compression stroke, and this can be easily determined by removing the side tappet cover from the rocker box in order to expose the long push rod adjustable ends and the rocker arms.

To remove the rocker box, first raise the tank (or remove it) and then proceed as follows:—

Disconnect the main oil pipe that leads oil to the centre of the rocker box.

Slack off the bolt securing the engine steady stay to the clip on the frame tube (350 and 500 Models only) and, on 350 models, remove the nut and washer fixing the steady stay to the rocker box rear long bolt, and gently spring the stay clear of the rocker box bolt.

Remove the seven bolts that secure the rocker box to the cylinder head and then, the box, complete with the rockers, can be taken away.

Beware of losing the steel cap, or thimble, that is on each valve stem. These are disclosed when the rocker box is removed and, of course, should be in position, on the valve stems, before the box is replaced.

To refit the rocker box, first, thoroughly clean the top of the cylinder head and the lower face of the rocker box, and see that the composition washer is located between the cylinder head and the box.

Then, reverse the procedure described above. Remember there is a steel washer under the head of each of the rocker box fixing bolts and, when replacing these bolts, screw each down, bit by bit, in turn, until all are fully home.

To ensure the rocker box making an oil tight joint with the cylinder head it is essential the composition washer is faultless. Therefore if it is not in perfect condition, replace with new.

Composition washer, for rocker box. Part number, 39-8-E440, price each, 4d., postage 2d.

Tappet clearances must always be checked after refitting the rocker box, and adjusted, if necessary.

**(44). TO REMOVE AND REPLACE THE CYLINDER HEAD.
(All O.H.V. Models.)**

To remove the cylinder head, first raise (or remove) the petrol tank, remove the rocker box and then proceed as follows:—

Remove the exhaust system by slackening; the screw on the finned clamp on the cylinder head (when this is fitted—all models do not have one), and by removing all the bolts retaining the exhaust pipe and silencer to the frame and taking away the pipe and silencer as one unit. On two port models it is necessary to remove both pipes and silencers.

Unscrew the top cap of the carburetter mixing chamber and withdraw the throttle and air slides and also remove the sparking plug-

Remove the four bolts retaining the cylinder head to the cylinder barrel and the head is then free to be taken away. While doing this, the push rod cover tubes will come away with the head and the two long push rods should be removed (these will be exposed as the head and cover tubes are taken away). Lay aside the push rods so that they may be identified, because, although they are identical in construction and size, they should not be interchanged.

A gasket is fitted between the cylinder head and barrel. If this is damaged a new gasket should be used when refitting the head.

Head gasket, for all 250 O.H.V. Models. Part number, 20371, 6d.

Head gasket, for all 350 O.H.V. Models. Part number, 12268, 6d.

Head gasket, for all 500 O.H.V. Models. Part number, 38-G9-E4, 11d.

Postage 3d. extra on any of above gaskets.

To replace the cylinder head* reverse the procedure described above, taking care to replace the cylinder head gasket, the rubber gland rings at the bottom of the cover tubes and to see that the lower ends of the long push rods are lying in the cups of the tappets and that the overhead rocker arms are lying in the cups at the top of the long push rods. When refitting the cylinder head bolts, screw each down, bit by bit, in turn, until all are fully home.

(45). **COVER TUBE WASHERS.**

The top ends of the cover tubes are a push in fit in the cylinder head and a composition washer (tubular in shape) is fitted between each tube and the head. If the cover tubes are removed from the head (by pulling them away) the composition washers will probably remain in the head.

When fitting: a new washer it should be pushed into the cylinder head, and remember there is a metal washer on top of the composition washer. This should be inserted in the head first.

Composition washer, or tube, for top of cover tube (2 used), part number, 38-G4-E368, price each, 10d., postage 2d. extra.

A rubber gland ring is fitted at the bottom of each cover tube. This is used to ensure an oil tight joint between the cover tube and the crankcase.

Rubber gland, for cover tube, part number, STD 691, price each, 3d., postage 2d. extra.

(46). **TO REMOVE AND REPLACE THE CYLINDER HEAD.
(Model 9.)**

To remove the cylinder head, proceed as follows :—

Remove the sparking plug, unscrew the nuts fixing the head to the cylinder barrel, take away the washer that is under each nut and the head is then free to be taken away.

If the head fixing nuts have a dry, rusted, appearance, it is advisable to thoroughly soak them with paraffin before attempting to unscrew them.

A gasket is fitted between the cylinder head and the cylinder barrel and, if this adheres to either head or barrel, it should be gently eased off. An ordinary table knife is an excellent "tool" with which to do this. If the gasket is damaged it should be replaced with a new one when refitting the head. (Model 9. Gasket, for cylinder head. Part number, 37-9-E4, price each, 2s. 6d., postage 3d. extra.

The top face of the cylinder barrel, the face of the cylinder head and both sides of the gasket, must be quite clean before they are refitted.

To replace the cylinder head, reverse the procedure described above, taking care to refit the cylinder head gasket and, when replacing the cylinder head fixing nuts, screw each down, bit by bit, in turn, until all are fully home.

To facilitate subsequent removal of the head fixing nuts, it is a good tip is to smear the threads with graphite grease.

After the head has been replaced, and after the engine has run for a short time, it is advisable to go round all of the cylinder head fixing nuts, while the engine is warm, because it is most likely all can then be screwed up a bit tighter.

(47). **TO REMOVE AND REPLACE THE CYLINDER HEADS. (Models 2 and 2A.)**

To remove the cylinder heads, proceed to remove each head, in turn, as follows :—

Remove the sparking plug, unscrew the bolts holding the cylinder head to the cylinder barrel and the head is then free to be taken away.

A gasket is fitted between the cylinder head and the barrel and, if this adheres to either head or barrel, it can be removed as described in paragraph 46. If the gasket is damaged it should be replaced with a new one when refitting the head. (Gasket, for cylinder head. Part number, XE 1004, price each, 2s. 6d., postage 3d. extra).

The top face of the cylinder barrel, the face of the cylinder head and both sides of the gasket, must be quite clean before they are refitted.

To replace the cylinder head, reverse the procedure described above, taking care to refit the cylinder head gasket and, when replacing the cylinder head bolts, screw each down, bit by bit, in turn, until all are fully home.

To facilitate subsequent removal of the cylinder head fixing bolts it is a good tip to smear the threads with graphite grease.

After the head has been replaced, and after the engine has run for a short time, it is advisable to go round all of the head fixing bolts, while the engine is warm, because it is most likely all can then be screwed up a bit tighter.

(48). **TO REMOVE THE CYLINDER BARREL. (All O.H.V. Models.)**

To remove the cylinder barrel, first raise the petrol tank remove the rocker box and cylinder head, and then proceed as follows :—

Remove the four nuts that retain the barrel to the crankcase, and this will leave the barrel free to be taken away. While doing this, take care to ensure the piston assembly does not receive damage.

(49). **TO REMOVE THE CYLINDER BARREL. (Model 9.)**

To remove the cylinder barrel, remove the cylinder head and then proceed as follows :—

Remove the exhaust system by removing all the bolts that retain the exhaust pipe and silencer to the main frame, and removing the pipe and silencer as one unit.

Remove the tappet cover plate that is retained to the cylinder by two screws, and turn over the engine till both valves are closed. This is when the piston is at the top of its compression stroke.

Then, remove the three nuts that retain the barrel to the crankcase, and this will leave the barrel free to be taken away. While doing this, take care to ensure the piston assembly does not receive damage.

(50).TO REMOVE CYLINDER BARRELS. (Models 2 and 2A.)

To remove the cylinder barrels, remove the cylinder heads and then proceed as follows:—

Remove the front exhaust pipe and silencer, and rear exhaust pipe and silencer, as separate units, by removing all the bolts and slackening all the nuts that retain them to the main frame. (The rear pipe is secured to the frame by a bracket close to its front end).

Unscrew the two union nuts that retain the inlet pipe to the cylinders. This will enable the inlet pipe, complete with the carburetter, to be taken away.

Next, remove the two tappet cover plates, which are retained to the cylinder barrels by two screws, in the case of the front cylinder, and by a screw and knurled nut, in the case of the rear cylinder.

Next, turn over the engine till both of the valves of the front cylinder are closed. This is when the piston is at the top of its compression stroke. Then remove the three nuts that retain the front cylinder to the crankcase, and this will leave the cylinder free to be taken away. While doing this, take care to ensure the piston assembly does not receive damage.

Finally, remove the rear cylinder in exactly the same manner as described for the front cylinder.

(51).TO REMOVE A PISTON.

To remove a piston, having already removed the cylinder barrel, proceed as follows :—

Fill the throat of the crankcase with rag. Then, using the special pliers, included in the tool kit, compress the two ends of one of the gudgeon pin circlips and extract the circlip from the piston. It is immaterial which clip is extracted, because the gudgeon pin is parallel.

Next, push the gudgeon pin out of the piston, withdrawing it from the side from which the circlip was removed. This action frees the piston from the connecting rod so that it may be taken away.

The gudgeon pin is an easy sliding fit in the piston and the gudgeon pin bush, so that no difficulty should be met in removing it.

(52).PISTONS.

All standard compression pistons are grooved to accommodate three rings. The two top grooves are for rings 1/16in. wide, and the bottom groove is for rings 1/8in. wide.

All new single cylinder machines are equipped with compression rings in all three positions.

It is intended, if excessive oil consumption occurs, to discard the bottom 1/8in. compression ring and to fit in its place a slotted scraper ring. This action will restore the oil consumption to normal. (Considerable wear on pistons, piston rings and cylinder barrel also always results in a greatly increased oil consumption.)

Models 2 and 2A, as standard, are always equipped with scraper rings in the bottom grooves of the pistons.

Some single cylinder machines have been issued with standard compression pistons having grooves for three 1/16in. compression rings. Slotted scraper rings cannot be fitted to these pistons unless the bottom grooves are turned out to accommodate rings 1/8in. in width. There is ample material in the piston to permit this with safety.

For the convenience of "A.J.S." owners we list all piston rings on Page 28.

Cylinders may be rebored and oversize pistons, with rings, supplied to suit at inclusive charges, as under. Note the prices do not include new gudgeon pins and circlips and carriage is also additional.

The only size of rebore is .020in. larger than standard, and only rebores to provide standard compression ratios can be undertaken.

Models.	£	s.	d.	s.	d.
12, 12M and 22	1	8	6	(Pin and circlips 3 5 extra)	
22T and 22SS ...	1	9	6	(Pin and circlips 3 5 extra)	
16, 16M and 26	1	10	0	(Pin and circlips 3 8 extra)	
26T and 26SS ...	1	11	0	(Pin and circlips 3 8 extra)	
8 and 18 ...	1	14	6	(Pin and circlips 3 11 extra)	
18T and 18SS ...	1	15	6	(Pin and circlips 3 11 extra)	
9	1	14	6	(Pin and circlips 3 11 extra)	
2 and 2A (2 cyls.)	3	2	6	(Pin and circlips 11 4 extra)	

All the above prices are plus TEN PER CENT.

(53).COMPRESSION RATIOS.

Standard compression ratios are supplied unless a new machine is ordered otherwise.

To obtain standard compression ratios on all 250 and 350 c.c. machines it is only necessary to fit a standard piston.

On 500 c.c. O.H.V. Models the standard compression ratio is provided by fitting a standard piston and having a compression plate fitted between the crankcase and the cylinder barrel. On machines so equipped there is a thick steel washer above each gasket fitted to the top of the push rod cover tubes. (Actually, the washers and gaskets are situated in the cylinder head.)

To convert a 250 O.H.V. Model to high compression, it is necessary to fit a special piston and special compression plate between the crankcase and the cylinder barrel. (It is also necessary to fit longer cylinder base studs.) To obtain the Ultra high compression on 250 O.H.V. Models, it is necessary to fit the special piston without the compression plate under the cylinder.

To convert a 350 O.H.V. Model to high compression, it is necessary to fit a special high compression piston. To obtain an Ultra high compression, another special piston can be supplied.

To convert a 500 O.H.V. Model to high compression, it is necessary merely to remove the compression plate and also to discard the thick steel washers above the cover tube gaskets and to substitute washers much thinner. These thinner washers are sent out in the tool kit as part of the equipment of a new machine.

It should be noted that the compression plate is a standard fitment on all 500 O.H.V. Models.

An Ultra high compression ratio cannot be provided on 500 O.H.V. Models.

(54). PISTON RINGS FOR STANDARD COMPRESSION PISTONS.

Rings for 250 Models.	Part No.	Price.
Compression ring, 1/16" wide ...	DE-11	... 1s. 6d. each
Compression ring, 1/8" wide ...	38-G2-E11	... 1s. 6d. each
Scraper ring, 1/8" wide ...	38-G2-E111	... 2s. 3d. each
Rings for 350 Models.		
Compression ring, 1/16" wide ...	D3-E311	... 1s. 6d. each
Compression ring, 1/8" wide ...	38-G3-E11	... 1s. 6d. each
Scraper ring, 1/8" wide ...	38-G3-E111	... 2s. 3d. each
Rings for 500 Models.		
Compression ring, 1/16" wide ...	D5-E611	... 1s. 9d. each
Compression ring, 1/8" wide ...	38-G8-E11	... 1s. 9d. each
Scraper ring, 1/8" wide ...	38-G8-E111	... 2s. 9d. each
Rings for 990 Models.		
Compression ring, 1/16" wide ...	CE-311	... 1s. 9d. each
Scraper ring, 1/8" wide ...	36-2-E111	... 2s. 9d. each

(55). TO REMOVE AND REPLACE THE VALVES. (All O.H.V. Models.)

After the cylinder head has been removed in the manner already described, to remove the valves it will be found convenient to rest the head of each, in turn, on a small wood block while the valve springs are compressed, to allow the valve spring cap divided collets to be removed from the grooves cut in the valve stems. These collets are a taper fit, and it may be necessary to give the valve spring cap a sharp tap in order to release them.

Upon the removal of the split collet the pressure on the valve spring cap should be released, which will permit the removal of the valve spring cap and the springs, so that the valve will be free to be withdrawn from the head.

To replace the valves, smear each stem with engine oil and then reverse the procedure described above.

(56). TO REMOVE AND REPLACE THE VALVES. (Models 9, 2 and 2A.)

To remove a valve, first remove the cylinder head and the tappet chest cover, as already described, and then proceed as follows :

Using a stout screwdriver, or other suitable lever, raise the valve spring bottom collar, at the same time, holding the valve down on its seat, and withdraw the valve cotter. This action will free the valve so that it may be extracted.

To replace a valve, reverse the procedure described above.

(57). TO REFIT A PISTON AND CYLINDER BARREL.

All parts should be clean. Place the rings on the piston (see paragraph 58.)

Smear the gudgeon pin with clean engine oil, and, placing the piston over the connecting rod so that the slit in the piston faces to the FRONT of the machine, and so that the holes for the gudgeon pin are in line with the bush in the rod, introduce the gudgeon pin in the piston and centralise it.

Then fit the gudgeon pin circlip (or circlips, if both have been removed). To do this, the rounded ends of the special pliers should be inserted in the holes in the circlip and the pliers gently compressed. The circlip should then be introduced into the piston, with a rotary movement, until the whole of the circlip lies snugly in the groove which is machined in the gudgeon pin boss in the piston. This is most essential, because, if the circlips are not fitted properly, there is a possibility of the gudgeon pin working out of position and scoring the wall of the cylinder.

A paper washer is fitted between the base of the cylinder and the crankcase, and it is best to stick this to the base of the barrel with liquid jointing compound. Make sure none of the jointing compound closes the holes for lubricating the cylinder.

Paper washer, all 250 c.c.	37-12-E3	... 2d.	each.
Paper washer, all 350 c.c.	37-8-E3	... 2d.	each.
Paper washer, all 500 c.c. O.H.V.	37-8-E3	... 2d.	each.
Paper washer, Model 9	37-9-E3	... 2d.	each.
Paper washer, Models 2 and 2A	37-2-E3	... 2d.	each.

Postage 2d. extra.

Next, smear the cylinder wall and the piston with clean engine oil, fit and space the three piston rings so that the gaps are evenly spaced at approximately 120 degrees to each other and proceed to fit the cylinder barrel, taking care that the piston rings are fully compressed into the grooves, in turn, as the barrel passes over them.

When the barrel is down on to the crankcase, replace the holding down nuts, screwing down each, bit by bit, in turn, until all are fully home.

(58). **DECARBONISATION** .

The period for which an engine will run satisfactorily without being decarbonised depends to a great extent, upon the driving conditions. Generally, this process should be carried out every 1,500 to 2,000 miles.

The need for decarbonising will be indicated by a tendency to "pink," or knock, when ascending hills, or upon accelerating after rounding a corner, and particularly so when the engine is hot.

Although it is only necessary to take off the cylinder head to remove carbon deposit, it is advisable to also remove the cylinder barrel every 5,000 miles to inspect the piston rings and to remove any carbon there may be in the piston ring grooves.

All piston rings should have a uniform matt appearance on their exterior, and any having black portions on their exterior (a sign leakage has occurred) should be replaced with new.

All carbon should be scraped off the top of the piston and the inside of the cylinder head, and do not overlook any deposit there may be in the inlet and exhaust valve ports.

A blunt screwdriver having a wide blade makes an excellent scraper for both piston and head. Do not use emery cloth or any other abrasive to remove carbon from the piston crown.

(59). VALVE GRINDING.

It is advisable to grind in the valves upon each occasion the engine is decarbonised.

First, scrape off all carbon deposit that is on the valve heads and clean the stems with very fine emery cloth by holding the cloth between the thumb and forefinger and moving it up and down the stem.

Then smear the face of each valve, in turn, with valve grinding paste and revolve the valve on its seat in a slight forward and backward direction, at the same time, maintaining slight pressure on the valve head to keep it on its seat.

During this operation, occasionally raise the valve off its seat and turn it slightly, afterwards lowering the valve to the seat and repeating the forward and backward movement.

Generally, one application of grinding paste will be ample for the inlet valve, but two or three applications may be necessary for the exhaust valve before the seating is restored. The grinding may be considered satisfactory and completed when a continuous matt ring is observed on both valve and valve seat.

Finally, remove all traces of grinding paste from the valves and seatings by washing off with petrol and pass a piece of clean rag through each valve guide to remove any abrasive that may have collected.

(60). SPECIAL TOOLS.

On O.H.V. models, decarbonisation is considerably facilitated by the use of two special tools. These are described and priced below.

VALVE SPRING COMPRESSOR. Part number TTK8, price each, 7s., postage id. extra.

This is a clamp like tool which compresses coil pattern valve springs and also holds the valve on its seat. It is suitable for all O.H.V. Models. This tool is not included in the standard tool kit of the machine.

VALVE GRINDING TOMMY. Part number 3282, price each, 7d., postage 2d. extra. This is a clamp to fit on the valve stem to facilitate the rotation of the valve during valve grinding. It is suitable for all O.H.V. Models and is not included in the standard tool kit of the machine.

(61). **GASKETS.**

Although many of the gaskets used on "A.J.S." Motor Cycles can be used after being dismantled, it is never possible to be sure on that point until after the engine has been taken apart and the various gaskets carefully examined.

Therefore, we suggest that all "A.J.S." owners should keep by them a complete set of gaskets, so that, when one is required, it is instantly available.

We supply gaskets, either as individual spares, or in complete sets. Particulars of these sets are given below. We suggest, that before dismantling an engine for decarbonisation or other service work, a set of gaskets, suitable for the Model, is available.

(62). **GASKET SET. Suitable for all 250 O.H.V. Models.**

CONTENTS.—1 washer, for cylinder base.
1 Gasket, for cylinder head.
1 Composition washer, for rocker box.
1 Washer, for timing gear cover.
2 Composition rings, for top of cover tubes.
2 Rubber rings, for bottom of cover tubes.
1 Rubber fillet, for rocker box cover.
2 Cork washers, for rocker inspection caps.
3 Fibre washers, for rocker box cover knurled nuts.
2 Washers, for oil pump end caps.
2 Gaskets, for carburetter.

Part number, 39-EQ-11, price, per set, 4s. 9d., postage 3d. extra.

(63). **GASKET SET. Suitable for all 350 O.H.V. Models.**

CONTENTS.—1 washer, for cylinder base.
1 Gasket, for cylinder head.
1 Composition washer, for rocker box.
1 Washer, for timing gear cover.
2 Composition rings, for top of cover tubes.
2 Rubber rings, for bottom of cover tubes.
1 Rubber fillet, for rocker box cover.
2 Cork washers, for rocker inspection caps.
3 Fibre washers, for rocker box cover knurled nuts.
2 Washers, for oil pump end caps.
2 Gaskets, for carburetter.

Part number, 39-EQ-12, price, per set, 4s. 9d., postage 3d. extra.

(64). **GASKET SET. Suitable for all 500 O.H.V. Models.**

CONTENTS.—1 washer, for cylinder base.
1 Gasket, for cylinder head.
1 Composition washer, for rocker box.
1 Washer, for timing gear cover.
2 Composition rings, for top of cover tubes.
2 Rubber rings, for bottom of cover tubes.
1 Rubber fillet, for rocker box cover.
2 Cork washers, for rocker inspection caps.
3 Fibre washers, for rocker box cover knurled nuts.
2 Washers, for oil pump end caps.
2 Gaskets, for carburetter.

Part number, 39-EQ-13, price, per set, 4s. 9d., postage 3d. extra.

(65). **GASKET SET. Suitable for Model 9.**

CONTENTS.—1 Washer, for cylinder base.
1 Gasket, for cylinder head.
1 Washer, for timing gear cover.
2 Washers, for oil pump end caps.
1 Cork washer, for tappet chamber cover.

Part number, 39-EQ-14, price, per set, 3s. 3d., postage 3d. extra.

(66). **GASKET SET. Suitable for Models 2 and 2A.**

CONTENTS.—2 Washers, for cylinder base.
2 Gaskets, for cylinder head.
2 Washers, for oil pump end caps.
2 Cork washers, for tappet chamber covers.

Part number, 39-EQ-15, price, per set, 5s. 11d., postage 3d. extra.

(67). **TAPPET ADJUSTMENT. (All O.H.V. Models.)**

The top ends of the tappet long push rods have screwed extensions. These are locked in position by nuts, and this provides tappet adjustment.

The correct tappet clearance between the rocker ends and the valve ends, when the valves are completely closed and the engine is cold, is the nearest possible approach to nil. This means the push rods should be free enough to be able to revolve them without any binding, and, at the same time, there should be no appreciable up and down movement possible. To adjust the tappet clearance, proceed as follows:—

Remove the nut, or nuts, that retain the rocker box cap. This frees the cap for removal, and this reveals the adjustable screwed ends, mentioned above.

Revolve the engine until the piston is at the top of its compression stroke, in which position both of the valves will be closed.

With spanners, hold the body C and slacken lock nut B. Then screw, in or out, the head A until the clearance is nil. Next, tighten lock nut B and recheck the clearance. (See illustration 2.)

Finally, replace the rocker cap, taking care to replace the fibre washer that is under each knurled nut.

Do not overtighten these nuts because the joint is made with a rubber fillet, and undue pressure is not necessary. Excessive pressure may crack the cap.

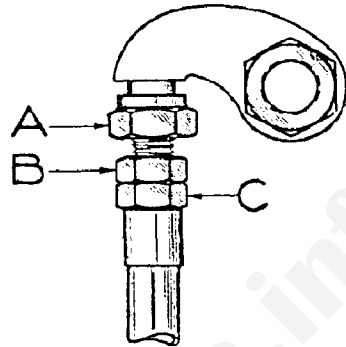

Illustration 2.

(68). **TAPPET ADJUSTMENT. (All Side Valve Models.)**

The top ends of the tappets have screwed heads. These are locked in position by nuts and this movement provides tappet adjustment. (See illustration 3.)

The correct clearances between the valve stems and the tappet heads, when the valves are completely closed and the engine is warm (not hot) are:—

Models 2, 2A and 9—

Inlet clearance004in.

Exhaust clearance .006in.

To adjust the tappet clearance, proceed as follows:—

Remove the tappet chamber cover and turn over the engine until both valves are closed.

With spanners, hold the body C and slacken the lock nut B. Then screw, in or out, the tappet head A, until the clearance is as set out in the above table. Next, tighten lock nut B and recheck the clearance.

Finally, replace the tappet chamber cover. Note that this has a cork washer and it is advisable to stick this washer to the cover with some liquid jointing compound.

A feeler gauge will greatly facilitate setting the tappet clearances, and a set of feeler gauges can be purchased at all tool stores for a few pence.

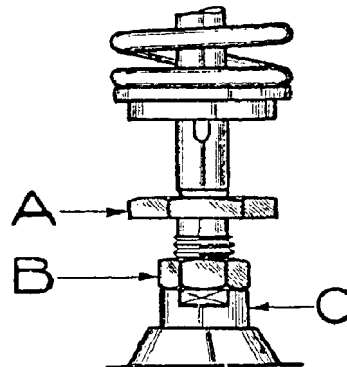

Illustration 3.

(69). **VALVE TIMING.** (All Models except 2 and 2A.)

The timing gears are marked to facilitate their replacement. The valve timing is given in paragraph 124 and, when checking it, the tappet clearances must be set to .016in. (See paragraph 71.)

To reset the timing gears, by using the marks on the gears, proceed as follows:—

Turn over the engine till the mark on the small timing-pinion D is in line with the centre of the inlet (rear) camshaft bush. (See illustration 4.)

Insert the inlet c a m s h a f t " IN " so that the mark on it is in mesh with the mark on the small pinion D.

Then rotate the engine in a FORWARD direction till the mark on the small timing pinion D is in line with the centre of the exhaust

(front) camshaft bush. (See Illustration 5.)

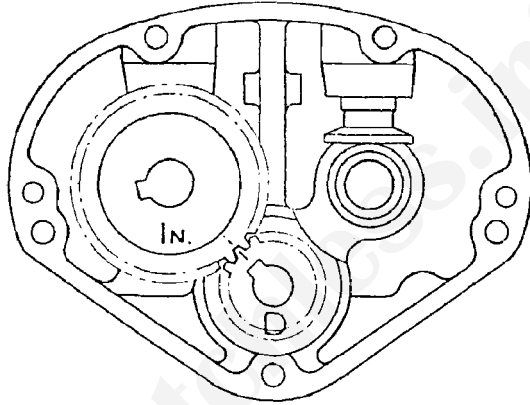

Illustration 4.

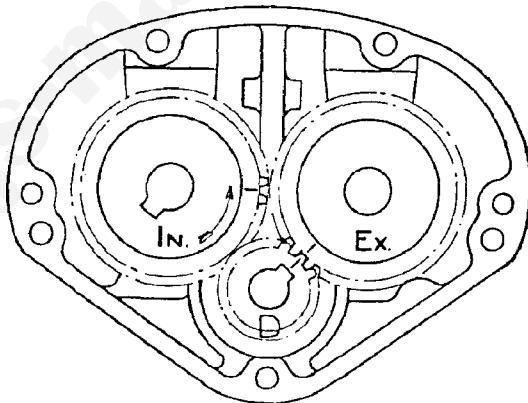

Illustration 5.

Then insert the exhaust camshaft " EX " so that the mark on it is in mesh with the mark on the small timing gear D.

(70). **VALVE TIMING. (Models 2 and 2A.)**

The timing gears are marked to facilitate their replacement. The valve timing; is given in paragraph 164, and, when checking it the tappet clearances must be set to .016in. (See paragraph 71.)

To reset the timing gears, by using the marks on the gears, obtain four bolts, or pieces of metal, each about 1 3/8in. long and not more than 7/16in. in diameter, and proceed as follows:—

Remove the tappet chamber covers from the cylinders and turn over the engine until the mark on the small timing pinion is pointing to the centre of the bush for the timing camshaft.

Take all spring pressure off the timing cam levers by placing the pieces of metal between the valve spring bottom collars and the base of the valve chamber.

Next, insert the camshaft so that the mark on it is exactly opposite to the mark on the small timing pinion.

Finally, remove the four pieces of metal from under the valves, replace the tappet chamber covers, and, of course, the timing gear cover, magneto chain and chaincase, etc.

(71). **CAM CONTOUR.**

Owing to the presence, on the cam flanks, of what are technically known as quietening curves (which actually are very slight inclines from the base circles of the cams to the feet of the humps), it is necessary to make certain that the tappet ends are on the base circles when checking valve clearances.

It is for this reason that the clearances should be checked when the piston is at the top of its compression stroke, at which position both tappets are well clear of the quietening curves.

For the same reason, it is necessary to check the valve timing with a tappet clearance of .016in., which is sufficient to skip the slight incline.

The nut retaining the small timing pinion has a left hand thread.

(72). **STEERING HEAD ADJUSTMENT.**

The steering head races are of the floating, self-aligning type, and have spherical seats. The two races in the head lug and and race in the head clip are all identical.

Occasionally test the steering head for correct adjustment by exerting pressure, upwards, from the extreme ends of the handlebars (The steering damper should be completely slack.)

Should any shake be apparent, jack up the front of the machine so that all weight is taken off the front wheel, slacken the top nut on the steering column and screw down the lower nut until all trace of slackness has disappeared. Then tighten the upper nut, holding the lower nut while doing so. It is of the utmost importance that the upper nut is most securely tightened.

(73). **FORK SPINDLE ADJUSTMENT.**

Never attempt to adjust more than one spindle at a time. Slack off both spindle nuts, and, by means of the small hexagon on the right-hand side of the spindle, turn the spindle in a clockwise direction to take up play between the fork girders and the links. Do not turn the spindle more than half a revolution before tightening the two spindle lock nuts and testing the adjustment. Guard against having the adjustment too tight, because then the fork will be very stiff in action, or, most probably, refuse to function.

The washers, which are fitted on the spindle ends, are not provided for frictional purposes, but to prevent actual seizure in the event of the fork spindle adjustment being too tight.

(74). **FORK DAMPER ADJUSTMENT.**

The fork damper is best adjusted when the machine is actually in motion. A road with a badly corrugated surface provides the best conditions for this purpose.

The ebonite hand nut should be screwed home, in a clockwise direction, sufficiently to make the fork action sluggish under the circumstances described above, and, subsequently, should require very little attention for other conditions.

(75). **STEERING DAMPER ADJUSTMENT.**

The steering damper is controlled by the ebonite hand nut mounted on top of the steering column. This nut should be turned in a clockwise direction to increase the damping action. Normally, very little damper action is required or is desirable.

(76). **TO REMOVE THE FRONT WHEEL. (All 250 and 350 c.c.)**

To remove the front wheel, proceed as follows:—

Place the machine on the rear and front stands. Remove the split pin and pin retaining the front brake yoke end to the front brake expander lever. Unscrew the speedometer driving cable from the speedometer gear box.

Slacken both nuts on the front wheel centre solid spindle, unscrewing them several turns, and then, if the two washers on the centre spindle are slid outwards, along the spindle, till they are clear of the recesses in the fork end lugs, the wheel is free to drop out.

(Lower the right side axle first to disengage the brake anchor plate from the fork girder.)

To refit the front wheel, reverse the procedure described above, taking care to engage the slot in the brake cover plate with the peg brazed to the inside of the left fork girder.

(77). TO REMOVE THE FRONT WHEEL. (All 500 c.c.)

To remove the front wheel, proceed as follows :—

Place the machine on the rear and front stands. Remove the split pin and pin retaining' the front brake cable yoke end to the front brake expander lever. Unscrew the speedometer driving cable from the speedometer gear box.

Remove the nuts and bolt that secures the front brake anchor plate to the left fork girder. Slacken both nuts on the front wheel centre solid spindle, unscrewing them several turns, and then, if the two washers on the centre spindle are slid outwards, along the spindle, till they are clear of the recesses in the fork end lugs, the wheel is free to drop out.

To refit the front wheel, reverse the procedure described above. It is essential the brake cover plate anchor bolt nuts are most securely tightened.

(78). TO REMOVE THE FRONT WHEEL. (Models 2 and 2A.)

The front wheel is identical to the rear and is quickly detachable. To remove the front wheel, proceed as follows :—

Place the machine on the rear and front stands.

Remove the three square headed sleeve nuts that secure the hub flange to the brake drum. (A tubular spanner is included in the tool kit.)

Remove the extended nut, and the washer under it, from the left hand side of the centre solid spindle. Withdraw the centre solid spindle. This action will free the distance piece between the right hand end of the hub and the inside of the right fork girder. Remove this distance piece and then, by moving the wheel to the right, in order to clear the flange from the three studs in the brake drum, the wheel can be taken away.

(79). TO REMOVE THE REAR WHEEL, (Models 12, 12M, 22, 22SS, 16, 16M, 26, 26SS.)

To remove the rear wheel, proceed as follows :—

Place the machine on the rear stand and disconnect the rear lamp cable connector that is inserted in the cable at a point just above the rear wheel axle, on the right hand side.

Take away the two nuts and washers that retain the back half of the rear mudguard to the fixed front half, and slacken the two nuts that retain the rear tubular arch to the studs in the rear fork ends. This will enable the rear half of the rear mudguard with the tubular arch to be taken away from the machine.

Take out the split pin in the bolt that retains the rear brake anchor plate to the rear fork tube, remove the nut and washer on the bolt and remove the bolt.

Revolve the rear wheel until the spring connecting link in the rear chain is accessible and remove the spring link. Loop up the two free ends of the chain so that they are out of the way.

Remove the knurled adjusting nut from the rear end of the rear brake rod.

Slacken the nut on either side of the rear wheel axle, undoing each nut two or three turns, and this will leave the rear wheel free to be withdrawn, towards the rear, till it is clear of the machine.

To replace the rear wheel reverse the procedure described above, taking care, after replacing it to check the rear brake adjustment as detailed in paragraph 85.

(80). TO REMOVE THE REAR WHEEL. (Models 22T, 26T, 8, 9, 18, 18SS, 18T, 2 and 2A.)

The rear wheel is of the quick detachable type and, in order to remove it, there is no need to disturb any part of the rear brake and final drive.

To remove the rear wheel, proceed as follows :—

Place the machine on the rear stand and disconnect the rear lamp cable connector that is inserted in the cable at a point just above the rear wheel centre solid spindle on the right hand side.

Take away the two nuts and washers that retain the back half of the mudguard to the fixed front half, and slacken the two nuts that retain the rear tubular arch to the studs in the rear fork ends. This will enable the rear half of the rear mudguard with the tubular arch to be taken away from the machine.

Remove the three square headed sleeve nuts that secure the hub flange to the brake drum. (A tubular spanner is included in the tool kit).

Remove the nut on the wheel centre solid spindle (left hand side of the machine), and withdraw the spindle from the right hand side of the machine. This action will free the distance piece fitted on the centre solid spindle and located between the inside of the right fork end and the hub.

Then, by moving the wheel to the right, in order to disengage it from the driving studs in the brake drum, it is free to be taken away from the machine.

To refit the rear wheel, reverse the procedure described above.
IN NO CIRCUMSTANCES MUST THE CENTRE SOLID SPINDLE BE REMOVED UNTIL THE MACHINE IS PLACED ON THE REAR STAND, AND THE SPINDLE MUST ALWAYS BE IN POSITION BEFORE THE MACHINE IS TAKEN OFF THE STAND.

If it is desired merely to remove the inner tube of the rear tyre, this can be done without removing the wheel from the machine.

To do this, proceed as follows:—

Place the machine on the rear stand, remove the tube from the tyre. (See paragraph 130.)

Remove the nut on the rear wheel centre solid spindle (on left side of machine), withdraw the spindle and spring the right fork sufficient to allow the distance piece, that is on the solid spindle and located between the inside side of the fork end and the hub, to drop out.

This will leave sufficient space between the fork end and the hub to enable the inner tube to be taken away.

To refit the inner tube, reverse the procedure described above.

PERIODICALLY TEST, WITH SPANNERS, THE NUT ON THE CENTRE SOLID SPINDLE AND THE THREE SLEEVE NUTS AND KEEP THEM TIGHT.

If the sleeve nuts are loose, a dull hammering will be felt, and heard, when driving at slow speeds. If this is noticed, tighten the three sleeve nuts without delay.

(81). **WHEEL BEARINGS.**

The wheel bearings are of the taper roller type.

A complete bearing, for one wheel, consists of the following parts:—

- 1 Hollow spindle.
- 2 Sets of rollers (mounted in 2 cages).
- 2 Outer bearing rings.

The above parts are only sold complete as one unit—i.e., parts cannot be supplied.

The outer bearings rings are pressed into the hub shell. That on the left hand side has a positive location. (A spring ring fits into the shell to locate this ring). That on the right hand side can be adjusted in position. The adjustment is obtained by a ring that is screwed into the hub shell and abuts against the movable bearing ring. The adjusting ring is locked in position by a large, circular locking ring.

It is of the utmost importance that the bearings are not adjusted too tightly, as this would ruin them in a very short distance. There must always be a slight degree of end play. This should be about .002in.

To adjust a wheel bearing, proceed as follows:—

Slacken the large locking ring on the right hand side of the hub. Then, screw inwards, or outwards, the adjusting ring on which the locking ring is threaded, until the correct adjustment is obtained. (Inwards to tighten, outwards to loosen the bearing adjustment.) (See Illustration 6.)

Finally, tighten the locking ring, taking care that the adjusting ring does not creep forward and make the bearings too tight.

Always check the adjustment after tightening the locking ring.

Special spanners are provided, in the tool kits, to facilitate these operations.

(82). TO DISMANTLE A WHEEL BEARING.

To dismantle the bearings in a wheel, having removed the wheel from the machine (see paragraphs 76, 77, 78, 79 and 80), proceed as follows:—

If the wheel is a front wheel, remove the nut on the left hand side of the centre solid spindle, withdraw the spindle and remove the brake cover plate.

Then, slacken the locking ring B, that is on the right hand side of the hub (see illustration 6), and completely unscrew the adjusting ring A, which will come away with the locking ring B.

A dished plate, felt washer and a plain plate is then free to be removed. Do this and turn to the opposite side of the hub.

A spring ring will be observed, just under the hub shell, remove this and this will permit the removal of another felt washer assembly consisting of two metal plates, a felt washer and a spacing ring.

The hollow spindle, complete with rollers and cages and one outer bearing ring, can then be pressed out of the hub shell, from either end, leaving one outer bearing ring in position. If desired, this remaining ring can then be driven, or pressed, out.

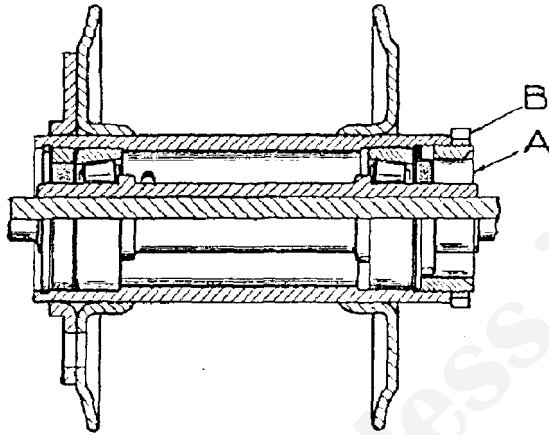

Illustration 6.

(83). TO ASSEMBLE A WHEEL BEARING.

It will be noticed that the tracks for the rollers on the hollow spindle are not evenly spaced. It is essential that the longer end of the spindle is assembled in the hub so that it is on the adjusting side. (Right hand side of wheel.) (See illustration 6.)

To assemble the wheel bearings, proceed as follows:—

First, thoroughly clean all parts as well as the interior of the hub.

Press one of the outer bearing rings into the plain end of the hub so that the thinner end of the ring is inward and its position a little nearer the centre of the hub than it normally occupies. Take care, when pressing this ring into the hub that it is quite square to the hub body.

Next, replace the felt washer and plate assembly that was removed from this end of the hub and finally, replace the spring ring. Illustration No. 6 clearly shows the order of assembly of these parts.

Then, from the threaded end of the hub, force back the outer bearing ring until the felt washer assembly is tight against the spring ring.

Next, from the threaded end of the hub, introduce the hollow Spindle, entering the shorter end first, and push it, without undue force, as closely to the outer bearing ring as is possible.

Then press the second outer bearing ring (thinner edge inwards), into the hub shell until there is about 1/16in. play in the bearings.

Next, replace the right hand side felt washer assembly, followed by the screwed adjusting ring with its locking ring, and proceed to adjust the bearing as described in paragraph 81.

Inject a quantity of grease into the hub and the wheel is then ready for fitting to the machine.

(84). BRAKE PEDAL ADJUSTMENT.

The position of the rear brake foot pedal can be adjusted within narrow limits. This is done by means of a small bolt screwed into the heel of the pedal. The adjusting bolt is locked with a thin nut. After altering this adjustment, always check the rear brake rod adjustment as described in paragraph 85.

Note that no adjustment is provided for the brake pedal on Model 2A.

(85). BRAKE ROD ADJUSTMENT.

A finger operated nut on the rear end of the rear brake rod provides a means of making minor adjustment to the rear brake. This nut is locked in position by a spring that encircles the brake rod.

The finger nut should be screwed on the rod so far that the brake shoes are just clear of the brake drum when in the " Off " position.

When making this adjustment it is advisable to have the machine on the rear stand so that it may be observed the wheel is free to revolve when the brake is " Off."

(86). BRAKE SHOE ADJUSTMENT.

As the brake linings wear, this can be taken up by suitably adjusting the finger nut on the rear brake rod, but, after some considerable mileage, this continual adjustment causes the brake expander to lie in such a position that the leverage available is considerably reduced and consequently the brake loses in efficiency.

To overcome this difficulty, the brake shoes are fitted with detachable heel pads. As will be seen from illustration No. 7, these fit in the heel of each brake shoe and take the thrust of the brake cam or expander.

When it no longer becomes desirable to take up the wear of the brake linings by adjustment of the finger nut on the brake rod, the brake shoes should be removed and then, if the steel pads are taken away from the shoes, one or more steel shim washers can be placed on the stem of each pad. This will have the effect of centralising the cam expander, thereby restoring the efficiency of the brake to " as new condition."

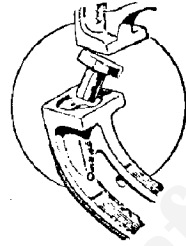

Illustration 7.
("Motor Cycling")

When the wear is taken up in this manner it is, necessary to slack out the brake rod finger nut adjustment, and to reset that adjustment to suit the new position of the brake shoes. (See paragraphs 85, 87 and 88.)

The front brake shoes are also fitted with detachable heel pads, thereby providing major adjustment for the front brake. A supply of shim washers for the heel pads is sent out in the tool kit as part of the equipment of all new machines.

(87). FRONT BRAKE ADJUSTER. (All 250 and 350 c.c.)

Major adjustment of the front brake is made on the heel pads in the brake shoes, as described in paragraph 86.

Minor adjustment of the front brake is made by the knurled nut that is mounted near the top end of the front brake rod.

When adjusting the front brake it is advisable to place the machine on both rear and front stands and the knurled nut should be unscrewed (as viewed from above the nut) so that when the brake is " Off " the brake shoes are just clear of the brake drum and the wheel consequently free to revolve.

Minor adjustment may also be made by the brake cable adjuster, as described in the final part of paragraph 88.

(88). FRONT BRAKE ADJUSTMENT. (All 500 and 990 c.c.)

Major adjustment of the front brake is made on the heel pads in the brake shoes, as described in paragraph 86.

Minor adjustment of the front brake is made by the front brake cable adjuster.

When adjusting the front brake it is advisable to place the machine on both rear and front stands.

The front brake cable adjuster is located at the top of the left side fork girder, and is locked in position with a nut. The brake cable passes through the adjuster, and both the adjuster and lock nut have large knurled bodies so they may be finger operated.

To " take up " the front brake adjustment, the adjuster should be unscrewed from the fork girder until the brake shoes are just clear of the brake drum, and the wheel consequently free to revolve. Then tighten down the lock nut.

(89). **TO REMOVE THE OUTER HALF OF THE FRONT CHAIN CASE. (All Models except 2 and 2A.)**

The outer half of the front chain case is retained to the back half by a centre nut and an exterior metal band. Between the metal band and the chain case is a rubber fillet, or packing strip.

To remove the outer half of the front chain case, proceed as follows :—

Place a tray under the chain case in which to collect the oil that will be released when the outer half of the case is free.

Remove the finger adjusting nut from the rear end of the rear brake rod.

Remove the screw that binds the two ends of the metal band that encircles the case, this will free the band for removal, after which, remove the rubber fillet.

Next, remove the centre nut and washer, and then, if the rear brake foot pedal is fully depressed, the outer half of the case can be taken away.

To replace the outer half of the front chain case, proceed as follows :—

Clean both sides of the outer half of the case and also the outer face of the rear half of the case. Place a line of liquid jointing compound on the face of the front half of the case, and, by depressing the rear brake foot pedal, place the outer half of the case in position.

Replace the centre washer and nut, and, when tightening the nut, move the outer half of the case, as necessary, to make it register with the back half. Smear some more liquid jointing compound round the edges of the case and press the rubber fillet in position, so that the two free' ends meet at the rear of the larger end of the case.

Then, refit the metal band, starting at the narrow, front end of the case, and, drawing the two free ends together with one hand, replace the binding screw with the other.

Replace the rear brake rod finger adjusting nut, and adjust its position as described in paragraph 85.

Finally, after the jointing compound has set, remove the inspection cap in the outer half of the case, and fill with engine oil to the level detailed in paragraph 24.

(90). **TO REMOVE THE OUTER HALF OF THE FRONT CHAIN CASE. (Models 2 and 2A.)**

Remove the plated dome over the clutch. This is done by removing the six screws that retain it to the front half of the chain case, and then, if the rear brake foot pedal is depressed, it may be taken away.

Next, remove the complete clutch from the gear box main shaft. To do this, proceed as follows :—

Unscrew the five clutch spring adjusting nuts and remove the spring pressure plate, complete with the five clutch springs and the five clutch spring cups.

Extract the clutch plain steel plates and the clutch friction plates and unscrew the centre nut that secures the clutch hub to the gear box main shaft and remove the spring and plain washers that are under it.

Then withdraw the clutch hub. This is a splined and parallel fit on the shaft, and no difficulty should be met in withdrawing it. Then lift away the large metal washer and the tubular spacing piece behind it.

The six bolts that fix the clutch case to the sprocket are now exposed. Under each pair of bolts is a tab washer, and the two extreme ends of each tab washer are turned up to lock the bolts in position. These turned-up ends must be flattened down, and the best way of doing so is to lever them away from the heads of the bolts by using a screwdriver and then tap them flat.

Next, unscrew the six fixing bolts and the clutch case may be taken away.

Then place a tray under the chain case in which to collect the oil that will be released when the outer half of the case is free, and proceed to remove the outer half of the case, as follows :—

Remove the screw that binds the two ends of the metal band that encircles the case, this will free the band for removal, after which, remove the rubber fillet.

Remove the centre fixing bolt and the outer half of the front chain case is then free to be taken away.

To replace the outer half of the front chaincase.

After cleaning both sides of the outer half of the case and also the outer face of the rear half of the case, proceed to refit the outer half as follows:—

Place a line of liquid jointing compound on the face of the outer half of the case and place it in position, against the rear half.

Replace the centre fixing bolt, and, when tightening this, move the outer half, as necessary, to make it register with the back half. Smear some liquid jointing compound round the edges of the case and press the rubber fillet in position, so that the two free ends meet at the rear of the larger end of the case.

Then refit the metal band, starting at the front, narrow end, and, drawing the two free ends together with one hand, replace the binding screw with the other.

Then proceed to refit the clutch, as follows :—

Show up to the clutch sprocket the clutch case and fit the six fixing bolts, taking care that a tab washer is under each two adjacent bolts. Screw the bolts right home and then turn up the two ends of each tab washer, knocking the turned-up ends close against one of the flats of each bolt head.

Next, place the tubular spacing piece on the gear box main shaft, followed by the large metal washer. Then replace the clutch hub on the shaft and push it right home. Follow this, by replacing the plain metal washer, the spring washer, and, finally, the nut. Make sure the nut is fully tightened.

Next, replace the four clutch steel plain plates and the three clutch friction plates, taking care that each friction plate has a plain plate on either side of it. Follow this by replacing the spring pressure plate with the five clutch spring cups and five clutch springs and refit the five clutch spring adjusting nuts.

Screw these nuts right home as far as they will go, and then slacken each, in turn, five complete revolutions.

Finally, replace the clutch plated dome with its six fixing screws.

(91). **FRONT CHAIN ADJUSTMENT.**

To provide front chain adjustment, the gear box hinges on its lower fixing bolt, while the top fixing bolt can slide in slots cut in the engine plates to allow the hinging movement.

This movement is controlled by an eyebolt which encircles the top fixing bolt, and the threaded end of which, passes through a block that is secured to the right side engine plate.

By altering the position of the eye bolt in the block, the gear box top fixing bolt can be moved in its slots. This action swings the gear box, and, according to the direction of the swing, the front chain can be tightened or loosened. The gear box must be swung backwards to tighten the chain.

The movement of the eyebolt in the block is controlled by two nuts that are threaded on it and are located on either side of the block.

(92). **TO ADJUST THE FRONT CHAIN. (Models 12, 12M, 22, 22SS.)**

To tighten the front chain, remove the inspection cap from the front chain case, and proceed as follows :—

Slacken the nuts on the right-hand ends of the top and bottom fixing bolts of the gear box and unscrew the forward nut that is on the eyebolt two or three complete turns.

Then, unscrew the rear nut that is on the eyebolt until, by testing through the front chain case inspection cap orifice, it is felt the front chain adjustment is correct.

If the chain can whip, or move, about 3/8in. as it is pressed up and down, midway between the sprockets, the adjustment is correct.

Check the whip in more than one position. (See paragraph 97.)

Finally, tightly screw down the forward nut on the eyebolt, tighten the nuts on the top and bottom gear box fixing bolts, recheck the amount of whip and replace the chain case inspection cap.

(93). **TO ADJUST FRONT CHAIN. (Models 22T, 26T, 18T, 8, 9, 18, 18SS, 16, 16M, 26, 26SS, 2 and 2A.)**

To tighten the front chain, remove the inspection cap from the front chain case, and proceed as follows:—

Slacken the nuts on the right-hand ends of the top and bottom fixing bolts of the gear box and screw up the forward nut that is on the eyebolt two or three complete turns.

Then, screw up the rear nut that is on the eyebolt until, by testing through the front chain case inspection cap orifice, it is felt the front chain adjustment is correct.

If the chain can whip, or move, about fin. as it is pressed up and down, midway between the sprockets, the adjustment is correct.

Check the chain whip in more than one position. (See paragraph 97.)

Finally, unscrew the forward nut on the eyebolt till it is tightly down on the block, tighten the nuts on the top and bottom gear box fixing bolts, recheck the amount of whip and replace the chain case inspection cap.

(94). **REAR CHAIN ADJUSTMENT.**

To provide rear chain adjustment, the rear wheel is bodily moved in the frame. To provide this movement, the rear wheel axle is anchored in open-ended slotted fork ends, and the movement is controlled by a bolt screwed into each fork end. Each bolt impinges on the rear axle and is locked in position by a nut. (A collar is placed on each bolt, between the nut and the fork end, to facilitate access to the nut.) (No collars on Models 2 and 2A.)

(95). **TO ADJUST THE REAR CHAIN. (Models 12, 12M, 22, 22SS, 16, 16M, 26, 26SS.)**

To tighten the rear chain, slacken the nut on either side of the rear wheel axle and then proceed as detailed in paragraph 96.

TO ADJUST REAR CHAIN. (Models 22T, 26T, 8, 18, 18T, 18SS, 9, 2 and 2A.)

To tighten the rear chain, slacken the nut on the centre solid spindle and the nut that locks the brake drum sleeve to the fork end. Both of these nuts are on the left-hand side of the machine and are concentric to each other. Then proceed as detailed in paragraph 9G.

(96). **TO ADJUST THE REAR CHAIN. (All Models.)**

To tighten the rear chain, prepare as described in paragraph 95 and then proceed as follows:—

Slacken the nut on each chain adjuster bolt and screw it two or three turns towards the hexagon head of the bolt.

Then screw each bolt further into the fork end, in turn, until the chain adjustment is correct, taking care to move each bolt an equal distance.

If the chain can whip, or move, about fin. to Jin. as it is pressed up and down, midway between the sprockets, the adjustment is correct.

Check the whip in more than one position, (See paragraph 97.)

Finally, tighten the wheel spindle nuts, recheck the whip and screw the nuts on the chain adjusting bolts tightly down to the fork ends.

(97). **NOTES ON CHAIN ADJUSTMENT.**

Before tightening the rear chain, the adjustment of the front chain should be checked, and, if attention is necessary, this should be adjusted first.

It should be remembered that altering the adjustment of the front chain affects the adjustment of the rear chain. Also, that altering the adjustment of the rear chain will probably upset the adjustment of the rear brake.

Therefore, after filtering the adjustment of the rear chain, always check the adjustment of the rear brake, and, if necessary, re-adjust the brake as detailed in paragraph 85.

The whip of chains should be tested midway between the two sprockets. Always turn the sprockets and test in several positions, and set the adjustment for the tightest position found. This is because chains never wear evenly, and there is usually one position where the chain is tighter than in any other.

When adjusting the rear chain care should be taken to leave the rear wheel in correct alignment.

When correct, a piece of thin string stretched taut across both wheels, about four inches from and parallel to the ground, should just touch each tyre at both sides of the wheel centres.

Alternatively, a straight wood batten, about five feet long, is handy to use for checking wheel alignment. This should be applied, as in the case of string, parallel to and about four inches from the ground.

(98). **CHAIN CONNECTING LINKS.**

The free ends of the front and rear driving chains are connected by a quickly removable link.

This link consists of three parts. One is a side plate having two pins rivetted to it. The second is a plain side plate, having two holes in it. These holes accommodate the two pins in the other plate. The third part is a flat spring clip, of hairpin shape. Two notches are cut in the spring clip. This spring clip lies against the outer face of the plain link and the notches lie in the grooves that are cut on each end of the two pins.

To demount a chain connecting link it is necessary to spring the open ends of the spring clip apart so that they disengage from the groove in the pin nearest to the open end of the clip. This can be done with a pair of pliers or a screwdriver. Then, if the clip is slid along the second pin till that pin is near the open end of the clip it may be removed by slightly springing it over the pin.

Next, lift away the plain link and the other link, with its pins, may be withdrawn from the two ends of the chain.

To refit a chain connecting link, reverse the procedure described above.

These operations are best performed when several links of chain, on either side of the connecting link, are engaged with teeth on the rear wheel sprocket (in the case of the rear chain) or clutch sprocket (in the case of the front chain).

The closed end of the spring clip should always face towards the direction of chain movement. (So that, in the event of it coming in conflict with any part of the machine, there will be no tendency for it to be knocked out of position.) It is also more convenient to fit the connecting link so that the spring clip is facing away from the centre of the machine.

Dynamo and magneto driving chains are rivetted up as "endless" chains, and consequently are not fitted with detachable connecting links.

(99). **DYNAMO CHAIN ADJUSTMENT.**

The dynamo armature shaft is eccentric to the body of the dynamo. Therefore, by partially revolving the dynamo in its housing (the engine plates) the distance between the two dynamo driving sprockets can be varied.

Provision is made to revolve the dynamo in order to adjust the driving chain. This is done by applying a thin spanner to the boss that is cast on the driving side of the dynamo body. (On all Models except 12 and 16, this boss is just under the word "LUCAS," while on Models 12 and 16, it is under the letters "D.V.R."). A thin spanner is included in the tool kit to fit the boss.

To adjust the dynamo driving chain, proceed as follows:—

Remove the inspection cap from the front chain case and slacken the dynamo clamping bolt.

Rotate the dynamo, in a forward direction, until, by passing a finger through the inspection cap orifice, it can be felt the dynamo chain has a whip of about $\frac{1}{4}$ in. This adjustment is important.

Finally, tighten the dynamo clamping bolt, recheck the whip and replace the inspection cap.

SHOULD IT EVER BE NECESSARY TO REMOVE THE CHAIN SPROCKET FROM THE DYNAMO ARMATURE SHAFT, IT IS ABSOLUTELY ESSENTIAL TO HOLD THE SPROCKET WITH A SPANNER, WHILE LOOSENING THE SPROCKET RETAINING NUT. BEFORE ATTEMPTING TO LOOSEN THAT NUT IT IS ESSENTIAL TO REMOVE THE SPRING RING THAT ENCIRCLES IT AND THE LOCK WASHER THAT IS NEXT TO THE SPRING RING.

There are two flats on the boss of the sprocket to accommodate a spanner. The above action is necessary to relieve the armature shaft of any twisting or bending stress and must also be taken when refitting the sprocket.

(100). **MAGNETO CHAIN ADJUSTMENT. (AH Models except 12, 16, 2 and 2A.)**

The magneto platform is secured to the crankcase by two bolts and four nuts (two on each bolt.) The platform hinges on the forward bolt and the rear of the platform is slotted. The rear fixing bolt passes through these slots. This arrangement provides movement of the platform to enable the magneto driving chain to be adjusted.

To adjust the magneto driving chain, proceed as follows:—

Slacken the nuts on the left hand side of the two bolts that retain the magneto platform to the crankcase, and remove the cover of the magneto driving chain case.

Insert a lever under the rear edge of the magneto platform and, using the crankcase as a fulcrum, prise the platform upwards until the whip of the driving chain is $\frac{1}{4}$ in.

Finally, tighten the nuts on the platform fixing bolts, recheck the chain whip and replace the chain case cover.

(101). **MAGDYNO CHAIN ADJUSTMENT. (Models 2 and 2A.)**

The magdyno platform is secured to the rear engine plates by two bolts. The platform hinges on the rear bolt and the front of the platform is slotted. The front fixing bolt passes through these slots. This arrangement provides for movement of the platform to enable the magdyno driving chain to be adjusted.

To adjust the magdyno driving chain, proceed as follows:—

Slacken the two bolts that retain the magdyno platform to the rear engine plates and remove the cover of the magdyno driving chain case. (The heads of the two bolts are on the left hand side of the machine.)

Then, by exerting pressure, in a rearward direction, on the top of the magdyno unit, it can be tilted to the rear and this will tighten the driving chain.

The magdyno should be moved in this manner until the whip of the driving chain is $\frac{1}{4}$ in.

Finally, tighten the two platform fixing bolts, recheck the chain whip and replace the chain case cover.

(102). **CONTROL CABLE ADJUSTMENT.**

All flexible control cables have a screwed adjuster. Cables should be adjusted so that there is a definite amount of free movement of the control levers before the load resistance is felt. This free movement is most important, especially so in the case of the exhaust valve lifter and clutch controls.

To shorten the effective length of a control cable—i.e., to take up lost motion at the lever, unscrew the cable adjuster from its anchorage.

CARBURATION.

(103). STANDARD CARBURETTER SETTINGS.

The correct sizes of main jets, chokes and throttle slides, as per the table below, have been decided after much experiment and testing and should not be altered save for some very good reason.

Models.	Main Jet.	Choke.	Throttle Slide.
250 c.c. 120	5-058	5x3.
350 c.c. 150	6-058	6x4.
9 150	6-057	6x4.
500 c.c. O.H.V. 180	29-068	29x4.
2 and 2A 130	6-058	6x4.

(104). CARBURATION.

The carburetter is tuned during the road tests of the machine, and it should not be necessary to interfere with the standard setting. However, we give below an outline of how the carburetter functions and how adjustment may be made.

The petrol level is maintained by a float and needle valve, and in no circumstances should any alteration be made to this. In the event of a leaky float or a worn needle valve the part should be replaced with new.

The petrol supply to the engine is controlled, firstly, by the main jet, and secondly, by means of a taper needle which is attached to the throttle valve and operates in a tubular extension of the main jet.

The main jet controls the mixture from three quarters to full throttle, and the adjustable taper needle from three quarters down to one quarter throttle, the cut away portion of the intake side of the throttle valve from one quarter down to about one eighth throttle, and a pilot jet, having an independently adjusted air supply, takes care of the idling from one eighth throttle down to the almost closed position.

These various stages of control must be kept in mind when any adjustment is contemplated.

With the standard setting it is possible to use full, or nearly full, air in all conditions, except, perhaps, when the engine is pulling hard up hill or is on full throttle, when some benefit may be obtained by slightly closing the air control.

Weak mixture is always indicated by popping, or spitting, at the air intake. A rich mixture usually causes bumpy, or jerkv running, and, in some cases of extreme richness, is accompanied by the emission of black smoke from the exhaust.

A rough test to ascertain if the setting is correct, is to warm up the engine and, with the ignition fully retarded, and the

air about three-quarters open, slowly open the throttle to full open, during which the engine should respond without a misfire, but, upon a sudden opening of the throttle, it should splutter and stop. (The engine should not be run more than a few seconds with the ignition fully retarded).

To check the setting of the pilot jet and its air control, warm up the engine, then, with the ignition about two-thirds advanced and the air about three-quarters open, the engine should idle positively and evenly when the throttle is almost closed. If it fails to do so, adjust the pilot jet air screw, inwards or outwards, until even firing is obtained. (The pilot jet air screw will be observed at the base of the mixing chamber and its position is locked by a nut). This adjustment is not unduly sensitive, and it should be possible to obtain the correct adjustment in a few seconds.

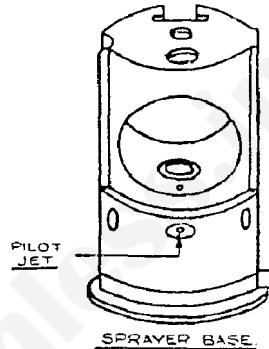

In the event of the adjustment of the air screw failing to provide the required result, it is possible the pilot jet is obstructed with dirt. The pilot jet is actually a passage cut in the sprayer base, or choke, and is very small, so there is always a latent danger of this becoming choked. Upon removing the float chamber and the large union nut at the bottom of the mixing chamber, the sprayer base can be pushed out of the mixing chamber and the jet can then be cleared by using a strand of fine wire. Illustration No. 8 shows clearly the location of the pilot jet in the sprayer base, or choke.

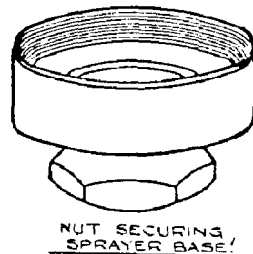

Illustration 8.

A throttle stop screw, that can be locked in position by a nut, is located in the side of the mixing chamber. This screw runs obliquely into the chamber and is situated above the pilot jet air adjusting screw.

The position of the throttle stop screw determines the position of the throttle when "closed."

Some riders prefer to set this so that when the throttle control (twist grip) is in the closed position, the throttle is completely closed and the engine cannot run. Others prefer to set it so that when the throttle control is "closed" the throttle is prevented from completely closing and the engine can therefore continue to run at idling speed.

Before concluding that incorrect carburation is responsible for heavy petrol consumption, and before carrying out any of the tests and adjustments described above, it is most important to make sure the ignition is set correctly. (See paragraph 164 for correct settings). Late ignition usually causes a great increase in petrol consumption.

(105). **POSSIBLE CARBURATION TROUBLES.**

Poor idling may be due to:—

Air leaks. (Either at the junction of the carburetter and the engine, or by reason of a badly worn inlet valve stem or guide).

Faulty valve seatings. (Engine valves).

Faulty sparking plug or the points set too closely.

Ignition advanced too much.

Contact breaker points dirty, or set too closely.

Defective high tension cable.

Pilot jet not operating correctly. (May be choked).

Tappets adjusted too closely.

Heavy petrol consumption may be due to:—

Late ignition setting.

Bad air leaks. (Probably at carburetter and engine joint).

Weakened valve springs.

Leaky float. (Causing flooding).

Taper needle extension insufficient,

Poor compression, due to worn piston rings or defective valve seatings. (Always test compression with throttle wide open).

(106). **TWIST GRIP ADJUSTMENT.**

A screw is provided in one half of the twist grip body to regulate the spring tension on the twist grip rotating sleeve. This screw is locked by a nut and must be screwed into the body to increase the tension. (This does not apply to Model 2A.)

The most desirable state of adjustment is that when the grip is quite free and easy to turn, but, at the same time, will stay in the position in which it is placed.'

(107). **CARBURETTER CABLE ADJUSTMENT.**

The throttle and air control cables are provided with screwed adjusters. The cables should be adjusted so that there is an appreciable degree of slack from the fully closed position of the control lever (or twist grip) before the valve commences to move.

This commencement of movement can always be felt on the control lever by virtue of the increased resistance, as the valve is lifted against the spring pressure that is used to return the valve to the closed position.

GEAR BOXES.

(108). GEAR BOXES.

Burman four-speed gear boxes, having foot' gear control and hand clutch control, are fitted to all models. All the gears are constantly in mesh and the changes are made with dog clutches.

Models 12, 12M, 22 and 22SS are fitted with Type H.P. gear boxes.

Models 16, 16M, 26, 26SS, 8, 9, 18, 18SS are fitted with Type C.P. boxes having three plate clutches.

Models 22T, 26T are fitted with Type C.P. boxes having four plate clutches.

Model 18T is fitted with Type C.P. boxes having five plate clutches.

Models 2 and 2A are fitted with Type B.A.P. gear boxes.

The general design of these boxes is similar, and illustration No. 9 shows an exploded view of a typical box. The illustration is actually that of a C.P. box as fitted to Models 22T, 26T and 18T.

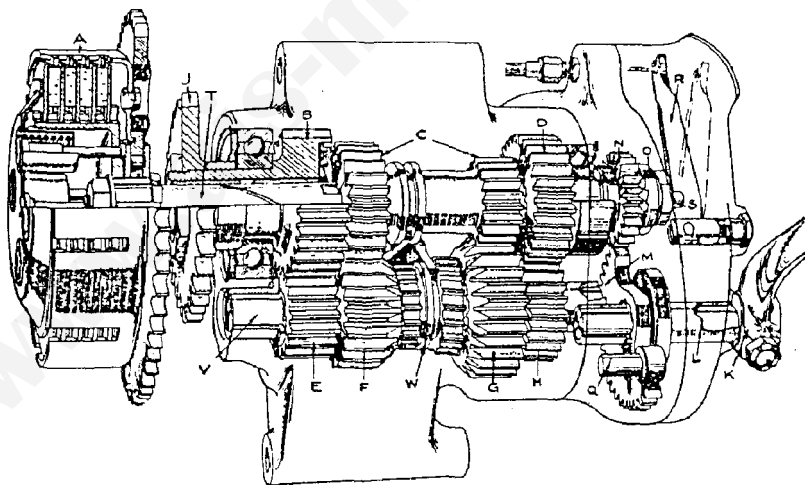

Illustration 9.

- A is the clutch assembly.
- B is the main gear wheel.
- C is the mainshaft sliding gear. (It has a pinion each end.)
- D is the mainshaft third gear.
- E is the layshaft small gear.
- F is the layshaft second gear.
- G is the layshaft first gear.
- H is the layshaft third gear.
- J is the gear box final drive sprocket.
- K is the kickstarter crank.
- L is the kickstarter axle.
- M is the kickstarter quadrant.
- N is the kickstarter ratchet pinion.
- O is the kickstarter ratchet driver.
- P is the kickstarter return spring.
- Q is the stop for the kickstarter.
- R is the gear box clutch operating lever.
- S is the clutch thrust rod.
- T is the gear box main shaft.
- V is the layshaft.
- W is the sliding clutch on the layshaft.

The engine sprocket is connected to the clutch sprocket A by the front driving chain, and the sprocket on the rear wheel is connected to the gear box final drive sprocket J by the rear driving chain.

(109). **KICKSTARTER OPERATION.**

When the kickstarter crank K is depressed it rotates the axle L, and, in turn, the quadrant M. This quadrant engages in the ratchet pinion N, which, in turn, engages with the ratchet driver O, and as this is secured to the mainshaft T, the shaft turns, causing the clutch and the clutch sprocket A to rotate, thereby rotating the engine via the front driving chain and the engine sprocket. The kickstarter crank is returned to its upright position by a spring and located by a rubber covered stop pin Q.

Although the effective movement of the kickstarter crank is only about half a complete revolution this is geared up through the quadrant M and the ratchet pinion N and through the clutch sprocket to the engine sprocket so that one movement of the crank causes the engine to rotate three or four times.

(110). **TRANSMISSION OF POWER THROUGH GEARS.**

The transmission of power, or the drive, through the various gears may be easily traced on Illustration 9, as follows : —

When the first, or lowest, gear is engaged the sliding gear on the mainshaft remains in the position shown in the illustration—i.e., disengaged from pinions B and D, and the sliding clutch W moves to the right and engages with pinion G. The drive is taken through the clutch A, to mainshaft T, to sliding gear C, to pinion G, to clutch W, to layshaft V, to pinion E, to main gear B, to chain sprocket J, and thence, by the rear driving chain, to the rear wheel.

When the second gear is engaged the sliding gear on the mainshaft remains in the position shown in the illustration—i.e., disengaged from pinions B and D, and the sliding clutch W moves to the left and engages with pinion F. The drive is taken through the clutch A, to mainshaft T, to the larger gear on sliding gear C, to pinion F, to clutch W, to layshaft V, to pinion E, to main gear B, to chain sprocket J, and thence, by the rear driving chain, to the rear wheel.

When the third gear is engaged the sliding clutch on the layshaft remains in the position shown in the illustration—i.e., disengaged from pinions F and G, and the sliding gear on the mainshaft moves to the right and engages with pinion D. The drive is taken through the clutch A, to mainshaft T, to sliding gear C, to pinion D, to pinion H, to layshaft V, to pinion E, to main gear B to chain sprocket J, and thence, by the rear driving chain to the rear wheel.

When the fourth, or top gear is engaged the sliding clutch on the layshaft remains in the position shown in the illustration—i.e., disengaged from pinions F and G, and the sliding gear on the mainshaft moves to the left and engages with main gear B. The drive is taken through the clutch A, to mainshaft T, to sliding gear C, to main gear B, to chain sprocket J, and thence, by the rear driving chain, to the rear wheel.

No adjustment to any of the parts mentioned above is ever required, and no provision is made for adjustment.

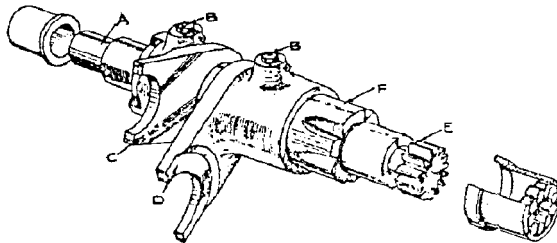

Illustration 10.

(111). **GEAR BOX CAMSHAFT AND FORKS.**

Illustration 10 shows the camshaft and shifting forks used in C.P. and B.A.P. gear boxes as fitted to Models 16, 16M, 22T, 26, 26SS, 26T, 8, 18, 18T, 18SS, 9, 2 and 2A.

The shaft A has profiled grooves cut in it and the pegs B, in the forks C and D, engage in these grooves. The fork C engages in the sliding gear on the mainshaft and the fork D engages in the sliding clutch on the layshaft.

These forks cannot move in an up and down direction, in virtue of their fork like construction, but are free to slide endways on the shaft A. These sliding movements are controlled by the profiled cam grooves cut in the shaft and the partial rotation of the shaft will set up the endways sliding movements.

The rotation of the shaft is made by the small pinion E, which is an integral part of the shaft. This pinion meshes with the toothed sector which is a part of the foot control mechanism. The notches F which are cut in the shaft accommodate a spring loaded pawl, the function of which is to positively lock the shaft in any of the desired gear positions and thereby prevent the shaft from moving on its own account under the influence of vibration or other outside cause.

The H.P. gear boxes fitted to Models 12, 12M, 22 and 22SS do not have this camshaft method of gear changing, but utilise a rocking lever which imparts a sliding movement to the sliding gears and too, is locked with a spring loaded pawl.

(112). **THE CLUTCH.**

Illustration 11 shows the clutch and gear box mainshaft with clutch operating mechanism as fitted on the B.A.P. gear boxes used on Models 2 and 2A. Except for detail differences, the design is similar on the C.P. gear boxes fitted to Models 16, 16M, 26, 26SS, 8, 9, 18, 18SS, also on Models 22T, 26T and 18T, but these three have four and five plate clutches.

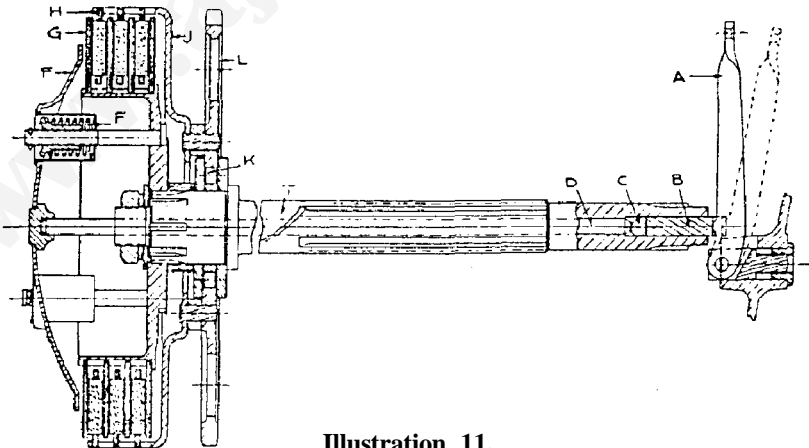

Illustration 11.

A similar design, with clutch operating mechanism as described in paragraph 114 is used in the H.P. gear boxes as fitted to Models 12, 12M, 22, 22SS.

The clutch operating lever A is in the dotted position when the clutch is engaged and in the firm line position when the clutch is free or " out."

When the handlebar clutch lever is lifted, this action moves the gear box operating lever A and causes the lever A to press against the fork B which, in turn, presses the steel ball C against the clutch thrust rod D which pushes against the clutch spring pressure plate F (shown immediately under the letters H and G in the illustration). This action compresses the clutch springs F so that their pressure is released from compressing the clutch plain plates G and the clutch friction plates H.

This enables the clutch sprocket L to revolve on its bearing K without rotating the clutch hub (which is secured to the mainshaft B). Consequently no power is transmitted to the rear wheel and the clutch is said to be " out," or free.

On allowing the handlebar clutch lever to return to its normal position so that the gear box clutch operating lever A is free, the clutch thrust rod D, ball C and fork B, move to the right, under the influence of the pressure exerted by the clutch springs F. The whole of the spring pressure is thereby transferred to the clutch spring pressure plate F (shown immediately under the letters H and G in the illustration), and this forces the clutch plain plates G tightly against the clutch friction plate H so that the power transmitted by the engine to the clutch sprocket is transferred, via the clutch case J to the friction plates H and through them to the steel plates G, to the clutch hub which causes the mainshaft T to revolve.

(113). **CLUTCH OPERATION.**

Illustration 12 shows the gear box clutch operating lever, and its parts, as used on all C.P. and B.A.P. gear boxes fitted to all Models except 12, 12M, 22 and 22SS.

175-X-4 is the gear box clutch operating lever and 66-X-7 is the pin on which it hinges. 329-X is the fulcrum for the lever and this slides in the kickstarter case cover, its position being determined by the sleeve nut 331-X.

The fork 330-X transfers the pressure from lever 175-X-4, through ball 67-X to the clutch thrust rod that passes through the centre of the gear box shaft,

The cap 328-X is secured to the outside of the kickstarter case cover by the two screws 333-X. The inner side of this cap has a hexagonal recess that just fits over the sleeve nut 331-X, thereby locking the position of that nut.

It is essential that there is about $\frac{1}{32}$ in. clearance between the fork 330-X and the nose on the lever 175-X-4 when the clutch is engaged.

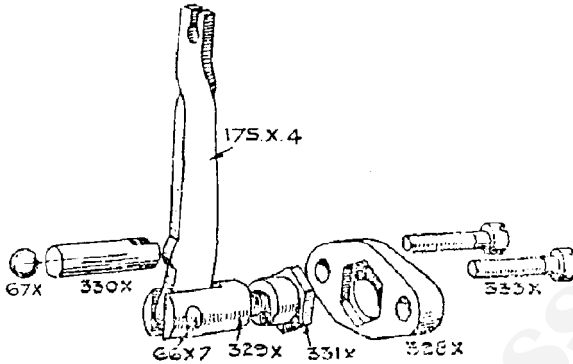

Illustration 12.

This means that it must be possible to move the handlebar clutch lever about $\frac{1}{2}$ in., measured at the tip of the lever, before the hand can feel the resistance set up when the lever 175-X-4 commences to overcome the spring tension on the clutch plates during the action of freeing the clutch. Full instructions on how to obtain this setting are given in paragraph 117.

(114). **CLUTCH OPERATION.**

Illustration 13 shows the gear box clutch operating lever used on H.P. gear boxes as fitted to Models 12, 12M, 22 and 22SS.

In operation, the clutch cable lifts the clutch operating lever A, and the cam noses on the lever exert pressure on the thrust piece B, through ball C, and then through the clutch thrust rod (through the centre of the gear box main shaft) to the clutch spring pressure plate shown in Illustration 14.

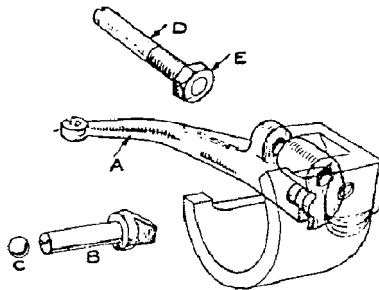

Illustration 13.

D is the pin on which the gear box clutch operating lever is hinged, and E is its lock nut.

It is essential that there is about $\frac{1}{32}$ in. clearance between the cam noses on the gear box clutch operating lever A and the thrust piece B when the clutch is engaged.

Screwed into the centre of the clutch spring pressure plate Z is a thrust screw Y which can be locked in position by nut X.

This means that it must be possible to move the handlebar clutch lever about $\frac{1}{2}$ in., measured at the tip of the lever, before the hand can feel the resistance set up when the lever A commences to overcome the spring tension on the clutch plates during the action of freeing the clutch. Full instructions on how to obtain this setting are given in paragraph 110.

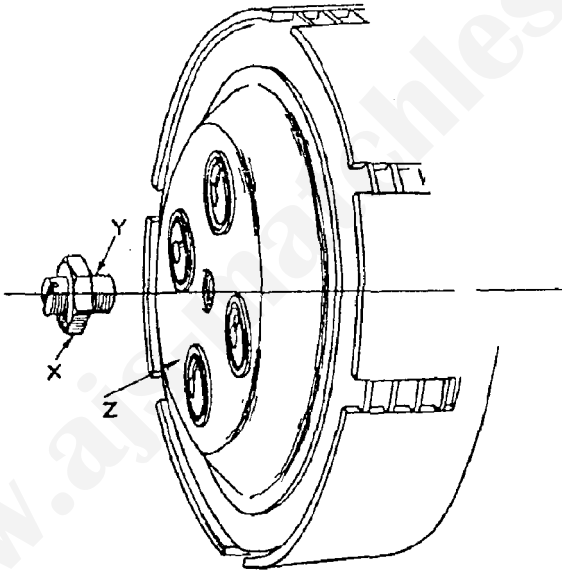

Illustration 14.

(115). CLUTCH CONTROL.

It will be appreciated that, as the result of wear on the clutch inserts (in the clutch friction plates) the plates will tend to close up towards each other. This action increases the effective length of the clutch rod, while, on the other hand, the clutch operating inner wire tends to stretch in use.

Although these two actions will neutralise each other, inasmuch as the first (plates closing down) make the effective length of the clutch thrust rod longer, and the second (inner wire stretch) will make the clutch rod effective length shorter, the fact remains it is necessary, from time to time, to adjust the rod clearance as well as take up cable stretch.

It has been shown in paragraphs 113 and 114 it is essential there is about 1/32in. clearance on the clutch rod. Reference to Illustration 11 will show the necessity for this clearance because it will be noticed if the clutch thrust rod is too long the clutch spring pressure will be exerted solely on the clutch rod and not on the clutch steel and friction plates. That condition will allow the clutch to slip instead of transmitting the engine power through the gears to the rear wheel.

Clutch slip caused in this manner will rapidly ruin the fabric inserts in the clutch friction plates and cause the clutch rod to wear in a most rapid manner. In addition, the slip may be so intensive that very considerable heat is generated, and this may ruin the hardening and tempering of the clutch springs and the two ends of the clutch thrust rod. Therefore, we must stress the importance of seeing that the clutch operating gear is adjusted correctly, and also the importance of regular inspection to see the adjustment is maintained.

The clearances mentioned in paragraphs 113 and 114 may be set, in the case of H.P. gear boxes, by adjusting the clutch control cable stop and by adjusting the screw in the centre of the clutch spring pressure plate, and, in the case of C.P. and B.A.P. gear boxes, by adjusting the clutch control cable stop and by adjusting the position of the clutch operating lever fulcrum in the kickstarter case cover.

Generally, it may be taken that minor adjustment should be made by adjusting the cable stop (see paragraph 116) and major adjustments should be made by the clutch lever (see paragraph 117) in the case of C.P. and B.A.P. boxes, and by the plate screw (see paragraph 119) in the case of H.P. boxes.

(116). **CLUTCH CABLE ADJUSTMENT.**

The clutch cable adjustment is made at the clutch cable stop that is threaded into the kickstarter case. The clutch cable passes through it and its position is located by a lock nut. On all Models except 12, 12M, 22 and 22SS, this adjustment may be made with the fingers. A spanner is needed on Models 12, 12M, 22 and 22SS. To decrease the effective length of the clutch operating cable—i.e., to take up play between the control and the clutch thrust rod, the adjuster should be unscrewed from the kickstarter case cover. The amount of play, or free movement, can easily be discovered by virtue of the greatly increased resistance of the handlebar lever as the declutching action commences.

(117). **CLUTCH OPERATING LEVER ADJUSTMENT. (All Models except 12, 12M, 22, 22SS and 2A.)**

Reference to Illustration 11 shows that if the fulcrum on which the lever is hinged is moved bodily towards the clutch any excessive clearance between the nose on the lever and the clutch rod can be taken up.

This is done by removing the two screws 333-X, shown in Illustration 12, and which are situated on the outside of the kickstarter case cover, and removing the cap that they retain to the cover.

This action discloses the sleeve nut 331-X and, to take up clearance, this must be unscrewed. Do this one turn at a time, and, holding the head of the sleeve nut tightly pressed against the kickstarter case cover, test the clearance. Repeat, if necessary, until the clearance is correct. (See paragraph 113.) Finally, replace the cap and its retaining screws.

(118). **CLUTCH OPERATING LEVER ADJUSTMENT. (Model 2A.)**

On Model 2A (four speed and three speed with reverse), the clutch operating lever is external to the gear box. The fulcrum of this external lever is fixed but, in the lever, an adjustable screw provides the necessary adjustment.

This screw engages in a threaded sleeve, on which is two flats, and the two flats and the head of the screw are located in position by the turned up construction of the clutch lever. The sleeve fits over the clutch operating rod that passes through the gear box mainshaft and the end of the screw abuts against the end of the clutch rod.

To alter the position of the screw the clutch cable must be disconnected from the end of the external lever and the lever swung downwards out of the way. Then, if the sleeve is held by a spanner engaging in the flats, the screw can be turned either way to obtain the necessary adjustment. Unscrew the screw from the sleeve to increase the clearance between the screw and the clutch rod and vice versa to decrease the clearance.

(119). **CLUTCH SPRING PRESSURE PLATE SCREW ADJUSTMENT. (Models 12, 12M, 22 and 22SS.)**

Reference to Illustration 13 will show that clutch rod clearance can be adjusted by altering the position of the thrust screw Y in the spring pressure plate Z.

This is done by removing the outer portion of the front chain case (see paragraph 89), and then slackening the lock nut X. The screw Y should then be screwed further into plate Z to take up clearance and unscrewed to increase the clearance. After moving this screw about one complete turn, check the adjustment. Finally, tighten the lock nut, recheck the adjustment and replace the chain case front.

(120). **ACCESS TO CLUTCH CABLES.**

Access to the gear box end of the clutch control cable can be obtained, on all Models except 12, 12M, 22, 22SS and 2A, by removing the screwed cap that is located on the top edge of the kickstarter case cover.

Similar access can be obtained on Models 12, 12M, 22 and 22SS, by removing the steel plate (that is retained by two nuts) on the front of the gear box immediately under the point where the clutch cable enters the box.

(121). **CLUTCH ADJUSTMENT.**

In the event of clutch slip being experienced, the most likely cause is incorrect cable adjustment. If the cable adjustment is found to be satisfactory—i.e., there is the clearance mentioned in paragraph 113, then the clutch spring adjuster nuts should be adjusted.

Each of these nuts (four on all Models except 2 and 2A, which have five) should be screwed in exactly one half of a complete turn, when a retrial should be made. If necessary, repeat, but be careful to adjust each of the nuts a similar amount. (See paragraph 90 to obtain details of the standard setting of these nuts).

If it is necessary to nearly completely screw home the clutch spring adjuster nuts in order to remedy clutch slip this is a clear indication the springs have lost their strength and/or the fabric inserts in the friction plates have worn so they are past further useful service. The obvious remedy then is to replace with new. (Clutch springs cost 6d. each, and new fabric inserts can be fitted to your plates at a cost of 3s. 0d. per plate, postage is extra.) (3s. 6d. per plate for Models 2 and 2A.)

It is very important, to obtain the full gripping power of the clutch, that the inserts are perfectly flat and to size. It is for this reason we recommend the clutch friction plates are returned to us when new inserts are needed.

(122). **GEAR BOX TROUBLES THAT MAY OCCUR AFTER EXTENSIVE USE.**

GEARS JUMPING OUT. This may be due to weakening of the spring that operates the pawl in the gear box shell, the function of which is to lock the gear change mechanism when a gear has been selected. It might also be due to wear on the ratchet in the foot change mechanism. It can also be due to excessive wear on the two bushes in the main gear Pinion.

KICKSTARTER JAMMING. This may be due to the quadrant teeth and the ratchet pinion teeth not engaging properly, due to the sharp edge on the ratchet pinion teeth having worn. The cure for this is to file the teeth to a sharp point, and if the first tooth of the quadrant is damaged, this should also be filed to give a suitable lead. These "repairs" should only be considered a temporary nature and the first opportunity should be taken to replace the worn parts with new.

KICKSTARTER SLIPPING. This is due either to a stripped quadrant or worn ratchet teeth.

FOOT CHANGE LEVER NOT RETURNING TO POSITION. This, in most cases, is due to a broken centralising spring.

KICKSTARTER CRANK NOT RETURNING TO POSITION. This is generally due to a broken kickstarter return spring.

(123). **DISMANTLING AND ASSEMBLY.**

We do not recommend the dismantling of gear boxes to any but those who have had a mechanical training. Though dismantling, in itself, is not a difficult task, the reassembly calls for accuracy in positioning and fitting that can easily lead a novice astray. To the latter we recommend the despatch of the box to ourselves or a competent mechanic.

All the nuts and bolts used in the box have right hand threads. When fitting the kickstarter return spring, it is best to tightly coil it up and bind with string or wire and then to release it after it is in position. Otherwise, attach each end of the spring to its pins and then, with the kickstarter axle only partly home "wind up" the axle two to two and a half complete turns, after which, push the axle right home.

On H.P. type gear boxes the two centralising springs on the foot change mechanism should be mounted in such a way that the two arms of each spring lie on either side of each pin. In no circumstances should the arms of a spring be crossed, although, a new spring will have the arms crossed, due to the natural tend of the spring.

On C.P. and B.A.P. gear boxes, when assembling the toothed sector of the foot change mechanism it is important to see that the sector meshes with the small pinion on the end of the camshaft so that the marks on each part are in mesh.

(124). **GEAR RATIOS.**

The engine sprockets on all "A.J.S." SINGLE CYLINDER MODELS are interchangeable and can be supplied with 16, 17, 18, 19, 20 and 21 teeth, at a cost of 10s. 5d. each, plus 4d. postage.

The engine sprockets used on MODELS 2 and 2A are only suitable for those models and can be supplied with 20, 21, 22 and 23 teeth, at a cost of 11s. 7d. each, plus 6d. postage.

In the following table the top gear ratio given by each size of sprocket is shown, and the size of sprocket that is fitted to each model, as standard, is also indicated.

	Top Gear Ratio on Models:		Standard Fitting on Model,	
Engine Sprocket,	12, 12M, 22, 22SS.	16, 16M, 26, 26SS, 26T, 8, 9, 18, 18T, 18SS.	2 and 2A.	
16 teeth ...	6.25 ...	6.56 ...	— ...	All 250 c.c.
17 teeth ...	5.88 ...	6.17 ...	— ...	26T.
18 teeth ...	5.55 ...	5.83 ...	— ...	All 350 c.c. but 26T.
19 teeth ...	5.26 ...	5.52 ...	— ...	All 500 c.c. S/C.
20 teeth ...	5.00 ...	5.25 ...	5.43 ...	—
21 teeth ...	4.76 ...	5.00 ...	5.17 ...	All 500 c.c. Solo.
21 teeth ...	4.76 ...	5.00 ...	5.17 ...	2, 2A Sidecar.
22 teeth ...	— ...	— ...	4.94 ...	—
23 teeth ...	— ...	— ...	4.72 ...	2, 2A Solo.

(125). **TO DETERMINE GEAR RATIOS.**

Top gear ratio equals:—

$$\frac{\text{Rear Wheel Sprocket}}{\text{Small gear Box Sprocket}} \times \frac{\text{Large Clutch Sprocket}}{\text{Engine Sprocket}}$$

For example :—If the rear wheel sprocket has 50 teeth, the small gear box sprocket has 20 teeth, the clutch sprocket has 40 teeth and the engine sprocket has 25 teeth, the resulting equation would be :—

$$\frac{50}{20} \times \frac{40}{25} = \text{Top gear ratio of 4 to 1.}$$

(126). **GEAR BOX RATIOS.**

The ratios provided by the trains of gears in the gear boxes are as follows :—

Type of Box.	Fitted to Models.	Top Ratio.	Third Ratio.	Second Ratio.	First Ratio.
H.P.	... 12, 12M, 22, 22SS	... 1	... 1.4	... 1.79	... 2.97
C.P.	... 16, 16M, 26, 26SS	... 1	... 1.28	... 1.76	... 2.67
C.P.	... 8, 9, 18, 18SS	... 1	... 1.28	... 1.76	... 2.67
C.P.	... 22T, 26T, 18T	... 1	... 1.51	... 2.08	... 3.16
B.A.P.	... 2	... 1	... 1.26	... 1.57	... 2.67
B.A.P.	... 2A (Four speed)	... 1	... 1.26	... 1.57	... 2.67
B.A.P.	... 2A (Three speed)	... 1	... —	... 1.84	... 3.14

The reverse gear ratio, on Model 2A, when fitted with three speed and reverse gear box, is 2.76.

To determine the actual ratio of any one gear, multiply the ratio, as given above, by the top gear ratio.

For example :—

The second gear ratio on Model 26T is top gear, 5.83 (see paragraph 124) multiplied by 2.08 (see paragraph 126) which equals 12.12.

NOTE:—The C.P. gear boxes fitted to Models 16, 16M, 26, 26SS, 8, 9, 18, 18SS, have main gear pinions with 30 teeth and layshaft small pinions with 20 teeth.

The C.P. Gear boxes fitted to Models 22T, 26T and 18T have main gear pinions with 32 teeth and layshaft small pinions with 18 teeth.

**GENUINE
A.J.S.
PARTS**

PURCHASED DIRECT FROM THE FACTORY OR FROM AN AUTHORISED "A.J.S." DEALER, ARE IDENTICAL WITH THE PARTS ORIGINALLY BUILT INTO YOUR MOTOR CYCLE. BY USING GENUINE SPARES, YOU ARE ASSURED THEY WILL FIT ACCURATELY AND GIVE SATISFACTORY SERVICE.

TYRES.

(127). TYRES AND SERVICE.

Obtaining satisfactory life and service from the tyres is largely a matter within the user's control, because the first essential to obtain this is proper inflation.

The correct pressure is substantially governed by the load to be carried and it is therefore somewhat difficult to lay down a hard and fast rule. Assuming the driver's weight to be normal, the pressures recommended in paragraph 129 may be regarded as satisfactory. All users are urged to make a practice of checking the actual pressure in each tyre by a low pressure Schrader tyre gauge. This takes only a few seconds to do and will amply repay the owner by reason of additional service and immunity from failures.

This test should be made at least once a week.

Avoid unnecessary or "stunt" acceleration and fierce braking, which wear out tyres rapidly by causing wheel spin.

Avoid driving in tramlines. Apart from its danger, the up-standing edge often deeply cuts the loaded tyre.

Do not allow flints, etc., to remain embedded in the tread. They will work through, puncturing the tube and destroying the canvas casing.

Keep oil away from the tyres and from the spokes. If any finds its way on to the tyres, clean it off by using petrol sparingly.

(128). INFLATION PRESSURES. (General Table.)

The following are correct minimum inflation pressures for specified loads per tyre :—

Load per tyre, 200 lbs.—Pressure, 16 lbs. per square inch.

Load per tyre, 240 lbs.—Pressure, 18 lbs. per square inch.

Load per tyre, 280 lbs.—Pressure, 20 lbs. per square inch.

Load per tyre, 350 lbs.—Pressure, 24 lbs. per square inch.

Load per tyre, 400 lbs.—Pressure, 28 lbs. per square inch.

Load per tyre, 440 lbs.—Pressure, 32 lbs. per square inch.

Consequently the best method of ascertaining the correct pressures is to actually weigh the loads on the front and rear tyres on a weighbridge and this is a service that can usually be provided by a corporation or railway company.

(129). **INFLATION PRESSURES. (Approximate.)**

For those owners who do not wish to go to the trouble of actually weighting the loads, we give below, in tabular form, suggested inflation pressures for solo riding, when the rider is of average weight. For riders of abnormal weight, or when a pillion passenger is carried, add 2 lbs. per square inch, to the rear tyre only.

Models.	Front. lbs.,	Rear. lbs.
12, 12M, 22 16 18
16, 16M, 26, 8, 9, 18 17 20
22T, 26T, 18T 20 24
22SS, 26SS, 18SS 20 24
2 and 2A 18 18

(130). **TYRE REMOVAL.**

To take off an outer cover and remove the inner tube, proceed as follows :—

Take off the valve cap and unscrew the nut on the valve stem.

Completely deflate the tube by removing the valve inside. (The valve cap is provided with a slotted top to facilitate this operation).

Then, push the edge of the cover, that is immediately opposite to the valve, into the well of the rim, and, using the tyre lever that is included in the tool kit, pick up the edge of the cover close to the valve, so that it comes off over the edge of the rim, and then it will be found quite easy to slip the remainder of the cover off the rim, without the need to use force.

Next, push the valve stem upwards, through the hole in the rim, and the inner tube can be taken away.

If it is desired to remove the cover from the rim, all that now has to be done is to push the side of the cover that is still on the rim, right into the well of the rim at one place, and pick up the opposite edge and slip the cover off the rim.

(131). **TYRE FITTING.**

To refit an inner tube and outer cover, proceed as follows :—

Place one edge of the cover right into the well of the rim and, commencing opposite to that spot and using the hands only, work the cover over the edge of the rim. This is a very easy operation.

Replace the valve inside in the valve and slightly inflate the inner tube. (Do not distend the tube). Fit the valve into its hole in the rim and replace the valve stem nut, only screwing it on the stem about half an inch or so. Tuck in the inner tube so that it lies snugly in the cover. Then introduce the outer edge of the cover into the rim, at a spot opposite to the valve.

Get this edge right into the well of the rim and then, by working round the cover equally on either side, the cover will slip into place without excessive exertion. There should be no need to use the tyre lever when refitting the cover. That portion of the cover nearest to the valve should be refitted last.

Next, half inflate the tyre and spin the wheel and test for trueness, because it is essential the pattern on the tread of the cover runs quite evenly and the cover must be manipulated until this condition is obtained. The tyre should then be fully inflated to the pressure recommended in paragraphs 128 and 129.

Finally, screw home the valve stem nut and replace the valve cap.

Never run without the valve caps in position, otherwise dirt will enter the valve and, upon the application of a tyre pump, some will get on the valve seating, thereby preventing the valve making an air tight seal and deflation will result.

(132). **SECURITY BOLTS.**

On those Competition machines that have tyre security bolts these should be released and removed exactly as would a valve.

When refitting, the security bolt, or bolts, should be replaced in the rim before the inner tube is inserted in the cover, and, when replacing the outer cover edge, it is necessary to take great care the edge of the cover lies UNDER the lip of the security bolt and also that the inner tube is not trapped between the lip and the cover.

ACCESSORIES.

(133). PILLION SEATS.

Pillion seats can be supplied for all models. Two types are available.

One pattern is secured to the rear mudguard by four bolts, washers and nuts. The other is designed to clamp to the rear carrier, that can be supplied, as an extra, to all standard models. (Not suitable for Competition Models).

Pillion seat, with fittings, mudguard fitting. All Models except 2 and 2A, part number 39-EQ-9, 12s. 6d.

Pillion seat, with fittings, carrier fitting. All Models except 22T, 26T and 18T, part number 39-EQ-10, 13s. 6d.

Postage 6d. extra on any of above items.

(134). PILLION FOOTRESTS.

Pillion footrests can be supplied for all models. Two types are available.

One pattern is suitable for all models except Models 12, 12M, 16 and 16M. These fit into special sockets that are integral with the rear fork ends and are secured in position by lock nuts.

They are quickly and easily fitted or removed and fold so that, when not in use, they are well out of the way and are almost inconspicuous. (See Illustration No. 15.)

These pillion footrests, being designed and made exclusively for "A.J.S." Motor Cycles, are greatly superior to the type that are sold with adjustable fittings to enable them to be clamped to machines of any make.

The part number is 39/EQ/2 and the price 12s. 6d. per pair, complete, postage being 6d. extra.

These footrests are made in the "A.J.S." factory and cannot be fitted to machines of 1938 or earlier make.

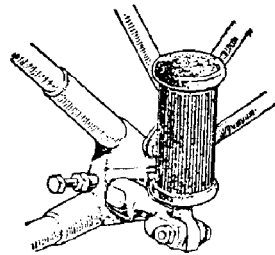

Illustration 15.

("Motor Cycling")

The second type of pillion footrests is designed for Models 12, 12M, 16 and 16M. This type does not fold. The part number is 38/G3/EQ242 and the price 7s. 6d. per pair, complete, postage 6d. extra. This pattern of pillion footrests may be fitted to "A.J.S." Motor Cycles of 1938 and earlier make. They are made in the "A.J.S." factory.

(135). **PROP STANDS.**

Prop stands are standard fitting on Models 18T, 22T and 26T but, any other single cylinder model can be equipped with but little trouble and expense.

It is necessary to discard the left side footrest hanger and replace it with one of another type that has a boss on it to accommodate the prop stand leg, and to fit to that hanger a complete prop stand assembly, as detailed below. The fitting need only take a few minutes. This prop stand conversion set is an exclusive "A.J.S." design and is made in the "A.J.S." factory. It can be applied just as easily to all "A.J.S." Motor Cycles of 1937 and 1938 design. (See Illustration 16.)

1939 "A.J.S." prop stands conversion set, part number 39/EQ/1, consisting of:—

- 1 Special footrest hanger, for left side.
- 1 Prop stand leg.
- 1 Hinge bolt, for prop stand leg.
- 1 Nut, for prop stand hinge bolt.
- 1 Adjusting screw, for prop stand.
- 1 Nut for prop leg, adjusting screw.
- 1 Return spring, for prop stand leg.
- 1 Anchor bolt, for prop stand return spring.
- 1 Nut, for anchor bolt.

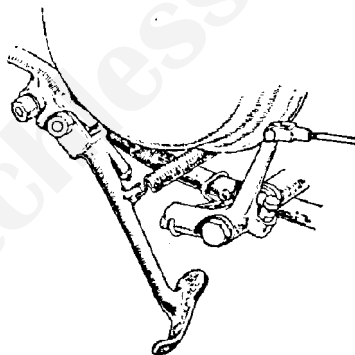

Illustration 16.
("Motor Cycling")

(The rear mudguard on all single cylinder models, is drilled to accommodate the anchor bolt for the spring. Normally, this hole is " filled " by a bolt and nut.)

Price of complete conversion set, 16s. 6d., postage 6d. extra.

(136). **WATCHES.**

Provision is made to mount a watch in the instrument panel that is on the top of the tank of all except Competition Models. Normally, the aperture for the watch is closed by a plated cap.

The watch is made by Messrs. Smith and Sons, Ltd. The part number is 24142 and the price is £ 1 10s., postage 4d. extra.

To fit the watch it is necessary to remove the panel from the tank, unscrew the two nuts that fix the bridge retaining the plated cap in the top of the panel, and the watch can then be easily fitted in the aperture.

ELECTRICAL SECTION.

(137). **ELECTRICAL EQUIPMENT.**

Machines having: Magneto Ignition are fitted with Lucas Electrical Equipment. Those having Coil Ignition have Miller Equipment.

On all Models, the dynamo charge rate is automatically controlled by a constant voltage unit. This unit functions when the voltage, generated by the dynamo, rises above 7.3 to 7.5 volts and then, with a fully charged battery and under "No Load " conditions, only a small current flows through the system.

As the load is switched on, the dynamo output is automatically increased to meet the demand. Therefore, it is only when the battery is in a run down condition, and during daylight running, that the ammeter will show a high charging rate, when a charge rate as high as from 5 to 6 amps may be recorded. Under normal conditions, the charge rate is between 2 and 4 amps, according to the state of the battery.

This constant voltage system is designed to maintain a fully charged battery without the risk of overcharging, which was once so commonly experienced with lighting sets having only switch charging control.

All the wiring is the single pole type, the frame of the machine being used for the negative, or earth, return.

Except on Competition Models, the main lighting switch is located in the panel mounted on top of the petrol tank. On Competition Models it is located in the back of the head lamp.

(138). **VOLTAGE CONTROL UNIT.**

The voltage control unit consists of a regulator which is mounted together with the cut-out.

The regulator causes the dynamo to give an out-put which varies according to the load on the battery and its state of charge.

When the battery is discharged the dynamo gives high out-put, so that the battery receives a quick recharge which brings it back to its normal state in the minimum possible time. On the other hand, if the battery is fully charged, the dynamo is arranged to give only a trickle charge which is sufficient to keep it in good condition without the possibility of causing damage to the battery by overcharging.

In addition to controlling out-put of the dynamo according to the condition of the battery, the regulator provides for an increase of out-put to balance current taken by the lamps or other accessories whenever they are switched on.

This compensated voltage control system ensures the battery is charged, even during the winter, and it eliminates the danger of a discharged battery.

Should the battery become disconnected, or is removed, the machine may still be used without fear of damage to the electrical equipment.

The cut-out is an automatic switch which prevents the discharge of the battery when the dynamo is stationary. Its contacts close when the dynamo voltage rises above that of the battery, as the engine speed rises, and open when the speed drops and the voltage falls below that of the battery.

The cut-out is incorporated with the voltage control regulator and the complete assembly is located on the back of the oil tank, behind the battery. (Except on Models 2 and 2A, on which it is secured to the side of the battery carrier).

(139). **DYNAMO.**

The dynamo is fitted with two brushes, the positive is insulated and the negative is earthed.

Before removing the dynamo cover for any reason, disconnect the positive wire from the battery, otherwise there is a danger of reversing the polarity of the dynamo or short circuiting the battery, either of which might cause serious damage.

Occasionally examine the dynamo brushes. They can be removed from their holders when the spring lever is held aside. They should slide freely in their holders and make good contact with the commutator. If the brushes are dirty or greasy, clean them with a cloth moistened with petrol. Replace the brushes in their original position.

After long service, when the brushes have become so worn that they will not bear properly on the commutator, they should be replaced with new. Brushes are sold in complete sets.

Keep the commutator clean and free from oil. The best method of cleaning is, without disconnecting any leads (wires), to remove one of the brushes from its holder and, inserting in its place a soft duster, hold the duster, by means of a suitably shaped piece of wood, against the surface of the commutator, at the same time, turning the engine so as to rotate the armature.

A magdyno unit is fitted to Models 2 and 2A. This is a combined magneto and dynamo, and both are self contained units. The magneto portion forms the base part and takes the drive from the engine camshaft chain and the dynamo is secured to it by a strap and screws, and is driven from the magneto armature shaft by a train of gears.

(140). **BATTERY MAINTENANCE.**

The electrolyte is a dilute solution of sulphuric acid. This has a corrosive action on most metals and burns fabric and human skin. Any that gets on the machine, hands or clothes, through being spilt, should be immediately washed off with plenty of water or else neutralised by washing with an alkaline solution made with ammonia or washing soda (sodium carbonate) and water.

At least once a month, the vent plugs in the top of the battery should be removed, and the level of the acid solution (electrolyte) examined. The solution should be just over the top of the lead plates of the battery. If necessary, distilled water, which can be obtained from all chemists and most garages, should be added to bring the level to just over the top of the plates. However, if any of the acid solution has been spilled, this should be replaced by a dilute sulphuric acid solution of the same specific gravity. When examining the cells, do not hold naked lights near the vents because there is a danger of igniting the gases coming from the plates.

It is advisable to complete the inspection by measuring the specific gravity of the acid in each cell, as this gives a very good indication of the state of charge of the battery.

An instrument known as a "Hydrometer" is employed for this purpose. This can be bought at any Lucas Service Station and from most garages.

The specific gravity figures are:—

- 1.285 to 1.300 when fully charged.
- About 1.210 when half discharged.
- About 1.150 when fully discharged.

These figures are given assuming the temperature of the solution is about 60 degrees F.

Take readings of the acid in each cell. The readings should be approximately the same for all of the cells. If one cell gives a reading very different from the rest it may be that the acid has been spilled or has leaked from this particular cell, or there may be a short between the plates. In this case we advise the owner to have the battery examined by a service depot to trace the cause and to prevent the trouble from developing.

If the equipment is laid by for several months, the battery must be given a small charge from a separate source of electrical energy about once a fortnight, in order to obviate any permanent sulphation of the plates. In no circumstances must the electrolyte be removed from the battery and the plates allowed to dry, as then certain changes take place which result in loss of capacity.

(141). **LIGHTING SWITCHES. (Magneto Models.)**

On all models equipped with magneto ignition (except Competition Models), the main lighting switch is located in the bottom end of the panel mounted on top of the petrol tank. On Competition Models the switch is mounted in the back of the head lamp. The switches are identical.

The switch has three positions, marked, " OFF," " L" and " H." When in the " OFF " position no lamps are alight. In the " L" position the pilot bulb in the head lamp, the rear lamp and the speedometer bulb are alight. In the " H " position the main bulb in the head lamp, the rear lamp and the speedometer bulb are alight.

The switch must be in either the " L" or " H " position before the inspection lamp can be lit.

The dynamo can charge the battery in all switch positions (including the " Off " position). There is no risk of over charging the battery because the Voltage Control Unit automatically looks after that. (See paragraph 138.)

(142). **LIGHTING SWITCHES. (Coil Ignition Models.)**

On all models equipped with Coil Ignition, the main lighting switch is located in the bottom end of the panel that is mounted on the top of the petrol tank.

The switch has five position, marked, " PARK," " OFF," " I.G. and C.H." " H " and " L." When in the " OFF " position no lamps are alight and it is impossible to start the engine. In the " I.G. and C.H." position the current is " ON " for the ignition and for charging the battery. In the " L" position the current is " ON " for the ignition and the pilot bulb in the head lamp, the rear lamp and the speedometer bulb are alight. In the " H " position the current is " ON " for the ignition and the main bulb in the head lamp, the rear lamp and the speedometer bulb are alight. In both " H " and " L" positions the dynamo can charge the battery. In the " PARK " position only the pilot bulb in the head lamp and the rear lamp are alight and the switch should always be placed in this position when leaving the machine parked at night.

Normally, the switch handle is loose and does not operate the switch when it is moved. To move the switch it is necessary to insert a key in the switch handle. Always switch off when you stop the engine and it is advisable to remove the key, otherwise a meddler may move the switch to a position where the current to the ignition is " ON " and thereby discharge the battery. It is impossible to start the engine when the battery is discharged.

Two ignition keys are supplied with each machine.

(143). **HEAD LAMPS.**

The head lamps are fitted with double filament bulbs, 6 volts, 24 and 24 watts. One filament is arranged to be at the focus of the reflector and gives a normal driving light, while the other, mounted slightly above the first, gives a dipped, anti-dazzle beam for use when meeting other traffic or driving in fog. This anti-dazzle device is controlled by the two way switch on the left handlebar. A small pilot bulb, 6 volts, 3 watts, is provided for use when the machine is stationary or for town riding.

To remove the front of the head lamp, it is necessary to release the clip at the bottom of the rim. Then pull the bottom of the rim outwards and it will come away from the body, complete with the reflector and bulb assembly, which are attached to it.

The main bulb can be focussed by altering its position in the holder.

On Lucas head lamps the bulb holder is a sliding lit in the reflector and is locked in position by a small clamp and screw. If this screw is slackened a few turns the holder can be slid inwards or outwards to the required position, after which the screw should be tightened.

On Miller lamps the bulb holder also slides but it is located by a trigger working in a notched slot. This trigger is retained by a small spring and in practice, it is only necessary to turn the bulb a trifle to the right to release the trigger, move the bulb holder into the required new position and then, when releasing the bulb, see that the trigger engages in another notch.

To fit a new main or pilot bulb it is necessary to detach the bulb holder assembly from the reflector.

First of all, remove the front rim from the body of the lamp, as already explained. Then, on Lucas lamps, it will be seen the bulb holder assembly is retained by two long wire springs, these can be pushed sideways, away from the centre, and this releases the holder assembly and allows it to be taken away from the reflector. On Miller lamps, the bulb holder assembly is a "push-in" fit in the reflector and is located by a tongue that fits in a slot cut in the reflector. To remove this assembly it is only necessary to pull it upwards and outwards till the tongue is clear of the slot.

On all models it is not necessary to disconnect any of the wiring in order to fit a new bulb.

The tilt of the headlamp can be adjusted by slightly slackening the two bolts fixing the lamp to the brackets, placing the lamp in the desired position, and tightening the bolts.

(144). **HEAD LAMP REMOVAL.**

On Competition machines provision is made to quickly and easily remove the head lamp without disturbing any of the wiring.

This is done by fixing a four point socket to the fork girder, to which the cables from dynamo and battery are attached and on the companion four point plug, fixing the cables leading from the lamp.

Therefore, when it is desired to remove the head lamp, all that has to be done is to take away the two fixing bolts in the side of the lamp body and to separate the connection socket and plug. This leaves the lamp, with its cables, free to be removed.

Finally, if the four bolts that retain the lamp stays to the fork girder are slackened, the stays can be swung back, in line with the girder and then, if the bolts are tightened, the stays will be retained in that position, out of the way.

(145). **REAR LAMPS.**

The rear lamp is in two pieces. The portion that carries the ruby glass is fixed to the number plate, the other portion, which carries the bulb, is attached to the main body by a bayonet clip.

To remove the portion carrying the bulb, it is necessary to rotate it in an anti-clockwise direction, about a third of a turn in the case of Lucas lamps and about a quarter turn in the case of Miller lamps.

On those models fitted with streamline rear number plates, in which the rear lamp is mounted in the centre of the top of the plate, the rear lamps are of different design to that mentioned in the two preceeding paragraphs. In this type of lamp the main body, which holds the bulb, is fixed to the plate and the part containing the red glass is removable.

To remove the part containing the red glass, in order to get access to the bulb, slightly depress the two spring clips projecting from the body and twist the body in an anti-clockwise direction, when the body can be pulled away.

The bulbs used in the rear lamps are identical with those used in the pilot position in the head lamps. (6 volts, 3 watts).

A quickly detachable connector is inserted in the rear lamp cable at the point where it is just over the centre of the rear wheel axle. This is fitted so that, when it is desired to remove the rear portion of the rear mudguard, there is no need to disconnect the cable from the rear lamp.

On machines equipped with magneto ignition this connector takes the form of two brass screwed sleeves that can be separated by unscrewing. The sleeves are covered by a rubber

sleeve and to disconnect, it is only necessary to slide the rubber sleeve along the cable, to expose the brass sleeves and then to unscrew the two halves of the connector.

On machines equipped with coil ignition the connector is a plain plug and socket, each with ebonite insulation, and, to disconnect, it is necessary to pull apart the two halves.

(146). **INSPECTION LAMPS.**

All Models, except Competition Models and Models equipped with Coil Ignition, are provided with an inspection lamp. This is located in the centre of the panel mounted on top of the petrol tank and serves the dual purpose of illuminating the ammeter and inspection lamp.

For illuminating the ammeter it is necessary to turn the top of the lamp in the direction indicated by an arrow. For service as an inspection lamp it is necessary to remove it from the panel. (See Illustration 17.)

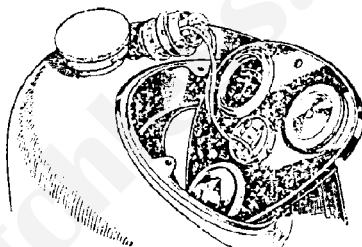

Illustration 17.

("The Motor Cycle")

Note that Illustration No. 17 shows the inspection lamp detached from the instrument panel, and also the panel removed from the top of the tank so that it may be passed through the centre of the tank when removing the tank from O.H.V. 350 and 500 c.c. Models, of course, it is not necessary to detach the panel from the tank when it is desired to use the inspection lamp.

To do this, the small spring pin at the base of the lamp, on the right hand side, should be depressed and the whole lamp tilted to the left, so that the depressed pin can clear the flange in which it fits. The lamp can then be lifted away from the panel. Attached to it is a length of wire, sufficient to allow the lamp to be of service when working on any part of the machine. This lamp will only light up when any of the other lamps are switched on.

The bulb is identical to those used in the head lamp as a pilot bulb and in the rear lamp. (6 volts, 3 watts). In an emergency, the inspection lamp bulb can be used in the rear lamp or as a pilot bulb.

On some machines the inspection lamp is retained to the panel by a bayonet fitting, similar to the method used on the rear lamp. To remove a lamp of this type it is merely necessary to press downwards and rotate it in an anti-clockwise direction for about one third of a complete turn, when it will be free to be taken from the panel.

(147). **THE MAGNETO.**

Occasionally remove the high tension pickup, remove the carbon brush and spring that slide in the brass lined sleeve of the pickup and, with petrol and rag, clean away all traces of oil and carbon dust. Then clean the slip ring, which is on the end of the magneto armature and on which the carbon brush presses. The best way of doing this is to take an ordinary lead pencil and, on the unsharpened end, wrap one or two folds of a soft duster, insert this in the opening disclosed by the removal of the pickup and push gently against the bottom of the slip ring, at the same time revolving the engine.

Then replace the carbon brush and spring in the pickup and fix the pickup to the magneto. Take the opportunity of examining the high tension cable, and, if it appears perished, denoted by the surface being covered by a multiplicity of small cracks, it is advisable to replace with new.

About every three months, it is advisable to remove the contact breaker cover and examine the contacts. One contact point is mounted on the narrow end of the spring blade. The other point is adjustable and screws into the face of the magneto and is locked in position by a nut. If the points are burned or blackened, clean them with the finest grade of emery cloth and afterwards clean with a rag that is moist with petrol.

Check the gap between the two points by turning the engine till both points are separated and measure the gap. The gap should be .012in. and a gauge this thickness is a part of the magneto spanner. The gauge should just pass between the points without any binding or slackness. If necessary, adjust the gap by slackening the lock nut on the adjustable point and screwing the point inwards, to increase the gap, or outwards, to decrease it. Then tighten the lock nut and recheck the gap.

On Models 2 and 2A the magdyno has a rotating type of contact breaker. One contact point is mounted on the end of a steel rocker arm and the other, which is adjustable, is screwed into a brass block in the centre of the contact breaker. To decrease the gap between the points this adjustable point is unscrewed and vice versa to increase the gap.

On this type of contact breaker it is essential the rocker arm is quite free. If its movement appears to be sluggish, slacken the two screws that secure the two ends of the rocker arm spring, swing aside the spring blade that retains the arm in position and pull the arm from the pin on which it hinges. Clean the steel pin, and the fibre bush mounted in the rocker arm, with rag moistened with petrol, and lubricate the pin with an extremely minute quantity of vaseline, finally replacing the arm, the spring blade and tightening the two spring retaining screws.

(148). **COIL IGNITION CONTACT BREAKER.**

On models equipped with Coil Ignition the contact breaker is mounted in an aluminium housing that is an integral part of the timing gear cover on the crankcase.

One contact point is mounted on the end of a steel rocker arm, the other, which is adjustable, is screwed into a bracket in the centre of the contact breaker. This point is locked in position by a nut.

Check the gap between the points by turning the engine till both points are separated and measure the gap. The gap should be .018in. and a gauge this thickness should just pass between the points without any binding or slackness. If necessary, adjust the gap by slackening the lock nut on the adjustable point and screwing this point inwards, to increase the gap, or outwards, to decrease it. Then lighten the lock nut and recheck the gap.

The interior of the aluminium housing should be kept clean of oil and this can best be done by applying a little petrol with a brush. After doing this, make sure all petrol has been wiped and has dried out before starting the engine.

(149). **SPECIAL NOTE RE CONTACT BREAKERS.**

Check the contact breaker point gap after the first 100 and 500 miles. Owing to an initial settling down, there is a tendency for the gap to alter in the first few hundred miles of use. This may seriously affect the ignition setting. Subsequent adjustment will only be required at long intervals, but it is as well to check the gap every 2,000 miles.

(150). **TO RETIME THE IGNITION.**

Have available a stout screwdriver, or an old type tyre lever having a short turned up end, and a bar of metal not less than 3/16in. in diameter and approximately 5½ins. long. (The tommy bar of a tubular box spanner is suitable).

Prepare by :—On Magneto Models, remove the sparking plug, the outer cover of the magneto chaincase and the contact breaker cover.

On Coil Ignition Models, remove the sparking plug and the contact breaker cover.

On all O.H.V. Models, remove the rocker side cover plate.

On all Side Valve Models, remove the tappet chamber cover plate. (The plate on the rear cylinder on Model 2 and 2A.)

Then proceed as follows, according to the model.

(151). **IGNITION TIMING. (Models 12M, 22, 22T, 22SS, 16M, 26, 26T, 26SS, 9, 8, 18, 18SS and 18T.)**

Unscrew the nut that retains the lower magneto sprocket and, with the screwdriver or tyre lever, gently lever the sprocket from the taper on the camshaft to which it is attached.

Turn over the engine until both valves are closed and, with the rod inserted through the plug hole, feel the piston till, by partially rotating the engine, forwards or backwards, it is felt the piston is at the extreme top of its stroke.

Place a mark on the bar, level with the top of the plug hole, remove the bar, measure above the mark the advance recommended in paragraph 164 and record the position on the bar.

Place the handlebar ignition control lever in the fully advanced position, re-insert the bar in the plug hole and slightly rotate the engine BACKWARDS until the upper mark on the bar is level with the top of the plug hole.

By turning the sprocket on the magneto shaft, rotate the magneto in an anti-clockwise direction (as seen when viewing sprocket) until the contact breaker points are just about to separate.

Tighten the nut on the camshaft, taking care not to move the engine and/or the magneto shaft when doing so. Recheck the setting.

Finally, replace the contact breaker cover, magneto chaincase cover, sparking plug and tappet cover.

(152). **IGNITION TIMING. (Models 2 and 2A.)**

Proceed exactly as described in paragraph 151, but time on the rear cylinder and the lower of the two humps, or cams, on the contact breaker cam ring.

(153). **IGNITION TIMING. (Models 12 and 16.)**

Slacken the screw securing the contact breaker cam, and, with a small punch operating in one of the slots in this cam, give a sharp but light tap. This will loosen the cam from the tapered end of the shaft to which it is attached.

Turn over the engine until both valves are closed and, with the rod inserted through the plug hole, feel the piston till, by partially rotating the engine, forwards or backwards, it is felt the piston is at the extreme top of its stroke,

Place a mark on the bar, level with the top of the plug hole, remove the bar, measure above the mark the advance recommended in paragraph 164, and record the position on the bar.

Place the handlebar ignition control lever in the fully advanced position, re-insert the bar in the plug hole and slightly rotate the engine BACKWARDS, until the upper mark on the bar is level with the top of the plug hole.

Gently rotate the contact breaker cam, with the fingers, in an anti-clockwise direction, until the contact points are just about to separate, in which position carefully retighten the screw that retains the cam. Recheck the setting.

Finally, replace the contact breaker cap, sparking plug and tappet cover.

(154). **SPECIAL NOTES RE-IGNITION TIMING.**

Before timing the ignition, check the gap between the contact points, as described in paragraphs 147 and 148, and adjust, if necessary.

To find the exact moment for the commencement of the point separation, place a piece of tissue paper between the points and turn the magneto armature until the paper is just released, and no more, upon a gentle pull.

(155). **SPARKING PLUGS.**

All models, except Models 9, 2 and 2A, are equipped with LODGE Type H 53 sparking plugs. Models 9, 2 and 2A, are equipped with LODGE Type C 14 plugs.

These plugs have a 14 m.m. thread and are of the detachable type. The gap between the points should be from .018in. to .020in. and when buying new plugs it is necessary to see that the new purchase is a plug set to that gap.

If the plug points are set too closely there will be a tendency to misfire and this may be accompanied with explosions in the silencer.

If the plug points are set too far apart, starting will be difficult and, in any case, an undue strain will be placed on the insulation of the magneto armature, or, in the case of coil ignition, on the coil.

(156). **WARNING LAMP.**

In the centre of the panel, on all coil ignition models, is a small lamp having a red glass. This lights up when the current is " ON " to the ignition and the engine is not running (or is only running very slowly and also sometimes, at very high engine speeds).

This lamp acts as a warning to remind the driver to switch off the current when the engine is not running. It goes out immediately the dynamo is running fast enough to supply sufficient current to close the contact points of the automatic cut-out.

GENERAL INFORMATION.

(157). **MECHANICAL TROUBLES.**

Sudden failures are generally due to one definite thing. Gradual failure may be clue to a combination of circumstances.

In any case of failure in operation no adjustments should be made, nor should any part be tampered with, until the cause of the trouble has been located. Otherwise adjustments which are correct may be deranged.

In paragraphs 158 to 163, inclusive, are particulars of failures and troubles that can occur together with the probable reasons. These troubles are arranged in the order of possibility.

(158). **ENGINE FAILS TO START OR IS DIFFICULT TO START.**

May be due to :—

- Throttle opening too large.
- Petrol tap closed.
- Air lever in open position.
- Ignition not set just off the fully advanced position.
- Not enough petrol in the tank.
- Lack of fuel because of insufficient flooding.
- Lack of fuel because of pipe or tap obstruction.
- Excessive flooding of carburetter.
- Pilot jet choked.
- Oiled up or fouled sparking plug.
- Stuck up engine valve.
- Valve stem sticky with burnt oil.
- Weak valve spring.
- Valve not seating properly.
- Contact points dirty.
- Incorrect contact point gap.
- Water on high tension pickup.
- Water on sparking plug.
- Vent hole in filler cap choked.

(159). **ENGINE MISSES FIRE.**

May be due to:—

- Defective or oiled sparking plug.
- Incorrect contact point gap.
- Contact breaker blade sticking.
- Tappet adjustment incorrect.
- Oil on contact breaker points.
- Weak valve springs.
- Defective sparking plug cable.
- Partially obstructed petrol supply.

(160). **LOSS OF POWER.**

May be due to :—

- Faulty sparking plug.
- Lack of oil in tank.
- No tappet clearance or too much clearance.
- Weak valve spring or sticky valve stem.
- Valve not seating properly.
- Brakes adjusted too closely.
- Ignition lever creeps to full retard position.
- Badly fitting or broken piston rings.
- Punctured carburettor float.
- Engine carbonised.
- Choked silencer.

(161). **ENGINE OVER HEATS.**

May be due to:—

- Lack of proper lubrication. (Quantity or quality of oil).
- Faulty sparking plug.
- Air control to carburettor out of order.
- Punctured carburettor float.
- Engine carbonised.
- Weak valve springs.
- Pitted valve seats.
- Worn piston rings.
- Ignition lever creeps to full retard position.
- Ignition setting incorrect.
- Choked silencer.

(162). **ENGINE STOPS SUDDENLY.**

May be due to:—

- No petrol in tank, or choked petrol supply.
- High tension wire detached from sparking plug.
- Choked main jet.
- Oiled up or fouled sparking plug.
- Water on high tension pickup.
- Water in float chamber.
- Choked vent hole in petrol tank filler cap.

(163). **EXCESSIVE OIL CONSUMPTION.**

May be due to :—

- Clogged, or partly clogged, felt filter in oil tank.
- High crankcase pressure, caused by in-operative release valve action. (The disc in the valve may be damaged or jammed with dirt),
- Stoppage, or partial stoppage, in the pipe returning oil from the engine to the oil tank.
- Badly worn, or stuck up, piston rings. (Causing high pressure in the crankcase),
- Air leak in dry sump oiling system.

(164). **USEFUL INFORMATION.**

Bore (in millimetres)	All 250 Models	62.5
	All 350 Models	69
	All 500 Models	82.5
	All 990 Models	85.5
Stroke (in millimetres)	All 250 Models	80
	All 350 Models	93
	All 500 Models	93
	All 990 Models	85.5
Capacity	Models 12, 12M, 22, 22SS,	
	(in cubic centimetres) 22T	246
	Models 16, 16M, 26, 26SS,	
	26T	347
	Models 8, 18, 18SS, 18T,	
9	498	
Models 2, 2A	990	
Horse Power	All 250 Models	2.46
	(A.C.U. rating) All 350 Models	3.47
	All 500 Models	4.98
	All 990 Models	9.9
Valve Timing		
In. Opens B.T.D.C. ...	All Models, except 2, 2A	20°
	Models 2, 2A	15°
In. Closes A.B.D.C. ...	Alt Models, except 2, 2A	67°
	Models 2, 2A	50°
Ex. Opens B.B.D.C. ...	All Models, except 2, 2A	78°
	Models 2, 2A	58°
Ex. Closes A.T.D.C. ...	All Models, except 2, 2A	28°
	Models 2, 2A	12.5°
Tappet Clearance.	Inlet ... All O.H.V. Models	Nil
	All Side Valve Models004"
	Exhaust All O.H.V. Models	Nil
	All Side Valve Models006"
Ignition Advance (max.) ...	All Models, except 12, 9,	
	2 and 2A	7/16"
	Model 12	5/16"
	Models 9, 2 and 2A	1/4"
Sparkling Plug (Lodge) ...	All Models, except 9, 2,	
	2A	H53
	Models 9, 2, 2A	C14
Sparkling Plug Gap	All Models, from .018" to	.020"

Size of Main Jet	All 250 O.H.V. Models ...	120
	All 350 O.H.V. Models ...	150
	All 500 O.H.V. Models ...	180
	Model 9 (500 S.V.)	150
	Models 2, 2A (Big Twin)	130
Size of Choke	All 250 O.H.V. Models ...	5-058
	All 350 O.H.V. Model ...	6-058
	All 500 O.H.V. Models ...	29-068
	Model 9 (500 Side Valve)	6-057
	Models 2, 2A (Big Twin)	6-058
Size of Throttle Slide	All 250 O.H.V. Models ...	5x3
	All 350 O.H.V. Models ...	6x4
	All 500 O.H.V. Models ...	29x4
	Model 9 (500 Side Valve)	6x4
	Models 2, 2A (Big Twin)	6x4
Petrol Tank Capacity	All Models, except 22T, (In gallons) 26T and 18T	3
	Models 22T, 26T, 18T ...	2
Oil Tank Capacity (In pints)	All Models	5
Piston Ring Gap	All Models. Genuine A.J.S. piston rings are "fitted" before despatch from the factory and are ready for fitting to engine.	
Standard Compression Ratio	Model 12	6.33 to 1
	Models 12M, 22, 22T, 22SS	7.0 to 1
	All 350 O.H.V. Models	6.6 to 1
	Model 9	5.0 to 1
	All 500 O.H.V. Models	5.9 to 1
	Model 2 and 2A ...	5.4 to 1
High Compression Ratio ...	Models 12M, 22, 22T, 22SS	9.0 to 1
	All 350 O.H.V. Models	8.18 to 1
	All 500 O.H.V. Models	7.1 to 1
Ultra High Comp'n. Ratio	Models 12M, 22, 22T, 22SS	11.0 to 1
	All 350 O.H.V. Mods.	11.0 to 1

(165). **PROPRIETARY FITTINGS.**

No expense is spared to secure and fit the most suitable and highest quality instruments and accessories for the standard equipment of our machines. Nevertheless, our Guarantee does not cover such parts and, in the event of trouble being experienced the parts in question should be returned to, and claims made, direct on the actual manufacturers who will deal with them on the terms of their respective guarantees, as follows :—

Carburetters.	Messrs. Amalgamated Carburetters, Ltd., Perry Barr, Birmingham.*
Chains.	The Renold and Coventry Chain Co., Ltd., Didsbury, Manchester.*
Electrical Equipment.	Messrs. Joseph Lucas, Ltd., Great King Street, Birmingham, 19.* Messrs. H. Miller and Co., Ltd., Aston Brook Street, Birmingham, 6.*
Gear Boxes.	Messrs. Burman and Sons, Ltd., Ryland Street, Birmingham.*
Horns.	Messrs. Joseph Lucas, Ltd., Great King Street, Birmingham, 19.* Messrs. Clear Hooters, Ltd., 79-81, Lombard Street, Birmingham, 12.*
Saddles.	Messrs. Lycetts and Motor Accessories Co., Ltd., Western Works, Arthur Street, Small Heath, Birmingham, 10. Messrs. Herbert Terry and Sons, Ltd., Redditch. Messrs. Dunlop Rubber Co., Ltd., Fort Dunlop, Birmingham.
Sparking Plugs.	Messrs. Lodge Plugs, Ltd., Rugby.*
Speedometers.	Messrs. S. Smith and Sons (M.A.), Ltd., Cricklewood, London.*
Tyres.	Messrs. Dunlop Rubber Co., Ltd., Fort Dunlop, Birmingham.* Messrs. Firestone Tyre and Rubber Co., Ltd., Great West Road, Brentford, Middlesex.*
Watches.	Messrs. S. Smith and Sons (M.A.), Ltd., Cricklewood, London.*

*These manufacturers issue instructive literature regarding their products which are fitted to "A.J.S." Motor Cycles,