



motorcycles

A division of NORTON VILLIERS LIMITED

STORMER

Y SERIES

RIDERS MANUAL





250 cc

(15 cu. in.)

370 cc

(22 cu. in.)

INTRODUCTION

In compiling this handbook, no attempt has been made to be over comprehensive. All operations are described in a straightforward manner and assume that you, as the owner or rider, have already a sound knowledge of motorcycles. You will find the Stormer unit both robust and easy to work on. The power units provide plenty of horsepower with a sensible torque curve to produce maximum flexibility. The clutch is an all metal unit to withstand considerable abuse.

The cycle parts are designed for cross-country use exclusively and your AJS STORMER has such features as

completely sealed steering head, wheel and swinging arm pivot bearings. The telescopic forks are specially sealed and forged alloy fork yokes provide tremendous strength with extreme lightness. The frame is based on a large top tube to resist stresses, strains and violent twisting motions, whilst twin downtubes are added purely to form a motor and gearbox cradle.

We have drawn on the practical experience of our works riders and Competition Department in preparing this handbook. This is the start of our association and we want you to enjoy your ownership of an AJS.

INDEX OF CONTENTS

| | |
|---|------|
| Air Filter | 18 |
| Alternative Sprockets | 12 |
| Before You Start | 10 |
| Breaking In | 10 |
| Carburetor | 17 |
| Clutch | 15 |
| Data 250 Stormer | 6, 7 |
| Data 370 Stormer | 8, 9 |
| First Aid Kit | 19 |
| Ignition System | 16 |
| Ignition Timing | 16 |
| Lubrication | 10 |
| Motor/Gearbox/Clutch Unit Removal | 13 |
| Pre Meeting Check List | 11 |
| Rear Chain Adjustment | 14 |
| Reboring | 18 |
| Sprockets — Alternatives | 12 |
| Stand — How to Make Up | 13 |
| Setting Up Your Stormer Kit | 3 |
| Servicing Notes | 18 |
| Suspension Units | 17 |
| Tools You Need for Stormer | 12 |
| Tire Pressures | 17 |
| Warming Up | 11 |
| Wheel — Front | 14 |
| Wheel — Rear | 14 |
| Wheel Bearings | 15 |

SETTING UP YOUR STORMER KIT

For the purposes of this instruction
Left Hand side is the clutch side of the
machine.

1. Find a suitable box or stand on which to rest the main body of the machine—this needs to be 18" high so both wheels can be fitted.
2. Unwrap the main body (KIT A) and KIT B and check off the contents to following list.
Handlebar, grips, twistgrip, clutch and front brake levers. Front brake cable.
Front mudguard (fender) with support.
Rear guard (fender) with front fixings.
Fork legs, torque arm bolt and cable stop.
Front axle with nut and washer.
Footpegs complete.
Rear Chain.
Front number plate and hardware.
Rear Brake Pedal and rod with hardware.
Rear Wheel with tire and tube, brake, torque arm and bolt.
Front Wheel with tire and tube, brake, torque arm and bolt.
Gearshift lever.
Notify any shortages to the supplier.
3. Tires are fitted on one bead only except for the USA market. On these machines fit the second beads to the rims, taking care when fitting the security bolts so that the tubes are not nipped. Finally, inflate the tires (see page 17 for pressures).
4. To aid assembly, remove the finger tight bolts holding torque arms to each wheel and lift the torque arms clear.
5. Rest the main body of the machine on a box at the crankcase skid plate.
6. Take the rear fender blade (the wider one). The front end bolt and nut should be taken out of the triangular front bracket. Refit the bolt with the head below the guard. Remove the R.H. side number plate (2 nuts only) to give access for the rear fender forward bolt nut which is located behind the ignition coil. Refit the number plate.
7. Take the longer axle (this is the rear axle) and run the one locknut onto the threads until two threads are exposed. If the brake assembly is removed from the brake drum, the sealing 'piston' ring will need pressing home carefully with a screwdriver blade if the brake assembly is to be refitted without breaking the ring. Remove the sleeve, large and small washers and other nut and smear the axle with oil. Offer the complete wheel to the swinging fork with the sprocket to the left side. Place the spacer between axle and the R.H. end of the hub. Offer the axle to the swinging fork, fit the washer over the axle and tap the spindle home. The washer fits between the anchor plate and the swinging arm. Place the other washer and nut loosely on the axle. Secure the chain guide and torque arm (chain guide loop inboard) with the front end of the arm inside swinging arm lug. Secure the bolts at both ends. Lock up the axle nuts.

8. Remove the bolts, large and small washer and two anti-shock rubbers from each fender lug on the rear frame loop. Lift the tail of the rear fender, centralise it to the tyre and, whilst supporting the blade, drill through the blade in line with the lugs with an oversize 4" drill. (The rear fender lugs may need re-positioning slightly before drilling) Assemble the fender bolts, with the bolt heads beneath the blade. The order of assembly is: bolt head, large steel washer, rubber, blade, rubber, frame loop lug, plain washer and nut.
9. Take the footpegs: remove the loose clamping nut and bolt completely from each. Offer the footpegs to the splines to give a suitable riding position then lock up the clamp bolts on both footrests.
10. Take the rear brake pedal, pull out the split pin and screw in the stop bolt a little. Grease the pivot spindle. Place the large washer on the shaft inside the frame and fit the split pin, opening this out.
11. Take the rear brake rod and remove the clip and clevis pin. Remove the knurled knob, trunnion and spring, leaving the nut in situ. Place the trunnion through the brake cam lever, the trunnion counterbore towards the rear. Place the spring over the brake rod. Pass the threaded end of the rod through the trunnion and fit the knurled nut loosely. Offer the forked end of the brake rod over the brake pedal arm, insert the clevis pin and secure from behind with the spring clip. Fit one end of the pedal return spring into the eyelet of the brake rod and one into the hole in the swinging arm torque stay lug.
12. Offer the rear chain over the countershaft (gearbox) sprocket, join the ends of the chain over the rear wheel sprocket and fit the split link. Fit the spring link with the closed end forwards over the sprocket.
13. Adjust the rear chain by slackening off the locknuts at the swinging arm pivot side plate slots. Slacken the main pivot bolt at the right hand end. Place a spanner over the L.H. captive nut and turn clockwise to increase free play on the chain and vice versa. Aim for ¾" UP and DOWN movement on a **new** chain. Tighten the small locking nuts but do not overtighten. Now lock up the main spindle nut. Adjust the rear brake to suit.
14. Ensure that the chain runs centrally in the chain guide and reposition the guide if necessary.
15. Assemble the gear shift lever— position this on the splines to suit.
16. Fit the front fender blade, long end forwards. The fender bracket bolts thread directly into the fork bottom yoke. Lock up the bottom yoke pinch bolt at the stem—the fender will require setting when assembly is complete.
17. Take the fork leg with the cable stop—this is the R.H. leg. Pass up through the middle lug with a twisting motion, entering the main fork tube into the top yoke. Replace the cap nut and large washer loose assembled.
18. Repeat the operation for the L.H. leg.

19. To fit the front wheel, first ensure that the torque arm is fitted correctly. It should be assembled with the angled portion and two holes in such a position that it aligns with the fork leg bolt holes. Lubricate the front axle. If the brake assembly is removed from the brake drum, the sealing 'piston' ring will need pressing home carefully with a screwdriver blade if the brake assembly is to be refitted without breaking the ring. Enter the threaded end of the axle through the left hand fork leg and tap it through to locate in the right hand leg. Fit the large torque arm by the two bolts and the axle nut loosely. Attach the self-locking nuts to the lug on the fork leg, nuts on the inside. The fork legs must now be aligned on the axle by grasping the front wheel and pulling upwards to compress the fork legs. The legs will now be aligned on the axle. Now tighten securely the large axle nut and lock up the four axle clamping bolts. Add the recommended quantity and grade of oil to each fork leg. Tighten securely (do not overtighten) the stem nut and the stem pinch bolt. Fit and tighten securely the leg cap nuts and tighten securely the top and middle lug pinch bolts (4 off).
20. Take off the top handlebar clamps and place the handlebar in position with the serrated portions laying on the clamps. Fit the top clamps and secure with the handlebar at the desired height using the socket headed screws.
21. Offer up the front number plate and secure with the two bolts supplied (large washers under the bolt heads fitted from the front). Tighten up the number plate bracket bolts (these also retain the handlebar clamps) taking care not to distort the number plate.
22. Fit the front brake and clutch levers to the bar, the cable slot below the lever in each case. To fit the clutch cable to the handlebar lever first slacken off all adjustment and then slide the nipple home. Allow 1/8" minimum free play at the handlebar lever. Fit the clutch cable rubber clips on the left down tube. Fit the front brake cable adjuster into the abutment on the fork leg with the adjuster nut beneath the abutment. Fit the nipple at the handlebar lever first. Now connect the stirrup and clevis at the brake operating lever. Secure with the clevis pin, the split pin inboard.
23. Fit the throttle cable to the twist-grip and assemble the grip to the bar with the cable leaving from the top of the twistgrip body.
24. Finally, fill the gearbox and primary cases with the correct grade and quantity of oils, add fuel and the machine is completed and ready for use.

DATA 250 STORMER

MOTOR

Type: Single cylinder two stroke; light alloy cylinder with centrifugally cast iron liner; gravity die-cast light alloy piston with two cast-iron piston rings.

Bore x Stroke 68 x 68 mm
 Compression ratio 11:1
 ignition timing 2.5 mm before Top Dead Centre
 (or 20/22 degrees of crankshaft advance)

SPARK PLUG Champion N3

CARBURETOR Amal Concentric type 932

Bore 32 mm
 Main jet 280
 Needle jet 107
 Throttle valve 3
 Pilot jet 20
 Needle middle position

TRANSMISSION SPROCKETS

Engine shaft 20T
 Clutch 43T
 Gearbox (Countershaft) 13T
 Rear wheel (Y4) 61T
 Rear wheel (Y40) 57T

PRIMARY CHAIN $\frac{3}{8}$ " x $\frac{1}{2}$ " duplex

FINAL DRIVE CHAIN $\frac{5}{8}$ " x $\frac{1}{4}$ "

GEARBOX INTERNAL RATIOS (Y4)

Bottom 2.00 Third 1.25
 Second 1.51 Third 1.25

GEARBOX INTERNAL RATIOS (Y40)

Bottom 2.52 Third 1.26
 Second 1.66 Top 1

CLUTCH All-metal, 5 plates with diaphragm spring

SUSPENSION

Front Telescopic fork (7" travel) with hydraulic damping
Rear Pivoted fork (3¼" travel) with Girling spring damper units (75 lb)

WHEELS AND BRAKES

Front tire 2.75 x 21"
Rear tire 4.00 x 18"
Spokes 10 SWG. 40 per wheel
Brakes 5" diameter

CAPACITIES

Fuel tank 2 Imp. gallons/2.4 US gallons/9 litres
Gearbox 1 Imp. pint/20 fluid oz/0.57 litre R40
Primary chaincase 5 fl. oz./125cc (SAE5 or 10)
Front fork 7½ fl. oz./210 cc each leg (SAE30)

DIMENSIONS

Wheelbase 55½"/ 143.3cm Ground clearance 9"/23 cm
Seat height 31"/ 79cm

USE 100 OCTANE (PREMIUM GAS) FUEL MIXED IN 20 : 1 RATIO WITH R40

MODEL VARIANTS

Y4 (U.K. and Europe) 250 c.c. fitted Close Ratio gearbox, Paper type Air Cleaner Element and supplied with TV suppressor (loose).
Y40 (U.S.A.) 250 c.c. fitted Wide Ratio Gearbox and Filtron Air Cleaner.

Norton Villiers reserves the right to vary the specification of all motorcycles and spare parts without notice and this information does not therefore constitute a term of any sale. All descriptions and claims are made in good faith but are intended to apply generally and variations in performance and construction of individual machines may occur. In particular, performance will be affected by the conditions, circumstances and the rider.

DATA 370 STORMER

MOTOR

Type: Single cylinder two stroke; light alloy cylinder with centrifugally cast iron liner; gravity die-cast light alloy piston with two cast-iron piston rings.

| | |
|-------------------|---|
| Bore x Stroke | 83 x 68 mm |
| Compression ratio | 10.5 : 1 |
| Ignition timing | 2.5 mm before Top Dead Centre (or 20/22 degrees of crankshaft advance) |

| | |
|-------------------|-------------|
| SPARK PLUG | Champion N3 |
|-------------------|-------------|

| | |
|-------------------|---------------------------|
| CARBURETOR | Amal Concentric type 1034 |
| Bore | 34 mm |
| Main jet | 360 |
| Needle jet | 107 |
| Throttle valve | 2½ |
| Pilot jet | 25 |
| Needle | middle position |

TRANSMISSION SPROCKETS

| | |
|------------------------|-----|
| Engine shaft | 24T |
| Clutch | 40T |
| Gearbox (Countershaft) | 12T |
| Rear Wheel (Y5) | 65T |
| Rear wheel (Y50) | 61T |

| | |
|----------------------|----------------|
| PRIMARY CHAIN | ⅝" x ½" duplex |
|----------------------|----------------|

| | |
|--------------------------|---------|
| FINAL DRIVE CHAIN | ⅝" x ¼" |
|--------------------------|---------|

GEARBOX INTERNAL RATIOS

| | | | |
|--------|------|-------|------|
| Bottom | 2.52 | Third | 1.25 |
| Second | 1.66 | Top | 1 |

| | |
|---------------|---|
| CLUTCH | All-metal, 5 plates with diaphragm spring |
|---------------|---|

SUSPENSION

Front Telescopic fork (7" travel) with hydraulic damping
Rear Pivoted fork (3¼" travel) with Girling spring damper units (110 lb)

WHEELS AND BRAKES

Front tire 2.75 x 21"
Rear tire 4.00 x 18"
Spokes 9 SWG. 40 per wheel
Brakes 5" diameter

CAPACITIES

Fuel tank 2 Imp. gallons/2.4 US gallons/9 litres
Gearbox 1 Imp. pint/20 fluid oz/0.57 litre R40
Primary chaincase 5 fl. oz./125cc (SAE5 or 10)
Front fork 7½ fl. oz./210cc each leg (SAE30)

DIMENSIONS

Wheelbase 55½"/143.3cm Ground clearance 9"/23cm
Seat height 31"/79cm

USE 100 OCTANE (PREMIUM GAS) FUEL MIXED IN 20 : 1 RATIO WITH R40

MODEL VARIANTS

Y5 (UK and Europe) 370 c.c. fitted Wide Ratio Gearbox, Paper type Air Cleaner Element and supplied with TV suppressor (loose).
Y50 (U.S.A.) 370 c.c. fitted Wide Ratio Gearbox and Filtron Air Cleaner.

Norton Villiers reserves the right to vary the specification of all motorcycles and spare parts without notice and this information does not therefore constitute a term of any sale. All descriptions and claims are made in good faith but are intended to apply generally and variations in performance and construction of individual machines may occur. In particular, performance will be affected by the conditions, circumstances and the rider.

BEFORE YOU START

Nobody can design a motorcycle which will fit everyone straight away. So the first step is to make sure you are comfortable by altering the position of the handlebar and control levers to suit your own particular riding style. There is a limited degree of adjustment of footpeg and gearshift pedal position, and a stop screw is provided so that brake pedal angle can be modified.

WARNING. The glass fibre fuel tank will disintegrate if filled with a dope fuel such as methanol.

LUBRICATION

Check that the gearbox and chaincase are properly filled with oil and that the correct petrol mixture is in the fuel tank. The motor operates on a 20 to 1 petrol (gasoline) oil mixture. Use premium petrol (gasoline) or not less than 98 octane (4 Star) rating. We recommend a castor-base oil of SAE40 viscosity, such as Castrol R40. Modern castor base oils mix with petrol (gasoline) quite readily, but it is best to mix the oil and petrol (gasoline) thoroughly in a clean can before putting it into the fuel tank.

NEVER MIX CASTOR BASE AND MINERAL OILS

GEARBOX

Here you can use Castrol R40, as in the motor (you'll probably find it more convenient to buy one lot of oil for both purposes) or Castrol Hypoy 90 mineral oil. But having made your choice stick to it.

PRIMARY CHAINCASE

Use a mineral oil.

Raise the front wheel when draining the chaincase or gearbox. Refill the chaincase with a quarter pint of oil (5 fluid oz US or 125 cc) (SAE 5 or 10). As a security measure, it is a good idea to wire the chaincase and gearbox drain plugs in place.

FRONT FORK

We find straight SAE30 mineral oil is quite satisfactory in most conditions. The capacity of each fork leg is 1/3 pint (210 cc or 7½ US fluid oz). Overfilling the fork could cause the oil seals to leak, so take care.

Drain plugs are located at the lower rear of each leg. Drain each leg in turn, by removing the drain plug and the fork cap nut, then pumping the fork up and down to extract the last dribble of oil. Refill and replace the fork cap nut before tackling the other leg.

RUNNING IN

Obviously a cross country or competition rider can't be expected to honour the traditional "30 mph for the first 500 miles" rule. Every AJS engine is given a thorough bench test at the factory, but it will still need a little time to settle down.

Go gently during the first few outings and, if entering racing events, make use of whatever practice time may be available. Utilize the gearbox sensibly to keep the loading as light as possible, don't let the engine slog, and avoid very high rpm.

Nuts and bolts, too, settle down after a while. Run your spanners over the whole machine after each ride to check that everything is as tight as it should be.

WARMING UP

A two stroke motor may suffer broken piston rings or some other disaster if screamed away from starting stone-cold. On the other hand, any air cooled motor will overheat if it is kept standing with the motor running for an unnecessary length of time.

WARMING UP FOR RACING

Our own riders have found that it pays to start the motor about ten minutes before race time, then blip the throttle steadily (allowing engine revs to drop almost to tickover between blips of 4,000 to 5,000 rpm) until the motor is nicely warm. The motor is then stopped and fuel turned off until it is time to leave the paddock for the start line. Always try to start the machine with the fuel tap turned off, turning the supply on when the motor has started. This minimises the risk of flooding or oiling the spark plug.

FOR MOTOCROSS RIDERS ONLY PRE-MEETING CHECK LIST

1. Before leaving for the meeting

Check tightness of all accessible nuts and bolts. Check wheelrims for truth, spokes for correct tension, state of tires and chains.

Check that all controls operate smoothly, and that the front and rear suspension is in first class order.

Check that you have everything which may be needed at the track; tools, sufficient fuel and oil, competition licence (if applicable), all necessary forms and passes, can of water, wash basin, towel and soap.

2. After practice and between races

If time permits, clean machine as much as possible, check spokes (particularly if it is a hard or rocky course), chain adjustments, tyre pressures. (See Tyre Pressures, page 17.)

Wipe over the competition numbers before leaving the paddock; this helps the lap scorers to identify you and so credit you with your rightful position in the race.

3. After the meeting

As soon as possible, use a hose or a bucket of warm water laced with detergent to get the machine thoroughly clean. Caked mud comes away more easily when it is damp, rather than when it has been left to dry on the machine.

REMOVE, INSPECT AND IF NECESSARY RENEW THE AIR FILTER ELEMENT.

Check controls and lubricate as necessary. Take off rear chain, brush clean in a bath of petrol (gasoline). Oil or grease thoroughly before refitting.

4. After 5 or 6 meetings

Drain and refill gearbox and chaincase. Detach rear damper units and check the damper rods as described under "Rear Suspension Units", page 17 (particularly necessary if the machine has been dropped heavily or has been in a collision). Check brake shoes and drums. Clear out any dust from inside brake drums. Extract and lightly grease brake cam spindles.

5. After about 15 meetings

Remove cylinder barrel and head, inspect piston rings and renew as necessary.

Check for play in big end and small end bearings.

Mainshaft oil seal behind contact breaker assembly may be due for change (see Maintenance and Adjustments).

6. At end of season

Start overhaul of machine for next season. You may think "Plenty of time for that"—yet every year, the first race on the calendar catches many riders with their work programme only half done. Make a list of any parts to be renewed, and get in touch with your AJS agent as soon as you can.

ALTERNATIVE SPROCKETS

(Standard sprockets shown in data pages)

| GEARBOX | (Countershaft) | REAR | WHEEL |
|---------|----------------|------|---------|
| 12T | 0710044 | 57T | 0700375 |
| 13T | 0710023 | 61T | 0700395 |
| | | 65T | 0700371 |
| | | 66T | 0700277 |

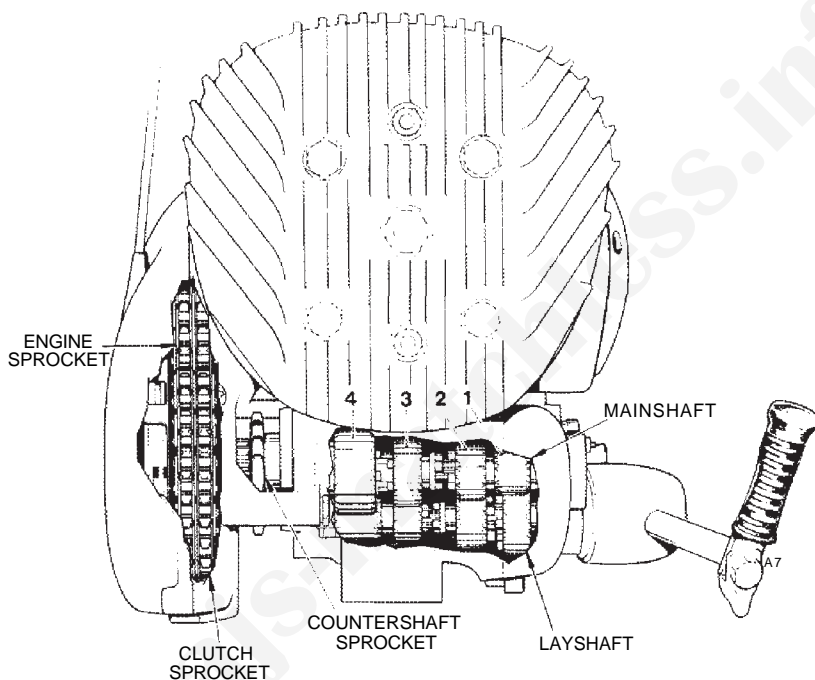

TOOLS YOU NEED TO SERVICE THE STORMER

For normal paddock work, the following handtools should suffice:—

| | | |
|--------------------|---------------------------|----------------------|
| 1/2" A/F Spanner | 2BA Spanner | Medium Screwdriver |
| 9/16" A/F Spanner | 1/4" x 3/16" Whit Spanner | Phillips Screwdriver |
| 3/4" A/F Spanner | 7/32" Allen Key | Pliers |
| 1 1/2" A/F Spanner | 3/16" Allen Key | |

For more major attention, the following additional items would prove helpful:—

| | |
|--|------------------------------------|
| 1 1/16" A/F Spanner (Flywheel) | 'C' Spanner (gearbox sprocket nut) |
| 1 3/16" A/F Spanner (Engine Sprocket Nuts) | Inside and outside circlip pliers. |

and SPECIAL SERVICING TOOLS:—

- 0710060 Engine sprocket puller.
- 0710061 Flywheel strap.
- 0710062 Clutch spring compressor.
- 0710069 Mainshaft circlip expander.

TO MAKE UP A WORKING STAND

You will find that working on the machine will be facilitated greatly by making up a stand of tubular steel, similar in design and dimensions to

that shown below. The bottom tubes of the frame below the gearbox will then rest on the stand.

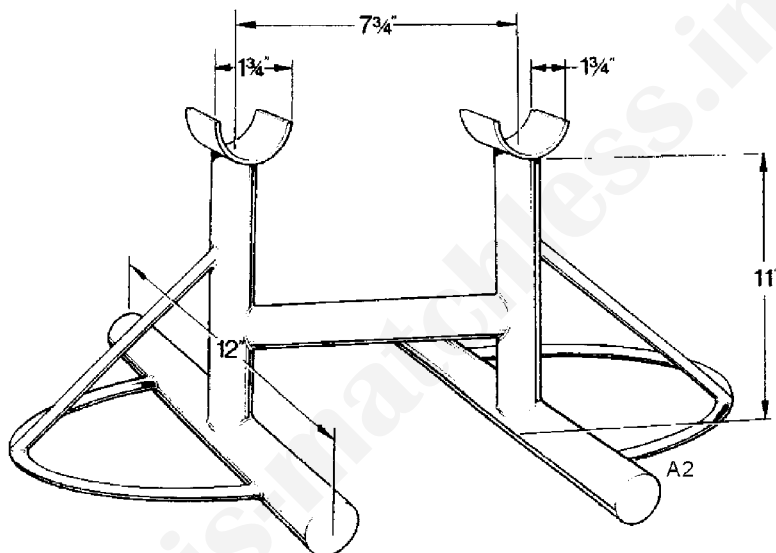

TO REMOVE THE MOTOR/GEARBOX/CLUTCH UNIT

Remove fuel tank. Drain the fuel in the pipe.

Remove righthand number plate. Undo rear exhaust pipe bracket and front bracket. Draw the pipe out forwards.

Take off the carburetor and induction pipe. Take care not to break gasket. Leave carb hanging but tucked away.

Push clean rag down inlet port. Disconnect clutch cable from handlebar

lever. Prise off both coil terminals. There are two cable retaining clips, one alongside the coil and the second on the rear engine shield. Remove these. Remove rear chain. Remove the 3 engine bolts in the following sequence: bottom, front, rear.

Hold the clutch side locknuts and undo the timing side nuts on the bottom and front engine bolts but remove both nuts on the rear bolt, knocking out the stud from clutch side. Pull out the motor/gearbox/clutch unit.

TO REMOVE FRONT WHEEL

To remove: Disconnect the cable and brake torque arm. Detach the axle nut, slacken the four fork end clamp socket screws, insert a short tommy bar through the drilling at the left end of the axle and pull the axle out.

Before refitting the wheel, wipe the axle clean and grease lightly. Push in spindle, fit and tighten the spindle nut. Leave the four socket screws slack at this stage, apply front brake and pump the forks up and down a few times: this centralises the brake shoes and permits the fork ends to align themselves on the axle.

Finally, tighten the fork end socket screws, refit cables and torque arm.

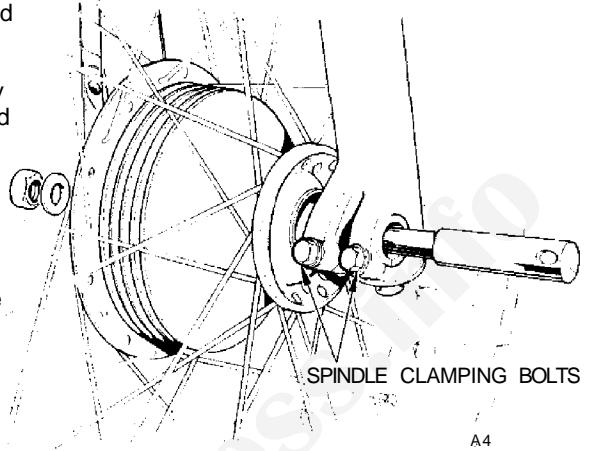

Front Wheel removal

TO REMOVE REAR WHEEL

REAR WHEEL

The axle is a knock-out type
To remove: Disconnect rear chain, detach brake anchor arm from the fork arm, remove brake rod adjuster nut.

and there is only need to detach one of the axle nuts.

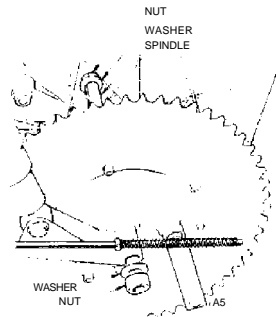

Rear Wheel removal

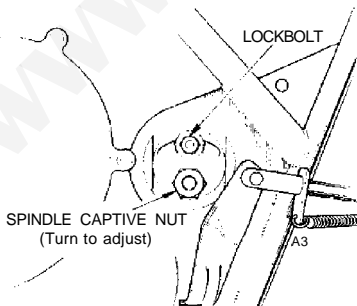

Rear Chain adjustment

REAR CHAIN ADJUSTMENT

This is made at the rear fork pivot and therefore the rear wheel stays in alignment at all times. Slacken the two smaller self-locking nuts. Slacken the right hand pivot spindle nut. By applying a spanner to the left hand (welded-on) pivot spindle nut, the entire fork can be moved fore or aft as required.

WHEEL BEARING RENEWAL

These are sealed and should not require attention. When worn wheel bearings are to be replaced, take note that the right hand bearing of each wheel is located by a circlip at both sides; no circlip is used at the left hand bearing.

Remove the outer right hand circlip and tap out the bearing with the aid

of a drift from inside the hub. The inner circlip can be left undisturbed. Extract the spacer tube then tap out the left hand bearing. insert the new right hand bearing until it abuts to the inner circlip, then fit the outer circlip. Fit the spacer tube, then tap in the new left hand bearing until it is hard against the tube.

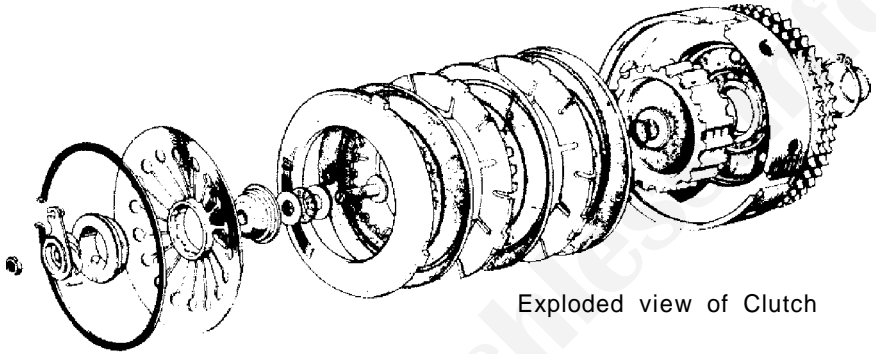

Exploded view of Clutch

CLUTCH

The all-metal clutch of the AJS should last the lifetime of the machine if kept in correct adjustment. First essential is that there should be $\frac{1}{8}$ "— $\frac{3}{16}$ " (3.2—4.7mm) free movement at the clutch operating lever, access to which is gained by removing the cover plate on the outside of the primary chaincase.

Disconnect the cable from the handlebar lever, check for operating lever clearance, and correct as necessary by slackening the lock nut and moving the adjusting screw in or out. Reconnect the cable to the handlebar lever and use the cable adjuster to obtain $\frac{1}{8}$ " (3.2mm) clearance at the handlebar.

Before the clutch can be dismantled, a special tool (Part No. 0710062) is necessary to release diaphragm spring tension.

DO NOT ATTEMPT TO DISMANTLE THE CLUTCH WITHOUT THIS SPECIAL TOOL OR SERIOUS PERSONAL INJURY COULD RESULT

Serious clutch drag is unlikely, but if it does occur, check for buckled clutch plates. Clutch slip is equally unlikely if the clearances at the handlebar and operating levers are correct; if slip is present, strip the clutch, wash the plates in petrol and check that they move freely on the inner and outer splines of the clutch centre, then refill the chaincase with clean oil. If it still persists, a new spring may be the answer.

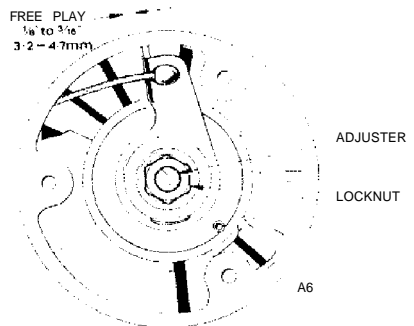

Clutch adjustment

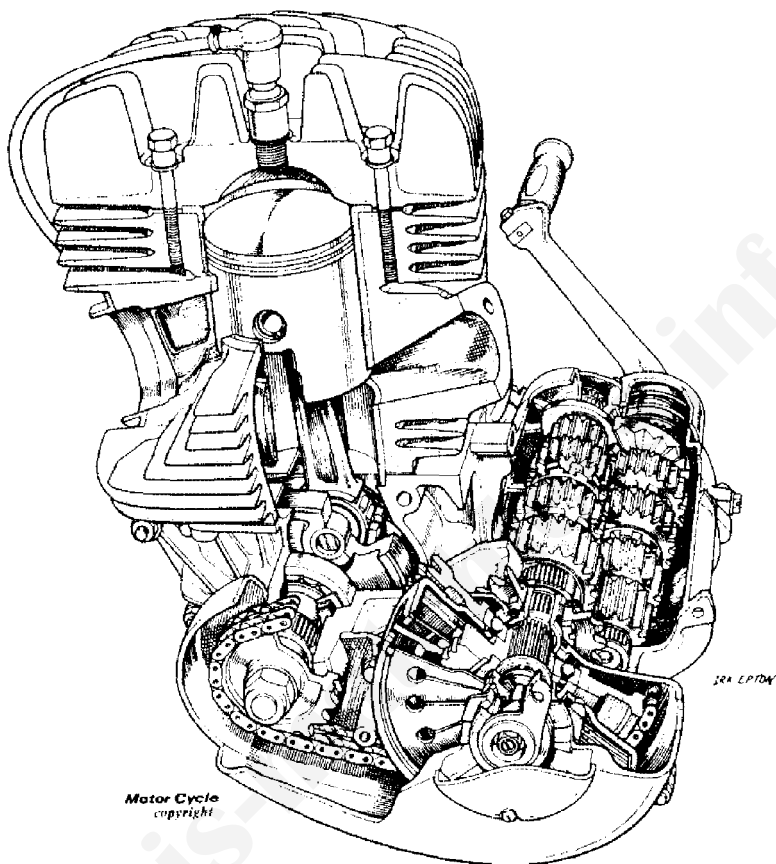

Motor Cycle
copyright

Stormer Motor

IGNITION SYSTEM

The AJS motor employs energy transfer type ignition, comprising a flywheel generator and remote ignition coil.

Access to the contact breaker assembly is obtained by removing the three screws which hold the cover plate on the right of the engine. To adjust the points gap (0.015 to 0.018") (.38 to .46mm) slacken the single screw which secures the moveable arm and adjust as necessary.

IGNITION TIMING

Remove the cylinder head. Attach a dial gauge to a cylinder stud so that the leg of the gauge rests on the piston crown. Turn the motor slowly until TDC is found, then reset the gauge position so that zero is shown at this point. Rotate the engine shaft backwards until the dial gauge shows a reading of 0.090 to 0.110" (2.29/2.79mm), The points should now be separating. If they are not, reset by slackening the three crosshead

screws holding the contact breaker backplate and rotating the backplate as required. Tighten the three screws. Separation of points can be checked easily by inserting a cigarette paper between the points and tugging gently; the paper will come free as the points start to open. Alternatively (and we would recommend this method), a battery and bulb can be connected across the points. The bulb will light when the points are closed, and extinguish as they open.

CARBURETOR

Principal factor in obtaining correct carburation is the main jet, and correct jetting can only be established at the fastest part of the course, not in the pits.

It is unlikely that anything smaller than a 270, or bigger than a 320 main jet will be required. A demand for anything outside those limits could point to trouble elsewhere—perhaps a choked airfilter element or worn oil seals.

Plug condition is the barometer of carburation. A dry, brown deposit on the centre electrode insulator indicates a weak mixture. A heavy, oily black deposit means over-richness. For safety, it is best to jet slightly on the black side.

The only other jet which may need attention is the pilot. Check this by starting the motor and blipping to about one-quarter throttle meanwhile letting the revs drop almost to zero. When the motor has warmed to working temperature adjust the pilot jet screw in or out, a little at a time, and listen to the reaction. If the screw is too far in, the motor will four-stroke before it picks up. If it is too far out, a hesitation will be noticed.

THROTTLE CABLE

If you have fitted a new throttle cable, check **before starting the engine** that there is about $\frac{1}{32}$ " (.81mm) free play in the cable, and that the twistgrip snaps shut when the hand is taken away. Listen for the click as the throttle slide hits bottom.

HANDLEBAR

If the bar is to be removed from the machine completely, leave the clamp screws in place and undo the two set screws which will be found beneath the fork crown under each clamp bracket.

REAR SUSPENSION UNITS

To check for damper rod truth, remove each suspension unit from the machine in turn. Grip the lower eye of the unit in a vice, hold the upper spring cap firmly and give a downward jerk; this should free the two collets holding the spring cap in place (you may need help to extract these), and so allow the spring to be removed. Spin the damper rod and check that it revolves truly and easily. If it has been bent, the unit will not operate correctly and a new assembly will be required.

TYRE PRESSURES

The following table is a guide to correct tyre pressures in various kinds of going.

Of course, much depends upon the exact conditions on each ride and the riders' weight. Use the recommendations **ONLY** as a rough guide.

Dry, Hard Conditions

15lb per sq. in. (1.1kg) Front & rear

Medium Hard or Sandy Conditions

12lb per sq. in. (.84kg) Front & rear

Soft or Slippery Conditions

10lb per sq. in. (.70kg) Front & rear

Very Muddy Conditions

8lb per sq. in. (.56kg) Front & rear

AIR FILTER

This is mounted within the frame structure and access is made by removing the left hand number plate. The filter has a paper element which must NOT be washed. The only safe way to clean it temporarily is to blow it clear with an air line from the **inside** surface. When refitting the element,

smear the locating spigot face liberally with grease so that it makes an airtight joint against the element. Paint the entire inner surface of the airlifter box with grease—this will attract most of the dust and mud and prevent the filter element from clogging.

REBORING

It is recommended that this work be carried out by an AJS agent. Oversize pistons and rings of $+0.010"/0.020"/0.030"$ and $0.040"$ are available. As

the tolerances of these rebored cylinders are critical ($\pm 0.002"$) a full breaking-in session is required on fitting the new parts.

SERVICE NOTES

Although this publication does not aim to give a step by step strip and re-build sequence, the following random notes will save time in stripping assemblies unnecessarily.

- (a) To change the barrel and piston merely remove the expansion chamber completely and there is room to remove the top end without disturbing the fuel tank or dropping the motor in the frame.
- (b) To remove the carburetor: this will be found easiest if the carburetor complete with manifold is detached at the cylinder barrel.
- (c) To gain access to the crankshaft, remove the motor and gearbox assembly from the frame. Dis-

mantle the primary drive and covers, detach the gearbox complete from the back of the crankcase and keep the gearbox gaskets safely for re-use. Remove the C.B. point cover, detach the black/white lead from the C.B. points and lift away the outer cover with the C.B. points still assembled. After taking off the contact breaker cam circlip, slide the cam clear and remove the key—this is essential. Use the fly-wheel strap 0710061 to prevent movement whilst the self extracting nut is used. Remove the inner cover with stator attached. As the crankcases are parted the crankshaft will lift out complete with main bearing inner races.

PARTS LIST

A fully illustrated parts catalogue is available through AJS stockists and we recommend that this publication

as being of considerable help both in ordering replacement parts and as a quick reference during overhauls.

FIRST AID KIT

A first aid kit of parts is available, one for 250 c.c. models and one for 370 c.c. models. The kit comprises the following parts:

| | | |
|---------|---|---|
| 0700132 | Throttle cable | 1 |
| 0700134 | Clutch cable | 1 |
| 0700124 | Front brake cable | 1 |
| 0710001 | Spark plug (N3 or N190) | 1 |
| 0700365 | Rear chain split link | 1 |
| 86-9517 | Set of contact breaker points | 1 |

| | | |
|---------|---------------------------------------|---|
| 0710067 | Feeler gauges .015 and 0.18 | 1 |
| 0710057 | Timing tool | 1 |

Also:

| | |
|-------------------------------------|---|
| either 250 c.c. Piston ring (40976) | 2 |
| or 370 c.c. Piston ring (0710015) | 2 |

The purchase of the relative kit is strongly recommended to all owners. The part number of the 250 c.c. kit is 071006 and of the 370 c.c. kit is 0710066.

SPARE PARTS

We supply spare parts from the factory direct only to appointed AJS spares stockists. Any parts you require should be ordered from your AJS

stockist. Any part not held in stock will be obtained quickly by the stockist from the factory, or overseas from the main distributor.

SPECIAL NOTE

Riders are asked to note that, whilst every reasonable care is taken in the manufacture of these models, as cross country and competition use imposes unusually severe stresses and strains, we offer no warranty of any sort. Naturally, if within the very early life

of one of these models, a failure occurs and the factory (or the main distributor overseas) considers that a definite manufacturing fault may have arisen, we would be prepared to examine the failed part and deal with it purely on its merits.

