

DAELIM

OWNER'S MANUAL

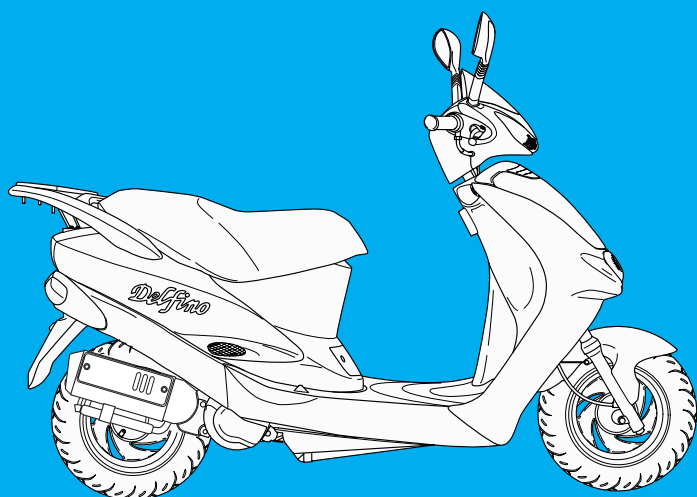

Delfino

CONTENTS

SPECIFICATION	3	Seat Lock	14
OPERATION INSTRUCTION	4	Front Under Cover	14
Safety Precautions	4	Trunk	15
Prior to Starting Vehicle	5	Document Storage Area	16
Correct Attire	5	Bag Holder	16
Operation	6	Brake Lock Lever	16
Cargo	6	Correct Driving Operation	17
Modification	7	Starting the Engine	18
Muffler	7	If Engine cannot be Started	20
Parts Location	8	After Starting Engine	20
Meter Reading and Usage	10	Proper Driving Methods	21
Meter	10	Stopping	23
Warning and Indicator Lamps	10	Self Inspections before Operation	24
Switch Operation	11	Inspection of Concerned Area	25
Main Switch	11	Brake Inspection	26
Starter Button	11	Tire Inspection	26
Headlight	12	Fuel Check	28
Winker Switch	12	Engine Oil Check	29
Horn Button	13	Lights and Winker Inspection	29
Equipment Usage	13	Back Mirror Inspection	29
Handle Bar Lock	13	Fuel Leak Inspection	29

License Plate Inspection	29
Regular Inspection	30
Regular Inspection Times	30
Simple Maintenance	32
Brake Lever Adjustment	32
Rear Brake Shoe Inspection	33
Replenishing Brake Fluid	33
Brake Hose, Pipe Leakage, Damage, Assembly State	34
Brake Pad Inspection	34
Replenishing Engine Oil	35
Transmission Oil Inspection	36
Wheel Removal	37
Bulb Replacement	38
Spark Plug	41
Battery Inspection	42
Changing Fuse	43
Air Cleaner Element Inspection	44
Inspection of Cable Rubber Part	45
Notables for Car Washing	45
Frame and Engine Number	46

SPECIFICATION

ITEM	DATA	ITEM	DATA
LENGTH × WIDTH × HEIGHT(mm)	1,810 × 720 × 1,130	IGNITION SYSTEM	C.D.I
WHEEL BASE(mm)	1,290	BATTERY CAPACITY	12V3AH(MF TYPE)
GROUND CLEARANCE(mm)	110	FUEL CAPACITY(l)	7.2
SEAT HEIGHT(mm)	760	OIL CAPACITY(l)	1.2
DRY WEIGHT(kgf)	85	TIRE SIZE	FR. 100 / 90 - 10 56J
PASSENGER	2		RR. 100 / 90 - 10 56J
ENGINE TYPE	AIR COOLED 2 STROKE	SUSPENSION	FR. TELESCOPIC
PISTON DISPLACEMENT(cc)	99.7		RR. UNIT SWING OIL DAMPER
BORE AND STROKE(mm)	50.6 × 49.6	BRAKE	FR. HYDRAULIC DISK
STARTING SYSTEM	START MOTOR / KICK		RR. DRUM BRAKE
TRANSMISSION TYPE	V - MATIC	SPARK PLUG	BR8HS
		FUSE(A)	7

OPERATION INSTRUCTION

This manual describes matters pertaining to correct operation, safe operation and simple maintenance of the vehicle you purchased.

To ensure more comfortable and safer operation, make sure to read this manual carefully prior to operation.

- The photographs and drawings shown in this manual may differ from those of actual vehicles due to changes in vehicle specifications and modifications made.
- This vehicle is designed for 2 riders including the operator.

Caution

- Do not use polluted gasoline.
Using polluted gasoline will cause rust inside the fuel tank, and will close the supply of fuel to the carburetor, leading to an improper engine starting or may cause serious damage to an engine.
- Do not use polluted or low-grade oil.
Always use genuine oil to protect and extend vehicle performance and its life span.
- If any failure occurs due to the use of polluted gasoline or oil, such failure will be excluded from being eligible for repairs under the warranty.

Safety Precautions

- Careful driving and the wearing of proper attire and safety equipment are the most important factors in the safe operation of the delfino scooter. Please obey traffic regulations and do not be hurried and careless.
- Many new vehicle owners operate their newly purchased vehicles with great care and attention to safety factors. However, after becoming accustomed to the operations are often discarded, which can lead to accidents. Please don't let this happen to you and always approach the operation of your vehicle with the safety considerations needed.
When operating the vehicle, always keep in mind and obey the notes of precaution printed on the "Safety Precaution Label" attached to the vehicle.

- Always wear helmet.
- Observe posted speed limits.
- Park vehicle away from people (especially children) as the muffler can get very hot.
- For safety, do not illegally modify the vehicle.
- If exposed to direct sunlight for a long period of time, the visual display panel may temporarily be fogged.
- Regularly conduct specified maintenance inspections.
<Maintenance Inspection Points>
Brakes, Tires, Oil, Lights, Horn, Instruments

Prior to starting vehicle

- Read user's manual carefully.
- Conduct maintenance checks prior to operation.
- Always maintain vehicle in clean status and carry out specified maintenance checks.
- Make sure to stop engine and stay away from fire when fueling.
- Exhaust gas contains harmful substance such as carbon monoxide. Start engine in well-ventilated places.

Correct Attire

- Always make sure to wear helmet for safety. Wear gloves and safety goggles.
- Do not wear uniforms which might hinder operation. It is dangerous if the uniform is caught by brake lever.

A helmet should always be worn and the helmet chin strap should be securely fastened.

Correct shirts or jackets with tight-fitting sleeves should be worn,

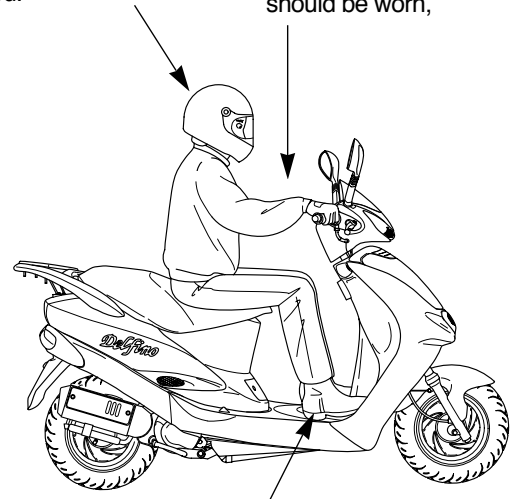

Shoes should fit properly, and shoes having little or no heel should be worn.

Operation

- Operators should naturally fix bodies to keep smooth driving.
- Please check whether or not you are unnaturally strained and strung up.
- Driving pose has a great influence on safe operation.
Please always maintain the center of your body in the middle of seat.
Especially do not sit at the rear seat because it may lessen the weight of front wheel and cause trembling steering wheel.
- Passengers should accurately fix bodies using both hands and put both feet on floor panel.

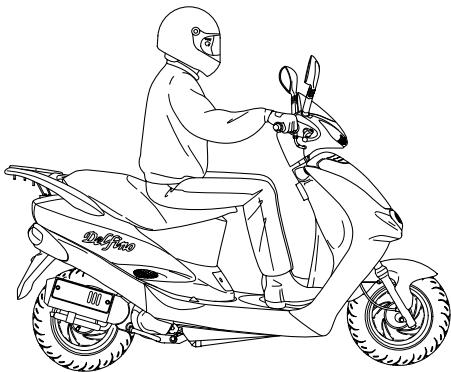

Cargo

When carrying cargo, you must keep in mind that operating the vehicle, especially when turning, will be different. Make sure not to overload the vehicle with goods as this can make the vehicle unstable during operation.

FRONT UNDER COVER
MAXIMUM LOAD : 1.5kg

REAR CARRIER MAXIMUM LOAD : 3kg

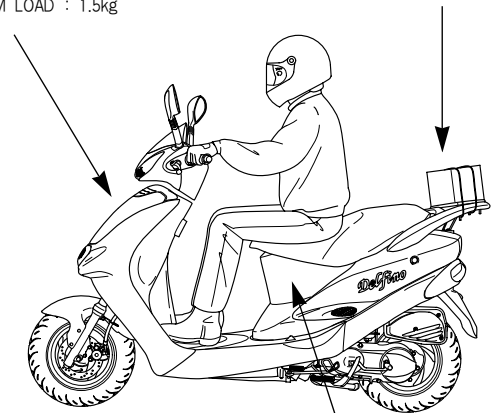

TRUNK MAXIMUM LOAD : 10kg

Caution

- Only load cargo in or on designated areas as placing or fastening cargo to other areas can cause damage to the vehicle.
- Do not place articles between the frame body cover and engine as this can burn the goods.

Modification

Modification of vehicle structure or function deteriorates manipulability or causes exhaust noise to become louder shortening the vehicle life. These modifications are not only prohibited by law but also are the acts harmful to other people. Modifications are not covered by warranty.

Muffler

- Pay particular attention to fellow passenger so that he/she can prevent getting burnt by the hot muffler during travel.

Parts Location

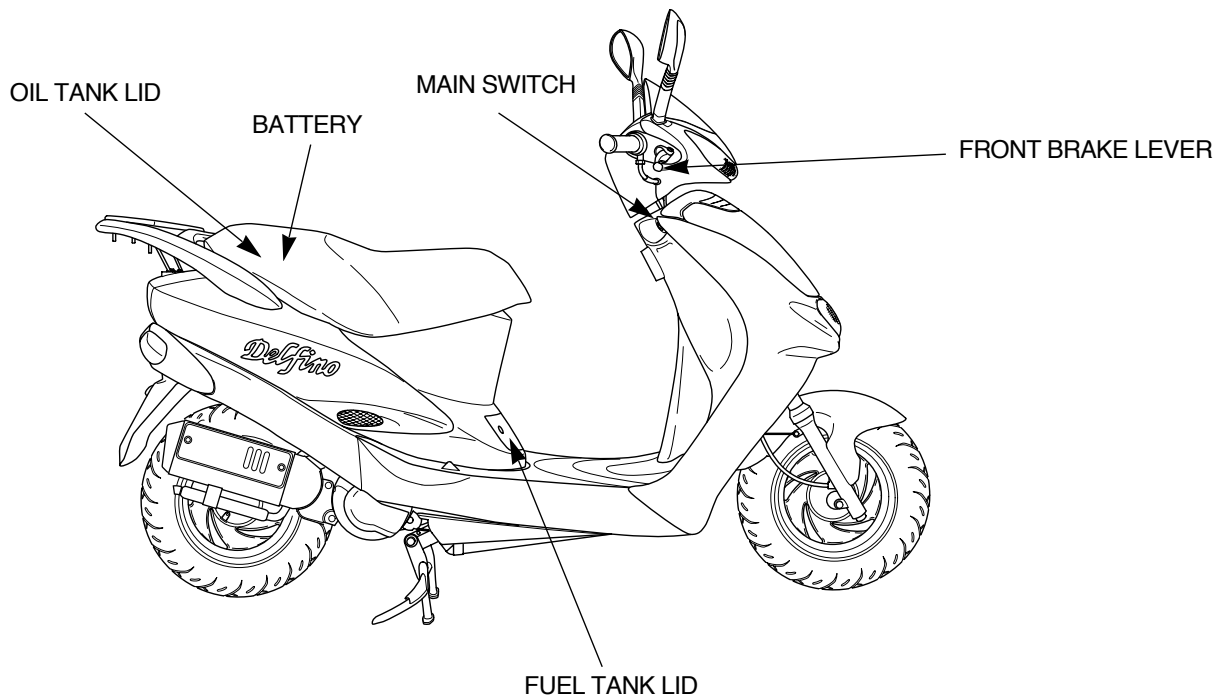

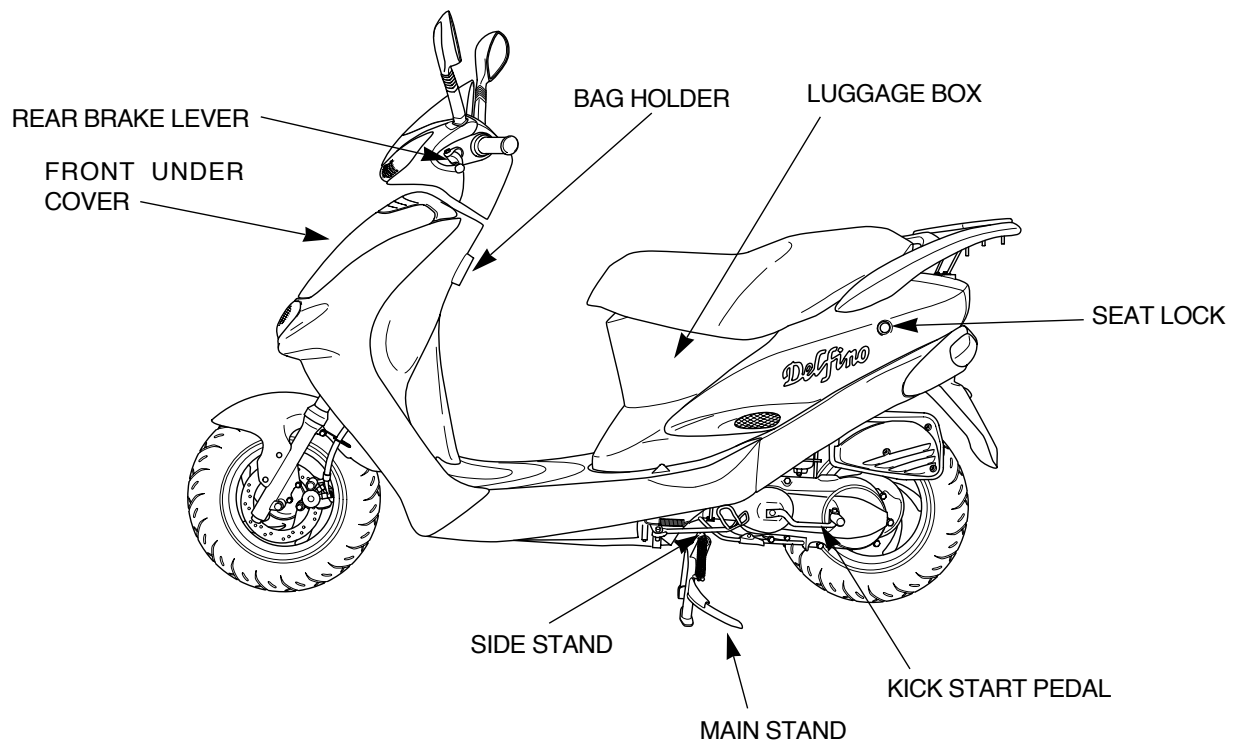

Meter Reading and Usage

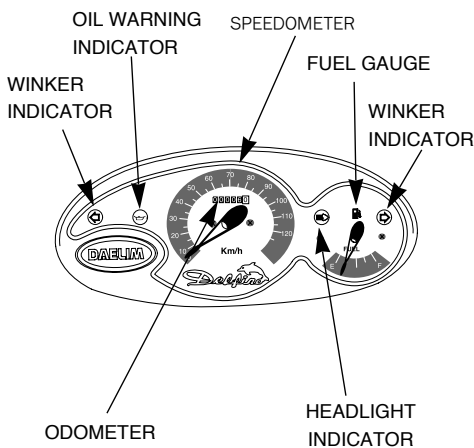

Meter

[Speedometer]

Indicates driving speed. Maintain legal speed limits to ensure safe operation.

[Odometer]

Indicates total distance in kilometers travelled by the vehicle.

[Fuel gauge]

The fuel gauge indicates the gasoline level inside the fuel tank.

Gasoline should be put in the fuel tank as soon as possible if the needle is resting in the red area. When the needle is resting in the E mark (red zone).

- Fuel Capacity : 7.2 l
- Reserve fuel capacity : 1.9 l

Warning and Indicator Lamp

[Oil Warning Indicator]

When oil in the oil tank is low, the oil warning indicator turns on. When this happens, fill the oil tank with pure oil.

Caution

- If the oil warning indicator turns on after the main switch is placed to an "ON" position, quickly fill the oil tank using pure oil

[Winker Indicator]

If the winker switch is operated, the winker indicator flashes in unison with the flashing of the turn signals.

Switch Operation

Main Switch

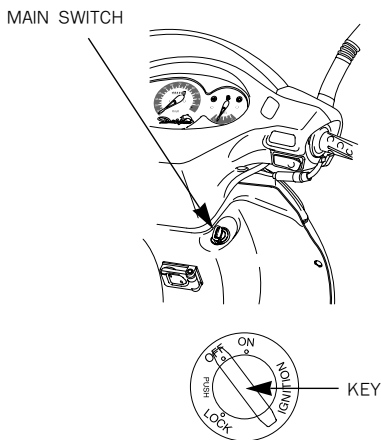

1. On.... Starts engine. Key can not be pulled out.
2. OFF....Stops engine. Key can be placed in or taken out of the main switch.
3. LOCK....Locks handle bars. Key can be placed in or taken out of the main switch.

Caution

- Do not manipulate main switch key during operation. If the main switch key is placed on "Off" or "Lock" position, all electrical system will not function. Never operate the main switch key during travel as it might cause unexpected accidents, If it is necessary to remove the main switch key, stop the vehicle first prior to removing.
- When you park the delfino and leave it, please lock handle bars and take out the key.
- If the key is left in "ON" position without starting engine, battery is discharged.
- Do not use a number of keys together with a metal key holder. The keys and the key holder may cause scratches or other damage to the cover while operating the vehicle.
(Recommend cloth or leather key holders)

Starter Button

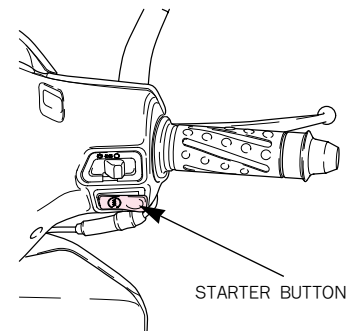

The engine is started pressing this button when pressed in a state where the main switch key is placed to an ON position and the brake lever is pulled.

Caution

- The engine will not start if the brake lever is not pulled.

Headlight

[Turning on headlight]

Put main switch key in "ON" position and turn on headlight switch.

HEADLIGHT SWITCH

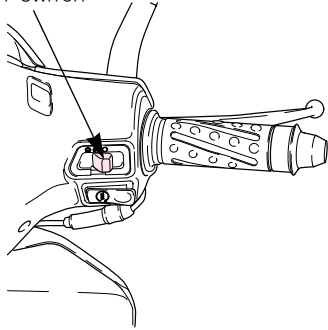

<Lighting>

To light headlight, turn the rightside light-switch-button to the side of "*" mark.

<Extinguishing>

To extinguish headlight, turn the right-side light-switch-button to the side of "O" mark.

[Headlight high/low beam switch]

High beam or low beam can be operated by the use of high/low beam switch.

HEADLIGHT HIGH/LOW
BEAM SWITCH

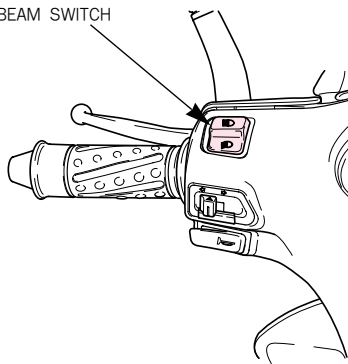

High Beam

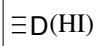
 used when needing extra light.

Low Beam

 used when other vehicles are present, in the city, etc.

Winker Switch

WINKER SWITCH

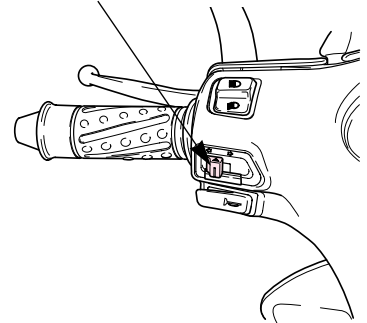

If this switch is turned on when the main switch is in an ON position, the winker will operate.

⇒ (R)....used when making a right turn.

⇐ (L)....used when making a left turn.

Caution

- The winker switch does not automatically turn back to its original position after completing the turn. Please set the switch back to its center position after turning.

Horn Button

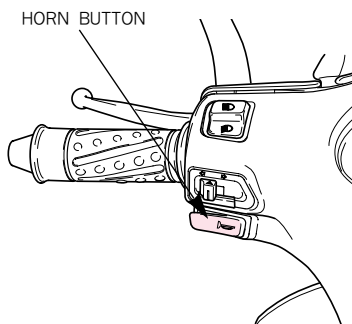

The horn is sounded if the horn button is pressed when the main switch is in an ON position.

Equipment Usage

Handle Bar Lock

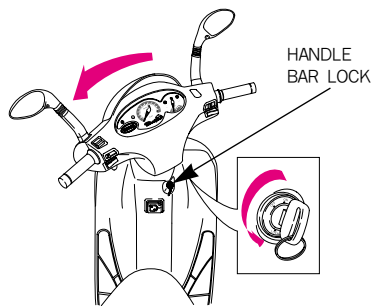

When parking, make sure to lock handle bars to prevent theft of the vehicle.

<Locking>

Turn the handle bars all the way to the left, and while pushing on the main switch key, turn the main switch to the LOCK position.

<Unlocking>

Unlocking is accomplished by simply turning the main switch to the OFF position.

Caution

- Check to see that the handle bars have been securely locked by lightly moving the handle bars to the left and right.
- Make sure to park the vehicle in a location where traffic and always are not blocked.

Seat Lock

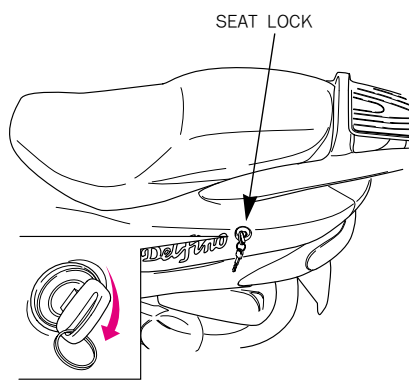

<Locking>

- The seat automatically locks when the seat is pushed in its downward position,
- Lightly pull upward on the seat to make sure the seat has been properly locked.

<Unlocking>

- Turn the seat lock switch to the right using the main switch key.

Caution

- As the seat automatically locks, take special care not to accidentally leave the key in the trunk.
- Driving with unlocked seat lock may cause danger.

Front Under Cover

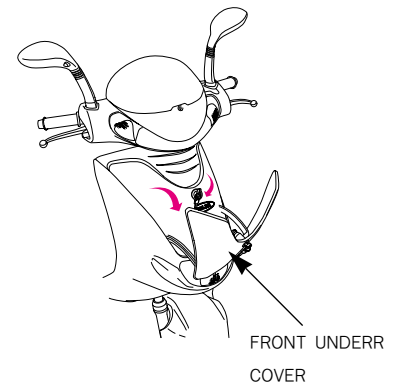

The main switch key is used to open and close the front under cover.

<Locking>

- Turn the front under cover switch to the right using the main switch key. In this state, close the cover, turn the key to the left and then remove the key.

<Unlocking>

- Turn the front under cover switch to the right using the main switch key and the front under cover will easily open.

Caution

- Do not place valuable or fragile goods in the inner box.
- Make sure to remove important items out of front under cover when washing the vehicle as water can enter the inner box.

Trunk

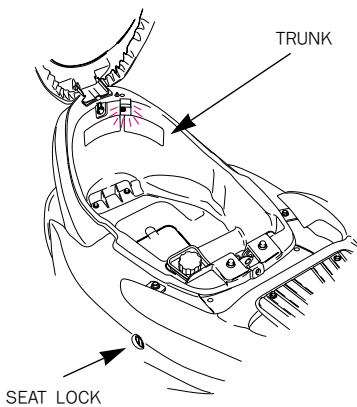

- There is a trunk under the seat.
- The seat is opened to gain access to the trunk by using the main switch key on the seat lock.
- The lamp inside the trunk will be turned on if the seat is opened.

Trunk maximum load:10kg

Caution

- Make sure that the seat is securely locked after closing the seat.
- An unlocked seat can hinder the operation of the vehicle.
- The temperature inside the trunk rises due to heat from the engine. Do not place foodstuffs and other articles that can be damaged easily by heat. Also do not place flammable materials in the trunk.
- Do not place valuable or fragile goods in trunk.
- As water can enter the trunk when washing, make sure to remove articles that can be damaged by water.
- Do not load uncloseable size of helmet and thing in the trunk, otherwise, the battery can be discharged with the trunk lamp on.

Document Storage Area

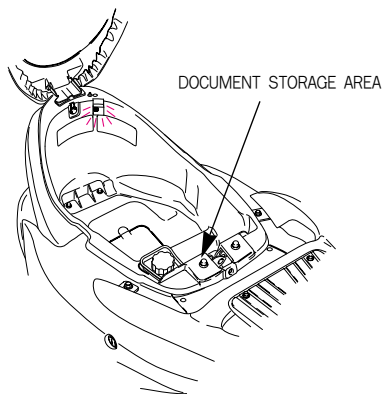

There is a document storage area on the bottom of the seat. Store the owner's manual and the maintenance notebook in this area.

Bag Holder

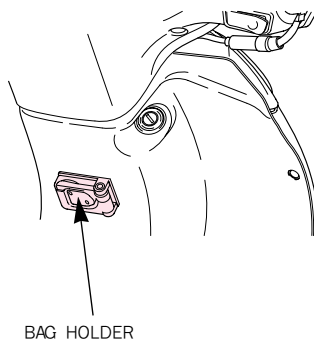

- For ease in carrying bags and similar items, they should be hung from the bag holder which is fitted for this purpose.
- When using the bag holder, place it in the open position and return it to the normal position when not in use.
- Do not attempt to carry very heavy or bulky loads since this would affect the stability and steering characteristics of the scooter.

Brake Lock Lever

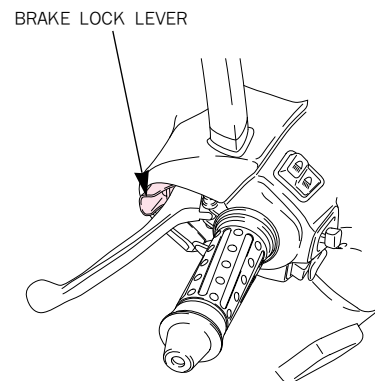

Caution

- If the rear brake is not adjusted properly, it will not be able to lock. Please refer to page 33 for instructions on rear brake adjustment.

<Setting>

- ① Squeeze tightly on the rear brake lever.
- ② Move the brake lock lever in the direction of the arrow in the drawing and place it in the groove of the brake lever.
- ③ Release your hand from the rear brake lever and the rear wheel will be locked.

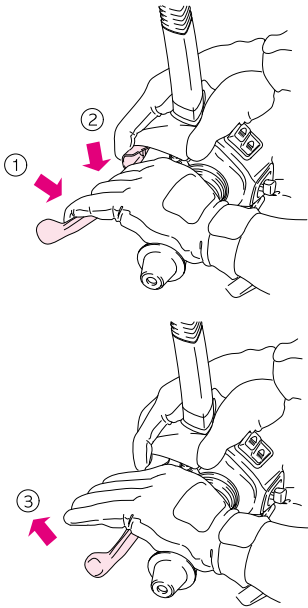

<Releasing>

- ① Squeeze tightly on the rear brake lever and the lock lever will be automatically released.
- ② Release your hand from the rear brake lever and the rear wheel will be unlocked.

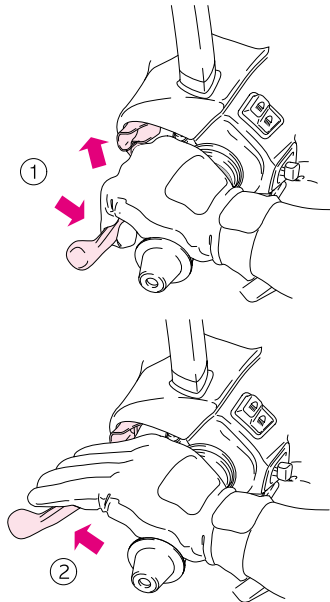

Correct Driving Operation

- Make sure to check the oil, gasoline, etc., before starting the engine.
- Please ensure that the main stand is in a down position when starting the engine.

Caution

- Make sure that the rear wheel is locked when starting the engine to prevent an unexpected quick start of the vehicle.
 - Locking is not possible if the rear wheel brake is not adjusted correctly.
-
- Drive with care for both safety reasons and longer vehicle life.
 - For 1 month (or 1,000km) after purchasing the vehicle, drive moderately avoiding fast starts and fast acceleration.

Starting the Engine

- 1 Lock the rear wheel.(see p. 18)

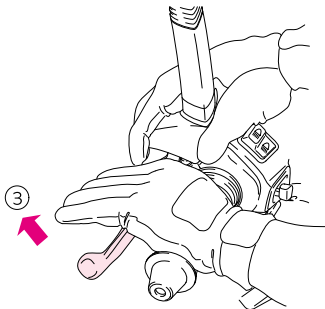
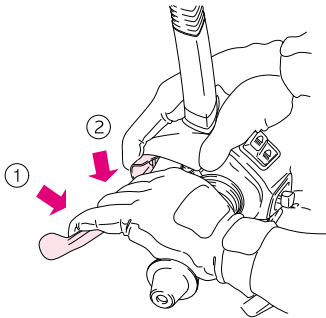

- 2 Turn the main switch to an ON position.

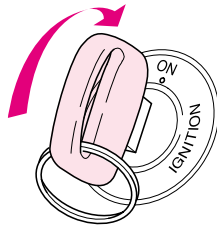

Caution

- If the oil warning indicator turns on after the main switch is placed to an "ON" position, quickly fill the oil tank using pure oil.

- 3 Start engine with cell or kick.

<Using the electric start(cell)>

- Press the starter button without rotating the starter grip (opening the throttle).

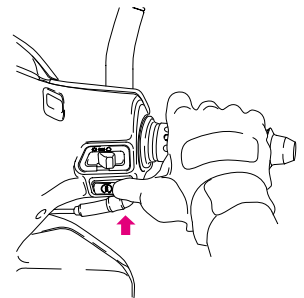

Caution

- Immediately release the starter button as soon as the vehicle has started.
 - Do not press the starter button when the engine is running. This can damage the engine.
- If the engine is hot and does not start after pressing the starter button for 3~4 seconds, rotate the throttle grip to 1/8~1/4 of a rotation and try again. This will allow easy starting.

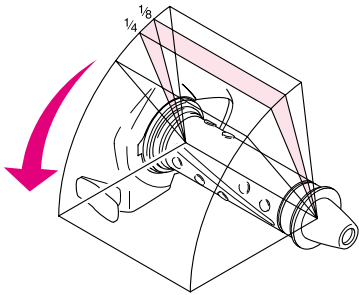

- It is possible that starting will be more difficult if the vehicle has not been used for a long period of time or if the fuel hole is plugged up (starting problems even when there is sufficient fuel in the fuel tank may be an indication of a plugged fuel hole).

When this happens, do not rotate the throttle grip and try the starter button a few times.

- To prevent the battery from losing its charge, do not keep the starter button pressed for more than 5 seconds at a time. If the engine does not start after pressing the starter button for 5 seconds, wait 10 seconds and try again.

<Without electric start(kick)>

- Erect main stand and hold rear brake lever and then step kick starter pedal strongly.

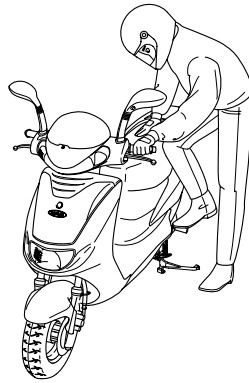

- 4 When the engine is cold, let the engine idle for a short period allow the engine to warm up.

Caution

- Keep holding rear brake until start.
- Exhaust has contains harmful substance such as carbon monoxide. Start engine in well-ventilated places.

Caution

- Make sure to place kick starter in its original position after the engine has been started.
- Be sure to erect main stand and side stand when starting.
- Do not use the starter button and the kick-starter pedal simultaneously.

If Engine cannot be Started

If engine cannot be started or vehicle does not move, check the followings.

- Is there fuel in fuel tank?
- Are you operating in accordance with the instructions given in owner's manual?
- Is fuse not cut?
- Is starter motor running?
- If starter motor is not running due to battery consumption, try starting motor by using kick start technique.

After Starting Engine

- 1 Fold the main stand.
 - Push the vehicle forward to fold the main stand and make sure that the brake lever does not become released during this operation.

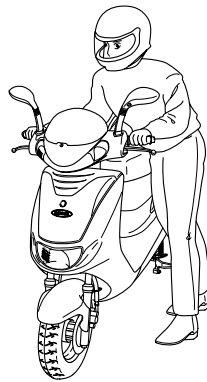

Caution

- Do not excessively open the throttle until you actually start the driving operation of the vehicle.

- 2 Get on the vehicle.
 - Mounting should be done from the left side, and you should sit squarely on the seat. Leave either one foot or both feet planted on the ground.

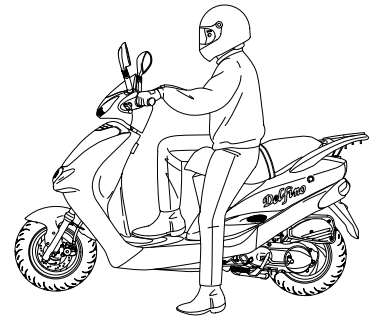

Caution

- Keep holding rear brake lever before starting.

- ③ Squeeze tightly on the rear brake lever and the lock lever will be automatically released.

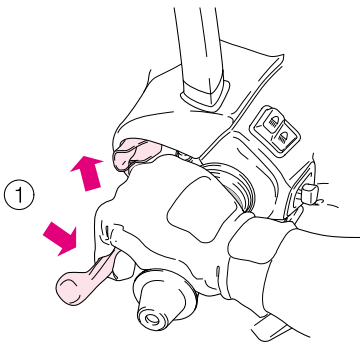

Caution

- Do not rapidly turn the throttle grip when you release the rear brake lock. The vehicle may spring out, causing injury or damage.

- ④ Release the squeezing tension on the rear brake lever and slowly begin to rotate the throttle grip to allow for a slow and easy start.

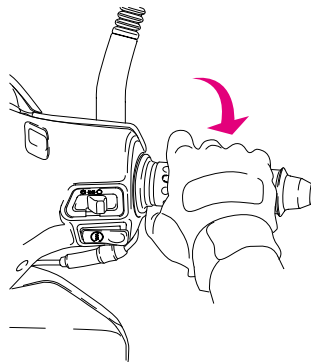

Caution

- A quick rotating of the throttle grip will cause the vehicle to move suddenly forward.

Proper Driving Methods

- Before entering traffic, use the correct turn signal to forward other drivers of your intentions.

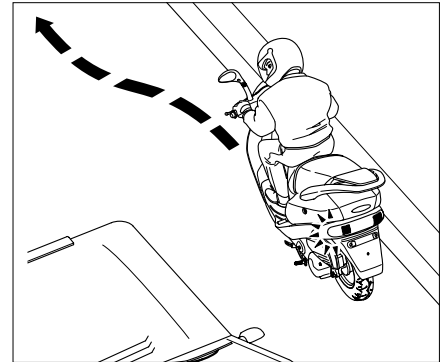

Speed is controlled by the operation of the throttle grip.

- If the throttle grip is rotated.....
The speed of the vehicle increases. Please rotate the throttle grip slowly. When climbing a hill, the throttle grip need to be rotated further to give the vehicle more power.
- If the throttle grip is allowed to rotate back.....
Speed decreases. This can be done slowly or quickly, depending on how quickly you need to decelerate.

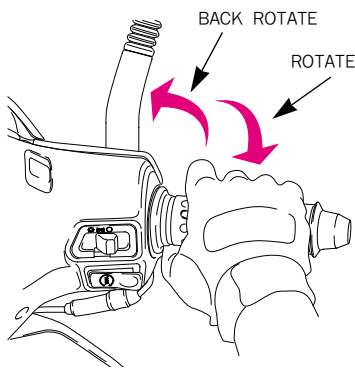

Work the front and rear brakes together.

- Allow the throttle grip to rotate back to its beginning position and then squeeze the brake levers.
- It is best to operate the brakes by first lightly squeezing the brake levers and then changing to a more firm squeeze.

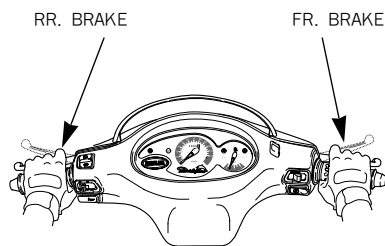

Caution

- If only one of the brakes is used, it is possible for the vehicle to experience sliding.

The brakes should never be suddenly applied and the handle bars should never be suddenly turned.

- Sudden braking or turning can cause the vehicle to slide and tip over.
- It is especially dangerous to perform sudden braking on wet roads or in rainy weather as the tires can lose traction and slip easily.

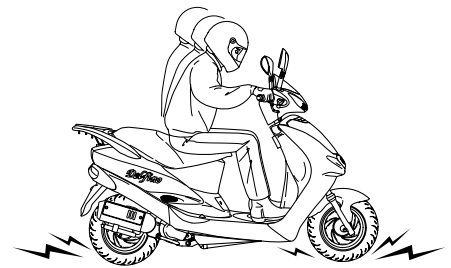

Special care in driving should be taken during rainy weather.

- More braking distance is needed when driving on wet roads or in the rain. Reduce speed and be sure to initiate the braking operation sooner than when driving in normal conditions.
- On downgrades, allow the throttle grip to rotate back to its initial position to reduce speed, and apply the brakes and drive slowly down the hill.
- It is possible for the brakes to temporarily lose operative ability after driving through a puddle or when driving in the rain. To ensure that the brakes are operating properly, slow down (after checking for other vehicles) and while driving slowly, lightly apply the brakes to rid the brakes of any excess water and to dry them.
- Be extremely careful when driving in the snow or on icy roads. When driving in these conditions, both the tires lose much of their traction and the rear tire can slip when opening the throttle.

Stopping

- 1 When approaching the desired stopping area.
 - Activate the proper winker, and after checking for other vehicles, slowly turn into the area in which you want to stop.
 - Allow the throttle grip to rotate completely back and apply the front and rear brakes. The brake light will shine to alert vehicles in back of you that you are stopping.

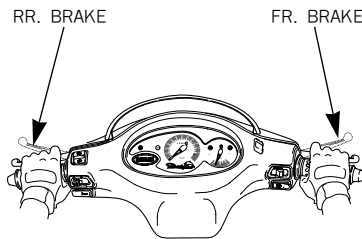

- 2 After the vehicle has come to a complete stop.

- Return the winker switch to the center position and turn the main switch to OFF. This will turn the engine off.

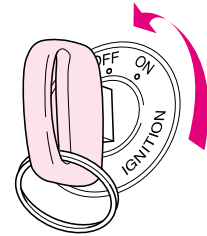

Caution

- Do not rotate the main switch key while driving. If the main switch is turned to an OFF or LOCK position, the electrical system will not operate. Operating the main switch key while driving can be very hazardous. Only turn the main switch key to OFF or LOCK positions after completing stopping the vehicle.

3 Dismount on the left side and lower the main stand on a flat surface.

- Be sure to park in an area that is free of traffic. Also, the vehicle can tip over if the main stand is not placed on a stable and flat surface.
- The main stand is lowered by grasping the handle bars with the left hand, holding the rear carrier with the right hand, and stepping firmly on the stand with the right foot. In this position, lift the rear carrier upward, which will secure the main stand.

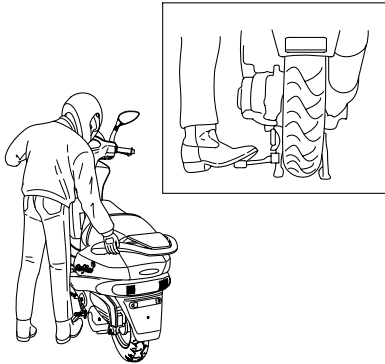

4 To prevent theft, be sure to lock handle bars when parking.

Caution

- Park in a safe area that will not block traffic. When you parked the vehicle after driving, make sure foot the vehicle beyond man's reach because engine and muffler are still hot.

Self Inspections before Operation

Self inspect the vehicle and have regular maintenance inspections for increased safety and the prevention of accidents. Regular maintenance inspections should be performed even if the vehicle has not been used for a long period of time.

Self inspections before operation should be performed on a daily basis prior to operating the vehicle.

- Inspections of concerned Area
- Brake inspection
- Tire inspection
- Fuel check
- Engine oil check
- Lights and winker inspection
- Back mirror inspection
- Fuel leak inspection
- License plate inspection

Caution

Observe safety rules when conducting inspections.

- Exhaust gas contains harmful substance such as carbon monoxide. Do not carry out inspections on vehicle in closed places, or in poorly ventilated places, with engine running.
- Conduct inspections on flat, solid ground with the stand erected.
- Be careful of burns when conducting inspections immediately after engine is stopped because the engine and muffler are hot.
- Stop engine and remove the key prior to the vehicle maintenance service.
- Use appropriate types of tools.

- If you are unable to correct trouble even after you make adjustment or correction, contact authorized maintenance shops, dealers or designated repair shops for necessary inspection and repairs.

Inspection of concerned Area

Check areas which caused for concern when last operating the vehicle.

Brake Inspection

[Brake Lever Free play]

Lightly squeeze the brake levers until tension is felt to check for an appropriate amount of free play. No free play in the brake levers or overly loose brake levers are indication of a problem in the brake system.

Brake lever Free play: 10~20mm



[Check of Brake Fluid]

This is checked by placing the vehicle on its main stand on a flat surface. Make sure that the handle bars are at a horizontal level. Check to see if the fluid is below the LOWER level.

If brake fluid is significantly low, this may indicate that there is leakage in the brake system. Inspect the brake hose to check for leaks.

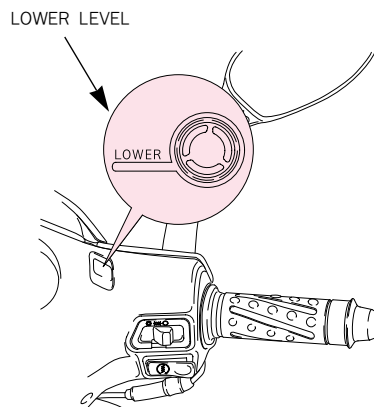

Tire Inspection

[Air Pressure Check]

Check for an appropriate level of air pressure by examining how the tire sits on the ground. If you notice any abnormalities in the shape of the tire with regard to the area contacting the ground, use a tire gauge to check tire pressure and adjust the tire pressure to the appropriate level.

<Tire Pressure>

Size	Front	100/90-10 56J	
	Rear	100/90-10 56J	
Air Pressure (kgf/cm ²)	1 person riding	Front	1.50
		Rear	1.75
	2 person riding	Front	1.50
		Rear	2.25

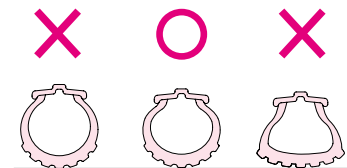

[Cracks/Damage]

Check tire tread and sides for cracks and damage.

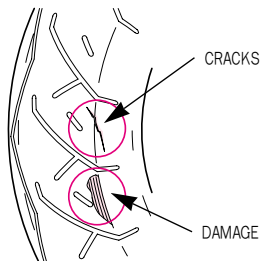

[Abnormal Wear]

Check tire tread for signs of abnormal wear.

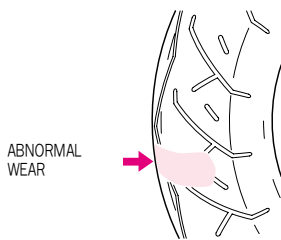

[Foreign Materials]

Check tire tread and sides for nails, rocks, etc. That might have become wedged in the tire.

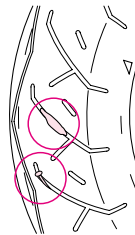

[Tread Depth]

- Check the wear indicator (wear limit marking) to see if there is an insufficient amount of tread remaining.
- If the indicators are visible, replace tire with a new one.

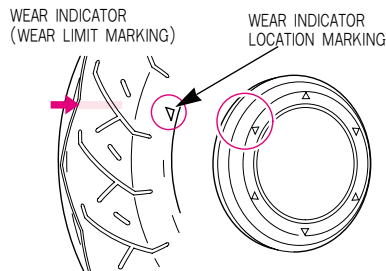

Caution

- If air pressure is inadequate or if there are cracks, damage or abnormal wear on tires, it may cause trembling steering wheel and flat tire.
- This vehicle is equipped with tubeless tires. If you have flat tires, please contact authorised maintenance shops for inspection.

Fuel Check

[Check]

Check gasoline to see if there is a sufficient amount of gasoline to reach your destination.

- If the fuel gauge needle indicates E mark (red portion), fill fuel tank with gasoline as soon as possible.

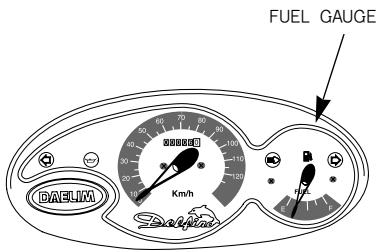

[Refueling]

- Use the main switch key to open the fuel tank lid (the key must be turned to the right).

- Turn the fuel tank cap counterclockwise, and remove it.
- Fill the tank with gasoline until it reaches the bottom of the level plate.
- Turn the fuel tank clockwise until the "△" mark on the fuel tank cap is aligned with the "△" mark located above the fuel tank opening.

Caution

- Make sure to stop engine and stay away from fire when refueling.
- Do not fill gasoline past the level plate. Gasoline may leak out of the fuel tank when replacing the fuel tank cap if too much gasoline is put in the fuel tank.
- Don't fill low grade gasoline. Using it can cause damage (bending, getting worn, etc.) to combustion chamber and parts of fuel.

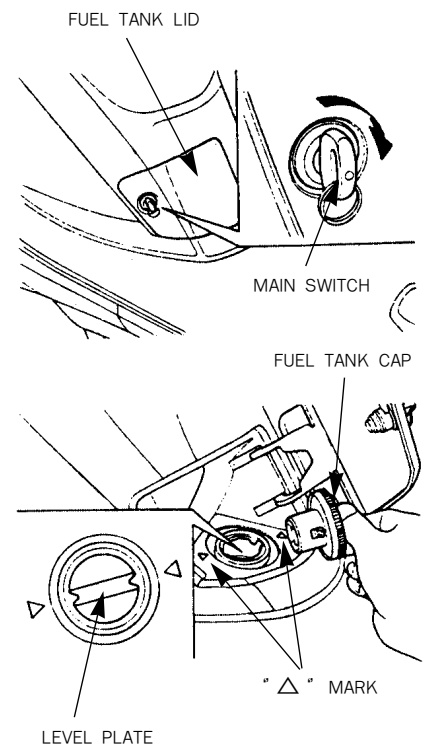

Engine Oil Check

[Check]

If the oil is low, the oil warning indicator will turn on. Turn the main switch to ON in order to check whether the oil warning indicator switches on. If it does, put oil in the oil tank.

OIL WARNING INDICATOR

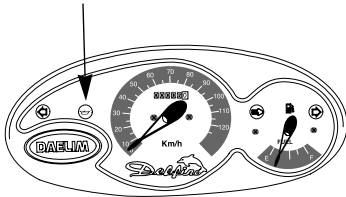

Caution

- Do not allow the engine to stay at a low level. The engine will become severely damaged if the vehicle is driven while the oil warning indicator is on.

Lights and Winker Inspection

[Headlight, Taillight]

Start the engine and make sure the lights turn on. Also check to see if the lights are damaged or if there is dirt on them.

[Brake Light Check]

Turn the main switch to ON.

While separately operating the front and rear brakes, check to see if the brake light turns on. Also check to see if there is any damage to the lens or if there is dirt on the brake light.

[Winker Check]

Turn the main switch to ON.

Check to see if all the winker in the front and rear of the vehicle (including left and right sides) are flashing properly. At the same time, check to make sure that the automatic sound signal of the winker is working. Check also to see if any of the lens are damaged or dirty.

Back Mirror Inspection

Sit squarely on the seat and check to see if you have a good view behind the vehicle by looking at the back mirrors. Also check for dirt and damage on the back mirrors.

Fuel Leak Inspection

Check to see if there is any leaking fuel by thoroughly checking the fuel tank, hose, carburetor, etc.

License Plate Inspection

Check to see if there is any dirt or damage to the license plate.

Also check to see if the license plate is firmly secured to the vehicle.

Regular Inspection

Regular Inspection Times

Carry out the self inspections before operation as described in this owner's manual at each regular maintenance time.

I: Inspect and, if necessary, clean, adjust, lubricate or replace parts.

R: Replace L: Lubricate C: Clean

Travel Distance Item		Travel Distance(Caution 1)				Remark
		1,000km	4,000km	8,000km	12,000km	
★	Fuel line	I	I	I	I	
★	Throttle Operation	I	I	I	I	
	Air Cleaner	C (per 1,000km)				Caution 2
	Spark Plug	I	I	R	I	
★★	Carbon Removal			C		
★	Carburetor Idle	I	I	I	I	
★	Oil pump, Oil line		I	I	I	
	Transmission Oil	I			R	
★	Brake Fluid	I	I	I	R	Caution 3

Part		Travel Distance	Travel Distance(Caution 1)				Remark
			1,000km	4,000km	8,000km	12,000km	
★	Brake Shoe / Pad Wear		I	I	I		
	Brake System	I	I	I	I		
★	Brake Light Switch	I (Per 1,000km)					
★	Headlight Adjustment	I	I	I	I		
★	Suspension		I	I	I		
★	Bolt and Nut Tightness	I		I			
★★	Wheels / Tires		I	I	I		
★★	Steering Handle Bearing	I			I		
★★	Drive Belt		I	I	I		
★★	Weight Roller			I	I		
★★	Slide Piece			I	I		

- ★ If you do not have the appropriate tools or information to conduct maintenance, or if you feel you are not capable to perform maintenance on this vehicle, contact authorized dealers or repair shops for maintenance and repairs.
- ★★ To ensure safety, inspections and maintenance of these parts must be carried out by dealers, or repair centers.

Caution

1. After 12,000km, start from the beginning of the above chart and repeat maintenance inspections at the specified times.
2. If the vehicle is operated in area having high humidity or a large amount of dust, maintenance and inspections will need to be performed more frequently.
3. Replace every two years. These parts must be replaced every two years.

Simple Maintenance

The following is an explanation of correct inspection methods, cleaning and parts replacing. Please always refer to this section when wanting to inspect or repair your vehicle.

Caution

- Always observe safety rules when performing maintenance on the vehicle.
- Choose a flat surface and make sure the main stand is in a secure down position.
- Use correct tools.
- Conduct engine maintenance with the engine key out of the ignition.
- Be careful around the engine and muffler when performing maintenance as these areas can become extremely hot.

Brake Lever Adjustment

Brake lever free play is adjusted by rotating the adjuster of the brake arm.

After adjustment, check the brake lever to ensure that the clearance is not above or under the prescribed amount.

Brake Lever Free Play : 10~20mm

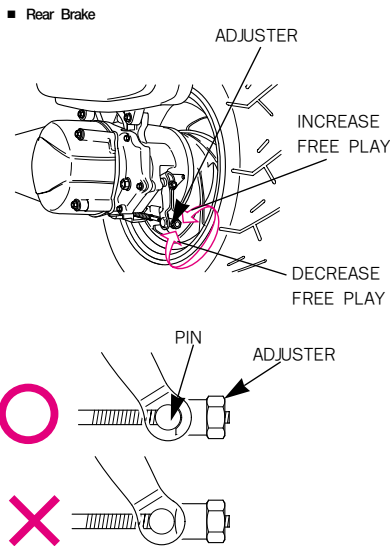

Caution

- After adjusting the brake, make sure that “ㄣ” part of the adjuster contacts the pin as in the drawing below. Brake clearance can change when driving if this is not done.
- It is not necessary to adjust the front brake.

Rear Brake Shoe Inspection

After adjusting the brakes, check the wear of the brake shoe. While tightly squeezing the rear brake lever, if the “△” mark of the brake arm is aligned with the “△” mark of the brake panel, this indicates that the brake shoe is worn. Please take the vehicle to a service center for repair.

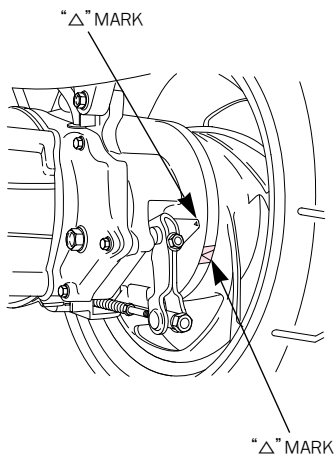

Replenishing Brake Fluid

1. Remove the screw rivet and take the brake fluid maintenance lid off.
2. Clean dust and other foreign materials around reserve tank to prevent foreign materials from falling inside tank.
3. Remove the screws and take oil cup cap, diaphragm plate, diaphragm off.
4. Replenish recommended brake oil to the upper level inside reserve tank.

Recommended brake oil is DOT 3 or DOT 4

5. Reinstall the diaphragm, diaphragm plate, and oil cup cap.
6. Tighten the screws securely.
7. Install the brake fluid maintenance lid.

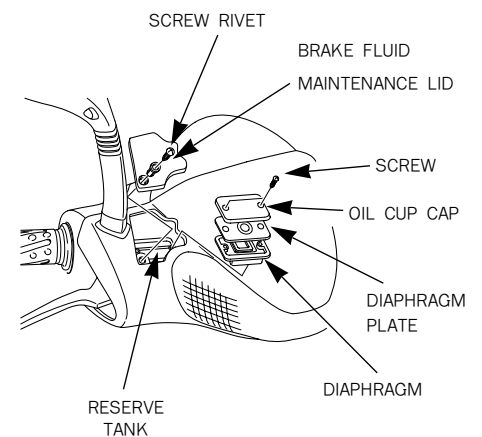

- Check the brake pads for wear when refilling with brake fluid.
- A low fluid level may be due to wear of the brake pads.
- If the brake pads are not worn and the fluid level is low, check for leakage.

Caution

- When adding brake fluid, be very careful not to allow foreign materials to enter the reserve tank. Foreign materials can clog the system, causing a reduction or complete loss of braking ability.
- Do not fill past upper level. This can cause brake fluid to leak out of the reserve tank.
- Do not let brake fluid contact vehicle parts as this damages painted areas. If oil contacts parts, quickly clean the fluid off using a dry cloth.
- Use recommended brake fluid as other types can undergo chemical changes.
- If brake fluid is exceedingly low, this can be indication of damage to the brake system.
- A leak in the brake system can lead to reduced braking efficiency and possible loss of braking ability.

Brake Hose, Pipe Leakage, Damage, Assembly State

Visually check for fluid leaks or damage and, using a spanner, check joints and clamps for clearance. Also, check hose and pipe protective parts to see if they contact other parts when turning the handle bars or due to vibration when driving.

Brake Pad Inspection

Operate the brake lever to check the wear of the brake pad. While looking at the brake caliper, if the wear limit line is not visible, the pads need to be replaced.

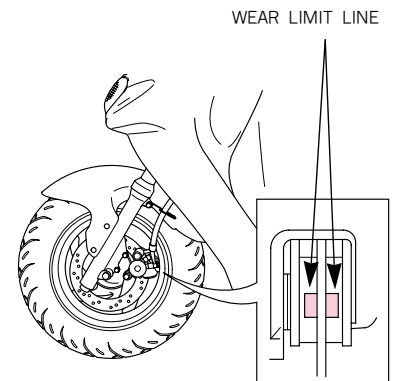

Replenishing Engine Oil

<Inspection>

If the oil is low, the oil warning indicator will turn on. Turn the main switch to ON in order to check whether the oil warning indicator switches on. If it does, put oil in the oil tank.

<Replenishing>

1. Set vehicle on main stand in upright position on level ground.
2. Open the seat.
3. Turn the oil cap counterclockwise, and remove it.
4. Fill the oil tank to the fill level.
5. Turn the oil cap clockwise, and install it.
6. Close the Seat. Check to see if the seat lock has latched.

<Recommended Oil>

If oil sold on markets or privately manufactured oil (oil-grade) is used, engine life is adversely affected, and the privilege of warranty repairs cannot be guaranteed.

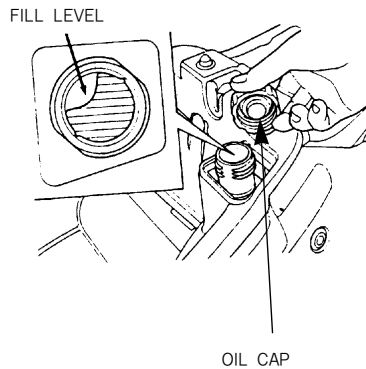

Caution

- Do not fill past the fill level. Oil will leak out if this is done.
- Immediately replace oil cap after filling oil tank with oil.
- Make sure that foreign materials do not enter the oil tank.
- Do not use other manufacturers oil and do not use low quality oil.

Transmission Oil Inspection

<Oil Level>

- Park vehicle and lower main stand on a flat surface. Wait at least 2~3 minutes after engine has been turned off remove the oil check bolt and make sure that the oil level is up to the lower edge of the bolt hole.
- Refill to the lower edge of the oil level check bolt hole with the recommended oil if the level is low.
- Securely fix the check bolt.

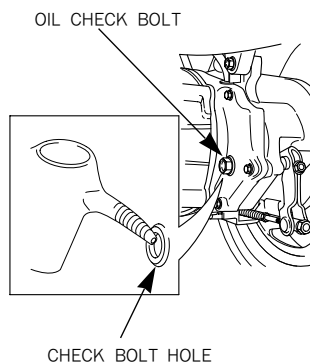

<Recommended Oil>

Pure 4-Cycle Engine Oil

Caution

- Pay special attention not to let rubber etc., enter the check bolt hole.
- When draining the oil, make sure that all of the oil is removed.
- The engine can be harmed if there is too much or not enough oil.
- Do not use other manufacturers oil or low-quality oil. These oils can change quality overtime and can cause damage.

<Fluid Leak>

Check to see if transmission oil leaks out of the transmission case.

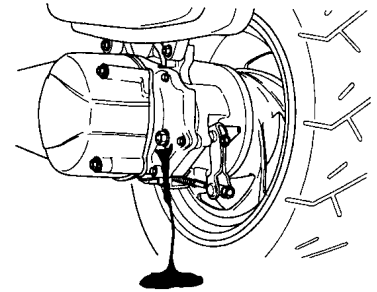

Wheel Removal

[Front Wheel Removal]

- ① Raise the front wheel off the ground by placing a support block under the engine.
- ② Loosen the oval screw and remove the speedometer cable.

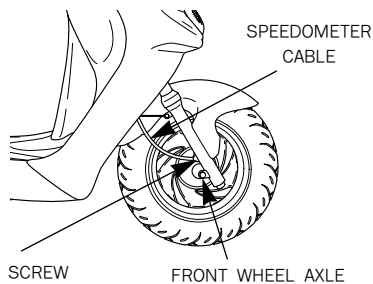

- ③ Remove the front caliper assembly from the front fork by removing the fixing bolts.

Caution

- Do not operate brake lever after the front wheel is removed. It will make wheel assembling difficult.

- ④ Loosen the axle nut.
- ⑤ Withdraw the front wheel axle and remove the front wheel.

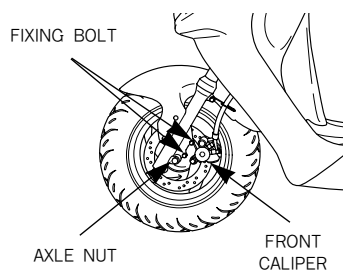

- ⑥ Install in the reverse order of removal.

Caution

- When installing the wheel, carefully fit the left brake disk between the brake pads to avoid damaging the pads.

- Fit the caliper over the disc, taking care not to damage the brake pads. Install the caliper fixing bolts, and tighten to a torque of : **2.7kgf · m**

- Tighten the front axle nut to the specified torque.

Front axle nut torque : 5.0~7.0kgf · m

- ⑦ After assembling, operate brake for a number of times and see if wheel is turning smoothly without getting interruption.

Caution

- If a torque wrench was not used for installation, see your authorized dealer as soon as possible to verify proper assembly. Improper assembly may lead to loss of braking capacity.

[Rear Wheel Removal]

- ① Set vehicle on main stand in upright position on level ground.
- ② Loosen the rear brake adjuster nut and remove the brake cable.
- ③ Loosen the brake arm setting bolt, and remove the spring.

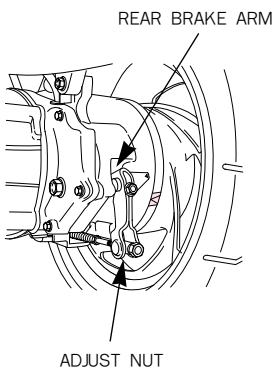

- ④ Remove the muffler.
- ⑤ Loosen the rear wheel axle nut.
- ⑥ Remove the lock washer and the rear wheel.

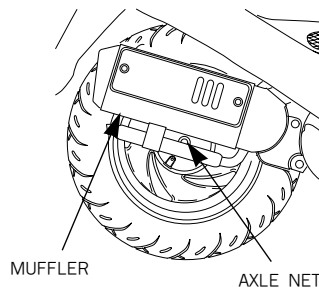

- ⑦ Install in the reverse order of removal.
Rear axle nut torque : 6.0~8.0kgf · m

Caution

- If a torque wrench was not used for installation, see your authorized dealer as soon as possible to verify proper assembly. Improper assembly may lead to loss of braking capacity.

Bulb Replacement

- Be sure to turn the ignition switch OFF when replacing the bulb.
- Do not use bulbs other than that specified.
- After installing a new bulb, check that the light operates properly.

Caution

- The light bulb becomes very hot while the light is ON, and remain hot for a while after it is turned OFF. Be sure to let it cool down before servicing.
- Do not put finger prints on the headlight bulb, as they may create hot spots on the bulb and cause it to break. Wear clean gloves while replacing the bulb. If you touch the bulb with your bare hands, clean it with a cloth moistened with alcohol to prevent its early failure.

[Headlight Bulb]

- ① Turn the front under cover switch to the right using the main switch key and the front under cover will easily open.
- ② Remove the headlight maintenance lid.

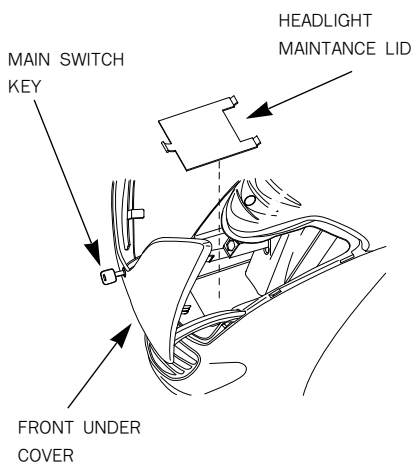

- ③ Remove the rubber cover.
- ④ Turn the socket clockwise, and remove it.
- ⑤ Slightly press down on the bulb and turn it counterclockwise.
- ⑥ Install a new bulb in the reverse order of removal.

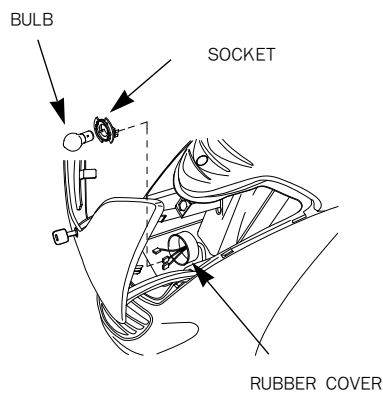

[Tail/stoplight Bulb]

- ① Loosen the pan screws and remove the rear combination light lens.
- ② Loosen the tapping screw and remove the tail/stop lens.
- ③ Slightly press down on the bulb and turn it counterclockwise.
- ④ Install a new bulb in the reverse order of removal.

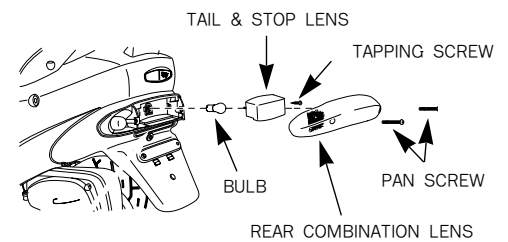

[Winker Bulb]

<Front winker bulb>

- ① Remove the right/left back mirror.
- ② Loosen the tapping screws and remove the wind screen.
- ③ Loosen the washer screw and the tapping screws.
- ④ Pull the front handle cover forward, and remove the wiring.
- ⑤ Remove the front handle cover.

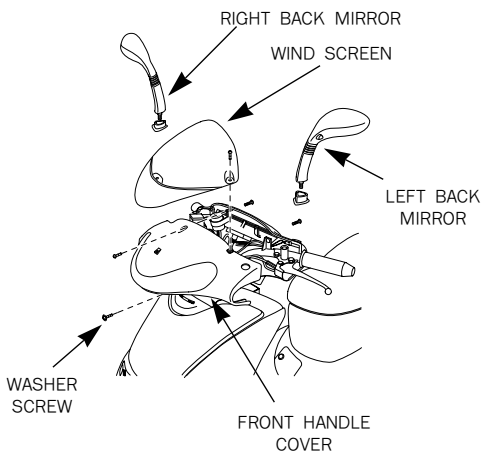

- ⑥ Loosen the screws and remove the sockets.
- ⑦ Slightly press down on the bulbs and turn it counterclockwise.
- ⑧ Install a new bulbs in the reverse order of removal.

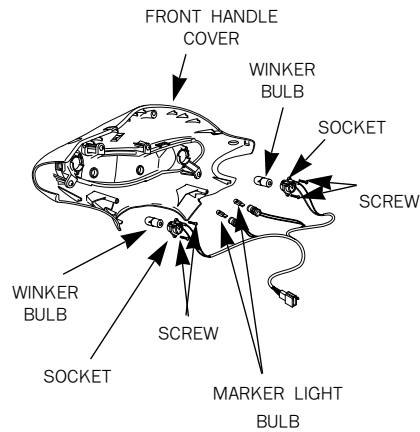

<Rear Winker bulb>

- ① Loosen the pan screws and remove the rear combination light lens.
- ② Loosen the tapping screws and remove the winker lens.
- ③ Slightly press down on the bulbs and turn it counterclockwise.
- ④ Install a new bulbs in the reverse order of removal.

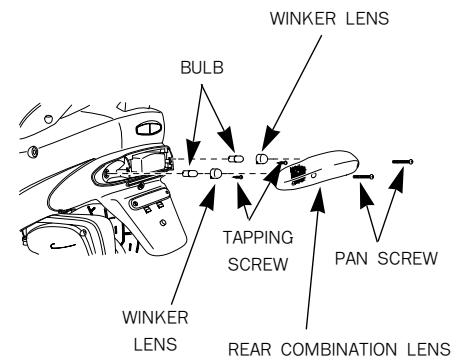

Spark Plug

If electrode is stained or clearance is not right, satisfactory spark is not produced. Clean and make adjustment.

- ① Turn the seat lock switch to the right using the main switch key.
- ② Remove the plug maintenance cover.
- ③ Remove the spark plug cap.
- ④ Clean around the plug.
- ⑤ Using a plug wrench, remove the plug.

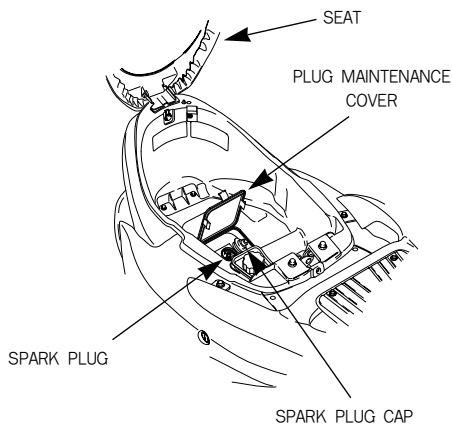

- ⑥ Clean plug with plug cleaner.
- ⑦ Check electrode for wear and corrosion.
- ⑧ Check the plug gap using a feeler gauge.
Plug Gap : 0.8~0.9mm
- ⑨ Tighten with hands until the plug washer touches cylinder head.
Standard plug: BR8HS
- ⑩ If new plug is installed, turn 1/2 and tighten using a plug wrench.
If plug is reused, turn 1/3~1/4 and tighten.

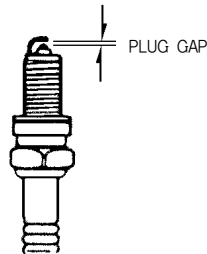

- ⑪ Install in the reverse order of removal.

Caution

- If plug of different maker or different heat value is used, it causes unsatisfactory engine starting, inadequate engine revolution and output deterioration.
- The spark plug must be securely tightened. An improperly tightened plug can become very hot and possibly damage the engine.

Battery Inspection

[Cleaning Battery Terminals]

- ① Turn the seat lock switch to the right using the main switch key.
- ② Loosen the washer screw and remove the battery cover.
- ③ Loosen the tapping screw and remove the battery holder.
- ④ If the battery terminal is polluted, or in rust, separate battery and clean it.
- ⑤ Battery terminal in rust with white powder should be cleaned with warm water.
- ⑥ In case of serious rust of battery terminal, disassemble the battery cord and grind it with wirebrush or s

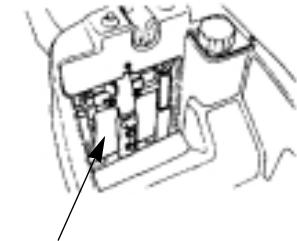

BATTERY

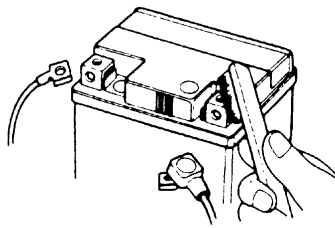

Caution

- Turn the ignition switch OFF before disconnecting the terminal from the battery.
- When cleaning battery, do not disassemble the battery cap to prevent foreign materials from falling inside battery.
- Remove the negative pole \ominus side cord first and the positive pole \oplus side cord next.
- Make sure, at this time, that \oplus side cord is connected first, followed by \ominus side cord.

[Replenishing Battery Water]

This vehicle doesn't need either replenishing or checking battery water because of the equipment of enclosed MF battery. In case battery needs a checking, it should be cared of by service center.

Caution

- Be careful not to disassemble injection part of enclosed battery.
- When not using vehicle during a long time, take off the battery from the vehicle to keep from self-discharge and electric discharge. Put the battery in a well ventilated place after charging fully. In case it isn't available to take battery off from the vehicle, disconnect "-" terminal.

Changing Fuse

Turn off the main switch to see if the fuse is severed. If the fuse is severed, exchange the fuse into 7A fuse.

- To change a fuse, first take off battery cover. Then, disconnect a “fuse connector” after opening a “fuse holder.”
- If the fuse immediately becomes severed after being changed with the new one, check another problem of the electric system.

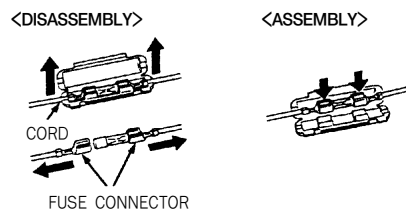
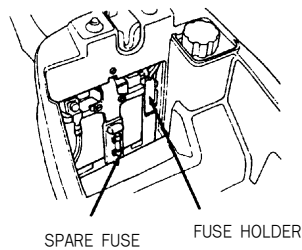

Caution

- When disassemble fuse, make sure that fuse holder isn't separated.
 - After assembling fuse in the part of connector, check if fuse moves easily to a line. If fuse moves easily, it may cause an accident at heating.
 - Do not use a fuse having a larger voltage as the wire can become overheated and damaged.
- When replacing any of the electrical parts (lights and gauges), be sure to replace them with the recommended parts. Using different parts can lead to the fuses burning out or damage to the battery.
- When washing the vehicle, take special care not to allow to be splashed in the area of the fuses.

Air Cleaner Element Inspection

[Removal]

- ① Loosen the pan screws and remove the rear combination light.
- ② Loosen the washer screws and remove the rear mudguard.
- ③ Loosen the body cover clip and remove the left side cover.
- ④ Loosen the washer screws and remove the air cleaner case cover.

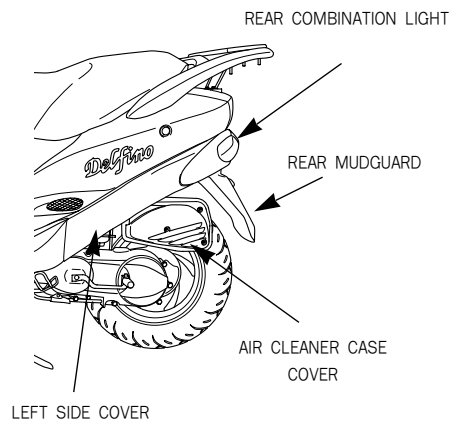

[Cleaning]

- Clean the air cleaner element in clean oil, squeeze excess oil, and then, wrapping it in a dry cloth, squeeze it again.
- Make sure all excess oil removed and reassemble the air cleaner element.

Oil : 4 CYCLE GEAR OIL

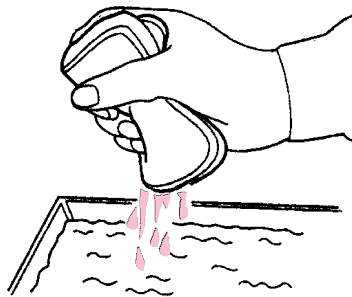

- ⑤ Install in the reverse order of removal.

Caution

- Do not use gasoline or other materials having a low ignition point as this can be a fire hazard.
- If the air cleaner element is inadequately assembled, dust and other waste materials can directly enter the engine. This results in increased cylinder wear and reduced power, and reduced durability of the engine.
- When washing the vehicle, be careful not to allow water to get into the air cleaner. Difficulties in starting the engine may result if this happens.

Inspection of Cable Rubber Part

A rubber part is assembled on the cable to protect the inner cable.

Make sure that this part is placed firmly around the correct part of the cable. When washing the car, do not directly spray water on to the rubber part is dirty, use a dry cloth to clean this area.

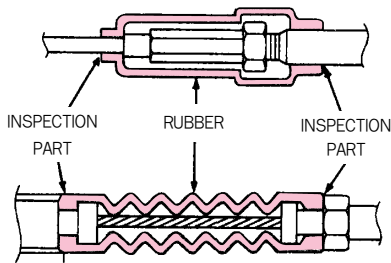

Notables for Car Washing

- Make sure to stop the engine prior to car washing.
- Be careful not to allow water to enter the muffler during the washing. Water inside the muffler may cause an improper engine starting or rust occurrence.
- Do not let water get inside the braking system during the washing, as water inside the brake system may weaken the braking power. Upon completion of washing, select a safe place where there is no traffic obstruction, and start the vehicle. Lightly apply the brake while driving at a slow speed and check the braking power. If the braking power has been weakened, apply brake lightly while driving at a slow speed to dry up the brake system.

- Take precautions when waxing the vehicle. Excessive polish of the painted section and/or the resin part with compound wax might damage the painted section causing discoloration of the affected area.

Frame and Engine Number

- The frame number is stamped on the front central part of the frame.
- The engine number is stamped on the rear face of the left crankcase.
- The frame and engine numbers will be used as the basis of recovering the vehicle when is stolen.
- Record the frame and engine numbers along with the vehicle license plate numbers and keep them separately from the vehicle.

