

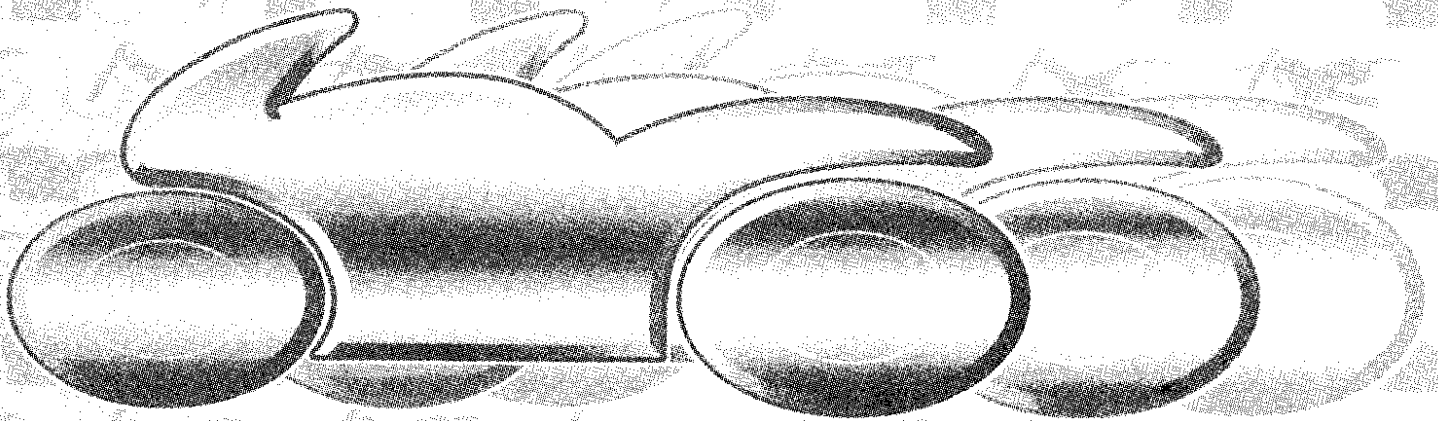

OWNER'S MANUAL



**PLEASE READ THIS MANUAL
BEFORE OPERATING**

MONKEY

About this manual

- This operator's manual outlines proper handling, safe riding, and simple inspections to be performed on the motorcycle. Please read through this manual in order to safely enjoy riding this motorcycle. Also read through the maintenance notes and safety points.
- Read this manual even if you are familiar with vehicle handling as this manual is specific to this motorcycle.
- This manual should be included if the motorcycle is being re-sold.
- **NOTE:** Some of the pictures included in this manual may differ from the actual motorcycles available on the market due to changes in design and specifications.

About safety symbols

- Safety symbols and indications
Matters that could cause major accidents to the rider or other people are indicated with symbols below. Read and recognize these properly.
 - DANGER** - Ignoring instructions is likely to cause death or major damage and/or casualties.
 - WARNING** - Ignoring instructions may cause death or major damage and/or injuries.
 - CAUTION** - Ignoring instructions may cause damage and/or injuries.
 - NOTICE** - Important knowledge for proper handling of the vehicle
 - NOTICE** - Useful knowledge for proper handling of the vehicle

Table of Contents

For safe riding	5	Refueling	25
Names of Parts	12	Fuel cock.....	27
How to read/use the meters	14	Transporting the motorcycle	28
Gauges	14	Correct riding / operation	30
Speedometer.....	14	Starting the engine.....	30
Odometer.....	14	Changing gears.....	33
Warning lamps	15	Riding.....	34
Speed warning lamp.....	15	Using the brakes.....	36
Neutral indicator lamp.....	15		
Using the switches	16		
Main switch (ignition).....	16		
Hi/low beam switch.....	17		
Indicator.....	18		
Horn.....	19		
Using the equipment	20		
Helmet holder.....	20		
Handle lock.....	21		
Collapsing handle bars.....	22		
U-shaped lock holder.....	23		
Document storage / Tool box.....	24		

Safe maintenance	38
Daily / regular cheks, easy maintenance	41
Daily checks	43
Regular inspections	46
Easy maintenance	48
Brakes	49
Front brake.....	49
Brake lever play (check).....	49
Rear brake.....	50
Brake pedal play (check).....	49
Front / rear brakes.....	53
Brake shoe wear checks.....	53
Tires	54
Inspecting tire pressures.....	67
Checking for signs of damage.....	55
Abnormal wear checks.....	56
Tread depth checks.....	56
Replacement tires.....	57
Drive chain	58
Inspecting chain adjustment.....	58
Applying lubricant / cleaning.....	59

Engine oil	60
Inspecting the engine oil level.....	60
Engine oil type.....	61
Clutch	65
Inspecting clutch lever play.....	65
Battery	67
Removing/attaching battery.....	68
Fuse	70
Inspecting the fuse & replacement.....	70
Air cleaner	72
Air cleaner installtion / removal.....	72
Checking the air cleaner element.....	73
Cleaning the air cleaner element.....	74
Cable / wires	75
Checking rubber boots.....	75
Checking cables and wiring condition.....	75

--

Taking care of the motorcycle.....	76
Storing the motorcycle.....	79
Protecting the environment.....	80
Disposing of the motorcycle/parts..	80
Ordering colored parts.....	83
Exhaust pipe authenticity logo.....	83
Frame number.....	84
Starting problems.....	85
Main specifications.....	86
Service data.....	88

For safe riding

The items outlined below are basic rules to be followed on a daily basis. Always adhere to these points and aim to safely and take care when riding this motorcycle.

*There is a speed warning light placed on top of the headlight casing. This will start to flash when the motorcycle's speed goes over 30km/hr to urge the rider to slow down.

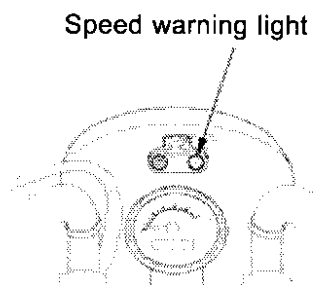

Before riding

Perform pre-ride inspections

Always keep the motorcycle clean and perform the compulsory inspections and maintenance. The pre-ride inspections are outlined on page 43.

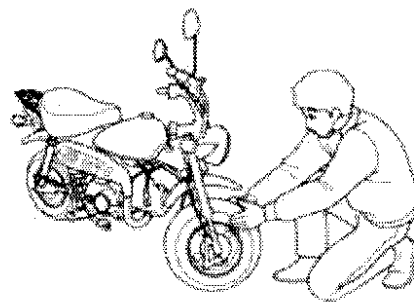

-Carry out regular inspections.
(Refer to page 46 for regular inspections)

For safe riding

Always stop the engine when refueling. Refuelling close to fire hazards is dangerous.

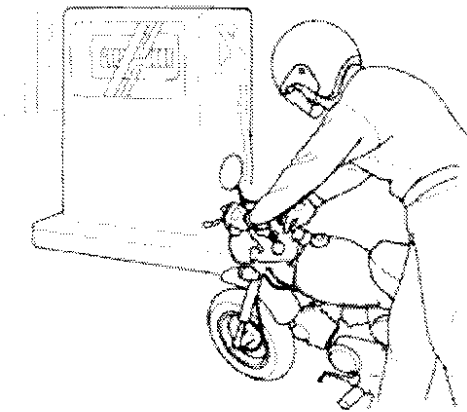

Exhaust fumes contain carbon monoxide and other poisonous gases. **Start the engine in a well-ventilated, open area.**

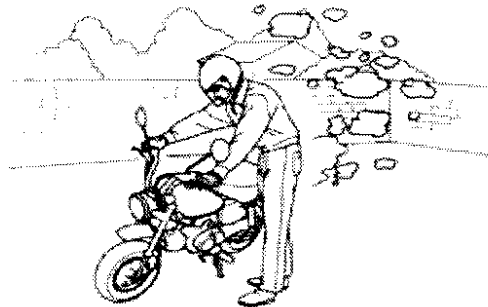

Riding gear

Always wear a helmet. This is also a legal requirement when riding this motorcycle. Make sure that the helmet is fastened securely underneath the jaw.

All helmets should conform to any necessary safety tests carried out in your country.

Make sure that the helmet also fits securely and is comfortable.

Always wear the correct safety gear as listed below:

A face shield or safety goggles

Boots that cover the heel and ankle correctly.

(Any recommended motorcyclists boot.

Hard wearing leather gloves

Long sleeve jacket and long sleeve trousers.

The jacket should have reflectorised tape as well as being bright to be seen easily at night.

Any jacket or pants must be of a loose fit but not too loose that it will get caught between the

mechanism and yourself.

Warning!

Severe injury or even death may result in the event of an accident if the helmet is not worn correctly.

Make sure that all riders wear helmets at all times .

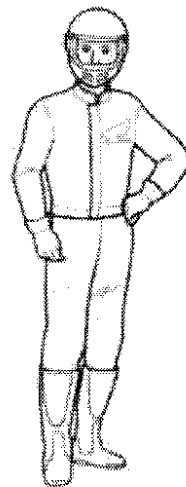

For safe riding

Riding

- The rider must place both hands on the handle-bars and both feet on the foot pegs provided.

- **Avoid sudden steering maneuvers and single handed riding.**

These rules are the most basic safety points for motorcycle riding.

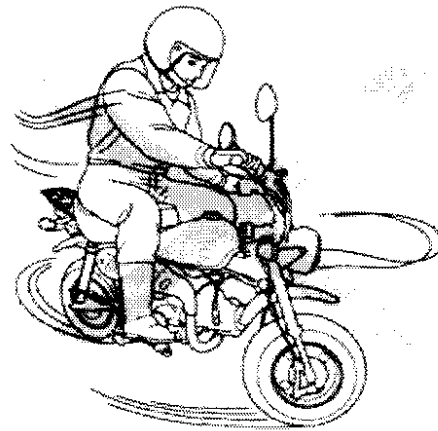

Load

The handling characteristics of the motorcycle will change when carrying a load.

Always secure any load firmly and never carry any excess load.

Placing any load too close to the handle bars will adversely effect the steering of the motorcycle.

Placing loads too near the headlight may also cause problems of the headlight over heating and/or burning the load itself.

The maximum load that the rear carrier is designed for is 3kg.

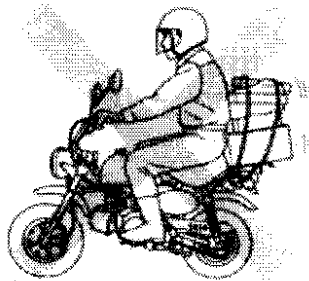

Modifications

Modifying the structure and performance of the motorcycle can affect handling, increase exhaust volume and shorten the life of the machine. Modifications as such are illegal and inconsiderate of the general public. The warranty does not cover modified machines.

This model was built to exhaust standards of 1998. Therefore adding louder more open mufflers cause the machine to fall outside of those standards.

For safe riding

Parking

- Turn the steering wheel left and park the vehicle on a level surface. The following positions will cause the vehicle to fall from imbalance.
- Parking with the steering wheel turned right.
- Parking on slopes, metal/gravel roads, uneven surfaces, and soft ground.

- When parking in any of the position/places listed above is unavoidable, take the necessary precautions to provide safety and to prevent the motorcycle from moving or toppling.

Using the side-stand for parking

- Park on level, stable ground.
- Choose a safe parking spot that will not interfere with pedestrian or road traffic.
- The exhaust pipes will become heated during use. Park the motorcycle in a safe place to avoid contact with people.
- Do not touch the exhaust pipe or the engine while the engine is running.

Make sure that the motorcycle is parked out of the way, so that people will not touch the hot parts of the machine after it has been running.

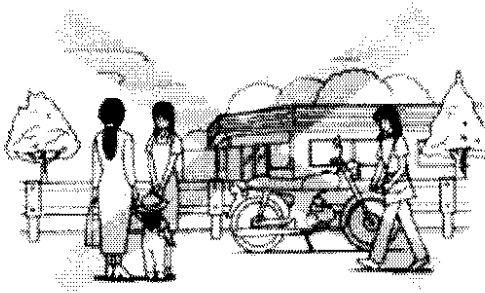
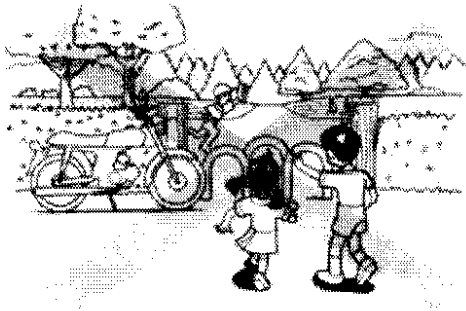

Do not touch the muffler directly after the motorcycle has been running as this will be very hot.

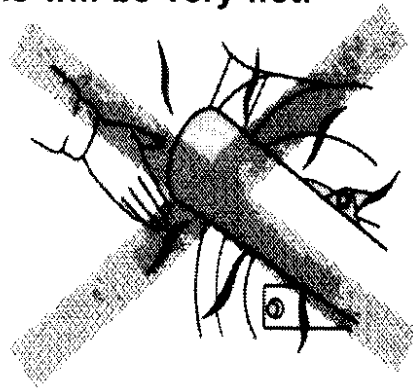

ATTENTION

The exhaust pipes and engine will remain extremely hot during and after use. Avoid direct contact with any engine/exhaust components. Also park in a safe spot that will prevent others from touching the vehicle.

Names of parts

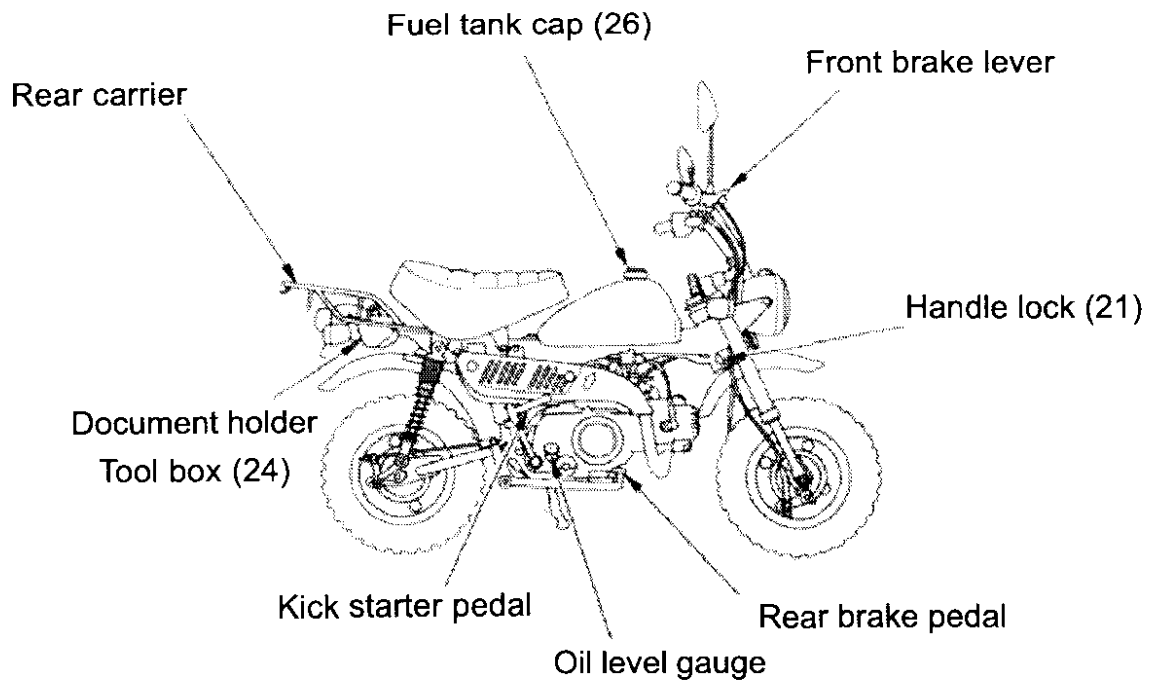

Names of parts

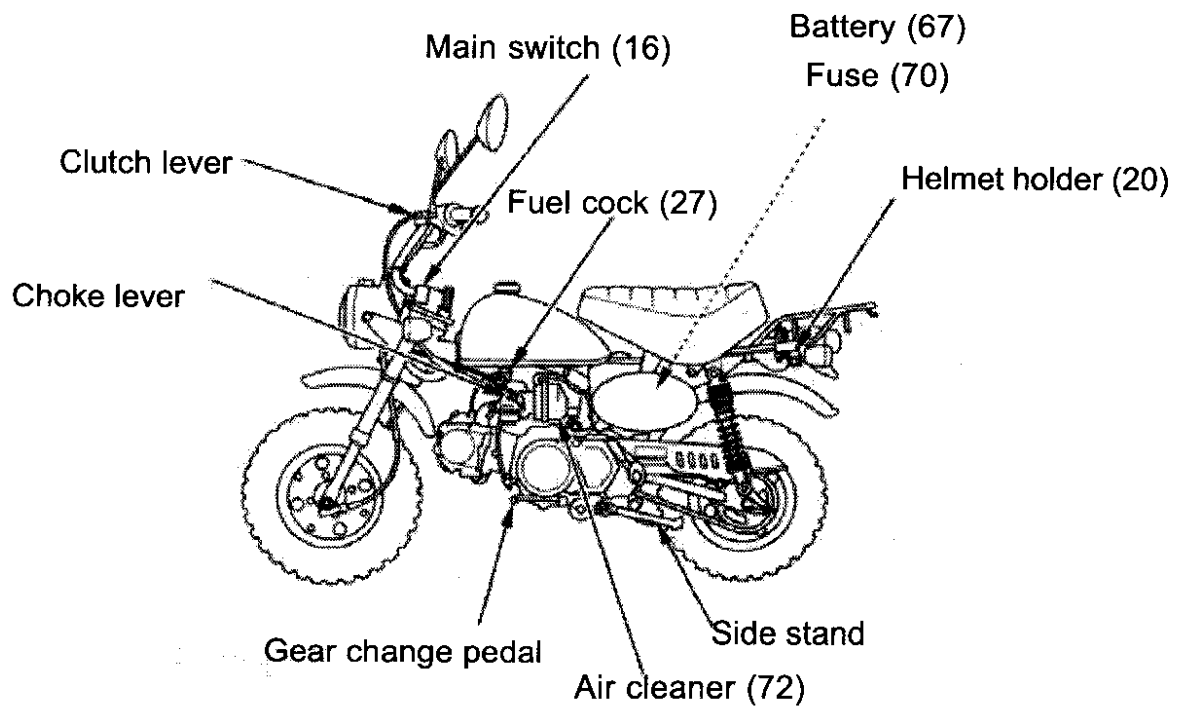

How to read and use the instrument panel

Gauges

Speedometer

This measures speed while traveling. Travel safely and keep to the regulation speed limit.

The top speed range designed for each gear is also shown on the display.

Pushing the engine beyond the limits stated will have an adverse affect on the engine.

Odometer

This measures the total distance travelled and displays it in km units. Black figures on a white background are displayed in 100 m units.

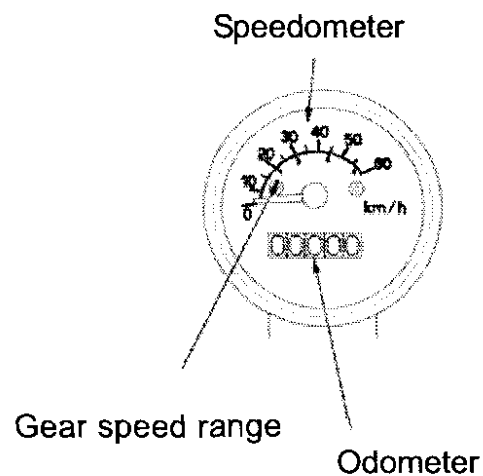

Speed warning light

This light will start to flash when the motorcycle is traveling over 30km/hr.

Neutral light

This light will show when the main switch is in the "ON" position and the transmission is in neutral.

Neutral display light Speed warning light

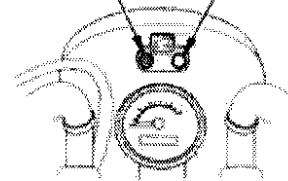

Using the switches

Ignition/Main switch

The main switch controls the on/off for the electrical system.

NEVER operate the switch when traveling.

When the main switch key is "OFF", the electrical system will not work. Operating the main switch while traveling may result in unexpected accidents, only operate this switch when the vehicle is stationary.

NOTICE

When leaving the motorcycle, always apply the handle lock and remove the key.

Key position	Usage	Key
ON	Start Day/Night riding Horn, indicators, brake light will operate	Key cannot be removed
OFF	Stop Electrical system is completely shut OFF	Key can be removed

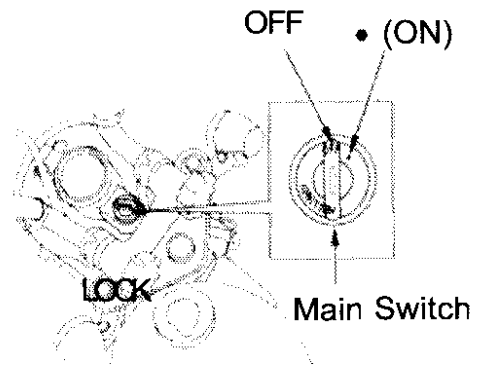

How to read and use the meters

Headlight selection switch

Headlight lamp selection

Select either HIGH beam or LOW beam with this switch.

HIGH beam position

LOW beam position

Select LOW beam during daylight hours.

HIGH/LOW beam selection
switch

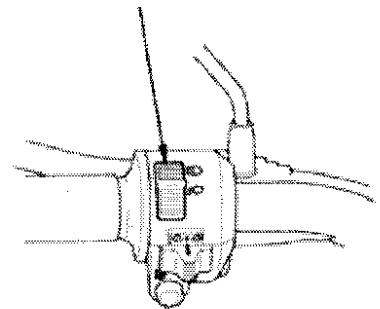

Using the switches

Indicator switch

Use this switch to activate the right/left indicator as required when turning or changing lanes.

Operation

This device operates only when the key is in the ON position.

The selection can be cancelled by simply pressing in the center of the switch.

NOTICE

The indicator will not cancel by itself. Make sure that you cancel the indicator after completing the desired turn or lane change.

Leaving the indicator in a selected position will confuse other road users.

Make sure that if you replace an indicator bulb that it is the correct wattage as incorrect bulbs may not work.

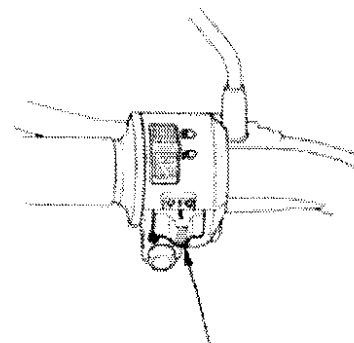

Indicator selection switch

Using the switches

Horn

The horn will sound when the main switch is in the "ON" position and the Horn switch is pressed.

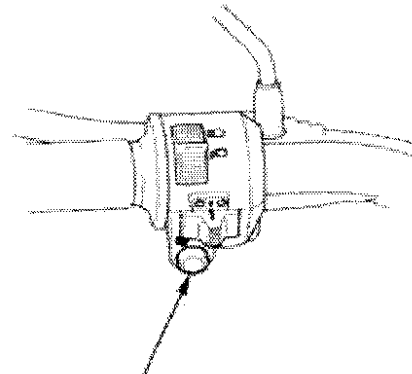

Horn switch

Using the options

Helmet holder

Only use the helmet holder when the motorcycle is parked. Riding with a helmet in the holder may obstruct normal riding and/or cause damage to the bike or the helmet itself.

Operation

1. Insert the main ignition key into the lock position and turn it to the left. This will unlock the holder pin.
2. Place the holder pin into the helmet's clip and then press the pin to lock in place.

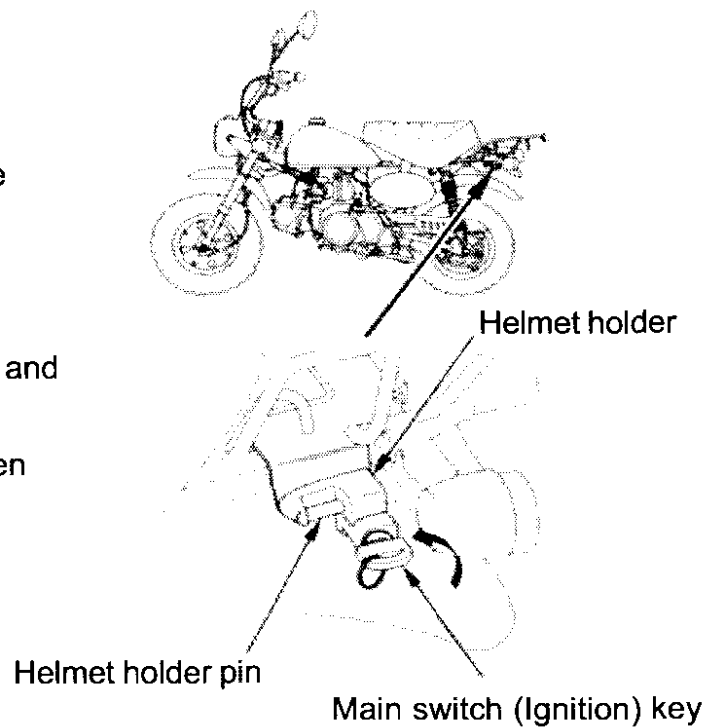

Using the options

Handle lock

Always use this device when leaving the motorcycle in a parked state to help prevent theft. Chain and U shaped type locks are also recommended.

Operation

1. Turn the handle bars to the left fully.
2. Place the Main switch (ignition) key into the handle lock device.
3. Turn the key 180 degrees to the right to lock the device. (Move the handle bars to the right/left slightly if it is difficult to maneuver the lock into place).
4. Remove the key.

Unlocking

Follow the above operation in reverse.

Make sure that the handle bars will turn to the left and right completely before attempting to ride once more.

NOTICE

Always park the motorcycle out of harms way.

Make sure that the handle lock is in place by gently moving the handle bars to the right/left.

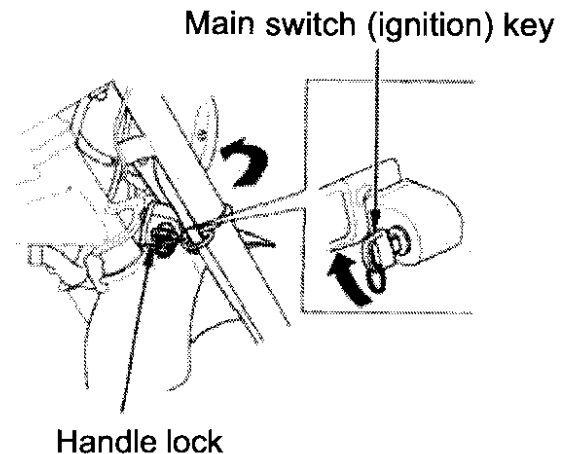

Using equipment

Collapsing the handle bars

Make sure that the cables are not damaged when folding the handle bars down.

Collapsing

1. Loosen off the knob while supporting the handle bars by hand.
2. Move the handle bars forward to remove from the stopper alignment point.
3. Lower the handle bars and then tighten the knob after alignment into the shallow groove stopper point.

Reassembly

Follow the above operation in reverse considering the following points:

- *Make sure that the handle bar fitting for the deeper stopper groove point is fixed in place correctly.
- *Make sure that there is no abnormal or loose handle bar movement when assembled again.
- *Make sure that all items are working correctly.

Collapsing

Knob

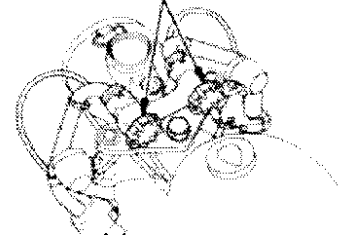

Reassembly

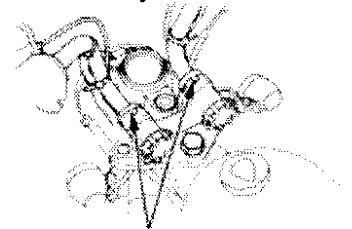

Stopper

Using equipment

Side cover

Take care when handling the side cover as it will be hot directly after the engine has been running.

Removal

Pull the side cover outward and remove it from its grommets.

Attachment

Insert the side cover hook onto the frame grommets.

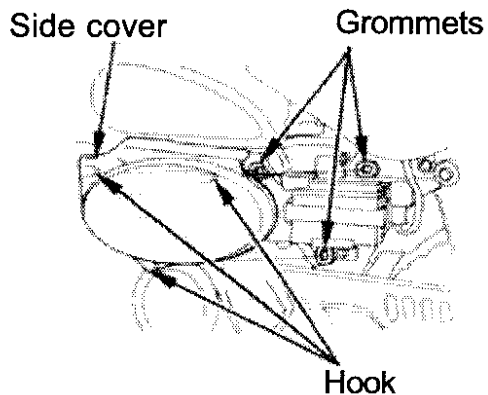

U shaped lock storage space

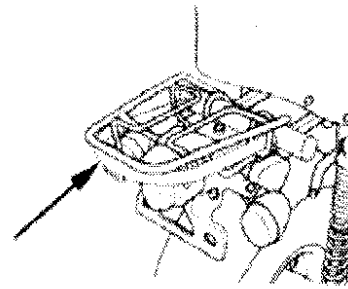

The carrier can support and is designed for holding a U shaped locking device.

Place the U shaped lock onto the carrier as shown in the above diagram and make sure that it is locked in place.

*The U shaped lock is an optional device.

NOTICE

Some U shaped locks may not be suitable for this motorcycle.

Using equipment

Document / portable tool box storage

Document and tool box storage is under the seat. The instruction manual and maintenance notebook should be stored here within a plastic bag.

NOTICE

Do not apply water directly at the storage area when washing the motorcycle as water may get inside.

Portable tool box

A convenient portable tool box is placed under the seat. Use the rubber holder band to hold it in position.

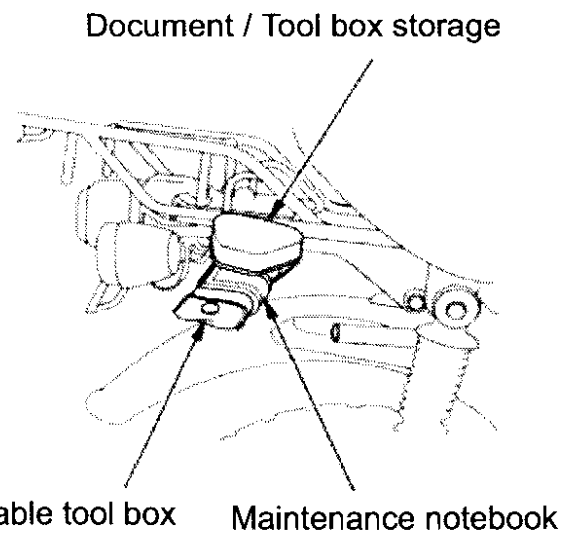

Refueling

Specified Fuel

Unleaded petrol 91octane (RON) or higher

NOTICE

Always make sure that you refill with unleaded petrol. High octane or alcohol based fuels may cause damage to the engine and the fuel system. Old petrol or low grade fuel will have an adverse affect on the engine and should always be avoided.

Always stop the engine when refueling.
Never refuel in close proximity of fire hazards.

WARNING!

-Petrol is highly flammable, and may lead to injuries including severe burns.

When handling petrol:

-Turn off the engine. Never refuel in close proximity to fire hazards such as naked flames, fireworks etc.

-Always refuel outside.

- Any fuel spills must be wiped off immediately.

Extreme care must be taken around fuels as static electricity etc can cause sparks which could lead to igniting fuel fumes.

When refuelling:

-Remove any static electricity on the motorcycle, pump or any other metal area by touch before opening the fuel tank.

-Make sure that anyone else entering the immediate vicinity has released any static electricity build up.

Refueling

1. Open the key cover on the fuel tank. Insert the ignition switch key and turn clockwise to open the fuel tank cap.

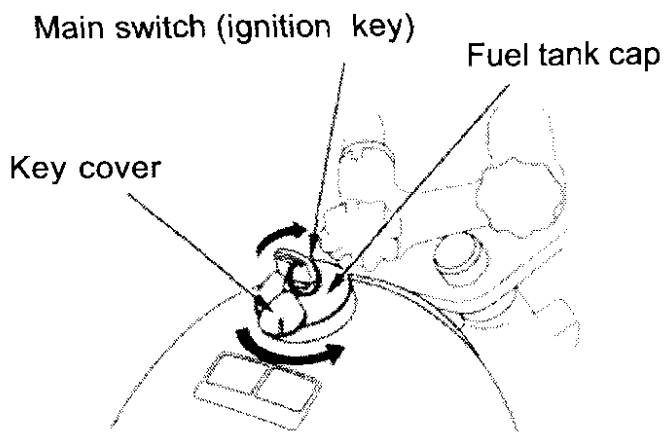

Refuelling

2. Fill the fuel to the bottom of the lower level plate.

If fuel is filled to a position over the bottom of the lower level plate, fuel will seep from the overflow breather opening on the fuel tank cap.

3. Hold the fuel tank cap down and remove the ignition key.

If the gas tank cap does not close properly then the ignition key cannot be removed.

4. Close the key cover.

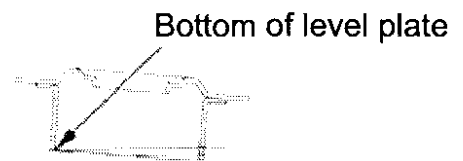

Tank fuel cock

Position of the level shows the fuel cock status.

ON – The gasoline will flow into the carburetor. When starting the engine, place in this position.

OFF – The fuel will not flow to the carburetor. Place in this position when storing vehicle for long periods of time, or when inspecting or servicing the vehicle, .

RES – This position draws fuel from the reserve tank. Place in this position when the gasoline has fully run out in the "ON" position. Refuel as soon as possible. After refueling, return to the 'ON' position. Leaving in the RES position will consume the fuel in the reserve tank, leaving no reserve if fuel runs out. (Reserve tank capacity: Approximately 1.0 L)

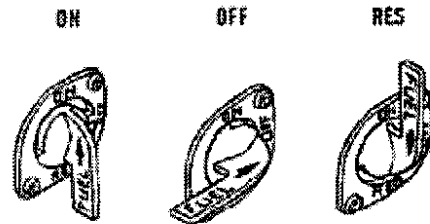

Lifting / transporting the motorcycle

Make sure that petrol inside the tank is removed before transporting.

Always make sure that the engine is turned OFF when refuelling or draining petrol.

WARNING!

-Petrol is highly flammable, and may lead to heavy injuries including severe burns.

When handling gasoline:

-Turn off the engine. Never refuel in close proximity to fire hazards such as naked flames, fireworks etc.

-Always refuel outside.

-Any fuel spills must be wiped off immediately.

Extreme care must be taken around fuels as static electricity etc can cause sparks which could lead to igniting fuel fumes.

When refuelling:

-Remove any static electricity on the motorcycle, pump or any other metal area by touch before opening the fuel tank.

-Make sure that anyone else entering the immediate vicinity has released any static electricity build up.

As the engine and the muffler etc will be hot directly after riding, wait for these areas to cool down before attempting to remove fuel from the tank.

Make sure that you remove fuel in a well ventilated area.

1. Make sure that the motorcycle is in an upright position.
2. Use a normal handpump to transfer fuel from the fuel tank to a storage holder.
3. Place the fuel cock onto the RES position.
4. Place a fuel capturing container underneath the carburettor drain tube.
5. Open the carburettor drain screw, and close off the fuel drain screw.
6. Place the fuel cock in the "OFF" position.

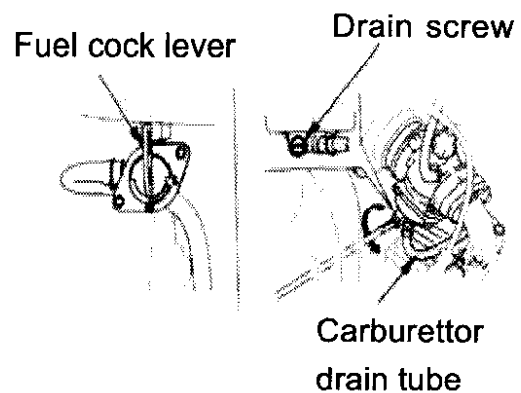

When lifting/transporting the motorcycle Collapse the handle bars wherever necessary as explained on page 22.

When loading onto / into a vehicle Always make sure that the motorcycle is upright and that it is securely fastened before transporting.

Correct riding

Starting the engine

Exhaust fumes contain hazardous gases such as carbon monoxide. Always start the engine in an open and well ventilated area. Follow the instructions on page 31~32 for starting the engine.

NOTICE

Placing the motorcycle into gear with the side stand down will automatically shut off the engine. Always have the side stand up when starting.

NOTICE

Do not overrev the engine under no load or leave the motorcycle idling for extended periods as this will not only waste fuel but may also adversely affect the engine.

Starting the engine

-WHEN THE ENGINE IS COLD

1. Check that the handle lock is released.
2. Check to see that the fuel cock lever is set to "ON".
3. Turn the ignition switch "ON".
4. Place the transmission in neutral (confirm this with the neutral display lamp).
5. Fully Lift the choke lever to the ON position.
6. Turn the throttle grip between 1/8~1/4 and then firmly kick start the motorcycle.
7. Gradually push back the choke lever as the engine starts. Wait until the engine is warm and completely push back the choke lever as the engine rpm returns to a smooth operating range.
8. Make sure that the side stand is properly housed away before riding.

NOTICE

DO NOT ride with the choke on for long periods as this will only use more fuel and may cause an adverse effect on the engine.

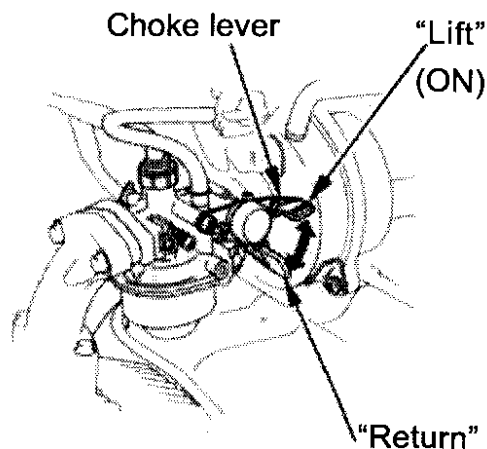

Refer to page 85 if the engine will not start.

Starting cont:

-WHEN THE ENGINE IS WARM

1. Check the handle lock is released.
2. Confirm that the fuel cock lever is switched to "ON".
3. Turn the ignition switch "ON".
4. Place the transmission in neutral (confirm this with the neutral display lamp).
5. Turn the throttle grip between $1/8 \sim 1/4$ and then firmly kick start the motorcycle.
6. Adjust engine RPM to a smooth level by the throttle.
7. Make sure that the side stand is properly housed away before riding.

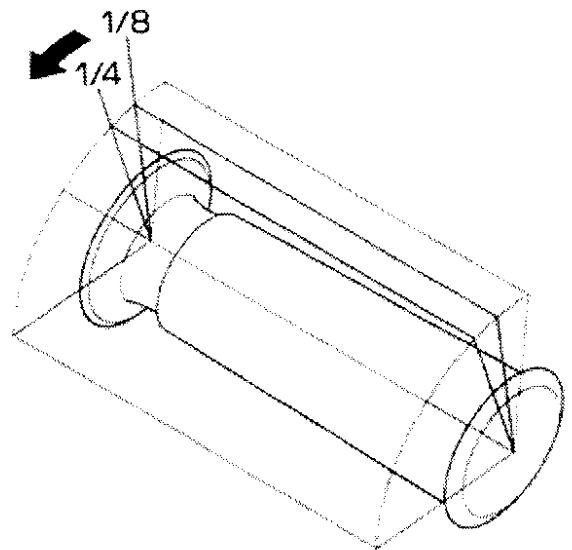

-Refer to the instructions outlined on page 85 if the engine fails to start.

Changing gears

The gear box on this motorcycle is a 4 speed type as shown in the diagram on the right.

-Close the throttle, engage the clutch lever then change gears.

-Lightly use the tip of your foot to change gears.

Applying excessive force to the gear change lever can damage the gear box.

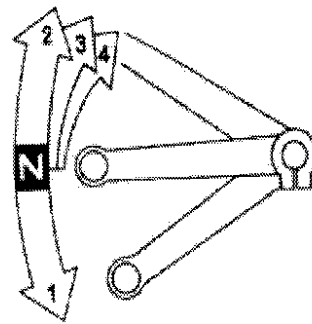

Correct operation

Riding

- Check to see that the kick starter pedal and the sidestand are housed away properly.

-The gears on this motorcycle should be changed according to the traveling speed. The table on the right indicates the speed range each gear is smoothly capable of traveling in.

-Avoiding unnecessary acceleration is the key to saving fuel and prolonging the useful life of this motorcycle.

NOTICE

-Immediately request an inspection by a Honda dealer if any abnormal sounds can be heard from the engine.

NOTICE

-Immediately request an inspection by a Honda dealer if any abnormal sounds can be heard from the engine.

	Speed range
1 st gear	0~20 km/h
2 nd gear	5~30 km/h
3 rd gear	10~45 km/h
4 th gear	Over 20km/hr

< Running in >

Avoid aggressive starting and acceleration during the first 500kms of riding, and ride well below the speed range indicated above. Properly running in the engine will prolong the useful life of this motorcycle.

NOTICE

- Start the vehicle in a courteous manner.
- Ride within the speed limit.

< Shifting down >

Shifting down will provide the necessary acceleration when overtaking other vehicles etc. Shifting down at excessively high speeds will cause the engine rpm to rise abruptly, possibly affecting the engine and the gear box. Perform the down changes in the speed ranges displayed in the diagram below.

Permissible shift-down speed range	
4 th – 3 rd gear	30km/h and below
3 rd – 2 nd gear	20km/h and below
2 nd – 1 st gear	10km/h and below

Correct operation

Using the brakes

-Both front and rear brakes should be applied **at the same time**.

-Avoid unnecessary abrupt braking. Sudden braking can cause the wheels to lock up making the motorcycle unstable and possibly causing an accident.

-Applying only the front or rear brake can cause the tires to lose traction, resulting in a fall.

-Excessively applying the brakes in the rain or when the road surface is wet can cause the tires to lose traction, resulting in a fall. Ride slowly in these conditions and leave enough time to apply the brakes gradually.

-Avoid continuous and consecutive application of the brakes as this can cause the brakes to heat up, decreasing their performance.

- The brake performance may decrease after riding through a water puddle or in wet conditions. Always apply brakes gently at low speed after riding through any kind of water hazard including puddles and check the performance of the brakes (Make sure that the traffic is clear before doing so). If the brakes are not functioning properly, apply further gentle braking to dry out the brake system.

Correct operation

Engine braking

Closing the throttle will start the engine braking function. If more powerful engine braking is necessary, shift down (3rd~2nd...gear) and close the throttle.

Abrupt downshifting can cause the rear tire to lock up and lose traction. Refer to the table on page 35 for instructions on downshifting.

Combine braking and the engine braking on long or steep down hill runs.

Safely performing inspections and maintenance

-Make sure that the ignition key switch is off before starting maintenance.

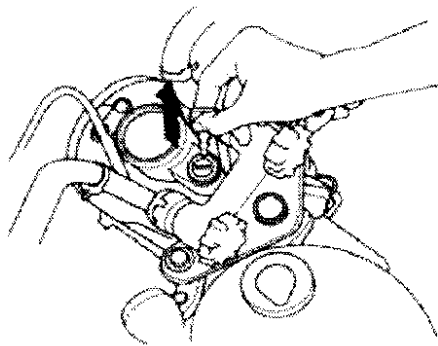

-Secure a safe, flat parking spot and place the motorcycle on its stand before starting maintenance.

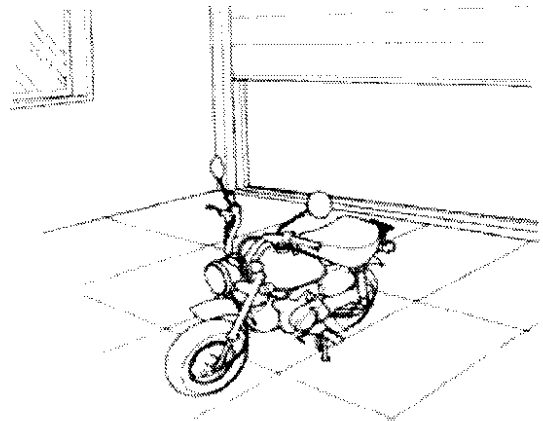

-The exhaust pipes and engine unit are hot after running. Take care to avoid burns when inspecting or maintaining the motorcycle directly after the engine has been running.

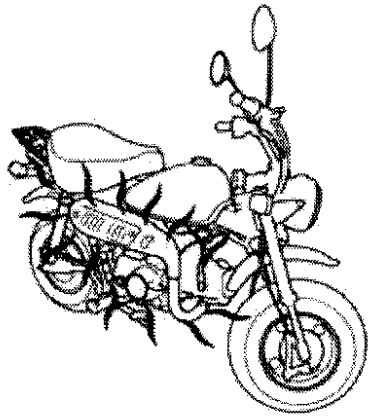

-Exhaust fumes contain carbon monoxide and other poisonous gases. **Start the engine in an open, well-ventilated area.** Do not start the engine for inspection/ maintenance within an enclosed garage or places that lack adequate ventilation.

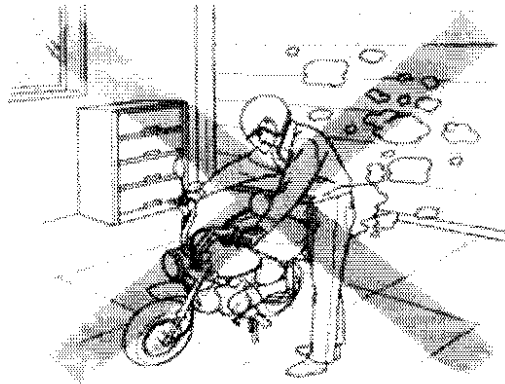

Safe maintenance

-Choose a safe appropriate spot and pay attention to the traffic conditions when test rides are to be conducted.

- Always use appropriate tools as required

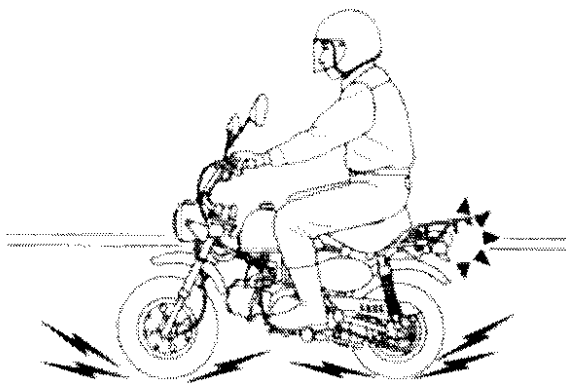

Daily/regular inspections, and easy maintenance

Inspections must be carried out daily for safety. More thorough inspections should be carried out every 6 months, and every 12 months.

WARNING!

If regular inspections are not carried out correctly, inappropriate servicing, or neglecting to repair the motorcycle may lead to serious accidents.

- Always follow this manual or the service manual when inspecting your motorcycle.
- Repair any faults before riding.

Refer to the following pages for respective inspection / maintenance areas:

Monthly inspections.....	42
Replacement parts.....	42
Daily inspections.....	43
Maintenance parts diagram.....	44
Regular inspections.....	46
Inspections to be undertaken every	
6 months.....	47
Easy maintenance.....	48
Brake.....	49
Tires.....	54
Drive chain.....	58
Engine oil.....	60
Clutch.....	65
Battery.....	67
Fuse.....	70
Air cleaner.....	72
Cables / wires.....	75

Daily/regular inspections, and easy maintenance

First month inspection

The first month (or the first 1000km) of riding when the motorcycle is new can greatly effect the future life of the machine.

Please contact your local AUTHORISED HONDA dealer for service.

Any labour, oil, consumables, or parts required will be charged to the customer in this inspection.

Replacement parts

Any parts that need replacing during the various inspections that the motorcycle will go through, should always be replaced with "HONDA Genuine Parts".

These parts have all been passed by a strict examination process to be given the HONDA mark.

See your AUTHORISED HONDA dealer for details. All of these parts will bear the following logo.

HONDA

GENUINE PARTS

Daily inspections

Inspections must always be carried out once daily for safety before riding. Detailed instructions are available in the "Easy maintenance" section for the underlined items. The following pages show important maintenance parts / location with diagrams. Also refer to the "Maintenance notebook" for inspection methods.

The following items must be inspected daily:

- Brake
 - Lever play
 - Pedal play
 - Brake performance
 - Brake fluid level
- Tires
 - Air pressure
 - Cracks, damages
 - Excessive wear
 - Tread depth (*)
- Engine
 - Engine oil level (*)
 - Starting up, irregular noise(*)
 - Slowing, accelerating operation (*)
- Lighting devices and indicating lamps
- Any faults detected from previous day Items with (*) mark should be carried out depending on the mileage of the motorcycle or the state of the ride quality.

Daily inspections

Maintenance parts diagram

Refer to the "Easy maintenance" section of this manual, and the separate maintenance notebook for detailed inspection methods.

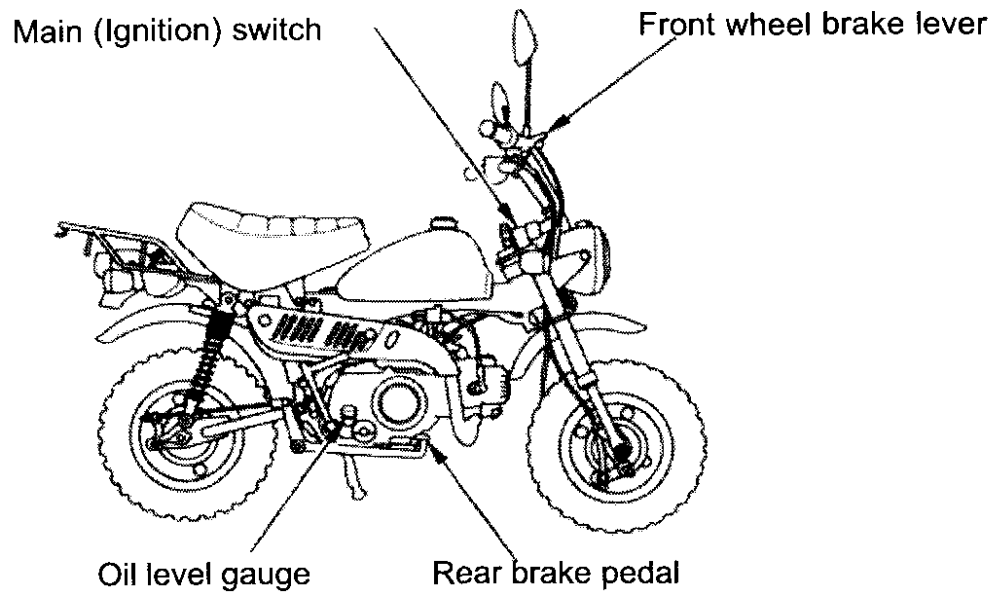

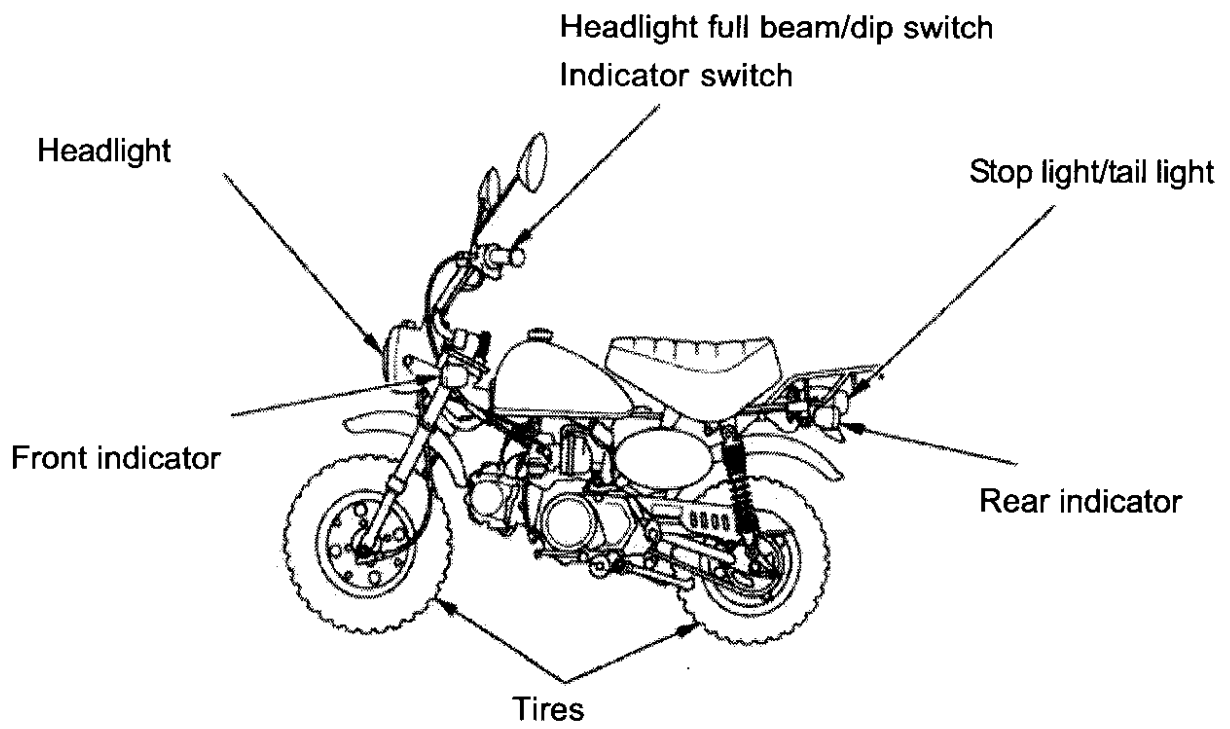

Regular inspections

Motorcycles must undergo 3 regular inspections - 6 and 12 monthly inspections, and a one month (or after 1000km) inspection.

There are also other items that should be checked as recommended by HONDA.

Carry out all these inspections for the safety of the motorcycle and the rider.

It is the owner's responsibility to carry out these inspections. It is also the owner's responsibility to take the motorcycle to a workshop if inspections cannot be carried out by the owner.

- Consult your nearest AUTHORISED HONDA dealer if these inspections cannot be carried out by yourself.

- Carry out inspections within your range of knowledge and ability. Consult the nearest AUTHORISED HONDA dealer if the inspection process is too difficult for you.

Inspection results should be recorded into the "Maintenance notebook" for reference, and should be stored separately away from the motorcycle.

Refer to page 88 for service data on inspection/maintenance figures.

The inspection items for 6 monthly inspections are shown on the following page.

6 monthly inspections (Check in your maintenance notes for more details)

- Ignition device Spark plugs condition
- Engine Exhaust gas status
 Air cleaner element dirt/blockage
- Lubrication Engine oil leaks
- Clutch Clutch lever play
 Clutch function
- Chain & sprockets Chain adjustment
- Brake pedal & lever Play
 Brake performance
- Brake drum & shoes Gap between drum and lining
- Wheel Tire pressure
 Wheel bolt / nut tightness

Easy maintenance

This section will list and explain the most common maintenance procedures conducted for inspections, cleaning, adjustments, and replacement.

For safety, only undergo maintenance that can be carried out by using your skill and knowledge, and use the appropriate tools. Consult the nearest AUTHORISED HONDA dealer if you are not qualified.

Brakes

Front Brake

<Inspecting lever play>

Pull in the front brake lever until resistance can be felt. Measure the play and confirm that the play is within the specified range by using a scale

Front brake lever play: 10-20 mm

Adjust the play if it is outside the specified range. Place the handle bars so that the motorcycle would travel forward in a straight line. Adjust by tightening (or loosening) the brake arm adjuster.

*Adjustments should be carried out by half turns on the adjuster.

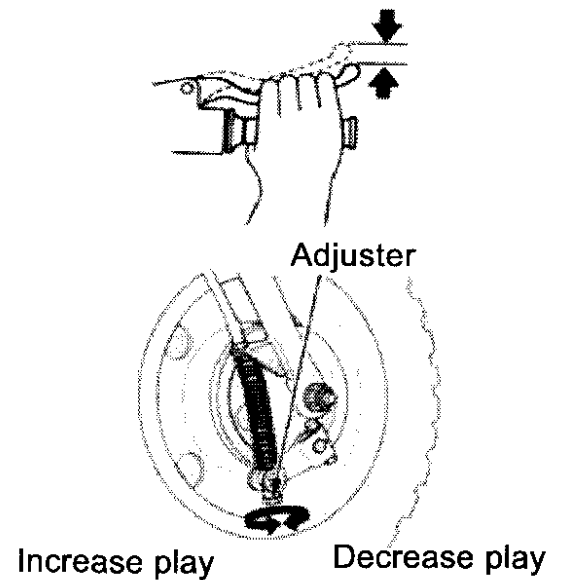

Easy maintenance

After adjusting, check the gap between the adjuster and the pin by pushing the brake arm inwards.

Check the level of play after carrying out the adjustment process.

For further details check with your HONDA dealer.

Check with your HONDA dealer if the level of play exceeds the adjustable range.

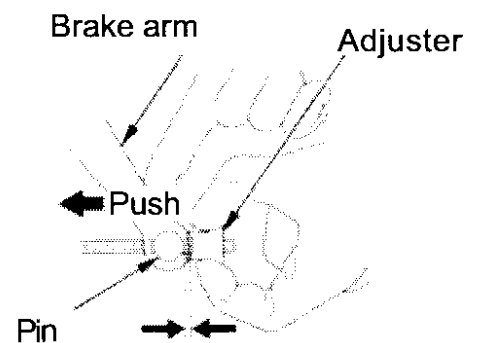

Rear brake

<Inspecting pedal play>

Push down on the rear brake pedal until resistance can be felt. Measure the play and confirm that the play is within the specified range by using a scale

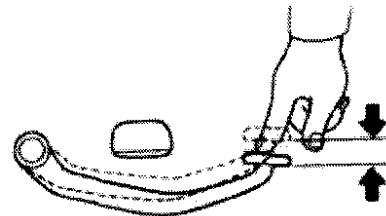

Rear brake lever play: 10-20 mm

Adjust the play if it is outside the specified range.

Adjustment

Adjust by tightening (or loosening) the brake arm adjuster.

*Adjustments should be carried out by half turns on the adjuster.

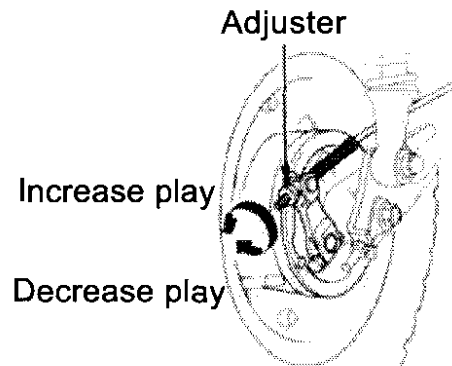

Easy maintenance

After adjusting, check the gap between the adjuster and the pin by pushing the brake arm inwards.

Check the level of play after carrying out the adjustment process.

For further details check with your HONDA dealer.

Check with your HONDA dealer if the level of play exceeds the adjustable range.

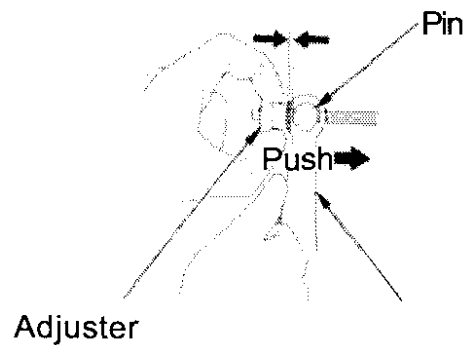

Checking front/rear brake

wear

Check that the indicator on the brake arm and the grooved point on the brake panel are not overlapping each other. If the two points are overlapping each other, it shows that the brake shoes have worn to their limit and will need replacement.

Contact your HONDA dealer for replacement of the brake shoes.

Front wheel

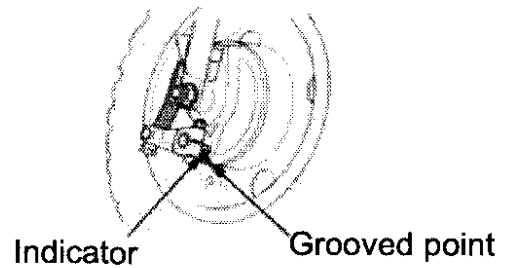

Rear wheel

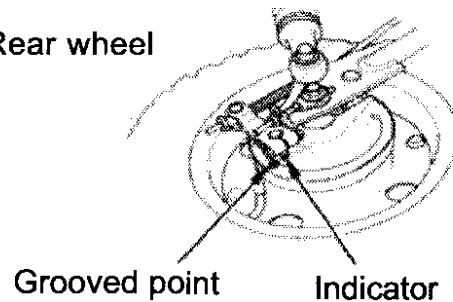

Tires

Tires must be in good condition in order to ride your motorcycle safely.

Always keep the tire pressure within the specified range. Replace tires that are worn out.

WARNING

Worn out tires and wrong tire pressures may cause accidents and injuries. Always adhere to specified tire pressure and replace worn out tires.

<Checking air pressure>

Check the tire shape when the wheels are in contact with the ground. If the shape of the tire looks abnormal, check the tire pressure when cold with a tire air pressure tester.



OK

NOT OK

Tire pressure will gradually decrease. It is also very difficult to judge whether a tire is losing air pressure depending on the type of tire used by sight alone. Therefore tire pressure should be checked at least once monthly.

Always check tire pressure when tires are cold as the air pressure will increase inside the tires when they are hot after the motorcycle has been used.

Tire air pressure

Front wheel	100kPa (1.00 kgf/cm ²)
Rear wheel	125kPa (1.25 kgf/cm ²)

< Tire damage >

Check the tires daily before riding for any signs of damage from nails, stones, ruptures, cracking etc. Also check the tires for any signs of damage after riding on rough surfaces such as road curbing or over potholes etc.

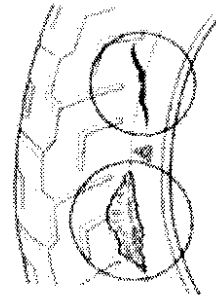

Easy maintenance

Checking for abnormal wear

Check for any signs of wear where the tires strike the ground.

Have your HONDA dealer check for any imbalances if you find any abnormal wear.

< Tread depth >

Use the wear indicator mark to inspect the remaining tread on a tire. Replace the tires immediately when the wear indicator mark appears.

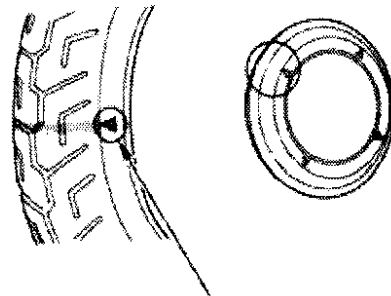
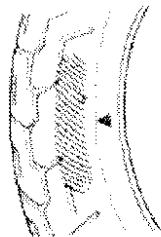

Wear indicator

Selecting new tires

Make sure that you always replace worn tires with the specified standard tire for this motorcycle.

Tires outside the specified standard may cause handling, steering or other type of riding problems.

Check with your HONDA dealer when tires are due to be replaced.

Front wheel	Size	13.50-8.35J (With tube)
Rear wheel	Size	3.50-8.35J (With tube)

WARNING!

Riding on incorrect sized tires can cause handling or steering problems. This is extremely dangerous and can be the cause of accidents resulting in seriously injury or even death.

Always replace worn tires with the specified tires as shown in this handbook.

Easy maintenance

Inspecting the drive chain

Drive chain slack

Using a ruler, inspect the slack of the drive chain by placing the motorcycle on its stand and lifting up the mid-section of the chain, approximately halfway between the front and rear sprockets.

Specified chain slack range: 10-20mm

Do not ride if the chain slack is over 40 mm.

Inspect the smoothness of the chain movement by standing the motorcycle upright and pushing it forward. The chain needs to be attended to if the chain movement is not smooth or if abnormal sounds can be heard. Consult the nearest **AUTHORISED HONDA** dealer for drive chain adjustment.

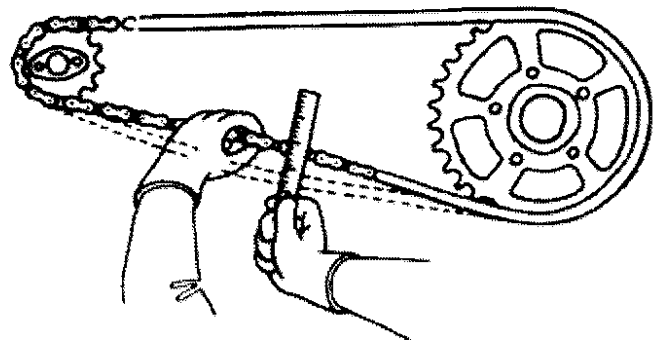

Drive chain play

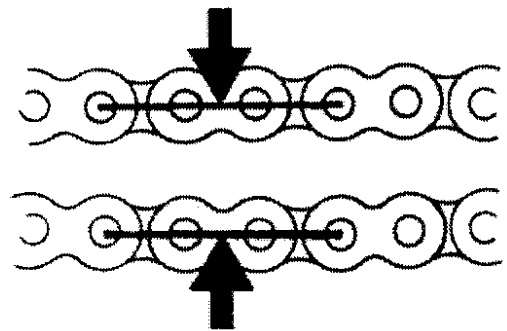

Lubricating the drive chain

- Remove any dirt/grime from the chain and sprockets (using brushes etc.) by moving the motorcycle back and forth.

Lubricate the chain after removing any dirt/grime.

Lubricate the inner sides of the chain roller to soak the oil into the chain.

< Specified lubricant >

“Honda genuine chain oil”, commercially available equivalent or gear oil (#80~#90)

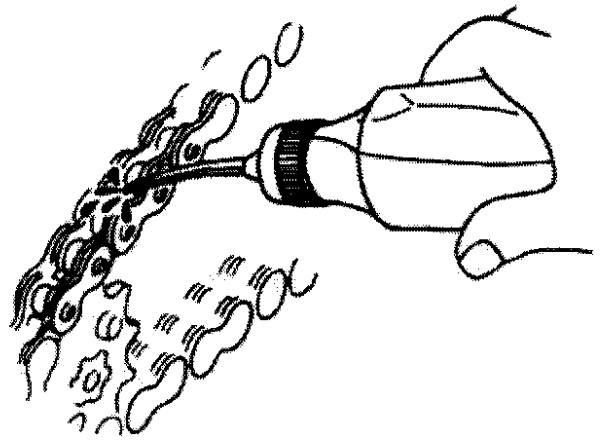

Easy maintenance

Engine oil

The oil in the engine must be checked regularly and topped up as required in order to maintain the motorcycle to its optimum condition. Any oil that is dirty or old will have an adverse effect on the engine and therefore should be replaced.

The exhaust pipes and engine unit are hot after running. Take care to avoid burns when inspecting or maintaining the motorcycle directly after running.

< Oil level inspection >

1. Leave the engine to idle for 3~5 minutes on a flat parking surface, then stop the engine.
2. Remove the oil level gauge after standing the motorcycle for 2-3 minutes.

3. Wipe any excess oil from the oil level gauge.

4. Stand the motorcycle upright and reinsert the oil level gauge without screwing it in fully.

5. Make sure that the oil level is between the upper and lower mark on the oil level gauge. Top up oil if necessary (Refer to the next page) and re-check.

6. Screw in the oil level gauge correctly and securely.

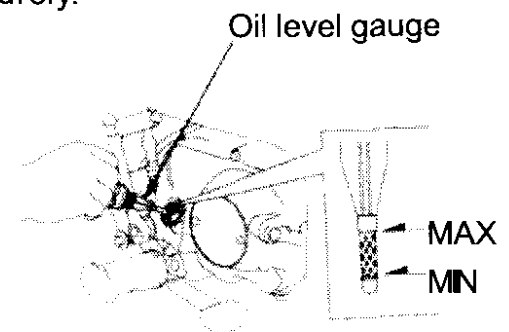

Engine oil type

< Specified oil >

Use HONDA genuine oil (4 stroke oil for motorcycles)

	JASO T 903 Standard	SAE Standard	API Mix
GN4	MA	10W-30	SJ Grade

If using a similar product:

Check the rating on the outside of the container. The oil must meet the following standards:

-JASO T 903 Standard: Motorcycle oil):MA

-SAE Standard: Can be selected according the oils stated on this page depending on the outside temperature where the machine will be used.

-API MIX: Applicable for SG, SH, SJ

Only oils that meet the above standards can be used in this motorcycle.

NOTICE

The clutch is soaked in engine oil. The clutch may slip or may not function properly if the engine oil uses anti-friction chemicals. This could also result in deteriorating engine performance and lowering the engine life.

- Do not use engine oils that have excessive amounts of anti-friction chemicals.
- Do not add anti-friction additives.
- Do not mix different grades of engine oil.
- Do not use engine oils that do not suit this motorcycle, as it may lead to engine breakdown.

Easy maintenance

NOTICE

Products with API standard marks shown are recommended only when they do not have the Energy Conserving logo shown as this type of oil has low friction additives and may affect the clutch performance.



NOT Recommended

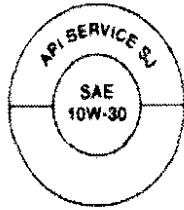

Recommended

NOTICE

The JASO T 903 standard is a 4 cycle engine oil standard. Oils that have complied with the standard have the following markings on their packaging.



Reference number

Capacity type: MA capacity

MA capacity recommended by HONDA as complying with JASO T 903.

Outside temperature and oil viscosity

Base the correct engine oil for your motorcycle on the temperature / viscosity chart as shown below.

(SAE Standard)

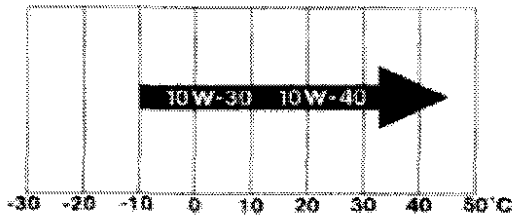

(Outside temp.)

Replacement timing:

1st replacement: After the first 1000km or 1 month

Normal replacement: Every 3000km or once yearly.

See your AUTHORISED HONDA dealer for oil replacement.

Easy maintenance

Refilling engine oil

1. Idle the engine for 3~5 minutes on a flat surface.
2. Stop the engine and remove the oil level gauge after 2~3 minutes.
3. Wipe off any oil on the level gauge.
4. Stand the motorcycle upright and refill engine oil until the oil level reaches the upper limit on the oil level gauge.

Make sure that no foreign particles can enter the oil filler port and also clean up any oil spillage correctly with a cloth.

5. Firmly replace the oil filler cap.

NOTICE

If the engine oil is below or above the specified level, it will have an adverse effect on the engine.

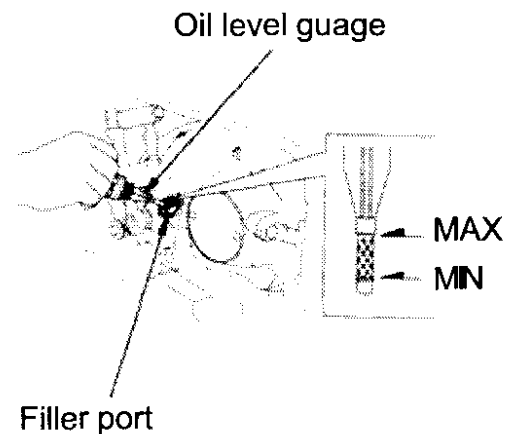

Inspecting the clutch

< Lever play >

Pull in the clutch lever until resistance can be felt. Measure the play and confirm that the play is within the specified range by using a ruler.

Clutch lever play: 10-20 mm

Adjust the play if it is over the specified range. Refer to next page for adjustment.

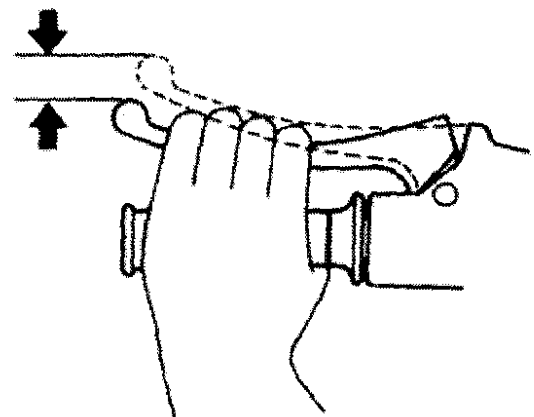

Easy maintenance

Adjusting the clutch lever play

Adjust the clutch lever play with the adjusters located on the clutch cable.

- Loosen the locknut and turn the adjuster.
- Tighten the locknut after adjustment.

After adjustment, pull in the clutch lever until resistance can be felt. Measure the play and confirm that the play is within the specified range using a ruler.

Also inspect for smooth gear changes and ensure that the engine does not stall or cause the motorcycle to engage abruptly after the adjustment.

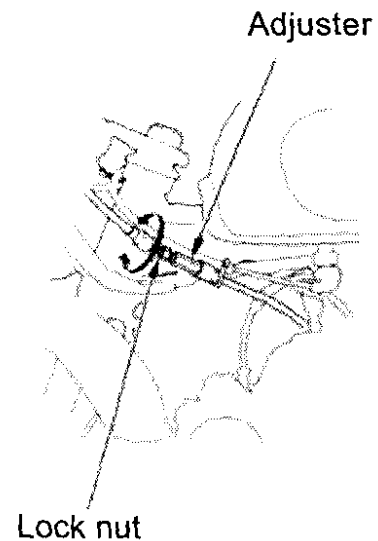

Inspecting battery fluid levels

This motorcycle was equipped with a sealed maintenance free battery at the time of manufacture. Inspection/refilling of the battery fluid is not necessary. Clean terminal areas only if there are any stains or corrosion.

- Never handle the battery near fire hazards.
- Battery fluid is acidic. Do not bring into contact with eyes and skin.

NOTICE

- A sealed type battery is used for this motorcycle. Never remove the battery fluid cap.
- If the motorcycle is going to be stored for a long period of time, remove its battery to prevent drainage and current leakage. Fully charge the battery and store in a dark, well ventilated area. If the battery is going to be stored within the motor bike, remove the negative terminal.

WARNING

The battery pack contains acidic liquid as an electrolyte. Acidic liquid is highly corrosive, and may cause burns if in contact with skin or eyes.

- Wear protective glasses and clothing if working near batteries.
- Keep batteries out of reach of children.

EMERGENCY PROCEDURES

- If acid comes in contact with eyes
Rinse with water for at least 15 minutes. Do not use pressured water as it could cause injury to the eyes.
- If acid comes in contact with clothing, remove clothing immediately and wash with plenty of water.
- If acid is swallowed. Drink water or milk.
Seek medical advice immediately.

Easy maintenance

NOTICE

The battery terminals fitted to this battery are designed to clean themselves when the connectors are removed or inserted. Do not use wire brushes or sand paper to clean them.

ALWAYS use the same kind of battery when replacing it.

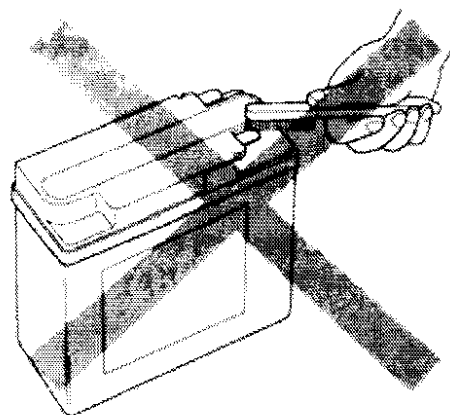

< Attachment and removal of the battery >

Removal

1. Remove the side cover (refer to page 23).
2. Remove the band.
3. Remove the battery.
4. Remove the battery connector by pushing on both sides and pulling it out.

Attachment

- Reverse the removal procedure.

make sure that the battery connector "clicks" in place when inserting to ensure that the terminal section is securely fastened.

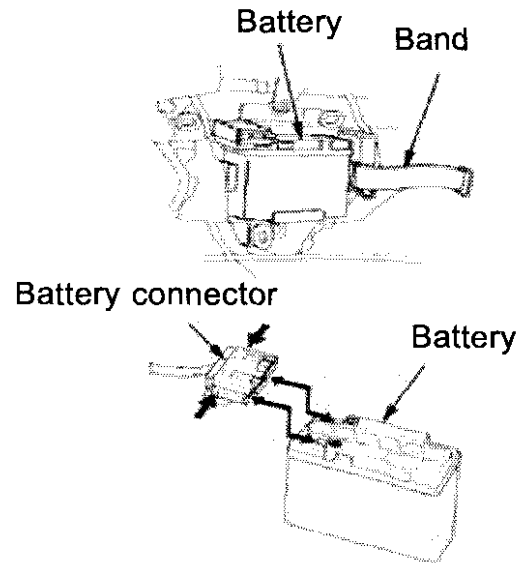

Easy maintenance

Air cleaner

This motorcycle has an oil based urethane foam air cleaner element fitted to it. The condition of the air cleaner element should be checked every 6 months.

<Air cleaner element removal and installation>

Removal

1. Remove the screw and then the air cleaner element cover.
2. Remove the air cleaner element.

Installation

- Reverse the removal procedure.

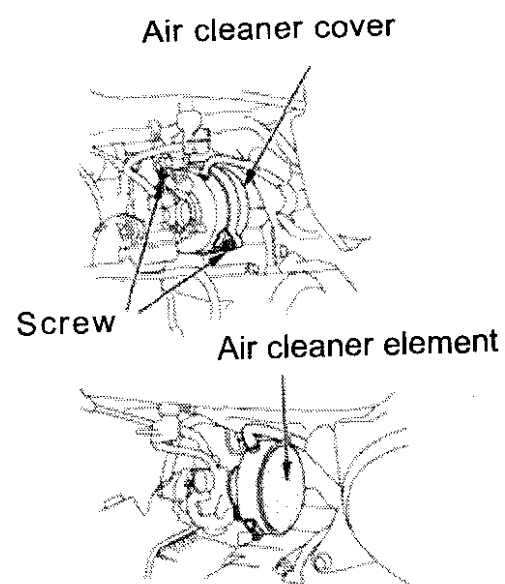

NOTICE

If the air cleaner element is not replaced correctly, it could allow foreign particles or dust directly into the engine causing friction or wear resulting in engine trouble.

Always make sure that the air cleaner is correctly installed again after removal.

Make sure that you do not squirt water directly into the air cleaner element when washing the motorcycle as this may allow water into the air cleaner making starting the engine difficult.

NOTICE

Remove the air cleaner element and check for any signs of wear, dirt, clogging or other kind of damage.

*Clean the element if you find it to be dirty or clogged.

*Replace the element if you find it to be damaged in any way.

Easy maintenance

<Cleaning the air cleaner element>

Do not use extremely flammable substances to clean the air cleaner element.

1. Remove the air cleaner element.
2. Clean the air cleaner element in clean oil based cleaner. Ring out the air cleaner element and then dry it.
3. Apply clean oil to the air cleaner element, ring out the excess and then reinstall.

Oil: Gear oil (#80~#90)

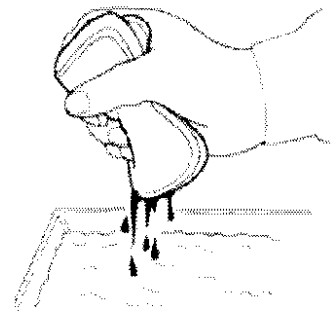

Cable wire

<Checking rubber boots>

Rubber boots are fitted to protect the inner cables. Regularly check these areas to make sure that the cables are protected correctly. Take care when washing not to apply water or cleaning brushes directly to these areas. Use a damp clean cloth to clean around these areas if they are significantly dirty.

<Checking cables / wires>

Check the operating functions of the brake lever, clutch lever, and the throttle grip to make sure they are working correctly and smoothly. When released they should move back to their original positions with ease. Check with your HONDA dealer if you find any abnormalities in any of the cables or wires on this motorcycle.

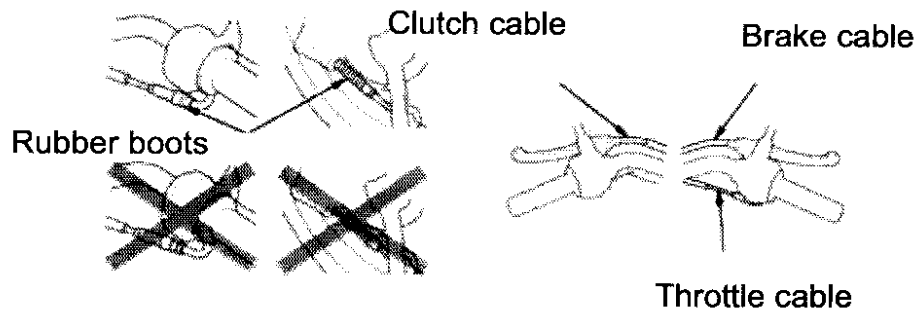

Taking care of your motorcycle

- Ensure that no water enters the exhaust pipe during cleaning. Water within the exhaust pipe can cause corrosion as well as starting problems.
- Do not apply water on or into the brake system as it can lower the performance of the brakes. Always inspect the effectiveness of the brakes at a safe location after washing the motorcycle. If effectiveness of the brakes are weak, gently apply the brakes to dry the brake system.

- Avoid applying excessive pressure when waxing the motor bike. Using wax and compound on the paint or resin surfaces can result in damaging the paint, causing discolouring.

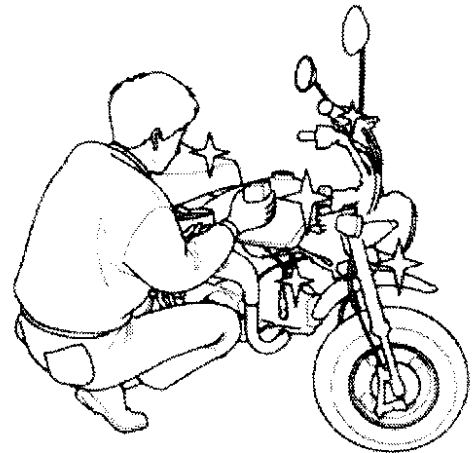

Only wash the motorcycle when the engine is cold.

Do not use high pressured hoses to clean the motorcycle and never aim water directly at any of the electrical areas or moving parts as this may cause damage or operating problems later.

Make sure that you do not allow water into the muffler when washing. This may create starting problems and also may lead to rusting.

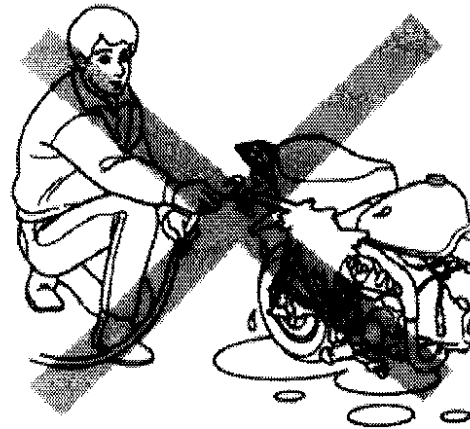
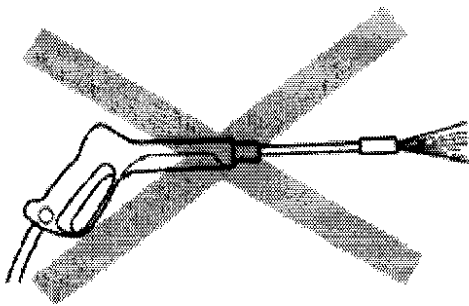

Taking care of your motorcycle

Make sure that water is not squirted directly at the brakes or braking system when washing. Wet brakes can become less effective.

Always check that the brakes are working correctly after washing by testing the brakes while riding in an open area at low speed.

Lightly “apply” the brakes by squeezing them on and off a few times to help dry them out if they are wet.

-Check all wax types or chemicals before using them in cleaning. There is risk of damaging the painted areas of the motorcycle, it is recommended that these products be tried on a painted area of the motorcycle that is not seen first.

Storing the motorcycle

If possible always use a body cover when storing the motorcycle for extended periods. (Make sure that the body cover is placed over the bike after it has cooled down sufficiently). Apply wax over the different areas of the machine that are prone to rust. Remove the battery in order to avoid discharge. Remove the battery connector from the battery if leaving it on the motorcycle.

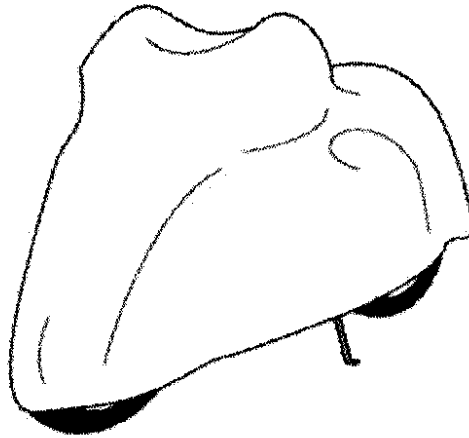

Protecting the environment

Care must be taken when disposing of used items such as used batteries, tires and oil. Contact your HONDA dealer for designated places to take these.

When the motorcycle is eventually no longer usable, it is recommended that it is taken to a designated motorcycle wrecker.

MEMO

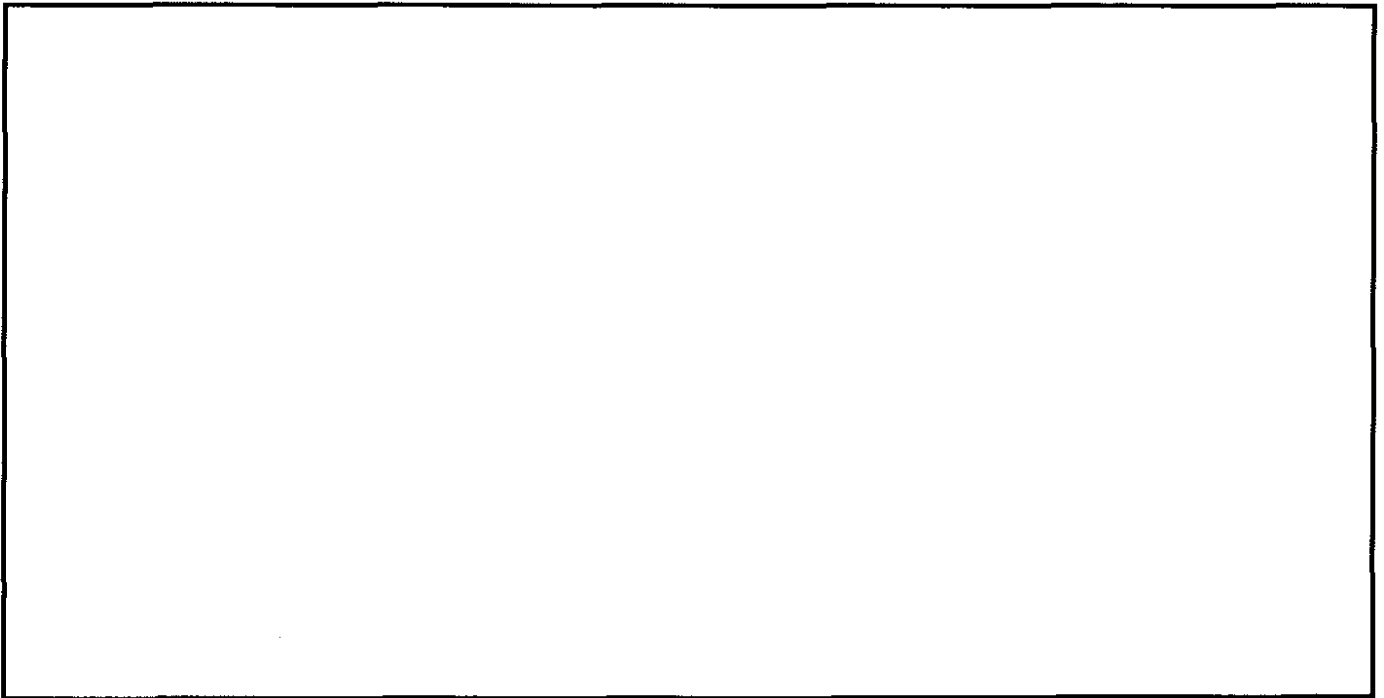

Protecting the environment

For the sake of our environment, appropriately dispose used batteries, tires, or engine oil. This also applies to the disposal of the entire vehicle.

Ordering coloured parts

To make sure that the correct colour is ordered when replacing parts, the colour label has the model name, colour and its correct code noted on it.

Remove the seat to check the colour label for this information and quote to your dealer or parts provider.

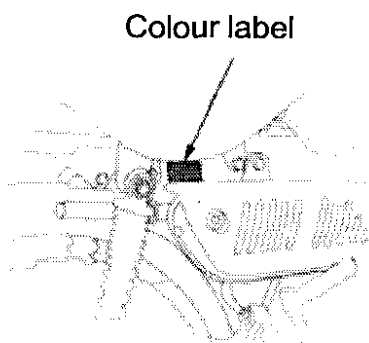

Exhaust pipe authenticity logo

There is a "HONDA" logo engraving at the rear end of the exhaust pipe to show its authenticity.

Genuine parts

Use genuine HONDA parts for your motorcycle. Genuine parts undergo detailed and meticulous inspections for the fitting of these parts to HONDA motor cycles.

Genuine parts can be purchased at HONDA dealers. Genuine parts have a HONDA logo inscribed on them.

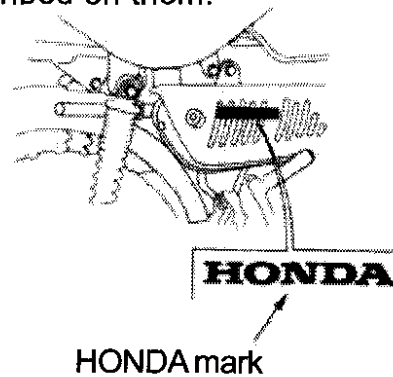

Frame number

The frame number is required when ordering parts.

The frame number is also useful to track down stolen vehicles. It is recommended that the engine number and the frame number are recorded and be kept in a safe place.

Frame number

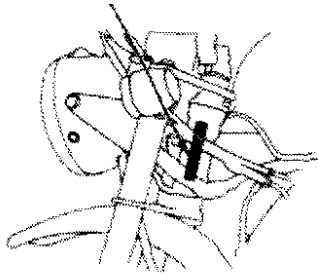

Engine number

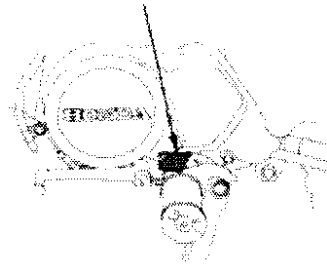

Trouble shooting (If the engine fails to start)

Check the following points if the engine stops or fails to start.

- Have you started the engine according to the operator's manual?
- Is there gasoline in the fuel tank?

Breakdown repairs

- Request the closest HONDA dealer for repairs.
- Avoid attempting to hastily repair the motorcycle on your own.

Requesting a HONDA dealer for inspection/maintenance at your earliest convenience is the best way to prolonging the useful life of your motorcycle.

Main Specifications

Model	BA-AB27	
Length	1365mm	
Width	600mm	
Height	850mm	
Wheelbase	895mm	
Engine type / Engine capacity	Gasoline / 4 stroke 0.49 liters	
Total weight	63Kg	
Maximum Load	1 person	
Tire Size	Front	3.50-8 35J
	Rear	3.50-8 35J
Ground clearance	150mm	
Fuel consumption*	90.0km / liter (average speed of 30km/h on even road test)	
Minimum turning radius	1.4m	
Compression ratio	10.0	
Maximum power output	2.3kW (3.1 PS) / 7500rpm	
Maximum torque	3.1 N.m (0.32kg.m) / 6000rpm	
Fuel tank capacity	4.5l	

86 *Fuel consumption test results were achieved under test conditions and therefore may differ depending on the environment you are riding in.

Main Specifications

Ignition system	CDI
Ignition timing	BTDC 27degrees/2000rpm
Idling speed	2000rpm
Spark plug NGK DENSO	CR5HSA, CR6HSA, CR7HSA U16FSR-U, U20FSR-U, U22FSR-U
Battery	12V-2.3Ah
Primary reduction ratio (engine to transmission)	4.312
Clutch type	Wet multi-plate type
Gear box type	Constant mesh transmission
Gear changing	Left foot pedal
Gear ratio 1st gear 2nd gear 3rd gear 4th gear	3.272 1.937 1.350 1.043
1st speed reduction	2.384

Service Data

Drive chain (Play)		10-20mm
Front brake lever play		10-20mm
Rear brake pedal play		10-20mm
Tire pressure	Front	100kPa (1.00 kgf/cm ²)
	Rear	125kPa (1.25kgf/cm ²)
Engine oil	Total	0.8l
	When replaced	0.6l
Clutch lever play		10-20mm
Fuse		10A
Spark plug clearance		0.6-0.7mm
Air cleaner element	Form	Urethane foam
Bulb types	Headlight	12V 30/30W
	Stop tail lamp	12V 10/5W
	Front indicator lamp	12V 10W
	Rear indicator lamp	12V 10W