

HONDA **ELSINORE** **MR 50**

OWNER'S MANUAL



© HONDA MOTOR CO., LTD. 1973

IMPORTANT NOTICE

- **FOR OFF-THE-ROAD USE ONLY.**

This motorcycle is designed and manufactured for off-the-road use exclusively. Do not operate on public streets, roads, or highways.

- **OPERATOR ONLY.**

This motorcycle is designed and constructed as an operator only model. The vehicle load limit and seating configuration do not safely permit the carrying of a passenger.

- **ADULT SUPERVISION REQUIRED**

- **READ OWNER'S MANUAL CAREFULLY**

- **NOT RECOMMENDED FOR CHILDREN UNDER 7 YEARS OLD.**

////////////////////// **PREFACE** ////////////////////////

It is with great pleasure that we welcome you as a new owner of a HONDA motorcycle. The MR50 is designed and constructed as an off-the-road motorcycle for the junior rider.

This manual is provided so that you may operate and maintain your HONDA MR50 at the highest level of performance.

Therefore, it is **IMPORTANT** for you to

read and carefully observe the information contained herein.

When assistance and servicing are necessary, consult any authorized HONDA dealer for prompt and satisfying service.

We take this opportunity to thank you for selecting a HONDA and to assure you of our continuing interest in your safe and pleasant motorcycling.

////////////////////////////////////MESSAGE TO THE PARENTS////////////////////////////////////

This motorcycle is designed for junior riders (rider weight of 80 pounds or less). It is a fine learning motorcycle as long as the following precautions are observed:

- The parent or instructor must be fully familiar with the motorcycle, the motorcycle controls and the control functions before starting to teach a junior rider. Both instructor and student must fully understand everything in this manual before riding instruction begins.
- The MR 50 is an OPERATOR ONLY model. The rider weight limit of 80lb (36 kg) must be observed.
- A potential student rider must be of sufficient size to hold the motorcycle up while he is straddling it with both feet on the ground. He must also have sufficient strength to right the motorcycle if it is laid on its side.
- The student rider must be dressed protective apparel including a helmet, goggles, gloves, boots and heavy clothing.
- The practice location must be a level uncongested area.
- It is illegal to ride the MR 50 on public streets, roads or highways. It must be ridden only in off-the-road areas where such activities are permitted.

- Keep the adjustable throttle at the lowest setting (MIN) for all initial learning stages. Increase the throttle opening only when the student rider has achieved sufficient skill to warrant an increase in engine power and top speed.
- Empty the fuel tank before transporting the motorcycle.
- For safety, the MR 50 must be properly adjusted and maintained. Be sure to make a "Pre-Riding Inspection" and be sure to impress the student rider with the importance of checking all the items thoroughly before riding the motorcycle.
- A prime objective in the instruction process is developing the student's self-confidence. This self-confidence comes with a total familiarization with the motorcycle controls and their functions.

WARNING:

Flared pants or pants with large cuffs can catch on control levers, kick starter, foot pegs and drive chain and, consequently, are specifically NOT RECOMMENDED as rider apparel.

- Always obey local off-road riding laws and regulations and show respect for private property by obeying posted signs.
- Always preserve nature and watch for fire hazards such as dry grass conditions, etc.
- Clean up trash and do not litter.
- When off-road riding, ride in the company of a friend on another motorcycle so that you can be of mutual assistance to each other in the event of trouble.

- Familiarity with your motorcycle is critically important in off-road riding. NEVER ride beyond your ability and experience.
- Know the terrain on which you are riding. Always ride so that your visibility is sufficient to give adequate warning of upcoming hazards.
- NEVER ride faster than conditions warrant.
- Don't modify your exhaust system. Remember that excessive noise antagonizes everyone and creates a bad image for motorcycles.

//////////////////////**CONTENTS**//////////////////////

SERIAL NUMBER LOCATION	8
CONTROL LOCATIONS	9
OPERATING INSTRUCTIONS	10
Throttle Adjuster	10
Fuel	12
Transmission Oil	13
Tire Recommendation	14
Tool Kit	15
Pre-Riding Inspection.....	16
Starting the Engine.....	17
Ignition Switch.....	17
Fuel Valve	17
Shifting the Transmission	22
Riding the Motorcycle.....	24
Braking the Motorcycle.....	28
Shutting Off the Engine	30
Parking the Motorcycle.....	31
INSTRUCTING THE JUNIOR RIDER	32
Control Familiarization—Walk-Around Inspection	32
Control Familiarization—Sitting on the Motorcycle.....	32
Control Familiarization—Dry Runs.....	32

Controlled Riding—With the Engine Shut Off.....	33
Controlled Riding—With the Engine Running.....	33
Supervised Riding.....	34
MAINTENANCE SCHEDULE.....	36
MAINTENANCE OPERATIONS.....	38
Spark Plug Replacement and Adjustment.....	38
Ignition Timing Adjustment.....	39
Carburetor Adjustment.....	40
Throttle Grip Adjustment.....	42
Clutch Adjustment.....	43
Fuel Filter Maintenance.....	44
Front Brake Adjustment.....	45
Rear Brake Adjustment.....	46
Drive Chain Maintenance.....	47
Wheel Inspection.....	50
Front Wheel Removal.....	50
Rear Wheel Removal.....	51
Decarbonizing.....	52
Transmission Oil Level.....	54
Transmission Oil Change.....	54
Front Suspension Inspection.....	55
Front Fork Oil Change.....	56
Rear Suspension Inspection.....	57

Air Cleaner Maintenance	57
Spark Arrestor Maintenance.....	59
TROUBLE SHOOTING	60
SPECIFICATIONS	62
WIRING DIAGRAM	64

//////////////////// SERIAL NUMBER LOCATION //////////////////////

The frame serial number ① is stamped on the left side of the steering head, and the engine serial number ② is located on the left side crankcase above the left foot peg. These numbers are required when register-

ing the motorcycle. Refer to the frame or engine serial numbers when ordering replacement parts to ensure that you will obtain the correct parts for your model series.

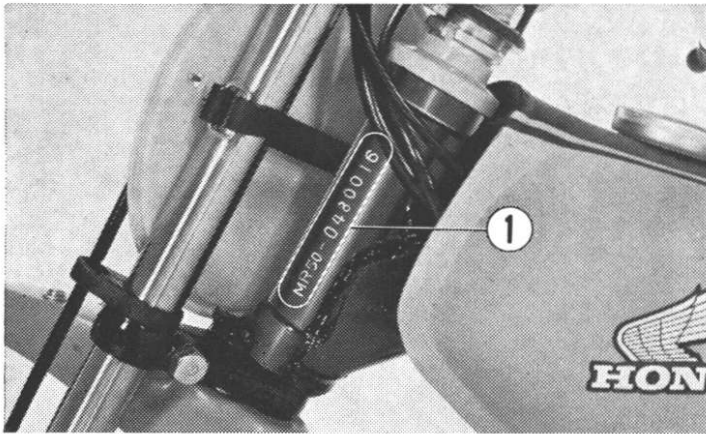

① Frame serial number

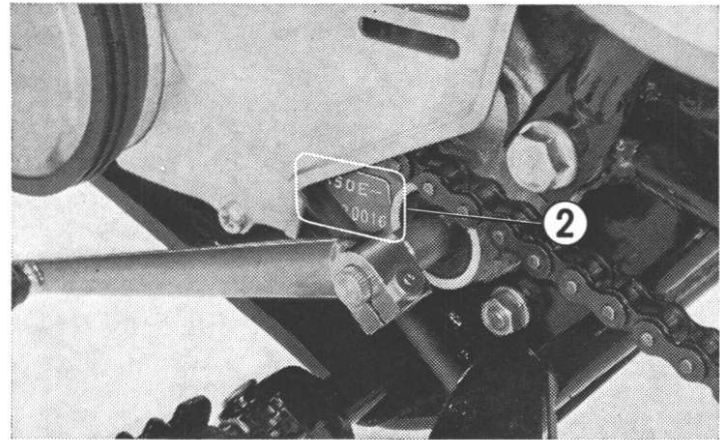

② Engine serial number

CONTROL LOCATIONS

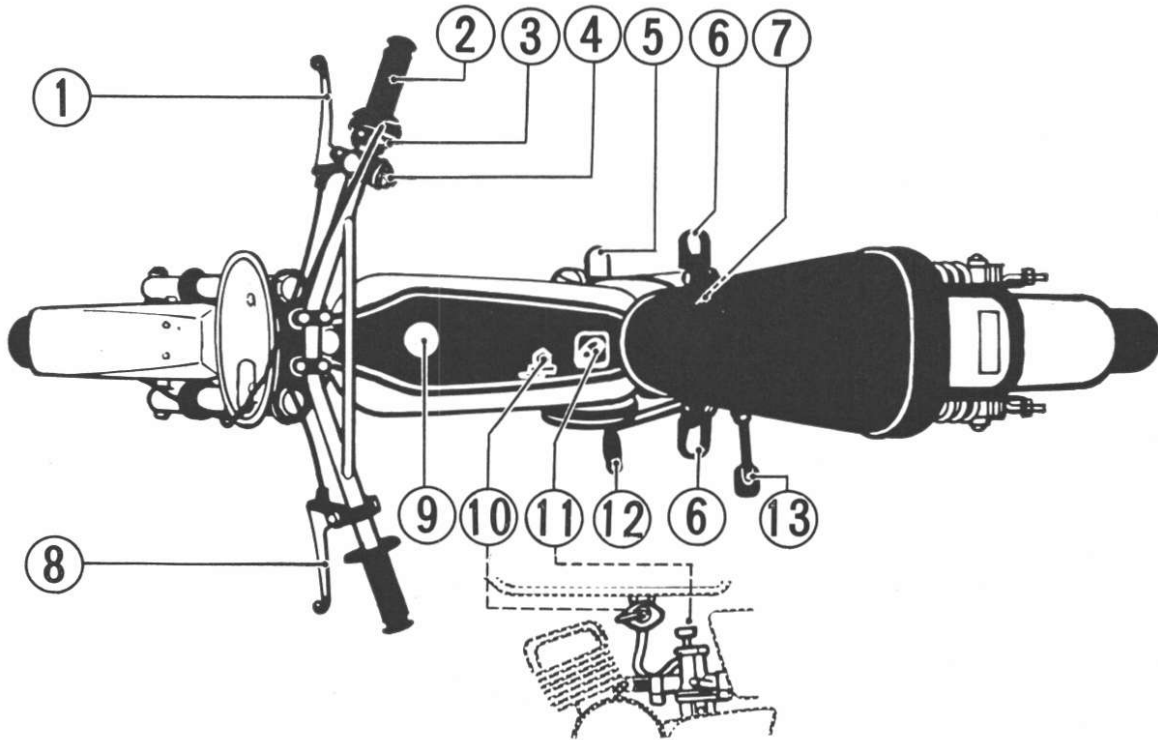

① Front brake lever
 ② Throttle grip
 ③ Throttle adjuster
 ④ Ignition switch

⑤ Rear brake pedal
 ⑥ Foot peg
 ⑦ Kick starter pedal

⑧ Clutch lever
 ⑨ Fuel tank cap
 ⑩ Fuel valve

⑪ Fuel mixture enrichment knob
 ⑫ Gear change pedal
 ⑬ Side stand

OPERATING INSTRUCTIONS

Throttle Adjuster

The MR50 is equipped with an adjustable throttle grip stop that allows the instructor to limit the throttle opening and control the maximum power and maximum speed of the motorcycle.

The throttle adjuster ① is secured to the throttle grip bracket with a special screw ②. When the screw is installed in the "MAX" position full throttle operation is possible. When the screw is installed in the "MIN" position the maximum throttle

opening is limited to 1/4 of the total throttle travel.

The throttle stop is adjusted by removing the throttle adjusting screw and reinstalling it after aligning the desired throttle adjuster with the hole in the throttle grip bracket.

NOTE:

The throttle adjusting screw is removed and installed with the throttle adjuster wrench ③ supplied with the tool kit.

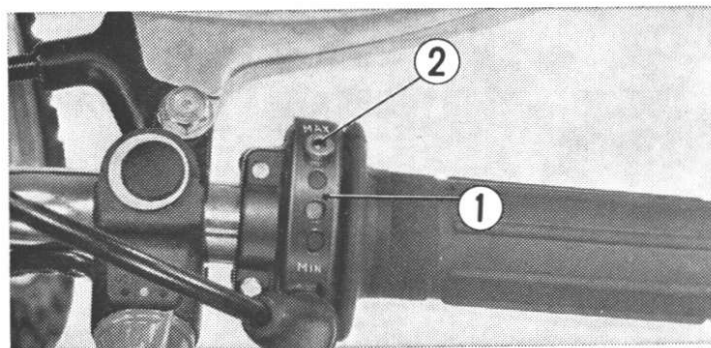

① Throttle adjuster ② Special screw

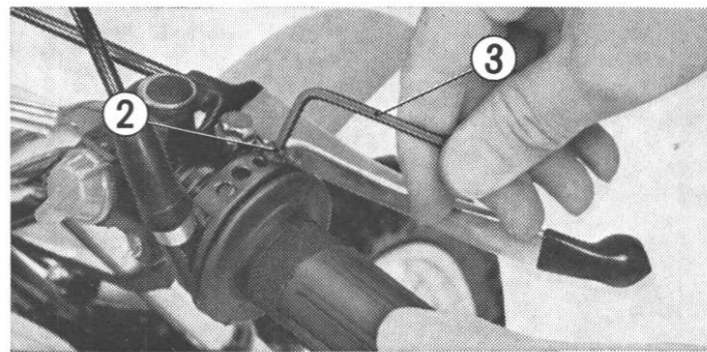

③ Throttle adjuster wrench

There are four stop positions marked on the throttle adjuster. The throttle stop position should be determined by the instructor's evaluation of the student's riding skills and abilities.

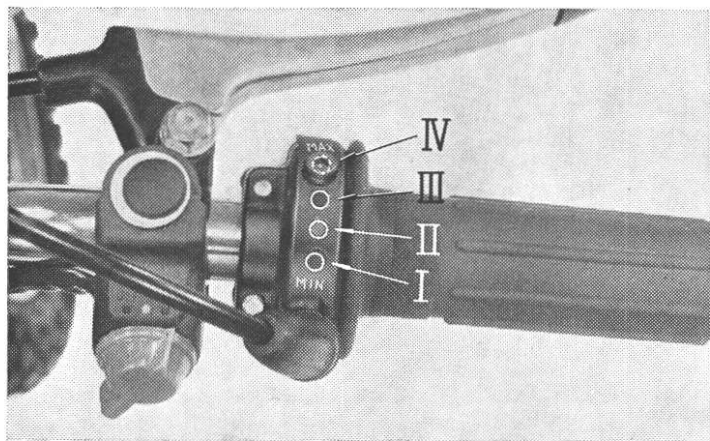

The percentage table below shows the approximate maximum engine output at each throttle adjuster position.

Throttle adjuster position	Max. output
I (MIN)	40%
II	70%
III	90%
IV (MAX)	100%

WARNING:

- Do not allow the student rider adjust the throttle stop position.
- The throttle adjuster should be in the "MIN" position for all initial training periods.

Fuel

The HONDA MR50 is equipped with a two-cycle engine and uses a gasoline-oil mixture.

The correct mixing ratio for the gasoline and oil is **25:1**. Put gasoline and oil (in the ratio of 25:1) in a clean container and shake until they are mixed thoroughly. Fill the fuel tank with the mixture. The capacity of the fuel tank is 0.66 U.S. gal. (2.5 l).

Gasoline and oil recommendation

Gasoline	Octane number: 91 or higher
Oil	Two-stroke oil

CAUTION:

- **Too much oil in the fuel may result in excessive smoking, or a fould spark plug. Too little oil in the fuel may**

result in an overheated engine and damaged engine parts.

- **If the gasoline-oil mixture is left standing in the container for a long period of time, it will deteriorate.**

WARNING:

- **Gasoline vapor is flammable. Be sure to shut off the engine when refueling.**
- **Never allow your child to refuel the motorcycle.**
- **Do not allow sparks, open flames, or any person who is smoking near the motorcycle when refueling.**

-----Transmission Oil-----

Transmission Oil Recommendation

Use only high detergent, premium quality motor oil.

The regular use of special oil additives is unnecessary and will only increase operating expenses.

Transmission oil should be changed at the intervals prescribed in the maintenance schedule on page 37.

NOTE:

Non-detergent and low quality oils are specifically not recommended.

Viscosity

Viscosity selection should be based on the average atmospheric temperature in your riding area. Change to the proper viscosity oil whenever changes in average atmospheric temperature require it.

Recommended oil viscosity:

General, all temperatures

SAE 10W-30 or SAE 10W-40

Alternate:

Above 59°F (15°C)	SAE 30
32° (0°) to 59°F (15°C)	SAE 20 or 20W
Below 32°F (0°C)	SAE 10W

Tire Recommendation

Off-the-road tires are standard on this model. Select the tires in accordance with the table below and check the tire pressure frequently.

Cold tire inflation pressure	Front: 17 psi (1.2 kg/cm ²) Rear: 20 psi (1.4 kg/cm ²)
Tire size	Front: 2.25-14 Rear: 3.00-12
Vehicle capacity load	80 lb (36 kg)

CAUTION:

- **Overinflation or underinflation of the tires will cause abnormal tread wear or other damage and create a safety hazard. Riding with underinflated tires will cause the tires to slip on the rims damaging the innertubes. Severe underinflation may result in loss of the tire from the rim.**
- **Check tire pressures frequently and adjust if necessary.**
- **Replace the tires when the tread depth at the center of the tire is less than 0.12 in. (3 mm).**
- **Periodically check the tire surfaces for cuts, abrasions and any other defects.**

-----Tool Kit-----

The tool kit ① is secured to the front brake cable guide located at the front number plate. It contains the service tools shown at right.

CAUTION:

Do not allow a student rider perform unsupervised maintenance operations or adjustments to the motorcycle.

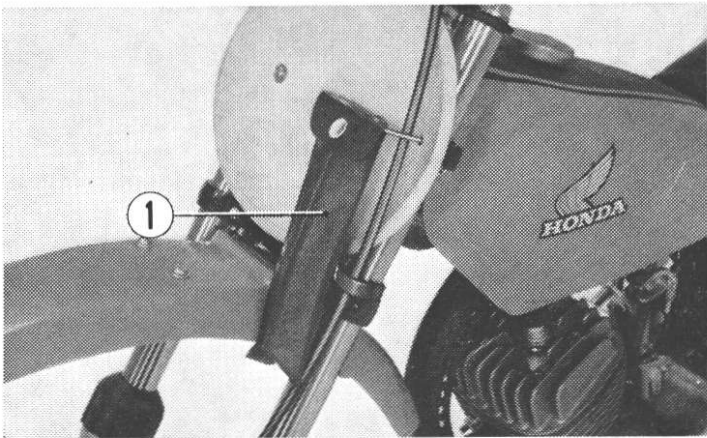

① Tool kit

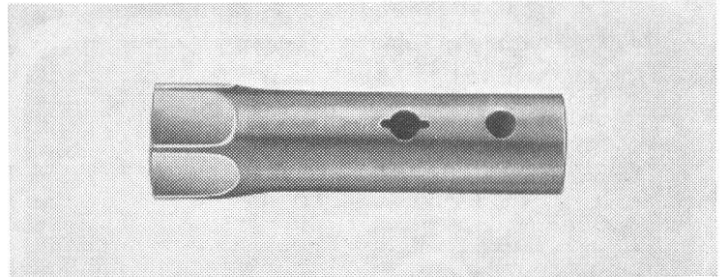

Spark plug wrench

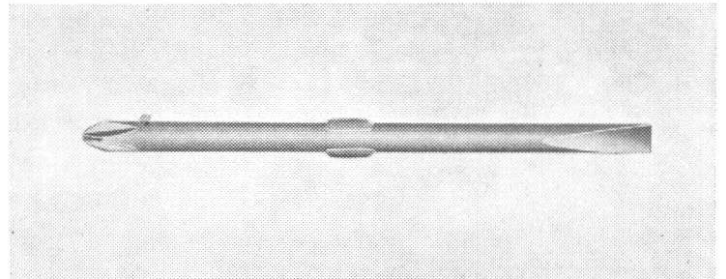

Phillips and standard screwdrivers

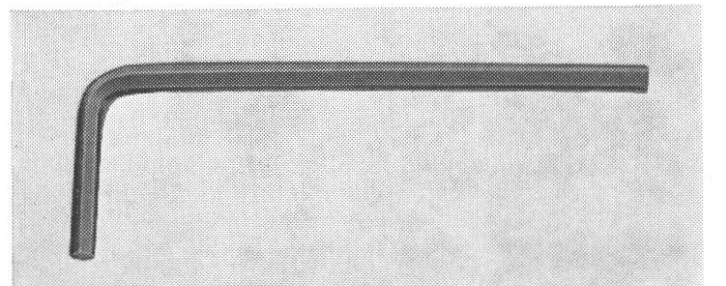

Throttle adjuster wrench

-----Pre-riding Inspection-----

Before riding the motorcycle, make sure it is in good, safe operating condition. Check the following items and adjust or service if necessary.

1. FUEL—Check the fuel level and refill the tank with gasoline-oil mixture if necessary. (See page 12.)
2. TRANSMISSION OIL—Check the oil level and refill if necessary. (See page 54.)
3. BRAKES—Check the front and rear brake operation. Adjust free play if necessary. (See pages 45 and 46.)
4. TIRE PRESSURE—Check the tire pressures with a tire pressure gauge. (See page 14.)
5. DRIVE CHAIN—Check the drive chain for wear or damage and replace if necessary. (See page 47.)
Ensure that the chain is properly lubricated. Lubricate if necessary. Measure the chain slack and adjust if necessary.
6. THROTTLE—Check throttle for proper operation in all steering positions. If the throttle will not operate smoothly, replace the cable or route it correctly. Adjust the throttle grip free play if necessary. (See page 42.)
7. FRONT AND REAR SUSPENSION—Check suspension for proper operation. (See pages 55 and 57.)

Starting the Engine

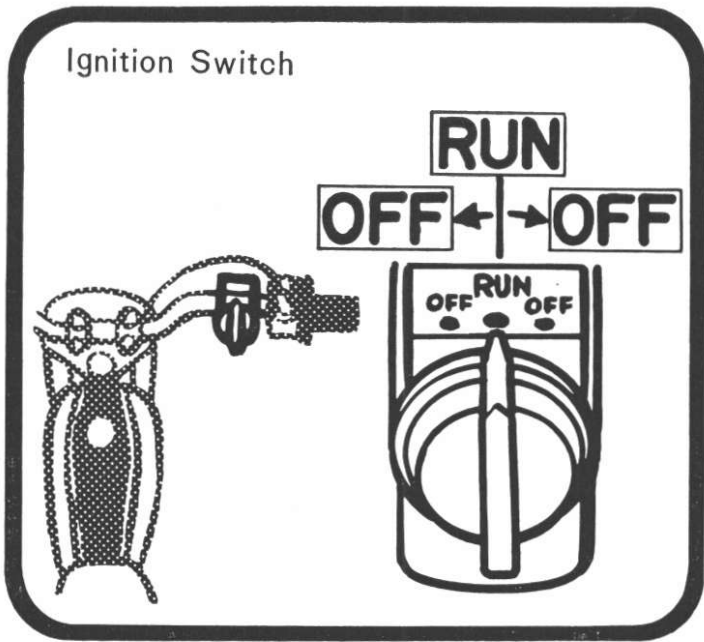

To start the engine, turn the ignition switch to the "RUN" position (red-dot). To shut off the engine, turn the switch to "OFF" position (black-dot).

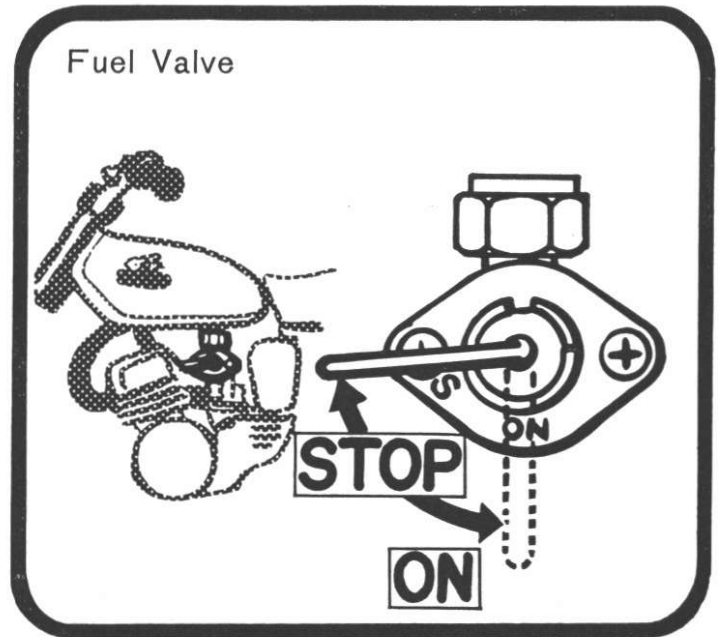

Before starting the engine, move the fuel valve control lever to the "ON" position. After shutting the engine OFF, always move the lever to "S" position.

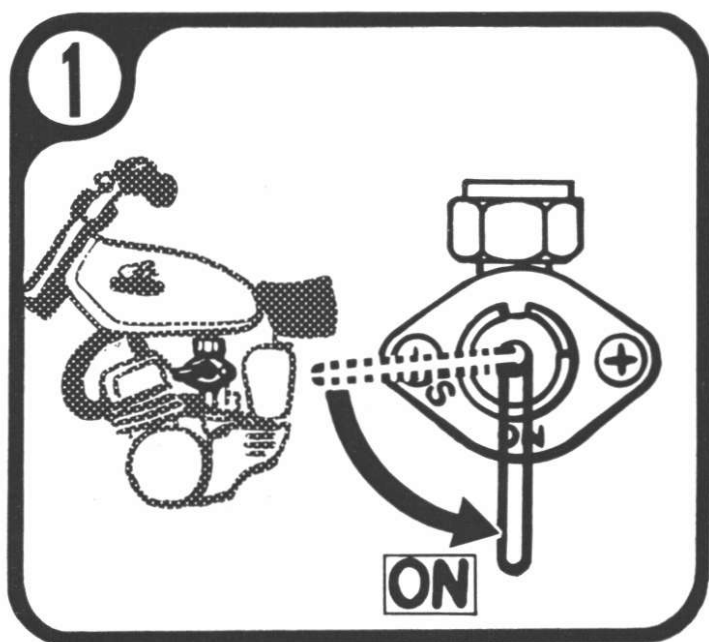

1 Move the fuel valve control lever to the "ON" position.

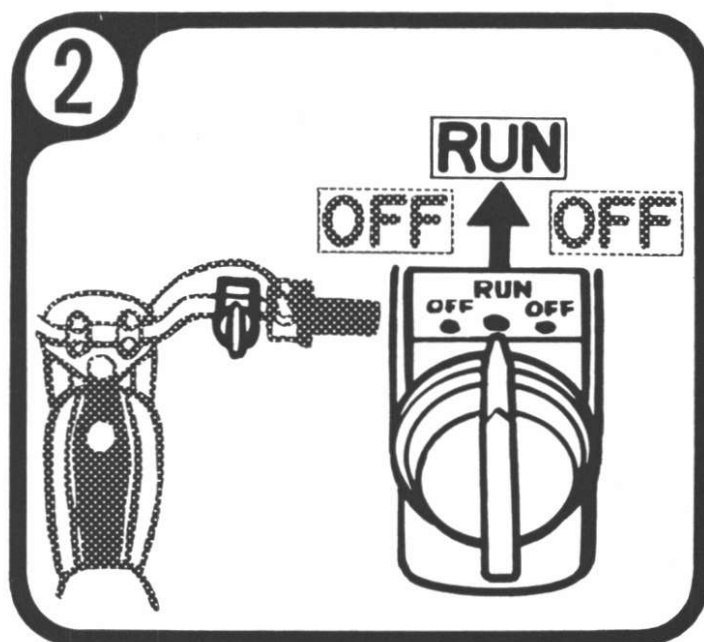

2 Move the ignition switch to the "RUN" position (red-dot).

3

Fuel Mixture
Enrichment Knob

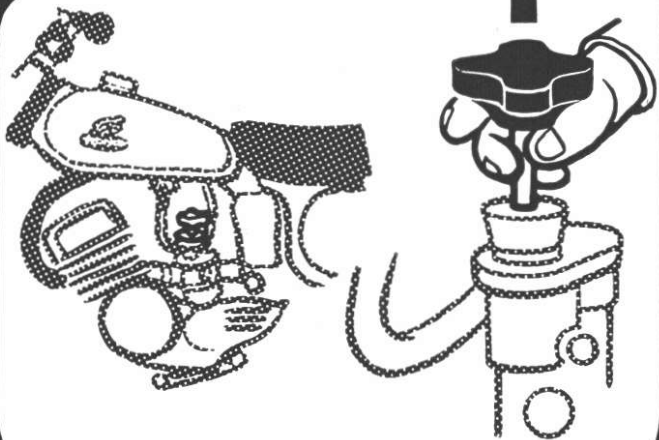

Pull out the fuel mixture enrichment knob (black) located on the carburetor.

4



Determine if the transmission is in gear by moving the motorcycle back and forth. If the motorcycle does not roll freely the transmission is in gear and must be placed in the neutral position before attempting to start the engine.

WARNING: Do not start the motorcycle while the transmission is in gear.

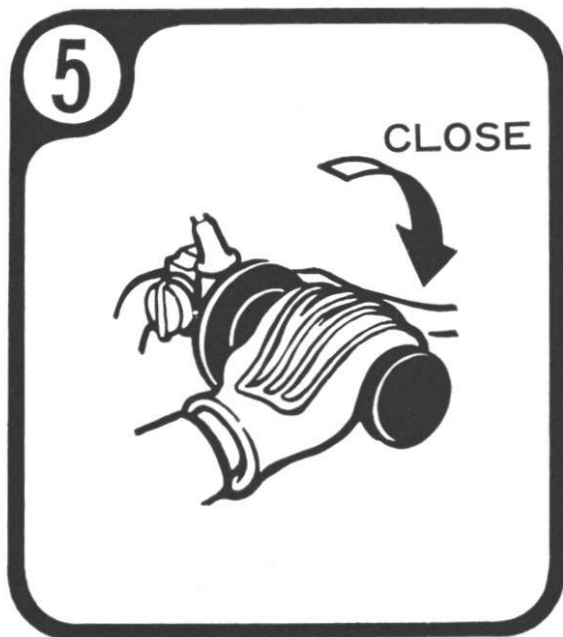

Completely close the throttle.

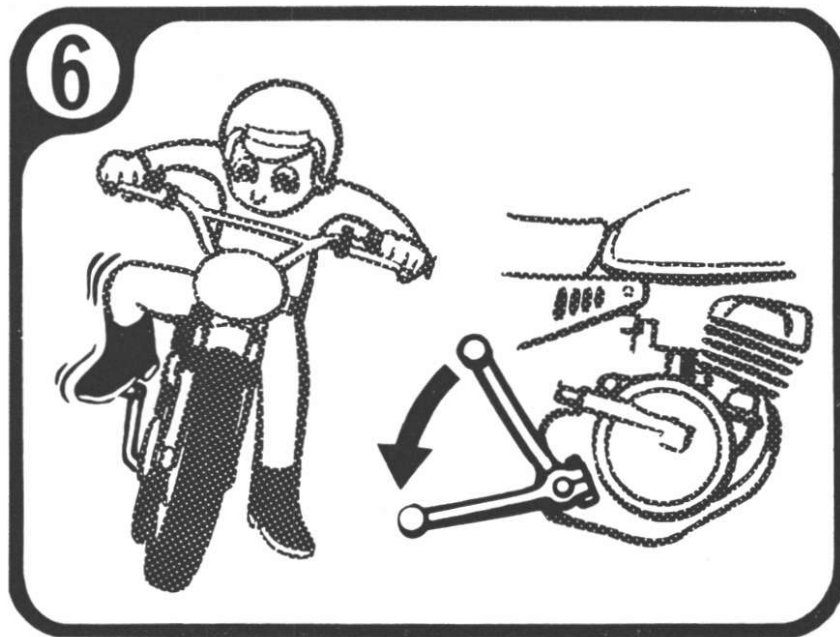

Sit on the motorcycle. Operate the kick starter pedal with the right foot, starting at the top of the stroke and following through to the bottom with a rapid and continuous motion.

NOTE:

When the engine fails to start, push down the knob and operate the kick starter pedal.

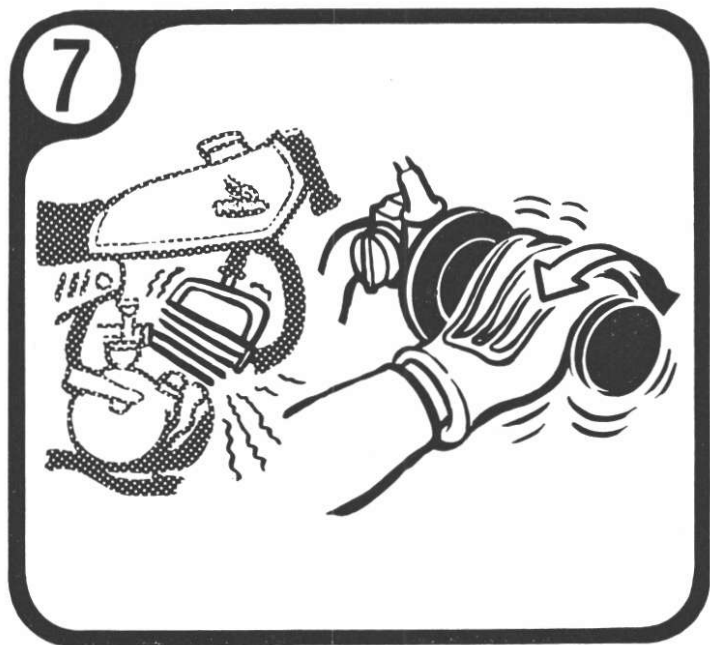

After the engine starts, operate at $\frac{1}{4}$ throttle for a few minutes to allow the engine to warm up before riding the motorcycle.

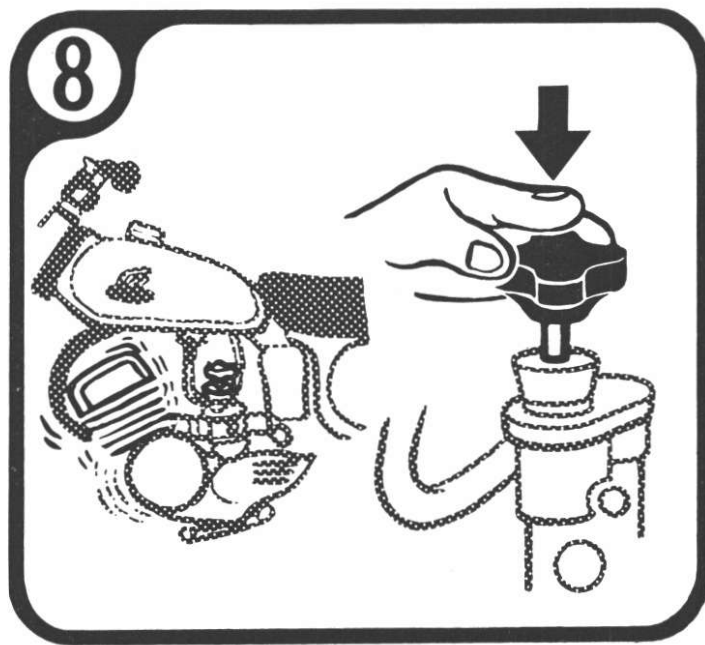

When the engine is running smoothly, push down the fuel mixture enrichment knob.

WARNING:

Exhaust gases contain poisonous carbon monoxide. Never run the engine in a closed garage or in a confined area.

Shifting the Transmission

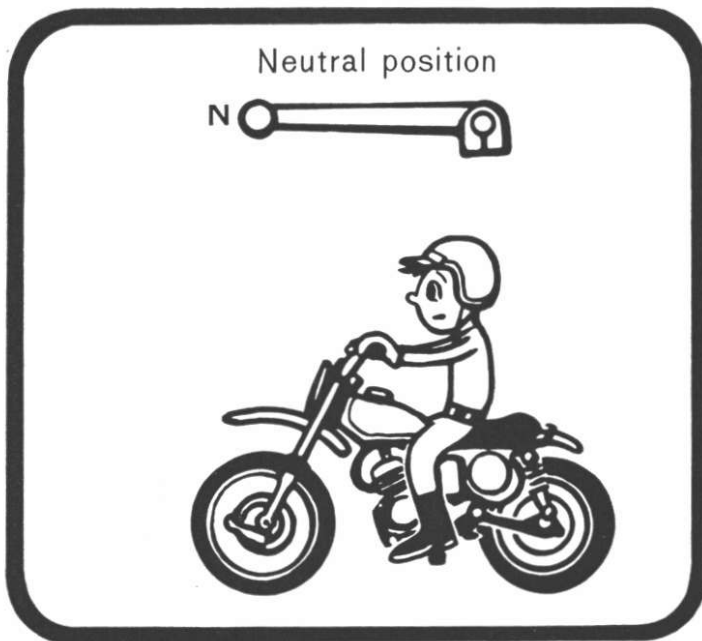

The neutral position is used for starting the engine or for other circumstances when engine power is not to be transmitted to the rear wheel.

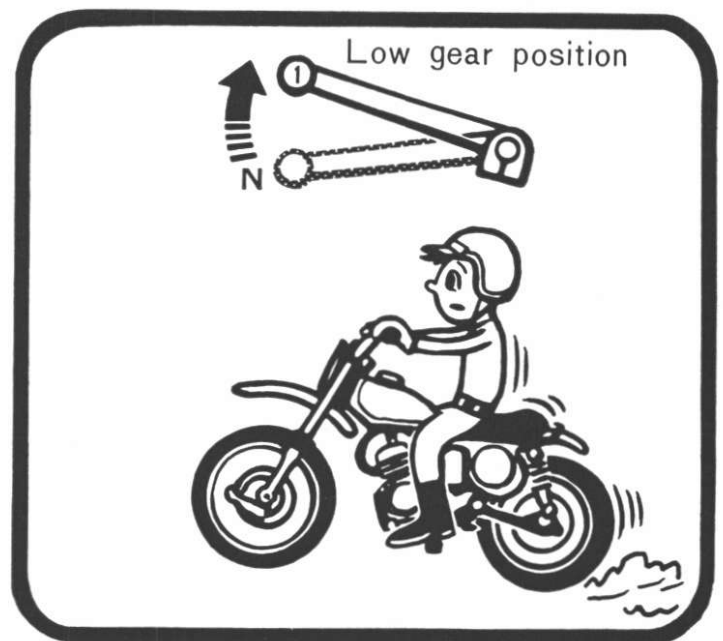

Low gear is used when starting and when going up a steep grade, and for riding at low speeds over rough terrain.

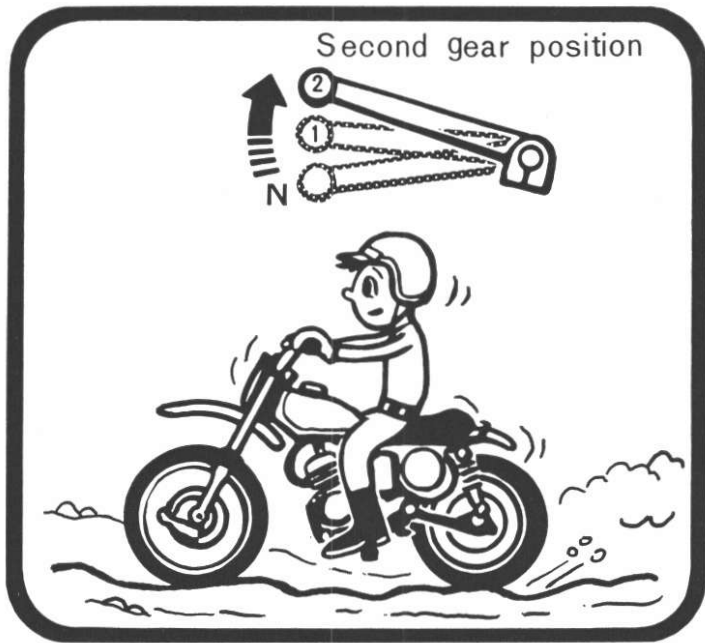

Second gear is used when riding the motorcycle at higher speeds than in low gear, on comparatively level ground.

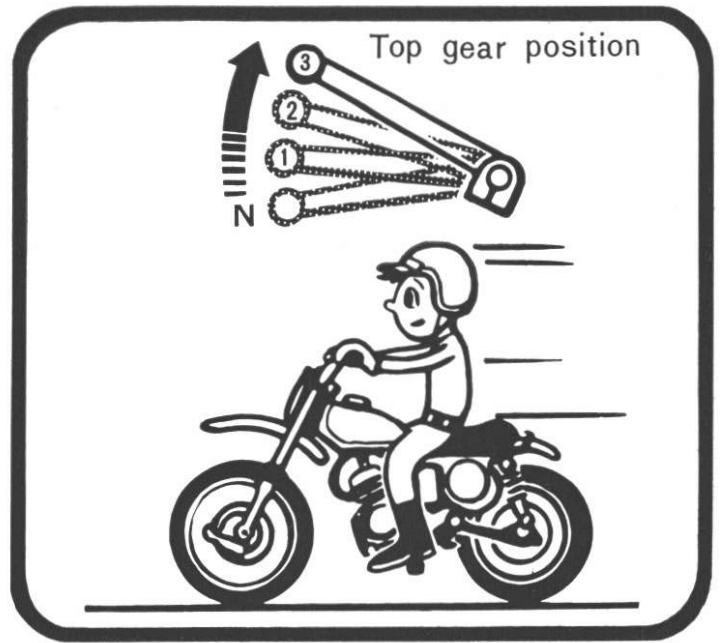

Top gear is used when riding the motorcycle at the highest speeds on level ground. Slow down and shift to a lower gear when cornering or when terrain becomes rough.

Riding the Motorcycle

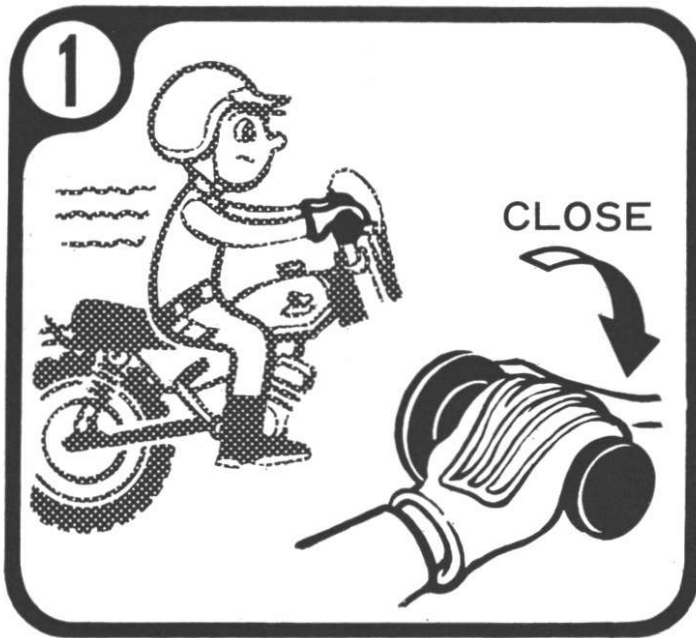

Make sure that the side stand is raised off the ground.

After the engine is warmed up, close the throttle.

Pull in the clutch lever.

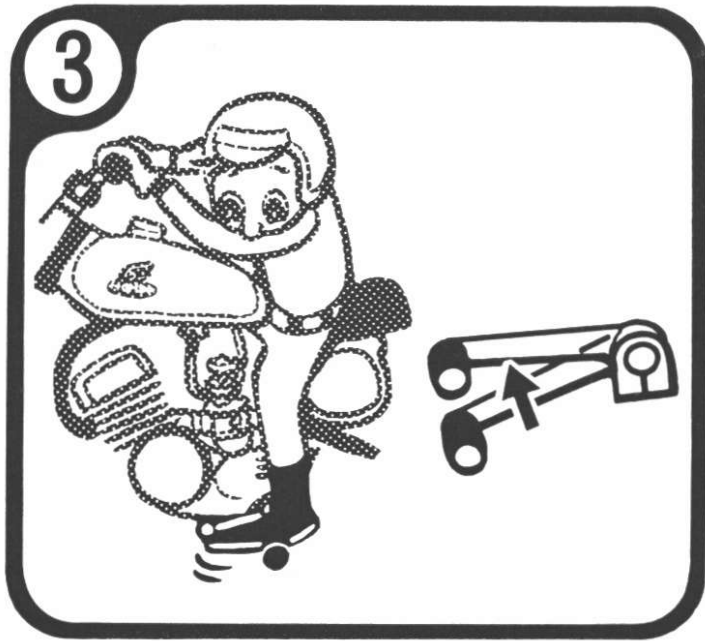

Shift into low gear.

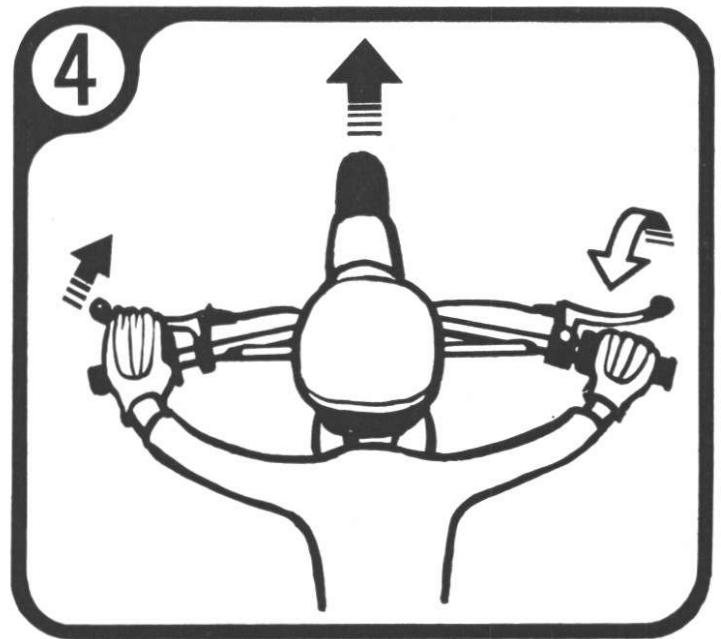

Open the throttle slowly and release the clutch lever very gradually.

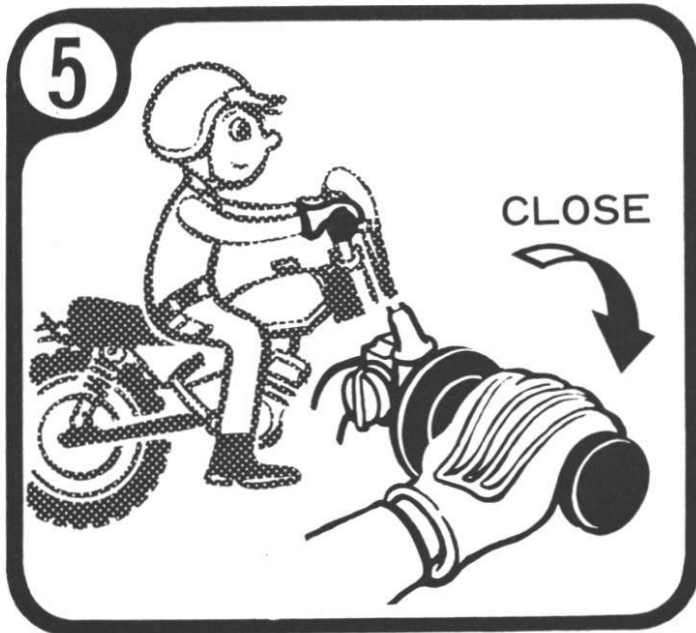

Close the throttle.

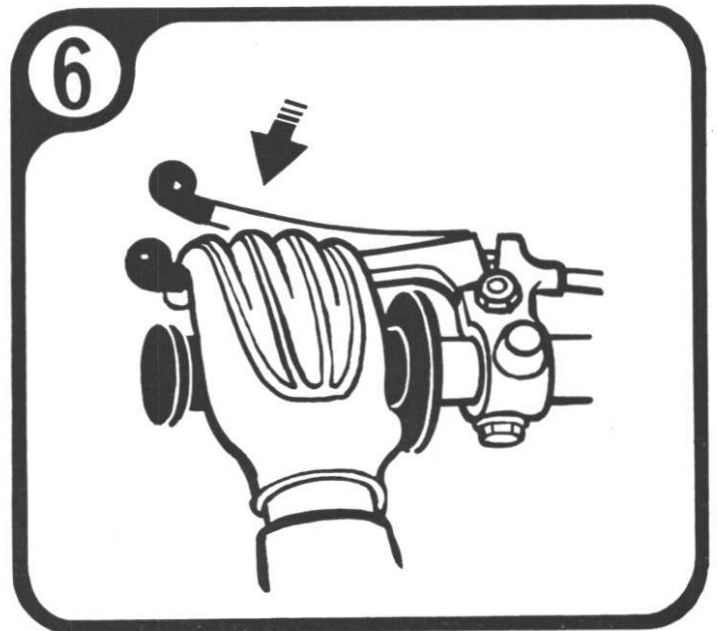

Pull in the clutch lever.

7

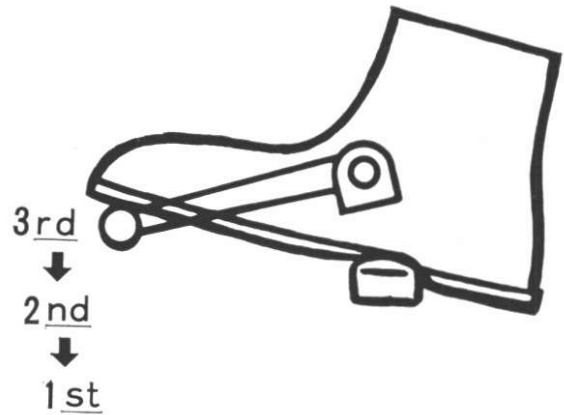
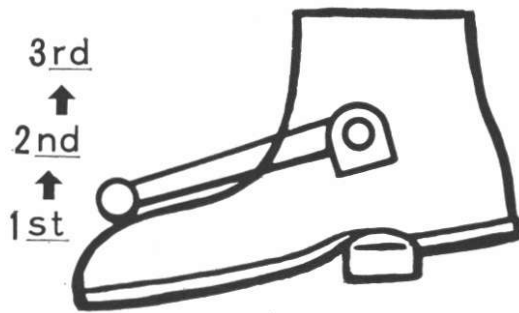

Lift the gear change pedal to shift into second and third gears. Downshift by closing the throttle, pulling in the clutch lever, depressing the gear change pedal, and releasing the clutch.

CAUTION: Do not shift the gears quickly.

-----Braking the Motorcycle-----

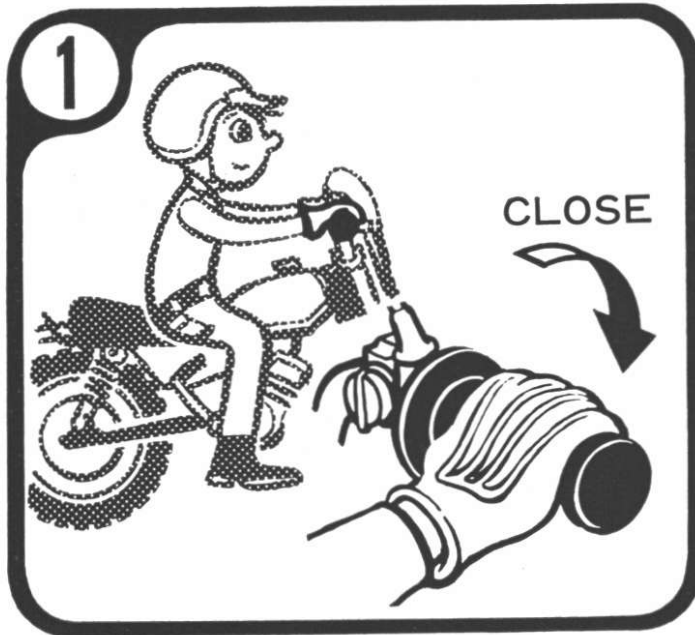

Close the throttle.

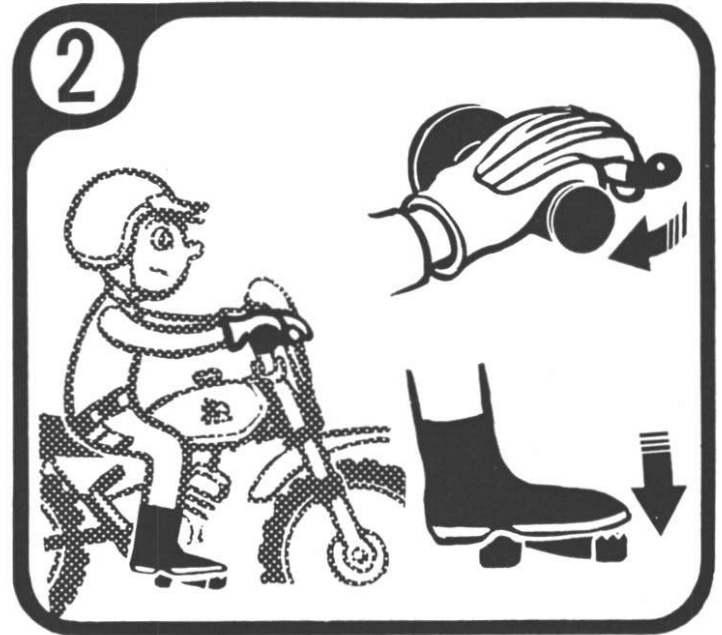

Apply both the front and rear brakes and as the motorcycle slows down sufficiently pull in the clutch lever and shift the transmission into neutral.

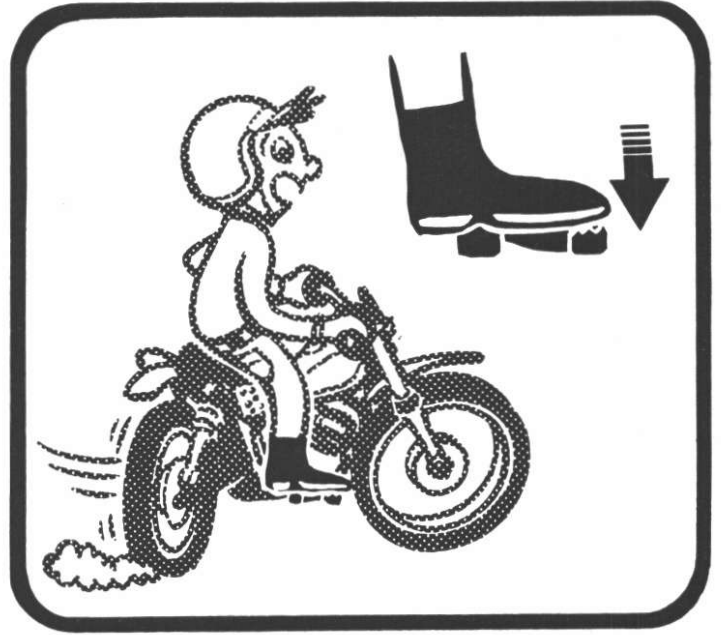
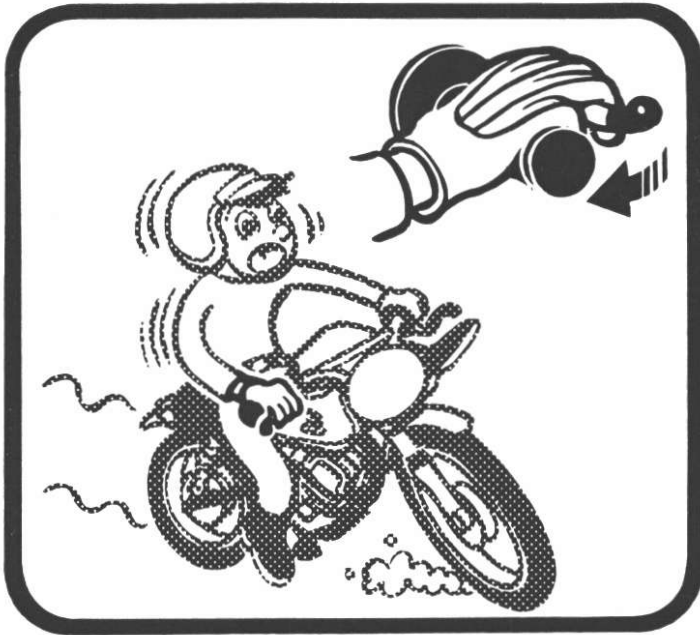

WARNING:

Independent use of only the front or rear brake increases stopping distance and reduces braking effectiveness. Abrupt brake application may cause either wheel to lock, reducing control of the motorcycle.

Shutting Off the Engine

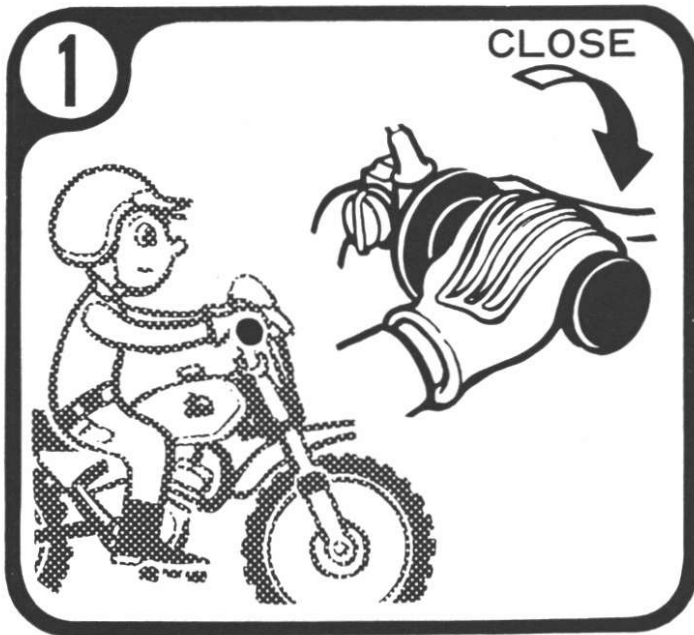

Close the throttle.

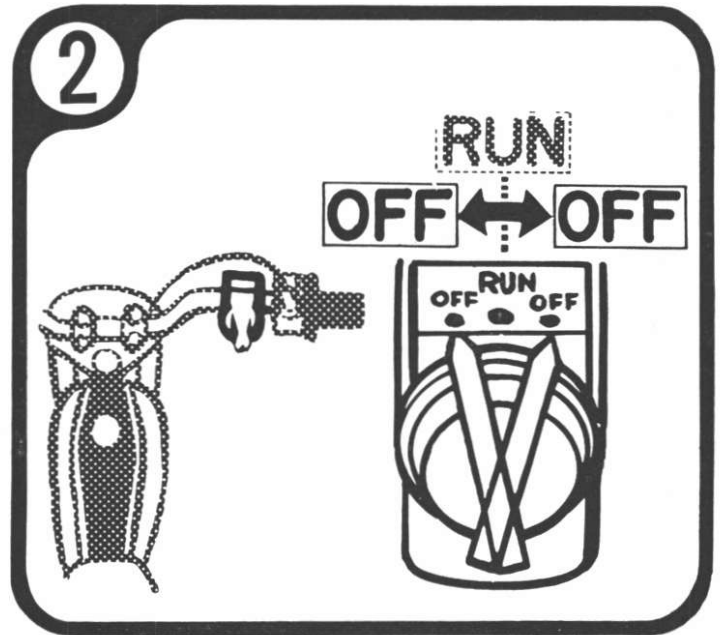

Move the ignition switch to the "OFF" position.

-----Parking the Motorcycle-----

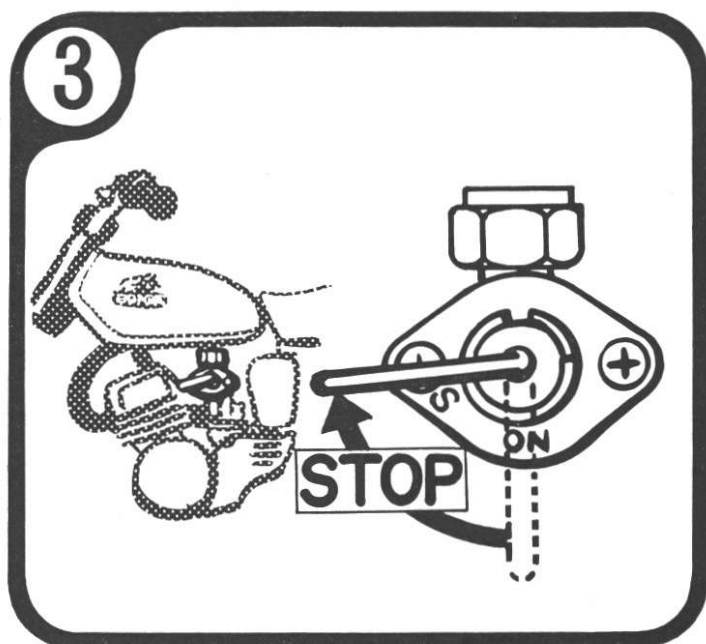

Move the fuel valve control lever to the "S" position.

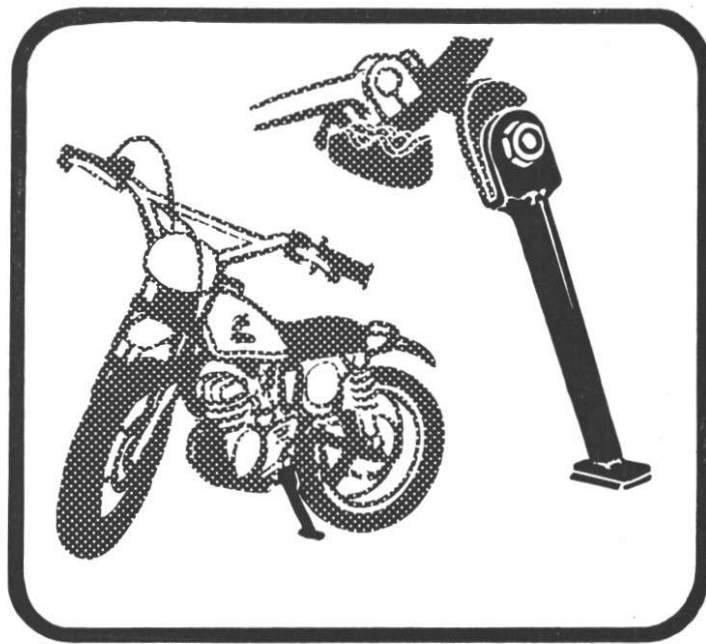

Always use the side stand when parking the motorcycle. Laying the motorcycle on its side will cause fuel to leak from the tank.

WARNING: To prevent burns do not touch the engine or exhaust system immediately after the engine is shut off.

//////////INSTRUCTING THE JUNIOR RIDER//////////

Control Familiarization

—Walk-around Inspection—

During this initial session the instructor points out the locations of the controls and features of the motorcycle and then describes and demonstrates their functions to the student rider. This is done in a walk-around "Pre-Riding" type of inspection. This session should be the most thorough class-room type instruction period of all the sessions. The importance of having the correct tire pressures, sufficient oil quantity, sufficient fuel quantity, a clean air filter, and a properly oiled and adjusted drive chain must be fully explained. The use and function of the clutch lever, brake controls, kick starter, throttle grip, fuel enrichment knob, ignition switch, and kick stand must be fully understood by the student before he mounts the motorcycle. When the student can dupli-

cate the instructor's demonstrations satisfactorily he may then move on to the next step.

Control Familiarization

—Sitting on the Motorcycle—

The instructor demonstrates the controls again and has the student work with them for the first time. The student learns the gear shift pattern. Most importantly, he learns to find neutral. The student learns to operate the brake controls smoothly and effectively. He learns how to reach and operate the fuel valve, fuel enrichment knob, and ignition switch. He learns how to use the kick starter.

Control Familiarization—"Dry Runs"

The instructor teaches the student the correct sequence for operating the different systems of the motorcycle. The student

is taught the starting sequence (fuel valve, fuel enrichment knob, ignition switch, neutral transmission position, throttle, and kick starter). He is taught the importance of braking with the rear brake initially and then additionally applying the front brake. He is taught the importance of coordinating the clutch release and throttle opening. The student must then satisfy the instructor with his knowledge by making several "Dry Runs" (simulating engine starting, warm-up, gear selection, clutch engagement, shifting up and down, braking, engaging neutral, and shutting off the engine), without actual riding.

Controlled Riding

—With the engine shut off—

The instructor first teaches the student to balance the motorcycle when it is standing still with the rider mounted and the kick stand in the up position. The student then learns to slow and stop the motor-

cycle with the brakes as the instructor pushes him forward. The instructor should keep his hand on the seat or frame to help stabilize the motorcycle for the rider during this exercise. The student then learns to balance the motorcycle by himself as the instructor releases his hold from time to time. The instructor should run along side of the motorcycle to give the student confidence and stabilize the motorcycle if the rider should happen to falter. This exercise is continued until the student feels comfortable balancing the motorcycle while braking and stopping.

Controlled Riding

—With the engine running—

Both the student and the instructor go through the starting sequence with the student actually working the controls. This is still under Dry Run conditions. When the student can satisfactorily demonstrate the starting procedure he is allowed to

start the motorcycle.

WARNING:

The instructor must ensure that the adjustable throttle stop is in the first position (MIN).

With the transmission in neutral the student is taught to increase and decrease engine speed by moving the throttle grip. When the student feels comfortable with the engine running, the instructor should shift the transmission into first gear, assist the student in coordinating the clutch release and throttle opening, and jog along with the motorcycle as the student rides in first gear at idle speed. The instructor may have to help the student balance the motorcycle by holding onto the seat or frame. The student should now be learning to operate the throttle, brakes and clutch when stopping and starting the motorcycle. When the student starts off he should be learning to coordinate the clutch with the throttle and when he

slows and stops he should be learning to pull in the clutch lever and shift from first gear to neutral.

The next step for the student should be starting from the neutral position, shifting into first gear and then moving forward without the instructor's physical assistance. The instructor should, however, still run along side of the student in case there is a need to steady the motorcycle. Again, the student should be concentrating on coordinating the clutch lever with the throttle.

The student should now be ready to shift gears. Again the instructor jogs along with the motorcycle as he directs the student's shifting from first gear to second gear and from second gear to third gear. The student should also be learning to downshift properly at this time.

Supervised Riding

When the instructor feels that the student

is totally familiar with the clutch and brake operation he may be allowed his first solo ride. The student should negotiate an oval with the instructor standing at the center giving directions for starting, stopping and shifting gears. The instructor should have the student travel clockwise and then stop and travel counterclockwise around the oval course.

The instructor should then direct the student through a figure 8 course so that he will receive practice at turning right and left.

WARNING:

Do not change the throttle stop setting until the student and instructor are

confident that the student can properly control the increased power and speed.

When the student feels comfortable in his left and right turning maneuvers he should be ready to negotiate a pylon slalom course.

NOTE:

Pylons should be items which are easily crushed or easily knocked out of the path of the motorcycle such as empty plastic liquid containers or small empty cardboard boxes. The pylons can be arranged in slalom courses of increasing difficulty to challenge the new rider and help him develop his control skills.

////////////////////// MAINTENANCE SCHEDULE ////////////////////////

The maintenance intervals shown in the following schedule are based upon average riding conditions. Machines subjected to severe use, or ridden in unusually dusty areas, require more frequent servicing. Items marked* should be serviced by an

authorized HONDA dealer, unless the owner has proper tools and is mechanically proficient. Other maintenance items are simple to perform and may be serviced by the owner.

	INITIAL SERVICE PERIOD	REGULAR SERVICE PERIOD	
	1 month	6 months	12 months
SPARK PLUG— Clean and adjust gap or replace if necessary.		○	
*CONTACT POINTS AND IGNITION TIMING— Clean, check, and adjust or replace if necessary.	●	○	
*CARBURETOR—Check, and adjust if necessary.		○	
THROTTLE OPERATION— Inspect cable. Check, and adjust free play.	●	○	
*CLUTCH—Check operation, and adjust if necessary.	●	○	

	INITIAL SERVICE PERIOD	REGULAR SERVICE PERIOD	
	1 month	6 months	12 months
FUEL FILTER SCREEN—Clean		○	
*BRAKE SHOES—Inspect, and replace if worn.			○
BRAKE CONTROL LINKAGE— Check linkage and adjust free play if necessary.	●	○	
DRIVE CHAIN AND SPROCKET— Check, lubricate, and adjust if necessary.	●	○	
*WHEEL RIMS AND SPOKES— Check. Tighten spokes and true wheels, if necessary.	●	○	
*CYLINDER, CYLINDER HEAD, PISTON AND MUFFLER— Clean			○
TRANSMISSION OIL—Change	●		○
POLYURETHANE FOAM AIR CLEANER ELEMENT— Clean and oil		○	
ALL NUTS, BOLTS, AND OTHER FASTENERS— Check security and tighten if necessary	●	○	

CAUTION: To maintain the safety and reliability of your HONDA motorcycle do not modify the motorcycle and use only genuine HONDA parts when servicing or repairing.

MAINTENANCE OPERATIONS

Spark Plug Replacement and Adjustment

The standard spark plug for this model is the **NGK B6HS**.

Be sure to clean mud and sand from around the spark plug before removing.

1. Disconnect the plug lead and remove the spark plug with the spark plug wrench provided in the tool kit.
2. Inspect the electrodes and center porcelain of the spark plug for deposits, eroded electrodes, or carbon fouling. If the spark plug deposits are heavy, or if the electrodes appear to be eroded excessively, replace the spark plug with a new one. If the spark plug is carbon or wet fouled, the plug can sometimes be cleaned with a stiff wire brush.
3. Adjust the spark plug gap ① to **0.024–0.028 in. (0.6–0.7 mm)**. The gap can be measured with a feeler gauge. The adjustment is made by bending the

side (ground) electrode ②.

Before installing the spark plug, clean any oil or dirt from the spark plug seat in the cylinder head.

Install the spark plug by hand until finger tight. Then use the spark plug wrench to tighten the plug an additional 1/2 to 3/4 turn or until the sealing gasket is compressed.

CAUTION: Do not allow the plug lead to come near or touch the muffler.

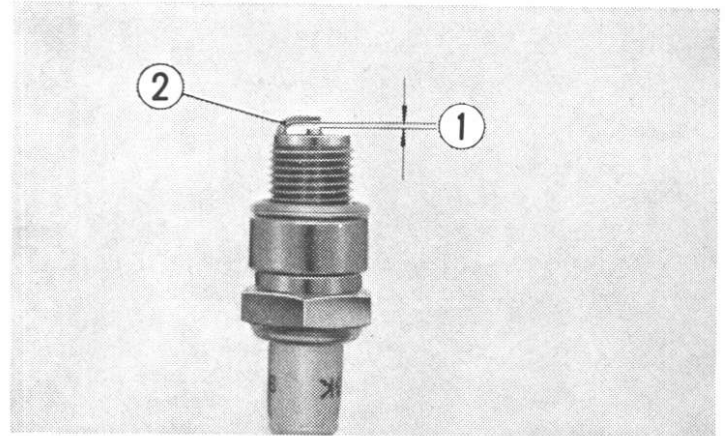

① Spark plug gap

② Side electrode

Ignition Timing Adjustment

1. Remove the generator cover.
2. Clean and inspect the contact breaker points ③. Replace if worn or badly pitted. Light pitting may be removed with an ignition point file.
3. Rotate the generator rotor counterclockwise until the "F" mark ① aligns with the index mark ②. When these marks align, the contact breaker points should just begin to open.

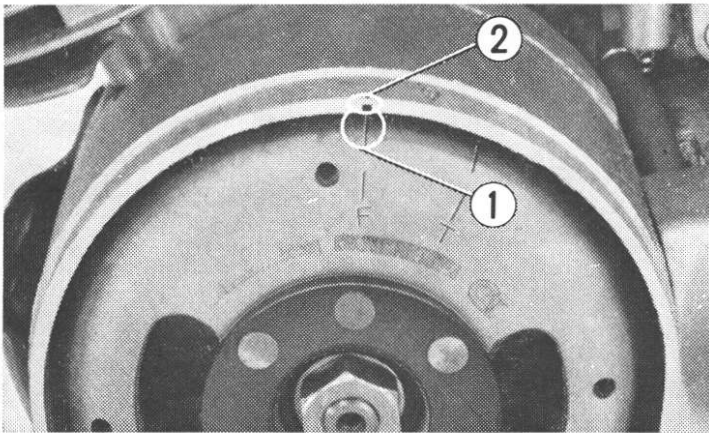

- ① "F" mark
- ② Index mark

4. If ignition timing requires adjustment, loosen the point base locking screw ④, and move the point base ⑤, to increase or decrease the contact breaker point gap.

Widening the gap will advance ignition timing, and narrowing the gap will retard timing.

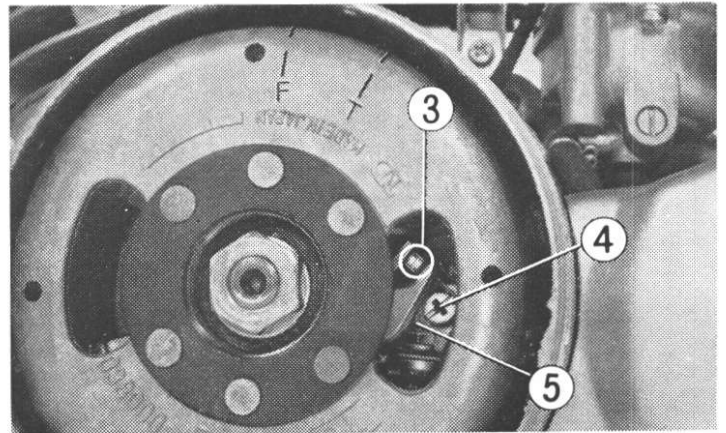

- ③ Contact breaker points
- ④ Point base locking screw
- ⑤ Point base

After adjusting the contact breaker point gap, tighten the point base locking screw, and recheck ignition timing.

5. When ignition timing is properly adjusted, rotate the generator rotor counterclockwise until the breaker points fully open, and check the gap with a feeler gauge. The gap should be **0.008–0.024 in. (0.2–0.6 mm)**.

If the maximum gap is not within these limits after ignition timing has been correctly adjusted, the contact breaker points should be replaced and ignition timing reset.

Carburetor Adjustment

The carburetor should be adjusted only after the engine has attained operating temperature, and when all other tune-up specifications are correct.

1. Adjust the idle speed screw ① until the engine idles at approximately **1,500 rpm**. Turn the idle speed screw clockwise to increase idle speed or counterclockwise to decrease idle speed.

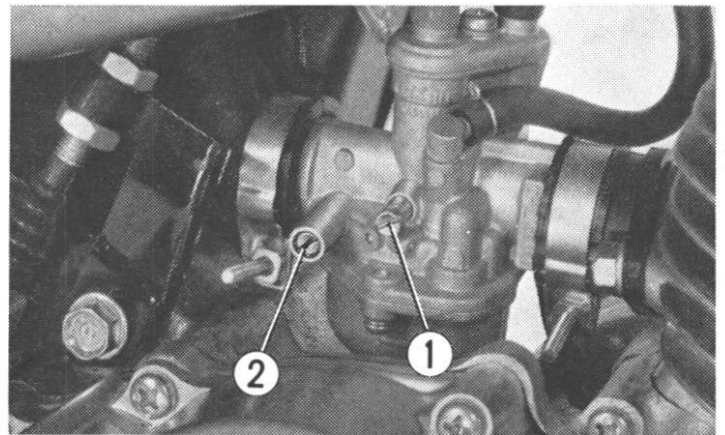

- ① Idle speed screw
- ② Air screw

2. Turn the air screw ② clockwise until you hear the engine begin to miss or decrease in speed, then counterclockwise until the engine again misses or decreases in speed. Center the air screw exactly between these two extreme positions. Usually the correct setting (between extremes of rich and lean) will be found to be $1\frac{3}{4}$ – $2\frac{1}{4}$ turns open from a fully closed position.
3. If idle speed changes after adjusting fuel mixture, readjust the idle speed screw.

NOTE:

Before making adjustments to the carburetor, be sure the ignition system is functioning properly and the engine has good compression. Do not attempt to compensate for other faults by carburetor adjustment.

Throttle Grip Adjustment

As shown in the figure, the normal free play of the throttle grip ① is **0.2 in. (5 mm)** on the external circumference of the grip. To adjust, proceed as follows:

1. Remove the rubber cap ② from the throttle cable adjuster ③.
2. Turn the throttle cable adjuster in

direction ④ to increase the free play and in direction ⑤ to decrease the free play.

3. After adjusting, twist the throttle grip inward and outward to check for smooth operation.

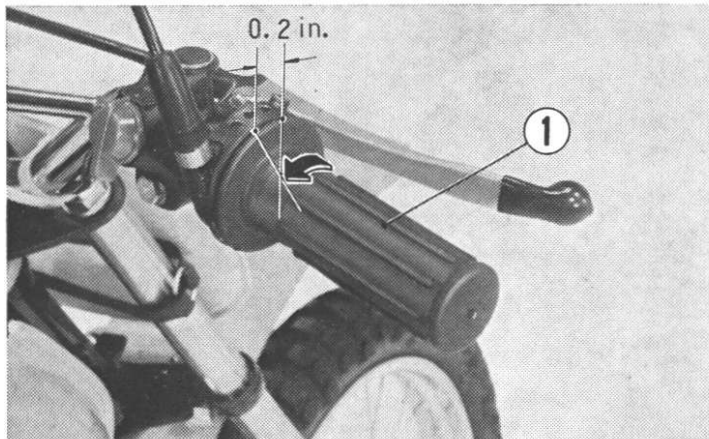

① Throttle grip

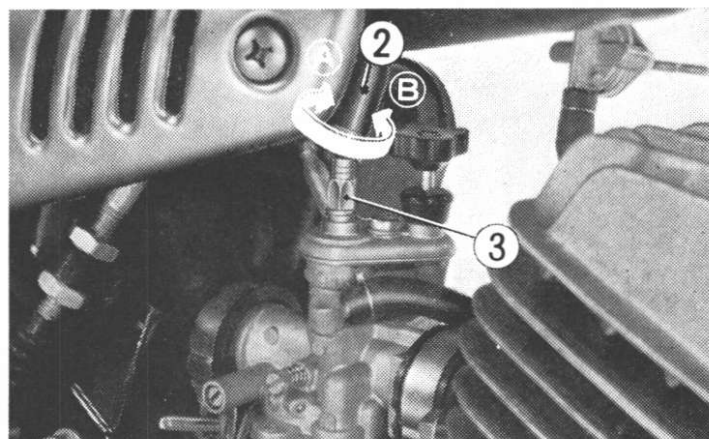

② Rubber cap
③ Throttle cable adjuster

Clutch Adjustment

The clutch should be adjusted so that pulling back the clutch lever will completely disengage the transmission. Too much free play will prevent full clutch disengagement, causing difficult shifting, and creeping or stalling when stopped. Too little free play will cause the clutch to slip during acceleration and may cause rapid clutch wear.

1. The normal clutch lever free play is **0.4–0.8 in. (10–20 mm)** at the tip of the lever.

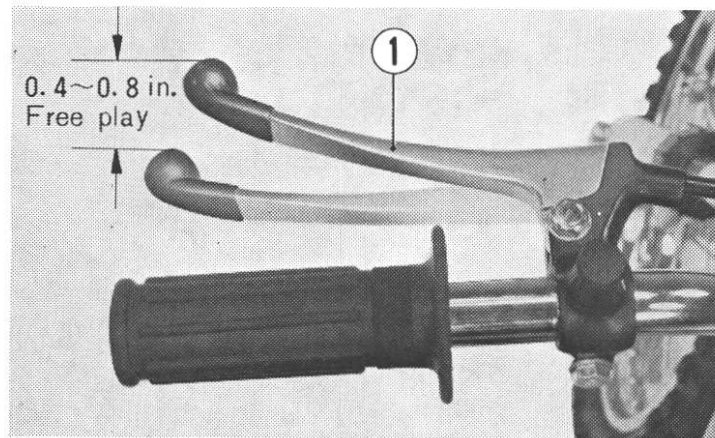

① Clutch lever

2. To adjust the free play, loosen the lock nut ② and turn the clutch adjuster nut ③ in direction ① to decrease the free play and in direction ② to increase the free play. After adjusting, retighten the lock nut.
3. Test ride to be sure the clutch operates properly, without slip or drag. If clutch operation is not satisfactory after adjustment, check the condition of the clutch plates and friction discs.

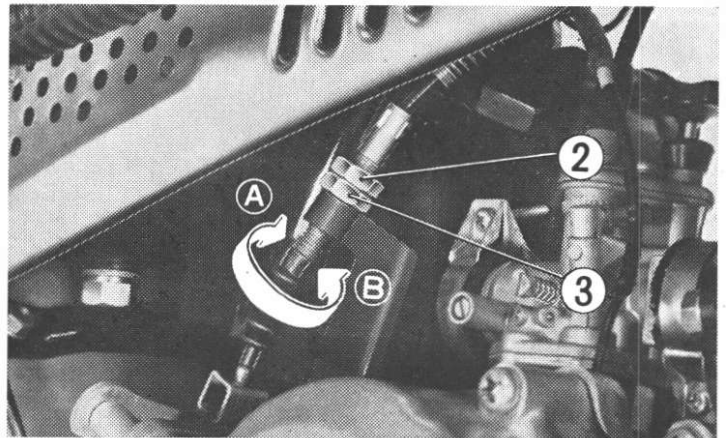

② Lock nut

③ Clutch adjuster nut

Fuel Filter Maintenance

The fuel filter is incorporated in the fuel valve ① which is mounted on the bottom of the fuel tank at the left side. Accumulation of dirt in the filter will restrict the flow of the fuel and cause the carburetor to malfunction; therefore, the fuel filter should be serviced periodically.

1. Drain the fuel tank.
2. Loosen the fuel valve fixing nut ② and remove the fuel valve ① from the fuel

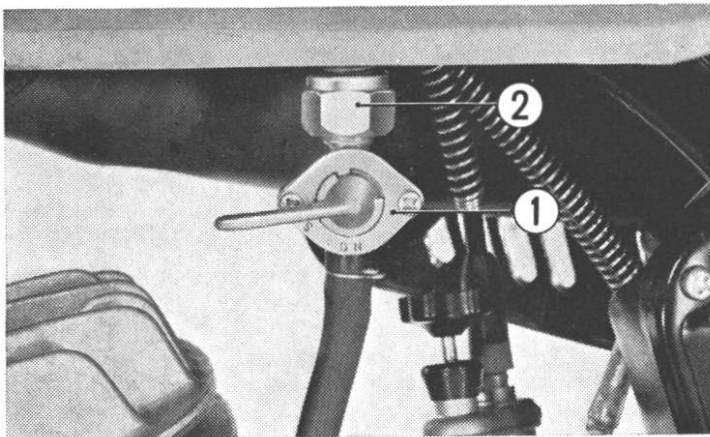

① Fuel valve
② Fuel valve fixing nut

tank.

3. Clean the fuel filter ③ using cleaning fluid.
4. Install the fuel filter in the fuel valve. Then secure the fuel valve to the fuel tank with the fuel valve fixing nut.
5. After installing, check for fuel leaks with the fuel valve control lever in the "ON" position.

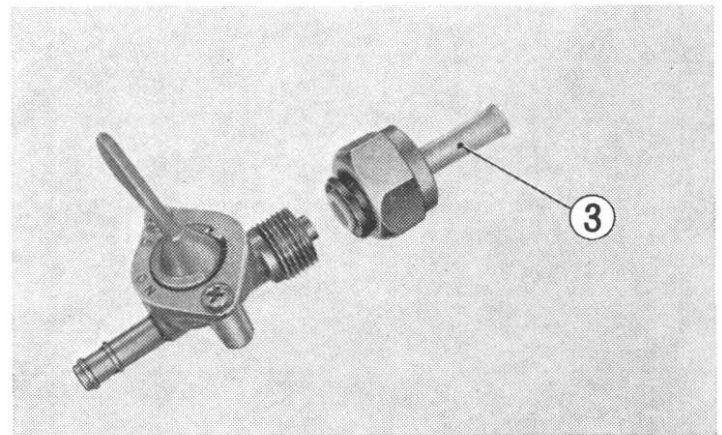

③ Fuel filter

Front Brake Adjustment

Free play, measured at the tip of the front brake lever ①, should be maintained at **0.8–1.2 in. (20–30 mm)**. Free play is the distance the brake lever moves before the brake starts to engage.

1. To adjust the free play, turn the front brake adjuster ② in direction ④ to decrease the free play and in direction ⑤ to increase the free play.

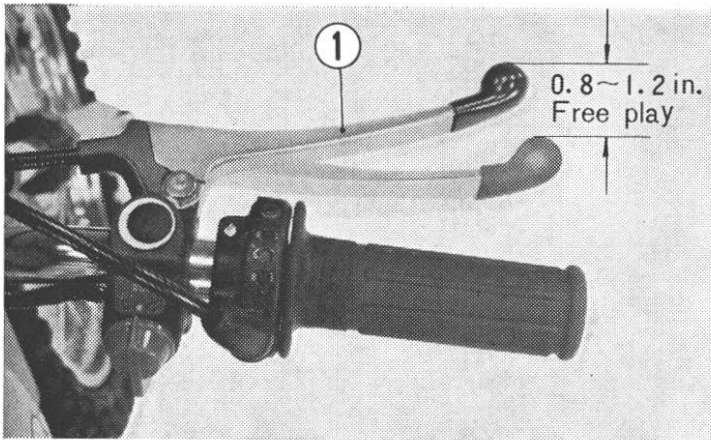

① Front brake lever

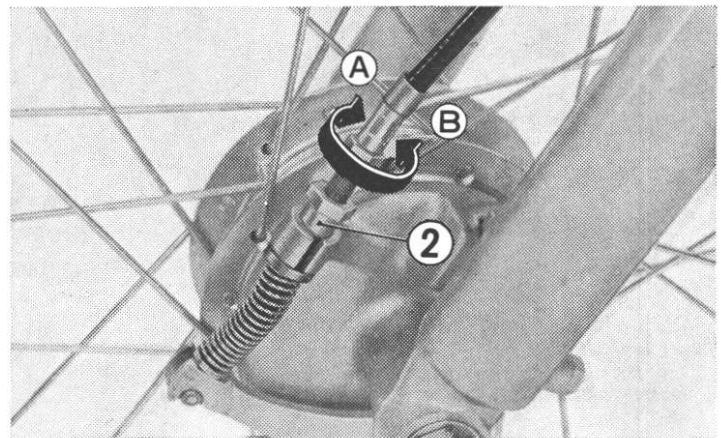

② Front brake adjuster

Rear Brake Adjustment

Rear brake pedal free play, measured at the tip of the rear brake pedal ①, should be maintained at **0.8–1.2 in. (20–30 mm)**. Free play is the distance the brake pedal moves before the brake starts to engage.

1. To adjust the free play, turn the rear brake adjuster ② in direction ④ to decrease the free play and in direction ⑤ to increase the free play.

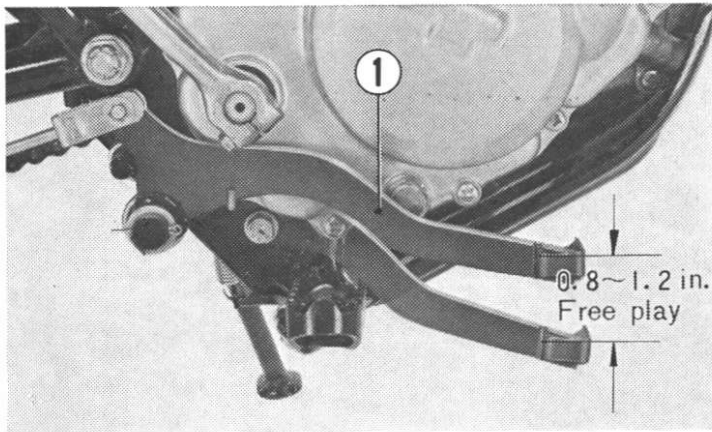

① Rear brake pedal

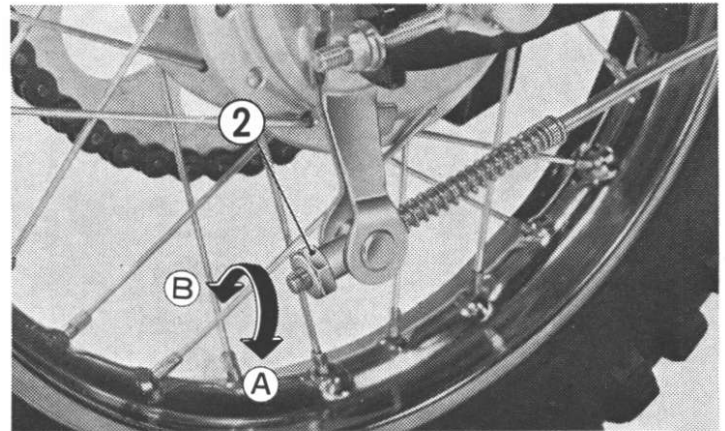

② Rear brake adjuster

Drive Chain Maintenance

Proper tensioning and lubrication will help extend the service life of the drive chain and ensure smooth power transmission to the rear wheel. Under severe usage, or when the motorcycle is ridden in unusually dusty areas, more frequent maintenance is necessary.

Tension Adjustment:

1. Place the motorcycle on a support block to raise the rear wheel off the ground. Shift the transmission into neutral.
2. Check vertical movement of the lower length of the drive chain at a point midway between the sprockets. Move the chain up and down with your fingers and observe the amount of slack. Drive chain tension should be adjusted to allow approximately $\frac{3}{4}$ " vertical movement at this point. Rotate the rear wheel and check drive

chain tension throughout its length. Drive chain tension should remain constant as the wheel is rotated. If the chain is found to be slack in one segment of its length and taut in another, this indicates that some of the links are either worn or kinked and binding. Kinking and binding can frequently be eliminated by lubrication.

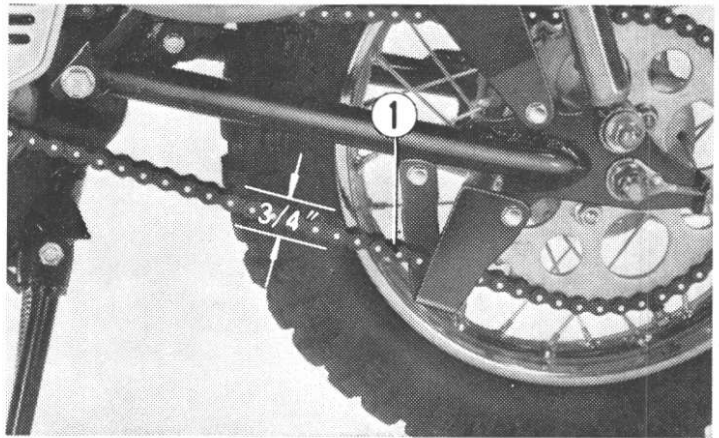

① Drive chain

3. If the drive chain is found to require adjustment, the procedure is as follows:
 - a. Remove the rear axle nut cotter pin ② and loosen the rear axle nut ③.
 - b. Turn the adjusting nut ④ to increase or decrease chain tension. Align the chain adjuster index marks ⑤ with the reference marks ⑥ on both sides of the rear fork.

- c. Tighten the rear axle nut and secure the nut with a new cotter pin.
- d. Check rear brake adjustment.

CAUTION:

Check alignment of the chain protector ⑦. If the chain protector should become bent, it may rub against the drive chain and cause rapid wear.

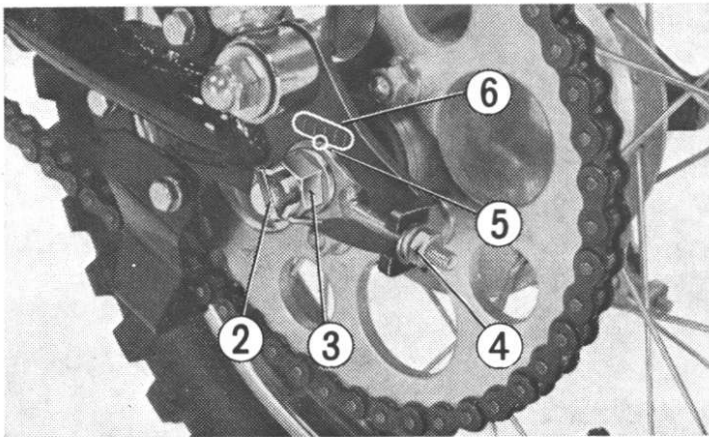

- | | |
|-----------------|-------------------|
| ② Cotter pin | ⑤ Index mark |
| ③ Rear axle nut | ⑥ Reference marks |
| ④ Adjusting nut | |

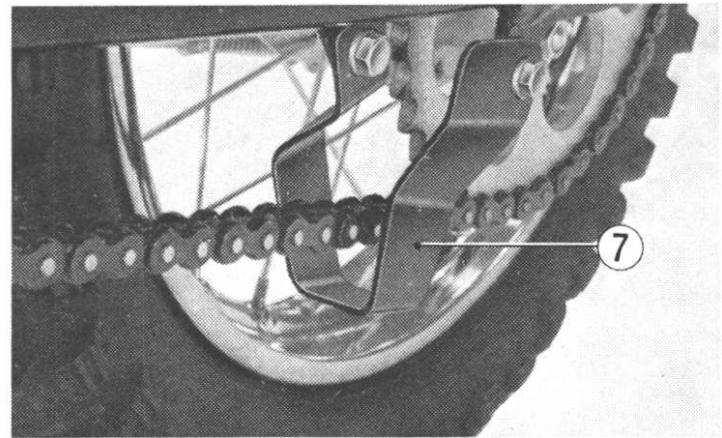

- ⑦ Chain protector

Lubrication:

Lubricate the drive chain every 500 miles. Commercially prepared drive chain lubricants may be purchased at most motorcycle shops and should be used in preference to motor oil or other lubricants. Saturate each chain joint so that the lubricant will penetrate the space between adjacent surfaces of link plates and rollers.

Removal and Cleaning:

When the drive chain becomes extremely dirty, it should be removed and cleaned prior to lubrication.

1. Carefully remove the master link retaining clip with pliers. Do not bend or twist the clip. Remove the master link. Remove the drive chain from the motorcycle.
2. Clean the drive chain in solvent and allow to dry. Inspect the drive chain for possible wear or damage. Replace any chain that has damaged rollers,

loose fitting links, or otherwise appears unserviceable.

3. Inspect the sprocket teeth for possible wear or damage. Replace if necessary. Never use a new drive chain on badly worn sprockets. Both chain and sprockets must be in good condition, or the new replacement chain or sprocket will wear rapidly.
4. Lubricate the drive chain.
5. Pass the chain over the sprockets and join the ends of the chain with the master link. For ease of assembly, hold the chain ends against adjacent rear sprocket teeth while inserting the master link. Install the master link retaining clip ⑧ (page 50) so that the closed end of the clip will face the direction of forward wheel rotation. The master link is the most critical part affecting the security of the drive chain. It is recommended that a new master link retaining clip be installed

whenever the drive chain is reassembled.

6. Adjust the drive chain to the proper tension, following the instructions on pages 47~48.

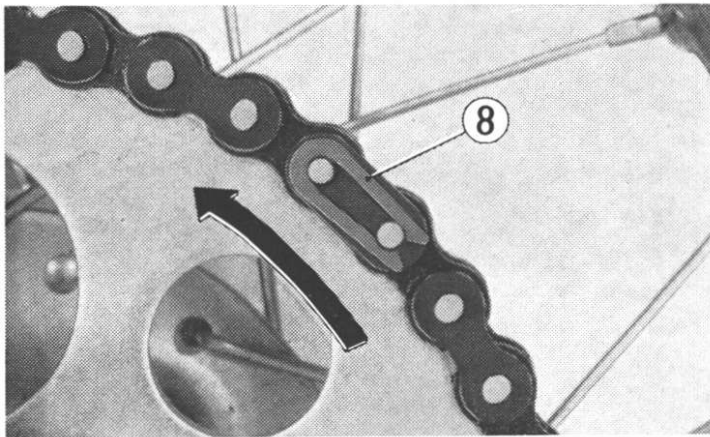

⑧ Retaining clip

Wheel Inspection

Check the wheels for bent rims and loose spokes and, if necessary, consult your HONDA dealer for repair.

Check the tires for general condition.

Front wheel removal

1. Place a support stand under the engine to raise the front wheel off the ground.
2. Turn the front brake adjuster ① all the way in direction A and disconnect the brake cable end ② from the brake arm ③.
3. Pull the cotter pin ④ out of the axle nut ⑤.
4. Remove the axle nut and pull out the front axle ⑥. The front wheel can now

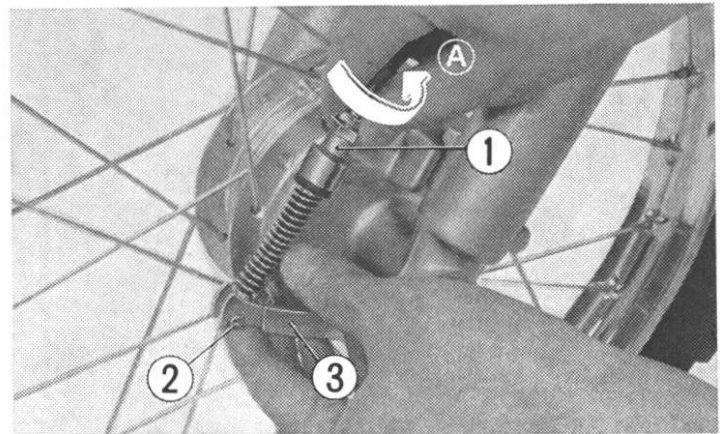

- ① Front brake adjuster
- ② Front brake cable end
- ③ Brake arm

be removed.

5. To install, reverse the removal procedure. Be sure to fit the tongue of the left fork leg into the groove ⑦ in the brake backing plate. Always use a new cotter pin after tightening the axle nut.
6. Check front brake adjustment.

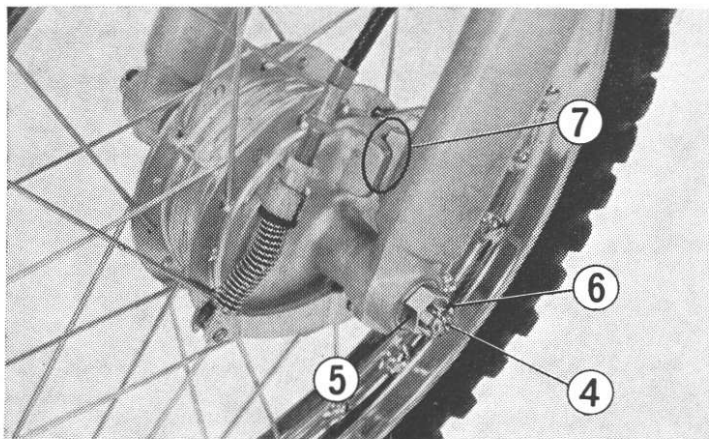

- ④ Cotter pin
- ⑤ Front axle nut
- ⑥ Front axle
- ⑦ Front brake backing plate groove

Rear wheel removal

1. Remove the rear brake adjuster ①.
2. Remove the drive chain. (See page 49)
3. Pull the cotter pin ② out of the rear axle nut ③.
4. Remove the rear axle nut and pull out the rear axle ④. The rear wheel can now be removed.
5. To install, reverse the removal procedure. Be sure to fit the tongue of

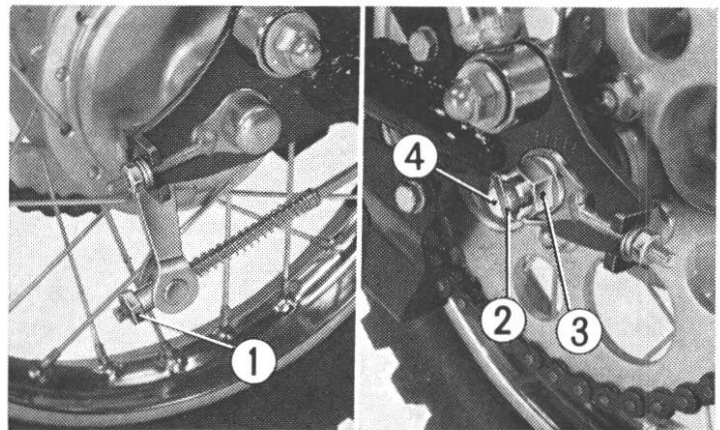

- ① Rear brake adjuster
- ② Cotter pin
- ③ Rear axle nut
- ④ Rear axle

the rear fork into the groove in the brake backing plate.

Always use a new cotter pin after tightening the axle nut.

6. Check rear brake adjustment.

Decarbonizing

Carbon deposits on the cylinder head, combustion chamber walls, piston crown and ring grooves, exhaust port, the front part of muffler, etc. may result in reduced horsepower or in overheating.

Decarbonize the above parts in accordance with the maintenance schedule.

Muffler:

1. Remove the seat.
2. Remove the upper part of the left rear shock absorber from the frame bolt.
3. Remove the attaching bolt from the center of the frame.
4. Remove the two 6mm tightening nuts on the cylinder side and remove the muffler.
5. Decarbonize the muffler tail pipe using a wire brush.

NOTE: The tightening torque of the 6mm muffler tightening nuts is 3.6–5.8lb-ft (50–80kg-cm).

Cylinder Head, Cylinder and Piston:

1. Remove the seat and remove the fuel tank.
2. Remove the spark plug and cylinder head nuts and remove the cylinder head.
3. Decarbonize the combustion chamber walls and piston crown using a scraper of soft material.

- Take care not to score or scratch the surfaces. Ensure that debris does not enter ports when working on piston.
4. To assemble, reverse the disassembly procedure.

NOTE: Use a new gasket when reassembling the cylinder head.

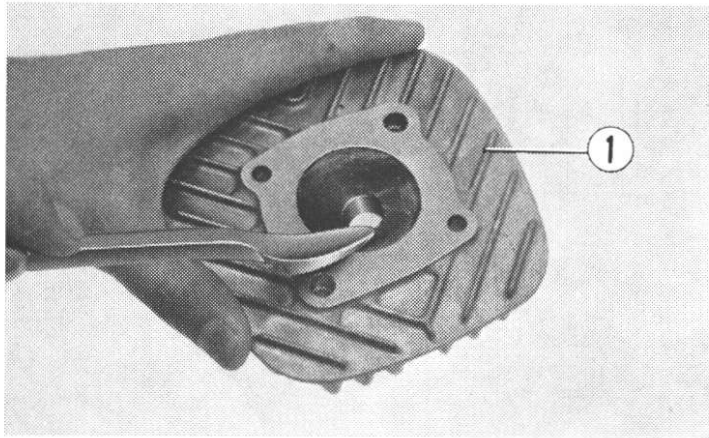

① Cylinder head

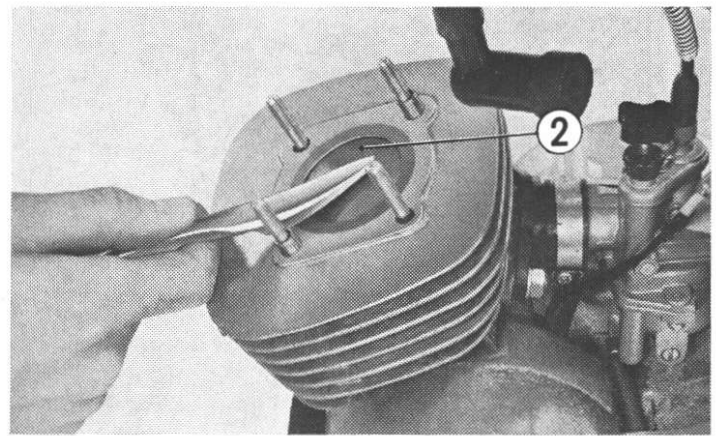

② Piston

Transmission Oil Level

To check the oil level and add oil, proceed as follows:

1. Stop the engine. Place the motorcycle in an upright level position.
2. Remove the oil filler cap ①, and check the oil level with the dipstick. If it is below the level mark ② on the dipstick add oil up to the mark.

NOTE: When checking the oil level, insert the dipstick into the oil filler hole, but do not screw it in.

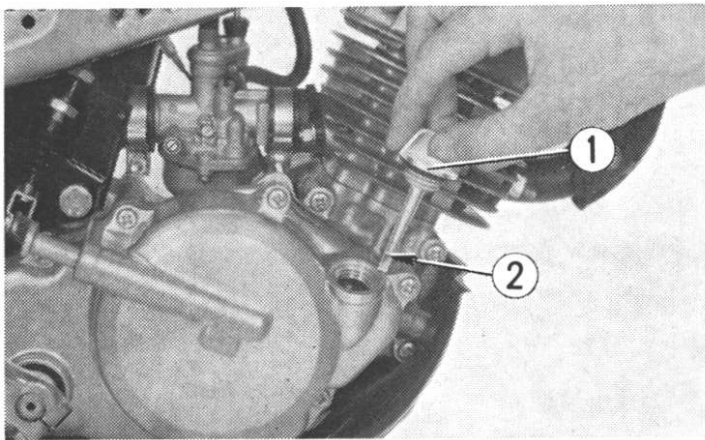

① Oil filler cap ② Oil level mark

Transmission Oil Change

Use only motor oil of the grade and viscosity recommended on page 13. When changing oil, drain the used oil from the crankcase while the engine is warm. This will ensure complete and rapid draining.

1. Remove the oil filler cap ① from the right crankcase cover.
2. Place a drip pan under the engine to catch the oil, and then remove the drain plug ③ with a 17 mm wrench.

NOTE:

To remove the drain plug, it is advisable

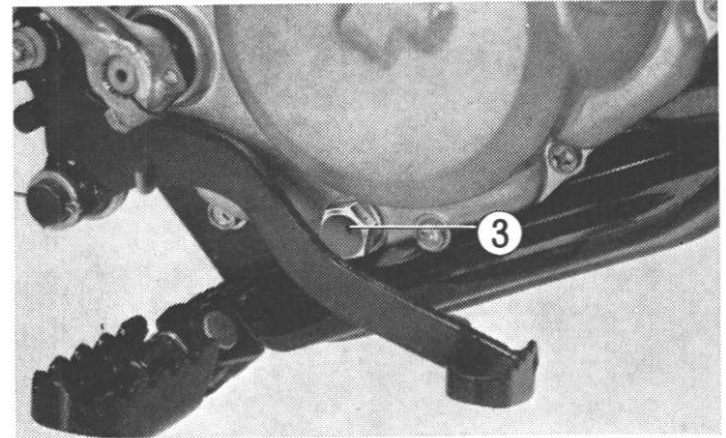

③ Drain plug

to loosen the rear brake adjuster fully to allow the tip of the rear brake pedal to lower. After changing the oil, adjust the brake pedal free play (see page 46).

3. After the oil stops draining from the crankcase, operate the kick starter several times to drain any oil which may be left in the engine.
4. When the oil has been completely drained, ensure that the drain plug gasket is in good condition and reinstall drain plug securely.
5. Add the recommended oil (approx. **0.58 U.S. qt.** or **0.55 l**) slowly through the oil filler hole. Place the motorcycle in an upright position and check the oil level.

Front Suspension Inspection

Check front fork action by locking the front brake and pumping the forks up and down several times. The suspension should function smoothly, with no oil leakage from the fork legs. Damaged, binding, or leaking front forks should be repaired before the motorcycle is operated. Check security of all front forks and handlebar mounting bolts illustrated below.



Front Fork Oil Change

Oil in both front fork legs should be changed at least once a year.

1. Remove drain plug ① from each fork leg and pump the forks several times to ensure complete draining.
2. Reinstall drain plug and block up the front of the motorcycle.
3. Remove the oil filler plugs ②.
4. Refill each fork leg with **2.5 oz. (75 cc)** of premium quality automatic transmission fluid (ATF).
5. Install filler plugs, and remove block from under motorcycle.

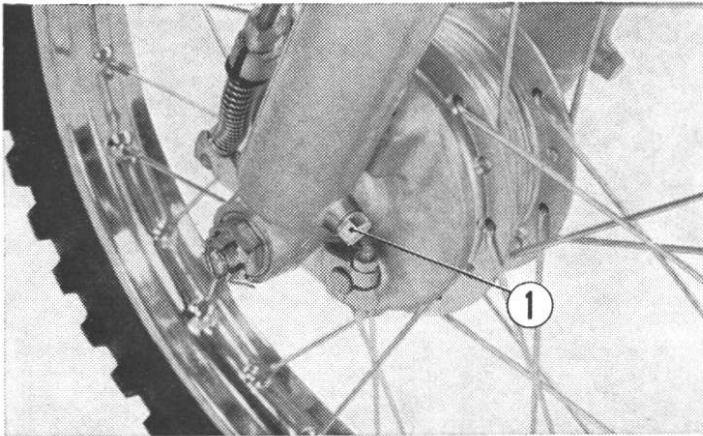

① Drain plug

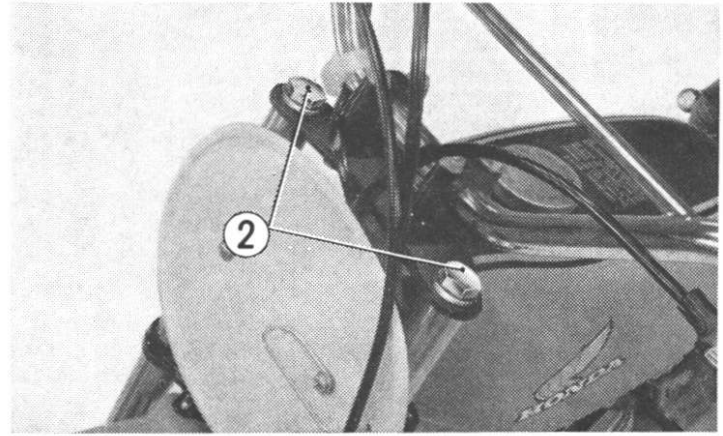

② Oil filler plugs

Rear Suspension Inspection

Check the rear suspension periodically by careful visual examination. Note the following items.

1. Rear fork bushing—this can be checked by pushing hard against the side of the rear wheel while the motorcycle is on a support block and feeling for looseness in the fork bushings.
2. Check side stand spring for damage.
3. Check all suspension component attachment points for security of their respective fasteners.
4. Check for oil leaks in rear damper units.
5. Check the rear fork pivot nut and the two rear frame tightening bolts for looseness.

NOTE: If any of the above components appear damaged or worn, consult your HONDA dealer for further inspection.

Air Cleaner Maintenance

To clean the air cleaner, proceed as follows:

1. Remove the left number plate.
2. Remove the three screws ① and remove the air cleaner case cover ②.

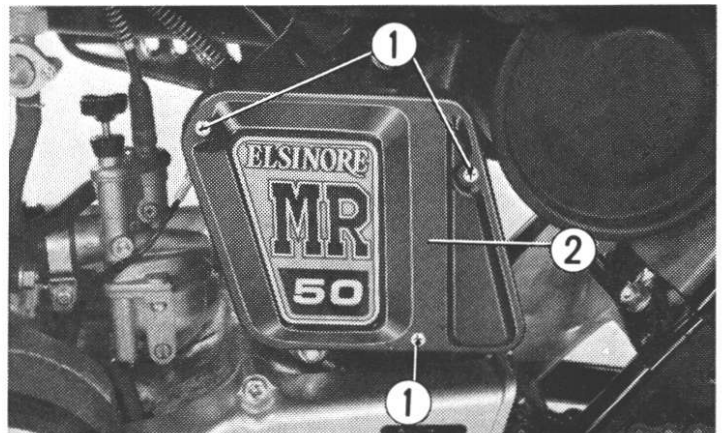

- ① Screws
② Air cleaner case cover

3. Remove the air cleaner element plate ③ and remove the air cleaner element ④.
4. Wash the element in clean stoddard solvent and dry thoroughly.
5. Soak the element in clean gear oil (SAE 80~SAE 90) until it is saturated. Then squeeze to remove excess oil.
6. Install the element.
7. Install the element plate and install the air cleaner case cover with the three screws.
8. Install the left number plate.

WARNING: Gasoline or low flash point solvents are highly flammable and must not be used to clean the air cleaner elements.

NOTE: When the motorcycle has been operated in extremely dusty conditions or deep mud and water, check the air cleaner for condition carefully.

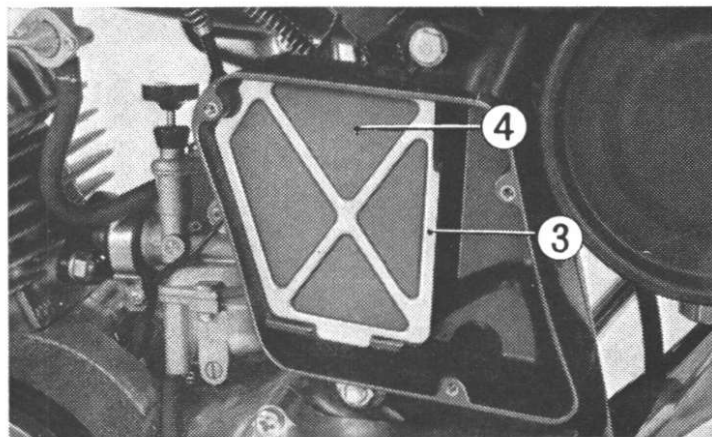

- ③ Air cleaner element plate
- ④ Air cleaner element

Spark Arrestor Maintenance

The exhaust system spark arrestor must be purged of accumulated carbon periodically. The spark arrestor is located under the seat directly in front of the rear fender and is cleaned in the following manner:

1. Remove the left side number plate.
2. Remove the two 17 mm plugs from the bottom of the spark arrestor. Take care not to lose the sealing washers.

3. Start the engine and rev several times while momentarily creating exhaust system back pressure by blocking the end of the exhaust pipe with a rag.
4. After clearing the spark arrestor of carbon reinstall the spark arrestor plugs, sealing washers, and number plate.

CAUTION:

- The exhaust system will heat up during this operation. Take care not to touch the muffler or exhaust pipe with bare hands.
- Ensure that this operation is performed where there is no fire hazard (gasoline vapor, flammable materials, etc.).
- Wear eye protection.

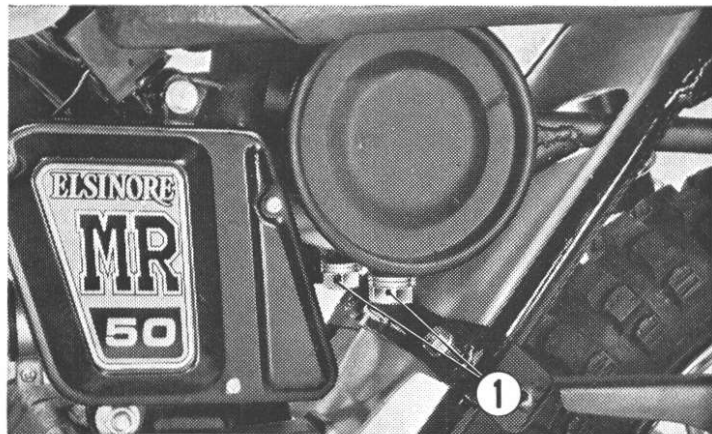

① 17 mm plugs

TROUBLE SHOOTING

Use the following table to help determine the cause of problems with your HONDA motorcycle. Contact your HONDA dealer for assistance in matters beyond the scope of the table.

1. Engine will not start.

	Cause	Remedy
Fuel system	<ol style="list-style-type: none"> 1. Insufficient gasoline. 2. Clogged fuel valve. 3. Clogged fuel tube. 	Add. Clean. Clean.
Electrical system	<ol style="list-style-type: none"> 1. Damaged, wet or fouled plug. 2. Incorrect plug gap. 3. Dirty or damaged contact points. 4. Incorrect point gap. 5. Incorrect ignition timing. 	Replace or clean. Adjust. Replace or clean. Replace or adjust. Adjust.
Compression	<ol style="list-style-type: none"> 1. Loose spark plug. 2. Loose cylinder head. 	Retighten. Retighten.

2. Engine does not develop sufficient power or overheats.

Cause	Remedy
1. Incorrect ignition timing. 2. Clogged air cleaner element. 3. Carbon deposits in muffler, cylinder head or on piston crown. 4. Clogged cylinder fins.	Adjust. Clean. Decarbon. Clean.

////////////////////////////////////// SPECIFICATIONS //

ITEM	
DIMENSIONS Overall length Overall width Overall height Wheel base	1,455 mm (57.3 in.) 645 mm (25.4 in.) 835 mm (32.9 in.) 990 mm (39.0 in)
WEIGHT Dry weight	42.5 kg (94.0 lb)
CAPACITIES Transmission oil Fuel tank Front fork	0.55 lit. (0.58 U.S. qt.) 2.5 lit. (0.66 U.S. gal.) 75 cc (2.5 oz.)

ITEM	
ENGINE Bore and stroke Compression ratio Displacement Contact breaker point gap Spark plug gap	40 × 39.7 mm (1.575 × 1.563 in.) 6.7 : 1 49 cc (2.99 cu. in.) 0.2~0.6 mm (0.008~0.024 in.) 0.6~0.7 mm (0.024~0.028 in.)
CHASSIS AND SUSPENSION Caster Trail Tire size, front Tire size, rear	62° 93 mm (3.66 in.) 2.25-14 (4 PR) 2.75-12 (4 PR)
POWER TRANSMISSION Primary reduction Final reduction Gear ratio. 1st. 2nd. 3rd.	3.111 3.583 3.083 1.578 1.130

WIRING DIAGRAM

