

HONDA QR50

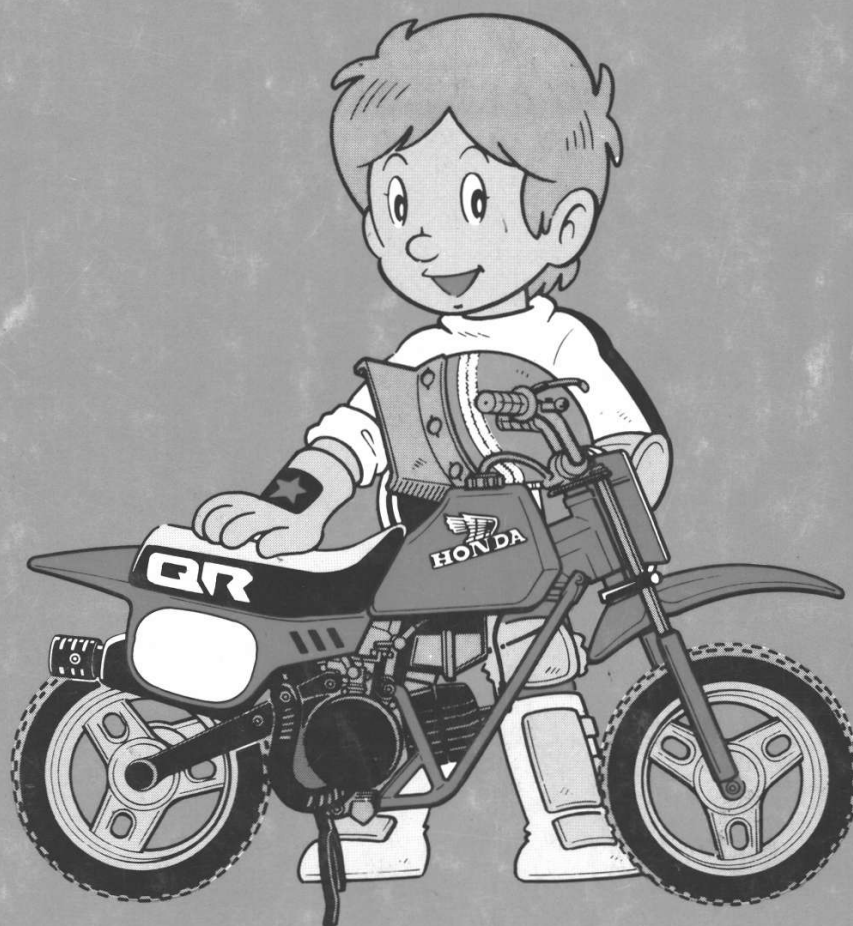

**OWNER'S MANUAL
MANUEL DU CONDUCTEUR
FAHRER-HANDBUCH**

HONDA

QR50

OWNER'S MANUAL

MANUEL DU CONDUCTEUR

FAHRER-HANDBUCH

IMPORTANT NOTICE

THIS MOTORCYCLE IS DESIGNED AND MANUFACTURED FOR JUNIOR RIDER ONLY AND IS SOLD "AS IS" WITH NO WARRANTY. IT DOES NOT CONFORM TO NATIONAL VEHICLE SAFETY STANDARDS AND OPERATION ON PUBLIC STREETS, ROADS, OR HIGHWAYS IS ILLEGAL.

FIRST DETERMINE THAT OPERATION IS LEGAL.

OPERATOR ONLY. NO PASSENGERS.

This motorcycle is designed and constructed as an operator only model. The vehicle load limit is 25 kg (55 lbs). Rider weight must not exceed this limit or damage to the motorcycle may result.

READ OWNER'S MANUAL CAREFULLY.

Pay particular attention to statements preceded by the following words:

▲ WARNING

Indicates a strong possibility of severe personal injury or death if instructions are not followed.

CAUTION:

Indicates a possibility of personal injury or equipment damage if instructions are not followed.

NOTE: Gives helpful information.

WELCOME

This booklet is your guide to the basic operation and proper maintenance of your new Honda QR50. Please take the time to read it carefully. Details necessary for riding the Honda QR50 are given on later pages to acquaint you with important items to be learned.

Your authorized Honda dealer will be glad to provide assistance or further information and is equipped to handle your future service needs.

Thank you for selecting a Honda. We wish you continued riding pleasure in the miles ahead.

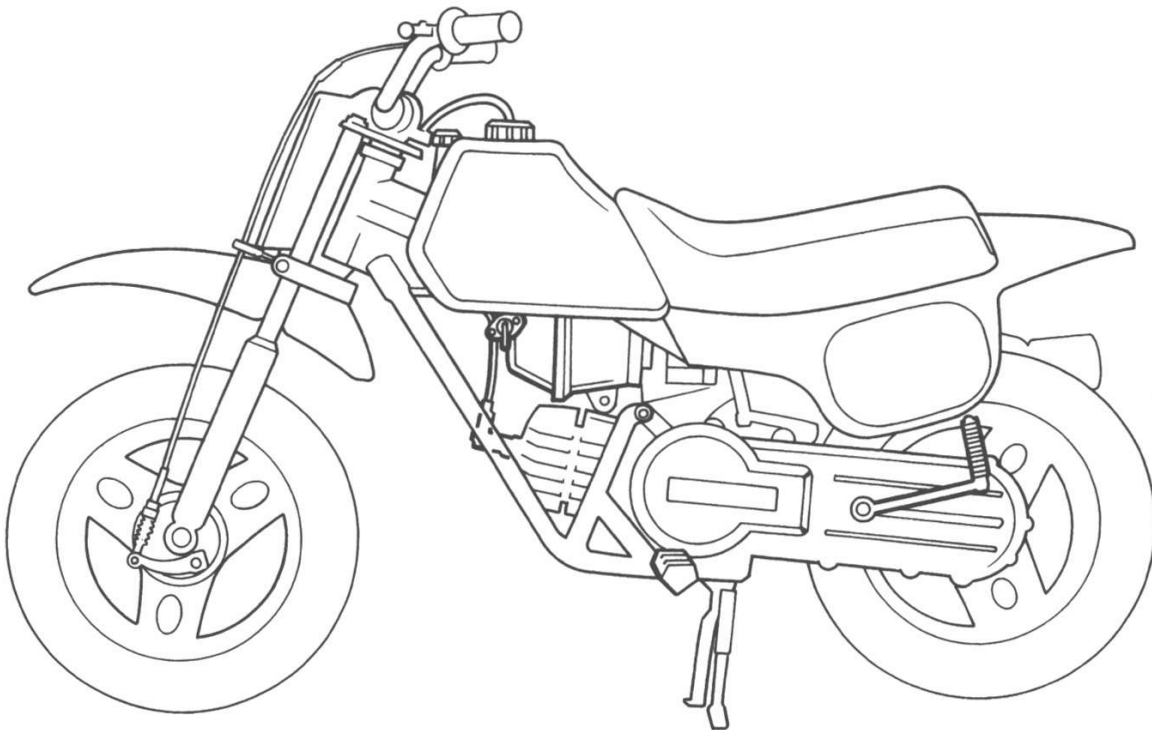

All information in this publication is based on the latest product information available at the time of approval for printing. HONDA MOTOR CO., LTD. reserves the right to make changes at any time without notice and without incurring any obligation.

No part of this publication may be reproduced without written permission.

CONTENTS

	Page
MESSAGE TO THE PARENTS	1
1. PRECAUTIONS	3
2. CONTROLS AND THEIR FUNCTIONS	9
• Engine stop switch	12
• Fuel cock	13
• Throttle limiter	14
• Power limiter	14
• Choke knob	15
• Brake levers	15
• Brake lock lever	16
3. OPERATION	17
• Starting the engine	17
• Riding	19
• Stopping the motorcycle	20
• Placing the motorcycle on the center stand	20
4. INSPECTION AND MAINTENANCE SERVICES..	21
• Oil level check and replenishment	21
• Fuel level and replenishment	22
• Spark plug inspection	23
• Handlebar inspection	23
• Brake inspection	24
• Air cleaner maintenance	25
• Idle speed adjustment	26
• Throttle free play adjustment	27
• Tyre air pressure	27
• Transmission oil change	28
5. SPECIFICATIONS	29

MESSAGE TO THE PARENTS

This motorcycle is designed for junior riders. Before your sons or daughters start to ride, it is important that you review the contents of this manual with them. A preliminary understanding of proper operation and maintenance will facilitate training and will contribute to their safety and the service life of the machine.

- The QR50 is an OPERATOR ONLY model.
- The vehicle load limit is 25 kg (55 lbs) . Rider weight must not exceed this limit.
- The junior rider must be of sufficient size to hold the motorcycle up while straddling it with both feet on the ground. He or she must also have sufficient strength to pick up the motorcycle if it is on its side.
- The parent and junior rider must be fully familiar with the motorcycle, the motorcycle controls and control functions. Both parent and junior rider must fully understand everything in this manual before riding begins.
- For safety, the QR50 must be properly adjusted and maintained. Be sure to make pre-practice and pre-race inspections and be sure to impress on the junior rider the importance of checking all the items thoroughly before riding the motorcycle.
- Take special precautions in observing the junior rider's first use of the motorcycle. Select an off-road practice location that is level, uncongested, and free of obstacles.
- Development of the junior rider's self confidence comes with a total familiarization with the motorcycle controls and their functions plus lots of PRACTICE.
- Before allowing the junior rider to enter competition events, it is the parents' responsibility to make sure he or she has the necessary riding skills and maturity.
- It is illegal to ride the QR50 on public roads or highways. If it becomes necessary to cross a public roadway, remember to get off the QR50 and push it across.
- Always obey local off-road riding laws and regulations.
- Obtain permission to ride on private property. Avoid posted areas and obey "no trespassing" signs.
- The junior rider should always ride in the company of at least one other rider so they can assist each other in the event of trouble.
- Familiarity with the motorcycle is critically important should a problem occur far from help.

-
-
- Caution the junior rider never to ride beyond his ability and experience or faster than conditions warrant.
 - If you are not familiar with the terrain, lead the way and ride cautiously. Hidden rocks, holes or ravines could spell disaster.
 - If the QR50 is to be carried, secure it in an upright position and drain all petrol from the fuel tank and carburetor to prevent leakage during transit.

1. PRECAUTIONS

READ WITH YOUR SON OR DAUGHTER

- Be sure to observe these precautions:

ALWAYS wear a helmet, face shield or goggles, boots, gloves, and protective clothing.

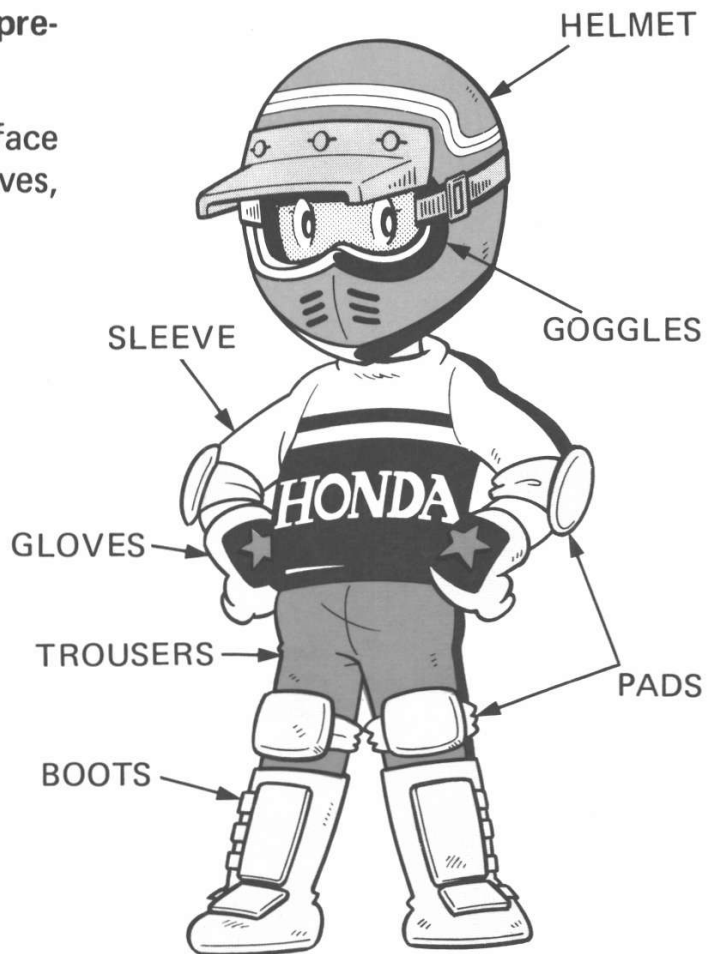

- **PERFORM** preliminary gymnastic before riding.
Practice as you do before you start swimming, etc.



-
-
- **NEVER** ride the QR50 unless it is inspected and adjusted by an expert or a coach.

Don't ride the motorcycle unless allowed to do so.

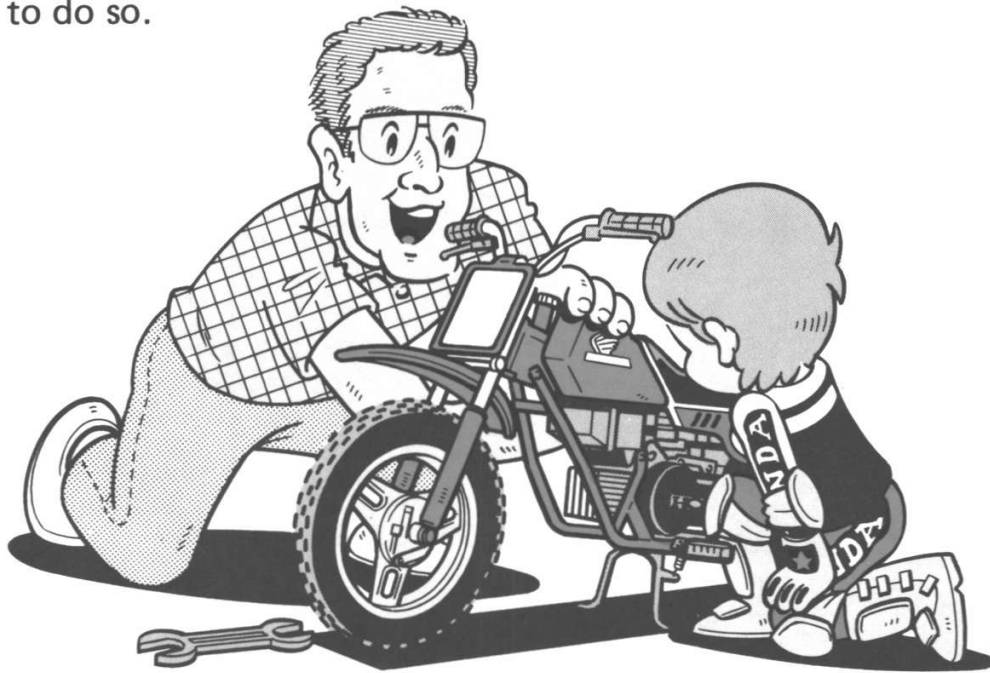

- **LEARN** to ride the QR50 properly.

Don't "pick up" riding. Get it from an expert. Good coaching shortens the learning process and ensures safety. If you judge your dad as an excellent rider, all the better.

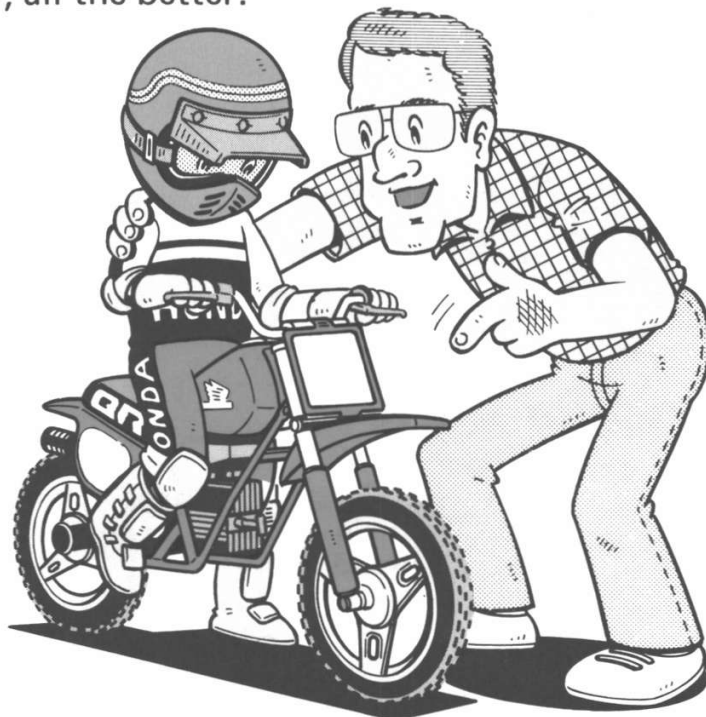

- **NEVER** ride the QR50 on public streets, roads or highways.

Practice only in practice areas. Transport the machine on a carrier and ride under supervision of your dad or coach and in company with at least one other rider so that they can help each other in case of trouble.

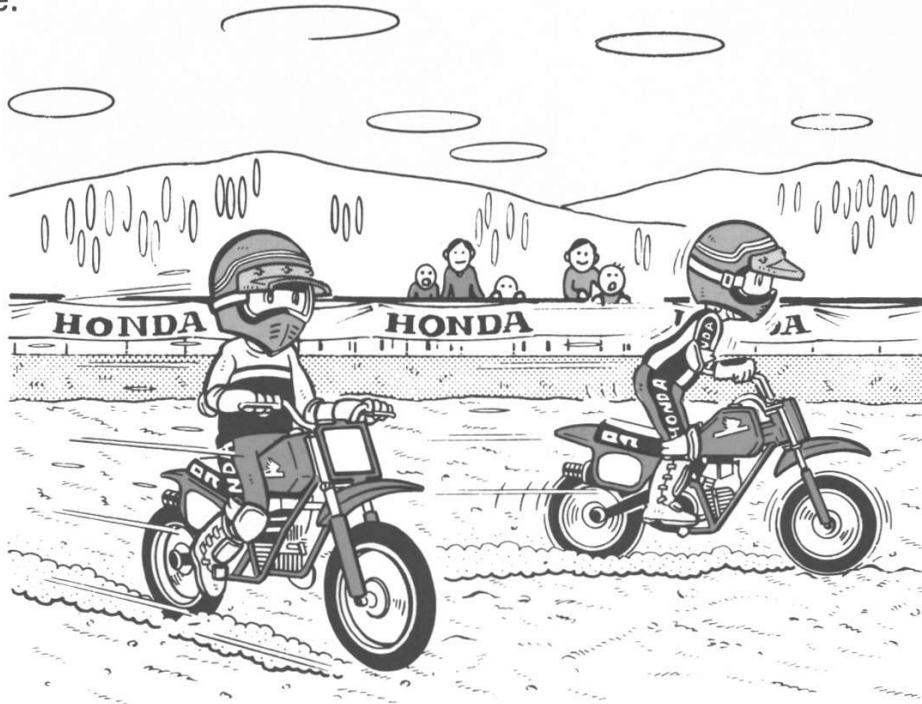

- **NEVER** run the engine in an enclosed area.
The exhaust contains poisonous CARBON MONOXIDE.

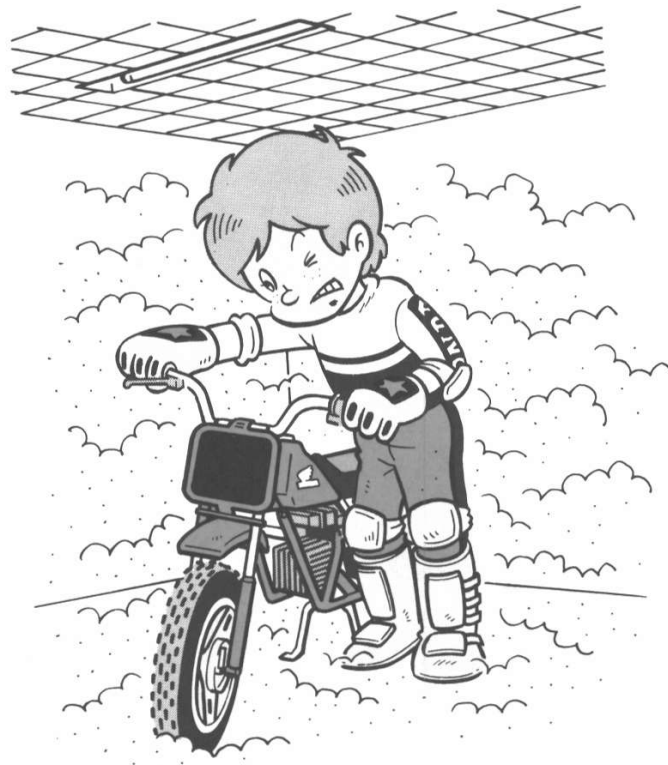

-
-
- The QR50 is an OPERATOR ONLY MODEL.

Riding with a passenger is particularly a hazard to safety and may cause damage to your motorcycle.

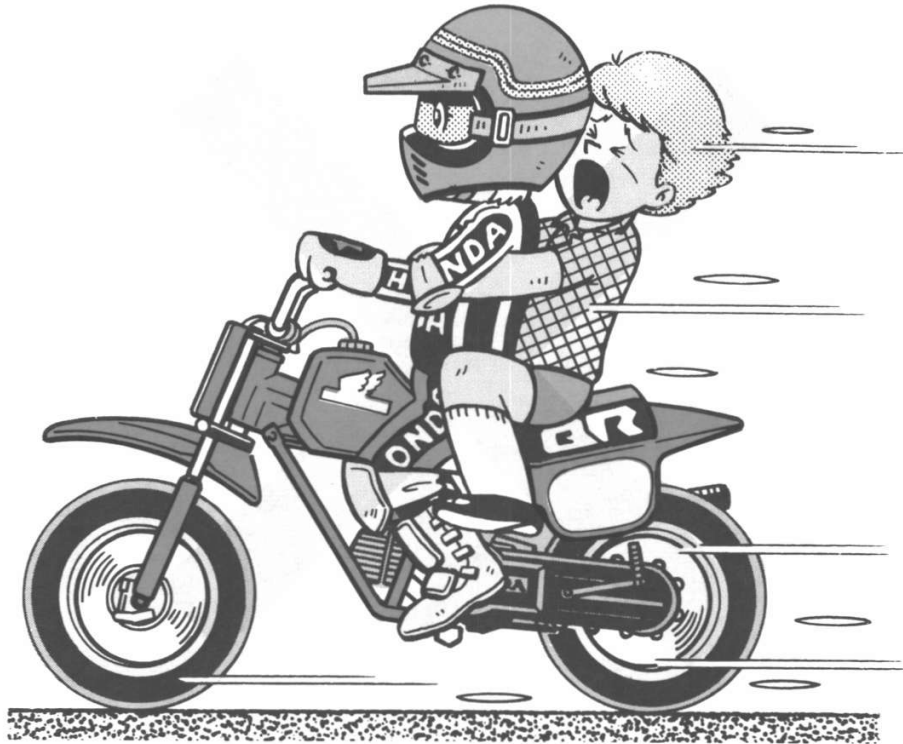

- **DON'T touch any part of the engine, muffler and exhaust pipe.**

The engine, muffler and exhaust pipe become very hot during operation and remain hot after operation.

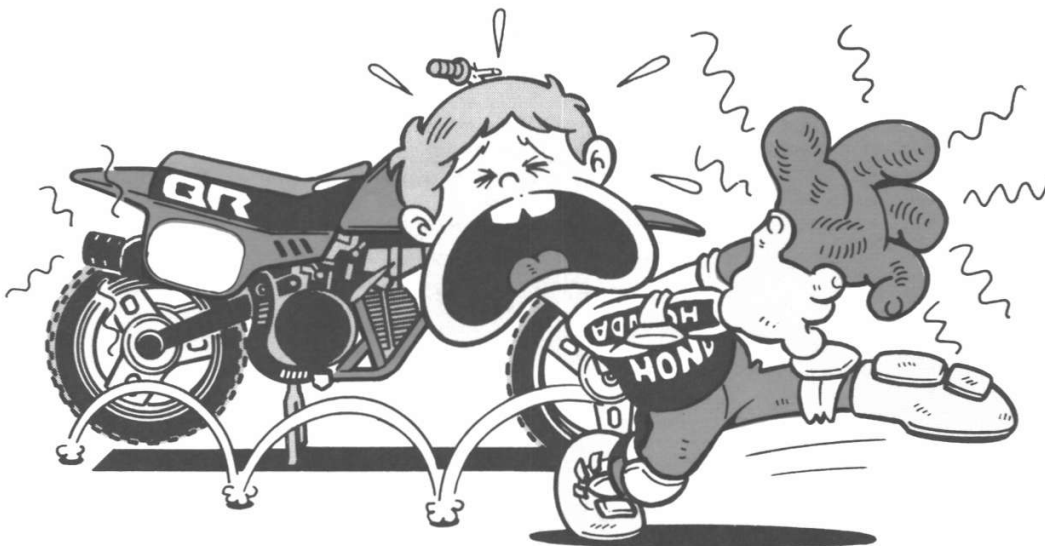

- **DON'T touch any part while it is running.**

Serious injury will result if you are caught in rotating gears, wheels, etc.

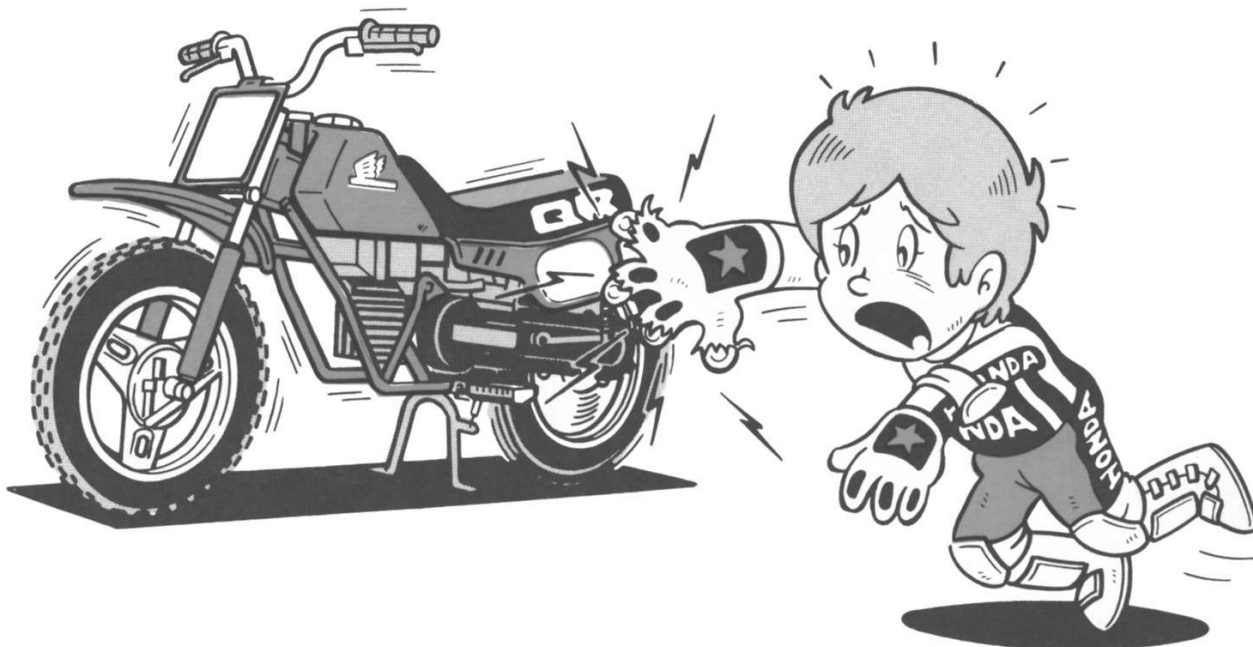

- **BE SURE to place the motorcycle on its center stand before attempting to start the engine.**

The machine may start off suddenly if the rear wheel is in contact with the ground.



- **ASK** your dad or coach to refuel the fuel tank.

Petrol is extremely flammable and is explosive under certain conditions.

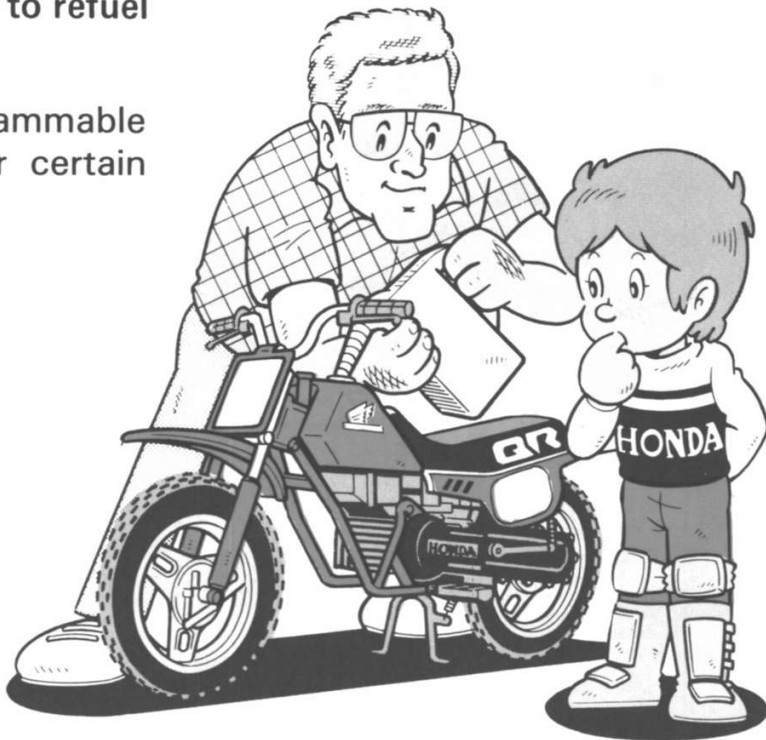

- **TURN** the fuel cock to **OFF** after riding.

The engine may not start easily if the fuel cock has been left **ON** for an extended period of time.

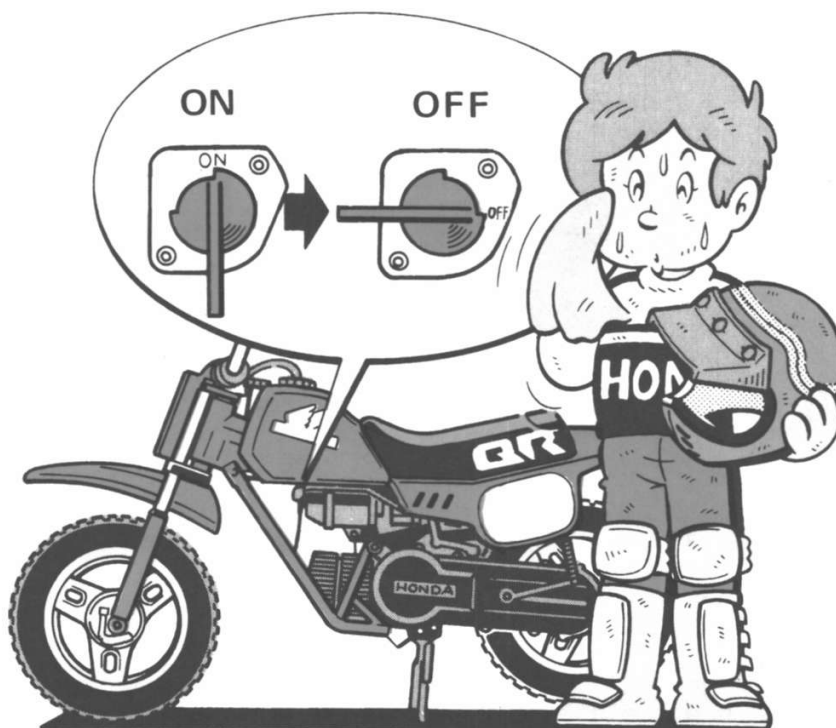

2. CONTROLS AND FUNCTIONS

Familiarize with the motorcycle controls and their functions :

- To remove the oil tank cap, pull it up by hand.
- To remove the fuel fill cap, turn it counterclockwise with your hand.

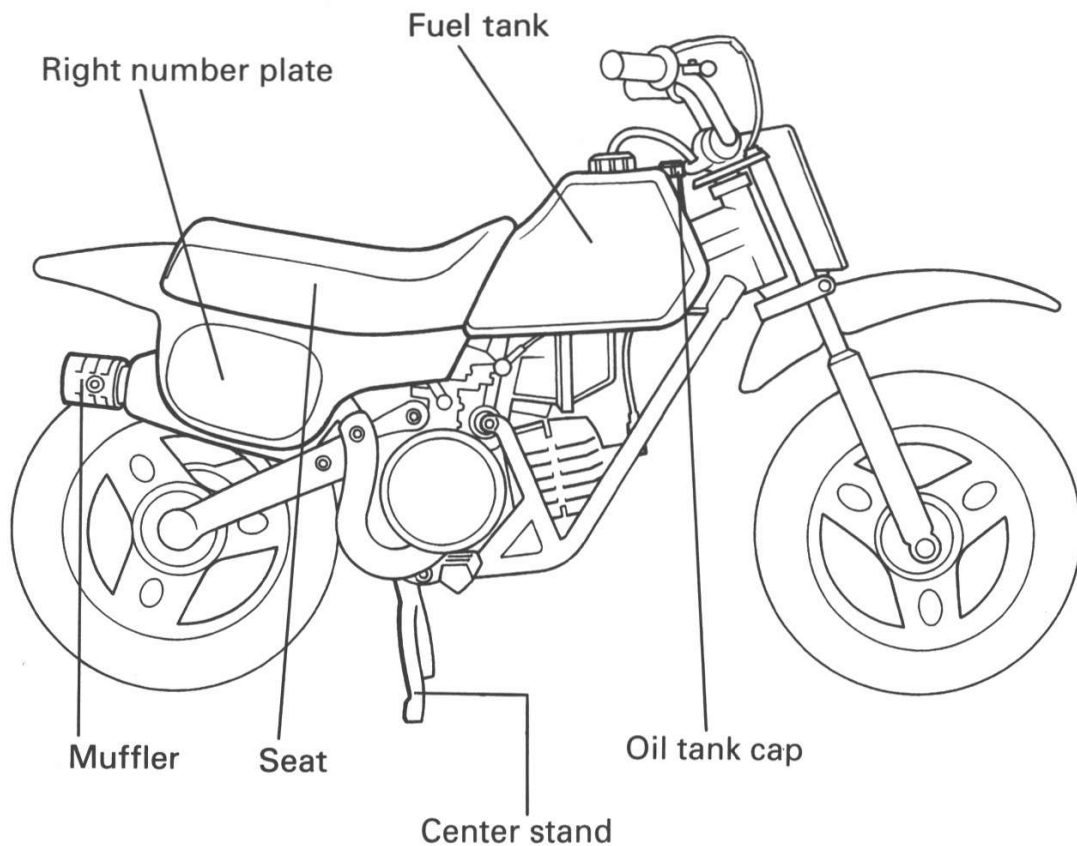
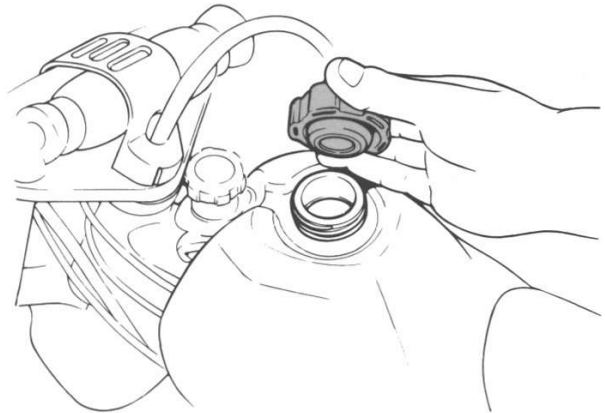
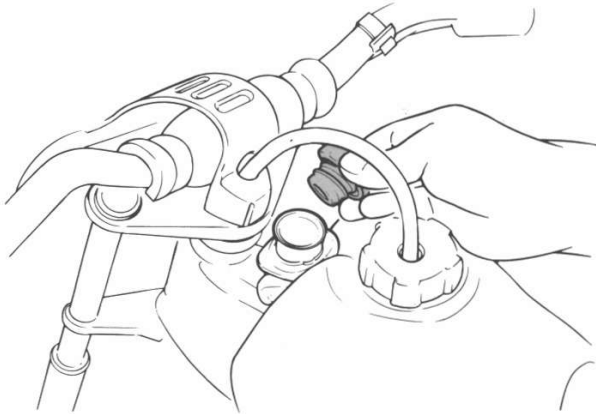

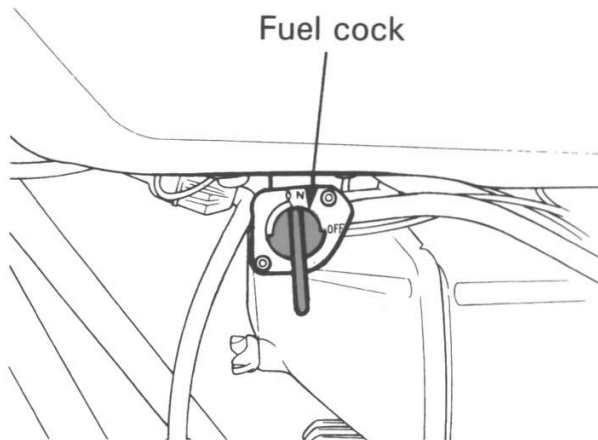

The fuel cock has two positions; "ON" and "OFF":

ON Turn the fuel cock to this position before riding.

OFF . . . No fuel flows from the fuel tank to the carburetor.

Turn the fuel cock to this position after riding.

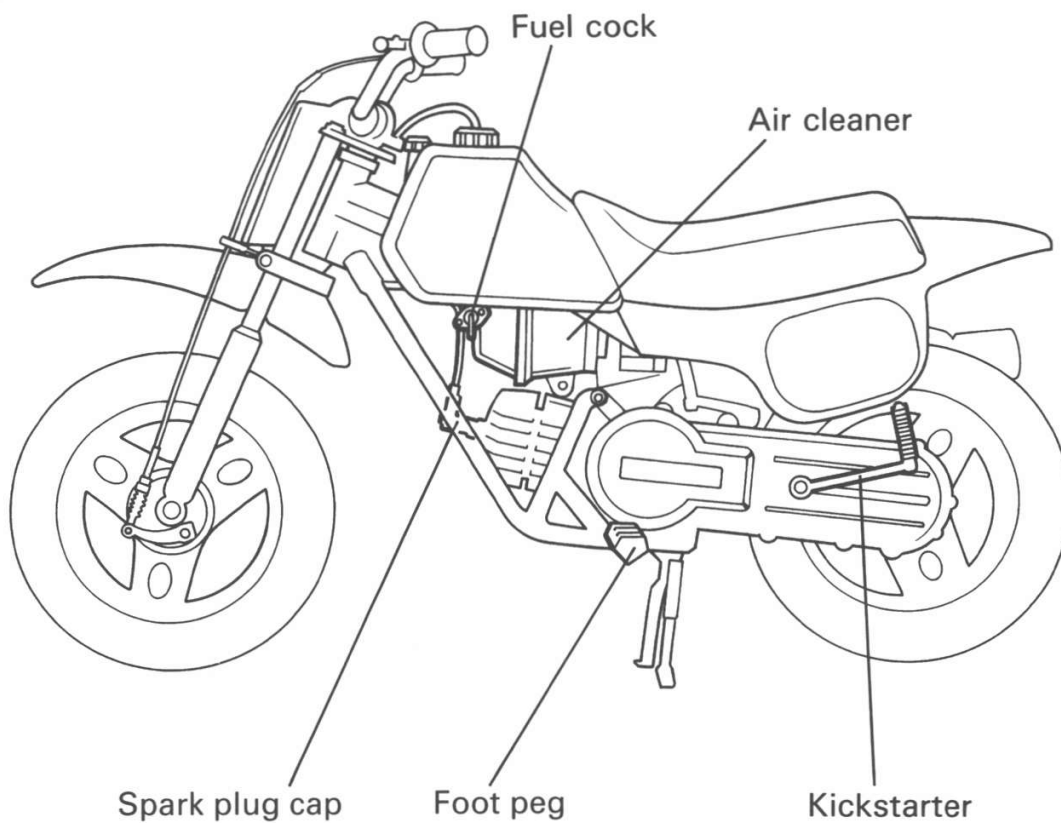

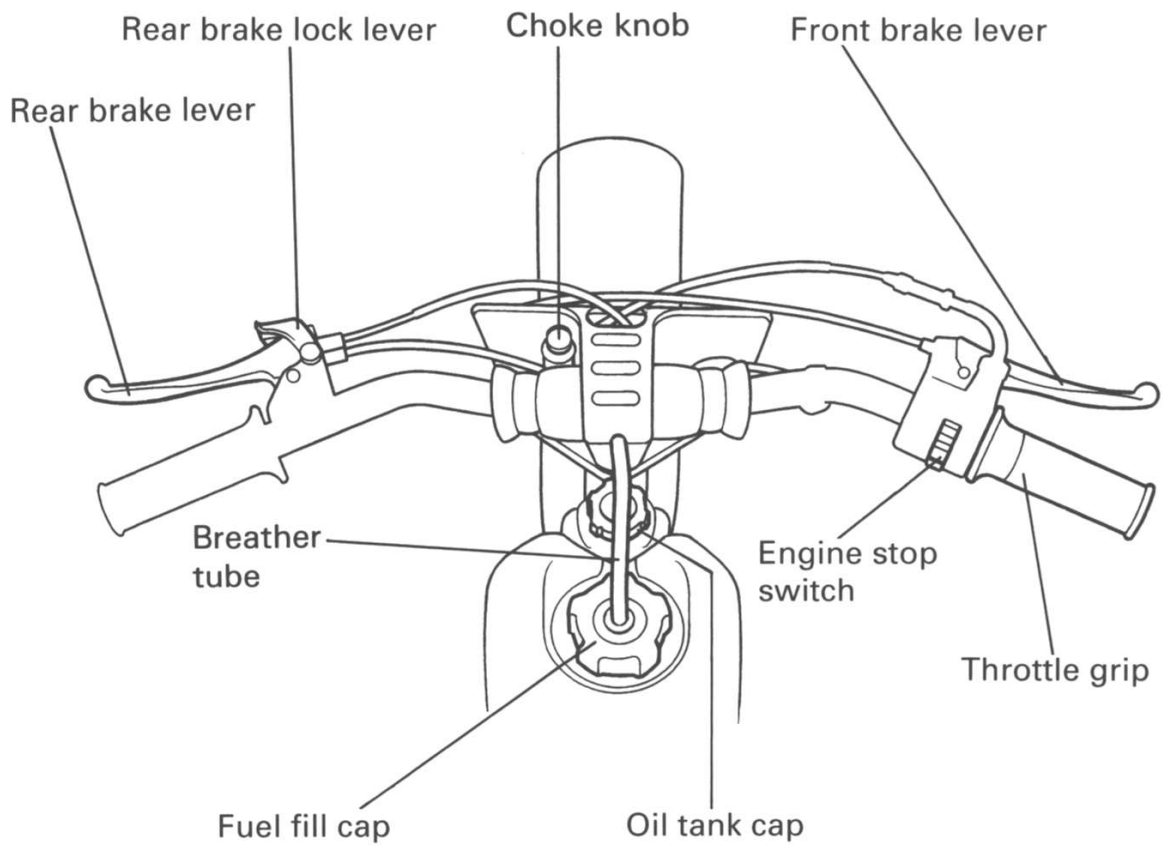

- ENGINE STOP SWITCH

RUN:

To start the engine, apply the rear brake lock lever, move the engine stop switch knob to this position, and then crank the engine.

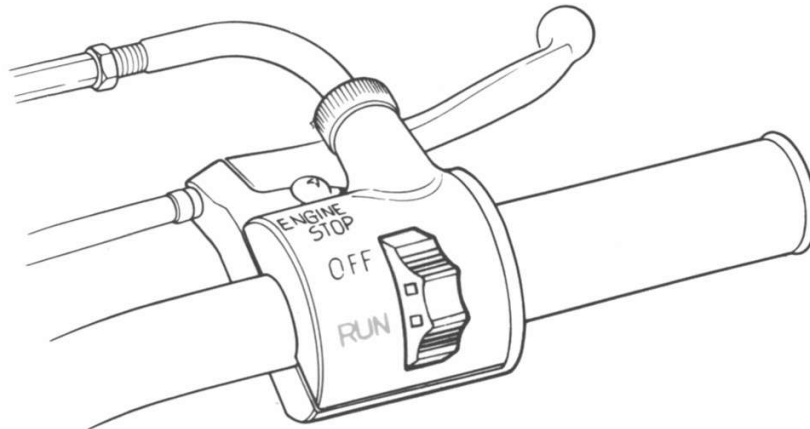

OFF:

To stop the engine, move the engine stop switch knob to this position. The engine cannot be started if the switch is in this position.

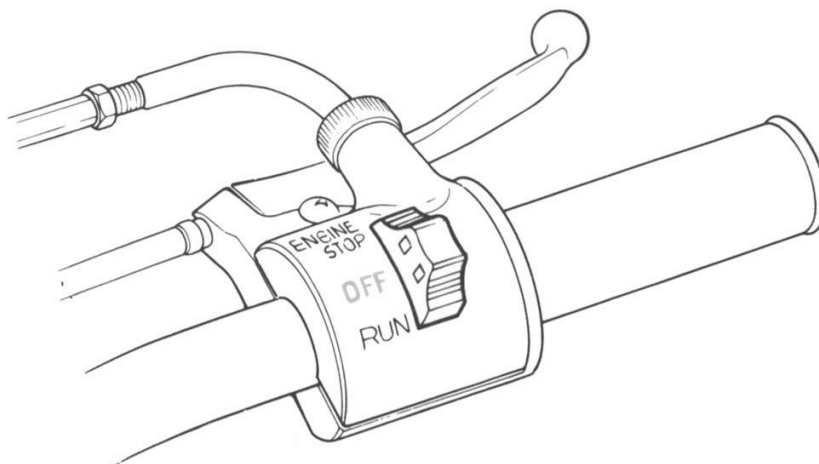

- FUEL COCK

ON:

Turn the fuel cock to this position before riding.

Fuel will flow from the fuel tank to the carburetor, making the engine ready for starting.

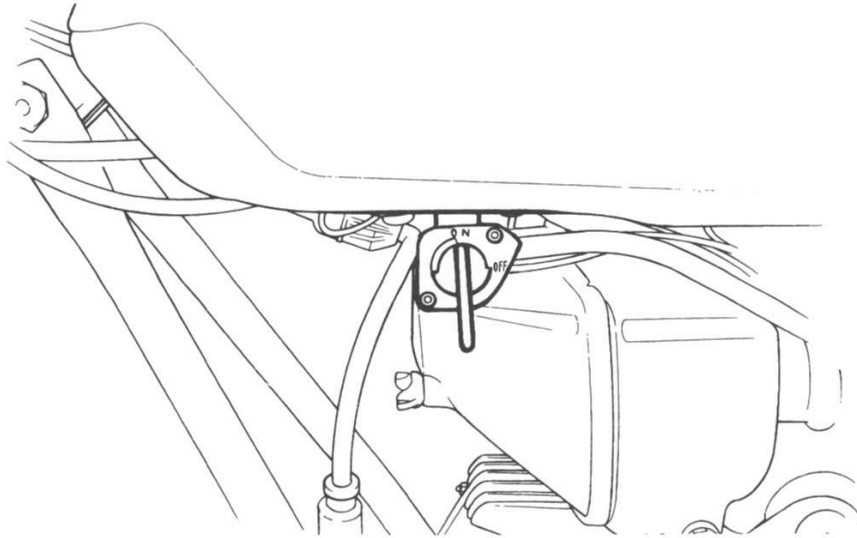

OFF:

Turn the fuel cock to this position after riding. Flow of fuel from the fuel tank to the carburetor is shut off.

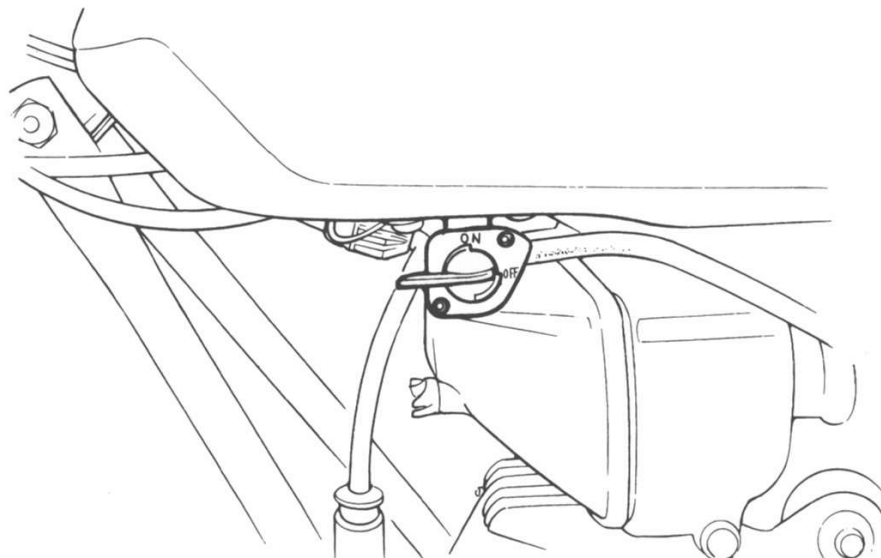

• THROTTLE LIMITER

The limiter restricts the throttle opening according to the degree the adjuster is turned. To adjust, loosen the adjuster lock nut and turn the adjuster. Tighten the lock nut securely.

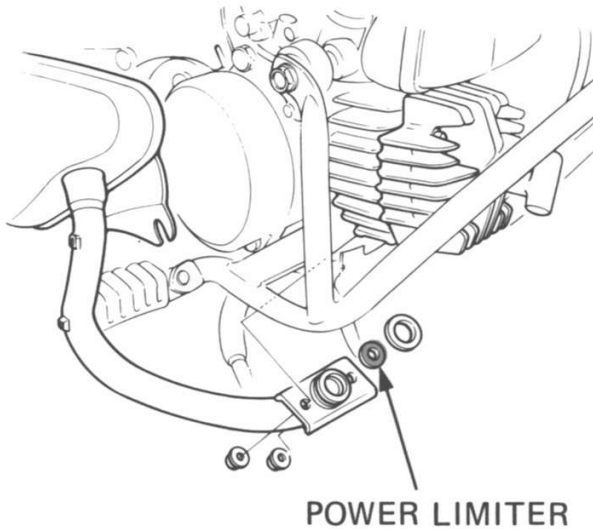
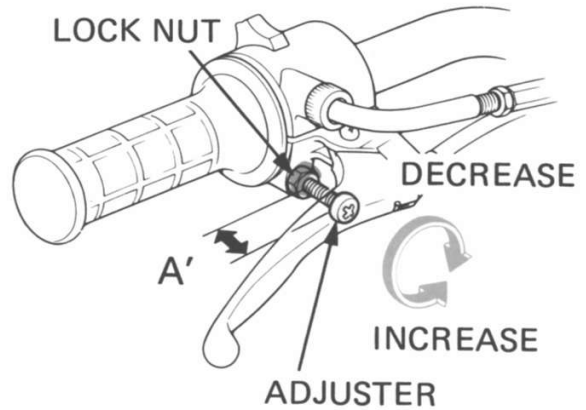

• POWER LIMITER

The unit imposes a limit on the output of the engine.

Use these controls according to the skill and maturity of your son or daughter as follows:

- (1) Do not adjust the throttle limiter or remove the power limiter from the beginning. (The throttle limiter is factory adjusted so that the distance A' is 18 mm (0.7 in). The power limiter is installed in the inlet flange of the exhaust pipe).
- (2) Remove the power limiter, then adjust the throttle limiter by turning the adjuster in according to the skill and maturity of your son or daughter when he or she is thoroughly familiar with the motorcycle's controls and their functions.

▲ WARNING

- * *Do not remove the power limiter or adjust the throttle limiter from the start, or you may endanger your son or daughter.*
- * *The throttle is fully open when the distance A' is 18 mm (0.7 in).*
- * *Do not remove the adjuster from the throttle limiter.*

• CHOKE KNOB

The choke is manually operated to control the air-fuel ratio for starting and warming up.

To use the choke, pull the knob up in the arrow direction.

Do not use the choke when the engine is warm.

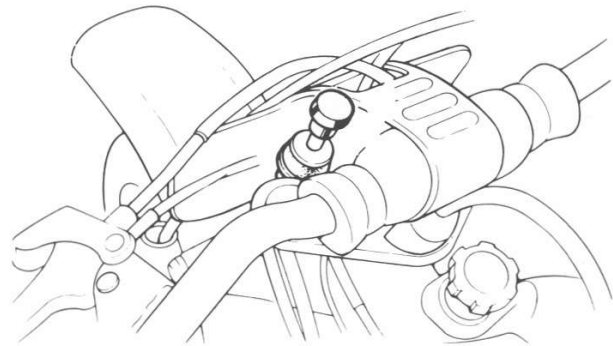
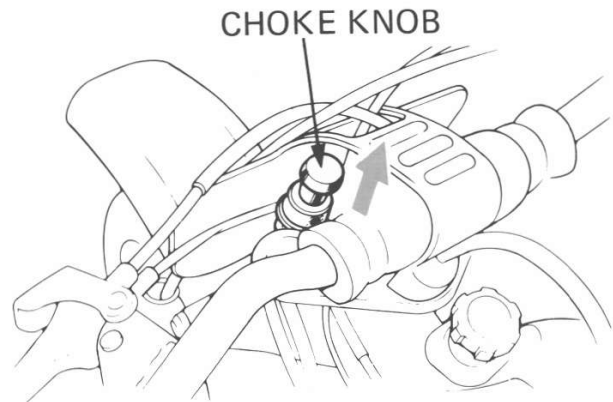

• BRAKE LEVERS

The motorcycle is equipped with the front and rear brake levers.

Apply both brakes simultaneously when you have to stop or slow the motorcycle.

Before applying the brakes, be sure to return the throttle to the fully closed position.

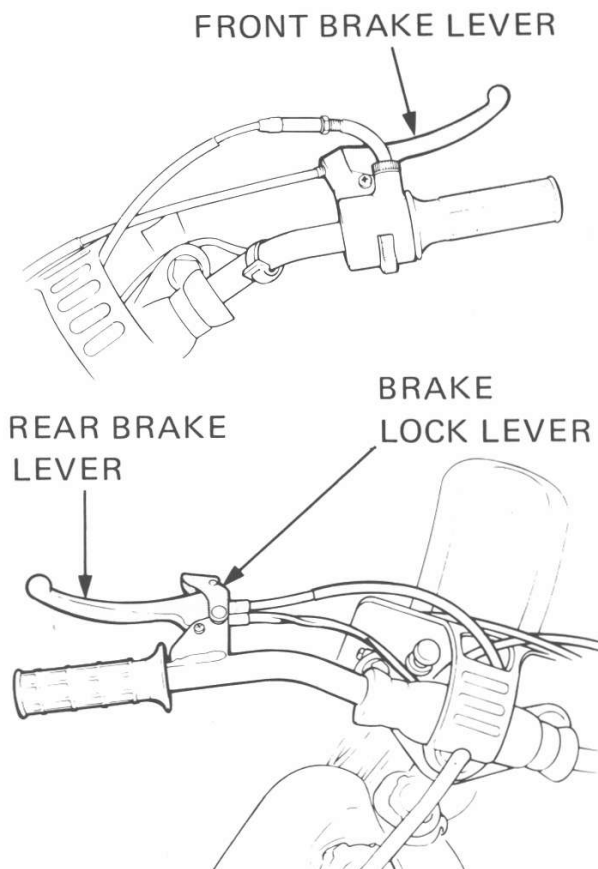

▲ WARNING

- * *Keep in a position that lets you reach both brake levers easily with your hands.*
- * *Never apply the brake lock while running as the wheel will be locked suddenly, and sudden wheel lock is particularly a hazard to safety.*

• BRAKE LOCK LEVER

The control is used when starting the engine and locks the rear brake lever in its applied position.

To apply lock lever:

- (1) Pull the rear brake lever in fully.
- (2) Slide the lock lever over the rear brake lever; release the rear brake lever.

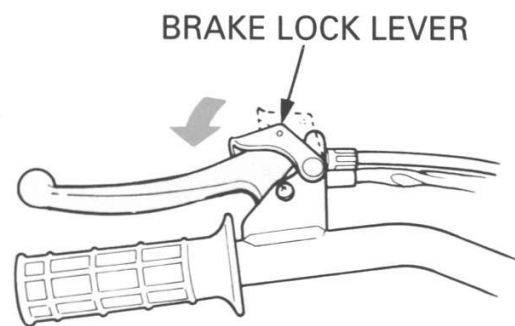
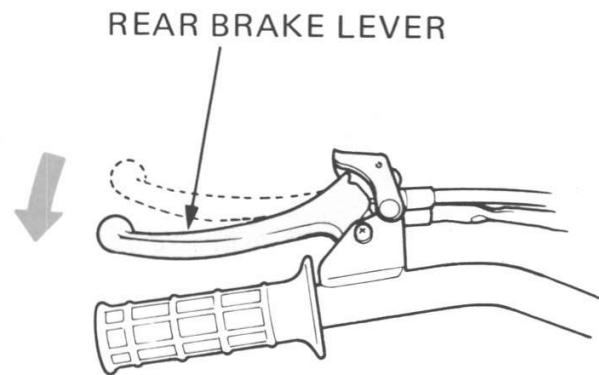

NOTE:

The rear brake will not be locked if the rear brake is not adjusted properly.

To release lock lever:

- (1) Squeezing the rear brake lever further in will release the lock lever automatically.
- (2) Release the hand from the rear brake lever.

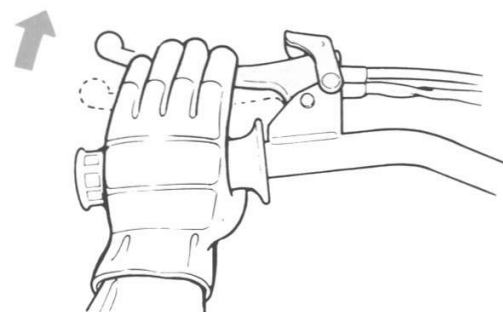
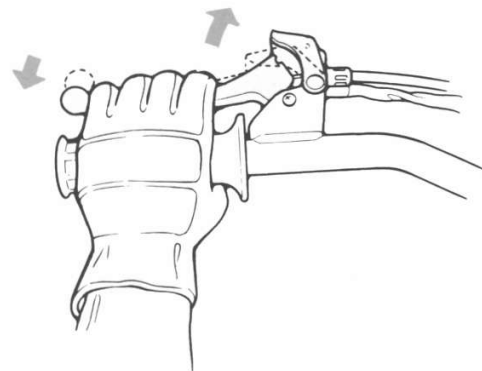

3. OPERATION

Practice the following steps until you know them in proper order and can do them smoothly.

• STARTING THE ENGINE

CAUTION:

- * *Inspect your motorcycle before you start the engine to see that the fuel and oil tanks are filled to the proper levels.*
- * *Place the motorcycle on the center stand whenever you start the engine.*

- (1) Turn the fuel cock to ON.
- (2) Turn the engine stop switch to RUN.

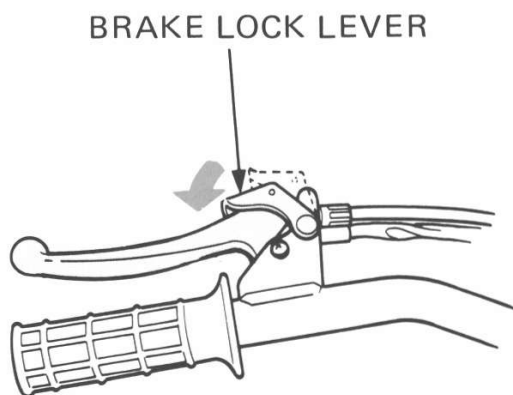
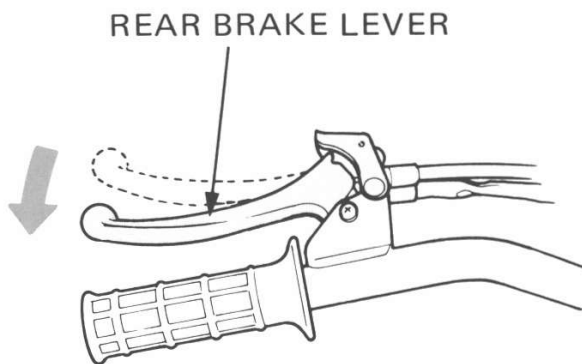
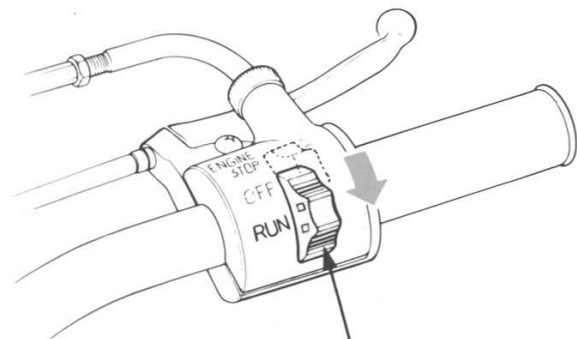
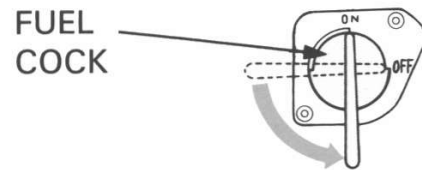

- (3) Pull in the rear brake lever fully and apply the brake lock (See Page 16).

NOTE:

The rear brake may not be locked securely if the rear brake is not adjusted properly.

-
-
- (4) Pull the choke knob up in the arrow direction.

The choke should not be used when the engine is hot.

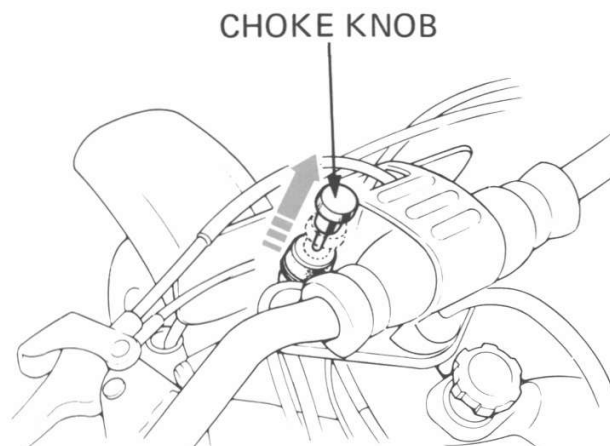

- (5) With closed throttle, operate the kickstarter several times. Starting from the top of the stroke, kick through to the bottom with a rapid, continuous motion.
- (6) After the engine starts, run it for 1–2 minutes until it warms up enough to idle. The choke knob should be returned as soon as possible to prevent spark plug fouling.

NOTE:

The engine cannot be started unless the rear brake lever is pulled in and locked by the lock lever.

• RIDING

- (1) Retract the center stand by pushing the motorcycle forward, being careful not to release the rear brake lock.

▲ WARNING

Do not rev up the engine after it has been started.

- (2) Straddle the motorcycle from the left side and hold it up with both feet on the ground.

▲ WARNING

Do not release the rear brake lever lock until you move off.

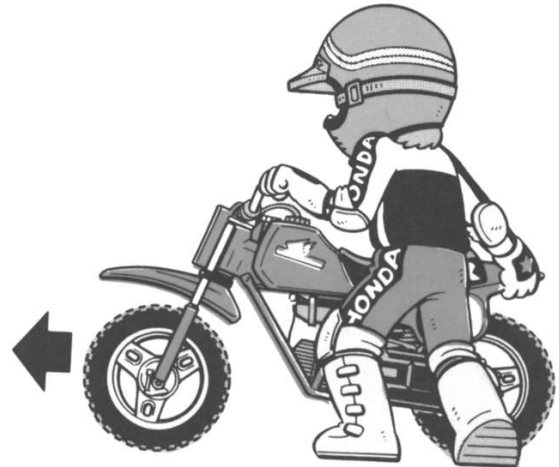
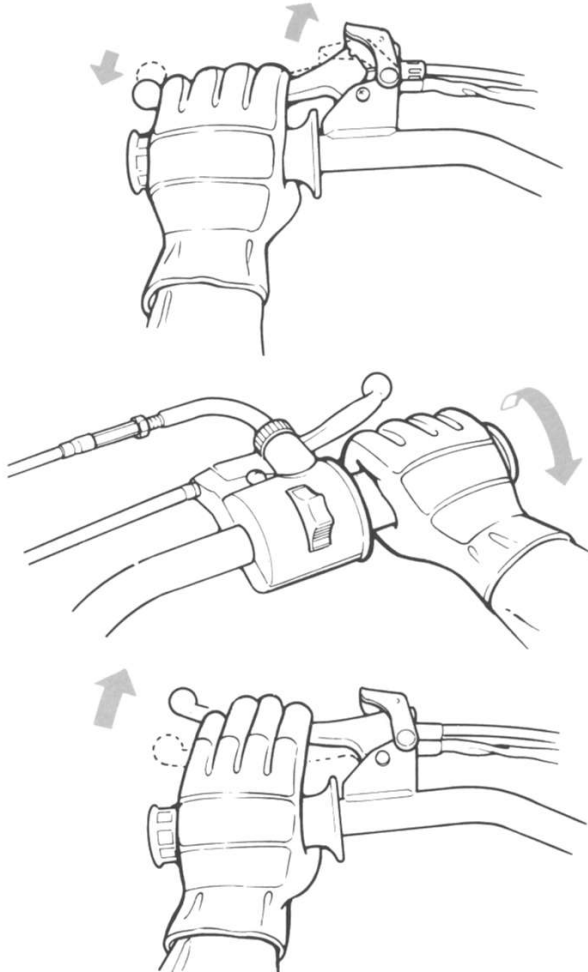

- (3) Release the rear brake lever lock by pulling in the rear brake lever further.

▲ WARNING

Do not open the throttle when releasing the rear brake lever lock.

- (4) Release the rear brake lever and gradually increase engine speed by opening the throttle.

▲ WARNING

When moving off from a standing start, be careful not to use too much throttle. The motorcycle may "wheelie" over backwards.

• STOPPING THE MOTORCYCLE

- (1) For maximum deceleration, close the throttle and apply both front and rear brakes equally.

In braking, apply enough gradual pressure to bring the motorcycle to a full stop.

⚠ WARNING

Failure to use both brakes simultaneously may cause the motorcycle to go into a skid, resulting in injury or damage.

- (2) Move the engine stop switch to OFF as the motorcycle comes to a stop.

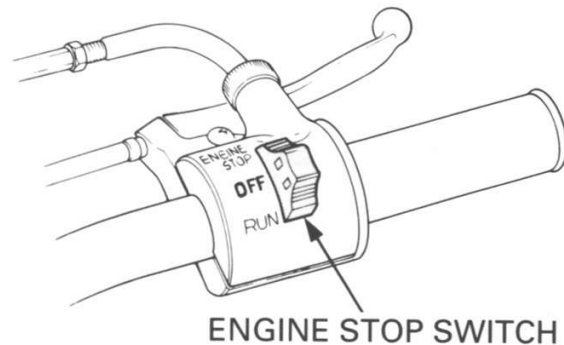
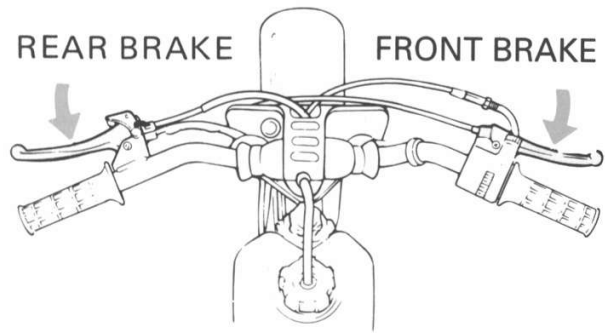

• PLACING THE MOTORCYCLE ON THE CENTER STAND

- Place the motorcycle on a level ground.
- Hold the handlebar straightahead with your left hand. Keeping a firm grip on the side grip with your right hand, pull the motorcycle up onto the center stand while stepping on the tab of the left leg.

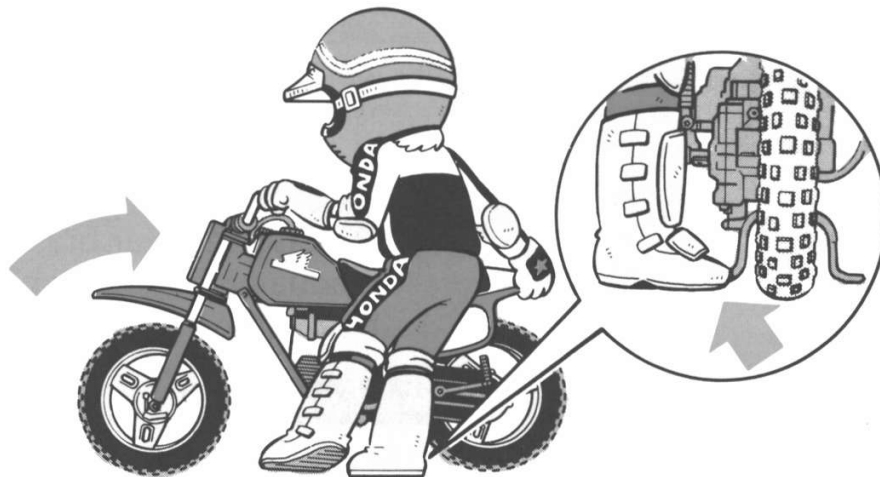

4. INSPECTION AND MAINTENANCE SERVICES

Perform the following inspection and maintenance services :

- OIL LEVEL CHECK AND REPLENISHMENT

Before riding, check the level of oil in the oil tank. The oil level should also be inspected when the fuel tank is replenished.

CAUTION:

- * *Keep sufficient oil in the oil tank.*
- * *Little or no oil will cause engine damage or premature wear.*

CAUTION:

- * *Use HONDA 2 STROKE INJECTOR OIL or equivalent.*
- * *Do not mix different brands of oils since they may not be compatible.*
- * *The capacity of the oil tank is 0.4 l (0.42 US qt, 0.35 Imp qt). Do not overfill (there should be no oil in the filler neck).*
- * *Press the oil cap into the filler opening until you are certain that it will no longer go.*

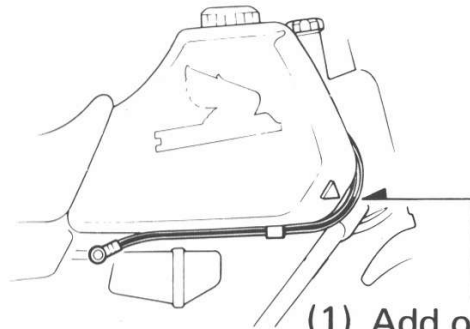

(1) Add oil if the level of oil in the oil inspection tube nears this point.

(2) Remove the cap while prying it side to side.

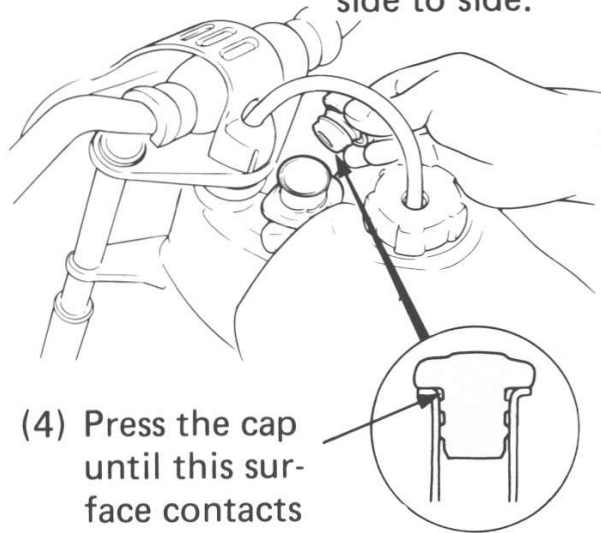

(4) Press the cap until this surface contacts the top of the filler neck.

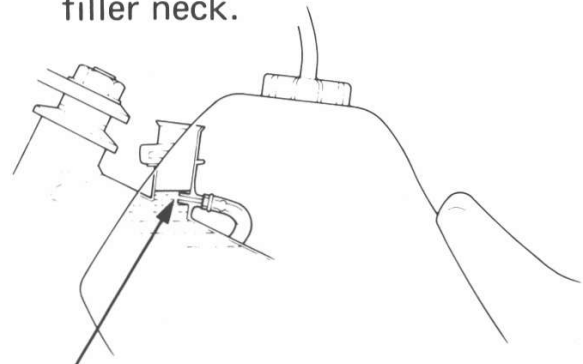

(3) Do not overfill beyond this line.

• FUEL LEVEL CHECK AND REPLENISHMENT

Before riding, check the fuel level in the fuel tank and add fuel if necessary. The fuel fill cap (1) is removed by twisting it counterclockwise. Automotive petrol with a pump octane number ($\frac{R+M}{2}$) of 86 or higher, or a research octane number of 91 or higher may be used.

FOR AUSTRALIA ONLY:

Use unleaded fuel with a research octane number of 91 or higher. If "knocking" or "pinging" occurs, try a different brand of petrol or a higher octane grade.

▲ WARNING

- * *Petrol is extremely flammable and is explosive under certain conditions. Refuel in a well-ventilated area with the engine stopped. Do not smoke or allow flames or sparks in the area where petrol is stored or where the fuel tank is refueled.*
- * *Do not overfill (there should be no fuel in the filler neck). Failure to fill the tank properly may cause fuel to leak through the fuel tank breather tube.*



CAUTION:

- * *Remove the fuel fill cap by slowly turning it by hand.*

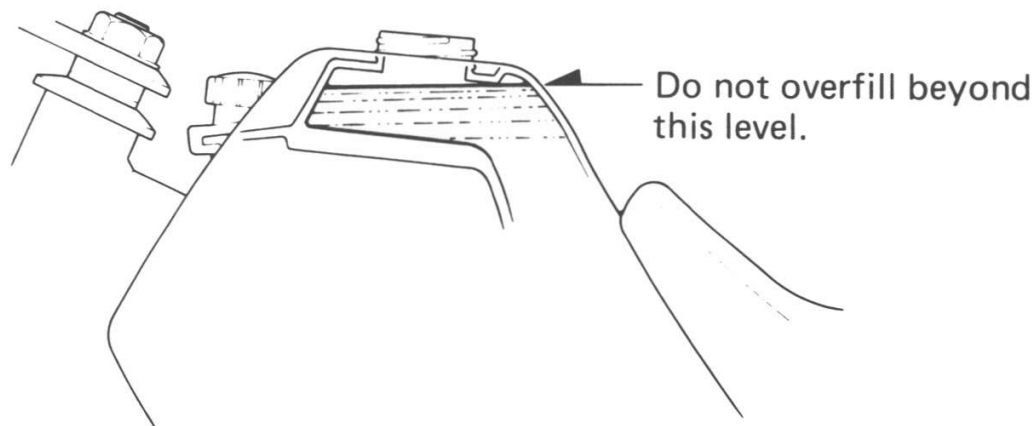

- SPARK PLUG INSPECTION

A fouled or worn spark plug can cause a host of engine malfunctions.

Cleaning

- Use a spark plug cleaner to clean the spark plug.
- If such a cleaner is not available, clean with a brittle wire brush or piece of wire.

Adjustment

- The spark plug gap should be adjusted to 0.6–0.7 mm (0.024–0.028 in). To adjust the plug gap, bend the side electrode carefully.

Recommended spark plug

BPR4HS (NGK) or

W14FPR-L (NIPPONDENSO)

- Do not use spark plug of incorrect size or heat range.

CAUTION:

- * *The engine is very hot immediately after stopping.*
- * *Install the spark plug by hand until finger tight, then using the spark plug wrench, tighten the spark plug 1/2 to 3/4 turn or until the sealing gasket is compressed.*

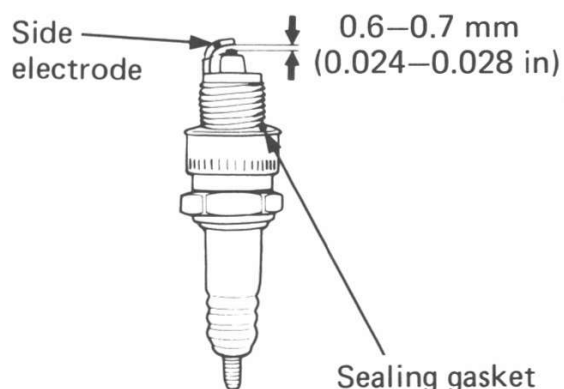

- HANDLEBAR INSPECTION

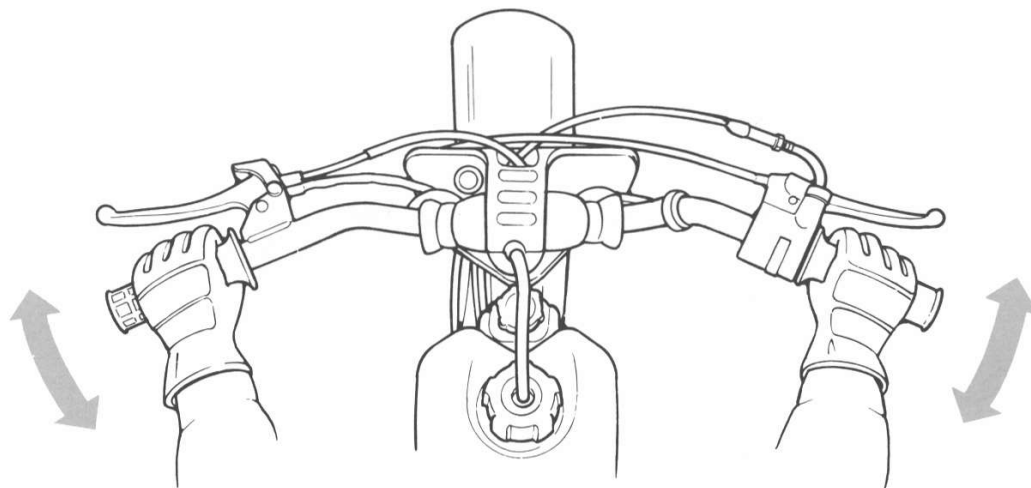

- Check for vertical play.
- Check for heavy or sluggish movement.
- Check for binding.
- See if the motorcycle is pulled to one side or unable to track straight.
- If there is any abnormality, see your authorized Honda Dealer.

- BRAKE INSPECTION

- Check the front and rear brake levers for free play.

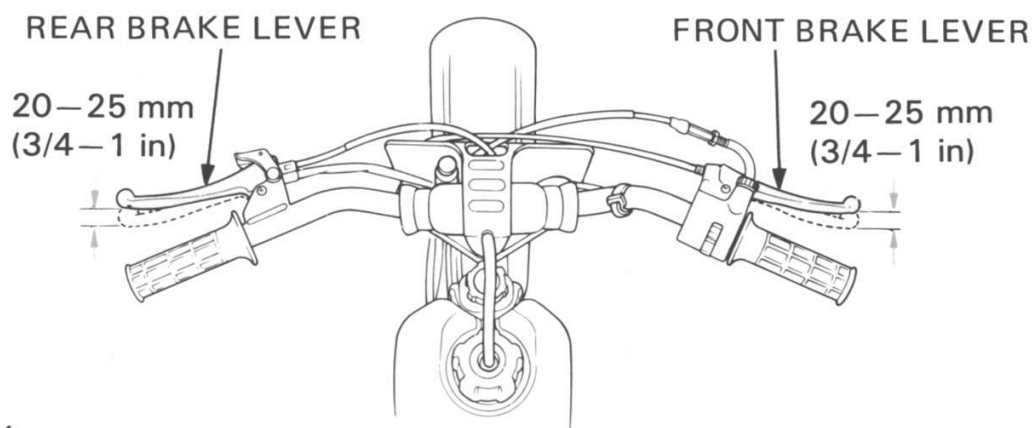

PLAY:

Measure the distance the brake lever moves before the brake starts to take hold.

Free play should be 20–25 mm (3/4–1 in).

- If adjustment is necessary, turn the brake adjusting nut.

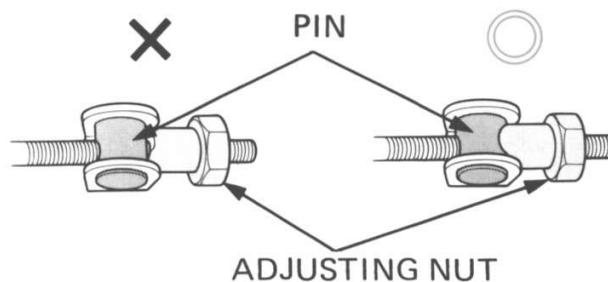
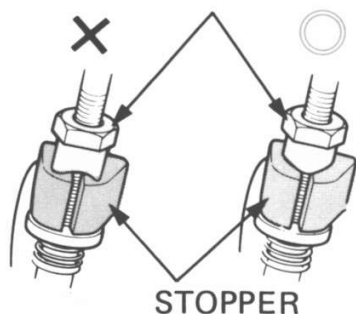
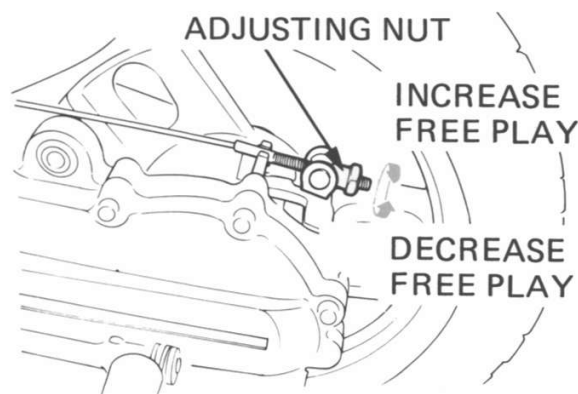
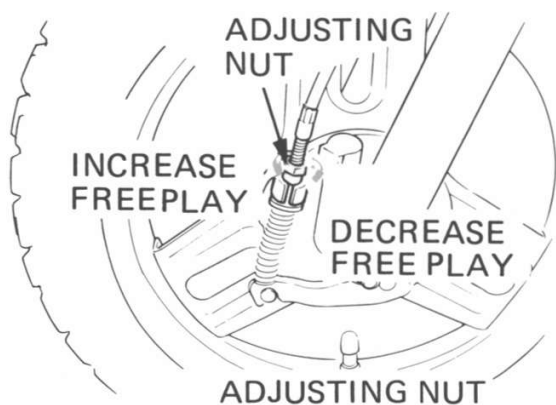

NOTE:

* **Front brake:** Make sure that the projection on the adjusting nut is aligned with the stopper.

Rear brake: Make sure that the cutout on the adjusting nut is seated on the brake arm pin.

* If proper adjustment cannot be obtained by these methods, see your authorized Honda dealer.

• AIR CLEANER MAINTENANCE

The air cleaner accumulates dust and must be inspected periodically. Dirt which accumulates at the air cleaner will restrict the flow of air, resulting in loss of power. To service the air cleaner, proceed as follows:

- (1) Remove the plug cap.
- (2) Remove the bolt and air cleaner.
- (3) Wash the air cleaner in clean stoddard solvent and allow to dry thoroughly.
- (4) Soak the air cleaner in clean motor oil (SAE10W-30) or clean gear oil (#80-90) until saturated, then squeeze out excess oil.

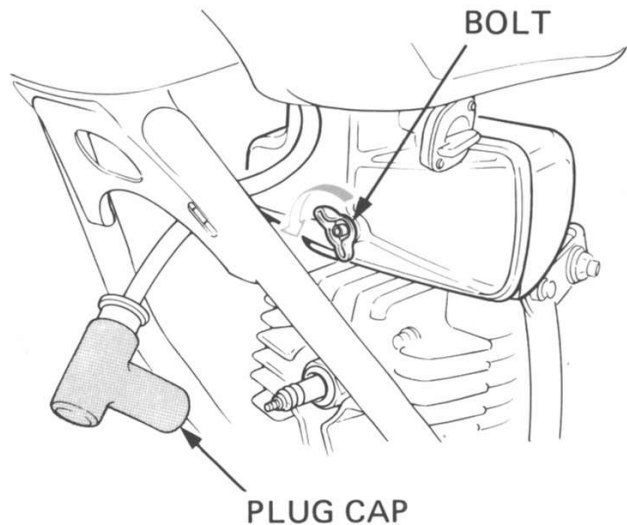

▲ WARNING

* *Petrol or low flash point solvents are highly flammable and must not be used to clean the air cleaner.*

NOTE:

If the air cleaner is not installed on the element holder properly, dirt and dust may enter, resulting in rapid wear of the piston rings and cylinder.

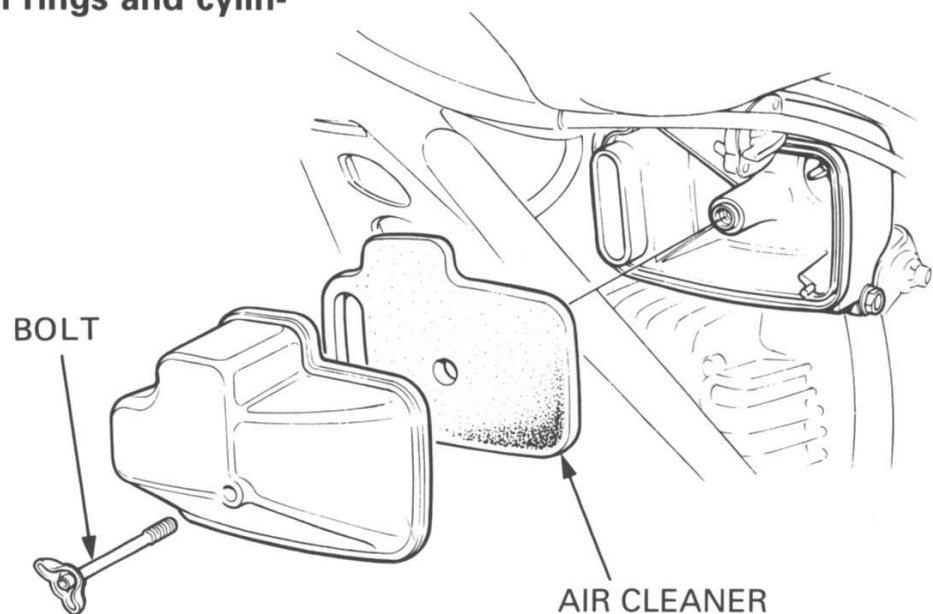

• IDLE SPEED ADJUSTMENT

Start the engine and warm it up to operating temperature.

Set the idle speed to 1,800 min⁻¹ (rpm) with the throttle stop screw.

If the engine misses or runs roughly when the throttle is "bripped", proceed to the following steps:

- (1) Screw the air screw in until it lightly seats; then back it off 1-1/4 turns (standard opening).
- (2) Set the idle speed to 1,800 min⁻¹ (rpm) with the throttle stop screw.
- (3) Turn the air screw in either direction to find the highest idle.
- (4) Again set the idle speed to 1,800 min⁻¹ (rpm) with the throttle stop screw.
- (5) If the idle speed still fluctuates when the throttle is "blipped", repeat the above steps (2) through (4) until it stabilizes.

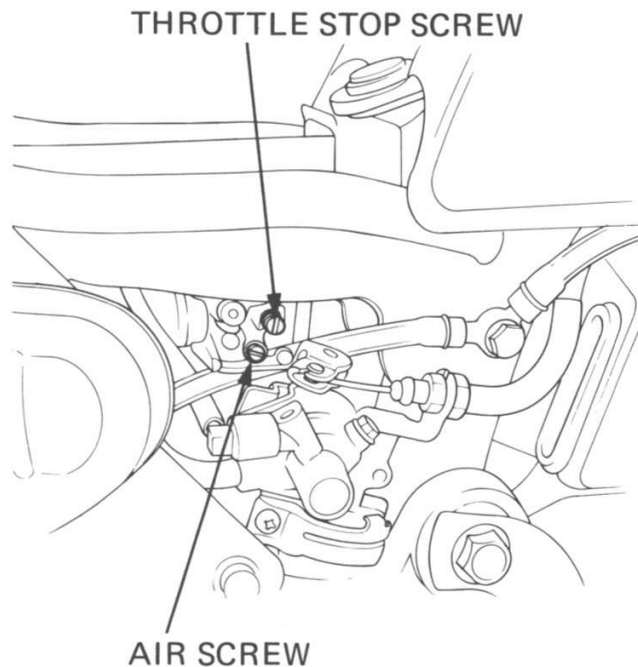

NOTE:

- * See your authorized Honda dealer for carburetor adjustment.
- * Hold the motorcycle upright on the center stand.

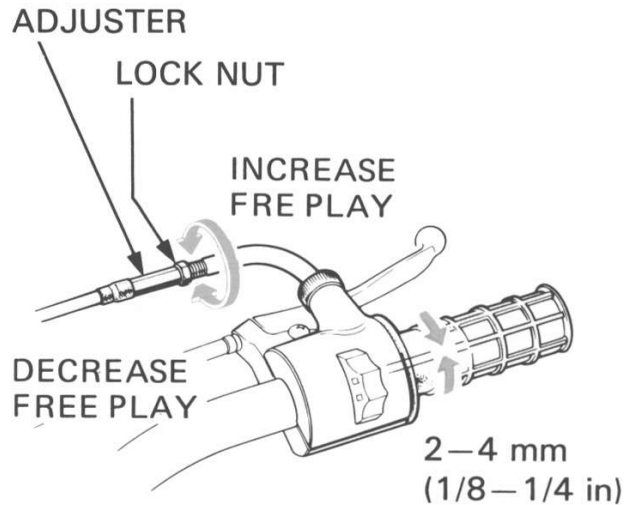

- THROTTLE FREE PLAY ADJUSTMENT

Check that throttle free play is 2–4 mm (1/8–1/4 in) of grip rotation.

To adjust free play, loosen the lock nut and turn the adjuster.

Tighten the lock nut after adjustment.

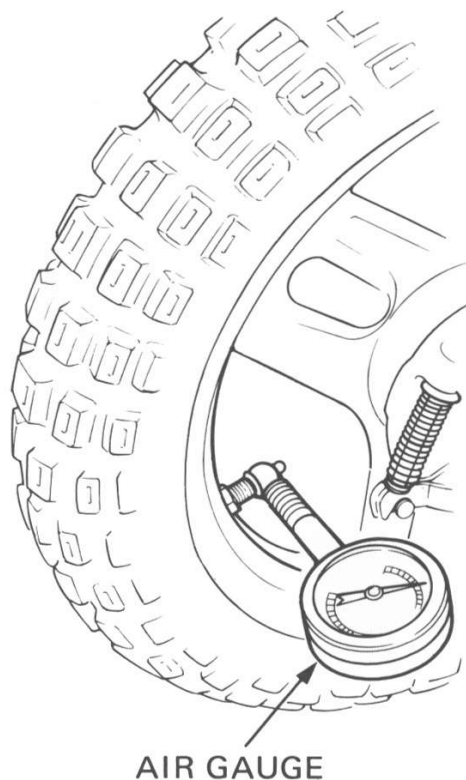

- TYRE AIR PRESSURE

Check tyre pressures frequently with an air gauge.

Tyre air pressures:

Front	100kPa (1.0 kg/cm ² , 14 psi)
Rear	100 kPa (1.0 kg/cm ² , 14 psi)

Proper air pressure will provide maximum stability, riding comfort and tyre life. If tyre pressures are incorrect, adjust as required.

Before riding, check the tyres for embedded nails, stones or sharp objects.

- TRANSMISSION OIL CHANGE

Recommended oil

HONDA 4-STROKE OIL, SAE 10W-30 or equivalent.

Capacity

- At disassembly:
0.75 l (0.79 US qt, 0.66 Imp qt)
- At draining:
0.60 l (0.63 US qt, 0.53 Imp qt)

Replacement interval

- Every 2 years

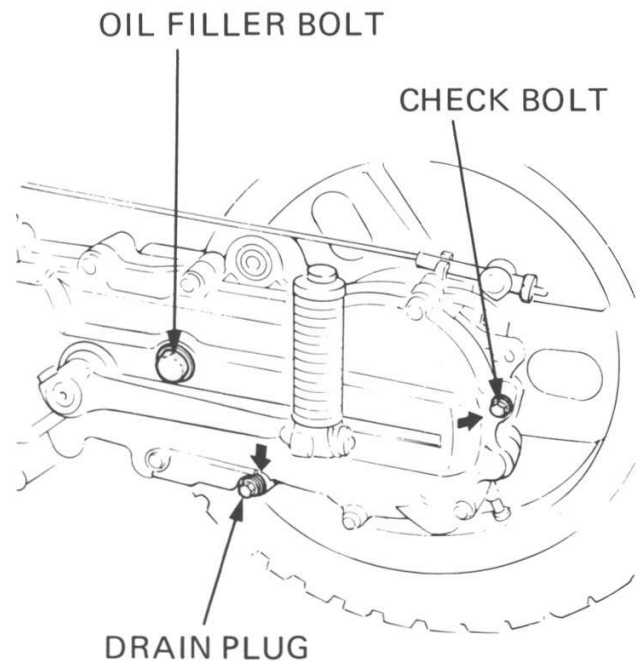

Replacement

- (1) Place the motorcycle upright on the center stand.
- (2) Remove the oil filler bolt and drain plug.
Drain the used oil from the transmission while the engine is warm.
This will ensure complete and rapid draining.
- (3) Clean and reinstall the drain plug.
- (4) Pour the recommended oil slowly through the oil filler bolt hole.
- (5) Loosen the oil check bolt. Oil should flow out of the oil check bolt hole. If oil does not flow out, add oil slowly through the oil filler hole until oil starts to flow out of the oil check bolt hole.
- (6) Tighten the oil check bolt and oil filler bolt securely.

5. SPECIFICATIONS

Item	Metric	English
Dimension		
Overall length	1,225 mm	48.2 in
Overall width	610 mm	24.0 in
Overall height	725 mm	28.5 in
Wheelbase	845 mm	33.2 in
Seat height	495 mm	19.5 in
Ground clearance	115 mm	4.5 in
Dry weight	35 kg	77.2 lb
Frame		
Type	Double cradle (Bolt-on)	
F. suspension, travel	Telescopic fork, travel 60 mm (2.4 in)	
R. suspension, travel	Unit swing mono shock	
F. tyre size, pressure	2.50–10, 100 kPa (1.0 kg/cm ² , 14 psi)	
R. tyre size, pressure	2.50–10, 100 kPa (1.0 kg/cm ² , 14 psi)	
Fuel capacity	2.0 ℓ	0.53 US gal 0.44 Imp gal
Caster angle	65°	
Trail length	51 mm	2.0 in
Engine		
Type	Air cooled, 2-stroke	
Cylinder arrangement	Horizontal single	
Bore and stroke	40 x 39.3 mm	1.57 x 1.55 in
Displacement	49.4 cm ³	3.0 cu-in
Compression ratio	7.2 : 1	
Transmission oil capacity	0.75 ℓ	0.79 US qt 0.66 Imp qt
Idle speed	1800 min ⁻¹	1800 rpm

Item	Metric	English
Carburetor		
Type	Piston valve	
Main jet	#78	
Venturi dia	12 mm	0.47 in
Air screw opening	1-1/4 turns	
Drive train		
Clutch type	Wet, twin shoe type	
Transmission	Automatic 1 speed	
Primary reduction	2.143	
Final reduction	5.357	
Electrical		
Ignition	CDI	
Strating system	Kickstarter	
Spark plug	NGK: BPR4HS NIPPONDENSO: W14FPR-L	
Spark plug gap	0.6 – 0.7 mm	0.024–0.028 in