

HYOSUNG

**HYOSUNG**

HYOSUNG MOTORS & MACHINERY INC.



*Prima*

**SERVICE MANUAL**

SERVICE MANUAL

99000-91310

## FOREWORD

*This manual contains an introductory description on HYOSUNG PRIMA(SF-50) and procedures for its inspection/service and overhaul of its main components. Other information considered as generally known is not included.*

*Read GENERAL INFORMATION section to familiarize yourself with outline of the vehicle and MAINTENANCE and other sections to use as a guide for proper inspection and service.*

*This manual will help you know the vehicle better so that you can assure your customers of your optimum and quick service.*

*\* This manual has been prepared on the basis of the latest specification at the time of publication.*

*If modification has been made since then, difference may exist between the content of this manual and the actual vehicle.*

*\* Illustrations in this manual are used to show the basic principles of operation and work procedures.*

*They may not represent the actual vehicle exactly in detail.*

*\* This manual is intended for those who have enough knowledge and skills for servicing HYOSUNG vehicles. Without such knowledge and skills, you should not attempt servicing by relying on this manual only.*

*Instead, please contact your nearby authorized HYOSUNG motorcycle dealer.*

## GROUP INDEX

**GENERAL INFORMATION**

**1**

**PERIODIC MAINTENANCE**

**2**

**ENGINE**

**3**

**FUEL SYSTEM**

**4**

**ELECTRICAL SYSTEM**

**5**

**CHASSIS**

**6**

**SERVICING INFORMATION**

**7**

**HYOSUNG MOTORS & MACHINERY INC.**

## HOW TO USE THIS MANUAL

### TO LOCATE WHAT YOU ARE LOOKING FOR:

1. The text of this manual is divided into sections.
2. As the title of these sections are listed on the previous page as GROUP INDEX, select the section where what you are looking for belong.
3. Holding the manual as shown at the right will allow you to find the first page of the section easily.
4. On the first page of each section, its contents are listed. Find the item and page you need.

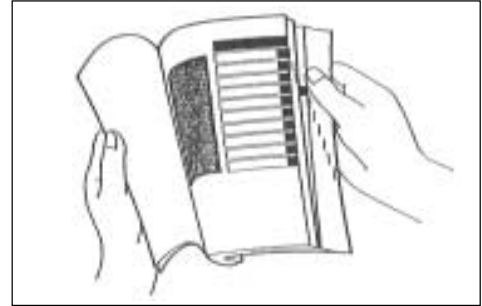





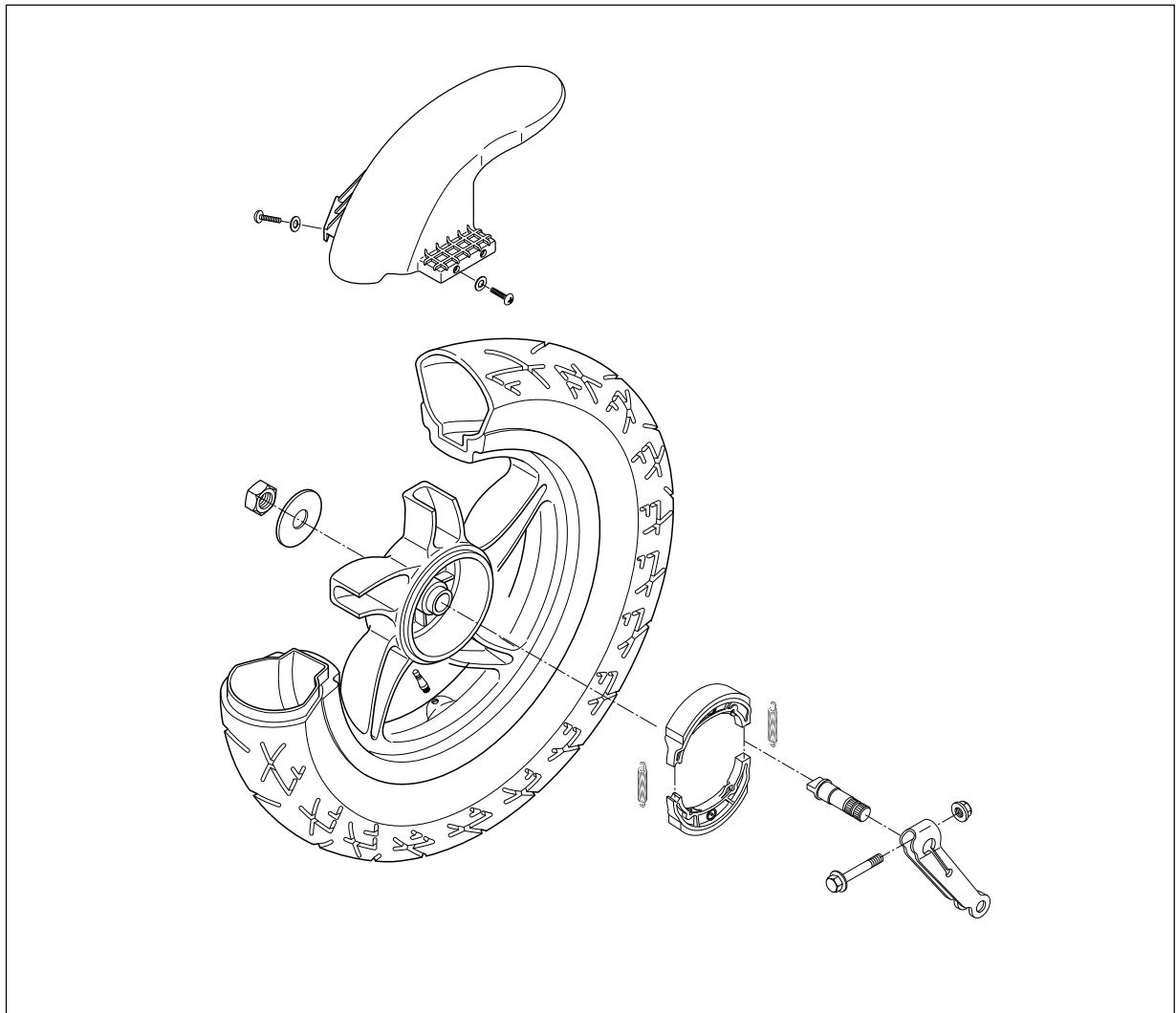







## COMPONENT PARTS

Example: Rear wheel/Rear brake



## SYMBOL

Listed in the table below are the symbols indicating instructions and other information necessary for servicing and meaning associated with them respectively.

SYMBOL	DEFINITION	SYMBOL	DEFINITION
	Torque control required. Data beside it indicates specified torque.		Apply THREAD LOCK "1324".
	Apply oil. Use engine oil unless otherwise specified.		Apply or use brake fluid.
	Apply SUPER GREASE "A".		Measure in voltage range.
	Apply SUPER GREASE "C".		Measure in resistance range.
	Apply SILICONE GREASE.		Measure in current range.
	Apply MOLY PASTE.		Use special tool.
	Apply BOND "1215".		



# GENERAL INFORMATION

1

## CONTENTS

<b>INFORMATION LABELS</b> .....	<b>1-1</b>
<b>GENERAL PRECAUTIONS</b> .....	<b>1-1</b>
<b>SERIAL NUMBER LOCATION</b> .....	<b>1-3</b>
<b>FUEL AND OIL RECOMMENDATIONS</b> .....	<b>1-3</b>
<b>BREAK-IN PROCEDURES</b> .....	<b>1-4</b>
<b>EXTERIOR ILLUSTRATION</b> .....	<b>1-5</b>
<b>SPECIFICATIONS</b> .....	<b>1-6</b>

### WARNING / CAUTION / NOTE

Please read this manual and follow its instructions carefully. To emphasize special information, the symbol and the words WARNING, CAUTION and NOTE have special meanings. Pay special attention to the messages highlighted by these signal words.

#### **WARNING**

Indicates a potential hazard that could result in death or injury.

#### **CAUTION**

Indicates a potential hazard that could result in vehicle damage.

#### *NOTE:*

*Indicates special information to make maintenance easier or instructions clearer.*

Please note, however, that the warning and cautions contained in this manual cannot possibly cover all potential hazards relating to the servicing, or lack of servicing, of the motorcycle. In addition to the WARNING and CAUTION stated, you must use good judgement and basic mechanical safety principles. If you are unsure about how to perform a particular service operation, ask a more experienced mechanic for advice.

## GENERAL PRECAUTIONS

#### **WARNING**

- Proper service and repair procedures are important for the safety of the service machanic and the safety and reliability of the vehicle.
- When 2 or more persons work together, pay attention to the safety of each other.
- When it is necessary to run the engine indoors, make sure that exhaust gas is forced outdoors.
- When working with toxic or flammable materials, make sure that the area you work in is wellventilated and that you follow all off the material manufacturer' s instructions.
- Never use gasoline as a cleaning solvent.
- To avoid getting burned, do not touch the engine, engine oil or exhaust system during or for a while after engine operation.
- After servicing fuel, oil, exhaust or brake systems, check all lines and fittings related to the system for leaks.

**⚠ CAUTION**

- If parts replacement is necessary, replace the parts with HYOSUNG Genuine Parts or their equivalent.
- When removing parts that are to be reused, keep them arranged in an orderly manner so that they may be reinstalled in the proper order and orientation.
- Be sure to use special tools when instructed.
- Make sure that all parts used in reassembly are clean, and also lubricated when specified.
- When use of a certain type of lubricant, bond, or sealant is specified, be sure to use the specified type.
- When removing the battery, disconnect the negative cable first and then positive cable. When reconnecting the battery, connect the positive cable first and then negative cable, and replace the terminal cover on the positive terminal.
- When performing service to electrical parts, if the service procedures do not require use of battery power, disconnect the negative cable at the battery.
- Tighten cylinder head and case bolts and nuts, beginning with larger diameter and ending with smaller diameter, from inside to outside diagonally, to the specified tightening torque.
- Whenever you remove oil seals, gaskets, packing, O-rings, locking washers, cotter pins, circlips, and certain other parts as specified, be sure to replace them with new ones. Also, before installing these new parts, be sure to remove any left over material from the mating surfaces.
- Never reuse a circlip. When installing a new circlip, take care not to expand the end gap larger than required to slip the circlip over the shaft. After installing a circlip, always ensure that it is completely seated in its groove and securely fitted.
- Do not use self-locking nuts a few times over.
- Use a torque wrench to tighten fasteners to the torque values when specified. Wipe off grease or oil if a thread is smeared with them.
- After reassembly, check parts for tightness and operation.

- To protect environment, do not unlawfully dispose of used motor oil and other fluids: batteries, and tires.
- To protect Earth's natural resources, properly dispose of used vehicles and parts.



## 1-3 GENERAL INFORMATION

### HYOSUNG PRIMA (SF-50)



RIGHT SIDE



LEFT SIDE

\* Difference between photographs and actual motorcycles depends on the markets.

### SERIAL NUMBER LOCATION

The frame serial number or V.I.N. (Vehicle Identification Number) is stamped on the right side of the frame under the footboard. The engine serial number is located on the up side of the crankcase assembly. These numbers are required especially for registering the machine and ordering spare parts.

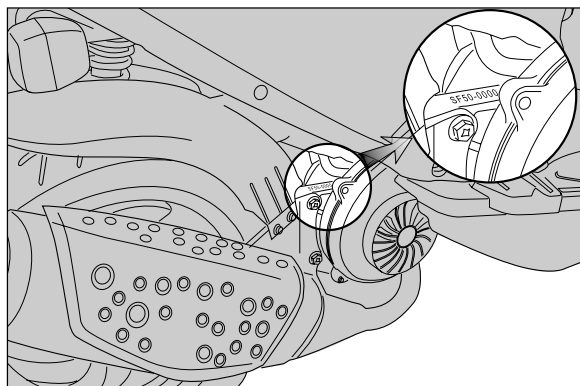
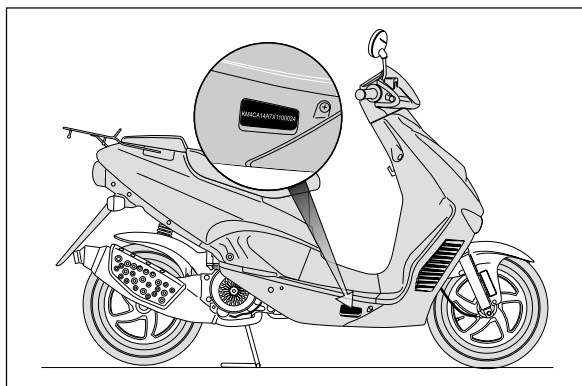

### FUEL AND OIL RECOMMENDATION

#### FUEL

Gasoline used should be graded 85-95 octane (Research Method) or higher. An unleaded gasoline type is recommended.

#### TRANSMISSION OIL

Make sure that the transmission oil you use comes under API classification of SH, SG or SF and that its viscosity rating is SAE 10W/30 or 10W/40. If an SAE 10W/30 or 10W/40 motor oil is not available, select an alternate according to the right chart.

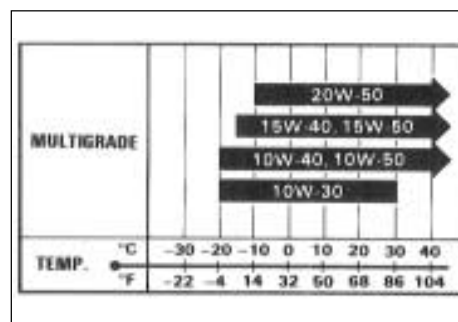

## ENGINE OIL

Specification and classification: APOLLOIL BIKE-K, HYPOL HS

## BRAKE FLUID

Specification and classification: DOT4

### WARNING

Since the brake system of this motorcycle is filled with a glycol-based brake fluid by the manufacturer, do not use or mix different types of fluid such as silicone-based and petroleum-based fluid for refilling the system, otherwise serious damage will result.

Do not use any brake fluid taken from old or used or unsealed containers.

Never re-use brake fluid left over from a previous servicing, which has been stored for a long period.

## FRONT FORK OIL

Use fork oil : TELLUS #37

## BREAK-IN PROCEDURES

During manufacture only the best possible materials are used and all machined parts are finished to a very high standard but it is still necessary to allow the moving parts to “BREAK-IN” before subjecting the engine to maximum stresses. The future performance and reliability of the engine depends on the care and restraint exercised during its early life. The general rules are as follows:

- Keep to these break-in engine speed limits:

*Up to 1,000km(600miles): Less than 1/2 throttle.*

- Upon reaching an odometer reading of 1,000 km you can subject the motorcycle to full throttle operation.
- Do not maintain constant engine speed for an extended period during any portion of the break-in. Try to vary the throttle position.

## EXTERIOR ILLUSTRATION

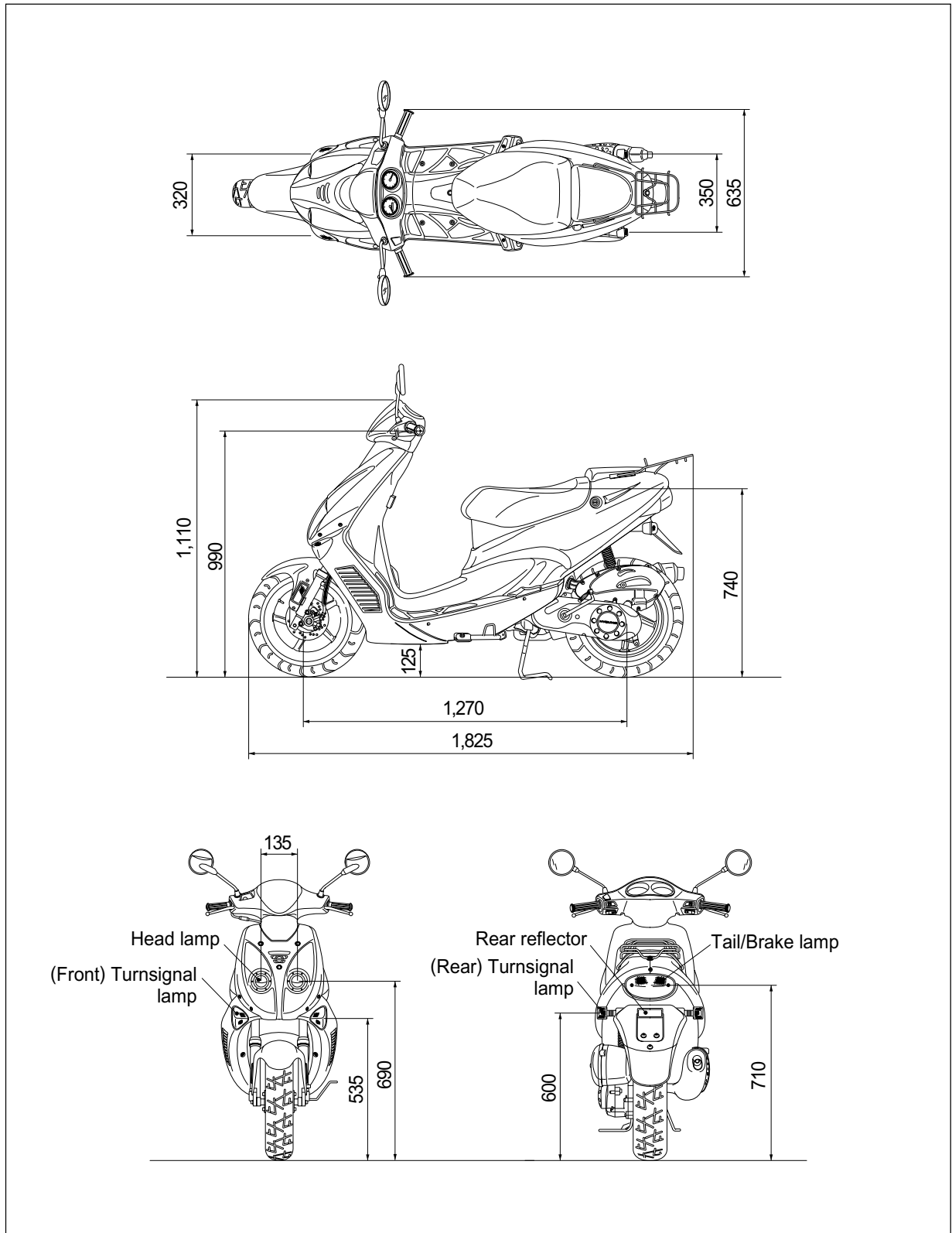

## SPECIFICATIONS

### DIMENSIONS AND DRY MASS

Overall length .....	1,825 mm (71.9 in)
Overall width .....	635 mm (25.0 in)
Overall height .....	1,110 mm (43.7 in)
Wheelbase .....	1,270 mm (50.0 in)
Ground clearance .....	125 mm (4.9 in)
Dry mass .....	88 kg (194 lbs)

### ENGINE

Type .....	Two-stroke, forced air cooled
Number of cylinder .....	1
Bore .....	41 mm (1.6 in)
Stroke .....	37.4 mm (1.5 in)
Piston displacement .....	49 <sup>cm</sup> (3.0 cu.in)
Carburetor .....	SIDE DRAFT VARIABLE VENTURI (PISTON)
Air cleaner .....	Wet filter type
Starter system .....	Kick/self starter
Corrected compression ratio .....	7.4 : 1
Intake system .....	Reed valve

### TRANSMISSION

Clutch .....	Dry shoe, automatic, centrifugal type
Reduction ratio .....	2.997~0.813
Drive system .....	V-belt drive

### CHASSIS

Front suspension .....	Telescopic type
Rear suspension .....	Coil spring type
Caster .....	25°
Trail .....	75mm (2.95in)
Steering angle .....	45° (right & left)
Front tire size .....	110/70-12 47J
Rear tire size .....	120/70-12 51J
Front brake .....	Disc
Rear brake .....	Drum

## 1-7 GENERAL INFORMATION

---

### ELECTRICAL

Ignition type .....	“CDI” type
Ignition timing .....	20° B.T.D.C. at 1,000 rpm
Spark plug .....	BR8HSA
Battery .....	12V 3Ah/10HR
Generator .....	Magneto
Fuse .....	10A
Headlamp .....	15W×2
Turn signal lamp .....	10W×4
Tail/Brake lamp .....	5/10W
Speedometer lamp .....	1.7W×2
Oil level indicator lamp .....	1.7W
Turn signal indicator lamp .....	1.7W

### CAPACITIES

Fuel tank .....	4.8 ℓ
Engine oil tank .....	1.0 ℓ
Transmission oil .....	110cc (Replace) 130cc (Overhaul)

#### NOTE:

*The specifications are subject to change without notice.*

# PERIODIC MAINTENANCE

## CONTENTS

<b>PERIODIC MAINTENANCE SCHEDULE</b> .....	<b>2- 1</b>
<b>MAINTENANCE PROCEDURES</b> .....	<b>2- 3</b>
<b>BATTERY</b> .....	<b>2- 3</b>
<b>CYLINDER HEAD NUTS AND EXHAUST PIPE NUTS</b> .....	<b>2- 4</b>
<b>CYLINDER HEAD AND CYLINDER</b> .....	<b>2- 4</b>
<b>SPARK PLUG</b> .....	<b>2- 4</b>
<b>FUEL LINE</b> .....	<b>2- 5</b>
<b>AIR CLEANER ELEMENT</b> .....	<b>2- 5</b>
<b>THROTTLE CABLE PLAY</b> .....	<b>2- 6</b>
<b>ENGINE IDLE SPEED</b> .....	<b>2- 7</b>
<b>OIL PUMP</b> .....	<b>2- 7</b>
<b>TRANSMISSION OIL</b> .....	<b>2- 8</b>
<b>BRAKES</b> .....	<b>2- 8</b>
<b>TIRES</b> .....	<b>2-10</b>
<b>STEERING</b> .....	<b>2-11</b>
<b>FRONT SUSPENSION</b> .....	<b>2-11</b>
<b>REAR SUSPENSION</b> .....	<b>2-12</b>
<b>CHASSIS AND ENGINE MOUNTING BOLTS AND NUTS</b> .....	<b>2-12</b>

## 2-1 PERIODIC MAINTENANCE

### PERIODIC MAINTENANCE SCHEDULE

The chart below lists the recommended intervals for all the required periodic service work necessary to keep the motorcycle operating at peak performance and economy.

**NOTE:**

*More frequent servicing should be performed on motorcycles that are used under severe conditions.*

### PERIODIC MAINTENANCE CHART

#### ENGINE

Item \ Interval	Initial 1,000 km	Every 4,000 km	Every 8,000 km	page
Battery	Inspect	Inspect	–	2-3
Cylinder head nuts exhaust pipe nuts	Inspect	Inspect	–	2-4
Cylinder head, cylinder.	–	–	Clean	2-4
Spark plug	Clean	Clean	Replace	2-4
Fuel line	Inspect	Inspect	–	2-5
	Replace every 4 years			
Air cleaner element	Clean every 3,000 km			2-5
Throttle cable play	Inspect	Inspect	–	2-6
Engine idle speed	Inspect	Inspect	–	2-7
Oil pump	Inspect	Inspect	–	2-7
Transmission oil	Inspect	–	Inspect	2-8

#### CHASSIS

Item \ Interval	Initial 1,000 km	Every 4,000 km	Every 8,000 km	page
Brakes	Inspect	Inspect	–	2-9
Brake hose	Inspect	Inspect	–	2-9
	Replace every 4 years			
Brake fluid	Inspect	Inspect	–	2-9
	Replace every 2 years			
Tires	Inspect	Inspect	–	2-10
Steering	Inspect	Inspect	–	2-11
Front suspension	Inspect	–	Inspect	2-11
Rear suspension	Inspect	–	Inspect	2-12
Chassis bolts and nuts	Inspect	Inspect	–	2-12

### LUBRICATION CHART

The maintenance schedule, which follows, is based on this philosophy. It is timed by odometer indication, and is calculated to achieve the ultimate goal of motorcycle maintenance in the most economical manner.

Item \ Interval	Initial and Every 4,000 km	Every 8,000 km
Throttle cable	Motor oil	–
Throttle grip	–	Grease
Brake cable	Motor oil	–
Speedometer cable	–	Grease
Speedometer gear box	–	Grease
Brake cam	–	Grease
Steering stem bearing	Grease every 2 years or 20,000 km	

**⚠ WARNING**

**Be careful not to apply too much grease into the brake cam. If grease is on the linings, brake slippage will result.**

Lubricate exposed parts which are subject to rust, with either motor oil or grease whenever the motorcycle has been operated under wet or rainy conditions.

Before lubricating each part, clean off rusty spots and wipe off grease, oil, dirt or grime.



## 2-3 MAINTENANCE PROCEDURE

### MAINTENANCE PROCEDURE

This section describes the service procedures for each section of the periodic maintenance.

#### BATTERY

**NOTE:**

*Inspect Initial 1,000 km and Every 4,000 km.*

- Remove the pillion seat for measure of battery voltage.
  - Remove the battery  $\ominus$  lead and then  $\oplus$  lead at the battery terminals and remove the battery.
  - Using pocket tester, measure the battery voltage.
- If the tester reading is less than 12.0V, recharge the battery with a battery charger. (Refer to page 5-13)

 Pocket tester : 09900-25002

<b>Battery voltage</b>	Minimum 12.0V
------------------------	---------------

<b>Recharge</b>	
Standard charge	0.4A × 5~10 Hours
Fast charge	4A × 30 Minutes

#### CAUTION

- When recharging the battery remove the battery from motorcycle. Otherwise, regulator/rectifier unit should be an obstacle.
- When recharging the battery, do not remove the caps.
- When recharging the battery, above the charge electric current and time should be kept as 12V.

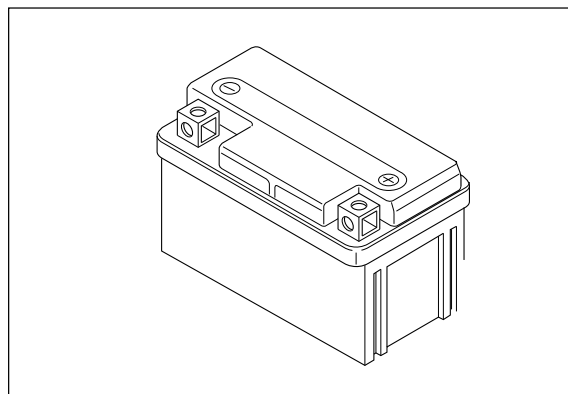
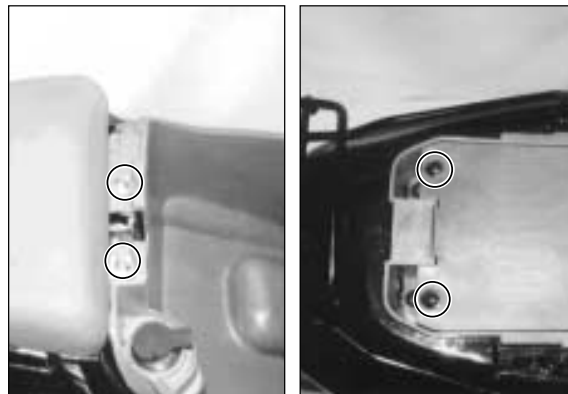

## CYLINDER HEAD NUTS AND EXHAUST PIPE NUTS

**NOTE:**

Inspect Initial 1,000 km and Every 4,000 km.

### CYLINDER HEAD NUTS

- Remove the personal trunk.
- Remove the spark plug cap.
- Remove the cylinder head cover bolt.  
(Refer to page 3-5)
- Tighten the four nuts ① to the specified torque with a torque wrench, when engine is cold.

 Cylinder head nut : 8~12 N · m (0.8~1.2 kg · m)

### EXHAUST PIPE NUTS

- Tighten the exhaust pipe nuts ② to the specified torque.

 Exhaust pipe nuts : 8~12 N · m (0.8~1.2 kg · m)

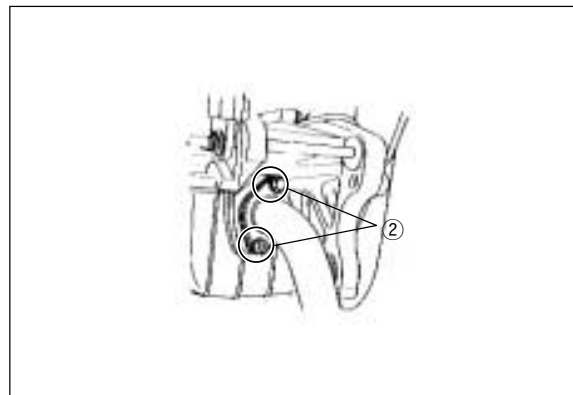
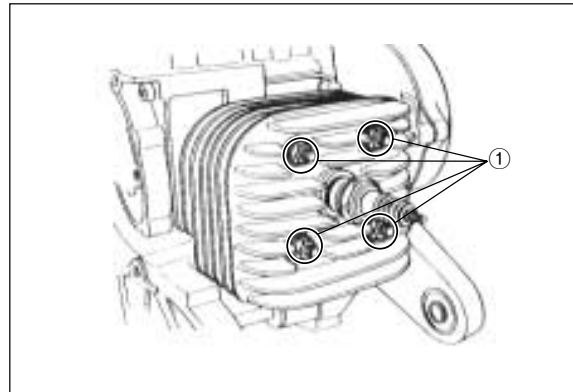

## CYLINDER HEAD AND CYLINDER

**NOTE:**

Remove carbon Every 8,000km.

Carbon deposits in the combustion chamber and the cylinder head will raise the compression ratio and may cause preignition or overheating. Carbon deposited at the exhaust port of the cylinder will prevent the flow of exhaust gases, reducing the output. Remove carbon deposits periodically.

## SPARK PLUG

**NOTE:**

Inspect Initial 1,000km and Every 4,000km,  
Replace every 8,000km.

Neglecting the spark plug maintenance eventually leads to difficult starting and poor performance. If the spark plug is used for a long period, the electrode gradually burns away and carbon builds up along the inside part. In accordance with the Periodic Inspection Chart, the plug should be removed for inspection, cleaning and to reset the gap.

- Carbon deposits on the spark plug will prevent good sparking and cause misfiring. Clean the deposits off periodically.

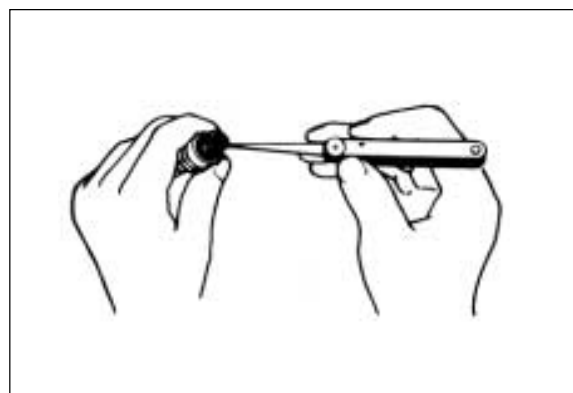
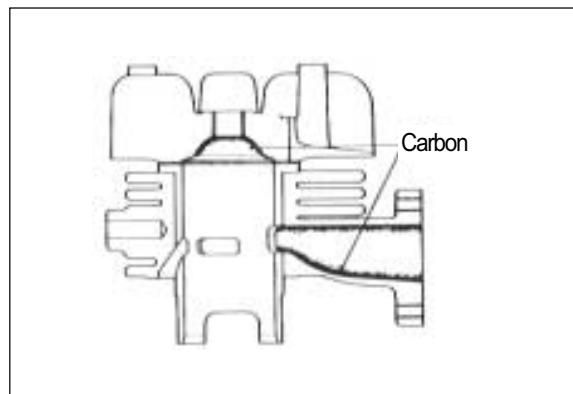

## 2-5 MAINTENANCE PROCEDURE

- If the center electrode is fairly worn down, the plug should be replaced and the plug gap set to the specified gap using a thickness gauge.

 Thickness gauge : 09900-20804

<b>Spark plug gap</b>	0.6 ~ 0.7 mm
-----------------------	--------------

- Check the spark plug for burnt condition. If abnormal, replace the plug as indicated in the chart.

TYPE	SPARK PLUG SPECIFICATION
Standard	BR8HSA

- Tighten the spark plug to the specification.

 Spark plug : 25~30 N · m (2.5~3.0 kg · m)

### CAUTION

- To check the spark plug, first make sure that the fuel used is unleaded gasoline, and if plug is either sooty with carbon or burnt white, replace it.
- Confirm the thread size and reach when replacing the plug.

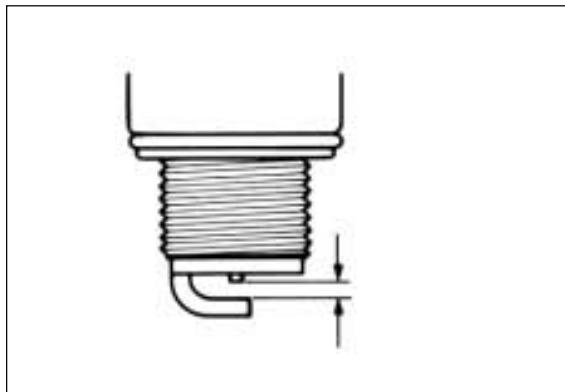

## FUEL LINE

### NOTE:

Inspect Initial 1,000 km and Every 4,000 km,  
Replace every four years.

Inspect leakage of the fuel line and connection part.  
If abnormal, replace it.

## AIR CLEANER ELEMENT

### NOTE:

Clean Every 3,000km and Replace Every 12,000km.

If the air cleaner is clogged with dust, intake resistance will be increased with a resultant decrease in power output and an increase in fuel consumption. Check and clean the element in the following manner.

- Remove the air cleaner cover by removing the eight screw.

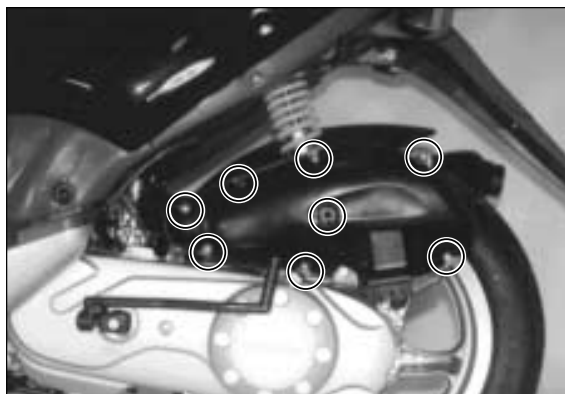

- Remove the air cleaner cover, separate the element.

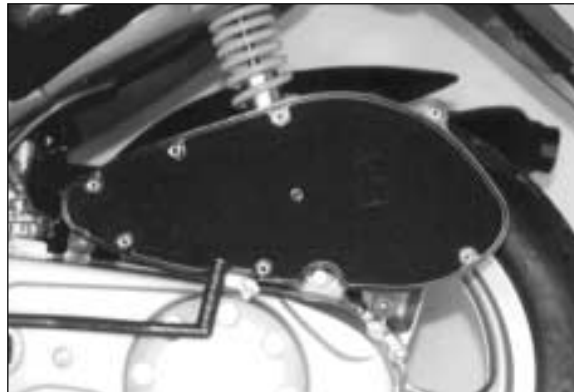

- Fill a washing pan of a proper size with non-flammable cleaning solvent. Immerse the element in the cleaning solvent and wash them clean.
- Squeeze the cleaning solvent out of the washed element by pressing it between the palms of both hands: do not twist or wiring the element or it will develop tears.
- Immerse the element in Hyosung genuine oil, and squeeze the oil out of the element leaving it slightly wet with oil.
- Fit the elements to the cleaner case properly.

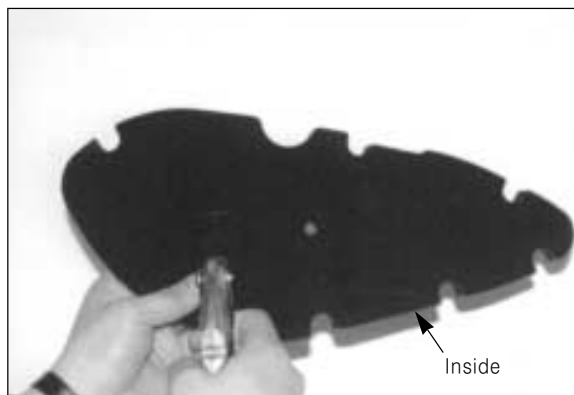

**⚠ CAUTION**

- Before and during the cleaning operation, inspect the element for tears. A torn element must be replaced.
- Be sure to position the element snugly and correctly, so that no incoming air will bypass it. Remember, rapid wear of piston rings and cylinder bore is often caused by a defective or poorly fitted element.

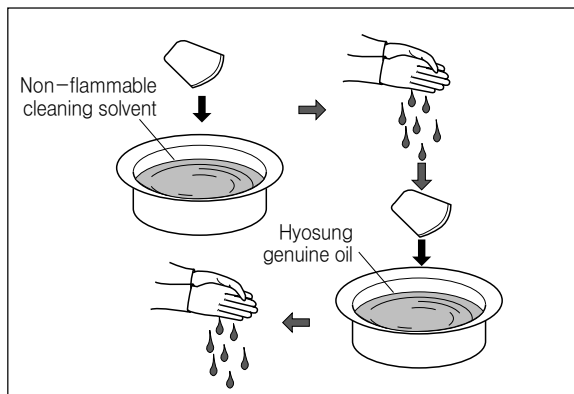

**THROTTLE CABLE PLAY**

**NOTE:**

Inspect Initial 1,000 km and Every 4,000 km.

- Loosen the lock nut ① and adjust the cable play ④ by turning adjuster ② in or out to obtain the following cable play. After adjusting play, tighten the lock nut.

<b>Throttle cable play</b>	0.5 ~ 1.0 mm
----------------------------	--------------

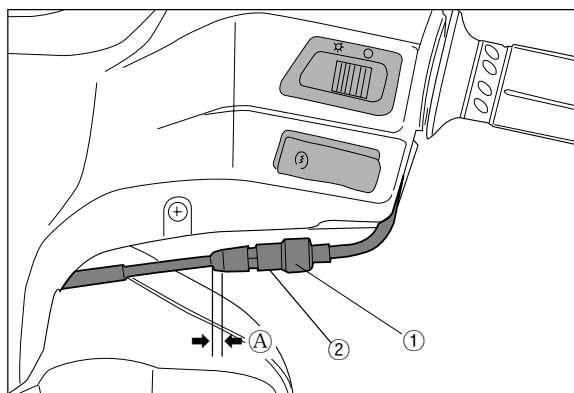

## 2-7 MAINTENANCE PROCEDURE

### ENGINE IDLE SPEED

**NOTE:**

Inspect Initial 1,000 km and Every 4,000 km.

**⚠ CAUTION**

**Make this adjustment when the engine is hot.**

- start up the engine and set its speed at anywhere between 1,750 and 1,850 rpm by turning the throttle stop screw ①.

<b>Engine idle speed</b>	1,800 ± 50 rpm
--------------------------	----------------

 Engine tachometer : 09900-26006



### OIL PUMP

**NOTE:**

Inspect Initial 1,000 km and Every 4,000 km.

The engine oil is fed by the oil pump to the engine. The amount of oil fed to it is regulated by engine speed and oil pump control lever which is controlled by amount of throttle opening.

Check the oil pump in the following manner to confirm correct operation for throttle valve full closing position.

- Fix the throttle grip. (The early idling condition)
- Check whether the mark ② on the oil pump control lever is aligned with the index mark ③ when the throttle grip is fixed as above.
- If the marks are not aligned, loosen lock nuts ④ and turn the adjuster ⑤ in or out to align the marks.
- After aligning the marks, tighten the lock nuts ④.

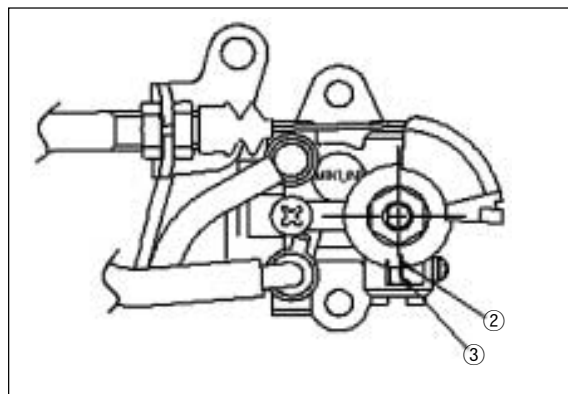
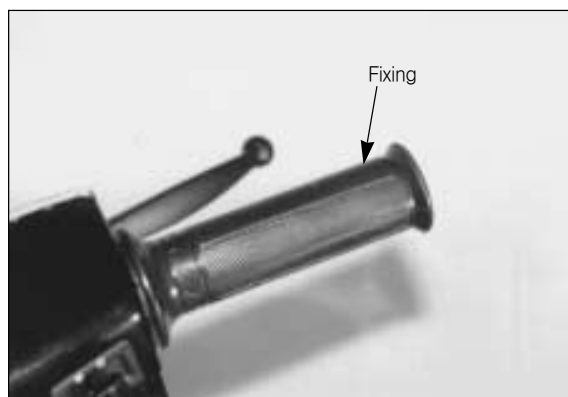

**⚠ CAUTION**

**Oil pump cable adjustment must be done after throttle cable adjustment.**

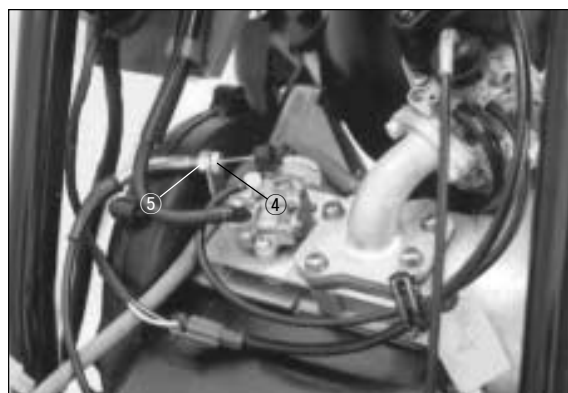

## TRANSMISSION OIL

**NOTE:**

Inspect Initial 1,000 km and Every 8,000 km.

Inspect transmission oil periodically following procedure below.

- Remove the low leg shield.
- Remove the clutch cover. (Refer to page 3-6)

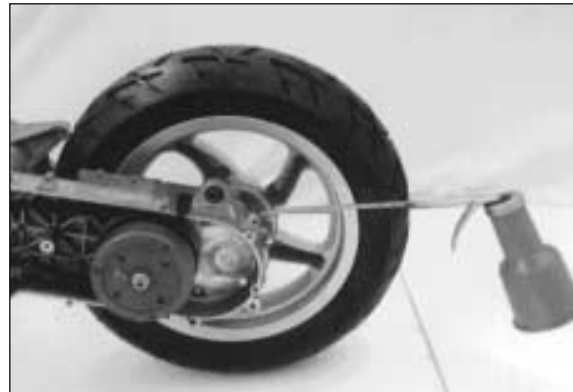

- Remove the oil level bolt ① and inspect oil level.  
If the level is below the level hole, add oil until oil flows from the level hole.
- Tighten the oil level bolt to the specified torque.

 Oil level bolt : 9~15 N · m (0.9~1.5 kg · m)

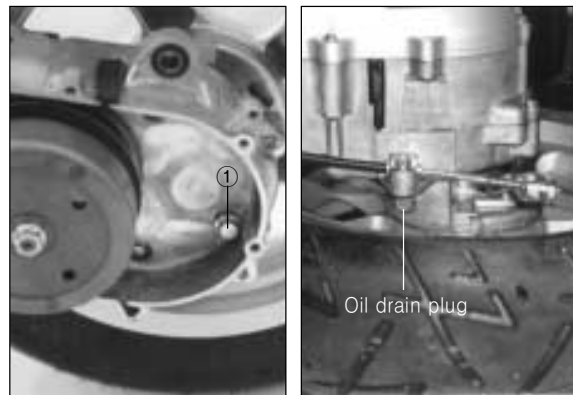

## BRAKES

**NOTE:**

Inspect Initial 1,000 km and Every 4,000 km.

Replace the hose Every four years.

Replace the brake fluid Every two years.

### FRONT BRAKE FLUID LEVEL

- Keep the motorcycle upright and place the handlebar straight.
- Check brake fluid level by observing the middle line on the brake fluid reservoir.
- When the level is below the middle line, replenish with brake fluid that meets the following specification.

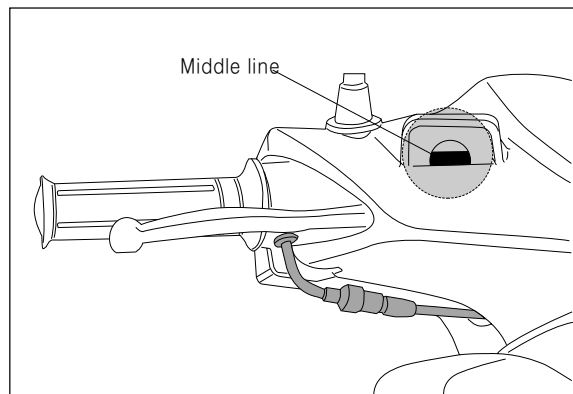

<b>Specification and classification</b>	DOT4
---	------

 HYOSUNG Brake fluid : 99000-23021

**⚠ WARNING**

The brake system of this motorcycle is filled with a glycolbased brake fluid. Do not use or mix different type of fluid such as silicone-based and petroleum-based. Do not use any brake fluid taken from old, used or unsealed containers. Never re-use the brake fluid left over from the last servicing and stored for long periods.

**⚠ WARNING**

Brake fluid, if it leaks, will interfere with safe running and immediately discolor painted surfaces. Check the brake hoses for cracks and hose joints for leakage before riding.



## 2-9 MAINTENANCE PROCEDURE

### BRAKE PADS

Wearing condition of brake pads can be checked by observing the limit line ① marked on the pad. When the wear exceeds the limit mark, replace the pads with new ones.

### BRAKE LAMP SWITCH

For the brake lamp come on after the brake lever is pulled, adjust the brake lamp switch.

### BLEEDING AIR FROM THE BRAKE FLUID CIRCUIT

Air trapped in the fluid circuit acts like a cushion to absorb a large proportion of the pressure developed by the master cylinder and thus interferes with the full braking performance of the brake caliper. The presence of air is indicated by "sponginess" of the brake lever and also by lack of braking force. Considering the danger to which such trapped air exposes the machine and rider, it is essential that, after remounting the brake and restoring the brake system to the normal condition, the brake fluid circuit be purged of air in the following manner:

- Fill up the master cylinder reservoir to the upper end of the inspection window. Replace the reservoir cap to prevent entry of dirt.
- Attach a pipe to the caliper bleeder valve, and insert the free end of the pipe into a receptacle.

 Bleeder valve : 6~9 N · m (0.6~0.9 kg · m)

- Bleed air from the bleeder valve.
- Squeeze and release the brake lever several times in rapid succession, and squeeze the lever fully without releasing it. Loosen the bleeder valve by turning it a quarter of a turn so that the brake fluid runs into the receptacle: this will remove the tension of the brake lever causing it to touch the handlebar grip. Then, close the valve, pump and squeeze the lever, and open the valve. Repeat this process until the fluid flowing into the receptacle no longer contains air bubbles.

#### CAUTION

**Replenish the brake fluid reservoir as necessary while bleeding the brake system.  
Make sure that there is always some fluid visible in the reservoir.**

- Close the bleeder valve, and disconnect the pipe. Fill the reservoir to the upper end of the inspection window.

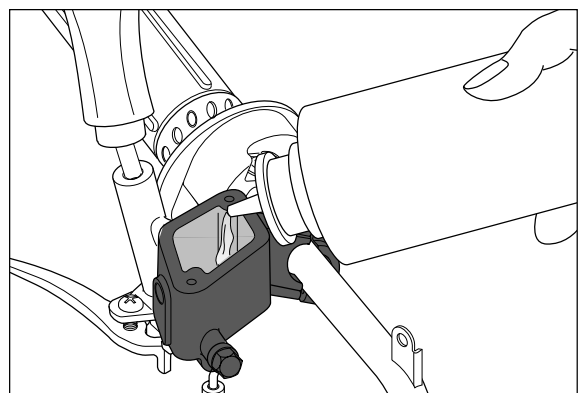
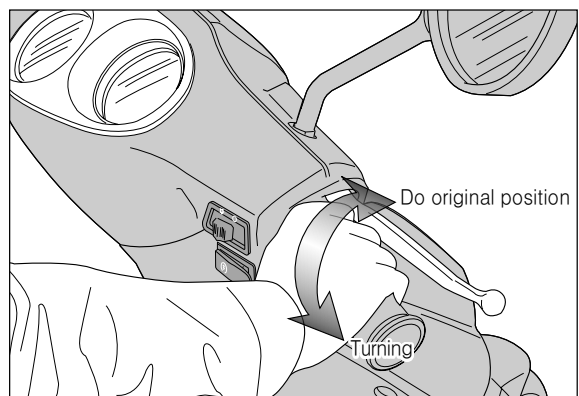
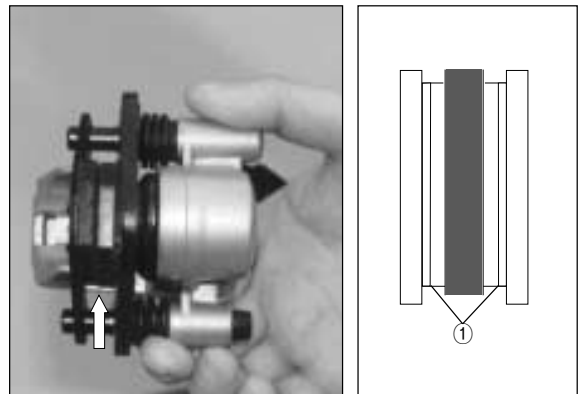

**⚠ WARNING**

Handle the brake fluid with care: the fluid reacts chemically with paint, plastics, rubber materials, etc.

**REAR BRAKE**

Adjust by turning the adjusting nut ① so that the play ② is 15~25 mm as shown in the illustration.

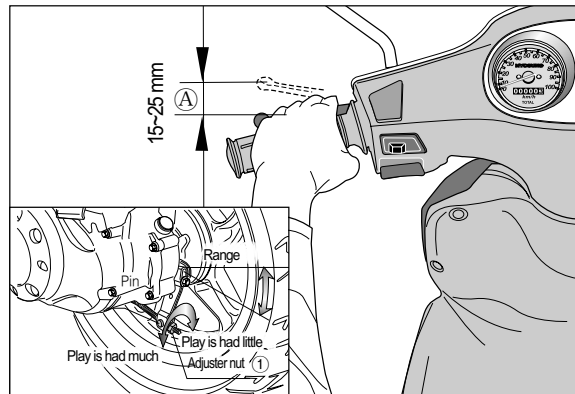

**Brake lining wear limit**

This motorcycle is equipped with the brake lining wear limit indicator on the rear brake. As shown in the illustration at right, at the condition of normal lining wear, an extended line from the index mark on the brake camshaft should be within the range embossed on the crankcase LH. To check wear of the brake lining, follow the steps below.

- First check if the brake system is properly adjusted.
- While operating the brake, check to see that the extension line from the index mark is within the range on the brake panel.
- If the index mark is outside the range as shown in the illustration at right, the brake shoe assembly should be replaced to ensure safe operation.

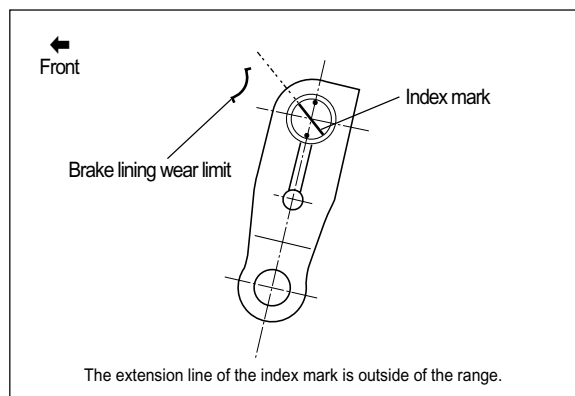
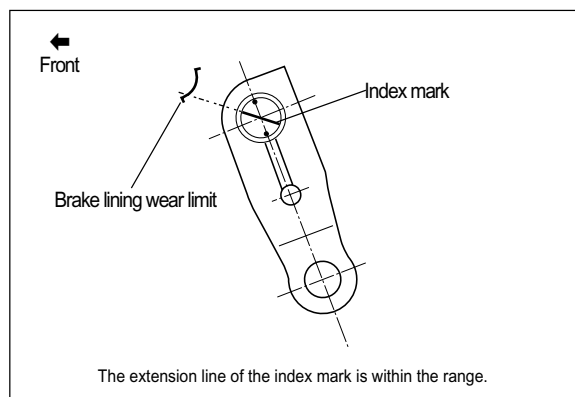

**TIRES**

**NOTE:**

Inspect Initial 1,000 km and Every 4,000 km.

**TIRE PRESSURE**

If the tire pressure is too high, the motorcycle will tend to ride stiffly and have poor traction. Conversely, if the tire pressure is too low, stability will be adversely affected. Therefore, maintain the correct tire pressure for good roadability and to prolong tire life.

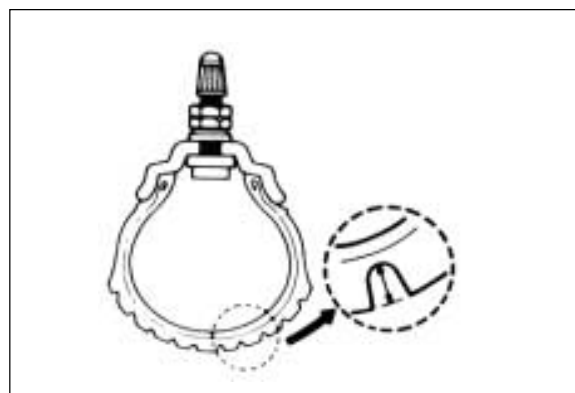



## 2-11 MAINTENANCE PROCEDURE

### ⚠ CAUTION

The standard tire fitted on this motorcycle is 110/70-12 47J for front and 120/70-12 51J for rear. The use of a tire other than the standard may cause handling instability. It is highly recommended to use a HYOSUNG Genuine Tire.

COLD INFLATION TIRE PRESSURE	NORMAL RIDING			
	SOLO RIDING		DUAL RIDING	
	kpa	kg/cm <sup>2</sup>	kpa	kg/cm <sup>2</sup>
FRONT	123	1.25	172	1.75
REAR	196	2.00	221	2.25

### TIRE TREAD CONDITION

Operating the motorcycle with the excessively worn tires will decrease riding stability and consequently invite a dangerous situation. It is highly recommended to replace the tire when the remaining depth of tire tread reaches the following specification.

TREAD DEPTH SERVICE LIMIT	
FRONT	1.6 mm
REAR	1.6 mm

### STEERING

#### NOTE:

Inspect Initial 1,000 km and Every 4,000 km.

Steering should be adjusted properly for smooth turning of handlebars and safe running. Too stiff steering prevents smooth turning of handlebars and too loose steering will cause poor stability.

Check that there is no play in the front fork assembly by supporting the machine so that the front wheel is off the ground, with wheel straight ahead, grasp lower shock absorber near the axle and pull forward. If play is found, perform steering bearing adjustment. (Refer to page 6-21)

### FRONT SUSPENSION

#### NOTE:

Inspect Initial 1,000 km and Every 8,000 km.

Inspect the front shock absorber for oil leakage or other damage, and replace the defective parts, if necessary.

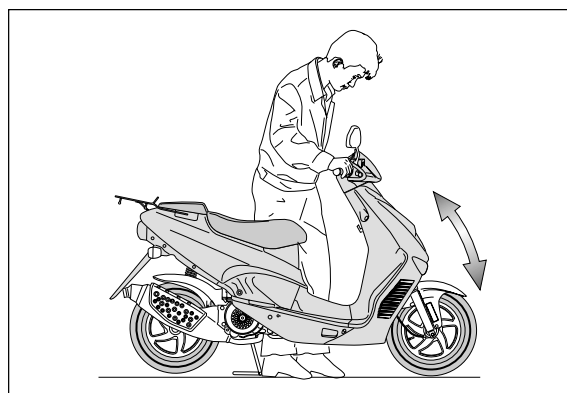
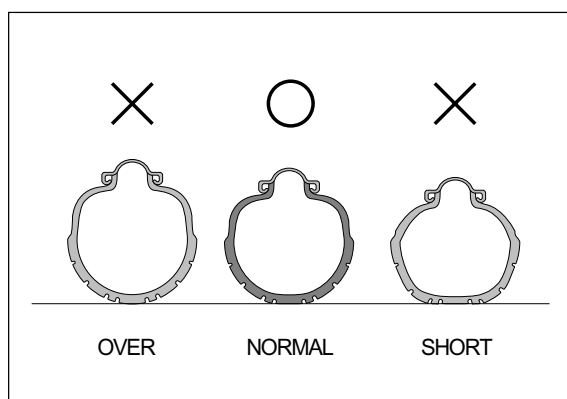
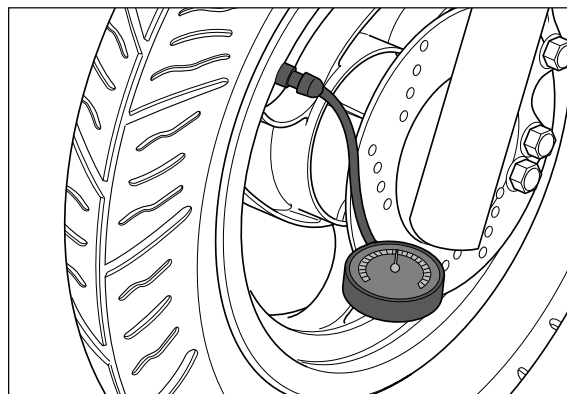

## REAR SUSPENSION

**NOTE:**

*Inspect Initial 1,000 km and Every 8,000 km.*

Inspect the rear shock absorber for oil leak and the mounting rubbers including engine mountings for wear and damage. Replace the defective part if necessary.















## CHASSIS AND ENGINE MOUNTING BOLTS AND NUTS

**NOTE:**

*Inspect Initial 1,000 km and Every 4,000 km.*

These bolts and nuts listed below are important safety parts. They must be loosened first and retightened, to the specified torque with a torque wrench.

-  Front axle nut(①) : 33~52 N · m (3.3~5.2 kg · m)
-  Steering stem lock nut (②) : 60~100 N · m (6.0~10.0 kg · m)
-  Handlebar clamp nut(③) : 48~52 N · m (4.8~5.2 kg · m)
-  Handlebar set bolt(④) : 22~28 N · m (2.2~2.8 kg · m)
-  Front brake master cylinder bolt(⑤) : 8~12 N · m (0.8~1.2 kg · m)
-  Front brake hose union bolt(⑥) : 20~25 N · m (2.0~2.5 kg · m)
-  Front brake caliper mounting bolt(⑦) : 18~28 N · m (1.8~2.8 kg · m)
-  Front brake air bleeder valve(⑧) : 6~9 N · m (0.6~0.9 kg · m)
-  Rear axle nut(⑨) : 60~90 N · m (6.0~9.0 kg · m)
-  Rear shock absorber bolt(upper and lower)(⑩) : 22~35 N · m (2.2~3.5 kg · m)
-  Rear brake cam lever nut(⑪) : 6~9 N · m (0.6~0.9 kg · m)
-  Engine mounting bracket bolt(⑫) : 48~72 N · m (4.8~7.2 kg · m)
-  Engine mounting bolt(⑬) : 40~60 N · m (4.0~6.0 kg · m)

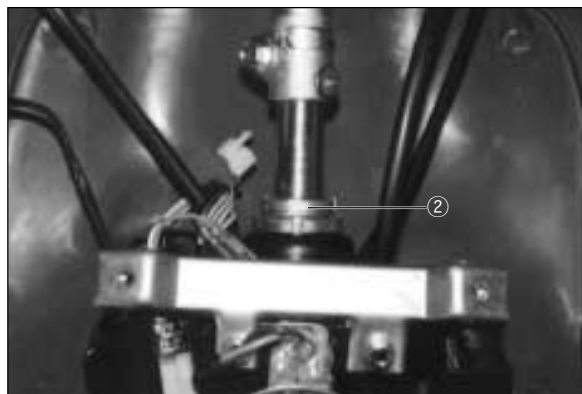

## 2-13 MAINTENANCE PROCEDURE

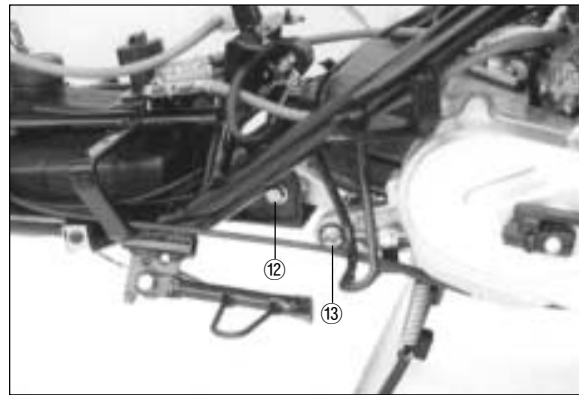
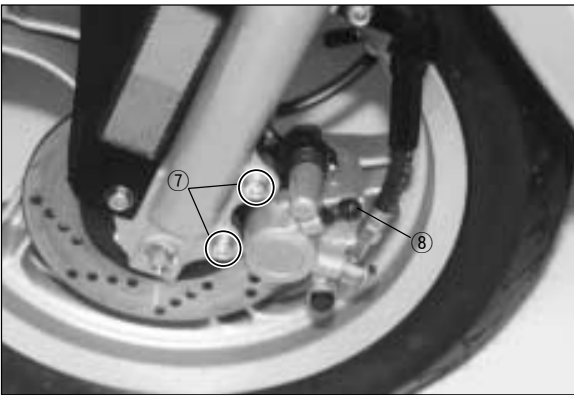
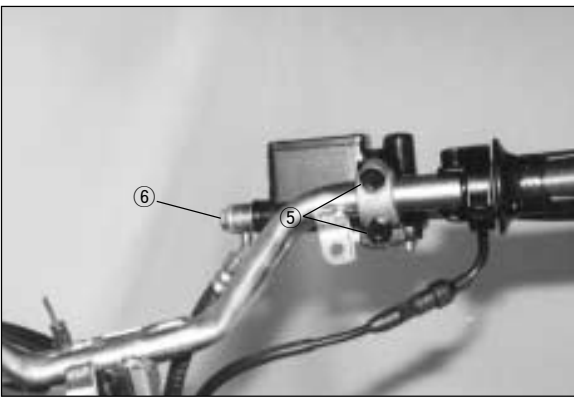
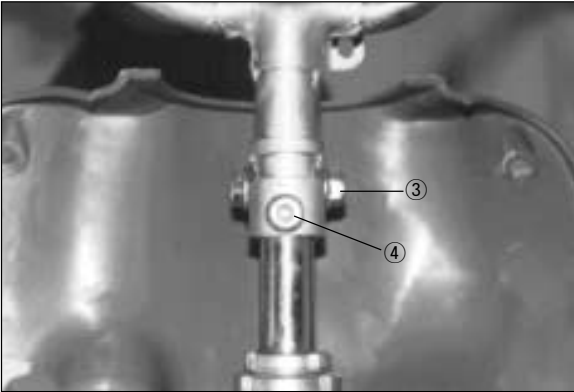

# ENGINE

## CONTENTS

<b>ENGINE REMOVAL AND REMOUNTING</b> .....	<b>3- 1</b>
<b>ENGINE REMOVAL</b> .....	<b>3- 1</b>
<b>ENGINE REMOUNTING</b> .....	<b>3- 3</b>
<b>ENGINE DISASSEMBLY</b> .....	<b>3- 4</b>
<b>ENGINE COMPONENTS INSPECTION AND SERVICING</b> .....	<b>3-14</b>
<b>BEARINGS</b> .....	<b>3-14</b>
<b>OIL SEALS</b> .....	<b>3-14</b>
<b>CRANKSHAFT</b> .....	<b>3-15</b>
<b>AUTOMATIC CLUTCH INSPECTION</b> .....	<b>3-15</b>
<b>CYLINDER HEAD</b> .....	<b>3-18</b>
<b>CYLINDER</b> .....	<b>3-19</b>
<b>PISTON</b> .....	<b>3-19</b>
<b>REED VALVE</b> .....	<b>3-22</b>
<b>ENGINE REASSEMBLY</b> .....	<b>3-22</b>
<b>OIL SEALS</b> .....	<b>3-22</b>
<b>BEARINGS</b> .....	<b>3-23</b>
<b>BUSHINGS</b> .....	<b>3-23</b>
<b>CRANKSHAFT</b> .....	<b>3-24</b>
<b>CRANKCASE</b> .....	<b>3-25</b>
<b>CENTER STAND</b> .....	<b>3-26</b>
<b>REAR AXLE SHAFT, BRAKE AND WHEEL</b> .....	<b>3-27</b>
<b>TRANSMISSION</b> .....	<b>3-29</b>
<b>STARTER DRIVEN GEAR AND STARTING MOTOR</b> .....	<b>3-31</b>
<b>MOVABLE DRIVEN AND CLUTCH</b> .....	<b>3-32</b>
<b>MOVABLE DRIVE</b> .....	<b>3-36</b>
<b>KICK STARTER</b> .....	<b>3-38</b>
<b>PISTON</b> .....	<b>3-40</b>
<b>OIL PUMP AND INTAKE PIPE</b> .....	<b>3-42</b>
<b>MAGNETO</b> .....	<b>3-43</b>
<b>MUFFLER</b> .....	<b>3-45</b>

## ENGINE REMOVAL AND REMOUNTING

### ENGINE REMOVAL

Before taking the engine out of the frame, thoroughly clean the engine with a suitable cleaner. The procedure of engine removal is sequentially explained as follows.

- Remove the low leg shield.
- Remove the air cleaner by removing the mounting bolts ① and clamp screw ②.
- Disconnect the ignition coil lead wires and spark plug cap.

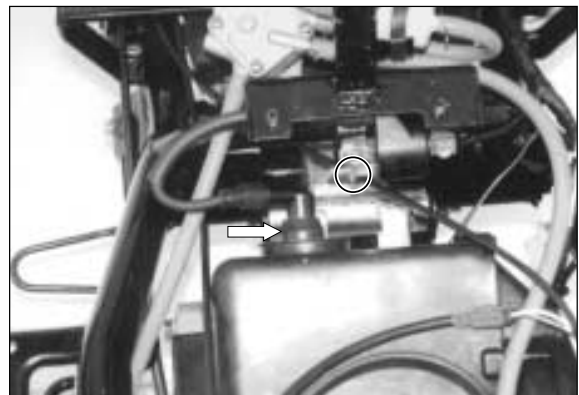
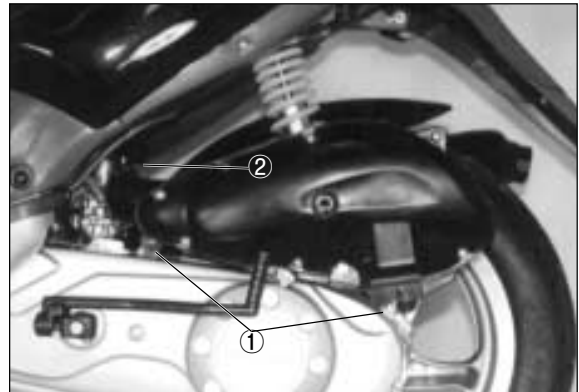

- Disconnect the oil pump cable ③ and the thermoelement lead coupler ④.
- Disconnect the throttle cable. (Refer to page 4-2)

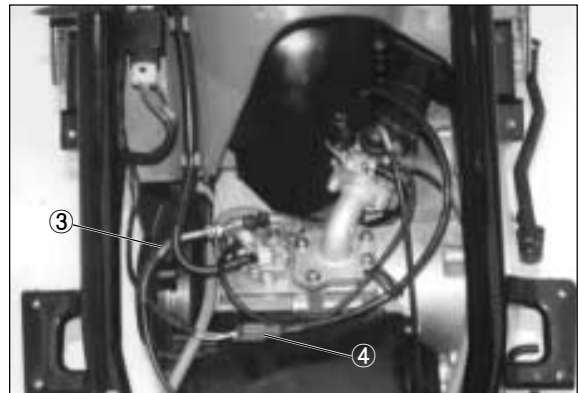

- Disconnect the vacuum hose ⑤, fuel hose ⑥ and oil hose ⑦.

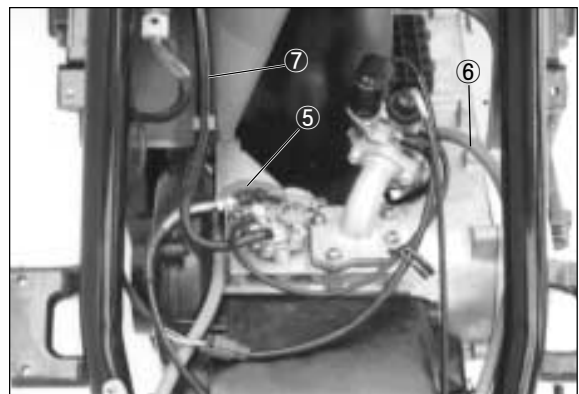

- Disconnect the magneto lead wire (A) and starting motor lead wire (B).

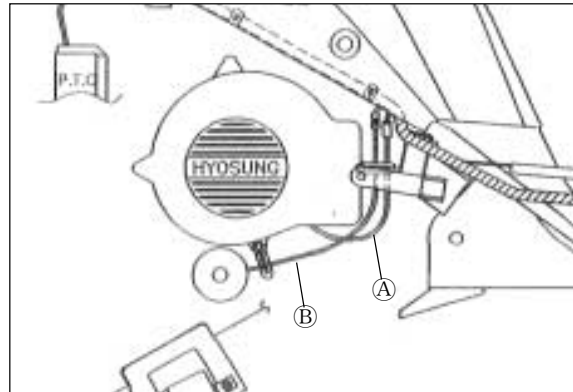

- Remove the rear brake cable (4) by removing the bolt (1), bolt (2) and adjuster nut (3).

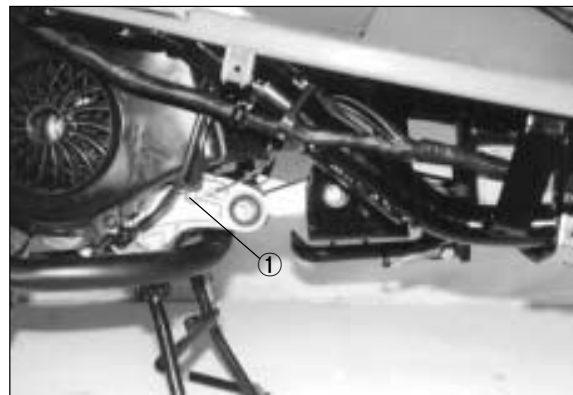

- Remove the rear shock absorber mounting lower bolt.





### 3-3 ENGINE

- Remove the engine mounting shaft and remove the engine from the frame.



### ENGINE REMOUNTING

The engine can be mounted in the reverse order of removal.

- Install the damper to the crankcase bracket as shown in the illustration.
- With “UP” mark faced upward, install the crankcase bracket ① on the frame. Do not tighten the bracket bolt ② at this stage. Pull up on the rear part of crankcase bracket and while holding it, tighten the bracket bolt ② to specification. Tighten both the rear shock absorber bolt ④ and engine mounting bolt ③ to specification.

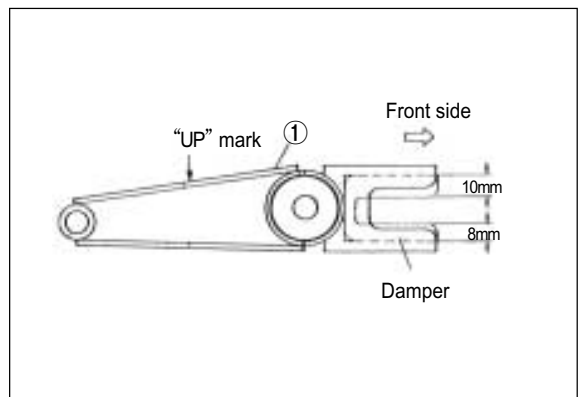

- 🔧 Engine mounting bracket bolt  
: 48~72 N · m (4.8~7.2 kg · m)
- 🔧 Engine mounting bolt  
: 40~60 N · m (4.0~6.0 kg · m)
- 🔧 Rear shock absorber bolt  
: 22~35 N · m (2.2~3.5 kg · m)

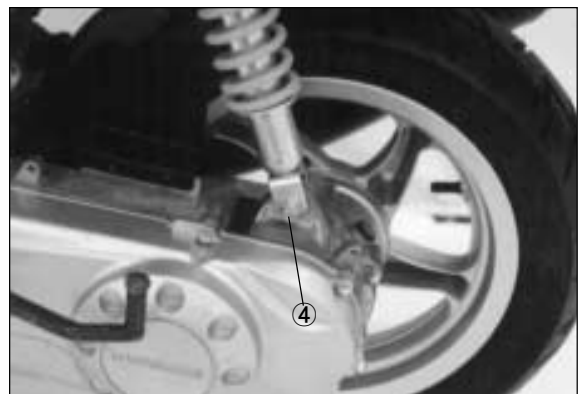
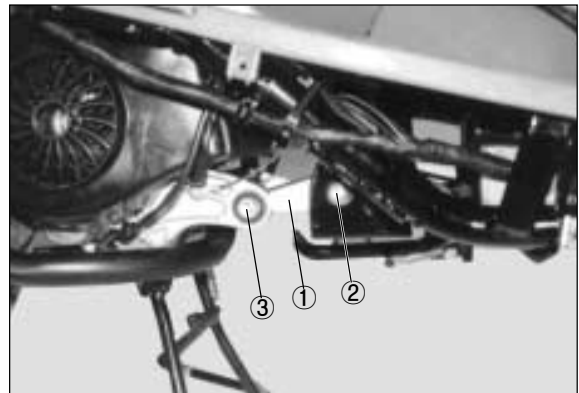

- Install the magneto lead wire (A) and starting motor lead wire (B) correctly.

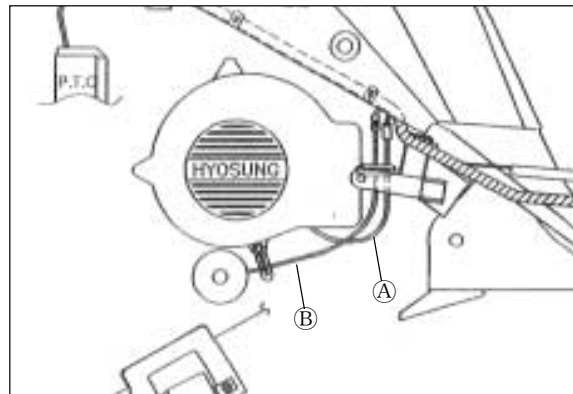

After remounting the engine, route the wiring harness properly and following adjustments are necessary.

	Page
· Throttle cable play .....	2-6
· Idling adjustment .....	2-7
· Oil pump cable paly .....	2-7
· Rear brake cable adjustment .....	2-10
· Air bleeding at oil pump .....	4-9



## ENGINE DISASSEMBLY

### MUFFLER

- Remove the muffler by removing the nuts.

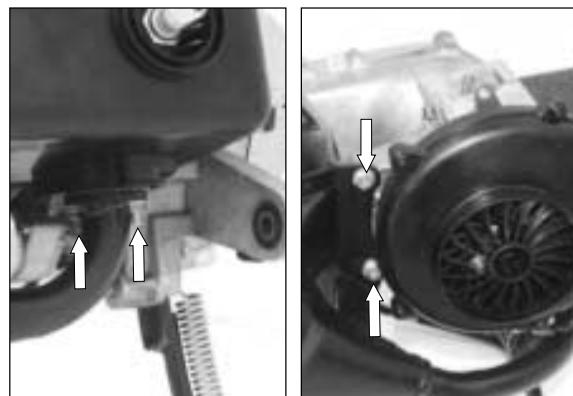

### MAGNETO

- Remove the cooling fan.
- Remove the magneto rotor nut (1) with the special tool.

 Rotor holder : 09930-40113

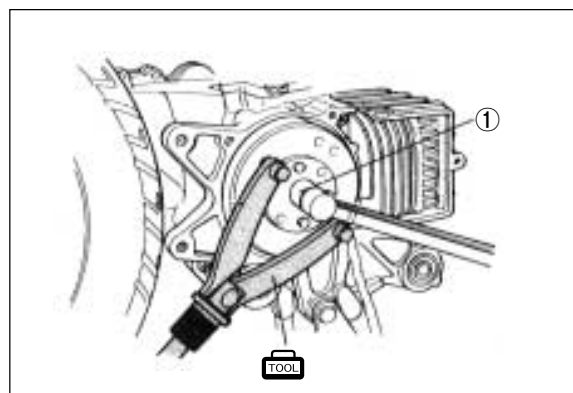



### 3-5 ENGINE

- Remove the magneto rotor with the special tool.



Rotor remover : 09930-30163

Rotor remover sliding shaft : 09930-30102

- Remove the magneto stator and key.

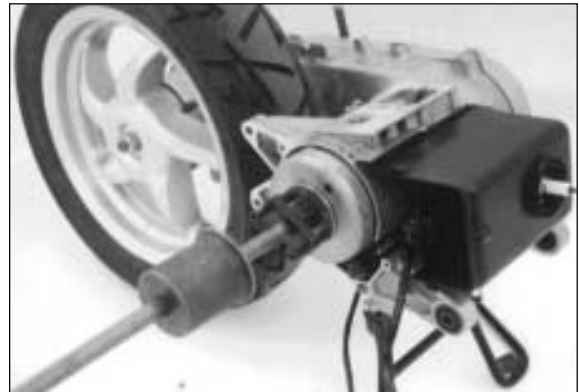

### REED VALVE

- Remove the intake pipe ② with reed valve ①.

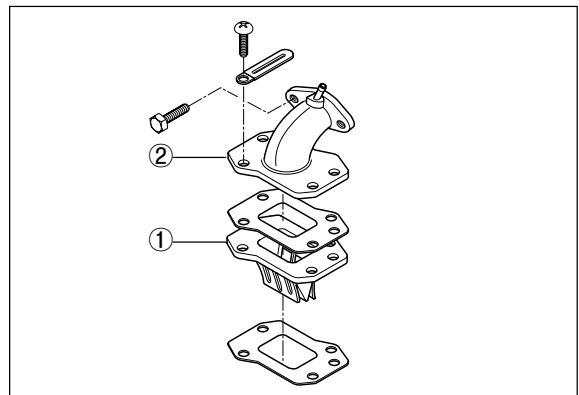

### OIL PUMP

- Remove the oil pump ③.
- Remove the oil pump driven gear ④.

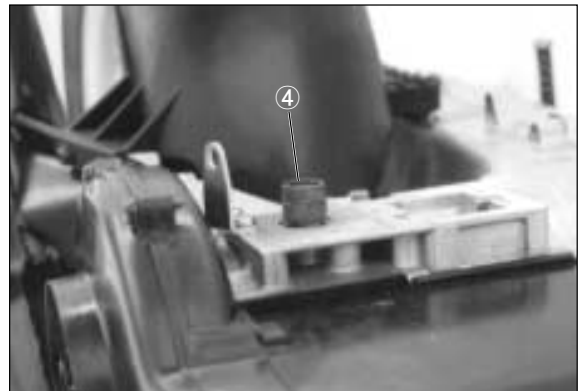
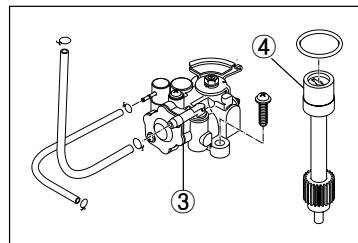

### CYLINDER

- Remove the cylinder cowling.
- Remove the cylinder head ⑤ and cylinder ⑥.

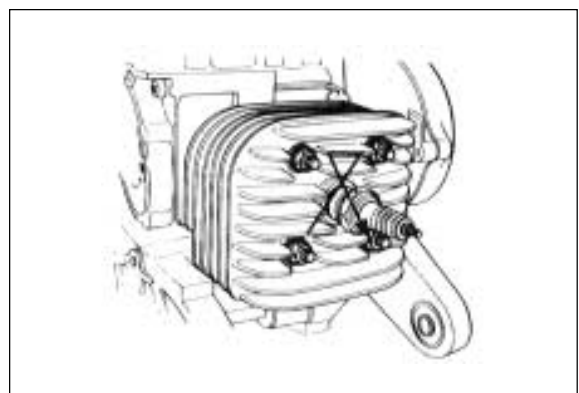
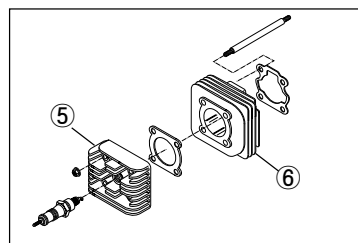

**PISTON**

- Place a cloth beneath the piston and remove the piston circlip ① with a long nose pliers.
- Remove the piston pin ② and piston ③.
- Remove the piston pin bearing ④.

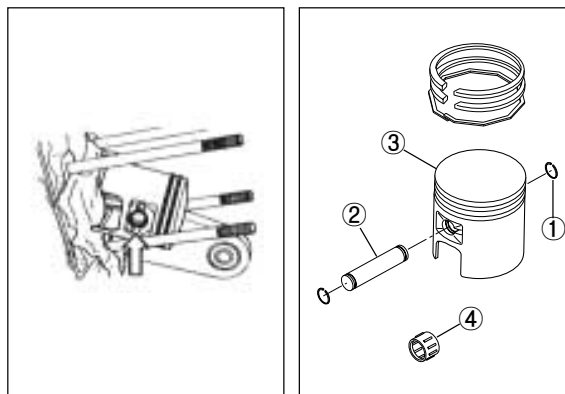
**KICK STARTER**

- Remove the kick starter lever ⑤.
- Remove the clutch cover ⑥.

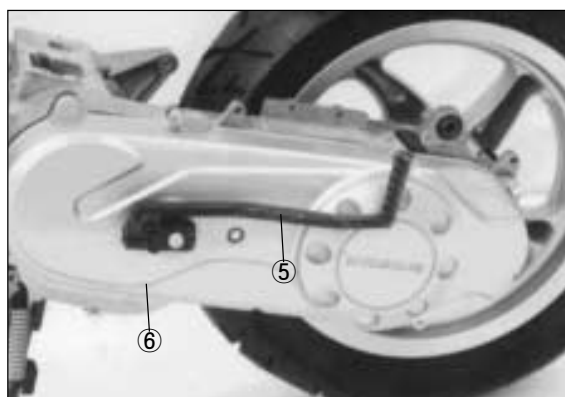

- Remove the kick starter shaft spring ⑦ and kick starter shaft ⑧.

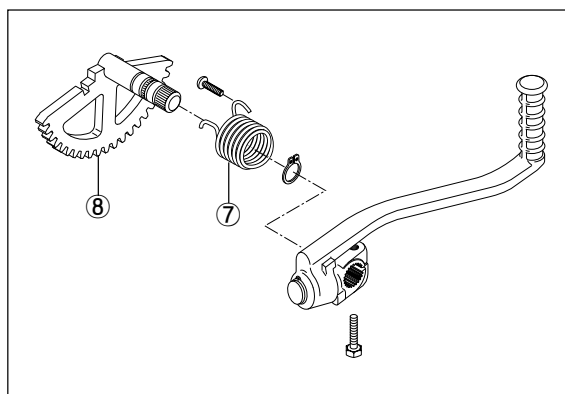
**KICK STARTER DRIVEN GEAR**

- Remove the E-ring ⑨ with the long nose plier.
- Remove the spacer ⑩, spring ⑪ and kick starter driven gear ⑫.

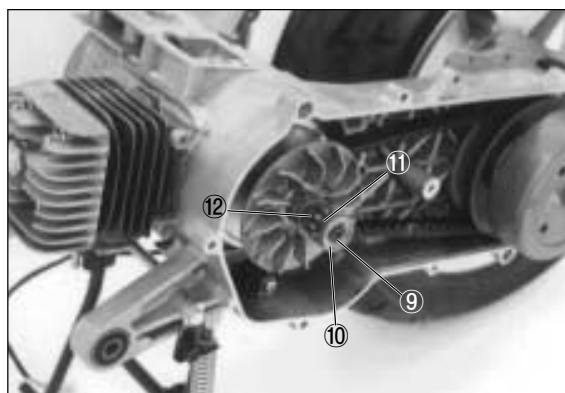

## 3-7 ENGINE

### MOVABLE DRIVE FACE

- Remove the kick starter driven nut ① with the special tool.

**CAUTION**

This nut has left-hand thread.

 Conrod holder : 09910-20115

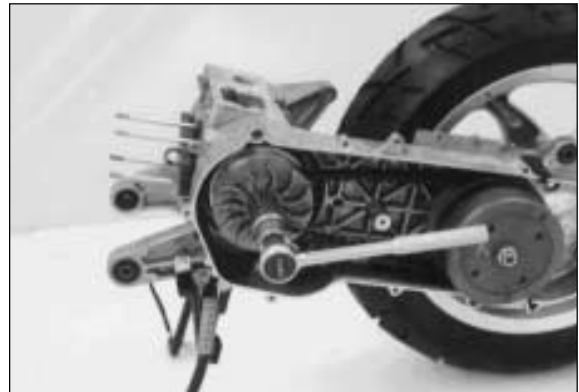

- Remove the fixed drive face ② and V-belt ③.
- Disassemble the movable drive face ④.

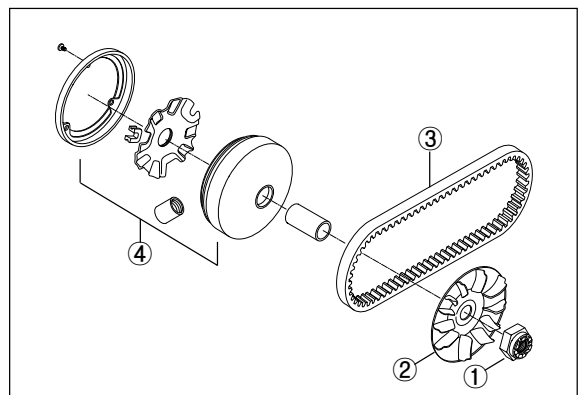

### STARTER DRIVEN GEAR

- Remove the starter driven gear ⑤.

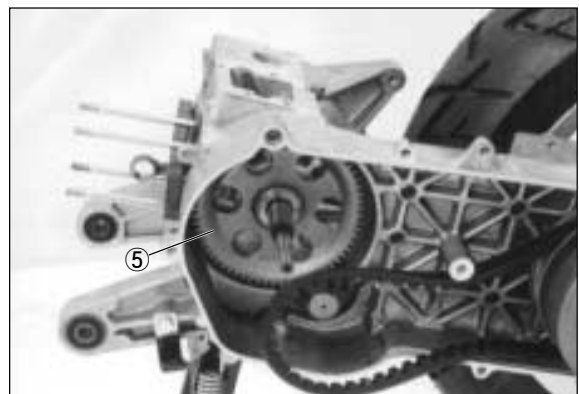

### MOVABLE DRIVEN FACE

- Remove the clutch housing ⑥ with the special tool.

 Rotor holder : 09930-40113

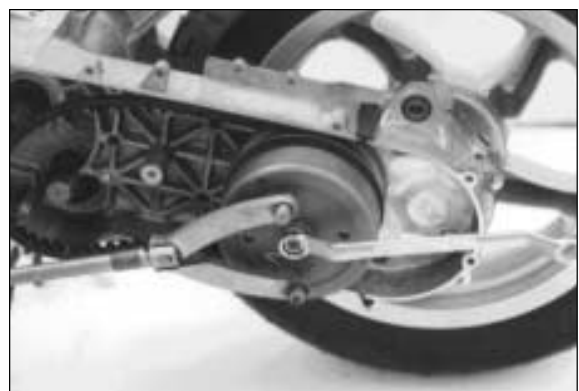
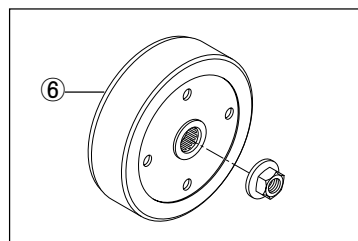

- Loosen the clutch shoe nut with the special tool.

 Rotor holder : 09930-40113

- Remove the nut while holding down the clutch shoe assembly ② by both hands as shown in the illustration.

**⚠ WARNING**

**Gradually back off the clutch shoe assembly pressed down by hand to counter the clutch spring load. Releasing the hand suddenly may cause the parts to fly apart.**

- Remove the nut ①.
- Remove the clutch shoe assembly ②.
- Remove the spring ③.

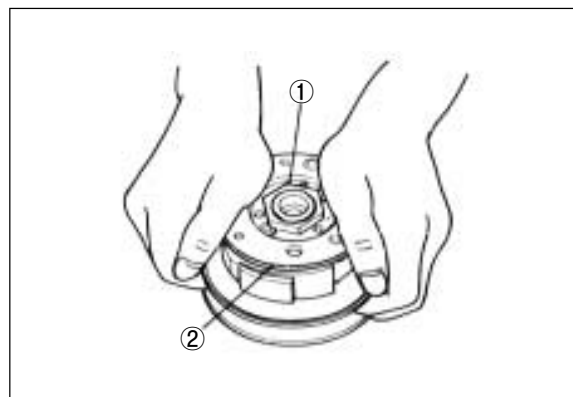
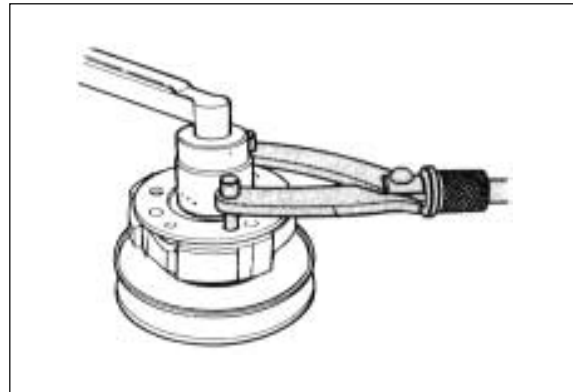
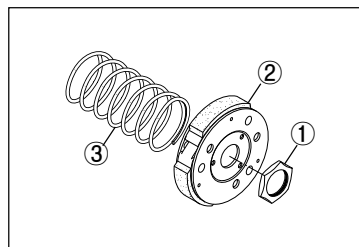

**⚠ CAUTION**

**Do not attempt to disassemble the clutch shoe assembly. It is not serviceable.**

- Using a thin blade screwdriver or the like, pry up the movable driven face spring guide ④.

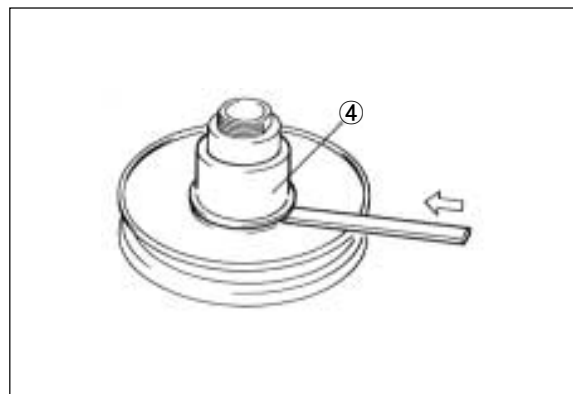

- Remove the pins ⑤, movable driven face ⑥ and fixed driven face ⑦.

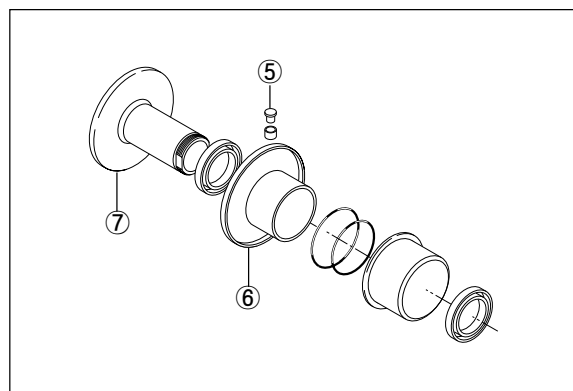

### 3-9 ENGINE

- Remove the roller bearing ① with the special tools.

 Bearing remover ( $\phi$  17 mm) : 09923-73210  
Rotor remover sliding shaft : 09930-30102

#### CAUTION

The removed bearing should be replaced with a new one.

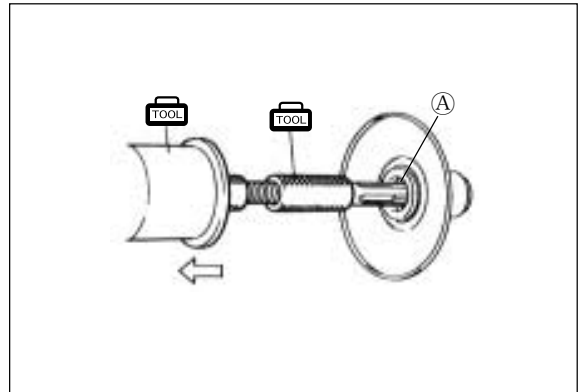

- Remove the circlip ②.

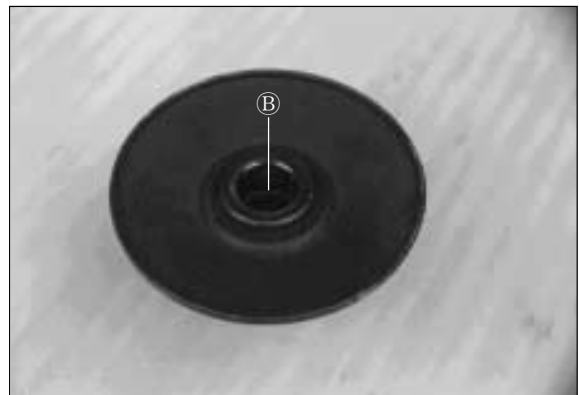
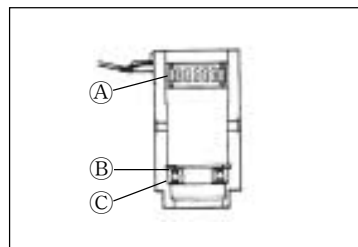

- Remove the bearing ③ with the special tool.

 Wheel bearing remover : 09941-50111

#### CAUTION

The removed bearing should be replaced with a new one.

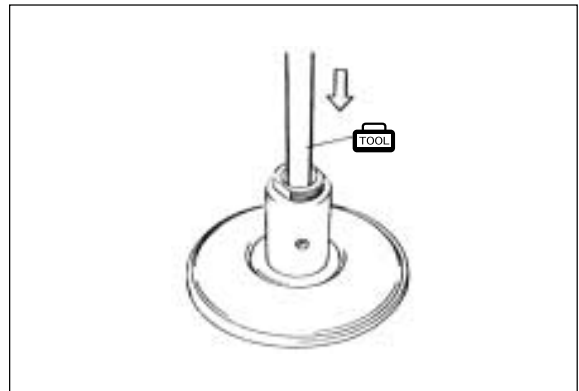

### TRANSMISSION

- Drain transmission oil.
- Remove the gear box cover ①.
- Remove the driveshaft ②.

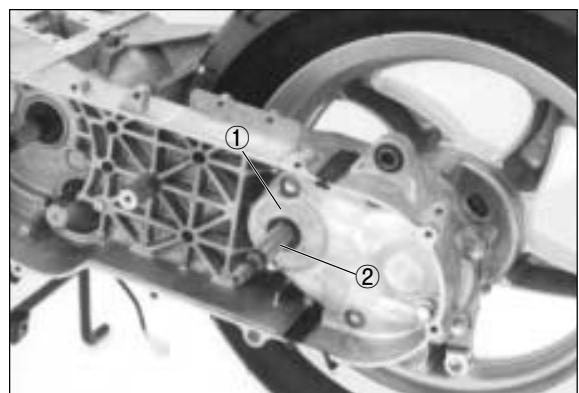

- Remove the oil seal ① from the gear box cover with the special tool.

 Oil seal remover : 09913-50121

**CAUTION**

The removed oil seal should be replaced with a new one.

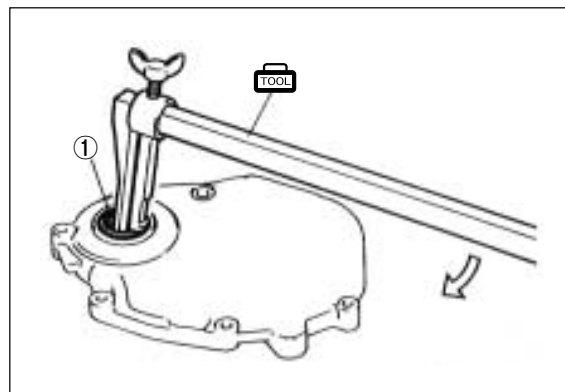

- Remove the bearing ② with the special tool.

 Bearing installer : 09913-76010

**CAUTION**

The removed bearing should be replaced with a new one.

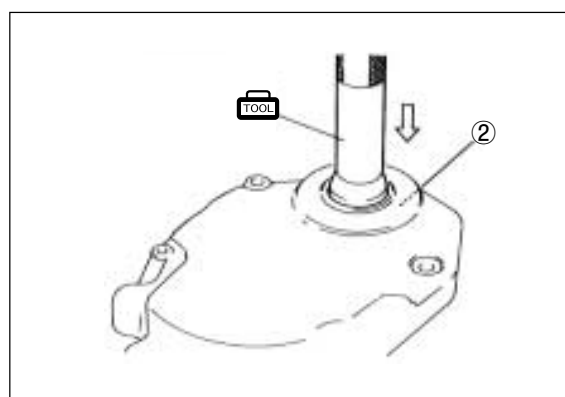

- Remove the circlip ③ and final driven gear ④.
- Remove the idle shaft ⑤.

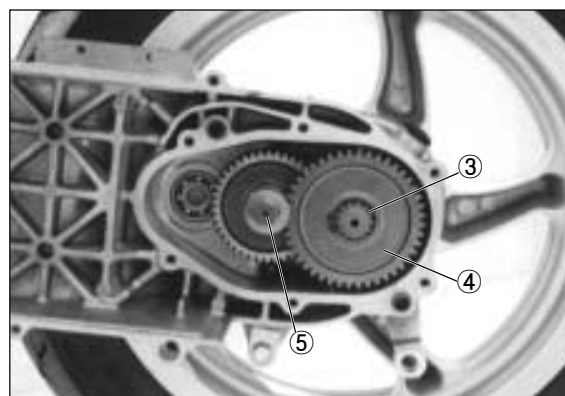

- Remove the drive shaft bearing ⑥.

 Rotor remover sliding shaft : 09930-30102  
 Bearing remover ( $\Phi$  12 mm) : 09921-20210

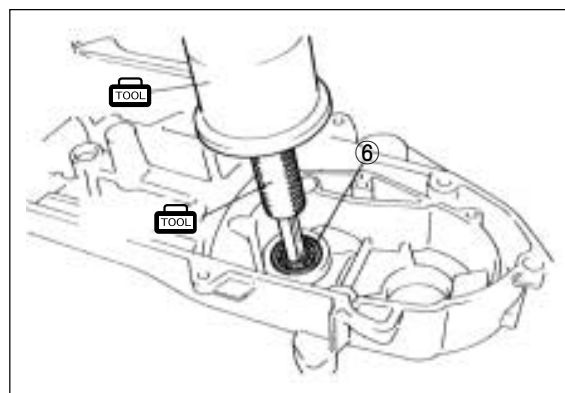

### 3-11 ENGINE

#### WHEEL, BRAKE

- Remove the rear axle nut ① and washer ②.
- Remove the rear wheel ③.

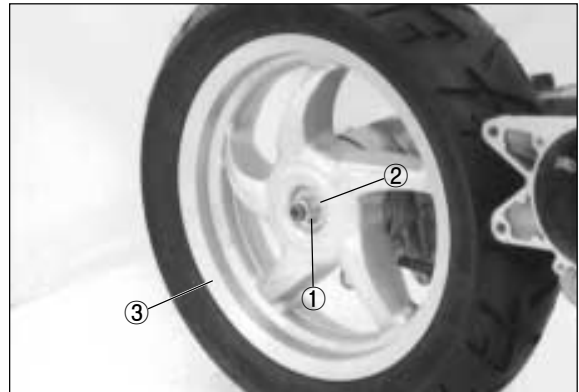

- Remove the brake shoes ④ and rear axle shaft ⑤.

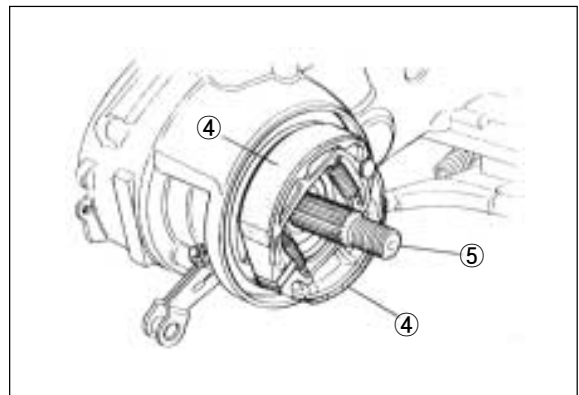

- Remove the bearing retainer ⑥.

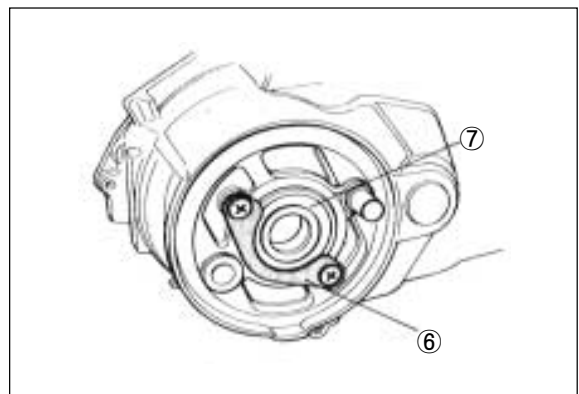

- Remove the bearing ⑦ with the special tool.

 Bearing installer : 09913-75820

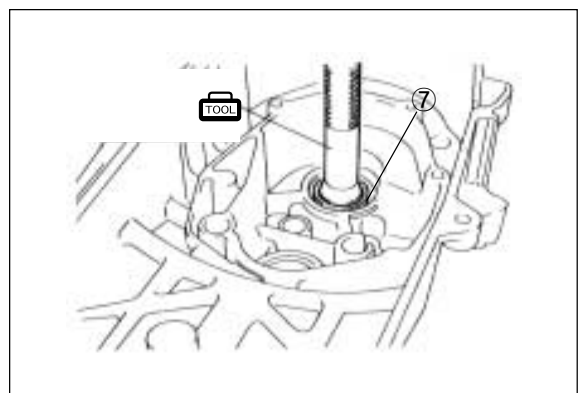



- Remove the oil seal ① with the special tool.

 Oil seal remover : 09913-50121

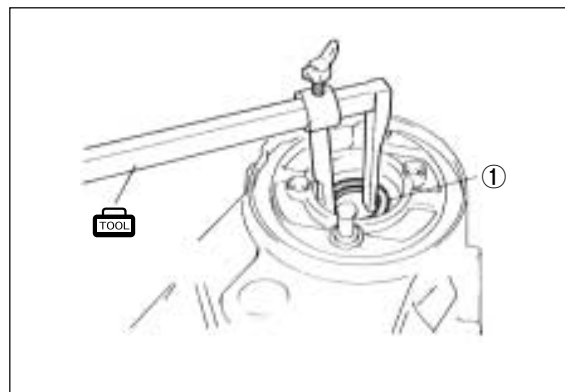

### CENTER STAND

- Remove the return spring ②.

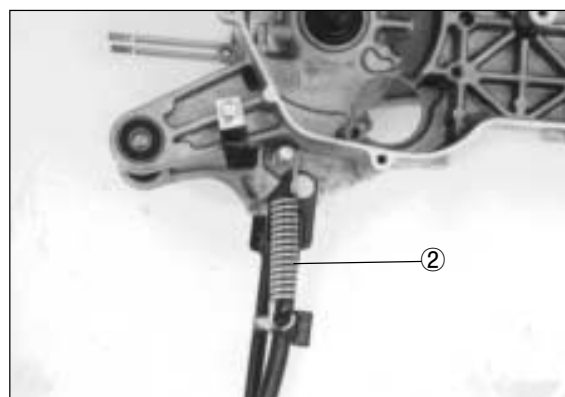

- Remove the cotter pin ③, washer ④ and shaft ⑤.
- Remove the center stand ⑥.

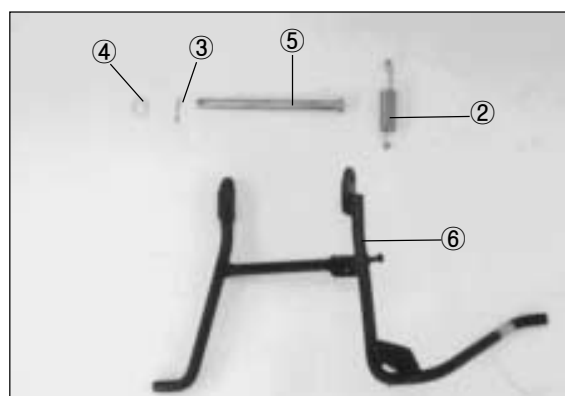

### CRANKCASE

- Remove the crankcase securing screws.

 **CAUTION**

**Loosen the crankcase screws diagonally.**

 Crankcase separator : 09920-13120





### 3-13 ENGINE

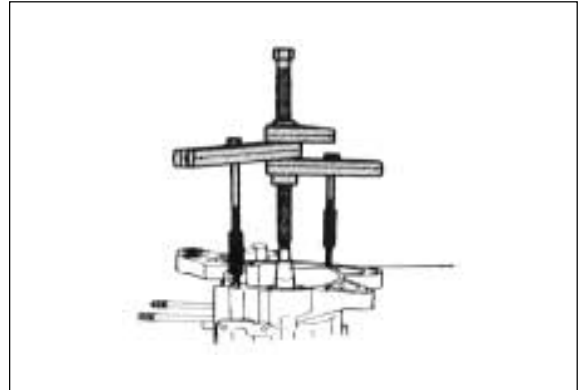

● Remove the crankshaft with the special tool.

 Crankcase separator : 09920-13120

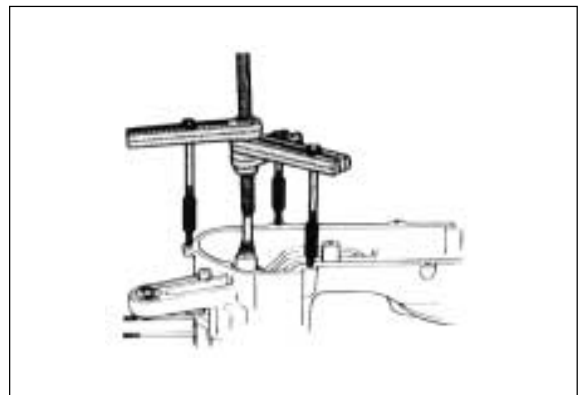

● Remove the bearings, oil seals and bushings.

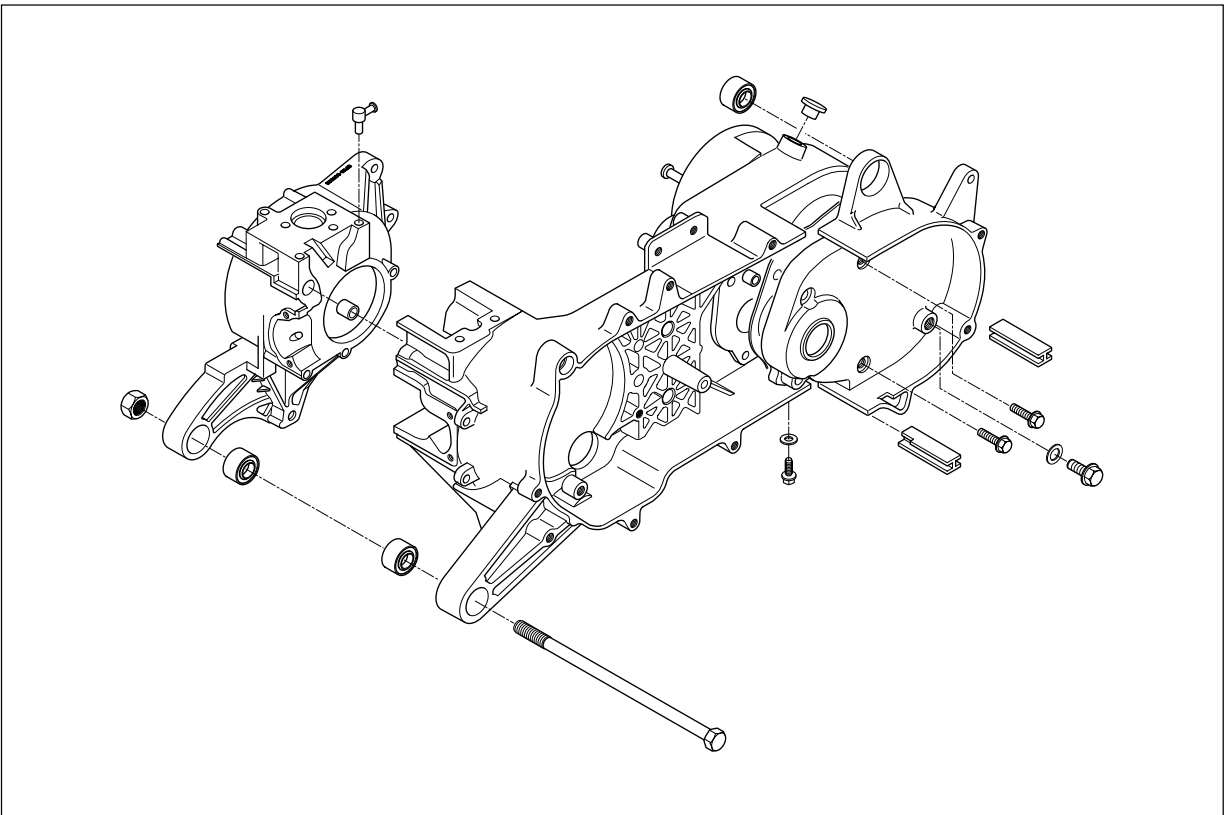

- Using two steel tubes of appropriate size, press out the engine mounting bushings on a vise as shown in the illustration.

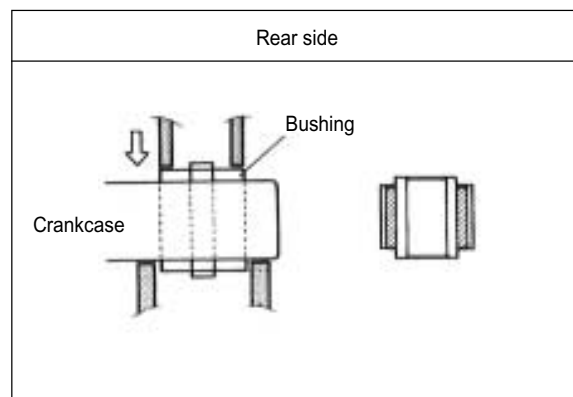
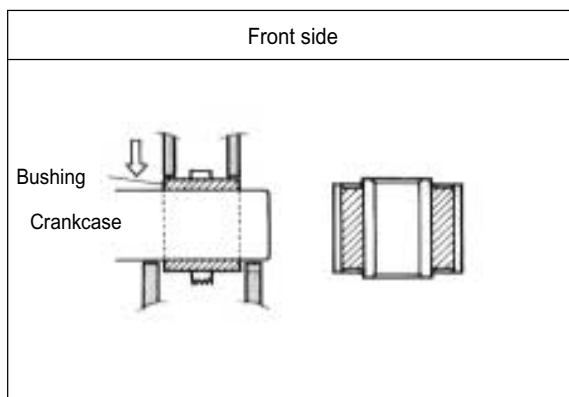
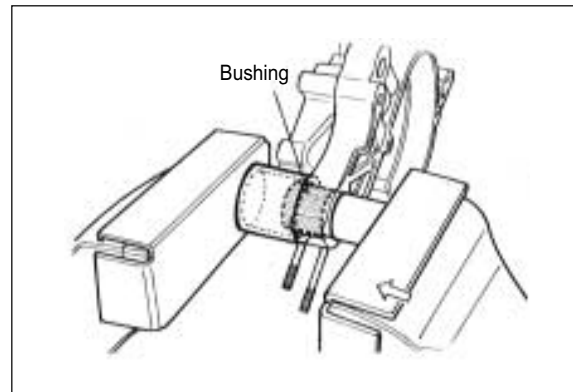

## ENGINE COMPONENTS INSPECTION AND SERVICING

### BEARINGS

Wash the bearing with cleaning solvent and lubricate with motor oil before inspecting.

Turn the inner ring and check to see that the inner ring turns smoothly. If it does not turn lightly, quietly and smoothly, or if noise is heard, the bearing is defective and must be replaced with a new one.

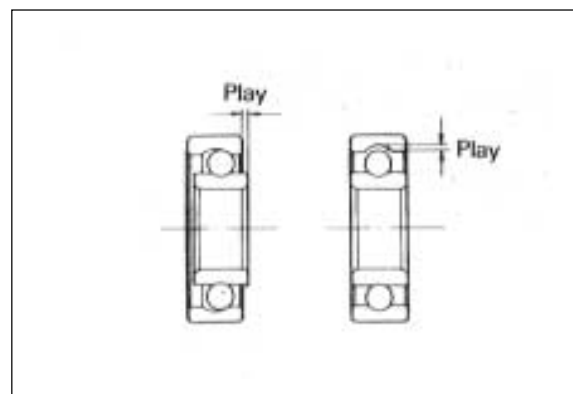

### OIL SEAL

Damage to the lip of the oil seal may result in leakage of the fuel-air mixture or oil. Inspect for damage and be sure to replace the damaged seal if found.



## 3-15 ENGINE

### CRANKSHAFT

#### CRANKSHAFT RUNOUT

Support crankshaft by "V" blocks, with the dial gauge rigged to read the runout as shown.

<b>Crankshaft runout</b>	Service limit 0.08 mm
--------------------------	-----------------------

Excessive crankshaft runout is often responsible for abnormal engine vibration. Such vibration shortens engine life.



V-block(100 mm) : 09900-21304

Magnetic stand : 09900-20701

Dial gauge(1/100 mm) : 09900-20606

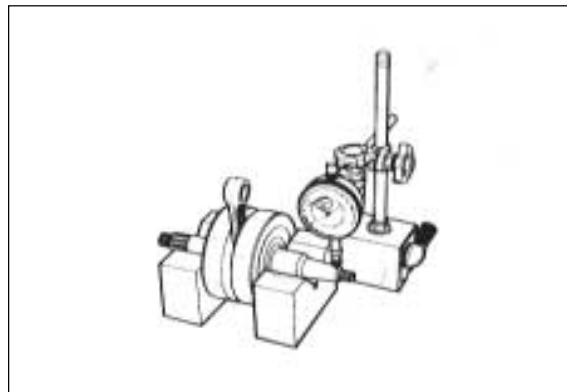

#### WEAR AND CLEARANCE OF CONROD BIG END

Turn the crankshaft with the conrod to feel the smoothness of rotary motion in the big end. Move the rod up and down while holding the crankshaft rigidly to be sure that there is no rattle in the big end.

Wear on the big end of the conrod can be estimated by checking the movement of the small end of the rod. This method can also check the extent of wear on the parts of the conrod's big end.

If wear exceeds the limit, conrod, crank pin and crank pin bearing should all be replaced.

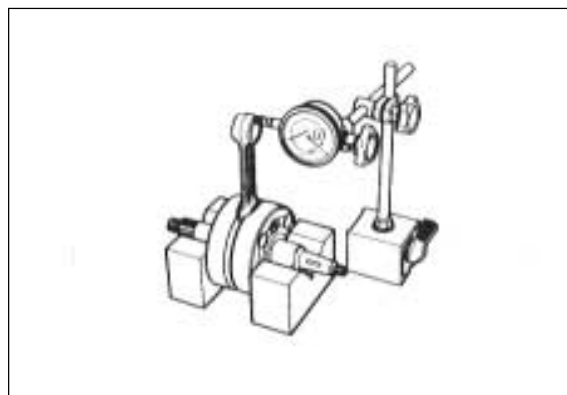

<b>Conrod big end runout</b>	Service limit 3.0 mm
------------------------------	----------------------

#### CONROD SMALL END BORE I.D.

Measure the conrod small end diameter with a caliper gauge.



<b>Conrod small end bore I.D.</b>	Service limit 14.047 mm
-----------------------------------	-------------------------

Dial calipers : 09900-20605

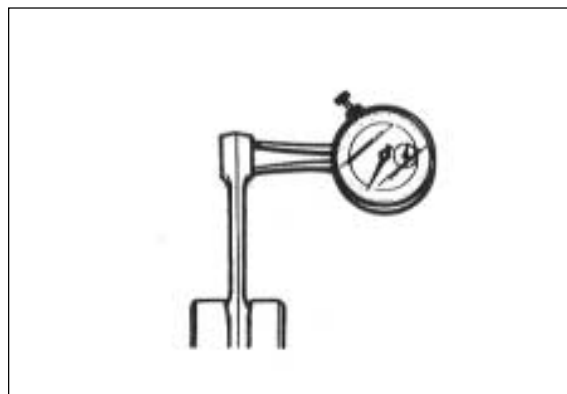

### AUTOMATIC CLUTCH INSPECTION

This motorcycle is equipped with an automatic clutch and variable ratio belt drive transmission. The engagement of the clutch is governed by engine RPMs and centrifugal mechanism located in the clutch.

To insure proper performance and longevity of the clutch assembly it is essential that the clutch engages smoothly and gradually. Two inspection checks must be performed to thoroughly check the operation of the drivetrain. Follow the procedures listed.

### 1. CLUTCH-IN INSPECTION

Warm up the motorcycle to normal operating temperature.

Remove the right frame side cover.

Connect an engine tachometer to the engine.

Seated on the motorcycle with the motorcycle on level ground, increase the engine RPMs slowly and note the RPM at which the motorcycle begins to move forward.

 Engine tachometer : 09900-26006

<b>Clutch-in RPM</b>	Standard	3,600 rpm
	Tolerance	± 200 rpm



### 2. CLUTCH TIGHT INSPECTION

Grip the front and rear brake lever fully, and measure the engine RPM when open the throttle.

Warm the engine to normal operating temperatures.

Connect an engine tachometer to the engine.

Apply the rear brake as firm as possible.

Briefly open the throttle fully and note the maximum engine RPMs sustained during the test cycle.

#### CAUTION

**Do not apply full power for more than 3 seconds or damage to the clutch or engine may occur.**

<b>Clutch tight RPM</b>	Standard	6,000 rpm
	Tolerance	± 200 rpm

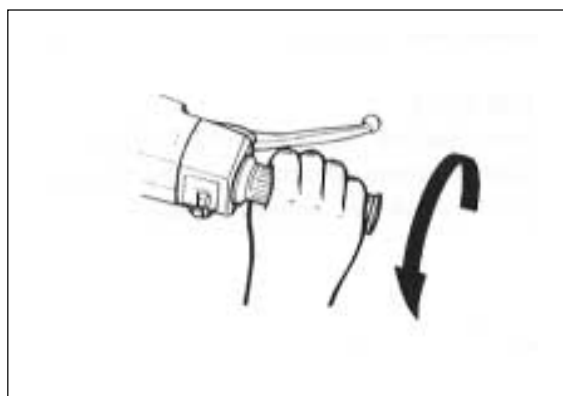
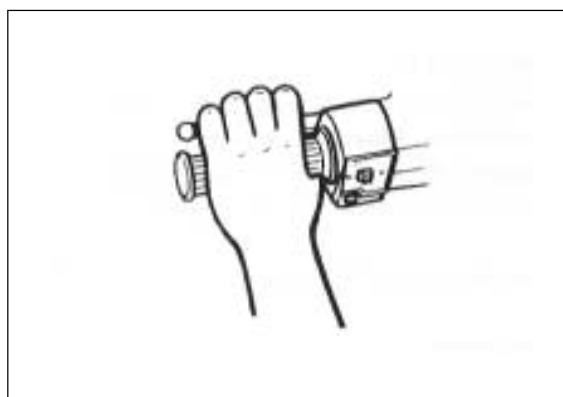

If the engine RPM does not coincide with the specified RPM range, then disassemble the clutch.

Clutch shoe - inspect the shoes visually for chips, cracking, uneven wear and burning, and check the thickness of the shoes with the vernier calipers. If the thickness is less than the following service limit, replace them as a set.

Clutch springs - visually inspect the clutch springs for stretched coils or broken coils.

<b>Clutch shoe thickness</b>	Service limit 2.0 mm
------------------------------	----------------------

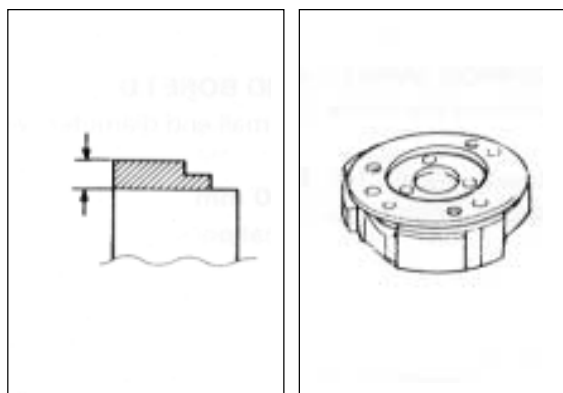

## 3-17 ENGINE

### **⚠ CAUTION**

**Clutch shoes or springs must be changed as a set and never individually.**

Clutch housing - inspect visually the condition of the inner clutch housing surface for scuffing, cracks, or uneven wear. Measure inside diameter of the clutch wheel with inside calipers. Measure the diameter at several points to check for an in-of-round condition as well as wear.

**Clutch housing I.D.** Service limit 110.35 mm

### **DRIVE V-BELT**

Remove the drive V-belt and check for cracks, wear and separation. Measure the drive V-belt width with a vernier calipers. Replace it if the drive V-belt width is less than the service limit or any defect has been found.

**Drive V-belt width** Service limit 15.3 mm

### **⚠ CAUTION**

**Always keep the drive belt away from any greasy mater.**

### **DRIVE FACE**

Inspect the V-belt contact surface of the drive faces for wear, scratches or any abnormality. If there is something unusual, replace the drive face with a new one.

### **ROLLER AND MOVABLE DRIVE SURFACE**

Inspect each roller and movable drive surface for wear or damage.

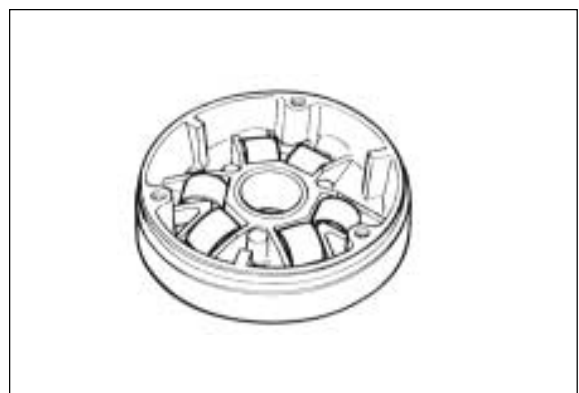
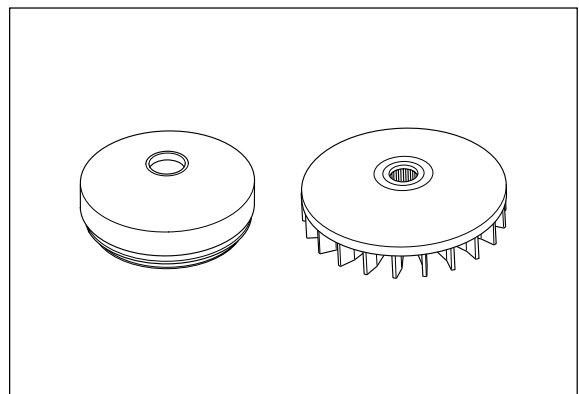
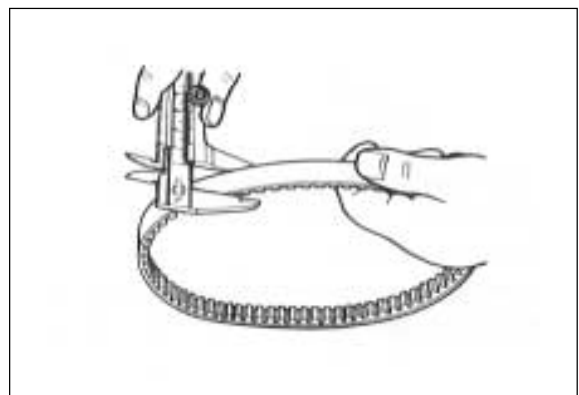

**MOVABLE DRIVEN SPRING**

Measure the free length of the movable driven spring. If the length is shorter than the service limit, replace the spring with a new one.

<b>Movable driven spring free length</b>	Service limit 135~153 mm
--	--------------------------

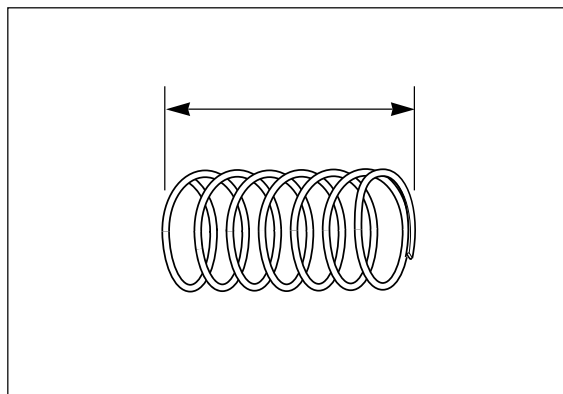
**MOVABLE DRIVEN FACE PIN AND OIL SEAL**

Turn the movable driven faces and check to see that the movable driven faces turn smoothly.

If not rotate smoothly, visually inspect the lip of oil seal, movable driven face sliding surface and sliding pins for wear or damage.

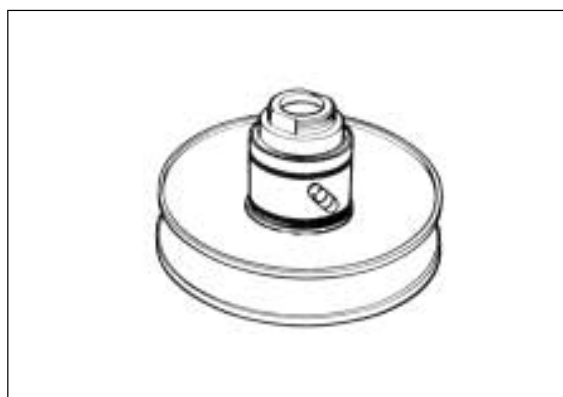
**MOVABLE DRIVEN FACE**

Inspect the V-belt contacting surface of both driven faces for any scratches, wear and damage.

Replace the movable driven face with new one if there are any abnormality.

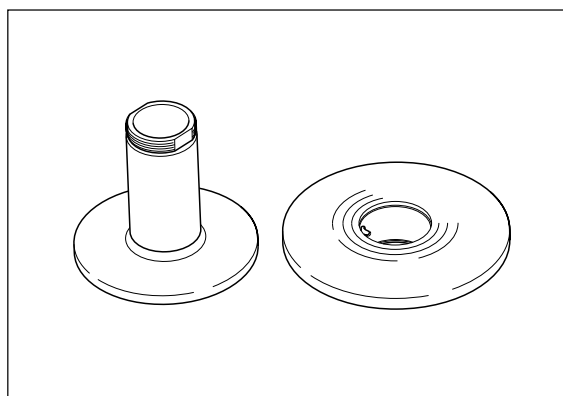
**CYLINDER HEAD**

Decarbon the combustion chamber.

Check the gasketed surface of the cylinder head for distortion with a straightedge and thickness gauge, taking a clearance reading at several places.

 Thickness gauge : 09900-20806

<b>Cylinder head distortion</b>	Service limit 0.1 mm
---------------------------------	----------------------

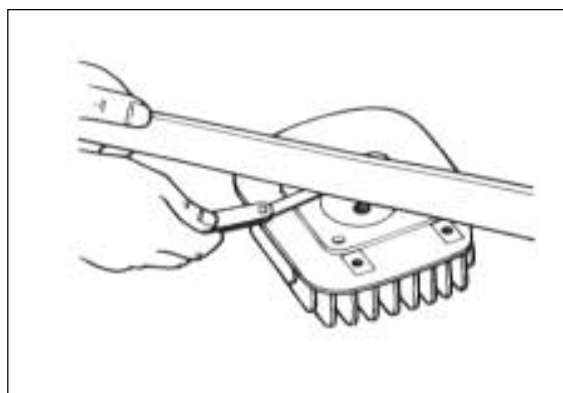

## 3-19 ENGINE

If the largest reading at any portion of the straightedge exceeds the limit, rework the surface by rubbing it against emery paper (of about # 400) laid flat on the surface plate in a lapping manner. The gasketed surface must be smooth and perfectly flat in order to secure a tight joint: a leaky joint can be the cause of reduced power output and increased fuel consumption.

### CYLINDER

Decarbon exhaust port and upper part of the cylinder, taking care not to damage the cylinder wall surface.

The wear of the cylinder wall is determined from diameter reading taken at 20 mm from the top of the cylinder with a cylinder gauge. If the wear thus determined exceeds the limit indicated below, rework the bore to the next oversize by using a boring machine or replace the cylinder with a new one.

 Cylinder gauge set : 09900-20508

**Cylinder bore**

Service limit 41.070 mm

After reworking the bore to an oversize, be sure to chamfer the edges of ports and smooth the chamfered edges with emery paper. To chamfer, use a scraper, taking care not to nick the wall surface.

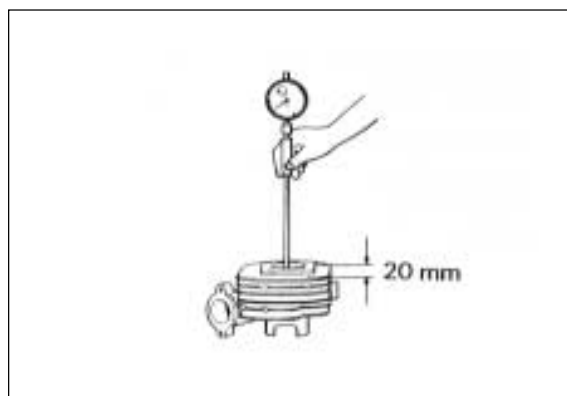
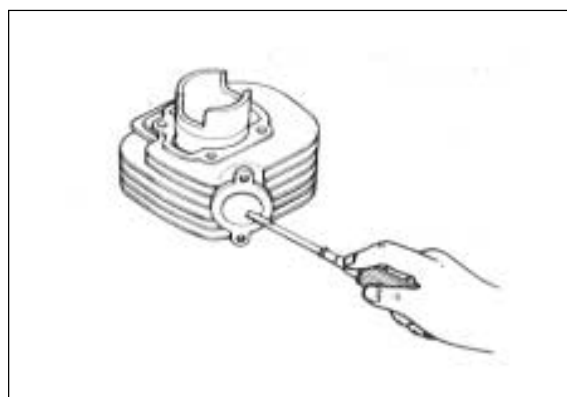
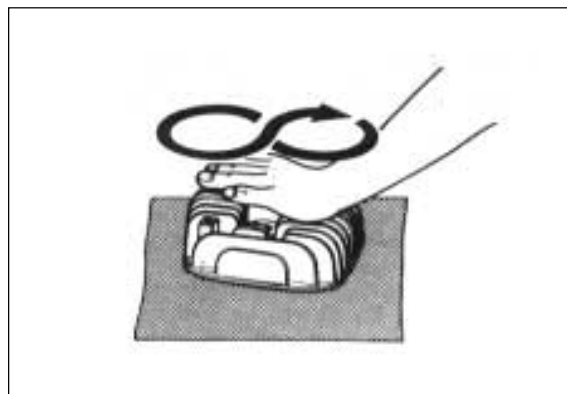

### PISTON

#### CYLINDER TO PISTON CLEARANCE

Cylinder-to-piston clearance is the difference between piston diameter and cylinder bore diameter. Be sure to take the maked diameter at right angles to the piston pin. The value of elevation  $\text{\textcircled{A}}$  is prescribed to be 15 mm from the skirt end.

 Micrometer(25~50 mm) : 09900-20202

**Piston diameter**

Service limit 40.885 mm

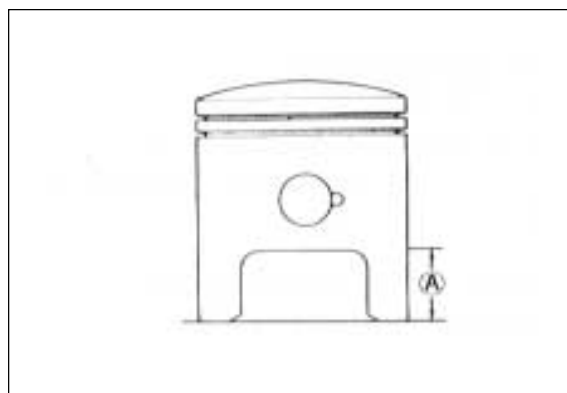

As a result of the above measurement, if the piston-to-cylinder clearance exceeds the following limit, overhaul the cylinder and use an oversize piston, or replace both cylinder and piston. The measurement for the bore diameter should be taken in the intake-to-exhaust port direction and at 20mm from the cylinder top surface.

	Standard	Service limit
<b>Cylinder bore</b>	41.005-41.020 mm	41.070 mm
<b>Piston diameter</b>	40.935-40.950 mm	40.885 mm
<b>Cylinder to piston clearance</b>	0.065-0.075 mm	0.120 mm



### DE-CARBONING

De-carbon the piston and piston ring grooves, as illustrated. After cleaning the grooves, fit the rings and rotate them in their respective grooves to be sure that they move smoothly.

Carbon in groove is liable to cause the piston ring to get stuck in the groove, and this condition will lead to reduced engine power output.

A piston whose sliding surface is badly grooved or scuffed due to overheating must be replaced. Shallow grooves or minor scuff can be removed by grinding with emery paper of about # 400.

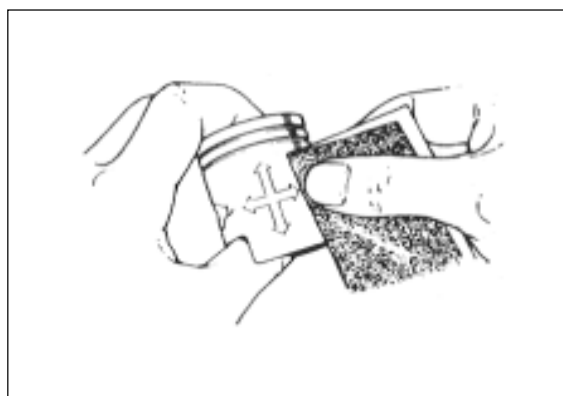

### PISTON PIN BORE I.D.

Using a caliper gauge, measure the piston pin bore inside diameter. If reading exceeds the following service limit, replace it with a new one.

 Dial calipers : 09900-20605

<b>Piston pin bore I.D.</b>	Service limit 10.030 mm
-----------------------------	-------------------------

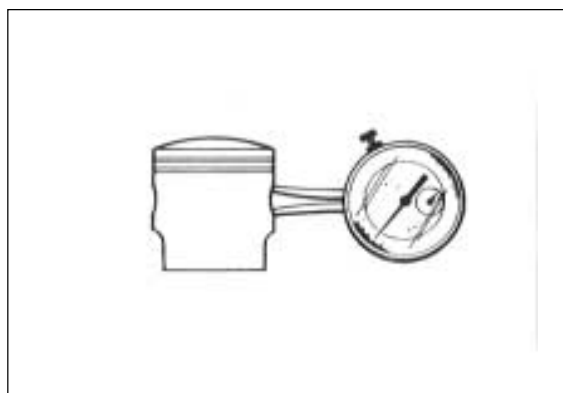



### 3-21 ENGINE

#### PISTON PIN O.D.

Using a micrometer, measure the piston outside diameter at three positions.

 Micrometer(0~25 mm) : 09900-20201

<b>Piston pin O.D.</b>	Service limit 9.980 mm
------------------------	------------------------

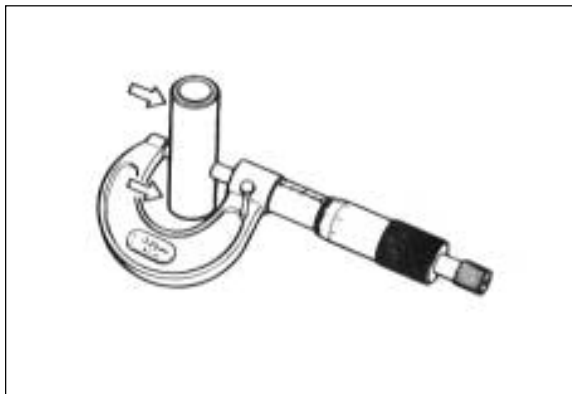

#### PISTON RINGS

Check each ring for end gap, reading the gap with a thickness gauge shown in the illustration. If the end gap is found to exceed the limit, indicated below, replace it with a new one.

The end gap of each ring is to be measured with the ring fitted squarely into the cylinder bore and held at the least worn part near the cylinder bottom, as shown in the illustration.

 Thickness gauge : 09900-20806

<b>Piston ring clearance (Assembly condition)</b>	Service Limit 0.75 mm
---	--------------------------

As the piston ring wears, its end gap increases reducing engine power output because of the resultant blow by through the enlarged gap. Here lies the importance of using piston rings with end gaps within the limit. Measure the piston ring free end gap to check the spring tension.

Piston ring clearance(Free condition)	Service limit
<b>1st</b>	3.2 mm
<b>2nd</b>	3.1 mm

Fix the piston ring in the piston ring groove, measure the ring side clearance with the thickness gauge while matching the sliding surfaces of piston and ring.

Piston ring-ring groove clearance	Standard
<b>1st</b>	0.02~0.06 mm
<b>2nd</b>	0.02~0.06 mm

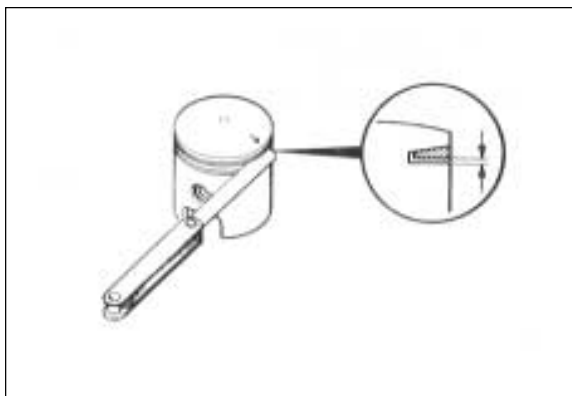
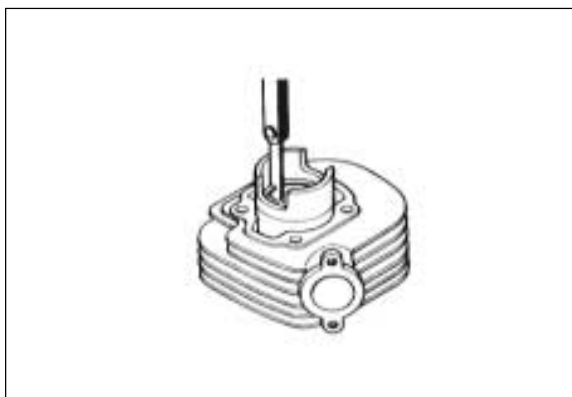

## REED VALVE

When reinstalling the reed valve and stopper plate to the body, align the both cut on the reed valve and stopper plate.

Apply **THREAD LOCK "1324"** to the stopper plate securing screws.

 Thread Lock "1324"



## ENGINE REASSEMBLY

Reassembly is generally performed in the reverse order of disassembly, but there are a number of reassembling steps that demand or deserve detailed explanation or emphasis. These steps will be taken up for respective parts and components.



## OIL SEALS

Fit the oil seals to the crankcase following the procedure below.

Replace removed oil seals with new ones.

- Coat **SUPER GREASE "A"** to the lip of the oil seals.

 Super Grease "A"

- Be sure to apply **THREAD LOCK "1324"** to outer surfaces of right and left crankshaft oil seals to prevent them from moving.

 Thread Lock "1324"

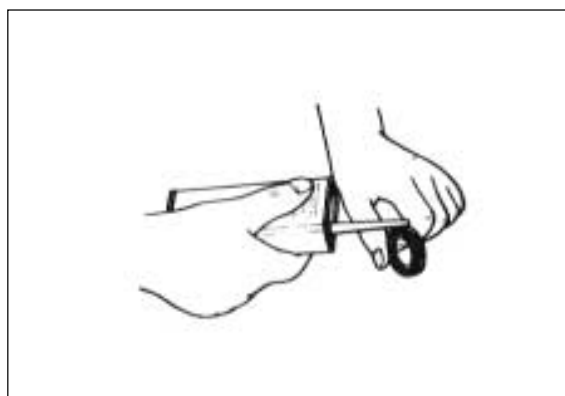

- When fitting the oil seal in the crankcase, insert it slowly with the special tools.

 Oil seal installer : 09913-75830  
Bearing installer attachment : 09924-74510  
Bearing installer pilot : 09924-74540

### NOTE:

Align the oil seal with edge **A** of the crankcase as shown in the illustration.

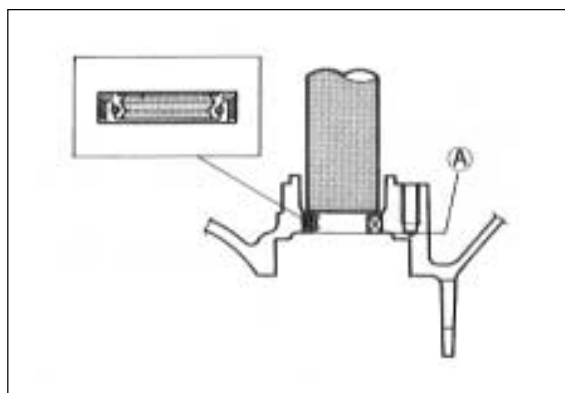

## 3-23 ENGINE

### BEARINGS

Install new bearings with the special tool.



Bearing installer : 09913-75810

Bearing installer : 09913-76010

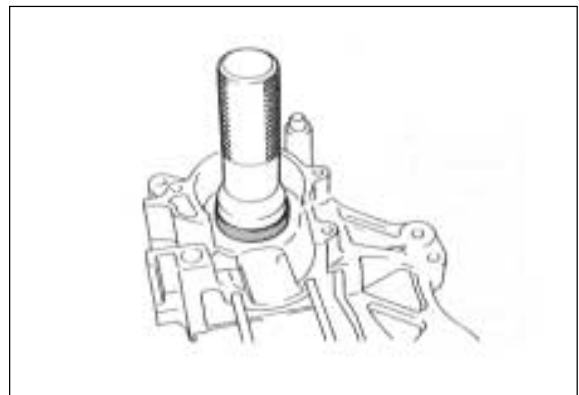
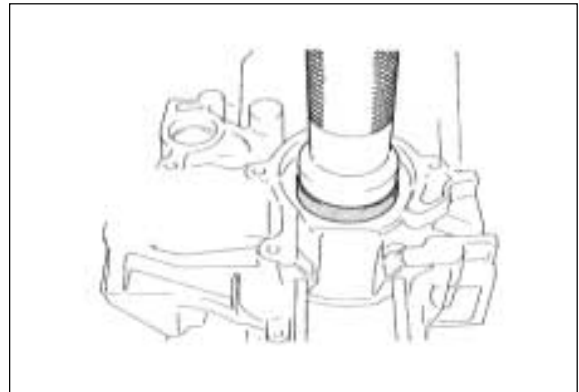

### BUSHINGS

Using two steel tubes of appropriate size and a vise, press the mounting bushings ① and ② into the crankcase holes as shown in the illustration.

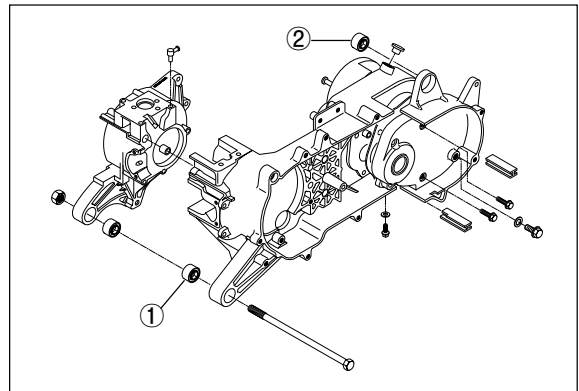

#### NOTE:

Knurled end ③ should face inside. Protrusion ④ and ⑤ should be in the same dimension.

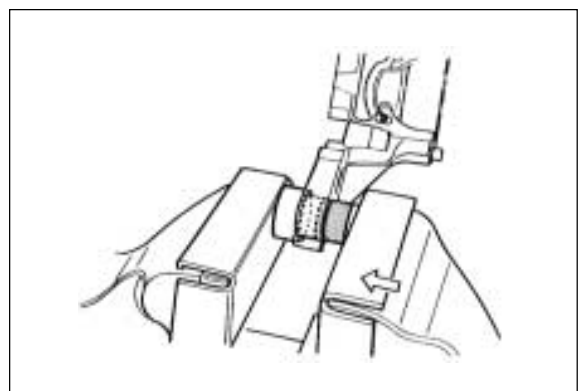

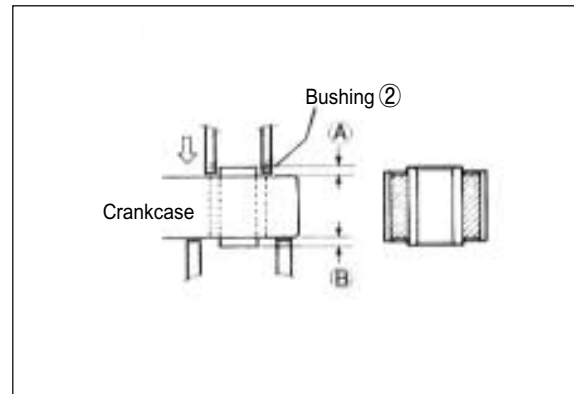
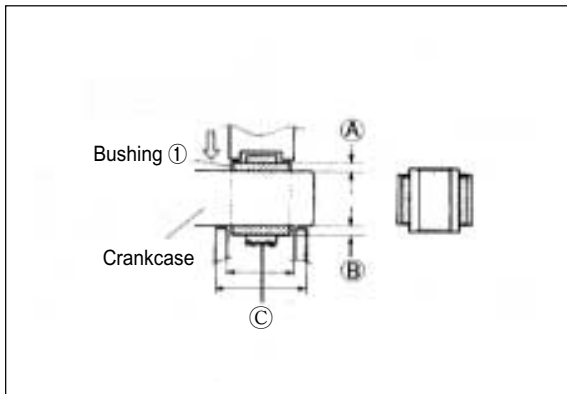

### CRANKSHAFT

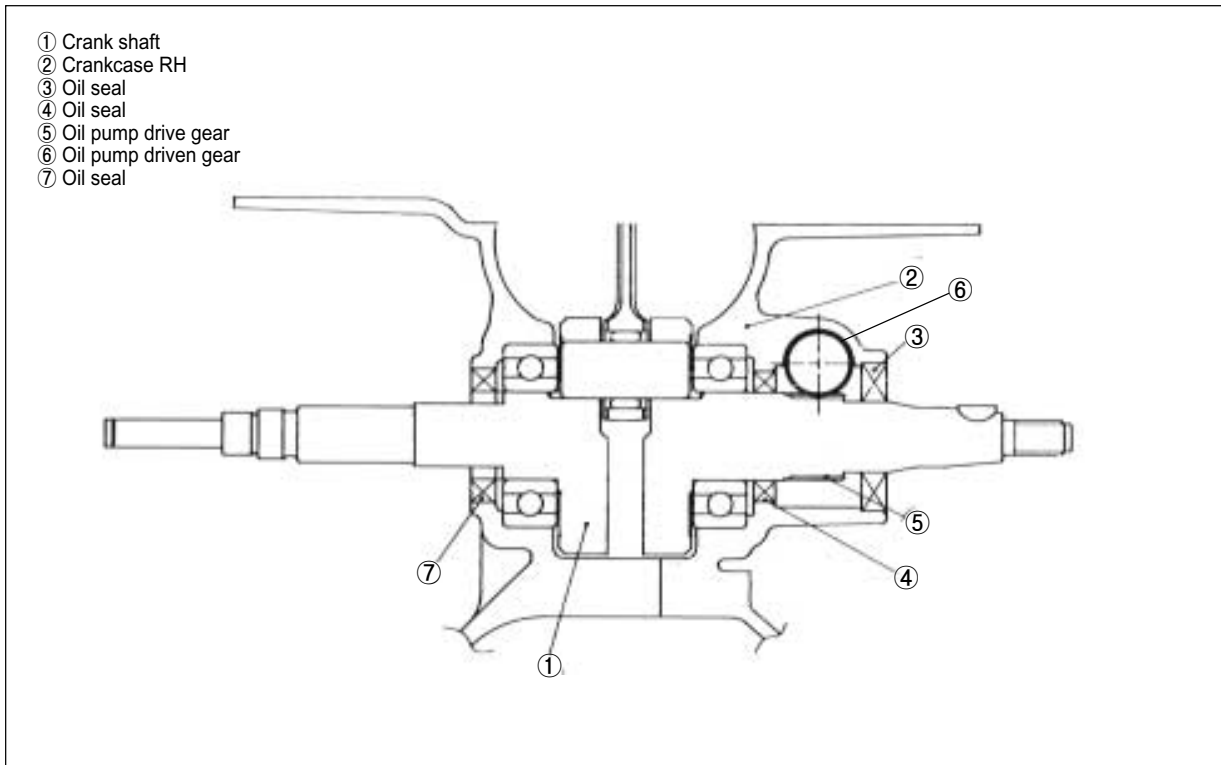

- Measure the length between the webs referring to the figure at right when rebuilding the crankshaft.

**Width between webs**     Standard  $35.0 \pm 0.1$  mm

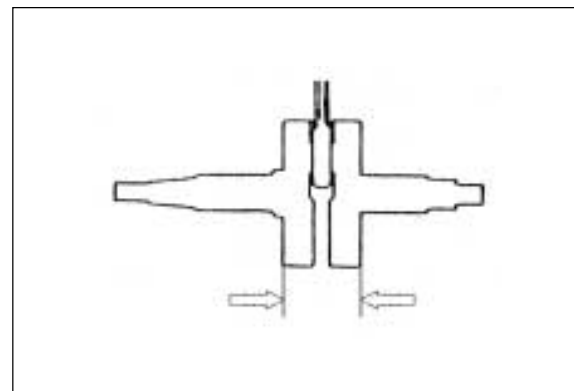

## 3-25 ENGINE

- When mounting the crankshaft into the crankcase, it is necessary to pull its left end into the crankcase with the special tool.

 Crankshaft installer : 09910-32812  
Conrod holder : 09910-20116

### CAUTION

**Never fit the crankshaft into the crankcase by driving it with a plastic hammer. Always use the special tool, otherwise crankshaft alignment accuracy will be affected.**

## CRANKCASE

- Wipe the crankcase mating surfaces(both surfaces)with cleaning solvent.
- Apply **BOND "1215"** uniformly to the mating surface of the left half of the crankcase, and install the dowel pins.

 BOND "1215"

- Install the two dowel pins.
- Tighten the crankcase screws securely.
- Check if the crankshaft rotates smoothly.

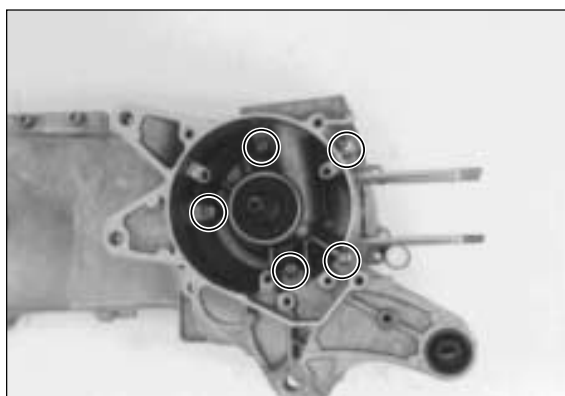
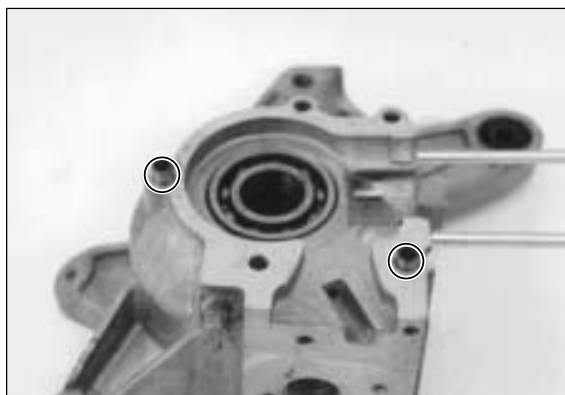
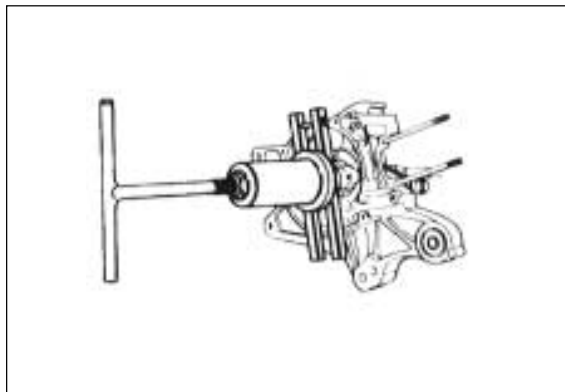

- Install the new oil seal ① to the crankcase with the special tool.

### NOTE:

Align the oil seal with edge ① of the crankcase as shown in the illustration.

 Bearing installer : 09913-85210

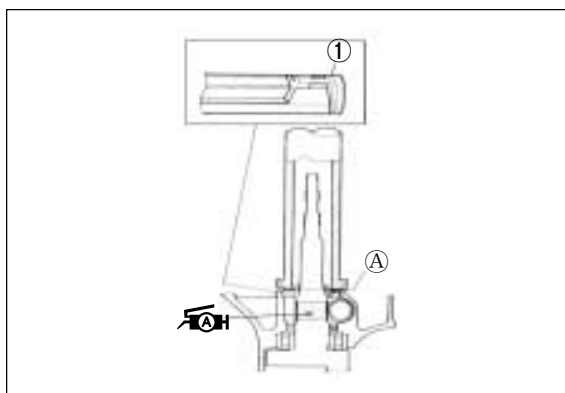

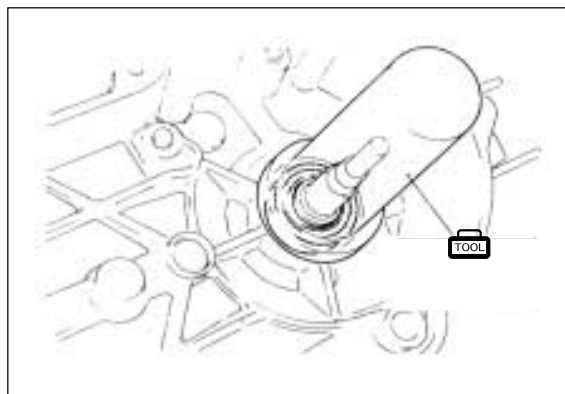

### CENTER STAND

- Install the center stand ①.
- Install the shaft ②, washer ③ and cotter pin ④.

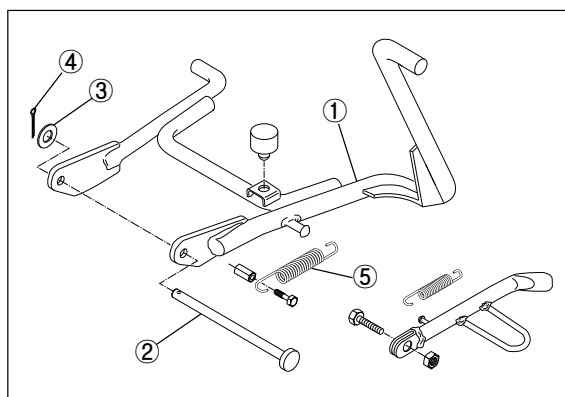

- Hook the center stand spring ⑤ into the crankcase.

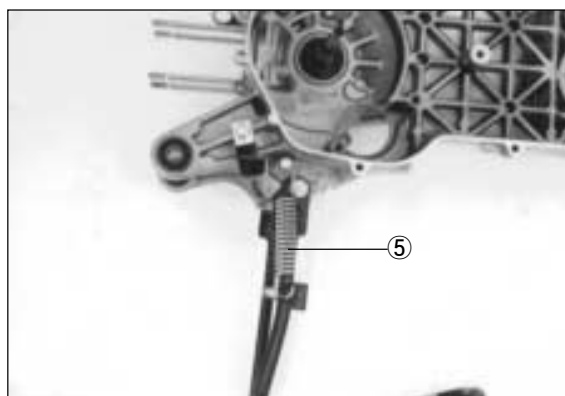

## REAR AXLE SHAFT, BRAKE AND WHEEL

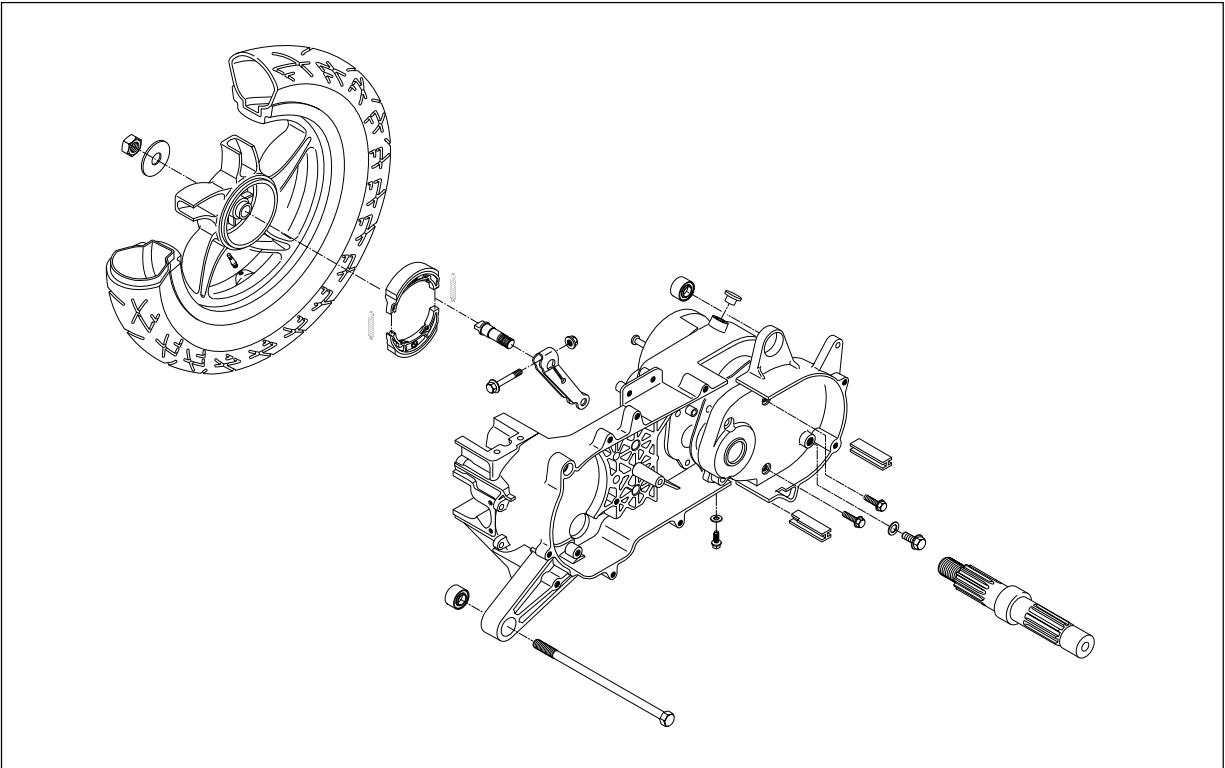

- Install the rear axle shaft ① into the crankcase by tapping its end lightly.
- Apply engine oil on the left end of the rear axle shaft being inserted later in the reduction rear box cover.

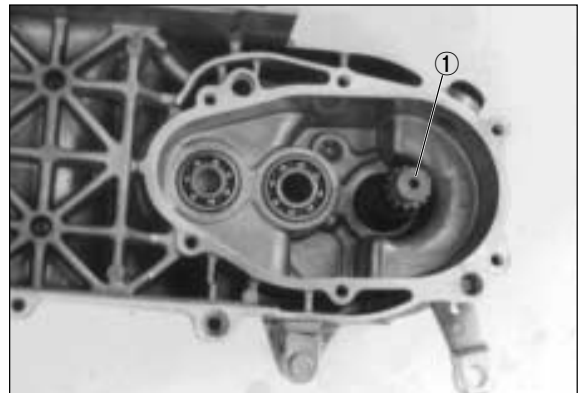

- Apply **SUPER GREASE "A"** lightly on the rear brake cam pivot part and install it to the crankcase.

 Super Grease "A"

- Turn to position the cam where the punched mark **A** on the end face is directed toward the axis of the rear axle shaft.

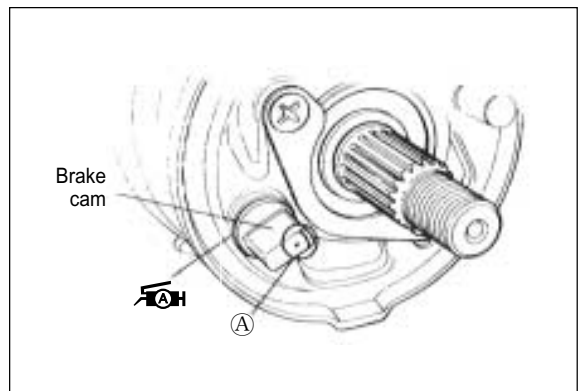

- When installing the cam lever ① to the cam, align the punched mark with the slit of cam lever.

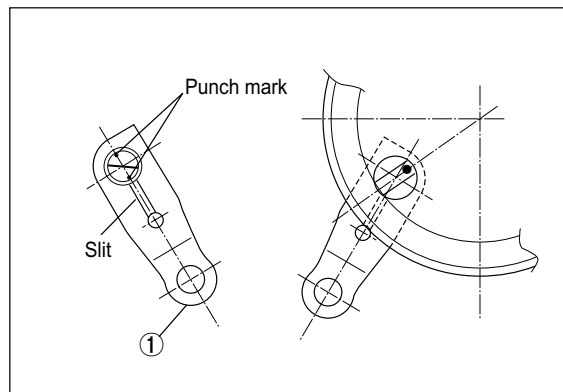

- Tighten the cam lever nut ② to the specified torque.
- 🔧 Rear brake cam lever nut : 6~9 N · m (0.6~0.9 kg · m)

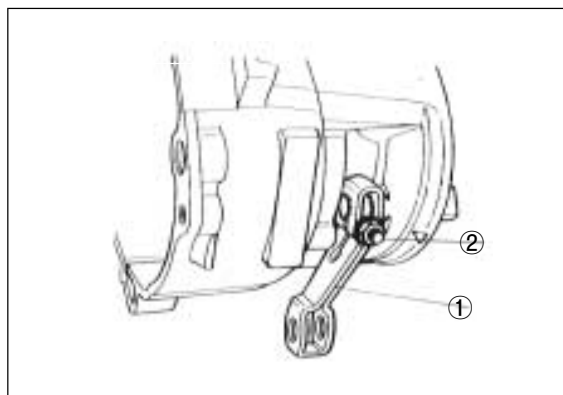

- Install the brake shoes.
- Apply **SUPER GREASE "A"** to the brake cam and pin before installing the brake shoes.

 Super Grease "A"

**⚠ CAUTION**

**Be careful not to apply too much grease to the brake cam and pin. If grease gets on the lining, brake effectiveness will be lost.**

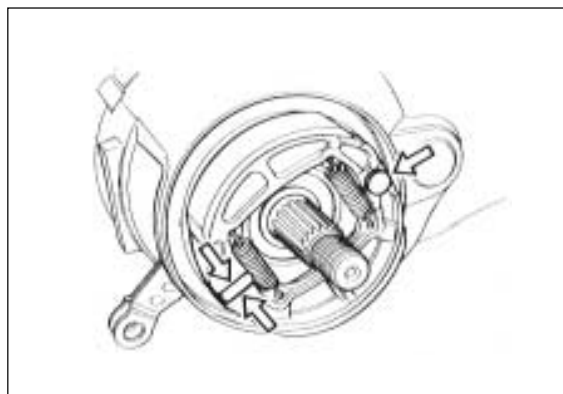

- Install the rear wheel and nut.
- 🔧 Rear axle nut : 60~90 N · m (6.0~9.0 kg · m)





TRANSMISSION

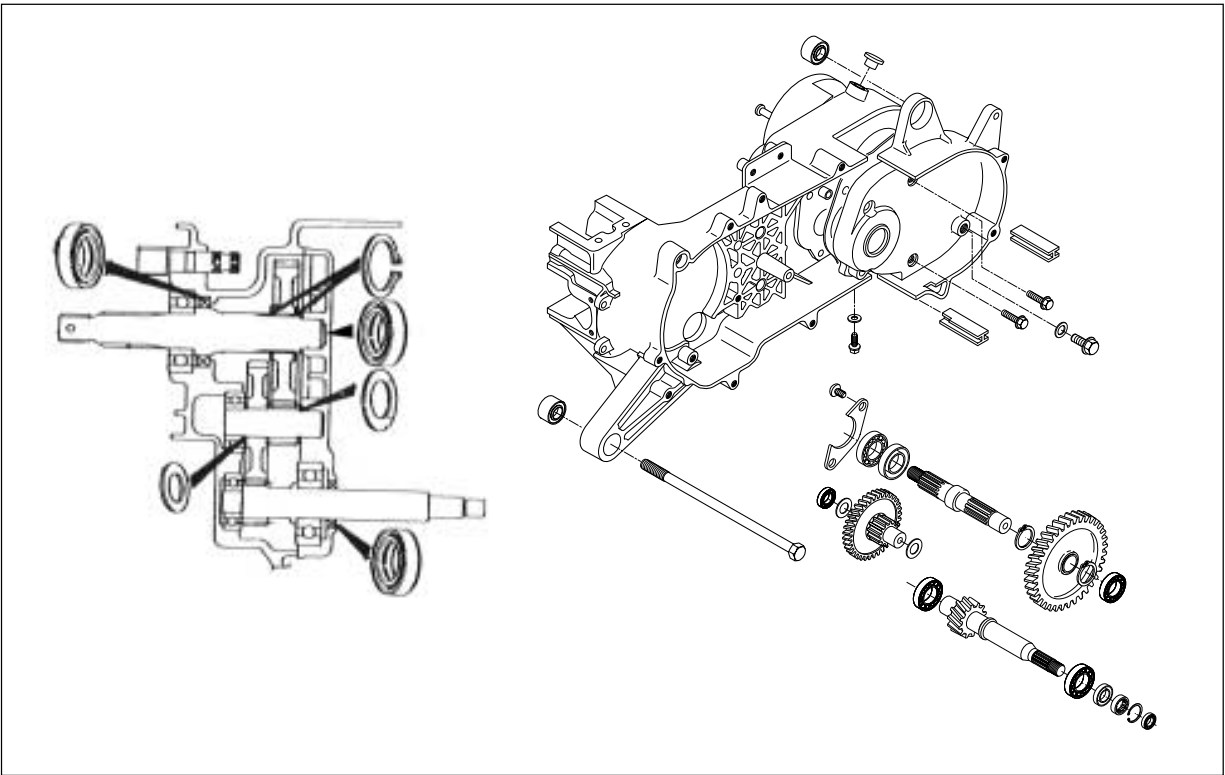

- Install the circlip ① on to the rear axle shaft ②.
- Assemble the idle shaft subassembly using the idle shaft ③ and thrust washer ④, then install the sub-assembly on the gear box.

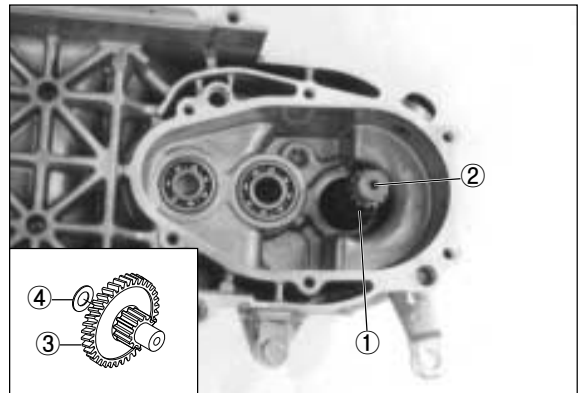

- Install the final driven gear ⑤ on the rear axle shaft using the circlip ⑥.

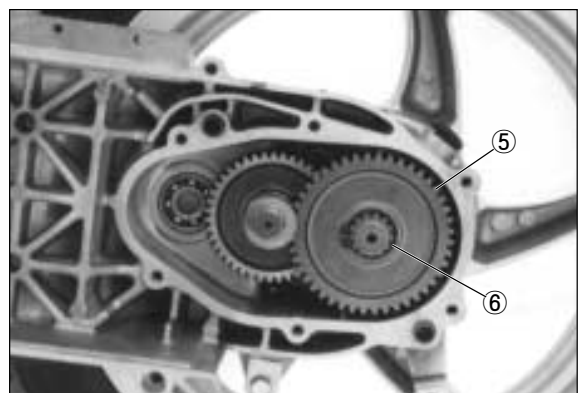
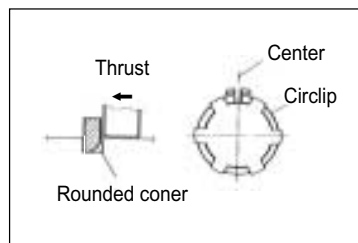

- Install the new bearing ①, ③ to the gear box cover ② with the special tool.

 Bearing installer : 09913-76010

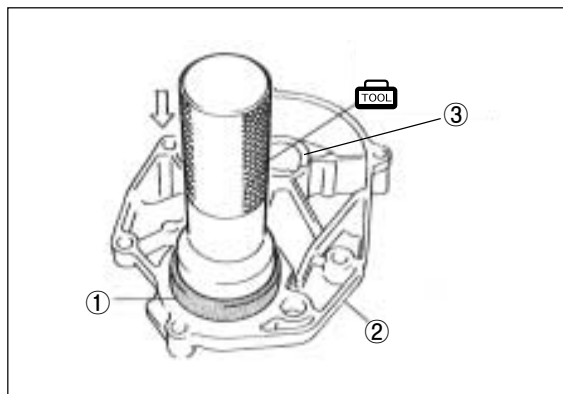

- Apply **SUPER GREASE "A"** to the lip of the oil seal ④ and install it to the gear box cover with the special tool.

 Super Grease "A"

 Bearing installer : 09913-70122

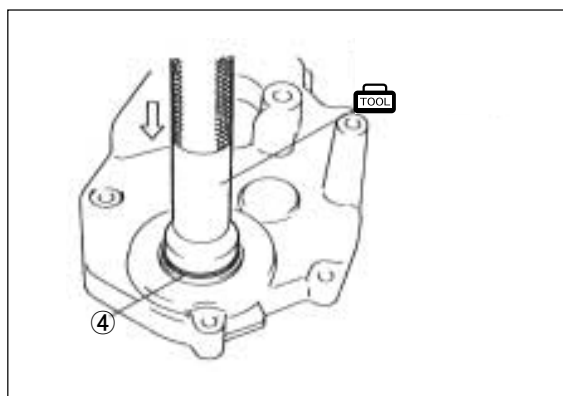
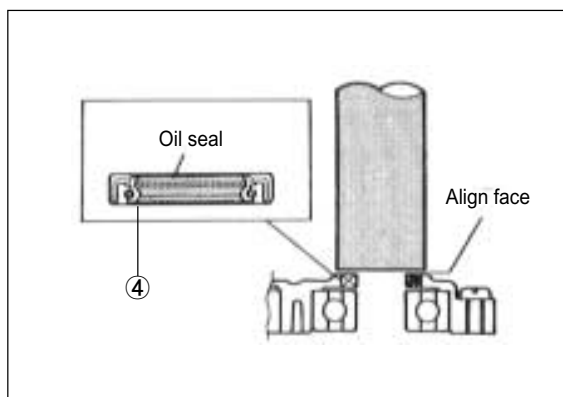

- Install the washer, new gasket and dowel pin ⑤.
- Install the driveshaft ⑥ to the gear box cover.

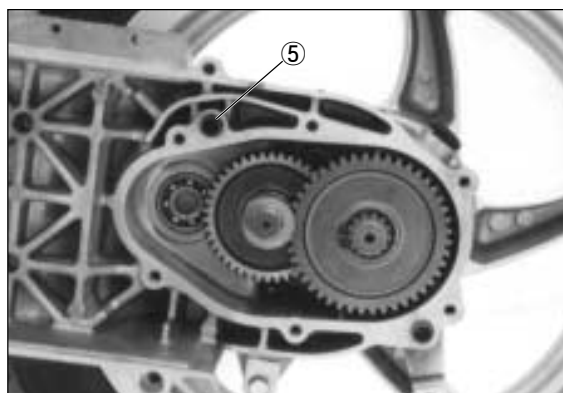
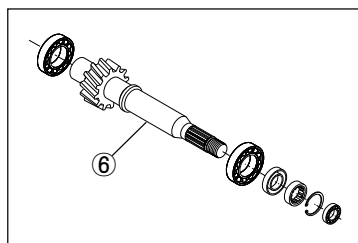

### 3-31 ENGINE

- Apply **BOND “1215”** at the hatched area shown in the illustration and install the gear box cover ① on the crankcase.

● **BOND “1215”**

- Tighten all the screws evenly one by one in a diagonal fashion.

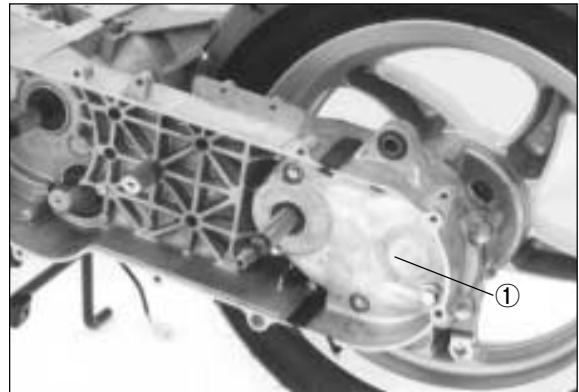

### STARTER DRIVEN GEAR AND STARTING MOTOR

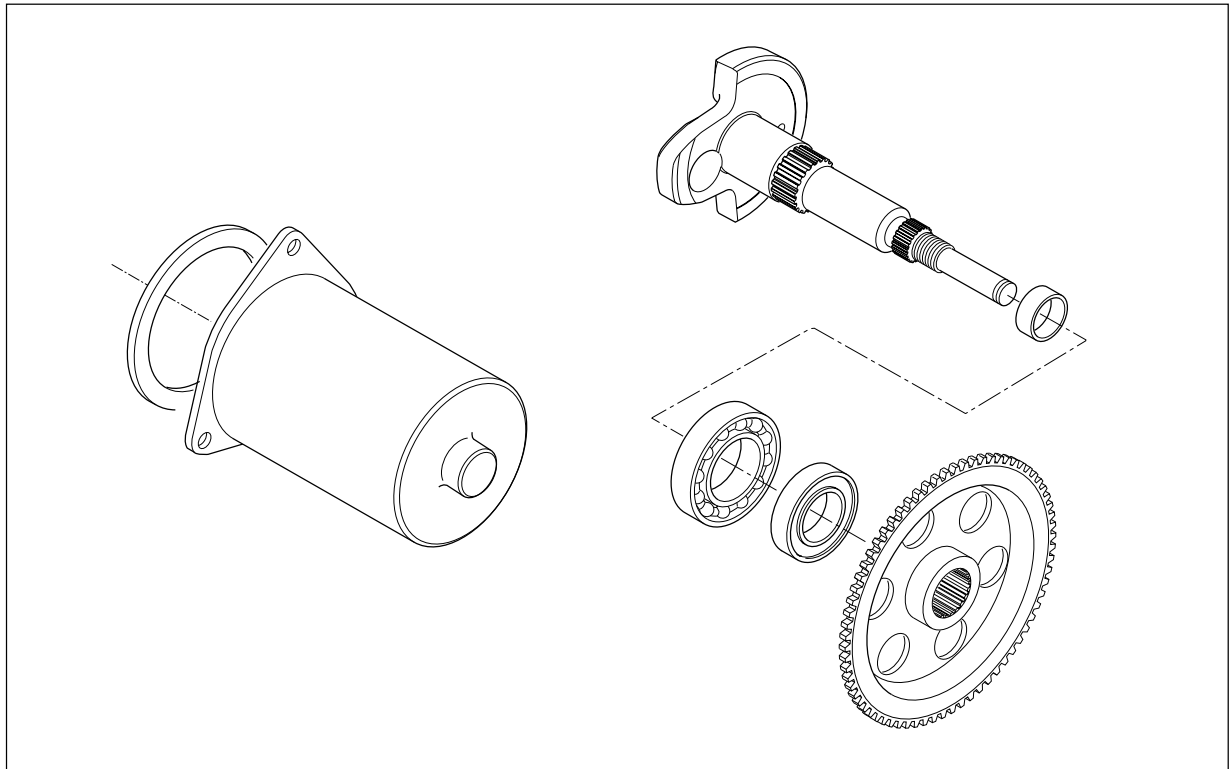

- Install the starter driven gear ② over the left crankshaft end.

**NOTE:**

*The convex side of hub should face outside when installed in proper position.*

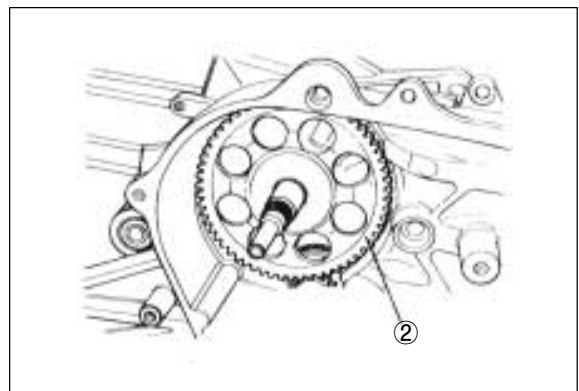

- Install the starting motor ①.

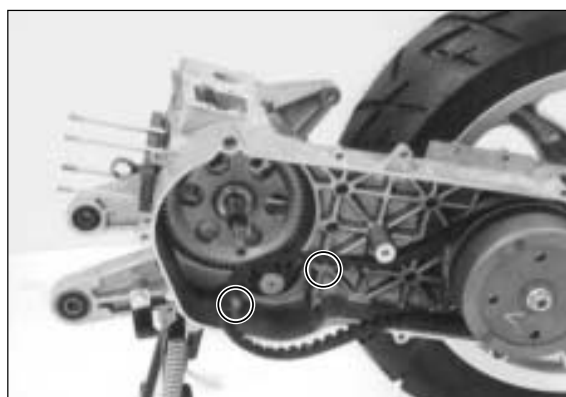
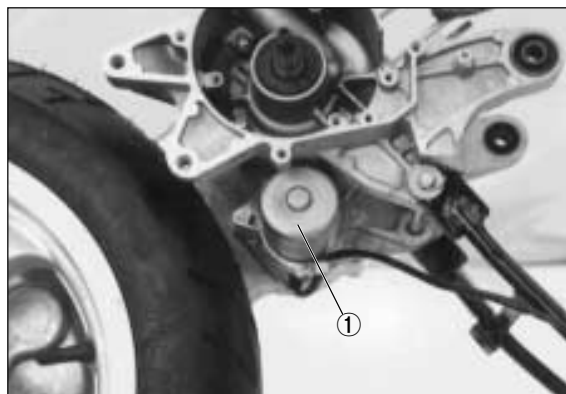

## MOVABLE DRIVEN AND CLUTCH

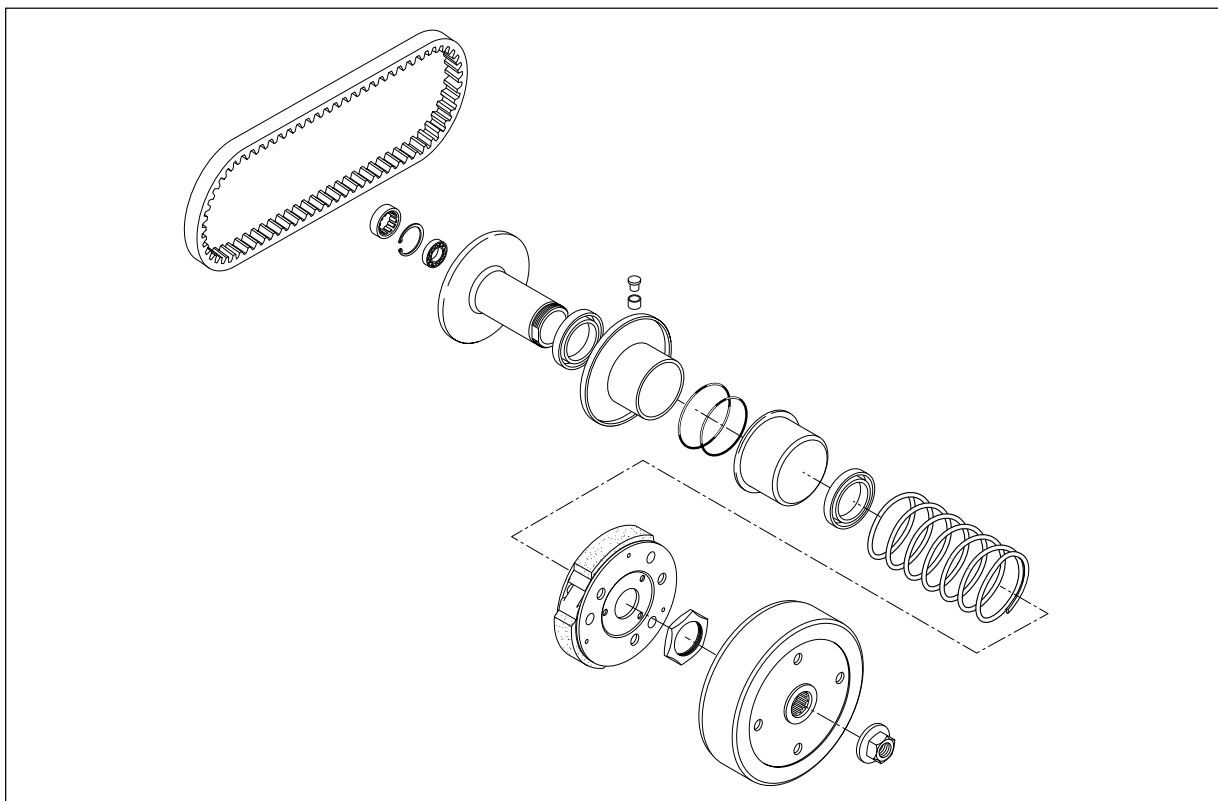

### 3-33 ENGINE

- Install the bearing ② in the fixed driven face ① with the special tool.

 Bearing installer : 09943-88211

**⚠ CAUTION**

Take care that hit inner race of the bearing.  
(Fall to ring in the bearing a case.)

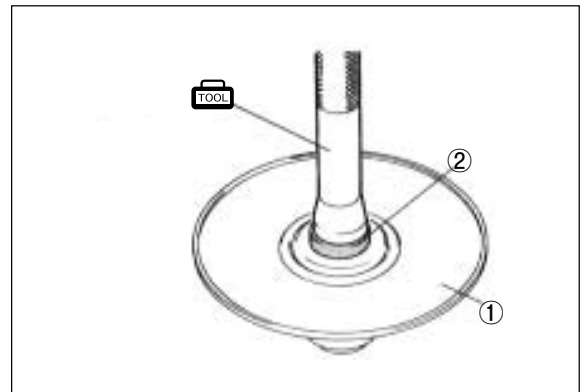

- Install the circlip ③.

**⚠ CAUTION**

Instert surely in the circlip groove.

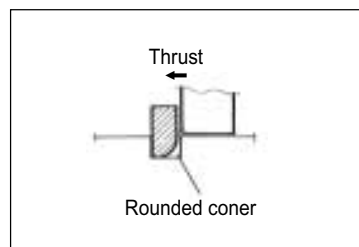

- Install the bearing ④ with the special tool.

 Bearing installer : 09943-88211

**⚠ CAUTION**

A mark part of the bearing is pointed to the out-side.

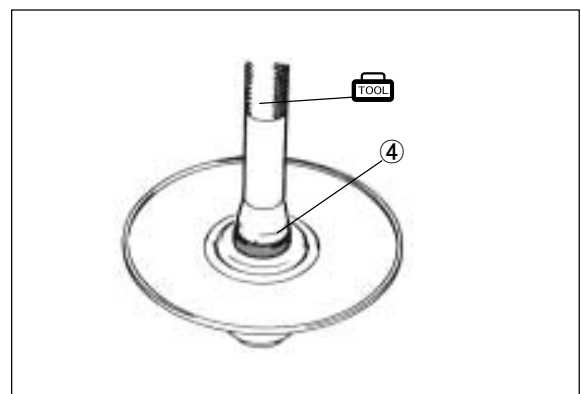

- Install the new oil seals (⑤, ⑥) to the movable driven face with the special tool.

 Bearing installer : 09913-76010

- Apply **SUPER GREASE "A"** to the lip of oil seals and groove of movable driven face's inside.

 Super Grease "A"

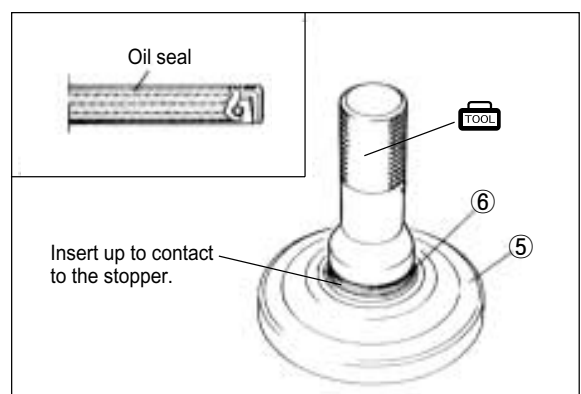

- Install the movable driven face ① to the fixed driven face ②.

**⚠ CAUTION**

When reinstalling the movable driven face to the fixed driven face, make sure that the oil seal is positioned properly.

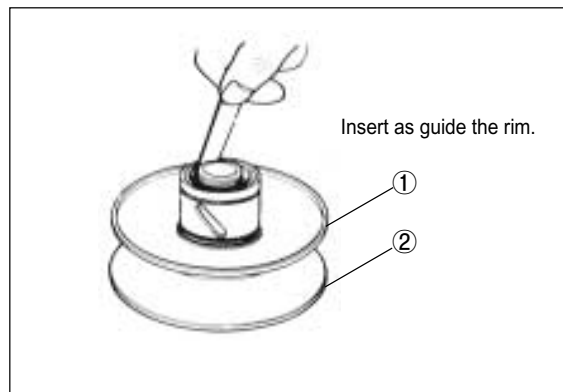

- Position the two O-ring ③.
- Install the pin ④ at three places on the driven face hub.
- Apply **SUPER GREASE "A"** lightly to the cam part where the pins are placed.

 Super Grease "A"

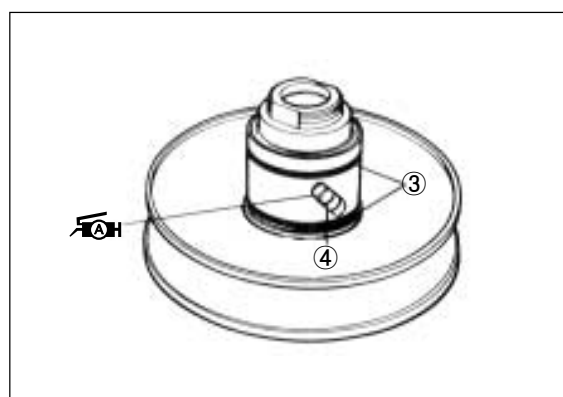
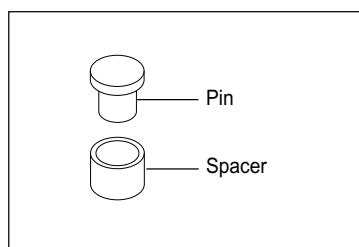

- Install the movable driven face seat ⑤.

**⚠ CAUTION**

The seat is installed rotatable naturally.  
The O-ring get damaged, in case of installed by force.

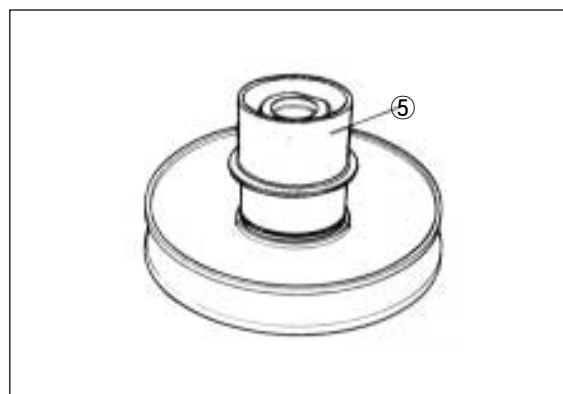

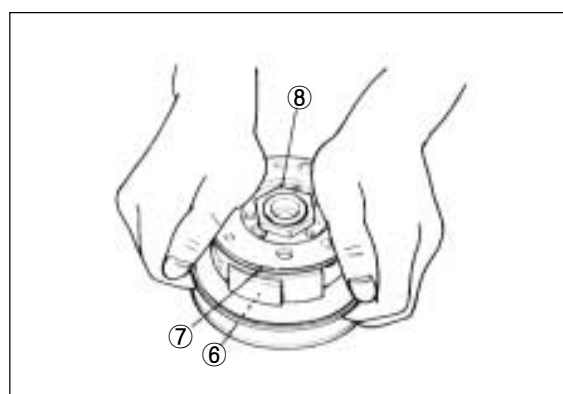

- Install the spring ⑥.
- Install the clutch shoe assembly ⑦ and nut ⑧.



### 3-35 ENGINE

- Tighten the clutch shoe nut to the specified torque with the special tool.

 Rotor holder : 09930-40113

 Clutch shoe nut : 40~60 N · m (4.0~6.0 kg · m)

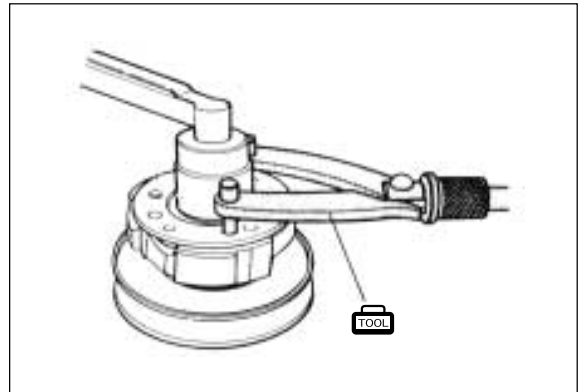

- Insert the V-belt between the driven faces as deep inside as possible while pulling the movable driven face all the way outside to provide the maximum belt clearance.

#### CAUTION

**The V-belt should be positioned so that the arrows on the belt periphery point the normal turning direction.**

**The V-belt contact face on the driven faces should be thoroughly cleaned to be free from oil.**

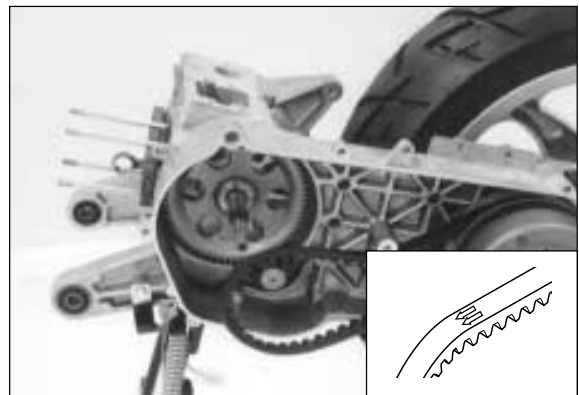

- Thoroughly clean the clutch housing ① to be free from oil and position it over the clutch shoe assembly.
- Tighten the clutch housing nut ② to the specified torque with the special tool.

 Rotor holder : 09930-40113

 Clutch housing nut : 40~60 N · m (4.0~6.0 kg · m)

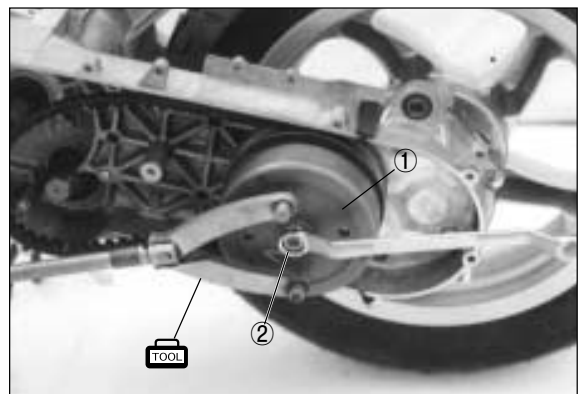



## MOVABLE DRIVE

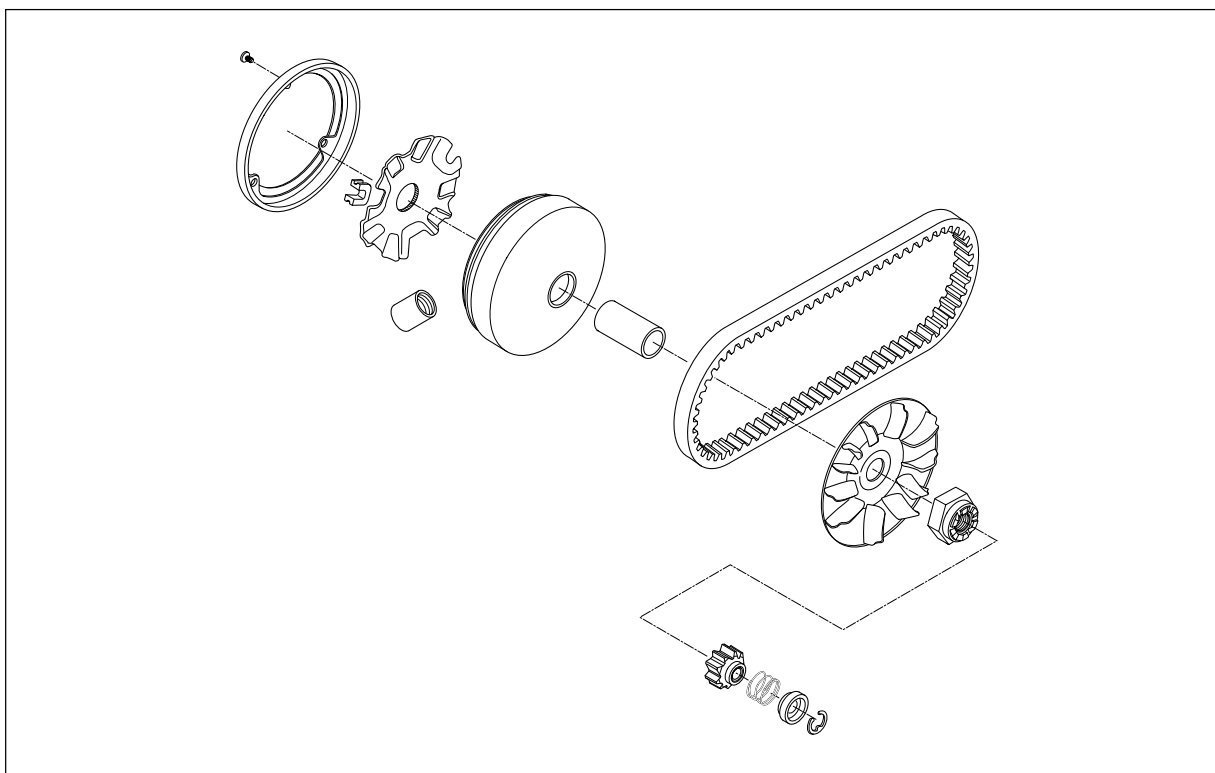

- Install the roller ② to the movable drive face ①.

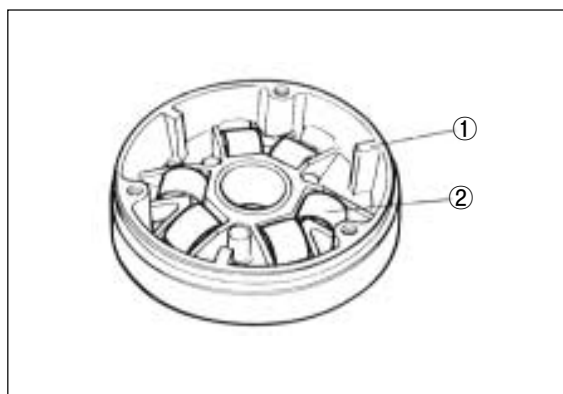

- Mount the three dampers ④ on the movable drive plate ③ and install it on the movable drive face ⑤.
- Position the O-ring ⑥ on the movable drive face.

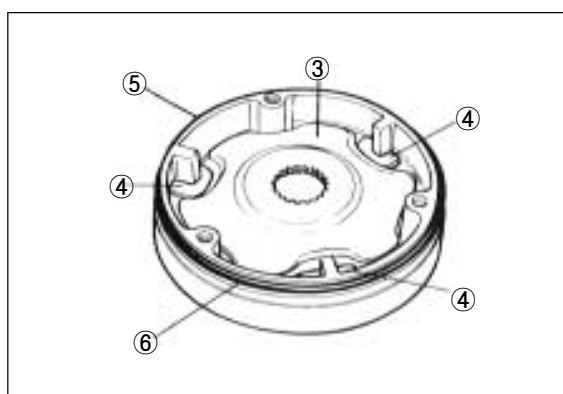



### 3-37 ENGINE

- Install the movable drive face cover ①.

**⚠ CAUTION**

Make sure that the movable drive plate is fully positioned inside, or the weight roller may come off.

- Insert the spacer ②.

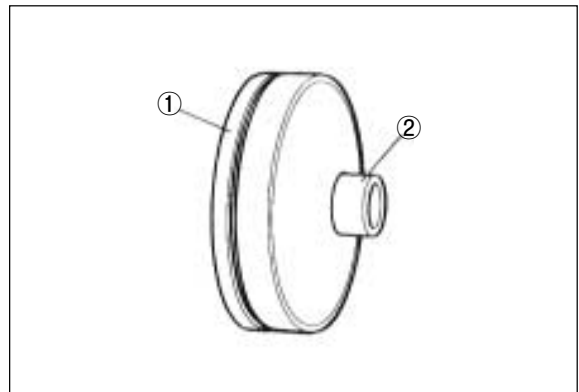

- Position the movable drive face subassembly on the crankshaft as shown in the photo.

**⚠ CAUTION**

Thoroughly clean the V-belt contact to be from oil.

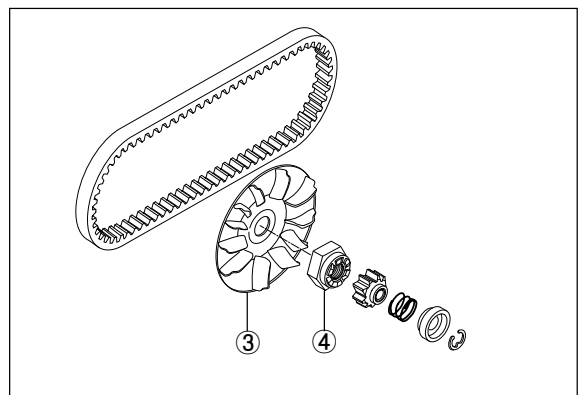

- Install the fixed drive face ③.
- Tighten the kick starter driven nut ④ to the specified torque with the special tool.

 Conrod holder : 09910-20115

 Kick starter driven nut : 40~60 N · m (4.0~6.0 kg · m)

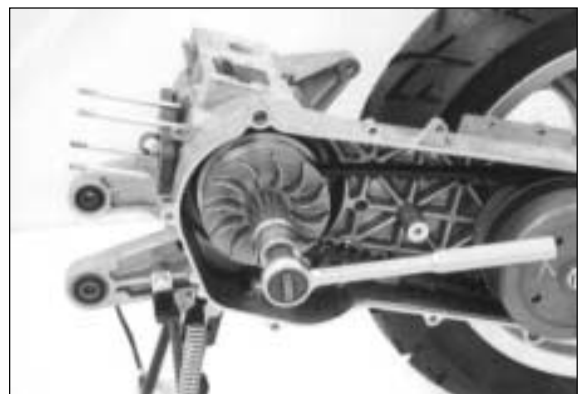

- Fill **SUPER GREASE "A"** in the groove provided inside sliding surface of the kick driven gear and install it ① on the end of the crankshaft. Wipe off excess grease.

 Super Grease "A"

- Install the spring ② and spacer ③.

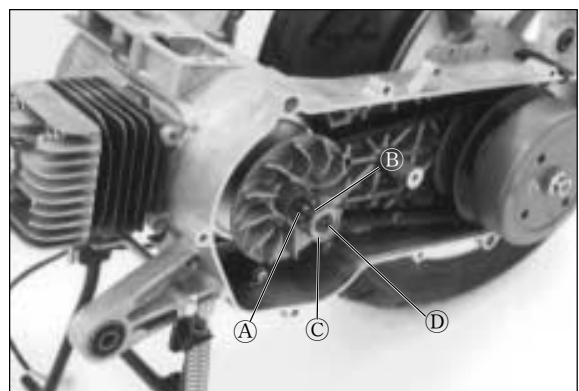

- Install the E-ring ④.

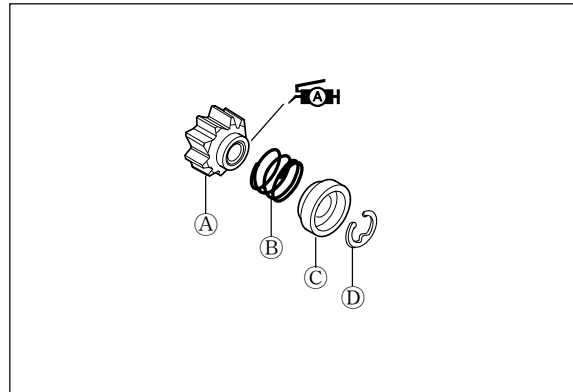

- Continue turning the fixed drive face ① by hand until the belt is seated in and both the drive and driven faces ② will move together smoothly without slip.
- Fill the final gear box with engine oil up to the level hole.

<b>Transmission oil capacity</b>	Replace	110 ml
	Overhaul	130 ml

- Tighten the oil level bolt ③ to the specified torque.

 Oil level bolt : 9~15 N · m (0.9~1.5 kg · m)

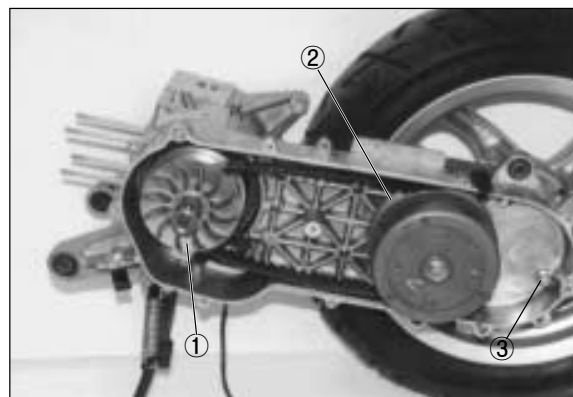

## KICK STARTER

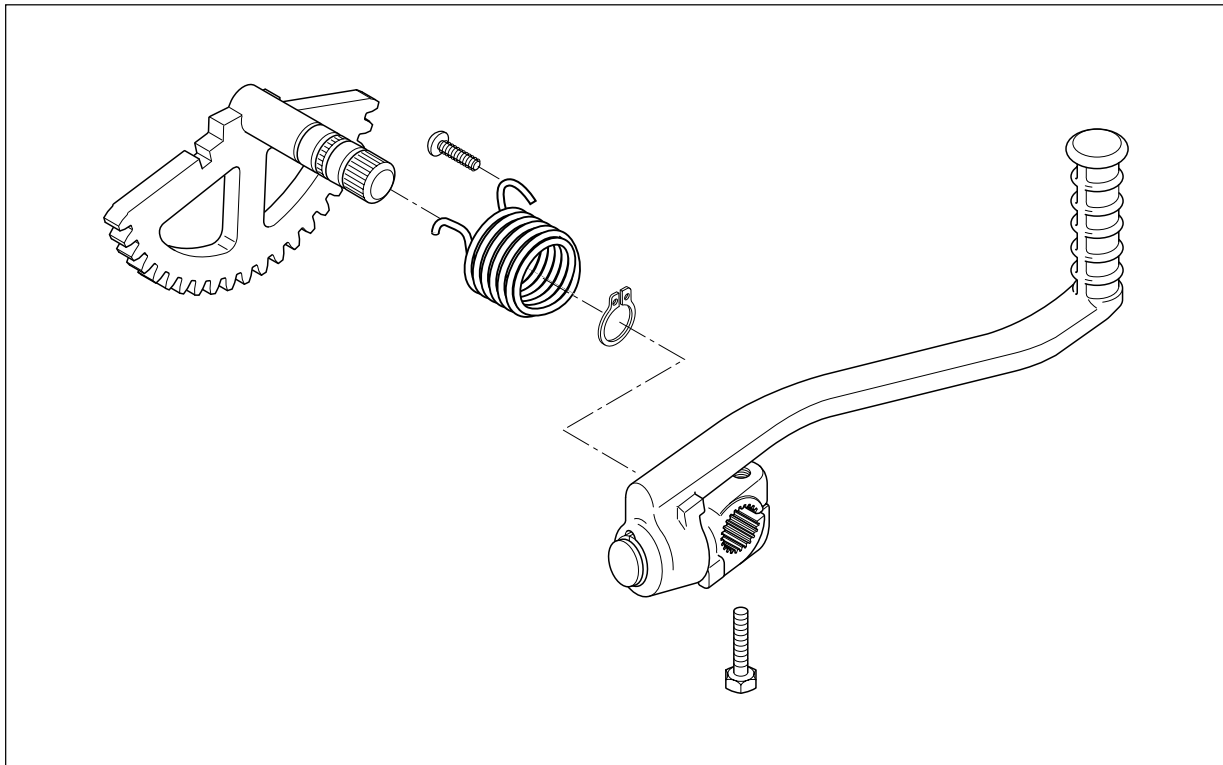

### 3-39 ENGINE

- Apply **SUPER GREASE “A”** lightly on the kick starter shaft rolling surface and install it on the crankcase cover.

 Super Grease “A”

- Position the kick starter shaft return spring and hook the spring end on the crankcase cover boss ①.

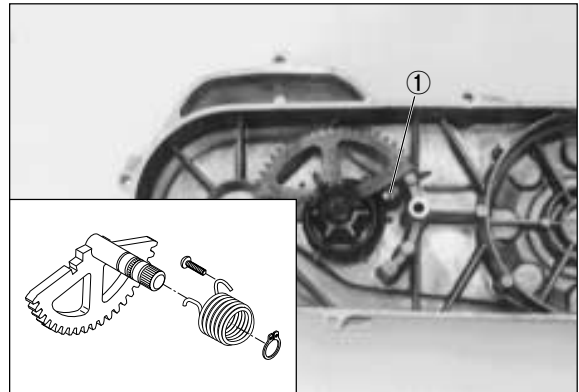

- Install the clutch cover and kick starter lever ②.

 **CAUTION**

Install the kick starter lever as shown in the illustration.

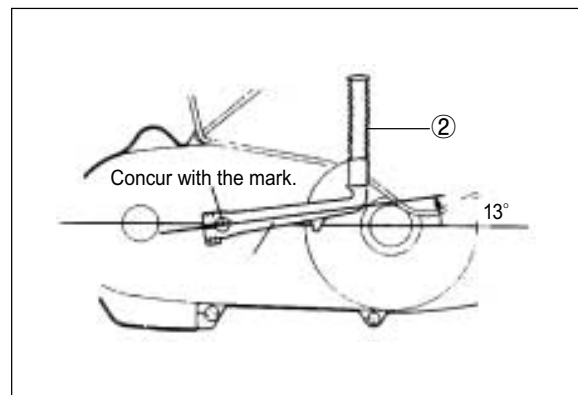

- Tighten the kick starter lever bolt to the specified torque.

 Kick starter lever bolt : 8~12 N · m (0.8~1.2 kg · m)

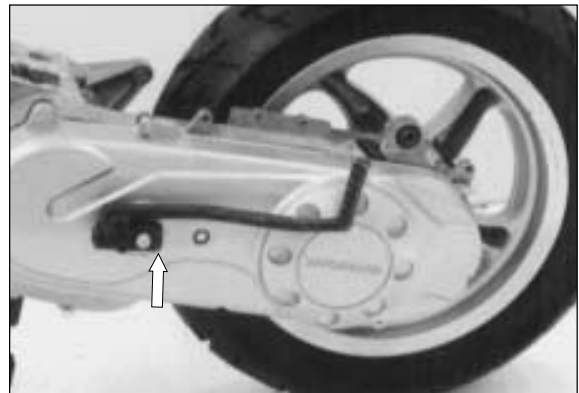

## PISTON

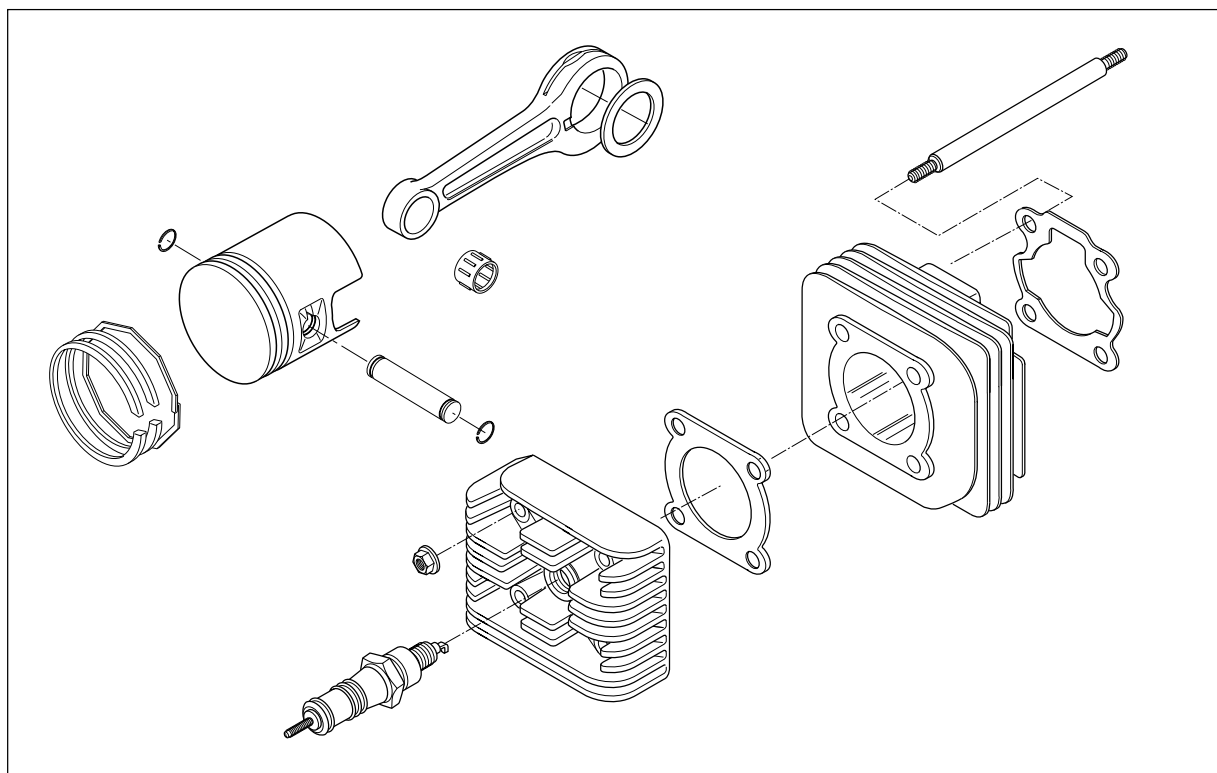

- Install the piston rings on the piston.

- 1st - Keystone ring
- 2nd - Barrel face ring
  - ↳ Expander ring

**⚠ CAUTION**

**Position the ring so that the marking is on upside.**

Position the ring so that the marking is on upside.



Locating pin

- It is extremely important that, when the piston is fed into the cylinder, each ring in place should be so positioned as to hug the locating pin as shown in the illustration.



CORRECT



INCORRECT

### 3-41 ENGINE

- Apply engine oil on the piston pin and install the piston to the conrod.

**⚠ CAUTION**

The arrow mark **Ⓐ** on the piston head should point the exhaust side.

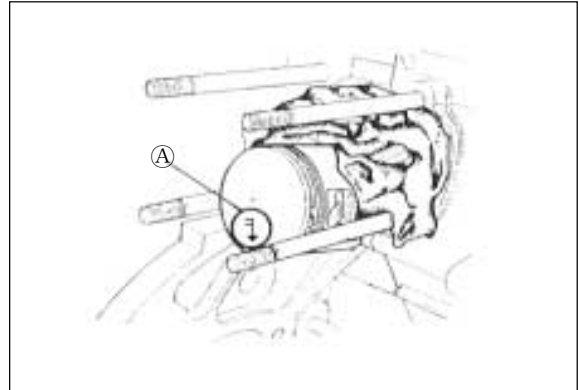

- The circlip should be mounted in such a position that the mating ends of the circlip do not coincide with the groove portion of the piston.
- Position the cylinder base gasket.
- Apply engine oil on the piston and cylinder wall surfaces and install the cylinder over the piston carefully.
- Install the cylinder head gasket and cylinder head.

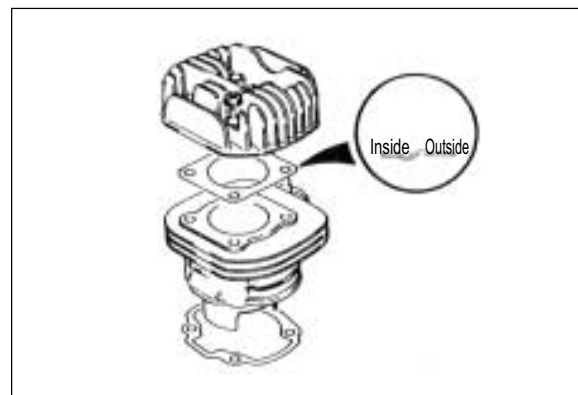

- Tighten the cylinder head nut to the specification, and tighten it diagonally several times as shown in the illustration.

 Cylinder head nut : 8~12 N · m (0.8~1.2 kg · m)

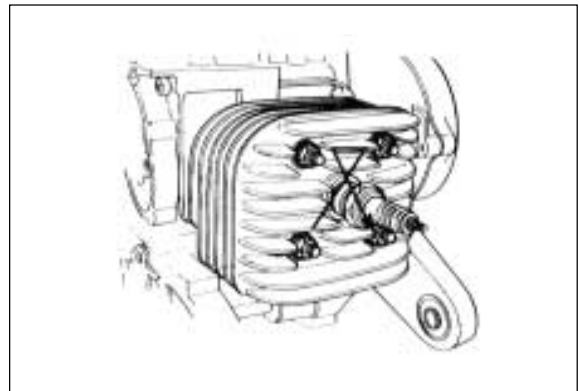

## OIL PUMP AND INTAKE PIPE

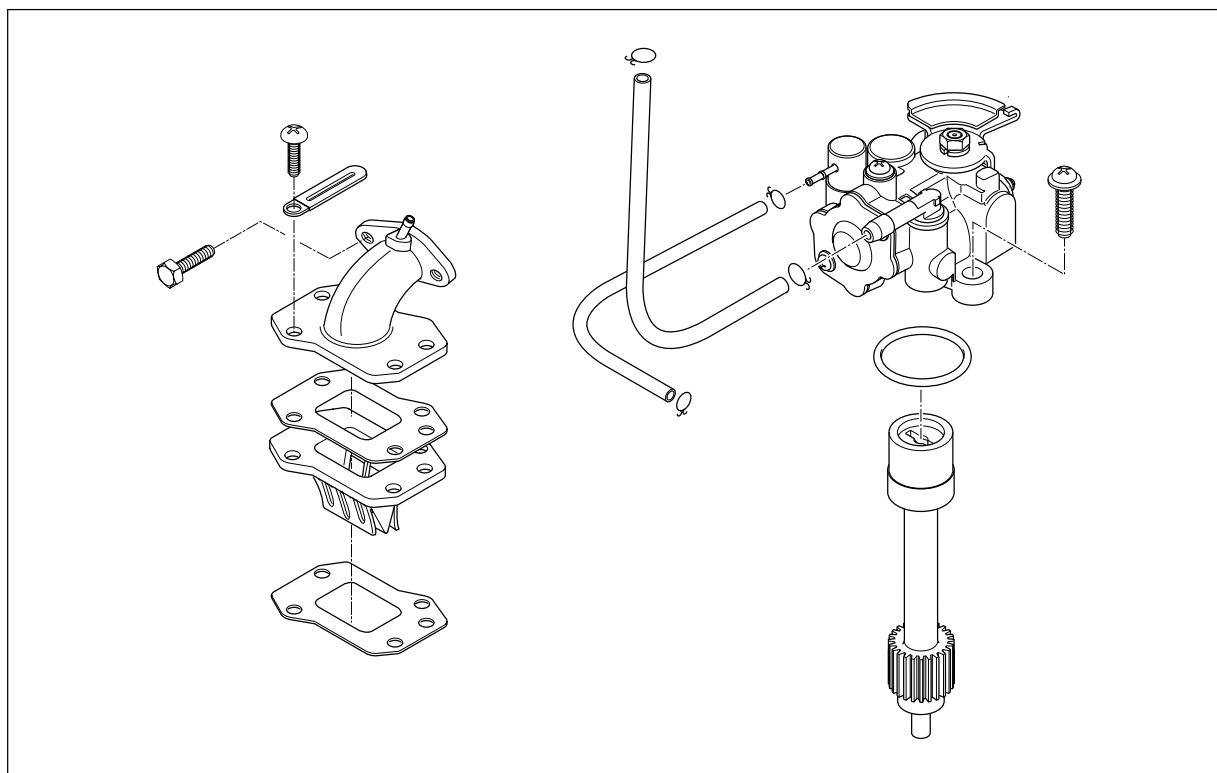

- Apply **SUPER GREASE "A"** to the oil pump driven gear ① and install it to the crankcase.

 Super Grease "A"

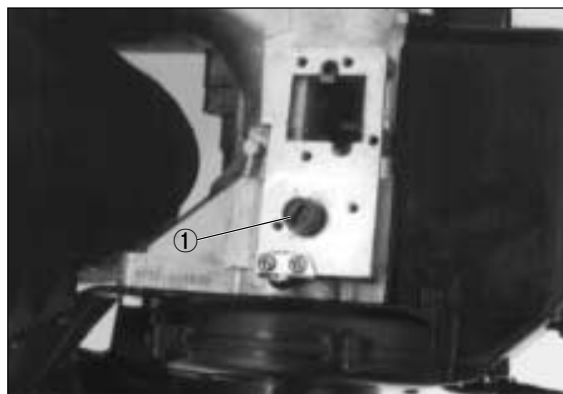

- Install the oil pump ② and tighten it to the specified torque.

 Oil pump bolt : 3~5 N · m (0.3~0.5 kg · m)

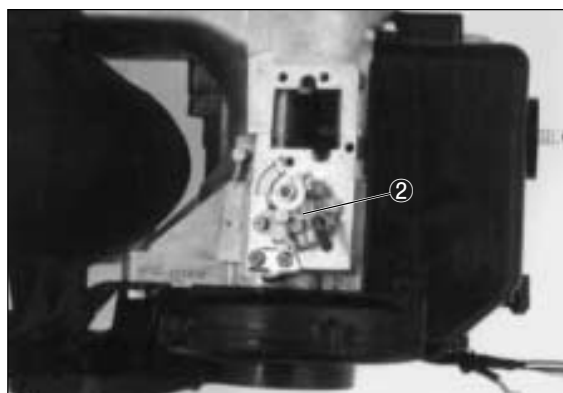

## 3-43 ENGINE

- Install the reed valve gasket ①, intake pipe gasket ② and intake pipe ④ with reed valve ③ to the crankcase.

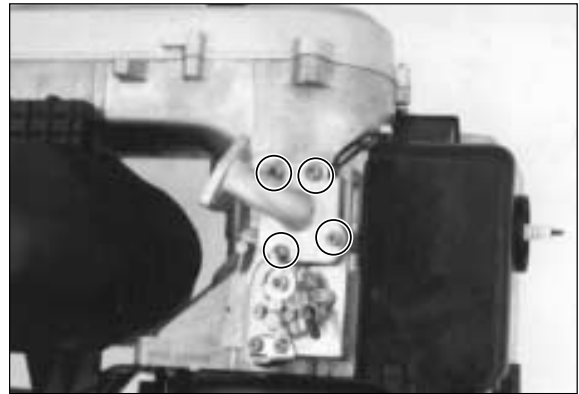
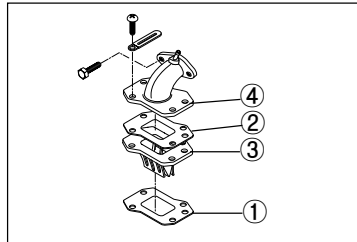

## MAGNETO

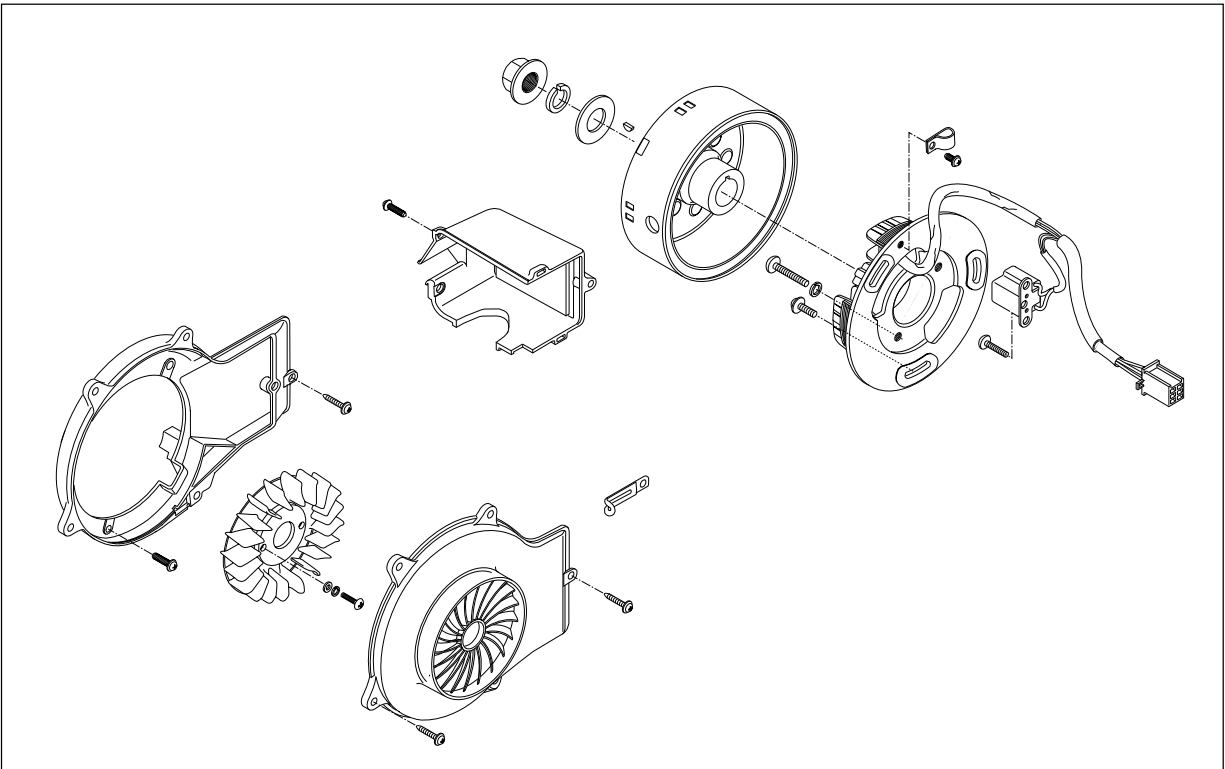

- Degrease the tapered portion of the crankshaft and also the magneto rotor.
- Install the stator ①.
- Install the key ②.

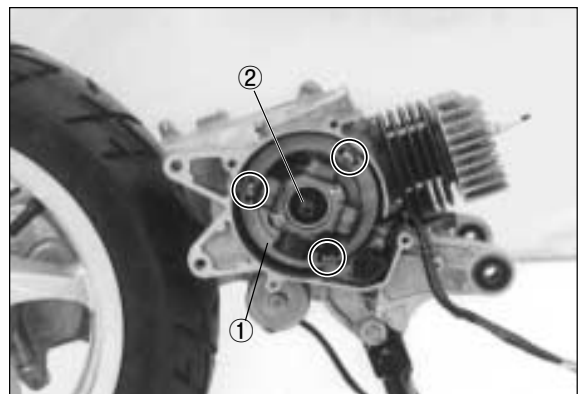

- Install the rotor ①.
- Apply **THREAD LOCK "1324"** to the rotor nut ② and tighten it to the specified torque with the special tool.

 Thread Lock "1324"

 Rotor holder : 09930-40113

 Magneto rotor nut : 35~45 N · m (3.5~4.5 kg · m)

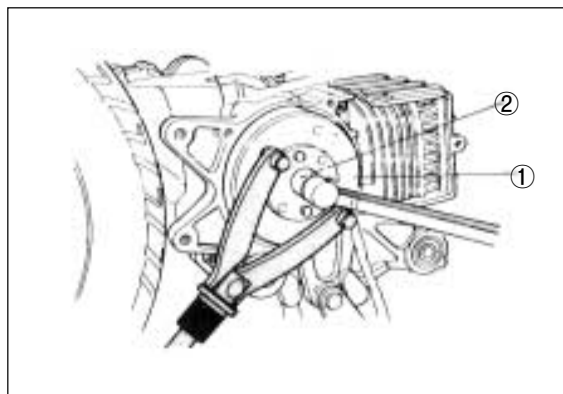

- Install the fan case ③.
- Install the magneto lead wire and starting motor lead wire.

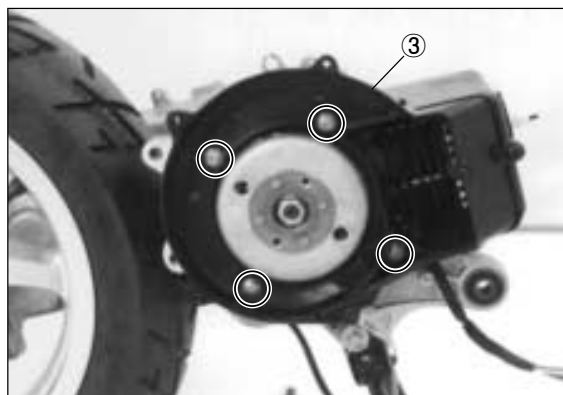

- Install the cooling fan ④.

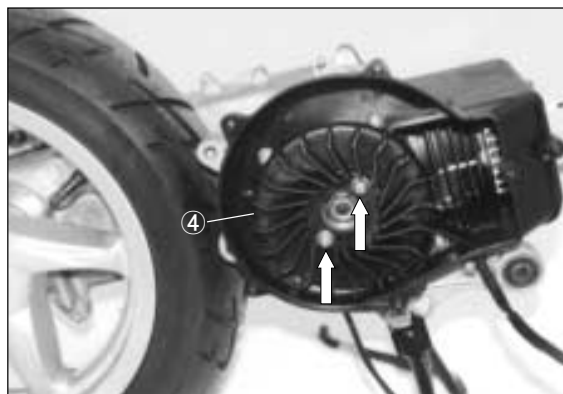

- Install the cooling fan cover ⑤.

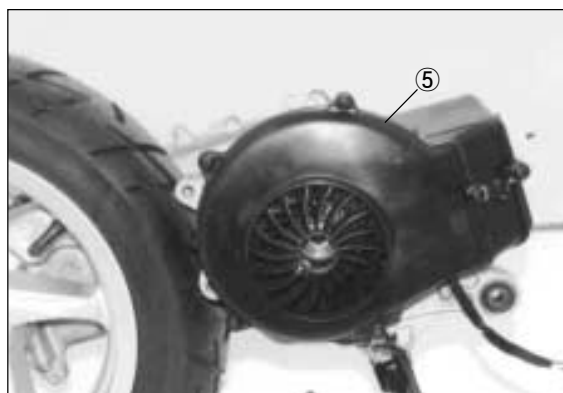



## 3-45 ENGINE

---

### MUFFLER

- Tighten the exhaust pipe bolts and muffler mounting bolts to the specified torque.

- ☑ Exhaust pipe bolt : 8~12 N · m (0.8~1.2 kg · m)
- Muffler mounting bolt : 18~28 N · m (1.8~2.8 kg · m)

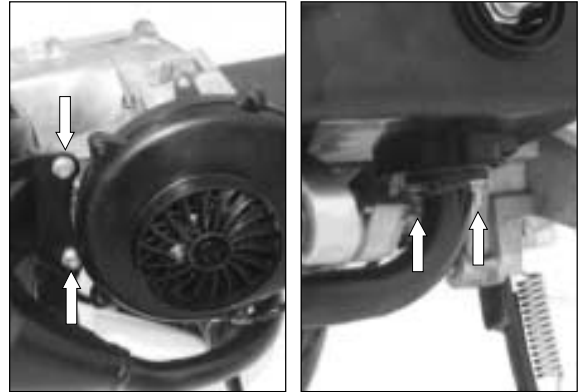

# FUEL SYSTEM

## CONTENTS

<b>CARBURETOR</b> .....	<b>4- 1</b>
<b>REMOVAL</b> .....	<b>4- 1</b>
<b>DISASSEMBLY</b> .....	<b>4- 2</b>
<b>INSPECTION</b> .....	<b>4- 4</b>
<b>REASSEMBLY AND REMOUNTING</b> .....	<b>4- 5</b>
<b>FUEL TANK</b> .....	<b>4- 7</b>
<b>REMOVAL</b> .....	<b>4- 7</b>
<b>CLEANING</b> .....	<b>4- 8</b>
<b>REMOUNTING</b> .....	<b>4- 8</b>
<b>OIL PUMP</b> .....	<b>4- 8</b>
<b>FUEL PUMP</b> .....	<b>4- 9</b>

## CARBURETOR

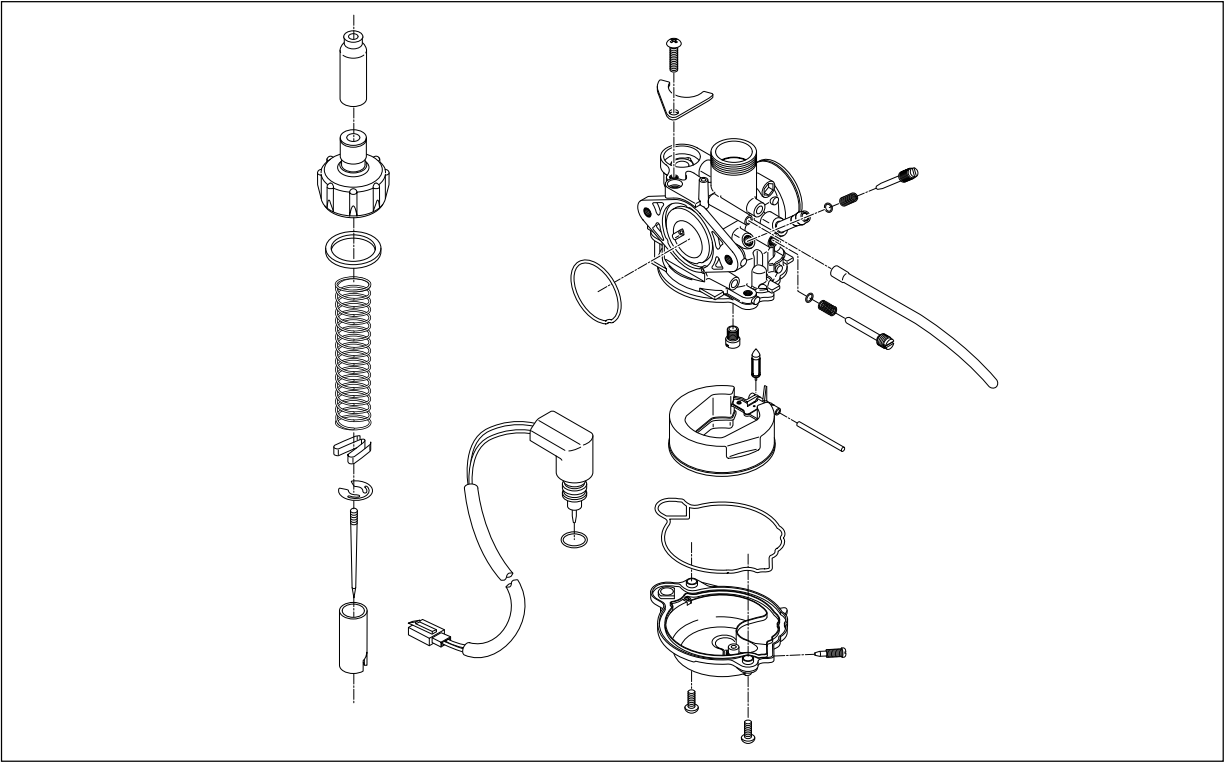

### REMOVAL

- Open the seat, and separate the helmet box by removing the four lock nuts.



- Remove the rear shock absorber mounting lower bolt.



- Remove the carburetor top cap ①, and disconnect the throttle cable ②.

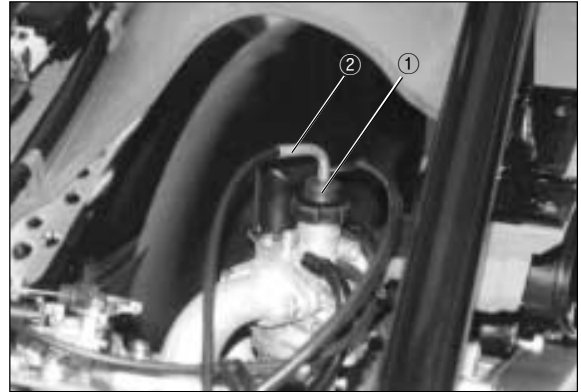

- Disconnect the air vent hose ③, oil hose ④, and fuel hose ⑤.

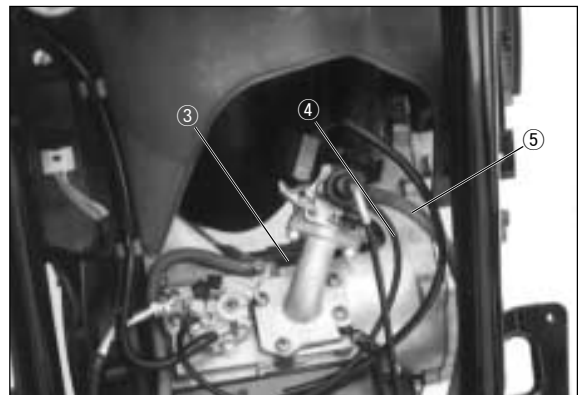

- Remove the carburetor by loosening the mounting bolts ⑥ and clamp screw ⑦.

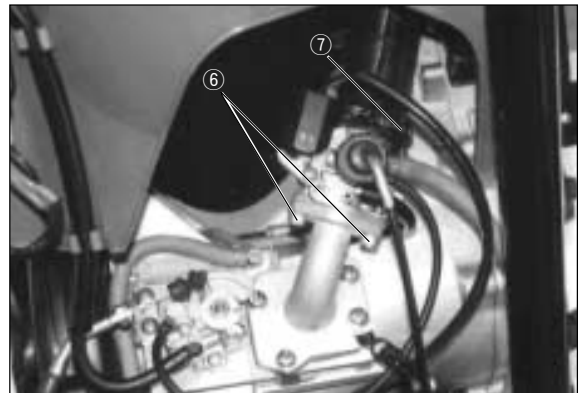

## DISASSEMBLY

- Remove the thermoelement assembly.



## 4-3 FUEL SYSTEM

---

**⚠ CAUTION**

Do not attempt to disassemble the thermoelement assembly.  
It is not serviceable.



- Remove the float chamber ①.

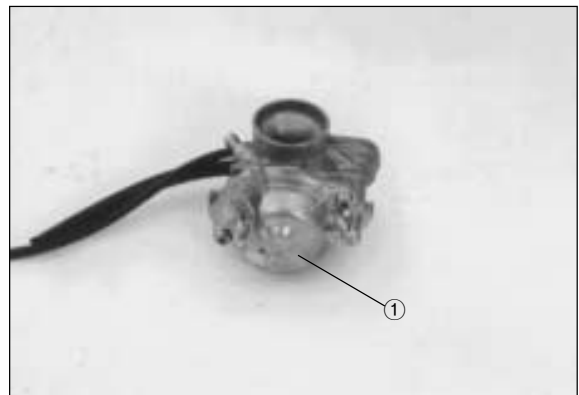

- Remove the float ④ by removing the screw ② and pin ③.

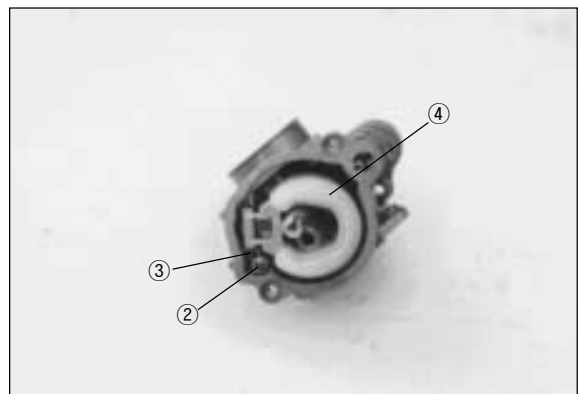

- Remove the needle valve ⑤.

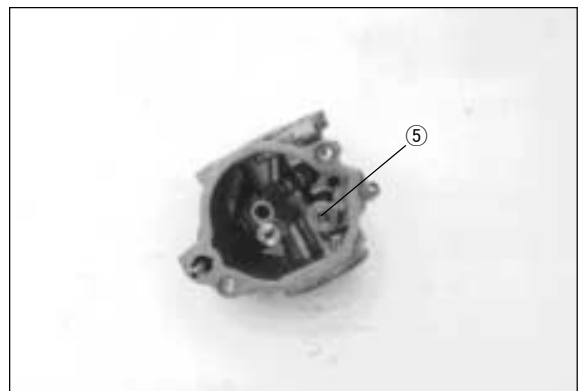

- Remove the throttle stop screw ① and pilot air screw ②.

**⚠ CAUTION**

When removing the pilot air screw, record the revolutions until tighten completely.

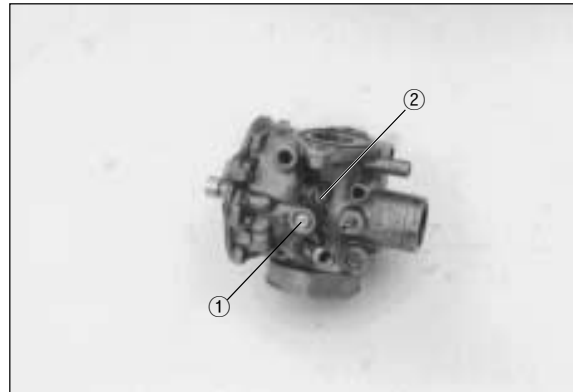
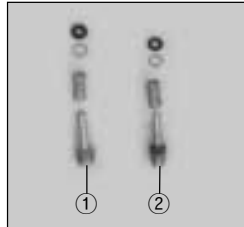

- Remove the main jet ③ and needle jet ④.

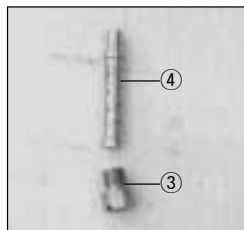

**INSPECTION**

Check following items for any damage or clogging.

- Pilot jet
- Main jet
- Pilot air screw
- Needle jet air bleeding hole
- Float
- Gasket
- Pilot outlet and bypass holes

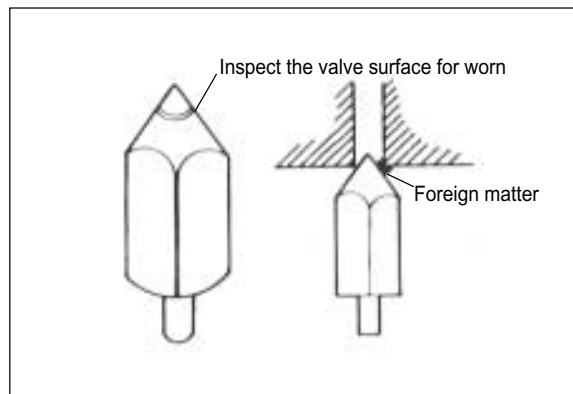

**NEEDLE VALVE INSPECTION**

If foreign matter is caught between the valve seat and the needle, the gasoline will continue flowing and cause it to overflow. If the seat and needle are worn beyond the permissible limits, similar trouble will occur. Conversely, if the needle sticks, the gasoline will not float chamber. Clean the float chamber and float parts with gasoline. If the needle is worn as shown in the illustration, replace it together with a valve seat. Clean the fuel passage of the mixing chamber with compressed air.

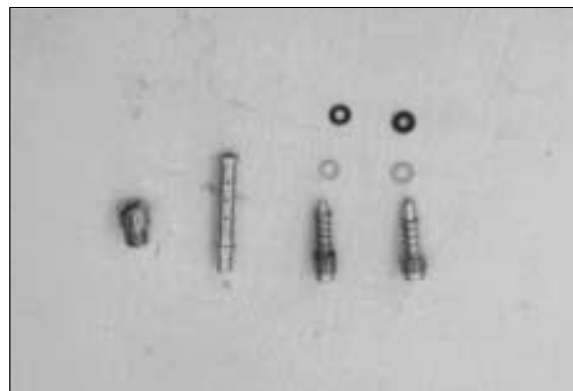

## 4-5 FUEL SYSTEM

### REASSEMBLY AND REMOUNTING

- Reassemble following items.

- ① Pilot air screw
- ② Throttle stop screw
- ③ Main jet
- ④ Needle jet

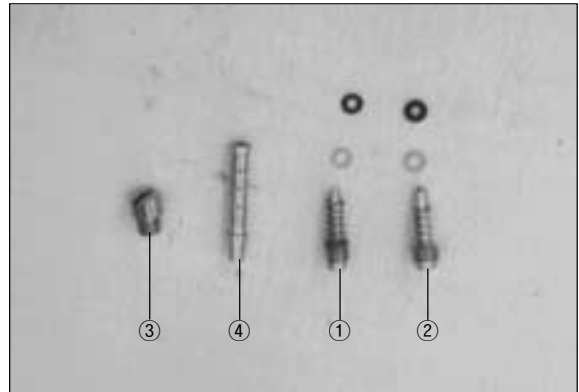

- Install the needle valve (5) and float (6) on the carburetor body.

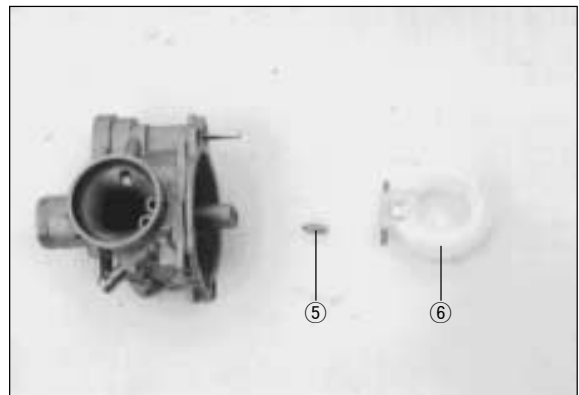

- Install the float pin and tightened the screw (7).
- Install the gasket and float chamber.

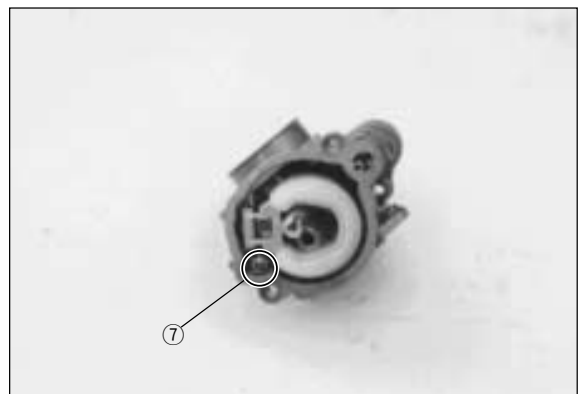

- Install the thermoelement assembly.



- Install the carburetor assembly.

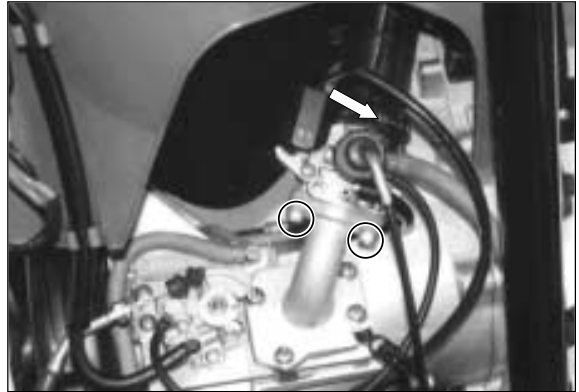

- Install the air vent hose ①, oil hose ② and fuel hose ③.

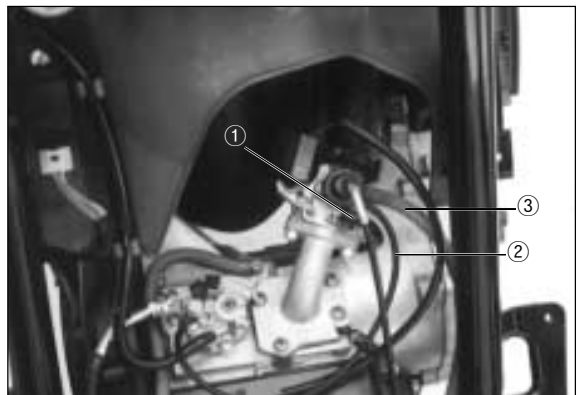

- Install the carburetor top cap.

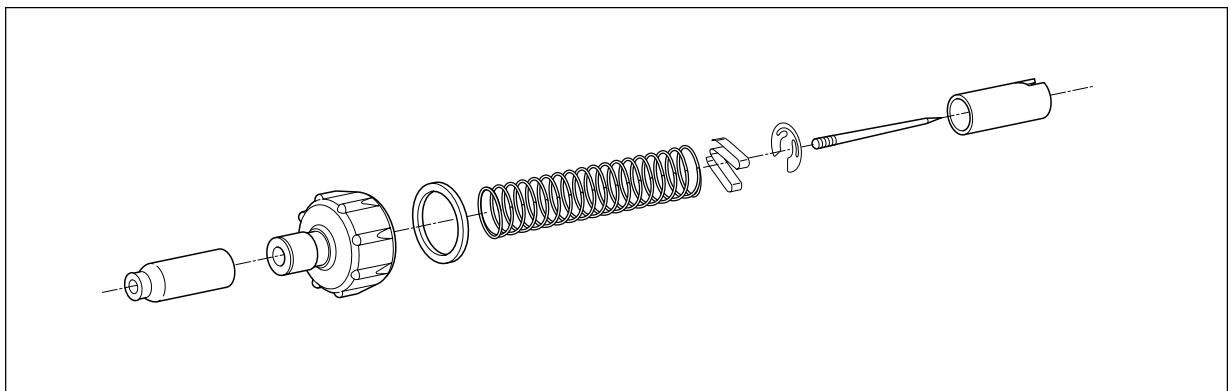
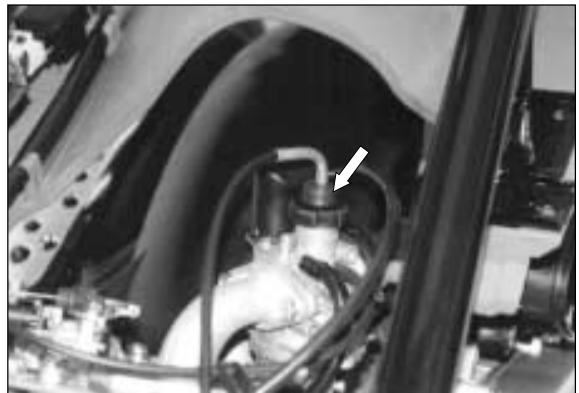



## 4-7 FUEL SYSTEM

---

### FUEL TANK

#### REMOVAL

- Remove the low leg shield ①.

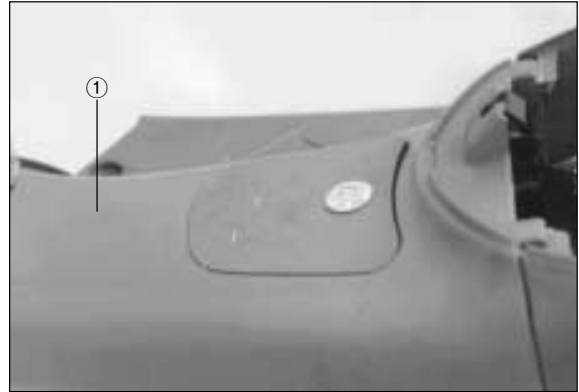

- Disconnect the fuel hose ②.

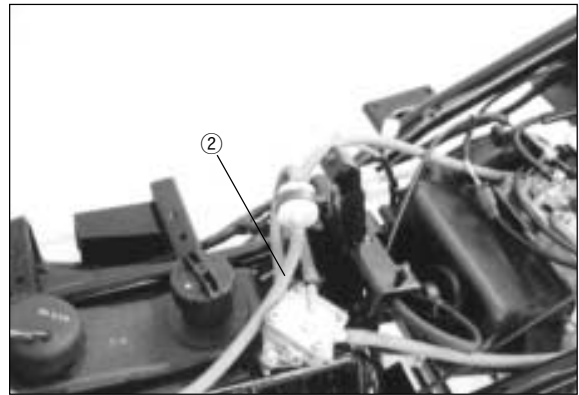

- Disconnect the fuel level gauge lead wire ③.

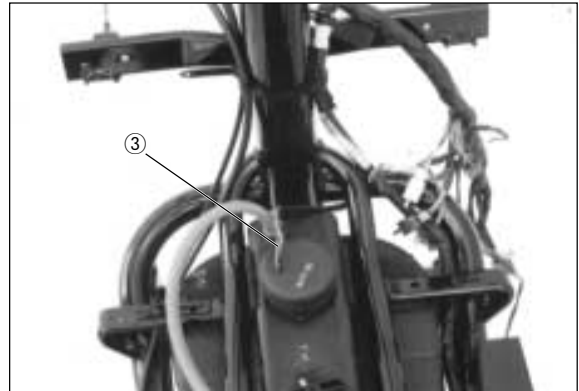

- Remove the six fuel tank mounting bolt.

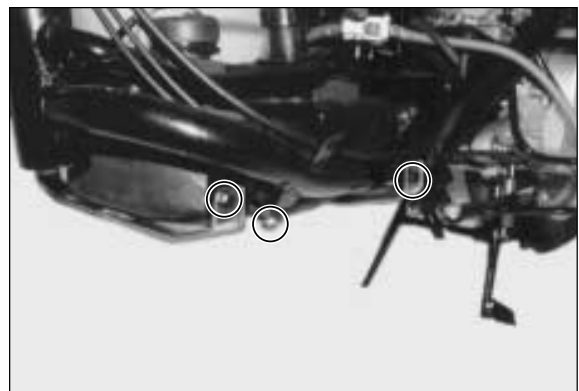

## CLEANING

Dust from the fuel tank tends to build up in the fuel filter which, when the fuel filter has been neglected for a long period, inhibits the flow of fuel.

Remove the dust from the fuel filter ① using compressed air.



## REINSTALLING

Reinstall the fuel tank in the reverse of removal.

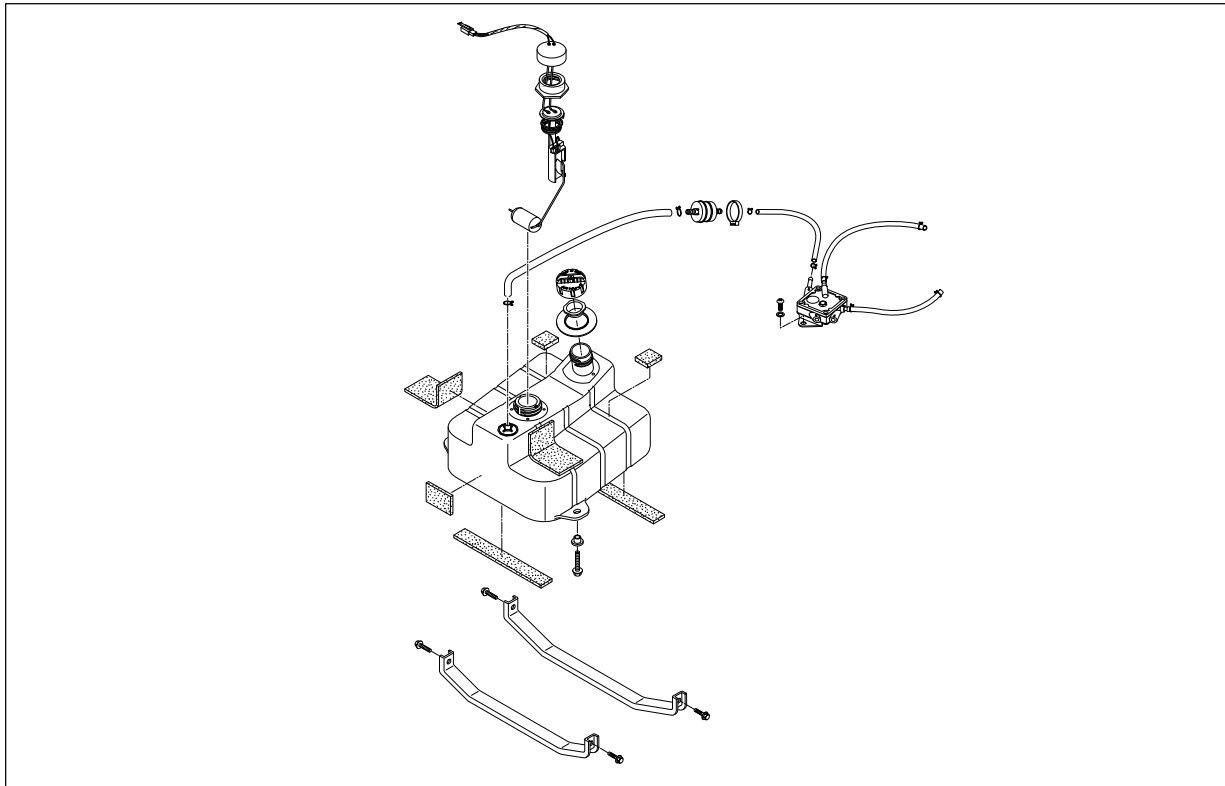

## OIL PUMP

### AIR BLEEDING

Whenever evidence is noted of some air having leaked into the oil pipe from the oil tank in a machine brought in for servicing, or if the oil pump has to be removed for servicing, be sure to carry out an air bleeding operation with the oil pump in place before returning the machine to the user.

To bleed air, hold the machine in standstill condition. Loosen the air bleeding screw ① to let out air and after making sure that the trapped air has all been bled, tighten the air bleeding screw completely.



## 4-9 FUEL SYSTEM

### CHECKING OIL PUMP

Use the special tool, to check the pump for capacity by measuring the amount of oil the pump draws during the specified interval.

- Remove the left side cover.
- Have the CCI Oil gauge filled with HYOSUNG HYPOL OIL and connect it to the suction side of the pump.
- Run the engine at 3,000 rpm.
- Holding engine speed at the same 3,000 rpm, let the pump draw for 5 minutes. For this operation, the reading taken on the device should be 6 ml.

 CCI Oil gauge : 09900-21602

<b>Engine oil discharge amount</b>	1.0 ~ 1.2 ml (at 3,000 rpm for 5 minutes)
------------------------------------	--

#### CAUTION

During this inspection, strictly follow the following points.

- The machine should be rested on the center stand.
- Do not touch the rear wheel while running the engine.



## FUEL PUMP

### REPLACE

- Remove the rear shock absorber, and support the center stand by a 70 mm wooden block.
- Open the seat, and remove the trunk by loosening the four nuts.
- Remove the one lock nut of fuel pump.
  - ① Disconnect the inlet hose.

#### CAUTION

Stop up an entrance of the hose, to prevent that the fuel leak out.

- ② Disconnect the vacuum hose and outlet hose.
- Remount in the reverse of removal after replacing the fuel pump.

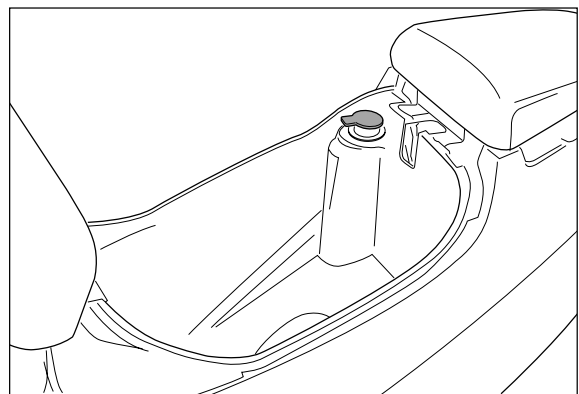

# ELECTRICAL SYSTEM

## CONTENTS

<b>ELECTRICAL PARTS</b> .....	<b>5- 1</b>
<b>IGNITION/CHARGING SYSTEM</b> .....	<b>5- 2</b>
<b>IGNITION COIL</b> .....	<b>5- 2</b>
<b>STATOR COILS</b> .....	<b>5- 3</b>
<b>REGULATOR/RECTIFIER</b> .....	<b>5- 4</b>
<b>STARTER SYSTEM</b> .....	<b>5- 4</b>
<b>STARTING MOTOR INSPECTION</b> .....	<b>5- 5</b>
<b>STARTER RELAY INSPECTION</b> .....	<b>5- 6</b>
<b>FUEL LEVEL GAUGE</b> .....	<b>5- 7</b>
<b>OIL LEVEL CHECK LIGHT</b> .....	<b>5- 8</b>
<b>THERMOELEMENT</b> .....	<b>5- 9</b>
<b>SWITCHES INSPECTION</b> .....	<b>5-10</b>
<b>BATTERY</b> .....	<b>5-11</b>

## ELECTRICAL PARTS

- ① Ignition coil
- ② Thermolement assembly
- ③ Fuel level gauge
- ④ Oil level gauge

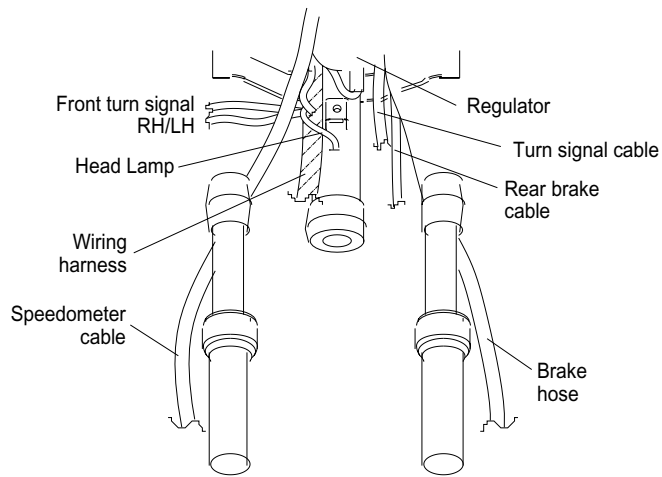
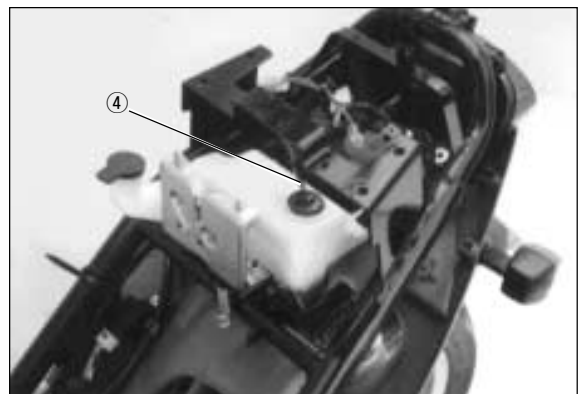
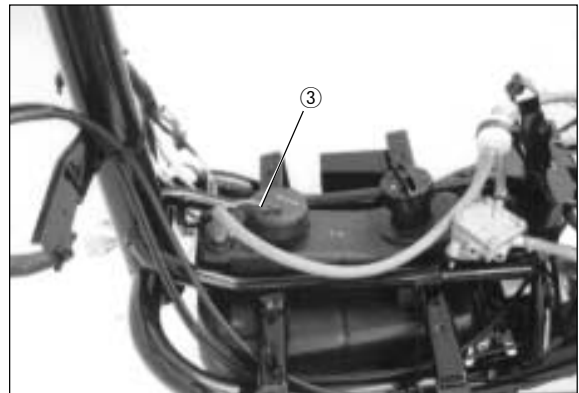
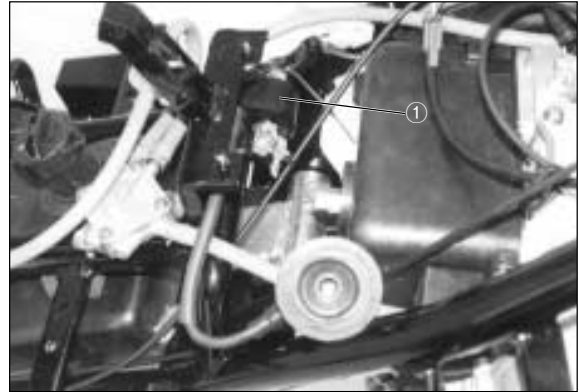

## IGNITION/CHARGING SYSTEM

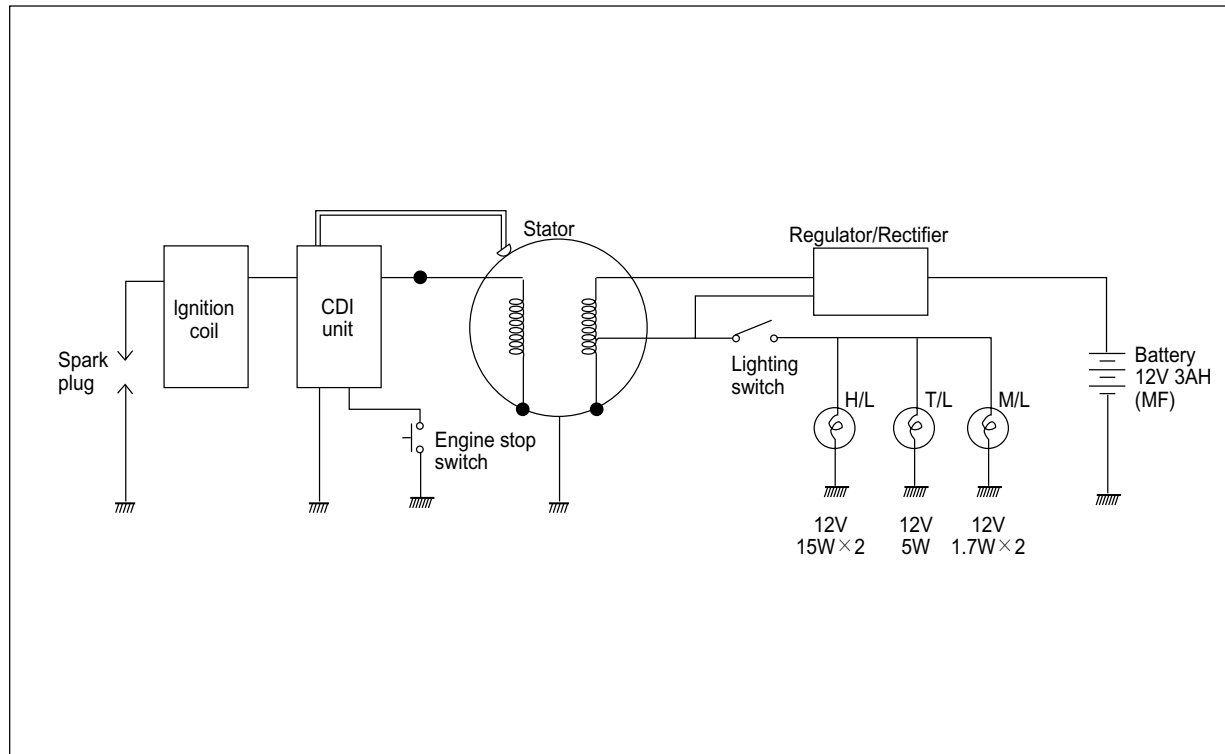

### IGNITION COIL

- Check the ignition coil with electro tester.
- Test the ignition coil for sparking performance. Test connection is as indicated. Make sure that the three-needle sparking distance is at least 8mm. Test it at least for 5 minutes.

 Electro tester : 09900-28106

**Spark performance**

Over 8 mm

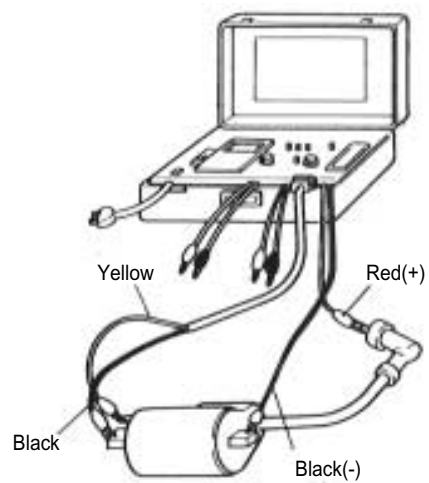
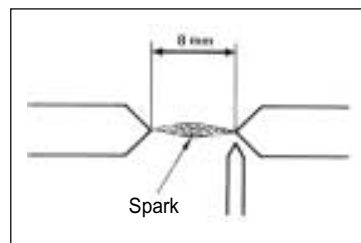

### 5-3 ELECTRICAL SYSTEM

- Check the ignition coil with the pocket tester.

 Pocket tester : 09900-25002

Ignition coil resistance	
Primary	0.19 ~ 0.24 Ω
Secondary	5.4 ~ 6.6 kΩ

#### C.D.I. UNIT

- Using the pocket tester (R × 1 kΩ range), measure the resistance between the lead wire in the following table.

 Pocket tester : 09900-25002

Unit : kΩ

		⊕ Probe of tester to :					
		B/Y	W/BL	B/R	B/W	W	Br
⊖ Probe of tester to :	B/Y		∞	∞	∞	∞	∞
	W/BL	14~18		7~10	3~4	7~10	5~7
	B/R	3~5	∞		∞	∞	∞
	B/W	7~11	∞	3~4.5		3~4.5	1.2~2.5
	W	12~16	∞	6~8	25~35		27~37
	Br	10~14	∞	5~7	1.2~2.5	5~8	

#### STATOR COILS

- Using the pocket tester, measure the resistance between the lead wire and ground. If the resistance checked is incorrect, replace the coil.

Unit : Ω

Stator coil resistance			
Lead wire of tester		Standard resistance	
⊕ (Red)	⊖ (Black)		
Y/W	Ground	Lighting coil	0.54 ~ 0.80 Ω
W/R	Ground	Charging coil	0.69 ~ 1.03 Ω
B/R	Ground	Exciting coil	220 ~ 260 Ω
Br	W	Pick-up coil	90 ~ 110 Ω

#### CHARGING OUTPUT CHECK

Start the engine and keep it running at 5,000 rpm with lighting switch turned "ON".

Measure the DC voltage between the battery terminal ⊕ and ⊖ with a pocket tester.

If the tester reads under or over following specification, check the no-load performance or replace the regulator/rectifier.

 **CAUTION**

**When making this test, be sure that the battery is in fully-charged condition.**

 Pocket tester : 09900-25002

Engine tachometer : 09900-26006

**Standard charging output** 13.0 ~ 16.0 V (at 5,000 rpm)

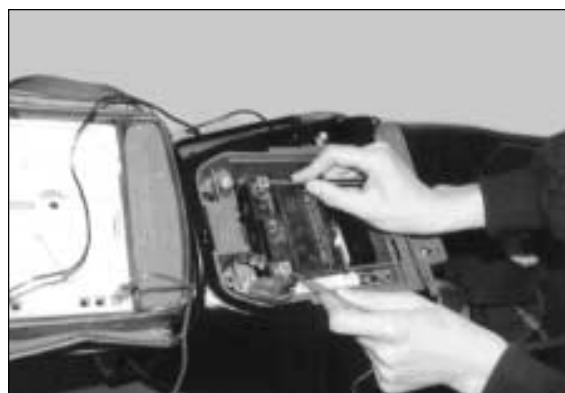
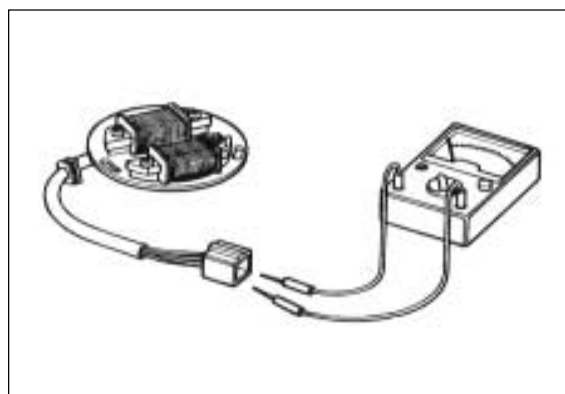
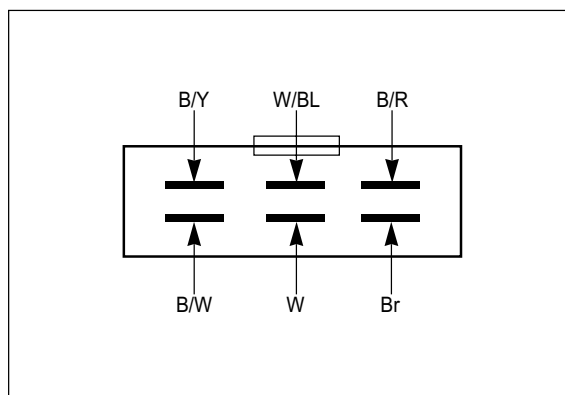
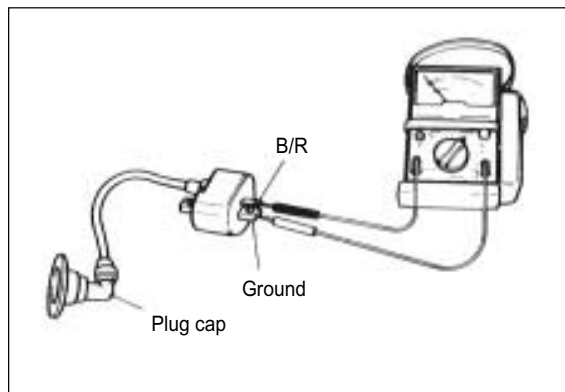

**NO-LOAD PERFORMANCE OF A.C. GENERATOR**

- Disconnect the magneto lead wire coupler.
- Start the engine and keep it running at 5,000 rpm.
- Using a pocket tester, measure the AC voltage between the three lead wire. If the tester reading is as follows, magneto is in good condition.

<b>Standard no-load performance of A.C. generator</b>	More than 17 V (at 5,000 rpm)
---	-------------------------------

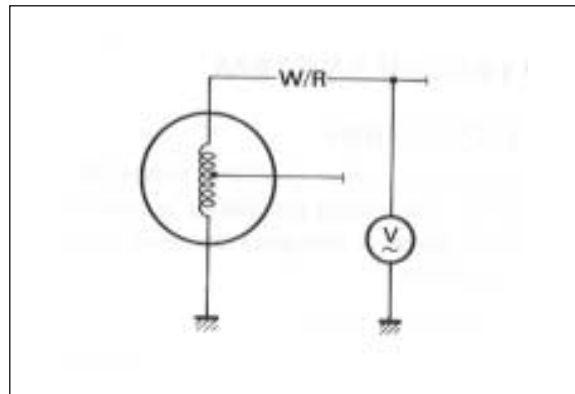

**REGULATOR/RECTIFIER**

- Disconnect the coupler.
- Using the pocket tester (× 1kΩ Range), measure the resistance between the terminals as shown in the following table. If the resistance checked is incorrect, replace the regulator/rectifier.

Pocket tester : 09900-25002

Unit : kΩ

		⊕ Probe of tester to:			
		1	2	3	4
⊖ Probe of tester to:	1		50 ~ 260	∞	∞
	2	50 ~ 230		∞	∞
	3	∞	∞		∞
	4	∞	∞	10 ~ 100	

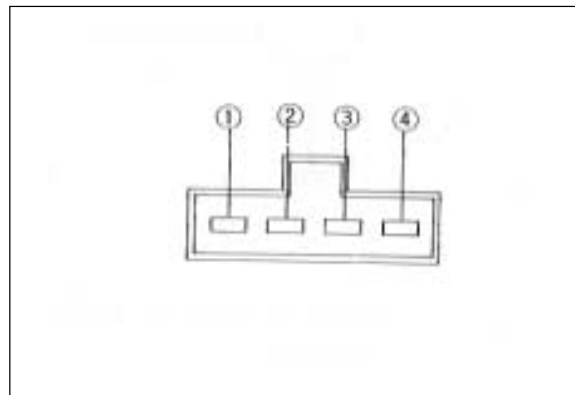

**STARTER SYSTEM**

The starter system is shown in the diagram below: namely, the starting motor, starter relay, starter switch and battery. Depressing the starter switch (on the right handlebar switch box) while squeezing the front or rear brake lever energizes the relay, causing the contact points to close which connects the starting motor to the battery.

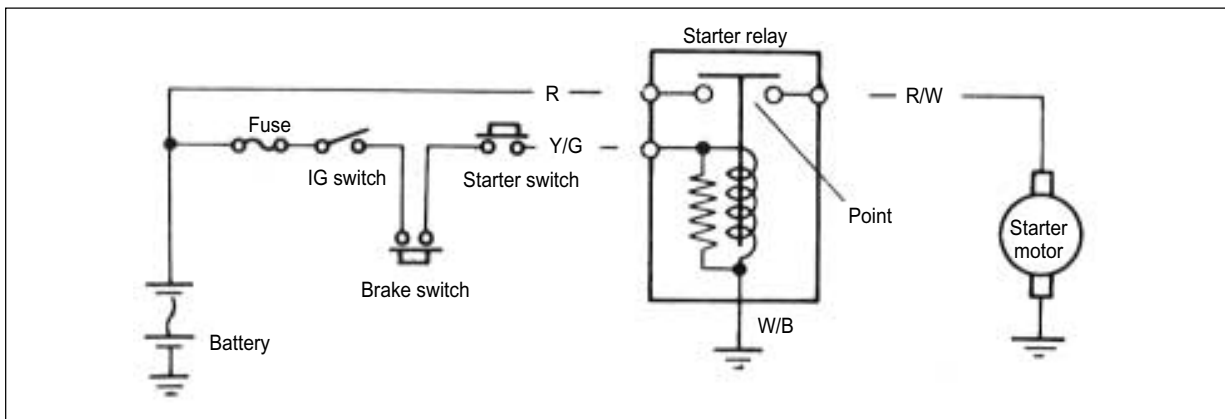



### STARTING MOTOR REMOVAL AND DISASSEMBLY

Remove the starting motor.

Disassemble the starting motor as shown in the illustration.

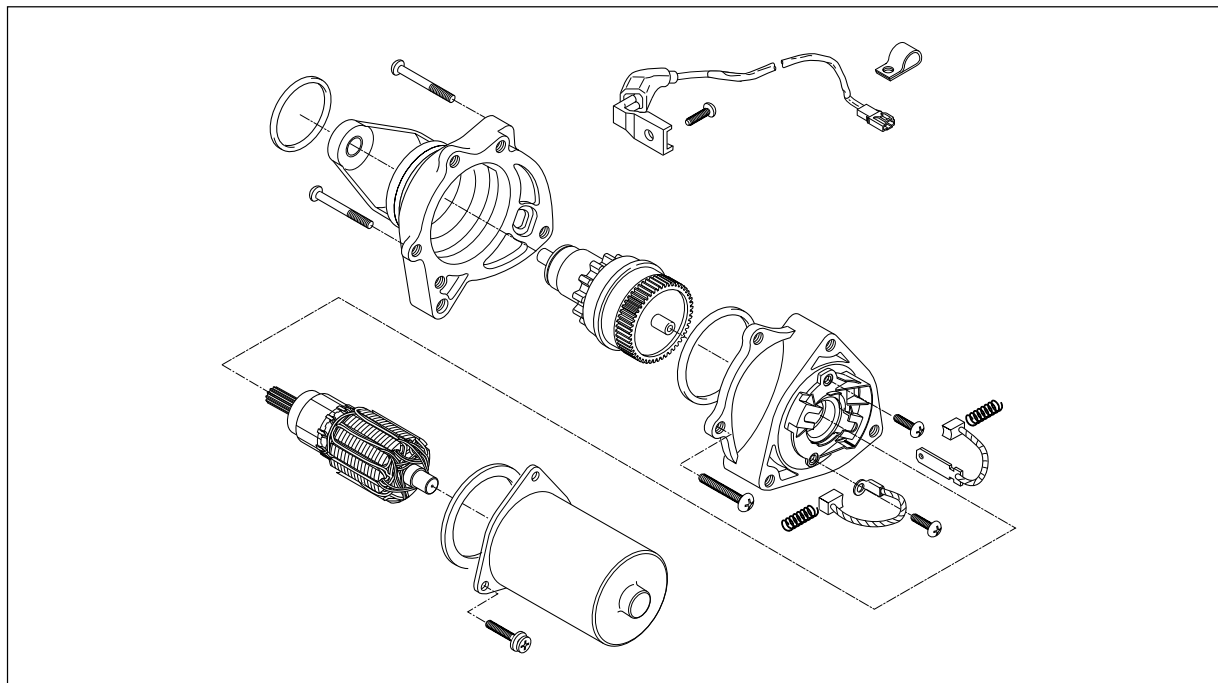

### STARTING MOTOR INSPECTION

#### CARBON BRUSHES

When the brushes are worn, the motor will be unable to procedure sufficient torque, and the engine will be difficult to turn over. To prevent this, periodically inspect the length of the brushes and replace them when they are too short or chipping.

**Carbon brushes wear**

Service limit 4 mm

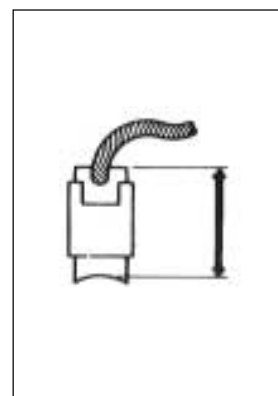

#### COMMUTATOR

If the commutator surface is dirty, starting performance will decrease. Polish the commutator with #400 or similar fine emery paper when it is dirty. After polishing wipe the commutator with a clean dry cloth. Measure the commutator under cut ①.

**Commutator under cut**

Service limit 4 mm

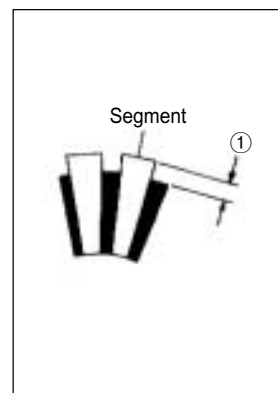
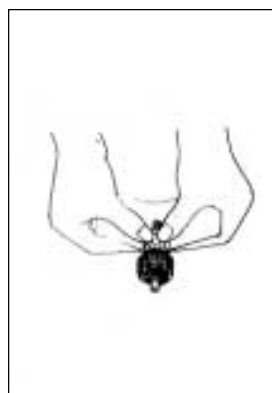

**ARMATURE COIL**

Using the pocket tester, check the coil for open and ground by placing probe pins on each commutator segment and rotor core (to test for ground) and on any two segments at various places (to test for open), with the brushes lifted off the commutator surface.

If the coil is found to be open-circuited or grounded, replace the armature. Continuous use of a defective armature will cause the starting motor to suddenly fail.

 Pocket tester : 09900-25002

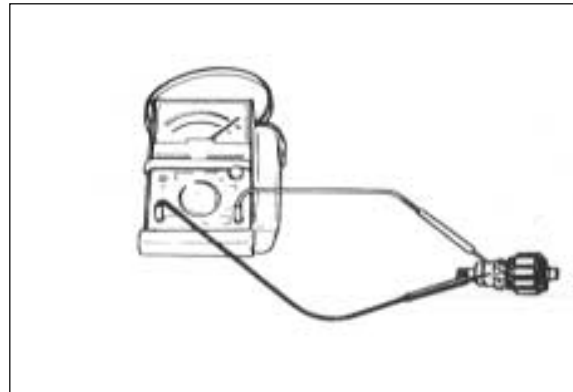
**STARTER RELAY INSPECTION**

- Disconnect the starter relay lead wire coupler. Check the coil for "open", "ground" and ohmic resistance. The coil is in good condition, if the resistance is as follows.

 Pocket tester : 09900-25002

**Starter relay standard resistance**    0 ~ 70  $\Omega$

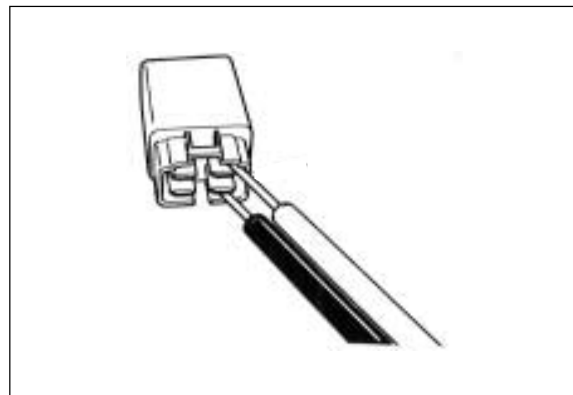

## FUEL LEVEL GAUGE

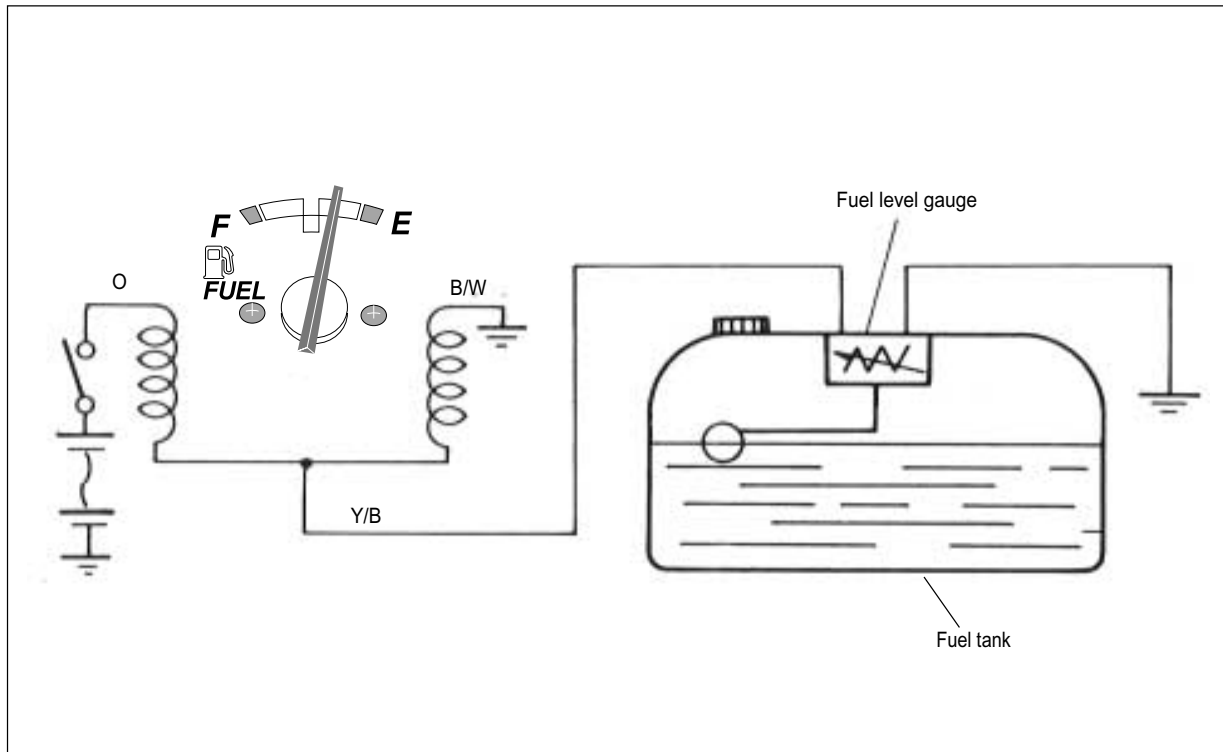

### FUEL LEVEL METER/GAUGE FUEL METER INSPECTION

To test the Fuel Meter two different checks may be used.

The first, and simplest test will tell if the meter is operating but will not indicate the meters accuracy throughout the range. To perform this test, lift the seat and remove the right frame cover, then disconnect the B/W and Y/B lead connector of the fuel gauge sending unit. Connect a jumper wire between B/W and Y/B wires coming from the main wiring harness. With the ignition switch turned ON, the fuel meter should indicate "F".

The second test will check the accuracy of the meter in the full and empty positions. Connect a 90 Ω resistor between the Y/B and B/W lead wires. The fuel meter is normal if its pointer indicates the E(empty) position when the specified voltage is applied to the circuit and if its pointer indicates the F(full) position when the resistor is changed to 10 Ω.

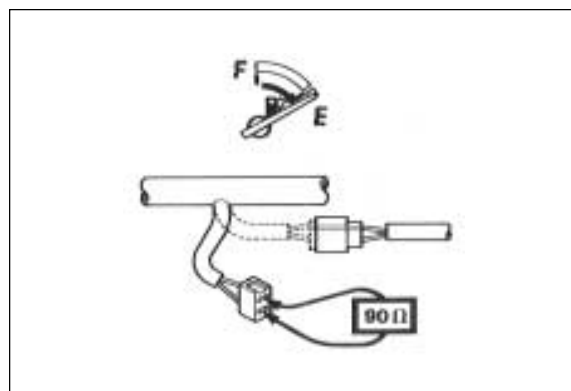
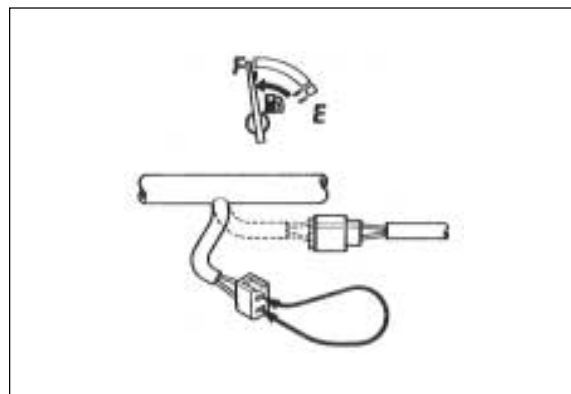

If either one or both indications are abnormal, replace the fuel meter with a new one.

#### FUEL GAUGE SENDING UNIT INSPECTION

- Disconnect the lead wires coming out of the fuel gauge and check resistance of each position.
- If the resistance measured is incorrect, replace the fuel gauge assembly with a new one.
- The relation between the position of the fuel gauge float and resistance is shown in the following table.

Relation between the position of the fuel gauge float and resistance	
Float position	Resistance
F(Full)	$10 \begin{smallmatrix} 0 \\ -6 \end{smallmatrix} \Omega$
1/2	$38 \Omega$
E(Empty)	$90 \begin{smallmatrix} +10 \\ 0 \end{smallmatrix} \Omega$

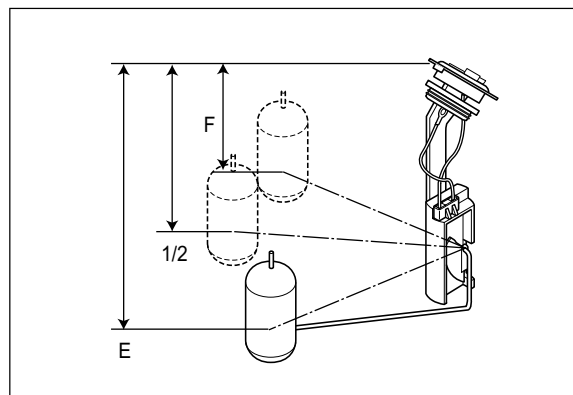
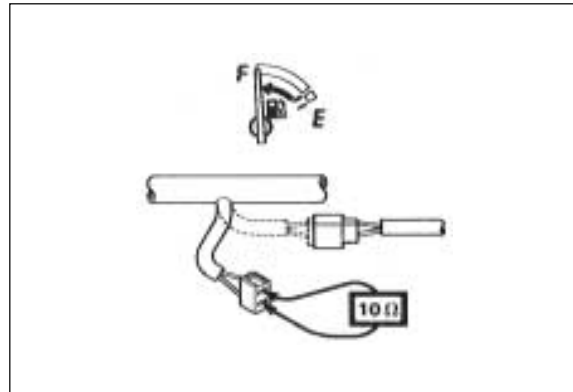

#### OIL LEVEL CHECK LIGHT

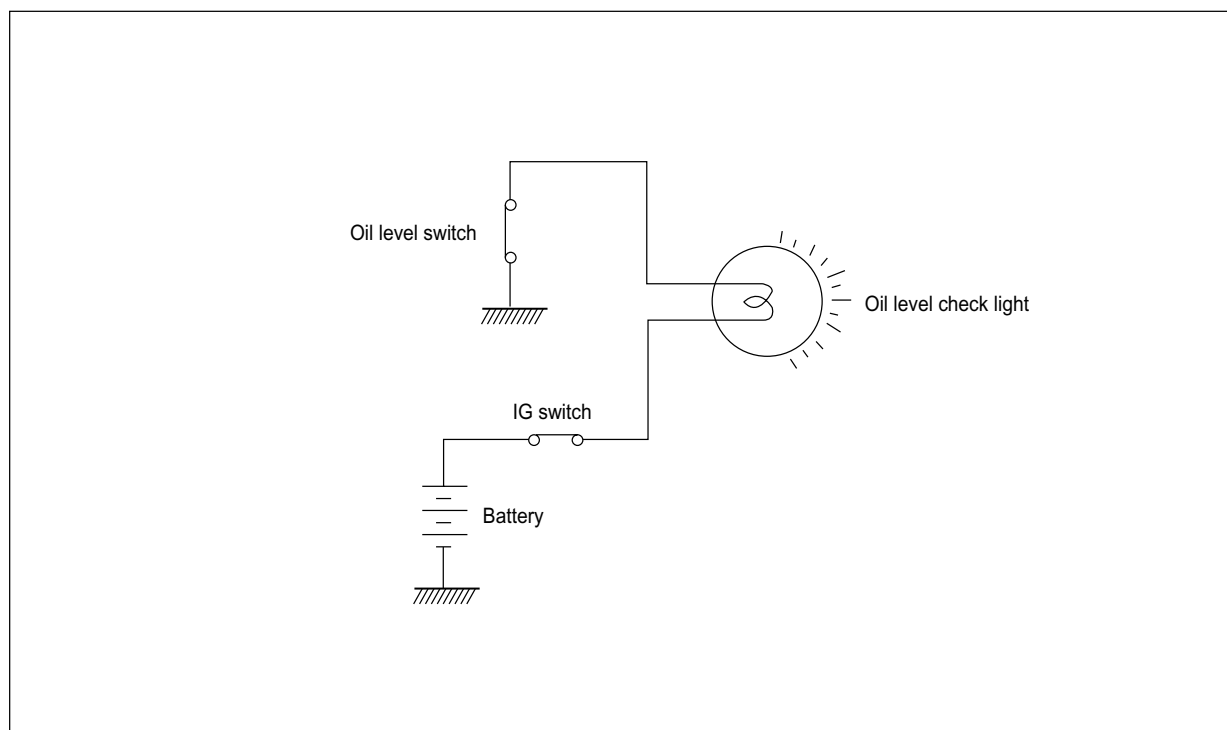

## 5-9 ELECTRICAL SYSTEM

### OIL LEVEL SWITCH INSPECTION

Check the oil level switch for continuity between the lead wire. If the tester does not show the value of  $0 \sim 1 \Omega$  when the switch ring is in bottom position, file the contact surface or replace the unit.

 Pocket tester : 09900-25002

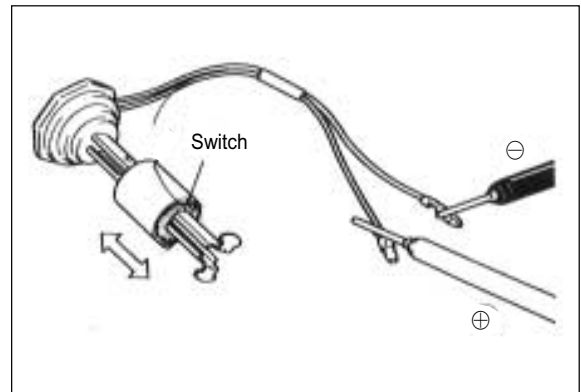

### OIL LEVEL CHECK LIGHT INSPECTION

Disconnect the L/W and B/W lead connector of the oil level check light.

Connect a jumper wire between L/W and B/W wires coming from the main wiring harness. With the ignition switch turned ON, the oil level check light should flash.

If there is no flash, check the wiring harness continuity and the bulb blown out.

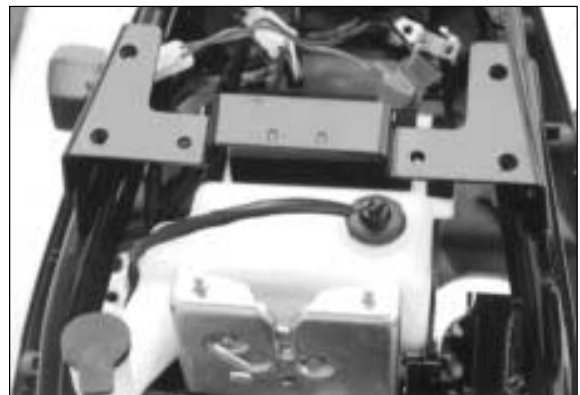

## THERMOELEMENT

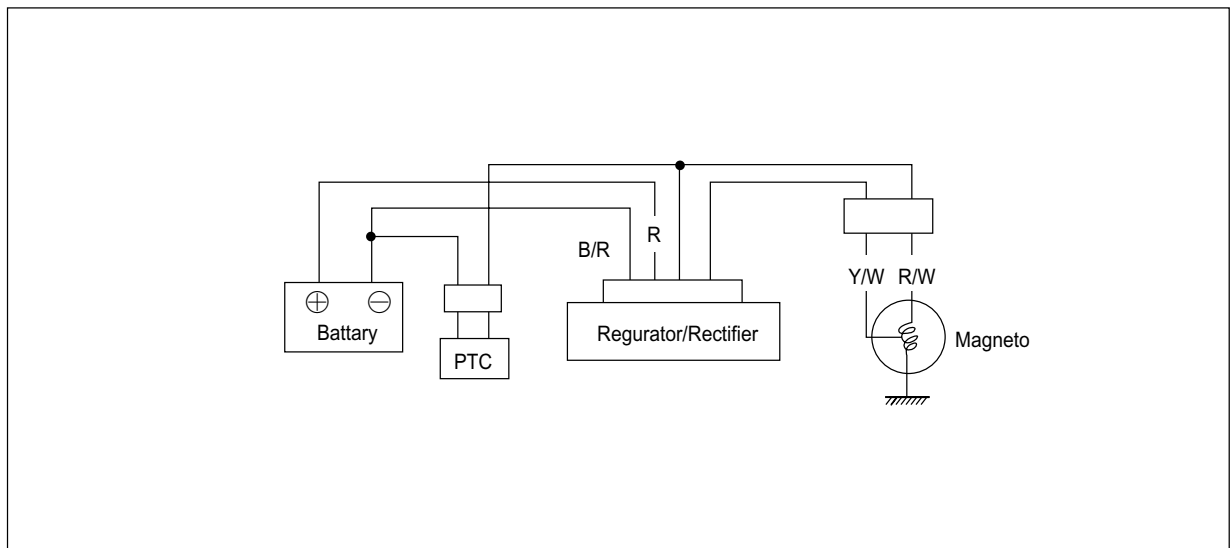

**INSPECTION**

- Disconnect the thermoelement coupler ①.
- Connect the thermoelement coupler ① to a 12V battery and touch the thermoelement ② to check the temperature being raised.  
The thermoelement ② should become heated to a temperature more than that of human body within five minutes. If not, replace with new one.

**⚠ CAUTION**

This check should be carried out when the carburetor is cold.



**SWITCHES INSPECTION**

Inspect each switch for continuity with the pocket tester referring to the chart. If it is found any abnormality, replace the respective switch assembly with new one.

 Pocket tester : 09900-25002

**WIRE COLOR**

- B ..... Black
- L ..... Blue
- G ..... Green
- Gr ..... Gray
- Sb ..... Light blue
- Lg ..... Light green
- O ..... Orange
- R ..... Red
- W ..... White
- Y ..... Yellow
- B/R ..... Black with Red tracer
- B/W ..... Black with White tracer
- W/B ..... White with Black tracer
- Y/W ..... Yellow with White tracer
- Y/G ..... Yellow with Green tracer
- L/W ..... Blue with White tracer

LIGHTING SWITCH		
	Gr	Y/W
ON	○-----○	
OFF		

STARTER SWITCH		
	W/B	Y/G
ON	○-----○	
OFF		

FRONT AND REAR LAMP SWITCH		
	O	W/B
ON	○-----○	
OFF		

TURN SIGNAL LAMP SWITCH			
	Lg	Sb	B
L		○-----○	
R	○-----○		

HORN SWITCH		
	B/W	G
ON	○-----○	
OFF		

IGNITION SWITCH					
	B/W	B/R	R	O	L/W
LOCK	○-----○				
OFF	○-----○				
ON			○-----○		
C	○-----○	○-----○	○-----○	○-----○	○-----○

## BATTERY

BATTERY	
Type	YT4L-BS
Capacity	12V, 3AH/10HR
Standard electrolyte S.G.	1.32(at 20°C)

### CAUTION OF BATTERY ELECTROLYTE TREATMENT

- Pay attention that the battery electrolyte not be stain the chasis or the humanbody.
- If be stain the chasis or the humanbody, at once wash a vast quantity of water.  
When it be stained, clothes should come into being a hole or painting should take off.  
Be cured from a doctor.
- When the battery electrolyte was dropped the surface of land, wash a vast quantity of water.  
Neutralize by hydroxide, bicarbonate of soda and so on.

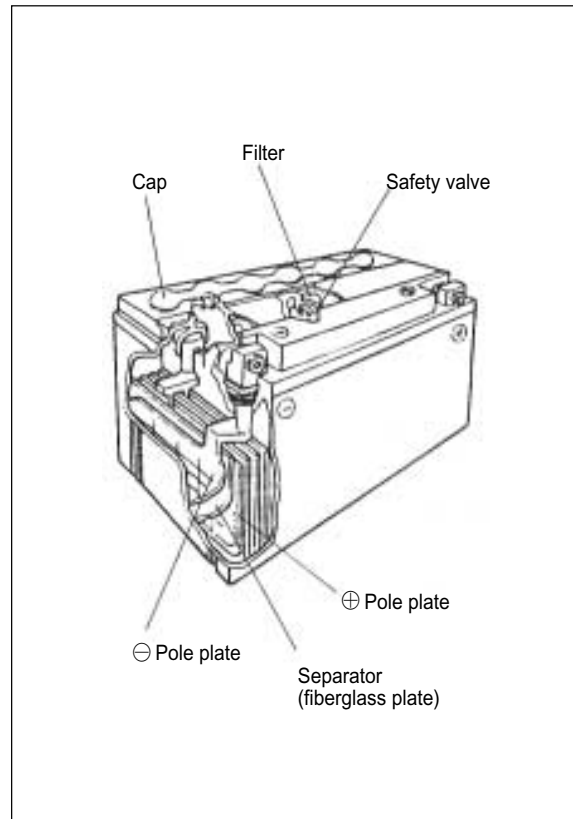

### INITIAL CHARGING FILLING ELECTROLYTE

- Remove the aluminum tape ① sealing the battery electrolyte filler holes ②.

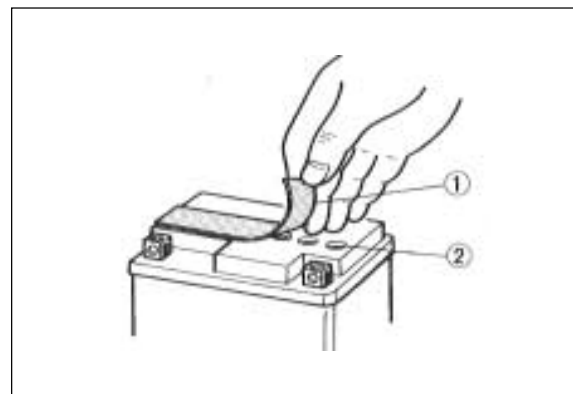

- Remove the caps ③.

**⚠ CAUTION**

- After filling the electrolyte completely, use the removed cap as the sealed caps of battery-filler holes.
- Do not remove or pierce the sealed areas ④ of the electrolyte container.

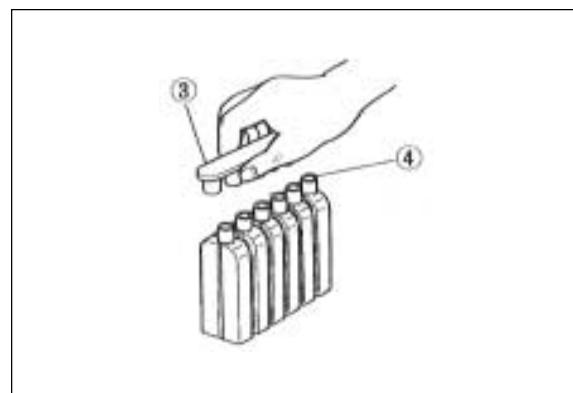

- Insert the nozzles of the electrolyte container into the battery's electrolyte filler holes, holding the container firmly so that it does not fall.

**⚠ CAUTION**

- Take precaution not to allow any of the fluid to spill.
- The electrolyte container insert at right angles so that it is not sloped.

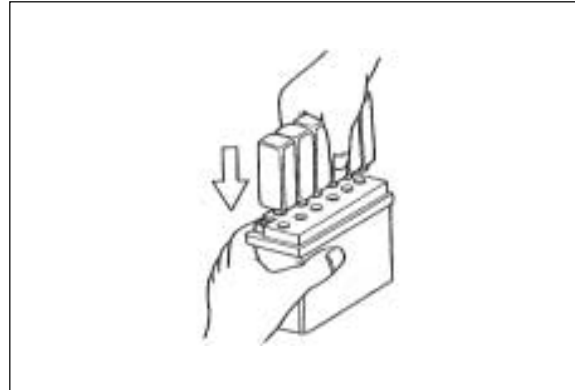

- Make sure air bubbles are coming up each electrolyte container, and leave in this position for about more than 20 minutes.



**NOTE:**

*If no air bubbles are coming up from a filler port, tap the bottom of the two or three times.*

*Never remove the container from the battery.*

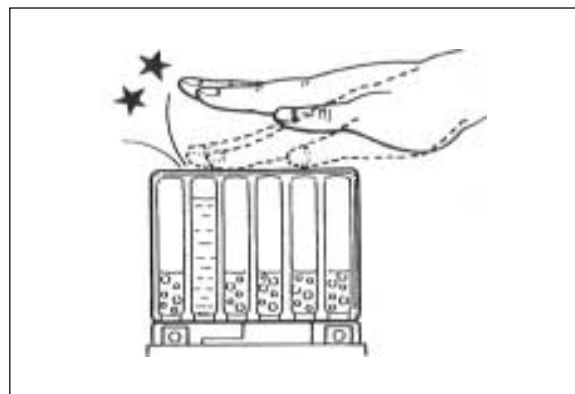

- After confirming that the electrolyte has entered the battery completely, remove the electrolyte containers from the battery. Wait for around 20 minutes.
- Insert the caps ① into the filler holes, pressing in firmly so that the top of the caps do not protrude above the upper surface of the battery's top cover.

**⚠ CAUTION**

- Clean completely in case that the electrolyte is adhered at the filler hole.
- Once install the caps to the battery, do not remove the caps.

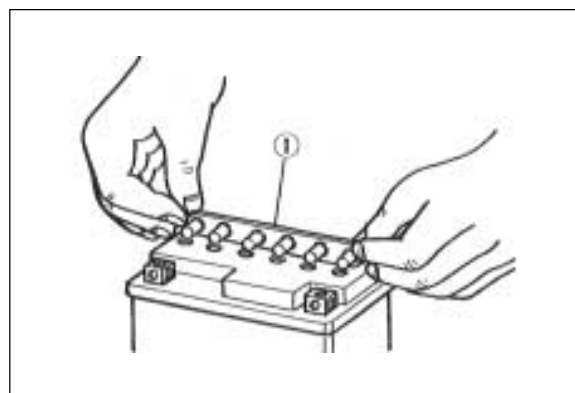



## 5-13 ELECTRICAL SYSTEM

- Using the pocket tester, measure the battery voltage. The tester should indicate more than 12.5-12.6 V(DC) as shown in the Fig. If the battery voltage is lower than the specification, charge the battery with a battery charger.

### NOTE:

Initial charging for a new battery is recommended if two years have elapsed since the date of manufacture.

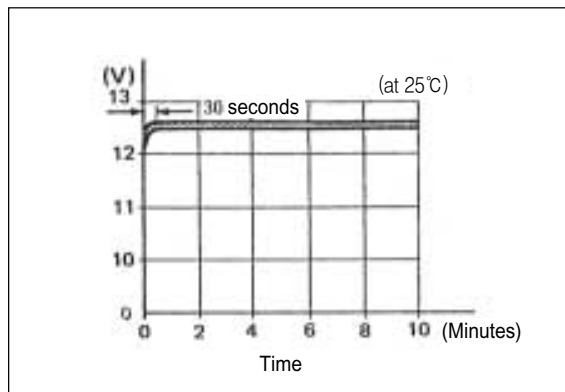

## CAUTION OF BATTERY TREATMENT

The battery is needed attention generally as occur flammability gas. If does not, it should be explosion and severe accident. Pay attention to the following points.

- Prohibit positively that come in contact with short, spark or firearms.
- The battery recharge where be well-ventilated wide place. Prohibit positively at the shut tight room.

## RECHARGING OPERATION

- Using the pocket tester, check the battery voltage. If the voltage reading is less than 12.0V(DC), recharge the battery with a battery charger.
- When recharging the battery, remove the battery from the motorcycle.
- Do the battery by standard charging usually.

BATTERY CHARGING CURRENT	
Standard	0.4A × 5~10 Hours
Fast	4A × 30 Minutes

- After recharging, wait for more than 30 minutes and check the battery voltage with a pocket tester.
- If the battery voltage is less than 12.0V, recharge the battery again.
- If the battery voltage is still less than 12.0V after recharging, replace the battery with a new one.

### NOTE:

When a battery is left for a long term without using, it is subject to discharge. When the motorcycle is not used for more than 1 month (especially during the winter season), recharge the battery once a month at least.

### ⚠ WARNING

- Charging equipment of this motorcycle is designed for the MF (Maintenance Free) battery.
- No use except the specified battery.

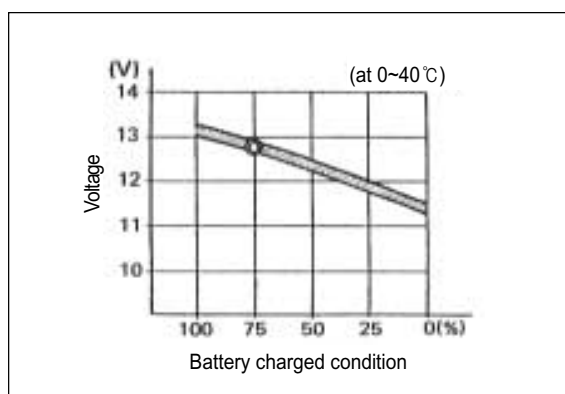
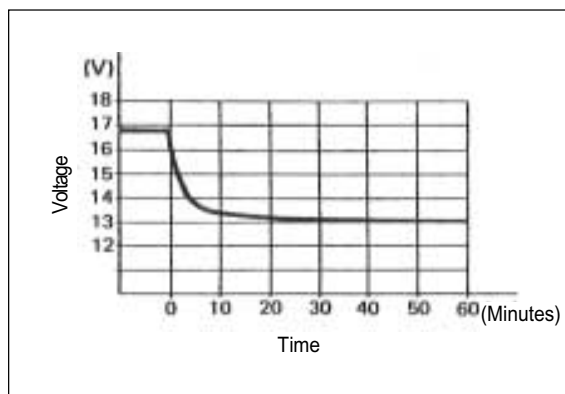

# CHASSIS

## CONTENTS

<b>FRONT WHEEL</b> .....	<b>6- 1</b>
<b>FRONT BRAKE</b> .....	<b>6- 7</b>
<b>FRONT FORK</b> .....	<b>6-14</b>
<b>STEERING</b> .....	<b>6-18</b>
<b>REAR WHEEL AND REAR BRAKE</b> .....	<b>6-22</b>

## FRONT WHEEL

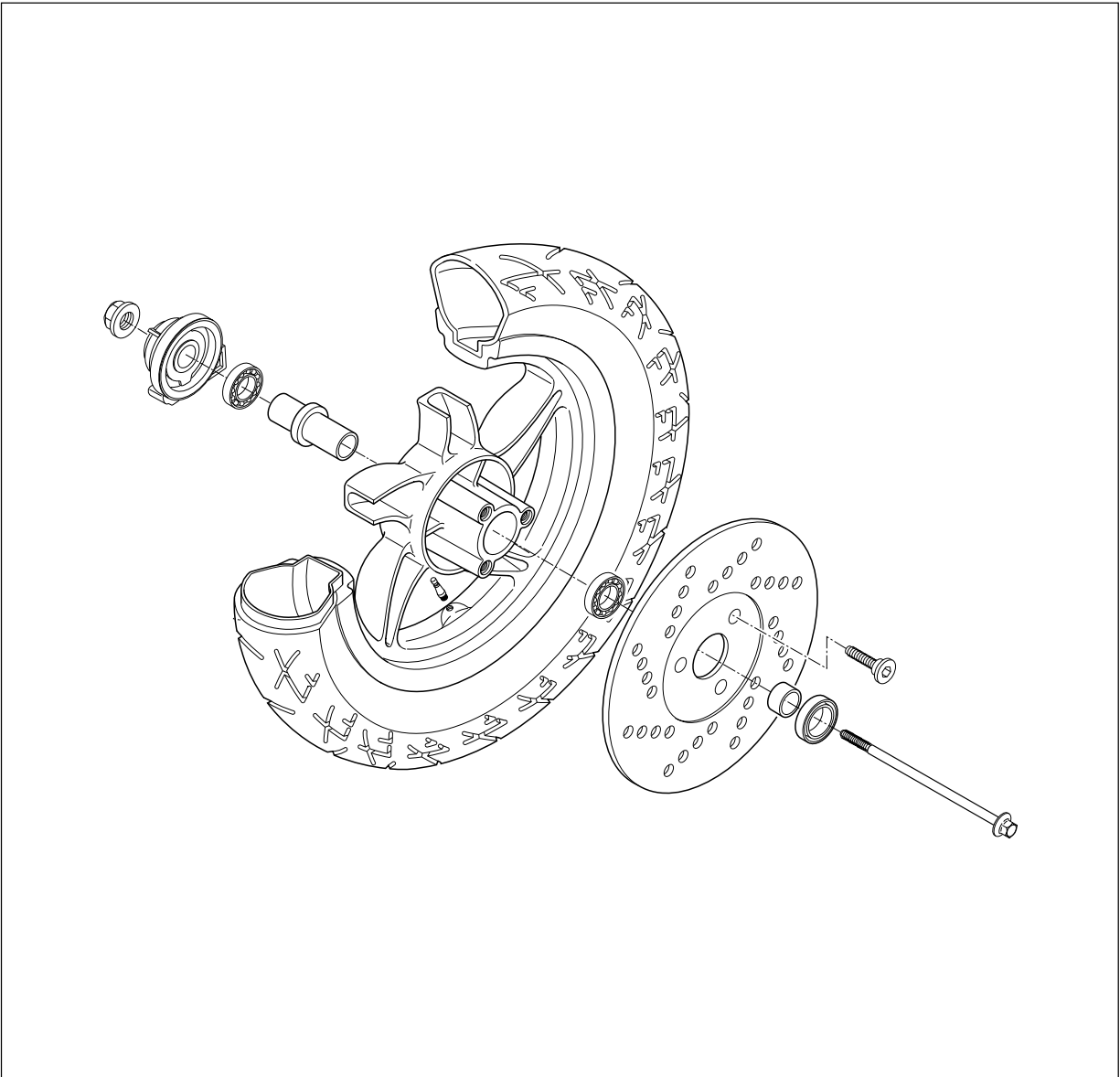

### REMOVAL AND DISASSEMBLY

- Remove the front brake caliper by removing the mounting bolts ①.

**⚠ CAUTION**

Do not operate the front brake lever while dismounting the caliper.

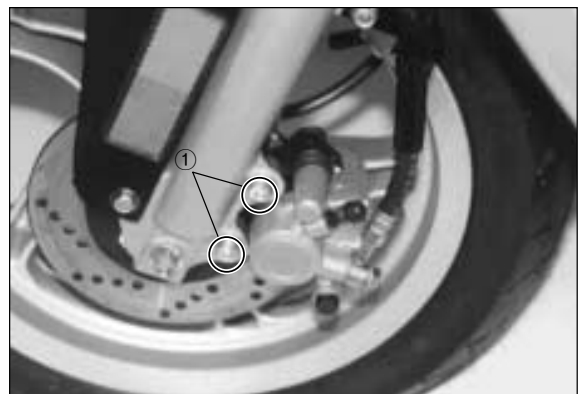

- Remove the front axle nut.
- Support the motorcycle by jack or wooden block.
- Remove the front wheel and speedometer gear box by removing the front axle shaft.



- Remove the disc plate ① by removing the bolts.



- Remove the spacer ②.

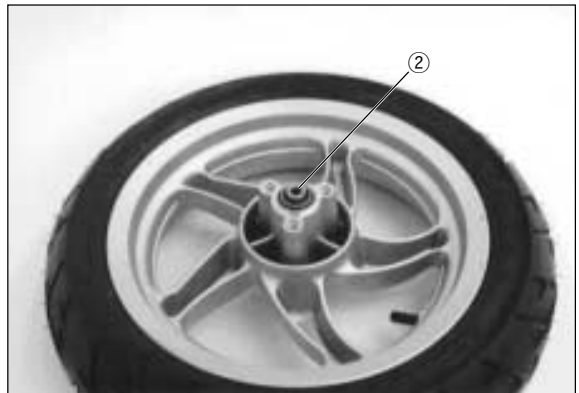

- Remove the oil seal ③ with the special tool.

 Oil seal remover : 09913-50121



## 6-3 CHASSIS

Drive out the both bearing with the special tool in the following procedures.

- Insert the adapter into the bearing.
- After inserting the wedge bar from the opposite side, lock the wedge bar in the slit of the adapter.
- Drive out the bearing by knocking the wedge bar.

 Wheel bearing remover : 09941-50111



### CAUTION

The removed dust seal and bearing should be replaced with new ones.

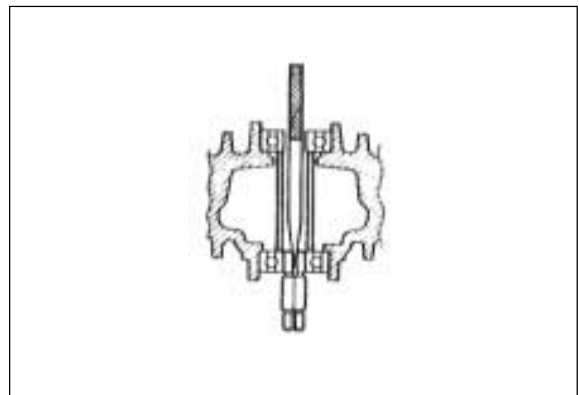

## INSPECTION

### WHEEL RIM

Make sure that the wheel rim runout does not exceed the service limit when checked as shown.

An excessive runout is usually due to worn or loose wheel bearings and can be reduced by replacing the bearings. If bearing replacement fails to reduce the runout, replace the wheel.

**Wheel rim runout  
(Axle and Radial)**

Service limit 3.0 mm

 Dial gauge(1/100 mm) : 09900-20606  
Magnetic stand : 09900-20701

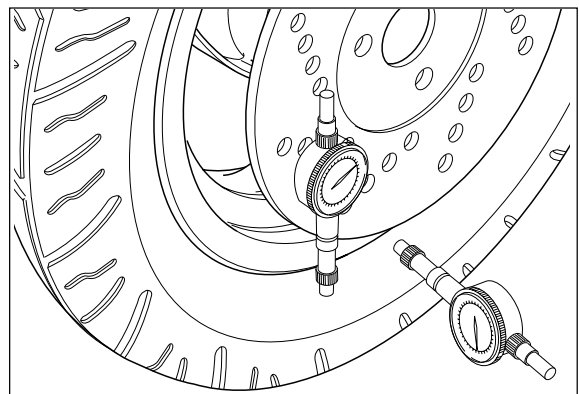

### TIRE

Inspect the tires for wear and damage, and check the tire tread depth as shown. Replace a badly worn or damaged tire. A tire with its tread worn down to the limit(in terms of tread depth) must be replaced.

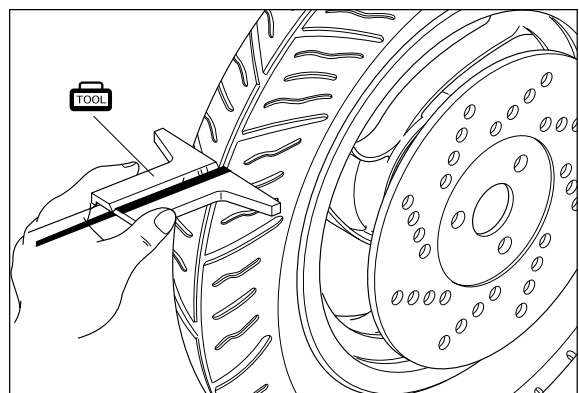

<b>Tire depth service limit</b>	Front	1.6 mm
	Rear	1.6 mm

Check the tire pressure, and examine the value for evidence of air leakage.

<b>TIRE PRESSURE Cold inflation</b>	Normal riding			
	Solo riding		Dual riding	
	kg/cm <sup>2</sup>	kPa	kg/cm <sup>2</sup>	kPa
<b>Front</b>	1.25	123	1.75	172
<b>Rear</b>	2.00	196	2.25	221

### REASSEMBLY AND REMOUNTING

Reassemble and remount the front wheel in the reverse order diassembly and removal, and also carry out the following steps.

#### WHEEL BEARING

- Apply **SUPER GREASE "A"** to the bearings before installing.

 Super Grease "A"

- Install the wheel bearings by using the special tool.

 Bearing installer set : 09924-84521

 **CAUTION**

**First install the wheel bearing for left side.**

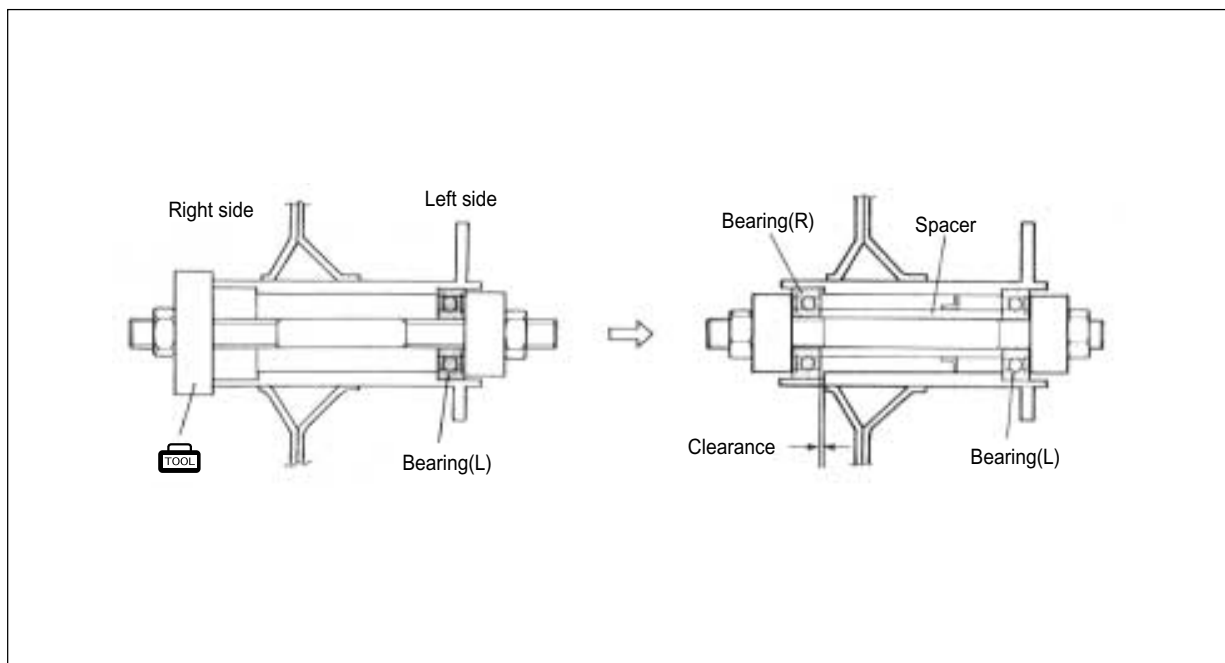

## 6-5 CHASSIS

### OIL SEAL

- Install the oil seal ① with the special tool.

 Oil seal installer : 09923-55131

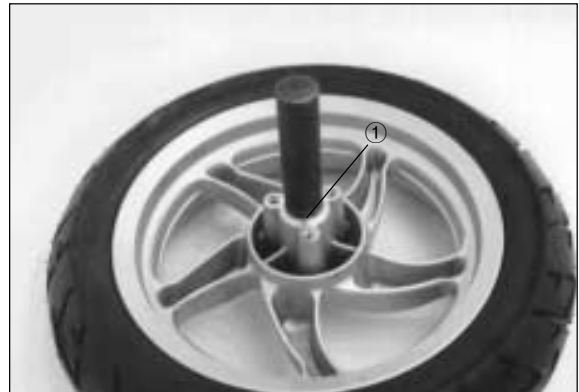

- Install the spacer ②.

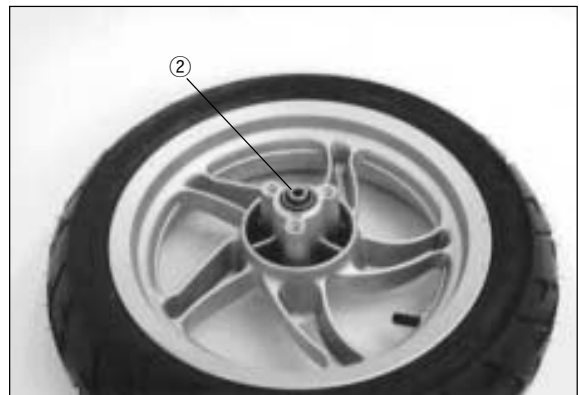

### DISC PLATE

- Install the disc plate and tighten them to the specified torque.

 Front brake disc bolt : 18 ~ 28 N · m (1.8 ~ 2.8 kg · m)

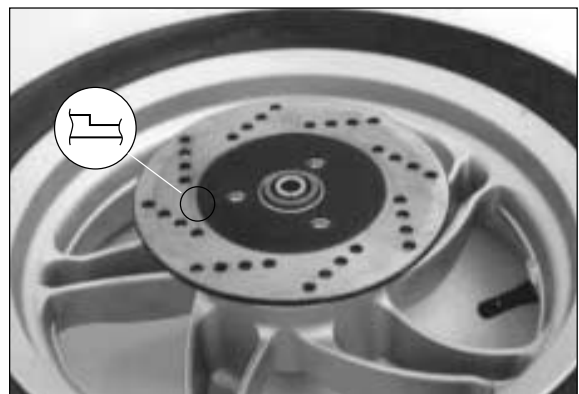

### SPEEDOMETER GEAR BOX

- When installing the speedometer gear box, align the two drive pawls ① with the two recesses ② of the wheel hub.

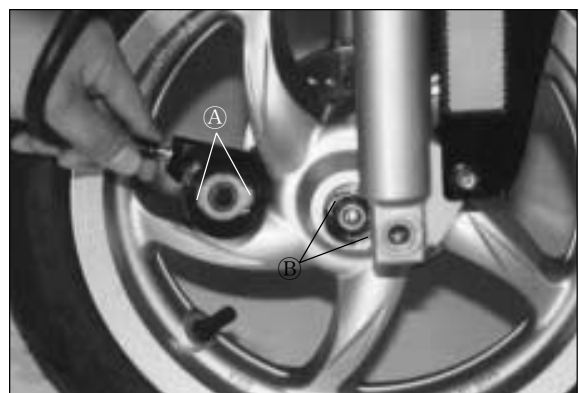

**⚠ CAUTION**

After touching the speedometer gear box ③ to the stopper ④, tighten the axle shaft.

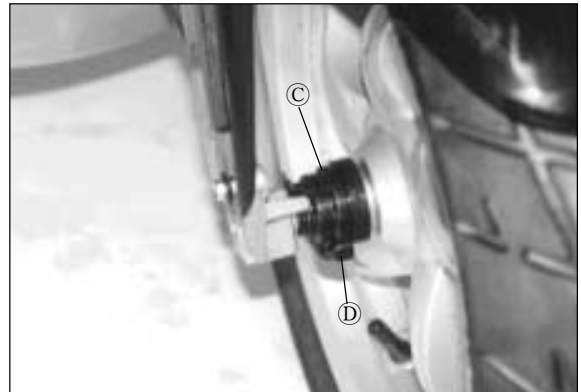
**FRONT WHEEL**

- Tighten the front axle nut to the specified torque.

 Front axle nut : 33 ~ 52 N · m (3.3 ~ 5.2 kg · m)



- Tighten the caliper mounting bolts to the specified torque.

 Front brake caliper mounting bolt  
: 18 ~ 28 N · m (1.8 ~ 2.8 kg · m)





## FRONT BRAKE

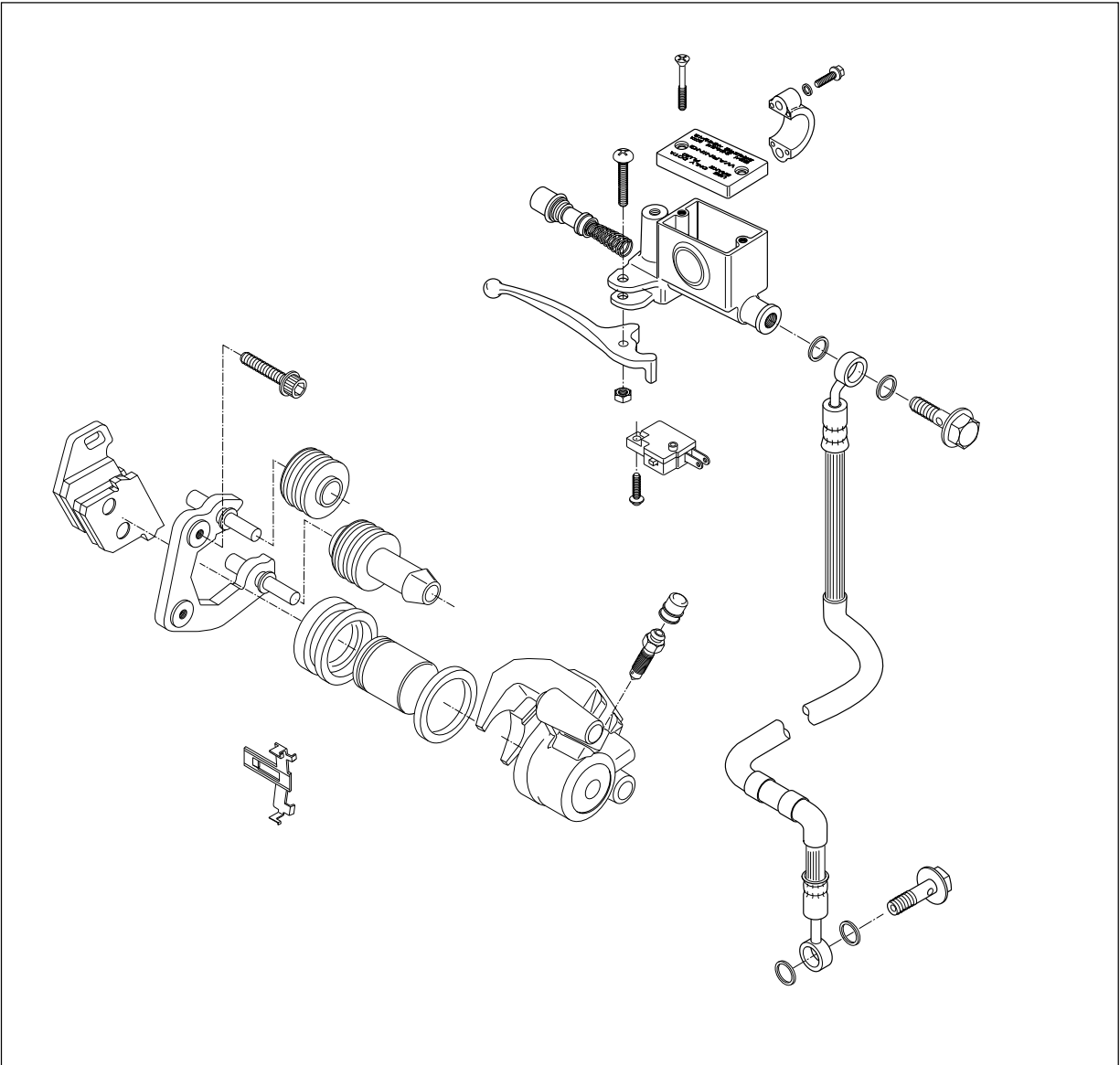

### BRAKE PAD REPLACEMENT

- Remove the caliper by removing the brake caliper mounting bolts ①.

**⚠ CAUTION**

Do not operate the front brake lever while dismounting the caliper.

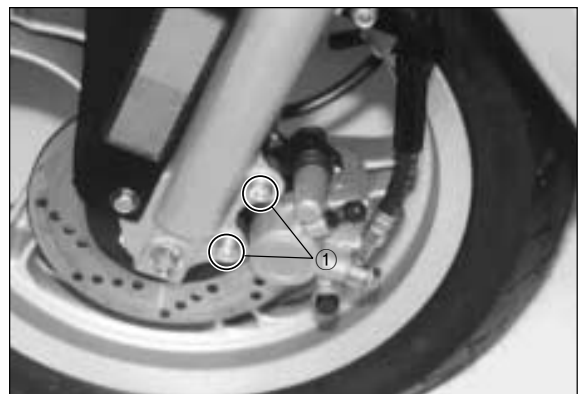

- Reassemble it after remove the brake pads ①.

**⚠ CAUTION**

Replace the brake pads as a set, otherwise braking performance will be adversely affected.

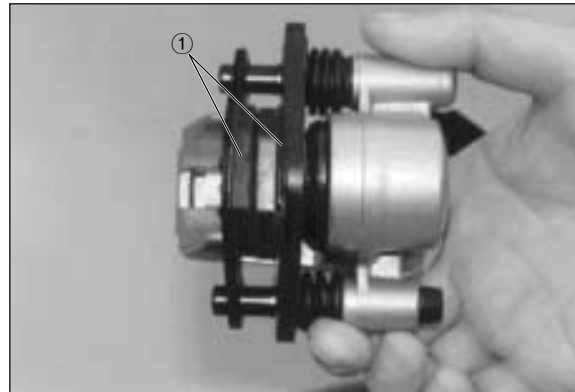

**CALIPER REMOVAL AND DISASSEMBLY**

- Remove the brake hose ② and catch the brake fluid in a suitable receptacle.
- Remove the caliper mounting bolt ③.

**⚠ CAUTION**

Never re-use the brake fluid left over from the last servicing and stored long periods.

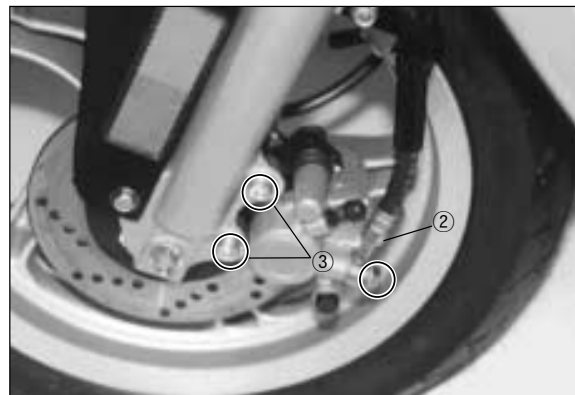

- Remove the caliper.
- Remove the brake pads.
- Remove the pad holder ④.

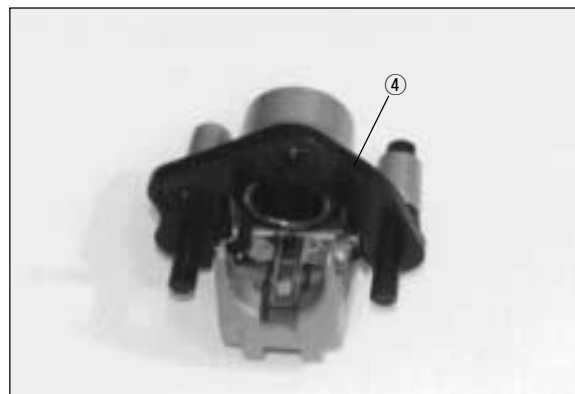

- Remove the spring ⑤.



## 6-9 CHASSIS

- Place a rag over the piston to prevent popping up.  
Force out the piston with a air gun.

**⚠ CAUTION**

**Do not use high pressure air to prevent piston damage.**



- Remove the dust seal ① and piston seal ②.

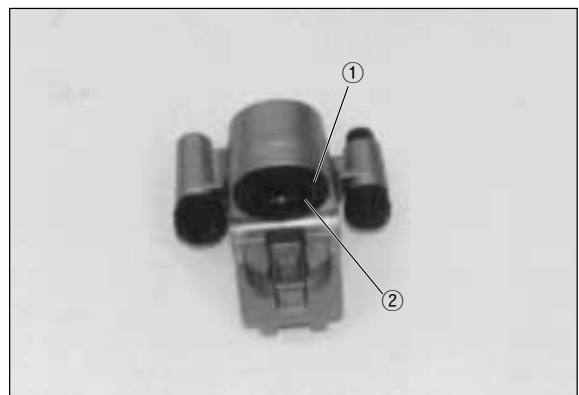

### CALIPER INSPECTION

Inspect the caliper cylinder bore wall for nicks, scratches or other damage.

Inspect piston for damage and wear.



Inspect each rubber part for damage and wear.



### CALIPER REASSEMBLY

Reassemble and remount the caliper in the reverse order of removal and disassembly, and also carry out the following steps.

**CAUTION**

Wash the caliper components with fresh brake fluid before reassembly. Never use cleaning solvent or gasoline to wash them. Apply brake fluid to the caliper bore and piston to be inserted into the bore.

- Apply **SILICONE GREASE** to the caliper holder.

 Silicone Grease

SPECIFIED TORQUE		
Item	N · m	kg · m
①	18 ~ 28	1.8 ~ 2.8
②	20 ~ 25	2.0 ~ 2.5

**WARNING**

Bleed the air from brake fluid circuit after reassembling caliper.(Refer to page 2-9)

### DISC PLATE REMOVAL AND DISASSEMBLY

- Remove the front wheel.(Refer to page 6-2)
- Remove the disc plate.(Refer to page 6-2)
- Install the disc plate.(Refer to page 6-4)

### DISC PLATE INSPECTION

- Check the disc for wear with a micrometer. Its thickness can be checked with disc and wheel in place. Replace the disc if the thickness exceeds the service limit.

<b>Disc thickness</b>	Service limit 3.5 mm
-----------------------	----------------------

 Micrometer(0 ~ 25mm) : 09900-20201

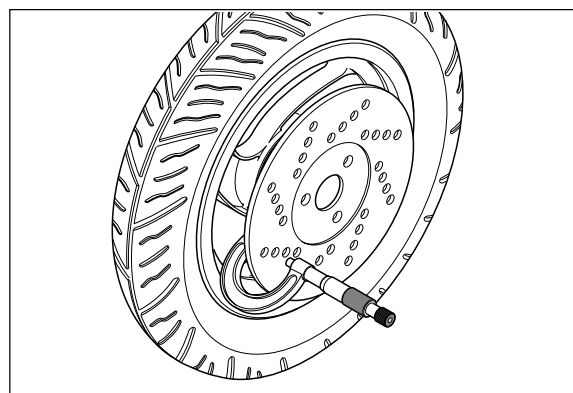
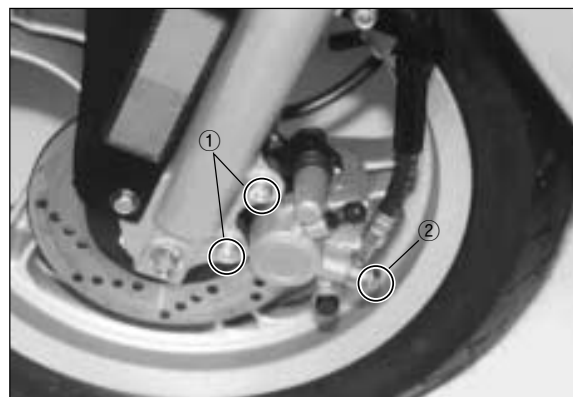
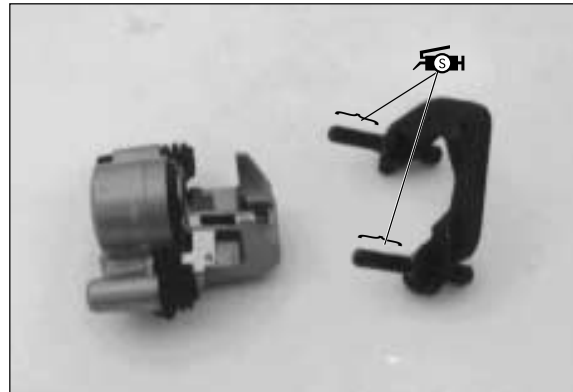

## 6-11 CHASSIS

- With the disc mounted on the wheel, check the disc for face runout with a dial gauge as shown. Replace the disc if the runout exceeds the service limit.

 Dial gauge(1/100 mm) : 09900-20606  
Magnetic stand : 09900-20701

**Disc runout**

Service limit 0.3 mm

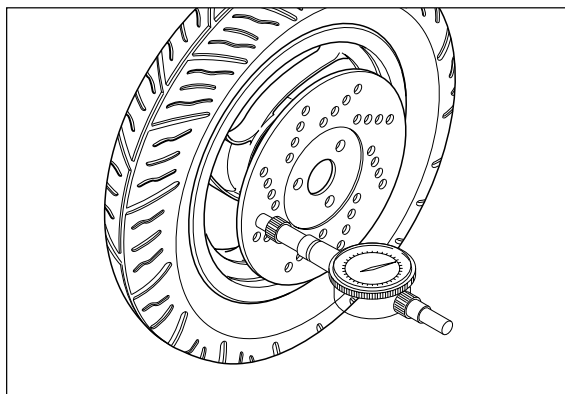

### MASTER CYLINDER REMOVAL AND DISASSEMBLY

- Remove the handlebar cover.
- Disconnect the front brake lamp switch lead wires.

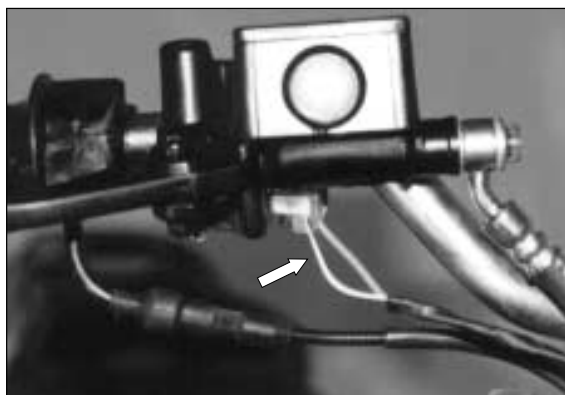

- Place a cloth underneath the union bolt on the master cylinder to catch spilled drops of brake fluid. Unscrew the union bolt and disconnect the brake hose/master cylinder joint.

#### CAUTION

Completely wipe off any brake fluid adhering to any part of motorcycle. The fluid reacts chemically with paint, plastics, rubber materials, etc.



- Remove the master cylinder.

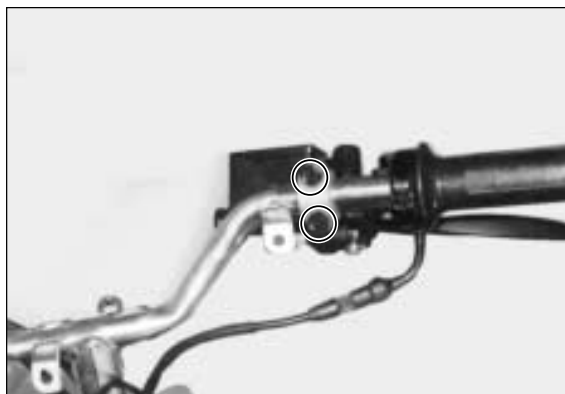

- Remove the brake lever ① and brake switch ②.

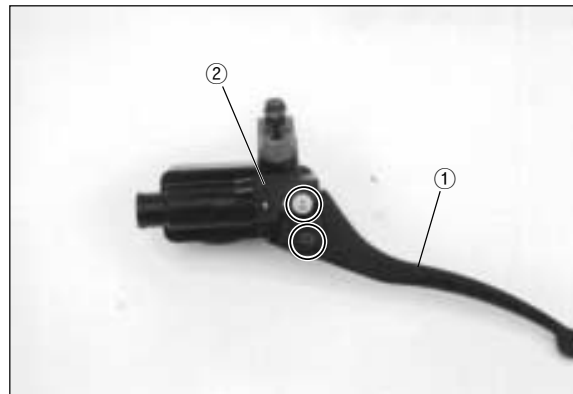

- Remove the dust boot ③.

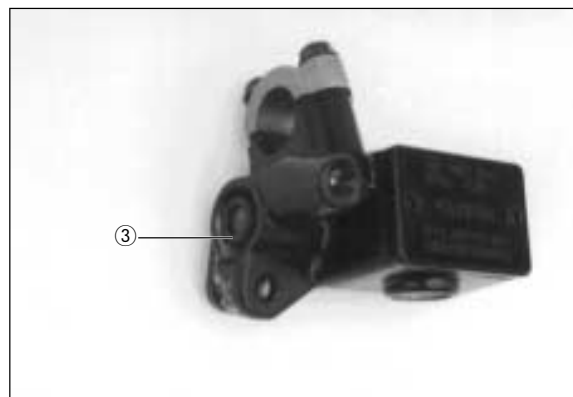

- Remove the circlip ④ with the special tool.

 Snapping pliers : 09900-06108

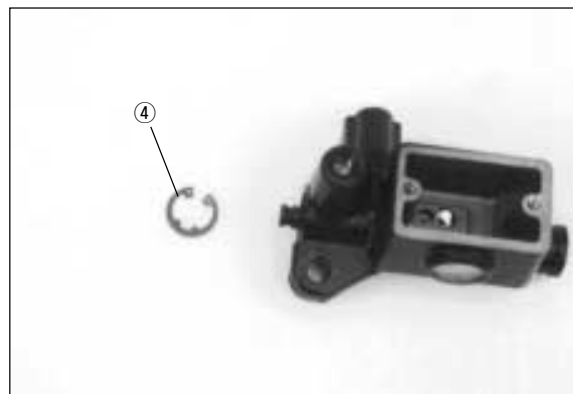

- Remove the piston/primary cup with return spring ⑤.
- Remove the reservoir cap ⑥ and diaphragm ⑦.
- Drain brake fluid.

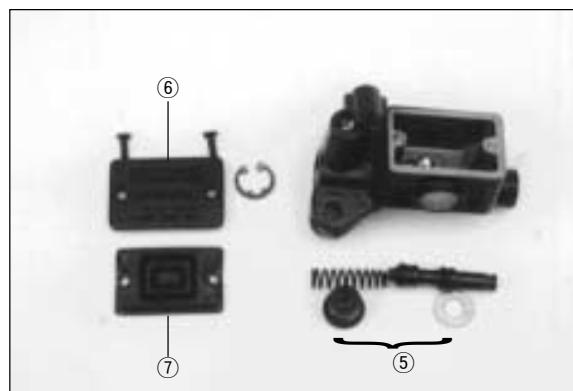

## 6-13 CHASSIS

### MASTER CYLINDER INSPECTION

Inspect the master cylinder bore for any scratches or other damage.

Inspect the piston surface for scratches or other damage.

Inspect the primary cup and dust boot for wear or damage.



### MASTER CYLINDER REASSEMBLY AND REMOUNTING

Reassemble and remount the master cylinder in the reverse order of removal and disassembly, and also carry out the following steps.

#### ⚠ CAUTION

**Wash the master cylinder components with fresh brake fluid before reassembly. Never use cleaning solvent or gasoline to wash them. Apply brake fluid to the cylinder bore and all the internals to be inserted into the bore.**

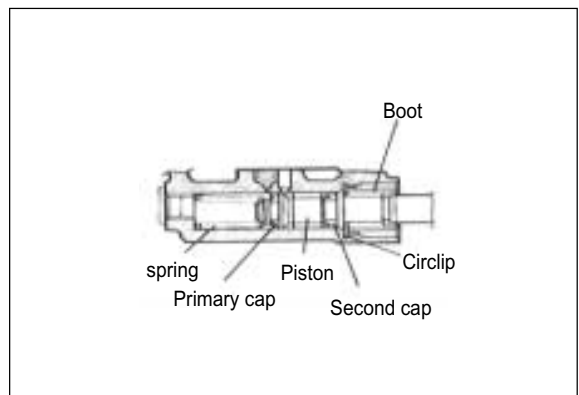

- Reassemble and remount the master cylinder. (Refer to page 6-11)
- When remounting the master cylinder on the handlebar, first tighten the clamp bolt for upside.

#### ⚠ CAUTION

**Bleed air after remounting the master cylinder.**

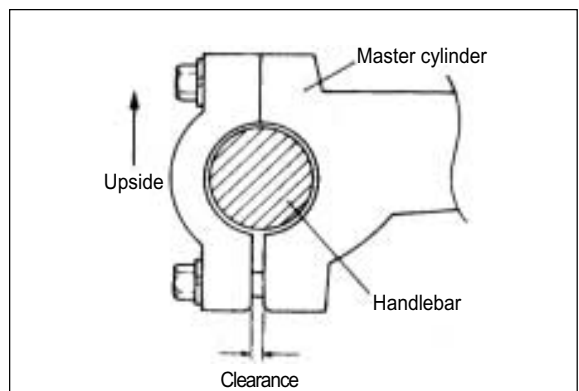

## FRONT FORK

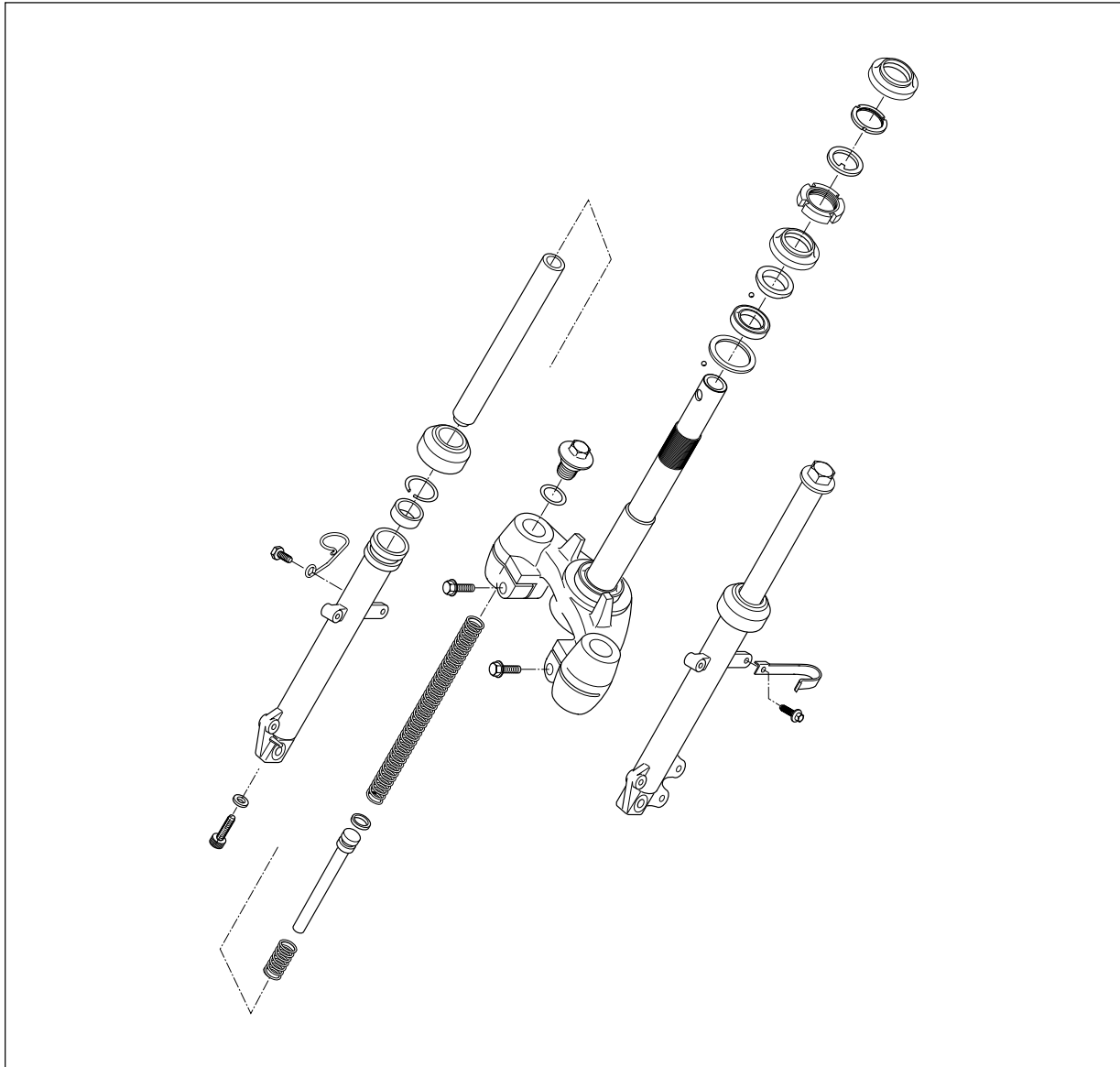

### REMOVAL AND DISASSEMBLY

- Remove the front leg shield.
- Remove the front brake caliper by removing the mounting bolts.

**⚠ CAUTION**

**Do not operate the front brake lever while dismounting the caliper.**

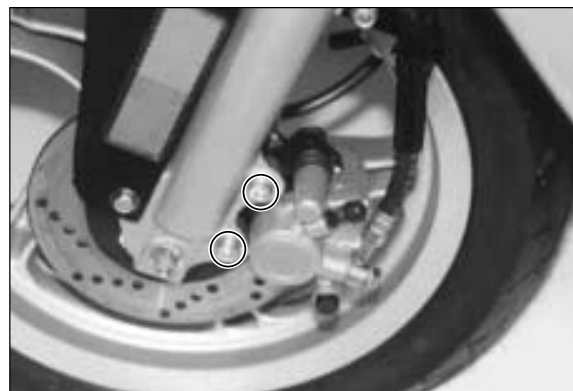



## 6-15 CHASSIS

- Remove the front axle nut.
- Support the motorcycle by jack or wooden block.
- Remove the front wheel by removing the front axle shaft.



- Loosen the front fork bolt, then draw out the fork spring.
- Loosen the front fork lower clamp bolts.

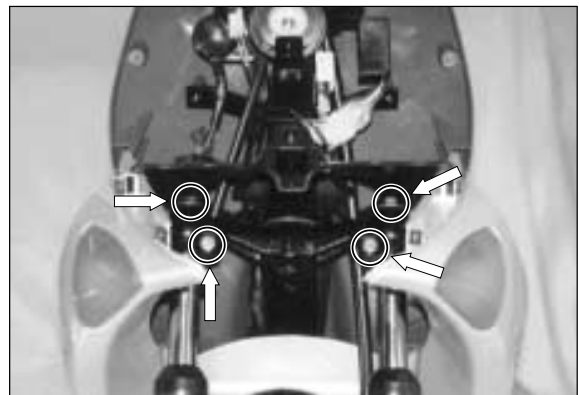
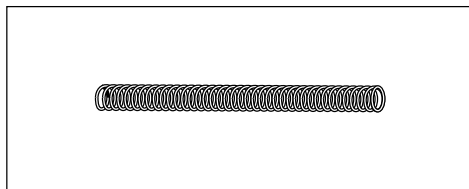

- Invert the fork and stroke it several times to remove the oil.
- Hold the fork inverted for a few minutes.

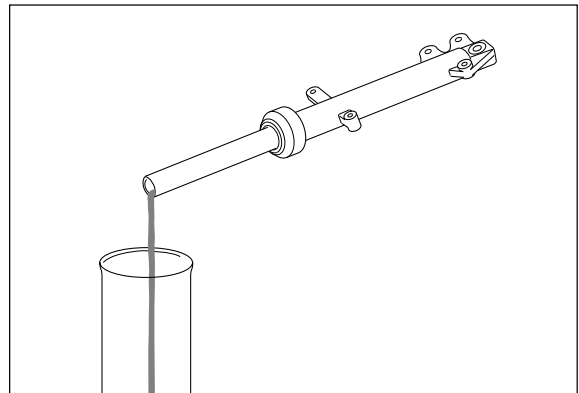

- Remove the socket bolt ① with the hexagon wrench.
- Separate the fork pipe ② and pipe seat ③.

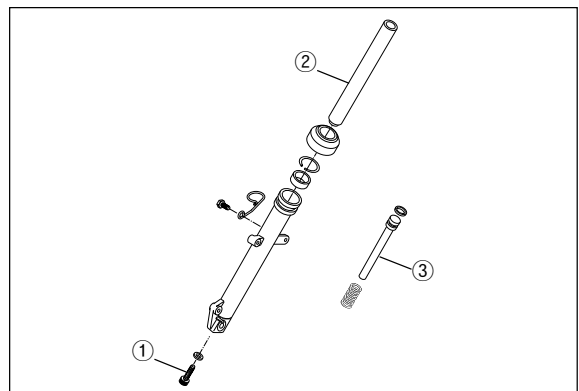

- Remove the dust boot ① and stopper ring ②.

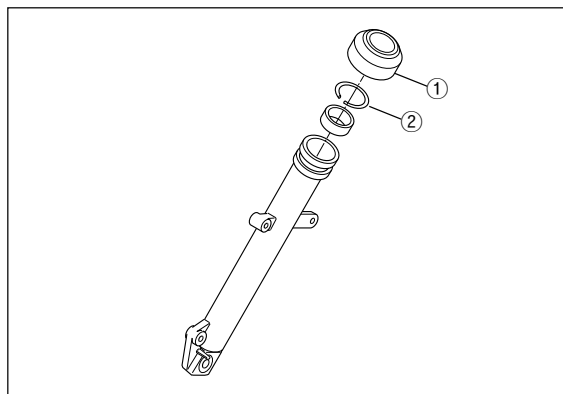

- Remove the oil seal by using the special tool.

**⚠ CAUTION**

The oil seal removed should be replaced with a new oil seal.

**TOOL** Oil seal remover : 09913-50121

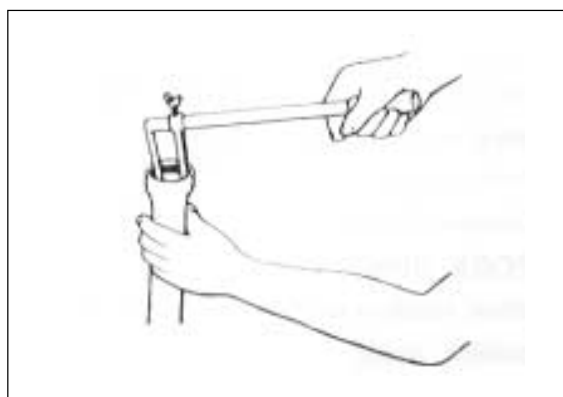

**INSPECTION**

- Inspect pipe seat for wear and damage.

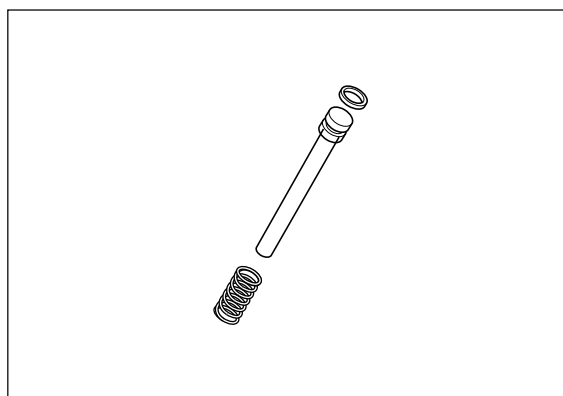

- Inspect fork pipe and bottom case sliding surfaces for any scuffing or flaws.

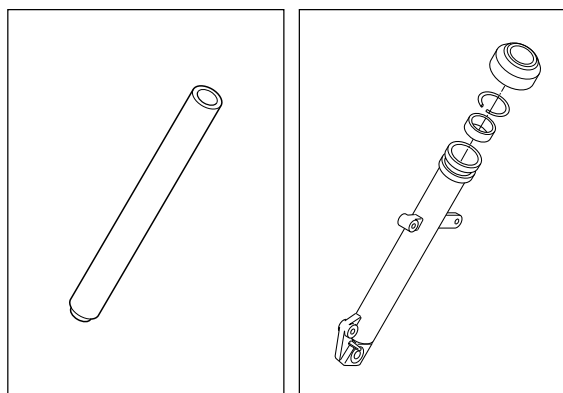

## 6-17 CHASSIS

### FORK SPRING

- Measure the fork spring free length.

<b>Fork spring free length</b>	Standard 290.9 mm
--------------------------------	-------------------

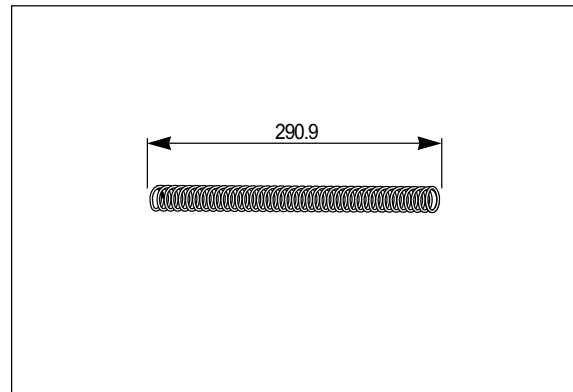

### REASSEMBLY AND REMOUNTING

Reassemble and remount the fork in the reverse order of removal and disassembly, and also carry out the following steps.

#### FRONT FORK BOLT

- Apply **BOND "1215"** and **THREAD LOCK "1324"** to the fork bolt and tighten the bolt with specified torque.

 Bond "1215"

 Thread Lock "1324"

 Front fork bolt : 35 ~ 55 N · m(3.5 ~ 5.5 kg · m)

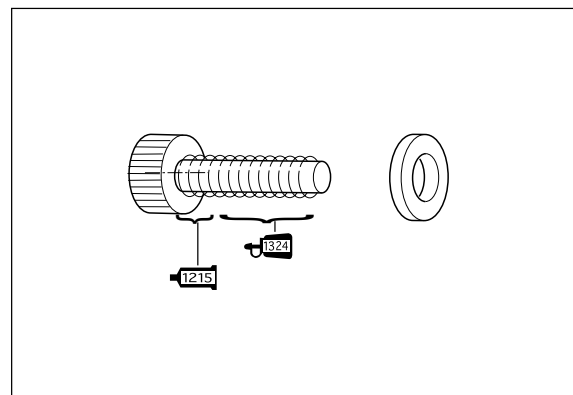

#### FORK OIL

- For the fork oil, be sure to use a front fork oil whose viscosity rating meets specification below.

<b>Fork oil type</b>	TELLUS # 37
<b>Capacity</b>	50 cc(One side)

#### CUSHION SPRING

- When installing the front fork spring, the close end should position upside.

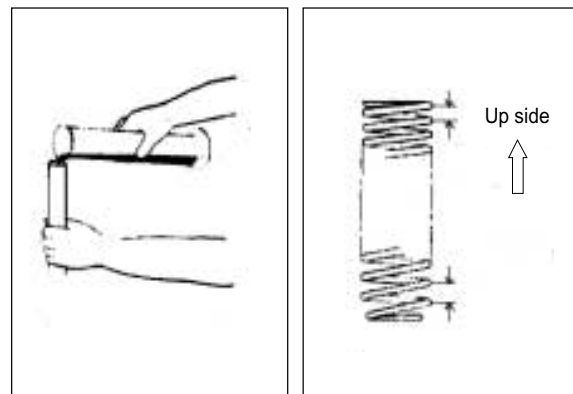

## STEERING

### REMOVAL AND DISASSEMBLY

- Remove the handlebar cover.
- Remove the handlebar by removing the clamp bolt ① and set bolt ②.

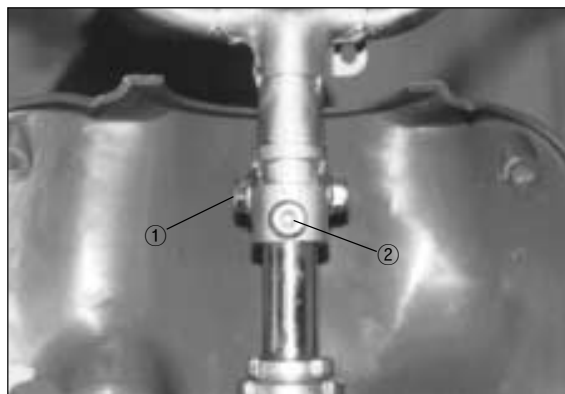

- Loosen the steering stem lock nut ③ with the special tool.

 Clamp wrench : 09940-10122

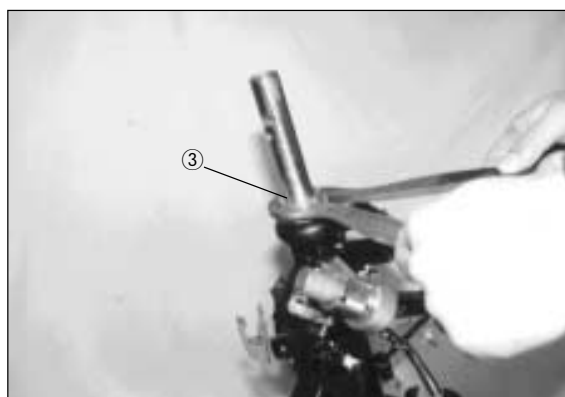

- Remove the front fork assembly by removing the lock washer ④, steering outer upper race ⑤ and dust seal ⑥.

#### CAUTION

Do not drop the steering stem steel balls.

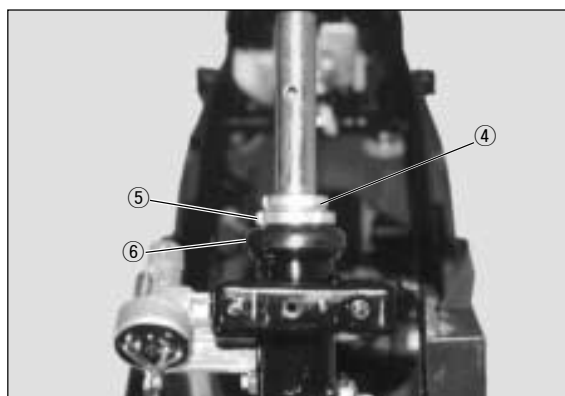

- Remove the steering outer lower race ⑦ with a chisel.

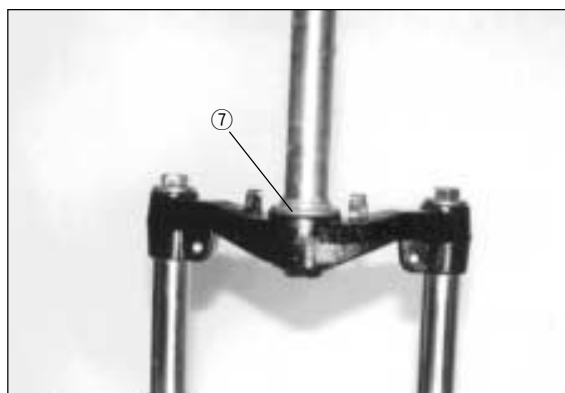

## 6-19 CHASSIS

- Remove the steering stem steel balls ①.

Number of steel ball	
Upper	22 pcs
Lower	25 pcs

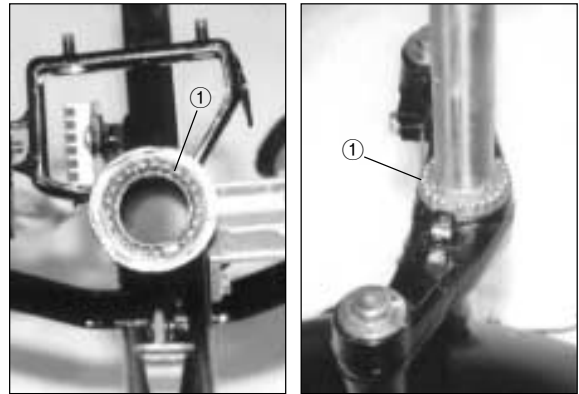

- Remove the upper and lower bearing inner race with an appropriate bar.



### INSPECTION

Inspect the removed parts for the following abnormalities.

- Bearing race wear and brinelling.
- Worn and damaged steel balls.
- Distortion of steering stem or handlebar.



### REASSEMBLY AND REMOUNTING

Reassemble and remount the steering stem, handlebar and front fork in the reverse order of disassembly and removal, and also carry out the following steps.

#### OUTER LOWER RACE

- Press in the outer lower race ②.

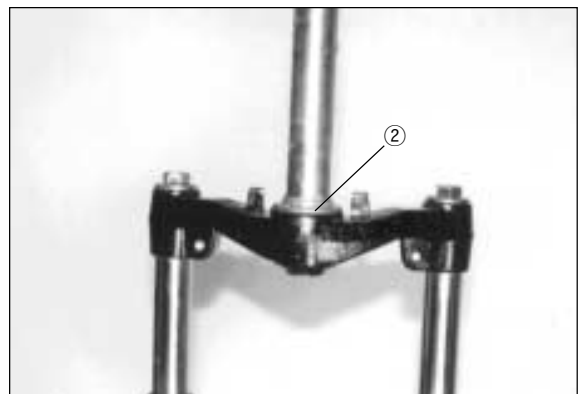

**INNER RACE**

- Press in the upper and lower inner races with the special tool.

 Steering race installer : 09941-34513



**STEEL BALL**

- Apply **SUPER GREASE "A"** when installing the upper and lower steel balls.

 Super Grease "A"

Number of steel ball	
Upper	22 pcs
Lower	25 pcs

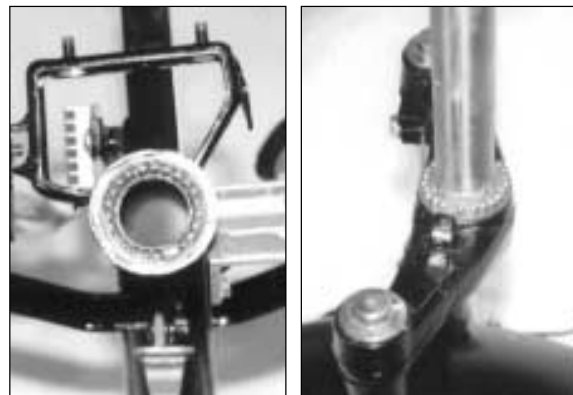

**STEERING OUTER UPPER RACE NUT**

- Tighten the steering outer upper race ① until resistance is felt, then loosen it 1/8 ~ 1/4 turn.

 **CAUTION**

**Make sure that the steering turns smoothly and easily, left to right.**

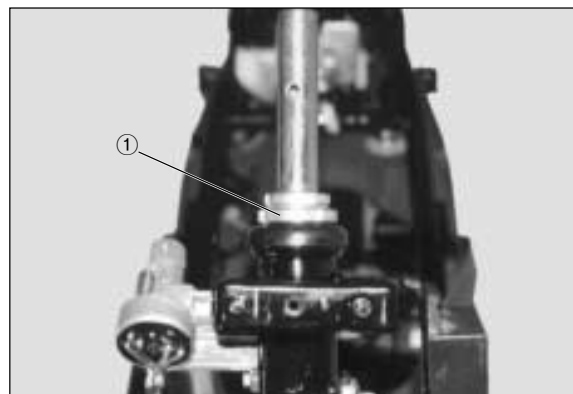

- Tighten the steering stem lock nut ② with the special tool.

 Clamp wrench : 09940-10122

 Steering stem lock nut  
: 60 ~ 100 N · m (6.0 ~ 10.0 kg · m)

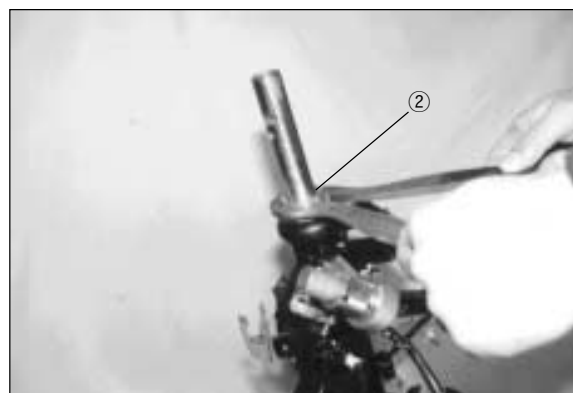

## 6-21 CHASSIS

---

- Install the handlebar and tighten the set bolt ① and clamp bolt ② to the specified torque.

- Handlebar set bolt : 22 ~ 28 N · m (2.2 ~ 2.8 kg · m)
- Handlebar clamp bolt : 48 ~ 52 N · m (4.8 ~ 5.2 kg · m)

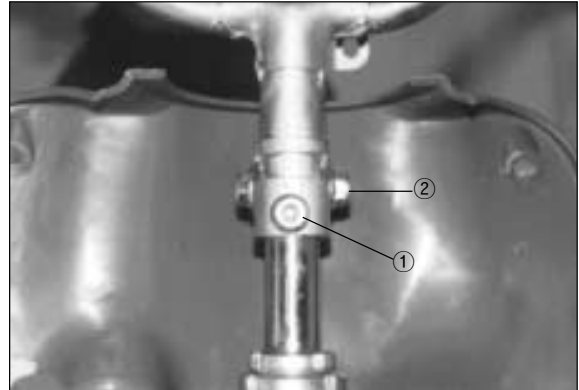

- After install the front fork and steering stem, inspect the following items.
  - Lift the front fork.
  - Inspect play of the front fork as that grasp lower of the front fork and shake it by the front and rear.
  - By the handle turning the right or left, inspect whether turning smoothly.
  - Adjust the outer upper race, if the steering is comed heavy and tight.
- Bleed air of the front brake. (Refer to page 2-9)



## REAR WHEEL AND REAR BRAKE

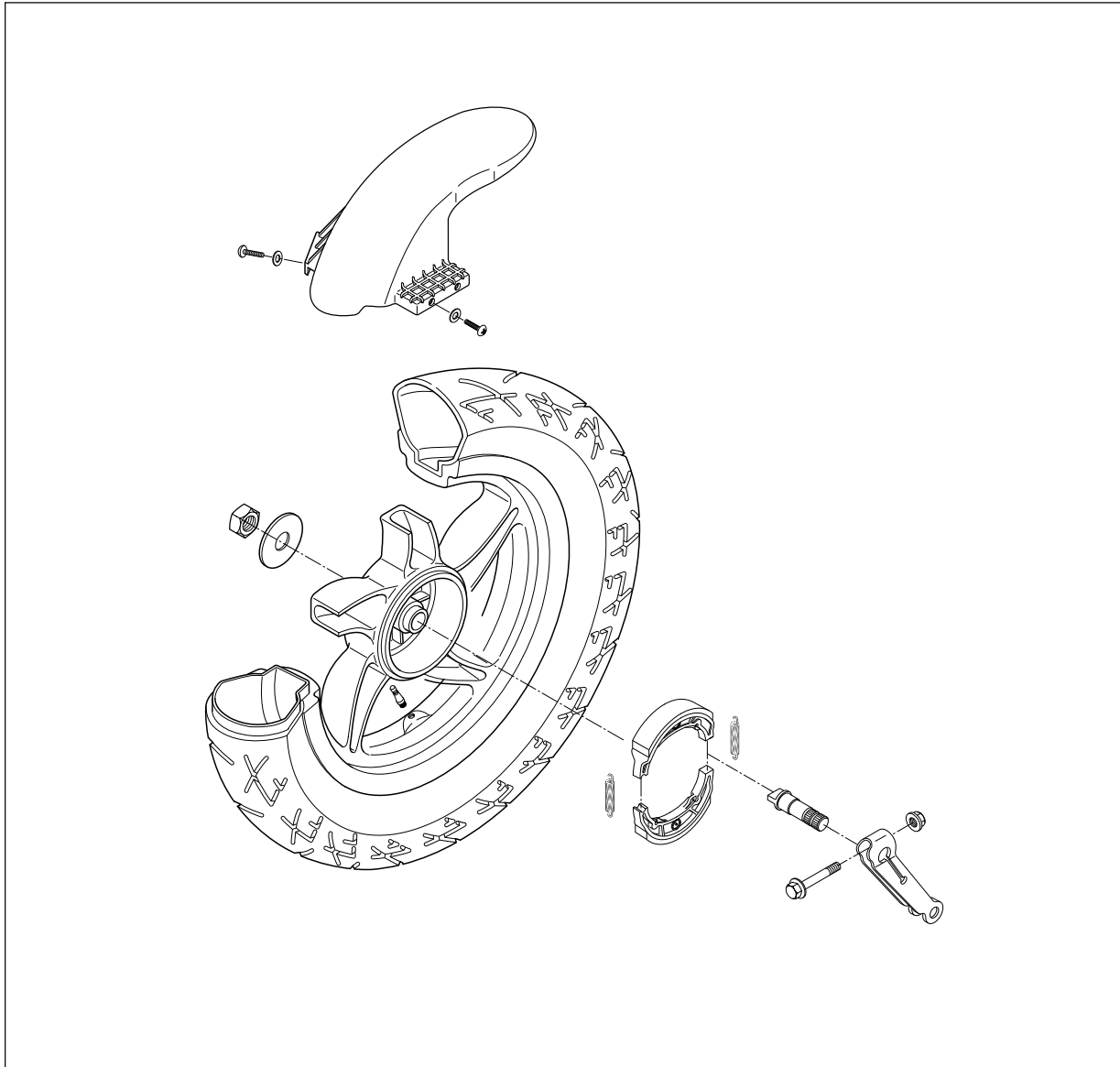

### REMOVAL AND DISASSEMBLY

- Place the motorcycle on level ground.
- Remove the muffer. (Refer to page 3-4)
- Remove the rear wheel by removing the axle nut ①.





## 6-23 CHASSIS

### INSPECTION

#### REAR BRAKE DRUM

Measure the brake drum I.D. to determine the extent of wear and, if the limit is exceeded by the wear noted, replace the drum. The value of this limit is indicated inside the drum.

**Rear brake drum I.D** Service limit 100.7 mm

#### BRAKE SHOE

Using a vernier calipers, measure the brake shoe outside diameter at the place as shown in the photo. If the measurement is less than the limit, replace the brake shoe.

**Brake shoe lining for thickness** Service limit 96 mm

#### ⚠ CAUTION

Replace the brake shoe with a set, otherwise braking performance will be adversely affected.

#### WHEEL

Refer to page 6-3.

#### TIRE

Refer to page 6-4.

### REASSEMBLY AND REMOUNTING

Reassemble and remount the rear wheel and brake in the reverse order of removal, and disassembly.

#### BRAKE CAM LEVER

- When installing the brake cam lever, align the punched mark of camshaft with the slit on cam lever.

 Brake cam lever bolt : 6 ~ 9 N · m (0.6 ~ 0.9 kg · m)

#### REAR BRAKE SHOE

- Apply **SUPER GREASE "A"** to the camshaft and pin before installing the brake shoes.

 Super Grease "A"

#### ⚠ CAUTION

Be careful not to apply too much grease to the camshaft and pin. If grease gets on the lining, brake effectiveness will be lost.

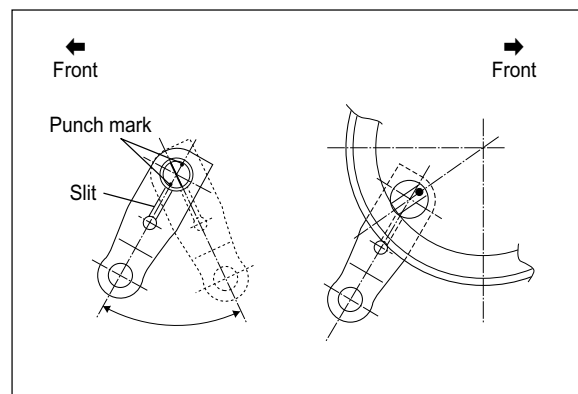
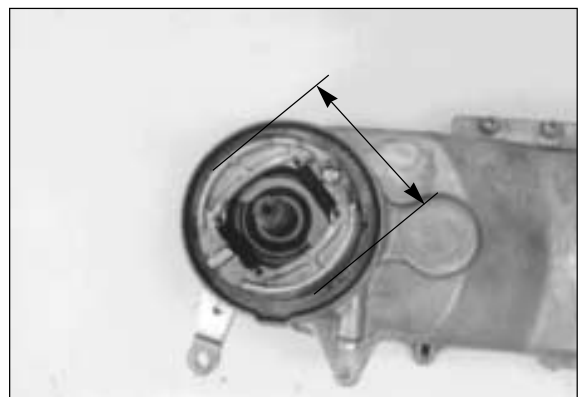

**REAR AXLE NUT**

● Tighten the rear axle nut to the specified torque.

🔧 Rear axle nut : 60 ~ 90 N · m (6.0 ~ 9.0 kg · m)



# SERVICING INFORMATION

## CONTENTS

<b>TROUBLESHOOTING</b> .....	<b>7- 1</b>
<b>SPECIAL TOOLS</b> .....	<b>7- 6</b>
<b>TIGHTENING TORQUE</b> .....	<b>7-10</b>
<b>SERVICE DATA</b> .....	<b>7-12</b>
<b>WIRE AND CABLE ROUTING</b> .....	<b>7-18</b>
<b>WIRING DIAGRAM</b> .....	<b>7-20</b>

## TROUBLESHOOTING

## ENGINE

Complaint	Symptom and possible causes	Remedy
<b>Engine does not start, or is hard to start.</b>	<p><b>Compression too low</b></p> <ol style="list-style-type: none"> <li>1. Excessively worn cylinder or piston rings.</li> <li>2. Stiff piston ring in place.</li> <li>3. Gas leaks from the joint in crankcase, cylinder or cylinder head.</li> <li>4. Damaged reed valve.</li> <li>5. Spark plug too loose.</li> <li>6. Broken, cracked or otherwise failed piston.</li> </ol> <p><b>Plug not sparking</b></p> <ol style="list-style-type: none"> <li>1. Damaged spark plug or spark plug cap.</li> <li>2. Dirty or wet spark plug.</li> <li>3. Defective CDI &amp; Ignition coil unit or stator coil.</li> <li>4. Open or short in high-tension cord.</li> <li>5. Defective ignition switch.</li> </ol> <p><b>No fuel reaching the carburetor</b></p> <ol style="list-style-type: none"> <li>1. Clogged hole in the fuel tank cap.</li> <li>2. Clogged or defective fuel cock.</li> <li>3. Defective carburetor float valve.</li> <li>4. Clogged fuel hose or defective vacuum hose.</li> </ol>	<p>Replace. Repair or replace. Repair or replace. Replace. Tighten. Replace.</p> <p>Replace. Clean and dry. Replace. Replace. Replace.</p> <p>Clean. Clean or replace. Replace. Clean or replace.</p>
<b>Engine stalls easily.</b>	<ol style="list-style-type: none"> <li>1. Carbon deposited on the spark plug.</li> <li>2. Defective CDI &amp; Ignition coil unit.</li> <li>3. Clogged fuel hose.</li> <li>4. Clogged jets in carburetor.</li> <li>5. Clogged exhaust pipe.</li> </ol>	<p>Clean. Replace. Clean. Clean. Clean.</p>
<b>Noisy engine.</b>	<p><b>Noise appears to come from piston</b></p> <ol style="list-style-type: none"> <li>1. Piston or cylinder worn down.</li> <li>2. Combustion chamber fouled with carbon.</li> <li>3. Piston pin, bearing or piston pin bore worn.</li> <li>4. Piston rings or ring grooves worn.</li> </ol> <p><b>Noise seems to come from crankshaft</b></p> <ol style="list-style-type: none"> <li>1. Worn or brunt crankshaft bearings.</li> <li>2. Worn or brunt conrod big-end bearings.</li> </ol> <p><b>Noise seems to come from final gear box</b></p> <ol style="list-style-type: none"> <li>1. Gears worn or rubbing.</li> <li>2. Badly worn splines.</li> <li>3. Worn or damaged bearings of drive shaft for rear axle shaft.</li> </ol>	<p>Replace. Clean. Replace. Replace.</p> <p>Replace. Replace.</p> <p>Replace. Replace. Replace.</p>
<b>Slipping clutch</b>	<ol style="list-style-type: none"> <li>1. Worn or damaged clutch shoes.</li> <li>2. Worn clutch drum.</li> </ol>	<p>Replace. Replace.</p>
<b>Engine idles poorly.</b>	<ol style="list-style-type: none"> <li>1. Excessively worn cylinder or piston rings.</li> <li>2. Stiff piston ring in place.</li> <li>3. Gas leaks from crankshaft oil seal.</li> <li>4. Spark plug gaps too wide.</li> <li>5. Defective CDI &amp; Ignition coil unit.</li> <li>6. Defective magneto stator coil.</li> <li>7. Float-chamber fuel level out of adjustment in carburetor.</li> <li>8. Clogged jets in carburetor.</li> <li>9. Broken or damaged reed valve.</li> </ol>	<p>Replace. Replace. Replace. Adjust or replace. Replace. Replace. Replace. Clean or adjust. Replace.</p>

Complaint	Symptom and possible causes	Remedy
<b>Engine runs poorly in high-speed range.</b>	<ol style="list-style-type: none"> <li>1. Excessively worn cylinder or piston rings.</li> <li>2. Stiff piston ring in place.</li> <li>3. Spark plug gaps too narrow.</li> <li>4. Ignition not advanced sufficiently due to poorly working CDI &amp; Ignition coil unit.</li> <li>5. Defective magneto stator coil.</li> <li>6. Float-chamber fuel level too low.</li> <li>7. Clogged air cleaner element.</li> <li>8. Clogged fuel hose, resulting in inadequate fuel supply to carburetor.</li> <li>9. Clogged fuel cock vacuum pipe.</li> </ol>	Replace. Replace. Adjust. Replace.  Replace. Adjust or replace. Clean Clean, and replace. Clean.
<b>Dirty or heavy exhaust smoke.</b>	<ol style="list-style-type: none"> <li>1. Too much engine oil to the engine.</li> <li>2. Use of incorrect engine oil.</li> </ol>	Check oil pump. Change.
<b>Engine lacks power.</b>	<ol style="list-style-type: none"> <li>1. Excessively worn cylinder or piston rings.</li> <li>2. Stiff piston ring in place.</li> <li>3. Gas leaks from crankshaft oil seal.</li> <li>4. Spark plug gaps incorrect.</li> <li>5. Clogged jets in carburetor.</li> <li>6. Float-chamber fuel level out of adjustment.</li> <li>7. Clogged air cleaner element.</li> <li>8. Fouled spark plug.</li> <li>9. Sucking air from intake pipe.</li> <li>10. Slipping or worn V-belt.</li> <li>11. Damaged/worn rollers in the movable drive face.</li> <li>12. Weakened movable driven face spring.</li> <li>13. Too rich fuel/air mixture due to defective starter system.</li> </ol>	Replace. Replace. Replace. Adjust or replace. Clean. Adjust or replace. Clean. Clean or replace. Retighten or replace. Replace. Replace. Replace. Replace.
<b>Engine overheats.</b>	<ol style="list-style-type: none"> <li>1. Heavy carbon deposit on piston crown.</li> <li>2. Defective oil pump or clogged oil circuit.</li> <li>3. Fuel level too low in float chamber.</li> <li>4. Air leakage from intake pipe.</li> <li>5. Use of incorrect engine oil.</li> <li>6. Use of improper spark plug.</li> <li>7. Clogged exhaust pipe/muffler.</li> </ol>	Clean. Replace or clean. Adjust or replace. Retighten or replace. Change. Change. Change. Clean or replace.

## CARBURETOR

Complaint	Symptom and possible causes	Remedy
<b>Trouble with starting.</b>	<ol style="list-style-type: none"> <li>1. Starter jet is clogged.</li> <li>2. Air leaking from a joint between starter body and carburetor.</li> <li>3. Air leaking from carburetor's joint or vacuum hose joint.</li> <li>4. Starter plunger is not operating properly.</li> </ol>	Clean. Check starter body and carburetor for tightness, and replace gasket. Check and replace. Check and replace.
<b>Idling or low-speed trouble.</b>	<ol style="list-style-type: none"> <li>1. Pilot jet, pilot air jet are clogged or loose.</li> <li>2. Air leaking from carburetor's joint, vacuum pipe joint, or starter.</li> <li>3. Pilot outlet is clogged.</li> <li>4. Starter plunger is not fully closed.</li> </ol>	Check and clean. Clean and replace. Check and clean. Check and replace.
<b>Medium or high-speed trouble.</b>	<ol style="list-style-type: none"> <li>1. Main jet or main air jet is clogged.</li> <li>2. Needle jet is clogged.</li> <li>3. Fuel level is improperly set.</li> <li>4. Throttle valve is not operating properly.</li> <li>5. Fuel filter is clogged.</li> </ol>	Check and clean. Check and clean. Check and replace. Check throttle valve for operation. Check and clean.
<b>Overflow and fuel level fluctuations.</b>	<ol style="list-style-type: none"> <li>1. Needle valve is worn or damaged.</li> <li>2. Spring in needle valve is broken.</li> <li>3. Float is not working properly.</li> <li>4. Foreign matter has adhered to needle valve.</li> <li>5. Fuel level is too high or low.</li> </ol>	Replace. Replace. Check and adjust. Clean. Adjust or replace.

## 7-3 SERVICING INFORMATION

### ELECTRICAL

Complaint	Symptom and possible causes	Remedy
<b>No sparking or poor sparking.</b>	<ol style="list-style-type: none"> <li>1. Defective CDI &amp; Ignition coil unit.</li> <li>2. Defective spark plug.</li> <li>3. Defective magneto stator coil.</li> <li>4. Loose connection of lead wire.</li> </ol>	Replace. Replace. Replace. Connect/tighten.
<b>Spark plug soon becomes fouled with carbon.</b>	<ol style="list-style-type: none"> <li>1. Mixture too rich.</li> <li>2. Idling speed set too high.</li> <li>3. Incorrect gasoline.</li> <li>4. Dirty element in air cleaner.</li> <li>5. Spark plug too cold.</li> <li>6. Incorrect engine oil.</li> </ol>	Adjust carburetor. Adjust carburetor. Change. Clean. Replace by hot type plug. Replace.
<b>Spark plug electrodes overheat or burn.</b>	<ol style="list-style-type: none"> <li>1. Spark plug too hot.</li> <li>2. The engine overheats.</li> <li>3. Spark plug loose.</li> <li>4. Mixture too lean.</li> <li>5. Not enough engine oil.</li> </ol>	Replace by hot type plug. Turn up. Retighten. Adjust carburetor. Check oil pump.
<b>Magneto does not charge.</b>	<ol style="list-style-type: none"> <li>1. Open or short in lead wires, or loose lead connections.</li> <li>2. Shorted, grounded or open magneto coil.</li> <li>3. Shorted or open regulator/rectifier.</li> </ol>	Repair, replace or retighten. Replace. Replace.
<b>Magneto charge, but charging rate is below the specifications.</b>	<ol style="list-style-type: none"> <li>1. Lead wires tend to get shorted or open-circuited or loosely connected at terminal.</li> <li>2. Grounded or open-circuited stator coils of magneto.</li> <li>3. Defective regulator/rectifier.</li> <li>4. Defective cell plates in the battery.</li> </ol>	Repair, or retighten.  Replace. Replace. Replace the battery.
<b>Magneto overcharges</b>	<ol style="list-style-type: none"> <li>1. Internal short-circuit in the battery.</li> <li>2. Resistor element in the regulator/rectifier damaged or defective.</li> <li>3. Regulator/rectifier unit poorly grounded.</li> </ol>	Replace the battery. Replace. Clean and tighten ground connection.
<b>Unstable charging.</b>	<ol style="list-style-type: none"> <li>1. Lead wire insulation frayed due to vibration, resulting in intermittent shorting.</li> <li>2. Magneto coil internally shorted.</li> <li>3. Defective regulator/rectifier.</li> </ol>	Repair or replace.  Replace. Replace.
<b>Starter button is not effective.</b>	<ol style="list-style-type: none"> <li>1. Battery run down.</li> <li>2. Defective switch contacts.</li> <li>3. Brushes not seating properly on commutator in starter motor.</li> <li>4. Defective starter relay.</li> <li>5. Defective starter pinion gears.</li> <li>6. Defective front or rear brake light switch circuit.</li> </ol>	Recharge or replace. Replace. Repair or replace. Replace. Replace. Replace or repair.

### BATTERY

Complaint	Symptom and possible causes	Remedy
<b>Battery runs down quickly.</b>	<ol style="list-style-type: none"> <li>1. The charging method is not correct.</li> <li>2. Cell plates have lost much of their active material as a result of over-charging.</li> <li>3. A short-circuit condition exists within the battery due to excessive accumulation of sediments caused by the incorrect electrolyte.</li> <li>4. Battery is too old.</li> </ol>	Check the magneto and regulator/rectifier circuit connections, and make necessary adjustments to obtain specified charging operation. Replace the battery, and correct the charging system. Replace the battery.  Replace the battery.
<b>Reversed battery polarity.</b>	<ol style="list-style-type: none"> <li>1. The battery has been connected the wrong way round in the system, so that it is being charged in the reverse direction.</li> </ol>	Replace the battery and be sure to connect the battery properly.
<b>Battery discharges too rapidly.</b>	<ol style="list-style-type: none"> <li>1. Dirty container top and sides.</li> <li>2. Battery is too old.</li> </ol>	Clean. Replace.

**CHASSIS**

Complaint	Symptom and possible causes	Remedy
<b>Handling feels too heavy.</b>	<ol style="list-style-type: none"> <li>1. Steering stem nut overtightened.</li> <li>2. Broken bearing/race in steering stem.</li> <li>3. Distorted steering stem.</li> <li>4. Not enough pressure in tires.</li> </ol>	Adjust. Replace. Replace. Adjust.
<b>Wobbly handle.</b>	<ol style="list-style-type: none"> <li>1. Loss of balance between right and left front suspension.</li> <li>2. Distorted front axle or crooked tire.</li> </ol>	Replace. Replace.
<b>Wobbly front wheel.</b>	<ol style="list-style-type: none"> <li>1. Distorted wheel rim.</li> <li>2. Worn front wheel bearings.</li> <li>3. Defective or incorrect tire.</li> <li>4. Loose nut on axle.</li> <li>5. Loose nuts on the rear shock.</li> <li>6. Worn engine mounting bushing.</li> <li>7. Loose nuts or bolts for engine mounting.</li> </ol>	Replace. Replace. Replace. Retighten. Retighten. Replace. Tighten.
<b>Front suspension too soft.</b>	<ol style="list-style-type: none"> <li>1. Weakened springs.</li> <li>2. Oil leakage of shock absorber.</li> </ol>	Replace. Replace.
<b>Front suspension too stiff.</b>	<ol style="list-style-type: none"> <li>1. Not enough grease.</li> <li>2. Worn suspension arm spacer.</li> </ol>	Refill. Replace.
<b>Noisy front suspension.</b>	<ol style="list-style-type: none"> <li>1. Not enough grease.</li> <li>2. Loose nuts on suspension.</li> </ol>	Refill. Retighten.
<b>Wobbly rear wheel.</b>	<ol style="list-style-type: none"> <li>1. Distorted wheel rim.</li> <li>2. Defective or incorrect tire.</li> <li>3. Loose nuts on the rear shock absorber.</li> <li>4. Worn engine mounting bushing.</li> <li>5. Loose nuts or bolts for engine mounting.</li> </ol>	Replace. Replace. Replace. Replace. Retighten.
<b>Rear suspension too soft.</b>	<ol style="list-style-type: none"> <li>1. Weakened spring.</li> <li>2. Oil leakage of rear shock absorber.</li> </ol>	Replace. Replace.
<b>Noisy rear suspension.</b>	<ol style="list-style-type: none"> <li>1. Loosen nuts on shock absorber.</li> <li>2. Worn engine mounting bushing.</li> </ol>	Retighten. Replace.

**BRAKES**

Complaint	Symptom and possible causes	Remedy
<b>Insufficient brake power.</b>	<ol style="list-style-type: none"> <li>1. Leakage of brake fluid from hydraulic system.</li> <li>2. Worn pad.</li> <li>3. Oil adhesion on engaging surface of pad.</li> <li>4. Worn disc.</li> <li>5. Air entered into hydraulic system.</li> <li>6. Worn shoe.</li> <li>7. Friction surfaces of shoes are dirty with oil.</li> <li>8. Excessively worn drum.</li> <li>9. Too much brake lever play.</li> </ol>	Repair or replace. Replace. Clean disc and pads. Replace. Bleed air. Replace. Replace. Replace. Adjust.
<b>Brake squeaking.</b>	<ol style="list-style-type: none"> <li>1. Carbon adhesion on pad surface.</li> <li>2. Tilted pad.</li> <li>3. Damaged wheel bearing.</li> <li>4. Worn pad.</li> <li>5. Foreign substance entered into brake fluid.</li> <li>6. Clogged return ports of master cylinder.</li> <li>7. Brake shoe surface glazed.</li> <li>8. Loose front-wheel axle or rear-wheel axle nut.</li> <li>9. Worn shoe.</li> </ol>	Repair surface with sandpaper. Modify and fitting. Replace. Replace. Replace brake fluid. Disassemble and clean master cylinder. Repair surface with sandpaper. Tighten to specified torque. Replace.









## 7-5 SERVICING INFORMATION









---

Complaint	Symptom and possible causes	Remedy
<b>Excessive brake lever stroke.</b>	<ol style="list-style-type: none"><li>1. Air entered into hydraulic system.</li><li>2. Insufficient brake fluid.</li><li>3. Improper quality of brake fluid.</li><li>4. Worn brake cam lever.</li><li>5. Excessively worn shoes and/or drum.</li></ol>	Bleed air. Replenish fluid to normal level;bleed air. Replace with correct fluid. Replace. Replace.
<b>Leakage of brake fluid.</b>	<ol style="list-style-type: none"><li>1. Insufficient tightening of connection joints.</li><li>2. Cracked hose.</li><li>3. Worn piston seal.</li></ol>	Tighten to specified torque. Replace. Replace.
<b>Brake drags.</b>	<ol style="list-style-type: none"><li>1. Rusty moving parts.</li></ol>	Clean and lubricate.





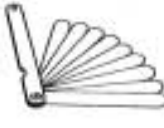













## SPECIAL TOOLS

Special tools	Part Number · Part Name · Description
	09900-00401 “L” type hexagon wrench set
	Tighten hexagon bolt
	09900-00410 Hexagon wrench set
	Tighten hexagon bolt
	09900-05108 Snap ring pliers
	Circlip remove and remounting
	09900-06105 Snap ring pliers
	Circlip remove and remounting
	09900-06107 Snap ring pliers
	Circlip remove and remounting
	09900-09003 Impact driver set
	Remove and remounting of fixed screw
	09900-20102 Vernier calipers
	Measure thickness
	09900-20202 Micrometer (1/100mm, 25-50mm)
	Measure height of cam
	09900-20203 Micrometer (1/100mm, 50-75mm)
	Measure outside diameter of piston









Special tools	Part Number · Part Name · Description
	09900-20205 Micrometer (1/100mm, 0-25mm)
	Measure outside diameter of piston pin
	09900-20508 Cylinder gauge set (1/100mm, 40-80mm)
	Measure inside diameter of cylinder
	09900-20602 Dial gauge (1/100mm, 1mm)
	Measure inside diameter of cylinder
	09900-20605 Dial calipers (1/100mm, 10-34mm)
	Measure width of conrod big-end
	09900-20606 Dial gauge (1/100mm, 10mm)
	Measure run-out of wheel
	09900-20701 Magnetic stand
	Used with Dial gauge
	09900-20806 Thickness gauge
	Measure clearance of piston ring
	09900-21304 V-block set
	Used with Magnetic stand
	09900-21602 CCI Oil gauge
	A gauge to inspect performance of oil pump

## 7-7 SERVICING INFORMATION

Special tools	Part Number · Part Name · Description
	09900-22301 Plastic gauge Measure clearance of crankshaft thrust
	09900-22401 Small bore gauge (10-18mm) Measure inside diameter of conrod small-end
	09900-25002 Pocket tester Measure voltage, electric current, resistance
	09900-26006 Tachometer Measure rotational frequency of engine
	09900-28107 Electro tester Inspect ignition coil
	09910-20115 Conrod holder Used to lock the crankshaft
	09910-32812 Crankshaft installer Used to install the crankshaft in the crankcase
	09913-14541 Fuel level gauge set Measure height of carburetor
	09913-50121 Oil seal remover Used to remove the oil seal



Special tools	Part Number · Part Name · Description
	09913-60710 Bearing remover Remove bearing with the rotor remove sliding shaft
	09913-75520 Bearing installer Used to drive bearing in
	09913-75821 Bearing installer Used to drive bearing in
	09913-75830 Bearing installer Install rear axle shaft oil seal
	09913-76010 Bearing installer Install crankshaft bearing
	09915-63310 Compression gauge adapter Used with compression gauge
	09915-64510 Compression gauge Measure cylinder compression
	09916-84511 Tweezers Remove and remounting valve cotter pin.
	09920-13120 Crankcase separator Separate to crankcase

Special tools	Part Number · Part Name · Description
	09921-20200 Bearing remover (10mm)
	Remove oil seal or bearing
	09921-20210 Bearing remover (12mm)
	Remove oil seal or bearing
	09922-55131 Bearing installer
	Used to drive bearing in
	09923-73210 Bearing remover (17mm)
	Remove bearing with the rotor remove sliding shaft
	09923-74510 Bearing remover (20~35mm)
	Remove bearing with the rotor remove sliding shaft
	09924-84521 Bearing installer
	Used to drive small bearing in
	09925-98221 Bearing installer
	Used to drive bearing in
	09930-10121 Spark plug socket wrench set
	Remove and remounting spark plug
	09930-30102 Rotor remove sliding shaft
	Used to with bearing remover or rotor remover

Special tools	Part Number · Part Name · Description
	09930-30163 Rotor remover
	Attached to the top of sliding shaft when removing rotor
	09930-32420 Rotor holder
	Remove and remounting rotor
	09930-40113 Rotor holder
	Widely used to lock rotary parts such as a flywheel magneto
	09940-10122 Clamp wrench
	A hook wrench to adjust the steering head of motorcycle
	09940-34520 T-handle
	Remove and remounting front fork oil cylinder
	09940-34561 Front fork assembling tool attachment "D"
	Used with T-handle
	09940-50113 Front fork oil seal installer
	Install front fork oil seal
	09941-34513 Bearing installer
	Install steering outer race
	09941-50110 Wheel bearing remover
	Remove wheel bearing

## 7-9 SERVICING INFORMATION

---

Special tools	Part Number · Part Name · Description
	09943-74111 Front fork oil level gauge
	Used to drain the fork oil to the specified level
	09943-88211 Bearing remover
	Remove rear axle shaft bearing
	09951-76010 Bearing installer
	Used to drive bearing in

## TIGHTENING TORQUE

### ENGINE

ITEM	N · m	kg · m
Magneto rotor nut	35 ~ 45	3.5 ~ 4.5
Muffler mounting bolt	18 ~ 28	1.8 ~ 2.8
Exhaust pipe nut	8 ~ 12	0.8 ~ 1.2
Spark plug	25 ~ 30	2.5 ~ 3.0
Cylinder head nut	8 ~ 12	0.8 ~ 1.2
Engine mounting bolt	40 ~ 60	4.0 ~ 6.0
Engine mounting bracket bolt	48 ~ 72	4.8 ~ 7.2
Oil drain plug	9 ~ 15	0.9 ~ 1.5
Oil level bolt	9 ~ 15	0.9 ~ 1.5
Oil pump bolt	3 ~ 5	0.3 ~ 0.5
Clutch shoe nut	40 ~ 60	4.0 ~ 6.0
Clutch housing nut	40 ~ 60	4.0 ~ 6.0
Kick starter driven nut	40 ~ 60	4.0 ~ 6.0
Kick starter lever bolt	8 ~ 12	0.8 ~ 1.2

## 7-11 SERVICING INFORMATION

### CHASSIS

ITEM	N · m	kg · m
Rear brake cam lever bolt	6 ~ 9	0.6 ~ 0.9
Rear shock absorber bolt	22 ~ 35	2.2 ~ 3.5
Rear axle nut	60 ~ 90	6.0 ~ 9.0
Steering stem lock nut	60 ~ 100	6.0 ~ 10.0
Front brake disc bolt	18 ~ 28	1.8 ~ 2.8
Front brake master cylinder bolt	8 ~ 12	0.8 ~ 1.2
Front brake air bleeder valve	6 ~ 9	0.6 ~ 0.9
Front brake caliper mounting bolt	18 ~ 28	1.8 ~ 2.8
Front brake hose union bolt	20 ~ 25	2.0 ~ 2.5
Front axle nut	33 ~ 52	3.3 ~ 5.2
Front fork bolt	35 ~ 55	3.5 ~ 5.5
Handlebar set bolt	22 ~ 28	2.2 ~ 2.8
Handlebar clamp nut	48 ~ 52	4.8 ~ 5.2

### TIGHTENING TORQUE CHART

For other bolts and nuts who's torque is not listed, refer to this chart :

Bolt Diameter (mm)	Conventional or "4" marked bolt		"7" marked bolt	
	N · m	kg · m	N · m	kg · m
4	1.0 ~ 2.0	0.1 ~ 0.2	1.5 ~ 3.0	0.15 ~ 0.3
5	2.0 ~ 4.0	0.2 ~ 0.4	3.0 ~ 6.0	0.3 ~ 0.6
6	4.0 ~ 7.0	0.4 ~ 0.7	8.0 ~ 12.0	0.8 ~ 1.2
8	10.0 ~ 16.0	1.0 ~ 1.6	18.0 ~ 28.0	1.8 ~ 2.8
10	22.0 ~ 35.0	2.2 ~ 3.5	40.0 ~ 60.0	4.0 ~ 6.0
12	35.0 ~ 55.0	3.5 ~ 5.5	70.0 ~ 100.0	7.0 ~ 10.0
14	50.0 ~ 80.0	5.0 ~ 8.0	110.0 ~ 160.0	11.0 ~ 16.0
16	80.0 ~ 130.0	8.0 ~ 13.0	170.0 ~ 250.0	17.0 ~ 25.0
18	130.0 ~ 190.0	13.0 ~ 19.0	200.0 ~ 280.0	20.0 ~ 28.0

**SERVICE DATA****CYLINDER + PISTON + PISTON RING**

Unit : mm

ITEM	STANDARD		LIMIT
Piston to cylinder clearance	0.065 ~ 0.075		0.120
Cylinder bore	41.005 ~ 41.020		41.07
Piston diam.	40.935 ~ 40.950 Measure at 15mm from the skirt end		40.885
Cylinder distortion	—		0.1
Cylinder head distortion	—		0.1
Piston ring clearance (Free condition)	1st	Approx. 4.5	3.2
	2nd	Approx. 4.3	3.1
Piston ring clearance (Assembling condition)	1st	0.10 ~ 0.25	0.75
	2nd	0.10 ~ 0.25	0.75
Piston ring - ring groove clearance	1st	0.02 ~ 0.06	—
	2nd	0.02 ~ 0.06	—
Piston pin bore I.D	10.002 ~ 10.010		10.030
Piston pin O.D	9.995 ~ 10.000		9.980

**CONROD + CRANKSHAFT**

Unit : mm

ITEM	STANDARD	LIMIT
Conrod small end I.D.	14.003 ~ 14.011	14.047
Conrod big end runout	—	3.0
Crank web to wed width	35 ± 0.1	—
Crankshaft runout	—	0.08

## 7-13 SERVICING INFORMATION

---

### OIL PUMP

Unit : mm

ITEM	STANDARD
Oil pump reduction ratio	30.000(30/1)

### CLUTCH

Unit : mm

ITEM	STANDARD	LIMIT
Clutch housing I.D.	110.00 ~ 110.15	110.35
Clutch shoe thickness	3.0	2.0
Clutch in rpm	3,600 ± 200 rpm	—
Clutch tight rpm	6,000 ± 200rpm	—

### TRANSMISSION

Unit : mm

ITEM	STANDARD	LIMIT
Final reduction ratio	12.0	—
Gear ratios	2.997 ~ 0.813	—
V-belt width	16.5 ± 0.6	15.3
V-belt thickness	8.0 ± 0.6	—
Movable drive face spring free length	143.8	135 ~ 153



**CARBURETOR**

Unit : mm

ITEM	SPECIFICATION
Carburetor type	VM14
Main bore size	φ 14
I.D. No.	HG 266
Idle rpm	1,800 ± 50 rpm
Fuel level	24.5
Main jet (M.J.)	55
Main air jet (M.A.J.)	1.0
Jet needle (J.N.)	3E17-3
Needle jet (N.J.)	E-2
Pilot jet (P.J.)	25
Throttle valve (T.V.)	3.0
By-pass (B.P.)	2.4 ± 0.05
Valve seat (V.S.)	1.2
Stater jet (G.S.)	25
Pilot screw (P.S.)	—
Pilot outlet (P.O.)	0.8
Throttle cable play	0.5 ~ 1.0

## 7-15 SERVICING INFORMATION

### ELECTRICAL

Unit : mm

ITEM		SPECIFICATION	NOTE
Ignition timing		20° at 1,000 rpm	
Spark plug	Type	BR8HSA	
	Gap	0.6 ~ 0.7	
Spark performance		Over 8 mm	
Ignition coil resistance	Primary	0.19 ~ 0.24 Ω	
	Secondary	5.4 ~ 6.6 kΩ	
Stator coil resistance	Lighting coil	0.54 ~ 0.80 Ω	Y/W-Ground
	Charging coil	0.69 ~ 1.03 Ω	W/R-Ground
	Exciting coil	220 ~ 260 Ω	B/R-Ground
	Pick-up coil	90 ~ 110 Ω	Br-W
Regulated voltage		13.0 ~ 16.0 V at 5,000 rpm	
No-load performance of A.C. generator		More than 17V (at 5,000 rpm)	
Starter relay resistance		0 ~ 70 Ω	
Battery	Type designation	YT4L-BS	
	Capacity	12V, 3AH	
	Standard electrolyte S.G.	1.32 at 20°C (68°F)	
Fuse		10 A	

### WATTAGE

Unit : W

ITEM	SPECIFICATION
Head lamp bulb	15W × 2
Tail/Brake lamp bulb	5 / 10W
Turn signal lamp bulb	10W × 4
Turn signal / Oil level check light pilot lamp	1.7W / 17W
Speedometer lamp bulb	1.7W × 2

**⚠ CAUTION**

Do not use except the specified bulb (Wattage).

**BRAKE+WHEEL**

Unit : mm

ITEM	STANDARD		LIMIT
Brake lever play	Front	5 ~ 20	—
	Rear	15 ~ 25	—
Brake drum I.D	Rear	100	100.7
Brake lining thickness	Rear	99.2	96
Brake disc plate thickness	Front	4.0 ± 0.2	3.5
Brake disc plate runout	Front	—	0.30
Master cylinder bore I.D.	Front	11.000 ~ 11.043	11.055
Master cylinder piston diam.	Front	10.957 ~ 10.984	10.945
Brake caliper I.D.	Front	30.230 ~ 30.306	30.315
Brake caliper piston diam.	Front	30.150 ~ 30.200	30.140
Wheel rim runout	Axial	—	3.0
	Radial	—	3.0
Axle shaft runout	Front	—	0.25
Tire size	Front	110/70-12 47J	—
	Rear	120/70-12 51J	—
Tire tread depth	Front	—	1.6
	Rear	—	1.6

## 7-17 SERVICING INFORMATION

### SUSPENSION

Unit: mm

ITEM	STANDARD	LIMIT
Front fork stroke	75	—
Front fork spring length(Free condition)	290.9	—
Front fork oil specification	TELLUS # 37	—
Front fork oil capacity(One side)	50 cc	—
Rear wheel travel	66	—

### TIRE PRESSURE

COLD INFLATION TIRE PRESSURE	SOLO RIDING		DUAL RIDING	
	kPa	kg/cm <sup>2</sup>	kPa	kg/cm <sup>2</sup>
FRONT	123	1.25	172	1.75
REAR	196	2.00	221	2.25

### FUEL + OIL

ITEM	SPECIFICATION	NOTE
Fuel type	Gasoline used should be graded 85 ~ 95 octane or higher. An unleaded gasoline is recommended.	
Fuel tank capacity	4.8 ℓ	
Engine oil type	APOLLOIL BIKE-K, HYPOL HS	
Engine oil capacity	1.0 ℓ	
Engine oil discharge amount	1.0 ~ 1.2 ml (at 3,000 rpm for 5 minutes)	I.D 60ml/Hr F.O 100ml/Hr
Transmission oil type	SAE 10W/30 or 10W/40 multi-grade motor oil	
Transmission oil capacity	Replace	110 ml
	Overhaul	130 ml
Brake fluid type	DOT 4	

# WIRE AND CABLE ROUTING

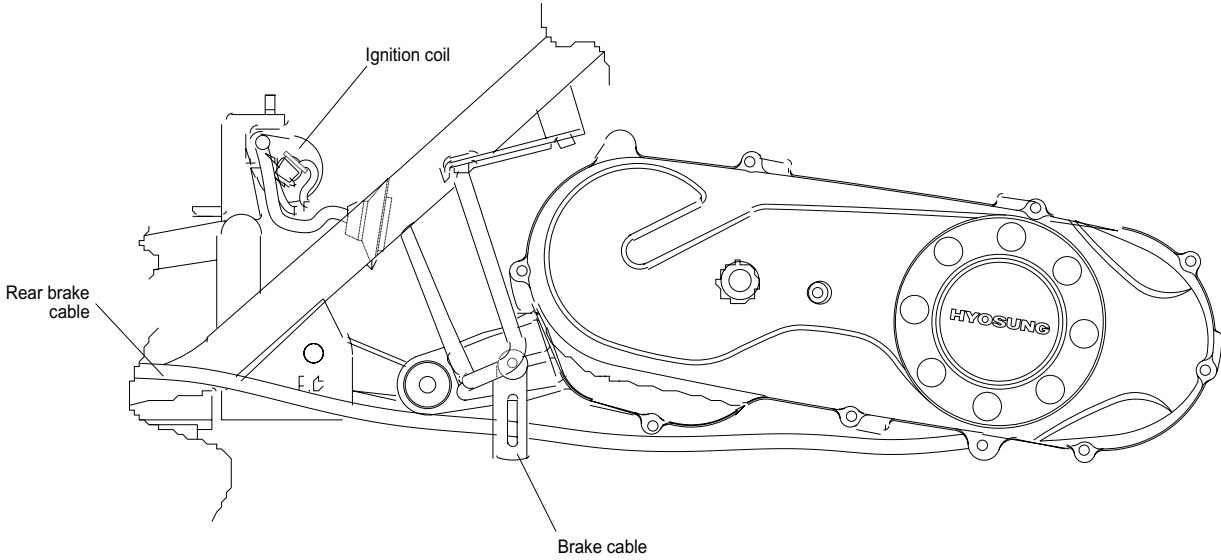
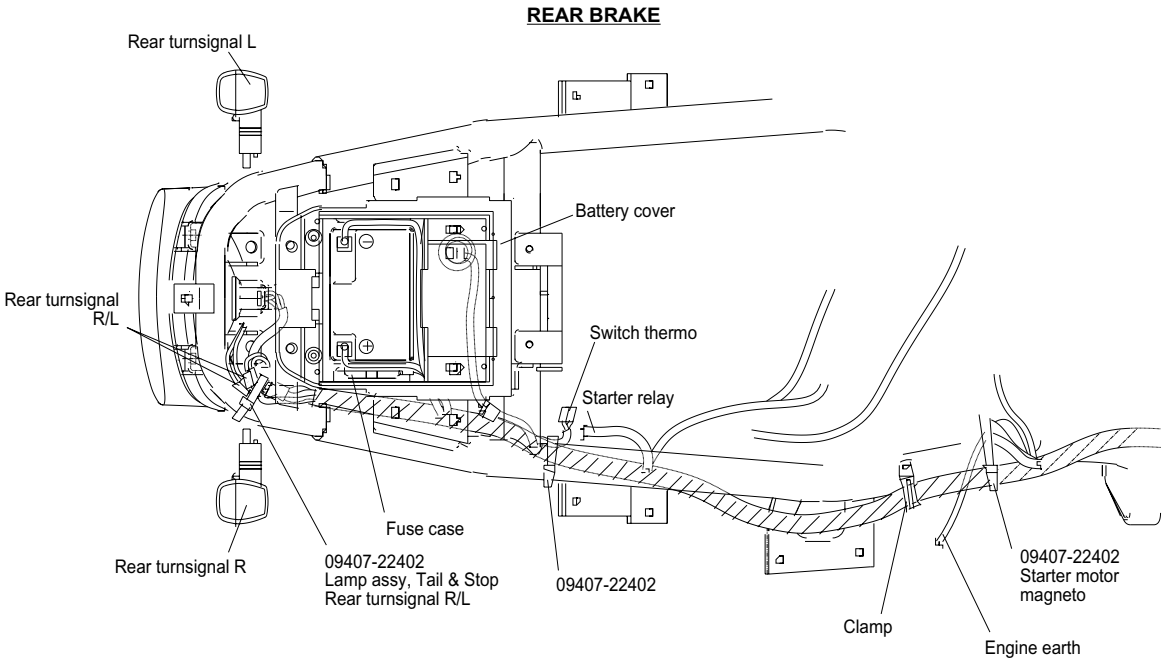

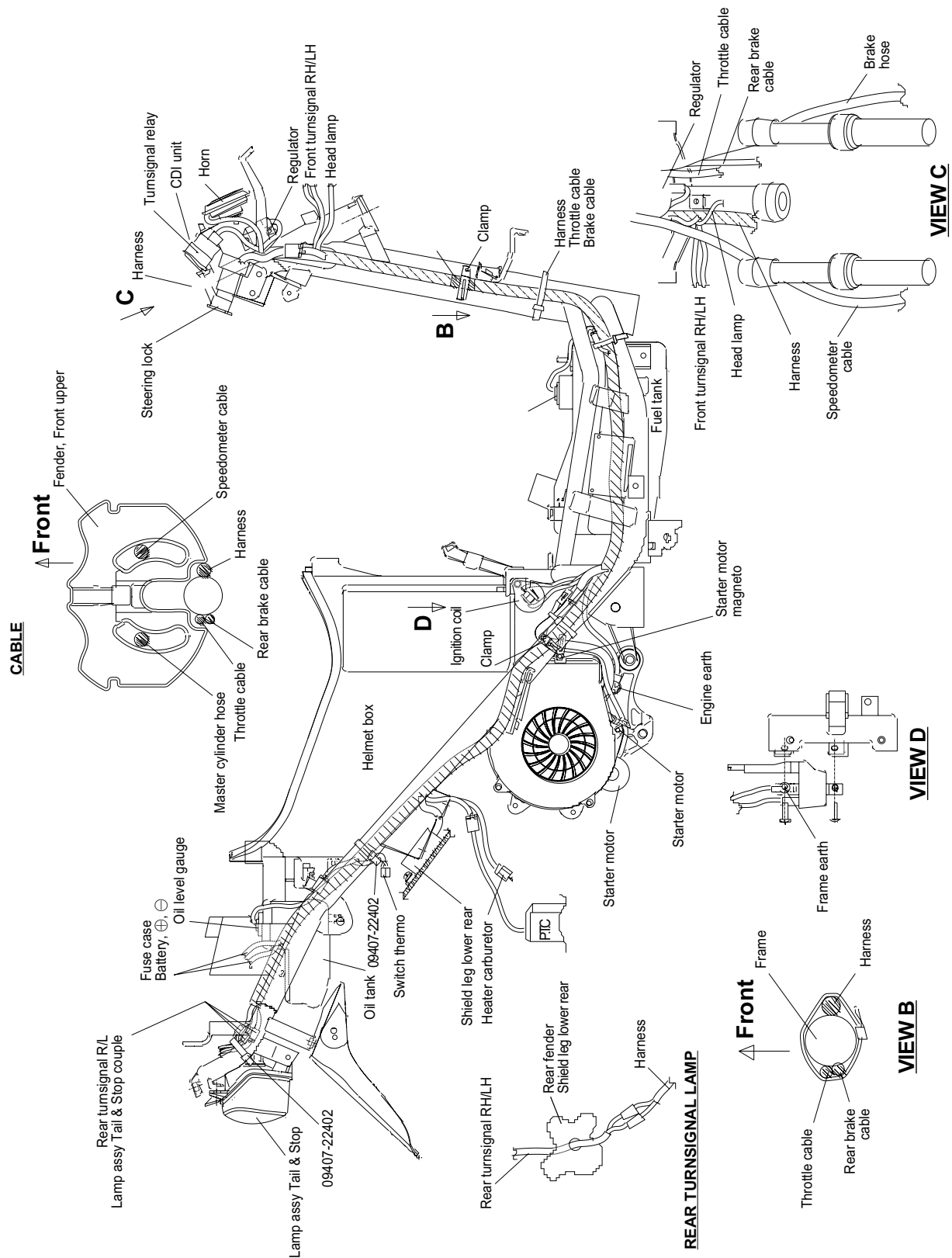

# WIRING DIAGRAM

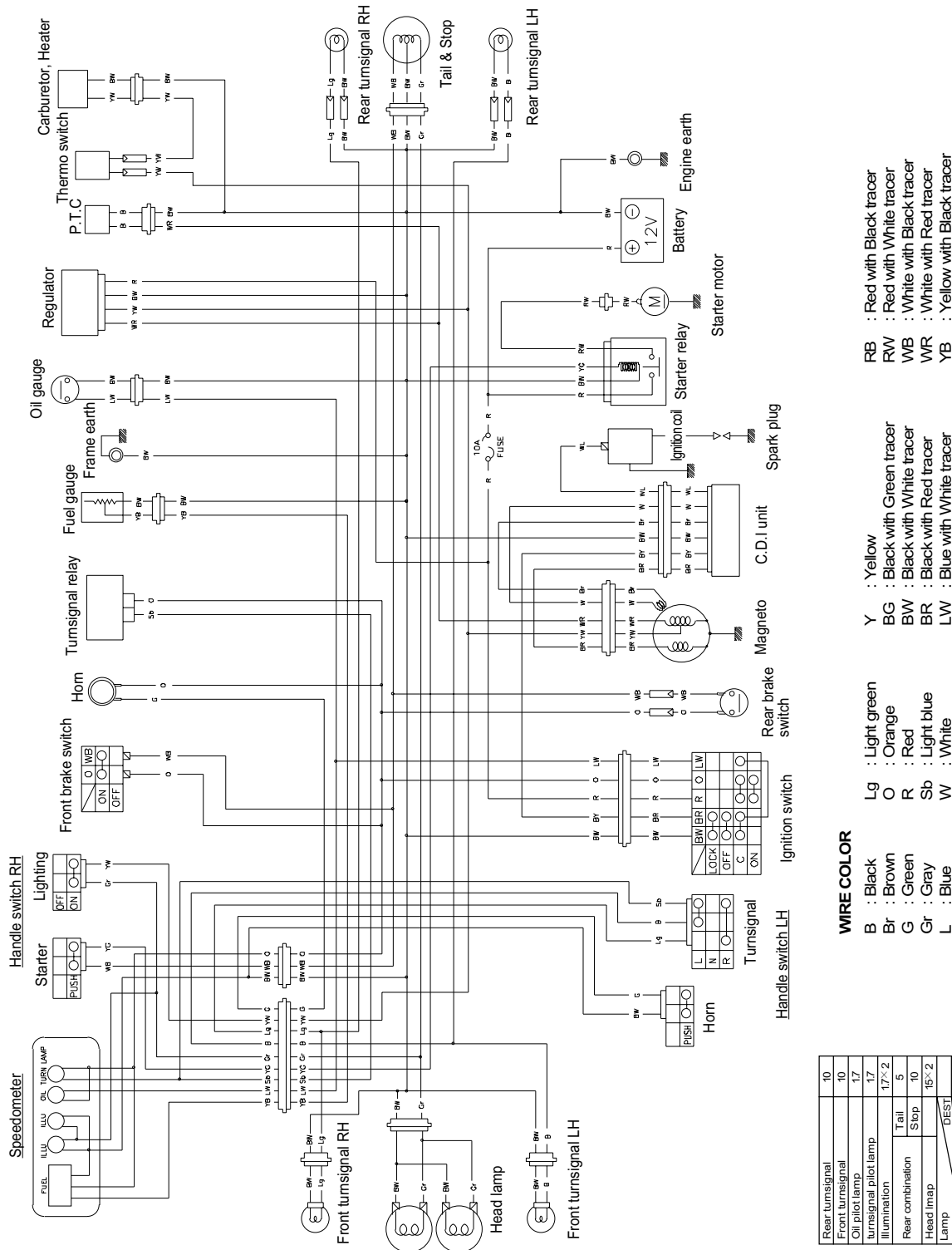

RB : Red with Black tracer  
 RW : Red with White tracer  
 WB : White with Black tracer  
 WR : White with Red tracer  
 YB : Yellow with Black tracer

Y : Yellow  
 BG : Black with Green tracer  
 BW : White with Black tracer  
 BR : Black with Red tracer  
 LW : Blue with White tracer

Lg : Light green  
 O : Orange  
 R : Red  
 Sb : Light blue  
 W : White

**WIRE COLOR**  
 B : Black  
 Br : Brown  
 G : Green  
 Gr : Gray  
 L : Blue

Rear turnsignal	10
Front turnsignal	10
Oil pilot lamp	1.7
Turnsignal pilot lamp	1.7
Illumination	17x2
Rear combination	5
Head lamp	10
Lamp	15x2
	DEST



Prepared by

**HYOSUNG MOTORS & MACHINERY INC.**

2nd Ed. NOV. 1999

Manual No. 99000-91310

Printed in Korea