

Chery S18D Service Manual

(Body Accessories & Dimensions)

After Sales Service Department of Chery Automobile
Co.,Ltd.



Contents

Chapter I Engine Hood & Luggage Boot.....	1
I. Removal and Installation of Engine Hood.....	1
1. Preparations.....	1
2. Precautions.....	1
3. Removal and Installation of Engine Hood Accessories.....	1
4. Removal & Adjustment of Engine Hood Assembly.....	1
5. Removal of Engine Hood Lock.....	2
6. Removal & Adjustment of Hood Cable.....	2
II. Removal and Installation of Trunk lid.....	3
1. Preparations.....	3
2. Removal of Trunk lid Trim Board.....	3
3. Removal and Installation of Luggage boot Lock.....	3
4. Removal of Luggage Boot Lock Cylinder.....	4
5. Removal of Rear Wiper Nozzle.....	5
6. Removal of Rear Wiper Motor.....	6
Chapter II Removal of Interior Trim Parts.....	8
I. Removal and Installation of Seat Belts.....	8
1. Preparations.....	8
2. Precautions.....	8
3. Removal and Installation of the Seat belt of Front Seats.....	8
4. Removal and Installation of the Seat belt of Rear Seats.....	10
II. Removal and Installation of Seats.....	11
1. Preparations.....	11
2. Removal of Front Seats.....	12
3. Removal of Rear Seats.....	12
4. Installation Procedure.....	13
III. Removal and Installation of Central Console.....	13
1. Preparations.....	13
2. Removal Procedure.....	13
3. Installation Procedure.....	14
IV. Removal and Installation of Carpet.....	14
1. Preparations.....	14
2. Removal Procedure.....	14
3. Installation Procedure.....	16
Chapter III Removal & Maintenance of Vehicle Doors.....	17
I. Removal, Installation & Maintenance of Front Doors.....	17
1. Preparations.....	17
2. Precautions.....	17
3. Removal Procedure.....	17
4. Installation Procedure.....	21
II. Removal & Installation of Rear Doors.....	21
1. Preparations.....	21
2. Precautions.....	21
3. Removal Procedure.....	22
4. Installation Procedure.....	25
Chapter IV Removal, Installation & Maintenance of Front/Rear Bumper.....	26



Chery S18D Service Manual

I. Removal, Installation & Maintenance of Front Bumper.....	26
1. Preparations.....	26
2. Precautions.....	26
3. Removal Procedure.....	26
4. Installation Procedure.....	27
II. Removal, Installation & Maintenance of Rear Bumper.....	27
1. Preparations.....	27
2. Precautions.....	27
3. Removal Procedure.....	27
4. Installation Procedure.....	28
Chapter V Removal and Installation of Outside Lamps.....	29
I. Preparations.....	29
II. Precautions.....	29
III. Removal Procedure of Headlamp.....	29
IV. Removal of Front Fog Lamp.....	30
V. Removal of Rear Fog Lamp.....	31
VI Removal of Tail Lamp.....	32
VII. Removal of License Lamp.....	32
VIII. Installation & Adjustment of Headlamp.....	33
IX. Installation of Tail Lamp.....	34
Chapter VI Removal and Installation of Vehicle Ceiling.....	35
I. Preparations.....	35
II. Precautions.....	35
III. Removal and Installation of Sun Visor.....	35
IV. Removal and Installation of Ceiling Armrest.....	35
V. Removal and Installation of Front Ceiling Lamp.....	36
VI. Removal and Installation of A-pillar Panel.....	36
VII. Removal and Installation of B-pillar Panel.....	37
VIII. Removal and Installation of C-pillar Panel.....	37
IX. Removal and Installation of Vehicle Ceiling.....	38
Chapter VII Removal and Installation of Instrument Panel & Instrument Panel Crossbeam.....	40
I. Removal of Instrument Panel.....	40
1. Removal Procedure.....	40
2. Installation Procedure.....	45
3. Methods for Clearing Instrument Maintenance Indicator.....	45
II. Removal of Instrument Panel Cross Beam.....	45
1. Removal Procedure.....	45
2. Installation Procedure.....	47
Chapter VIII Air Conditioning System.....	48
I. System Constitution.....	48
II. Removal of Evaporator Assembly.....	48



Chery S18D Service Manual

1. Preparations.....	48
2. Removal and Installation Procedures	48
3. Installation of Evaporator Assembly.....	50
III. Removal and Installation of Evaporator Interior	50
1. Preparation of Tools.....	50
2. Removal and Installation of Blower.....	50
3. Removal and Installation of Blower Speed Regulation Module.....	51
4. Removal and Installation of Heater Exchanger.....	51
5. Removal and Installation of Mode Air Door Related Mechanism.....	52
6. Removal and Installation of Blend Air Door Related Mechanism	53
7. Removal and Installation of Int./Ext.Air Door Motor & Related Mechanism	54
8. Removal and Installation of Evaporator.....	54
CHAPTER IX Body Dimension.....	56
I. Basic Instructions on BIW Maintenance.....	56
1. Vehicle Door Structure.....	57
2. Door Panel Maintenance Process.....	57
3. Main Contents of Door Panel Maintenance.....	58
4. Basic Methods for Door Panel Maintenance.....	59
II. Body Assembly Dimension.....	63
1. Left Front Axonometric Drawing.....	63
2. Left Rear Axonometric Drawing.....	64
III. Engine Compartment Dimension	65



Chapter I Engine Hood & Luggage Boot

I. Removal and Installation of Engine Hood

1. Preparations

Tools: slotted screwdriver, cross screwdriver, socket wrench, and etc.

2. Precautions

- 2.1. During removal and installation, be particularly careful to apply proper force and no abrupt or violent operation is allowed.
- 2.2. During removal and installation of the interior trimming, be particularly careful to avoid surface scratch.

3. Removal and Installation of Engine Hood Accessories

3.1. Removal Procedure

- 3.1.1. Pull off the washer fluid hose.



- 3.1.2. Press down the water nozzle clip under the engine hood, and then push it up while removing the nozzle outward.

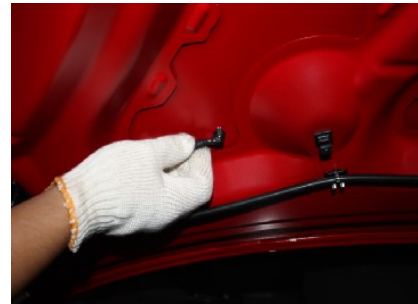

3.2. Installation Procedure

The installation procedures are reverse to those for removal. If the nozzle shall be replaced, please adjust the nozzle water injection to suitable height and width.

4. Removal & Adjustment of Engine Hood Assembly

- 4.1. Screw off the four adjusting bolts of the engine hood, and then the engine hood can be taken down. And the positing of the engine hood can be adjusted in left-right & front-rear directions by loosening the four adjusting bolts.

Installation torque: $25 \pm 2 \text{N.m}$



4.2. Installation of Engine hood Assembly:

The installation procedures are reverse to those for removal.



5. Removal of Engine Hood Lock

5.1. Removal Procedure

- 5.1.1. Remove three bolts on engine hood lock body with 10# socket wrench to remove the engine hood lock.

Installation torque: $7\pm 1\text{N.m}$



- 5.1.2. Remove the engine hood lock cable return spring from the engine hood lock assembly and remove the cable.



5.2. Installation Procedure

The installation procedures are reverse to those for removal.

6. Removal & Adjustment of Hood Cable

6.1. Removal & Adjustment Procedures

- 6.1.1. Remove the plastic nut behind the pull cover in driver's cab.



- 6.1.2. Pull out of the engine hood cable handle and remove the engine hood cable from the slot of pull rod.



6.2. Installation Procedure

The installation procedures are reverse to those for removal.



II. Removal and Installation of Trunk lid

1. Preparations

Tools: plastic screwdriver, socket wrench, cross ratchet wrench and etc.

Material: plastic clip

2. Removal of Trunk lid Trim Board

- 2.1. Pry up the trim board clearance with a plastic screwdriver, then remove the clips in sequence and remove the trunk lid interior trim board.

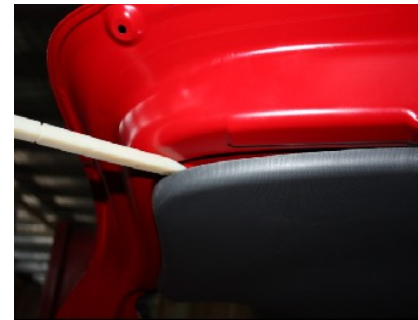

- 2.2. Remove the fixing bolts of license plate lamp trim board with 10# socket wrench; remove the license plate lamp trim board.



2.3. Installation of trunk lid trim board

Replace the damaged clips and align the clip with the installation hole; tap them for installation.

Remark: the trim board tapping force shall be suitable; clean the surface of interior trim board after installation..



3. Removal and Installation of Luggage boot Lock

3.1. Removal Procedure



- 3.1.1. Remove the pull rod from the upper lock body.



- 3.1.2. Disconnect the connector on upper lock body.



- 3.1.3. Remove the screws on the upper lock with cross ratchet wrench.

Installation torque: $12 \pm 1 \text{ N.m}$

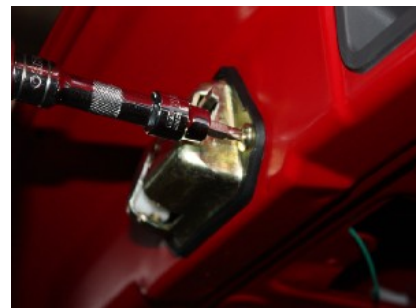

- 3.1.4. Remove the luggage boot lock.

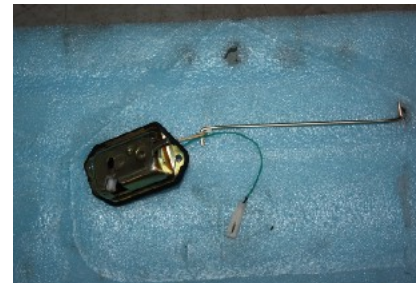

3.2. Installation Procedure

The installation procedures are reverse to those for removal.

Installation precautions: check if the lock cylinder has deformation, if the riveted joint is in position, if the luggage boot lock body sleeve is in good condition, if the lock tongue can open and shut freely.

4. Removal of Luggage Boot Lock Cylinder

4.1. Removal Procedure



- 4.1.1. Screw off the two fixing bolts of lock cylinder with 10# socket wrench.

Installation torque: $7\pm 1\text{N.m}$

- 4.1.2. Push the lock cylinder out and remove it.

Note: the lock cylinder washer shall not be thrown away.

4.2. Installation Procedure

The installation procedures are reverse to those for removal.

Note: the clearance between the lock cylinder and door sheet metal.



5. Removal of Rear Wiper Nozzle

5.1. Removal Procedure

- 5.1.1. Remove the fixing bolt of high mount brake lamp cover with a 10# socket wrench.



- 5.1.2. Remove the cover and disconnect the connector; remove the high mount brake lamp.

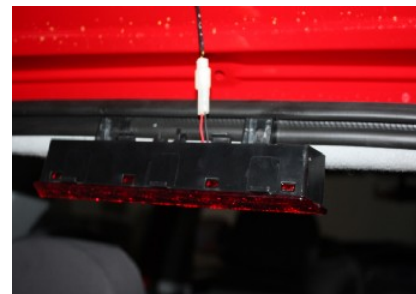



- 5.1.3. Pull off the rear water nozzle hose to remove the rear water nozzle.



5.2. Installation Procedure

The installation procedures are reverse to those for removal.

Note: water injection opening should be opposite to wiper motor steering shaft.

6. Removal of Rear Wiper Motor

6.1. Removal Procedure

- 6.1.1. Remove the rear wiper blade and arm seat cover.



- 6.1.2. Use a 10# socket wrench to loosen the nut above the motor, and remove the rear wiper blade.



Installation torque: $7\pm 1\text{N.m}$

- 6.1.3. Pull the wiper motor connector, remove three fixing bolts of the rear wiper motor with 10# socket wrench; remove the motor assembly.

Installation torque: $12\pm 1\text{N.m}$





Chery S18D Service Manual

6.2. Installation Procedure

The installation procedures are reverse to those for removal.

Notice to install the wiper seat sealing ring in place to avoid water leakage of rear windshield.





Chapter II Removal of Interior Trim Parts

I. Removal and Installation of Seat Belts

1. Preparations

Tools: plastic screwdriver, wrench, socket wrench and etc.

Parts: disposable clip, expansion bolt.

2. Precautions

Keep the seat belts clean and free of oil, and check them for any damage.

3. Removal and Installation of the Seat belt of Front Seats

3.1. Remove the front and rear door weather strip.



3.2. Pry out the front doorsill pressure plate with plastic screwdriver.



3.3. Remove the fixing bolts of rear doorsill with cross screwdriver and remove the rear doorsill pressure plate.



3.4. Remove the seat belt lower fixing bolt with 17# socket wrench.

Torque: $50 \pm 10 \text{N.m}$





Chery S18D Service Manual

3.5. Remove the two fixing screws of pillar B lower panel with cross screwdriver (each one for front and rear), remove the pillar B lower panel.

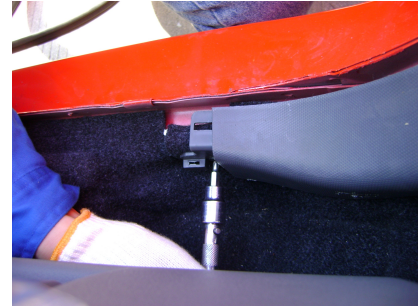

3.6. Remove the pillar B upper panel.



3.7. Remove the seat belt retractor assembly with 17# socket wrench.

Torque: 50 ± 10 N.m



3.8. Remove the seat belt guide plate with cross screwdriver.



3.9. Remove the seat belt upper fixing point bolt with 17# socket wrench.

Torque: 50 ± 10 N.m



3.10. Installation Procedure

The installation procedures are reverse to those for removal.



Note:

1. Keep the seat belt clean and away from oil, check if there is damage of seat belt, adding screw thread sealant during the mounting of seat belt fixing bolt.
2. The pillar panel shall be fit firmly with the body without any looseness, and it shall also be fit well with roof and weather strip.
3. The fit clearance between B pillar lower panel and front/rear doorsill pressure plate shall be even and less than 1 mm.

4. Removal and Installation of the Seat belt of Rear Seats

- 4.1. Remove the fixing screw of rear doorsill with cross screwdriver, remove the rear doorsill pressure plate. (refer to the removal and installation of the seat belt of front door)



- 4.2. Remove the seat belt bolt with 17# socket wrench.

Torque: 50 ± 10 N.m



- 4.3. Remove the back doorsill pressure plate with cross screwdriver.



- 4.4. Remove the lower panel fixing bolt with cross screwdriver and remove the lower panel.





4.5. Pry out the pillar C upper panel with plastic screwdriver.



4.7. Remove the rear seat belt upper and lower fixing point and rear seat fixing clip with 17# socket wrench.

Torque: 50 ± 10 N.m



4.8. Installation Procedure

The installation procedures are reverse to those for removal.

Note:

1. Keep the seat belt clean and away from oil, check if there is damage of seat belt, adding screw thread sealant during the mounting of seat belt fixing bolt.
2. The pillar panel shall be fit firmly with the body without any looseness, and it shall also be fit well with roof and weather strip.
3. The fit clearance between C pillar lower panel and rear doorsill pressure plate shall be even and less than 1 mm.

II. Removal and Installation of Seats

1. Preparations

Tools: socket wrench



2. Removal of Front Seats

- 2.1. Move the seat by pulling the movable handle under the seat, after the fixing bolts come out, use 13# socket wrench to remove the seat bolts.

Torque: $25 \pm 3 \text{N.m}$



- 2.2. Pull out the seat connector and remove the seat.



3. Removal of Rear Seats

- 3.1. Lift up the seat cushion and remove the fixing bolts of the rear seat cushion with the 14# socket wrench.

Torque: $25 \pm 3 \text{N.m}$



- 3.2. Remove the cushion after the removal of four fixing bolts.

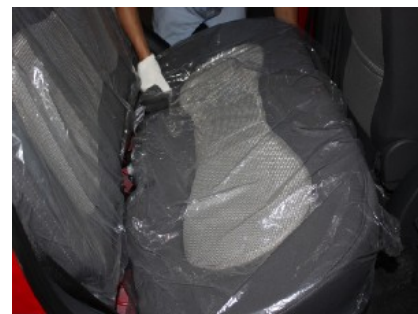

- 3.3. Open the luggage boot and take out the luggage boot carpet.

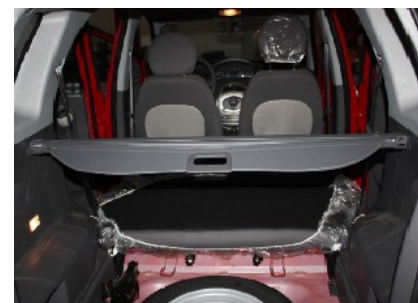



- 3.4. Remove the fixing bolts of the seat backrest with 13# socket wrench to remove the rear seat backrest (two bolts on each side).

Torque: $25 \pm 3 \text{N.m}$

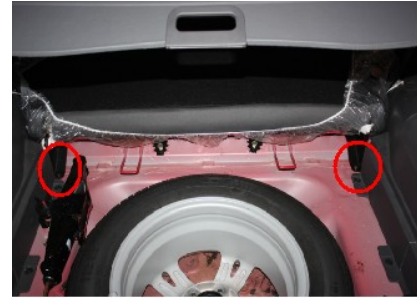

4. Installation Procedure

The installation procedures are reverse to those for removal.

Note: keep the cleanness of vehicle interior trim parts during removal and installation; avoid the trim parts surface scratch when moving the seat.



III. Removal and Installation of Central Console

1. Preparations

Tools: cross screwdriver, plastic screwdriver and etc.

2. Removal Procedure

- 2.1. Use plastic screwdriver to pry open the panel at the hand brake.



- 2.2. Use cross screwdriver to remove the front fixing screws of the central console assembly.





- 2.3. Use cross screwdriver to remove the rear fixing screws of the central console assembly and cup holder lower fixing screws.



- 2.4. Use plastic screwdriver to pry open the gearshift handle cover and rotate the gearshift handle in anti-clockwise direction to remove it.



- 2.5. Lift up the rear part of center console and pull the rear part to remove the center console.

3. Installation Procedure

The installation procedures are reverse to those for removal.

IV. Removal and Installation of Carpet

1. Preparations

Tools: slotted screwdriver, cross screwdriver; socket wrench and etc.

2. Removal Procedure

- 2.1. Remove the seats. (Refer the removal of seat)



Chery S18D Service Manual

- 2.2. Remove the central console (Refer the removal of central console)
- 2.3. Remove the seat belt, front and rear doorsill panel and the upper/lower panel of pillar B.
(Refer the removal of seat belt)
- 2.4. Pry out the footrest cover by slotted screwdriver.



- 2.5. Remove the footrest with 10# socket wrench.



- 2.6. Remove the pillar A lower panel with cross screwdriver.



- 2.7. Remove the seat cushion of rear seats (See removal of seats)

Remove the rear doorsill pressure plate with cross screwdriver.





- 2.8. Remove the the carpet fixing clip and remove the carpet.



3. Installation Procedure

Note: In installation, notice the carpet edges flatness and indoor related wiring harness direction.

- 3.1. Put the vehicle carpet inside the vehicle, and take out the harness connected with the seats, and then press the vehicle carpet besides the middle passage tightly.



- 3.2. Let the seat holes exposed.



- 3.3. Spread the carpet under foot pedal and press it tightly.



- 3.4. Spread the rear part of the carpet according to the shape of the vehicle floor, expose the mounting holes of the rear seats, and spread and press the rear part of the carpet according to the shape of the vehicle floor.





Chapter III Removal & Maintenance of Vehicle Doors

I. Removal, Installation & Maintenance of Front Doors

1. Preparations

Tools: slotted screwdriver, cross screwdriver, plastic screwdriver, socket wrench, pliers and etc.

2. Precautions

- 2.1. Wear necessary appliance for labor protection to prevent from accidents.
- 2.2. Disconnect the battery to prevent damage for electrical equipments.
- 2.3. To prevent glass from being damaged, pay attention to take correct steps during removal and installation.

3. Removal Procedure

- 3.1. Pry out the door inner triangular block with plastic screwdriver.



- 3.2. Disconnect the wiring harness of exterior rear view mirror.



- 3.3. Remove the three fixing nut of exterior rear view mirror with 10# socket wrench, remove the exterior rear view mirror.





Chery S18D Service Manual

3.4. Pry out the cover in the inner door handle slot with slotted screwdriver.



3.5. Remove the five fixing screws of door inner panel with cross screwdriver (two screws on panel front surface and three screws on panel side surface).



3.6. Pry out the protective cover of door inner armrest groove with slotted screwdriver.



3.7. Remove the screw that fix the door inner armrest with cross screwdriver.





3.8. Pry up the door inner armrest assembly with plastic screwdriver and take it out.



3.9. Pull out the exterior rear view mirror adjusting switch (only driver side) and window regulator control switch connector.



3.10. Pry out the door inner panel from edge with the plastic screwdriver.



3.11. Pull off the door inner handle cable.



3.12. Remove the two screws of front door armrest fixing bracket with cross screwdriver.





3.13. Remove the anti-water protective layer.



3.14. Connect the battery and connect the window regulator switch connector, lower the window glass at a proper position and remove the two screws that fix the glass.



3.15. Take out the glass carefully.



3.16. Remove the five screws that fix the window regulator with 10# socket wrench.



3.17. Pull off the window regulator connector and take out the window glass regulator assembly.





- 3.18. Remove the two fixing screws with 10# socket wrench, remove the door outside handle.



- 3.19. Remove the three screws fixing the lock cylinder with cross screwdriver, remove the lock cylinder.



- 3.20. Remove the two screws that fix the lock cylinder with cross screwdriver, remove the lock cylinder.



- 3.21. Use 13# socket wrench to remove the four fixing screws of the hinge that fix the vehicle door, remove the door.

Torque: 32±3 N.m



4. Installation Procedure

The installation procedures are reverse to those for removal.

Note: The removal procedures for the right-front door can refer to those for the left-front door.

II. Removal & Installation of Rear Doors

1. Preparations

Tools: slotted screwdriver, cross screwdriver, socket wrench and etc.

2. Precautions

- 2.1. Wear necessary appliance for labor protection to prevent from accidents.
- 2.2. Disconnect the battery to prevent damage for electrical equipments.



2.3. To prevent glass from being damaged, pay attention to take correct steps during removal and installation.

3. Removal Procedure

3.1. Pry out the rear door inner triangular block with plastic screwdriver.



3.2. Pry out the protective cover of door inner armrest groove with slotted screwdriver, expose the fixing screw.



3.3. Remove the fixing screw of the door inner armrest with cross screwdriver.



3.4. Pry out the window regulator switch with slotted screwdriver, pull off the connector of window regulator and remove it.





Chery S18D Service Manual

3.5. Remove the fixing screws of door panel on its front and side with cross screwdriver.



3.6. Pry out the door inner panel from edge with the plastic screwdriver.



3.7. Pull off the door inner handle cable.





3.8. Remove the door inner armrest bracket with cross screwdriver.



3.9. Remove the anti-water protective layer.



3.10. Remove the door outside handle fixing nuts with 10# socket wrench, remove the door outside handle.



3.11. Connect the battery and lower the window glass at a proper position (let the glass fixing screws be exposed on the two installation holes as shown in figure) and remove the two screws that fix the glass with cross screwdriver, remove the glass carefully.

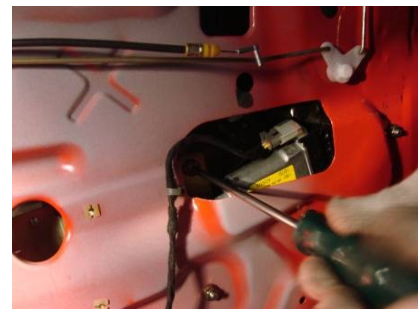
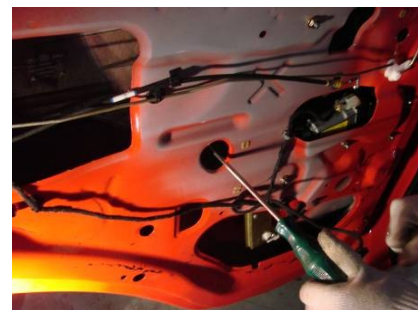



- 3.12. Remove the five screws that fix the window regulator with 10# socket wrench, remove the window regulator.



- 3.13. Remove the fixing bolts of rear door and hinge with 10# socket wrench, remove the rear door assembly.

Torque: 32 ± 3 N.m



4. Installation Procedure

The installation procedures are reverse to those for removal.

Note: The removal procedures for the right-rear door can refer to those for the left-rear door.





Chapter IV Removal, Installation & Maintenance of Front/Rear Bumper

I. Removal, Installation & Maintenance of Front Bumper

1. Preparations

Socket wrench, cross screwdriver, slotted screwdriver, plastic screwdriver.

Parts: expansion bolt.

2. Precautions

- 2.1. Wear necessary appliance for labor protection to prevent from accidents.
- 2.2. Try to avoid scratching the paint of the bumper during the removal operation.

3. Removal Procedure

- 3.1. Open the Engine hood.
- 3.2. Remove the fixing screws on upper of front bumper with cross screwdriver.



- 3.3. Remove the bumper lower fixing screw with cross screwdriver and 7# socket wrench.

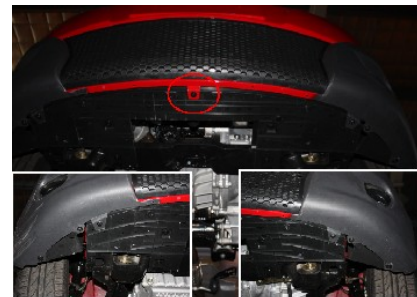

- 3.4. Remove the fixing screw that connects the front bumper and fender with 7# socket wrench.

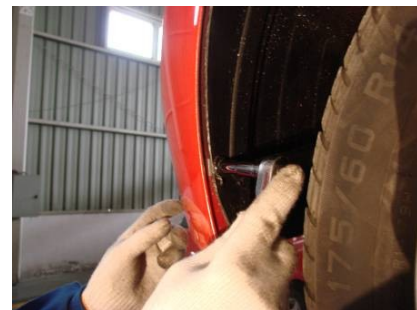



3.5. Remove the left and right fog lamp wiring harness connectors, remove the front bumper (the front bumper is connected and fixed with the fender by clip; do not break the clip during removal of bumper).



3.6. Remove the two fixing bolts of upper air intake grille with cross screwdriver to remove the air intake grille.



3.7. Use plastic screwdriver to pry out the edges of lower air intake grille to remove it.

Note: the air intake grille can be replaced directly without removing the lower bumper.

4. Installation Procedure

The installation procedures are reverse to those for removal.



II. Removal, Installation & Maintenance of Rear Bumper

1. Preparations

Tools: cross screwdriver, slotted screwdriver, socket wrench and etc.

Parts: expansion bolt

2. Precautions

- 2.1. Wear necessary appliance for labor protection to prevent from accidents.
- 2.2. Try to avoid scratching the painted surface of the bumper when removing it.

3. Removal Procedure

3.1. Open the luggage boot lid and use a cross screwdriver to loosen off the four fixing screws on the rear bumper.





3.2. Use a cross screwdriver to loosen off the screws fixing the rear bumper bottom and the vehicle body.



3.3. Use a 7# socket wrench to loosen the screws connecting the fender and the bumper.



3.4. Apply the force vertical to fender surface to outwards to separate the bumper and fender clips and remove the bumper.

Note: notice the force applied to avoid the damage of clips during removal.



3.5. Remove the connectors of reverser radar and left & right rear fog lamp.

Note: notice to avoid the wiring harness being pulled by bumper when removing the wiring harness connector.

3.6. Remove the rear bumper rod.

(the rear bumper rod is fixed with wheelhouse by clips, notice to avoid the damage of clips during removal of rear bumper rod)



3.7. Push the reverse radar from inside of bumper towards outside to remove the reverse radar.

Note: during the installation of reverse radar, the locating pin of reverse radar shall be aligned with the bumper locating hole (as right figure).



4. Installation Procedure

The installation procedures are reverse to those for removal.



Chapter V Removal and Installation of Outside Lamps

I. Preparations

Tools: socket wrench, cross screwdriver and etc.

II. Precautions

- 2.1. Wear necessary appliance for labor protection to prevent from accidents.
- 2.2. Try to avoid scratching the paint surface of the bumper when removing it.
- 2.3. Pay attention not to scratch the headlamp surface during removal or placing it.

III. Removal Procedure of Headlamp

3.1. Remove the headlamp wiring harness connector.



3.2. Remove the three headlamp fixing screws on the engine compartment cross beam and fender with 10# socket wrench and remove the headlamp.



3.3. Open the headlamp high beam holder shield by hand.



3.4. Disconnect the connector of high and low beam lamp holder.

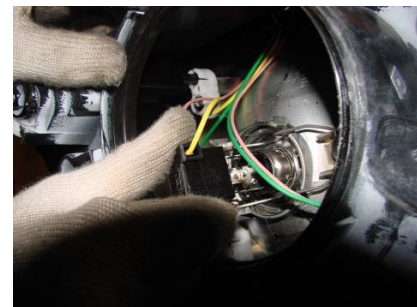



3.5. Press down the bulb fixing clip by hand and turn the clip over to take out the high/low beam bulb.



3.8 Pull off the front position lamp wiring harness connector and remove the front position lamp bulb.



3.9. Screw off the turn signal lamp holder by hand and can replace the turn signal lamp bulb.



IV. Removal of Front Fog Lamp

4.1. Remove the front wheel mud guard.





4.2. Remove the front fog lamp fixing boltr with cross screwdriver to remove the front fog lamp.



4.3. Press down the bulb fixing clip by hand and turn the clip over to take out the high/low beam bulb.



V. Removal of Rear Fog Lamp

5.1. Remove the rear bumper (see the removal and installation of rear bumper for details)

5.2. Remove the rear fog lamp fixing bolts with cross screwdriver and remove the fog lamp.



5.3. Rotate the rear fog lamp holder in anti-clockwise direction to remove the rear fog lamp bulb.





VI Removal of Tail Lamp

6.1. Remove the baffle on luggage boot inner tail lamp.



6.2. Remove the three nuts fixing tail lamp in luggage boot compartment with 10\$ socket wrench.



6.3. Pull off the tail lamp wiring harness connector and remove the tail lamp assembly.



6.4. Rotate the bulb seat anti-clockwise by hand to remove the bulb.



VII. Removal of License Lamp

7.1. Use a cross screwdriver to remove the license lamp fixing bolts.





- 7.2. Pull off the harness connector and remove the license lamp.



VIII. Installation & Adjustment of Headlamp

8.1. Installation Procedures for the Headlamp

The installation procedures of headlamp are reverse to those for removal.

8.2. Function of headlamp

8.2.1. Front view

As shown in right figure:

- 1 Low beam lamp
- 2 Turn lamp
- 3 High beam lamp and position lamp



8.2.2. Back view

- 1 High beam lamp up & down adjusting nut
- 2 High and low beam lamp and position lamp rear cover
- 3 Turn lamp bulb holder
- 4 Low beam left & right adjusting nut
- 5 Low beam lamp rear cover
- 6 Low beam lamp up & down adjusting nut

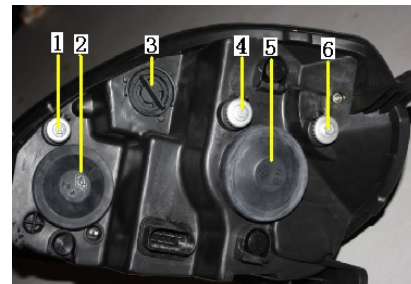

8.3. Adjustment of Headlamp

8.3.1. Pay attention to law and regulations and verify the following items before adjustment:

- 1). The tire air pressure should comply with the related standard;
- 2). Vehicle is unloaded (except for spare tire and equipping tools, and include driver's weight for sedan);
- 3). The vehicle should be parked on level and smooth road or field;
- 4). The matched mirror surface of the headlamp should be fresh of dirt;
- 5). The power supply should work normally and the bulb should be properly installed.

- 8.3.2. Insert a hexagon wrench into corresponding adjusting hole to adjust the lamp.



IX. Installation of Tail Lamp

9.1. Installation Procedure of tail lamp

The installation procedures of tail lamp are reverse to those for removal.

9.2. Function of tail lamp

9.2.1. Front view

- 1). Brake lamp/ position lamp (one bulb has two filaments)
- 2). Turn lamp
- 3). Reverse lamp

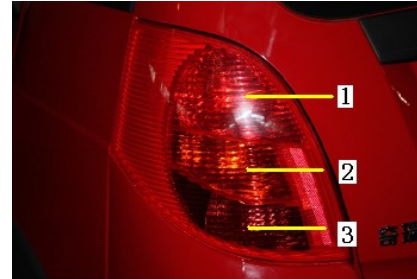

9.2.2. Rear view

As shown in right figure:

- 1). Reverse lamp holder
- 2). Turn lamp holder
- 3). Brake lamp/ position lamp holder

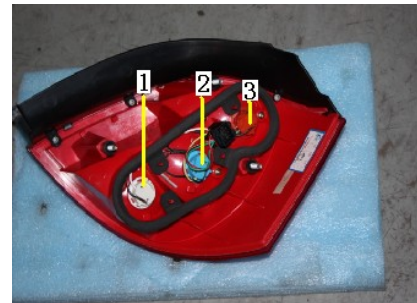



Chapter VI Removal and Installation of Vehicle Ceiling

I. Preparations

Tools: socket wrench, cross screwdriver, slotted screwdriver and etc.

Parts: expansion bolt.

II. Precautions

1. During the removal and installation, make sure to apply proper force and violent operation is not allowed.
2. During removal and installation of the inner trims, make sure to protect the trims from being scratched.

III. Removal and Installation of Sun Visor

1. Removal Procedure

- 1.1. Use a cross screwdriver to remove the screws on sun visor in left of the driver's cab and remove the sun visor.



- 1.2. The removal procedures for the right sun visor are reverse to those for removal of the left one.

2. Installation Procedure

The installation procedures are reverse to those for removal.

IV. Removal and Installation of Ceiling Armrest

1. Removal Procedure

- 1.1. Open the ceiling armrest screw cover over the co-driver's seat by hand, and then use a cross screwdriver to loosen off the left and right fixing screws.





1.2. Remove the ceiling armrest.



2. Installation Procedure

The installation procedures are reverse to those for removal.

V. Removal and Installation of Front Ceiling Lamp

1. Removal Procedure

1.1. Align a slotted screwdriver with the groove along the ceiling lamp edge to pry it open.

Note: Do not scratch part surface.



1.2. Remove the three fixing screws of the front ceiling lamp.



1.3. Disconnect the harness connector and remove the front ceiling lamp assembly.



2. Installation Procedure

The installation procedures are reverse to those for removal.

VI. Removal and Installation of A-pillar Panel

1. Removal Procedure



- 1.1. Remove the weather strip of the right A-pillar panel, and then pry out the left A-pillar panel with slotted screwdriver.



- 1.2. The removal procedures of the left A-pillar panel can refer to the removal procedures of right A-pillar panel.

2. Installation Procedure

The installation procedures are reverse to those for removal.

VII. Removal and Installation of B-pillar Panel

1. Removal Procedure

- 1.1. Remove the B-pillar lower panel (See Removal and Installation of Seat belt).

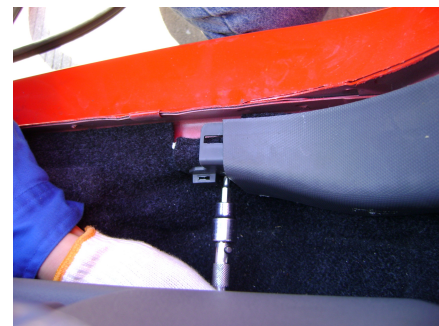

- 1.2. Use a plastic screwdriver to pry out the B-pillar upper panel.



2. Installation Procedure

The installation procedures are reverse to those for removal.

VIII. Removal and Installation of C-pillar Panel

1. Removal Procedure



- 1.1. Use a socket wrench to remove the seat belt bolts (See Removal and Installation of Rear Seats & Seat belts).

Torque: 50 ± 10 N.m



2. Installation Procedure

The installation procedures are reverse to those for removal.

IX. Removal and Installation of Vehicle Ceiling

1. Removal Procedure

- 1.1. Remove the left/right sun visors and their fixing seat. (See Removal and Installation of Sun Visor)
- 1.2. Remove the front ceiling lamp. (Refer to removal and installation of front ceiling lamp)
- 1.3. Remove all interior ceiling armrests. (See removal and installation of ceiling armrest)
- 1.4. Remove the A/B/C-pillar panel. (See removal and installation of A/B/C-Pillar Panel)
- 1.5. Use a slotted screwdriver to loosen off the vehicle ceiling clips (3 in all).



- 1.6. Remove the four doors and back door weather strips.





Chery S18D Service Manual

1.7.Remove the vehicle ceiling.



2. Installation Procedure

The installation procedures are reverse to those for removal.



Chapter VII Removal and Installation of Instrument Panel & Instrument Panel Crossbeam

I. Removal of Instrument Panel

Tools: socket wrench, cross screwdriver, slotted screwdriver and etc.

1. Removal Procedure

1.1. Remove the center console. (See the removal and installation of center console).



1.2. Remove the three fixing screws of instrument panel with cross screwdriver, remove the top cover of instrument panel.



1.3. Loosen the five screws on lower cover of instrument panel with cross screwdriver.





Chery S18D Service Manual

1.4. Remove the lower cover of instrument panel
(avoid the break of the two clips in inner side)



1.5. Remove the two fixing screws connecting the
dashboard and instrument panel body with
cross screwdriver.



1.6. Pry out the dashboard body with slotted
screwdriver.



1.7. Pull off the harness connector on instrument
panel body and remove it.



1.8. Pry out the dashboard brightness adjusting
switch with slotted screwdriver.





Chery S18D Service Manual

- 1.9. Screw off the fixing nut of engine hood handle and remove the handle and cable. (See the removal and installation procedures of engine hood handle and cable)



- 1.10. Pry out the central control panel shield with slotted screwdriver.



- 1.11. Pull off the A/C regulating switch harness and central control panel switch harness.

Note: during installation, notice the color marked by the harness shall be correspond to the color of the connector on switch back, wrong installation is not allowed.

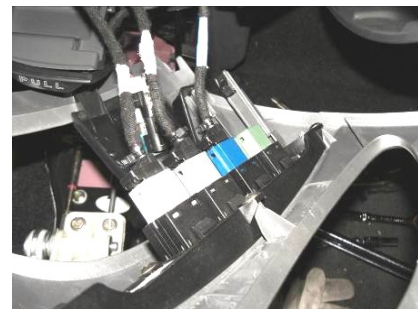

- 1.12. Remove the fixing screw of radio cassette player.

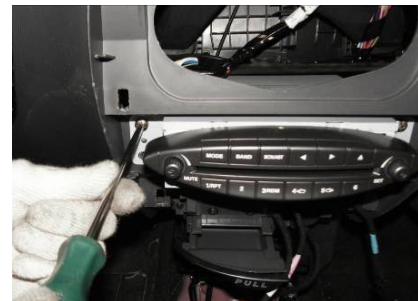



Chery S18D Service Manual

1.13. Pull off the harness and antenna connector of radio cassette player, remove the radio cassette player.



1.14. Loosen the two bolts besides the name car box with 10# socket wrench.



1.15. Pry out the speaker shield with slotted screwdriver.

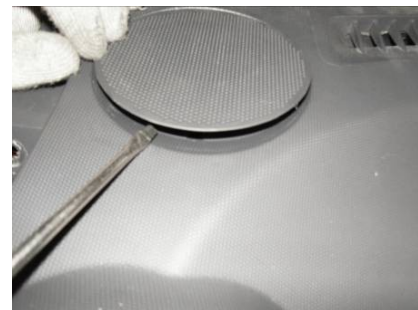

1.16. Remove the speaker body with slotted screwdriver.

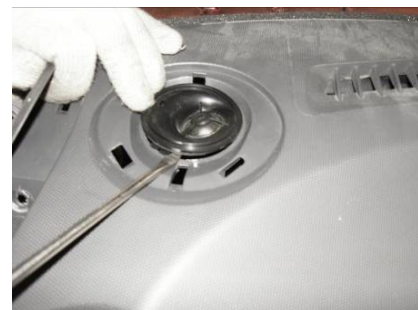

1.17. Remove the two screws on pillar-A lower panel with cross screwdriver, remove the pillar-A lower panel.





Chery S18D Service Manual

1.18. Remove the fixing bolt of instrument panel body and hinge inner side sheet metal with 10# socket wrench.



1.19. Remove the panel on two sides of instrument panel body.



1.20. Remove the fixing screws on two sides of instrument panel body with cross screwdriver.



1.21. Remove the fixing bolt between body sheet metal and the instrument panel body beside speaker with 10# socket wrench.



1.22. Remove the instrument panel body.





Note:

1. Disconnect the battery negative before removing the electrical equipment.
2. Don't wait until all the instrument panel bolts are removed before you remove the ones on the other side, or the instrument panel are likely to get deformed.

2. Installation Procedure

The installation procedures are reverse to those for removal.

Note:

- ①. Double-wind channels should agree with the air-conditioner outlet connector and be installed properly without any air leak, and the Instrument Panel air channel should not conflict with the Instrument Panel crossbeam, the evaporator and other parts, or the Instrument Panel and its accessories will not be installed properly.
- ②. The Instrument Panel should not interfere with the front windscreen or affects its installation and the clearance shall be even.
- ③. The clearances between the instrument panel and either sides of the vehicle body should be consistent and meet the requirements for assembling the door weather strips.

3. Methods for Clearing Instrument Maintenance Indicator

Following is the clearing method:

- ①. Insert the key into the ignition switch and turn the key to the position "ACC";
- ②. Press the adjusting button by hand and hold it, then turn the key to "ON" position;
- ③. Press the adjusting knob and hold it for about 20 seconds before you release the knob, and then the maintenance indicator will be cleared.

II. Removal of Instrument Panel Cross Beam

Tools: socket wrench, cross screwdriver, slotted screwdriver and etc.

Parts: harness strap

1. Removal Procedure

- 1.1. Remove the instrument panel assembly (see the removal of instrument panel)
- 1.2. Remove the connector of interior wiring harness and instrument panel wiring harness.





1.3. Pull off the connector of ECU wiring harness and instrument panel wiring harness.



1.4. Remove the connector of instrument panel wiring harness and engine wiring harness.

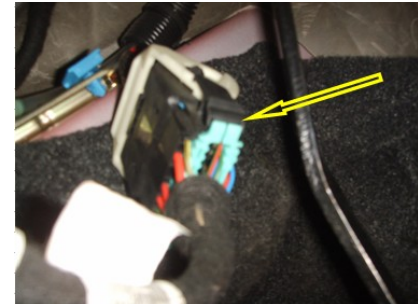

1.5. Remove the connectors of A/C wiring harness and ceiling wiring harness; remove all ground points of instrument panel wiring harness.



1.6. Remove the fixing bolt of anti-theft controller with 10# socket wrench, and then remove its connector.

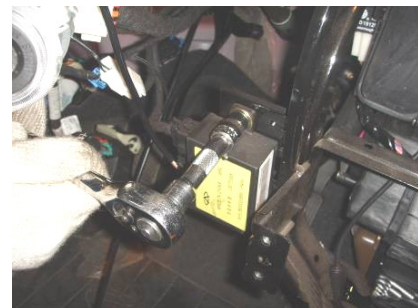

1.7. Remove the fixing bolt on two ends of instrument panel crossbeam with 10# socket wrench.

Torque: $25 \pm 2 \text{N.m}$





Chery S18D Service Manual

- 1.8. Remove the two fixing nuts between the instrument panel cross beam and steering column with 13# socket wrench.

Torque: $23 \pm 2 \text{N.m}$



- 1.9. Remove the three fixing bolts connecting instrument panel cross beam top cover and vehicle body with 10# socket wrench.

Torque: $25 \pm 2 \text{N.m}$



- 1.10. Remove the four bolts on the lower fixing points of middle support on instrument panel cross beam with 10# socket wrench.

Torque: $7 \pm 1 \text{N.m}$



- 1.11. Take out the instrument panel cross beam (Pay attention to the ground point connected with floor).

2. Installation Procedure

The installation procedures are reverse to those for removal.



Chapter VIII Air Conditioning System

I. System Constitution

Air adjustment and distributing system: HVAC air mixing and distributor part, inside/outside circulation air inlet, air outlet, outside circulation air filter.

Control system: control panel assembly, micro motor, blower, speed regulating mode, high/low pressure switch, A/C temperature sensor.

Heating system: heater water tank, hot water pipe, and engine cooling water system.

Cooling system: compressor, condenser, reservoir dryer, expansion valve, evaporator and pipe.

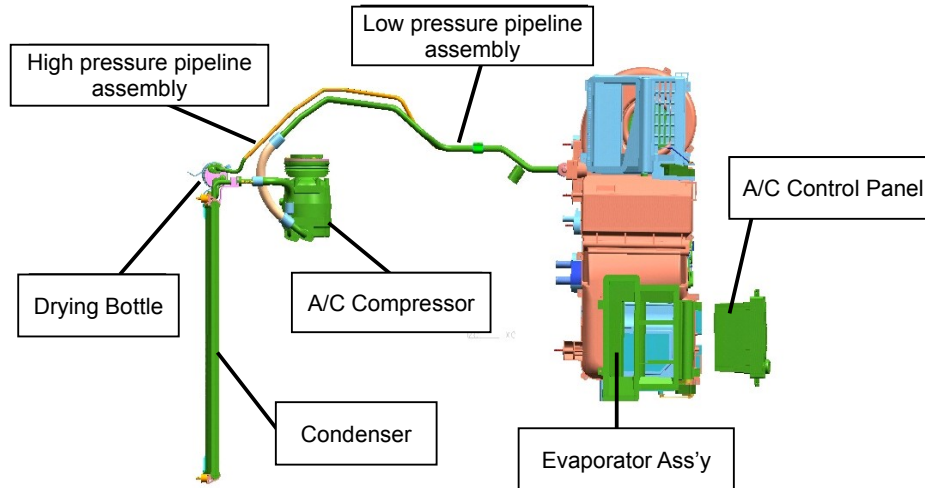

II. Removal of Evaporator Assembly

1. Preparations

Tools: cross screwdriver, clamp pliers, socket wrench and etc.

Auxiliary material: refrigerant, antifreeze, sponge rubber strip

2. Removal and Installation Procedures

2.1. Use coolant recycling machine to recycle the coolant.

Note:

- (1) Don't handle with the coolant in any closed place or near flame.
 - (2) Do not splash the refrigerant onto eyes and skin.
- 2.2. Remove the instrument panel assembly and the front crossbeam, and disconnect the related electrical equipment connectors. (See Removal and Installation of Instrument Panel)
- 2.3. Loosen off the fixing nuts of the high/low pressure pipe with 5# inner hexagon wrench and pull out the high/low pressure pipe.

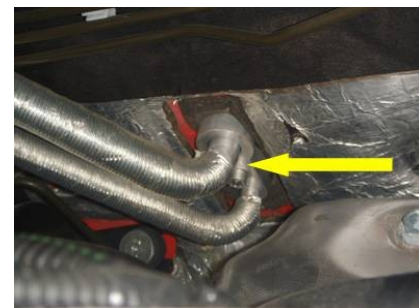



2.4. Remove the two evaporator nuts fixed onto sheet metal with 10# socket wrench.

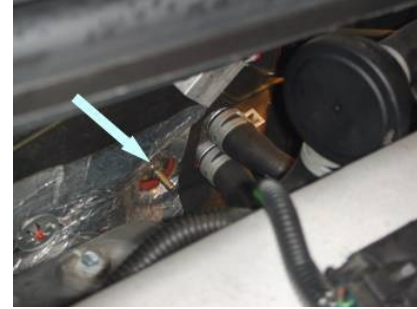

2.5. Use clamp pliers to remove the inlet/outlet water pipes of the evaporator and pull out the pipes.

Note: Coolant will flow out from the water pipe, pay attention to recycle the coolant.



2.6. Loosen off the 3 fixing nuts that fix the evaporator assembly on the sheet metal with 10# socket wrench (See the following figures for detailed positions).

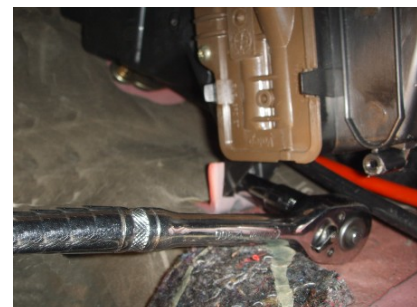



2.7. Take the evaporator assembly out of the driver's cab.

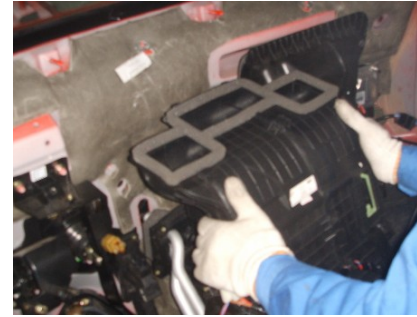

3. Installation of Evaporator Assembly

The installation procedures are reverse to those for removal.

III. Removal and Installation of Evaporator Interior

1. Preparation of Tools

Cross screwdriver, slotted screwdriver, inner spline wrench and etc.

2. Removal and Installation of Blower

2.1. Removal Procedure

2.1.1. Remove the blower motor and relay module connector.



2.1.2. Push down the clip and rotate the blower clockwise to remove it.



2.2. Installation Procedure



The installation procedures are reverse to those for removal.

3. Removal and Installation of Blower Speed Regulation Module

3.1. Removal Procedure

3.1.1. Pull out the speed regulation module connector.



3.1.2. Use a cross screwdriver to remove the fixing screws on speed regulation module.

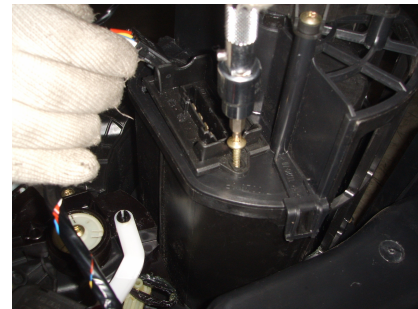

3.1.3. Pull out the speed regulation module.



3.2. Installation Procedure

The installation procedures are reverse to those for removal.

4. Removal and Installation of Heater Exchanger

4.1. Removal Procedure

4.1.1. Disassemble the evaporator assembly. (See Removal of Evaporator Assembly)

4.1.2. Disassemble the air-conditioner harness. (See Removal of Instrument Panel Cross Beam)



- 4.1.3. Remove the two screws on rear end of hot water pipe with cross screwdriver.



- 4.1.4. Remove the two screws on front end of hot water pipe with cross screwdriver.



- 4.1.5. Tear off the sponge around the water inlet and outlet pipe and remove the heater exchanger.

Note: the sponge seal around the housing is disposable.



4.2. Installation Procedure

The installation procedures are reverse to those for removal.

After the installation, the system should be evacuated, proper pressure should be maintained and anti-freeze agent should be filled to check for any leakage. Check if the radiator is blocked and compressed air can be used to clean it.

5. Removal and Installation of Mode Air Door Related Mechanism

5.1. Removal Procedure

- 5.1.1. Pull out the control motor connector.





- 5.1.2. Remove the two fixing screws on control motor with inner spline wrench and remove the control motor.



5.2. Installation Procedure

The installation procedures are reverse to those for removal.

6. Removal and Installation of Blend Air Door Related Mechanism

6.1. Removal Procedure

- 6.1.1. Pull out the blend air door motor connector.



- 6.1.2. Remove the blend door control plate with inner spline wrench.





- 6.1.3. Align with the slot opening on one end of control arm and remove the control arm.



6.2. Installation Procedure

The installation procedures are reverse to those for removal.

7. Removal and Installation of Int./Ext.Air Door Motor & Related Mechanism

7.1. Removal Procedure

- 7.1.1. Pull out the motor connector.

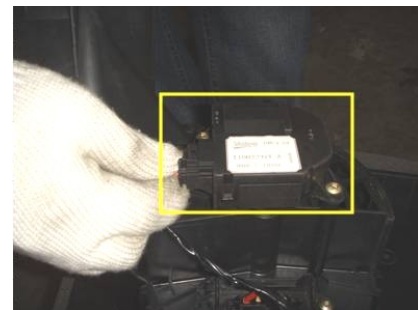

- 7.1.2. Remove the fixing screws of control motor and remove the motor.



7.2. Installation Procedure

The installation procedures are reverse to those for removal.

8. Removal and Installation of Evaporator

8.1. Removal Procedure



- 8.1.1. Remove the air-conditioner harness (See removal of air-conditioner harness)
- 8.1.2. Remove the five fixing screws on evaporator housing.

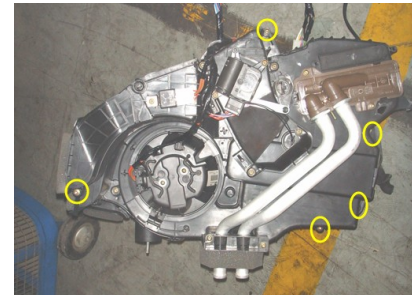
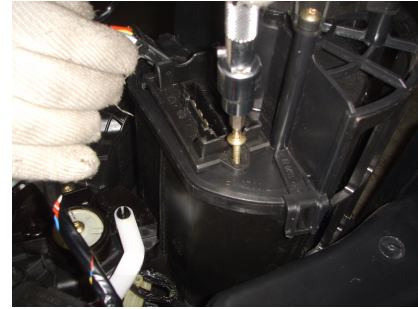

- 8.1.3. Remove the evaporator top cover.



- 8.1.4. Remove the evaporator core.



8.2. Installation of evaporator assembly

The installation procedures are reverse to those for removal.

After the installation, the system should be evacuated, proper pressure should be maintained and anti-freeze agent should be filled to check for any leakage. Check if the radiator is blocked and compressed air can be used to clean it.



CHAPTER IX Body Dimension

I. Basic Instructions on BIW Maintenance

Vehicle body maintenance should be carried out by professionals according to the requirements of the manufacturer, and only in this way will the promises of “rust free” and “paint defect free” be effective.

1. Only adopt the materials specified by the manufacturer;
2. When welding the outside metal of the vehicle body, make sure protective coating is applied to the inner side;
3. When spot-welding, make sure zinc coating is used;
4. Before air-tight sealing the welded parts, apply a layer of filling coating to the inner side and outer side;
5. Before protecting the chassis with paint, apply protective coating to protect the chassis from rock bumping;
6. When the coating is sprayed, all opening parts at this position should be secured with fasteners;

In some cases, the vehicle must be placed on a hoister platform, for removal of spare parts may affect the distribution of various parts in the vehicle body.

Before spot-welding, make sure the battery connector is unplugged, and check if the ventilation is good enough before welding.

In maintaining the vehicle body in a certain area, take care to protect other vehicles in this area.

Be particularly careful when spraying sand or welding near the oil tank or fuel system, and disassemble them if the safety can not be assured.

When maintaining or spray-painting the vehicle body, take all possible measures of preventing accidents.

When welding galvanized steel sheets, the spot-welding current should be raised by 30%, and the electrodes should be pointed, and the clamping force of the electrodes should be increased; and when doing gas shielded welding, the welding current should be further intensified.

Do not weld the air-conditioning parts or try to weld the parts on the vehicle whose temperature are easily raised. When spray-painting the vehicle frame, the temperature either in the drying oven or the pre-heating oven should not go beyond 80°C.

Take the following measures during welding operation to prevent shaking the electronically welded equipment:

Connect the grounding of the electronic welding equipment directly to the welded parts. And check to make sure no other parts or insulative parts exists between the ground wiring connector and the spot-welded parts;

First disassemble the ECU, and prevent the electronic device or circuit from contacting the ground wiring connector or welding wire.

Corrections:

The vehicle body and the chassis are manufactured off the production-line by low-temperature tempering and cold die casting. Therefore, when the metal parts are damage in any accident, the same processes must be used to restore them, and no heating is allowed. If they are damaged very seriously and can not be restored, the damaged parts must be removed after the connecting surface is corrected.

The car bodies are made up of various members, pressing panels and other parts, of which the doors are the most complexly processed parts of the vehicle body. They involve processes like part stamping and welding, assembly of spare parts and assemblies, for which the dimensional fits and technical requirements are quite strict, so the car doors are difficult to maintain and the quality requirements are fairly high, and only the service personnel understand the structure of the car doors thoroughly and are



qualified for the maintaining operations.

1. Vehicle Door Structure

Generally speaking, the vehicle doors consist of outside plates, inside plates, window frames, glass guide rails, hinges, locks and window accessories and so on. The inside door plates are equipped with accessories including glass lifter, locks and so on. To secure the assembly, some parts of the inside door plates need to be fortified. To increase safety level, the inner parts of the outside plates are usually equipped with impact bars. The outside plates and inside plates are connected by flanging, adhesion, seam welding and so on. Depending on different bearing capabilities, the outside plates should be light and the inside plates should have higher rigidity and be able to stand stronger impact.

The BIW vehicle door assemblies have relatively fewer components, and usually consist of inside plates, outside plates, glass guide rails, window frame reinforcing plates, lock mounting plates, hinges reinforcing plates, impact bar assemblies and so on; The figure below is a typical structure drawing of a vehicle door.

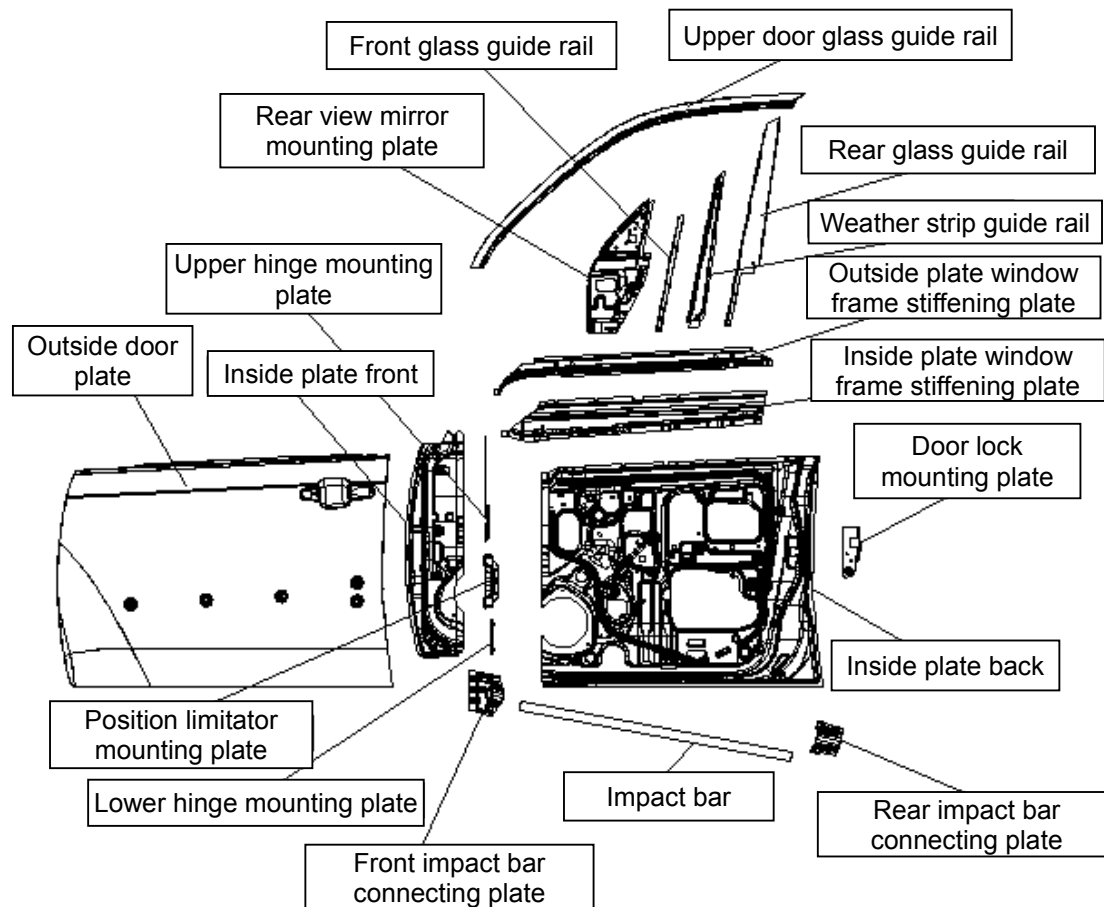

2. Door Panel Maintenance Process

Generally speaking, the basic maintenance methods for car doors and hoods are the same as those for ordinary plate work, and the following procedures apply to both of them:

- (1) Primary tests. The positions of the door panels as related to other assemblies of the vehicle body as well as the dimensions of their tolerance clearances should be tested



- (2) Clean the vehicle doors. Use fresh water or detergent to clean the dirt and greasy spots on the door panels, and let them thoroughly dry for tests.
- (3) Maintenance appraisal. Appraise the scope and degree of damage to the door panels by testing and decide the maintenance methods.
- (4) Clear the old paint. Before cleaning or maintenance, get rid of the old paint according to the actual situation, especially when there exists obvious rust, cracks or dents; The paint can be got rid of in manual, heating, mechanic or chemical method(s).

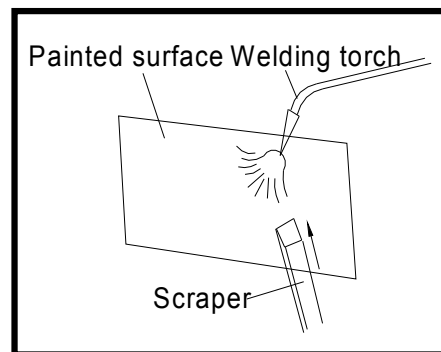

Fig.3

- (5) Tests after the removal, including the measurements of the geometric dimensions between various plate work pieces, tests of specific damage spots of various plate work pieces, recognition of damage types, analyses of damage causes and choices of maintenance schemes.

3. Main Contents of Door Panel Maintenance

Generally speaking, the causes of door panel damages are related to the following 4 aspects: structure design defects, manufacturing defects, chemical erosion, and physical damage. And the most common damage causes can be classified as the following types:

1. Abrasion: The surfaces of plate work pieces may contact each other and relative movements will take place and cause surface friction, which will lead to abrasion. For example, the long time friction between the hinge hole and the shaft of the vehicle door hinge will increase their tolerance clearance and cause to vehicle doors to drop.
2. Erosion: This is generally due to the oxidation caused by the mud deposit and dirt; or the rust caused by lack of anti-erosion processing after welding; or erosion caused by chemicals. This type of damage usually occurs between the plate work pieces, in overlapped parts of spot-welded pieces, and at other similar places.
3. Cracks or breaks: The metal plates may develop fatigue under repeated inner/outer stress where the stress concentrates and the structure is the weakest, causing cracks and even breaks.



Chery S18D Service Manual

4. Dents or wrinkles: Dents develop because the door panel is subjected to bumping or pressing, leading to elastic or plastic deformations.
5. Bends or twists: They are mainly caused by too much load the door panel receives in use or the plastic deformation due to bumps.

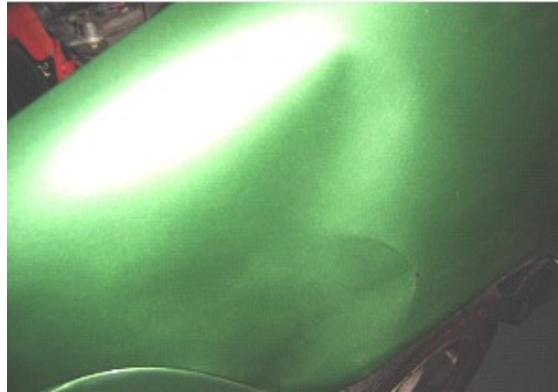

4. Basic Methods for Door Panel Maintenance

The basic maintenance methods for the above door panel damage types include dent reconditioning, flame correction, welding, repairing and mending, wrinkle spreading and so on.

4.1. Reconditioning of Dents

For convex-concave damages in the outside door panels, if they are indirectly caused by structural pieces or reinforcers, the structural pieces should be corrected first, and then the outside panel breaks or dents are to be corrected. If the backs of the metal panels are accessible, hand hammers and underlay irons or spoon-shaped irons, tommy bars, flat punches and so on can be used for primary repairs. For enclosed metal panels or parts that are difficult to access from the backs, other tools can be used for repairing, such as slide hammers and pointed hammers.

Here are some common ways of dent reconditioning:

- (1) Repair the dents with underlay irons and hand hammers: the commonest practice is to beat the damaged metal panels with underlay irons and hand hammers. Both sides of the metal panel to be repaired must be accessible to the hand-held underlay iron and there are two ways of using the underlay iron as the supporting piece for the hand hammer:
 - ① Beat with a hammer from above the underlay iron. This approach is suitable for correcting smaller and shallower dent or breaks.

When beating with a hammer from above the underlay iron, the hand-held underlay iron should be placed against the back of the metal panels, and then beat the convex part. The beating of hand hammer can make the metal panel contract and finally smooth the metal panel.





- ② Beat with a hand hammer from other parts than from directly above the underlay iron. The underlay iron is placed against the lowest part of the dent, and then the higher parts near the dent are beaten with a hand hammer.

Generally, when trying to repair the dent with a hand hammer and an underlay iron, the convex side is beaten with the hand hammer and the concave side is pressed against the underlay iron. First do brief correction by beating the damaged part with a wooden hammer, and then do finer repairing with an iron hammer. For a larger area of dent, the underlay iron should be placed against the place where the dent is shallower, and the hand hammer should beat the higher parts. Besides, the wooden hammer and the iron one should be used alternatively according to the actual situation.

- (2) Repair the dent with a shaping spoon or tommy bar. Shaping spoons and tommy bars are commonly used tools for door panel maintenance, and they are customized according the characteristics of the vehicle body. They can reach the limited space between door panels to push up the dent. This method is suitable for the narrow room between the door panels where it is inaccessible for the underlay iron or the hammer, and the shaping spoon can act as a underlay iron to distribute the impact of the hammer over a larger area.
- (3) Restore the dent with a dent smoother. The dent smoother is applied to the inner side of the metal panel and it is used for the dents that are hardly accessible to other tools and it is usually operated in the following two ways:

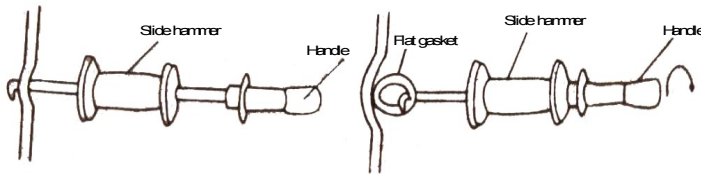

Fig. 8

Fig. 9

Puncturing: Drill a small hole in the dent with a hand power drill, and then insert a pull-rod with threaded head or hook-shaped head into the hole. Slide the slide hammer on the metal pull-rod and impact the handle repeatedly so as to pull up the dent gradually. Make more than one holes when necessary, and fill the hole(s) by soldering and polish the spot(s) when the dent(s) is/are smoothed.

Electrode welding: Weld a peg or a flat gasket onto the dent with a special spot-welder, and then use a dent smoother to pull at the peg or flat gasket till the dent is smoothed. More than one peg or flat gaskets can be welded when necessary so that the whole dented area can be dragged out. Finally, break the peg or flat gasket, and polish the welded scar with a sand mill. This method can avoid drilling the metal panels and prevent potential erosion, so it is widely used.

4.2. Restoration of Stretched Parts

When the metal panel is impacted, the dented area would be stretched. At times even proper operations can not restore it, the heating-contracting method is sometimes used to achieve the desired



repairing effect.

- (1) Heated position and flame intensity: The effect of flame correction depends on the heated position and the flame intensity. Different heated spots bring about different effects, and the heated position should be where the material is deformed the most and the metal panel is stretch the most, or the furthest part outward that is bent and deformed. Different flame intensities also lead to different correcting effects. The intenser the flame is, the faster the metal panel is heated and the more concentrated the heat is, and then the stronger the contracting capability is. The low-carbon steel panel, for example, should be heated till it gets cherry red (600°C - 800°C).
- (2) Heating ways normally adopted for flame correction in the vehicle body maintenance are:
 - ① Spot heating: The heated area is a round spot of a certain diameter, which is usually 15 - 30mm. One or more spots can be heated according to the actual deformity situation. When more than one spot is heated, the spots are arranged in a plum pattern. And this way is often used for contracting the convex area in the middle of the panel.
 - ② Triangle heating: The heated area resembles a triangle, and this way is often used for correcting strip-shaped materials and deformed panel edges.

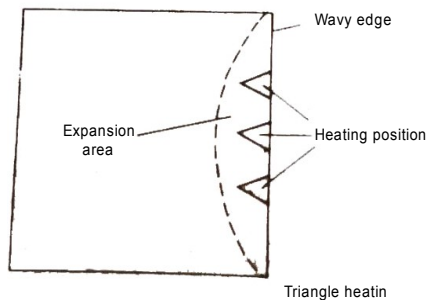

Fig. 11

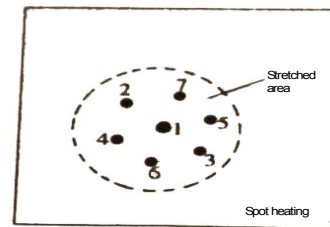

Fig. 10

- (3) Cooling-contracting way: When the flame is taken away, proper cooling ways should be chosen according to the stretched degrees of the metal panels. Different cooling ways bring about different contracting effects.
 - ① Natural cooling-contracting, or cooling in the air naturally, which is suitable for smaller areas of deformities.
 - ② Water cooling, or covering the heated area with wet cotton cloth to make it cool suddenly. The contraction of metal plate cooled in this way is larger than that of the naturally cooled one, but it may make the steel panel fragile.
 - ③ Natural cooling and hammering, usually operated with a hand hammer and a underlay iron. During the operation, beat around the heated area quickly to increase the compressing stress and the contraction till that area is smoothed. The wooden hammer is preferred and do not use too strong a force, or the metal panel may get re-stretched.

4.3. Restoration of Cutting & Patching

When any part of the metal door panel is eroded or damaged beyond repair, it should be removed and replaced with a new piece by welding. The repairing methods include patching repair and cutting.

Procedures for cutting repair are as follows:

- (1) Check the damaged part and determine the repairing area.
- (2) Make a paper model according to the determined area.
- (3) Draw lines on the metal plates and cut material according to the paper model, and leave proper processing allowance.



- (4) Select proper processing and shaping methods so that the patch matches well with the part to be removed.
- (5) Apply the patch to the intended position and press it tightly, draw a line along the edge of the part to be removed and cut it out, using methods like gas cutting or excising according to the actual situation, and then align the patch with the excised area.
- (6) Weld the seam by gas welding or carbon oxide protection welding. Spot-weld it at a pace of 30-50mm to fix it and then weld it again in a certain order after beating it smooth. For seams requiring welding of higher strength, double-sided welding is preferred.
- (7) Smooth the welded seam by beating it with flat hammer, release the welding pressures, and then shape it and polish the seam with a grinding machine.

4.4. Restoration of Wrinkled Parts

Depending on the damage extent of the plate work pieces, the wrinkles are divided into "live wrinkles" and "dead wrinkles". The "live wrinkles" are slight ones and can be directly removed by beating the convex part with a hammer. The "dead wrinkles" refer to seriously damaged parts. Since the wrinkles are folded and pressed against each other, so if you hammer the most convex part, the wrinkles would get even more seriously and harder to release, hence the name "dead wrinkles". The principle of correcting the wrinkles is to spread "dead wrinkles" first so that they become "live wrinkles", and then "live wrinkles" are converted into convex-concave shape, and finally restore the damaged parts just as you deal with convex-concave damages. The repairing procedures are as follows:

- (1) First use support-draw method to apply a correcting force in the direction opposite to that of the impact at the wrinkled part of the plate work, and then spread and ease the wrinkles.
- (2) Remove the wrinkled plate work and lay it on a platform and then, beginning with the inner side of the wrinkled area, pry up the wrinkles with a proper prying tool and heat the "dead wrinkles" one by one with a welding torch at the same time. Finally all "dead wrinkles" are pried up and eased and converted into "live wrinkle".
- (3) Beat and smooth the "live wrinkles" from the inner side outward. The hammered spots should be near the most convex part of the "live wrinkles". At the same time make sure the platform can support every beaten spot. When the wrinkles in one side of the plate are almost smoothed, turn it over to beat the other side till all wrinkles are completely spread out.
- (4) Measure with a templet, and at the same time heat and beat the convex-concave part to restore it to its original shape.
- (5) When the vehicle body is assembled, test with a templet again and make finer correction to achieve the final requirements.
- (6) The seriously damaged wrinkles that can not be restored can be excised and repaired.

4.5. Welding of Four Doors and Two Covers

When welding the door panel, choose proper welding methods: gas welding (oxygen and acetylene welding), CO₂ shielded welding, manual arc welding, resistance spot welding, braze welding and so on. Besides, in order not to reduce the original strength and durability of the vehicle body, try to adopt the welding methods used in manufacturing the door panels, and the dimensions and types of all weld joints should be similar to those used by the original manufacturer.

As for appearance and quality, no burnt-through spots, half points, cracks, a lot of burrs or other defects should exist at the welded parts. The welded surface should be smooth and nice-looking, no obvious twist or deformation is allowed, and the indentation depth should be less than 1/5 of the plate thickness. Flat spade and iron hammer can be used to carry out non-destructive tests of the welded spots' strength. Insert the flat spade between two welded spots to see if they are easy to separate, and then beat the welded part with an iron hammer to restore it. No welding spatter is allowed at the welded seam, and the overlapped seam should be nice-looking with no defects like air holes or cracks. Defects like undercut, welding beading and burning through are also not allowed.



II. Body Assembly Dimension

1. Left Front Axonometric Drawing

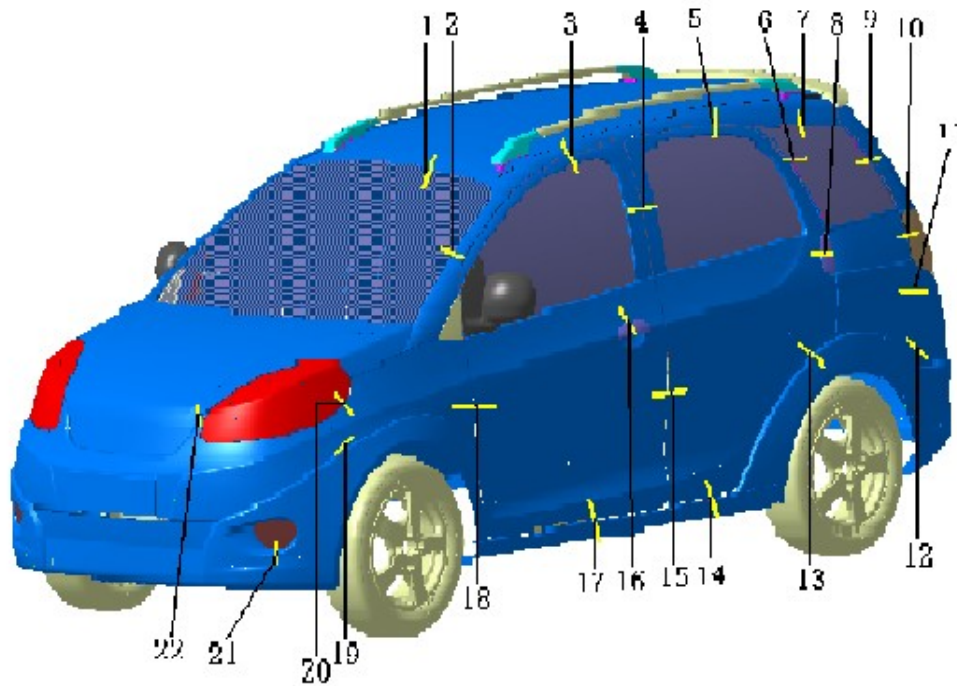

No.	Clearance position	Clearance value(mm)	Flatness value(mm)
1	Front windshield and ceiling	7 ± 1	—
2	Front windshield and pillar A	5 ± 1	—
3	Front door and ceiling	4 ± 1	2 ± 1
4	Front door and rear door (upper)	$4_{-0.5}^{+1}$	0_0^{+1}
5	Rear door and ceiling	4 ± 1	2 ± 1
6	Rear side windshield and rear door	$4_{-0.5}^{+1}$	0_0^{+1}
7	Rear side windshield and ceiling	4.5 ± 1	—
8	Rear door outside handle and rear door	$2_{-0.5}^0$	—
9	Rear side windshield and back door	$4\sim 5.5$	—
10	Tail lamp and fender	2 ± 0.5	—
11	Rear bumper and fender (upper part)	$0_{+0.5}^0$	$-0.7_{-0.3}^{+0.7}$
12	Rear bumper and fender (lower part)	$0_{+0.5}^0$	0.7 ± 0.5
13	Door outer trim panel and door clearance	$0_{+0.5}^0$	—
14	Rear door and side wall trim panel	$5_{-1}^{+1.5}$	—
15	Front door and rear door(lower part)	4_0^{+1}	0_0^{+1}
16	Front door handle and door	$2_{+0.5}^0$	—
17	Front door and side wall trim panel	$5_{-1}^{+1.5}$	—
18	Front door and front fender	4 ± 1	0_0^{+1}



No.	Clearance position	Clearance value(mm)	Flatness value(mm)
19	Front bumper and front fender	$0_0^{+0.5}$	—
20	Headlamp and fender	3 ± 1	$-0.7^{+0.5}_{-1.0}$
21	Front fog lamp and front bumper	2 ± 0.5	—
22	Engine hood and front bumper	$3.5^{+1}_{-0.5}$	—

Note: as for the flatness value, the former part is the comparatively higher part in the text description.

E.g. in No.9, the flatness value of the fender and front door is 4_0^{+1} mm.

It means fender is higher than front door. Difference is 4_0^{+1} mm(4~5mm).

2. Left Rear Axonometric Drawing

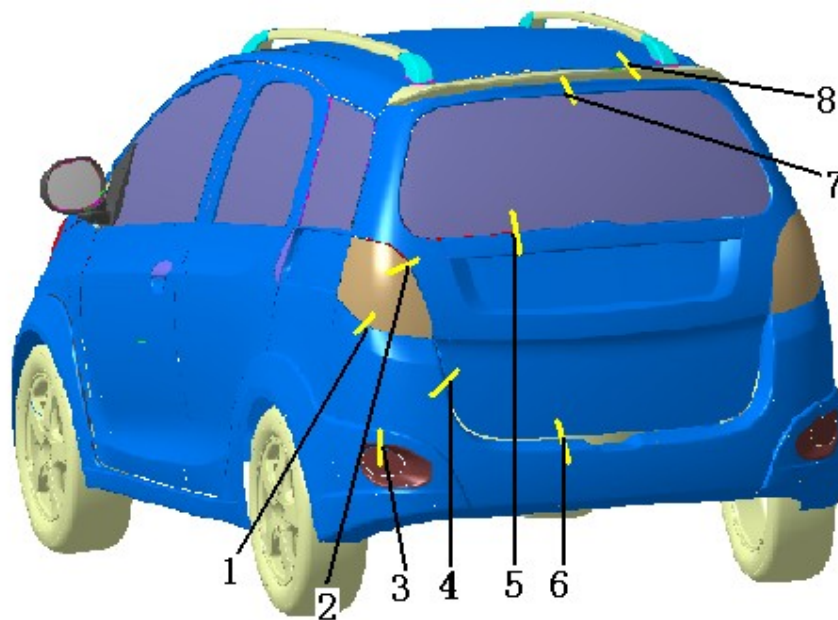

No.	Clearance position	Clearance value(mm)	Flatness value(mm)
1	Rear bumper and tail lamp	2 ± 1	—
2	Back door and tail lamp	5 ± 0.5	$-0.7^{+0.5}_{-1.0}$
3	Rear fog lamp and rear bumper	2 ± 0.5	—
4	Back door and rear bumper (upper part)	6 ± 1	—
5	Rear windshield and back door (lower part)	$3.5^{+1.5}_0$	—
6	Back door and rear bumper (lower part)	6 ± 1	—
7	Rear windshield and back door (upper part)	$3.5^{+1.5}_0$	—
8	Ceiling and back door	$7^{+1.5}_{-0.5}$	1^{+1}_0

Note: in flatness value, the former part is the comparatively higher part in the text description.

E.g. in No.3, the flatness value of side wall and rear bumper is 0.7 ± 0.5 mm.

It means the side wall is higher than rear bumper. Difference is 0.7 ± 0.5 mm(0.2~1.2mm).



III. Engine Compartment Dimension

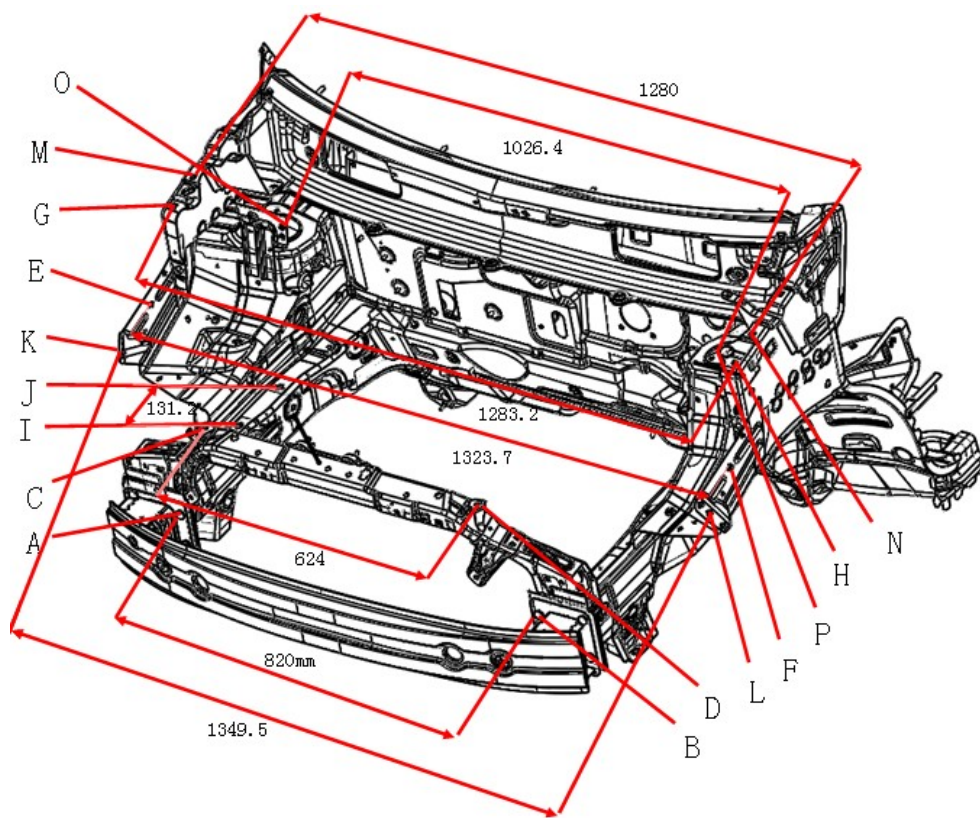

No.	Name	Central Distance of Holes (mm)
A/B	Front bumper cross beam installation hole	820
C/D	Headlamp installation hole	624
E/F	Headlamp installation hole	1323.7
G/H	Headlamp installation hole	1283.2
I/J	Engine right mounting bracket hole	131.2
K/L	Fender installation	1349.5
M/N	Fender installation	1280
O/P	Shock absorber hole	1026.4