

HONDA
Z360
600 *coupe*
SHOP MANUAL



HONDA MOTOR CO., LTD.

HONDA Z360/600 COUPE

SHOP MANUAL

AMENDMENT RECORD

This page provides a record of the latest amendments which have been released since the 1st edition Shop Manual. Insert this page into your shop manual with revised pages and retain until the next amendment is received.

| NUMBER | ISSUE DATE | QUOTE PART NUMBER | SUBJECT |
|--------|----------------|-------------------|--|
| 1. | December, 1972 | | Added brake booster Section 11A pages 123 thru 134 Revised transmission Section 6 pages 78 thru 94 Revised table of contents |

FOREWORD

This manual is prepared to provide the service personnel of HONDA automobile dealers with the information on the maintenance and repair of HONDA Z 360/600 Coupe.

The information and instructions based on 600 Coupe are grouped into the two sections; in-car inspection and adjustment operations and normal repair and overhaul operations.

This manual should be kept where service technicians working on these HONDA cars are able to reach easily at any time. If this manual is properly utilized and referred to, the workshop will be able to provide owners of HONDA cars with better service and good reputation for reliable service.

All information, illustration and specifications contained in this manual are based upon the latest product information available at the time of publication approval. The right is reserved to make any changes at any time without notice and obligation.

HONDA MOTOR CO., LTD.

SERVICE PUBLICATIONS OFFICE

CONTENTS

| | |
|---|----|
| 1. GENERAL INFORMATION | 1 |
| 1-1 Specifications | 1 |
| 1-2 Lubrications | 6 |
| 1-3 Physical Dimensions | 8 |
| 1-4 Location of the Serial Numbers | 9 |
| 1-5 Standard Tightening Torque | 9 |
| 1-6 Maintenance Schedule | 10 |
| 1-7 Vehicle Supporting Position | 11 |
| 2. INSPECTION AND MAINTENANCE | 13 |
| 2-1 Steering System | 13 |
| 2-2 Brake System | 18 |
| 2-3 Wheels | 25 |
| 2-4 Suspension System | 27 |
| 2-5 Clutch, Transmission, Drive Shaft, Wheel Hubs | 31 |
| 2-6 Electrical System | 34 |
| 2-7 Engine | 40 |
| 2-8 Miscellaneous | 51 |
| 3. ENGINE REMOVAL AND INSTALLATION | 57 |
| 3-1 Removal | 57 |
| 3-2 Installation | 60 |
| 4. ENGINE | 62 |
| 4-1 Cylinder Head | 63 |
| 4-2 Pistons and Cylinder | 68 |
| 4-3 Primary Drive and Oil Pump | 69 |
| 4-4 Right Side Cover | 71 |
| 4-5 Crankshaft | 72 |
| 4-6 Cooling Fan | 74 |
| 5. CLUTCH | 76 |
| 6. TRANSMISSION | 78 |
| 6-1 Specifications | 78 |
| 6-2 Description | 79 |
| 6-3 Operation | 79 |
| 6-4 Disassembly | 81 |
| 6-5 Inspection | 83 |
| 6-5 Gear Shift Mechanism | 88 |
| 6-7 Gear Shift Lever and Rod | 92 |
| 7. DIFFERENTIAL | 95 |
| 8. CARBURETOR | 96 |

CONTENTS

| | |
|---|-----|
| 9. DRIVE SHAFT | 101 |
| 10. STEERING SYSTEM | 104 |
| 10-1 Steering Shaft | 104 |
| 10-2 Steering Gear Box | 107 |
| 11. BRAKE SYSTEM | 110 |
| 11-1 Brake Master Cylinder | 110 |
| 11-2 Front Brake | 113 |
| 11-3 Rear Brake | 117 |
| 11-4 Brake Pipes and Hoses | 121 |
| 11-5 Vacuum Booster | 122 |
| 11A. BRAKE BOOSTER | 123 |
| 11A-1 Specifications | 123 |
| 11A-2 Description | 124 |
| 11A-3 Operation | 124 |
| 11A-4 Testing | 127 |
| 11A-5 Disassembly | 129 |
| 11A-6 Assembly | 131 |
| 11A-7 Inspection | 133 |
| 12. SUSPENSION SYSTEM | 135 |
| 12-1 Front Suspension | 135 |
| 12-2 Rear Suspension | 137 |
| 13. FUEL SYSTEM | 139 |
| 13-1 Fuel Tank | 139 |
| 13-2 Fuel Pump and Fuel Strainer | 141 |
| 14. EXHAUST SYSTEM | 142 |
| 15. INSTRUMENT PANEL | 144 |
| 16. HEATER AND VENTILATION | 149 |
| 17. DOOR | 153 |
| 18. TAIL GATE | 157 |
| 19. ELECTRICAL SYSTEM | 159 |
| 19-1 Starter Motor | 159 |
| 19-2 A.C. Generator | 162 |
| 20. MAINTENANCE STANDARD | 164 |
| 20-1 HONDA 600 Coupe | 164 |
| 20-2 HONDA Z 360 | 171 |

SPECIAL TOOL LIST

WIRING DIAGRAM

1. GENERAL INFORMATION

1-1. Specifications

Model HONDA 600 Coupe

| | Item | Metric | English | Note |
|-----------------|-----------------------------|--|-------------------|----------------|
| Dimension | Overall length | 3,120 mm | 122.83 in. | |
| | Overall width | 1,295 mm | 50.98 in. | |
| | Overall height | 1,280 mm | 50.39 in. | |
| | Wheelbase | 2,000 mm | 78.74 in. | |
| | Track F/R | 1,165/1,125 mm | 45.87/44.29 in. | |
| | Ground clearance | 155 mm | 6.10 in. | |
| | Dry weight | 575 kg | 1,268 lbs | |
| | Curb weight | 595 kg | 1,311.98 lbs | |
| | Gross vehicle weight rating | 889 kg | 1,960 lbs | |
| | Weight distribution F/R | 385/210 kg | 848.93/463.01 lbs | For curbweight |
| | Seating Capacity | 4 | | |
| | Overhang F/R | 605/515 mm | 23.8/20.3 in. | |
| | Type | Forced air cooled 4 cycle O. H. C. gasoline engine | | |
| | Cylinder arrangement | 2 in-line transverse | | |
| Engine | Bore and stroke | 74 × 69.6 mm | 2.91 × 2.74 in. | |
| | Displacement | 598.4 cc | 36.5 cu. in. | |
| | Compression ratio | 8.5 : 1 | | |
| | Carburetor, venturi dia. | Side draft, Venturi dia. 32 mm | | |
| | Valve train | Sprocket, chain | | |
| | Lubrication system | Plunger pump | | |
| | Fuel required | Regular gasoline | | |
| | Engine weight | 96.5 kg | 212.78 lbs | |
| | Clutch | Single plate dry type, diaphragm spring | | |
| | Transmission | Synchronized 4 forward, 1 reverse | | |
| | Transmission | Primary reduction | Chain 2.050 | |
| Gear ratio I | | 2.470 | | |
| II | | 1.500 | | |
| III | | 0.967 | | |
| IV | | 0.675 | | |
| Reverse | | 2.437 | | |
| Final reduction | | Single helical gear, 3.200 | | Type, ratio |
| Steering system | Clutch facing area | 118.8 cm ² | 18.41 sq. in. | |
| | Type | Rack and pinion | | |
| | Overall ratio | 17.8 | | |
| | Turns, lock-to-lock | 3.1 | | |
| | Steering wheel dia. | 380 mm | 14.96 in. | |

1. GENERAL INFORMATION

| | Item | Metric | English | Note | |
|-------------------|---------------------------------------|---|--|------|--|
| Suspension system | Type, F | Coil spring | | | |
| | Type, R | Semielliptic leaf spring | | | |
| | Shock Absorber F/R | Hydraulic double acting | | | |
| | Type, F | MacPherson, independent | | | |
| | Type, R | Rigid axle | | | |
| Axle | Front wheel alignment, | | | | |
| | camber | | 1° positive | | |
| | caster | | 1° positive | | |
| | Toe-in | Out 2 mm | 0.078 in. | | |
| | Kingpin inclination | | 13°35' | | |
| Brake system | Type, F | Power-assisted disk brake | | | |
| | Type, R | Leading-trailing shoe type | | | |
| | Swept area, F | 36 × 10 × 52 ~7488 mm ² | 14.2 × 0.39 × 2.04 ~11.6 sq. in. ² | | |
| | Swept area, R | 35 × 5.4 × 14.5 ~19800 mm ² | 13.8 × 0.20 × 5.57 ~30.7 sq. in. ² | | |
| | Parking brake type | Mechanical on rear wheels | | | |
| Tires | F/R | 145 SR 10/145 SR 10 | | | |
| Electrical system | Battery | 12 V-45 AH | | | |
| | Starting motor | 12 V-1.0 kw | | | |
| | Alternator | 12-40 A | | | |
| | Fuses | 15 A × 3, 10 A × 5 | | | |
| | Main fuse | 45 A | | | |
| | Headlight | Sealed beam 12 V-50/40 W | | | |
| | Position light | --- | | | |
| | Front turn signal light/parking light | 12 V-32/4 cp | | | |
| | Front side marker light | 12 V-4 cp | | | |
| | Gauge, indicator, warning light | 12 V-3 W | | | |
| | Interior light | 12 V-5 W | | | |
| | Rear turn/stop/taillight | 12 V-32/4 cp | | | |
| | Stop/taillight | --- | | | |
| | Rear turn signal light | --- | | | |
| | Back-up light | 12 V-32 cp | | | |
| | Licence light center/side | 12 V-4 cp | | | |
| | (Engine) | | | | |
| | Ignition timing | B.T.D.C. 10° | | | |
| | Service data | Valve timing IN open | B.T.D.C. 5° | | |
| | | IN close | A.B.D.C. 20° | | |
| EX open | | B.B.D.C. 40° | | | |
| EX close | | B.T.D.C. 10° | | | |
| Plug | | NGK B-8ES, ND W-24ES | | | |
| Plug gap | 0.7~0.8 mm | 0.028~0.032 in. | | | |

| | Item | Metric | English | Note | |
|--------------------------------|----------------------|--|------------------------------|-------------|--|
| Service data (cont'd) | Idling speed | 1,100~1,200 rpm | | | |
| | Engine oil capacity | 3 ℓ | 3.2 U.S. qt., 2.6 Imp. qt. | | |
| | Fuel tank capacity | 26 ℓ | 6.9 U.S. gal., 5.7 Imp. gal. | | |
| | Fan belt tension | 15~20 mm | 0.59~0.78 in. | | |
| | Speedometer range | I | 0~32 kph | 0~20 mph | |
| | | II | 24~56 kph | 15~35 mph | |
| | | III | 32~80 kph | 20~50 mph | |
| | | IV | 48~120 kph | 30~75 mph | |
| | Tachometer red zone | 6,000 rpm | | | |
| | Valve clearance | 0.08~0.12 mm | 0.004±0.0008 in. | IN, EX cold | |
| | Point gap | 0.3~0.4 mm | 0.0032~0.0047 in. | | |
| | Compression pressure | 12.5±0.5 kg/cm ² at 400 rpm | 178±7.1 psi at 400 rpm | | |
| | Engine oil | API service SD or SE | | | |
| | Transmission oil | — | | | |
| | (Chassis) | | | | |
| | Tire pressures F/R | 1.8/1.8 kg/cm ² | 26/26 psi | | |
| | Brake fluid | DOT3 brake fluid meets the SAE J1703 specification. Outside the U.S.A., use SAE J1703 brake fluid. | | | |
| Brake pedal free play | 1~5 mm | 0.04~0.08 in. | | | |
| Brake pedal-to-floor clearance | 50 mm | 2.0 in. | | | |
| Brake pad wearing limit | 2 mm | 0.08 in. | | | |
| Brake shoe wearing limit | 2 mm | 0.08 in. | | | |

Model HONDA Z360

| | Item | Metric | English | Note |
|-----------|-------------------------|----------------|-----------------|----------------|
| Dimension | Overall length | 3,120 mm | 122.83 in. | |
| | Overall width | 1,295 mm | 50.98 in. | |
| | Overall height | 1,275 mm | 50.20 in. | |
| | Wheelbase | 2,000 mm | 78.74 in. | |
| | Track F/R | 1,165/1,125 mm | 45.87/44.29 in. | |
| | Ground clearance | 170 mm | 6.69 in. | |
| | Dry weight | — | | |
| | Curb weight | 525 kg | 1,157.4 lbs | |
| | Loaded weight | 819.5 kg | 1,807.4 lbs | |
| | Weight distribution F/R | 340/185 kg | 749.7/507.2 lbs | for curbweight |
| | Seating capacity | 4 | | |
| | Overhang F/R | — | | |

| | Item | Metric | English | Note |
|-------------------|--------------------------|--|--|-------------|
| Engine | Type | Forced air cooled 4-cycle O.H.C. gasoline engine | | |
| | Cylinder arrangement | 2 in-line traverse | | |
| | Bore and stroke | 62.5 × 57.8 mm | 2.46 × 2.28 in. | |
| | Displacement | 354 cc | 21.6 cu. in. | |
| | Compression ratio | 8.5 : 1 | | |
| | Carburetor, venturi dia. | Side draft, venturi dia. 32 mm | | |
| | Valve train | Sprocket, chain | | |
| | Lubrication system | Torochooid pump | | |
| | Fuel required | Regular gasoline | | |
| | Engine weight | — | | |
| Transmission | Clutch | Single plate dry type, diaphragm spring | | |
| | Transmission | Synchronized 4 forward, 1 reverse | | |
| | Primary reduction | Chain, 2.812 | | Type, ratio |
| | Gear ratio I | 2.470 | | |
| | II | 1.565 | | |
| | III | 0.967 | | |
| | IV | 0.675 | | |
| Steering system | Reverse | 3.200 | | |
| | Final reduction | Single helical gear, 3.739 | | Type, ratio |
| | Type | Rack and pinion | | |
| | Overall ratio | 17.8 | | |
| | Turns, lock-to-lock | 3.1 | | |
| Suspension system | Steering wheel dia. | 380 mm | 14.96 in. | |
| | Type, F | Coil spring | | |
| | Type, R | Semielliptic leaf spring | | |
| Axle | Shock absorber F/R | Hydraulic double acting | | |
| | Type, F | MacPherson, independent | | |
| | Type, R | Rigid axle | | |
| | Front wheel alignment, | | | |
| | camber | 1° positive | | |
| | caster | 1° positive | | |
| | Toe-in | OUT 2 mm | 0.078 in. | |
| Brake system | Kingpin inclination | 13°35' | | |
| | Type, F | Leading-trailing shoe type drum | | |
| | Type, R | Leading-trailing shoe type drum | | |
| | Swept area, F | 35 × 5.4 × 141.5 ~19800 mm ² | 13.8 × 0.20 × 5.57 ~30.7 sq. in. ² | |
| | Swept area, R | 35 × 5.4 × 141.5 ~19800 mm ² | 13.8 × 0.20 × 5.57 ~30.7 sq. in. ² | |
| | Parking brake type | Mechanical on rear wheels. | | |
| Tires | F/R | 5.20-10-4PR/ 5.20-10-4PR | | |

| | Item | Metric | English | Note | |
|--------------------------------|---|---------------------------------------|--------------------------------|-----------|-------------|
| Electrical system | Battery | 12 V-35 A (NS 40) | | | |
| | Starting motor | — | | | |
| | Alternator | — | | Auxiliary | |
| | Fuses | 15 A × 3, 10 A × 5 | | | |
| | Main fuse | 45 A | | | |
| | Headlight | 50/40 W | | | |
| | Position light | — | | | |
| | Front turn signal light | 21 W | | | |
| | Front side light | 5 W | | | |
| | Gauge, indicator light | 3 W | | | |
| | Interior light | 5 W | | | |
| | Rear turn/stop/taillight | — | | | |
| | Stop/taillight | 21 W/5 W | | | |
| | Rear turn signal light | 21 W | | | |
| | Back-up light | 21 W | | | |
| | Licence light | 5 W | | | |
| | Starter-generator | 12 V | | | |
| Service data | (Engine) | | | | |
| | Ignition timing | 10°/1400 rpm | | | |
| | Valve timing IN open | 0° BTDC | | | |
| | IN close | 30° A.B.D.C. | | | |
| | EX open | 40° B.B.D.C. | | | |
| | EX close | 0° A.T.D.C. | | | |
| | Plug | NGK B-7ES ND W-22ES | | | |
| | Plug cap | 0.7~0.8 mm | 0.028~0.032 in. | | |
| | Idling speed | 1,300~1,100 rpm | | | |
| | Engine oil capacity | 3.0 ℓ | 3.2 U.S. qt. 2.2 Imp. qt. | | |
| | Fuel tank capacity | 26 ℓ | 6.9 U.S. gal. 5.7 Imp. gal. | | |
| | Fan belt tension | 15~20 mm | 0.59~0.78 in. | | |
| | Speedometer range I | 0~25 kph | 0~16 mph | | |
| | II | 10~40 kph | 6~25 mph | | |
| | III | 20~65 kph | 12~40 mph | | |
| | IV | over 30 kph | over 20 mph | | |
| | Tachometer red zone | 8,500 rpm | 8,500 rpm | | |
| | Valve clearance | 0.08~0.12 mm | 0.0032~0.0047 in. | | IN, EX cold |
| | Point gap | 0.3~0.4 mm | 0.012~0.016 in. | | |
| | Compression pressure | 11.5 kg/cm ² at 400 rpm | 149.3 psi at 400 rpm | | |
| | Engine oil | API Service SD or SE | | | |
| | Transmission oil | API Service SD or SE | | | |
| | (Chassis) | | | | |
| Tire pressures F/R | 1.6/1.2 kg/cm ² | 23/17 psi | | | |
| Brake fluid | DOT 3 brake fluid meets the SAE J1703 specification. Outside the U.S.A., use SAE J1703 brake fluid. | | | | |
| Brake pedal free play | 1~10 mm | 0.04~0.39 in. | | | |
| Brake pedal-to-floor clearance | 50 mm | 2.0 in. | | | |
| Brake shoe wearing limit | 2.5 mm | 0.098 in. | | | |

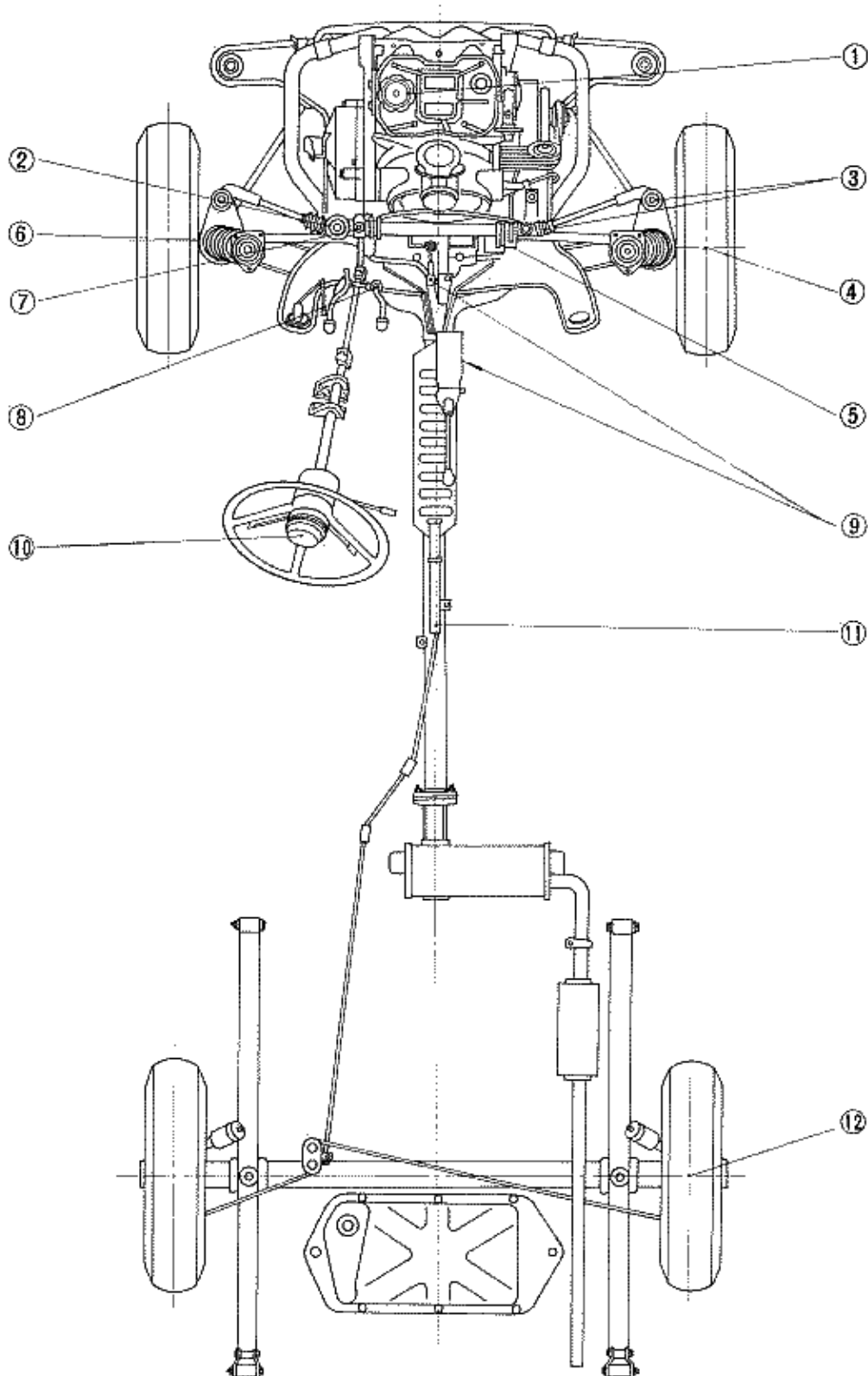
1-2. Lubrications

| No. | Lubricants | Type of Oil and Grease | Remarks |
|-----|-----------------------------------|------------------------|--|
| 1. | Engine, Transmission Differential | Engine oil (See below) | Oil Change First 600 miles (1,000 km) Every 3,000 miles (5,000 km) |
| 2. | Brake master cylinder | SAE J1703 | Add if necessary after checking |
| 3. | Steering ball joint | Grease | Factory sealed-lubrication system, oil supplied during overhaul. Supply or change after every 50,000 km (30,000 miles) Factory sealed-lubrication system, grease supplied only during overhaul. Supply or change after every 50,000 km (30,000 miles) |
| 4. | Front wheel bearing | Grease | |
| 5. | Drive shaft joint | Grease | |
| 6. | Suspension ball joint | Grease | |
| 7. | Steering gear box | Grease | |
| 8. | Pedal linkage | Grease | |
| 9. | Shift lever linkage | Grease | |
| 10. | Steering horn bushing | Grease | |
| 11. | Parking brake lever linkage | Grease | |
| 12. | Rear wheel bearing | Grease | |

RECOMMENDED LUBRICANTS

| TEMPERATURE | | GRADE | CLASS |
|-------------------|-----------------------|----------------------------|---|
| ENGINE OIL | | | |
| SINGLE GRADE | -4°F~32°F (20°C~0°C) | SAE 10 W | Certified to meet or exceed US car manufacturer's requirements for Service SD or SE |
| | 32°F~59°F (0°C~15°C) | SAE 20 W SAE 20 | |
| | 59°F~86°F (15°C~30°C) | SAE 30 | |
| | Above 86°F (30°C) | SAE 40 | |
| MULTI-GRADE | Above 5°C (-15°C) | SAE 10 W/40 | |
| | 5°F~86°F (-15°C~30°C) | SAE 10 W/30 | |
| | Above 32°F (0°C) | SAE 20 W/40 SAE 20 W/50 | |
| GREASE | | | |
| Multipurpose | | NLG1 NO. 2 | Multipurpose Type |

NOTE:

1. The temperature indicated in the table is the average atmospheric temperature in which the vehicle is being operated.
2. The engine, transmission and differential form an integral unit housed in the crankcase. Therefore, lubricant is required only in the crankcase.
3. In an extremely cold area where the average atmospheric temperature is below -4°F (-20°C), grade SAE 5W or 5W/20 oil may be used. However, make sure to change to the proper viscosity oil when the atmospheric temperature changes.

1-3. Physical Dimensions
Model HONDA Z600 COUPE

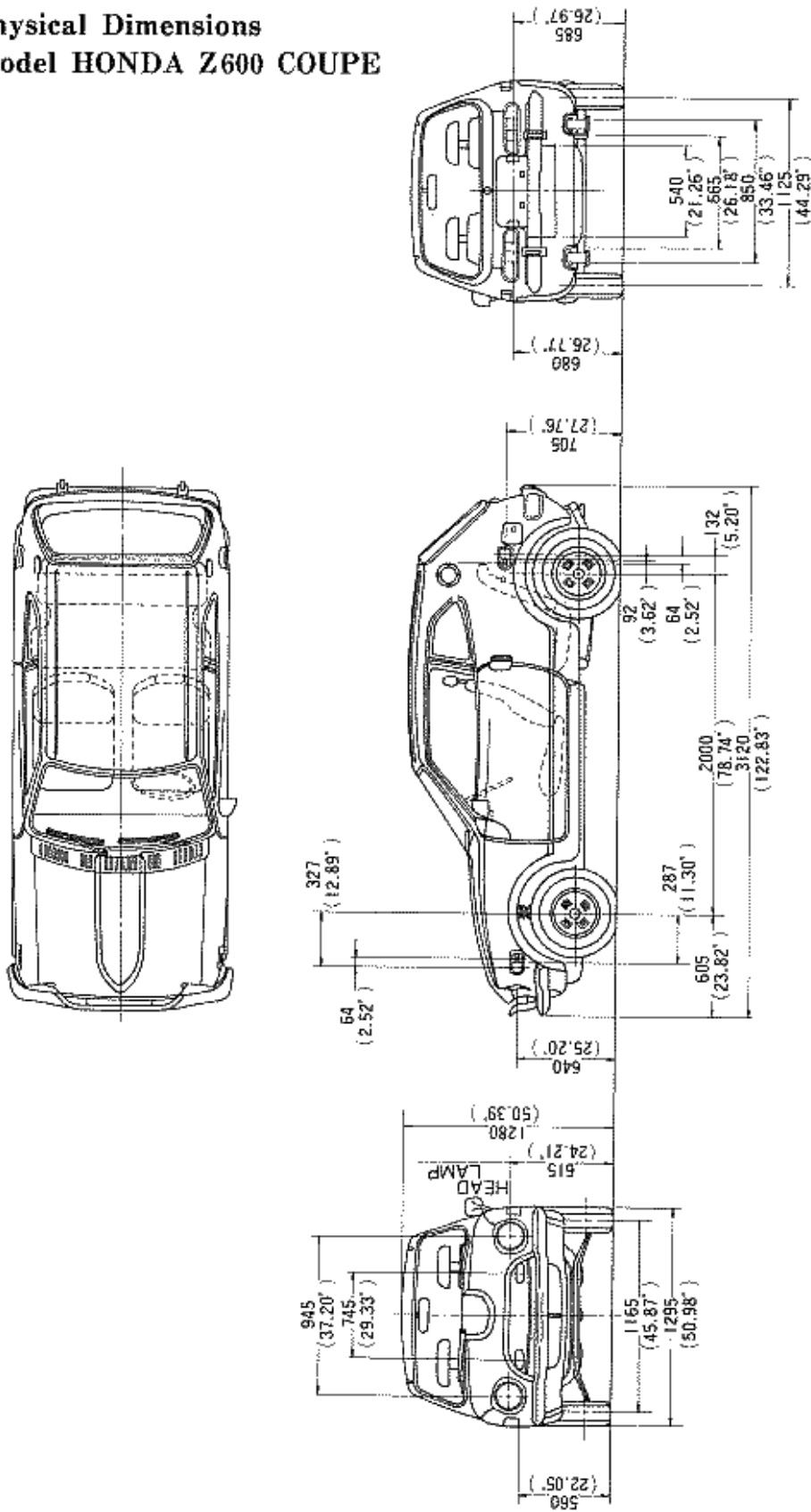

1-4. Location of the Serial Numbers

The engine number is stamped on the crankcase.

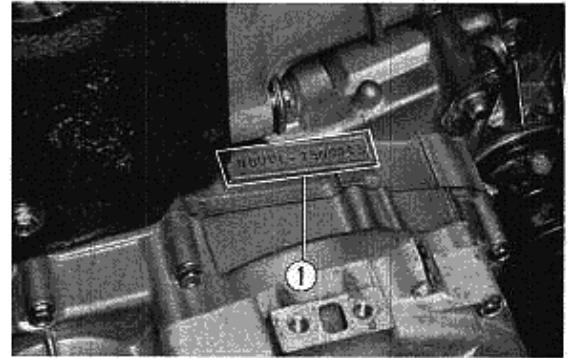

Fig. 1-1 ① Engine Number

The chassis number is stamped on the upper dashboard in the engine compartment in front of the air cleaner case.

Always order replacement parts by chassis number and engine number.

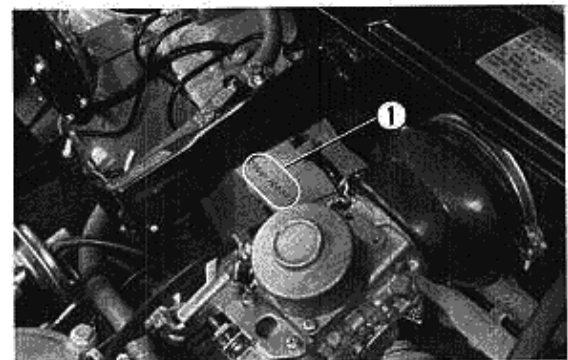

Fig. 1-2 ① Chassis Number

1-5. Standard Tightening Torque

Unless otherwise specified, the bolts and nuts should be tightened to the torque value listed in the following table.

Standard Torque Table

| Bolt/Nut nominal diameter (mm) | Thread pitch (mm) | Torque (kgm (lbf)) |
|--------------------------------|-------------------|----------------------|
| 4 | 0.7 | 0.2~0.3 (1.45~2.15) |
| 5 | 0.9 | 0.45~0.7 (3.25~5.05) |
| 6 | 1.0 | 0.8~1.2 (5.80~8.70) |
| 8 | 1.25 | 2.0~2.8 (14.5~20.0) |
| 9 | 1.25 | 3.0~4.0 (22.0~29.0) |
| 10 | 1.25 | 4.0~5.0 (29.0~39.0) |
| 12 | 1.25 | 7.0~8.5 (50.5~61.5) |

1-6 Maintenance Schedule

⊕ Additional service required at this mileage
 ○ Replace

| Service to be performed | Mileage interval | 600 | 3,000 | 6,000 | 9,000 | 12,000 | 15,000 | 18,000 | 21,000 | 24,000 | 27,000 | 30,000 |
|--|--|------------------------|------------------------|-------------------------|-------------------------|-------------------------|-------------------------|-------------------------|-------------------------|-------------------------|-------------------------|-------------------------|
| | | Miles (1,000 km) | Miles (5,000 km) | Miles (10,000 km) | Miles (15,000 km) | Miles (20,000 km) | Miles (25,000 km) | Miles (30,000 km) | Miles (35,000 km) | Miles (40,000 km) | Miles (45,000 km) | Miles (50,000 km) |
| Change Engine Oil** | Every 3,000 Miles (5,000 km) | ⊕ | ● | ● | ● | ● | ● | ● | ● | ● | ● | ● |
| Drain Air Filter Oil Chamber* | | ⊕ | ● | ● | ● | ● | ● | ● | ● | ● | ● | ● |
| Check Wear of Front Brake Pads and Movement of Yoke* | | | | ● | ● | ● | ● | ● | ● | ● | ● | ● |
| Adjust Rear Brakes and Parking Brake (Including Front Brakes for Z 360) | | | | ● | ● | ● | ● | ● | ● | ● | ● | ● |
| Check Brake System for Leaks or Damage - Master Cylinder, Brake Booster, Brake Hoses & Lines and Brake Fluid Level | | ⊕ | ● | ● | ● | ● | ● | ● | ● | ● | ● | ● |
| Check Battery Electrolyte and Add Distilled Water if Necessary | | ⊕ | ● | ● | ● | ● | ● | ● | ● | ● | ● | ● |
| Rotate Tires, Reset Tire Pressures and Check Wheel Balance | | | | ● | ● | ● | ● | ● | ● | ● | ● | ● |
| Check Breaker Point Gap and Ignition Timing | | ⊕ | ● | ● | ● | ● | ● | ● | ● | ● | ● | ● |
| Check Carburetor Adjustment | ⊕ | ● | ● | ● | ● | ● | ● | ● | ● | ● | ● | |
| Check Valve Adjustment | Every 6,000 Miles (5,000 km) | | ⊕ | ● | | ● | | ● | | ● | | ● |
| Check Cooling Fan Belt Tension | | | ⊕ | ● | | ● | | ● | | ● | | ● |
| Change Oil Filter Element | | ⊕ | | ● | | ● | | ● | | ● | | ● |
| Clean Air Filter Element (Change Every 12,000 Miles (20,000 km)) | | | | ● | | ○ | | ● | | ○ | | ● |
| Check Front Wheel Alignment | | | | ● | | ● | | ● | | ● | | ● |
| Check Wear of Rear Brake Linings (Including Front Brake Linings for Z 360) | | | | ● | | ● | | ● | | ● | | ● |
| Clean Hydromaster Brake Booster Filter* | | | | ● | | ● | | ● | | ● | | ● |
| Clean and Adjust Spark Plugs (Change Every 12,000 Miles (20,000 km)) | | | | ● | | ○ | | ● | | ○ | | ● |
| Check All Engine, Heat Exchanger, Exhaust Silencer and Suspension Mounting Bolts | | | | ● | | ● | | ● | | ● | | ● |
| Check Clutch Pedal Free Play | | ⊕ | ⊕ | ● | | ● | | ● | | ● | | ● |
| Check Steering Operation and Tie Rod Ends, Adjust Rack Guides | ⊕ | ⊕ | | | ● | | | | ● | | | |
| Grease Steering Gear Box | | | | | ● | | | | ● | | | |
| Change Fuel Filter | | | | | ● | | | | ● | | | |
| Overhaul Hydromaster Brake Booster* | Every 24,000 Miles (40,000 km) or 24 Months Whichever Occurs First | | | | | | | | ● | | | |
| Change Brake Fluid | | | | | | | | | ● | | | |

* These servicing items are not applied to Z 360.

** Change at 3 month intervals if vehicle is driven less than 3,000 miles (5,000 km) in 3 months.

1-7. Vehicle Supporting Position

1. Supporting by a Jack

Front

Park the car on level ground.

When raising a **front wheel**, pull the parking brake lever until the rear wheels are locked to prevent the vehicle from rolling. Apply a jack at the center of subframe front side.

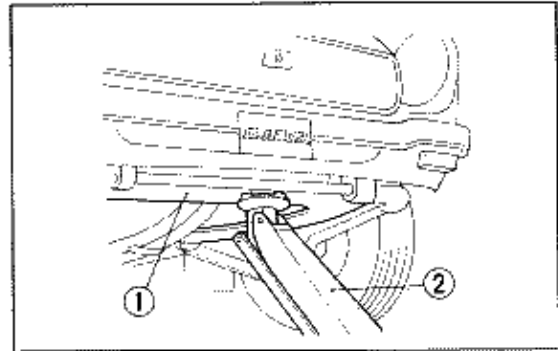

Fig. 1-3 ① Sub Frame
② Jack

Rear

When raising a **rear wheel**, put the transmission in first gear and block the front wheels to prevent rolling. Apply a jack at the middle of the rear axle beam.

CAUTION: Do not extend the jack any higher than necessary. Never get beneath the car when it is supported only by the jack; but always use safety stands to securely support the car.

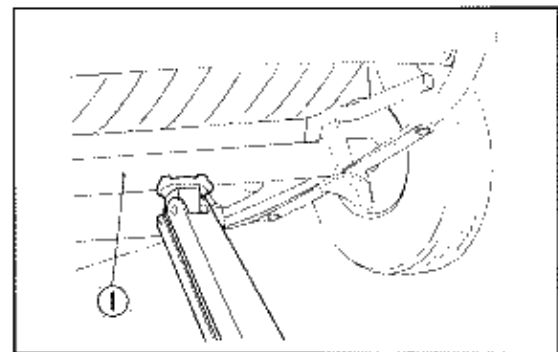

Fig. 1-4 ① Axle Beam

2. Supporting by Safety Stands

Front

Apply safety stands at the side sill.

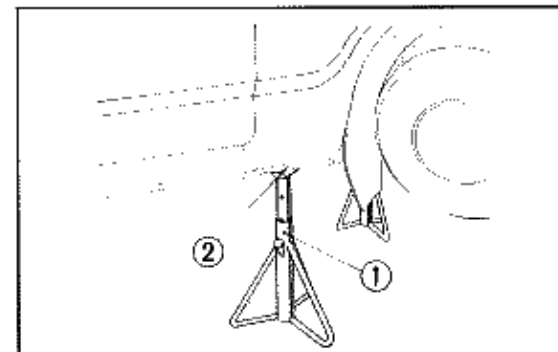

Fig. 1-5 ① Safety Stand
② Side Sill

Rear

Apply safety stands at the both ends of the axle beam.

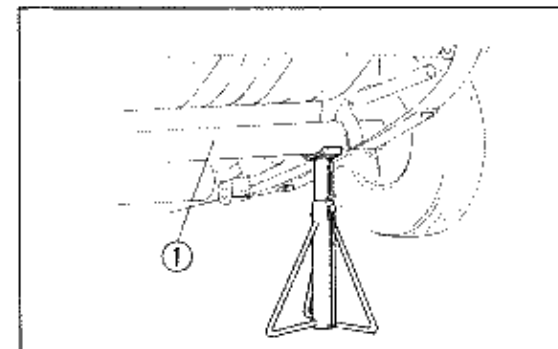

Fig. 1-6 ① Rear Axle Beam

2. INSPECTION AND MAINTENANCE

2-1. Steering System

A. Steering Wheel

1. Axial and Radial Play

- Place the front wheels in the straight-ahead position. Turn the steering wheel as shown. (Fig. 2-1) Measure the wheel free-play at the edge of the steering wheel.

| | |
|----------------|-------------------------|
| Specified play | Less than 10mm (0.39in) |
|----------------|-------------------------|

When the play is excessive, inspect for the following conditions:

- 1) Worn steering rack and pinion.
 - 2) Loose or worn steering linkage and joints.
2. Check the steering wheel for axial play by moving the wheel in the axial direction (Fig. 2-2). When the play is excessive, inspect for the following conditions:
 - 1) Loose steering hanger retaining bolts.
 - 2) Loose steering wheel retaining nut.
 - 3) Worn steering column bushing.



Fig. 2-1

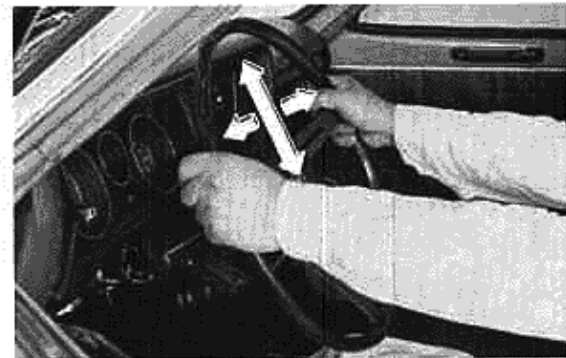

Fig. 2-2

2. Steering Wheel and Joints

1. Remove the steering wheel safety pad and check the steering wheel retaining nut for looseness with a torque wrench.
2. Check the steering joint bolts for looseness.

| | Specified torque |
|------------------------------|-----------------------------------|
| Steering wheel retaining nut | 2.3-2.8 kg-m (16.6-20.3 lb-ft) |
| Steering wheel joint nut | 2.0-2.4 kg-m (14.5-17.4 lb-ft) |

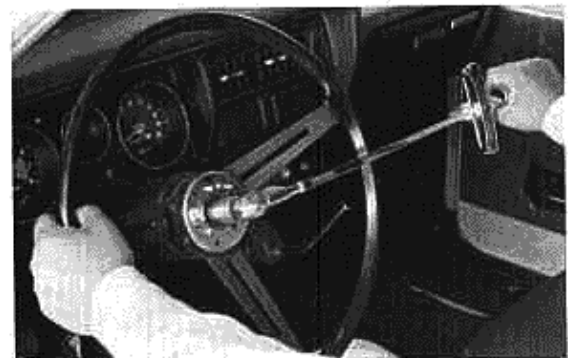

Fig. 2-3



Fig. 2-4

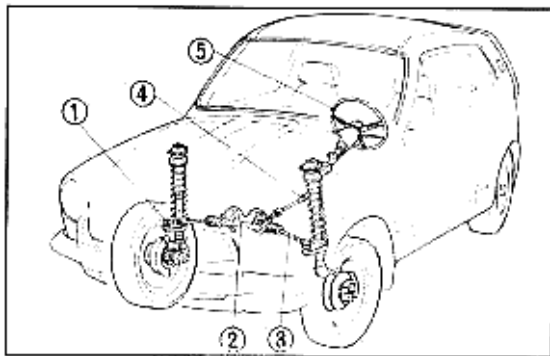

Fig. 2-5 ① Tie Rod End. ④ Steering Joint
 ③ Steering Gear Box ⑤ Steering Wheel
 ② Tie Rod.

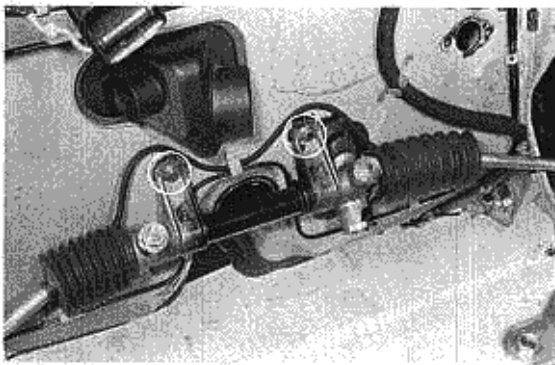

Fig. 2-6

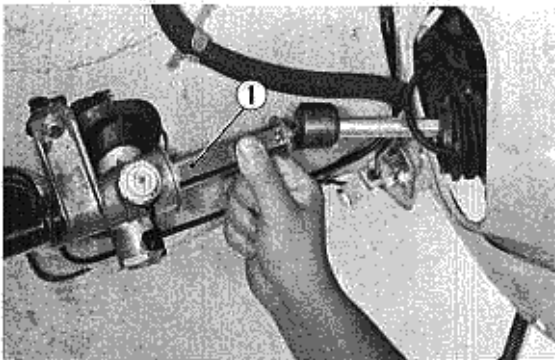

Fig. 2-7

3. Operation

1. Test drive the car and inspect the steering system condition.
2. If an abnormal condition exists:
 - 1) Check the tire pressures.
 - 2) Check the wheel alignment (section 1-8).
3. If the condition continues, raise the front of the car and place the wheels in a straight-ahead position. Check the force required to turn the wheel by hooking a spring scale to the wheel spoke. Read the load when the wheel begins to move.

| | |
|----------------|--------------------------------|
| Specified load | Below 1.3-1.7 kg (2.9-3.7 lbs) |
|----------------|--------------------------------|

4. If the steering force is excessive, or the steering appears to be faulty, inspect for the following conditions:
 - 1) Insufficient grease in the steering gear box.
 - 2) Improper adjustment of the steering gear box.
 - 3) Insufficient grease in the joints.
 - 4) Worn steering rack or pinion bushing.

B. Steering Gear Box

1. Gear box retaining bolts

Check the gear box retaining bolts for looseness. Retighten them if necessary.

| | |
|---------------------------------|--------------------------------|
| Steering gear box retaining nut | 2.0-2.4 kg-m (14.5-17.4 lb-ft) |
|---------------------------------|--------------------------------|

2. Pinion-to-steering rack clearance

Raise the front of the car enough to lift the front wheels. Remove the steering pinion dust seal and try to move the pinion axially (in and out). If the pinion moves, check the pinion adjusting plate for wear or damage. If the pinion moves radially (left and right) check the pinion and bushing for wear.

3. Rack guide adjustments

1. If excessive movement is found at the rack bushing, adjust the rack by turning the rack adjusting bolt: Place the front wheels in the straight-ahead position, tighten the adjusting bolt fully to lock the rack, and back it off 15-25 degrees. Hold the adjusting nut and tighten the locknut. If the adjusting nut moves when tightening the locknut, the adjustment will be incorrect.

| Specified torque. | |
|-----------------------------|--------------------------------|
| Steering rack adjusting nut | 2.0-2.5 kg-m (14.5-18.0 lb/ft) |
| Pinion washer nut | 2.0-2.5 kg-m (14.5-18.0 lb/ft) |

2. After the adjustment is completed, check the load applied to the steering wheel with a spring scale (refer to page 14). Also check the wheel for play.
3. Remove the tie rod dust seal from the gear case. Apply grease to the grease fitting with a grease gun until the old grease is forced out of the rack bushings.

NOTE: An assistant should turn the steering wheel while the steering rack is being greased.

4. Gear backlash

Check the pinion gear for backlash. If the steering wheel is loose or noisy while driving, check and adjust the steering pinion guide. Be sure that the backlash is zero when the front wheels are in the straight-ahead position.

C. Rods and Arms

1. Joints

1. Check the steering column joint for looseness and damage.
2. Remove the tie rod end boot and check the rack end ball joint for looseness and damage.
3. Check the tie rod end lock nut for looseness.
4. Check the tie rod end ball joint for looseness or damage.
5. Check the dust seal on the tie rod end ball joint for damage.
6. Check the tie rod bellows for damage.
7. Check the breather tube for a loose connection.
8. Check the rack end for tightness. If loose, replace the tie rod lock washer with a new one and tighten the rack.

| Specified torque | |
|------------------|--------------------------------|
| Rack | 5.5-6.0 kg-m (39.8-43.4 lb-ft) |

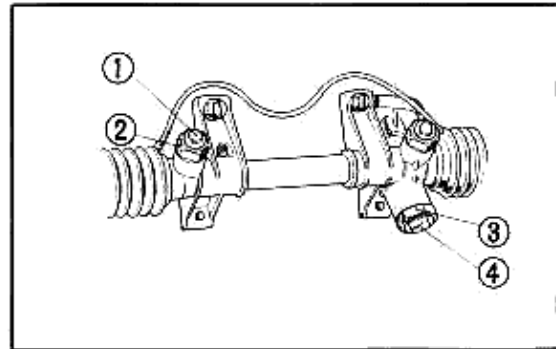

Fig. 2-8 ① Rack Adjusting Nut
② Rack Adjusting Bolt
③ Pinion Washer Nut
④ Pinion Washer Bolt

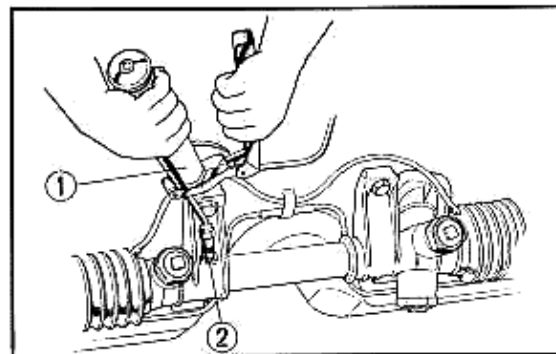

Fig. 2-9 ① Grease Gun ② Grease Fitting

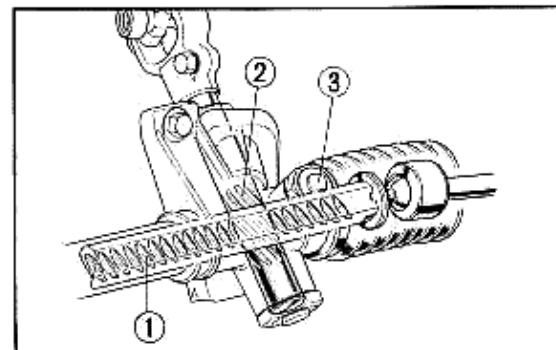

Fig. 2-10 ① Rack ② Pinion Gear ③ Rack Adjusting Bolt



Fig. 2-11 ① Tie Rod ② Lock Nut ③ Ball Joint

2. Knuckle Arm

1. Check the knuckle-to-tie rod end connection for damage.
2. Check the tie rod end ball joint for looseness or damage.
3. Check the welded joint of the knuckle.

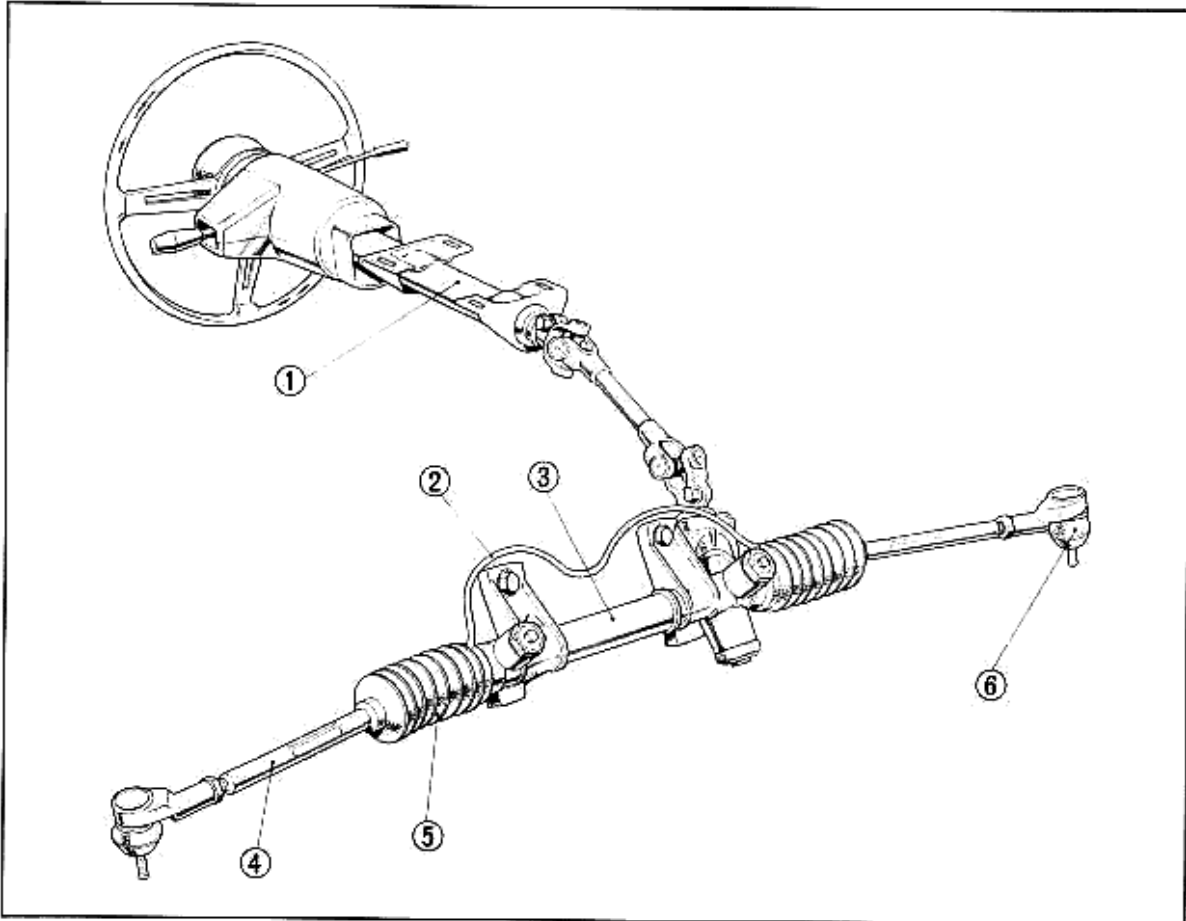

Fig. 2-12 ① Steering Column ③ Gear Box ⑤ Tie Bellow
 ② Breather Tube ④ Tie Rod ⑥ Tie Rod End Boot

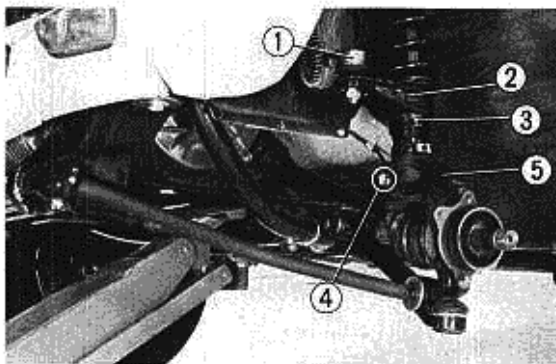

Fig. 2-13 ① Tie Rod end Ball Joint
 ② Knuckle Arm
 ③ Welded Joint
 ④ Front Damper Lock Bolt

D. Knuckle

1. Check the front damper lock nut for looseness.

| | Specified torque |
|-----------------------|--------------------------------|
| Front damper lock nut | 4.5-5.0 kg-m (32.5-36.2 lb-ft) |

E. Wheel Alignment

Because of the various types of alignment equipment on the market, specific alignment procedures will not be given. Refer to the instructions given by the manufacture of the equipment used.

1. Before proceeding with the alignment, check for incorrect tire pressure, rim or wheel distortion, and any other irregularities that may affect alignment results.
2. Check caster and camber. If the readings are out of specification, check for any damage and correct.
3. Adjustment
 - 1) Center the pinion on the steering rack. The steering wheel should be centered and locked in position. If the steering wheel is not centered when the rack is centered, the steering wheel must be repositioned on the steering shaft.
 - 2) Loosen the tie rod adjusting (lock) nuts and turn the steering rack end assembly to increase or decrease the toe-in.

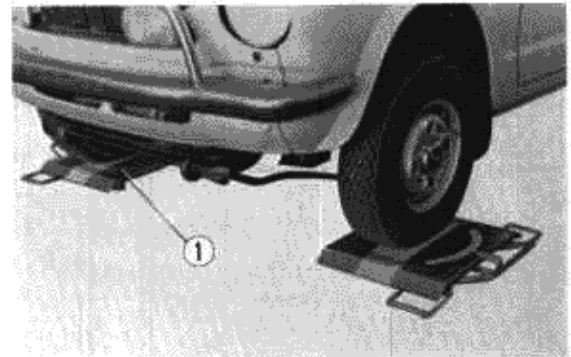

Fig. 2-14 Turning Radius Gauge

NOTE:

1. The adjustment should be made while measuring with the gauge.
2. Turn both tie rods an equal amount until toe-out becomes 2mm (.08in). 1~3mm is the total toe-out allowance.
3. Be sure to tighten the tie rod lock nuts after completing the adjustment.
4. Recheck the alignment gauge readings.

2-2. Brake System

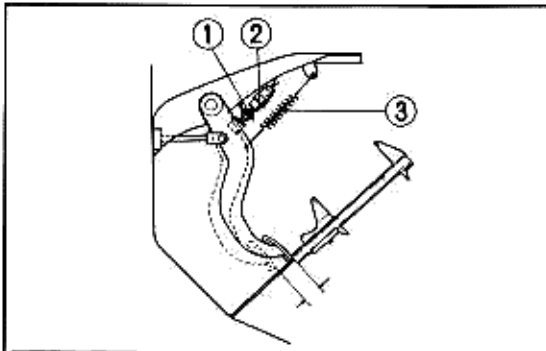

Fig. 2-15 ① Lock Nut
② Stop Switch (Adjuster)
③ Pedal Return Spring
④ Free Play (Measured with Return Spring Connected)



Fig. 2-16 ① 1~10mm Play

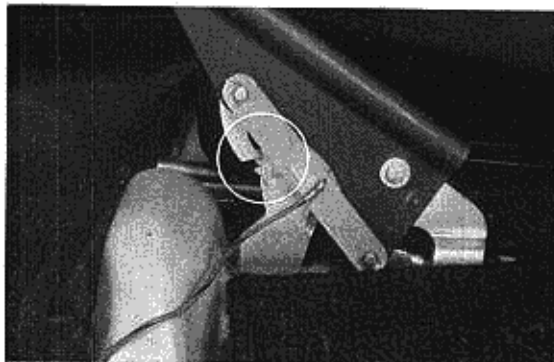

Fig. 2-17

A. Brake Pedal

1. Pedal free-play

With the depth gauge end of the vernier calipers, measure the distance from the floor (remove the carpet) to the brake pedal. Then disconnect the brake pedal return spring and again measure the distance from the floor to the brake pedal. The difference in the two measurements is the brake pedal free-play. The specified free-play is **1~10 mm (0.04~0.34 in)**. Free-play adjustment is made by means of the stop light switch. To adjust, loosen the lock nut and rotate the switch body.

1. If clearance is excessive, turn the stop light switch in until there is a free-play of **1~10 mm**.
2. If there is an inadequate clearance, turn the stop light switch out until there is a free-play of **1~10 mm**.

2. Brake performance

If braking difficulties are experienced, the following procedure should be followed:

- * Check and adjust the tire inflation pressure.
- * Check the front pads for wear, and the movement of the brake yokes (see page 23 section G.1.2).
- * Check the drums for wear and adjust the linings.

B. Parking Brake

1. Brake lever stroke

The rear wheels should be locked when the lever is pulled **1~5 notches** on the ratchet serration.

Adjustment should be made by turning the adjusting nut located at the rear axle shaft. Check the ratchet for wear.

NOTE: Any adjustment should be performed after the rear brakes have been adjusted.

2. Parking brake operation

Check the parking brake for correct operation by parking the car on a grade. Release the lever and note any brake drag. Adjust accordingly.

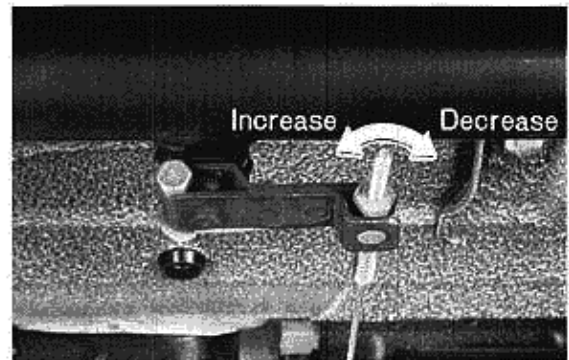

Fig. 2-18

C. Rods and Cables

1. Check the cables for wear and damage. Check the cable guide and equalizer for looseness.
2. Check the equalizer cable where it contacts the equalizer for any signs of wear. Apply grease between the equalizer and cable if necessary.

Recommended grease:

NLGI No. 2 Multipurpose

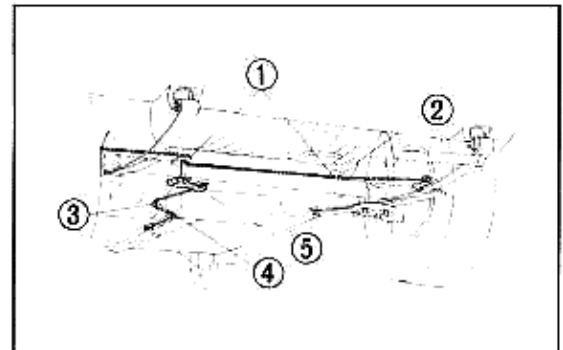

Fig. 2-19 ① Apply Grease ④ Apply Grease
② Guide ⑤ Equalizer
③ Guided

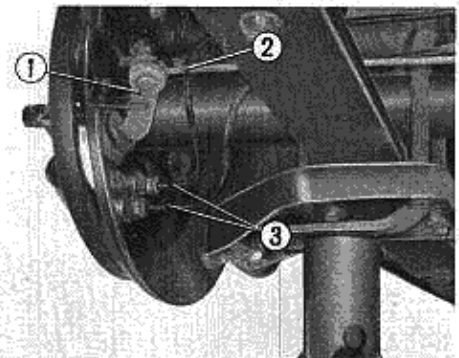

Fig. 2-20 ① Brake Lever
② Parking Brake
③ Brake Pipe

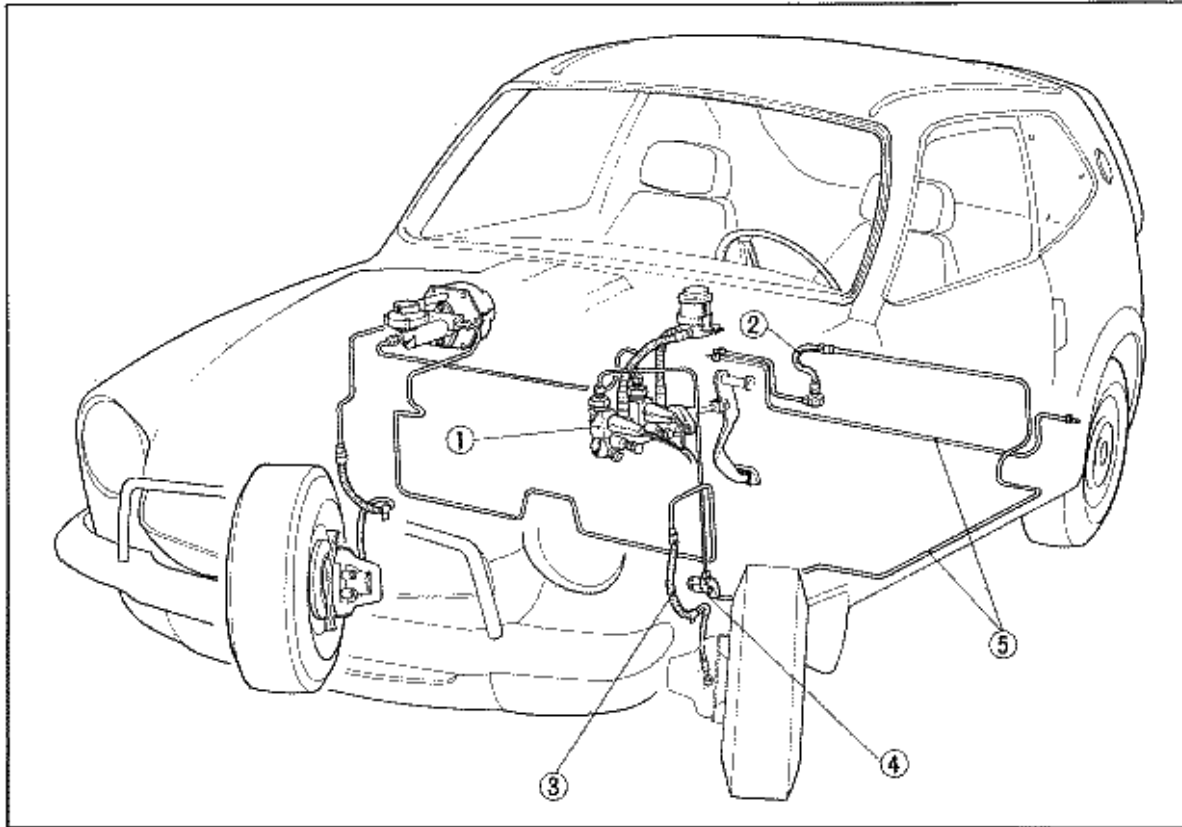

Fig. 2-21 ① Master Cylinder ③ Front Brake Hose ⑤ Brake Pipe
 ② Rear Brake Horse ④ Proportioning Valve

D. Brake Hoses and Pipes

1. Inspection

1. Check the brake hoses, pipes, and all joints and connections for any sign of leakage.
2. Check the hoses and pipes for any damage.
3. Check to see that they are mounted securely in place.

2. Adjustment

1. Retighten any loose joints or connections.
2. Replace any damaged hose or pipe.
3. Check the brake fluid level.
4. Bleed all entrapped air.

E. Brake Fluid

1. Checking the brake fluid level

Periodically checking the level of the brake fluid reservoir will insure a correct fluid level at all times. A constant loss of fluid indicates a leak in the system. Infrequent topping-off will be required in normal use due to pad wear.

NOTES:

1. Use only recommended brake fluid when replacement is necessary. Recommended: DOT3 brake fluid meets the SAE J1703 specification. Outside the U.S.A., use SAE J1703 brake fluid.
2. Never re-use brake fluid, or use fluid that is dirty, cloudy or has air bubbles.

3. Store brake fluid in a clean dry place in the original container. Cap tightly and do not puncture a breather hole in the container.
4. Carefully remove any dirt from around the master cylinder cap before opening.
5. Take special care not to spill the fluid, otherwise the painted surfaces of the vehicle may be damaged.

2. Changing the brake fluid

When it is necessary to flush the brake hydraulic system because of parts replacement or fluid contamination, the procedure listed below should be followed:

1. Begin the fluid change at the wheel furthest away from the master cylinder.
 2. Loosen the wheel cylinder bleeder screw. Drain the brake fluid by pumping the brake pedal.
 3. Pump the pedal until all of the old fluid has been pumped out and replaced by new fluid.
 4. The flushing procedure should be performed in the following sequence:
 - 1) Bleed the left rear brake.
 - 2) Bleed the right front brake.
 - 3) Bleed the left front brake.
 5. Maintain the correct fluid level in the master cylinder reservoir with fresh brake fluid.
 6. Using the same sequence, bleed the entire system until all the air is removed.
- NOTE:** Do not allow air to enter the master cylinder when adding fresh fluid.

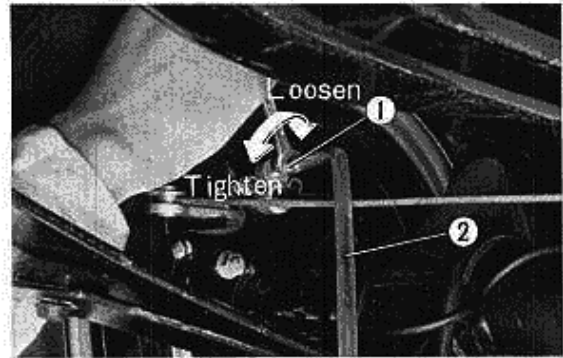

Fig. 2-22 ① Bleeder Screw ② Vinyl Tube

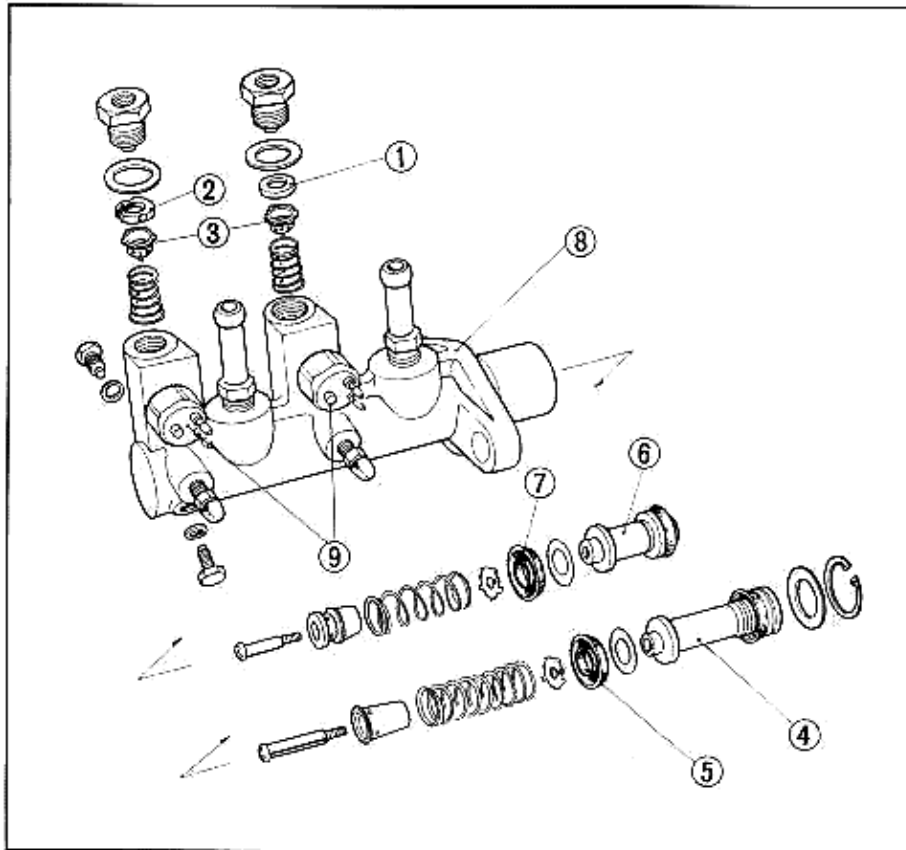

Fig. 2-23

- ① Check Valve Seat (Aluminum)
- ② Check Valve Seat (Rubber)
- ③ Check Valve
- ④ Primary Piston
- ⑤ Primary Piston Cup
- ⑥ Secondary Piston
- ⑦ Secondary Piston Cup
- ⑧ Master Cylinder Body
- ⑨ Stop Switch

3. Brake master cylinder and wheel cylinders

1. Check the master cylinder and brake cylinders for brake fluid leakage.
2. If leakage is found, disassemble the cylinder for inspection. Check each part for wear, corrosion or any other damage.
3. Measure the clearance between the piston and cylinder bore with a thickness gauge.

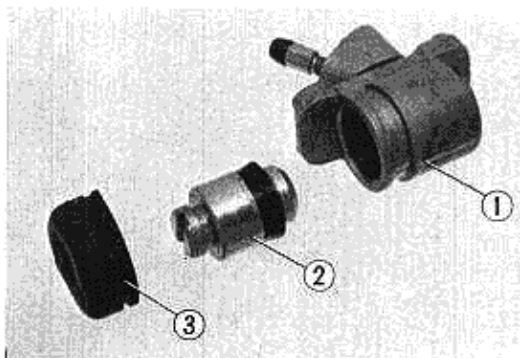

Fig. 2-24 ① Wheel Cylinder
② Piston
③ Dust Seal

| | Standard mm | Service limit mm |
|--|----------------------------------|---------------------|
| Brake master cylinder bore-to-piston clearance | 0.02-0.105 (0.00079-0.004 in) | 0.15 (0.0059 in) |
| Wheel cylinder bore-to-piston clearance | 0.02-0.105 (0.00079-0.004 in) | 0.15 (0.0059 in) |

4. After reassembling the cylinder, bleed off any entrapped air. Operate the brake system and check for any leakage. Check pedal travel and adjust the rear brakes if necessary.

F. Drum Brake

1. Drum-to-lining clearance (rear brake)

1. Jack up the rear of the car and depress the brake pedal 2-3 times.
2. Turn the adjusting screws located at the rear side of the backing plate clockwise until the wheel is locked.
3. Then, back off the screw one click and depress the brake 2-3 times.
4. If the drum is binding when turning the wheel, back off the adjusting screw one more click.
5. Perform the same procedure on the other wheel. Check the brakes for control after the adjustment.

2. Wear of the rear brake linings

1. If the linings are found worn beyond specification when measured with a vernier caliper, they should be replaced with new linings.
2. Check the brake drums for wear or any other damage.

| | Standard (mm) | Service limit (mm) |
|------------------|---------------|--------------------|
| Lining thickness | 5 (0.20in) | 2.0 (0.08in) |
| Drum I.D. | 180 (7.086in) | 181 (7.126in) |

NOTE: If the lining is worn excessively or abnormally on one wheel, but not on the other, the worn lining should be replaced. Normally the brake linings should be replaced on both rear wheels at the same time.

G. Front Disk Brake

1. Checking disk-to-pad clearance

1. Jack up to the car and rotate the front wheels by hand to see if the pads are dragging.
2. Remove the wheels and check the disk-to-pad clearance. If there is no clearance, or excessive clearance, check the following:
 - 1) If no clearance, check the yoke movement. If lining wear differs between the inner and outer pads, the caliper may be unable to move properly due to rust and dirt on the sliding surfaces. Clean the sliding part of the caliper and apply grease (NLGI No. 2 Multipurpose). Measure the amount of force required to slide the caliper with a spring scale. Standard reading: 25kg (55lbs.)
 - 2) If excessive clearance, check the movement of the pistons (a & b).
 - 3) Check the pads.

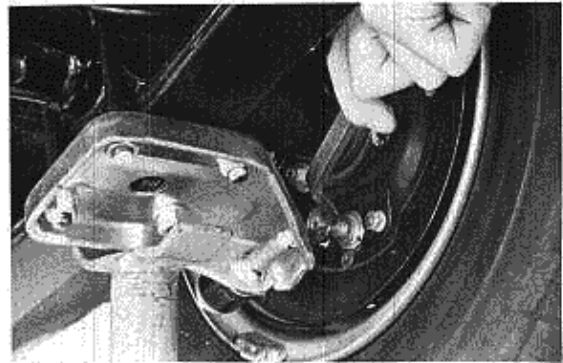

Fig. 2-25

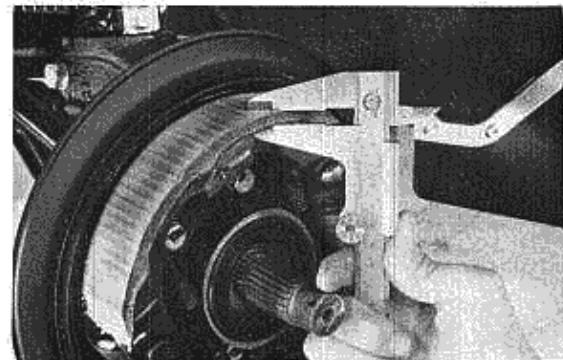

Fig. 2-26

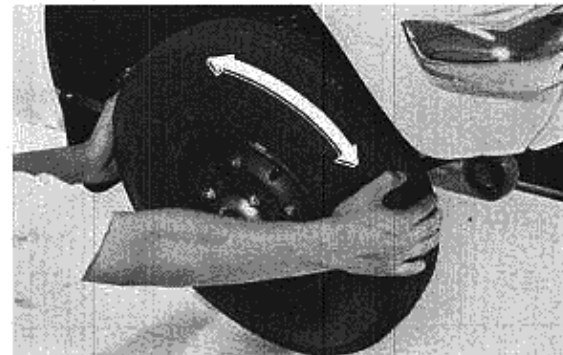

Fig. 2-27

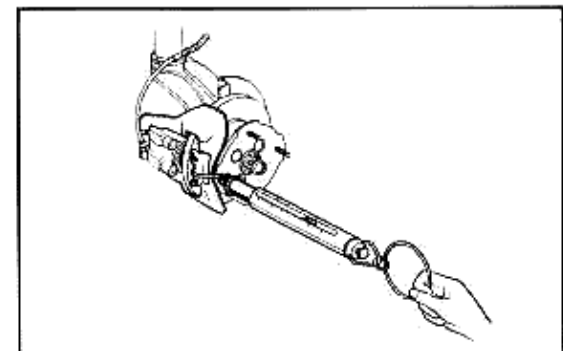

Fig. 2-28

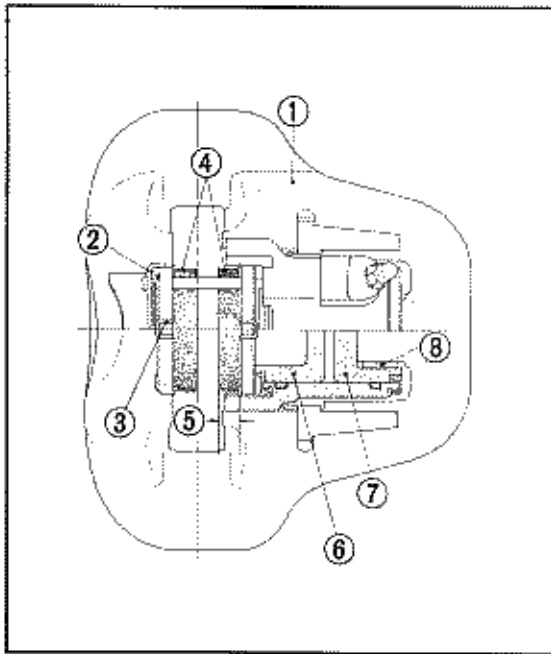

Fig. 2-29 ① Yoke ⑤ Thickness
② Shim ⑥ Piston B
③ Retaining Clip ⑦ Piston A
④ Pad ⑧ Balas Ring

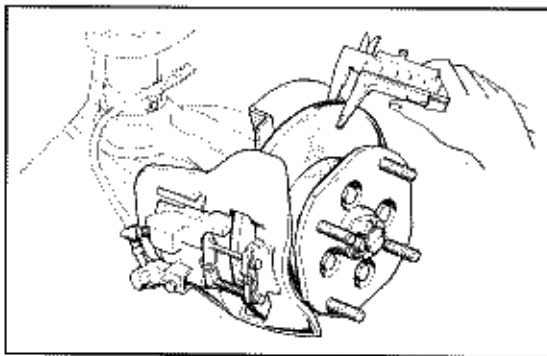

Fig. 2-30

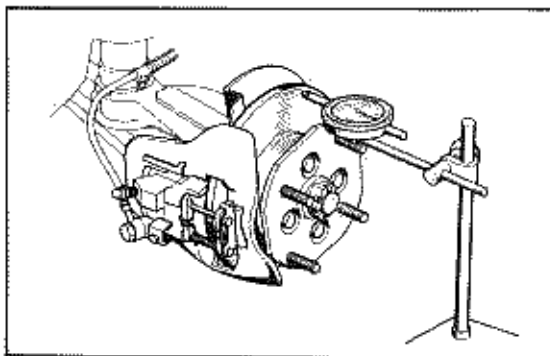

Fig. 2-31

2. Brake pad inspection

1. Remove the brake pads and measure the pad lining thickness with a vernier caliper or micrometer. The measurement should be made at the point of maximum wear.

| | Standard (mm) | Service limit (mm) |
|---------------|-----------------|--------------------|
| Pad thickness | 10.3 (0.41 in.) | 2.0 (0.08 in.) |

2. When the pads are replaced or when the brakes are noisy apply a thin coat of grease (NLGI No. 2 Multipurpose) to the backside (rear) of the pads.

NOTES:

1. When replacing the pads, also replace the springs, shims, and retaining clips.
2. Prior to replacing the pads, reduce the amount of brake fluid in the reservoir to prevent it from spilling out.

3. Disk inspection

1. Remove the front wheels and measure the thickness of the disk with a micrometer. The measurement should be made on the most worn part of the disk thickness.

NOTE: When measuring the disk thickness, do not include the ridge around the disk circumference.

| | Standard (mm) | Service limit (mm) |
|----------------|-----------------|--------------------|
| Disk thickness | 9.6 (0.378 in.) | 9.0 (0.354 in.) |

2. Check the disk for damage.

NOTE: When removing the front hub, do not hit it with a hammer; otherwise the hub may be damaged. Use a puller if necessary.

3. Checking disk face runout and parallelism

1. Measure the face runout at the center of the disk with a dial indicator. The maximum allowable runout is 0.1 mm (0.004 in.). Replace the disk if the runout exceeds the specification.
2. Measure the parallelism of the disk faces around the entire friction surface of the disk with two dial indicators placed opposite each other. The maximum allowable variation in the width of the disk is 0.07 mm (0.003 in.).

2-3. Wheels

A. Wheels and Tires

1. Wheel tire inflation pressure

1. Check the tires for correct inflation pressure with a tire gauge. Correct the pressure if necessary.

NOTE: All four tires should be inflated equally. Correct tire pressures are given on the label attached to the back of the glove box door.

2. Also check the inflation pressure of the spare tire and inflate it to a maximum of 2.2 kg/cm² (32 psi).

TIRE PRESSURES

| | | | |
|-----------|-------|------------------------|----------|
| 600 Coupe | Front | 1.8 kg/cm ² | (26 psi) |
| | Rear | 1.8 kg/cm ² | (26 psi) |

2. Excessive wear and other tire damage

1. Check the tires for excessive tread wear while on a lift, or by jacking up each wheel. When the tread wear indicator appears as a solid band across the tread, the tire should be replaced.
2. Check the entire surface of the tire for any damage. Replace if necessary.
3. Check for gravel or sharp objects embedded in the tread and remove them with a pair of pliers.

3. Checking wheel balance

Before balancing the wheel and tires, check the following:

1. Check the tire pressure.
2. Check the wheel setting (lug) nuts for tightness.
3. Spin the wheel by hand to check for wheel bearing play.
4. Check the tire for roundness.
5. Check the tire for wear and any other damage.
6. Check the rim for any damage.

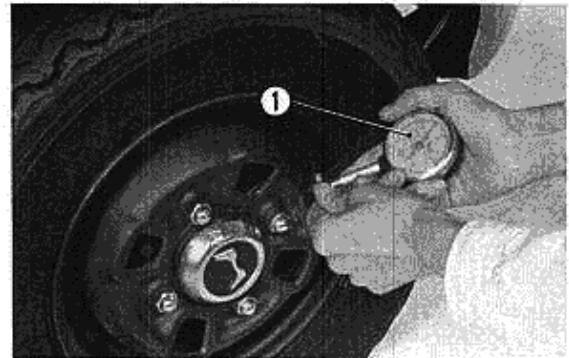

Fig. 2-32 Tire Gauge

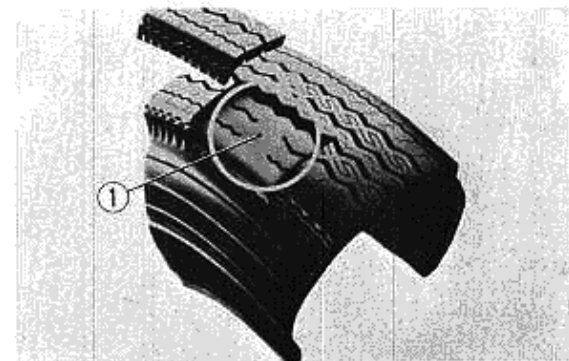

Fig. 2-33 ① Wear Indicator



Fig. 2-34 ① Castellated Nut

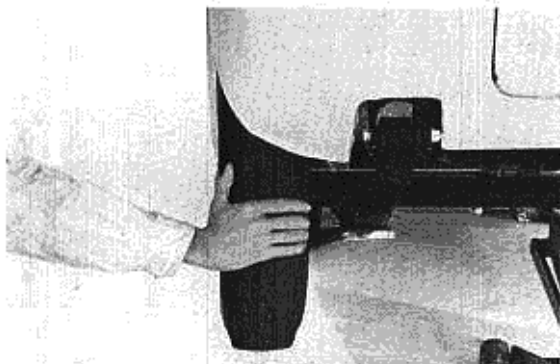

Fig. 2-35

4. Wheel rim inspection

1. Raise the car and rotate the wheels by hand to check for lateral runout. Measure the rim end-play with a dial indicator. If the runout is greater than 3 mm (0.12 in) measured externally remove the tire and measure the runout (3mm-0.12 in) on the inside lip of the rim.
2. Check the rim of the wheels for any damage. Repair or replace as necessary.

NOTE: When repairing or replacing the wheel rim, the wheel balance must be rechecked.

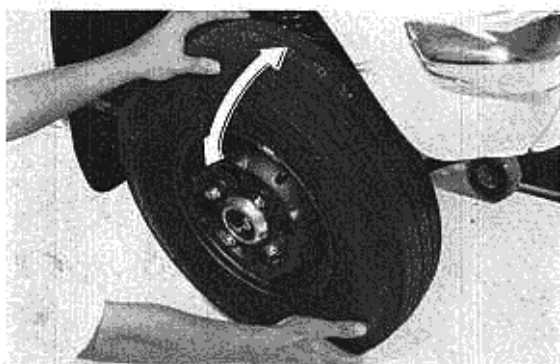

Fig. 2-36

5. Wheel bearing

Jack up each wheel to clear the ground. Hold the wheel and shake it as shown to check the wheel bearings for any play. If any play is felt, tighten the castellated nut to the specified torque and re-inspect. If play is still present, replace the bearing.

NOTE:

1. Over-tightening the castellated nuts will cause excessive bearing friction and will result in rough wheel rotation and bearing failure.
2. After inspection, apply grease to the wheel bearings. Recommended grease:
NLGI No. 2 Multipurpose

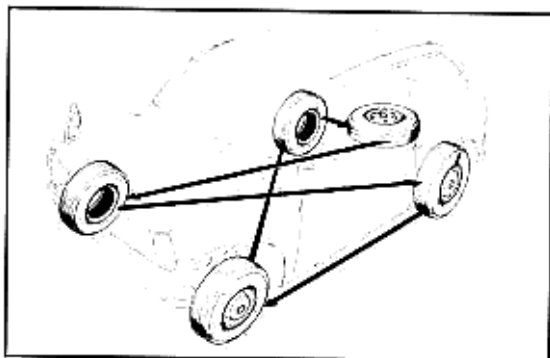

Fig. 2-37

6. Wheel-tire rotation

If the tires are used for a long period of time at the same position, they will wear unevenly resulting in shorter tire life. To prevent this, rotate the tires as required in the maintenance schedule.

2-4. Suspension System

A. Front Suspension

1. Damage and oil leakage

1. Check the front damper springs for damage.
2. Check the front suspension main shafts for damage and oil leakage.

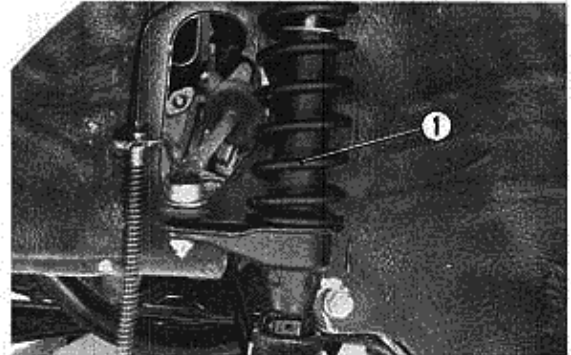

Fig. 2-38 ① Front Damper Spring

2. Looseness

Check the front damper mounting nuts for looseness. Check the front suspension main shaft and damper mounting cap for looseness.

| | | |
|----------------------------|---------|-----------------------------------|
| Front damper mounting nuts | (upper) | 4.5-5.0 kg-m (32.6-36.2 lb-ft) |
| | (lower) | 2.5-3.0 kg-m (18.1-21.7 lb-ft) |

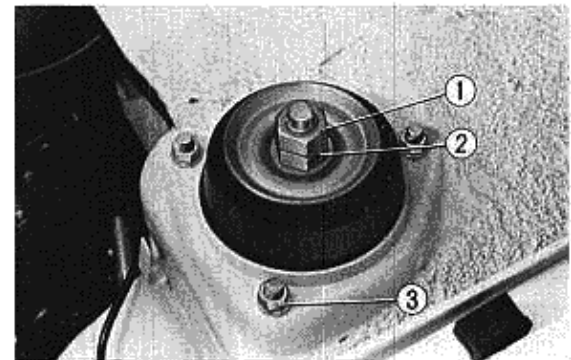

Fig. 2-39 ① Upper 4.5-5.0 kg-m
② Lower 2.5-3.0 kg-m
③ 1.5-2.0 kg-m

B. Rear Suspension

1. Damage and oil leakage

1. Check the rear leaf spring for any damage.
2. Check the rear shock absorbers for damage and oil leaks.

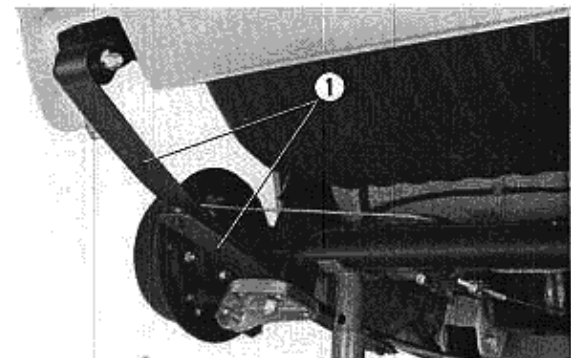

Fig. 2-40 ① Rear Leaf Spring



Fig. 2-41

If adjustment of the shackles does not correct the inclination, check the leaf springs and rear shock absorbers, and make the necessary repairs or replacements.

2. Inspection of the rear suspension

1. Adjust the tire inflation pressure to the specified value and place the car on level ground.
2. Check the car by viewing it from the rear for lateral inclination (lean). If there is noticeable inclination, check the condition of the leaf spring shackles. Improper fastening of the spring shackle bolts will cause body lean. Loosen the two spring bolts on the higher side, level the car, and retighten the bolts.

C. Front Suspension Joints and Connections

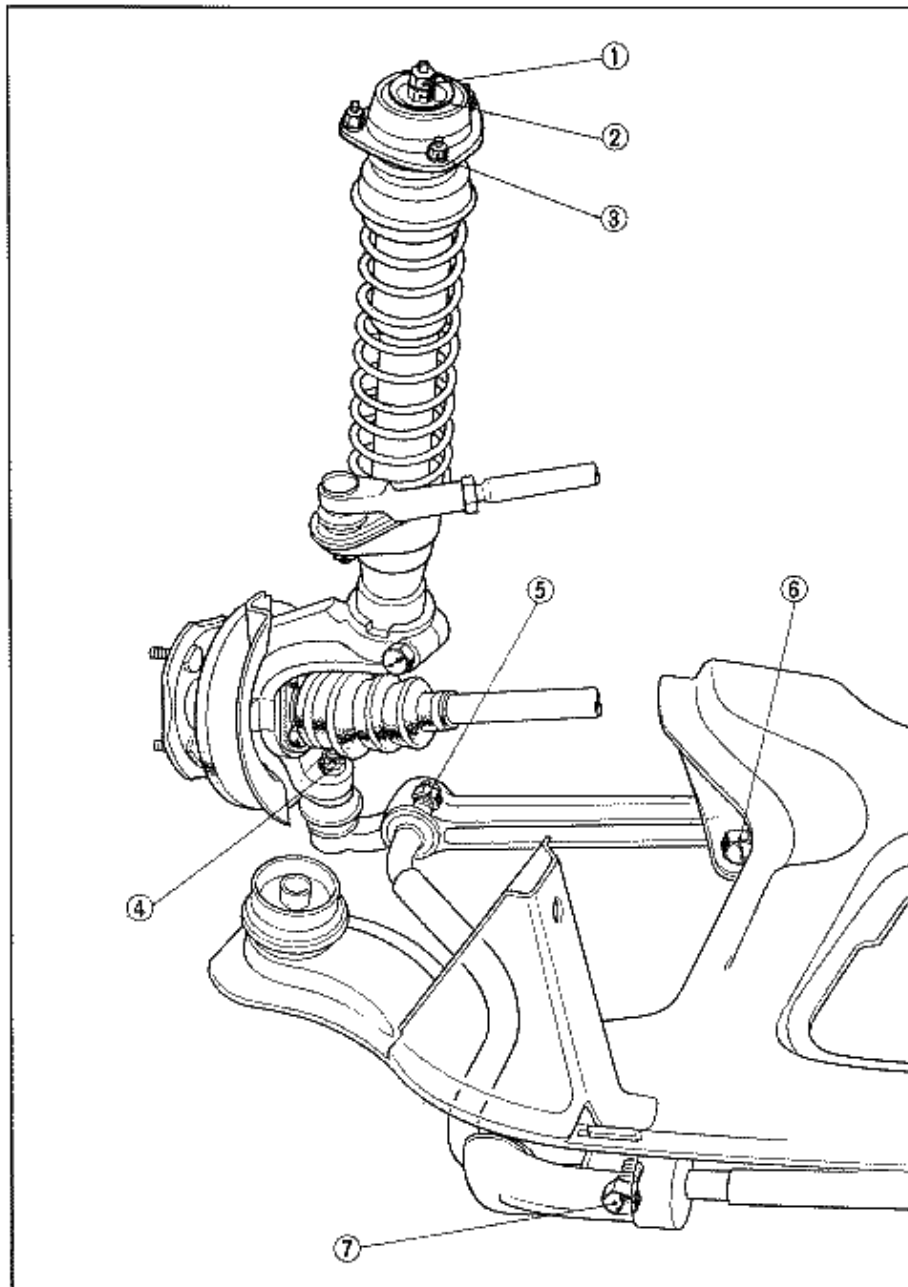

- ① 4.5-5.0 kg-m
(32.5-36.2 lbs-ft)
- ② 2.5-3.0 kg-m
(18.1-21.7 lbs-ft)
- ③ 1.5-2.0 kg-m
(10.8-14.5 lbs-ft)
- ④ 3.0-4.0 kg-m
(21.7-28.9 lbs-ft)
- ⑤ 4.0-8.0 kg-m
(29-58 lbs-ft)
- ⑥ 4.0-4.8 kg-m
(28.9-34.7 lbs-ft)
- ⑦ 2.0-2.4 kg-m
(14.5-17.4 lbs-ft)

Fig. 2-42

1. Check the lower arm and stabilizer shaft for bending and any other damage. Replace any defective parts.
2. Check the double nuts of the front suspension main shaft upper mount for tightness.
3. Check the lower arm to the sub-frame mounting.
4. Check the front suspension ball joint for tightness. If loose, retighten the joint to the specified torque. Recheck the joint, and replace if still loose.
5. Check the suspension ball joint boot for damage or improper installation.

D. Rear Suspension Joints and Connections

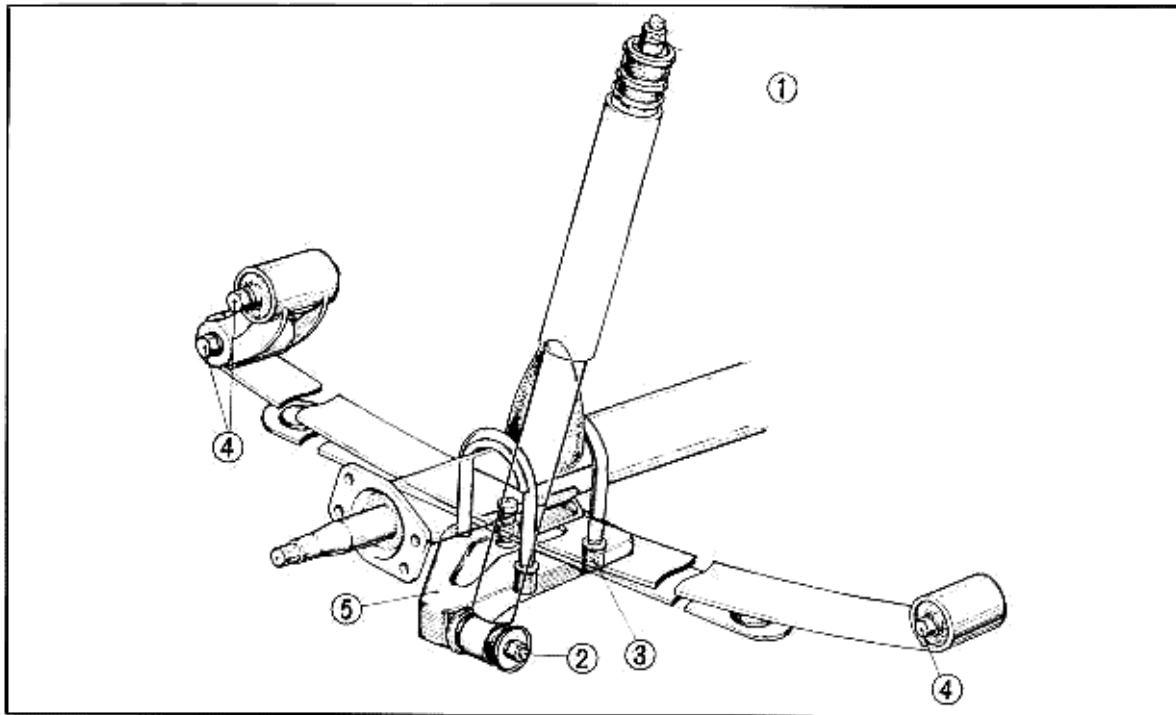

Fig. 2-43 ① Rear Dumper Double Nut 1.2-1.5 kg-m ③ U Bolt 4.0-4.5 kg
② Rear Dumper 1.6-2.0 kg-m ④ Rear Shackle and Leaf Spring 4.0-4.8 kg-m

1. Check the rear suspension mounting bolts and nuts for tightness or any other damage.
2. Check the front and rear shackle bushings of the rear springs for excessive end and radial play. Check them for wear. Also check the rear shock absorber cushions for deterioration.

NOTE: Always tighten all bolts to the specified torque. DO NOT over torque.

3. Check the rear leaf springs for misalignment. Check the leaf spring center bolt (Fig. 4-6) for looseness or any other damage.

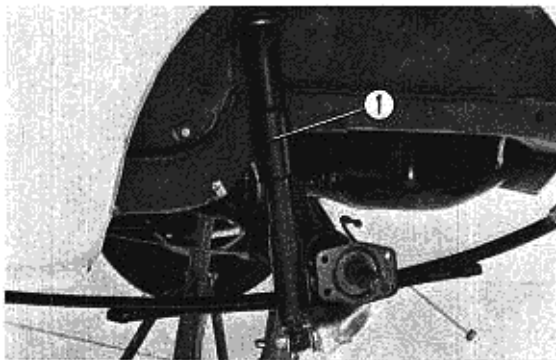

Fig. 2-44 ① Rear Shock Absorber Assy

4. Check the leaf spring front bracket, retaining plates, and shackles for damage.

E. Front and Rear Shock Absorbers

1. Check the front and rear shock absorbers for oil leaks. Remove the wheels and check for damage.
2. Check the mounting of the shock absorbers for looseness by rocking the car body.
3. Check the upper seat and bump stopper rubbers of the front shock absorber (front suspension main shaft) for cuts or any other damage.

2-5. Clutch, Transmission, Drive Shafts, Wheel Hubs

A. Clutch

1. Checking the clutch operation

Idle the engine and check the clutch operation as follows:

1. Depress the clutch pedal and check the clutch for noise, vibration, or any abnormal condition.
2. Gradually release the clutch pedal while increasing the engine rpm and check the clutch engagement. If any abnormal condition is found, the following items should be inspected:
 - 1) Improper adjustment of the clutch.
 - 2) Clutch cable damage.
 - 3) Wear of the friction disk.
 - 4) Oil or grease in contact with the clutch facing.

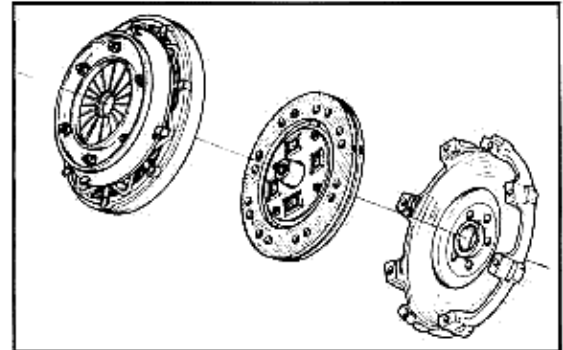

Fig. 2-45

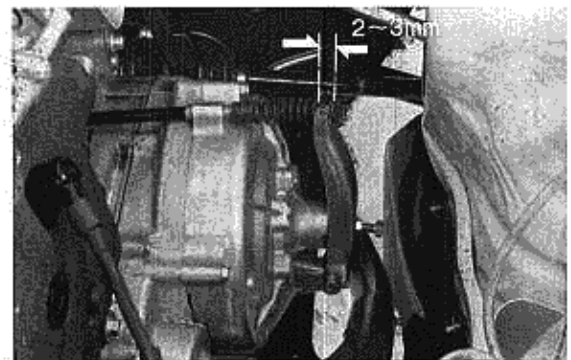

Fig. 2-46

2. Checking clutch pedal play

1. The specified clutch release lever play is 2-3mm (0.08-0.12in). The clearance between the tip of the pedal and the floor mat is 40mm (1.6in) at the point of engagement. If the play is out of specification, adjust as follows:
 - 1) Loosen the lock nut and turn the adjusting bolt.
 - 2) Turn the adjusting bolt in to decrease the play.
 - 3) Tighten the lock nut after the adjustment.
2. If necessary, adjust the clutch pedal to match the brake pedal height with the adjusting bolt located near the top of the pedal. After adjusting, check for adequate pedal free-play and engagement distance.

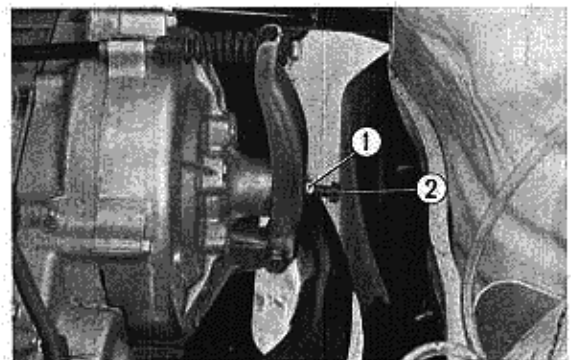

Fig. 2-47 ① Lock Nut
② Adjusting Bolt

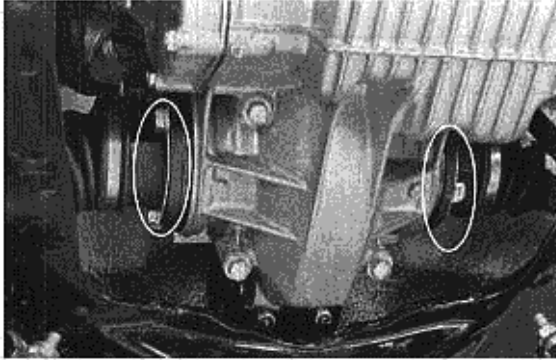

Fig. 2-48

B. Transmission

1. Oil leakage

Check the drive shaft joint flange for oil leaks. If oil is leaking, it may be due to a defective differential oil seal and/or drive pinion O-ring.

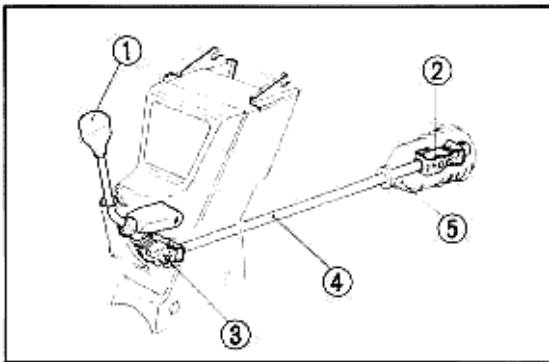

Fig. 2-49 ① Gear Shift Lever
② Gear Shift Rod Joint
③ Gear Shift Lever Joint
④ Gear Shift Rod
⑤ Gear Shift Rod Bellow

2. Gear shift mechanism

1. With the engine running, place the transmission in neutral and check the gear shift lever for vibration. If vibration is noticed, check the shift lever bracket mounting bolts.
2. With the clutch disengaged, place the transmission in each gear to check for correct gear engagement. A large amount of grinding into gear indicates possible clutch misadjustment.
3. Check the gear shift rod bellows and shift lever bellows for damage or incorrect installation.

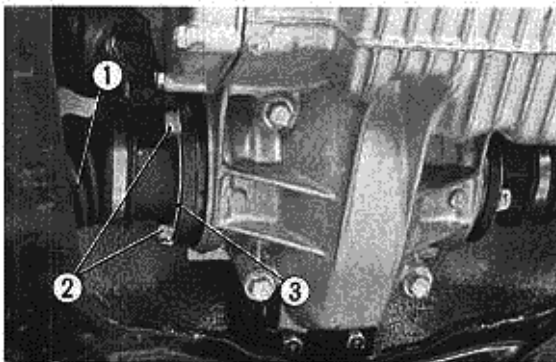

Fig. 2-50 ① Inboard Joint Bellow
② Ball Joint Setting Bolt
③ Joint Setting Bolt Lock Washer

C. Drive Shaft

1. Ball joint setting bolt

Check the ball joint setting bolts for looseness, and retighten if loose.

NOTE: Make sure to replace the joint setting bolt lock plates with new ones before retightening the bolts.

| | Specified torque |
|-------------------------|--------------------------------|
| Ball joint setting bolt | 2.8-3.2 kg-m (20.3-23.2 lb-ft) |

2. Spline and joint bellows

1. Check the splines of the inboard joint for wear. Raise the front wheels and with the transmission in gear, rotate the drive shaft and check for looseness which indicates wear.
2. Check the inboard and outboard joint bellows for any damage or interference.
3. Place the shift lever in neutral and check the condition of the drive shaft splines by rotating the drive shaft back and forth. If the shaft is loose or noisy, remove the brake front hub and check the driveshaft and hub splines for damage. Replace if damaged.

| | Specified Torque |
|-------------------------|-----------------------------------|
| Front castellated nut | 14-20 kg-m (101.5-144.7 lb-ft) |
| Wheel setting (lug) nut | 6.0-7.0 kg-m (43.4-50.6 lb-ft) |

3. Front shaft wheel hub nut tightening procedure

1. Clean and lubricate the drive shaft threads, washer and nut. Using a torque wrench, tighten the hub nut to 14kg-m (101lb-ft). Check the alignment of the hub nut castellation and the cotter pin hole, however, **DO NOT** install the cotter pin at this time. Tighten the nut to the next alignment position and install a new cotter pin. If the alignment can not be attained within the specified torque range, (14-20kg-m) install a new front hub washer and repeat the tightening sequence.

NOTE: The torque specification must be observed.

4. Rear wheel hub nut tightening procedure

1. Remove the wheel caps.
2. Remove the rear wheel bearing caps and check the rear castellated nuts for tightness. Also, check the cotter pin installation.
3. If the rear castellated nut is loose, pull out the cotter pin and retighten the nut to the specified torque.

| | Specified torque |
|----------------------|---------------------------------|
| Rear castellated nut | 10-13 kg-m (72.3-94.0 lb-ft) |

4. Be sure to use new cotter pins.

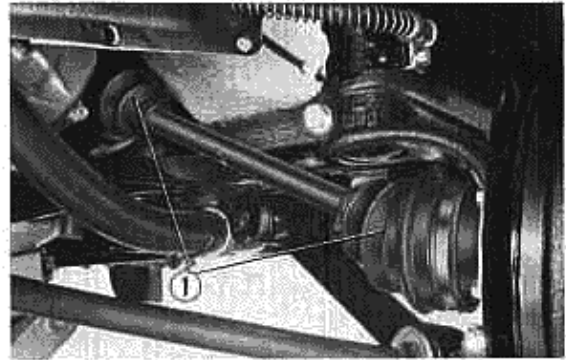

Fig. 2-51 ① Bellows

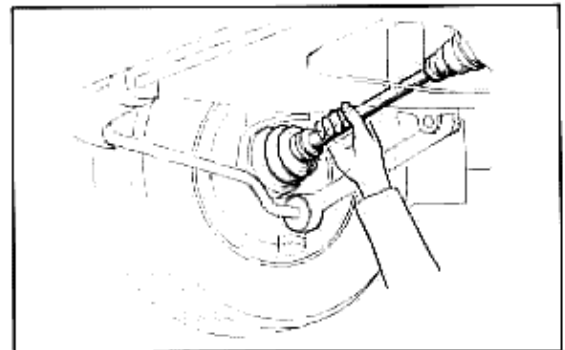

Fig. 2-52

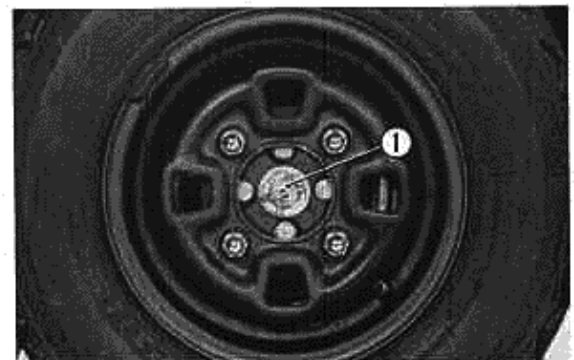

Fig. 2-53 ① Castellated Nuts

2-6. Electrical System

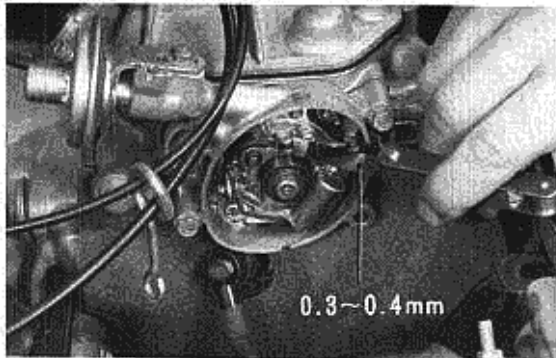

Fig. 2-54

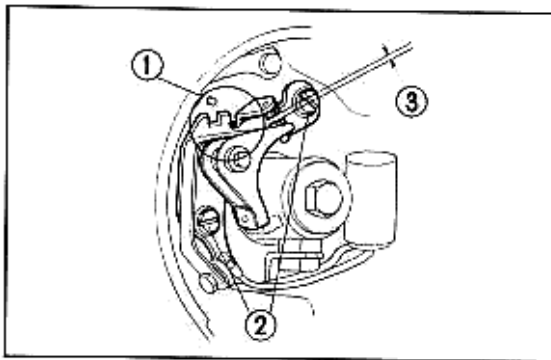

Fig. 2-55

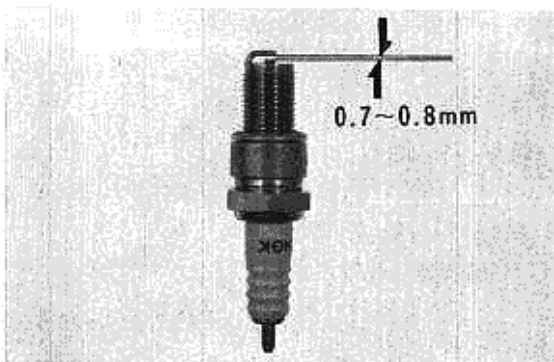

Fig. 2-56

A. Ignition System

1. Breaker point gap

(1) Inspection

1. Check the surfaces of the contact breaker points and breaker arm for deterioration. If pitted or worn, dress the contact points with a point file.
2. Slowly turn the crankshaft pulley until the point gap is at its maximum (when the breaker arm slipper is on the highest point of the cam). At this position, measure the gap with a blade type thickness gauge.

| | |
|---------------------|--------------------------------|
| Specified point gap | 0.3-0.4 mm (0.012-0.016 in) |
|---------------------|--------------------------------|

(2) Adjustment

1. Loosen the two breaker point set screws and adjust the point assembly with a screwdriver to obtain the proper clearance. Retighten the screws and check the clearance.
2. Check the breaker arm spring for tension.

2. Spark Plug Condition

1. Remove the spark plugs with a plug wrench and check them for burnt electrodes, broken insulators, or any other damage.
2. Clean dirty plugs with a plug cleaner or wire brush. Do not use gas or solvent to clean plugs.

NOTE: Be certain that all the cleaning material is removed from the plugs if a plug cleaner is used. Grit from the cleaner can cause rapid wear of the cylinders and piston rings.

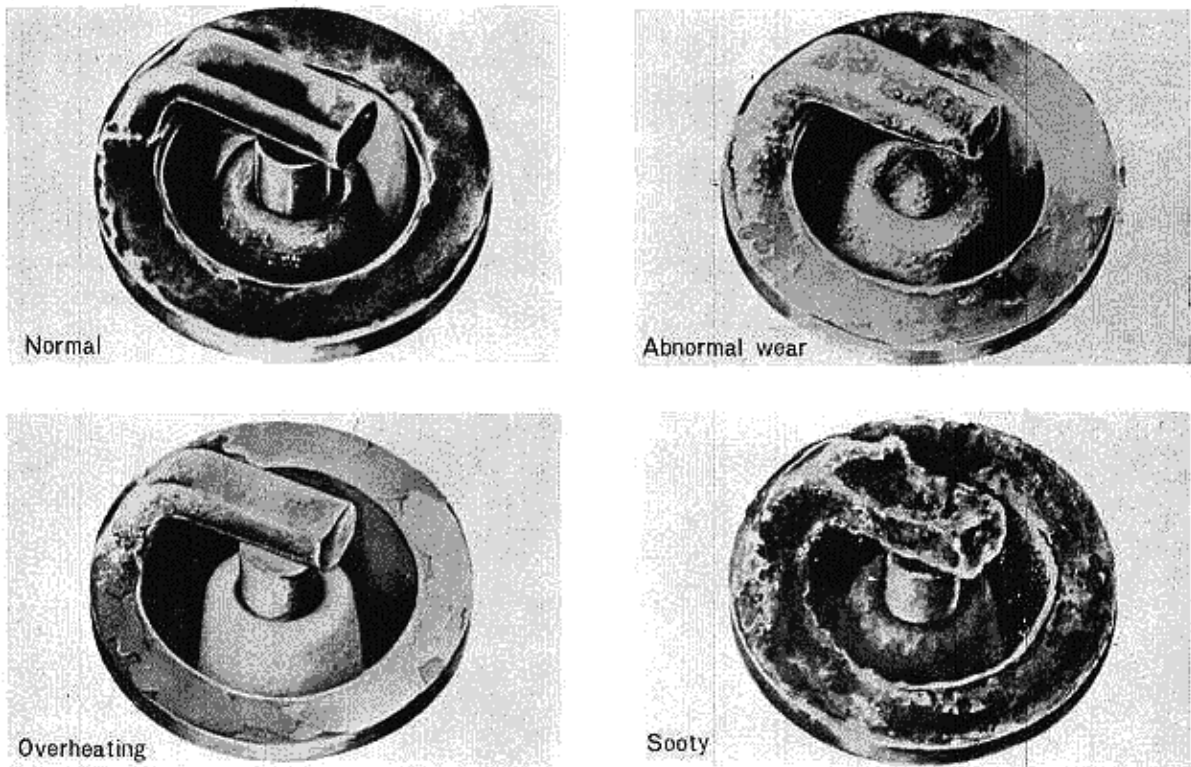

Fig. 2-57 Plug Condition

3. Measure the electrode gap with a wire type thickness gauge, and if necessary adjust the gap to specification by bending the ground electrode.

| | | |
|----------------|--------------------------------|-----------|
| Specified gap | 0.7-0.8 mm (0.028-0.032 in) | |
| Standard plugs | NGK B-8ES | ND W-24ES |

4. To install, insert carefully and thread by hand as far as possible. Tighten securely with a spark plug wrench.

3. Ignition Timing

(1) Testing with an ohmmeter

1. Disconnect the primary lead (blue) at the connector to the contact breaker. Connect the positive probe of the tester to the connector, and ground the negative lead to the engine.
2. Rotate the crankshaft in the normal direction by turning the bolt on the fan belt drive pulley with a wrench.
3. Check to see if the tester indicates the loss of continuity just when the notch on the fan belt drive pulley is aligned with the "F" mark on the flywheel cover.

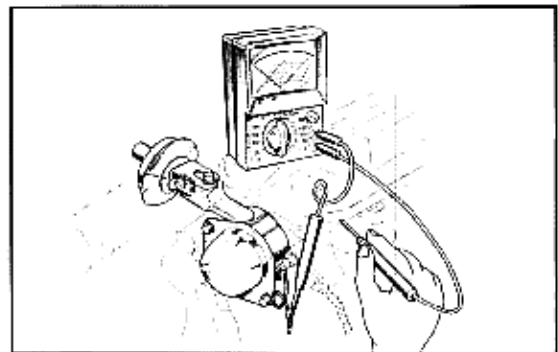

Fig. 2-58

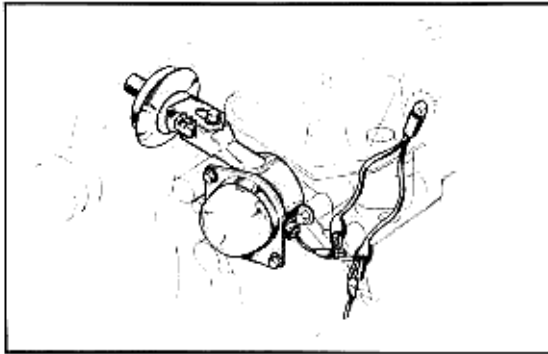

Fig. 2-59

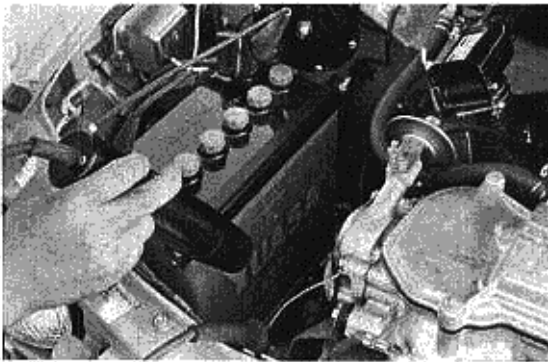

Fig. 2-60

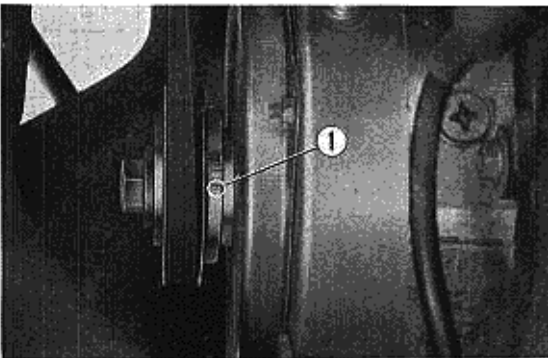

Fig. 2-61 ① F. Mark

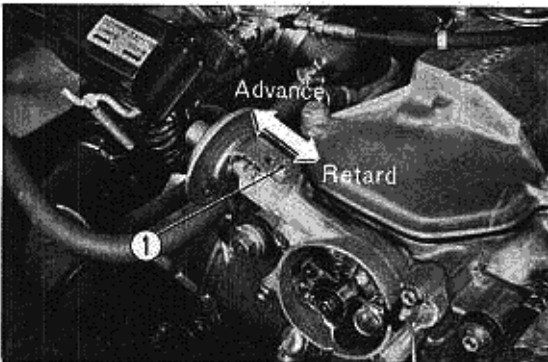

Fig. 2-62 ① Lock Bolt

(2) Testing with a 12 V lamp

1. Disconnect the primary lead (blue) at the connector to the contact breaker and connect a 12 V-3 W lamp between the connector and the distributor as shown. Turn the ignition switch on.
2. Rotate the crankshaft in the normal direction by turning the bolt securing the fan belt drive pulley with a wrench.
3. Check to see if the lamp goes out just when the notch on the fan belt drive pulley is aligned with the "F" mark on the flywheel cover.

(3) Testing with a timing light

1. Disconnect the vacuum advance tube.
2. Connect a timing light as shown.
3. Start the engine and adjust the idle to 1,150 rpm.
4. Point the timing light at the timing marks and push the timing light button. Check to see if the timing is set to the "F" mark.

(4) Adjustments

1. Prior to adjustment, be sure that the right-side camshaft holder is securely in place.
2. Loosen the vacuum advance lock bolt and move the advancer to adjust the timing.

3. Moving the advancer forward will retard the timing, and backward will advance it.
4. After adjustment, tighten the lock bolt to secure the advancer in place.
5. Recheck the timing.

| | |
|-----------------|---------------------------------|
| Ignition timing | $10^{\circ} \pm 2^{\circ}$ BTDC |
| Idling rpm | 1150 ± 50 rpm |

4. Advancer Angles

Check the spark and vacuum timing advance angles with a timing light.

(1) Mechanical spark ignition advance

1. Disconnect the vacuum advance tube at the carburetor.
2. Put marks on the fan belt drive pulley at angular intervals of 10 degrees before the "F" mark for reference in determining the amount of spark advance.
3. Connect a timing light and tachometer.
4. Take several readings of ignition timing at various engine speeds.

| Engine rpm | Advance angle (degrees) |
|------------|-------------------------|
| 2000 | 10-14 |
| 3000 | 16-24 |
| 4000 | 27-34 |

(2) Ignition vacuum advance

1. Disconnect the vacuum advance tube from the carburetor.
2. Suck on the tube by mouth (or use a vacuum pump if available) while the engine is idling.
3. Read the ignition timing at the crankshaft pulley with a timing light.
4. The maximum advance should be 17-23 degrees when applying a vacuum of -180 mmHg (-7.1 inHg) or more.

B. Charging System

1. Charging

The discharge warning light should go off when the engine is running at idle speed (1,150 rpm).

1. If the light remains on when the engine is running (at idle or above), an inspection of the charging system is required.
2. If the discharge light is working properly, but the battery boils over from an overcharge, or the battery cannot hold a charge, a charging system inspection is required.

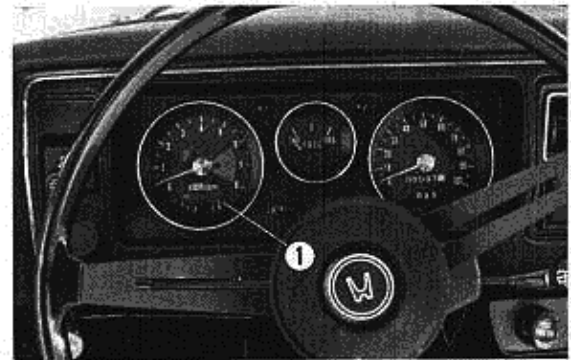

Fig. 2-63 Charge Pilot Lamp

2. Charging System Inspection

1. Install an ammeter in series between the main fuse (45 A) and the positive battery post.
2. Start the engine and allow it to warm up. Adjust the idle to 1,800 rpm. Read the amount of charge or discharge. If charging is indicated, check the discharge warning relay of the voltage regulator (Shop Manual sec. 17, page 25). If no charging is shown, connect a jumper wire from the battery positive post to the rotor coil wire (white with red tracer). If this produces a charging condition, check the voltage regulator (Shop Manual sec. 17, page 25).
3. If application of battery voltage to the rotor coil wire (white with red tracer) does not produce a charging condition, disconnect the three white wires from the stator and check the amount of AC voltage being produced. If approximately 20 or more volts AC is being produced (from each wire) at 1,800 rpm, check the rectifier (Shop Manual sec. 17, page 28). If the AC voltage being produced is under 20 V, remove the brushes and inspect their movement and length. Connect an ohmmeter (R \times 1 scale) to the rotor slip rings. If normal (4.05 ohms), attach the ohmmeter lead to the stator leads (Shop Manual sec. 17, page 24, fig. 17A-65, 67). BE CERTAIN that the white wire with the black tracer is disconnected before testing the stator.

NOTE: All references are to the Honda 360/400/600 SEDAN Shop Manual.

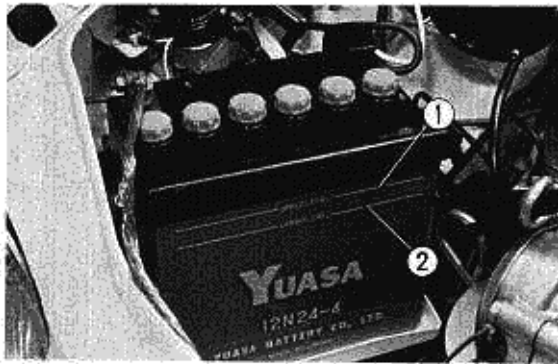

Fig. 2-64 ① Upper Level ② Lower Level

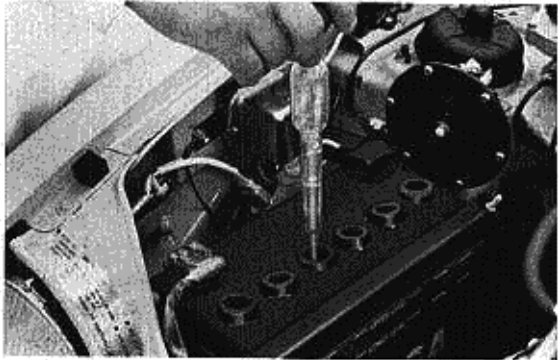

Fig. 2-65

C. Battery

1. Electrolyte

The battery electrolyte should always be kept above the lower level. If the electrolyte is below the lower level, remove the six filler plugs and add distilled water up to the upper level.

2. Specific Gravity of Battery Electrolyte

Using a hydrometer, measure the specific gravity of electrolyte in each cell. The specific gravity of a fully-charged battery is 1.280 at 20°C (68°F). Recharge the battery if the specific gravity is below 1.220.

| | Fully charge | Half charged |
|------------------------------|------------------------|--------------|
| Electrolyte specific gravity | 1.28 at 20°C (at 68°F) | Below 1.22 |

NOTE: Specific gravity varies with a change in electrolyte temperature. To compensate, add .004 for every 10° above 80°F, and subtract .004 for every 10° below 80°F. Specific gravity will decrease due to liquid expansion caused by an increase in temperature, and vice-versa.

D. Electrical Wiring

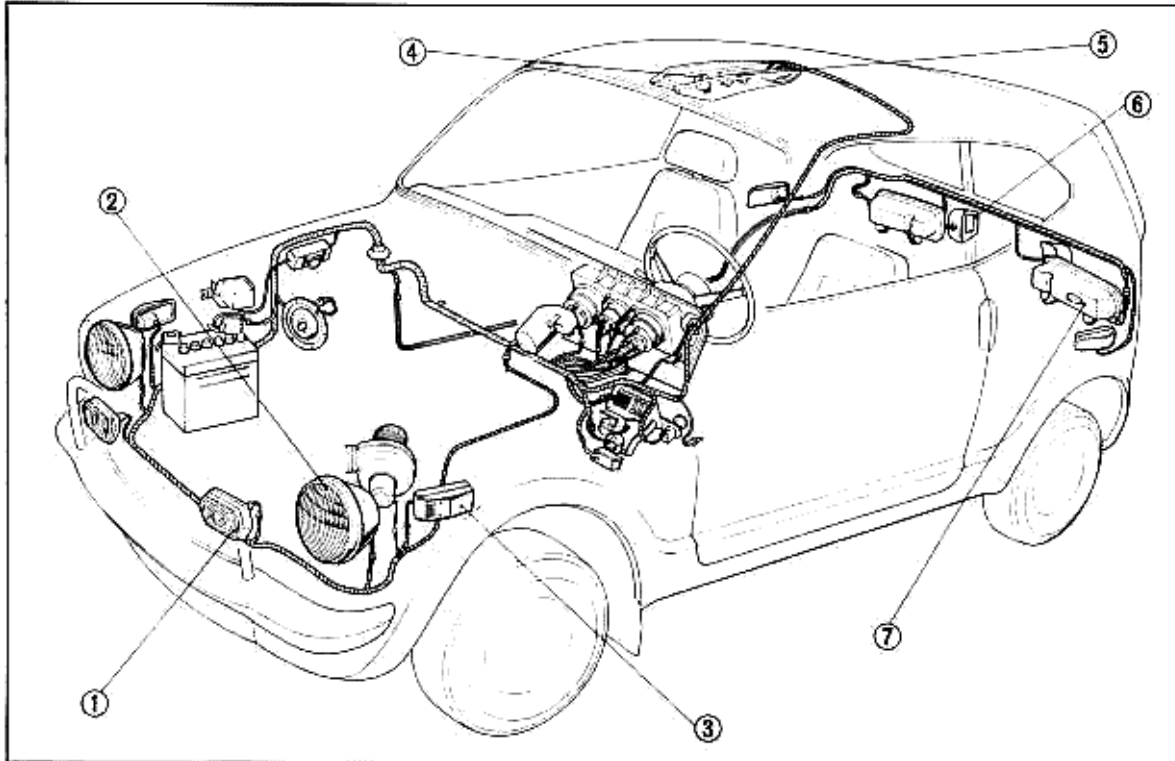

Fig. 2-66 ① Front Combination Light ④ Spot Light ⑦ Rear Combination
 ② Head Light ⑤ Room Lamp
 ③ Front Side Marker Light ⑥ License Light

1. Loose and damaged connectors

Check the condition of the wire harness couplers and connectors. Also check the wire harness for damage and make repairs or replacement as required.

E. Cigar Lighter (Optional)

1. Operate the lighter to insure that it returns to the normal position.
2. Check the heater element of the cigar lighter for fouling, and clean if necessary.
3. Check if any overheating and/or shorting occurs due to improper return.

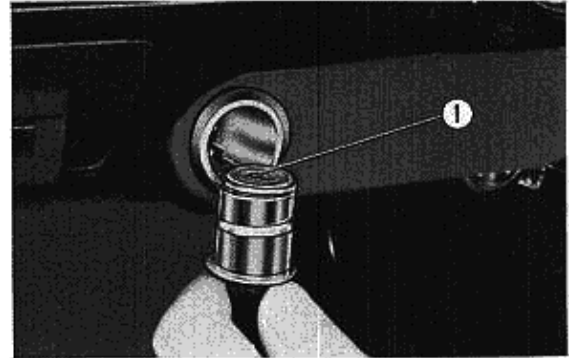

Fig. 2-67 (1) Heater Element

2-7. Engine

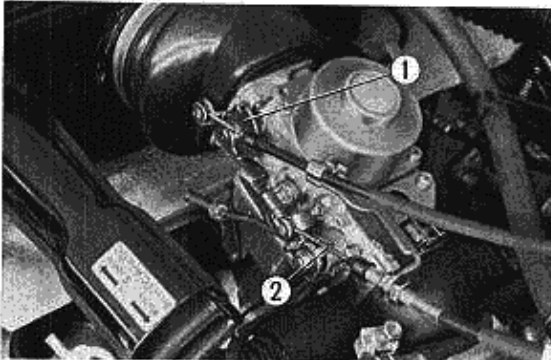

Fig. 2-68 ① Choke Cam ② Throttle Wire

A. Maintenance

1. Starting

Check the operation of the choke and throttle valves by operating the choke cam and throttle lever. Start the engine and note any difficulties in starting and/or any abnormal noise. If hard starting is encountered, refer to Section 2 in the HONDA 360/400/600 SEDAN Shop Manual. If abnormal noise is heard, check to see:

1. If the valve-tappet clearance is excessive.
2. If the cam chain is elongated.
3. If the carburetor intake manifold is leaking.

2. Low speed operation and acceleration

After the engine is warmed up, place the gear shift lever in the neutral position and check the engine idle. Then check it as it is gradually revved up from the idling speed. The accelerator pedal should move smoothly and the engine should neither stall or knock.

3. Exhaust gas condition

If abnormal performance or gas mileage is noticed, an inspection of the exhaust gases may indicate the problem area. Warm the engine, place the transmission in neutral, and note the exhaust color:

1. The exhaust gases will be colorless or light blue when combustion is complete.
2. If the exhaust is black in color throughout the rpm range, it is an indication of incomplete combustion.
3. If the exhaust gases are black when the engine is running at high speed, an improperly adjusted pilot screw and/or excessive fuel level in the float chamber is the probable cause.
4. If the exhaust gases are black at medium and high speeds, improper positioning of the needle jet, a worn main jet, and/or excessive fuel level in the float chamber may be the cause.
5. If the exhaust is a thick smoky blue, excessive oil in the crankcase, oil pumping, or oil leak-down is the probable cause. Check the oil level.
6. If the exhaust is a thick smoky blue, and the oil level is correct, worn cylinders, piston rings, or valve guides may be the cause. Check the compression.

4. Air cleaner element

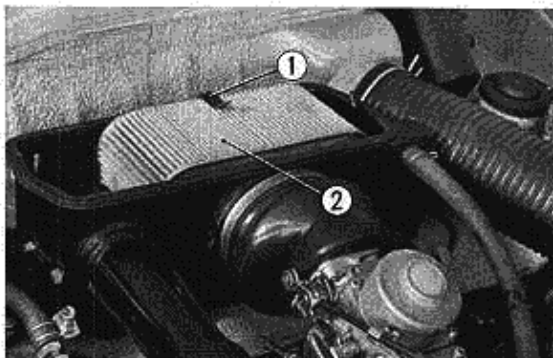

Fig. 2-69 ① Element Spring ② Element

The air cleaner is a paper element type. Clogging in the element will decrease the air flow and cause poor engine performance resulting in increased fuel consumption.

1. Lightly tap the air cleaner element on a wooden surface to knock the dirt off, then direct a blast of compressed air at the element from the inside. Replace if necessary.
2. Clean the air cleaner case and check the case cover seal and washers for deterioration.
3. Drain the oil from the breather chamber by

- removing the rubber drain plug.
- Replace dirty or damage parts.
 - Tightening of exhaust manifold and cylinder head**
 - Check the exhaust manifold for loose nuts and exhaust gas leakage. Retighten the nuts if necessary.

| | Specified torque |
|--------------------------------|-----------------------------------|
| Exhaust manifold retaining nut | 2.0-2.4 kg-m (14.5-17.4 lb-ft) |

- Check the intake manifold retaining bolts for tightness. Retighten the bolts if loose.

6. Compression Test

- Remove the right and left spark plug.
- Press the compression gauge into the spark plug hole so that gas cannot escape.
- Open the throttle and choke valves fully. Turn the starter switch and run the engine until the compression gauge reads the maximum value.

| | |
|-----------------------|--|
| Specified compression | 11.0±0.5 kg/cm ² (156±7 psi) |
|-----------------------|--|

NOTE:

- The compression pressure test should be performed after the valve clearance is adjusted and with the engine warmed up.
- Be sure to open the throttle and choke valves fully by depressing the accelerator pedal to the floor and pushing the choke knob in.

If the compression pressure is above the specified value, carbonization is suspected in the combustion chamber or on the piston head. If the pressure is under the specified value, gas leakage from valves, piston rings or head gasket may be the cause.

7. Valve clearance

If the rocker arm to camshaft clearance is excessive, the valves will open late and close too soon, causing poor performance, an increase in fuel consumption, and noisy valve operation. Further, the cam lobes will wear quickly because the rocker arm will not make proper contact with the cam lobe, resulting in a shock contact. If the clearance is too small, the valves will open too soon and close too late, causing poor compression, rough engine idling, backfiring, and possible damage to valves and valve seats.

Inspection

Remove the camshaft housing cover. Rotate the crankshaft until the left intake and right exhaust valve rocker arms are raised the same amount. The left exhaust and right intake rockers should now be loose.

At this position, check the valve clearance with

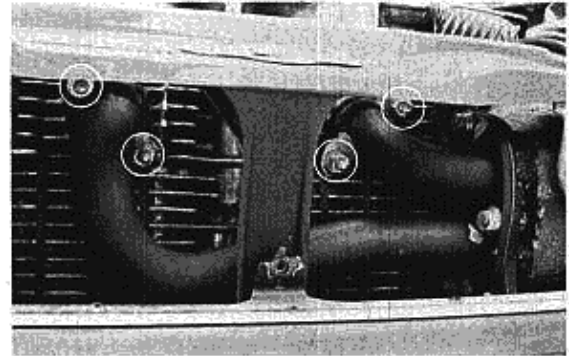

Fig. 2-70

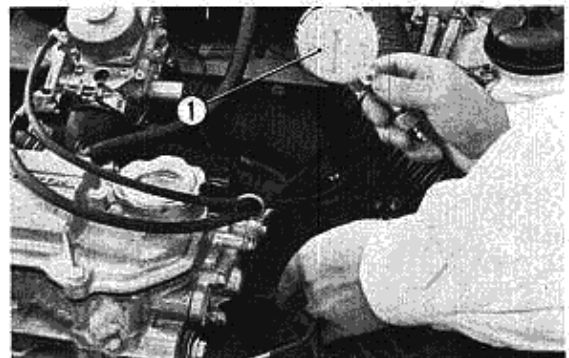

Fig. 2-71 ① Compression Gauge

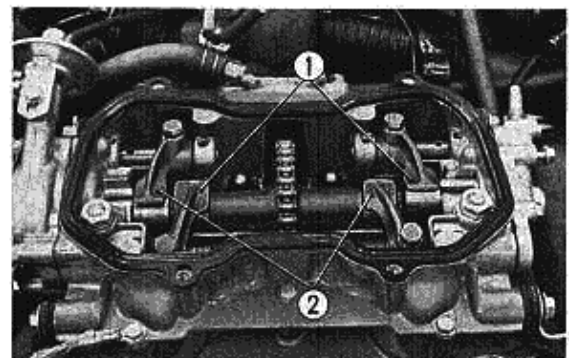

Fig. 2-72 ① Both Right and Left Valve Lifted
② Measure Clearance

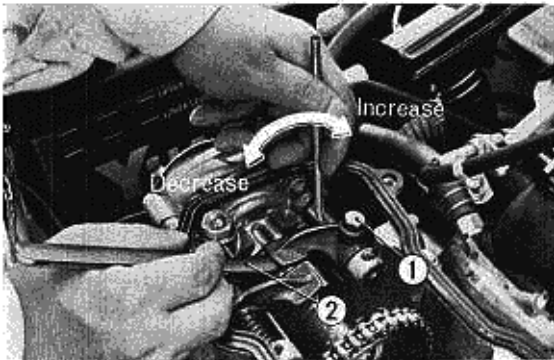

Fig. 2-73 ① Lock Bolt
② Thickness Gauge

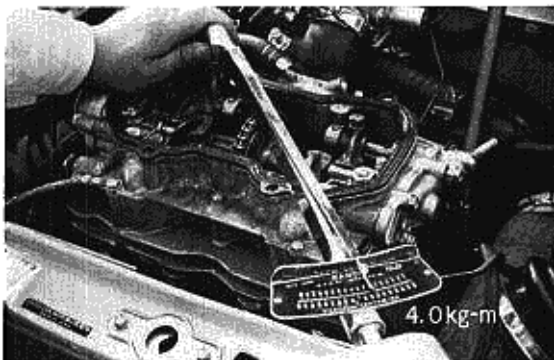

Fig. 2-74

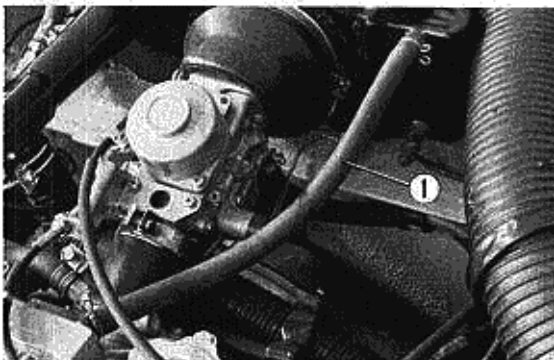

Fig. 2-75 Breather Tube

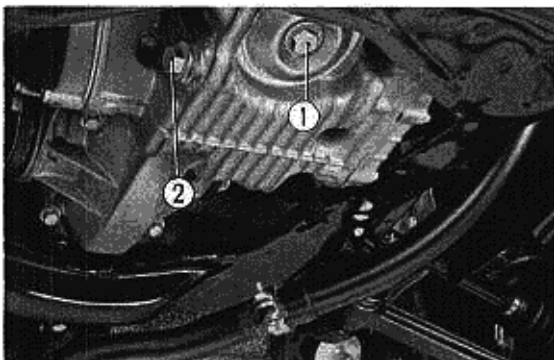

Fig. 2-76 ① Oil Filter Center Bolt
② Drain Plug

a thickness gauge as shown.

Now rotate the crankshaft until the right intake and left exhaust valve rocker arms are raised, and measure the clearance of the left intake and right exhaust valve rocker arms.

NOTE: The valve clearance adjustment must be performed only when the engine is cold, since the clearance will increase as engine temperature rises due to the difference in expansion of the aluminum cylinder head and the valves.

If adjustment is necessary, perform the following:

1. Loosen the rocker arm lock bolt. Turn the rocker arm shaft inward to decrease the valve clearance, or outward to increase it.
2. Tighten the lock bolt with a torque wrench to 3.5–4.0 kg-m (25.3–28.6 lb-ft) after completing adjustment.
3. Recheck valve clearances.

B. Positive Crankcase Ventilation

1. Remove the breather tube at both ends and check for any clogging or damage.
2. Remove the rubber drain plug from the air cleaner and drain any accumulation of oil.

C. Lubrication System

1. Checking the oil

(1) Leakage

Check the crankcase, cylinder head, cam case and side cover gaskets for leaks.

(2) Contamination

The most important item relating to satisfactory engine reliability is the condition of the oil. To ensure reliability the oil must be replaced every 3 months or 3,000 miles to keep the level of contaminants and viscosity deterioration within acceptable limits. If the oil is not properly maintained, the lubricating ability and cleaning capacity is seriously reduced, resulting in rapid wear of engine parts.

2. Changing oil

1. Drain the engine oil by removing the drain plug while the engine is warm. Removal of the filler cap will make oil draining easier.
2. Refill with fresh oil through the camshaft housing cover filler cap.

| | |
|-----------------------|--|
| Standard transmission | Capacity (including filter) 3.0 liters-3.2 quarts |
|-----------------------|--|

3. Replace the oil filter element according to the maintenance schedule. The element may be removed by removing the center bolt. At this time, clean the oil filter housing with solvent, and replace all oil seals (supplied with filter) in the order of removal. After mounting, check for oil leakage while running the engine. Recheck the oil level.

NOTE: Periodic replacement is necessary to prevent clogging of the filter element. Replace the oil filter element at 600 miles, 6,000 miles, and thereafter at 6,000 mile intervals.

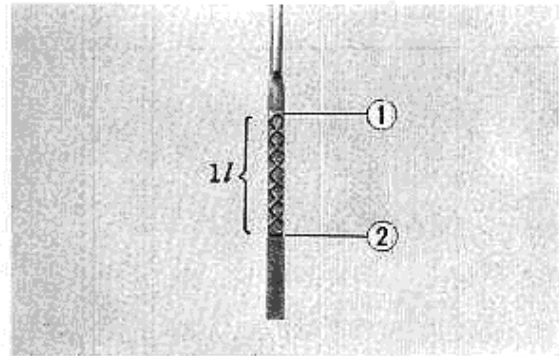

Fig. 2-77 ① Upper Level
② Lower Level

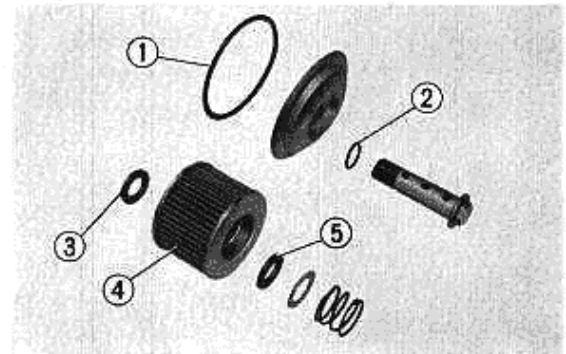

Fig. 2-78 ① 84 x 3.9 O Ring ④ Filter Element
② 17.4 x 2.4 O Ring ⑥ Element Seal
③ Element Seal B

D. Fuel System

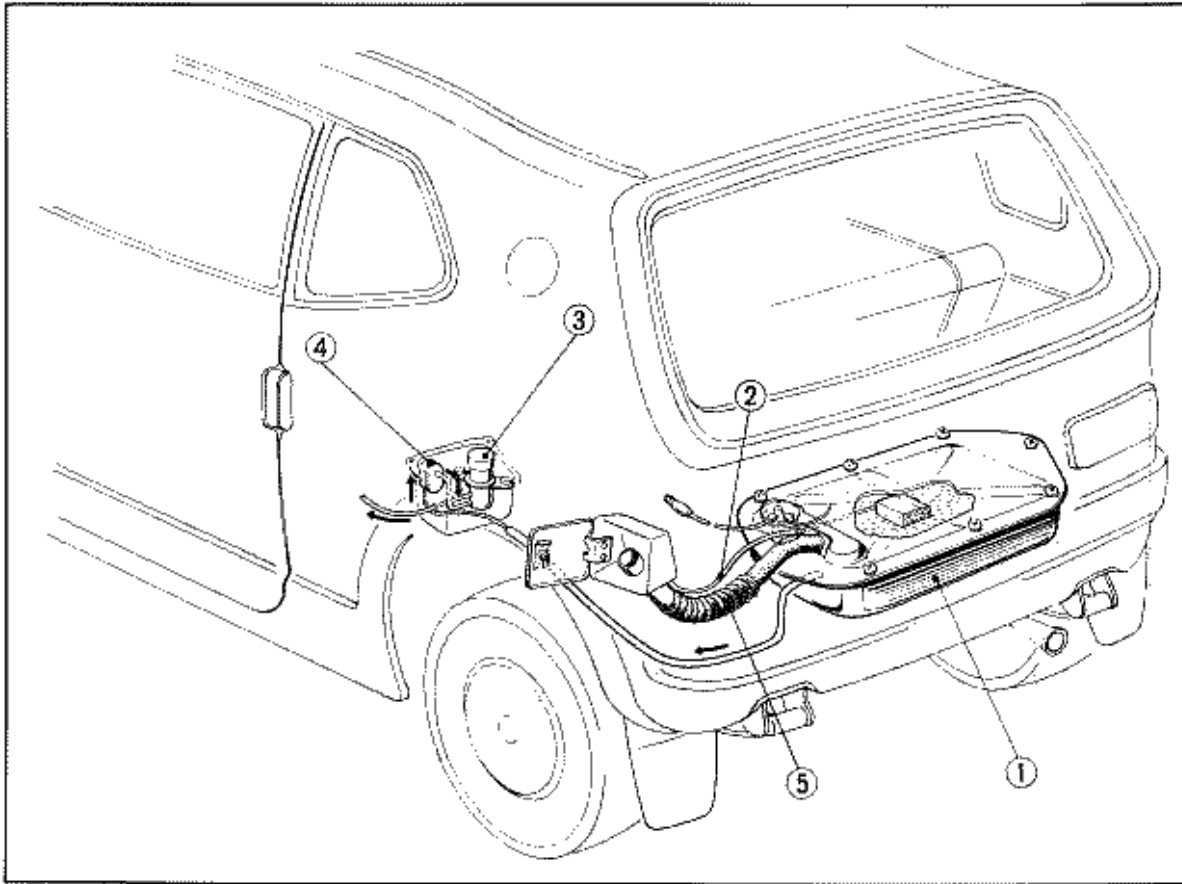

Fig. 2-79 ① Fuel Tank ③ Fuel Pump ⑤ Filler Neck Connecting Tube
 ② Breather Tube ④ Fuel Strainer

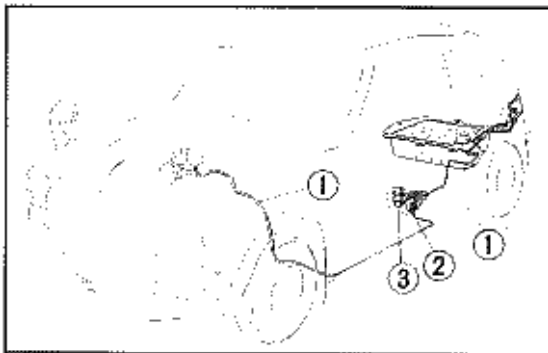

Fig. 2-80 ① Fuel Tube
 ② Fuel Strainer
 ③ Fuel Pump

1. Fuel leakage

Periodically inspect all connections, joints, and fuel lines for leaks or damage. Check the fuel filler cap for leaks by noting any gas spillage when the car is driven with a full tank of gas.

2. Checking the carburetor

Check the carburetor for leaks or damage. Disassemble and clean if contaminated.

NOTE: If a carburetor cleaner is used, the manufacturer's directions must be followed. Improper use of such cleaner may damage the parts involved.

3. Carburetor linkage inspection

1. Check the throttle valve, choke valve and fast idle system for damage.
2. Check the throttle cable for wear and other damage.

4. Checking the throttle and choke valves

1. Check to see if the throttle valve is fully opened when the accelerator pedal is completely depressed.
2. Check to see if the relief valve will fully open (by hand) with the choke valve butterfly closed.
3. Check the shafts of the throttle valve and choke valve for damage.

5. Checking float level

Poor fuel combustion, black sooty exhaust, and fuel overflow are indications of improper float level.

To check the level, remove the carburetor from the engine and proceed as follows:

1. Set up the carburetor as shown.
2. Move the float up and down by hand so that the end of the valve comes into slight contact with the float arm, or there is an approximately 0.1 mm clearance between them.
3. Measure the height of "h" as shown Fig. 7-16 with a float level gauge.
4. Correct the level, if necessary, by bending the float arm.

NOTE:

1. Be careful not to push in the float valve spring when checking the float valve and arm.
2. When measuring the height "h", place the float level gauge so that it is next to the mark on the edge of the float bowl casting.

"h"..... 20.5 mm \pm 0.5 (0.82 \pm 0.002 in.)

6. Carburetor adjustment

1. Idling adjustment

Warm the engine and adjust the throttle stop screw to maintain an engine idle of 1150 rpm. Next, adjust the idle mixture by adjusting the pilot screw. Turning the pilot screw in will decrease the amount of fuel in the mixture, and turning it out will increase it. To correctly adjust the idle mixture, a CO meter should be used. The adjustment is correct when the CO concentration is less than 4.5%. After adjusting the pilot screw, re-adjust the throttle stop screw to maintain an idle of 1150 rpm.

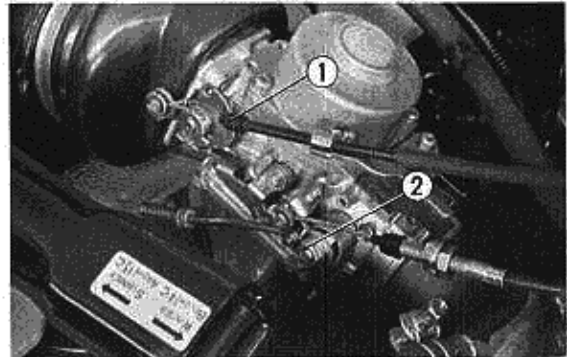

Fig. 2-81 ① Boots
② Throttle Valve Shaft

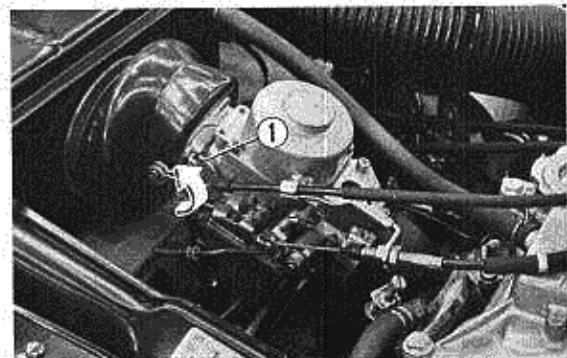

Fig. 2-82 ① Relief Valve Lever

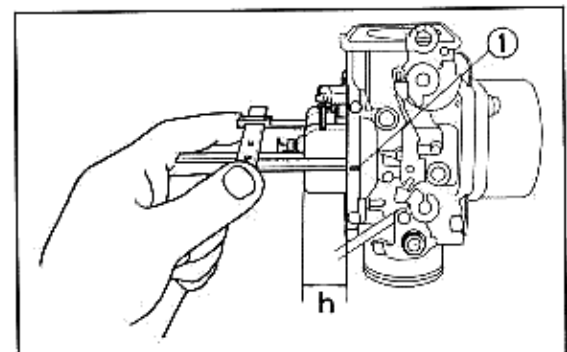

Fig. 2-83 ① Gauge Match Mark

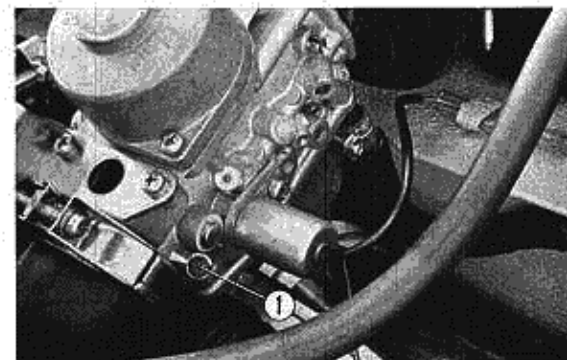

Fig. 2-84 ① Pilot Screw

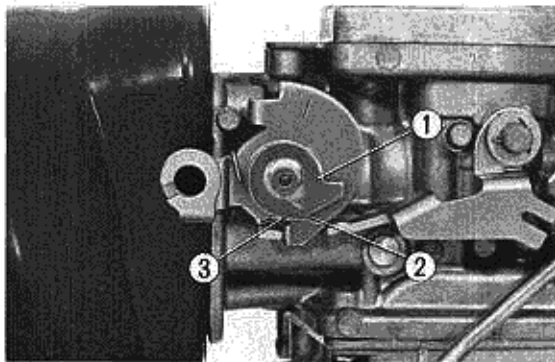

Fig. 2-85 ① Arctic Area
② Standard
③ Relief Spring

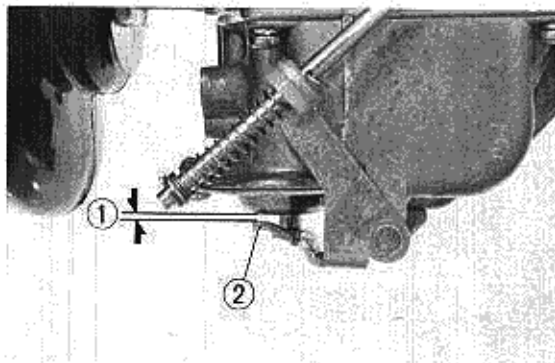

Fig. 2-86 ① Stroke
② Rocker Arm

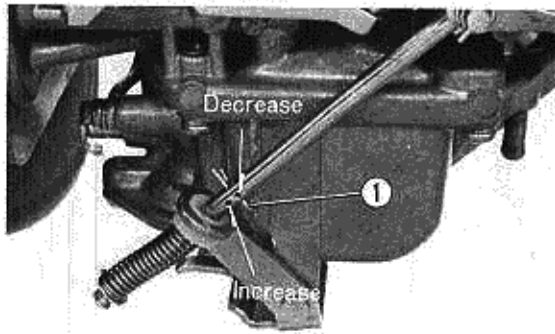

Fig. 2-87 ① Adjusting Clip

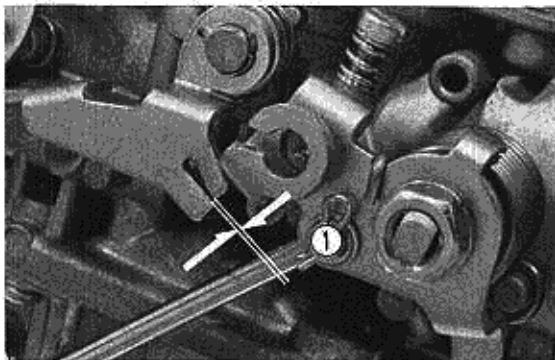

Fig. 2-88 ① The Point to be Adjusted

2. Chock relief valve

When the engine is hard to start or driving is impossible with the choke closed, reposition the relief spring to increase the spring tension.

NOTE: The spring must be securely hooked.

3. Accelerator pump discharge rate

- 1) Turn the idle stop screw out until the screw no longer contacts the throttle stop plate, to completely close the throttle butterfly.
- 2) Measure the clearance between the rocker arm and pump cover with a thickness gauge. This clearance corresponds to the pump stroke.
- 3) Relocate the clip along the pump rod to adjust the pump stroke to 0.25–0.45 mm (0.010–0.018 in.)

| Clip position | Pump stroke |
|---------------|-------------|
| Lower | Increase |
| Upper | Decrease |

- 4) When the specified stroke cannot be obtained by repositioning the clip, readjust the stroke by bending the end of the rocker arm.

4. Fast idling

If the engine fails to run properly, or if the engine over-revs with the choke knob pulled out in cold weather, the idle system should be adjusted. To adjust, proceed as follows:

- 1) Open the choke valve completely.
- 2) Close the throttle valve fully by backing off the throttle stop screw.
- 3) After the engine has reached normal operating temperature, pull the choke knob out. The engine should be idle at 4,000 rpm.
- 4) To adjust the fast idle speed, bend the tip of the throttle link plate with a screw driver to obtain the necessary amount of clearance between the lever and the fast idle cam.

7. Fuel Filter Replacement

A cartridge type fuel filter is used and it can not be disassembled for cleaning. Disconnect the fuel feed tubes and remove the filter together with the fuel pump. Replace the filter if necessary.

NOTE: When installing the filter, be sure that the inlet and outlet tubes are correctly connected.

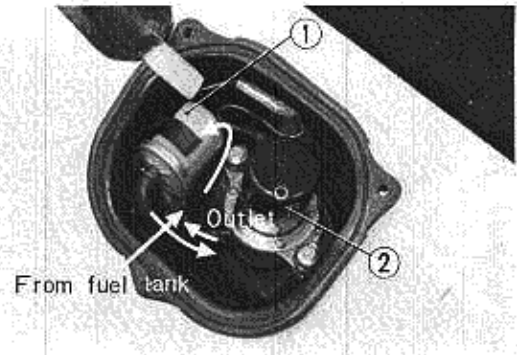

Fig. 2-89 ① Fuel Strainer
② Fuel Pump

8. Fuel Pump Operation

To check the fuel pump, disconnect the fuel tube from the carburetor, turn the ignition switch to the "ON" position, and allow the fuel to flow into a container. When the fuel pump is functioning properly the delivery rate will be 250cc (0.25 qts.) or more per minute. When installing the fuel pump, ground the fuel pump properly and connect the fuel tubes securely.

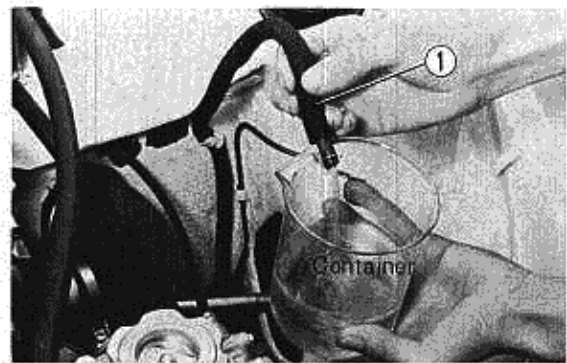

Fig. 2-90 ① Fuel Tube

9. Inspection of the fuel tube

Check the fuel tube for any damage or crack. Pay particular attention to the tube at the carburetor inlet.

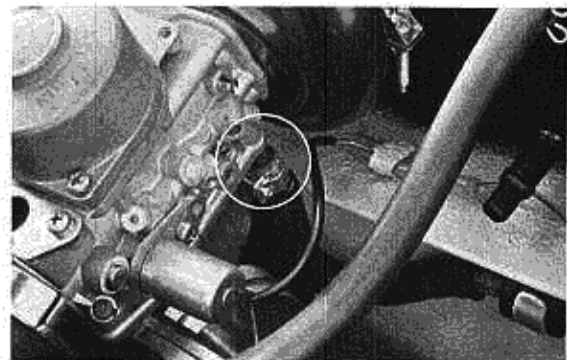

Fig. 2-91

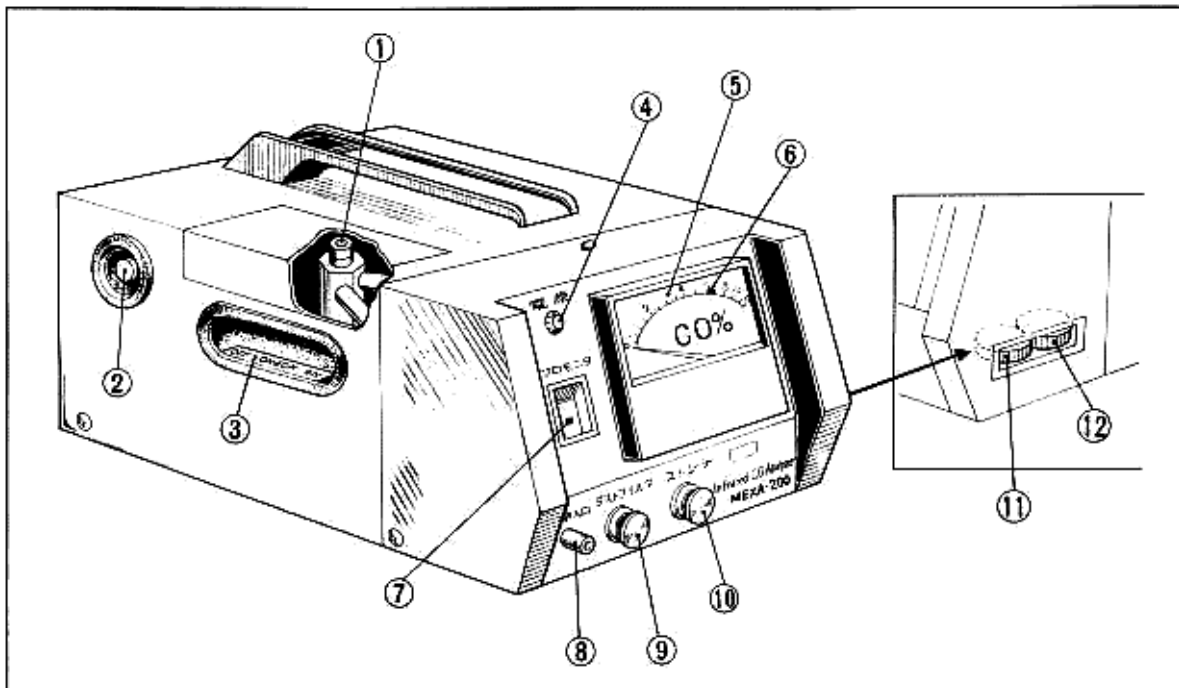

Fig. 2-92 ① Span Gas Inlet (Reference Gas) ⑤ Indicator
 ② Check Knob ⑥ Green belt
 ③ Measurement Switch ⑦ Flow Mounting
 ④ Pilot Lamp

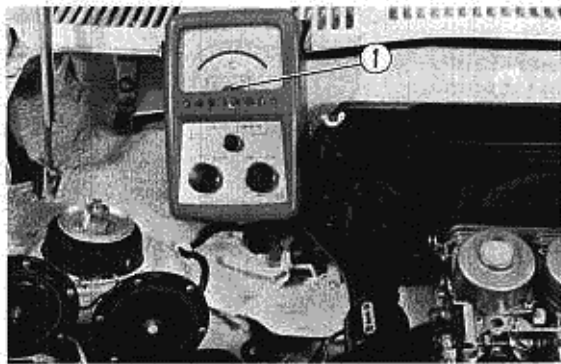

Fig. 2-93 ① Thermometer
 the mechanical and vacuum advance units.

- 3) Spark plug electrodes.
- 4) Carburetor.
- 5) Valve clearances.
- 6) Breather tube and drain tube.
- 7) Air intake heating control change-over valve (set according to season).

2. Adjustment of the idle mixture screw

To measure and control CO in exhaust gases when the engine is running at idling speed, proceed as follows:

- 1) Insert a thermometer into the oil level gauge (dipstick) hole, and seal the end. Start the engine and warm it up until the oil temperature reaches the range between 60° and 80°C (140°-170°F). Make certain that the thermometer is inserted the same length as the dipstick.

2. How to measure and control CO

1. Preliminary steps

Before measuring the CO concentration in the exhaust, functionally check the following items:

- 1) Air cleaner element.
- 2) Ignition timing (including operation of

| Oil temperature (°C) | Specified RPM | CO concentration (%) |
|----------------------|---------------|----------------------|
| 60-80°C (140-177°F) | 1150±50 | 2.0-4.5 |

- 2) After the engine is warmed, connect a tachometer and adjust the idle speed.
 - a) Adjust the throttle stop screw to run the engine at the specified rpm, and adjust the pilot screw to obtain maximum rpm. Then readjust the throttle stop screw to obtain the specified rpm.
 - b) Repeat the above procedures and check with a tachometer to insure that the optimum setting is reached.

3. Measurement and adjustment of CO

1. When the oil temperature rises to within range (60–80°C: 140–170°F), close the hood and run the engine at idling speed for several minutes.
2. Plug the muffler condensation drain hole.
3. Depress the accelerator pedal to rev the engine to 2,000 rpm for about five seconds and then slow the engine down to idling speed just before inserting the sampling probe of the CO meter into the tail pipe.
4. Insert the sampling probe into the tail pipe at least 40 cm (16 in).
5. Read the CO meter when the meter pointer steadies. The correct CO value is 2–4.5%. If the value is higher than 4.5%, proceed as follows :

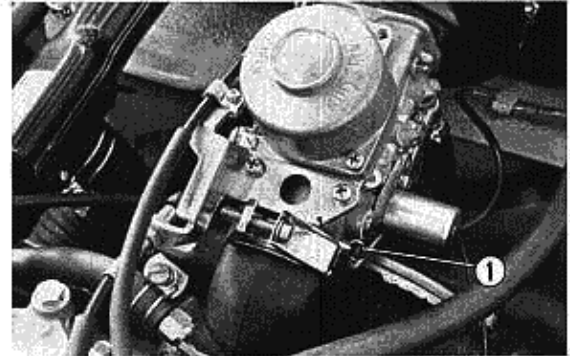

Fig. 2-94 ① Pilot Screw

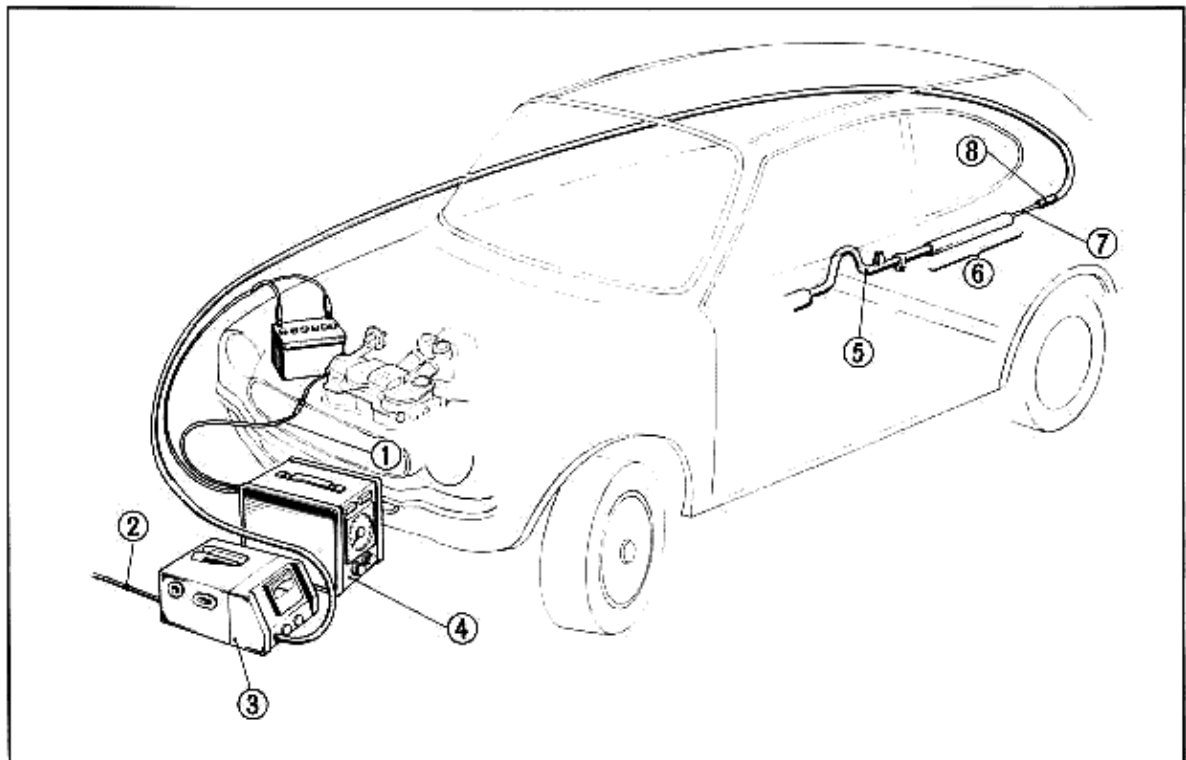

Fig. 2-95 ① Primary Lead Wire
 ② Power Supply
 ③ Co Meter
 ④ Tachometer
 ⑤ Tail Pipe
 ⑥ Pipe Attachment (600 mm long)
 ⑦ Collector Tube
 ⑧ Filter

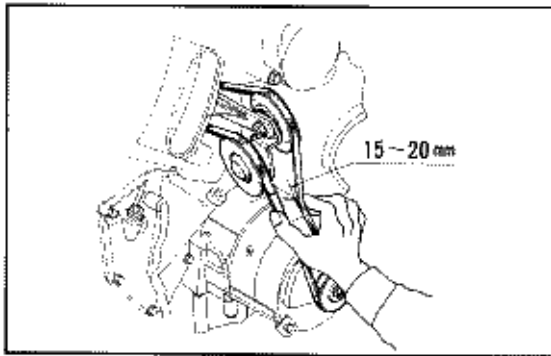

Fig. 2-96

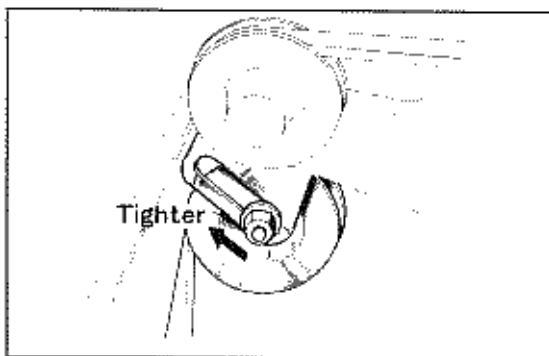

Fig. 2-97

Turn the pilot screw in $1/16$ turn and adjust the engine speed to the specified rpm with the throttle stop screw. Then read the meter. Repeat the procedure until the value indicates less than 4.5%. If the measured value is not within the range of 4.5% or less, or if the car accelerates poorly even though CO concentration is within the allowable range, check the inspection and adjustment items and measuring conditions prescribed above, and take the measurement again.

F. Cooling System

1. Check the fan belt tension by pressing both sides of the belt together as shown. The proper distance between the inner faces of the belts is 15–20 mm (0.59–0.78 in).
2. Adjustment of the tension is made by loosening the tension pulley nut and moving the pulley along the bracket in either direction.

2-8. Miscellaneous

A. Lighting Equipment

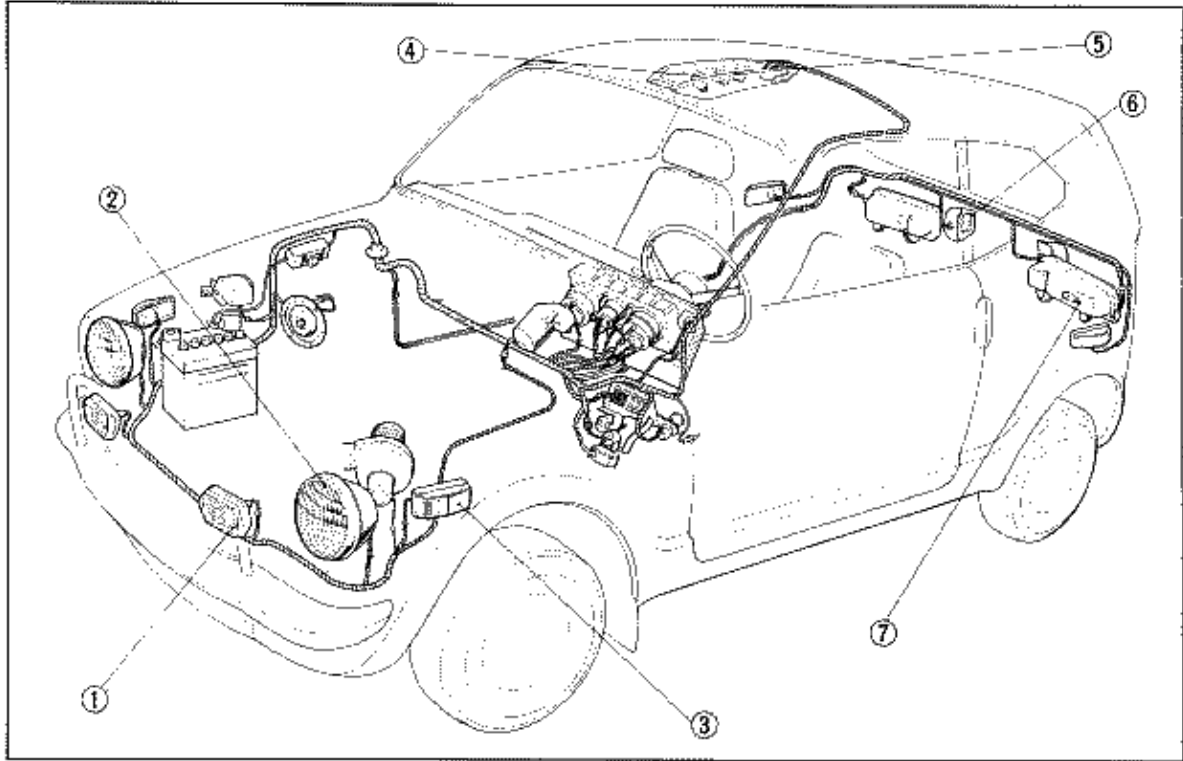

Fig. 2-98 ① Front Combination Light
 ② Head Light
 ③ Front Side Marker Light
 ④ Spot Light
 ⑤ Room Lamp
 ⑥ License Light
 ⑦ Rear Combination Light

1. Function

1. Turn on the headlights (high and low beams), parking lights, backup lights, side marker lights, interior lights (room light), instrument lights, hazard warning lights, turn signals, and brake lights, to insure that they are functioning properly. Replace any defective bulbs.

NOTE: If the flashing frequency of the turn signal lamps is less than 50 times per minute, the turn signal relay should be replaced.

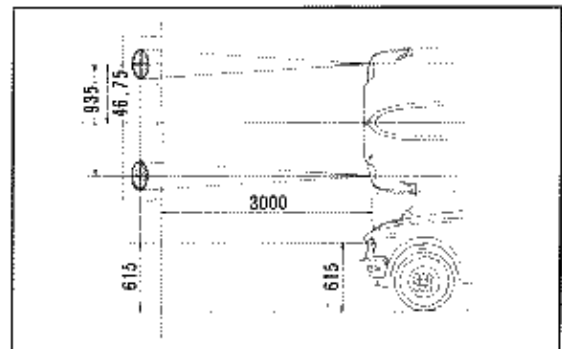

Fig. 2-99

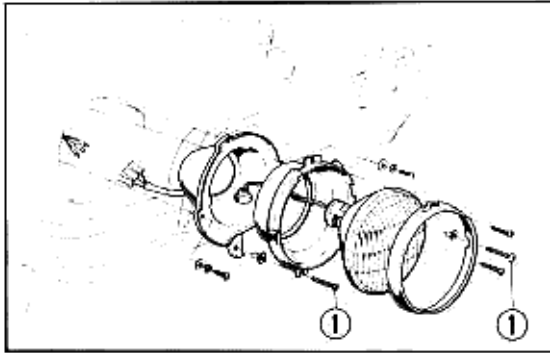

Fig. 2-100 ① Focus Adjusting Screw

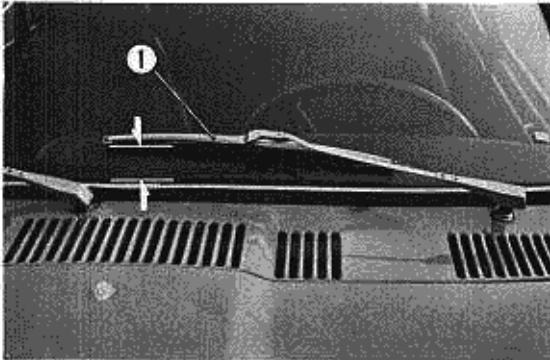

Fig. 2-101 ① Windshield Wiper

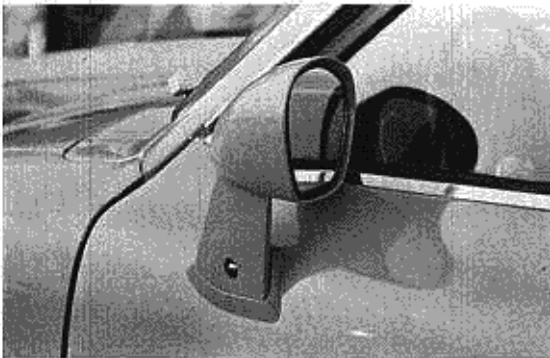

Fig. 2-102

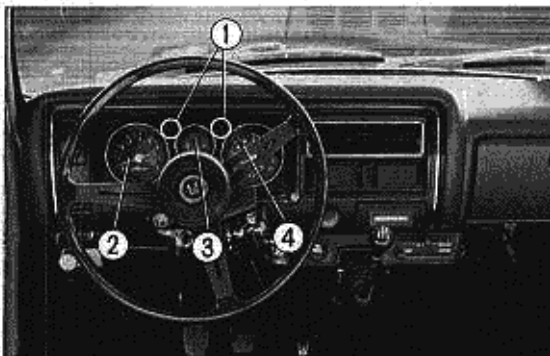

Fig. 2-103 ① Turn Signal Indicator Lamp
 ② Tachometer
 ③ Fuel meter
 ④ Speedometer

2. Headlight maintenance and adjustment

1. If replacement of a sealed beam is necessary, the lamp may be replaced by removing the two retaining ring screws, the retainer, and the connector terminal from the lamp.
2. Headlight adjustment can be accomplished by means of two screws located behind the headlight retainer (on the mounting ring.) For correct alignment procedure, refer to the HONDA 360/400/600 Sedan Shop Manual, section 17, page 35-1. For specifications, refer to state and local regulations.

B. Windshield Wiper Operation

The rest position of the windshield wiper arm should be 10-20 mm (0.39-0.78 in) above the upper edge of the weather strip when it stops. If the arm stops at any other position, adjust it by changing the position of the arm on the shaft.

NOTE: Do not operate the windshield wiper without wetting the windshield, otherwise the glass and wiper blades may be damaged and the motor may overheat.

C. Rear View Mirrors

1. Check interior and outside rear view mirrors for loose mounting and/or vibration.
2. Check the mirror surfaces for any oil and rust, and clean if necessary.

D. Operation of Instruments

1. Turn the ignition switch to the "ON" position and check if the charge lamp and the parking brake warning lamp (with the parking brake engaged) come on. If one or both lamps do not operate, check for blown fuses, burned out bulbs, or improper wiring.
2. Start the engine. The charge lamp (discharge warning lamp) should go off when the engine is at idle. If the lamp remains on, the charging system should be checked. Refer to section 6-7 in this manual.
3. Check the operation of the speedometer:
Allowable error of speedometer

| | | | |
|-----------------------|---------|--------------|------|
| When the car speed is | 35 km/h | +15% | -10% |
| | | (32-40 km/h) | |
| | 22 mph | +15% | -10% |
| | | (25-20 mph) | |

E. Exhaust Pipes and Exhaust Silencers

Fig. 2-104 ① Exhaust Pipe ② Silencer

1. Exhaust system inspection

1. Check the exhaust pipes for loose mountings, clamps, cracks or other damage.
2. Check the exhaust silencer A for damage.
3. Check the exhaust silencer B and mounting rubber for damage.

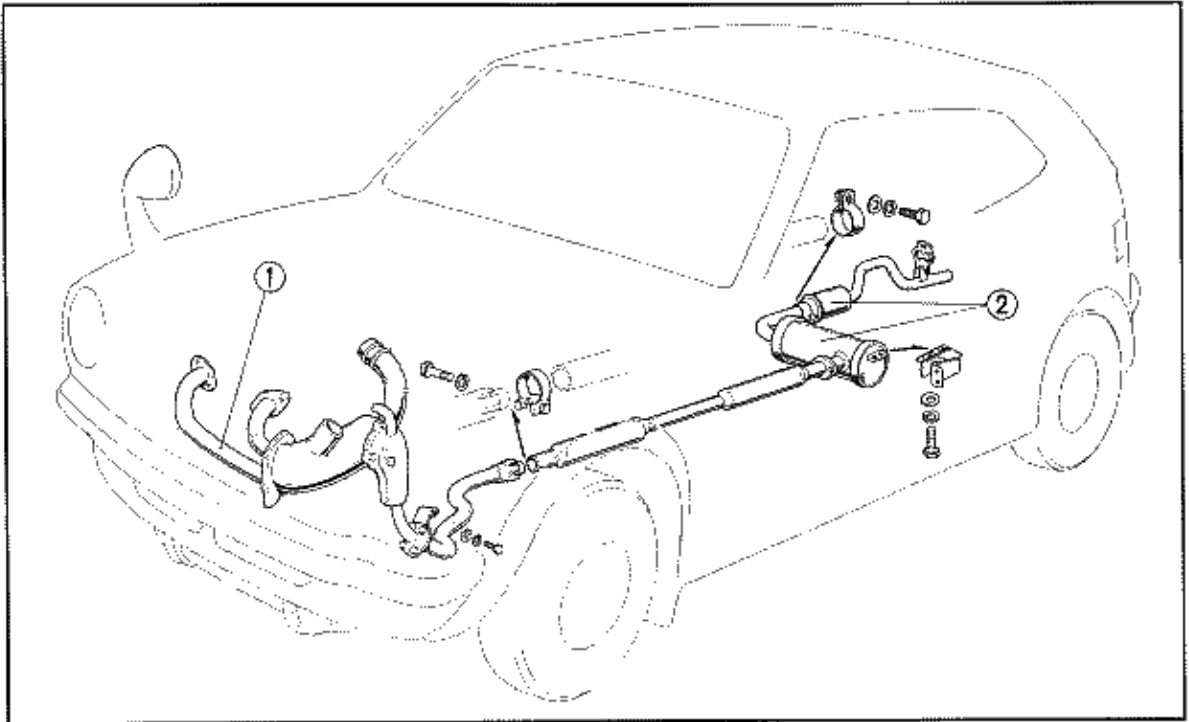
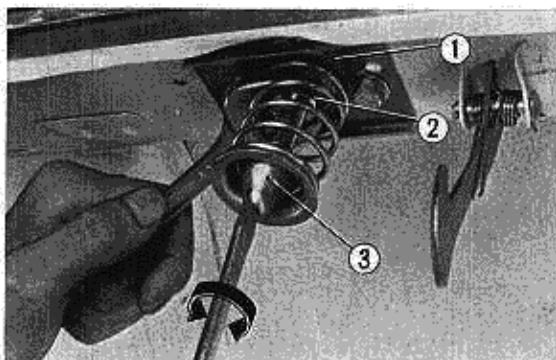

Fig. 2-105 ① Striker Bracket
② Lock Nut
③ Striker

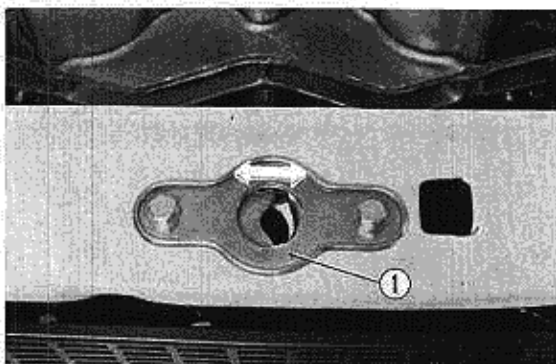

Fig. 2-106 ① Bonnet Striker-Guide Plate

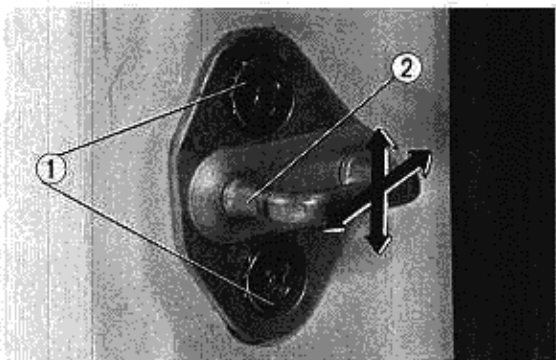

Fig. 2-107 ① Bolt
② Door Lock Striker

F. Hood and Hood Latch

1. Inspection

Check the hood, hood latch, and safety latch for proper alignment and operation.

2. Adjustment

1. Check the alignment of the hood, and if necessary, adjust by loosening the four hinge bolts and moving the hood left, right, up or down.
2. Lock the hood latch and check if it is properly latched. Also check for proper release. To adjust, loosen the lock nut on the hood lock dowel and turn the dowel inward to decrease free-play, and outward to increase free-play. Retighten the lock nut.
3. If difficulty is experienced when opening or closing the hood due to misalignment of the hood latch striker, there are two adjustments that can be performed:
 - 1) Loosen the bolts holding the striker bracket and adjust the bracket by moving it in the axial direction.
 - 2) Loosen the bolts holding the hood striker guide plate and adjust the guide plate by moving it in the lateral direction.
4. Check for correct operation of the hood safety latch. Repair or replace as necessary.
5. Apply grease to the striker upon completion of the adjustments.

G. Door Lock Operation

1. Inspection

Check the engagement of the door lock and the door lock striker. There should be no indication of rattling when the door is closed.

2. Adjustment

If lock engagement is not satisfactory, loosen the two striker plate screws and adjust the striker plate.

1. If the door does not close completely and firmly, slide the striker plate inward to increase the door closing stroke.
2. If the door is hard to close, slide the striker plate outward.
3. If door alignment is normal, but there is contact at the bottom (top) of the striker, lower (raise) the striker plate slightly.
4. If the door is misaligned, and the door closing action is poor, adjust with shims and/or hinge bolts.

H. Tail Gate Operation

1. Check the clearance and alignment between the tail gate and body, and if necessary adjust the location of the tail gate hinges with the retaining bolts loosened.
2. With the tail gate door closed, lightly push against the door to insure that the lock is operating correctly. Note any door movement when locked and adjust accordingly:
 - 1) Loosen the two bolts holding the striker to adjust for misalignment in the vertical direction.
 - 2) Loosen the two bolts holding the latch assembly to adjust for misalignment in the lateral direction.



Fig. 2-108 ① Tail Gate

I. Seats

1. Seat belts

1. Check to see if the tongue plate and buckle can be securely engaged. Also, check the belt straps for damage.
2. Check the seat belt anchor bolts for looseness. Retighten if loose.

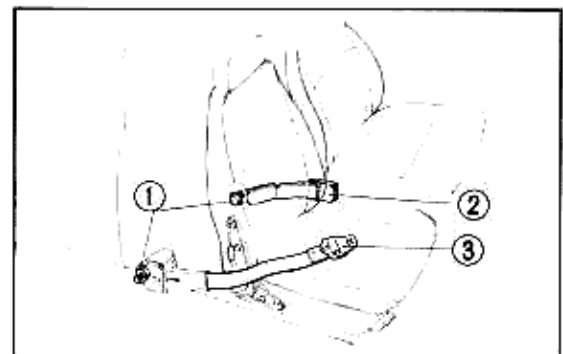

Fig. 2-109 ① Seat Belt Anchor Bolt
② Buckle
③ Tongue Plate

2. Head rest

1. Check the mounting of the head rest to see if it can be securely locked in the elevated positions.
2. Shake the head rest back and forth to see if there is any rattle.
3. The correct height for the head rest is when it comes to the ear-level of the seat occupant.

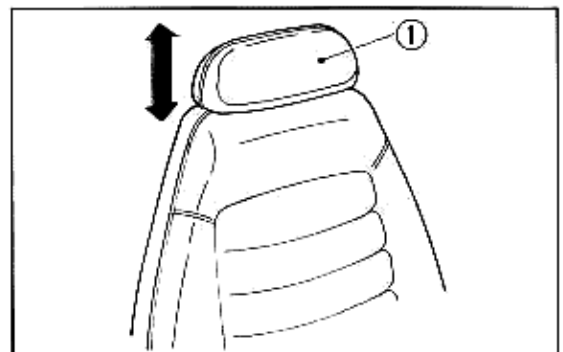

Fig. 2-110 ① Head Rest

J. Dashboard Grommets

1. Mounting condition

If the grommets are not correctly fitted, water and dust will enter the interior. Check the seating position of the grommets. Replace them if the rubber is cracked. If the fit of the grommet to the hole is loose, seal the opening with weatherstrip cement.



Fig. 2-111

K. Body, Sub-Frame and Engine Mounting Bolts

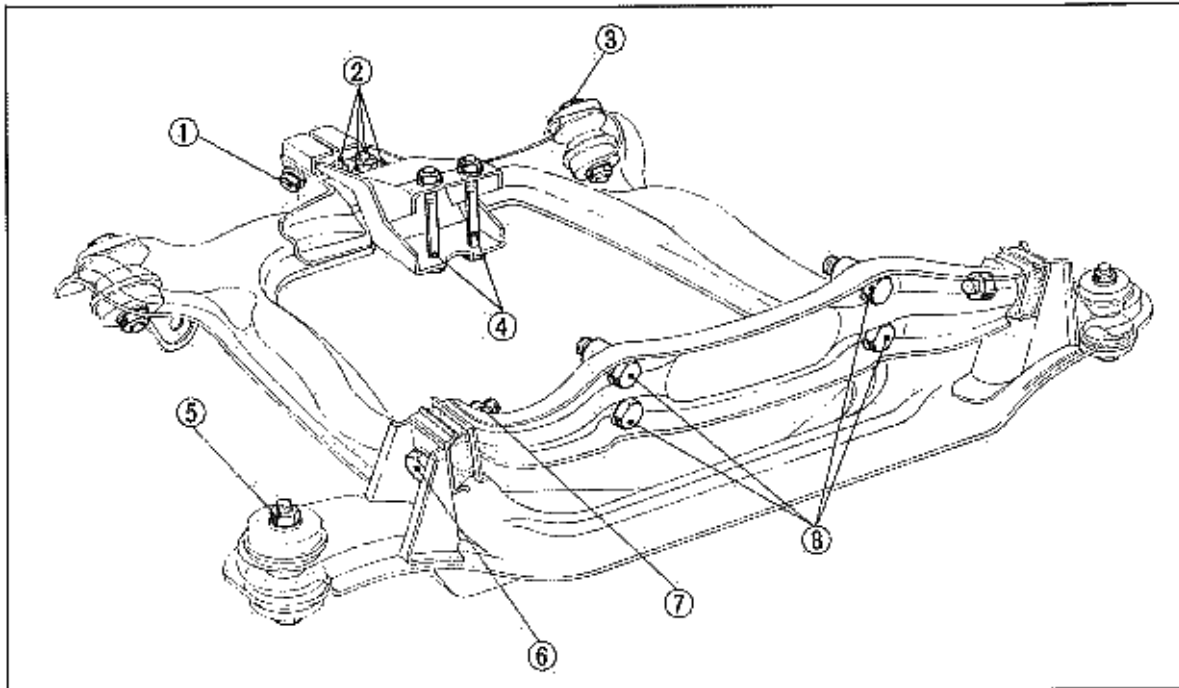

Fig. 2-112 ① Rear Engine Mount Rubber-Sub Frame 2.0-2.4 kg-m
 ② Rear Engine Mount Rubber-Bracket 0.8-1.0 kg-m
 ③ Sub Frame Rear-Body 4.0-4.8 kg-m
 ④ Bracket Crankcase 2.0-2.4 kg-m
 ⑤ Sub Frame Front Body 4.0-4.8 kg-m
 ⑥ Engine Mount Rubber-Sub Frame 2.1-2.5 kg-m
 ⑦ Front Extension-Crankcase 3.0-3.5 kg-m

Check the body, sub-frame and engine mounting bolts for looseness or damage. Retighten any loose bolts. Replace any damaged bolts.

3. ENGINE REMOVAL AND INSTALLATION

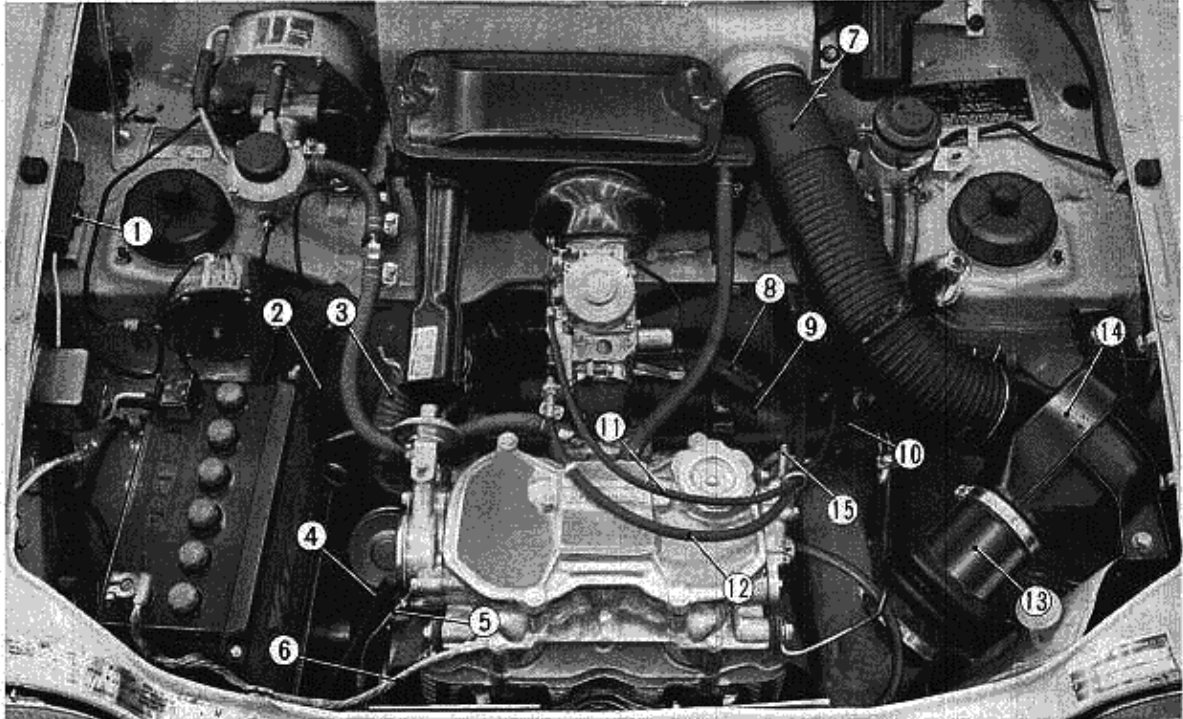

Fig. 3-1

| | | |
|---------------------------|------------------------|--------------------------|
| ① Main Fuse | ⑥ Engine Ground Strap | ⑩ Choke Control Cable |
| ② Speedometer Drive Cable | ⑦ Heater Duct B | ⑪ Throttle Control Cable |
| ③ Exhaust Air Duct | ⑧ Heater Duct | ⑬ Heater Duct A |
| ④ High Tension Cable | ⑨ Hot Air Duct | ⑭ Heater Blower Unit |
| ⑤ Ignition Primary Wire | ⑫ Clutch Control Cable | ⑮ Tachometer Drive Cable |

3-1. Removal

1. Drain the crankcase lubricating oil by removing the drain plug.
2. Disconnect the negative and positive cables from the battery and remove the battery. Disconnect the positive cable from the main fuse.
3. Disconnect the following control cables and electrical wiring from the engine:
 - Throttle and choke control cables.
 - Tachometer drive cable.
 - Engine ground strap.
 - Ignition primary wire (blue).
 - High Tension cables.
 - Back-up switch wires.
4. Disconnect the breather tube from the camshaft housing cover.
5. Disconnect the fuel line and vacuum advance tube from the carburetor assembly. Disconnect the fuel solenoid. Remove the carburetor bellows from the air cleaner and then remove the carburetor and intake manifold as an assembly from the engine.
6. Disconnect the following ducts from the engine:
 - Hot air duct
 - Heater duct

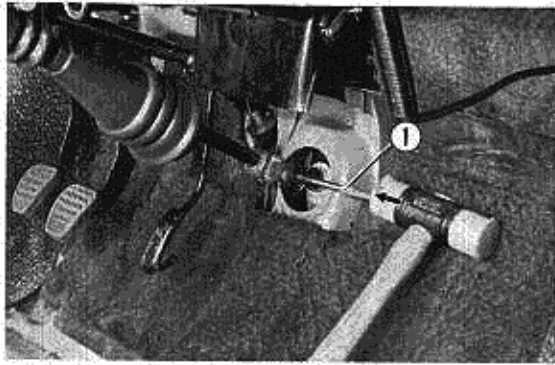

Fig. 3-2 ① Gear Shift Rod Pin Driver

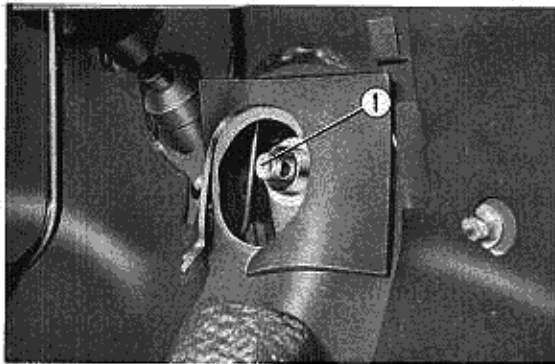

Fig. 3-3 ① Gear Shift Rod

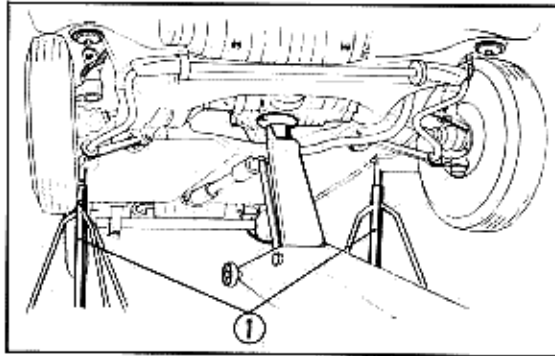
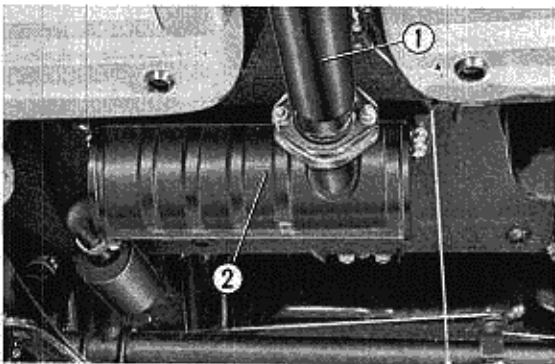

Fig. 3-4 ① Stand

Fig. 3-5 ① Exhaust Silencer A
② Exhaust Main Silencer

Heater duct A
Heater duct B
Exhaust air duct

7. Remove the heater blower from the engine compartment.
8. Separate the speedometer drive cable and clutch control cable from the engine unit. Disconnect the starter solenoid and generator wiring.
9. Using the special tool (gear shift rod joint pin driver) and a hammer, remove the pin at the joint as shown in Fig. 3-2.
10. Push the gear shift rod in to prevent it from touching the floor board when the engine is removed.

11. Place a floor jack under the crankcase, and raise the front end of car. Place jack stands under the body and then remove the floor jack.

NOTES:

1. The car body should be raised until the lowest part of the front mask skirt is at least 850 mm (34 in.) above the floor.
2. When positioning the jack stands, place wooden blocks on top of the stands to prevent damage to the car body. Also be careful no to damage the brake hoses and fuel pipes running along the left-hand side of the car.
12. Raise the jack until the jack head takes the load of the engine unit.
13. Separate the exhaust silencer A from the exhaust main silencer at the flange.
14. Remove the left and right front wheels.
15. Remove the left and right front splash-guards.

16. Disconnect the brake hoses at the front brake calipers, or remove the front calipers from the steering knuckles and attach them to the front shock absorber assemblies with a piece of wire.
17. Remove the front shock absorber assemblies from the steering knuckles (See Section 12-1).

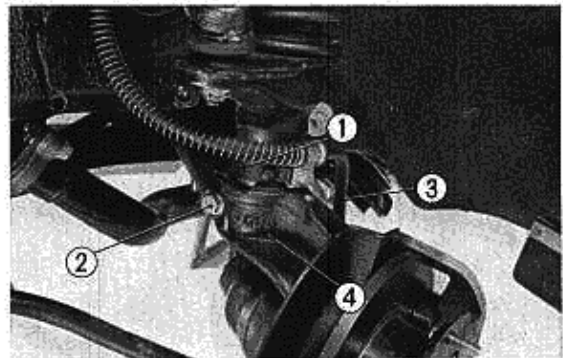

Fig. 3-6 ① Front Shock Absorber Assembly
② Front Dumper Lock Bolt
③ Brake Hose
④ Knuckle

18. Remove the subframe rear mounting bolts. Then remove the subframe front mounting bolts.
19. Carefully lower the engine as an assembly including the subframe, exhaust pipe and silencer.

NOTE: Before lowreing the engine and subframe, check again to see that all electrical wires and control cables are completely disconnected

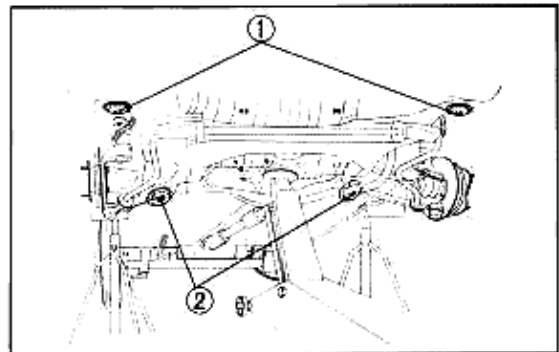

Fig. 3-7 ① Front Mounting Bolt
② Rear Mounting Nut

20. Lower the engine until it can be moved from under the body.
21. Disconnect the joint pipe A from the exhaust joint pipe and remove the joint pipe A, heat exchanger and exhaust manifold from the engine unit.
22. Remove the drive shafts from the differential.
23. Remove the four bolts securing the engine to the engine mounting bracket. Remove the rear engine mounting bolt and rear engine bracket bolts. The engine may now be removed from subframe and mounted on the engine stand (special tool).

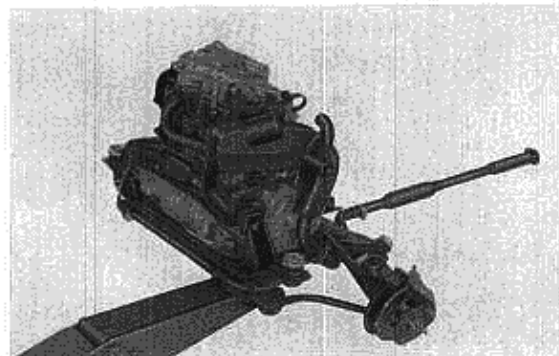

Fig. 3-8

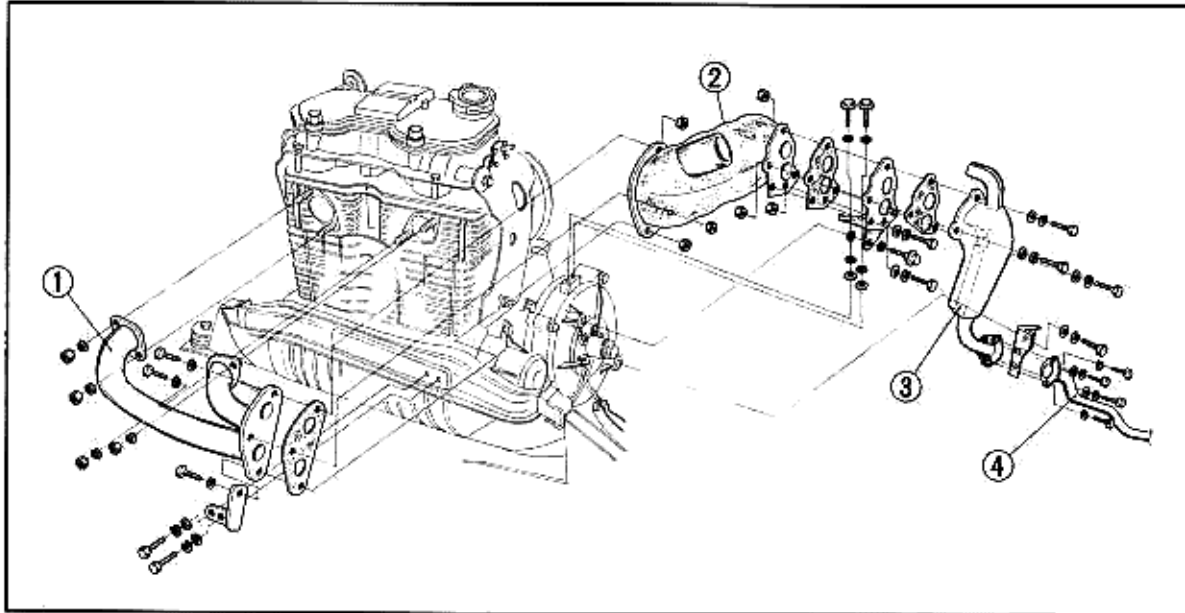

Fig. 3-9 ① Exhaust Manifold
② Heat Exchanger

③ Joint pipe A
④ Exhaust Joint pipe

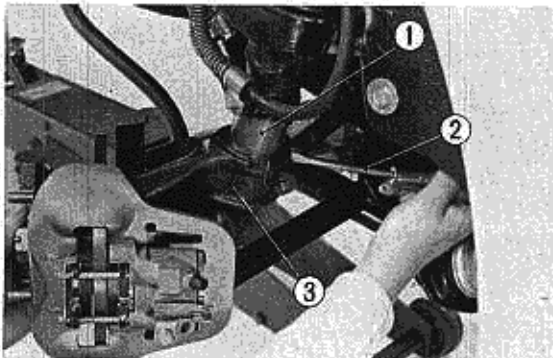

Fig. 3-10 ① Front Shock Absorber Assembly
② Screwdriver
③ Knuckle

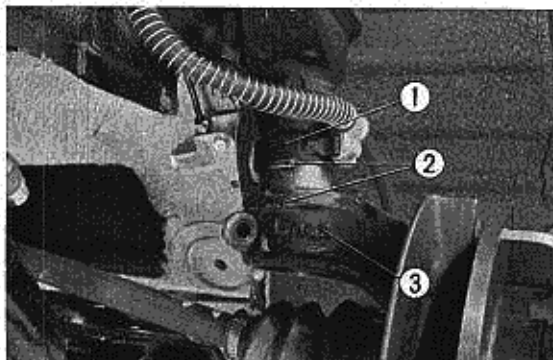

Fig. 3-11 ① Front Shock Absorber Assembly
② Aligning Groove
③ Knuckle

3-2. Installation

To install the engine, reverse the removal procedure. Pay careful attention to the following items.

- * When installing the knuckle to the front shock absorber assembly, spread the knuckle by inserting a screwdriver into the knuckle slot as shown.
- * Raise the engine and subframe assembly about half way into position and align the tabs on the front suspension main shafts with the slots in the knuckles.
- * Check to be sure that the gear shift rod is not interfering with the car body.
- * After mounting the engine unit, the following items should be checked:
 - Bleed the air from the brake system
 - Carburetor idle adjustment
 - Ignition timing
 - Clutch adjustment
 - Front suspension alignment (toe-in).

When tightening the engine mounting bolts and nuts, follow the torque specifications given on the following page.

Engine Mounting Bolt and Nut Torque Specifications

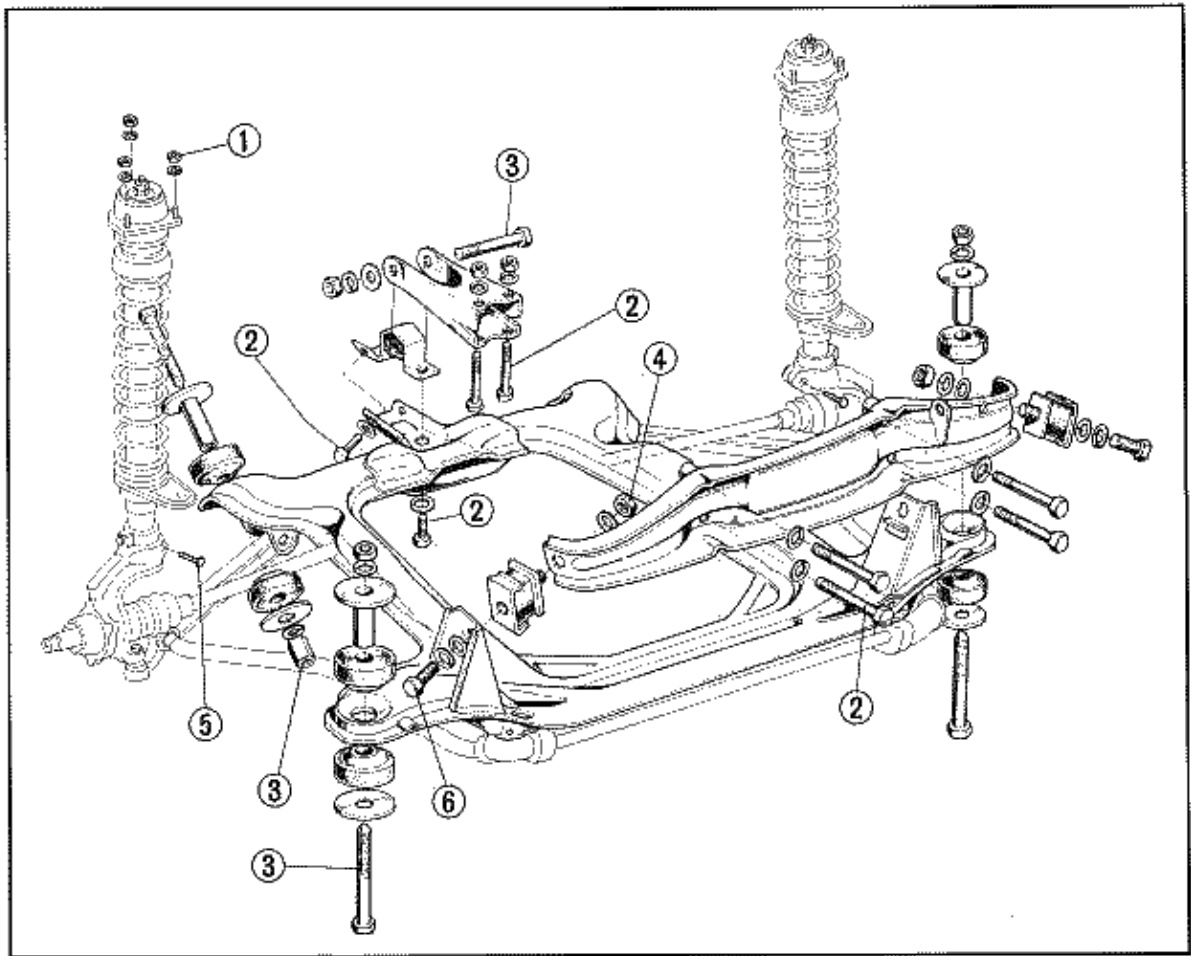

Fig. 3-12. ① 1.5~2.0 kg-m (11~14 lbs-ft) ④ 3.0~3.5 kg-m (22~25 lbs-ft)
 ② 2.0~2.4 kg-m (14~17 lbs-ft) ⑤ 4.5~5.0 kg-m (33~36 lbs-ft)
 ③ 4.0~4.8 kg-m (29~35 lbs-ft) ⑥ 2.1~2.5 kg-m (15~18 lbs-ft)

4. ENGINE

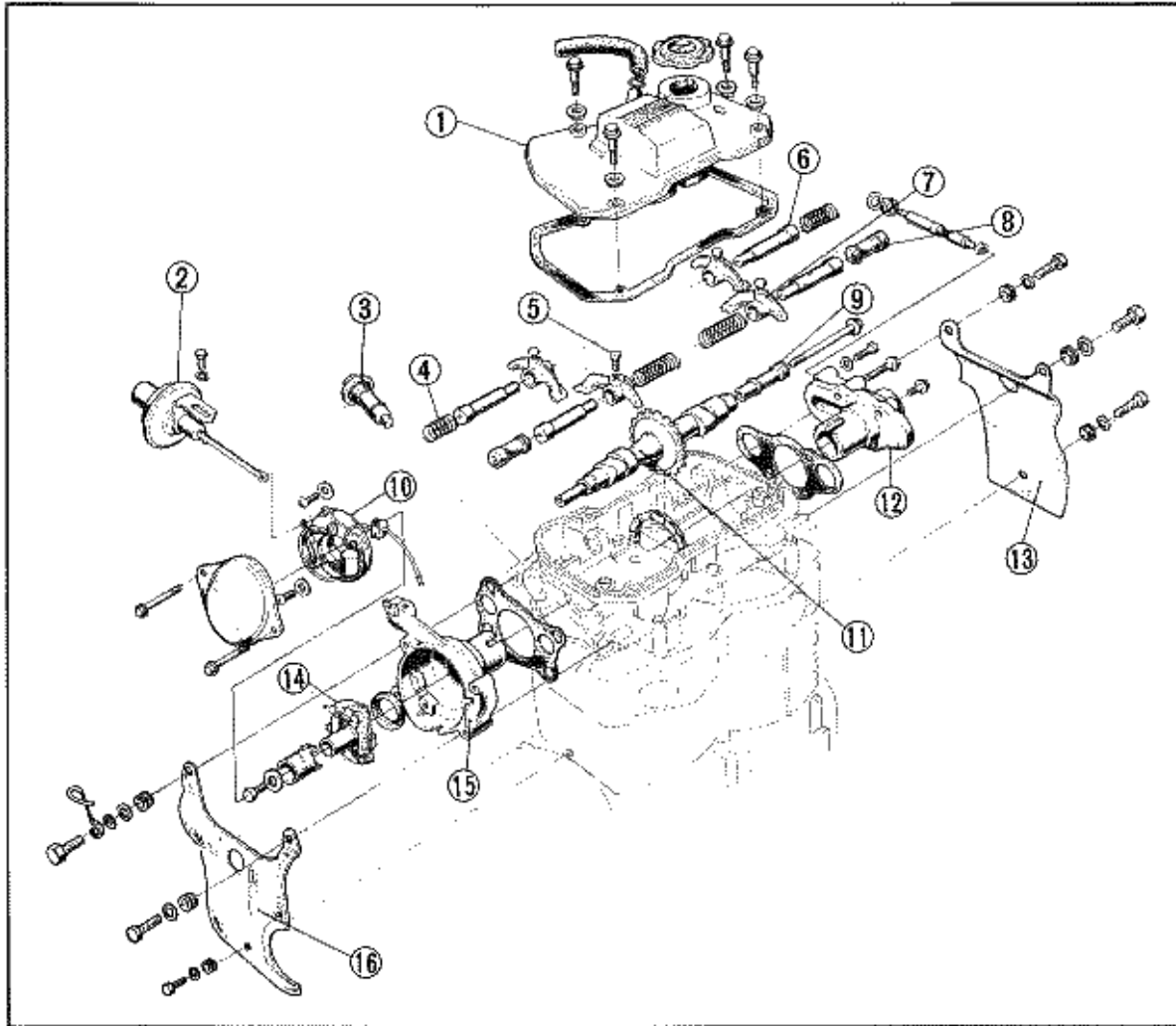

Fig. 4-1

| | | |
|--------------------------------------|----------------------------|--------------------------------------|
| ① Camshaft Housing Cover | ⑥ Inlet Rocker Arm Shaft | ⑫ Camshaft Holder, L |
| ② Vacu Spark Advancer Assembly | ⑦ Rocker Arm, L | ⑬ Engine Shroud Assembly, L |
| ③ Tensioner Push Rod Holder Assembly | ⑧ Exhaust Rocker Arm Shaft | ⑭ Mechanical Spark Advancer Assembly |
| ④ Inlet Rocker Arm Spring | ⑨ Tachometer Pinion | ⑮ Camshaft Holder, R |
| ⑤ Rocker Arm Lock Bolt | ⑩ Contact Braker Assembly | ⑯ Engine Shroud Assembly, R |
| | ⑪ Camshaft | |

4-1. Cylinder Head

Removal of camshaft

1. Remove the right and left shrouds and then remove the cooling fan housing.
2. Loosen and remove the camshaft chain tensioner push rod holder assembly.
3. Remove the camshaft housing cover.
4. Turn the camshaft to the position where the right cam lobes do not push the rocker arms up. (The notch on the flywheel pulley will be aligned with the "T" on the flywheel housing cover—This is top dead center for the compression stroke.)
5. Remove the bolt securing the mechanical spark advancer to the camshaft and then remove the right camshaft holder.
6. When removing the right camshaft holder, exercise care to prevent the inlet rocker shaft springs from jumping out.
7. Rotate the camshaft until the left cam lobes do not push the rocker arm up, and remove the left camshaft holder.
8. Remove the rocker arm shafts and rocker arms.
9. Remove the tachometer pinion from the camshaft.
10. Remove the camshaft drive chain from the camshaft sprocket and place it on the right side of the sprocket.
11. Push the camshaft to the right until it clears the camshaft housing on the left, then lift it up and out to the left.

Installation of camshaft

To install the camshaft, reverse the removal procedure. The following items must be carefully checked when the camshaft is installed:

* Install of camshaft drive chain

Turn the crankshaft in its normal rotating direction and align the notch on the fan belt drive pulley with the "T" mark on the flywheel housing cover. Pull the camshaft drive chain up and install it on the camshaft sprocket with the valve timing line on the side face of camshaft sprocket held parallel to the top face of camshaft housing (Fig. 4-5).

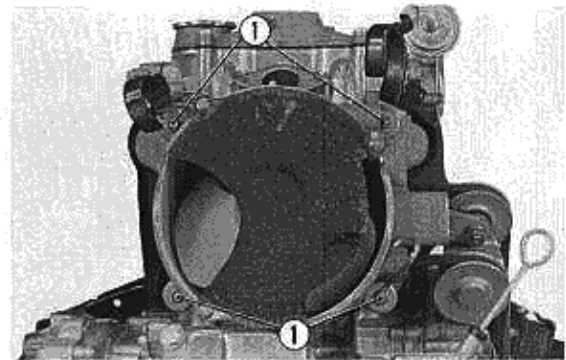

Fig. 4-2 ① Retaining Bolt

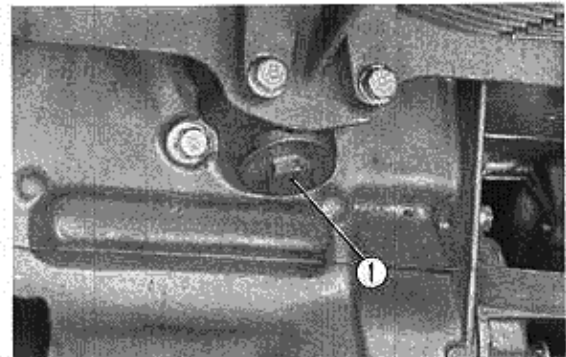

Fig. 4-3 ① Tensioner Push Rod Holder Assembly

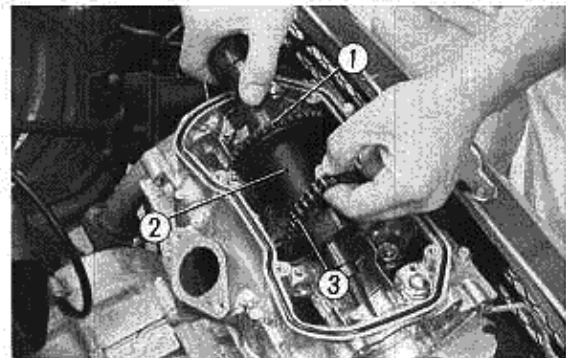

Fig. 4-4 ① Camshaft Sprocket
② Camshaft
③ Camshaft Drive Chain

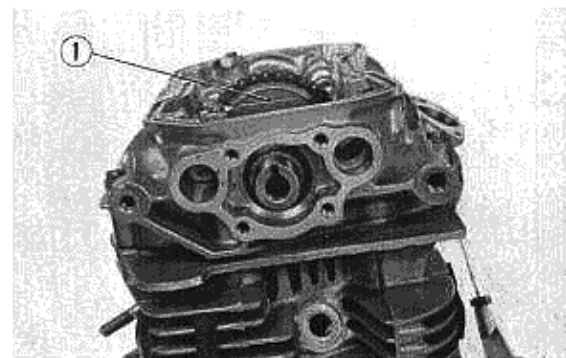

Fig. 4-5 ① Valve Timing Line

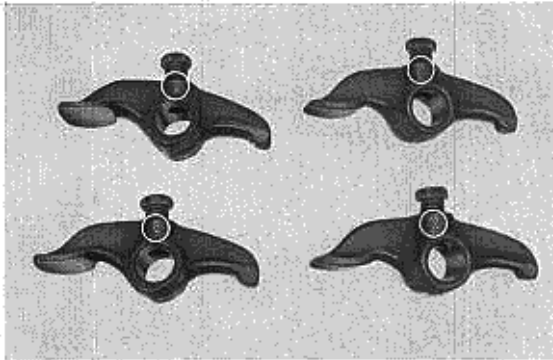

Fig. 4-6

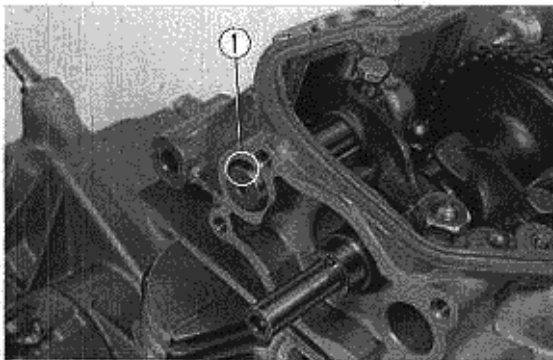

Fig. 4-7 ① Punch Mark

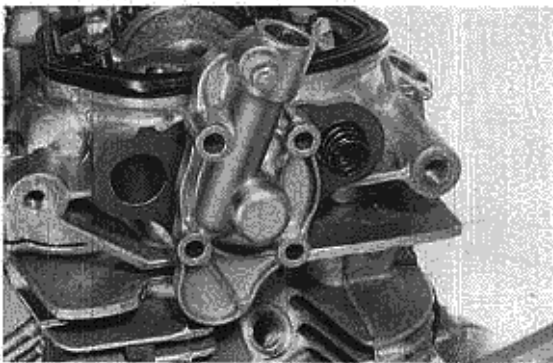

Fig. 4-8

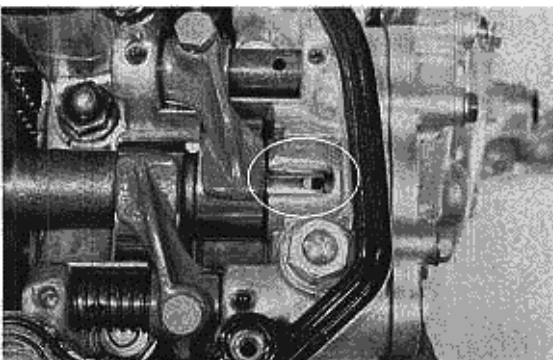

Fig. 4-9

Check to make sure that the notch cut in the left end of camshaft faces upward.

NOTE: A joint type chain is available as a replacement part.

Each rocker arm is marked either "R" or "L". Install the arms with "R" marks on the right side and the arms with "L" marks on the left side (Fig. 4-6).

* Install the right side rocker arms and camshaft holder first. Install the rocker arm shafts with the mark up. This will give the largest valve clearance and will facilitate installation of camshaft holder (Fig. 4-7).

* Turn the crankshaft and align the "T" mark on the fan belt drive pulley with the mark on the flywheel housing cover so that the right side piston is at top dead center on compression stroke for installation of the right camshaft holder.

* After installing the right camshaft holder, turn the crankshaft 360° to align notch on the fan belt drive pulley with the "T" on the flywheel housing cover.

Fit the left camshaft holder at an angle of 90° to the normal position as shown in Fig. 4-8.

Then install the rocker arms and rocker arm shafts.

Turn the camshaft holder to normal position and secure it with the appropriate bolts.

When installing the right and left camshaft holders be careful not to allow spring B and the set springs to tear the camshaft holder gaskets.

* Valve timing inspection

After installing the camshaft holders, check the valve timing before adjusting the valve clearances. Check to insure that the camshaft notch is centered in the left cam holder notch when the notch on the fan belt drive pulley is aligned with the "T" mark on the flywheel housing cover. If these notches are not aligned, remove one of the camshaft holders and reposition the camshaft drive chain on the camshaft. When the valve timing is properly set, install the cam chain tensioner.

* Upon completion of the installation, adjust the valve clearance, contact point gap and ignition timing.

Removal and assembly of camshaft housing and cylinder head.

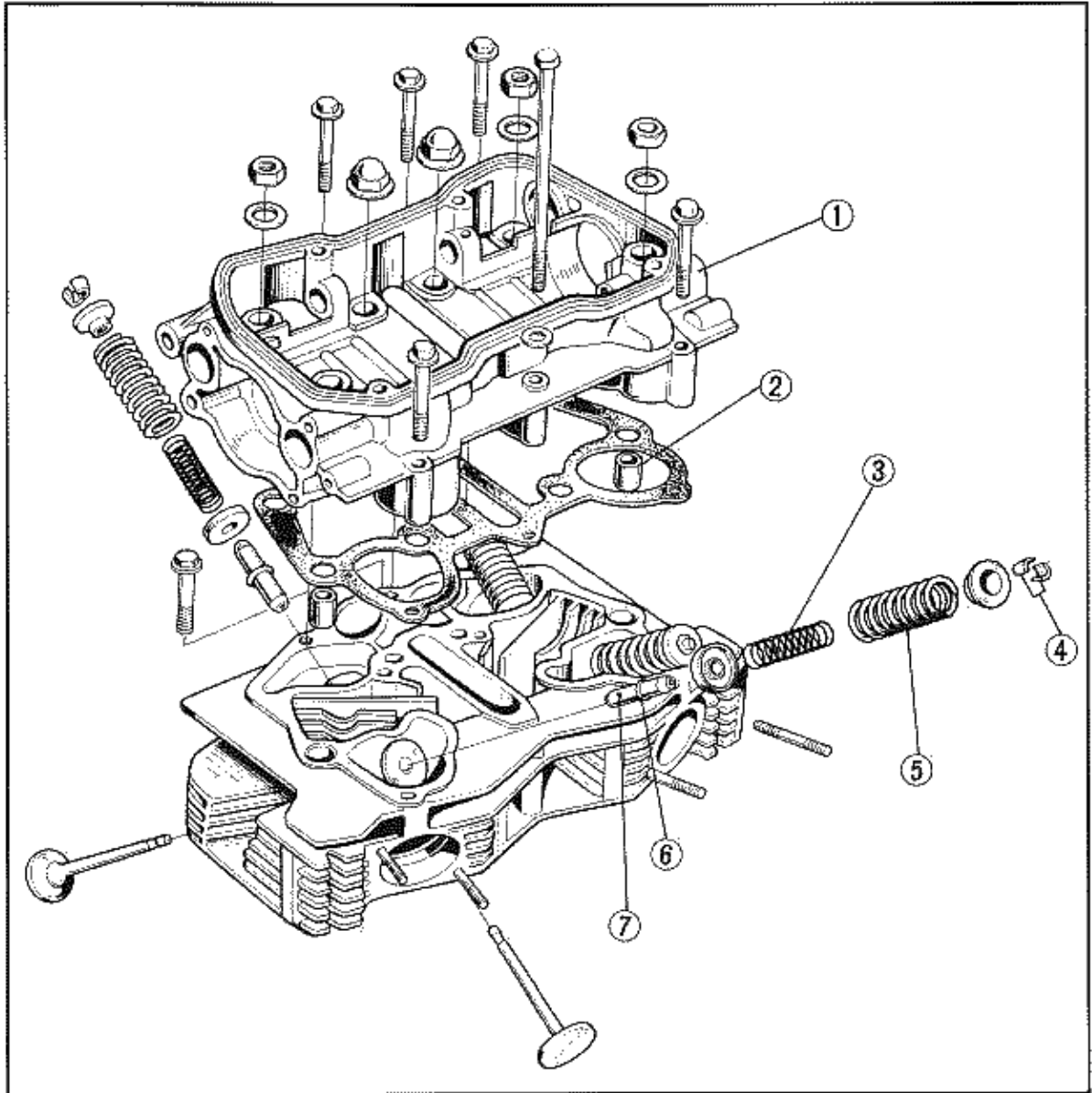

Fig. 4-10 ① Camshaft Housing ④ Valve Cotter ⑥ Valve Guide Clip
 ② Hollow Pin ⑤ Valve Outer Spring ⑦ Exhaust Valve Guide
 ③ Valve Inner Spring

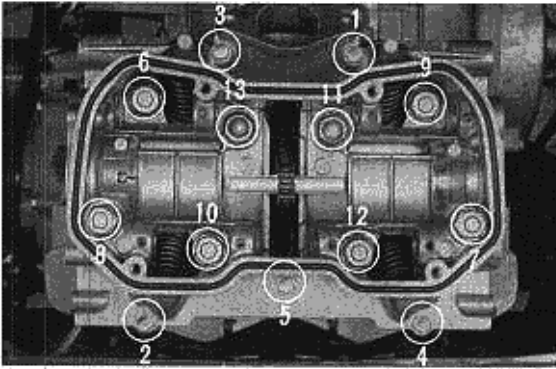

Fig. 4-11

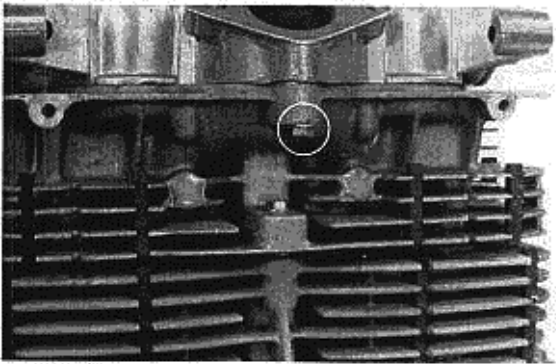

Fig. 4-12

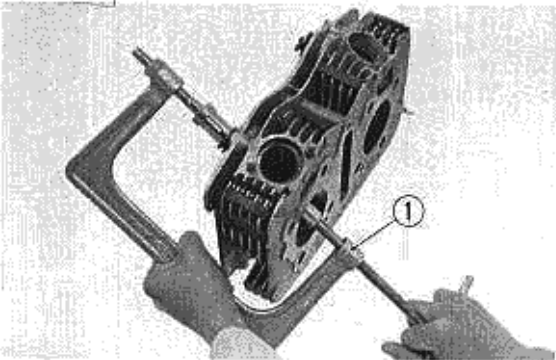

Fig. 4-13 ① Valve Lifter

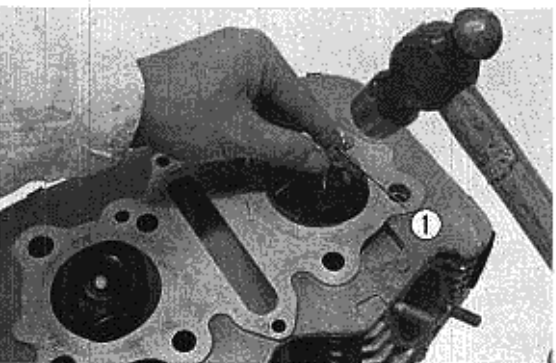

Fig. 4-14 ① Valve Guide Driver

1. Remove the 6mm bolts holding the camshaft housing. Loosen the 10mm nuts in a criss-cross pattern, starting with the external ones first, then remove the camshaft housing.

2. Remove the 6mm cylinder head bolts located below the intake manifold and remove the cylinder head.

3. Removal of valves and valve springs
Compress the valve spring with the valve lifter (special tool) and remove the keepers. Loosen the lifter carefully and remove the valves and valve springs from the cylinder head.

4. Removal of the valve guides
Remove the valve guides with a hammer and the valve guide driver (special tool). Drive the guides out from the combustion chamber side.

Installation of camshaft housing and cylinder head

To install the camshaft housing and cylinder head, reverse the removal procedure. The following should be carefully checked when the camshaft housing and cylinder head are installed.

- * Four hollow pins (two on each side) are provided for proper alignment of the cylinder head and camshaft housing. Be certain they are installed prior to reassembly.
- * During reassembly, tighten the cylinder head and camshaft housing retaining bolts and nuts with a torque wrench to the following specifications.
 - 10mm nuts: 3.7~4.3kg-m (26.7~31.1lbs-ft)
 - 6mm bolts: 1.0~1.4kg-m (7.2~10.1lbs-ft)

When tightening these bolts, follow the sequence shown in Fig. 4-17.

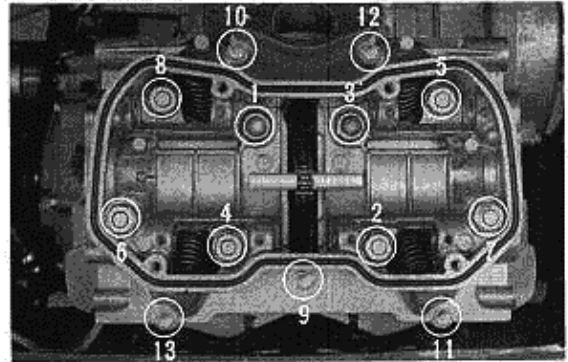

Fig. 4-15

Removal of the cylinder head, cylinder barrel and pistons without removing the engine from the automobile

1. Disconnect the positive and negative cables from the battery and remove the battery.
 2. Disconnect the following control cables and electrical wiring from the engine:
 - Tachometer drive cable
 - Engine ground strap
 - Ignition primary wire (blue)
 - High tension cables
 - Fuel solenoid wiring
 3. Disconnect the breather tube from the camshaft housing cover.
 4. Disconnect the vacuum booster hose at the intake manifold.
 5. Remove the throttle and choke cable stay.
 6. Disconnect the fuel tube at the carburetor.
 7. Remove the intake manifold, carburetor and air cleaner bellows as an assembly and place them on the left damper mounting cap.
 8. Disconnect the following ducts from the engine:
 - Hot air duct
 - Heater duct
 - Exhaust air duct
 9. Remove the front bumper guard, right and left front combination lights and the front grill.
 10. Remove the exhaust manifold.
 11. Remove the camshaft—see pages 4-2.
 12. Remove the 6mm bolts holding the camshaft housing. Loosen the 10mm nuts in a criss-cross pattern, starting on the external ones first, and remove the camshaft housing.
 - * Four hollow pins (two on each side) are provided for proper alignment of the cylinder head and camshaft housing. Be certain they are installed prior to re-assembly.
 13. Remove the 6mm cylinder head bolts located below the intake manifold and remove the cylinder head.
 - * During re-assembly, tighten the cylinder head and camshaft housing retaining bolts and nuts with a torque wrench to the following specifications:
 - 10mm nuts: 3.7~4.3kg-m (26.7~31.1lbs-ft.)
 - 6mm bolts: 1.0~1.4kg-m (7.2~10.1lbs-ft.)
- When tightening these bolts, follow the sequence shown in Fig. 4-15.

4-2 Pistons and Cylinder

Removal

1. Remove the camshaft drive chain guide roller.
2. Remove the three 6mm bolts (one in the front and two in the rear) holding the cylinder barrel to the upper crankcase and pull out the cylinder barrel. If the cylinder barrel does not lift out easily, tap it lightly with a rubber mallet.

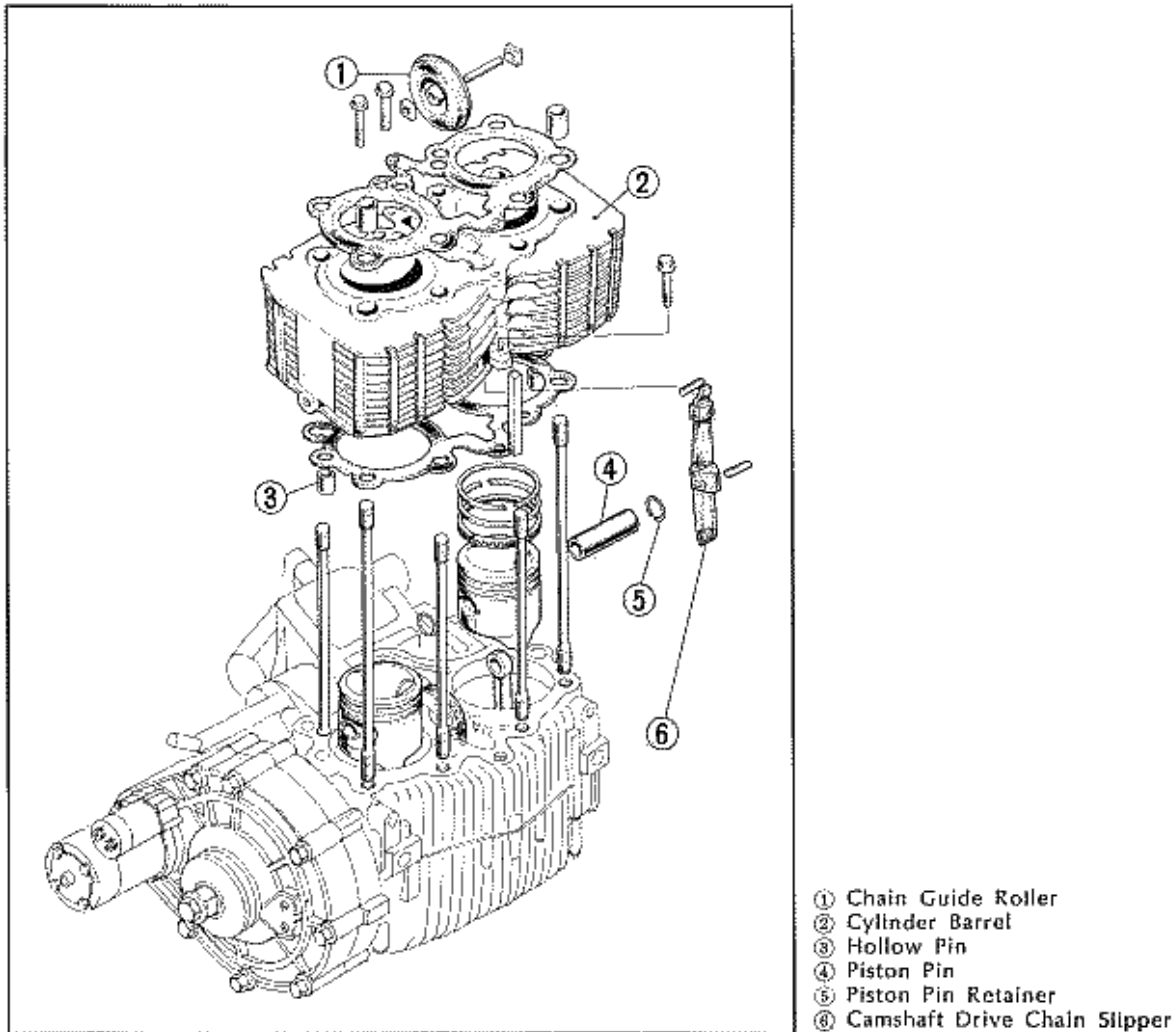

Fig. 4-16

3. Piston removal

Remove the piston pin retainers pull the piston pin out and separate the piston from the connecting rod.

NOTE: Cover the upper crankcase with a rag before removing the pistons to prevent the piston pin retainers from falling into the crankcase.

4. Removal of piston rings

Remove the first and second rings (compression) and then the oil ring.

5. Removal of camshaft drive chain slipper

Pull the pin at the top of cam drive chain slipper out and remove it from the bottom of the cylinder barrel.

Installation

* Installation of piston rings

To install the piston rings, reverse the removal procedure. Install the oil ring, then the second ring and top ring with the mark on the rings facing upward. Position the rings so that their gaps are equally spaced at an angular interval of 120° . Do not allow any of the gaps to come to the piston pin boss side or at right angles to the piston pin.

* Install each piston with the "IN" mark on the piston crown facing the inlet side.

Installation of the cylinder barrel

Place the piston seats (special tool) beneath the pistons and compress the piston rings with the piston ring compressors. Gently lower the cylinder barrel and allow the pistons to fit in the cylinder. Remove the piston ring compressors and piston seats after all the rings are in the cylinder.

Attach a thin wire to the camshaft drive chain and pull it through the cylinder barrel before the barrel is completely lowered into position.

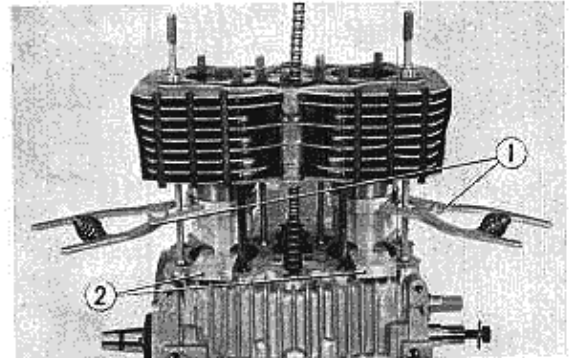

Fig. 4-17 ① Piston Ring Compressors
② Piston Seats

4-3 Primary Drive and Oil Pump

Removal and disassembly

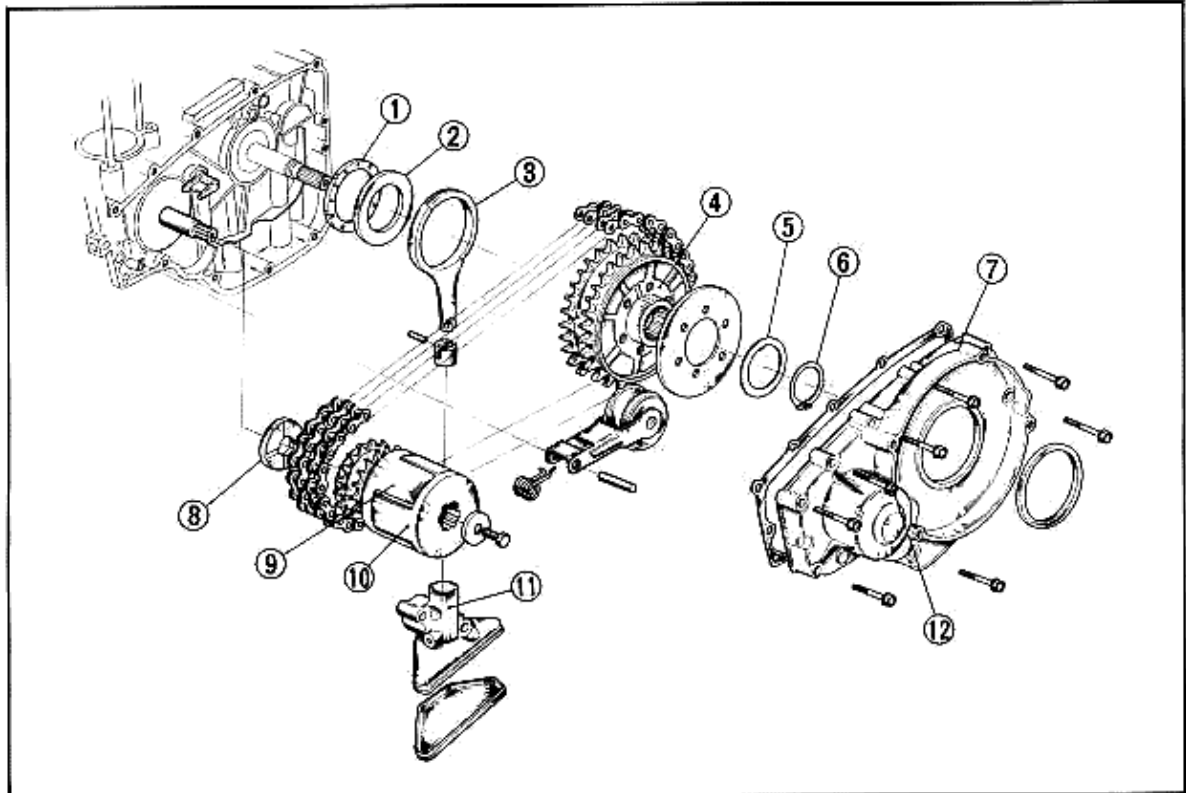

Fig. 4-18 ① Needle Thrust Bearing
② Clutch Thrust Plate
③ Oil Pump Rod
④ Primary Driven Sprocket Assembly
⑤ Driven Sprocket Thrust Washer
⑥ External Circlip, 25 mm
⑦ Crankcase Side Cover, L
⑧ Flat Washer, 25 mm
⑨ Primary Drive Shaft
⑩ Drive Sprocket Damper Adapter
⑪ Oil Pump Body
⑫ Thread Lock Cement

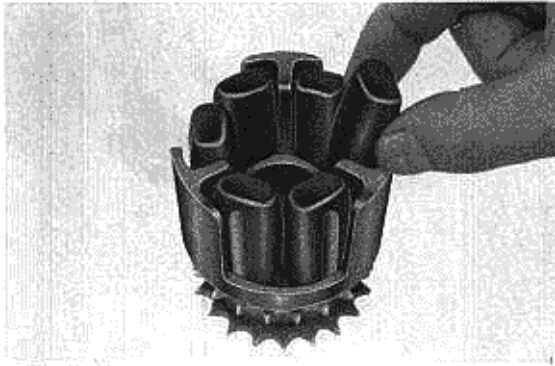

Fig. 4-19

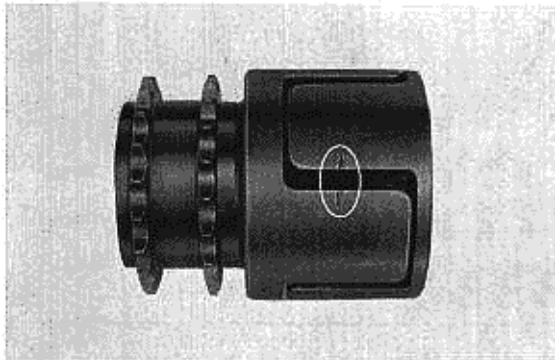

Fig. 4-20

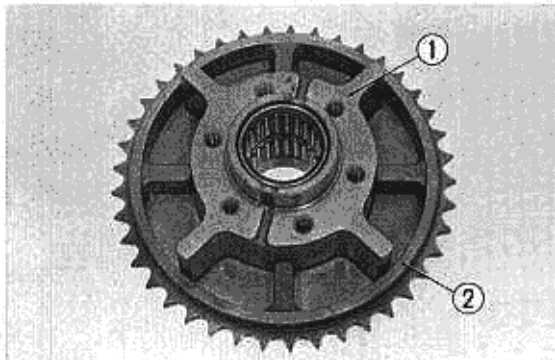

Fig. 4-21 ① Driven Sprocket Hub
② Primary Driven Sprocket

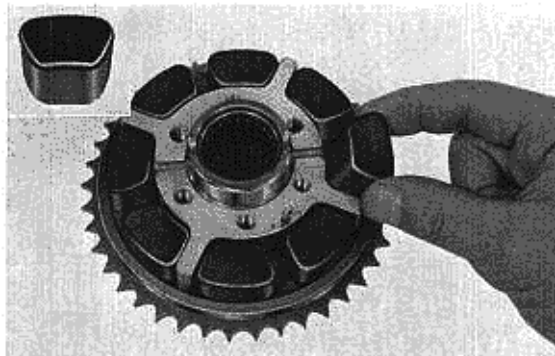

Fig. 4-22

1. Remove the clutch assembly (see page 5-1)
2. Remove the left side cover.
3. (600 only) Check the side clearance of the primary drive sprocket. See 600 SEDAN Shop Manual 4-45.
4. Remove the drive sprocket mounting bolt and drive chain tensioner.
5. Remove the circlip and thrust washer from the driven sprocket.
6. Remove the two bolts holding the oil pump body to the lower crankcase.
7. Remove the primary drive shaft and the primary driven sprocket together with the chains. Then remove the oil pump as an assembly.
8. Remove the thrust washer and needle thrust bearing from the mainshaft.
9. Disassembly of the primary drive sprocket dampers
The dampers can be removed if the drive sprocket damper adapter is removed from the primary drive shaft.
10. Disassembly of the oil pump
Inspect the oil pump strainer and clean or replace as necessary.

NOTE: When assembling the oil pump, install the piston rod with its rib side facing the transmission.

Assembly and Installation

To assembly and install the primary drive and oil pump, reverse the removal and disassembly procedures. The following items must be carefully checked when the primary drive and oil pump are assembled and installed.

* Install the primary drive sprocket dampers in the primary drive shaft as shown in Fig. 4-19.

Install the drive sprocket damper adapter on the primary drive shaft with the mating marks aligned.

* Installation of the primary driven sprocket damper

Fit the inner primary driven sprocket to the driven sprocket hub.

Then install the primary driven sprocket dampers with the letter (Y) embossed on the end face of the primary driven sprocket facing outward (clutch side).

After installing the primary driven sprocket dampers, install the other primary driven sprocket so that the marks on the sprockets are 180° apart (Fig. 4-23).

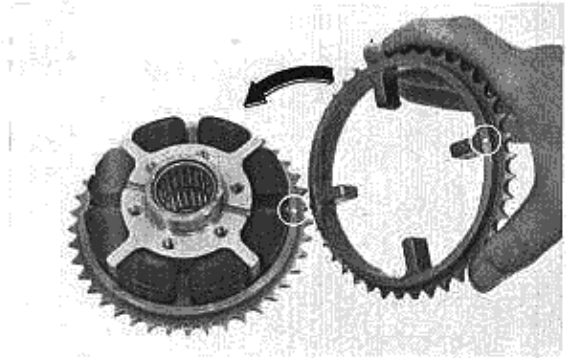

Fig. 4-23

The teeth on the two primary driven sprockets will be misaligned or displaced half pitch when the primary driven sprockets are assembled properly.

- * Installation of the main disk setting plate
Fit the main disk setting plate on the driven sprocket hub with the chamfered side of the plate bore facing toward the hub.
- * A 25mm flat washer is fitted to the crankshaft (Fig. 4-18).
- * Mount the needle thrust bearing on the outer race of the main shaft ball bearing and install the oil pump assembly with the clutch thrust plate. Then install the primary drive shaft, primary driven sprocket together with the chains as an assembly. Install the primary drive chain tensioner and then install the left side cover.
- * Apply thread lock cement, before tightening, on the bolt ② for the left crankcase side cover (Fig. 4-18).

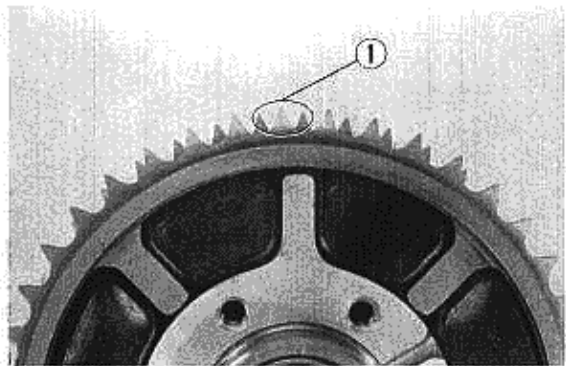

Fig. 4-24 ① Half Pitch

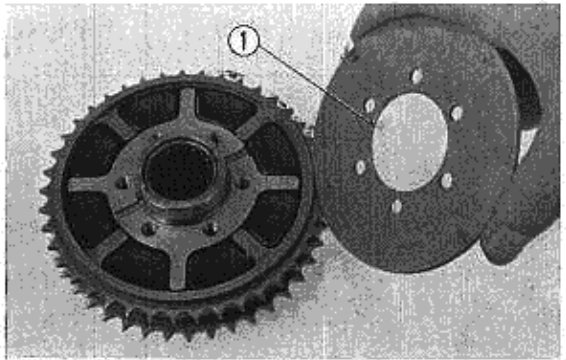

Fig. 4-25 ① Chamfered Side

4-4 Right Side Cover

1. Remove the speedometer gear and the back-up light switch from the side cover.
 2. Remove the speedometer, O-ring and oil seal from the speedometer gear holder
 3. Remove the right side cover, the reverse shift fork, idle gear and gear shaft may now be serviced in the car.
- * To install the right side cover, reverse the removal procedure.

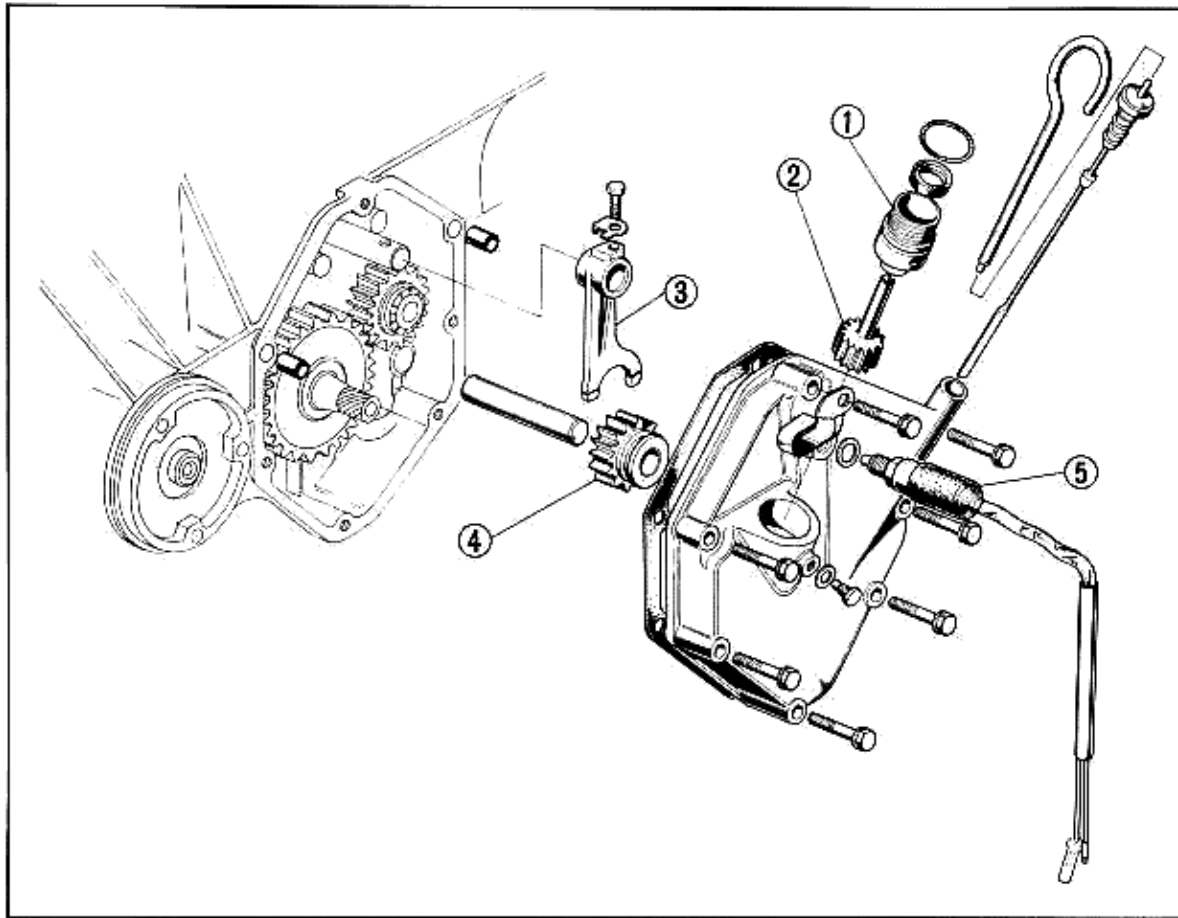

Fig. 4-26 ① Speedometer Gear Holder ③ Reverse Shift Fork ⑤ Back-up Light Switch Assembly
 ② Speedometer Gear ④ Reverse Idle Gear

4-5. Crankshaft

Removal and installation of the starter motor and A.C. generator

See Section 19, paragraphs 19-1 and 19-2.

Lower crankcase removal

1. Remove the bolt in the upper crankcase located to the left of the camshaft drive chain tensioner. (Fig. 4-27)
2. Remove the four bolts holding the right main bearing roller retainer holder.

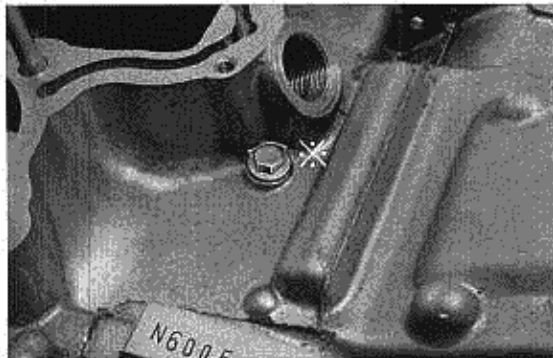

Fig. 4-27

- Turn the engine upside down and remove the ten 6mm bolts and eight 8mm bolts. Separate the lower crankcase from the upper crankcase. Tap the case lightly with a wooden hammer to facilitate the removal because the mating surfaces are sealed with a liquid gasket. Also tap the right main bearing roller retainer holder to loosen the joint between the crankcase and right main bearing roller retainer holder.

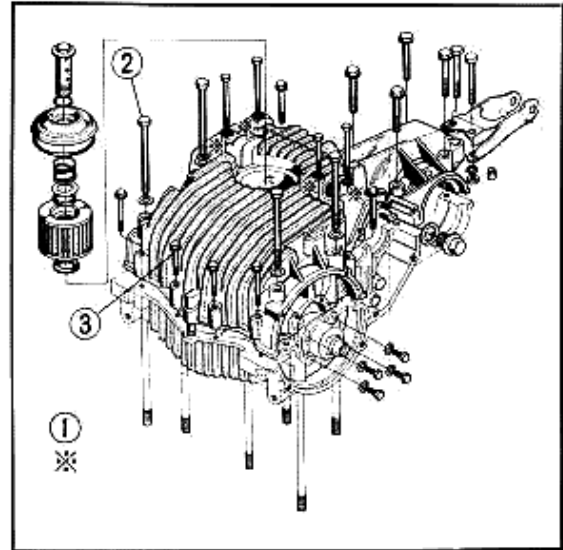

Fig. 4-28 ① Flat Washer
② 8 mm Bolt 2.3~2.8 kg-m (17~20 lbs-ft)
③ 6 mm Bolt 0.9~1.2 kg-m (7~9 lbs-ft)

Crankshaft Removal

Remove the center bearing holder and pull the crankshaft out of the upper crankcase with the right and left main bearing roller retainer holders, and camshaft drive chain still attached.

Crankshaft Installation

To install the crankshaft, reverse the removal procedure. Check the following items carefully when the crankshaft is installed:

- * The right center main bearing and left center main bearing are positioned with dowel pins fitted to the main bearing roller retainer holders. The dowel pin for left center main bearing is located at the separation of the crankcases. Install the right main bearing roller retainer holder so that the dowel is centered in the hole in the bearing "cap" in the upper crankcase.

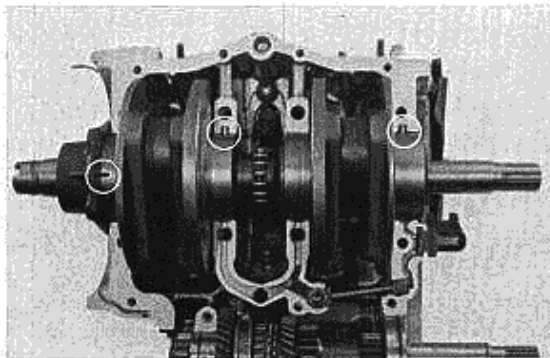

Fig. 4-30

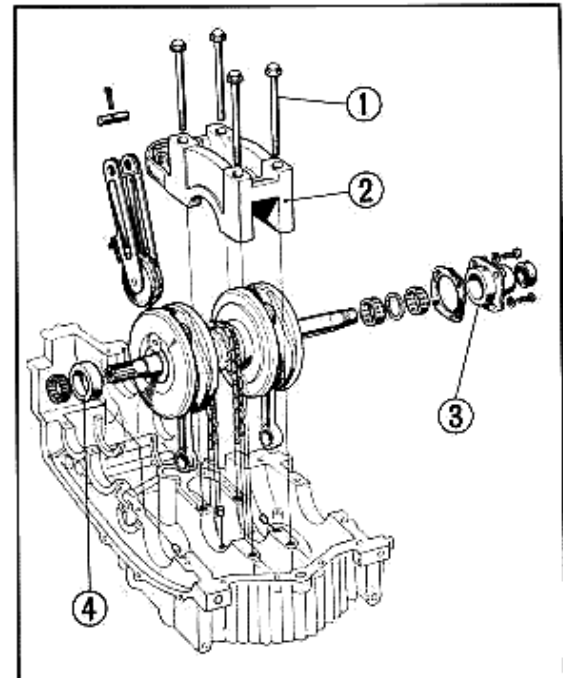

Fig. 4-29 ① 3.5~4.0 kg-m (25~29 lbs-ft)
② Center Bearing Holder
③ Main Bearing Roller Retainer Holder, R
④ Main Bearing Roller Retainer Holder, L

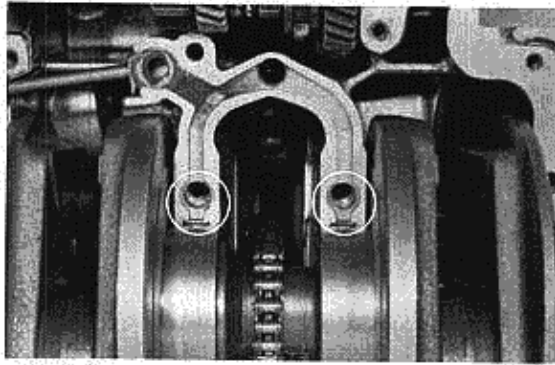

Fig. 4-31

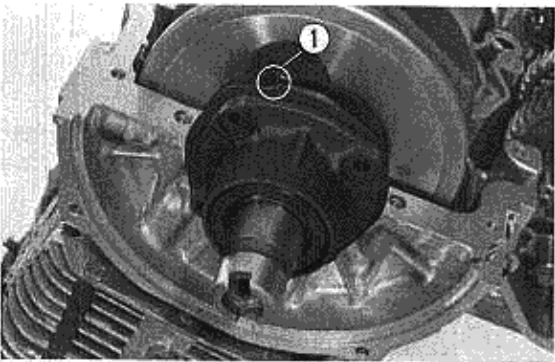

Fig. 4-32 ① R.H. Retainer Holder Gasket

* Check to be sure that the oil holes in the center bearing holder are in alignment with the grooves in the crankcase. Be sure that the camshaft drive chain is properly seated on the sprocket before tightening the center main bearing retaining bolts.

- * The right retainer holder gasket is provided with a lubricating oil groove. The notch will be aligned with the oil passage when it is positioned so that the protrusion on its edge is located toward the lower crankcase.
- * For five of the 6 mm bolts holding the lower crankcase, located at the transmission, use flat washers. Exercise care not to misinstall these washers. (Figs. 4-27, 28)

Torque Specifications

| | |
|---------------------------------|----------------------------------|
| Center bearing holder bolts: | 3.5~4.0 kg-m (25.3~28.9 lbs-ft.) |
| Crankcase retaining bolts (8mm) | 2.5~2.8 kg-m (18.1~20.3 lbs-ft.) |

4-6. Cooling Fan

Removal and Installation

1. Loosen the belt tension pulley and remove the cooling fan drive belt from the fan belt drive pulley.
 2. Remove the cooling fan housing.
 3. Remove the fan belt drive pulley.
- * To install the cooling system, reverse the removal procedure. This will be easier if the fan drive belt is fitted to the cooling fan pulley and then to the fan belt drive pulley. Adjust the fan drive belt tension by changing the position of belt tension pulley. Pinch the belt together at a point half way between the tension and idle pulleys and the fan belt drive pulley. Then make adjustment so that the gap between the inside faces of belts are 15~20 mm (.59~.78 in.) apart.

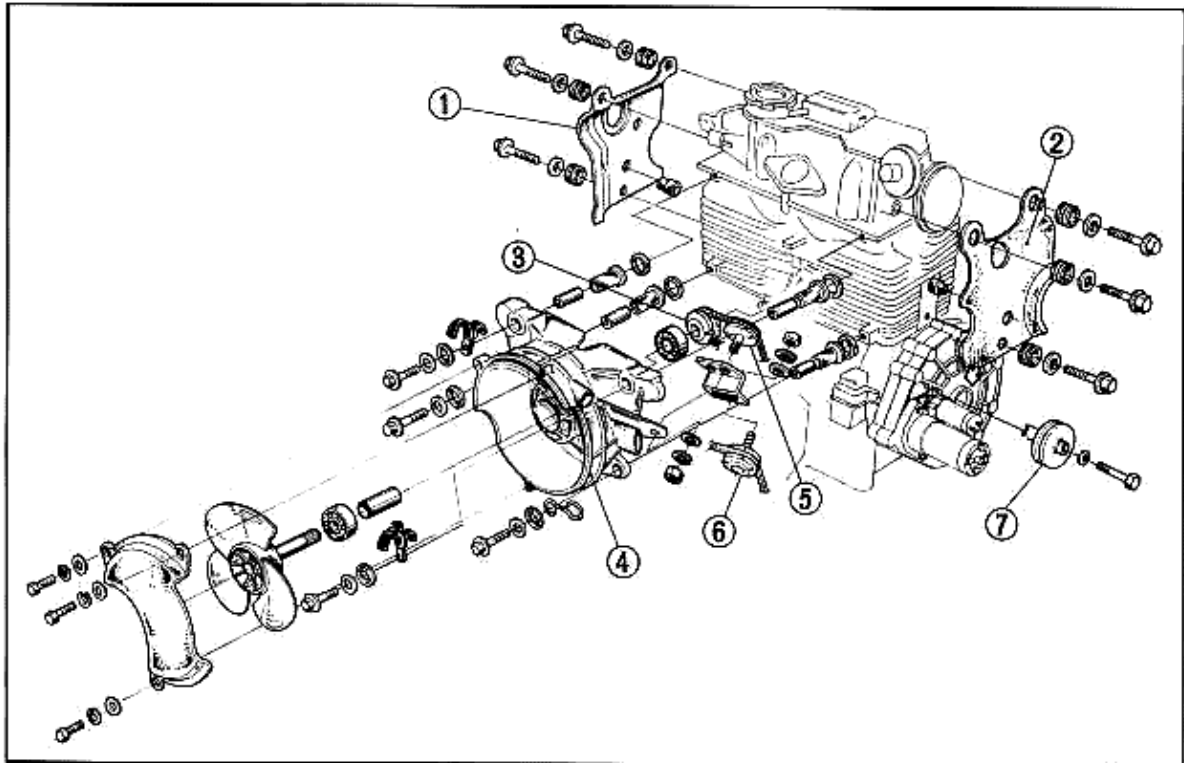

Fig. 4-33 ① Engine Shroud Assembly, L ④ Cooling Fan Housing ⑥ Belt tension Pulley Assembly
 ② Engine Shroud Assembly, R ⑤ Idle Pulley Assembly ⑦ Fan Belt Drive Pulley
 ③ Cooling Fan Pulley

Disassembly and installation

* Cooling fan pulley removal

The cooling fan pulley is press fitted to the cooling fan shaft. Remove the pulley with a hydraulic press. The fan housing ribs may be damaged if removal is attempted by hammering. Use a hydraulic press for installing the pulley. Remove the two ball bearings and spacers from the shaft.

* To install the fan pulley, reverse the removal procedure.

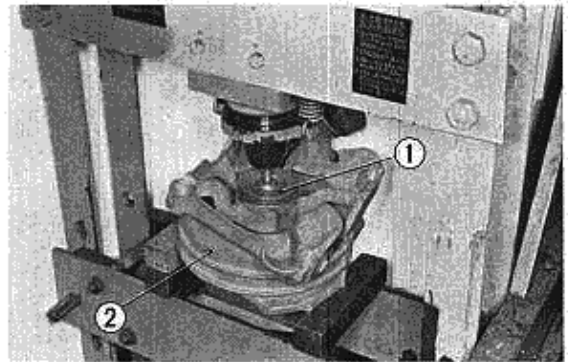

Fig. 4-34 ① Cooling Fan Pulley
 ② Cooling Fan Housing

5. CLUTCH

Disassembly and installation

1. Remove the heater blower unit from the engine compartment.
2. Remove the joint pipe "A" assembly.
3. Remove the two bottom side bolts from the heat exchanger stay.
4. Remove the adjusting bolt on the clutch release lever and remove the clutch control cable from the release lever and from the clutch housing.
5. Remove the clutch housing retaining bolts and remove the housing from the left side cover.
6. Remove the pressure disk assembly from the clutch drum.
7. Remove the clutch friction disk from the main shaft.
8. Remove the clutch drum.
9. Remove the cotter pin at the end of the clutch release rod and remove the clutch release bearing from the clutch housing. The clutch release rod and bearing can be separated by tapping the rod with a pin punch lightly. When driving the rod into the clutch release bearing, install the rod so that the side of the bearing on which the outer race protrudes beyond the face of inner race faces the clutch diaphragm spring (Fig. 5-2).

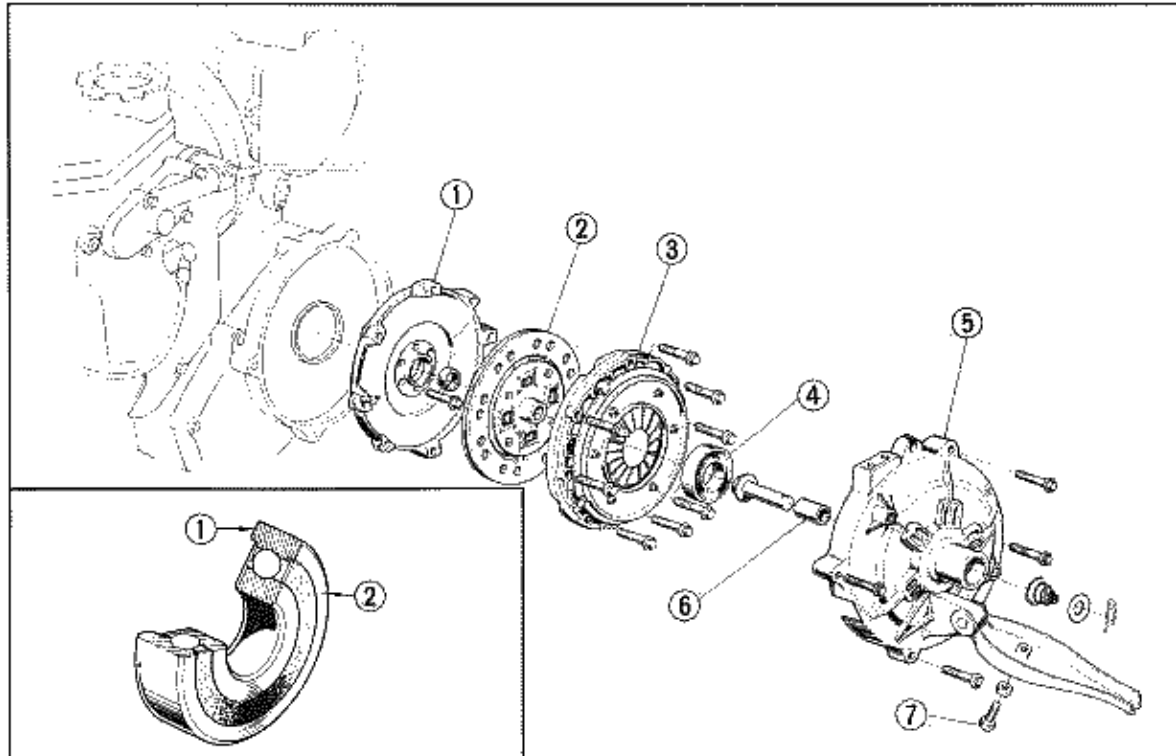

Fig. 5-2

- ① Diaphragm Spring Side
- ② Release Bearing shaft Side

Fig. 5-1

- ① Clutch Drum
- ② Clutch Friction Disk
- ③ Pressure Disk Assembly
- ④ Clutch Release Bearing
- ⑤ Clutch Housing
- ⑥ Clutch Housing Bushing
- ⑦ Release Lever Adjusting Bolt

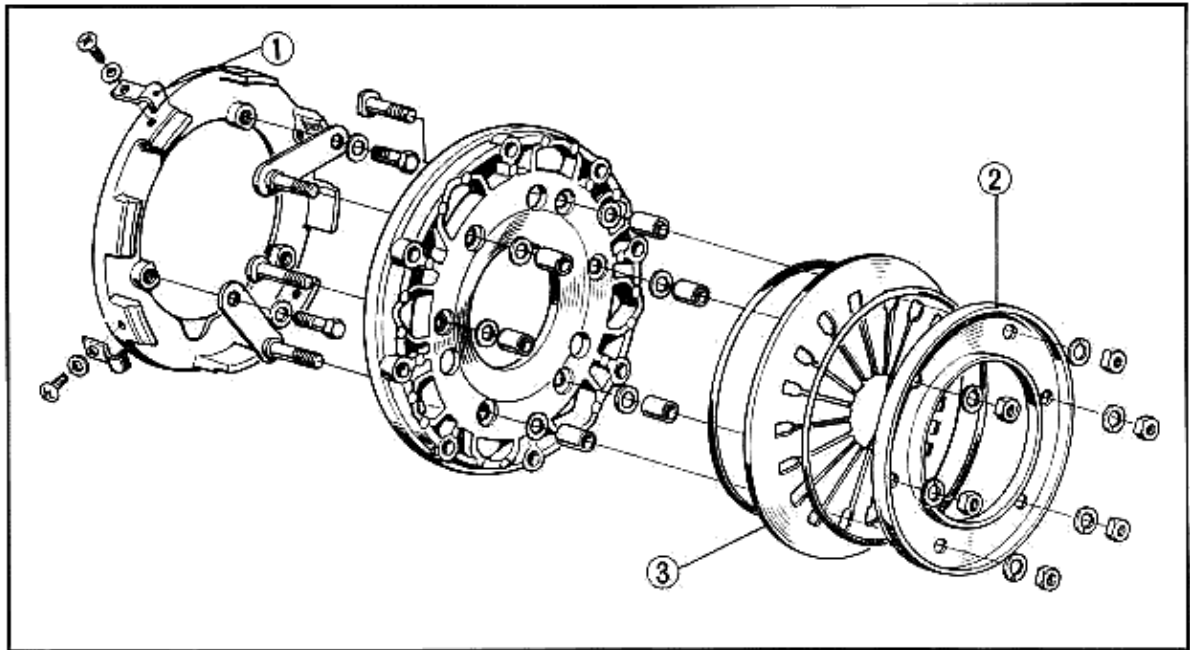

Fig. 5-3 ① Pressure Disk Retaining Spring ③ Clutch Diaphragm Spring
 ② Diaphragm Setting Plate

10. Disassembly of the pressure disk

Remove the four pressure disk retaining springs and then remove the nuts holding the diaphragm setting plate shown in Fig. 5-3.

- * To assemble and install the clutch, reverse the removal and disassemble procedures.
- When installing the pressure disk to the clutch disk, align the punch marks (Fig. 5-4).
- * When installing the clutch drum do not damage the oil seal nor fold the seal lip.
- * Before the final tightening of the clutch housing, align the heat exchanger stay with all bolts in place. Tighten the clutch housing bolts and then remove the bolts necessary to install the joint pipe "A" assembly.
- * Apply "thread" lock to the clutch drum retaining bolts when installing.

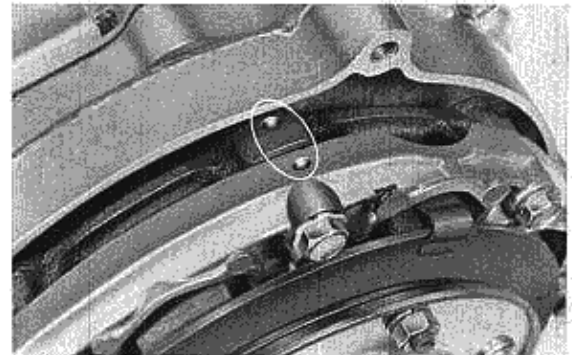

Fig. 5-4

Torque Specification

| | |
|------------------------------|-----------------------------------|
| Clutch disk retaining bolts: | 1.2-1.6 kg-m (8.7-11.6 lbs-ft) |
|------------------------------|-----------------------------------|

6. TRANSMISSION

6-1 SPECIFICATIONS

| | | | | |
|-------------|--------------|-------|-----------------|-------|
| Gear Ratios | 1st Gear | 2.470 | 3rd Gear | 0.967 |
| | 2nd Gear | 1.565 | 4th Gear | 0.675 |
| | Reverse Gear | 3.200 | Final Reduction | 3.739 |

| | ASSEMBLY STANDARD IN MILLIMETERS (INCHES) | SERVICE LIMIT |
|----------------------------------|--|------------------|
| Gear Backlash (all gears) | 0.064-0.128 (.0025-.0050) | 0.2 (.0078) |
| Gear I.D. | | |
| First | 23.0-23.027 (.9055-.9066) | 23.08 (.9086) |
| Second | 26.0-26.027 (1.0236-1.0247) | 26.08 (1.0268) |
| Third | 30.0-30.02 (1.1811-1.1819) | 30.05 (1.1831) |
| Fourth | 26.007-26.02 (1.0264-1.0244) | 26.05 (1.0256) |
| Reverse Idler | 14.077-14.050 (.5542-.5531) | 14.2 (.5590) |
| Gear Side Play | | |
| First | 0.2-0.5 (.0079-.0197) | 0.8 (.01350) |
| Second | 0.1-0.5 (.0039-.0197) | 0.8 (.01350) |
| Third | 0.1-0.4 (.0039-.0157) | 0.8 (.01350) |
| Fourth | 0.35-0.65 (.0139-.0256) | 1.0 (.03937) |
| Mainshaft | | |
| Bearing Journal Dia. | 19.98-19.959 (.7866-.7858) | 19.92 (.7842) |
| Fourth Gear Journal Dia. | 22.00-21.987 (.8661-.8656) | 21.95 (.8642) |
| Third Gear Journal Dia. | 26.00-25.987 (1.0236-1.0231) | 25.95 (1.0216) |
| Countershaft | | |
| Bearing Journal Dia. | 19.98-19.959 (.7866-.7858) | 19.92 (.7842) |
| Second Gear Journal Dia. | 25.98-25.959 (1.0228-1.0220) | 25.92 (1.0205) |
| First Gear Journal Dia. | 22.98-22.959 (.9047-.9039) | 22.92 (.9024) |
| Reverse Gear Idler | | |
| Shaft O.D. | 13.982-13.966 (.5505-.5498) | |
| Shaft Holder I.D. | 14.000-14.027 (.5512-.5522) | |
| Shaft Holder Clearance | 0.016-0.061 (.0006-.0002) | |
| Shaft Gear Clearance | 0.066-0.11 (.0025-.0043) | 0.2 (.0079) |

| | ASSEMBLY STANDARD IN MILLIMETERS (INCHES) | SERVICE LIMIT |
|---|--|------------------|
| Blocking Ring | | |
| Inner Groove Surface | Visual Inspection | |
| Teeth | | |
| Blocking Ring to Gear Clearance | 1.2-1.0 (.4724-.3937) | 0.5 (.0197) |
| Shift Forks | | |
| Shift Fork Fingers | 5.75-5.85 (.2264-.2303) | 5.45 (.2146) |
| Shift Fork-Synchronizer Sleeve Clearance | 0.1-0.3 (.0039-.0118) | 0.8 (.0315) |
| Gear Shift Rod Clearance | 0.038-0.099 (.0015-.0039) | 0.13 (.0051) |

6-2 DESCRIPTION

This is a constant mesh transmission with four fully synchronized forward speeds and one reverse speed. Power is transmitted from the crankshaft through the primary drive chain, to the clutch, on to the transmission mainshaft, to the countershaft and to the differential and front wheels.

6-3 OPERATION

Each set of forward speed gears are constantly meshed with each other. The mainshaft receives the power and transmits it to the countershaft which in turn drives the differential. The main and countershaft each have a synchronizer unit which turns with the shaft and controls the powerflow of the transmission.

Adjacent to (on each side of) these synchronizers is a gear which rotates freely on its shaft. When a forward gear is being engaged the synchronizing sleeve moves toward one of

the free rotating gears and locks onto it. This gear is now turning with its shaft and transmits the power. Fig. 6-1 shows the position of the synchronizer and the powerflow of the transmission in neutral, reverse and each of the forward speeds.

The synchronizer unit consists of a hub, sleeve, spring and blocking ring. The hub is splined to the main or countershaft and the sleeve is splined to the hub. The internal splines of the sleeve match the teeth on the blocking ring and the teeth on the engaging portion of the gear. When a gear is engaged, the shift forks move the sleeve toward the gear to be locked. Three pair of the internal splines on the sleeve are slightly larger and they contact the spring on the blocking ring first, pushing the ring towards the cone portion of the gear. This initial contact of the blocking ring and gear cone will synchronize the speed of the gear and synchronizing unit. Once this has taken place the sleeve may slide over the blocking ring and engaging teeth on the gear.

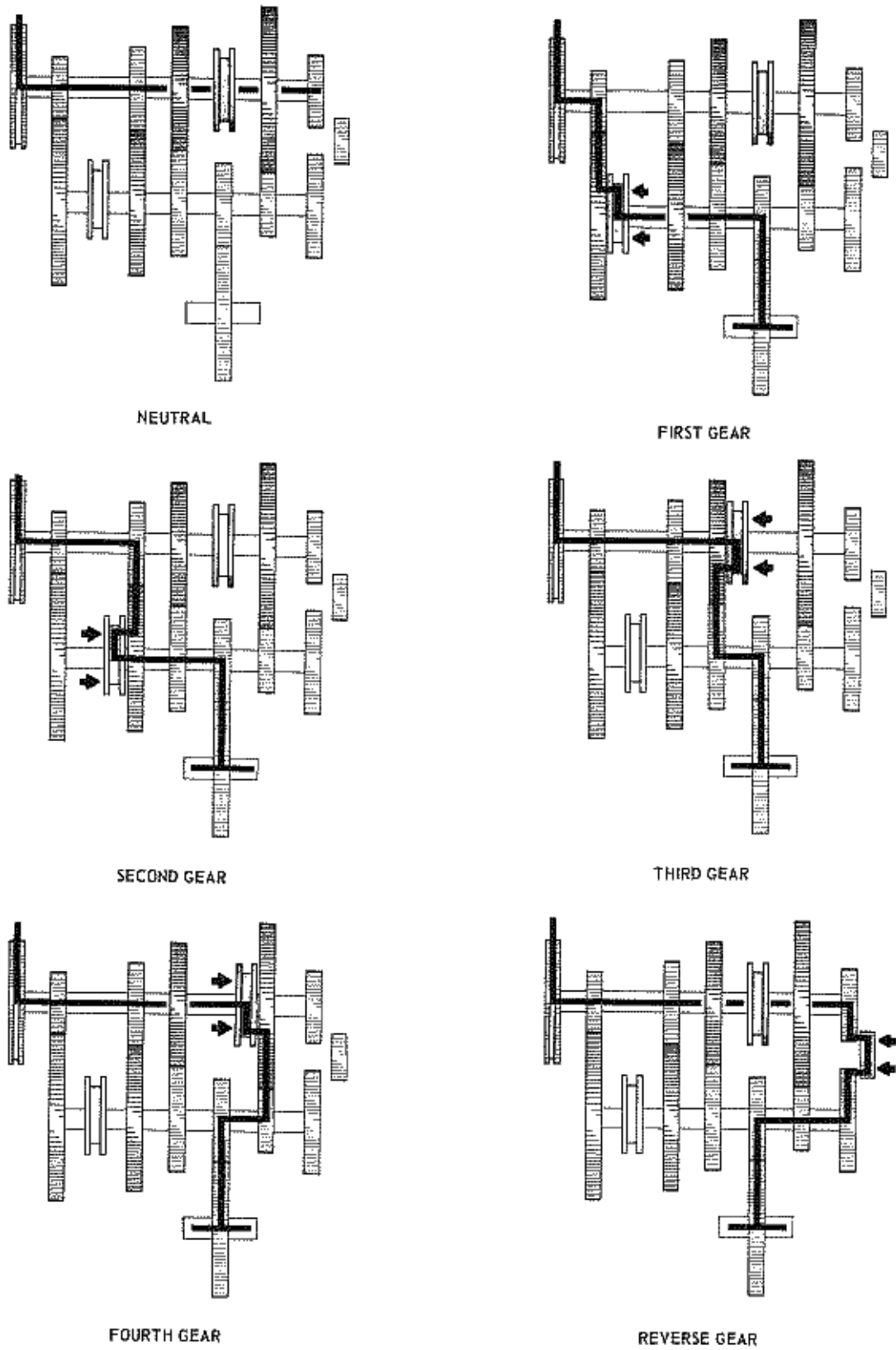

Fig. 6-1 Transmission Power Flow

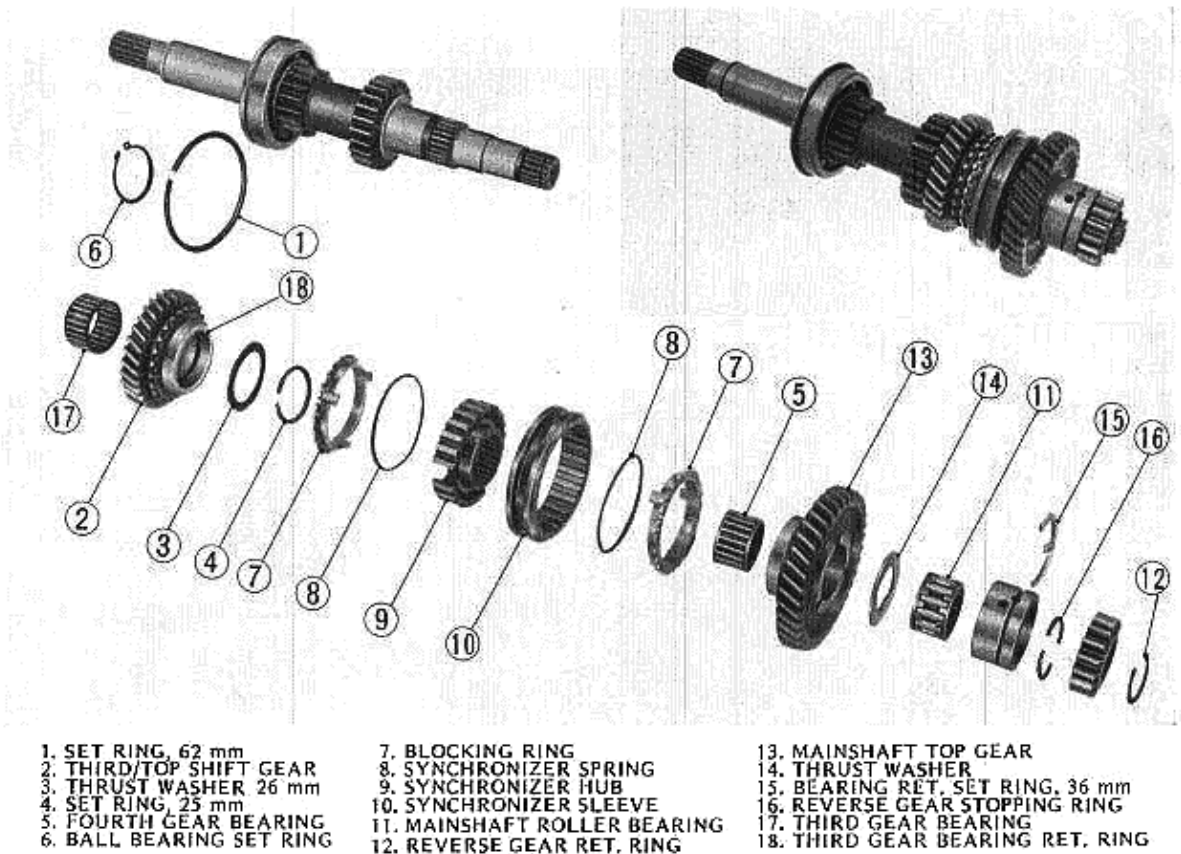

Fig. 6-2 Mainshaft

6-4 DISASSEMBLY

A. Removal

Separate the upper and lower engine crankcase. (See Section 4-3 and 4-5 Crankshaft Removal.)

NOTE: Reverse gears may be inspected without removing engine (See Section 6-5, G).

B. Mainshaft

1. Lift the mainshaft out of the crankcase.
2. Remove the external retaining ring, reverse gear and reverse gear stopping ring.
3. Remove needle bearing set ring, outer race and needle bearing.
4. Next remove thrust washer, fourth gear and fourth gear needle bearing.

5. Remove synchronizer as a unit or piece by piece. If removed separately, the parts disassemble in this order: blocking ring and spring, sleeve, hub and blocking ring and spring.

6. Finally remove set ring, thrust washer, third gear and third gear bearing. If third gear is replaced, install a new bearing retaining ring.

7. Mainshaft can now be inspected as shown in Section 6-5, A.

8. To assemble the mainshaft, reverse the disassembly procedure and use Fig. 6-2 as reference.

NOTE: Before assembly, read Section 6-4, D, for proper alignment of the synchronizer unit.

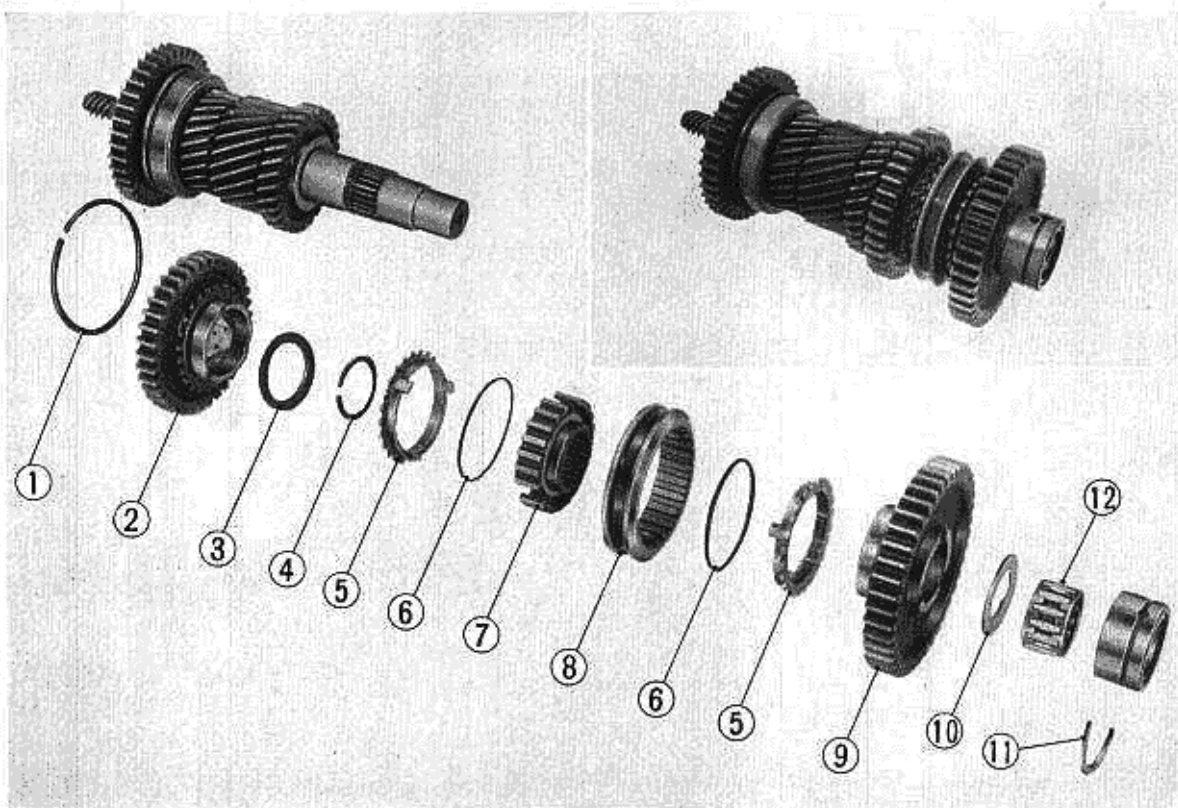

1. SET RING, 62 mm
 2. COUNTERSHAFT SEC. GEAR
 3. THRUST PLATE, 26 mm
 4. SET RING, 25 mm

5. BLOCKING RING
 6. SYNCHRONIZER SPRING
 7. SYNCHRONIZER HUB
 8. SYNCHRONIZER SLEEVE

9. COUNTERSHAFT LOW GEAR
 10. THRUST WASHER
 11. BEARING RET. SET RING, 36 mm
 12. COUNTERSHAFT ROLLER BEARING

Fig. 6-3 Countershaft

C. Countershaft

CAUTION: Gears will slide off the countershaft if the small bearing end of the shaft is not tilted upwards.

1. Lift the countershaft from the crankcase.
2. Remove the needle bearing set ring, outer race and needle bearing.
3. Remove thrust washer and first gear.
4. Remove synchronizer as a unit or piece by piece; if removed separately the parts should disassemble in this order: block-

ing ring and spring, sleeve, hub and blocking ring and spring.

5. Remove second gear retaining snap ring, thrust washer and second gear.
6. The large ball bearing on the shaft is not removable. A new shaft must be installed to replace the bearing.
7. To assemble the countershaft, reverse the disassembly procedure and use Fig. 6-3 as reference.

NOTE: Before assembly, read Section 6-4, D, for proper alignment of the synchronizer unit.

D. Synchronizer Unit.

Special care should be taken when assembling the synchronizer unit. Close inspection will reveal that all the spline teeth on the inner portion of the sleeve are not the same. At three locations 120° apart are a pair of teeth which are larger. Likewise on the hub are three pair of spline grooves 120° apart which are deeper. When assembling the sleeve over the hub these teeth and grooves must match. If assembled properly, the punch mark on the sleeve must be centered in one of the three slots in the hub. See Fig. 6-4.

NOTE: Place the synchronizer unit with the grooved sleeve on the mainshaft only. Groove may face either direction.

E. Installation

After assembly the main and countershaft may be installed into the crankcase. Make sure to align the holes on the needle bearing retainer with the protrusions on the set rings. Once installed, check backlash and side clearance of all gears.

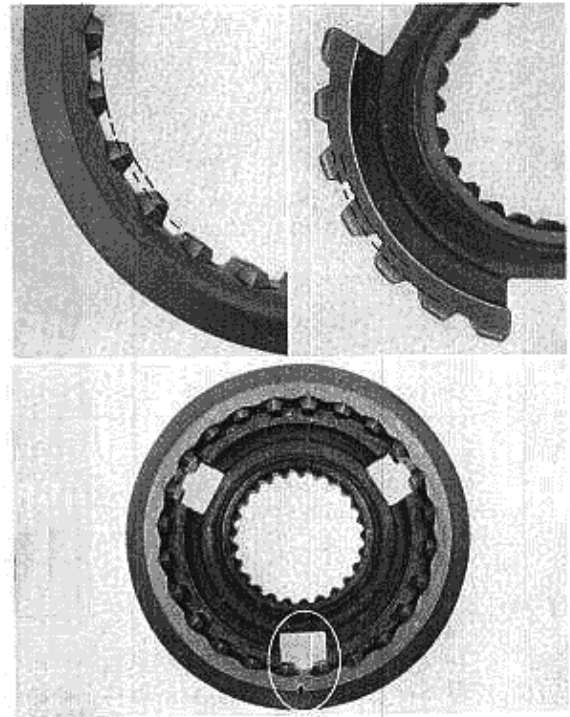
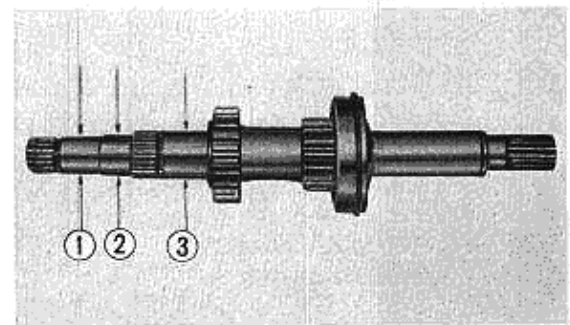

Fig. 6-4 Synchronizer Alignment

6-5 INSPECTION

A. Mainshaft

After the mainshaft has been disassembled, inspect the remaining gears for chips, cracks or abnormal wear. The bearing surfaces should be checked for wear as shown in Fig. 6-5. The ball bearing should be checked and replaced if necessary.



① MAINSHAFT BEARING JOURNAL
② 4TH GEAR BEARING JOURNAL
③ 3RD GEAR BEARING JOURNAL

Fig. 6-5 Mainshaft Bearing Check

| MAINSHAFT | ASSEMBLY STANDARD | SERVICE LIMIT |
|--------------------------|------------------------------|----------------|
| Bearing Journal Dia. | 19.98-19.959 (.7866-.7858) | 19.92 (.7842) |
| Fourth Gear Journal Dia. | 22.00-21.987 (.8661-.8656) | 21.95 (.8642) |
| Third Gear Journal Dia. | 26.00-25.987 (1.0236-1.0231) | 25.95 (1.0216) |

B. Countershaft

After the countershaft has been disassembled check the remaining gears for chips, cracks or abnormal wear. The bearing surfaces should be checked for wear as shown in Fig. 6-6. Check the ball bearing for wear. This bearing is not removable and if it shows wear the countershaft must be replaced.

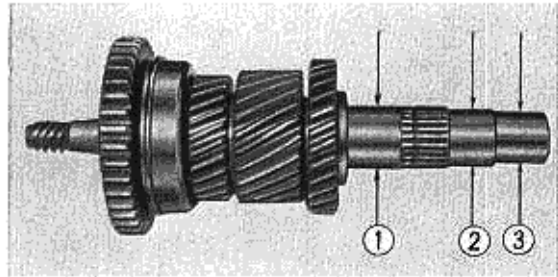

① 2ND GEAR BEARING JOURNAL
② 1ST GEAR BEARING JOURNAL
③ COUNTERSHAFT BEARING JOURNAL

Fig. 6-6 Countershaft Bearing Check

| COUNTERSHAFT | ASSEMBLY STANDARD | SERVICE LIMIT |
|--------------------------|------------------------------|----------------|
| Bearing Journal Dia. | 19.98-19.959 (.7866-.7858) | 19.92 (.7842) |
| Second Gear Journal Dia. | 25.98-25.959 (1.0228-1.0220) | 25.92 (1.0205) |
| First Gear Journal Dia. | 22.98-22.959 (.9047-.9039) | 22.92 (.9024) |

C. Gears

The free rotating gears that have been removed from the main and countershaft should be checked for chips, cracks or abnormal wear. Check the internal diameter of the gear bushing or bearing as shown in Fig. 6-7, replace if wear is beyond service limit. If third gear on the mainshaft is replaced be sure to install a new bearing retaining ring in the gear.

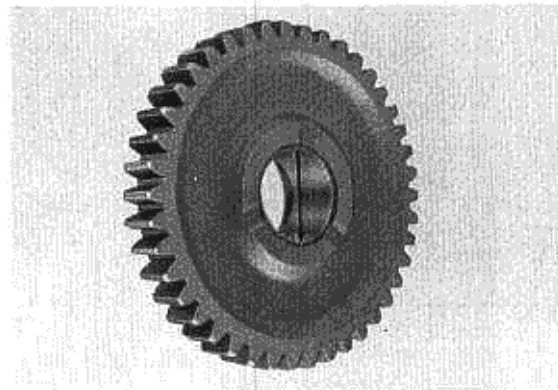

Fig. 6-7 Measuring Gear I.D.

| GEAR I.D. | ASSEMBLY STANDARD | SERVICE LIMIT |
|---------------|------------------------------|----------------|
| First | 23.0-23.027 (.9055-.9066) | 23.08 (.9086) |
| Second | 26.0-26.027 (1.0236-1.0247) | 26.08 (1.0268) |
| Third | 30.0-30.02 (1.1811-1.1819) | 30.05 (1.1831) |
| Fourth | 26.007-26.02 (1.0264-1.0244) | 26.05 (1.0256) |
| Reverse Idler | 14.077-14.050 (.5542-.5531) | 14.2 (.5590) |

D. Backlash and Side Clearance

NOTE: Backlash and side clearance measurements are made with the shafts installed in the crankcase.

1. Backlash can be checked by locking one gear and measuring the amount of play in the meshing gear. Excessive backlash is cured by replacing the gear or gears in question.

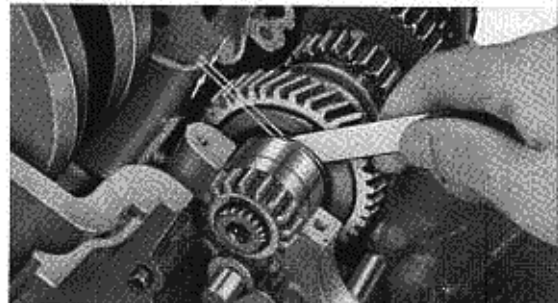

Fig. 6-8A Measuring Gear Side Play

2. Gear side clearance should be measured with a feeler gauge at the locations shown in Figs. 6-8A & B, side clearances which are not within specifications should be noted for reassembly. Varying thickness thrust washers are available to obtain proper side clearance of fourth gear on the mainshaft and first gear on the countershaft.

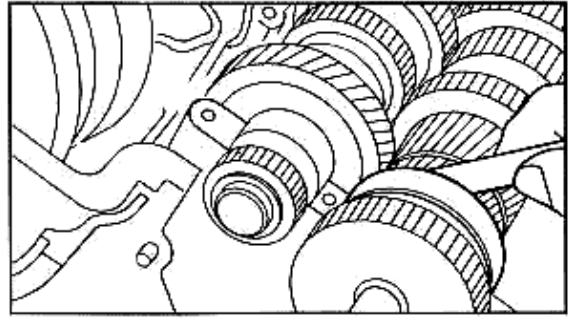

Fig. 6-8B Measuring Gear Side Play

| BACKLASH | ASSEMBLY STANDARD | SERVICE LIMIT |
|---------------------------|---------------------------|---------------|
| Gear Backlash (all gears) | 0.064-0.128 (.0025-.0050) | 0.2 (.0079) |

| GEAR SIDE PLAY | ASSEMBLY STANDARD | SERVICE LIMIT |
|----------------|-------------------------|---------------|
| First | 0.2-0.5 (.0079-.0197) | 0.8 (.0135) |
| Second | 0.1-0.5 (.0039-.0197) | 0.8 (.0135) |
| Third | 0.1-0.4 (.0039-.0157) | 0.8 (.0135) |
| Fourth | 0.35-0.65 (.0139-.0256) | 1.0 (.0394) |

3. Main and countershaft end play is determined by the amount of clearance between the ball bearing snap ring, the groove in the bearing outer race and the groove in the crankcase.
- Remove the bearing retaining ring and visually check the sides for obvious signs of wear. If worn, replace it.
 - Using a new or the old usable bearing retaining ring, check the clearance between it and the groove in the crankcase and the groove in the outer bearing race. Standard clearance is .03-.05 mm. (.0012-.0025 in.). Maximum allowance is .07 mm. (.0028 in.) total.

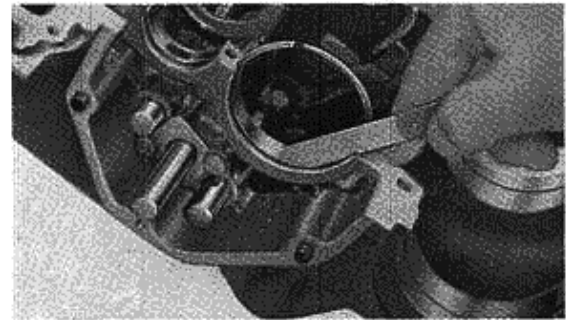

Fig. 6-9 Main and Countershaft End Play

E. Synchronizing Unit

1. **Blocking Ring.**—A visual inspection should be made of the grooves on the inside of the ring, the teeth along the outer edge and the top of the three index fingers which support the spring. The best method is to compare the old ring with a new one. If the grooves,

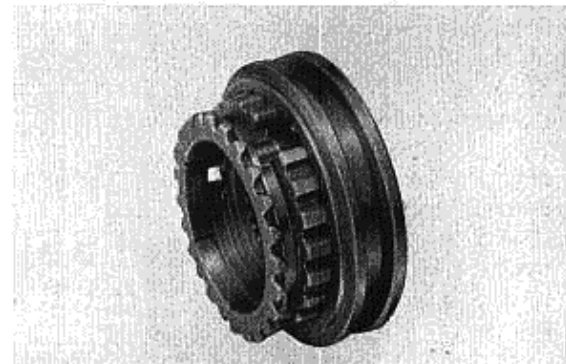

Fig. 6-10 Synchronizer Unit

teeth or fingers appear to be worn, the ring should probably be replaced. To verify possible wear of grooves, take the following steps:

- a. Lay a gear on a bench, cone side up.
- b. Lightly coat the cone portion with oil.
- c. Place the blocking ring over the cone, push down on the ring while giving a slight twist. This should seat the ring on the cone.
- d. Measure the clearance between the ring and the gear face as shown in Fig. 6-12.
- e. Replace the ring if necessary and repeat this procedure with the new blocking ring. If the clearance is still not proper the cone portion of the gear is worn and the gear should also be replaced.

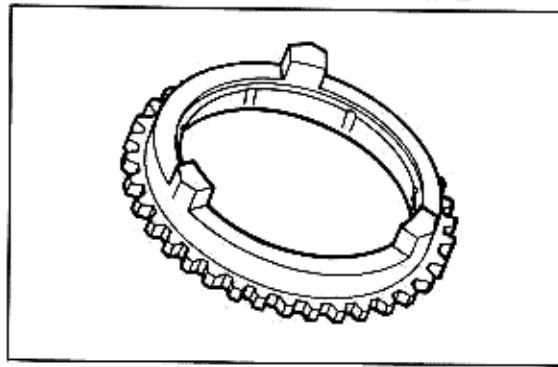

Fig. 6-11 Blocking Ring

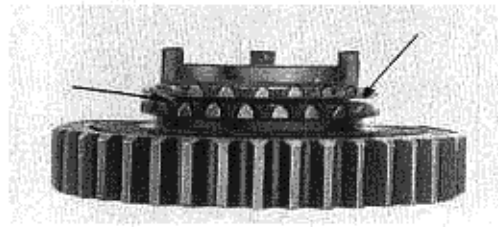

Fig. 6-12 Checking Blocking Ring Wear

| BLOCKING RING | ASSEMBLY STANDARD | SERVICE LIMIT |
|------------------------------|-----------------------|---------------|
| Inner Groove Surface | Visual Inspection | 0.5 (.0197) |
| Teeth | | |
| Blocking Ring Gear Clearance | 1.2-1.0 (.0472-.0394) | |

2. **Hub.**—The synchronizer hub is subject to little wear under normal conditions. Visually inspect the hub for chips or cracks. Check the inner and outer splines for grooving or scuffing.



Fig. 6-13 Synchronizer Sleeve

3. **Sleeve.**—The sleeve should be visually inspected. Pay close attention to the condition of the toothed portion at the end of each spline. Worn teeth cause the transmission to slip out of gear. Also check the side of each spline to see if a groove has been worn in it. (See Fig. 6-14.) Slide the sleeve back and forth over the hub to check for a smooth unrestricted motion. If the condition of the splines is questionable it is usually wise to replace the sleeve.

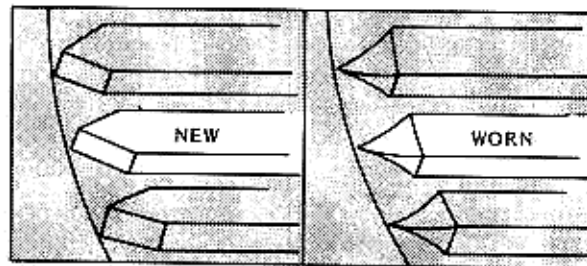

Fig. 6-14 Worn Sleeve Teeth

4. **Spring.**—Visually inspect the spring by comparing it with a new one. If it appears to be worn, has flat spots or is bent, replace it.

F. Shift Forks

Measure the wear to the shift fork fingers as shown in Fig. 6-14. Standard tolerances are 5.75–5.85 mm. (.2264–.2303 in.). Service limit is 5.45 mm. (.2146 in.). Also check the clearance between the shift fork fingers and the synchronizer sleeve. Standard clearance is 0.1–0.3 mm. (.0039–.0118 in.), maximum is 0.8 mm. (.0315 in.). Visually inspect the forks to see if they are bent. Replace the shift fork, sleeve or both if necessary.

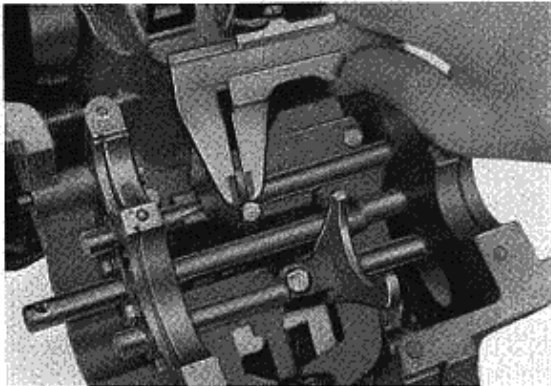

Fig. 6-15 Measuring Shift Fork Fingers.

G. Reverse Gear

1. The mainshaft reverse gear, idler gear and idler shaft can be inspected with the engine in the car by removing the right hand crankcase cover. If reverse gear on the countershaft is to be replaced the transmission must be disassembled.
2. Chipped reverse gears may indicate that reverse gear engagement has been forced.

In this event, the reverse idler gear shift fork must be inspected for warpage.

- a. With the reverse gears assembled, shift the transmission into the reverse position. At least 60% of the idler gear should mesh with the reverse gears.
 - b. If the idler gear meshes less than 60% of its total width, replace the shift fork.
 - c. Repeat Step A. If the idler gear still meshes less than 60% then the transmission should be disassembled, and the shifting mechanism inspected for damage to reverse shift plate.
3. If there are signs of wear on the fork at places other than the gear holding pads, replace the fork.
 4. Check the idler gear to shaft clearance and the reverse idle shaft holder bearings in the lower crankcase and the right crankcase sidecover.

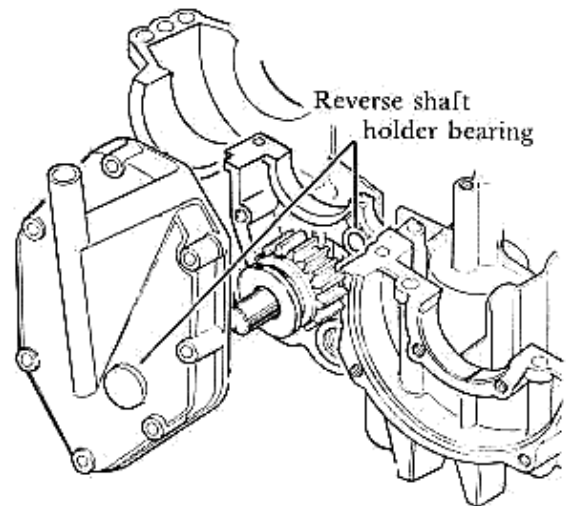

Fig. 6-16 Reverse Gear Shaft

| REVERSE GEAR IDLER | ASSEMBLY STANDARD | SERVICE LIMIT |
|------------------------|-----------------------------|---------------|
| Shaft O.D. | 13.982-12.996 (.5505-.5498) | |
| Shaft Holder I.D. | 14.000-14.027 (.5512-.5522) | |
| Shaft Holder Clearance | 0.016-0.061 (.0006-.0002) | |
| Shaft Gear Clearance | 0.066-0.11 (.0025-.0043) | 0.2 (.0079) |

6-6 GEAR SHIFT MECHANISM

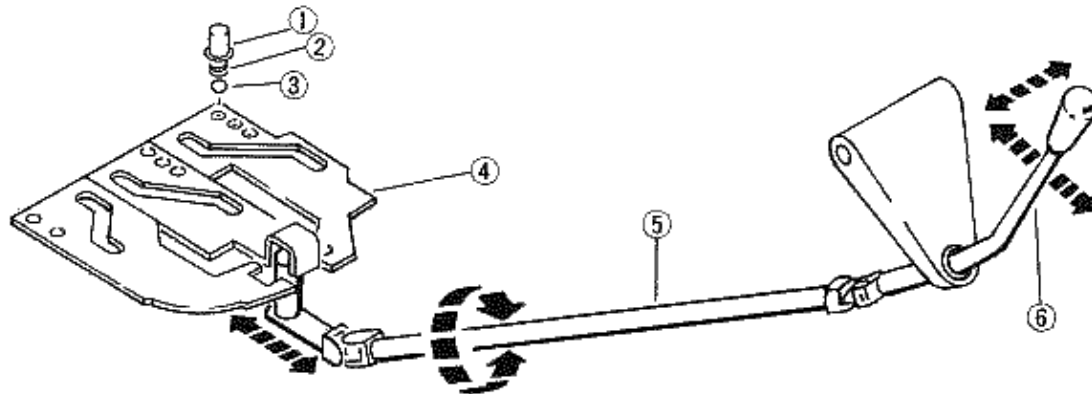

Fig. 6-17 Gear Shift Mechanism

| | |
|--------------|---------------|
| ① RETAINER | ④ SHIFT PLATE |
| ② SPRING | ⑤ SHIFT ROD |
| ③ STEEL BALL | ⑥ SHIFT LEVER |

A. Description and Operation

1. The gear shifting mechanism consists of three shift plates, shift forks and shift shafts, which are actuated by the shift lever and rod. A steel ball and spring contact each shift plate insuring a positive shift into each gear. An interlock mechanism acting upon the shift shafts prevents engagement of more than one gear at a time. (See Fig. 6-17.)
2. **Shift Plates**—There are three shift plates: first/second, third/fourth and reverse. The shift plates are actuated by moving the shift lever and shift rod. Each shift plate has a diagonal slot machined in it which accepts the top end of a shift fork. Movement of the plate causes movement of the shift fork and shift shafts. (See Fig. 6-18.)
3. **Shift Fork and Shafts**—Each shift fork is rigidly attached to a shift shaft which is used to guide the forks. The finger portion of the shift forks fit into a synchronizer sleeve and provide it with movement for engaging adjacent gears. (See Fig. 6-18.)

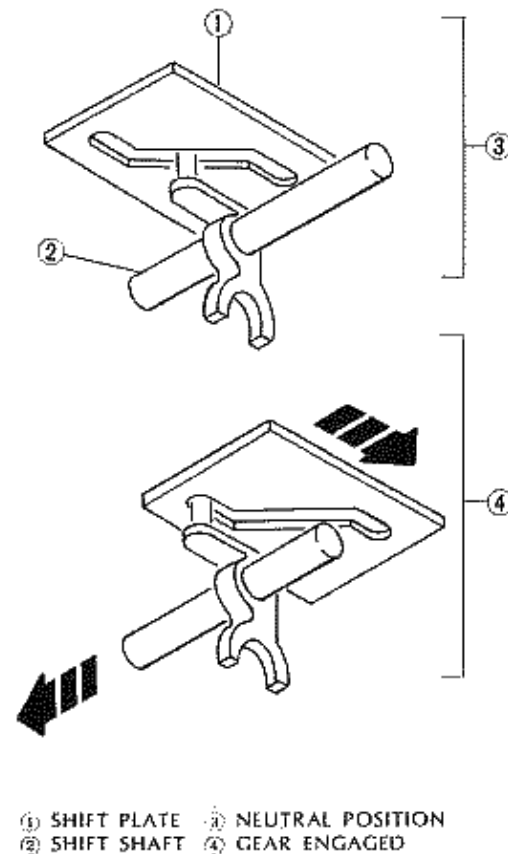
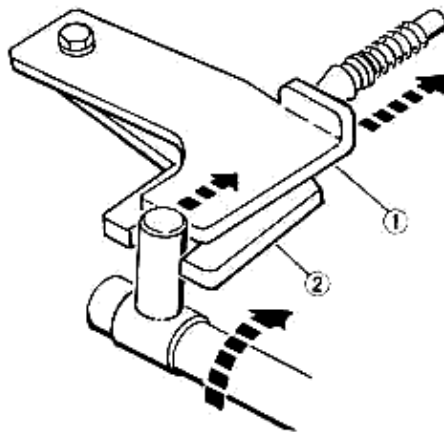

Fig. 6-18 Shift Plate and Fork

| | |
|---------------|--------------------|
| ① SHIFT PLATE | ③ NEUTRAL POSITION |
| ② SHIFT SHAFT | ④ GEAR ENGAGED |



① REVERSE SELECT LEVER
② REVERSE SHIFT PLATE

Fig. 6-19 Reverse Select Lever

4. **Reverse Select Lever**—The reverse select lever prevents accidental shifting into reverse gear. It is a spring actuated lever which must be overridden for the shift arm to engage the reverse gear shift plate. (See Fig. 6-19.)

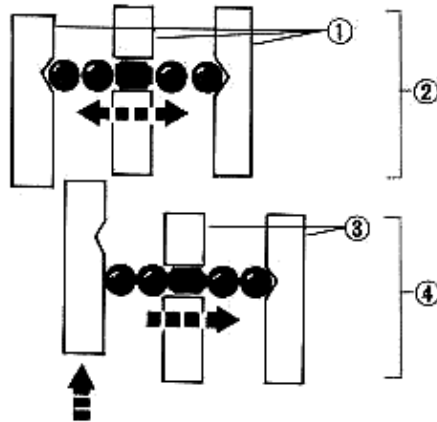

① SHIFT SHAFTS ③ THESE SHAFTS LOCKED
② NEUTRAL POSITION ④ GEAR ENGAGED

Fig. 6-20 Interlock Mechanism

5. **Interlock Mechanism** — The interlock mechanism consists of four steel balls and a pin which work in conjunction with the shift shafts. Its purpose is to prevent engaging two gears at the same time. It is simple in operation. (See Fig. 6-20.) When one shift shaft moves, the steel balls lock the other two shafts in place.

B. Disassembly

1. Bend out the lock tabs, and remove the bolts from the three shift forks.
2. Remove the set bolts and the interlock guide plate.
3. Slide the three shift shafts out of the case, be sure to retain the interlock pin and four steel balls.
4. Removal of the shift shafts also allows removal of shift forks.
5. Remove the two lock ball spring retaining bolts, washers, lock ball springs and steel balls.

NOTE: When assembling, torque bolts to 3 to 4 Kg-M (22 to 30 ft. lb.).

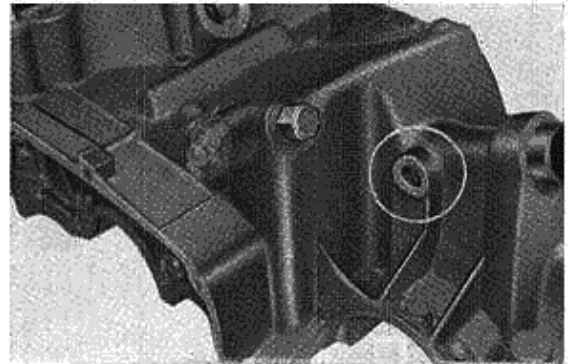
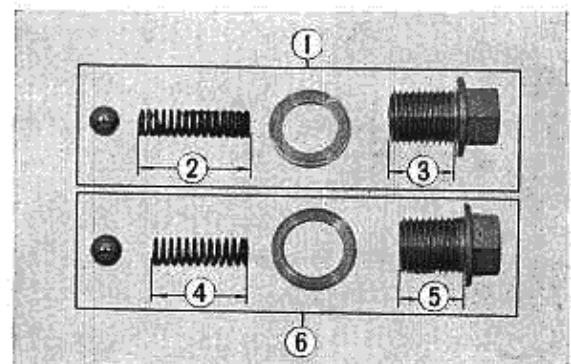
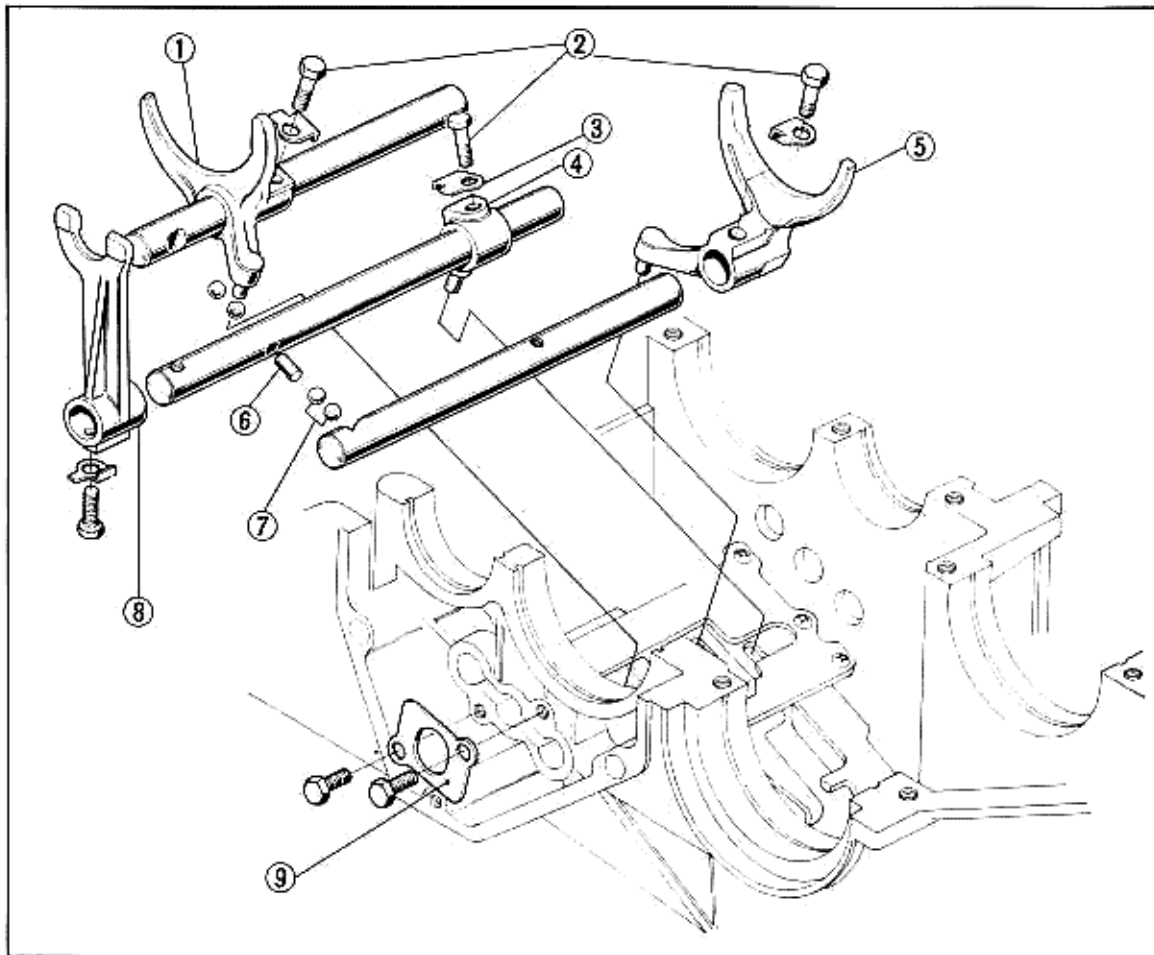

Fig. 6-21 Lock Ball Retaining Bolts



1. FOR GEAR SHIFT ROD
2. 33.5 MM
3. 26.5 MM
4. 28.0 MM
5. 23.5 MM
6. FOR REVERSE GEAR RESTRICTING PIN

Fig. 6-22 Lock Ball Mechanism



- | | | |
|----------------------------|-----------------------------------|--------------------------|
| 1. THIRD/FOURTH SHIFT FORK | 4. REVERSE SHIFTER | 7. STEEL BALL |
| 2. SHIFT FORK SETTING BOLT | 5. FIRST/SECOND SHIFT FORK | 8. REVERSE SHIFT FORK |
| 3. LOCK WASHER | 6. SHIFT FORK SHAFT INTERLOCK PIN | 9. INTERLOCK GUIDE PLATE |

Fig. 6-23 Shift Forks and Shafts

6. Remove the bolts, the reverse pin return spring seat and the seat gasket followed by removal of the reverse gear pin spring and the reverse gear restriction pin.
7. Bend out the locking tab and remove the shift arm set bolt. (See Fig. 6-23.)
8. Pull out the gear shift rod and disassemble the gear shift arm, oil seal seat, and the oil seal.
9. Remove the gear shift plate assembly set bolts and separate the gear shift guide plate assembly from the lower crankcase.

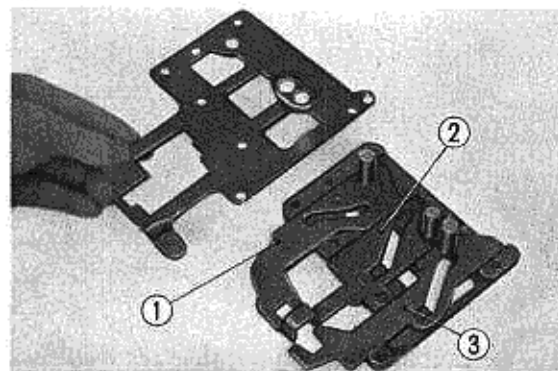
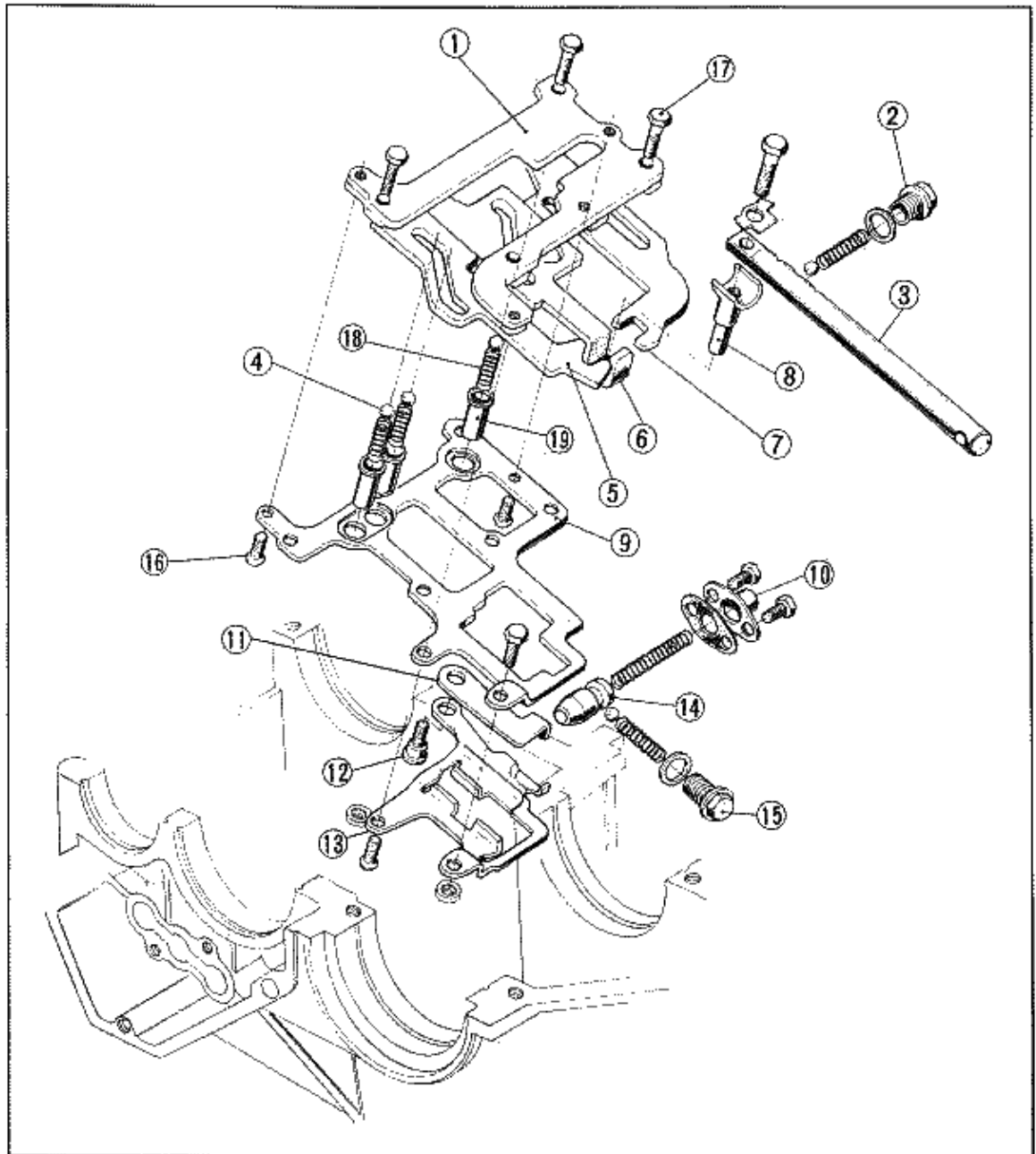

Fig. 6-24 Shift Plates

| |
|-----------------------|
| ① REVERSE SHIFT PLATE |
| ② LOW/2ND SHIFT PLATE |
| ③ 3RD/TOP SHIFT PLATE |



- | | | |
|-------------------------------|----------------------------------|---------------------------------|
| 1. GEAR SHIFT PLATE COVER | 7. REVERSE SHIFT PLATE | 14. REV. GEAR RESTRICTING PIN |
| 2. BALL SPRING RETAINING BOLT | 8. GEAR SHIFT ARM | 15. BALL SPRING RETAINING BOLT |
| 3. GEAR SHIFT ROD | 9. SHIFT GUIDE LOWER PLATE | 16. SHIFT GUIDE RETAINING BOLTS |
| 4. STEEL BALL | 10. REV. PIN SPRING SEAT | 17. SHIFT PLATE SET SCREWS |
| 5. THIRD/TOP SHIFT PLATE | 11. REVERSE SELECT LEVER | 18. STOPPER BALL SPRING |
| 6. LOW/SECOND SHIFT PLATE | 12. REV. SELECT LEVER PIVOT BOLT | 19. STOPPER BALL SPRING RET. |
| | 13. SHIFT GUIDE UPPER PLATE | |

Fig. 6-25 Gear Shifting Mechanism

10. To disassemble the shift plate assembly:
 - a. Remove the three shift plate setting screws.
 - b. Remove the reverse select lever pivot bolt.
 - c. Remove the lower plates from the plate assembly.
 - d. Disassemble the stopper ball spring retainers, the stopper ball springs and steel balls.

C. Assembly

To assemble the shift mechanism, reverse disassembly order.

D. Gear Shift Plate Inspection

1. Measure the width of the shifting slots in 3rd/4th plate, 1st/2nd plate and the reverse shift plate. Standard tolerance is 7.2-7.3 mm. (.284-.287 in.). Replace if measurement exceeds 7.5 mm. (.295 in.).

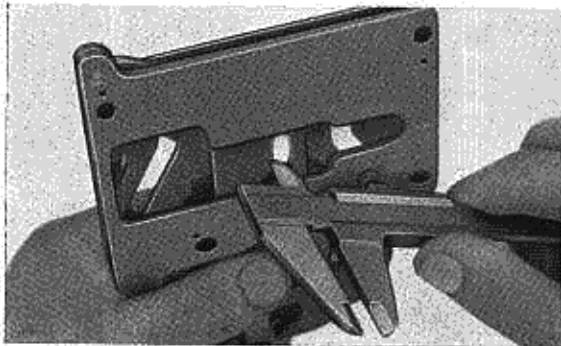

Fig. 6-26 Measuring Shift Plate Slot

2. Check all the shift plates for unusual wear, warpage and cracks. When the gear shift mechanism is assembled, make sure the plates and shafts move smoothly.

6-7 GEAR SHIFT LEVER AND ROD

A. Description

The shift lever which protrudes from the crankcase is directly connected through U-joints to the transmission rod. It is supported by a shift lever bracket which is bolted to the underside of the dash.

B. Removal and Installation

1. Slide back the large rubber boot located where the shift rod passes through the floor. Place the shift lever in first gear.
2. Remove the pin on the engine side of the universal joint with a shift rod pin driver (special tool) and separate the shift rod.

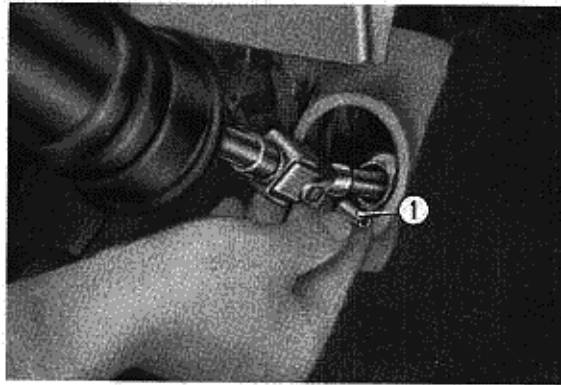

① JOINT PIN

Fig. 6-27 Joint Pin Removal

3. Remove the three nuts and washers retaining the shift lever bracket. The entire shift lever and rod may now be removed from the car.

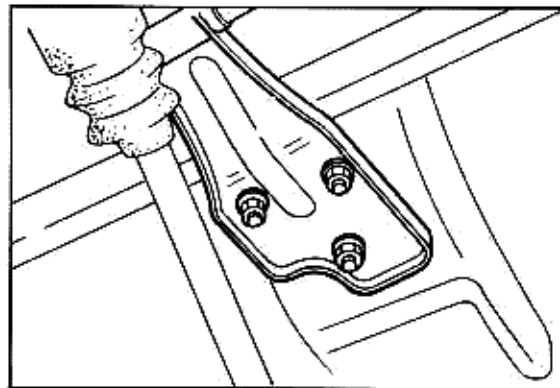
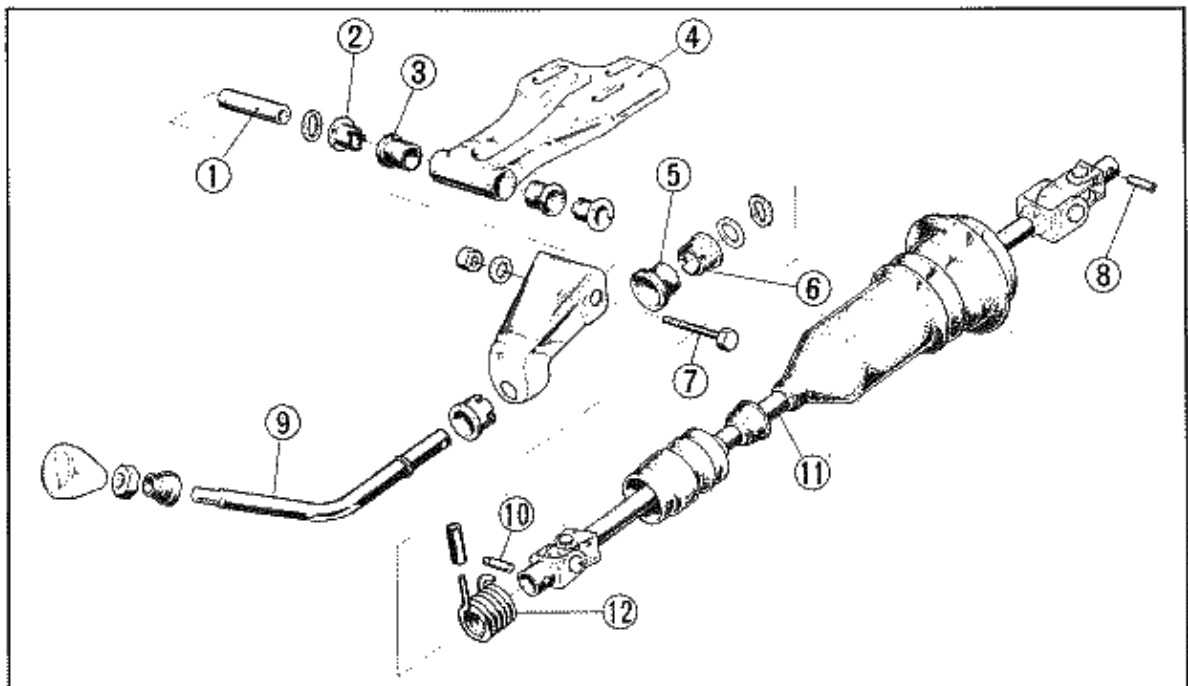

Fig. 6-28 Shift Bracket Removal



1. LEVER STAY PIVOT COLLAR
2. PIVOT PIN BUSHING
3. PIVOT PIN BUSHING
4. SHIFT ROD BRACKET

5. SHIFT LEVER BUSHING CUSHION
6. SHIFT LEVER BUSHING
7. SHIFT LEVER BOLT
8. GEAR SHIFT ROD JOINT PIN

9. GEAR SHIFT LEVER
10. SHIFT LEVER PIN
11. GEAR SHIFT ROD
12. RETURN SPRING

Fig. 6-29 Gear Shift Rod and Lever

4. To install, reverse the removal sequence.
 - a. Use the following procedure to adjust shift lever position:
 1. With the shift lever in first gear, adjust the mounting bracket so the knob is approximately 2-3 inches from the front of the dashboard.
 - b. Make sure the spring and universal joints have a coating of grease.
- C. Disassembly and Assembly**
1. Remove the nut, washer and shift lever pin (bolt). Separate the shift rod bracket. Do not lose the spring washer.
 2. Removal of the lever stay pivot collar, pivot pin side pushing and pivot pin bushing should not be attempted unless they are to be replaced. The bushings must be destroyed to be removed.
 3. Remove the shift lever pin and then the gear shift rod.
 4. Remove the return spring, flat washer, spring washer and gear shift lever.
 5. The remaining parts which are the shift lever bushing cushion and shift lever bushing need not be removed unless they are to be replaced.
 6. To assemble, reverse the disassembly procedure and be sure to install the shift lever pin in the proper direction so it will retain the return spring. The lip which retains the spring should face the passenger side of the car.

D. Inspection

1. Check the large rubber boot for splits or cracks. This boot seals the passenger compartment from the engine. If this boot will not provide an adequate seal then replace the boot.
2. If the bushings within the assembly are worn allowing an excessive amount of clearance, replace the bushings. Check Section 6-1 for gear shift lever clearance and end play.
3. All other parts should be visually inspected for signs of excessive wear and replaced if necessary.

CAUTION: Do not remove bushings unless you intend to replace them.

7. DIFFERENTIAL

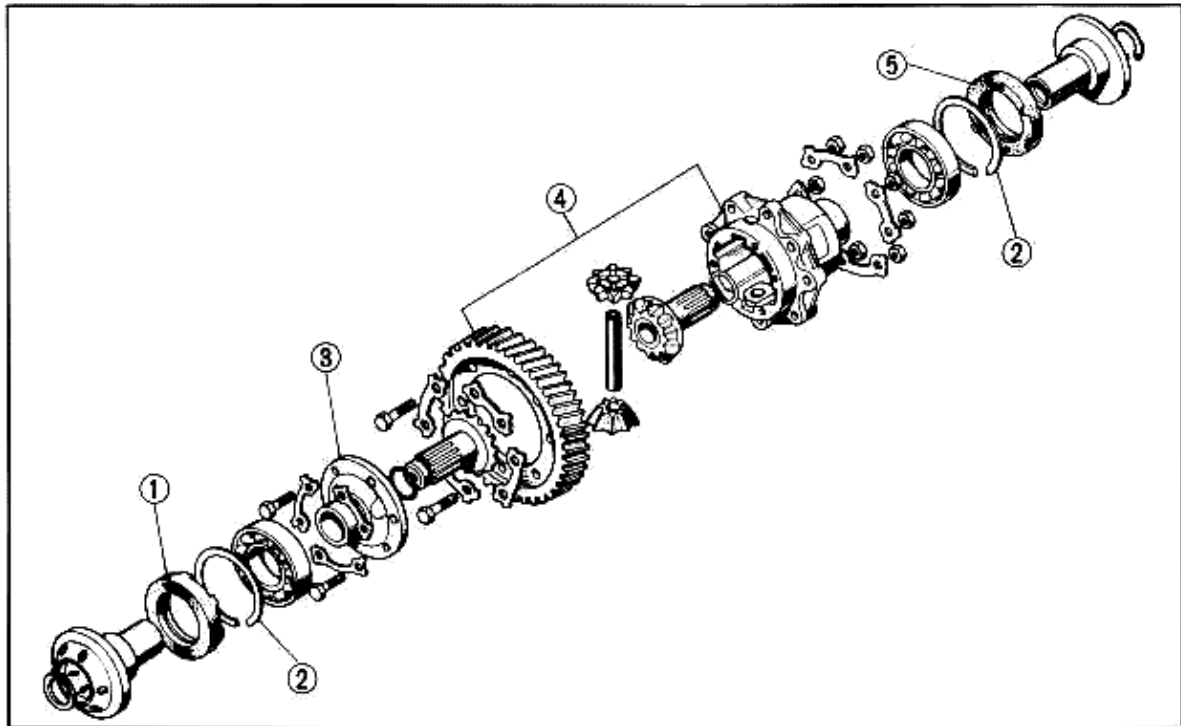

Fig. 7-1 ① Oil Seal, L ③ Differential Gear Case Cap ⑤ Oil Seal, R
 ② Set Ring ④ Final Direction Gear Assembly

Disassembly and assembly

- * The differential may be disassembled and assembled by referring to Fig. 7-1.
- * Replace the lock washers with new ones.
- * Separate oil seals are used for the left side and the right side. When installing the oil seals, make sure that each one is correctly positioned and the lips are not folded.
- * Install the 80 mm set rings so that their gaps face the lower crankcase side.
- * Install the differential gear case B so that it comes to the left side.

Differential oil seal replacement

Oil leakage from the differential gear is usually due to a worn oil seal (54×75×12) or a defective O-ring. If the oil seal is found defective upon inspection, replace it with oil seal

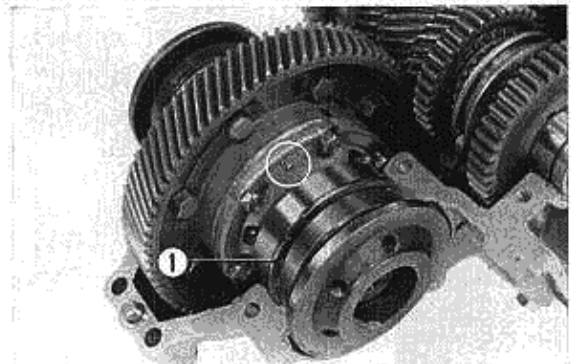

Fig. 7-2 ① Set Ring

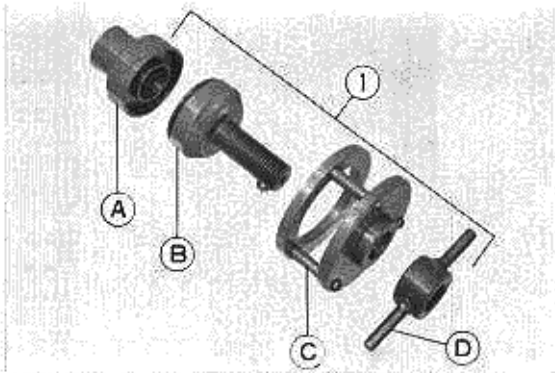

Fig. 7-3 ① Oil Seal Driver C (Special Tool)

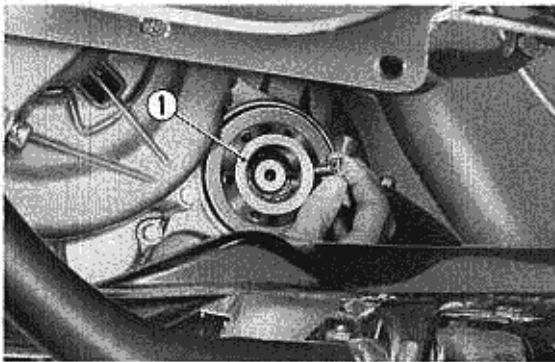

Fig. 7-4 ① Joint Flange

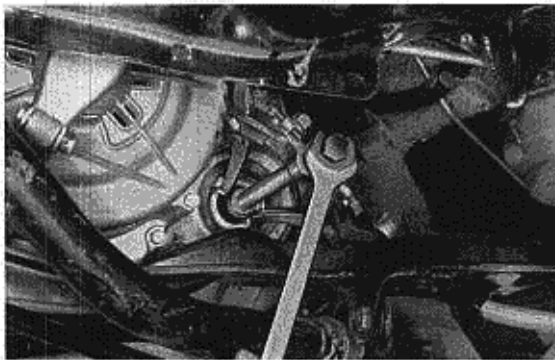

Fig. 7-5

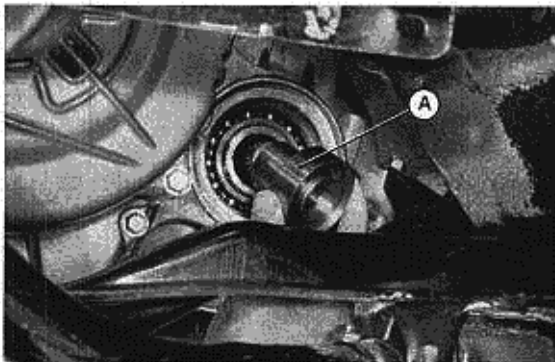

Fig. 7-6

driver C (special tool). When this replacement is made with the engine unit disassembled use of the special tool is not necessary. If the engine is installed in the car, observe the following procedure.

1. Jack up the body and drain the engine crankcase.
(approximately 1.5 liters (1.6 qts))
2. Clean the linkage between the drive shaft and the differential flange joint.
3. Disconnect the drive shaft from the joint flange. (Refer to Section 9. DRIVE SHAFT)
4. Remove the external circlip (22 mm) with a snap ring pliers and remove the joint flange by pulling it out with the bolt attached (Fig. 7-4).

NOTE: The oil may spill out at this time so position a container to catch it beforehand.

5. Remove the defective oil seal with the puller. Check to see that the oil seal spring has not been left in the differential gear case after removal.

6. Insert Ⓐ of the oil seal driver C into the side gear, and fit the external circlip (22 mm).

NOTE: The circlip must be properly installed.

7. Thread part ② of the tool into part ③.

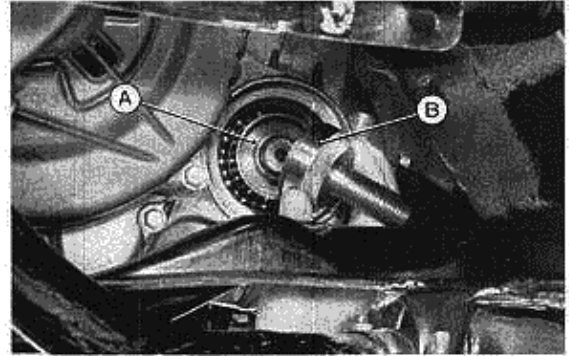

Fig. 7-7

8. The oil seal has grooves (refer to the Fig. 7-6) to return the oil to the differential gears and to prevent leakage. For this reason, the seal has to be installed correctly. The arrow marks and the "R" and "L" marks on the side of the oil seal, face the direction of rotation and the position of installation, respectively: "R" for right side, "L" for left side.

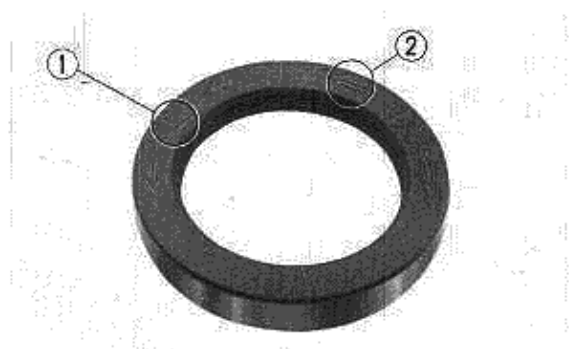

Fig. 7-8 ① Letter "R" or "L" ② Arrow

9. Fit the new seal over the entire circumference, and apply a soapy water solution or grease to outer edge of the oil seal to facilitate installation.

10. Attach part ④ of the tool to the oil seal.

11. Press the oil seal into position by turning the handle ⑤ of the seal driver C onto part ⑥.

12. After checking the oil seal fit, remove the tool and fit the external circlip (22 mm).

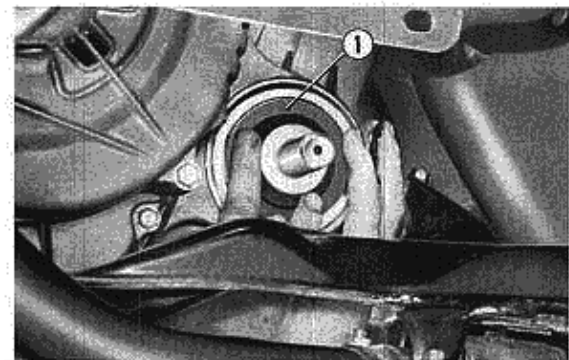

Fig. 7-9 ① Oil Seal

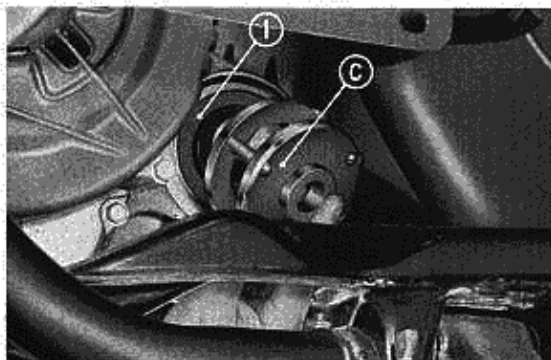

Fig. 7-10 ① Oil Seal

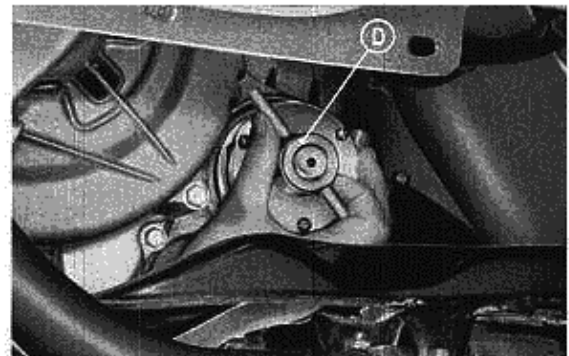

Fig. 7-11

8. CARBURETOR

Removed and disassembly

1. Disconnect the choke and accelerator wires from the plate A stay and also from the relief lever and throttle lever respectively.
2. Remove the connector from fuel solenoid valve and disconnect the unipower tube A. Disconnect the ground wire of the valve from the engine.
3. Separate the fuel tube from the carburetor. Cover the end of the fuel tube with a cap or vinyl or the like to prevent dust entry.
4. Remove the intake manifold clamp and remove the carburetor assembly by referring to Fig. 8-1.

NOTES:

1. Carefully disassemble the carburetor assembly on a clean plate so that the parts should not be lost or damaged.
2. Before assembling the carburetor assembly, wash its metal parts with cleaning solvent and its rubber parts with alcohol.

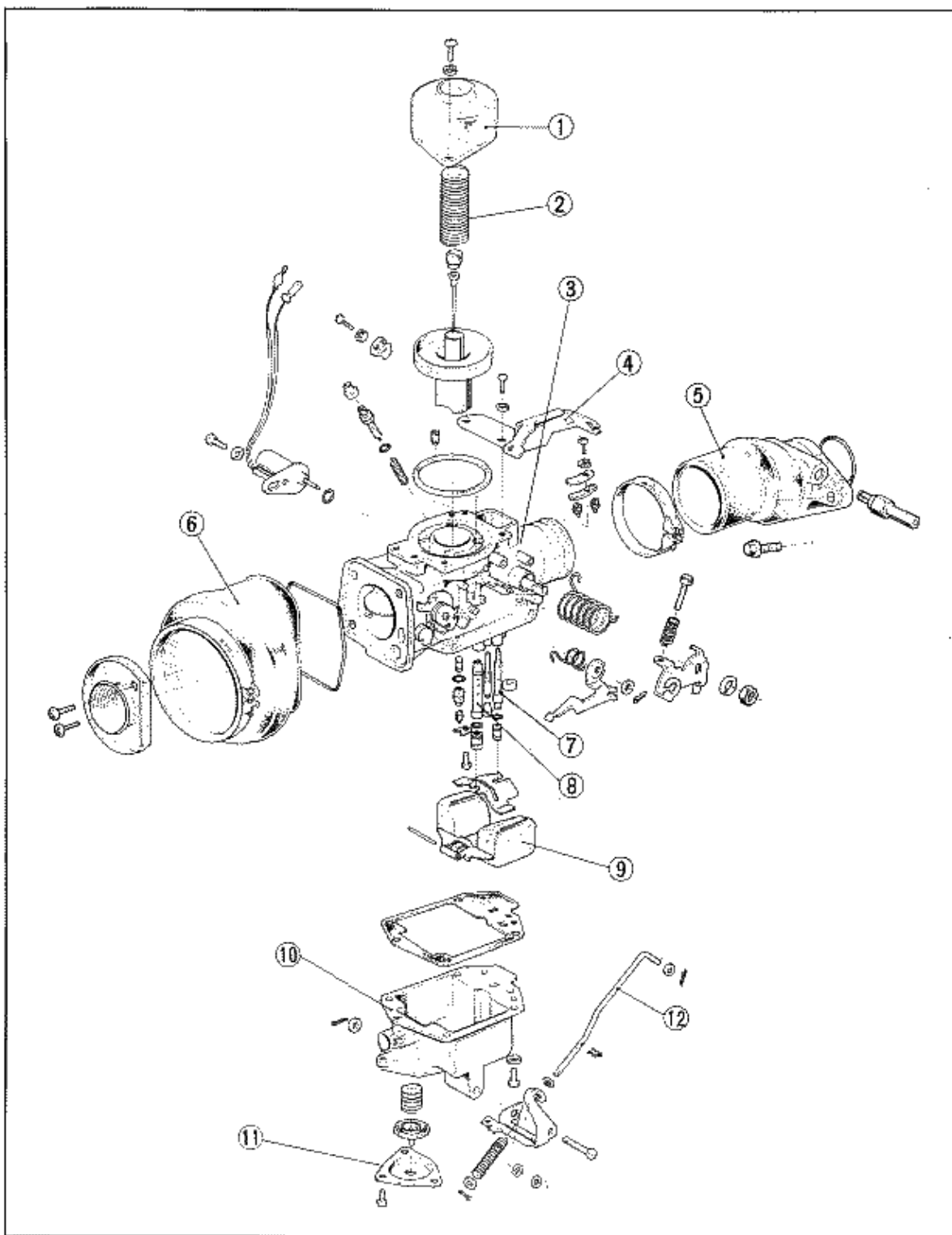

Fig. 8-1 ① Carburetor Cap ⑤ Intake Manifold ⑨ Carburetor Float
 ② Vacuum Piston Spring ⑥ Air Cleaner-To-Carburetor Bellows ⑩ Float Chamber Body
 ③ Carburetor Body ⑦ Primary Main Jet Nozzle ⑪ Accelerator Pump Cover
 ④ Plate A Stay ⑧ Needle Jet ⑫ Accelerator Pump Drive Rod

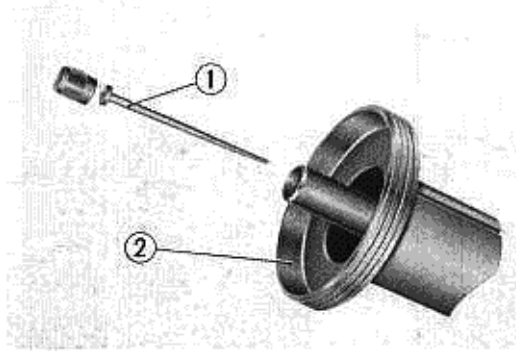

Fig. 8-2 ① Jet Needle
② Vacuum Piston Assembly

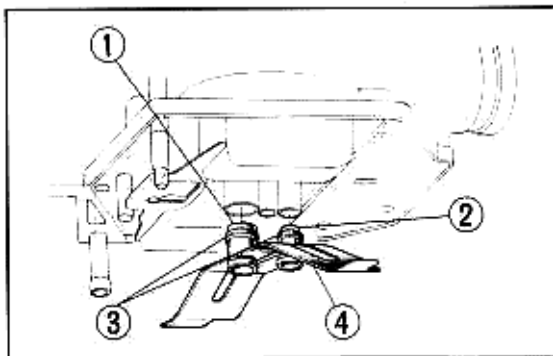

Fig. 8-3 ① Needle Jet ③ O-Ring
② Primary Main Jet Nozzle ④ Clip Plate A

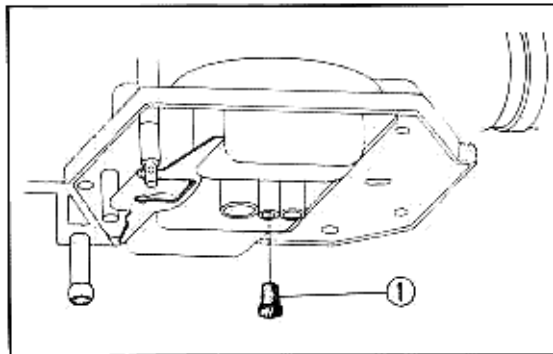

Fig. 8-4 ① Rubber Cap

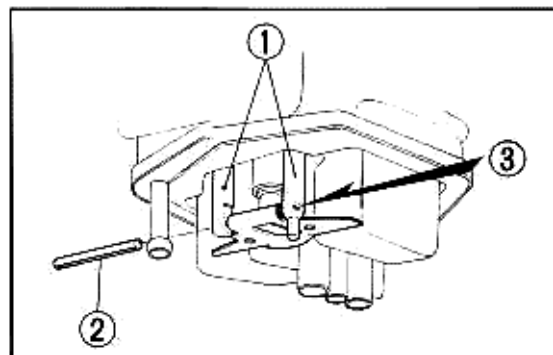

Fig. 8-5 ① Float Holder ② Float Pivot Pin
③ Lightly Tap Out Float Pivot Pin From
Longer Float Holder

Installation

* Precautions during assembly

1. Jet needle

Check the primary main jet nozzle and needle jet for clogging. Thoroughly clean them and apply compressed air if dirty.

- * Never use wire for cleaning the air and fuel passages of the primary main jet nozzle and needle jet, otherwise they may be damaged. Check the jet needle for bend. Replace it with new one if necessary. Check the contact of the vacuum piston assembly for damage. Replace it with new one if damaged. Check the vacuum piston assembly for smooth operation with a hand.

2. Primary main jet nozzle and needle jet

Check the O-rings of the primary main jet nozzle and needle jet for any damage. Replace any O-ring if damaged. The primary main jet nozzle and needle jet are installed to the carburetor body together with the carburetor float and float chamber body. When installing them to the carburetor body, securely tighten the float chamber body.

- * Exercise particular care that the clip plate should be installed in correct orientation (Fig. 8-3).

3. Slow jet rubber cap

A rubber cap is installed to the end of the slow jet. When the primary main jet nozzle and needle jet are removed, the rubber cap may become loose. Be sure that the cap is installed in place. Properly reinstall it if loose.

4. Float pivot pin

The float pivot pin is press-fitted into the float holders. Be sure to pull it out from the holders in the direction of arrow in Fig. 8-5 by lightly tapping it at the longer float holder side. Press-fit the float pivot pin into the float holders in the direction opposite to that in which it was removed.

- * Never tap the float holders during removing and installing the pin.

9. DRIVE SHAFT

Removal and disassembly

1. Remove the wheel cap, cotter pin, and loosen the castellated nut. Then raise car and remove front wheel.

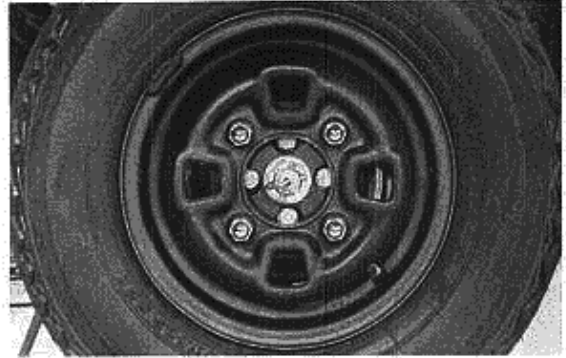

Fig. 9-1

2. Straighten the joint setting bolt lock plate tabs and remove the ball joint setting bolts.

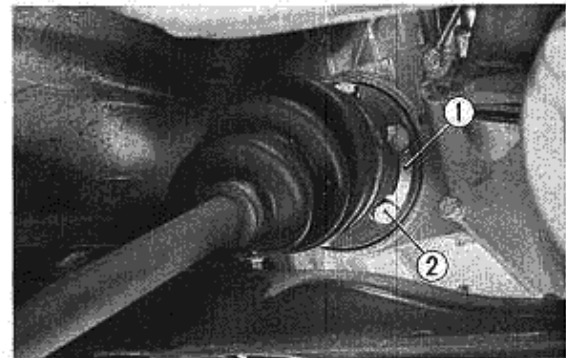

Fig. 9-2 ① Joint Setting Bolt Lock Plate
② Ball Joint Setting Bolt

3. Remove the front brake caliper as an assembly.

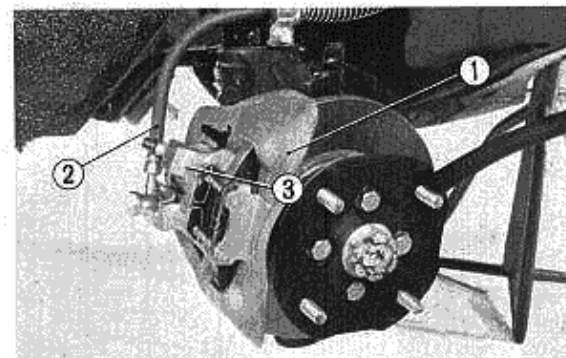

Fig. 9-3 ① Front Brake Yoke Unit
② Front Brake Hose
③ Front Brake Caliper Assembly

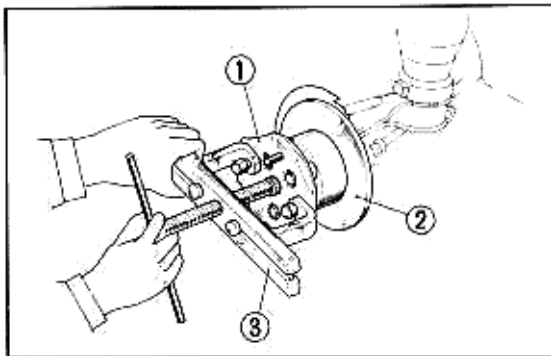

Fig. 9-4 ① Front Hub ③ Brake Drum Puller
② Front Brake Disk

4. Remove the front hub and front brake disk as an assembly.

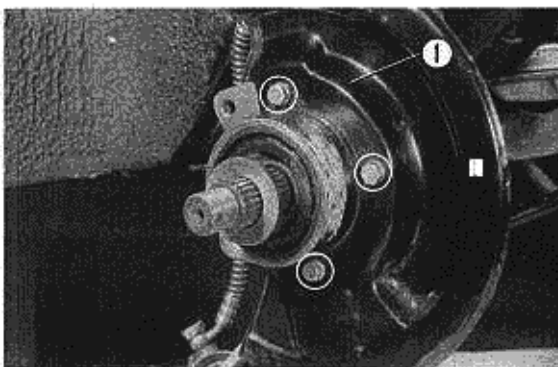

Fig. 9-5 ① Mudguard

5. Remove the front brake mudguard.

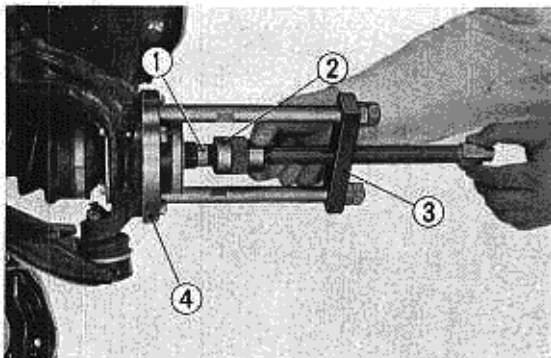

Fig. 9-6 ① Axle Shaft ③ Drive Shaft Replacer
② Attachment ④ Flange

6. Install the drive shaft replacer (special tool) with the drive shaft replacer flange bolted to the knuckle and the attachment set to the axle shaft as shown. Tighten the center bolt of the replacer with a socket wrench. Then separate the drive shaft from the knuckle.

NOTE: When the center bolt is hard to tighten, tap the bolt with a hammer while tightening.

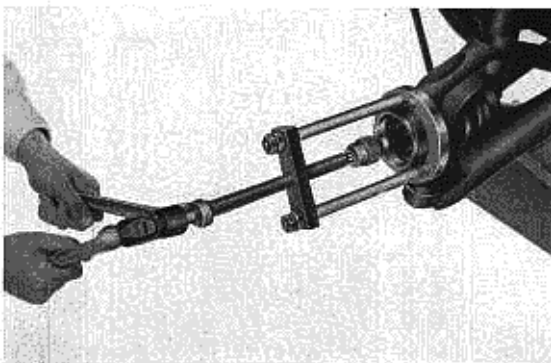

Fig. 9-7

7. Disassemble the ball joint as described below.
 - 1) Remove the bellows band.
 - 2) Remove the stopper ring with a screwdriver.
 - 3) Remove the external circlip. Now the inboard joint and inner retainer can be removed.

Assembly and installation

To assemble and install the drive shaft, reverse the removal and disassemble procedures. The following items must be carefully checked when the drive shaft is assembled and installed:

- * Wash all of the parts prior to assembly and check them for damage and excessive wear. Replace the bellows if broken or cracked.
- * Fit the bellows to the drive shaft and set the inner retainer on the drive shaft with a circlip.
- * Fill the joint flange with the recommended lubricant (Texaco "Molytex Grease 2"). Insert the joint flange and secure it with the internal stop ring.
- * Install the bellows band with the band fastener (special tool) and stake it at two places with a punch fitted to the fastener. Then cut off the end of the band leaving about 10mm (.39in) and bend it in such a manner as to cover up the staked portion.
- * To install the drive shaft assembly, reverse the removal procedure using the drive shaft replacer.

Torque Specification

| | |
|--------------------|-------------------------------|
| Drive shaft bolts: | 2.8-3.2kg-m (20.3-23.1lbs-ft) |
|--------------------|-------------------------------|

NOTES:

1. If the front hub is loose on the spindle, replace the hub or drive shaft with a new one.
2. For tightening the castellated nut, refer to Section 11-13.

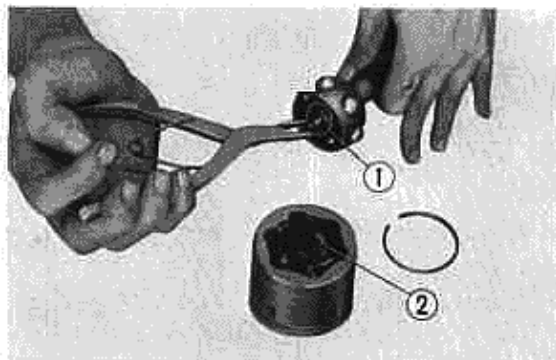

Fig. 9-10 (1) External Circlip (2) Grease

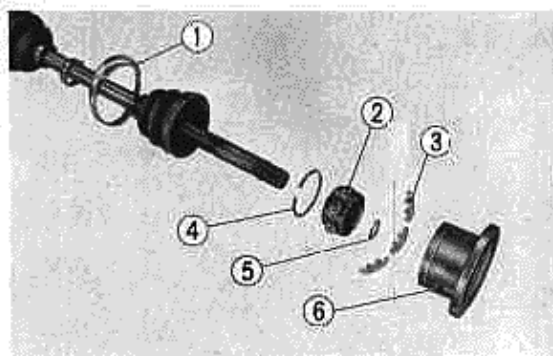

Fig. 9-8 (1) Band (2) Inner Retainer (3) Joint Setting Bolt Lock Plate (4) Ring (5) External Circlip (6) Inboard Joint

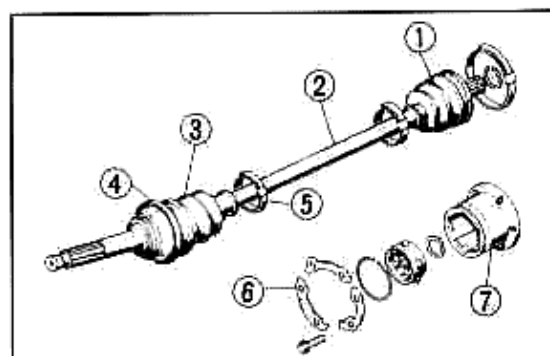

Fig. 9-9 (1) Inboard Joint Bellows (2) Drive Shaft (3) Outboard Joint Bellows (4) Joint Bellows Band (5) Joint Bellows Neck Band (6) Joint Setting Bolt Lock Plate (7) Inboard Joint

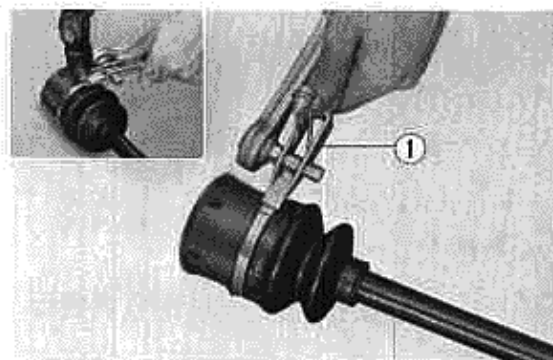

Fig. 9-11 (1) Band Fastener

10. STEERING SYSTEM

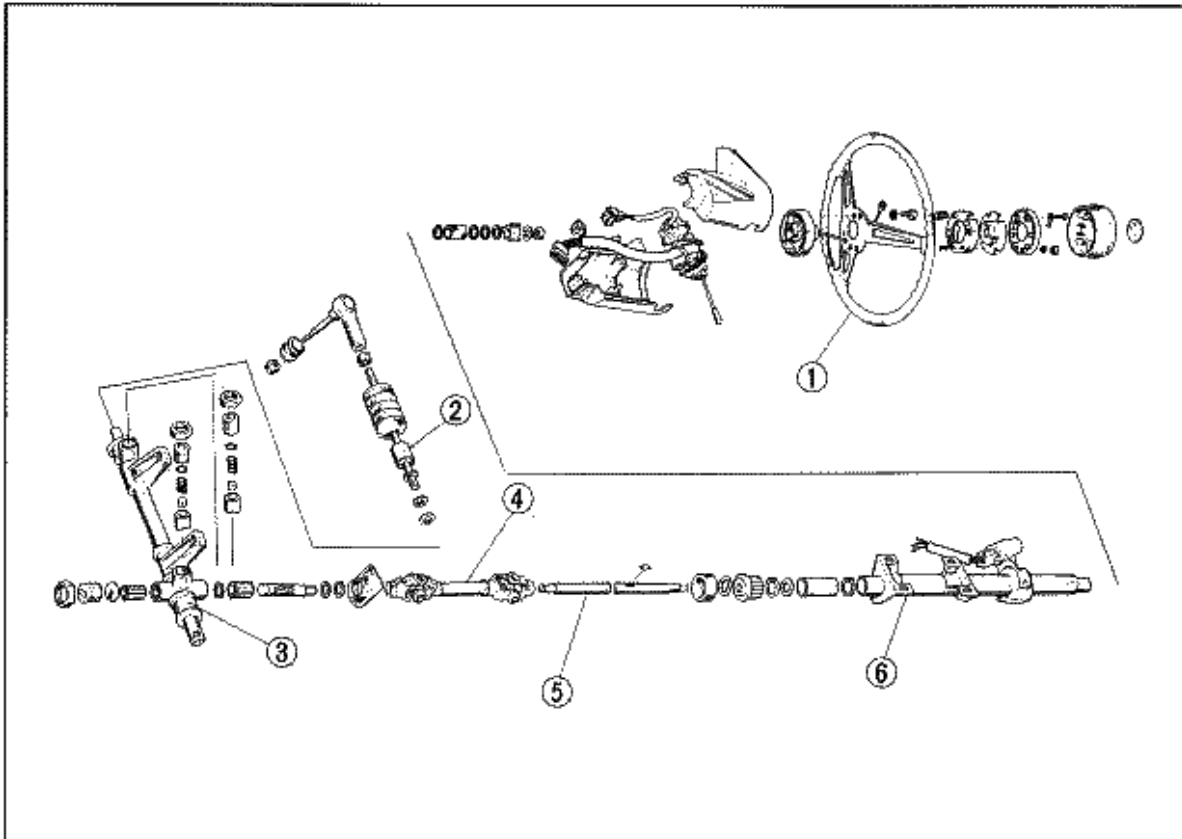

Fig. 10-1 ① Steering Wheel ③ Steering Gear Box Unit ⑤ Steering Shaft
 ② Steering Rack End Assembly ④ Steering Shaft Joint Assembly ⑥ Steering Column

10-1. Steering Shaft

Removal of steering wheel

1. Pull the steering wheel safety pad (horn button) off.
2. Remove the steering wheel retaining nut.
3. Disconnect the ground wire from the horn switch and remove the horn switch from the steering wheel.
4. Remove the steering wheel from the steering wheel foundation.
5. Remove the steering wheel foundation by using the steering wheel puller (special tool). (Fig. 10-2)

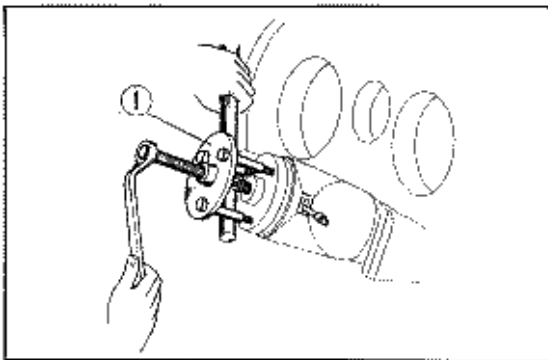

Fig. 10-2 ① Steering Wheel Puller

6. Pull the cancelling cam spring and spring washer off of the steering shaft.
7. The horn switch can be disassembled as shown in Fig. 10-3.

Installation

To install the steering wheel, reverse the removal procedure. The following are the items which must be checked carefully when the steering wheel is installed :

- * Align the lug on cancelling cam spring with the groove in the steering wheel foundation.
- * Apply a thin coat of grease to the spring set plate on the rear side of the steering wheel foundation.

Torque Specification

| | |
|--------------------------------|-------------------------------|
| Steering wheel retaining nuts: | 2.3-2.8kg-m (16.6-20.3lbs-ft) |
|--------------------------------|-------------------------------|

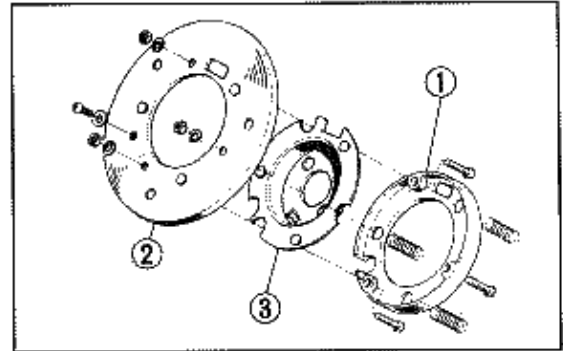

Fig. 10-3 ① Horn Insulator
② Horn Pad Retainer
③ Contact Plate Seat

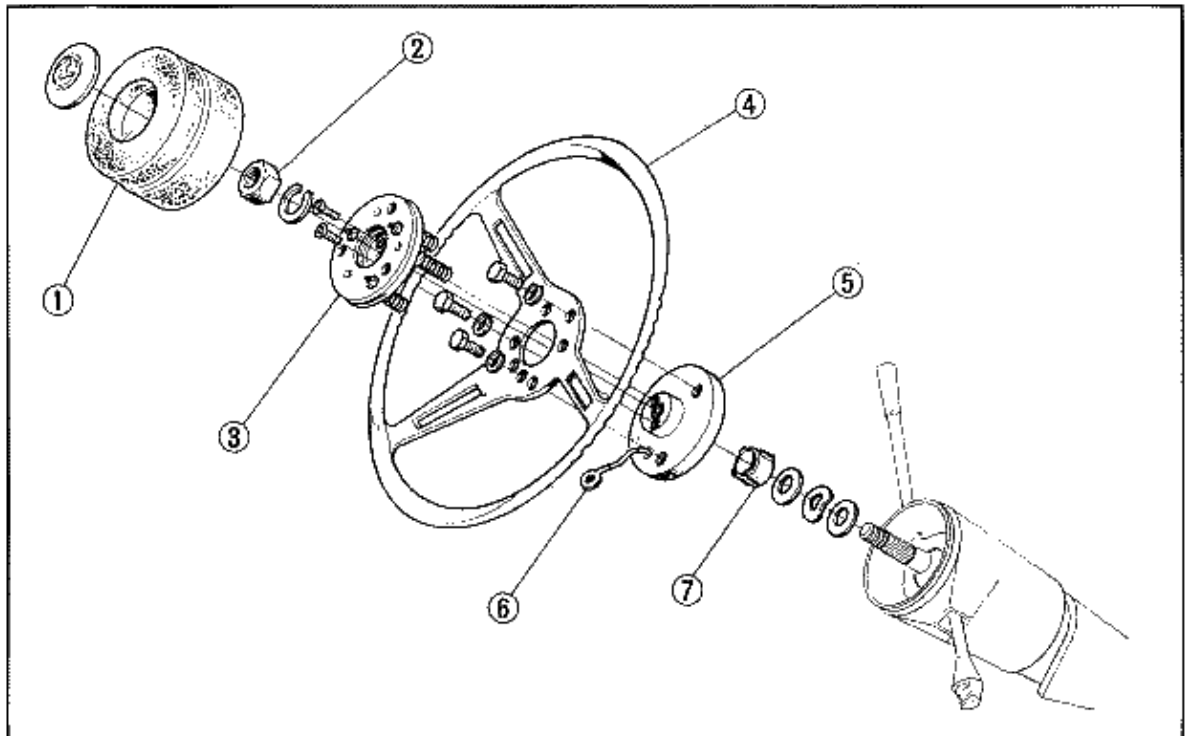

Fig. 10-4 ① Steering Wheel Safety Pad ④ Steering Wheel ⑦ Cancelling Cam Spring
② Steering Wheel Nut ⑥ Steering Wheel Foundation
③ Horn Signal Switch Assembly ⑧ Ground Wire

Disassembly and assembly of the steering shaft

1. Remove steering wheel (See 10-2 and 10-3).
2. Remove the steering column retaining bolts.
3. Remove the yoke retaining bolts at both ends of the joint assembly and separate the joint from the steering pinion gear and steering shaft.
4. Remove the upper and lower covers from the column.
5. Loosen the screws holding the key nut at the turn signal. Remove the key nut by lightly tapping the head of screws and remove the turn signal switch assembly.
6. Remove the wiper and washer switch as an assembly from the turn signal switch.
7. Pull the steering shaft out of the column and remove the bushings at the top and bottom of column. Replace the old bushings with new ones.

NOTE: Be sure to release the steering lock and leave the key in the steering lock when pulling out the steering shaft.

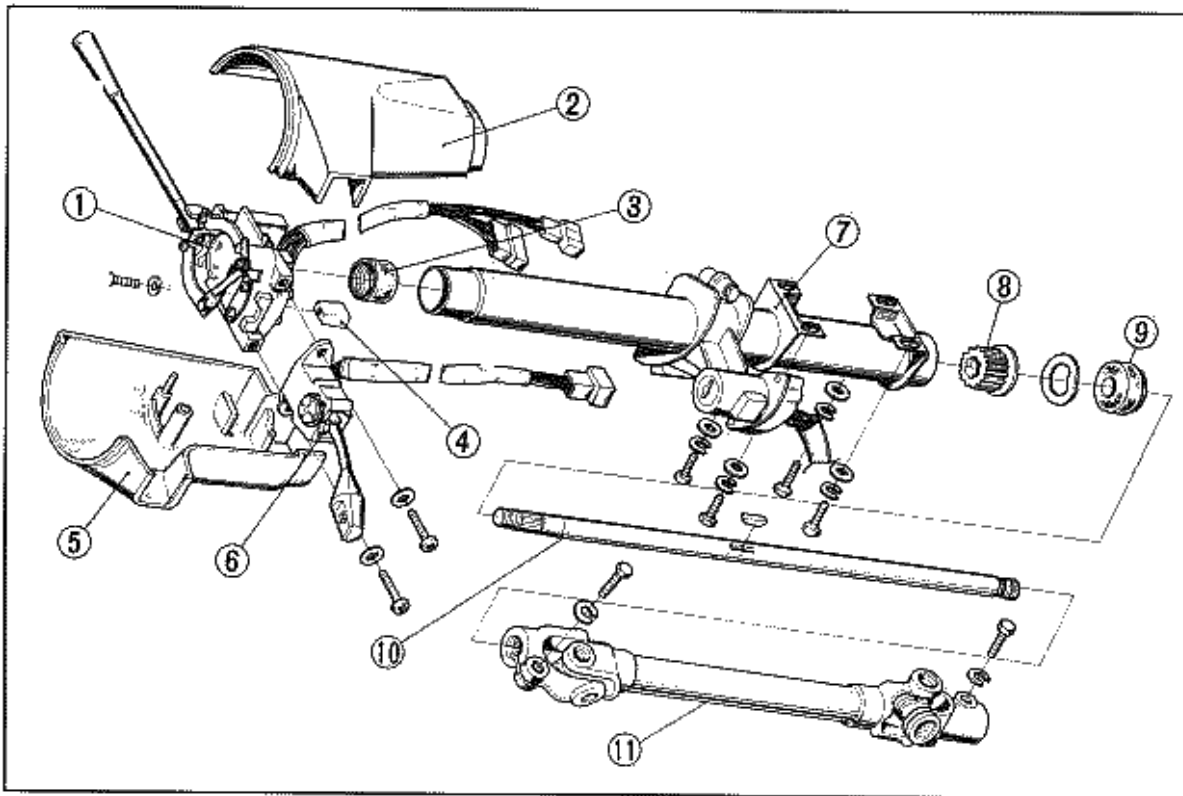

Fig. 10-5

| | |
|---------------------------------------|---------------------------------|
| ① Turn Signal Switch Assembly | ⑦ Steering Column |
| ② Steering Column Housing Upper Cover | ⑧ Steering Shaft Bottom Bushing |
| ③ Steering Shaft Top Bushing | ⑨ Rubber Spacer |
| ④ Key Nut | ⑩ Steering Shaft |
| ⑤ Steering Column Housing Lower Cover | ⑪ Steering Shaft Joint Assembly |
| ⑥ Wiper and Washer Switch Assembly | |

To assemble the steering shaft, reverse the disassembly procedure. The following items must be checked carefully when the shaft is assembled.

- * Align the lug and notch when installing the turn signal switch on the steering column.
- * The key nut functions as a wedge to lock the turn signal switch in place. Care should be exercised to position the key nut in proper direction.
- * Positioning of the steering column should be done after the steering wheel and joint assembly are in place.

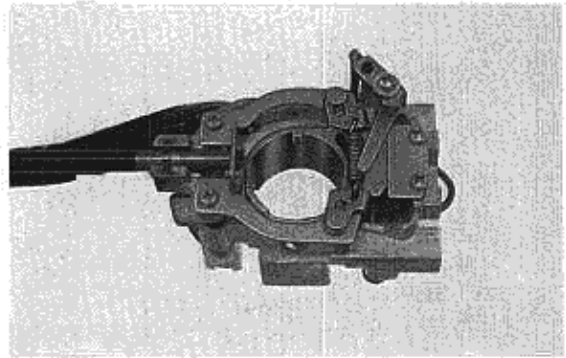

Fig. 10-6

10-2. Steering Gear Box

Removal and disassembly

Remove heater blower unit, carburetor, and fan housing.

1. Remove the castellated nuts at the tie-rod ends and separate the tie-rods from the knuckle arms with the tie-rod ball joint puller (special tool)
2. Disconnect the steering pinion from the steering joint.
3. Remove the steering gear box retaining bolts, two from the engine compartment side and two from the interior, and remove the gear box unit.
4. Removal of steering rack end assembly
Straighten the tie-rod lock washer. Turn the tie-rod with a wrench and separate the tie-rod from the steering rack.
5. Rack guide removal
Loosen the rack adjusting nut. Remove the rack adjusting bolts and take out the rack guide inner and outer springs, rack guide center (the one on pinion side only) and rack guide.
6. Turn the pinion clockwise and pull out the rack.
7. Removal of steering pinion
Loosen the pinion washer nut. Remove the washer bolt and push the steering pinion downward. Remove the pinion thrust washer and pull the pinion up and out.

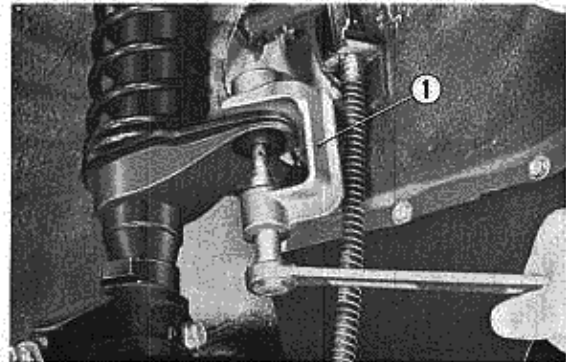

Fig. 10-7 ① Tie-Rod Ball Joint Puller

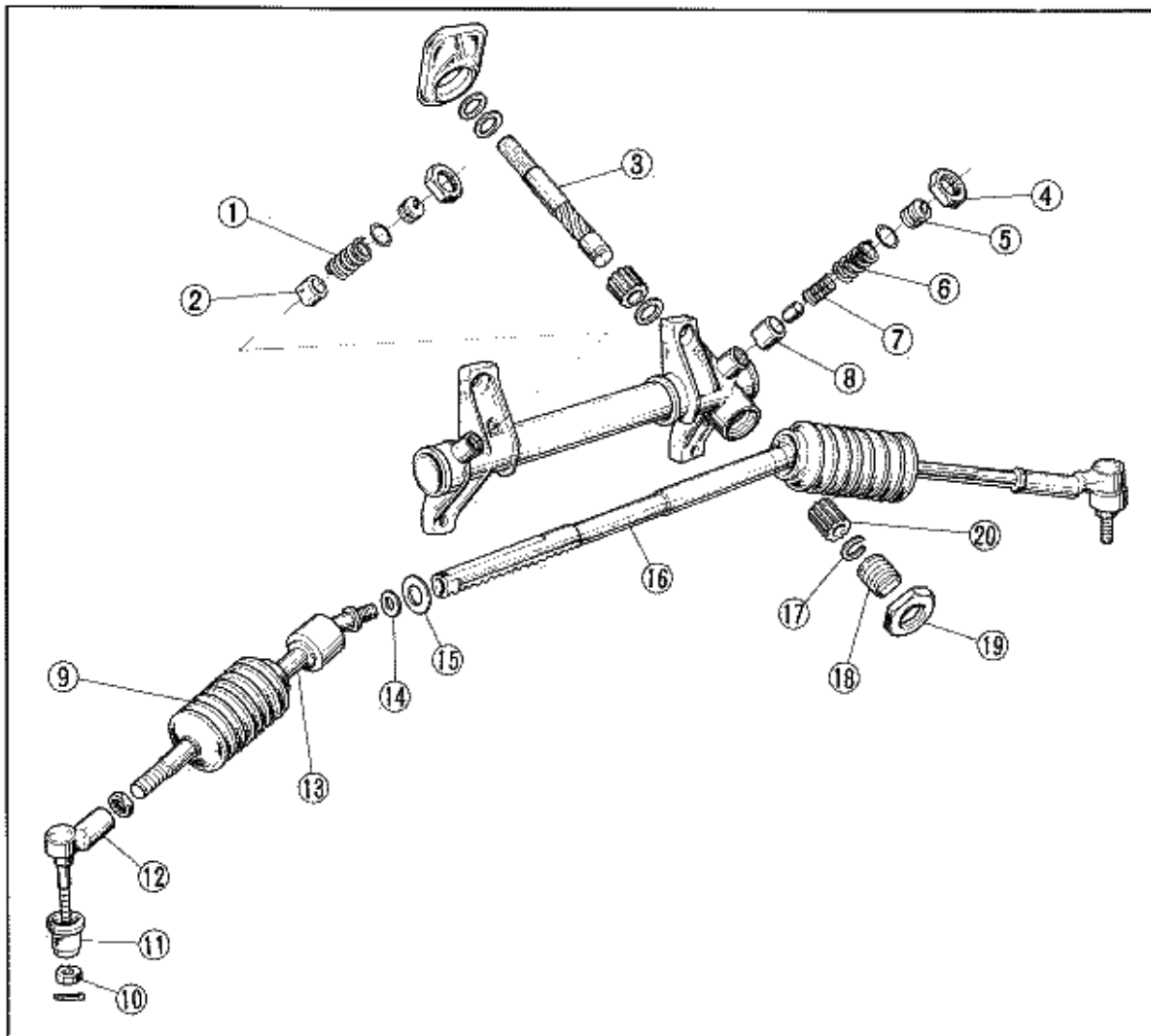

Fig. 10-B

| | | |
|-----------------------------|-----------------------------------|------------------------|
| ① Rack Guide Inner Spring B | ⑧ Rack Guide A | ⑬ Tie-Rod Thrust Plate |
| ② Rack Guide B | ⑨ Tie-Rod Bellows | ⑭ Steering Rack |
| ③ Steering Pinion | ⑩ 4.0-4.5 kg-m (28.9-32.5 lbs-ft) | ⑮ Pinion Thrust Washer |
| ④ Rack Adjusting Nut | ⑪ Tie-Rod End Boot | ⑯ Pinion Washer Bolt |
| ⑤ Rack Adjusting Bolt | ⑫ Tie-Rod End Assembly | ⑰ Pinion Washer Nut |
| ⑥ Rack Guide Outer Spring | ⑬ Steering Rack End Assembly | ⑱ Pinion Bushing |
| ⑦ Rack Guide Inner Spring | ⑭ Tie-Rod Lock Washer | |

Assembly and installation

To assemble and install the steering gear box, reverse the removal and disassembly procedures. The following items must be carefully checked when the steering gear box is assembled and installed :

- * Replace the tie-rod lock washers and cotter pins with new ones when installing the steering rack end assembly.

* Check the rack end ball joint for wear by shaking it fore-and-aft.

Check the pull or operating force of the joint with a spring scale at the time when the joint starts moving, making sure that it is within the range of standard value, 0.26–1.5kg (0.57–3.3lbs).

Another simple way of checking the force is to hold the rack in the horizontal position. The condition is satisfactory if the steering rack end does not lower by its own weight.

Torque Specifications

| | |
|--|-------------------------------|
| Rack end ball joint | 5.5–6.0kg-m (39.8–43.4lbs-ft) |
| Gear box retaining bolts | 2.0–2.4kg-m (14.5–17.4lbs-ft) |
| Tie-rod end lock nut | 4.0–4.5kg-m (28.9–32.5lbs-ft) |
| Tie-rod ball joint (to knuckle arm) | 4.0–4.5kg-m (28.9–32.5lbs-ft) |

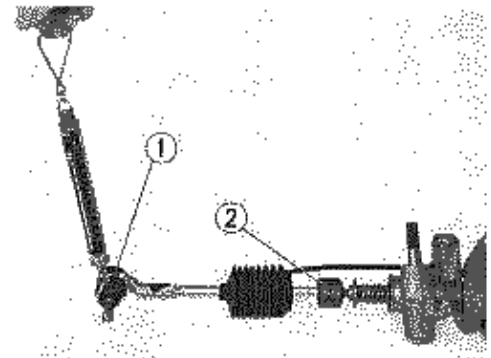

Fig. 10-9 ① Tie-Rod Ball Joint
② Rack End Ball Joint

11. BRAKE SYSTEM

General Precaution for Servicing

- * The brake system is the most important component of the automobile from the standpoint of driving safety. Of its several components, rubber parts play a particularly critical role. Whenever any damage or deterioration of these dust and fluid seals is noted, they must be replaced immediately.
- * Cover the painted surfaces with fender covers and rags so that they will not be damaged by the brake fluid.
- * Remove dirt and dust from the surfaces of the brake parts prior to disassembly of the brake system in order to prevent entry of dirt and water into the system.
- * The brake parts should be washed with new brake fluid after removing dust and dirt. The cylinder cups and other similar parts should be washed again with new brake fluid in a separate container prior to assembly.

11-1 Brake Master Cylinder

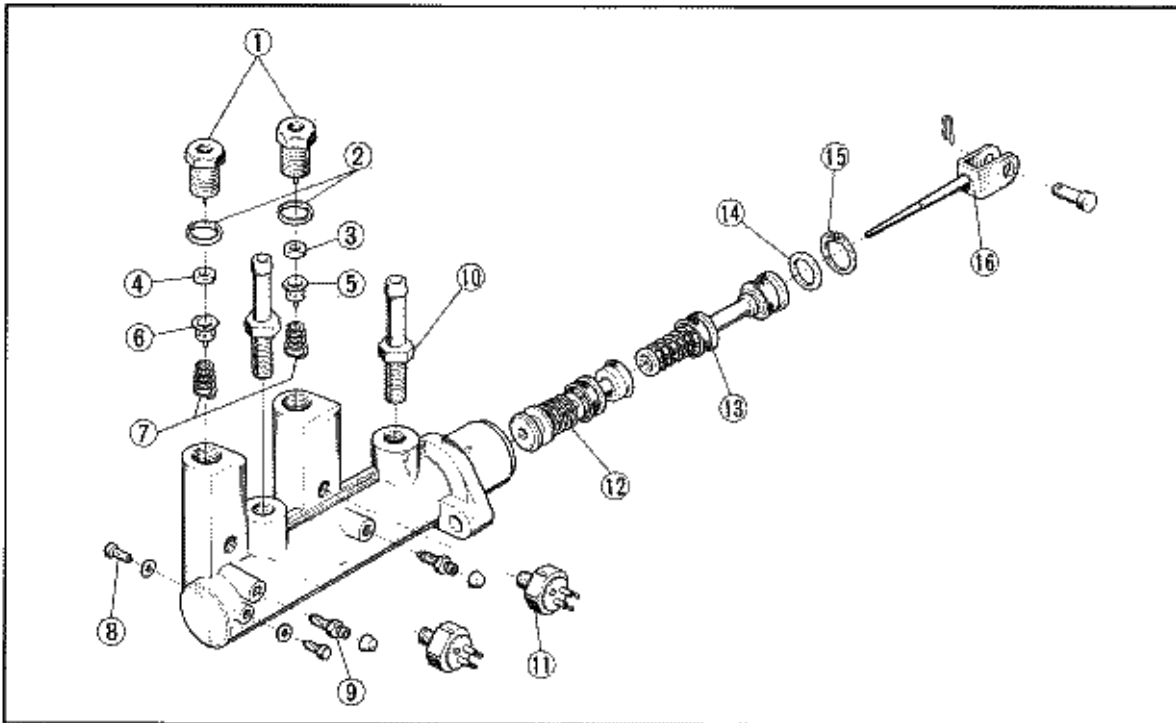

Fig. 11-1 ① Union Cap Assembly ⑦ Check Valve Spring ⑬ Secondary Piston Unit
 ② Union Cap Gasket ⑧ Stopper Bolt ⑭ Push Rod Bump Plate
 ③ Check Valve Washer ⑨ Bleeder Valve ⑮ Internal Circlip
 ④ Check Valve Seat ⑩ Brake Fluid Tube Connector ⑯ Push Rod Assembly
 ⑤ Check Valve (Rear) ⑪ Low Brake Fluid Warning Switch
 ⑥ Check Valve (Front) ⑫ Primary Piston Unit

Removal and disassembly

Cover the body surfaces with fender covers and rags when removing the brake master cylinder so that the painted surfaces will not be damaged by spilled brake fluid.

1. Remove the pedal link pin connecting the brake pedal and push rod. Then separate the push rod from the brake pedal.

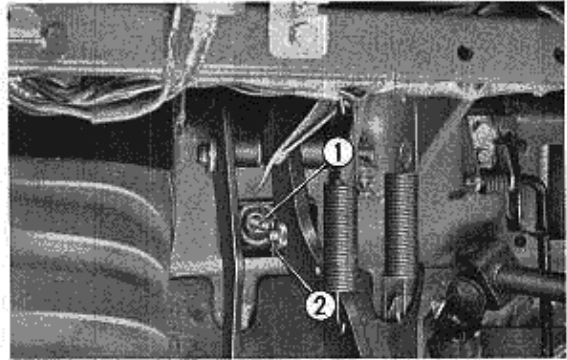

Fig. 11-2 ① Push Rod ② Pedal Link Pin

2. Remove the brake system warning switch wires, brake fluid tube and brake pipe from the brake master cylinder.

NOTE: Be careful not to spill brake fluid during these operations.

3. Remove the two master cylinder retaining bolts and remove the master cylinder as an assembly.

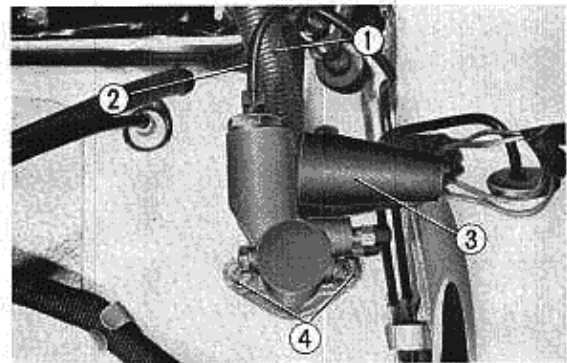

Fig. 11-3 ① Brake Fluid Tube
② Brake Pipe
③ Stop Switch Cord
④ Retaining Bolt

4. Remove the internal circlip and two stopper bolts, and remove the primary and secondary piston units.

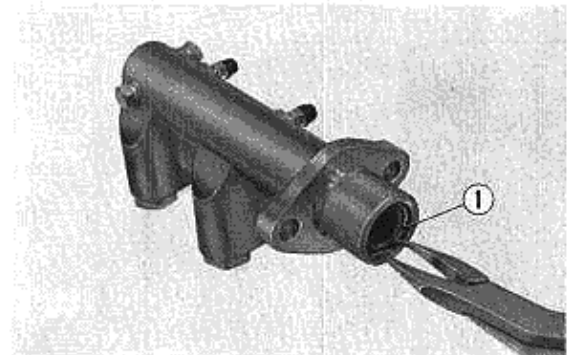

Fig. 11-4 ① Internal Circlip

5. Remove the brake pipe joints and check valves.

NOTE: Be careful not to interchange the front and rear check valves when assembling the brake pipe joints.

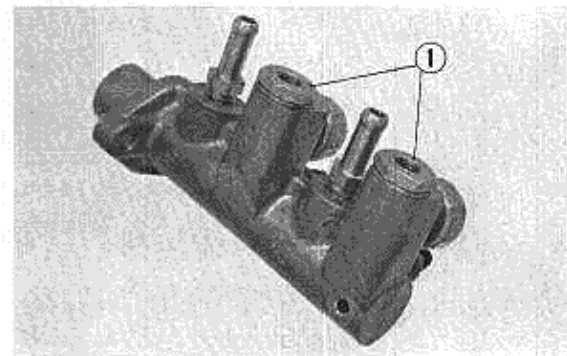

Fig. 11-5 ① Union Cap Assembly

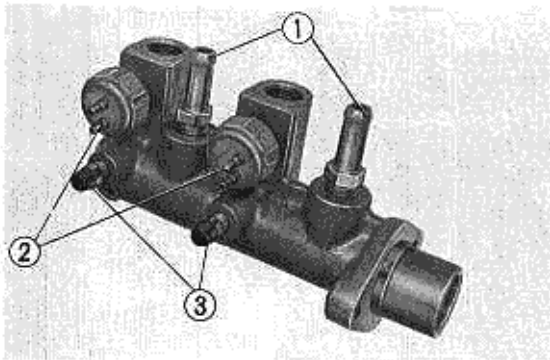

Fig. 11-6 ① Brake Fluid Tube Connector
② Low Brake Fluid Warning Switch
③ Bleeder Valve

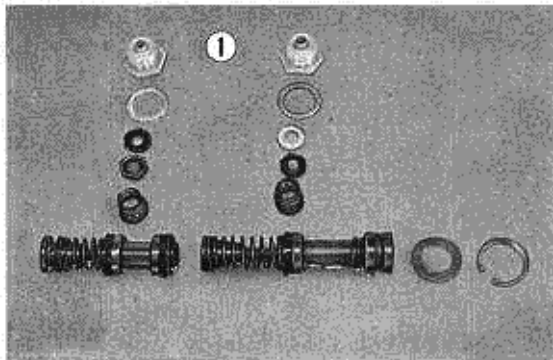

Fig. 11-7 ① Brake Fluid

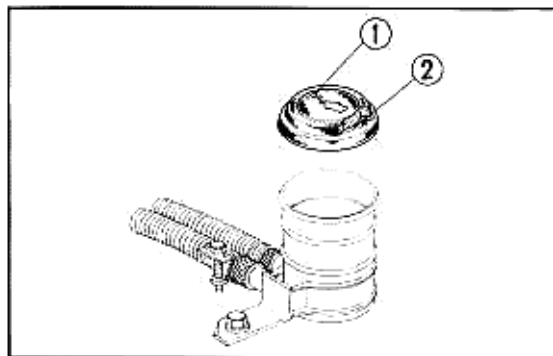

Fig. 11-8 ① "F" Mark Should be Faced Forward
② Breather

NOTES:

1. Do not mix different brands of brake fluid; a chemical reaction could occur, resulting in poor braking.
2. Never use any oil other than brake fluid.
3. Install the brake fluid reservoir cap with the "F" mark facing forward, this will prevent water from entering the reservoir through the breather hole in the cap.
4. If brake fluid is poured into the reservoir quickly, air bubbles will be trapped in the brake fluid. Fill it slowly.
5. Bleed the brakes according to the following sequence:
 1. Back of the master cylinder (front brakes)
 2. Front of the master cylinder (rear brakes)

6. Remove the bleeder valves, brake fluid tube connectors, and low brake fluid warning switches.
7. Wash the disassembled parts with brake fluid.
8. Inspect the piston and check valves for damage. Replace if necessary.
9. After washing, store the parts in a water-tight plastic container to prevent contamination.

Assembly and installation

To assemble and install the brake master cylinder, reverse the removal and disassembly procedures. The following items must be carefully checked when the brake master cylinder is assembled and installed.

1. Again wash the brake parts in fresh brake fluid.

NOTES:

1. Never wash the parts with a mineral oil such as gasoline or solvent.
2. Exercise particular care to prevent contamination by dust or mineral oil during assembly.
2. Apply brake fluid to the piston and the inside surfaces of cylinder when assembling the brake master cylinder. Insert the check valve set and piston into the cylinder. Fit the push rod bump plate and secure it with the circlip.

NOTE: Do not damage the piston. It should be replaced with a new one if it is worn beyond the service limit or damaged even to a minor extent.

3. Connect the push rod to the brake pedal and then install the master cylinder.

Torque Specification

| | |
|----------------------------------|---------------------------------|
| Master Cylinder retaining bolts: | 2.0-2.4 kg-m (14.5-17.4 lbs-ft) |
|----------------------------------|---------------------------------|

4. Fill the master cylinder with the recommended brake fluid, SAE J1703a HD Type.

3. Left front brake
4. Right front brake
5. Left rear brake
6. Check the brake operation and inspect for brake fluid leaks.
 - *Check the brake pipe joints and connections jointed with circlips for leakage.
 - *Test drive the car to check the operation of the brake system and then inspect for brake fluid leakage again.

11-2 Front Brake

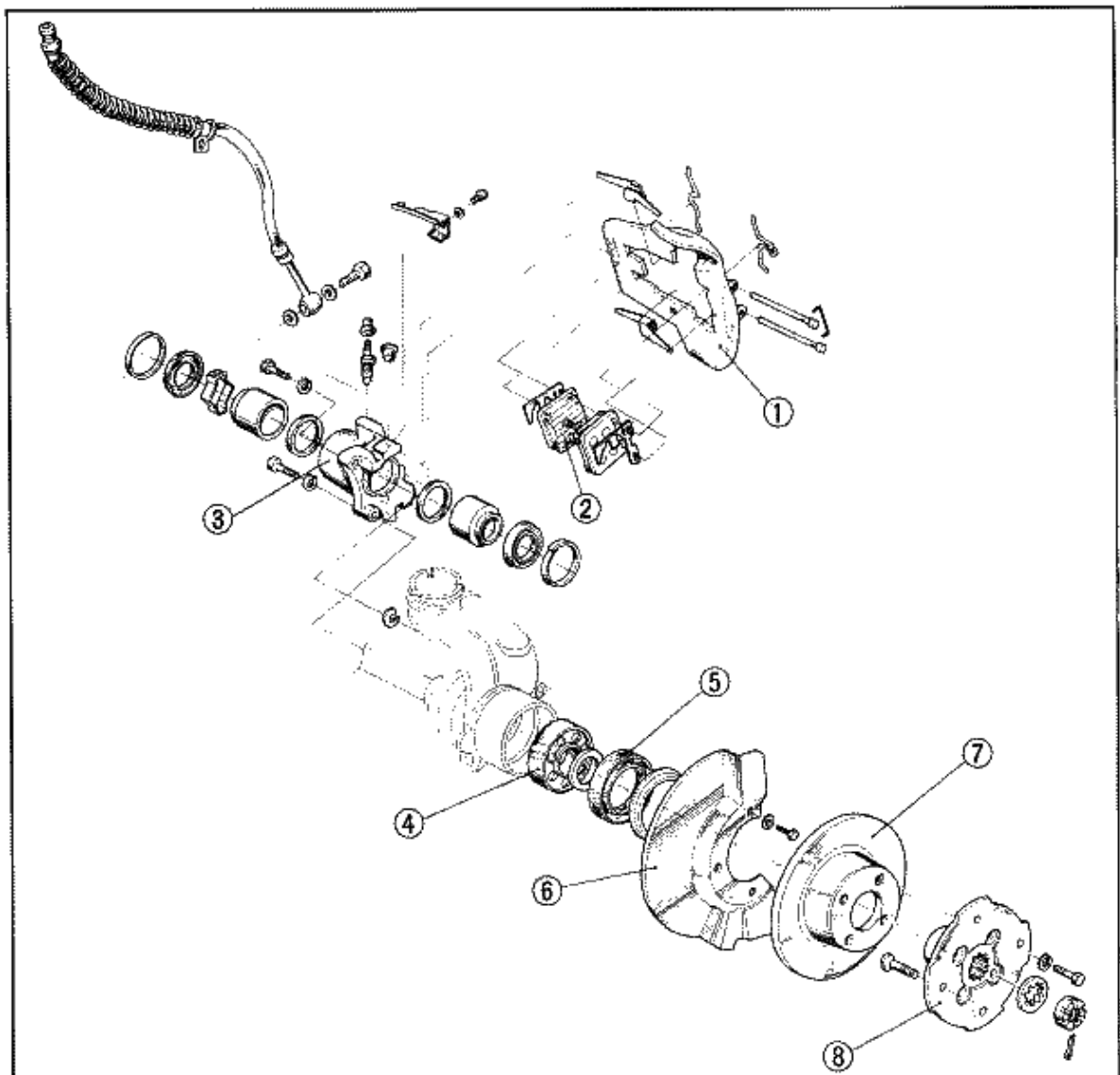

Fig. 11-9 ① Front Brake Yoke Unit ④ Front Wheel Bearing ⑦ Front Brake Disk
 ② Front Brake Pad ⑤ Disk Brake Dust Seal ⑧ Front Hub
 ③ Front Brake Body ⑥ Front Brake Mudguard

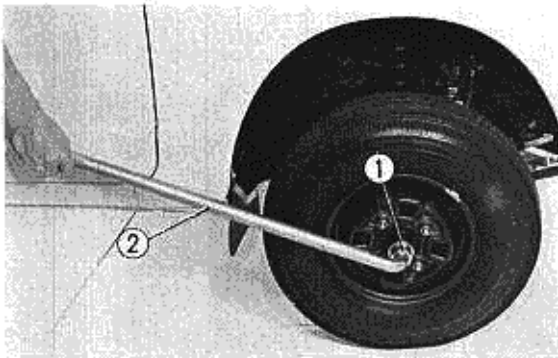

Fig. 11-10 ① Socket, 32 mm
② Socket Wrench Handle

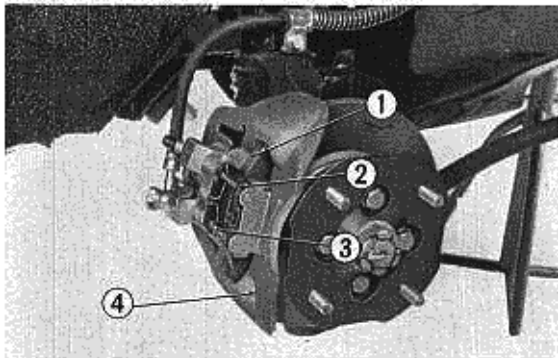

Fig. 11-11 ① Front Brake Disk
② Front Brake Pad
③ Pad Release Spring
④ Caliper Assembly

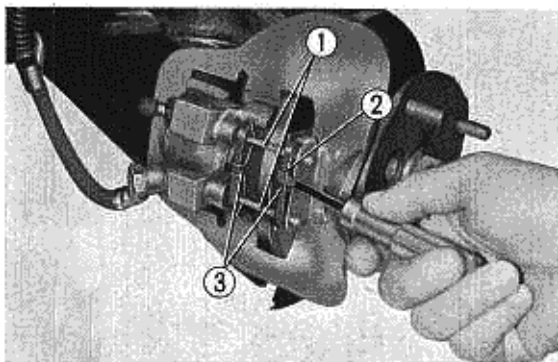

Fig. 11-12 ① Pad Retaining Pin
② Pin Retaining Clip
③ Pad fitting Spring

Removal and disassembly

1. Remove the wheel cap from the front wheel and pull the cotter pin from the castellated nut.
2. Loosen the castellated nut with a socket wrench (special tool).
3. Raise the front end of the car with a jack and position the jack stands to permit the removal of the front wheels.
4. Remove the front wheels.
5. Remove the pad retaining clip which is fitted into the hole in the pad retaining pin.

6. Remove the two pad retaining pins and the two pad fitting springs with plier as shown. When removing them, care must be taken to prevent the springs from flying apart.

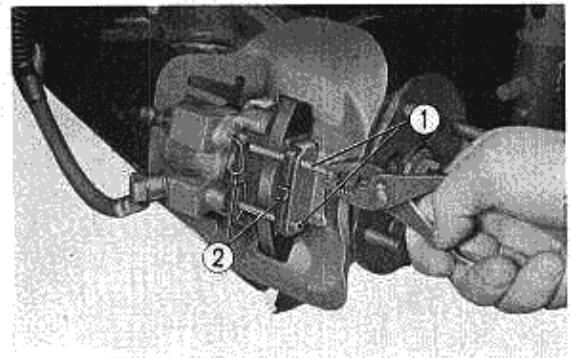

Fig. 11-13 ① Pad Retaining Pin
② Pad fitting Spring

7. The front brake pad can be removed together with the shim after removing the springs and pins. If the pads are difficult to remove, open the bleeder valve and move the yoke in the direction of the piston. The pads will become loose and can be easily removed.

NOTE: After the pads are removed, the brake pedal must not be touched.

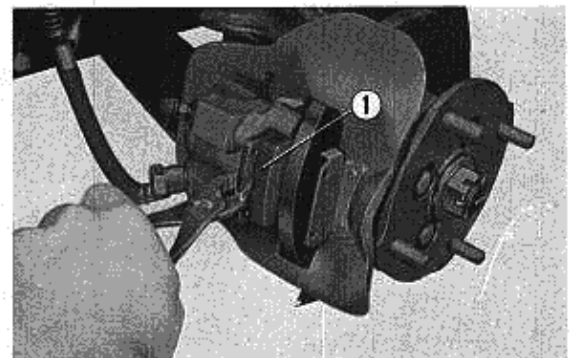

Fig. 11-14 ① Front Brake Pad

8. Remove the brake hose and remove the front brake yoke unit.

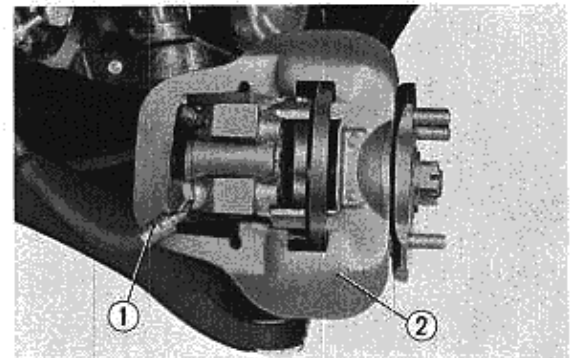

Fig. 11-15 ① Brake Hose
② Front Brake Yoke Unit

9. Remove the front hub and brake disc with the brake drum puller (special tool). (See Fig. 9-4)
10. Remove the front brake mudguard.

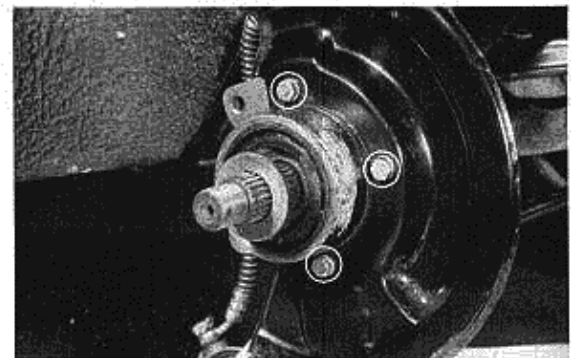

Fig. 11-16

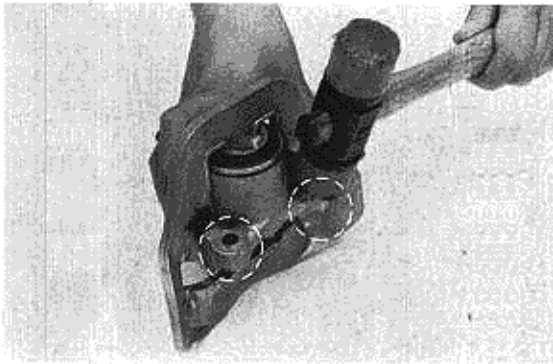

Fig. 11-17

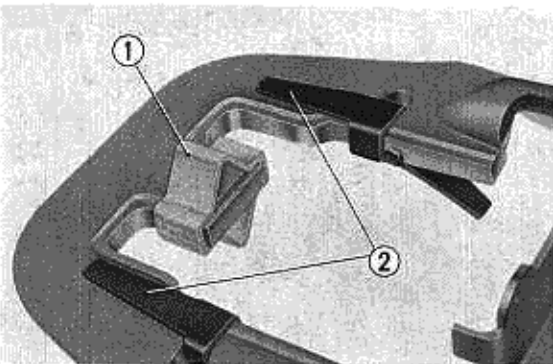

Fig. 11-18 ① Bias Ring ② Yoke Spring

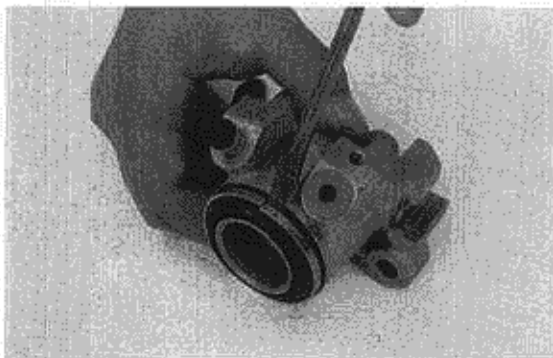

Fig. 11-19

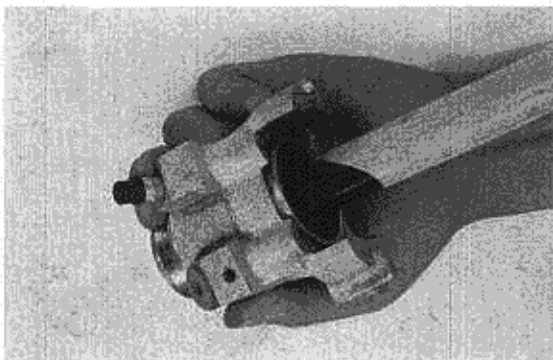

Fig. 11-20

11. Tap the cylinder body lightly with a plastic hammer at the points shown in Fig. 11-17 to remove the cylinder body. Then remove the cylinder body from the caliper. Exercise extreme care to avoid damage to the cylinder body. At this time, if only the cylinder body moved while the outer piston is held stationary on the caliper, a gentle tap on the piston should loosen the piston. Do not hit the rubber boot. Tap the areas indicated by the circles.
12. Remove the bias ring and the two yoke spring from the caliper.
13. Remove the retaining rings at the both ends of the cylinder, with a screwdriver and exercise care not to damage the front brake boot.
14. Both pistons (inner and outer) can be removed from the cylinder body by pushing through from one end, with a wooden rod as shown.

15. Remove the piston seals installed on the inside of the cylinder at the both ends with a screwdriver.

Assembly and installation

NOTE: The front brake pads should be replaced with new ones when they are worn beyond the service limit.

1. When attaching the brake hoses, check to insure that they are not twisted or binding against other parts.
2. When tightening the castellated nuts, be sure to use a torque wrench.

Torque Specification

| | |
|------------------|-----------------------------|
| Castellated nut: | 14-20 kg-m (101-145 lbs-ft) |
|------------------|-----------------------------|

Clean and lubricate drive shaft threads, washer and nut. Using a torque wrench, tighten the hub nut to 14 kg-m (101 lb-ft). Check the alignment of the hub nut castellation and the cotter pin hole, however, **DO NOT** install the cotter pin at this time. Tighten the nut to the next alignment position and install a new cotter pin. If the alignment can not be attained within the specified torque range, install a new front hub washer and repeat the tightening sequence.

3. After assembly, adjust the rear brakes, parking brakes and bleed the hydraulic system.
4. Check the brakes with a brake tester. Be sure that the brakes do not pull to either side.
5. Check the hydraulic system for leaks.

11-3. Rear Brake

Removal and disassembly

1. Loosen the four wheel nuts.
2. Jack up the rear axle beam and place stands under the beam.
3. Remove the wheel. Remove the rear wheel bearing cap and then remove the castellated nut and brake drum.

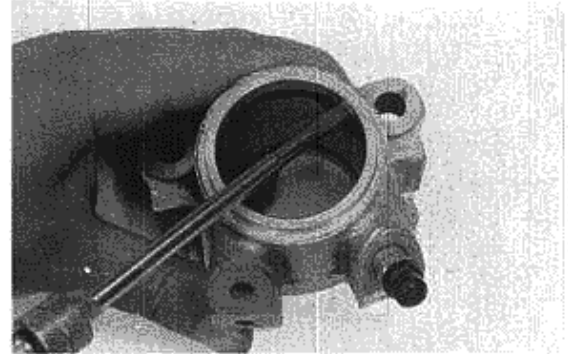

Fig. 11-21

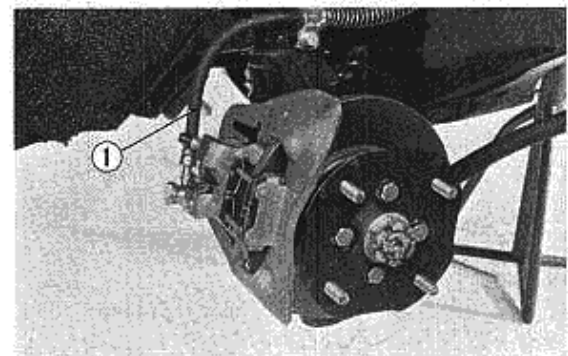

Fig. 11-22 ① Brake Hose

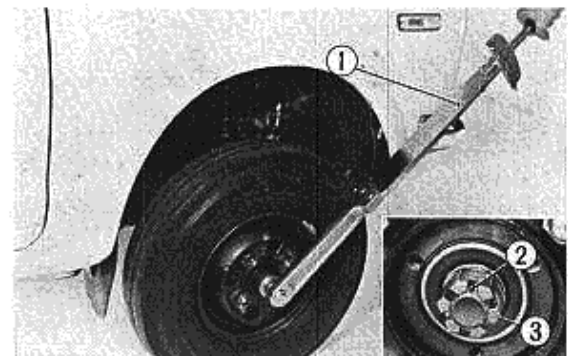

Fig. 11-23 ① Torque Wrench
② Cotter Pin Hole
③ Castellated Nut

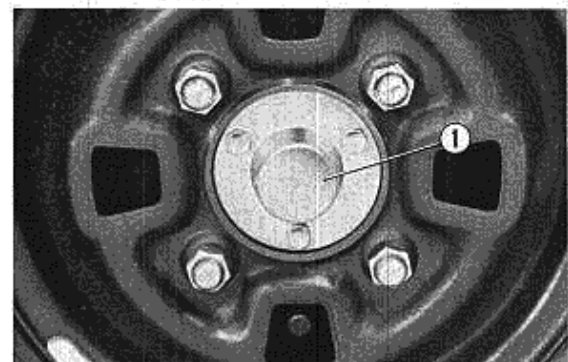

Fig. 11-24 ① Rear Wheel Bearing Cap

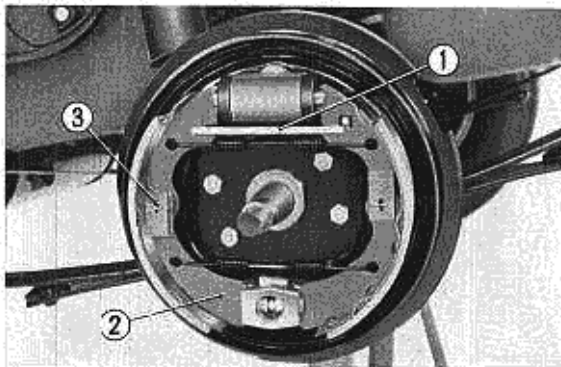

Fig. 11-25 ① Parking Brake Arm
② Rear Brake Shoe
③ Tension Pin

4. Remove the tension pin and then remove the rear brake shoes so that the shoe return springs are extended.

NOTE: The rear brake wheel cylinder and brake adjuster can be removed when the shoe which is not actuated by the parking brake arm is removed.

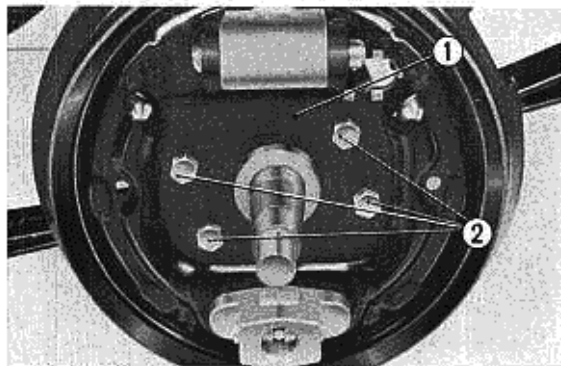

Fig. 11-26 ① Rear Brake Back Plate
② Retaining Bolt

5. Disconnect the parking brake cable and rear brake pipe at the rear of the brake back plate.
6. Remove the four backing plate retaining bolts to allow the removal of the backing plate together with the rear brake wheel cylinder from the rear axle beam.

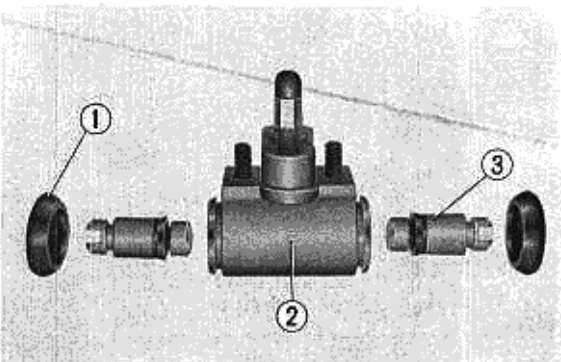

Fig. 11-27 ① Wheel Cylinder Dust Seal
② Rear Brake Cylinder
③ Wheel Cylinder Piston Set

7. Rear brake wheel cylinder
Remove the wheel cylinder by removing the two retaining nuts on the back side. Remove the wheel cylinder dust seal from the wheel cylinder groove to permit removal of the wheel cylinder piston set.

8. Rear brake adjuster

Remove the rear brake adjuster by removing retaining nuts on the back side of the rear brake backing plate. Fully screw in the adjuster bolt to separate the adjuster from the brake adjuster body.

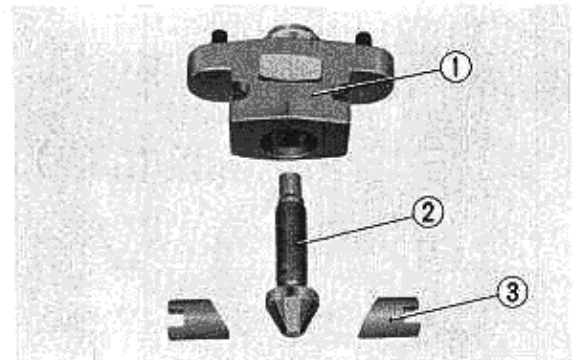

Fig. 11-28 ① Brake Adjuster Body
② Adjuster Bolt
③ Brake Adjuster Piston

9. Rear brake drum

The rear wheel bearing dust seal, inside and outside bearings and axle distance collar can be removed as shown.

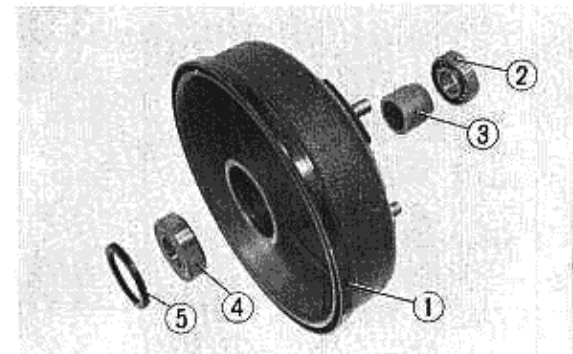

Fig. 11-29 ① Rear Brake Drum
② Rear Wheel Outside Bearing
③ Rear Axle Distance Collar
④ Rear Wheel Inside Bearing
⑤ Rear Wheel Bearing Dust Seal

Assembly and installation

NOTE: Replace the rear brake wheel cylinder or the wheel cylinder piston set if wear is beyond service limit or if any damage is evident.

1. Fit the rear wheel bearing cap O-ring and rear axle distance collar to the rear axle and install the rear brake back plate.
2. Immerse the rear wheel cylinder cup in brake fluid. Install the piston set in the rear wheel cylinder and then install them to the back plate.

NOTE: Exercise care not to damage the cup when assembling the wheel cylinder.

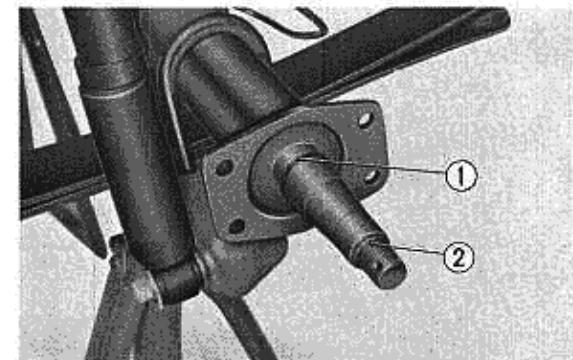

Fig. 11-30 ① Rear Wheel Bearing O-Ring
② Rear Axle

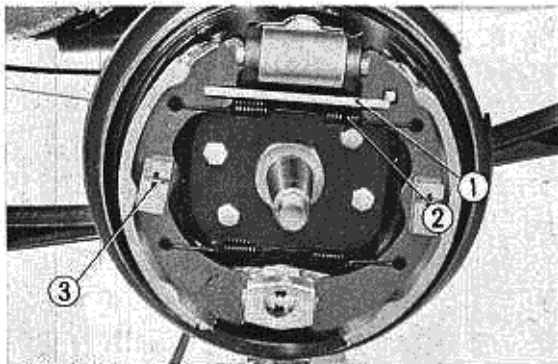

Fig. 11-31 ① Parking Brake Arm
② Shoe Return Spring
③ Tension Pin

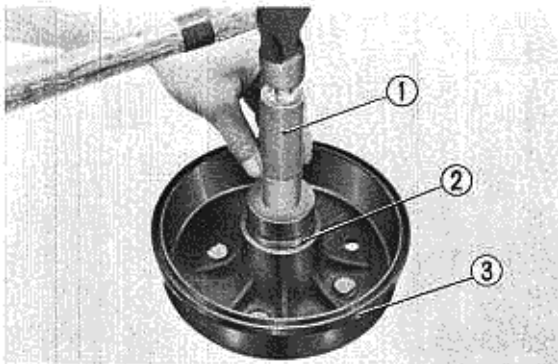

Fig. 11-32 ① Bearing Driver
② Rear Wheel Bearing
③ Rear Brake Drum

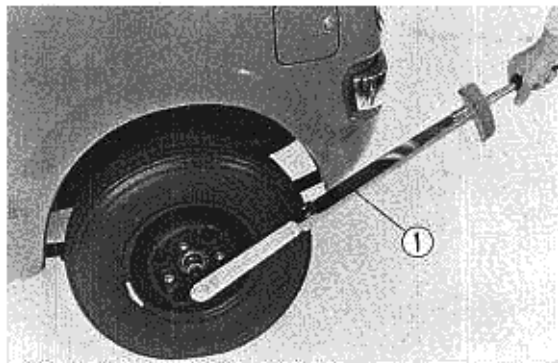

Fig. 11-33 ① Torque Wrench



Fig. 11-34 ① Rear Wheel Bearing Cap O-Ring
② Cotter Pin

3. Install the rear brake adjuster after applying grease to its sliding surface.
4. Install the parking brake arm to the rear brake shoe. Fit the spring to the shoe. Then extend and fit the shoe with the tension pin.

5. Press-fit the rear wheel bearing into the rear brake drum with bearing driver (special tool) as shown.

NOTE: Drive in the outer race horizontally for press fitting. Apply grease to the bearing after installation. When installed, the rear wheel bearing dust seal should not be tilted and should not protrude from the drum surface.

6. Install the rear brake drum. Install the rear hub washer. Tighten the castellated nut and lock the nut with a new cotter pin.

Torque Specification

| | |
|------------------|-------------------------------|
| Castellated nut: | 10-13 kg-m (72.3-94.0 lbs-ft) |
|------------------|-------------------------------|

7. Install the rear wheel bearing O-ring and rear wheel bearing cap.
8. Install the rear wheel and tighten the wheel setting nuts after the wheel is lowered.

Torque Specification

| | |
|--------------------|-----------------------------|
| Wheel setting nut: | 6-7 kg-m (43.4-50.6 lbs-ft) |
|--------------------|-----------------------------|

9. After installation, adjust the brakes and bleed the air out of the brake system. (See the topics "Periodic Maintenance" for air bleeding procedure.)

NOTE: Air bleeding should begin at the master cylinder and work away from it (see 11-6).

10. Test drive the car to check the operation of the brake system. Check carefully for pull to either side and for brake fluid leakage.

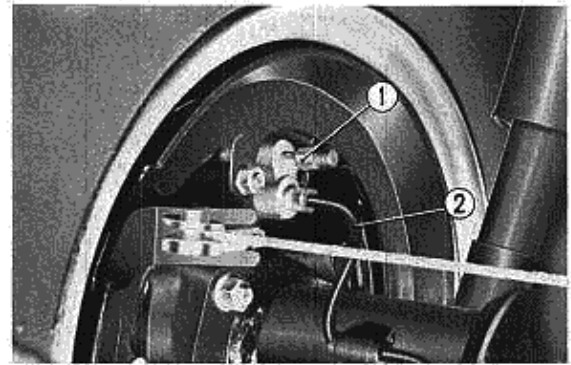

Fig. 11-35 ① Bleed Screw ② Brake Pipe

11-4. Brake Pipes and Hoses

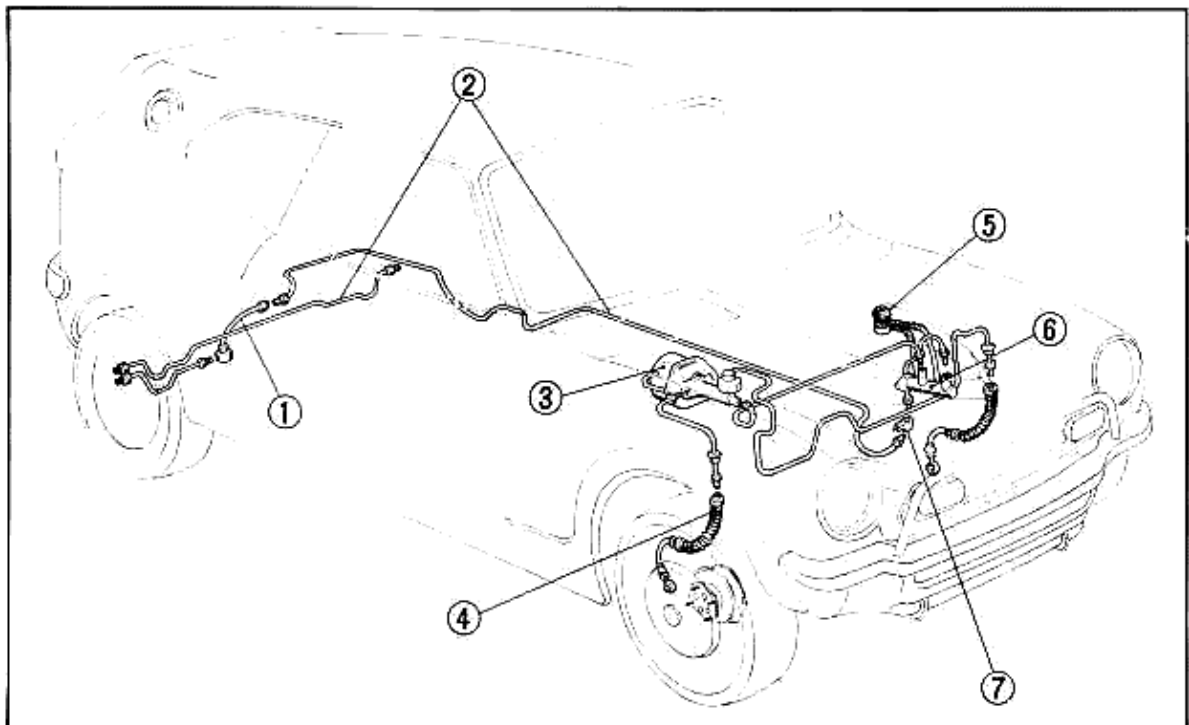

Fig. 11-36 ① Rear Brake Hose ④ Front Brake Hose ⑦ Proportioning Valve
 ② Brake Pipe ⑤ Brake Fluid Reservoir ⑥ Brake Master Cylinder
 ③ Vacuum Booster

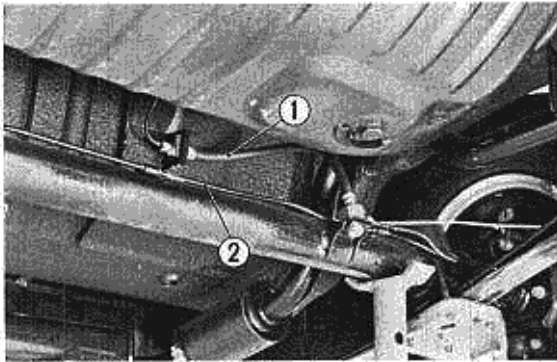

Fig. 11-37 ① Rear Brake Hose
② Brake Pipe

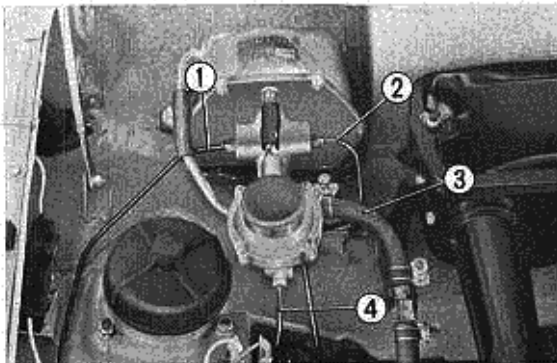

Fig. 11-38 ① Brake Pipe D ③ Unipower Tube B
② Brake Pipe F ④ Brake Pipe B

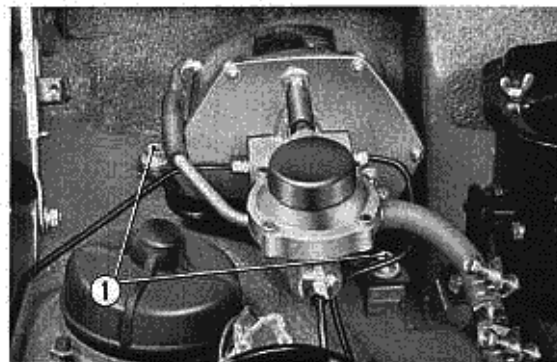

Fig. 11-39 ① Retaining Bolt

General servicing precautions

- * Check the brake hoses and pipes for leakage of brake fluid. Pay particular attention to the joints.
- * Check the hose fittings for twisting and for any possibility of interference with other parts.
- * Replace brake fluid bolts and gaskets with new ones.
- * Replace hose and pipes with new ones if damaged or deteriorated.

11-5. Vacuum Booster

Removal

1. Remove the unipower tubes A and B.
2. Disconnect brake pipes B, D and F.

3. Remove unipower bracket retaining bolts and then the unipower assembly can be removed from the body.

Installation

To install the vacuum booster, follow the reverse of removing procedures. The following items are to be carefully observed when the vacuum booster is installed:

1. Bleed air out of the brake system and test the vacuum booster for operation after installation.
2. Be sure to use disk brake fluid specified DOT3 brake fluid meets the SAE J1703 specification. Outside the U.S.A., use SAE J1703 brake fluid.

11A. BRAKE BOOSTER

11A-1 SPECIFICATIONS

| | ASSEMBLY STANDARD IN MILLIMETERS (INCHES) | SERVICE LIMIT |
|-----------------------------|--|------------------|
| Hydraulic Cylinder Bore | | |
| Inlet | 14.27-14.38 (.5618-.5661) | 14.40 (.5669) |
| Outlet | 19.03-19.15 (.7492-.7539) | 19.17 (.7547) |
| Cylinder Bore to Piston | | |
| Inlet | 0.09 (.0035) | 0.11 (.0043) |
| Outlet | 0.010 (.0039) | 0.12 (.0047) |
| Puller Rod to Head Plate | 0.02-0.08 (.0008-.0032) | 0.12 (.0047) |
| Relay Piston | 0.02-0.07 (.0008-.0028) | 0.10 (.0039) |
| Output Pressure | See Page | |

11A-2 DESCRIPTION

The Honda Coupe's brake system incorporates a Unipower (NISSIN MODEL 130V1) power assist unit. This unit is placed between the master cylinder and front brakes and uses engine vacuum to increase hydraulic pressure to the front brakes. If the booster becomes inoperative only normal (unassisted) pedal pressure is required to activate the brakes.

11A-3 OPERATION

A. Brakes At Rest (Fig. 11A-2)

1. With the engine running and no pressure on the brake pedal the booster is at rest. The relay valve is closed and there is vacuum on each side of the booster diaphragm. Therefore there is no booster piston movement and no pressure to the front brakes.

B. Brakes Applied (Fig. 11A-3)

1. When the brakes are applied hydraulic pressure from the master cylinder

raises the relay valve. Air may now enter the rear side of the booster diaphragm. The vacuum will move the diaphragm and booster piston exerting hydraulic pressure on the front brakes.

C. Brakes Released (Fig. 11A-5)

1. When the brakes are released master cylinder pressure drops allowing the relay valve to close. Engine vacuum will now remove all 'air' in the system and the booster piston will return to its at rest state. Pressure will be removed from the front brakes.

D. Brakes Applied--Booster Inoperative

1. If the brakes are applied and for some reason the booster will not activate the pressure from the master cylinder will open the booster ball valve. The brake fluid can then pass through the booster and activate the front brakes. (Fig. 11A-4)

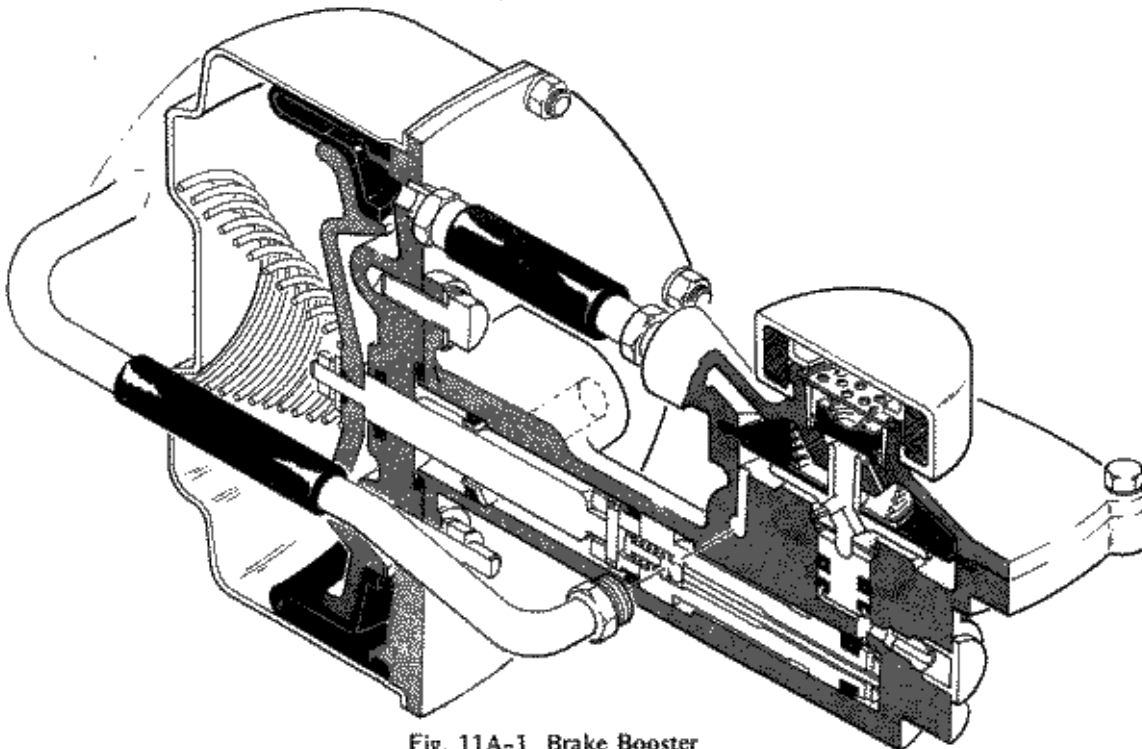

Fig. 11A-1 Brake Booster

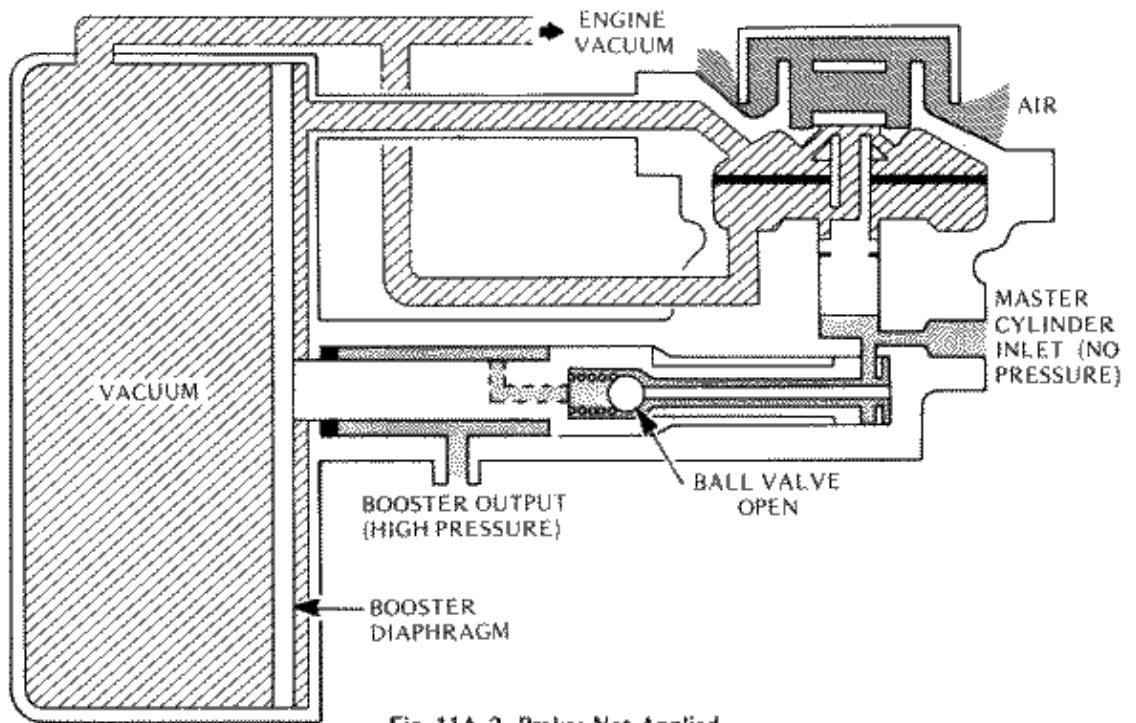

Fig. 11A-2 Brakes Not Applied

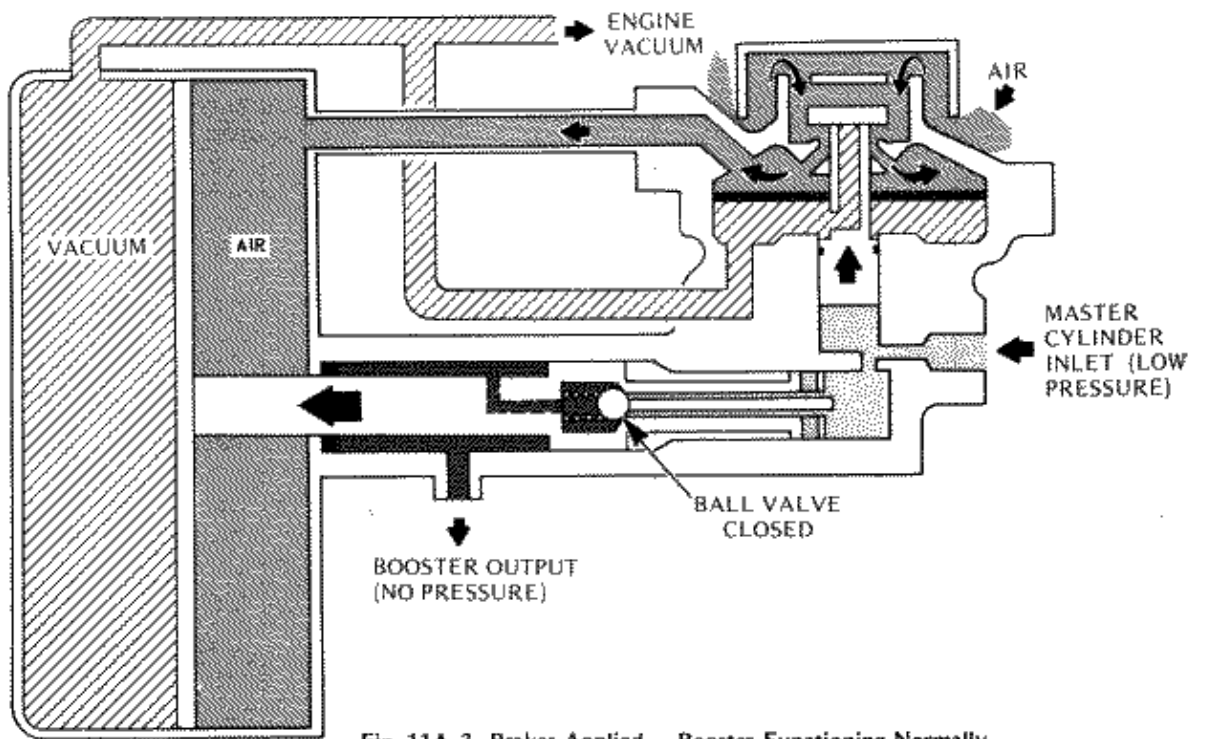

Fig. 11A-3 Brakes Applied – Booster Functioning Normally

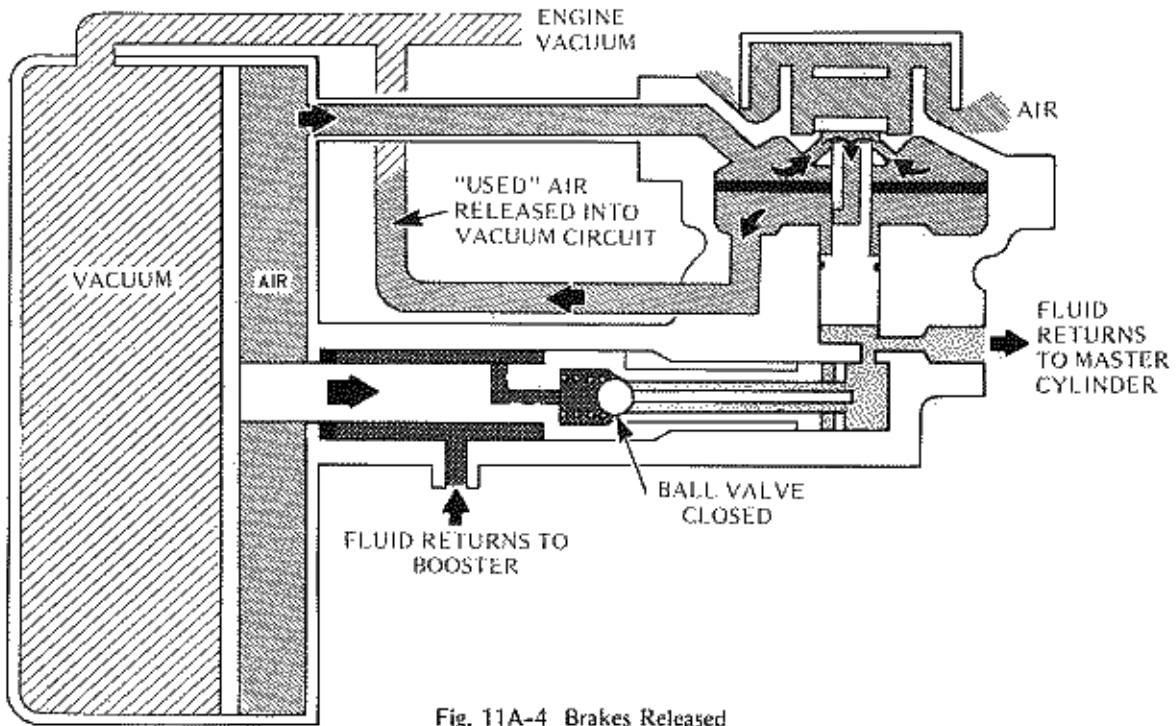

Fig. 11A-4 Brakes Released

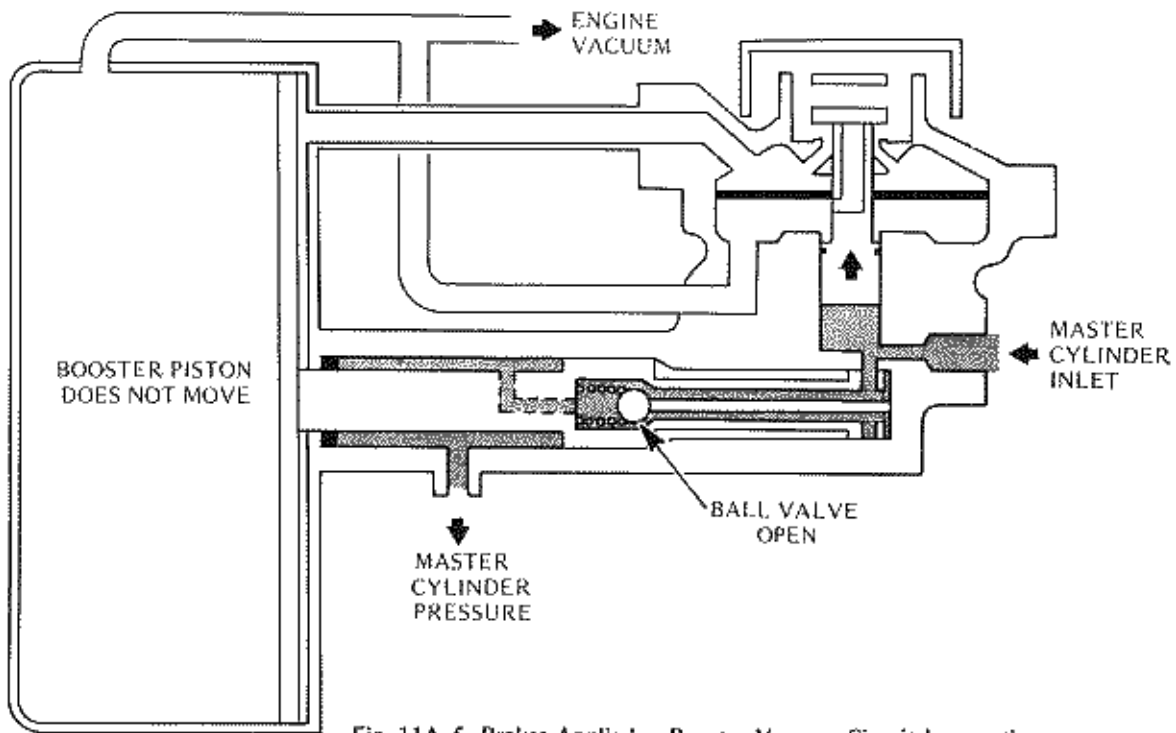

Fig. 11A-5 Brakes Applied -- Booster Vacuum Circuit Inoperative

11A-4 TESTING

A. Preliminary Checks

1. Lightly depress the brake pedal and start the engine. Note the movement of the pedal. If it moves slightly forward when the engine is started the booster is operating. If the pedal does not move, make the tests outlined below.

1. Pull off the rubber cap containing the filter element. Remove the filter element and clean it in solvent. Do not let the rubber cap contact oil or gasoline. If the cap is swollen by oil or gasoline contact, replace it.

CAUTION: The filter element must be completely dry before installing.

2. Remove the check valve. Test the check valve to make sure it is operating properly. If it shows any signs of leakage or malfunction replace it.
3. Repeat the test as described in the above paragraph. If the test reveals that the booster is still inoperative proceed with the following tests.

B. Gauge Installation

NOTE: To proceed with the testing it is necessary to have a hydraulic pressure gauge calibrated to 160 KG-CM² (2200 PSI) and a vacuum gauge calibrated to 760 m.m. Hg. (29.9 in. Hg.).

1. Remove the bleeder screw from the left front wheel cylinder. Install the hydraulic pressure gauge 160 KG-CM² (2200 PSI) in the bleeder screw hole. Bleed the wheel cylinder using the bleeder on the gauge.
2. Remove the vacuum hose connecting the check valve and the booster. Insert a vacuum gauge 760 m.m. Hg. (29.9 in. Hg.) between the check valve and booster (See Fig. 11A-8.)

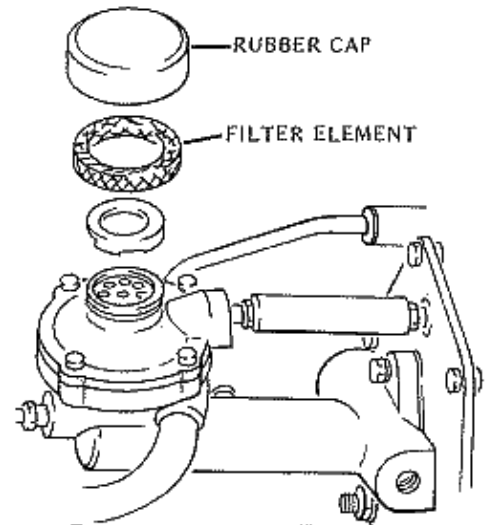

Fig. 11A-6 Booster Filter

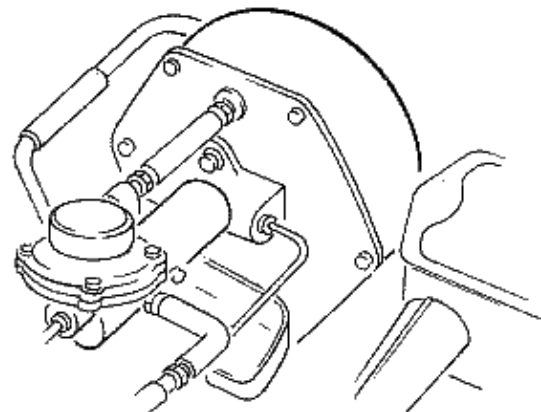

Fig. 11A-7 Check Valve

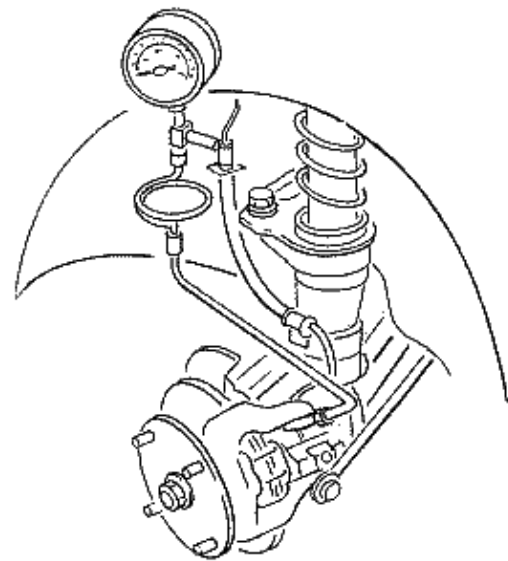

Fig. 11A-8 Installing Hydraulic Pressure Gauge

C. Detail Tests

1. With the gauges installed start the engine. Increase engine rpm until the vacuum gauge reads 500 m.m. Hg. (19.68 in. Hg.) and then stop the engine. A pressure drop of 0-20 m.m. Hg. (0.79 in. Hg.) in 30 seconds is normal. A drop of more than 20 m.m. Hg. (.79 in. Hg.) indicates a faulty vacuum hose or check valve.

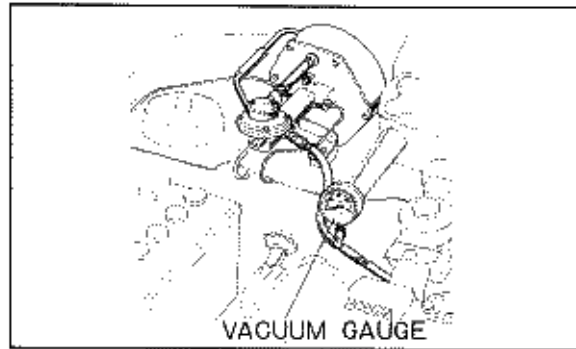

Fig. 11A-9

NOTE: If a minimum reading of 300 m.m. Hg. (11.81 in. Hg.) cannot be attained or if pressure fluctuates make the following adjustments.

1. Set idle speed to 1100-1200 rpm.
 2. Check the valve clearance and timing.
 3. Check ignition timing.
 4. Clean filter cap element.
2. Install a pedal pressure gauge and start the engine. Depress the pedal with 20 KG (44 LBS.) of pressure. Check the reading on the hydraulic pressure gauge. (Check table below for output pressures). If the pressure at the wheel cylinder is not within specified limits the booster is defective and must be disassembled and inspected.

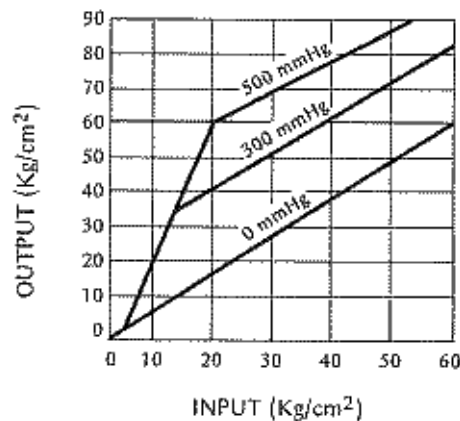

Fig. 11A-10 Performance Characteristics

| VACUUM AT BOOSTER | PEDAL PRESSURE | HYDRAULIC PRESSURE TO CALIPER | |
|-------------------|----------------|--|--|
| | | TO AZ600-1005966 | FROM AZ600-1005967 |
| 300 mmHg | 20 Kg (44 lbs) | 31-35 Kg/cm ² (440-497 psi) | 28-33 Kg/cm ² (398-469 psi) |
| 400 mmHg | 20 Kg (44 lbs) | 46-49 Kg/cm ² (654-696 psi) | 40-46 Kg/cm ² (568-654 psi) |
| 500 mmHg | 20 Kg (44 lbs) | 49-57 Kg/cm ² (696-810 psi) | 42-52 Kg/cm ² (597-739 psi) |

11A-5 DISASSEMBLY

NOTE: Disassembly Precautions.

- . Clean the exterior surfaces of the booster prior to disassembly to help prevent contamination of the components by dirt and water.
- . Keep all of the components and your tools clean.
- . Use all of the components supplied in the overhaul kit.

A. Booster Vacuum Unit

1. Slide the vacuum pipe joint hose toward the booster shell until the end of the vacuum pipe can be seen.

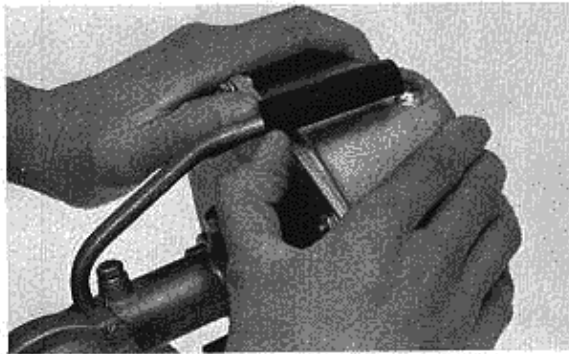

Fig. 11A-11 Removing Vacuum Hose

2. Remove the six nuts and bolts holding the booster shell and head plate together and remove the shell.

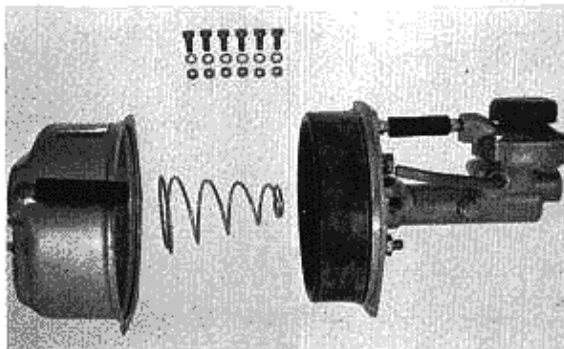

Fig. 11A-12 Booster Shell

3. Remove the booster plate nut, washers and O-ring and then remove the booster diaphragm.

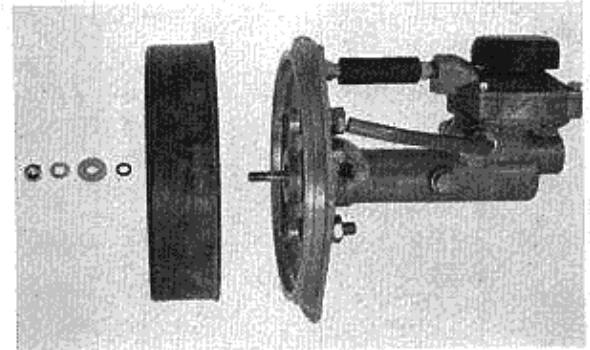

Fig. 11A-13 Booster Diaphragm

NOTE: If the puller rod turns when loosening the booster plate nut, separate the head plate and puller rod from the booster cylinder. Then, hold the piston as shown in the illustration with a pair of pliers and unscrew the nut.

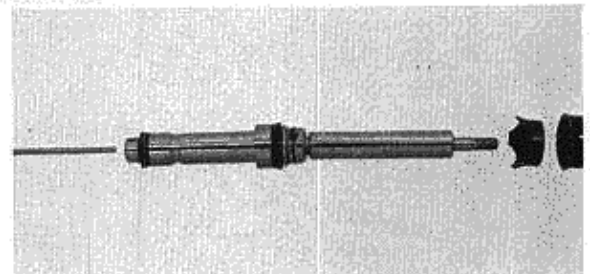

Fig. 11A-14 Holding Puller Rod

4. Remove the two bolts securing the booster cylinder to the head plate and then remove the head plate while separating the joint hose from the hose fitting. Carefully remove the O-rings from the cylinder and the head plate with a screw driver or piece of wire. Do not damage the O-ring seats or mating surfaces.



Fig. 11A-15 Removing Head Plate

B. Relay Valve

NOTE: The relay valve can be removed without disassembling other components.

1. Remove the filter cap and the poppet valve circlip with a pair of snap ring pliers as shown. Then lift the poppet valve and spring from the cylinder.

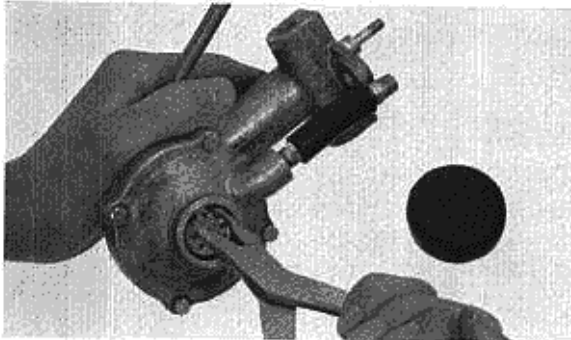
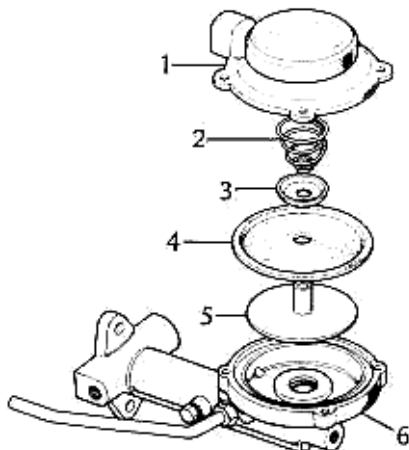

Fig. 11A-16 Poppet Valve Circlip

2. Remove the poppet valve housing bolts (4), separate the hose from the hose fitting and then remove the relay spring, spring seat, diaphragm and lifter.



- | | |
|---------------------|------------------|
| 1. HOUSING | 4. DIAPHRAGM |
| 2. DIAPHRAGM SPRING | 5. LIFTER |
| 3. SPRING SEAT | 6. CYLINDER BODY |

Fig. 11A-17

3. Remove the relay piston circlip with a pair of snap ring pliers and then remove the relay piston from the hydraulic cylinder with compressed air.

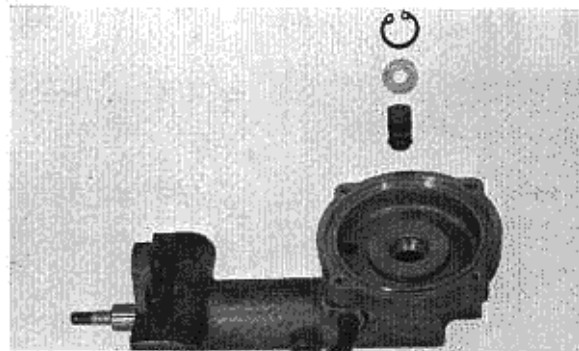

Fig. 11A-18 Relay Piston Circlip

C. Hydraulic Cylinder

1. Remove the vacuum pipe attached to the side of the booster cylinder.
2. Gently remove the puller rod and piston from the booster cylinder.

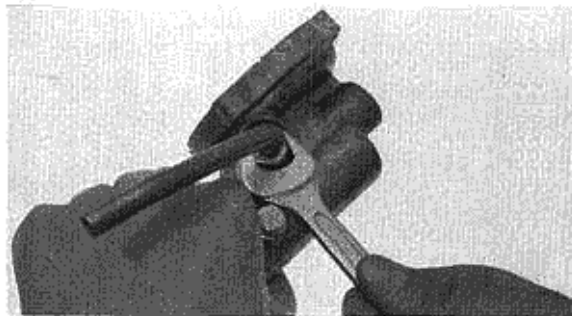

Fig. 11A-19 Vacuum Pipe Removal

NOTE: There may be some brake fluid left in the cylinder. It will splatter if the puller rod is removed quickly.

CAUTION: Be careful not to damage the puller rod or piston. If the piston is upside down, the ball valve pin in the piston will drop out. Do not lose the pin.



Fig. 11A-20 Piston and Puller Rod Removal

11A-6 ASSEMBLY

CAUTION: The 'UNIPOWER' used on the HONDA 600 COUPE has many critical rubber components. Even minor deformations or scratches on these parts will severely affect brake performance. When re-assembling the booster, do not reuse the rubber parts—replace them. Use extreme care to prevent contamination by dirt, water, grease mineral oil and other foreign matter. Use compressed air to blow off any contaminants on the components. Rinse the components in clean brake fluid to facilitate assembly. **DO NOT USE SOLVENT, GASOLINE OR MINERAL OIL.**

A. Booster Cylinder

1. Insert the ball valve pin into the end of the hydraulic piston. The ball pin should extend 1-2mm (.04-.08 in.) from the end of the piston. Tilt the piston upward and rotate it slowly while inserting it into the hydraulic cylinder.

CAUTION: Forcing the piston may damage the cup.

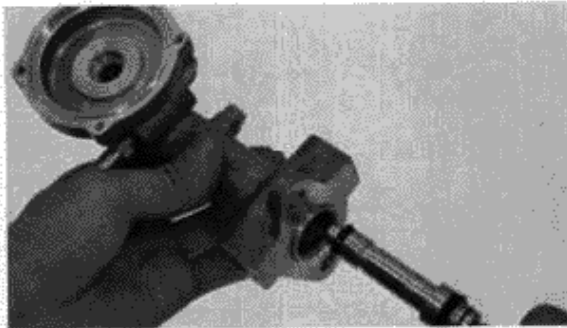

Fig. 11A-21 Inserting Booster Piston

2. Lubricate the puller cup and retainer with clean, fresh brake fluid and mount them in the cylinder. Lubricate the O-ring and the groove in the head plate with brake fluid and mount the O-ring to the booster cylinder.

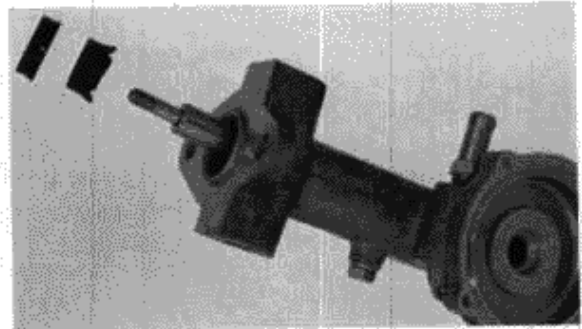

Fig. 11A-22 Puller Cup and Retainer

3. Mount the cylinder to the head plate and tighten the mounting nuts to 1.5-2.0 Kg-M (.0591-.0787 LB-FT). Check to insure that the puller-piston assembly moves smoothly. Attach the vacuum pipe to the booster cylinder.

NOTE: During re-assembly, install a new O-ring in the head plate.

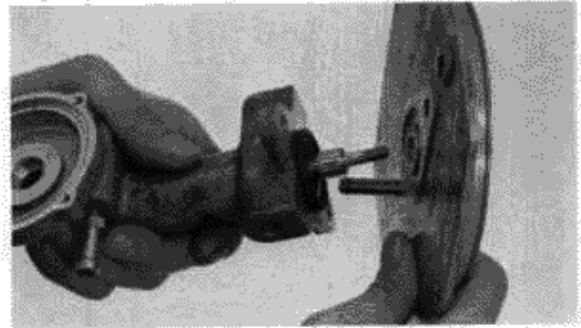

Fig. 11A-23 Mounting Head Plate

B. Relay Valve

1. Lubricate the relay piston seals with clean, fresh brake fluid and then mount them on the piston.

CAUTION: Be sure the relay piston and seals are clean to prevent damage to the seals during installation.

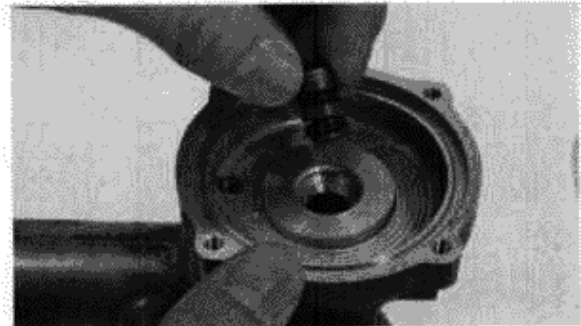

Fig. 11A-24 Relay Piston

2. Insert the assembled relay piston carefully. Install the relay stopper and fit the circlip with a pair of snap ring pliers.

NOTE: Be sure the circlip is properly installed by rotating it in the groove with a pair of snap ring pliers.

3. If the portion of the relay valve lifter that contacts the housing is damaged, it must be replaced. Install the lifter, relay diaphragm, spring seat and then the diaphragm spring.

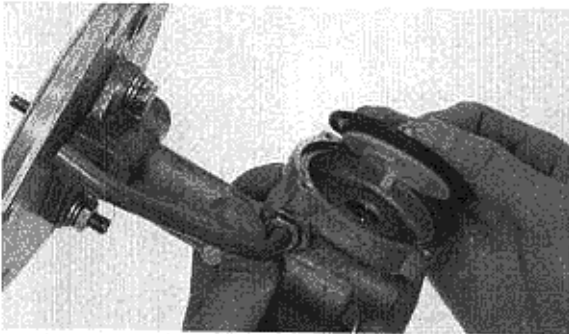

Fig. 11A-25 Relay Diaphragm

4. Mount the hose fitting to the head plate and install the hose and relay valve housing. Tighten bolts to 0.3-0.5 Kg-M (2.17-3.62 LB-FT). Install the poppet valve, spring and plate and then fit the circlip in the relay valve cover.

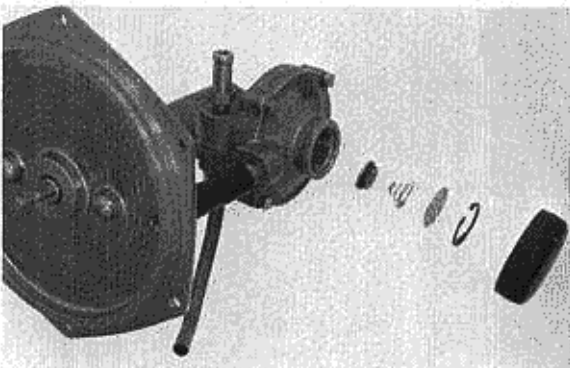

Fig. 11A-26 Poppet Valve

Before mounting the filter cap, check to insure that the circlip is properly fitted by sliding it in the mounting groove with a pair of snap ring pliers.

C. Booster Shell

1. Mount a new booster diaphragm and O-ring to the end of the puller rod with the flat washer, spring washer and nut. Tighten the nut to 0.8-0.10 Kg-M (5.83-7.24 LB-FT). If the piston turns when tightening the nut, hold with pliers as shown below.

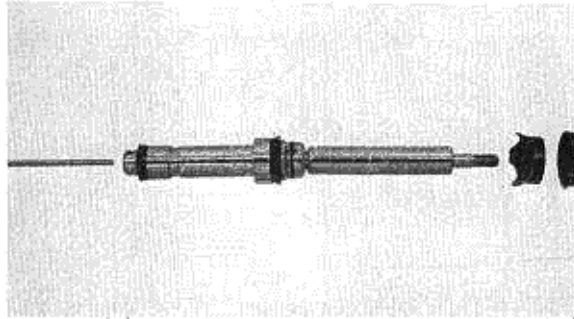

Fig. 11A-27 Holding Puller Rod

2. Fit the booster diaphragm around the groove in the head plate. Check to be sure that it is properly seated.

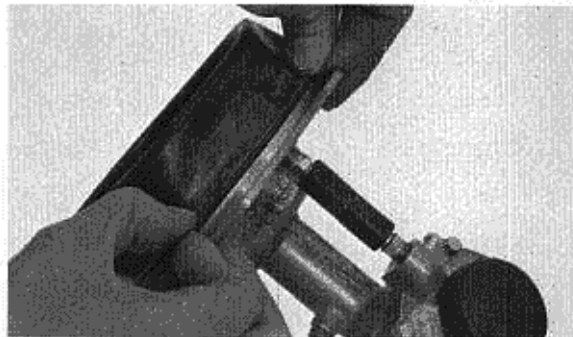

Fig. 11A-28 Booster Diaphragm

3. Fit the booster spring in the shell and mount the shell to the head plate. Tighten the shell mounting nuts to 0.3-0.4 Kg-M (2.17-3.62 LB-FT) in a criss-cross pattern.

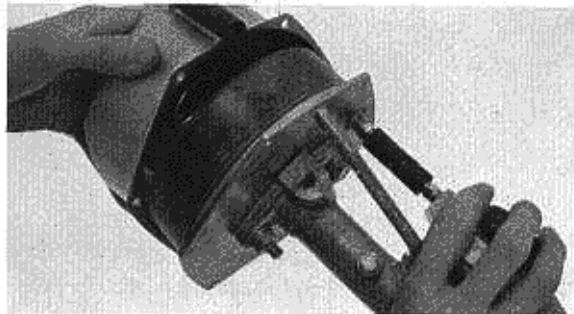

Fig. 11A-29 Booster Shell and Spring

4. Slide the vacuum hose onto the pipe coming from the relay valve. Install the booster in the chassis and then fit the brake pipes and vacuum hoses securely. Fill the master cylinder with clean fresh brake fluid and bleed the brake system using the following sequence:

1. Back of the master cylinder.
2. Front of the master cylinder.
3. Left front brake.
4. Right front brake.
5. Left rear brake.

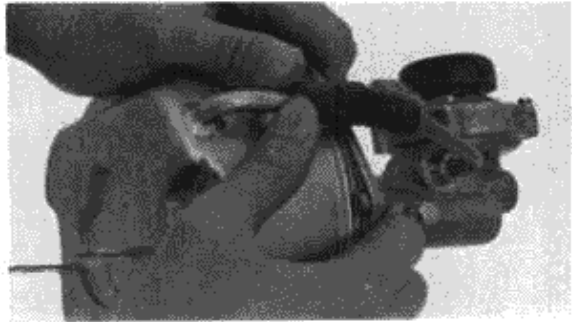

Fig. 11A-30 Vacuum Hose

11A-7 INSPECTION

NOTE: The following parts are the only replacement parts available for the booster. If any parts other than these are defective, the entire brake booster must be replaced. (See Fig. 11A-31.)

1. Relay valve diaphragm
2. Relay piston
3. Booster diaphragm
4. Filter element (complete)
5. Poppet valve housing assembly
6. Hydraulic piston assembly

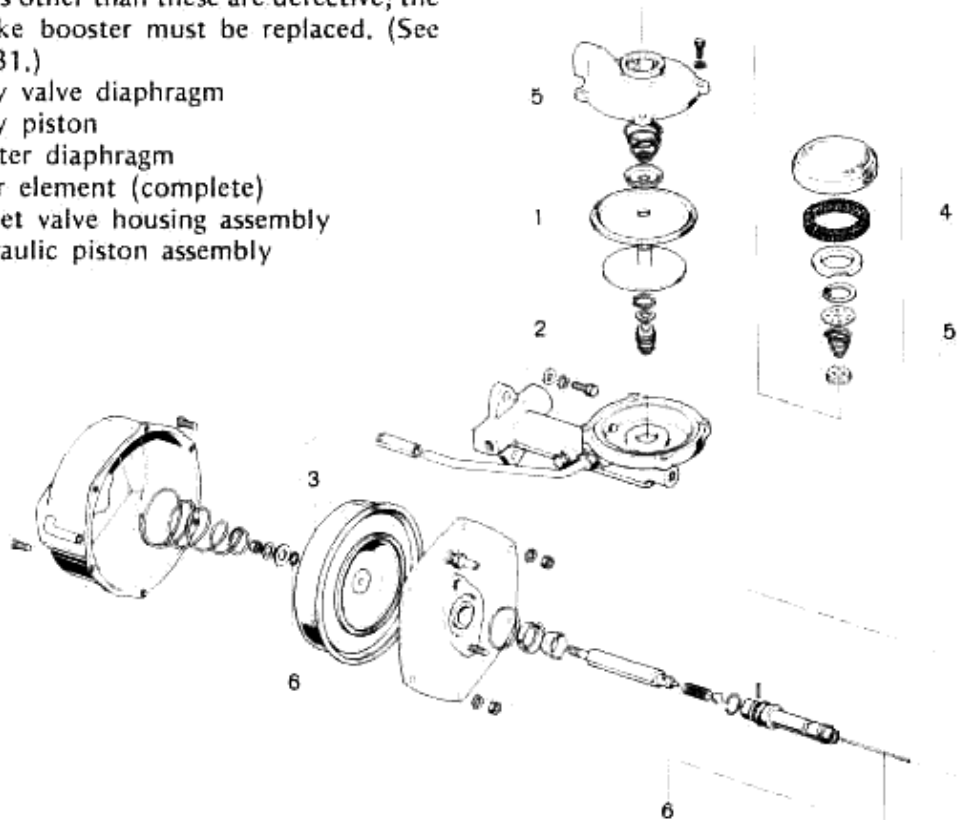

Fig. 11A-31 Replacement Parts For Brake Booster

A. Booster Piston and Cylinder

1. Visually inspect the piston and cylinder for scores and scratches. Replace if necessary.
2. Measure the cylinder bore at the inlet and outlet side. See Fig. 11A-32. If the cylinder bore is beyond the service limit, replace the entire brake booster.
3. Also measure the piston diameter on the inlet and outlet side. See Fig. 11A-32. Compare these measurements with those of the cylinder bore to determine clearance.

B. Puller Rod

1. Check for score or scratch marks on the outer surface of the rod. Measure the O.D. of the puller rod and the I.D. of the head plate to determine the clearance between these two parts.

C. Relay Piston

1. Check for score or scratch marks on the piston and the cylinder face. Measure the relay piston O.D. and the cylinder bore I.D. to determine clearance.

| CYLINDER BORE | STANDARD LIMIT | SERVICE LIMIT |
|---------------|---------------------------|---------------|
| Inlet | 14.27-14.38 (.5618-.5661) | 14.40 (.5669) |
| Outlet | 19.03-19.15 (.7492-.7539) | 19.17 (.7547) |

| CYLINDER BORE TO PISTON | STANDARD LIMIT | SERVICE LIMIT |
|-------------------------|----------------|---------------|
| Inlet | .09 (.0035) | .11 (.0043) |
| Outlet | .010 (.0039) | .12 (.0047) |

| PULLER ROD CLEARANCE | STANDARD LIMIT | SERVICE LIMIT |
|----------------------|-----------------------|---------------|
| | .02-.08 (.0008-.0032) | .12 (.0047) |

| RELAY PISTON CLEARANCE | STANDARD LIMIT | SERVICE LIMIT |
|------------------------|-----------------------|---------------|
| | .02-.07 (.0008-.0028) | .10 (.0039) |

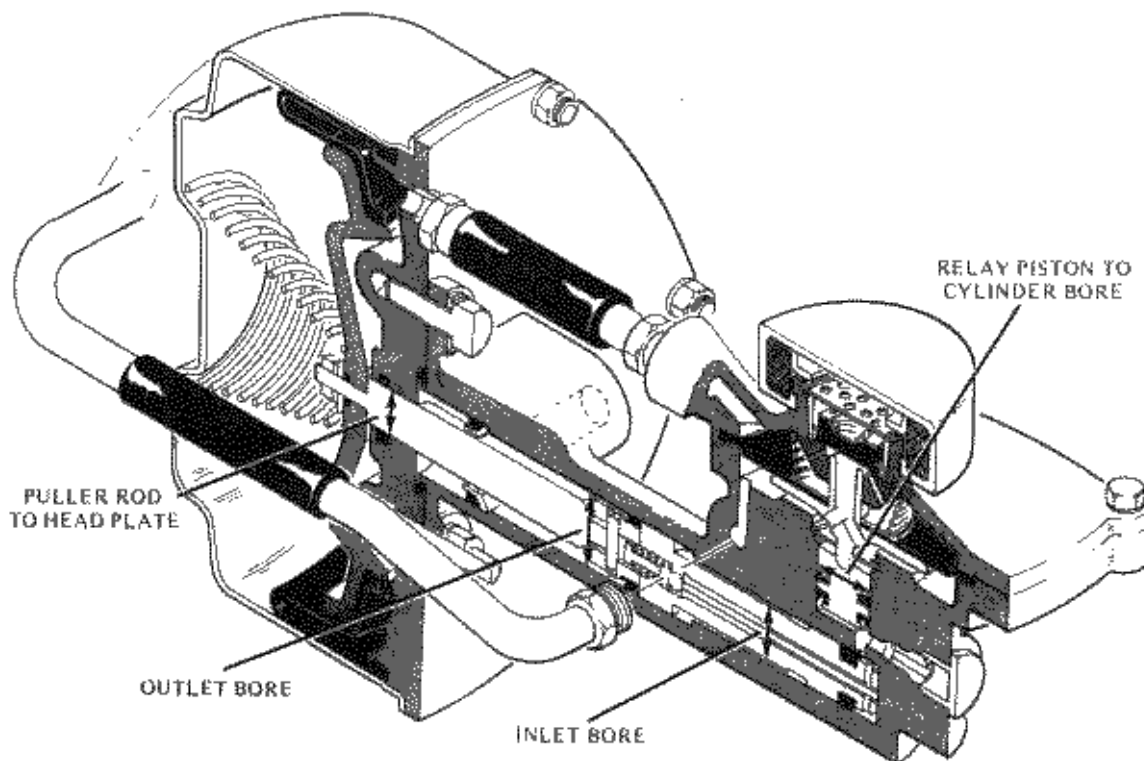

Fig. 11A-32 Cut-away Brake Booster

12. SUSPENSION SYSTEM

12-1. Front Suspension

Removal of front shock absorber

1. Separate the front suspension ball joint from the knuckle with the special tool (See Fig. 10-7).
2. Remove the front stabilizer bar from the subframe (See Fig. 12-3).
3. Remove the front damper lock bolts.
4. Separate the knuckle and front shock absorber by tapping the knuckle with a copper hammer,

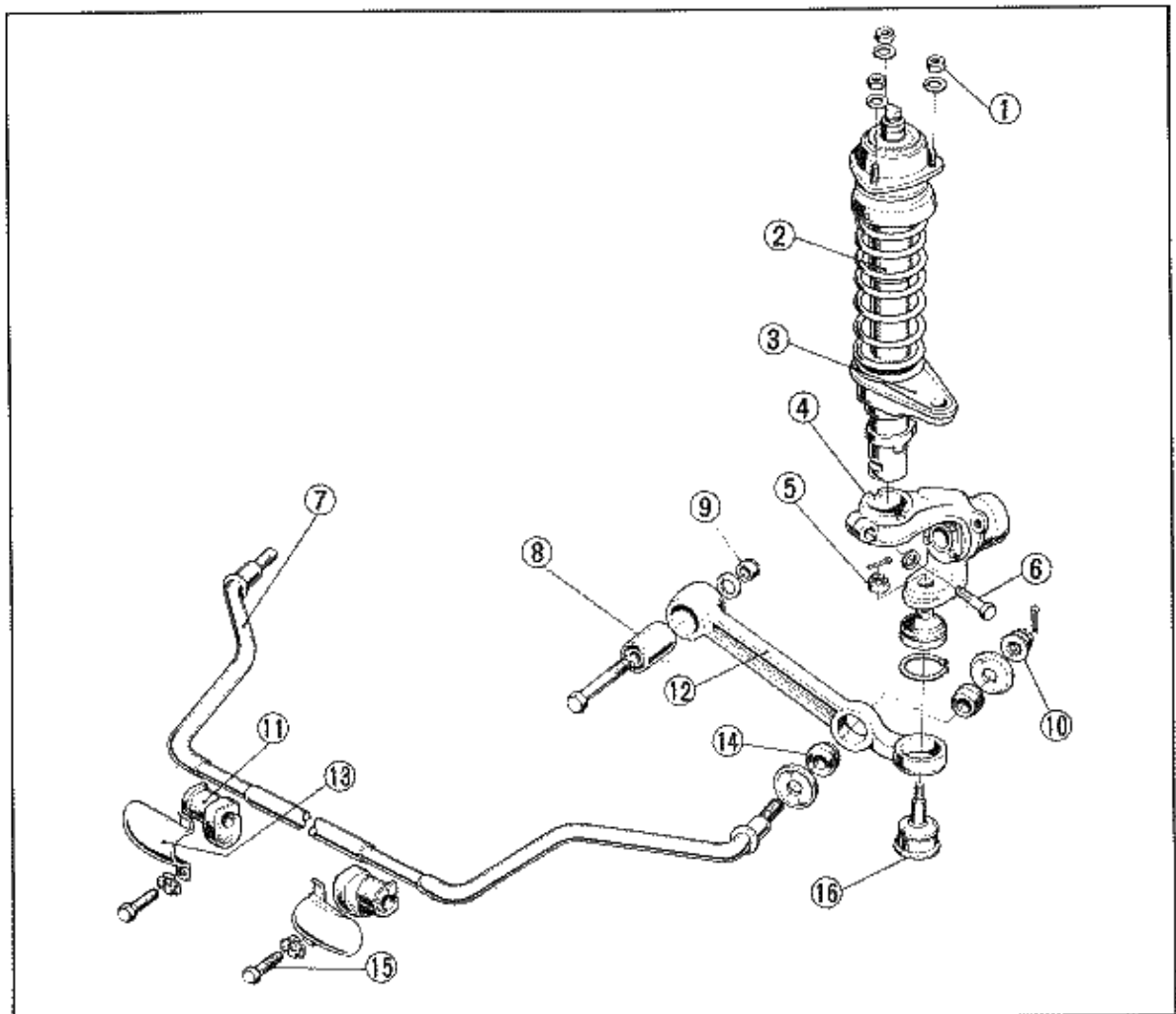

Fig. 12-1

| | | |
|-------------------------------|-------------------------------|--|
| ① 1.5~2.0 kg-m (11~14 lbs-ft) | ⑦ Stabilizer Shaft | ⑮ Stabilizer Shaft Bracket |
| ② Front Suspension Main Shaft | ⑧ Lower Arm Bushing | ⑯ Stabilizer Bushing A |
| ③ Knuckle Arm | ⑨ 4.0~4.8 kg-m (29~35 lbs-ft) | ⑰ 2.0~2.4 kg-m (14~17 lbs-ft) |
| ④ Knuckle | ⑩ 4.0~8.0 kg-m (29~58 lbs-ft) | ⑱ Front Suspension Ball Joint Assembly |
| ⑤ 3.0~4.0 kg-m (22~29 lbs-ft) | ⑪ Stabilizer Bushing R | |
| ⑥ 4.5~5.0 kg-m (33~36 lbs-ft) | ⑫ Lower Arm | |

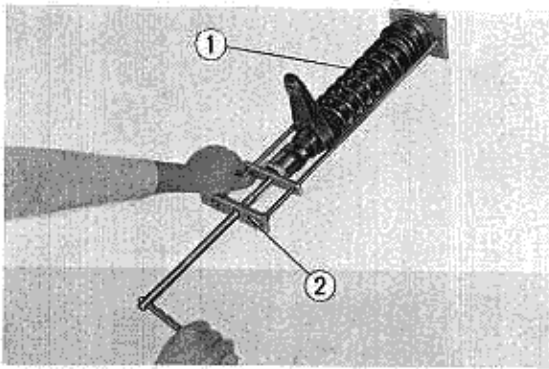

Fig. 12-2 ① Front Shock Absorber Assembly
② Front Damper Compressor

5. Remove the nuts holding the damper mounting cap to the body and remove the front shock absorber. (Loosen the 14 mm nuts before removing the shock absorber from the body to facilitate disassembly.)

* Place a jack underneath the front suspension main shaft arm and lightly compress the front shock absorber to fit the knuckle during installation.

* See Fig. 12-1 for torque specification.

The specified torque for tightening the castellated nut connecting the front suspension ball joint to the knuckle arm is 4.0-4.5 kg-m (28.9-32.6 lb-ft).

Disassembly and installation of the front shock absorber

1. Remove the damper mounting nuts and washers, and the damper mounting cap.

2. Set the front damper compressor (special tool) as shown in Fig. 12-2. Compress the the front damper spring gradually by turning the handle and remove the cotter ring.

3. Loosen the handle and remove the front damper unit.

* Use the same special tool for assembly.

CAUTION: Align the needle bearing before compressing the front damper springs.

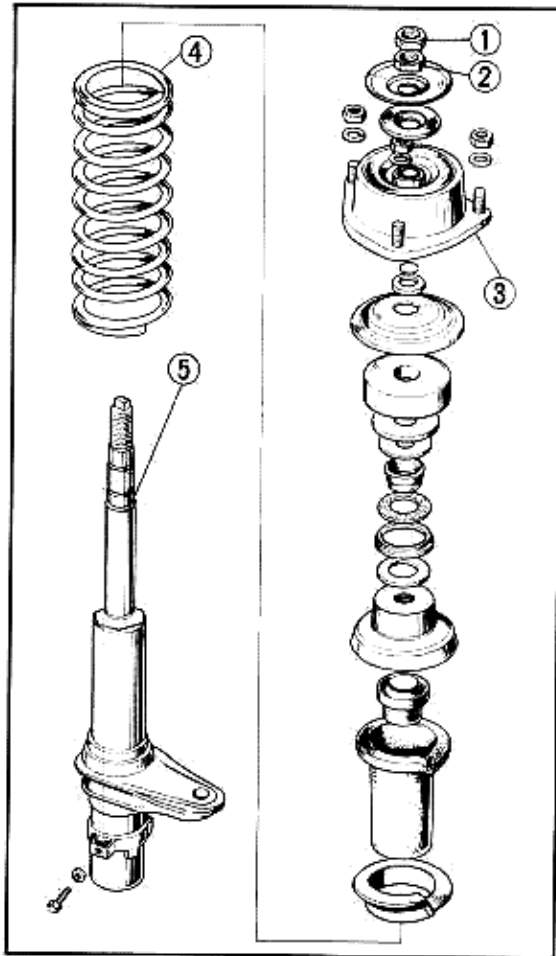

Fig. 12-3 ① 4.5~5.0 kg-m (33~36 lbs-ft)
② 2.5~3.0 kg-m (18~22 lbs-ft)
③ Damper Mounting Cap
④ Front Damper Spring
⑤ Front Suspension Main Shaft

Removal and installation of the stabilizer bar

1. Remove the right and left stabilizer brackets.

2. Remove the cotter pins at the stabilizer ends. Remove the castellated nuts and pull the stabilizer shaft forward and out of the lower arms.

Check the stabilizer bar for any signs of damage.

* To install, fit the stabilizer ends in the mounting holes in the lower arms, tighten the castellated nuts lightly and install the stabilizer shaft brackets. Then tighten the castellated nuts at the stabilizer ends to the specified torque 4.0-8.0 kg-m (28.9-57.9 lbs-ft) and lock with new cotter pins. The specified torque for tightening the stabilizer shaft bracket retaining bolts is 2.0-2.4 kg-m (14.5-17.4 lbs-ft).

Removal, disassembly and installation of knuckle

Loosen the hub nut before removing the wheel

1. Remove the front brake pads.
2. Remove the front brake caliper.
3. Remove the front hub and front brake disk with the brake drum puller (special tool). (see Fig.9-4)
4. Separate the stabilizer from the subframe (See 12-3).
5. Remove the front suspension ball joint and separate the knuckle from the lower arm.
6. Remove drive shaft ball joint setting bolts.
7. Remove the front damper lock bolt and separate the knuckle from the front shock absorber.
8. Remove the front wheel bearing dust cover, bearing dust seal cover and front wheel bearing O-ring from the knuckle, and remove the front wheel bearings from both sides.

* To install the knuckle, reverse the removal and disassembly procedures. Apply the recommended grease to the dust seal lip. Fill the front wheel bearings with the recommended grease.

* See Fig. 12-1 for torque specifications.

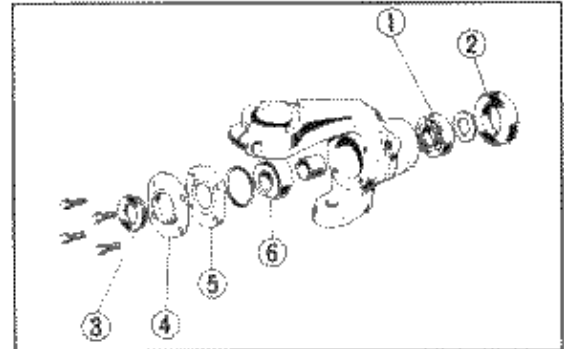

Fig. 12-4

| | |
|----|-------------------------------|
| 1: | Front Wheel Bearing |
| 2: | Disk Brake Dust Seal |
| 3: | Front Wheel Bearing Dust Seal |
| 4: | Bearing Dust Seal Cover |
| 5: | Front Wheel Bearing Cover |
| 6: | Front Wheel Bearing |

12-2 Rear Suspension

Removal of rear brake

1. Remove the rear wheel bearing cap and remove the castellated nut.
2. Remove the rear brake drum with the brake drum puller.

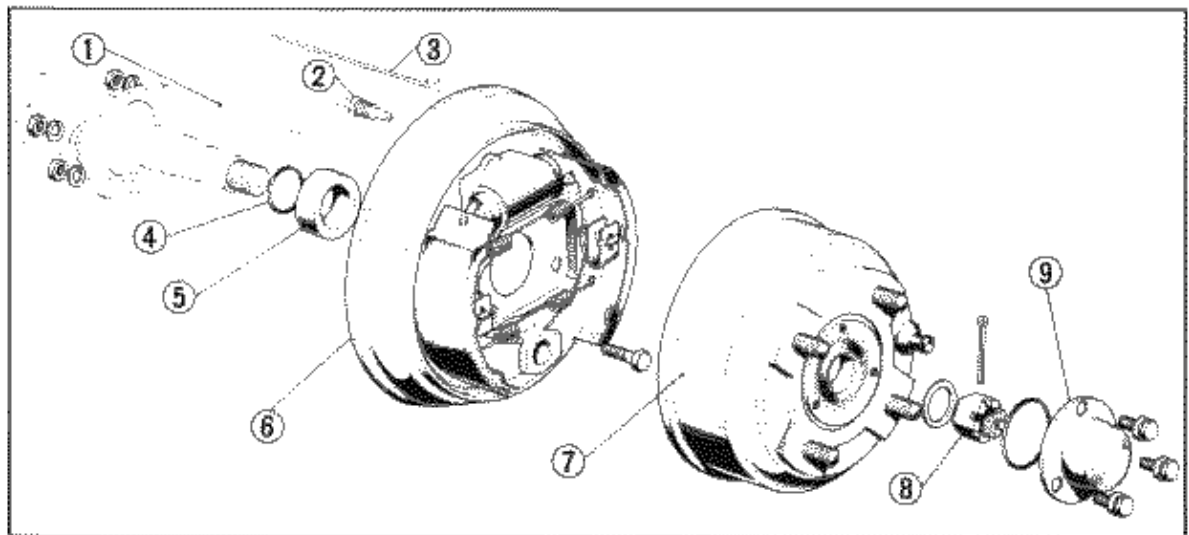

Fig. 12-5

| | | | | | |
|----|----------------------------|----|-----------------------|----|---------------------------|
| ①: | Brake Pipe | ④: | O-Ring | ⑦: | Rear Brake Drum |
| ②: | 1.3~1.5 kg-m (9~11 lbs-ft) | ⑤: | Axle Shaft Collar | ⑧: | 10~13 kg-m (72~94 lbs-ft) |
| ③: | Parking Brake Cable B | ⑥: | Rear Brake Back Plate | ⑨: | Rear Wheel Bearing Cap |

3. Remove the brake springs, shoes and tension pins.
4. Disconnect the brake pipe from the rear brake wheel cylinder and remove the parking brake cable B from the parking brake lever.
5. Remove the rear brake backing plate from the the rear axle beam.

Removal of the rear shock absorbers

1. Separate the rear shock absorber from the leaf spring retaining plate.
2. Remove the rear seat back and disconnect the rear shock absorber from the rear wheel housing.

Removal of the rear axle beam and rear leaf spring

1. Disconnect the brake hose and parking brake cable B from the rear axle beam.
2. Remove the retaining bolts at the front and rear of the rear leaf spring and remove the axle beam and rear leaf spring as an assembly.
3. The rear axle beam and rear leaf springs can be separated after the leaf spring retaining U-bolts are removed.

Installation

- * To install the rear brake, reverse the removal procedure. See Figs. 12-5 and 12-6 for the torque specifications.
- * Measure the body height after installing the rear leaf springs. Adjust the locations of leaf spring shackles if there is any inclination. (See the "Periodic Maintenance" for this procedure.)

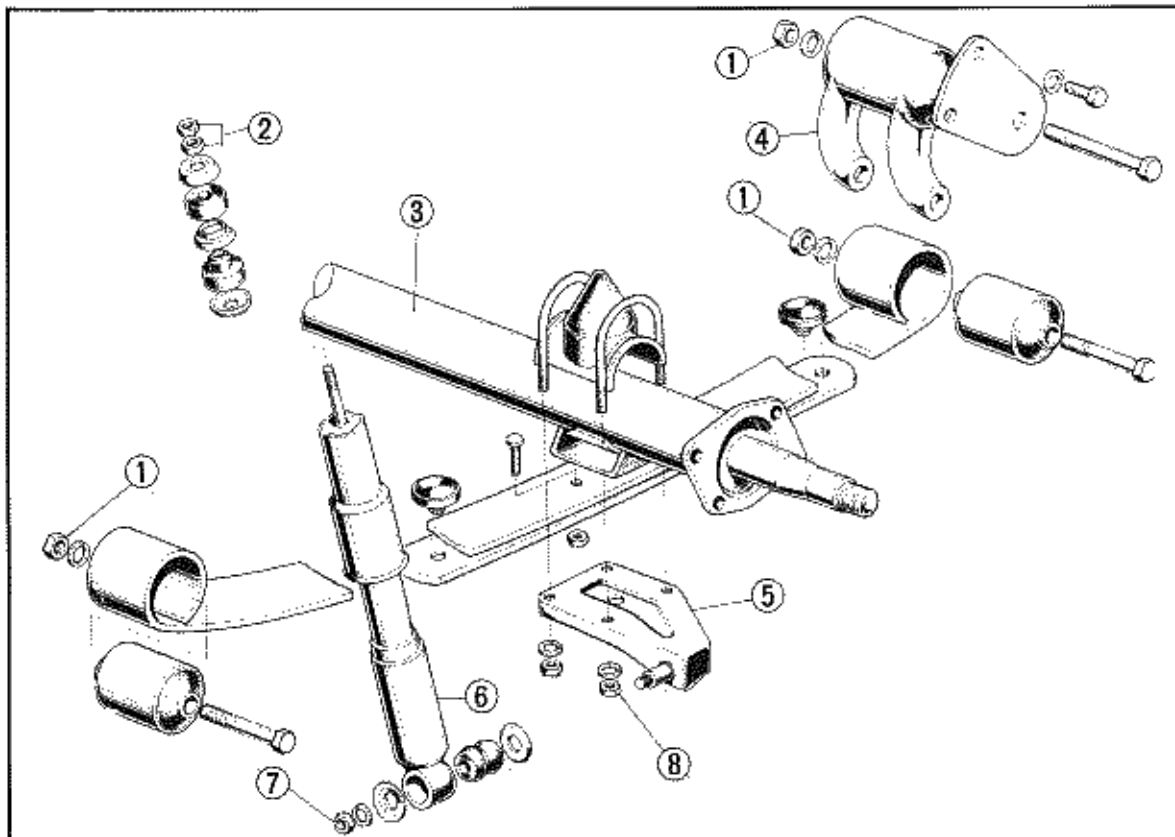

Fig. 12-6 ① 4.0~4.8 kg-m (29~35 lbs-ft) ④ Leaf Spring Shackle ⑦ 1.6~2.0 kg-m (11.6~14 lbs-ft)
 ② 1.2~1.5 kg-m (9~11 lbs-ft) ⑤ Leaf Spring Retaining Plate ⑧ 4.0~4.5 kg-m (29~35 lbs-ft)
 ③ Rear Axle Beam ⑥ Rear Shock Absorber Assembly

13. FUEL SYSTEM

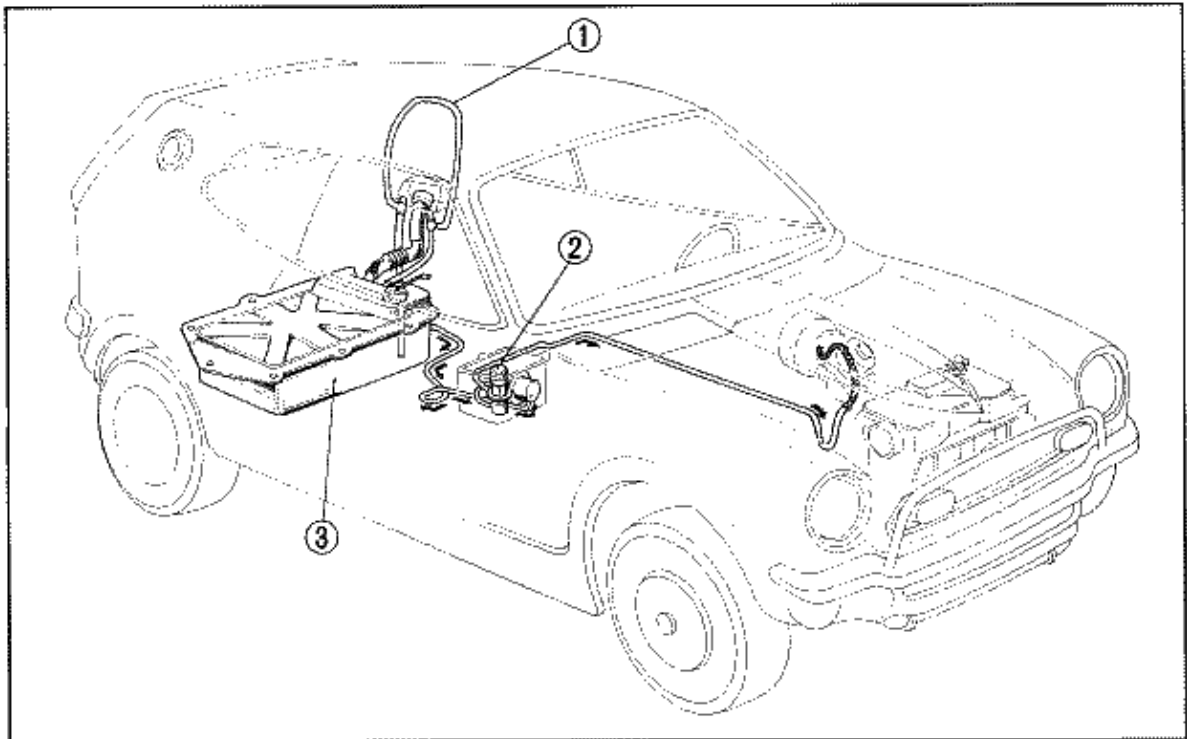

Fig. 13-1 ① Air Vent Tube ② Fuel Pump Assembly ③ Fuel Tank

NOTE: Replace the fuel hoses and clips with new ones if any are damaged during disassembly.

13-1. Fuel Tank

Removal

1. Drain the fuel tank.
2. Lay the rear passenger seat back on the rear seat cushion and take spare tire out of the tire compartment.
3. Remove the left side rear lining and remove the trunk floor mat.
4. Remove the fuel hose cover.
5. Remove the filler neck connecting tube and air breather tube B from the fuel tank. Disconnect the wire harness from the fuel meter unit. (Fig. 13-3)
6. Disconnect the fuel feed tube from the fuel tank.
7. Remove the three fuel tank retaining bolts from the rear compartment and three retaining nuts from under the fuel tank. Remove the fuel tank.

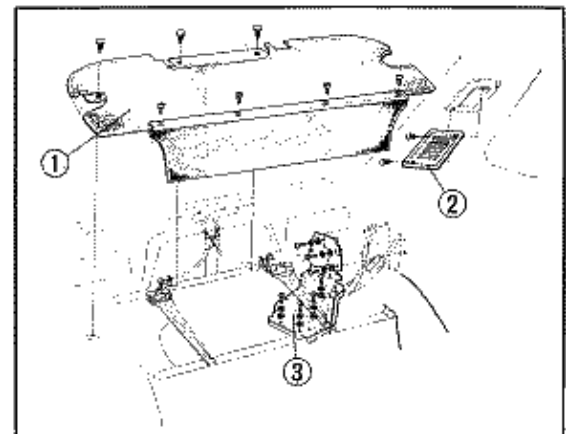

Fig. 13-2 ① Trunk Floor Mat Assembly
② Rear Pillar Lining
③ Fuel Hose Cover

8. If the fuel meter unit is removed, apply sealant to the mating surfaces and to the thread.

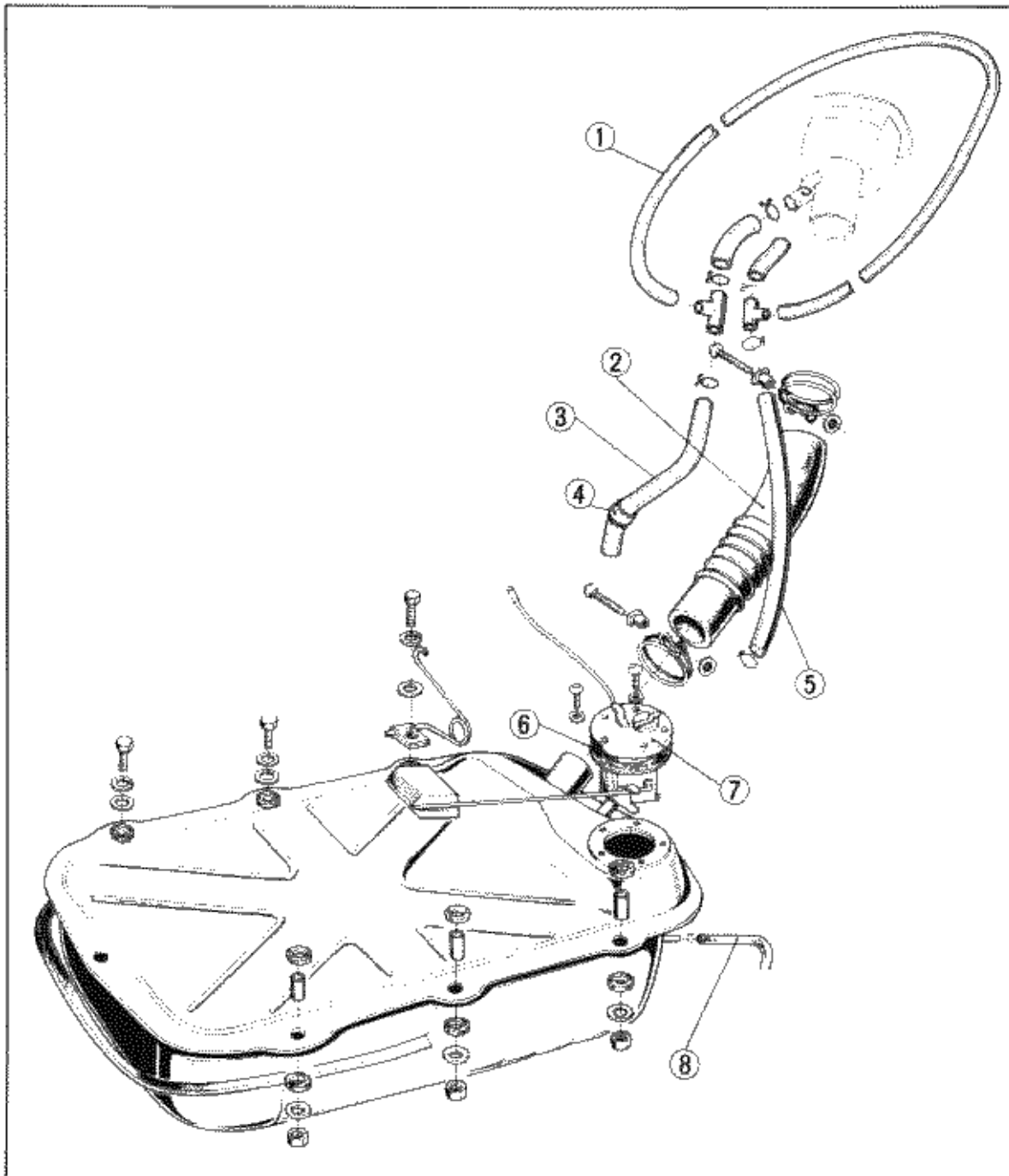

Fig. 13-3 ① Air Vent Tube ④ Fuel Drain Tube Grommet ⑦ Fuel Meter Unit
 ② Filler Neck Connecting Tube ⑤ Air Breather Tube, B ⑧ Fuel Tube
 ③ Fuel Drain Tube, B ⑥ Fuel Meter Gasket

Installation

To install the fuel tank, reverse the removal procedures.

Torque Specification

| | |
|-----------------|---------------------------------|
| Retaining bolts | 2.0-2.4 kg-m (14.5-17.4 lbs-ft) |
| Retaining nuts | 1.0-1.3 kg-m (7.2-9.4 lbs-ft) |

NOTE: The air vent tube can be removed by removing the left rear pillion lining.

13-2. Fuel Pump and Fuel Strainer

Removal

1. Remove the rear seat cushion and then remove the pump inspection lid.
2. Disconnect the fuel feed pipe from the fuel pump and from the fuel strainer.
3. Remove the fuel pump by removing the two pump mounting bolts.

Installation

To install the fuel pump and fuel strainer, reverse the removal procedure.

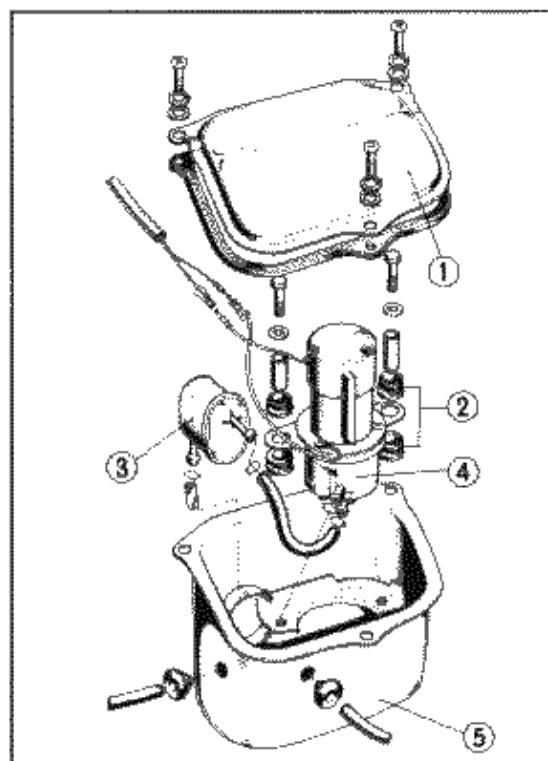

Fig. 13-4 ① Fuel Pump Inspection Lid
 ② Fuel Pump Mounting Cushion
 ③ Fuel Strainer Assembly
 ④ Fuel Pump Assembly
 ⑤ Fuel Pump Cavity

14. EXHAUST SYSTEM

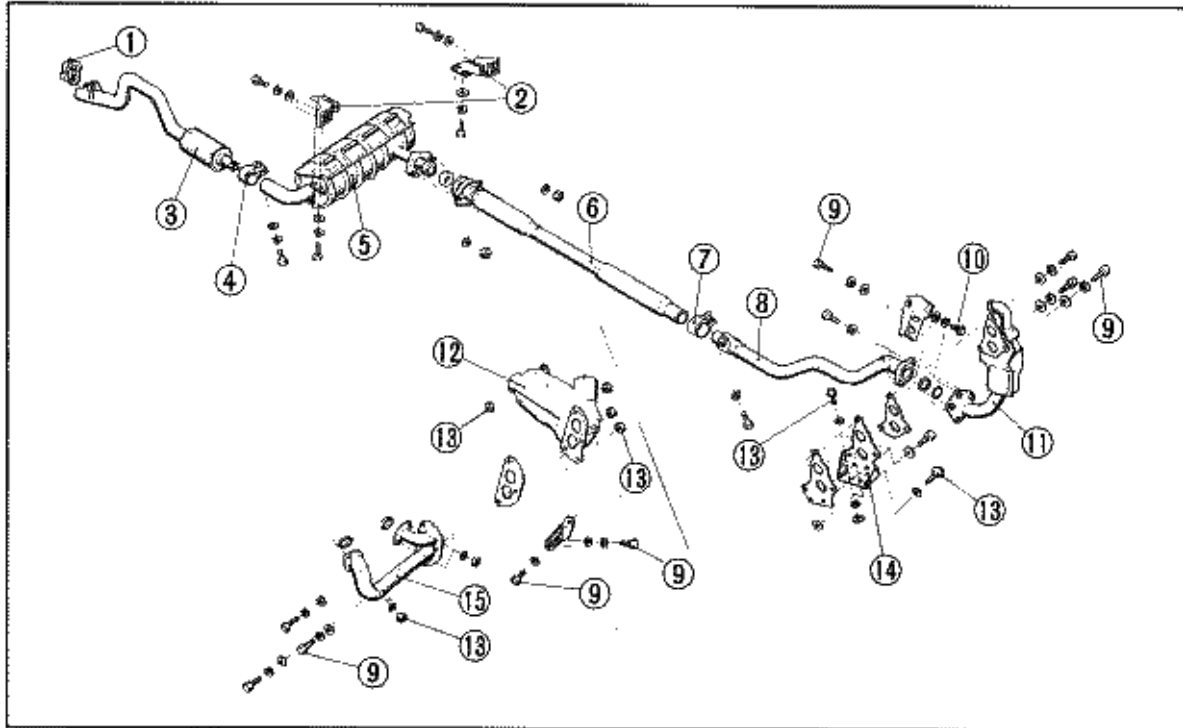

Fig. 14-1

| | | |
|---------------------------------|-----------------------------------|-----------------------------------|
| ① Exhaust Pipe Mounting Cushion | ⑥ Exhaust Silencer A | ⑪ Joint Pipe A Assembly |
| ② Exhaust Pipe Mounting Bracket | ⑦ Exhaust Pipe Joint Clamp | ⑫ Heat Exchanger |
| ③ Tail Pipe | ⑧ Exhaust Joint Pipe | ⑬ 2.0~2.4 kg-m (14.5~17.4 lbs-ft) |
| ④ Exhaust Pipe Clamp | ⑨ 2.4~2.8 kg-m (17.4~20.2 lbs-ft) | ⑭ Exchanger Stay |
| ⑤ Exhaust Main Silencer | ⑩ 4.0~4.8 kg-m (28.9~34.7 lbs-ft) | ⑮ Exhaust Manifold |

NOTES:

1. Replace any part with a new one if it is found to be worn, damaged or deteriorated.
2. Always install new gaskets whenever the components are disassembled

Removal

1. Disconnect the hot air duct, heater duct and heater ducts A and B from the engine (Fig. 3-1).
2. Remove the heater blower unit from the engine. (Fig. 3-1)
3. Remove the front bumper.
4. Remove the front bumper guard, left and right front turn signal lights and the grill.
5. Remove the front grill.
6. Separate the exhaust joint pipe from the joint pipe A.
7. Remove the heater duct, duct A and duct B from the heat exchanger then remove the heater blower unit from the engine compartment.
8. Remove the joint pipe A assembly from the heat exchanger. Remove the joint pipe A bracket from the clutch housing and then remove the joint pipe A assembly from the engine compartment.

9. Separate the exhaust manifold from the heat exchanger and then remove the heat exchanger.
10. Remove the exhaust manifold from the cylinder head.
11. Loosen the exhaust pipe joint clamp. Separate the exhaust joint pipe from the exhaust silencer A with the exhaust pipe adapter (special tool) as shown in Fig. 14-2.
12. Separate the exhaust silencer A from the exhaust main silencer by loosening the retaining nuts.
13. The exhaust main silencer and tail pipe can be removed as an assembly by removing the right and left mounting brackets and the exhaust pipe mounting cushion.
14. Separate the tail pipe from the exhaust main silencer.

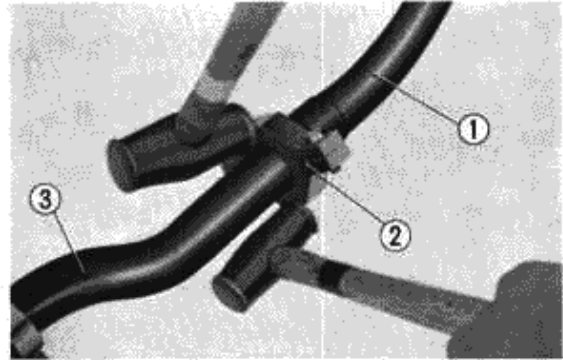

Fig. 14-2 ① Exhaust Silencer A
② Exhaust Pipe Removing Adapter
③ Exhaust Joint Pipe

Installation

To install the exhaust system, reverse the removal procedures. The following items must be carefully checked when the exhaust system is installed:

1. Install the exchanger stay.
2. Temporarily tighten the exhaust manifold.
3. Install the joint pipe A and heat exchanger, and then tighten them temporarily.
4. Retighten the exhaust manifold, joint pipe A and heat exchanger to the specified torque (Fig. 14-1).
5. Always use new gaskets. **DO NOT** reuse exhaust system gaskets.

15. INSTRUMENT PANEL

Removal of center panel

1. Remove the panel cover.
 2. Remove the center panel by removing two screws. Then the fresh air outlet assembly and air outlet holder can be separated.
- + To install the center panel assembly, reverse the removal procedure.

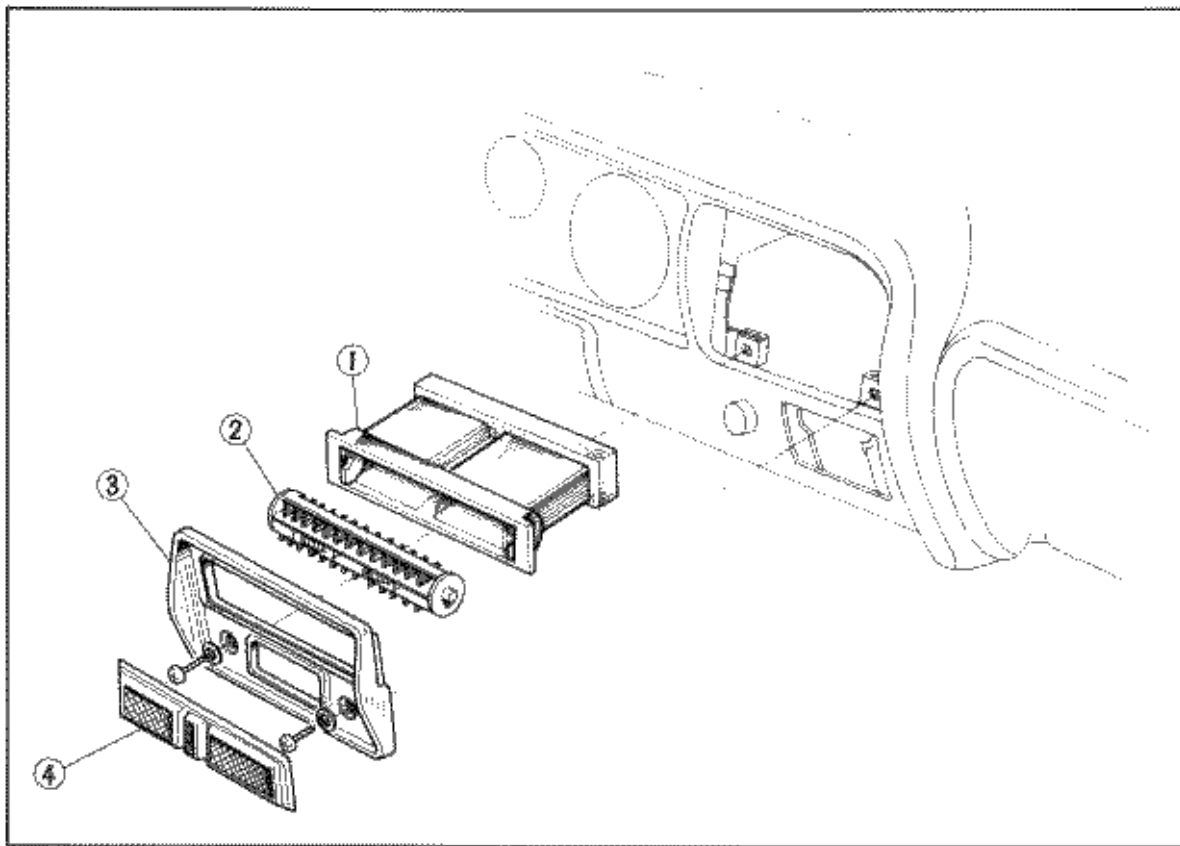

Fig. 15-1 ① Air Outlet Holder ② Fresh Air Outlet Assembly ③ Center Panel ④ Panel Cover

Removal of glove box

Open the glove box lid and remove four screws to remove the glove box from the instrument panel.

Remove the glove box lid, glove box lock and glove box lock base by referring to Fig. 15-2.

*To install the glove box, reverse the removal procedure.

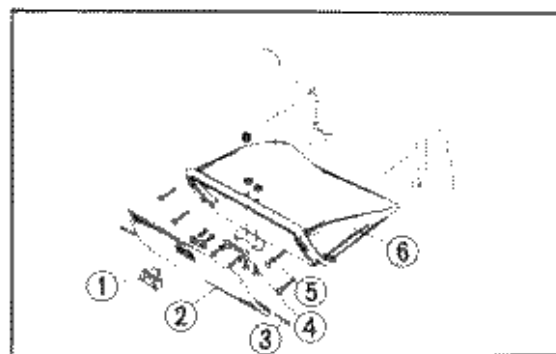

Fig. 15-2 ① Glove Box Lock
② Glove Box Lid
③ Glove Box Hinge Pin
④ Lock Female
⑤ Glove Box Lock Base
⑥ Glove Box

Removal of instrument panel

1. Remove the glove box.
(Refer to "Removal of glove box".)
2. Remove the switch panel: Remove the lighting knob and its ring nut. (Fig. 15-3)
3. Remove the steering hanger retaining bolts and lower the steering shaft and wheel to the floor.
4. Disconnect the wire harness at the coupler and connector. Disconnect the parking brake switch cord while raising the floor mat.
5. Remove the ignition key removal warning buzzer and disconnect the ground wire at the buzzer.
6. Disconnect the choke control cable at the carburetor and push it toward the interior through the dashboard.
7. Remove the heater control assembly.
8. Remove the instrument panel retaining screws and pull out the instrument panel. Disconnect the speedometer and tachometer drive cables at the speedometer and tachometer respectively.

NOTE: Exercise care not to drop off the bushings used in the meter drive cables.

9. Remove the instrument panel as an assembly.

*To install the instrument panel, reverse the removal procedure.

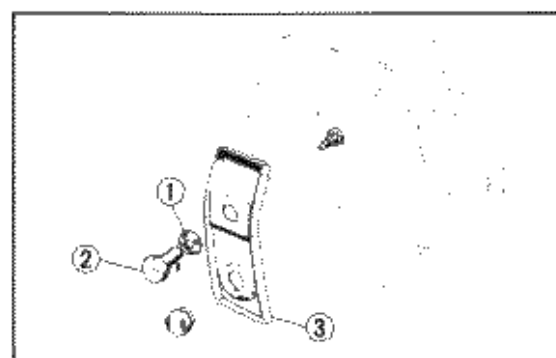

Fig. 15-3 ① Ring Nut ⑤ Switch Panel
② Lighting Knob

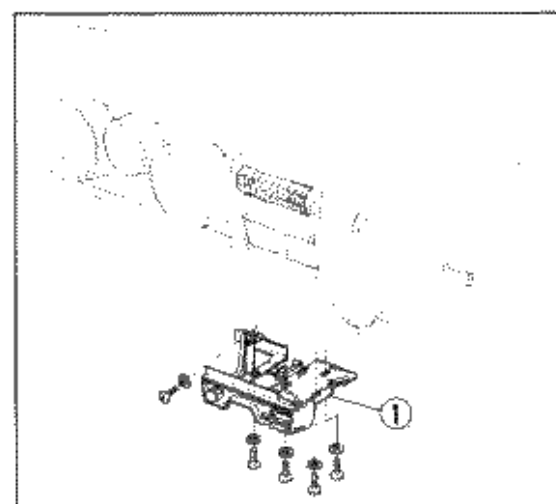

Fig. 15-4 ① Heater Control Assembly

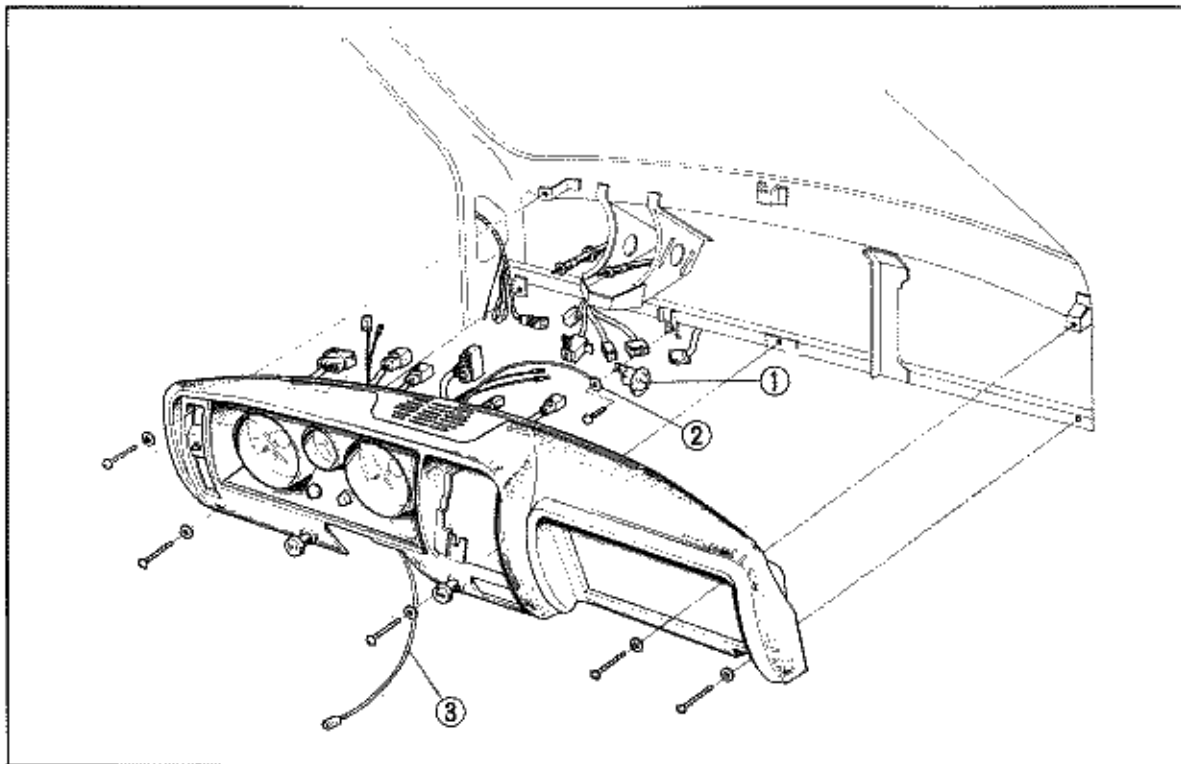

Fig. 15-5 ① Ignition Key Removal Warning Buzzer ② Ground Wire ③ Parking Brake Switch Cord

Removal and disassembly of meter panel

The meter panel can be removed from the body independently of the instrument panel.

1. Remove the center panel. (Refer to "Removal of center panel" in this section.)
2. Remove the choke cable assembly.
3. Remove the steering shaft hanger retaining bolts and lower the steering shaft and wheel to the floor.
4. Remove the meter panel retaining screws and pull out the meter panel. Disconnect the speedometer and tachometer drive cables at the speedometer and tachometer respectively and the wire harness at the couplers.
5. Disconnect the wire harness from the lighting switch, brake trouble warning light, turn signal pilot lamp, beam pilot lamp, fuel meter, speedometer and tachometer (Fig. 15-7).
6. Remove respective meters (Fig. 15-8).

* To install and assemble the meter panel, reverse the removal procedures.

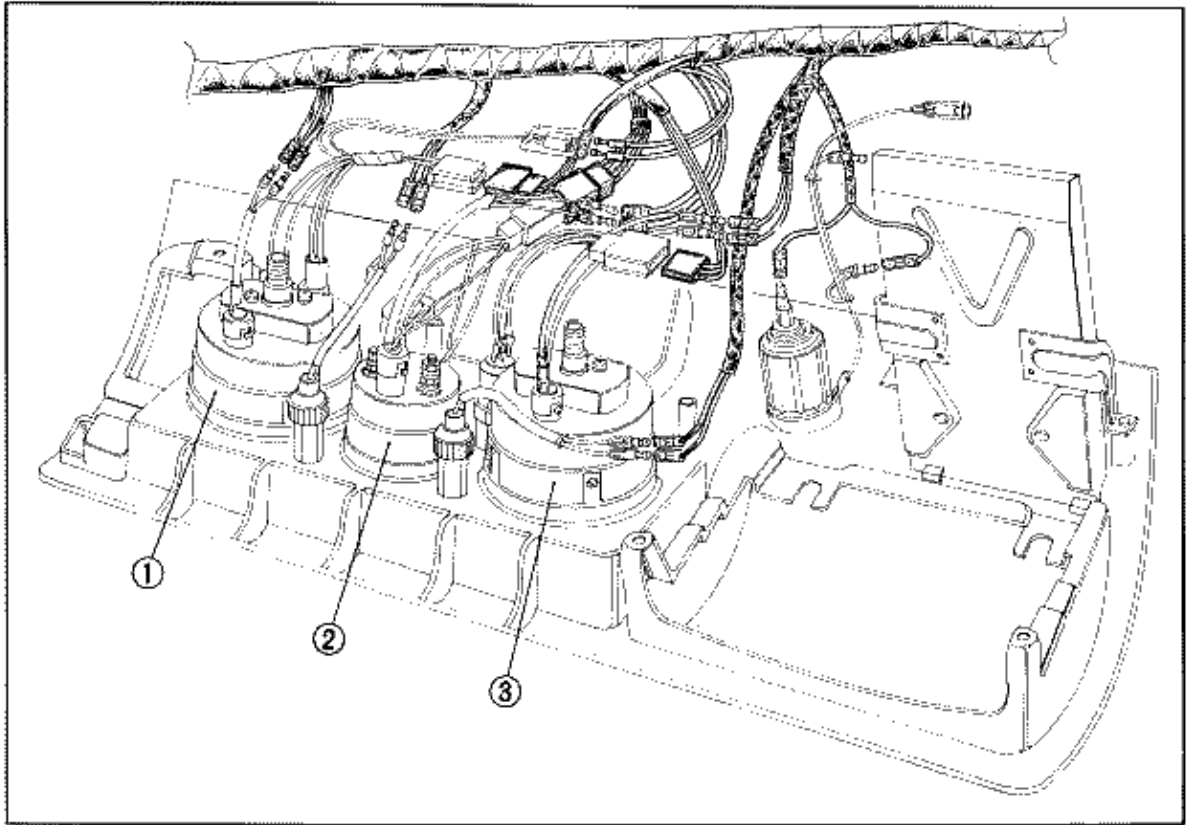

Fig. 15-6 ① Tachometer

② Fuel Meter

③ Speedmeter

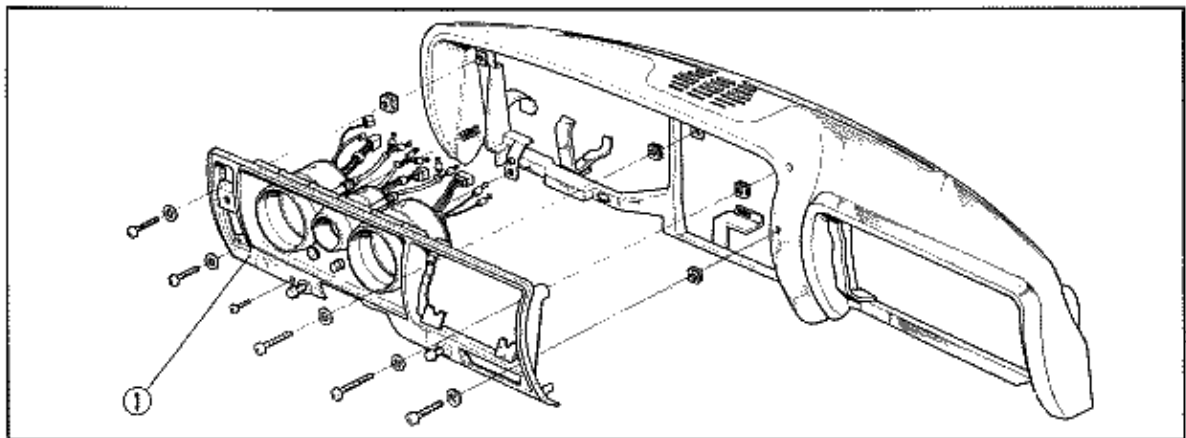

Fig. 15-7 ① Meter Panel

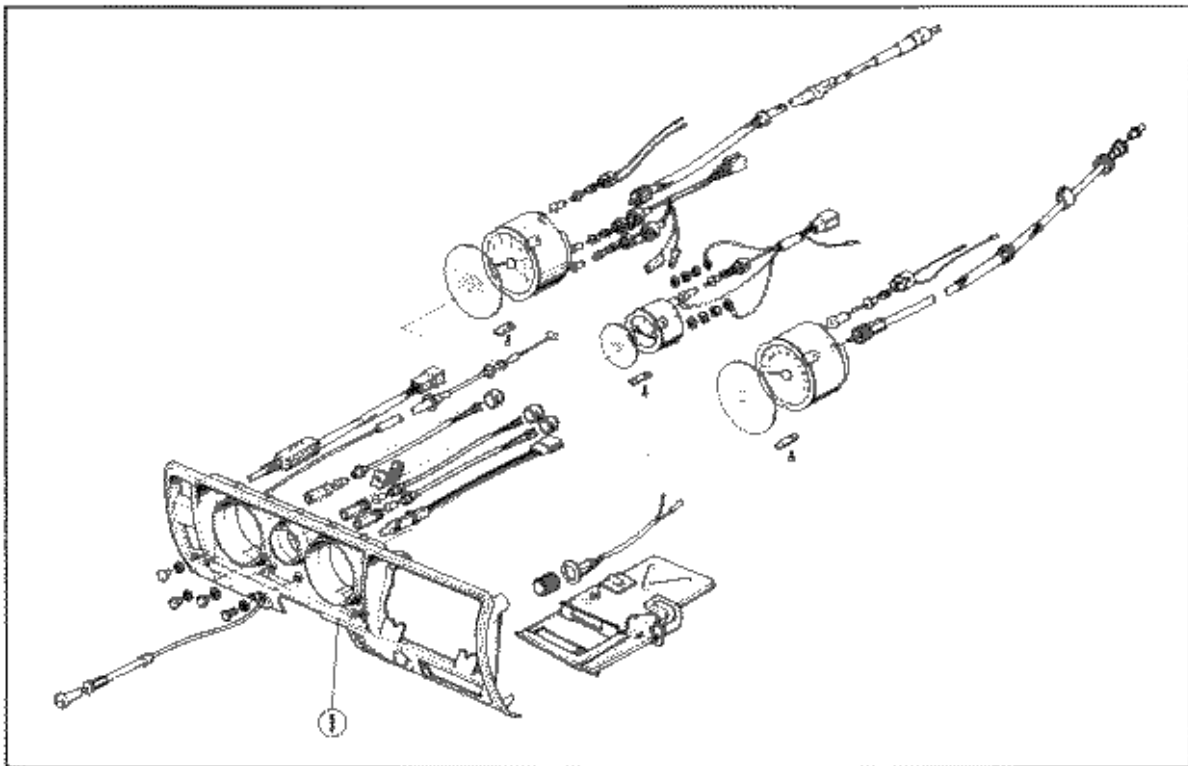

Fig. 15-8 ① Motor Panel

16. HEATER AND VENTILATION

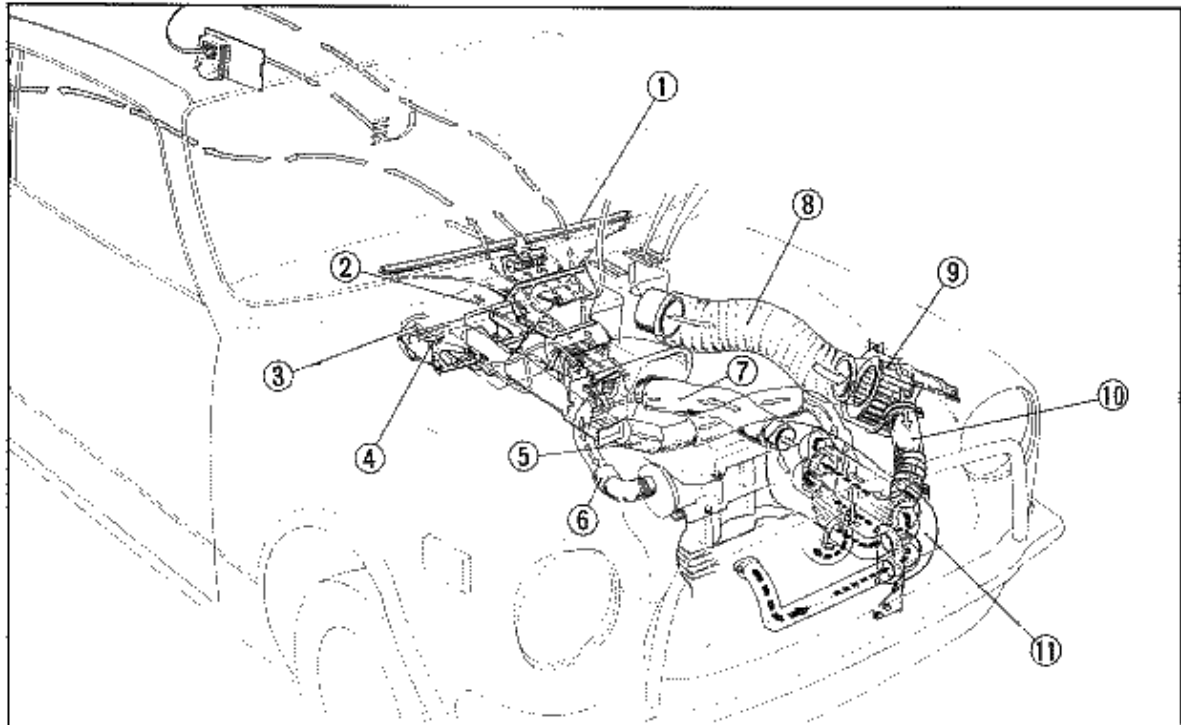

Fig. 16-1 ① Defroster Upper Nozzle ⑤ Hot Air Duct ⑨ Heater Blower Unit
 ② Fresh Air Control Shaft ⑥ Exhaust Air Duct ⑩ Heater Duct A
 ③ Heater Control Lever ⑦ Heater Duct ⑪ Heat Exchanger
 ④ Defroster Control Lever ⑧ Heater Duct B

Removal of defroster lower nozzle and heater outlet box

1. Remove the instrument panel. (Refer to Section 15, "INSTRUMENT PANEL")
2. Disconnect the ventilator valve cable and remove the defroster lower nozzle.
3. Disconnect the ducts at the rear side of the heater inlet box.
4. Remove the heater outlet box comp. together with the R. H. heater air duct joint by removing air control stay retaining bolt.

NOTE: The heater outlet box can be removed without removing the instrument panel.

* To install defroster lower nozzle and heater outlet box, follow the reverse of removing procedure.

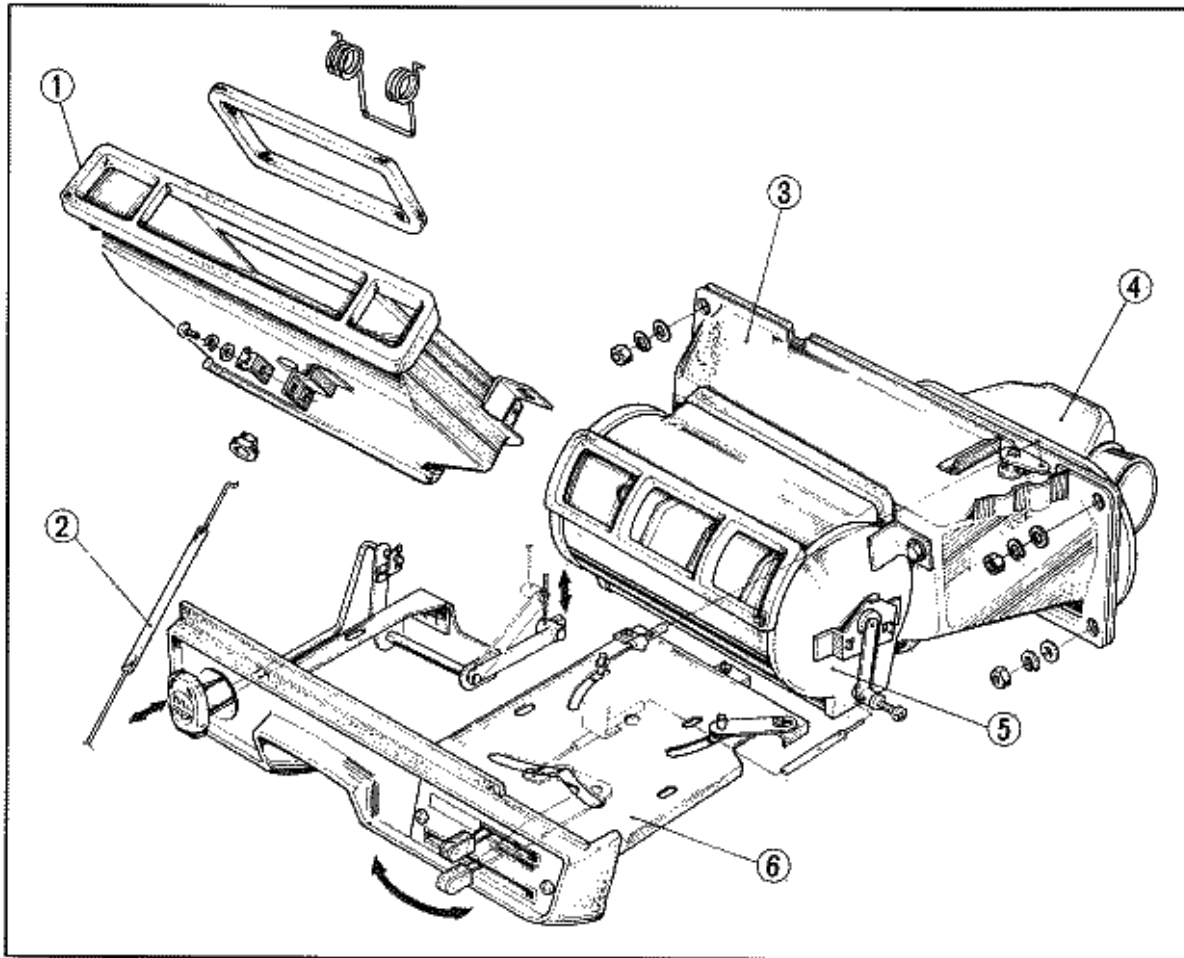

Fig. 16-2 ① Defroster Lower Nozzle ③ Heater Outlet Box Comp ⑤ Air Control Box
 ② Ventilator Valve Cable ④ Heater Inlet Box ⑥ Heater Control Assembly

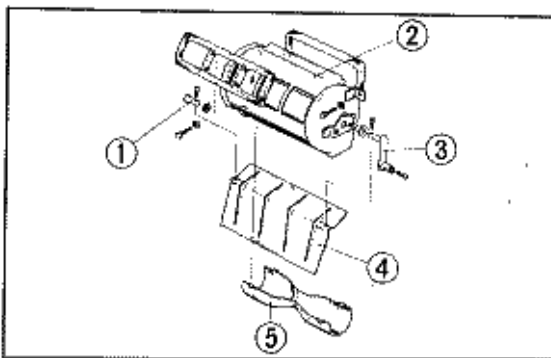

Fig. 16-3 ① Air Control Valve Shaft B
 ② Air Control Box
 ③ Air Control Valve Shaft A
 ④ Air Control Valve
 ⑤ Air Control Valve Guide

Disassembly of air control box

1. Remove the air control valve guide.
2. Remove the air control box comp. from the heater outlet box comp. by removing two retaining bolt.
3. Remove the air control valve shafts. A and B from the air control valve.

* To assemble the control box, reverse the disassembling procedure.

Disassembly of heater outlet box

1. Remove the heater control assembly.
 2. Remove the air control box comp. from the heater outlet box comp. by removing two retaining bolts.
 3. Disconnects the ducts at the rear side of the heater inlet box.
 4. Remove four retaining nuts to separate the heater outlet box from the heater inlet box.
- * To assemble the heater outlet box, reverse the disassembling procedure.

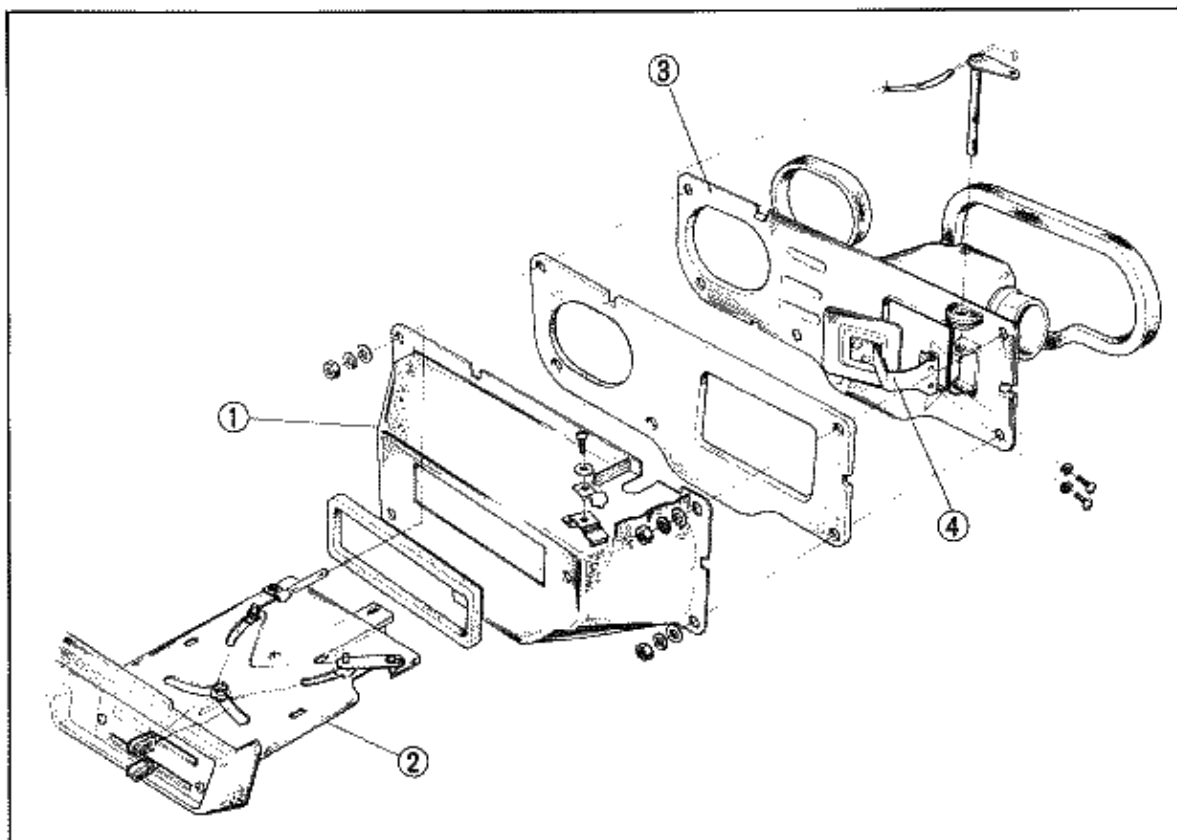

Fig. 16-4 ① Heater Outlet Box Comp
② Heater Control Assembly

③ Heater Inlet Box Comp
④ Heater Air Valve, R

Removal of defroster upper nozzle

1. Remove the instrument panel. (Refer to Section 15 "INSTRUMENT PANEL".)
 2. Remove the defroster upper nozzle by removing three retaining screws.
 3. Remove the defroster garnish by removing the retaining nuts and bolts. Remove the center panel bracket.
- To install the defroster upper nozzle, reverse the removal procedure.

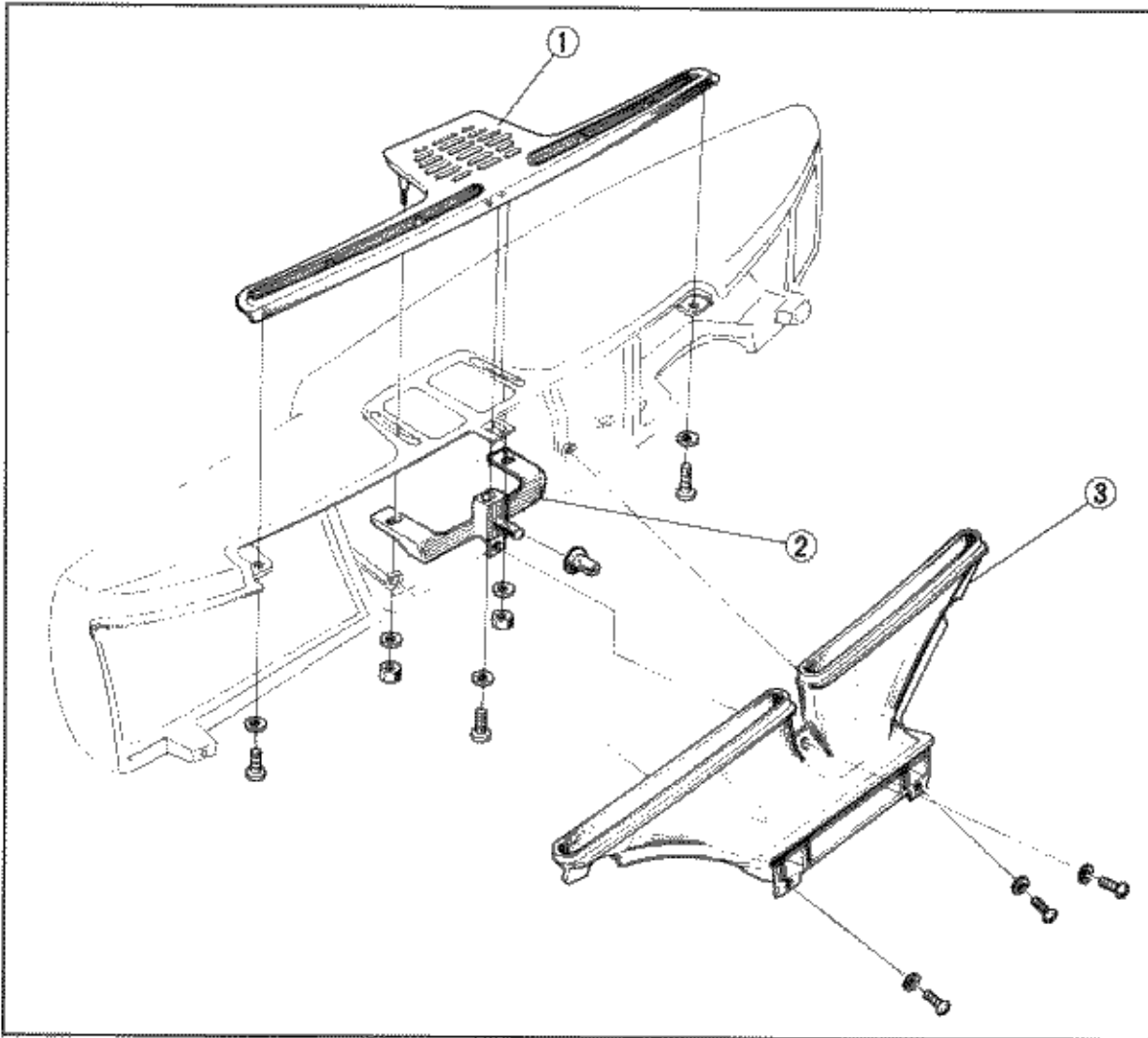

Fig. 16-5 ① Defroster Garnish

② Center Panel Bracket

③ Defroster Upper Nozzle

17. DOOR

Door lining

1. Remove the door lock lever housing.
2. Pull out the door glass regulator handle retainer and remove the regulator handle and regulator handle escutcheon.
3. Remove the door lining retainers one by one from the retainer catches, starting the retainer located at the corner, and remove the door lining.

NOTE: Exercise care not to damage the lining when removing the door lining retainers.

4. Remove the inside door handle.

* To install the door lining, reverse the removal procedure. The following items should be carefully checked when the door lining is installed:

1. Fit the door lining retainer catches into the door frame and adjust the locations of the retainers on the lining before fitting them to the catches.
2. The door glass regulator handle should be installed in such a way that it is parallel to

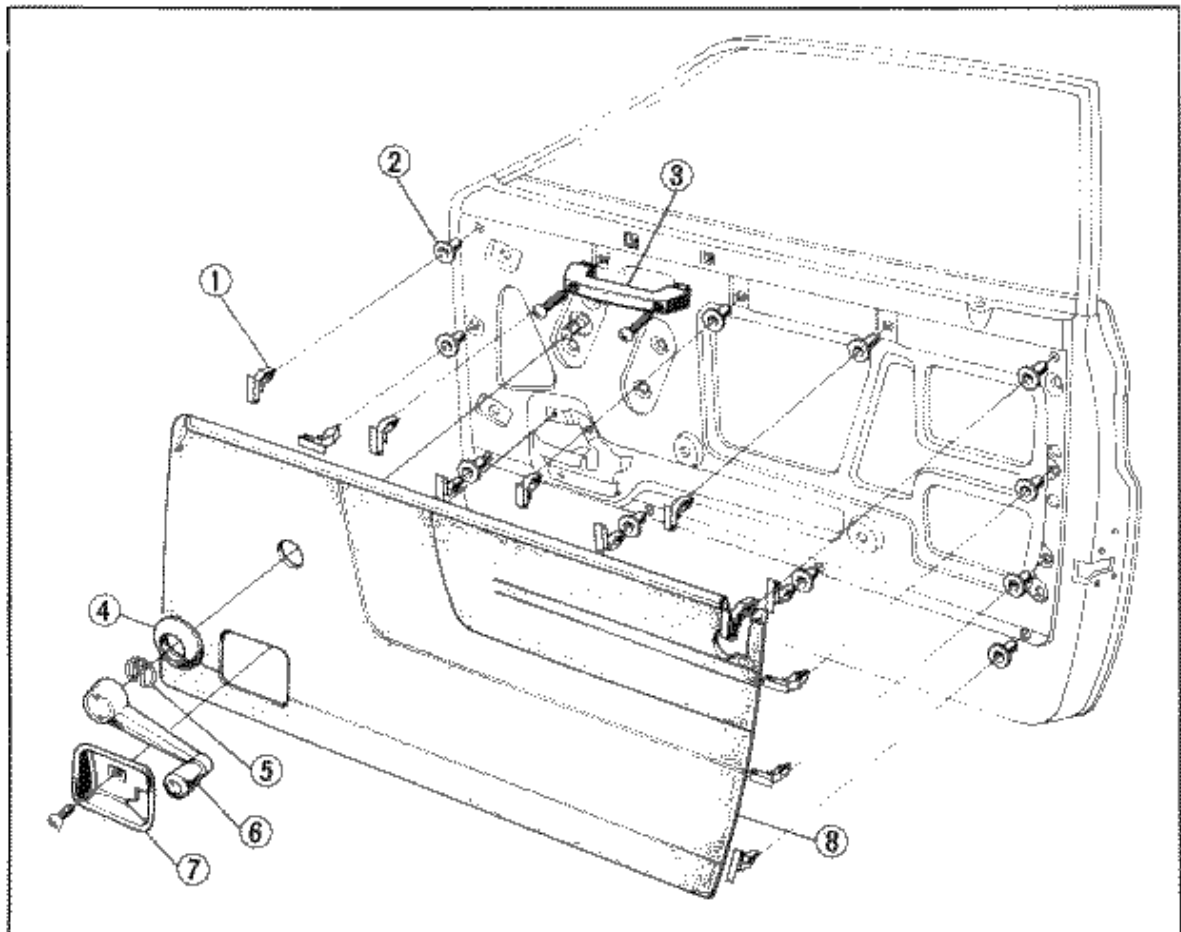

Fig. 17-1 ① Door Lining Retainer ④ Regulator Handle Escutcheon ⑦ Door Lock Lever Housing
 ② Retainer Catch ⑤ Door Inside Handle ⑧ Door Lining
 ③ Door Glass Regulator Handle Assembly

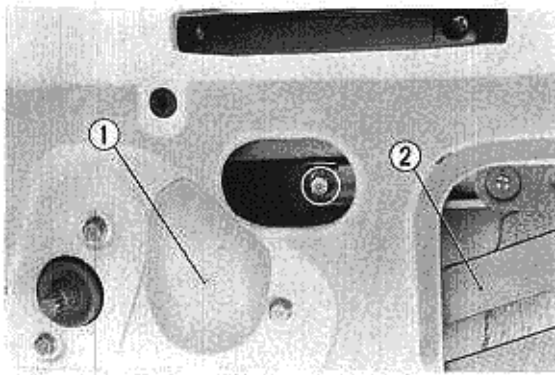

Fig. 17-2 ① Door Fitting Hole Seal
② Door Glass Regulator Assembly

the door upper sash (the front pillar) when the door glass is fully closed.

Removal and installation of door glass, door glass regulator and door glass run channel.

1. Separate the door glass holder and regulator. The door glass holder is mounted to the door glass at two places.

Separate the front of the glass from the holder by removing the door fitting hole and door panel seals and then removing the 6 mm bolts that secure the glass holder to the window regulator guide.

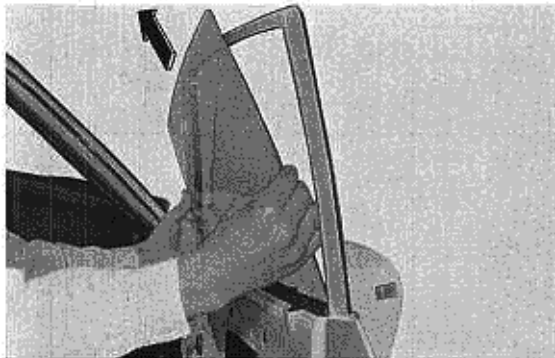

Fig. 17-3

2. Lower the front edge of the glass, then tilt the upper rear corner inward and pull the glass out.

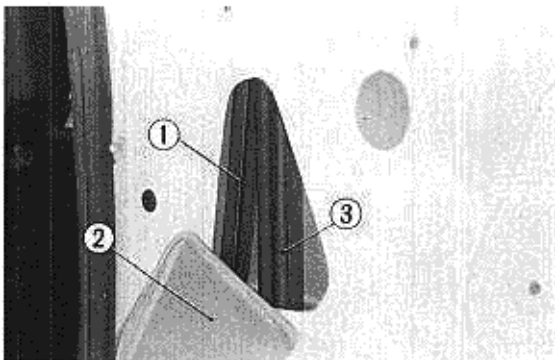

Fig. 17-4 ① Door Front Sash
② Door Inside Handle Hole Seal
③ Door Glass Run Channel

3. Remove the door glass run channel from the door upper sash.

Remove the door inside handle seal for this operation.

4. Remove the front and rear door sashes.

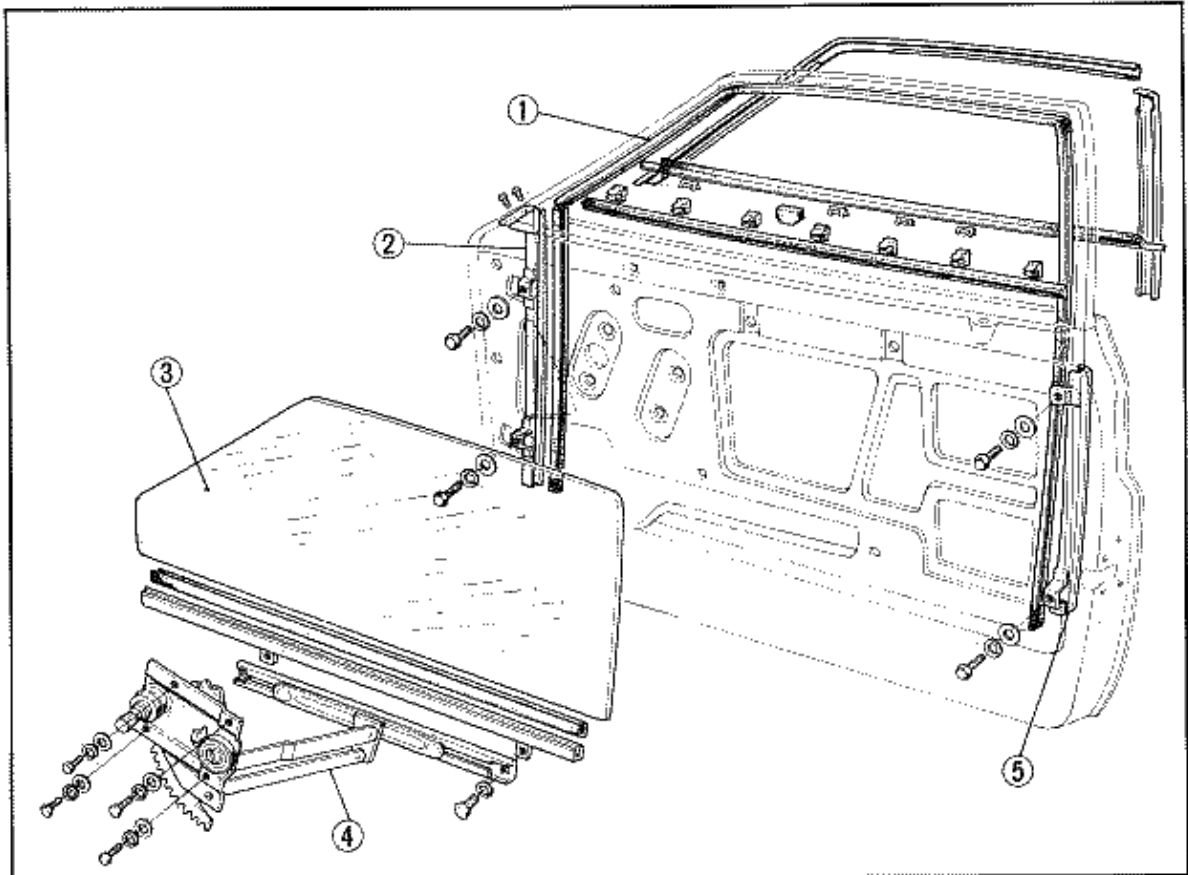

Fig. 17-5 ① Door Glass Run Channel ③ Door Glass ⑥ Door Rear Sash
 ② Door Front Sash ④ Door Glass Regulator Assembly

5. Remove the door glass regulator from the door frame.

* To install the door glass, regulator and run channels, reverse the removal procedure.

Door lock mechanism

1. Remove the door remote control retaining bolts. Straighten the clip at the inside handle rod and remove the door remote control and inside handle rod from the hole in the door lock.
2. Remove the door inside lock rod knob. Straighten the door lock cylinder rod clip to separate the door lock cylinder from the door lock. Then remove the inside handle rod from the hole in the door lock cylinder.
3. Remove the door lock from the door frame.
4. The door cylinder can be removed by removing the lock cylinder setting spring.

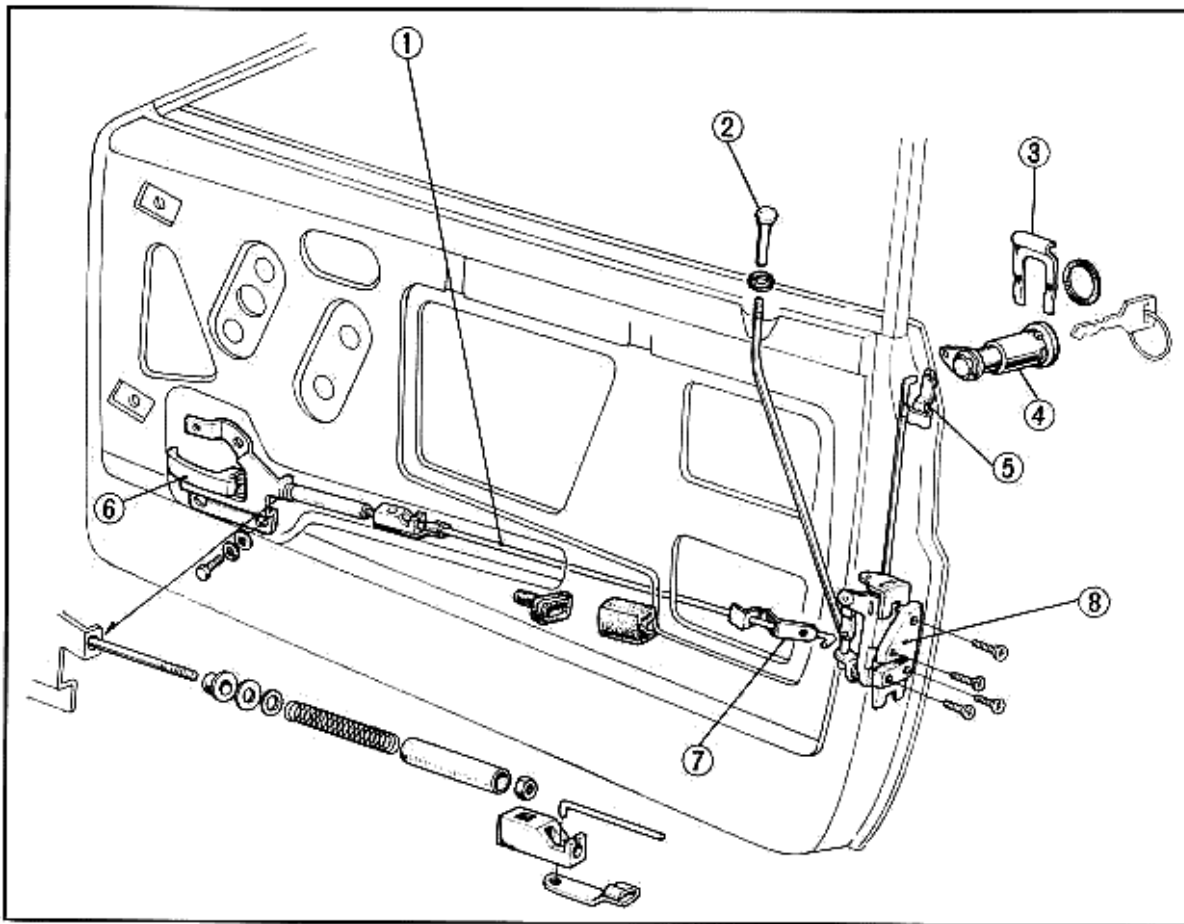

Fig. 17-6 ① Inside Handle Rod Assembly ④ Door Lock Cylinder ⑦ Clip
 ② Door Inside Lock Rod Knob ⑤ Clip ⑧ Door Lock Assembly
 ③ Lock Cylinder Setting Spring ⑥ Inside Handle

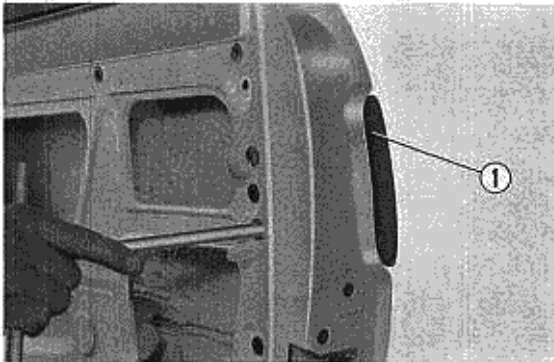

Fig. 17-7 ① Outside Handle

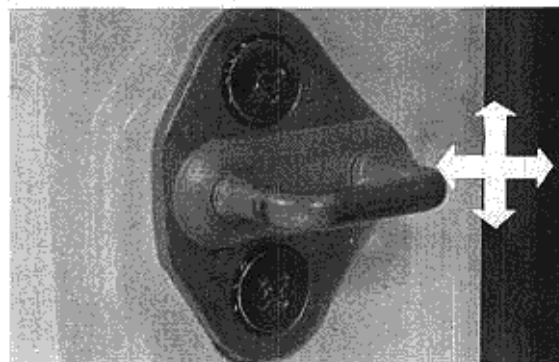

Fig. 17-8

5. Removal of door outside handle

Remove the retaining nut with a socket wrench. Apply grease to the moving parts when the door outside handle is installed.

- * The position of door lock striker can be adjusted by moving it vertically and horizontally after its bolts are loosened.

Adjust the position of striker so that the door locks securely, and opens and closes smoothly.

18. TAIL GATE

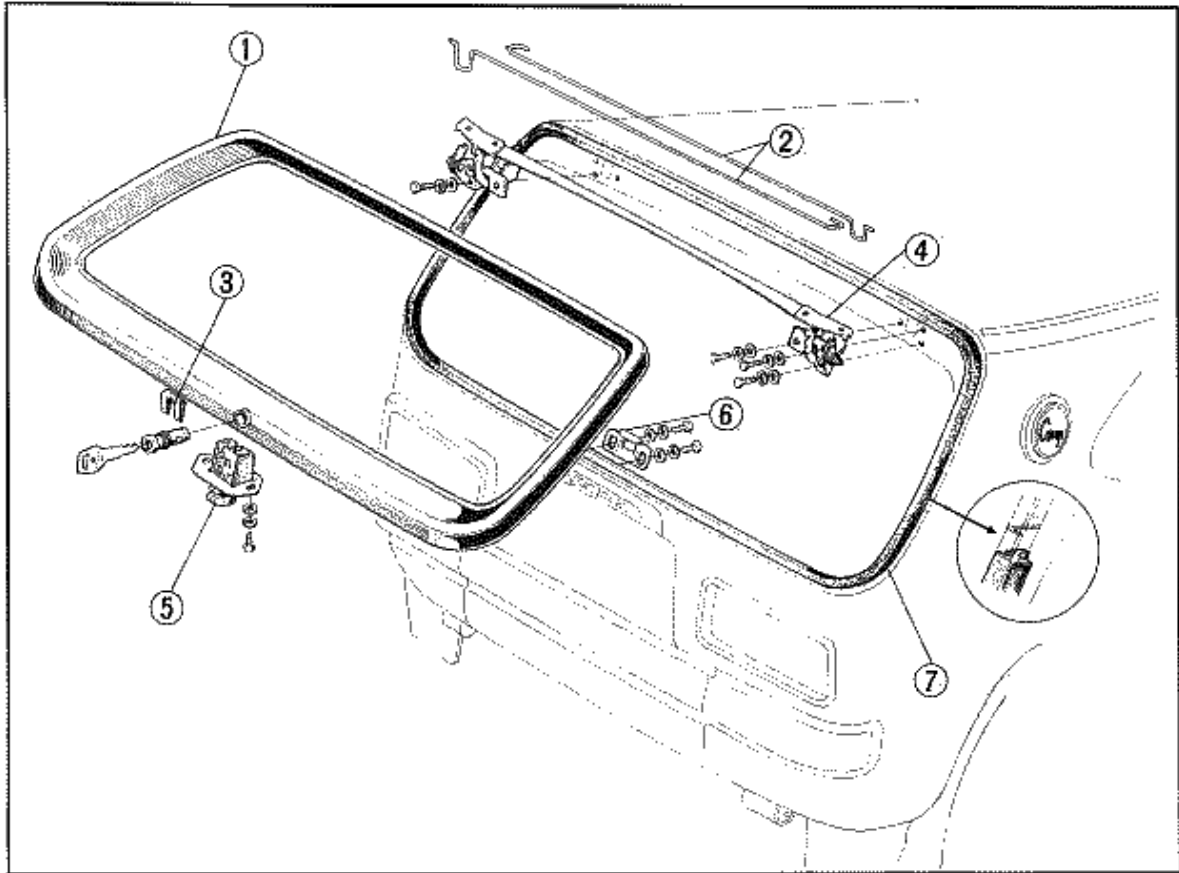

Fig. 18-1 ① Tail Gate Unit ④ Tail Gate Hinge ⑦ Tail Gate Weather Strip
 ② Torsion Bar ⑤ Tail Gate Lock Assembly ⑥ Tail Gate Striker
 ③ Lock Cylinder Setting Spring

Removal and disassembly

1. Remove the torsion bars from the tail gate hinges with the torsion bar remover (Special tool) as shown in Fig. 18-2.

NOTE: Exercise care not to damage the roof when removing the torsion bars from the hinges.

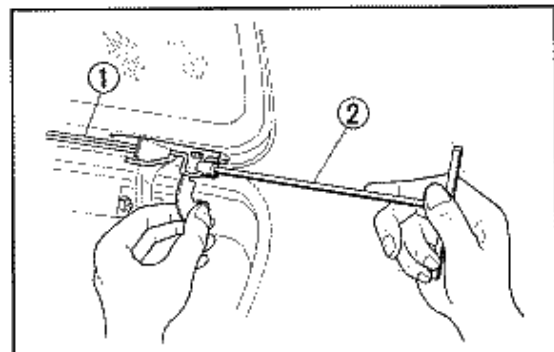

Fig. 18-2 ① Torsion Bar ② Torsion Bar Remover

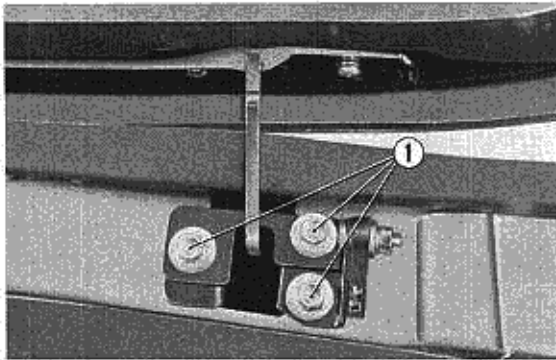

Fig. 18-3 ① Hinge Retaining Bolt

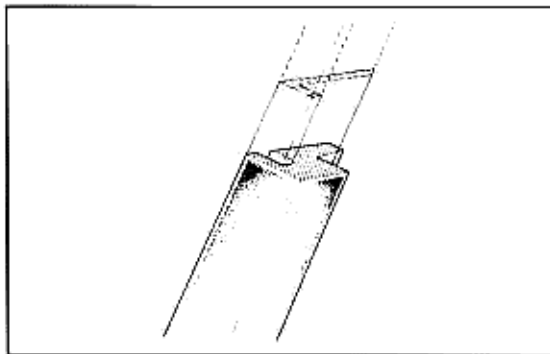

Fig. 18-4

Fig. 18-5 ① Torsion Bar ③ Torsion Bar Link
② Torsion Bar Remover

Fig. 18-6

2. Remove the bolts holding the hinges to the body and remove the tail gate together with the hinges.
3. Remove the hinges from the tail gate.
4. Remove the tail gate lock from tail gate.

Assembly and installation

1. Clean the mating surfaces of the tail gate weather strip of dirt and oil. Apply weather strip cement uniformly to the weather strip and its mating surfaces.

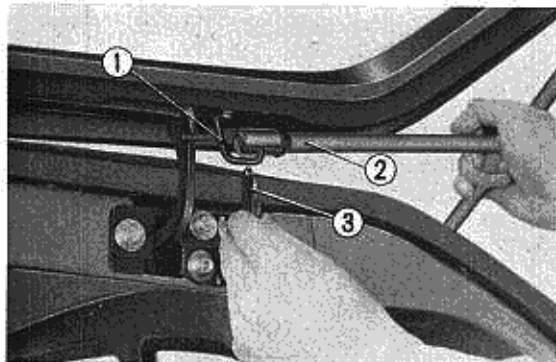
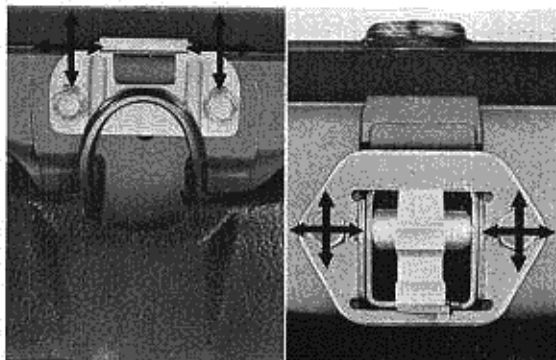
NOTES:

- 1) Apply the adhesive in a width slightly less than the sealing width so that the excess adhesive does not flow out.
- 2) Mount the weather strip with finger pressure when the adhesive no longer adheres to the fingers but before it is completely dry.
2. Install the tail gate hinges and lock and then install the tail gate to the body.

NOTE: Place a rag between the body and the tail gate during the installation work to prevent damage to the body.

3. Install the torsion bars with the torsion bar remover (special tool) in the same manner as removal.
4. Adjust the clearance and alignment between the tail gate and body by varying the location of tail gate hinges with the retaining bolts loosened.
5. Adjust the engagement of tail gate lock and striker by varying the location of the lock and striker.
6. Check the tail gate lock for engagement and check the weather strip for any leakage of water into the interior.



Fig. 18-7 ① Adjust Tail Gate-to-Body Clearance Uniformly

19. ELECTRICAL SYSTEM

19-1. Starter Motor

Removal and disassembly

1. Remove the ground cable from the (-) terminal of the battery.
 2. Remove the left splashguard.
 3. Remove the starter cable and the black lead from the "B" and "S" terminals of the magnetic switch.
 4. Remove the two starter motor retaining bolts, and remove the starter motor from the flywheel housing.
-
5. Loosen the "M" terminal nut on the magnetic switch and remove the cable.

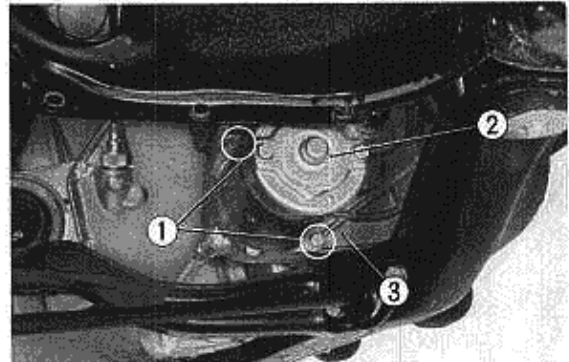

Fig. 19-1 ① Mounting Bolts ② Starter Motor ③ Flywheel Housing

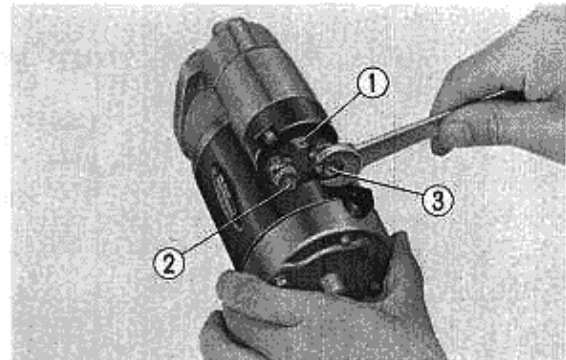

Fig. 19-2 ① Terminal S ② Terminal B ③ Terminal M

6. The magnetic switch is mounted on the case with three bolts. Remove these bolts with a screwdriver and take the magnetic switch together with the return spring from the starter motor.

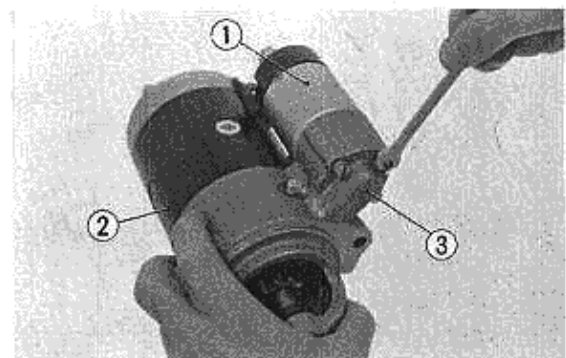

Fig. 19-3 ① Magnetic Switch Assembly ② Starter Motor ③ Case Assembly

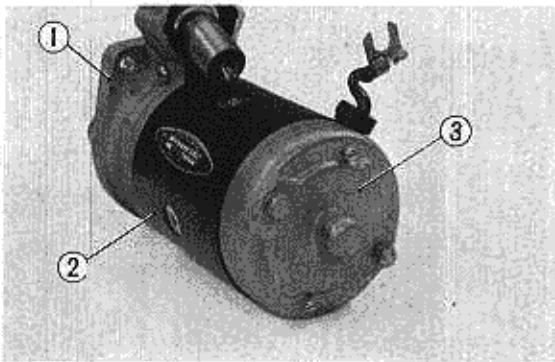

Fig. 19-4 ① Case Assembly ② Yoke Assembly ③ Starter Rear Cover

7. Detach the starter rear cover from the yoke by removing rear cover screws and through bolts.
8. Remove the four carbon brushes from the brush holder, and remove the brush holder.
9. Separate the yoke from the case. The yoke is provided with a hole in which the gear case lock pin is inserted. This is for yoke positioning.

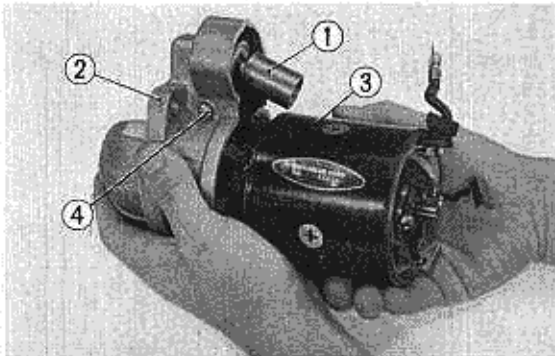

Fig. 19-5 ① Plunger ② Case Assembly ③ Yoke Assembly ④ Shift Lever Pin

10. Remove the shift lever pin, and then the plunger from the shift lever (Fig. 19-5).

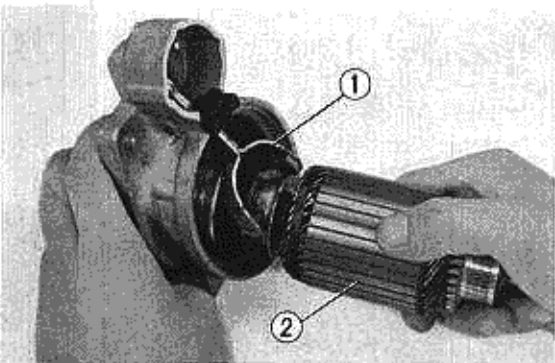

Fig. 19-6 ① Shift Lever ② Armature Unit

11. Pull out the armature unit from the case and remove the shift lever.

12. Armature disassembly

The armature can be disassembled as shown in Fig. 19-7.

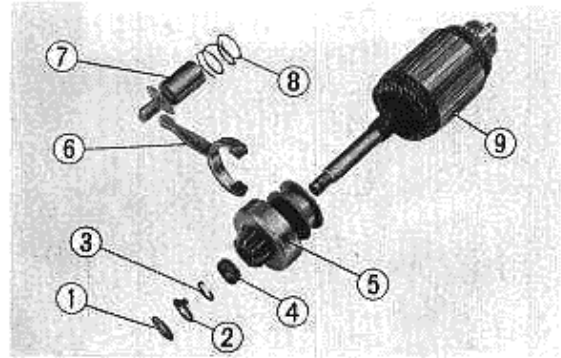

Fig. 19-7 ① Thrust Washer A (1.6 mm)
 ② Pinion Stopper Washer
 ③ Pinion Stopper Clip
 ④ Pinion Stopper
 ⑤ Pinion Assembly
 ⑥ Shift Lever
 ⑦ Plunger
 ⑧ Plunger Return Spring
 ⑨ Armature unit

After removing the thrust washer, A from the shaft, remove the pinion stopper washer.

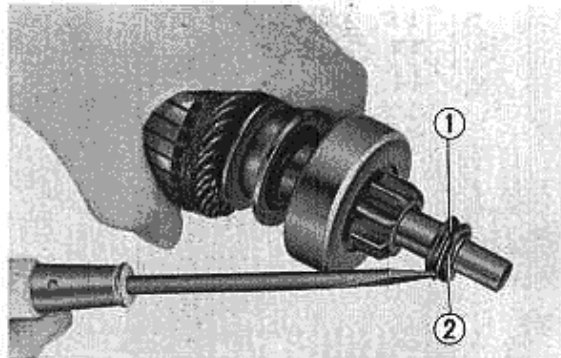

Fig. 19-8 ① Pinion Stopper
 ② Pinion Stopper Washer

Then, slide the pinion stopper toward the armature and remove the pinion stopper clip with pliers.

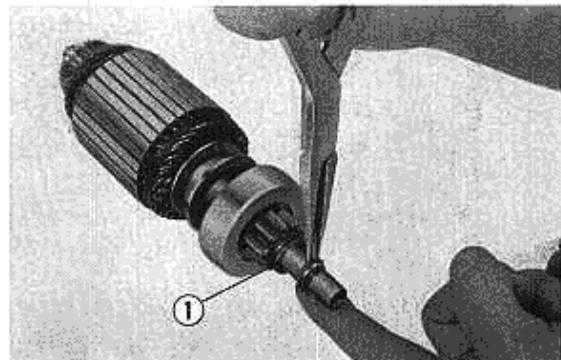

Fig. 19-9 ① Pinion Stopper

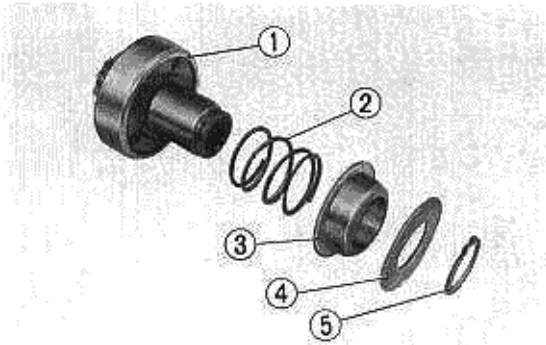

Fig. 19-10 ① Pinion Assembly
 ② Pinion Spring
 ③ Pinion Sleeve
 ④ Pinion Sleeve Washer
 ⑤ Pinion Sleeve Clip

The pinion assembly can then be disassembled as shown in Fig. 19-10.

The overrunning clutch cannot be disassembled.

Installation and assemble

To install and assemble the starter motor, reverse the removal and disassembly procedures.

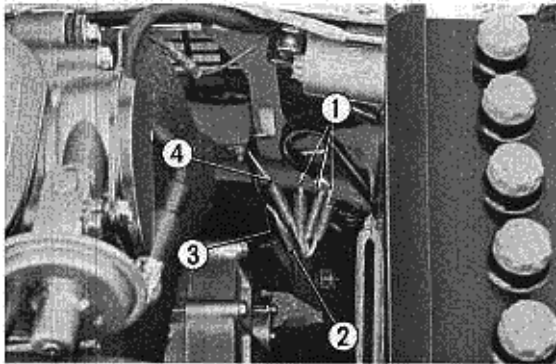

Fig. 19-11 ① White
 ② White with Red Stripe
 ③ Black
 ④ White and Black

19-2. A. C. Generator

Removal

1. After removing the ground cable (-terminal) from the battery, remove the three white leads and a white and black lead from the rectifier.
2. Separate the white and red striped lead from the black lead, connected to the generator brushes.
3. Remove the starter motor. (Refer to "Starter motor, removal and disassembly".)
4. Remove the cooling fan belt from the fan belt drive pulley. (Refer to SECTION 4, "Removal of cooling fan pulley".)
5. Hold the fan belt drive pulley with a 22mm wrench and remove the retaining bolt.

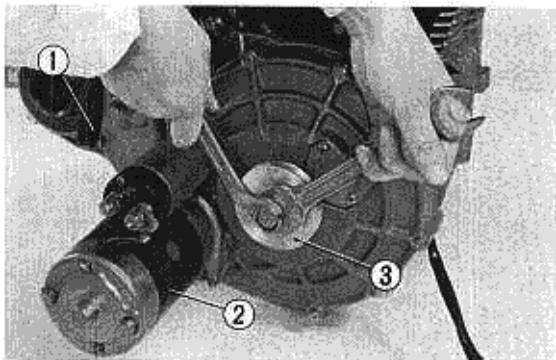

Fig. 19-12 ① Cooling Fan Belt
 ② Starter Motor ③ Crankshaft Pulley

6. Remove the two brush holder set screws, and remove the brush holder assembly.
7. Remove the flywheel housing cover retaining bolts, and then remove the cover.

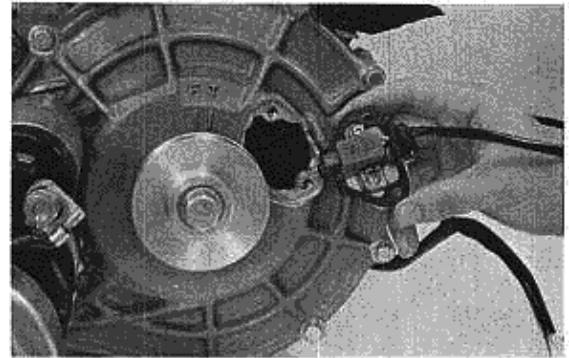

Fig. 19-13

8. When removing the generator rotor unit, install a rotor holder (special tool) as shown with two flywheel housing bolts. Then fully thread in the rotor remover (special tool), and tap out the rotor by hammering the head of the rotor remover lightly. The rotor unit is taper fitted in the crankshaft.

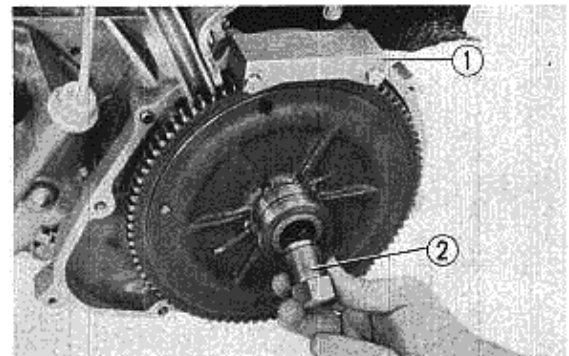

Fig. 19-14 ① Rotor Holder ② Rotor Remover

9. The generator stator unit is installed in the flywheel housing. Separate the flywheel housing from the engine after removing the four bolts.

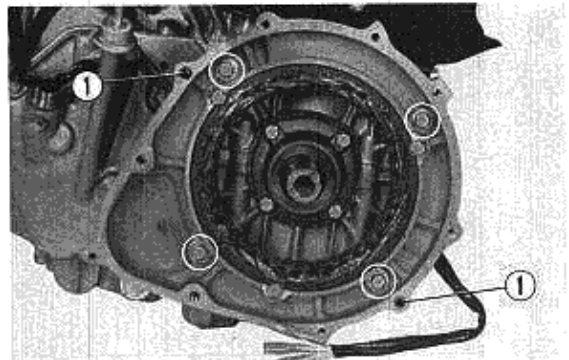

Fig. 19-15 ① Dowel Pin

10. When it is necessary to replace the generator stator unit due to a short circuit, etc., remove the three mounting bolts.

Installation

To install the generator, reverse the removal procedures.

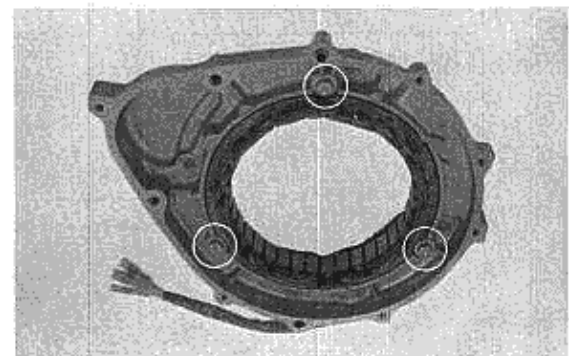

Fig. 19-16

20-1 HONDA 600 COUPE

Unit: mm (in.)

| Group | Part or item | Assembly standard | Repair limit |
|---|---|-----------------------------------|-----------------------|
| Engine | Cylinder head | | |
| | Gasketed surface warpage | 0~0.02 (0~0.0008) | 0.1 (0.0039) |
| | Cylinder | | |
| | I. D. | 74.00~74.01 (2.9134~2.9138) | 74.10 (2.9174) |
| | Piston | | |
| | Piston skirt O. D. | 73.95~73.97 (2.9114~2.9122) | 73.90 (2.9094) |
| | Piston pin hole I. D. | 17.0002~17.008 (0.6694~0.6696) | 17.055 (0.6715) |
| | Piston-to-cylinder clearance | 0.03 (0.0012) minimum | 0.05 (0.0020) minimum |
| | Piston ring groove width | | |
| | Top ring | 1.535~1.55 (0.0604~0.0610) | |
| | Second ring | 1.505~1.52 (0.0593~0.0599) | |
| | Oil ring | 2.505~2.52 (0.0986~0.0992) | |
| | Piston ring | | |
| | Piston ring thickness | | |
| | Top ring | 1.475~1.49 (0.0581~0.0587) | |
| | Second ring | 1.475~1.49 (0.0581~0.0587) | |
| | Oil ring | 2.475~2.49 (0.0974~0.0980) | |
| | Piston ring-to-piston ring groove clearance | | |
| | Top ring | 0.045~0.075 (0.0018~0.0030) | 0.105 (0.0041) |
| | Second ring | 0.015~0.045 (0.0006~0.0018) | 0.105 (0.0041) |
| | Oil ring | 0.015~0.045 (0.0006~0.0018) | 0.105 (0.0041) |
| | Piston ring gap | | |
| | Top ring | 0.2~0.4 (0.008~0.016) | 0.6 (0.024) |
| | Second ring | 0.2~0.4 (0.008~0.016) | 0.6 (0.024) |
| | Oil ring | 0.2~0.4 (0.008~0.016) | 0.6 (0.024) |
| | Piston pin | | |
| | Piston pin hole-to-piston pin clearance | 0.002~0.014 (0.00008~0.0006) | 0.050 (0.0020) |
| Connecting rod | | | |
| Connecting rod-to-piston pin clearance | 0.016~0.040 (0.0006~0.0016) | 0.050 (0.0020) | |
| End play of connecting rod big end (as installed to crankshaft) | 0.12~0.33 (0.0047~0.0130) | 0.5 (0.0197) | |
| Crankshaft | | | |
| Crankshaft end play | 0.15~0.3 (0.0059~0.0118) | 0.3 (0.0118) | |
| Crankshaft O. D. | | | |
| R/H | 34.000~33.988 (1.3386~1.3381) | | |
| L/H | 34.000~33.988 (1.3386~1.3381) | | |

Unit: mm (in.)

| Group | Part or item | Assembly standard | Repair limit |
|--------------------------------|--|--|-----------------|
| Engine (cont'd) | Crankshaft-to-crankcase clearance | | |
| | R/H | 0.007~0.017 (0.0003~0.0007) | |
| | L/H | 0.007~0.017 (0.0003~0.0007) | |
| | Camshaft | | |
| | Camshaft journal O. D. | 23.93~23.95 (0.9421~0.9429) | 23.90 (0.9409) |
| | Camshaft journal-to-camshaft holder clearance | 0.05~0.091 (0.0020~0.0036) | 0.15 (0.0059) |
| | Camshaft end play | 0.1~0.35 (0.0039~0.0138) | 0.5 (0.0197) |
| | Cam height | | |
| | Inlet | 40.281 (1.5855) | 40.101 (1.5787) |
| | Exhaust | 40.281 (1.5855) | 40.101 (1.5787) |
| | Valve | | |
| | Valve head thickness | | |
| | Inlet | 0.9~1.1 (0.035~0.043) | 0.6 (0.024) |
| | Exhaust | 1.4~1.6 (0.055~0.063) | 0.95 (0.0374) |
| | Valve clearance | | |
| | Inlet | 0.08~0.12 (0.0032~0.0047) | (cold climate) |
| | Exhaust | 0.08~0.12 (0.0032~0.0047) | (cold climate) |
| | Valve stem O. D. | | |
| | Inlet | 6.58~6.59 (0.2591~0.2595) | 6.55 (0.2579) |
| | Exhaust | 6.55~6.56 (0.2579~0.2583) | 6.52 (0.2567) |
| | Valve stem-to-valve guide clearance | | |
| | Inlet | 0.01~0.04 (0.0004~0.0016) | 0.08 (0.0032) |
| | Exhaust | 0.04~0.07 (0.0016~0.0028) | 0.11 (0.0043) |
| Valve seat width | 0.8~1.0 (0.032~0.039) | 1.5 (0.059) | |
| Valve spring | | | |
| Free length | | | |
| Inner | 42.0 (1.654) | 41.0 (1.614) | |
| Outer | 44.8 (1.764) | 43.8 (1.724) | |
| Load/length (as installed) | | | |
| Inner | 10.8~11.35 kg/34.5 mm (78.1~82.08 lbs/249.5 ft) | 9.3 kg/34.5 mm (67.31 lbs/249.5 ft) | |
| Outer | 22.5~25.5 kg/36.5 mm (162.7~184.4 lbs/264.0 ft) | 19.65 kg/36.5 mm (142.1 lbs/264.0 ft) | |
| Rocker arm shaft | | | |
| Shaft O. D. | | | |
| Minor | 11.95~11.968 (0.4705~0.4712) | 11.05 (0.4350) | |
| Major | 16.95~16.968 (0.6673~0.6680) | 17.05 (0.6713) | |
| Camshaft housing | | | |
| Rocker arm shaft journal I. D. | | | |
| Minor | 12.0~12.028 (0.4724~0.4735) | 12.1 (0.4764) | |
| Major | 17.0~17.028 (0.6693~0.6704) | 17.1 (0.6732) | |

Unit: mm (in.)

| Group | Part or item | Assembly standard | Repair limit |
|------------------------------------|---|---|-----------------------------|
| Lubricating system | Oil pump | | |
| | Body I. D. | 22~22.021 (0.8661~0.8670) | 22.05 (0.8681) |
| | Sprocket-to-pump rod clearance | 0.06~0.12 (0.0024~0.0047) | 0.25 (0.0098) |
| | Pump rod-to-plunger clearance | 0.026~0.074 (0.0010~0.0029) | 0.15 (0.0059) |
| | Plunger O. D. | 21.96~21.93 (0.8646~0.8634) | 21.91 (0.8626) |
| Fuel system | Fuel pump | | |
| | Discharge pressure | More than 0.145 kg/cm ² (2.062 psi) | |
| | Discharge capacity | 0.22~0.25 ℓ/min (0.4651~0.5285 U.S. pt.) (0.3872~0.4400 Imp. pt.) | |
| | Carburetor | | |
| | Venturi bore dia. | | |
| | Primary | 15.5φ | |
| | Secondary | 32φ | |
| | Main jet bore dia. | | |
| | Primary | ±90 | |
| | Secondary | ±160 | |
| Main air bleed hole dia. | | | |
| Primary | ① 0.7 (4) ② 0.7 (4) ③ 0 ④ 0 ⑤ 0 | | |
| Secondary | ① 0.6 (4) ② 0.6 (2) ③ 0.6 (2) ④ 0 ⑤ 0 | | |
| Oil level | 20.5 (0.807) | ±0.5 (0.020) | |
| Cooling system | Fan belt | | |
| | Belt tension between belt tension, idle pulleys and crankshaft pulley | 15~20 (10 kg) (0.59~0.79 (22.05 lbs)) | |
| | Battery | | |
| Lighting capacity (20 hour rating) | 45 AH | | |
| Electrical system | Ignition coil | | |
| | Voltage | 12 V | |
| | Testing spark gap | More than 8 (0.31) | 5 (0.20) |
| | Insulation resistance | More than 10 MΩ | |
| | Advancer system | | |
| | Spark advancer angle | | |
| | Starting | 10°~1,650 rpm | 1,400 rpm~1,900 rpm |
| | Maximum | 30°~4,000 rpm | 27°~33°~3 800 rpm~4,200 rpm |
| | Vacuum advancer angle | | |
| | Starting | 0°~70 mmHg | 60 mmHg~80 mmHg |
| Maximum | 20°~200 mmHg | 17°~23° | |
| Contact breaker | | | |
| Point gap | 0.3~0.4 (0.012~0.016) | | |
| Condenser | | | |
| Capacity | 0.20~0.24 μF | | |
| Insulation resistance | More than 10 MΩ | | |

Unit: mm (in.)

| Group | Part or item | Assembly standard | Repair limit |
|---|---|---|--------------|
| Electrical system (cont'd) | Spark plug | | |
| | Type | NGK B-8ES, ND W-24ES | |
| | Electrode gap | 0.7~0.8 (0.028~0.032) | |
| | AC generator | | |
| | Voltage | 12 V | |
| | Output | 480 W | |
| | No-load speed | 14 V-1,000 rpm | |
| | On-load speed | 14 V-40 A-5,000 rpm | |
| | Slip ring dia | 49.3~49.7 (1.941~1.957) | |
| | Insulation resistance | Infinity (with tester) | |
| | Slip ring brush height | 14.2~14.8 (0.559~0.583) | |
| | Brush service limit | 7.5 (0.295) | |
| | Brush spring tension | 255~345 g (0.56~0.76 lbs) as pressed up 2 mm (0.08 in.) | |
| | Brush dimension (Width, Thickness, Height) | 7, 6, 14.5 (0.28, 0.24, 0.571) | |
| | AC regulator | | |
| | Construction | Tirril type | |
| | Regulator relay | Twine contact type | |
| | Adjust value measured at specified generator revolution | 13.5 V~14.5 V-5,000 rpm | |
| | Pilot lamp relay | Twine contact type | |
| | Starter motor | | |
| | Voltage | 12 V | |
| | Output | 1.0 KW | |
| | No-load starting current (at 20°C) | Less than 60 A | |
| | Insulation resistance | Infinity (with tester) | |
| | Pinion meshing method | Magnet switch | |
| | Gear ratio (ring gear/pinion) | 10/1 | |
| | Commutator dia. | 35 (1.38) | |
| Commutator dia. service limit | 33 (1.30) | | |
| Commutator wear limit | 0.4 (0.016) | | |
| Commutator cutting limit | 0.05 (0.0020) | | |
| Commutator mica depth | 0.5~0.8 (0.020~0.032) | | |
| Commutator mica depth limit | 0.2 (0.008) | | |
| Brush service limit | 12.5 (0.492) | | |
| Brush spring tension | 800 g (1.761 lbs) | 700~900 g (1.54~1.98 lbs) | |
| Lighting equipment | | | |
| Headlights (Sealed-beam) | 12 V, 50/40 W | | |
| Front turn signal lights/parking lights (combination) | 12 V, 32/4 cp | | |
| Gauges, indicator, warning lights | 12 V, 3 W | | |
| Interior light | 12 V, 5 W | | |
| Stop light | 12 V, 5 W | | |

Unit: mm (in.)

| Group | Part or item | Assembly standard | Repair limit |
|--|---|---|---------------------|
| Electrical system (cont'd) | Side marker lights (front and rear) | 12 V, 4 cp | |
| | Rear turn signal lights, stop lights/taillights (combination) | 12 V, 32/4 cp | |
| | Back-up lights | 12 V, 32 cp | |
| | License plate lights | 12 V, 4 cp | |
| Transmission | Clutch spring | | |
| | Free height | 15.6 (0.614) | 14.0 (0.551) |
| | Load/height (as installed) | 360~390 kg/0.6 mm (793.80~859.95 lbs/0.024 in) at level time | 340 kg (749.70 lbs) |
| | Pressure Plate | | |
| | Plate surface warpage | 0.03 (0.0012) | 0.05 (0.0020) |
| | Friction disk | | |
| | Disk depth (up to rivet head) | 0.7 (0.028) | 0.1 (0.004) |
| | Disk face runout | 0.6 (0.024) | |
| | Spline radial play | 0.02~0.08 (0.0008~0.0032) | 0.5 (0.020) |
| | Facing thickness | 7.15~7.85 (0.2815~0.3091) at free time | 5.75 (0.2264) |
| | Clutch housing bushing | | |
| | I. D. | 12.15~12.22 (0.4784~0.4811) | 12.5 (0.4921) |
| | Release shaft | | |
| | O. D. | 11.99~11.95 (0.4721~0.4705) | 11.90 (0.4685) |
| | Release shaft-to-clutch housing bushing clearance | 0.16~0.27 (0.0063~0.0106) | 0.4 (0.016) |
| Clutch pedal | | | |
| Pedal end play | 2~3 (0.08~0.12) | | |
| Pedal-to-floor mat clearance when disengaged | 40 (1.57) | | |
| Driven sprocket | | | |
| Bottom land dia. | 117.91~117.99 (4.6421~4.6453) | 117.80 (4.6378) | |
| Transmission gear | | | |
| Backlash | 0.064~0.128 (0.0025~0.0050) | 0.2 (0.008) | |
| Main shaft | | | |
| Thrust washer thickness | | 0.2 (0.008) | |
| Countershaft | | | |
| Thrust washer thickness | | 0.2 (0.008) | |
| Third gear | | | |
| End play | 0.1~0.4 (0.004~0.016) | 0.8 (0.032) | |
| Countershaft low gear | | | |
| End play | 0.2~0.5 (0.008~0.020) | 0.8 (0.032) | |
| Main shaft top gear | | | |
| | 0.35~0.65 (0.014~0.026) | 1.00 (0.039) | |

Unit: mm (in.)

| Group | Part or item | Assembly standard | Repair limit |
|-------------------------------------|--|-----------------------------|---------------|
| Transmission (cont'd) | Countershaft second gear | 0.1~0.5 (0.004~0.020) | 0.8 (0.032) |
| | Gear shift rod | | |
| | Gear shift rod-to-crankcase clearance | 0.038~0.099 (0.0015~0.0039) | 0.13 (0.0051) |
| | Shift fork | | |
| | Shift fork-to-synchronizer sleeve clearance | 0.1~0.3 (0.004~0.012) | 0.8 (0.032) |
| | Gear shift lever | | |
| | Gear shift lever-to-shift lever bushing clearance | 0 (0) | 0.2 (0.0079) |
| | End play | 0.8 (0.032) | 1.5 (0.059) |
| | Universal ball joint | | |
| | End play of inner spring spline | 0.02~0.33 (0.0008~0.0130) | 1.0 (0.039) |
| | Radial play of inner spring spline | | 0.3 (0.012) |
| | Propeller shaft drive pinion | | |
| | Backlash | 0.08~0.18 (0.0032~0.0071) | 0.2 (0.008) |
| Radial play of pinion spline | 0.06~0.25 (0.0024~0.0098) | 0.35 (0.0138) | |
| Final driven gear | | | |
| Face runout of ring assembly | | 0.1 (0.0039) | |
| Backlash | 0.068~0.135 (0.0027~0.0053) | 0.15 (0.0059) | |
| Differential pinion | | | |
| Pinion-to-pinion shaft clearance | 0.032~0.086 (0.0013~0.0034) | 0.15 (0.0059) | |
| Differential gear case | | | |
| Gear case-to-joint flange clearance | 0.025~0.075 (0.0010~0.0030) | 0.15 (0.0059) | |
| Drive shaft | | | |
| Spline radial play | 0 (0) | 0.2 (0.008) | |
| Bend | 0 (0) | 1.0 (0.039) | |
| Steering system | Steering wheel | | |
| | Wheel play (measured at the periphery of the wheel) | Less than 10 (0.39) | 10 (0.39) |
| | Backlash (measured at the point 25 mm apart from the center of joint yoke end) | Less than 0.4 (0.016) | |
| Steering column | | | |
| Column bushing-to-column clearance | | 0.1 (0.004) | |
| Column shaft O.D. | 16.957~17.000 (0.6676~0.6693) | 16.900 (0.6654) | |
| Suspension system | Front damper spring | | |
| | Free length | 358 (14.09) | |

Unit: mm (in.)

| Group | Part or item | Assembly standard | Repair limit |
|---|--|----------------------------|---------------|
| Brake system | Parking brake | | |
| | Lever entire stroke | 7 notches | |
| | Effective stroke | 1~5 notches | |
| | Foot brake pedal | | |
| | Pedal height | 130 (5.12) | |
| | As-depressed pedal-to-floor mat clearance | More than 50 (1.97) | |
| | Pedal end play (measured at the tip of the pedal) | 1~5 (0.04~0.20) | |
| | Master cylinder | | |
| | Cylinder-to-piston clearance | 0.02~0.105 (0.0008~0.0041) | 0.15 (0.0059) |
| | Free length of return spring | 66.4 (2.614) | |
| Load/length of return spring (as installed) | 0.8 kg/47.7 mm (1.764 lbs/1.878 in.) | | |
| Wheel cylinder | | | |
| Cylinder-to-piston clearance | 0.02~0.105 (0.0008~0.0041) | 0.15 (0.0059) | |
| Brake lining thickness | | | |
| Rear | 5.0 (0.20) | 2 (0.08) | |
| Brake fluid | | | |
| Type | DOT 3 brake fluid meets the SAE J1703 specification. Outside the U.S.A., use SAE J1703 brake fluid | | |
| Disk brake | | | |
| Brake pad thickness | 10.3 (0.406) | 2.0 (0.079) | |
| Disk thickness | 9.6 (0.378) | 9.0 (0.354) | |
| Disk face runout | | 0.10 (0.0039) | |
| Disk parallelism | 0.07 (0.0028) | | |

20-2 HONDA Z360

Unit: mm (in.)

| Group | Part or item | Assembly standard | Repair limit |
|---|---|----------------------------------|-----------------|
| Engine | Cylinder head | | |
| | Gasketed surface warpage | 0~0.02 (0~0.0008) | 0.1 (0.0039) |
| | Cylinder | | |
| | I. D. | 62.5~62.51 (2.4606~2.4610) | 62.6 (2.4646) |
| | Piston | | |
| | Piston skirt O. D. | 62.45~62.47 (2.4587~2.4595) | 62.4 (2.4567) |
| | Piston pin hole I. D. | 17.002~17.008 (0.6694~0.6696) | 17.055 (0.6715) |
| | Piston-to-cylinder clearance | 0.03 (0.0012) minimum | 0.05 (0.0020) |
| | Piston ring groove width | | |
| | Top ring | 1.535~1.55 (0.0604~0.0610) | |
| | Second ring | 1.505~1.52 (0.0593~0.0599) | |
| | Oil ring | 2.505~2.52 (0.0986~0.0992) | |
| | Piston ring | | |
| | Piston ring thickness | | |
| | Top ring | 1.475~1.49 (0.0581~0.0587) | |
| | Second ring | 1.475~1.49 (0.0581~0.0587) | |
| | Piston ring-to-piston ring groove clearance | | |
| | Top ring | 0.045~0.075 (0.0018~0.0030) | 0.105 (0.0041) |
| | Second ring | 0.015~0.045 (0.0006~0.0018) | 0.105 (0.0041) |
| | Piston ring gap | | |
| | Top ring | 0.2~0.4 (0.008~0.016) | 0.6 (0.024) |
| | Second ring | 0.2~0.4 (0.008~0.016) | 0.6 (0.024) |
| | Oil ring | 0.2~0.9 (0.008~0.035) | 1.1 (0.043) |
| Piston pin | | | |
| Piston pin hole-to-piston pin clearance | 0.002~0.014 (0.00008~0.0006) | 0.050 (0.0020) | |
| Connecting rod | | | |
| Connecting rod-to-piston pin clearance | 0.016~0.040 (0.0006~0.0016) | 0.050 (0.0020) | |
| End play of connecting rod big end (as installed to crankshaft) | 0.12~0.33 (0.0047~0.0130) | 0.5 (0.0197) | |
| Crankshaft | | | |
| Crankshaft end play | 0.15~0.3 (0.0059~0.0118) | 0.3 (0.0118) | |
| Crankshaft O. D. | | | |
| R/H | 27.99~28.0 (1.1019~1.1024) | | |
| L/H | 27.99~28.0 (1.1019~1.1024) | | |
| Crankshaft-to-crank-case clearance | | | |
| R/H | 0.007~0.017 (0.0003~0.0007) | | |
| L/H | 0.007~0.017 (0.0003~0.0007) | | |

Unit: mm (in.)

| Group | Part or item | Assembly standard | Repair limit |
|--------------------------------|---|--|--|
| Engine (cont'd) | Camshaft | | |
| | Camshaft journal O. D. | 23.93~23.95 (0.9421~0.9429) | 23.90 (0.9409) |
| | Camshaft journal-to-camshaft holder clearance | 0.05~0.091 (0.0020~0.0036) | |
| | Camshaft end play | 0.1~0.35 (0.0039~0.0138) | 0.5 (0.0197) |
| | Cam height | | |
| | Inlet | 39.766~39.926 (1.5656~1.5719) | 39.6 (1.5591) |
| | Exhaust | 39.766~39.926 (1.5656~1.5719) | 39.6 (1.5591) |
| | Valve | | |
| | Valve head thickness | | |
| | Inlet | 0.9~1.1 (0.035~0.043) | 0.6 (0.024) |
| | Exhaust | 1.4~1.6 (0.055~0.063) | 0.95 (0.0374) |
| | Valve clearance | | |
| | Inlet | 0.08~0.12 (0.0032~0.0047) (cold climate) | |
| | Exhaust | 0.08~0.12 (0.0032~0.0047) (cold climate) | |
| | Valve stem O. D. | | |
| | Inlet | 6.58~6.59 (0.2591~0.2595) | 6.55 (0.2579) |
| | Exhaust | 6.55~6.56 (0.2579~0.2583) | 6.52 (0.2567) |
| | Valve stem-to-valve guide clearance | | |
| | Inlet | 0.01~0.04 (0.0004~0.0016) | 0.08 (0.0032) |
| | Exhaust | 0.04~0.07 (0.0016~0.0028) | 0.11 (0.0043) |
| | Valve seat width | 0.8~1.0 (0.032~0.039) | 1.5 (0.059) |
| | Valve spring | | |
| | Free length | | |
| | Inner | 42.0 (1.654) | 41.0 (1.614) |
| | Outer | 44.8 (1.764) | 43.8 (1.724) |
| | Load/length (as installed) | | |
| | Inner | 10.8~11.35 kg/34.5 mm (78.1~82.008 lbs/249.5 ft.) | 9.3 kg/34.5 mm (67.3 lbs/249.5 ft.) |
| Outer | 22.5~25.5 kg/36.5 mm (162.7~184.4 lbs/264.0 ft.) | 19.65 kg/36.5 mm (142.1 lbs/264.0 ft.) | |
| Rocker arm shaft | | | |
| Shaft O. D. | | | |
| Minor | 11.95~11.968 (0.4705~0.4712) | | |
| Major | 16.95~16.968 (0.6673~0.6680) | | |
| Camshaft housing | | | |
| Rocker arm shaft journal I. D. | | | |
| Minor | 12.0~12.028 (0.4724~0.4735) | 12.1 (0.4764) | |
| Major | 17.0~17.028 (0.6693~0.6704) | 17.1 (0.6732) | |

Unit: mm (in.)

| Group | Part or item | Assembly standard | Repair limit |
|-------------------------|---|---|--------------|
| Lubricating system | Oil pump | | |
| | Oil pump rotor inner-to-oil pump rotor outer tip clearance | 0.04~0.12 (0.0016~0.0047) | |
| | Oil pump rotor height Inner/outer | 5.48~5.50 (0.2158~0.2165) | |
| | Oil pump rotor-to-oil pump cover side clearance | 0.04~0.09 (0.0016~0.0035) | |
| | Oil pump rotor outer-to-oil pump cover clearance | 0.1~0.155 (0.0039~0.0061) | |
| Fuel system | Fuel pump | | |
| | Discharge pressure | More than 0.145 kg/cm ² (2.062 psi) | |
| | Discharge capacity | 0.22~0.25 ℓ/min (0.4651~0.5285 U.S. pt) (0.3872~0.4400 Imp. pt) | |
| | Carburetor | | |
| | Venturi bore dia | 32φ | |
| Main jet bore dia | #145 | | |
| Main air bleed hole dia | ① 0.7 (4) ② 0.7 (2) ③ 0.7 (2) ④ 0.7 (2) ⑤ 0.7 (2) | | |
| Oil level | 20.5 (0.807) | ±0.5 (±0.020) | |
| Cooling system | Fan belt | | |
| | Belt tension between belt tension, idle pulleys and crankshaft pulley | 15~20 (10 kg) (0.59~0.79 (22.05 lbs)) | |
| Electrical system | Battery | | |
| | Capacity (20 hour rating) | 26 AH | |
| | Ignition coil | | |
| | Voltage | 12 V | |
| | Testing spark gap | more than 8 (0.31) | |
| | Insulation resistance | more than 10 MΩ | |
| | Advancer system | | |
| Spark advance angle | | | |
| Starting | 10°~1,400 rpm | | |
| Maximum | 30°~4,000 rpm | | |
| Vacuum advance angle | | | |
| Starting | 0°~60°~80 mmHg | | |
| Maximum | 8.5°~11.5°~180 mmHg | | |
| | Contact breaker | | |
| | Point gap | 0.3~0.4 (0.012~0.016) | |
| | Condenser | | |
| | Capacity | 0.216~0.264 μF | |
| | Insulation resistance | more than 10 MΩ | |

Unit: mm (in.)

| Group | Part or item | Assembly standard | Repair limit |
|--|---|---|-----------------|
| Electrical system (cont'd) | Spark plug | | |
| | Type | NGK B-7ES ND W-22ES | |
| | Electrode gap | 0.7~0.8 (0.028~0.032) | |
| | DC generator/Starter Motor | | |
| | Voltage | 12 V | |
| | Output | 250 W/350 W | |
| | Insulation resistance | 1 MΩ | |
| | Brush service limit | 7.5 (0.295) | |
| | Brush spring tension | 600~700 g (1.32 lbs~1.54 lbs) | |
| | Brush dimension (Width, Thickness, Height) | 12, 5, 25~26 (0.4724, 0.1969, 0.9843~1.0236) | 12 (0.4724) |
| | Commutator O. D. | 52.4 (2.0630) | |
| | Commutator cutting limit | 50.4 (1.9842) | |
| | Commutator wear | 0~0.05 (0~0.0020) | 0.4 (0.016) |
| | Commutator mica depth | 0.5~0.8 (0.020~0.032) | 0.2 (0.008) |
| | AC generator | | |
| | Rated speed | 1,000~11,000 rpm | |
| | Output | 75 W | |
| | Output (with 14 V voltage at normal temperature) | 14 V electric power 5000 rpm~10,000 rpm | |
| | White-Yellow | (Less than 1,000 rpm) more than 2 A | Less than 3.3 A |
| | White-(Yellow, White/Red) | (More than 10,000 rpm) more than 4.8 A | Less than 6.5 A |
| Regulator | | | |
| No load voltage | 14.8~15.8 V-4,000 rpm | | |
| Ampere limit | 18 A | | |
| Charge starting voltage | 13.5 V-1,350 rpm | | |
| Voltage relay point gap (at a standstill) | 0.25~0.45 (0.0098~0.0177) | | |
| Cut out relay point gap (at a standstill) | 0.4~1.2 (0.016~0.0472) | | |
| Voltage relay (current coil-to- steel center clearance) | more than 0.3 at magnetic drag (0.0118) | | |
| Cut out relay (current coil-to- steel center clearance) | 0.4~1.2 (0.016~0.0472) | | |
| Lighting equipment | | | |
| Headlights (Sealed-beam) | 12 V, 50/40 W | | |
| Front turn signal lights | 12 V, 21 W | | |
| Gauges, indicator warning lights | 12 V, 3 W | | |
| Interior light | 12 V, 5 W | | |
| Front side light | 12 V, 5 W | | |
| Rear turn signal lights | 12 V, 21 W | | |
| Stop lights/Taillights | 12 V, 21/5 W | | |
| Back-up lights | 12 V, 21 W | | |
| License plate lights | 12 V, 5 W | | |

Unit: mm (in.)

| Group | Part or item | Assembly standard | Repair limit |
|--|--|--|--------------------|
| Transmission | Clutch spring | | |
| | Free height | 156 (0.614) | 15.0 (0.5906) |
| | Load/height (as installed) | 320~370 kg/0.6mm (705.60~825.85 lbs/0.024 in.) at level time | 270 kg (594.45 kg) |
| | Pressure plate | | |
| | Plate surface warpage | 0.03 (0.0012) | 0.05 (0.0020) |
| | Friction disk | | |
| | Disk depth (up to rivet head) | 0.7 (0.028) | 0.1 (0.004) |
| | Disk face runout | 0.3 (0.0118) | 0.6 (0.0236) |
| | Spline radial play | 0.02~0.08 (0.0008~0.0032) | 0.5 (0.020) |
| | Facing thickness | 7.15~7.85 (0.2815~0.3091) at free time | 5.75 (0.2264) |
| | Clutch housing bushing | | |
| | I. D. | 12.15~12.22 (0.4784~0.4811) | 12.5 (0.4921) |
| | Release shaft | | |
| | O. D. | 11.99~11.95 (0.4721~0.4705) | 11.90 (0.4685) |
| | Release shaft-to-clutch housing bushing clearance | 0.16~0.27 (0.0063~0.0106) | 0.4 (0.016) |
| Clutch pedal | | | |
| Pedal end play | 2~3 (0.08~0.12) | | |
| Pedal-to-floor mat clearance when disengaged | 40 (1.57) | | |
| Driven sprocket | | | |
| Bottom land dia. | 116.525~116.775 (4.5878~4.5968) | 116.0 (4.5669) | |
| Transmission gear | | | |
| Backlash | 0.064~0.128 (0.0025~0.0050) | 0.2 (0.008) | |
| Main shaft | | | |
| Thrust washer thickness | 1.0, 1.25, 1.5, 1.75, 2.0 (0.0394, 0.0492, 0.0591, 0.0689, 0.0787) | | |
| Countershaft | | | |
| Thrust washer thickness | 1.0, 1.25, 1.5, 1.75, 2.0 (0.0394, 0.0492, 0.0591, 0.0689, 0.0787) | | |
| Third gear | | | |
| End play | 0.030~0.530 (0.0012~0.0209) | 0.8 (0.032) | |
| Countershaft low gear Top gear | | | |
| End play | 0.2~0.5 (0.008~0.020) | | |
| Countershaft second gear | | | |
| End play | 0.03~0.630 (0.0012~0.0248) | 0.9 (0.035) | |

Unit: mm (in.)

| Group | Part or item | Assembly standard | Repair limit |
|--|--|--|---|
| Transmission (cont'd) | Gear shaft rod Gear shaft rod-to-crankcase clearance | 0.038~0.099 (0.0015~0.0039) | 0.13 (0.0051) |
| | Shift fork Shift fork-to-synchronizer sleeve clearance | 0.1~0.3 (0.004~0.012) | |
| | Gear shift lever Gear shift lever-to-shift lever bushing clearance | 0 (0) | 0.2 (0.0079) |
| | End play | 0.8 (0.032) | 1.5 (0.059) |
| | Universal ball joint End play of inner ring spline Radial play of inner ring spline | 0.02~0.33 (0.0008~0.0130) | 1.0 (0.039) 0.3 (0.012) |
| | Propeller shaft drive pinion Backlash Radial play of pinion spline | 0.08~0.018 (0.0032~0.0071) 0.06~0.25 (0.0024~0.0098) | 0.2 (0.008) 0.35 (0.0138) |
| | Final driven gear Backlash | 0.068~0.135 (0.0027~0.0053) | 0.15 (0.0059) |
| | Differential gear case Gear case-to-joint flange clearance | 0.025~0.075 (0.0010~0.0030) | 0.15 (0.0059) |
| | Drive shaft Spline radial play Bend | 0 (0) 0 (0) | 0.2 (0.008) 1.0 (0.039) |
| | Steering system | Steering wheel Wheel play (measured at the periphery of the wheel) Backlash (measured at the point 25 mm apart from the center of joint yoke end) | Less than 10 (0.39) Less than 0.4 (0.016) |
| Steering column Column bushing-to-column clearance Column shaft O. D. | | | 0.1 (0.004) 16.957~17.000 (0.6676~0.6693) 16.900 (0.6654) |
| Front damper spring Free length | | 322~328 (12.68~12.91) | 307 (12.09) |
| Brake system | Parking brake Lever entire stroke Effective stroke | 7 notches 1~5 notches | |
| | Foot brake pedal Pedal height Pedal-to-floor mat clearance when depressed fully | 130 (5.12) more than 60 (2.3622) | 50 (1.9685) |

Unit: mm (in.)

| Group | Part or item | Assembly standard | Repair limit |
|-----------------------|---|---|------------------------------|
| Brake system (cont'd) | Foot brake pedal Pedal end play (measured at the tip of the pedal) | 7~10 (0.04~0.39) | |
| | Master cylinder Cylinder-to-piston clearance free length of return spring Load/length of return spring (as installed) | 0.02~0.105 (0.0008~0.0041) 66.4 (2.614) 0.8 kg/47.7 mm (1.764 lbs/1.878 in.) | 0.15 (0.0059) 65 (2.559) |
| | Wheel cylinder Cylinder-to-piston clearance | 0.02~0.105 (0.0008~0.0041) | 0.15 (0.0059) |
| | Brake lining thickness Front Rear | 5.0 (0.20) 5.0 (0.20) | 2.5 (0.0984) 2.5 (0.0984) |

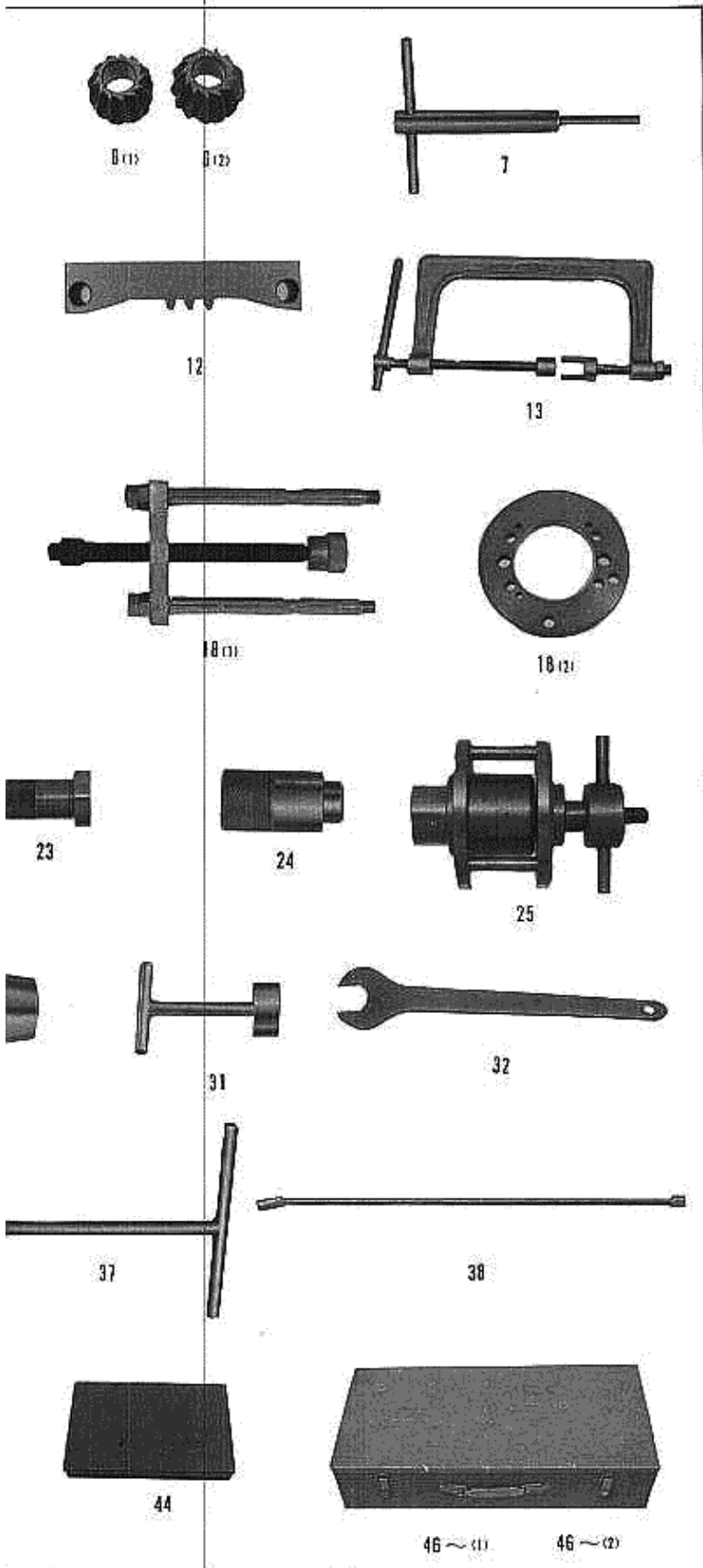

| | TOOL NO. | Z 360 | 600 Coupe |
|------------|-------------|-------|-----------|
| | 07001-55101 | ○ | |
| | 07001-56801 | | ○ |
| F | 07002-55101 | ○ | |
| | 07002-56801 | | ○ |
| | 07003-55101 | ○ | |
| | 07003-56801 | | ○ |
| 0° | 07004-55101 | ○ | |
| | 07004-56801 | | ○ |
| | 07005-55101 | ○ | |
| | 07005-56801 | | ○ |
| P | 07006-55101 | ○ | |
| P | 07006-56801 | | ○ |
| | 07007-55101 | ○ | |
| | 07008-55101 | ○ | |
| | 07009-57906 | ○ | |
| | 07019-51201 | ○ | |
| | 07011-55101 | ○ | |
| | 07011-56801 | | ○ |
| | 07023-56802 | | ○ |
| | 07031-25001 | ○ | |
| | 07032-55101 | ○ | |
| | 07032-56801 | | ○ |
| | 07033-25001 | ○ | |
| essor Main | 07034-55110 | ○ | |
| Flange | 07034-55115 | ○ | |
| | 07043-55101 | ○ | |
| | 07045-56805 | ○ | |
| | 07045-56810 | ○ | |
| ment | 07045-56820 | ○ | |
| | 07046-55101 | ○ | |
| | 07047-55101 | ○ | |
| A | 07048-55110 | ○ | |
| B | 07048-55101 | ○ | |
| | 07048-56725 | ○ | |
| | 07054-55102 | ○ | |
| (I Gear) | 07054-56801 | ○ | |
| | 07057-55103 | ○ | |
| | 07059-55102 | ○ | |
| | 07066-55101 | ○ | |
| | 07066-56801 | | ○ |
| | 07066-56802 | | ○ |
| ter | 07066-55121 | ○ | |
| | 07066-56812 | | ○ |
| er | 07066-55111 | ○ | |
| | 07071-56801 | ○ | |
| | 07079-55105 | ○ | |
| lr | 07071-55102 | ○ | |
| | 07083-60105 | ○ | |
| | 07083-60110 | ○ | |
| | 07089-55101 | ○ | |
| | 07092-55103 | ○ | |
| Tool | 07090-60501 | ○ | |
| Wrench | 07093-55101 | ○ | |
| ch Holder | 07093-55105 | ○ | |
| | 07094-55101 | ○ | |
| | 07094-57901 | ○ | |
| | 07778-99952 | ○ | |
| | 07996-99944 | ○ | |
| | 07997-55101 | ○ | |
| | 07000-60501 | ○ | |
| | 07000-56811 | | ○ |
| | 07790-56805 | ○ | |
| | 07790-56810 | ○ | |

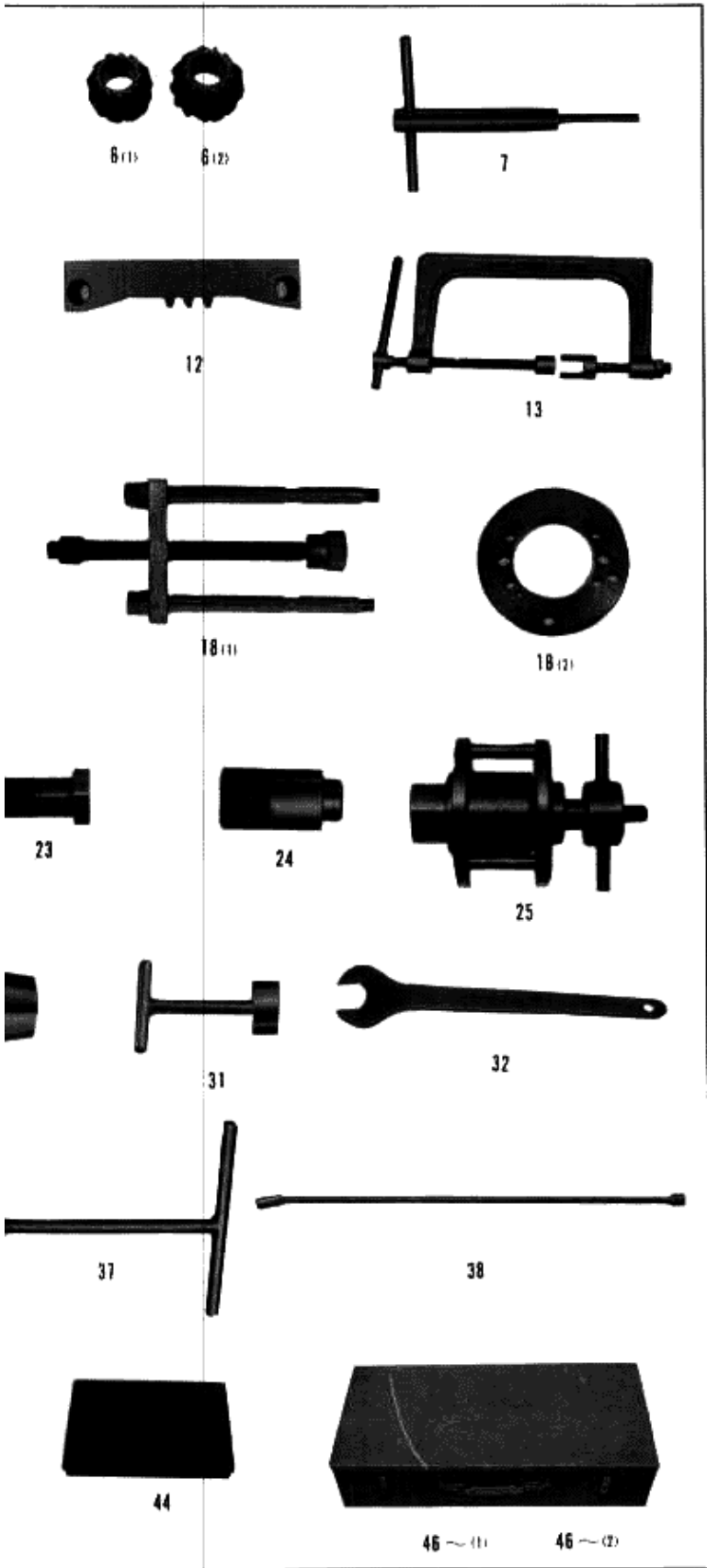

HONDA 600 Coupe (c) V

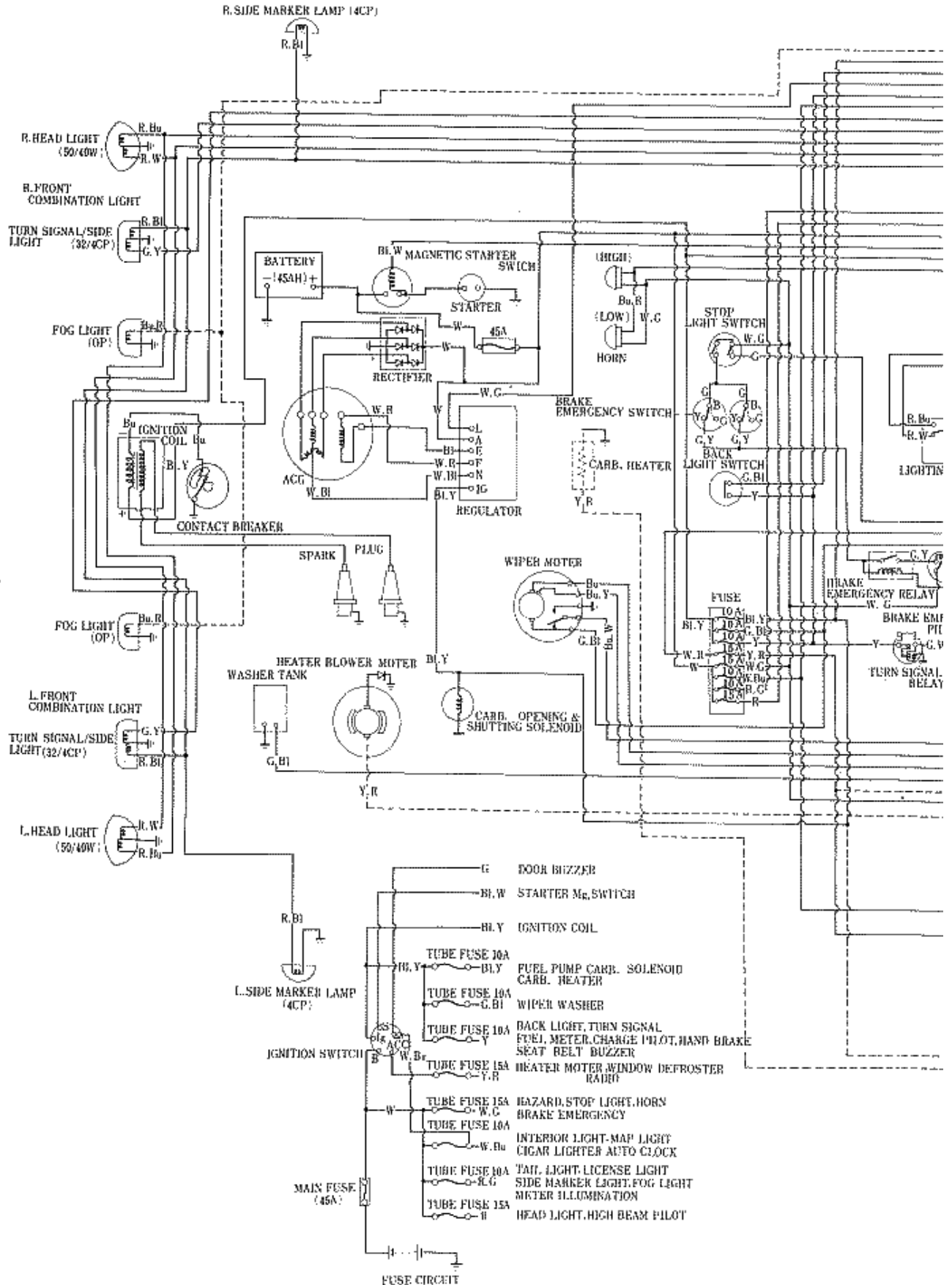

WIRING DIAGRAM

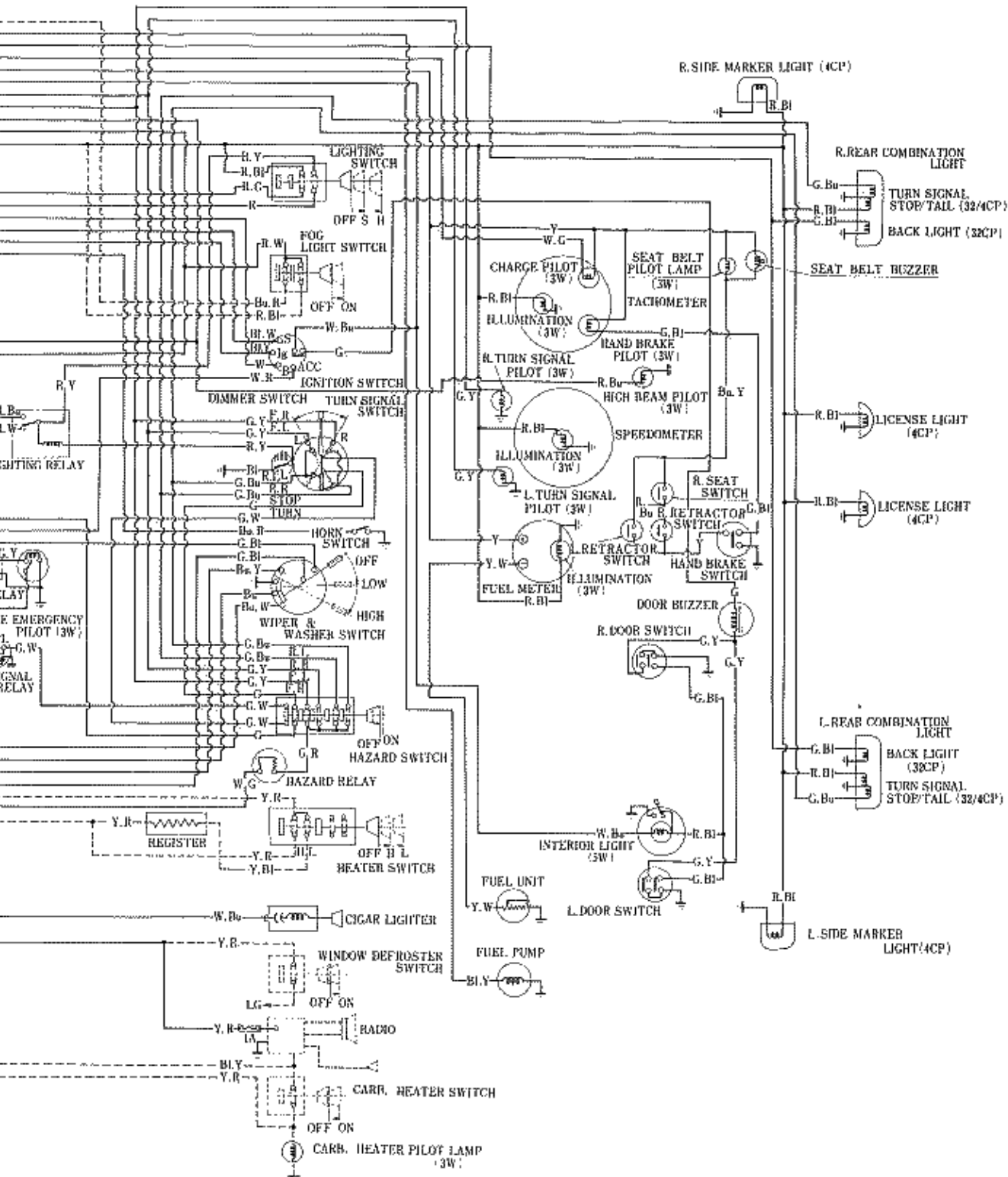

| | | | | | |
|----------|---------------------|------------|------------------------|----------|---------------------|
| Bu. : | Blue | G. R. : | Green/red stripe | R. W. : | Red/white stripe |
| Bu. R. : | Blue/red stripe | G. W. : | Green/white stripe | W. : | White |
| Bu. W. : | Blue/white stripe | G. Y. : | Green/yellow stripe | W. R. : | White/red stripe |
| Bu. Y. : | Blue/yellow stripe | L. G. : | Light Green | W. Y. : | White/yellow stripe |
| Bl. W. : | Black/white stripe | L. G. R. : | Light Green/red stripe | W. Bu. : | White/blue stripe |
| Bl. : | Black | R. : | Red | W. G. : | White/green stripe |
| Bl. Y. : | Black/yellow stripe | R. Bl. : | Red/black stripe | Y. : | Yellow |
| G. : | Green | R. Bu. : | Red/blue stripe | Y. Bl. : | Yellow/black stripe |
| G. Bl. : | Green/black stripe | R. G. : | Red/green stripe | Y. R. : | Yellow/red stripe |
| G. Bu. : | Green/blue stripe | R. Y. : | Red/yellow stripe | Y. W. : | Yellow/white stripe |

HONDA 600 Coupe W

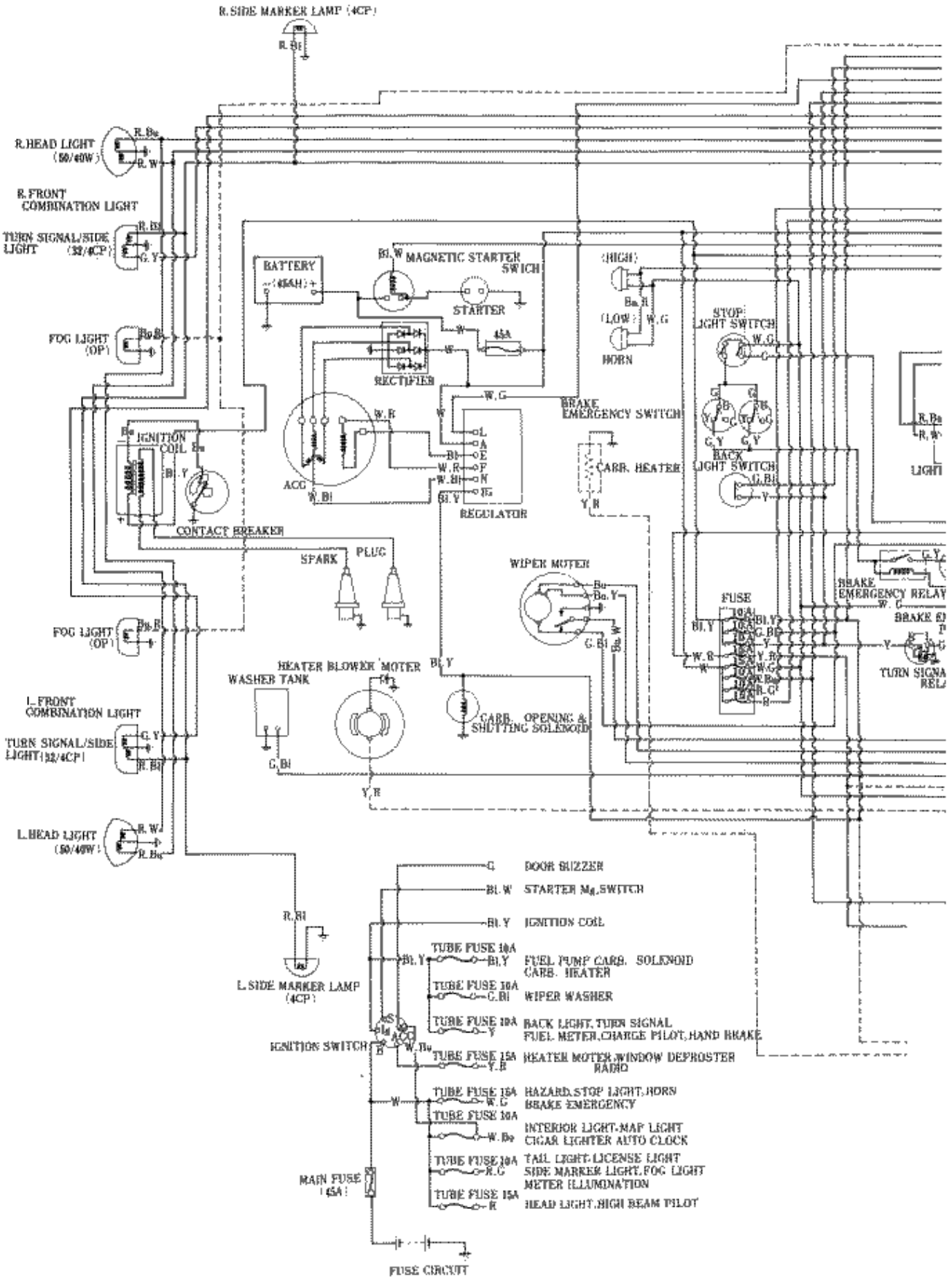

WIRING DIAGRAM

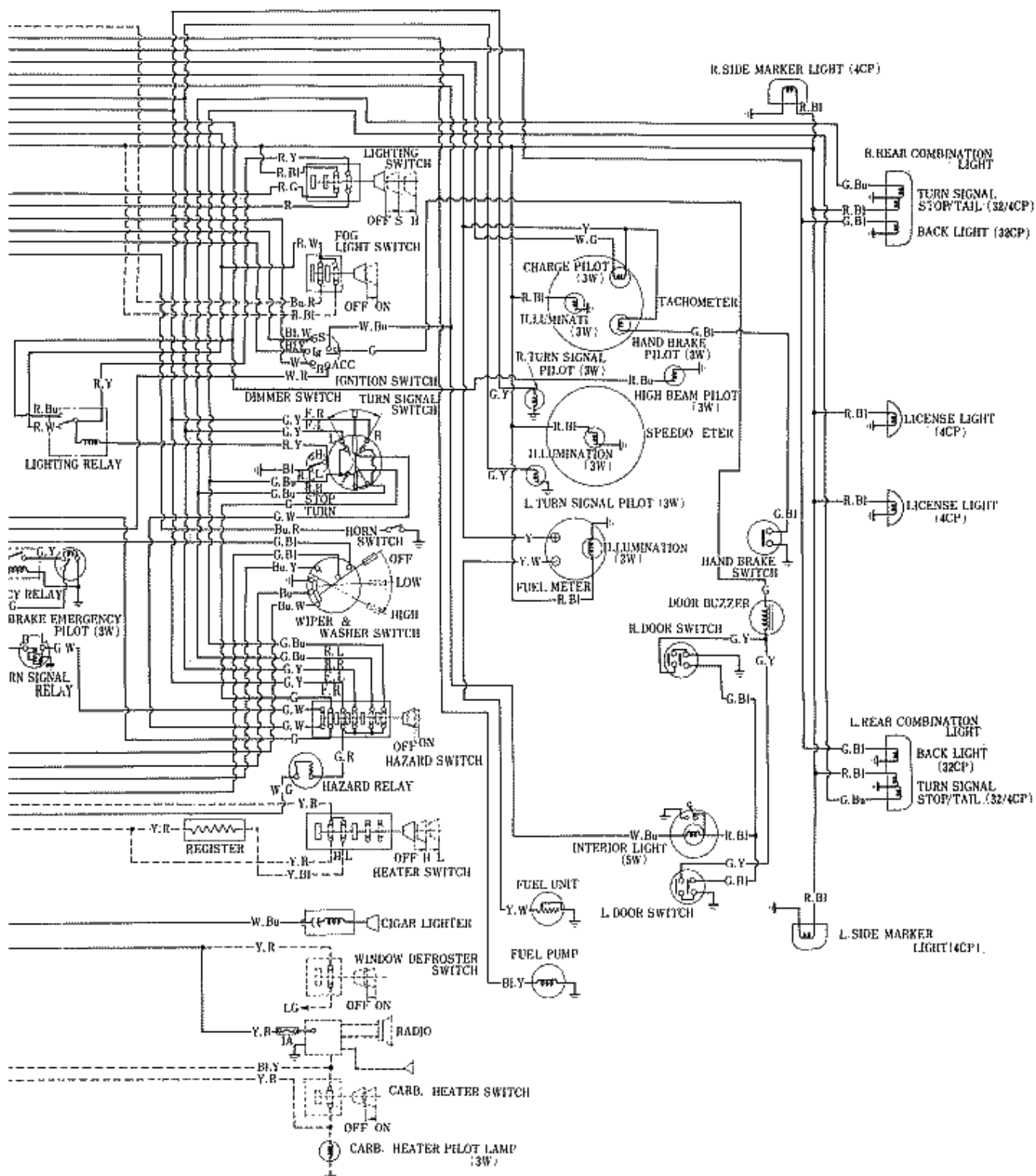

| | | | | | |
|--------|-----------------------|--------|--------------------------|--------|-----------------------|
| Bu. | : Blue | G. R. | : Green/red stripe | R. W. | : Red/white stripe |
| Bu. R. | : Blue/red stripe | G. W. | : Green/white stripe | W. | : White |
| Bu. W. | : Blue/white stripe | G. Y. | : Green/yellow stripe | W. R. | : White/red stripe |
| Bu. Y. | : Blue/yellow stripe | L. G. | : Light Green | W. Y. | : White/yellow stripe |
| Bl. W. | : Black/white stripe | LG. R. | : Light Green/red stripe | W. Bu. | : White/blue stripe |
| Bl. | : Black | R. | : Red | W. G. | : White/green stripe |
| Bl. Y. | : Black/yellow stripe | R. Bl. | : Red/black stripe | Y. | : Yellow |
| G. | : Green | R. Bu. | : Red/blue stripe | Y. Bl. | : Yellow/black stripe |
| G. Bl. | : Green/black stripe | R. G. | : Red/green stripe | Y. R. | : Yellow/red stripe |
| G. Bu. | : Green/blue stripe | R. Y. | : Red/yellow stripe | Y. W. | : Yellow/white stripe |

HONDA Z360 WIRING

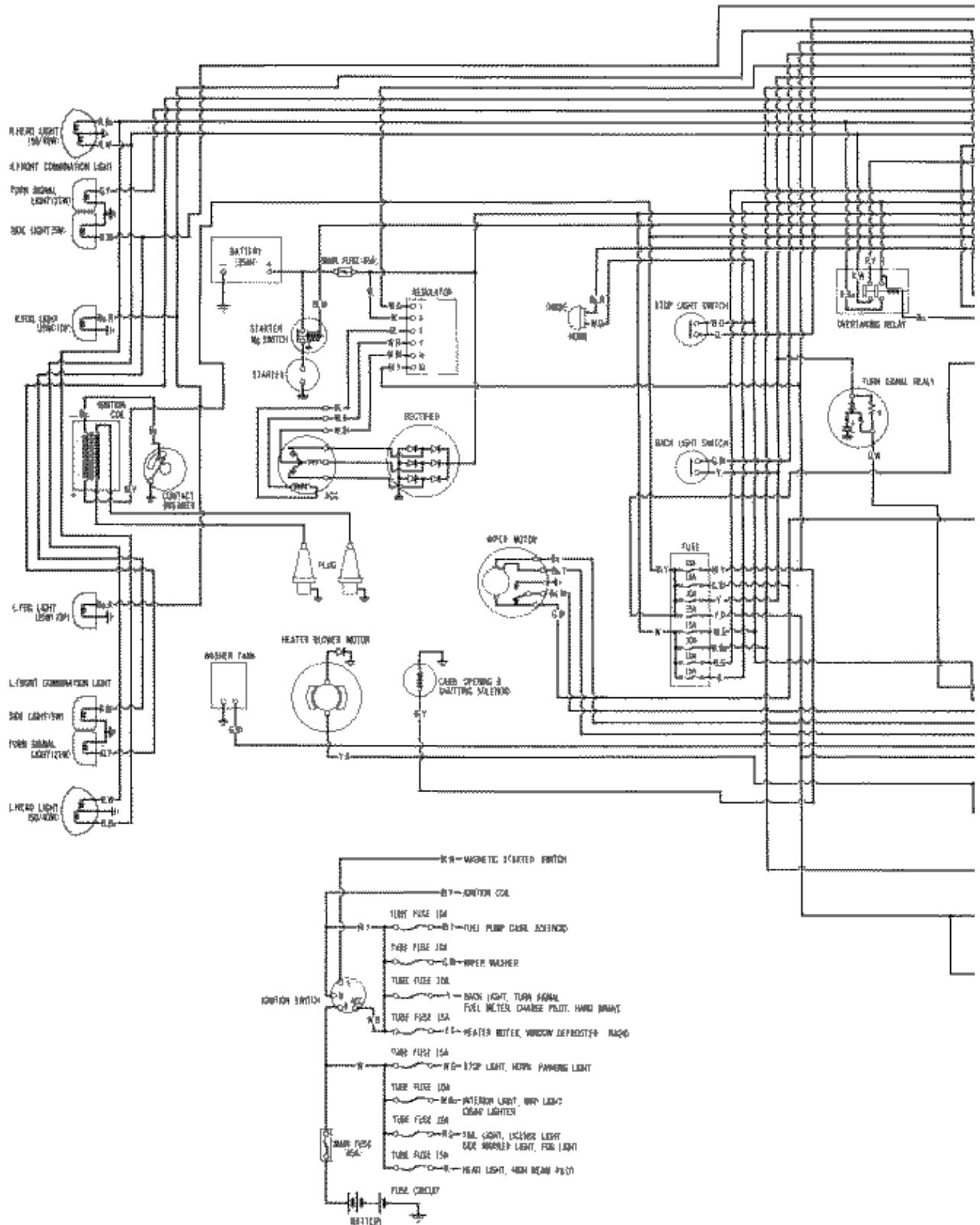

RING DIAGRAM

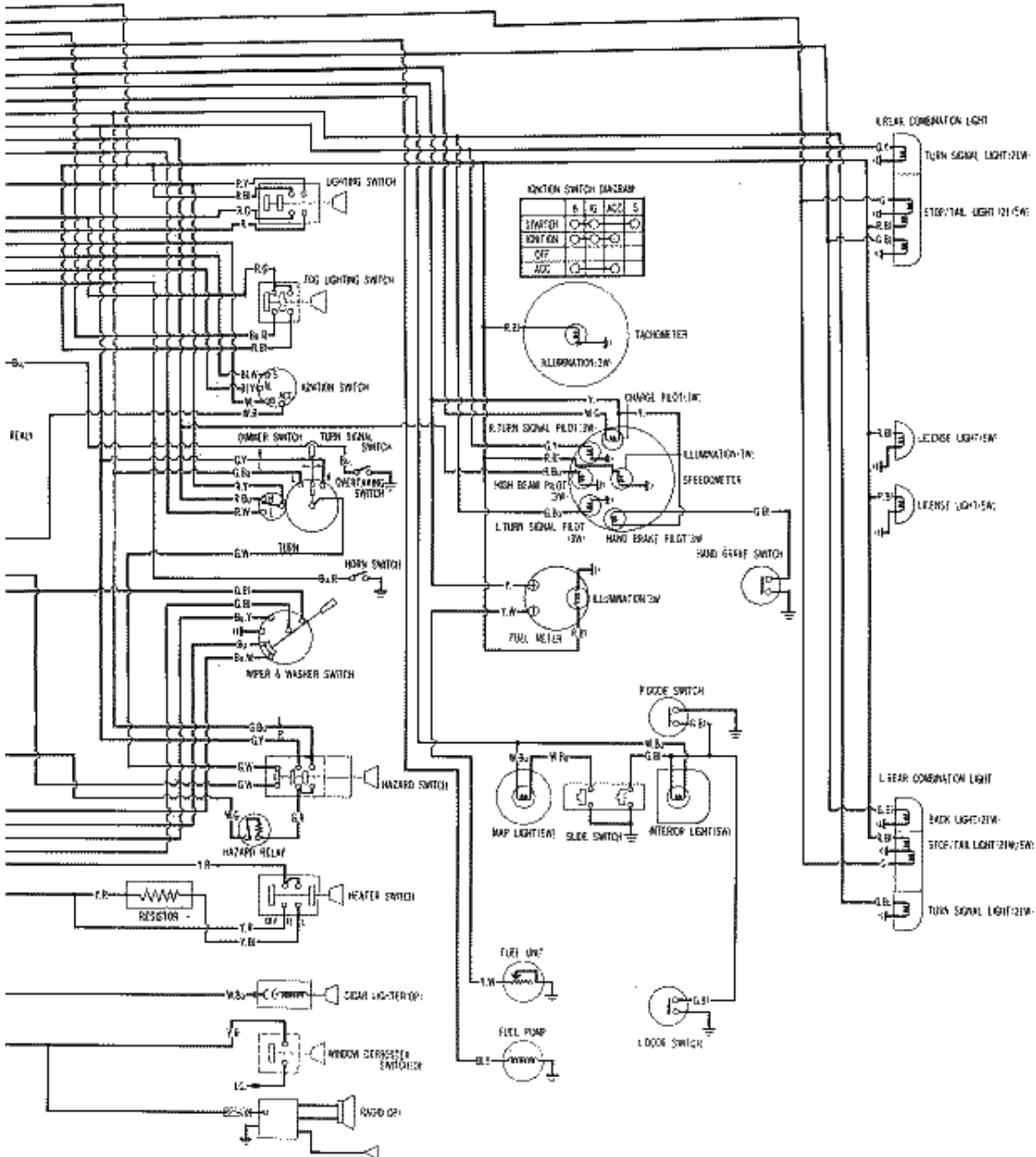

- | | | | | | |
|-----|--------------------|-----|---------------------|-----|---------------------|
| B. | Blue | GR | Green/Red stripe | W | White |
| B.R | Blue/Red stripe | GW | Green/White stripe | W.G | White/Green stripe |
| B.W | Blue/White stripe | G.Y | Green/Yellow stripe | W.B | White/Blue stripe |
| B.Y | Blue/Yellow stripe | LG | Light Green | W.S | White/Black stripe |
| B. | Blue | R | Red | W.G | White/Green stripe |
| B.W | Blue/White stripe | R.B | Red/Black stripe | Y | Yellow |
| B.Y | Blue/Yellow stripe | R.B | Red/Blue stripe | Y.B | Yellow/Black stripe |
| B.R | Blue/Red stripe | R.G | Red/Green stripe | Y.R | Yellow/Red stripe |
| G. | Green | R.Y | Red/Yellow stripe | Y.W | Yellow/White stripe |
| G.B | Green/Blue stripe | R.W | Red/White stripe | | |
| G.R | Green/Red stripe | | | | |