



# Introduction of the New smart Model Series 453 smart fortwo coupé/ smart forfour

Introduction into Service Manual



Mercedes-Benz Service

**Introduction of the New smart fortwo coupé  
and smart forfour  
Model Series 453**

## Information and Copyright

### Product Portfolio

You can also find comprehensive information about our complete product portfolio on our Internet portal:

Link: <http://aftersales.mercedes-benz.com>

### Questions and Suggestions

If you have any questions or suggestions concerning this product, please write to us.

E-mail: [customer.support@daimler.com](mailto:customer.support@daimler.com)

© 2014 by Daimler AG

This document, including all its parts, is protected by copyright. Any further processing or use requires the previous written consent of Daimler AG, Department GSP/OR, D-70546 Stuttgart. This applies in particular to reproduction, distribution, alteration, translation, microfilming and storage and/or processing in electronic systems, including databases and online services.

Image no. of title image: P00.01-4476-00

Image no. Poster: P00.00-5278-00, P00.00-5279-00

Order no. of this publication: HLI 000 000 15 78

Preface	5
<b>Overview</b>	<b>6</b>
Models and major assemblies	6
Brief description	8
<b>Overall vehicle</b>	<b>19</b>
Vehicle views	19
Dimensions	22
Technical data	26
Panoramic roof	28
Folding roof	29
Interior	30
Seats	37
<b>Maintenance</b>	<b>40</b>
Maintenance	40
<b>Powerplant</b>	<b>42</b>
Engine data	42
Engine M281	43
Cooling	46
Exhaust system	47
Fuel system	48
<b>Transmission</b>	<b>50</b>
5-speed manual transmission	50
twinamic 6-speed dual clutch transmission	52
<b>Chassis</b>	<b>56</b>
Axles and suspension	56
Steering	60
Brake system	61
Wheels and tires	63
<b>Networking</b>	<b>65</b>
Overall network	65
Automatic start/stop	70
<b>Lights</b>	<b>72</b>
Exterior lights	72
Interior illumination	74
<b>Safety</b>	<b>75</b>
Active/passive safety	75

<b>Driving assistance systems</b>	<b>78</b>
Systems at a glance	78
Lane Keeping Assist	80
Tire pressure monitor	81
Rear parking assist	82
Reversing camera	83
Distance warning function	84
<b>Comfort</b>	<b>86</b>
Climate control	86
Power windows	93
Seat heater	95
<b>Vehicle protection</b>	<b>96</b>
Anti-theft alarm system	96
Central locking	97
<b>Audio and communications</b>	<b>98</b>
Telematics	98
<b>Body</b>	<b>104</b>
Bodyshell	104
Force progression during an accident	109
Assembly parts	111
<b>Special tools</b>	<b>112</b>
Chassis	112
Engine/transmission	113
Body	115
<b>Workshop equipment</b>	<b>116</b>
Body repair systems	116
<b>Annex</b>	<b>117</b>
Abbreviations	117
Index	119

### Dear Reader,

This Introduction into Service Manual presents the new smart fortwo coupé and new smart forfour of model series 453.

The purpose of this manual is to inform you of the technical highlights featured in this new vehicle in advance of its market launch. This brochure is intended to provide information for people employed in service, maintenance and repair as well as for aftersales staff. It is assumed that the reader is already familiar with the Mercedes-Benz and smart model series currently on the market.

In terms of the contents, the emphasis in this Introduction into Service Manual is on presenting new and modified components and systems.

This Introduction into Service Manual is not intended as an aid for repairs or for the diagnosis of technical problems. For such needs, more extensive information is available in the Workshop Information System (WIS) and Xentry Diagnostics.

WIS is updated continuously. The information available there always reflects the latest technical status of our vehicles.

This Introduction into Service Manual presents initial information about the new smart fortwo coupé and new smart forfour. The Introduction into Service Manual is not stored in this form in WIS. The contents of this brochure are not updated. No provision is made for supplements.

We will publicize modifications and new features in the relevant WIS documents. The information presented in this Introduction into Service manual may therefore differ from the more up-to-date information found in WIS.

All of the information relating to specifications, equipment and options is valid as of the copy deadline in June 2014 and may therefore differ from the current production configuration.

### Daimler AG

Retail Operations (GSP/OR)

#### Note

Wherever possible, the images in this brochure have been designed to be language-neutral. Where this was not possible, German or English texts appear in exceptional cases.

#### Note

Information about the vehicles and about operating the vehicle functions can be found online in the interactive owner's manual.

## Models and major assemblies

Designation	Model	Engine	Transmission	Market launch
smart fortwo coupé	453.341	281.920	700.121 700.410	02/2015
smart fortwo coupé	453.342	281.920	700.121 700.410	11/2014
smart fortwo coupé	453.344	281.910	700.122 700.411	12/2014
smart forfour	453.041	281.920	700.120 700.410	03/2015
smart forfour	453.042	281.920	700.120 700.410	11/2014
smart forfour	453.044	281.910	700.123 700.411	02/2015



External view of smart fortwo coupé

P00.10-5664-00



External view of smart forfour

P00.10-5665-00



## Brief description

### Vehicle concept

The new smart is being introduced in November 2014 as the successor to model series 451.

The new smart is available as the smart fortwo coupé (C453) and smart forfour (W453). In order to take individual customer preferences into account, the new generation of the smart features a "lines" concept.

Starting with the standard equipment, customers will have the option of customizing their vehicle with three additional lines which incorporate both technical and design variations. The drivetrain concept is based solely on the three-cylinder gasoline engines which are installed at the rear end of the vehicle.

### Dimensional concept

The new smart fortwo coupé and the new smart forfour renew and expand the smart product range in the segment of micro-compact vehicles. The proportions of the predecessor generation have largely been retained. Accordingly, the two-seater smart fortwo coupé has the same vehicle length of 2.69 m. The smart forfour contains the same features as the smart fortwo coupé, the sole differences being a longer wheelbase, an extended tridion safety cell and four doors instead of two.

#### **i** Note

Further information on the electrical systems in model series 453 (e.g. function descriptions and locations of electrical components) is available in the Workshop Information System (WIS) under the Basic Knowledge/Functions (GF) information type.

## Innovations and new features

### Active safety and driver assistance systems

- Distance warning function with visual and acoustic warning (SA)
- Crosswind Assist (standard)
- Rear parking assist (SA)
- Reversing camera (SA)
- Lane Keeping Assist (SA)

### Powerplant

- New twinamic 6-speed dual clutch transmission (SA)
- Wide range of powerful, consumption/emission-reduced and NVH-optimized gasoline engines

### Suspension, chassis systems and brakes

- Sports suspension lowered by 10 mm (SA)
- Direct steering (SA) with small turning circle
- Vertically adjustable steering column (SA)

### Information, multimedia and communications systems

- Audio system with AUX/USB interface, Bluetooth® interface with hands-free system and audio streaming for music transmission (SA)
- Digital radio for the DAB and DAB+ standards (SA)
- JBL sound system incl. 8-channel DSP amplifier and removable subwoofer in trunk (SA)
- Media system with multi-touch display, AUX/USB/SD interface in the center console, voice control, Bluetooth® interface with hands-free system and audio streaming as well as TomTom LIVE services as standard incl. communication costs and roaming for three years (SA)
- Radio preinstallation (SA)

### Environment

- ECO start/stop function in combination with 52 kW and 66 kW engine version
- Gearshift recommendation indicator
- Ancillary equipment controlled according to demand

### Body and interior equipment

- Readyspace seats for the rear of the smart forfour for optimal expansion of transport capacity according to needs (SA)

## Brief description

	453 E10 R (45 kW MT)	453 E10 (52 kW MT)	453 E10 (52 kW DCT)	453 E09 LA (66 kW MT)	453 E09 LA (66 kW DCT)
<b>Brakes, powertrain</b>					
5-speed manual transmission	Standard	Standard	-	Standard	-
twinamic 6-speed dual clutch transmission	-	-	Standard	-	Standard
Automatic start/stop	-	Standard	Standard	Standard <sup>1</sup>	Standard <sup>1</sup>
<b>Equipment variants – Lines</b>					
Standard equipment	Code ICPA	Code ICPA	Code ICPA	Code ICPA	Code ICPA
passion	-	Code ICLA	Code ICLA	Code ICLA	Code ICLA
prime	-	Code ICVA	Code ICVA	Code ICVA	Code ICVA
proxy	-	Code ICTA	Code ICTA	Code ICTA	Code ICTA
<b>Equipment variants – Packages</b>					
Sport package	-	Code P70	Code P70	Code P70	Code P70
Comfort package	Code P74	Code P74	Code P74	Code P74	Code P74
Cool & audio package	Code P31 <sup>2</sup>	Code P31	Code P31	Code P31	Code P31
Cool & media package	-	Code P26	Code P26	Code P26	Code P26
LED & sensor package	-	Code P25	Code P25	Code P25	Code P25
<b>Equipment variants – Special models</b>					
edition #1	-	Code P88	Code P88	Code P88	Code P88

<sup>1</sup> Not for USA

<sup>2</sup> In combination with 45 kW variant with manual air conditioning and smart audio system

	453 E10 R <sup>1</sup> (45 kW MT)	453 E10 (52 kW MT)	453 E10 (52 kW DCT)	453 E09 LA (66 kW MT)	453 E09 LA (66 kW DCT)
<b>Tires and light alloy wheels</b>					
Summer tires	Standard	Standard	Standard	Standard <sup>1</sup>	Standard <sup>1</sup>
Winter <sup>2</sup>	Code R28	Code R28	Code R28	Code R28 <sup>1</sup>	Code R28 <sup>1</sup>
38.1 cm (15") steel wheels with wheel caps	Standard (Code R82)	Standard (Code R82)	Standard (Code R82)	Standard (Code R82)	Standard (Code R82)
38.1 cm (15") steel wheels with hubcaps <sup>3</sup>	Code R83	Code R83	Code R83	Code R83	Code R83
38.1 cm (15") light alloy wheels in 8-spoke design, painted silver <sup>5</sup>	Code R88	Code R88	Code R88	Code R88	Code R88
38.1 cm (15") light alloy wheels in 8-spoke design, painted black and highly polished <sup>4</sup>	Code R86	Code R86	Code R86	Code R86	Code R86
38.1 cm (15") light alloy wheels in 5-spoke design, painted black and highly polished <sup>4,6</sup>	Code R87	Code R87	Code R87	Code R87	Code R87
40.6 cm (16") light alloy wheels with 8-Y-spoke design, painted black <sup>7</sup>	-	Code R95	Code R95	Code R95	Code R95
40.6 cm (16") light alloy wheels in 5-double spoke design, painted black and highly polished <sup>8</sup>	-	Code R91	Code R91	Code R91	Code R91
<b>Chassis</b>					
Sports suspension (-10 mm)	-	Package component	Package component	Package component	Package component
Direct steering <sup>9</sup>	Code 213	Code 213	Code 213	Code 213	Code 213

1 Not for USA

2 Not for 40.6 cm (16") wheels

3 Only with code ICPA

4 Not with code ICTA

5 Not for code ICTA, standard for code ICLA

6 Standard for code ICVA

7 Only with code ICTA, standard for code P70

8 Only with code P70, standard for code ICTA

9 Standard for code ICLA, ICVA, ICTA

## Brief description

	453 E10 R <sup>1</sup> (45 kW MT)	453 E10 (52 kW MT)	453 E10 (52 kW DCT)	453 E09 LA (66 kW MT)	453 E09 LA (66 kW DCT)
<b>Climate control</b>					
Heating	Standard	Standard	Standard	Standard	Standard
Manual air conditioning <sup>2</sup>	Code I77	-	-	-	-
Automatic air conditioning <sup>3</sup>	-	Code I01	Code I01	Code I01	Code I01
<b>Light systems</b>					
H4 headlamps with integrated daytime running lights	Standard	Standard	Standard	Standard	Standard
Front fog lamps	Code V07	Code V07	Code V07	Code V07	Code V07
<b>Safety and theft protection</b>					
Airbags for driver and front passenger	Standard	Standard	Standard	Standard	Standard
Sidebags for driver and front passenger	Standard	Standard	Standard	Standard	Standard
Knee airbag for driver	Standard	Standard	Standard	Standard	Standard
Crash sensor for activation of hazard warning system	Standard	Standard	Standard	Standard	Standard
Seat belt warning system for driver and front passenger seat	Standard	Standard	Standard	Standard	Standard
Rear seat belt status indicator <sup>4</sup>	Standard	Standard	Standard	Standard	Standard
Seat belts with emergency tensioning retractor and belt force limiter	Standard	Standard	Standard	Standard	Standard
Anti-theft alarm system	Code V19	Code V19	Code V19	Code V19	Code V19
DRIVE LOCK	Standard	Standard	Standard	Standard	Standard

1 Not for USA

2 Standard for code P31

3 Standard for code P31, code ICTA

4 Only for W453

	453 E10 R <sup>1</sup> (45 kW MT)	453 E10 (52 kW MT)	453 E10 (52 kW DCT)	453 E09 LA (66 kW MT)	453 E09 LA (66 kW DCT)
<b>Safety and theft protection</b>					
Lockable service flap <sup>2</sup>	-	Code V32	Code V32	Code V32	Code V32
<b>Driving assistance systems</b>					
Rear parking assist	Code 220	Code 220	Code 220	Code 220	Code 220
Reversing camera <sup>5</sup>	-	Code 218	Code 218 <sup>3</sup>	Code 218	Code 218 <sup>3</sup>
Lane Keeping Assist	Code 238	Code 238	Code 238	Code 238 <sup>4</sup>	Code 238 <sup>4</sup>
Distance warning function	Code 252	Code 252	Code 252	Code 252	Code 252
Tire pressure monitor	Standard	Standard	Standard	Standard	Standard
Cruise control with variable speed limiter <sup>6</sup>	Standard	Standard	Standard	Standard	Standard
Hill Start Assist	Standard	Standard	Standard	Standard	Standard
Crosswind Assist	Standard	Standard	Standard	Standard	Standard

1 Only for ECE/RoW RHD

2 Not for standard equipment

3 Not for Japan

4 Not for USA

5 Only in combination with code P26

6 Cruise control only without variable speed limiter in USA/Canada

## Brief description

	453 E10 R <sup>1</sup> (45 kW MT)	453 E10 (52 kW MT)	453 E10 (52 kW DCT)	453 E09 LA (66 kW MT)	453 E09 LA (66 kW DCT)
<b>Infotainment, navigation and communications</b>					
Radio preinstallation	Code C08	Code C08	Code C08	Code C08	Code C08
Audio system	Code 537	Code 537	Code 537	Code 537	Code 537
Media system <sup>3</sup>	-	Code 535	Code 535	Code 535	Code 535
Digital radio (DAB)	Code C04	Code C04	Code C04	Code C04	Code C04
Smartphone bracket	Code C67	Code C67	Code C67	Code C67	Code C67
iPad bracket <sup>1</sup>	-	Code 864	Code 864	Code 864	Code 864
JBL sound system	-	Code 810	Code 810	Code 810	Code 810
<b>Comfort systems</b>					
Seat heaters for driver and front passenger	Code 873	Code 873	Code 873	Code 873	Code 873
Power windows with convenience feature and anti-pinch protection	Standard	Standard	Standard	Standard	Standard
Panoramic roof incl. sun protection	Code E22	Code E22	Code E22	Code E22	Code E22
Electric fabric folding roof <sup>1</sup>	Code E55	Code E55	Code E55	Code E55	Code E55
Ashtray and cigarette lighter	Code I32	Code I32	Code I32	Code I32	Code I32
Vertically adjustable steering column	Code J37 <sup>2</sup>	Code J37	Code J37	Code J37	Code J37

1 Not for USA

2 Only for W453

3 Standard for code P74

### Equipment lines

The following list of equipment lines for the new smart enables the customer to design the interior and exterior of their vehicle to meet individual requirements.

### Passion (code ICLA)

The passion line features either a black/orange or black/white color combination in the interior, giving it a very stylish and modern appearance. The leather multifunction steering wheel, the instrument cluster with 3.5" color display and the direct steering combine a high-quality interior ambiance with functionality.

Exterior features of the passion line:

- 38.1 cm (15") light alloy wheels in 8-spoke design, painted silver
- Black radiator grille
- Outside mirror caps in tridion color
- passion lettering in mirror triangle
- Lockable service cover

Interior features of the passion line:

- Seats with black/orange fabric upholstery or seats with black/white fabric upholstery
- Matching instrument panel and door center panel in orange fabric and accent trim parts in black/grey or instrument panel and door center panel in black fabric and accent trim parts in white
- Leather multifunction steering wheel with 3-spoke design
- Leather shift lever knob
- Stowage compartment in liftgate

Comfort and functional equipment of passion line:

- Direct steering with speed-dependent steering force assistance and variable steering ratio
- Instrument cluster with color 8.9 cm (3.5") display with TFT technology and on-board computer
- Center console with drawer and double cup holder
- Reading lamp for front passenger
- Vanity mirror in sun visor for driver and front passenger
- Eyeglasses compartment for driver
- Grab handle for front passenger
- Trunk illumination
- Interior door opener in matt chrome



## Brief description

### Prime (code ICVA)

The prime line features a classically elegant design thanks to its black leather seats, among other features. Seat heaters for the driver and front passenger add to the comfort, while the Lane Keeping Assist system offers extra safety.

Exterior features of the prime line:

- 38.1 cm (15") light alloy wheels in 5-double spoke design, painted black and highly polished
- Black radiator grille
- Outside mirror caps in tridion color
- prime lettering in mirror triangle
- Lockable service cover

Interior features of the prime line:

- Seats with black leather upholstery and white decorative seams
- Instrument panel and door center panels in black fabric and accent trim parts in white
- Leather multifunction steering wheel with 3-spoke design
- Leather shift lever knob
- Stowage compartment in liftgate

Comfort and functional equipment of prime line:

- Direct steering with speed-dependent steering force assistance and variable steering ratio
- Lane Keeping Assist with acoustic and visual warning
- Instrument cluster with color 8.9 cm (3.5") display with TFT technology and on-board computer
- Seat heaters for driver and front passenger
- Center console with drawer and double cup holder
- Reading lamp for front passenger
- Vanity mirror in sun visor for driver and front passenger
- Eyeglasses compartment for driver
- Grab handle for front passenger
- Trunk illumination
- Interior door opener in matt chrome

**Proxy (code ICTA)**

The proxy line is innovative and trendsetting. Its highlights include the panoramic roof as well as leather-look seats and white/blue fabric. A high level of entertainment and air conditioning comfort is provided by the Cool & Audio package, while the standard sport package with 16" light alloy wheels adds to the dynamism of the vehicle.

Exterior features of the proxy line:

- White tridion safety cell
- Panoramic roof with sun protection (smart fortwo coupé only)
- 40.6 cm (16") light alloy wheels in 5-double spoke design, painted black and highly polished
- Sports suspension lowered by 10 mm
- White radiator grille
- Outside mirror caps in tridion color
- proxy lettering in mirror triangle
- Exhaust system with chrome-plated exhaust tip
- Lockable service cover

Interior features of the proxy line:

- Seats in white/blue leather-look/fabric
- Instrument panel and door center panel in blue fabric
- Leather multifunction sport steering wheel with 3-spoke design
- Leather shift lever knob
- Sports pedal assembly made of brushed stainless steel with rubber naps
- Stowage compartment in liftgate

Comfort and functional equipment of prime line:

- Direct steering with speed-dependent steering force assistance and variable steering ratio
- Lane Keeping Assist with acoustic and visual warning
- Cool & Audio package with automatic air conditioning and audio system
- Instrument cluster with color 8.9 cm (3.5") display with TFT technology and on-board computer
- Center console with drawer and double cup holder
- Lockable glove compartment
- Reading lamp for front passenger
- Vanity mirror in sun visor for driver and front passenger
- Eyeglasses compartment for driver
- Grab handle for front passenger
- Trunk illumination
- Interior door opener in matt chrome

## Brief description

### Equipment packages

The following list of equipment packages for the new smart enables the customer to design the interior and exterior of their vehicle to meet individual requirements.

### Cool & Audio package (code P31)

The Cool & Audio package includes the following components:

- Manual air conditioning with dust and pollen filter (45 kW engine)
- Automatic air conditioning with automatic temperature control and combination filter with activated charcoal (52 kW and 66 kW engine)
- Smart audio system with AUX/USB interface, Bluetooth® interface with hands-free system, audio streaming for music transmission and smart cross connect for iOS and Android

### Cool & Media package (code P26)

The Cool & Media package includes the following components:

- Automatic air conditioning with automatic temperature control and combination filter with activated charcoal
- smart media system with 17.8 cm (7") capacitive multi-touch display, AUX/USB interface (center console), voice control, Bluetooth® interface with hands-free system, audio streaming for music transmission, navigation system incl. three years of Live Services

### Comfort package (code P74)

The Comfort package includes the following components:

- Electrically adjustable and heated outside mirrors
- Vertically adjustable driver seat
- Steering column with manual vertical adjustment

### LED & sensor package (code P25)

The LED & sensor package includes the following components:

- Rain/light sensor
- Front fog lamps
- H4 headlamps with welcome function, integrated daytime running lights with LED fiber-optic technology and LED taillamps

### Sport package (code P70)

Exterior features of sport package:

- 40.6 cm (16") light alloy wheels with 8-Y-spoke design, painted black
- Sports suspension lowered by 10 mm
- Exhaust system with chrome-plated exhaust tip

Interior features of sport package:

- Leather multifunction sport steering wheel with 3-spoke design
- Sports pedal assembly in brushed stainless steel with rubber naps

## Front

Now in its third generation, the smart has a more mature overall appearance and yet remains unmistakably smart. Typical features of the brand include the graphic elements separating the components through a dual color scheme and the striking tridion design in conjunction with the compact front and rear ends.

The previous "onebox" proportions have been slightly changed in the area of engine hood height in order to improve active/passive safety. Simply changing the angles at the front end has improved pedestrian protection, which is of particular importance in urban traffic situations. The refined radiator grille looks like an integrated net, which is smoothly amalgamated into the front-end design. The new headlamps with their design principles and clear glass lenses emphasize the newfound maturity of this vehicle generation.



P00.00-5254-00

Front view of smart fortwo coupé



P00.00-5253-00

Front view of smart forfour

## Vehicle views

### Rear end

At the rear end of the new smart fortwo coupé, the raised lettering on the lower part of the split liftgate indicates the brand identity. As on predecessor models, the separation of the upper and lower parts provides loading versatility for both light and heavy items. The top edge takes the form of a roof spoiler with integrated center high-mounted brake lamp.

The rear lamps, which are set into the tridion safety cell, give the design a particular sense of quality and underline the width of the vehicle at the rear end. The license plate is mounted between the lamps in the liftgate. The bottom edge of the bumper, which is painted in the vehicle color, is black and has a cutout on the left (viewed in the direction of travel) for the visible tailpipe of the exhaust system. A sport exhaust tip is available for the exhaust system, while the bumper also houses the distance sensors.

In principle, the smart forfour features the same design elements as the smart fortwo coupé. However, it has a one-piece, upward-opening liftgate with smart logo, which also accommodates the reversing camera special equipment. On this variant, the license plate is fitted to the dual-color bumper.



P00.00-5255-00

Rear view of smart fortwo coupé



P00.00-5256-00

Rear view of smart forfour

**Side**

The most noticeable difference between the two-seater and four-seater is found at the side: The smart fortwo coupé has large doors, which extend into the B-pillar, and frameless windows. The door contour and the tridion safety cell reflect the smart design genes even when viewed from some distance, which is what makes the vehicle so unmistakable on the road. The brand image is further enhanced by a characteristic swage line on each vehicle, positioned roughly in the center of the doors. These features are further complemented by the tank cap on the right and the air inlet for the rear-mounted engine on the left underneath the B-pillar.

The side view of the four-seater reveals the same elements as the two-seater, but with two additional doors and a longer tridion safety cell. The front and rear overhangs have an identical appearance to those of its little brother.

The range of wheels extends from steel wheels through to exclusive light alloy wheels (15 and 16-inch) in monochrome or high-sheen machined versions.



P00.00-5258-00

Side view of smart fortwo coupé



P00.00-5259-00

Side view of smart forfour

# Dimensions

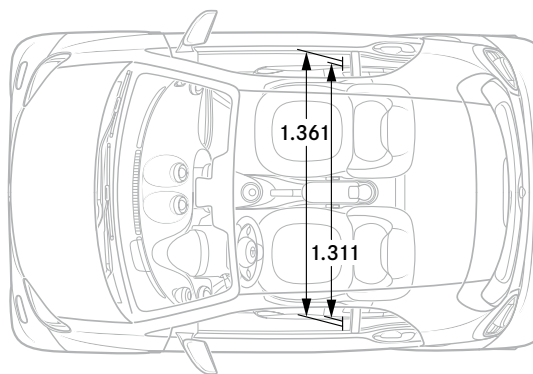
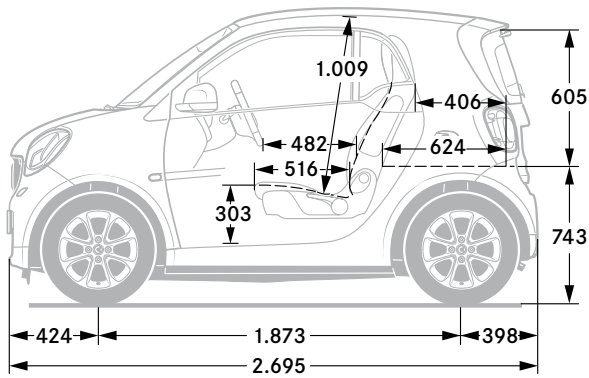
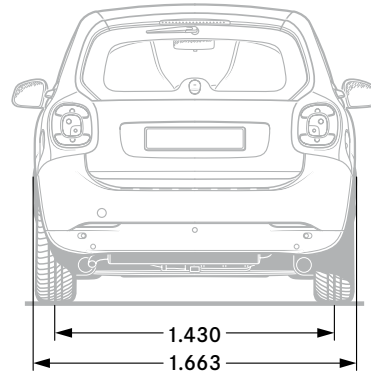
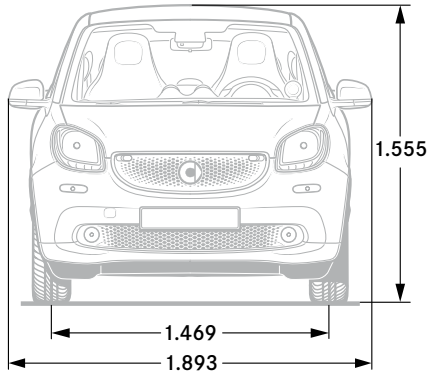

Vehicle dimensions of C453  
 Dimensions under no load

P00.10-5666-00

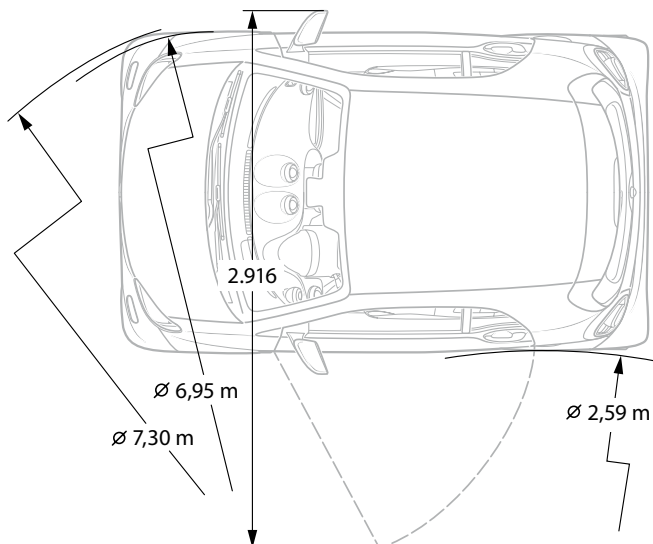
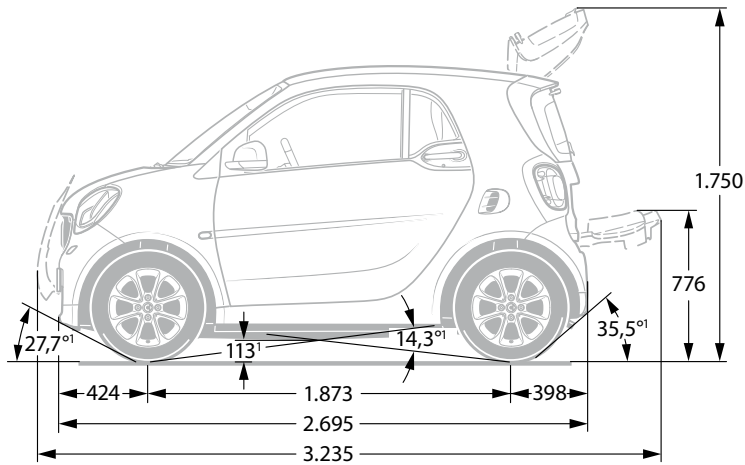
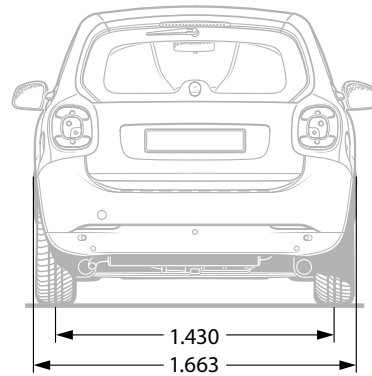
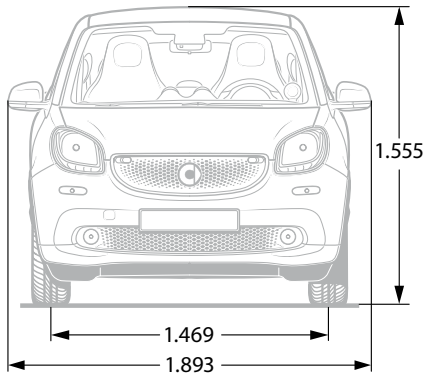

Vehicle dimensions (garage dimensions) C453  
 Dimensions under no load

P00.10-5667-00



# Dimensions

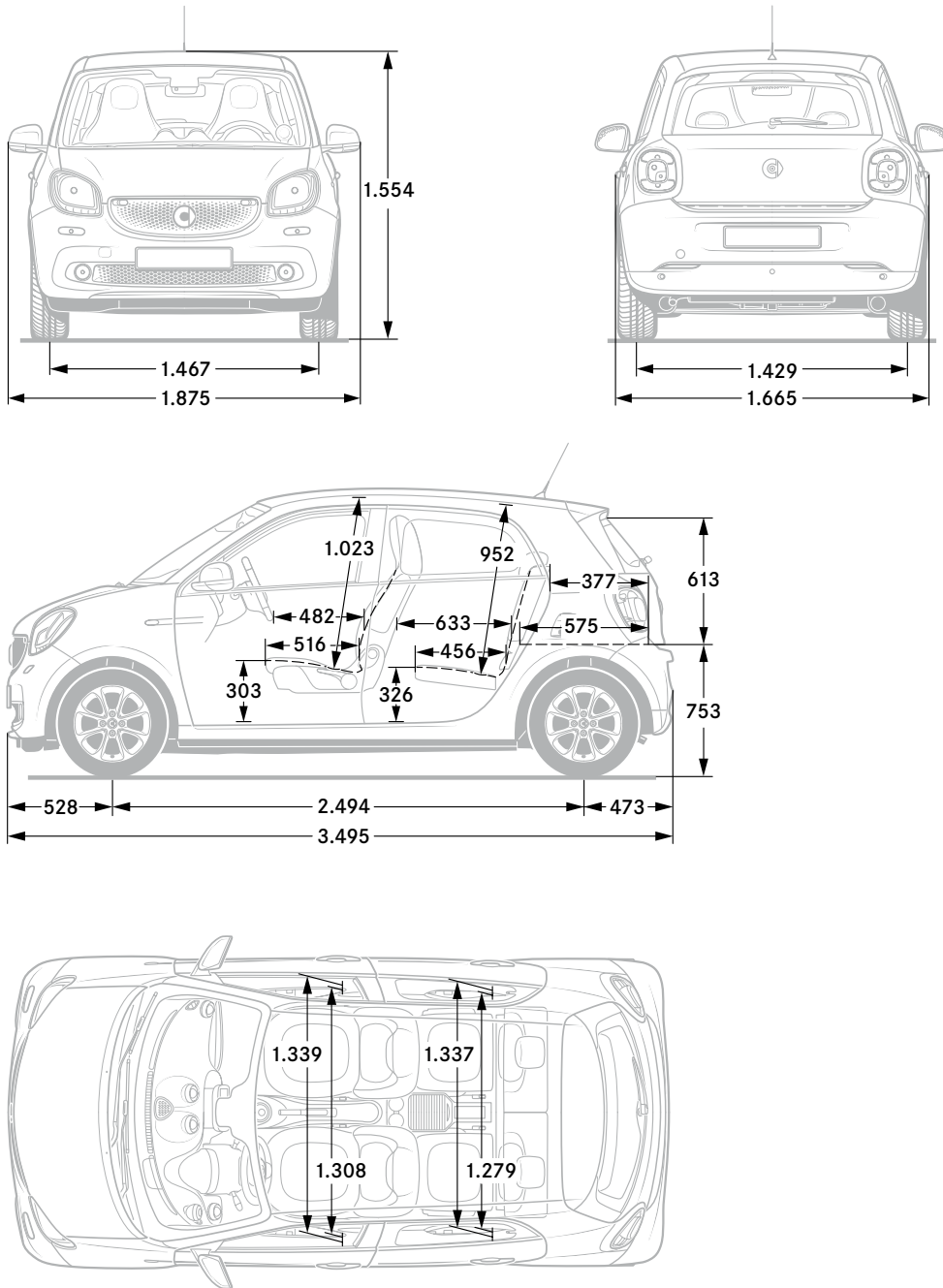

Vehicle dimensions W453  
Dimensions under no load

P00.10-5668-00

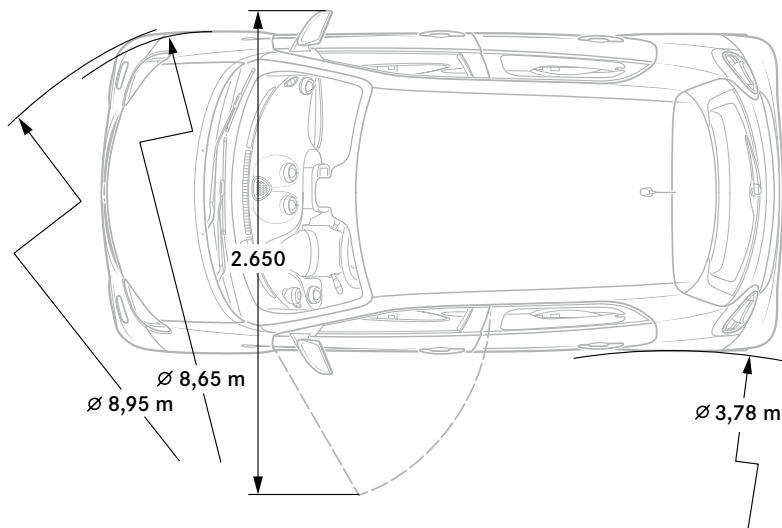
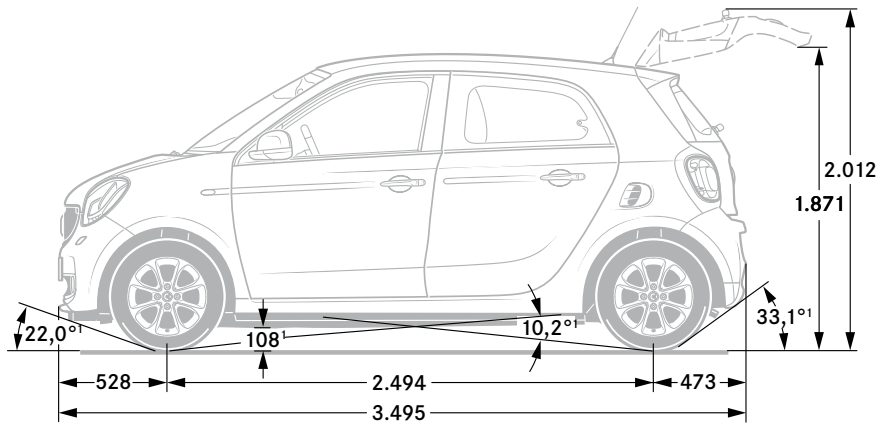
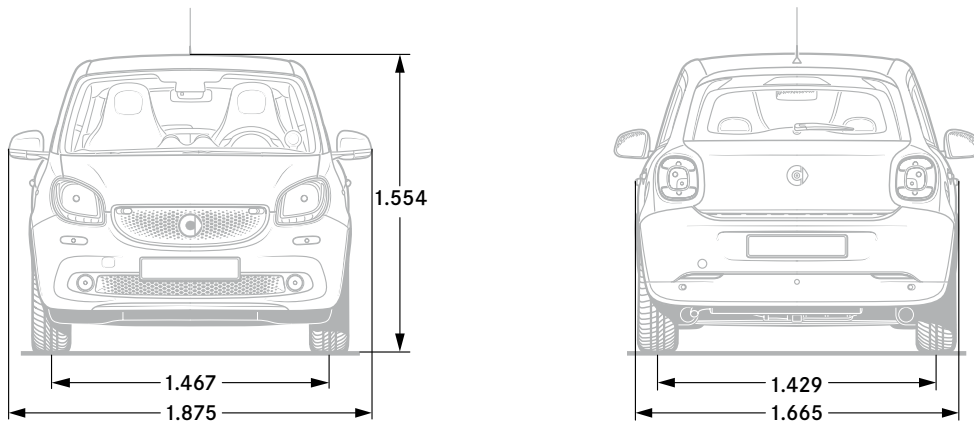

Vehicle dimensions (garage dimensions) W453  
 Dimensions under no load

P00.10-5669-00

## Technical data

### Comparison of model series 451 with model series 453

Dimensions and weights	Unit	C451	C453	W453
Vehicle length	mm	2695	2695	3495
Vehicle width with outside mirrors folded out	mm	1752	1893	1875
Vehicle width With outside mirrors folded in	mm	No data	1747	1733
Vehicle height	mm	1565	1555	1554
Wheelbase	mm	1867	1873	2494
Front overhang	mm	425	424	528
Rear overhang	mm	403	398	473
Front track width	mm	1283	1469	1467
Rear track width	mm	1385	1430	1429
Curb weight (DIN)	kg	750	880	975
Permissible gross vehicle weight	kg	1020	1150	1400
Max. payload (DIN)	kg	270	270	425
Max. seating capacity		2	2	4
Trunk capacity (with TIREFIT)	l	220/340	260/350	185-255
Turning circle (wall-to-wall)	m	8.75	7.30	8.95
Tank capacity	l	33	28	28

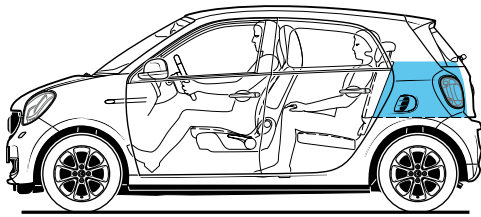

V 211-2:  
Open luggage compartment behind rear seats  
Loaded to top edge of rear backrest  
Volume 185 liters

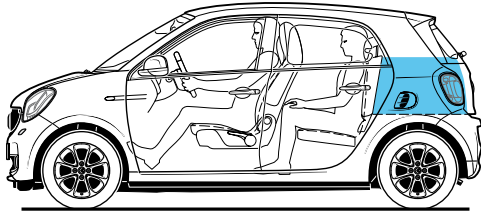

V 211-2: Cargo position:  
Open luggage compartment behind rear seats  
Rear backrest in cargo position  
Loaded to top edge of rear backrest  
Volume 215 liters

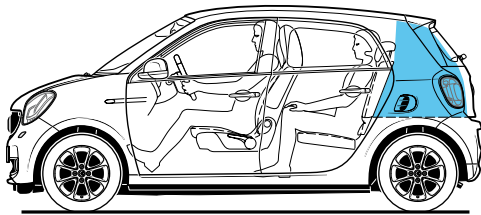

V 214-2:  
Open luggage compartment behind rear seats  
Loaded to roof  
Volume 255 liters

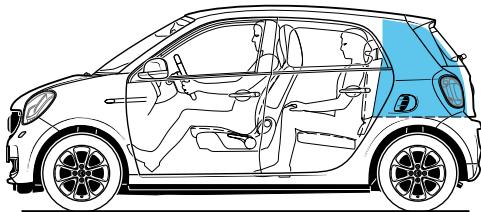

V 214-2: Cargo position:  
Open luggage compartment behind rear seats  
Rear backrest in cargo position  
Loaded to roof  
Volume 315 liters

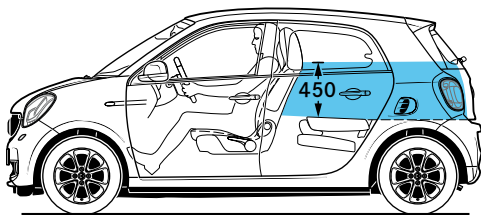

V 211-1:  
Open luggage compartment behind driver seat  
Rear backrest folded down  
Loaded to 450 mm above loading floor  
Volume 730 liters

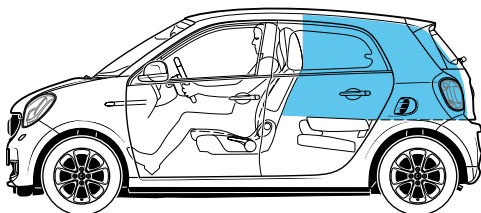

V 214-1:  
Open luggage compartment behind driver seat  
Rear backrest folded down  
Loaded to roof  
Volume 975 liters

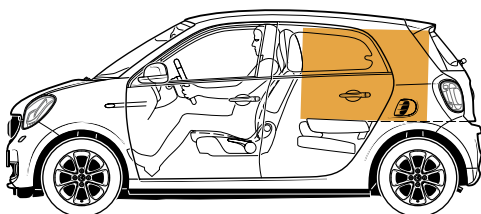

Largest rectangular object:  
Dimensions 950 x 800 x 450 mm  
Volume 255 liters

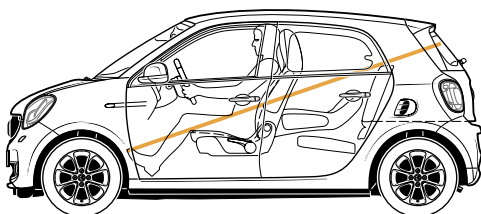

Longest board:  
Dimensions: 2600 x 25 x 25 mm

P00.00-5261-00

Cargo area variants as per DIN 70020 (W453)

## Panoramic roof

### Panoramic roof

A transparent panoramic roof with manually adjustable sun protection is available as special equipment for the new smart.

The sun protection takes the form of a fabric roller blind and extends across the entire transparent area of the panoramic roof.

The panoramic roof enhances the feeling of space in the vehicle. The roller blind allows the entry of heat to be reduced in direct sunlight.

As is usual on smart vehicles, the roof module is bonded to the vehicle cell. On the smart coupé, the panoramic roof is made of polycarbonate. Two panes of mineral glass are used on the smart sedan.



P77.21-2471-00

View of panoramic roof incl. sun protection on C453



P77.21-2472-00

View of panoramic roof incl. sun protection on W453

**Electric fabric folding roof (W453 only)**

An electrically powered folding roof made of fabric is available as special equipment. Extending almost to the C-pillar, the folding roof provides the largest possible opening and creates a friendly and bright interior compartment when open.

The folding roof is made of black fabric, mounted on a plastic frame of the same color and guided by rails at the side. The fabric is stretched across several bows for the purpose of stabilization. On the inside, the folding roof is lined with grey fabric. The control unit for the functions of the folding roof is integrated in the electric drive unit, which is located in the rear roof area.

The folding roof opens or closes after actuation of the control (long push) in approx. 10 seconds. In the process, the front roof bow moves back towards the rear end of the vehicle or forward towards the windshield. The operating switch is located in the center console. It is possible to close the roof while driving up to max. 100 km/h.



Electric fabric folding roof (W453 only)

P77.00-2511-00

## Interior

### Interior design

Careful attention has been paid to developing the interior, which presents itself in a high-quality, modern and much more emotional design. Large areas of the instrument panel have a textile covering, providing a unique "feeling of home" with very good haptic properties. It is a unique selling proposition for vehicles of this class.

A three-spoke steering wheel with keypad allows operation of the smart media system, which is positioned centrally in the instrument panel (volume, voice control). This takes the form of is a touch-operated human-machine interface, which appears to float over the instrument panel and features a design in harmony with contemporary consumer electronics.

A new additional instrument for the combined display of rpm and the time is located next to the instrument panel. The eyeball vents are operated easily and intuitively and ensure maximum ventilation comfort.

An optional panoramic roof and, for the smart forfour, a fabric folding roof are available to provide a particularly light and airy feeling in the interior compartment. On the four-seater, the readyspace seats special equipment option is available in place of the rear bench seat as a clever space-saving solution. This quickly and easily creates additional space for suitcases and luggage, without having to fold down the backrest of the rear bench seat.



Interior design

P68.00-7741-00



Rear interior design of sedan

P91.12-3836-00



readyspace seats interior concept

P91.12-3837-00



## Interior

### Storage and stowage compartments

Alongside the glove compartment located in the instrument panel, the new smart is equipped with door stowage compartments at the front and rear as standard (W453 only). A lockable glove compartment is available as special equipment. The improved center console features a drawer and a pen tray.

In addition, the new smart has cupholders in the front and rear area of the center console as well as a rear center console with roller blind compartment and double cupholder (only with readyspace option W453).

Ruffled pockets on the driver and front passenger backrests are available optionally.

A stowage compartment in the liftgate is available as special equipment on the smart fortwo coupé. The customer can also choose between the following load compartment covers:

- Load compartment cover (roller blind), C453 (SA)
- Load compartment cover (stowage tray), W453 (SA)

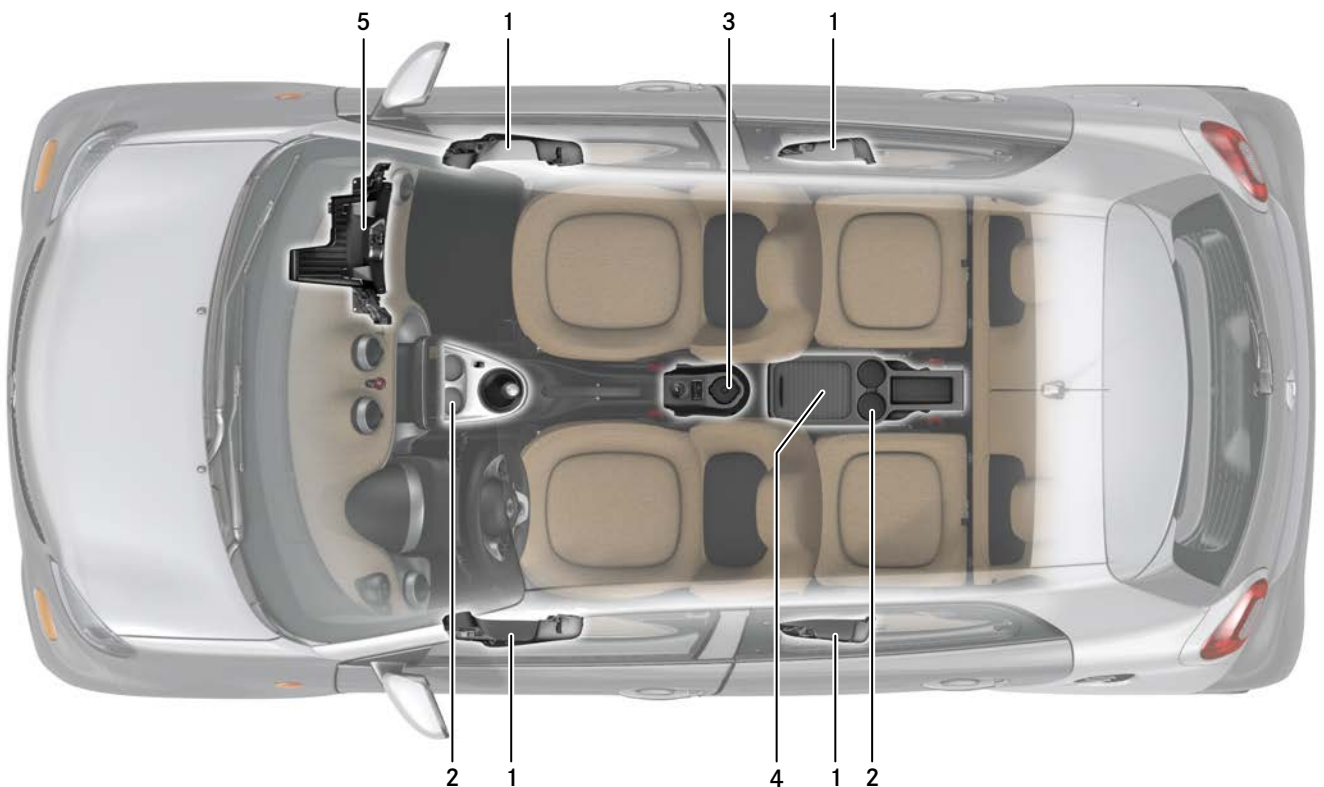

### Storage and stowage compartments (W453)

- |   |                          |   |   |
|---|--------------------------|---|---|
| 1 | Door stowage compartment | 4 | Rear center console with roller blind compartment |
| 2 | Double cup holder        | 5 | Glove compartment                                 |
| 3 | Single cup holder        |   |   |

P68.00-7742-00

### Instrument panel

The upper part of the instrument panel is injection molded with a pitted surface (standard equipment) or can optionally be manufactured with a natural fibre carrier material, which is covered with a fabric variant corresponding to one of the equipment lines. As on other model series, the cockpit module is also preassembled according to standard assembly principles.

The preassembled components include the cockpit cross-member, air conditioner housing, wiring harness, telematics units and others. The preassembled module is then bolted to the vehicle in the longitudinal and transverse directions.

The controls on the instrument panel include a switch panel for the driver assistance systems next to the steering wheel and the controls for the hazard warning system and door locking system positioned centrally above the smart audio system or smart media system. The operating unit for the heater/air conditioning is also located centrally under the smart audio system or smart media system.



P68.10-4770-00

Instrument panel

## Interior

### Instrument cluster

A semi-circular instrument cluster provides the driver with all of the information required to operate the vehicle. The basic version of the instrument cluster features a centrally located LCD display of approx. 76 x 39 mm in size. On the Passion, Prime and Proxy equipment lines, there is a color display in the same position (resolution 360 x 240 pixels) for the on-board computer. The speed is displayed on an arc around the edge of the display, while warning messages and indicators for the various systems are arranged concentrically around it.

Depending on the vehicle equipment, the menu functions are controlled via buttons on the control stalk or buttons on the multifunction steering wheel.

The additional instruments for time and rpm previously installed in the center of the instrument panel will in future be combined in one indicator (SA) next to the instrument cluster.



P54.33-4117-00

Instrument cluster (standard)



P54.33-4118-00

Instrument cluster (equipment line)



P54.33-4119-00

Additional instrument (SA)



### Menu navigation button group

S4/5s1 Scroll forward button

S4/5s2 OK button

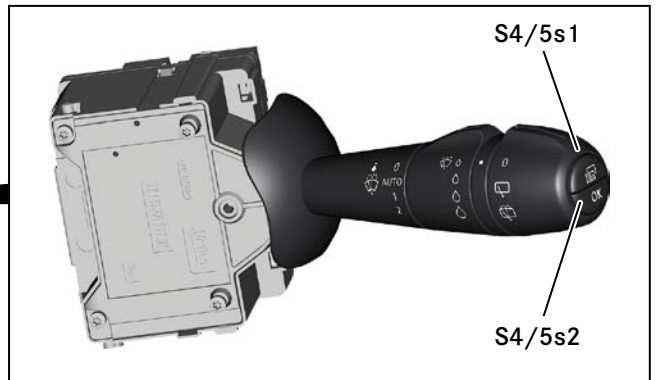

P54.33-4120-00

## Arrangement of indicators

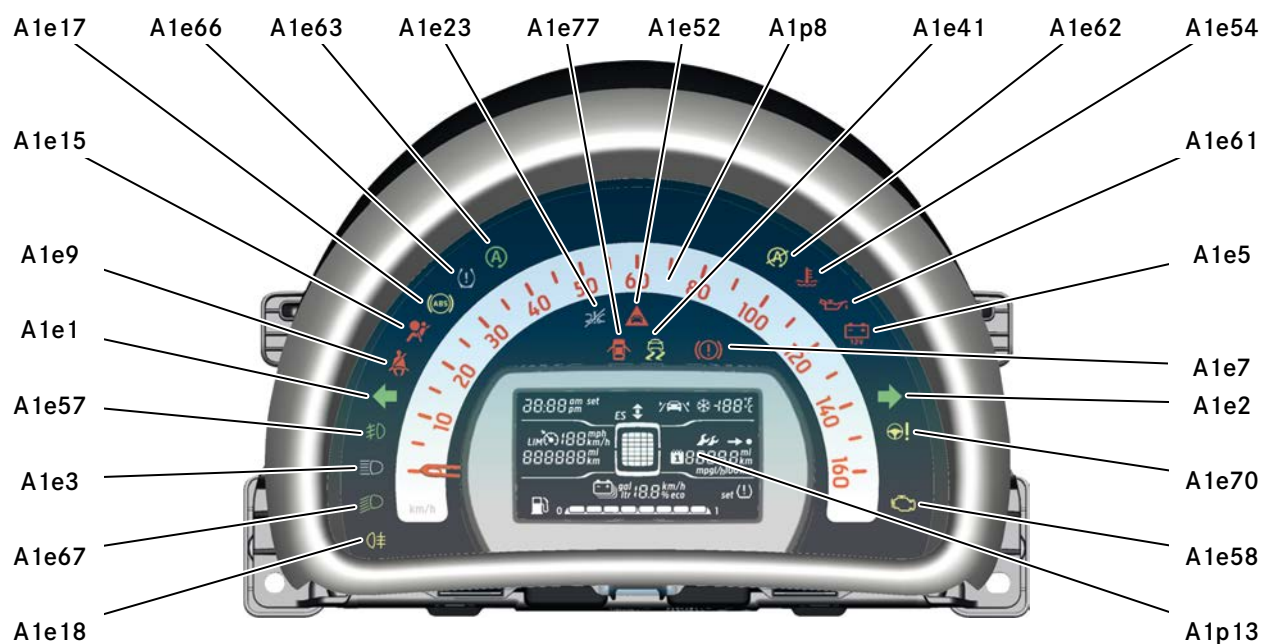

P54.33-4121-00

## Instrument cluster (ECE) arrangement

A1e1	Left turn signal indicator light	A1e54	Coolant temperature warning lamp
A1e2	Right turn signal indicator light	A1e57	Front fog lamp indicator lamp
A1e3	High beam indicator lamp	A1e58	Engine diagnosis indicator lamp
A1e5	Alternator warning lamp	A1e61	Oil pressure warning lamp
A1e7	Brake fluid and parking brake warning lamp	A1e62	ECO start/stop function not available indicator lamp
A1e9	Seat belt warning lamp	A1e63	ECO start/stop function available indicator lamp
A1e15	Supplemental restraint system indicator lamp	A1e66	Tire pressure monitor warning lamp
A1e17	Anti-lock braking system indicator lamp	A1e67	Low beam indicator lamp
A1e18	Rear fog light indicator lamp	A1e70	Power steering warning lamp
A1e23	Distance warning function indicator lamp	A1e77	Door open warning lamp
A1e38	Standing lights indicator lamp	A1p8	Speedometer
A1e41	Electronic Stability Program warning lamp	A1p13	Multifunction display
A1e52	Distance warning function warning lamp		

## Interior

### Center console

The center console consists of three parts. The first part joins up with the instrument panel at the front and features a double cup holder, pen tray and drawer. The center part is positioned behind it with the gearshift/selector lever and mount for the handbrake lever. Next to the gearshift/selector lever on the right is the switch for the optional electric fabric folding roof or a coin holder. To the left are the switches for the shift programs of the twinamic 6-speed dual clutch transmission. Further to the rear are the handbrake lever, a 12 V socket, an additional cupholder and an armrest as special equipment as well as the Connectivity Hub as part of the "smart media system" special equipment.



P68.20-4851-00

Center console - Rear area



P68.20-4852-00

Center console - Front area

## Seats

The seats in both the front and the rear have a striking sporty design and are similar in appearance to integral sport seats with integrated head restraints. The left and right seats in the rear have the characteristics of individual seats. The high variability of the seats provides a versatile vehicle interior.

The new seats fulfill a wide range of different requirements in the areas of seating comfort, ergonomics, passive safety and sportiness.

The characteristic features of the seats include the use of high-strength steels, the half-cushion shell with comfort supporting springs and high backrests with pronounced side supports. The padding of the seat cushions and backrests consists of PUR foam.

In order to simultaneously fulfill the requirements for comfort and lateral support, the foam cushion padding incorporates different hardness zones, while the side areas make use of harder foam.

Due to the higher backrest pivot point, it is possible to fold the backrests down fully onto the seat cushion. Depending on the equipment installed, this is facilitated by a latch fitting on the front passenger seat. Latch fittings are available on the driver and front passenger seat on the coupé. The front passenger seat of the coupé is equipped with ISOFIX mounts with insertion guides for convenient attachment of a child seat.



Front seats

P91.00-2331-00

## Seats

### Rear seats of smart forfour

The rear seats of the smart forfour provide great variability for the interior compartment. In addition, the backrests are optionally available with a 50:50 folding split. Even on vehicles with standard equipment, the entire backrest can be folded down onto the seat cushions after the backrest lock is released, to provide an almost flat cargo area. The rear seats have a distinct individual seat character with removable L-shaped head restraints. The standard ISOFIX mounts each have an insertion guide for more convenient attachment of a child seat.

The backrests of the rear bench seat can be moved into a 12° steeper position (cargo position), thus enlarging the cargo area volume (special equipment). Despite the more upright position of the backrest, the rear bench seat can be used by vehicle occupants. It is possible to use a rearward-facing infant seat in both backrest positions.



P68.80-2110-00

Rear seat of smart forfour in cargo position



P68.80-2111-00

Rear seat of smart forfour folded down

**readyspace seats in smart forfour**

The readyspace seats are available in place of the rear bench seat as special equipment. This solution quickly and easily creates additional space for suitcases and luggage, without having to fold down the backrest of the rear bench seat. The seat cushions of the rear bench seat can easily and individually (50:50) be swiveled into the footwell in front of the bench seat, thus providing a lowered and flat surface for larger objects.



P91.12-3839-00

**readyspace seats in smart forfour**



## Maintenance

### Maintenance concept

Maintenance of the new model series 453 (smart) consists of requirement-based maintenance (BOW) for the first time. Here, the age and mileage of the vehicle are taken into account for the service scopes. In addition, use of the DSB (Digital Service Booklet) by workshops will also be possible at market launch in those countries which already offer it for Mercedes-Benz cars.

Another area where maintenance has been harmonized with Mercedes-Benz cars is in the changes to "Oil Service Plus" and "Maintenance". Like Mercedes-Benz cars, smart maintenance now also consists of an alternating Service A and B as well as an optionally available "customer package". The following fixed maintenance intervals apply, with the exception of possible country-specific variations in the kilometer intervals:

- Service A after 20,000 km or one year
- Service B after 40,000 km or two years

### Maintenance interval display (WIA)

The maintenance interval display is located within the multi-function display of the instrument cluster. It shows the remaining distance (in km/mi) or the remaining time (in days) until the next service. The number of wrenches indicates the type of service due. The symbol with one wrench means Service A and the service with two wrenches means Service B.

If a service is due within the next 1500 km or 30 days, the driver is notified of this on the instrument cluster every time he or she restarts the vehicle in the form of a wrench symbol which flashes for 10 seconds. On equipment lines with TFT display, a text message appears on the screen. Once the service has been completed, the service interval display can be reset either using STAR DIAGNOSIS or directly on the instrument cluster.

### Changes to additional maintenance operations in comparison with model series 451

Service	Service interval of model series 451	Service interval of model series 453
Replace air filter element	Every 40,000 km	Every 60,000 km/3 years *
Replace spark plugs	Every 40,000 km	Every 80,000 km/4 years *
Engine: Replace coolant	Every 60,000 km/4 years *	Every 120,000 km
Replace brake fluid	After 2 years for the first time	After 3 years for the first time, then every 2 years
Check and correct headlamp adjustment	At each Service B	After 3 years for the first time, then every 2 years
Rear axle: Check brake pad thickness	At each Service A/B	At 80,000 km for the first time/then at each Service B

\* depending on first occurrence

### Maintenance points in front compartment

As on the predecessor model series 451, the vehicle features a service flap which is fixed in place with straps and extends across almost the entire width of the vehicle at the front.

This allows convenient access to all maintenance items in the front compartment.

The most important maintenance points in the front compartment are:

- Windshield washer fluid reservoir
- Coolant expansion reservoir
- Brake fluid reservoir
- Lamp units for bulb replacement

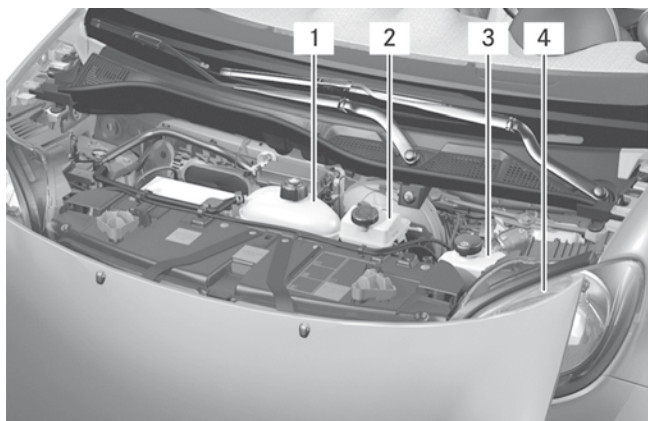

P00.20-2824-00

### Maintenance points in front compartment

- 1 Coolant expansion reservoir
- 2 Brake fluid reservoir
- 3 Windshield washer fluid reservoir
- 4 Lamp units for bulb replacement

### Maintenance points in engine compartment

As in model series 451, the maintenance points in the engine compartment are accessible through an engine compartment cover in the luggage compartment floor.

The most important maintenance points in the engine compartment are:

- Oil filler neck
- Oil dipstick
- Air filter housing
- Spark plugs

### Note

For more information on maintenance of model series 453, see the corresponding AP documents in WIS.

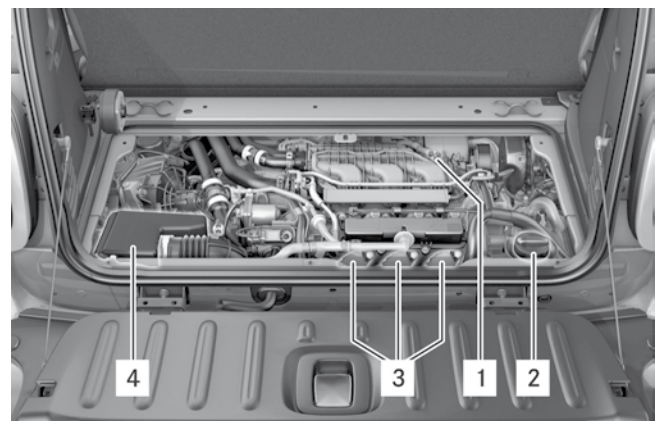

P00.20-2825-00

### Maintenance points in engine compartment

- 1 Oil dipstick
- 2 Oil filler neck
- 3 Spark plugs
- 4 Air filter housing

## Engine data

	Unit	M281 E10 R	M281 E10	M281 E09 LA
<b>Engine data</b>				
Engine model designation		281.920	281.920	281.910
Engine designation		M281 NA (45 kW)	M281 NA (52 kW)	M281 TC (66 kW)
Cylinder configuration and number		Inline/3	Inline/3	Inline/3
Cylinder angle	°	49	49	49
Displacement	cm <sup>3</sup>	999	999	898
Bore	mm	72.2	72.2	72.2
Stroke	mm	81.3	81.3	73.1
Compression ratio $\epsilon$		10.5	10.5	9.5
Fuel		Premium 95 RON	Premium 95 RON	Premium 95 RON
Maximum speed	km/h	151	151	165 (W453) 155 (C453)
Exhaust emission regulation (ECE)		EURO 6	EURO 6	EURO 6

**Brief description**

The new smart will be launched with a newly developed 3-cylinder gasoline engine.

The M281 is available in three power variants in model series 453:

- Power-reduced naturally aspirated engine (45 kW)
- Naturally aspirated engine (52 kW)
- Turbocharged engine (turbocharger) (66 kW)

The new M281 gasoline engines are all based on the same engine platform. The different power variants are obtained through different software versions and turbocharging.

The different power variants of the M281 all fulfill the EU 6 emissions standard.

**Charging**

A turbocharger with bypass valve (wastegate) is used on the new smart.

On the turbocharged engine, boost pressure control is carried out through an electronically controlled boost pressure control flap, which is actuated by the engine control unit in accordance with a characteristics map and the load requirement.

**Note**

Further information on the engine control system can be found in the relevant GF documents in WIS.



M281 (naturally aspirated engine)

P01.10-3270-00

## Engine M281

	Unit	M281 E10 R	M281 E10
<b>Engine data</b>			
Rated output	kW	45	52
at engine speed	rpm	6000	6000
Rated torque	Nm	87	91
at engine speed	rpm	3500	2850
Boost pressure max.	bar	-	-
Compression ratio $\epsilon$		10.5	10.5

	Unit	M281 E09 LA
<b>Engine data</b>		
Rated output	kW	66
at engine speed	rpm	5500
Rated torque	Nm	135
at engine speed	rpm	2500
Boost pressure max.	bar	2.3
Compression ratio $\epsilon$		9.5

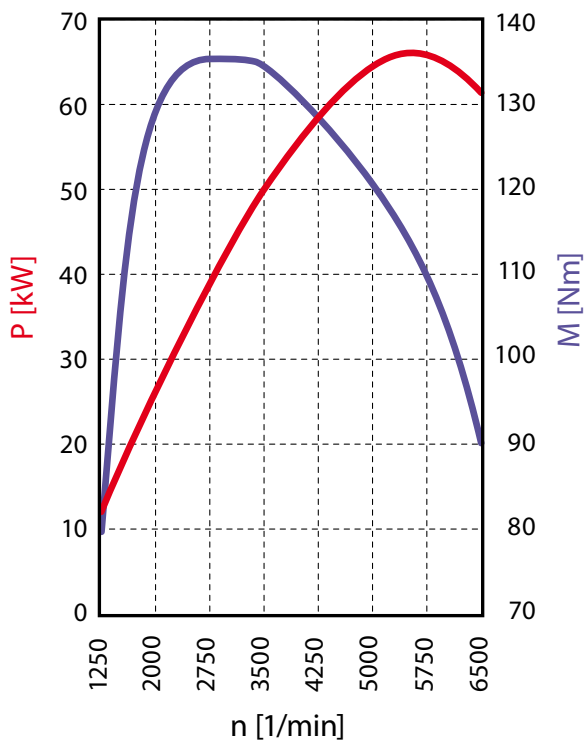

Performance graph of M281.920 (66 kW)

P01.00-3568-00

- M Torque
- P Power
- n Rpm

## Cooling

### Cooling system

Depending on the equipment variant, the new smart can be equipped with up to two independently operating coolant circuits. A high-temperature (HT) circuit, which also cools the turbocharger in addition to the engine and cylinder head, as well as a low-temperature (NT) circuit used for temperature regulation of the charge air.

Vehicles without turbocharger are only equipped with a high-temperature (HT) circuit.

The vehicle is also equipped with an additional fan at the rear end.

#### ⓘ Note

The cooling system must be filled and bled only when the engine is cold.

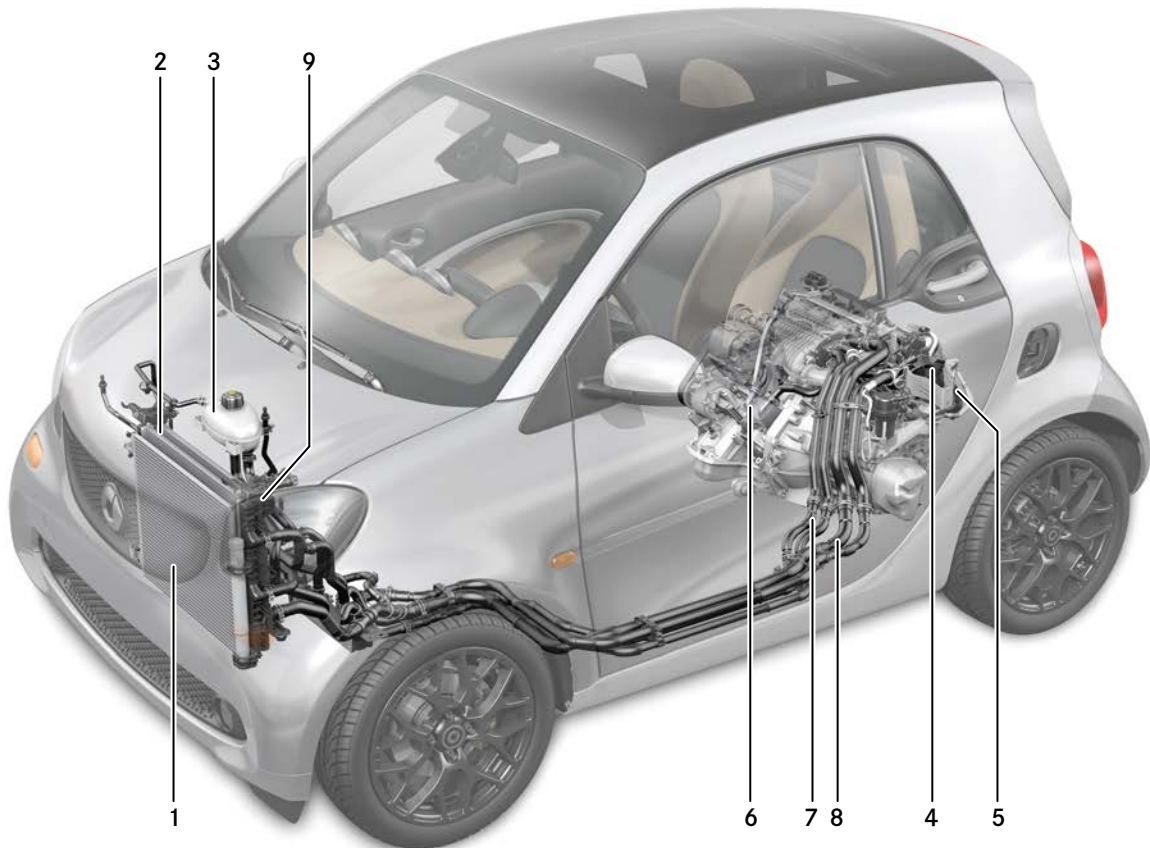

#### Cooling components of turbocharged engine

- |   |                               |   |                            |
|---|-------------------------------|---|----------------------------|
| 1 | NT radiator (only with turbo) | 6 | Engine oil cooler          |
| 2 | Engine radiator (HT radiator) | 7 | Low-temperature circuit    |
| 3 | Expansion reservoir           | 8 | High-temperature circuit   |
| 4 | Additional fan                | 9 | Fan housing with fan motor |
| 5 | Turbocharger                  |   |                            |

P20.00-2542-00

**M281 exhaust system**

Two variants of exhaust system are used to remove the combustion gases of the rear-mounted engine:

- Exhaust system of naturally aspirated engine
- Exhaust system of turbocharged engine
- Exhaust system of naturally aspirated engine for sport package
- Exhaust system of turbocharged engine for sport package

These exhaust systems differ with respect to their internal and external design.

The exhaust systems consist of:

- Catalytic converter
- Decoupling element
- Rear muffler

Vehicles with sport package feature an exhaust system with chrome-plated exhaust tip.

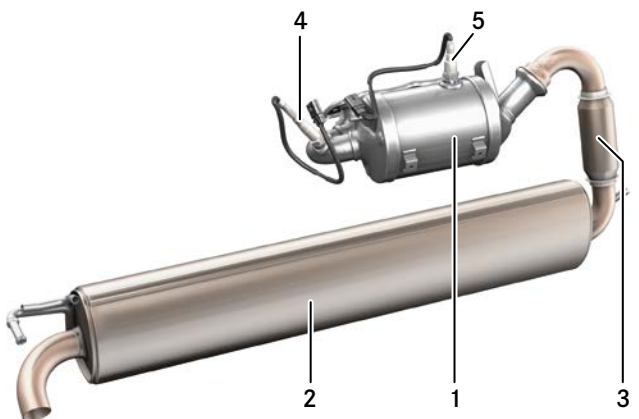

P49.10-3083-00

**Exhaust system of naturally aspirated engine**

- 1 Catalytic converter
- 2 Rear muffler
- 3 Decoupling element
- 4 Oxygen sensor upstream of catalytic converter
- 5 Oxygen sensor downstream of catalytic converter

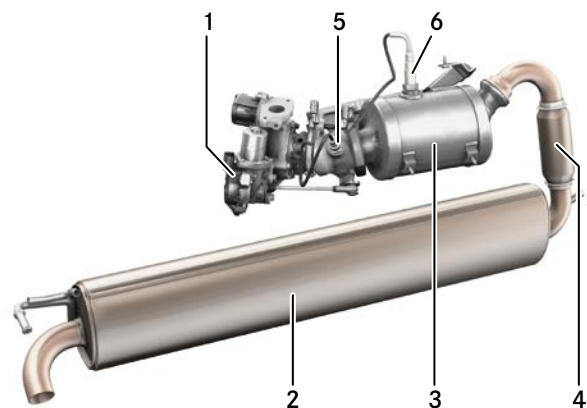

P49.10-3084-00

**Exhaust system of turbocharged engine**

- 1 Turbocharger
- 2 Rear muffler
- 3 Catalytic converter
- 4 Decoupling element
- 5 Oxygen sensor upstream of catalytic converter
- 6 Oxygen sensor downstream of catalytic converter



## Fuel system

### M281

A non-return fuel system is used for the fuel supply in model series 453.

The fuel is delivered to the engine by a vertical delivery module integrated in the fuel tank. On this system, the fuel pump supplies the required quantity of fuel at the required pressure (max. 5.2 bar) to the fuel injection system (fuel distribution rail).

The fuel tank fill level is measured by a float-and-lever sensor and evaluated and displayed on the instrument cluster.

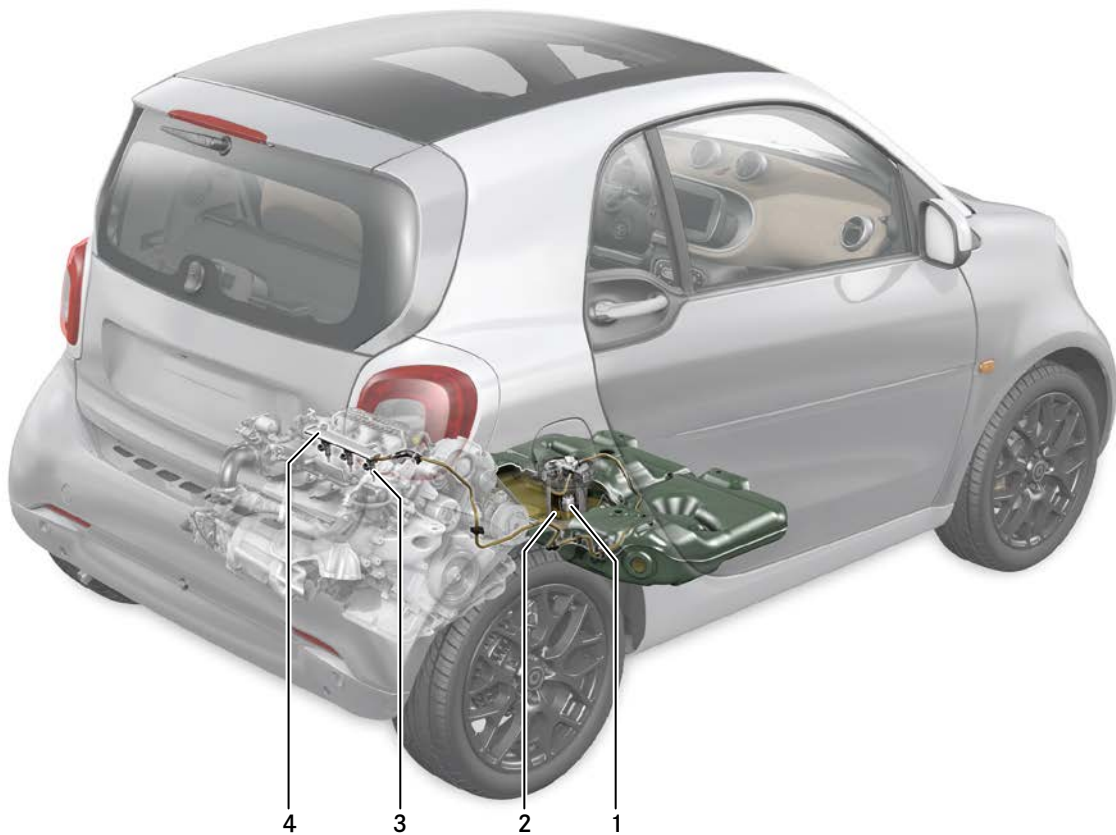

View of M281 fuel system (ECE/RoW)

- |  |                          |
|--|--------------------------|
| 1 Pump   | 3 Injection nozzle       |
| 2 Delivery module with integrated filter and fuel pressure regulator | 4 Fuel distribution rail |

P47.00-2240-00

### Fuel tank

The fuel tank is located in front of the rear axle viewed in the direction of travel.

The fuel tank is manufactured using a co-extrusion process and features six layers of high-density polyethylene (HDPE) with a block layer of ethylene vinyl alcohol copolymer (EVOH).

The filling capacity of the fuel tank is 28 liters, including a reserve of 5 liters. A tank with 35-liter capacity is available optionally.

The expansion volume is inside the fuel tank itself.

For permeation-related reasons, the US version of the tank features a stainless steel filler neck and the tank has a filling capacity of 33 liters.



View of gasoline engine fuel tank

P47.10-2765-00

## 5-speed manual transmission

### Brief description

The manual transmission of model 700.1 is a fully synchronized two-shaft transmission with five forward gears and one reverse gear.

The transmission housing of the manual transmission is made of a light alloy and the housing parts are sealed with liquid gasket.

The essential features of the manual transmission are:

- Gear request transmission via cables
- Hydraulically operated central clutch release bearing for clutch operation
- Double-cone synchronization for transferring high frictional forces during acceleration or braking of the control gears during gear changing
- Integrated pinion differential
- Contactless position determination of main shifter shaft
- Consumption and rpm-reducing fifth gear
- Rotation direction reversal without reversing gear

The 5-speed manual transmission is available for all engine power variants of the new smart.

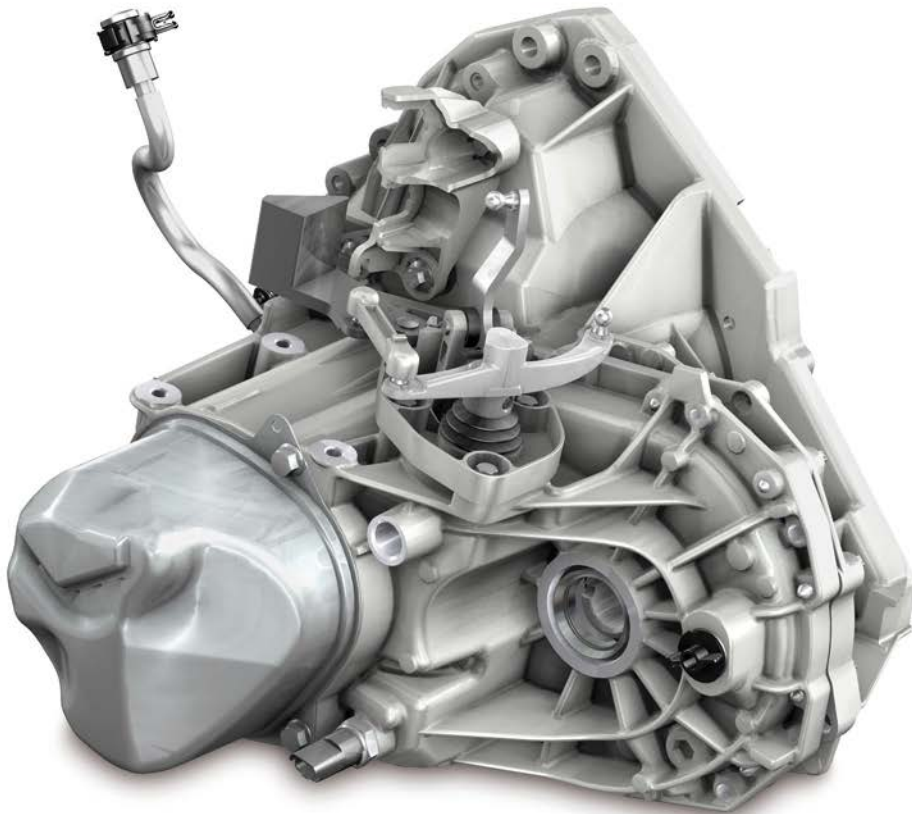

5-speed manual transmission

P26.00-2173-00

**Lubrication supply**

Lubricant supply for the manual transmission takes the form of centrifugal and immersion lubrication. Adequate supply of the rear gear sets and synchronizers with lubricating oil is achieved through a transmission oil ducting system. The differential runs in the oil sump.

**Shift mechanism**

The manual transmission of model 700.1 is characterized by a precise, smooth shift mechanism as well as short shift travel distances. Synchronization of the first and second gear is carried out by a double-cone synchronizer, while the third, fourth and fifth gear together with the reverse gear are synchronized by a single-cone synchronizer.

**Advantages**

The manual transmission has the following advantages:

- Compact design with low weight
- Low maintenance costs due to lifetime filling
- Precise and smooth gearshifting
- Low driving noise
- High reliability and long service life

**! Note**

For information about adjusting the cables and gearshift lever, see the Workshop Information System (WIS).

	Unit	M281 E10 R	M281 E10	M281 E09 LA
<b>Technical data</b>				
Transmission model		700.120 700.121	700.120 700.121	700.122 700.123
Number of gears (forward/ reverse)		5/1	5/1	5/1
Maximum transferable torque	Nm	160	160	160
Weight (without oil charge)	kg	34.4	34.4	34.4
Oil charge	l	2.6	2.6	2.6
Starting device		Hydraulically operated single-plate dry clutch		

## twinamic 6-speed dual clutch transmission

### Brief description

Model series 453 is available with the newly developed twinamic 6-speed dual clutch transmission.

This dual clutch transmission has a three-shaft design and consists of two sub-transmissions, each with its own clutch, with six forward gears and one reverse gear.

The dual clutch transmission provides sporty vehicle dynamics while also offering customers the convenience of an automatic transmission.

The most important features of the twinamic are:

- Dry, electromechanically operated dual clutch
- Integrated pinion differential
- Gear changing without power interruption
- "Shift by wire, park by cable"
- Steering wheel gearshift buttons for engaging the individual gears when "Manual" transmission mode is selected (SA)
- Transmission control unit integrated in the transmission housing

The twinamic is suitable for usage with the start/stop function.

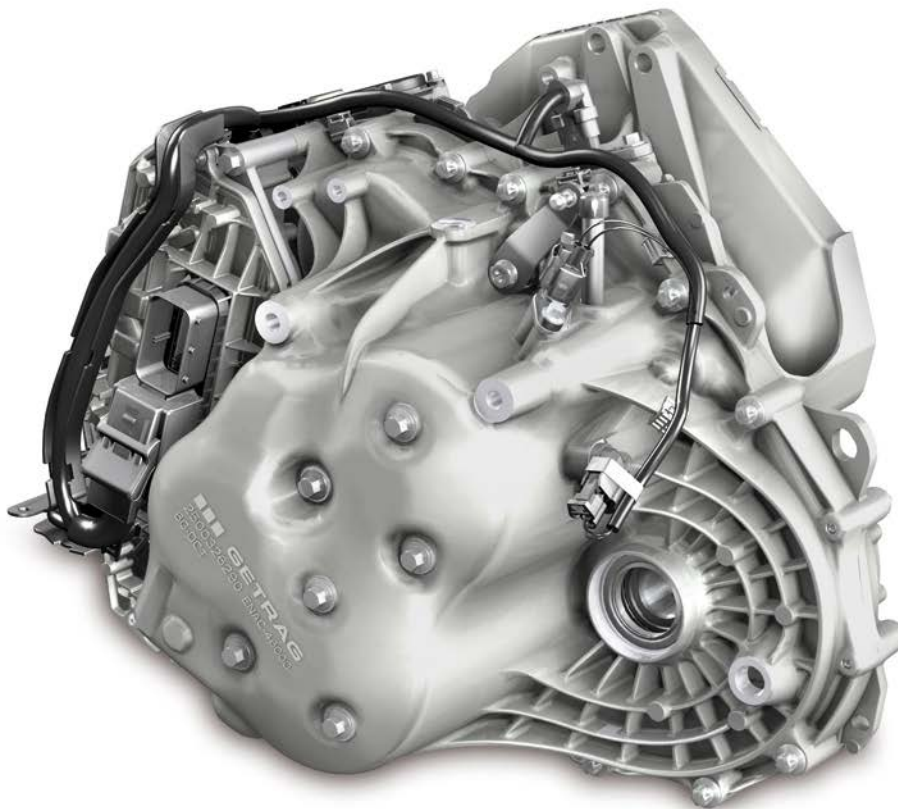

twinamic 6-speed dual clutch transmission

P27.00-2443-00

**Shift mechanism**

On the twinamic 6-speed dual clutch transmission, the engine torque is transferred from the crankshaft of the combustion engine to a two-mass flywheel. From there, the power flows to the internal shaft or external shaft of the dual clutch transmission depending on the clutch engaged. A single-cone carbon synchronizer is used to synchronize the first, third, fourth and reverse gear. A double-cone sintered synchronizer is used for the second gear. Synchronization of the fifth to the sixth gear is carried out with a single-cone sintered synchronizer. The transmission operates without an additional oil cooling system.

**Process**

During driving operation, a gear is always engaged in each of the two sub-transmissions. The gear which is expected to be engaged next is pre-engaged in the second sub-transmission by the transmission control system. The clutch for the gear currently in use is engaged, while that of the gear which is expected to be used is disengaged. To change gears, clutch 1 (currently engaged) is opened, while clutch 2 is engaged.

**Summary**

The dual clutch transmission operates without any interruption of tractive power. If necessary, the electronic control system skips individual gear ranges instead of downshifting the gears one after the other. It thus provides the convenience of an automatic transmission combined with the efficiency of a manual transmission.

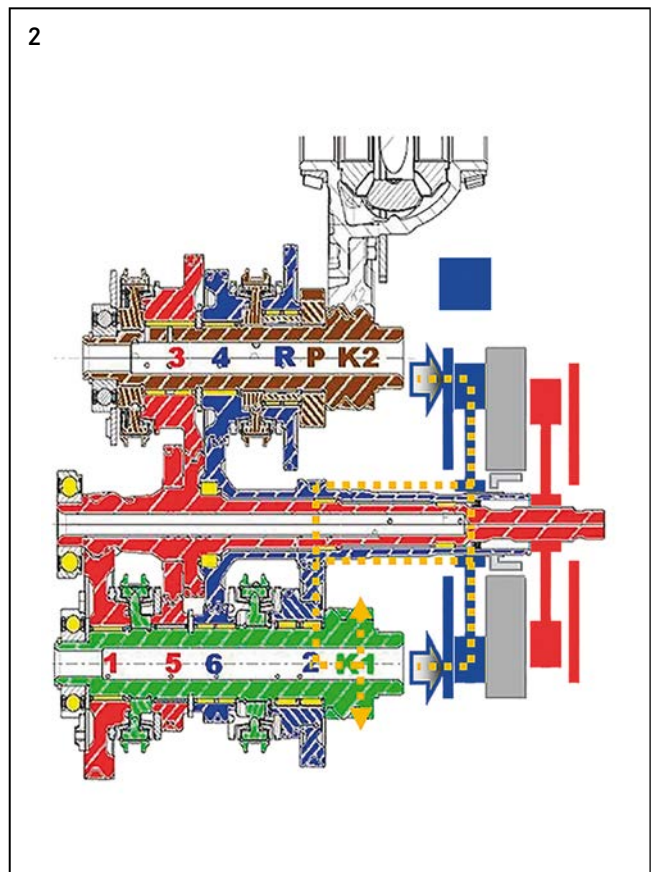
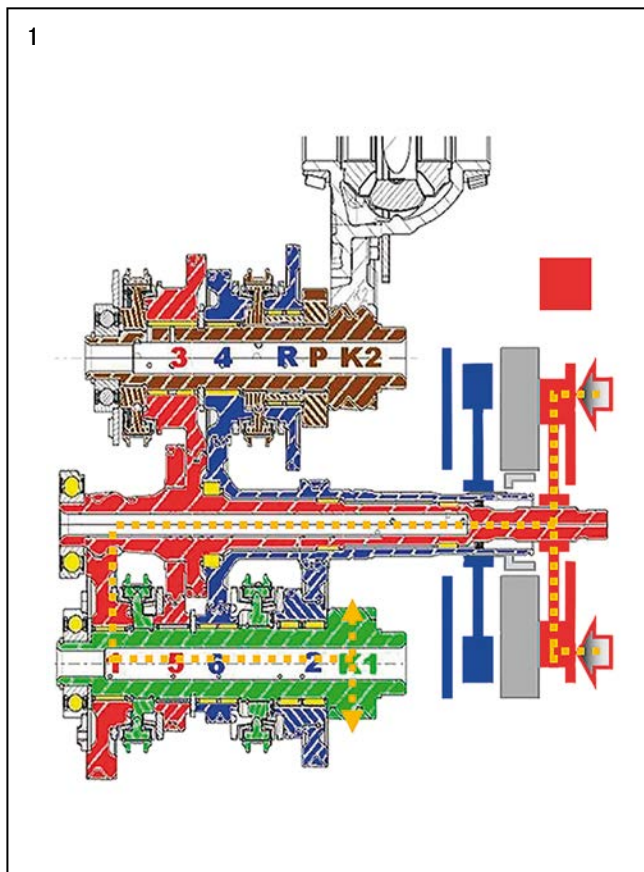

Shift mechanism of dual clutch transmission

- 1 1st gear
- 2 2nd gear

- Sub-transmission 1: 1st, 3rd, 5th gear
- Sub-transmission 2: 2nd, 4th, 6th, R gear

P27.00-2444-00

## twinamic 6-speed dual clutch transmission

	Unit	M281 E10	M281 E09 LA
<b>Technical data</b>			
Transmission model		700.410	700.411
Number of gears (forward/reverse)		6/1	6/1
Maximum transferable torque	Nm	150	150
Weight (without oil charge)	kg	65.65	65.65
Oil charge	l	1.7	1.7
	kg	1.45	1.45
Starting device		Dry dual clutch	

**Control options**

**Selector lever module**

Selector lever positions "P", "R", "N" and "D" can be selected by pressing the selector lever module in the center console forwards or pulling it backwards.

If the selector lever is pushed to the left in the "D" position, the transmission switches to "Manual" transmission mode. It is then possible to upshift and downshift in this position by pushing the selector lever forwards or pulling it backwards.

**Steering wheel gearshift**

In addition to operating the system using the selector lever, it is also possible to perform gear shifting via the steering wheel gearshift buttons on vehicles equipped with the "Multi-function sport steering wheel with shift paddles".

**Transmission modes**

It is possible to select two different transmission modes using the Economy mode switch:

- Economy "E" transmission mode: The "Economy" transmission mode is designed for optimal fuel consumption. It is characterized by early upshifting and a low rpm level.
- Standard "S" transmission mode: The "Standard" transmission mode is designed for active driving. It is characterized by its readiness to downshift and a higher rpm level.

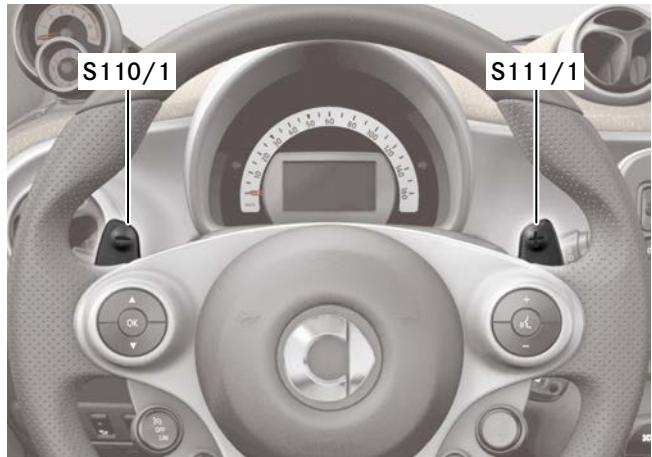

P46.10-3452-00

**View of steering wheel gearshift buttons**

- S110/1 Steering wheel downshift button
- S111/1 Steering wheel upshift button



P27.60-3825-00

**Economy mode switch**

- S6/10 Economy mode switch



P27.60-3826-00

**View of dual clutch**



## Axes and suspension

### Front axle

As in the predecessor model, the front axle of the new smart is a classic MacPherson strut design.

The main advantages of this front axle design include:

- Small space requirement
- Low unsprung masses
- Large support base
- Low forces

Wheel control on each wheel is performed by a transverse control arm below wheel center, a suspension strut and a tie rod.

The focus during the redevelopment of the front axle of model series 453 was on achieving a high level of driving safety, a high level of manoeuvrability and improved ride comfort compared to the predecessor model series. A high level of driving safety was achieved through the design of the axle kinematics and by adjusting the tuning. To improve the ride comfort, the spring travel both at the front axle and at the rear axle was increased. The newly developed front axle is now equipped with a transverse control arm with one guide bearing and one comfort bearing respectively, which produces greater longitudinal flexibility and improved suspension response. In order to achieve the desired reduction in the turning circle, the front axle was designed to allow very large outside wheel turn angles. This necessitated a suitable integral carrier design, long toothed rack travel distances and suitable tie rod kinematics.

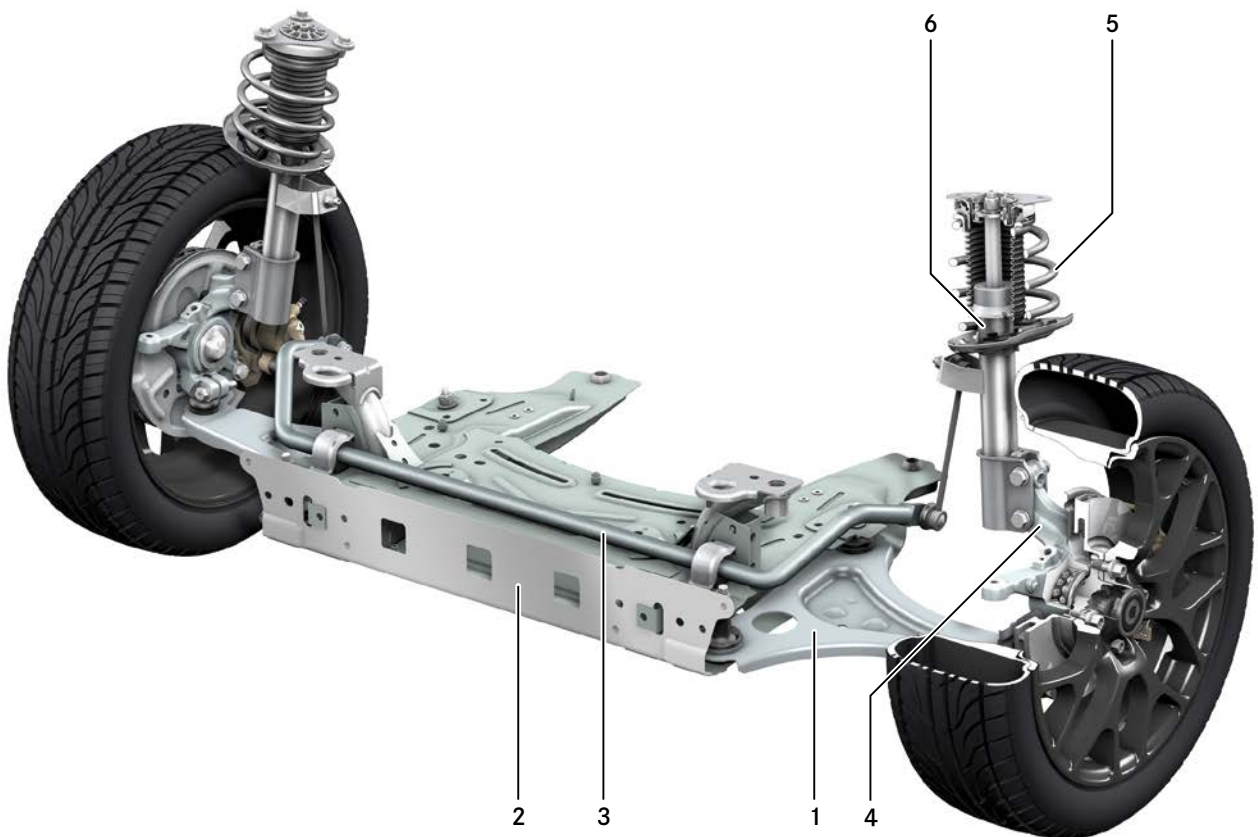

### Front axle of smart model 453

- |   |  |   |                                     |
|---|--|---|-------------------------------------|
| 1 | Transverse control arm with supporting joint | 4 | Wheel carrier                       |
| 2 | Integral carrier                             | 5 | Coil spring (side load spring)      |
| 3 | Stabilizer bar                               | 6 | Twin-tube gas-filled shock absorber |

P33.00-2144-00

The front axle integral carrier is larger compared to that of the predecessor model series and, with its extended support base, not only holds the guide and comfort bearings of the transverse control arm, but also the steering. It also serves as the crash element for the third (lower) plane. The component is designed on a load-dependent basis.

### Rear axle

Like model series 451, model series 453 is equipped with a De Dion rear axle directly mounted to the bodyshell with lateral support from cross struts.

The use of this axle design made it possible to develop a rear axle with competitive features in spite of the relative lack of available space due to the rear-mounted engine.

The rear axle carrier taken over from the predecessor model series was integrated into the bodyshell for weight-optimization reasons. The De Dion rear axle of the new smart is thus mounted directly on the body.

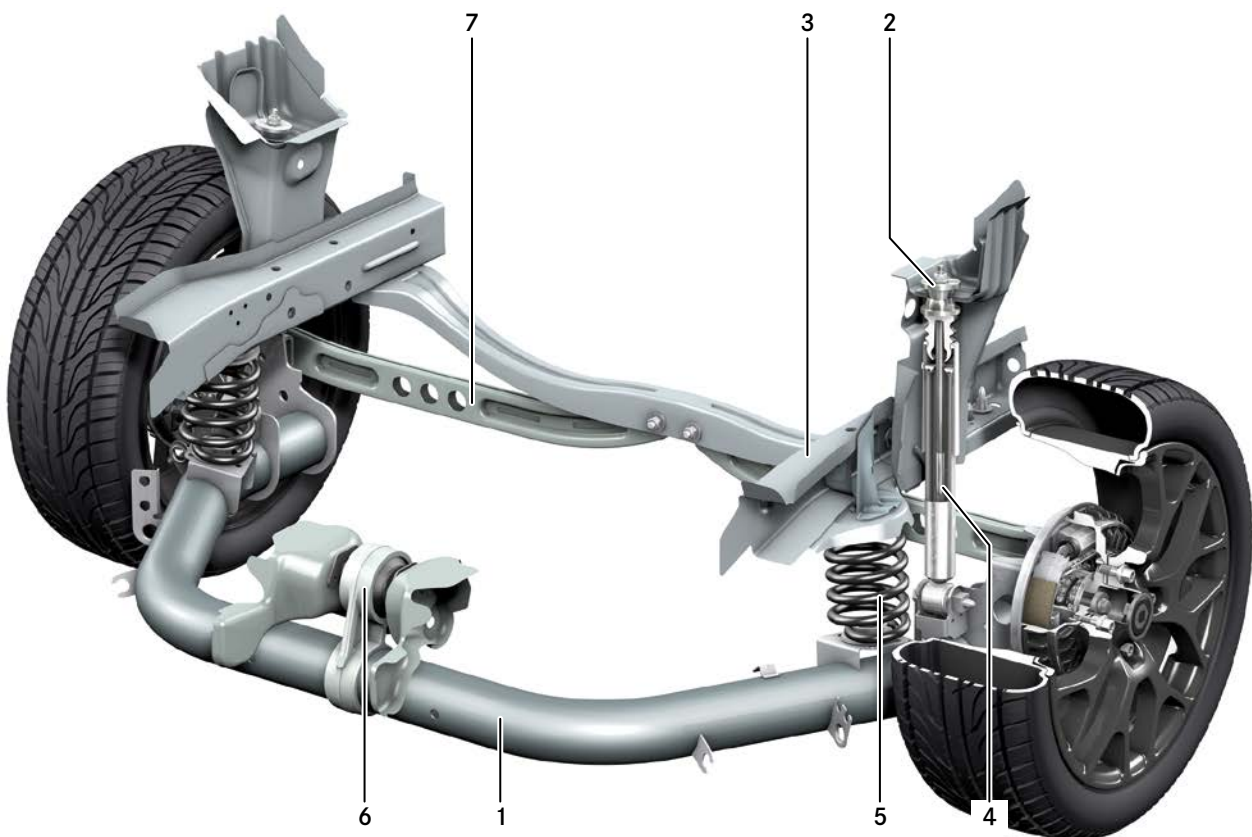

### Rear axle of smart model 453

- |  |                  |
|--|------------------|
| 1 Axle tube                                      | 5 Coil spring    |
| 2 Twin-tube shock absorber pin bearing           | 6 Center bearing |
| 3 Rear longitudinal member (bodyshell structure) | 7 Bar link       |
| 4 Twin-tube damper                               |                  |

P35.00-2122-00

## Axles and suspension

### Suspension and damping

The suspension of the new smart consists of twin-tube MacPherson suspension struts on the front axle and twin-tube shock absorbers with separate springs on the rear axle.

### Front axle suspension

The front axle consists of MacPherson suspension struts for wheel control, consisting of coil springs optimized for transverse forces, auxiliary springs, twin-tube gas-filled shock absorbers and compact support bushings. The support bushing has a three-path design i.e. force application by the shock absorber, spring and auxiliary spring are decoupled from each other. The shock absorber is supported by the inner elastomer bearing, which is optimally tuned to the response characteristics of the shock absorber.

The comfort-enhancing polyurethane auxiliary spring features a progressive characteristic and is supported against the body through the bearing housing. The force from the coil spring is transferred through the ball bearing to the body.

Noise insulation is achieved by means of a bottom spring mount made of elastomer. In order to reduce friction in the seal guide unit of the shock absorber, the coil springs are geometrically designed as "side load springs", which compensate for the effect of the vertical wheel force on the transverse force in the seal guide unit. This produces optimized shock absorber response characteristics.

The suspension strut features a clamping bracket for assembly-related reasons, a large spring retainer with spring catching function and a weight-reduced hollow piston rod.

The torsion bar also has a tubular design for weight-related reasons, with torsion bar mounts vulcanized onto it.



View of support bushing

P32.00-2076-00

### Rear axle suspension

A new feature of the De Dion rear axle are the twin-tube shock absorbers with separate, barrel-shaped coil springs. Effective noise insulation of the coil springs between the body and rear axle is achieved by means of two elastomer shims.

The shock absorber is connected to the body by a pin bearing. This has a soft cardan bearing which contributes to a reduction of friction in the shock absorber and thus an improvement in response characteristics. The location and ratio of the shock absorbers provides suspension tuning with a favorable compromise between damping of roll and pitch. In addition, the deliberate inclination of the shock absorbers produces longitudinal damping of the axle.

### Suspension variants

A standard and a sports suspension are available for the new smart.

On the standard suspension, longer spring travel distances, a friction-optimized supporting length and precise lateral force compensation create the prerequisites for comfortable suspension behavior.

The sports suspension available as special equipment features tighter front and rear axle springs and the vehicle level is lowered by 10 mm at the front and rear axle compared to the standard suspension.



P32.00-2077-00

Sectional view of rear axle damping/springing

## Steering

### Steering

The new smart is equipped with a mechanical rack-and-pinion steering gear as standard, which is located in front of the wheel center position. An electric steering assist system with variable steering assistance is available optionally. The newly developed electric steering assist system of model series 453 is designed as a direct steering system with variable gearing. For minor steering movements, the steering has a more indirect design which improves straight-ahead running. In the medium steering angle range encountered during normal urban driving, the steering ratio increases and the customer has to move the steering wheel through a reduced angle e.g. when turning or maneuvering.

The electric steering power assistance system consists of the rack-and-pinion steering gear, torque sensor, actuator motor and control unit.

Compared to a conventional hydraulic solution, electric steering force assistance offers the following advantages:

- No hydraulic fluid necessary
- Fuel saving due to greater efficiency
- Improved steering feel
- Optimized assembly process
- Active return improves steering centering
- Diagnosis capability

#### ! Repair information

When removing/installing the steering gear, all the fasteners (bolts, nuts and triangular brackets) must be renewed. A parts kit for this is available in the EPC.

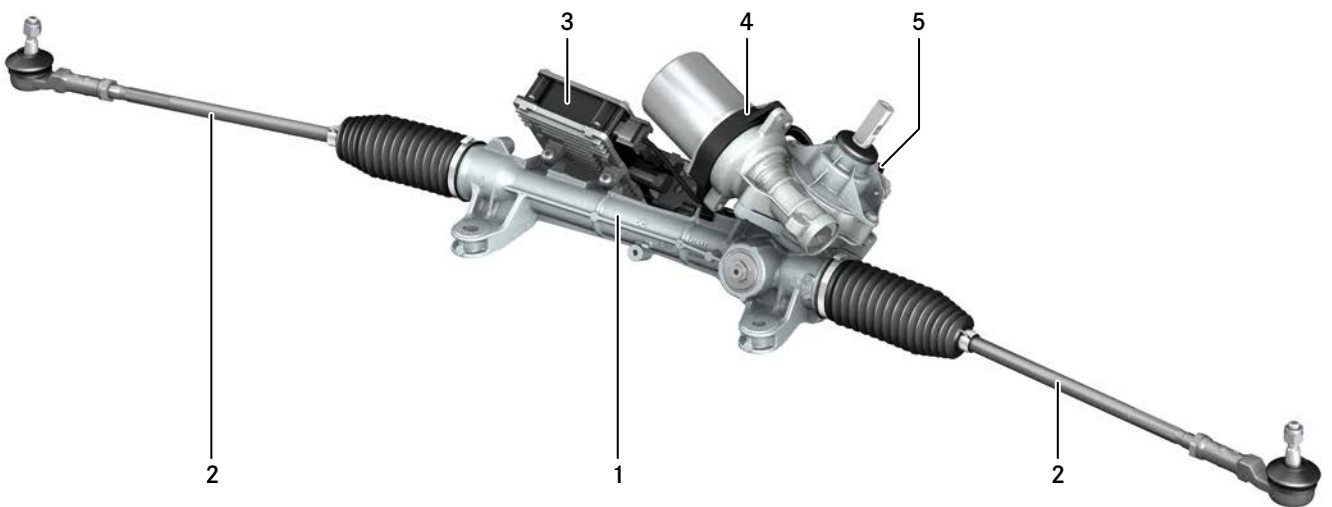

P46.35-2121-00

#### Electric power steering of model 453

- |   |  |   |  |
|---|--|---|--|
| 1 | Rack-and-pinion steering gear                | 4 | Electric power steering actuator motor |
| 2 | Tie rod                                      | 5 | Electric power steering torque sensor  |
| 3 | Electrical power steering control unit (N68) |   |  |

**Brake system**

The brake system of model series 453 is designed as a hydraulic dual-circuit brake system with diagonal split.

The brake control system of the brake system comprises the familiar functions of ABS, ESP®, ASR, BAS, GMR and Hill-Start Assist. The Crosswind Assist function is a new feature in this segment.

**Parking brake with manual operation**

As on the predecessor model series, the new smart uses a lever-type handbrake which acts on the drum brakes of the rear axle.

Cable slack adjustment can be carried out manually on model series 453 under the handbrake lever trim.

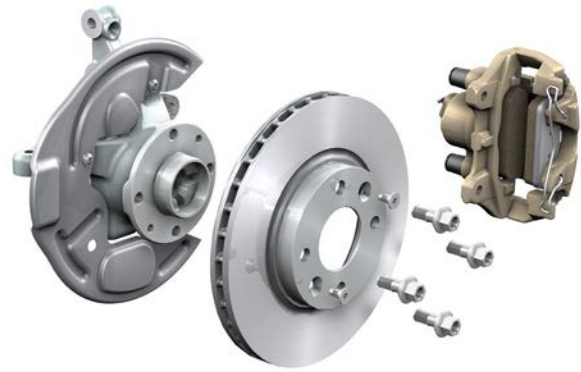

View of front brake system (internally ventilated)

P42.00-2194-00



View of rear brake system

P42.00-2195-00



View of brake control system

P42.00-2196-00

## Brake system

Brake system	Unit	C453	W453
<b>Front brake system</b>			
Type of brake		Disk brake, 1-piston fixed caliper	
Brake disk		Solid (naturally aspirated engine) Internally ventilated (turbocharged engine)	Internally ventilated
Piston diameter	mm	48	48
Brake disk diameter	mm	259	258
Brake disk thickness	mm	12	22
Pad area	cm <sup>2</sup>	2312 (ECE) 2326 (US)	2312 (ECE) 2326 (US)
<b>Rear brake system</b>			
Type of brake		Drum brake, 1-piston simplex	
Drum diameter	mm	20.64	22
Piston diameter	mm	21.2	21.2
Drum width	mm	37	40

	Front wheel	Front tire	Rear wheel	Rear tire
<b>Steel wheels</b>				
Code R82	5J x 15 ET 32	165/65 R 15	5.5J x 15 ET 42	185/60 R 15
Code R83	5J x 15 ET 32	165/65 R 15	5.5J x 15 ET 42	185/60 R 15
<b>Light alloy wheels</b>				
Code R88	5J x 15 ET 32	165/65 R 15	5.5J x 15 ET 42	185/60 R 15
Code R86	5J x 15 ET 32	165/65 R 15	5.5J x 15 ET 42	185/60 R 15
Code R87	5J x 15 ET 32	165/65 R 15	5.5J x 15 ET 42	185/60 R 15
Code R95	6J x 16 ET 44	185/50 R 16	6.5J x 16 ET 40	205/45 R 16
Code R91	6J x 16 ET 44	185/50 R 16	6.5J x 16 ET 40	205/45 R 16



P40.10-6732-00

Steel wheel (code R82)



P40.10-6733-00

Steel wheel (code R83)



P40.10-6734-00

Light alloy wheel (code R88)



P40.10-6735-00

Light alloy wheel (code R86)



## Wheels and tires



Light alloy wheel (code R87)

P40.10-6736-00



Light alloy wheel (code R95)

P40.10-6737-00



Light alloy wheel (code R91)

P40.10-6738-00

P00.19-5552-00

Overall network of model series C453

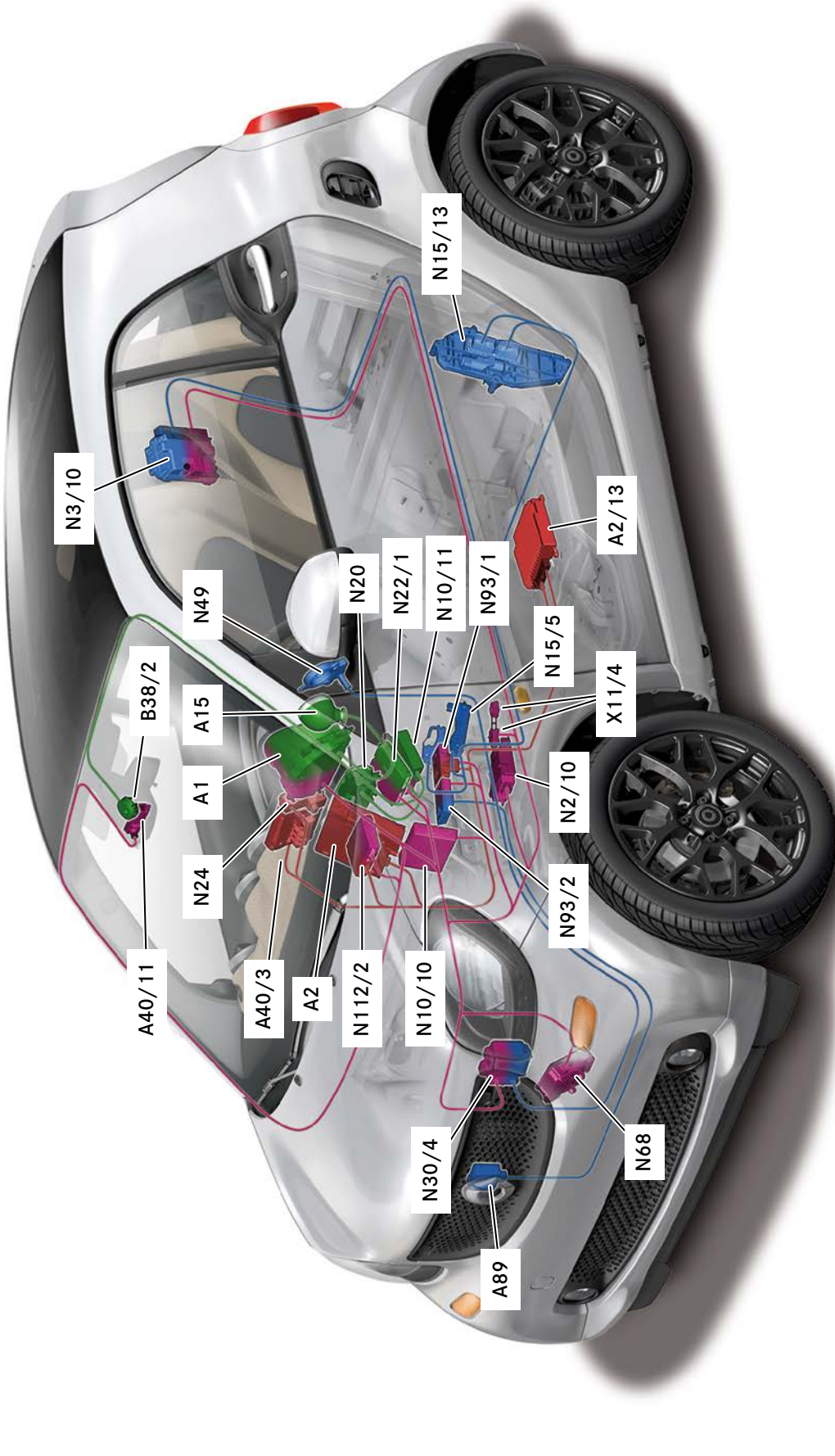

- Telematics CAN
- Interior CAN
- Drive train CAN

- Chassis CAN
- Front end CAN
- LIN bus

## Overall network

**Telematics CAN**

A2	Radio
A2/13	Sound system amplifier control unit
A40/3	smart Radio Multimedia Navigator
A40/3s1	ON/OFF button
A40/3s2	Home button
A40/3s3	Mute function and menu scroll button
N24	Multimedia operating unit
N93/1	Audio gateway control unit
N112/2	Telematics services communications module

**Interior CAN**

A1	Instrument cluster
A2	Radio (only valid without multifunction steering wheel and without sound amplifier)
A40/11	Multifunction camera
N2/10	Supplemental restraint system control unit
N3/10	ME-SFI [ME] control unit (M281)
N10/10	Center SAM control unit
N10/11	Driver-side SAM control unit
N22/1	Climate control control unit
N30/4	Electronic Stability Program control unit
N68	Electric power steering control unit
N93/1	Audio gateway control unit
N93/2	Distance function gateway
N112/2	Telematics services communications module
X11/4	Diagnostic connector

**Drive train CAN**

N3/10	ME-SFI [ME] control unit (M281)
N15/5	Electronic selector lever module control unit
N15/13	Dual clutch transmission control unit

**Front end CAN**

A89	Controller unit for distance warning function with radar sensor
N93/2	Distance warning function gateway

**Rain and light sensor LIN**

B38/2	Rain/light sensor
N10/11	Driver-side SAM control unit

**Chassis CAN**

N30/4	Electronic Stability Program control unit
N49	Steering wheel angle sensor

**AC operation LIN**

N20	Climate control operating unit
N22/1	Climate control control unit

**Additional instruments LIN**

A1	Instrument cluster
A15	Additional instruments

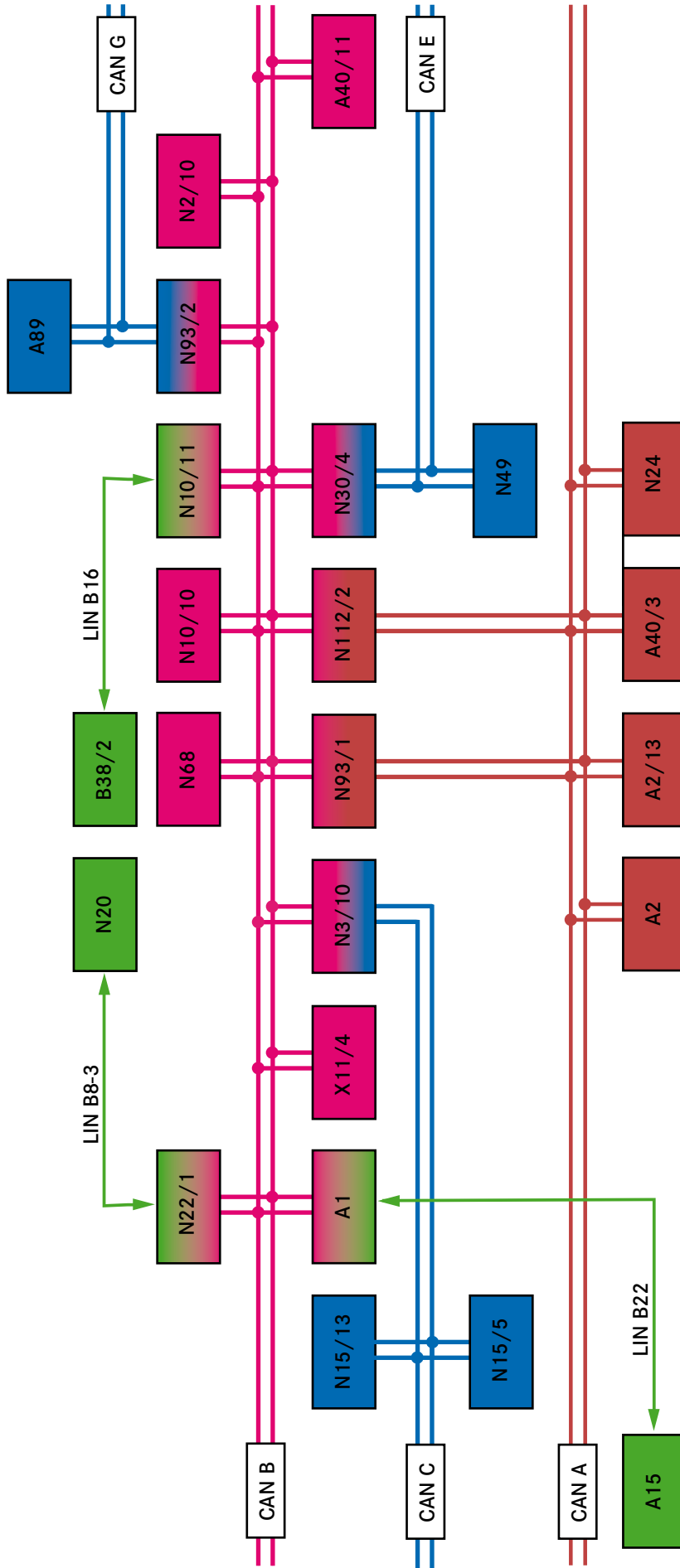

P00.19-5553-00

## Overall network

**Telematics CAN**

A2	Radio
A2/13	Sound system amplifier control unit
A40/3	smart Radio Multimedia Navigator
A40/3s1	ON/OFF button
A40/3s2	Home button
A40/3s3	Mute function and menu scroll button
N24	Multimedia operating unit
N93/1	Audio gateway control unit
N112/2	Telematics services communications module

**Interior CAN**

A1	Instrument cluster
A2	Radio (only valid without multifunction steering wheel and without sound amplifier)
A40/11	Multifunction camera
N2/10	Supplemental restraint system control unit
N3/10	ME-SFI [ME] control unit (M281)
N10/10	Center SAM control unit
N10/11	Driver-side SAM control unit
N22/1	Climate control control unit
N30/4	Electronic Stability Program control unit
N68	Electric power steering control unit
N93/1	Audio gateway control unit
N93/2	Distance function gateway
N112/2	Telematics services communications module
X11/4	Diagnostic connector

**Drive train CAN**

N3/10	ME-SFI [ME] control unit (M281)
N15/5	Electronic selector lever module control unit
N15/13	Dual clutch transmission control unit

**Front end CAN**

A89	Controller unit for distance warning function with radar sensor
N93/2	Distance warning function gateway

**Rain and light sensor LIN**

B38/2	Rain/light sensor
N10/11	Driver-side SAM control unit

**Chassis CAN**

N30/4	Electronic Stability Program control unit
N49	Steering wheel angle sensor

**AC operation LIN**

N20	Climate control operating unit
N22/1	Climate control control unit

**Additional instruments LIN**

A1	Instrument cluster
A15	Additional instruments

### Overview

Along with increasing requirements, e.g. in the areas of communication, diagnosis or vehicle safety, the data volume which is exchanged between control units has also increased proportionally.

However, finite installation space and efforts to lower vehicle weight make conventional data transmission methods impossible.

This is why the use of bus systems is required.

In the new smart, the vehicle electronics are networked via the following data bus systems:

- Telematics CAN
- Interior CAN
- Drive train CAN
- Chassis CAN
- Front end CAN
- AC operation LIN
- Rain and light sensor LIN
- Additional instruments LIN

The data transfer rate of the CAN bus systems in the new smart is 500 kBd.

### Gateway

Control units with gateway function are linked with two or more data bus systems. This means that they can send and receive signals to and from several bus systems.

Control units with gateway function:

- ME-SFI control unit
- Audio gateway control unit
- Electronic Stability Program control unit
- Telematics services communications module
- Distance warning function gateway

### Fuses

The maxi and ATO fuses that are accessible for the customer are located in the following positions in the vehicle:

- Fuse box in front compartment under service flap
- Fuse box in glove compartment

### On-board electrical system battery

The 12 V on-board electrical system battery of size H5 is located in front of the passenger compartment under the front hood on all models.

#### **Note**

The procedures for disconnecting the battery are documented in the Workshop Information System (WIS).



Front compartment fuse box

P54.15-3733-00



Fuse box in glove compartment

P54.15-3734-00

## Automatic start/stop

### Automatic start/stop

In order to reduce the fuel consumption and exhaust emissions of the vehicle, the new smart is equipped with an automatic start/stop function as standard (does not apply to 45 kW version).

The automatic start/stop function shuts off the engine automatically when the vehicle stops if the relevant conditions are fulfilled. The engine then restarts automatically to drive off again.

The driver-side SAM control unit acts as the master control unit for the automatic start/stop function. It prompts the ME-SFI [ME] control unit to stop or start the engine depending on incoming sensor data and the data which it receives from the center SAM control unit, Electronic Stability Program control unit, climate control control unit and Supplemental Restraint System control unit. The output device for start/stop system messages is the instrument cluster.

### Conditions for automatic engine stop

For the automatic start/stop function to automatically shut off the engine, the driver must brake the vehicle to a standstill, put the vehicle into neutral and release the clutch pedal or select gear range N. If the following conditions are also met, the engine is shut off and the ECO start/stop function "available" indicator lamp lights up on the instrument cluster:

- Engine is at operating temperature
- Driver door is closed and driver seat belt is fastened
- Battery is sufficiently charged
- Temperature in vehicle interior corresponds to setting
- Outside temperature is within a suitable range for the system
- Automatic start/stop indicator lamp is not on
- Liftgate is closed

### Conditions for automatic engine start

The engine is started automatically when

- The driver depresses the clutch pedal
- The automatic start/stop function is switched off via the automatic start/stop button
- The temperature in the vehicle interior is no longer within the set range

If all of the conditions for an automatic engine start are not fulfilled, the ECO start/stop function "not available" indicator lamp lights up.

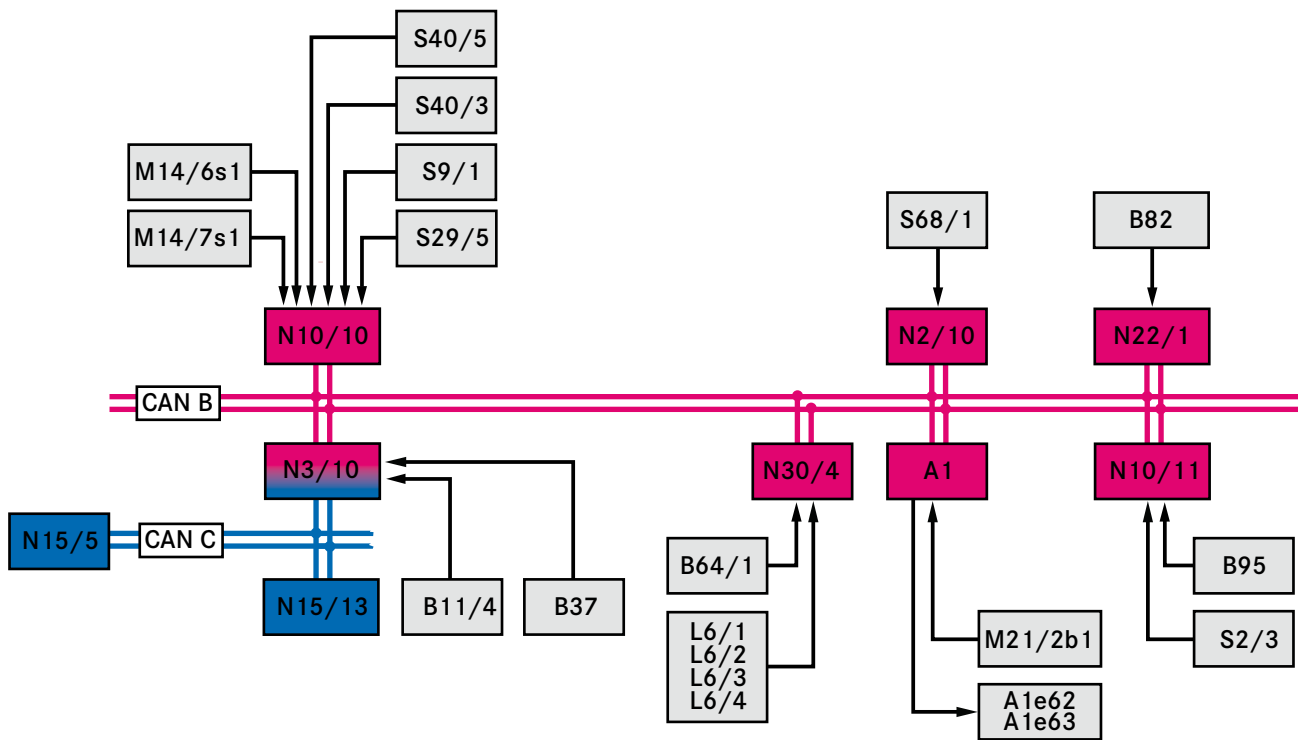

P15.00-2206-00

**Block diagram of automatic start/stop function**

A1	Instrument cluster	N2/10	Supplemental restraint system control unit
A1e62	ECO start/stop function "not available" indicator lamp	N3/10	ME-SFI [ME] control unit
A1e63	ECO start/stop function "available" indicator lamp	N10/10	Center SAM control unit
B11/4	Coolant temperature sensor	N10/11	Driver-side SAM control unit
B37	Accelerator pedal sensor	N15/5	Electronic selector lever module control unit
B64/1	Brake vacuum sensor	N22/1	Climate control control unit
B82	Vehicle interior humidity and temperature sensor	N30/4	Electronic Stability Program control unit
B95	Battery sensor	S2/3	Start/stop button
L6/1	Left front axle rpm sensor	S9/1	Brake light switch
L6/2	Right front axle rpm sensor	S29/5	Backup light activation/idle recognition switch
L6/3	Left rear axle rpm sensor	S40/3	Clutch pedal switch
L6/4	Right rear axle rpm sensor	S40/5	Start enable clutch pedal switch
M14/6s1	Driver door central locking microswitch	S68/1	Left front seat belt buckle switch
M14/7s1	Liftgate central locking microswitch	CAN B	Interior CAN
M21/2b1	Outside temperature sensor	CAN C	Drive train CAN



## Exterior lights

### Headlamps

The new smart is equipped with H4 halogen headlamps as standard. The main headlamp is divided into two segments. The high and low beam are positioned centrally, with the daytime running light function underneath. The turn signal indicators are arranged separately outside of the main headlamp, while the optional front fog lamps are housed in the bumper.

A halogen headlamp, which differs from the basic headlamp due to a different daytime running light design, is available as special equipment in combination with certain equipment packages.

This is a particularly eye-catching feature because a honeycomb structure in the headlamp is projected using white LEDs when the vehicle is opened and closed.

The high beam and low beam functions are still positioned centrally. The turn signal indicators and front fog lamps are also in the same position as on the basic version.

### Headlamp range adjustment

The new smart is equipped with manually-operated electric headlamp range adjustment. The headlamps are adjusted using a selector wheel on the left of the instrument panel next to the steering wheel.

### Front fog lamps

The optional front fog lamps are located in the bumper under the headlamps.



Front lamp unit (standard)

P82.10-7637-00



Front lamp unit (SA)

P82.10-7638-00



Front lights

P00.10-5670-00

### Rear lamps

On the basic version, the dual color (red/white) rear lamps of the new smart feature conventional bulb technology. The outer red circular segment performs the taillight and brake light function (top) and the rear fog lamp function (bottom). The inner white segment houses the turn signal indicator on the outside and the reversing lamp on the inside. The reflectors are positioned outside the rear lamp in the bumper.

In combination with the optional headlamps, the rear lamps are partially equipped with LED technology. Specifically, the taillights, brake lights and rear fog lamp use LED technology. The arrangement of the light functions in the outer circular segment is also different, as the LEDs are distributed all the way around. The positions of the turn signal indicators and reversing lamps remain unchanged, while the reflectors are also still outside the rear lamps in the bumper.

### Center high-mounted stop lamp

The center high-mounted brake lamp is equipped with LEDs and is located in the roof spoiler.



P82.10-7639-00

Rear lamp (standard)



P82.10-7640-00

Rear lamp (SA)



P00.10-5671-00

Rear lights

## Interior illumination

### General

For the purpose of interior illumination, the new smart is equipped with a front dome lamp, a rear dome lamp (W453 only), switch and controls illumination/symbol illumination for the control buttons and instrument illumination.

Customers can choose to add a load compartment lamp through the equipment lines.

There are several operating and function options for activating the interior lights.

Activation options:

- Press the switch on the front dome lamp or rear dome lamp
- Open the vehicle doors
- Open the liftgate
- Lock or unlock the vehicle via the central locking

### Ambiance illumination

Also available as special equipment is indirect illumination of the vehicle interior, in the form of ambiance illumination.

The ambiance illumination includes:

- Left/right cockpit ambiance illumination
- Center cockpit ambiance illumination
- Left/right front door ambiance illumination
- Left/right footwell lamp
- Glove compartment lamp



Ambiance illumination

P82.20-4345-00

In the new smart (C/W453), improved driving and stress-reducing safety is achieved above all by the following systems:

- ABS, BAS, ESP® with Hill-Start Assist (standard)
- Crosswind Assist (standard)
- Flashing adaptive brake lights (standard)
- Cruise control with variable speed limiter (standard)
- Tire pressure monitor (standard)
- Reversing camera (SA)
- Rear parking assist (SA)
- Lane Keeping Assist (SA)

The distance warning function driver assistance system (SA) forms part of the safety concept which acts preventively when the system registers signs of danger.

#### **Protective measures for pedestrians**

Reducing the severity of accidents is particularly important for collisions with weaker road users without crumple zones e.g. pedestrians. In addition to the active measures which help to avoid accidents or minimize the severity of accidents, the passive pedestrian protection measures on the new smart have also been further optimized. For example, to reduce the loads that occur during an impact on the front hood of the vehicle, the deformation clearances between the front hood and the components underneath have been optimized. The deformation properties of the front hood were developed specifically to meet these requirements. The design of the front of the vehicle has produced a more favorable, larger impact area. In combination with the structural design of the front bumper, this reduces the stress applied if the vehicle collides with the legs of a pedestrian.

## Active/passive safety

### Restraint systems

Particularly effective protection is achieved through the interaction of the body, seat belts, airbag systems and sensors. The forward displacement areas for the occupants are designed so that there is a suitable deceleration travel distance for the occupants in the event of a collision in order to keep accident stresses as low as possible.

### Seat belts

The driver and front passenger seats are each equipped with a three-point seat belt with belt force limitation and pyrotechnical emergency tensioning retractor as standard. On the sedan, the outer rear seats are equipped with a three-point seat belt with seat belt retractor with tensioning and belt force limitation. The center seat has a three-point seat belt of standard design.

In the USA and Canada, the C453 is additionally equipped with anchor fitting tensioners and two-stage, switchable belt force limiters for the driver and front passenger.

### Child restraint systems

The ISOFIX system incl. Top Tether connection, which allows certain child seats to be connected to the vehicle, is provided as standard equipment on the front passenger seat and, on the sedan, on the rear seats.

### Driver/front passenger airbag, kneebag

The smart is equipped with a driver airbag, driving kneebag and front passenger airbag as standard. The gas generators for the driver airbag and front passenger airbag operate on a single-stage basis. The kneebag has a positive influence on occupant kinematics in the event of a frontal impact and thus offers the driver additional protection potential in many frontal impact situations.

In the USA and Canada national versions of the smart fortwo coupé, two-stage driver and front passenger airbags are used.

The front passenger airbag is equipped with an additional third pyrotechnical unit in order to adjust the hardness of the airbag to the particular load case and occupant. A front passenger kneebag is also installed in these national versions.

### Sidebags

The sidebags (head/thorax bags) are standard equipment and are located in the backrest of the driver and front passenger seat. They cover the head and chest of the respective occupants from the side. When triggered in side collisions, they can minimize the loads applied to the chest area and reduce the risk of the occupant's head directly hitting the side window or dangerous objects e.g. power poles, trees or parts of a colliding vehicle.

The sidebags are triggered on the impact side if the central electronic unit detects a side crash of a certain severity level. Furthermore, emergency tensioning retractors are triggered on both the impact side and the opposite side (depending on the seat belt status on the USA national version). A reel tensioner and anchor fitting tensioner on the impact side and the opposite side are additionally triggered on the USA national version.

On the USA and Canada national versions of the smart fortwo coupé, thorax/pelvis airbags and window airbags are used instead of the head/thorax airbags (same integration, different protection area). The window airbags cover the whole area between the A and B-pillar at the sides.

### Restraint system control unit

The smart is equipped with an electronic control unit which triggers restraint systems depending on the expected impact severity. On the USA and Canada national versions, two up-front sensors are installed additionally on the flexural member at the front end.

In order to better detect side impacts, the central crash sensor is supported by satellite sensors in the area of the B-pillar base and by pressure sensors in the front doors.

Depending on the seat occupancy detection status and seat position detected via the seat position switch, the seat occupied recognition system can suppress or adjust airbag triggering on the passenger side on the USA and Canada national versions. Seat position switches control the switchable belt force limiters and activation of the ventilation valve by a squib in the front passenger airbag.

A seat belt buckle switch monitors the belt status at each position: "engaged" or "not engaged". A visual/acoustic seat belt reminder warning function is provided for the two front seats depending on the country. The indicator lamp is located in the instrument cluster. The front passenger seat has a seat belt reminder mat. The indicator lamp for the rear seats is located in the overhead control panel.



Airbag system (full equipment)

P91.60-4767-00

## Systems at a glance

### General

The new smart (C/W453) makes use of driver assistance systems which help the driver to drive safely, reduce the stress on the driver and increase driving comfort.

Several of these systems are not available individually, but only in combination with or as a component of various equipment packages.

### Assistance systems at a glance

- Cruise control with variable speed limiter
- Distance warning function
- Lane Keeping Assist
- Rear parking assist
- Reversing camera
- Tire pressure monitor
- Crosswind Assist

**Cruise control with variable speed limiter**

smart model series 453 is equipped with a cruise control function which maintains a preset speed and an additional variable speed limiter function which helps the driver to avoid exceeding a speed. The variable speed limiter function can be adjusted via the multifunction steering wheel. The cruise control with variable speed limiter is standard equipment on all vehicles irrespective of the engine/transmission combination.

Excepted from this are the USA and Canada national versions, on which the cruise control function is only available without variable speed limiter function.

**Crosswind Assist**

The new smart is equipped with the Crosswind Assist function as standard. This system helps the driver by significantly weakening any influence on the straightahead running of the vehicle caused by strong crosswind. The vehicle's deviation from its intended path and the steering effort required by the driver are significantly reduced in this situation. The existing sensors of the ESP® system are used to detect interference from crosswind. Crosswind Assist is active as of 70 km/h and takes effect when driving straight ahead or during light cornering. Crosswind interference is compensated for by a single-sided brake system intervention initiated by the ESP® system.

The customer benefit of Crosswind Assist is that the vehicle's deviation from its intended path and yaw response in heavy crosswind are reduced and the driver has to countersteer less.



## Lane Keeping Assist

### Lane Keeping Assist

The Lane Keeping Assist (LDW) system uses a camera in the area of the inside rearview mirror to detect when the vehicle crosses lane markings and warns the driver when the vehicle unintentionally leaves the detected lane. The warning takes the form of an acoustic warning and visual feedback (tell-tale) on the instrument cluster. Lane Keeping Assist (LDW) is active at vehicle speeds as of 70 km/h.

The Lane Keeping Assist system is activated using a switch in the left switch panel next to the steering wheel.

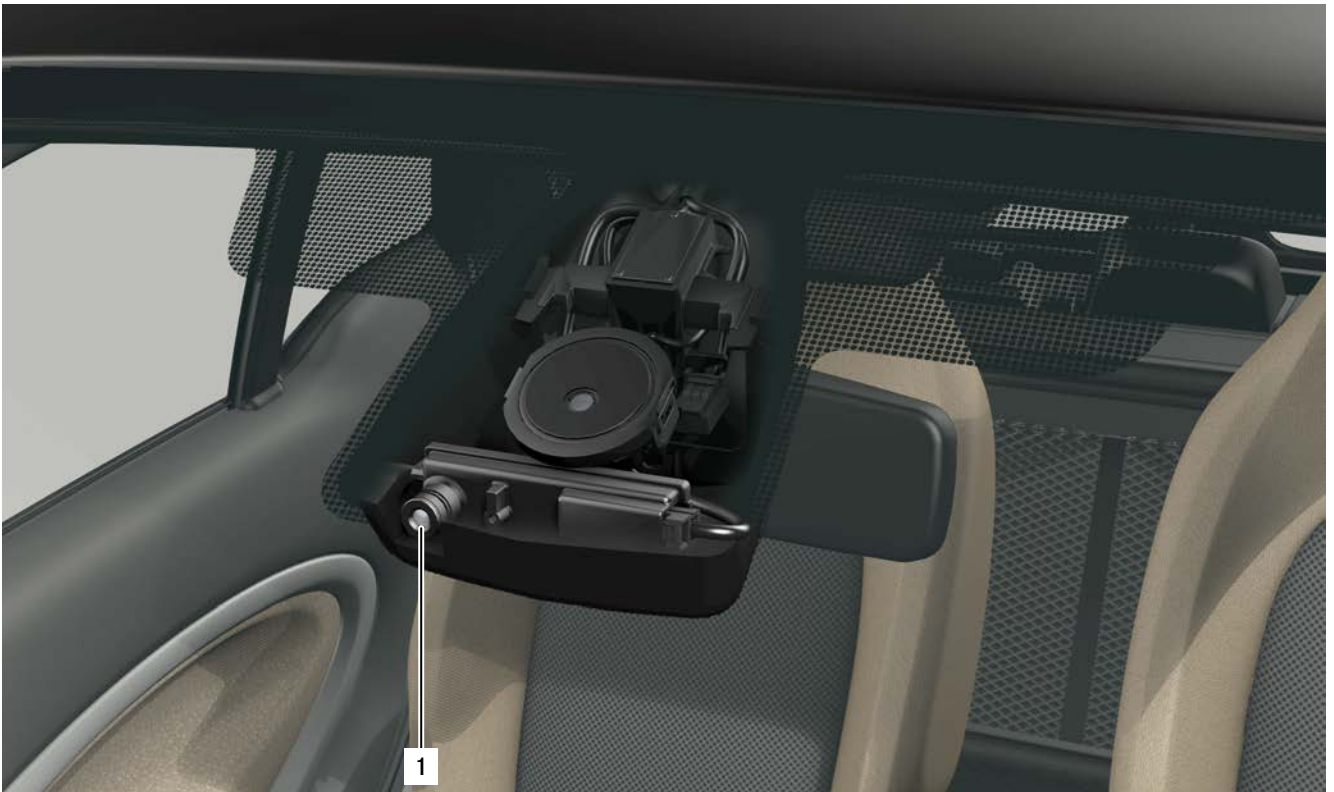

View of Lane Keeping Assist camera

P30.00-2011-00

**Tire pressure monitor**

The smart (C/W453) is equipped with directly measuring tire pressure monitor (TPM) as standard (not for all countries). On vehicles with tire pressure monitor, a sensor is attached to the valve on the inside of each wheel. While driving, the sensors transmit radio signals containing information about the pressure, temperature and rotation direction of the wheels as well as an individual identification number (to distinguish between sensors). The data which is transmitted via radio signal is received and evaluated by the SAM control unit via an integrated antenna. The tire pressure monitor issues a warning using an indicator lamp on the instrument cluster if the air pressure drops below a certain value. The TPM system has to be recalibrated when new wheels are installed.



View of wheel sensor with valve

P40.15-2591-00

## Rear parking assist

### Rear parking assist

The new smart is equipped with a rear parking assist system as special equipment. The rear parking assist system helps the driver when reversing in tight conditions.

With the aid of ultrasonic signals that are reflected by obstacles, an electronic control unit computes the distance between the vehicle and the detected obstacle. The signal transmitters and receivers are combined in the ultrasonic sensors and there are three sensors distributed along the rear bumper. There is a button to switch the function on and off positioned on the left next to the steering wheel.

If the system detects an object within the monitoring range behind the vehicle while reversing, this is indicated by an acoustic warning. The time interval between tones provides an indication of the distance remaining to the detected object. The acoustic warning varies as the vehicle approaches from long intervals through to a continuous signal.

When reverse gear is engaged with parking assist active, an acoustic notification tone sounds.



Location of ultrasonic sensors in bumper

1 Ultrasonic sensors

P54.65-5461-00

### Reversing camera

The smart is equipped with a reversing camera as special equipment to assist the driver when reversing or reversing into a parking spot. This is integrated into the licence plate recess (in the brand logo on the smart forfour). When reverse gear is engaged, the image from the wide-angle lens reversing camera is displayed on the large touchscreen display of the smart media system. Dynamic guide lines allow the particular driving path of the vehicle to be better assessed depending on the steering angle.

The camera control system features intelligent shutoff logic so that the picture is displayed continuously during a maneuver and is not turned off because reverse gear is no longer engaged.



View of reversing camera on smart coupé

P54.65-5462-00

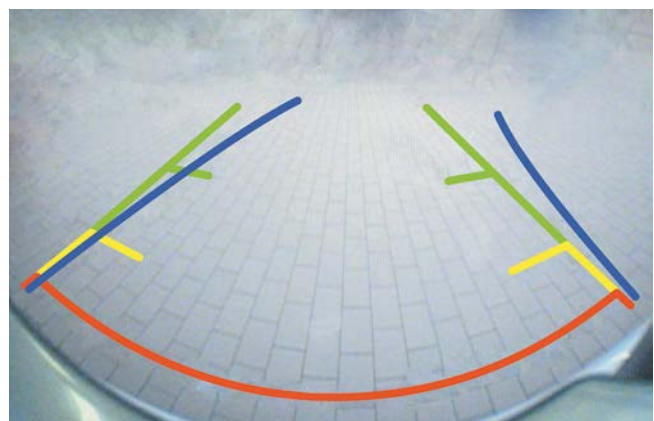

Example of camera image with guide lines

P54.65-5463-00

## Distance warning function

### Distance warning function

The distance warning function driver assistance system provides a static and dynamic distance warning in certain situations. In technical terms, the system consists of a distance warning controller unit with radar sensor and the distance warning function gateway.

### Static distance warning

A visual warning (warning lamp on instrument cluster) is triggered as soon as a vehicle is detected in front and a certain time gap between the vehicle in front is dropped below i.e. the following distance is too short. The static distance warning only operates for moving objects as of a systems vehicle speed of 30 km/h.

### Dynamic distance warning

A dynamic distance warning is triggered if the systems vehicle approaches a detected vehicle in front at high speed or high acceleration relative to the vehicle in front. In this case, both a visual and an acoustic warning are issued. The dynamic distance warning only operates for moving/stopping objects at a maximum speed of 7 km/h and for stationary objects up to 70 km/h.

### Customer benefits

The aim of the distance warning function is to inform an inattentive driver that there is a risk of a rear-end collision.

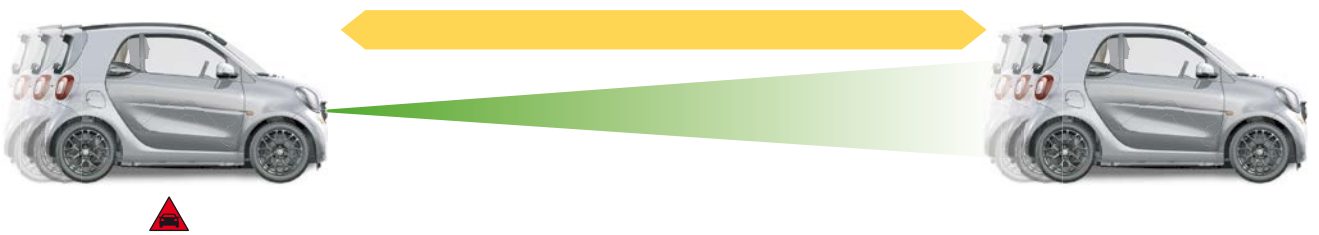

Static distance warning

P30.30-2764-00

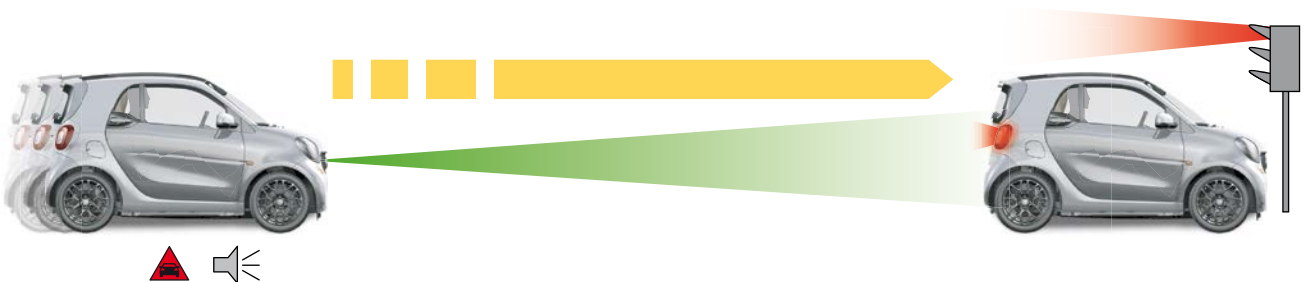

Dynamic distance warning

P30.30-2765-00



P30.30-2766-00

**View of system components of front end distance warning function**

- 1 Distance warning function controller unit with radar sensor

## Climate control

### General

Three climate control variants are available for model series 453. The basic system consists of a heater, with a manual air conditioning system without automatic temperature control or a fully automatic air conditioning system with controllable air distribution available optionally. The heater and manual air conditioning versions are equipped with a dust and pollen filter, while the automatic air conditioning system features a combination filter with activated charcoal.

### Heater and manual air conditioning system

The standard heater and optional manually controlled air conditioning system are equipped in principle with the same operating unit with rotary actuators. The three controls are used to adjust the air distribution (left), the fan setting (center) and the temperature (right). The switch for the rear window heater is also located in the control panel. In addition, the manual air conditioning features an A/C switch for switching the refrigeration system on and off.

The features of the manual air conditioning include:

- Manual adjustment of temperature, blower setting and air distribution via rotary switches
- Scale indicators on the rotary switches
- Defrost Max and recirculated air selector lever
- A/C button
- Temperature sensor in interior compartment

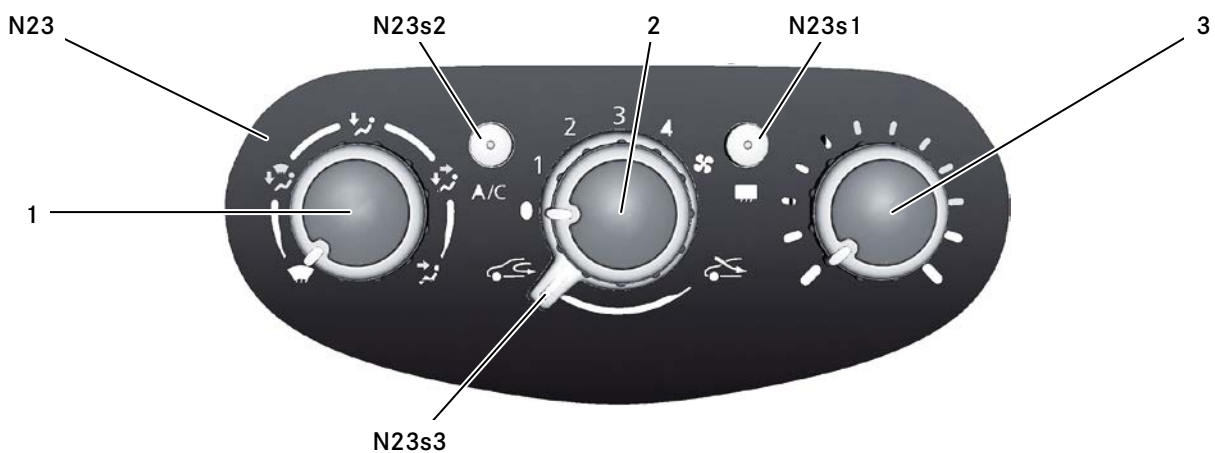

### Climate control control and operating unit (N23) (manual air conditioning)

1	Air distribution selector wheel	N23s1	Rear window heater button
2	Air flow selector wheel	N23s2	"A/C" button
3	Temperature selector wheel	N23s3	Fresh air/air recirculation mode switch

P83.30-4973-00

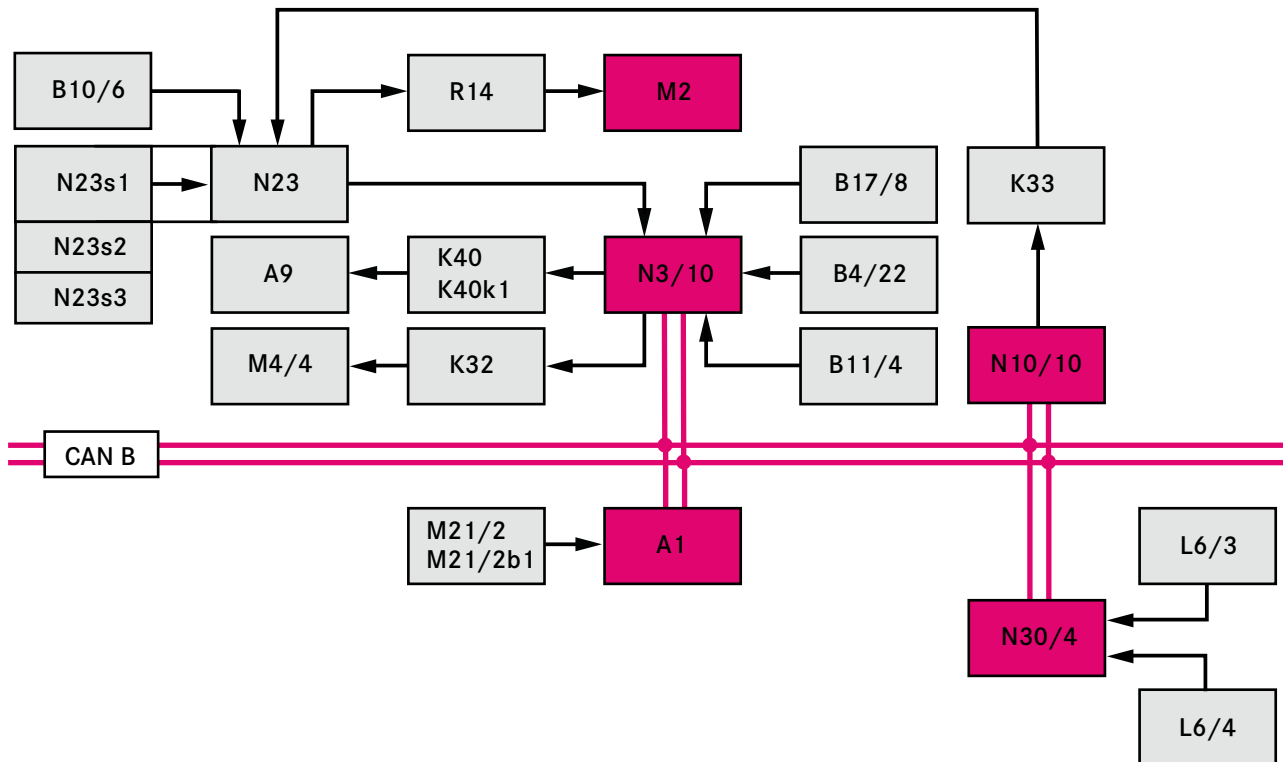

Climate control block diagram (manual air conditioning (code I77))

P83.30-4974-00

A1	Instrument cluster	M4/4	Fan
A9	Refrigerant compressor	M21/2	Right electrically adjustable and heated outside mirror
B4/22	Coolant pressure sensor	M21/2b1	Outside temperature sensor
B10/6	Evaporator temperature sensor	N3/10	ME-SFI [ME] control unit
B11/4	Coolant temperature sensor	N10/10	Center SAM control unit
B17/8	Charge air temperature sensor	N23	Climate control control and operating unit
K32	Fan solenoid switch, combustion engine cooling system (ICE)	N23s1	Rear window heater button
K33	Air conditioning power supply solenoid switch	N23s2	"A/C" button
K40	Combustion engine relay module	N23s3	Fresh air/air recirculation mode switch
K40k1	Refrigerant compressor relay	N30/4	Electronic Stability Program control unit
L6/3	Left rear axle rpm sensor	R14	Blower motor series resistor
L6/4	Right rear axle rpm sensor	CAN B	Interior CAN
M2	Blower motor		



## Climate control

### Automatic air conditioning

The automatic air conditioning system features an operating unit with a display for the temperature selection. The usual controls for the fan setting, air distribution, rear window heater, A/C on/off etc. are arranged around this display in the form of control buttons. Illuminated segments around the edge of the operating unit indicate which functions and settings are active.

On the automatic air conditioning, the functions of the manual air conditioning system are supplemented by additional comfort-related features:

- Automatic regulation of manual temperature setting
- Three sensors in addition to interior temperature sensor for climate control (sun sensor, air humidity sensors)
- Adjustment via push buttons and slider

The A/C function is activated at the same time when the AUTO button is pressed. A/C is considered part of the AUTO function and switches itself on and off automatically depending on the climate conditions in the vehicle. When the A/C button is pressed, the A/C compressor remains on or off for the current ignition sequence. If the AUTO-LED only is still on and A/C is pressed, the AUTO LED goes out even though automatic control still takes place in the background.

If AUTO and A/C are active and the customer switches off the A/C, all of the LEDs go out because the AUTO LED is linked to the A/C. However, the air flow and air distribution continue to be regulated automatically as before. Only the A/C is switched off.

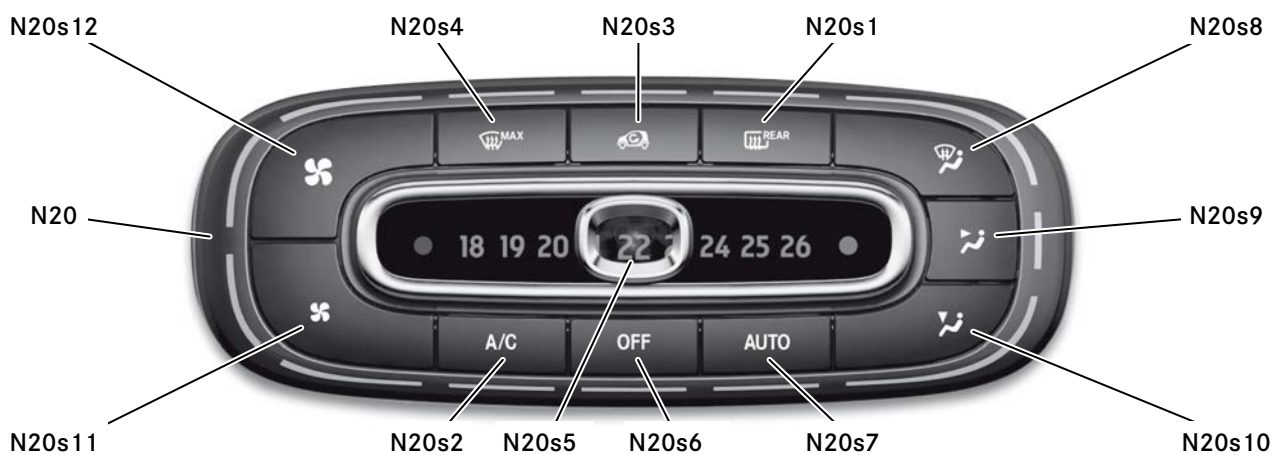

#### Climate control operating unit (N20) (automatic air conditioning)

- N20s1 Rear window heater button
- N20s2 "A/C" button
- N20s3 Air recirculation mode button
- N20s4 Defrost button
- N20s5 Temperature control
- N20s6 "OFF" button

- N20s7 "AUTO" button
- N20s8 Windshield air distribution button
- N20s9 Instrument panel air distribution button
- N20s10 Footwell air distribution button
- N20s11 Reduce air flow button
- N20s12 Increase air flow button

P83.30-4975-00

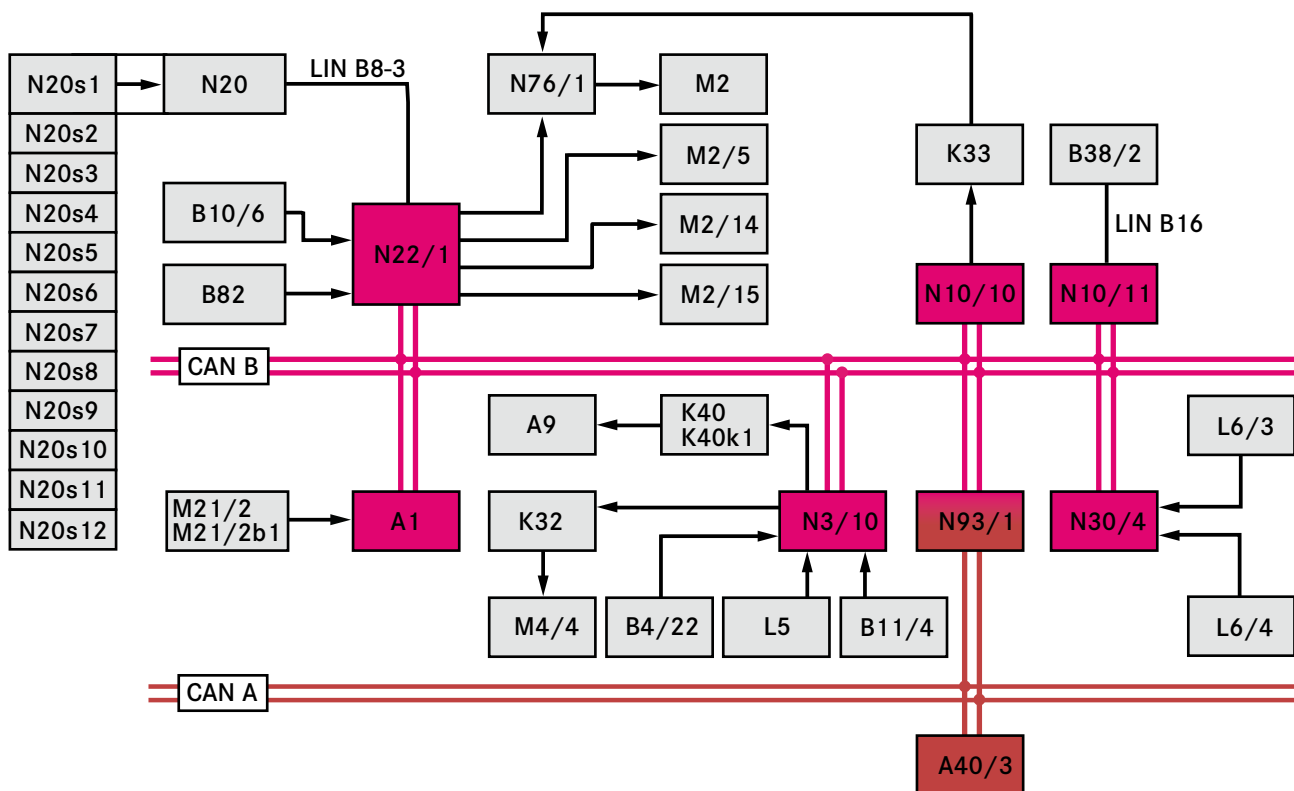

P83.30-4976-00

Climate control block diagram (Automatic air conditioning (code I01))

A1	Instrument cluster	N10/10	Center SAM control unit
A9	Refrigerant compressor	N10/11	Driver-side SAM control unit
A40/3	smart Radio Multimedia Navigator	N20	Climate control operating unit
B4/22	Coolant pressure sensor	N20s1	Rear window heater button
B10/6	Evaporator temperature sensor	N20s2	"A/C" button
B11/4	Coolant temperature sensor	N20s3	Air recirculation mode button
B31	Air quality sensor	N20s4	Defrost button
B38/2	Rain/light sensor	N20s5	Temperature control
B82	Vehicle interior humidity and temperature sensor	N20s6	"OFF" button
K32	Fan solenoid switch, combustion engine cooling system (ICE)	N20s7	"AUTO" button
K40	Combustion engine relay module	N20s8	Windshield air distribution button
K40k1	Refrigerant compressor relay	N20s9	Instrument panel air distribution button
L5	Crankshaft position sensor	N20s10	Footwell air distribution button
L6/3	Left rear axle rpm sensor	N20s11	Reduce air flow button
L6/4	Right rear axle rpm sensor	N20s12	Increase air flow button
M2	Blower motor	N22/1	Climate control control unit
M2/5	Fresh air/recirculated air flap actuator motor	N30/4	Electronic Stability Program control unit
M2/14	Blend air flap actuator motor	N76/1	Blower regulator
M2/15	Footwell flap actuator motor	N93/1	Audio gateway control unit
M4/4	Fan	CAN A	Telematics CAN
M21/2b1	Outside temperature sensor	CAN B	Interior CAN
N3/10	ME-SFI [ME] control unit	LIN B8-3	A/C operation LIN

## Climate control

### Heater and refrigerant circuit

The heat exchanger of the heater circuit has a heat output of 8.7 kW. The output of the flat-tube evaporator is 5.8 kW. The refrigerant compressor features two-stage control (on/off) and is integrated into the belt drive by a clutch.

### Preventing ice and fogging

When the Defrost Max position is activated, the maximum air flow is directed against the windshield depending on the engine temperature to remove any ice and fogging. The air conditioning is switched on to dry the air depending on the outside conditions.

The following air vent openings are distributed through the vehicle:

- Defroster vent along entire length at bottom of windshield
- Fixed side defrosters on side of cockpit
- Swiveling center air vents pointing into the passenger compartment
- Swiveling round side air vents
- Cross duct with two outlets in the footwell for driver and front passenger

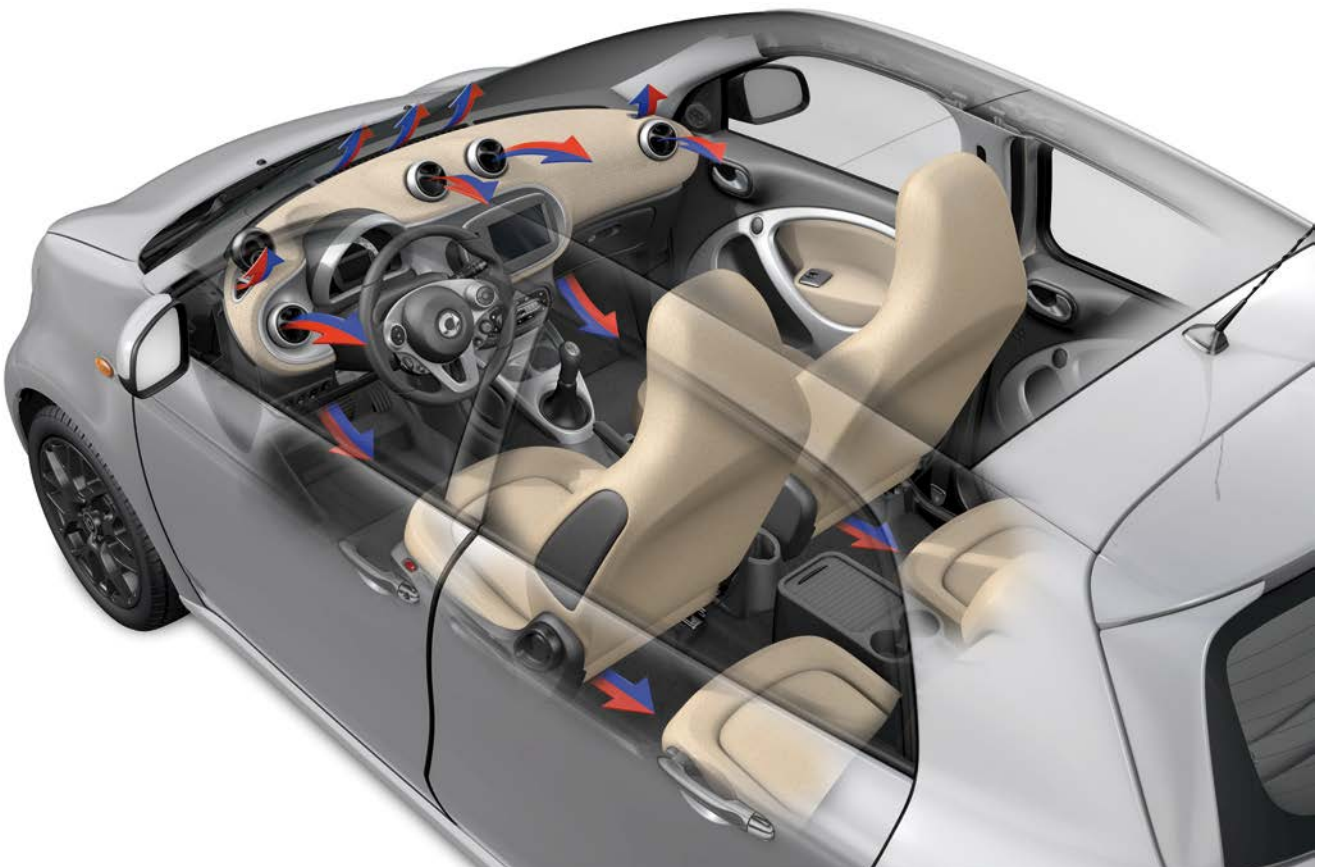

P83.10-2901-00

Air outlets of the interior climate control system

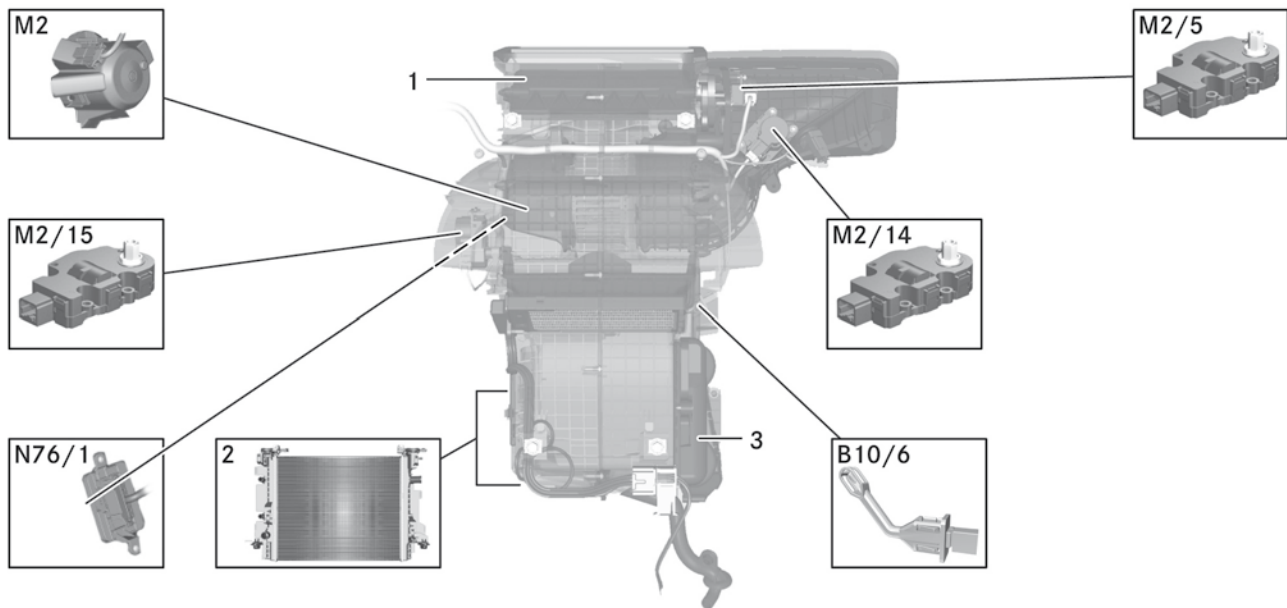

#### Climate control system components, code (I01) Automatic air conditioning

1	Air conditioner housing
2	Condenser
3	Heat exchanger
B10/6	Evaporator temperature sensor
M2	Blower motor

M2/5	Fresh air/recirculated air flap actuator motor
M2/14	Blend air flap actuator motor
M2/15	Footwell flap actuator motor
N76/1	Blower regulator

P83.00-2415-00

# Climate control

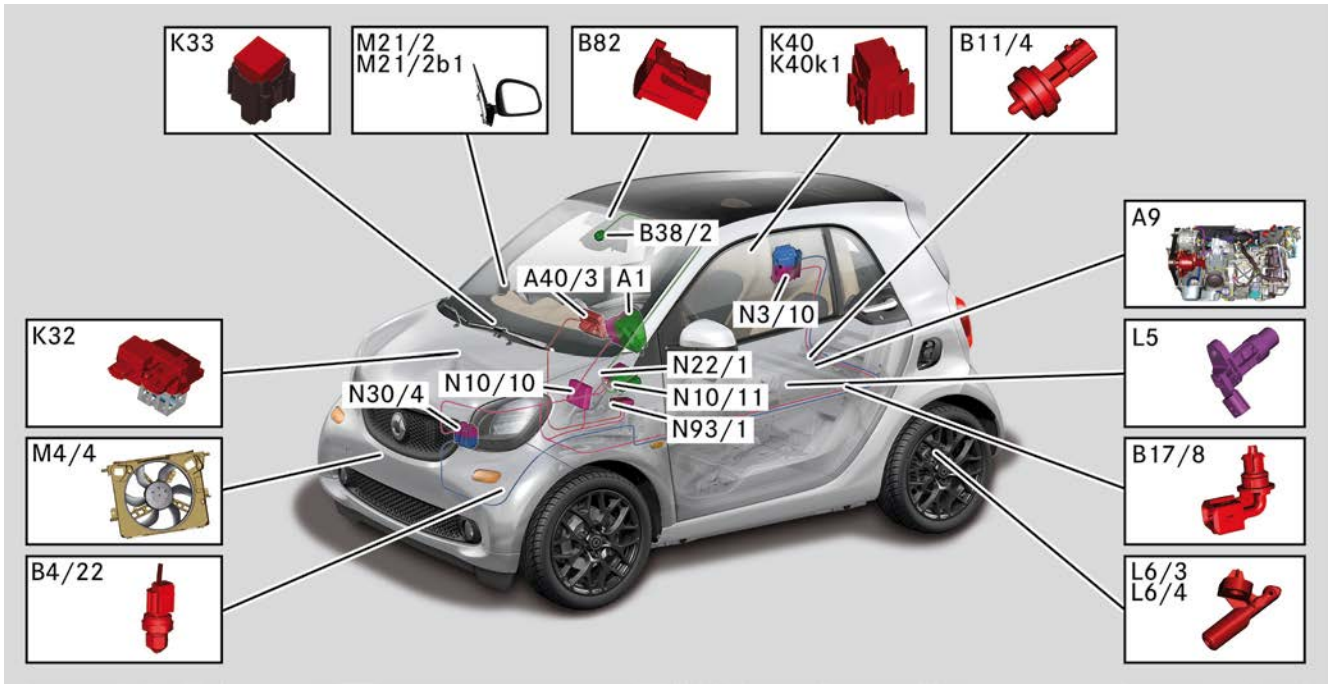

P83.00-2416-00

### Overview of climate control system components

A1	Instrument cluster	L5	Crankshaft position sensor (only with code (I07))
A9	Refrigerant compressor	L6/3	Left rear axle rpm sensor
A40/3	smart Radio Multimedia Navigator (only with code (I07))	L6/4	Right rear axle rpm sensor
B4/22	Coolant pressure sensor	M4/4	Footwell flap actuator motor
B11/4	Coolant temperature sensor	M21/2	Right electrically adjustable and heated outside mirror
B17/8	Charge air temperature sensor (only with code (I77))	M21/2b1	Outside temperature sensor
B38/2	Rain/light sensor (only with code (I07))	N3/10	ME-SFI [ME] control unit
B82	Vehicle interior humidity and temperature sensor (only with code (I07))	N10/10	Center SAM control unit
K32	Fan solenoid switch, combustion engine cooling system (ICE)	N10/11	Driver-side SAM control unit (only with code (I07))
K33	Air conditioning power supply solenoid switch	N22/1	Climate control control unit (only with code (I07))
K40	Combustion engine relay module	N30/4	Electronic Stability Program control unit
K40k1	Refrigerant compressor relay	N93/1	Audio gateway control unit (only with code (I07))

**Power windows**

The new smart features power windows as standard equipment.

Operation of the power windows is carried out using the driver-side power window switch group and the passenger-side power window switch group. The controls are located in the armrest of the respective door panel.

The electric power window function is split into manual and automatic opening and closing.

**Manual opening and closing**

Pulling or pushing the power window switch as far as the actuation point opens or closes the window according to the actuation direction. When the power window switch is released, the window stops in its current position.

**Automatic opening and closing**

Briefly pulling the power window switch beyond the actuation point causes the window on the driver or passenger side to move to the fully open position automatically.

It is closed automatically in the same way by operating the switch in the other direction.



P72.29-2831-00

View of power window switch group, driver side



P72.29-2832-00

View of power window switch, passenger side

Power windows

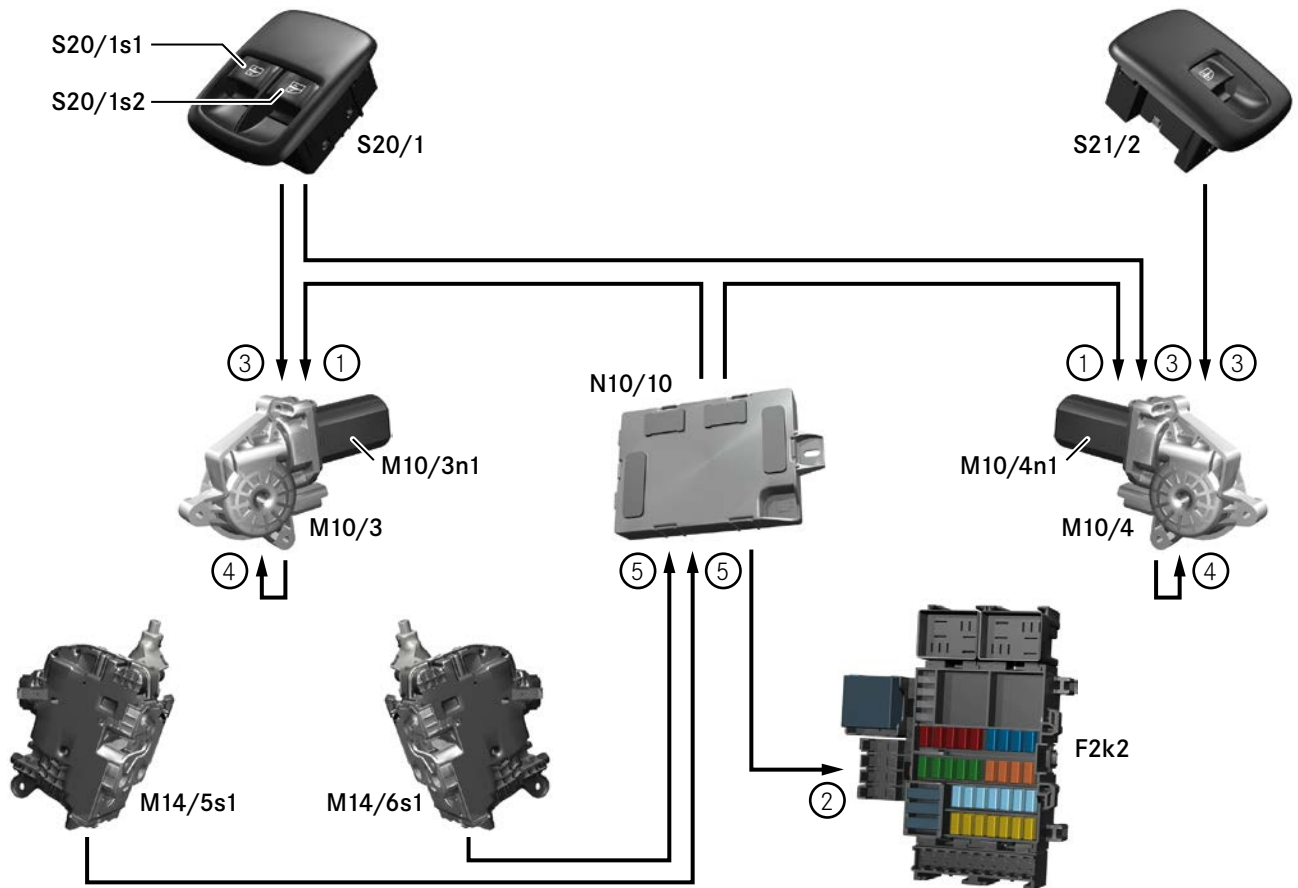

P72.29-2833-00

Data flow chart of power windows with convenience feature and anti-pinch protection

1	Power window enable signal	M10/4	Right front power window motor
2	Power window power supply, actuation	M10/4n1	Right front power window motor actuation unit
3	Power window, request	M14/5s1	Front passenger door central locking microswitch
4	Power window motor, actuation	M14/6s1	Driver door central locking microswitch
5	Central locking microswitch, status	S20/1	Power window switch group, driver side
F2k2	Front power window relay	S20/1s1	Left front power window switch
M10/3	Left front power window motor	S20/1s2	Right front power window switch
M10/3n1	Left front power window motor actuation unit	S21/2	Power window switch, passenger side

**Seat heater**

As on the predecessor model series, seat heaters are available for the driver and front passenger seat as special equipment.

These consist of two heating elements connected in series on the driver and front passenger seat respectively, which are installed in the seat bolster and backrest padding.

The seat heaters are activated separately for each side using the left or right front seat heater switch and are controlled by the driver/front passenger seat heater control unit integrated in the front seat surface heater pad.

Pressing the left or right front seat heater switch again deactivates the seat heater.

**Automatic shutoff due to overtemperature**

If the seat heater control unit detects overtemperature via the integrated seat heater temperature sensor, it shuts off the power supply to the heater pads. Once the heater pad temperature has dropped below the specified value again, the seat heater control unit switches the power supply back on. During this process, the LED status indicator in the front seat heater switch remains switched on.

**Automatic time-based shutoff**

If the seat heater has been active for 12 minutes, seat heater control unit automatically switches off the seat heater and the LED status indicator in the seat heater switch goes out.



View of front seat heater switch

P91.30-2652-00



## Anti-theft alarm system

### Anti-theft alarm system (ATA)

An anti-theft alarm system is available as special equipment in the new smart.

The customer can choose between two variants of the anti-theft alarm system.

- Anti-theft alarm system (code V19)
- Anti-theft alarm system with interior monitoring and tow-away protection (code 885)

On vehicles with code (V19), the SAM control unit is the master control unit for the anti-theft alarm system.

If the vehicle is locked with the transmitter key, the anti-theft alarm system function is activated.

When armed, the SAM control unit monitors the central locking microswitches of the vehicle doors, the liftgate and the ATA switch on the battery. If it detects a status change in the central locking microswitches or ATA switch on the battery, it actuates the turn signal lights and the horn.

Vehicles with code (885) are equipped with ultrasonic sensors in the interior, a sensor for tow-away protection, a battery-buffered alarm horn and a controller unit.

### Tow-away protection

If the position of the vehicle is changed, the ATA inclination sensor detects this and sends a message to the ATA control unit, which then triggers the alarm.

### Interior protection

Interior protection is activated approx. thirty seconds after the vehicle is locked.

Using the ultrasonic sensors mounted centrally on the headliner of the vehicle, the ATA control unit monitors the incoming and outgoing wave patterns. If anything enters the vehicle without authorization, these change significantly and an alarm is triggered.

### Alarm output

The alarm is output via the battery-buffered alarm horn.

### Drive authorization system

The drive authorization system of the new smart represents a system network of the following components:

- Center SAM control unit (N10/10)
- Transponder coil (L11)
- Vehicle key (A8/1)
- ME-SFI [ME] control unit (N3/10)
- Electronic Stability Program control unit (N30/4)
- Dual clutch transmission control unit (N15/13) (with automatic transmission)

If the key is turned to the position "Ignition ON" in the ignition lock, data is exchanged between the vehicle key and the transponder coil. The center SAM control unit receives the data of the vehicle key from the transponder coil and evaluates it.

At the same time, the center SAM control unit initiates authentication of the Electronic Stability Program control unit and the dual clutch transmission control unit via CAN bus. If the authentication of both control units is successful and the vehicle key is recognized as belonging to the vehicle, the center SAM control unit sends an enable signal to the engine control unit. The vehicle can now be started.

### Central locking

The central locking system is part of the standard equipment on model series 453.

As on the predecessor model series, the master control unit of the central locking is the center SAM control unit.

The central locking system comprises locking and unlocking of the vehicle doors as well as opening of the trunk lid/liftgate.

The following operating possibilities are available to the customer:

- Locking and unlocking with the transmitter key
- Manual unlocking with the transmitter key at the driver door lock
- Locking or unlocking via the instrument panel switch group
- Remote liftgate/trunk opening via transmitter key
- Opening of liftgate/trunk lid via handle switch

The vehicle doors can always be opened from the inside with the door handle at a vehicle speed of < 7 km/h, regardless of the status of the central locking. This unlocks all of the vehicle doors.

### Automatic functions

If the vehicle exceeds a speed of 7 km/h, the doors are automatically locked by the center SAM control unit. This function can be activated and deactivated with a locking switch. This function is deactivated by default.

The vehicle is also automatically locked by the center SAM control unit if the vehicle doors are not opened two minutes after the vehicle is unlocked.

If a crash signal is sent out by the Supplemental Restraint System control unit in the event of an accident, all of the vehicle doors are unlocked by the central locking.



P80.20-3876-00

View of liftgate of C 453

1 Handle switch



P80.20-3877-00

View of liftgate of W453

1 Handle switch

#### **Note**

The radio signal for unlocking the door is picked up by an antenna integrated in the SAM control unit. There is no external antenna for the central locking.

## Telematics

### General

The following equipment is available for the new smart:

- Radio preinstallation (code C08)
- smart audio system
- smart media system
- Digital radio (DAB) (code C04)
- JBL sound system including removable subwoofer in trunk

### Radio preinstallation (code C08)

A radio preinstallation consisting of speaker cables in the front doors, two front speakers, 1-DIN slot and FM/AM antenna is available for retrofitting a radio. The vehicle can also be purchased without a radio preinstallation. It is then no longer possible to retrofit a radio.

### smart audio system

A radio with the following features is installed as special equipment:

- FM/AM single tuner with the three memory levels of FM1, FM2 and AM (vehicles equipped with "Digital radio (DAB)" special equipment additionally feature DR1 and DR2 memory levels),,
- Two USB connections for USB media
- Media player connection for MP3 and AAC formats
- AUX jack
- Bluetooth® audio streaming
- Telephone connectivity via Bluetooth®

Other functions such as RDS functions and manual updating of the radio station list with currently available stations are also included.

The sound settings (bass, treble, fader (S4S only) and balance) can be adjusted. The sound settings are the same for all audio sources (radio, USB). Separate volume adjustment for audio and telephone is another feature. The volume can also be controlled via the multifunction steering wheel.

The information is displayed on a matrix display. The display is located on the front of the smart audio system in the instrument panel underneath the center air vents.



P82.60-9470-00

smart audio system

### smart media system

A radio with navigation system and touch operation is available as a further option. The system can be operated quickly and intuitively using the 7-inch display and the control buttons (hard keys) positioned to the left of it. In combination with a multifunction steering wheel, operation is also possible via voice command.

The unit has the following features:

- Multimedia Connectivity Hub in center console (1 USB, 1 SD, 1 AUX)
- smart media system with/without DAB digital radio reception (standard or special equipment depending on country)
- 7-inch touchscreen
- Communications module with integrated SIM card



smart media system

P82.89-1612-00

## Telematics

### Multimedia Connectivity Hub

The new smart features a "Multimedia Connectivity Hub" in the center console for connecting and playing back the music files stored on an SD card, USB stick or iOS device. This hub has the following connection options:

- 1 x SD card
- 1 x USB, iPod via USB
- AUX jack

The Multimedia Connectivity Hub is a part of the smart media system.

To use the navigation function, the navigation SD card must be permanently inserted in the SD card slot of the Multimedia Connectivity Hub.

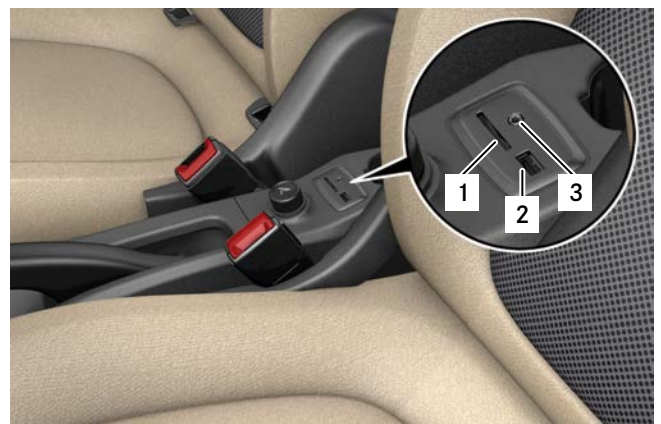

P82.60-9471-00

### Multimedia Connectivity Hub

- 1 SD card
- 2 USB port
- 3 AUX jack

**Digital radio (DAB)**

The new smart is equipped with digital radio as special equipment (standard or special equipment depending on country). Digital radio reception is possible with the smart audio system and smart media system. The features of the latest generation of digital radio include:

- Support for DAB and DAB+ audio codes
- Detection/display of names of all currently available stations and ensembles (DAB dual tuner)
- Detection/display of EPG data (Electronic Program Guide) such as start and finish time of programs (depending on station support)
- Simulcasting between DAB stations with identical station identifier (only on smart media system)
- Simulcasting between DAB and
- FM stations under regular conditions with largely unnoticeable switching (seamless linking) (only on smart media system)
- Display of radio text (dynamic label) from the current radio station
- DAB station memory for twelve stations
- Reception capability for DAB band-III frequency band

**Antenna systems**

The smart is equipped with different antenna systems depending on the vehicle variant.

The two-seater is equipped with a modern film antenna behind the left front fender. The four-seater has a conventional rod antenna on the rear roof edge.

**Telephony**

The mobile telephone of the customer is connected via Bluetooth® to the smart audio system and smart media system.

## Telematics

### Speaker systems

Two bass/midrange speakers are installed in the front doors for the smart audio system.

On vehicles equipped with the smart media system, two tweeters are installed in the mirror triangles and two bass/midrange speakers in the front doors, with two additional bass/midrange speakers in the rear doors of the four-door model.



P82.62-4217-00

**View of speakers in front door**

- 1 Bass/midrange speaker
- 2 Tweeter



P82.62-4218-00

**View of bass/midrange speaker in rear door**

- 1 Bass/midrange speaker

### Sound system with removable bass box

For more volume and listening pleasure, an optional sound system is available. In order to increase the transport capacity in the trunk, the bass box can be removed easily. The sound system comes with an additional amplifier and additional speakers.

In the two-seater\_

- 1 broadband center speaker
- 2 tweeters in mirror triangle with JBL Brand chrome ring
- 2 bass/midrange speakers in the front doors
- An 8 x 40 watt amplifier (240 watt)
- 2 broadband rearfill speakers
- and a Design bass box on the left of the trunk which can be removed without tools

In the four-seater:

- 1 broadband center speaker
- 2 tweeters in mirror triangle with JBL Brand chrome ring
- 2 bass/midrange speakers in the front doors
- An 8 x 40 watt amplifier (320 watt)
- 2 tweeters and 2 bass/midrange speakers in the rear doors
- 2 broadband rearfill speakers
- and a Design bass box on the left of the trunk which can be removed without tools



View of Design bass box (removable without tools)

P82.62-4219-00



## Bodyshell

### Bodyshell structure

The bodyshell of model series 453 is basically a further developed version of the predecessor with adaptations. These relate to the changes in boundary conditions, such as the shared platform with the smart forfour, its production at various production locations and advanced technical requirements, particularly in relation to crashes (e.g. stricter rating requirements, USA).

The development process took into account both the requirements of the powerplant variants with conventional combustion engine and the requirements of the subsequently planned variants with electric motor.

Specific crash requirements for markets in Europe, Asia and America were also incorporated in the development process.

The most important features of this shared platform include:

- Special yielding crossmembers under the windshield
- Center tunnel designed as a closed section
- No longitudinal members under the main floor
- Central connection of De Dion rear axle
- Realization of a load stage through different mounting points for the integral carrier variants (for requirement-based adaptation to vehicle weight and crash design)
- V-shapes as additional load path (smart fortwo only)

Each individual bodyshell element has been developed to suit the loads it will encounter in terms of its geometry, material thickness, joining technology and material quality.

In contrast to the predecessor model series 451, the bodyshell of model series 453 has a greater proportion of ultrahigh strength, press-hardened steels as well as ultrahigh strength multiphase steels (27 % in two-seater/24 % in four-seater) in order to fulfill passive safety requirements. These are used both in the sidewalls and to a large extent in the substructure as well, particularly on the two-seater.

The bodyshell of the new smart is subdivided into the following assemblies:

- Front end
- Front end with firewall
- Substructure including rear end structure
- Left/right side wall
- Roof

### Front end

The front end largely consists of plastic assembly parts as well as a bolted flexural member with crashboxes made of ultrahigh strength sheet steel (for ease of replacement in event of repair).

The different crashboxes are matched to the different vehicle weights:

- Light two-seater
- Heavy two-seater and four-seater

### Front end with firewall

The front end structure largely consists of the front longitudinal members with integrated front integral carrier mounts, the suspension strut supports, the inner A-pillar structure including second longitudinal member plane and connecting carriers with integrated rear integral carrier mounts (for two integral carrier variants). The firewall and a crossmember which meets pedestrian protection requirements under the windshield form the boundary to the interior compartment.

In the event of a collision, the loads are distributed through the front end elements, the A-pillars, the crossmember and the connecting carrier towards the rocker panels, center tunnel, roof structure and doors.

### Sidewall

The sidewall of the new smart has a three-piece structure across almost its entire length. This consists of an inner sidewall, a reinforcing frame and a one-piece panel.

To provide optimal protection in the event of a collision and maintain the integrity of the tridion safety cell, the reinforcement frame largely consists of high strength and ultrahigh strength steels.

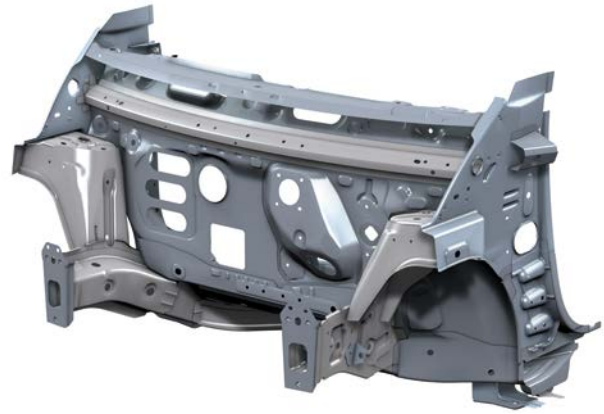

View of front end with firewall

P62.00-2117-00



Sidewall of C453

P63.10-5289-00

## Bodyshell

### Substructure

Instead of using two parallel longitudinal members, the substructure in the area of the main floor is formed from a center tunnel designed as a closed section. The reason for this was to take into account the powerplant variant with electric motor and the resulting requirement to accommodate the batteries.

### Roof

The following roof variants are possible depending on the vehicle variant.

#### Roof variants of C453

- Fixed roof with sandwich design
- Transparent panoramic roof made of polycarbonate with fabric roller blind

#### Roof variants of W453

- Roof made of sheet steel
- Panoramic glass roof with fabric roller blind
- Electric folding/sliding roof (fabric)

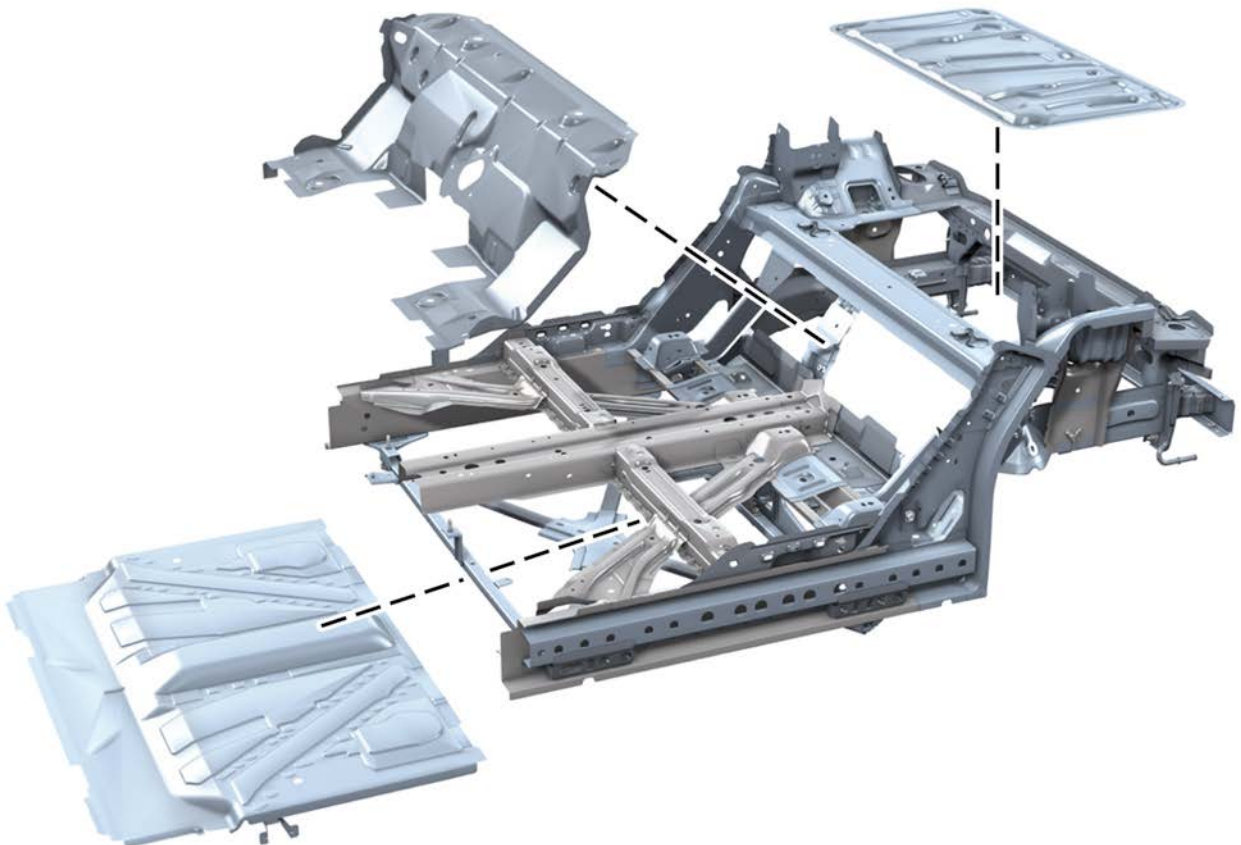

View of substructure

P61.00-2059-00

P40.00-3045-00



Bodyshell structure of C453



P60.00-3046-00

Bodyshell structure of W453



Main load paths in bodyshell during head-on collision C453

P60.00-3047-00



Main load paths in bodyshell during side impact C453

P60.00-3048-00

Force progression during an accident



Main load paths in bodyshell during head-on collision W453

P60.00-3049-00



Main load paths in bodyshell during side impact W453

P60.00-3050-00

**Front fenders**

The front fenders are made of plastic in order to reduce weight.

**Front hood**

The front hood is also made of plastic and is only intended to be opened for servicing or maintenance.

**Doors**

The doors of the smart forfour have a conventional steel construction with window frames, while the doors of the smart fortwo coupé are frameless.

The door panels on the smart fortwo coupé are made of plastic. The smart forfour has a conventional door construction with sheet steel paneling.

**Split liftgate and rear-end door**

As previously, the liftgate of the smart fortwo coupé has a two-piece design. The paneling of the lower section is made of plastic.

The smart forfour has a rear-end door which is hinged at the top, with a steel structure, a fixed rear window and plastic paneling.

**Bumper covers and longitudinal member panels**

The front and rear bumper covers are made of plastic. Depending on the color variant, the plastic parts are supplied either as colored plastic or with 2-coat metallic paintwork.



View of coupé paneling

P88.00-2575-00



## Chassis

## Lowering pin

<b>Use</b>	For lowering the rear module for repair purposes
<b>MB number</b>	W453 589 00 62 00
<b>FG</b>	-
<b>Set</b>	-
<b>Category</b>	Basic Operations Mandatory/No Exemptions
<b>Note</b>	Only in combination with GOTIS assignment: A-01-01 Major assembly lifting platform, GOTIS assignment: A-01-01 Universal mount, Adapter W453 589 01 62 00

## Clamping plates

<b>Use</b>	For removing/installing the front axle springs
<b>MB number</b>	W453 589 00 63 00
<b>FG</b>	-
<b>Set</b>	-
<b>Category</b>	Basic Operations Mandatory/Approved for Cooperation
<b>Note</b>	Only in combination with tensioning device W203 589 01 31 00

## Adapter

<b>Use</b>	For measuring the vehicle axle geometry
<b>MB number</b>	W453 589 01 31 00
<b>FG</b>	-
<b>Set</b>	-
<b>Category</b>	Basic Operations Mandatory/Approved for Cooperation
<b>Note</b>	Only in combination with quick clamping device W124 589 01 31 00

**Adapter**

<b>Use</b>	For removing/installing the entire engine with transmission
<b>MB number</b>	W453 589 01 62 00
<b>FG</b>	-
<b>Set</b>	-
<b>Category</b>	Basic Operations Mandatory/Approved for Cooperation
<b>Note</b>	Only in combination with GOTIS assignment: A-01-01 Major assembly lifting platform, GOTIS assignment: A-01-01 Universal mount

**Pliers**

<b>Use</b>	For removing rubber hangers of exhaust system
<b>MB number</b>	W453 589 00 37 00
<b>FG</b>	-
<b>Set</b>	-
<b>Category</b>	Basic Operations Recommended
<b>Note</b>	-

**Drift**

<b>Use</b>	For installing the radial shaft sealing rings on the output side of the differential
<b>MB number</b>	W700 589 10 15 00
<b>FG</b>	-
<b>Set</b>	-
<b>Category</b>	Basic Operations Mandatory/No Exemptions
<b>Note</b>	-

## Engine/transmission

### Blocking device

<b>Use</b>	For locking the crankshaft belt pulley in place
<b>MB number</b>	W281 589 00 40 00
<b>FG</b>	-
<b>Set</b>	-
<b>Category</b>	Basic Operations Mandatory/No Exemptions
<b>Note</b>	-

### Lifting eye

<b>Use</b>	For hanging up the engine for various repair processes
<b>MB number</b>	W281 589 00 61 00
<b>FG</b>	-
<b>Set</b>	-
<b>Category</b>	Basic Operations Mandatory/No Exemptions
<b>Note</b>	Only in combination with engine hoist W639 589 00 61 00, Supports W451 589 01 62 00

### Holding device

<b>Use</b>	For adjusting the timing and holding the camshafts in place when replacing the timing chain and camshaft sprockets.
<b>MB number</b>	W281 589 01 40 00
<b>FG</b>	-
<b>Set</b>	-
<b>Category</b>	Special Operations
<b>Note</b>	-

---

**Support**

---

<b>Use</b>	For supporting the frame when installing the windshield
------------	---

---

<b>MB number</b>	W453 589 00 40 00
------------------	-------------------

---

<b>FG</b>	-
-----------	---

---

<b>Set</b>	-
------------	---

---

<b>Category</b>	Basic Operations Mandatory/No Exemptions
-----------------	--

---

<b>Note</b>	-
-------------	---

---

---

**Calibration device**

---

<b>Use</b>	For calibrating the camera for the Lane Keeping Assist system
------------	---

---

<b>MB number</b>	W000 589 03 21 00
------------------	-------------------

---

<b>FG</b>	-
-----------	---

---

<b>Set</b>	-
------------	---

---

<b>Category</b>	Special Operations
-----------------	--------------------

---

<b>Note</b>	-
-------------	---

---

## Body repair systems

The following packages will be available for model series C/W453 to supplement the existing body straightening systems of CELETTE, CAR BENCH and CAR-O-LINER respectively:

Manufacturer	CELETTE	CAR BENCH	CAR-O-LINER
<b>Article</b>	Straightening and portal straightening set	Construction plan	Data sheet
<b>Order number</b>	7453.5A (Basic straightening tool set) 7453.8A (Basic portal tool set)	A4170600/EVO A4170601/EVO	24:123 C 24:124 NAFTA/EV 24:125 W 24:126 NAFTA/EV
<b>Note</b>		Only available in combination with PAC.SA/8 or complete as PACDIMA.8 (Mercedes-Benz basic system). If using the previously specified universal straightening set A 353, note that this must be upgraded to the A 353 EVO with supplementary kit A 353 KITEVO.	To use straightening tool set EVO 3.3, the EVO 1-3.1 standard package as well as straightening frame and electronic measuring system are required. Details are available in the Mercedes-Benz System Catalog. This is available directly from CAR-O-LINER.

<b>ABS</b> Anti-lock Braking System	<b>ESP®</b> Electronic Stability Program
<b>AG</b> Stock corporation	<b>ETS</b> Electronic Traction System
<b>AM</b> Amplitude Modulation	<b>EVOH</b> Ethylene Vinyl Alcohol (thermoplastic)
<b>ASR</b> Acceleration skid control	<b>FCW</b> Forward Collision Warning (distance warning function)
<b>ATO</b> Automotive Technology Organization	<b>FM</b> Frequency Modulation
<b>AUX</b> Auxiliary input for audio signals	<b>GF</b> Basic knowledge - Functions, as-built configurations
<b>BAS</b> Brake Assist System	<b>GMR</b> Yaw moment control
<b>BOW</b> Requirement-based maintenance	<b>GSP</b> Global Service & Parts
<b>CAN</b> Controller Area Network (serial bus system)	<b>HDPE</b> High-Density Polyethylene
<b>DAB</b> Digital Audio Broadcasting	<b>HT</b> High Temperature
<b>DCT</b> Digital Audio Broadcasting	<b>ISO-FIX</b> Mounting system for child seats
<b>DIN</b> Deutsches Institut für Normung (German Standards Institute)	<b>LCD</b> Liquid Crystal Display
<b>DSB</b> Digital Service Booklet	<b>HDPE</b> High-Density Polyethylene
<b>DSP</b> Digital Signal Processor	<b>LDW</b> Lane Departure Warning
<b>ECE</b> Economic Commission for Europe	<b>LED</b> Light-Emitting Diode
<b>EDW</b> Anti-theft alarm system (ATA)	<b>LHD</b> Left-Hand Drive
<b>EPG</b> Electronic Program Guide	<b>LIN</b> Local Interconnect Network (serial communication system)

## Abbreviations

**ME**

Motor Electronics (ME-SFI)

**MP3**

MPEG Audio Layer 3

**NT**

Low temperature

**NVH**

Noise, Vibration and Harshness

**RDK**

Tire pressure monitor (TPM)

**RDS**

Radio Data System, for transmitting additional information via radio broadcasts

**RoW**

Rest of World

**ROZ**

Research octane number (RON)

**SA**

Special equipment

**SAM**

Signal acquisition and actuation module

**TFT**

Thin Film Transistor

**TPO**

Thermoplastic PolyOlefin

**USB**

Universal Serial Bus

**WIA**

Maintenance interval display

**WIS**

Workshop Information System

- A**
- Air conditioning 10, 11, 18, 33, 86, 87, 88, 89, 90, 92
  - Ambiance illumination 74
  - Antenna systems 101
  - Automatic air conditioning 88
- B**
- Bodyshell structure 57, 104, 107, 108
  - Brake system 61
- C**
- Central locking 71, 74, 94, 96, 97
  - Charging 43
  - Cooling system 46
  - Crosswind Assist 9, 13, 61, 75, 78, 79
  - Cruise control with variable speed limiter 75, 78, 79
- D**
- Dampening 58, 59
  - Digital radio 9, 14, 98, 101
  - Dimensional concept 8
  - Dimensions 22
  - Distance warning function 9, 13, 35, 66, 68, 69, 75, 78, 84, 85, 117
- E**
- Economy mode 55
  - Equipment 34, 55, 102
  - Exhaust system 17, 18, 20, 47, 113
- F**
- Front axle 56, 58, 71
  - Front end 104, 105
  - Front end 104, 105
  - Front fog lamps 12, 18, 35, 72
  - Fuel tank 48, 49
  - Fuses 69
- G**
- Gateway 66, 68, 69, 84, 89, 92
- H**
- Headlamp range adjustment 72
  - Headlamps 19, 72
- I**
- Innovations 9
  - Instrument cluster 15, 16, 17, 30, 34, 35, 40, 48, 66, 68, 70, 71, 80, 81, 84, 87, 89, 92
  - Instrument panel 15, 16, 17, 30, 32, 33, 34, 72, 88, 89, 97, 33
  - Integral carrier 56
  - Interior design 30, 31
- L**
- Lane Keeping Assist 9, 13, 16, 17, 75, 78, 80, 117
  - Load compartment variants 27
  - Lubricant supply 51
- M**
- Maintenance concept 40
  - Maintenance interval display 40, 118
  - Maintenance points 41
  - Maintenance 40, 41, 111, 117
  - Multimedia Connectivity Hub 99, 100
- N**
- Navigation system 18, 99
  - Networking 65, 69
  - On-board electrical system battery 69
- P**
- Panoramic roof 14, 17, 28, 30, 28
  - Parking brake 61
  - Power windows 14, 93, 94
- R**
- Rear axle 40, 49, 56, 57, 58, 59, 61, 71, 87, 89, 92
  - Rear lamps 20, 73
  - Rear parking assist 9, 13, 75, 78, 82
  - Restraint system 77
  - Reversing camera 9, 20, 75, 78, 83
  - Roof , 104, 27



## Index

---

### S

Seat belts 12, 76  
Seat heater 14, 16, 95  
Seats 9, 15, 16, 17, 30, 31, 37, 39  
Selector lever module 55, 66, 68, 71  
Shift mechanism 51, 53  
Sidewall 104, 105  
Sound system 9, 14, 66, 68, 98, 103  
Speakers 102, 103  
Steering 57, 60  
Stowage compartments 32  
Stowage compartments 32  
Substructure 104, 106  
Suspension variants 59  
Suspension 56, 58, 59

### T

Telephony 101  
Tire pressure monitor 13, 35, 75, 78, 81, 118

### V

Vehicle concept 8

